

AD-A045 584

ARMY CONCEPTS ANALYSIS AGENCY BETHESDA MD  
A COMPUTER MODEL FOR THE ASSESSMENT OF RAID TRACKS THROUGH HIMA--ETC(U)  
JUL 77 J J CONNELLY

F/G 15/3

UNCLASSIFIED

CAA-TP-77-5

NL

1 OF 1  
AD  
A045584



END  
DATE  
FILMED  
11 - 77  
DDC

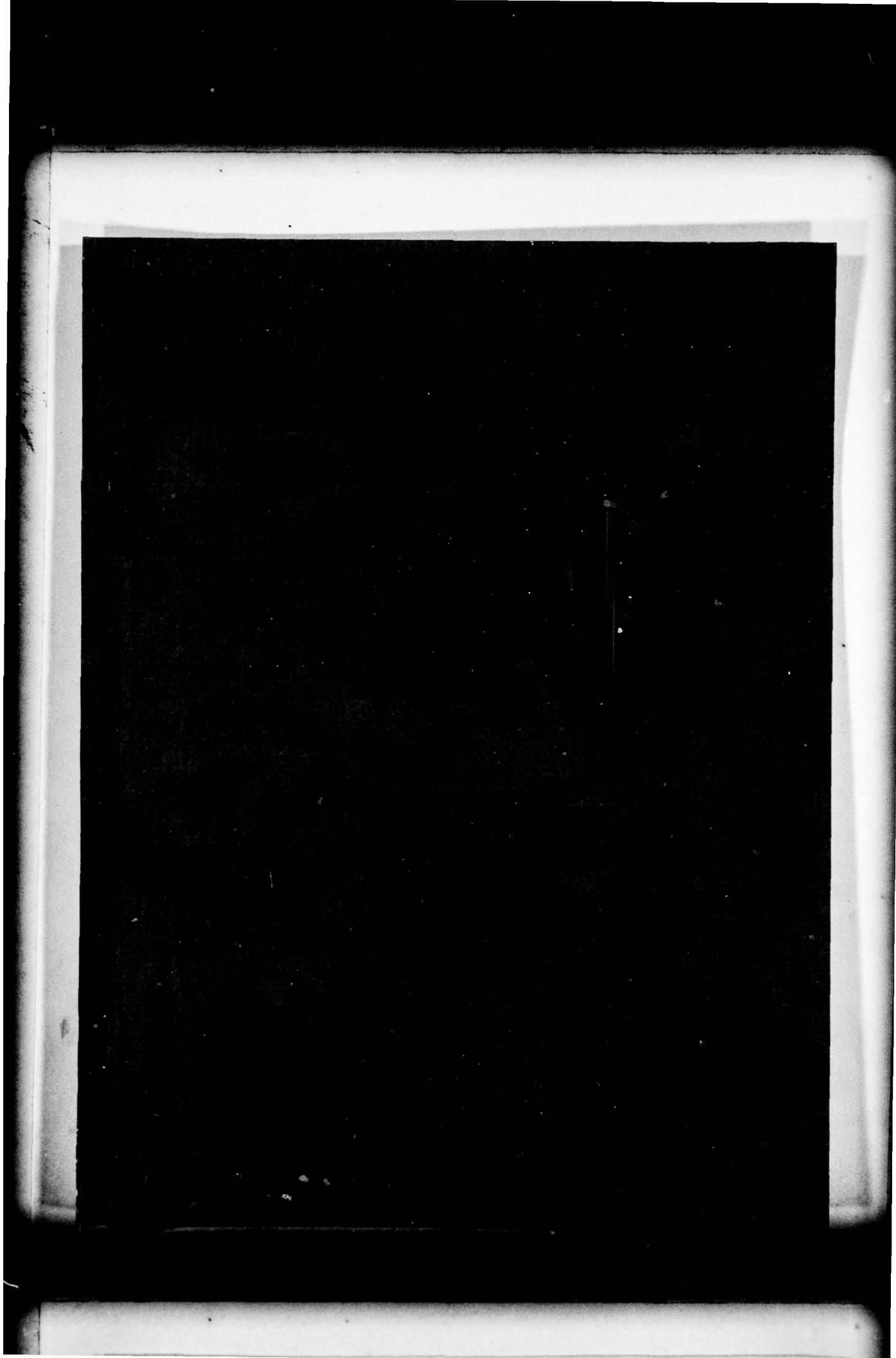



**DISCLAIMER**

The findings of this report are not to be construed as an official Department of the Army position unless so designated by other authorized documents. Comments, suggestions, or inquiries should be addressed to:

Commander  
USA Concepts Analysis Agency  
ATTN: Director, Systems Force Mix  
8120 Woodmont Avenue  
Bethesda, MD 20014

UNCLASSIFIED

SECURITY CLASSIFICATION OF THIS PAGE (When Data Entered)

REPORT DOCUMENTATION PAGE		READ INSTRUCTIONS BEFORE COMPLETING FORM
1. REPORT NUMBER <b>14</b> CAA-TP-77-5	2. GOVT ACCESSION NO.	3. RECIPIENT'S CATALOG NUMBER
4. TITLE (and Subtitle) <b>6</b> A Computer Model for the Assessment of Raid Tracks Through HIMAD Defended Airspace (RAIDTRAC Model).	5. TYPE OF REPORT & PERIOD COVERED <b>9</b> Final rept.	
7. AUTHOR(s) <b>10</b> James J. Connelly	6. PERFORMING ORG. REPORT NUMBER	
9. PERFORMING ORGANIZATION NAME AND ADDRESS US Army Concepts Analysis Agency MOCA-SMS, 8120 Woodmont Avenue Bethesda, Maryland 20014	8. CONTRACT OR GRANT NUMBER(s)	
11. CONTROLLING OFFICE NAME AND ADDRESS	12. REPORT DATE <b>11</b> July 1977	13. NUMBER OF PAGES 96 <b>12</b> 99p.
14. MONITORING AGENCY NAME & ADDRESS (if different from Controlling Office)	15. SECURITY CLASS. (of this report) UNCLASSIFIED	
16. DISTRIBUTION STATEMENT (of this Report) <b>DISTRIBUTION STATEMENT A</b> Approved for public release; Distribution Unlimited		
17. DISTRIBUTION STATEMENT (of the abstract entered in Block 20, if different from Report)		
18. SUPPLEMENTARY NOTES		
19. KEY WORDS (Continue on reverse side if necessary and identify by block number) Deterministic Computer Model      Raid Planning HIMAD      Raid Tracks Air Defense Coverage Air Defense Suppression      (high-to-medium altitude air defense) A		
20. ABSTRACT (Continue on reverse side if necessary and identify by block number) The RAIDTRAC Model is a fast-running, deterministic computational methodology for the assessment of issues of concern to analysts involved in HIMAD air defense planning or analysts planning raids through HIMAD defended areas. The model is structured for assessment of ground HIMAD technology providing sector (less than full circle) coverage with a capability for multiple (rather than sequential) engagement of targets. The model quantifies: (1) the coverage achieved by a prescribed air defense deployment; (2) the coverage effectiveness.		

DDC  
RECEIVED  
OCT 27 1977  
RECEIVED

*[Handwritten signature]*



(cont A  
P1473A)

UNCLASSIFIED

SECURITY CLASSIFICATION OF THIS PAGE (When Data Entered)

(i.e., intercepts against a prescribed raid track, and (3) estimates of the assets required to suppress the air defense engaging along the track. The model thus provides a quantitative basis for the selection of: candidate HIMAD deployments and against specific raid tracks, candidate raid tracks through specified HIMAD deployments and candidate air defense suppression missions associated with such tracks. The resultant selections among the candidates may then become part of the input to a formal large-scale simulation or serve as stand-alone results.

(1473 B)

A THREATS TO THE  
model of the  
hazardous

SECURITY CLASSIFICATION OF THIS PAGE (When Data Entered)

CAA-TP-77-5

A Computer Model for the Assessment of  
Raid Tracks Through HIMAD Defended Airspace  
(RAIDTRAC Model)

July 1977

Prepared by  
Systems Force Mix Directorate  
US Army Concepts Analysis Agency  
8120 Woodmont Avenue  
Bethesda, Maryland 20014

ACCESSION FOR	
DTIC	White Section <input checked="" type="checkbox"/>
DOC	Defi Section <input type="checkbox"/>
UNANNOUNCED	<input type="checkbox"/>
JUSTIFICATION	
<i>Letter on file</i>	
BY	
DISTRIBUTION/AVAILABILITY CODES	
Dist.	AVAIL. AND/OR SPECIAL
A	



## PRECIS

1. The RAID TRACK Assessment (RAIDTRAC) Model described in this report is an outgrowth of raid planning activity carried out as a part of the air defense studies conducted by the US Army Concepts Analysis Agency. The model is basically conceived of as a simulation study support tool, but may be used for stand alone analysis. It provides the analyst with a fast running, deterministic, computational methodology for the assessment of the viability of raid tracks through airspace defended by high-to-medium altitude air defense (HIMAD) units.
2. The model is structured to address issues of concern to analysts involved in HIMAD planning or analysts planning raids through HIMAD defended areas. The assessment quantifies: (1) the coverage achieved by a prescribed air defense deployment; (2) the coverage effectiveness (i.e., intercepts) against a prescribed raid track and (3) estimates of the assets required to suppress the air defense engaging along the track. The model thus provides a quantitative basis for the selection of candidate HIMAD deployments against specific raid tracks, candidate raid tracks for specific HIMAD deployments and candidate air defense suppression missions associated with such raid tracks. The resultant selections among the candidates may then become input to a formal, large-scale simulation or serve as stand-alone results.
3. The model is structured for assessment of ground HIMAD technology designed for sector (less than full circle) coverage, with a capability for multiple (rather than sequential) engagement of targets.
4. The speed of the model is achieved by using once-through analytic techniques rather than event or time-stepped techniques and by providing high speed (low resolution) line printer graphics rather than slower (high resolution) plotter graphics.
5. Specific recommendations are included for refinement of the model to increase its ease of use and to extend its application to include short range air defense (SHORAD) and airborne intercept.

ACKNOWLEDGEMENTS

The author gratefully acknowledges the encouragement given to the modeling effort by LTC B. P. Manderville, Jr. and the counsel to proceed to documentation offered by Mr. Saul Penn. Programing assistance in several troublesome areas was affably provided by CPT R. Read, Dr. J. Dockery and Mr. Herald Mohr. Particularly appreciated has been the detailed and thoughtful review of the report conducted by Mr. Penn. The effort has greatly benefited by the contributions of these individuals and to all my thanks and appreciation.



## CONTENTS

	Page
PRECIS . . . . .	iii
CHAPTER	
1 Introduction. . . . .	1-1
Nature of the Problem . . . . .	1-1
Nature of the Solution. . . . .	1-3
Anticipated Benefits. . . . .	1-3
2 Model Utilization . . . . .	2-1
Qualifications. . . . .	2-1
Scenario. . . . .	2-3
Interaction Levels . . . . .	2-4
Optional Outputs. . . . .	2-28
3 Model Mechanization . . . . .	3-1
Organization . . . . .	3-1
Code Block Descriptions . . . . .	3-1
Program Code Listing. . . . .	3-8
Program Data Listing. . . . .	3-8
Job Day File. . . . .	3-8
4 Model Refinement. . . . .	4-1
Introduction. . . . .	4-1
Enhanced Coverage Display . . . . .	4-1
Simplified Raid Track Specification . . . . .	4-1
Raid Sortie Specification . . . . .	4-2
Iterative Capability. . . . .	4-3
Target Utility Measures . . . . .	4-3
Counterair Assessment . . . . .	4-4
SHORAD Assessment . . . . .	4-4
APPENDIX	
A Program Code Listing. . . . .	A-1
B Program Data Listing. . . . .	B-1
C Glossary. . . . .	C-1
D Distribution. . . . .	D-1



## FIGURES

FIGURE		Page
2-1	Model Interaction Levels . . . . .	2-6
2-2	HIMAD Unit List Display . . . . .	2-7
2-3	HIMAD Unit Deployment Display . . . . .	2-8
2-4	Target List Display . . . . .	2-10
2-5	Target Array Display . . . . .	2-11
2-6	HIMAD Unit Coverage Display . . . . .	2-13
2-7	HIMAD Launcher Coverage Display . . . . .	2-14
2-8	Raid Track Line Segments . . . . .	2-17
2-9	Track Specification to Model . . . . .	2-18
2-10	Track Point List Display . . . . .	2-20
2-11	HIMAD Unit Intercepts Display . . . . .	2-21
2-12	HIMAD Launcher Intercepts Display . . . . .	2-22
2-13	Track Intercepts Summary Display . . . . .	2-24
2-14	HIMAD Suppression Estimate Display . . . . .	2-26
2-15	Intercept Range Table Display . . . . .	2-31
2-16	Intercept Sector Matrix Display with Overmark . . . . .	2-32
2-17	Map Symbology Selection Display . . . . .	2-34
2-18	Boundary Segment List Display . . . . .	2-35
3-1	Model Organization by Code Blocks . . . . .	3-2
3-2	Job Day File . . . . .	3-9

## TABLES

TABLE		Page
2-1	Target Type Codes . . . . .	2-9
2-2	Assessment Issues Addressed by Model Displays . . . . .	2-29

A COMPUTER MODEL FOR THE ASSESSMENT OF  
RAID TRACKS THROUGH HIMAD DEFENDED AIRSPACE  
(RAIDTRAC Model)

CHAPTER 1  
INTRODUCTION

1-1. NATURE OF THE PROBLEM. a. The Qualitative Process

(1) Raid track selection in support of air defense evaluation has been conducted to date on a qualitative basis. The locations of air defense units have been plotted on a map of the defended area. Raid tracks are then placed as overlays on this map and adjusted by visual inspection to minimize the encounters of the raiding aircraft with the air defense, while achieving the access to the targets prescribed by the raid scenario. The process is limited by the requirement to visually estimate which HIMAD will enter into play. The present model considers this process as applied to the ground HIMAD technology designed for sector (less than full circle) coverage and with a capability for multiple (rather than sequential) engagement of targets. The estimate is complicated by the fact that intercepts by systems employing this technology are influenced both by the raid aircraft altitude and the bearing of the raid aircraft with respect to the individual HIMAD units.

(2) The visual estimate must first take into account that the HIMAD intercept range is a function of the altitude of the aircraft. For raids which ingress at a fixed altitude, the value of intercept range is the same throughout the region. When raids change altitude during ingress, the intercept range is different for each altitude. Visualizing these different intercept ranges complicates the estimate of intercept conditions, particularly in the areas where the transition in flight altitude occurs.

(3) The visual estimate must then take into account the bearing of the target with respect to the sector covered by the system. If the target is within the primary intercept sector, intercept is possible by all launchers of the HIMAD unit. If, however, the target lies outside of this sector, then the sector orientation must be adjusted to bring the target within the sector. As the amount of necessary adjustment becomes larger, the shift results in the unit losing those launchers which do not share the sector with the target. In the limit, the shift will be such that no unit launchers share the sector with the target, and engagement is not possible. From the standpoint of visual inspection of the tracks and unit it may be difficult to assess when this limiting condition has been reached.



(4) The principal graphic technique for dealing with this visual estimate of intercept range and sector coverage, is the use of a template scaled to the range of interest and the angle of the intercept sector. The template is positioned at the location of the HIMAD unit and oriented to the azimuth of the sector coverage. It is then possible to more accurately estimate if an intercept will occur by noting either an intersection of the track with the template or an intersection as the template is rotated about the unit location.

(5) The template procedure can be repeated, as necessary, at each HIMAD unit location in the vicinity of the track and the cases of intercept tabulated or otherwise noted. Typically, this process will be repeated for a number of track possibilities before a final selection of track(s) is made.

b. Shortcomings of the Process. This process has a number of shortcomings, as described in the following, which led to development of the RAIDTRAC Model detailed in the report.

(1) A shortcoming arises from the essentially graphical nature of the track evaluation process. The numerous HIMAD units' locations and sector coverage, as well as the target array they defend, must be manually plotted. This presents opportunities for errors in plotting and errors in assigning identifying symbology to the HIMAD units and targets.

(2) A shortcoming arises from the positioning of the template which defines the sector within which intercept must take place. Positioning of the template at the site location and adjustment of the orientation, as necessary, to assess the intercept condition can introduce errors, particularly in marginal (tangential) conditions of intercept.

(3) A shortcoming arises from the need to repeat the graphical workload for examination of each alternate raid track or each new deployment of air defense units. For the case of iteration of a raid, a new overlay of the track must be prepared and the assessment of the HIMAD intercept conditions must be repeated. For the case of redeployment of the HIMAD units, the unit locations and their associated primary target lines (PTL), defining the azimuth orientation of the sector, must be replotted.

(4) These shortcomings, while manageable, do create a pressure for economizing on the number and scope of the alternative scenarios considered. The model described herein is meant to relieve the analyst of much of the detailed effort involved in examination and tabulation of the HIMAD intercept conditions. This

reduction of the graphical workload should encourage more systematic and expansive consideration of raid tracks and air defense deployment conditions.

1-2. NATURE OF THE SOLUTION. a. The manual graphical process of raid track assessment has been replaced with an automated process. The automated process models, in a more precise form, each of the manual steps and, in addition, provides for assessment of air defense suppression as it would apply to clearing a raid corridor aligned along the raid track under consideration.

b. The process is organized around the concept of user interaction with the model. Three levels of interaction are provided. At Interaction Level 1 the user is concerned with HIMAD coverage, at Interaction Level 2 the user is concerned with the intercept conditions along the raid track, and at Interaction Level 3 the user is concerned with estimating the air defense suppression required along the raid track. For each interaction, the user specifies input to the model and receives output. The levels are organized such that interaction at one level presupposes interactions have occurred at the lower levels. That is, there has been a specification of input appropriate to the lower levels to support the higher interaction level. For example, consideration of HIMAD suppression (Level 3) presupposes selection of HIMAD deployment (Level 1) and selection of a raid track (Level 2).

c. Using the interaction capability, either singly or in appropriate combinations, the user may generate individual or parametric studies of HIMAD deployments, raid tracks through the HIMAD units and/or HIMAD suppression. The interactions provide both the necessary computations and a convenient record of the analyses undertaken. The model thus expedites the systematic consideration of alternatives and the choice of final values for insertion into the associated large-scale simulations (e.g., COMO) or for use as free-standing, nonsimulation results.

1-3. ANTICIPATED BENEFITS. The principal benefit to be derived from the use of the Raid Track Assessment Model is the quantitative data which are made available to answer or evaluate the following issues.

a. Air Defense Coverage Issues

o Are there any unacceptable gaps in the air defense coverage?

o Are there any weak points in the air defense coverage, such that loss of a single site would open an unacceptable gap in the air defense?



CAA-TP-77-5

o Has the desired level of redundancy in air defense been achieved around vital areas?

o What are the likely routes available to raid aircraft against prescribed targets?

b. Raid Track Vulnerability Issues

o What number or percentage of the deployed HIMAD can engage on the track?

o What number of missiles or average number of missiles per HIMAD unit can engage on the track?

o What is the depth of the HIMAD defense (number or percentage of air defense units) for a particular target?

c. Air Defense Suppression Issues

o Which HIMAD units should be attacked?

o In what order should HIMAD units be attacked?

o How many air defense suppression aircraft are required to carry out the suppression mission?

o How are incremental changes in the number of targets (or percentage of the target array) to be attacked related to the number (or percentage of) air defense suppression required?

d. Issue Sets. It is anticipated that the answers to the questions above will be sought for sets of tracks and air defense deployments. The sets of results will provide families of data and permit detailed comparison of track and/or deployment features.

CHAPTER 2  
MODEL UTILIZATION

2-1. QUALIFICATIONS. A number of qualifications have been invoked in the design of the model which have a direct bearing on the way in which data are utilized and presented. The qualifications are presented in the following paragraphs. Refinements to the model which relax some of these qualifications are presented in Chapter 4.

a. Raid Track

(1) Only one track (corridor) is addressed during any one exercise of the model. (Refinement presented in paragraph 4-5.)

(2) The raid track is considered to consist of one or more line segments, forming a main track and a series of spur tracks off the main track leading to the individual targets.

(3) The sequence in which the main and spur track segments are specified determines the sequence in which the targets are attacked. Artificial main and spur track segments are used to maintain track continuity but do not enter into the intercept calculations. (Refinements presented in paragraphs 4-3 and 4-6.)

b. Raid Aircraft

(1) The raid track is explicitly defined by the user. In the case of the raid planner, this is the actual track to be evaluated. In the case of the air defense planner this is an estimate of the track likely to be employed to breach the overall defense.

(2) The model assumes a mass raid (target rich) condition, such that the number of aircraft traversing any track segment saturate the HIMAD defense in that region. (Refinement presented in paragraph 4-4.)

(3) Raid aircraft fly down tracks at altitudes which correspond to preselected flight profiles over the defended area. Provision is made to store three such profiles, representing various combinations of altitudes at which the raid aircraft traverse the division, corps and rear areas. The model analyzes intercepts based upon this explicit knowledge of raid aircraft altitude and implicit knowledge of other significant aircraft factors (radar cross-section, speed, formation and maneuver), as incorporated in



the values of HIMAD intercept range which are given as a function of altitude.

c. Air Defense Systems

(1) The location of each HIMAD unit and the orientation of its PTL is explicitly defined by the user. In the case of the raid planner, the locations are estimates of the deployment of the defense. In the case of the air defense planner the locations are the actual deployment to be evaluated.

(2) The model assumes that each HIMAD intercepts at the first opportunity, that is, at the maximum intercept range for the altitude involved.

(3) The model assumes (as noted earlier) a mass raid (target-rich) environment and commits all available missiles of the HIMAD unit to the intercept. (Refinement presented in paragraph 4-4.)

(4) Each HIMAD unit PTL is adjusted in azimuth to permit intercept on a track segment with the maximum possible number of launchers.

(5) A HIMAD unit, once adjusted (in PTL) to intercept on one track segment, is considered totally committed and not available for further intercepts on other segments.

(6) The model assumes that the HIMAD launchers are deployed equidistant in azimuth across the angle of the intercept sector.

(7) The model assumes that the raid is timed so that all raid aircraft pass through the defense before reload of the systems can take place (there is thus no opportunity for a unit to repeatedly engage ingressing raid aircraft).

(8) Engagement of egressing raid aircraft is not considered.

(9) The model is not intended to account for SHORAD or counterair effects. (Refinement presented in paragraphs 4-8 and 4-9.)

(10) The model is based on the concept of sector coverage but can be expanded to full circle coverage if desired.

d. HIMAD Suppression

(1) Only those HIMAD which engage along the track are attacked. The suppression is carried out along each track segment in sequence.



(2) A mix of air defense suppression aircraft is assumed available for suppression. Both the proportion of the mix and the total number of aircraft available are specified as a user input to the model. No allowance is included in the model for attrition of these aircraft, in the course of carrying out their mission.

e. Model Graphics

(1) Scaling. The map-like graphics provided by the model are scaled to display an area 500 km (east-west) by 250km (north-south) in 5km intervals on a single printer page. The user specifies the lower coordinate limit of each scale. The coordinates are limited to a maximum of four digits. Conversion of standard geographic reference system coordinates (e.g., UTM) to conform to this limit must be made by the user.

(2) Symbol Set Limitations. Use of the printer symbol set imposes two limitations on the model graphics.

(a) First, the graphics have been proportioned to fit on a single line printer page. This has required scaling the defended region to fit in its east-west dimension within the 130+ character spaces on a line printer line. The north-south dimension is required to fit within the 50+ lines per printer page. A scale of 5km per character has been selected as being most effective for the display of the information of interest within the constraints of the page size. This results in display of a defended area of 500 km east-west by 250 km north-south. The printer page size limitation could be removed by display of the model output on a plotter, where a higher resolution could be readily achieved, but at a significant increase in display generation time. (Refinement presented in paragraph 4-2.)

(b) Second, the use of the printer symbol set to display the map information produces a distortion of angle information, since the X-axis increment per symbol is less than the Y-axis increment per symbol. This precludes reading-off angles relating to sector coverage or track segment orientations; but does not affect the validity of position-oriented information (i.e., target locations, track segment end-points). The angle limitation may be lifted by preparation of a specially calibrated protractor which employs a non-linear scale for angle read-off.

2-2. SCENARIO. a. The model is used to evaluate the interaction of a particular air defense and a particular air threat with respect to a particular target array. The particularities to be addressed are provided by a scenario which brings together realistic estimates of air defense and air threat for a particular time

frame. From the scenario is derived: the size and deployment of the HIMAD; the number, type, and location of military assets they defend, and the intentions of the air threat, both with respect to the target array and the associated air defense.

b. The use of the model is illustrated by a scenario. The number of HIMAD units and their deployment is hypothetical but considered illustrative of an area defense of six on-line divisions, two corps areas and a rear theater area. In the interests of clarity, only a portion of the defended assets are included in the illustrations of model outputs, namely: four rear area targets, four corps area targets and four divisions area targets.

2-3. INTERACTION LEVELS. a. Concept. The model is intended as a flexible analytical tool to be employed in an iterative manner to generate a family of results from which a preferred result may be extracted. To illustrate this flexibility, the use of the model is described in terms of three levels of interaction, which may be used selectively to develop parametric variations of the air defense issues of interest. The three interaction levels are:

Level	Air Defense Issues
1	HIMAD Coverage
2	Raid Track Intercepts
3	HIMAD Suppression

Interaction at a higher level presupposes that lower level interactions have occurred or will occur simultaneously with the higher level (i.e., air defense suppression analysis (Level 3) presupposes specification of HIMAD unit locations (Level 1) and a raid track (Level 2)). Each of the three interaction levels provides for three user activities:

- an input to the model
- an analysis of the model outputs
- a decision as to whether the outputs are acceptable and, if not, revising the inputs in anticipation of achieving more acceptable results.

The following paragraphs describe the specific user activities involved for each of the three interaction levels.



b. Interaction Level 1 - HIMAD Coverage. The user activities associated with Interaction Level 1 are flow diagrammed in Figure 2-1(a) and discussed in the following paragraphs.

(1) Enter HIMAD, Target and Raid Altitude Profile.

(a) The user specifies the HIMAD deployment for the region, identifying for each HIMAD unit the following characteristics:

- coordinates of position
- principal area defended (division, corps, rear)
- azimuth of PTL
- number of launchers available

For the scenario under consideration, these data are as shown in Figure 2-2. The figure illustrates the HIMAD Unit List display, as provided by the model. As read from left to right the display tabulates the HIMAD unit reference number (NR), X-coordinate (X), Y-coordinate (Y), principal area (AREA) defended (D=division, C=corps, R=rear), azimuth of the PTL (PTL) and number of launchers available (NLHR). A map display, the HIMAD Unit Deployment, is also provided by the model, as shown in Figure 2-3. The map display contains two basic sets of information, the location (\*) and reference number (e.g., 36) of the individual HIMAD units (AD) and the boundary points (+-symbols) which divide the area into the division, corps and rear areas. The display provides an overall picture of the pattern of the deployment and provides a quick check on the accuracy of the unit location data points since inaccurately plotted units should be apparent as a departure from the intended pattern. In Figure 2-3, the HIMAD units are deployed in a lattice-like area defense of the division, corps and rear areas.

(b) The user also identifies the target array in the defended area. The following characteristics are identified for each target:

- coordinates of position
- type of target (see Table 2-1)
- area where located (division, corps, rear)

CAA-TP-77-5

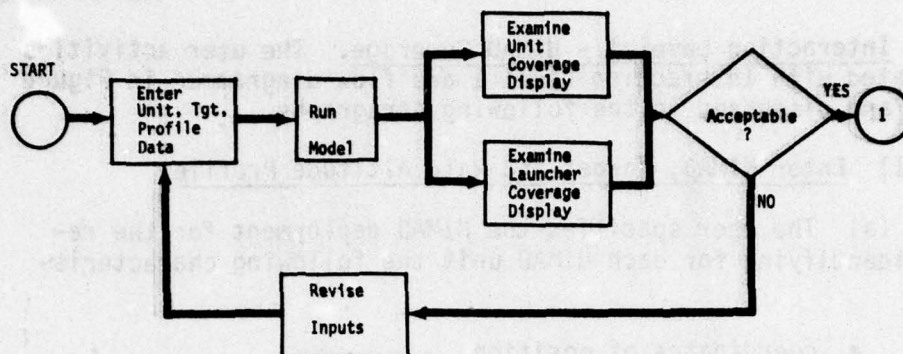

(a) Interaction Level 1 - Air Defense Coverage

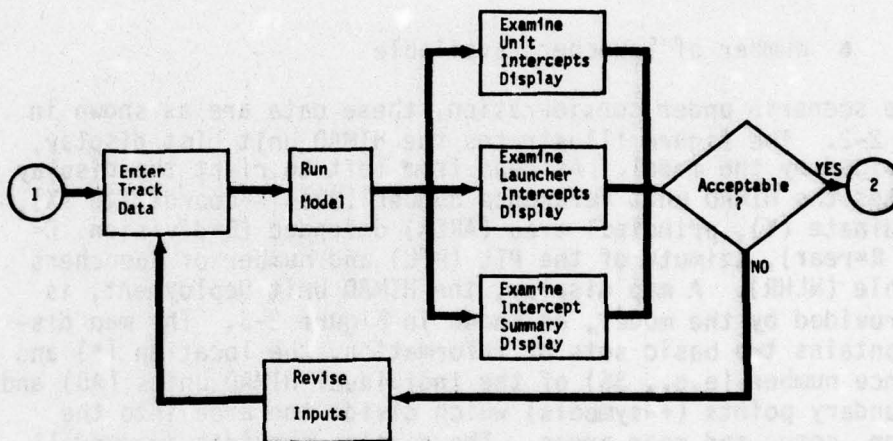

(b) Interaction Level 2 - Raid Track Intercepts

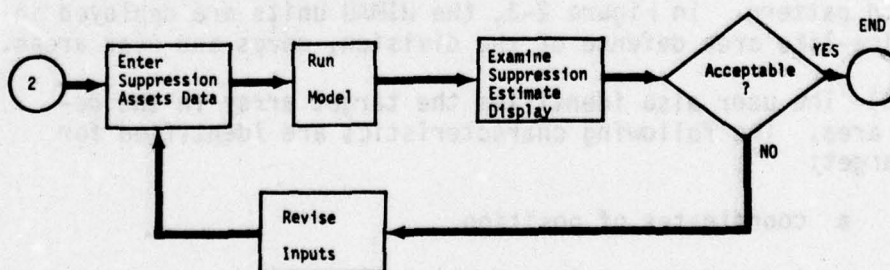

(c) Interaction Level 3 - Air Defense Suppression

Figure 2-1. Model Interaction Levels



## RTA-A OUTPUT

NR	X	Y	AREA	PTL	NLHR
AD 1	450.0	410.0	D	90.0	5
AD 2	450.0	380.0	D	90.0	5
AD 3	450.0	350.0	D	90.0	5
AD 4	450.0	320.0	D	90.0	5
AD 5	450.0	290.0	D	90.0	5
AD 6	450.0	260.0	D	90.0	5
AD 7	450.0	230.0	D	90.0	5
AD 8	410.0	410.0	C	90.0	5
AD 9	410.0	380.0	C	90.0	5
AD10	410.0	350.0	C	90.0	5
AD11	410.0	320.0	C	90.0	5
AD12	410.0	290.0	C	90.0	5
AD13	410.0	260.0	C	90.0	5
AD14	410.0	230.0	C	90.0	5
AD15	370.0	410.0	C	90.0	5
AD16	370.0	380.0	C	90.0	5
AD17	370.0	350.0	C	90.0	5
AD18	370.0	320.0	C	90.0	5
AD19	370.0	290.0	C	95.0	5
AD20	370.0	260.0	C	90.0	5
AD21	370.0	230.0	C	90.0	5
AD22	330.0	410.0	R	90.0	5
AD23	330.0	380.0	R	90.0	5
AD24	330.0	350.0	R	90.0	5
AD25	330.0	320.0	R	90.0	5
AD26	330.0	290.0	R	90.0	5
AD27	330.0	260.0	R	90.0	5
AD28	330.0	230.0	R	90.0	5
AD29	290.0	410.0	R	90.0	5
AD30	290.0	380.0	R	90.0	5
AD31	290.0	350.0	R	90.0	5
AD32	290.0	320.0	R	90.0	5
AD33	290.0	290.0	R	90.0	5
AD34	290.0	260.0	R	90.0	5
AD35	290.0	230.0	R	90.0	5
AD36	250.0	410.0	R	90.0	5
AD37	250.0	380.0	R	90.0	5
AD38	250.0	350.0	R	90.0	5
AD39	250.0	320.0	R	90.0	5
AD40	250.0	290.0	R	90.0	5
AD41	250.0	260.0	R	90.0	5
AD42	250.0	230.0	R	90.0	5

Figure 2-2. HIMAD Unit List Display

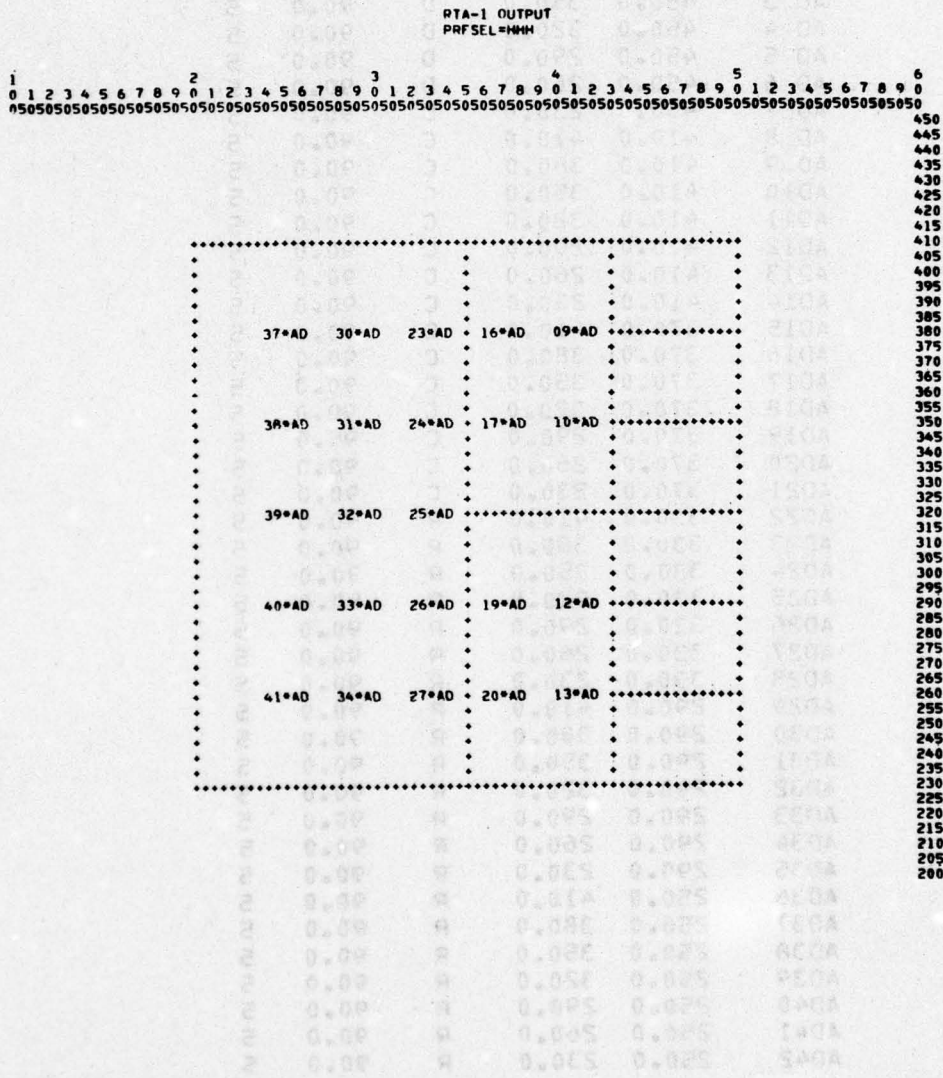

Figure 2-3. HIMAD Unit Deployment Display



Table 2-1. Target Type Codes

Target Type Code	Target Type
AB	Air Base
HQ	Division HQ
HH	Higher HQ
PL	POL Dump
PM	Pershing Missile
LP	Lance Platoon
A8	8-in FA Bn
A5	155mm FA Bn
SP	SASP
RS	Reserve Unit
CR	CRC
EW	EW/CRP

For the scenario under consideration these data are as shown in Figure 2-4. The figure illustrates the Target List display provided by the model. As read from left to right, the display tabulates the target reference number (NR), X-coordinate (X), Y-coordinate (Y), type of target (TYPE) and area (AREA) where located. A map display, the Target Array, is also provided by the model as shown in Figure 2-5. The map readily indicates the location (\*) and type (e.g., AB) of the targets and their distribution in the division, corps and rear areas. The target array display may be conveniently used to investigate and establish the location of the raid track (see paragraph 2-3c).

(c) The user identifies from a preselected set, the altitude profile the raid aircraft will use in crossing the defended air-space. The profile defines the altitude used by the raid aircraft over the division, corps and rear areas, and is used by the model to establish the intercept range for the HIMAD located in these areas. The preselected profiles, for illustration, might be:



Table 2-4. Target Type Codes

NR	X	Y	TYPE	AREA
TG 1	480.0	375.0	A5	D
TG 2	485.0	325.0	AR	D
TG 3	465.0	365.0	HQ	D
TG 4	465.0	310.0	HQ	D
TG 5	410.0	350.0	LP	C
TG 6	410.0	290.0	LP	C
TG 7	390.0	340.0	HH	C
TG 8	390.0	300.0	PL	C
TG 9	335.0	350.0	EW	R
TG10	320.0	290.0	HH	R
TG11	310.0	340.0	AB	R
TG12	290.0	300.0	AB	R

For the scenario under consideration these data are shown in Figure 2-4. The figure illustrates the target type display provided by the system. As noted from the figure, the display labels the target reference number (NR), X and Y coordinates, distance (Y), type of target (TYPE) and area (AREA) where located. A map display, the Target Array, is also provided by the model as shown in Figure 2-5. The map readily indicates the location of and type (e.g., HQ) of the targets and their distribution in the division, corps and rear areas. The target array display may be conveniently used to investigate and establish the location of the target (see paragraph 2-3c).

(c). The user identifies from a prescribed set, the altitude profile the aircraft will use in crossing the defended area space. The profile defines the altitude used by the aircraft over the division. To establish the interest range for the HMD located in these areas, the prescribed profiles for illustration, right be.

Figure 2-4. Target List Display

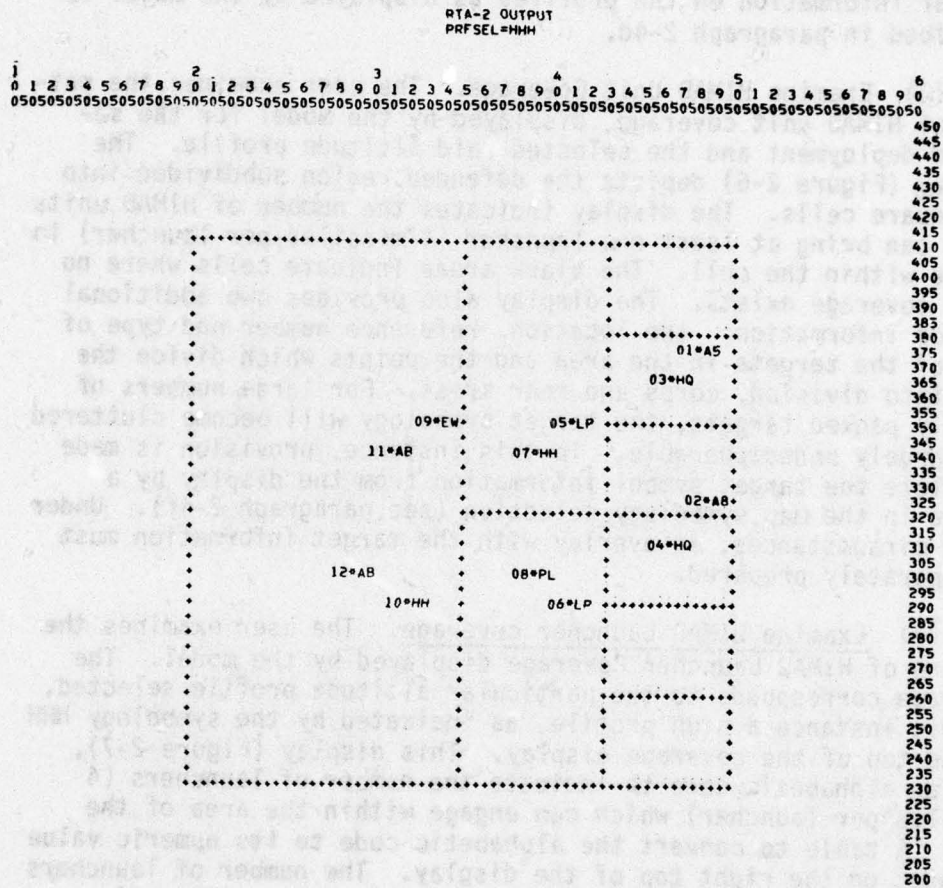

Figure 2-5. Target Array Display



CAA-TP-77-5

- HHH - high over the division, corps, and rear areas
- LLL - low over the division, corps, and rear areas
- HOP - hop (high) over the division (SHORAD) and low over the corps and rear areas

Further information on the profiles as displayed by the model is described in paragraph 2-4d.

(2) Examine HIMAD Unit Coverage. The user examines the pattern of HIMAD unit coverage, displayed by the model for the selected deployment and the selected raid altitude profile. The display (Figure 2-6) depicts the defended region subdivided into 5km square cells. The display indicates the number of HIMAD units which can bring at least one launcher (4 missiles per launcher) to engage within the cell. The blank areas indicate cells where no basic coverage exists. The display also provides two additional sets of information: the location, reference number and type of each of the targets in the area and the points which divide the area into division, corps and rear areas. For large numbers of closely packed targets, the target symbology will become cluttered and largely undecipherable. In this instance, provision is made to delete the target symbol information from the display by a change in the map symbology selection (see paragraph 2-4f). Under these circumstances, an overlay with the target information must be separately prepared.

(3) Examine HIMAD Launcher coverage. The user examines the pattern of HIMAD Launcher Coverage displayed by the model. The coverage corresponds to the particular altitude profile selected, in this instance a high profile, as indicated by the symbology HHH at the top of the coverage display. This display (Figure 2-7), uses an alphabetic code to indicate the number of launchers (4 missiles per launcher) which can engage within the area of the cell. A table to convert the alphabetic code to its numeric value is inset on the right top of the display. The number of launchers in each cell is derived directly as the sum of the number of launchers associated with the units shown on the HIMAD Unit Coverage display. Again, the blank areas indicate cells where no basic coverage exists. In this instance, the target information shown on the HIMAD Unit Coverage display has been deleted.

(4) Basic Coverage. The HIMAD Unit and Launcher Coverage displays (Figures 2-6 and 2-7) depict basic coverage. That is, the coverage available when the unit PTL line is coincident with the centerline of the launcher complex. This condition represents the preferred orientation of the unit to meet the postulated threat.

RTA-3 OUTPUT  
PRFSEL=MMH

1	2	3	4	5	6
0 1 2 3 4 5 6 7 8 9 0	0 1 2 3 4 5 6 7 8 9 0	0 1 2 3 4 5 6 7 8 9 0	0 1 2 3 4 5 6 7 8 9 0	0 1 2 3 4 5 6 7 8 9 0	0 1 2 3 4 5 6 7 8 9 0
					450
					445
					440
					435
					430
					425
					420
					415
					410
					405
					400
					395
					390
					385
					380
					375
					370
					365
					360
					355
					350
					345
					340
					335
					330
					325
					320
					315
					310
					305
					300
					295
					290
					285
					280
					275
					270
					265
					260
					255
					250
					245
					240
					235
					230
					225
					220
					215
					210
					205
					200

Detailed description of Figure 2-6: This is a coverage display for the HIMAD unit. It shows a grid of 200 rows (line numbers 200 to 450) and 6 columns. The columns are labeled 1 through 6 at the top. Each cell contains alphanumeric characters (0-9, \*, .) or is empty. The display shows a complex pattern of characters, including strings like '11111', '11112', '11122', '22222', and various alphanumeric codes such as '11 09\*EW', '1 05\*LP', '11\*AR 23', '12\*AR', '10\*MH', and '1 06\*LP'. There are several lines with dotted patterns, likely indicating specific data points or boundaries. The overall appearance is that of a technical or diagnostic output.

Figure 2-6. HIMAD Unit Coverage Display





Under raid conditions, however, there will be early warning data on the specific direction of the threat. Given these data, there will, typically, be time to shift the PTL to the direction of the threat, but, not sufficient time to reposition the launcher sets. As the PTL is moved, with the launcher set centerline remaining fixed, individual launcher sets will drop out of the radar set pattern and become unassignable to targets.

(5) Decide Coverage Acceptability. The user must decide if the coverage shown is adequate. In making this determination, the user may interpret the HIMAD Unit Coverage display as offense-oriented and the HIMAD Launcher Coverage display as defense-oriented. The number of HIMAD units is a measure of the threat posed by the defense to the attackers. A basic response available to the attackers is one of suppressing the HIMAD units by denying them the use of their radar, as differentiated from a direct attack on the launchers. This makes the number of units, not the number of launchers, a principal measure of concern to the offense. The defense on the other hand, is primarily concerned with engagement, and each launcher provides four opportunities for engagement. More specifically, the defense is concerned with the opportunities for engagement throughout the region (cell-by-cell) and this measure is provided directly by the HIMAD Launcher Coverage display.

(6) Revise Inputs. If the coverage is considered to have unacceptable gaps or inadequate depth or inadequate intensity with respect to specific areas, individual HIMAD units may be redeployed, adjustments made in individual unit PTL's or both. The user then revises the input accordingly and repeats the steps of this interaction level, resulting in adjusted basic coverage displays. The iteration of the interaction is then continued with revised inputs and resultant coverage, until an acceptable deployment is established. The user may then proceed to the next level of interaction--a consideration of possible raid tracks through the defense.

c. Interaction Level 2 - Raid Track Intercepts. The user activities associated with Interaction Level 2 are flowcharted in Figure 2-1(b) and discussed in the following paragraphs.

(1) Enter Track Data. In this step, the user defines the track the aircraft take through the defended airspace. The process of track specification can be described as occurring in three sub-steps.

(a) In the first sub-step the user examines the target array to be attacked by the raid force. The array may be inspected as part of the symbol information included in the HIMAD

Unit and Launcher Coverage Displays (Figures 2-6 and 2-7), or by direct inspection of the Target Array Display (Figure 2-5).

(b) In the second sub-step the user establishes a main raid track, starting outside the FEBA and extending through the target array as shown in Figure 2-8. The main track is drawn as one or more straight line segments each of which may approximate a least squares fit to portions of the target array, considered as a scatter diagram. The user positions the main track to avoid the areas of higher air defense intensity as much as possible. For a well constituted defense, however, it will be difficult to choose a preferred path. The choice in this case would probably be that of the shortest route--to minimize exposure time and thereby minimize the opportunity for the defense to accumulate intelligence about the raid. To further circumscribe the raid, parallel lines are constructed on both sides of the track (see Figure 2-8) representing the overall corridor limits in which the raid will take place. The corridor width is based on a conservative estimate of the distance aircraft can depart from the track and still be protected by the air defense suppression conducted as part of the raid. The width can be varied as experience with the air defense is developed.

(c) In the third sub-step the user defines the spurs off the main raid track which take the aircraft into the targets. The spurs are taken at some convenient turnoff angle with respect to the main track, as shown in Figure 2-8. The definition of the track spurs is important, since each spur becomes a line segment of the track and must be accounted for in the track specification to the model. To accommodate the spurs, which leave the main track and stop, an artificial spur is introduced in each case to bring the free end of the spur back to the main track. The technique is illustrated in Figure 2-9. Each of the dotted segments is identified to the model by its end points and its artificial status identified by use of a "backtrack" flag, which allows the model to ignore the segment for computational purposes, while maintaining the integrity of the track segment sequence. The user identifies for each segment of the track the following characteristics:

- reference number and type of target, if any, associated with an end point,
- track segment backtrack indicator.



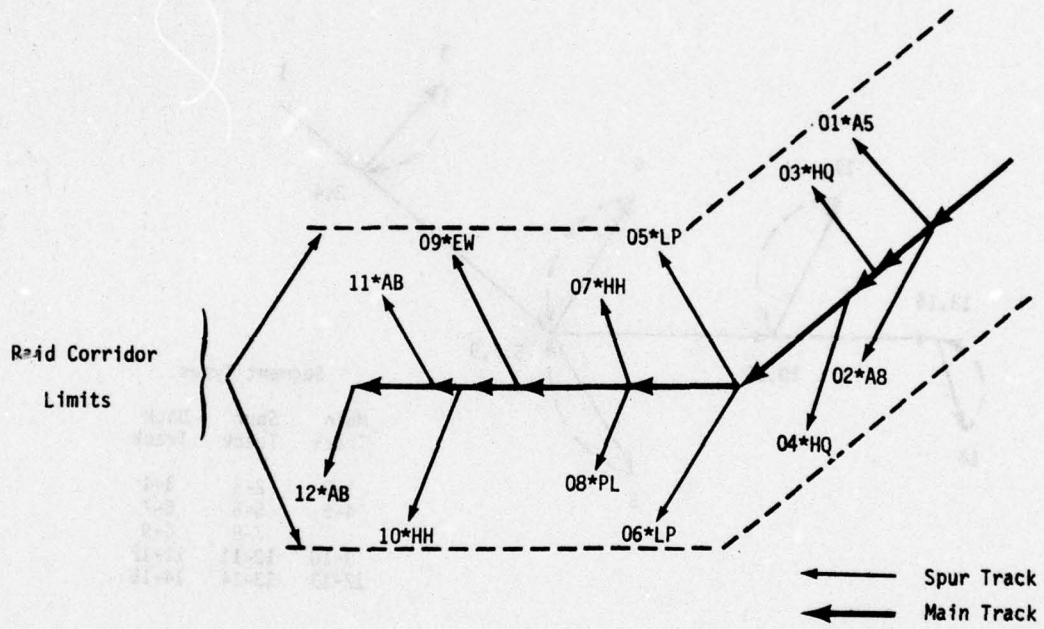

Figure 2-8. Raid Track Line Segments

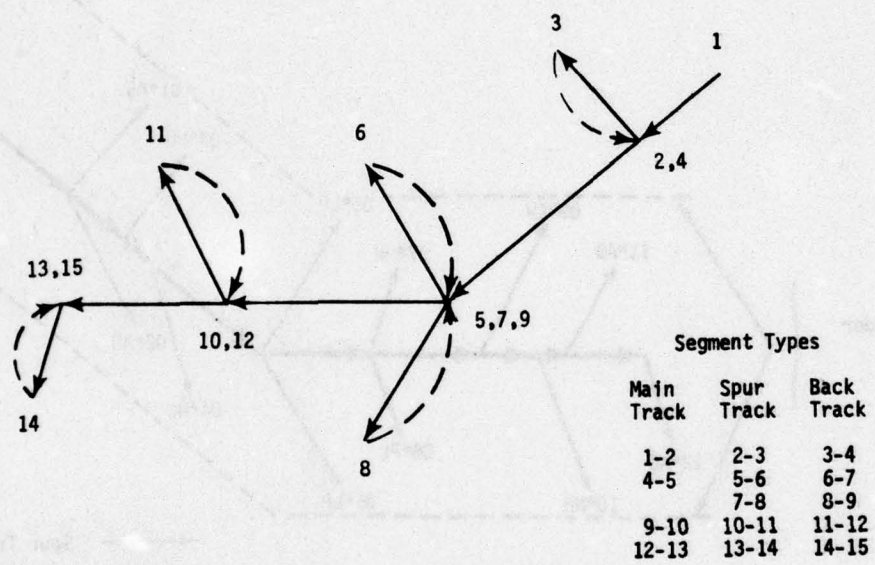

Figure 2-9. Track Specification to Model

For the scenario under consideration, the track data are as shown in Figure 2-10. As read from left-to-right, the display tabulates for each Track Point the reference number (NR), the X-coordinate (X), Y-coordinate (Y), the presence (1) or absence (0) of a continuity indicator (BKTRK), the target reference number (TGNR), if any, associated with the point, and the target type (TGTY) corresponding to the target reference number.

(d) With the use of the artificial line segments it becomes possible to arrange the raid track segments in any order, and thereby reflect the sequence in which targets are to be attacked. Deep targets, for example, can be attacked by one wave before shallow targets are attacked by a second wave by specifying the line segments to the deep targets and then using the backtrack indicator to bring the track back to the area of the shallow targets. Turn-offs to these targets can then be specified. This timing aspect is significant from an intercept standpoint. Intercepts are computed on a first opportunity basis. A deep raid preceding a shallow raid may cause the intercepts to accumulate on the deep raid track segments, leaving the shallow raid targets less well defended. A shallow raid preceding a deep raid may shift the intercepts to the shallow track segments and leave the deep targets less well defended.

(2) Examine HIMAD Unit Intercepts. The user examines the HIMAD Unit Intercepts display for the intercepts along the raid track completed by the model. The display format (Figure 2-11) is that used earlier in that it depicts the defended region, as subdivided into 5km square cells. The display shows the raid track points including both main track and spur track segments, along with target information. The line segments connecting the track segment points are added manually, at the option of the user, to increase the clarity of the display. On each segment (approximately at the midpoint) is shown the number of HIMAD units intercepting on the segment. Further details of the intercept on each segment are provided in the Track Intercept Summary display described in paragraph 2-3c(4).

(3) Examine HIMAD Launcher Intercepts. The user examines the HIMAD Launcher Intercepts display for launcher intercepts along the raid track. This display (Figure 2-12), is the intercept counterpart of the HIMAD Launcher Coverage display, in that it shows the number of launchers intercepting along each track segment.



## RTA-C OUTPUT

NR	X	Y	BKTRK	TGNR	TGTY
TP 1	540.0	370.0	0	-	MT
TP 2	510.0	355.0	0	-	MT
TP 3	480.0	375.0	0	1	A5
TP 4	510.0	355.0	1	-	MT
TP 5	485.0	325.0	0	2	AB
TP 6	510.0	355.0	1	-	MT
TP 7	490.0	345.0	0	-	MT
TP 8	465.0	365.0	0	3	HQ
TP 9	490.0	345.0	1	-	MT
TP 10	480.0	340.0	0	-	MT
TP 11	465.0	310.0	0	4	HQ
TP 12	480.0	340.0	1	-	MT
TP 13	440.0	320.0	0	-	MT
TP 14	410.0	350.0	0	5	LP
TP 15	440.0	320.0	1	-	MT
TP 16	410.0	290.0	0	6	LP
TP 17	440.0	320.0	1	-	MT
TP 18	400.0	320.0	0	-	MT
TP 19	390.0	340.0	0	7	HH
TP 20	400.0	320.0	1	-	MT
TP 21	390.0	300.0	0	8	PL
TP 22	400.0	320.0	1	-	MT
TP 23	360.0	320.0	0	-	MT
TP 24	335.0	350.0	0	9	EW
TP 25	360.0	320.0	1	-	MT
TP 26	340.0	320.0	0	-	MT
TP 27	320.0	290.0	0	10	HH
TP 28	340.0	320.0	1	-	MT
TP 29	330.0	320.0	0	-	MT
TP 30	310.0	340.0	0	11	AB
TP 31	330.0	320.0	1	-	MT
TP 32	300.0	320.0	0	-	MT
TP 33	290.0	300.0	0	12	AB

Figure 2-10. Track Point List Display

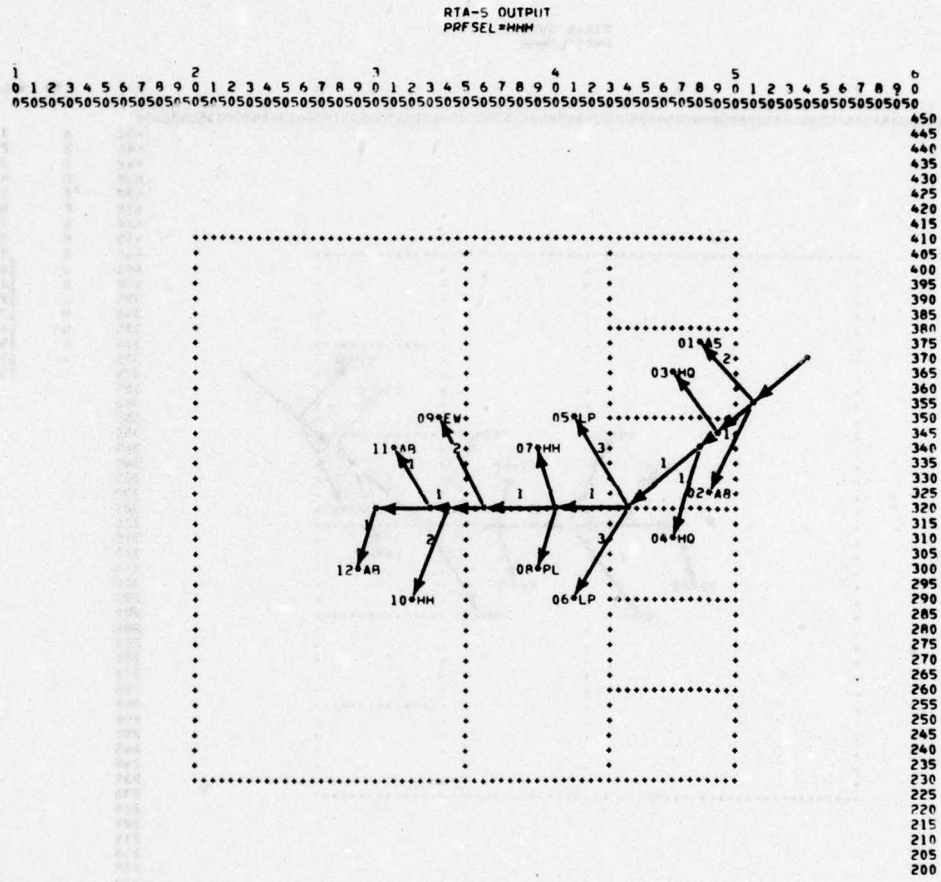

Figure 2-11. HIMAD Unit Intercepts Display

RTA-6 OUTPUT  
PRFSEL=MMH

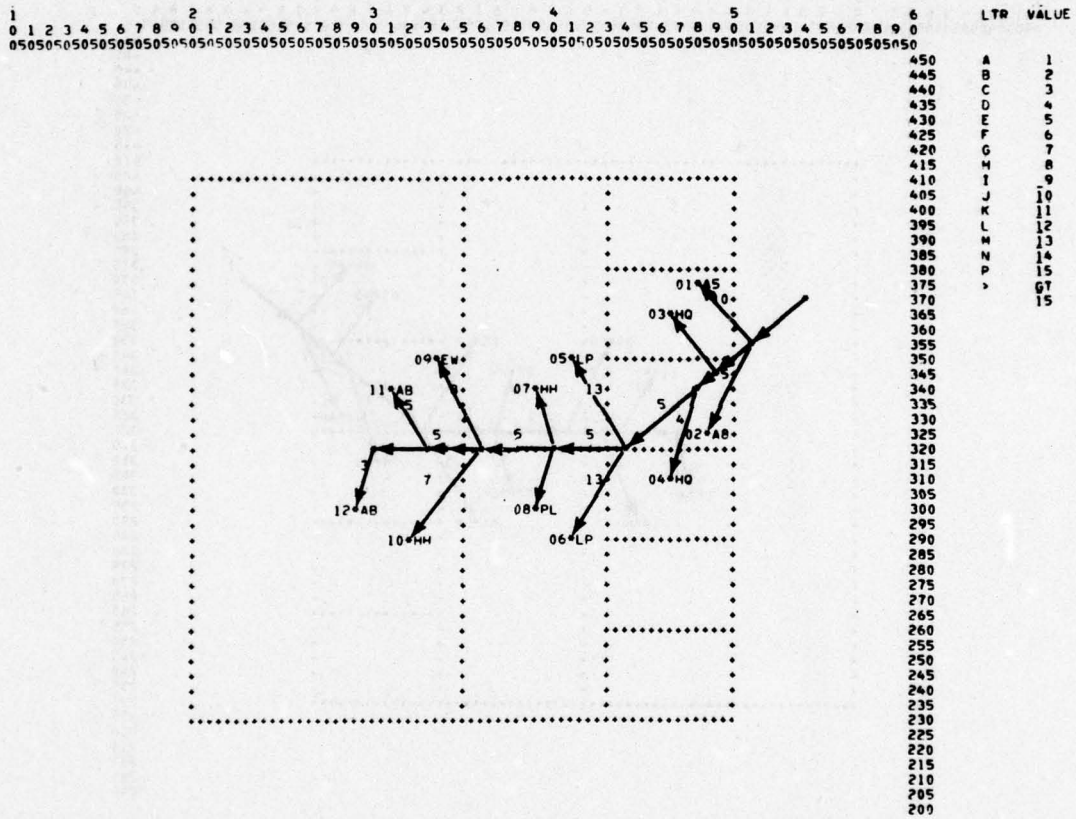

Figure 2-12. HIMAD Launcher Intercepts Display



(4) Examine Intercept Summary. The user examines the Track Intercepts Summary display. This display (Figure 2-13) gives details of each intercept, in segment order. The data of particular interest to the user are enclosed within the rectangular blocks. Within block A are the data associated with the identification of the intercept, that is, a reference number (NR) of the intercept, the target number (TGNR) and target type (TGTY) associated with the segment in which the intercept occurs (MT under TGTY refers to an intercept on main track segment), the track segment on which the intercept occurs (SGMT) and the reference number (AD) of the intercepting HIMAD Unit. Within Block B are the coordinates (XI, YI) at which the intercept occurs. Within Block C are the data associated with the intercept conditions, that is, the PTL azimuth, adjusted as necessary to permit intercept (ADJPT), the number of launchers which engage (NLHR) and the cumulative number of missiles (CUMMSL) which engage on the track, up to the present intercept point. The remaining columns of information provide intermediate results of the intercept calculations for reference purposes as follows: the slope (M) and Y-intercept (YO) of the line segment on which the intercept occurs, the coordinates of the unit (XS, YS) conducting the intercept, the range to the target at intercept (R), the original PTL of the HIMAD Unit (PTL), the angle between the line connecting the unit and the target and the positive X-axis (ARCTAN), the angle between this line and the positive Y-axis (AZI), the angle between this line and the PTL (AZD) and the angle through which the PTL must be moved to permit intercept (PTLCHG).

(5) Decide Intercept Acceptability

(a) The user must decide if the pattern of intercepts as shown is acceptable. The air defender is concerned that the pattern represents the best possible defense. The attacker is concerned that the pattern represents the best possible evasion of the defense.

(b) There can be, however, appreciable variation in this intercept pattern, due to the sector coverage characteristics of the HIMAD, depending upon the structure of the raid track (i.e., the disposition of the main track and spur tracks). For raids which make limited excursions to either side of the track, a Conservation of Defense principle may be considered to be in effect, namely, that the total number of intercepts remains approximately constant and is redistributed depending upon the structure of raid. Put another way, deeply raiding aircraft penetrating along the main raid track could encounter reduced opposition if a preceding attack by aircraft striking shallow targets causes missile exhaustion before reload is possible. The exploitation of this effect is the task of the user.

RTA-7 OUTPUT  
PRF SEL \*\*\*\*\*

NR	TMR	TCTV	SGWT	AD	M	Y6	X5	Y5	R	XI	YI	PTL	ARCTAN	AZI	AZD	PILCHG	ADJPTL	NLMR	CUMMSSL
1	1	AS	2-3	3	-0.67	695.0	450.0	380.0	40.0	488.5	369.3	90.0	-15.5	105.5	15.5	0.0	90.0	5	20
2	1	AS	2-3	3	-0.67	695.0	450.0	350.0	40.0	482.5	373.3	90.0	35.7	54.3	-35.7	0.0	90.0	5	40
3	2	AS	4-5	4	1.20	-257.0	450.0	320.0	40.0	489.8	329.6	90.0	13.9	76.1	-13.9	0.0	90.0	5	60
4	4	MO	10-11	5	2.00	-620.0	450.0	290.0	40.0	471.8	323.6	90.0	57.0	33.0	-57.0	-12.0	78.0	4	76
5	-	MT	12-13	11	.50	100.0	410.0	320.0	40.0	449.7	324.9	90.0	7.0	83.0	-7.0	0.0	90.0	5	96
6	5	LP	13-14	9	-1.00	760.0	410.0	380.0	40.0	419.0	341.0	90.0	-77.0	167.0	77.0	32.0	122.0	3	108
7	5	LP	13-14	17	1.00	760.0	410.0	350.0	40.0	438.3	321.7	90.0	-45.0	135.0	45.0	0.0	90.0	5	128
8	5	LP	13-14	17	-1.00	760.0	370.0	350.0	40.0	410.0	350.0	90.0	0.0	90.0	0.0	0.0	90.0	5	148
9	6	LP	15-16	12	1.00	-120.0	410.0	290.0	40.0	438.3	318.3	90.0	45.0	45.0	-45.0	0.0	90.0	5	168
10	6	LP	15-16	13	1.00	-120.0	410.0	260.0	40.0	419.0	299.0	90.0	77.0	13.0	-77.0	-32.0	58.0	3	180
11	6	LP	15-16	19	1.00	-120.0	370.0	290.0	40.0	410.0	290.0	95.0	0.0	90.0	-5.0	0.0	95.0	5	200
12	-	MT	17-18	18	0.00	320.0	370.0	320.0	40.0	410.0	320.0	90.0	0.0	90.0	0.0	0.0	90.0	5	220
13	-	MT	22-23	25	0.00	320.0	330.0	320.0	40.0	370.0	320.0	90.0	0.0	90.0	0.0	0.0	90.0	5	240
14	9	EW	23-24	23	-1.20	752.0	330.0	380.0	40.0	341.8	341.8	90.0	-72.8	142.8	72.8	27.8	117.8	3	252
15	9	EW	23-24	24	-1.20	752.0	330.0	350.0	40.0	358.4	321.9	90.0	-44.7	134.7	44.7	0.0	90.0	5	272
16	-	MT	25-26	26	0.00	320.0	330.0	290.0	40.0	356.5	320.0	90.0	48.6	41.4	-48.6	-3.6	86.4	4	288
17	10	HH	26-27	27	1.50	-190.0	330.0	260.0	40.0	326.6	299.9	90.0	94.9	355.1	-94.9	-49.9	40.1	2	296
18	10	HH	26-27	33	1.50	-190.0	280.0	290.0	40.0	328.1	302.2	90.0	17.7	72.3	-17.7	0.0	90.0	5	316
19	-	MT	28-29	32	0.00	320.0	290.0	320.0	40.0	330.0	320.0	90.0	0.0	90.0	0.0	0.0	90.0	5	336
20	11	AR	29-30	31	-1.00	650.0	290.0	350.0	40.0	322.8	327.2	90.0	-34.8	124.8	34.8	0.0	90.0	5	356
21	12	AR	32-33	34	2.00	-280.0	290.0	280.0	40.0	290.0	300.0	90.0	90.0	360.0	-90.0	-45.0	45.0	3	368

BLOCK C

BLOCK B

BLOCK A

Figure 2-13. Track Intercepts Summary Display



(6) Revise Inputs. If the pattern of intercepts is unacceptable or if alternative tracks are suggested which will favorably alter the intercept distribution, then revised inputs are prepared. The user continues to iterate the steps of this interaction level until an acceptable pattern of engagement is achieved. The user may then proceed to the next level of interaction--a consideration of possibilities for HIMAD suppression.

d. Interaction Level 3 - HIMAD Suppression. The user activities associated with Interaction Level 3 are flowcharted in Figure 2-1(c) and discussed in the following paragraphs.

(1) Enter Suppression Data. The user identifies both the total number and mix of air defense suppression assets available to clear the raid track. In the present model, the mix is specified in terms of the proportions of each of three types of air defense suppression assets, namely: stand-off (ARM) aircraft, ground attack (rocket) aircraft and decoy (unarmed remotely-piloted) aircraft. The assets, as input for the model for the scenario under consideration, are shown as Part 1 of the HIMAD Suppression Estimate display described in the following paragraph.

(2) HIMAD Suppression Estimate. The user examines the HIMAD Suppression Estimate as displayed by the model. The estimate (Figure 2-14) is organized in three parts.

(a) In Part I of the display the characteristics are given for each of the three aircraft types (AC1, AC2, AC3). For each aircraft type there is a specification of the number of the particular air defense suppression weapon carried (WPNR), the single shot kill probability of the weapon (WPPR) and the desired cumulative kill probability to be achieved using the weapon against a single HIMAD unit (ADPR). It will be noted that for AC3, the unarmed remotely piloted aircraft, the "kill" mechanism is that of depleting the resources of the HIMAD Unit engaged by successfully decoying each of the unit missiles. As a consequence, the WPNR, WPPR and ADPR data are not displayed for AC3. Part 1 also includes an additional line of information identified as PERAD. This line indicates the number of aircraft of each type, computed by the model being required to kill an individual HIMAD Unit to the probability specified in ADPR. In the case of AC3, the value is set equal to the maximum number of missiles per unit. These values are used later in the calculation of the overall suppression estimate.



CAA-TP-77-5

RTA-R OUTPUT  
PRFSEL=HHH

PART 1

	AC1	AC2	AC3
WPNR	2	4	
WPPR	.250	.100	
ADPR	.900	.900	
PERAD	5	6	20

PART 2

PCT TGMSR 1 (N= 12)	AC1 (PC= 50)	NR AC2 (PC= 25)	AC3 (PC= 25)	TL (TTLAC=100)	AC UR	PCT AD (N= 21)
10	9	4	4	18	.180	9
20	13	6	6	27	.270	14
30	13	6	6	27	.270	14
40	18	9	9	36	.360	19
50	49	24	24	99	.990	52
60	54	27	27	108	1.080	57
70	54	27	27	108	1.080	57
80	67	33	33	135	1.350	71
90	81	40	40	162	1.620	85
100	94	47	47	189	1.890	100

PART 3

PCT TGMSR 2 (N=2369)	AC1 (PC= 50)	NR AC2 (PC= 25)	AC3 (PC= 25)	TL (TTLAC=100)	AC UR	PCT AD (N= 21)
10	18	9	9	36	.360	19
20	36	18	18	72	.720	38
30	49	24	24	99	.990	52
40	54	27	27	108	1.080	57
50	54	27	27	108	1.080	57
60	61	40	40	162	1.620	85
70	81	40	40	162	1.620	85
80	90	45	45	180	1.800	95
90	94	47	47	189	1.890	100
100	94	47	47	189	1.890	100

Figure 2-14. HIMAD Suppression Estimate Display

(b) Part 2 (and Part 3) of the HIMAD Suppression Estimate provides two basic sets of information, with respect to achieving access to (stated percentages of) the target array. First it indicates the number of air defense suppression aircraft by type (AC1, AC2, AC3) and total number of aircraft (TL) which are required to suppress the air defense units defending the stated percentage of the target array (PCT TGMSR 1). The display also indicates the fraction (or multiple) of the available aircraft this number of aircraft represents (see AC UR column). The (N) value under PCT TGMSR 1 indicates the total number of targets. The (PC) values under the aircraft columns are the percentage of each aircraft type used. The (TTLAC) value is the total number of aircraft available. Second, the display indicates the percentage of the HIMAD units suppressed (PCT AD) in achieving access to the stated percentage of the target array. The (N) value under the PCT AD column is the total number of HIMAD units carrying out intercepts.

The first and last columns of Part 2 of this display thus provide trade-off information on the percent of targets accessed versus the percent of HIMAD suppressed in achieving this access. For example, to attack 60 percent of the targets would require 54 stand-off attack aircraft, 27 ground attack aircraft and 27 decoy aircraft and would suppress 57 percent of the HIMAD. The aircraft utilization (ACUN) in this instance is 1.080, that is, 8 percent more aircraft than the 100 specified as available, are required to carry out the suppression.

(c) Part 3 of the HIMAD Suppression Estimate display provides similar information except that percent of the target array is replaced by a weighted measure of the target array (TGMSR 2). Targets are weighted by their distance down the track. Deep targets now have greater value than shallow targets. This measure attempts to compensate for the, typically, unequal geographic distribution of targets, with the preponderance of targets shallow on the track and only a few deep on the track. By way of example, and as a comparison with Part 2, to attack 60 percent of the weighted target array would require 81 stand-off attack aircraft, 40 ground attack aircraft and 40 decoy aircraft and would suppress 65 percent of the HIMAD. The aircraft utilization (ACUR) in this instance is 1.62, that is, 62 percent more aircraft than that specified as available are required to carry out the suppression.

(3) Decide HIMAD Suppression Estimate Acceptability. The user must decide how effective the suppression has been against the HIMAD as related to the amount of the target array opened to attack. If the necessary numbers of aircraft are not available the user has several options available. He may elect to change



the mix of suppression aircraft; he may decide to limit the attack to some percentage of the target array; or he may decide to delete targets and associated track spurs to consolidate the attack, thereby reducing the number of HIMAD units in play.

(4) Revise Inputs. As necessary, the user modifies the input, either with respect to the mix of suppression aircraft, the number of targets associated with the raid track, or both. The steps of the interaction level are then iterated until an acceptable application of suppression assets are achieved.

e. Holistic View of Interaction. The model has been described in terms of discrete, sequential steps of interaction. This is a simplification for purposes of exposition. In actual use, changes may be made at several levels of interaction at once, to accomplish an analysis more broad in scope than that presented by way of illustration. As an operating entity, the model accepts the inputs associated with the three levels at one time and generates all outputs in a single computation process. Depending upon the interest of the user, the inputs at any level of interaction may be fixed and the model iterated with respect to the remaining level(s). For example, an air defense planner might hold the track fixed (Level 2), the air defense suppression fixed (Level 3), and vary the HIMAD deployment (Level 1). A raid planner might hold the deployment fixed (Level 1), the raid track fixed (Level 2), and vary the suppression assets (Level 3). Viewed holistically, the model provides eight displays of information considered essential to the understanding and resolution of the issues associated with raid track assessment itemized in the Introduction (Paragraph 1-3). The relationship of each of these issues to each of these displays is summarized in Table 2-2.

2-4. OPTIONAL OUTPUTS. The model automatically provides the map and summary outputs associated with the interaction levels described in the preceding paragraphs. In addition, there are available, on request, outputs which display the input data. These outputs are provided so that the user may have a convenient reference to the input information. The user may, however, elect to discontinue receiving any or all of these displays as the work with the model progresses. A total of seven such outputs are available, as described in the following sections.

a. HIMAD Unit List. This display lists the HIMAD characteristics input by the user. The display has been previously discussed (paragraph 2-3.b(1)(a)) and shown in Figure 2-2.

b. Target List. This display lists the target characteristics input by the user. The display has been previously discussed (paragraph 2-3.b(1)(b)) and shown in Figure 2-4.



Table 2-2. Assessment Issues Addressed by Model Displays

Assessment issue	Model Display							
	HIMAD deployment	Target array	HIMAD unit coverage	HIMAD LCHR coverage	HIMAD unit intercepts	HIMAD LCHR intercepts	Track intercept summary	HIMAD suppression estimate
<b>Air Defense Coverage</b>								
• Gaps	X		X					
• Weak points	X		X	X				
• Redundancy	X		X	X				
• Raid routes	X	X	X					
<b>Raid Track Vulnerability</b>								
• Units intercepts					X		X	
• Missile intercepts						X	X	
• Target-by-Target intercepts					X	X	X	
<b>Air Defense Suppression</b>								
• Suppression objectives							X	
• Suppression order							X	
• Suppression force composition								X
• Suppression - effort vs target trade-offs								X

CAA-TP-77-5

d. Intercept Range Table. This display (Figure 2-15) is a table which shows the HIMAD intercept ranges input by the user for the division, corps and rear areas for each of three flight profiles (high, low and hop). These intercept range values are determined by the user from performance curves for the HIMAD which relate intercept range to altitude. The particular values are those which correspond to the altitudes at which the raid aircraft will fly as they transit the division, corps and rear areas. It should be noted that the HIMAD performance curves for intercept distance are stated for particular conditions of aircraft size, formation and movement as well as prevailing ECM conditions. As such, they implicitly attribute these conditions to the raid under assessment. The range values shown in the display are quantized by the model into units of 5 km, to match the resolution of the map display. The input is considered preset, as a HIMAD technology characteristic, not subject to user manipulation as part of the analysis process.

e. Intercept Sector Matrix. This display (Figure 2-16) shows the square (20 x 20) matrix repeatedly used by the program to generate the HIMAD Unit Coverage and HIMAD Launcher Coverage displays. The numbers are positioned in the matrix so that the selection of all the elements with a particular number forms (approximately) a sector 22.5 degrees in width. Recall that the matrix is actually square and that the angle shown in the figure is distorted by the line printer. An intercept sector, of say 90 degrees, may thus be formed by selecting the elements corresponding to four ( $4 \times 22.5 = 90^\circ$ ) consecutive numbers (with appropriate adjustments where the numbers revert from 16 back to 1). The PTL of the sector is taken into account by selecting the sequence of four numbers which orient the sector in the direction of the PTL. The figure illustrates the situation of a 90 degree sector oriented to a PTL of 90 degrees by selection of numbers 5 through 8. The intercept range associated with the sector is accounted for by interpreting the matrix as a series of concentric rings (squares) ranging out from the center, each ring being 5 km in width, corresponding into the resolution of the coverage displays. The 20x20 array thus contains 10 rings. Ring 10, for example, consists of the numbers on the periphery of the matrix, and represents a range of 50-54 km, while Ring 1 consists of the 4 zeros at the center of the matrix, with a range of 5 km. The matrix is employed in this manner to determine the sector coverage of each HIMAD unit. The pattern of elements thus obtained is transferred to the coverage displays positioned on the HIMAD unit location.



RTA-D OUTPUT

PRFTYP	D	C	R
HHH	40	40	40
LLL	25	25	25
HOP	40	25	25

Figure 2-15. Intercept Range Table Display



RTA-E OUTPUT

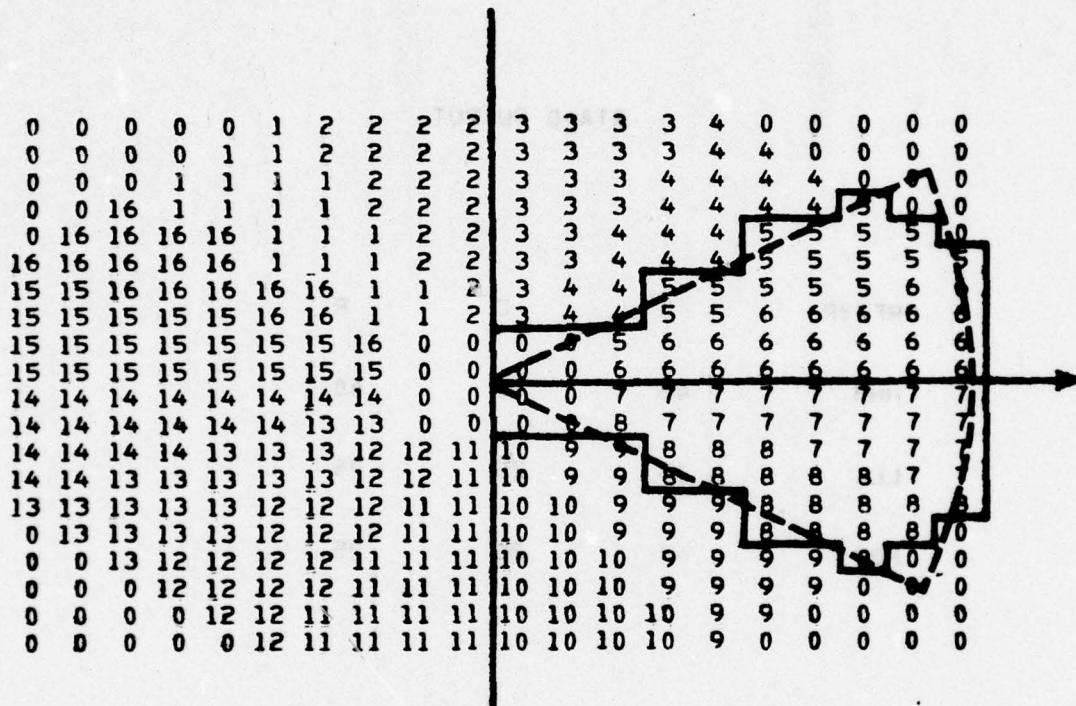

Overmark illustrates use of matrix values (bounded by solid line) to approximate an intercept sector (dashed line) extending out 50 km (to edge of matrix) at PTL azimuth of 90 degrees.

Figure 2-16. Intercept Sector Matrix Display with Overmark

Since the coverage of units may overlap, provision is made to sum the coverage in map cells where this occurs. It should be noted that the matrix, with its limited representation of the actual intercept sector, is only used for mapping purposes. The calculation of intercepts, as shown in the Track Intercept Summary, is done analytically in a subroutine to the main program.

f. Map Symbology Selection. This display (Figure 2-17) is a table which shows the symbols set information selected by the user to be printed in the map displays. The symbols sets available for printing are:

- HIMAD Unit Locations (Units)
- Targets Locations (TGTS)
- Track Points (TRKPTS)
- Boundary Segments (BDYSGM)

The model makes six passes in producing map displays and the symbology is separately specified for each pass. A "1" entry indicates the symbol set is to appear, a "0" entry that it is not to appear. The basic idea is to limit the amount of information displayed to that which the user can most effectively use. The selection is indicated as part of the user input data (see paragraph 3-4e).

g. Boundary Segment List. This display (Figure 2-18) lists the boundary segment information input by the user. For each segment, the list indicates the segment number and the coordinates of each end of the segment (X1, Y1, X2, Y2). The present design of the model only allows for specification of either horizontal or vertical segments. The segments delineate the division, corps, and rear areas to orient the user to the region under analysis.

RTA-G OUTPUT

MAPNR	DATA SET			
	UNITS	TGTS	BDYLNS	TRKPTS
1	1	0	1	0
2	0	1	1	0
3	0	1	1	0
4	0	0	1	0
5	0	1	1	1
6	0	1	1	1

Figure 2-17. Map Symbology Selection Display



## RTA-F OUTPUT

NR	X1	Y1	X2	Y2
BS 1	200	410	500	410
BS 2	430	380	500	380
BS 3	430	350	500	350
BS 4	350	320	500	320
BS 5	430	290	500	290
BS 6	430	260	500	260
BS 7	200	230	500	230
BS 8	200	230	200	410
BS 9	350	230	350	410
BS 10	430	230	430	410
BS 11	500	230	500	410

Figure 2-18. Boundary Segment List Display

## CHAPTER 3

## MODEL MECHANIZATION

3-1. ORGANIZATION. The program is organized into blocks of FORTRAN code and associated subroutines as shown in Figure 3-1. The program first carries out the computations of HIMAD coverage and HIMAD intercepts along the raid track. The program next iterates through a map generation sequence, with each iteration producing one of six map outputs descriptive of the input, coverage and intercept conditions. The model next produces a tabular summary of the intercept conditions and then proceeds to compute and print the estimate of the HIMAD suppression associated with the raid track. An overview description of the model code blocks which carry out these operations is given in the following paragraphs.

3-2. CODE BLOCK DESCRIPTIONS. a. Block 000 - Declare Variables. This block is used to declare the type and size of arrays and to assign values to variables. The arrays are sized to handle up to the following number of elements.

- HIMAD Units 60
- Targets 20
- Track points 40

b. Block 100 - Read-In Control Data. This block is used to read into the model all the data values which are preset, that is, not subject to user manipulation as part of the analysis process. Six types of input are involved as follows:

(1) Target Types. A single punched card is used to identify the symbols used for the twelve target types on the map display (see Table 2-1 for list).

(2) Area Types. A single punched card is used to identify the symbols used for the three area types (D for Division, C for Corps, R for Rear).

(3) Quantized Intercept Range Table. A three-card set is used to identify the quantized intercept ranges associated with the three flight profiles (HHH, LLL, HOP) used in the model.



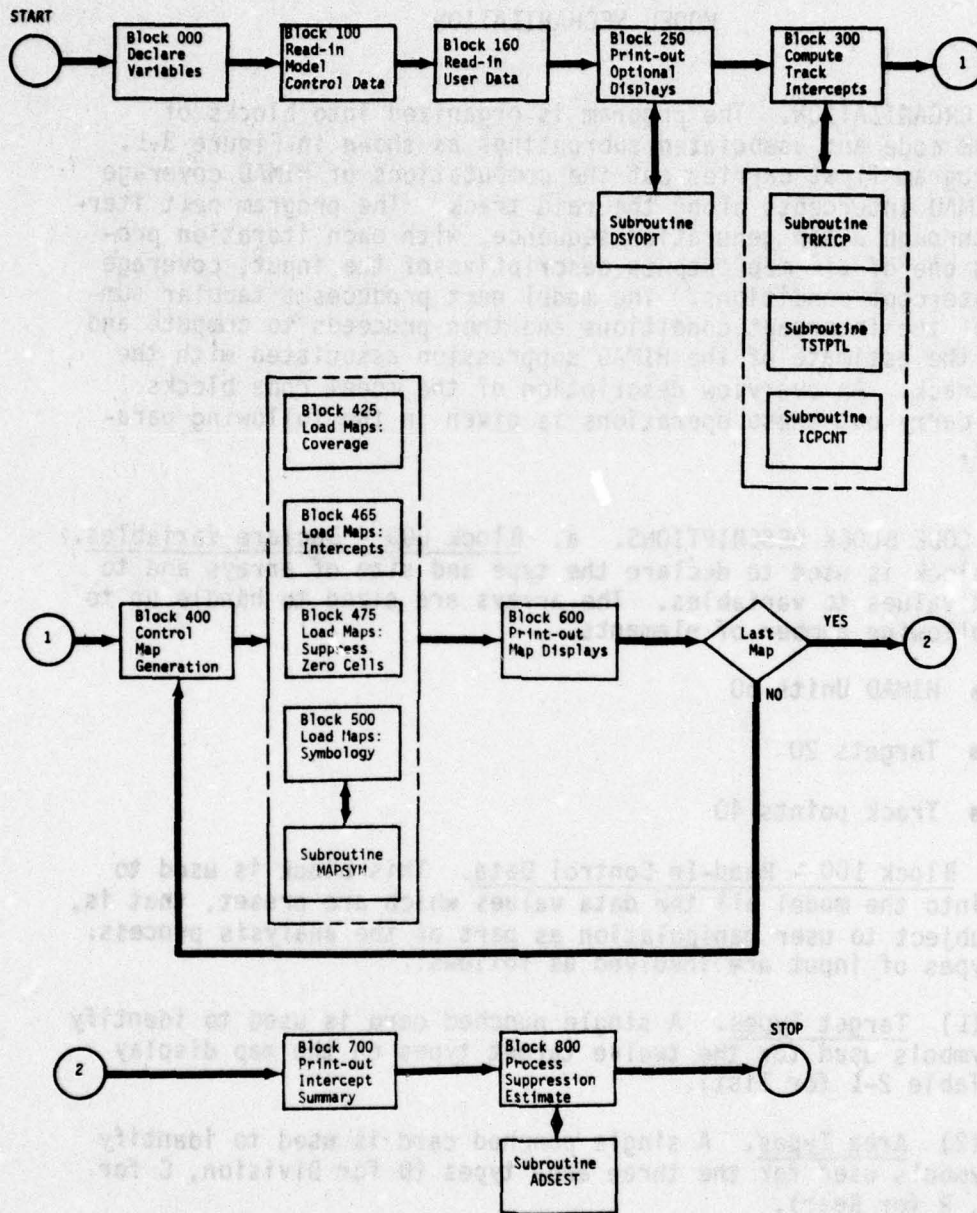

Figure 3-1. Model Organization by Code Blocks



(4) Alpha-to-Numeric Conversion Table. A single punched card is used to identify the conversion table which appears as an inset in the HIMAD Launcher Coverage (Figure 2-7) and HIMAD Launcher Intercepts (Figure 2-12) displays.

(5) Intercept Sector Template. A multi-card set is used to identify the intercept sectors at various azimuths of PTL for use in the mapping of the HIMAD Unit Coverage (Figure 2-6) and HIMAD Launcher Coverage (Figure 2-7) displays.

(6) Boundary Segments. A multi-card set is used to identify the X and Y coordinates of the boundary segment end points which divide the defended region into division, corps and rear areas.

c. Block 160 - Read-In User Data. This block is used to read-in data prepared by the user for the purposes of analysis. Eight types of user input are involved as follows:

(1) Raid Aircraft Data. A single punched card is used to indicate

- flight profiles (e.g. selected from those available high (HHH), low (LLL) or division hop(HOP))
- total number of air defense suppression aircraft available
- mix (in percentages) of three types of air defense suppression aircraft available.

(2) Suppression Data. A two-card set is used to indicate the characteristics of the two armed types of armed aircraft used for HIMAD suppression. Each aircraft type carries the other and to a single weapon type matched to the performance characteristics of the aircraft. One card is used for each aircraft to indicate:

- single shot probability of kill for weapon type carried
- number of weapons carried
- cumulative probability of kill of HIMAD to be achieved by weapon

The third aircraft type, the remotely piloted vehicle, is considered unarmed. The model employs these aircraft solely to deplete the missile stock of a HIMAD unit and expends 20 aircraft per HIMAD unit in making the suppression calculations.

(3) Graphics Scale Data. A single card is used to indicate the lower values of the x scale and y scale to be used in the map graphic outputs.

(4) Optional Display Selection. A single card is used to indicate which of the optional model outputs are desired. The selection is indicated by setting a flag to "1" if the output is desired or "0" if it is not. The available optional displays, as described in paragraph 2-4, are as follows.

- HIMAD Unit List
- Target List
- Track Point List
- Quantified Intercept Range Table
- Intercept Sector Matrix
- Map Symbology Selection
- Boundary Segment List

(5) Map Symbology Selection. A six-card set is used to indicate which of the four available sets of map symbols are to appear in the map displays. One card is used for each map and the selection is indicated by setting a flag to "1" if the symbols are desired, or "0" if they are not. The available symbol sets are as follows:

- HIMAD units
- Targets
- Boundary segments
- Track points

(6) HIMAD Unit Data. A set of punched cards is used to identify the HIMAD deployment. One card is used for each HIMAD unit to indicate:

- unit reference number
- Y-coordinate
- X-coordinate



- Defended area (division, corps, rear)
- PTL azimuth
- number of launchers at ready

(7) Target Data. A set of punched cards is used to identify the target array. One card is used for each target to indicate:

- target reference number
- X-coordinate
- Y-coordinate
- target type (12 types)
- area (division, corps, rear)

(8) Track Points. A set of punched cards is used to identify the end points of the line segments which make up the raid track. The track is considered to be made up of a main track and spur tracks which branch off the main track to take the aircraft to the individual targets. The track is defined by a sequence of points which divide the track into continuous segments. One punched card is used for each track point to indicate:

- Point reference number
- X coordinate
- Y coordinate
- Reference number of target associated with point, if any
- Type of referenced target, if any
- Backtrack indicator

d. Block 250 - Print-out Optional Displays. This block tests to determine if the user requires any of the optional model outputs. If any outputs are required, the block performs a call to the subroutine DSYOPT to generate the outputs.

e. Block 300 - Compute Track Intercepts

(1) This block carries out the track intercept calculations by a series of calls to three subroutines. The call to the first



subroutine (TRKICP) initiates testing of all track segments against all HIMAD units. The subroutine determines whether a line segment comes within a circle corresponding to the HIMAD unit intercept range (i.e., an intercept prospect). The intercept range used is based on the aircraft altitude, determined in turn from the flight altitude profile for the defended area over which the aircraft is flying. Recall that the user indicated a defended area (division, corps, rear) for each HIMAD unit and also selected the flight altitude profile. Where an intercept prospect is noted for a particular unit on a particular track segment, a prospect flag is set for that HIMAD unit indicating the track segment involved. The coordinates of the point of intersection are also stored.

(2) Upon completion of the intercept prospect calculations, the block passes control to the second subroutine (TSTPTL). This subroutine examines all the intercept prospects identified in the first subroutine and determines whether the intercept prospect can be exploited. The determination is based upon the orientation of the target with respect to the intercept sector of the HIMAD unit. The intercept sector is set to a width of 90 degrees in the present design but may be adjusted to other values by suitable changes to the code in TSTPTL. For prospects which occur within the basic coverage intercept sector, intercept by all system launchers is possible. For prospects outside the basic sector, the sector orientation is changed and the number of launchers available for intercept are reduced. Finally, for prospects which require a sector reorientation beyond the system limits, no launchers are available and the HIMAD unit cannot exploit the opportunity. For those intercept prospects which can be exploited (worked), the subroutine calculates any changes necessary in the sector orientation and also calculates the resultant number of launchers available for intercept. A "worked" flag is set to indicate when the HIMAD unit is committed to an intercept and on which segment the intercept takes place.

(3) Upon completion of the intercept processing, the block passes control to a third subroutine (ICPCNT). This subroutine examines each worked flag to identify the segment on which the intercept occurred. The subroutine counts and stores the total number of intercepts which have occurred on each segment. A separate count is made of the number of units and the number of launchers which intercept on each segment. This completes processing by the block.

f. Block 400 - Control Map Generation. This block controls the generation of the six map displays produced by the model. The block produces each map, in turn, by routing the model processing

through the appropriate blocks of codes. (Blocks 425, 465, 475, and 500.) As each map is produced, the program returns to this block for routing instructions for the next map, until all six maps have been produced. The block routinely clears the data associated with the last map before going on to the next map.

(1) Block 425 - Load Maps: Sector Coverage. This block is the first of four blocks used to insert data into the arrays which produce the map displays. The block uses the intercept sector matrix to transfer the intercept sector of each HIMAD to the map arrays. The transfer is carried out for each HIMAD unit and the coverage is summed in those cells where overlap occurs.

(2) Block 465 - Load Maps: Intercept Counts. This block loads the map arrays with the counts of the intercepts which occur along the individual raid track segments as determined in the ICPNT subroutine. The counts are positioned approximately midway along the segment. On the first pass through the block, the map is loaded with the count of unit intercepts on each segment. On the second pass, the count of launcher intercepts is loaded.

(3) Block 475 - Load Maps: Suppress Zero Cells. This block suppresses the contents of all map cells with zero entries (i.e., a lack of coverage), to simplify the appearance of the map. The block accomplishes this by generating a character version of the (numeric) map arrays and in the process substitutes a blank symbol for all map cells with a (numeric) zero entry.

(4) Block 500 - Load Maps: Symbology. This block tests to determine the symbol sets which are to be included in each map display. The symbols available are HIMAD and target locations, boundary segments and track points. The block then performs a call to the subroutine (MAPSYM) to generate the desired symbology. The choice of symbology is a user input.

(5) Block 600 - Print-out Maps. This block prints out the map displays. The print-out function is activated six times, one for each map display.

g. Block 700 - Print-out Track Intercept Summary. This block prints-out the details of the track intercepts computed by the subroutines called by Block 300. The data are presented in track segment order. In addition, the block makes a calculation of the cumulative number of missiles (not launchers) committed to intercept on the track up to each intercept point.

h. Block 800 - Process Suppression Estimates. This block makes a call to the subroutine ADSEST. This subroutine calculates



and displays the estimate of air defense suppression. The estimate is calculated in the form of trade-off. The calculation determines the number of suppression aircraft (of a specific mix) needed to clear access to various percentages of the target array. The subroutine computes the percentages of the target array twice, using two separate measures of the target array. One measure is a simple count of the number of targets in the array. The other measure weights each target by its distance down the raid track and sums these values as a weighted count of the target array. The subroutine then displays the two separate sets of trade-off data, corresponding to the two definitions of the target array.

3-3. PROGRAM CODE LISTING. A listing of the program code is shown in Appendix A. The code executes on a CDC 6600.

3-4. PROGRAM DATA LISTING. A listing of the model inputs used to generate the displays appearing as figures in this report is shown in Appendix B.

3-5. JOB DAY FILE. The machine utilization (CDC 6600) associated with compilation and execution of the program to produce the outputs illustrated in this report is summarized in the job day file shown in Figure 3-2.



```
MFA      SCOPE 3.4.4   RELEASE420 03/05/76
13.30.45.CDJJC45 FROM /A7
13.30.45.IPR 0005568 WORDS - FILE INPUT * DC 00
13.30.45.CDJJC.T24. CONNELLY
13.30.45.TASK(TNCD79505.Pw*****.TRTS) CONNELLY
13.30.47.FTN.
13.31.36.      5.655 CP SECONDS COMPILATION TIME
13.31.37.LGO.
13.31.43. CM LWA+1 =100630P. LOADER USED 113300R
13.31.49.      STOP
13.31.49.      2.038 CP SECONDS EXECUTION TIME
13.31.49.0PP 00013120 WORDS - FILE OUTPUT * DC 40
13.31.49.MS 14336 WORDS ( 25088 MAX USED)
13.31.49.FL 100700 WORDS MAXIMUM CORE UTILIZED
13.31.49.CPA      8.494 SEC.      .754 $ CP
13.31.49.ID      4.459 SEC.      .098 $ IO
13.31.49.CM      192.918 KWS.     .642 $ CM
13.31.49.SS MAINFRAME CHARGES      1.496 TOT.
13.31.49.      * * * * * NOTE * * * * *
13.31.49.CHARGES FOR CARDS READ/PUNCHED AND
13.31.49.LINES PRTD NOT INCLUDED. ADD $1.00 FOR
13.31.49.EACH TAPE/DISK MOUNTED. MIN CHARGE OF
13.31.49.$5.00 APPLIES TO CENTRAL SITE BATCH.
13.31.49.AND $1.00 TO REMOTE BATCH.
13.31.49.PP      20.296 SEC.      DATE 03/31/77
13.31.49.EJ END OF JOB. 47
```

Figure 3-2. Job Day File

## CHAPTER 4

## MODEL REFINEMENT

4-1. INTRODUCTION. Model development tends to become a self-generating activity. Experience with the design and use of the model continually generates ideas for refinements which appear to have merit and deserve implementation. The present model is no exception. However, a cut-off in development at the present level of capability, which provides a basic tool for HIMAD studies, is appropriate. For the record, then, several refinements are proposed to enhance the present capability and to include the contribution of the other elements of air defense, namely SHORAD and counterair. These refinements are discussed in the following paragraphs.

4-2. ENHANCED COVERAGE DISPLAY. a. Proposal. The HIMAD Unit Coverage display (Figure 2-6) and HIMAD Launcher Coverage display (Figure 2-7) as presently produced by the model provide numeric and alpha values, respectively, in each cell of the display to indicate the level of coverage achieved. This requires a cell-by-cell inspection of the display to comprehend the information in all its detail. It is proposed to preprocess the coverage information and present a display shaded to various degrees, to reflect the various coverage levels. This will provide a more readily interpretable display and more clearly indicate the variability in the defense posture.

b. Critique. The change involves the use of a printer line-feed hold command which will permit more than one symbol to be printed per display cell. The number and type of symbols per cell is chosen to produce a filling of the cell space with character strikes, which is visually sensed as a darkening of the cell. The effect is graduated so that the shading reflects operationally significant increments in the defense. Some experimentation with the shading effect will be needed, but the technique is well understood and available for application.

4-3. SIMPLIFIED RAID TRACK SPECIFICATION. a. Proposal. As presently structured, the model requires the user to completely specify each point along the track. This involves determining the end points for each segment of the main track and each spur track. It also requires specification of the track segments included for continuity (i.e., setting the "backtrack" indicator). A substantial simplification in this procedure could be achieved by limiting the user input requirement to specification of the main track, combined with a specification of the targets to be attacked. The



targets would be identified by target reference number in the order in which they are to be attacked. This technique would eliminate most of the specification of track point X and Y coordinates required by the present specification scheme.

b. Critique. There are several implementation alternatives associated with this proposal. In order of increasing complexity they are:

(1) Alternative 1. User adds to the target identification the number of the main track segment and the X (or Y) coordinate of the point on this segment from which the raid aircraft turn-off to attack the target. The X (or Y) coordinate is then used in conjunction with the slope of the segment to compute the corresponding Y (or X) coordinate. This turn-off coordinate pair, in conjunction with the coordinate pair of the target, define the spur to the target, and provide the information necessary to set the continuity indicator for the back-track segment.

(2) Alternative 2. User adds to the target identification the main track segment from which the raid aircraft turn-off to the target. In this alternative, the point of turn-off from the segment is selected by the model using a turn-off point algorithm. This establishes the point of turn-off from the main track, and the calculations proceed as in Alternative 1.

(3) Alternative 3. User specifies the targets in order. The model then uses a track number algorithm to select the particular track segment for turn-off and a turn-off point algorithm to select the point of turn-off from this segment. The calculations then proceed as in Alternative 1.

4-4. RAID SORTIE SPECIFICATION. a. Proposal. The model in its present form assumes a mass raid (target rich) environment and allocates all available missiles to each intercept opportunity. There is no need to maintain unit-by-unit missile availability counts since each engagement is assumed to totally deplete the missile stocks as far as the raid in progress is concerned. There may be situations however, where this assumption results in unrealistically large numbers of missiles being committed to the protection of targets. It is proposed therefore to modify the model to specify the number of raid aircraft sorties per target and thereby more realistically model the number of missiles committed per intercept opportunity.

b. Critique. There are a number of ways of mechanizing this limitation, two of which will be indicated.

(1) Alternative 1. User specifies the number of raid aircraft sorties for each target. The model compares this number with the number of missiles available for intercept and chooses the lesser number as the quantity summed into the count of missiles expended.

(2) Alternative 2. User specifies a table of the number of raid aircraft sorties by target type. The table value is then automatically applied by type to each target in the array and the calculations proceed as in Alternative 1.

4-5. ITERATIVE CAPABILITY. a. Proposal. As presently structured, the model accepts one set of user inputs at a time, and presents the results for this input. A substantial increase in flexibility could be achieved by making provision for multiple sets of input data and multiple outputs. Included in these outputs would be one or more summaries of the data across the set of all inputs. Such summaries would expedite the parametric analysis and provide compact records of the results.

b. Critique. The changes involved are minimal, but questions arise regarding selection of the variations in input which would be most appropriate to the users needs. That is to say the inputs to be considered and the order of their consideration is not readily apparent. To provide a generalized input set capability would be possible but would involve development of an input specification language of substantial proportions. Alternately, the model could automatically carry out parametric variations of a single set of user inputs. It would appear to be better to wait on a period of working level experience with the model. This would give insight into the preferred sequences for variation of the input parameters and preferred formats for display of the results across families of variations.

4-6. TARGET UTILITY MEASURES. a. Proposal. The present model generates a HIMAD-Suppression Estimate (paragraph 2-3.d(2)). This display provides trade-off data between number of air defense suppression aircraft and targets accessed by suppressing the defense. Two basic measures of the targets are provided in setting-up this trade-off. One measure counts the number of targets and works with percentages of this count in the calculation of the number of suppression aircraft required. The other measure weighs each target by its distance down the track and works with percentages of the sum of these target-distance products in the calculation of the number of suppression aircraft. The proposal would replace both these measures by a user specified utility for each target or type of target. The required suppression assets could then be calculated using the sum of the target utilities.



b. Critique. The concept of utility is well understood in principal, but consistently hard to apply in practice. There is reluctance to do much more than partition entities into those which have priority and those which do not have priority.

4-7. INTERACTIVE GRAPHICS. a. Proposal. Both the logical structure and projected mode of usage of the model are compatible with operation of the model from a graphics terminal. It is proposed therefore, in the long term, that the model be adapted for use with an interactive graphics terminal.

b. Critique. Such an interactive capability would substantially expedite the assessment process by putting the user in more direct contact with the assessment process. The user would be able to choose any aspect of the assessment process, which the immediately prior results suggest as being the most fruitful avenue for further investigation. To implement this capability it would be necessary to develop an interface package which would pass commands for model outputs from the terminal to the model and route graphics commands corresponding to the model outputs to the terminal for display. The reproduction facility associated with the terminal could be used to provide hard copy documentation of terminal displays, as desired.

4-8. COUNTERAIR ASSESSMENT. a. Proposal. The present model excludes consideration of the contribution of counterair to the regional air defense. In the present calculation, air defense suppression aircraft proceed against the HIMAD units without experiencing any opposition from counterair. It is proposed to introduce an analytical representation of counterair as an attrition factor against suppression aircraft.

b. Critique. The inclusion of counterair will introduce consideration of ground controlled intercept and air engagement tactics into the development of the model inputs. This could be a substantial conceptual undertaking and may or may not be reducible to relatively simple computational procedures. Work has been done by Project Successor (Redstone Arsenal, Huntsville, AL) on a stand-alone model for assessment of counterair attrition, but no evaluation of its contribution in the context of this proposal has been made.

4-9. SHORAD ASSESSMENT. a. Proposal. The present model does not consider the contribution of SHORAD. It is proposed to introduce an analytical representation of SHORAD as an attrition factor against the suppression aircraft.



b. Critique. The inclusion of SHORAD, as it functionally complements the HIMAD, is a logical extension of the air defense assessment capability provided by the model. A deterministic formulation of the play, could be derived from the results of existing COMO simulations.

APPENDIX A  
PROGRAM CODE LISTING

```

PROGRAM RTAMK2      76/76  OPT=1                      FTN 4.6+420      03/31/77  13.38.47

1      PROGRAM RTAMK2 (INPUT,OUTPUT)
C
C .....
C BLOCK 000 - DECLARE VARIABLES
C .....
C
C      INTEGER  ADICP(60)
C      DIMENSION  ADJPTL(60)
C      DIMENSION  ADPT(160,2)
10     DIMENSION  ADPR(2)
C      INTEGER  ADARA(60)
C      INTEGER  ADWKO(60)
C      DIMENSION  ALHR(100,50)
C      DIMENSION  AZI(60)
15     DIMENSION  AZD(60)
C      DIMENSION  ARCTAN(60)
C      DIMENSION  ASIT(100,50)
C      INTEGER  BPX1(20),BPY1(20),BPX2(20),BPY2(20)
C      INTEGER  BKTRK(40)
20     INTEGER  CUMMSL(60)
C      INTEGER  DOPT(7)
C      INTEGER  ICPAD(60)
C      DIMENSION  ICPDST(60)
C      DIMENSION  ILLHR(100,50)
25     DIMENSION  ISITE(100,50)
C      REAL  KEY(2,50)
C      DIMENSION  MIXAC(3)
C      DIMENSION  NLHR(60)
C      REAL  NUMB(10)
30     DIMENSION  PRFTYP(3)
C      DIMENSION  PTL(60)
C      DIMENSION  PTLCHG(60)
C      DIMENSION  RNG(60)
C      INTEGER  RNGT(3,4)
35     INTEGER  SGAD(40)
C      INTEGER  SGLHR(40)
C      DIMENSION  SGPT(40,2)
C      DIMENSION  SGSUM(40)
C      DIMENSION  SLOPE(40)
40     INTEGER  SYMSEL(6,4)
C      INTEGER  TGARA(60)
C      INTEGER  TGTYP(60)
C      DIMENSION  TGPT(20,2)
C      DIMENSION  TGNR(40)
45     DIMENSION  TGTY(40)
C      INTEGER  TPTG(40)
C      DIMENSION  TYPTGT(12,2)
C      DIMENSION  TYPARA(4)
C      DIMENSION  TYPAD(2)
50     INTEGER  THRLT(20,20)
C      INTEGER  VRTSEG(40)
C      INTEGER  WPNR(2)
C      DIMENSION  WPPR(2)

```



PROGRAM RTANK2 74/74 OPT=1 FTN 4.6+420 03/31/77 13.30.47

```

55      DIMENSION YICP (40)
        DIMENSION XI (60)
        DIMENSION YI (60)
        INTEGER XSCL (6)
C
60      A  INTEGEF XDT,YQT,ENDSET,TMPLTV,SECTLO,SECTHI,XO,YO,
          PTLO,RO,PRFSEL,TTLAC,XLO,YLO,YHI
C
        DATA NIMB /1H0,1H1,1H2,1H3,1H4,1H5,1H6,1H7,1H8,1H9/
        DATA BLANK /1H /
        DATA DOLLAR /1H$/
65      DATA PLUS /1H+/
        DATA DINT /1H$/
        DATA TYPAD /1HA,1HD/
C
70      CALL DATE (ADATE)
C
        NSITES=NTPTS=NSGMTS=NTGTS=NBPTS=MAPNR=NICP=NDSY=NMSL=IFLAG=0
C
        DO 20 I=1,2
        DC 20 J=1,50
          KEY(I,J)=BLANK
20      C NTINUE
C
        DO 40 I=1,60
          ADICP(I)=0
          ADWKO(I)=0
80      C NTINUE
C
        DO 60 I=1,20
          VRTSEG(I)=0
85      C NTINUE
C
        *****
        C BLOCK 100 - READ-IN MODEL CONTROL DATA
        C *****
90      C
        C READ-IN TGT TYPES.
        READ 100,((TYPTGT(I,J),J=1,2),I=1,12)
        FORMAT (9X,12(3X,2A1,1X))
100     C READ-IN ARFA TYPES.
        READ 105,(TYPARA(I),I=1,4)
        FORMAT (8X,4(4X,A1))
95     C READ-IN PROFILE TYPES AND QUANTIZED INTERCEPT RANGE DATA.
        DO 120 I=1,3
          READ 110,PRFTYP(I),(RNGJ(I,J),J=1,3)
          FORMAT (12X,A3,3(3X,1Z))
100     110 C NTINUE
        C READ-IN ALPHA TO NUMERIC CONVERSION TABLE USED WITH ALMR-OUTPUT.
        READ 130,((KEY(I,J),I=1,2),J=1,17)
        FORMAT (5X,17(A1,A2,1X))
105     130 C READ-IN AD INTERCEPT SECTOR TEMPLATE.
        DO 140 I=1,20
    
```

PROGRAM RTAMK2 74/74 OPT=1 FTN 4.6+420 03/31/77 13.38.47

```

135      READ 135, (TMPLT(I,J),J=1,20)
140      FORMAT (17X,20I2)
110      C N T I N I E
      C   READ-IN POINTS DEFINING DIVISION, CORPS, AND REAR AREA BOUNDARIES
      DO 155 I=1,30
150      READ 150, ENDSSET, BPIX(I),BPI1(I),BPIX2(I),BPI2(I)
      FORMAT (2X,I2,4(7X,I3))
115      IF (ENDSET.EQ.99)                GO TO 160
      NRPPTS=NBPTS+1
155      C N T I N I E
      C .....
      C   BLOCK 160 - READ-IN USER DATA
      C .....
120      C   READ-IN ANALYSIS PARAMETERS.
160      READ 163, PRFSEL, TTLAC, (MIXAC(I), I=1,3)
163      FORMAT (19X, I2, 4(9X, I3))
      DO 165 I=1,2
125      164      READ 164, WPNR(I), WPPR(I), AOPR(I)
      165      FORMAT (19X, I1, 2(9X, F5.3))
      C N T I N I E
      C   READ-IN MAPSCALE DATA.
130      166      READ 166, XLO, YLO
      166      FORMAT (3X, 2(6X, I3))
      C   ESTABLISH X-SCALE VALUES FOR MAP DISPLAYS.
      DO 167 I=1,6
167      167      XSFL(I)=XLO/100*(I-1)
      C N T I N I E
      C   COMPUTE UPPER VALUE FOR Y-SCALE.
135      168      YH=YLO+250
      C   READ-IN OPTIONAL DISPLAYS REQUIRED.
      170      READ 170, (DOPT(I), I=1,7)
      170      FORMAT (7(9X, I1))
140      C   READ-IN SELECTION OF SYMBOL INFORMATION TO APPEAR IN MAP DISPLAYS.
      DO 173 I=1,6
172      172      READ 172, (SYMSEL(I,J), J=1,4)
173      173      FORMAT (4(9X, I1))
      C N T I N I E
145      C   READ-IN INDIVIDUAL AD SITE DATA.
      DO 180 I=1,100
175      A   175      READ 175, ENDSSET, (ADPT(I,J), J=1,2), ADARA(I),
      175      PTL(I), NLHR(I)
      175      FORMAT (2X, I2, 7X, F5.1, 5X, F5.1, 18X, I1, 8X, F5.1, 6X, I1)
150      IF (ENDSET.EQ.99)                GO TO 185
      NSITES=NSITES+1
180      C N T I N I E
      C   READ-IN INDIVIDUAL TGT DATA.
155      185      DO 195 I=1,100
      190      READ 190, ENDSSET, (TGPT(I,J), J=1,2), TGTYP(I), TGARA(I)
      190      FORMAT (2X, I2, 7X, F5.1, 5X, F5.1, 8X, I2, 8X, I1)
195      IF (ENDSET.EQ.99)                GO TO 200
      NTGTS=NTGTS+1
      C N T I N I E
      C   READ-IN POINTS WHICH DIVIDE TRACK INTO LINE SEGMENTS.

```



```

PROGRAM RTAMK2      74/74  OPT=1                      FTN 4.6+420      03/31/77  13.30.47

160      200      DO 210 I=1,100
                READ 205,ENDSET,(SGPT(I,J),J=1,2),BKTRK(I),TGNR(I),
A          TGTY(I)
205          FORMAT (2X,I2,2X,2(5X,F5.1),9X,I1,2(8X,A2))
                IF (ENDSET.EQ.99) GO TO 215
165          NTPTS=NTPTS+1
210          C 'NTINHE
C          ESTABLISH INDEX FOR NUMBER OF TRACK SEGMENTS.
215          MSGMTS=NTPTS-1
                C 'NTINHE

170          C
C          *****
C          BLOCK 250 - PRINT-OUT OPTIONAL DISPLAYS (INPUT DATA) AS REQD
C          *****
C          C
175          C          TEST IF ANY OPTIONAL DISPLAYS HAVE BEEN REQUESTED.
                DO 250 I=1,5
                NDSY=NDSY+DOPT(I)
250          C 'NTINHE
                IF (NDSY.EQ.0) GO TO 300

180          C          CALL D=YOPT (ADATE,PREYTP,HNGT,TMPLT,TGPT,BKTRK,TGNR,
A          TYPTGT,YPARA,PRFSEL,ADARA,ADARA,
B          PTL,NLHR,ILHR,NSITES,NTGTS,NBPTS,TGTY,
C          TGTYP,TGARA,DOPT,SYMSEL,SGPT,NTPTS,
185          D          BPX1,BPY1,BPX2,BPY2)

C          C
C          *****
C          BLOCK 300 - COMPUTE TRACK INTERCEPTS
C          *****
190          C
300          C          CALL TRKICP (BKTRK,NSITES,VRTSEG,ADPT,SLOPE,YICP,
A          RNG,AZI,ARCTAN,ADICP,XI,YI,MSGMTS,
B          RNGT,PRFSEL,ADARA,SGPT)
195          C          CALL 'STPTL (AZI,PTL,AZD,PTLCHG,AD,JPTL,NLHR,ADWKD,
A          ADICP,ARCTAN,NSITES,ADPT,XI,YI)
                CALL ICPCNT (ADWKD,SGAD,SGLNR,MSGMTS,NSITES,NLHR)
C          C
C          *****
C          BLOCK 400 - CONTROL MAP GENERATION
C          *****
200          C          ESTABLISH INDEX FOR MAP COUNT.
400          MAPNR=MAPNR+1
C          CLEAR INTEGER AND CHARACTER MAP ARRAYS TO INITIAL VALUES.
                DO 410 I=1,100
205          DO 410 J=1,50
                ILHR(I,J)=0
                ALHR(I,J)=BLANK
                ISITE(I,J)=0
                ASTIT(I,J)=BLANK
210          C 'NTINHE
C          ROUTE MAP PROCESSING.
                GO TO (500,500,425,425,465,465) MAPNR

```

PROGRAM RTANK2 74/74 OPT=1

FTN 4.6-420

03/31/77 13.30.47

```

C .....
C BLOCK 425 - LOAD MAPS: SECTOR COVERAGE
C .....
215 C LOAD AD SITES ONE-BY-ONE.
C DO 462 I=1,NSITES
C ESTABLISH INDEX FOR TEMPLATE TRANSFER RANGE.
425 C
C 430 P0=RNGT(PRFSEL,ADARA(I))/5
C 220 QUANTIZE AD SITE COORDINATES INTO SKM CELL COORDINATES FOR USE
C IN ILHR-ARRAY.
C XQ= (ADPT(I,1)-XLO)/5 +1
C YQ=(YHI-ADPT(I,2))/5+1
C 225 COMPUTE COORDINATES OF REFERENCE POINT IN ILHR-ARRAY
C AS ORIGIN FOR TRANSFER OF SITE INTERCEPT SECTOR FROM TEMPLATE TO
C ARRAY.
C XQ=XQ-RQ
C YQ=YQ-RQ
C 230 QUANTIZE PTL OF AD SITE INTO 22.5 DEG INTERVALS FOR USE WITH
C INTERCEPT SECTOR TEMPLATE.
C ADPTL=ADPT(I)
C PTLQ=ADPTL /22.5+1
C 235 IDENTIFY INDICES OF SECTORS TO BE READ FROM TEMPLATE BASED ON
C AZIMUTH OF QUANTIZED PTL.
C 235 SECTLO=PTLQ
C SECTHI=PTLQ+3
C ESTABLISH LIMITS FOR TEMPLATE SCAN.
C N1=11-RQ
C N2=RQ+10
C 240 TRANSFER SITE INTERCEPT SECTOR FROM TEMPLATE TO ILHR-ARRAY
C AND ISITE-ARRAY.
C DO 461 J=N1,N2
C YJT=YQT+J-1
C IF(YJT.LT.1 .OR.YJT.GT.50 ) GO TO 461
C 245 DO 460 K=N1,N2
C XKT=XQT+K-1
C IF(XKT.LT.1 .OR.XKT.GT.100) GO TO 460
C IF (PTLQ.GE.14.AND.TMPLT(J,K).LE.3) GO TO 450
C IF (TMPLT(J,K).GE.SECTLO.AND.TMPLT(J,K).LE.SECTHI)
C 250 A GO TO 440
C GO TO 440
C 450 IF (TMPLT(J,K).EQ.0 ) GO TO 460
C TMPLTV=TMPLT(J,K)+16
C IF (TMPLTV .GE.SECTLO.AND.TMPLTV .LE.SECTHI)
C 255 A GO TO 440
C GO TO 460
C 440 ILHR(XKT,YJT)=ILHR(XKT,YJT)+NLHR(I)
C ISITE(XKT,YJT)=ISITE(XKT,YJT)+1
C 460 C NTINHE
C 260 461 C NTINHE
C 462 C NTINHE
C GO TO 475
C .....
C BLOCK 465 - LOAD MAPS: INTERCEPT COUNTS
C .....
265 C

```



```

PROGRAM RTAMK2      74/74  OPT=1                      FTN 4.6+420      03/31/77  13.30.47

465      DO 470 I=1,NSGMTS
C      INSERT INTERCEPT COUNTS INTO ALHR-ARRAY AND ASITE-ARRAYS.
      XSGAV=(SGPT(I+1,1)+SGPT(I,1))/2+0.5
      YSGAV=(SGPT(I+1,2)+SGPT(I,2))/2+0.5
270      C      XQ=(XSGAV-XLO)/5+1
      YQ=(YSGAV-YLO)/5+1
      C
      J=SGAD(I)/10+1
275      IF (J.EQ.1)                                GO TO 466
      ASIT(XQ-1,YQ)=NUMB(J)
      C
466      K=SGAD(I)+1-10*(J-1)
      IF (J.EQ.1.AND.K.EQ.1)                        GO TO 467
280      ASIT(XQ,YQ)=NUMB(K)
      C
467      J=GLHR(I)/10+1
      IF (J.EQ.1)                                GO TO 468
285      ALHR(XQ-1,YQ)=NUMB(J)
      C
468      K=GLHR(I)+1-10*(J-1)
      IF (J.EQ.1.AND.K.EQ.1)                        GO TO 470
      ALHR(XQ,YQ)=NUMB(K)
290      470      C NTINIE $ GO TO 500
      C .....
      C BLOCK 475 - LOAD MAPS: BLANK CELLS
      C .....
      C TRANSLATE NUMERIC VALUE OF CELLS IN ILHR-ARRAY TO CHARACTERS
      C AND INSERT IN CORRESPONDING CELLS OF ALHR-ARRAY.
295      475      DO 480 I=1,100
      DO 480 J=1,50
      IF (ILHR(I,J).EQ.0)                            GO TO 480
      N=ILHR(I,J)
      IF (N=15)                                       478,478,477
300      477      ALHR(I,J)=KEY(1+16)
      GO TO 480
      478      ALHR(I,J)=KEY(1+N)
480      C NTINIE
      C TRANSLATE NUMERIC VALUE OF CELLS IN ISITE-ARRAY TO CHARACTERS
305      C AND INSERT IN CORRESPONDING CELLS OF ASIT-ARRAY.
      DO 495 I=1,100
      DO 495 J=1,50
      IF (ISITE(I,J).EQ.0)                            GO TO 495
      N=ISITE(I,J)+1
      IF (N=10)                                       494,494,493
310      493      ASIT(I,J)=PLUS
      GO TO 495
494      ASIT(I,J)=NUMB(N)
495      C NTINIE
315      C .....
      C BLOCK 500 - LOAD MAPS: SYMBOLOGY
      C .....

```

PROGRAM RTANK2 74/74 OPT=1 FTN 4.6\*420 03/31/77 13.30.47

```

C
320 500 CALL MAPSYM (SYMSEL,MAPNR,NSITES,NTGTS,NBPTS,NTPTS,
      A NIMB,DOLLAR,POINT,BLANK,TGTY,XLO,YHI,ALHR,ASIT,
      B ADPT,TYPAD,SGPT,TGPT,TYPTGT,ADWKO,TGTYP,
      C RPX1,BPY1,BPX2,BPY2)
C
325 C *****
C BLOCK 600 - PRINT-OUT MAPS
C *****
C
600 IF (MAPNR.EQ.4.OR.MAPNR.EQ.6) GO TO 655
330 C PRINT OUT ASIT-ARRAY.
      PRINT 610,MAPNR, ADATE,PRFTYP(PRFSEL)
      FORMAT (I1,10X,*MOCA-SMS*,43X,*RTA-*,I1,
      A * OUTPUT*,40X,A10/62X,*PRFSEL=*,A3//)
610 PRINT 630,(XSCL(I),I=1,6)
335 630 FORMAT (13X,5(I2,18X),I2/14X,
      A 5(*0 1 2 3 4 5 6 7 8 9 *),*0*/14X,50(*05*),*0*)
      DO 650 J=1,50
      NR=YHI-5*(J-1)
340 640 PRINT 640,(ASIT(I,J),I=1,100),NR
      FORMAT (14X,100A1,I3)
650 C CONTINUE
      PRINT 685,YLO
      GO TO 400
C
345 C PRINT OUT ALHR ARRAY.
655 PRINT 660,MAPNR, ADATE,PRFTYP(PRFSEL)
660 FORMAT (I1,10X,*MOCA-SMS*,43X,*RTA-*,I1,
      A * OUTPUT*,40X,A10/62X,*PRFSEL=*,A3//)
670 PRINT 670,(XSCL(I),I=1,6)
350 670 FORMAT (13X,5(I2,18X),I2,
      A 7X,*LTR*,2X,*VALUE*/14X,
      B 5(*0 1 2 3 4 5 6 7 8 9 *),*0*/14X,50(*05*),*0*)
      DO 690 J=1,50
      NR=YHI-5*(J-1)
355 680 PRINT 680,(ALHR(I,J),I=1,100),NR,(KEY(I,J),I=1,2)
      FORMAT (14X,100A1,I3,5X,A1,5X,A2)
690 C CONTINUE
695 PRINT 685,YLO
      FORMAT (14X,I3)
      IF (MAPNR.LT.6) GO TO 400
360 C
C *****
C BLOCK 700 - PRINT-OUT TRACK INTERCEPT SUMMARY
C *****
C
365 700 PRINT 700,ADATE,PRFTYP(PRFSEL)
      FORMAT (I1,10X,*MOCA-SMS*,43X,*RTA-7 OUTPUT*,40X,A10/
      A 62X,*PRFSEL=*,A3//)
      PRINT 710
370 710 FORMAT (1X,*NR*,1X,*TGNR*,1X,*TGTY*,2X,
      A *SGMT*,3X,*AD*,5X,*M*,5X,*Y0*,5X,*XS*,5X,
      B *YS*,6X,*R*,5X, *XI*,5X,*YI*,5X,*PTL*,3X,

```



CAA-TP-77-5

```

PROGRAM RTAMK2      74/74  OPT=1      FTN 4.6+420      03/31/77  13.30.47

C
D      *ARCTAN*.4X.*AZI*.5X.*AZD*.3X.
D      *PTLCHG*.2X.*ADJPTL*.1X.*NLHR*.1X.*CUMMSL*//)
375 DO 780 I=1,NSGMTS
      DO 770 J=1,NSITES
          IF (ADMKD(J).NE.1)          GO TO 770
          NICP=NICP+1
          NMSL=NMSL+6*NLHR(J)
          PRINT 750,NICP,TGMR(I+1),TGTY(I+1),I,I+1,J,
380           SLOPE(ADMKD(J)),YICP(ADMKD(J)), (ADPT(J,L),L=1-2),
          B           RNG(J),XI(J),YI(J),PTL(J),ARCTAN(J),
          C           AZI(J),AZD(J), PTLCHG(J),ADJPTL(J),NLHR(J),
          D           NMSL
750     FORMAT (2X,I2,1X,A2,3X,A2,3X,I2,1X,1X,I2,2X,I2,2X,
385     A           F5,2,7(1X,F6.1),
          B           5(2X,F6.1),2X,I2,3X,I4)
          IFLAG=1
770     C *TINUE
          IF (IFLAG.EQ.0)          GO TO 780
390     PRINT 775
          FORMAT (/)
          IFLAG=0
780     C *TINUE
395 C .....
C BLOCK 800 - PROCESS SUPPRESSION ESTIMATE
C .....
          CALL ADEST (MIXAC,SGPT,ADPR,WPPR,WPNR,TTLAC,ADMKD,
          A           TGTY,NSITES,NSGMTS,ADATE,PRFTYP,PRFSEL,SGAD,BKTRK)
C .....
400 C *TINUE
      850 STOP
          END

```

SURROUTINE DSYOPT 74/74 OPT=1 FTN 4.6\*420 03/31/77 13.30.47

```

1      C .....
      A      SUPROUTINE DSYOPT (ADATE,PRFTYP,RNGT,TMPLT,TGPT,BKTRK,TGNR,
      B      TYPTGT,TYPARA,PRFSEL,ADPT,ADARA,
      C      PTL,NLHR,ILHR,NSITES,NTGTS,NRPTS,TGT,
      D      TGTY,TGARA,DOPT,SYMSEL,SGPT,NTPTS,
      E      BPX1,BPY1,BPX2,BPY2)
      C .....
10     A      DIMENSION PRFTYP(3),TGPT(20,2),TYPTGT(12,2),TYPARA(4),
      B      ADPT(60,2),PTL(60),SGPT(40,2),TGNR(40),TGTY(40)
      C      INTEGRO RNGT(3,4),TMPLT(20,20),NLHR(60),
      D      ILHR(100,50),TGTY(60),TGARA(60),T.A.DOPT(7),
      E      SYMSEL(6,4),ADARA(60),BKTRK(40),
      F      BPX1(20),BPY1(20),BPX2(20),BPY2(20)
15     C      IDENTIFY OPTIONAL DISPLAYS TO BE PRINTED-OUT.
      D      DO 120 IGO=1,7
      E      IF (DOPT(IGO).NE.1) GO TO 100
      F      GO TO (150,170,179,300,400,500,600) IGO
20     C      CONTINUE
      D      RETURN
      C .....
25     C      PRINT-OUT QUANTIZED INTERCEPT RANGE DATA.
      D      PRINT 160,ADATE
      E      FORMAT(1H1,10X,*MOCA-SMS*,43X,*RTA-D OUTPUT* ,40X,A10//)
      F      PRINT 162
      G      FORMAT (4(/),44X,*PRFTYP*,9X,*D*,9X,*C*,9X,*R*,2(/))
      H      DO 169 I=1,3
      I      PRINT 165,PRFTYP(I),(RNGT(I,J),J=1,3)
      J      FORMAT (45X,A3,2X,3(8X,I2)//)
30     C      CONTINUE
      K      GO TO 100
      C .....
35     C      PRINT-OUT INTERCEPT SECTOR TEMPLATE.
      D      PRINT 171,ADATE
      E      FORMAT(1H1,10X,*MOCA-SMS*,43X,*RTA-E OUTPUT* ,40X,A10,
      F      10(/))
      G      DO 175 I=1,20
      H      PRINT 172, (TMPLT(I,J),J=1,20)
      I      FORMAT (40X,20(12,1X))
40     C      CONTINUE
      J      GO TO 100
      C .....
45     C      PRINT-OUT TGT DATA.
      D      PRINT 180,ADATE
      E      FORMAT(1H1,10X,*MOCA-SMS*,43X,*RTA-B OUTPUT* ,40X,A10//)
      F      PRINT 185
      G      FORMAT (50X,*NR*,6X,*X*,6X,*Y*,5X,*TYPE*,2X,*AREA*,2(/))
      H      DO 195 I=1,NTGTS
      I      T=TGTYP(I)
      J      A=TGARA(I)
      K      PRINT 190,I,(TGPT(I,J),J=1,2),(TYPTGT(T,J),J=1,2),
      L      TYPARA(A)
50     A      FORMAT (49X,*TG*, 12,2X,2(2X,F5.1),4X,2A1,4X,A1)
      C      CONTINUE
      D      GO TO 100

```

```

SUBROUTINE DSYOPT      74/74  OPT=1                      FTN 4.6+420      03/31/77  13.30.47

C      PRINT-OUT AD SITE DATA.
55      300      PRINT 310,ADATE
310      FORMAT (1H1,10X,*MOCA-SMS*,43X,*RTA-A OUTPUT* ,40X,
A          A10//)
315      PRINT 315
60      315      FORMAT (50X, *NR*,7X,*X*,6X,*Y*,5X,*AREA*,
A          2X,*PTL*,2X,*NLHR*//)
      DO 330 I=1,NSITES
A          A=ADARA(I)
      PRINT 320,I,(ADPT(I,J),J=1,2),
A          TYPARA(A),PTL(I),NLHR(I)
65      320      FORMAT (49X,*AD*,I2,2X,2(2X,F5.1),4X, A1,3X,F5.1,3X,
A          I1)
330      C *TINIE
                                           GO TO 100

C      PRINT-OUT TRACK SEGMENT POINTS.
70      400      PRINT 420,ADATE
420      FORMAT (1H1,10X,*MOCA-SMS*,43X,*RTA-C OUTPUT*,
A          40X,A10.4//)
440      PRINT 440
75      440      FORMAT (45X,*NR*,7X,*X*,9X,*Y*,9X,*BKTRK*,
A          6X,*TGNR*,7X,*TGT*Y*,2//)
      DO 480 I=1,NTPTS
A          PRINT 460,I,(SGPT(I,J),J=1,2),BKTRK(I),TGNR(I),TGT*Y(I)
460      PRINT 460,I,(SGPT(I,J),J=1,2),BKTRK(I),TGNR(I),TGT*Y(I)
480      C *TINIE
                                           GO TO 100

C      PRINT-OUT MAP SYMBOL SELECTION.
80      500      PRINT 510,ADATE
510      FORMAT (1H1,10X,*MOCA-SMS*,43X,*RTA-G OUTPUT*,
A          40X,A10.4//)
85      520      PRINT 520
520      FORMAT (44X,*MAPNR*,16X,*DATA SET*//54X,*UNITS*,4X,
A          *TGTS*,4X,*BDYLNS*,3X,*TRKPTS*//)
      DO 550 I=1,6
A          PRINT 540,I,(SYMSEL(I,J),J=1,4)
90      540      FORMAT (46X,I1,1X,4(8X,I1)//)
550      C *TINIE
      IFI AG=0
                                           GO TO 100

C      PRINT-OUT AREA BOUNDARY LINES.
95      600      PRINT 620,ADATE
620      FORMAT (1H1,10X,*MOCA-SMS*,43X,*RTA-F OUTPUT*,
A          40X,A10.4//)
640      PRINT 640
100     640      FORMAT (45X,*NR*,7X,*X1*,9X,*Y1*,8X,*X2*,8X,*Y2*,2//)
      DO 660 I=1,NBPTS
A          PRINT 650, I,(BPX1(I),BPY1(I),BPX2(I),BPY2(I)
650      PRINT 650, I,(BPX1(I),BPY1(I),BPX2(I),BPY2(I)
660      C *TINIE
                                           GO TO 100

105     END

```



SUBROUTINE TRKICP 74/74 OPT=1 FTN 4.6+420 03/31/77 13.30.47

```

1      C *****
      C SUBROUTINE TRKICP (BKTRK,NSITES,VRTSEG,ADPT,SLOPE,YICP,
      A   RNG,AZI,ARCTAN,ADICP,XI,YI,NSGMTS,
      B   RNGT,PRFSEL,ADARA,SGPT)
5      C *****
      C INTEGRATE BKTRK(40),VRTSEG(40),ADICP(60),
      A   RNGT(3,4),PRFSEL,ADARA(60)
      A   DIMENSION ADPT(60,2),SLOPE(40),YICP(40),RNG(60),AZI(60),
      A   ARCTAN(60),XI(60),YI(60),SGPT(40,2)
10     C EXAMINE EACH TRACK SEGMENT IN TURN FOR INTERCEPTS.
      C DO 280 I=1,NSGMTS
      C SET SEGMENT INTERCEPT FLAG TO ZERO.
      C TEST IF SEGMENT POINTS DECLARED AS UNAVAILABLE FOR INTERCEPT
      C ANALYSIS.
15     C IF (BKTRK(I+1).EQ.1) GO TO 280
      C FOR AVAILABLE POINTS, ESTABLISH FOR BOTH X AND Y WHICH VALUES
      C ARE HIGHER (XH, YH) AND WHICH VALUES ARE LOWER (XL, YL).
      C   X=SGPT(I,1)
      C   Y=SGPT(I,2)
      C   XP=SGPT(I+1,1)
      C   YP=SGPT(I+1,2)
      C   IF (X-XP)
205      XH=XP
      XL=X
25     C SET FLAG TO INDICATE TRACK SEGMENT IS VERTICAL.
      C   VRTSEG(I)=1
207      XH=X
210      XL=X
      C   IF (Y-YP)
30     215      YH=YP
      C   YL=Y
      C   GO TO 226
225      YH=Y
      C   YL=YP
35     226      IF (VRTSEG(I).EQ.1) GO TO 250
      C COMPUTE SLOPE AND Y-INTERCEPT OF TRACK LINE SEGMENTS.
      C   SLOPE(I)=(YP-YI)/(XP-XI)
      C   YICP(I)=Y-SLOPE(I)*X
40     C CONTINUE
      C TEST AD SITES TO FIND THOSE WHICH INTERSECT LINE SEGMENT. EXCLUDE
      C SITES WHICH HAVE BEEN ALREADY BEEN
      C FOUND TO INTERSECT EARLIER SEGMENTS.
45     C DO 270 J=1,NSITES
      C   IF (ADICP(J).NE.0) GO TO 270
      C   X=ADPT(J,1)
      C   Y=ADPT(J,2)
      C ESTABLISH INTERCEPT RANGE FOR SITE.
      C   IF (VRTSEG(I).EQ.1) GO TO 255
50     C   RNG(J)=RNGT(PRFSEL,ADARA(J))
      C COMPUTE COEFFICIENTS OF QUADRATIC EQUATION WHOSE SOLUTIONS ARE
      C INTERSECTIONS BETWEEN LINE SEGMENT AND CIRCLE OF AD INTERCEPT
      C BOUNDARY. FOR VERTICAL SEGMENTS (SLOPE INFINITE), TRANSFER TO

```

```

SUBROUTINE TRKICP      76/76  OPT=1                FTN 4.6420      03/31/77  13.30.47

      C      SPECIAL CALCULATION.
55      A=1+SLOPE(I)**2
          B= 2*(XS-SLOPE(I))*(YICP(I)-YS)
          C=X5**2*(YICP(I)-YS)**2-RNG(J)**2
      C      EVALUATE COEFFICIENTS TO DETERMINE IF SOLUTION IS REAL (INTERSECT
      C      EXISTS) OR IMAGINARY (NO INTERSECTIONS).
60      IF (4*A*C.GT.B**2)          GO TO 270
      C      FOR REAL SOLUTION, COMPUTE INTERSECTION POINTS.
          DF=SQRT(B**2-4*A*C)
          XI1=( B-DF)/(2*A)
          XI2=( B+DF)/(2*A)
65      C      FIND INTERSECTION NEAREST FIRST POINT OF SEGMENT (FIRST INTERCEPT
      C      OPPORTUNITY.
          XI0=XI1-X
          XI2=XI2-X
          IF (ABS(XI1D).GT.ABS(XI2D))          GO TO 252
          XI(J)=XI1                          GO TO 253
252      XI(J)=XI2
253      YI(J)=SLOPE(I)*XI(J)+YICP(I)          GO TO 250
75      C      COMPUTE INTERSECTION POINTS FOR SPECIAL CASE OF A VERTICAL TRACK
      C      SEGMENT.
255      IF (RNG(J)**2.LT.(XS-X)**2)          GO TO 270
          SLOPE(I)=YICP(I)-A=B=C=999.9
          XI(J)=X
          DY=SQRT(RNG(J)**2-(XS-X)**2)
80      IF (Y-YS)                          256,257,257
          YI(J)=YS-DY
          AZI(J)=180.0
          ARCTAN(J)=-90.0
85      IF (YI(J).GE.YL.AND.YI(J).LE.YH)    GO TO 250
          YI(J)=YS+DY
          AZI(J)=0.0
          ARCTAN(J)= 90.0
90      C      TEST TO ESTABLISH IF INTERSECTION LIES BETWEEN SEGMENT END POINTS
      C      OR ON PORTION OF LINE WHICH EXTENDS BEYOND END POINTS.
258      IF (XI(J).GE.XL.AND.XI(J).LE.XH)    GO TO 259
          GO TO 270
259      IF (YI(J).GE.YL.AND.YI(J).LE.YH)    260,270
      C      SET INDICATOR TO RECORD THAT OPPORTUNITY FOR INTERCEPT BY SITE J
      C      ON SEGMENT I.
260      ANICP(J)=I
270      C      CONTINUE
280      RETURN
100     END

```

```

SURROUTINE TSTPTL      76/76  OPT=1                FTR 4.6+420      03/31/77  13.38.47

1      C .....
      C SURROUTINE TSTPTL (AZI,PTL,AZD,PTLCHG,ADJPTL,NLHR,
      A      ADWKD, ADICP,ARCTAN,NSITES,ADPT,XI,YI)
      C .....
5      I'ITEGE= ADWKD(60),ADICP(60)
      DIMENSION AZI(60),PTL(60),AZD(60),PTLCHG(60),ADJPTL(60),
      A      NLHR(60),ARCTAN(60),
      R      ADPT(60,2),XI(60),YI(60)

10     C
      C EXAMINE EACH SITE IN TURN FOR AN INTERCEPT OPPORTUNITY.
      DO 270 J=1,NSITES
      C IF (ADICP(J).EQ.0) GO TO 270
      C COMPUTE AZIMUTH OF LINE CONNECTING AD SITE WITH POINT OF
      C INTERSECTION.
15     YD=YI(J)-ADPT(J,2)
      XD=XI(J)-ADPT(J,1)
      ARCTAN(J)=ATAN2(YD,XD)*57.296
      IF (ARCTAN(J)-90.0)
20     A71(J)=90.0-ARCTAN(J)
      GO TO 130
120    A71(J)=360.0-(ARCTAN(J)-90.0)
      C COMPUTE DIFFERENCE BETWEEN AD SITE PTL AND INTERCEPT AZIMUTH.
      C ADJUST PTL AND NR LAUNCHERS BASED ON DIFFERENCE.
130    AZD(J)=AZI(J)-PTL(J)
      IF (ABS(AZD(J)).GT.135.1.AND.ABS(AZD(J)).LT.224.9)
25     A
      IF (ABS(AZD(J)).LE.135.1) GO TO 266
      IF (AZD(J)) GO TO 170
      A71(J)=(360.0-AZD(J))
30     GO TO 170
150    GO TO 170
160    A71(J)=-(360.0-AZD(J))
170    IF (ABS(AZD(J)).LE.45.1) GO TO 262
      IF (AZD(J)) GO TO 262,262,263
35     261 PTLCHG(J)=AZD(J)+45.0
      GO TO 264
262    PTLCHG(J)=0.0
      GO TO 264
263    PTLCHG(J)=AZD(J)-45.0
40     264 ADJPTL(J)=PTL(J)+PTLCHG(J)
      IF (ADJPTL(J).LT.0.0) ADJPTL(J)=360.0+ADJPTL(J)
      DO 265 K=1,5
      IF (ABS(PTLCHG(J)/22.5).LE.(5.1-K)) NLHR(J)=K
45     C NTINIE
      C SET INDICATOR TO RECORD THAT SITE HAS WORKED THE OPPORTUNITY
      C IDENTIFIED AND ITS ASSETS ARE NO LONGER AVAILABLE.
      ADWKD(J)=ADICP(J)
      GO TO 270
50     C RESET SITE INTERSECTION OPPORTUNITY FLAG TO ZERO.
      ADICP(J)=0
270    C NTINIE
      C
      RETURN
      END

```



```

SUBROUTINE ICPCNT      74/74  OPT=1                FTH 4.6-428      03/31/77  13.30-67

1      C .....
      C SURRO TIME ICPCNT (ADMKD,SGAD,SGLHR,NSGMTS,NSITES,NLHR)
      C .....
      C INTEGER ADMKD(60),SGAD(40),SGLHR(40)
5      C DIMENSION NLHR(60)
      C INITIALIZE ARRAYS.
      C DO 110 I=1,40
          SGAD(I)=0
          SGLHR(I)=0
10     110 CONTINUE
      C COMPUTE NUMBER OF SITES INTERCEPTING ON EACH SEGMENT AND
      C CORRESPONDING NUMBER OF LAUNCHERS.
      C DO 120 I=1,NSGMTS
          DO 120 J=1,NSITES
15          IF (ADMKD(J).NE.I) GO TO 120
              SGAD(I)=SGAD(I)+1
              SGLHR(I)=SGLHR(I)+NLHR(J)
20     120 C HITINIE
          C RETURN
          C END
  
```

```

SUBROUTINE MAPSYM 74/74 OPT=1 FTM 4.6*426 03/31/77 13.38.47

1 C .....
  SURRO: TINE MAPSYM (SYNSEL,MAPNR,NSITES,NTGTS,NBPTS,NTPTS,
  A NUMB,DOLLAR,POINT,BLANK,TGTY,XLO,YHI,ALHR,ASIT,
  B ADPT,TYPAD,SGPT,TGPT,TYPTGT,ADWKD,TGTYP,
  5 C BPX1,BPY1,BPX2,BPY2)
  C .....
  DIMENSION ALH(100,50),ASIT(100,50),TGTY(40),
  A ADPT(60,2),SGPT(40,2),TGPT(20,2),TYPTGT(12,2),
  B TYPAD(2)
10 2 INTEGER ADWKD(60),SYNSEL(6,4),TGTYP(60),
  BPX1(20),BPY1(20),BPX2(20),BPY2(20)
  REAL NUMB(10)
  INTEGER XQ,YQ,DX,DY,DXQ,DYQ,XLO,YHI
15 C DATA OSTS /1H7/, PLUS /1H-/
  IDENTIFY MAP SYMBOLS TO BE INSERTED IN DISPLAY.
  DO 120 IGO=1,4
    IF (SYNSEL(MAPNR,IGO),NE.1) GO TO 100
    C NTIME
    C NTIME
    RETURN
  C INSERT AD SITE SYMBOLOGY.
  200 DO 280 I=1,NSITES
    IF (MAPNR.LE.4) 220,210
    25 210 IF (ADWKD(I).EQ.0) GO TO 280
    220 XQ=(ADPT(I,1)-XLO)/5+1
    YQ=(YHI-ADPT(I,2))/5+1
  C
  C CLEAR WINDOW IN COVERAGE ARRAYS FOR SITE LABELS.
  30 IF (MAPNR.EQ.3.OR.MAPNR.EQ.4) 230,250
  230 XQ=XQ-4
    YQ=YQ-2
  DO 240 J=1,7
  DO 240 K=1,3
  35 ALHR((XQ+J),(YQ+K))=BLANK
    ASIT((XQ+J),(YQ+K))=BLANK
  240 C NTIME
  250 J=I/10+1
    ALHR(XQ-2,YQ)=NUMB(J)
    ASIT(XQ-2,YQ)=NUMB(J)
  40 C
    K=I+1-10*(J-1)
    ALHR(XQ-1,YQ)=NUMB(K)
    ASIT(XQ-1,YQ)=NUMB(K)
  45 C
    ALHR(XQ,YQ)=POINT
    ASIT(XQ,YQ)=POINT
  C
  50 ALHR(XQ+1,YQ)=TYPAD(1)
    ASIT(XQ+1,YQ)=TYPAD(1)
  C
    ALHR(XQ+2,YQ)=TYPAD(2)
    ASIT(XQ+2,YQ)=TYPAD(2)

```

SUBROUTINE MAPSYM 74/74 OPT=1 FTN 4.6+420 03/31/77 13.30.47

```

55      C
      280      C NTINIE $ GO TO 100
      C      INSERT TARGET SYMBOLOGY.
      300      DO 380 I=1,NTGTS
      C
      XQ=(TGPT(I,1)-XLO)/5+1
      YO=(YHI-TGPT(I,2))/5+1
60      C
      C      CLEAR WINDOW IN COVERAGE DISPLAYS FOR TGT LABEL.
      C      IF (MAPNR.EQ.3.OR.MAPNR.EQ.4) 330,350
      330      XQ=XQ-4
      YO=YO-2
65      DO 340 J=1,7
      DO 340 K=1,3
      ALHR(XQR+J,YQR+K)=BLANK
      ASIT(XQR+J,YQR+K)=BLANK
70      340      C NTINIE
      350      J=I/10+1
      ALHR(XQ-2,YQ)=NUMB(J)
      ASIT(XQ-2,YQ)=NUMB(J)
      C
      K=I-1-10*(J-1)
75      ALHR(XQ-1,YQ)=NUMB(K)
      ASIT(XQ-1,YQ)=NUMB(K)
      C
      ALHR(XQ,YQ)=POINT
80      ASIT(XQ,YQ)=POINT
      C
      ALHR(XQ+1,YQ)=TYPTGT(TGTYP(I,1))
      ASIT(XQ+1,YQ)=TYPTGT(TGTYP(I,1))
      C
85      ALHR(XQ+2,YQ)=TYPTGT(TGTYP(I,2))
      ASIT(XQ+2,YQ)=TYPTGT(TGTYP(I,2))
      C
      380      C NTINIE $ GO TO 100
      C      INSERT BOUNDARY SEGMENT SYMBOLOGY.
      400      DO 480 I=1,NBPTS
      C
      DY=BPX2(I)-BPX1(I)
      OY=BPY2(I)-BPY1(I)
95      C
      IF (DX) 402,404,404
      C
      402      XP=BPX2(I) $ GO TO 406
      404      XP=BPX1(I)
      C
      406      IF (DY) 408,410,410
      C
      408      YP=BPY2(I) $ GO TO 412
      410      YP=BPY1(I)
105      C
      412      XQ=(XP-XLO)/5+1
      YO=(YHI-YP)/5+1

```



```

SUBROUTINE MAPSYM      74/74  OPT=1                      FTN 4.6+420      03/31/77  13.30.47

      C
      DXQ=IABS(DX)/5+1
      DYQ=IABS(DY)/5+1
110      C
      IF (DXQ.EQ.1.AND.DYQ.GT.1) 460,415
      IF (DXQ.GT.1.AND.DYQ.EQ.1) 420,430
      C
      SYMB=PLUS $ GO TO 440
115      SYMB=OSTN
      DO 450 IX=1,DXQ
      ALHR(XQ+IX-1,YQ)=SYMB
      ASIT(XQ+IX-1,YQ)=SYMB
      C
120      C NTINIE $ GO TO 480
      C
      SYMB=PLUS
      DO 470 IY=1,DYQ
      ALHR(XQ,YQ-IY+1)=SYMB
      ASIT(XQ,YQ-IY+1)=SYMB
125      C
      C NTINIE $ GO TO 100
      C
      INSERT TRACK POINT SYMBOLOGY.
      DO 500 I=1,NTPPTS
130      C
      XQ=(SGPT(I,1)-XLO)/5+1
      YQ=(YHI-SGPT(I,2))/5+1
      C
      A
      IF (SYMSEL(NAPNP,2).EQ.0.OR.TGTY(I).EQ.2HMT)
135      C
      ALHR(XQ,YQ)=POINT
      ASIT(XQ,YQ)=POINT $ GO TO 580
      C
      IF (ALHR(XQ,YQ).EQ.POINT.AND.ASIT(XQ,YQ).EQ.POINT)
140      C
      A
      ALHR(XQ,YQ)=OSTN
      ASIT(XQ,YQ)=OSTN
      GO TO 580
      C
145      C NTINIE
      END
      GO TO 100

```

SUBROUTINE ADSEST T4/74 OPT=1 FTR 4.6\*420 03/31/77 13.30.47

```

1      C *****
      C SURROUTINE ADSEST (MIXAC,SGPT, ADPR,WPPR,WPNR,TTLAC,ADWKO,
      A      TGTY,NSITES,NSGMTS,ADATE,PRFTYP,PRFSEL,SGAD,BKTRK)
      C *****
5      DIMENSION MIXAC(3),MAD(2,10),NAC(2,10,4),UTLRT(2,10),SGSUM(40),
      A      ADPR(2),WPPR(2),PRFTYP(3),TGTY(40),SGPT(40,2),
      A      INTEGFR ADWKO(60),PAD(2,10),PERAD(3),SGAD(40),SGMSR(40),
      A      TGMSR(2,40),WPNR(2),BKTRK(40)
10     INTEGER TTI AC,TGTL,TGDSTL,ADTL,PRFSEL
      C ADTL=TGTL=TGDSTL=0
      C CLEAR ARRAYS TO ZERO.
      C DO 60 I=1,NSGMTS
      C   SGMSR(I)=0
15     DO 40 J=1,2
      C   TGMSR(J,I)=0
      C CONTINUE
20     C CONTINUE
      C COMPUTE SEGMENT MEASURE: CUMULATIVE NUMBER OF INTERCEPTING
      C SITES PER SEGMENT.
      C DO 140 I=1,NSGMTS
      C   ADTL=ADTL+SGAD(I)
      C   SGMSR(I)=ADTL
25     C CONTINUE
      C COMPUTE LENGTH OF EACH TRACK SEGMENT AND CUMULATIVE LENGTH
      C FROM START OF TRACK TO END OF SEGMENT.
      C SGCUM=0
      C DO 160 I=1,NSGMTS
      C   SGCUM(I)=SGCUM
      C   SGLLEN=SQRT((SGPT(I+1,1)-SGPT(I,1))**2 +
30     A   (SGPT(I+1,2)-SGPT(I,2))**2)
      C   IF (BKTRK(I).EQ.1) SGLLEN=-SGLLEN
      C   SGCUM=SGCUM+SGLLEN
      C CONTINUE
35     C COMPUTE TARGET MEASURES.
      C (1) CUMULATIVE NUMBER OF TARGETS PER SEGMENT
      C (2) CUMULATIVE TARGET-DISTANCE PRODUCT PER SEGMENT.
      C DO 240 I=1,NSGMTS
      C   IF (TGTY(I+1).EQ.2HMT) GO TO 250
40     TGTL=TGTL+1
      C   TGDSTL=TGDSTL+1+SGSUM(I)*0.5
      C   TGMSR(1,I)=TGTL
      C   TGMSR(2,I)=TGDSTL
240    CONTINUE
45     C COMPUTE WHOLE NUMBER OF ADS ASSETS, BY TYPE, NEEDED PER SITE.
      C DO 320 I=1,2
      C   PERAD(I)=ALOG(1-ADPR(I)) / ALOG((1-WPPR(I))*WPNR(I)+1)
320    C CONTINUE
      C SFT TYPE 3 ASSETS NEEDED TO 20.
      C PERAD(3)=20
50     C COMPUTE NUMBER AND PERCENTAGE OF INTERCEPTS GENERATED AS PAID
      C DEEPENS. PAID DEPTH IS MEASURED BY INCRFASING INCREMENTS
      C OF TARGET MEASURES.
      C DO 460 I=1,2

```

```

SUBROUTINE ADESE7      74/74  OPT=1                      FTN 4.6*420      03/31/77  13.30.47

DO 440 J=1.10
  NTG=J*0.1*TGMSR(I,NSGMTS)
DO 420 K=1,NSGMTS
  IF (TGMSR(I,K).LT,NTG)                                GO TO 420
  NAD(I,J)=SGMSR(K) *
  PAD(I,J)=(100*SGMSR(K))/SGMSR(NSGMTS)*0.5            GO TO 440
60
420  C *TIME
440  C *TIME
460  C *TIME
C      COMPUTE TOTAL NUMBER OF ADS ASSETS NEEDED TO SUPPRESS SITES
C      ASSOCIATED WITH GIVEN PERCENTAGE INCREMENT OF TARGET
65  C      MEASURE. REPEAT FOR BOTH TARGET MEASURES.
C      DO 540 I=1,2
C      DO 520 J=1.10
70  A      NAC(I,J,4)= NAD(I,J)* (PERAD(1)*MIXAC(1)+
C      * PERAD(2)*MIXAC(2)+PERAD(3)*MIXAC(3))/100*0.5
520  C *TIME
540  C *TIME
C      COMPUTE NUMBER OF ADS ASSETS, BY TYPE, NEEDED TO SUPPRESS SITES
C      ASSOCIATED WITH GIVEN PERCENTAGE INCREMENT OF TARGET
75  C      MEASURE. REPEAT FOR BOTH TARGET MEASURES. ALSO COMPUTE ADS ASSETS
C      UTILIZED FOR EACH INCREMENT FOR BOTH MEASURES.
C      DO 660 I=1,2
C      DO 640 J=1.10
80  C      UTIRT(I,J)=FLOAT(NAC(I,J,4))/TTLAC
C      DO 620 K=1,3
C      NAC(I,J,K)=(MIXAC(K)*NAC(I,J,4))/100*0.5
620  C *TIME
640  C *TIME
660  C *TIME
85  C      PRINT-OUT SUPPRESSION ESTIMATE.
C      PRINT 810,ADATE,PRFTYP(PRFSEL)
810  C      FORMAT(1H1,10X,'MOCA-SMS',42X,'RTA-8 OUTPUT',40X,A10,/
C      61X,'PRFSEL=',A3,J(/))
A      IPART=1
90  C      PRINT 815,IPART
815  C      FORMAT(61X,'PART ',I1//)
C      PRINT 820,(WPNR(I),I=1,2),(WPPR(I),I=1,2),
A      (ADPR(I),I=1,2),(PERAD(I),I=1,3)
820  C      FORMAT(57X,'AC1',4X,'AC2',4X,'AC3',2(/),
A      48X,'WPNR',1X,2(6X,I1)/48X,'WPPR',1X,2(2X,F5.3)/
B      48X,'ADPR',1X,2(2X,F5.3)//47X,'PERAD',1X,
C      3(5X,I2),2(/))
C      DO 880 I=1,2
C      IPART=IPART+1
100  A      PRINT 840,IPART,I,TGMSR(I,NSGMTS),(MIXAC(L),L=1,3),TTLAC,
C      SGMSR(NSGMTS)
840  C      FORMAT(4(/),61X,'PART ',I1//
A      27X,'PCT',6X,18X, 2X,'NR',18X, 8X,'AC',7X,'PCT',
B      25X,'TGMSR ',I1,
C      7X,'AC1',9X,'AC2',9X,'AC3',8X,'TL',8X,
105  C      'UR',8X,'AD',24X,'(N=',I4,')',4X,'(PC=',I3,')',

```



SUBROUTINE ADSEST 74/74 OPT=1 FTN 4.6+420 03/31/77 13.30.47

```

      E      4X,*(PC=*,I3,*)*.4X,*(PC=*,I3,*)*.1X,
      F      *(TTLAC=*,I3,*)*.11X,*(N=*,I3,
      G      *)*.2(/)
110      DO R60 J=1,10
           JJ=J*10
           PRINT 950,JJ, (NAC(I,J,K),K=1,4),UTLRT(I,J),PAD(I,J)
           FORMAT (18X,4(9X,I3),7X,I3,6X,F5.3,6X,I3)
115      R50      CONTINUE
           R60      CONTINUE
           R80      RETURN
           END
```

APPENDIX B

```

R      01=AR,02=HQ,03=HM,04=PL,05=PM,06=LP,07=AB,08=A5,09=SP,10=RS,11=CR,12=EW
C      01=D,02=C,03=R,04=T
D01    01=MMH,D=40,C=40,R=40
D02    02=LLL,D=25,C=25,R=25
D03    03=MOP,D=40,C=25,R=25
E      A 1,B 2,C 3,D 4,E 5,F 6,G 7,H 8,I 9,J10,K11,L12,M13,N14,P15,>GT, 15
F01    0 0 0 0 1 2 2 2 3 3 3 3 4 0 0 0 0 0
F02    0 0 0 0 1 1 2 2 2 3 3 3 3 4 0 0 0 0
F03    0 0 0 1 1 1 2 2 2 3 3 3 4 4 4 0 0 0
F04    0 0 1 1 1 1 2 2 2 3 3 3 4 4 4 5 0 0
F05    016161616 1 1 1 2 2 3 3 4 4 4 5 5 5 5 0
F06    1616161616 1 1 1 2 2 3 3 4 4 4 5 5 5 5 5
F07    151516161616 1 1 2 3 4 4 5 5 5 5 6 6
F08    151515151616 1 1 2 3 4 4 5 5 6 6 6 6 6
F09    15151515151516 0 0 0 0 5 6 6 6 6 6 6 6
F10    15151515151515 0 0 0 0 6 6 6 6 6 6 6 6 6
F11    1414141414141414 0 0 0 0 7 7 7 7 7 7 7 7 7
F12    1414141414141313 0 0 0 0 8 7 7 7 7 7 7 7
F13    14141414131313121110 9 9 8 8 8 7 7 7 7
F14    14141313131312121110 9 9 8 8 8 8 8 7 7
F15    131313131212121111010 9 9 8 8 8 8 8 8
F16    013131313121212111010 9 9 8 8 8 8 8 8
F17    0 0131212121211111101010 9 9 9 9 8 8 0 0
F18    0 0 01212121211111101010 9 9 9 9 0 0 0 0
F19    0 0 0 012121111111101010 9 9 0 0 0 0 0 0
F20    0 0 0 0 012111111110101010 9 0 0 0 0 0 0 0
BP01   X1=200 Y1=410 X2=500 Y2=380
BP02   X1=430 Y1=380 X2=500 Y2=380
BP03   X1=430 Y1=350 X2=500 Y2=350
BP04   X1=350 Y1=320 X2=500 Y2=320
BP05   X1=430 Y1=290 X2=500 Y2=290
BP06   X1=430 Y1=260 X2=500 Y2=260
BP07   X1=200 Y1=230 X2=500 Y2=230
BP08   X1=200 Y1=230 X2=700 Y2=410
BP09   X1=350 Y1=230 X2=350 Y2=410
BP10   X1=430 Y1=230 X2= 30 Y2=410
BP11   X1=500 Y1=230 X2=500 Y2=410
BP99

```

```

PRFSEL=01 TTLAC=100 MIXAC1= 50 MIXAC2= 25 MIXAC3= 25
WPNR1=2 WPPR1=0.750 ADPR1=0.900
WPNR2=4 WPPR2=0.100 ADPR2=0.900
XLO=100 YLO=200
RNGTBL=1 TMPLT=1 TGTLS=1 SITLST=1 TRKPTS=1 SYMLST=1 BDYPTS=1
SITES=1 TGT=0 BDYPTS=1 TRKPTS=0
SITES=0 TGT=1 BDYPTS=1 TRKPTS=0
SITES=0 TGT=1 BDYPTS=1 TRKPTS=0
SITES=0 TGT=1 BDYPTS=1 TRKPTS=0
SITES=0 TGT=1 BDYPTS=1 TRKPTS=1
SITES=0 TGT=1 BDYPTS=1 TRKPTS=1
AD01 X=450.0 Y=410.0 AREA=1 PTL=090.0 NCHR=5
AD02 X=450.0 Y=380.0 AREA=1 PTL=090.0 NCHR=5
AD03 X=450.0 Y=350.0 AREA=1 PTL=090.0 NCHR=5
AD04 X=450.0 Y=320.0 AREA=1 PTL=090.0 NCHR=5
AD05 X=450.0 Y=290.0 AREA=1 PTL=090.0 NCHR=5
AD06 X=450.0 Y=260.0 AREA=1 PTL=090.0 NCHR=5
AD07 X=450.0 Y=230.0 AREA=1 PTL=090.0 NCHR=5
AD08 X=410.0 Y=410.0 AREA=2 PTL=090.0 NCHR=5
AD09 X=410.0 Y=380.0 AREA=2 PTL=090.0 NCHR=5
AD10 X=410.0 Y=350.0 AREA=2 PTL=090.0 NCHR=5
AD11 X=410.0 Y=320.0 AREA=2 PTL=090.0 NCHR=5
AD12 X=410.0 Y=290.0 AREA=2 PTL=090.0 NCHR=5
AD13 X=410.0 Y=260.0 AREA=2 PTL=090.0 NCHR=5
AD14 X=410.0 Y=230.0 AREA=2 PTL=090.0 NCHR=5
AD15 X=370.0 Y=410.0 AREA=2 PTL=090.0 NCHR=5

```

CAA-TP-77-5

AD16	X=370.0	Y=380.0		AREA=2	PTL=090.0	NCHR=5
AD17	X=370.0	Y=350.0		AREA=2	PTL=090.0	NCHR=5
AD18	X=370.0	Y=320.0		AREA=2	PTL=090.0	NCHR=5
AD19	X=370.0	Y=290.0		AREA=2	PTL=095.0	NCHR=5
AD20	X=370.0	Y=260.0		AREA=2	PTL=090.0	NLHR=5
AD21	X=370.0	Y=230.0		AREA=2	PTL=090.0	NCHR=5
AD22	X=330.0	Y=410.0		AREA=3	PTL=090.0	NCHR=5
AD23	X=330.0	Y=380.0		AREA=3	PTL=090.0	NCHR=5
AD24	X=330.0	Y=350.0		AREA=3	PTL=090.0	NCHR=5
AD25	X=330.0	Y=320.0		AREA=3	PTL=090.0	NCHR=5
AD26	X=330.0	Y=290.0		AREA=3	PTL=090.0	NCHR=5
AD27	X=330.0	Y=260.0		AREA=3	PTL=090.0	NCHR=5
AD28	X=330.0	Y=230.0		AREA=3	PTL=090.0	NCHR=5
AD29	X=290.0	Y=410.0		AREA=3	PTL=090.0	NCHR=5
AD30	X=290.0	Y=380.0		AREA=3	PTL=090.0	NCHR=5
AD31	X=290.0	Y=350.0		AREA=3	PTL=090.0	NCHR=5
AD32	X=290.0	Y=320.0		AREA=3	PTL=090.0	NCHR=5
AD33	X=290.0	Y=290.0		AREA=3	PTL=090.0	NCHR=5
AD34	X=290.0	Y=260.0		AREA=3	PTL=090.0	NCHR=5
AD35	X=290.0	Y=230.0		AREA=3	PTL=090.0	NCHR=5
AD36	X=250.0	Y=410.0		AREA=3	PTL=090.0	NCHR=5
AD37	X=250.0	Y=380.0		AREA=3	PTL=090.0	NCHR=5
AD38	X=250.0	Y=350.0		AREA=3	PTL=090.0	NCHR=5
AD39	X=250.0	Y=320.0		AREA=3	PTL=090.0	NCHR=5
AD40	X=250.0	Y=290.0		AREA=3	PTL=090.0	NCHR=5
AD41	X=250.0	Y=260.0		AREA=3	PTL=090.0	NLHR=5
AD42	X=250.0	Y=230.0		AREA=3	PTL=090.0	NLHR=5
AD99						
TG01	X=480.0	Y=375.0	TYPE=0R	AREA=1		
TG02	X=485.0	Y=325.0	TYPE=07	AREA=1		
TG03	X=465.0	Y=365.0	TYPE=02	AREA=1		
TG04	X=465.0	Y=310.0	TYPE=02	AREA=1		
TG05	X=410.0	Y=350.0	TYPE=06	AREA=2		
TG06	X=410.0	Y=290.0	TYPE=06	AREA=2		
TG07	X=390.0	Y=340.0	TYPE=03	AREA=2		
TG08	X=390.0	Y=300.0	TYPE=04	AREA=2		
TG09	X=335.0	Y=350.0	TYPE=12	AREA=3		
TG10	X=320.0	Y=290.0	TYPE=03	AREA=3		
TG11	X=310.0	Y=340.0	TYPE=01	AREA=3		
TG12	X=290.0	Y=300.0	TYPE=01	AREA=3		
TG99						
TP01	X=540.0	Y=370.0	BKTRK=0	-	MT	
TP02	X=510.0	Y=355.0	BKTRK=0	-	MT	
TP03	X=480.0	Y=375.0	BKTRK=0	TGNR= 1	TGTY=A5	
TP04	X=510.0	Y=355.0	BKTRK=1	-	MT	
TP05	X=485.0	Y=325.0	BKTRK=0	TGNR= 2	TGTY=A8	
TP06	X=510.0	Y=355.0	BKTRK=1	-	MT	
TP07	X=490.0	Y=345.0	BKTRK=0	-	MT	
TP08	X=465.0	Y=365.0	BKTRK=0	TGNR= 3	TGTY=H0	
TP09	X=490.0	Y=345.0	BKTRK=1	-	MT	
TP10	X=480.0	Y=340.0	BKTRK=0	-	MT	
TP11	X=465.0	Y=310.0	BKTRK=0	TGNR= 4	TGTY=H0	
TP12	X=480.0	Y=340.0	BKTRK=1	-	MT	
TP13	X=440.0	Y=320.0	BKTRK=0	-	MT	
TP14	X=410.0	Y=350.0	BKTRK=0	TGNR= 5	TGTY=LP	
TP15	X=440.0	Y=370.0	BKTRK=1	-	MT	
TP16	X=410.0	Y=290.0	BKTRK=0	TGNR= 6	TGTY=LP	
TP17	X=440.0	Y=320.0	BKTRK=1	-	MT	
TP18	X=400.0	Y=320.0	BKTRK=0	-	MT	
TP19	X=390.0	Y=340.0	BKTRK=0	TGNR= 7	TGTY=HH	
TP20	X=400.0	Y=320.0	BKTRK=1	-	MT	
TP21	X=390.0	Y=300.0	BKTRK=0	TGNR= 8	TGTY=PL	
TP22	X=400.0	Y=320.0	BKTRK=1	-	MT	
TP23	X=340.0	Y=320.0	BKTRK=0	-	MT	
TP24	X=335.0	Y=350.0	BKTRK=0	TGNR= 9	TGTY=EW	
TP25	X=360.0	Y=320.0	BKTRK=1	-	MT	



CAA-TP-77-5

TP26	X=340.0	Y=320.0	BKTRK=0	-	MT
TP27	X=320.0	Y=290.0	BKTRK=0	TGNR=10	TGT Y=HH
TP28	X=340.0	Y=320.0	BKTRK=1	-	MT
TP29	X=330.0	Y=320.0	BKTRK=0	-	MT
TP30	X=310.0	Y=340.0	BKTRK=0	TGNR=11	TGT Y=AB
TP31	X=330.0	Y=320.0	BKTRK=1	-	MT
TP32	X=300.0	Y=320.0	BKTRK=0	-	MT
TP33	X=290.0	Y=300.0	BKTRK=0	TGNR=12	TGT Y=AH
TP99					

5470 104

## APPENDIX C

## GLOSSARY

A5	155 millimeter field artillery battalion
A8	8-inch field artillery battalion
AB	air base
AC	ADS Aircraft
AC1	ADS Aircraft Type 1 (ARM)
AC2	ADS Aircraft Type 2 (Rocket)
AC3	ADS Aircraft Type 3 (Decoy)
AD	Air Defense (HIMAD) Unit
ADJPTL	PTL azimuth adjusted for intercept
ADPR	cumulative probability of killing HIMAD unit using specified weapon type
ADS	Air Defense Suppression
ARCTAN	angle between line connecting HIMAD unit location with target intercept point and positive X-axis
AZD	azimuth difference angle between line connecting HIMAD unit with target and PTL azimuth of HIMAD unit
AZT	angle between line connecting HIMAD unit location with target intercept point and positive Y-axis
BKTRK	backtrack (indicator)
BS	boundary segment connecting points which delimit operational areas
C	Corps (area)
COMO	Computer Model (model system for simulation of air defense)



CAA-TP-77-5

CRC	control and reporting center
CUMMSL	cumulative number of missiles engaging along track up to particular track point
D	division (area)
DST	distance (down raid track)
EW	early warning/control and reporting center
HH	higher headquarters
HHH	flight profile high over division, rear and corps areas
HIMAD	high-to-medium altitude air defense
HOP	flight profile high over division area and low over rear and corps areas
HQ	division headquarters
ICP	intercept(s)
ICPS	intercepts
km	kilometer(s)
LLL	flight profile low over division rear and corps areas
LP	LANCE platoon
M	slope of raid track line segment
msl	missile(s)
N	number
NLHR	number of launchers
NR	number
pct	percent
PL	petroleum, oil and lubricants dump



PM	PERSHING missile
PRFSEL	profile selected
PTL	primary target line
PTLCHG	angle through which HIMAD unit PTL must be moved to permit intercept by unit
R	rear area; range from HIMAD unit location to target intercept point
RS	unit in reserve
SGMT	track segment number (pair)
SHORAD	short-range air defense
SP	special ammunition supply point
TG	target point
TGMSR 1	target measure type 1 (sum of targets)
TGMSR 2	target measure type 2 (sum of target-distance)
TGMR	target reference number
TGTS	targets
TGTY	target type
TL	Total number (of ADS aircraft)
TP	track point
TTLAC	total number of available ADS aircraft
UR	utilization ratio (fraction/multiple of ADS aircraft available)
UTM	universal transverse mercator (map projection)
WPNR	number of weapons of a weapon type
WPPR	single kill probability of weapon type

CAA-TP-77-5

- X X-coordinate
- XI X-coordinate of target intercept point
- XS X-coordinate of a HIMAD unit
- Y Y-coordinate
- YO Y-intercept of raid track line segment
- YI Y-coordinate of target intercept point
- YS Y-coordinate of a HIMAD unit



**APPENDIX D  
DISTRIBUTION**

<u>Army Addressee</u>	<u>Copies</u>
DUSA (OR) WASH DC 20310	1
HQDA (DAMO-ZD) WASH DC 20310	1
HQDA (DAMO-RQA) WASH DC 20310	1
HQDA (DAMA-WSM) WASH DC 20310	1
HQDA (DAMA-RAZ-A) WASH DC 20310	1
HQDA (DAMA-ARZ-A) WASH DC 20310	1
HQDA (DAMI-FIT) WASH DC 20310	1
Commander US Army Materiel Development and Readiness Command ATTN: DRCDE-DA DRCPA 5001 Eisenhower Avenue Alexandria, VA 22333	1 1
Commander US Army Air Defense School ATTN: ATSA-CD ATSA-SM-S ATSA-SM-L ATSA-SM-P ATSA-SM-R Ft Bliss, TX 79916	1 1 1 1 1
Commander US Army Training and Doctrine Command ATTN: ATCD-CF-A ATCD-D/ALPO Ft Monroe, VA 23651	1 1



CAA-TP-77-5

Army Addressee

Copies

Commander  
US Army Missile Research  
and Development Command  
ATTN: DRDMI-DS  
DRDMI-TD  
Redstone Arsenal, AL 35809

1  
1

Commander  
US Army Combined Arms Center  
Development Activity  
ATTN: ATCA-CCC-A  
Fort Leavenworth, KS 66027

1

Project Manager, PATRIOT  
ATTN: DRCPM-MD-TP  
Research Park  
Huntsville, AL 35809

1

Director  
US Army TRADOC Systems Analysis Activity  
ATTN: ATAA-TBB  
White Sands Missile Range, NM 88002

1

Director  
US Army Materiel Systems Analysis  
Activity  
ATTN: DRXSY-A  
DRXSY-AD  
Aberdeen Proving Ground, MD 21005

1  
1

Air Force

HQAF (AFSA)  
WASH DC 20310

2

CINCUSAFE/RC  
DALFA  
APO NY 09012

2

HQ TAC  
ATTN: 4525 CAS/ALFA  
Langley AFB, VA 23665

2

<u>NATO</u>	<u>Copies</u>
SHAPE Technical Center USRADCO, STC APO NY 09159	2
<u>Other</u>	
Defense Documentation Center ATTN: DDC-TA Alexandria, VA 22314	2
The Army Central Library ATTN: Reference Dept. WASH DC 20310	1
<u>Local</u>	
Chief, AD, ATTN: Library Branch Director, SM	2 12