

AFRRI
TECHNICAL
NOTE

**MICROWAVE EXPOSURE ARRAY:
IMPROVED FIELD MEASUREMENTS**

S. A. Oliva
G. N. Catravas

April 1977

Approved for public release; distribution unlimited

ARMED FORCES RADIOBIOLOGY RESEARCH INSTITUTE
Defense Nuclear Agency
Bethesda, Maryland 20014

AFRRI TN77-1

REVIEWED AND APPROVED

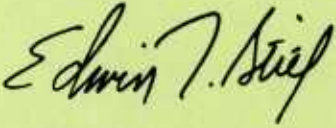

EDWIN T. STILL
Lieutenant Colonel, USAF, VC
Research Program Coordinator

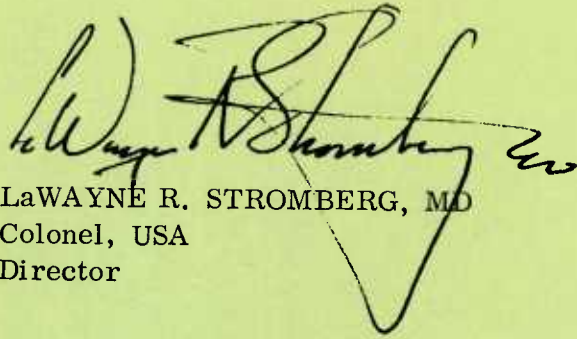

LaWAYNE R. STROMBERG, MD
Colonel, USA
Director

Research was conducted according to the principles enunciated in the "Guide for the Care and Use of Laboratory Animals," prepared by the Institute of Laboratory Animal Resources, National Research Council.

UNCLASSIFIED

SECURITY CLASSIFICATION OF THIS PAGE (When Data Entered)

REPORT DOCUMENTATION PAGE		READ INSTRUCTIONS BEFORE COMPLETING FORM	
1. REPORT NUMBER AFRRI TN77-1	2. GOVT ACCESSION NO.	3. RECIPIENT'S CATALOG NUMBER	
4. TITLE (and Subtitle) MICROWAVE EXPOSURE ARRAY: IMPROVED FIELD MEASUREMENTS		5. TYPE OF REPORT & PERIOD COVERED	
		6. PERFORMING ORG. REPORT NUMBER	
7. AUTHOR(e) S. A. Oliva and G. N. Catravas		8. CONTRACT OR GRANT NUMBER(e)	
9. PERFORMING ORGANIZATION NAME AND ADDRESS Armed Forces Radiobiology Research Institute Defense Nuclear Agency (AFRRI) Bethesda, Maryland 20014		10. PROGRAM ELEMENT, PROJECT, TASK AREA & WORK UNIT NUMBERS NWED QAXM C 303 12	
11. CONTROLLING OFFICE NAME AND ADDRESS Director Defense Nuclear Agency (DNA) Washington, D. C. 20305		12. REPORT DATE April 1977	
		13. NUMBER OF PAGES 16	
14. MONITORING AGENCY NAME & ADDRESS (if different from Controlling Office)		15. SECURITY CLASS. (of this report) UNCLASSIFIED	
		15a. DECLASSIFICATION/DOWNGRADING SCHEDULE	
16. DISTRIBUTION STATEMENT (of this Report) Approved for public release; distribution unlimited			
17. DISTRIBUTION STATEMENT (of the abstract entered in Block 20, if different from Report)			
18. SUPPLEMENTARY NOTES			
19. KEY WORDS (Continue on reverse side if necessary and identify by block number)			
20. ABSTRACT (Continue on reverse side if necessary and identify by block number) Improved field measurements for Styrofoam and Plexiglas cages and a micro-wave exposure array previously designed and constructed at AFRRI are described. A new miniature isotropic electric field probe designed by the Bureau of Radiological Health was used. The new measurements demonstrated the effectiveness of the cages for microwave research. The microwave exposure array was shown to provide equal average power density to all exposed animals to within ± 5 percent.			

TABLE OF CONTENTS

	Page
Introduction	3
Materials and Methods	3
Results and Conclusion	6
References	12

LIST OF FIGURES

Figure 1. Styrofoam and Plexiglas cage	3
Figure 2. Testing apparatus	4
Figure 3. Microwave irradiation array	6
Figure 4. Power density in cage with bars perpendicular to E field and to axis of transmission	7
Figure 5. Power density in cage with bars perpendicular to E field and to axis of transmission; rotated 90 ^o with bars facing antenna	8
Figure 6. Power density in cage with bars perpendicular to E field and parallel to axis of transmission	9
Figure 7. Power density in cage with bars parallel to E field and perpendicular to axis of transmission	10
Figure 8. Power density in cage 1 with all other cages empty	11
Figure 9. Power density in given cage with rats in all other cages	11

INTRODUCTION

Previously we reported the results of testing quinine-coated Styrofoam and Plexiglas cages in a microwave field² and described the design of a microwave exposure array for multiple animal exposure at equal power density.³ The physical size of the probe used in the original evaluation of the cages made extensive field measurements difficult. The recent availability of a miniature isotropic field probe¹ permitted more complete measurements of the fields in the interior of the cages, and also allowed improved measurements of the entire microwave exposure array.

MATERIALS AND METHODS

Measurements of the field in the near vicinity and the interior of an individual quinine-coated cage (Figure 1) were conducted utilizing the facilities of the Electromagnetics Branch, Bureau of Radiological Health (BRH), Rockville, Maryland. The facilities consisted of a small anechoic chamber, and an S-band

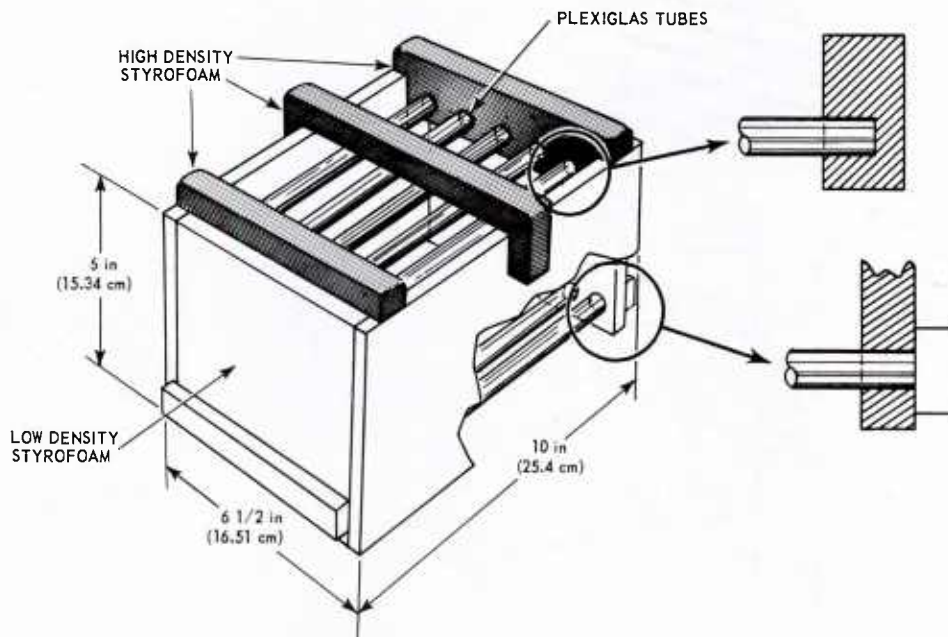

Figure 1. Styrofoam and Plexiglas cage

truncated pyramidal horn with 10-dB gain (Scientific-Atlanta Model 23-1.7/8). The microwave energy was generated from a crystal-controlled oscillator at a frequency of 2450 MHz, driving a traveling wave tube amplifier with a leveling loop, directed to the antenna by coaxial cable. The cage was mounted on Styrofoam blocks and placed on a platform of microwave absorbing material, with the center of the cage on the axis of the transmitting antenna. The probe was mounted on a motor-driven slide assembly which was shielded by microwave absorbing material. The probe was driven in a fixed plane perpendicular to the axis of transmission of the antenna at a distance of 3.77 ft (1.15 m) from the front edge of the horn antenna and at various heights parallel to the top of the table (Figure 2). Probe location perpendicular to the axis of transmission was measured by a calibrated digital readout of the voltage on potentiometers connected to the probe driving mechanisms. The probe was oriented such that its

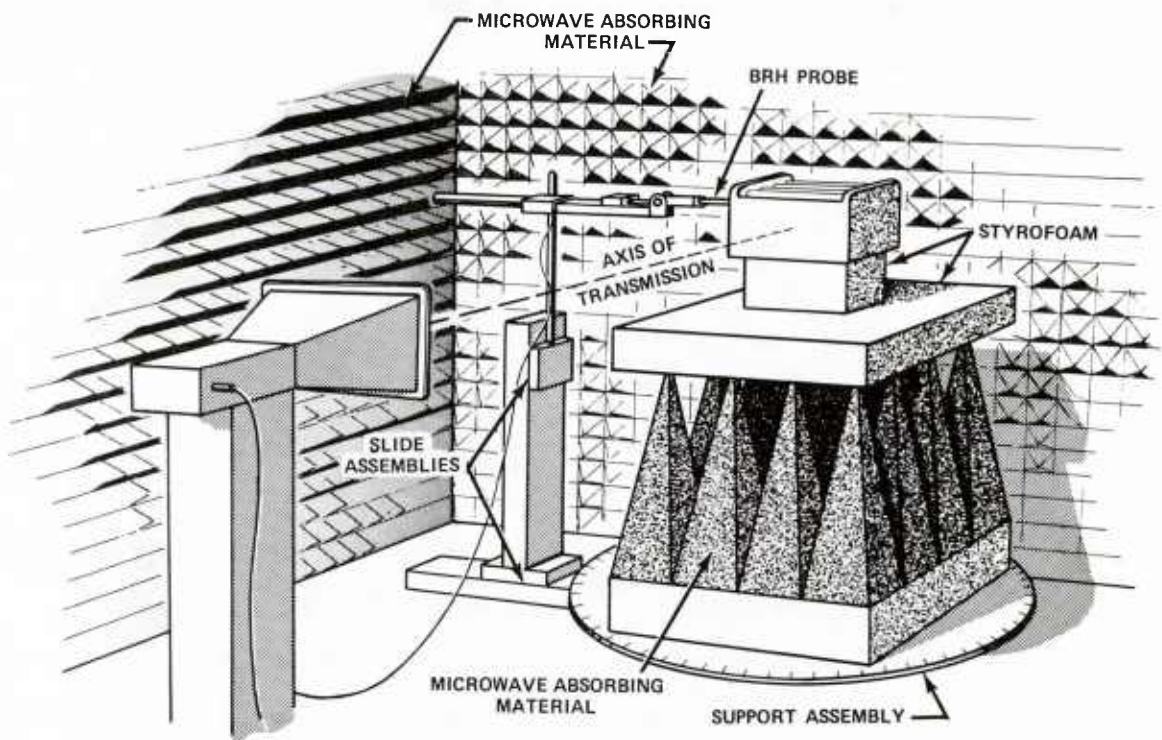

Figure 2. Testing apparatus

center dipole was parallel to the E field vector. During use, the readings from all three dipoles were summed. The probe was inserted using the slide assemblies, through 1-cm holes placed in the walls of the cage for this purpose, or through the bars, depending on cage orientation. The cages were tested in three orientations: with the bars perpendicular to the axis of transmission and perpendicular to the E field; with the bars parallel to the axis of transmission and perpendicular to the E field; and with the bars parallel to the E field. The probe was inserted at various heights from the axis of transmission depending on cage orientation. The cage was moved closer or farther from the antenna allowing the probe to be inserted in the various positions.

Measurements of the field in the center of the cages of the microwave irradiation array (Figure 3) were conducted in the same anechoic chamber previously used at the Walter Reed Army Institute of Research (WRAIR), Department of Microwave Research, Silver Spring, Maryland. Microwave energy was generated from a Klystron tube driven at a frequency of 2450 MHz and directed to the S-band standard gain pyramidal horn antenna by wave guides and coaxial cable. The size of the chamber was 37 ft x 13 ft x 15 ft (11.27 m x 3.96 m x 4.57 m). Using a distance from the horn antenna to the center cage of 19 ft (5.79 m) the cages were placed generally along the equal power density locus, as described previously.³ After all cages were positioned, the probe was consecutively placed in the center of cages 1-6 and the positions of the cage supports slightly adjusted to ensure equal power density in the center of each cage. Strip chart (Bausch & Lomb Model VOM-7) recordings of the power density starting at transmitter turn-on were made. Sprague-Dawley 200-gram rats were then introduced to all cages except one, which contained the probe. A 10-minute recording of power density was made using the strip chart recorder. This was repeated sequentially for cages 1-6, with rats in all nine other cages. Measurements were not made in cages 7-10 due to the symmetry of the array about the transmitting axis of the antenna, and the difficulty of physical access to cages 7-10 from the walkway of the anechoic chamber. All measurements

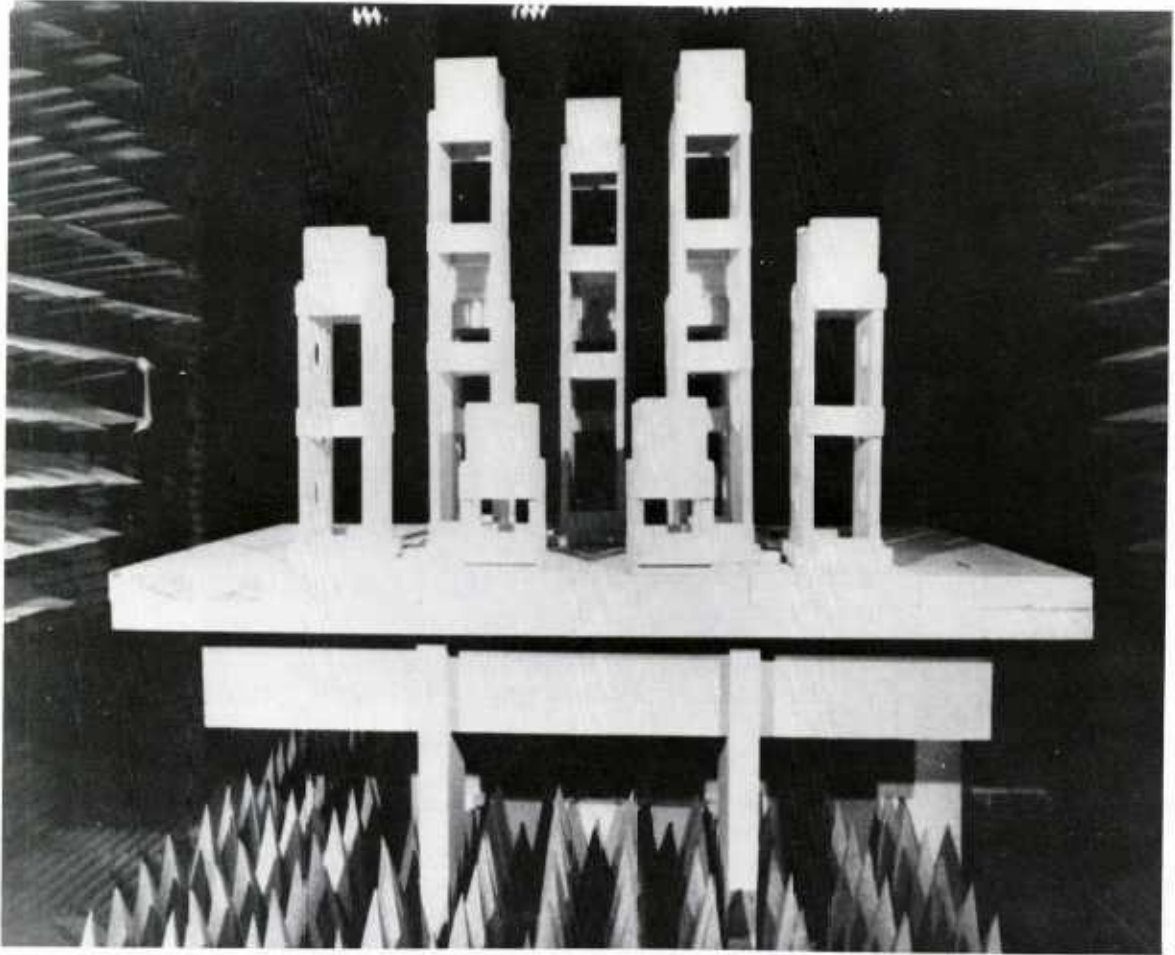

Figure 3. Microwave irradiation array

were made with the center dipole of the probe parallel to the E-field vector, and the readings from all three dipoles summed.

RESULTS AND CONCLUSION

The results of the field measurements of the quinine-coated cages at BRH are shown for various cage orientations (Figures 4-7). The Styrofoam and Plexiglas cages utilized in the microwave array are shown to cause field perturbations of from 0 to .65 dB, depending on cage orientation and the location at which the probe was inserted in the cage.

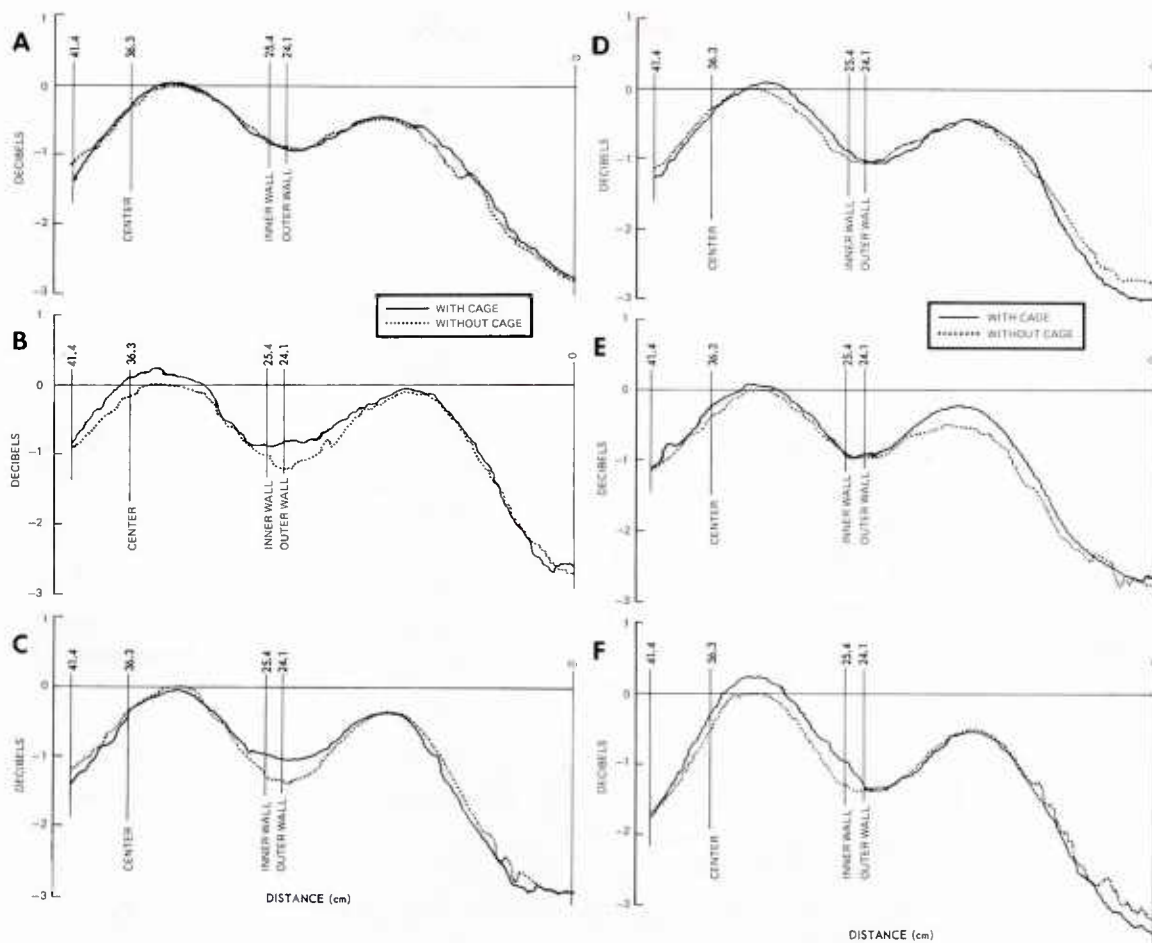

Figure 4. Power density in cage. Cage oriented with bars perpendicular to E field and perpendicular to axis of transmission. A. Probe height 0 in. (0 cm) from axis. Center of cage 3.77 ft (1.15 m) from edge of horn. B. Probe height 0 in. (0 cm) from axis. Center of cage 3.90 ft (1.19 m) from edge of horn. C. Probe height 0 in. (0 cm) from axis. Center of cage 3.64 ft (1.11 m) from edge of horn. D. Probe height 0 in. (0 cm) from axis. Center of cage 3.47 ft (1.06 m) from edge of horn. E. Probe height 0 in. (0 cm) from axis. Center of cage 4.07 ft (1.24 m) from edge of horn. F. Probe height 1.5 in. (3.81 cm) above axis. Center of cage 3.77 ft (1.15 m) from edge of horn.

The results of field measurements of the complete array at WRAIR without rats (Figure 8) and with rats in all cages (Figure 9) are shown. Although the power density in the exposure array as shown in Figure 9 varied by as much

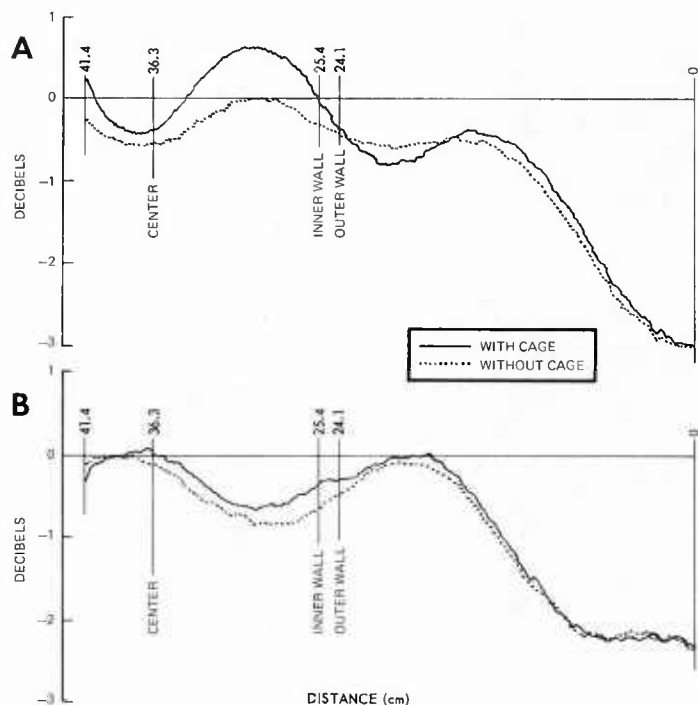

Figure 5. Power density in cage. Cage oriented with bars perpendicular to E field and perpendicular to axis of transmission. (Cage rotated 90° from Figure 4, bars facing antenna.) A. Probe height .5 in. (1.27 cm) above axis. Center of cage 3.77 ft (1.15 m) from edge of horn. B. Probe height 2 in. (5.08 cm) above axis. Center of cage 3.77 ft (1.15 m) from edge of horn.

as ± 23 percent from the average power density in the cages farthest from the antenna due to scattering from the moving rats in other cages, the average value in any cage varied by no more than ± 5 percent from the composite average of all cages. The phase difference between cages was not considered as the size of the cages was greater than one wavelength (12.24 cm) in all dimensions. The animals, being free to move, would thus be exposed to the field in many different phases, depending on their location in the cage at the time. The array was located in the far field of the antenna. The closest cage was 4.5 meters from the antenna.

Although it is obvious that none of the animals exposed would be in the ideal situation of being in the far field of a perfect plane wave, it is shown that

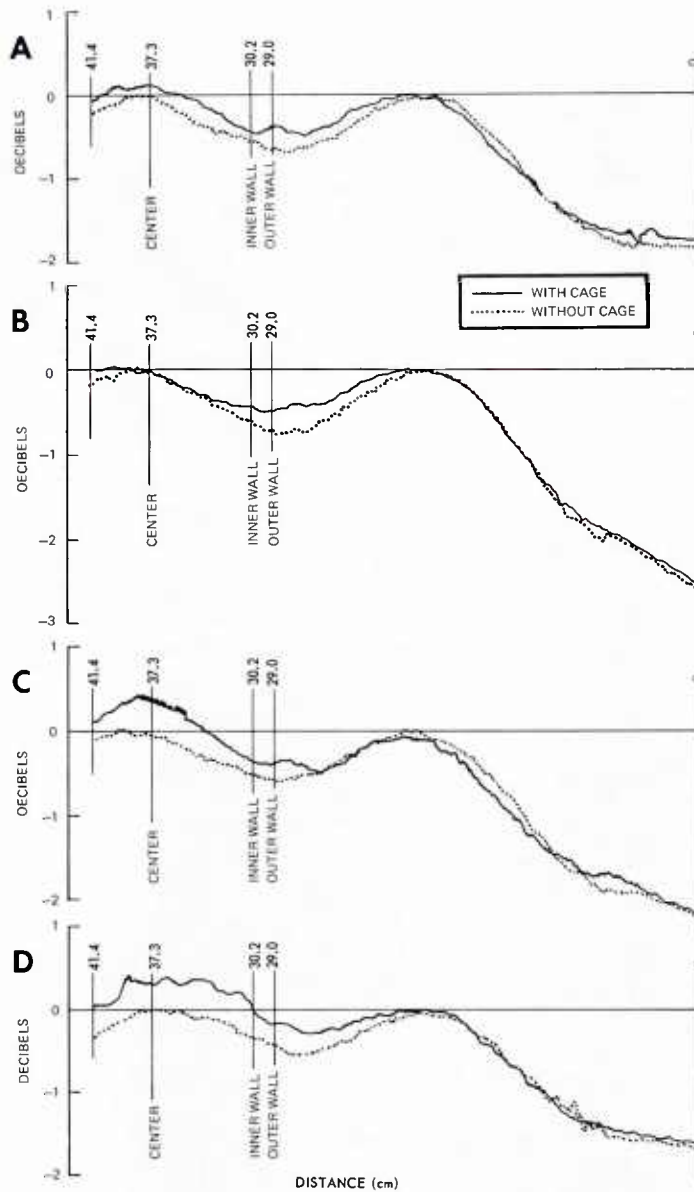

Figure 6. Power density in cage. Cage oriented with bars perpendicular to E field and parallel to axis of transmission. A. Probe height 0 in. (0 cm) from axis. Center of cage 3.77 ft (1.15 m) from edge of horn. B. Probe height 0 in. (0 cm) from axis. Center of cage 4.02 ft (1.22 m) from edge of horn. C. Probe height 0 in. (0 cm) from axis. Center of cage 3.52 ft (1.07 m) from edge of horn. D. Probe height 1.5 in. (3.81 cm) above axis. Center of cage 3.72 ft (1.15 m) from edge of horn.

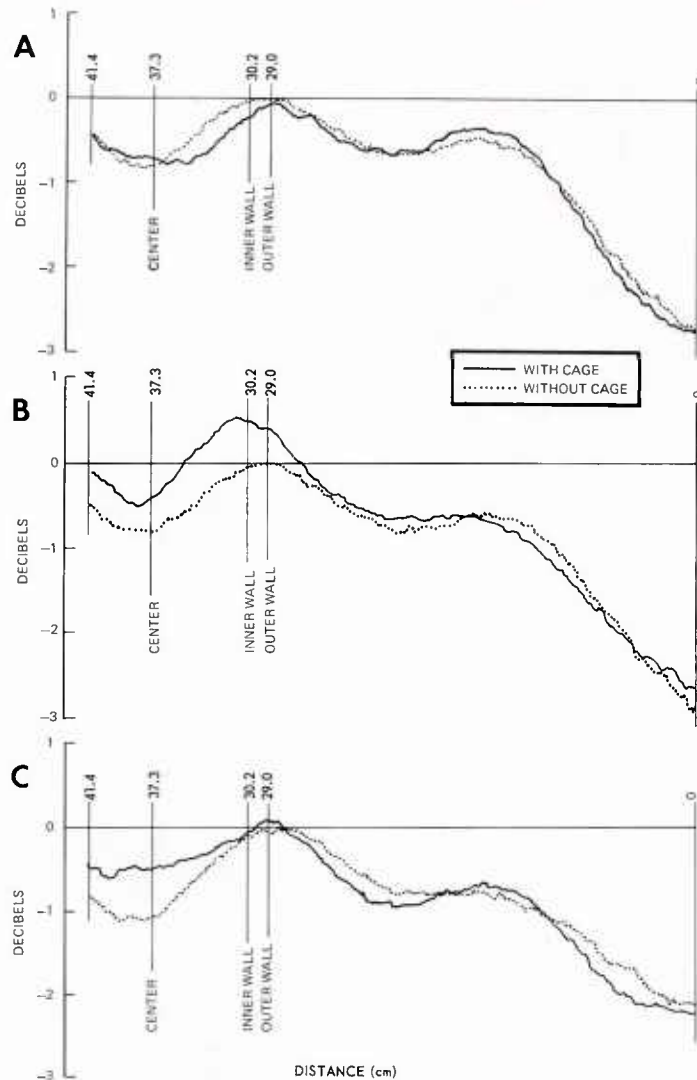

Figure 7. Power density in cage. Cage oriented with bars parallel to E field and perpendicular to axis of transmission. A. Probe height 2 in. (5.08 cm) above axis. Center of cage 3.77 ft (1.15 m) from edge of horn. B. Probe height 2 in. (5.08 cm) above axis. Center of cage 3.65 ft (1.11 m) from edge of horn. C. Probe height 5.5 in. (13.97 cm) above axis. Center of cage 3.77 ft (1.15 m) from edge of horn.

all animals exposed in a given experiment would receive equal exposure to within ± 5 percent at the given average power density. The improved measurements made possible by the miniature isotropic electric field probe developed by BRH

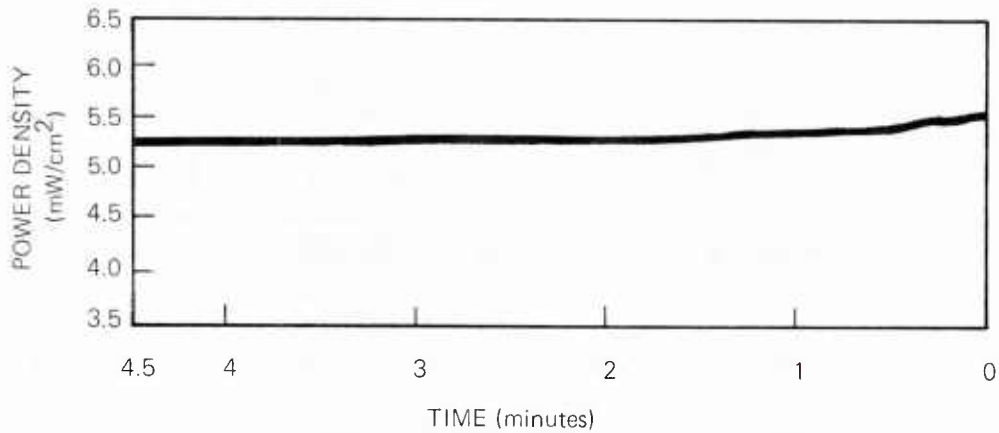

Figure 8. Power density in cage 1 with all other cages empty

show that the array described provides significant advantages to many of the facilities for multiple animal exposure currently in use by providing equal average power density exposures to multiple animals.

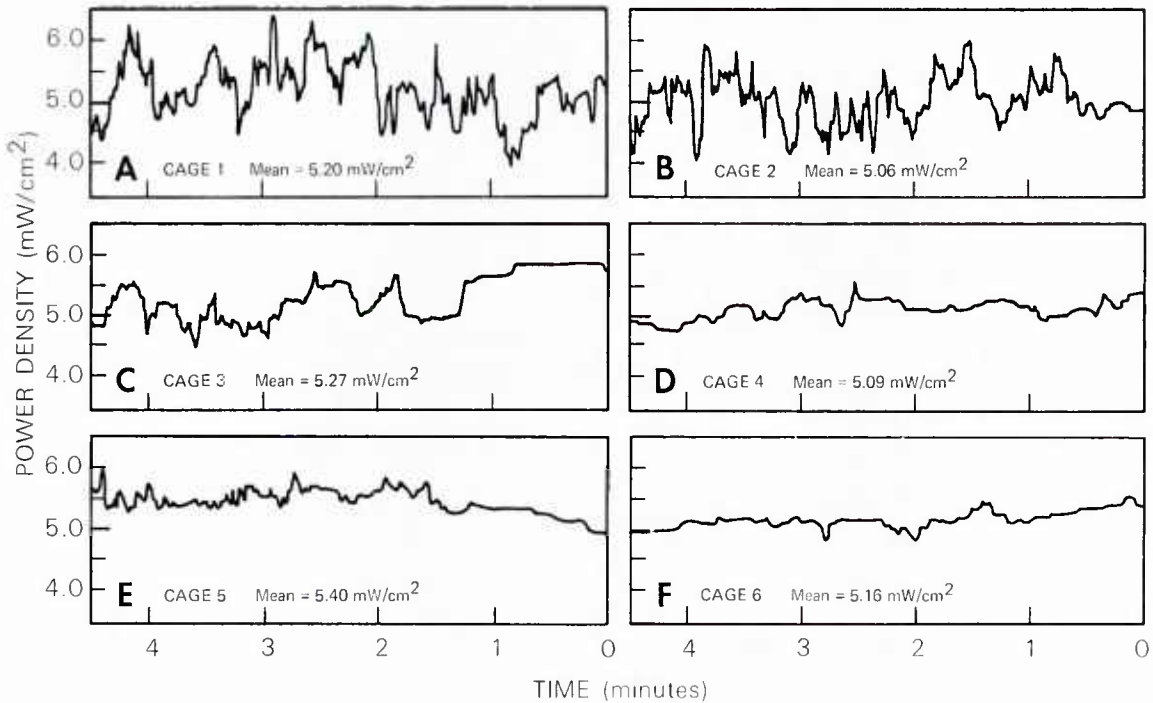

Figure 9. Power density in given cage with rats in all other cages

REFERENCES

1. Bassen, H. , Swicord, M. and Abita, J. A miniature broad-band electric field probe. Ann. N. Y. Acad. Sci. 247:481-493, 1975.
2. Catravas, G N. Styrofoam cages for rats used in microwave research: coating with quinine. Bethesda, Maryland, Armed Forces Radiobiology Research Institute Technical Note TN75-8, 1975.
3. Oliva, S. A. and Catravas, G. N. Microwave exposure facility: multiple animal exposure at equal power density. Bethesda, Maryland, Armed Forces Radiobiology Research Institute Scientific Report SR76-12, 1976.

DEFENSE NUCLEAR AGENCY

**ARMED FORCES RADIOBIOLOGY RESEARCH INSTITUTE
BETHESDA, MARYLAND 20014**

OFFICIAL BUSINESS

PENALTY FOR PRIVATE USE, \$300