

AD-A043 839

ARMY COMMAND AND GENERAL STAFF COLL FORT LEAVENWORTH KANS F/G 19/1
THE SIMULATION OF TACTICAL SMOKE ON THE MODERN BATTLEFIELD. (U)
JUN 77 C J NEEDELS

UNCLASSIFIED

| OF |
AD
A043839

NL



END
DATE
FILMED
9-77
DDC

code
23
2
NW

REPORT DOCUMENTATION PAGE		READ INSTRUCTIONS BEFORE COMPLETING FORM	
1. REPORT NUMBER	2. GOVT ACCESSION NO.	3. RECIPIENT'S CATALOG NUMBER	
4. TITLE (and Subtitle) THE SIMULATION OF TACTICAL SMOKE ON THE MODERN BATTLEFIELD		5. TYPE OF REPORT & PERIOD COVERED Final Report 0 Jun 77	
7. AUTHOR(s) MAJ Christopher J. Needels		8. PERFORMING ORG. REPORT NUMBER	
9. PERFORMING ORGANIZATION NAME AND ADDRESS Student at the US Army Command and General Staff College, Fort Leavenworth, KS 66027		10. CONTRACT OR GRANT NUMBER(s)	
11. CONTROLLING OFFICE NAME AND ADDRESS US Army Command and General Staff College ATTN: ATSW-SE		12. REPORT DATE 10 Jun 77	
14. MONITORING AGENCY NAME & ADDRESS (If different from Controlling Office)		13. NUMBER OF PAGES 76	
		15. SECURITY CLASS. (of this report) UNCLAS	
		15a. DECLASSIFICATION/DOWNGRADING SCHEDULE	
16. DISTRIBUTION STATEMENT (of this Report) Approved for public release; distribution unlimited			
17. DISTRIBUTION STATEMENT (of the abstract entered in Block 20, if different from Report) Approved for public release; distribution unlimited			
18. SUPPLEMENTARY NOTES Master of Military Art and Science (MMAS) Thesis prepared at CGSC in partial fulfillment of the Masters Program requirements, US Army Command and General Staff College, Fort Leavenworth, KS 66027			
19. KEY WORDS (Continue on reverse side if necessary and identify by block number) Smoke Obscuration Smoke Employment Smoke Simulation Smoke modeling			
20. ABSTRACT (Continue on reverse side if necessary and identify by block number) Recent intelligence reports indicate that Warsaw Pact forces are placing increased emphasis on the use of tactical smoke. In response, US forces have begun to evaluate their own capabilities to employ smoke. One method of conducting this evaluation is to include smoke employment in combat models. This thesis presents a computer model, SIMSMOKE, which has this capability. The first part of the model consists of simulating the smoke			

ADA043839

DDO
REFORMED
AUG 17 1977
A
037 260

COPY AVAILABLE TO DDC DOES NOT PERMIT FULLY LEGIBLE PRODUCTION

DDC FILE COPY

DD FORM 1 JAN 73

1473 EDITION OF 1 NOV 65 IS OBSOLETE

Book # 20: Abstract (continued)

employment tactics within a given tactical scenario. Input variables pertaining to command guidance, type of operation, weather conditions, and weapons and ammunition available provide the setting. At the appropriate time during the battle, smoke is automatically placed on or near the opposing force's location so that the smoke clouds drift into the line-of-sight between the attacker and defender.

The second part of the model consists of computing if intervisibility exists between opposing forces at each second of the battle. As a representation of a smoke cloud, a sphere is used to simulate white phosphorous (WP) and a cone is used to simulate hexachloroethane (HC). The program calculates if the line-of-sight intersects any part of either one of these types of three dimensional figures. If an intersection occurs, the line-of-sight is blocked; therefore, intervisibility does not exist.

A series of test runs were conducted to verify the model. Bursting radii of the smoke rounds, atmospheric stability conditions, type of smoke munitions, wind speeds, and wind directions were the parameters varied for the tests. In all cases the model produced results consistent with the expected outcome.

The methodology used in this study provides a basis for future simulations of tactical smoke employment in computerized combat models.

THE SIMULATION OF TACTICAL SMOKE
ON THE MODERN BATTLEFIELD

A thesis presented to the Faculty of the U.S. Army
Command and General Staff College in partial
fulfillment of the requirements for the
degree

MASTER OF MILITARY ART AND SCIENCE

by

C. J. NEEDELS, MAJ, USA
B.S., United States Military Academy, 1965
M.S., Naval Postgraduate School, 1976

Fort Leavenworth, Kansas
1977

AD BELLUM PACE PARATI

MASTER OF MILITARY ART AND SCIENCE
THESIS APPROVAL PAGE

Name of Candidate Christopher J. Needels

Title of Thesis The Simulation of Tactical Smoke on the Modern Battlefield

Approved by:

David S. Lawrence, Research Advisor

Leslie E. Davis, Member, Graduate Faculty

W. Kent Ricketts, Member, Graduate Faculty

JM Littenchwaeger Member, Consulting Faculty

ADVISOR'S FOR	
NTIS	White Jacket <input checked="" type="checkbox"/>
DDI	Diff. Section <input type="checkbox"/>
UNCLASSIFIED	<input type="checkbox"/>
PROLIFERATION	<input type="checkbox"/>
DISTRIBUTION, AVAILABILITY STATEMENT	
Dist.	AVAIL. AND/OR SPECIAL
A	23

Accepted this 31st day of May 1977 by [Signature],
Director, Master of Military Art and Science.

The opinions and conclusions expressed herein are those of the individual student author and do not necessarily represent the views of either the U.S. Army Command and General Staff College or any other governmental agency. (References to this study should include the foregoing statement.)

ABSTRACT

Recent intelligence reports indicate that Warsaw Pact forces are placing increased emphasis on the use of tactical smoke. In response, US forces have begun to evaluate their own capabilities to employ smoke. One method of conducting this evaluation is to include smoke employment in combat models. This thesis presents a computer model, SIMSMOKE, which has this capability.

The first part of the model consists of simulating the smoke employment tactics within a given tactical scenario. Input variables pertaining to command guidance, type of operation, weather conditions, and weapons and ammunition available provide the setting. At the appropriate time during the battle, smoke is automatically placed on or near the opposing force's locations so that the smoke clouds drift into the line-of-sight between attacker and defender.

The second part of the model consists of computing if intervisibility exists between opposing forces at each second of the battle. As a representation of a smoke cloud, a sphere is used to simulate white phosphorous (WP) and a cone is used to simulate hexachoroethane (HC). The program calculates if the line-of-sight intersects any part of either one of these types of three dimensional figures. If an intersection occurs, the line-of-sight is blocked; therefore, intervisibility does not exist.

A series of test runs were conducted to verify the model. Bursting radii of the smoke rounds, atmospheric stability conditions, type of smoke munitions, wind speeds, and wind directions were the parameters varied for the tests. In all cases the model

produced results consistent with the expected outcome.

The methodology used in this study provides a basis for future simulations of tactical smoke employment in computerized combat models.

TABLE OF CONTENTS

LIST OF TABLES vi

LIST OF FIGURES. vii

I. INTRODUCTION 1

II. TACTICAL SMOKE EMPLOYMENT. 5

 OFFENSE. 6

 DEFENSE. 7

 RETROGRADE 8

 RIVER CROSSING 9

 MINEFIELD BREACHING. 10

III. MODEL DESCRIPTION. 14

 THE MAIN PROGRAM 16

 LINE-OF-SIGHT SUBROUTINES. 24

 SIMSMOKE INTERFACE WITH OTHER MODELS 27

IV. VERIFICATION AND SENSITIVITY ANALYSIS. 30

V. CONCLUSIONS AND RECOMMENDATIONS. 37

APPENDIX A: USER'S GUIDE. 41

APPENDIX B: SIMSMOKE PROGRAM LISTING. 46

APPENDIX C: MATHEMATICS OF LINE-OF-SIGHT
CALCULATIONS. 66

REFERENCES CITED 70

BIBLIOGRAPHY 71

LIST OF TABLES

Table	Page
1. Weapons Available to a US Battalion	5
2. Output Matrix of Input Variables.	30
3. Sample Excerpt of Output Data	32
4. Summary of Results.	33
5. Sensitivity Results	35

LIST OF FIGURES

Figure	Page
1. The Offense	7
2. The Defense	8
3. The Withdrawal.	9
4. The River Crossing.	10
5. The Minefield Breaching	11
6. Major Decision Rules.	13
7. Model Structure	15
8. Command Guidance.	17
9. Type of Operation	18
10. Weather Conditions.	19
11. Sample Scenario	20
12. Smoke Round Impact Points Under Various Wind Conditions	21
13. Smoke Cloud Movement.	23
14. Cloud Shape Approximation	25
15. Geometric Representation of Cloud Movement.	26
16. Model Interface	28
17. Terrain and Route	34

CHAPTER I

INTRODUCTION

Recent intelligence reports indicate that Warsaw Pact forces are increasing their use of tactical smoke in training exercises. There are also indications that they are updating their smoke delivery means and improving their smoke protective systems.¹ As a result of these new activities, US forces have begun to evaluate their own capabilities to employ smoke, and to determine what effects smoke employment by either side might have on the outcome of future battles.

Although smoke was used during the Korean War and occasionally in the Vietnam conflict, documentation and technology have advanced little since World War II. Many field manuals and technical manuals^{2,3} which describe US delivery means and employment policies show little change from their 1940 and 1950 predecessors. The smoke generating units used in WW II and Korea have been inactivated and their equipment has been turned over to unmanned units or salvaged. US smoke capability today is primarily artillery delivered white phosphorous (WP) and hexachloroethane (HC). The ammunition is mostly the same type as that used in the Korean War or earlier.

In the past three years the US Army has become increasingly interested in improving its smoke program. Headquarters, Training and Doctrine Command (TRADOC) has become particularly active in examining US capability to employ smoke. TRADOC has also been interested in US forces' ability to survive in a smoke environment. Field tests have been conducted and more are scheduled on the effectiveness of smoke munitions and their effect on US weapons systems.⁴ New ammunitions, particularly the artillery "wick"

round, are under development. Army officials have now appointed a smoke Project Manager under the proponency of the US Army Material Development and Readiness Command.

The use of smoke on the battlefield poses many complex questions:

- a. When should it be employed?
- b. How should smoke be employed?
- c. What type of ammunition is best for a given situation?
- d. What are the effects on target acquisition?
- e. Will US weapons performance be seriously degraded?

These are just a few problems which face Army tacticians and technicians.

One approach to answering these questions is to use computerized combat simulations. Recognizing this fact, Headquarters, TRADOC directed that current combat models be modified so that smoke could be represented. To support this effort, TRADOC sponsored two workshops at Fort Leavenworth. Modelers from major Army analysis agencies met in May 1976 and July 1976 to pool their knowledge and to provide direction for the modeling effort. The resulting document from the meetings was the Modeler's Guide to the Tactics and Doctrine of Smoke Employment.⁵

The purpose of this thesis is to develop and present a computer model which can represent tactical smoke. The program is designed to be used with external terrain and movement subroutines. Collectively these routines may be used to drive larger combat simulations or be used independently in order to conduct analysis of smoke operations.

The scope of the study is limited by the following:

- a. Only intentional smoke is modeled, i.e., non-deliberate smoke such as that generated by battlefield fires and high explosive rounds

is not represented.

b. Ammunition which is not currently in the Army inventory, such as the new wick round, is not represented since there is a lack of validated performance data on the newer rounds. In particular, only current HC and WP munitions are considered.

c. The model considers only obscuration effects on lines-of-sight between friendly and enemy elements. Factors such as degradation of maneuverability and probabilities of hit are not represented.

d. The tactics and doctrine of smoke employment used in the model are established for modeling purposes only. They are incorporated in the model in such a manner that they may be readily changed as US and Warsaw Pact tactics and doctrine change.

There are terms frequently used in smoke studies which have dual definitions and, therefore, are misleading. For this study the following definitions are provided:

a. Smoke Screen: A cloud of smoke used to obscure vision.

b. Effective Fire: Direct or indirect fire which either suppresses or destroys the enemy. More specifically, if a friendly force uses smoke on an enemy, both sides are obscured. However, the friendly force can still place fire in the general location of the enemy thereby either suppressing or destroying him. On the other hand, the enemy is within the smoke cloud and therefore has no way of effectively tracking and thereby suppressing the friendly force.

c. Point Smoke: Smoke fired by an artillery or mortar unit at a single point using normal round dispersion.

d. Smoke Sheaf: A smoke screen created by smoke rounds impacting along a straight line.

Chapter II is largely an expansion and revision of the Modeler's

Guide to the Tactics and Doctrine of Smoke Employment. Chapter III presents a detailed description of the smoke simulation model (SIMSMOKE), followed in Chapter IV by a discussion of the results of verification and sensitivity runs of the smoke program. The final chapters presents conclusions and recommendations, as well as areas for further research.

CHAPTER II

TACTICAL SMOKE EMPLOYMENT

A battle between NATO and Warsaw Pact forces in the next decade will undoubtedly be extremely violent and very complex. Unit commanders will have far more sophisticated weapons and far more fire power than ever before. Confusion on the battlefield will be a constant problem for both sides. Even without intentional smoke, obscuration created by explosions alone will plague opposing forces. A look at the weapons which might be available to a single battalion commander on the US side emphasizes this point.

81mm Mortar	LAW
4.2 in Mortar	DRAGON
155 mm Howitzer (HE)	TOW
8 in Howitzer (HE)	7.62 mm Machine Gun
XM1 Tank	50 Caliber Machine Gun
BUSHMASTER	Attack Helicopter
FASCAM	Close Air Support (USAF)
CLGP	VULCAN

Table 1. Weapons Available to a US Battalion

If the opposing battalion commander has similar weaponry and in an equal or greater quantity, then direct fire engagement ranges may be significantly decreased because of acquisition and tracking problems caused by obscuration. If smoke is introduced on the battlefield by either side, visibility could further be degraded to the point that maximum effective ranges of weapons may become a purely

academic number. In fact, the dominant weapons performance characteristic may become the minimum effective range. Antitank guided missiles may never have a chance to be acquired by their trackers. In the most extreme cases of obscuration, forces might even pass through each other without acquiring a target.

Given that smoke can be an important factor in determining combat effectiveness, the question arises, "What is the best way to employ smoke?" Several Army documents provide general guidelines which are particularly useful to the tactician;^{6,7} however, the technician attempting to simulate smoke employment needs more definitive guidance.

For the purpose of this study the use of smoke in the three major types of operations -- the offense, defense, and retrograde -- are discussed. In addition, two special types of offensive operations -- the river crossing and the minefield breaching -- are separately considered. The objective of the discussion is to explain the criteria for determining impact points and when to fire the smoke rounds. The rationale for these recommendations is also discussed so that the technicians who simulate smoke operations will better understand the tacticians' decision process.

Offense

In the offense the objective of the attacker is to obscure the defender's vision so that the attacker can move swiftly towards his enemy without coming under effective fire. This can best be accomplished by placing a smoke screen in a sheaf immediately in front of and parallel to the defender's frontline, direct fire weapons and point smoke on suspected and known artillery forward

observer locations. An example is depicted in Figure 1.

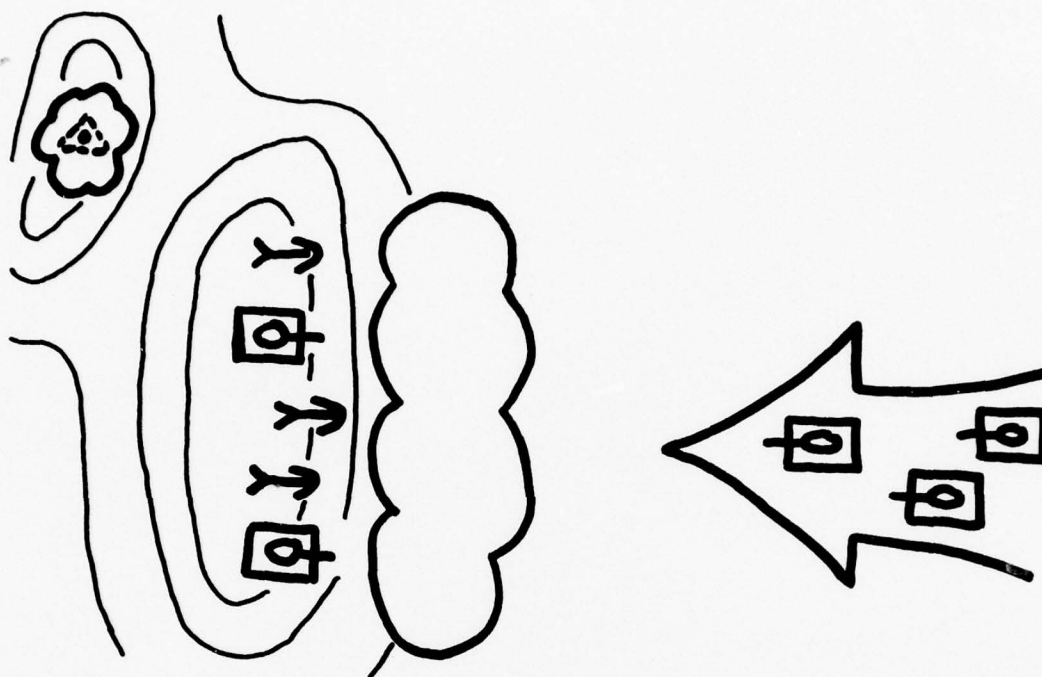

Figure 1. The Offense

Defense

In the defense the objective of the defender is to obscure the attacker's vision at and immediately beyond the defender's primary antitank weapons' maximum effective range. The purpose of this tactic is to service enemy targets as soon as they break out of the smoke screen and are just inside of the maximum effective range of the defender's antitank guided missiles (ATGM). Hopefully the attacker will be slowed down and disoriented, and will have difficulty acquiring defender targets. Additionally, smoke should be fired in a sheaf immediately in front of and parallel to any overwatch

positions. As with the offense, the defender should place point smoke on suspected or known enemy forward observer locations.

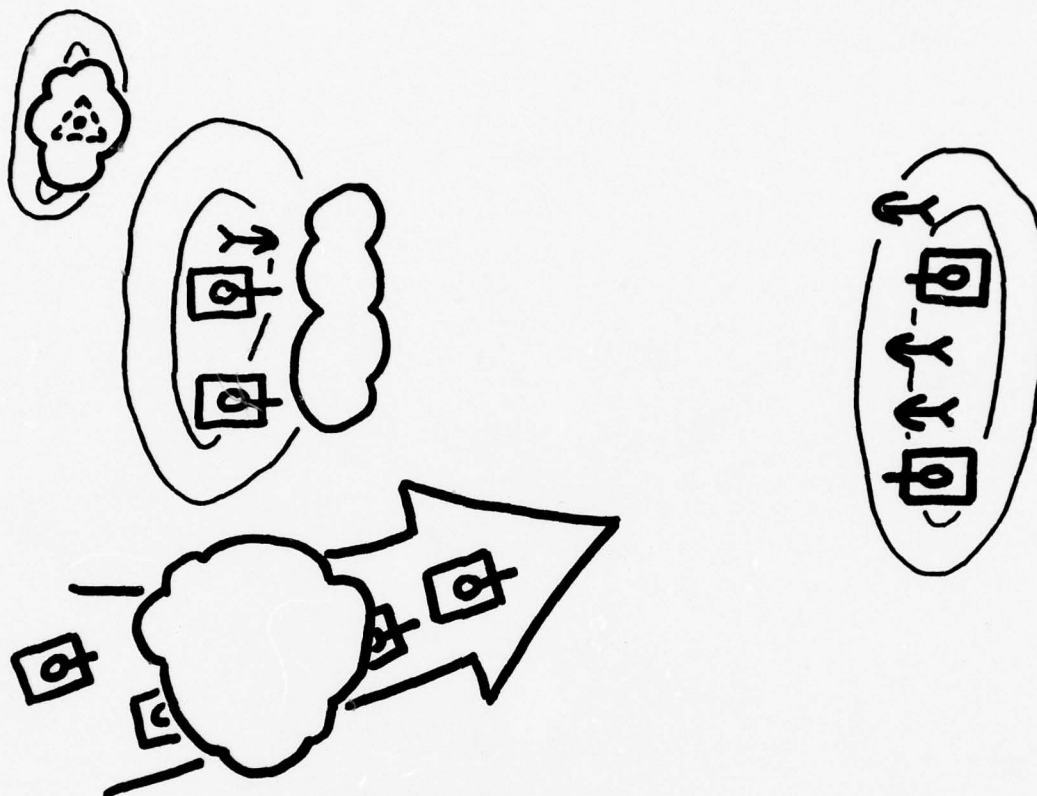

Figure 2. The Defense

Retrograde

Of the three types of retrograde operations, delay, withdrawal, and retirement, only the first two will be considered since the latter should not require smoke.

In the delaying action forces left in contact are essentially fighting a temporary defensive battle and, therefore, should employ smoke as in the defense.

In the withdrawal the objective of the withdrawing force is to mask its movement to the rear. Therefore, smoke should be fired in a sheaf immediately to the rear of the withdrawing elements.

This will not only screen the friendly force but also will obscure the enemy's vision as he pursues through the smoke cloud. For higher resolution models individual tanks and reconnaissance vehicles should be represented using exhaust smoke such as the Teledyne system or smoke grenades such as the XM-239 system. As in the other type operations, point smoke should be fired on suspected or known enemy forward observer locations.

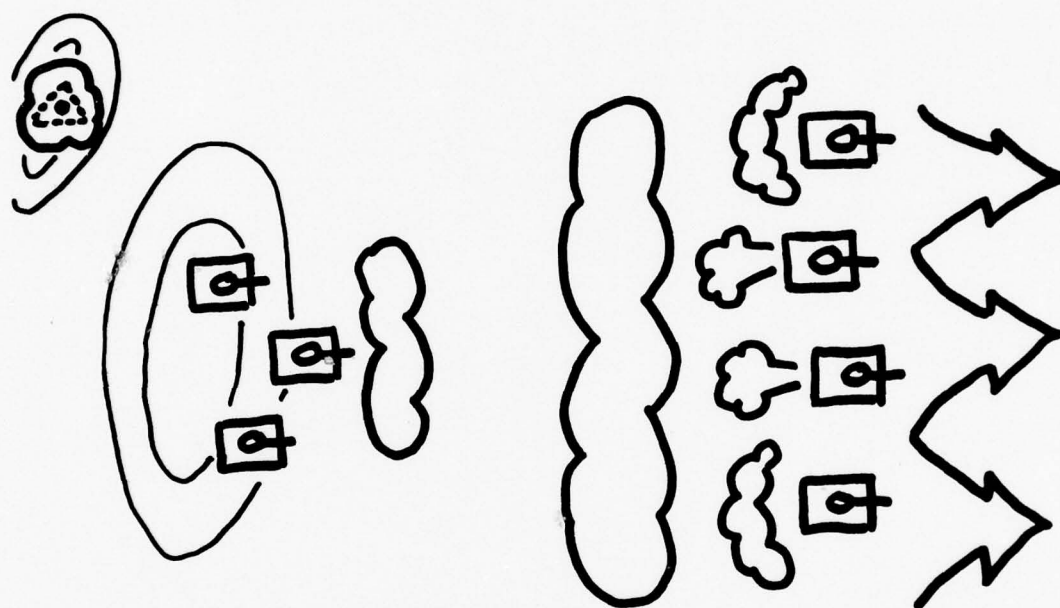

Figure 3. The Withdrawal

River Crossing

The river crossing is a special type of offensive operation. The objective of the attacker is to obscure the defender's vision as the attacker crosses the water obstacle. As in the offensive operation discussion, the attacker should place a smoke sheaf immediately in front of the defender's forward positions and place point smoke on the enemy's forward observer locations. Additionally, the attacker should place smoke on both banks of the river and on the water, if

necessary, in order to mask the crossing and to deceive the enemy as to the actual crossing site. This normally will be done using smoke generators or pots.

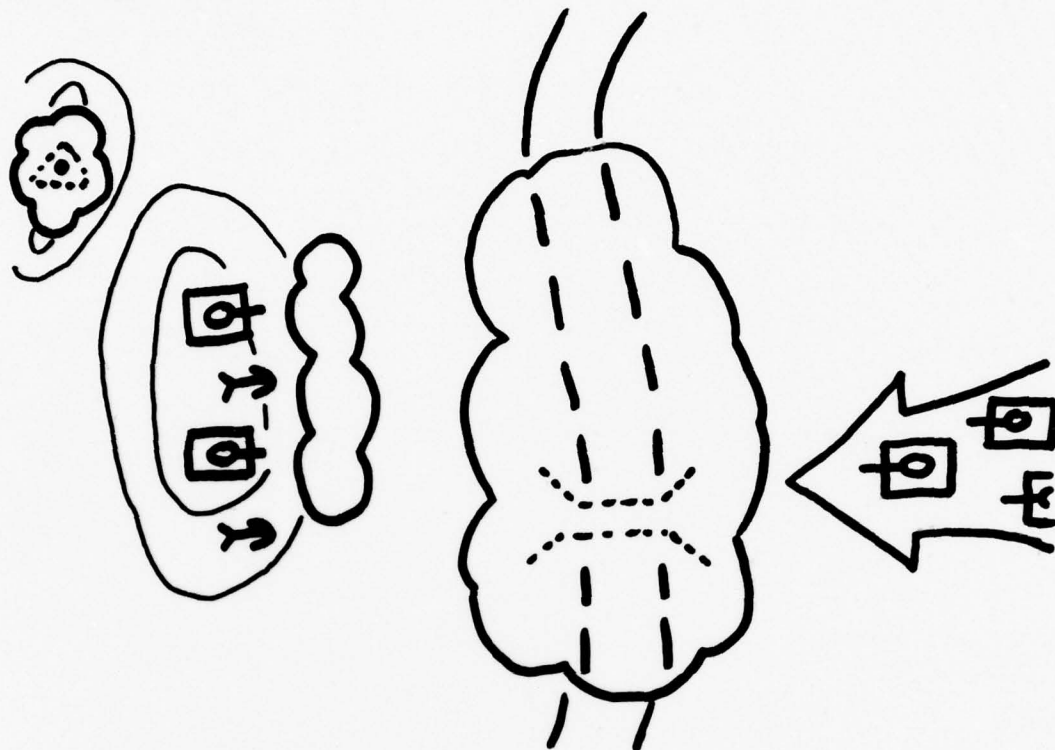

Figure 4. The River Crossing

Minefield Breaching

The minefield breaching is also a special case of an offensive operation. The objective of the attacker is to obscure the enemy's vision as the attacker crosses the minefield. It should be assumed that the defender has registered preplanned artillery fires on the minefield; therefore, smoke can do little to degrade the indirect fire effectiveness. However, the enemy's direct fire weapons must still be aimed. To assist in countering the threat, the force crossing the minefield should place a sheaf immediately in front of the breaching elements in order to obscure the defender's vision.

Smoke should also be employed as in any offensive operation.

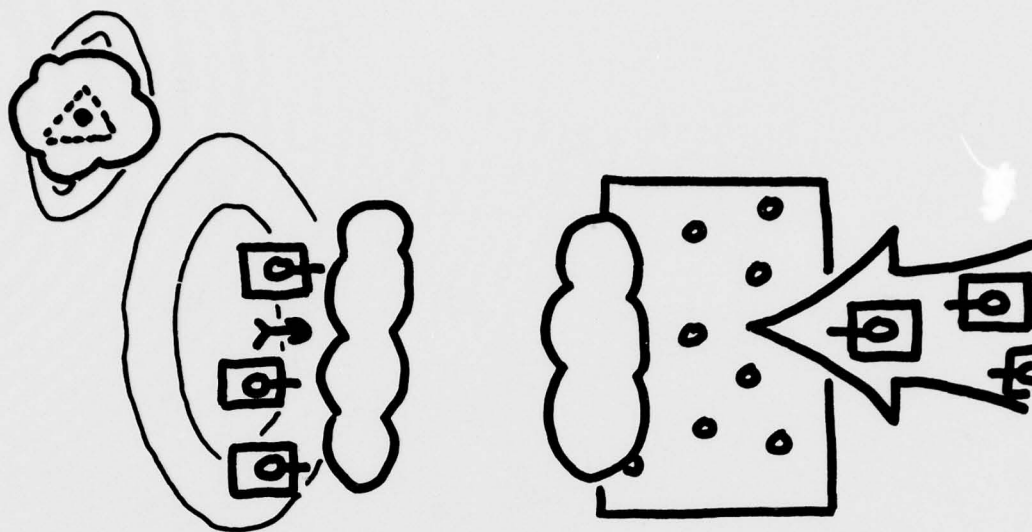

Figure 5. The Minefield Breaching

It is recognized that a commander may not desire to use smoke in every instance and at every location just discussed. However, the model should be designed to provide the capability for representing such employment should the need arise.

Besides the tactical considerations of placement and timing of smoke screens, several other kinds of variables must be considered. Typical questions which remain unanswered include the following:

- a. What guidance has been issued from higher headquarters?
- b. Which of the operations just discussed is to be conducted (offense, defense, or retrograde)?
- c. What are the atmospheric conditions?
- d. What are the macro-terrain features?
- e. What are the quantity and kinds of smoke rounds available?

Although these questions can be answered in a variety of ways, a convenient method is to divide them into five major categories and to respond to each category in a logical order. These groupings include command guidance, tactical situation, weather and terrain, weapons available, and ammunition available. A flow chart of these is shown in Figure 6 on the following page.

Within these broad categories are many smaller, more specific problems which must be solved before smoke can be represented in a combat model. These are discussed in the next chapter as a part of the description of the SIMSMOKE model.

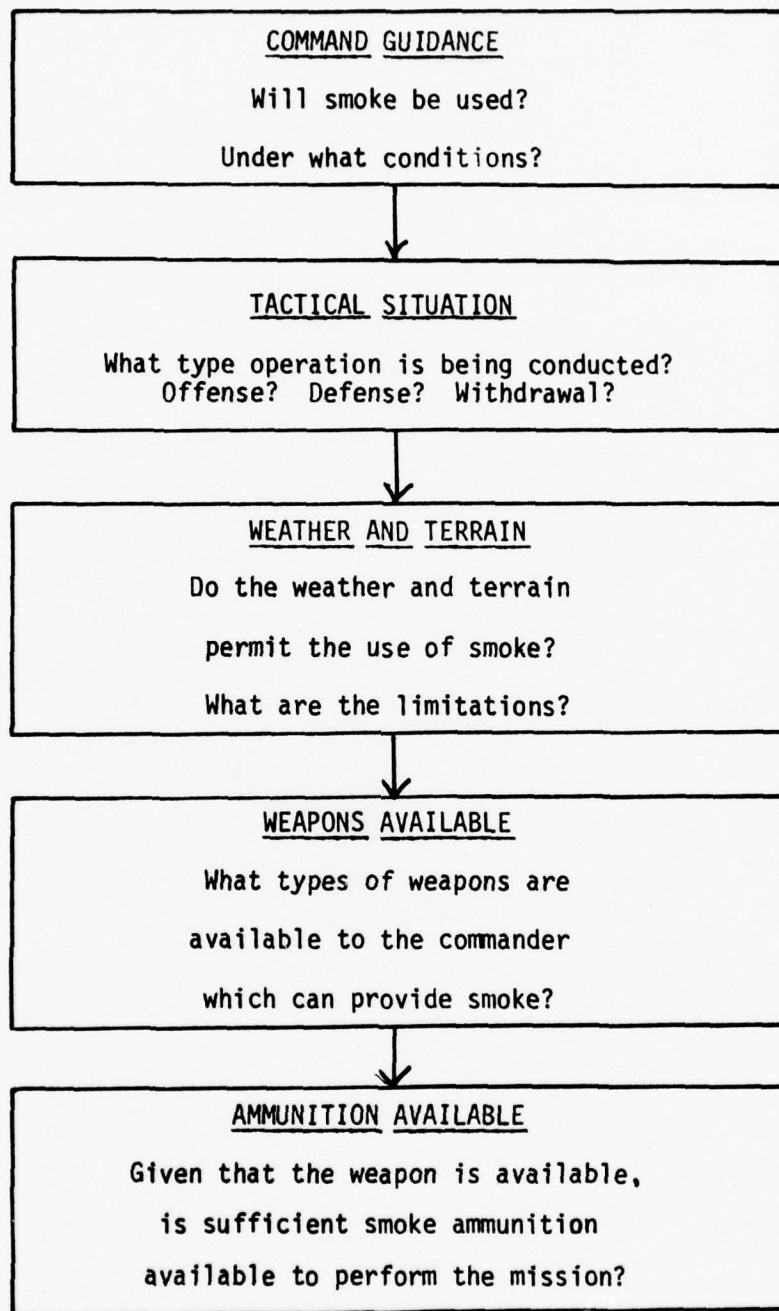

Figure 6. Major Decision Rules

CHAPTER III

MODEL DESCRIPTION

SIMSMOKE is a computer model which determines if intervisibility exists between an attacker and a defender under simulated smoke conditions. The smoke may be fired by either side or both, using either HC or WP munitions, and under a variety of atmospheric conditions. The program is designed to be used with terrain and movement subroutines as a line-of-sight preprocessor for combat models or as a subroutine to the Simulated Terrain Model (SIMTER).⁸ If used as a preprocessor, the smoke is treated as moving macro-terrain, thereby raising elevation data in those areas in which the smoke is present. For this particular study, however, SIMSMOKE is used in conjunction with SIMTER. SIMSMOKE/SIMTER model structure is shown in Figure 7.

SIMTER is a computer model which simulates continuous macro-terrain by randomly creating bivariate normal distributions which graphically resemble hills. Since the terrain is continuous, lines-of-sight can be determined at any time without approximating the terrain elevation between discrete points. Furthermore, intervisibility output data is provided at one second time intervals as the attacker moves towards his objective. This frequent output is particularly useful for conducting sensitivity analysis of smoke employment techniques when the SIMSMOKE subroutine is used.

The simulated smoke model has two main parts. The first is the main program which handles the processing of external guidance and variables. It represents both the tactical and technical decision logic which is necessary to employ tactical smoke. The second part,

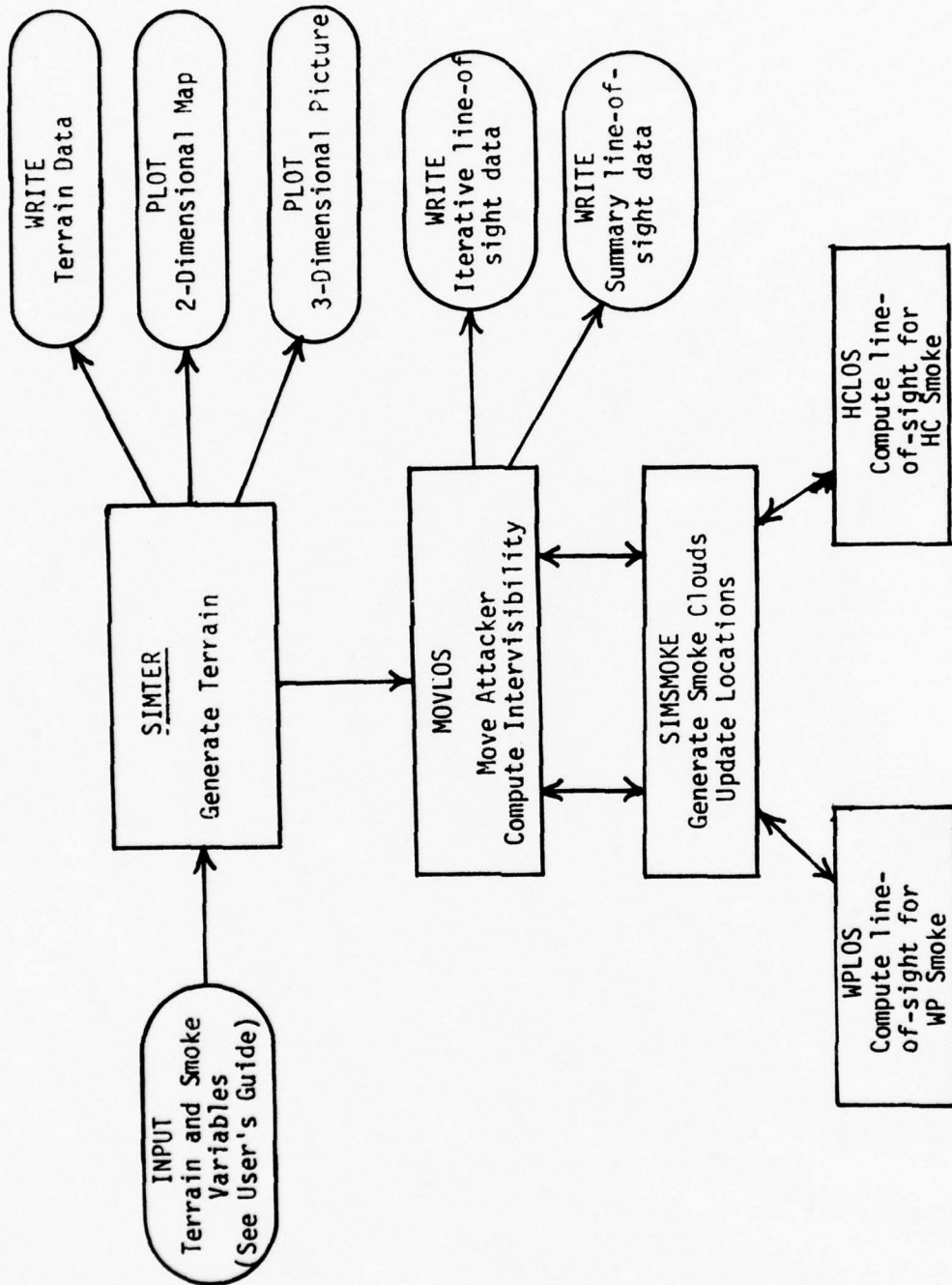

Figure 7. Model Structure

which consists of two subroutines, does the line-of-sight calculations. By checking to see if any smoke is directly between the attacker and defender, intervisibility is determined. One of the subroutines is used for HC smoke, the other for WP. Both the main program and the subroutines are discussed in detail in the following sections.

The Main Program

Once SIMTER has determined that intervisibility exists between two points, it calls the SIMSMOKE subroutine to see if smoke interferes with this line-of-sight. Several input variables are passed along with the call. These variables are discussed as they are used in the program, and are further explained in the User's Guide at Appendix A.

The first part of SIMSMOKE is called "command guidance". This is a check to see if the user desires for the west force (defender) or the east force (attacker) or for both forces to employ smoke. The input variable is ICG, and can be assigned a value of zero through three. Zero indicates that neither side uses smoke, one means that only east uses smoke, two means that only west uses smoke, and three means both sides use smoke. A flow chart of command guidance is shown in figure 8.

Since an attacker and a defender use different smoke employment tactics, the program does line-of-sight calculations twice if both sides use smoke. The program logic is different for each side.

The second block of logical statements is "type of operation". The subroutine examines if the east force is moving toward his objective, not moving at all, or moving away from his objective. The appropriate type of operation is assigned to the variable TYP.

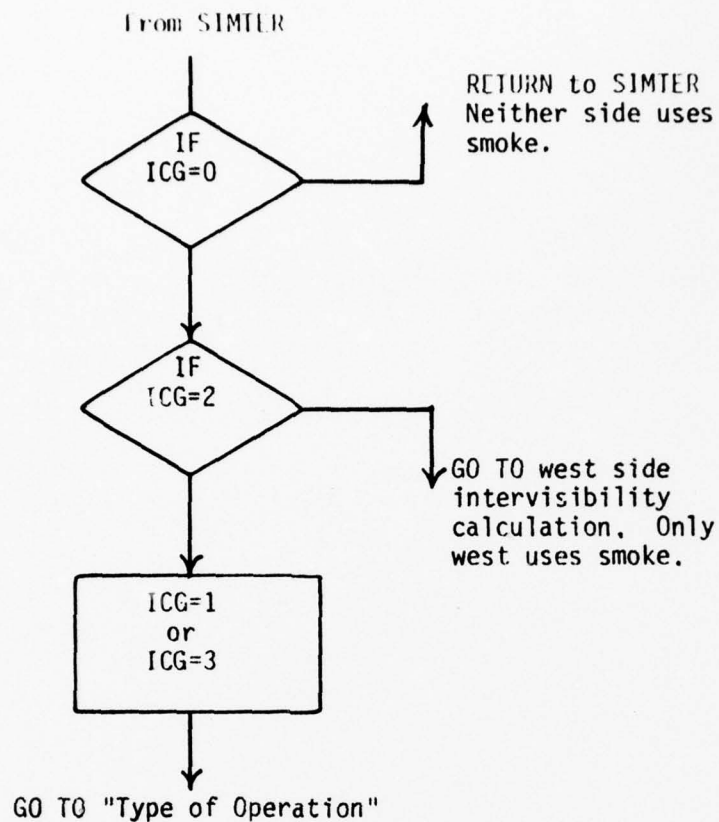

Figure 8. Command Guidance

The weather in a battle area has considerable effect on smoke employment. It determines whether or not smoke should be used and how it should be used. The significant factors include wind speed, wind direction, temperature, humidity, precipitation, cloud cover, and temperature gradient. For the purpose of incorporating smoke into SIMSMOKE and most other Army simulations these factors may be aggregated into wind speed, wind direction, and atmospheric stability. The latter term is a parameter which is used to predict whether a smoke cloud will rise rapidly (lapse), rise moderately (neutral), or remain at a constant altitude (inversion). The wind direction for this model may be categorized as a headwind, tailwind, crosswind, or quartering wind. Under certain circumstances the wind conditions

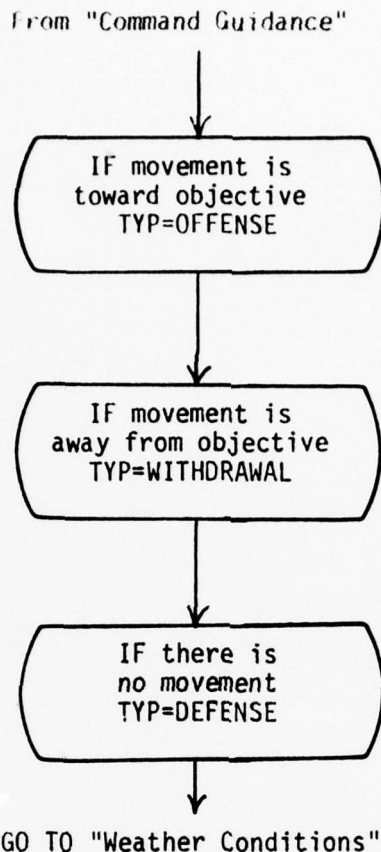

Figure 9. Type of Operation

dictate courses of action. One case is when the wind is greater than 8 meters per second. The wind is too strong for the smoke to form into a useful size and shape cloud; consequently, smoke should not be used. A second case is when an attacker has a headwind. If he fires smoke in front of his objective, the smoke will drift back onto his own forces. Again, smoke should not be used. The flow chart for the weather logic is provided on the following page. WS is the wind speed, WD is the wind direction, STB is the stability condition, and ZV is the rate of rise of the smoke cloud,

The final set of questions answered by SIMSMOKE before the smoke rounds are fired include "How many rounds are available to fire the

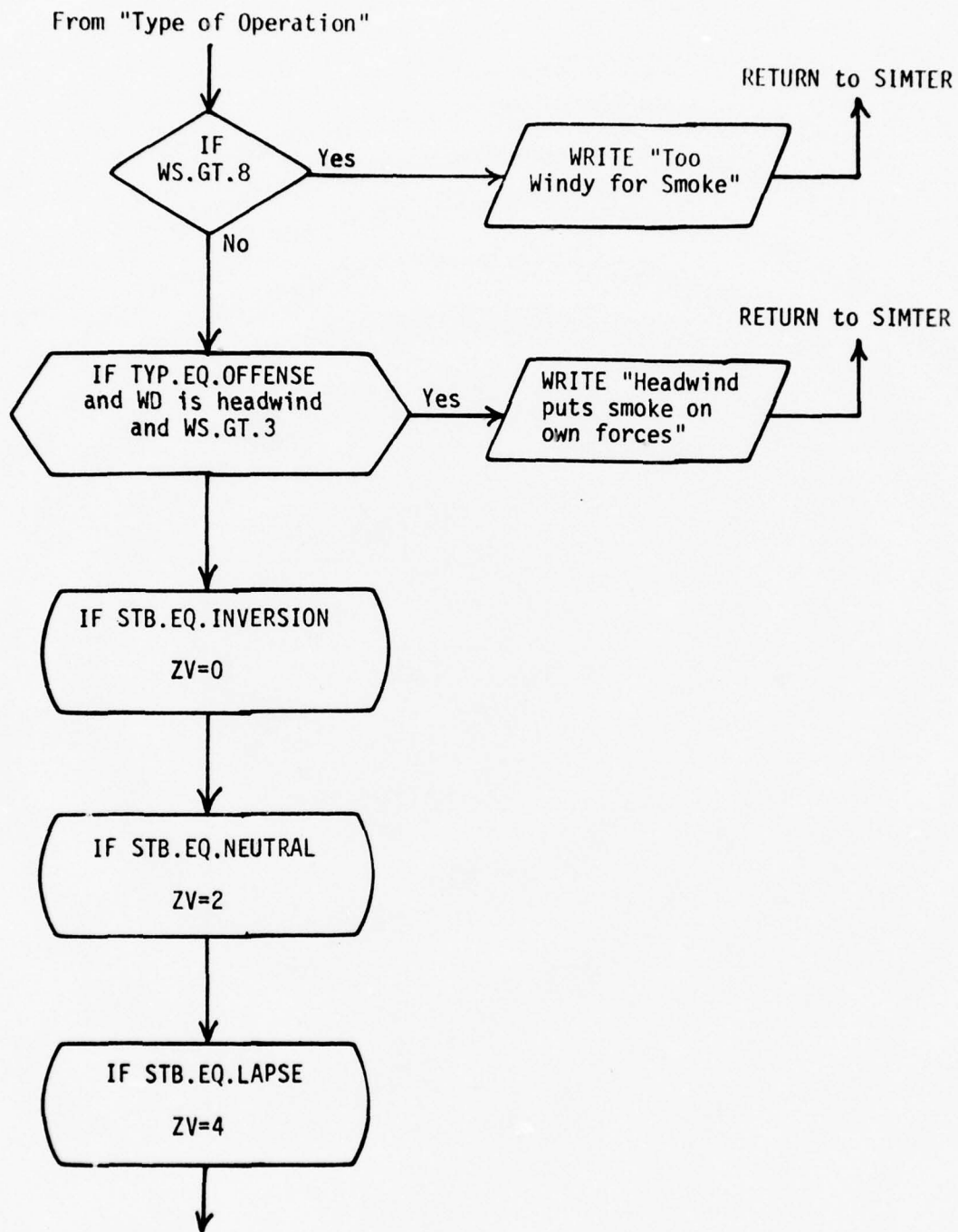

Figure 10. Weather Conditions

mission?", "What kind of smoke rounds are they?", and "How many tubes are available to fire them?" All of these are answered using input data.

The remainder of the main program includes the dynamics of firing the rounds, calling the line-of-sight subroutines, and updating the locations of the smoke clouds as they drift downwind. To assist in the explanation of these dynamics, illustrations and a sample scenario are provided.

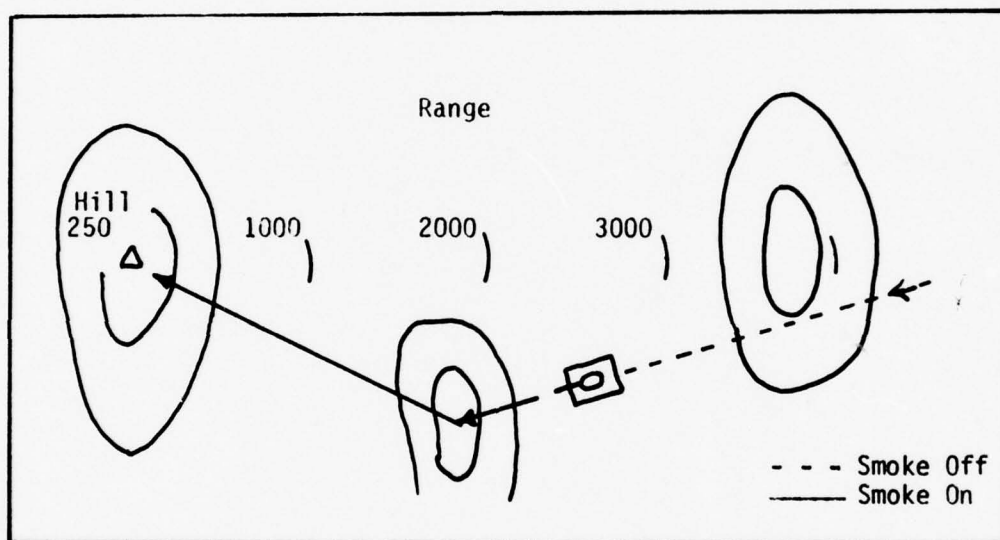

Figure 11. Sample Scenario

An attacker is moving from east to west along a preselected route. His objective is to assault the defending force on Hill 250. Assuming that the attacker has been directed to use smoke on his objective, the first question he will ask is "When should I have my artillery or mortars fire smoke?" To answer this, the model first calculates the distance between the attacker and the objective. If the attacker is beyond the range of the defender's ATGM, no smoke

is fired. However, as soon as he moves within range, the program automatically represents smoke in accordance with the doctrine mentioned in Chapter II. Likewise, when the attacker reaches the vicinity of his objective, the smoke is shut off. The next question for the attacker to answer is "Where should I fire the smoke?" The answer to this depends upon the wind. In all cases the model will place the smoke between the attacker and the defender, never on or behind. The objective is to have all of the cloud between the two forces. A smoke cloud which lands to the rear of the defender may drift onto him but much of the smoke will be wasted. Since the purpose of employing smoke is to obscure the defender's view of the attacker, the smoke is placed so that it will always drift into the lines-of-sight. Possible cases are illustrated below.

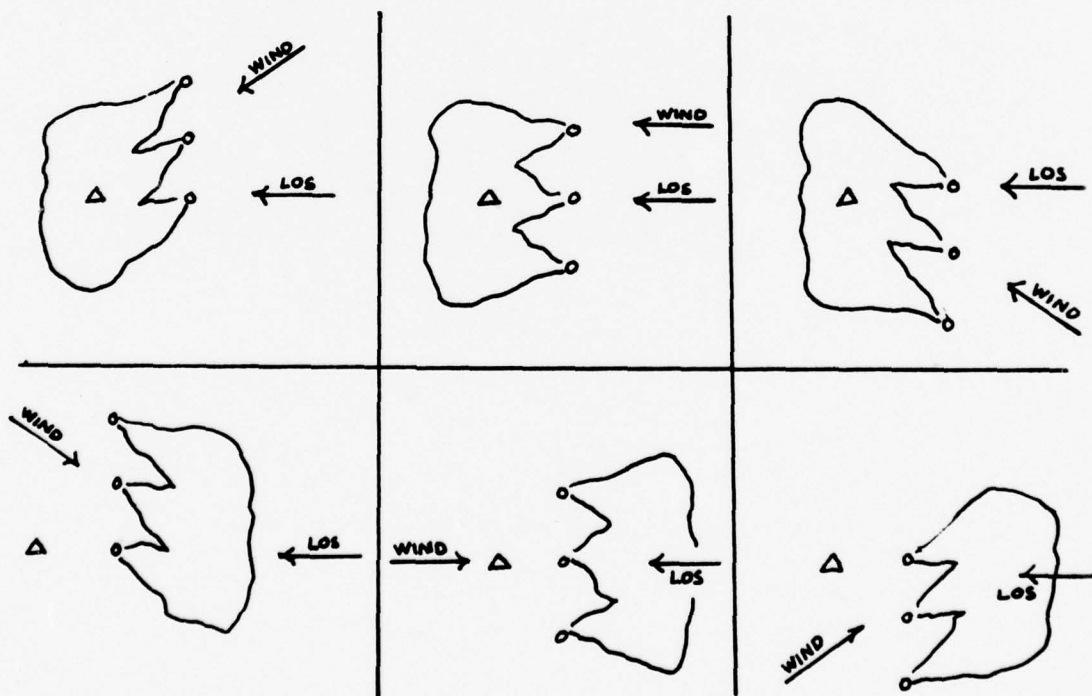

Figure 12. Smoke round impact points under various wind conditions.

Once the general location of the center of mass of the smoke sheaf has been determined, the next step is to determine the impact points of individual rounds. It is assumed that the first rounds of smoke will be fired simultaneously by all tubes of the battery or platoon. They will also impact in a sheaf with rounds fairly equally spaced apart. The distance between the rounds will be determined by the width of the sheaf. Subsequent rounds will arrive at the average firing rate of the battery as a whole, and the rounds will impact at random points along the long axis of the sheaf. If at any time during this firing, the number of rounds fired exceeds the number of rounds allocated, the smoke mission is automatically terminated.

At this point in SIMSMOKE, the HC or WP line-of-sight subroutines are called to see if intervisibility exists. These subroutines are covered in detail in the next section.

The remainder of the main program deals with moving the center of mass of the WP smoke cloud and the tail of the HC smoke cloud downwind. This consists of finding the product of the wind speed, time interval, and appropriate trigonometric function of the wind direction. The vertical movement is also updated based on the input atmospheric stability conditions.

If the user should desire to have the defender (west) employ smoke, then the model will direct that intervisibility again be determined. The defender version of the main program is almost identical to that of the attacker. The only major difference is that the defender fires smoke on the lead element of the attacker at the maximum effective range of the defender's ATGM. In the

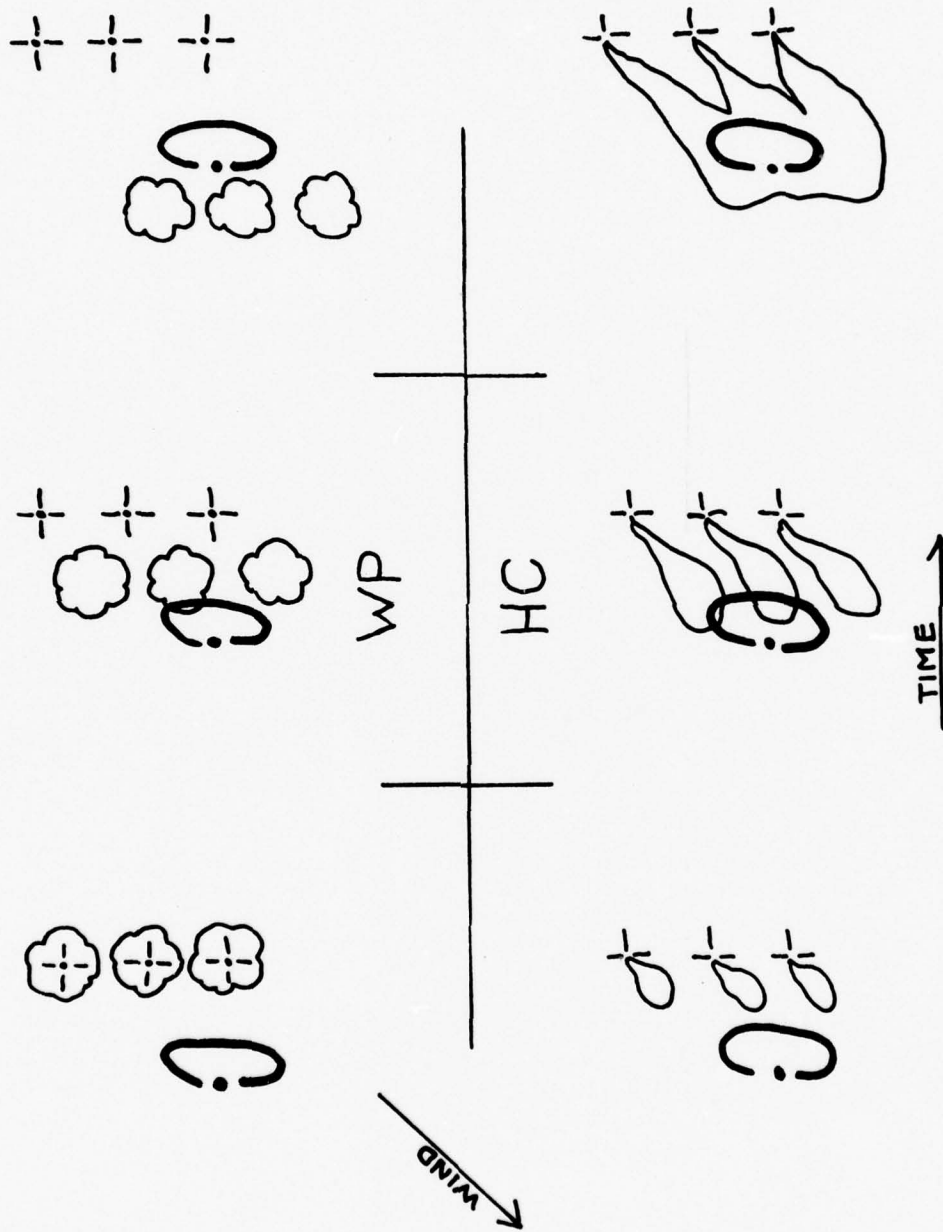

Figure 13. Smoke Cloud Movement

case just covered, smoke was fired in front of the enemy.

Line of Sight Subroutines

Both of the line-of-sight subroutines compute if a straight line and a three dimensional solid intersect. In these cases the straight line represents the line between the attacker position and the defender position, and the solid represents a smoke cloud. If the line intersects any one of the solids, then the smoke blocks line-of-sight and, therefore, intervisibility does not exist.

The first subroutine, WPLOS, does the calculations for the white phosphorous rounds. The assumption is made that the shape of a WP cloud is spherical. The main program passes the current locations of the center of masses of each smoke round and the location of both the attacker and defender. The subroutine converts this information into equations, and calculates if the perpendicular distance between the line-of-sight and each of the sphere's centers is larger or smaller than each of the sphere's radius. If one of the distances is less than a radius, then there is no intervisibility. The subroutine returns a binary response to the intervisibility query, i.e., "1" indicates there is line-of-sight or "0" indicates there is not.

The HC subroutine is more complicated. The first problem was to determine if there is a fairly common three dimensional figure which closely resembles the HC smoke cloud. A three dimensional cone appeared to be the most realistic and subsequently was selected. Although not as simple as solving for the intersection of a line and a spheroid, the solution for a line and a cone is a trivial operation for the computer. The mathematics consists of determining

the shortest distance between two straight lines in three space. One line is the attacker-defender line, the other is the axis of the cone. If this distance is greater than the radius of the cone's cross section along the perpendicular line then intervisibility does exist. The method used to determine the shortest distance between the two lines consists of finding the cross product of the two vectors in order to find a line perpendicular to both; and then solving a system of three simultaneous, parametric equations in order to find the points of intersection. A summary of the mathematics is presented in Appendix C,

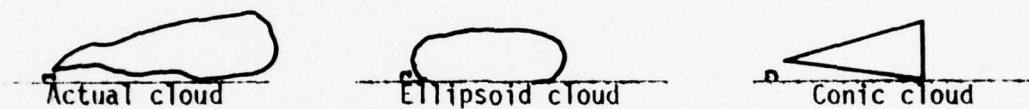

Figure 14. Cloud Shape Approximations

As with WPLOS, the HC subroutine returns either 0 or 1 in response to intervisibility.

Figure 15 on the following page illustrates typical smoke missions and how the clouds react over time.

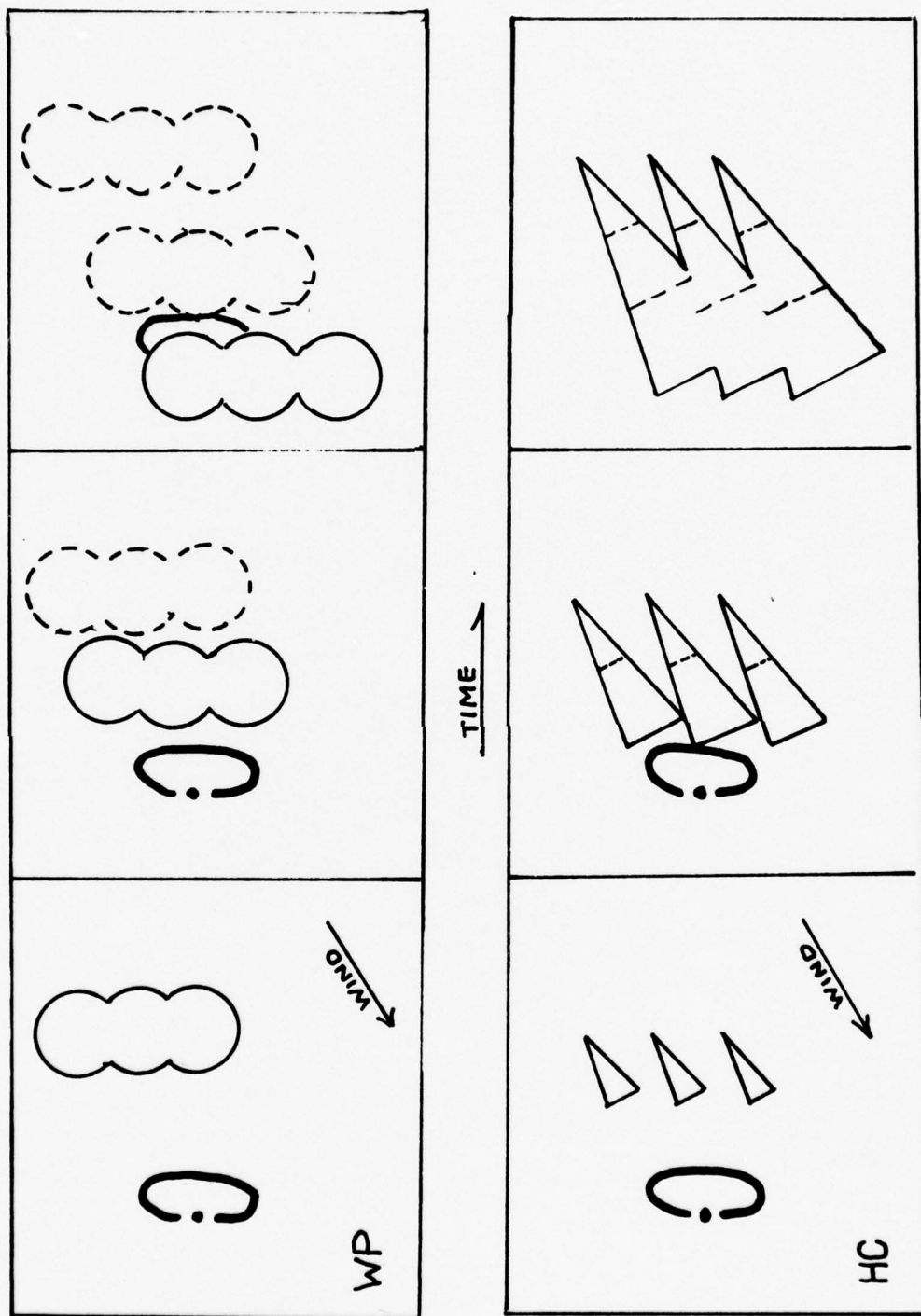

Figure 15. Geometric Representation of Cloud Movement

SIMSMOKE Interface with Other Models

The first two sections of this chapter dealt with using SIMSMOKE as a subroutine to SIMTER. For users desiring to employ SIMSMOKE with other models, this section provides additional information for affecting the interface.

SIMSMOKE requires three major types of input as shown in Figure 16. The first of these is user guidance which includes command guidance, type of operation, weather conditions, and weapons and ammunition available. These are discussed in detail in the first section of this chapter and are further discussed in Appendix A, User's Guide.

The second block of input information required by SIMSMOKE is terrain data. The program must be provided with the altitude of the terrain on which the attacker and the defender are located, as well as the altitude of the terrain at the points of impact of the smoke rounds. When SIMSMOKE is used with SIMTER, the altitude of the smoke rounds' impacts are determined within SIMSMOKE.

The third type of input data consists of the map coordinates of the opposing elements. The defender location will be fixed, while the attacker location will consist of an array of (X,Y) data points as the attacker moves towards the defender. Depending upon the models with which SIMSMOKE is used, terrain and route information may be combined. The important point is that SIMSMOKE must have X, Y, and Z values for the attacker, defender, and smoke round impacts in order to develop equations for intervisibility calculations.

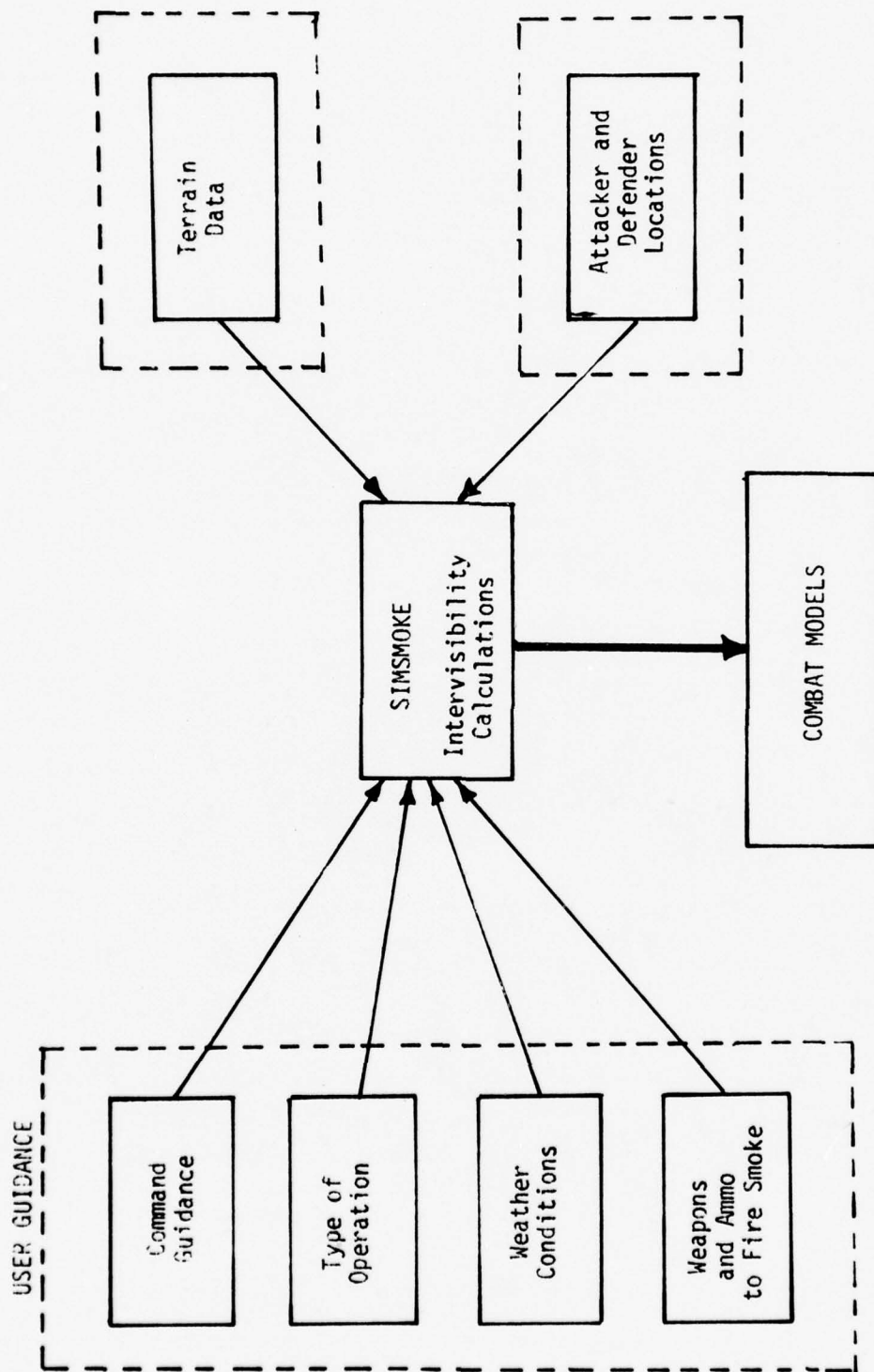

Figure 16. Model Interface

The output provided by SIMSMOKE is a "1" for intervisibility or a "0" for no intervisibility. Since many high resolution combat models have sophisticated probability of detection routines, this binary response should be expanded as smoke performance data becomes available. Chapter V presents recommendations on this subject.

So far in this section on interface, the discussion has been limited to what SIMSMOKE requires and what it provides a larger model. It is also necessary to comment on where in a simulation SIMSMOKE will be placed. Most Army combat models have a similar sequence of events. This includes the following:

- a. Determining if intervisibility exists between opposing elements.
- b. Determining if each side detects the other, once intervisibility has been established.
- c. Firing at the targets detected in the previous step.
- d. Assessing the damage which results from the firing engagement.

Depending upon the model with which SIMSMOKE is used, SIMSMOKE will most likely be placed between (a) and (b) above.

CHAPTER IV

VERIFICATION AND SENSITIVITY ANALYSIS

The purpose of this chapter is to demonstrate that SIMSMOKE is in fact representing smoke as explained in the previous chapter and that the model does respond to changes in input variables selected by the user. There is no attempt here to draw conclusions about the effectiveness of smoke employment on the outcome of a battle.

The output information available to the user is first explained as an aid to understanding the model. That portion of output which pertains solely to SIMTER is discussed in detail in the SIMTER reference.⁹ The explanation which follows is limited primarily to the SIMSMOKE model.

The first block of information is a matrix of the input variables supplied by the user.

	WEST	EAST
WILL EMPLOY SMOKE	NO	YES
NUMBER OF TUBES	6	6
NUMBER OF ROUNDS	50	50
BURSTING RADIUS	20,0000	20,0000
FIRING RATE	.2000	.2000
SCREEN SIZE	200,0000	200,0000
RANGE AT A-T WPNS	3000,0000	3000,0000

Table 2. Output Matrix of Input Variables

The second block of output information is a second-by-second description of attacker locations and speed of movement, followed by intervisibility data. The first column supplies the time in seconds. At the beginning of each battle the time is set to zero. The next three columns are map coordinates and elevation of the attacker, and the fifth column indicates attack speed along a predetermined attack route. For all iterations executed in this study, the speed is a function of the terrain slope. The next column, labeled "Visper", indicates whether (1) or not (0) the attacker can be seen by the defender. Visper, along with "% Exposed" and "Tgt (area) Exposed", pertain to terrain masking only. Since the outer edge of a smoke cloud is not clearly defined, the target is treated as a point target. The final three columns indicate the number of smoke rounds fired by each side and whether smoke interferes with intervisibility. The last entry mentioned, "Vismok", returns either a "0" or a "1". Table 3 presents an excerpt of a sample output.

The final output data (Table 4) consists of a summary of results of each run of the program. This includes a list of the intervisibility segments and their lengths, distance traveled both covered and uncovered, average length of intervisibility segments, and per cent of the time intervisibility exists. The last entry mentioned pertains only to terrain masking.

In order to demonstrate the SIMSMOKE program's ability to represent tactical smoke, numerous test runs of the model were conducted. The objective of these test runs was to test the model's sensitivity to changes in external variables. In particular, wind speed, wind direction, bursting radius, atmospheric

TIME	REF COORDINATES	COL VATION	SPTRC	VISPER	% EXPOSED	TGT EXPOSED	RD# E	RD# H	VISMOK
1	5800.000 2700.000	72.72001	0.000	0	0.000	0.000	0	0	0
2	5795.126 2296.954	73.07042	5.766	0	0.000	0.000	0	0	0
3	5730.260 2201.000	77.41224	5.762	0	0.000	0.000	0	0	0
4	5795.362 2290.579	77.72482	5.776	0	0.000	0.000	0	0	0
5	5780.431 2297.772	74.01676	5.791	0	0.000	0.000	0	0	0
130	4835.582 1739.714	80.74269	6.538	0	0.000	0.000	0	0	0
131	4829.429 1737.467	79.62022	6.565	0	0.000	0.000	6	0	0
132	4823.259 1735.195	78.49070	6.571	1	.874	.124	6	0	0
133	4817.075 1732.903	77.36222	6.566	1	16.927	2.272	6	0	0
134	4810.879 1730.595	76.23491	6.501	1	31.793	4.491	6	0	0
135	4804.667 1728.335	75.10895	6.510	1	47.084	6.776	6	0	0
136	4798.444 1726.069	74.98360	6.528	1	64.951	9.125	6	0	0
137	4792.211 1723.810	73.85821	6.541	1	81.683	11.534	7	0	0
138	4785.964 1721.529	72.73198	6.552	1	99.267	14.001	7	0	0
139	4779.703 1719.226	71.60273	6.563	1	100.000	14.091	7	0	0
200	4773.442 1716.920	70.47940	6.574	1	100.000	14.076	7	0	0
201	4767.167 1714.603	69.35485	6.585	1	100.000	14.061	7	0	0
202	4760.885 1712.284	68.23001	6.592	1	100.000	14.046	8	0	1
203	4754.595 1710.019	67.10520	6.700	1	100.000	14.031	8	0	1
411	35974.100 1265.579	75.12166	5.692	0	0.000	0.000	49	0	0
412	3591.927 1263.706	74.00090	5.656	0	0.000	0.000	50	0	0
413	3586.653 1261.772	72.87640	5.620	0	0.000	0.000	51	0	0
414	3581.380 1259.832	71.75300	5.584	0	0.000	0.000	52	0	0
415	3576.105 1257.897	70.63053	5.550	0	0.000	0.000	53	0	0

Table 3. Sample Excerpt of Output Data

INTERVISIBILITY SEGMENT LENGTHS

1	167.907
2	154.190
3	146.699
4	23.084
5	118.557
6	49.660
7	1856.918

DISTANCE UNCOVERED	DISTANCE COVERED	TOTAL DISTANCE	AVG DISTANCE INTERVISIBLE	PER CENT TIME INTERVISIBLE
2517.014	1919.219	4436.233	314.627	.638

Table 4. Summary of Results

stability conditions, and type of smoke were each altered on separate executions of the program. Screen width and number of weapons firing were not changed because of their interdependence with bursting radius. To separate terrain masking from smoke masking an initial run was made without smoke. The results indicated that the attacker, as he moved upon his objective, was not visible to the defender 36.20 per cent of the time. The terrain and route shown in Figure 17 remained unchanged for all subsequent executions of the program. Average height of the peaks is 100 meters.

The test consisted of two major blocks, attacker using WP smoke and attacker using HC smoke. Within these blocks the other external variables were changed. The first group of tests used wind speeds of one, four, and nine meters per second. The difference in distance traveled while masked by smoke or terrain using windspeeds of one and four meters per second was about

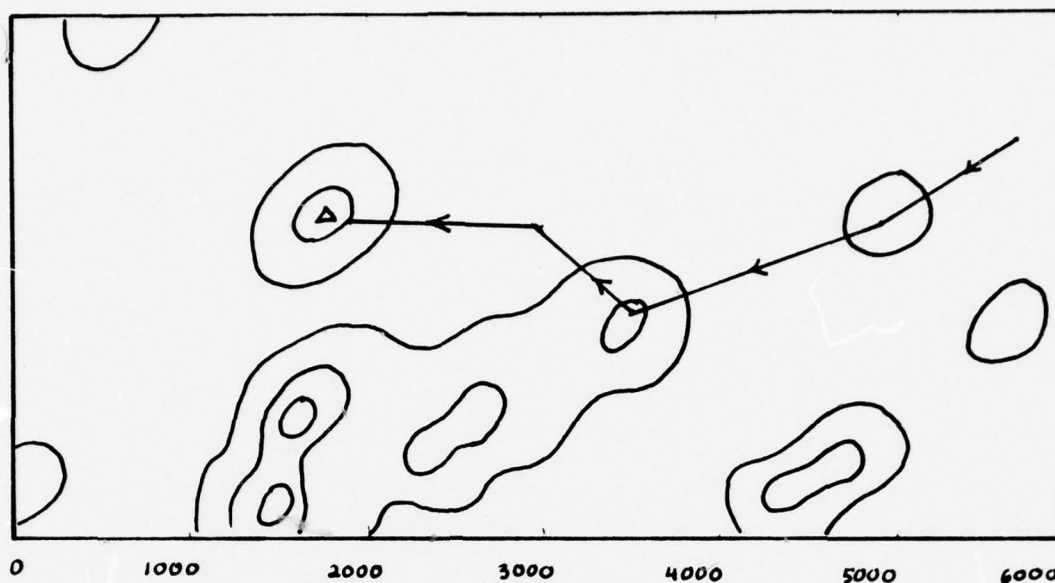

Figure 17. Terrain and Route

one per cent, or 42.09 and 43.26 per cent as compared with the initial masking of 36.20 per cent with no smoke. The nine meters per second wind speed returned a "Too windy for smoke" error message.

The second series of tests changed wind direction, using a fixed wind speed of two meters per second. Applying wind directions of 300 and 150 degrees, the masking again changed about one per cent.

The final test in the first block consisted of increasing the bursting radius of the smoke rounds from twenty up to forty meters. As expected, the change was significant. Distance traveled while totally obscured jumped from 43.51 per cent to 52.87 per cent. With six rounds equally spaced over a 200 meter screen width, the bursting radii overlap.

The second block of tests, which consisted of the attacker

BLOCK 1
East Force Using WP Smoke

Run Number	Wind Speed	Wind Direction	Bursting Radius	Atmosphere Stability	Per Cent Masked
0	-----		Smoke Not Used	-----	36.20
1A	1	60	20	Neutral	42.09
2A	4	60	20	Neutral	43.26
3A	9	60	20	Neutral	Too Windy
4A	2	300	20	Neutral	42.54
5A	2	150	20	Neutral	43.51
6A	2	150	40	Neutral	52.87

BLOCK 2
East Force Using HC Smoke

Run Number	Wind Speed	Wind Direction	Bursting Radius	Atmosphere Stability	Per Cent Masked
1B	1	60	20	Neutral	41.36
2B	4	60	20	Neutral	39.09
3B	9	60	20	Neutral	Too Windy
4B	2	300	20	Neutral	41.27
5B	2	150	20	Neutral	42.29
6B	2	150	40	Neutral	51.30

Additional Runs

Run Number	Wind Speed	Wind Direction	Bursting Radius	Atmosphere Stability	Per Cent Masked
7 West WP	2	150	20	Neutral	48.51
8 West HC	2	150	20	Neutral	27.01
9 East WP	2	150	20	Inverse	56.75
10 East WP	2	150	20	Lapse	39.30
11 East WP	--	Same as 5A but impact moved to 25 meters from defender location --			42.77

Table 5, Sensitivity Results

using HC smoke instead of WP, was conducted using the same values for the external variables as were used in the first block. These results are displayed in Table 5. In general, the results of the HC runs were comparable to those of the WP runs.

Five additional test runs were executed. The first two were to check if the program operated properly if the defender used smoke. The second two were to check the effect of changing the values of vertical wind velocity. The assumptions used in this program are that under inversion stability conditions the smoke does not rise, under neutral it rises at two meters per second, and under lapse it rises at four meters per second. As the results indicate, the difference between inversion and lapse is significant, 39 percent to 56 percent. The final run had the smoke impact points moved from 50 meters to 25 meters in front of the defenders. The result was a slight drop in obscuration.

Numerous other verification runs were executed, but not reported. These runs consisted of such tests as checking to see if the smoke clouds were in fact moving downwind, or that the smoke had a vertical rise commensurate with the atmospheric stability conditions. These were accomplished by recording and manually plotting the coordinates of each smoke cloud after each iteration of line-of-sight calculations.

The results of these verification runs, along with the sensitivity runs depicted in Table 5, suggest that the SIMSMOKE program does represent tactical smoke employment in a rational and reasonably realistic manner.

Chapter V

CONCLUSIONS AND RECOMMENDATIONS

The length of time an attacking armored vehicle can be seen by a defender, once the attacker is within range of the defender's weapons, is extremely important. During this intervisibility segment, the defender must acquire his target, launch his ATGM, and track the round until it strikes its target. If the intervisibility time is less than the sum of the times it takes the defender to complete these three activities, he will miss his opportunity to kill his target. Therefore, the effect of reducing this intervisibility time by employing smoke is quite significant.

Since tactical smoke is important, it should be represented in appropriate combat simulations. SIMSMOKE is a model which does make it possible to simulate smoke. Used with terrain and movement routines, SIMSMOKE can be used to conduct smoke effectiveness research or to drive larger combat simulations which are used for war gaming or weapons effectiveness analysis.

In its current form, the primary product of SIMSMOKE is the methodology it uses to simulate smoke. Although the model has been used effectively in its present configuration, the program should be modified to meet the requirements of the larger simulations with which it might be used. Both the scope and the resolution should be altered to provide the appropriate interface. Here the term scope refers to the types of smoke sources available. More specifically, this study is limited to artillery or mortar delivered white phosphorous or HC

munitions. As more smoke performance data becomes available, artillery wick rounds, tank smoke exhaust systems, and other smoke dispensing systems could be added. Smoke grenades, smoke pots, and even smoke from battlefield fires could be modeled.

The resolution of SIMSMOKE should also be modified. For combat models which do not simulate elements smaller than a battalion, the assumption that a smoke cloud either totally obscures a target or does not obscure a target at all may be adequate. However, for high resolution models such as DYN-TACS¹⁰ more detailed data is required. Variables such as smoke cloud density, growth rates, terrain interaction, and electromagnetic wave attenuation by frequency affect the outcome of these models.

An assumption of SIMSMOKE is that the spherical or conical clouds are completely opaque throughout their volumes. This applies regardless of the frequency of the electromagnetic waves attempting to penetrate the smoke. An algorithm which uses variables such as smoke particle sizes and available light could be added to provide varying degrees of obscuration either for visible light or other frequency waves such as near or far infrared.¹¹ This capability would be particularly useful for determining probabilities of detection and hit.

Another assumption of SIMSMOKE is that a WP round instantaneously assumes a spherical shape with a radius equal to the input bursting radius. Moreover, the cloud holds this constant shape as it drifts downwind. If empirical data were available on the smoke cloud growth as a function of time, a suitable equation could be added to the program which would enlarge the radius as the smoke drifted.

A final assumption which should be examined is that under inversion or neutral atmospheric stability conditions, drifting smoke clouds which meet hills do not move up the slopes, while under lapse conditions they do. Interaction between terrain and smoke needs further research,

This study demonstrates that tactical smoke employment can be a part of computerized combat models. SIMSMOKE provides a methodology and a base for future smoke modeling.

APPENDIX A. User's Guide

APPENDIX A. User's Guide

The purpose of this appendix is to provide the user with information necessary to execute SIMSMOKE as a subroutine to the terrain generating model, SIMTER. The entire program as listed in Appendix B, consists of the main program and six subroutines.

The main program, SIMTER, creates a random piece of terrain which represents the battlefield. It is up to the user to determine the size of the battlefield and to decide a general roughness of the terrain. This is explained in more detail in the input section.

The first subroutine, MOVLOS, moves a simulated armored vehicle along a predetermined route towards its objective. At one second intervals the program computes intervisibility between the vehicle and its enemy. Function RANORM, the last subroutine which is a basic part of SIMTER, creates random normal deviates for use in shaping the terrain.

Subroutine SMOKE, along with its own subroutines WPLOS and HCLOS, make up the SIMSMOKE package. Collectively these routines fire the simulated smoke rounds, move the smoke clouds downwind, and further determine intervisibility.

The final subroutine, DUMMY, is simply used to answer any call statements from SIMTER for which there is no answering program. In particular, programs CONTUR and PLT3D1 are two and three dimensional terrain plotting routines, respectively. These, or similar routines, can be particularly useful for examining the randomly created terrain and for determining routes to be used on this terrain. It is recommended that the user add plotting

packages which are best suited for his computer and plotting hardware.

Input

The input data may be considered to have three distinct groupings. The first ten cards pertain to the SIMTER terrain generation; the second group of ten cards pertains to the SIMSMOKE smoke representation; and the remaining cards provide the MOVLOS route selection and target size. A complete display of the data deck, to include variable names and formats, is pictured on the following page.

The material which follows is a complete list and explanation of the input variables:

SIMTER Variables

N is the number of hills to be placed randomly about the battlefield. As point of reference, the map shown in Figure 17 of the main text has 12 hills. That terrain may be considered as consisting of gently rolling hills.

ISEED, JSEED, KSEED are the seeds for the various random number generators used throughout the program.

XMEL, YMEL, HITE shape the N number of hills. XMEL and YMEL are the standard deviations in the X and Y directions of a modified bivariate normal distribution which shape each hill. HITE is the average altitude of the peaks of each hill. For this study the hills have a spread (standard deviation) of 300 meters in both the X and Y direction, and an average peak height of 100 meters.

RUFX, RUFY, RUFP are the standard deviations of a normal distribution. In order for the hills to be different from one another, their spreads and heights are permitted to vary normally around an average XMEL, YMEL, and HITE. Values used here are 20 meters for all three parameters.

RHO is the correlation coefficient of the modified bivariate normal distribution. Zero is usually the value provided; however, any value in the interval $(-1,1)$ may be used. The result will appear as hills rotated in the X, Y plane.

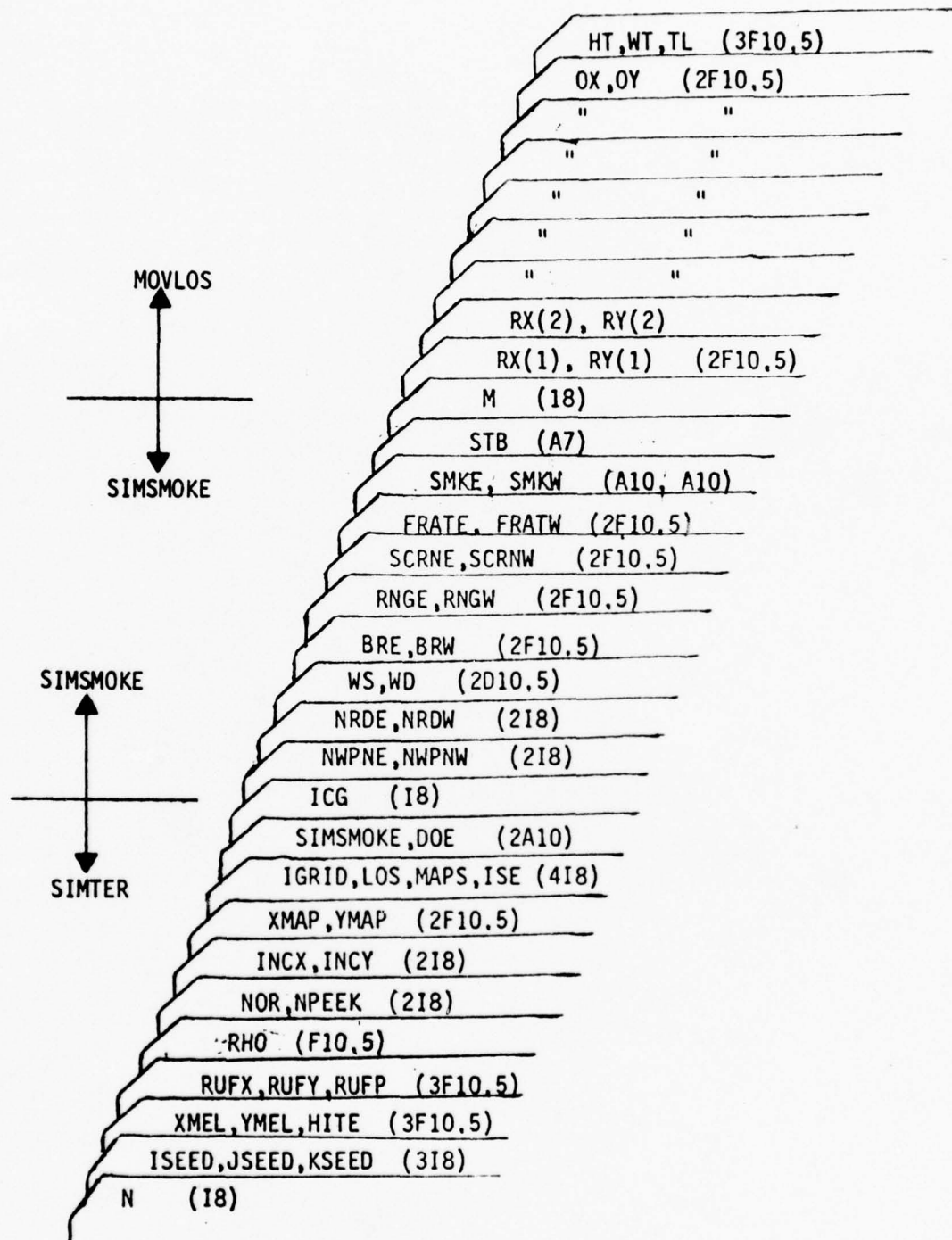

Figure A-1. Input Data Deck

NOR, NPEEK indicate whether the user desires to vary the shape of the hills as mentioned in RUFY, RUFY, and RUFY. The parameters are binary, with "1" being used throughout this study. NOR is for the spread and NPEEK is for the altitude.

INCX, INCY determine the size of the grid system for the terrain map if digitized terrain for plotting or other purposes is desired. To prevent the use of excessive amounts of core storage a grid system of no smaller than 100 by 100 meters is recommended.

XMAP, YMAP are the desired dimensions of the battlefield. Throughout this study, a battlefield of 6000 by 3000 meters has been used.

IGRID, LOS, MAPS, ISE determine the subroutines to be used. IGRID provides digitized terrain data (X,Y, and Z) for use with other models or for creating plots. LOS signals the program to call MOVLOS and determine intervisibility. MAPS indicates whether or not plots are desired, and ISE indicates that smoke is to be fired. Data values are either "0" or "1".

SIMSMOKE, DOE are sample titles for labelling the plots. Any letters may be used as long as they fit within the limits of the format.

SIMSMOKE Variables

ICG tells the SIMSMOKE program which side, if any, is to employ smoke. "0" indicates neither, "1" means only east, "2" only west, and "3" both sides.

NWPNE, NWPNW are the numbers of weapons to be used by east and west, respectively, to fire smoke rounds.

NRDE, NRDW are the numbers of smoke rounds to be fired by each side.

WS, WD are the wind speeds in meters per second and wind direction in radians.

BRE, BRW are the bursting radii of the smoke rounds of each side. These apply only to WP smoke. HC smoke is assumed to build up over time instead of exploding.

RNGE, RNGW are the ranges of each side's antitank weapons.

SCRNE, SCRNW are the widths of the smoke screens desired by each side.

FRATE, FRATW are the firing rates of each side's indirect fire weapons in number of rounds per second. For most runs this rate will be given as a fraction of a round.

SMKE, SMKW indicate which type of smoke each side will employ. Either HC or WHITE PHOS are the input variables.

STB is the atmospheric stability condition. The input variables are LAPSE, NEUTRAL, or INVERSE.

MOVLOS Variables

M is the number of turning points along the route of the attacker, to include the starting and ending points.

The next M number of cards are the X and Y coordinates of each turning point along the predetermined route selected by the user.

OX, OY are the fixed coordinates of the defender.

HT, WT, TL are the height, width and depth of the target in meters as seen by the defender. For this study 3, 3, and 6.5 were used.

Output

The output information available is discussed in Chapter IV. In order to suppress any part of this data, the user may simply remove the appropriate WRITE statement.

APPENDIX B. SIMSMOKE Program Listing

The listing in this appendix was written for use with the CDC 6500 computer which is operated by the TRADOC Data Processing Field Office, Fort Leavenworth, Kansas,

```

PROGRAM SIMTERR(INPUT,OUTPUT,TAP5,TAP6=INPUT,TAP6=OUTPUT)
C SIMTERR - TERRAIN SIMULATION
C
C
C EXPLANATION OF INPUT VARIABLES
C
C *N- NUMBER OF TERRAIN FEATURES (HILLS)
C *XMH, YMH- SPREAD OF HILLS (STD DEV FOR BIVARIATE NORMAL)
C *HTE- ELEVATION OF PEAKS OF HILLS
C *RUEX, RUEY, RUEH- IF THE SPREAD AND HEIGHT OF THE HILLS ARE TO BE
C NORMALLY DISTRIBUTED, THEN THESE PARAMETERS ARE THE STD DEV.
C *RHC- THE CORRELATION COEFFICIENT FOR THE BIVARIATE NORMAL HILLS
C *NOR- DETERMINES IF THE HILLS ARE TO BE CONSTANT IN SPREAD OR TO
C VARY NORMALLY (0=CONSTANT SPREAD, 1=NORMALLY SPREAD, 2=CIRCULAR
C NORMAL AND VARYING)
C *NRIG- DETERMINES NUMBER OF RIDGE LINES, IF ANY, (0,1,2,3)
C *NRPK- DETERMINES IF THE PEAKS OF THE HILLS SHOULD BE CONSTANT
C OR VARY NORMALLY (0=CONSTANT, 1=VARYING)
C *INX, INY- GRID INCREMENT FOR THE TERRAIN MATRIX
C *XMAP, YMAP- SIZE OF THE GRID SYSTEM (MAP) IN METERS
C *IGRID- DETERMINES IF A GRID SYSTEM IS DESIRED (0=NO, 1=YES)
C *LOC- DETERMINES IF THE LINE OF SIGHT ROUTINE IS TO BE CALLED
C *MAPS- DETERMINES IF MAPS ARE TO BE USED
C *N- NUMBER OF TURNING POINTS ALONG THE ROUTE OF THE TARGET
C *RX, RY- TURNING POINTS ALONG THE ROUTE OF TARGET
C *OX, OY- LOCATION OF OBSERVER
C *HT, WT, TL- HEIGHT, WIDTH, AND LENGTH OF THE TARGET
C
C DIMENSION XMU(50), YMU(50), SDX(50), SDY(50), XX(60), YY(30),
177(60,30), A7(50), ZMU(50), PEAK(50)
C DIMENSION KX(160), KY(160), RIZ(2), F(2), WK(50,30,3)
C DIMENSION TTL(2)
C DIMENSION CL(50)
C DIMENSION PX(10), PY(10)
C COMMON/FAFAC/IOG, MWENT, NUONW, NEDE, NROW, WS, WD, BFF, BRW,
10NGE, ENGW, SCEN, SCENW, FRATE, FRATW, SMKE, SMKW, STB
C COMMON/PAPRY/TA, TD, OFF, OFF, IOY, ITC, ISL, YOUN, YSUP, IO, JO, TMSK, TMSK
C LOGICAL TDN(60,30)
C REAL NO
C LOGICAL LTC(3)
C CALL TRNSET(200,300,-1.1,0,210)
C YOUN=0.0
C YSUP=0.0
C SC=2HND
C WD=2HND
100 FORMAT (I8)
101 FORMAT (8Y,TR,8Y,FR.3,8Y,FR.3,2X,FR.3,2X,FR.3,2X,FR.3,2X,FR.3)
102 FORMAT ("0",10Y,"CENTERS OF MOUNTAINS AND ELEVATIONS AT PEAKS")
103 FORMAT (8Y,F10.5,10X,F10.5,10Y,F10.5,/"0")
104 FORMAT (2TR)
105 FORMAT ("0",20Y,"MATRIX OF GRID SYSTEM VALUES")
106 FORMAT ("0",10Y,"X GRID Y GRID ELEVATION")
107 FORMAT (17X,F10.5,7X,F10.5,7X,F10.5)
108 FORMAT (2F10.5)

```

```

109 FORMAT(F10.5)
110 FORMAT(2A10)
111 FORMAT(3I9)
112 FORMAT(3F10.5)
113 FORMAT(11X,F8.3,2X,I8,2X,I8,2X,I8,2X,I8,2X,I8,2X,I8,2X,I8,2X,F8.3,2X,F8.7,
17"0")
114 FORMAT("0",14X,"N",8X,"M",4X,"H",4X,"FL",4X,"HIT",4X,"RUEX",
16X,"HUEX",4X,"DUEX")
115 FORMAT("0",13X,"T",8X,"H",4X,"HOF",4X,"SNOKE",4X,"DUEK",4X,"TNOX",
16X,"TNOY",4X,"XMAP",4X,"YMAP")
116 FORMAT("0",10X,3I1,/"0")
119 FORMAT(4I9)
159 FORMAT(I9)
160 FORMAT(2I9)
161 FORMAT(2F10.5)
162 FORMAT(A10,A10)
163 FORMAT(A7)
164 FORMAT("0",24X,"WEST",10X,"EAST")
171 FORMAT("0",1X,"WILL SLEELY SMOKE",6X,A4,10X,A4)
172 FORMAT("0",1X,"NUMBER OF CIGETS",4X,I4,10X,I4)
173 FORMAT("0",1X,"NUMBER OF CIGARS",3X,I4,10X,I4)
174 FORMAT("0",1X,"PUSHTING RADIUS",5X,F8.4,5X,F8.4)
155 FORMAT("0",1X,"FIFTING RATE",9X,F8.4,5X,F8.4)
156 FORMAT("0",1X,"SCREEN SIZE",9X,F8.4,5X,F8.4)
157 FORMAT("0",1X,"RANGE OF AGE WONG",1X,F10.4,3X,F10.4,/"0")
271 FORMAT(10Y,F10.5)
272 FORMAT(120Y,F10.5)
READ(9,100)N
READ(9,111)T000,ISEED,KSTED
READ(9,112)XNFL,YNFL,HITE
READ(9,112)RUEX,RUEY,RUEP
READ(9,100)PHO
READ(9,104)N09,FR0EK
READ(9,104)TNOX,TNOY
READ(9,108)XMAP,YMAP
READ(9,110)T000,LOG,MARS,ISF
READ(9,110)(TTL(I),I=1,2)
IF(T00.EQ.0)GO TO 37
READ(9,159)ICG
READ(9,160)NWONG,NWONW
READ(9,160)NEOR,NENW
READ(9,161)NS,WE
READ(9,161)R0E,FRW
READ(9,161)ONCE,PNOW
READ(9,161)SEINE,COENW
READ(9,162)SMKE,SMKW
READ(9,163)STR
IF(T06.EQ.1)NS=3HYE
IF(T06.EQ.3)NS=3HYE
IF(T06.EQ.2)NO=3HYE
IF(T06.EQ.3)NO=3HYE
C NEXT EIGHT STATEMENTS INITIALIZE SMOKE SURROUTINE COUNTERS
37 T00=

```

```

TO=0
JO=0
TA=2
CPR=1.0
CPE=0.0
ICT=1
ITC=1
WRITE(6,116)ISFEQ,JSFEQ,KFEQ
WRITE(6,114)
WRITE(6,101)N,XMEL,YMEL,HITS,HEX,UEY,UEP
WRITE(6,115)
WRITE(6,113)RHO,NOF,ISE,NOFEK,INCX,INCY,XMAP,YMAP
IF(ISO.EQ.0)GO TO 2
WRITE(6,158)
WRITE(6,171)NO,ES
WRITE(6,172)NUPRN,UNENC
WRITE(6,173)NCOM,NODE
WRITE(6,175)RUM,RE
WRITE(6,155)ELATU,ELAT
WRITE(6,156)SOLNW,SOLNE
WRITE(6,157)RNGM,ENGE
C THIS PORTION OF THE PROGRAM DETERMINES THE CENTER OF
C MASS OF THE MOUNTAINS (XY PLANE)
2 DO 9 L=1,N
C RANDOM NUMBER CALL STATEMENT DEPENDS UPON TYPE COMPUTER
  YMU(L)=YMAP*FRNF(C)
  9 CONTINUE
C RANDOM NUMBER CALL STATEMENT DEPENDS UPON TYPE COMPUTER
  CALL RANSET(JSFEQ)
  6 DO 10 I=1,N
  YMU(I)=YMAP*FRNF(C)
  10 CONTINUE
C THIS PORTION OF THE PROGRAM COMPUTES THE PEAKS OF THE MOUNTAINS
  IF(NOF.EQ.0) GO TO 11
  IF(NOF.EQ.2) GO TO 26
  DO 12 I=1,N
  SOX(I)=XMEL+RUEY*RANOM(ZY)
  SOY(I)=YMEL+RUEY*RANOM(ZY)
  12 CONTINUE
  GO TO 14
  26 DO 27 IL=1,N
  SOX(IL)=XMEL+RUEX*RANOM(ZY)
  SOY(IL)=SOX(IL)
  27 CONTINUE
  GO TO 14
  11 DO 17 J=1,N
  SOX(J)=XMEL
  SOY(J)=YMEL
  13 CONTINUE
  14 IF(NFEK.EQ.0) GO TO 22
  DO 21 J=1,N
  PEAK(J)=HITS+RUPR*RANOM(ZY)
  21 CONTINUE
  GO TO 24

```

```

22 DO 23 K=1,N
    PEAK(K)=HITS
23 CONTINUE
24 WRITE (6,102)
    DO 15 K=1,N
    WRITE(6,103)XMU(K),YMU(K),PEAK(K)
15 CONTINUE
    IF(LCS.EQ.0)GO TO 33
    READ(9,100)M
    READ(9,106)(RX(I),RY(I),I=1,M)
    READ(9,108)OX,OY
    READ(9,112)HT,WT,TL
    CALL MOVLC(RX,RY,M,N,XMU,YMU,SDX,PEAK,OY,OY,HT,WT,TL)
33 IF(IGRID.EQ.0)GO TO 32
C THIS PORTION OF THE PROGRAM SETS UP THE GRID SYSTEM
C AND MATRIX OF COORDINATES AND ELEVATION
    NROW=XMAP/INCY
    NCOL=YMAP/INCY
    XY(1)=0.0
    YY(1)=0.0
    DO 16 K=2,NROW
    XY(K)=XY(K-1)+INCY
16 CONTINUE
    DO 17 L=2,NCOL
    YY(L)=YY(L-1)+INCY
17 CONTINUE
    WRITE(6,105)
    WRITE(6,106)
C THIS PORTION OF THE PROGRAM CREATES TERRAIN FEATURES (HILLS)
C BY USING A MODIFIED BIVARIATE NORMAL DISTRIBUTION.
    DO 18 II=1,NROW
    X=XY(II)
    DO 19 JJ=1,NCOL
    Y=YY(JJ)
30 Z=0.0
    IF(NCS.EQ.2) GO TO 28
    DO 20 J=1,N
    FA=PEAK(J)
    FB=1.0/(2.0*(1.0-1.0*PHO))
    FC=((X-XMU(J))/SDX(J))**2
    FD=(2.0*PHO*(X-XMU(J))*(Y-YMU(J)))/(SDX(J)*SDY(J))
    FE=((Y-YMU(J))/SDY(J))**2
    A7(J)=FA*EXP(-FB*(FC-FD+FE))
    IF(A7(J).GT.Z)Z=A7(J)
20 CONTINUE
    GO TO 31
28 DO 22 J=1,N
    A7(J)=PEAK(J)*EXP(-((Y-XMU(J))**2+(Y-YMU(J))**2)/(2.*SDX(J)**2))
    IF(A7(J).GT.Z)Z=A7(J)
29 CONTINUE
31 IF(7.LT.00001)Z=0.0
    ZZ(II,JJ)=Z
19 CONTINUE
18 CONTINUE

```

```
C THIS PORTION OF THE PROGRAM SETS UP AND PRODUCES A THREE DIMENSIONAL
C PLOT USING PLT3D1.
C
C THIS PORTION OF THE PROGRAM SETS UP AND CALLS FOR
C A THREE DIMENSIONAL PLOT
  IF(MARS.EQ.0) GO TO 32
  ALPHA=30.
  BETA=45.
  F(1)=1.0E4
  F(2)=1.0E4
  SIZE(1)=8.
  SIZE(2)=4.
  JKXY=160
  LINES=0
  CALL PLT3D1(XX,NROW,YY,NCOL,ZZ,ALPHA,BETA,F,TTL,SIZE,WK,ICN,KX,
  1KY,JKXY,LINES)
C
C THIS PORTION OF THE PROGRAM SETS UP AND PRODUCES A TWO DIMENSIONAL
C CONTOUR PLOT
  CL(1)=0.0
  DO 25 IK=2,50
  CL(IK)=CL(IK-1)+50.0
25 CONTINUE
  NL=25
  IW=3
  IH=6
  LTG(1)=.FALSE.
  LTG(2)=.TRUE.
  LTG(3)=.FALSE.
  CALL CONTUR(ZZ,NROW,NCOL,NROW,CL,NL,TTL,IW,IH,LTG)
32 STOP
  END
C
```



```
FUNCTION RANORM(Z)  
CALL RANGET(ISEED)  
Y=RANF(A)  
Y=RANF(B)  
RANORM=(SORT(-2.0*ALOG(Y)))*SIN(6.2832*Y)  
RETURN  
END
```

```

SUBROUTINE MOVLOS(RX,RV,N,N,XMU,YMU,SDX,PEAK,OX,OY,HT,WT,TL)
  DIMENSION RX(10),RY(10),XMU(50),YMU(50),SDX(50),BZ(50),PEAK(50),
  1YI(50),YI(50),CZ(50),FZ(50)
  DIMENSION UNC(30),SOY(50)
  COMMON/FARMER/ICG,NWPNF,NWPNW,NPDF,NRDW,WS,WD,BRF,BRW,
  1RNGE,RNGW,SCPNE,SCPNW,FRATE,FRATW,SMKE,SMKW,STB
  COMMON/PAPPY/IA,IR,DR,DRF,ICT,ITC,ISE,YCUM,YSUM,IQ,JO,TMSK,TNSK
  INTEGER TYP,SMK,STB
  REAL NEUTRAL,INVEPS,LAESE
120 FORMAT("0",20X,"PER CENT VISIBLE= ",F10.5)
130 FORMAT("0",4X,"TIME",4X,"MAP COORDINATES",3X,"ELEVATION",2X,
  1" SPEED",3X,"VISPER",3X,"< EXPOSED",2X,"TGT EXPOSED")
140 FORMAT(3X,I5,2X,F8.3,2X,F8.3,2X,F9.5,2X,F6.3,5X,I3,5X,F8.3,3X,
  1FA,3)
150 FORMAT("0",20X,"OBSERVER COORDINATES")
158 FORMAT(3X,I5,2X,F8.3,2X,F8.3,2X,F9.5,2X,F6.3,5X,I3,5X,F8.3,3X,
  1F8.3,2X,I5,2X,I5,2X,I3)
160 FORMAT(10X,F10.5,2X,F10.5,2X,F10.5,/"0")
149 FORMAT(2X,F6.3,1X,F6.3,1X,F6.7,1X,F6.3,1X,F6.3,1X,F6.3)
151 FORMAT("0",3X,"DISTANCE",4X,"DISTANCE",4X,"TOTAL",5X,
  1"AVG DISTANCE",3X,"PER CENT TIME")
152 FORMAT(3X,"UNCOVERED",3X,"COVERED",4X,"DISTANCE",3X,
  1"INTERVISIBLE",3X,"INTERVISIBLE")
153 FORMAT(4X,F8.3,3X,F8.3,3X,F8.3,5X,F8.3,7X,F8.3)
154 FORMAT("0",10X,"INTERVISIBILITY SEGMENT LENGTHS")
155 FORMAT(12X,I8,5X,F8.3)
164 FORMAT("0",4X,"TIME",4X,"MAP COORDINATES",3X,"ELEVATION",2X,
  1" SPEED",3X,"VISPER",3X,"< EXPOSED",2X,"TGT EXPOSED",2X,"RD# F",
  22X,"RD# W",2X,"VISMOK")
  TMSK=0.0
  TNSK=0.0
  IT=1
  VFL=0.0
  KJ=0
  ISEE=0
  COCV=0.0
  CUNC=0.0
  CSUM=0.0
  DSUM=0.0
  J=0
  K=1
C ELEVATION OF OBSERVER
  F7=0.0
  DO 38 I=1,N
  FEYP=((OY-XMU(I))**2+(OY-YMU(I))**2)/(2.*SDX(I)**2)
  FZ(I)=PEAK(I)*EXP(-FEYP)
  IF(F7(I).GT.EZ)EZ=FZ(I)
38 CONTINUE
  WRITE(6,150)
  WRITE(6,160)OX,OY,FZ
  IF(ISE.EQ.0)GO TO 91
  WRITE(6,164)
  GO TO 92
91 WRITE(6,130)

```

```

92 DO 35 IR=2,M
  THETA=ATAN((PY(IR)-PY(IR-1))/(PX(IR)-PX(IR-1)))
  X=PX(IR-1)
  Y=PY(IR-1)
36 DOT=SQRT((Y-OY)**2+(Y-OY)**2)
C
C
C THIS PORTION OF MOVLOS COMPUTES LINES OF SIGHT
  Z=0.7
C ELEVATION OF TARGET
  DO 37 J=1,N
    DEXP=((X-XMU(J))**2+(Y-YMU(J))**2)/(2.*SDX(J)**2)
    BZ(J)=PEAK(J)*EXP(-DEXP)
    IF(BZ(J).GE.Z)Z=BZ(J)
    IF(BZ(J).GE.Z)L=J
37 CONTINUE
  SLOP=(Y-OY)/(X-OX)
  DZ=0.0
C HEIGHT OF TERRAIN AT INTERSECTION
  DO 39 I=1,N
    SDY(I)=SDY(I)
    IF(XMU(I).LT.OX)GO TO 39
    IF(XMU(I).GT.X)GO TO 39
    XI(I)=(SLOP**2*OX-SLOP*OY+XMU(I)+SLOP*YMU(I))/(1.+SLOP**2)
    YI(I)=SLOP*(XI(I)-OX)+OY
    FEXP=((XI(I)-XMU(I))**2+(YI(I)-YMU(I))**2)/(2.*SDX(I)**2)
    CZ(I)=PEAK(I)*EXP(-FEXP)
    IF(CZ(I).GE.DZ)DZ=CZ(I)
    IF(CZ(I).GE.DZ)KL=I
39 CONTINUE
C HEIGHT OF OBSERVER-TARGET LINE AT INTERSECTION
  ZNUM=SQRT((XI(KL)-OX)**2+(YI(KL)-OY)**2)
  HLIN=ZNUM*ABS(Z-FZ)/DOT
  IF(HLIN.GT.DZ)JSEE=JSEE+1
  JSEE=0
  IF(HLIN.GT.DZ)JSEE=1
  IF(JSEE.EQ.0)GO TO 61
  NSEE=JSEE
  PHI=ATAN(ABS(Y-OY)/(ABS(X-OX)))
  CALL SMOKE(X,Y,Z,OX,OY,EZ,JSEE,PX,PY,TP,XMU,YMU,SDX,SDY,N,PEAK,
1PHI)
61 PCFX=0.0
  HD=HLIN-DZ
  IF((HD.GE.0.).AND.(HD.LE.HT))PCFX=HD/HT
  IF(HD.GT.HT)PCFX=1.0
  FPS=ARS(THETA)
  A=PHT-FPS
  IF(FPS.GT.PHI)A=FPS-PHI
  B=1.570796-A
  TA=TL*COB(A)
  TB=WT*COB(A)
  FFL=TA+TB
  EYA=PCFX*HT*EFL
  PXC=PCFX*100.0

```

```

IF(TSEE.EQ.0)GO TO 58
WRITE(6,158)IT,X,Y,Z,VEL,NSFF,FXC,EXA,IA,IS,JSEF
GO TO 59
58 WRITE(6,140)IT,X,Y,Z,VEL,JSEF,FXC,EXA
59 KJ=KJ+1
CX=PEAK(L)*(X-XMU(L))/SDX(L)**2
CY=PEAK(L)*(Y-YMU(L))/SDY(L)**2
CFYP=((X-XMU(L))**2+(Y-YMU(L))**2)/(2.*SDX(L)**2)
PX=CX*EXP(-CFXP)
PY=CY*EXP(-CFYP)
DEL=PX*COS(THETA)+PY*SIN(THETA)
VEL=9.0-4.0*DEL
DIST=VEL
IT=IT+1
IF(JSEF.EQ.0) GO TO 41
J=J+K
DUNC=DUNC+DIST
UNC(J)=DUNC
K=0
41 DSUM=DSUM+DIST
IF(JSEF.EQ.0)K=1
IF(JSEF.EQ.0)DUNC=0.
X=X-DIST*COS(THETA)
Y=Y-DIST*SIN(THETA)
IF(X.LE.RX(IP))GO TO 35
GO TO 36
35 CONTINUE
JK=J
VISPER=FLOAT(TSEE)/FLOAT(KJ)
WRITE(6,154)
DO 42 J=1,JK
SUNC=SUNC+UNC(J)
WRITE(6,155)J,UNC(J)
42 CONTINUE
DOCV=DSUM-SUNC
AVTN=SUNC/FLOAT(J)
WRITE(6,151)
WRITE(6,152)
WRITE(6,153)SUNC,DOCV,DSUM,AVTN,VISPER
53 RETURN
END

```

```

SUBROUTINE SMOKE(X,Y,Z,OX,OY,OZ,JSEF,RX,RY,IP,XMU,YMU,SOX,SOY,N,
1PEAK,PHI)
C XMU, YMU, SOX, SOY, N, PEAK, AND PHI ARE SIMTER VARIABLES.
C REMOVE FROM CALLING STATEMENT AND DIMENSION STATEMENT IF USING
C SIMSMOKE WITH OTHER TERRAIN/MOVEMENT PROGRAM
  DIMENSION XMU(50),YMU(50),SOX(50),SOY(50),PEAK(50),RX(10),RY(10),
1YFD(110),YFD(110),ZPD(110),ZPD(110),XDR(110),YDR(110),ZDF(110),XHC(110),
2YHC(110),ZHC(110),XCH(110),YCH(110),ZCH(110)
  REAL NEUTRAL,INVERSE,LAPSE
  COMMON/PAPRY/TA,IP,OPR,OPR,ICD,ITC,ISE,YCUM,YSUM,IQ,JO,TMSK,TNSK
  COMMON/FAPWR/ICG,NWRNE,NWRPW,NRDE,NRDW,WS,WD,BPE,BPW,
1RNGE,RNGW,SCPNE,SCPnw,FRATE,FRATW,SMKE,SMKW,STR
  INTEGER TYP,SMK,STR
1110 FORMAT(1X,F10.5)
1001 FORMAT("0",20X,"HEADWIND PUTS SMOKE ON OWN FORCES IN ATTACK")
1002 FORMAT("0",1X,"SMOKE DRIFTING ON TO OWN POSITION")
1100 FORMAT("0",1X,"TOO WINDY FOR SMOKE")
C
C COMMAND GUIDANCE
C   ICG=0  NEITHER SIDE USES SMOKE
C   ICG=1  ONLY EAST USES SMOKE
C   ICG=2  ONLY WEST USES SMOKE
C   ICG=3  BOTH SIDES USE SMOKE
  IF(ICG.EQ.2) GO TO 5
  IF(ICG.EQ.0) RETURN
C ***** EAST ***** USES ***** SMOKE *****
C
C TYPE OF OPERATION
C
  TYP=7HOFFENSE
  TVL=RX(IP-1)-RX(IP)
  IF(TVL.LT.0.0) TYP=8HWTHDRAW
  IF(TVL.EQ.0.0) TYP=7HDEFENSE
C WEATHER
C
  IF(WS.GT.8.0)WRITE(6,1100)
  DIF=PHI-WD
  IF((TYP.EQ.7HOFFENSE).AND.(DIF.GT.4.36).AND.(DIF.LT.5.06).AND.(WS
1.GT.1.5)) GO TO 6
  GO TO 7
6 WRITE(6,1001)
  RETURN
C CHECK STABILITY CONDITIONS
7 ZV=0.0
  IF(STR.EQ.7HNEUTRAL) ZV=2.0
  IF(STR.EQ.5HLAPSE) ZV=4.0
C
C
C WEAPONS AVAILABLE (EXTERNAL GUIDANCE)
C FUTURE DEVELOPMENTS WILL DICTATE EXPANSION OF THIS SECTION
C
C AMMUNITION AVAILABLE
C NUMBER OF BOUNDS AVAILABLE IS NRDF
  IF(TA.GE.NRDE) GO TO 24

```



```

      GO TO 25
24 IF (TA.GE.NRDE)IQ=IA
    IA=0
    RETURN
C   TYPE OF SMOKE AVAILABLE (SMKE)
C
C** THIS PART OF THE PROGRAM COMPUTES LINE OF SIGHT FOR THE EAST USING
C   SMOKE IN THE OFFENSE
25 IF (TYP.FO.7HDEFENSE)RETURN
    IF (IQ.GE.NRDE)RETURN
C   DETERMINE WHEN TO FIRE
    RHPY=SQRT((OX-X)**2.0+(OY-Y)**2.0)
    IF (RHPY.GT.PNGW)GO TO 5
    IF (RHPY.LT.100.0)GO TO 5
C   SMOKE IS SHUT OFF WHEN ATTACKER GETS WITHIN 100 METERS OF IMPACT
C   FIRST FIND CENTER OF MASS OF SHEAF
C   DETERMINE WHERE TO FIRE SMOKE
C   ALL SHEAF ARE ORIENTED NORTH-SOUTH
C   SHEAFS ARE FIRED 50 METERS IN FRONT OF ENEMY POSITION
C   POSITION OF SHEAF (ALONG Y AXIS) IS DETERMINED BY WIND DIRECTION
C   FIRST DO HW,TW, AND CALM (ONE CASE)
    9 XS=OY+50.0
    IF ((WS.LT.1.5).OR.((WD.GT..785).AND.(WD.LT.2.35)).OR.((WD.GT.3.927
1) .AND.(WD.LT.5.49)))YSTH=OY-SCRNE/2.0
C   THIS PORTION COMPUTES SHEAF LOCATION FOR CROSSWINDS
    IF ((WD.GF.5.49).OR.(WD.LF..785))YSTH=OY
    IF ((WD.GF.2.35).AND.(WD.LF.3.92))YSTH=OY-SCRNE
C   COMPUTE INDIVIDUAL IMPACT POINTS
20 TMSK=TMSK+1.0
    IF (TMSK.FO.1.0) GO TO 11
    GO TO 12
C   (XPD(I),YPD(I)) ARE COORDINATES OF THE IMPACT OF THE ITH ROUND.
11 DO 9 I=1,NWPNE
    XFD(I)=XS
    YCUM=YCUM+SCRNE/NWPNE
    YPD(I)=YSTH+YCUM-(SCRNE/NWPNE)/2.
C   THE NEXT EIGHT STATEMENTS COMPUTE THE ALTITUDE OF THE
C   SMOKE ROUND IMPACT POINT. THESE ARE BASED ON SIMTER
C   DATA. CHANGE FOR USE WITH OTHER PROGRAMS.
    ZZR=0.0
    DO 10 J=1,N
    ZPEX=((XPD(I)-XMU(J))**2.+(YPD(I)-YMU(J))**2.)/(2.*SDX(J)*
1SDY(J))
    ZRT=PEAK(J)*EXP(-7REX)
    IF (ZPT.GF.ZZR)ZZR=ZRT
10 CONTINUE
    ZPD(I)=ZZR
    9 CONTINUE
    IA=NWPNE
    GO TO 83
C
C   FIRST BATTERY/PLATOON ROUNDS WILL ARRIVE SIMULTANEOUSLY
C   SUCCEEDING ROUNDS ARRIVE AT DESIGNATED FIRING RATES
12 CFR=CFR+FRATE

```

```

IF(CFR.LE.IGI) GO TO 83
IA=IA+1
YPD(IA)=XS
C  RANDOM NUMBER CALL STATEMENT DEPENDS UPON TYPE COMPUTER
YPD(IA)=YSTH+SCRNE*RAMF(B)
C  THE NEXT EIGHT STATEMENTS COMPUTE THE ALTITUDE OF THE
C  SMOKE ROUND IMPACT POINT.  THESE ARE BASED ON SIMTER
C  DATA.  CHANGE FOR USE WITH OTHER PROGRAMS.
ZZR=0.0
DO 14 J=1,N
ZPEX=((XRD(IA)-XMU(J))**2.+(YPD(IA)-YMU(J))**2.)/(2.*SDX(J)*
1SDY(J))
ZPT=PEAK(J)*EXP(-ZPEX)
IF(ZPT.GE.ZZR)ZZR=ZPT
14 CONTINUE
ZPD(IA)=ZZR
C  ALL ROUNDS NOW HAVE IMPACT COORDINATES FOR HW,TW, OR CALM
C  IF SLOPE AT IMPACT IS DESIRED, INSERT CALCULATIONS HERE
C
83 IF(SMKE.EQ.10HWHITE PHOS) GO TO 21
IF(TMSK.GT.1.0) GO TO 54
DO 53 I=1,NWPNF
YHC(I)=XRD(I)
YHC(I)=YPD(I)
ZHC(I)=ZRD(I)
53 CONTINUE
GO TO 55
54 YHC(I)=XPD(IA)
YHC(I)=YRD(IA)
ZHC(I)=ZPD(IA)
55 RPD=RPE
CALL HCLOS(X,Y,Z,OX,OY,OZ,XRD,YPD,ZPD,JSEE,IA,TMSK,XHC,YHC,ZHC,
1RPD)
GO TO 51
21 CALL WPLOS(X,Y,Z,OX,OY,OZ,XRD,YPD,ZRD,RPE,JSEE,IA,TMSK)
C  MOVE THE SMOKE CLOUDS DOWNWIND
51 IK=TMSK+1
IJ=TMSK
DO 17 I=1,IA
XRD(I)=XRD(I)-WS*SIN(WD)
YPD(I)=YPD(I)-WS*COS(WD)
ZPD(I)=ZPD(I)+ZV
17 CONTINUE
C  ASSUMPTION: IF THE SMOKE CLOUD STRIKES TERRAIN IT WILL ASSUME THE
C  TERRAIN ALTITUDE IF STABILITY CONDITION IS LAPSE.
IF((STB.EQ.7HINVERSE).OR.(STB.EQ.7HNEUTRAL)) GO TO 81
ZZP=0.0
DO 18 I=1,IA
DO 19 J=1,N
ZREX=((XPD(I)-XMU(J))**2.+(YRD(I)-YMU(J))**2.)/(2.*SDX(J)*
1SDY(J))
ZPT=PEAK(J)*EXP(-ZREX)
IF(ZPT.GE.ZZP)ZZP=ZPT
19 CONTINUE

```

```

      IF (ZRD(I).LT.ZZR) ZRD(I)=ZZR
18  CONTINUE
81  IF (ICR.GT.ICT) ICT=ICT+1
C   THIS COMPLETES FAST IN THE OFFENSE USING SMOKE.
C   FAST IN THE DEFENSE IS NOT PLAYED BECAUSE ENEMY IS ALSO IN DEF.
C
C ***** WEST ***** USES ***** SMOKE *****
C
C   REPLACE OX WITH Y TO SHIFT IMPACT POINTS FROM IN FRONT
C   OF WEST TO ON TOP OF EAST LEAD ELEMENT.
      5  OA=X
      IF (ICG.EQ.1) RETURN
C
C   TYPE OF OPERATION -- WEST ALWAYS IN THE DEFENSE
C
C WEATHER
      IF (WS.GT.8.0) WRITE (6,1100)
C   CHECK STABILITY CONDITIONS
      ZV=0.0
      IF (STR.EQ.7) NEUTRAL) ZV=2.0
      IF (STR.EQ.5) HLAPSE) ZV=4.0
C
C WEAPONS AVAILABLE (EXTERNAL GUIDANCE -- NWPW)
C
C AMMUNITION AVAILABLE (EXTERNAL GUIDANCE -- NROW)
      IF (TR.GE.NROW) GO TO 41
      GO TO 42
41  IF (IR.GE.NROW) JC=TR
      IR=0
      RETURN
C   TYPE OF SMOKE AVAILABLE (SMKW)
C
C ***** THIS PART OF THE PROGRAM COMPUTES LINE OF SIGHT FOR WEST USING
C   SMOKE IN THE DEFENSE *****
C
C   DETERMINE WHEN TO FIRE
42  PHYP=SQRT((OX-X)**2.0+(OY-Y)**2.0)
C   SMOKE IS FIRED WHEN FAST REACHES MAX EFFECTIVE RANGE OF WEST ATGM
      IF (PHYP.GT.RNGW) GO TO 100
C   SMOKE IS SHUT OFF WHEN ENEMY NEARS DEFENSIVE POSITIONS (150)
      IF (PHYP.LT.150.0) GO TO 100
C   CHECK FOR WIND FROM THE EAST WHICH WOULD DRIFT SMOKE INTO DEFENDER
C   POSITION, THEREBY NEGATING ITS USEFULNESS.
      IF ((WD.LT.2.35).AND.(WD.GT..785)) GO TO 87
      GO TO 84
87  WRITE (6,1002)
      RETURN
84  XS=X
C   DETERMINE WHERE TO FIRE
C   CENTER OF MASS OF SHEAF IS ON LEAD ELEMENT AT MAX EFFECTIVE RANGE
      XS=Y
      YS=Y
C
C   COMPUTE INDIVIDUAL IMPACT POINTS
      YSTH=YS-SCRNW/2.0

```

```

TNSK=TNSK+1.0
IF(TNSK.EQ.1.0)GO TO 30
GO TO 31
30 DO 33 I=1,NWPNW
  XDP(I)=YS
  YSUM=YSUM+SCRNW/NWPNW
  YDP(I)=YSTH+YSUM-(SCRNW/NWPNW)/2.
C THE NEXT EIGHT STATEMENTS COMPUTE THE ALTITUDE OF THE
C SMOKE ROUND IMPACT POINT. THESE ARE BASED ON SIMTER
C DATA. CHANGE FOR USE WITH OTHER PROGRAMS.
  ZZF=0.0
  DO 34 J=1,N
    ZFEF=((YDP(I)-XMU(J))**2.+(YDP(I)-YMU(J))**2.)/(2.*SDX(J)*SDY(J))
    ZRT=FFAK(J)*EXP(-ZFEF)
    IF(ZRT.GE.ZZF)ZZF=ZRT
  34 CONTINUE
  ZDP(I)=ZZF
33 CONTINUE
  IR=NWPNW
  GO TO 35
C FIRST BATTERY/PLATOON ROUNDS WILL ARRIVE SIMULTANEOUSLY
C SUCCEEDING ROUNDS ARRIVE AT DESIGNATED FIRING RATES
31 CRF=CRF+FFATW
  IF(CRF.LE.ITC) GO TO 35
  IB=IB+1
  XDP(IR)=XS
C RANDOM NUMBER CALL STATEMENT DEPENDS UPON TYPE COMPUTER
  YDP(IR)=YSTH+SCRNF*FANE(IB)
C THE NEXT EIGHT STATEMENTS COMPUTE THE ALTITUDE OF THE
C SMOKE ROUND IMPACT POINT. THESE ARE BASED ON SIMTER
C DATA. CHANGE FOR USE WITH OTHER PROGRAMS.
  ZZR=0.0
  DO 36 J=1,N
    ZREX=((YDP(IR)-XMU(J))**2.+(YDP(IR)-YMU(J))**2.)/(2.*SDX(J)*
    1SDY(J))
    ZRT=FFAK(J)*EXP(-ZREX)
    IF(ZRT.GE.ZZR)ZZR=ZRT
  36 CONTINUE
  ZDP(IR)=ZZR
C ALL ROUNDS NOW HAVE IMPACT COORDINATES
C
35 IF(SMKW.EQ.10)WHITE PHOS) GO TO 37
  IF(TNSK.GT.1.0) GO TO 56
  DO 57 I=1,NWPNW
    XCH(I)=XDP(I)
    YCH(I)=YDP(I)
    ZCH(I)=ZDP(I)
  57 CONTINUE
  GO TO 58
  56 XCH(I)=XDP(IR)
    YCH(I)=YDP(IR)
    ZCH(I)=ZDP(IR)
  58 RDD=RRW

```

```

      CALL HCOLG(X,Y,Z,OX,OY,OZ,XDR,YDR,ZDR,JSEL,IP,TNSK,XCH,YCH,ZCH,
1880)
      GO TO 52
*7 CALL WPLOS(X,Y,Z,OX,OY,OZ,XDR,YDR,ZDR,BRW,JSEL,IB,TNSK)
C   MOVE THE SMOKE CLOUDS DOWNWIND
52 IK=TNSK+1
   TI=TNSK
   DO 38 I=1,IP
   XDR(I)=XDR(I)-WS*SIN(WD)
   YDR(I)=YDR(I)-WS*COS(WD)
   ZDR(I)=ZDR(I)+7V
38 CONTINUE
C   ASSUMPTION: IF THE SMOKE CLOUD STRIKES TERRAIN IT WILL ASSUME THE
C   TERRAIN ALTITUDE IF STABILITY CONDITION IS LAPSE
   IF((STR.EQ.7HINVERSE).OR.(STR.EQ.7HNEUTRAL)) GO TO 84
   ZZR=0.0
   DO 39 J=1,IB
   DO 40 J=1,N
   ZPEX=((XDR(I)-XMU(J))**2.+(YDR(I)-YMU(J))**2.)/(2.*SDX(J)*SDY(J))
   ZRT=PEAK(J)*EXP(-ZPEX)
40 CONTINUE
   IF(ZDR(I).LT.ZZR) ZDR(I)=ZZR
39 CONTINUE
C   THIS COMPLETES WEST IN THE OFFENSE
85 IF(ORF.GT.ITC) ITC=ITC+1
100 RETURN
      END

```



```

SUBROUTINE WPLOS(X,Y,Z,OX,OY,OZ,XPD,YPD,ZPD,BRE,JSEF,IA,TMSK)
DIMENSION XRD(150),YRD(150),ZRD(150),TT(150)
C
C LINE OF SIGHT MUST BE COMPUTED FOR EACH ROUND
C LOS IS COMPUTED BY SEEING IF THE O-T LINE PASSES AT A CLOSER DIST-
C ANCE TO THE CENTER OF THE SMOKE CLOUD THAN ITS OUTER SURFACE.
C THIS IS ACCOMPLISHED BY CONSTRUCTING A LINE FROM THE CENTER OF
C THE SMOKE CLOUD PERPENDICULAR TO THE OT LINE. THIS DISTANCE IS
C COMPARED WITH THE RADIUS OF THE CLOUD
C
      B1=OX-X
      B2=OY-Y
      B3=OZ-Z
      IK=TMSK
      DO 15 I=1,IA
      HYPT=SQRT(B1*B1+B2*B2+B3*B3)
      AT=SQRT((XRD(I)-X)**2.+(YRD(I)-Y)**2.+(ZRD(I)-Z)**2.)
      BT=SQRT((XPD(I)-OX)**2.+(YPD(I)-OY)**2.+(ZPD(I)-OZ)**2.)
      ST=(AT+BT+HYPT)/2.
      SLFN=(2./HYPT)*(SQRT(ST*(ST-AT)*(ST-BT)*(ST-HYPT)))
      KSEE=1
      IF(SLFN.LE.BRE)KSEE=0
C NOTE! IF THE SMOKE CLOUD IS TO GROW OVER TIME, REPLACE BRE W/ A FON
      IF((XPD(I).LE.OX).OR.(XRD(I).GT.X))KSEE=1
      TF(KSEE.EQ.0) JSEF=0
      IF(KSEE.EQ.0) RETURN
15 CONTINUE
      RETURN
      END

```

```

SUBROUTINE HCLOS(X,Y,Z,OX,OY,OZ,XRD,YPD,ZPD,JSEE,IA,TMSK,XHC,YHC,
1ZHC,RRD)
DIMENSION XHC(150),YHC(150),ZHC(150),XRD(150),YRD(150),ZRD(150)
COMMON/FARMER/ICG,NWFNE,NWPNW,NRDF,NRDW,WS,WD,BRE,BRW,
1RNRF,RNGW,SCRNF,SCRNW,FRATE,FRATH,SMKE,SMKW,STB
C LINE OF SIGHT MUST BE COMPUTED FOR EACH ROUND.
C EACH ROUND PRODUCES A CONE OF SMOKE WHICH HAS ITS FOCUS AT THE
C POINT OF IMPACT. THE CONE EXPANDS DOWNWIND OF THIS POINT. BOTH
C THE RADIUS AND THE LENGTH OF THE CONE ARE A FUNCTION OF WIND SPEED.
C THIS SUBROUTINE CHECKS FOR AN INTERSECTION OF THE O-T LINE AND
C ONE OF THE CONES
C
A=X-OX
B=Y-OY
C=Z-OZ
C XPD,YPD,ZPD ARE THE COORDINATES OF THE EXPANDING END OF THE CONE
C XHC,YHC,ZHC ARE THE COORDINATES OF THE FIXED FOCUS OF THE CONE
DO 5 I=1,IA
P=XHC(I)-XRD(I)
Q=YHC(I)-YRD(I)
R=ZHC(I)-ZPD(I)
D=P*P-C*Q
E=P*C-A*R
F=A*Q-P*B
SQ=A*A*Q-A*P
SS=A*Q-P
FC=P*C*D/SQ-A*C*P*E/SQ+C*D/A-P*D/SS+A*R*E/SS-F
FD=ZHC(I)+A*P*OY/SS+R*XHC(I)/SS-R*OX/SS+A*R*YHC(I)/SS-OZ-C*XHC(I)
1/A-A*P*C*OY/SQ-C*P*XHC(I)/SQ+P*C*OX/SQ-A*C*P*YHC(I)/SQ+C*OX/A
U=FD/FC
S=(A*OY+XHC(I)+D*U-OX+A*YHC(I)-A*E*U)/SS
T=(XHC(I)+S*P+D*U-OX)/A
TX=OX+T*(X-OX)
TY=OY+T*(Y-OY)
TZ=OZ+T*(Z-OZ)
HX=XRD(I)+S*(XHC(I)-XRD(I))
HY=YRD(I)+S*(YHC(I)-YRD(I))
HZ=ZPD(I)+S*(ZHC(I)-ZPD(I))
C DST IS THE PERPENDICULAR DISTANCE BETWEEN THE O-T LINE AND THE CONE
DST=SQRT((TX-HX)**2.0+(TY-HY)**2.0+(TZ-HZ)**2.0)
C DST IS THE DISTANCE FROM THE CONE FOCUS TO THE PERPENDICULAR LINE
CST=SQRT((HX-XHC(I))**2.0+(HY-YHC(I))**2.0+(HZ-ZHC(I))**2.0)
C CALCULATE RADIUS OF CONE AT PERPENDICULAR LINE. IF RADIUS IS
C SHORTER THAN PERPENDICULAR LINE THEN INTERVISIBILITY EXISTS
ACN=(WS-20.0)/34.377
RAD=CST*SIN(ACN)
KSEF=1
1F(DST.LE.BPD)KSEE=0
IF(KSEE.EQ.0)JSEE=0
C CONTINUE
C RETURN
C END

```

SUBROUTINE DUMMY
ENTRY CONTUR
ENTRY PLT301
RETURN
END

APPENDIX C. MATHEMATICS OF LINE-OF-SIGHT CALCULATIONS

APPENDIX C. MATHEMATICS OF LINE-OF-SIGHT CALCULATIONS

WPLOS

The WPLOS subroutine determines if the line drawn between an attacker and a defender (O-T line) touches or passes through any part of a spherical smoke cloud. It does this by using geometry. If straight lines are drawn between the attacker, defender, and smoke cloud's center, a triangle is formed. Assuming that the triangle's base is the O-T line, the program determines the altitude of the triangle and compares it with the radius of the sphere. If the altitude is longer than the radius then the O-T line misses the smoke cloud, i.e., intervisibility does exist.

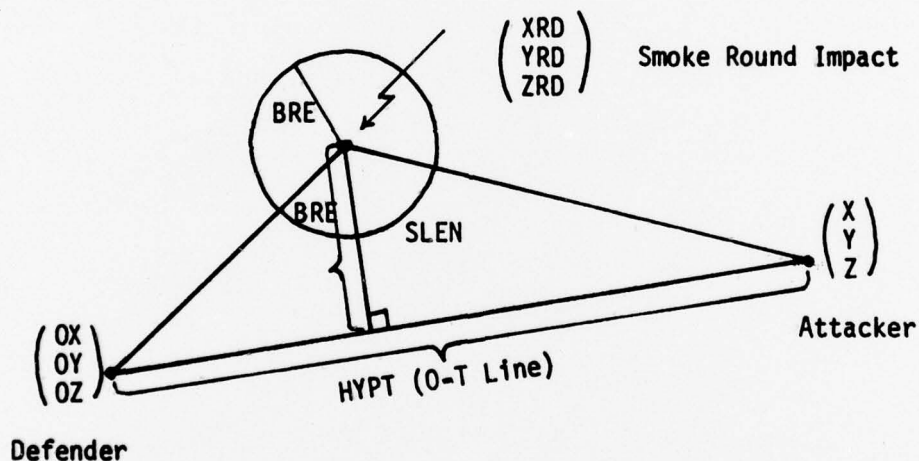

Figure C-1. Sphere/Line Intersection

HCLOS

Because a cone does not have a single center but rather a locus of centers running through its central axis, a different approach is used. The problem is to determine the shortest distance between the cone and the O-T line, and then compare this distance with the

radius of the cone, measured at the intersection of the shortest distance line and the cone's outer surface,

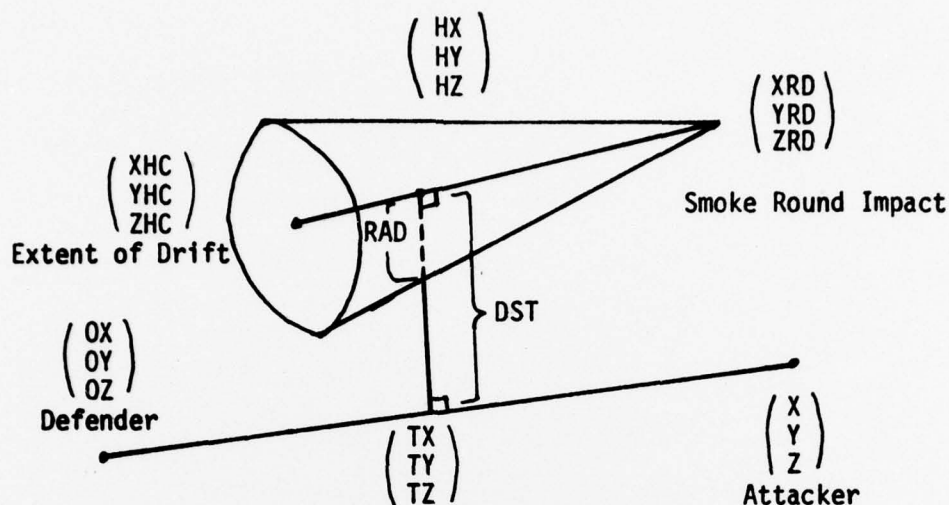

Figure C-2. Cone/Line Intersection

The shortest distance between any two vectors in three space is equal to the length of the line drawn between and perpendicular to the two vectors. The method used to determine this shortest distance consists of finding the cross product of the two vectors in order to find the line perpendicular to both and then solving a system of three simultaneous equations for these lines in order to find their points of intersection. Once the two points of intersection (HX, HY, HZ) and (TX, TY, TZ) are located, the Pythagorean theorem is applied to find the length of the line (DST) between the two points. If DST is greater than the radius (RAD) , then intervisibility exists.

A summary of the mathematics for the HC cloud is as follows:

1. Form equations for the O-T line and for the axis of the cone,

O-T Vector

$$TX=OX+t(X-OX)$$

$$TY=OY+t(Y-OY) \quad (C-1)$$

$$TZ=OZ+t(Z-OZ)$$

Cone Axis Vector

$$HX=XHC+s(XHC-XRD)$$

$$HY=YHC+s(YHC-YRD) \quad (C-2)$$

$$HZ=ZHC+s(ZHC-ZRD)$$

2. Take the cross product of the two vectors in step (1) to get the direction number for the line perpendicular to both.

$$\begin{pmatrix} X-OX \\ Y-OY \\ Z-OZ \end{pmatrix} \times \begin{pmatrix} XRD-XHC \\ YRD-YHC \\ ZRD-ZHC \end{pmatrix}$$

$$\text{let } X-OX=a$$

$$Y-OY=b$$

$$Z-OZ=c$$

$$\text{let } XRD-XHC=p$$

$$YRD-YHC=q$$

$$ZRD-ZHC=r$$

$$\text{then } \begin{pmatrix} a \\ b \\ c \end{pmatrix} \times \begin{pmatrix} p \\ q \\ r \end{pmatrix} = \begin{matrix} br-cq \\ pc-ar \\ aq-pb \end{matrix}$$

3. Form an equation for the line perpendicular to the O-T line and the axis of the cone.

$$TX=HX+u(br-cq)$$

$$TY=HY+u(pc-ar) \quad (C-3)$$

$$TZ=HZ+u(aq-pb)$$

$$\text{let } (br-cq) = d$$

$$(pc-ar) = e$$

$$(aq-pb) = f$$

4. Substitute (C-1) and C-2) into (C-3)

$$OX+at = XHC+sp+u(br-cq)$$

$$OY+bt = YHC+sq+u(pc-ar) \quad (C-4)$$

$$OZ+ct = ZHC+sr+u(aq-pb)$$

5. All quantities in (C-4) are known except for parameters s , t , and u . Therefore, the system of equations (C-4) has three equations and three unknowns and can be solved by a series of substitutions.
6. Once the program has solved for s , t , and u , it substitutes these value in (C-1) and (C-2). The two equations can then be solved for $(TX, TY, \text{ and } TZ)$ and $(HX, HY, \text{ and } HZ)$.
7. Using Pythagorean Theorem, the length DST is computed.
8. DST is compared in length to the radius (RAD) for determination of intervisibility.

REFERENCES CITED

1. U.S. Army Training and Doctrine Command Bulletin (Draft), Employment of Smoke on the Modern Battlefield, 1976, p. 3.
2. Department of the Army Field Manual, FM 3-50, Chemical Smoke Generator Units and Smoke Operations, April 1967.
3. Department of the Army Technical Manual, TM 3-240, Field Behavior of Chemical, Biological, and Radiological Agents, April 1969.
4. Field Tests have been conducted at Jefferson Proving Ground, Fort Carson, and Fort Sill. The Fort Sill smoke test, which is the most recent of the three, was conducted under the proponentcy of Army Material Systems Analysis Activity.
5. U.S. Army Combined Arms Combat Developments Activity Technical Memorandum, TM 4-76, Modeler's Guide to the Tactics and Doctrine of Smoke Employment, October 1976.
6. U.S. Army Training and Doctrine Command Bulletin (Draft), Employment of Smoke on the Modern Battlefield, 1976.
7. U.S. Army Field Artillery School Training Circular, TC6-20-5, Field Artillery Smoke, August 1975.
8. Needels, C.J., Parameterization of Terrain in Army Combat Analysis, Naval Postgraduate School, March 1976.
9. Needels, C.J., Parameterization of Terrain in Army Combat Analysis, Naval Postgraduate School, March 1976, p. 28.
10. Bishop, A.B. and Clark, G.M., The Tank Weapon System, Systems Research Group, Ohio State University, October 1969, p. 1-17.
11. Johnson, Morris C. and Forney, Paul P., The Effectiveness of Obscuring Smoke (Draft), U.S. Army Material Systems Analysis Activity, 1977, Appendices C and D.

BIBLIOGRAPHY

- Bishop, Albert B. and Clark, Gordon M., The Tank Weapon System, Systems Research Group, Ohio State University, October 1969.
- Department of the Army Field Manual, FM 3-50, Chemical Smoke Generator Units and Smoke Operations, April 1967.
- Department of the Army Technical Manual, TM 3-240, Field Behavior of Chemical, Biological, and Radiological Agents, April 1969.
- Johnson, Morris C. and Forney, Paul P., The Effectiveness of Obscuring Smoke (Draft), US Army Material Systems Analysis Activity, 1977.
- Needels, Christopher J., Parameterization of Terrain in Army Combat Analysis, Naval Postgraduate School, March 1976.
- Pickett, Kent H., Smoke Modeling Concept Paper, US Army Combined Arms Combat Developments Activity, 1977.
- US Army Combined Arms Combat Developments Activity Technical Memorandum, TM 4-76, Modeler's Guide to the Tactics and Doctrine of Smoke Employment, October 1976.
- US Army Field Artillery School Training Circular, TC 6-20-1, Suppression of Direct Fire Weapons, May 1975.
- US Army Field Artillery School Training Circular, TC 6-20-5, Field Artillery Smoke, August 1975.
- US Army Training and Doctrine Command Bulletin, Employment of Smoke on the Modern Battlefield (Draft), 1976.
- US Army Training and Doctrine Command Bulletin Number 3, Smoke Obscuration Capabilities, How to Use Them (Draft), 1976.
- US Army Training and Doctrine Command Message 0722198 Feb 75 (S), Subject: Weekly Intelligence Briefing 06-75.
- US Defense Intelligence Agency Document DST-1600S-034-76-SUP (S), "Chemical and Biological Warfare Capability-USSR".
- US Defense Intelligence Agency Document, ST-CR-20-9-Int (S), "Smoke Dissemination Devices: USSR and Poland", April 1969.
- Weir, Maurice D., Topics in Calculus Two, Naval Postgraduate School, September 1973.