

AD-A043 712

NAVAL INTELLIGENCE SUPPORT CENTER WASHINGTON D C TRA--ETC F/G 11/6
A STUDY OF THE EFFECT OF WELDING STRESSES ON THE SUPPORTING POW--ETC(U)
MAY 77 A N SERENKO, S K RAMAZANOV

UNCLASSIFIED

NISC TRANS-3931

NL

| OF |
AD
A043712



END
DATE
FILMED
9 -77
DDC

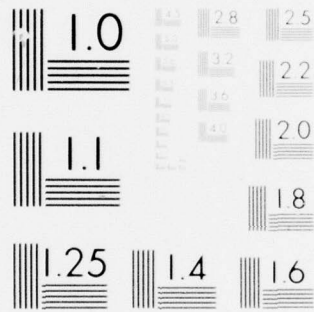

MICROCOPY RESOLUTION TEST CHART
NATIONAL BUREAU OF STANDARDS-1963-A



DEPARTMENT OF THE NAVY
NAVAL INTELLIGENCE SUPPORT CENTER
TRANSLATION DIVISION
4301 SUITLAND ROAD
WASHINGTON, D.C. 20390

3
mic

AD A 043712

CLASSIFICATION: UNCLASSIFIED

TITLE: 6 A Study of the Effect of Welding Stresses on the Supporting Power of Titanium Alloy Welded Members under Static and Cyclic Loading

(Issledovaniye vliyaniya svarochnykh napryazheniy na nesushchuyu sposobnost' svarnykh elementov iz titanovogo splava pri staticheskom i tsiklicheskom nagruzhenii)

AUTHOR(S): 10 A.N. Serenko, A.N. and Ramazanov, S. Kh. S. Kh.

PAGES: 16

SOURCE: 21 Trans. of Transactions of M.I. Kalinin Leningrad Polytechnic Institute, (USSR) No. 262, 1966, pp. 26-34, 1966.

ORIGINAL LANGUAGE: Russian

TRANSLATOR: C

14 NISC TRANSLATION 3931

APPROVED P.T.K.

11 DATE 19 May 1977

AD No.
DDC FILE COPY

DISTRIBUTION STATEMENT A
Approved for public release;
Distribution Unlimited

12 17p.
DDC
RECEIVED
SEP 2 1977
B

407682

A STUDY OF THE EFFECT OF WELDING STRESSES ON THE SUPPORTING POWER OF TITANIUM ALLOY WELDED MEMBERS UNDER STATIC AND CYCLIC LOADING

[Serenko, A. N. and Ramazanov, S. Kh.; Issledovaniye vliyaniya svarochnykh napryazheniy na nesushchuyu sposobnost' svarnykh elementov iz titanovogo splava pri staticheskom i tsiklicheskom nagruzhenii; Transactions of M. I. Kalinin Leningrad Polytechnic Institute, No. 262, 1966, pp. 26-34; Russian]

Determining the degree to which welding stresses affect the performance of welded members and structures under various types of operational loads is of important practical significance. Scientific studies in the field of welding, therefore, have long focused on resolving questions connected with this problem.

/26

As a result of the ever-increasing demands on the supporting power of welded structures and the growing complexity of the conditions under which they operate, as well as the increasingly wide-spread use of new structural metals and alloys in industry, the problem of the effect of welding stresses on the strength of welded structures remains current at the present time.

Although there is as yet no consensus on this question, nevertheless, numerous experimental and theoretical works have to a certain degree made it possible to eliminate the previous diversity of viewpoints.

It has, thus, become generally recognized that under a

static or impact load welding stresses do not in practice reduce the performance of welded structures if the metal has not become brittle, as noted in reference [1]. The matter is more complex in the case of cyclic loading. As is well-known, residual stresses occur during welding due to the appearance of plastic compression deformations in the weld-affected zone at the time of preheating. After cooling, part of the plastic compression deformations disappears due to the occurrence of plastic dilatational strains, while the remainder of the plastic compression deformations results in an internally balanced welding stress field. It can be seen from the preceding that the process by which residual stresses arise is essentially accompanied by a thermal mechanical treatment cycle of those points on the weld joint where residual tensile stresses occur.

Various metals and alloys react differently to the effect of the welding cycle. This is reflected both in the level of residual stresses and in the degree of change in the properties of the metal located in the area of thermal plastic deformations. As a result, when there is no geometric stress concentrator, the supporting power of a welded member under a cyclic load will be determined both by magnitude of the residual stresses and by the coefficient of the original metal's properties and those of the metal with altered properties in the plastic deformation zone.

127

ACCESSION for	
NTIS	White Section <input checked="" type="checkbox"/>
DDC	Buff Section <input type="checkbox"/>
UNANNOUNCED	<input type="checkbox"/>
JUSTIFICATION	
PER FORM 50 OF FILE	
BY	
DISTRIBUTION/AVAILABILITY CODES	
Dist	AVAIL. and/or SPECIAL
A	

For low-carbon steels this coefficient is such that, despite the presence of residual stresses equal to the yield strength, the supporting power of a welded member under a cyclic load is no lower than the strength of the original metal, as noted in reference [2].

It should be born in mind, however, that such a condition may not hold if other, little-studied metals and alloys are used.

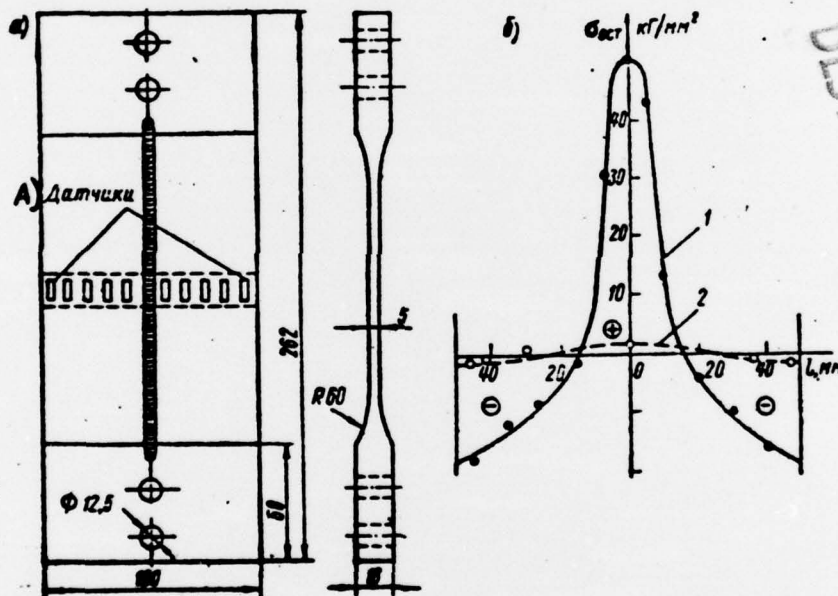

A) Sensors

Fig. 1. The specimen used in tests (a), and the residual stress curves (b): 1 - after penetration; 2 - after thermal treatment.

Titanium and its alloys, as a new construction material, are beginning to be more widely used in various areas of industry. Nevertheless, there is a limited number of studies dealing with

the behavior of titanium and its alloys, as well as welded members from them, under various stress conditions and under various types of operational loads.

In particular, there is as yet no clear understanding of how residual stresses affect the strength properties of welded members and titanium alloy constructions.

The present article is based on experimental studies conducted in this field.

Exactly the same type of specimen, whose form and dimensions can be seen in Fig. 1, a, was adopted for both static and cyclic tests. All the specimens were cut from the same rolled titanium plate, the specimen's longitudinal axis being oriented along the direction of the roll. The specimen's effective working surfaces were formed by milling, the machining scratches being located along the specimen's longitudinal axis. All specimens were divided into four series. Series I included specimens in their initial state (the parent metal); series II - specimens with a longitudinal bead; series III - parent metal specimens after thermal treatment and series IV - specimens with a bead after thermal treatment. The longitudinal welds located in the middle of the specimen were performed by penetrating the specimen with a nonconsumable electrode in an argon atmosphere without additives. Penetration was carried out in one pass on an ADSV-2 automatic welder for $I = 130a$, $U = 11b$, $v = 0.39$ cm/sec, $q = 1300$ cal/cm.

As a result of penetration residual stresses occurred in the specimen. The nature and magnitude of these stresses were determined by means of narrow grid electrical resistance sensors. The sensors were glued in the positions shown in Fig. 1, a and cut out after the initial reading; then a second reading was taken.

The measurement results for the residual stresses in the specimen after beading are shown in Tab. 1; a residual stress curve (a continuous line) has been plotted in Fig. 1, a on the basis of these data.

Table 1

Residual stress values as a function of the distance of the sensor from the weld axis

A) Параметры	B) Числовые значения параметров для датчиков										
	1	2	3	4	5	6	7	8	9	10	11
B) Расстояние датчика от оси шва, мм	45	35	26	15	7	0	5,5	10	20	30	40
C) Остаточные напряжения, $\sigma_{ост}$, кг/мм ²	-18	-12	-8,6	-1,55	+34	+50	+43,6	+13,5	-4,35	-9,7	-16,1

- A) Parameters
- B) Distance of the sensor from the weld axis, mm
- C) Residual stresses, $\sigma_{ост}$, kg/mm²
- D) Numerical parameter values for the sensors

As can be seen from the curve in Fig. 1, the maximum residual tensile stresses are equal to 50 kg/mm, which is signi-

ificantly lower than the yield point of the parent metal ($\sigma_{0.2} = 75 \text{ kg/mm}^2$). This is a distinguishing feature of titanium alloys in comparison with steel, for which, as is well-known, maximum residual stresses are, as a rule, equal to the yield point.

In order to eliminate the residual stresses half of the built-up specimens together with part of the series I specimens (the parent metal) were thermally treated in an open air atmosphere. The thermal treatment was carried out in an open air atmosphere according to the following mode. The furnace temperature before charging was equal to 200°C . The maximum heating temperature reached 630°C , at which holding lasted for 2 hours. The specimens were subsequently cooled together with the furnace to 200°C ; then they were air cooled.

The degree to which the residual stresses were eliminated after thermal treatment of the specimens with a weld was also controlled by cutting out the members with glued on sensors. Fig. 1, δ shows a second residual stress curve (the dotted line curve), plotted on the basis of experimental points. One can see from the stress curve that after thermal treatment the residual stresses were almost completely eliminated, although the nature of their distribution over the cross section of the specimen remains unchanged.

Two specimens were taken from each series for a tensile test, which was conducted in a machine with a maximum breaking

stress $P_{\max} = 50T$. The specimen test results are shown in Tab. 2. The cited relative elongation due to the limitation of the specimen's longitudinal dimension was determined for a 80 mm base, which does not correspond to the standard length for the specimen's cross section. This is not significant, however, for a comparative analysis.

Table 2

Mechanical properties of the specimens
in various states

A № серии	B Предел прочности σ_s		C Относительное сужение ψ		D Относительное удлинение δ	
	кг/мм ²	% от серии I	%	% от серии I	%	% от серии I
I	$\frac{79.4-79.6}{79.5}$	100	$\frac{13.1-14.5}{13.8}$	100	$\frac{12.2-16.0}{14.1}$	100
II	$\frac{78.7-78.7}{78.7}$	99	$\frac{11.8-13.5}{12.6}$	92	$\frac{11.4-14}{12.7}$	91
III	$\frac{79.8-80.0}{79.9}$	100.5	$\frac{11.6-14}{12.8}$	93	$\frac{11.0-14.8}{12.9}$	92
IV	$\frac{78.2-78.6}{78.4}$	98.7	$\frac{10-12.8}{11.4}$	83	$\frac{10.0-10.8}{10.4}$	74

- A) Series N^o
- B) Yield point σ_s
- C) Relative reduction in area ψ
- D) Relative elongation δ
- E) % of series I

As was to be expected, all tested specimens, regardless of the presence or absence of internal stresses created by welding, possess practically identical supporting power. It is characteristic that in all cases destruction was accompanied by significant

plastic deformations (Fig. 2). This in itself attests to the fact that by the time destruction occurs the specimens could not have differed significantly under stress. An insignificant deterioration of the plastic properties (ψ and δ) after thermal treatment is apparently due to a saturation of the surface layers of the specimen's metal with elements which reduce these properties.

As previously mentioned, welding stresses can change a structure's supporting power under static loading only if that structure's metal due to the effect of any factors (low temperature, the presence of a stress concentration, etc.) becomes brittle. As applied to titanium alloys, however, brittleness does not set in even in the presence of sharp notches and even at temperatures ranging as low as -150°C , as noted in reference [3]. This suggests that under static loading welding stresses cannot negatively affect the strength of welded members and structures of titanium alloys even under extremely heavy working conditions, which are possible in the presence of a high stress concentration and during loading under low temperature conditions.

The remaining specimens (Fig. 2, σ and δ) were tested under cyclic loading, carried out in a fatigue test machine, a diagram of which is shown in Fig. 3. A specimen mounted in the machine undergoes alternating bending with axial compression and stretching by means of a power-driven lever joined by an adjustable connecting rod to a revolving eccentric. Based on their

magnitude, however, stresses from axial compression and stretching comprise an insignificant share of the bending stresses (about 0.4%); they are, therefore, negligible and one may regard the specimen as undergoing pure alternating bending with a symmetrical loading cycle. A test base was adopted equal to 10^7 cycles, but in some cases the number of loading cycles reached $1.5 \cdot 10^7$ cycles.

L30

The cyclic load test results for the specimens of all the series are shown in Fig. 4. The cited test data show that after beading the specimen's fatigue strength decreased by almost half (46%) in comparison to what it was without beading. Such a marked decrease in the fatigue strength of titanium specimens after beading is not normal if one takes into account the fact that the fatigue strength of low carbon steel welded members does not decrease due to welding.

L32

Possible causes of the decrease in the fatigue strength of titanium alloy specimens with a weld are:

- 1) low fatigue strength of the weld, which has a large columnar cast structure differing markedly from the structure of the parent metal;

- 2) residual stresses not accompanied by an increase in the strength properties of the metal of the weld or the weld-affected zone.

The first of these possible causes apparently must not lead to a decrease in fatigue strength, since otherwise the thermal

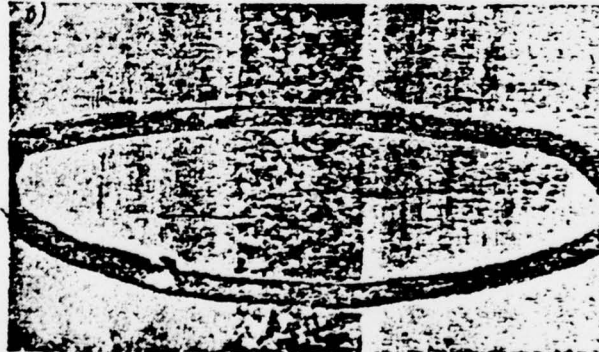
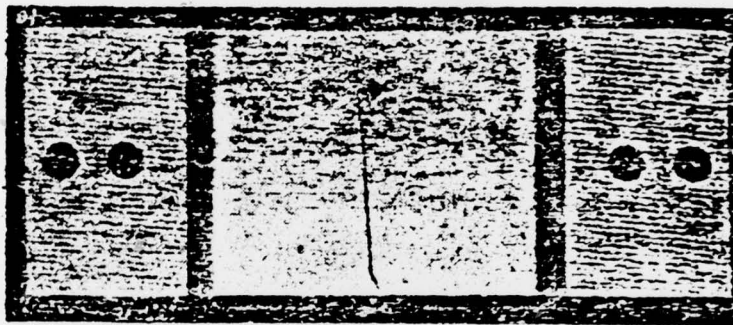
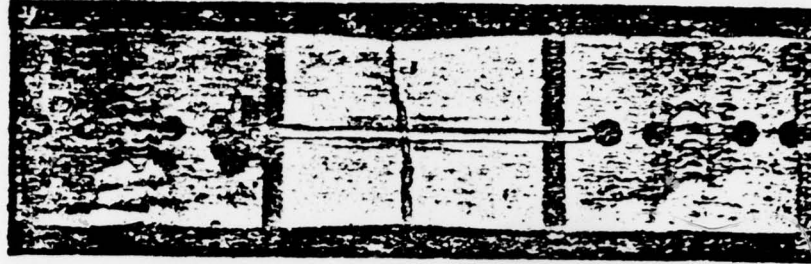

Fig. 2. The nature of the specimens' destruction: *a* - under static loading of a specimen with a weld; *b* - under cyclic loading of a basic metal specimen; *c* - under cyclic loading of a specimen with a weld without thermal treatment.

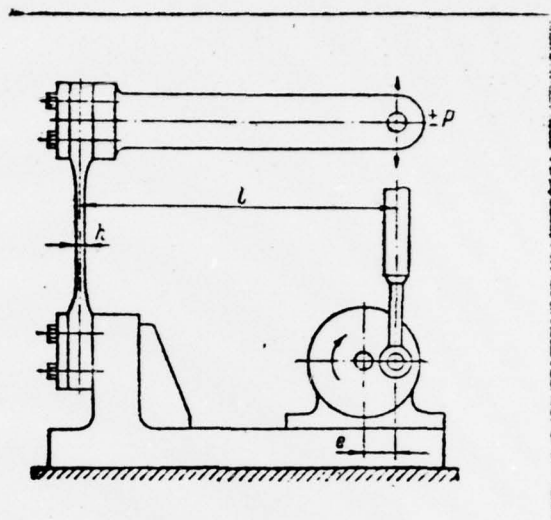

Fig. 3. A diagram of the fatigue test machine (P - force)

treatment of specimens with a weld should not have increased their fatigue strength, inasmuch as the adopted thermal treatment mode does not alter the weld structure. The most probable cause of the decrease in fatigue strength, therefore, is the second.

It is well-known that in summing up the stresses induced by an external load with residual stresses resulting from welding, the nature of the cycle changes. In the area affected by the residual tensile stresses the magnitude of the average stresses will be increased; this should have led to a drop in the cycle's amplitude.

As previously noted, however, welded members and structures manufactured from low carbon steel and stress concentrators do not reduce fatigue strength due to the action of residual welding stresses, since the occurrence of the latter is accom-

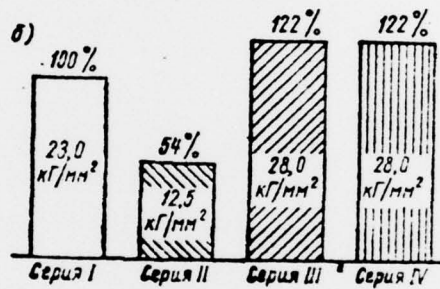
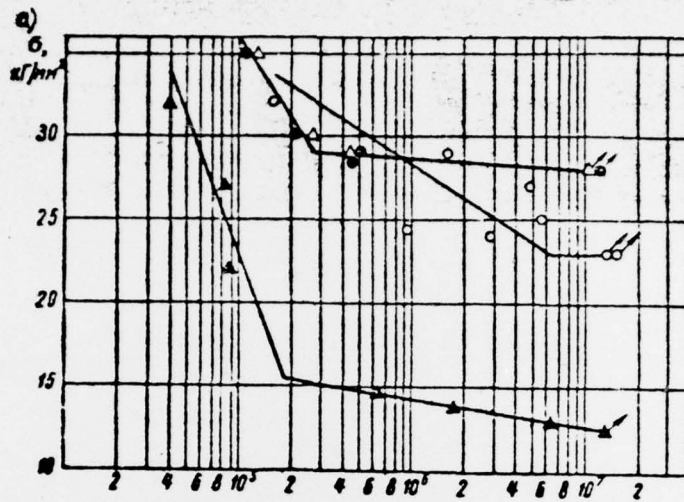

Fig. 4. Specimen cyclic load test results: *a* - fatigue curves in semi-logarithmic coordinates; *b* - the correlation of the fatigue strengths of the various series: o, I - parent metal; \blacktriangle , II - specimens with a weld without thermal treatment; \triangle , III - parent metal after thermal treatment; \bullet , IV - specimens with a weld after thermal treatment

panied by a simultaneous increase in the material's mechanical properties precisely in those areas where the residual tensile stresses act.

If for some reason, however, the mechanical properties of those areas remain at their previous level, then the full effect of the residual stresses will occur. One may assume, therefore,

that the marked drop in the fatigue strength of titanium alloy specimens observed after performance of the weld is due to the fact that titanium alloys, unlike steel, do not alter the mechanical properties of the metal in the plastic deformation zone.

In fact, as mechanical tests of small samples 3 mm in diameter, cut from various areas of the weld, the thermally affected zone (ZTV) and the parent metal (OM), have shown, all properties have practically identical values for all zones. This can be seen from the test results for these specimens (the average of three values) obtained on a IM-4R machine. The test results are cited in Table 3.

Table 3

The mechanical properties of individual weld joint zones

A Вид вырезки образца	E Предел текучести $\sigma_{0.2}$		F Предел прочности σ_b		G Относительное удлинение δ		H Относительное сужение ψ	
	кг/мм ²	% от OM	кг/мм ²	% от OM	%	% от OM	%	% от OM
B) OM	75,0	100	81,0	100	14,2	100	35,8	100
C) ЗТВ	75,0	100	82,3	102	13,2	93	39,9	111
D) Шов	77,0	102	82,3	102	13,5	95	40,7	114

- A) Zone of the specimen's cut
- B) OM (parent metal)
- C) ZTB (thermally affected zone)
- D) Weld
- E) Yield strength
- F) Tensile strength
- G) Relative elongation
- H) Relative reduction in area

If one assumes that the approximate Goodman diagram (Fig. 5) is also valid for titanium alloys, then one may write

$$\sigma_q = \sigma_{-1} + \sigma_{ocT} \left(1 - \frac{\sigma_{-1}}{\sigma_s}\right), \quad (1)$$

where σ_q is the fatigue strength for an asymmetric cycle

σ_{-1} is the fatigue strength for a symmetric cycle

σ_{ocT} is the average stresses

σ_s is the tensile strength.

Substituting numerical values into this formula one obtains the following equation:

$$\sigma_q = 61 \text{ kg/mm}^2. \quad (2)$$

The stress amplitude value is then found from the correlation (Fig. 5):

$$\sigma_a = \sigma_q - \sigma_{ocT} = 61 - 50 = 11 \text{ kg/mm}^2. \quad (3)$$

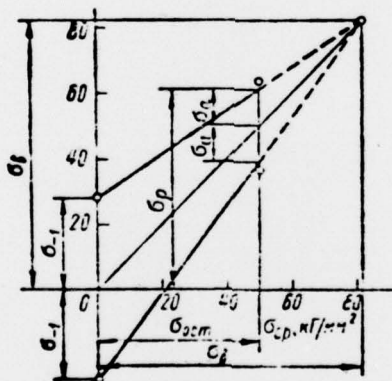

Fig. 5. Simplified fatigue strength diagram

As a rule this value is fairly close to that which has been found experimentally ($\sigma_a = 12.5 \text{ kg/mm}^2$).

It is, thus, clear from the preceding that due to the

specific reaction of titanium alloys to the cycle of welding which is included in the unalterable features of the plastic deformation zone, the residual stress field leads to a reduction in the welded member's fatigue strength.

Welded specimens which underwent thermal treatment resulting in the elimination of welding stresses proved to have a fatigue strength equal to that of the parent metal (see Fig. 4, 6, series III and IV).

It is interesting to note that various specimen series behaved differently with respect to the point of origin of the fatigue breakdown. In parent metal specimens the fatigue crack thus always originated on one of their edges, while in thermally treated specimens with a weld they always began in the area of the weld (see Fig. 2, 6 and 6). After thermal treatment both of the OM (parent metal) specimens and of the specimens with a weld, the point of origin of the fatigue crack was again located on the edges of the specimens.

It should be noted that series I(OM) specimens after annealing increased their fatigue strength by 22%; in absolute magnitude their fatigue strength became identical to that of the annealed specimens with a weld. The reason for the increase in the fatigue strength of the parent metal after thermal treatment is still not totally clear. One can only note here that the observed increase in the parent metal specimens' fatigue strength after thermal treatment may have been due to a change in the properties of their surface layers resulting from the thermal

treatment. Since the thermal treatment was carried out in an open air atmosphere, the surface layers of the specimens naturally became enriched with such elements as nitrogen, oxygen and hydrogen, which increase the strength properties (σ_r , σ_d) and, accordingly, the strength fatigue.

In conclusion, it might be noted that the demonstrated harmful effect of residual stresses on the fatigue strength of welded members of titanium alloys requires that in planning and designing welded members and structures intended for work under conditions of cyclic loading measures be taken to off set their negative effect.

References

1. Okerblom, N.O. Svarochnyye napryazheniya v metallokonstruktsiyakh. (Welding Stresses in Metal Structures.) Moscow-Leningrad. Mashgiz Publishing House, 1950.
2. Okerblom, N. O. Raschet vynoslivosti svarnykh konstruktsiy s uchetom napryazheniy, vznikayushchikh pri svarke. (Fatigue Stress Design for Welded Structures Taking into Account Stresses which Occur during Welding.) Trudy LPI, N^o 100, Moscow-Leningrad. Mashgiz Publishing House, 1959.
3. Neiss Volker, Sessler Iohu. Analysis of the effects of test temperature on the notch strength shut alloys. Preprint. ASTM. 1961, N 80d, 1-15.