

AD-A043 364

HONEYWELL INC HORSHAM PA POWER SOURCES CENTER  
LITHIUM INORGANIC ELECTROLYTE BATTERY INVESTIGATION.(U)  
APR 77 D L CHUA, C R WALK

F/G 10/3

F33615-74-C-2071

UNCLASSIFIED

AFAPL-TR-77-21

NL

1 of 2  
AD  
A043364

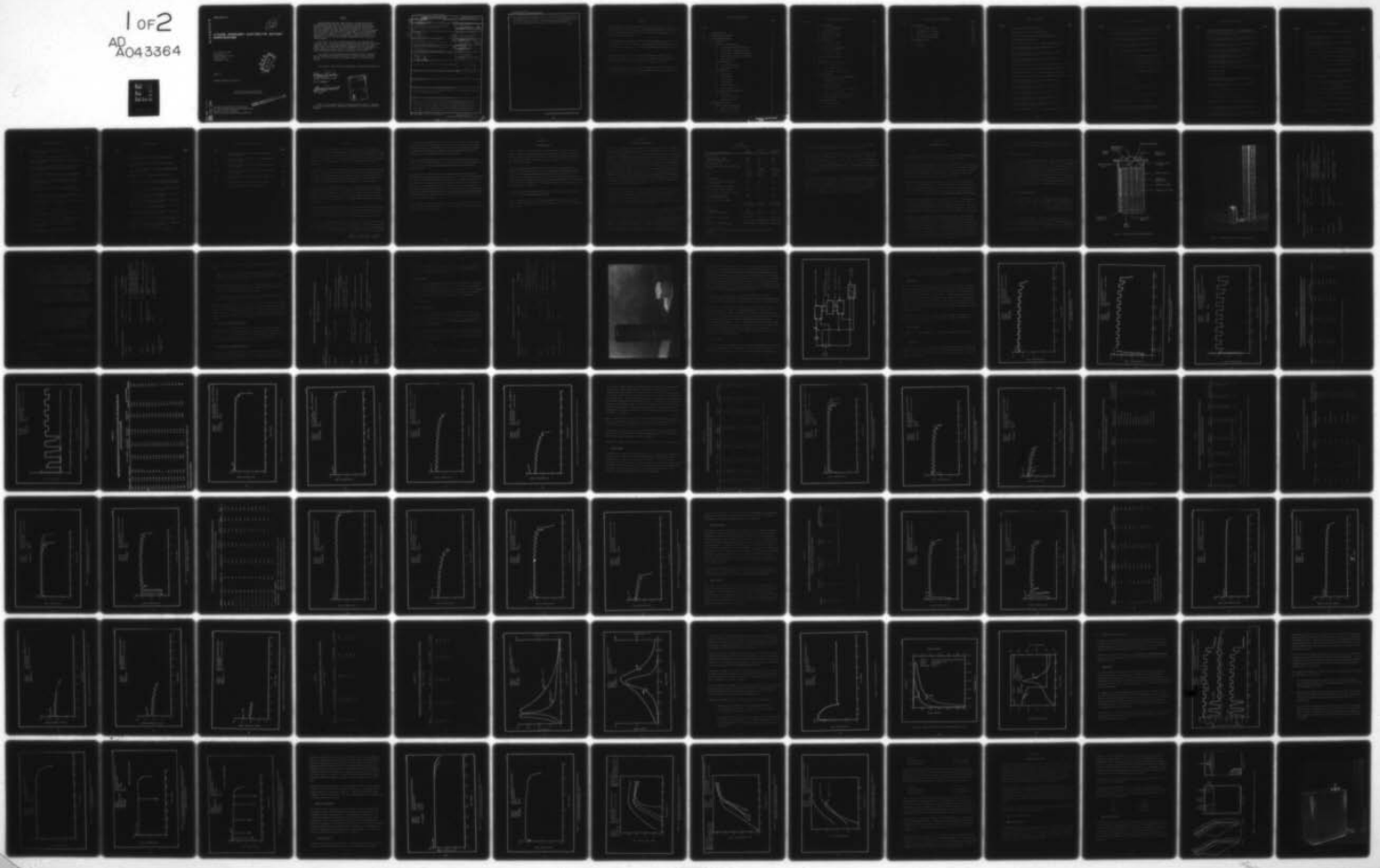

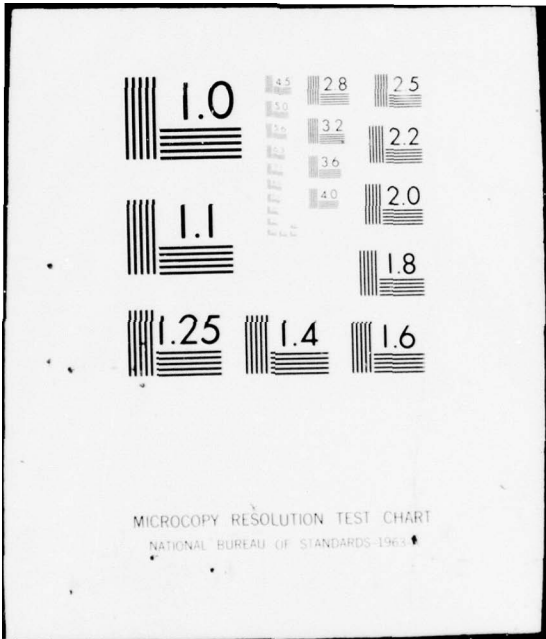

MICROCOPY RESOLUTION TEST CHART  
NATIONAL BUREAU OF STANDARDS-1963-A

AD A 043364

AFAPL-TR-77-21

12

# LITHIUM INORGANIC ELECTROLYTE BATTERY INVESTIGATIONS

*D. L. Chua and C. R. Walk*  
HONEYWELL, INC.  
POWER SOURCES CENTER  
104 ROCK ROAD  
HORSHAM, PA. 19044

DDC  
AUG 22 1977  
HONEYWELL

APRIL 1977

TECHNICAL REPORT AFAPL-TR-77-21

Approved for public release; distribution unlimited.

ORIGINAL CONTAINS COLOR PLATES; ALL DDC REPRODUCTIONS WILL BE IN BLACK AND WHITE.

DDC FILE COPY

AIR FORCE AERO PROPULSION LABORATORY  
AIR FORCE WRIGHT AERONAUTICAL LABORATORIES  
AIR FORCE SYSTEMS COMMAND  
WRIGHT-PATTERSON AIR FORCE BASE, OHIO 45433

NOTICE

When Government drawings, specifications, or other data are used for any purpose other than in connection with a definitely related Government procurement operation, the United States Government thereby incurs no responsibility nor any obligation whatsoever; and the fact that the government may have formulated, furnished, or in any way supplied the said drawings, specifications, or other data, is not to be regarded by implication or otherwise as in any manner licensing the holder or any other person or corporation, or conveying any rights or permission to manufacture, use, or sell any patented invention that may in any way be related thereto.

This final report was submitted by Honeywell, Inc. under Contract F33615-74-C-2071. The effort was sponsored by the Air Force Aero Propulsion Laboratory, Air Force Systems Command, Wright-Patterson AFB, Ohio under Project 3145, Task 314522 and Work Unit 31452268 with W.S. Bishop/POE-1 as Project Engineer in charge. Mr C.R. Walk and Dr D. Chua of Honeywell Power Sources Center were technically responsible for the work.

This report has been reviewed by the Information Office, (ASD/OIP) and is releasable to the National Technical Information Service (NTIS). At NTIS, it will be available to the general public, including foreign nations.

This technical report has been reviewed and is approved for publication.

*W.S. Bishop*  
W.S. BISHOP/GS-13  
Project Engineer/Scientist

FOR THE COMMANDER

*Donald P. Mortel*  
DONALD P. MORTEL  
Tech Manager

ACCESSION for	
NTIS	White Section <input checked="" type="checkbox"/>
DOC	Buff Section <input type="checkbox"/>
BY	
EXTENDED TECHNICAL ABILITY CODES	
SPECIAL	
A	

Copies of this report should not be returned unless return is required by security considerations, contractual obligations, or notice on a specific document.

REPORT DOCUMENTATION PAGE		READ INSTRUCTIONS BEFORE COMPLETING FORM
1. REPORT NUMBER 18 AFAPL-TR-77-21	2. GOVT ACCESSION NO.	3. RECIPIENT'S CATALOG NUMBER
4. TITLE (and Subtitle) 6 LITHIUM INORGANIC ELECTROLYTE BATTERY INVESTIGATION	5. TYPE OF REPORT & PERIOD COVERED 9 Final report 9 Sept 1974 - 31 Jan 1977	6. PERFORMING ORG. REPORT NUMBER
7. AUTHOR(s) 10 D. L. Chua C. R. Walk	8. CONTRACT OR GRANT NUMBER(s) 15 F33615-74-C-2071	
9. PERFORMING ORGANIZATION NAME AND ADDRESS Honeywell Inc. Power Sources Center, 104 Rock Road Horsham, Pa. 19044	10. PROGRAM ELEMENT PROJECT TASK AREA & WORK UNIT NUMBERS 16 Project 3145 Task 314522 Work Unit 31452268 17 22	
11. CONTROLLING OFFICE NAME AND ADDRESS Air Force Aero Propulsion Laboratory AFAPL/POE-1 Wright-Patterson AFB, Ohio 45433	12. REPORT DATE 11 April 1977	13. NUMBER OF PAGES 153
14. MONITORING AGENCY NAME & ADDRESS (if different from Controlling Office) 12 168 P.	15. SECURITY CLASS. (of this report) UNCLASSIFIED	15a. DECLASSIFICATION DOWNGRADING SCHEDULE
16. DISTRIBUTION STATEMENT (of this Report) Approved for public release; distribution unlimited		
17. DISTRIBUTION STATEMENT (of the abstract entered in Block 20, if different from Report)		
18. SUPPLEMENTARY NOTES		
19. KEY WORDS (Continue on reverse side if necessary and identify by block number) Lithium Batteries, Primary Batteries, Lithium-Thionyl Chloride Batteries, Inorganic Electrolyte Batteries		
20. ABSTRACT (Continue on reverse side if necessary and identify by block number) Lithium Thionyl Chloride Batteries were investigated for three potential applications and their performance measured under simulated loads. The problem of passivation during storage was investigated and additions of 5 weight percent sulfur dioxide was found beneficial in reducing the effects of passivation. Some preliminary capacity retention and safety data were generated. Three sizes of cells (1.6, 165, & 350 ampere hours) were		

DDC  
RECEIVED  
AUG 22 1977  
REGISTERED  
C

408995

Y/B

UNCLASSIFIED

SECURITY CLASSIFICATION OF THIS PAGE(When Data Entered)

*CU IN*  
→ fabricated and tested. Performance was 130 watt hours/lb and 11.8 watt hours/in<sup>3</sup> for the 1.6 Ah cells. The large 531 ampere hour cells delivered over 280 Wh/lb and 19 Wh/in<sup>3</sup>. Some information was generated on the nature of the film formed on the lithium electrode during storage. ↑

*CU IN*

SECURITY CLASSIFICATION OF THIS PAGE(When Data Entered)

## PREFACE

This final report is submitted in fulfillment of Air Force Contract F33615-74-C-2071 and describes the development of the lithium-thionyl chloride electrochemical system towards goals specified for three specific cell sizes ranging in capacity from 2.6 to 600 ampere-hours.

The effort ranged from experimental laboratory cell studies through the development and testing of full size hardware. Energy densities ranging from 13.5 Wh/in<sup>3</sup> and 140 Wh/lb in small cells to 18.6 Wh/in<sup>3</sup> and 286 Wh/lb in the large cells were achieved.

Grateful acknowledgements are extended to all participants in this work. In particular, our thanks to Mr. W. S. Bishop, the Air Force Project Monitor, for his many valuable suggestions throughout the course of the contract.

Our thanks also to Mr. J. F. Fitzgerald, Supervisor, and Mr. D. W. Mueller, Test Engineer of Honeywell's Ordnance Proving Grounds for their cooperation and help in testing of the large cells of this project.

## TABLE OF CONTENTS

SECTION	Page
I. INTRODUCTION	1
II. TECHNICAL APPROACH	2
III. LIFE SUPPORT CELLS	5
A. GENERAL	5
B. DESIGN & FABRICATION	6
1. First Series (Honeywell #G3013)	6
2. Second Series (Honeywell #G3013)	10
3. Third Series (Honeywell #G3013C)	12
4. Fourth Series (Honeywell #G3013C)	12
5. PRC-90 Battery	14
C. TEST PROGRAM	14
1. Project Requirements	14
2. Description of Tests	14
D. TEST RESULTS	17
1. First Series	19
2. Second Series	19
3. Third Series	19
4. Fourth Series	31
5. PRC-90 Batteries	45
6. Safety Testing	45
E. ANALYSIS OF TEST RESULTS	63
1. Passivation	63
2. Effect of Temperature	69
3. Cell Performance	69
IV. SPACECRAFT CELLS	76
A. DESIGN AND FABRICATION	76
1. Spacecraft "A" Cell	76
2. Spacecraft "B" Cell	77



TABLE OF CONTENTS (CON'T)

SECTION	Page
B. TEST PROGRAM	82
1. Project Requirements	82
2. Description of Tests	84
3. Spacecraft "A" Cell	84
4. Spacecraft "B" Cell	88
C. TEST RESULTS	91
1. Spacecraft "A" Cell	91
2. Spacecraft "B" Cell	103
D. ANALYSIS OF TEST RESULTS	111
1. Spacecraft "A" Cell	111
2. Spacecraft "B" Cell	116
V. CELL IMPROVEMENT STUDIES	119
A. GENERAL	119
B. EXPERIMENTAL TECHNIQUES	119
1. Laboratory Cell	119
2. Cyclic Voltammetry	121
3. Scanning Electron Microscopy	121
C. ANODE STUDIES	122
1. Analysis of the Passivation Problem	124
2. Investigative Procedures	125
3. Results of the Anode Studies	126
D. ELECTROLYTE STUDIES	136
1. Effect of Excess Aluminum Chloride	137
2. Effect of Iron and Water	137
3. Effect of Electrolyte Concentration	140
4. Effect of Sulfur Dioxide Doping	140
E. CATHODE STUDIES	142
1. Cathode Structure	142
2. Spacecraft "B" Battery	144

TABLE OF CONTENTS (CON'T)

SECTION		Page
VI.	CONCLUSIONS	148
	A. LIFE SUPPORT CELL	148
	B. SPACECRAFT "A" CELL	150
	C. SPACECRAFT "B" CELL	150
	D. LABORATORY STUDIES	151
VII.	RECOMMENDATIONS	152
	A. SAFETY	152
	B. STORAGE	152

## LIST OF FIGURES

<u>Figure</u>		<u>Page</u>
1	Cross Section of Life Support Cell	7
2	Photographic View of a Life Support Cell	8
3	Lithium/Thionyl Chloride PRC-90 Cell and Battery	16
4	Life Support Cell Test Circuit	18
5	Discharge Performance of a Fresh Life Support Cell at 75°F	20
6	Discharge Performance of a Life Support Cell at 75°F After 3 Weeks Storage at 75°F	21
7	Discharge Performance of a Life Support Cell at 120°F After 3 Weeks Storage at 75°F	22
8	Discharge Performance of a Life Support Cell at 75°F After One Month Storage at 140°F	24
9	Discharge Performance of a Fresh Life Support Cell at 165°F	26
10	Discharge Performance of a Fresh Life Support Cell at 75°F	27
11	Discharge Performance of a Fresh Life Support Cell at 0°F	28
12	Discharge Performance of a Fresh Life Support Cell at -20°F	29
13	Discharge Performance of Life Support Cells at 75°F After One Month Storage at 140°F	32
14	Discharge Performance of Life Support Cells at 32°F After One Month Storage at 140°F	33
15	Discharge Performance of Life Support Cells at 0°F After One Month Storage at 140°F	34
16	Discharge Performance of Life Support Cells at 165°F After Five Months Storage at 140°F	38
17	Discharge Performance of a Life Support Cell at 75°F After Five Months Storage at 140°F	39
18	Discharge Performance of a Fresh Life Support Cell at 75°F	41

LIST OF FIGURES (CON'T)

<u>Figure</u>		<u>Page</u>
19	Discharge Performance of a Fresh Life Support Cell at -20°F	42
20	Discharge Performance of a Life Support Cell at 75°F After 2 Months Storage at 140°F	43
21	Discharge Performance of a Life Support Cell at -20°F After 2 Months Storage at 140°F	44
22	Discharge Performance of a Life Support Cell at 75°F After 5 Months Storage at 140°F	47
23	Discharge Performance of a Life Support Cell at 32°F After 5 Months Storage at 140°F	48
24	Discharge Performance of a Fresh PRC-90 Battery at 75°F	50
25	Discharge Performance of a Fresh PRC-90 Battery at 32°F	51
26	Discharge Performance of a Fresh PRC-90 Battery at -20°F	52
27	Discharge Performance of a Fresh PRC-90 Battery at -40°F	53
28	Discharge Performance of a Fresh PRC-90 Battery at -65°F	54
29	Short-Circuit Test at 75°F	57
30	Maximum Power Test at 75°F	58
31	Forced Discharge Test at 75°F	60
32	Short-Circuit Test of a Life Support Cell at 75°F	61
33	Forced Discharge Test at 75°F	62
34	Cyclic Load Voltages and Reference Voltages of a Life Support Cell at 75°F	64
35	Low Rate Discharge Performance of a Passivated Life Support Cell at 75°F	66
36	Low Rate Discharge Performance of a Passivated Life Support Cell Including One Pulse Load Response at 75°F After 3-1/2 Months Storage at 140°F	67

LIST OF FIGURES (CON'T)

<u>Figure</u>		<u>Page</u>
37	Low Rate Discharge Performance of a Passivated Life Support Cell at 75°F Including Several Pulse Load Responses After 3-1/2 Months Storage at 140°F	68
38	Low Rate Discharge Performance of Life Support Cells at 75°F After 5 Months Storage at 140°F	70
39	Low Rate Discharge Performance of a Life Support Cell at 75°F After 5 Months Storage at 140°F	71
40	Life Support Cell Delivered Capacity as a Function of Temperature and Storage Time at 140°F	72
41	Life Support Cell Midpoint Voltage as a Function of Temperature and Storage Time at 140°F	73
42	Life Support Cell Delivered Capacity as a Function of Temperature and Storage Time at 140°F	74
43	Representative Cross Section of Spacecraft "A" and "B" Cells	78
44	Spacecraft "A" Cell	79
45	Spacecraft "B" Cell	81
46	Honeywell Ordnance Proving Grounds Test Facility for Spacecraft "A" & "B" Batteries	85
47	Honeywell Ordnance Proving Grounds Test Facility for Spacecraft "A" Batteries	86
48	Activation Set-Up for Spacecraft Batteries	87
49	Test Circuit for Spacecraft "A" Cells	89
50	Test Circuit for Spacecraft "B" Cells	90
51	Discharge Performance of a Fresh Spacecraft "A" Cell at 75°F	92
52	Discharge Performance of a Spacecraft "A" Cell at 91°F ± 20°F After 48 Days Storage at 95°F ± 18°F	93
53	Voltage Delay of Spacecraft "A" Cells at Approximately 93°F After 48 Days Storage at 95°F ± 18°F	94

LIST OF FIGURES (CON'T)

<u>Figure</u>		<u>Page</u>
54	Discharge Performance of a Fresh Spacecraft "A" Cell at $\approx 80^{\circ}\text{F}$	95
55	Discharge Performance of a Spacecraft "A" Cell After One Month Storage at $80^{\circ}\text{F}$	96
56	Discharge Performance of a Spacecraft "A" Cell After Three Months Storage at $80^{\circ}\text{F}$	97
57	Voltage Delay of Spacecraft "A" Cells After Storage at $80^{\circ}\text{F}$	98
58	Reversal Test Data for a Spacecraft "A" Cell (Final Build)	100
59	Salvaged Parts from Spacecraft "A" Battery After Explosion	101
60	Short-Circuit Test of Spacecraft "A" Cell (Final Build)	102
61	Discharge Performance of a Fresh Spacecraft "B" Cell (400 Ahr Design) at $87^{\circ}\text{F}$	104
62	Discharge Performance of Spacecraft "B" Cell (400 Ahr Design) at $89^{\circ}\text{F}$ After 48 Days Storage at $84^{\circ}\text{F}$	105
63	Discharge Performance of a Fresh Spacecraft "B" Cell (500 Ahr Design) at $80^{\circ}\text{F}$	106
64	Discharge Performance of a Spacecraft "B" Cell (500 Ahr Design) After Three Months Storage at $80^{\circ}\text{F}$	107
65	Voltage Delay at $80^{\circ}\text{F}$ of Spacecraft "B" Cells (500 Ahr Design) After Three Months Storage at $80^{\circ}\text{F}$	108
66	Discharge Performance of a Spacecraft "B" Cell (500 Ahr Design) at the 100-Hour Rate at $60-70^{\circ}\text{F}$	109
67	Spacecraft "B" Cell (500 Ahr Design) - Charging Test at Constant Current	110
68	Spacecraft "B" Cell (400 Ahr Design) - Reversal Test at 15A Constant Current	112
69	Short-Circuit Test ( $\approx 0.02$ Ohm) of a Spacecraft "B" Cell (500 Ahr Design)	114

LIST OF FIGURES (CON'T)

<u>Figure</u>		<u>Page</u>
70	Discharge Performance Versus Storage Time for Spacecraft "A" Cells	115
71	Typical Laboratory Cell in Sealed Glass Test Vehicle	120
72	Effect of Electrolyte Salt Grades on Cyclic Voltammograms of $\text{SOCl}_2$ Solutions	127
73	Surface Structure of Lithium When Stored in 1.0M $\text{LiAlCl}_4$ (Prepared according to pending vendor patent)· $\text{SOCl}_2$ at 165°F for 11 Days	129
74	Surface Structure of Lithium When Stored in 1.0M $\text{LiAlCl}_4$ (Fused)· $\text{SOCl}_2$ + 5% by Weight $\text{SO}_2$ at 162°F for One Week	130
75	Discharge Performance of Life Support Cells at 75°F After Four Months Storage at 165°F (Nominal Fresh Cell Dis- charge Time is 16 Hours)	131
76	Discharge Performance of a Fresh Life Support Cell at Room Temperature Using Electrolyte Solution Doped with 15% S	133
77	Discharge Performance of a Fresh Life Support Cell at -20°F using Electrolyte Solution Doped with 15% S	134
78	Pretreated Lithium Surface with $\text{SO}_2$ After Two Weeks at 165°F	135
79	Solution Vapor Pressure Vs. Temperature	138
80	Solution Vapor Pressure Vs. Temperature	139
81	Capacity Performance of Cells Using 1.0 Molar or 1.5 Molar $\text{LiAlCl}_4$ · $\text{SOCl}_2$ Electrolyte Solutions	141
82	Compatibility of Lithium with 1.5M $\text{LiAlCl}_4$ · $\text{SOCl}_2$ Electrolyte Solution in the Presence of Various Amounts of $\text{SO}_2$	143
83	Cathode Design Studies for Improving Performance of Life Support Cells	145
84	Pulse Polarization of Various Cathode Thicknesses for Scale-up of Spacecraft "B" Cell Design	147

## LIST OF TABLES

<u>Table</u>		<u>Page</u>
I	Battery Goals	3
II	Component Designs Used in the First Build of Life Support Cells	9
III	Component Designs Used in the Second Build of Life Support Cells	11
IV	Component Designs Used in the Third and Fourth Builds of Life Support Cells	13
V	Component Designs of Cells Used in the PRC-90 Batteries	15
VI	Discharge Performance of Life Support Cells of the First Build as a Function of Temperature After 3 Weeks Storage at 75°F	23
VII	Discharge Performance of Fresh Life Support Cells of the Third Build as a Function of Temperature	25
VIII	Discharge Performance of the Third Build of Life Support Cells After One Month Storage at 140°F	30
IX	Voltage Characteristics of the Third Build of Life Support Cells After One Month Storage at 140°F	35
X	Discharge Performance of the Third Build of Life Support Cells After Two Months Storage at 140°F	36
XI	Voltage Characteristics of the Third Build of Life Support Cells After Two Months Storage at 140°F	37
XII	Discharge Performance of the Fourth Build of Life Support Cells - Fresh and After Two Months Storage at 140°F	40
XIII	Discharge Performance of the Fourth Build of Life Support Cells After Five Months Storage at 140°F	46
XIV	Discharge Performance of Fresh PRC-90 Batteries	49



LIST OF TABLES (Continued)

<u>Table</u>		<u>Page</u>
XV	Short-Circuit Test Results of Life Support Cells of the First Build	55
XVI	Maximum Power Test Results of Life Support Cells of the First Build	56
XVII	Hardware and Internal Component Designs for Spacecraft "A" Cells	80
XVIII	Hardware and Internal Component Designs for Spacecraft "B" Cells	83
XIX	Short-Circuit ( $\approx 0.02$ Ohms) Testing of a Spacecraft "B" Cell	113
XX	Discharge Performance of Spacecraft "B" Cells	117
XXI	Second Build of Life Support Cells Test Plan	123

## SUMMARY

In accordance with requirements of Air Force Contract No. F33615-74-C-2071, Honeywell Power Sources Center designed, fabricated, and tested hardware versions of the lithium inorganic electrolyte oxychloride battery system. Batteries for three potential operational uses were investigated in an effort to evaluate their performance capabilities for meeting optimum requirements for life support and spacecraft applications.

Goals embodying the desired performance of lithium inorganic electrolyte oxychloride batteries for future and conceptual equipment were defined in the Statement of Work as targets for the tasks specified. The results achieved in prototype hardware versions show improvement over current operational systems, and considerable progress toward achieving the goals set for operational uses of this technology.

The state of the art at the start of the project was embodied in the first series of Life Support Cells, built on the basis of previous experience with this technology at Honeywell and investigation into the literature. Two later series of Life Support Cells and two series each of the two different types of Spacecraft cells were built and tested on the basis of an analysis of the baseline series and ongoing cell improvement studies.

Recognizing the highly reactive chemistry of the cells, Honeywell performed tests on the larger Spacecraft Cells at their ordnance testing ground and devised a scheme for remote activation. Safety testing beyond that required by the project was carried out, which justified the care exercised in handling the Spacecraft Cells.

The most severe problem encountered with the baseline series of cells was polarization of the lithium anode due to a severely passivating film. Dramatic improvement was effected by the addition of 5 percent by weight of  $\text{SO}_2$  to the electrolyte solution. This response to the passivation problem was developed by laboratory studies based

BEST AVAILABLE COPY

on Honeywell's observation that cells stored after being partially discharged were less passivated than stored cells having no predischARGE and that SO<sub>2</sub> was among the discharge products. The studies also showed that a better quality electrolyte salt resulted in the formation of a thinner, less passivating film and that poor quality lithium also contributed to the passivation problem.

Another important improvement over the baseline cells developed by laboratory studies was in the cathode structure. The excellent voltage regulation exhibited by the later series of Life Support and Spacecraft Cells was due to an improved cathode structure.

By testing hardware models of cells and conducting cell improvement studies, Honeywell's efforts during this project advanced the state of the art of this technology as it applies to Life Support and Spacecraft functions. In so doing, specific areas were identified for continuing studies for meeting the goals set for these Air Force applications. The combination of long-term high-temperature storage and low-temperature operation still presents severe problems for meeting the requirements of Life Support Cells, but the less severe storage and performance requirements of the Spacecraft Cells can be met with only slight improvements to the state of the art as advanced during this project.

Recommendations indicated by this project include further experiments with electrolyte composition and the investigation of related inorganic electrochemical systems employing less reactive materials.

## SECTION I

### INTRODUCTION

Air Force Contract No. F33615-74-C-2071 provides for the design, fabrication, and test of lithium inorganic electrolyte oxychloride cells. The technical effort is divided into three separate tasks directed toward three applications referred to in the Statement of Work as Life Support (Task I), Spacecraft "A" (Task II), and Spacecraft "B" (Task III).

Fabrication requirements and performance goals for the three applications are presented in the body of this report. Briefly, Honeywell was required to design, fabricate, and evaluate an initial lot of cells in each category, based on prior experience and information contained in the literature; and to conduct exploratory development before designing, fabricating, and evaluating additional lots of improved cells. There were three lots of the Life Support Cell and two each of the Spacecraft "A" and Spacecraft "B" Cells.

This report also contains a detailed disclosure of cell design features and composition as required by the Statement of Work.

Efforts directed to Tasks I, II, and III of the Statement of Work are described under Life Support Cell, Spacecraft "A" Cell, and Spacecraft "B" Cell, respectively, in this report.

## SECTION II

### TECHNICAL APPROACH

This project was limited to wet-type lithium inorganic electrolyte cells for three classes of Air Force application, characterized as Life Support (Task I), Spacecraft "A" (Task II), and Spacecraft "B" (Task III). Specific design requirements for each application were implied in the performance goals set for each class of cell. Initial weight and volume objectives were calculated based on capacity objectives, anticipated average cell voltages and energy objectives. Current handling capability was the commanding requirement for the Life Support Cell and the Spacecraft "A" Cell, and volumetric energy density capability was the commanding requirement for the Spacecraft "B" Cell. Current densities of  $5.0 \text{ mA/cm}^2$  and  $10.0 \text{ mA/cm}^2$  were used for the initial design of cell components for Life Support Cells and Spacecraft "A" cells, respectively. These goals represent desired performance for batteries to be applied to future and conceptual equipment. Table I contains a summary of these objectives for the three types of cells.

An initial series of Life Support Cells was developed to demonstrate the state of the art for this type of cell using a  $1.5\text{M LiAlCl}_4\text{-SOCl}_2$  electrolyte formulation. A test program was established to fully evaluate cells in terms of their ability to meet program goals and a cell improvement program was established to define and evaluate system loss factors and to implement improvements in design, components, and materials over those used in the initial construction.

The test results document the feasibility of developing a lithium inorganic electrolyte oxychloride battery that will meet the requirements for life support and the two types of spacecraft applications defined in the Statement of Work for this project. Not only has considerable progress been made toward achieving the optimum requirements for these Air Force operational applications, but also the problems requiring solution to meet these goals fully have been identified. The vastly improved performance of the later series of Life Support Cells and of the Spacecraft "A" and Spacecraft "B" Cells was based on the analysis of the baseline performance and the

TABLE I  
BATTERY GOALS

Battery Performance Objective	Life Support	Spacecraft "A"	Spacecraft "B"
Energy Density:			
Watt-hours per pound	120 <sup>2</sup>	175	350
Watt-hours per cubic inch	18 <sup>2</sup>	15	25
Capacity (Amp hours)	2.64 <sup>2</sup>	220	600
Expected System Operating Voltage (Avg)	3.3	3.2	3.5
Weight <sup>1</sup>	1.2 oz (33 g)	4.02 lb (1.82 kg)	6.0 lb (2.72 kg)
Volume <sup>1</sup>	0.4 in <sup>3</sup> (6.6 cc)	47 in <sup>3</sup> (770 cc)	84 in <sup>3</sup> (1377 cc)
Voltage Regulation:			
% of Avg load plateau voltage for % of useful life	± 2 80	± 2 95	± 2 95
Open Circuit and End of useful Life:			
% of Avg load plateau voltage	± 20	± 25	± 20
Voltage Rise Time for all load changes:			
% of Avg Plateau voltage Time (milliseconds)	± 20 100	± 10 5	± 10 5
Operating Temperature Range:			
F	-65 to 165	50 to 140	40 to 120
C	-53.9 to 73.9	10 to 60	4.4 to 48.9
Storage Loss:			
% Allowable/ Duration/Temperature	20% 5 yr/ 75° F/ or 1 yr/ 140° F	16% 1 yr/ 80° F	5% 6 mo/ 80° F
Reliability/Confidence Level	0.999/0.95	0.999/0.97	0.999/0.97
Safety	Safe to carry	Not Specified	Not Specified
Cost/Watt-hour/Quantity Basis	\$0.25/150000	Not Specified	Not specified

<sup>1</sup> Based on Expected System Operating Voltage (average) and Energy Density Objective.

<sup>2</sup> Above 50° F (10° C).

cell improvement studies that resulted from this analysis and from Honeywell's experience with the lithium inorganic electrolyte oxychloride technology.

Prior experience at Honeywell also dictated that the same chemistry could be used to meet the goals of all three cell types in the project. Therefore, the large part of the cell improvement studies were conducted on the less expensive Life Support Cells. A whole series of these cells (second series) were used for cell improvement studies addressing the lithium passivation problem. The resulting improvements were incorporated into the final two series of Life Support Cells and all series of the Spacecraft Cells.

Special attention was given to safety considerations throughout the project, especially in the handling of the Spacecraft Cells. This emphasis had led to formulating detailed logistic procedures in carrying out tests on large Li/SOCl<sub>2</sub> cells. Also, examination of materials compatibility, the measurement of vapor pressure and density of the electrolyte, and other investigations that did not result in improvements to the final series of cells were investigated for use in future cell studies.

SECTION III  
LIFE SUPPORT CELLS

A. GENERAL

The total program effort for the Life Support Cell resulted in the fabrication of four series of experimental hardware cells and 10 prototype PRC batteries.

The first series of Life Support Cells fabricated and tested under this program provided the baseline data representing the state of the art at the beginning of the project. Improvements were incorporated into other series of Life Support Cells as well as into both series of Spacecraft "A" and Spacecraft "B" Cells on the basis of the experience gained and observations made on this first series.

Although exploratory development was planned from the outset to improve cells scheduled for subsequent fabrication, the severe polarization experienced with the first series of Life Support Cells caused the priorities of cell improvement studies to shift to the solution of anode passivation, the cause of the severe polarization. The second series of Life Support Cells was devoted to the solution of this problem.

The third series was then subject to the established test and evaluation program, but further passivation problems prompted Honeywell to produce and evaluate a fourth series on their own initiative to provide a better example of the state of the art in accomplishing the goals set forth for this Air Force application. (The entire passivation problem is discussed under "Cell Improvement Studies" in this report.)

The final series of Life Support Cells tested under this program approached the capacity and energy goals set for Air Force application to life support equipment under optimum conditions of storage and temperature during discharge testing. They exhibited a marked improvement over the baseline performance of the first series. Their performance at low temperature after high temperature storage, however, was far short of these performance goals. Even under these adverse conditions, however, the improvements incorporated into the later series of Life Support Cells resulted in a marked improvement over the baseline performance.



The design, fabrication, and evaluation of the PRC batteries was the result of a tradeoff of original project tasks mutually advantageous to the Air Force and Honeywell.

## B. DESIGN AND FABRICATION

The cross section of the Life Support Cell in Figure 1 and the photograph in Figure 2 apply to each of the four series of cells fabricated. Many of the cell components are standard Honeywell parts. As Figure 1 shows, the case is 316L stainless steel and the terminal pin incorporated into the glass-to-metal seal is 52 alloy. After construction of the spiral-wrap electrodes in the case, the cover was projection-welded in place. The cells were built in Honeywell's dry room facility, where the relative humidity is maintained below 4 percent. Activation was accomplished in a closed system, by first evacuating the cell through a hole in the bottom of the case, and then automatically metering the electrolyte into the cell. The final seal is a hermetic, ball seal.

### 1. First Series (Honeywell #G3013)

One hundred cells were built for this series. Table II presents a description of the component designs. Cathode thicknesses and weights were controlled within  $\pm 0.003$  inch and at 0.563 ( $\pm 0.012$ ) gram, respectively. The anodes weighed an average of 0.375 gram and were capable of providing a capacity of 1.45 ampere-hours. The electrode designs were such that cell capacity was to be limited by the positive electrode.

The electrolyte (1.5M  $\text{LiAlCl}_4 \cdot \text{SOCl}_2$ ) was prepared using lithium tetrachloroaluminate salt (7.4 parts per million iron) purchased from Foote Mineral Company, and thionyl chloride purchased from Matheson, Coleman & Bell. The  $\text{SOCl}_2$  had a yellow coloration which may be attributed to impurities such as sulfur chlorides, sulfur dioxide, and/or sulfuryl chloride.

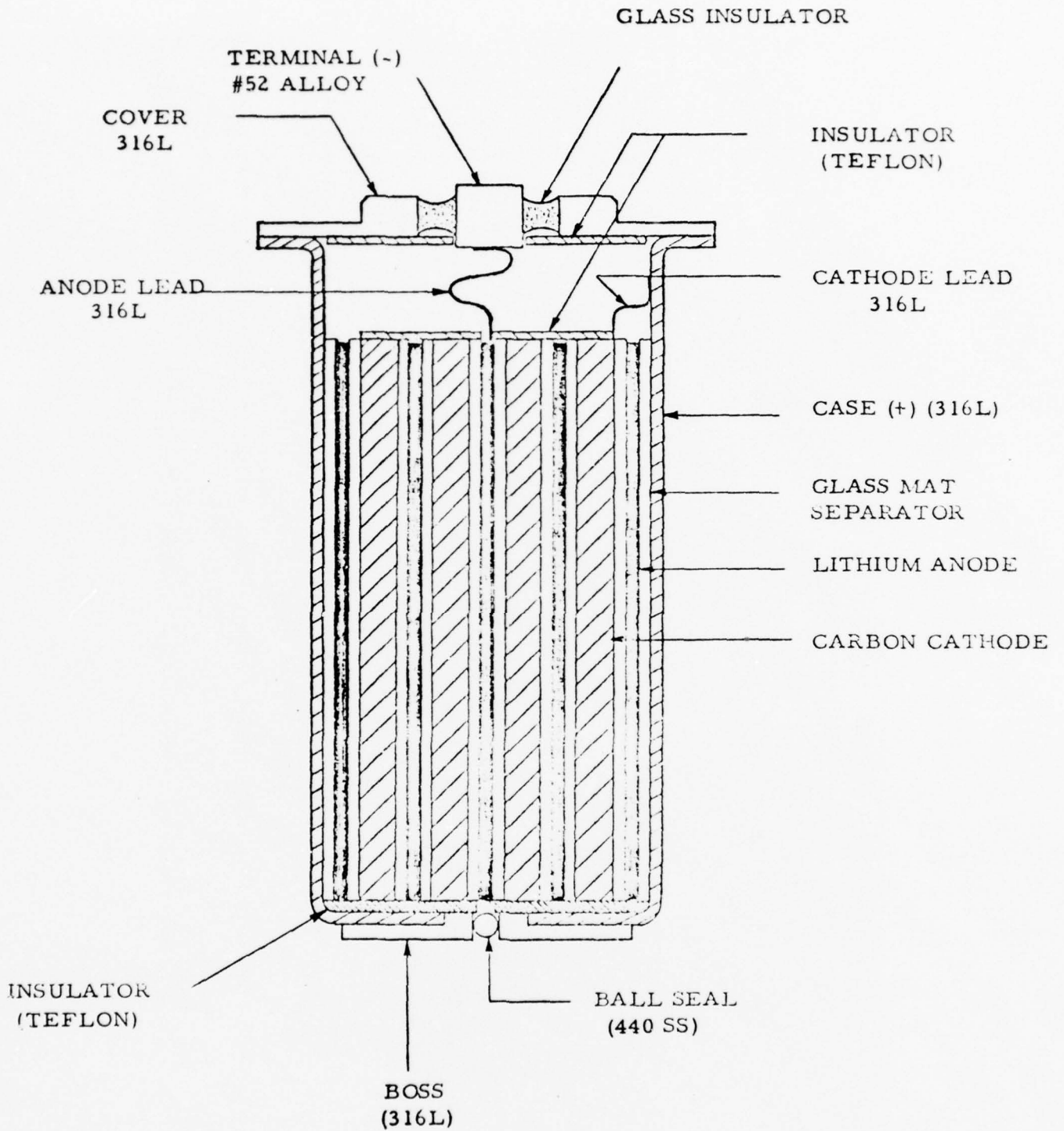

Figure 1. Cross Section of Life Support Cell



Figure 2. Photographic View of a Life Support Cell

TABLE II  
COMPONENT DESIGNS USED IN THE FIRST BUILD OF LIFE SUPPORT CELLS

<u>Hardware/Internal Components</u>	<u>Dimensions</u>	<u>Description</u>
Cell Case	ID: 0.580"	316L Stainless Steel
Cathode	1.880" x 0.970" x 0.062"	1) Cathode made by slurry process 2) Cathode Composition: 80% Shawinigan Carbon and 20% TFE binder 3) Net cathode weight: 0.563 g 4) Collector Grid: (Delker) 5-316L-8-284
Anode	2.600" x 0.970" x 0.017"	1) Lithium 2) Collector Grid: (Delker) 5-316L-8-284
Separator	9.500" x 1.050" x 0.015" (one layer)	Hollingsworth H-932 Glass Mat
Electrolyte	3.70 cc	1) LiAlCl <sub>4</sub> Concentration: 1.5 Molar 2) Density: 1.685 g/cc
Carbon to Electrolyte Weight Ratio	0.07	

During electrolyte preparation, the solution coloration changed from light brown to pink, and finally to deep purple after an overnight stand. This was attributed to the presence of an organic solvent\* in the  $\text{LiAlCl}_4$  salt. Salt containing large amounts of the organic solvent appears yellow, compared to the light brown color of material made in-house by fusing  $\text{LiCl}$  and  $\text{AlCl}_3$ . The capacity delivered from freshly activated cells using the yellowish salt was severely degraded. Therefore, only  $\text{LiAlCl}_4$  salt prepared "in-house" was used in the electrolyte preparation for later series.

Cathodes were made by a slurry process. A mixture of 11.43 grams carbon and 700 cc (approx.) distilled  $\text{H}_2\text{O}$  was stirred gently with an electric mixer until thorough dispersion was achieved. Under controlled conditions, 3.2 cc of PTFE\*\* (Type-30 dispersion) was then added. When the mixture became slurry, 0.72 gram of paper pulp was introduced, and the mixture was stirred at 500 rpm for approximately 1 minute.

To form the cathodes, half of the slurry was poured into a vacuum mold 7-3/4 inches x 7-3/4 inches to remove the excess water. A sharkskin filter paper had been placed on the bottom of the mold. An electrode collector grid was then pressed onto the molded mix, and the remaining half of the slurry was poured on top. After the excess water was again removed and a second sharkskin filter paper had been placed on top of the molded cathode, the package was sandwiched between two blotter papers and subjected to 25 psi hydraulic pressure to remove most of the remaining water.

The cathodes were trimmed to their predetermined dimensions and placed in an air oven at +685 F for 15 minutes to burn off the paper pulp and to sinter the cathodes.

## 2. Second Series (Honeywell #G3013)

Eighty-six cells were built for this series. Table III presents a description of the component designs.

\* Vendor patent pending.

\*\* Polytetrafluoroethylene.

TABLE III

## COMPONENT DESIGNS USED IN THE SECOND BUILD OF LIFE SUPPORT CELLS

Hardware/Internal Components	Dimensions	Description
Cell Case	ID: 0.590"	316L Stainless Steel
Cathode	2.900" x 0.950" x 0.042"	1) Cathode made by cold press process 2) Cathode composition: 80% Shawinigan Carbon and 20% TFE binder 3) Net cathode weight: 0.800 g 4) Collector grid: (Delker) 5-316L-8-284
Anode	3.600" x 0.970" x 0.016"	1) Lithium 2) Collector grid: (Delker) 5-316L-8-284
Separator	10.000" x 1.100" x 0.005" (two layers)	Mead's p-255 Glass Mat with acrylic binder
Electrolyte	3.50 cc	1) LiAlCl <sub>4</sub> concentration: 1.5 Molar 2) Density: 1.685 g/cc
Carbon to Electrolyte Weight Ratio	0.108	

To improve cell performance for this series, the following changes were incorporated:

- a. Apparent surface area was increased for both the negative and positive electrodes. This was expected to reduce cathode polarization and the voltage delay associated with passivated anodes.
- b. Cathode structures were prepared by a dry compaction process. The use of unsintered cold-pressed cathodes circumvented possible problems with carbon oxidation in cathodes made by the slurry technique.
- c. Carbon active sites were increased and electrodes were optimized for thickness. This was expected to improve cell capacity.

The dry compaction process used to prepare the cathodes for this series employed the same basic technique described for the slurry process, but paper pulp was not added. Instead, the carbon-PTFE mix was poured into a vacuum mold to remove the excess water, placed in a vacuum oven at 300°F, and the resultant dry mix was micronized and then put into a mold under a pressure of approx. 100 psi. The cathodes were not sintered.

### 3. Third Series (Honeywell #G3013C)

One hundred cells were built for this series. These cells incorporated design changes developed during laboratory studies on the second series to alleviate severe passivation. The most significant differences were net cathode weight, dimensions of the lithium electrode, and the composition of the electrolyte solution. Table IV presents a description of the component designs.

### 4. Fourth Series (Honeywell #G3013C)

Forty cells were built for this series, which was independent of the contract and aimed at producing cells embodying the best state-of-the art knowledge in Li/SOCl<sub>2</sub> technology. Component designs were the same as those used in the third series.

TABLE IV

COMPONENT DESIGNS USED IN THE THIRD AND FOURTH BUILDS OF

LIFE SUPPORT CELLS

<u>Hardware/ Internal Components</u>	<u>Dimensions</u>	<u>Description</u>
Cell Case	ID: 0.590"	316L stainless steel
Cathode	2.90" x 0.95" x 0.045"	1) Cathode made by cold press process. 2) Cathode Composition: 80% Shawinigan Carbon and 20% TFE binder 3) Net Cathode Wt: Mean - 0.905 g 4) Collector Grid: (Delker) 5-316L-8-284
Anode	2 layers (one 3.60" x 0.97" x 0.010" & one 2.10" x 0.97" x 0.010")	1) Lithium 2) Collector Grid: (Delker) 5-316L-8-284
Separator	10.0" x 1.10" x 0.005"	Mead's p-255 glass mat w/acrylic binder
Electrolyte	Fill Volume: Mean - 3.69 cc Standard Dev. - ± 0.08 cc	1) Composition: 1.5M LiAlCl <sub>4</sub> ·SOCl <sub>2</sub> + 5.0% SO <sub>2</sub> by weight 2) Density: 1.655 g/cc
Carbon to Electrolyte Weight Ratio	0.12	



(See Table IV) The lithium, however, was purchased from a different supplier, in an attempt to overcome the passivation problem which persisted during the third series and had been traced to the lithium used.

#### 5. PRC-90 Battery

Ten PRC-90 batteries were built based on the Life Support Cell design. A description of the cell design is presented in Table V. The battery contains four series-connected cells jacketed with ABS plastic, as illustrated in Figure 3. It was designed to deliver 1.8 ampere-hours and an energy density of 12 watt-hours/in<sup>3</sup> when discharged under cyclic loads of 120 mA (30 minutes) and 45 mA (30 minutes).

### C. TEST PROGRAM

#### 1. Project Requirements

Discharge conditions specified for testing Life Support Cells were 120 mA for 30 minutes followed by 45 mA for 30 minutes, the two conditions alternating until the voltage drops below 80 percent of the average voltage. Tests were to be conducted at temperatures ranging from -65°F to 165°F following temperature soak for 16 hours at the specified temperatures.

It was further specified that the cells should be safe to carry on one's person and that a voltage delay of no more than 100 ms be achieved. (Voltage delay is the time required for a cell to attain 80 percent of its average discharge voltage at the start or after a change in external load.)

#### 2. Description of Tests

The test plan for the Life Support Cells consisted of discharge testing, storage testing, and safety testing.

TABLE V

COMPONENT DESIGNS OF CELLS USED IN THE PRC-90 BATTERIES

<u>Hardware/Internal Components</u>	<u>Dimensions</u>	<u>Description</u>
Cell Case	ID: 0.917"	1) 304 stainless steel
Cathode	0.49" x 5.70" x 0.04"	1) Cathode made by cold press process
		2) Cathode Composition: 80% Shawinigan Carbon and 20% Teflon binder
		3) Net Cathode Weight: 0.893 g
		4) Collector Grid: 5SS8-284 (Delker)
Anode	0.49" x 7.07" x 0.02"	1) Lithium
		2) Collector Grid: 5Ni8-289
Separator	0.51" x 16.0" x 0.005" (2 layers)	1) Material: Mead's p-255 glass mat
Electrolyte	3.73 cc	1) Composition: 1.5M LiAlCl <sub>4</sub> ·SOCl <sub>2</sub> + 5 wt % SO <sub>2</sub>
Carbon to Electrolyte Wt Ratio	0.116	

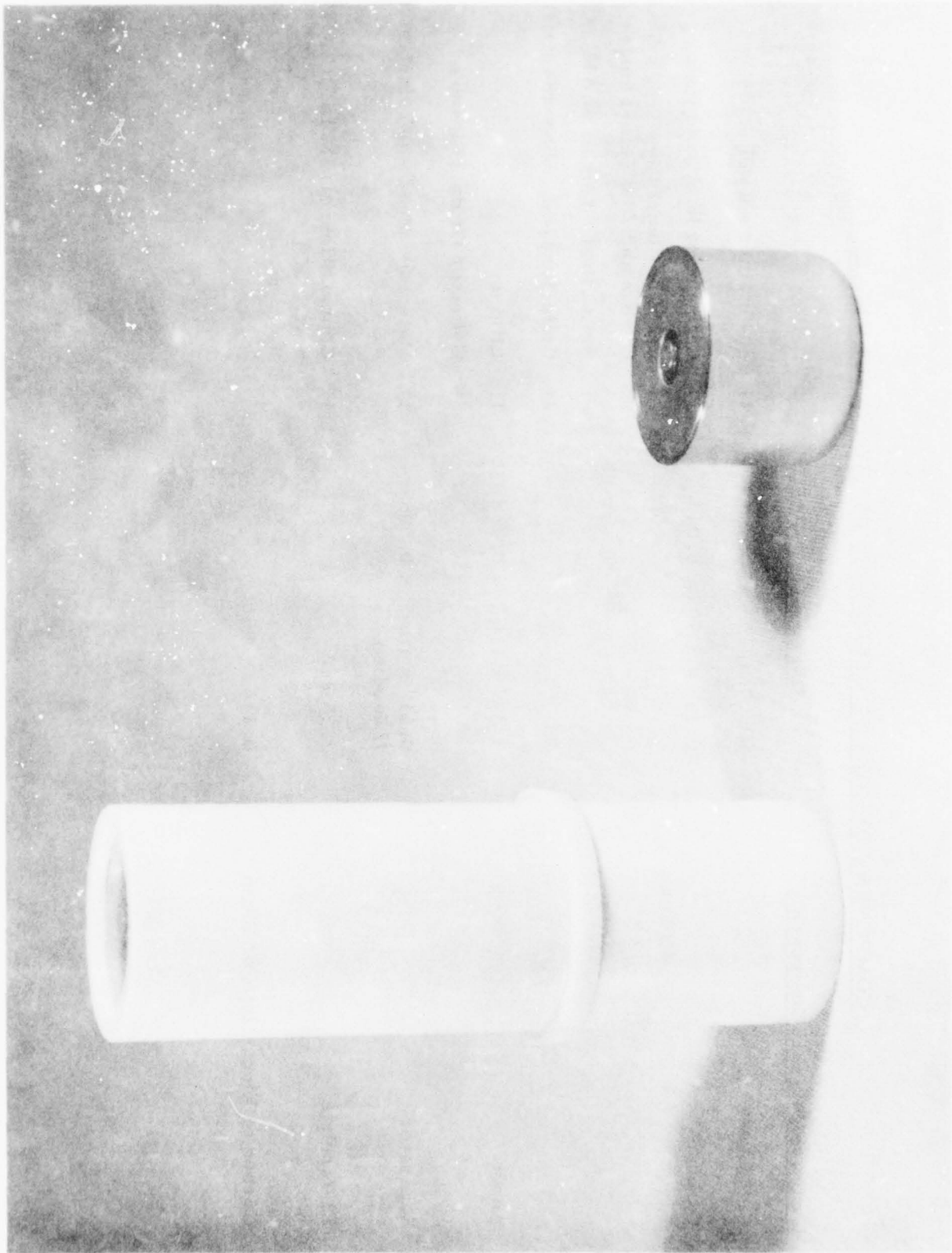

Figure 3. Lithium/Thionyl Chloride PRC-90 Battery and Cell

The discharge tests were performed using the circuit illustrated in Figure 4, two randomly selected cells being tested at each of nine different temperatures from  $-65^{\circ}\text{F}$  to  $165^{\circ}\text{F}$ . The cells were subjected to temperature conditioning for 16 hours under OCV conditions before testing at the specified temperatures. The discharge was under constant current conditions starting with a load of 120 mA for 30 minutes, followed immediately by a load of 45 mA for 30 minutes - the cycle being repeated until the cell voltage falls more than 20 percent below the average voltage level. The basic raw data collected was (1) cell voltage versus time and (2) the voltage response at the start of the 120 mA load application on stored cells.

The storage test consisted of storage at  $140^{\circ}\text{F}$  for periods of 1, 2, 5 and 12 months. After storage, randomly selected cells were subjected to discharge testing to determine the effects of long-term, high-temperature storage on cell performance.

Five cells each of the first and third series were subjected to short circuit test, and five to maximum-power testing. All testing of this type was conducted at room temperature ( $\approx 72^{\circ}\text{F}$ ). For short-circuit tests, the resistance value of an ammeter in the circuit was used to record the short circuit current until the cell was depleted. The temperature of the case was monitored throughout the test by attaching a chromel-alumel thermocouple to the case. Dimensional and physical characteristics of the cell before and after short circuit were recorded. The maximum power point was found by determining experimentally the voltage at which the product of cell voltage and the current is a maximum. The cells were then tested under the I (max) E (max) condition for maximum power.

#### D. TEST RESULTS

This section contains the data produced by the regular test program set up in response to the project requirements. Developmental tests performed in connection with laboratory studies are reported in the section entitled "Cell Improvement Studies".

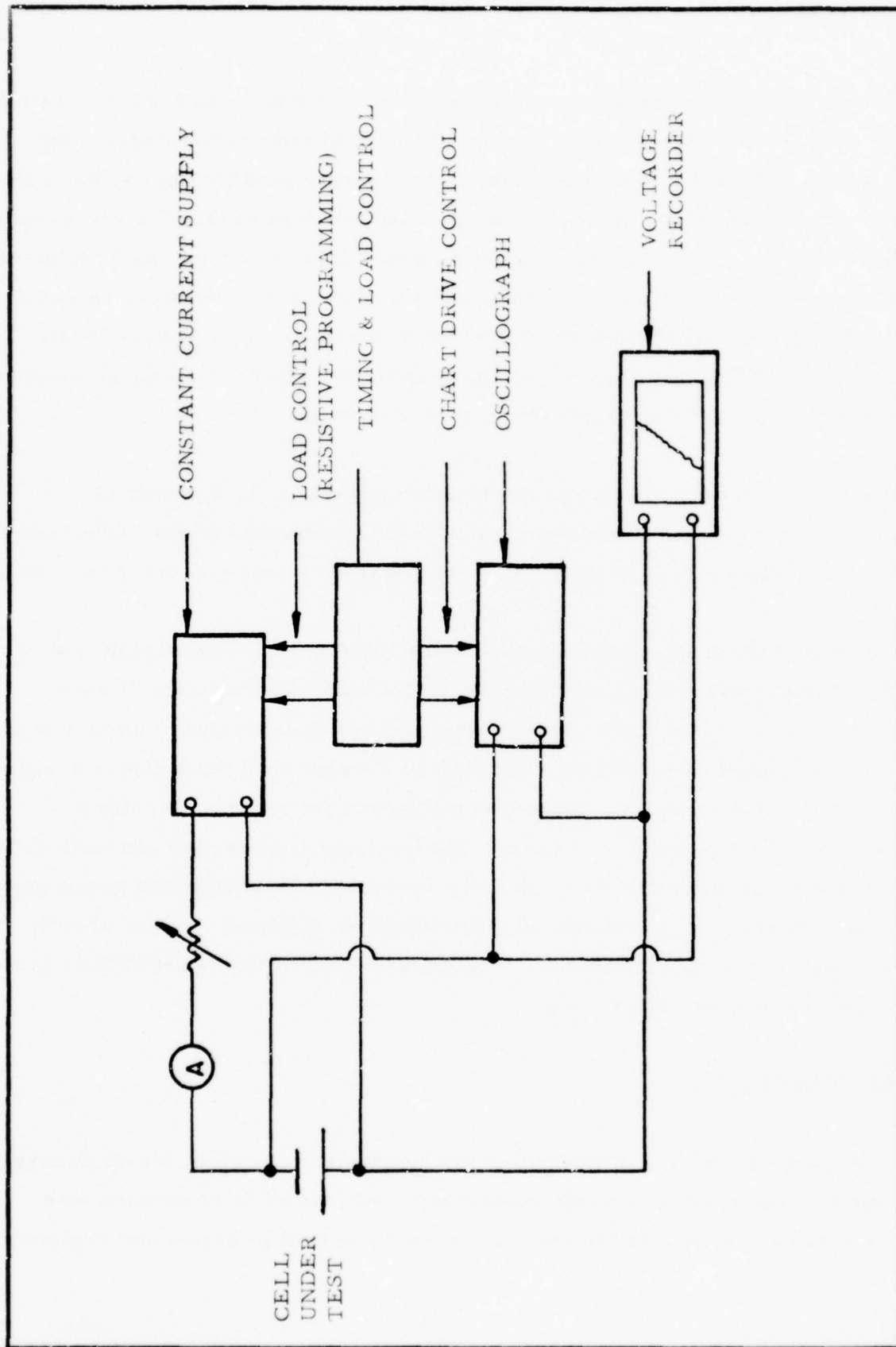

Figure 4. Life Support Cell Test Circuit

The second series of cells were not subject to the test program; therefore they are not reported in this section. Cells from the first and third series subjected to safety tests are reported in a separate subsection below.

### 1. First Series

Only one fresh cell of the first series was discharged immediately after activation. The 18 cells that were to provide baseline information for fresh cell performance at the nine temperatures between  $-65^{\circ}\text{F}$  and  $165^{\circ}\text{F}$  showed severe passivation after being kept at room temperature for only 3 weeks. The discharge history of the one fresh cell is presented in Figure 5. Figures 6 and 7 illustrate the discharge performance of 2 of the 18 cells after storage for 3 weeks at room temperature. Tests were not run at temperatures below  $75^{\circ}\text{F}$  because of the anode passivation. Table VI contains a summary of the results of tests on the first series after storage at 3 weeks at room temperature.

To evaluate the performance of the 72 cells subjected to high temperature storage several cells were discharged after 1 month storage. Figure 8 confirms the severe effects of passivation.

### 2. Second Series

Not subject to test as explained above. (See Section entitled "Cell Improvement Studies".)

### 3. Third Series

Two fresh cells at each of nine different temperatures were subjected to discharge testing. All performance data are presented in Table VII. Figures 9, 10, 11, and 12 show the discharge performance of four of the fresh cells at  $165^{\circ}\text{F}$ ,  $75^{\circ}\text{F}$ ,  $0^{\circ}\text{F}$  and  $-20^{\circ}\text{F}$ , respectively.

System: Li/1.5M LiAlCl<sub>4</sub>/SOCl<sub>2</sub>/SOCl<sub>2</sub>, C  
Device: Life Support Cell  
Loads: 120 mA (30 min) - 45 mA (30 min)  
Cell No: LS-108  
Cell Build: First

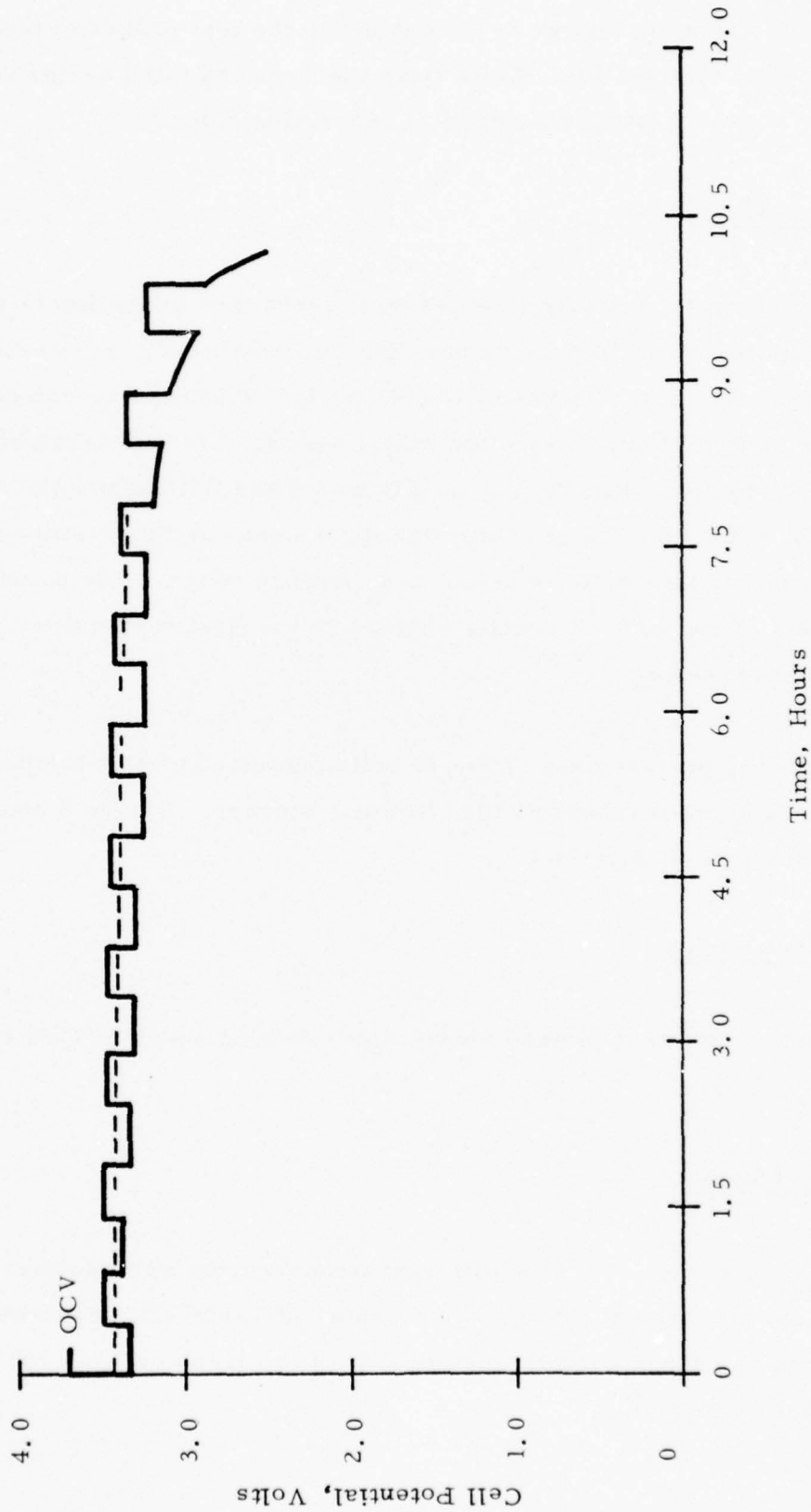

Figure 5. Discharge Performance of a Fresh Life Support Cell at 75°F

System: Li/1.5M LiAlCl<sub>4</sub>·SOCl<sub>2</sub>/SOCl<sub>2</sub>, C  
Device: Life Support Cell  
Loads: 120 mA (30 min) - 45 mA (30 min)  
Cell No: 120  
Cell Build: First

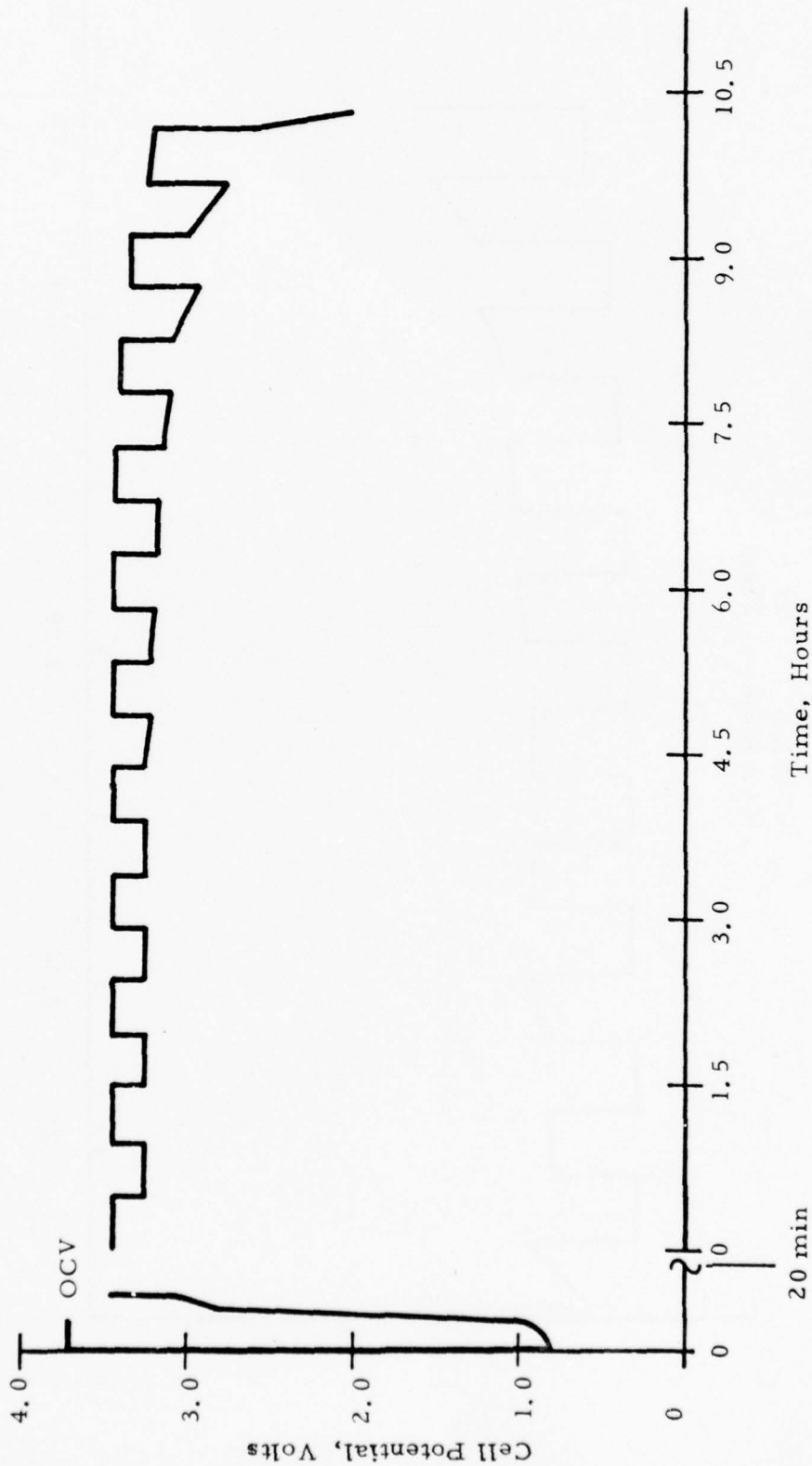

Figure 6. Discharge Performance of a Life Support Cell at 75°F  
After 3 Weeks Storage at 75°F



System: Li/1.5M LiAlCl<sub>4</sub>.SOCl<sub>2</sub>/SOCl<sub>2</sub>, C  
Device: Life Support Cell  
Loads: 4 Ω to 0.5V followed by 120 mA (30 min)  
- 45 mA (30 min)  
Cell No: 72  
Cell Build: First

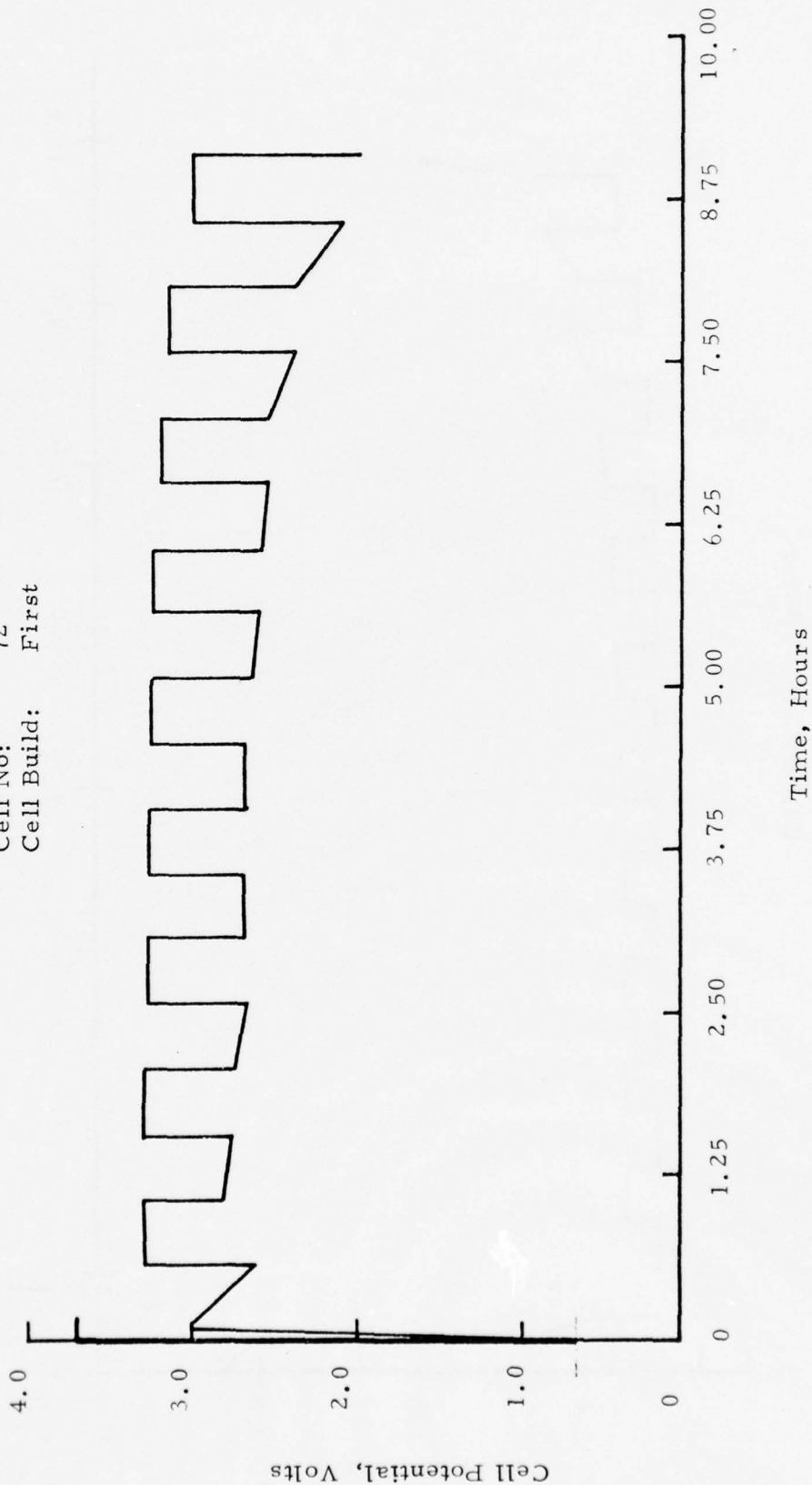

Figure 7. Discharge Performance of a Life Support Cell at 120°F After 3 Weeks Storage at 75°F

TABLE VI

DISCHARGE PERFORMANCE OF LIFE SUPPORT CELLS OF THE FIRST SERIES  
AS A FUNCTION OF TEMPERATURE AFTER 3 WEEKS STORAGE AT +75°F

Cell No.	Average Plateau Voltage	Capacity, Ahr*	Energy Density		Temp., °F
			Whr/in <sup>3</sup>	Whr/lb	
120	3.33	0.85	7.08	70.76	75
71	2.85	0.71	5.06	50.59	75
72	2.95	0.67	4.94	49.41	120
73	2.76	0.45	3.10	31.05	120
74	3.06	0.72	5.51	55.08	165
75	2.79	0.59	4.11	41.15	165

\*Capacity based on a cell cutoff voltage of 80% of average plateau voltage.

System: Li/1.5M LiAlCl<sub>4</sub> · SOCl<sub>2</sub>/SOCl<sub>2</sub>, C  
Device: Life Support Cell  
Loads: 120 mA (30 min.) - 45 mA (30 min)  
Cell No: 91  
Cell Build: First

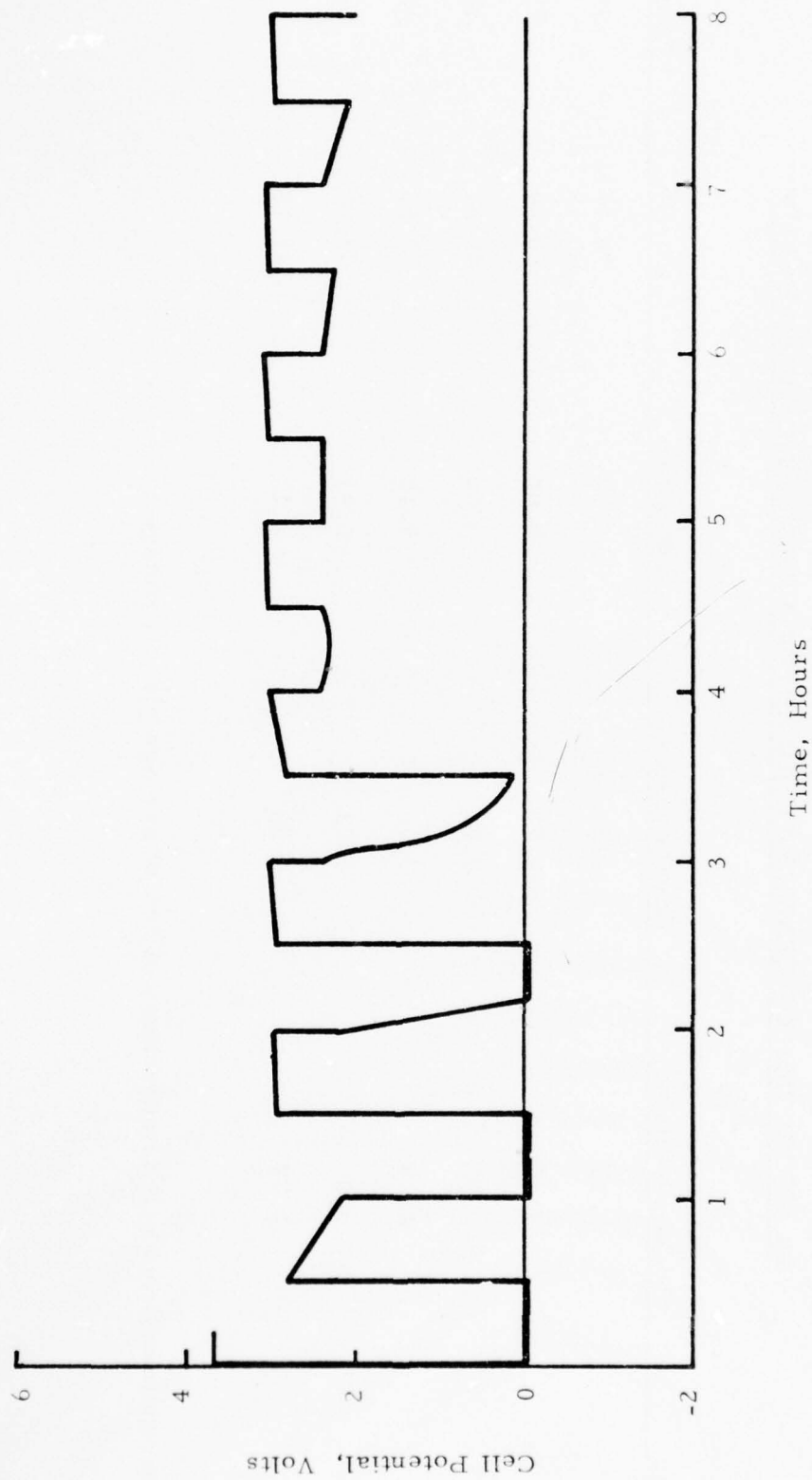

Figure 8. Discharge Performance of a Life Support Cell at 75°F  
After One Month Storage at 140°F

TABLE VII

DISCHARGE PERFORMANCE OF FRESH LIFE SUPPORT CELLS OF THE THIRD BUILD AS AFUNCTION OF TEMPERATURE

Cell #	OCV	Temp., °F	Wt. of SOCl <sub>2</sub> , g	Utilization <sup>**</sup> of SOCl <sub>2</sub> , %	Midpoint Voltage, V	Capacity,* Ahr	Whr/in <sup>3</sup>	Energy Density Whr/lb
303	3.66	165	4.91	70.9	3.54	1.57	12.9	139
304	3.66	165	4.99	67.1	3.54	1.51	12.4	134
315	3.67	124	4.75	75.2	3.50	1.61	13.1	141
314	3.67	124	4.73	73.6	3.50	1.57	12.8	137
302	3.64	75	5.07	72.6	3.41	1.66	13.2	142
308	3.64	75	4.62	76.8	3.41	1.60	12.7	136
316	3.68	50	4.91	71.8	3.37	1.59	12.5	134
317	3.68	50	4.78	72.8	3.37	1.57	12.3	132
318	3.70	32	4.78	68.2	3.26	1.47	11.1	120
319	3.70	32	4.81	66.8	3.28	1.45	11.1	119
320	3.70	0	4.79	53.7	3.00	1.16	8.1	87
321	3.70	0	4.78	53.8	3.00	1.16	8.1	87
311	3.70	-20	4.82	35.0	2.90	0.76	5.1	55
313	3.70	-20	4.90	35.3	2.90	0.78	5.3	57
309	3.72	-40	4.99	29.3	2.70	0.66	4.1	45
310	3.72	-40	4.73	29.3	2.70	0.66	4.1	45
305	3.70	-65	4.85	19.2	2.62	0.42	2.6	28
306	3.70	-65	4.98	18.7	2.62	0.42	2.6	28

\*Based on 2.0 volt cutoff at the average life support load of 0.0825 amp.

\*\* Based on a net 2e reaction.

System: Li/1.5M LiAlCl<sub>4</sub> · SOCl<sub>2</sub> · SO<sub>2</sub>/SOCl<sub>2</sub>, C  
Device: Life Support Cell  
Loads: 120 mA (30 min) - 45 mA (30 min)  
Cell No: 303  
Cell Build: Third

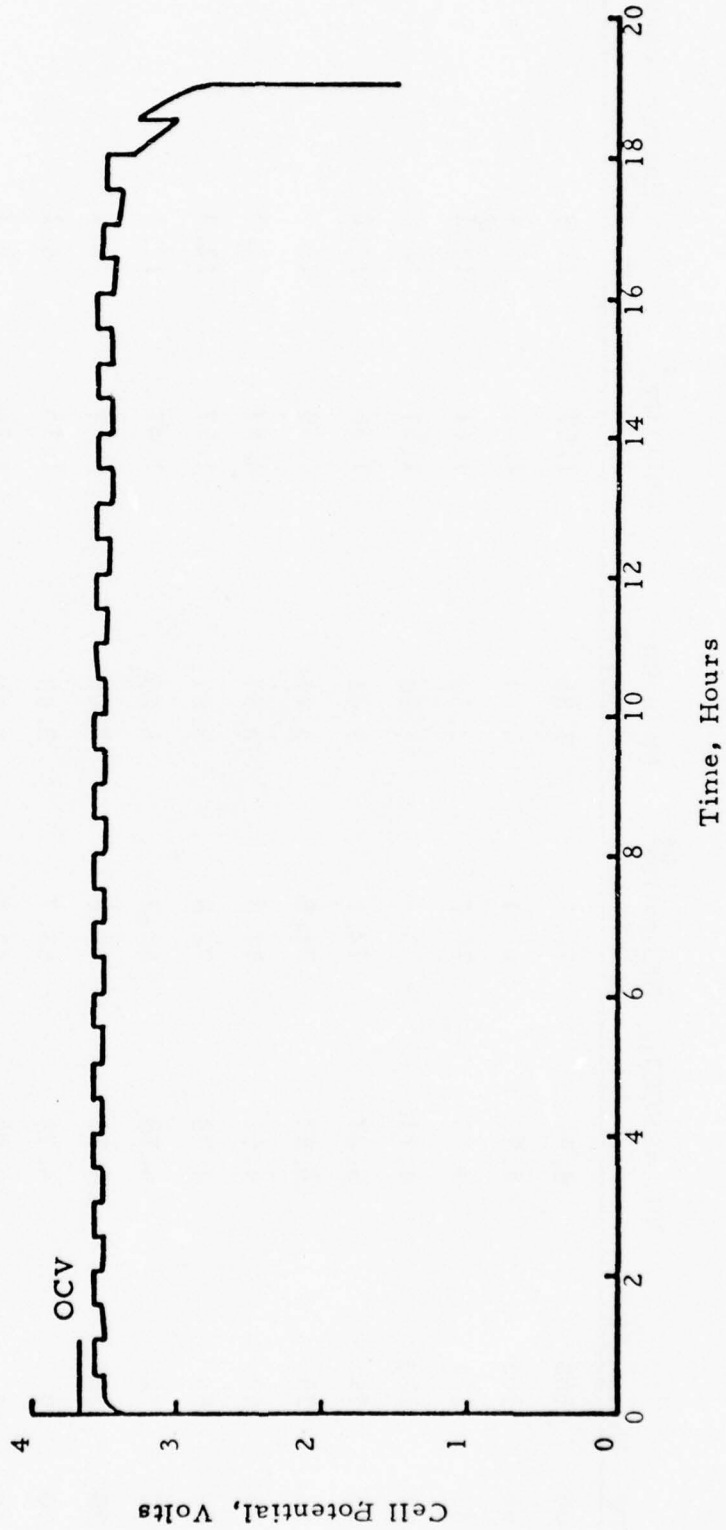

Figure 9. Discharge Performance of a Fresh Life Support Cell at 165°F

System: Li/1.5M LiAlCl<sub>4</sub> · SOCl<sub>2</sub> · SO<sub>2</sub>/SOCl<sub>2</sub>, C  
Device: Life Support Cells  
Loads: 120 mA (30 min) - 45 mA (30 min)  
Cell No: 302  
Cell Build: Third

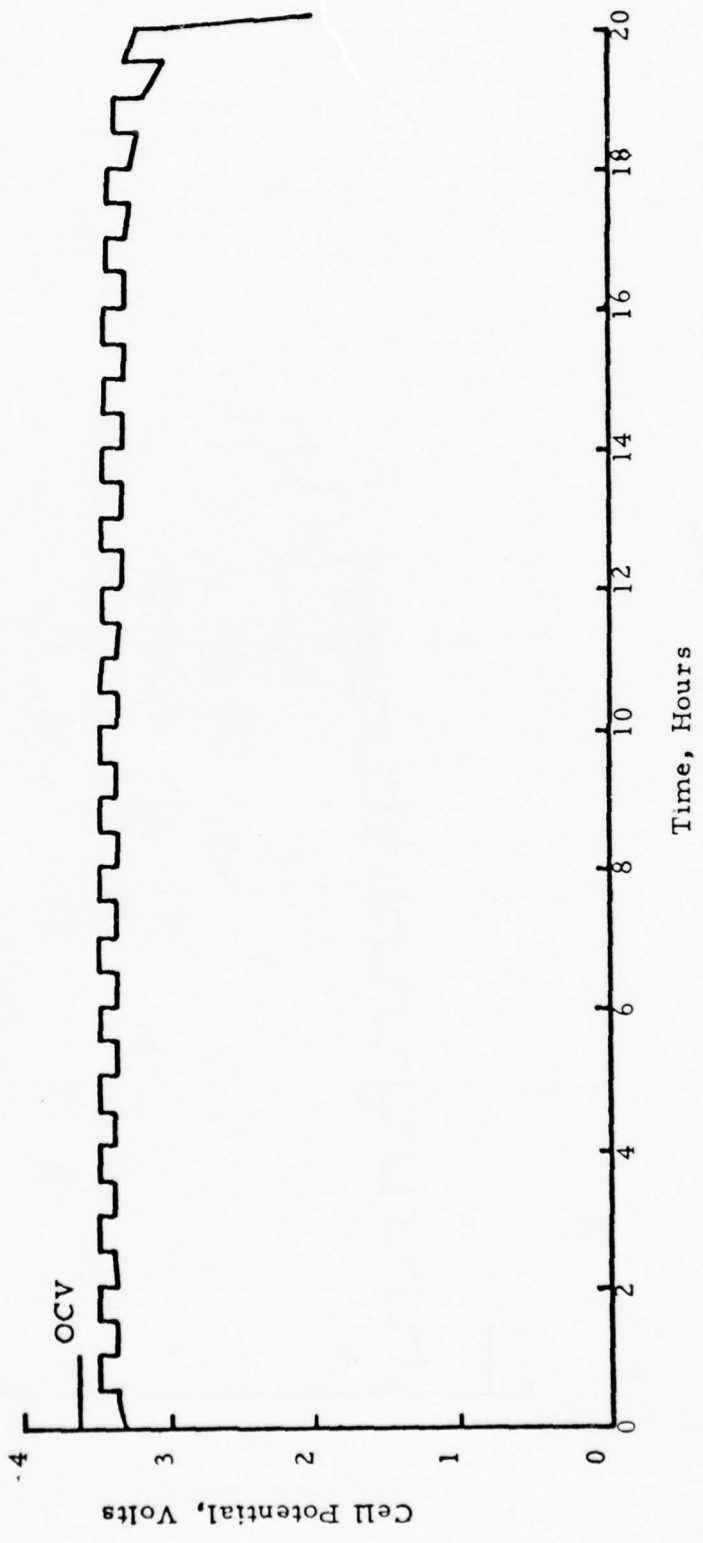

Figure 10. Discharge Performance of a Fresh Life Support Cell at 75°F

System: Li/1.5M LiAlCl<sub>4</sub> · SOCl<sub>2</sub> · SO<sub>2</sub>/SOCl<sub>2</sub>, C  
Device: Life Support Cell  
Loads: 120 mA (30 min) -45 mA (30 Min)  
Cell No: 321  
Cell Build: Third

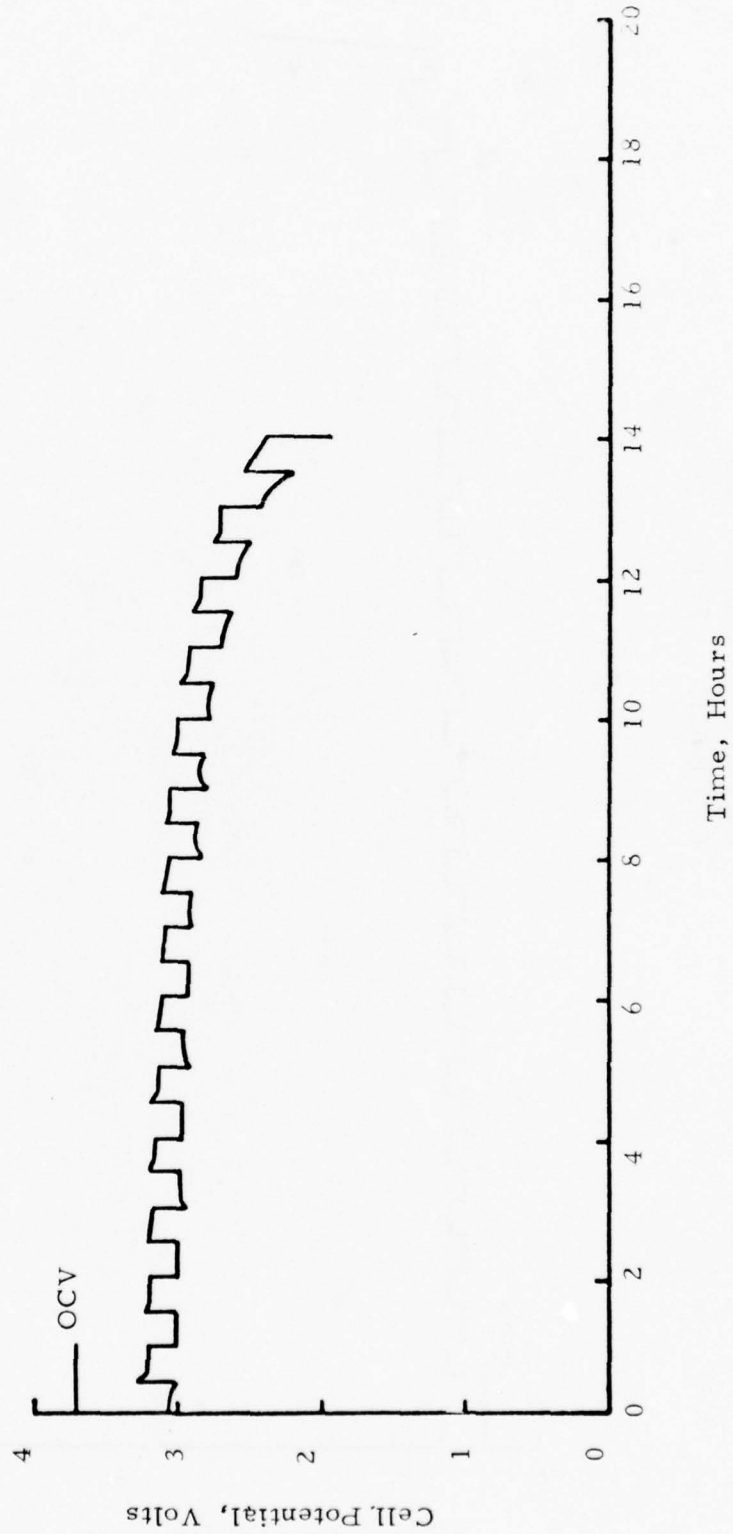

Figure 11. Discharge Performance of a Fresh Life Support Cell at 0°F

System: Li/1.5M LiAlCl<sub>4</sub> · SOCl<sub>2</sub> · SO<sub>2</sub>/SOCl<sub>2</sub>, C  
Device: Life Support Cell  
Loads: 120 mA (30 min) - 45 mA (30 min)  
Cell No: 313  
Cell Build: Third

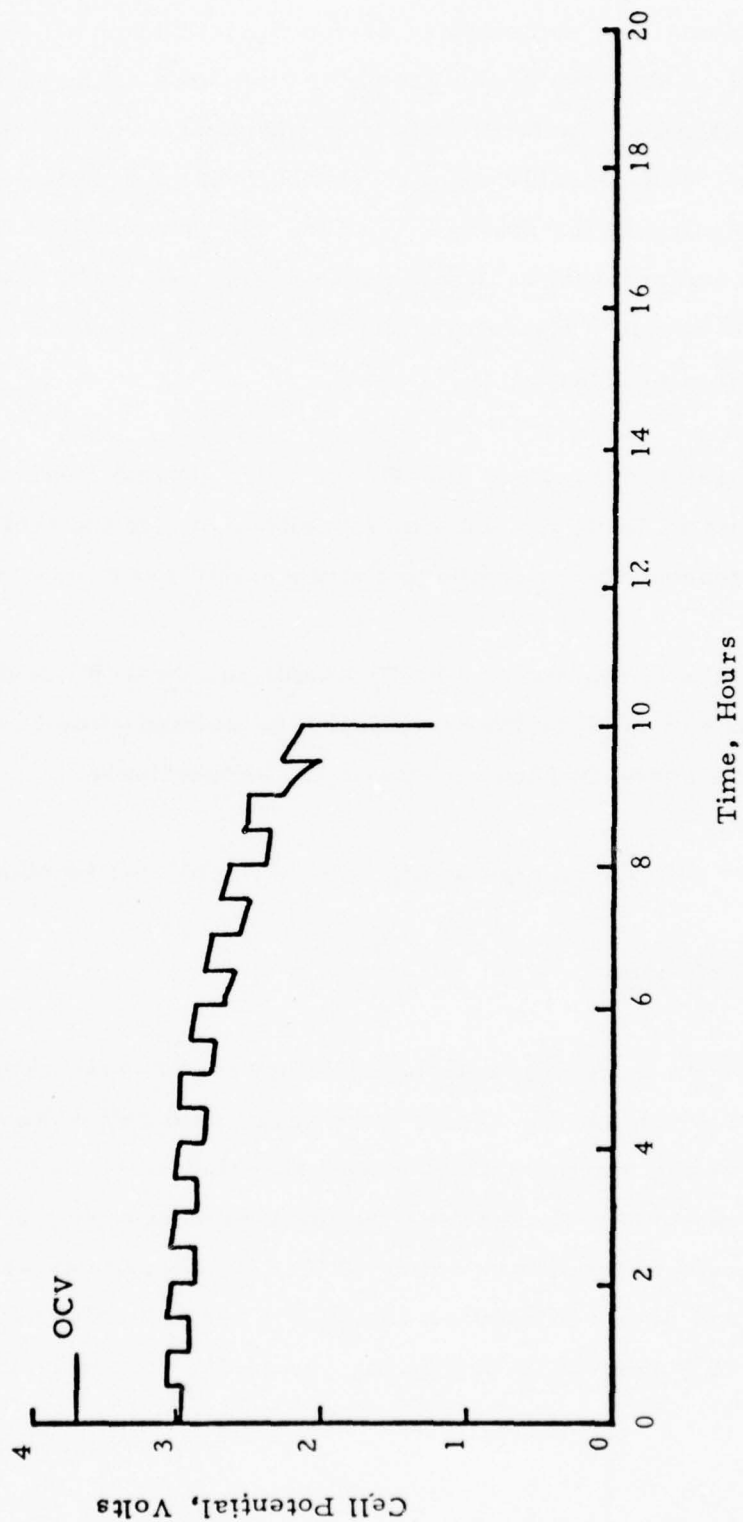

Figure 12. Discharge Performance of a Fresh Life Support Cell at -20°F



After 1 month storage at 140°F, the third series of cells began to show the effects of passivation. Heavy polarization precluded test at temperatures below 0°F. Table VIII contains a summary of performance data on all cells tested and Figures 13, 14, and 15 show the discharge history of three of the cells at 75°F, 32°F, and 0°F, respectively. Table IX shows the initial cell voltage response measured during these tests. Voltage delay characteristics become a consideration as passivation of the anode occurs during storage. In general, this problem increases at lower discharge test temperatures. Aberrations in this delay data (especially at 0°F) are probably the result of the limited quality control standards possible in a fabrication for this kind of program.

After 2 months of storage at 140°F, the cells showed continuing effects of passivation as shown in Table X. Only those cells shown in the table could be tested. Table XI presents the cell voltage characteristics for the 2 month tests.

After 5 months of storage at 140°F, useful cell capacity could not be obtained at temperatures of 50°F or lower. Discharge voltage-time curves of cells at 165°F and 75°F are shown in Figures 16 and 17, respectively.

After twelve months storage useful capacity could not be obtained at any temperature.

#### 4. Fourth Series

Table XII shows a summary of the performance of fresh cells and cells subjected to 2 months storage at 140°F. Tests were performed only at temperatures shown in this table for the fourth series. Notice that the tests at -20°F after 2 months storage show some cell capacity - an improvement over the third series which showed no capacity after two months below 32°F. Discharge curves for fresh cells at 75°F and -20°F are shown in Figures 18 and 19, respectively, and after two months storage at 75°F and -20°F in Figures 20 and 21, respectively.

TABLE VIII

DISCHARGE PERFORMANCE OF THE THIRD BUILD OF LIFE SUPPORT CELLS  
AFTER ONE MONTH STORAGE AT +140°F

Cell No.	OCV	Temp., °F	Wt. of SOCl <sub>2</sub> g	Utilization of SOCl <sub>2</sub> , %	Midpoint Voltage, V	Capacity,* AHr	Energy Density WHr/in <sup>3</sup>	Energy Density WHr/lb
334	3.67	+165	4.77	61.8	3.50	1.33	10.8	116
335	3.67	+165	4.79	58.3	3.50	1.26	10.2	110
323	3.70	+124	4.73	63.3	3.48	1.35	10.9	117
324	3.70	+124	4.68	63.5	3.48	1.34	10.8	117
337	3.73	+75	4.82	61.6	3.37	1.34	10.5	113
338	3.73	+75	4.86	67.5	3.36	1.48	11.6	124
339	3.73	+75	4.79	62.0	3.34	1.34	10.4	112
332	3.71	+50	4.83	55.1	3.13	1.20	8.7	94
333	3.71	+50	4.65	59.6	3.13	1.25	9.1	98
330	3.71	+32	4.77	44.2	3.02	0.95	6.7	72
331	3.71	+32	4.73	44.5	3.02	0.95	6.7	72
328	----	0	4.83	8.7	2.75	0.19	1.2	13
329	----	0	4.81	24.9	2.82	0.54	3.5	30

Cells allocated for -20°F, -40°F, and -65°F tests exhibited heavy polarizations at the 120 mA load.

\* Based on 80% of the midpoint cell voltage at average life support load of 0.0825 amp.

System: Li/1.5M LiAlCl<sub>4</sub> · SOCl<sub>2</sub> · SC<sub>2</sub>/SOCl<sub>2</sub>, C  
Device: Life Support Cell  
Loads: 120 mA (30 min) - 45 mA (30 min)  
Cell Nos: --- 337 & 339  
          - - - 338  
Cell Build: Third

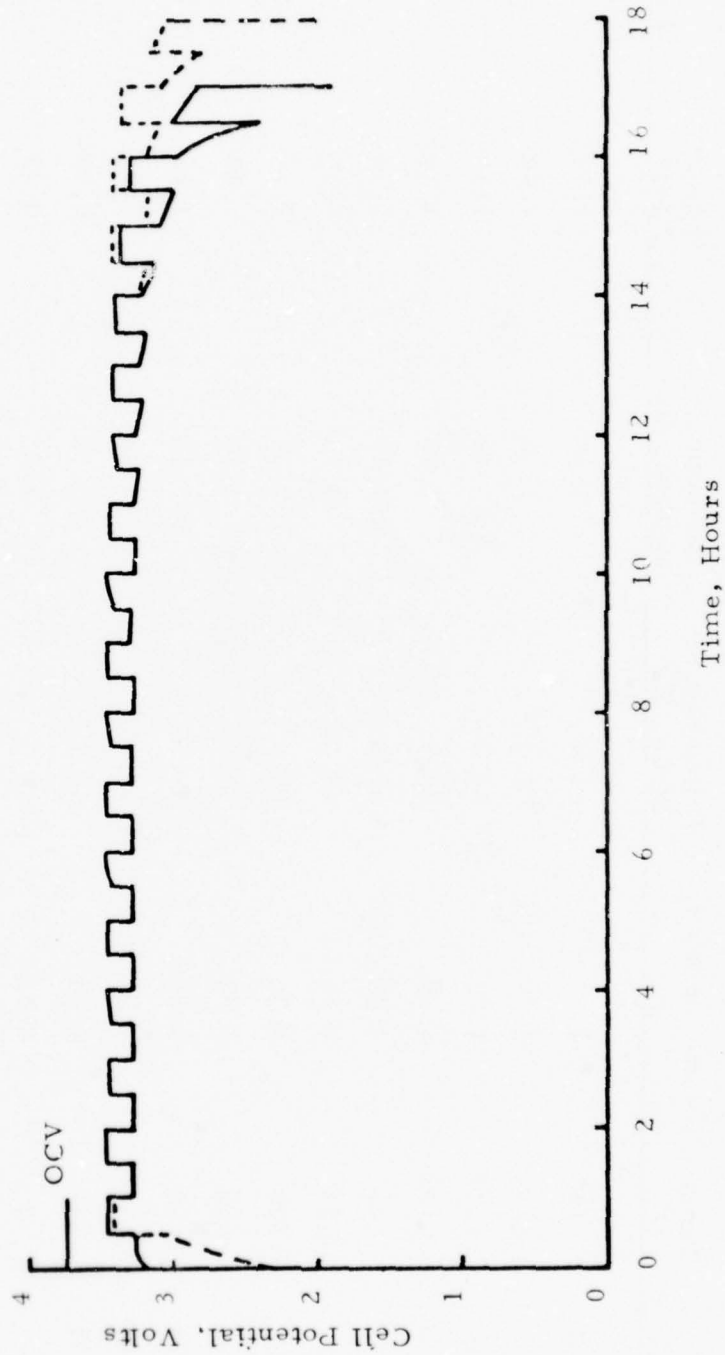

Figure 13. Discharge Performance of Life Support Cells at 75°F  
After One Month Storage at 140°F

System: Li/1.5M LiAlCl<sub>4</sub>·SOCl<sub>2</sub>·SO<sub>2</sub>/SOCl<sub>2</sub>, C  
Device: Life Support Cell  
Loads: 120 mA (30 min) - 45 mA (30 min)  
Cell Nos: 331  
          ---330  
Cell Build: Third

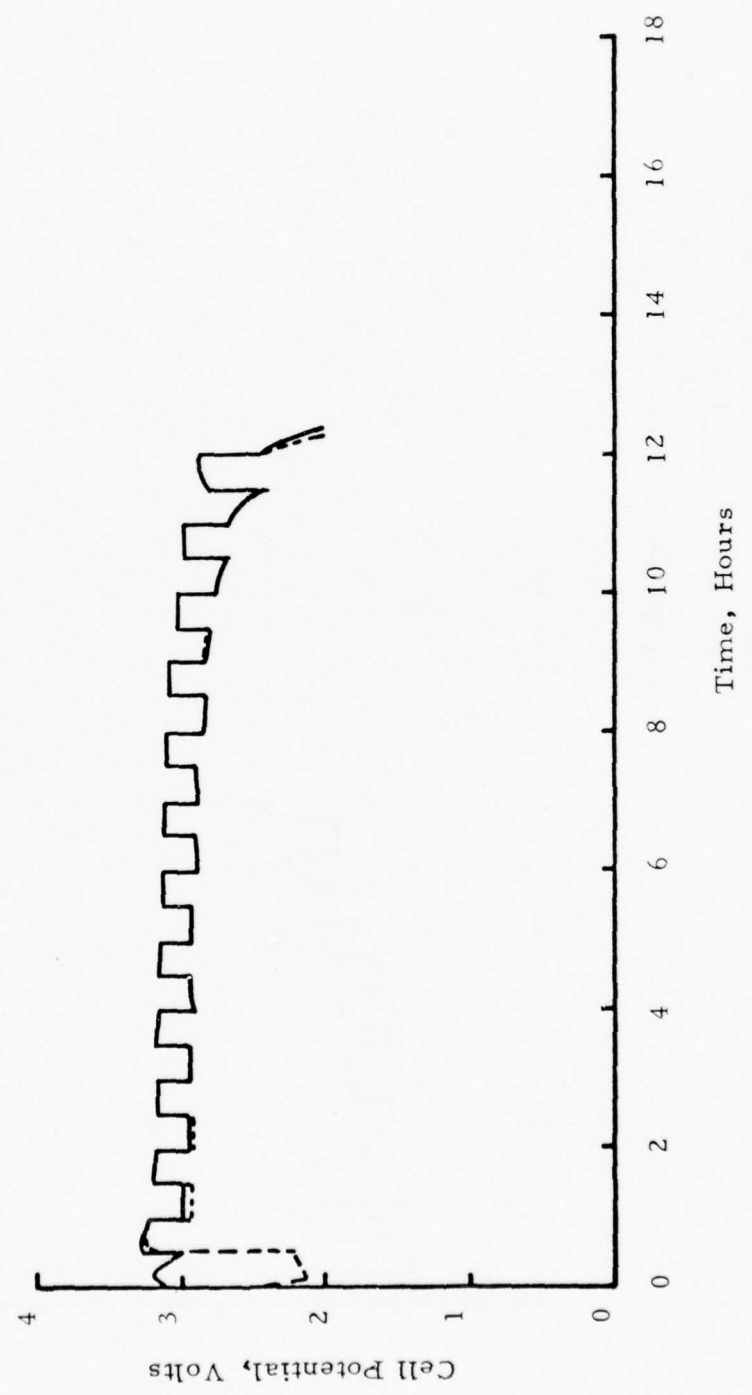

Figure 14. Discharge Performance of Life Support Cells at 32°F  
After One Month Storage at 140°F

System: Li/1.5M LiAlCl<sub>4</sub>.SOCl<sub>2</sub>.SO<sub>2</sub>/SOCl<sub>2</sub>, C  
Device: Life Support Cell  
Loads: 120 mA (30 min) - 45 mA (30 min)  
Cell Nos: 329  
          ---328  
Cell Build: Third

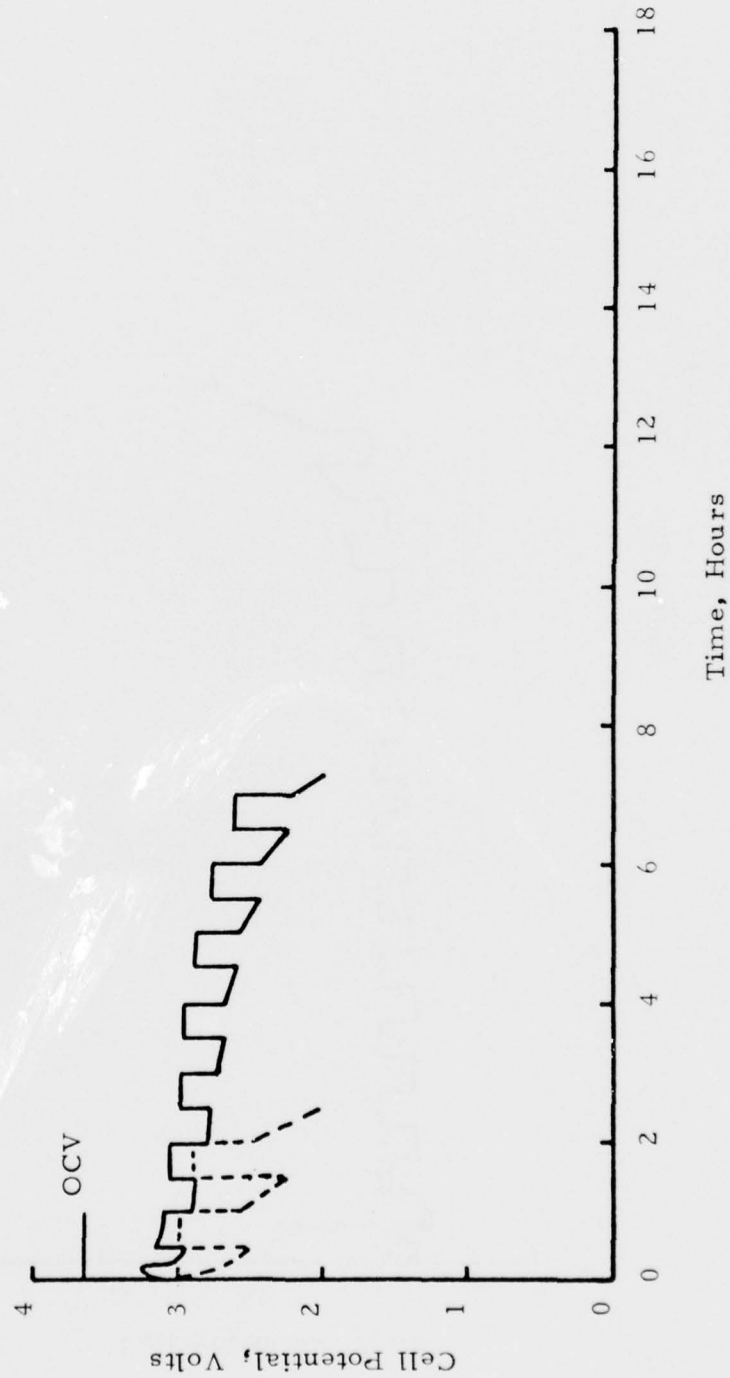

Figure 15. Discharge Performance of Life Support Cells at 0°F  
After One Month Storage at 140°F

TABLE IX

VOLTAJE CHARACTERISTICS OF THE THIRD BUILD OF LIFE SUPPORT CELLS  
AFTER ONE MONTH STORAGE AT 140°F

Cell No.	Temp., °F	Midpoint Voltage, V	Time to Reach $\pm 20\%$ of Midpoint Voltage	Voltage Regulation over at least 80% of Useful Cell Life, %
334	165	3.50	Immediately	$\pm 6.0$
335	165	3.50	260 milliseconds	$\pm 6.0$
323	124	3.48	50 milliseconds	$\pm 3.5$
324	124	3.48	10 milliseconds	$\pm 3.5$
337	75	3.37	10 milliseconds	$\pm 5.0$
338	75	3.36	11 minutes	$\pm 5.0$
339	75	3.34	10 milliseconds	$\pm 5.0$
332	50	3.13	30 minutes	$\pm 5.8$
333	50	3.13	7.5 minutes	$\pm 5.5$
330	32	3.02	30 minutes	$\pm 11.0$
331	32	3.02	Immediately	$\pm 11.0$
328	0	2.75	< 10 milliseconds	$\pm 21.0$
329	0	2.82	< 10 milliseconds	$\pm 13.0$

TABLE X

DISCHARGE PERFORMANCE OF THE THIRD BUILD OF LIFE SUPPORT CELLS  
AFTER TWO MONTHS STORAGE AT 140°F

Cell No.	OCV	Temp., °F	Wt of SOCl <sub>2</sub> , g	Utilization of SOCl <sub>2</sub> , %	Midpoint Voltage, V	Capacity, Ahr	Energy Density, Whr/in <sup>3</sup>	Energy Density, Whr/lb	
344	3.68	165	4.85	56.8	3.47	1.24	10.0	108	
345	3.68	165	4.69	55.9	3.47	1.18	9.5	102	
346	3.70	75	4.87	62.1	3.32	1.36	10.5	113	
348	3.70	75	4.82	64.5	3.31	1.40	10.8	116	
349	3.69	50	4.95	47.1	3.05	1.05**	7.5	80	
350	3.69	50	4.70	44.4	3.04	0.94	6.6	71	
351	3.70	32	Cell cannot support 120 mA load.						
352	3.70	32	6.07	25.6	2.88	0.70**	4.7	50	

\* Based on 80% of the midpoint cell voltage at average life support load of 0.0825 amp.

\*\* Capacities corrected against voltage delay time.

NOTE: Cells allocated for 0°F tests exhibited heavy polarization at both the 120 mA and the 45 mA loads.

TABLE XI

VOLTAGE CHARACTERISTICS OF THE THIRD BUILD OF LIFE SUPPORT CELLS  
AFTER TWO MONTHS STORAGE AT 140°F

Cell No.	Temp., °F	Midpoint Voltage, V	Time to Reach $\pm 20\%$ of Midpoint Voltage	Voltage Regulation Over at Least 80% of Useful Cell Life, %
344	165	3.47	1.9 sec	$\begin{cases} +1.7 \\ -4.9 \end{cases}$
345	165	3.47	1.4 sec	$\begin{cases} +1.7 \\ -4.9 \end{cases}$
346	75	3.32	Immediately	$\begin{cases} +3.0 \\ -4.8 \end{cases}$
348	75	3.31	30 min.	$\begin{cases} +3.0 \\ -6.3 \end{cases}$
349	50	3.05	2.5 Hrs *	$\pm 6.0$
350	50	3.04	Immediately	$\begin{cases} +11.5 \\ -8.5 \end{cases}$
352	32	2.88	1.5 Hrs *	$\begin{cases} +6.9 \\ -11.8 \end{cases}$

\* Voltage delay time due to the 120 mA load.



System: Li/1.5M LiAlCl<sub>4</sub>.SOCl<sub>2</sub>.SOCl<sub>2</sub>, C  
Device: Life Support Cell  
Loads: 120 mA (30 min) - 45 mA (30 min)  
Cell Nos: 366  
          ---365  
Cell Build: Third

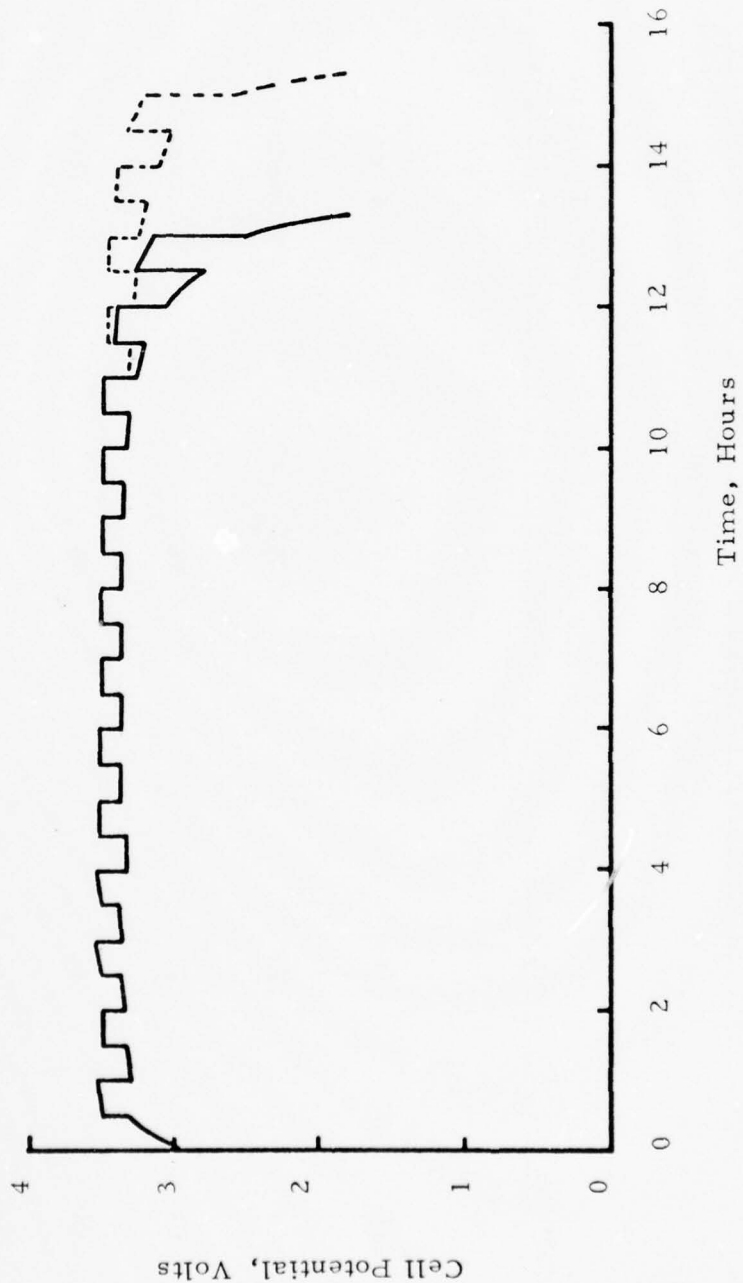

Figure 16. Discharge Performance of Life Support Cells at 165°F  
After Five Months Storage at 140°F

System: Li/1.5M LiAlCl<sub>4</sub>.SOCl<sub>2</sub>.SO<sub>2</sub>/SOCl<sub>2</sub>, C  
Device: Life Support Cell  
Loads: 120 mA (30 min) - 45 mA (30 min)  
Cell No: 369  
Cell Build: Third

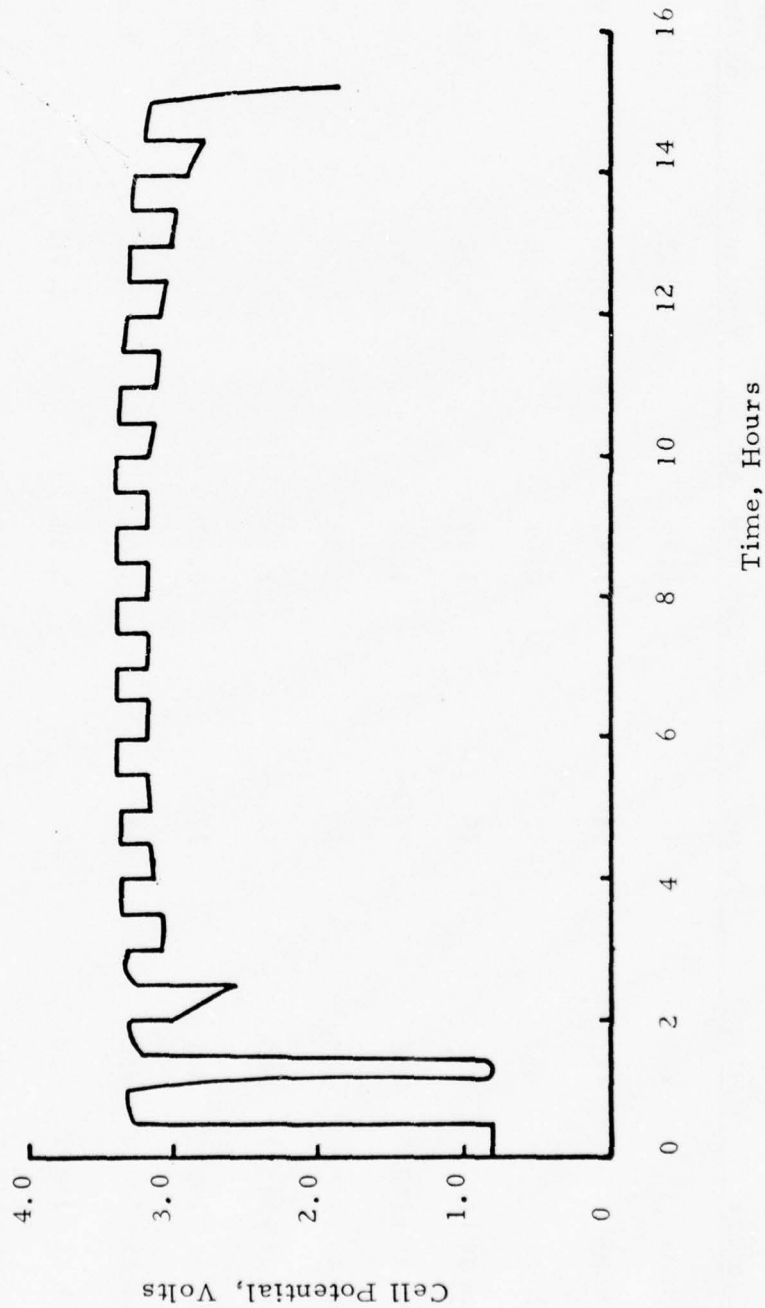

Figure 17. Discharge Performance of a Life Support Cell at 75°F After Five Months Storage at 140°F

TABLE XII

DISCHARGE PERFORMANCE OF THE FOURTH BUILD OF LIFE SUPPORT CELLS-  
FRESH AND AFTER TWO MONTHS STORAGE AT 140°F

Storage	Cell No.	Temp., °F	Capacity, Ahr	Midpoint Voltage, V*	Energy Density Wh/in <sup>3</sup>	Energy Density Wh/lb	Energy, Wh
None	440	75	1.75	3.32	13.5	155	5.80
None	447	32	1.51	3.28	11.5	134	4.96
None	467	-20	0.91	2.88	6.1	73	2.62
2 mos at +140°F	455	75	1.40	3.32	10.8	130	4.65
2 mos at +140°F	458	75	1.51	3.34	11.8	138	5.05
2 mos at +140°F	459	50	1.08	3.09	7.8	94	3.34
2 mos at +140°F	460	50	1.18	3.12	8.6	102	3.69
2 mos at +140°F	461	32	0.97	2.95	6.7	78	2.86
2 mos at +140°F	462	32	1.08	3.02	7.6	89	3.25
2 mos at +140°F	463	-20	0.50	2.77	3.2	39	1.39
2 mos at +140°F	464	-20	0.36	2.80	2.3	28	1.01
2 mos at +140°F	465	-40	None	----	---	---	----
2 mos at +140°F	469	-40	None	----	---	---	----

\* Voltage at 50% of capacity.

Voltage Delay: Cell No. 458 - 7 minutes at 120 mA, lowest voltage at 2.14V.

Cell No. 461 - 1 hour at 120 mA, lowest voltage at 2.0V.

Cell No. 462 - 30 minutes at 120 mA, lowest voltage at 2.0V.

System: Li/1.5M LiAlCl<sub>4</sub>.SOCl<sub>2</sub>.SO<sub>2</sub>/SOCl<sub>2</sub>, C  
Device: Life Support Cell  
Loads: 120 mA (30 min) - 45 mA (30 min)  
Cel. No: 440  
Cell Build: Fourth

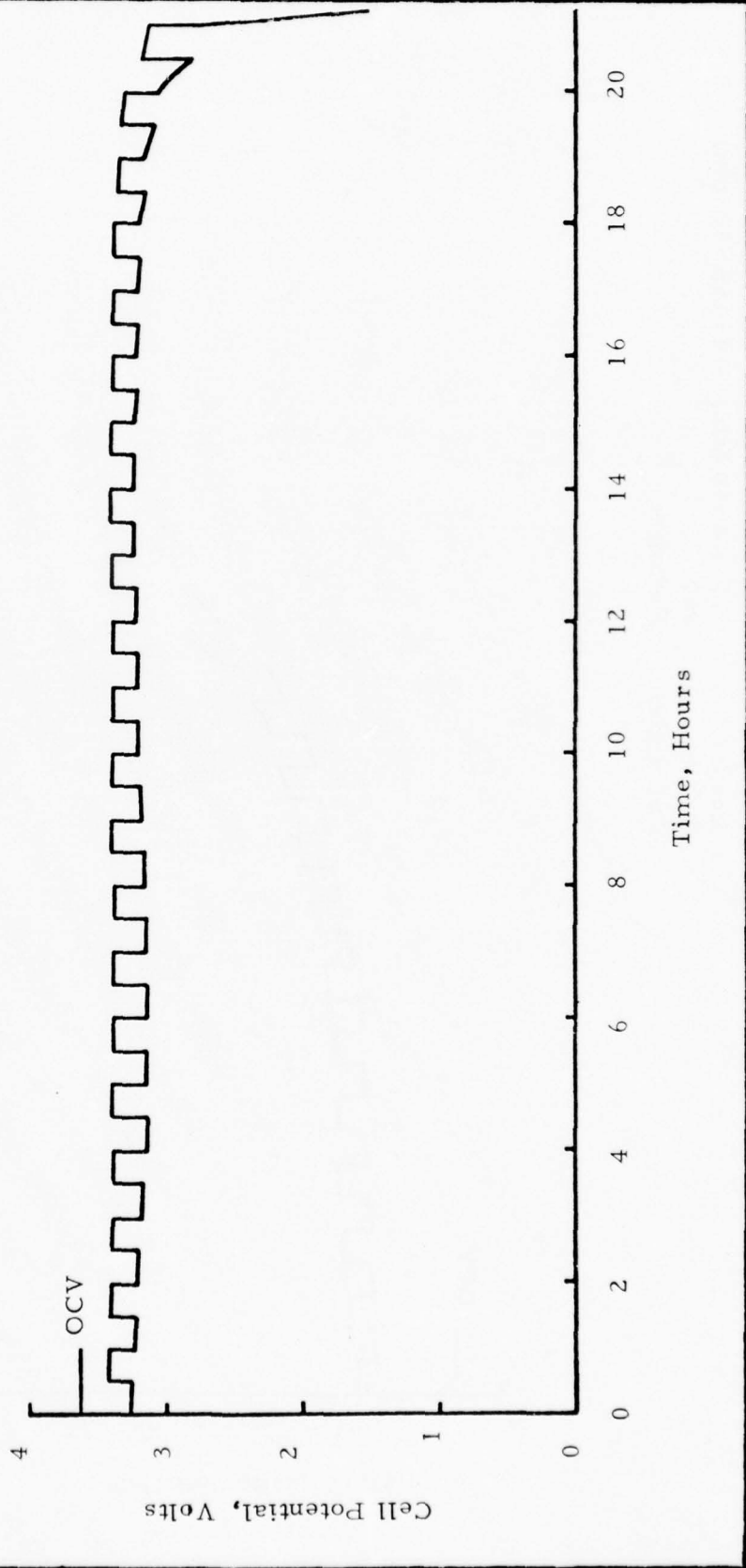

Figure 18. Discharge Performance of a Fresh Life Support Cell at 75°F

System: Li/1.5M LiAlCl<sub>4</sub>.SOCl<sub>2</sub>.SO<sub>2</sub>/SOCl<sub>2</sub>, C  
Device: Life Support Cell  
Loads: 120 mA (30 Min) - 45 mA (30 min)  
Cell No: 467  
Cell Build: Fourth

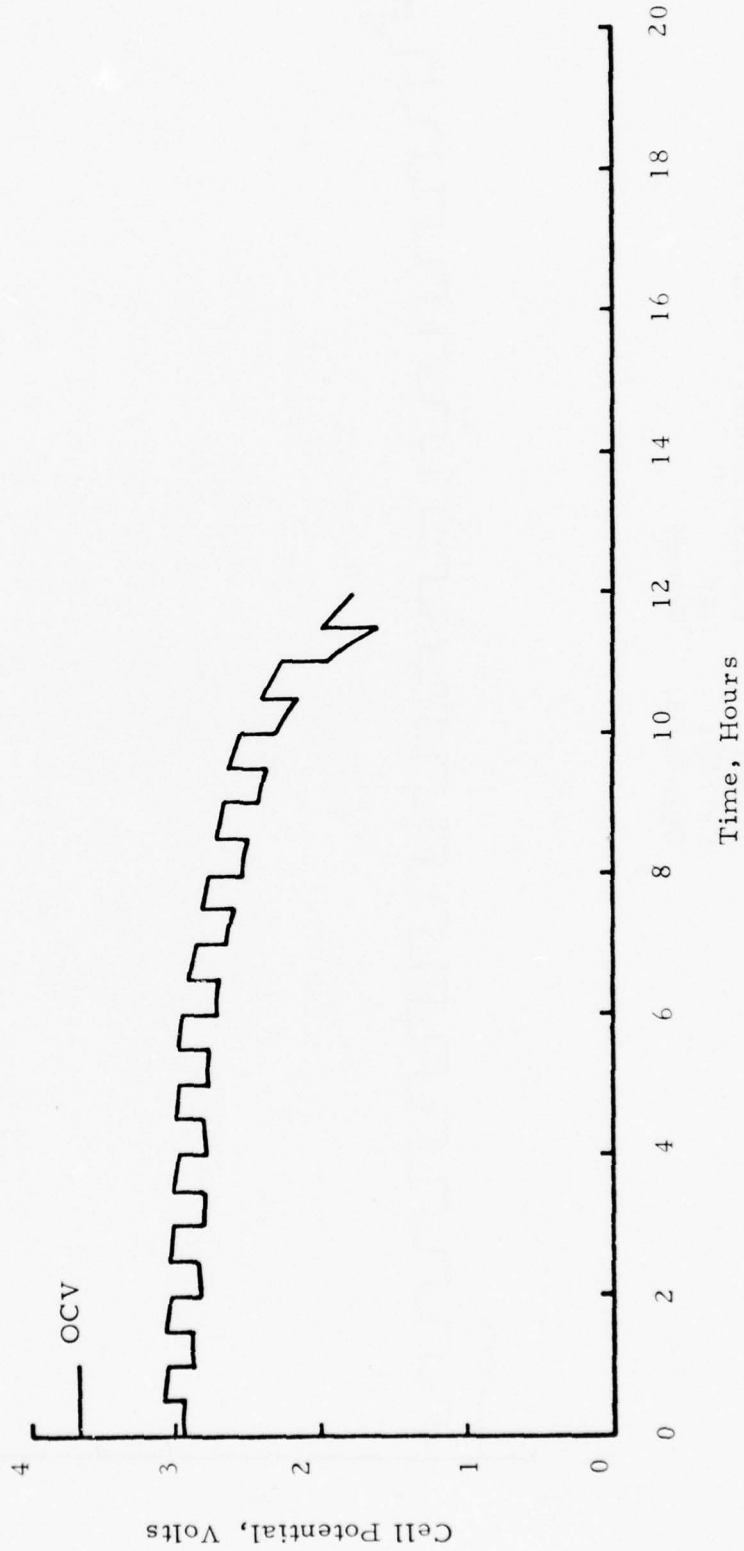

Figure 19. Discharge Performance of a Fresh Life Support Cell at -20°F

System: Li/1.5M LiAlCl<sub>4</sub>.SOCl<sub>2</sub>.SO<sub>2</sub>/SOCl<sub>2</sub>, C  
Device: Life Support Cell  
Loads: 120 mA (30 min) - 45 mA (30 min)  
Cell No: 455  
Cell Build: Fourth

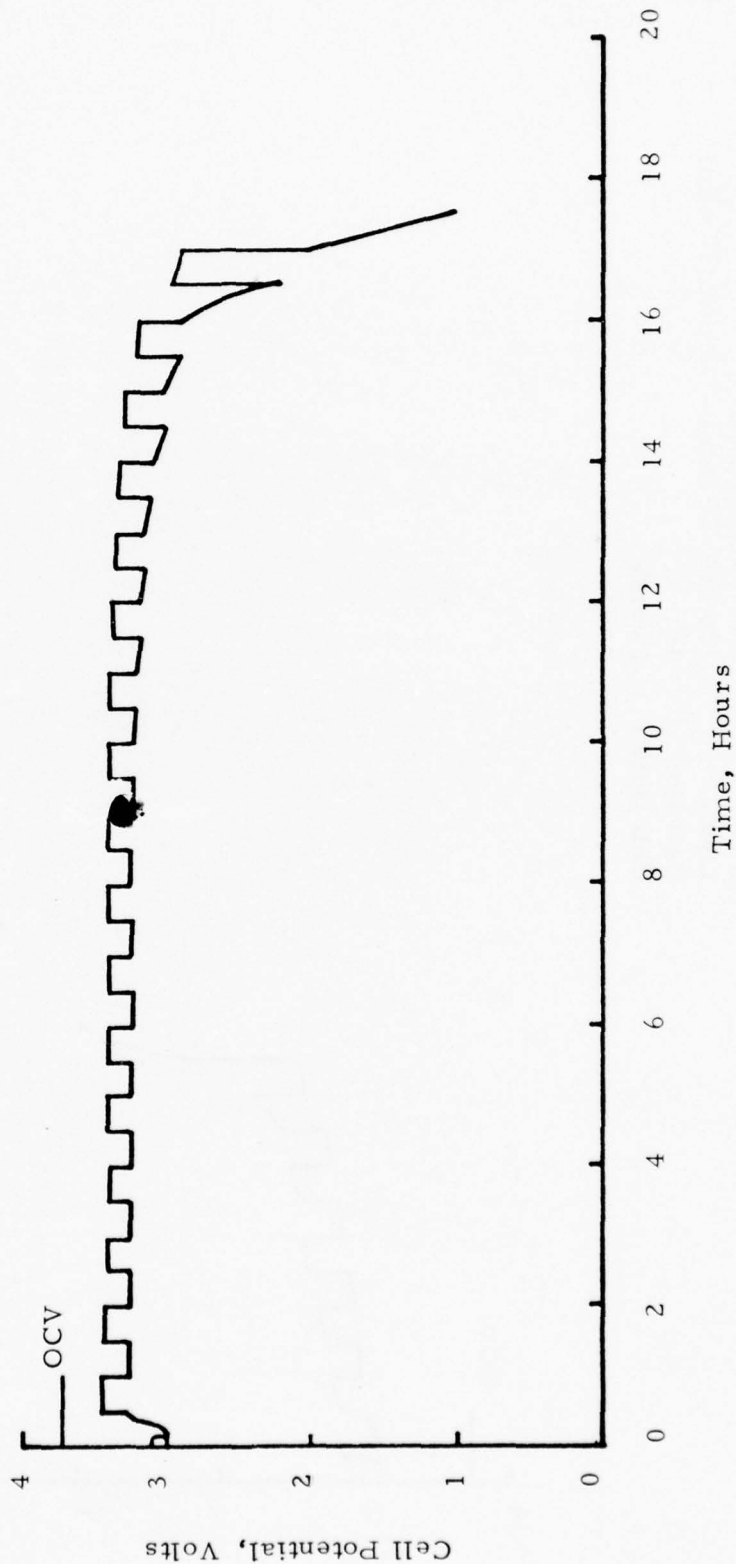

Figure 20. Discharge Performance of a Life Support Cell at 75°F  
After 2 Months Storage at 140°F

System: Li/1.5M LiAlCl<sub>4</sub>.SOCl<sub>2</sub>.SO<sub>2</sub>/SOCl<sub>2</sub>, C  
Device: Life Support Cell  
Loads: 120 mA (30 min) - 45 mA (30 min)  
Cell No: 463  
Cell Build: Fourth

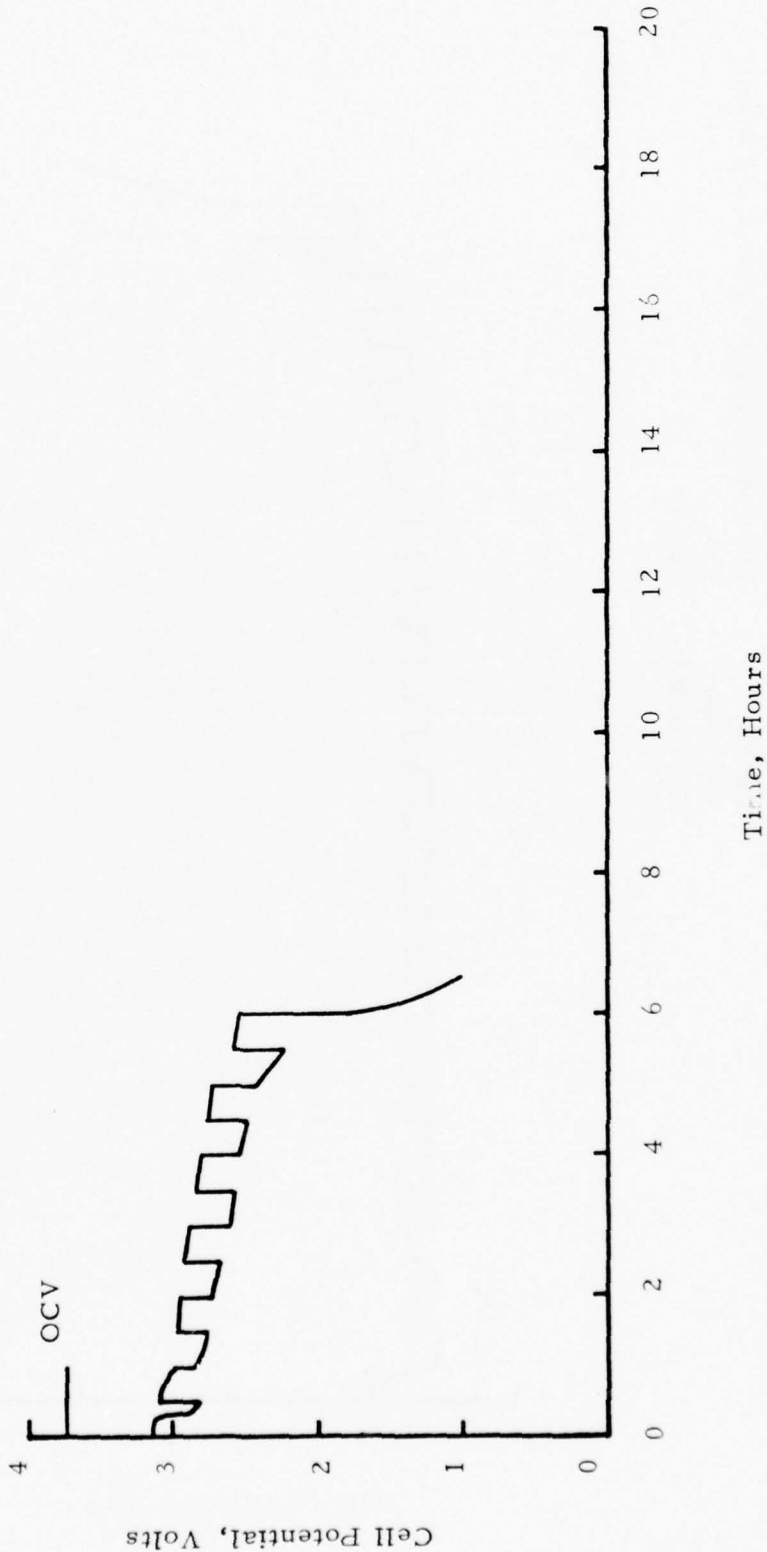

Figure 21. Discharge Performance of a Life Support Cell at -20°F  
After 2 Months Storage at 140°F

After five months storage at 140°F, five cells of the fourth series were tested and exhibited the results shown in Table XIII. Discharge data for the cells tested at 75°F and at 32°F are shown in Figures 22 and 23, respectively.

#### 5. PRC-90 Batteries

The design, fabrication and evaluation of Li/SOCl<sub>2</sub> batteries around the requirement for the PRC-90 battery was the result of original project task tradeoffs mutually advantageous to the Air Force and Honeywell. Specifically, the fabrication and testing of nine Spacecraft "A" units were eliminated and the design, fabrication and testing of ten PRC-90 Li/SOCl<sub>2</sub> batteries made up of four cells connected in series were substituted. To accomplish this within the time constraints of the contract, cell parts already available in-house were modified. Terminal plates containing the glass-to-metal seal were long lead time order items of which only 43 were available. Therefore, a total of 43 cells of the size to be used in the PRC-90 battery were fabricated. During electron beam welding of the terminal plate to the cell case, eleven cells were lost because of internal shorting. Eight batteries were made from the remaining 32 cells.

The eight PRC-90 Li/SOCl<sub>2</sub> batteries were tested according to the prescribed life support loads. Table XIV summarizes their performance and Figures 24 through 28 show their performance at 75, 32, -20, -40, and -65°F, respectively.

#### 6. Safety Testing

Nine cells from the first series were subject to short circuit and maximum power tests, the results being tabulated in Tables XV and XVI, respectively. Representative plots of current, temperature, and power versus time curves are shown in Figures 29 and 30. The rising portion of the power curve in Figure 30 is attributed to the existing passivating film at the lithium electrode; this anodic film could also affect the magnitude of the short circuit current values shown in Figure 29. None of the cells exhibited any dimensional change.



TABLE XIII

DISCHARGE PERFORMANCE OF THE FOURTH BUILD OF LIFE SUPPORT CELLS  
AFTER FIVE MONTHS STORAGE AT 140°F

<u>Cell No.</u>	<u>Test Temp., °F</u>	<u>Midpoint Voltage, Volts</u>	<u>Capacity* Ahr</u>	<u>Energy Density Whr/in<sup>3</sup></u>	<u>Energy Density Whr/lb</u>
432	+75	3.33	1.13	8.8	106
433	+50	3.05	1.26	8.9	102
434	+32	2.98	1.10	7.6	85

Cells exhibited heavy polarization at both 120 mA and 45 mA loads.

\* Cutoff cell voltage: 80% of midpoint voltage.

System: Li/1M LiAlCl<sub>4</sub>.SOCl<sub>2</sub>.SO<sub>2</sub>/SOCl<sub>2</sub>, C  
Device: Life Support Cell  
Loads: 120 mA (30 min) - 45 mA (30 min)  
Cell No: 432  
Cell Build: Fourth

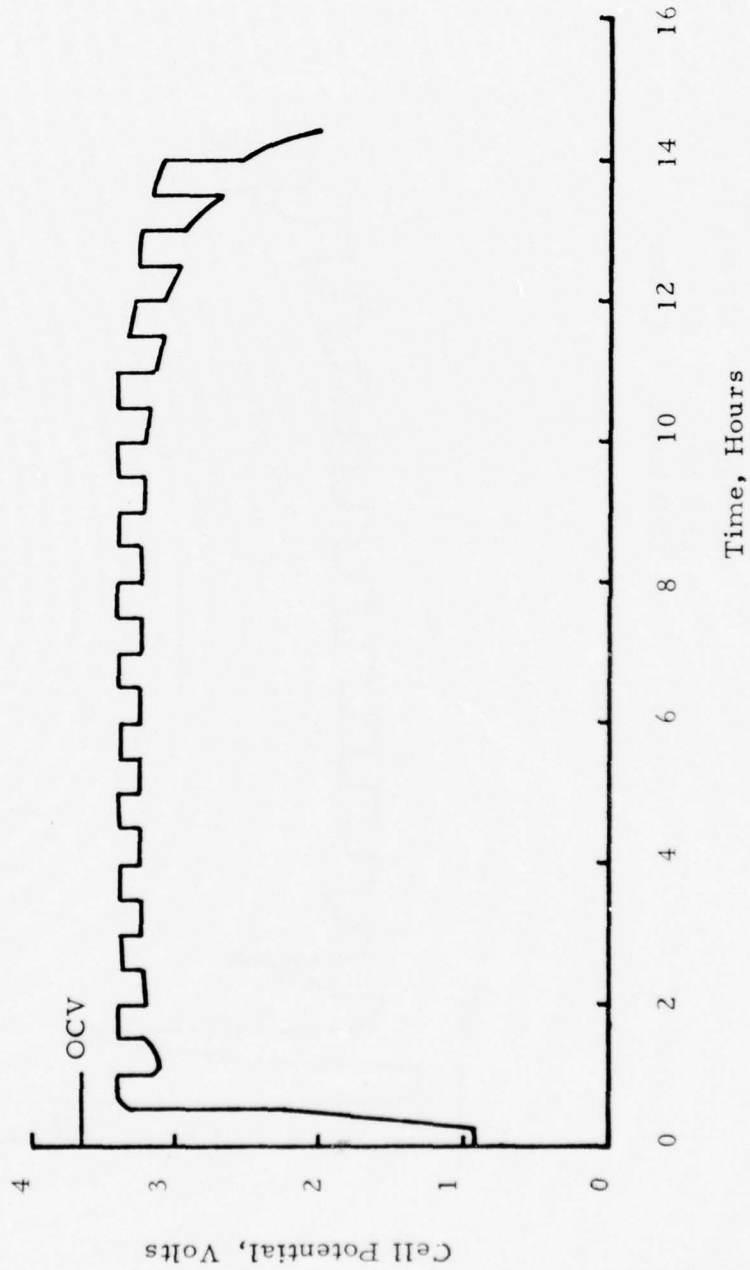

Figure 22. Discharge Performance of a Life Support Cell at 75°F  
After 5 Months Storage at 140°F

System: Li/1.5M LiAlCl<sub>4</sub>.SOCl<sub>2</sub>.SO<sub>2</sub>/SOCl<sub>2</sub>, C  
Device: Life Support Cell  
Loads: 120 mA (30 min) - 45 mA (30 min)  
Cell No: 434  
Cell Build: Fourth

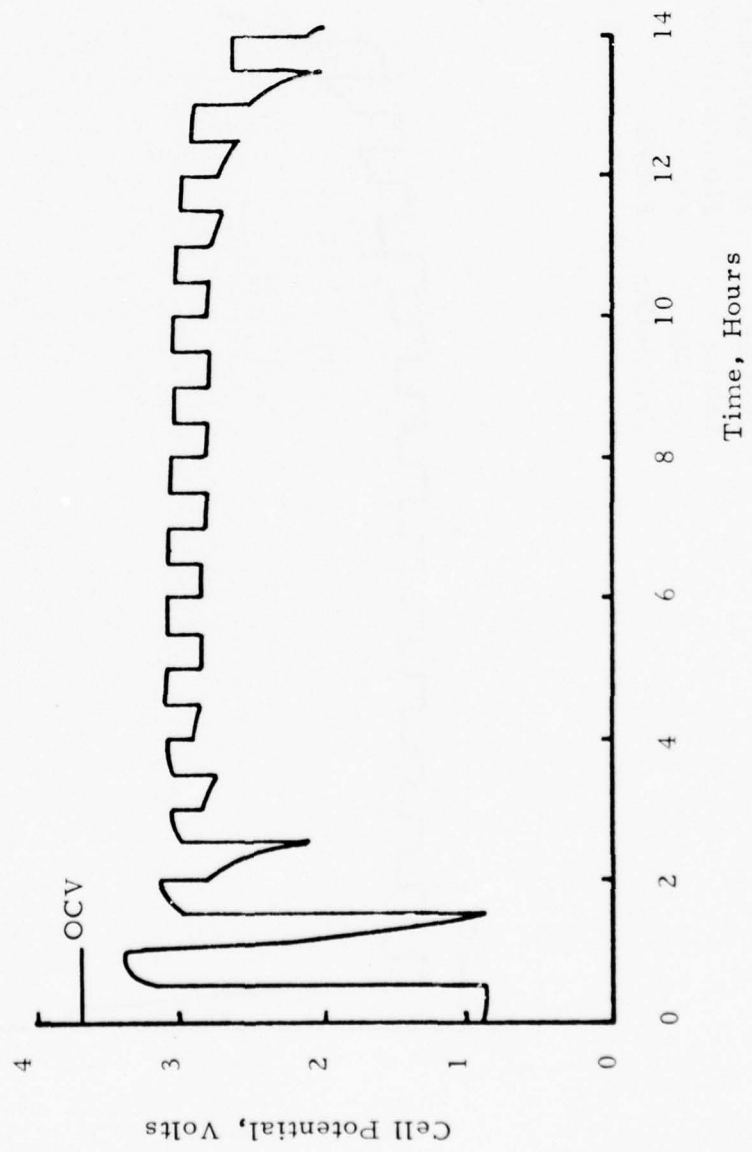

Figure 23. Discharge Performance of a Life Support Cell at 32°F  
After 5 Months Storage at 140°F

TABLE XIV

DISCHARGE PERFORMANCE OF FRESH PRC-90 BATTERIES

Battery No.	Temperature, °F	Midpoint Voltage, V	Capacity, * Ahr	Whr/in <sup>3</sup>	Energy Density Whr/lb
1	75	13.30	1.61	11.6	134
2	75	13.25	0.19**	1.4	16
6	32	10.12***	1.67***	9.2	106
4	-20	12.74	1.51	10.5	120
3	-20	11.62	0.54	3.4	39
7	-40	11.39	0.51	3.2	36
5	-65	11.00	0.37	2.2	25
8	-65	10.25	0.04	0.2	3
		10.62	0.16	0.9	11

\* Based on 10.0 volts cutoff.

\*\* One of the four cells in the battery failed shortly after test began.

\*\*\* Based on 5.0 volts cutoff.

System: Li/1.5M LiAlCl<sub>4</sub>.SOCl<sub>2</sub>.SO<sub>2</sub>/SOCl<sub>2</sub>, C  
Device: PRC-90 Battery  
Loads: 120 mA (30 min) -45 mA (30 min)  
Battery No: 1

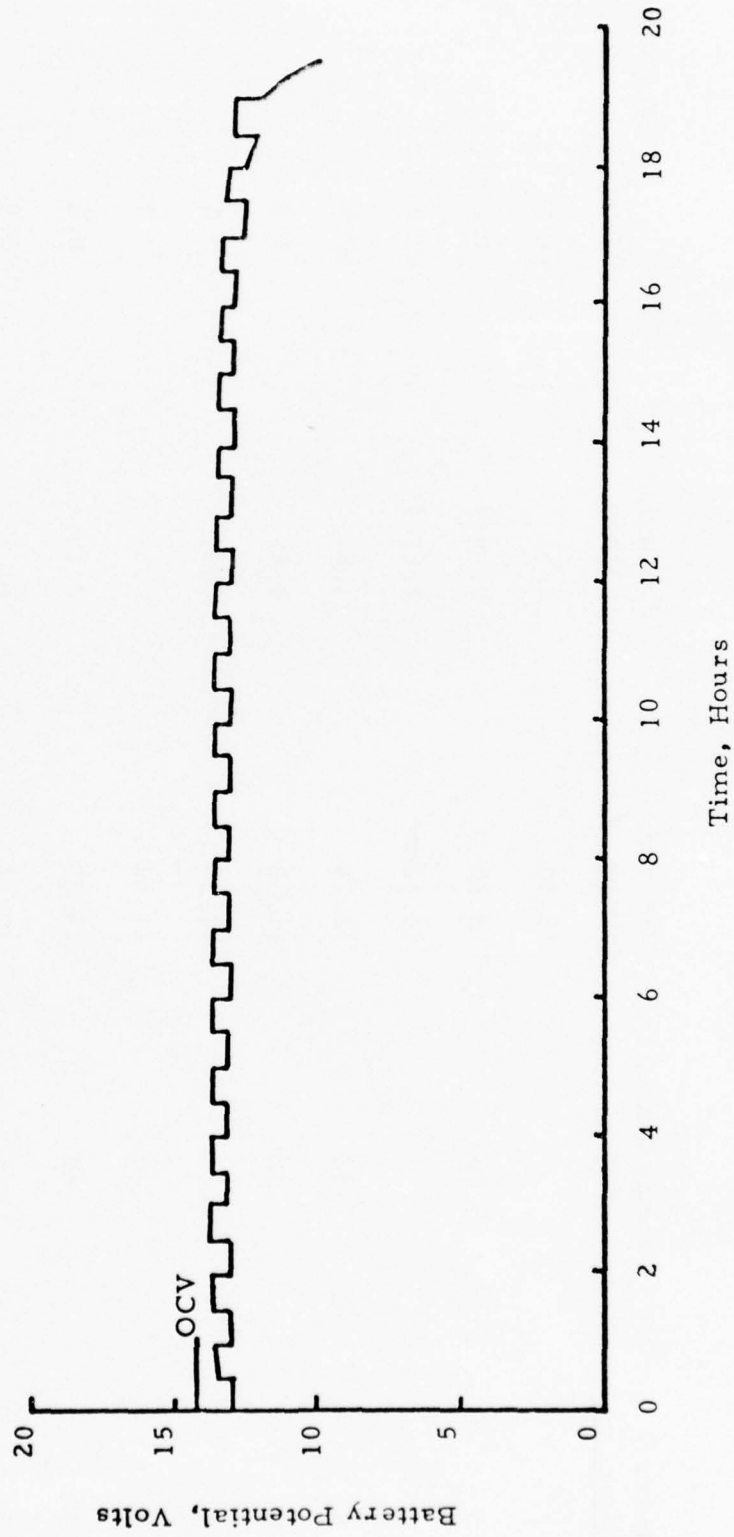

Figure 24. Discharge Performance of a Fresh PRC-90 Battery at 75°F

System: Li/1.5M LiAlCl<sub>4</sub>.SOCl<sub>2</sub>.SO<sub>2</sub>/SOCl<sub>2</sub>, C  
Device: PRC-90 Battery  
Loads: 120 mA (30 min) - 45mA (30 min)  
Battery No: 6

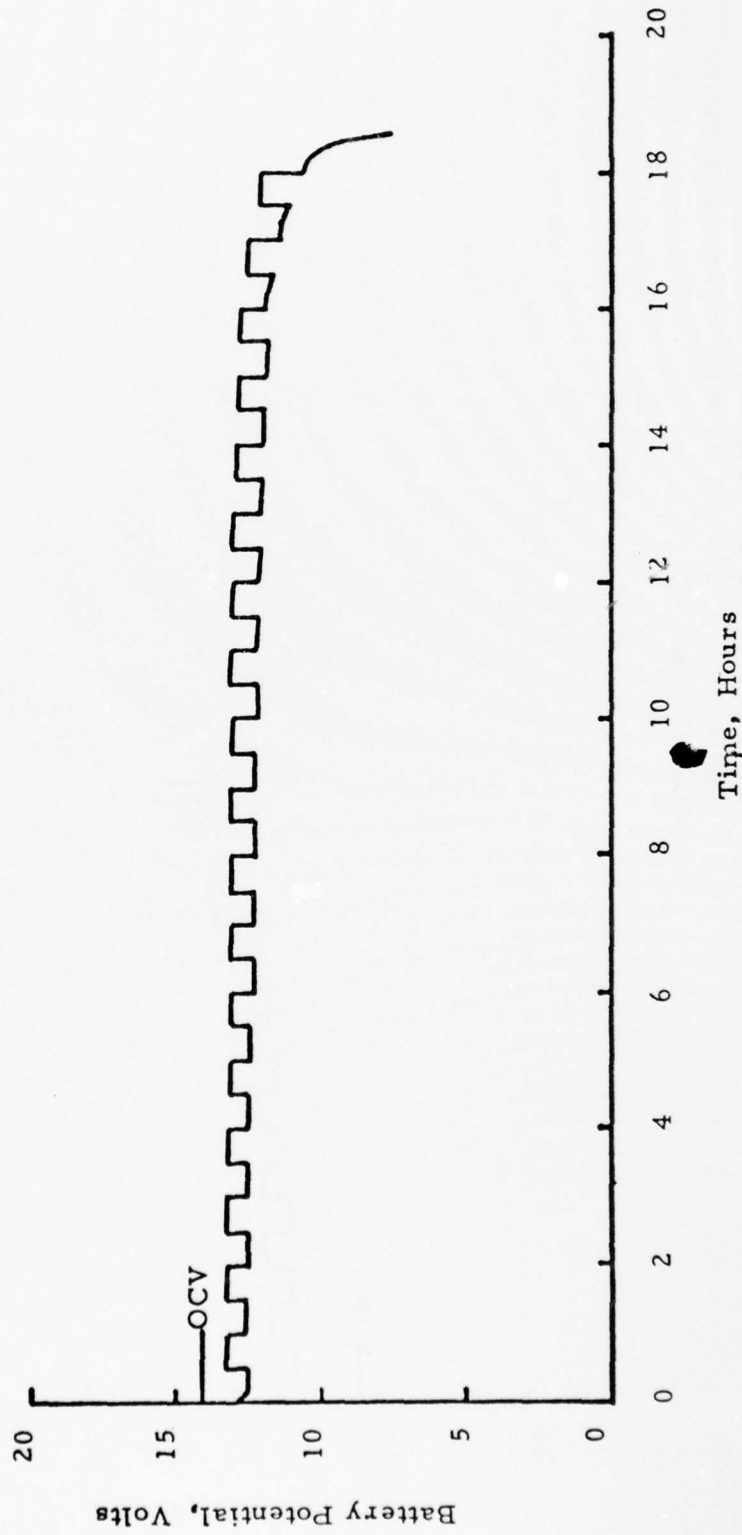

Figure 25. Discharge Performance of a Fresh PRC-90 Battery at 32°F

System: Li/1.5M LiAlCl<sub>4</sub>.SOCl<sub>2</sub>.SOCl<sub>2</sub>, C  
Device: PRC-90 Battery  
Loads: 120 mA (30 min) - 45 mA (30 min)  
Battery No: 4

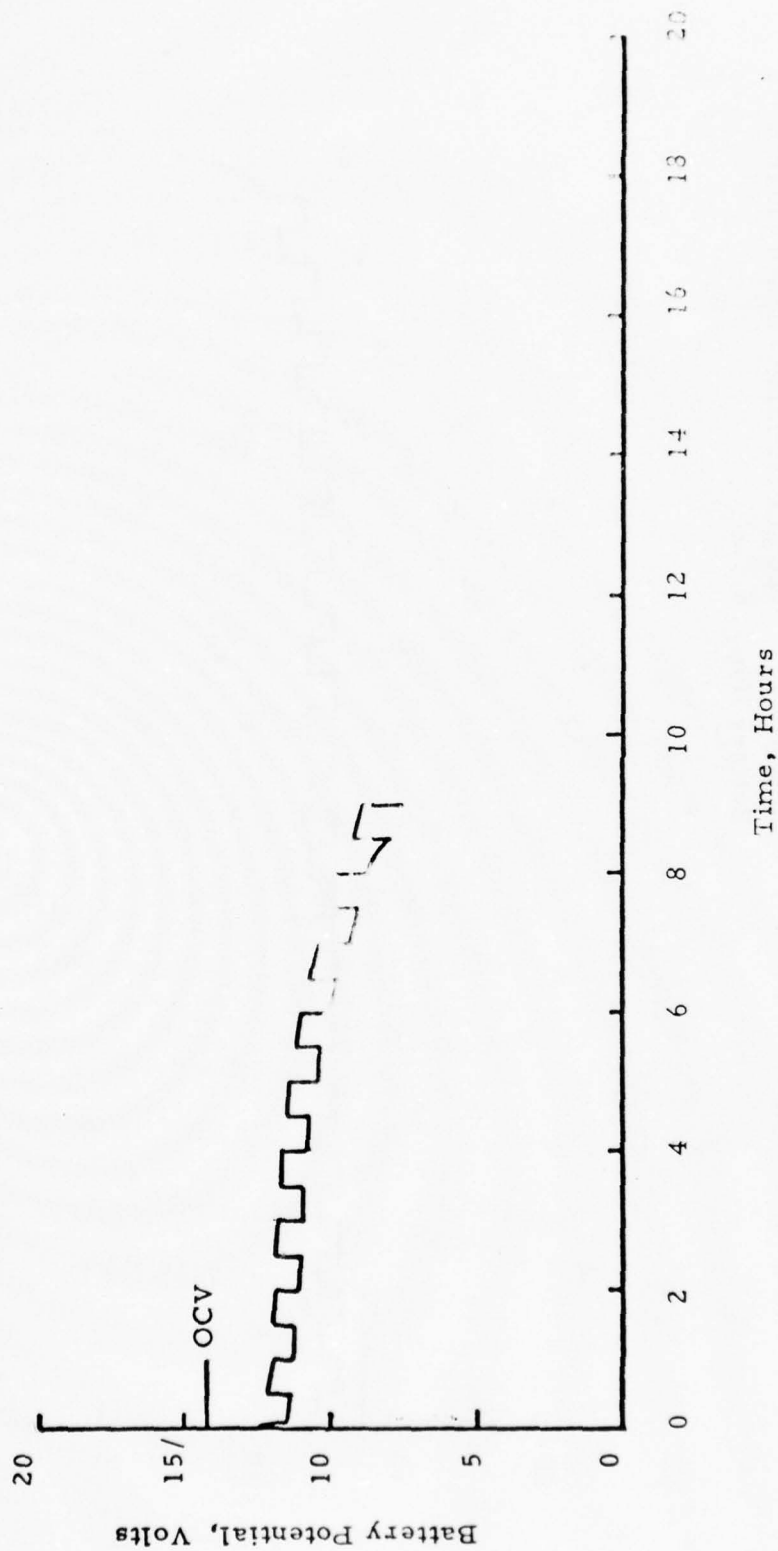

Figure 26. Discharge Performance of a Fresh PRC-90 Battery at -20°F

System: Li/1.5M LiAlCl<sub>4</sub>.SOCl<sub>2</sub>.SO<sub>2</sub>/SOCl<sub>2</sub>, C  
Device: PRC-90 Battery  
Loads: 120 mA (30 min) -45 mA (30 min)  
Battery No: 7

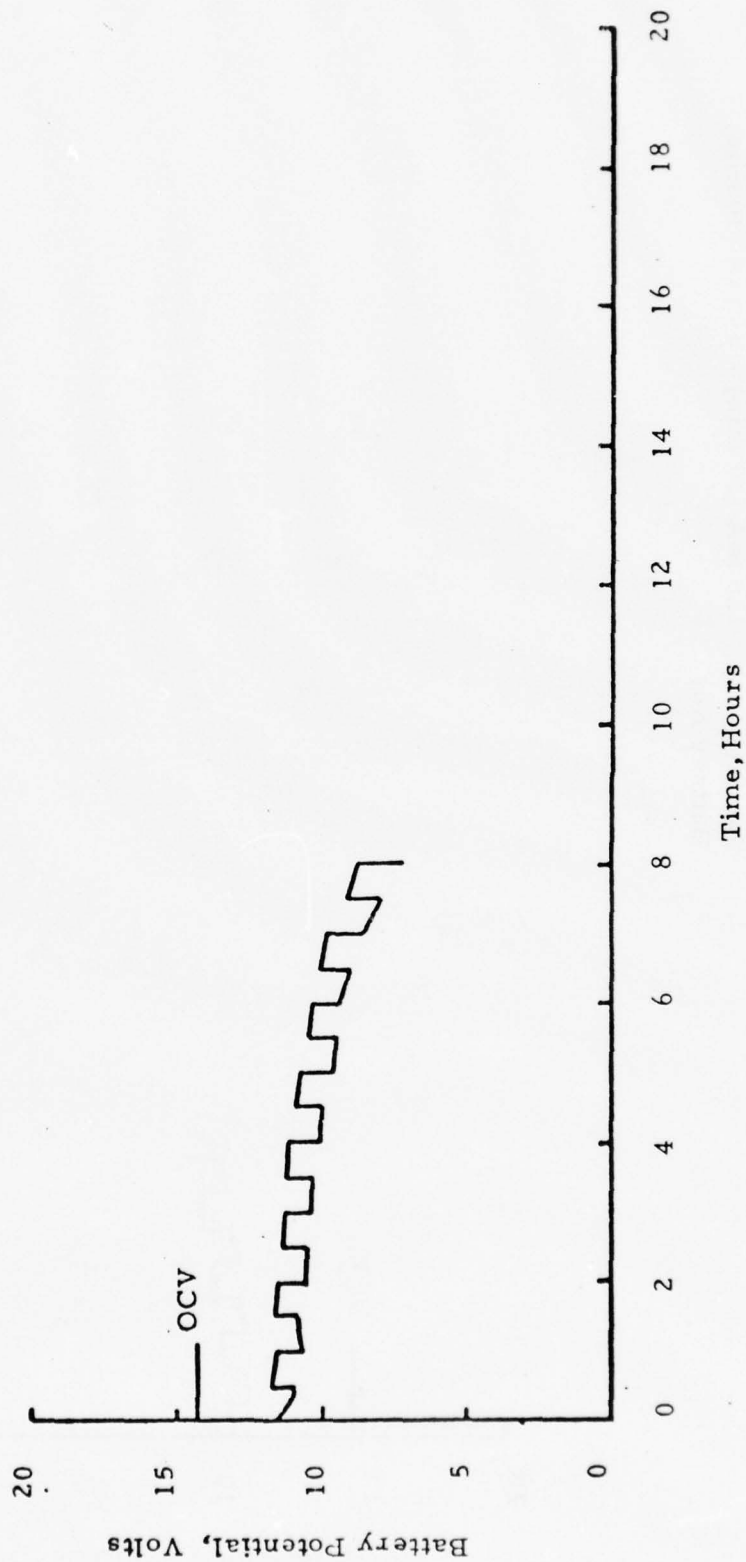

Figure 27. Discharge Performance of a Fresh PRC-90 Battery at -40°F



System: Li/1.5M LiAlCl<sub>4</sub>.SOCl<sub>2</sub>.SO<sub>2</sub>/SOCl<sub>2</sub>, C  
Device: PRC-90 Battery  
Loads: 120 mA (30 min) - 45 mA (30 min)  
Battery No: 8

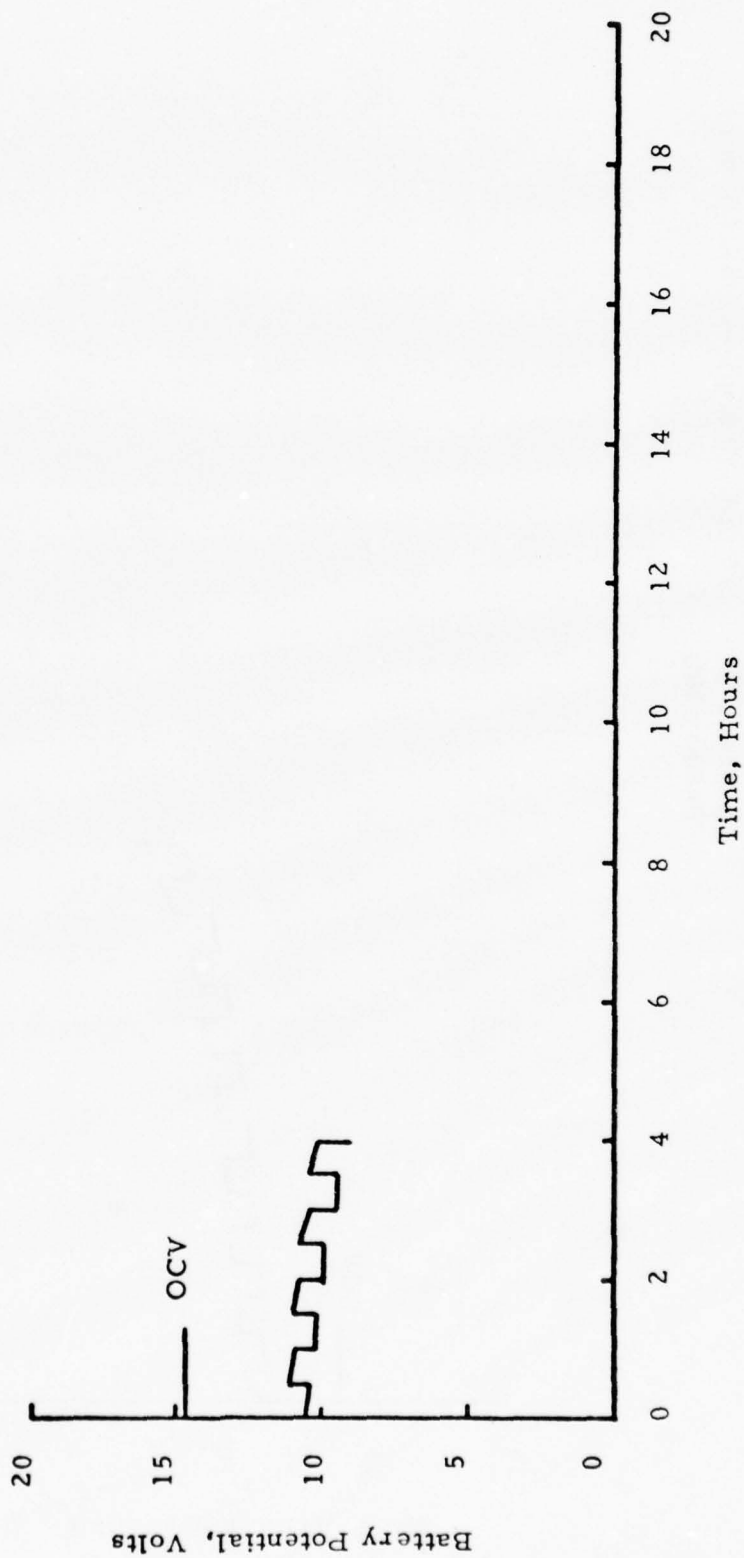

Figure 28. Discharge Performance of a Fresh PRC-90 Battery at -65°F

TABLE XV

SHORT-CIRCUIT TEST RESULTS OF LIFE SUPPORT CELLS OF THE FIRST BUILD

Load = 0.02 ohms

Cell No.	Max. Current, Ampere	Max. Temp., °F	OCV (original)	OCV (Final)
15	1.66	194	3.66	3.68
13	1.42	198	-----	-----
83	0.82	171	3.63	3.67
84	1.80	195	3.64	3.67
85	1.24	187	3.63	3.67

TABLE XVI

MAXIMUM POWER TEST RESULTS OF LIFE SUPPORT CELLS OF THE FIRST BUILD

Load = 2.3 ohms

Cell No.	Max. Power, Watt	Max. Temp., °F	OCV (Original)	OCV (Final)
24	3.0	131	3.66	3.62
27	1.6	124	3.66	3.63
18	2.2	132	3.66	3.65
19	2.3	123	3.66	3.65

77-040

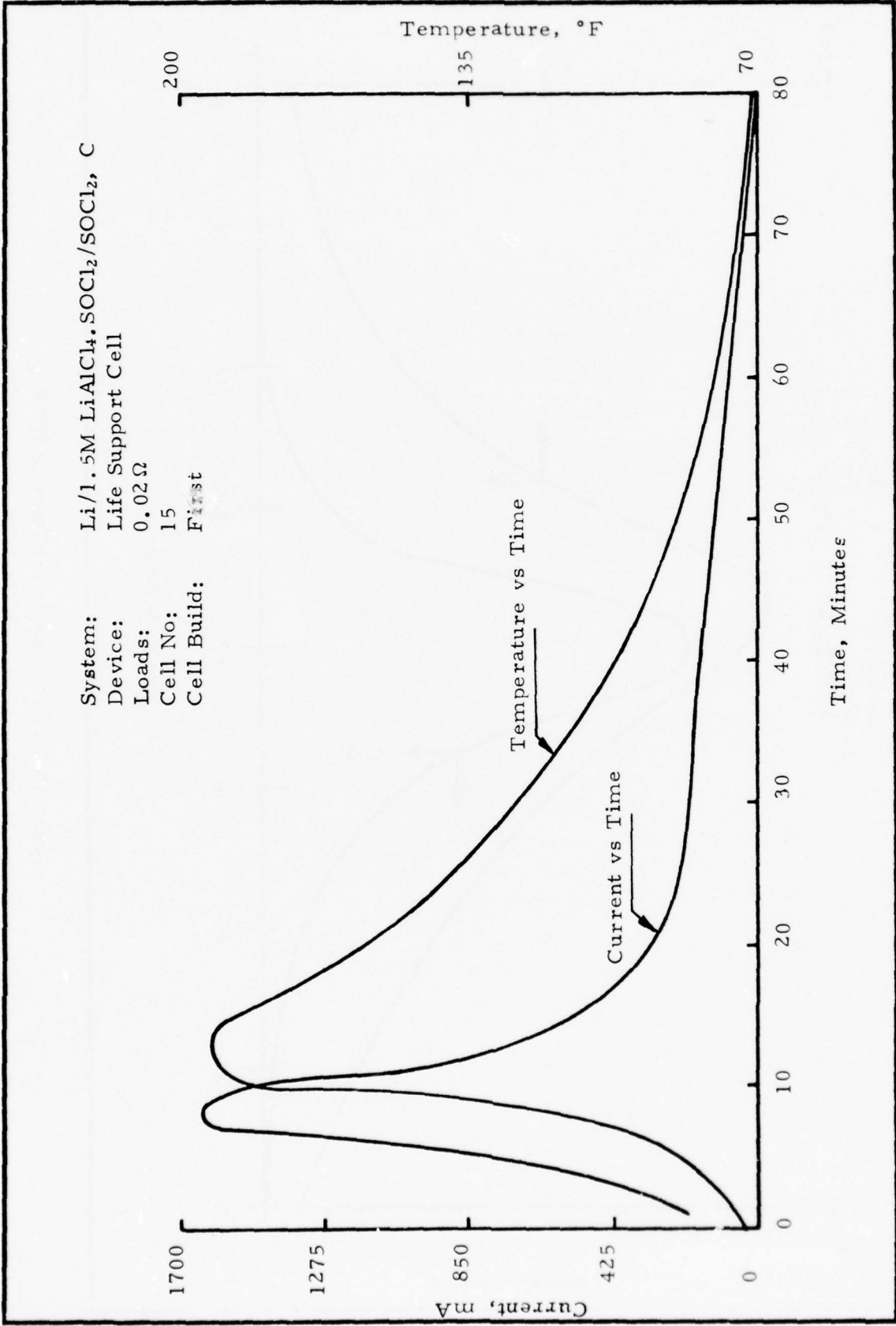

Figure 29. Short-Circuit Test at 75°F

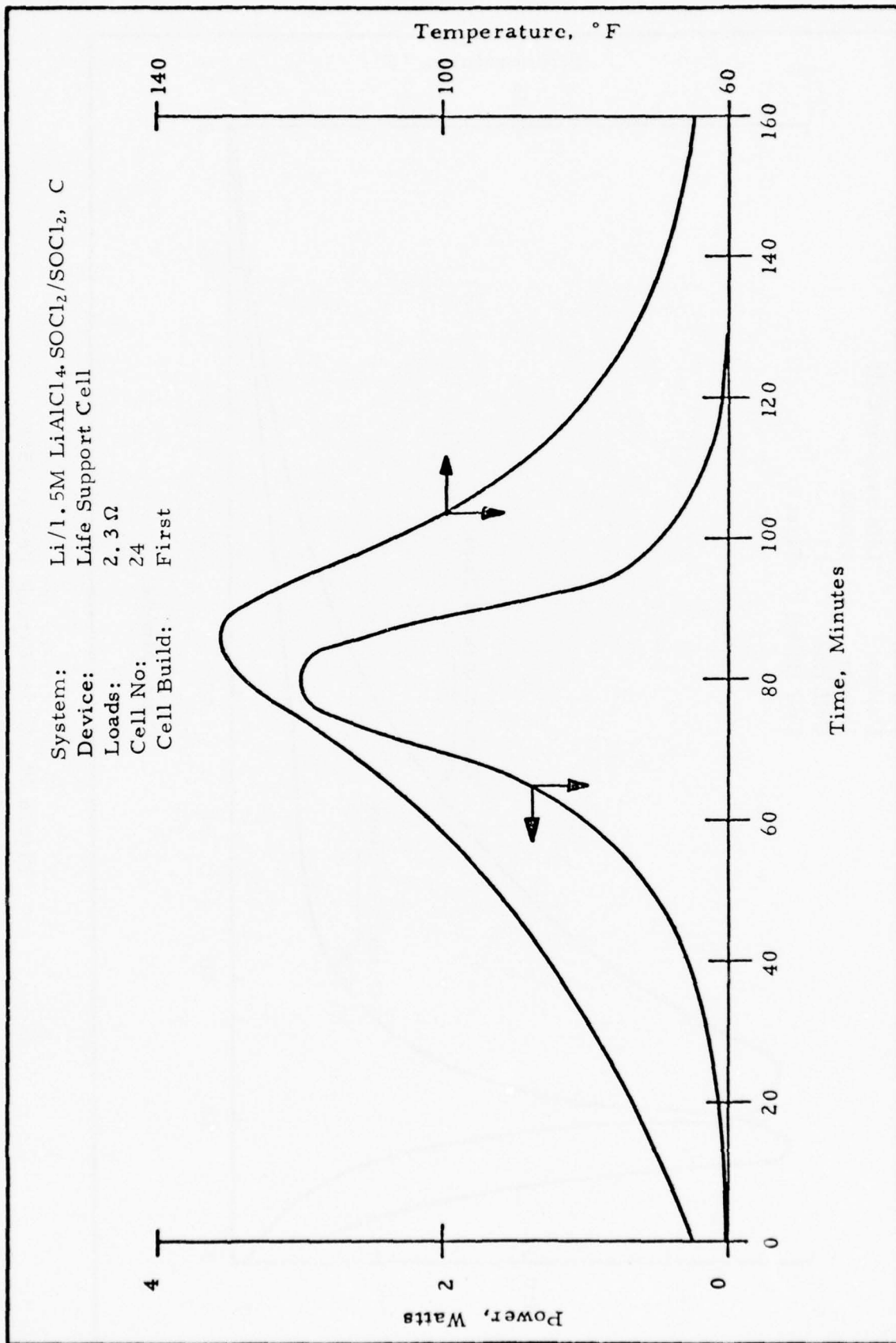

Figure 30. Maximum Power Test at 75°F

One cell of the first series was subject to forced discharging. Using a constant current of 120 mA or 5 mA/cm<sup>2</sup>, the cell was allowed to go into reversal for 24 hours. Figure 31 shows that the cell went into reversal during the initial portion of discharge - attributed to passivation at the negative electrode. Neither cell temperature rise nor dimensional change was detected.

Because of the effects resulting from passivation from the first series of cells, additional safety testing was performed on the third series of cells. Of the four cells of the third series tested, two were short-circuited and two were force discharged at 1 amp constant current (28 mA/cm<sup>2</sup>). All the cells were insulated with asbestos paper and tested at 70°F without adverse incident.

Representative results of the short-circuit and forced-discharge tests are shown in Figures 32 and 33, respectively. During the short-circuit tests, the current peaked instantaneously to about 6.8 amp, and the skin temperature of the case rose to a maximum of +278°F in 5 minutes.

Under forced discharge conditions of 1 amp constant current (28 mA/cm<sup>2</sup>), the maximum temperature (+216°F) occurred 15 minutes after 0.75 amp-hour had been withdrawn from the cell. An exponential temperature decay then occurred as the cell remained at the 1 amp load for one additional hour.

Additional results that are safety related to these Life Support Cells are:

- Heating of one cell containing 1.5M LiAlCl<sub>4</sub>·SOCl<sub>2</sub> electrolyte to 600°F did not cause the cell to explode even after maintaining this temperature for over three hours.
- A group of cells were allowed to be discharged over a weekend; one cell was found to have ejected itself from the plastic sample holder. Burn spots were noticed near the bottom of the cell and at the bottom of the sample holder.

System: Li/1.5M LiAlCl<sub>4</sub>.SOCl<sub>2</sub>/SOCl<sub>2</sub>, C  
Device: Life Support Cell  
Loads: 120 mA  
Cell No: 114  
Cell Build: First

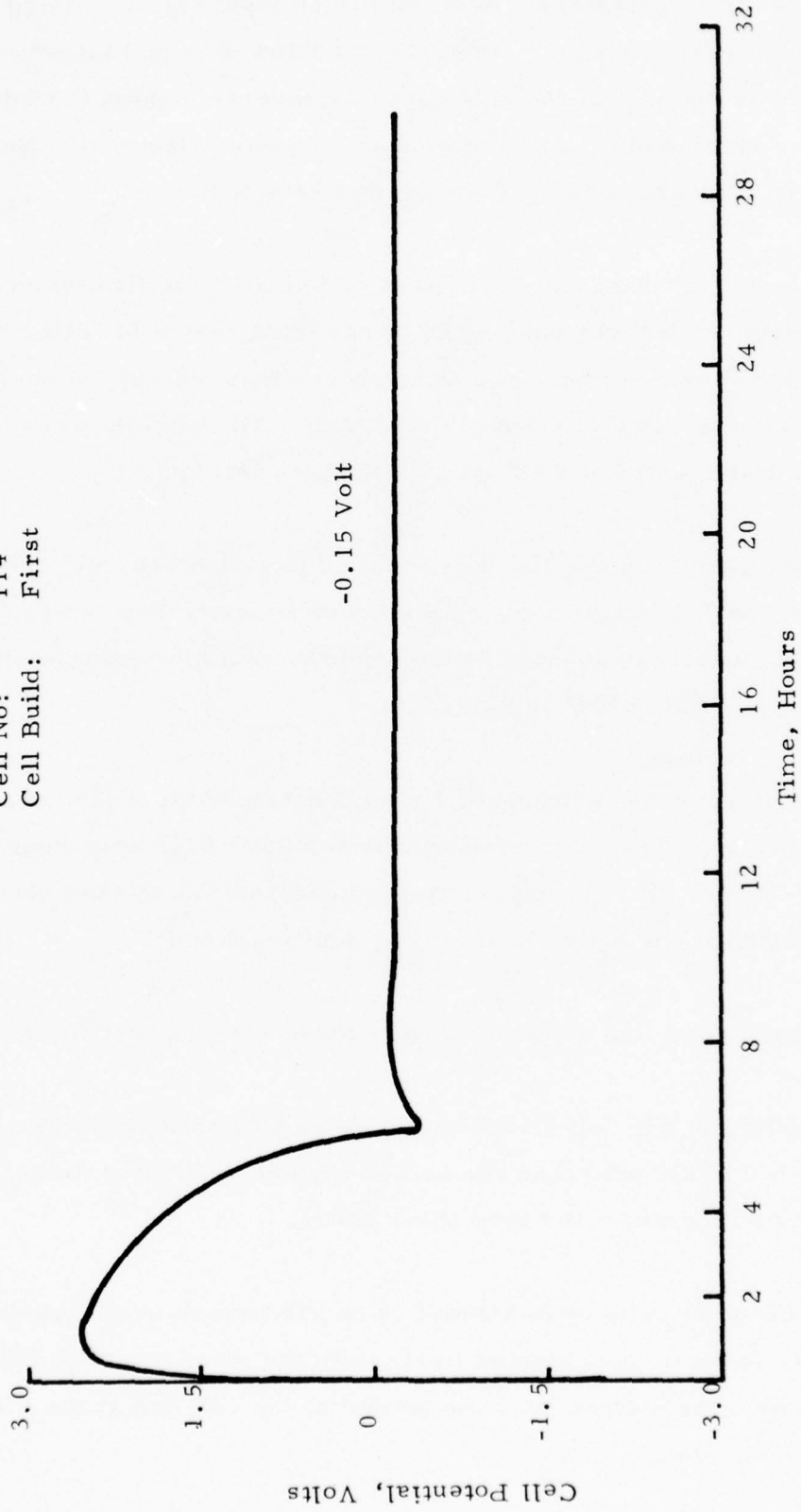

Figure 31. Forced Discharge Test at 75°F

77-042

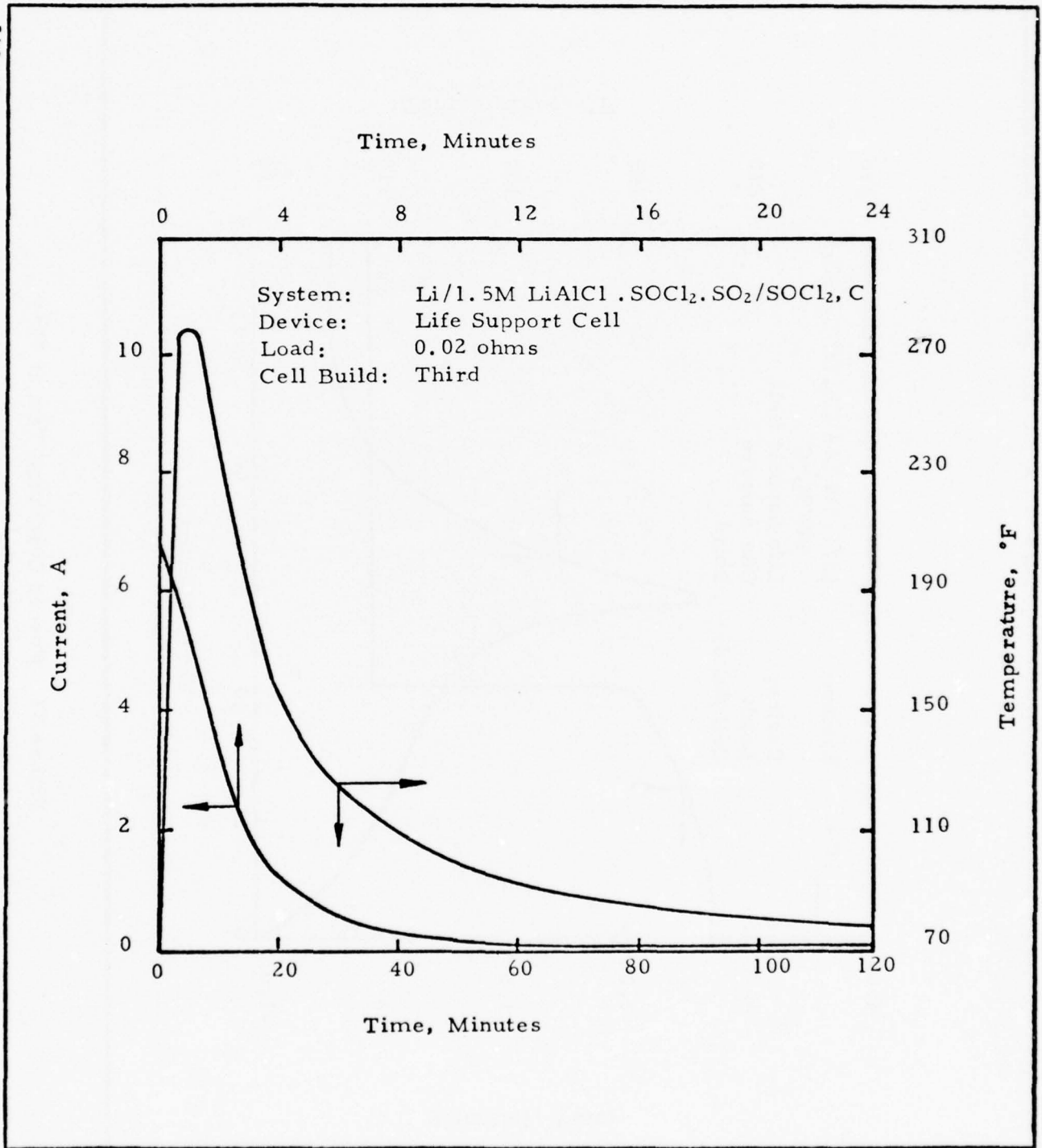

Figure 32. Short-Circuit Test of a Life Support Cell at 75°F



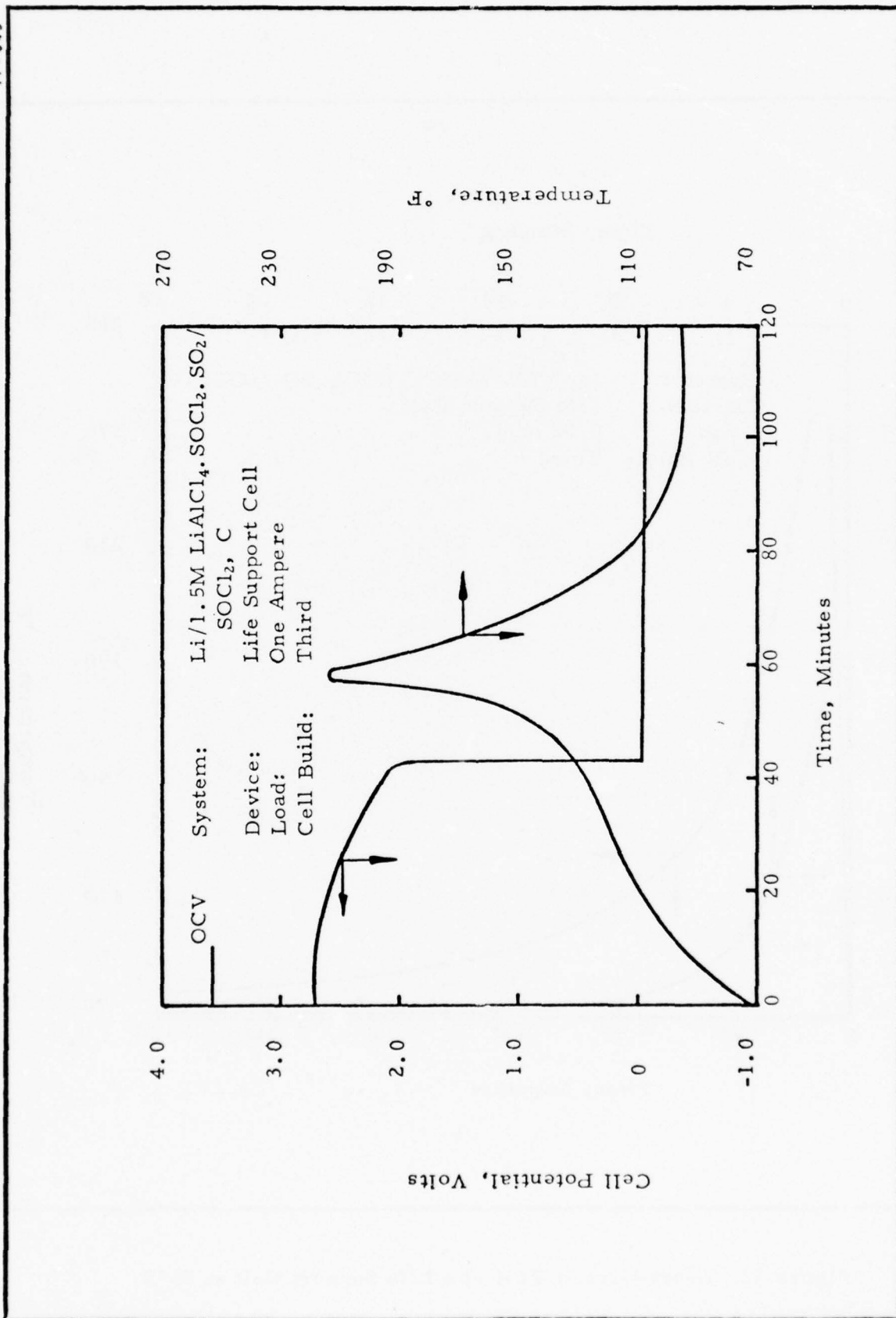

Figure 33. Forced Discharge Test at 75°F

## E. ANALYSIS OF TEST RESULTS

The first series of Life Support Cells constitutes the baseline performance for the entire project. The basic chemistry was the same for the three types of cell considered; therefore, the first series of both Spacecraft "A" and Spacecraft "B" cells also represent further extensions of this baseline performance.

Only one fresh cell of the first series was subjected to the regular discharge test, because of the unexpectedly severe passivation described in the previous section under Test Results.

### 1. Passivation

The poor performance of the first series of Life Support Cells after only three weeks storage at room temperature was attributed to a passivation film that developed on the lithium anode. Previous data identified the passivating film to be predominantly LiCl with trace amounts of S, which was known to develop during high temperature storage, but was not expected to be as severe during short term storage at room temperature.

To confirm the occurrence of lithium electrode passivation, the bottom of a cell from the first series was removed to permit the monitoring of both the positive and negative electrode potentials with respect to a lithium reference. The cell bottom was separated from the lithium reference by a glass separator and tested in a sealed glass vehicle. The results shown in Figure 34 substantiate that the cause of cell degradation is anode passivation.

A postmortem on the same cell indicated no signs of corrosion on the 316L stainless steel collectors, leads, nor at the spot-welded junction between the cathode lead and the 316L stainless steel can.

System: Li/1.5M LiAlCl<sub>4</sub>·SOCl<sub>2</sub>/SOCl<sub>2</sub>

Device: Life Support Cell

Loads: 120 mA (30 min) - 45 mA (30 min).

Cell No: 59

Cell Build: First

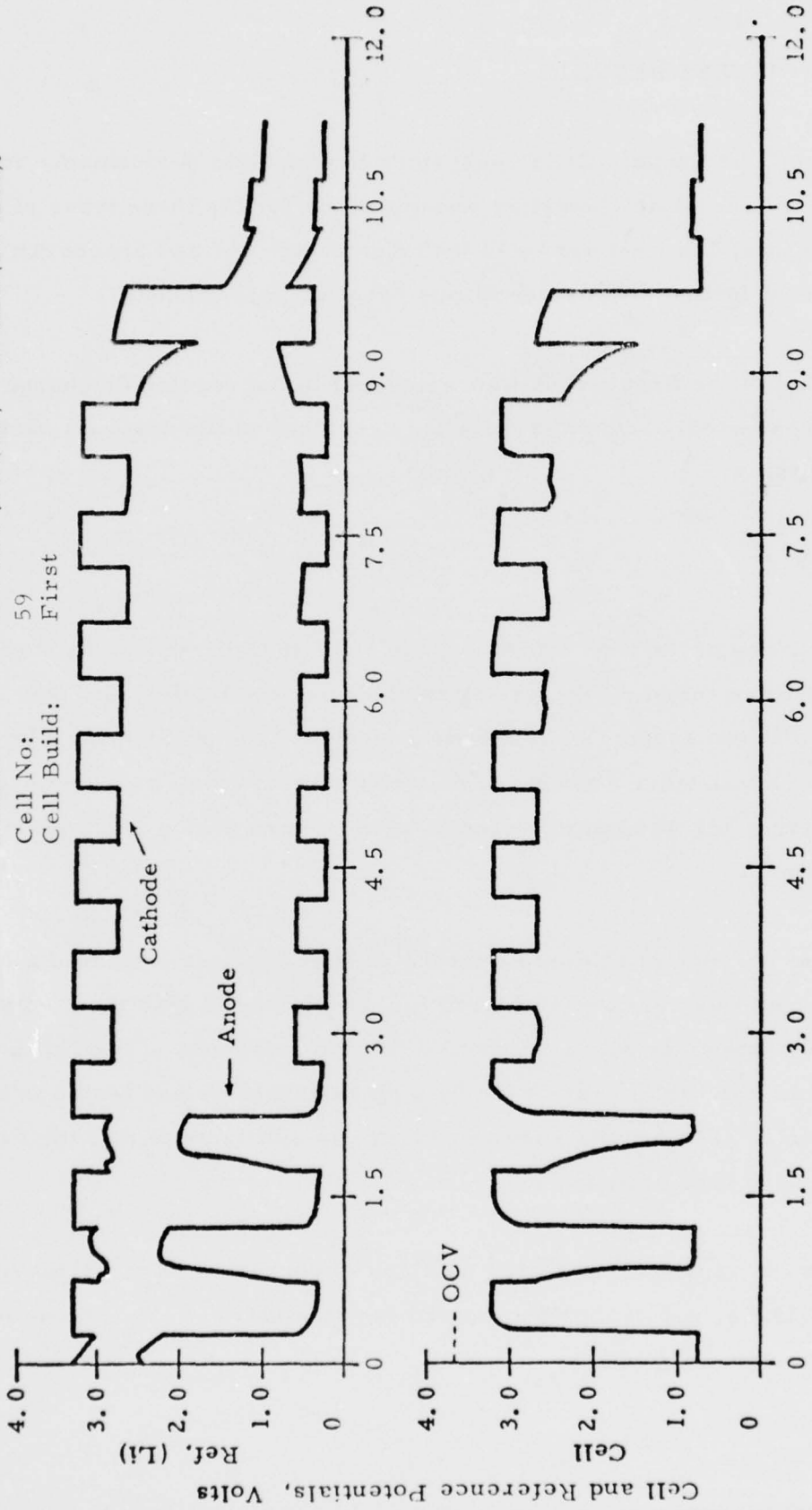

Time, Hours

Figure 34. Cyclic Load Voltages and Reference Voltages of a Life Support Cell at 75°F

At temperatures below 75°F, all cells were given a 5 ohm load in an attempt to reduce the effect of anode film on cell polarization, but to no avail. Only at current densities below 0.1 mA/cm<sup>2</sup> could a passivated cell be efficiently discharged as shown in Figure 35. Total cell current was 2.4 mA discharged to a 2.0 volt cutoff. It delivered 1.24 amp-hours and energy densities of 10.8 watt-hours/in<sup>3</sup> and 108 watt-hours/lb.

Two cells of the first series were subjected to discharge at 0.1 mA/cm<sup>2</sup> after 3.5 months storage at 140°F and still demonstrated efficient performance. One cell was given a 28.6 ohm (≈ 120 mA at 3.2V) pulse load for 5 seconds after 338 hours of discharge and the other the same pulse load at various intervals as shown in Figures 36 and 37, respectively.

As a result of this analysis of the effect of the passivating film on cell performance the following points can be made:

- a. The passivation phenomenon does not interfere with the cell chemistry, because heavily passivated cells did not exhibit significantly reduced capacity when discharged at a low rate.
- b. Passivation adversely affects cell performance in two ways: (1) increased time delay in reaching acceptable voltage levels at the onset of load application and (2) decreased cell capacity at high discharge rates, and at low temperatures.
- c. The improved performance after high temperature storage of the third and fourth series of Life Support Cells shows the effectiveness of the measures taken to counteract anode passivation during this project; viz. adding 5 percent weight SO<sub>2</sub> to the electrolyte solution and using a good-quality lithium and LiAlCl<sub>4</sub>.

System: Li/1.5M LiAlCl<sub>4</sub>·SOCl<sub>2</sub>/SOCl<sub>2</sub>  
Device: Life Support Cell  
Loads: 2.4mA  
Cell No: 110  
Cell Build: First

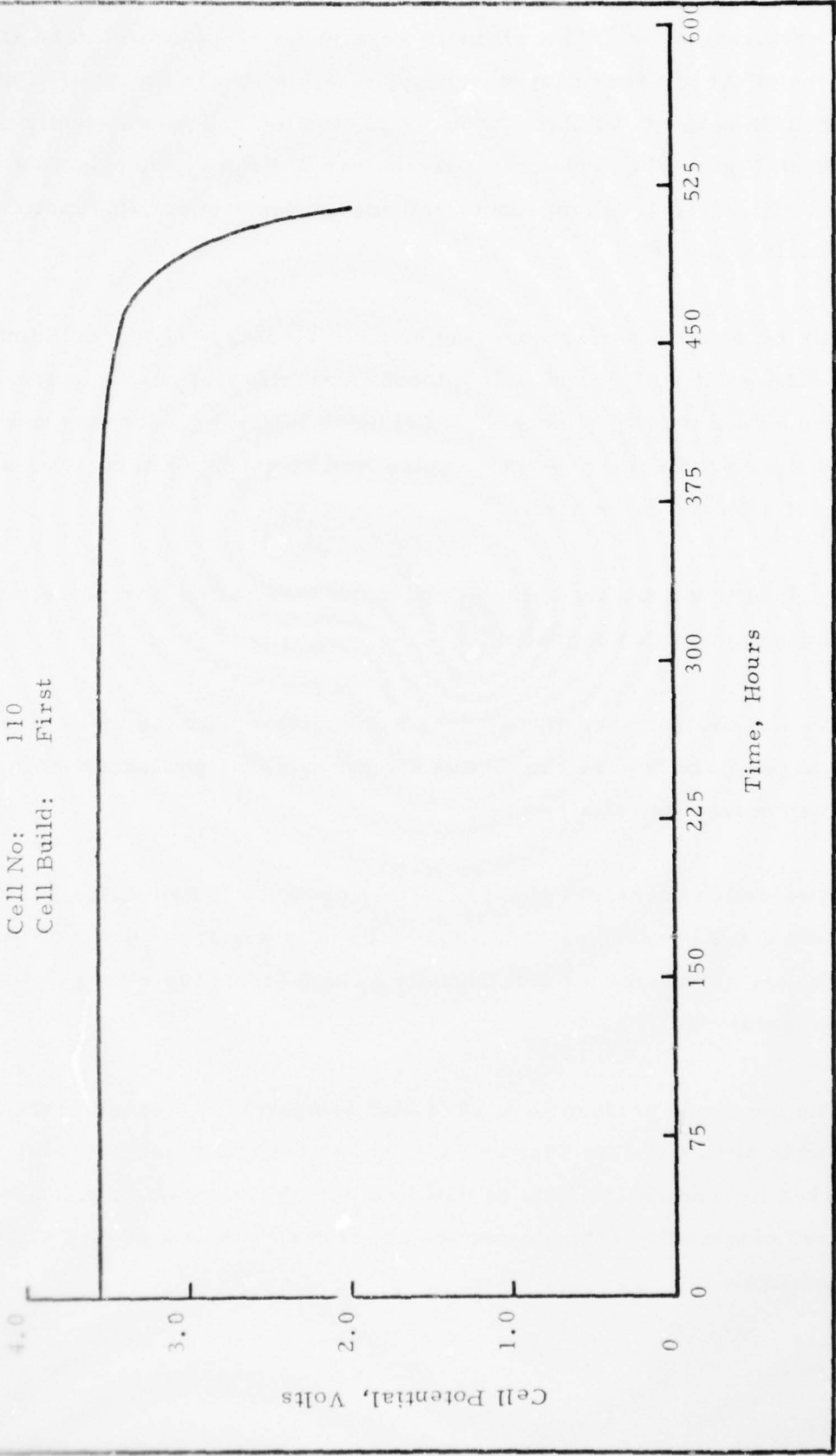

Figure 35. Low Rate Discharge Performance of a Passivated Life Support Cell at 75°F

System: Li/1.5M LiAlCl<sub>4</sub>·SOCl<sub>2</sub>/SOCl<sub>2</sub>, C  
Device: Life Support Cell  
Continuous Load: 2.4 mA  
Pulse Load: 28.6 ohms  
Cell No: 40  
Cell Build: First

⊙ Pulse voltage response

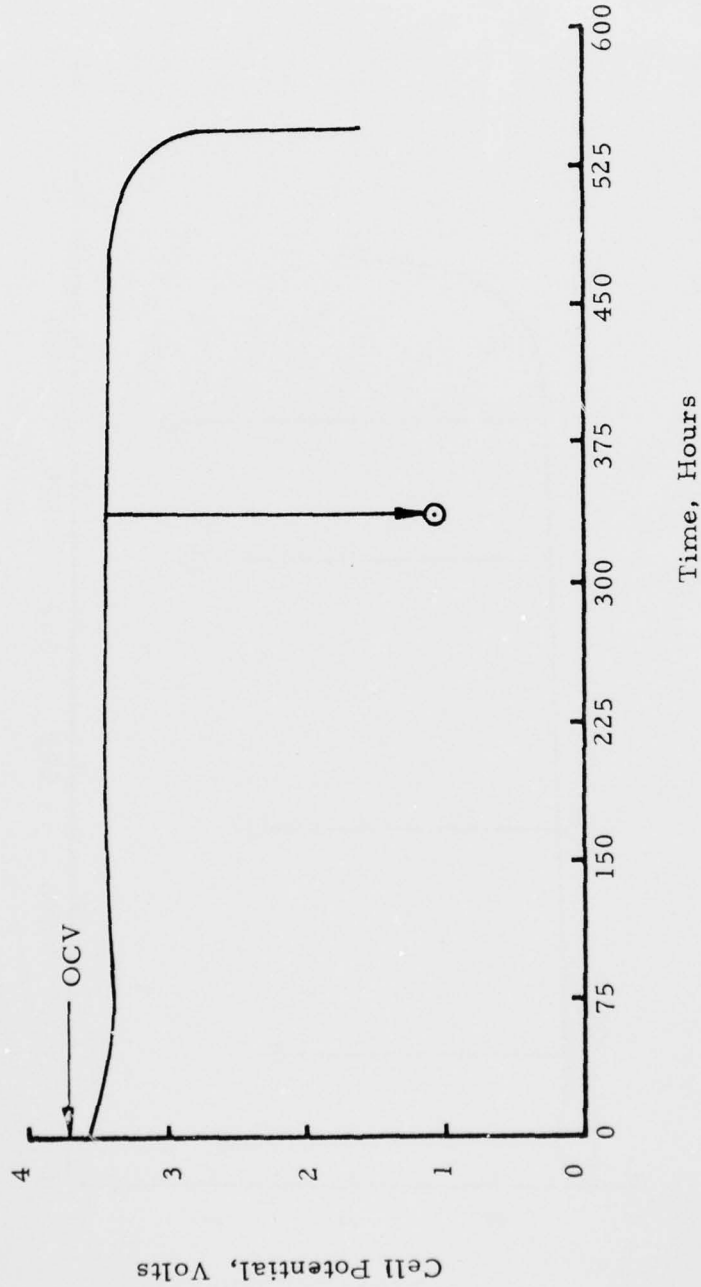

Figure 36. Low Rate Discharge Performance of a Passivated Life Support Cell Including One Pulse Load Response at 75°F After 3-1/2 Months Storage at 140°F

System: Li/1.5M LiAlCl<sub>4</sub>·SOCl<sub>2</sub>/SOCl<sub>2</sub>, C  
Device: Life Support Cell  
Continuous Load: 2.4 mA  
Pulse Load: 28.6 Ohms  
Cell No: 41  
Cell Build: First

⊙ Pulse Voltage Response

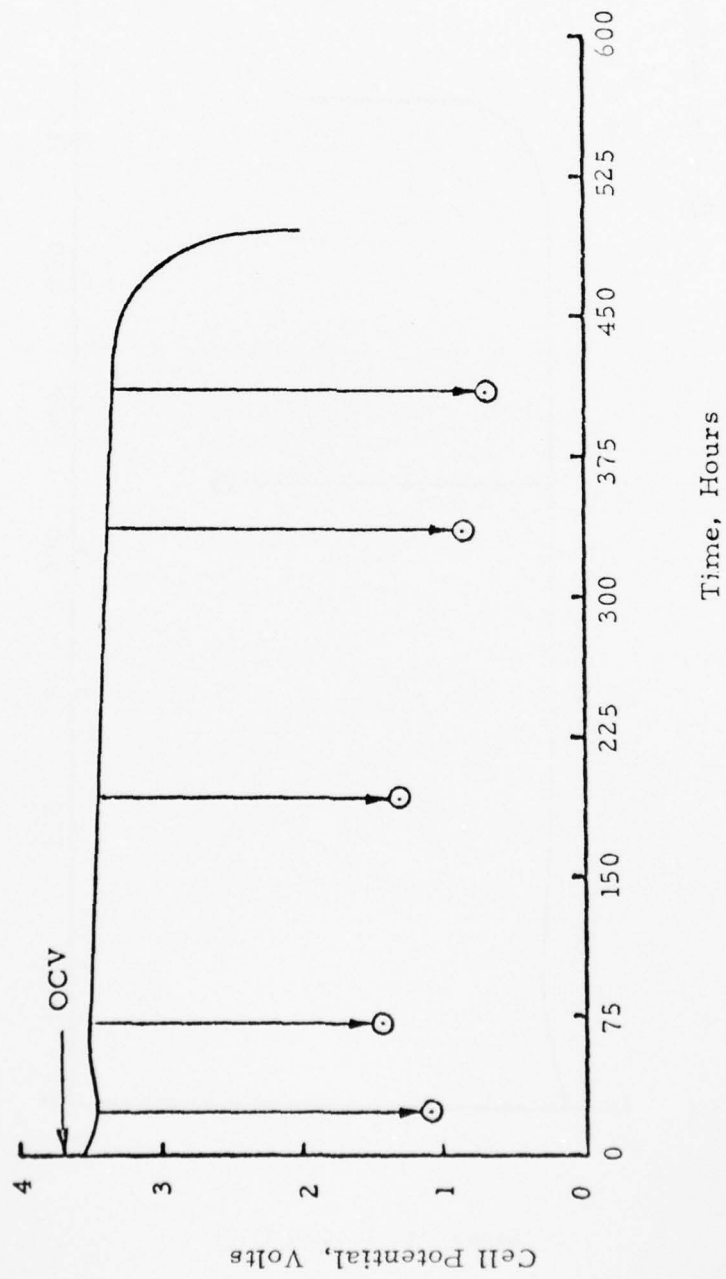

Figure 37. Low Rate Discharge Performance of a Passivated Life Support Cell at 75°F Including Several Pulse Load Responses After 3-1/2 Months Storage at 140°F

The effects of passivation on cell performance of the first series of Life Support Cells are considerably reduced in the third and fourth series as demonstrated by their performance after various durations of storage at high temperature. The fourth series shows a noticeable improvement over the third series that is due entirely to decreased passivation because the only difference in cell design and fabrication is the use of a better grade of lithium in the construction of the anode for the fourth series. Even after 5 months storage at high temperature, cells of the fourth series show considerable capacity when discharged at the prescribed rates.

Cells from the fourth series after 5 months storage at 140°F were discharged at 1 mA/cm<sup>2</sup> (36 mA) (greater than ten times the discharge rate of the low rate discharge of the first series) and at 2.0 mA/cm<sup>2</sup>. Their performances are shown in Figures 38 and 39, respectively. The cells exhibited at least 98% of the capacity of a fresh cell (nominal 1.60 Ahr).

## 2. Effect of Temperature

The results of discharge testing of cells in all series, both fresh and after high temperature storage, show a deterioration in performance characteristics at temperatures below room temperature. The deterioration includes lower cell capacity and midpoint voltage and longer delays in reaching 80 percent of midpoint voltage at the start and during a change in the load of a discharging cell. Data for the third build of cells illustrating the effect of temperature on cell capacity are shown in Figure 40 and on midpoint voltage in Figure 41. Capacity data as a function of temperature for the fourth build is shown in Figure 42. The figures also show performance after storage at high temperature.

## 3. Cell Performance

The optimum performance demonstrated by a Life Support Cell during this project was that of a fresh cell of the fourth series, which exhibited the following:



System: Li/1.5M LiAlCl<sub>4</sub>. SOCl<sub>2</sub>/SO<sub>2</sub>/SOCl<sub>2</sub>, C  
Device: Life Support Cell  
Loads: 36 mA  
Cell No: 437  
          438  
Cell Build: Fourth

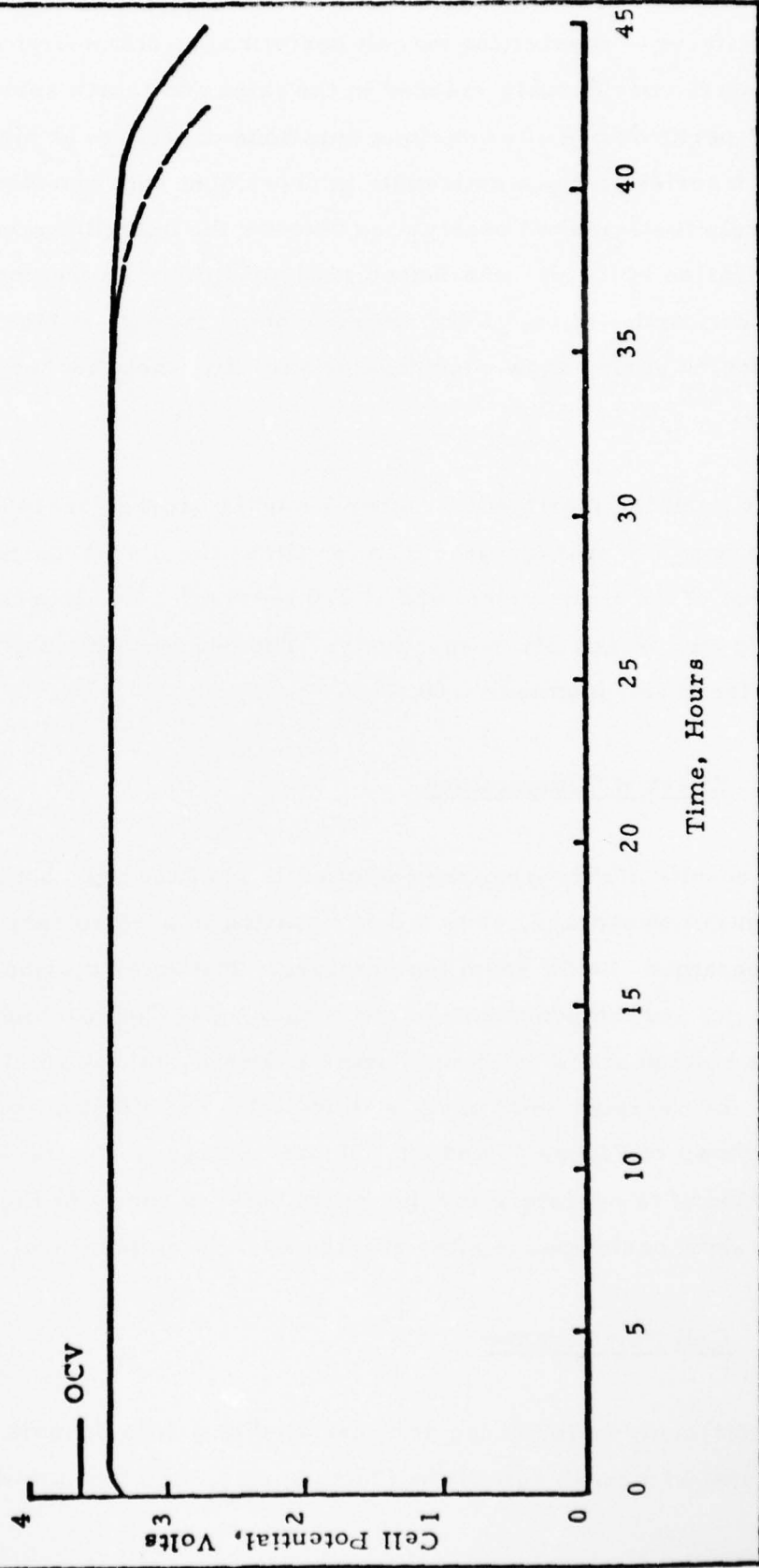

Figure 38. Low Rate Discharge Performance of Life Support Cell at 75°F After 5 Months Storage at 140°F

System: Li/1.5M LiAlCl<sub>4</sub>.SOCl<sub>2</sub>.SO<sub>2</sub>/SOCl<sub>2</sub>, C  
Device: Life Support Cell  
Loads: 72 mA  
Cell No: 441  
Cell Build: Fourth

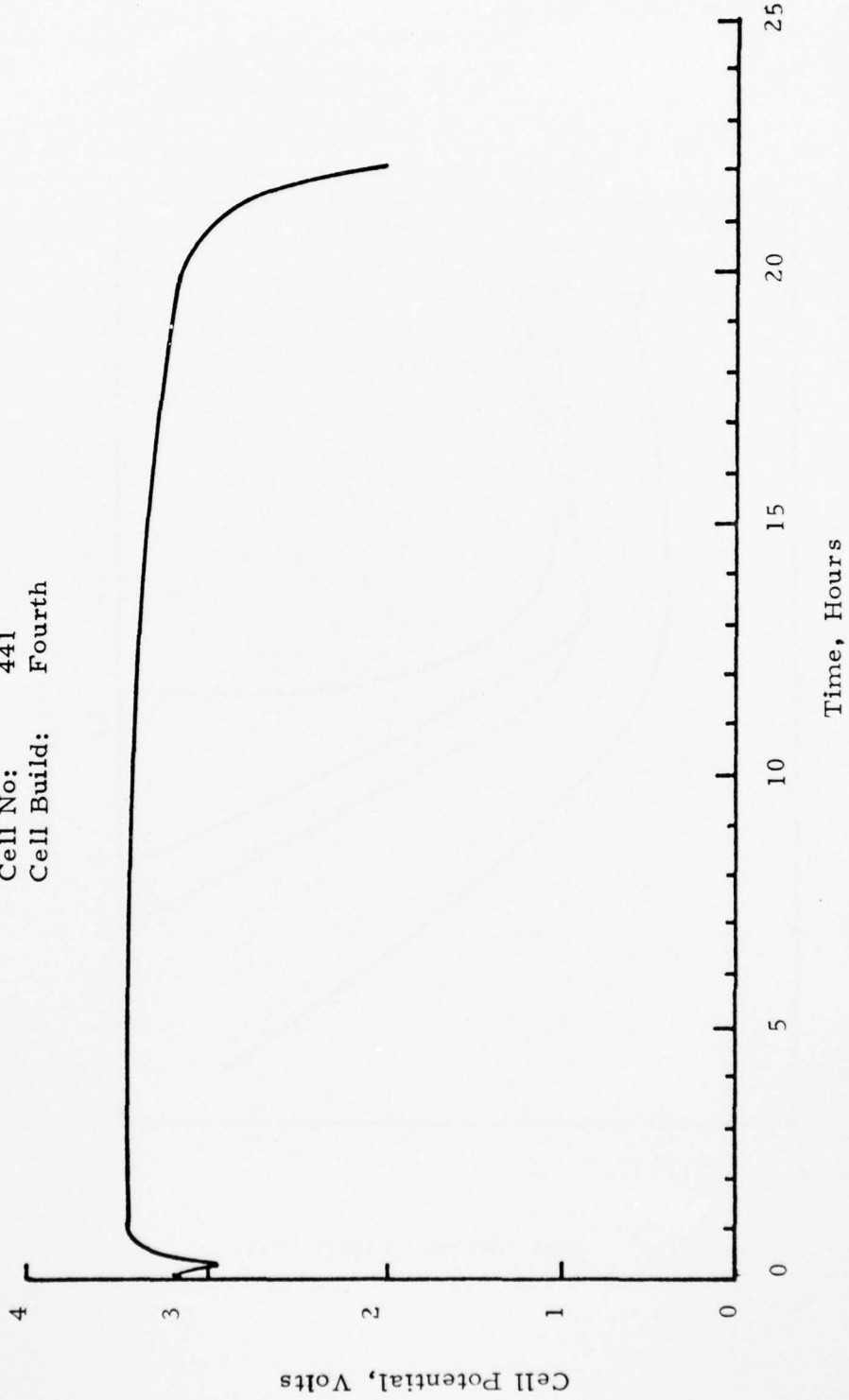

Figure 39. Low Rate Discharge Performance of a Life Support Cell at 75°F After 5 Months Storage at 140°F

System: Li/1.5M LiAlCl<sub>4</sub>.SOCl<sub>2</sub>.SO<sub>2</sub>/SOCl<sub>2</sub>, C  
 Device: Life Support Cell  
 Loads: 120 mA (30 min) - 45 mA (30 min)  
 Cell Builds: Third

○ Fresh Cells  
 △ One month storage at 140°F  
 □ Two months storage at 140°F  
 ◇ Five months storage at 140°F

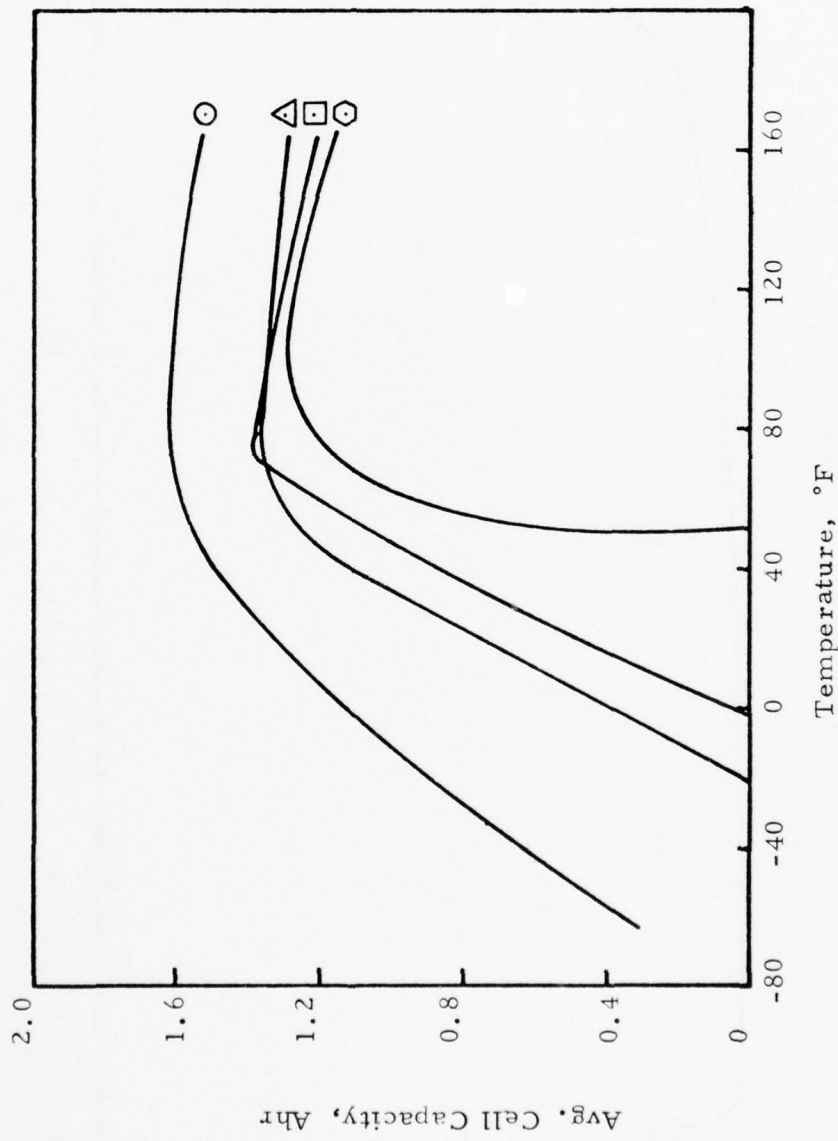

Figure 40. Life Support Cell Delivered Capacity as a Function of Temperature and Storage Time at 140°F

System: Li/i, 5M LiAlCl<sub>4</sub>·SOCl<sub>2</sub>·SO<sub>2</sub>/SOCl<sub>2</sub>, C  
 Device: Life Support Cell  
 Loads: 120 mA (30 min) - 45 mA (30 min)  
 Cell Build: Third

- ⊙ Fresh Cells
- △ One month storage at 140°F
- Two months storage at 140°F
- ⊙ Five months storage at 140°F

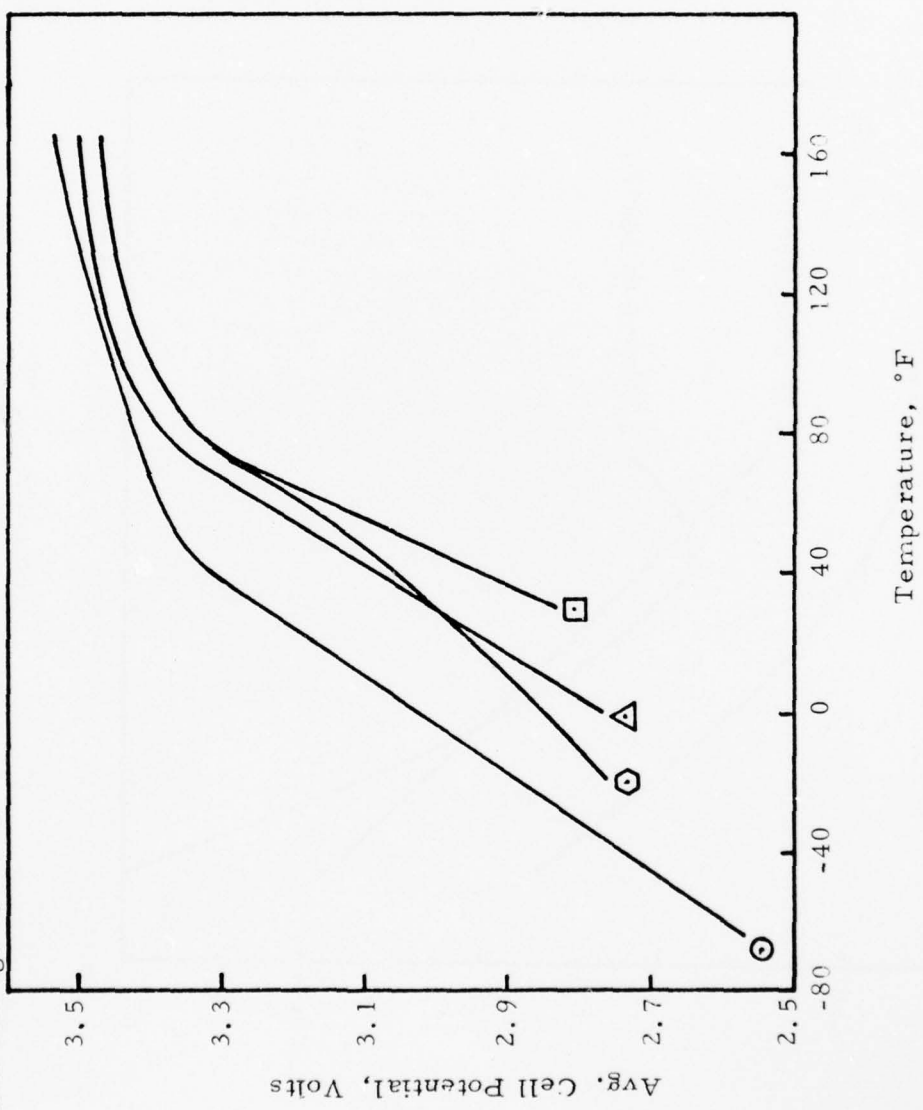

Figure 41. Life Support Cell Midpoint Voltage as a Function of Temperature and Storage Time at 140°F

System: Li/1.5M LiAlCl<sub>4</sub>·SOCl<sub>2</sub>·SO<sub>2</sub>/SOCl<sub>2</sub>, C  
Device: Life Support Cell  
Loads: 120 mA (30 min) - 45 mA (30 min)  
Cell Build: Fourth

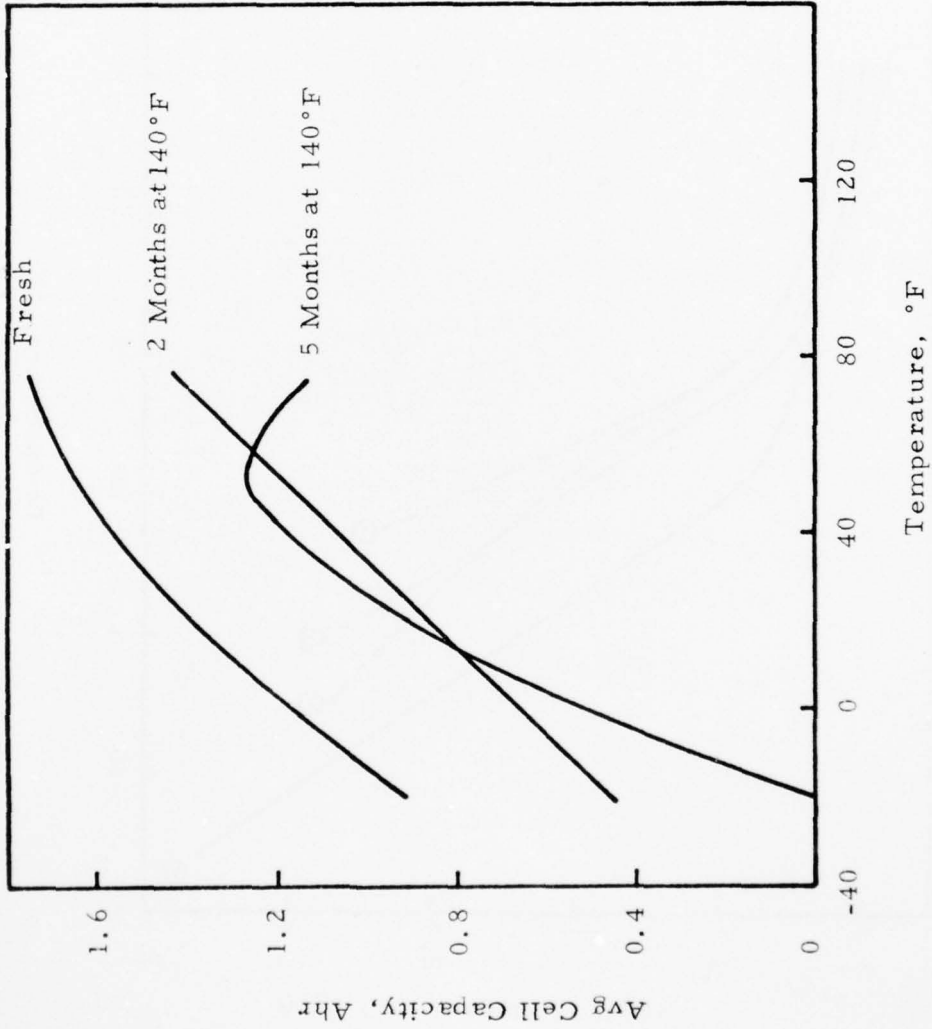

Figure 42. Life Support Cell Delivered Capacity as a Function of Temperature and Storage Time at 140°F

Capacity	-	1.75 Ahr
Energy Density/Vol	-	13.5 watt-hours/in <sup>3</sup>
Energy Density/Wt	-	155 watt-hours/lb

These results approach the ultimate performance goals that will be required for future Air Force application as described in the Statement of Work and even exceed the goal set for energy density by weight. They further compare favorably with the best performance of a fresh cell of the first series fabricated to provide base-line data and representative of the state of the art at the start of the project:

Capacity	-	0.85 Ahr
Energy Density/Vol	-	7.1 watt-hours/in <sup>3</sup>
Energy Density/Wt	-	70.8 watt-hours/lb

These results represent the best performance from each respective series of fresh cells tested at room temperature. As described above, the performance deteriorates in cells stored at high temperature and discharged at lower than room temperature. The test results show, however, that these deteriorating influences were considerably abated in the later series of cells, that incorporated changes identified and developed in cell improvement studies carried on during the project.

The discharge time and battery voltage of the PRC-90 batteries, an adaptation of the G3013 Life Support Cell, are consistent with the fresh cell data provided by the Life Support Cells. The battery can operate above 10.0 volts at temperatures as low as -65°F. The discharge time ranges from about 19 hours at +75°F to 1.2 hours at -65°F.

One of the batteries discharged at +75°F exhibited very early voltage drop to 10.0 volts after 2 hours of run time. The cause of this problem was due to an abnormal behavior in one cell. After about 19 hours of run time had passed, this cell exhibited a voltage of -68 mv at the 120 mA load and -24 mv at the 45 mA load. Deep discharging of this cell did not, however, cause adverse safety hazards.

## SECTION IV

### SPACECRAFT CELLS

The Spacecraft Cells consist of two types: Spacecraft "A" - a high power output cell with a nominal capacity of 200 Ahrs, and Spacecraft "B" - a low power output cell with a nominal capacity of 500 Ahrs. Two series each of these cells were built and tested, the first series of each incorporating improvements based on studies conducted after the first series of Life Support Cells. The second series of cells of each type exhibited performance characteristics that approached the goals for capacity and energy output set for Air Force applications.

Elaborate safety precautions were taken in handling and testing the Spacecraft cells including the use of the Honeywell Ordnance Proving Ground at Elk River, MN., and the remote activation of cells. These measures were taken because Honeywell's in-house experience with cells of this type and familiarity with the literature on the subject dictated that caution be observed with cells of this size and electrochemical system.

The chemistry of the Spacecraft Cells is the same as that developed during laboratory studies on the second series of Life Support Cells

#### A. DESIGN AND FABRICATION

##### 1. Spacecraft "A" Cell

The design and fabrication effort for the Spacecraft "A" Cell resulted in the production of two series of experimental hardware cells. Although the project originally specified that each series was to contain 20 batteries, changing requirements and tradeoffs during the course of the project resulted in the production of two cells in the first series and nine cells in the second series.

Figure 43 shows a representative cross section of the Spacecraft Cells and the Figure 44 photograph applies to each of the two series of Spacecraft "A" cells fabricated. The case and terminal plate were positive and made of 316L stainless steel. The negative terminal was made of nickel and its isolation was provided by a glass-to-metal seal using a 316L stainless steel header. This header was then projection welded to the terminal plate. Final closure of the terminal plate to the cell case was accomplished using electron beam welding.

The hardware and internal component designs for the first series of Spacecraft "A" Cells is presented in Table XVII.

This basic design was retained in the second series, except that the number of cathodes was increased from 26 to 27, thus increasing the total cathode area from 4843 cm<sup>2</sup> to 5029 cm<sup>2</sup>. The operating current densities under the Spacecraft "A" load profile for this final design are:

50A	-	9.9 mA/cm <sup>2</sup>
30A	-	6.0 mA/cm <sup>2</sup>
25A	-	5.0 mA/cm <sup>2</sup>
16A	-	3.2 mA/cm <sup>2</sup>

## 2. Spacecraft "B" Cell

The design and fabrication effort for the Spacecraft "B" Cell resulted in the production of two series of experimental hardware cells. As a result of changing requirements and priorities during the project, the original requirement for 12 units in each series was reduced to three units in the first series and nine units in the second series. A representative cross section of the Spacecraft "B" Cell, shown in Figure 38 and the photograph in Figure 40 apply to each of the two series of cells fabricated.



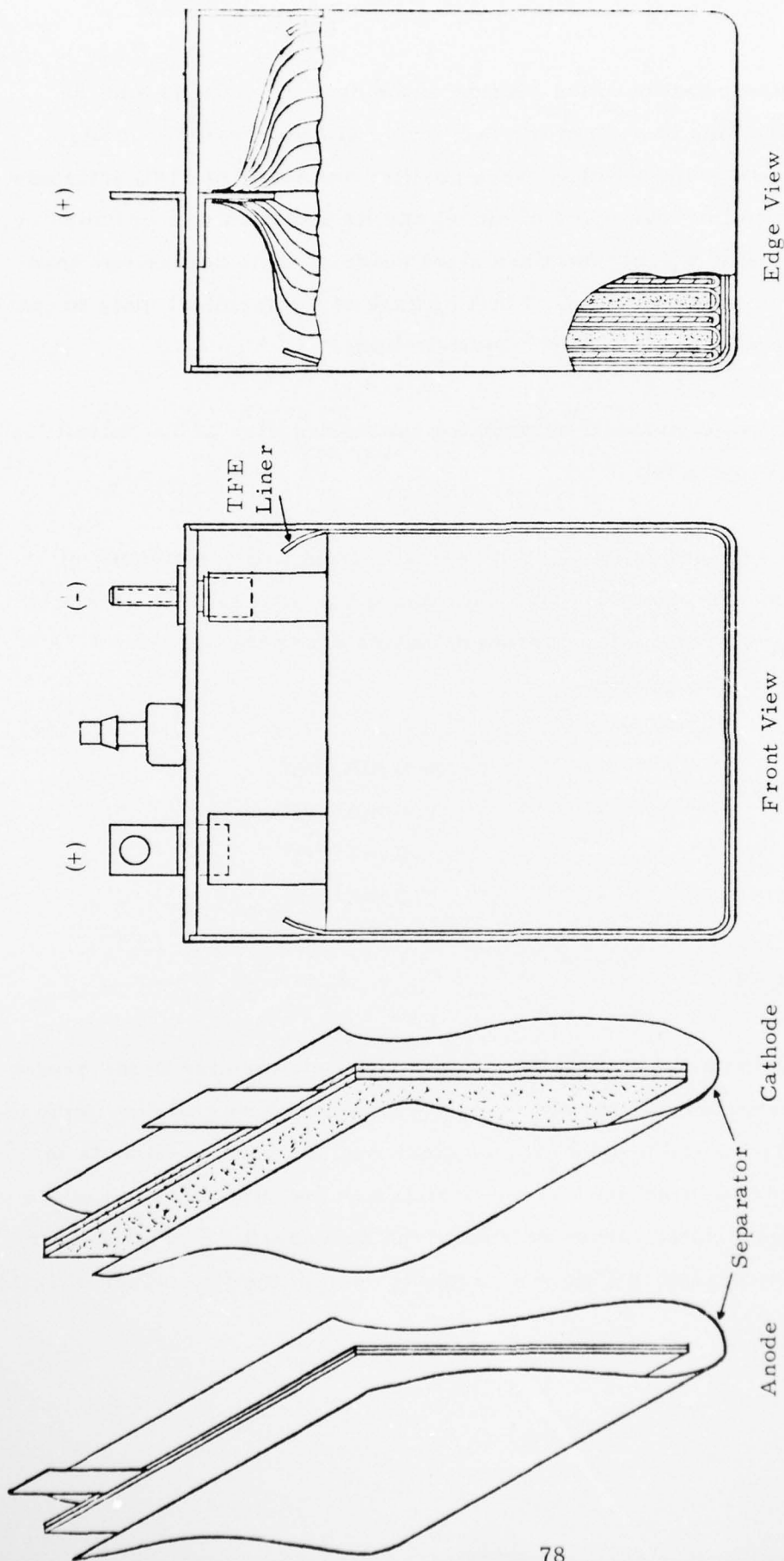

Figure 43. Representative Cross Section of Spacecraft "A" and "B" Cells

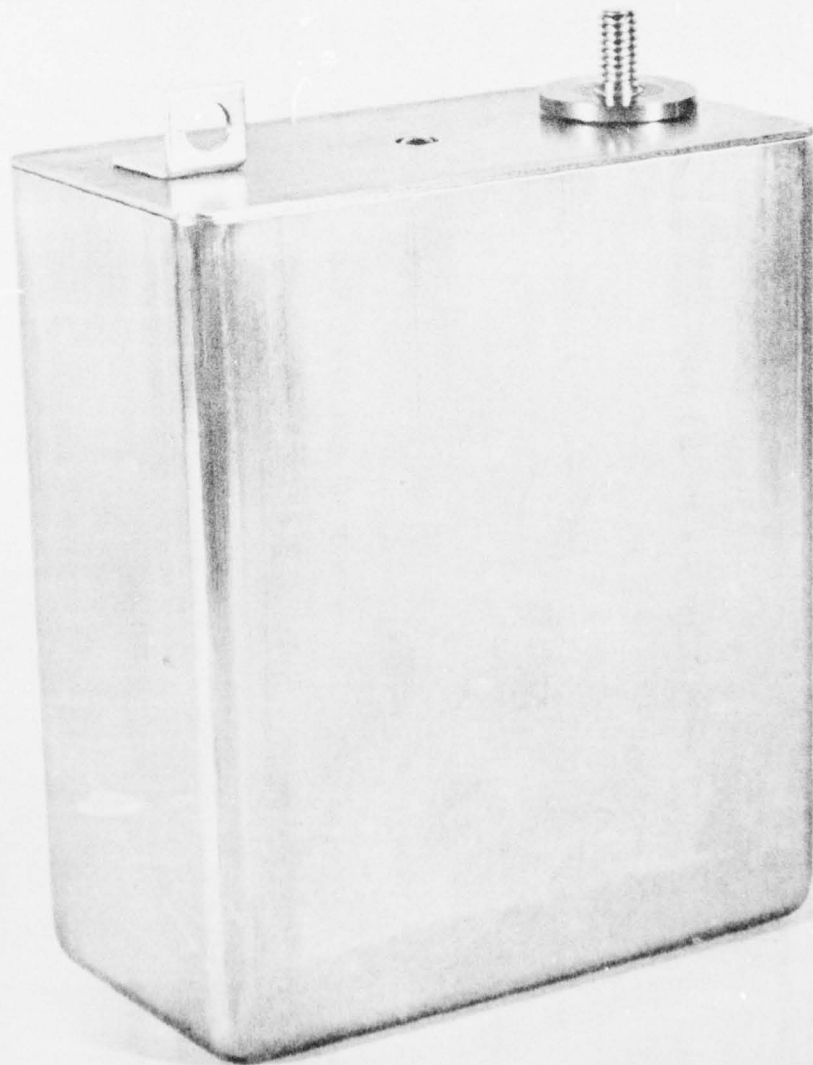

Figure 44. Spacecraft "A" Cell

AD-A043 364

HONEYWELL INC HORSHAM PA POWER SOURCES CENTER  
LITHIUM INORGANIC ELECTROLYTE BATTERY INVESTIGATION.(U)  
APR 77 D L CHUA, C R WALK

F/G 10/3

F33615-74-C-2071

UNCLASSIFIED

AFAPL-TR-77-21

NL

2 of 2  
AD A043364

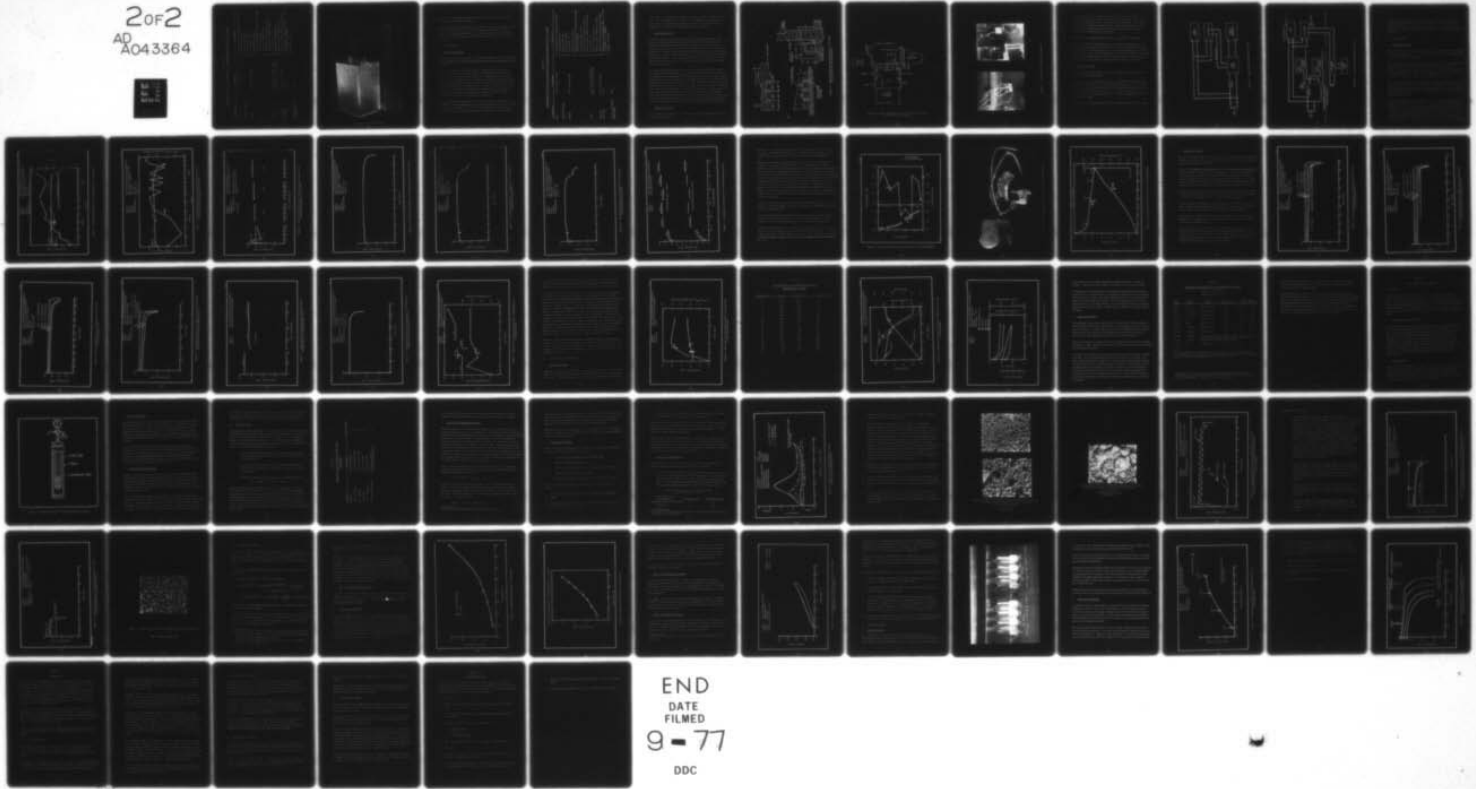

END  
DATE  
FILMED  
9-77  
DDC

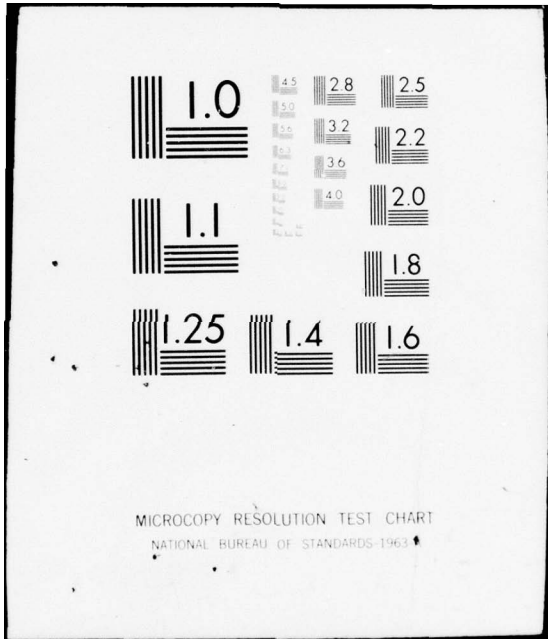

TABLE XVII  
 HARDWARE AND INTERNAL COMPONENT DESIGNS FOR SPACECRAFT "A" CELLS

Components	Dimensions	Description
Case	2.250" x 4.188" x 5.055"	1) Excluding positive and negative terminals 2) 316L Stainless steel
Negative Terminal		1) Glass-to-metal seal 2) Pin material: Nickel
Cathode	3.80" x 3.80" x 0.042"	1) No. of plates: 26 2) Cold pressed cathodes 3) Cathode composition: 80% Shawinigan carbon and 20% TFE binder
Anode	3.80" x 3.80" x 0.015"; End plates: 3.80" x 3.80" x 0.0075"	4) Net cathode weight: 4.37 g 5) Apparent cathode density: 0.45 g/cc 6) Cathode grids: (Delker) 3SSI5-189
Separator	4.12" x 9.0" x 0.005"	1) No. of plates: 27 2) Lithium: Foote Mineral Co. 3) Collector grids: (Delker) 5-Ni8-284
Electrolyte	491 cc	Mead's p-255 glass mat w/acrylic binder 1) Composition: 1.5M LiAlCl <sub>4</sub> ·SOCl <sub>2</sub> + 5.0% SO <sub>2</sub> (by weight or 1.3M SO <sub>2</sub> ) 2) Density: 1.655 g/cc
Carbon to Electrolyte Weight Ratio	0.116	

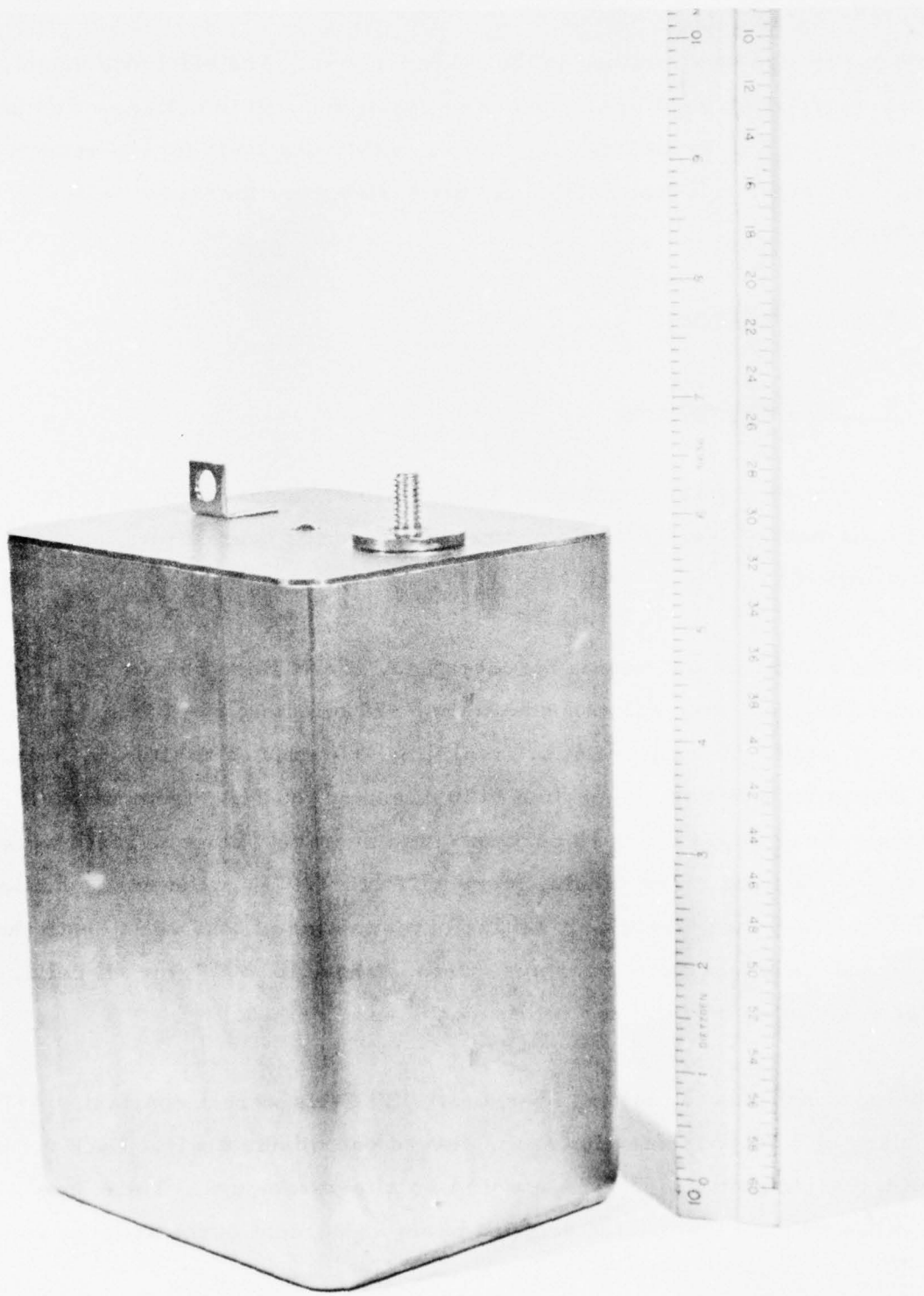

Figure 45. Spacecraft "B" Cell

The hardware and internal component designs for the first series of Spacecraft "B" Cells is presented in Table XVIII.

This basic design was retained in the second series. The electrode height, however, was increased from 3.30 to 4.3 inches to enable the cell to deliver a nominal capacity of 500 Ahr by making more active carbon available for the reduction of  $\text{SOCl}_2$ . The outer cell dimensions for this series were increased to 3.63 x 4.25 x 6.18 inches.

## B. TEST PROGRAM

### 1. Project Requirements

Consideration of storage conditions, load profiles, temperature and safety specified in the Statement of Work for this project governed the overall plan used for cell test and evaluation.

Discharge conditions for testing Spacecraft "A" Cells were 50A for the first 30 seconds; 30A from time +31 seconds to time +10 minutes; 25A, from time +10 minutes to time + 60 minutes; 50A, from time +60 minutes to time +61 minutes; 25A, from time +61 minutes to time +120 minutes; and 16A, from time +120 minutes until the voltage drops below 75 percent of the average voltage. Tests were to be conducted at temperatures ranging from 50°F to 140°F. However, due to modifications in the scope of work, resulting in the testing of less cells, both the storage and/or discharge temperature were changed to 80°F for all cells. A voltage delay of no more than 5 milliseconds was desired.

Discharge conditions for testing Spacecraft "B" Cells were a constant 0.417 A with two pulses of 5 seconds duration each, spaced one minute apart. Each set of pulses was of the same amplitude, 7.5A and 15A on alternate hours. These conditions were repeated until the voltage dropped below 75 percent of the average voltage.

TABLE XVIII

## HARDWARE AND INTERNAL COMPONENT DESIGNS FOR SPACECRAFT "B" CELLS

Components	Dimensions	Descriptions
Case	3.625" x 4.250" x 5.555"	1) Excluding positive and negative terminals 2) 316L Stainless steel
Negative terminal		1) Glass-to-metal seal 2) Pin material: Nickel
Cathode	3.60" x 3.30" x 0.140"	1) No of plates: 14 2) Cold pressed cathodes 3) Cathode composition: 80% Shawinigan carbon and 20% TFE binder 4) Net cathode weight: 12.4 g 5) Apparent cathode density: 0.45 g/cc 6) Collector grids: (Delker) 5-316L-8-284
Anode	3.60" x 3.30" x 0.072"; End plates: 3.60" x 3.30" x 0.032"	1) No. of plates: 15 2) Lithium: Foote Mineral Co. 3) Collector grids: (Delker) 5-Ni-8-284
Separator	4.15" x 8.0" x 0.005"	1) Mead's p-255 glass mat w/acrylic binder
Electrolyte	810 cc	1) Composition: 1.5M LiAlCl <sub>4</sub> ·SOCl <sub>2</sub> + 5.0% SO <sub>2</sub> (by weight, or ≈ 1.3M SO <sub>2</sub> ) 2) Density: 1.655 g/cc
Carbon to Electrolyte Weight Ratio	0.104	



Tests were to be conducted at temperatures ranging from 40°F to 120°F. However, due to modifications in the scope of work, resulting in the testing of less cells, both the storage and/or discharge temperature was changed to 80°F. A voltage delay of no more than 5 milliseconds was to be achieved.

## 2. Description of Tests

For safety reasons, a test program was devised for the testing of Spacecraft Cells which would eliminate contact between personnel and the activated cells. The tests were conducted at the Honeywell Ordnance Proving Ground in Elk River, Minnesota, according to the set-up shown in Figures 46 and 47. Test boxes were insulated for controlled temperature testing. Not shown were x-rod shaped charges located so as to destroy discharged cells. The set-up shown in Figure 46 was used to store Spacecraft "A" cells, and discharge fresh and store Spacecraft "B" cells. Discharging fresh Spacecraft "A" cells and safety testing of these cells used the set-up shown in Figure 47.

An in-house built electrolyte activation scheme (shown in Figure 48) was used. It was prepared in the following way: (1) a 1/4" OD Swagelok port connector with a 1/4" Swagelok nut was welded to the terminal plate of the cell; (2) a one-way Whitey ball-valve was screwed onto the nut; (3) the outlet of this valve was connected to an 11-foot 316L stainless steel tube with a 1/4" OD. (An 8-inch diameter port provided entry into the control house.); (4) a one-way shut-off valve was connected to the end of the 11 foot tube, the other end of which was connected to a "T" union; (5) the "T" union connected the electrolyte reservoir with a vacuum pump via Teflon lines fitted with Swagelok nuts, one of which was connected to the reservoir and one to the vacuum pump by a one-way ball valve. After activation, the outlet of the shut-off valve was disconnected from the "T" union and capped tightly with a Swagelok cap.

## 3. Spacecraft "A" Cell

The test plan for the Spacecraft "A" Cells consisted of discharge testing, storage testing and safety testing.

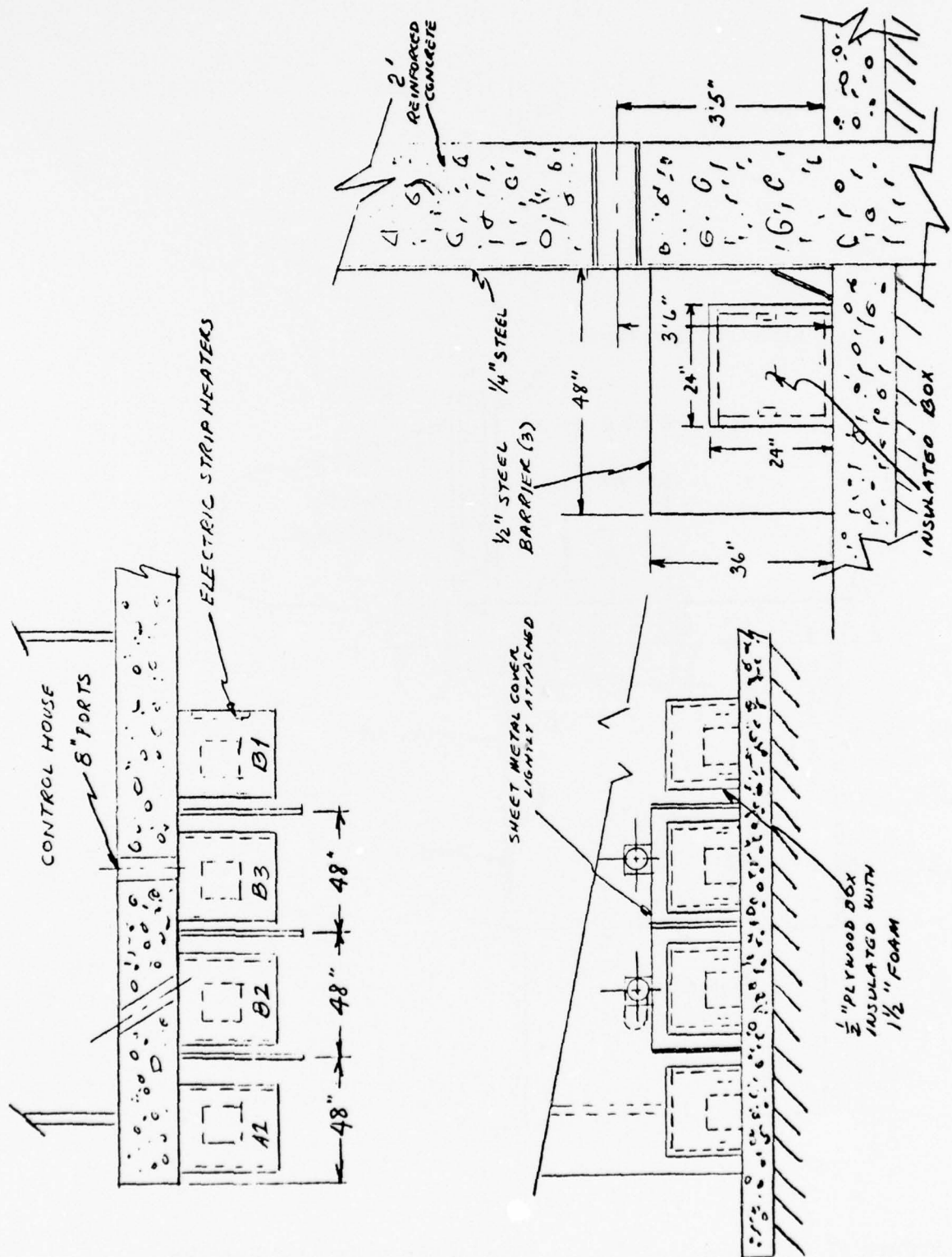

Figure 46. Honeywell Ordnance Proving Grounds Test Facility for Spacecraft "A" and "B" Batteries

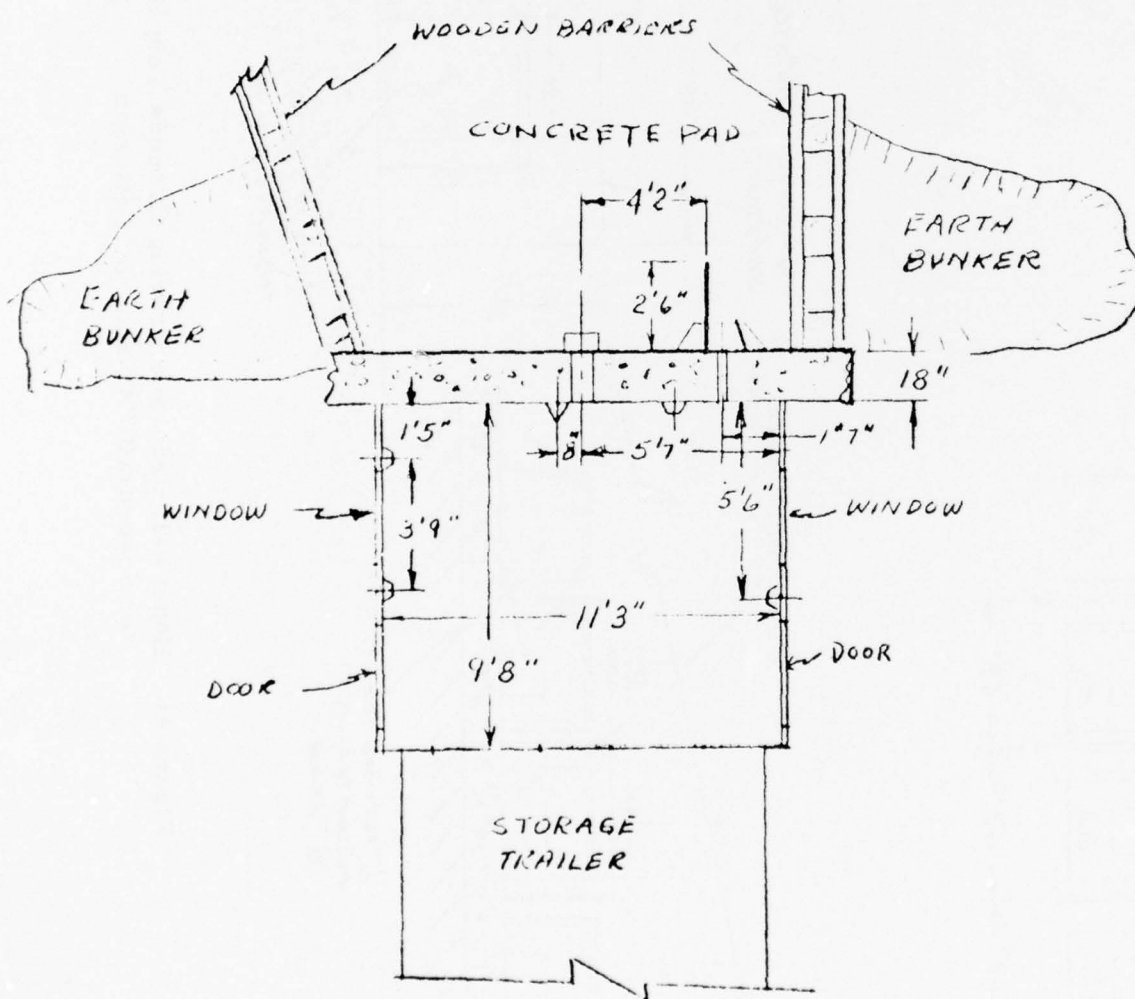
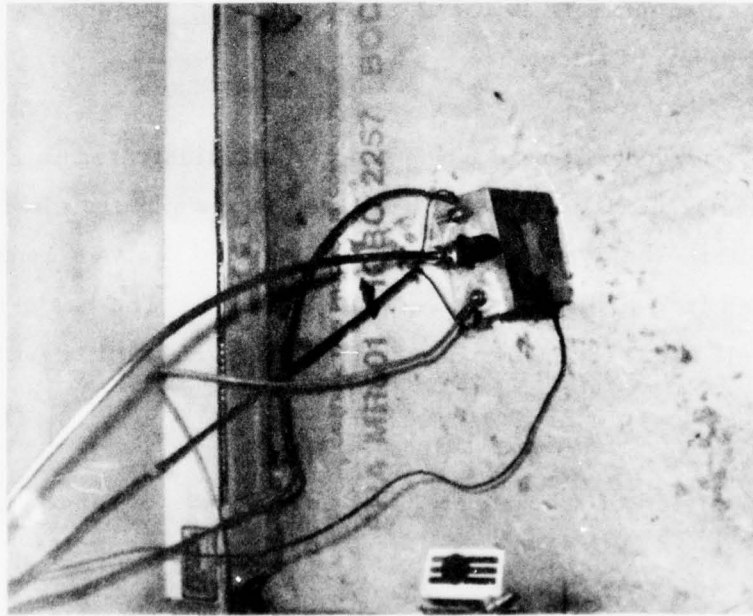
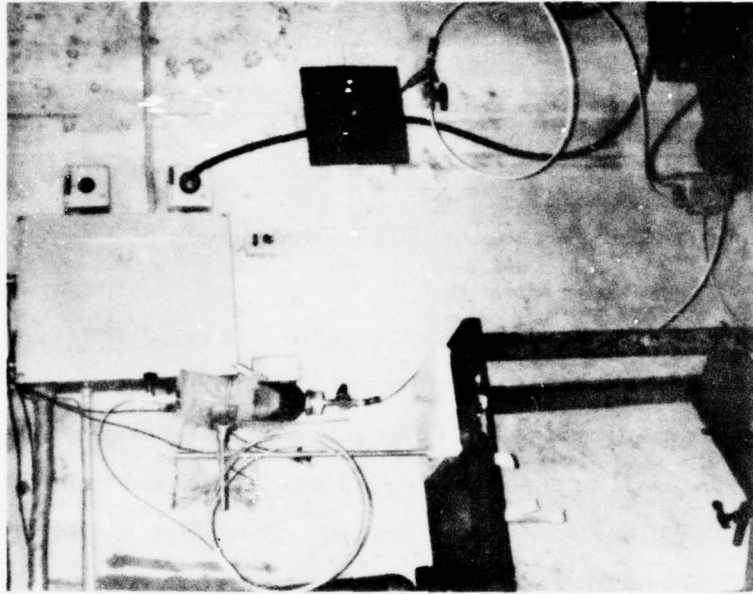

Figure 47. Honeywell Ordnance Proving Grounds Test Facility for Spacecraft "A" Batteries



A



B

Figure 48. Activation Set-up for Spacecraft Batteries

The discharge tests were performed using the circuit illustrated in Figure 49 at a controlled temperature of 80°F. Cells were allowed to remain for two hours after electrolyte filling under OCV conditions before discharging. The discharge was conducted according to the prescribed load profile for Spacecraft "A" Cells. The basic raw data collected was (1) cell voltage versus time and (2) voltage stability within 5 milliseconds after load change.

The storage test consisted of storage at 80°F for periods of 1 and 3 months.

To obtain safety data for high discharge rate applications, discharged cells from both the first and second series were subjected to continuing discharge after the cutoff voltage was reached (forcing the cells into reverse polarity) and to charging test (first series). One cell of the final series was subjected to short circuit testing. This test was conducted using No. 8 size copper wires series-connected through a shunt and a relay. The total loop resistance of this circuit was 0.026 ohms.

#### 4. Spacecraft "B" Cell

The test plan for the Spacecraft "B" Cells also consisted of discharge testing, storage testing and safety testing.

The discharge tests were performed using the circuit illustrated in Figure 50 at a controlled temperature of 80°F. Cells remained for two hours after electrolyte filling at OCV conditions before discharging. The discharge was conducted according to the prescribed load profile of Spacecraft "B" Cell. The basic raw data collected was (1) cell voltage versus time and (2) voltage stability within 5 milliseconds of load change.

The storage test consisted of storage at 80°F for periods of three and six months.

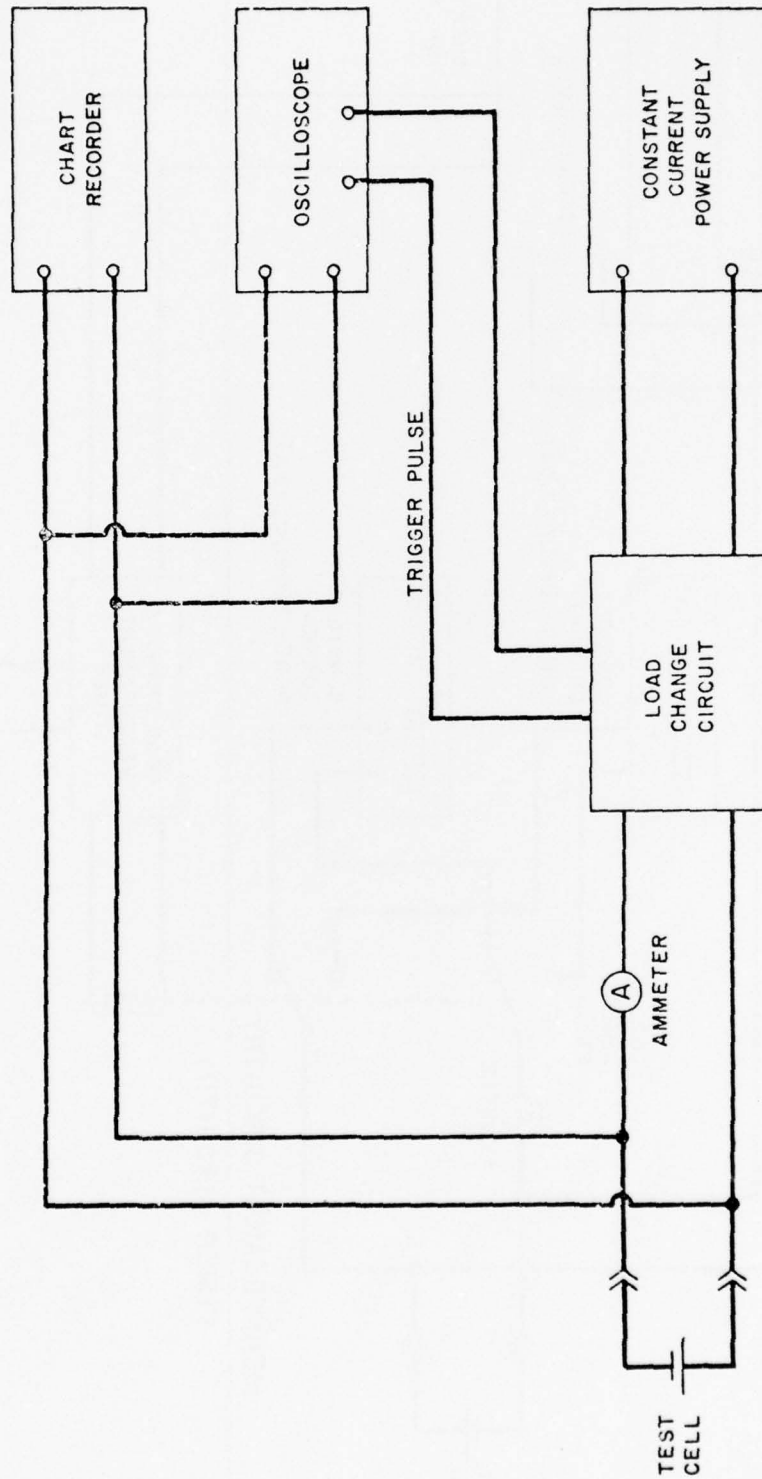

Figure 49. Test Circuit for Spacecraft "A" Cells

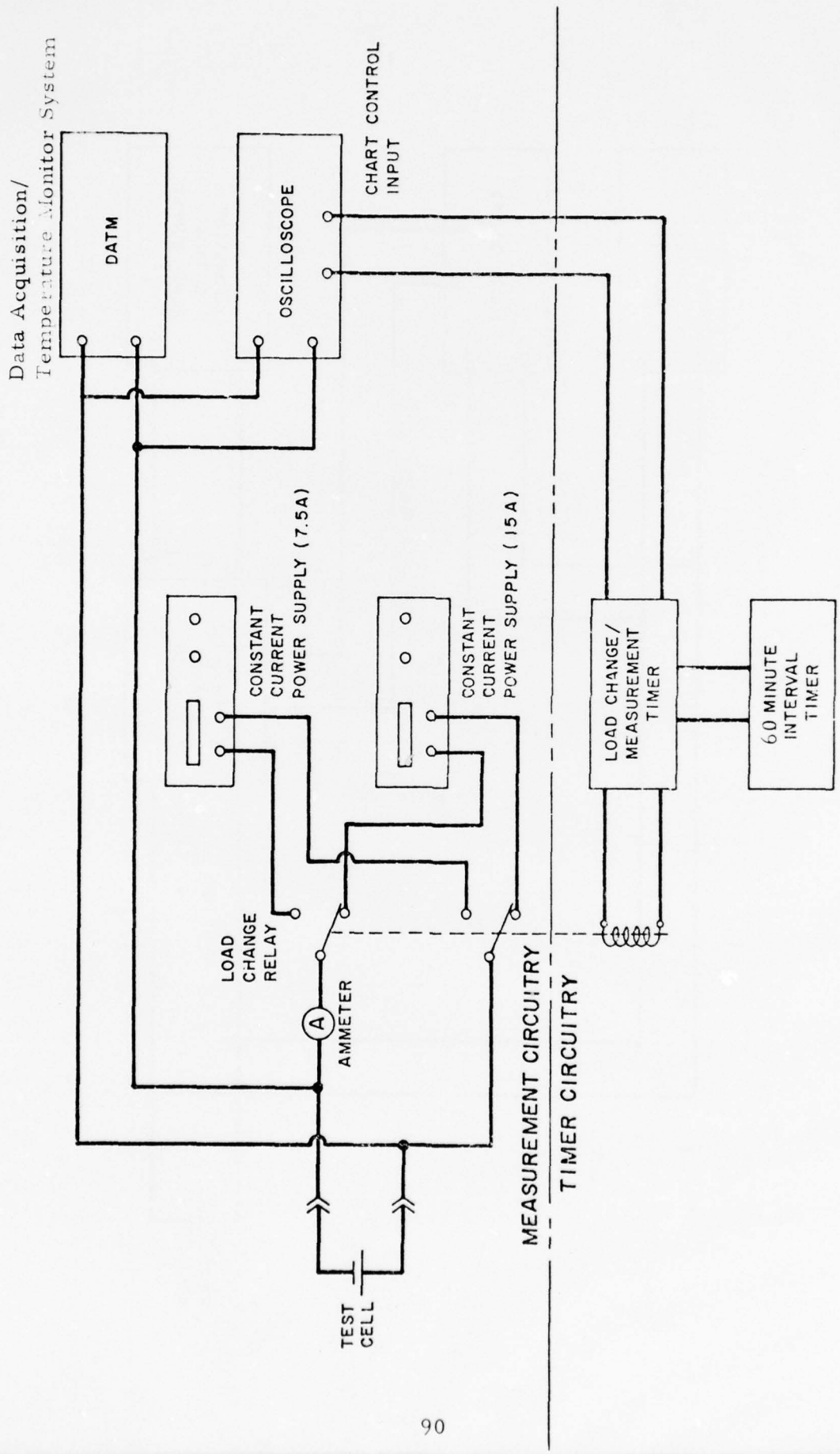

Figure 50. Test Circuit for Spacecraft "B" Cells

To obtain safety data on these large, low discharge rate cells, one cell of the first series was subjected to a charging test and one to a polarity reversal test using discharged cells. Two cells of the second series were subjected to short-circuit testing. Voltage, current and temperature data were monitored throughout the tests.

## C. TEST RESULTS

### 1. Spacecraft "A" Cell

This section contains results of tests on Spacecraft "A" Cells conducted in response to the project requirements. They are reported by series except that safety testing is reported in a separate subsection.

Of the two Spacecraft "A" Cells of the first series, one was subjected to discharge within 2 hours of cell activation and the other after 48 days of storage at  $95^{\circ}\text{F} \pm 18^{\circ}\text{F}$ . The voltage and temperature history of both cells during discharge testing is shown in Figures 51 and 52. The voltage delay characteristics of the stored cell is shown in Figure 53. The fresh cell exhibited no voltage delay.

The fresh cell delivered 166.2 Ahr of capacity and energy densities of 11.6 watt-hours/in<sup>3</sup> and 153 watt-hours/lb. The stored cell exhibited a 7.7 percent degradation in capacity and a 10.3 percent drop in energy densities. Neither cell exhibited thermal runaway, and both maintained a voltage regulation within  $\pm 10$  percent over 95 percent of useful life.

Three of the nine cells of the second Spacecraft "A" series were short circuited during electrode stack insertion into the case and after electron beam welding of the terminal covers. Of the remaining six cells, one was safety tested, one discharged fresh, two discharged after 1 month storage and two after 3 months storage at  $80^{\circ}\text{F}$ . The discharge history of the fresh cell, a typical cell after 1 month storage, and a typical cell after 3 months storage are shown in Figures 54, 55, and 56, respectively. Voltage delay data of the stored cells are shown in Figure 57.



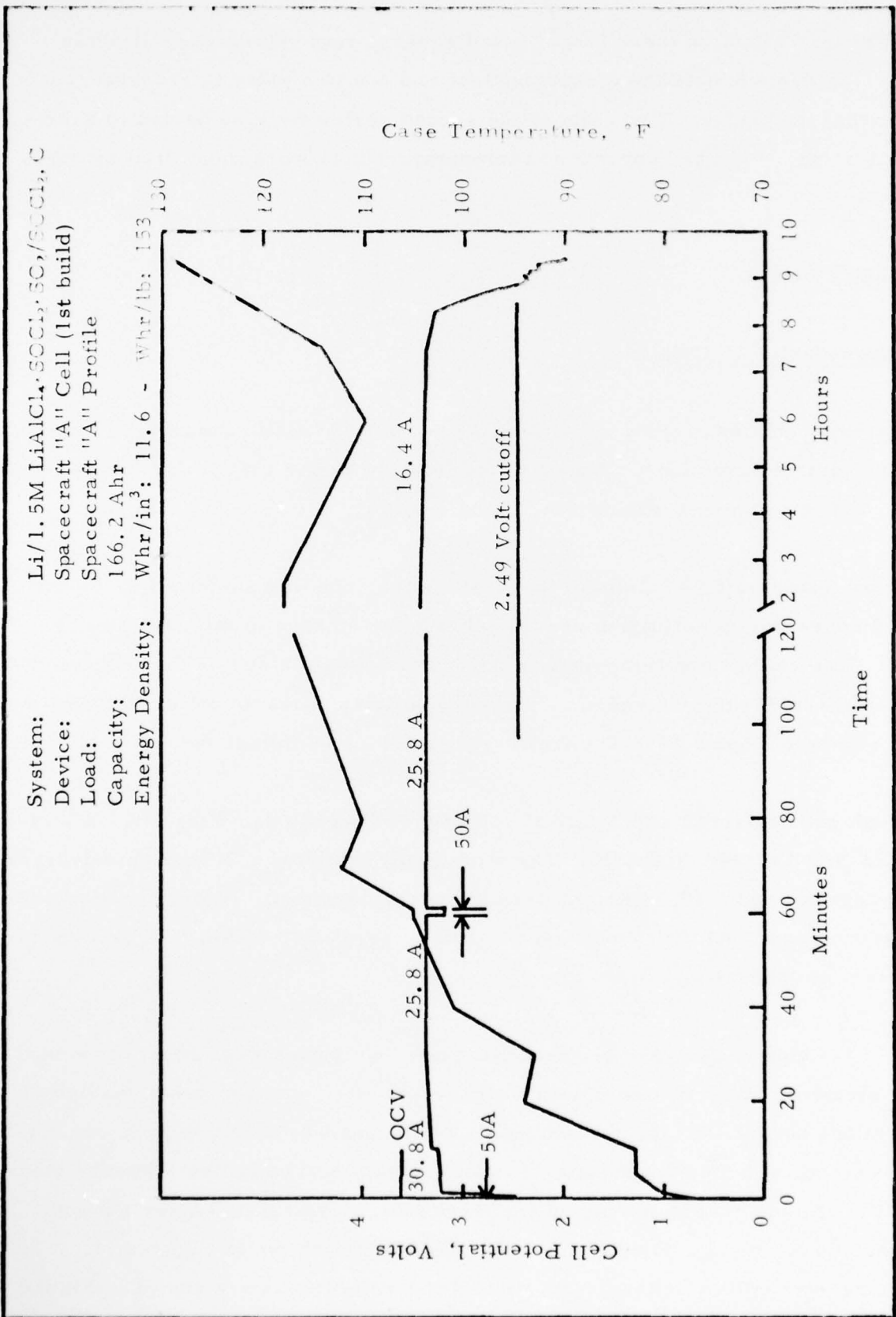

Figure 51. Discharge Performance of a Fresh Spacecraft "A" Cell at 75°F

System: Li/1.5M LiAlCl<sub>4</sub>·SOCl<sub>2</sub>·SO<sub>2</sub>/SOCl<sub>2</sub>, C  
 Device: Spacecraft "A" Cell (1st build)  
 Load: Spacecraft "A" Profile  
 Capacity: 153.4 Ahr  
 Energy Density: Whr/in<sup>3</sup> - 10.4  
 Whr/lb - 137

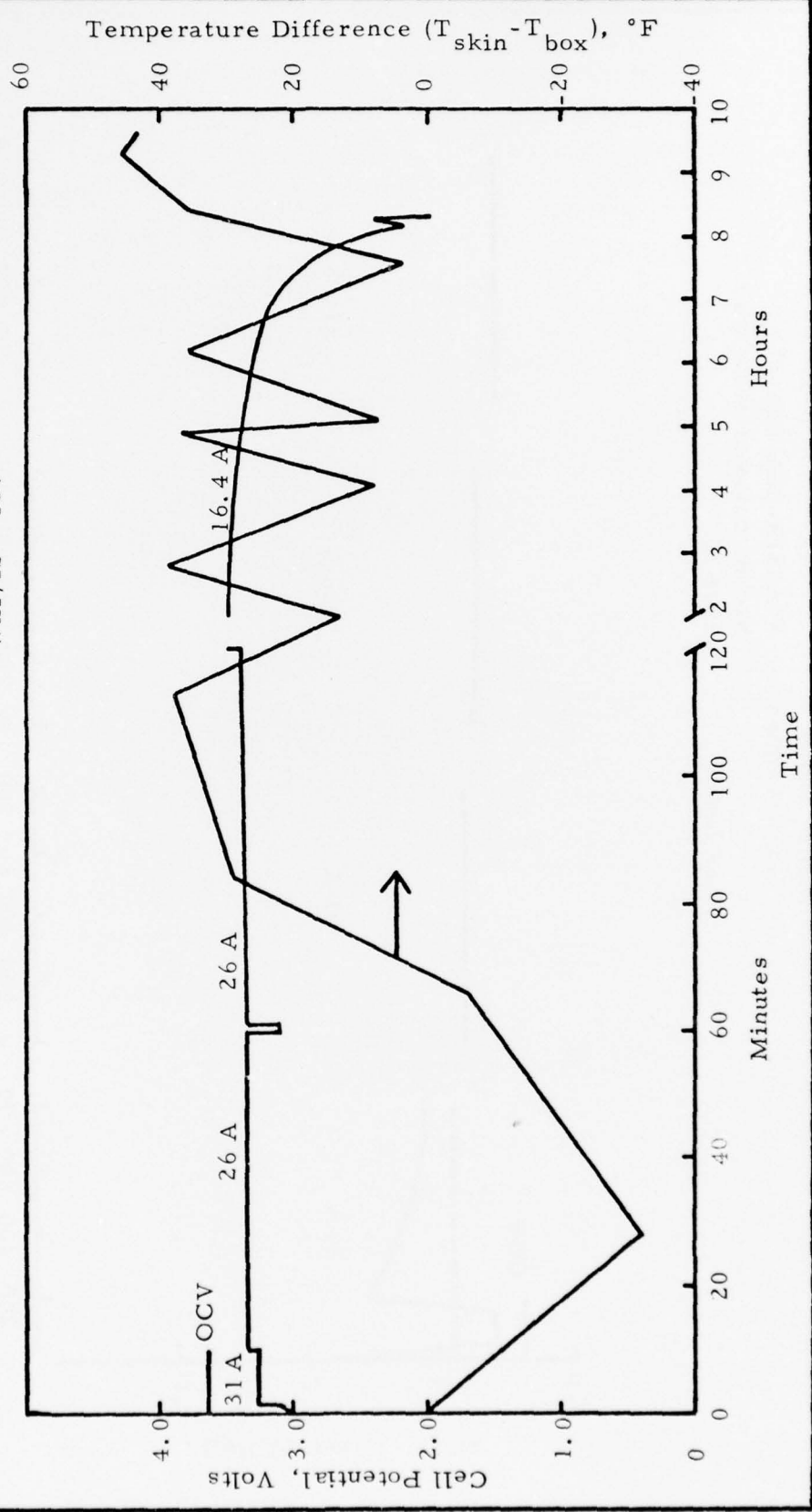

Figure 52. Discharge Performance of a Spacecraft "A" Cell at 91°F ± 20°F After 48 Days Storage at 95°F ± 18°F

System: Li/1.5M LiAlCl<sub>4</sub>·SOCl<sub>2</sub>/SC<sub>2</sub>/SOCl<sub>2</sub>, C  
Device: Spacecraft "A" Cell (1st build)  
Applied Pulse  
Loads Sequence: 50A-31A-26A-50A-26A  
Second pulse of same load  
16.4 A  
Base Load: 16.4 A

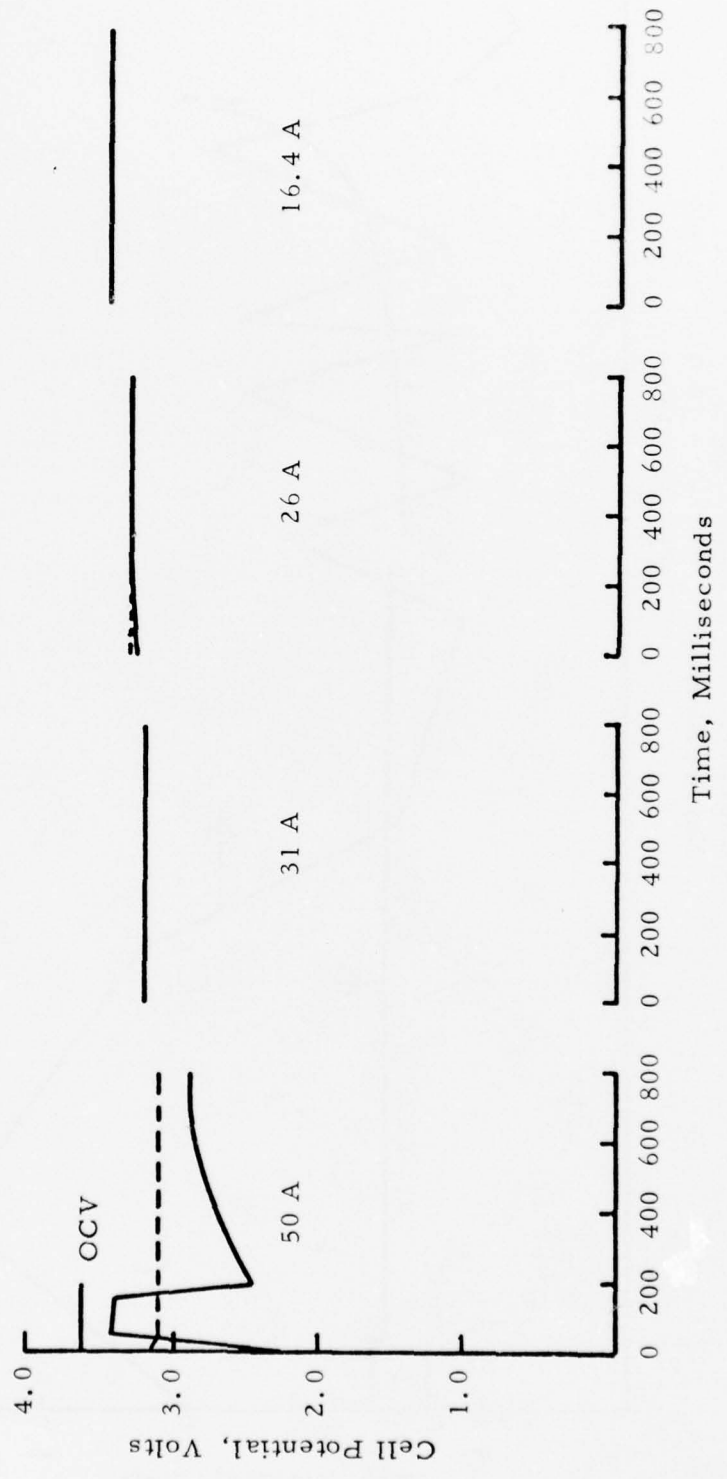

Figure 53. Voltage Delay of Spacecraft "A" Cells at Approximately 93° F  
After 48 Days Storage at 95° F ± 18° F

System: Li/1.5M LiAlCl<sub>4</sub>·SOCl<sub>2</sub>·SO<sub>2</sub>/SOCl<sub>2</sub>, C  
Device: Spacecraft "A" Cell (2nd build)  
Load: Spacecraft "A" Profile  
Capacity: 184.1 Ahr  
Energy Density: Whr/in<sup>3</sup> - 13.1  
Whr/lb - 175

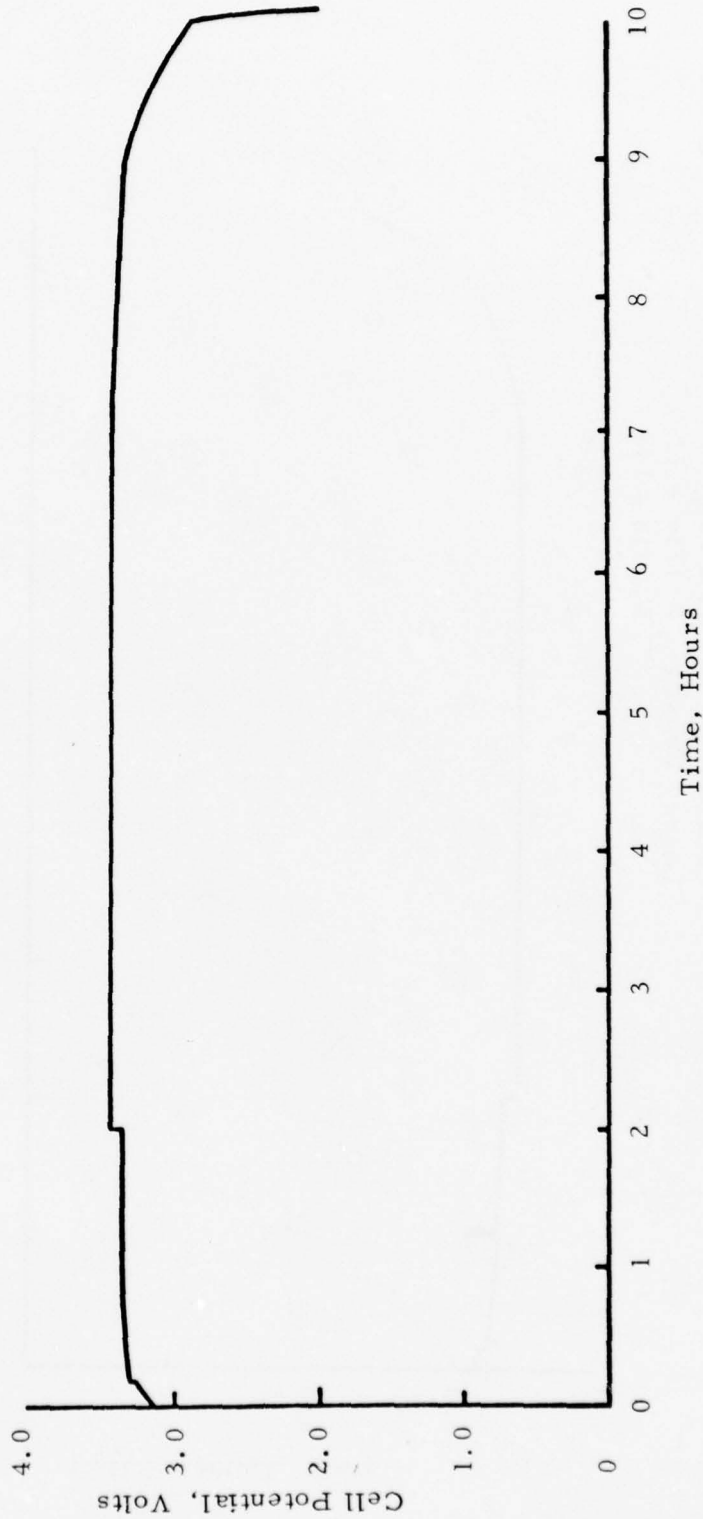

Figure 54. Discharge Performance of a Fresh Spacecraft "A" Cell at  $\approx 80^{\circ}\text{F}$

System: Li/1.5M LiAlCl<sub>4</sub>·SCCl<sub>2</sub>/SO<sub>2</sub>/SCCl<sub>2</sub>, C  
Device: Spacecraft "A" Cell (Cnd build)  
Load: Spacecraft "A" Profile  
Capacity: 159.2 Ahr  
Energy Density: Whr/in<sup>3</sup> - 11.1  
Whr/lb - 148

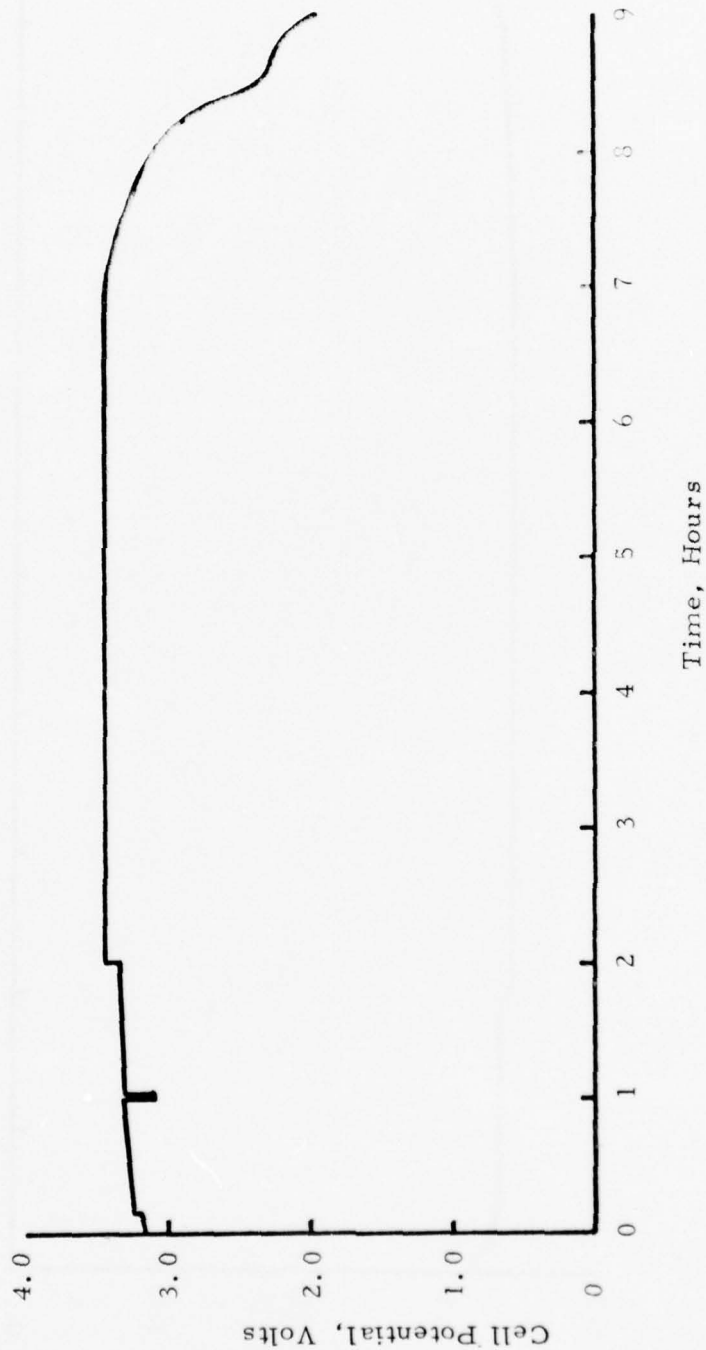

Figure 55. Discharge Performance of a Spacecraft "A" Cell After One Month Storage at 80°F

System: Li/1.5M LiAlCl<sub>4</sub>·SOCl<sub>2</sub>·SO<sub>2</sub>/SOCl<sub>2</sub>, C  
Device: Spacecraft "A" Cell (2nd build)  
Load: Spacecraft "A" Profile  
Capacity: 159.2 Ahr  
Energy Density: Whr/in<sup>3</sup> - 10.9  
Whr/lb - 146

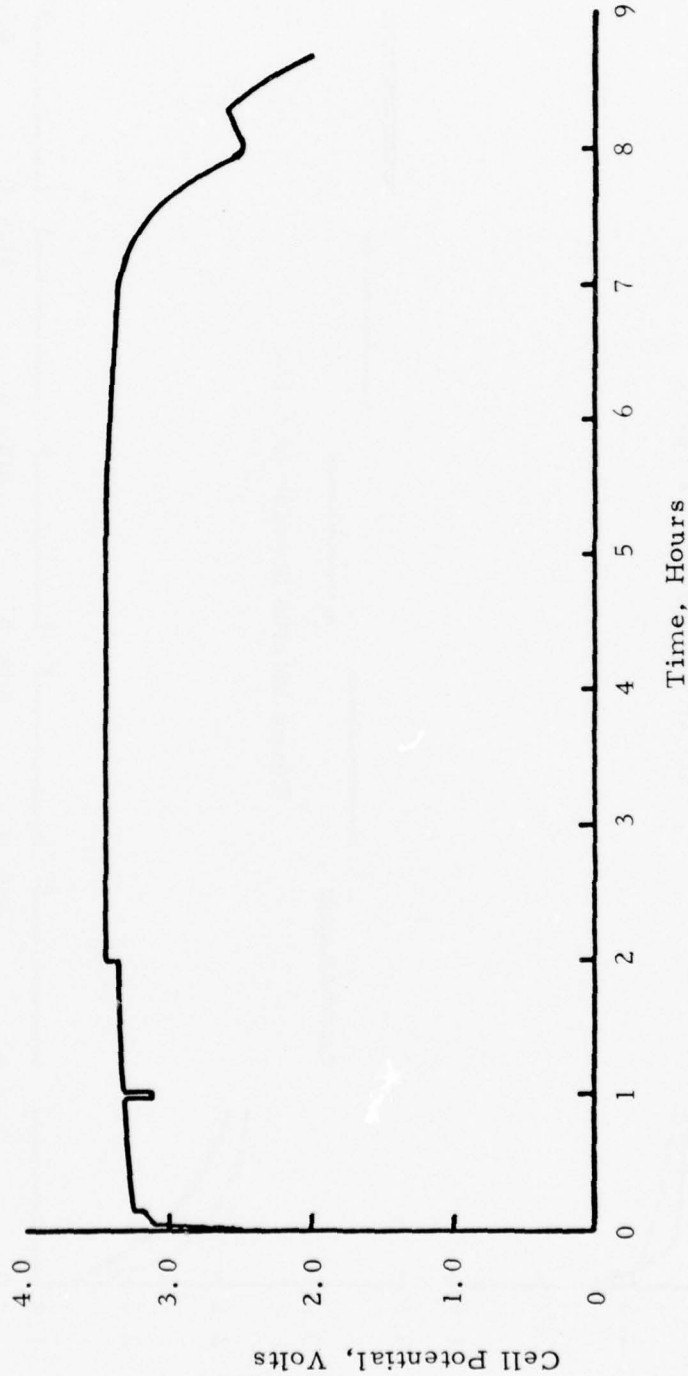

Figure 56. Discharge Performance of a Spacecraft "A" Cell After Three Months Storage at 80°F

System: Li/1.5M LiAlCl<sub>4</sub>·SOCl<sub>2</sub>·SO<sub>2</sub>/SOCl<sub>2</sub>, C  
Device: Spacecraft "A" Cell

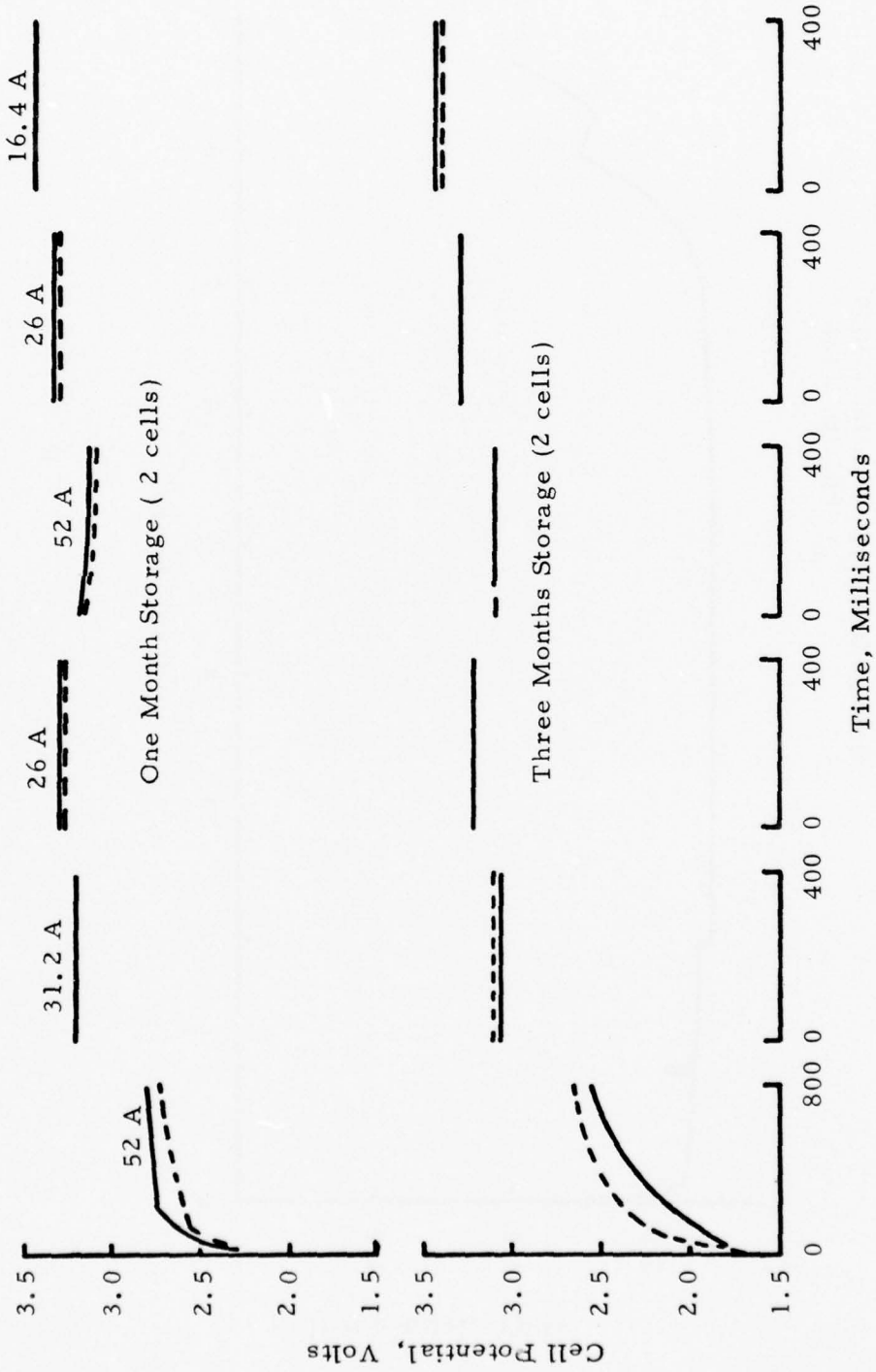

Figure 57. Voltage Delay of Spacecraft "A" Cells After Storage at 80°F

Safety tests were conducted on the Spacecraft "A" Cells to determine the effects of charging already discharged cells, or of continuing discharge past the cutoff voltage, forcing voltage reversal. A short circuit test was also conducted.

After the cutoff voltage was reached on the first cell tested, the discharge was continued. The voltage remained positive for one minute and then electrode polarity reversal occurred. (See Figure 58 for analysis of voltage and case temperature versus time.) Nothing unusual occurred in the first 15 minutes while subjected to a 16A load (the steady state load for this type of cell). The load was then increased to 25A. Three minutes later the case temperature rose rapidly from 121°F to 147°F accompanied by a "pressure release sound" of moderate noise level. Within one minute after the noise, case temperature rose rapidly to about 196°F. Three minutes after that, the case temperature decreased to about 149°F (not shown on figure). (Above "pressure release sound" may be due to breakage of the glass-to-metal seal ) The cell did not explode and was destroyed by the charge placed on the cell before activation.

After the cutoff voltage was reached on the second cell tested, the cell was put on charge at a constant current of 16A. After 62 minutes, the cell exploded. Salvaged parts are shown in Figure 59.

One cell of the final series was allowed to undergo a deep discharge through 0.0 volts and was then subjected to cell reversal for about 36 minutes at a constant current of 16.4A. Neither violent reactions nor cell venting were detected.

Another cell of the final series was subjected to short circuit testing. For safety reasons, the lowest resistance which could be applied was 0.026 ohms. After 37.5 minutes, the battery voltage dropped instantly to 0.35 volts and the battery exploded. (See Figure 60 for an analysis of current and case temperature versus time during this test.)



77-088

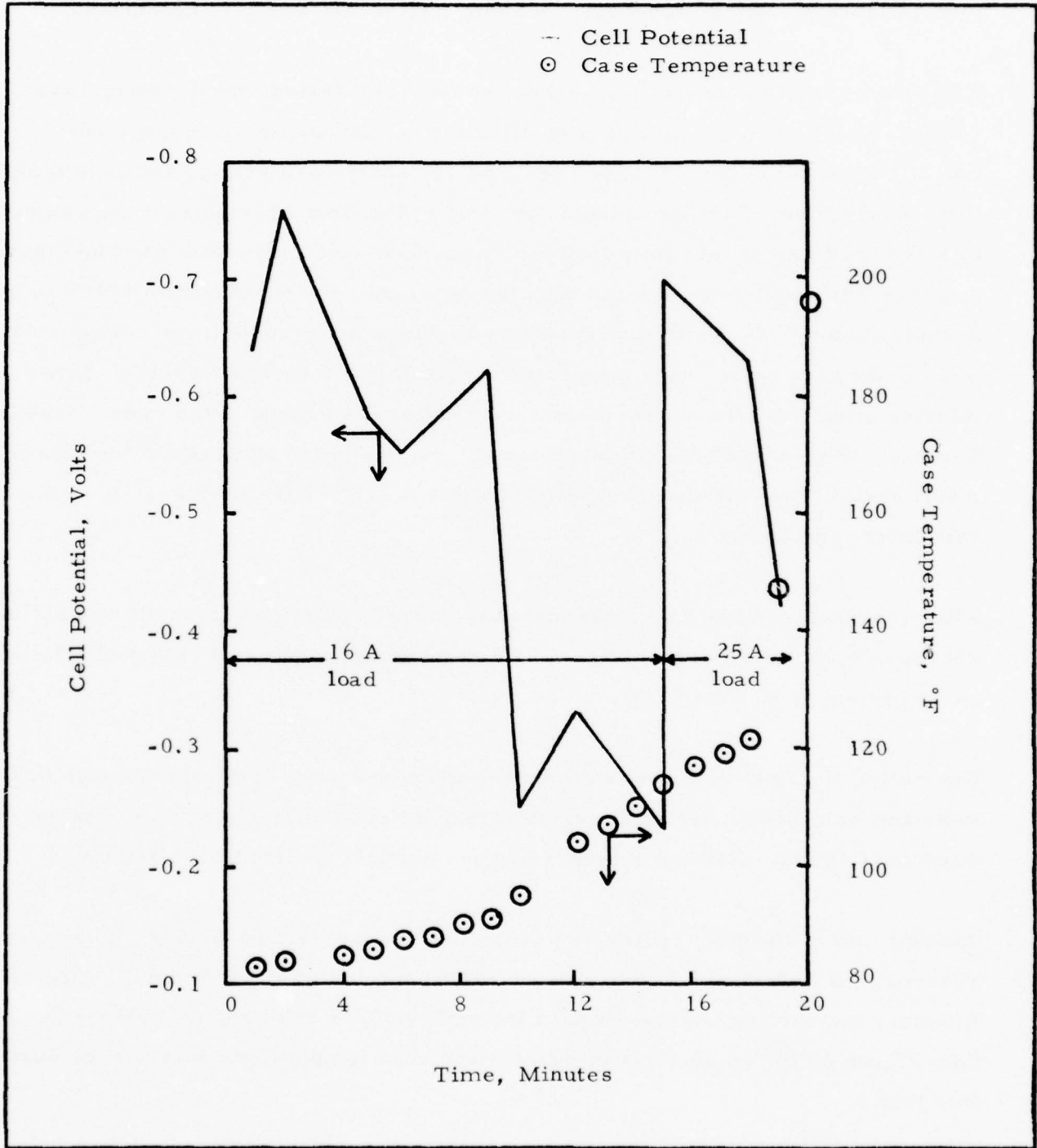

Figure 58. Reversal Test Data for a Spacecraft "A" Cell (Final Build)

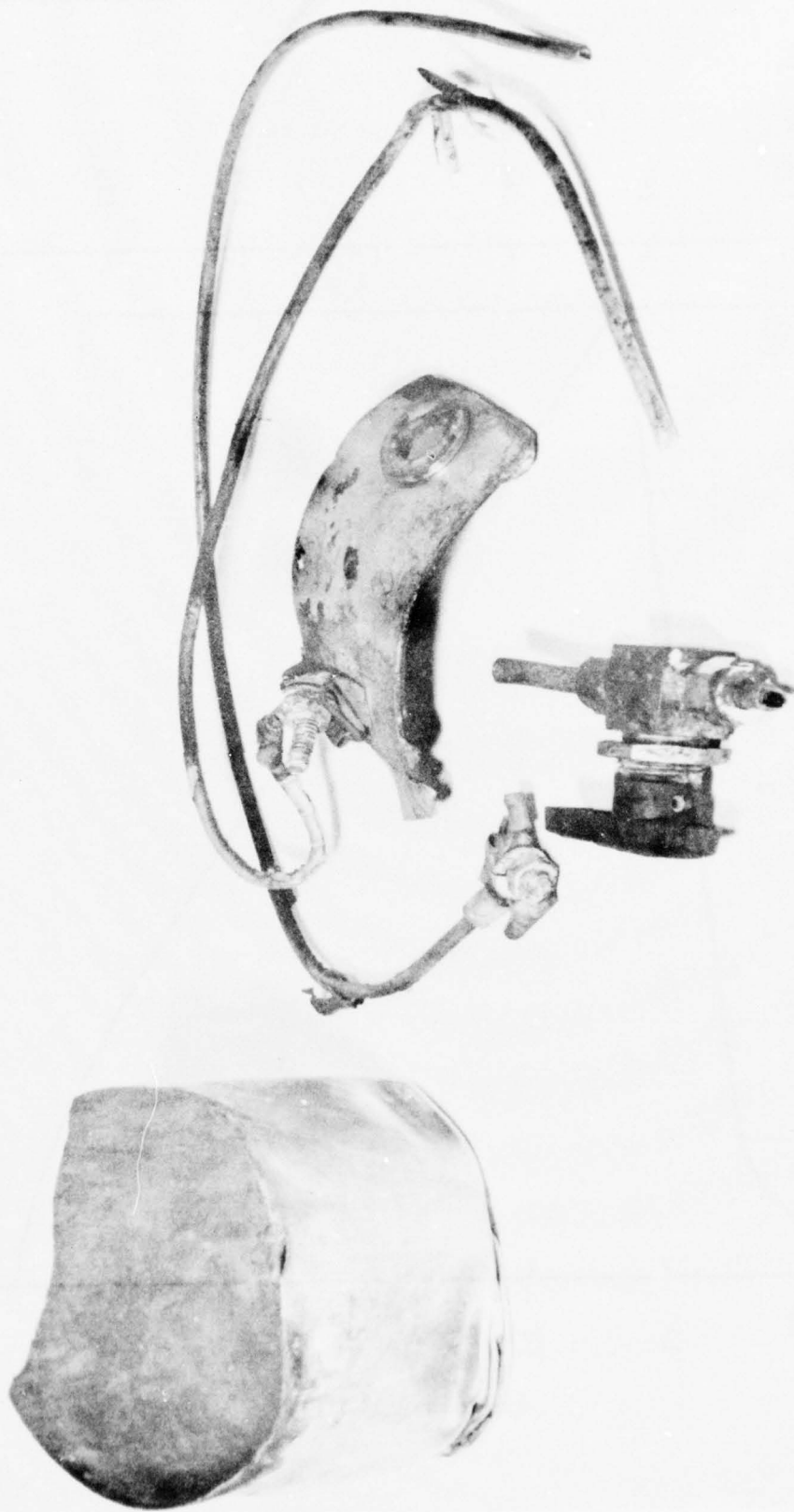

Figure 59. Salvaged Parts from Spacecraft "A" Battery After Explosion

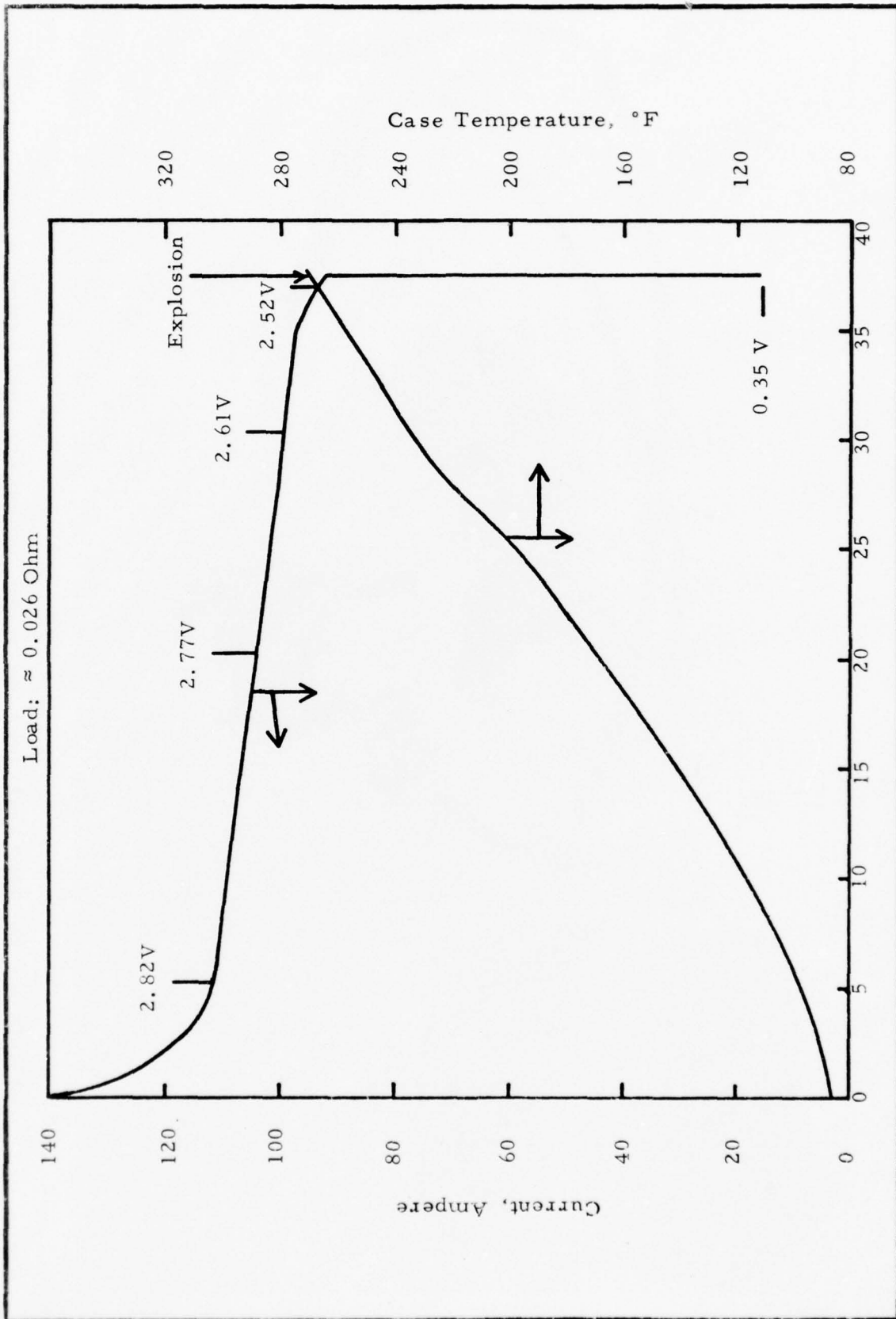

Figure 60. Short-Circuit Test of Spacecraft "A" Cell (Final Build)

## 2. Spacecraft "B" Cell

This section contains results of tests on Spacecraft "B" Cells conducted in response to the project requirements. They are reported by series except that safety testing is reported in a separate subsection.

The discharge histories of a fresh Spacecraft "B" Cell and of one stored at 84°F for 48 days are shown in Figures 61 and 62, respectively. The fresh cell delivered 390.1 Ahr of capacity and 16.4 watt-hours/in<sup>3</sup> and 262 watt-hours/lb of energy density. During the 863.4 hours of discharge, the average voltage was at 3.6 volts more than 95 percent of the time. After storage, the cell exhibited no change in voltage characteristics, but the capacity and energy density dropped 2.3 percent.

The discharge history of fresh Spacecraft "B" Cells from the second series as well as cells stored at 80°F for 3 months are shown in Figures 63 and 64. Voltage delay characteristics on the cells stored for 3 months are shown in Figure 65.

In order to determine whether the cathode structure used for the Spacecraft "B" Cell can sustain higher continuous discharge rate, one cell from the final series was discharged at the 100-hour rate. These data are shown in Figure 66.

Safety tests were conducted on the Spacecraft "B" Cells to determine the effects resulting from charging cells at a constant current, from reversing cell polarity, or from short circuiting the cells.

One discharged cell of the first series was subjected to a charging test at 7.5A and 15A constant current. Voltage and case temperature data versus time are shown in Figure 67. It is noteworthy that this cell was able to accept 7.5 hours of charge without generating a hazardous incident. In contrast, the Spacecraft "A" Cell exploded after accepting charge for only one hour.

System: Li/1.5M LiAlCl<sub>4</sub>·SOCl<sub>2</sub>·SO<sub>2</sub>/SOCl<sub>2</sub>, C  
Device: Spacecraft "B" Cell (1st build)  
Load: Spacecraft "B" Profile  
Capacity: 390.1 Ahr  
Energy Density: Whr/in<sup>3</sup> - 16.4  
Whr/lb - 262

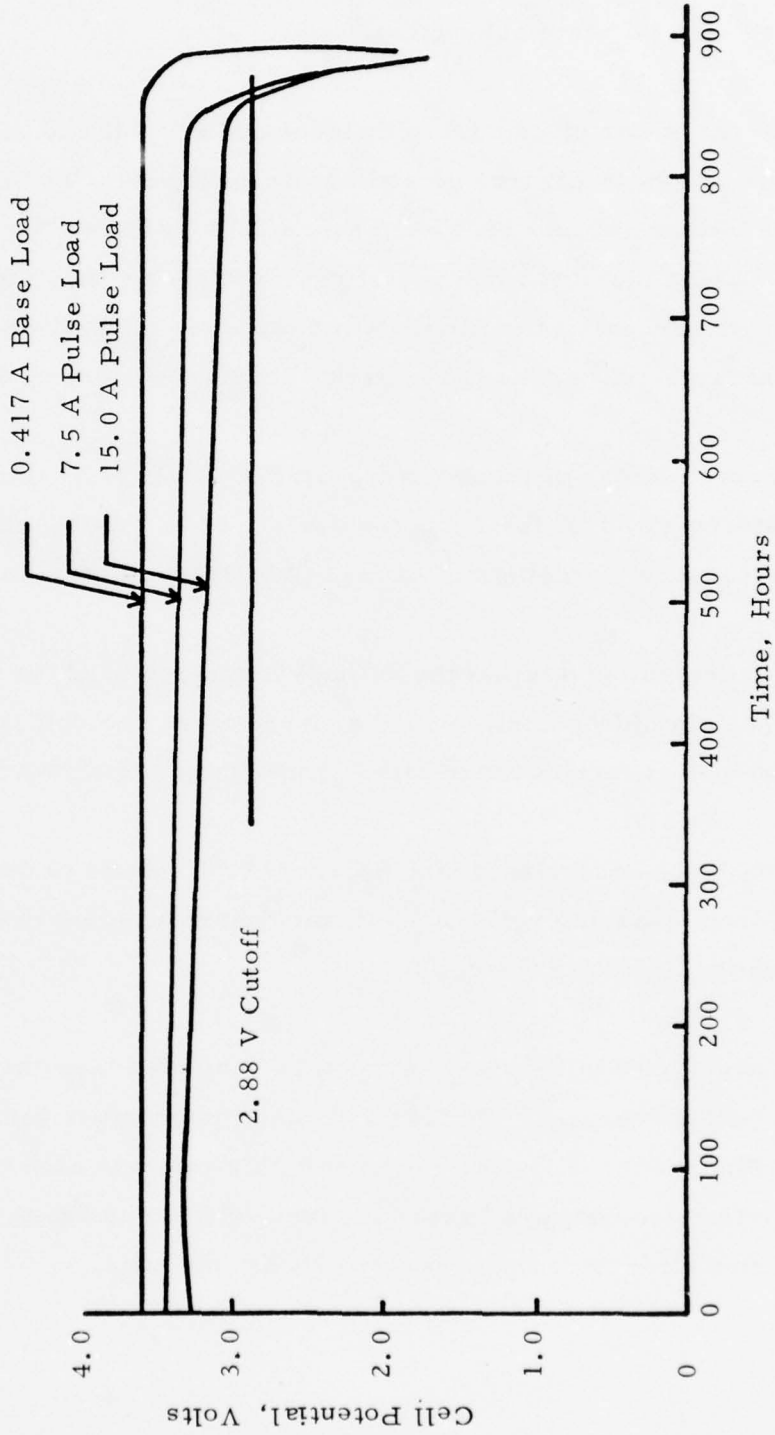

Figure 61. Discharge Performance of a Fresh Spacecraft "B" Cell (400 Ahr Design) at 87°F

System: Li/1.5M LiAlCl<sub>4</sub>·SOCl<sub>2</sub>·SO<sub>2</sub>/SOCl<sub>2</sub>, C  
 Device: Spacecraft "B" Cell (1st build)  
 Load: Spacecraft "B" Profile  
 Capacity: 381 Ahr  
 Energy Density: Whr/in<sup>3</sup> - 16  
 Whr/lb - 256

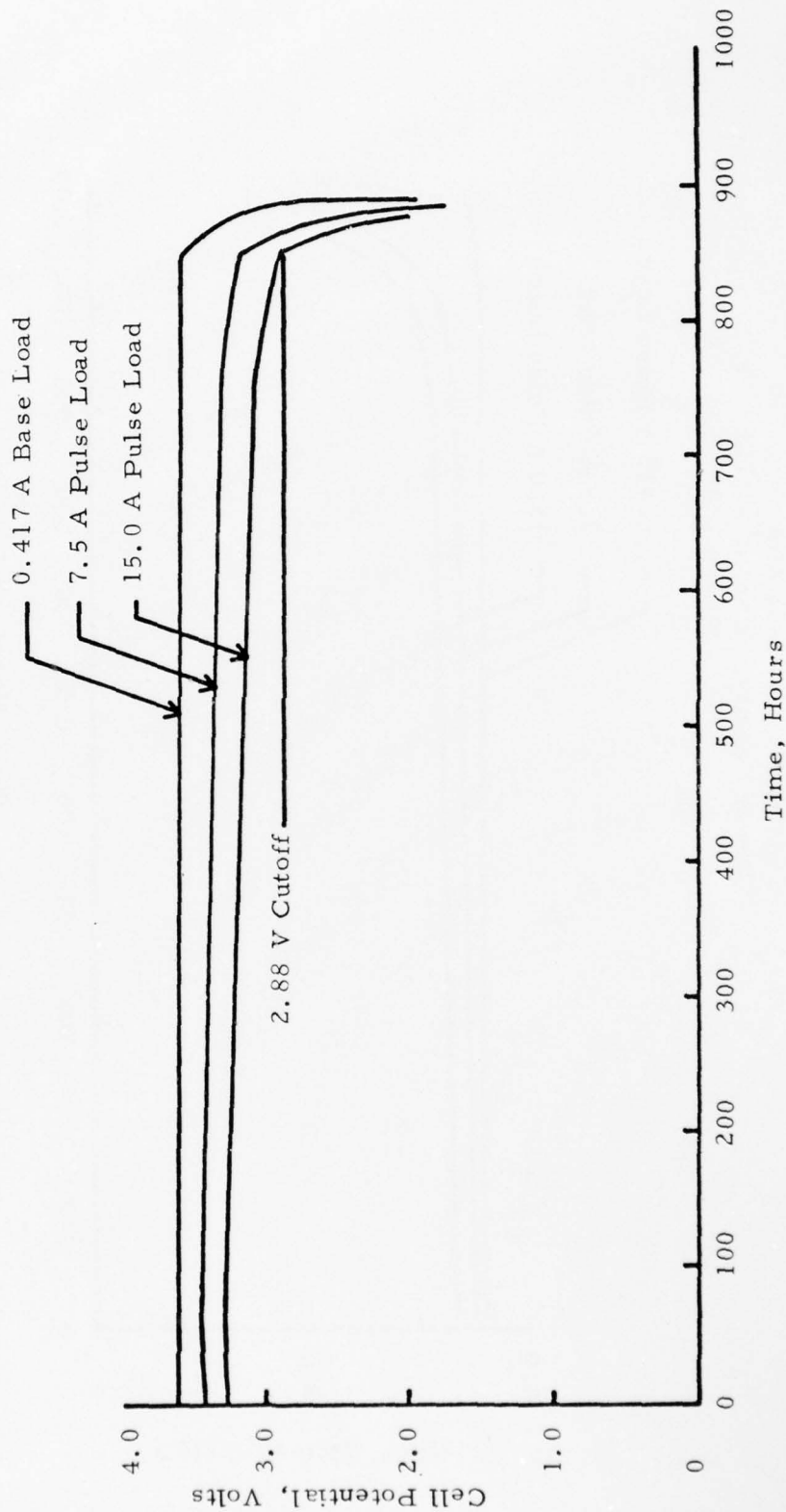

Figure 62. Discharge Performance of Spacecraft "B" Cell (400 Ahr Design) at 89°F After 48 Days Storage at 84°F

System: Li/1.5M LiAlCl<sub>4</sub>·SOCl<sub>2</sub>/SO<sub>2</sub>/SOCl<sub>2</sub>, C  
Device: Spacecraft "B" Cell (2nd build)  
Load: Spacecraft "B" Profile  
Capacity: 452 Ahr  
Energy Density: Whr/in<sup>3</sup> - 17.2  
Whr/lb - 262

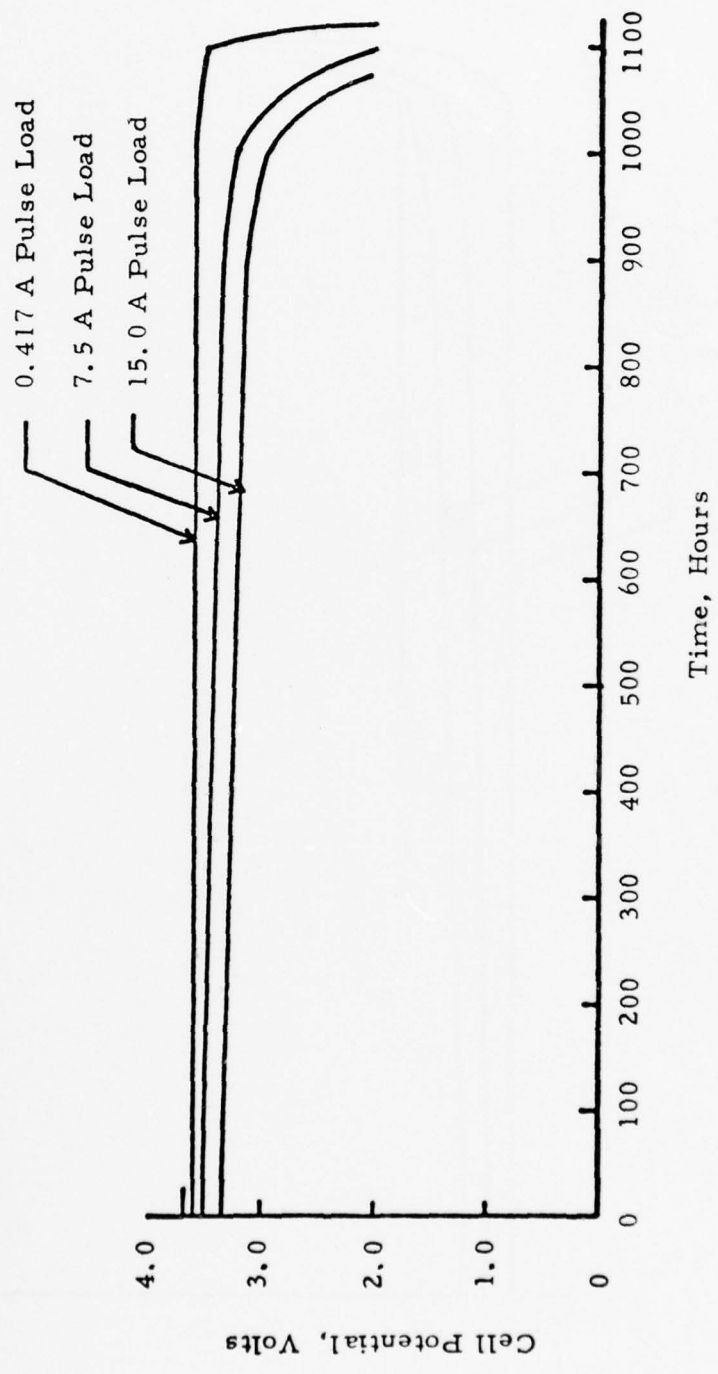

Figure 63. Discharge Performance of a Fresh Spacecraft "B" Cell (500 Ahr Design) at 80°F

System: Li/1.5M LiAlCl<sub>4</sub>·SOCl<sub>2</sub>·SO<sub>2</sub>/SOCl<sub>2</sub>, C  
Device: Spacecraft "B" Cell (2nd build)  
Load: Spacecraft "B" Profile  
Capacity: 454.5 Ahr  
Energy Density: Whr/in<sup>3</sup> - 17.3 -- Whr/lb - 262

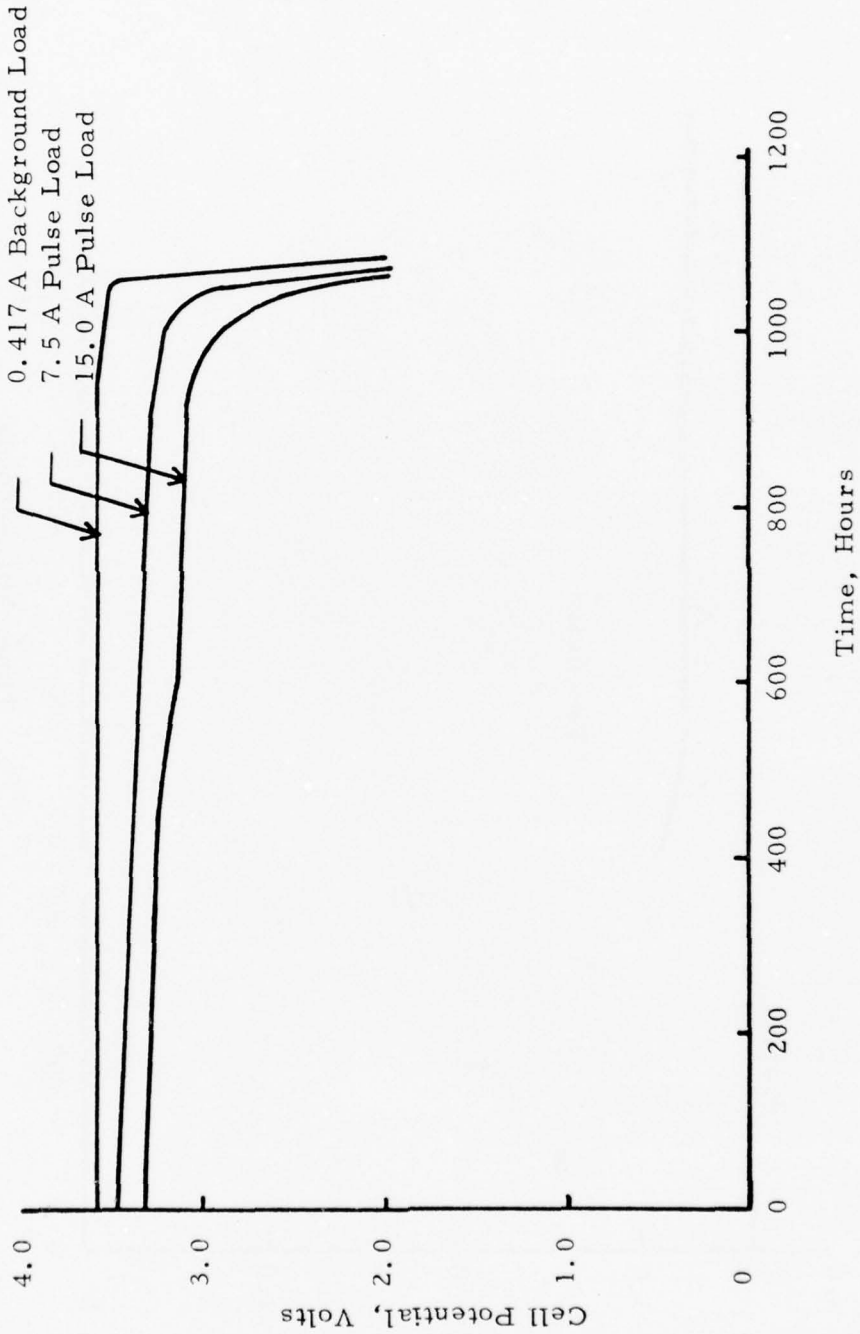

Figure 64. Discharge Performance of a Spacecraft "B" Cell (500 Ahr Design) After Three Months Storage at 80°F



System: Li/1.5M LiAlCl<sub>4</sub>·SOCl<sub>2</sub>·SO<sub>2</sub>/SOCl<sub>2</sub>, C  
Device: Spacecraft "B" Cell (2nd build)

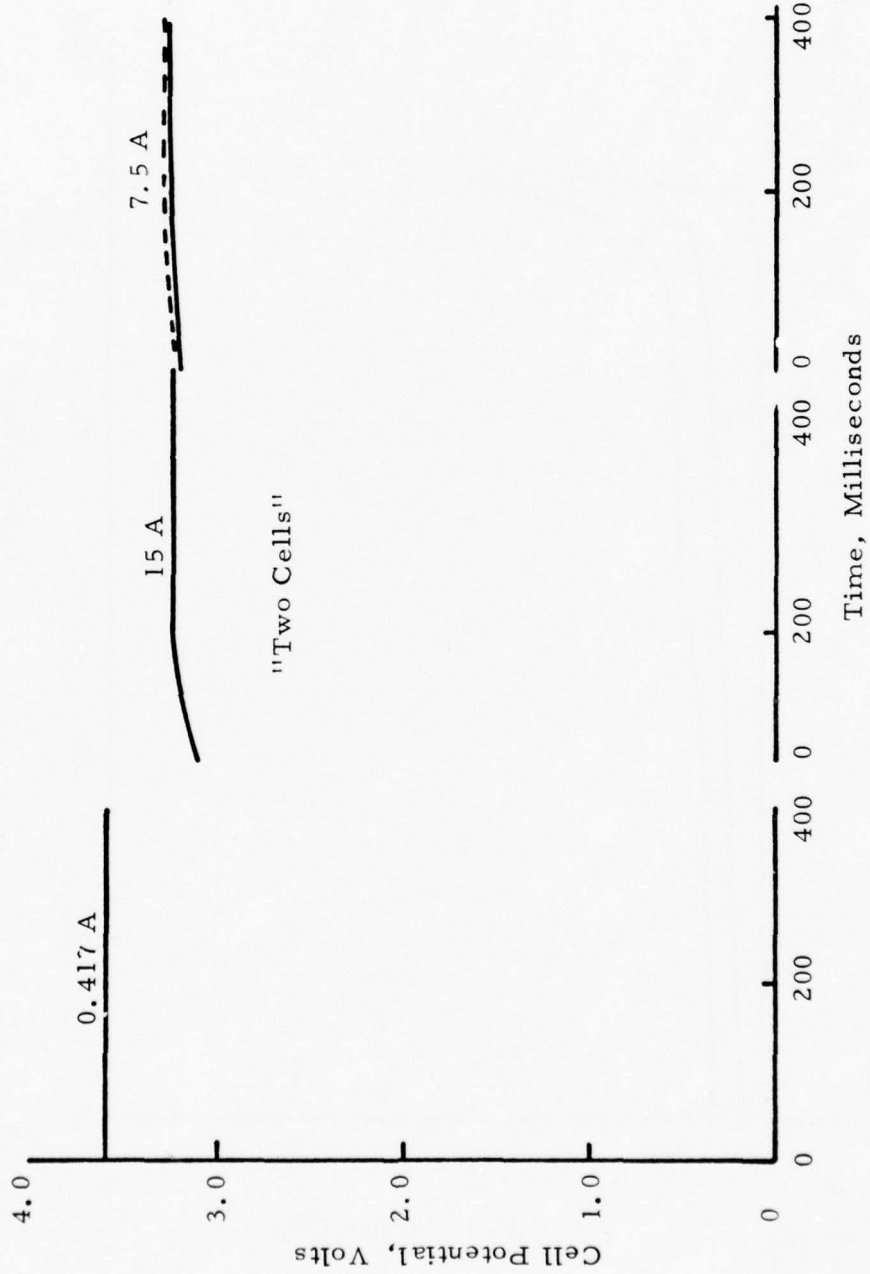

Figure 65. Voltage Delay at 80°F of Spacecraft "B" Cells (500 Ahr Design) After Three Months Storage at 80°F

System: Li/1.5M LiAlCl<sub>4</sub>·SOCl<sub>2</sub>·SO<sub>2</sub>/SOCl<sub>2</sub>, C  
Device: Spacecraft "B" Cell (1st build)  
Load: 0.7 ohm  
Current Density: 1.7 mA/cm<sup>2</sup>  
Capacity: 517.6 Ahr  
Energy Density: Whr/in<sup>3</sup> - 18.6  
Whr/lb - 286

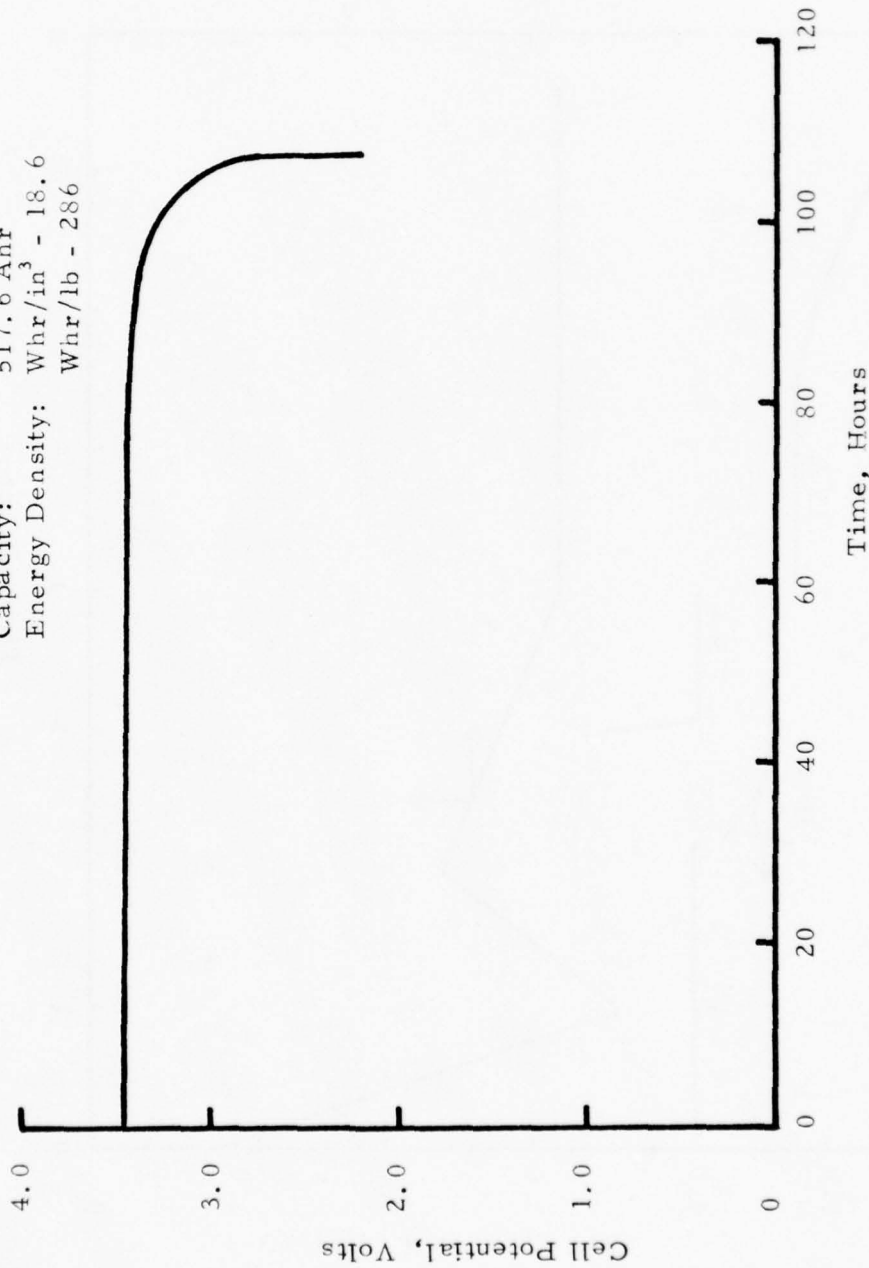

Figure 66. Discharge Performance of a Spacecraft "B" Cell (500 Ahr Design) at the 100-Hour Rate at 60-70°F

System: Li/1.5M LiAlCl<sub>4</sub>·SOCl<sub>2</sub>·SO<sub>2</sub>/SOCl<sub>2</sub>, C  
Device: Spacecraft "B" Cell (1st build)  
Box Temp: +90°F

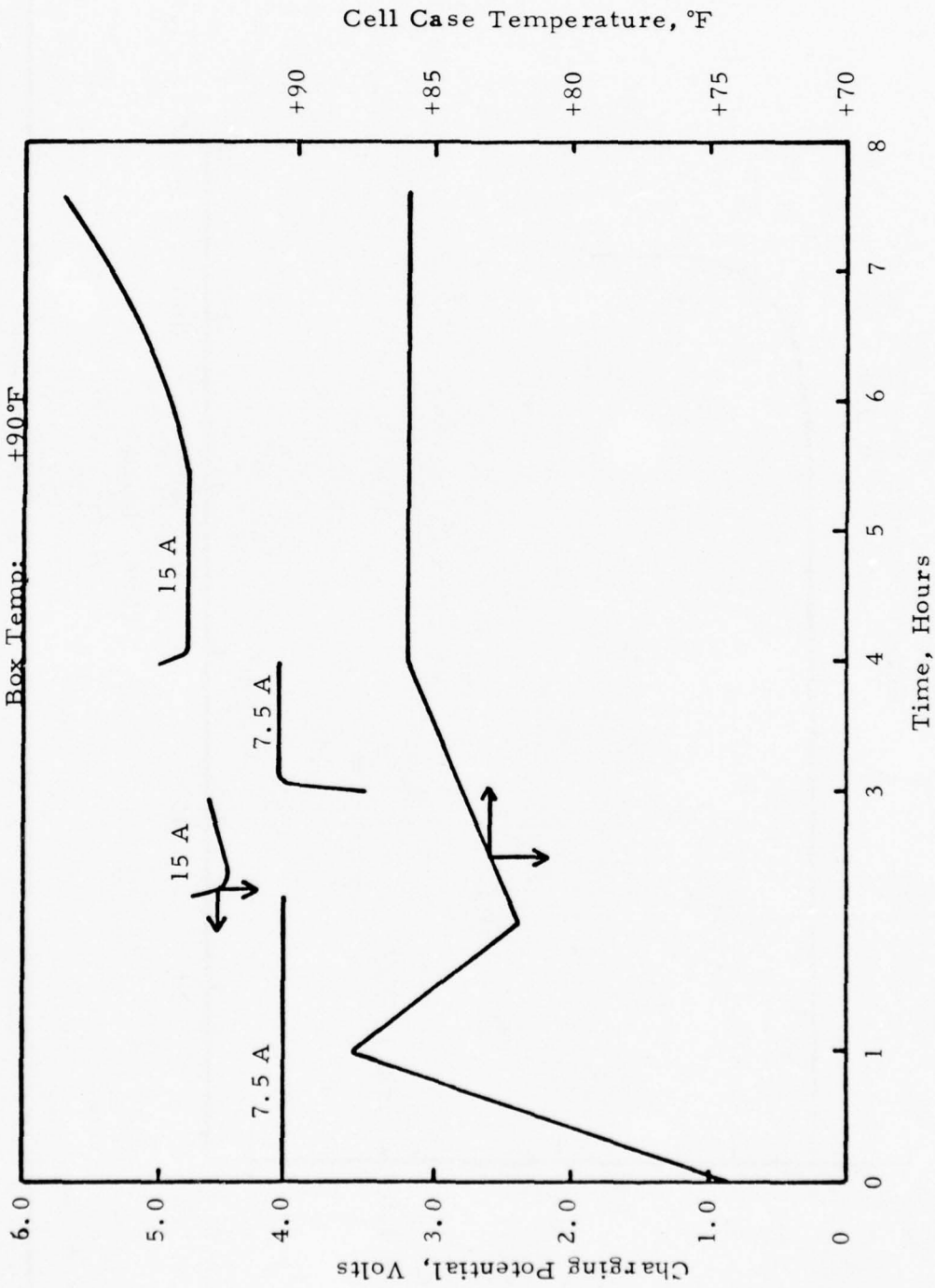

Figure 67. Spacecraft "B" Cell (500 Ahr Design) - Charging Test at Constant Current

Another discharged cell of the first series was subjected to a reversal test at 15A constant current. Figure 68 presents voltage and temperature data versus time. Again, no hazardous incident occurred even after five hours of polarity reversal.

Two cells of the final series were subjected to short circuit testing. (Actual loads of 0.020 and 0.026 ohms were applied due to the resistance of the shunt wiring.) Data drawn from Table XIX are presented in Figure 69 showing plots of current, case temperature and power as functions of time. Ambient temperature during the test ranged from 65°F to 75°F. The maximum case temperature reached was 214°F, which is 16° below the melting point of sulfur and 142° below the melting point of lithium. Results indicate that these low discharge rate cells can be safely short-circuited for at least one hour (longer tests were not conducted.) After removal of the short circuit, this cell was permitted to remain at OCV for about 18 hours. The cell was again reshorted for about 30 minutes exhibiting a peak current of 44 ampere. Approximately 35 minutes after removing the short circuit, this cell was subjected to rifle fire. Three (3) .22 long rifle slugs caused no change in cell performance (OCV) although the can was dented. A fourth .22 long rifle slug penetrated the can and some sparks and smoke occurred. The voltage dropped to 2.70 volts.

Shots with an M-1 (30-06) rifle were taken. During this time the voltage fluctuated around 2.75 to 2.80 volts, decreasing to 2.12 volts and rising as high as 3.15 volts, then decreasing to 1.87 volts and rising to 2.87 volts. At this time the case was penetrated by a 30-06 slug and an explosion occurred. A large cloud of white smoke engulfed the test pad.

#### D. ANALYSIS OF TEST RESULTS

##### 1. Spacecraft "A" Cell

Figure 70 summarizes the performance results on the final series of Spacecraft "A" Cells. After one month storage, capacity and energy density performance degraded by about 13%. This degradation rate then decreases an additional 2.9% with respect

System: Li/1.5M LiAlCl<sub>4</sub>·SOCl<sub>2</sub>·SO<sub>2</sub>/SOCl<sub>2</sub>, C  
Device: Spacecraft "B" Cell (1st build)  
Box Temp: 56°F

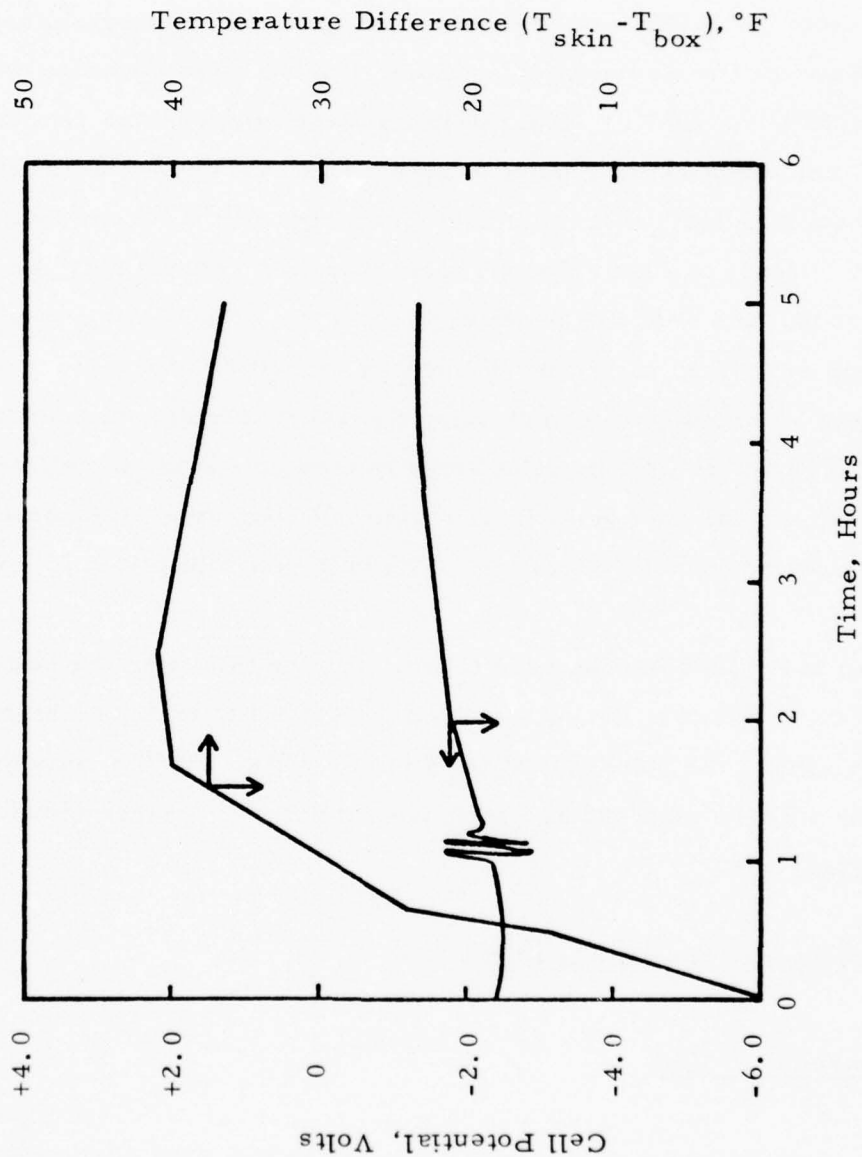

Figure 68. Spacecraft "B" Cell (400 Ahr Design) - Reversal Test at 15A Constant Current

TABLE XIX

SHORT CIRCUIT ( $\approx 0.02$  OHMS) TESTING OF A  
SPACECRAFT "B" CELL

<u>Time, Minutes</u>	<u>Voltage</u>	<u>Current, Amps</u>	<u>Temperature, °F</u>
0	1.85	119	64
1	1.93	104.6	-
2	2.00	100.8	66
3	2.03	99.6	71
4	2.05	98.8	75
5	2.07	98.2	80
10	2.09	98.6	97
15	2.07	96.6	113
20	2.03	95	132
25	1.96	92.4	142
30	1.87	91.8	156
35	1.68	84	172
40	1.49	78.4	190
45	1.11	61.2	202
50	.71	43	208
55	.51	36.8	210
60	.52	34.6	214

System: Li/1.5M LiAlCl<sub>4</sub>·SOCl<sub>2</sub>·SO<sub>2</sub>/SOCl<sub>2</sub>, C  
Device: Spacecraft "B" Cell (2nd build)

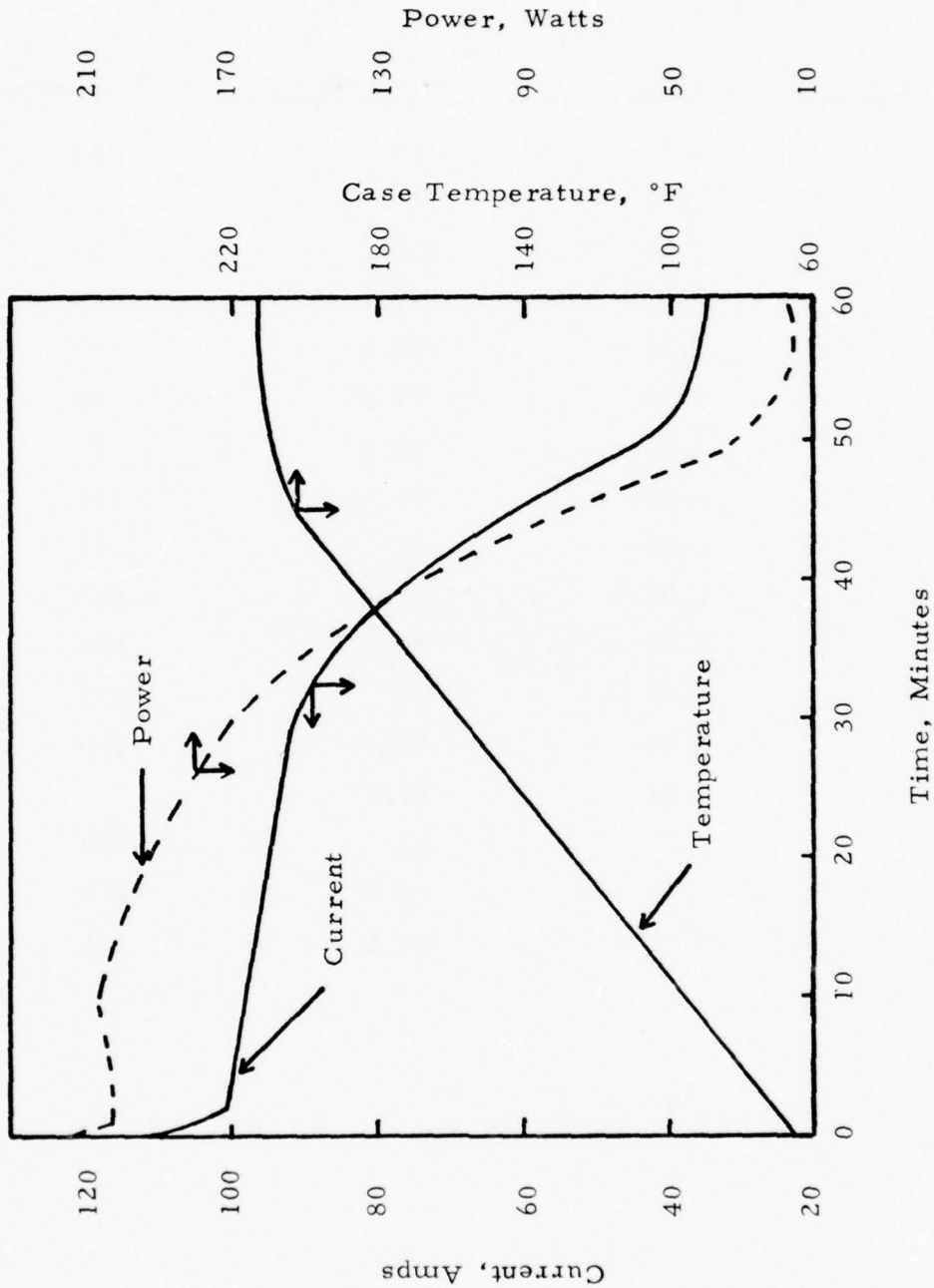

Figure 69. Short-Circuit Test ( $\approx 0.02$  Ohm) of a Spacecraft "B" Cell  
(500 Ahr Design)

System: Li/1.5M LiAlCl<sub>4</sub>·SOCl<sub>2</sub>·SO<sub>2</sub>/SOCl<sub>2</sub>, C  
 Device: Spacecraft "A" Cells  
 Temp: Storage - 80°F  
 Discharge - 80°F

- ⊕ Cell Potential (avg)
- ⊙ Capacity
- △ Whr/lb
- ⊠ Whr/in<sup>3</sup>

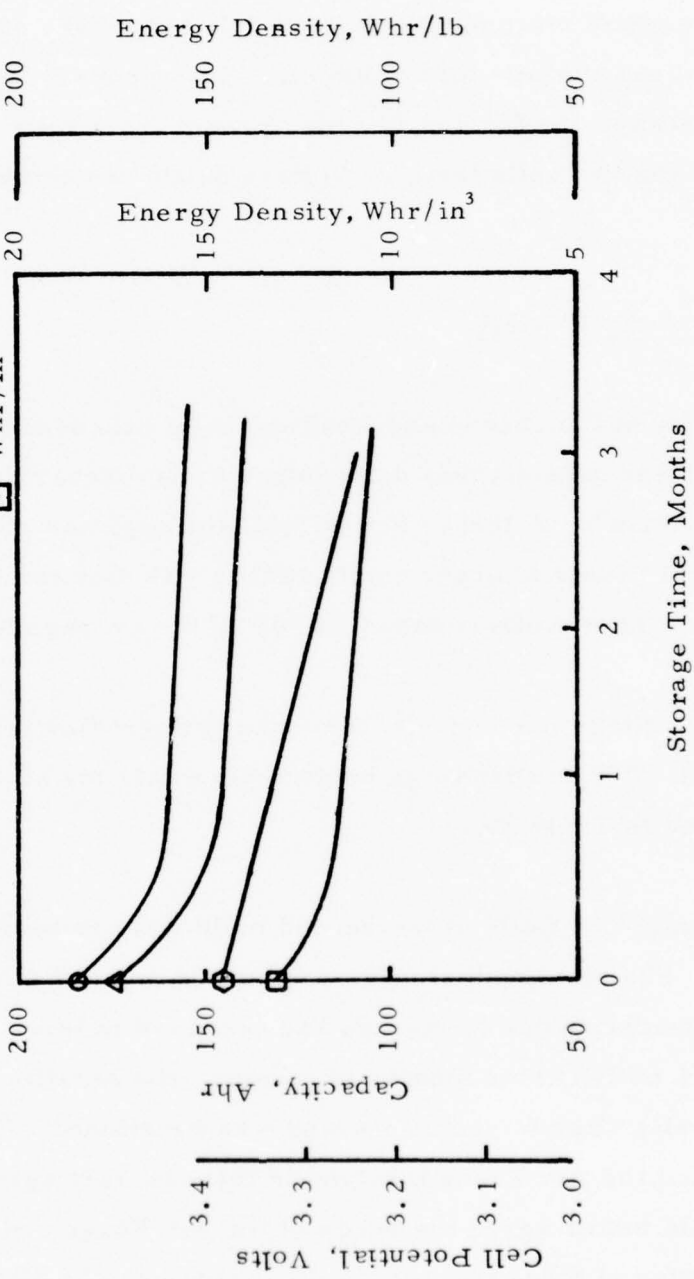

Figure 70. Discharge Performance Versus Storage Time for Spacecraft "A" Cells



to the capacity and 7.0% with respect to the energy density after 3 months of storage. A linear drop in cell voltage occurred at a rate of 50 mv per month.

Continued drop in the instantaneous cell voltage and voltage delay time based on the first 50A ( $9.9 \text{ mA/cm}^2$ ) pulse were exhibited during the course of cell storage. After one month of storage, the voltage delay time was 80 ms to recover to 2.49 volts (75% of the average load voltage). This recovery time increased, after 3 months of storage, to 320 and 560 ms to reach 2.45 volts (75% of the average load voltage) for the two cells tested. Voltage delay was exhibited at only the starting 50A pulse.

## 2. Spacecraft "B" Cell

The capability of the second and final series of Spacecraft "B" Cells to deliver a nominal 500 Ahr capacity was demonstrated via discharging a cell at the 100-hour rate ( $1.7 \text{ mA/cm}^2$ ). A lesser output (452 Ahr avg) was obtained at the prescribed Spacecraft "B" loads whereby cutoff voltage was dictated by the 15A pulse ( $5.8 \text{ mA/cm}^2$ ) to a cutoff voltage based on 80% of the average load voltage.

Neither cell voltage nor capacity showed any degrading trend based on three months of storage at 80°F. Discharge performance data for all Spacecraft "B" Cells tested are presented in Table XX.

Two Spacecraft "B" Cells of the second build were to be discharged after 6 months of storage. The six month storage period was completed on 15 November 1976. Since no degradation due to storage had occurred in three months and OCV values were good (3.68V) after 6 months of storage, the benefits of discharging these two remaining cells after 6 months storage was questioned. The technical people at Honeywell and the Air Force involved in this contract agreed that longer term storage would better serve the needs of the Air Force and therefore storage and eventual testing of these two cells will be continued by Honeywell at no cost to the Government.

TABLE XX

DISCHARGE PERFORMANCE OF SPACECRAFT "B" CELLSStorage Temp:  $\approx 80^{\circ}\text{F}$ Discharge Temp:  $\approx 80^{\circ}\text{F}$ 

Cell* Build	Storage Time	Discharge Load	Capacity Delivered, Ahr	Energy Density	
				Whr/lb	Whr/in <sup>3</sup>
First	None	Spacecraft "B"	390	262	16.4
First	1.5 months	Spacecraft "B"	381	256	16.0
First	1.5 months	Spacecraft "B"	354	238	14.8
Second	None	Spacecraft "B"	452	262	17.2
Second	None	Spacecraft "B"	444	257	16.9
Second	3 months	Spacecraft "B"	455	262	17.3
Second	3 months	Spacecraft "B"	455	262	17.3
Second	6 months	At the completion of this contract, OCV values were 3.68V for both Cells. Due to the need for long term storage, these cells are still on storage at 80°F.			
Second	6 months	At the completion of this contract, OCV values were 3.68V for both Cells. Due to the need for long term storage, these cells are still on storage at 80°F.			
Second	None	0.7 Ohms	518	286	18.6

## Note:

The cells tested under the Spacecraft "B" load profile were considered complete when the 15 A pulse load first reached 2.88V. Approximately 10% more capacity was delivered before the voltage of the background load (0.417 A) reached 2.88V.

\* First and Second cell builds were of identical designs except that the cells of the second build were larger. Cell dimensions are: First build - 3.6 inches x 4.3 inches x 5.5 inches; Second build - 3.6 inches x 4.3 inches x 6.2 inches.

After the three month storage period, voltage delay was not displayed at either the 0.417A background load or the 7.5A and 15A pulse loads based on recovery time to 80% of the average load voltage.

Operation of the Spacecraft "A" and "B" Cells under the normal discharging and deep discharging modes did not cause any adverse pressure venting and/or explosions to occur. The high rate Spacecraft "A" design is more dangerous since it exhibited either instantaneous pressure venting and/or cell explosion when subjected to charging, polarity reversal and short circuit testings. For the low rate Spacecraft "B" design, neither pressure venting nor cell explosion occurred when they were charged, force discharge into polarity reversal or short circuited.

## SECTION V

### CELL IMPROVEMENT STUDIES

#### A. GENERAL

The Statement of Work for this project called for exploratory development to improve the performance of the cells. The laboratory studies conducted were based on Honeywell's previous R&D experience with the Li/SOCl<sub>2</sub> system, familiarity with recently published material, and the results of various tests on the first series of Life Support Cells. Particular attention was focused on (1) negative electrode passivation, (2) optimization of the positive electrode structure, and (3) electrolyte studies.

#### B. EXPERIMENTAL TECHNIQUES

As a result of previous experience with the Li/SOCl<sub>2</sub> system, Honeywell employed several devices and techniques that have proved useful in diagnosing the cause of poor cell performance and either effecting improvements or identifying promising areas for further exploratory development. Some of these devices and techniques are: (1) a laboratory cell sealed in a glass test vehicle, (2) cyclic voltammetry for determining anodic film thickness, and (3) scanning electron microscopy for analyzing the surface structure of anodic films. Standard techniques were used also for measuring the vapor pressure, density and other properties of the electrolyte solution and for the preparation of an improved electrolyte salt.

##### 1. Laboratory Cell

Figure 71 shows a typical laboratory cell in a sealed glass test vehicle. This cell used a three-plate electrode configuration. It was used to conduct studies for improvement in cathode structure and to determine the vapor pressure build up during cell discharge. The glass vehicle was also used to obtain vapor pressure data on electrolyte solutions as a function of temperature.

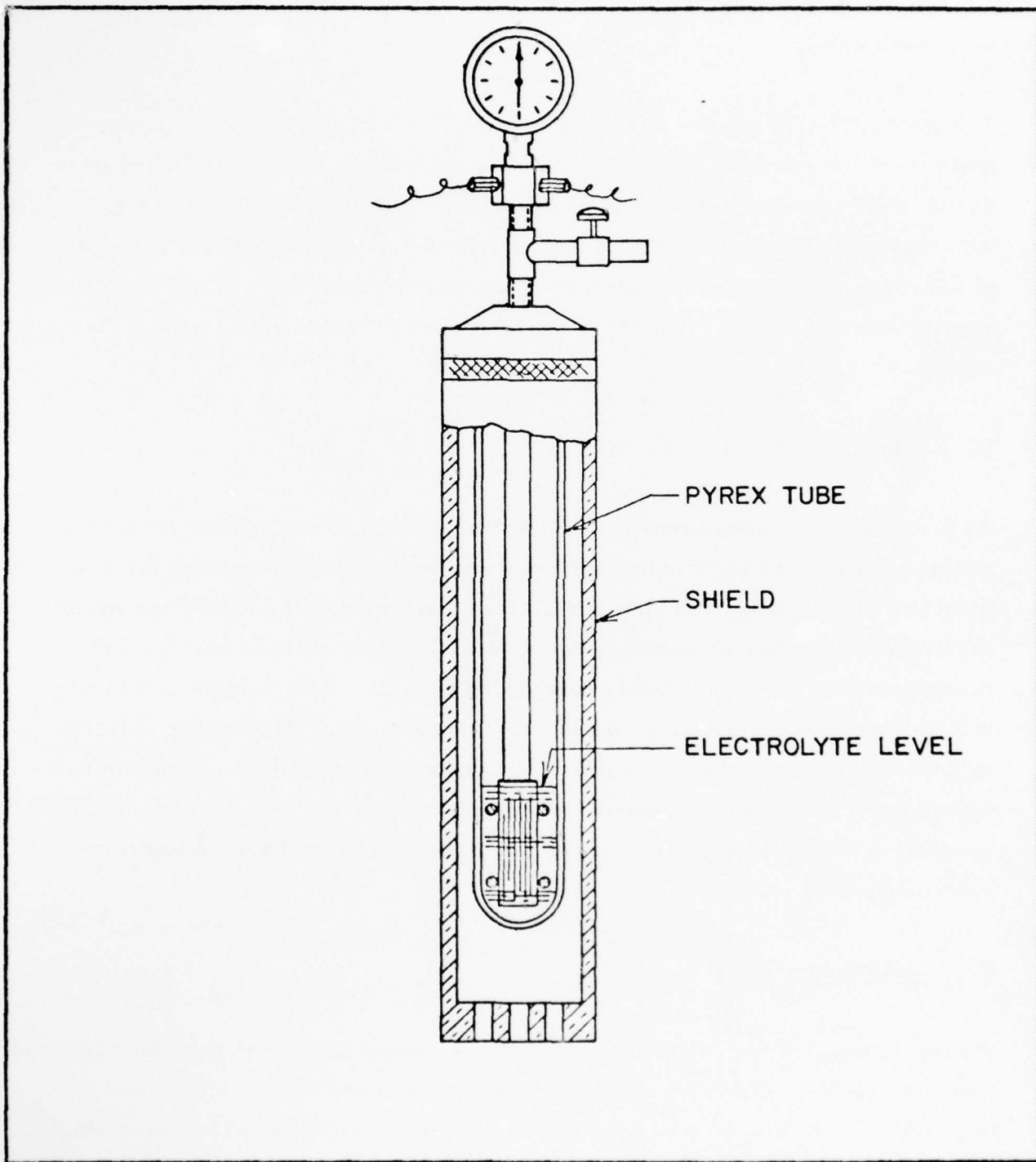

Figure 71. Typical Laboratory Cell in Sealed Glass Test Vehicle

## 2. Cyclic Voltammetry

Severe polarization of the anode revealed during testing of the first series of Life Support Cells prompted the use of cyclic voltammetry to investigate the purity of the electrolyte solution. Also the improved voltage delay performance of some partially discharged cells prompted its use in evaluating the effect of employing additives based on the discharge products. The technique also proved useful in making approximate calculations on the thickness of film formation at the working electrode.

All the conducted experiments used a Princeton Applied Research Electro-analytical Instrument Model No. 170. A polarographic cell, Model No. 9312, was employed and it comprised of a lithium reference electrode, a working platinum electrode and a platinum auxiliary electrode. Before each experiment, the surface of the working electrode was wiped with a soft paper cloth and then rinsed in distilled water. Scan rate was fixed at 100 *mv/sec*.

## 3. Scanning Electron Microscopy

Further information concerning anode passivation was obtained by observing the LiCl film with the aid of the scanning electron microscope. It was impossible to obtain photomicrographs of actual cell anodes because the glass separator could not be removed without damaging the lithium surface. Photomicrographs were obtained, however, of lithium strips stored in sealed glass ampuls in the electrolyte solution selected for study.

After a specified period of storage, the ampuls were broken and the specimens thoroughly rinsed in pure  $\text{SOCl}_2$ . After allowing the specimens to dry in a desiccator, they were pasted onto aluminum mounts with Ag paint. Up to this point, specimen preparation was conducted in a dry room with  $\text{RH} \leq 5\%$ . Neither dry room nor glove box facilities were available at the SEM site. Therefore, the time period required

to transfer the specimen mount to the microscope chamber was kept to a minimum and was never allowed to exceed ten seconds. Control specimen using pure Li confirmed that no "artifacts" were created during this ten second time period.

### C. ANODE STUDIES

The unexpectedly severe passivation of the anode that occurred on the first series of Life Support Cells after only 3 weeks storage at room temperature caused most of the cell improvement effort to be directed to the solution of the anode passivation problem. As stated earlier, the entire second series of cells was employed in laboratory studies addressing this problem. One approach to solving the passivation problem was based on the following considerations:

- The poor voltage delay response and poor cell capacity of the first series of cells proved to be largely caused by the passivated condition of the lithium anode.
- It was observed that partially discharged cells exhibited temporary improvement in voltage delay response after storage when compared with fresh cells.
- Honeywell's analysis of the chemical reaction during discharge was:



These considerations led to studies of the effect of pretreating the lithium anode with anhydrous  $\text{SO}_2$ , hopefully, to effect a lithium dithionite coating, using pre-discharged electrolyte, and doping electrolyte solutions with various amounts of S, S +  $\text{SO}_2$  and  $\text{SO}_2$  (a concept borrowed from the Li/ $\text{SO}_2$  technology). The effects of these modifications were analyzed in laboratory cells and on the anode itself by means of cyclic voltammetry and scanning electron microscopy and on the second series of Life Support Cells by varying the chemistry of the electrolyte as described in Table XXI.

TABLE XXI

SECOND BUILD OF LIFE SUPPORT CELLSTEST PLAN

<u>Variables</u>	<u>Description</u>	<u>Number of Cells</u>
Baseline	1.5M LiAlCl <sub>4</sub> ·SOCl <sub>2</sub>	6
Partial Discharge	7, 10, 20 and 40% levels	16
SO <sub>2</sub> + Baseline	5, 10, 20 and 40% levels	32
S + Baseline	7.5 and 15% levels	16
S + SO <sub>2</sub> + Baseline	7.5% S and 5% SO <sub>2</sub>	8
Discharged Electrolytes	Electrolyte subjected to 3.84 amp-hours of discharge	8



Also considered in the studies of anode passivation were the quality and purity of materials used in cell fabrication especially the electrolyte salt and the lithium.

#### 1. Analysis of the Passivation Problem

Previous Honeywell work on the lithium inorganic system indicated that the cause of lithium passivation is due to the  $\text{LiAlCl}_4$  salt. X-ray diffraction and x-ray energy dispersive studies identified the passive film at the lithium surface to be predominantly  $\text{LiCl}$  and trace amounts of sulfur. Dark field optical microscopy and SEM work showed conclusively that the lithium surface remained clean for as long as one year at  $165^\circ\text{F}$  when exposed to pure  $\text{SOCl}_2$  containing no salt. Presence of excess  $\text{AlCl}_3$  in the salt can accelerate the growth rate of the anodic film. Strong evidence exists to support this adverse role of  $\text{AlCl}_3$  on film formation based on detailed morphological studies on lithium surface exposed to electrolyte solutions doped with excess  $\text{AlCl}_3$ \*. It is imperative then to determine the effect of different grades of the  $\text{LiAlCl}_4$  salt on the relative degree of negative electrode passivation.

Based on the results obtained through x-ray diffraction and gas chromatographic analyses, Honeywell believes that the overall cell reaction during discharge in the  $\text{Li}/\text{LiAlCl}_4:\text{SOCl}_2/\text{SOCl}_2:\text{C}$  system is:



Lithium chloride exists as the insoluble solid product at the cathode during discharge. The observation that partially discharging a cell can provide a temporary solution on minimizing Li passivation directed importance to the functional role of  $\text{SO}_2$  and S. It is further believed that on a partially discharged cell stored at  $140^\circ\text{F}$  and above, a concomitant reaction:



---

\* Work performed by Honeywell prior to award of this contract.

could occur which gives stronger support to the beneficial role of  $\text{SO}_2$  in minimizing anode passivation. The proposed reaction (2) could be used also to account for the lower capacity output obtained at high temperature and also the trace amount of sulfur detected on the surface of the Li stored at high temperature.

Sulfur dioxide may act as a complexing agent in the  $\text{SOCl}_2$  solution. The solubility of  $\text{SO}_2$  in pure  $\text{SOCl}_2$  is 5.0% by weight and 11.5% by weight in a 1.5M  $\text{LiAlCl}_4 \cdot \text{SOCl}_2$  solution (See Electrolyte Studies).

## 2. Investigative Procedures

Based on the analysis of the passivation problem discussed under the preceding heading, the following variables were investigated:

- The use of purer and better quality electrolyte salt.
- The use of partially discharged cells.
- The use of electrolyte from cells discharged in laboratory cells.
- Pretreating the lithium anode with  $\text{SO}_2$ .
- Doping the electrolyte with S,  $\text{SO}_2$  and S +  $\text{SO}_2$  in various quantities.

The effects of these variables on the passivation problem were analyzed as follows:

- a. Measuring the voltage delay and capacity characteristics in laboratory cells.
- b. Evaluation of the anode film structure and thickness by cyclic voltammetry and scanning electron microscopy.

- c. Fabricating hardware cells containing all possible electrolyte variations and discharging them after storage at high temperature.

When the investigation indicated that doping the electrolyte solution with  $\text{SO}_2$  was the most effective response to the passivation problem, the effect on a strip of lithium of partial immersion in an electrolyte solution containing 0%, 5%, 10%, and 20% by weight of  $\text{SO}_2$  was determined.

When the third series of Life Support Cells exhibited poorer performance than expected after storage at high temperature, it was attributed to a worsening of the passivation problem. A group of hardware cells were fabricated to investigate all possible variation between the better performing cells resulting from studies on the second series and the cells of the third series.

### 3. Results of the Anode Studies

The following is a summary of the results of the separate investigations into possible causes of anode passivation and remedies to reduce it:

- a. Cyclic voltammograms (Figure 72) indicated distinct difference among the three grades of  $\text{LiAlCl}_4$  salts (See Electrolyte Studies). The peak area is relatable to film thickness using a model calculation proposed by Shaw<sup>1</sup>. Film thickness calculations presented below show detrimental effects of the poorer quality  $\text{LiAlCl}_4$  prepared by a vendor from an organic solvent.

Calculated Film Thicknesses on Platinum Surface  
From Cyclic Voltammetry Data

<u>Preparation Method of <math>\text{LiAlCl}_4</math></u>	<u>Temperature, °C</u>	<u>Film Thickness, Å</u>
Supplied by vendor's patent pending	24	896
Methathetical	24	293
Fused	24	259

<sup>1</sup> M. Shaw, "Electrochemical Characterization of Systems for Secondary Battery Applications", NASA CR-72069.

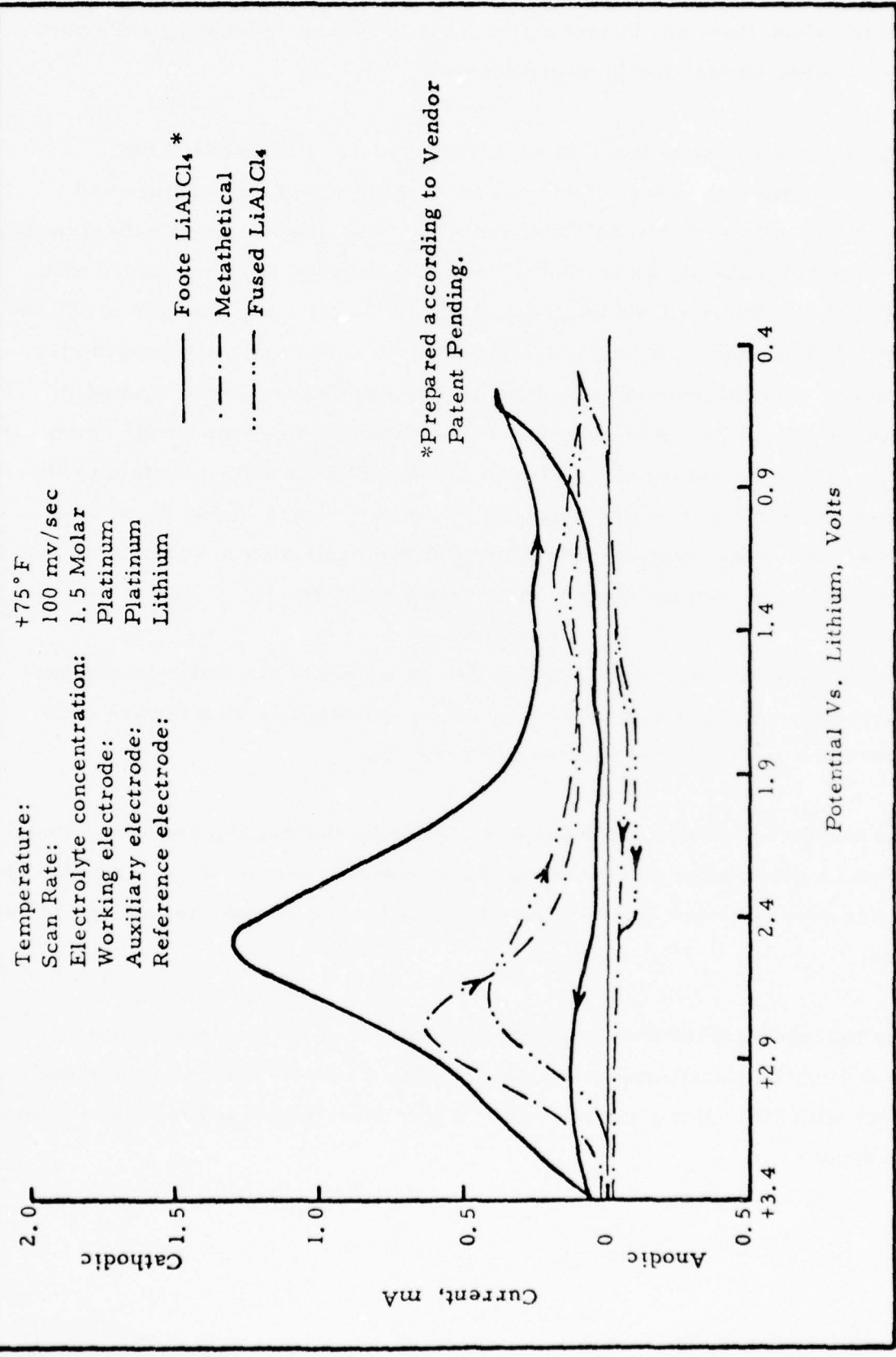

Figure 72. Effect of Electrolyte Salt Grades on Cyclic Voltammograms of SOCl<sub>2</sub> Solutions

These calculations are consistent with the hardware results (Life Support Cells) based on high temperature storage.

- b. Doping the electrolyte solution with 5% by weight of  $\text{SO}_2$  caused the greatest reduction in the effects of anode passivation. Laboratory and hardware cells so doped exhibited better voltage delay response characteristics and cell capacity after high temperature storage when compared with cells with undoped electrolyte, cells doped with different amounts of  $\text{SO}_2$  or other doping, and cells partially discharged or containing discharged electrolyte. Typical photomicrographs of lithium surfaces are presented in Figures 73 and 74, showing respectively a highly preferred surface structure after high temperature storage in an  $\text{LiAlCl}_4 \cdot \text{SOCl}_2$  solution containing the fused salt and 5 percent by weight of  $\text{SO}_2$  dopant, and a highly passivated surface after high temperature storage in the same solution containing salt prepared in an organic medium with no  $\text{SO}_2$  additive.
- c. Doping the electrolyte with 10% and 20% by weight of  $\text{SO}_2$  had a detrimental effect on the voltage delay characteristics and capacity of hardware cells after storage at high temperature (Figure 75).
- d. The quality and purity of the lithium used in fabricating the anode has some effect on passivation as evidenced by the superior performance of the fourth series over the third series of Life Support Cells after storage at high temperature.
- e. The following procedures resulted in no improvement in cell passivation: (1) doping the electrolyte with S and S +  $\text{SO}_2$ ; (2) pretreatment of the lithium anode with  $\text{SO}_2$ ; (3) the use of predischarged electrolyte; and (4) partially discharging cells.



A



B

Figure 73. Surface Structure of Lithium when Stored in 1.0M  $\text{LiAlCl}_4$   
(Fused)  $\cdot \text{SOCl}_2$  + 5% by Weight  $\text{SO}_2$  at  $162^\circ\text{F}$  for One Week  
SEM SECONDARY MODE

- A. Mag. 200X
- B. Mag. 500X

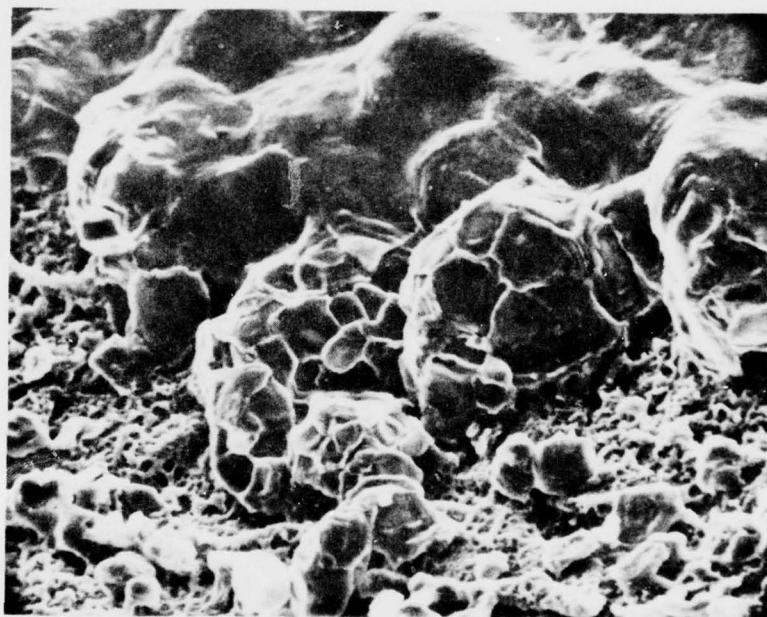

Figure 74. Surface Structure of Lithium When Stored in 1.0M  $\text{LiAlCl}_4 \cdot \text{SOCl}_2$  at  $165^\circ\text{F}$  for 11 Days

SEM SECONDARY MODE  
MAG. 100X

System: Li/1.5M LiAlCl<sub>4</sub>·SOCl<sub>2</sub>·SO<sub>2</sub>/SOCl<sub>2</sub>, C  
 Device: Life Support Cell  
 Loads: 120 mA (30 min) - 45 mA (30 min)  
 SO<sub>2</sub> Doping Levels: 5, 10 and 20 wt %

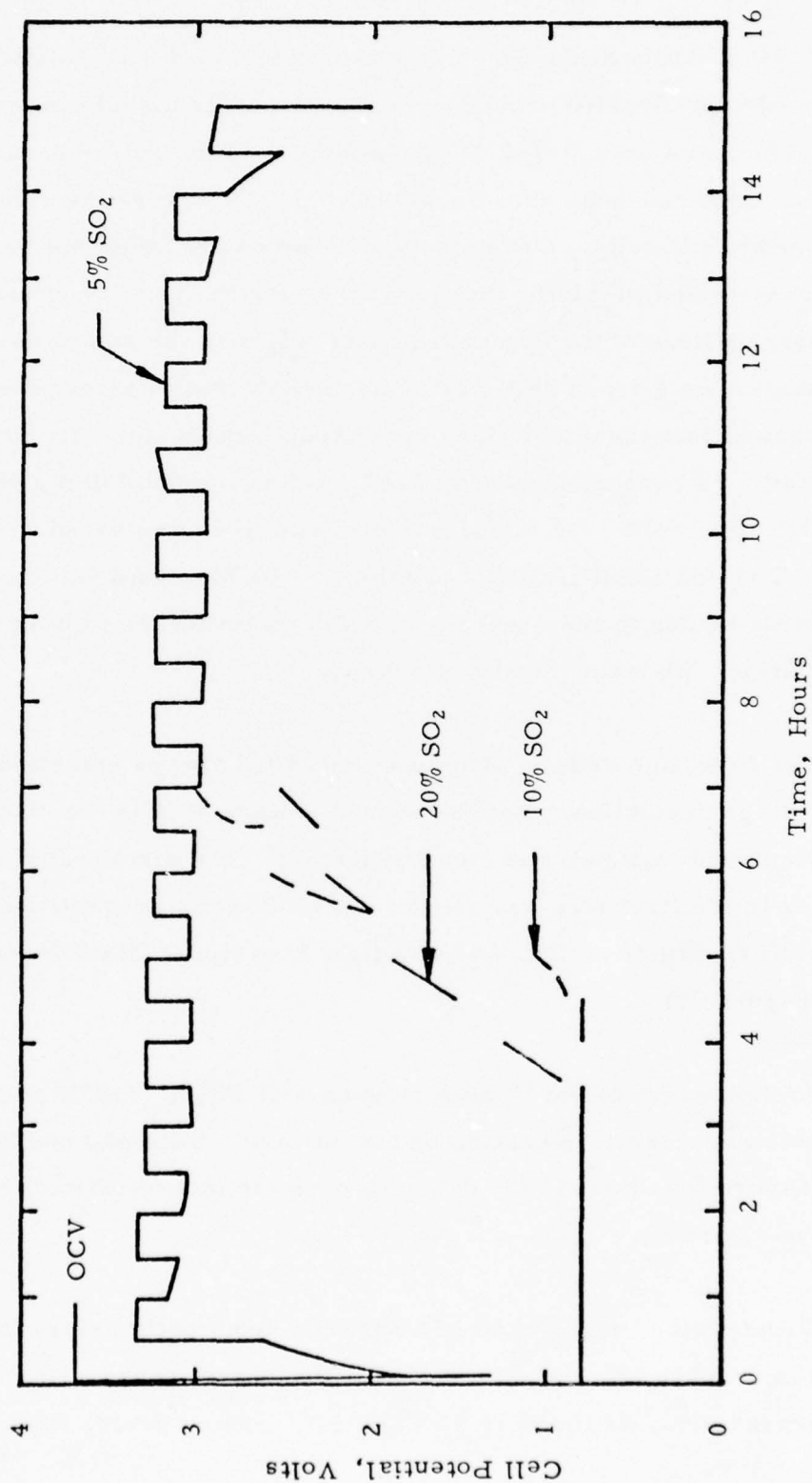

Figure 75. Discharge Performance of Life Support Cells at 75°F After Four Months Storage at 165°F (Nominal Fresh Cell Discharge Time is 16 Hours)



Other noteworthy points are:

1. 5M  $\text{LiAlCl}_4 \cdot \text{SOCl}_2$  electrolyte solution doped with yellow sulfur would not dissolve at room temperature. Its dissolution in the electrolyte takes place only at  $140^\circ\text{F}$  and above. All the sulfur in the sulfur-doped solutions had been pre-dissolved at  $165^\circ\text{F}$  before the solutions were used to fill cells. Once dissolved, the sulfur would not reprecipitate when cooled providing more evidence for the validity of reaction (2). Irrespective of the doping levels of sulfur in the solutions, polarization studies on a fresh cell (cell voltage (E) versus current density (I) curves) showed that these solutions give exceptionally high cell voltages under load. At current density of  $3.47 \text{ mA/cm}^2$ , about 130 mv difference (baseline cell: 3.37 volts) was obtained when compared to the baseline cell (1.5M  $\text{LiAlCl}_4 \cdot \text{SOCl}_2$  solution). The high load voltages could probably be due to the presence of  $\text{S}_2\text{Cl}_2$  (reaction (2) - giving rise to two distinct "plateaus" during discharge.

The first high voltage plateau (3.55 volts) always exhibited very good voltage regulation. But the second voltage step in the discharge always displayed high polarization (Figure 76). The discharge time corresponding to the first step was found to vary directly with the doping level of sulfur. Significantly, only the first step can be discharged at  $-20^\circ\text{F}$  (Figure 77).

Pretreatment of the lithium surface with  $\text{SO}_2$  at  $165^\circ\text{F}$  did not effect a uniform protective coating on the surface. SEM photomicrograph (Figure 78) showed only discrete crystals (not identified) being formed on the surface.

Withdrawing only 5% and 10% capacity from cells before they were subjected to storage at  $140^\circ\text{F}$  for one month caused drastic capacity degradation, as much as 37% and 54%, respectively, when discharged at  $75^\circ\text{F}$ .

System: Li/1.5M LiAlCl<sub>4</sub>·SOCl<sub>2</sub>·S/SOCl<sub>2</sub>, C  
 Device: Life Support Cell  
 Loads: 120 mA (30 min) - 45 mA (30 min)  
 Energy Density: Whr/in<sup>3</sup> - 6.2 -- Whr/lb - 72  
 Cell Build: Second

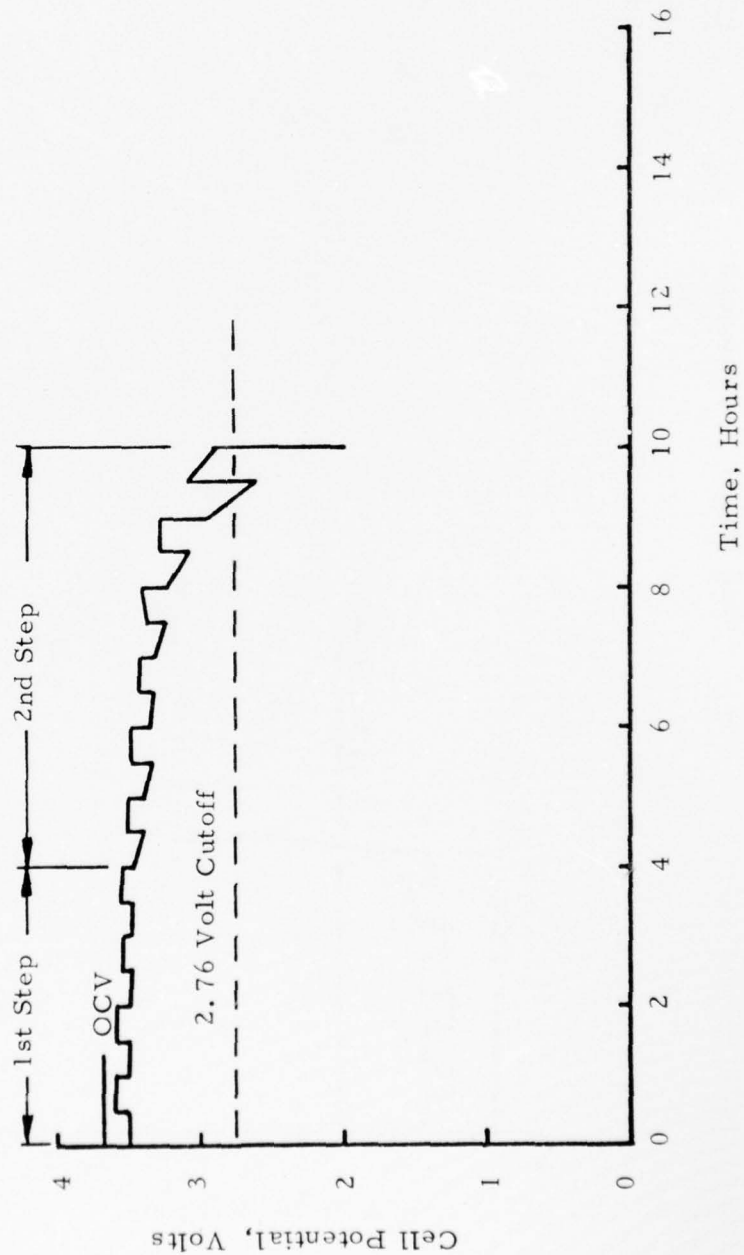
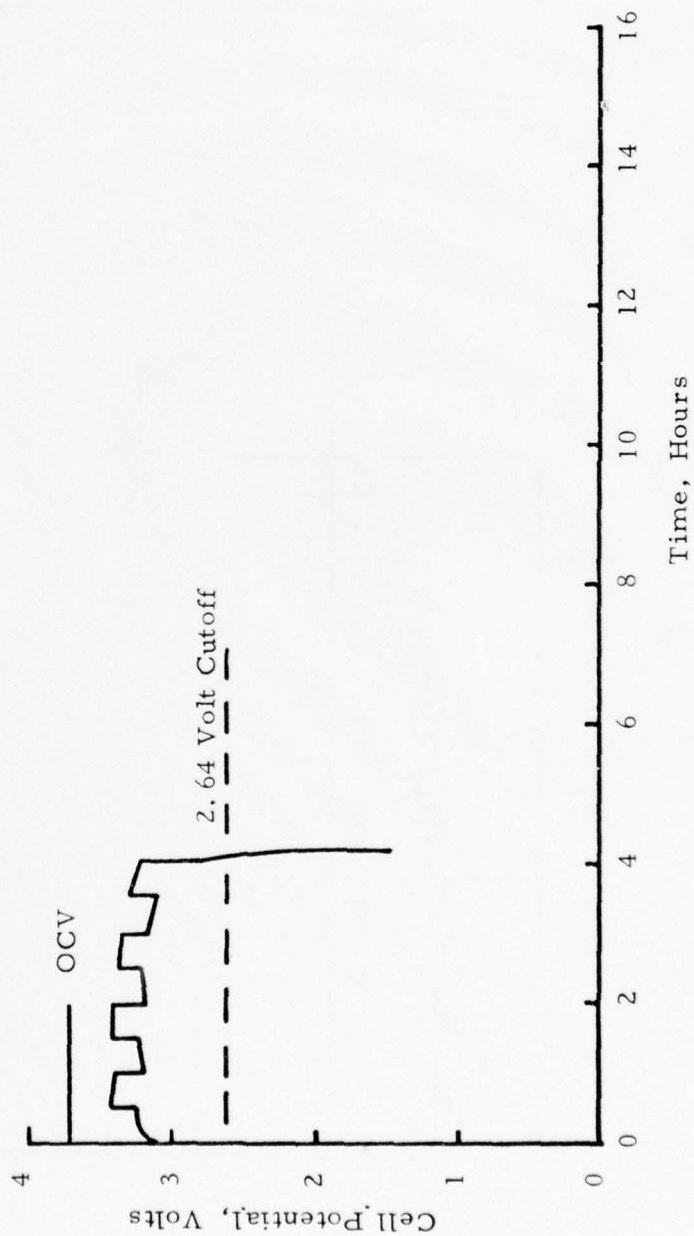

Figure 76. Discharge Performance of a Fresh Life Support Cell at Room Temperature Using Electrolyte Solution Doped with 15% S

System: Li/1.5M LiAlCl<sub>4</sub>·SOCl<sub>2</sub>·S/SOCl<sub>2</sub>, C  
 Device: Life Support Cell  
 Loads: 120 mA (30 min) ~ 45 mA (30 min)  
 Energy Density: Whr/in<sup>3</sup> - 2.6 --Whr/lb - 30  
 Cell Build: Second



FORM FM-101

Figure 77. Discharge Performance of a Fresh Life Support Cell at  $-20^{\circ}\text{F}$  using Electrolyte Solution Doped with 15% S

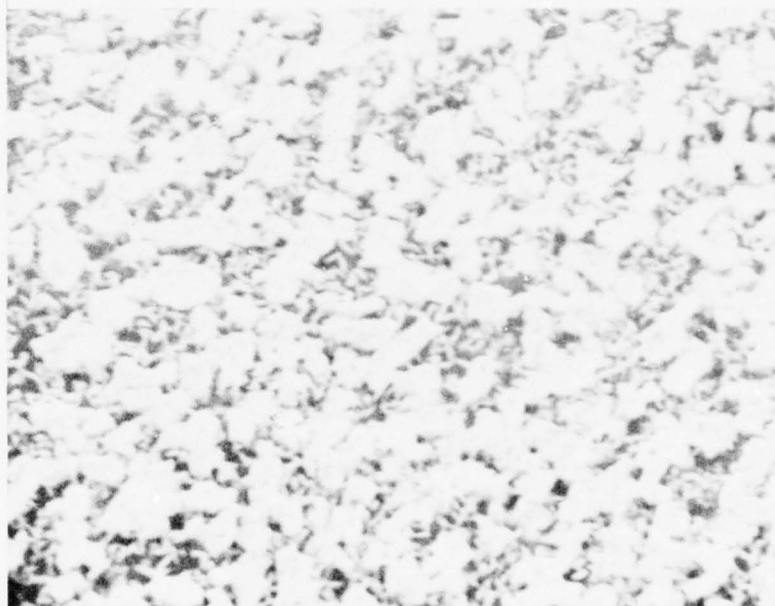

Figure 78. Lithium Surface Pretreated with  $\text{SO}_2$  After Two Weeks at  $165^\circ\text{F}$

SEM SE MODE MAG. 200X

#### D. ELECTROLYTE STUDIES

To effectively evaluate cell reactions, characterization of the electrolyte during and at end of discharge must be considered. As it was determined in work previous to this contract that the  $\text{LiAlCl}_4$  salt caused passivation, attempts were made to evaluate different forms of this salt to determine their comparative effects on the system.

Three grades of  $\text{LiAlCl}_4 \cdot \text{SOCl}_2$  electrolyte solutions have been considered for use in these cells:

1.  $\text{LiAlCl}_4^{(1)} + \text{SOCl}_2^{(2)} \xrightarrow{75^\circ\text{F}} \text{LiAlCl}_4 \cdot \text{SOCl}_2$
2.  $2.1 \text{ moles LiCl}^{(3)} + 2.0 \text{ moles AlCl}_3^{(4)} \xrightarrow{280-300^\circ\text{F}} \text{LiAlCl}_4 \text{ (neutral)}$   
 $\text{LiAlCl}_4 \cdot \text{SOCl}_2 \xleftarrow[75^\circ\text{F}]{+ \text{SOCl}_2^{(2)}} \text{LiAlCl}_4 \text{ (neutral)}$
3.  $(X + 1.05X) \text{ mole LiCl}^{(3)} + X \text{ mole AlCl}_3^{(4)} \xrightarrow[75^\circ\text{F}]{\text{SOCl}_2^{(2)}} \text{LiAlCl}_4 \cdot \text{SOCl}_2 \text{ (basic)}$

The fused solution (2 above) had a clear amber color. The metathetical solution (3 above) was clear and colorless.

The specific conductance of the above electrolyte solutions were found to be equivalent using a Jones-type conductivity cell with a cell constant of  $100 \text{ cm}^{-1}$ . The conductance value of 23 mmhos/cm for 1.5M  $\text{LiAlCl}_4 \cdot \text{SOCl}_2$  solutions at room temperature was obtained using an AC impedance bridge at 100K Hz.

- 
- (1) Purchased material prepared by vendor in an organic medium (patent pending).
  - (2) Matheson, Coleman & Bell Grade. Thionyl chloride is clear and colorless and was used as received without further distillation.
  - (3) Matheson, Coleman & Bell Grade.  $\text{LiCl}$  salt was vacuum dried at  $150^\circ\text{C}$ .
  - (4) Fluka Grade. Water and iron free.

Measured density of a 1.5M  $\text{LiAlCl}_4 \cdot \text{SOCl}_2$  electrolyte was 1.685 g/cc at 75°F. It reduced to 1.655 g/cc when the electrolyte was doped with 5% by weight of  $\text{SO}_2$ .

The vapor pressure characteristics were significantly different between the two electrolytes - 1.5M  $\text{LiAlCl}_4 \cdot \text{SOCl}_2$  (Figure 79) versus 1.5M  $\text{LiAlCl}_4 \cdot \text{SOCl}_2 + 5\%$  by weight of  $\text{SO}_2$  (Figure 80). As expected, the cells containing electrolyte solution doped with  $\text{SO}_2$  exhibited higher pressure build-up during the course of discharge. Using the doped electrolyte solution (5% by weight of  $\text{SO}_2$ ), a laboratory cell containing a PRC-90 cell wrap started with a pressure of 5 psig and ended at 14 psig after it had been discharged to 0.8 volt at 75°F. After about one month at the same temperature, the pressure gage registered 35 psig. This pressure then remained constant for one additional month.

#### 1. Effect of Excess Aluminum Chloride

Electrolyte containing excess  $\text{AlCl}_3$  was observed to cause the cell to have high open circuit voltage; also, it caused even fresh cells to perform at reduced capacity. Of more importance, however, was its adverse effect on materials corrosion during high temperature storage.

#### 2. Effect of Iron and Water

To avoid possible attack on the materials components by HCl (due to reaction of moisture and  $\text{SOCl}_2$ ) and because of the difficulty in drying  $\text{AlCl}_3$ ,  $\text{LiAlCl}_4$  salts prepared by the fusion process was selected to serve as the baseline electrolyte salt. The  $\text{LiAlCl}_4$  salt prepared for the third series of cells contained a lower water content (1500 ppm) than that used in the preliminary series of cells (3000 ppm). Since the performance of the third series was poorer than expected despite the use of lower water content, it appears that doubling the moisture content from 1500 to 3000 ppm does not add, in any significant way, to the degree of Li passivation.

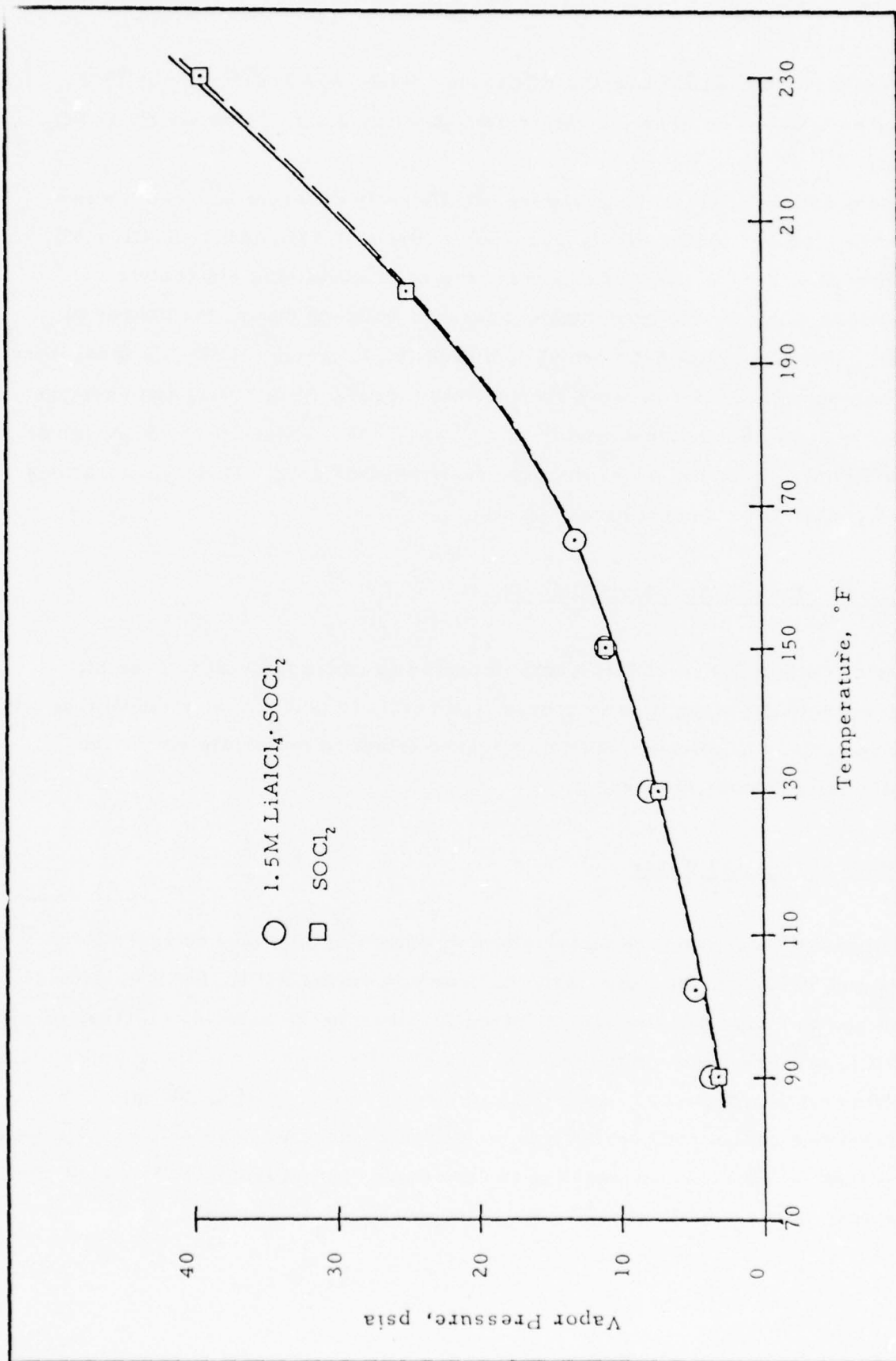

Figure 79. Solution Vapor Pressure Vs. Temperature

Electrolyte Concentration: 1.5M LiAlCl<sub>4</sub>·SOCl<sub>2</sub> + 5 wt % SO<sub>2</sub>

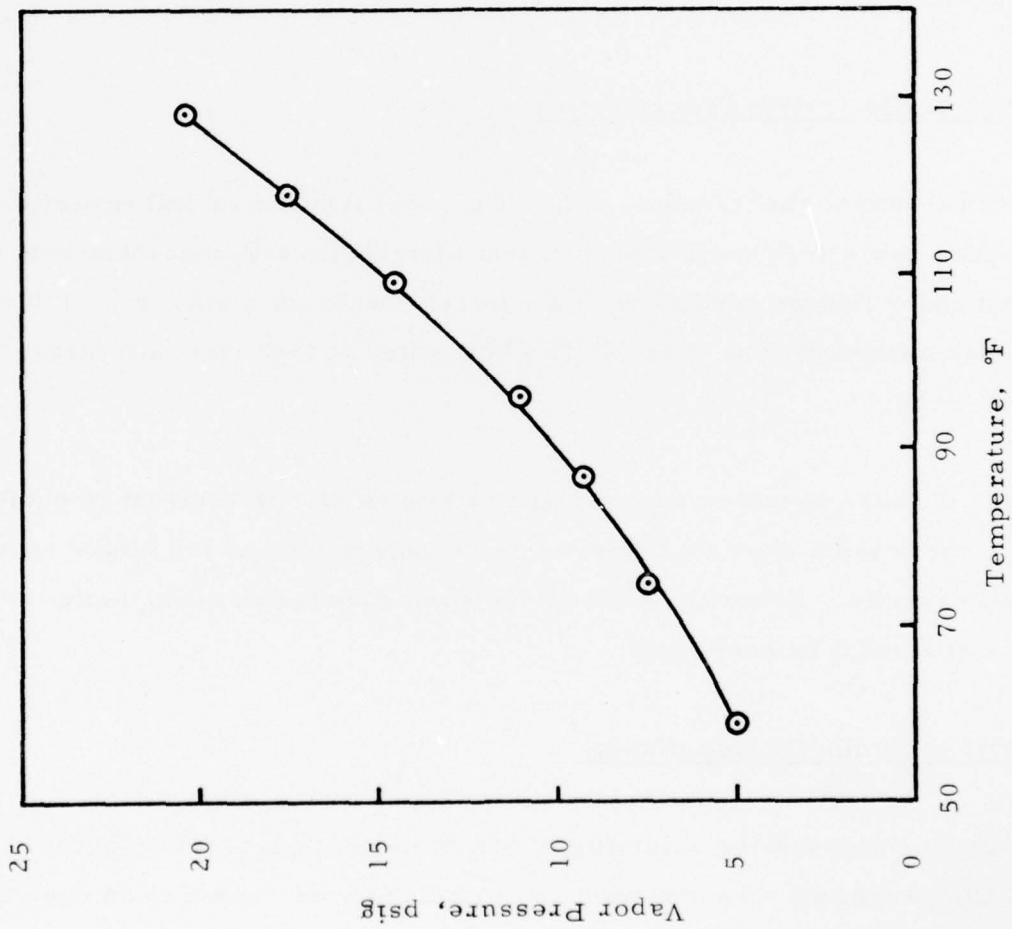

Figure 80. Solution Vapor Pressure Vs. Temperature



The electrolyte used to fill both the third and the fourth series of cells contained 0.8 ppm Fe (Fe content of fused  $\text{LiAlCl}_4$ : 7.7 ppm). Electrolyte solution stored in a 304 SS container had an Fe concentration ranging from 0.3 - 3 ppm after about 2 months storage at ambient condition. Since the basic cell design was around a positive case configuration, it simulates the above storage tank condition.

In cases where there was severe lithium passivation, the sources other than Fe causing the problem were identified.

### 3. Effect of Electrolyte Concentration

In a test to determine the influence of  $\text{LiAlCl}_4$  concentration on cell capacity, twelve 3-plate laboratory cells with different electrolyte salt concentrations were discharged under flooded conditions at a current density of  $5 \text{ mA/cm}^2$ . 1.0 molar vs 1.5 molar concentrations of the salts were tested at three temperatures:  $-40^\circ\text{F}$ ,  $75^\circ\text{F}$ , and  $165^\circ\text{F}$ .

The results of these tests are summarized in Figure 81. In contrast to published results<sup>(2)</sup>, these tests show that electrolyte concentrations of 1.5 molar result in higher cell capacity. However, whether the same conclusion could apply to hardware cells still must be confirmed.

### 4. Effect of Sulfur Dioxide Doping

In a test which compared the solubility of  $\text{SO}_2$  in pure  $\text{SOCl}_2$  to its solubility in a 1.5M  $\text{LiAlCl}_4 \cdot \text{SOCl}_2$  solution, a known quantity of liquid  $\text{SO}_2$  was added to an equivalent amount of pure  $\text{SOCl}_2$  and to an equivalent amount of  $\text{LiAlCl}_4 \cdot \text{SOCl}_2$  solution. The mixtures were left at  $-20^\circ\text{F}$  and shaken to insure proper mixing.

---

(2) Sealed Primary Lithium Inorganic Electrolyte Cell, Report ECOM-74-0109-1, July, 1974.

System: Li/XM LiAlCl<sub>4</sub>·SOCl<sub>2</sub>/SOCl<sub>2</sub>  
Device: Laboratory Cell  
Load: 5 mA/cm<sup>2</sup>  
Cathode Surface area: 12 cm<sup>2</sup>

— 1.5 Molar  
- - - 1.0 Molar

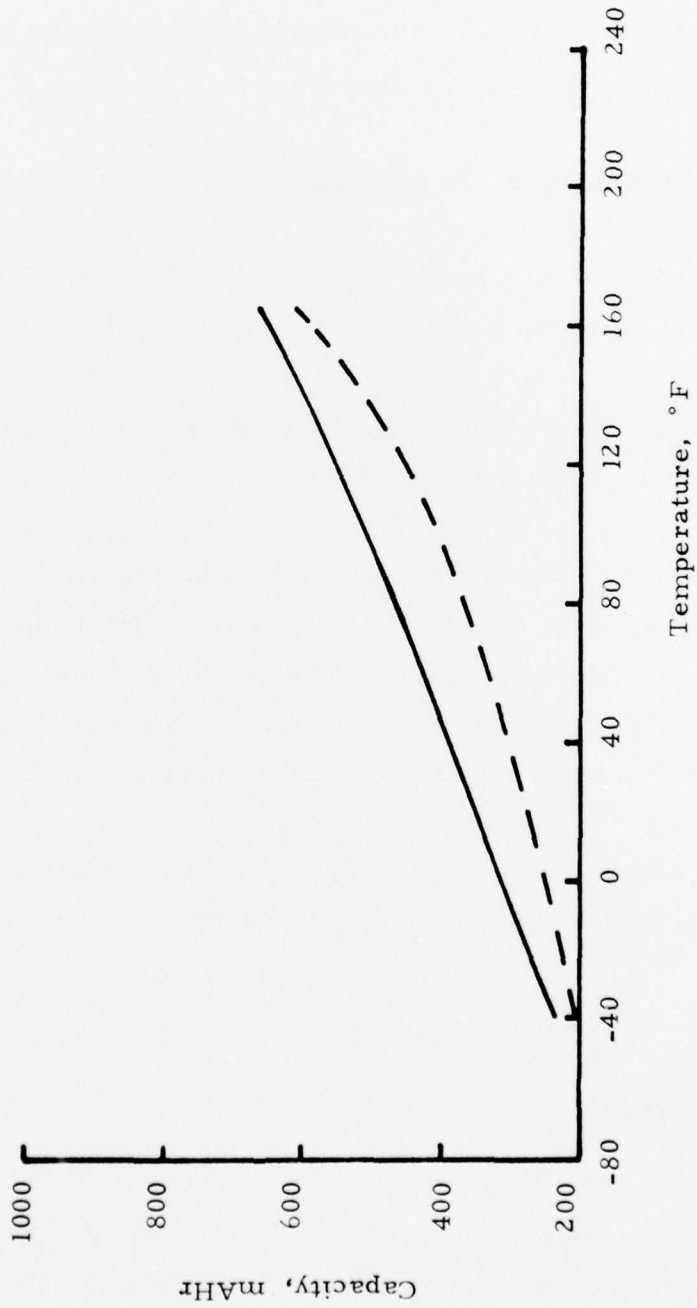

Figure 81. Capacity Performance of Cells Using 1.0 Molar or 1.5 Molar LiAlCl<sub>4</sub>·SOCl<sub>2</sub> Electrolyte Solutions

Results of the test showed that the solubility of  $\text{SO}_2$  in pure  $\text{SOCl}_2$  was 5.0% by weight and in 1.5M  $\text{LiAlCl}_4 \cdot \text{SOCl}_2$  solution was 11.5% by weight indicating that the  $\text{LiAlCl}_4$  salt contributes significantly to the solubility of  $\text{SO}_2$  in  $\text{SOCl}_2$  electrolyte solutions. The color of the mixed solution was a clear brown.

The effects of doping a 1.5M  $\text{LiAlCl}_4 \cdot \text{SOCl}_2$  electrolyte solution with various levels of  $\text{SO}_2$  (0%, 5%, 10%, and 20% by weight) were determined in sealed glass ampuls and in the presence of Li strips after storage times of one month and of ten months at 140°F.

The following conclusions can be derived from these tests (illustrated in Figure 82):

- a. Fresh electrolyte containing 0%  $\text{SO}_2$  is clear and colorless. After storage, however, the solution becomes a clear yellow color.
- b. The coloration of the electrolyte solution was more sensitive to  $\text{SO}_2$  levels than to storage time or temperature.
- c. The color of the electrolyte solution deepened as the  $\text{SO}_2$  concentration increased. A sharp change in color occurred between the 0% level and the other levels. Although a marked change can be noted between the 10% and the 20% levels, no change at all is apparent between the 5% and 10% levels. At the 20% level, severe corrosion was observed on the lithium surface.
- d. The observations noted in a, b, and c above appear to correlate to the degradation in cell performance seen with  $\text{SO}_2$  doping concentrations higher than 5%.

## E. CATHODE STUDIES

### 1. Cathode Structure

The cell design used for the first series of Life Support Cells was capable of delivering maximum energy densities of 7.1 watt-hours/in<sup>3</sup> and 70.8 watt-hours/lb. In the absence of anodic passivation, however, a wide variety of energy densities

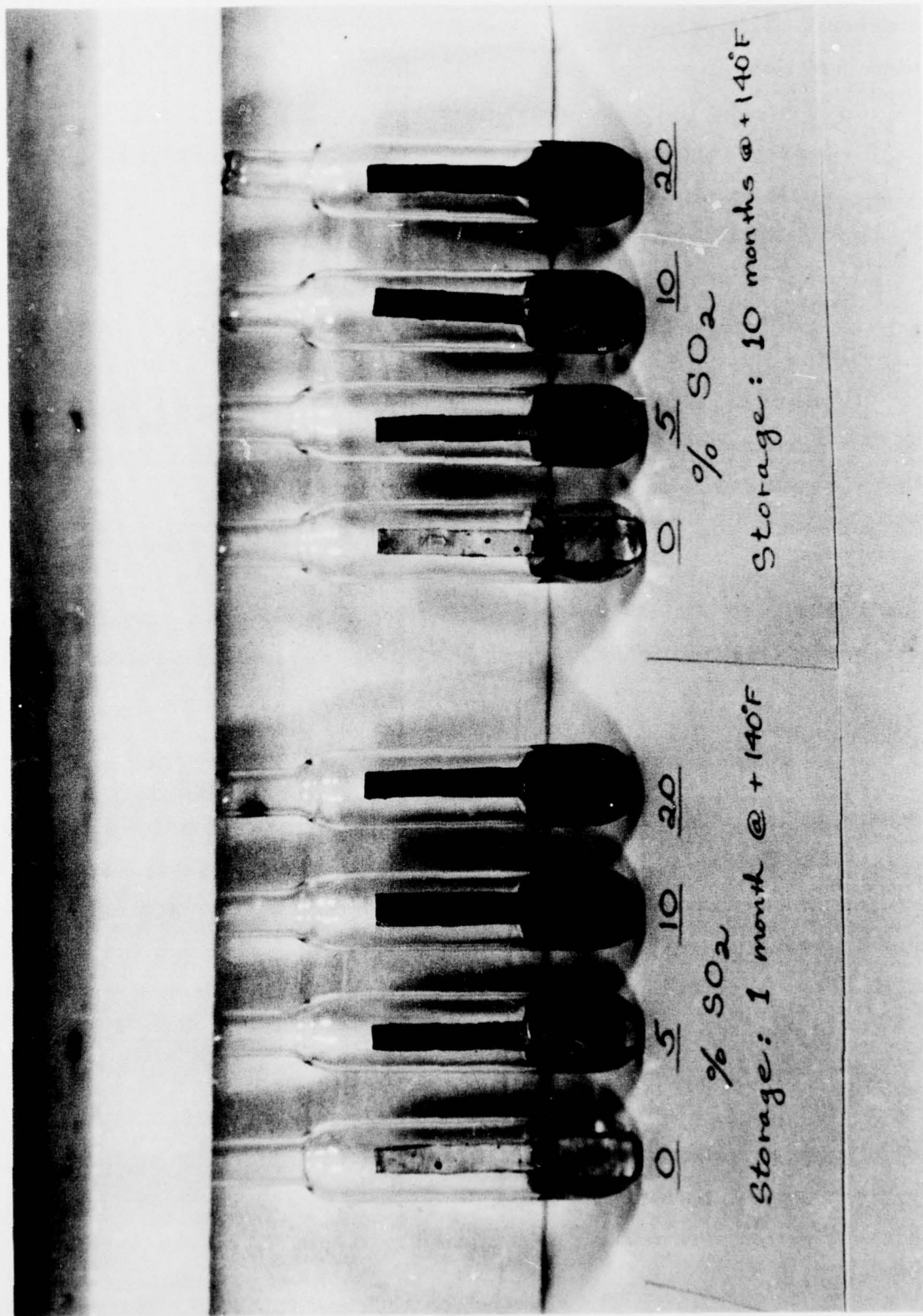

Figure 82. Compatibility of Lithium with 1.5M LiAlCl<sub>4</sub>·SOCl<sub>2</sub> Electrolyte Solution in the Presence of Various Amounts of SO<sub>2</sub>

was observed. This performance variability was attributed to the cathodes, which exhibited variations in voltage when polarized in laboratory cells.

Studies showed that cathode polarization can be attributed primarily to overmixing the carbon slurry when preparing the cathodes, but that the sintering process also effects significant polarization.

Changing the internal component designs and preparing the cathodes by an unsintered, dry-compaction process (rather than a slurry/sintering process) produced significant improvement in cell design. These improvements, discussed under CELL DESIGN AND FABRICATION (Second Series of Life Support Cells) resulted in a cell design capable of delivering maximum energy densities of 13.5 watt-hours/in<sup>3</sup> and 155 watt-hours/lb.

Additional studies showed that optimum packaging efficiency can be attained with cathodes having a net weight of 800 mg and a thickness of 0.040 inch (See Figure 83).

## 2. Spacecraft "B" Battery

To obtain an optimum cathode design, cathode capacity was evaluated at four plate thicknesses: 0.080, 0.160, 0.320, and 0.480 inch. A total cathode thickness of 2.24 inches was used as the design parameter to determine the required number of plates of a specific plate thickness. By this method, the maximum and minimum current densities required to meet the 15 A and 0.417 A loads respectively for the Spacecraft "B" Battery were fixed.

Electrolyte-flooded laboratory cells of the three-plate configuration were used to evaluate cathode performance. Test cells were discharged continuously at the minimum current density, as a function of plate thicknesses. At various times during the discharge period, the cells were subjected to 45-second pulse polarization tests.

System: Li/1.5M LiAlCl<sub>4</sub>·SOCl<sub>2</sub>/SOCl<sub>2</sub>, C  
Device: Life Support Wrap (flooded)  
Load: 82.5 mA  
Cathode Area: 36 cm<sup>2</sup>  
Temperature: 75°F

Cathode Thickness: ↓

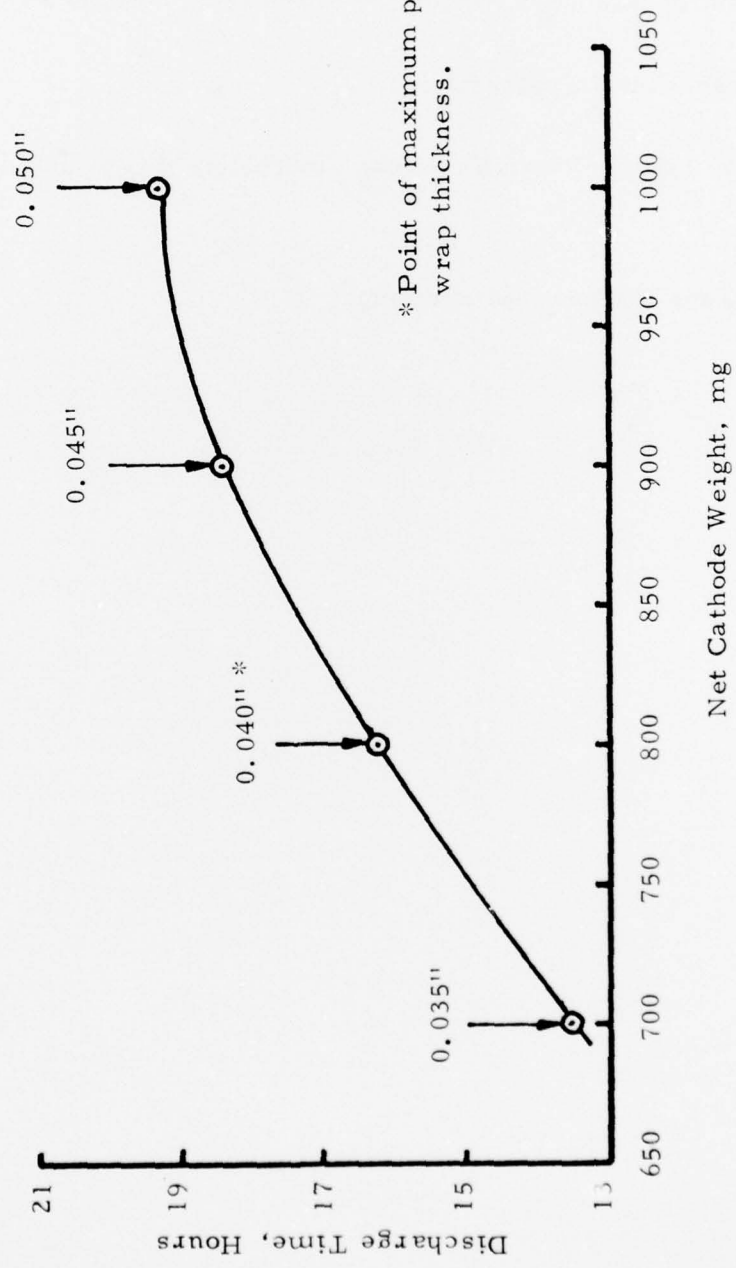

\* Point of maximum practical wrap thickness.

Figure 83. Cathode Design Studies for Improving Performance of Life Support Cells

As expected, the average voltage drop and reduction in capacity were shown to increase with increasing plate thickness (See Figure 84). The 0.080 inch thick plate, however, exhibited only marginally better performance, and the following advantages of the 0.160 inch thickness lead to its selection for the construction of the Spacecraft "B" Battery:

- a. Fewer plates required (14 for the 0.160 inch, versus 28 for the 0.080).
- b. Better handling characteristics.
- c. Maximum volume available to the electrolyte due to use of less inert materials.
- d. Less chance for internal shorting.

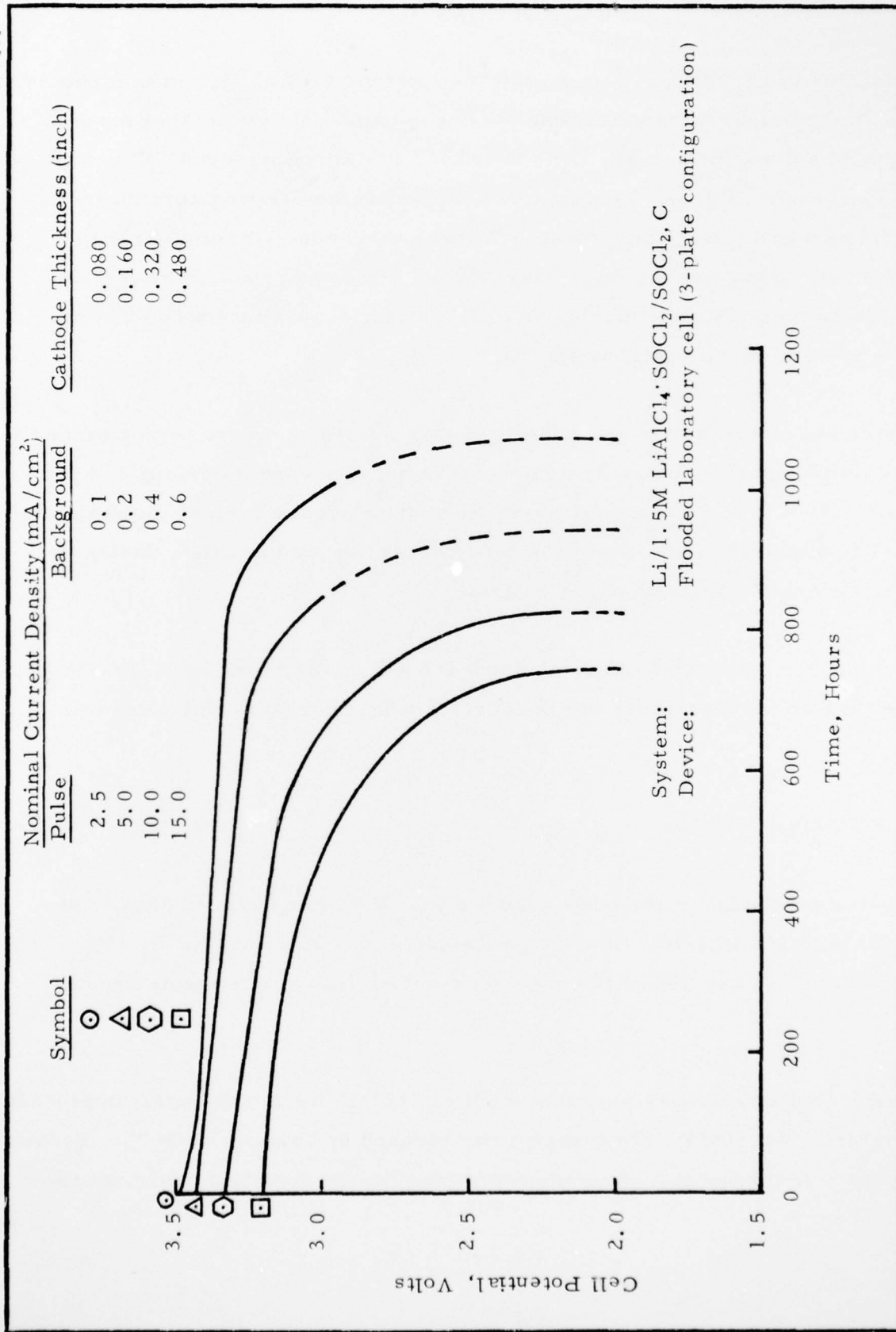

Figure 84. Pulse Polarization of Various Cathode Thicknesses for Scale-up of Spacecraft "B" Cell Design



## SECTION VI

### CONCLUSIONS

The capabilities of the lithium-thionyl chloride electrochemical system in terms of Life Support and Spacecraft applications have been demonstrated in this program. Three types of cells - the 1.6 Ahr (Life Support), 200 Ahr (Spacecraft "A"), and 500 Ahr (Spacecraft "B"), were used as vehicles for demonstrating performance against goals set forth in the Statement of Work for this contract for each of the three cell sizes. Some goals were achieved while others were not, however, in all areas the Lithium-thionyl chloride cell performance capabilities towards the specified goals was significantly improved.

In addition to the major task of improving and maximizing hardware performance, a significant portion of this contract was devoted to defining, understanding and providing solution(s) to two fundamental problems confronting the lithium-thionyl system; they are 1) detrimental anodic film growth during storage and 2) safety during the normal and abnormal operation of the system.

Below are specific points that can be concluded based on the experience and observation gained in both the laboratory and the developmental hardware phases of this program.

#### A. LIFE SUPPORT CELL

Best delivered performance for fresh cells were 1.75 Ahr and energy density of 13.5 Whr/in<sup>3</sup> and 155 Whr/lb. On a weight basis, it exceeded the goal by 29%, while it achieved 75% and 66% of the goals on a weight and capacity basis, respectively.

Interestingly, capacity outputs at temperatures  $\geq 124^{\circ}\text{F}$  were moderately dependent on temperature. At  $165^{\circ}\text{F}$ , the capacity was reduced by as much as 5.0%. Because of the higher cell voltage at high temperature, the energy density performance was

not affected and maintained its constancy at temperatures  $> 75^{\circ}\text{F}$ . A sharper dependency with temperature was found for both the capacity and energy density at temperatures below  $32^{\circ}\text{F}$ . Performance degraded at a rate of approximately 0.9% per degree Fahrenheit.

Starting at  $50^{\circ}\text{F}$ , a moderate 0.05% improvement in the average cell voltage per degree Fahrenheit can be achieved above this temperature, but it decreased at a rate of 0.2% per degree Fahrenheit at temperatures below  $50^{\circ}\text{F}$ . Voltage regulation as defined in the contract Statement of Work of  $\pm 3.5\%$  can be maintained at  $75^{\circ}\text{F}$ . It approached  $\pm 2.5\%$  at  $165^{\circ}\text{F}$  and 11.0% at  $-65^{\circ}\text{F}$ .

Through the use of 1.5M  $\text{LiAlCl}_4 \cdot \text{SOCl}_2$  electrolyte containing 5.0% by weight of  $\text{SO}_2$ , storage capability has been extended from 3 weeks at  $75^{\circ}\text{F}$  (First Series) to 5 months at  $140^{\circ}\text{F}$  (Fourth Series) whereby useful capacity can still be obtained at temperatures  $> 32^{\circ}\text{F}$ . Voltage delay, however, was still distinctly present at these temperatures ( $75$  to  $32^{\circ}\text{F}$ ). When the discharge rate was lowered from  $2.3 \text{ mA/cm}^2$  (average life support current density) to  $1.0 \text{ mA/cm}^2$ , about 98% of the nominal capacity (1.60 Ahr) can be obtained at  $75^{\circ}\text{F}$  without exhibiting any voltage delay.

The Life Support Cell was redesigned and four series-connected cells were built into PRC-90 type batteries. These batteries were tested to determine the performance capabilities of PRC-90 batteries should the  $\text{Li/SOCl}_2$  technology be used in the PRC-90 radio. At  $75^{\circ}\text{F}$  the battery had an OCV of 14.30 volts and an operating midpoint voltage of 13.30 volts. Delivered capacity and energy density were 1.61 Ahr,  $11.6 \text{ Whr/in}^3$  and  $134 \text{ Whr/lb}$ . The battery can operate above 10.0 volts at a temperature as low as  $-65^{\circ}\text{F}$  but at a significantly reduced capacity.

From the aspect of safety, the Life Support Cells were operated safely under both normal and abnormal modes (short circuit, deep discharge, forced discharge into cell polarity reversal and charge) of operations.

## B. SPACECRAFT "A" CELL

The delivered capacity was 84% of the project goal of 220 Ahr. This percentage reduced to 71% after three months of storage at 80°F. On a weight basis, the energy density met the goal of 175 Whr/lb, and achieved 87% of the goal (15 Whr/in<sup>3</sup>) on a volume basis. On the average, the achieved energy density was 76% of the goals after three months of storage at 80°F.

A typical fresh cell can maintain voltage regulation of +40% and -8.4% over 95% of the useful life of the cell. Because of the exceedingly high starting pulse current (9.9 mA/cm<sup>2</sup>), voltage delays ranging from 320 - 560 msec were displayed after three months of storage at 80°F. It should be noted, however, that no voltage delay were observed after the initial pulse had been applied.

Adverse safety problems did not occur during the normal and deep discharge (to 0.0 volt) operations of these high rate cells. However, extreme conditions (short circuit, forced discharge, or charge) caused either spontaneous pressure venting (polarity reversal) or explosions (short circuit and charging).

## C. SPACECRAFT "B" CELL

There was no trend indicating any performance losses based on 80°F storage for a period of three months. Achieved capacity was 75% of the goal of 600 Ahr. Energy density goals were 25 Whr/in<sup>3</sup> and 350 Whr/lb, and the achieved values were 69% and 75%, respectively.

After three months of storage at 80°F voltage delay was not observed at either the 0.417 A background load or the 7.5 A and 15 A pulse loads if the voltage recovery time is based on the time to reach 80% of the average voltage.

A typical fresh cell can maintain a regulation of +0.3% and -15% over 95% of the useful life.

Under both the normal and abnormal modes (short-circuit, deep discharge, forced discharged into polarity reversal and charge) of operation, neither spontaneous pressure venting nor cell explosion occurred.

#### D. LABORATORY STUDIES

Storage capability of the Li/SOCl<sub>2</sub> system appeared to be a one-time memory effect; that is, partially discharged cells caused dramatic reduction in cell capacity after they were placed on storage.

Capacity delivered from stored cells was found to be anode limited at low temperature. This appeared to be due to the effect of concentration polarization due to the existence of the anodic film barrier.

In terms of doping the SOCl<sub>2</sub> electrolyte with SO<sub>2</sub>, the effectiveness of minimizing lithium passivation can only be achieved at the five percent by weight level. In a 1.5M LiAlCl<sub>4</sub>·SOCl<sub>2</sub> electrolyte, the ratio of LiAlCl<sub>4</sub> to SO<sub>2</sub> was 1.16. Beyond the 5% weight SO<sub>2</sub> level, not only did it not improve voltage delay but it had a detrimental effect. Lithium strips partially immersed in the test solutions showed signs of severe corrosion beyond the 10% level. Furthermore, the surfaces exposed to the vapor phase tarnished more than the immersed surfaces.

Postmortem analysis on fresh cells that were subjected to storage gave evidence of lithium reaction with the glass separator. This evidence was supported by the inability to peel off the separator from the lithium surface.

SECTION VII  
RECOMMENDATIONS

The tasks expected to bring about the improvements required of the lithium inorganic electrochemical systems to provide even further advance in power source technology towards Air Force needs are listed below. The two broad areas requiring most development are Safety and Storage Capability.

A. SAFETY

- 1) Build a statistical data base on safety problems encountered in Li/SOCl<sub>2</sub> cells.
- 2) Elucidate reaction mechanism(s) operating during normal discharge and deep discharge.
- 3) Investigate other high energy inorganic systems:
  - Ca/SOCl<sub>2</sub>, SO<sub>2</sub>Cl<sub>2</sub>
  - Li/SO<sub>2</sub>Cl<sub>2</sub>
  - Li alloy/SOCl<sub>2</sub>, SO<sub>2</sub>Cl<sub>2</sub>
- 4) Investigate reserve packaging concepts for high rate Li/SOCl<sub>2</sub> cells.

B. STORAGE

- 1) Elucidate mechanism(s) responsible for beneficial effects of SO<sub>2</sub> at the 5% weight level in alleviating passivation.
- 2) Investigate reactivity/compatibility of glass separator with lithium anode in terms of reliable cell performance and very long term storage needs.

- 3) Evaluate separator materials other than glass mat, such as boron nitride paper.
- 4) Determine storage capability of cells as a function of state-of-charge.