

AD A 043266

CEEDO-TR-77-10

12

POLLUTANT GENERATION BY AIR FORCE ELECTROPLATING PROCESSES



JUNE 1977

FINAL REPORT FOR PERIOD
SEPTEMBER 1974-DECEMBER 1976

DDC
RECEIVED
AUG 25 1977
RECEIVED

CEEDO

Approved for public release; distribution unlimited

CIVIL AND ENVIRONMENTAL ENGINEERING DEVELOPMENT OFFICE

(AIR FORCE SYSTEMS COMMAND)

TYNDALL AIR FORCE BASE

FLORIDA 32403



DDC FILE COPY

DDC FILE COPY

REPORT DOCUMENTATION PAGE		READ INSTRUCTIONS BEFORE COMPLETING FORM
1. REPORT NUMBER CEEDO-TR-77-10	2. GOVT ACCESSION NO.	3. RECIPIENT'S CATALOG NUMBER (9)
4. TITLE (and Subtitle) POLLUTANT GENERATION BY AIR FORCE ELECTROPLATING PROCESSES		5. TYPE OF REPORT & PERIOD COVERED FINAL REPORT 1 Oct 74 - 1 Sep 76
7. AUTHOR(s) Peter S. Daley, Major, USAF		6. PERFORMING ORG. REPORT NUMBER
9. PERFORMING ORGANIZATION NAME AND ADDRESS Det 1 HQ ADTC/ECA Tyndall Air Force Base, Florida 32403		8. CONTRACT OR GRANT NUMBER(s)
11. CONTROLLING OFFICE NAME AND ADDRESS Det 1 (CEEDO) HQ ADTC Tyndall Air Force Base, Florida 32403		10. PROGRAM ELEMENT, PROJECT, TASK AREA & WORK UNIT NUMBERS 63723F (17) 16 2103 1A 15
14. MONITORING AGENCY NAME & ADDRESS (if different from Controlling Office)		12. REPORT DATE (17) June 77
		13. NUMBER OF PAGES 37 (42) 37p. 1
		15. SECURITY CLASS. (of this report) UNCLASSIFIED
		15a. DECLASSIFICATION/DOWNGRADING SCHEDULE
16. DISTRIBUTION STATEMENT (of this Report) Approved for public release; distribution unlimited.		
17. DISTRIBUTION STATEMENT (of the abstract entered in Block 20, if different from Report)		
18. SUPPLEMENTARY NOTES Available in DDC		
19. KEY WORDS (Continue on reverse side if necessary and identify by block number) Electroplating Pollution emission Pollution Emissions Chromium Factors Air pollution		
20. ABSTRACT (Continue on reverse side if necessary and identify by block number) A detailed study of the pollutants generated in Air Force electroplating was performed and pollution emission factors were recommended for a variety of electroplating operations. The largest single source of pollution in the plating operation was "dragout," the material removed by parts when they are withdrawn from solution and rinsed. For chromium plating, aerosol generation at the plating solution surface was significant, amounting to 0.12 g/A·da. This number was independent of a wide variety of		

**Best
Available
Copy**

20. Abstract (concluded)

electroplating variables and is recommended as an emission factor in chromium electroplating. Aerosol generation was not important in nickel, cadmium, or silver plating processes. Cyanide emissions in cadmium plating were independent of workload and depended primarily on tank surface area. An emission factor of $10 \text{ g/m}^2 \cdot \text{da}$ is recommended.

Collateral studies of scrubber efficiency for scrubber collection of chromium aerosols, quantitation of the dragout problem, and potential savings through chromium overplate recovery are presented. Chromium is identified as the major pollution problem resulting from electroplating. Logic is presented that could lead to the exemption of Air Force electroplating operations from federal electroplating emission standards.



PREFACE

This report documents work performed during the period 1 Oct 74 through 1 Sep 76 by the Air Force Civil Engineering Center, Air Force Systems Command, Tyndall Air Force Base, Florida, 32403.

The study of Air Force electroplating processes was prompted by the need to predict electroplating waste emission rates from the numerous Air Force plating operations without extensive field data collection and analysis. A concomitant product, the identification of the relative importance of various pollution sources within the electroplating facility was needed to enable the Air Force to formulate a control strategy for electroplating wastes.

The study involved five months of extensive field work and was made possible only by the outstanding cooperation of the Oklahoma City Air Logistics Center and the Tinker Air Force Base Civil Engineering Squadron. Specific credit goes to Mr Perry Fields of the former organization and Mr David Burris of the latter as well as to the numerous electroplating specialists who went far out of their way to assure that our special requirements for electroplating runs were met.

On 8 April, 1977, AFCEC was reorganized into two organizations. AFCEC became part of the Air Force Engineering and Services Agency (AFESA); the R&D function remains under Air Force Systems Command as Det 1 (Civil and Environmental Engineering Development Office-CEEDO) HQ ADTC. Both units remain at Tyndall AFB, FL 32403.

This report has been reviewed by the Information Office (OI) and is releasable to the National Technical Information Service (NTIS). At NTIS it will be available to the general public, including foreign nations.

This technical report has been reviewed and is approved for publication.

Peter S. Daley
PETER S. DALEY, Maj, USAF, BSC
Chief, Air Quality Research Div

Peter A. Crowley
PETER A. CROWLEY, Maj, USAF, BSC
Director of Environics

Donald G. Silva
DONALD G. SILVA, Lt Col, USAF, BSC
Commander

ACCESSION for		
NTIS	White Section	<input checked="" type="checkbox"/>
DDC	Buff Section	<input type="checkbox"/>
UNANNOUNCED		<input type="checkbox"/>
JUSTIFICATION		
BY		
DISTRIBUTION/AVAILABILITY CODES		
Dist.	Avail.	and/or SPECIAL
<i>A</i>		

TABLE OF CONTENTS

Section	Title	Page
I	INTRODUCTION	1
II	PROCESS DESCRIPTION	4
III	APPROACH AND PROCEDURES	7
IV	RESULTS	10
V	CONCLUSIONS AND RECOMMENDATIONS	25
	REFERENCES	27
	APPENDIX	29

LIST OF FIGURES

Figure	Title	Page
1	Schematic Diagram of the Chromium Electroplating System Studied	10
2	Duall FW-300 Vertical Pack Scrubber with Motor Blower	11
3	Variation in Chromium Plating Scrubber Efficiency with Changes in Water Flow Rate	13
4	Correlation between Chromium Aerosol Generated during the Electroplating of Various Parts and the Current Applied to the Plating Tank	17

LIST OF TABLES

Table	Title	Page
1	Drinking Water Standards	2
2	Metal Finishing Processes at the OCALC Electroplating Facility	4
3	Variables Determining Pollutant Generation Rates in Electroplating	7
4	Centerline versus Traverse Samples for Monitoring Chromium Stack Emissions	12
5	Characteristics of Parts Plated in Chrome Studies	15
6	Chrome Aerosols Collected at Surface of Plating Tanks	16
7	Pollutant Generation in Miscellaneous Processes	19
8	Dragout by Various Parts	22
9	Some Pollutants Emitted by Metal Finishing Processes per Unit Area Treated	23

SECTION I

INTRODUCTION

Electroplating is the process of forming a metallic layer on a substrate by deposition of metal ions from a solution. The metal ions are caused to migrate from the solution to the substrate by an applied or electrochemically induced electromotive force (voltage). Electroplating is usually performed for one of three reasons: (1) to produce a decorative surface, (2) to restore surfaces worn away through use, or (3) to apply durable, corrosion, or wear resistant surfaces. The Air Force operates numerous electroplating facilities devoted primarily to production of corrosion and wear resistant surfaces and to some extent to surface restoration. This is in contrast to commercial electroplating which tends to emphasize decorative applications.

Pollution generation in electroplating is a problem as old as the process itself. Electroplating solutions are often corrosive, highly acidic, highly colored or toxic. These properties lead to many waste discharge problems in addition to the potential health and biological hazards of the materials used. Perhaps the best indicator of the health hazard associated with electroplating effluents is found in federal drinking water standards. Of the nine compounds with firmly established limits for potable use as established by the standards, five are commonly used in electroplating, see Table 1 (Reference 1). These five include three of the frequently plated materials, hexavalent chromium, cadmium, and silver. They are all routinely plated in Air Force electroplating processes. In fact, chromium probably accounts for over one-half of the overall Air Force electroplating workload. The health hazard associated with chromium is emphasized by its long history as an industrial hygiene problem causing ulceration of the nasal septum, general irritation, and disabling disease as well as being suspected as a carcinogen (Reference 2).

Cadmium is also used frequently in Air Force electroplating. Its high toxicity is well known, causing severe acute poisoning (Reference 2) as well as painful chronic disease (Reference 3). Cadmium was recently detected in levels above the limit cited in Table I in the drinking water of 20 cities surveyed by the US Public Health Service (Reference 3).

TABLE 1. DRINKING WATER STANDARDS

The presence of the following substances in excess of the concentrations listed shall constitute grounds for rejection of the supply:	
Substance	Concentration in mg/l
Arsenic (As)	0.05
Barium (Ba)	1.0
Cadmium (Cd) ^a	0.01
Chromium (Hexavalent) (Cr ⁺⁶) ^a	0.05
Cyanide (CN) ^a	0.2
Fluoride (F) ^a	0.7 to 1.2 ^b
Lead (Pb)	0.05
Selenium (Se)	0.01
Silver (Ag) ^a	0.05

^aCommonly associated with electroplating operations.

^bDepends on average ambient temperature.

The importance of electroplating effluents cited above made it imperative that platers exercise control over pollutant releases to the air and water. This need is now a legal requirement governed by the recently passed federal electroplating point source effluent standards (Reference 4). Because of the Air Force's deep involvement in electroplating, the potential hazards associated with electroplating effluent releases and the cited legislation, this study of a large Air Force electroplating facility was undertaken. The objective of the study was fourfold: (1) to quantitate the release of pollutants from Air Force electroplating processes, (2) to determine the relationships between electroplating workload data and pollutant generation (if such relationships could be established) so that predictions of

effluent levels could be made, (3) to determine what sub-processes were primarily responsible for pollutant generation and to quantitate the fraction of pollutants generated by each significant subprocess, and (4) to determine how the process could best be altered to reduce pollutant releases. The fourth objective is treated in a separate report (Reference 5). This report will be devoted to the quantitation of the pollutant releases as described in the first three objectives. Three earlier DOD studies of electroplating operations have been made (References 6, 7, and 8) but these were limited to quantitating the air effluent without regard to workload. In this report all effluents will be explored and the results of this research will be correlated with workload factors.

SECTION II

PROCESS DESCRIPTION

The study was performed at the USAF Oklahoma City Air Logistics Center (OCALC), Tinker Air Force Base, Oklahoma. The plating facility is large by any standard. It includes 207 processing tanks with 30 different processes. Of the 207 tanks, approximately one-half are fitted with exhaust systems to draw off dangerous compounds emitted from the tanks' liquid surfaces. Air is exhausted via 88 completely independent exhaust systems through the roof. In four processes (chrome plating, alkali metal cleaning, and silver and nickel stripping) exhaust gases are passed through water scrubber systems to remove hazardous materials before they are released to the atmosphere. This information is summarized in Table 2.

TABLE 2. METAL FINISHING PROCESSES
AT THE OCALC ELECTROPLATING FACILITY

<u>Vented Tanks with Scrubbers</u>	<u>Vented Tanks without Scrubbers</u>
Chromium Plating	Cadmium Plating
Alkali Metal Cleaning (NaOH)	Nickel Strike
Silver stripping	Silver Plating
Nickel Stripping	Silver Strike
	Copper Strike
	Copper Plating
	Heated Rinses
	Black Oxide Finishing
	Chromium Stripping
	Acid Etching (H ₂ SO ₄)
	Neutralizer
	Sodium Bifluoride
	Acid Pickle
	Acid Deoxidizer
	Sealer
<u>Unvented Tanks</u>	
Nickel Plating	
Cold Rinses	
Cadmium Conversion Coating	
Electrolysis Nickel	
Tin Plating	
Chromate Coating	
Aluminum Conversion Coating	

For each metal finishing process, parts are passed through a series of preparatory procedures, e.g., surface etching in the acid etch tank, prior to treatment. In some cases, additional surface treatments follow the principal process. The exact sequence of subprocesses in each metal finishing operation is not important to this report and is discussed elsewhere (References 9, 10). In all processes, parts are rinsed between subprocesses to avoid cross-contamination of treatment baths and carrying of material to other parts of the building.

The rinsing process is one of the principal sources of pollution in electroplating and a significant fraction of this study was devoted to quantitating the pollution generated. The material carried from the process tanks with the parts is usually referred to as "dragout," which, if left on the part, may cause contamination problems in other processes, industrial hygiene or housekeeping problems or loss of a valuable raw material. The traditional way to eliminate the dragout problem is to rinse parts copiously with water. Through this process, a part contamination problem becomes a water pollution problem. Process controls available to eliminate or reduce the dragout problem are discussed elsewhere (References 5, 11, and 12).

As previously discussed, (see Table 2) four processes are equipped with scrubbers to control air contaminants generated at tank surfaces. Gases and aerosols escape from the tank surfaces for two reasons: gases evolve because their partial pressures in the ambient air are less than those in the solution and aerosols are generated by the bursting of uncountably numerous small bubbles of hydrogen and oxygen that rise through the solution after being generated by the electrolytic dissociation of water at the electrode surfaces (Reference 13). Under ideal plating conditions this would not occur; however, in reality, only part of the current applied to a plating or other electroprocessing tank is devoted to the neutralization of the desired metal ions. The remaining current is unavoidably devoted to the movement of other species, such as hydroxyl and hydrogen ions, and the subsequent production of hydrogen and oxygen gas at the electrodes. The degree of the gas generation problem is a function of many variables (Reference 10). It is significantly more severe in chrome plating than in the other processes listed in Table 1. In fact, aerosol generation at the tank surface is a problem unique to chromium plating. Because of the severity of this problem, the large workload in the chromium plating operation, and the hazardous nature of

chromium as a pollutant, the chromium plating process is by far the most important pollution source in Air Force metal finishing.

The use of water scrubbers to control gaseous and aerosol emissions from various processes solves the industrial hygiene and the air discharge problems. Unfortunately, this produces a water pollution problem when the scrubber discharge is released. As was the case with dragout, the purpose of this report is not to resolve the water pollution problem but to quantify it. However, through quantification, solutions may be indicated.

SECTION III

APPROACH AND PROCEDURES

1. APPROACH

The metal finishing subprocesses were each evaluated as a closed system. The aerosol emission, gas evolution, and dragout components were measured under various workload conditions when appropriate for a given process. For those processes not equipped with exhaust hoods, it was assumed that no pollutants of consequence were given off at the tank surface. This is a reasonable assumption because of the large body of literature devoted to the industrial hygiene aspects of electroplating operations (Reference 14). For processes with exhaust hoods, air samples were collected at the exhaust stack. Analyses were performed for the pollutants most likely to be significant as determined from the composition of the tank. Dragout studies were performed on operations selected because of the presence of known problem pollutants in the tank mixture.

The variables controlling gas and aerosol emission rates, Table 3, were studied independently, when possible.

TABLE 3. VARIABLES DETERMINING POLLUTANT GENERATION RATES IN ELECTROPLATING

- a. Considered in this Study
 - Total Current Applied to Tank
 - Plated Area Current Flux
 - Inter-electrode Distance
 - Electrode Geometry
- b. Not Considered in this Study (held constant for each subprocess studied).
 - Fluid Surface to Exhaust Hood Intake Distance
 - Tank Temperature
 - Tank Constituent Concentrations

However, operational limitations precluded the study of some parameters, for example, the concentration of the metal ion being deposited is normally held within sufficiently narrow limits that it is essentially a constant for any given process.

Different conditions were achieved by varying the type, location, and number of parts being processed in a tank. In several processes a review of the procedures alone was enough to verify that no significant pollutants were likely to be generated. The general approach taken was to look in detail at the chromium plating process because of its importance, to draw conclusions from this work, and to verify conclusions through more limited studies of other processes.

2. PROCEDURES

a. Stack sampling for airborne emissions.

Air samples were collected using procedures established by the US Environmental Protection Agency (Reference 15) in those cases for which specific procedures had been established. When procedures were not available, the EPA system was modified as required. Gelman E Fiberglass Filters were used for collecting all metal ion bearing aerosols. Filters were extracted with dilute, redistilled nitric acid. All metal ion analyses were performed using a Perkin-Elmer atomic absorption spectrometer. Cyanide samples were collected in 0.1 N. NaOH and analyzed using the silver nitrate titration technique with distillation (Reference 16). All collections were made with two fritted glass bubblers in series and no measurable cyanide was detected in the second bubbler in any case.

b. Water Sampling.

Water samples were collected from scrubbing effluents using a continuous sampling technique. Approximately 5 ml per minute were drawn from the effluent stream. The resulting samples were analyzed as discussed in paragraph a above. Water flow rates were measured by timing the filling of a container of known volume. Flow rates were determined at the beginning, end, and at least two intermediate points. For most runs at least seven flow rate observations were made.

In the dragout studies the parts were dipped in the process tank and then rinsed in a container filled with a known amount of water. Several repetitions were made in all cases. To determine the independent effects of part geometry and solution properties, a standard steel bar of 923 cm² surface area was used for all solutions as well as the parts in question.

c. Process Variable Investigation.

Process variables such as applied current, applied voltage, the number of parts in the tank, current flux, and part geometry were studied by measuring the emissions for a variety of conditions while controlling such variables as tank solution composition, depth, temperature, and scrubber operating conditions. The results of this procedure clearly indicated the important factors involved. These will be discussed in the following section.

SECTION IV

RESULTS

1. AEROSOL GENERATION IN CHROMIUM PLATING

Aerosols generated at the chromium plating tank surface were collected by the exhaust hood system and scrubber as shown in Figures 1 and 2. The air inlet slots ran the entire length of both sides of the tank. The tank surface dimensions were 1.2 x 2.1 m. Air flow rates were ranged from 60 to 80 m³/min. To assure that virtually all aerosols generated in the plating process were collected, a plastic sheet was used to cover approximately two-thirds of the tank surface.

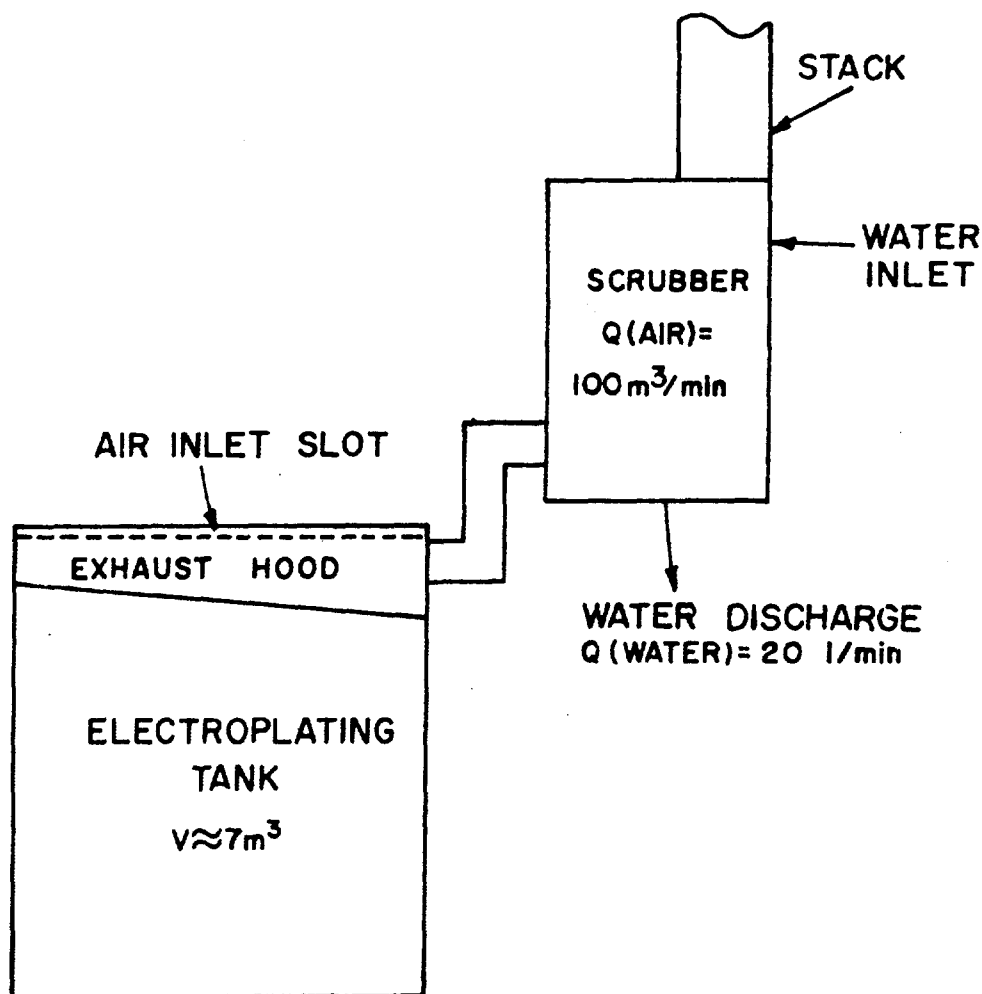
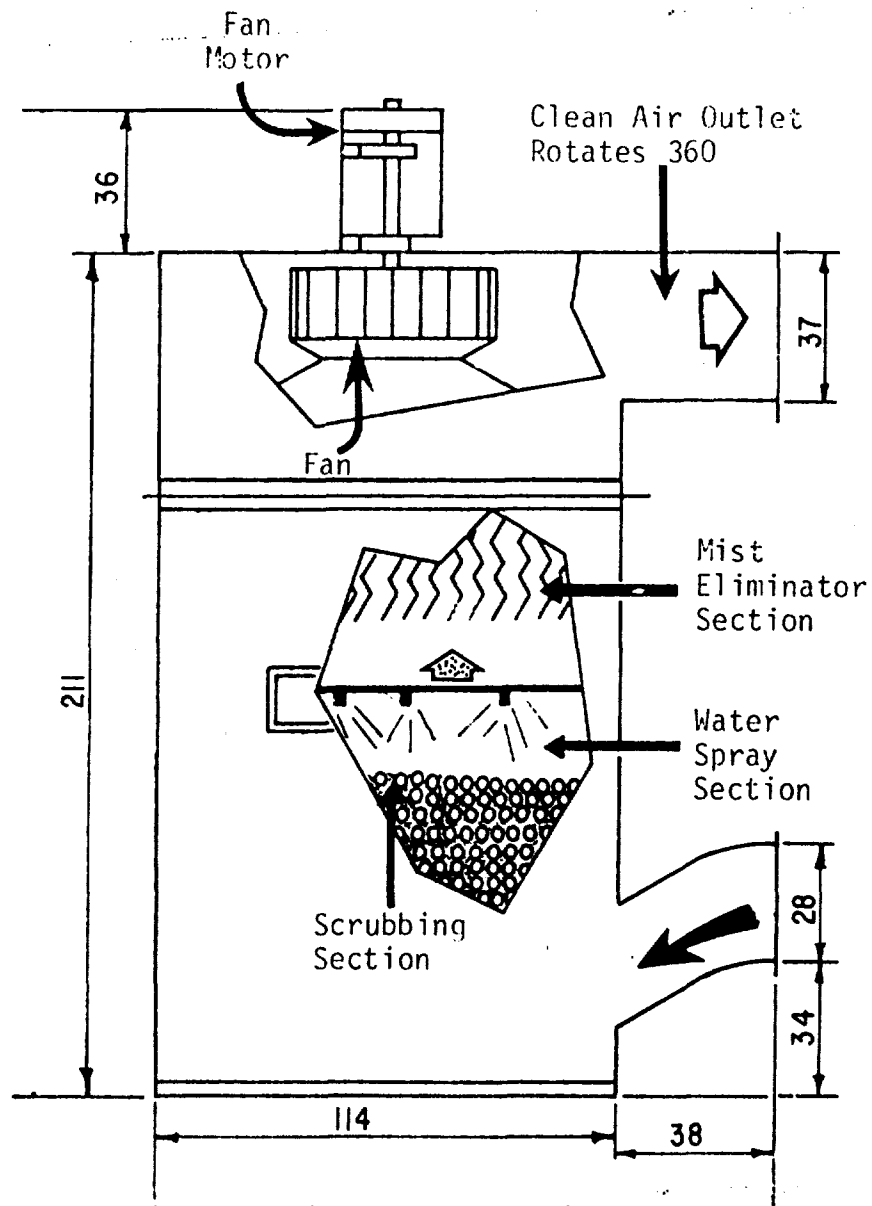

Figure 1: Schematic Diagram of the Chromium Electroplating System Studied. The chromium emission rate is the sum of the stack and scrubber water effluent emission. Chromium plating was typically carried out at $50 \pm 5^\circ \text{C}$ with chromium and sulfur concentrations of 125 ± 10 and $2.5 \pm 0.5 \text{ g/l}$, respectively.



Note: all dimensions in centimeters

Figure 2. DUAL PW-300 Vertical Pack with Motor Blower

To simplify the data collection procedures, two paired tests were performed to determine if it was necessary to do a complete traverse of the scrubber effluent stack as prescribed by standard EPA procedures (Reference 15) or if a centerline sample would suffice. The results of the test are shown in Table 4.

TABLE 4. CENTERLINE VERSUS TRAVERSE SAMPLES FOR MONITORING CHROMIUM STACK EMISSIONS

	<u>Centerline</u>	<u>Traverse</u>	<u>Percent Diff.</u>
Pair 1	0.116 mgCr/m ³	0.105 mgCr/m ³	+10.5
Pair 2	0.130	0.127	+ 2.3
Average per cent Diff.			+ 6.4

These results indicate a possible biasing of the results toward higher values by centerline sampling, but because of the lower manpower requirements this possible error was accepted and the remaining runs were made using centerline sampling only. The error in the total chromium aerosol production calculation caused by this assumption was much less than the 6 percent shown in Table 4 because approximately 95 percent of the aerosol particles generated were collected by the scrubber as discussed below.

Aerosol generation in the chromium plating process was calculated as the sum of the amount of chromium collected in the scrubber, as determined by scrubber effluent analysis, and the quantity exhausted by the stack. Because these two data items are all that are required to calculate scrubber efficiency, a brief study was conducted to determine the optimum scrubber water flow rate for later tests and utilities conservation purposes. The results of this testing are shown in Figure 3. From this result it is clear that little gain results from flow rates over 20 l/min. This is approximately one-half of the flow rate generally used in the shop prior to this study. A saving of 20 l/min for each of 16 scrubbers, if each were operated only one-half of the time, amounts to 84,000 m³ (22 million gallons) per year. At 60 cents per 1000 gallons for combined raw water and industrial wastes treatment costs (a conservative estimate). This is a potential saving of \$13,000 per year.

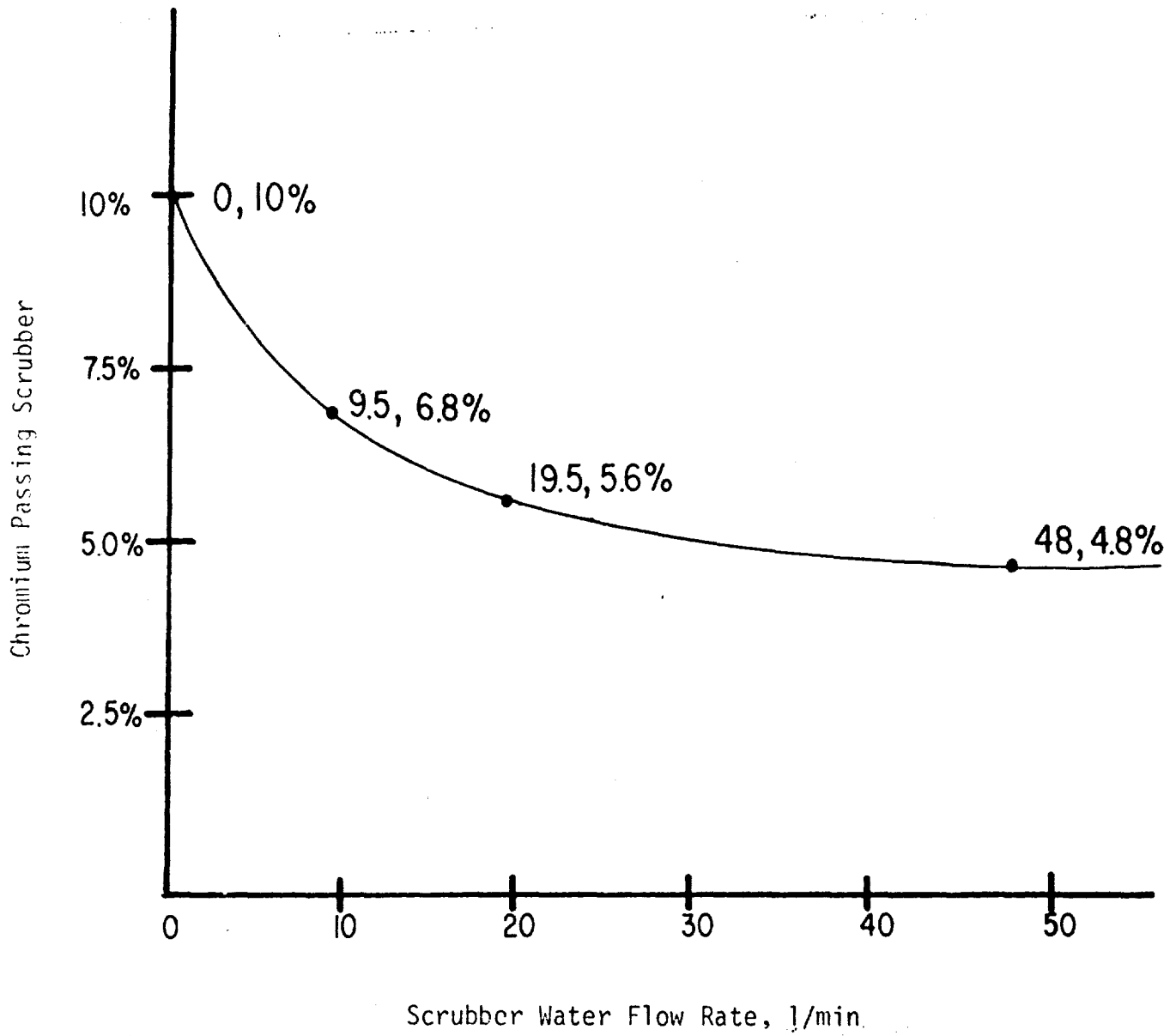

Figure 3. Variation in Chromium Plating Scrubber Efficiency with Changes in Water Flow Rate

Referring again to Figure 3 it is interesting to note that at zero scrubber flow the scrubber still passes only 10.2 percent of the chromium aerosol. Operation at zero flow is, however, not practical because the scrubber would eventually plug up. In addition, the decrease in the air effluent component from 10 percent to 5 percent by adding water is worthwhile. Therefore, it is appropriate to operate the scrubbers at approximately 20 l/min. This setting was used in the remaining testing.

It should be pointed out at this time that all aerosols generated at the tank surface are not truly measured by the techniques used in this study. Just as the scrubber captures aerosol particles and droplets without water flow, the portion of the collection system between the inlet slots and the scrubber also captures significant quantities of larger aerosol particles and droplets. This was apparent during the study as one could observe dried plating solution encrusted around the inlet slot and solution occasionally dripping from seams and joints in the ductwork. It must be assumed that most of this material eventually finds its way to the liquid waste streams via the floor drains. Thus, chromium emission rates calculated in this report are biased to the low side.

Table 5 describes the three parts used in the chromium aerosol generation study. Increasing numbers of these parts were plated in the same tank so that a graduation in workloads could be studied. The results of these tests were analyzed for each part independently and for the combination of all parts. The results of this testing are shown in Table 6 and Figure 4. For brevity, only the regression line for the combined data set ABCD is shown on Figure 4.

The important conclusion to be drawn from Figure 4 is that in spite of widely varying part geometries and plating conditions, the three parts fit the combined regression line as well as they do the individual lines as shown by the relatively consistent value for the correlation coefficient, r^2 , shown in Table 6. From this it must be concluded that within broad limits aerosol generation in chromium plating is a function only of the total current applied to the plating tank. This means that the regression line shown in Figure 4 may serve as a predictor for chromium aerosol generation in Air Force electroplating, one of the desired objectives of this study.

TABLE 5. CHARACTERISTICS OF PARTS
PLATED IN CHROME STUDIES

Common Name	Part Nomenclature	Part Description	Area Plated	Current Per Part (amps)	Cathode-Anode Distance (in)	Cathode-Anode Potential Difference (Volts)
4½ liners	Liner, turbine shaft, bearing seal, J-57	Simple cylinder, few cavities or flanges	Cylinder, Inside 4.9 in dia x 5 in 78 in ²	100	2	6.5-7
Hub	Hub, rear compressor J-57 engine	large hub, (.18 in long and 18 in diameter) only bearing surface plated	Cylinder, Outside 5.52 in dia x 4.5 in 78 in ²	225	12	6.5-7
Bean Pot	Support assembly #5, bearing seal, J-57 engine	large concave shape (.14 in dia), plated area small bearing surface in channel at bottom, inside	Cylinder, Inside 9.05 in dia x 1 in 28.4 in ²	40	1/2	3.5

TABLE 6. CHROME AEROSOLS COLLECTED
AT SURFACE OF PLATING TANKS

Parts plated	Emission ^a E, g/day	Regression A ₀ , g/day	Coefficients ^a A ₁ , g/day/amp	Correlation ² coefficient r ²	F ratio	No. of observations
A. Variable Load	Air ^b	-0.14	0.0058	0.72	18.38	9
	Water ^b	14.93	0.10	0.73	19.16	9
	Total ^b	14.79	0.11	0.76	22.73	9
B. 4 1/2 liners	Air	-0.31	0.0056	0.91	99.17	12
	Water	25.24	0.11	0.86	60.52	12
	Total	25.35	0.11	0.86	60.60	12
C. J-57 hubs	Air	-0.61	0.0083	0.92	68.95	8
	Water	19.36	0.95	0.91	64.54	8
	Total	18.75	0.10	0.93	83.90	8
D. Bean Pots	Air	0.11	0.0046	0.81	26.23	8
	Water	6.81	0.087	0.65	11.18	8
	Total	6.92	0.091	0.67	12.00	8
BCD	Air	-0.19	0.0060	0.87	150.21	24
	Water	10.76	0.11	0.89	186.92	24
	Total	10.57	0.12	0.91	210.18	24
ABCD	Air	-0.20	0.0060	0.86	197.80	33
	Water	10.50	0.11	0.89	241.15	33
	Total	10.30	0.12	0.90	273.29	33

^a Form of regression equation: $E = A_0 + A_1 I$; I = total plating current applied to tank, amps

^b The air emission is the chrome present in the scrubber air outlet stream.
The water emission is the chrome present in the scrubber water effluent stream.
The total is the sum of the air and water emissions.

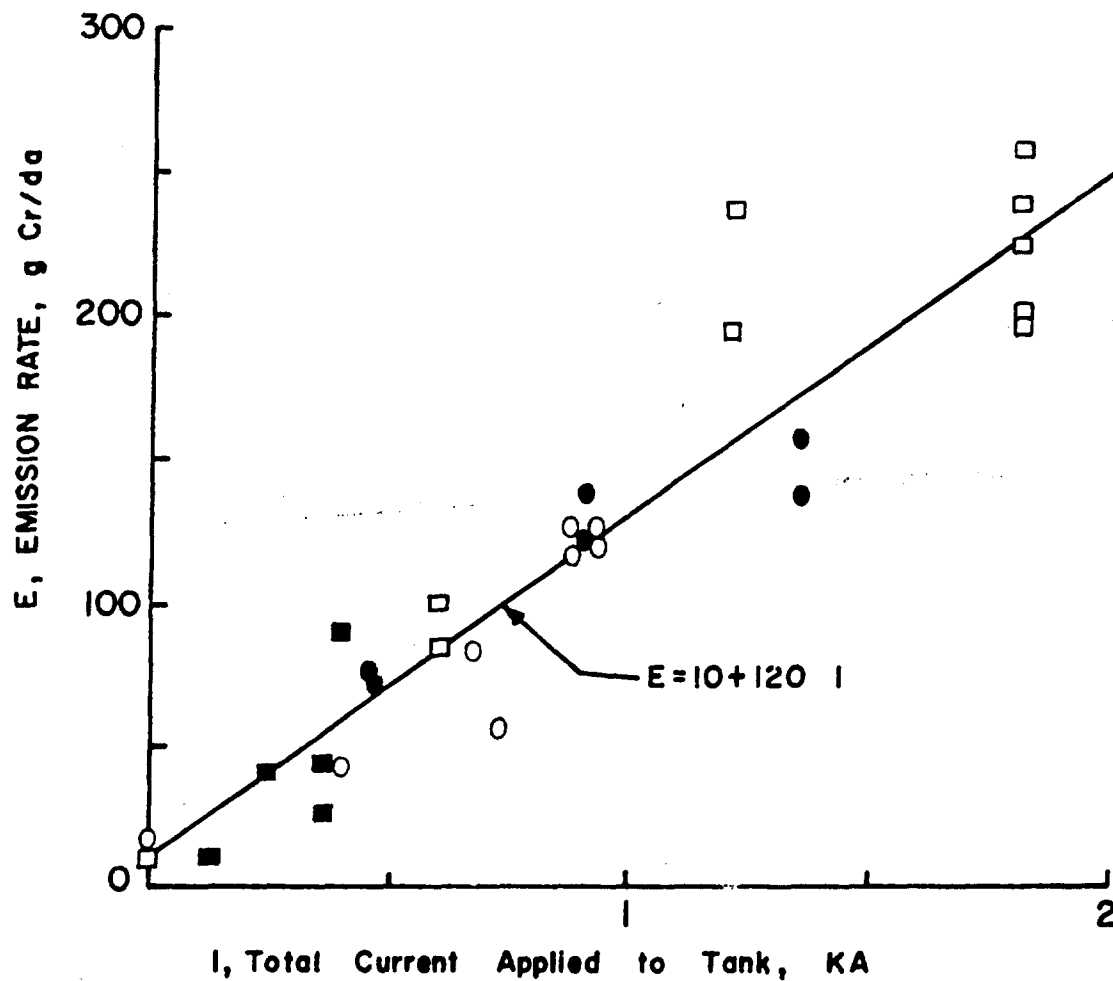

Figure 4. Correlation between Chromium Aerosol Generated During the Electroplating of Various Parts and the Current Applied to the Plating Tank. □ - 4.5-inch I.D. Sleeve bearings, ● - 6-inch O.D. turbine compressor hubs, ■ - 12-inch diameter internal bearing with conforming anode, ○ - mixture of miscellaneous parts. Correlation coefficient for regression line, $r = 0.95$. Tank conditions: $(CrO_3) = 250$ g/l, $(SO_4) = 2.5$ g/l, $T = 50^\circ C$.

Referring again to Figure 4, one question remains to be answered: Why is the ordinate intercept not zero? The presence of two completely independent data points significantly above zero at zero current supports the probability that this is not an artifact. One possibility is that chromium plating tanks operating in the shop were generating enough fugitive aerosols to yield this much chromium from shop background. Analysis of the ambient air using a high volume air sampling technique showed a chromium concentration of $2.4 \mu\text{g}/\text{m}^3$. This value may be compared to the TLV of $0.5 \text{ mg}/\text{m}^3$ for industrial hygiene purposes (Reference 17). This ambient level would account for $0.3 \text{ g}/\text{day}$ drawn in through the scrubber and is not sufficient to account for the intercept value of $10 \text{ g}/\text{day}$. One other possibility exists, i.e., that the time required to purge the scrubber of all chromium is so long that the 22-hour equilibration time normally used in this testing program was inadequate and thus the chromium measured at zero plating load was simply being purged from the system. This is probably the case since on certain occasions when the scrubber had been operated for long periods, several days, with little or no plating load, the effluent chromium concentration did indeed approach zero. In any case, an error in the regression line of $10 \text{ g}/\text{day}$ is generally insignificant and may be neglected when using the equation to predict chromium effluents. Thus, a chromium emission factor of $120 \text{ mg}/\text{A}\cdot\text{da}$ is reasonable.

2. AEROSOL AND GASEOUS POLLUTANT GENERATION IN OTHER PROCESSES.

Table 7 summarizes the aerosol and gaseous generation for the remaining processes with potentially significant emissions. Only cyanide appears to be generated in sufficient quantities to be of consequence. It is important to note, however, that the processes employing cyanide are used for cleaning and plating thin coatings. Therefore, they are rarely operated for extended periods as are nickel and chromium plating processes. For this reason perhaps the figure of most significance is the $10 \text{ g}/\text{m}^2$ (based on surface area of tank) cyanide generation for the cadmium plating operation in the absence of any plating activity. This figure is probably a reasonable estimate of the cyanide generation rate for similar processes such as silver and nickel-cadmium plating.

The emission rates for metal ions from silver and cadmium plating and the nickel strike process are generally low because of the relatively high plating efficiencies

TABLE 7. POLLUTANT GENERATION IN MISCELLANEOUS PROCESSES

Process	Tank Composition	Conditions	Area Processed	Emissions
Alkali Cleaning	[CN ⁻] = 104 g/l [NaOH] = 225 g/l	T = 55 C I = 60 A (current reversed every 20 g for 20 g)	930 cm ²	CN ⁻ , 46 g/da
Cadmium Plating	[Cd] = 7.2 g/l	T = 25 C Tank surface area = 2.8 m ² a. I = 0 b. I = 30 A	3200 cm ²	a. Cd, ~ 0 CN ⁻ , 10 g/m ² ·da ^a b. Cd, 1.2 mg/A·da CN ⁻ , not measured
Nickel Strike	[Ni] = 63 g/l [HCl] = 1.3 N	T = 25 C a. I = 0 b. I = 165 A	430 cm ²	a. Ni ~ 0 b. Ni, 5.4 mg/A·da CN ⁻ , not measured
Silver Plate	[Ag ₂] = 55 g/l [CN ⁻] = 57 g/l [KOH] = 7.5 g/l	T = 25 C a. I = 0 b. I = 24 A	310 cm ²	a. Ag, ~ 0 21 mg/A·da CN ⁻ , not measured
Chromium Strip	[NaOH] = 50 g/l [Na ₂ CO ₃] = 70 g/l Cr = 7 g/l	T = 80 C I = 150 A	3000 cm ²	Cr, 9- mg/da
Sulfuric Acid Etch	[H ₂ SO ₄] = 1.6 N	T = 25 C I = 250 A	3700 cm ²	SO ₄ ⁼⁼ , ~ 0

Note: All daily emission rates assume continuous 24-hour operation of process.

^a Based on surface area of tank.

(most current applied results in metal ion transport) for these processes (Reference 10). Any potential emission problem for these processes is further reduced because of the generally short plating periods. A typical tank may be operated for only a few hours per day. This is in contrast to chrome plating tanks which typically operate continuously.

3. A GENERALIZED MODEL FOR PREDICTING AEROSOL GENERATION IN ELECTROPLATING.

In Section II of this report it was pointed out that aerosol generation in electroplating results primarily from the bursting of numerous small bubbles generated by gas evolution at the electrodes. The quantity of gas so generated depends on the efficiency of the plating process. These efficiencies are generally known. The quantity of material aerosolized by this bubble bursting and the size distribution of the droplets formed during this process are a function of the physical properties of the fluid, most importantly the surface tension and density. A relatively simple model could therefore be developed to predict the aerosol generation rate for any given electroplating process. The following is suggested:

$$V = K I \gamma^n \rho^m (1-\epsilon)$$

V = volume of aerosol particles generated

K, m, n = empirical constants

γ = surface tension of fluid

ρ = fluid density

ϵ = plating efficiency

From this equation the mass generation rate for any particular component of the system may be calculated by the following equation:

$$m = Vc$$

m = mass generation rate

c = component concentration in solution.

The data upon which the present study is based are inadequate to test this hypothesis, however, the study would be of value if performed in the future.

4. DRAGOUT STUDIES

The quantity of material adhering to or otherwise removed by a part as it is withdrawn from a solution is known as "dragout." Dragout rates are a function of the surface characteristics and geometry of the part and the properties of the solution in which it has been immersed. Table 8 summarizes dragout rates for a variety of parts and solutions. From part A of Table 8 it is clear that both part surface and solution composition significantly affect the quantity of dragout. With the exception of the chromium solutions, however, an average thickness estimate of 100 μm for the adhering solution would be within 50 percent for all solutions tested. This number might prove useful in the absence of more specific data when rough estimates are required for plainly shaped parts. For complicated parts it appears that estimates of dragout are almost impossible. This is especially true since the handling of parts upon removal may be the controlling factor.

The lack of any suitable method to estimate dragout for Air Force plating processes is unfortunate because it means that rinse solution loads cannot be predicted for many important processes by any method short of using gross averages for existing shops. The importance of this conclusion is emphasized by Table 9. The data in the table have all been reduced to a basis of area plated or otherwise treated. This is to allow comparison to federal emission standards for metal finishing facilities (Reference 4) which are presented in this way. It is clear from the table that dragout is the most important emission source in all processes presented except chromium plating and in that case it is nonetheless a significant contributor.

Table 9 also points out the extreme difficulty the Air Force faces in meeting the federal emission standards. This problem is related to the atypical nature of our plating operations, e. g., for many parts the plated area is only a small fraction of the total area but the total area contributes to dragout. This issue is more fully discussed in the appendix. (See Reference 18.)

5. RECOVERY OF CHROMIUM OVERPLATE

For those electroplating processes in which thick plating layers are applied, a bead, flashing, or irregular metallic deposit often forms at the edges of the plated area: This material, called "overplate," is recovered in most processes

TABLE 8. DRAGOUT BY VARIOUS PARTS

A. Standard Bar, held vertically, drained 0.5 min.

<u>Bar Surface</u>	<u>Solution</u>	<u>Average Thickness of Fluid</u>
Clean, matte	Cadmium plate	77 μm
	Chromium plate	650
	Nickel plate	125
	Nickel strike	102
	Silver plate	139
Waxed	Chromium plate	150

B. Miscellaneous parts withdrawn from chromium plating solution

<u>Part Description</u>	<u>Dragout, cm^3/part</u>	<u>Notes</u>
4-in gear	1.1	
Standard bar, waxed ^a	1.4	
Standard bar, matte steel ^a	6.1	
4-in dia. turbine shaft lines	7.0	Approximately 1/2 waxed
Compressor housing, 15-in dia. (tipped to remove most of fluid from recesses)	114.0	} A complicated dish- shaped part plated concave side upward. Almost entirely waxed.
Compressor housing, 15-in (not tipped)	181.0	

^aSurface area of standard bar was 923 cm^2 .

TABLE 9. SOME POLLUTANTS EMITTED
BY METAL FINISHING PROCESSES PER UNIT AREA TREATED

Process	Aerosols ^a (mg/m ²)	Dragout (mg/m ²)	Total (mg/m ²)	A _p /A _t ^b
<u>Chromium plating</u>				
Chromium emission Liner, turbine shaft bearing seal, J-57 engine	4.5 x 10 ⁵	0.34 x 10 ⁵	4.8 x 10 ⁵	0.4
Support assembly, No. 5 bearing seal, J-57 engine	5.9 x 10 ⁵	2.0 x 10 ⁵	7.9 x 10 ⁵	0.1
Hub, rear compressor, J-57 engine	2.5 x 10 ⁵	-	-	0.07
Chromium standard ^c			16.0	
<u>Cadmium plate</u>				
Cadmium emission	negligible	4.5 x 10 ³	4.5 x 10 ³	1.0
Cadmium standard			96.0	
<u>Cyanide emission</u>				
Cyanide emission	negligible	1.5 x 10 ⁴	1.5 x 10 ⁴	1.0
Cyanide standard			160.0	
<u>Magnesium cleaner</u>				
Fluoride emission	negligible	5.85 x 10 ³	5.85 x 10 ³	1.0
Fluoride standard			6.4 x 10 ³	
<u>Nickel strike or nickel plate</u>				
Nickel emission	negligible	1.4 x 10 ³	1.4 x 10 ³	0.1
Nickel standard			160.0	
<u>Silver strike</u>				
Silver emission	negligible	4.3 x 10 ²	4.3 x 10 ²	1.0
Silver standard			16.0	
<p>^a Aerosols become water pollutants following collection by wet scrubbers.</p> <p>^b The fractional area of the part that is plated or finished by other processes. For unspecified parts, ratios are estimated process averages.</p> <p>^c Standards extracted from 40 FR 18136, 24 April 1975.</p>				

after it has been removed from the part. During this study it became apparent that large amounts of chromium overplate were being discarded. For four specific parts investigated it was found that the weight of overplate lost ranged from 39 to 153 percent of the useful plating deposit with an average of 104 percent.

Since this 104 percent amounts to approximately one-fourth of the chromium used annually, the potential saving to be realized through recovery is about \$6,000. If this figure is typical of each of the six major Air Force electroplating operations, the total potential savings is \$36,000 annually. A brief investigation into potential recovery schemes was not fruitful, and no ready market for the material could be found.

SECTION V

CONCLUSIONS AND RECOMMENDATIONS

1. The chromium scrubbers at the Oklahoma City Air Logistics Center (OCALC) remove 95 percent of the chromium collected by the exhaust system. The efficiency of the scrubbers is not a strong function of the scrubber water flow rate. Operation of the scrubber at a water flow rate of 20 l/min is recommended. This will yield a water utility saving of approximately 84,000 m³/year (22 million gallons).

2. The quantity of chromium collected from the surface of a chromium electroplating process is primarily dependent on the total current applied to the tank for the relatively wide range of conditions studied. The daily quantity of chromium aerosol generated in grams is 0.12 times the current applied to the tank in amps.

3. For nickel, silver, and cadmium electroplating, metal ion generation at the tank surface is negligible.

4. Cyanide generation in silver and cadmium plating processes is best estimated by a figure of 10 g/m²·da using the tank surface area as the basis of the calculation. Because of the nature of the workload in these operations the cyanide emission rate is essentially independent of it.

5. It should be possible to model aerosol evolution in all electroplating processes by considering only the current applied to the tank, the surface tension and density of the fluid, and the efficiency of the plating process. A form for this relationship is hypothesized.

6. The prime source of pollution from the metal finishing processes studied, except chromium plating, is the removal of material from process tanks as parts are withdrawn. The material so withdrawn is called "dragout" and becomes a pollutant when it is rinsed from the parts in subsequent cleaning.

7. It is not possible to quantify the dragout problem for Air Force electroplating processes except on the broadest terms. Soluting coating thicknesses for a variety of processes, excluding chrome plating, from 77 to 139 μm were determined for plain parts with an average of 100 μm recommended if estimates must be made. For chrome plating, plain part

coating thicknesses ranged from 150 to 650 μm and depended on the nature of the surface. For complicated parts, drag-out ranged from 1 to 181 cm^3/part . The former corresponded to a 4-inch gear and the latter to a large, 15-inch diameter, compressor housing.

8. Approximately \$6,000 worth of chromium metal is being lost in the OCALC plating shop annually because of our inability to effectively recycle the overplated material. It must be assumed that similar losses are encountered at the five other large Air Force electroplating facilities bringing the total annual loss to approximately \$36,000 per year. A study to determine methods to recycle this chromium may be worthwhile.

REFERENCES

1. US Dept of Health, Education, and Welfare, "Public Health Source Drinking Water Standards, 1962," US Government Superintendent of Documents, Washington, DC (1962).
2. Elkins, Horvey B., The Chemistry of Industrial Toxicology, 2nd Ed., John Wiley and Sons, NY (1959).
3. Ehrlich, P. R. and A. H., Population Resources and Environment, 2nd Ed., W. H. Freeman and Co., San Francisco (1972).
4. US Government, Code of Federal Regulation, Title 40, "Protection of Environment," 40 CFR 413, 1 July 1975.
5. Shelton, S. P., E. C. Frein, and P. S. Daley, "Water Reuse at Air Force Electroplating Facilities," AFCEC-TR-76-39, (July 1977).
6. Diamond, Phillip S. "Air Pollution Potential From Electroplating Operations," Report No. 69M-15, USAF Environmental Health Laboratory, McClellan AFB CA 95652 (April, 1969).
7. Carpenter, David, "An Air Emission Analysis of Scrubbers in Buildings 755 and 649 Plating Facility, Naval Rework Facility, Pensacola FL," Naval Engineering Support Office Report 2-014, 20 August 74.
8. Sweigart, Marlin L., "Air and Water Pollution Evaluation, Hill AFB UT," USAF Environmental Health Laboratory Report No. 75M-7, McClellan AFB CA 95652 (March 1975).
9. US Environmental Protection Agency, "Development Document for Interim Final Effluent Limitations Guidelines and Proposed New Source Performance Standards for the Metal Finishing Segment of the Electroplating Point Source Category," Report No. EPA-440/1-75/040-a, Group I, Phase II, USEPA, (April, 1975).
10. Lowenheim, F. A. (Ed), Modern Electroplating, 2nd Ed, Wiley and Sons, NY (1963).

11. US Environmental Protection Agency, " In-Process Pollution Abatement, Upgrading Metal-Finishing Facilities to Reduce Pollution," EPA Technology Transfer Seminar Publication, USEPA (July 1973).
12. US Environmental Protection Agency, " Waste Treatment. Upgrading Metal-Finishing Facilities to Reduce Pollution," USEPA Technology Transfer Seminar Publication, USEPA (July 1973).
13. MacIntyre, Ferren, "The Top Millimeter of the Ocean," Scientific American, 230 (5), May 1974, 62-77.
14. Jager, L. E., "Hazards in the Plating Industry," Michigan's Occupational Health, Vol II, No. 2, (Winter 1965-6).
15. US Government, "Standards for Performance of New Stationery Sources," Code of Federal Regulations, 40 CFR 60, US Govt Printing Office, Washington DC (1975).
16. Taras, M. J. et al (Ed), Standard Methods for Examination of Water and Wastewater, American Public Health Association, Washington, DC (1971).
17. "Threshold Limit Values for Chemical Substances and Physical Agents in the Workroom Environment with Intended Changes for 1975," American Conference of Governmental Industrial Hygienists, Cincinnati, Ohio (1975).
18. OLAA, AF Civil Engineering Center; Letter, Subject: "Effluent Standards for Electroplating Point Sources," sent to AF Systems Command/VN, 2 June 1975.

APPENDIX

THE AIR FORCE BASIS FOR EXCEPTION FROM THE ELECTROPLATING EMISSION STANDARDS

1. INTRODUCTION

The proposed federal standards for emissions from electroplating facilities provide for exceptions to be made by the Regional EPA Administrator if factors controlling the emissions are "fundamentally different from factors considered in the establishment of the guidelines." (Reference 40 FR 18137, part 413.12.) These "fundamentally different" factors appear to exist for many and possibly all Air Force plating operations. The following paragraphs describe the nature of these differences.

2. PART GEOMETRY

The proposed standards specifically state: "Facilities which immerse large amounts of masked area may warrant special consideration." (Reference 40 FR 18134, part 413(c)(2)). This statement applies directly to chromium and nickel plating of many turbine engine parts plated at engine overhaul ALCs. It may also apply to much of the work load at other locations, but this remains to be studied. The aforementioned turbine engine parts account for over half of the work load at the OCALC and SAALC. Many parts have over 90 percent of the surface masked and some have over 99 percent. The average fraction of the surface that is masked is not known for any plating shop. A request for relief from the standards on this basis must be preceded by a determination of surface masked area and the influence of part shape.

The fraction of the surface that is masked is important because the standards are based on the plated (unmasked) area. A part with 99 percent of its area masked (1 percent plated) will be permitted to emit only 1 percent of the quantity of pollutants emitted by a part with no masking. Thus, if the Air Force could show that for the total work load in a given shop, only one-tenth of the total surface processed is plated, justification is available to request a factor of 10 increase in the emission standard.

3. PLATING THICKNESS

For AF chromium plating, the plating thickness typically ranges from 10 to 20 mils. For commercial decorative chrome plating, typical thicknesses are on the order of 0.01 mils,

a difference of a factor of 1500. Because of the long plating time required to achieve a thick plating deposit, the aerosols collected during the plating process often comprise over one-half of the total emissions. For the short plating times usually encountered in decorative chrome plating, the aerosol contribution is generally negligible. Thus, the unusually thick chromium plating applied to AF parts may be classified as "fundamentally different" from the factors used in the establishment of the guidelines. A study of the guidelines' "Development Documents," indicates that plated thickness was not specifically addressed as a variable. It is estimated that a factor of two increase in the emissions permitted from chromium plating is reasonable given this exception.

4. EMPLOYEE NUMBERS

The fundamental criterion for determining exception from the majority of the proposed emission standards is employee numbers. Obviously, exemption from the standards would be the most economical solution to the emission problems. The EPA has proposed that the entire range of standards applies only to those facilities employing more than 10 persons, generating more than 7800 liters of waste water per hour (50,000 gpd) or processing more than 4.9 m² per employee per hour (Reference, 40 FR 18137, part 413.12(e)). AF plating shops tend to employ abnormally large numbers of workers. This results from the small degree of automation and the large amount of custom plating carried out (e.g., chromium and nickel bearings are often individually processed and plated to a specific thickness). This low productivity is clearly shown by the average employee work load of approximately 0.2 m² plated per hour at the OCALC facility, only one twenty-fifth of the rate cited by the EPA above. (This work load figure must be regarded as a rough estimate only because both the total area processed daily and the number of employees are approximations). The standards do not specify how the number of employees is determined. The above estimate is based on direct plating labor only and does not include those persons employed in part-masking and demasking which is a relatively large number because of the complex masking procedures utilized. Clarification of the method of employee counting is required.

5. CONCLUSION

Paragraphs 2 and 3 above indicate that the Air Force has good grounds to request some degree of relief from the chromium standard, our most severe problem. This relief could result in a raising of the standard from one to two

orders of magnitude. While not completely solving our problem, it makes it considerably more tractable. By obtaining relief from the manpower size criterion on the basis of the unusually high labor requirement in Air Force electroplating facilities, some of our shops may be exempt from the majority of standards.

INITIAL DISTRIBUTION

HQ USAF/PREE	1	AFRCE (CR)	1
HQ USAF/PREVP	1	AFRCE (WR)	1
HQ USAF/RDPS	2	Chief of Naval Op	1
HQ USAF/SAFOI	1	NESO, Code 25111	1
HQ USAF/SGPA	2	NCEL, Code L08A	1
AFLC/SGB	1	Technology Transfer Staff (EPA)	1
AFLC/DEPV	1	Office of R&D (EPA)	1
AFLC/MAUT	1	National Science Foundation	1
AFLC/MMRF	1	Det 1 HQ ADTC/EC	2
AFSC/DE	1	Det 1 HQ ADTC/PRL	1
AFSC/DEV	1	2854 ABGp/DE	1
AFSC/SGB	1	OCALC/MAWF	1
ATC/SGPAP	1	USAF Hospital Tinker/SGB	1
AAC/SGB	1	Det 1 HQ ADTC/ECW	1
MAC/SGPE	1	Naval Environ Support Office	1
CINCPACAF/DEMU	2	Battelle Columbus Laboratory	1
CINCPACAF/SGPE	1	USEPA National Enforcement Ofc	1
CINCSAC/DEPV	1	CINCAD/SGPAP	1
CINCSAC/SGPA	1		
TAC/DEEV	1		
TAC/SGPB	1		
CINCUSAFE/DEPV	2		
AFISC/SGMS	1		
AFISC/SES	2		
AFIT/DEM	1		
AUL	1		
AFML/DO (Library)	1		
OEHL/CC	3		
OEHL/OL-AA	1		
OEHL/OL-AB	1		
AFWL/SUL	1		
USAFSAM/EDE	2		
AMD/RDU	1		
SAALC/MAGCB	1		
1 Med Service Wg/SGB	1		
USAF Hospital/SGPM	1		
DDC/TCA	12		
Defense Research & Engrg/AD(E&LS)	1		
OASD/(I&L)ES	1		
USA Environ Hygn Agency	1		
Ch of Engrg/ENGMC-RD	1		
USA CERL	1		
Dir, USA Eng R&D Lab/MERDC	1		
Ch of R&D			
Dept of the Army/DARD-ARE-E	1		
AFRCE (ER)	1		