

AD-A043 219

ARMY TRIMIS AGENCY WASHINGTON D C
CONDITION-ACTION DIAGRAM FLOWCHARTS. LABORATORY SUBSYSTEM FOR D--ETC(U).
OCT 76 A L WEHRER, J ANSCHUTZ
TRIMIS-ARMY-TR-1-7

F/G 6/5

UNCLASSIFIED

NL

1 of 1
AD
A043219



END
DATE
FILMED
9-77
DDC

TRIMIS-Army Technical Report 1-7

LABORATORY SUBSYSTEM
FOR
DEPARTMENT OF PATHOLOGY



AD-A043219

CONDITION-ACTION DIAGRAM
FLOWCHARTS

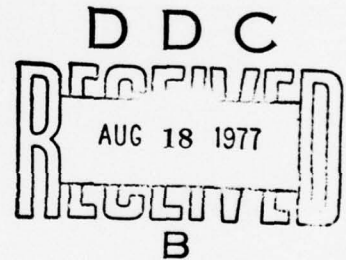

US ARMY TRIMIS AGENCY
Walter Reed Army Medical Center
Washington, DC 20012

October 1976

Approved for Public Release - Distribution Unlimited

"The views of the authors do not purport to reflect
the position of the Department of the Army or the
Department of Defense."

REPORT DOCUMENTATION PAGE		READ INSTRUCTIONS BEFORE COMPLETING FORM	
1. REPORT NUMBER TRIMIS-ARMY-1-7 ✓	2. GOVT ACCESSION NO.	3. RECIPIENT'S CATALOG NUMBER	
4. TITLE (and Subtitle) LABORATORY SUBSYSTEM FOR DEPARTMENT OF PATHOLOGY CONDITION-ACTION DIAGRAM FLOWCHARTS		5. TYPE OF REPORT & PERIOD COVERED	
		6. PERFORMING ORG. REPORT NUMBER N/A	
7. AUTHOR(s) Mrs. Anna Lea Weihrer, CPT Jim Anschutz		8. CONTRACT OR GRANT NUMBER(s) N/A	
9. PERFORMING ORGANIZATION NAME AND ADDRESS USA TRIMIS Agency WRAMC Washington, DC 20012		10. PROGRAM ELEMENT, PROJECT, TASK AREA & WORK UNIT NUMBERS	
11. CONTROLLING OFFICE NAME AND ADDRESS USA TRIMIS Agency WRAMC Washington, DC 20012		12. REPORT DATE October 1976	
		13. NUMBER OF PAGES 65	
14. MONITORING AGENCY NAME & ADDRESS (if different from Controlling Office) N/A		15. SECURITY CLASS. (of this report) UNCLASSIFIED	
		15a. DECLASSIFICATION/DOWNGRADING SCHEDULE N/A	
16. DISTRIBUTION STATEMENT (of this Report) Approved for public release: distribution unlimited			
17. DISTRIBUTION STATEMENT (of the abstract entered in Block 20, if different from Report) Same			
18. SUPPLEMENTARY NOTES For use in conjunction with TRIMIS-ARMY-TR-1-1 Overview.			
19. KEY WORDS (Continue on reverse side if necessary and identify by block number) Flowchart, Condition-Action Diagram, Health Care, Information System, Outpatient Services, Hospital, Clinical Laboratory, Pathology			
20. ABSTRACT (Continue on reverse side if necessary and identify by block number) The purpose of these condition-action diagrams for the non-computerized Walter Reed Army Medical Center (WRAMC) Department of Pathology was to depict the flow of documents and specimens, to provide a graphic representation of the major processes in the WRAMC laboratory, to document the type of records being kept, and to indicate the interfaces between this department and other departments (particularly Wards and Clinics) and the working relationships which existed in the Walter Reed laboratory during the time			

ACCESSION for	
NTIS	White Section <input checked="" type="checkbox"/>
DDC	Buff Section <input type="checkbox"/>
UNANNOUNCED	<input type="checkbox"/>
JUSTIFICATION	
BY _____	
DISTRIBUTION/AVAILABILITY CODES	
Dist.	AVAIL. and SPECIAL
A	

Block #20:

October 1974 to February 1975. The intent was to provide an understanding as to how the laboratory operated as it did in order to see where automation could help, what problems change would bring, and where computer automation might help the laboratory. It was further expected that these diagrams would be used by others to denote the type of activity and the procedures used by laboratories, and thus assist them in developing new, or adapting these, flow diagrams to their own laboratories. In producing flow diagrams, there is always information for immediate laboratory improvement which benefits the laboratory regardless of the decision to obtain computer support. These documents also are good training aids.

TABLE OF CONTENTS

	<u>Page</u>
Acknowledgments	
Narrative:	
Purpose	1
Background	1
Limitations	3
Objectives	3
Interfaces	3
Overview/General Flowchart Description	5
Amenability to ADP Support	8
Abbreviations/Definition of Terms	9
Condition-Action Diagram Interpretation Guide/Examples	12/14
Flowcharts:	16
1. Reception	16
2. Ward Rounds	18
3. Chemistry Accessioning/Preprocessing	21
4. Outpatient Laboratory	22
5. Chemistry Processing	24
6. Urinalysis	27
7. Hematology	30
8. STAT Lab Chemistry	32

Table of Contents (continued)

9. Microbiology	33
10. Cytology	42
11. SMA Processing	45
12. Chemistry Reporting	46
13. Histology	47
Blood Bank:	
14. Blood Product Request	50
15. Blood Product Inventory	55
16. Blood Donation	56
17. Donor Blood Processing	59
18. Chemistry Quality Control	63
Index to Charts	65

ACKNOWLEDGMENTS

The production of these laboratory flowcharts is the result of an analysis performed at the laboratory of Walter Reed Army Medical Center (WRAMC). The individuals participating in the effort were Mrs. Anna Lea Wehrer and CPT James H. Anschutz, TRIMIS-Army, and supervisory personnel at the WRAMC Department of Pathology.

LABORATORY SUBSYSTEM

NARRATIVE

1. PURPOSE

The purpose of these condition-action diagrams for the non-computerized Walter Reed Army Medical Center (WRAMC) Department of Pathology was to depict the flow of documents and specimens, to provide a graphic representation of the major processes in the WRAMC laboratory, to document the type of records being kept, and to indicate the interfaces between this department and other departments (particularly Wards and Clinics) and the working relationships which existed in the Walter Reed laboratory during the time October 1974 to February 1975. The intent was to provide an understanding as to how the laboratory operated as it did in order to see where automation could help, what problems change would bring, and where computer automation might help the laboratory.

The diagrams depict non-computer-supported procedures and, though they represent operations primarily as they existed in the department prior to the move to the new hospital, in a few areas some of the personnel roles projected for the new hospital were included. Since these flows were charted, personnel and policy changes have brought some changes to the department.

These charts were used by TRIMIS in developing functional requirements for computer support of the clinical laboratory with the goal of minimal change within the laboratory for administrative procedures, maximal elimination of clinical work by laboratory technicians, and increased specimen identification and result accuracy.

It was further expected that these diagrams would be used by others to denote the type of activity and the procedures used by laboratories, and thus assist them in developing new, or adapting these, flow diagrams to their own laboratories.

It should be noted that the "fee" or "charge" system is not present in the military system, but workload reporting is very important.

2. BACKGROUND

The Department of Pathology at WRAMC is physically divided into three areas: Anatomic Pathology, located in the Armed Forces Institute of Pathology (AFIP) building on the WRAMC campus; the main clinical laboratory, located in a temporary building connected to the main hospital; and a small laboratory and draw area, located in the basement of the outpatient clinic. It is expected that the latter two will be consolidated in the new hospital. In addition, a few tests are run

at the regional laboratory at Fort Meade, some 25 miles away, and at the Walter Reed Army Institute of Research (WRAIR), also on the WRAMC campus.

The Regional Army Laboratory at Fort Meade has recently come under the management of the WRAMC Department of Pathology. This laboratory receives mail-ins and specimens by messenger from many places throughout the northeast quadrant of the United States. This laboratory also does a large volume of testing for the Army drug detection and rehabilitation program. These processes are not diagrammed. It may be that some redistribution of work will be required and that much of the work at Fort Meade will be moved to WRAMC.

The forms in use were the standard DOD forms for laboratory test requesting, a few of which were modified for WRAMC as required for their environment. The use of a standard form for requesting, which is not specifically designed for the operation of the laboratory where it is used, creates some problems in work flow, and these problems are reflected in the actions diagrammed.

In military hospitals, phlebotomists draw only non-ambulatory patients. Ward rounds are usually conducted once a day (early morning) due to personnel shortages. To help distribute work, it was policy that all requests for ward rounds be sent to the laboratory, not held on the floor, and then given to the draw team. Ambulatory patients are sent to the laboratory for blood drawing, and all other specimen collections are the responsibility of the ward personnel.

The laboratory policy of accountability began when the specimen and its accompanying request were taken to the laboratory. The policy was that specimens not labeled, and/or not accompanied by a request, were destroyed. The specimens were received at a control desk (reception area) and then distributed to the various sections; e.g., chemistry, hematology, etc. Patients arriving at the reception area were drawn and their specimens given to the control desk for distribution.

One of the most important concepts to the operation of WRAMC's laboratory is that specimens are kept in ascending accession number order. Each section was responsible for its own records and reporting procedures. Sections developed their own control systems and answered telephone inquiries for tests they performed. Results were recorded on the request slip unless the instrument produced a printed output suitable for records. One copy remained in the section and the others were sent to the requesting ward or clinic.

Instrumentation at WRAMC included multiple- and single-channel instruments. Most of these instruments produced graphic results which required interpretation or calculations to be made. There were a few devices with digital displays or digital printouts. These devices, an SMA-12 in Chemistry, Coulter 'S' in Hematology, and an SMA-6 in the

Stat laboratory, did a specific set of procedures. The laboratory operated with a minimal staff for second and third shifts, and weekends.

The laboratory staff within a section rotate through the various work stations to reduce boredom, increase training, and permit better utilization of personnel.

3. LIMITATIONS

The flow diagrams depict what actually took place as best it could be determined. There is no attempt to justify or criticize a procedure. The flows are very much location-dependent and strongly reflect the WRAMC environment and the laboratory policy in force. There was no attempt to generalize these.

There are several special laboratories under specific departments which are not flowed (e.g., Nuclear Medicine has a laboratory for special studies under the Radiology Department).

4. OBSERVATIONS

By noting the document and specimen flow and the control logs used, an ADP data base could be constructed. Knowledge of the type of controls will help to determine the type of management information that will be required and so assist in the proper organization of this data base. Redundancy could be easily recognized. Problem areas, which prevent the timely reporting of results, can be identified. Logistics functions are not included.

Of prime importance in any laboratory system are specimen identification and control, the accuracy of reported results, the timeliness of result return, and the usefulness of the result to the care provider. Transcription errors can be reduced by standardized procedures and controls. Accuracy can be improved by a strict quality control (QC) program which permits early detection of potential problem areas.

In producing flow diagrams, there is always information for immediate laboratory improvement which benefits the laboratory regardless of the decision to obtain computer support. These documents also are good training aids.

5. INTERFACES

The laboratory interfaces with a variety of people and other hospital areas. When a health care provider orders the test in the ward or clinic area, the request for service is initiated. Presently,

the routine procedure is for the health care provider to fill out the request (test) portion and signature block of a request slip, or to write his order on an encounter sheet for outpatients or in an order book for inpatients, or verbally instruct another member of the health care team to request the tests. To provide legible patient and specimen identification, the embossed patient card is used to imprint the patient's identification on the request slip (three-copy form). The imprinters may have a requesting location imprinted at the same time. If not, the slips are stamped with the requesting location or it is written on the slip. Any special information about the patient or the specimen is also written on the slip and the priority and other required fields are marked.

If the specimen has been collected at the time the request is made, gummed labels are imprinted, using the patient's card. The specimen is then delivered to the laboratory by messenger service, the patient, or ward personnel, etc. If the specimen has not been collected, the request slip and required labels are given to the patient who is to deliver them to the laboratory and have the specimen drawn. If the patient is a non-ambulatory inpatient and the specimen is not a Stat, the request and labels are sent to the laboratory with an indication that the laboratory is to draw the specimen on ward rounds.

In addition to requests generated by WRAMC health care providers, patients may come to the laboratory for work requested by doctors at other military facilities or by civilian doctors. These requests may or may not have specimens already drawn but results must be returned to the appropriate physician for inclosure in the patient record.

Each patient requesting service must be eligible to receive care. The receptionist must check the patient's documents and then document the request and collect data required to insure the report gets to the appropriate place. This process of registration is the responsibility of the patient administration department. However, each area is responsible for insuring eligibility. Most patients bring requests which are WRAMC-generated and for whom eligibility has been checked, but patients whose initial contact with WRAMC is the laboratory must have the registration process initiated. On the flowcharts this is designated as a registration process.

Once the test has been completed, the results must be seen by the care provider and placed in the patient's medical record. The test results on the slips are placed in pickup boxes labeled by location. The ward/clinic personnel are responsible for picking up result slips, distributing them to the health care providers, and for seeing that they are placed in the record. The WRAMC policy is for a slip to be reviewed by the physician, initialed, and then placed in the chart. This procedure provides the opportunity for slips to be lost resulting in incomplete records. The report must contain the patient's full

FMP-SSN, clinic/ward, and requesting physician to be filed correctly. Many requests are not properly identified and become "lost elements" of the record. It would be possible for the original request/result to be sent to the record room and another copy sent to the physician (Copy 3, second carbon). At WRAMC, this presents a couple of problems: sorting of the doctor's copy and the fact that WRAMC requires the record copy to be signed. A deviation from existing policy is not feasible at this time but would be possible with ADP support.

Other interfaces are with: the Infection Control Committee, to identify possible infections early; the Tissue Committee, to control procedures; the various registries, to identify patients with specific disease entities; and the Transfusion Committee, to identify blood transfusion problems.

The logistics department does much of the supply requisitioning but the laboratory also does a great deal of supply ordering. This is not depicted in these diagrams.

6. OVERVIEW/GENERAL FLOW CHART DESCRIPTION

The organization of the flowcharts reflect the department's organization and the charts are divided either according to organization or function.

The laboratory reception function is the interface with the laboratory and the external environment, patients, health care providers, and other laboratories. Specimens and requests are received and stamped with receipt date/time. Patients arrive for specimen collection, to deliver specimens, to make appointments for special tests, or to have special procedures performed. In order to return results, the patient and requesting location must be correctly identified. The receptionist insures that this process can be completed.

Most control of specimens and results are done through hardback logs which record receipt, what is requested, and results or test completion. Most logs are kept by the sections but the receptionist keeps logs for specimens sent elsewhere for processing or for results which are to be returned to places not on the WRAMC campus.

Basically, specimens are obtained in three ways. One method is for phlebotomists under the direction of the laboratory to collect blood specimens on the wards. Ideally, specimens should be collected on demand for wards but in reality ward rounds are performed only in the early morning. Another method is for specimens to be obtained by the wards and clinics and sent to the laboratory. Finally, outpatients and ambulatory ward patients are sent to the laboratory to have the specimens drawn.

At WRAMC, all patients have embossed plastic cards which are used for imprinting the patient identification on requests and specimens. There are imprinters at each clinic/ward area.

WRAMC operates an outpatient laboratory which draws specimens for outpatients and which performs a limited number of tests, mostly hematology and urinalysis. For tests not performed in the outpatient laboratory, specimens are sent to the main laboratory by a messenger.

Due to its location, Urinalysis processes its own specimens which are received directly from patients or by messenger. This section does not perform accessioning of samples in the same way as Chemistry though it does assign processing numbers to specimens. If samples are required for analysis by other sections, a new slip is prepared and sent with the specimen. For a urinalysis, any positive qualitative test is confirmed with a quantitative test.

The chemistry section handles the largest numbers of specimens. Chemistry has a preprocessing room where specimens and slips are accessioned, worklists are prepared, and specimens are centrifuged and aliquoted for the various work benches. A specimen frequently has several aliquots. The laboratory has devised special processing racks which hold the clot tube and has room for aliquots for several commonly performed tests. Since the bulk of the samples are received early, technicians take turns working in the central area and many help in the early morning. To permit this arrangement, all specimens are kept in sequential order and aliquots in ascending order since not all accession numbers would request all tests. After accessioning, specimen identification is done using the accession number. The request slip does not accompany the specimen.

The flow diagrams depict processing that is done manually or by using automated procedures. The SMA-12 processing is done without going through the central processing area.

Some special microprocessors connected to programmable calculators were used for some tests for chemistry while others were performed on machines with digital read-out or printed results.

All Stat results are called to the wards and clinics. If a procedure not done in the Stat laboratory is requested Stat, it is processed prior to routine specimens. The Stat laboratory only performs certain tests. These are accessioned by this area with a special series. The tele-autograph permits results to be transmitted to a few areas. Each area performs its own QC and new procedure testing. In Chemistry, there is one person assigned to quality control.

Since blood for Hematology must be processed quickly, this section analyzes ten samples at a time basically unless the workload volume is extremely low. Stats are placed at the head of each lot.

The blood donor program is under the Department of Pathology. Tight QC controls are maintained since mislabeled blood is life-threatening. The donor center processes and classifies all blood obtained directly from donors or received from other blood banks.

Transfusion requests have a tighter specimen control than other test samples, due to the seriousness of mis-identification and also due to blood bank regulations. The FDA now registers blood banks. Though military hospitals do not require blood to be procured from registered labs, all blood sent from WRAMC to other FDA-approved transfusion centers must be registered. Blood transfusion requests must be filled out for each unit of blood requested, and blood is under blood bank control until ready for transfusion.

A request to obtain blood previously requested is transmitted through a prescription signed by an authorized health care provider. Any possible transfusion-related reaction is investigated by personnel from the blood bank.

Strict inventories of blood products are maintained and a computerized record is made of each blood product obtained and its final disposition. WRAMC does supply blood to, and receives blood from, other military facilities.

Microbiology does its own specimen-processing since organism counts can be seriously overstated if the specimens are not handled promptly. This section's reports differ from others in that it is desirable to produce interim or non-final reports on micro-specimens because testing time can take several days or weeks.

Anatomic Pathology, physically located in WRAIR, is connected to the hospital by a pneumatic tube system and by underground tunnel. This section performs histological and cytological examinations. Records of all malignancies, or possible malignancies, are maintained in addition to the original slide/block.

Workload reporting is a most important function since it greatly affects the resources allocated to a military facility. The CAP (College of American Pathology) weight-load factors are used to help normalize the varied amount of work per test required. This workload includes clerical procedures and other support functions required by the laboratory.

Though the laboratory has a supply group, this is detailed under logistics.

7. AMENABILITY TO ADP SUPPORT

Computer assistance for laboratories are well-advanced. These condition-action diagrams can be used to select a system which can be tailored to WRAMC; which will preserve or enhance the ability to obtain information, logs, etc.; and which will reduce the disruption a computer system will cause in the laboratory. These diagrams depict what information is required, who should collect it, who uses it, where clerical tasks can be eliminated, and how efficient/accurate reporting can be accomplished.

ABBREVIATIONS AND DEFINITION OF TERMS

Aerobic - Growing in the presence of free oxygen.

AFIP - Armed Forces Institute of Pathology.

Aliquot - Dividing the original specimen into smaller amounts for use by different tests.

Anaerobic - Growing in the absence of free oxygen.

ASAP - As soon as possible.

Autologous - Donor donates blood for himself.

Blood Segment - Piece of plastic tubing attached to unit of blood--containing a small sample of it.

9810 Calculator - An HP calculator interfaced to a laboratory instrument at WRAMC capable of printing digital test values and writing the test values to a tape cassette.

9830 Calculator - An HP calculator which uses a tape input to calculate laboratory tests values in an off-line mode.

Calibration - Setting high/low values of instrument.

Controls - Samples with known concentrations or values which are interspersed with samples to check drift and/or instrumentation problems.

CONUS - Continental United States.

CP - Care provider; e.g., nurse, medical records technician physician.

Diff - Cellular morphology for a blood specimen.

Donor - One who donates blood.

Eligibility for Care - The military hospital treats as non-emergencies only persons authorized such treatment. This activity is accomplished by Patient Administration personnel. Military regulations require Patient Administration to establish that patients admitted to local military treatment facilities are authorized such treatment.

FMP - A two-digit prefix used to identify the relationship of a patient to his sponsor.

Forest Glen - Annex to WRAMC.

Fort Meade - Army area laboratory now annexed to WRAMC.

GTT - Glucose tolerance test.

ID - A number which identifies a patient; consists of a family member prefix and social security number or a register number.

Lab Draw - Collecton method which means the patient is ambulatory and will be sent to the laboratory for specimen collection.

Lab Slip - Laboratory request form.

Load List - A list of specimens to be processed on an instrument which transmits test result data directly (on-line) to the data processing system. The list contains a sequence number for the accession number, quality control, standard, or blank included in the run. The technician operating the instrument follows this list in sequencing the samples processed by the instrument.

Loc - Location (ward/clinic).

Log - Entering of patient information into record; the logistics subsystem.

Long Draw - In obtaining a unit of blood from a donor, more than the prescribed amount is drawn. The unit cannot be used for human transfusion.

Normal Limits - A range of normal values for a lab test based on a patient's age and sex.

- Number.

Pat - Patient.

Patient Transfusion Record - This record contains the patient's PTID; group/type; each transfusion given with the date, time, and amount; requesting physician; problem patient; antibiotics; products cross-matched but not yet given or returned; and comments. A record is kept for each patient who receives blood.

pH - Hydrogen-ion concentration.

Phlebotomist - Person who draws blood for laboratory testing.

Phy - Physician.

QC - Quality control.

Short Draw - In obtaining a unit of blood, less than prescribed amount is drawn from the donor. The unit cannot be used for human transfusion.

SpG - Specific Gravity.

SSN - Used for record identification, this is the social security number of the sponsor of a patient.

Standard - A substance with a known value used in the laboratory to assay a volumetric solution of unknown strength. Usually, different concentrations are run, the values plotted, and linear curves drawn between the points for use in assaying an unknown sample.

STAT - Test request priority; indicates that the result is needed immediately. Usually implies special processing in the laboratory.

Technical Limits - A limit for a test that indicates an extremely abnormal result.

Ward Rounds - Collection method which means that the laboratory will collect the specimen from the patient on the ward when making ward rounds.

Wd - Ward.

Work List - This document presents a tabular listing of the specimens to be tested for specific laboratory requests. It provides a check list for the technician and may serve as an intermediate document on which results are manually recorded for subsequent transcription to patient reports.

WRAIR - Walter Reed Army Institute of Research.

WRAMC/WR - Walter Reed Army Medical Center.

CONDITION-ACTION
DIAGRAM INTERPRETATION GUIDE

1. ACTION

When an action circle is encountered, the specified action, procedure, function, or process is to be performed as noted. An action is performed. It never has a truth (true or false) value.



2. CONDITION

When a condition box is encountered, the specified condition is to be evaluated; and, if it holds true or succeeds, the following blocks on the diagram are to be executed. This box is also used to denote the condition which caused this path to be taken.

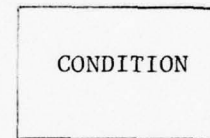

3. FLOWLINES

Flow proceeds through the diagram along the flowlines. When a flowline splits into multiple lines, all the lines must be followed (perhaps at once). If only one is intended, condition boxes will be used to select the proper line. When flowlines join or reconsolidate into a single line, that line is to be followed regardless of the number of joining lines that were active. Control, execution, or interpretation of the diagram is shown by solid flowlines. Data and information are usually assumed to accompany control; but, where necessary for clarity, it is shown by "dash" lines, regardless of media.

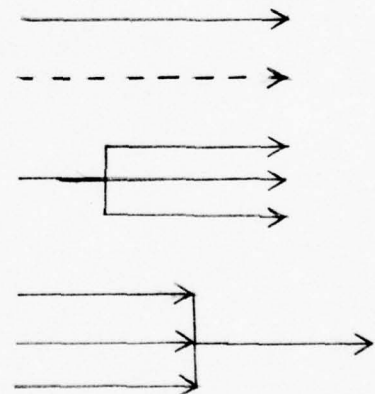

4. NOTE

Clarifying notes, comments, remarks, and other annotations, including references to additional documentation, are enclosed in "dash" note boxes and are connected to the annotated structure by "dash" lines.

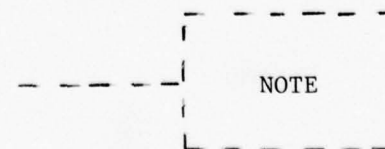

5. STORAGE

A triangular storage block indicates storage of information or data regardless of the medium of storage.



6. DOCUMENT

A document symbol represents information or data, regardless of format. (It may or may not physically reside on document). It is used only for clarity, as information such as that contained in the "document" is assumed to be always present along with the control flow.

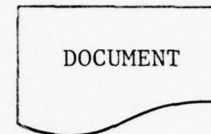

7. CONNECTOR

A connector circle specifies that the flow continues on another page or sections of this page. An out-connector contains a number (which is the sheet number at which the flow is continued) and a letter (which specifies which in-connector on that sheet is being referenced). The in-connector contains the matching number/letter code. Adjacent to the connectors is a notation as to the sheet and process to, or from, which the connectors refer.

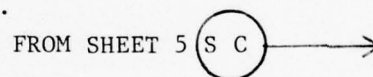
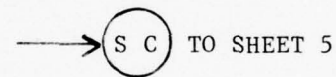

8. PROCESS

The process symbol at right indicates a process to be performed. The process referenced will be diagrammed in its own set of condition-action flowcharts which are included in the same packet of flowcharts for reference. After the process is performed, flow resumes.

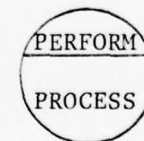

9. TERMINATOR

The oblong terminator symbol indicates that the current process or sub-process is complete. Normally, upon completion of a process, control returns to the process which invoked it and resumes where it left off in that process.

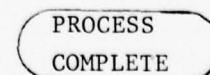

CONDITION-ACTION
EXAMPLES

Perform Action A first,
then in sequence,
perform B.

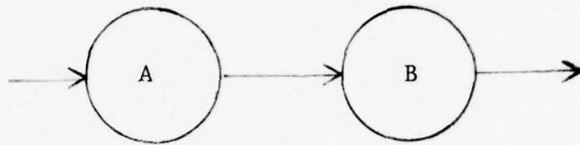

If Condition P holds true,
then perform Action A.

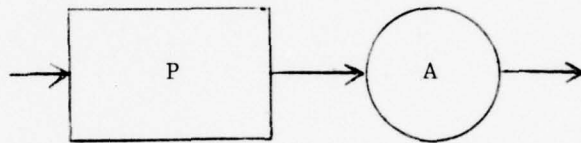

If both Condition P and
Condition Q hold true,
then perform A.

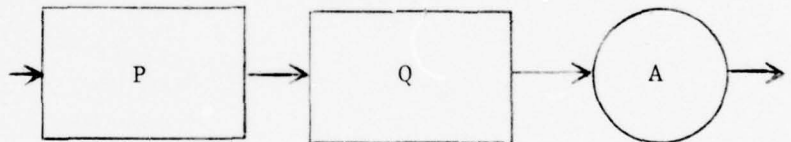

If either Condition P or
Condition Q holds true
(or both), then perform A.

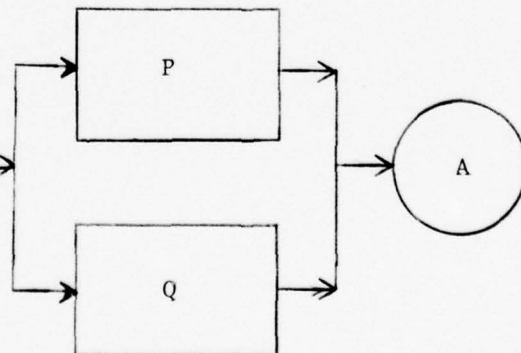

If Condition P holds true,
 then perform Action A, but
not B. If P does not hold,
 then perform B, but not A.
 In any case, when done,
 perform C.

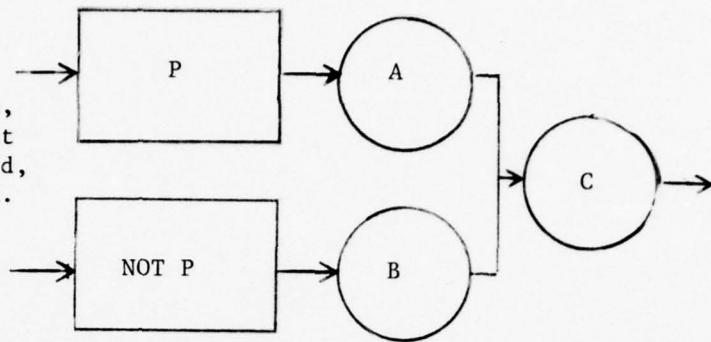

Perform Action A, utilizing
 information contained on
 the Document B which was
 retrieved from the File C.

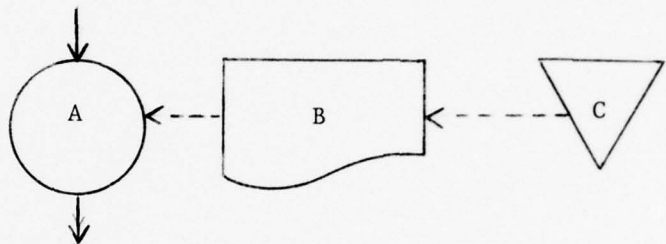

First perform Action A.
 Then perform Process B,
 which is itself flow-
 charted elsewhere in this
 set of charts. After B is
 completed, return to here
 and perform Action C.

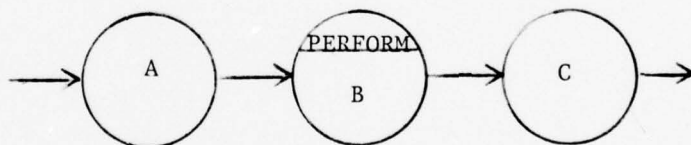

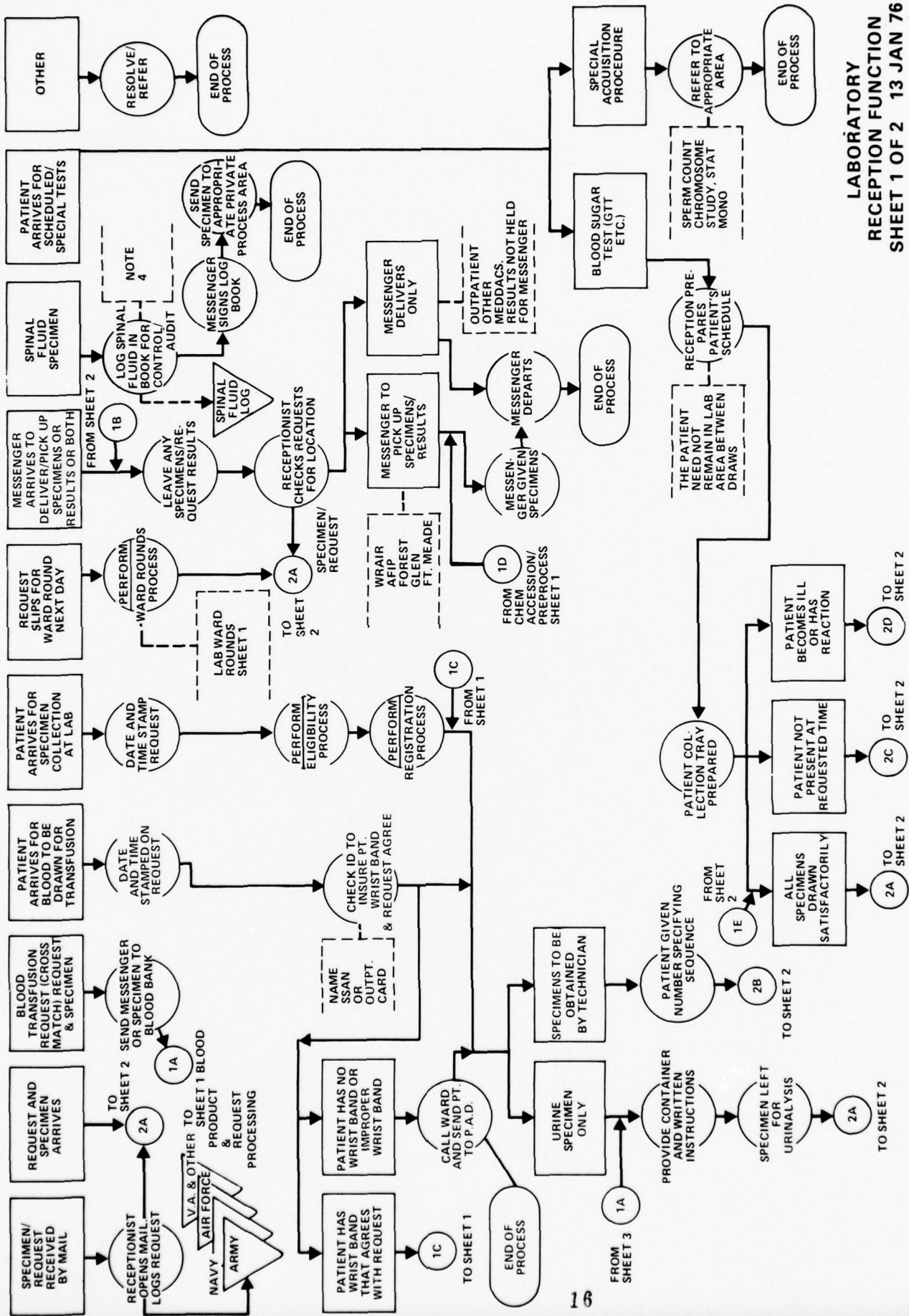

LABORATORY
WARD ROUNDS
SHEET 1 OF 3 13 JAN 76

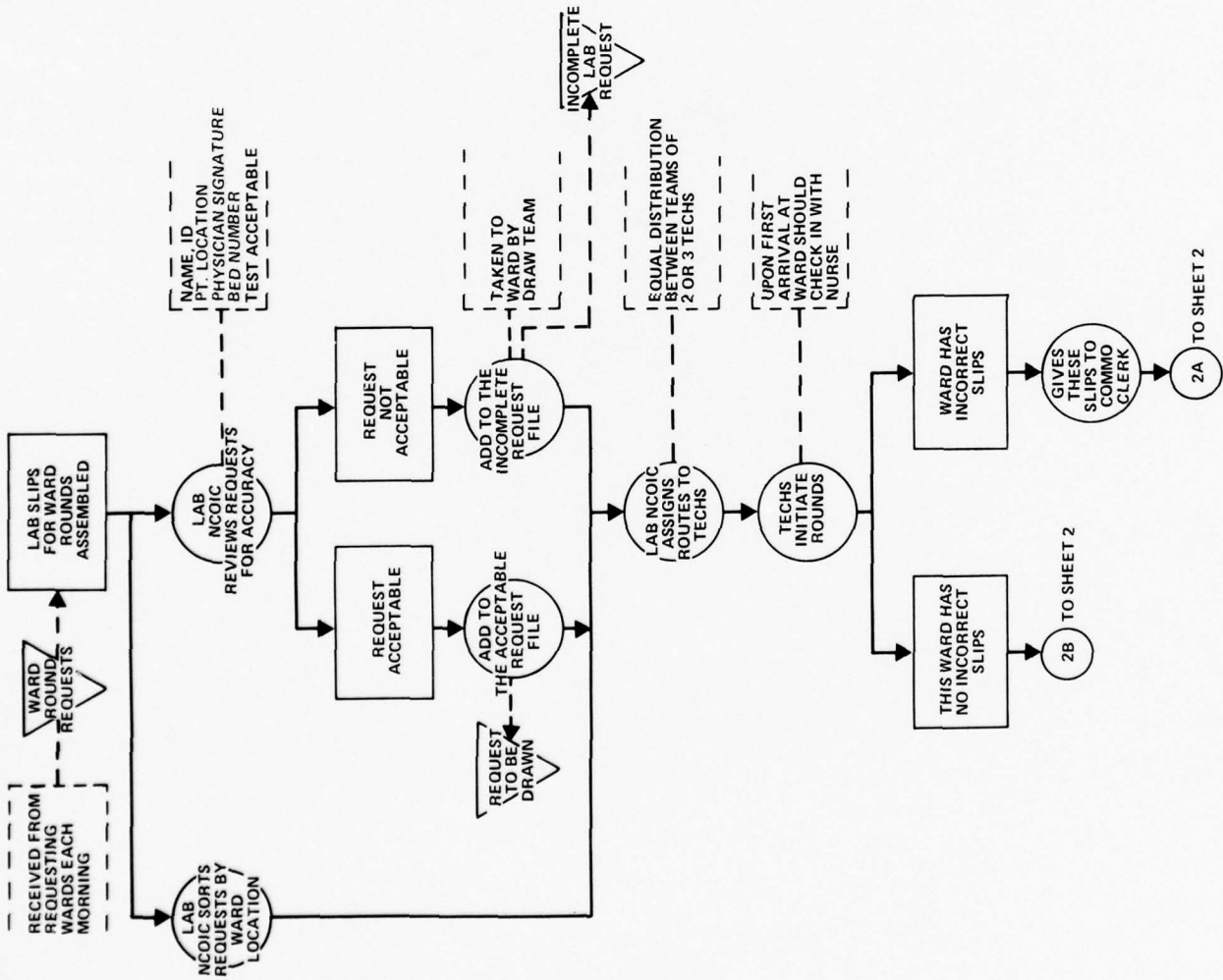

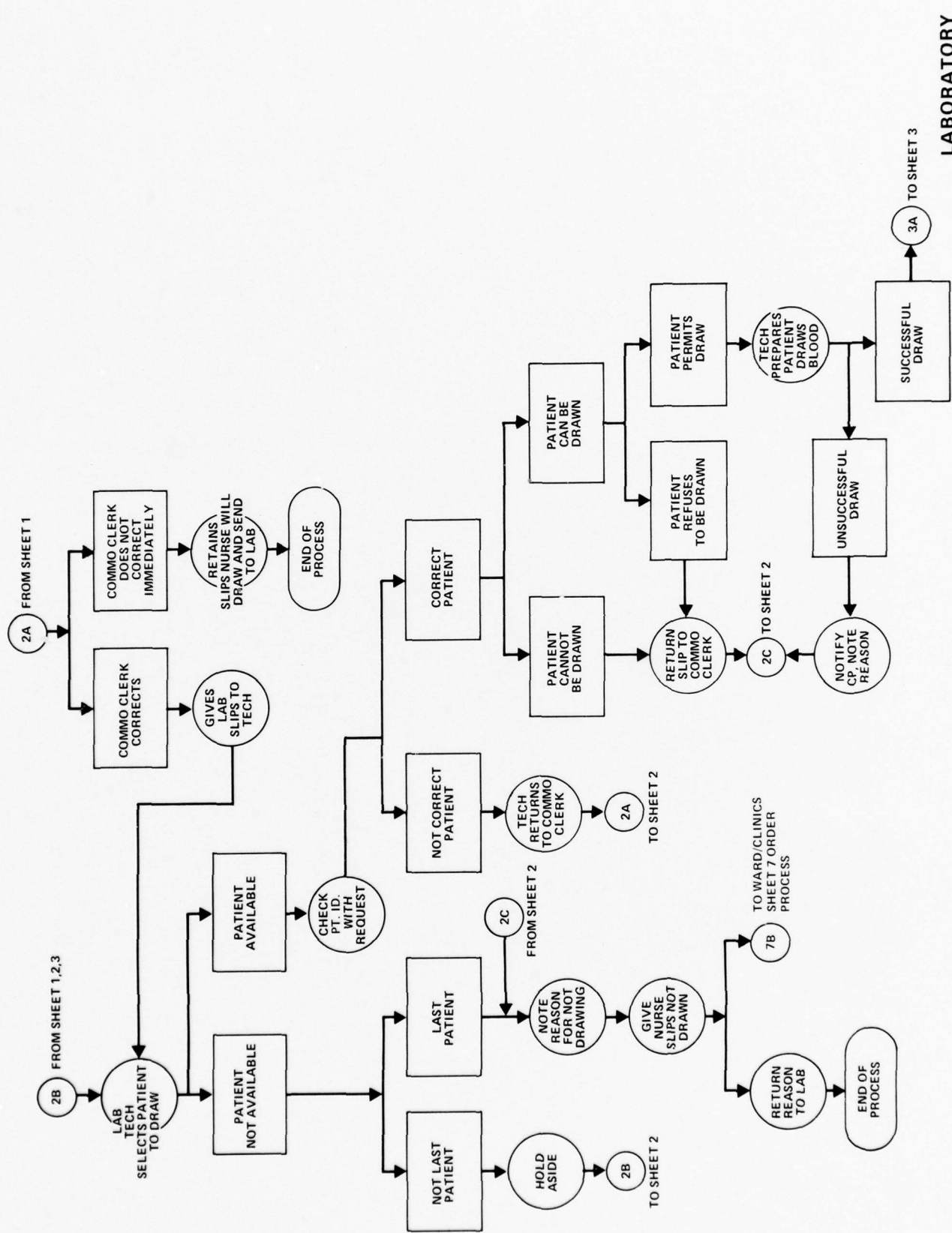

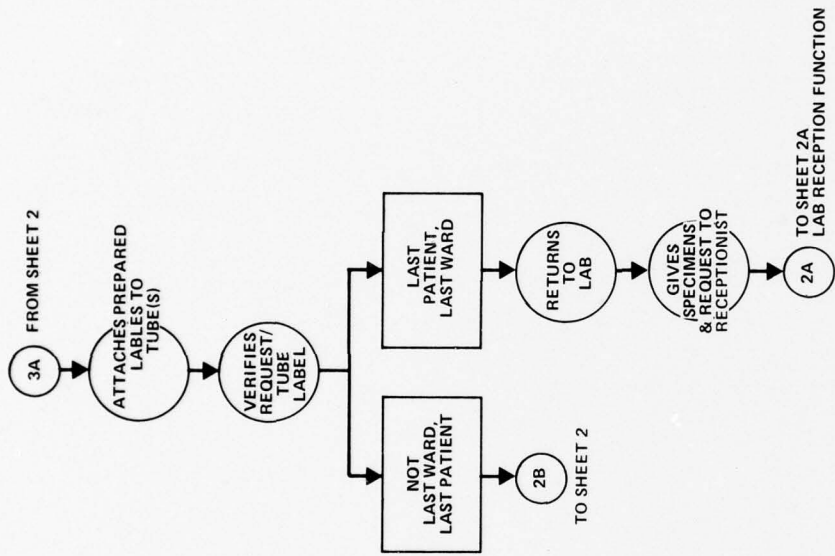

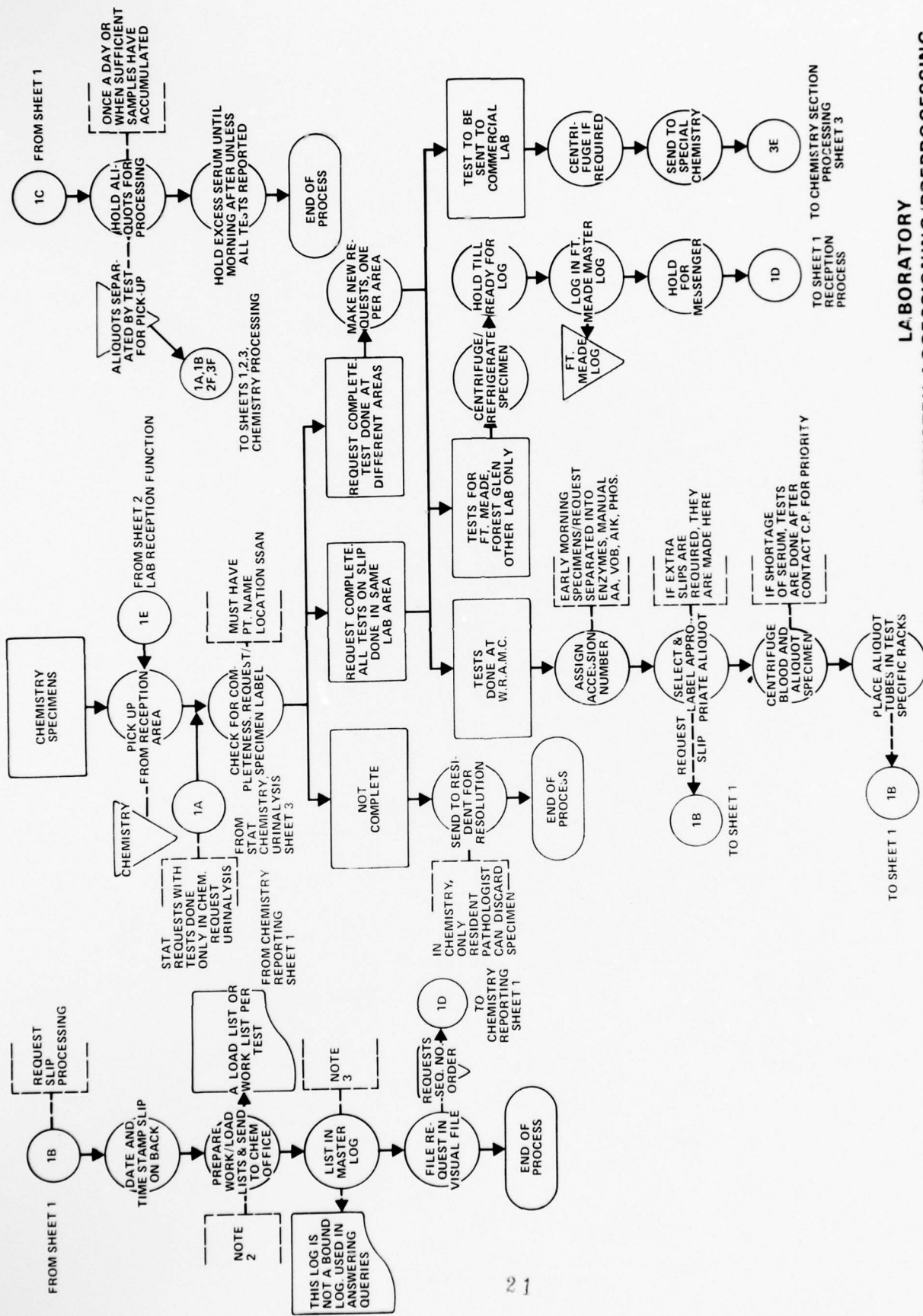

**LABORATORY
CHEMISTRY ACCESSIONING/PREPROCESSING**

SHEET 1 OF 1 13 JAN 76

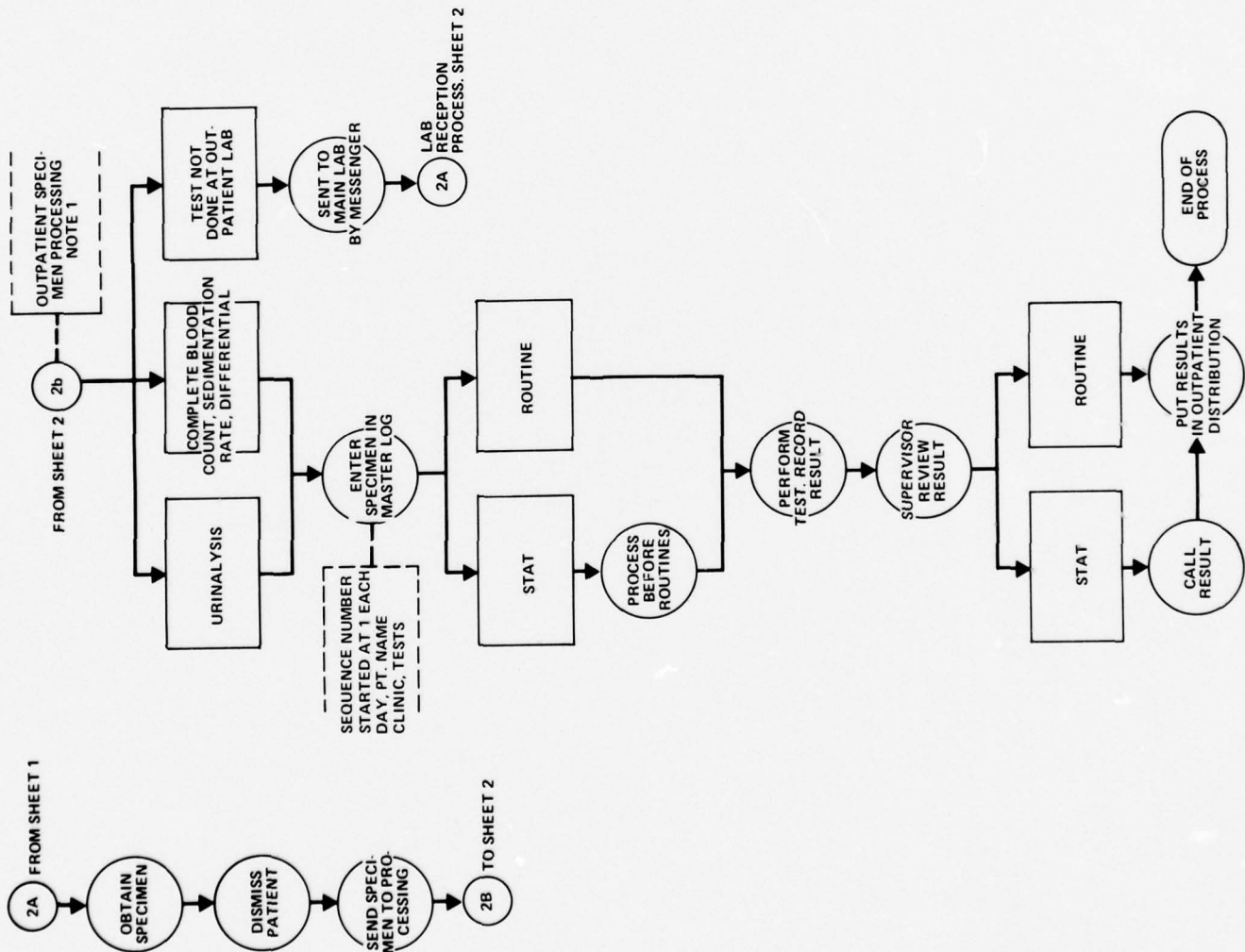

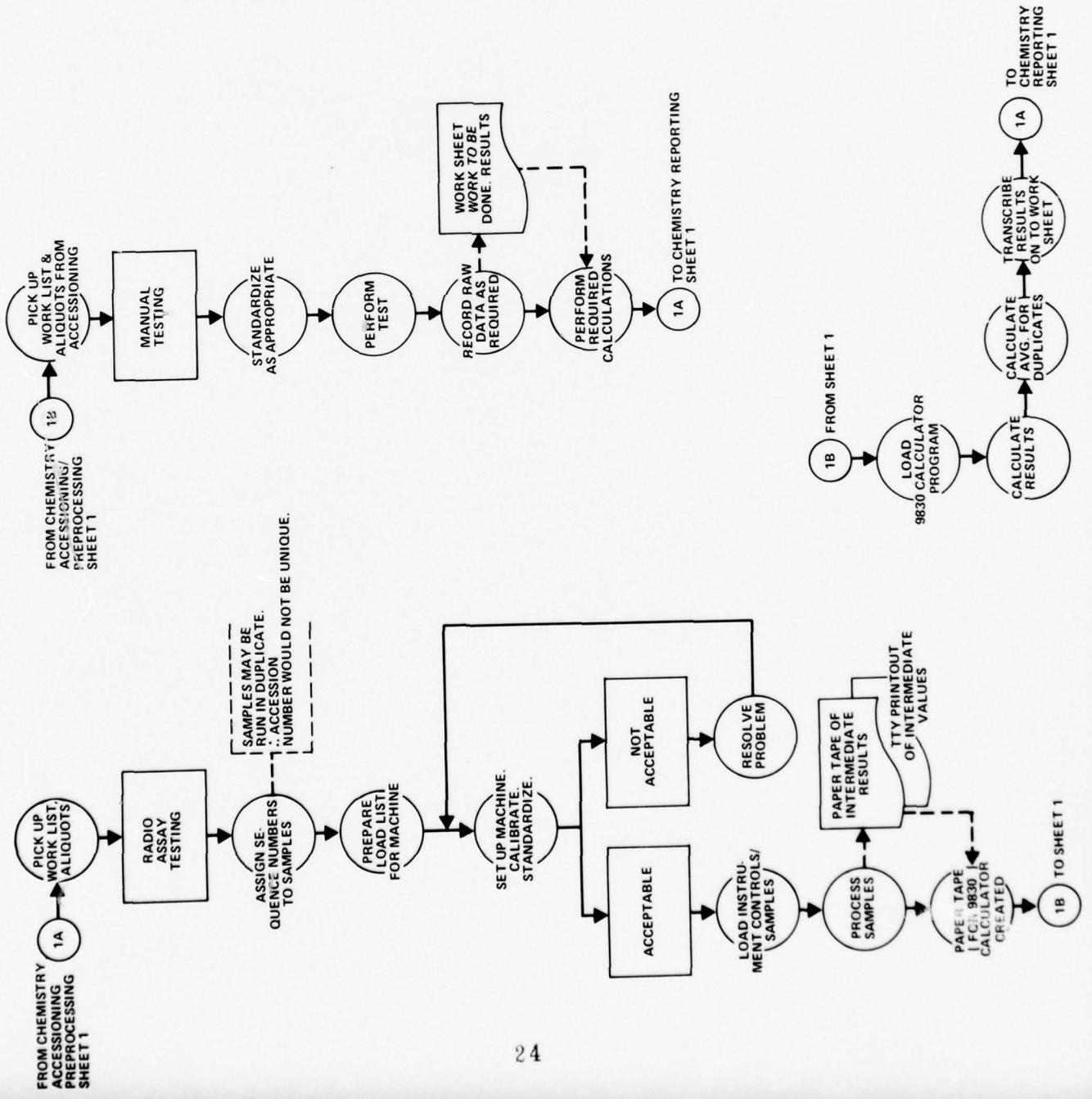

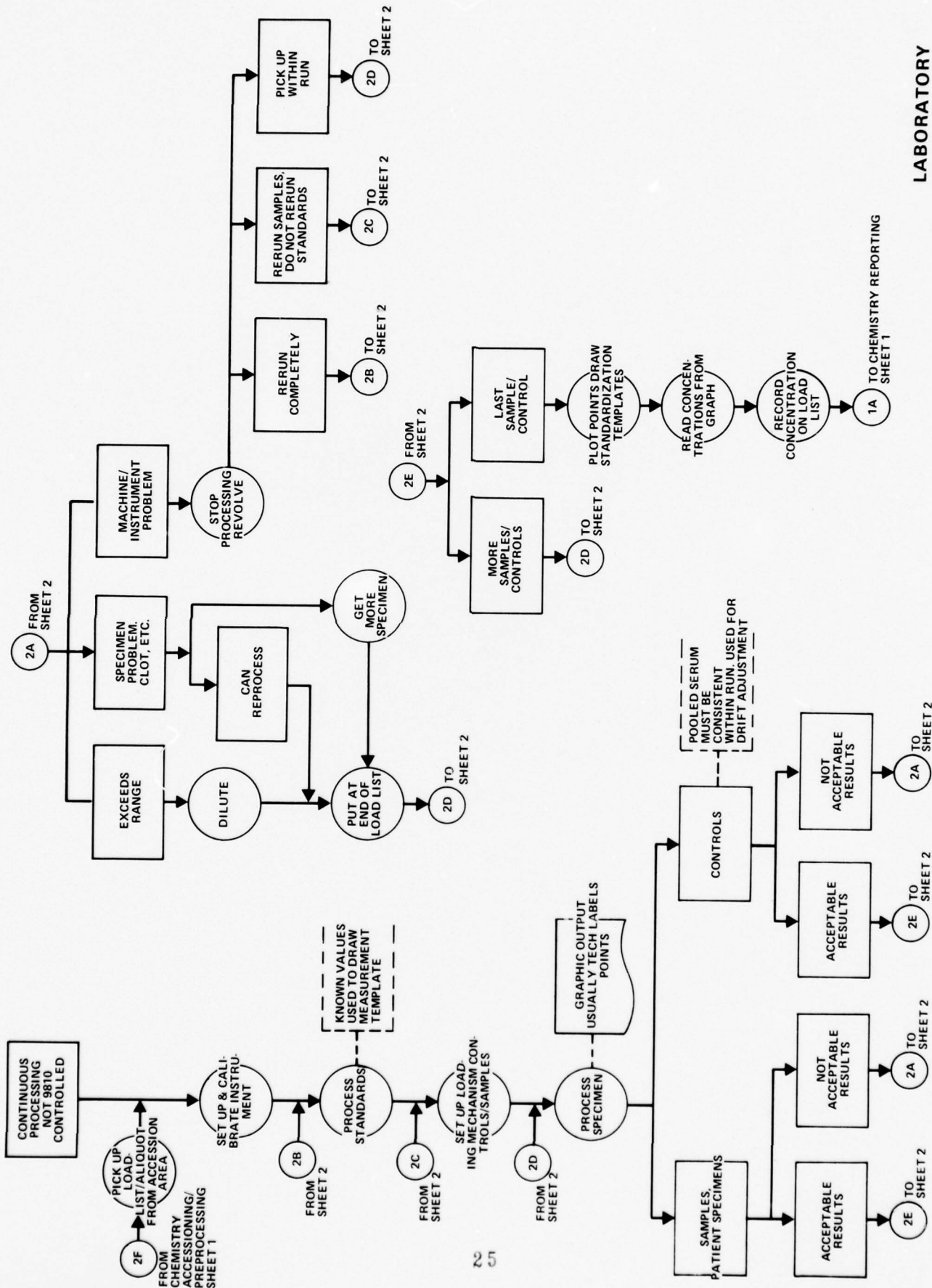

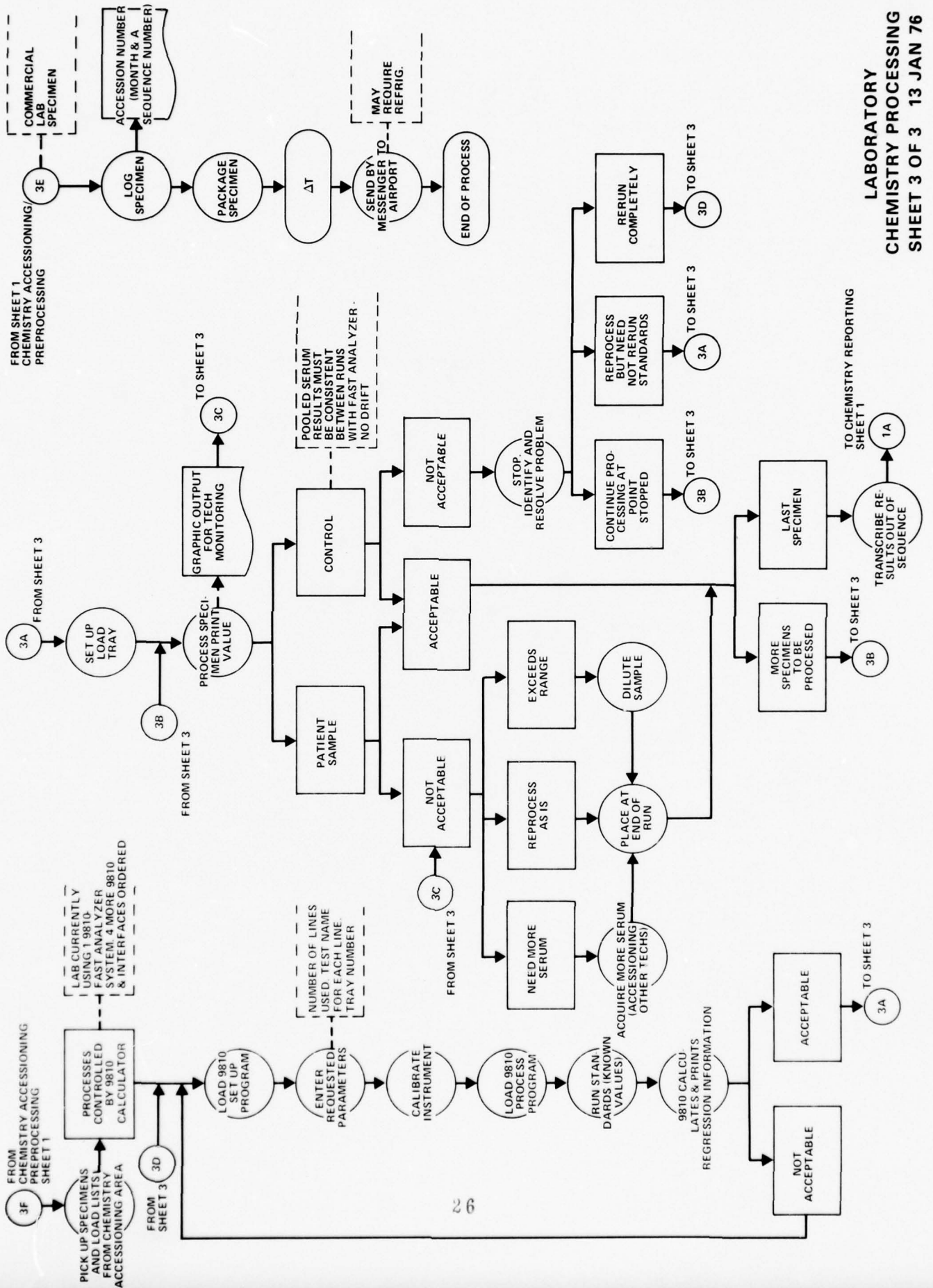

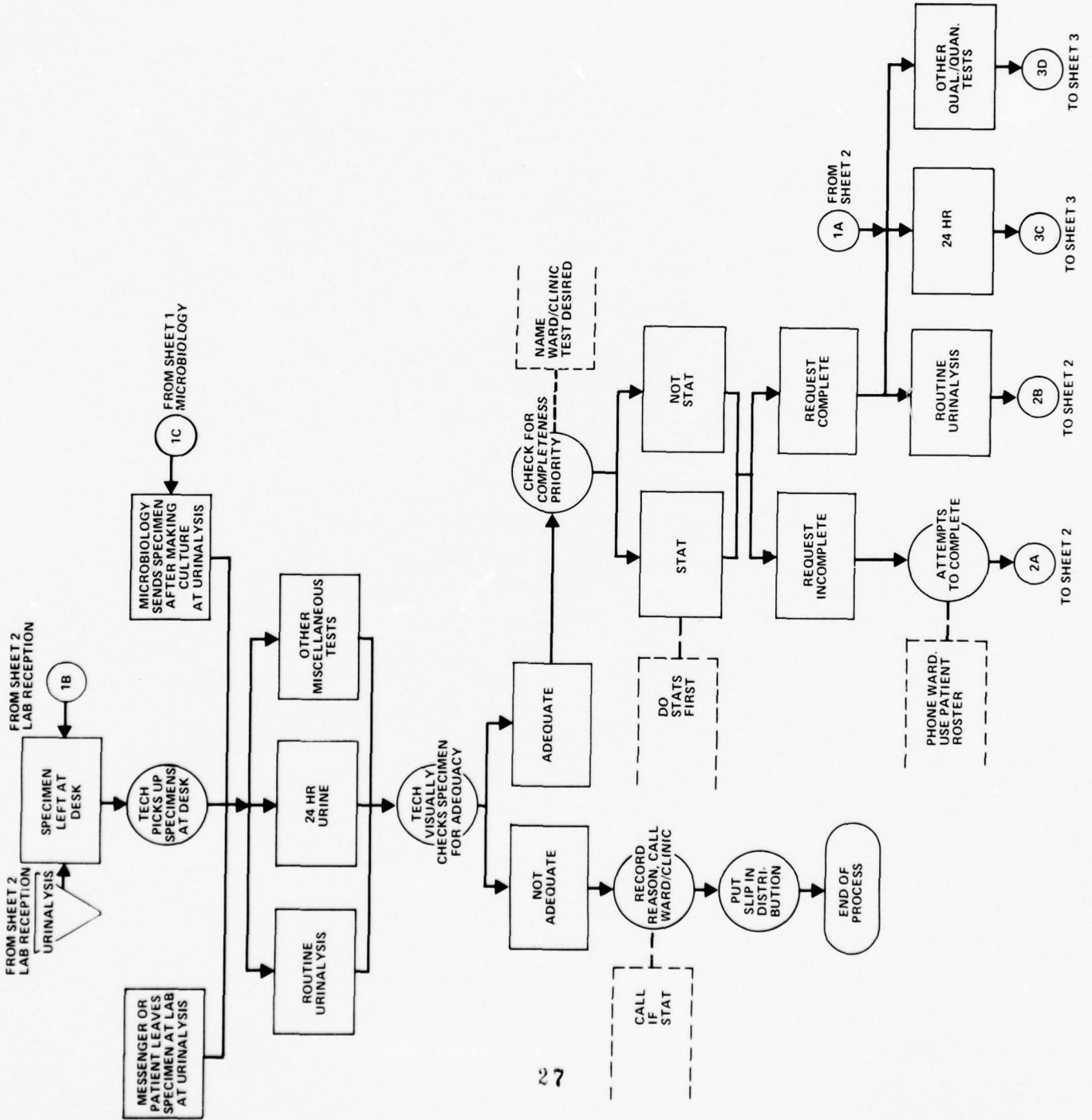

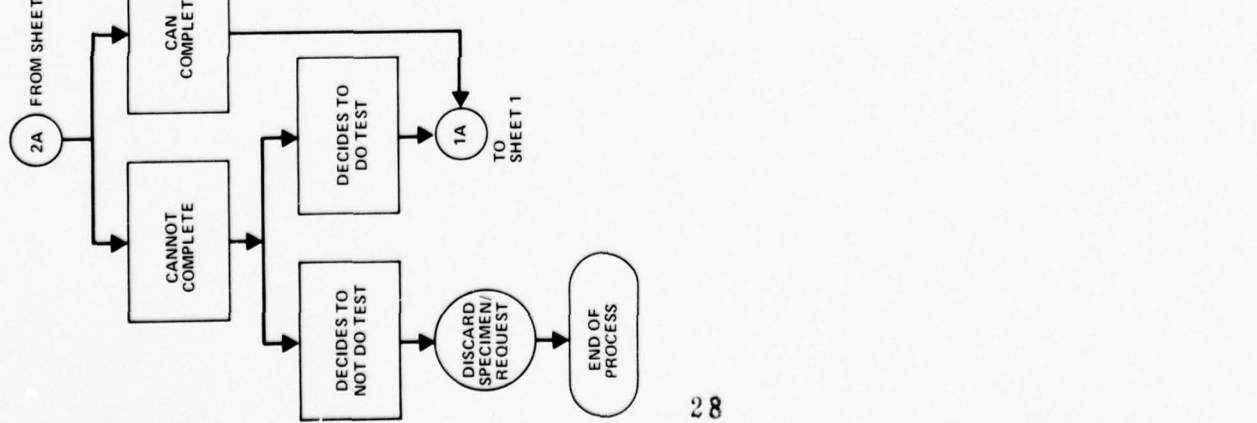
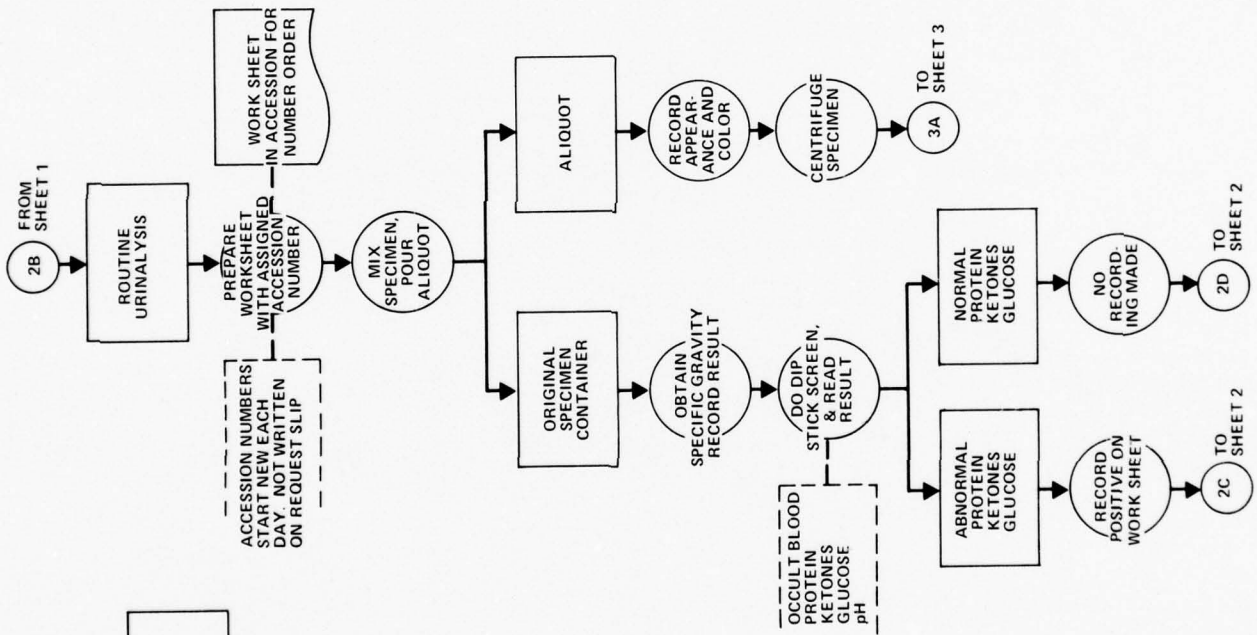
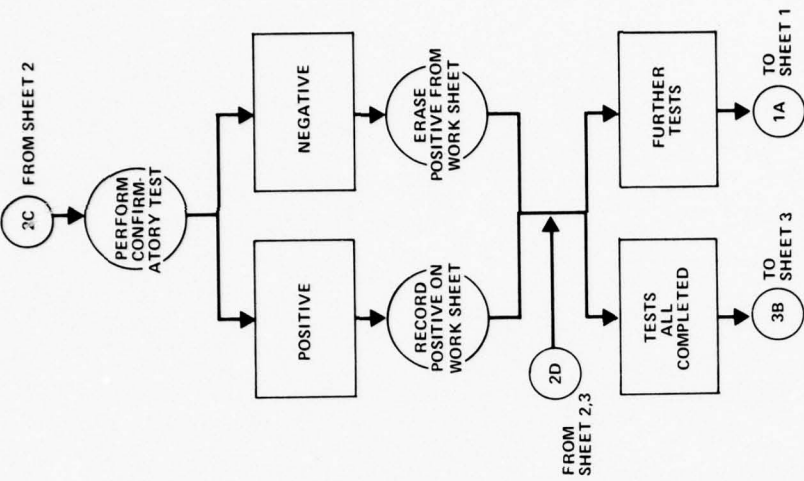

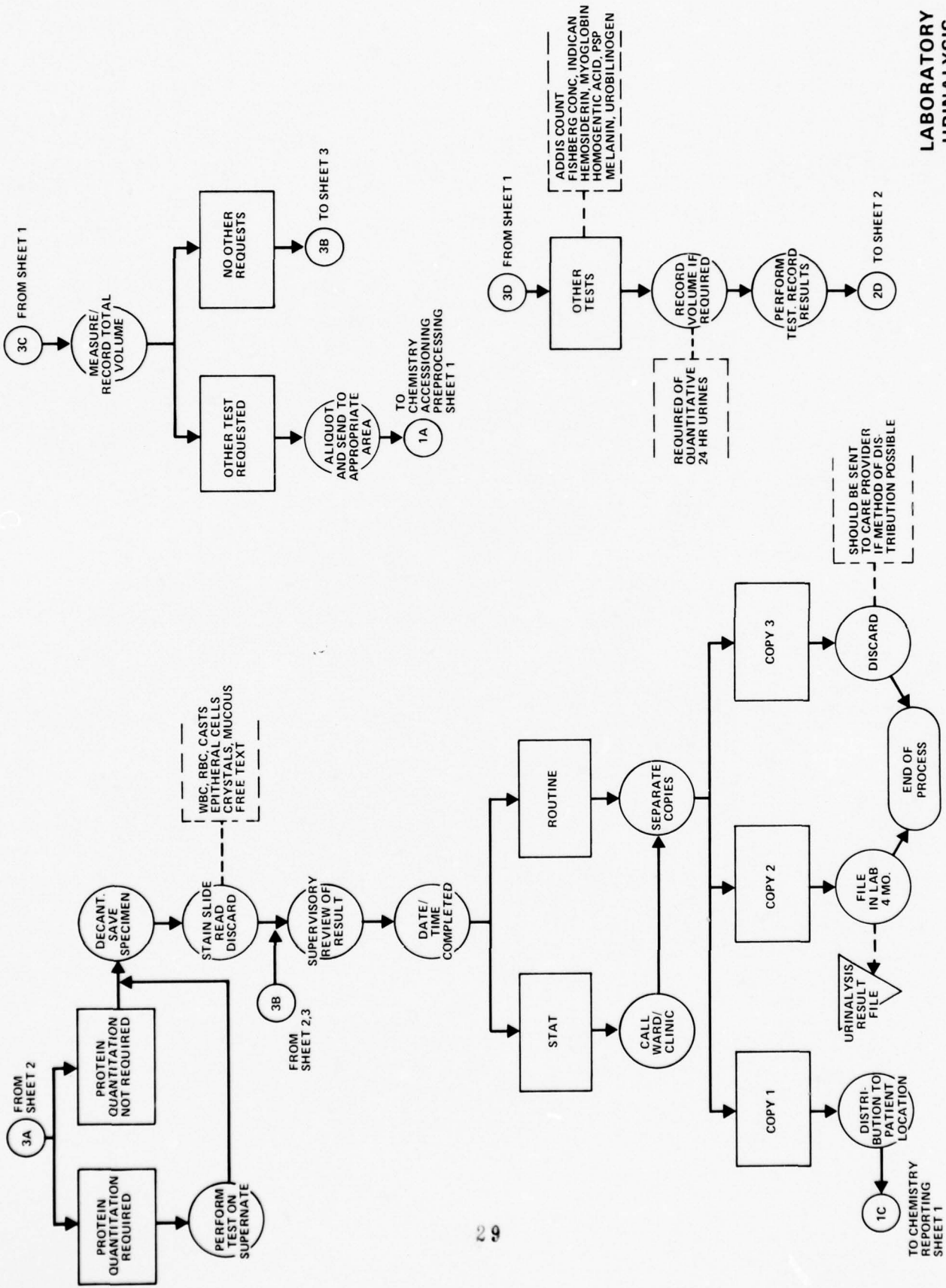

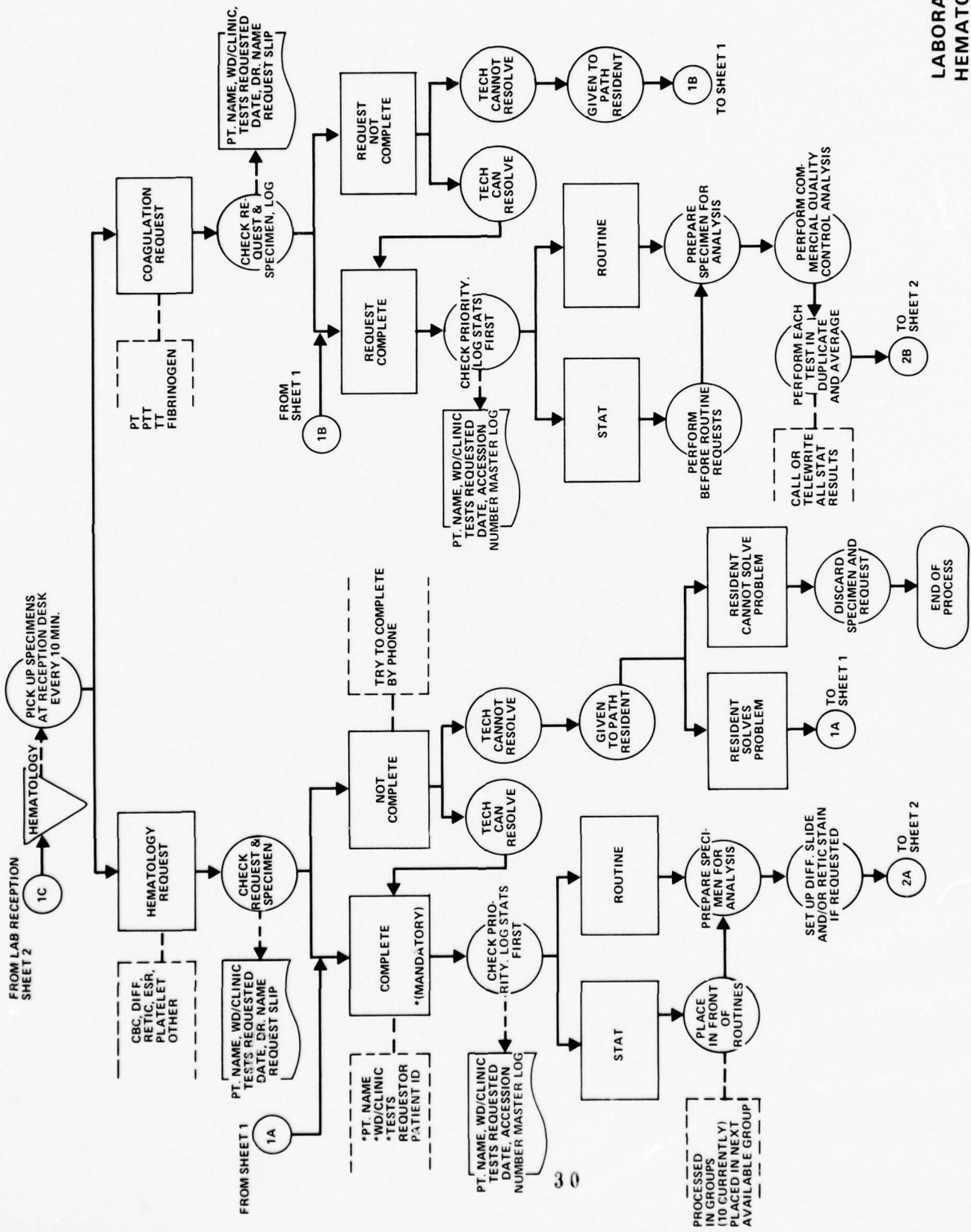

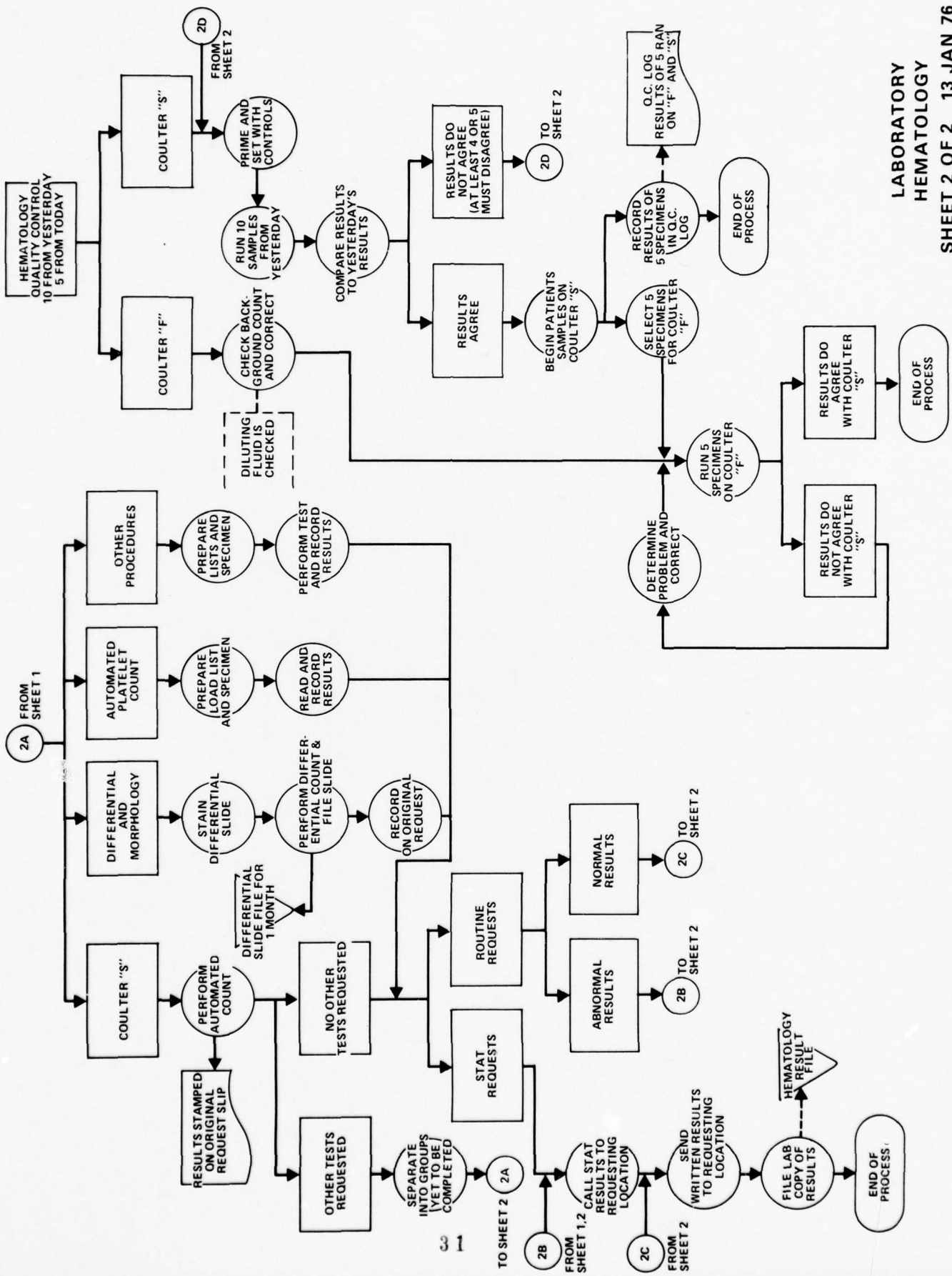

STAT REQUESTS AND SPECIMENS
FROM LAB RECEPTIONIST FUNCTION SHEET 2

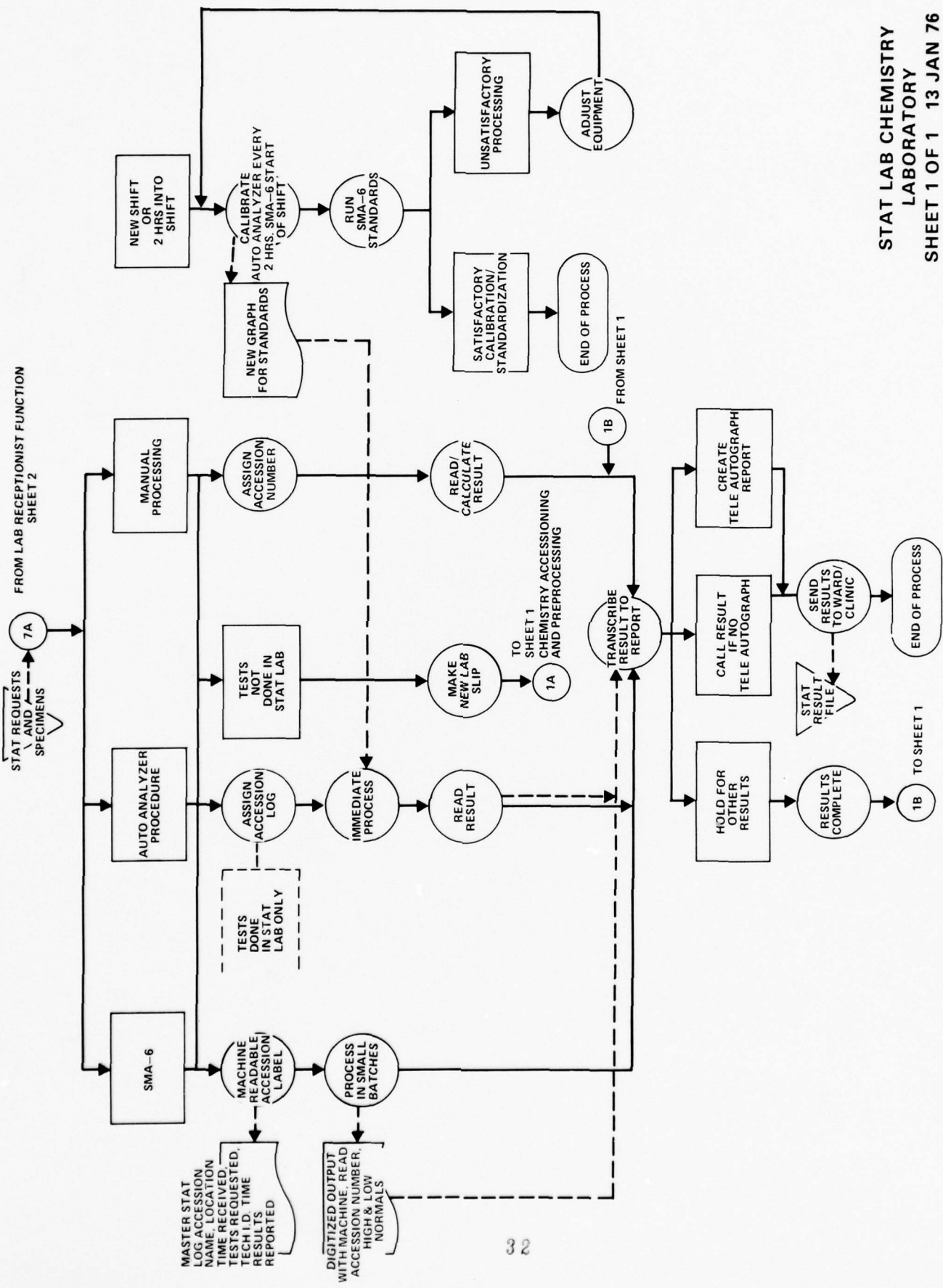

STAT LAB CHEMISTRY
LABORATORY
SHEET 1 OF 1 13 JAN 76

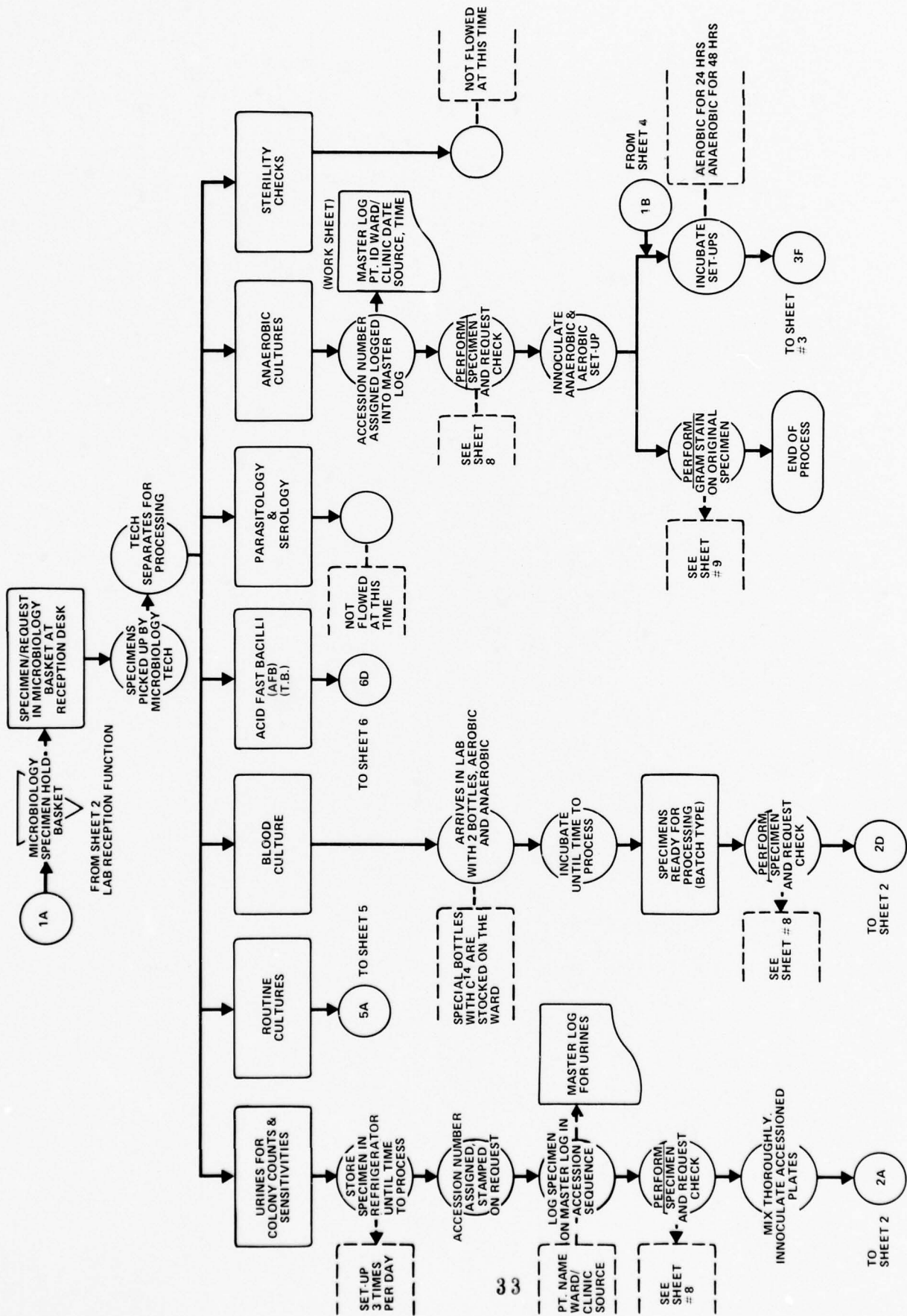

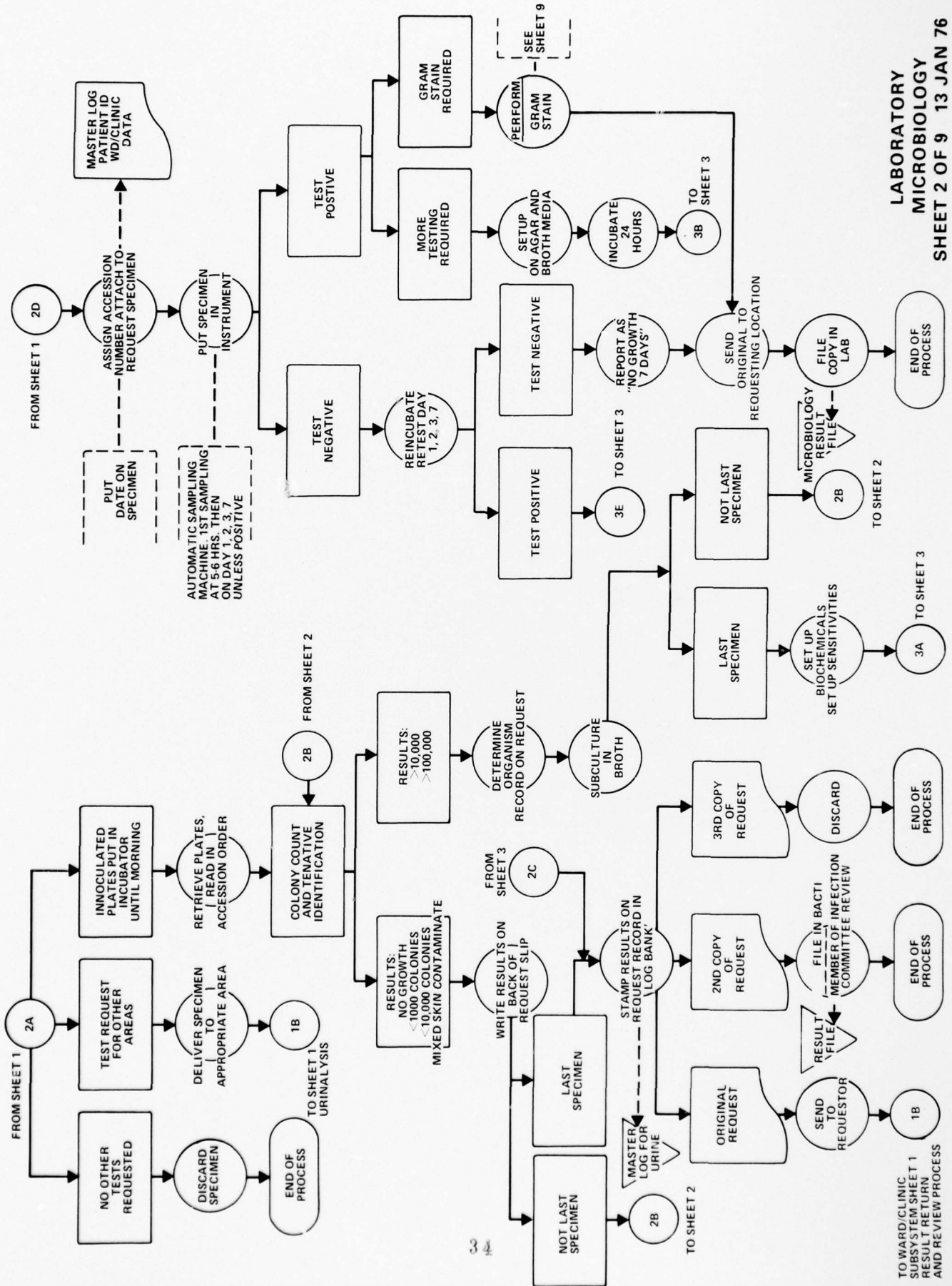

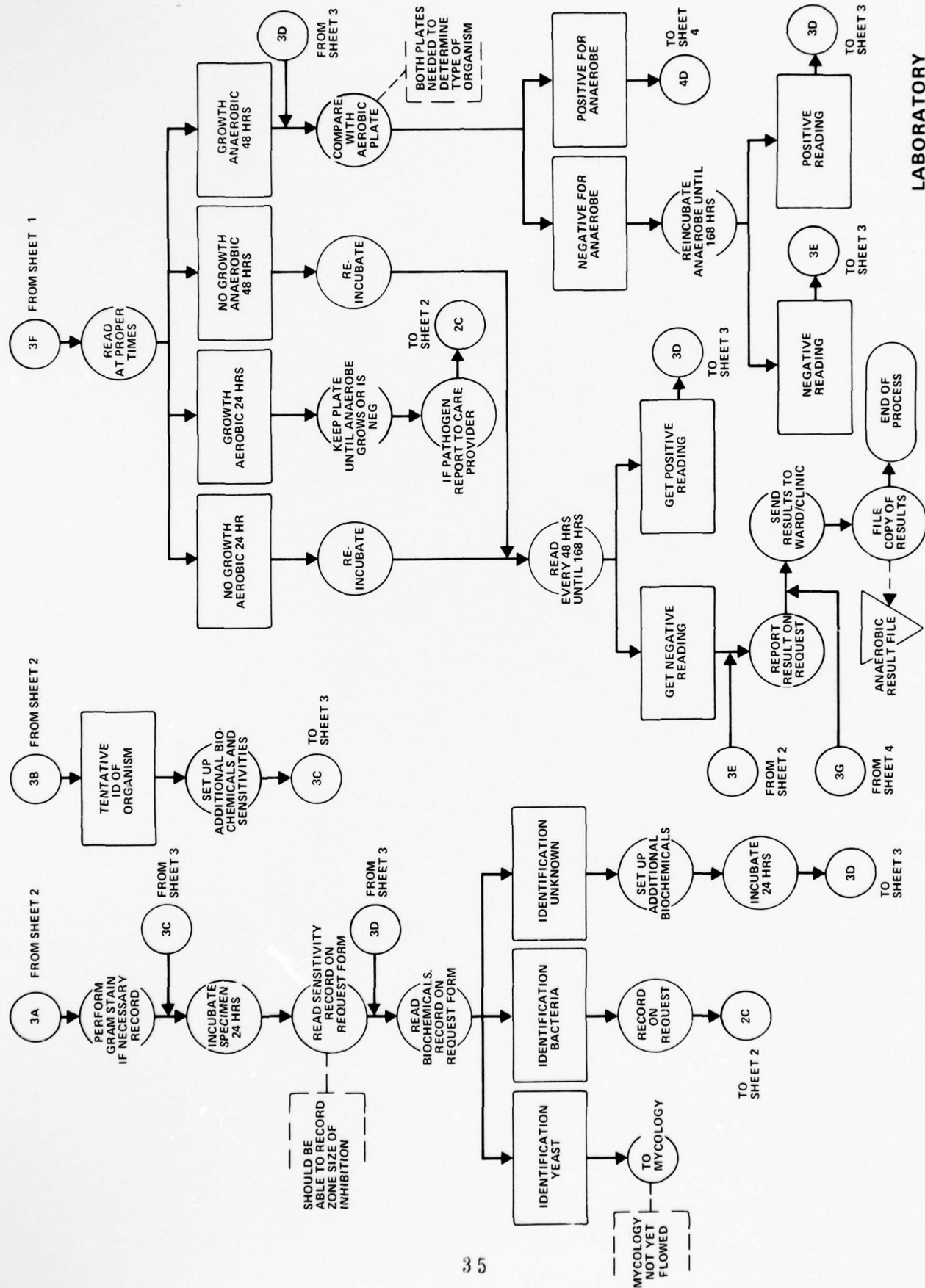

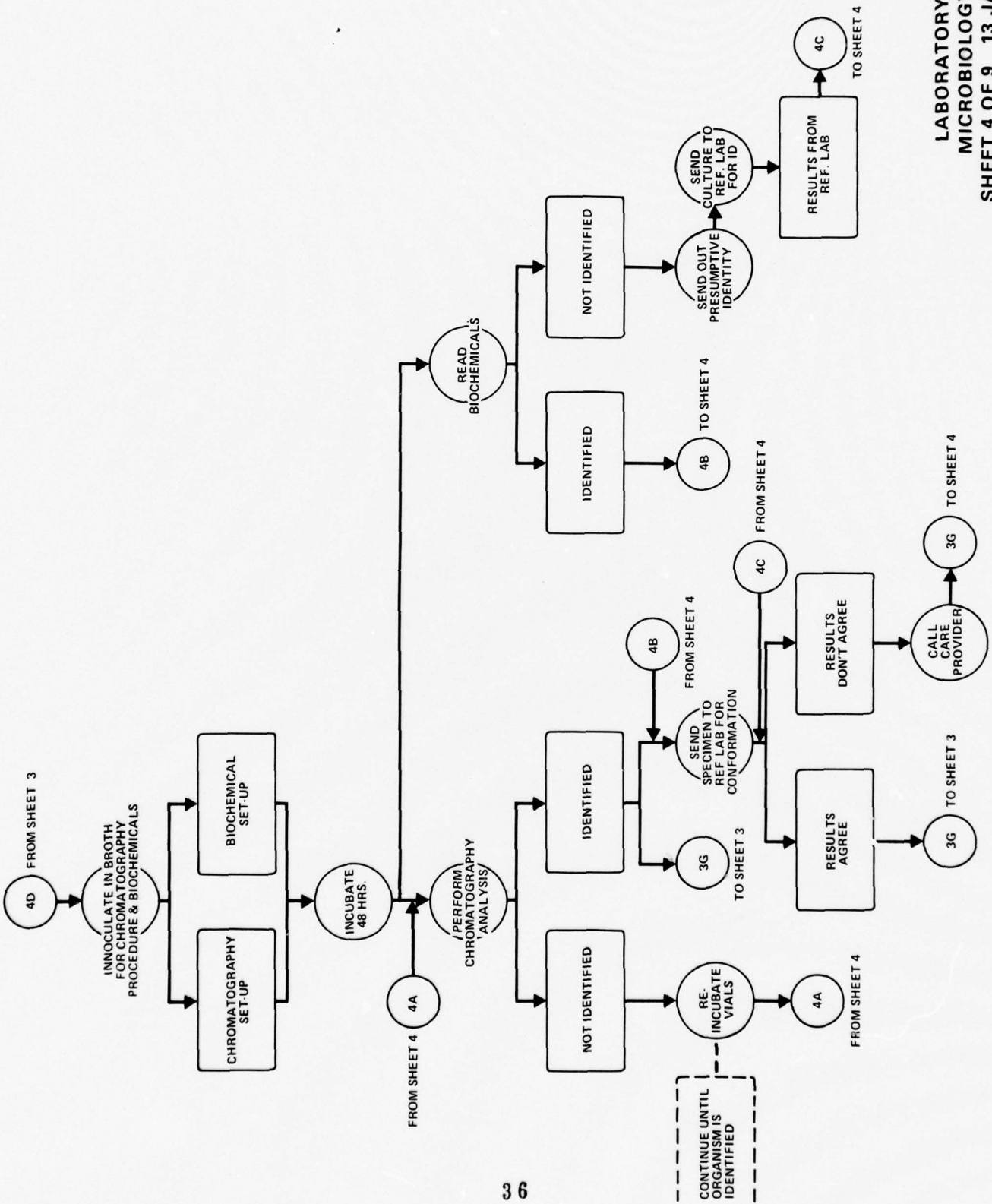

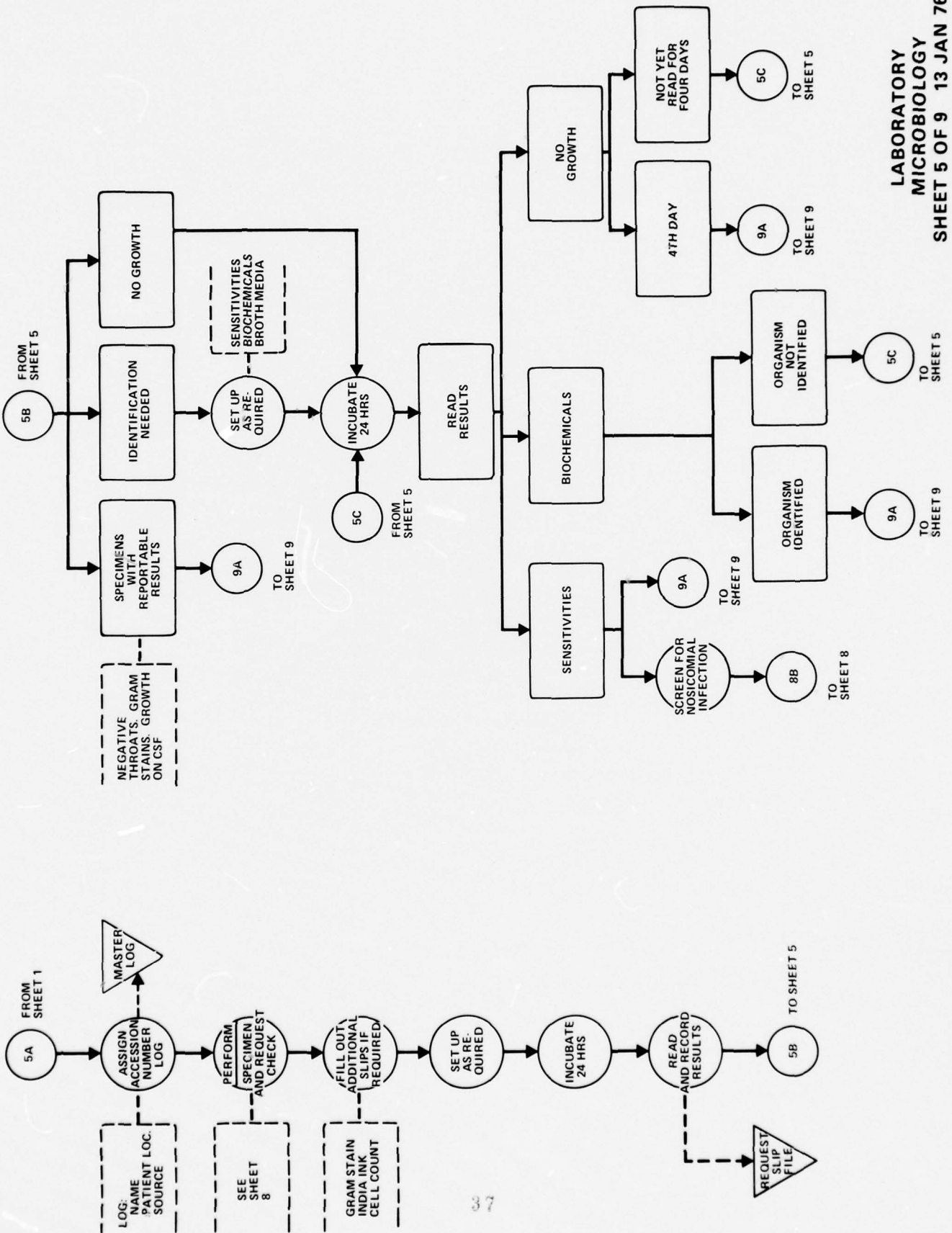

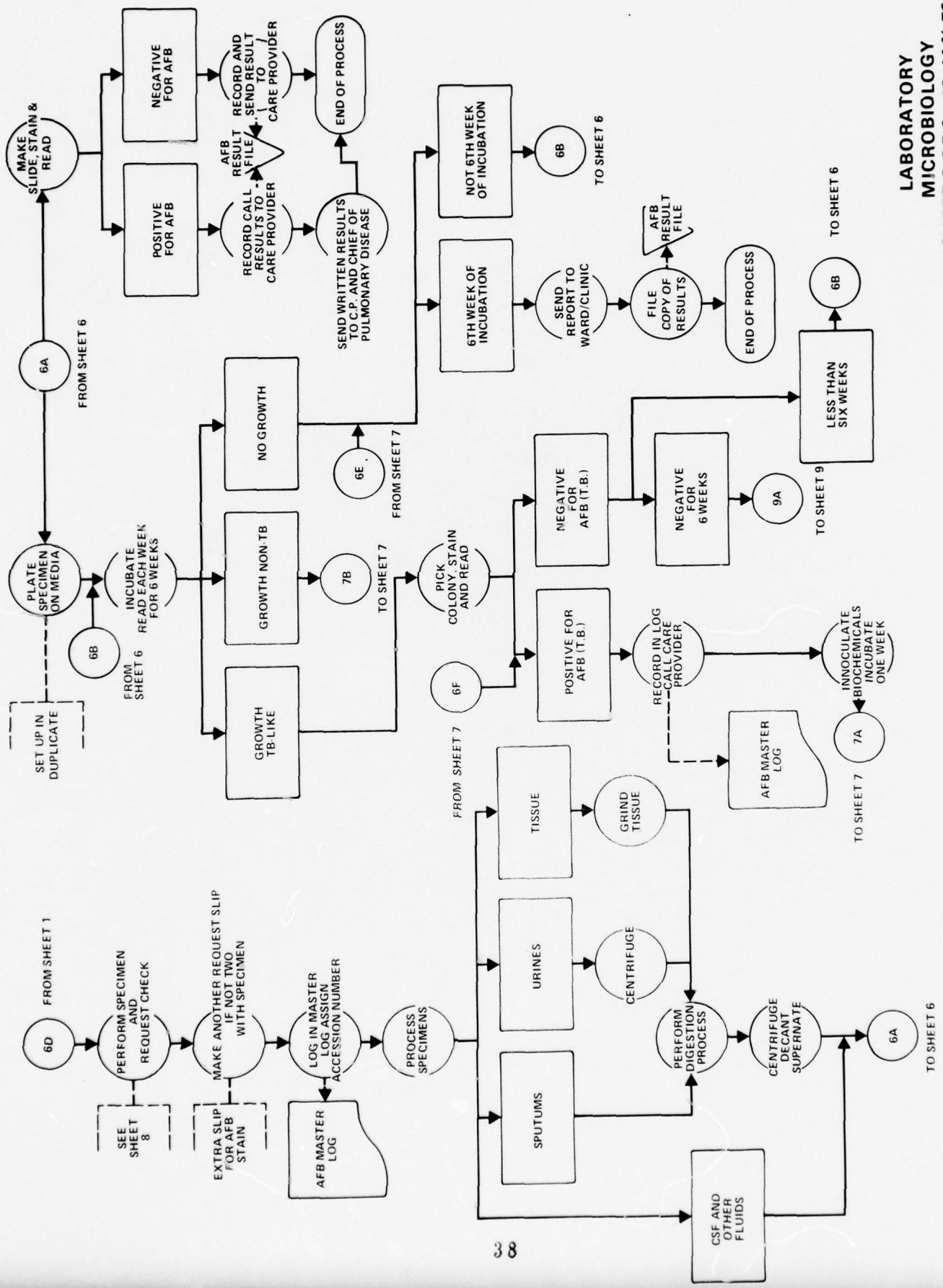

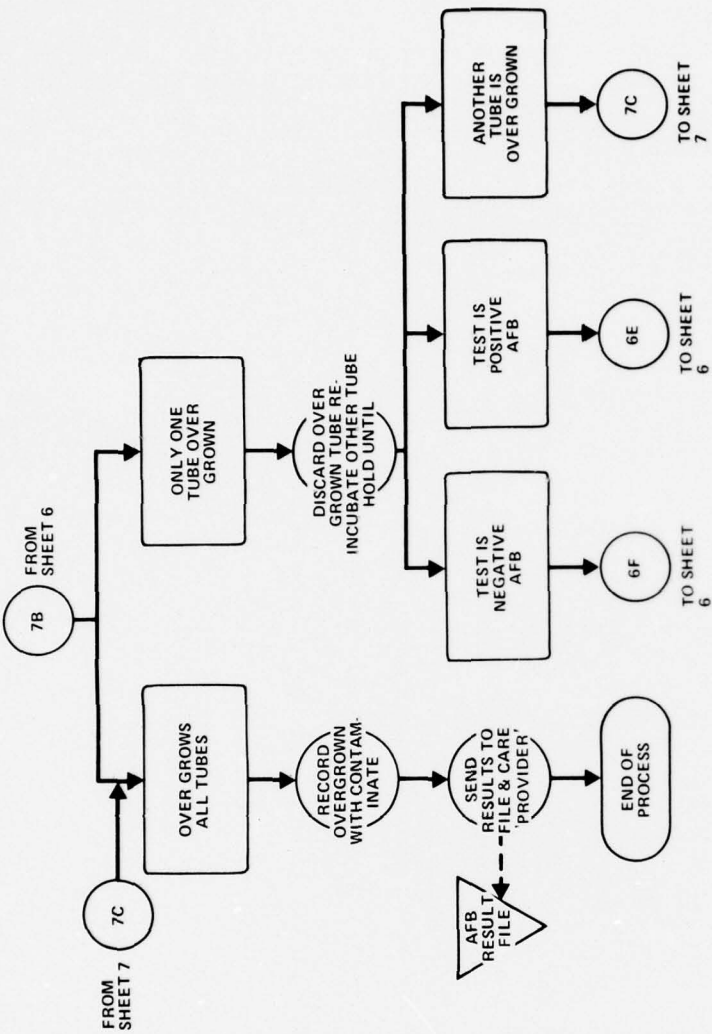
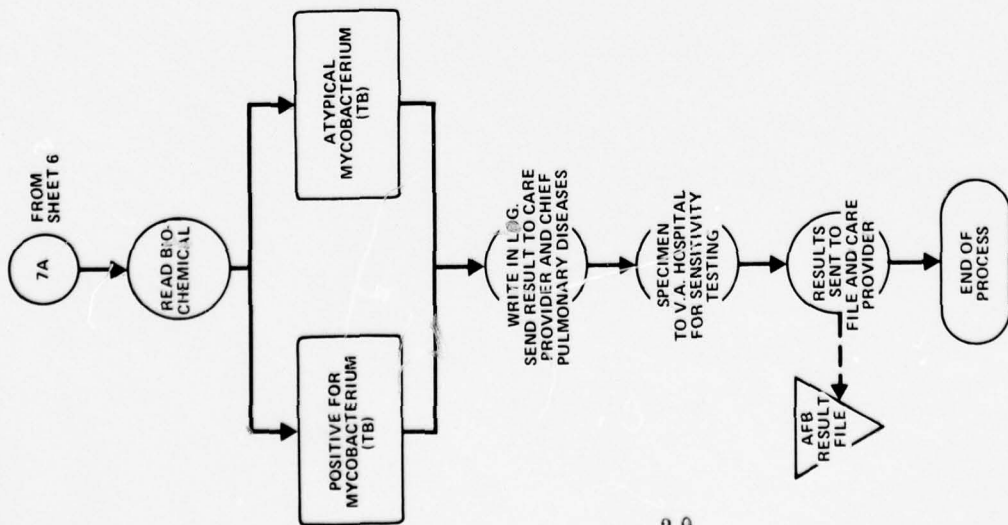

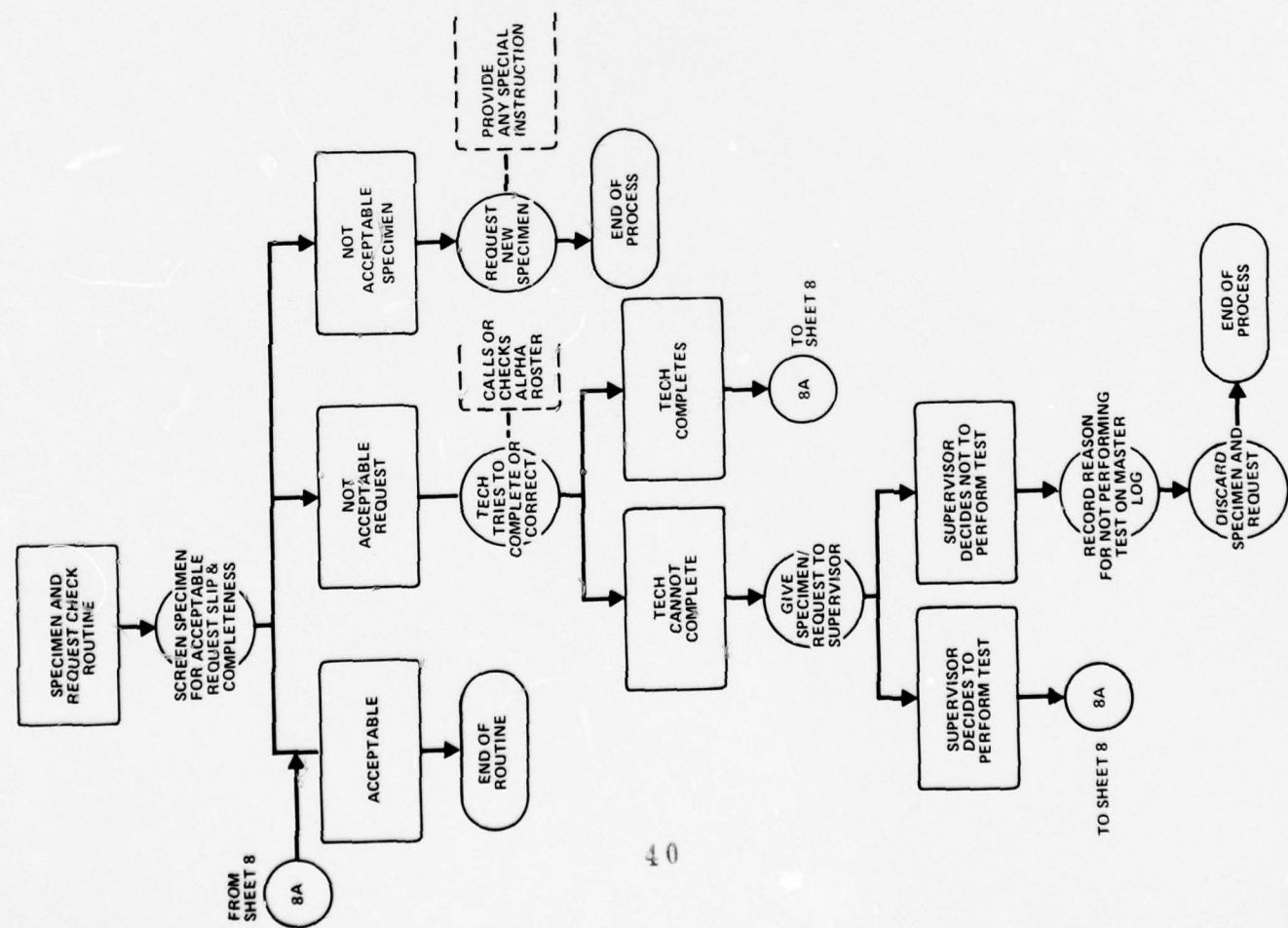
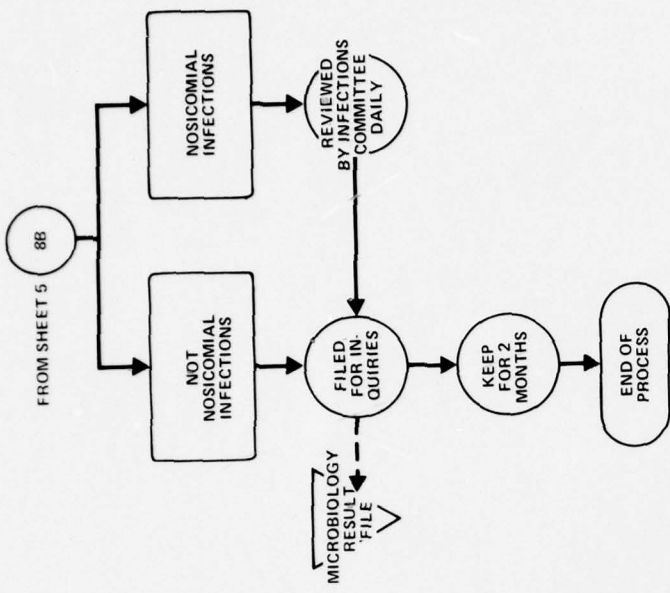

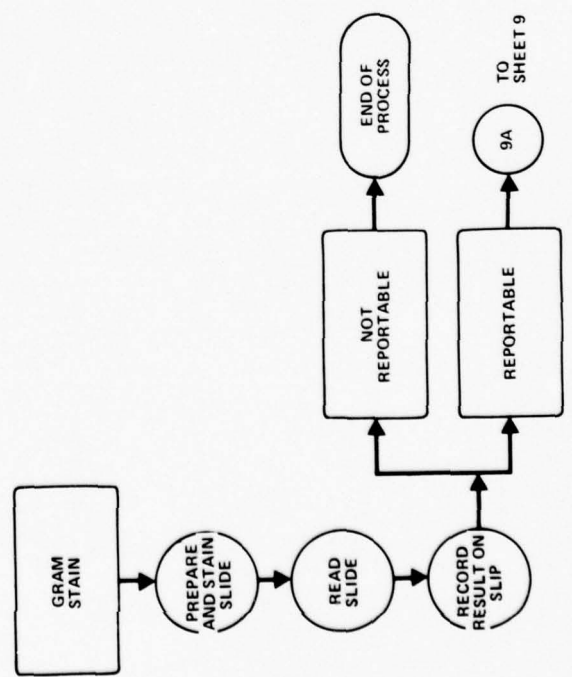
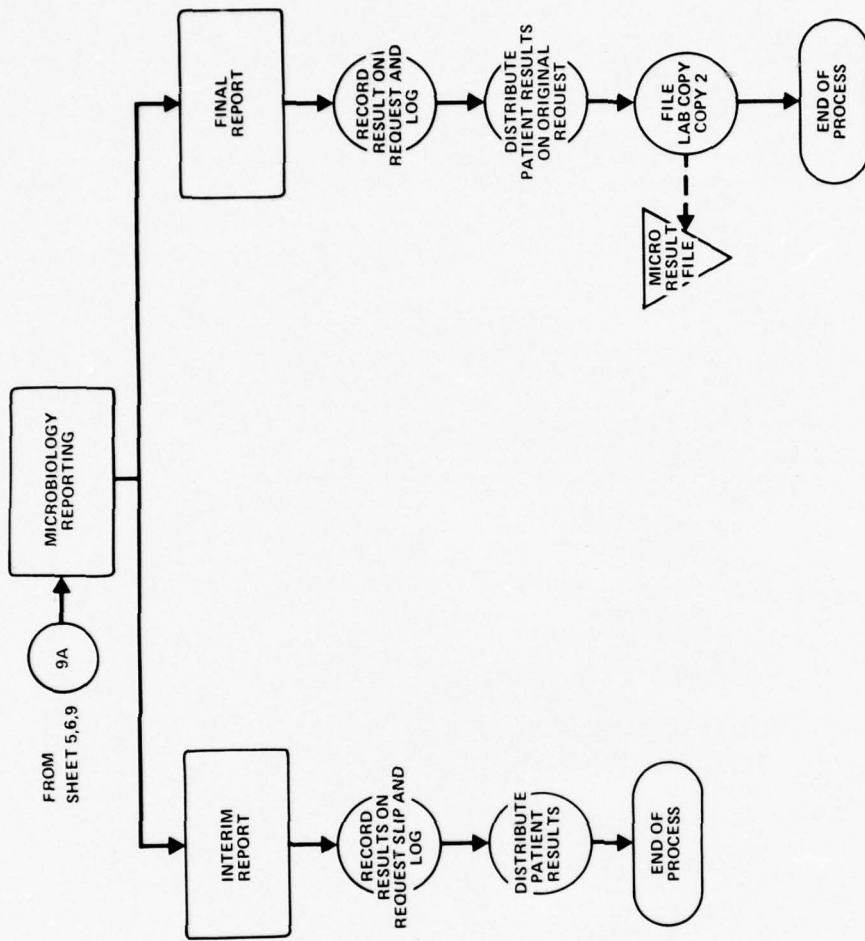

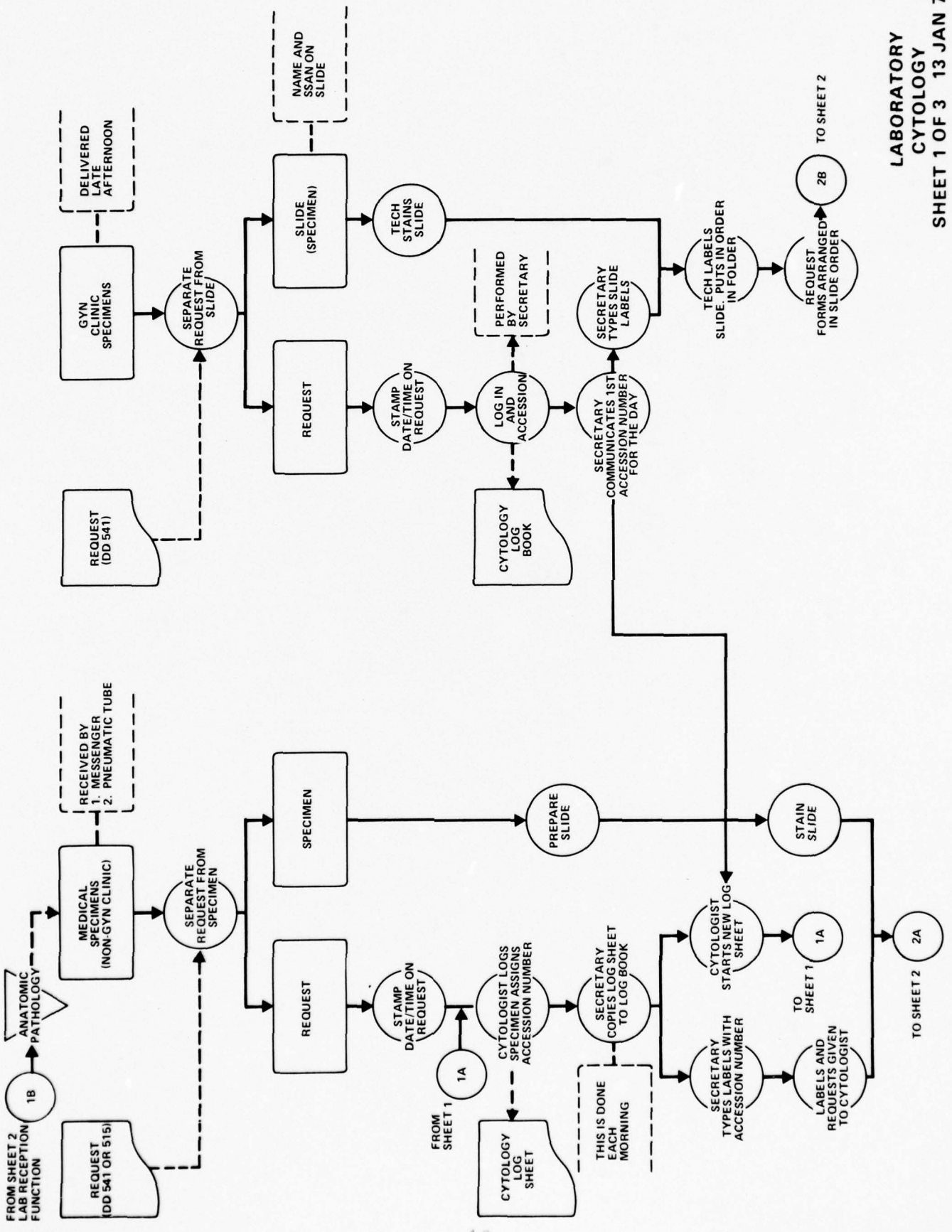

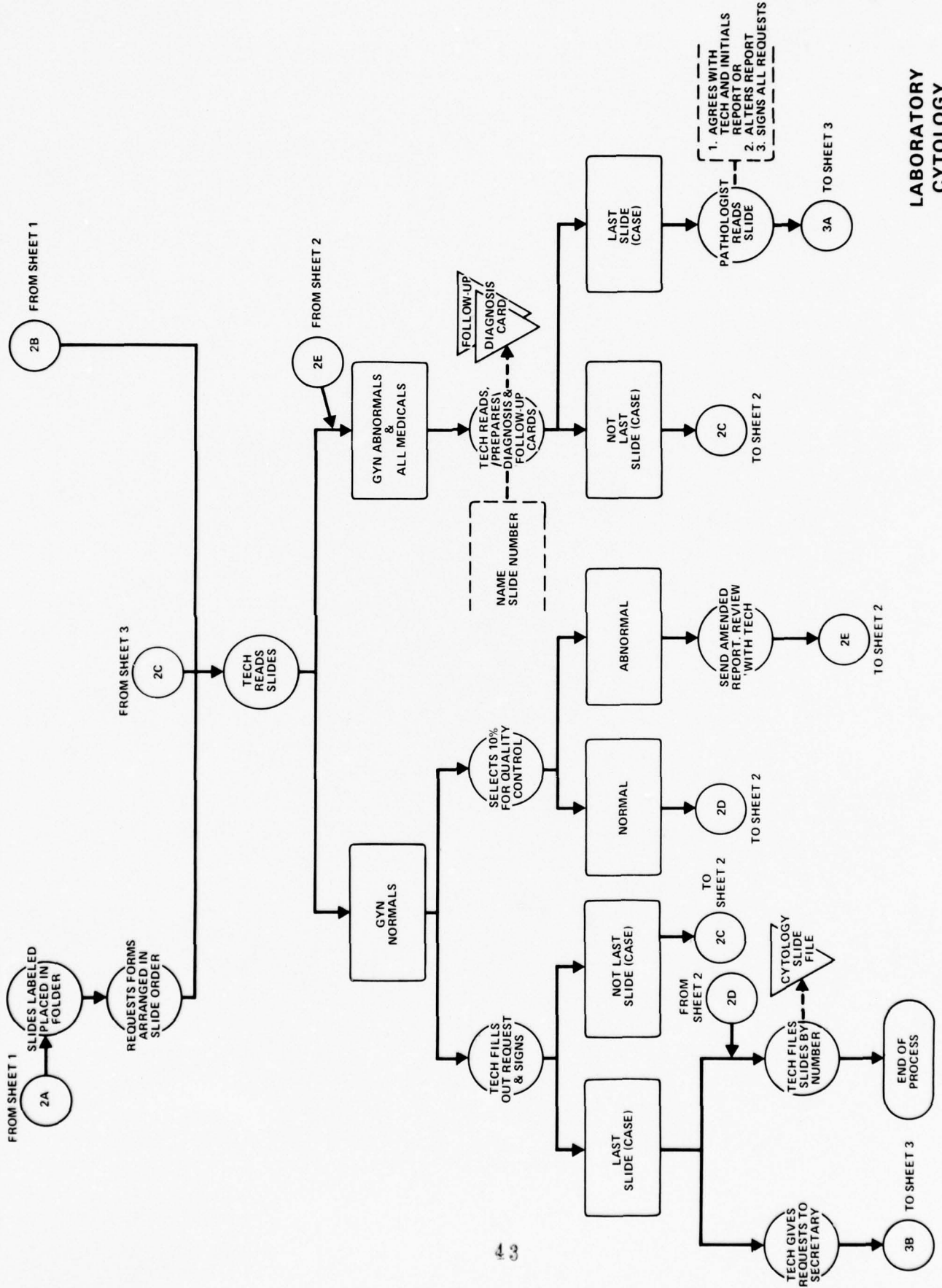

LABORATORY
CYTOLOGY
SHEET 2 OF 3 13JAN 76

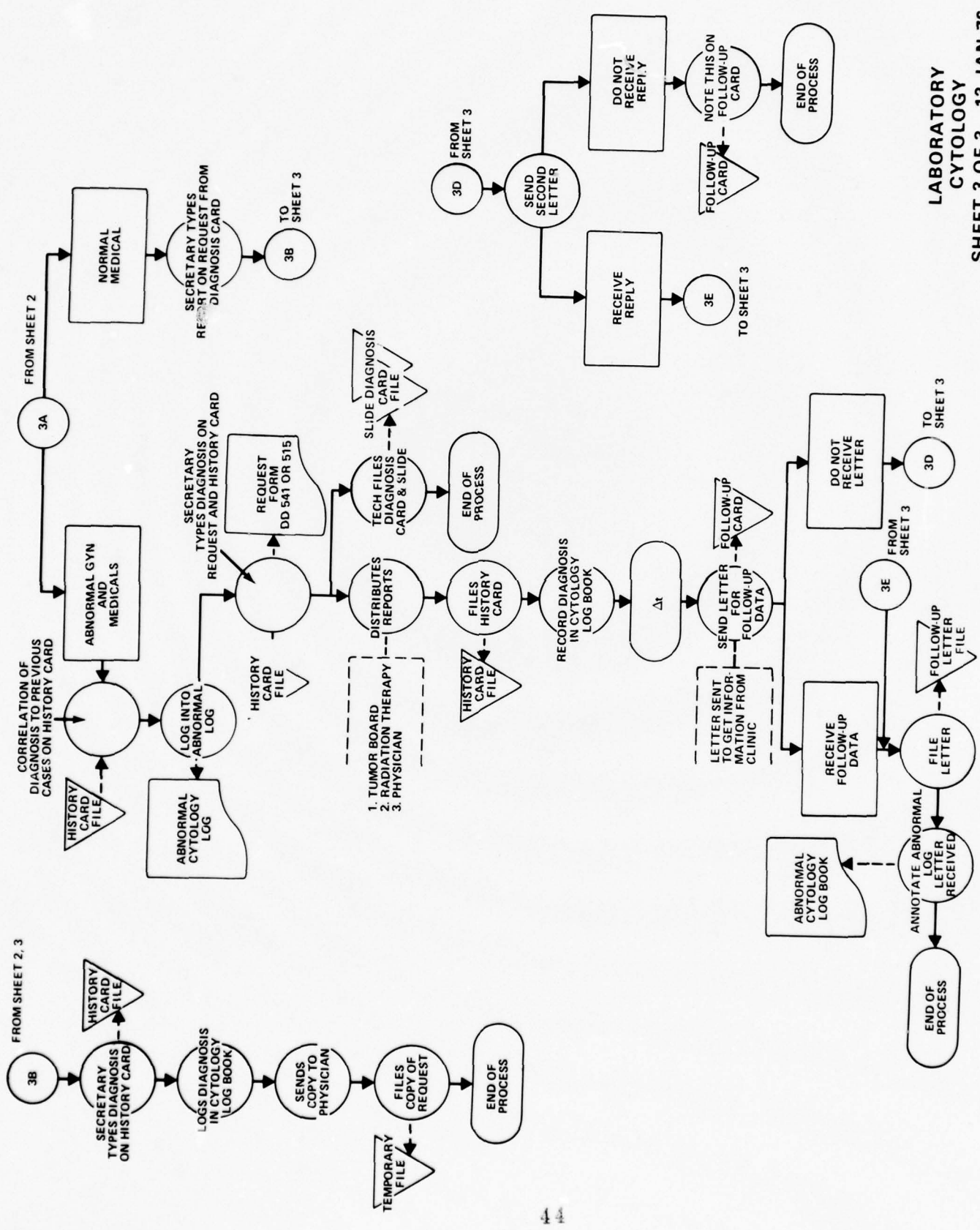

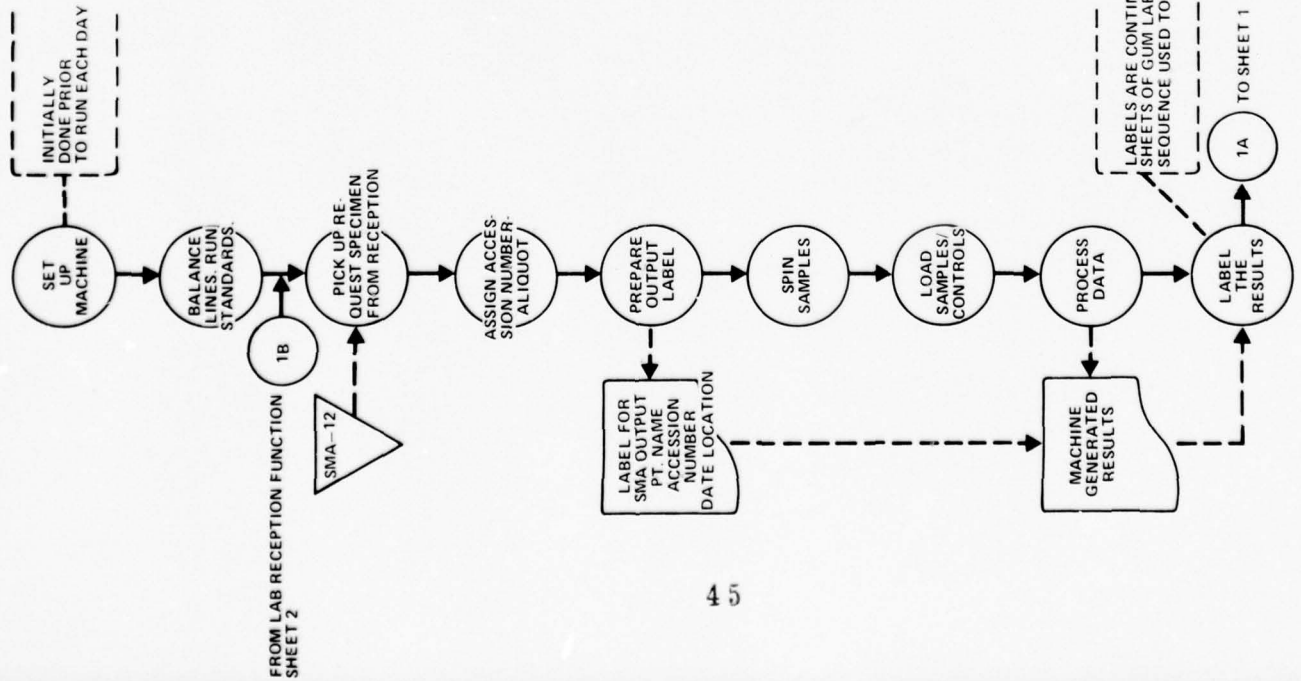

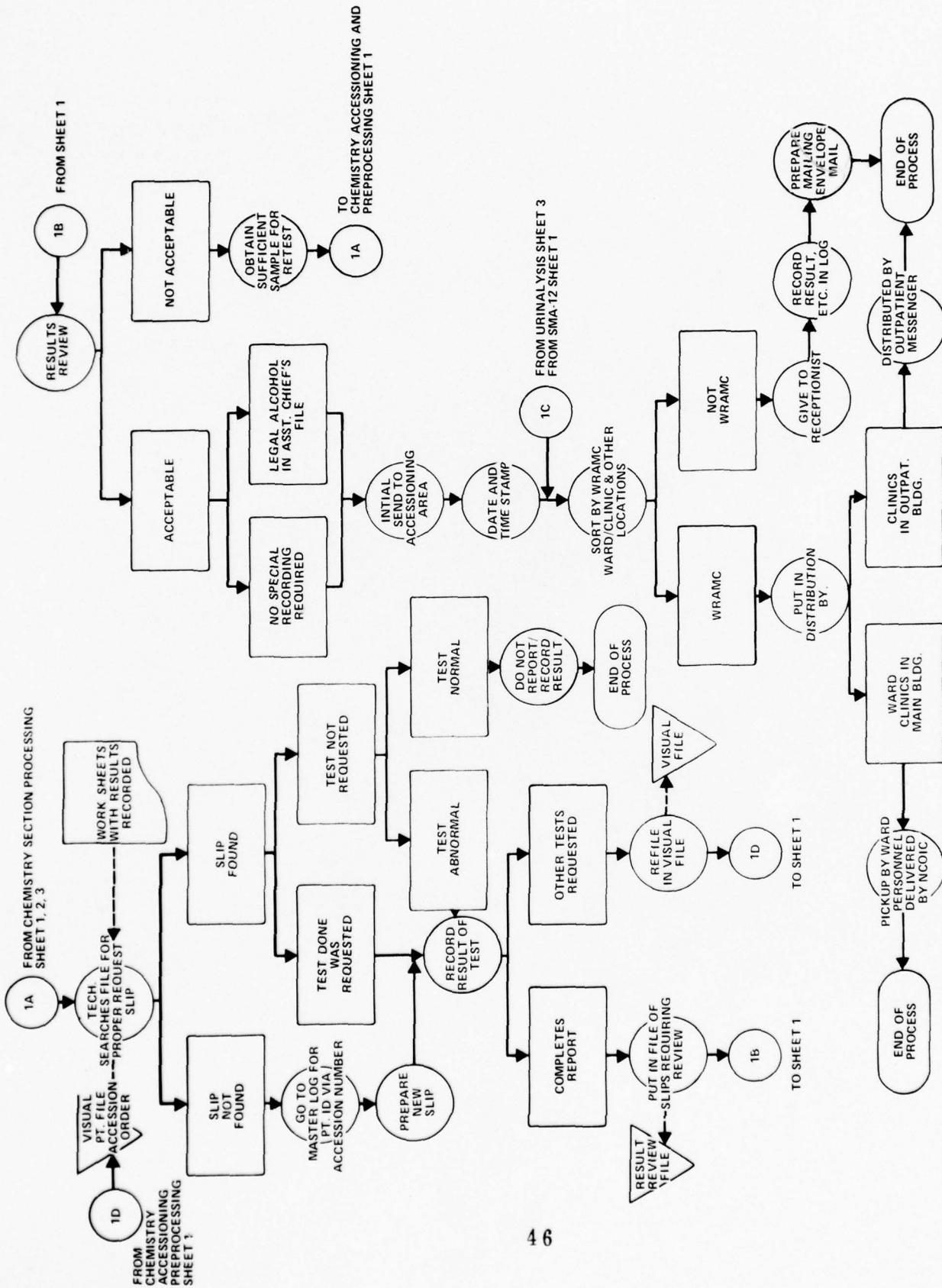

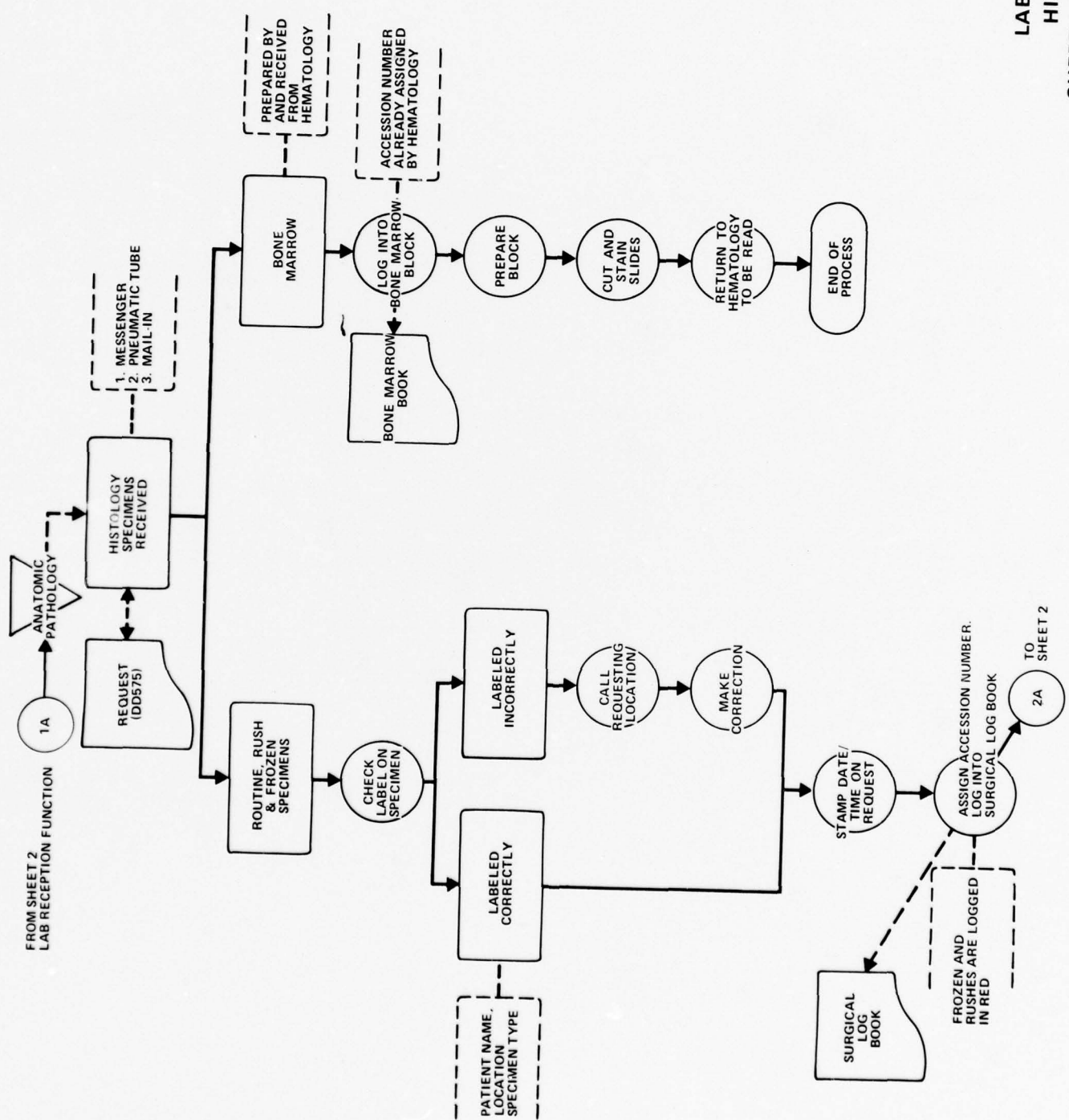

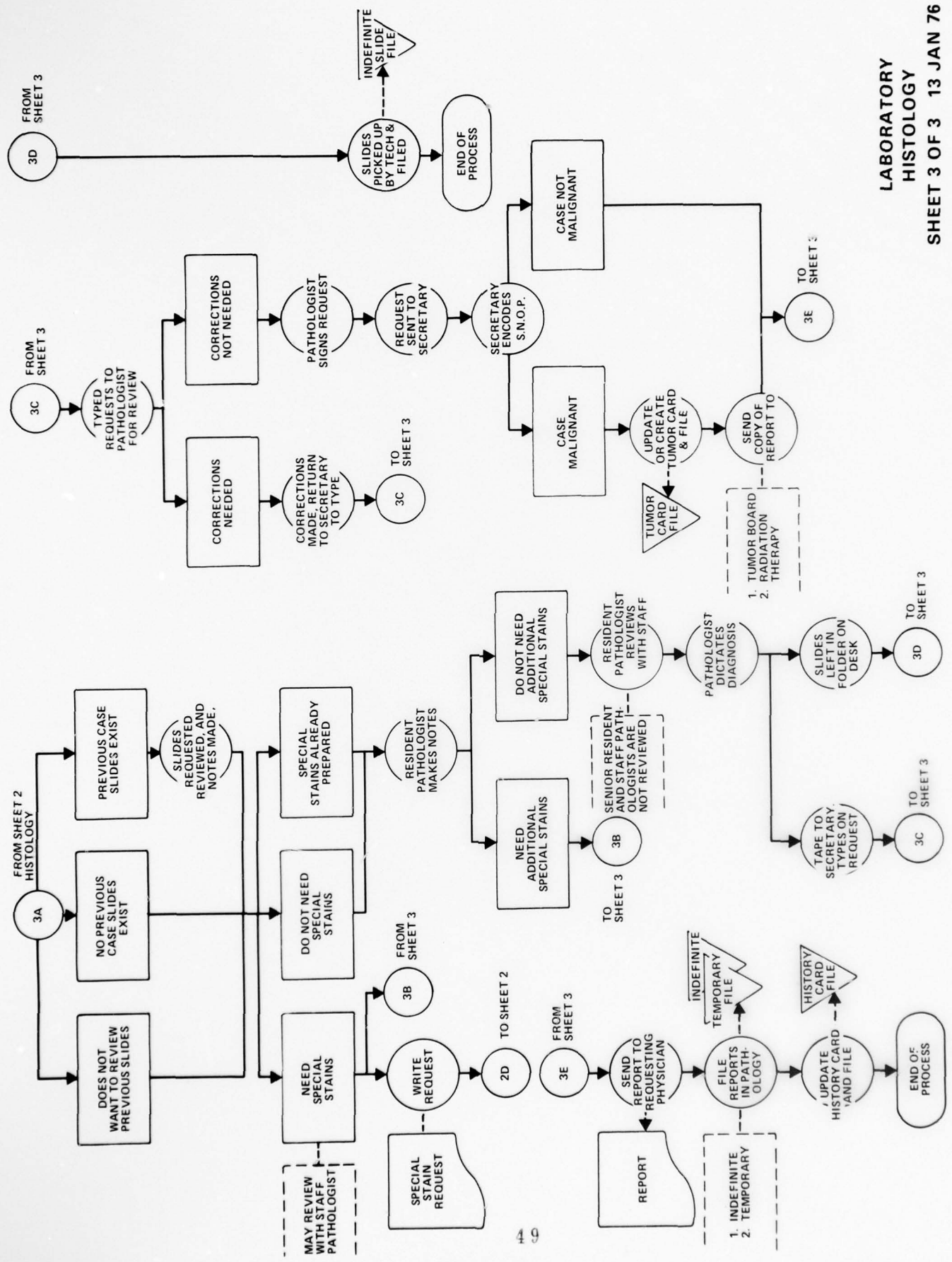

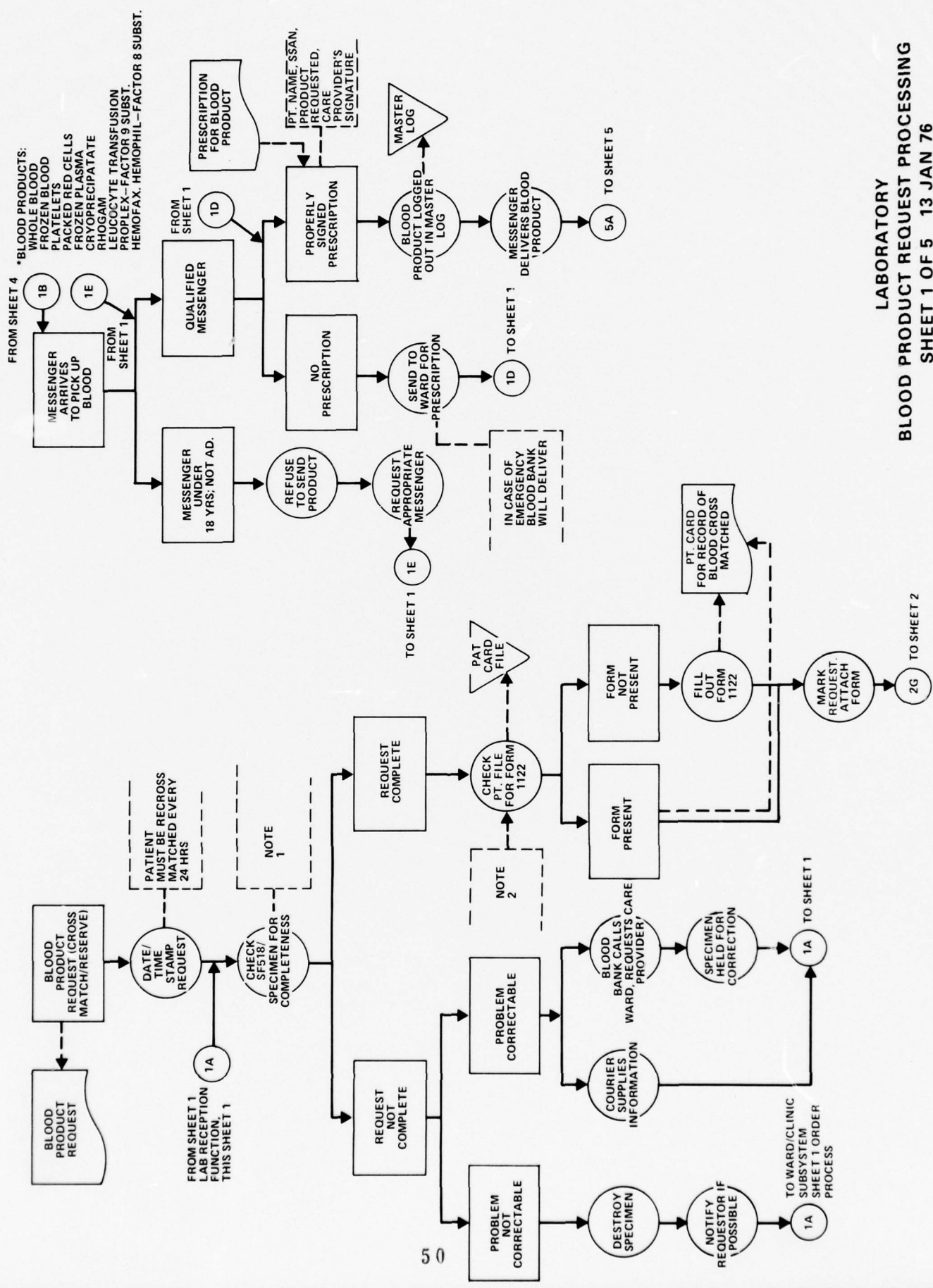

FROM SHEET 4

*BLOOD PRODUCTS:
 WHOLE BLOOD
 FROZEN BLOOD
 PLATELETS
 PACKED RED CELLS
 FROZEN PLASMA
 CRYOPRECIPITATE
 RHOGAM
 LEUCOCYTE TRANSFUSION
 PROPLEX-FACTOR 9 SUBST.
 HEMOFAX-HEMOPHIL-FACTOR 8 SUBST.

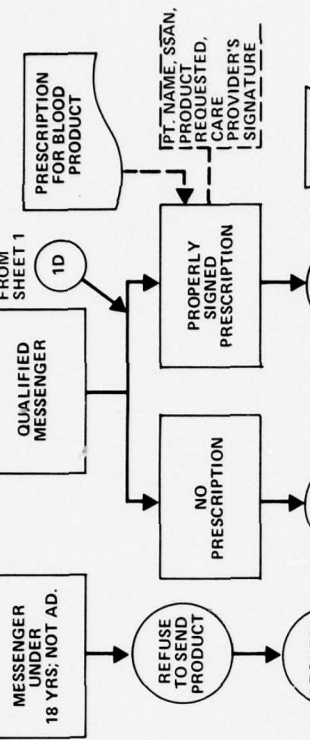

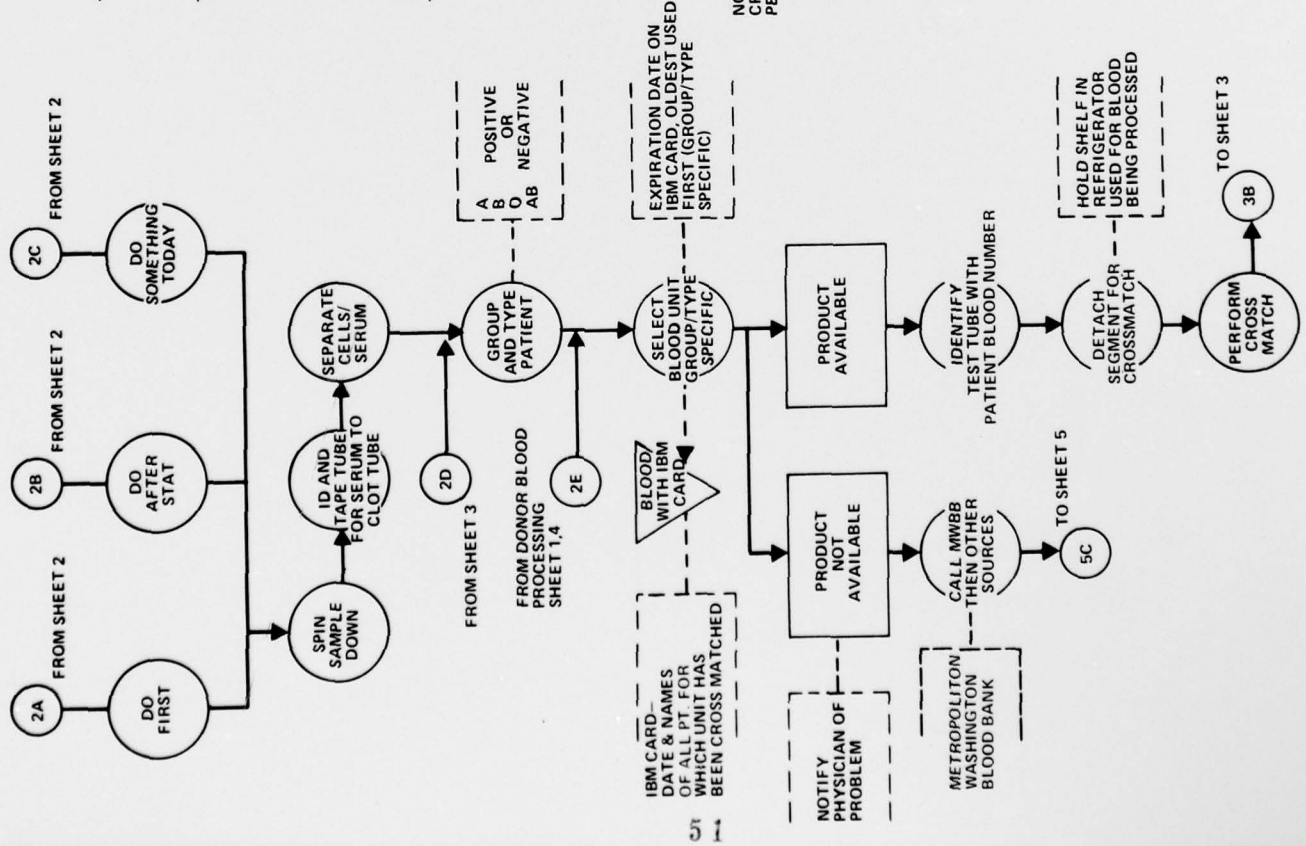
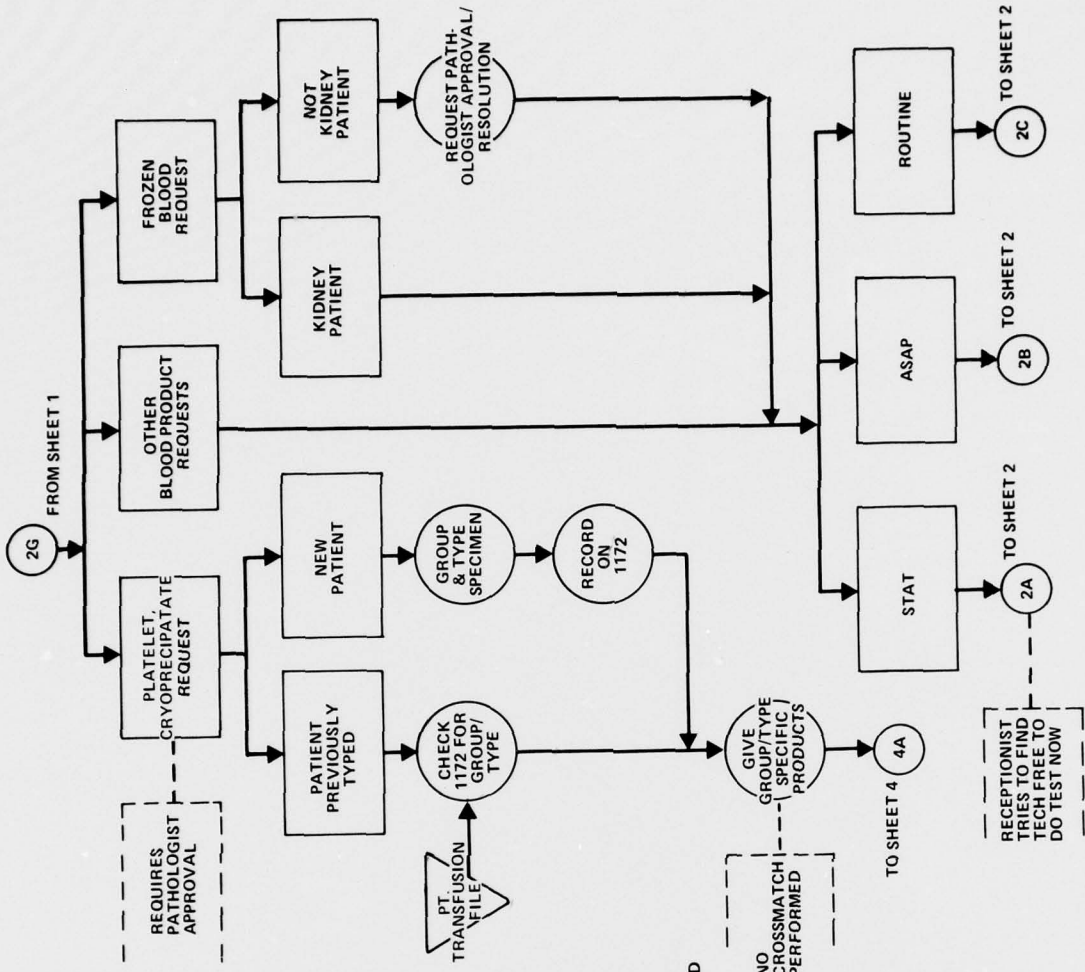

**LABORATORY
BLOOD PRODUCT REQUEST PROCESSING
SHEET 2 OF 5 13 JAN 76**

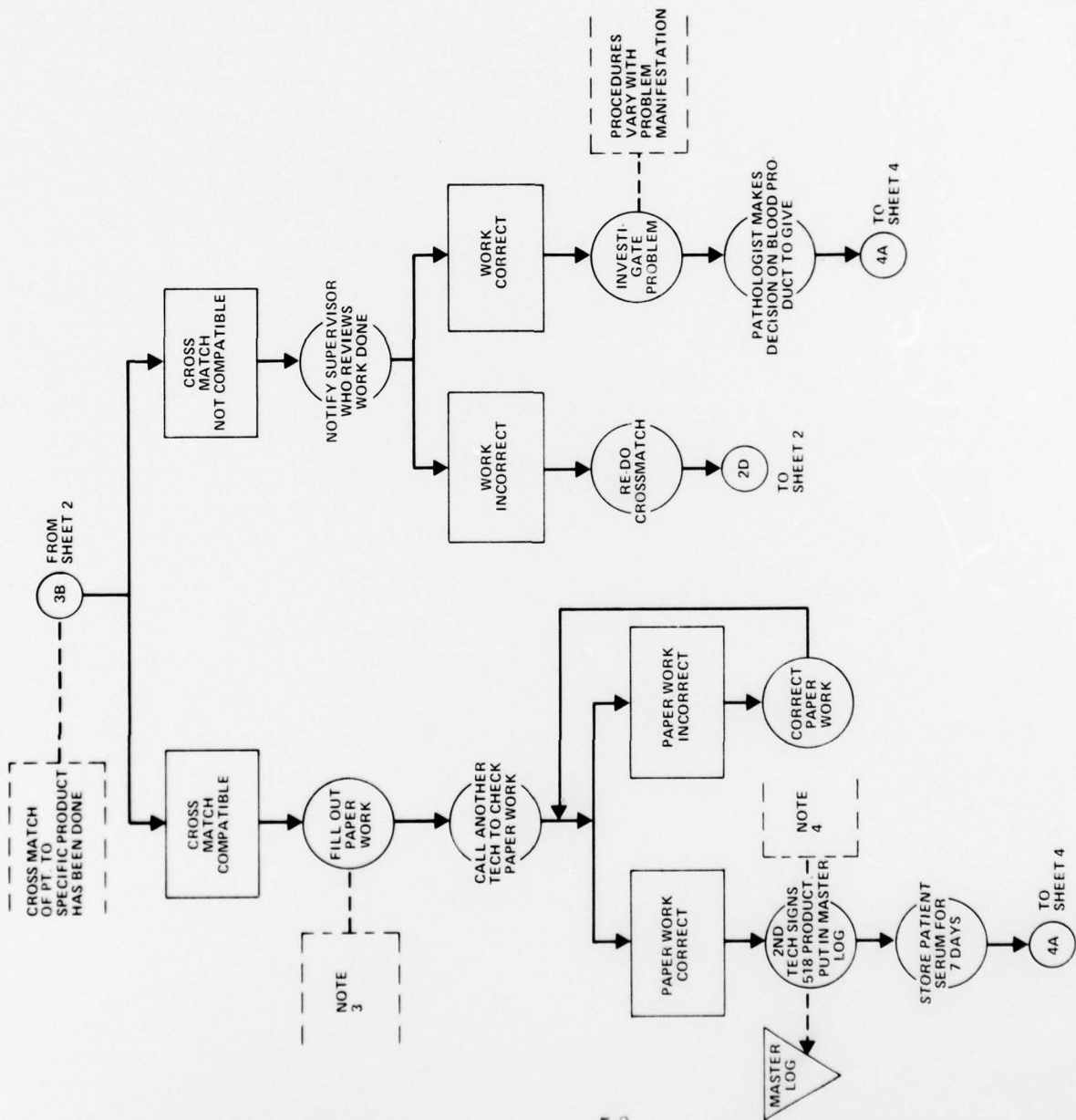

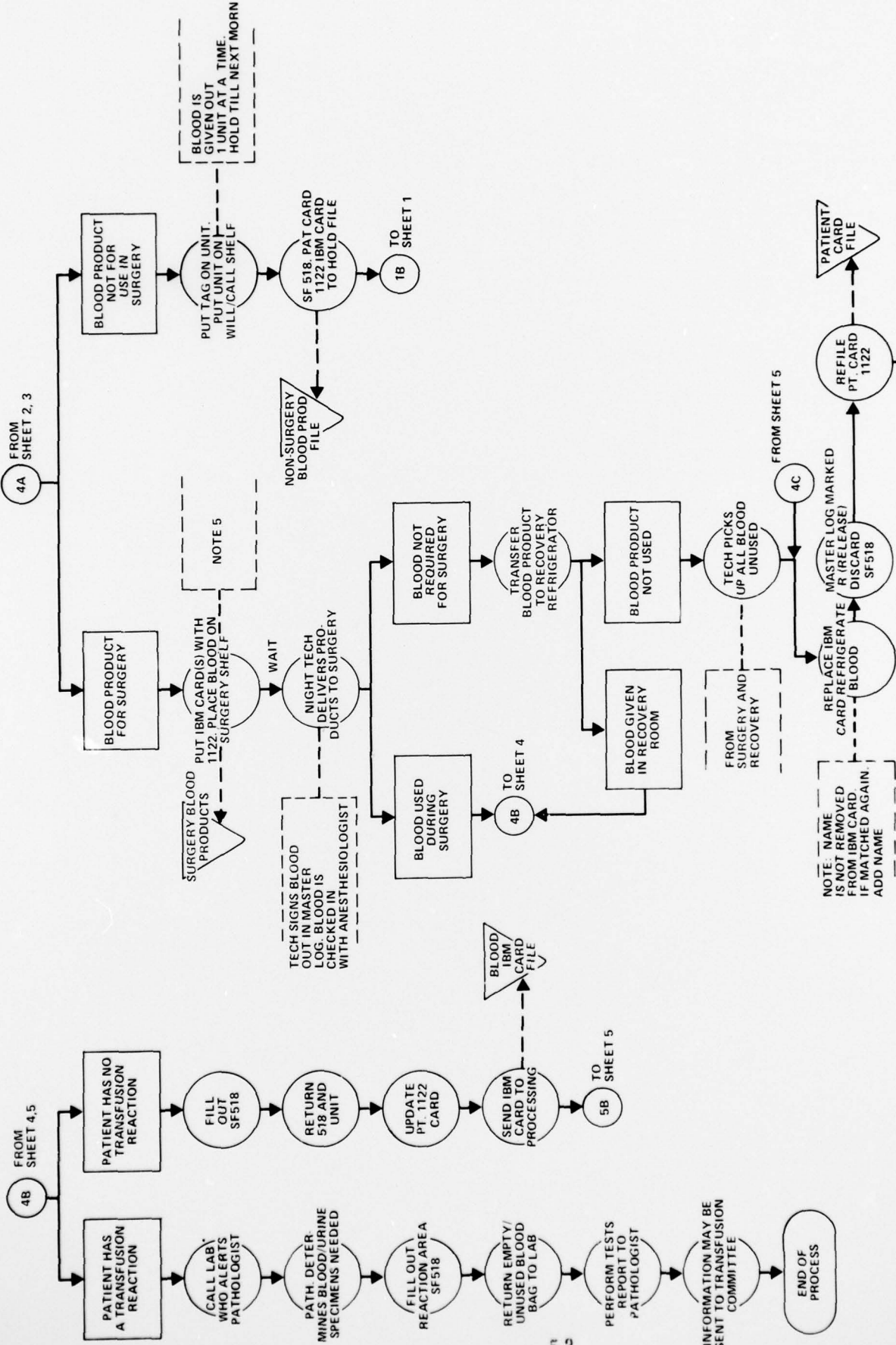

PROCESS COMPLETE

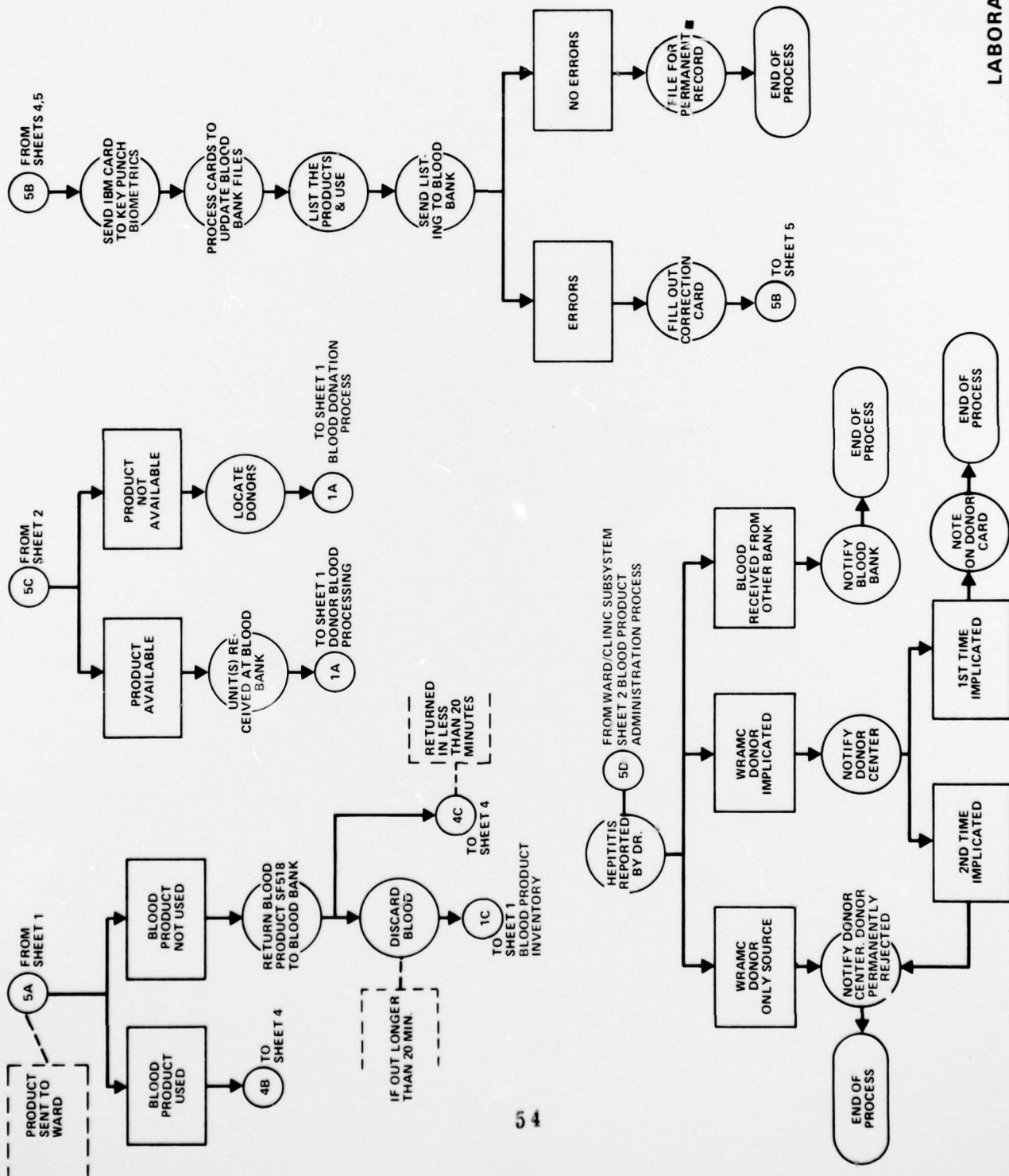

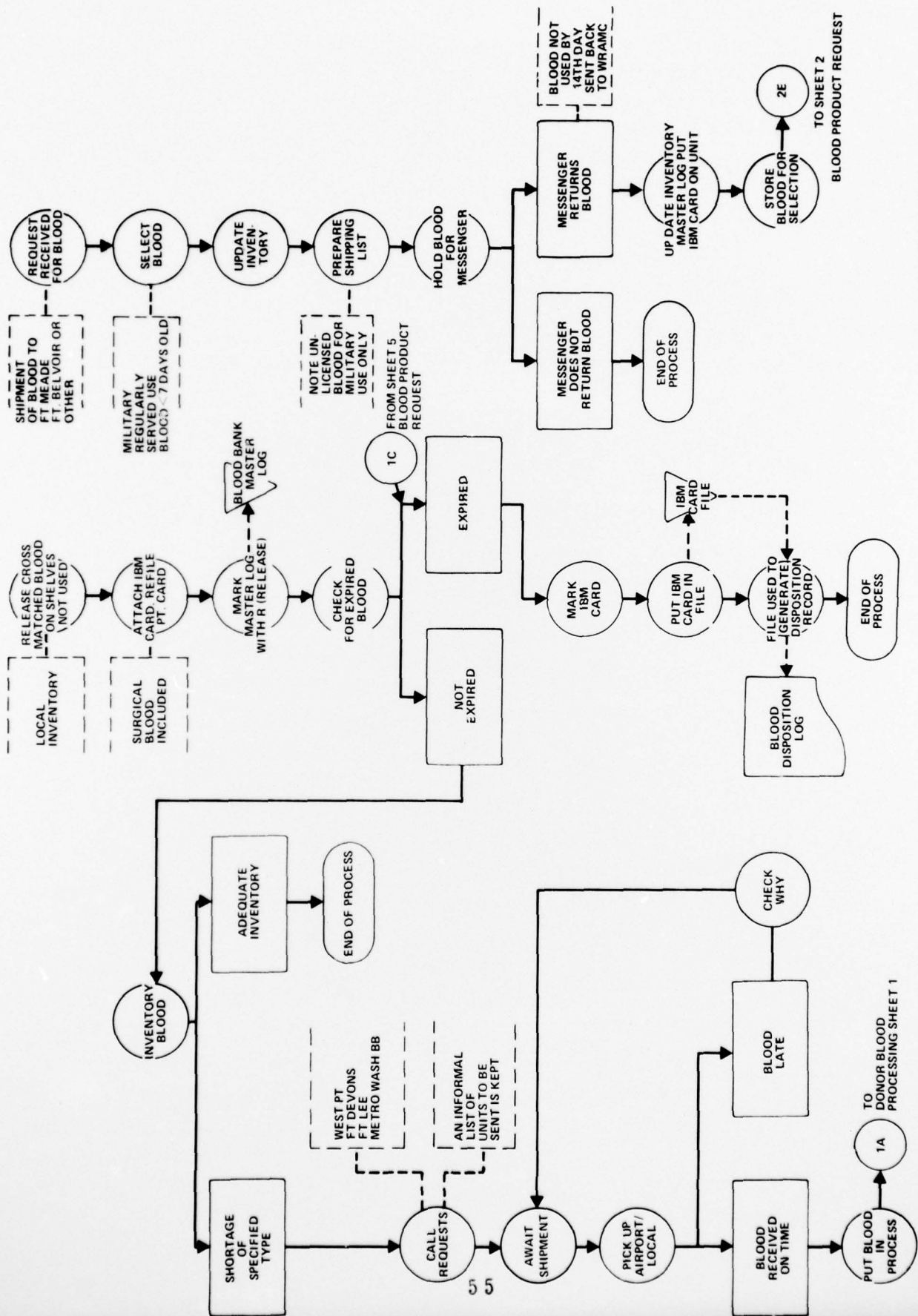

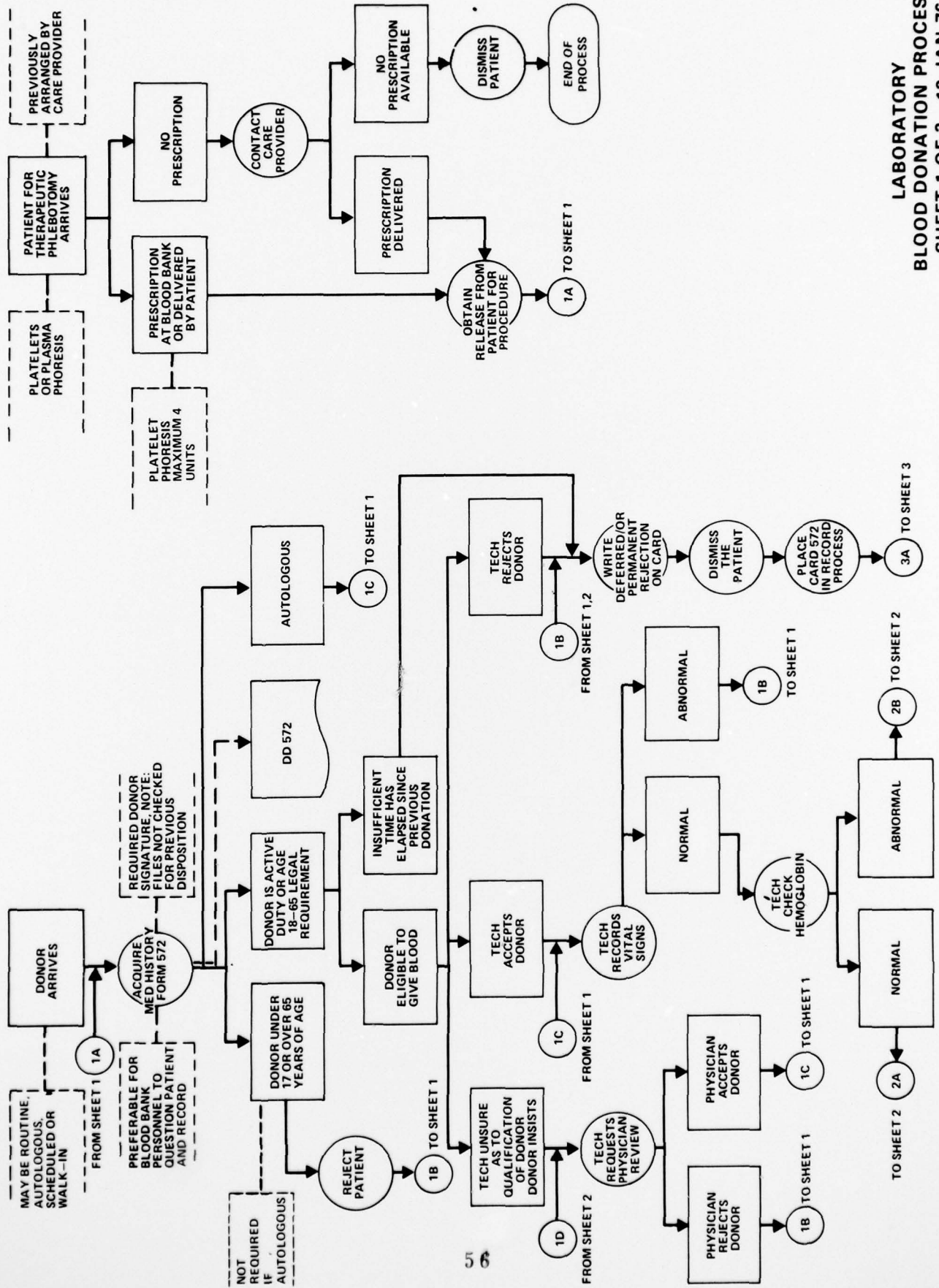

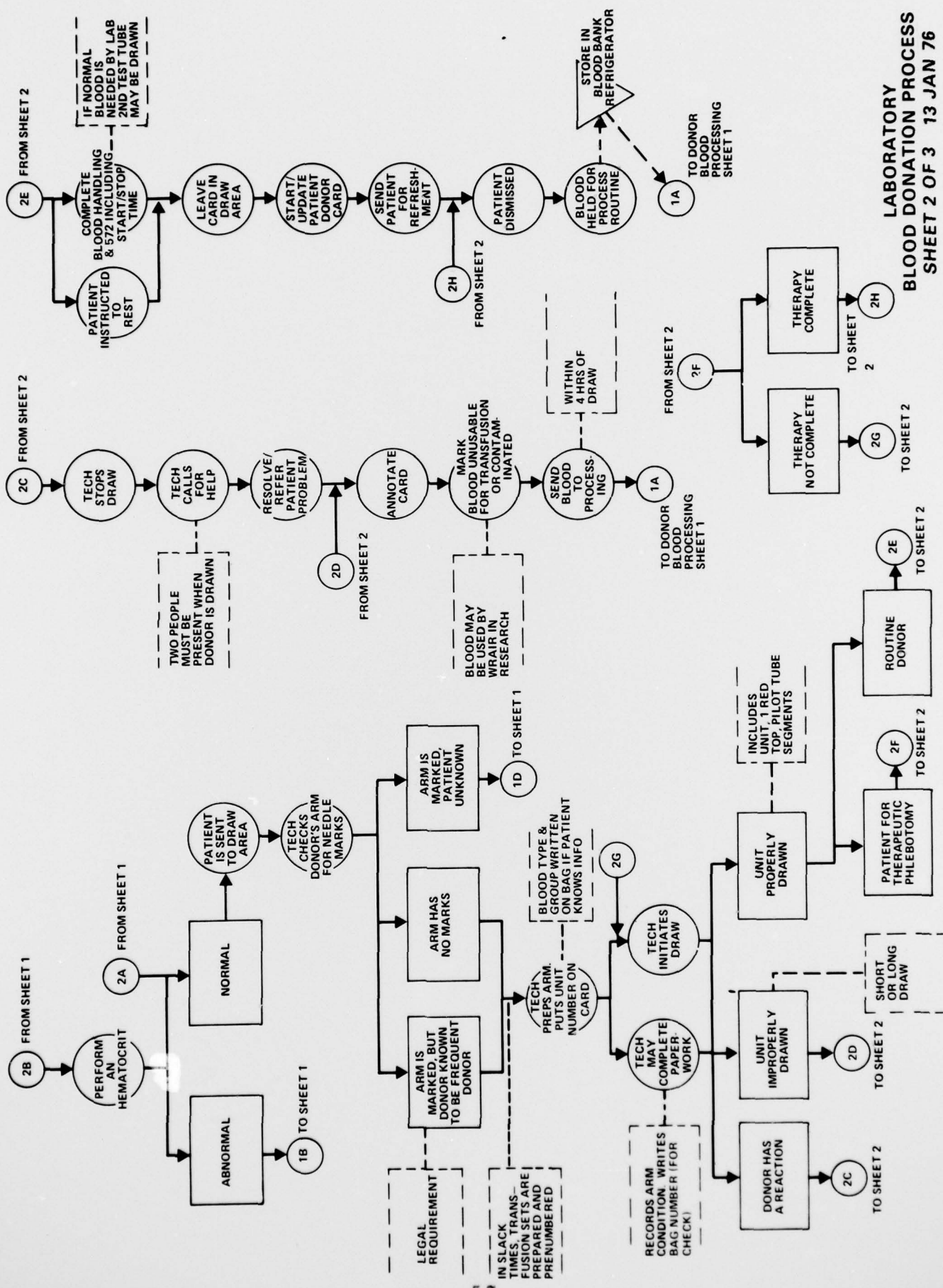

LABORATORY DONATION PROCESS
SHEET 2 OF 3 13 JAN 76

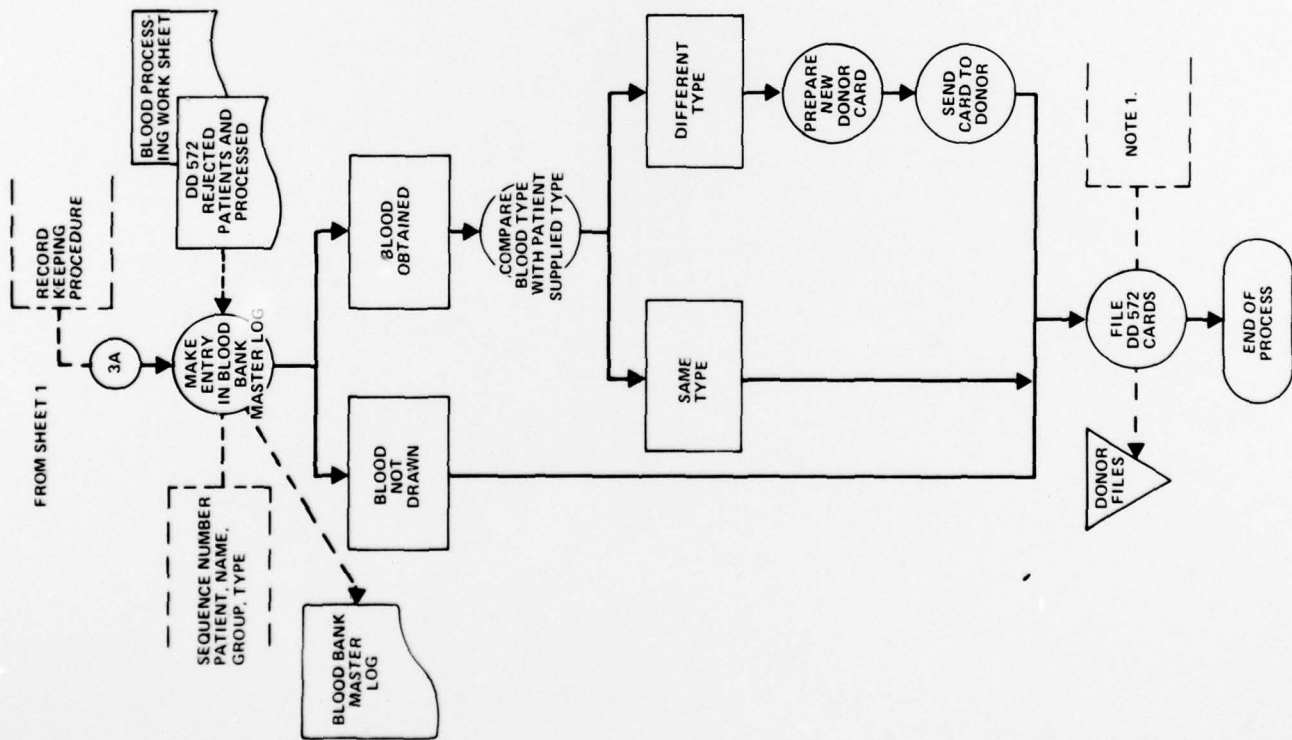

NOTE 1. THERE ARE SEVERAL FILES

- A. AUTOLOGOUS
- B. THERAPEUTIC
- C. RH NEG. WRAMC
- D. OTHER WRAMC
 - 1. CIVILIAN
 - 2. MILITARY
- E. OTHER AGENCY DONORS BY AGENCY

FILING IS ALPHABETIC

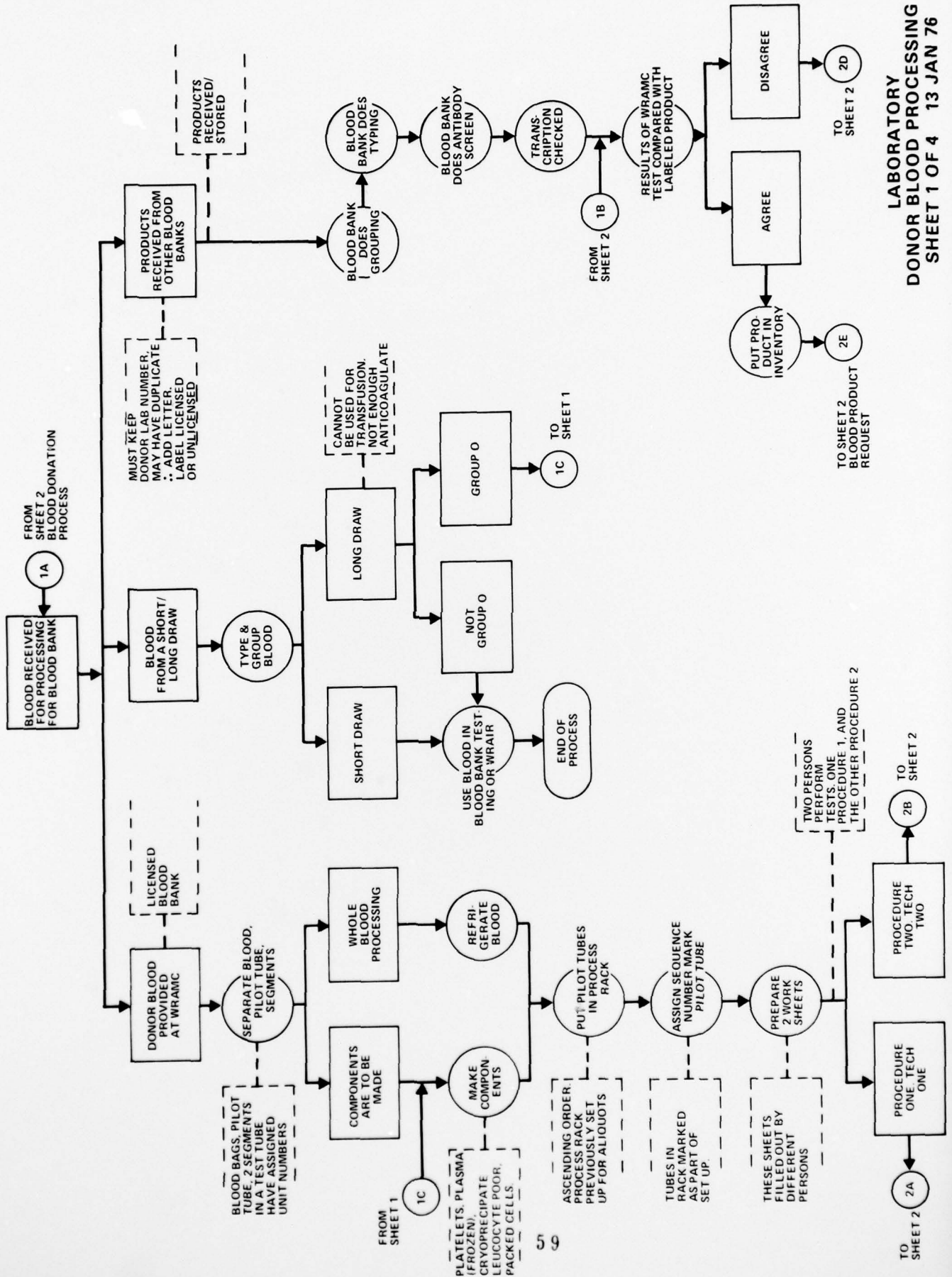

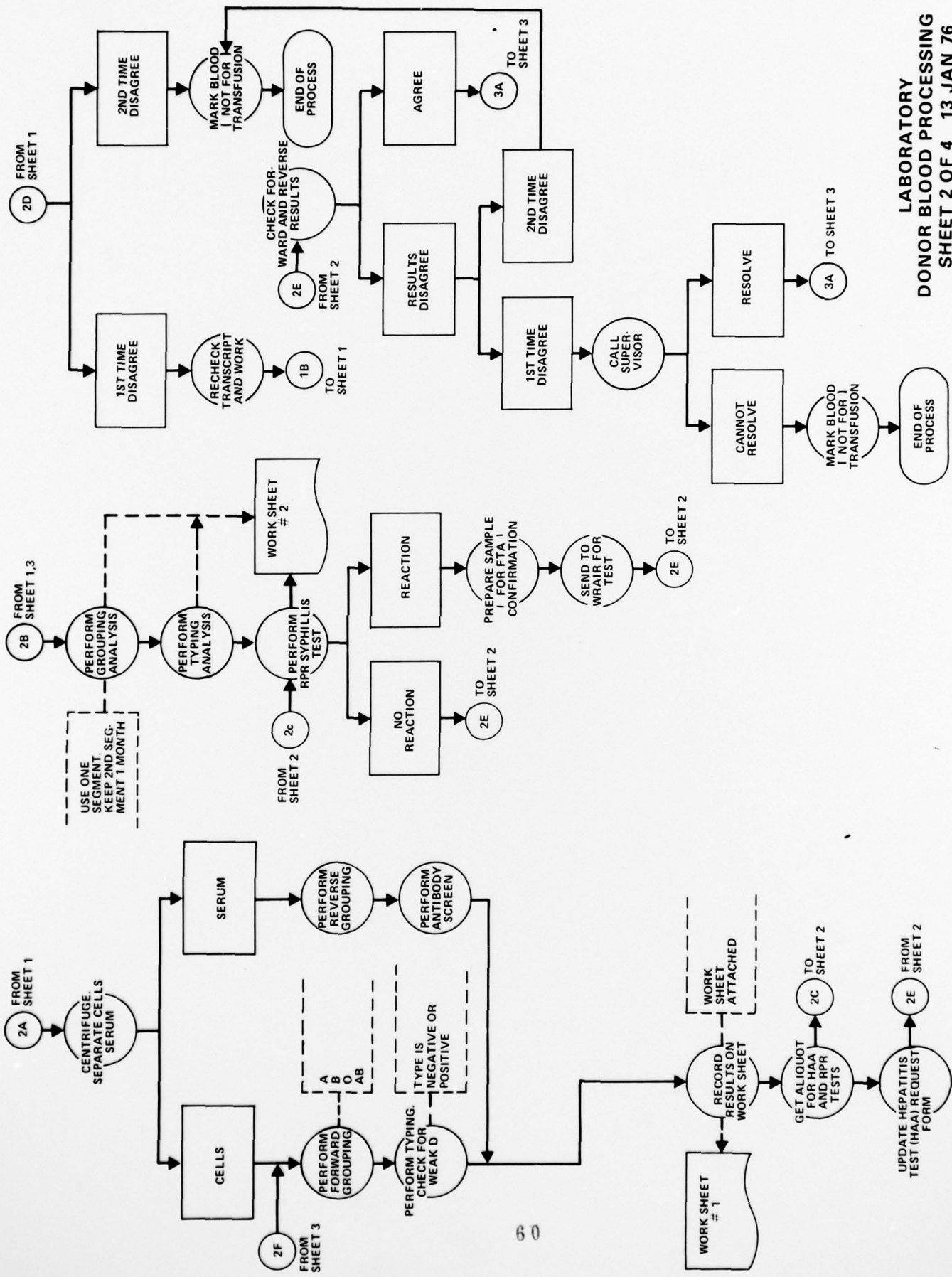

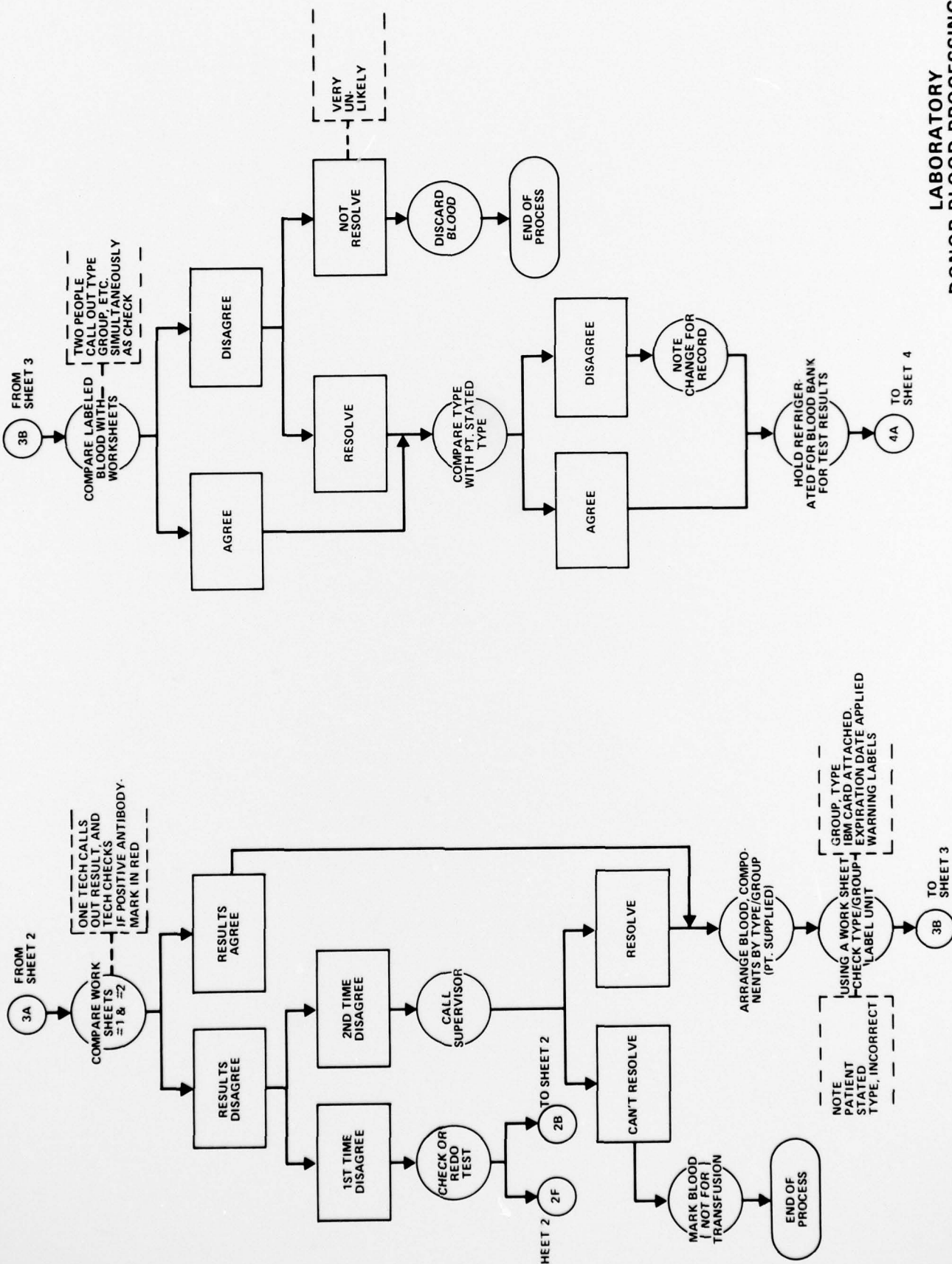

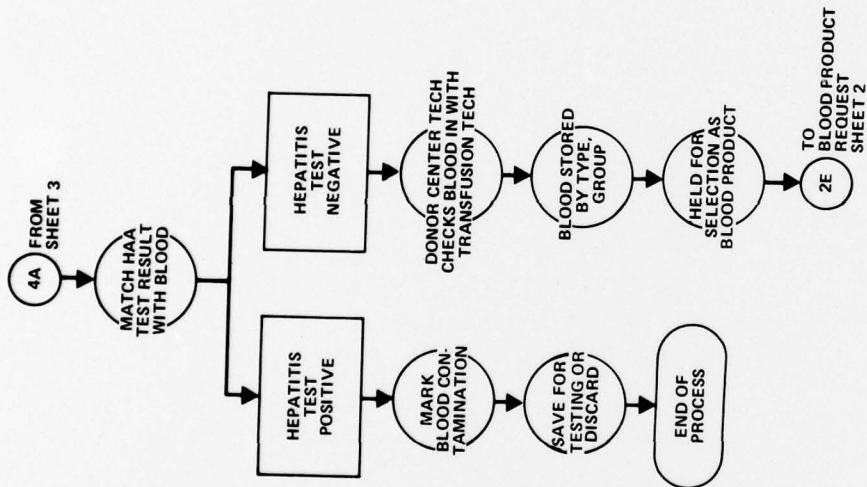

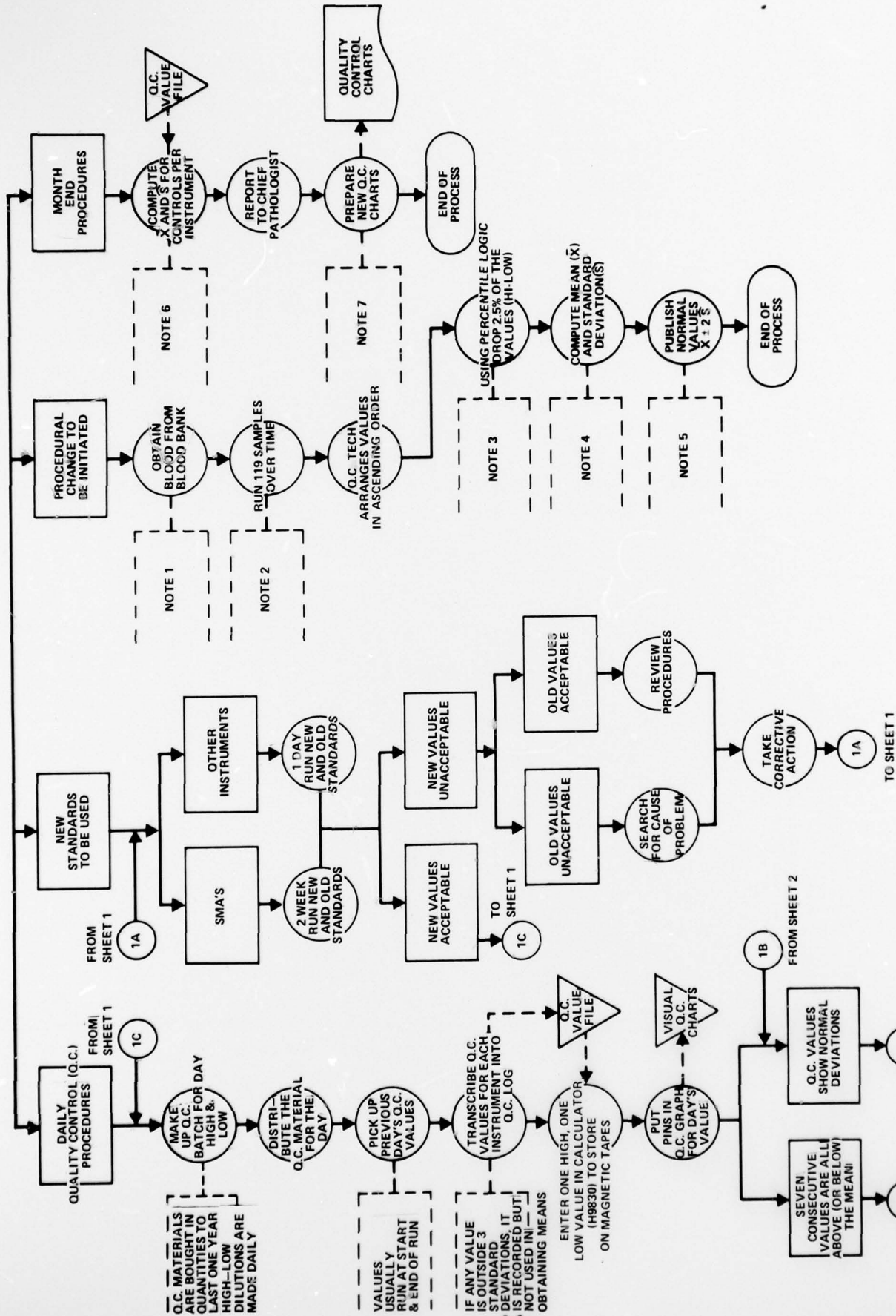

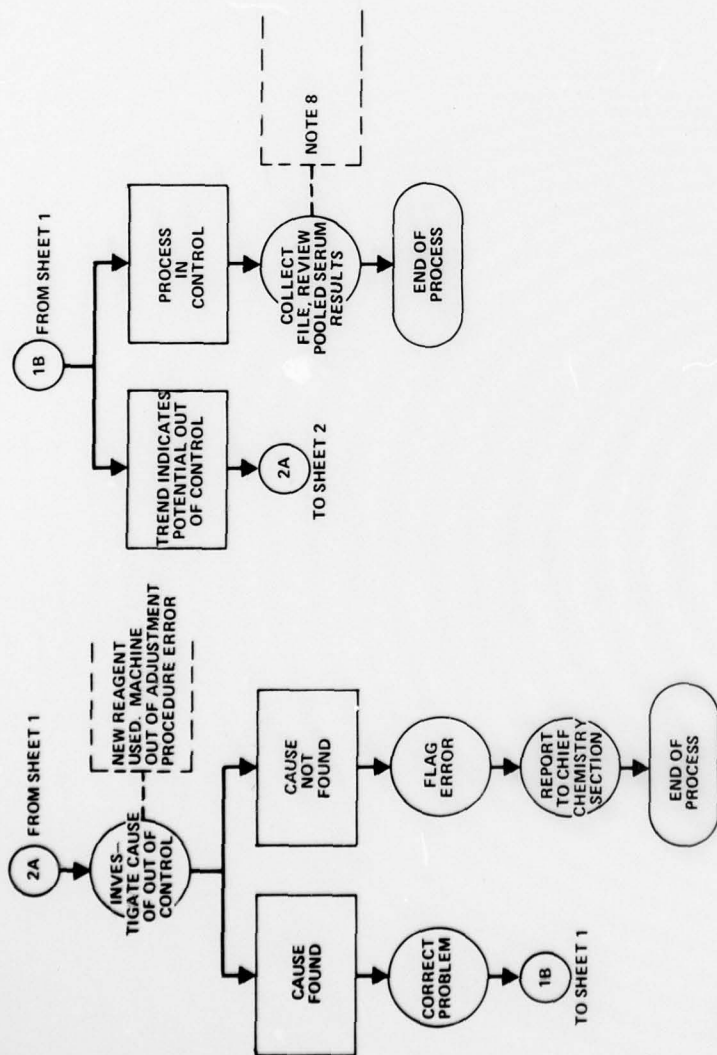

INDEX TO CHARTS

<u>Process</u>	<u>Page</u>
Blood Donation	56
Blood Bank: Blood Product Inventory	55
Blood Product Request Processing	50
Chemistry Accessioning/Preprocessing	21
Chemistry Processing	24
Chemistry Quality Control	63
Chemistry Reporting	46
Cytology	42
Donor Blood Processing	59
Hematology	30
Histology	47
Lab Reception	16
Microbiology	33
Outpatient Laboratory	22
SMA Processing	45
STAT Lab Chemistry	32
Urinalysis	27
Ward Rounds	18