

AD-A043 049

HARRY DIAMOND LABS ADELPHI MD
ARMS REMOTE USER'S MANUAL (U)
DEC 76 D J BUSCHER, M A RESSLER
HDL-SR-76-3

F/G 14/2

UNCLASSIFIED

NL

| OF |
ADA043049



END
DATE
FILMED
9-77
DDC

HDL-SR-76-3

J *12*

ADA043049

ARMS Remote User's Manual

December 1976

HDL-SR-76-3-ARMS Remote User's Manual-by David J Buscher, Marc A Ressler

DDC
RECEIVED
AUG 19 1977
h

AD No. _____
DDC FILE COPY.



U.S. Army Materiel Development
and Readiness Command
HARRY DIAMOND LABORATORIES
Adelphi, Maryland 20783

The findings in this report are not to be construed as an official Department of the Army position unless so designated by other authorized documents.

Citation of manufacturers' or trade names does not constitute an official indorsement or approval of the use thereof.

Destroy this report when it is no longer needed. Do not return it to the originator.

UNCLASSIFIED

SECURITY CLASSIFICATION OF THIS PAGE (When Data Entered)

REPORT DOCUMENTATION PAGE		READ INSTRUCTIONS BEFORE COMPLETING FORM
1. REPORT NUMBER HDL-SR-76-3	2. GOVT ACCESSION NO.	3. RECIPIENT'S CATALOG NUMBER
4. TITLE (and Subtitle) ARMS Remote User's Manual	5. TYPE OF REPORT & PERIOD COVERED Special Report	6. PERFORMING ORG. REPORT NUMBER
7. AUTHOR(s) David J. Buscher Marc A. Ressler	8. CONTRACT OR GRANT NUMBER(s) PRON: WD661WDA9	
9. PERFORMING ORGANIZATION NAME AND ADDRESS Harry Diamond Laboratories 2800 Powder Mill Road Adelphi, MD 20783	10. PROGRAM ELEMENT, PROJECT, TASK AREA & WORK UNIT NUMBERS Program Ele: MDINT	
11. CONTROLLING OFFICE NAME AND ADDRESS Bonneville Power Administration P.O. Box 3621 Portland, OR 97208	12. REPORT DATE December 1976	13. NUMBER OF PAGES 25
14. MONITORING AGENCY NAME & ADDRESS (if different from Controlling Office) 1224.	15. SECURITY CLASS. (of this report) Unclassified	15a. DECLASSIFICATION/DOWNGRADING SCHEDULE
16. DISTRIBUTION STATEMENT (of this Report) Approved for public release; distribution unlimited.		
17. DISTRIBUTION STATEMENT (of the abstract entered in Block 20, if different from Report)		
18. SUPPLEMENTARY NOTES HDL Project: 543652 DRCMS Code: 697000.00.00000		
19. KEY WORDS (Continue on reverse side if necessary and identify by block number) Power metering Revenue metering Demand metering		
20. ABSTRACT (Continue on reverse side if necessary and identify by block number) This manual explains the operation of the Automatic Revenue Metering System Remote Prototype, commonly called the "ARMS Remote or simply "Remote." The ARMS Remote interfaces existing power meters to an automated revenue metering system. The Remote is contained in a single 24-in. (610-mm) rack-mounted panel. It consists of power supplies, a processor module,		

D D C
RECEIVED
AUG 19 1977
C

163050

1B

UNCLASSIFIED

SECURITY CLASSIFICATION OF THIS PAGE(When Data Entered)

→ input/output (I/O) modules, a timing module, a tape cartridge recorder, a keypad, a 16-character alphanumeric display, status display lights, telemetry interface and tone equipment, a series of system test points, and I/O connectors to attach the Remote to the environment that it will monitor. This report discusses normal operation of the ARMS Remote from the user's viewpoint and describes all the steps required for successful use of the system.

Since no ARMS Master Station exists at this time, all Master Station functions will be performed locally via Teletype or Remote keypad. However, for understanding of the complete ARMS Remote/Master Station concept, Master Station functions are identified where possible. Information is included for the use of the local Teletype and keypad for Master Station actions.

↖

UNCLASSIFIED

2 SECURITY CLASSIFICATION OF THIS PAGE(When Data Entered)

CONTENTS

	<u>Page</u>
1. INTRODUCTION	5
2. SYSTEM INITIALIZATION	6
2.1 Data Entry	6
2.2 System Data Inialization	7
2.3 System Data Query	8
2.4 Time Initialization	10
3. RUN-TIME QUERIES	11
4. METERING CONFIGURATIONS	14
4.1 Metering Problem No. 1	14
4.2 Metering Problem No. 2	16
4.3 Digital Metering Mathematics	17
4.4 Analog Metering Mathematics	21
5. TAPE OPERATIONS	22
6. OPERATION OF PSEUDO MASTER STATION	24
DISTRIBUTION	25

FIGURES

1 Front panel rendition	5
2 Back panel rendition	6
3 Sample metering configuration	15

TABLES

I System Commands	12
II System Parametric Units	18

ACCESS ON for	
NIS	Write Section <input checked="" type="checkbox"/>
DDC	Buff Section <input type="checkbox"/>
UNANNOUNCED	<input type="checkbox"/>
DISTRIBUTION	
BY	
DISTRIBUTION/AVAILABILITY CODES	
01	1/17 SPECIAL

1. INTRODUCTION

This manual explains the normal operation of the Automatic Revenue Metering System (ARMS) Remote from a user's viewpoint. Technical detail such as theory of operation, installation, routine maintenance, and trouble-shooting procedures will be found in the ARMS Remote Maintenance Manual¹ and ARMS Remote Programmer's Manual.²

The Remote is contained in a single 24-in. (610-mm) rack-mounted panel that contains power supplies, a processor module, input/output (I/O) modules, a timing module, a tape cartridge recorder, a keypad, a 16-character alphanumeric display, status display lights, telemetry interface and tone equipment, a series of system test points, and I/O connectors to attach the Remote to the environment that it will monitor. Figure 1 is a rendition of the front panel of the Remote, and figure 2 shows the back panel.

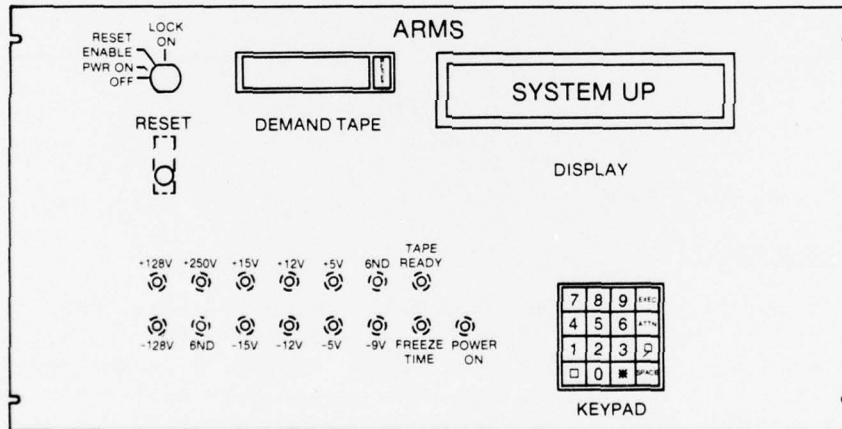

¹David J. Buscher and Marc A. Ressler, ARMS Remote Maintenance Manual, Harry Diamond Laboratories SR-77-3 (August 1977).

²David J. Buscher and Marc A. Ressler, ARMS Remote Programmer's Manual, Harry Diamond Laboratories SR-77-1 (July 1977).

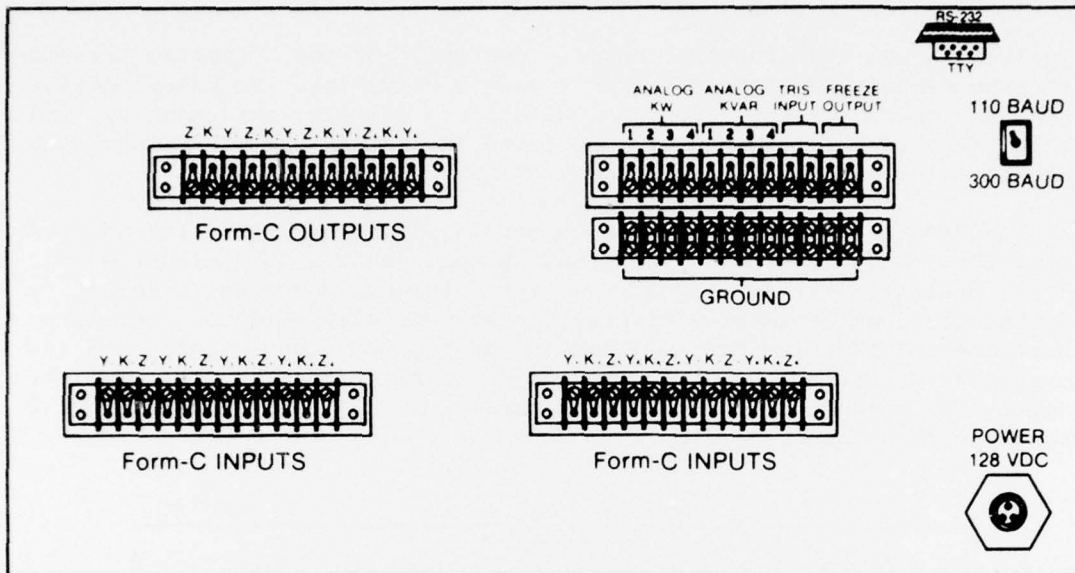

Figure 2. Back panel rendition.

2. SYSTEM INITIALIZATION

2.1 Data Entry

System initialization is normally performed once, when a Remote is activated for the first time at a specific site. The startup procedure consists of inserting a tape cartridge in the demand tape drive, turning the key switch on the upper left of the Remote front panel to the RESET ENABLE position, and then momentarily depressing the system reset switch and closing the reset switch protective cover. The keyswitch is then turned to the LOCK ON position and the key is removed. This removal deactivates the system reset switch so that it will not be pushed accidentally, thereby causing the system to initialize, with possible loss of data.

SYSTEM STARTUP

- (a) Turn keyswitch to RESET ENABLE
- (b) Momentarily depress system reset switch and close protective cover
- (c) Turn keyswitch to LOCK ON
- (d) Remove key

After the system reset switch is depressed, the system will rewind the tape while displaying the message

WORKING

on the display. If the record switch is not set on the cartridge, the system will display the message

TAPE NOT READY

If this message occurs, remove the cartridge and slide the black record switch in the direction indicated on the switch. Then re-insert the cartridge and the "TAPE NOT READY" message should be replaced by another system directive. If the message does not change, repeat the system startup procedure or insert a different cartridge.

2.2 System Data Initialization

After the tape has been inserted properly, the system displays the message

MSTR=1,LCL=2:A=?

The user must now type a "1" or "2" on the Remote keypad. As soon as a key is depressed, the "?" on the display will be replaced by the number of the depressed key. The user may change this number simply by depressing another number key. When satisfied that the correct number is on the display, he depresses the EXEC key to proceed. If a character other than "1" is typed, the system assumes a local restart mode.

If a "1" is typed, the initialization is performed via the Master Station in a preprogrammed sequence that specifies the Remote's specific configuration and the values for all settable parameters. In this mode the display shows the message "MASTER SELECTED." Once all parameters have been set, the display will request the demand period, data, time, station identification and method of startup in the same manner as the local startup procedure (see sect. 2.3).

If the user types a "2" to the initial Master/Local request, the system queries the user to determine the values of parameters and other necessary information normally specified by the Master Station. The display shows the following:

LOCAL SELECTED

This message will remain on the display for approximately 2 s and will be followed by a request for the number of meter inputs (total number of Form-C relays attached as inputs) the system will have. This and all subsequent messages requiring a response will display a number of question marks on the right of the display. The user must type in one number for each question mark.

2.3 System Data Query

If the user is satisfied that the entry is correct, he depresses the EXEC key and the Remote continues with the next message. If the data are not correct, he should enter the correct two-digit number and depress the EXEC key when the data are correct. The Remote then continues in the same manner with the following queries (here the Remote expects an EXEC function after each complete entry, once it is entered correctly).

METER INPUTS=?? Type two digits for the number of metering inputs. A leading 0 is necessary for numbers less than 10. The maximum acceptable number is 8 for the prototype.

METER OUTPUTS=?? Type two digits for the number of outputs. A leading 0 is necessary for numbers less than 10. The maximum acceptable number is 10 for the prototype.

KW FACTOR=???? Type four digits for the number of kilowatt equal to each increment of the analog to digital converter. See section 4.4 for computation of this value.

KVAR (kilovolt-ampere reactive) FACTOR=???? Same as above except for KVAR meter analog inputs.

Input and Output Parameter Values.--The Remote then queries the user for parameters for each input and output. The values for only one input and one output are shown here to conserve space. The input meter data for this example are for input metering point 4 and the output data are for output point 2.

I#04 POWER FLOW
IN=1,OUT=2:A=? Type "1" if input 4 represents power consumed by the customer. Type "2" if input 4 represents power supplied by the customer.

I#04 POWER TYPE
KW=1, KVAR=2:A=? Type "1" if the input is from a KWH meter. Type "2" if the input is from a KVARH meter.

I#04 SCALE = ???? Type a four-digit number which equals the number of KWH or KVARH represented by each Form-C pulse. Leading 0's are required. Section 4.3 shows how this value is used.

I#04 MAX TIME = ?? Type a two-digit number which equals the longest time in minutes expected between input pulses for this meter. This value is used to determine if a meter is functioning properly.

I#04 OUTPUTS = ?? Type a string of two-digit numbers, separated by commas, which references which output points are affected by the particular input. The string is terminated by typing an "EXEC." See section 4.3 for use of this value.

At this point, the Remote continues with input-5 requests if there is an input 5. After all inputs have been entered, the outputs are sequenced. For this example, assume output 1 has already been entered.

O#02 POWER TYPE Type "1" if the output is a KWH function.
KW=1,KVAR=2:A=? Type "2" if the output is a KVARH type.
O#02 SCALE=???? Same as for input scale above.

Initialization Procedure.--After all outputs are finished, the system requests certain general information necessary to initialize the system. At this point the user will have to enter data if either the local or master initialization was selected. The initialization proceeds as follows.

DEMAND PERIOD = ?? Type a two-digit number that represents the number of minutes in a demand period.

TODAY'S DATE = ??? Type a three-digit Julian date. Leading 0's are required.

HMS TIME = ?????? Type two digits each for hours, minutes, and seconds. Note that a 24-hr clock is used. Therefore, midnight occurs at 23:59:59 plus 1 s. Section 2.4 explains how the time is initialized.

STATION ID = ???? Type a four-digit code which represents the specific site of the Remote.

All pertinent information except the starting mode has been entered at this time. The system now dumps this information to tape while displaying the message "***WORKING**." Once the tape is written, the final stage of initialization begins with the selection of a starting method.

2.4 Time Initialization

Now that all the data have been entered and checked, the system is ready to start collecting data. The display outputs the messages.

SELECT START

S=1,G=2,T=3:A=?

At this time the system software clock has not started and therefore contains the time previously entered. If a synchronized start is selected (S=1) the message

DEMAND GO=??????

will be displayed. When an hour, minute, and second time is entered, this time will indicate when data are to be collected. When the EXEC KEY is depressed the software clock starts and the message

AWAITING SYNC

is displayed. When the software clock time matches the demand go time, the message

SYSTEM UP

will be displayed and all functions associated with a freeze pulse will occur. If a go start (G=2) was selected, the system displays the message

SYSTEM UP

and starts collecting data immediately and starts the software clock. The next freeze will occur in XX minutes, where XX was the demand period in minutes entered previously. If a trigger start was selected, the system displays the message

DEMAND GO=??????

A time in hours, minutes and seconds is entered into the software clock. Then the system displays the message

AWAITING SYNC

and waits for a dry Form-A relay closure on a hardware specified input line. When this relay closure occurs, the system clock contains the demand go time, data collection commences, and the message

SYSTEM UP

is displayed.

3. RUN-TIME QUERIES

During system operation certain system parameters may need to be examined or specific system functions may need to be started. All queries are initiated by depressing any keypad key. The system responds by displaying

TYPE OP-CODE ??

The user now types an operation code, after which he depresses the EXEC key. The system then executes the specified operation or displays one of the following messages.

PLEASE TRY AGAIN

WORKING

Requested functions fall into two classes. Those functions that are executed from the op-code immediately are called "inherent" functions. An example of such a function would be a request for the current date. Functions which require further data after the op-code are called "interactive" functions. These functions invoke questions on the display which the user is required to answer before the function can run to completion. An example of such a function is the request to display input meter data. The Remote then asks, "WHICH INPUT??" and follows with the question "WHICH DATA??" Table I defines all legal op-codes and their functions.

TABLE I. SYSTEM COMMANDS

Messages for op-codes 08, 09, 10, and 11 are also displayed on Teletype.

OP-CODE	Function	System request on display	User reply on keypad	Display format
00	Input meter data request	WHICH INPUT??	Type two-digit input number	05
		WHICH DATA ??	00=Pulses in current demand period (updated periodically)	1#05 PUL=1072
			01=KWH or KVARH in current demand period	1#05 KVA=0021440
			02=Pulses in last demand period	1#05 PUL=0927
			03=KWH or KVARH in last demand period	1#05 KVA=0018540
			04=Total pulses this billing period	1#05 PUL=090782
			05=Total KWH or KVARH this billing period	1#05 KVA=1815640
			06=Peak pulse demand for this billing period	1#05 PUL=1120
			07=Peak KWH or KVARH demand for this billing period	1#05 KVA=0022400
			08=Dropping load	DROPPING LOAD
			09=Resume load	RESUME LOAD
	10=Meter out of service (Display asks if meter function is replaced by another metering input. Type a two-digit input meter point and follow it with EXEC. If no replacement appears, type "00" then EXEC).	REPLACED BY ?? OUT OF SERVICE		
	11=Meter returned to service	BACK IN SERVICE		
01	Output data request	WHICH OUTPUT ??	Type two-digit output number	03
		WHICH DATA ??	00=Pulses in current demand period (updated periodically)	0#03 PUL=4567
			01=KWH or KVARH in current demand period	0#03 KWH=004560
			02=Pulses in last demand period	0#03 PUL=6289
			03=KWH or KVARH in last demand period	0#03 KWH=0062890
			04=Total pulses this billing period	0#03 PUL=150007
			05=Total KWH or KVARH this billing period	0#03 KWH=1500070
			06=Peak pulse demand for this billing period	0#03 PUL=6530
	07=Peak KWH or KVARH demand for this billing period	0#03 KWH=0065300		
02	Displays instantaneous value of KW. (This value will be automatically updated on the display each time a new value is read by the hardware.)			KW=104735

TABLE I. SYSTEM COMMANDS (Cont'd)

OP-CODE	Function	System request on display	User reply on keypad	Display format
03	Displays instantaneous value of KVAR (updated same as KW).	-	-	KVAR=±408834
41	Restarts program for demand period, day, time, ID and method of start. All other initialization or accumulated data remain unchanged. This requires a "Password."	PASSWORD=????	4 digit password number	DEMAND PERIOD=??
50	Displays the current value of the 24-hr software clock in HR:MI:SE format. (The clock display is updated every second unless other system functions have priority.)	-	-	13:02:58
51	Displays the current Julian date.	-	-	TODAY'S DATE=125
52	Displays the time of the next demand period.	-	-	NEXT FRZ 140000
60	Notifies the system that the demand tape is to be removed from the tape drive.	-	-	**WORKING** REMOVE TAPE NOW
61	Notifies the system that a new demand tape is to be loaded into the tape drive. If new tape, then a header will be written on the tape. If old tape, the system will move the tape to the last data and stop. It will not write any header information to the tape.	-	-	PLEASE LOAD TAPE NEW=1, OLD=2:A=?
70	Indicates to the system the Julian date when the next billing cycle starts. The system will update at 00 hours of the day. (First tick after midnight of the day preceding the new billing date.)	-	-	NEXT BILLING=???
80	Clears the display.	-	-	(Blank display)
81	Turn off alarm.	-	-	TYPE OP-CODE 81
82	Turn on alarm for 5 s.	-	-	TYPE OP-CODE 82
90	Dump RAM locations and content to Teletype.	-	-	TYPE OP-CODE 90
91	Dump contents of tape to Teletype. (If new tape, simply list tape from its current position. If old tape, rewind and then list tape.)	-	-	**WORKING** NEW=1, OLD=2: A=?

TABLE I. SYSTEM COMMANDS (Cont'd)

OP-CODE	Function	System request on display	User reply on keypad	Display format
93	Backspace tape the specified number of records and print the records on the Teletype.	-	-	HOW MANY BACK=??
94	Rewind tape	-	-	**WORKING**
95	Space tape forward one record. (This command will move tape to end of tape. If no records are forward of the current tape position.)	-	-	TYPE OP-CODE 95
96	Backspace tape one record	-	-	TYPE OP-CODE 96
97	Requests that system print the input and output values of the system at the end of each demand period.	-	-	TYPE OP-CODE 97
98	Requests that the function of OP-CODE 97 be suspended	-	-	TYPE OP-CODE 98

4. METERING CONFIGURATIONS

Since the metering information data structure is flexible, it allows for a variety of metering configurations. Figure 3 shows some of the ways pulse meter inputs can be interconnected to Form-C output relays. Note that (1) an input point can be connected to no outputs, (2) an input point can be connected to one or more outputs with different output scales, or (3) many inputs can be connected to one or more of the outputs. It is possible also to assign dummy outputs for totalization. That is, an output has been assigned in the data base but no physical output relay or output interface is supplied in the hardware.

To clarify the Remote metering capabilities, several metering problems are proposed and their ARMS solutions are shown.

4.1 Metering Problem No.1

Substation No. 1 has three watt-hour meters (A, B, and C), each with a power-in and a power-out relay. Separate totals must be kept for all six relays. Also, the combined totals must be maintained for meters A, B, and C for both in and out power flow. A Form-C pulse must be initiated for every 25 KWH of this combined total (output point X for power in and output Y for power out).

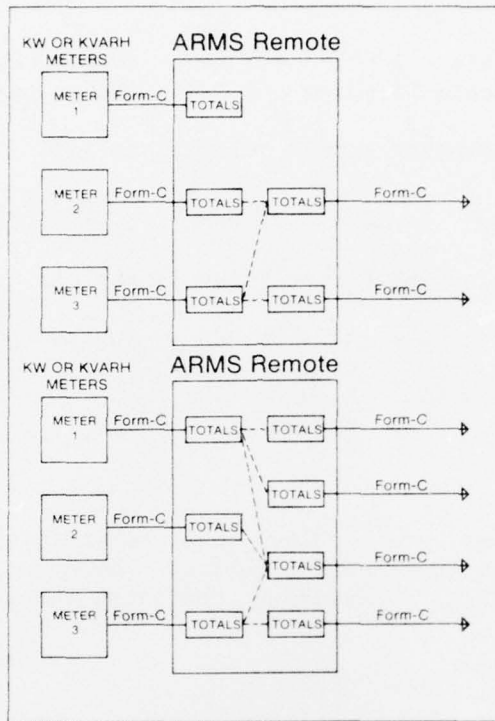

Figure 3. Sample metering configuration.

The analog KW requirements state that each of the above input meters has a full-scale 1-mA analog output current which corresponds to instantaneous power consumption of 60,000 KW. Therefore, at any time the sum of the inputs could equal 180,000 KW. To allow a margin of error, the value 256,000 KW is selected as the maximum KW reading.

Input Meter A

Power-in scale 1 pulse = 10 KWH (meter point 1)
 Power-out scale 1 pulse = 10 KWH (meter point 2)

Input Meter B

Power-in scale 1 pulse = 5 KWH (meter point 3)
 Power-out scale 1 pulse = 1 KWH (meter point 4)

Input Meter C

Power-in scale 1 pulse = 2 KWH (meter point 5)
Power-out scale 1 pulse = 3 KWH (meter point 6)

Output X (corresponding Form-C relay installed)

Output scale 1 pulse = 25 KWH (output point 1)

Output Y (corresponding Form-C relay installed)

Output scale 1 pulse = 25 KWH (output point 2)

KW FACTOR = 256000 ÷ 128 = 2000

KVAR FACTOR = 0000 (unused)

The above input values are defined to be compatible with the installed KWH meters. The outputs are defined because of specific site requirements. The input necessary to configure the above system is

Meter Inputs = 6, Meter Outputs = 2

KW Factor = 2000, KVAR Factor = 0

I#01 Flow = In, Type = KW, Scale = 10, Max Time = 02, Outputs 1

I#02 Flow = Out, Type = KW, Scale = 10, Max Time = 02, Outputs 2

I#03 Flow = In, Type = KW, Scale = 5, Max Time = 02, Outputs 1

I#04 Flow = Out, Type = KW, Scale = 1, Max Time = 02, Outputs 2

I#05 Flow = In, Type = KW, Scale = 2, Max Time = 02, Outputs 1

I#06 Flow = Out, Type = KW, Scale = 3, Max Time = 02, Outputs 2

O#01 Type = KW, Scale = 25

O#02 Type = KW, Scale = 25

To display individual data for the six meter inputs or two Form-C outputs, simply use the appropriate op-codes of section 3.

4.2 Metering Problem No. 2

Substation No. 2 has two watthour meters, each with power-in and power-out relays. Both power-in relay pulses should be summed, and both power-out relay pulses should be summed. Also, the in-meter function for meter A should be connected to an output and cause one output Form-C pulse for every input Form-C pulse. There is no analog requirement.

Input Meter A

1 pulse = 15 KWH (meter point 1)
1 pulse = 5 KWH (meter point 2)

Input Meter B

1 pulse = 20 KWH (meter point 3)
1 pulse = 10 KWH (meter point 4)

Output X (no relay attached)

Output scale 1 pulse = 25 KWH (output point 1)

Output Y (corresponding Form-C relay installed)

Output scale 1 pulse = 15 KWH (output point 2)

Output Z (no relay attached)

Output scale 1 pulse = 20 KWH (output point 3)

The inputs necessary to configure the above system are as follows:

Meter Inputs = 4, Meter Outputs = 3

KW Factor = 0, KVAR Factor = 0

I#01 Flow = In, Type = KW, Scale = 15, Max Time = 05, Outputs = 1,2

I#02 Flow = Out, Type = KW, Scale = 5, Max Time = 02, Outputs = 3

I#03 Flow = In, Type = KW, Scale = 20, Max Time = 02, Outputs = 1

I#04 Flow = Out, Type = KW, Scale = 10, Max Time = 10, Outputs = 3

O#01 Type = KW, Scale = 25

O#02 Type = KW, Scale = 15

O#03 Type = KW, Scale = 20

4.3 Digital Metering Mathematics

To fully use the variety of totalization modes, one needs to know something about the arithmetic capabilities of the ARMS Remote and associated acceptable limits for various system parameters. Further, four minimum units are employed in system calculations. They are (1) the pulse, represented by a change in state of a Form-C relay, (2) the KWH, which equals 1 KWH, (3) the KVARH (KVAR hour), and (4) the analog to digital converter (ADC) step. The KWH and KVAR are similar, and anything said about the KWH applies equally to KVARH's. The ADC step is the minimum digital increment for the ADC. Table II lists system parameters and their allowable values.

TABLE II. SYSTEM PARAMETRIC UNITS

Mnemonics	Description	Range (N)
NPULC	No. input pulses in current demand period	$0 \leq N \leq 9,999$
NPULL	No. input pulses in last demand period	$0 \leq N \leq 9,999$
NPULT	No. input pulses since initialization (not including NPULC)	$0 \leq N \leq 999,999$
INSCL	Input scale factor in l-KWH units	$0 \leq N \leq 65,535$
NOUTC	No. output pulses in current demand	$0 \leq N \leq 9,999$
NOU TL	No. output pulses in last demand period	$0 \leq N \leq 9,999$
NOUTT	No. output pulses since initialization (not including NOUTC)	$0 \leq N \leq 999,999$
OUTSCL	Output scale factor in l-KWH units	$0 \leq N \leq 65,535$
SOUTC	Current fractional pulse count in l-KWH units	$0 \leq N \leq 65,535$
	Displayable values	-
	KWH	$0 \leq N \leq 9,999,999$
	KVARH	$0 \leq N \leq 9,999,999$
	KW	$0 \leq N \leq 999,999$
	KVAR	$0 \leq N \leq 999,999$

On input, each pulse for each Form-C relay input is totaled separately for the current demand period. Historic pulse data also are maintained for the last demand period, and so is the total usage for the current billing period for every Form-C input and output. The KWH data for every input are derived by multiplying the pulse count by the input scale factor. For example, if the user requested the KWH for the current demand period for a given meter input point, the Remote would perform the calculation

$$CKWH = INSCL \times NPULC$$

where

CKWH = the current KWH demand value
 INSCL = the input power scale in l-KWH units
 NPULC = the current demand pulse count

and would display the value of CKWH. Similarly, to determine the total power at an input point, the Remote would perform the calculation

$$TKWH = INSCL \times NPULT$$

where

TKWH = the total KWH usage since initialization
NPULT = the total number of pulses since
initialization, excluding those pulses
in the current demand period

and would display the value of TKWH.

On the output side, separate pulse totals are maintained for each output point. These include the total number of pulses in this demand period, in the last demand period, and the total number of pulses for the current billing period (excluding those pulses in the current demand period). A fractional pulse counter and an output scale are also associated with each point, which is used to determine when it is time for an output pulse or pseudo-pulse (a pseudo-pulse being when there is no physical relay connected to an output point). It is important to note that output points depend completely on the inputs for their data. If an output point is defined, but never referenced by an input, its pulse values are always zero.

The chain of events which causes output data to be altered starts with the recognition of a Form-C pulse on a given input. The system then examines the data block for the input and updates those outputs referenced. The exact sequence is as follows:

- (a) Form-C recognized on input x
- (b) NPULC = NPULC + 1
- (c) Input x references output c
- (d) SOUTC = SOUTC + INSCL
- (e) IF (SOUTC \geq OUTSCL) THEN (FORM-C OUT, NOUTC=NOUTC+1 AND SOUTC = SOUT-OUTSCL) ELSE (CONTINUE)
- (f) Input x references output d
- (g) Repeat (d) and (e) for output d values
- (h) No more outputs referenced
- (i) Wait for next Form-C pulse input

where

NPULC = the current demand period pulse count for input x
SOUTC = the fractional pulse count for output c or d
OUTSCL = the output scale in 1-KWH units for outputs c or d
NOUTC = the current demand period pulse count for output c

The following numerical example clarifies preceding paragraphs.

Initial Conditions

These are three input meters, each having one Form-C relay. Their initial values and attachments to three output points are:

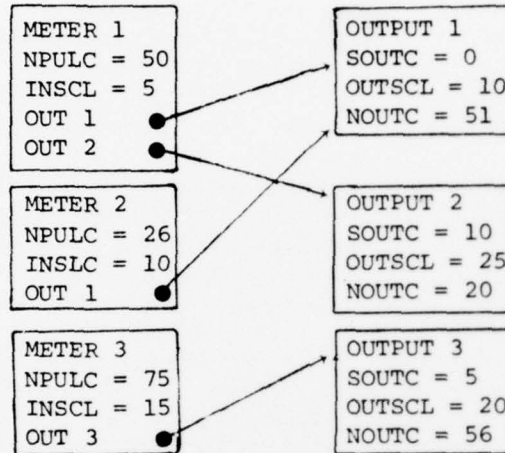

IF METER one generates 3 Form-C pulses then:

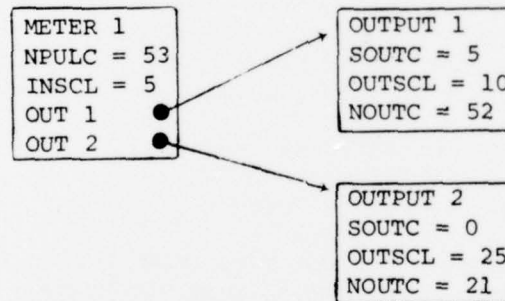

IF METER 2 now generates 2 Form-C pulses then:

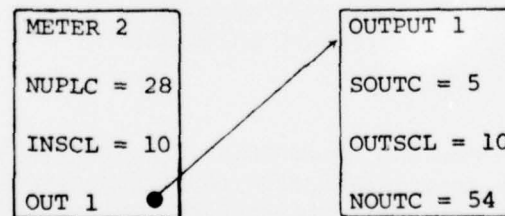

IF METER 3 generates 1 Form-C pulse, then:

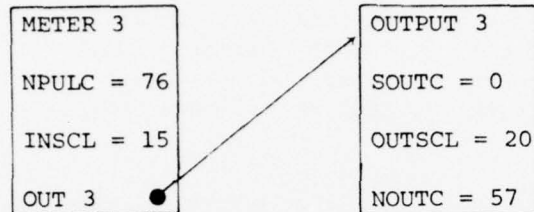

4.4 Analog Metering Mathematics

Analog metering is concerned with monitoring the instantaneous KW or KVAR readings from the analog output of a power meter. Each Remote has two separate analog summing input points, one for KW analog inputs and one for KVAR analog inputs. An ADC is switched between the two summing points to alternate between reading total KW and total KVAR. The ADC is 8-bits wide on the digital side and therefore has a range of 256 increments over the range of input voltages. Its analog range is 10 V, but it has gain and offset functions on its front end so that its effective range is ± 12 V. An example will illustrate the use of the analog inputs.

Conditions:

Eight analog meter inputs are to be attached to the Remote. There will be four KWH meters and four KVARH meters. Each meter has an analog output that is +1 mA full scale. The KWH meters (A, B, C, and D) are each scaled so that full-scale output = 63000 KW. The KVARH meters (W, X, Y, and Z) are each scaled so that full-scale output = 24000 KVAR.

Load Resistor Computations:

All these calculations are estimates. They assure that the analog voltages will not exceed the range of the input amplifiers. Gain and offset adjustments must be made to tailor a set of inputs to the Remote analog inputs.

To allow a voltage range of 8 V on the input, each meter output will be set to +1 V full scale. Therefore, each load resistor $R = (1 \text{ V}) \div (1 \text{ mA}) = 1 \text{ K}$.

Scale Factor Calculations:

KW Inputs: $(4 \text{ meters}) \times 63000 \text{ KW} = 252000 \text{ KW total}$.

To allow some safety margin, the total full-scale KW value is assumed to be 256000 KW. Therefore, KW Factor = $256000 \div 128 = 2000$.

KVAR Inputs: (4 meters) × 24000 KVAR = 96000 .

To allow a safety margin the total full-scale KVAR value is assumed to be 128000 KVAR. Therefore, KVAR Factor = $128000 \div 128 = 1000$. NOTE: The gain and offset values used to condition the analog inputs are discussed more fully in the ARMS Maintenance Manual.¹

5. TAPE OPERATIONS

The inserted tape is initialized by rewinding the tape and writing a header record to the tape. A tape may also be removed or inserted and initialized by use of the run-time function commands. (See table I.)

The tape can contain 100,000 characters of information on the average. All data are written onto the tape in packed binary-coded decimal (BCD) form. That is, two BCD characters are stored as one 8-bit byte on the tape. All physical records on the tape are separated by inter-record gaps and each record contains a record type in its first byte. The header for the tape contains the following records.

Main entries:

Record type = 1 byte
Julian date = 2 bytes
Current hr = 1 byte
Current min = 1 byte
Station ID = 2 bytes
No. of inputs = 1 byte
No. of outputs = 1 byte
KW scale factor = 2 bytes
KVAR scale factor = 2 bytes

Entries for each input:

Variable length list of attached outputs = N bytes terminated by a \$EE byte

Maximum time between pulses = 1 byte

Type of input and direction = 1 byte

Scale of input = 2 bytes

(The above data are repeated for each input.)

¹David J. Bushcher and Marc A. Ressler, ARMS Remote Maintenance Manual, Harry Diamond Laboratories SR-77-3 (August 1977).

Entries for each output:

Power type = 1 byte
Scale of output = 2 bytes

(The above data are repeated for each output.)

The record is terminated by \$FF byte as the last byte in the physical record.

The header is followed by demand data for all inputs and outputs at the end of every demand period; each demand-period data record contains the following information.

Main entries:

Record type = 1 byte
Julian date = 2 bytes
Current hr = 1 byte
Current min = 1 byte

Entries for each input:

Pulse count for period just ended = 2 bytes
Total pulse count = 3 bytes
Maximum demand = 2 bytes
Time of last pulse in minutes = 1 byte

(The above data are repeated for each input.)

Entries for each output:

Pulse count for period just ended = 2 bytes
Total pulse count = 3 bytes
Maximum demand = 2 bytes

(The above data are repeated for each output.)

The record is terminated, after all outputs, by a \$FF byte in the last position of the physical record.

If the tape ends, the cartridge is automatically rewound and a new header record is written. At this point the operator may remove the tape and replace it by another, or leave the tape in the drive to be overwritten by new data.

6. OPERATION OF PSEUDO MASTER STATION

The pseudo Master Station is to be used during the prototype testing phase to simulate certain Master Station functions. The pseudo Master Station consists of a Teletype for data input and output and certain Remote software and keypad functions (which are unique to the prototype and would not be in a final version of the ARMS Remote).

The Teletype keyboard can be used in the same manner as the keypad to query the system and to invoke system functions. The only difference is that the EXEC key of the keypad is replaced by the RETURN key on the Teletype. Therefore, to request the time of day from the Teletype the operator would type 50 followed by a RETURN.

The Teletype printer is used to display data that would normally be transmitted via telemetry link to the Master Station. These data consist of

- (a) System status reports
- (b) Random access memory (RAM) dumps
- (c) Power usage reports
- (d) Tape dumps

The Remote prototype software contains routines to handle pseudo Master Station functions such as Teletype input/output, freeze-time initiation, system-parameter initialization, and alarm functions. These functions are not all-inclusive in representing Master Station functions, but they are representative of those functions necessary to perform an evaluation of the Remote prototype.

The keypad, like the Teletype keyboard, allows certain system functions to be activated as if the request were from the Master Station. A list of all commands appears in table I. No attempt has been made to distinguish between Master Station functions and Remote functions because distinctions such as these will have to be made after the prototype evaluation period.

DISTRIBUTION

DEFENSE DOCUMENTATION CENTER
CAMERON STATION, BUILDING 5
ALEXANDRIA, VA 22314
ATTN DDC-TCA (12 COPIES)

COMMANDER
US ARMY MATERIEL DEVELOPMENT & READINESS COMMAND
5001 EISENHOWER AVENUE
ALEXANDRIA, VA 22333
ATTN DRXAM-TL, HQ TECH LIBRARY

US DEPARTMENT OF COMMERCE
ASSISTANT SECRETARY FOR SCIENCE
& TECHNOLOGY
WASHINGTON, DC 20230

US DEPARTMENT OF COMMERCE
NATIONAL BUREAU OF STANDARDS
WASHINGTON, DC 20230

US ENERGY RESEARCH & DEVELOPMENT
ADMINISTRATION
ALBUQUERQUE OPERATIONS
P.O. BOX 5400
ALBUQUERQUE, NM 87115

US ENERGY RESEARCH & DEVELOPMENT
ADMINISTRATION
TECHNICAL INFORMATION ORGANIZATION
P.O. BOX 62
OAK RIDGE, TN 37830

US DEPARTMENT OF THE INTERIOR
BONNEVILLE POWER ADMINISTRATION
P.O. BOX 3621
PORTLAND, OR 97208
ATTN ROBERT ELLINGWOOD (10 COPIES)
ATTN JAMES JONES

HARRY DIAMOND LABORATORIES
ATTN LOWREY, AUSTIN, III, COL, COMMANDER/
FLYER, I.N./LANDIS, P.E./
SOMMER, H./OSWALD, R. B.
ATTN CARTER, W.W., DR., TECHNICAL
DIRECTOR/MARCUS, S.M.
ATTN KIMMEL, S., PAO
ATTN CHIEF, LAB 500
ATTN RECORD COPY, BR 041
ATTN HDL LIBRARY (5 COPIES)
ATTN CHAIRMAN, EDITORIAL COMMITTEE
ATTN TECH REPORTS, 013
ATTN GIDEP OFFICE, 741
ATTN LANHAM, C., 0021
ATTN BUSCHER, D., (3 COPIES)
ATTN RESSLER, M., (3 COPIES)