

AD A 038691

AFAPL-TR-76-43 VOLUME III

12
NW

AIRCRAFT HYDRAULIC SYSTEMS DYNAMIC ANALYSIS

VOLUME III FREQUENCY RESPONSE (HSFR)

COMPUTER PROGRAM USER MANUAL

MCDONNELL AIRCRAFT COMPANY
MCDONNELL DOUGLAS CORPORATION
ST. LOUIS, MISSOURI

February 1977

TECHNICAL REPORT AFAPL-TR-76-43, VOLUME III

This document has been approved for public release.
Its distribution is unlimited.

DDC
APR 27 1976
B

AIR FORCE AERO PROPULSION LABORATORY
AIR FORCE SYSTEMS COMMAND
WRIGHT-PATTERSON AIR FORCE BASE, OHIO 45433

AD No. _____
DDC FILE COPY

NOTICE

When Government drawings, specifications, or other data are used for any purpose other than in connection with a definitely related Government procurement operation, the United States Government thereby incurs no responsibility nor any obligation whatsoever; and the fact that the government may have formulated, furnished, or in any way supplied the said drawings, specifications, or other data, is not to be regarded by implication or otherwise as in any manner licensing the holder or any other person or corporation, or conveying any rights or permission to manufacture, use, or sell any patented invention that may in any way be related thereto.

This report was submitted by McDonnell Douglas Corporation, under contract F3615-74-C-2016.

The effort was sponsored by the Air Force Aero Propulsion Laboratory, Air Force Systems Command, Wright-Patterson A.F.B., Ohio, under Project No. 3145-30-18 with AFAPL/POP/, and was under the direction of Paul Lindquist and William Kinzig.

Neil Pierce and Gerry Amies of McDonnell Douglas Corporation were technically responsible for the work.

This report has been reviewed by the Information Office, (ASD/OIP) and is releasable to the National Technical Information Service (NTIS). At NTIS, it will be available to the general public, including foreign nations.

ACCESSION FOR	
NTIS	WITH SYMBOLS <input checked="" type="checkbox"/>
DDC	WITH SYMBOLS <input type="checkbox"/>
UNANNOUNCED	<input type="checkbox"/>
JUSTIFICATION	
BY	
DISTRIBUTION/AVAILABILITY CODES	
Dist.	AVAIL. AND/OR SPECIAL
A	

Copies of this report should not be returned unless return is required by security considerations, contractual obligations, or notice on a specific document.

UNCLASSIFIED

SECURITY CLASSIFICATION OF THIS PAGE (When Data Entered)

19 REPORT DOCUMENTATION PAGE		READ INSTRUCTIONS BEFORE COMPLETING FORM	
18 1. REPORT NUMBER	2. GOVT ACCESSION NO.	3. RECIPIENT'S CATALOG NUMBER	
AFAPL-TR-76-43-VOL- 13 31		9	
6 4. TITLE (and Subtitle)	5. TYPE OF REPORT & PERIOD COVERED		
AIRCRAFT HYDRAULIC SYSTEM DYNAMIC ANALYSIS, VOLUME III, FREQUENCY RESPONSE (HSFR) COMPUTER PROGRAM USER MANUAL.	Interim Technical Report.		
	6. PERFORMING ORG. REPORT NUMBER		
	7. AUTHOR(s)		
Gerry/Amies Bob/Greene	8. CONTRACT OR GRANT NUMBER(s)		
	F3615-74-C-2016		
9. PERFORMING ORGANIZATION NAME AND ADDRESS		10. PROGRAM ELEMENT, PROJECT, TASK AREA & WORK UNIT NUMBERS	
McDonnell Douglas Corporation P O Box 516 St. Louis, Missouri 63166		16 3145-30-18	
11. CONTROLLING OFFICE NAME AND ADDRESS		12. REPORT DATE	
Air Force Aero Propulsion Laboratory Air Force Systems Command Wright-Patterson Air Force Base, Ohio 45433		11 Feb 1977	
14. MONITORING AGENCY NAME & ADDRESS (if different from Controlling Office)		13. NUMBER OF PAGES	
		77	
		15. SECURITY CLASS. (of this report)	
		UNCLASSIFIED	
		15a. DECLASSIFICATION/DOWNGRADING SCHEDULE	
16. DISTRIBUTION STATEMENT (of this Report)			
Approved for public release, distribution unlimited			
15 F33615-74-C-2016			
17. DISTRIBUTION STATEMENT (of the Abstract entered in Block 20, if different from Report)			
18. SUPPLEMENTARY NOTES			
19. KEY WORDS (Continue on reverse side if necessary and identify by block number)			
Computer Program		Pump Ripple	
Hydraulic System		User's Manual	
Frequency Response			
Acoustic Noise			
Pump Pulsations		62203F	
20. ABSTRACT (Continue on reverse side if necessary and identify by block number)			

See Reverse Side

UNCLASSIFIED

SECURITY CLASSIFICATION OF THIS PAGE(When Data Entered)

20. ABSTRACT

↙ The hydraulic system frequency response (HSFR) computer program was developed to simulate the dynamic response of a hydraulic system to the acoustic noise generated by the pump. Detailed instructions for modeling the system pump, lines, and components, and for using the program are presented.

For a selected system pressure, temperature, flow, and pump speed range, the program calculates the pulsation pressure and energy levels generated by the pump. It predicts the amplitude and location of the resulting acoustical standing waves, and how these waves are transmitted and attenuated throughout the hydraulic system. The program may be used for acoustical analysis in the pressure side or both the pressure and return sides of the hydraulic system. ↗

Estimated line lengths and sizes from preliminary design work give a good estimate of hydraulic system natural frequencies and pressure amplitudes. The program outputs plots of the peak flow, pressure, and impedance amplitudes of any selected harmonic of the pulsation noise versus pump speed for selected locations in the system. In addition, the program outputs plots of total acoustic energy density and intensity (power) versus pump speed.

TABLE OF CONTENTS

<u>SECTION</u>	<u>TITLE</u>	<u>PAGE</u>
	SUMMARY.	viii
1.	INTRODUCTION	1-1
2.	PROGRAM INPUT.	2-1
2.1	SYSTEM DESCRIPTION.	2-1
	2.1.1 ELEMENT DESCRIPTION.	2-4
	2.1.2 CIRCUIT TERMINATION.	2-4
2.2	GENERAL CONTROL INPUT DATA.	2-7
2.3	CIRCUIT ELEMENT INPUT DATA.	2-14
	2.3.1 LINES.	2-15
	2.3.1.1 RIGID LINE (TUBING)	2-15
	2.3.1.2 FLEXIBLE HOSE	2-17
	2.3.2 RESONATORS	2-19
	2.3.2.1 LUMPED VOLUME RESONATOR	2-19
	2.3.2.2 PULSCO ACOUSTIC FILTER.	2-21
	2.3.3 VOLUMES.	2-24
	2.3.3.1 VOLUME WITHOUT LOSSES	2-24
	2.3.4 VALVES	2-26
	2.3.4.1 SIMPLE VALVE.	2-26
	2.3.4.2 DETERMINATION OF VALVE GAIN	2-26
	2.3.5 ACCUMULATORS	2-29
	2.3.5.1 PISTON TYPE ACCUMULATOR	2-29
	2.3.6 BRANCH ELEMENT	2-32
	2.3.7 DUMMY ELEMENTS	2-34
	2.3.8 QUINCKE TUBE	2-36

TABLE OF CONTENTS (Continued)

<u>SECTION</u>	<u>TITLE</u>	<u>PAGE</u>
2.3.9	PUMPS (ROTARY AXIAL PISTONS, PRESSURE COMPENSATED).	2-42
2.3.9.1	COMPLETE PUMP MODEL	2-42
2.3.9.2	EMPIRICAL PUMP MODEL	2-49
2.4	OUTPUT REQUIREMENTS.	2-52
2.4.1	PREDEFINED OUTPUT	2-55
2.5	PROGRAM DECK AND INPUT DATA JOB SETUP.	2-56
3.	PROGRAM OUTPUT.	3-1
3.1	COMPUTER OUTPUT.	3-1
3.2	OUTPUT PLOTS	3-1
3.3	INTERPRETATION OF COMPUTER OUTPUT.	3-1

LIST OF ILLUSTRATIONS

<u>FIGURE</u>	<u>TITLE</u>	<u>PAGE</u>
2-1A	F-15 PC-1 SYSTEM DESCRIPTION - ELEMENT NUMBERING SCHEME.	2-2
2-1B	F-15 PC-1 SYSTEM DESCRIPTION - ALTERNATE ELEMENT NUMBERING SCHEME	2-2
2-1C	F-15 PC-1 PRESSURE AND RETURN SYSTEM ELEMENT NUMBERING SCHEME	2-3
2-2	ELEMENT INPUT DATA FOR F-15 PC-1 SYSTEM.	2-5
2-2.1	ELEMENT INPUT DATA FOR F-15 PC-1 PRESSURE AND RETURN SYSTEM. . .	2-6
2-3	PUMP CYLINDER BLOCK PARAMETERS	2-46
2-4	PUMP VALVE PLATE PARAMETERS.	2-47
2-5	SWASH PLATE PARAMETERS	2-48
2-6	HSFR PROGRAM DECK AND INPUT DATA JOB SETUP	2-57
3-1	TYPICAL PREPLOT COMPUTER OUTPUT.	3-2
3-2	COMPUTED AND MEASURED FUNDAMENTAL FREQUENCY RESPONSE, F-15 PC-1 SYSTEM.	3-5
3-3	STANDING PRESSURE HALF WAVE, F-15 PC-1 SYSTEM.	3-6
3-4	COMPUTED AND MEASURED FUNDAMENTAL FREQUENCY RESPONSE, TEST STAND F-4 ABEX PUMP.	3-7
3-5	STANDING PRESSURE HALF WAVE, TEST STAND F-4 ABEX PUMP.	3-8
3-6	EXAMPLE OF COMPUTED ACOUSTIC ENERGY DENSITY.	3-9
3-7	EXAMPLE OF COMPUTED ACOUSTIC ENERGY INTENSITY (POWER).	3-10

LIST OF PAGES

Title Page
ii through viii
1-1, 1-2
2-1 through 2-57
3-1 through 3-10

SUMMARY

The hydraulic system frequency response (HSFR) computer program was developed to simulate the dynamic response of a hydraulic system to the acoustic noise generated by the pump. Detailed instructions for modeling the system pump, lines, and components, and for using the program are presented.

For a selected system pressure, temperature, flow and pump speed range, the program calculates the pulsation pressure and energy levels generated by the pump. It predicts the amplitude and location of the resulting acoustical standing waves, and how these waves are transmitted and attenuated throughout the hydraulic system. The program may be used for acoustical analysis in the pressure side or both the pressure and return sides of the hydraulic system.

Estimated line lengths and sizes from preliminary design work give a good estimate of hydraulic system natural frequencies and pressure amplitudes. The program outputs plots of the peak flow, pressure, and impedance amplitudes of any selected harmonic of the pulsation noise versus pump speed for selected locations in the system. In addition, the program outputs plots of total acoustic energy density and intensity (power) versus pump speed.

1. INTRODUCTION

The Hydraulic System Frequency Response (HSFR) program predicts how oscillatory flows and pressures caused by the acoustical energy content of a pump output are transmitted through the lines and components of a hydraulic system. Resonance can occur if a frequency of this oscillatory output coincides with a natural frequency of the system, or of any part of the system. Patterns of standing waves similar to those observed in organ pipes are generated. A resonant condition can produce large oscillatory pressure and flow amplitudes. Resonant acoustical noise can cause excessive line motion and stresses resulting in premature failure of system lines or components.

The HSFR program predicts the pump speeds at which major resonances occur, and defines the amplitude and location of the oscillatory pressure and flow standing waves. The description of the system being simulated is easily changed to investigate various practical system modifications for the attenuation and/or relocation of the major resonant conditions. This capability allows potential problems related to hydraulic acoustic energy to be eliminated during the design stage.

The program is written in Fortran IV language for use on the CDC 6600 or IBM 360 computer systems. A punched card deck is used to input the program to the machine while output is by line printer.

A user's manual for the HSFR program is presented herein, describing in detail the simulation of a system and the interpretation of program output. Volume IV of this report, under separate cover, contains a detailed technical description of the HSFR computer program.

The user must describe the system to be simulated by means of punched data cards. The description includes the type and physical characteristics of each of the elements of the circuit. An element may be a pump, a section of line, a fitting, a component, or a branch. The F-15 aircraft number one power control system (PC-1) is used herein to illustrate circuit modeling and program output.

The user completes the problem statement by specifying the range of pump speed and the harmonic of interest, the locations at which flow, pressure, impedance, and/or energy levels are to be plotted, the fluid type, the fluid temperature, and the steady state pump output pressure. The program calculates the applicable fluid properties for the specified system temperature and steady state pressure via a special functional subroutine, FLUID.

The program calculates the oscillatory pressures and flows at the input to system elements. Standing wave characteristics produce large variations in pressure amplitude along the length of a line. Division of a length of line into small elements may be required to allow this standing wave pattern to be examined to ensure that an excessive pressure amplitude is not being ignored.

Acoustic analysis may be performed on the pressure side of the system, or on both the pressure and return sides of the system.

2. PROGRAM INPUT

2.1 System Description

The system to be investigated must be carefully described in block diagram form before the data input cards can be produced. The elements which make up the circuit must be identified by type and located sequentially. The only rule which must be applied to the sequential numbering process is as follows:

ALL ELEMENT WHICH ARE CONNECTED IN SERIES MUST BE NUMBERED SEQUENTIALLY, STARTING WITH THE PUMP AS ELEMENT NUMBER 1. A BRANCH LINE MUST ALSO BE NUMBERED SEQUENTIALLY, WITH THE HIGHEST NUMBER APPLIED TO THE TERMINATING ELEMENT.

Figure 2-1A illustrates the numbering scheme using the F-15 PC-1 pressure system as an example of a complex circuit containing several branches of various lengths. The logic of the program would deal correctly with the same system if the numbering scheme in Figure 2-1B were used.

Figure 2-1C illustrates the modeling of both the pressure and return sides of the F-15 PC-1 system. The pressure side is numbered as described above up through the terminating pressure element, in this case the servovalve, element #26. The next sequential element (#27) is the pump inlet which is identified as a dummy element, NTYPE 7 and KTYPE 1. The return system is then modeled sequentially from the pump inlet up through the terminating return side element. In this example the return side is modeled back to a single servovalve, which simulates termination of the return side at element #36.

Data cards must be stacked in order by the user, since the input data does not include the sequential element identification number. The

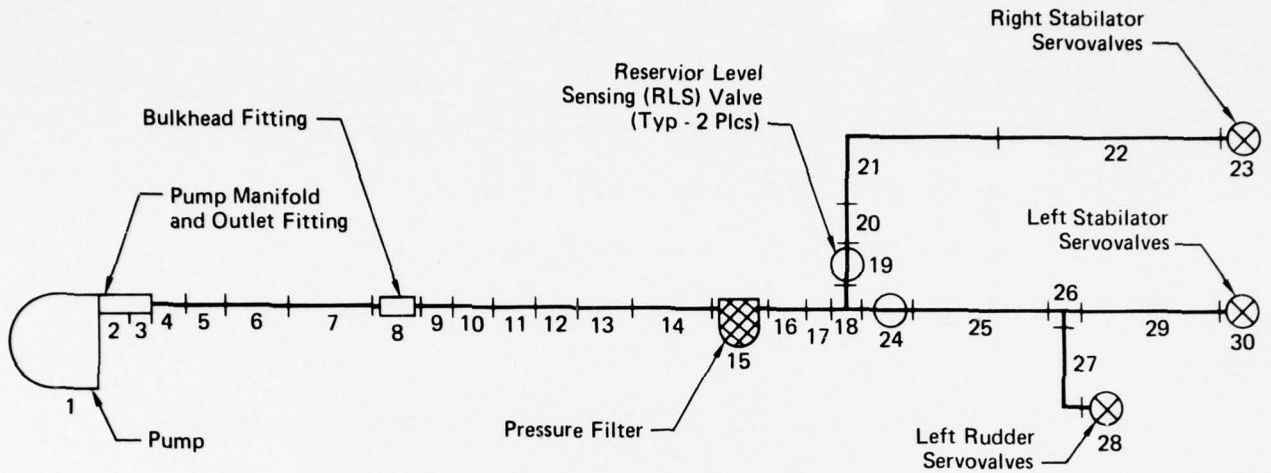

GP74-0771-1

FIGURE 2-1A
F-15 PC-1 SYSTEM DESCRIPTION ELEMENT NUMBERING SCHEME

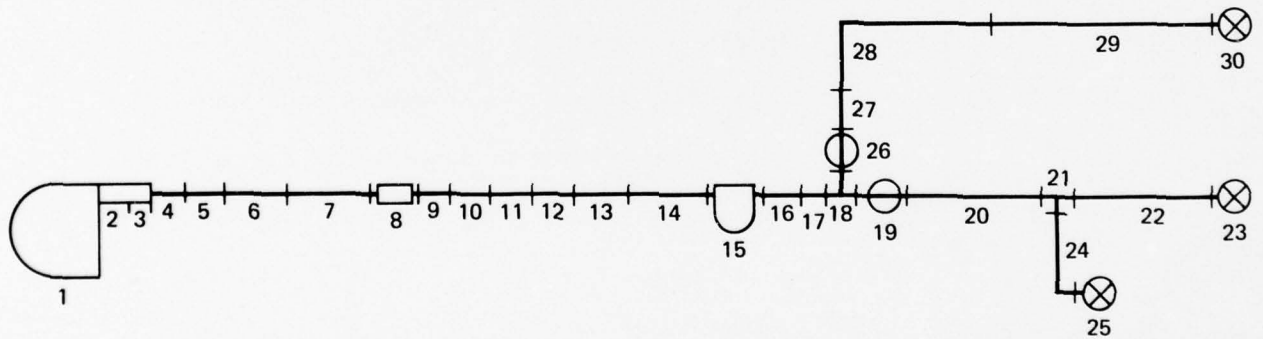

GP74-0771-2

FIGURE 2-1B
F-15 PC-1 SYSTEM DESCRIPTION ALTERNATE ELEMENT NUMBERING SCHEME

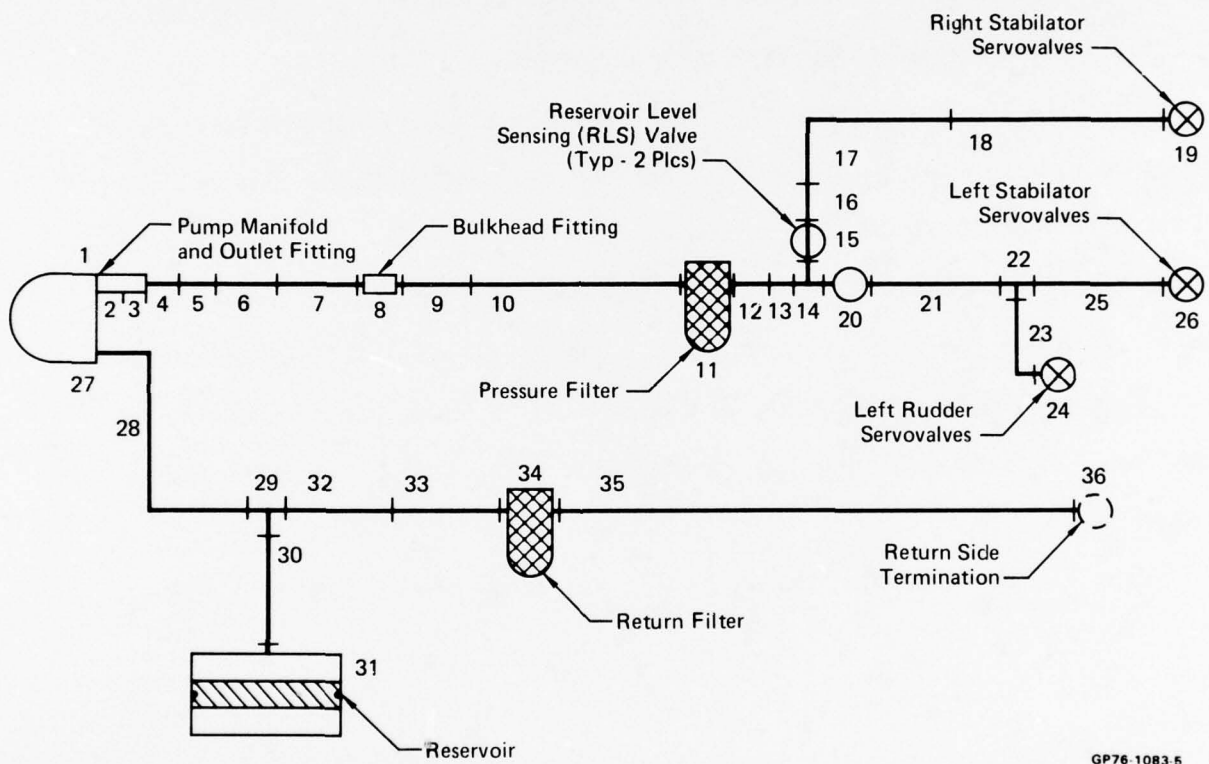

GP76-1083-5

FIGURE 2-1C
F-15 PC-1 PRESSURE AND RETURN SYSTEM ELEMENT NUMBERING SCHEME

sequential element identification number is printed out with the element input data, and should correspond to the numbers assigned by the user in describing the circuit. The program is presently dimensioned to handle a maximum of forty (40) circuit element records.

2.1.1 Element Description - Figure 2-2 illustrates the element descriptive data for the illustrated F-15 PC-1 pressure system, which is input to and printed out during execution of a typical program.

Figure 2-2.1 shows the element data for the illustrated F-15 PC-1 system combined pressure and return model. All the types of elements that the program is capable of describing are discussed in Section 2.3, including type numbers (NTYPE and KTYPE) and the physical characteristics required to define each type of element. For example, from Section 2.3.1 ELEMENT NUMBER 4 is seen to be a line (NTYPE 1) of length 4.50 in., outside diameter 0.625 in., wall thickness of 0.032 in., and modulus of elasticity 16×10^6 lbs/in.² (titanium).

Each element data list has space for a subtype number (KTYPE). KTYPE allows alternate element subtypes to be described, or allows subroutines of varying degrees of complexity to be called by the main program. Also, KTYPE is used to indicate that more than one data card must be read for a given element. In the example, KTYPE=21 for the pump (element number 1) indicates that two extra data cards (total of 3 cards) must be read for the pump (first KTYPE digit=2), and that the detailed PUMP subroutine is being used (second digit=1).

2.1.2 Circuit Termination - Each branch circuit must have a terminating element, otherwise, an error message is generated.

ELEMENT NUMBER			SYSTEM ELEMENT INPUT DATA									
			PHYSICAL DATA									
	N TYPE	F TYPE										
1	7	21	.150	.666	1.120	1.172	.698	.570	.180			
			.200	24.600	4.400	3.375	28.750	26.250	26.000	21.750		
			50.000	-0.000	-0.000	-0.000	-0.000	-0.000	-0.000	-0.000	-0.000	
2	1	-0	4.000	1.200	.100	30000000.000	-0.000	-0.000	-0.000	-0.000		
3	1	-0	2.500	1.200	.100	30000000.000	-0.000	-0.000	-0.000	-0.000		
4	1	-0	4.500	.625	.032	16000000.000	-0.000	-0.000	-0.000	-0.000		
5	1	-0	3.000	.625	.032	16000000.000	-0.000	-0.000	-0.000	-0.000		
6	1	-0	11.500	.625	.032	16000000.000	-0.000	-0.000	-0.000	-0.000		
7	1	-0	3.000	.625	.032	16000000.000	-0.000	-0.000	-0.000	-0.000		
8	1	-0	2.000	1.100	.100	16000000.000	-0.000	-0.000	-0.000	-0.000		
9	1	-0	2.500	1.000	.049	16000000.000	-0.000	-0.000	-0.000	-0.000		
10	1	-0	11.000	1.000	.049	16000000.000	-0.000	-0.000	-0.000	-0.000		
11	1	-0	2.000	1.000	.049	16000000.000	-0.000	-0.000	-0.000	-0.000		
12	1	-0	2.500	1.000	.049	16000000.000	-0.000	-0.000	-0.000	-0.000		
13	1	-0	4.500	1.000	.049	16000000.000	-0.000	-0.000	-0.000	-0.000		
14	1	-0	4.500	1.000	.049	16000000.000	-0.000	-0.000	-0.000	-0.000		
15	3	-0	14.500	-0.000	-0.000	-0.000	-0.000	-0.000	-0.000	-0.000		
16	1	-0	4.000	.750	.035	16000000.000	-0.000	-0.000	-0.000	-0.000		
17	1	-0	7.000	.750	.035	16000000.000	-0.000	-0.000	-0.000	-0.000		
18	4	5	1.000	-0.000	-0.000	-0.000	-0.000	-0.000	-0.000	-0.000		
19	4	-0	1.366	-0.000	-0.000	-0.000	-0.000	-0.000	-0.000	-0.000		
20	1	-0	21.000	.500	.024	16000000.000	-0.000	-0.000	-0.000	-0.000		
21	1	-0	364.000	.375	.016	16000000.000	-0.000	-0.000	-0.000	-0.000		
22	1	-0	44.000	.375	.032	16000000.000	-0.000	-0.000	-0.000	-0.000		
23	14	-0	2800.000	.770	-0.000	-0.000	-0.000	-0.000	-0.000	-0.000		
24	4	-0	.791	-0.000	-0.000	-0.000	-0.000	-0.000	-0.000	-0.000		
25	1	-0	234.000	.375	.016	16000000.000	-0.000	-0.000	-0.000	-0.000		
26	4	2	-1.000	-0.000	-0.000	-0.000	-0.000	-0.000	-0.000	-0.000		
27	1	-0	36.000	.250	.016	16000000.000	-0.000	-0.000	-0.000	-0.000		
28	14	-0	120.000	1.150	-0.000	-0.000	-0.000	-0.000	-0.000	-0.000		
29	1	-0	44.000	.375	.032	16000000.000	-0.000	-0.000	-0.000	-0.000		
30	14	-0	1500.000	1.540	-0.000	-0.000	-0.000	-0.000	-0.000	-0.000		

FIGURE 2-2 Element Input Data For F-15 PC-1 System

ELEMENT NUMBER *****SYSTEM ELEMENT INPUT DATA*****

ELEMENT NUMBER	N		PHYSICAL DATA								
	TYPE	K	TYPE								
1	9	23		.190	.666	1.120	1.172	.698	.570	.189	
				.20000	19.50000	9.40000	3.37500	28.75000	26.25000	26.00000	21.75000
				50.00000	.00000	.78000	2.20000	.00042	80.00000	200.00000	.64000
2	1	-0		8.000	1.200	.100	30000000.000	-0.000	-0.000	-0.000	
3	1	-0		3.500	1.200	.100	30000000.000	-0.000	-0.000	-0.000	
4	1	-0		4.500	.625	.032	16000000.000	-0.000	-0.000	-0.000	
5	1	-0		3.000	.625	.032	16000000.000	-0.000	-0.000	-0.000	
6	1	-0		11.500	.625	.032	16000000.000	-0.000	-0.000	-0.000	
7	1	-0		3.000	.625	.032	16000000.000	-0.000	-0.000	-0.000	
8	1	-0		2.000	1.100	.100	16000000.000	-0.000	-0.000	-0.000	
9	1	-0		13.500	1.000	.049	16000000.000	-0.000	-0.000	-0.000	
10	1	-0		20.000	1.000	.049	16000000.000	-0.000	-0.000	-0.000	
11	3	-0		14.500	-0.000	-0.000	-0.000	-0.000	-0.000	-0.000	
12	1	-0		6.000	.750	.035	16000000.000	-0.000	-0.000	-0.000	
13	1	-0		7.000	.750	.035	16000000.000	-0.000	-0.000	-0.000	
14	6	5		-0.000	-0.000	-0.000	-0.000	-0.000	-0.000	-0.000	
15	4	-0		.346	-0.000	-0.000	-0.000	-0.000	-0.000	-0.000	
16	1	-0		24.000	.500	.024	16000000.000	-0.000	-0.000	-0.000	
17	1	-0		364.000	.375	.016	16000000.000	-0.000	-0.000	-0.000	
18	1	-0		44.000	.375	.032	16000000.000	-0.000	-0.000	-0.000	
19	14	-0		3890.000	.770	-0.000	-0.000	-0.000	-0.000	-0.000	
20	4	-0		.761	-0.000	-0.000	-0.000	-0.000	-0.000	-0.000	
21	1	-0		284.000	.375	.016	16000000.000	-0.000	-0.000	-0.000	
22	6	2		-0.000	-0.000	-0.000	-0.000	-0.000	-0.000	-0.000	
23	1	-0		36.000	.250	.016	16000000.000	-0.000	-0.000	-0.000	
24	14	-0		3120.000	1.150	-0.000	-0.000	-0.000	-0.000	-0.000	
25	1	-0		44.000	.375	.032	16000000.000	-0.000	-0.000	-0.000	
26	14	-0		2590.000	1.540	-0.000	-0.000	-0.000	-0.000	-0.000	
27	7	1		-0.000	-0.000	-0.000	-0.000	-0.000	-0.000	-0.000	
28	1	-0		38.000	1.250	.065	16000000.000	-0.000	-0.000	-0.000	
29	6	2		-0.000	-0.000	-0.000	-0.000	-0.000	-0.000	-0.000	
30	1	-0		23.000	1.000	.042	10000000.000	-0.000	-0.000	-0.000	
31	13	-0		200.000	-0.000	-0.000	-0.000	-0.000	-0.000	-0.000	
32	1	-0		22.000	1.000	.042	10000000.000	-0.000	-0.000	-0.000	
33	1	-0		36.000	.750	.035	10000000.000	-0.000	-0.000	-0.000	
34	3	-0		14.500	-0.000	-0.000	-0.000	-0.000	-0.000	-0.000	
35	1	-0		350.000	.375	.028	10000000.000	-0.000	-0.000	-0.000	
36	14	-0		309.000	-0.000	-0.000	-0.000	-0.000	-0.000	-0.000	

FIGURE 2-2.1 Element Input Data for F-15 PC-1 Pressure and Return System

A branch circuit may be terminated by any element, except a pump. A circuit is usually terminated with a valve or a line element. Termination with any element other than a valve results in a closed circuit analysis, i.e. zero output flow. A valve termination (NTYPE=14) results in an open circuit analysis, where the output pressure is set to zero to simulate an open ended termination.

Circuit termination is indicated by the insertion of a "1" in front of the basic NTYPE number. For example, element number 23 is a valve terminating a branch line, consequently its NTYPE identification is 14, rather than 4.

2.2 General Control Input Data

This group must include three cards to input the title of the run, the number of elements in the model, the fluid type, the fluid temperature, the steady state system pressure, the pump speed range, and the harmonic of interest.

Card 1 - Title Card

Up to eighty characters may be used for a title, which will appear on each page of output. Use a blank card if there is no title.

Card 2 - Number of Elements, Fluid, Temperature, and Pressure

Contains the total number of elements (NEL) in the circuit, including the pump, whether the pump subroutine or the empirical pump model is to be used. System temperature is the average temperature of the circuit being analyzed. Pressure is the average steady state pressure in the circuit being analyzed. The user must specify the type of fluid used in the modeled system. A functional subroutine, FLUID, described in Volume IV, computes the required fluid properties for the fluid temperature and pressure specified by the user. The program computes properties for MIL-H-5606B, MIL-H-83282A, or Skydrol 500B fluids. The data used in the subroutine FLUID is based on the best source data available on fluid properties. The user may also input density, adiabatic bulk modulus, and viscosity data directly into the program, if it is desired to use data or a fluid type other than that provided by the subroutine FLUID. User specified fluid data must be as corrected to the specified fluid temperature and pressure. Fluid properties and the FLUID subroutine are discussed in Volume IV.

Card 3 - Pump Speed and Frequency Data

Contains the first and last pump speed (rpm) at which the program calculations are to be performed, the increment (rpm) between speed calculation points, the harmonic for which output plots are desired, and the number of pumping pistons.

To ensure that satisfactory output plots are obtained, the total number of increments should not exceed 100, the start, finish, and incremental rpm values should all be even numbers, and the start speed should not be zero. All input values are real numbers. If no harmonic is specified, the output plots will be for the first (fundamental) harmonic.

Card 3 - Continued

COLUMNS	FORMAT	DATA	DIMENSIONS
1-10	F10.0	Start speed	RPM
11-20	F10.0	Finish speed	RPM
21-30	F10.0	Speed increment	RPM
31-40	F10.0	First Harmonic=1., 0, or blank	-
		Second harmonic=2.	-
		Third harmonic=3.	-
		etc.=10. maximum	-
41-50	F10.0	Number of pumping pistons	-

50. 5000. 50. 1. 9.

C. FOR STATEMENT IDENTIFICATION

FORTRAN STATEMENT

```

00000000 00000000 00000000 00000000 00000000 00000000 00000000 00000000 00000000 00000000
11111111 11111111 11111111 11111111 11111111 11111111 11111111 11111111 11111111 11111111
22222222 22222222 22222222 22222222 22222222 22222222 22222222 22222222 22222222 22222222
33333333 33333333 33333333 33333333 33333333 33333333 33333333 33333333 33333333 33333333
44444444 44444444 44444444 44444444 44444444 44444444 44444444 44444444 44444444 44444444
55555555 55555555 55555555 55555555 55555555 55555555 55555555 55555555 55555555 55555555
66666666 66666666 66666666 66666666 66666666 66666666 66666666 66666666 66666666 66666666
77777777 77777777 77777777 77777777 77777777 77777777 77777777 77777777 77777777 77777777
88888888 88888888 88888888 88888888 88888888 88888888 88888888 88888888 88888888 88888888
99999999 99999999 99999999 99999999 99999999 99999999 99999999 99999999 99999999 99999999
    
```

MAC 20433 (27 JUL 59)

2.3 Circuit Element Input Data

This group must contain one card for each element, arranged in the same sequence as the elements were numbered in the block diagram discussed in Section 2.1. The pump card(s) is placed first, followed by the card(s) for element number 2, and then by the remaining cards in numerical order, up through the highest numbered terminating element, e.g. valve element number 30 for the circuit illustrated in Section 2.1.

The data required for all of the types of elements that the program is capable of describing, and example inputs for each, are discussed in the following paragraphs.

2.3.1 Lines

2.3.1.1 Rigid Lines (Tubing) - The input data required for a hard-line tubing element are line length, outside diameter, wall thickness, and Young's modulus of elasticity. A fitting element may be modeled using the same input data parameters as for a rigid line.

2.3.1.2 Flexible Hose - The input data for a hose are the active length excluding the hose end fittings, the inside diameter, and the volumetric expansion due to pressure expressed as an equivalent bulk modulus. Equivalent bulk modulus is obtained from experimental data centered about the working pressure according to the following expression.

$$\text{Bulk Modulus} = \frac{(\text{Pressure Change})}{(\text{Volume Change})} \times (\text{Total Hose Volume})$$

2.3.2 Resonators

2.3.2.1 Lumped Volume Resonators

The input data for a lumped volume resonator includes the length of the neck, inside diameter of the neck, neck wall thickness, Young's modulus of elasticity of the neck material, and cavity volume. Entrance angle effects are not considered.

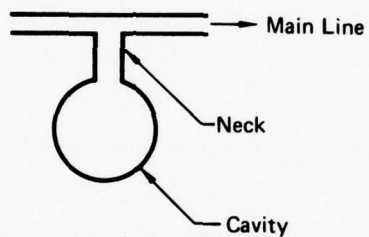

2.3.2.2 Pulscos Acoustic Filter

The input data for an acoustic filter is on four cards. The first card contains the three volumes. Each of the last three cards contains the length, outside diameter, wall thickness and line modulus of elasticity for each of the three internal lines. Line data is input in the order of line 1, line 2, and line 3.

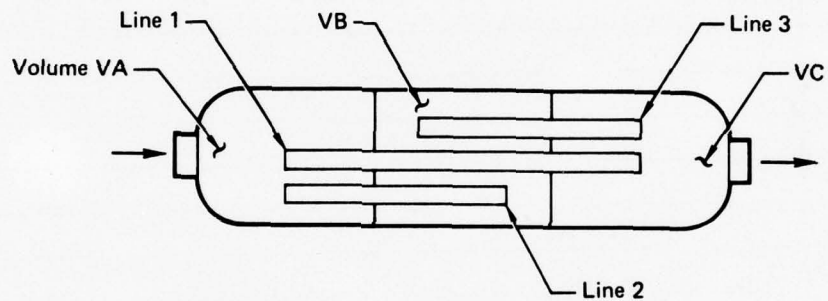

NOTE

This device is manufactured and marketed by the

Pulscos Division
American Air Filter Company, Inc.
Louisville, Kentucky

The design and/or inventions disclosed are the property of American Air Filter Company, Inc., Pulscos Division.

2.3.3 Volumes

2.3.3.1 Volume Without Losses

Input data for a volume element is the volume itself. This assumes no internal losses in the volume element. For example, a filter cavity may be modeled as a simple volume.

2.3.4 Valves

2.3.4.1 Simple Valves - The input data for a valve element includes the valve gain linearized at the steady state circuit flow through the valve. Determination of valve gain is discussed in section 2.3.4.2. Valve gain is expressed as pressure drop (psi) per unit flow rate (cubic inches per second). Flow out of the circuit being analyzed is input for terminating valve elements. This "overboard flow" is the steady state flow through the terminating valve at the input steady state system pressure.

2.3.4.2 Determination of Valve Gain - Typical valves which may be modeled are system shut-off valves (low gain), electrohydraulic servovalves, mechanical servovalves, and combinations of electro-mechanical servovalves, such as may be found in an integrated actuator package.

For a valve pressure/flow relationship of the form

$$P = KQ^n$$

where: P = pressure drop (psi)
Q = flow rate (cis)
K = constant
n = flow exponent

the linearized valve gain (G) may be determined from

$$G = \frac{dP}{dQ} = nKQ^{n-1}$$

but $K = \frac{P}{Q^n}$

therefore $G = \frac{nP}{Q}$.

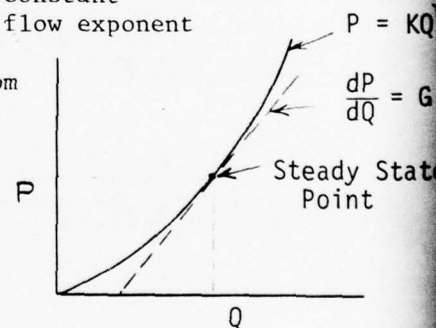

If the valve flow can be characterized as an orifice ($n = 2$), then the gain is $G = \frac{2P}{Q}$. The orifice relationship is typical of electrohydraulic servo valve steady state control flow. If the valve flow can be characterized as laminar for the steady state condition, then $n = 1$ and the gain is $G = \frac{P}{Q}$. The laminar relationship is typical for null leakage flow across lapped spool valves, e.g. mechanical servovalves, and the second stage of an electrohydraulic valve.

Parallel valve elements, for instance those within an electro-mechanical integrated servoactuator, may be combined for modeling as a single valve element by computing an equivalent gain (G_e) for all the parallel flow paths.

$$\frac{1}{G_e} = \frac{1}{G_1} + \frac{1}{G_2} + \frac{1}{G_3} \dots$$

Empirical pressure drop/flow data, if available, should be used to calculate the gain at the steady state flow condition. The flow relationship may be assumed unless the flow exponent is available from empirical data.

2.3.5 Accumulators

2.3.5.1 Piston Type Accumulators

The input data for a piston type accumulator are the piston mass, cylinder internal radius, cylinder wall thickness, cylinder modulus of elasticity, maximum gas volume (piston bottomed to oil side), minimum gas volume (piston bottomed to gas side), gas precharge pressure (piston bottomed to oil side), working pressure, and viscous friction damping. Two data cards are required.

Viscous friction damping data is not readily available. Its value will be determined experimentally; in the meantime an estimated value will be used.

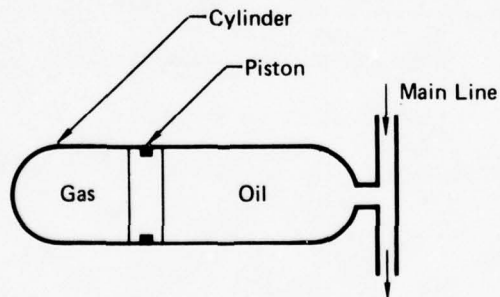

2.3.5.1 Piston Type Accumulators - Continued

First Card

COLUMNS	FORMAT	DATA	DIMENSIONS
1-5	I5	NTYPE=5	-
6-10	I5	KTYPE=10	-
11-20	F10.0	Piston Mass	LBS·SEC ² /IN
21-30	F10.0	Internal Radius	IN
31-40	F10.0	Wall Thickness	IN
41-50	F10.0	Modulus of Elasticity	PSI
51-60	F10.0	Maximum Gas Volume	IN ³
61-70	F10.0	Minimum Gas Volume	IN ³
71-80	F10.0	Precharge Pressure	PSI

```

    5          .0012      1.350      .100  30000000.   48.0      7.0   1500.
 1 2 3 4 5 6 7 8 9 10 11 12 13 14 15 16 17 18 19 20 21 22 23 24 25 26 27 28 29 30 31 32 33 34 35 36 37 38 39 40 41 42 43 44 45 46 47 48 49 50 51 52 53 54 55 56 57 58 59 60

 0 0 0 0 0 0 0 0 0 0 0 0 0 0 0 0 0 0 0 0 0 0 0 0 0 0 0 0 0 0 0 0 0 0 0 0 0 0 0 0 0 0 0 0 0 0 0 0 0 0 0 0 0 0 0 0 0 0 0 0 0 0 0 0 0 0 0 0 0
 1 1 1 1 1 1 1 1 1 1 1 1 1 1 1 1 1 1 1 1 1 1 1 1 1 1 1 1 1 1 1 1 1 1 1 1 1 1 1 1 1 1 1 1 1 1 1 1 1 1 1 1 1 1 1 1 1 1 1 1 1 1 1 1 1 1 1 1 1
 2 2 2 2 2 2 2 2 2 2 2 2 2 2 2 2 2 2 2 2 2 2 2 2 2 2 2 2 2 2 2 2 2 2 2 2 2 2 2 2 2 2 2 2 2 2 2 2 2 2 2 2 2 2 2 2 2 2 2 2 2 2 2 2 2 2 2 2 2 2 2 2 2
 3 3 3 3 3 3 3 3 3 3 3 3 3 3 3 3 3 3 3 3 3 3 3 3 3 3 3 3 3 3 3 3 3 3 3 3 3 3 3 3 3 3 3 3 3 3 3 3 3 3 3 3 3 3 3 3 3 3 3 3 3 3 3 3 3 3 3 3 3 3 3 3 3 3
 4 4 4 4 4 4 4 4 4 4 4 4 4 4 4 4 4 4 4 4 4 4 4 4 4 4 4 4 4 4 4 4 4 4 4 4 4 4 4 4 4 4 4 4 4 4 4 4 4 4 4 4 4 4 4 4 4 4 4 4 4 4 4 4 4 4 4 4 4 4 4 4 4 4
 5 5 5 5 5 5 5 5 5 5 5 5 5 5 5 5 5 5 5 5 5 5 5 5 5 5 5 5 5 5 5 5 5 5 5 5 5 5 5 5 5 5 5 5 5 5 5 5 5 5 5 5 5 5 5 5 5 5 5 5 5 5 5 5 5 5 5 5 5 5 5 5 5 5
 6 6 6 6 6 6 6 6 6 6 6 6 6 6 6 6 6 6 6 6 6 6 6 6 6 6 6 6 6 6 6 6 6 6 6 6 6 6 6 6 6 6 6 6 6 6 6 6 6 6 6 6 6 6 6 6 6 6 6 6 6 6 6 6 6 6 6 6 6 6 6 6 6 6
 7 7 7 7 7 7 7 7 7 7 7 7 7 7 7 7 7 7 7 7 7 7 7 7 7 7 7 7 7 7 7 7 7 7 7 7 7 7 7 7 7 7 7 7 7 7 7 7 7 7 7 7 7 7 7 7 7 7 7 7 7 7 7 7 7 7 7 7 7 7 7 7 7 7
 8 8 8 8 8 8 8 8 8 8 8 8 8 8 8 8 8 8 8 8 8 8 8 8 8 8 8 8 8 8 8 8 8 8 8 8 8 8 8 8 8 8 8 8 8 8 8 8 8 8 8 8 8 8 8 8 8 8 8 8 8 8 8 8 8 8 8 8 8 8 8 8 8 8
 9 9 9 9 9 9 9 9 9 9 9 9 9 9 9 9 9 9 9 9 9 9 9 9 9 9 9 9 9 9 9 9 9 9 9 9 9 9 9 9 9 9 9 9 9 9 9 9 9 9 9 9 9 9 9 9 9 9 9 9 9 9 9 9 9 9 9 9 9 9 9 9 9 9
 1 1 1 1 1 1 1 1 1 1 1 1 1 1 1 1 1 1 1 1 1 1 1 1 1 1 1 1 1 1 1 1 1 1 1 1 1 1 1 1 1 1 1 1 1 1 1 1 1 1 1 1 1 1 1 1 1 1 1 1 1 1 1 1 1 1 1 1 1 1 1 1 1 1 1
MCDONNELL AUTOMATION COMPANY
  
```

2.3.5.1 Piston Type Accumulator - Continued

Second Card

1-10	F10.0	Working Pressure	PSI
11-20	F10.0	Viscous Friction Damping	LBS·SEC/IN

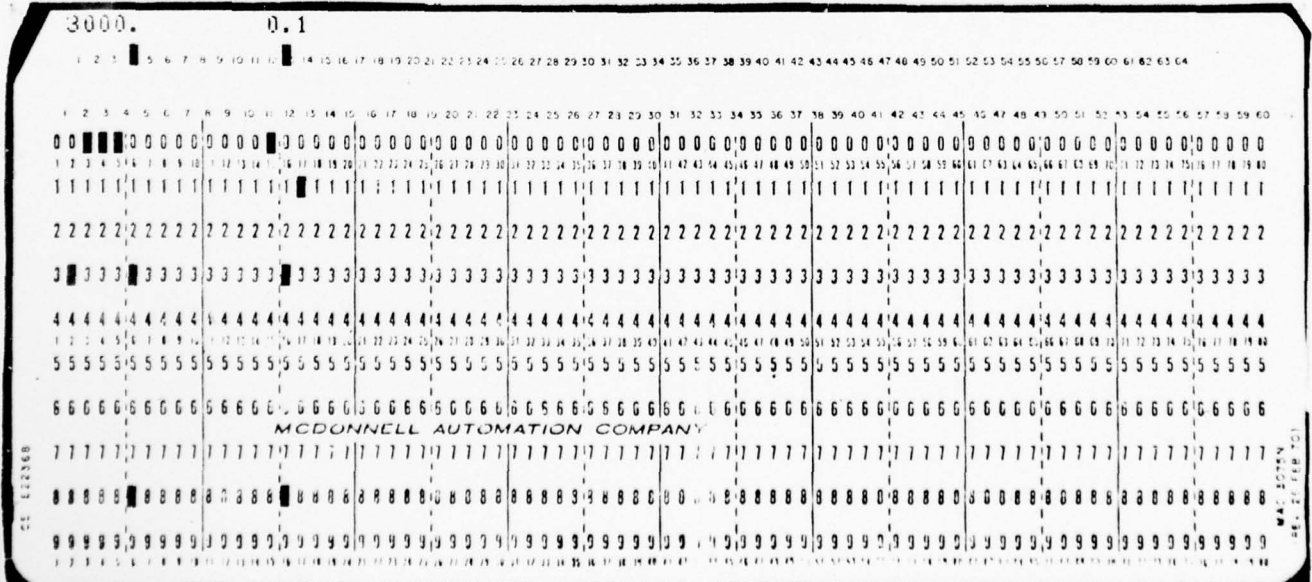

2.3.6 Branch Element

The data input required to describe a branch element is the total number of elements in the branch. For instance, in Figure 2-2 element number 18 is a branch with 5 elements in the branch, element number 26 is a branch with 2 elements in the branch. The number of elements in a branch is used as an integer number by the program.

2.3.7 Dummy Element

Input data required to represent a dummy element is NTYPE=7. Capability for the use of a dummy element is sometimes convenient to minimize element numbering changes for describing similar circuits. Subtype 1 is used to designate a pump inlet when modeling the return side of a system.

2.3.8 Quincke Tube - Input data for a wide band, helical Quincke tube resonant mode damper are outer (delay) tube length, inner tube inside and outside diameter, outer tube inside and outside diameter, wound element cross-sectional area, helix pitch, number of holes, hole length, hole spacing distances, and hole diameters. The maximum number of holes is 16 with the existing program.

This device is shown schematically below. The outer spiraled passage for the illustrated model is formed by winding a solid element around the straight inner tube, which is then enclosed in another straight outer tube.

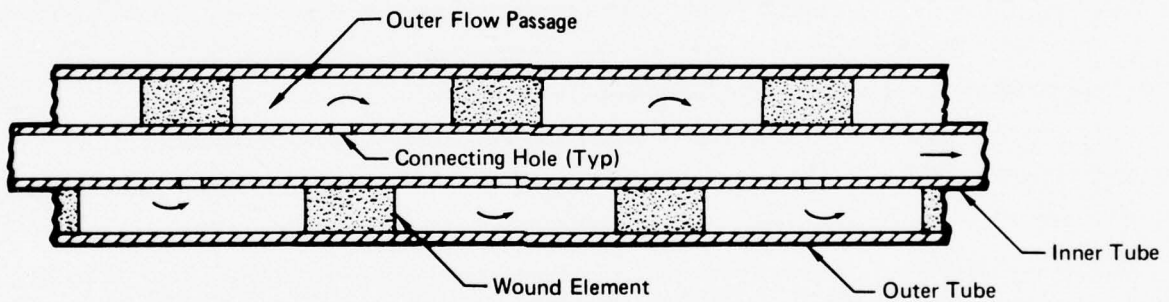

GP75 0099 15

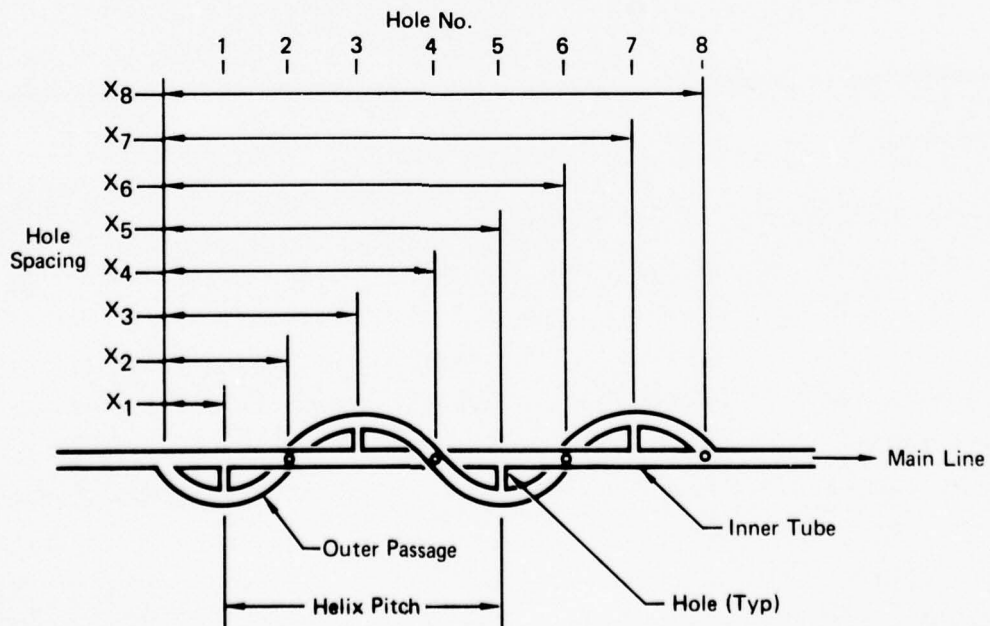

GP75 0108 15

2.3.8 Quincke Tube - Continued

First Card

COLUMNS	FORMAT	DATA	DIMENSIONS
1-5	I5	NTYPE=8	-
6-10	I5	KTYPE=0 or blank if no holes	-
		=30 if number of holes is 1-8.	
		=50 if number of holes is 9-16.	
11-20	F10.0	Length of Outer Tube	IN
21-30	F10.0	Inner Tube ID	IN
31-40	F10.0	Inner Tube OD	IN
41-50	F10.0	Outer Tube ID	IN
51-60	F10.0	Outer Tube OD	IN
61-70	F10.0	Wound Element Cross-Sectional Area	IN ²
71-80	F10.0	Helix Pitch	IN ²

NOTE: If there are no holes, only the first card is required.

8	30	36.0	.436	.500	.396	1.000	.0396	1.41
0	0	0	0	0	0	0	0	0
1	1	1	1	1	1	1	1	1
2	2	2	2	2	2	2	2	2
3	3	3	3	3	3	3	3	3
4	4	4	4	4	4	4	4	4
5	5	5	5	5	5	5	5	5
6	6	6	6	6	6	6	6	6
7	7	7	7	7	7	7	7	7
8	8	8	8	8	8	8	8	8
9	9	9	9	9	9	9	9	9

MCDONNELL AUTOMATION COMPANY

2.3.8 Quincke Tube - Continued

Third Card

COLUMNS	FORMAT	DATA	DIMENSIONS
1-10	F10.0	Distance to first hole	INCHES
11-20	F10.0	Distance to second hole	INCHES
21-30	F10.0	Distance to third hole	INCHES
31-40	F10.0	Distance to fourth hole	INCHES
41-50	F10.0	Distance to fifth hole	INCHES
51-60	F10.0	Distance to sixth hole	INCHES
61-70	F10.0	Distance to seventh hole	INCHES
71-80	F10.0	Distance to eighth hole	INCHES

.705	2.115	3.525	4.935	6.345	7.755	9.165	10.575
1 2 3 4 5 6 7 8 9 10 11 12 13 14 15 16 17 18 19 20 21 22 23 24 25 26 27 28 29 30 31 32 33 34 35 36 37 38 39 40 41 42 43 44 45 46 47 48 49 50 51 52 53 54 55 56 57 58 59 60							
00000000 0000 000000000000 000000000000 000000000000 000000000000 000000000000 000000000000 000000000000 000000000000							
1111111111 111111 11111111 111111111111 111111111111 111111111111 111111111111 111111111111 111111111111 111111111111							
2222222222 22222 22222 22222 22222 22222 22222 22222 22222 22222 22222 22222 22222 22222 22222 22222 22222 22222 22222 22222							
33333 33333 33333 33333 33333 33333 33333 33333 33333 33333 33333 33333 33333 33333 33333 33333 33333 33333 33333 33333							
44444 44444 44444 44444 44444 44444 44444 44444 44444 44444 44444 44444 44444 44444 44444 44444 44444 44444 44444 44444							
55555 55555 55555 55555 55555 55555 55555 55555 55555 55555 55555 55555 55555 55555 55555 55555 55555 55555 55555 55555							
66666 66666 66666 66666 66666 66666 66666 66666 66666 66666 66666 66666 66666 66666 66666 66666 66666 66666 66666 66666							
MCDONNELL AUTOMATION COMPANY							
77777 77777 77777 77777 77777 77777 77777 77777 77777 77777 77777 77777 77777 77777 77777 77777 77777 77777 77777 77777							
88888 88888 88888 88888 88888 88888 88888 88888 88888 88888 88888 88888 88888 88888 88888 88888 88888 88888 88888 88888							
99999 99999 99999 99999 99999 99999 99999 99999 99999 99999 99999 99999 99999 99999 99999 99999 99999 99999 99999 99999							

2.3.8 Quincke Tube - Cont'd

Fifth Card

If the number of holes is 1-8, this card is omitted.

If the number of holes is 9-16, this card contains the diameter of holes 1-8 as shown above.

Sixth Card

If the number of holes is 1-8, this card is omitted.

If the number of holes is 9-16, this card contains the diameter of holes 9-16.

2.3.9 Pumps (Rotating Axial Pistons, Pressure Compensated)

The hydraulic pump, i.e. the acoustic noise source, is always treated as the first element in the circuit, and is identified as a NTYPE "9" element. However, the program is capable of handling different pump subtypes. The user must select the pump model to be used, and input data accordingly, as described below. Two basic pump models are presently available, a complete model and an empirical model.

The complete pump model (PUMP subroutine) is based on actual physical dimensional data of the pump. The empirical pump model is based on experience gained while using the complete model, and may be used to save cost or until hardware data is available on a new pump. It may also be used to model other types of noise sources whose characteristics are known. Physical data for a given pump is read into the element data list in the same manner as for the other system elements. Required input data for the complete and empirical pump models are described in the following paragraphs and figures.

The complete pump model has three subtypes available for use. KTYPE 21 is used when analyzing the pressure side of the system, i.e. no return side model. KTYPE 22 is used for pressure side analysis, but also provides a limited pump inlet analysis sufficient for studying pump hanger torque characteristics without the need for a return system model. KTYPE 23 is used when analyzing both the pressure and return sides of the system.

Data for the pump is the same for all three pump subtypes. However, the system data must contain only the pressure side elements for KTYPE 21 and 22.

2.3.9.1 Complete Pump Model - Input data for the complete pump model requires three data cards in the sequence described below. Physical data are input for sixteen variables in the PUMP subroutine. Required input data are described in the following tables and/or diagrams.

2.3.9.1 Complete Pump Model - Cont'd

COLUMNS	FORMAT	DATA	DIMENSIONS
1-1	I5	NTYPE = 9	-
6-10	I5	KTYPE = 21 Pressure Acoustics	-
		KTYPE = 22 Pressure Acoustics, Hanger Torque	
		KTYPE = 23 Pressure and return acoustics, hanger torque	-
11-20	F10.0	R1 = Cylinder slot radius	INCHES
21-30	F10.0	SLOTW = Cylinder slot width	INCHES
31-40	F10.0	RV = Cylinder and valve plate slot centerline radius	INCHES
41-50	F10.0	RBORC = Cylinder centerline radius	INCHES
51-60	F10.0	DIAPIS = Piston diameter	INCHES
61-70	F10.0	POVOL = Oil volume between piston at mid-stroke and port face	IN ³
71-80	F10.0	R2 = Valve plate pressure slot radius	INCHES

9	21	.190	.666	1.120	1.172	.698	.570	.180																																																																							
1	2	3	4	5	6	7	8	9	10	11	12	13	14	15	16	17	18	19	20	21	22	23	24	25	26	27	28	29	30	31	32	33	34	35	36	37	38	39	40	41	42	43	44	45	46	47	48	49	50	51	52	53	54	55	56	57	58	59	60	61	62	63	64	65	66	67	68	69	70	71	72	73	74	75	76	77	78	79	80
0	0	0	0	0	0	0	0	0	0	0	0	0	0	0	0	0	0	0	0	0	0	0	0	0	0	0	0	0	0	0	0	0	0	0	0	0	0	0	0	0	0	0	0	0	0	0	0	0	0	0	0	0	0	0	0	0	0	0	0	0	0	0	0	0	0	0	0	0	0										
1	1	1	1	1	1	1	1	1	1	1	1	1	1	1	1	1	1	1	1	1	1	1	1	1	1	1	1	1	1	1	1	1	1	1	1	1	1	1	1	1	1	1	1	1	1	1	1	1	1	1	1	1	1	1	1	1	1	1																					
2	2	2	2	2	2	2	2	2	2	2	2	2	2	2	2	2	2	2	2	2	2	2	2	2	2	2	2	2	2	2	2	2	2	2	2	2	2	2	2	2	2	2	2	2	2	2	2	2	2	2	2	2	2	2	2	2	2	2																					
3	3	3	3	3	3	3	3	3	3	3	3	3	3	3	3	3	3	3	3	3	3	3	3	3	3	3	3	3	3	3	3	3	3	3	3	3	3	3	3	3	3	3	3	3	3	3	3	3	3	3	3	3	3	3	3	3	3	3																					
4	4	4	4	4	4	4	4	4	4	4	4	4	4	4	4	4	4	4	4	4	4	4	4	4	4	4	4	4	4	4	4	4	4	4	4	4	4	4	4	4	4	4	4	4	4	4	4	4	4	4	4	4	4	4	4	4	4	4																					
5	5	5	5	5	5	5	5	5	5	5	5	5	5	5	5	5	5	5	5	5	5	5	5	5	5	5	5	5	5	5	5	5	5	5	5	5	5	5	5	5	5	5	5	5	5	5	5	5	5	5	5	5	5	5	5	5	5	5																					
6	6	6	6	6	6	6	6	6	6	6	6	6	6	6	6	6	6	6	6	6	6	6	6	6	6	6	6	6	6	6	6	6	6	6	6	6	6	6	6	6	6	6	6	6	6	6	6	6	6	6	6	6	6	6	6	6	6	6																					
7	7	7	7	7	7	7	7	7	7	7	7	7	7	7	7	7	7	7	7	7	7	7	7	7	7	7	7	7	7	7	7	7	7	7	7	7	7	7	7	7	7	7	7	7	7	7	7	7	7	7	7	7	7	7	7	7	7	7																					
8	8	8	8	8	8	8	8	8	8	8	8	8	8	8	8	8	8	8	8	8	8	8	8	8	8	8	8	8	8	8	8	8	8	8	8	8	8	8	8	8	8	8	8	8	8	8	8	8	8	8	8	8	8	8	8	8	8	8																					
9	9	9	9	9	9	9	9	9	9	9	9	9	9	9	9	9	9	9	9	9	9	9	9	9	9	9	9	9	9	9	9	9	9	9	9	9	9	9	9	9	9	9	9	9	9	9	9	9	9	9	9	9	9	9	9	9	9	9																					

MCDONNELL AUTOMATION COMPANY

MAG. 3074N
1967 JAN-FEB 701

2.3.9.1 Complete Pump Model - Cont'd

Second Card

COLUMNS	FORMAT	DATA	DIMENSIONS
1-10	F10.0	R4 = Valve plate suction slot radius	INCHES
11-20	F10.0	SWASH = Maximum swash angle	DEGREES
21-30	F10.0	TLEAK = Pump internal leakage at	CIS
		input steady state	
		pressure	
31-40	F10.0	ANGCR = Swash plate fixed cross	DEGREES
		angle (90° to variable	
		swash angle plane)	
41-50	F10.0	THPRS = Valve plate pressure slot	DEGREES
		start angle	
51-60	F10.0	THPRE = Valve plate pressure slot	DEGREES
		end angle	
61-70	F10.0	THSUCS = Valve plate suction slot	DEGREES
		start angle	
71-80	F10.0	THSUCE = Valve plate suction slot	DEGREES
		end angle	

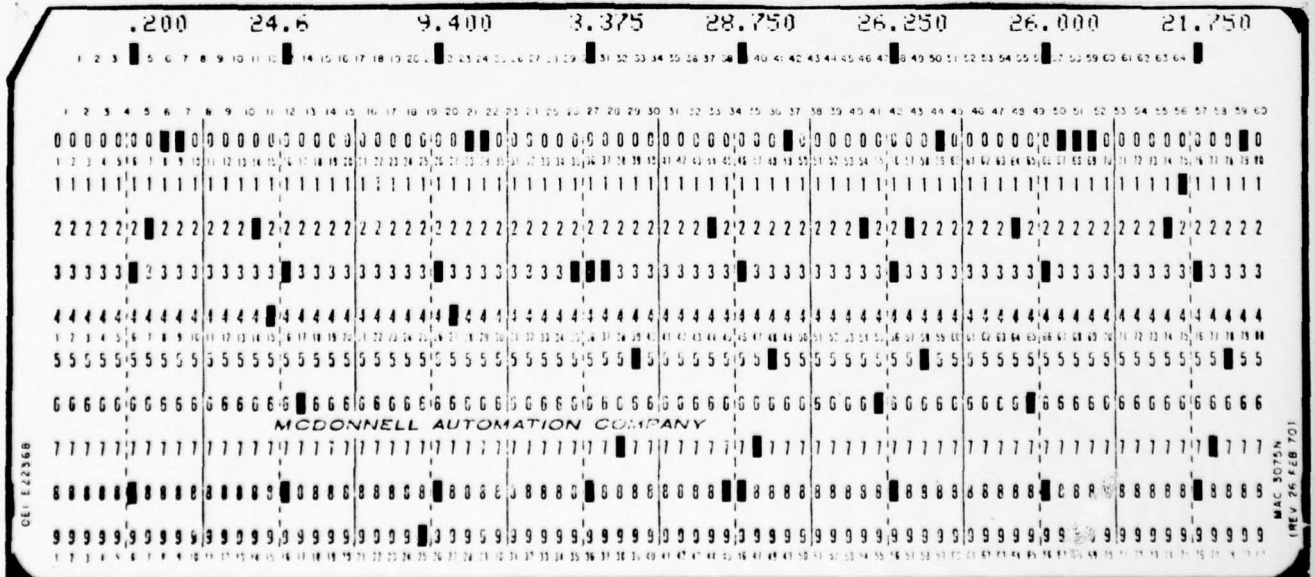

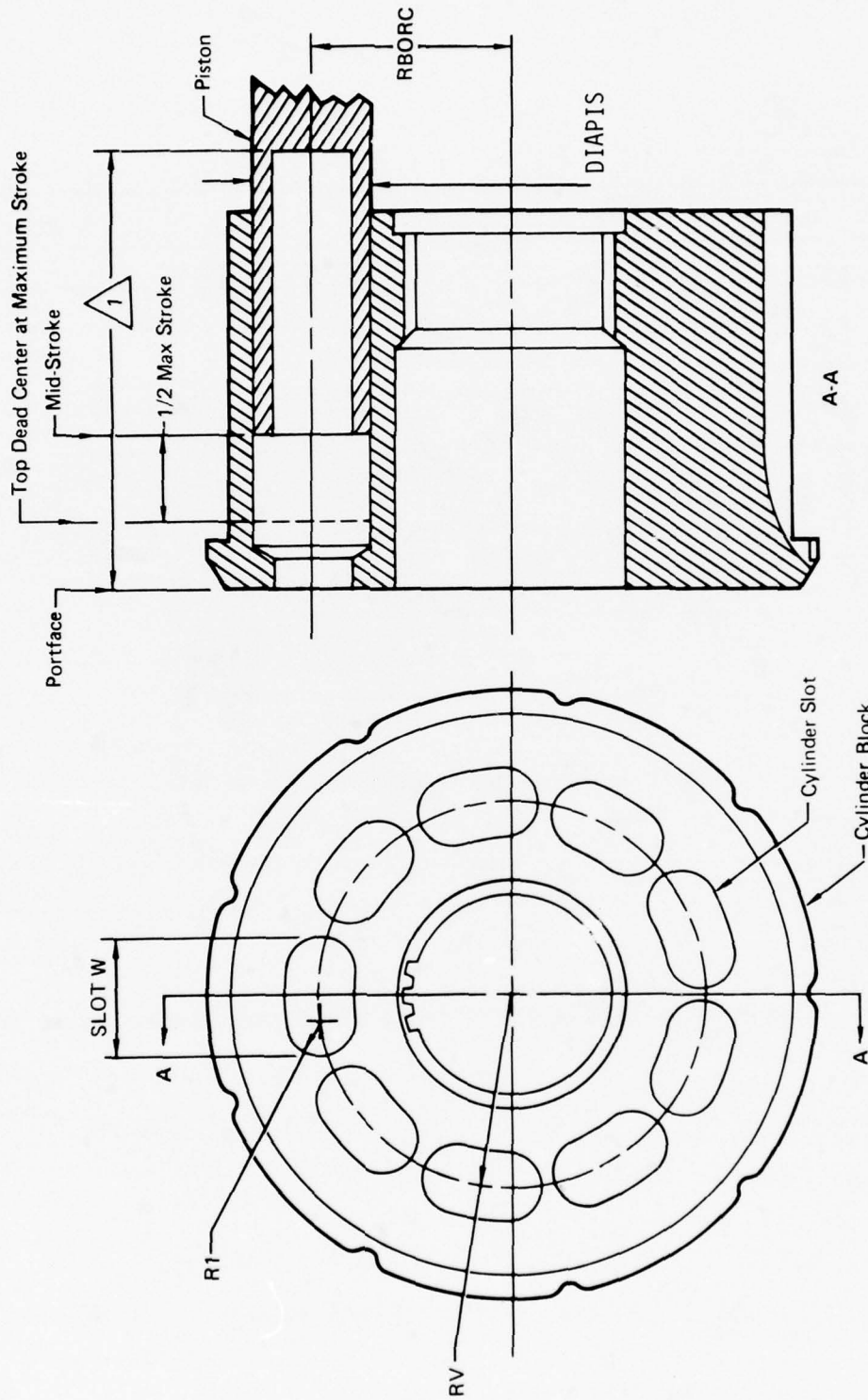
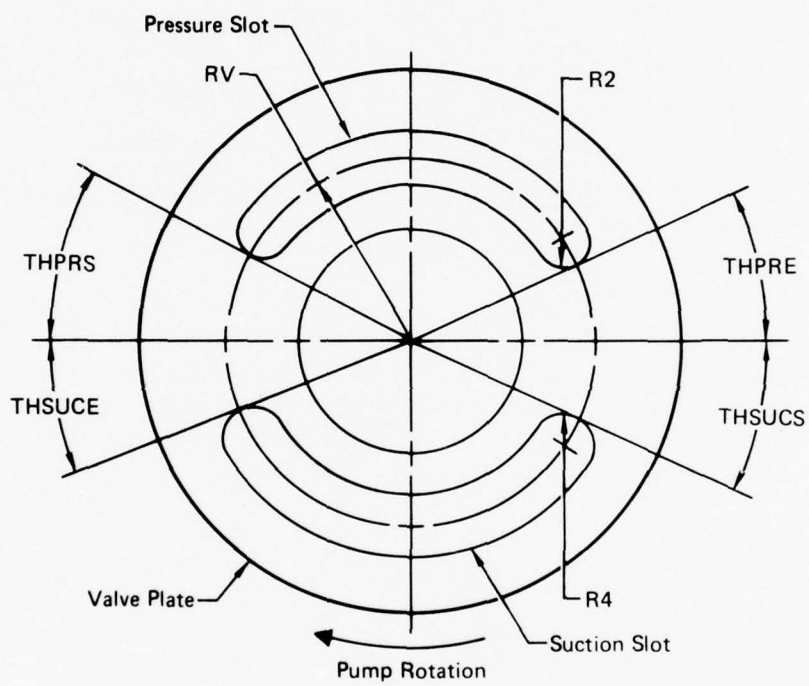
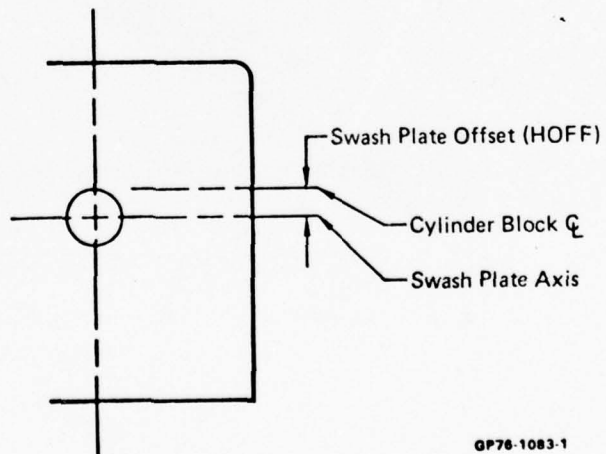
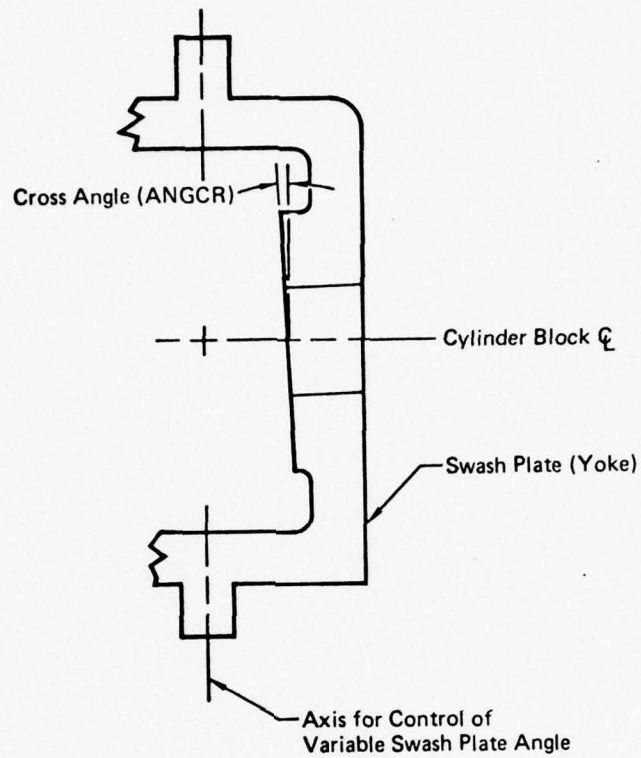

FIGURE 2-3
PUMP CYLINDER BLOCK PARAMETERS



GP75 0108 17

FIGURE 2-4
PUMP VALVE PLATE PARAMETERS



GP76-1083-1

**FIGURE 2-5
SWASH PLATE PARAMETERS**

2.3.9.2 Empirical Pump Model (KTYPE = 0)

Observations of the complete pump model show that the pump flow and shunt impedance can be approximated using values of the variables calculated by the complete model. Both the flow and the shunt impedance are kept in complex form to maintain the phase relation between these variables and pump rotation, as predicted by the complete model.

Pump Flow (QO)

An oscillatory flow output, QO, of the "constant current" source, is assumed to exist within the pump, and is represented by a complex number. The fundamental component of the pump dynamic flow output at 2500 rpm is quoted in cubic inches per second, rms. The program assumes the oscillatory flow to be proportional to pump speed, and calculates the input flow applicable to each rpm from the flow at 2500 rpm.

If the flow values could be obtained experimentally, the imaginary part of the complex flow could be zero, and the complex flows and pressures obtained for points elsewhere in the system would be phase referenced to this flow. However, if the flow figures are obtained from a prior program run in which the complete pump program was used, both real and imaginary parts will result as this flow, and all quantities calculated by the program will be phase referenced to valve port opening.

Pump Shunt Impedance (ZO)

An impedance, ZO is assumed to shunt the "constant current" flow source at 2500 rpm, and is represented by a complex number (psi rms/cis rms). The program currently assumes that the impedance input is proportional to the pump rpm, the fluid viscosity, and the fluid mass density. The shunt impedance for each pump rpm is calculated from the shunt impedance at 2500 rpm. This relationship is derived empirically.

Pump Pressure (PO)

The pump output pressure, PO, is represented by a complex number (psi rms). This input provision is intended to be used when test results from the circuit under investigation are available. Changes must be made to the program, however, to allow this input to be used.

2.4 Output Requirements

Input data cards are required in order to specify the desired program output results, which may consist of five categories: flow plots, pressure plots, impedance plots, acoustic energy density plots, and acoustic intensity plots, vs. pump speed (rpm). At least one card is required in each category to specify the total number of plots desired; and each location (element number) in the circuit for which a plot is to be generated. If no plots are desired in a category, a blank card must be included, in the proper order, for that category. All cards in this output group must be in the order specified below.

Each plot card contains a series of integer numbers. The first gives the total number of plots required in that category. The remaining numbers given the identifications of the circuit element numbers for which plots are to be produced. For instance, a flow plot specified for circuit element number 6 (line) in the system described in Section 2.1, produces a flow plot at the junction of elements 6 and 5; i.e. the input flow (upstream end) to the specified element (6). All input data numbers occupy five columns so that the eighty columns of a data card can contain sixteen numbers, the number of plots plus fifteen element numbers. When the card is read, the program reads the total number of plots required in that category and then looks for that number of element identifications. If the number is greater than 15 the program starts to read the next card. For example, in the pressure plot cards shown as an example, since the total number of pressure plots called for is 17, the program reads the first card and then completes its list of elements by reading the numbers it finds in the first two five-column fields on the second card. Example pressure cards are shown for the illustrated F-15 PC-1 system input data.

2.4 Output Requirements - Cont'd

First Card

COLUMNS	FORMAT	DATA	DIMENSIONS
1-5	I5	Number of plots for one category	-
6-10	I5	Element number for first plot	-
11-15	I5		
16-20	I5		
21-25	I5		
26-30	I5		
31-35	I5		
36-40	I5		
41-45	I5		
46-50	I5		
51-55	I5		
56-60	I5		
61-65	I5		
66-70	I5		
71-75	I5		
76-80	I5	Element number for fifteenth plot	-

Pressure Plots - First Card (Typical)

1	2	3	4	5	6	7	8	9	10	11	12	13	14	15
0	0	0	0	0	0	0	0	0	0	0	0	0	0	0
1	1	1	1	1	1	1	1	1	1	1	1	1	1	1
2	2	2	2	2	2	2	2	2	2	2	2	2	2	2
3	3	3	3	3	3	3	3	3	3	3	3	3	3	3
4	4	4	4	4	4	4	4	4	4	4	4	4	4	4
5	5	5	5	5	5	5	5	5	5	5	5	5	5	5
6	6	6	6	6	6	6	6	6	6	6	6	6	6	6
7	7	7	7	7	7	7	7	7	7	7	7	7	7	7
8	8	8	8	8	8	8	8	8	8	8	8	8	8	8
9	9	9	9	9	9	9	9	9	9	9	9	9	9	9

MCDONNELL AUTOMATION COMPANY

2.4.1 Pre-defined Output

Any of the normal five plot categories may be used to plot other variables computed within the program. This is useful for studying the behavior of certain variables as a function of pump speed. Normal output titles are retained when making special plots.

Eight variables associated with pump performance are currently pre-defined in the pump subroutine. Any or all of these variables will be plotted if they are selected in the normal manner as described in 2.4 above. These variables have been assigned in the last four positions of the flow (Q) and pressure (P) arrays. The position and description of the pre-defined variables are as follows.

<u>Assigned Name and Location</u>	<u>Description</u>	<u>Units</u>
Q(37)	Swash plate angle	DEGREES
Q(38)	Pre-compressed piston pressure minus steady state outlet pressure (absolute value)	PSI
Q(39)	Piston Pressure at start of decom- pression	PSI
Q(40)	Piston cavitation at end of decom- pression	IN ³ *1000
P(37)	Decompressed piston pressure minus steady state inlet pressure (absolute value)	PSI
P(38)	Piston cavitation at start of pre- compression	IN ³ *1000
P(39)	Piston pressure at start of pre- compression	PSI
P(40)	Swash plate torque due to piston pressure and piston acceleration forces	IN-LBS

The above plot(s), if selected for output, will plot regardless of the number of circuit elements in the model.

2.5 Program Deck and Input Data Job Set-Up

The program deck and input data cards are assembled as shown in Figure 2-6. All input data cards must be in the order shown. Circuit element data cards must be sequential starting with element number 1 and ending with the last, highest number terminated element. Job control card content and arrangement varies depending on the particular computer facility available to the user.

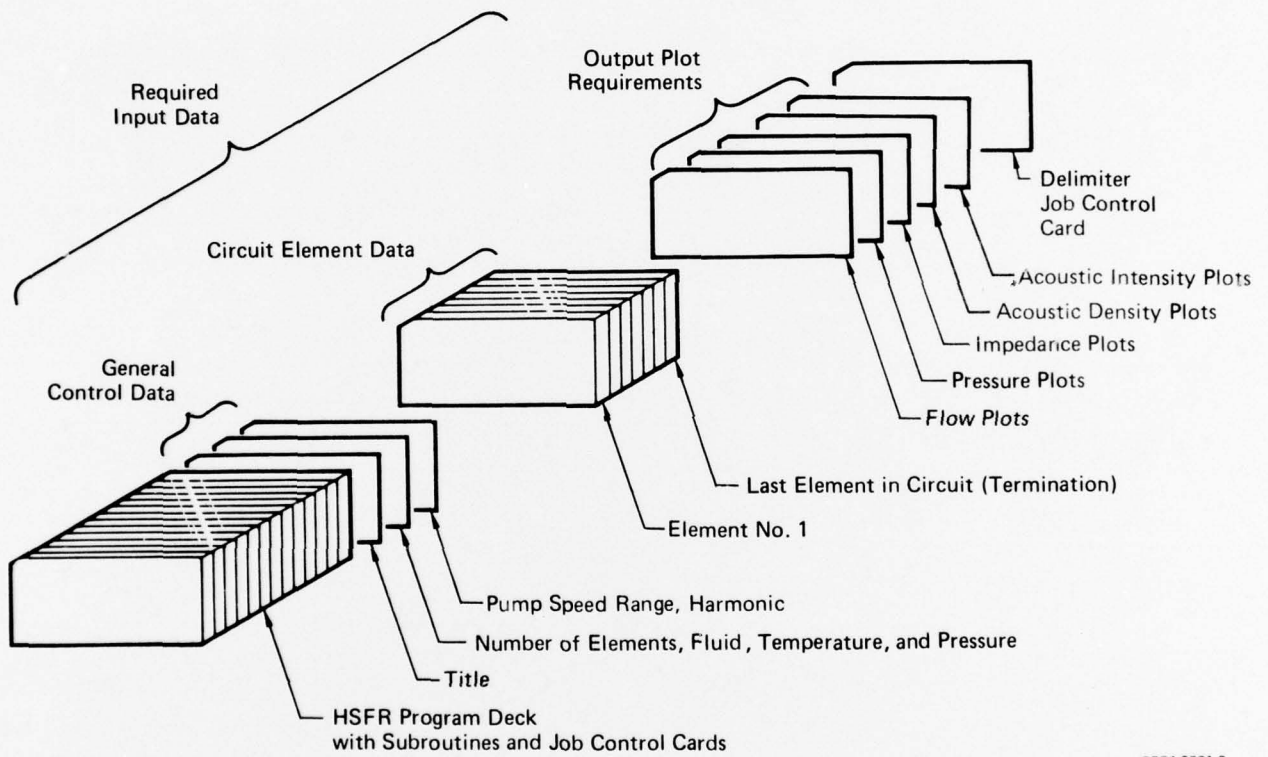

GP74-0771-3

FIGURE 2-6
HSFR PROGRAM DECK AND INPUT DATA JOB SETUP

3.0 PROGRAM OUTPUT

3.1 Computer Output

Figure 3-1 shows example outputs printed by the program prior to the output plots for the illustrated F-15 PC-1 system.

The program automatically prefaces the output with the program name, date of run, run title, pump speed range and increment, harmonic, and a list of the fluid properties calculated by the program for the specified fluid, temperature and pressure. Then, a list of all the elements used in the run, together with their input data, is printed. The program then prints the total number of flow, pressure, impedance, acoustic energy density, and acoustic energy intensity plots desired and, in each case, the specified circuit element numbers for which plots are desired.

In the absence of special instructions, the output print plots are printed next. Extra WRITE statements may be incorporated for printing out any desired parameter contained in the program. Extra WRITE statements are useful to investigate the behavior of certain variables.

3.2 Output Plots

The normal computed program output consists of plots of flow, pressure, impedance, and acoustic energy density and intensity versus pump rpm, for the selected junctions in the system being analyzed. The manner in which the user specifies the plots required is described in Section 2.4. The functional subroutine GRAPH2 used to produce the plots is described in Volume IV, and the restrictions placed by GRAPH2 in the specified pump speeds are given in Section 2.2.

3.3 Interpretation of Computer Output Plots

A typical computer print-plot output shown in Figure 3-2 is a plot of the first harmonic (fundamental) frequency amplitude of the oscillatory pressure, versus pump speed (rpm), for element number 7 in the illustrated F-15 PC-1 system. The

HYDRAULIC SYSTEM FREQUENCY RESPONSE PROGRAM
5/02/14.

F15 PC-1 PRODUCTION SYSTEM(NOW), PUMP TO RLS FREQUENCY RESPONSE

RESPONSE IS CALCULATED FROM 50.00 TO 5000.00 R.P.M. IN INCREMENTS OF 50.00 R.P.M.
RESPONSE IS PLOTTED FOR THE -FIRST- HARMONIC FREQUENCY

FLUID DATA FOR MIL-H-5606B AT 3000.0 PSIG AND 130.0 DEG F

VISCOSITY - .188E-01 IN**2/SEC
DENSITY - .813E-04 (LB-SEC**2)/IN**4
BULK MODULUS - .223E+06 PSI

ELEMENT NUMBER *****SYSTEM ELEMENT INPUT DATA*****

*****PHYSICAL DATA*****

ELEMENT NUMBER	N TYPE	K TYPE	1	2	3	4	5	6	7	8	9	10	11	12	13	14	15	16	17		
1	9	21	.190	.666	1.120	1.172	.698	.570	.180												
			.200	24.600	9.400	3.375	28.750	26.250	26.000												21.750
			50.000	-0.000	-0.000	-0.000	-0.000	-0.000	-0.000												-0.000
2	1	-0	8.000	1.200	.100	30000000.000	-0.000	-0.000	-0.000												
3	1	-0	3.500	1.200	.100	30000000.000	-0.000	-0.000	-0.000												
4	1	-0	4.500	.625	.032	16000000.000	-0.000	-0.000	-0.000												
5	1	-0	3.000	.625	.032	16000000.000	-0.000	-0.000	-0.000												
6	1	-0	11.500	.625	.032	16000000.000	-0.000	-0.000	-0.000												
7	1	-0	3.000	.625	.032	16000000.000	-0.000	-0.000	-0.000												
8	1	-0	2.000	1.100	.100	16000000.000	-0.000	-0.000	-0.000												
9	1	-0	2.500	1.000	.049	16000000.000	-0.000	-0.000	-0.000												
10	1	-0	11.000	1.000	.049	16000000.000	-0.000	-0.000	-0.000												
11	1	-0	9.000	1.000	.049	16000000.000	-0.000	-0.000	-0.000												
12	1	-0	2.700	1.000	.049	16000000.000	-0.000	-0.000	-0.000												
13	1	-0	4.500	1.000	.049	16000000.000	-0.000	-0.000	-0.000												
14	1	-0	4.000	1.000	.049	16000000.000	-0.000	-0.000	-0.000												
15	3	-0	14.500	-0.000	-0.000	-0.000	-0.000	-0.000	-0.000												
16	1	-0	6.000	.750	.035	16000000.000	-0.000	-0.000	-0.000												
17	1	-0	7.000	.750	.035	16000000.000	-0.000	-0.000	-0.000												
18	5	5	-1.000	-0.000	-0.000	-0.000	-0.000	-0.000	-0.000												
19	4	-0	.346	-0.000	-0.000	-0.000	-0.000	-0.000	-0.000												
20	1	-0	24.000	.500	.024	16000000.000	-0.000	-0.000	-0.000												
21	1	-0	344.000	.375	.016	16000000.000	-0.000	-0.000	-0.000												
22	1	-0	44.000	.375	.032	16000000.000	-0.000	-0.000	-0.000												
23	14	-0	1800.000	.770	-0.000	-0.000	-0.000	-0.000	-0.000												
24	4	-0	.791	-0.000	-0.000	-0.000	-0.000	-0.000	-0.000												
25	1	-0	244.000	.375	.016	16000000.000	-0.000	-0.000	-0.000												
26	5	2	-0.000	-0.000	-0.000	-0.000	-0.000	-0.000	-0.000												
27	1	-0	36.000	.750	.016	16000000.000	-0.000	-0.000	-0.000												
28	14	-0	1222.000	1.150	-0.000	-0.000	-0.000	-0.000	-0.000												
29	1	-0	44.000	.375	.032	16000000.000	-0.000	-0.000	-0.000												
30	14	-0	1590.000	1.540	-0.000	-0.000	-0.000	-0.000	-0.000												

4 0 PLOTS FOR INPUT TO ELEMENT NUMBERS 6 7 8 9
 1 7 PLOTS FOR INPUT TO ELEMENT NUMBERS 1 2 3 4 5 6 7 8 9 10 11 12 13 14 15 16 17
 4 7 PLOTS FOR INPUT TO ELEMENT NUMBERS 6 7 8 9
 2 7 PLOTS FOR INPUT TO ELEMENT NUMBERS 2 4 6 9 12 17 22 25 29
 2 7 PLOTS FOR INPUT TO ELEMENT NUMBERS 2 4 6 9 12 17 22 25 29

FIGURE 3-1 Typical Pre-Plot Computer Output

BEST AVAILABLE COPY

pressure amplitude is the peak value of the pressure sine wave for the fundamental frequency only, at the junction of elements 6 and 7. This plot is synonymous with test results obtained when using a spectrum analyzer storage oscilloscope to record fundamental frequency pressure amplitudes at that junction in the system as pump speed is varied over the rpm range (photograph in Figure 3-2).

Pump speeds which cause maximum amplitude resonant response in the circuit are identified by the major peak amplitudes, in this case at about 1450, 2850, and 3125 rpm. Note the numerous minor resonant responses which occur in a complex multi-branch circuit such as the illustrated F-15 PC-1 system. For a given major resonant speed (rpm), the computed peak input pressure at each element may be plotted (manually) against the physical location of each element in the circuit. The resulting standing wave pattern is shown in Figure 3-3, which compares computed pressures to actual test measurements made on the F-15 iron bird PC-1 hydraulic system. This form is useful in analyzing potential system modifications which may reduce and/or relocate major resonant conditions.

A similar computer output plot and standing wave plot are shown in Figures 3-4 and 3-5, respectively, for a simple, straight test circuit modeled and tested with the F-4 aircraft Abex pump. Note the lack of minor resonant responses in the simple circuit and the excellent prediction of both the first and second major resonant speeds. Fundamental frequency half wave amplitudes predicted by the earlier HSRF program, as shown in Figures 3-2 through 3-5, are about 20% lower than actual measured values. Amplitudes predicted by the current program are about 20% higher than measured values. This is primarily due to changes made in the PUMP subroutine.

It is necessary to understand the behavior of acoustic waves in a closed system in order to interpret the relationship between the pressure and flow at a particular point in a system, and the amplitudes at other positions. A typical system will contain a series of traveling and standing waves for each

harmonic frequency. Appendix A, Volume IV, describes how these waves are distributed along a line, and the relationship between pressure and flow, and distance along the line. The program user must understand this part of the subject to preclude drawing erroneous conclusions from the results of a single point pressure measurement, or calculation.

Acoustic energy analysis may also be performed with the program. Figure 3-6 is an output plot of the acoustic energy density at the input to element number 6 in the F-15 PC-1 system. The energy density represents the total of kinetic (flow) plus potential (pressure) acoustic energy. In this case, the total energy density is about 28 milliwatts per cubic inch at the low resonance speed. Figure 3-7 is an output plot of the acoustic intensity or power at element number 6. The acoustic intensity is analogous to active AC electrical power flowing past the junction of element numbers 5 and 6. The active power is product of the in-phase component of the oscillating flow and pressure. The active acoustic power at the low and high resonant speeds is 41 and 33 watts, respectively.

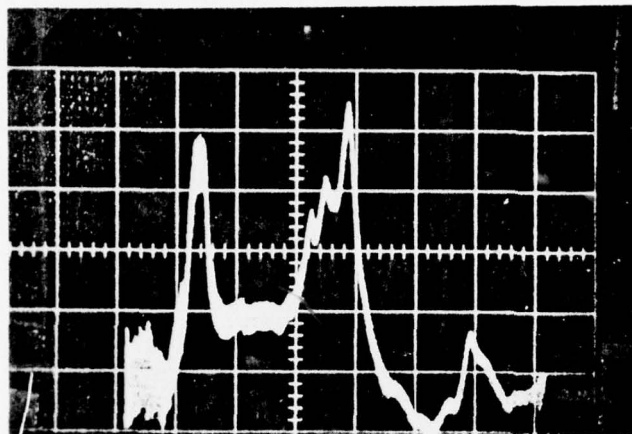

Spectrum Analyzer Output -
Run 4B, Y-Axis 19.7 PSI/CM
X-Axis 500 RPM/CM
0-5000 RPM

Peak pressure
measured at input
to element No. 7.

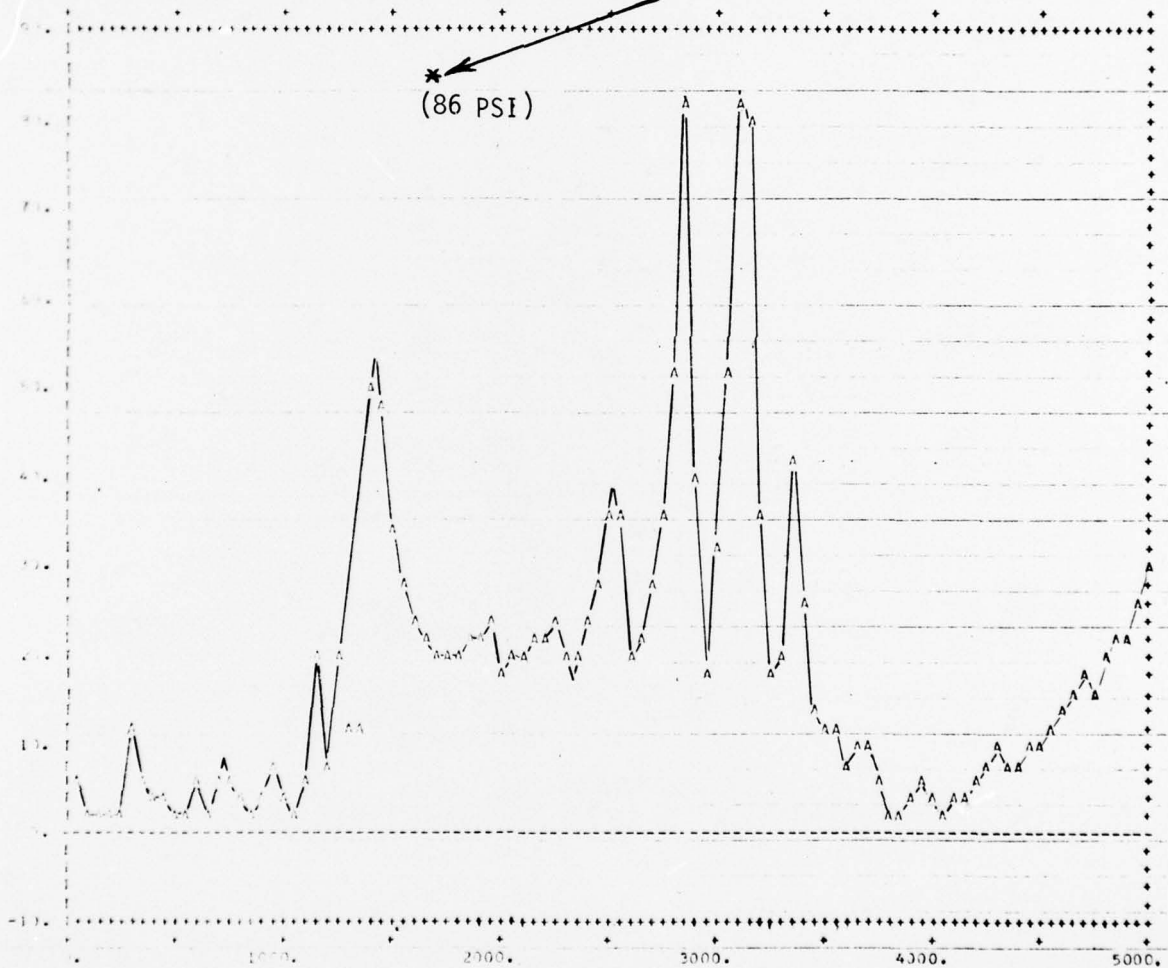

P 7 PRESSURE IN PSI VERSUS PUMP RPM

F15 PC-1 SYSTEM, PUMP TO RLS FREQUENCY RESPONSE, RLS A-B NORMAL

FIGURE 3-2

Computed and Measured Fundamental Frequency Response, F-15 PC-1 System

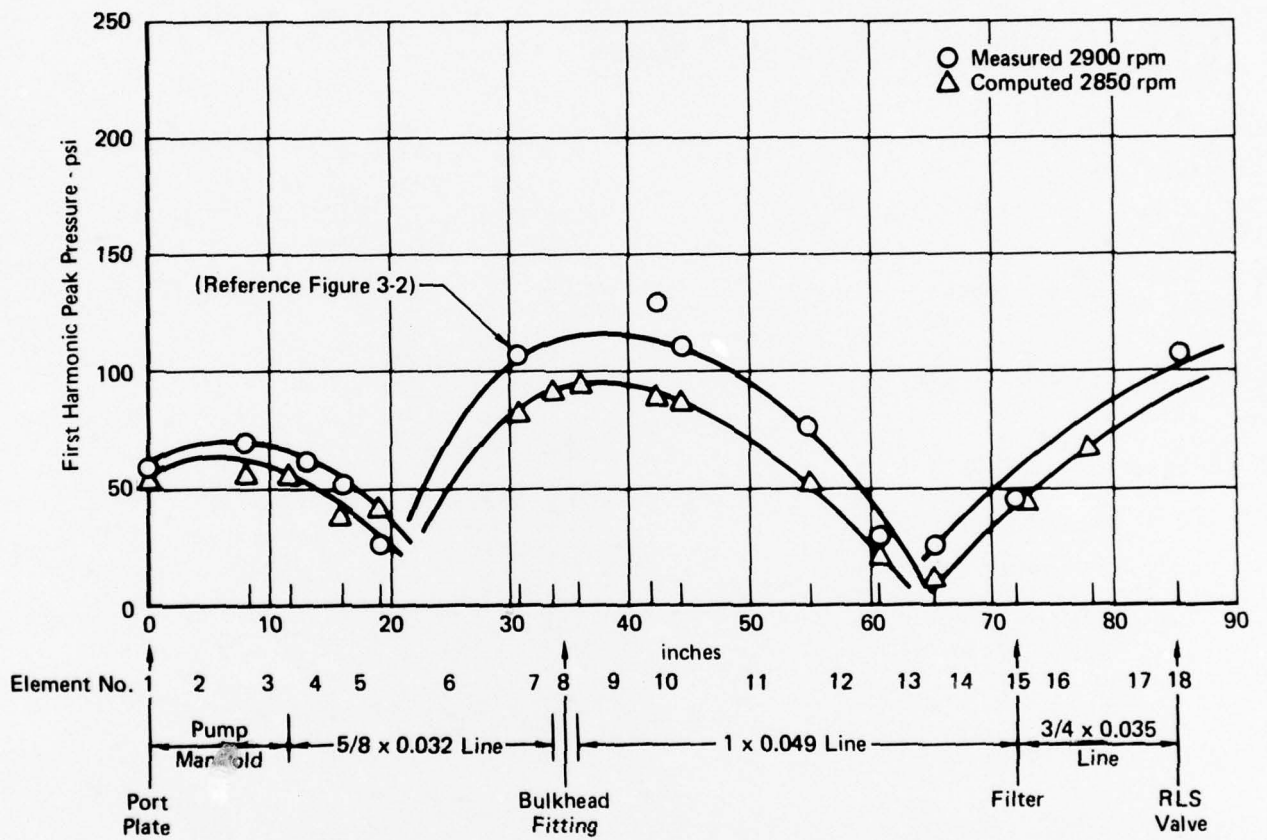

GP74-0771-4

FIGURE 3-3
STANDING PRESSURE HALF WAVE - F-15 PC-1 SYSTEM

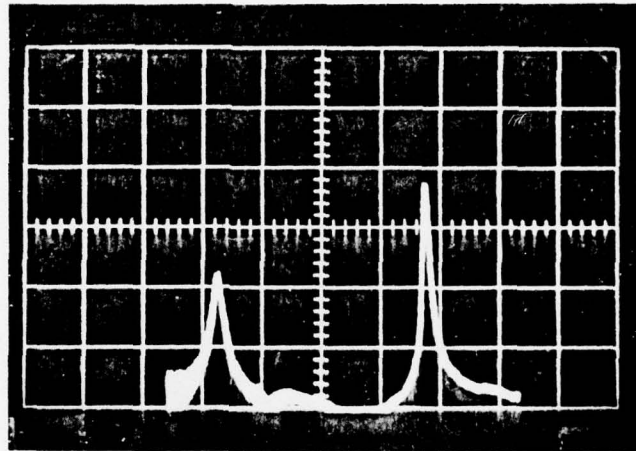

Spectrum Analyzer
 Output - Run 28
 Y-Axis 56 PSI/CM
 X-Axis 500 RPM/CM
 0-5000 RPM

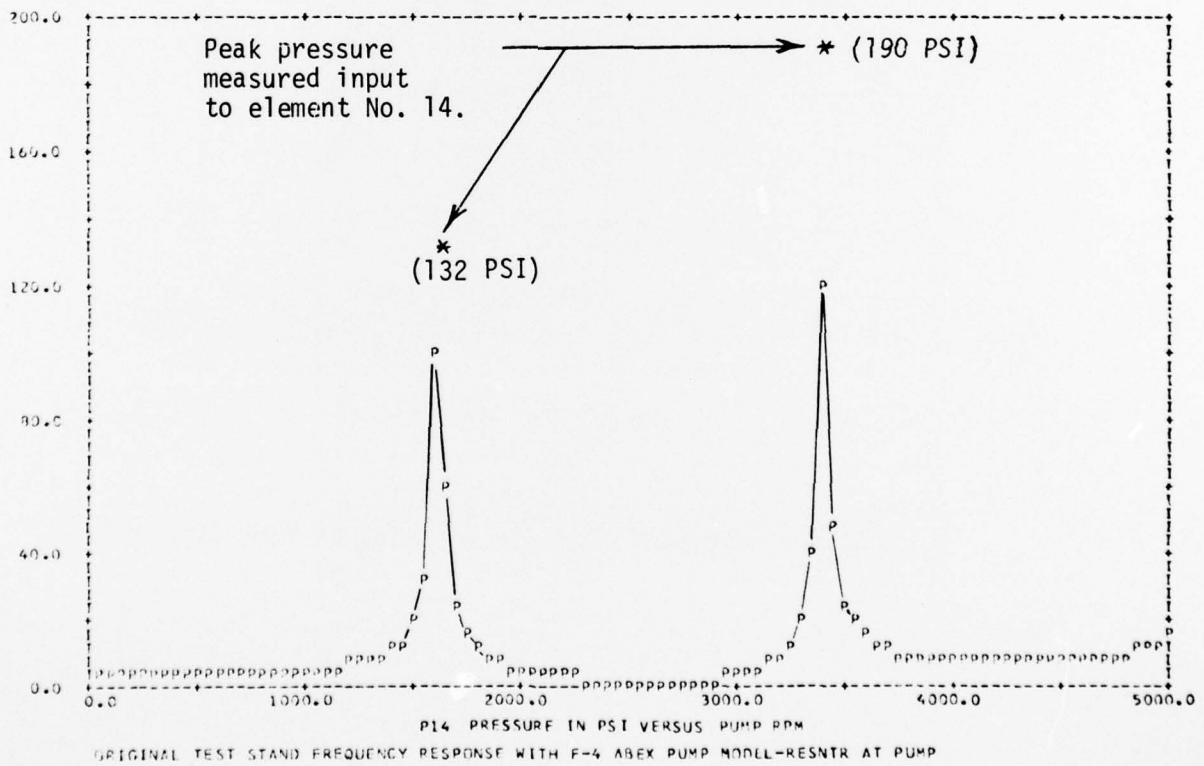

FIGURE 3-4

Computed and Measured Fundamental Frequency Response,
 Test Stand F-4 Abex Pump

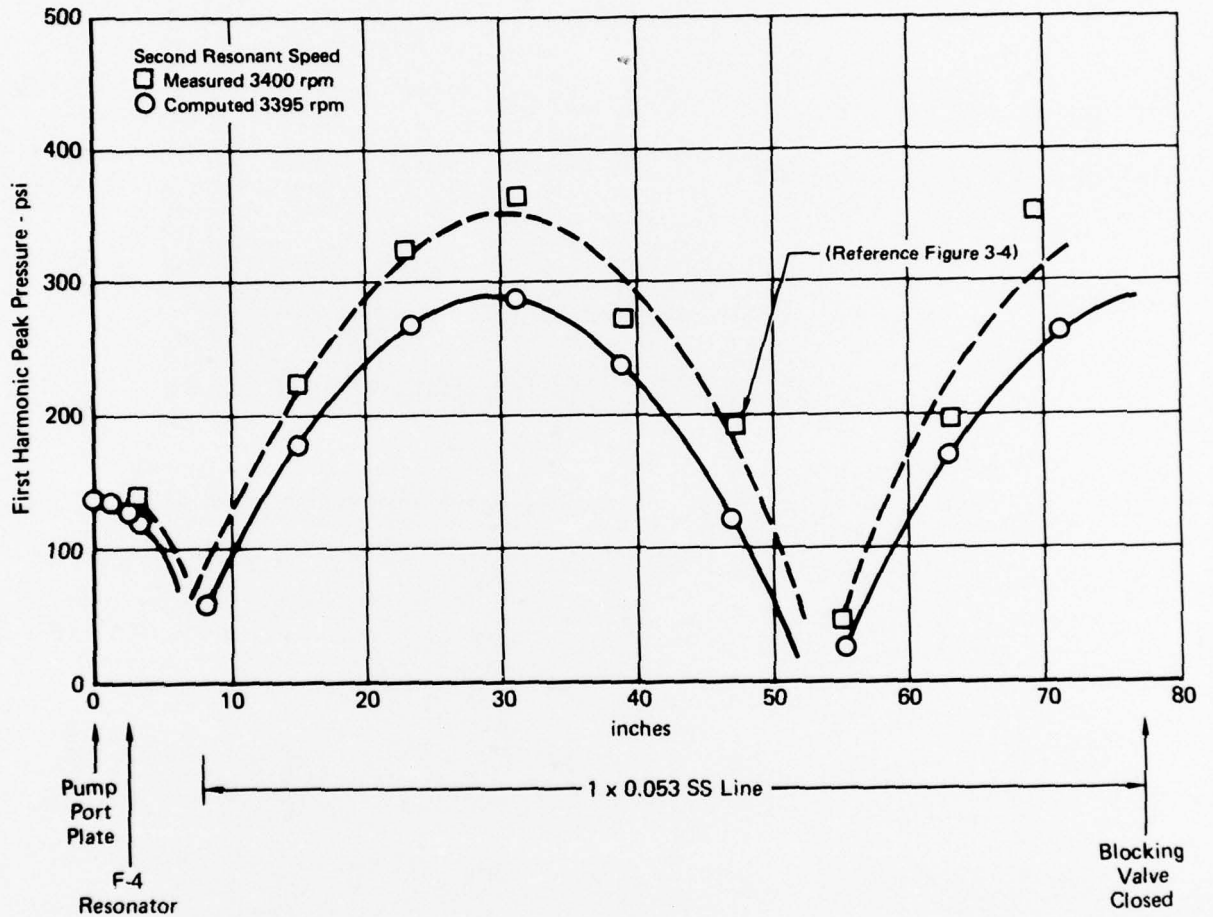

FIGURE 3-5
STANDING PRESSURE HALF WAVE, TEST STAND F-4 ABEX PUMP

GP74-0771-5

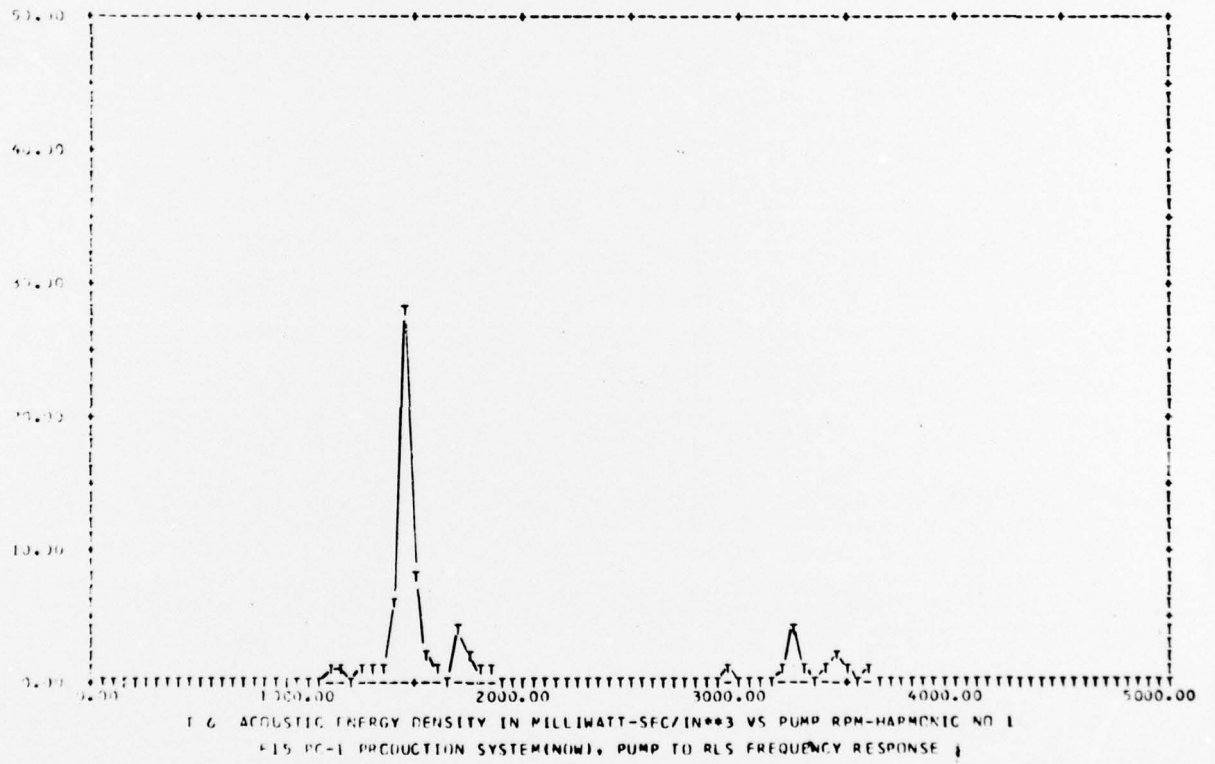

FIGURE 3-6

EXAMPLE OF COMPUTED ACOUSTIC ENERGY DENSITY

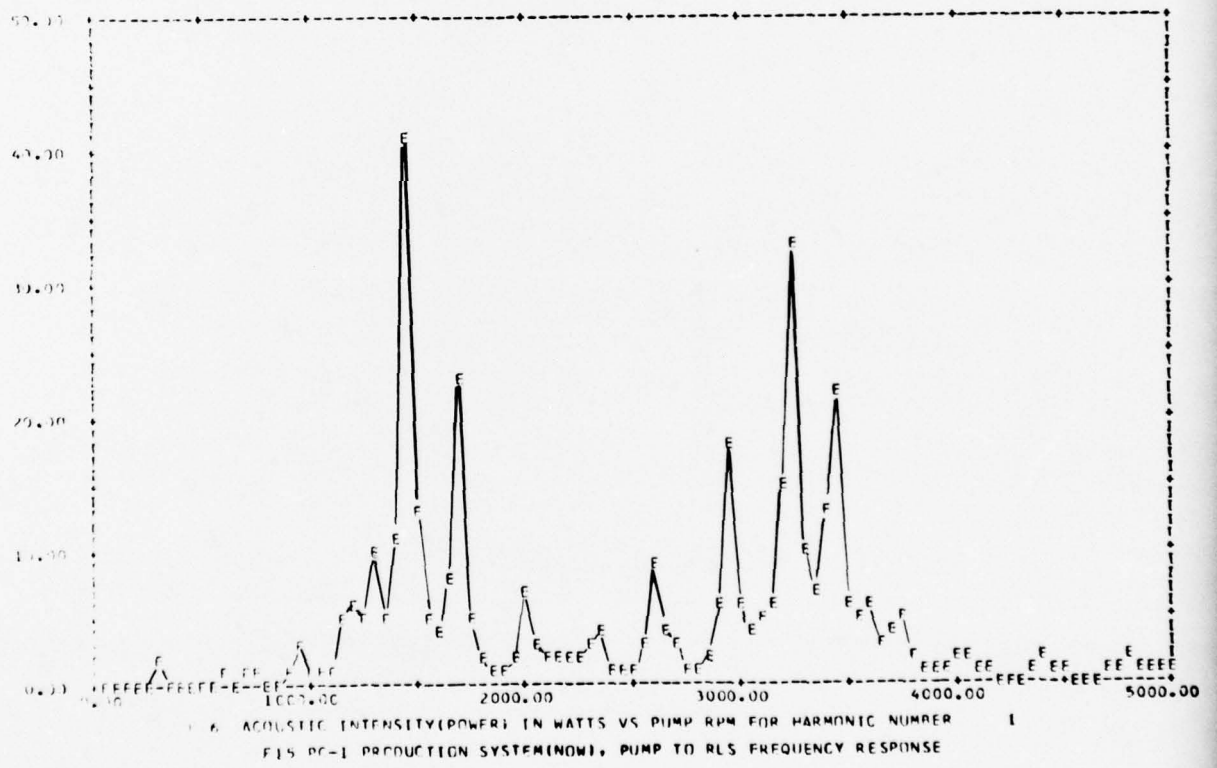

FIGURE 3-7
 EXAMPLE OF COMPUTED ACOUSTIC ENERGY INTENSITY (POWER)