

AD-A038 611

MCDONNELL DOUGLAS CORP ST LOUIS MO

AIRCRAFT HYDRAULIC SYSTEMS DYNAMIC ANALYSIS. VOLUME V. STEADY S--ETC(U)

FEB 77 R LEVEK, B YOUNG

F33615-74-C-2016

F/G 1/3

NL

UNCLASSIFIED

AFAPL-TR-76-43-VOL-5

1 OF 1  
AD  
A038611



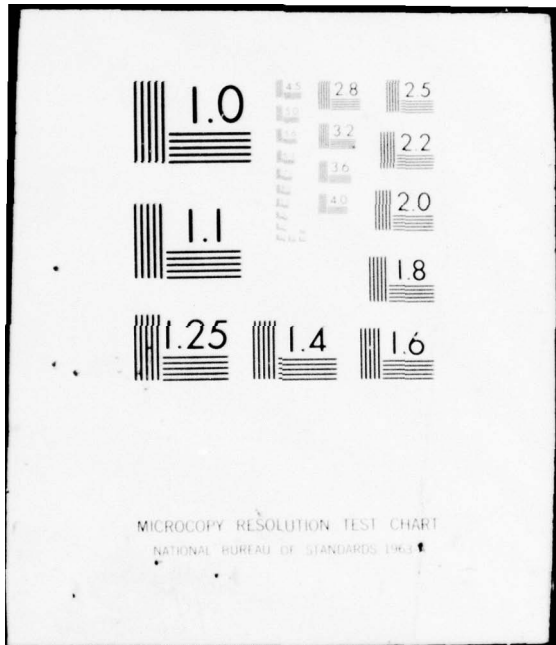

MICROCOPY RESOLUTION TEST CHART  
NATIONAL BUREAU OF STANDARDS 1963-A

AFAPL-TR-76-43 VOLUME V

*J* (13)

ADA 038611

# AIRCRAFT HYDRAULIC SYSTEMS DYNAMIC ANALYSIS

VOLUME V  
STEADY STATE FLOW ANALYSIS  
(SSFAN)

COMPUTER PROGRAM  
USER MANUAL

MCDONNELL AIRCRAFT COMPANY  
MCDONNELL DOUGLAS CORPORATION  
ST. LOUIS, MISSOURI

February 1977

DDC  
APR 26 1977  
AUGUST 1977

TECHNICAL REPORT AFAPL-TR-76-43, VOLUME V

This document has been approved for public release.  
Its distribution is unlimited.

AIR FORCE AERO PROPULSION LABORATORY  
AIR FORCE SYSTEMS COMMAND  
WRIGHT-PATTERSON AIR FORCE BASE, OHIO 45433

AD No. \_\_\_\_\_  
DDC FILE COPY

NOTICE

When Government drawings, specifications, or other data are used for any purpose other than in connection with a definitely related Government procurement operation, the United States Government thereby incurs no responsibility nor any obligation whatsoever; and the fact that the government may have formulated, furnished, or in any way supplied the said drawings, specifications, or other data, is not to be regarded by implication or otherwise as in any manner licensing the holder or any other person or corporation, or conveying any rights or permission to manufacture, use, or sell any patented invention that may in any way be related thereto.

This report was submitted by McDonnell Douglas Corporation, under contract ~~3~~3615-74-C-2016.

The effort was sponsored by the Air Force Aero Propulsion Laboratory, Air Force Systems Command, Wright-Patterson A.F.B., Ohio, under Project No. 3145-30-18 with AFAPL/POP/, and was under the direction of Paul Lindquist and William Kinzig.

Neil Pierce and Gerry Amies of McDonnell Douglas Corporation were technically responsible for the work.

This report has been reviewed by the Information Office, (ASD/OIP) and is releasable to the National Technical Information Service (NTIS). At NTIS, it will be available to the general public, including foreign nations.

NTIS	TRANSMISSION	<input type="checkbox"/>	<input type="checkbox"/>
DOC	2nd QUARTER		
UNCLASSIFIED			
ADDITIONAL			
BY	DISTRIBUTION AVAILABILITY CODES		
	Dist. Avail. Codes of SPECIAL		
	A		

Copies of this report should not be returned unless return is required by security considerations, contractual obligations, or notice on a specific document.



UNCLASSIFIED

SECURITY CLASSIFICATION OF THIS PAGE (When Data Entered)

<b>9 REPORT DOCUMENTATION PAGE</b>		<b>READ INSTRUCTIONS BEFORE COMPLETING FORM</b>
<b>18</b> 1. REPORT NUMBER AFAPL-TR-76-43-VOL-85	2. GOVT ACCESSION NO.	3. RECIPIENT'S CATALOG NUMBER
<b>6</b> 4. TITLE (and Subtitle) AIRCRAFT HYDRAULIC SYSTEMS DYNAMIC ANALYSIS, VOLUME V, STEADY STATE FLOW ANALYSIS (SSFAN) COMPUTER PROGRAM USER MANUAL,	<b>7</b> 5. TYPE OF REPORT & PERIOD COVERED Interim Technical Report	
	6. PERFORMING ORG. REPORT NUMBER	
<b>10</b> 7. AUTHOR(s) Ray/Levek Bob/Young	<b>15</b> 8. CONTRACT OR GRANT NUMBER(s) F33615-74-C-2016 <i>new</i>	
9. PERFORMING ORGANIZATION NAME AND ADDRESS McDonnell Douglas Corporation P O Box 516 St. Louis, Missouri 63166	<b>16</b> 10. PROGRAM ELEMENT, PROJECT, TASK AREA & WORK UNIT NUMBERS 3145-30-18 <b>10</b> 62203F	
11. CONTROLLING OFFICE NAME AND ADDRESS Air Force Aero Propulsion Laboratory Air Force Systems Command Wright-Patterson Air Force Base, Ohio 45433	<b>11</b> 12. REPORT DATE February 1977	
	13. NUMBER OF PAGES	
<b>12</b> 14. MONITORING AGENCY NAME & ADDRESS (if different from Controlling Office) 105p.	15. SECURITY CLASS. (of this report) UNCLASSIFIED	
	15a. DECLASSIFICATION/DOWNGRADING SCHEDULE	
16. DISTRIBUTION STATEMENT (of this Report)  Approved for public release, distribution unlimited		
17. DISTRIBUTION STATEMENT (of the abstract entered in Block 20, if different from Report)		
18. SUPPLEMENTARY NOTES		
19. KEY WORDS (Continue on reverse side if necessary and identify by block number)		
Computer Program	Flow Through Reservoir	Check Valve
Hydraulic System	Heat Exchanger	Flexible Hose
Steady State	Actuator	Accumulator
User Manual	Hydraulic Filter	Restrictor
Variable Delivery Pump	Solenoid Valve	
20. ABSTRACT (Continue on reverse side if necessary and identify by block number)		
<p>SSFAN is a steady state hydraulic flow and pressure analysis computer program. Its primary purpose is to analyze non-linear resistance aircraft hydraulic systems. The program handles complex flow networks containing flow and/or pressure discontinuities such as unbalanced area actuators and check valves. Solutions for a combination of simultaneously operating subsystems are easily obtained. The program is designed using a building block approach so that new component or element models may be added with minimum change to</p>		

DDPC  
 APR 26 1977  
 RECEIVED

404120

1B

UNCLASSIFIED

SECURITY CLASSIFICATION OF THIS PAGE(When Data Entered)

the main program. The solution method is a Matrix type, using iteration to obtain a final flow and pressure balance. The program internally corrects viscosities for pressure, determines whether flow is laminar, transition or turbulent for use of appropriate resistance factors and corrects reservoir pressure for altitude effects.

The program was written with the aircraft hydraulic system designer in mind. The terminology and units are commonly used terms such as fluid viscosity in centistokes, temperatures in degrees Fahrenheit and flow in gallons per minute. Conversion of units for calculation is accomplished internally in the program.



UNCLASSIFIED

iv SECURITY CLASSIFICATION OF THIS PAGE(When Data Entered)

TABLE OF CONTENTS

<u>Section</u>	<u>Title</u>	<u>Page</u>
1.0	INTRODUCTION . . . . .	1-1
1.1	General System Description. . . . .	1-2
1.2	Solution Technique. . . . .	1-2
1.3	General Program Operation Description . . . . .	1-4
1.4	Program Limitations . . . . .	1-6
2.0	PROGRAM INPUT. . . . .	2-1
2.1	Data Preparation. . . . .	2-1
2.1.1	Schematic Block Diagram. . . . .	2-1
2.1.2	Junction Point Numbering . . . . .	2-1
2.1.3	System Parameters. . . . .	2-3
2.1.3.1	Card 1 - Title Card . . . . .	2-4
2.1.3.2	Card 2 - Fluid Name . . . . .	2-5
2.1.3.3	Cards 3 and 4 - Viscosity-Temperature . . . . .	2-6
2.1.3.4	Card 5 - Density-Temperature and Viscosity . . . . .	2-9
2.1.3.5	Card 6 - System Temperature Flight Altitude and Data Output. . . . .	2-11
2.1.4	Element Data . . . . .	2-14
2.1.4.1	Type 1 - Tube . . . . .	2-17
2.1.4.2	Type 2 - Union. . . . .	2-21
2.1.4.3	Type 3 - Check Valve. . . . .	2-23
2.1.4.4	Type 4 - Simple Actuator. . . . .	2-25
2.1.4.5	Type 5 - Variable Delivery Pump . . . . .	2-28
2.1.4.6	Type 6 - Filter . . . . .	2-32
2.1.4.7	Type 7 - Accumulator. . . . .	2-35
2.1.4.8	Type 9 - Flow Through Reservoir . . . . .	2-37
2.1.4.9	Type 10 - Special (Flow vs $\Delta P$ ). . . . .	2-40
2.1.4.10	Type 11 - Flexible Hose . . . . .	2-43
2.1.4.11	Type 12 - Heat Exchanger or Radiator. . . . .	2-45
2.1.4.12	Type 21 - 45° Elbow . . . . .	2-47
2.1.4.13	Type 22 - 90° Elbow . . . . .	2-49
2.1.4.14	Type 23 - Reducer . . . . .	2-51
2.1.4.15	Type 24 - Tee . . . . .	2-53
2.1.4.16	Type 25 - Cross . . . . .	2-55
2.1.4.17	Type 31 - 1 Way Restrictor. . . . .	2-57
2.1.4.18	Type 32 - 2 Way Restrictor. . . . .	2-60
2.1.4.19	Type 33 - Relief Valve. . . . .	2-62
2.1.4.20	Type 34 - Solenoid Valve (4W-3P). . . . .	2-64
2.1.4.21	Type 41 - Servo-Actuator. . . . .	2-72
2.1.4.22	Type 91 - Appendix Reservoir. . . . .	2-73
2.1.4.23	Type 92 - Constant Pressure Reservoir . . . . .	2-75
2.1.5	End Card . . . . .	2-77
2.1.6	Program Deck and Input Data . . . . .	2-78
3.0	PROGRAM OUTPUT . . . . .	3-1
3.1	SSFAN Sample Case Number 1 . . . . .	3-1
3.2	SSFAN Sample Case Number 2 . . . . .	3-9
3.3	Other Output Types . . . . .	3-15

LIST OF FIGURES

<u>Number</u>	<u>Title</u>	<u>Page</u>
1-1	Example Hydraulic System . . . . .	1-3
1-2	SSFAN Flow Chart . . . . .	1-5
2-1	SSFAN Program - Partial System Block Diagram . . . . .	2-2
2-2	Partial System . . . . .	2-2
3-1	SSFAN Sample Case Number 1 - 2 Actuator Subsystem. . . . .	3-2
3-2	Example SSFAN First Page Data . . . . .	3-3
3-3	Example SSFAN Output Type 1 - Element Input Data . . . . .	3-5
3-4	Example SSFAN Output Type 1 - Element Input Data . . . . .	3-6
3-5	Example SSFAN Output Type 2 - Flow and Pressure Drop In Branch Legs . . . . .	3-7
3-6	Example SSFAN Output Type 3 - Pressures at Branch Points and End Points . . . . .	3-8
3-7	Example SSFAN Output Type 4 - Pump Reservoir and Actuator Pressures and Flows . . . . .	3-10
3-8	SSFAN Sample Case Number 2 - 3 Actuator Subsystem . . . . .	3-11
3-9	Example SSFAN Output Type 2 - Flow and Pressure Drop in Branch Legs . . . . .	3-12
3-10	Example SSFAN Output Type 3 - Pressures at Branch Points and End Points . . . . .	3-13
3-11	Example SSFAN Output Type 4 - Pump Reservoir and Actuator Pressures and Flows . . . . .	3-14

LIST OF PAGES

<u>Title</u>	<u>Page</u>
ii through vii	
1-1 through 1-6	
2-1 through 2-78	
3-1 through 3-15	



LIST OF TABLES

<u>Number</u>	<u>Title</u>	<u>Page</u>
2-1	Viscosity-Temperature Data . . . . .	2-6
2-2	Density-Temperature. . . . .	2-9

## 1.0 INTRODUCTION

SSFAN is a computer program developed to analyze the steady state flows in a closed aircraft hydraulic system; i.e. where the fluid leaving the pump circulates through the system and returns to the suction inlet of the pump, either via a reservoir, or by direct line return, or both. The program can be used to predict the steady-state subsystem performance, such as flight control surface rates (under load as well as no load), flap and landing gear extend and retract times, hydraulic-motor-driven gatling-gun firing rate, flows and pressures at any point in the system, etc. The performance is predicted based on operating any combination of subsystems simultaneously.

The solution method used in SSFAN is based on a one dimensional steady state flow throughout the network of branch legs in the system.

SSFAN is coded in FORTRAN IV and currently operable on the CDC 6500/6600.

SSFAN may be used as an analytical program to analyze an existing system with all the detail components accounted for in the analysis.

It may also be used as an advanced design or preliminary design tool to analyze and update new system designs as they are established.



## 1.1 General System Description

The system to be analyzed is first diagrammed as shown in Figure 1-1. Junction points are added and numbered. Each component or element in the system is defined by its physical characteristics and junction point numbers for input into SSFAN.

## 1.2 Solution Technique

SSFAN sorts the input data into branch legs from the junction point numbers and establishes continuity throughout the system. There is a branch point or end point at the end of each leg. Branch leg resistances are calculated and summed for all the elements within the leg.

Pressure points are established at each end of the leg. Fluid viscosity is internally corrected for pressure in each leg by taking the average leg pressure and using this for the viscosity correction pressure.

The Reynolds number is calculated for each leg. Flow is determined to be laminar, transition or turbulent. Appropriate resistance factors are used for each flow condition to calculate the pressure drop or resistances of each leg.

This resistance is temporarily assumed to be linear to use the Matrix solution technique in calculating pressures at all branch points in the system

$$\text{where } R_{12} = \frac{P_{12}}{Q}$$

$R_{12}$  = Resistance from end 1 to end 2 of the leg

$P_{12}$  = Pressure drop from end 1 to end 2 of the leg

$Q$  = Flow in the leg

Conductance is then defined as

$$G_{12} = \frac{1}{R_{12}}$$

where  $G_{12}$  = Conductance from end 1 to end 2 of the leg



then  $Q = G_{12} P_{12}$

The net flow at any branch point (where three or more legs come together) must be zero.

Therefore the flow requirement is satisfied if

$$\sum_J G_{IJ} [P_I - P_J \pm \Delta P_{IJ}] - \sum_K \pm Q_{IK} = 0$$

where

$P_I$  = pressure at branch point I

$P_J$  = pressure at branch point J

$\Delta P_{IJ}$  = a pressure rise or loss (from a pump or actuator) in branch leg IJ

$Q_{IK}$  = Fixed flow in branch leg IK connected to branch point I

Equations of the above form are input to the Matrix for solution of pressures at branch points. These matrix solution pressures are used in conjunction with the calculated conductance (G) to calculate a new flow guess in each leg. When two successive flow guesses for all branch legs in the system are within a specific tolerance such as .001 gpm, the solution has converged. See Volume II for a detailed discussion of the solution technique.

### 1.3 General Program Operation Description

The general SSFAN flow chart is shown in Figure 1-2. As the data is read into the program, it is sorted and stored in the appropriate element array. Some element data such as tubing bends are calculated for equivalent lengths as the data is read in. The total equivalent length of the bends for the tube is then stored in the array.

The pump is established as the first component in the system, unless an accumulator is designated as the pressure source. A search routine then searches the element data arrays and establishes system continuity for the total system. If system continuity cannot be established, error messages are output and the run stops. The branch leg resistances are

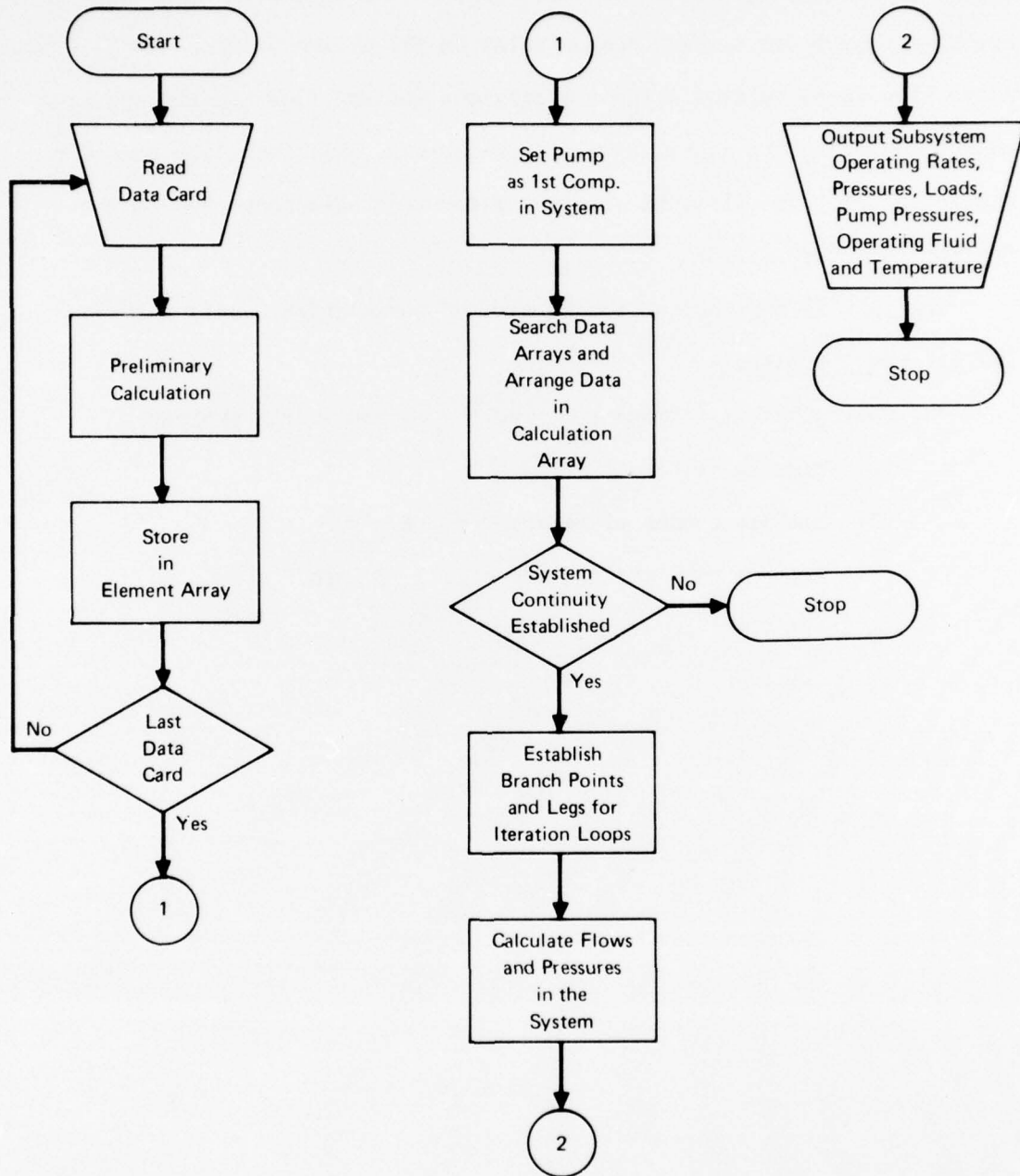

FIGURE 1-2  
SSFAN FLOW CHART

GP74-0772-29

established as the continuity search is made.

A branch leg array is established containing all the active branch legs. An initial flow guess is made for each leg in the system and pressures are then calculated at each branch point in the system using a Matrix solution. A new flow is calculated using the previous guessed flow and the new flow calculated using the matrix solution pressures. This iteration procedure continues until the flows in all the system legs have converged to the desired tolerance.

The data is then output in one more of the available output types.

#### 1.4 Program Limitations

The following limitations apply to the current SSFAN program.

- (1) Maximum number of pumps 4
- (2) Maximum number of reservoirs 1
- (3) Maximum tube and fitting size 3 inch



## 2.0 PROGRAM INPUT

Preparation of data for input into SSFAN consists of four basic steps:

(1) The user must draw a schematic block diagram of his system with all elements shown; (2) the schematic is numbered at all "in" and "out" junctions of the elements; (3) the system and fluid parameters such as fluid name, viscosity, density, system operating temperature along with the program title and data output are selected; and (4) each element is described with appropriate "in" and "out" junctions along with other physical data describing the element.

### 2.1 Data Preparation

#### 2.1.1 Schematic Block Diagram

The partial system schematic block diagram of Figure 2-1 shows how the system is to be diagrammed. It may be desirable to make the diagram blocks large enough to add additional reference data such as tube wall thickness, check valve cracking pressure, etc.

The system to be described may be visualized as shown in Figure 2-2. The elements of the system are looked at as if they are disassembled for preparation of the schematic block diagram.

#### 2.1.2 Junction Point Numbering

The point at which two elements meet is called a junction or junction point. These junctions are numbered using the series of numbers from 1 to 9999. It is recommended that an orderly sequence of numbering be used, preferably skipping numbers, so that if changes are made later, the new element numbers can be inserted in the corresponding sequence and will be easy to locate. It should be noted that this is not required for the computer program, but is recommended for the users own benefit.

Figure 2-1 illustrates a typical numbering of junction points. There are three junction points for the hydraulic pump (5, 10 and 15), two junction



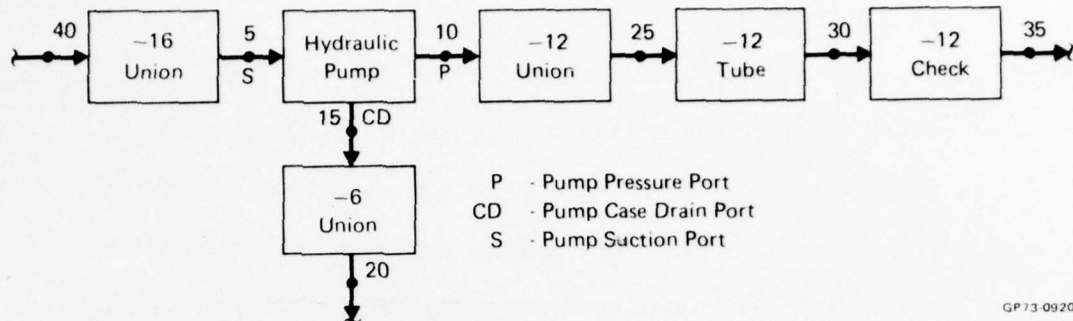

GP73 0920 44

**FIGURE 2-1**  
**SSFAN PROGRAM - PARTIAL SYSTEM BLOCK DIAGRAM**

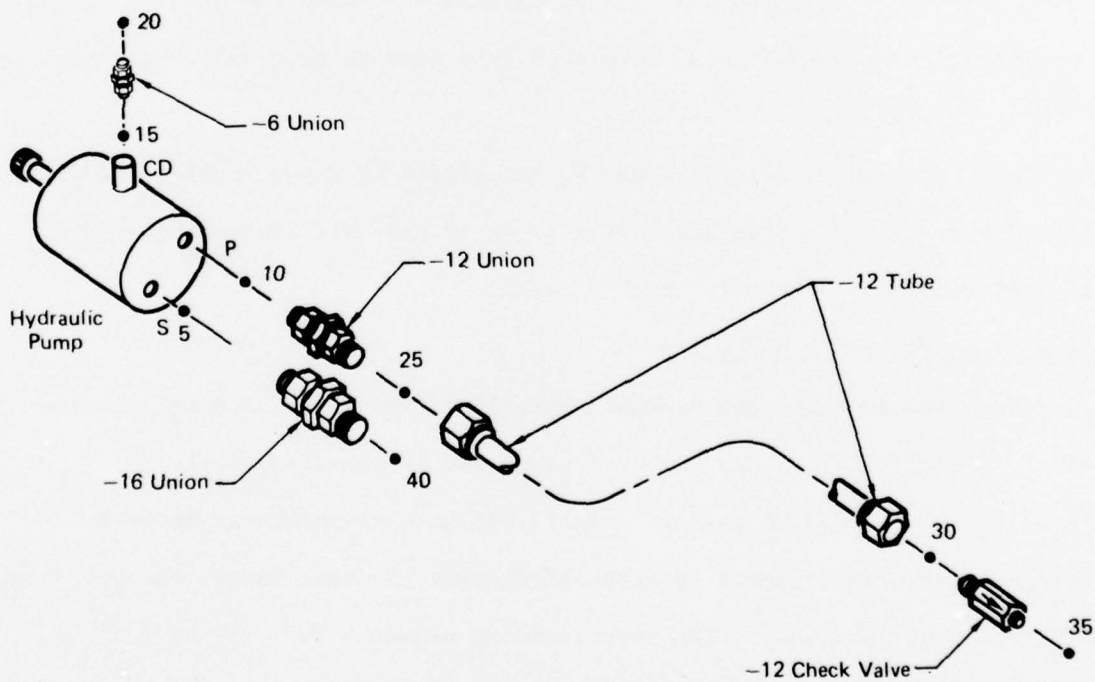

GP74 0772 9

**FIGURE 2-2**  
**PARTIAL SYSTEM**

points for the -12 union at the pump pressure port (10 and 25) and two junction points for the -12 check valve (30 and 35).

It is required that all junction points be numbered and that no two junction points have the same number.

These "in" and "out" junction points are required data for the individual element data inputs described later.

The program uses these junction points to internally locate each element, assemble the system and assemble the resistances for each branch leg in the system.

### 2.1.3 System Parameters

The system parameters are the first data cards to be assembled in the data deck, and these six cards are required to be in a particular order as noted below.





### 2.1.3.3 Cards 3 and 4 - Viscosity-Temperature

The selected fluid of 2.1.3.2 requires appropriate viscosity-temperature data. Table 2-1 gives some suggested viscosities for typical aircraft hydraulic fluids. Input viscosities to SSFAN are at atmospheric pressure. Viscosity and temperature units are centistokes and degrees Fahrenheit respectively. It should be noted that viscosity values are not consistent between literature sources, therefore the user is free to select and use his own desired viscosity data.

TABLE 2-1  
Viscosity-Temperature Data

TEMPERATURE (DEG F)	VISCOSITY (CENTISTOKES)				
	MIL-H-5606A	MIL-H-83282	SKYDROL 500B	MIL-H-5606B	
-65	2000.0	11500.0	3500.0	2000.0	
-40	385.0	2022.0	600.0	488.0	
0	130.0	270.0	155.0	135.0	
50	36.0	49.0	36.0	35.0	
100	14.6	16.0	11.75	14.5	
150	7.7	7.5	7.0	7.5	
200	4.8	4.3	4.2	4.6	
250	3.4	2.85	2.9	3.2	
300	2.4	2.05	2.15	2.4	

Input Data on Cards 3 and 4 are used to describe the viscosity-temperature points. Column 1 on Card 3 and Card 4 contain the same integer number which is the number of viscosity-temperature points to be input with a minimum of 2 and a maximum of 9.

Card 3 contains a viscosity at a point while Card 4 contains the corresponding temperature at the point.

Viscosities and temperatures must be in corresponding fields on their respective cards. The temperatures must be input in ascending order.









2.1.3.4 Card 5 - Density-Temperature and Viscosity

Density-Temperature - The density of the selected fluid is input for 2 points only since density is considered to change linearly with temperature. Usually these are given at extreme temperatures, but any 2 reasonably spaced temperatures will do since interpolation is linear and linear extrapolation is allowed. Table 2-2 gives some suggested aircraft hydraulic fluid densities at atmospheric pressure.

TABLE 2-2  
Density-Temperature

TEMPERATURE	DENSITY (LB/FT <sup>3</sup> )				
(DEG F)	MIL-H-5606A	MIL-H-83282	SKYDROL 500B	MIL-H-5606B	
-65	56.1	56.6	68.8	57.2	
275	49.9	48.6	59.5	51.0	

The input densities for Card 5 are weight densities. The first data field density corresponds with the third data field temperature and the second data field density corresponds with the fourth data field temperature.



#### 2.1.3.5 Card 6 - System Temperature Flight Altitude and Data Output

The desired operating fluid temperature and flight altitude are input on this card. Temperature is in Degrees Fahrenheit and flight altitude is in feet. A zero flight altitude is sea level. The SSFAN program is also capable of running at temperature increments specified by the user. Finally a series of number codes for various types of outputs. See Section 3 for examples of the output types listed below.

<u>Output Code Number (Columns 33-64)</u>	<u>Description</u>
1	= Element Input Data
2	= Flow and Pressure
3	= Pressures at Branch Points and End Points
4	= Selected Component Flows and Pressures

Branch point pressures include pressures at tees, and the inlet pressure to an actuator. End point pressures include pressures at an accumulator, the pump suction, pressure and case drain ports and the reservoir internal and bootstrap port pressures.

<u>Array Output Code Number (Columns 65-72)</u>	
1	= Leg assembly data, ILEP array, calculation parameters (number of nodes, number of legs), PQL array, BLEG array
2	= PQL and BLEG arrays
3	= BLEG array

The ILEP array contains the system leg numbers with their up and downstream node numbers. The PQL array has the system pressures and any

external flows to or from a node. The BLEG array is used in the steady state computation and it contains all the leg flow and pressure drop information. If 2 and 3 are selected from the array output code, PQL and BLEG will be printed for each iteration of the steady state program. Volume VI of AFAPL-TR-76-43 contains a further description of how these arrays are used and their contents.

Data field 1 contains the system operating temperature. Field 2 and 3 are for the final temperature and temperature increment. These may be left blank if not used. Field 4 is for the flight altitude in feet. A blank or zero indicates sea level altitude.

Data fields 5 through 8 are for selected type output data. If field 5 is left blank, the output will be types 1 and 2 above. Any one, combination of the four, or all the four type outputs may be specified. A suggested procedure is to use output 1 along with other outputs until the input data has been verified to be correct.

The ninth data field contains the output code for the arrays listed above.



COLUMNS	FORMAT	DATA	DIMENSIONS
1-8	F8.3	TEMPERATURE	DEG F
9-16	F8.3	FINAL TEMPERATURE	DEG F
17-24	F8.3	TEMPERATURE INCREMENT	DEG F
25-32	F8.3	ALTITUDE	FEET
33-40	F8.3	OUTPUT CODE NUMBER (OPTIONAL 1,2,3, AND 4)	---
41-48	F8.3	OUTPUT CODE NUMBER (OPTIONAL 1,2,3, AND 4)	---
49-56	F8.3	OUTPUT CODE NUMBER (OPTIONAL 1,2,3, AND 4)	---
57-64	F8.3	OUTPUT CODE NUMBER (OPTIONAL 1,2,3, AND 4)	---
65-72	F8.3	ARRAY CODE NUMBER (OPTIONAL 1,2, AND 3)	---

EXAMPLE CARD 6

System Fluid Temperature - Altitude - Output Data Type

100.	0.	0.	0.	1.	2.	3.	4.	1.
00000000	00000000	00000000	00000000	00000000	00000000	00000000	00000000	00000000
11111111	11111111	11111111	11111111	11111111	11111111	11111111	11111111	11111111
22222222	22222222	22222222	22222222	22222222	22222222	22222222	22222222	22222222
33333333	33333333	33333333	33333333	33333333	33333333	33333333	33333333	33333333
44444444	44444444	44444444	44444444	44444444	44444444	44444444	44444444	44444444
55555555	55555555	55555555	55555555	55555555	55555555	55555555	55555555	55555555
66666666	66666666	66666666	66666666	66666666	66666666	66666666	66666666	66666666
77777777	77777777	77777777	77777777	77777777	77777777	77777777	77777777	77777777
88888888	88888888	88888888	88888888	88888888	88888888	88888888	88888888	88888888
99999999	99999999	99999999	99999999	99999999	99999999	99999999	99999999	99999999

MCDONNELL AUTOMATION COMPANY



#### 2.1.4 Element Data

Elements are identified by numbers 1 through 99 in SSFAN. The most commonly used components are established as the lowest numbers. The general system of identification numbers is shown below. As noted, there are unused numbers which are reserved for development of future element models.

<u>Element Type</u>	<u>Description</u>	<u>Element Type</u>	<u>Description</u>
1	Tube	32	Restrictor-2 Way
2	Union	33	Relief Valve
3	Check Valve	34	Sol. Valve (4W-3P)
4	Simple Actuator	35	Sol. Valve (3W-2P)
5	Pump Variable Del.	36	Sol. Valve (2W-2P)
6	Filter Assy	37	
7	Accumulator	38	
8		39	
9	Reservoir-Flow Through	40	
10	Special (Flow vs. $\Delta P$ )	41	Servo-Actr (Deleted)
11	Hose	42	
12	Heat Exchanger	43	
13		44	
14		45	
15		46	
16		47	
17		48	
18		49	
19		50	
20		51	(Reserved for Pumps)
21	45° Elbow	52	
22	90° Elbow	53	
23	Reducer	54	
24	Tee	55	
25	Cross	56	
26	(Reserved for Fittings)	57	
27		58	
28		59	
29		60	(Reserved for Filter
30		61	Manifolds)
31	Restrictor-1 Way	62	

<u>Element Type</u>	<u>Description</u>	<u>Element Type</u>	<u>Description</u>
63	(Reserved)	81	(Reserved)
64		82	
65		83	
66		84	
67		85	
68		86	
69		87	
70		88	
71		89	
72		90	
73		91	Reservoir-Appendix
74		92	Reservoir-Constant
75		93	Pressure
76		94	
77		95	
78		96	
79		97	
80		98	

Individual element data cards do not have to be arranged in any particular order, except that if 2 or more data cards are required to describe one element. These cards do have to be in order. SSFAN sorts the element data and establishes continuity using the junction point numbers.

In the interest of using terminology which is familiar to aircraft hydraulic system designers and minimizing standard data input, the convention of using equivalent tube size is available as an option. For example the user may input for a tube either the actual tube O.D. in inches or the equivalent tube size in 16<sup>ths</sup> of an inch. The same is true for a fitting internal bore. The actual fitting internal bore may be input or the equivalent tube size may be input. The sizes and diameters listed below are currently used in SSFAN. The internal fitting bores established are the MS33649 and MS33656 series. These may be changed to any other set of standards desired by the user.

The system tubing and fittings are limited to a 3 inch maximum diameter or size.

### SIZE OPTION 1

The diameters listed under the "Actual" columns below are currently programmed into SSFAN and will be used for calculation when the equivalent tube size option is used. The equivalent tube size is input in the size column for element data. For example, when the user inputs 4. into a size column, the program uses a .25 diameter for a tube or a .172 diameter for a fitting bore and an internal port diameter.

<u>Equivalent Tube Size (16ths In.)</u>	<u>Actual Tube O.D. (In.)</u>	<u>Actual (MS) Internal FTG Bore (In.)</u>
4	.25	.172
5	.3125	.234
6	.375	.297
8	.50	.391
10	.625	.484
12	.75	.609
16	1.00	.844
20	1.25	1.078
24	1.50	1.312
28	1.75	1.547
32	2.00	1.781
40	2.50	2.281
48	3.00	2.781

### SIZE OPTION 2

The user has the option to input directly a tube outside diameter or the internal port or fitting bore diameter.

The format for all element input data has been established as follows:

- (1) Column 1 of the first data card describing an element contains the number of cards (1 or 2) required to describe the element. This is always an Integer (no decimal point following the number).
- (2) All other element input data requires a decimal point following the number regardless of whether or not the number is a whole number.

2.1.4.1 Type 1 - Tube

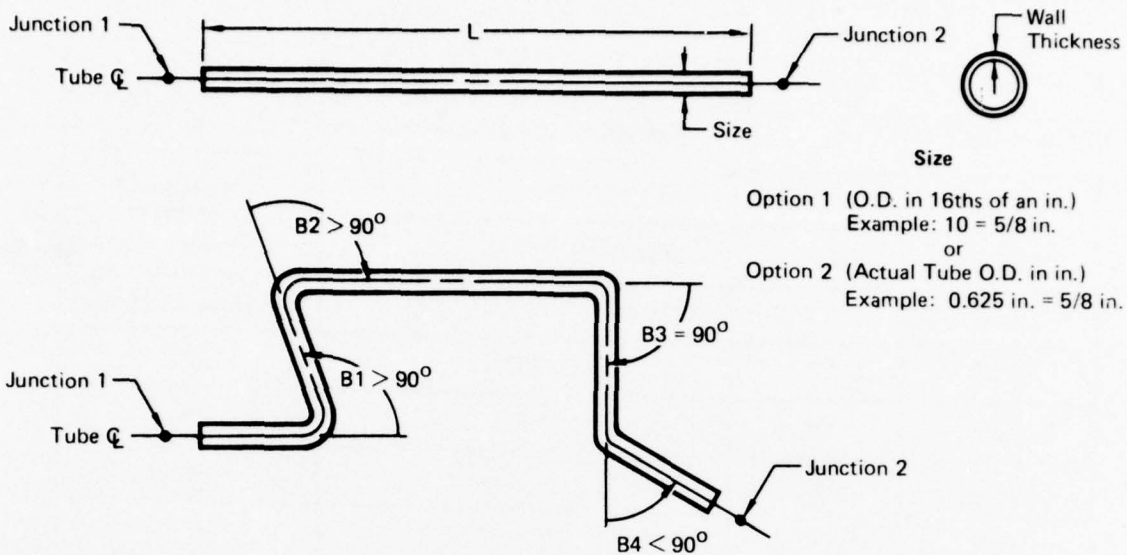

GP74-0772-8

**ELEMENT TYPE 1 - TUBE**

A tube element is a rigid pipe and may have bends and flared ends. Also, end nuts or "B" nuts may be attached. The tube element parameters are input on 1 or 2 data cards depending on the number of bends in the tube. If 4 or more bend angles are input, 2 data cards are required.

Junction point numbers are the assigned numbers from the block diagram. (Example: 230. and 235.). Size is the tube outside diameter and may be input as either option 1 or 2 shown above.

Wall thickness and tube length are in inches. Tube length is the length of the unbent tube. Bend angles are in degrees and are measured at the tube center line using the straight section after a bend as a zero reference for the next bend.

NOTE: Bend angles are converted to equivalent lengths as the data is read into the program. Output Type 1, see Figure 3-3, shows these bends as a total equivalent length for the bends.

CARD 1 FORMAT

COLUMNS	FORMAT	DATA	DIMENSIONS
1	I1	(NUMBER OF CARDS) 1 or 2	---
2-8	7X	BLANK	---
9-16	F8.3	(ELEMENT TYPE) 1.	---
17-24	F8.3	JUNCTION 1	---
25-32	F8.3	JUNCTION 2	---
33-40	F8.3	SIZE	IN. (See Options)
41-48	F8.3	WALL THICKNESS	IN.
49-56	F8.3	LENGTH	IN.
57-64	F8.3	BEND 1	DEG
65-72	F8.3	BEND 2	"
73-80	F8.3	BEND 3	"

CARD 2 FORMAT (IF REQUIRED)

COLUMNS	FORMAT	DATA	DIMENSIONS
1-8	F8.3	BEND 4	DEG
9-16	F8.3	BEND 5	"
17-24	F8.3	BEND 6	"
25-32	F8.3	BEND 7	"
33-40	F8.3	BEND 8	"
41-48	F8.3	BEND 9	"
49-56	F8.3	BEND 10	"
57-64	F8.3	BEND 11	"
65-80		BLANK	---







2.1.4.2 Type 2 - Union

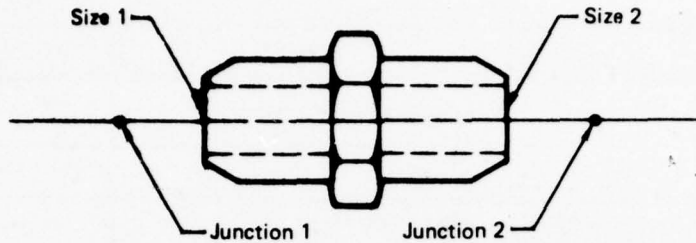

**Size 1 and Size 2**

Option 1 (Fitting End for Tube Size in 16ths of an in.)  
Example: 4 = 0.172 I.D.

or  
Option 2 (Actual Fitting I.D. at End for Size 1 and Size 2)  
Example: 0.172 in.

GP74-0772-5

**ELEMENT TYPE 2 - UNION**

A union is a connector commonly used to join 2 tubes or join a tube to a component such as a valve. The union may be a threaded or permanent type and is considered to be a constant diameter throughout its length. It should not be confused with the Type 23 reducer fitting.

The number of data cards required is always 1. Junction point numbers 1 and 2 are the assigned numbers from the block diagram (Example: 245. and 250.). Size 1 and Size 2 are equal and reflect the fitting internal diameter as option 1 or 2 shown in the above sketch.

CARD FORMAT

COLUMNS	FORMAT	DATA	DIMENSIONS
1	I1	(NUMBER OF CARDS) 1	---
2-8	7X	BLANK	---
9-16	F8.3	(ELEMENT TYPE) 2.	---
17-24	F8.3	JUNCTION 1	---
25-32	F8.3	JUNCTION 2	---
33-40	F8.3	SIZE 1	IN. (See Options)
41-48	F8.3	SIZE 2	
49- 80		BLANK	---

EXAMPLE

TYPE 2 UNION INPUT DATA

MCDONNELL AUTOMATION COMPANY

### 2.1.4.3 Type 3 - Check Valve

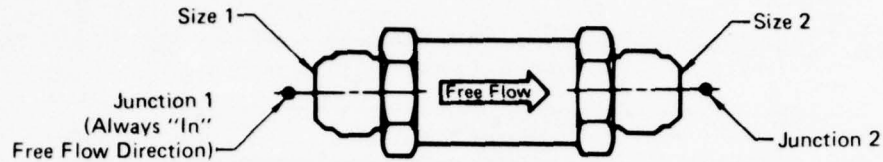

**Size 1 and Size 2**

Option 1 (Fitting End for Tube Size in 16ths of an in.)  
Example: 8 = 8/16 in.

or  
Option 2 (Actual Fitting I.D. at End for Size 1 and Size 2)  
Example: 0.391 in.

GP74-0772-1

#### **ELEMENT TYPE 3 - CHECK VALVE**

A check valve may be a ball type, guided poppet type or any other type. Its main purpose is to permit flow in one direction only. In the "free flow" direction as shown above, the pressure drop is normally low. The check valve should not be confused with the Type 31 one-way restrictor which allows a smaller restricted flow in the direction opposite "free flow."

One data card is required for the check valve input. Junction point numbers 1 and 2 are assigned numbers from the block diagram. (Example: 90. and 190.) Junction point 1 is always at the "in" port with flow going in the "Free flow" direction. Sizes 1 and 2 are the fitting end internal bore diameters, see options 1 and 2 above. The nominal check valve cracking pressure is normally input, but minimum or maximum cracking pressure could be used if desired.





#### 2.1.4.4 Type 4 - Simple Actuator

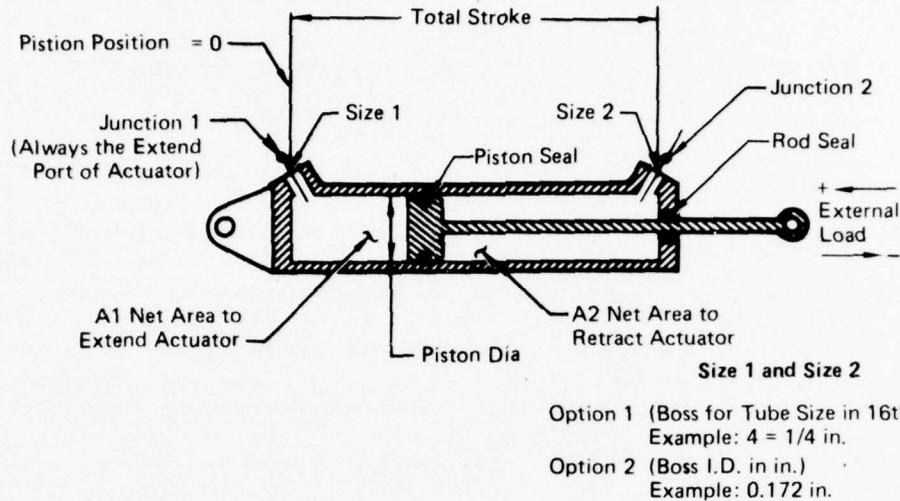

GP74-0772-2

#### ELEMENT TYPE 4 - SIMPLE ACTUATOR

The simple linear actuator is used to convert the system fluid power to linear mechanical motion, and is usually controlled by a valve. The piston and rod seals provide a viscous drag or damping force always opposing the direction of motion of the piston. There are several types of simple linear actuators all of which are Type 4. The above sketch shows an unbalanced (unequal areas) type. Other Type 4 actuators are balanced (areas same both sides of piston), partially balanced, parallel and tandem. (See Volume II)

One data card is required for input parameters. Junction 1 is always assigned to the extend port. Sizes 1 and 2 are noted as optional input. The net areas acting to extend and retract the piston are input along with an external load. A positive (+) load resists actuator extension and aids actuator retraction.

The net seal friction force is calculated as:  $SEAL\ FRICTION\ FORCE(LB) = 10X(SUM\ OF\ THE\ DYNAMIC\ SEAL\ O.D.S)$ . Piston diameter, total actuator stroke and initial piston position are also input. A piston position of 0 is when the actuator in the full retracted position.

CARD 1 FORMAT

COLUMNS	FORMAT	DATA	DIMENSIONS
1	I1	(NUMBER OF CARDS) 1	---
2-8	7X	BLANK	---
9-16	F8.3	(ELEMENT TYPE) 4.	---
17-24	F8.3	EXTEND JUNCTION 1	---
25-32	F8.3	RETRACT JUNCTION 2	---
33-40	F8.3	SIZE 1	IN. (See Options)
41-48	F8.3	SIZE 2	IN. (See Options)
49-56	F8.3	EXTEND AREA	IN <sup>2</sup>
57-64	F8.3	RETRACT AREA	IN <sup>2</sup>
65-72	F8.3	SEAL FRICTION	LB
73-80	F8.3	EXTERNAL LOAD	LB

CARD 2 FORMAT

COLUMNS	FORMAT	DATA	DIMENSIONS
1-8	F8.3	TOTAL STROKE	IN
9-16	F8.3	PISTON POSITION	IN
17-24	F8.3	PISTON DIAMETER	IN
25-32	F8.3	CONTROL VALVE JCT1	--
33- 80	F8.3	BLANK	--



#### 2.1.4.5 Type 5 - Variable Delivery Pump

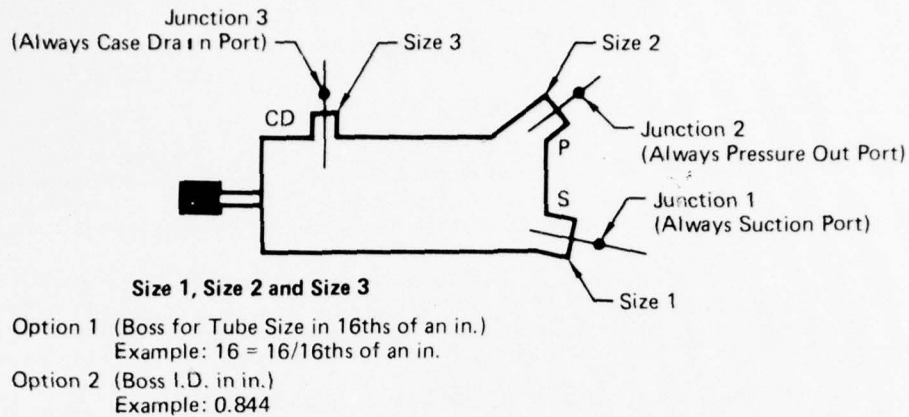

GP74-0772-3

#### ELEMENT TYPE 5 - VARIABLE DELIVERY HYDRAULIC PUMP

The variable displacement pump outputs flow in response to the load demands of the system. The pump has a basic flow pressure characteristic curve which is described by its rated flows and pressures. There is some internal leakage flow from the high pressure side back to the case drain port and also internal leakage from the pump case back to the inlet or suction port.

Two data cards are required for the pump input. The suction, pressure "out" and case drain junctions are numbered 1, 2 and 3 respectively. Sizes are input corresponding to junction points with options as noted. The pump actual RPM and rated RPM along with the rated pressures and the rated flow at rated pressure are also input.



The following pump characteristics are optional input parameters.

These are noted in Figure 2-3.

PSMIN - Rated minimum suction or inlet pressure.

Default value is 25 psia.

RCDP - Rated maximum pressure difference between the pump case and inlet. Default value is 300 psid.

RCDL - Rated flow out the case drain port under pump rated conditions. Default value is 1 gpm.

PSET - The pump case pressure when setting the rated flow and pressure. The default value is 50 psig.

If the columns are left blank on the data cards, the default values will be used.

CARD 1 FORMAT

COLUMNS	FORMAT	DATA	DIMENSIONS
1	I1	(NUMBER OF CARDS) 2	---
2-8	7X	BLANK	---
9-16	F8.3	(ELEMENT TYPE) 5.	---
17-24	F8.3	JUNCTION 1 (S)	---
25-32	F8.3	JUNCTION 2 (P)	---
33-40	F8.3	JUNCTION 3 (CD)	---
41-48	F8.3	SIZE 1	IN. (See Options)
49-56	F8.3	SIZE 2	IN. (See Options)
57-64	F8.3	SIZE 3	IN. (See Options)
65-72	F8.3	ACTUAL PUMP RPM	REV. PER MIN.
73-80	F8.3	RATED PUMP RPM	REV. PER MIN.

CARD 2 FORMAT

COLUMNS	FORMAT	DATA	DIMENSIONS
1-8	F8.3	RATED OUTPUT FLOW	GPM
9-16	F8.3	RATED PRESSURE (0 FLOW)	PSI
17-24	F8.3	RATED PRESSURE (FULL FLOW)	PSI
25-32	F8.3	PSMIN	PSIA
33-40	F8.3	RCDP	PSID
41-48	F8.3	RCDL	GPM
49-56	F8.3	PSET	PSIG
57- 80	-	BLANK	-

**EXAMPLE**  
**TYPE 5 VARIABLE DELIVERY PUMP**

**2 DATA CARDS REQUIRED**

**CARD 1**

2	5.	5.	10.	15.	16.	12.	4.	3750.	3750.
1 2 3 4 5 6 7 8 9	11 12 13 14 15 16 17	19 20 21 22 23 24	26 27 28 29 30 31	33 34 35 36 37 38	40 41 42 43 44 45	47 48 49 50	52 53 54 55 56 57 58 59 60	62 63 64	
000000000000	000000000000	000000000000	000000000000	000000000000	000000000000	000000000000	000000000000	000000000000	000000000000
111111111111	111111111111	111111111111	111111111111	111111111111	111111111111	111111111111	111111111111	111111111111	111111111111
222222222222	222222222222	222222222222	222222222222	222222222222	222222222222	222222222222	222222222222	222222222222	222222222222
333333333333	333333333333	333333333333	333333333333	333333333333	333333333333	333333333333	333333333333	333333333333	333333333333
444444444444	444444444444	444444444444	444444444444	444444444444	444444444444	444444444444	444444444444	444444444444	444444444444
555555555555	555555555555	555555555555	555555555555	555555555555	555555555555	555555555555	555555555555	555555555555	555555555555
666666666666	666666666666	666666666666	666666666666	666666666666	666666666666	666666666666	666666666666	666666666666	666666666666
777777777777	777777777777	777777777777	777777777777	777777777777	777777777777	777777777777	777777777777	777777777777	777777777777
888888888888	888888888888	888888888888	888888888888	888888888888	888888888888	888888888888	888888888888	888888888888	888888888888
999999999999	999999999999	999999999999	999999999999	999999999999	999999999999	999999999999	999999999999	999999999999	999999999999

MCDONNELL AUTOMATION COMPANY

**CARD 2**

26.	3000.	2950.	25.	300.	1.5	50.
1 2 3 4 5 6 7 8 9	11 12 13 14 15 16	19 20 21 22	24 25 26 27 28 29	31 32 33 34 35	36 37 38 39 40 41 42	44 45 46 47 48 49 50 51 52 53 54 55 56 57 58 59 60 61 62 63 64
000000000000	000000000000	000000000000	000000000000	000000000000	000000000000	000000000000
111111111111	111111111111	111111111111	111111111111	111111111111	111111111111	111111111111
222222222222	222222222222	222222222222	222222222222	222222222222	222222222222	222222222222
333333333333	333333333333	333333333333	333333333333	333333333333	333333333333	333333333333
444444444444	444444444444	444444444444	444444444444	444444444444	444444444444	444444444444
555555555555	555555555555	555555555555	555555555555	555555555555	555555555555	555555555555
666666666666	666666666666	666666666666	666666666666	666666666666	666666666666	666666666666
777777777777	777777777777	777777777777	777777777777	777777777777	777777777777	777777777777
888888888888	888888888888	888888888888	888888888888	888888888888	888888888888	888888888888
999999999999	999999999999	999999999999	999999999999	999999999999	999999999999	999999999999

MCDONNELL AUTOMATION COMPANY

#### 2.1.4.6 Type 6 - Filter

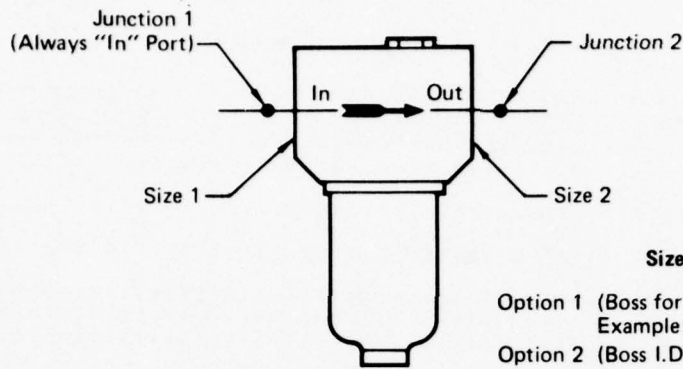

GP74-0772-4

#### ELEMENT TYPE 6 - FILTER ASSEMBLY

Filters are an essential part of all aircraft hydraulic systems. They are installed in strategic locations to protect components which are sensitive to contamination. Some filters have bypass relief valves. Type 6 filter is either a bypass or non-bypass type.

One card is required for input data. Junction 1 is always input as the inlet flow port. Sizes 1 and 2 correspond to junctions 1 and 2 with options as noted. The internal fluid volume is input along with the rated flow and pressure drop of a clean element. The next column contains the viscosity for the clean element at the rated conditions. The contamination factor is optional. A blank or 0. is a clean element. A value between 0. and 1. is the percent the element is contaminated. A value of 1. is a full contaminated element. A factor is input when the user wants to simulate a partially contaminated element and not a clean element. If there is a bypass relief, the nominal relief setting is input.

CARD 1 FORMAT

COLUMNS	FORMAT	DATA	DIMENSIONS
1	I1	(NUMBER OF CARDS) 2	---
2-8	7X	BLANK	---
9-16	F8.3	(ELEMENT TYPE) 6.	---
17-24	F8.3	JUNCTION 1	---
25-32	F8.3	JUNCTION 2	---
33-40	F8.3	SIZE 1	IN. (See Options)
41-48	F8.3	SIZE 2	IN. (See Options)
49-56	F8.3	INTERNAL FLUID VOLUME	IN <sup>3</sup>
57-64	F8.3	RATED FLOW OF CLEAN ELEMENT	GPM
65-72	F8.3	RATED PRESSURE DROP OF CLEAN ELEMENT	PSI
73-80	F8.3	VISCOSITY AT RATED CONDITIONS	CENTISTOKES

CARD 2 FORMAT

COLUMNS	FORMAT	DATA	DIMENSIONS
1-8	F8.3	CONTAMINATION FACTOR	PSI
9-16	F8.3	RELIEF SETTING	PSID
17-24	F8.3	BYPASS PRESSURE DROP AT RATED FLOW	PSI
25-80	--	BLANK	--





#### 2.1.4.7 Type 7 - Accumulator

- Size 1**
- Option 1 (Boss for Tube Size in 16ths of an in.)  
Example: 4 = 4/16 in.
- Option 2 (Boss I.D. in in.)  
Example: 0.172 in.

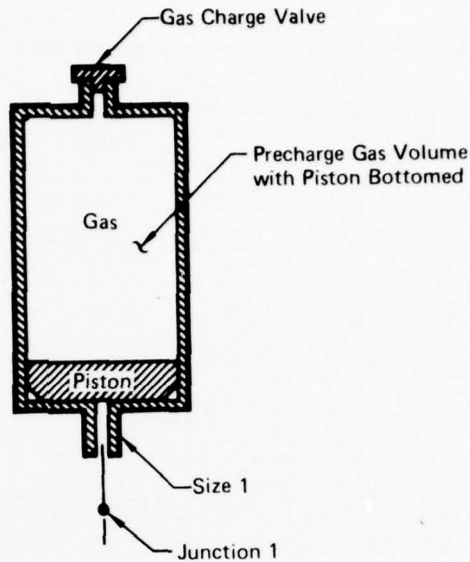

GP74 0772 6

#### **ELEMENT TYPE 7 - ACCUMULATOR**

An accumulator may be a piston type, bladder type, or an air to oil type. Any of these types can be input as Type 7 because an accumulator power capability is based on the precharge gas volume, pressure and temperature. The columns for initial accumulator pressure and  $\Delta$  volume interval are used when the accumulator is the system power source. If numbers are input in these columns when a pump is the power source, the numbers will be ignored and the accumulator is considered to be a static element. The column for  $\Delta$  volume interval is for future program development of the accumulator as power source.

The accumulator requires one data card for input. Only one junction point number and one size are required.



2.1.4.8 Type 9 - Flow Through Reservoir

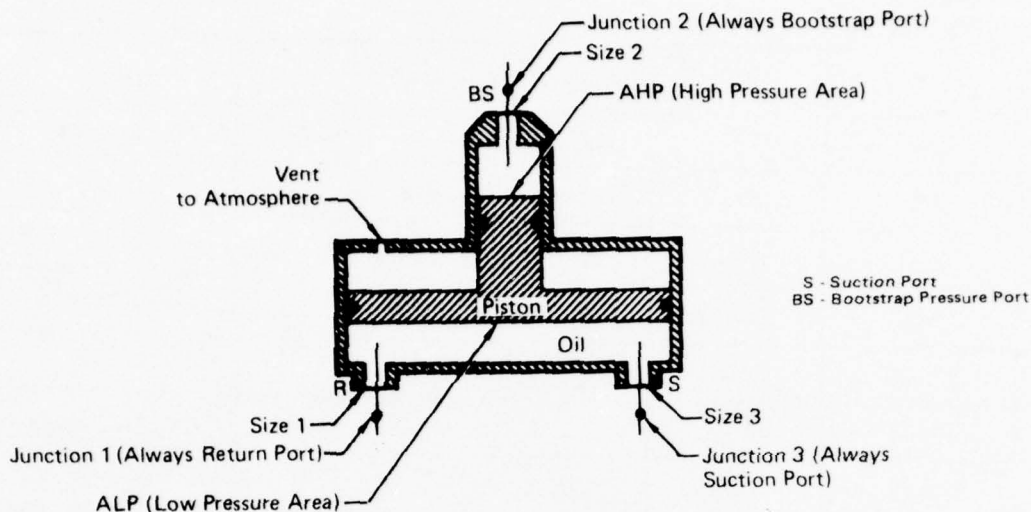

**Size 1, Size 2 and Size 3**

Option 1 (Boss for Tube Size in 16ths of an in.)

Example: 12 = 12/16 in.

Option 2 (Boss I.D. in in.)

Example: 0.609 in.

**ELEMENT TYPE 9 - FLOW THRU BOOTSTRAP RESERVOIR**

The **type 9** reservoir is a bootstrap pressurized flow through type with system return fluid normally passing through the reservoir before going to the pump suction port. The reservoir model is corrected for altitude from sea level.

Two cards are required for input data. The return port, bootstrap port and pump suction port must be numbered junctions 1, 2, and 3 respectively. Sizes 1, 2, and 3 correspond to the junction numbers. The area of the piston upon which bootstrap pressure is acting is input along with the area of the piston exposed to the low pressure fluid. Card 2 contains the equivalent seal friction force where:  $SEAL\ FRICTION\ FORCE(LB) = 10.X(SUM\ OF\ THE\ DYNAMIC\ SEAL\ ODS)$ .

CARD 1 FORMAT

COLUMNS	FORMAT	DATA	DIMENSIONS
1	I1	(NUMBER OF CARDS) 2	---
2-8	7X	BLANK	---
9-16	F8.3	(ELEMENT TYPE) 9.	---
17-24	F8.3	JUNCTION 1 (R)	---
25-32	F8.3	JUNCTION 2 (BS)	---
33-40	F8.3	JUNCTION 3 (S)	---
41-48	F8.3	SIZE 1	IN. (See Options)
49-56	F8.3	SIZE 2	IN. (See Options)
57-64	F8.3	SIZE 3	IN. (See Options)
65-72	F8.3	HIGH PRESSURE AREA	IN <sup>2</sup>
73-80	F8.3	LOW PRESSURE AREA	IN <sup>2</sup>

CARD 2 FORMAT

COLUMNS	FORMAT	DATA	DIMENSIONS
1-8	F8.3	SEAL FRICTION	LBS
9-80		BLANK	---





2.1.4.9 Type 10 - Special (Flow vs  $\Delta P$ )

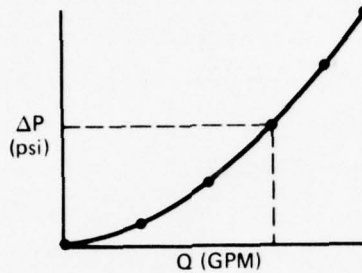
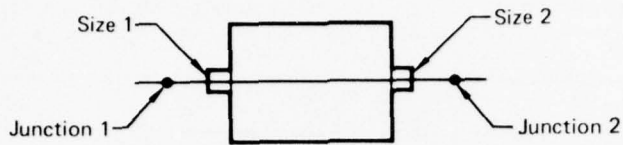

**Size 1 and Size 2**

- Option 1 (Fitting End or Boss for Tube Size in 16ths of an in.)  
Example: 6 = 3/8 in.
- Option 2 (Actual Fitting or Boss I.D. in in.)  
Example: 0.297 in.

**ELEMENT TYPE 10 - SPECIAL (FLOW vs  $\Delta P$ )**

The special category is used for elements which have a series of known measured flow versus pressure drop points. These may be input as  $\Delta P$  and Q values with up to six points used to describe the characteristic curve. The element is considered to have one inlet and one outlet port. The viscosity of the fluid for which the data was taken is also required.

Two cards are used for input data. Junction points 1 and 2 are the assigned numbers from the block diagram (Example: 1050. and 1060.). Sizes 1 and 2 are the fitting end or internal port inside diameters.

CARD 1 FORMAT

COLUMNS	FORMAT	DATA	DIMENSIONS
1	I1	(NUMBER OF CARDS) 2	---
2-8	7X	BLANK	---
9-16	F8.3	(ELEMENT TYPE) 10.	---
17-24	F8.3	JUNCTION 1	---
25-32	F8.3	JUNCTION 2	---
33-40	F8.3	SIZE 1	IN. (See Options)
41-48	F8.3	SIZE 2	IN. (See Options)
49-56	F8.3	FLUID DATA VISCOSITY	CENTISTOKES
57-64	F8.3	NUMBER OF POINTS	---
65-72	F8.3	PRESSURE DROP 1	PSI
73-80	F8.3	PRESSURE DROP 2	PSI

CARD 2 FORMAT

COLUMNS	FORMAT	DATA	DIMENSIONS
1-8	F8.3	PRESSURE DROP 3	PSI
9-16	F8.3	PRESSURE DROP 4	PSI
17-24	F8.3	PRESSURE DROP 5	PSI
25-32	F8.3	PRESSURE DROP 6	PSI
33-40	F8.3	FLOW 1	GPM
41-48	F8.3	FLOW 2	GPM
49-56	F8.3	FLOW 3	GPM
57-64	F8.3	FLOW 4	GPM
65-72	F8.3	FLOW 5	GPM
73-80	F8.3	FLOW 6	GPM



2.1.4.10 Type 11 - Flexible Hose

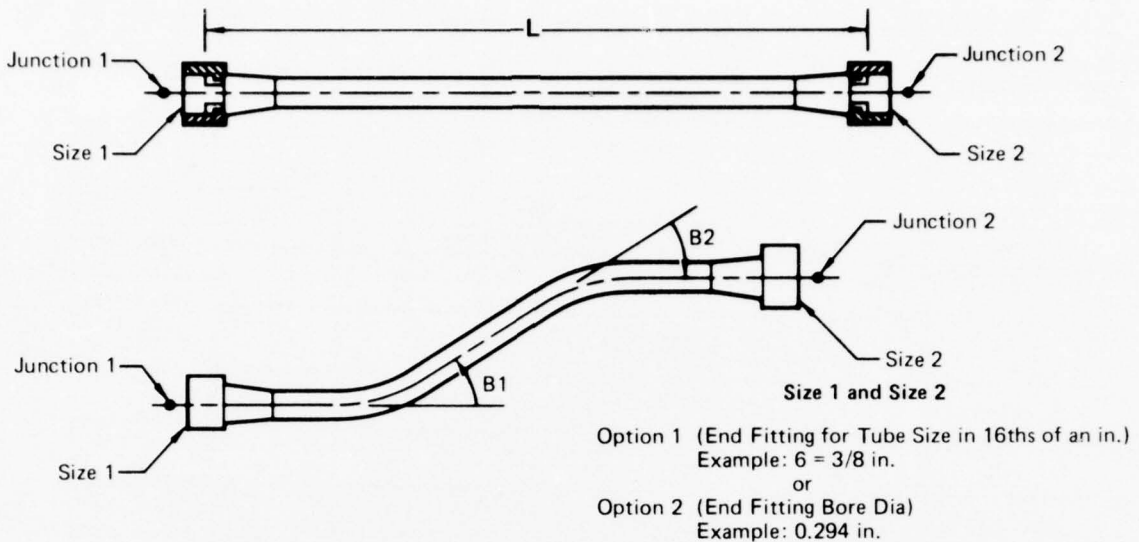

GP74-0772-14

**ELEMENT TYPE 11 - FLEXIBLE HOSE**

The flexible hose is used in applications where a rigid tube will not allow required motion or misalignment. The length of the hose is its straight length measured between the ends of the nipple assemblies.

One card is required for input data. A maximum of 3 bend angles are allowed. Bend angles are measured in degrees. Junction point numbers 1 and 2 are the assigned numbers from the block diagram (Example: 20. and 25.). Size is the equivalent tube size, but does not have the equivalent tube size options. For calculation the internal diameter is a required input.



CARD FORMAT

COLUMNS	FORMAT	DATA	DIMENSIONS
1	11	(NUMBER OF CARDS) 1	---
2-8	7X	BLANK	---
9-16	F8.3	(ELEMENT TYPE) 11.	---
17-24	F8.3	JUNCTION 1	---
25-32	F8.3	JUNCTION 2	---
33-40	F8.3	SIZE	IN. (16ths)
41-48	F8.3	HOSE INSIDE DIA.	IN.
49-56	F8.3	LENGTH	IN.
57-64	F8.3	BEND ANGLE	DEG
65-72	F8.3	BEND ANGLE	DEG
73-80	F8.3	BEND ANGLE	DEG

EXAMPLE

TYPE 11 FLEXIBLE HOSE INPUT DATA

1	11.	20.	25.	12.	1.69	25.	57.	30.	30.
1	11	20	25	12	1.69	25	57	30	30
0	0	0	0	0	0	0	0	0	0
1	1	1	1	1	1	1	1	1	1
2	2	2	2	2	2	2	2	2	2
3	3	3	3	3	3	3	3	3	3
4	4	4	4	4	4	4	4	4	4
5	5	5	5	5	5	5	5	5	5
6	6	6	6	6	6	6	6	6	6
7	7	7	7	7	7	7	7	7	7
8	8	8	8	8	8	8	8	8	8
9	9	9	9	9	9	9	9	9	9

MCDONNELL AUTOMATION COMPANY

MAG 1015N  
REV 15 (E3-70)

2.1.4.11 Type 12 - Heat Exchanger or Radiator

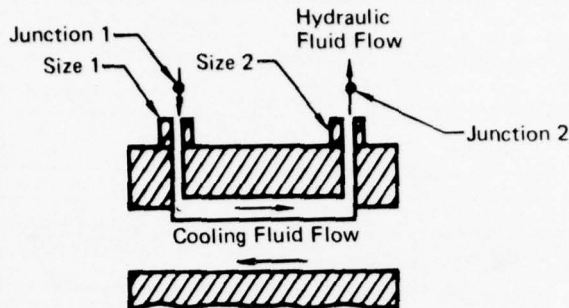

**Size 1 and Size 2**

Option 1 (Fitting End or Boss for Tube Size in 16ths of an in.)  
Example: 4 = 1/4 in.

or

Option 2 (Actual Fitting or Boss I.D. in in.)  
Example: 0.172 in.

GP74 0772-12

**ELEMENT TYPE 12 - HEAT EXCHANGER OR RADIATOR**

A heat exchanger is used to remove excess heat from the hydraulic fluid. The common type used in aircraft uses the engine fuel as a heat sink; however some usage is made of air as a cooling fluid.

One card is required for heat exchanger input data. Junction 1 is normally the inlet port and junction 2 the outlet port. Sizes 1 and 2 correspond with options noted. A rated flow and a rated pressure drop are input along with the fluid viscosity for the rated conditions.



2.1.4.12 Type 21 - 45° Elbow

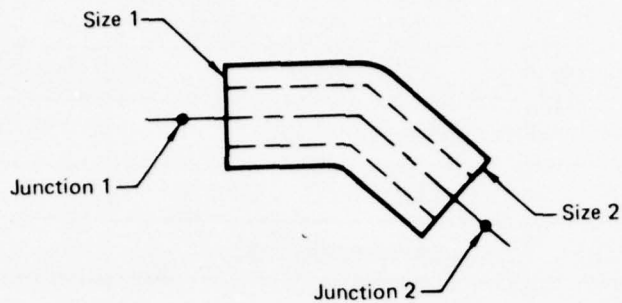

**Size 1 and Size 2**

- Option 1 (Fitting End or Boss for Tube Size in 16ths of an in.)  
Example: 8 = 8/16 in.)  
or  
Option 2 (Actual Fitting or Boss I.D.)  
Example: 0.391 in.

**ELEMENT TYPE 21 - 45° ELBOW**

GP74 0772-15

The 45° elbow like the union is also a connector to join 2 tubes or join a tube to a component. The elbow may be a threaded or permanent type. The ends may be internally or externally threaded.

The number of data cards required is always 1. Junction point numbers 1 and 2 are the assigned numbers from the block diagram (Example: 80. and 85.). Size 1 and Size 2 reflect the internal fitting diameters at each end (see options 1 and 2 in above sketch). These do not have to be identical.

CARD FORMAT

COLUMNS	FORMAT	DATA	DIMENSIONS
1	I1	(NUMBER OF CARDS) 1	---
2-8	7X	BLANK	
9-16	F8.3	(ELEMENT TYPE) 21.	---
17-24	F8.3	JUNCTION 1	---
25-32	F8.3	JUNCTION 2	---
33-40	F8.3	SIZE 1	IN. (See Options)
41-48	F8.3	SIZE 2	IN. (See Options)
49-80		BLANK	---

EXAMPLE

TYPE 21 45° ELBOW DATA INPUT

1	21.	80.	85.	6.	6.
1	21.	80.	85.	6.	6.
2					
3					
4					
5					
6					
7					
8					
9					
10					
11					
12					
13					
14					
15					
16					
17					
18					
19					
20					
21					
22					
23					
24					
25					
26					
27					
28					
29					
30					
31					
32					
33					
34					
35					
36					
37					
38					
39					
40					
41					
42					
43					
44					
45					
46					
47					
48					
49					
50					
51					
52					
53					
54					
55					
56					
57					
58					
59					
60					
61					
62					
63					
64					
65					
66					
67					
68					
69					
70					
71					
72					
73					
74					
75					
76					
77					
78					
79					
80					

MCDONNELL AUTOMATION COMPANY



2.1.4.13 Type 22 - 90° Elbow

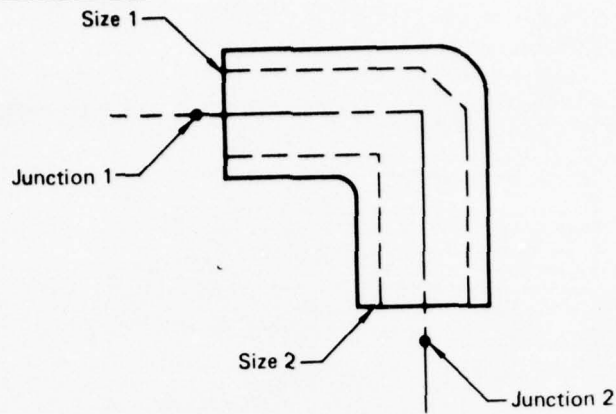

**Size 1 and Size 2**

- Option 1 (Fitting End or Boss for Tube Size in 16ths of an in.)  
Example: 8 = 8/16 in.  
or  
Option 2 (Actual Fitting or Boss I.D.)  
Example: 0.391 in.

GP74-0772-17

**ELEMENT TYPE 22 - 90° ELBOW**

The 90° elbow is a connector commonly used to change the piping run direction in a minimum distance. It may be a threaded or permanent type where the ends may be internally or externally threaded.

The number of data cards required is always 1. Junction point numbers are the assigned numbers from the block diagram (Example: 10. and 20.). Size 1 and Size 2 reflect the internal fitting diameters at each end (see options 1 and 2 in the above sketch). These do not have to be identical.

CARD FORMAT

COLUMNS	FORMAT	DATA	DIMENSIONS
1	I1	(NUMBER OF CARDS) 1	---
2-8	7X	BLANK	
9-16	F8.3	(ELEMENT TYPE) 22.	---
17-24	F8.3	JUNCTION 1	---
25-32	F8.3	JUNCTION 2	---
33-40	F8.3	SIZE 1	IN. (See Options)
41-48	F8.3	SIZE 2	IN. (See Options)
49-80		BLANK	---

EXAMPLE

TYPE 22 90° ELBOW INPUT DATA

1	22.	10.	20.	12.	12.
1	22.	10.	20.	12.	12.
2					
3					
4					
5					
6					
7					
8					
9					
10					
11					
12					
13					
14					
15					
16					
17					
18					
19					
20					
21					
22					
23					
24					
25					
26					
27					
28					
29					
30					
31					
32					
33					
34					
35					
36					
37					
38					
39					
40					
41					
42					
43					
44					
45					
46					
47					
48					
49					
50					
51					
52					
53					
54					
55					
56					
57					
58					
59					
60					
61					
62					
63					
64					
65					
66					
67					
68					
69					
70					
71					
72					
73					
74					
75					
76					
77					
78					
79					
80					

MCDONNELL AUTOMATION COMPANY

2.1.4.14 Type 23 - Reducer

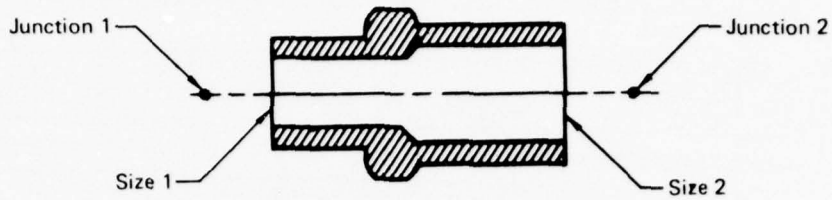

**Size 1 and Size 2**

Option 1 (Fitting End or Boss for Tube Size in 16ths of an in.)

Example: Size 1 = 8 = 8/16 in.

Size 2 = 10 = 10/16 in.

or

Option 2 (Fitting End or Boss I.D.)

Example: Size 1 = 0.391 in.

Size 2 = 0.484 in.

GP74-0772-16

**ELEMENT TYPE 23 - REDUCER**

The reducer fitting is commonly used to connect a tube or fitting to a different size fitting, tube or component port. These are commonly a threaded type.

One data card is required for input data. Junction point numbers 1 and 2 are the assigned numbers from the block diagram (Example: 900. and 905). Size 1 and Size 2 are generally not equal and reflect the internal diameters at each end. This fitting could also be an adapter which changes from an external thread at one end to an internal thread at the other. See the above sketch for Size 1 and Size 2 options.



2.1.4.15 Type 24 - Tee

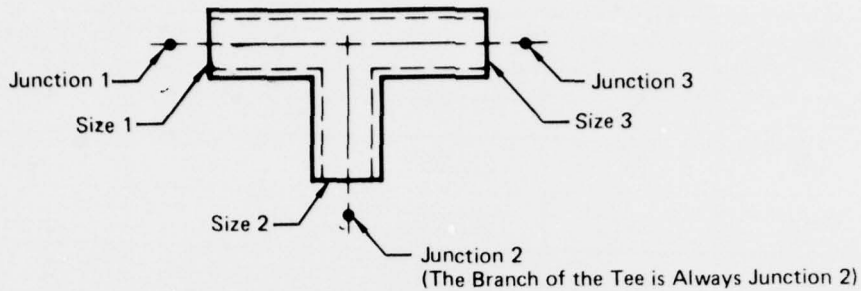

**Size 1, Size 2 and Size 3**

Option 1 (Fitting End or Boss for Tube Size in 16ths of an in.)  
Example: 8 = 8/16 in.

or

Option 2 (Actual Fitting or Boss I.D.)  
Example: 0.391 in.

GP74-0772-18

**ELEMENT TYPE 24 - TEE**

The tee is a connector commonly used to connect three elements which may be a combination of tubes, fittings or components. These are either a threaded or permanent type. The branch is considered to be at a 90° angle to the run.

One data card is required for input. Junction point numbers are the assigned numbers from the block diagram (Example: 35., 45., and 40.). It should be noted that junction point 2 has to be input as the branch of the tee. Size 1, Size 2 and Size 3 correspond to the ends with junction points of the same number. The sizes can be different and the ends internally or externally threaded. See the above sketch for size options.





2.1.4.16 Type 25 - Cross

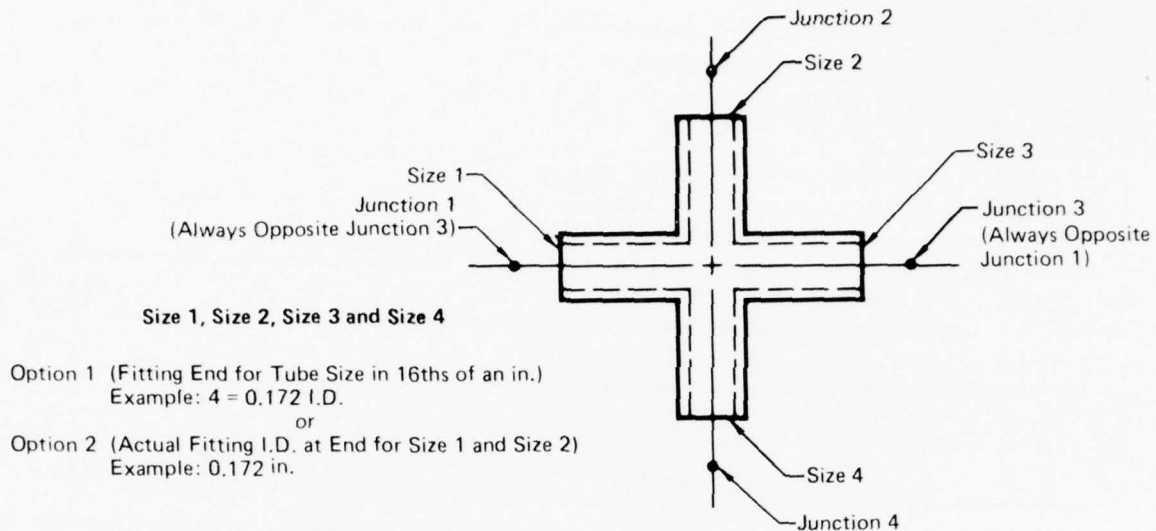

GP74-0772-11

**ELEMENT TYPE 25 - CROSS**

The cross fitting is used sparingly in hydraulic system design because it requires considerable space to connect 4 elements (probably tubes) at one point. The cross is a connector which may be a threaded or permanent type. Each port is at a 90° angle with each adjacent port.

One data card is required for input. Junction point numbers are the assigned numbers from the block diagram (Example: 920., 925., 930., and 935.). Note that junction point 3 is considered to be opposite junction 1 and the junction point and size data have to be input in the correct order. The sizes can be different and the ends internally or externally threaded. See the above sketch for size options and junction point numbering.

CARD FORMAT

COLUMNS	FORMAT	DATA	DIMENSIONS
1	I1	(NUMBER OF CARDS) 1	---
2-8	7X	BLANK	
9-16	F8.3	(ELEMENT TYPE) 25.	---
17-24	F8.3	JUNCTION 1	---
25-32	F8.3	JUNCTION 2	---
33-40	F8.3	JUNCTION 3	---
41-48	F8.3	JUNCTION 4	---
49-56	F8.3	SIZE 1	IN. (See Options)
57-64	F8.3	SIZE 2	IN. (See Options)
65-72	F8.3	SIZE 3	IN. (See Options)
73-80	F8.3	SIZE 4	IN. (See Options)

EXAMPLE

TYPE 25 CROSS INPUT DATA

MCDONNELL AUTOMATION COMPANY

#### 2.1.4.17 Type 31 - 1 Way Restrictor

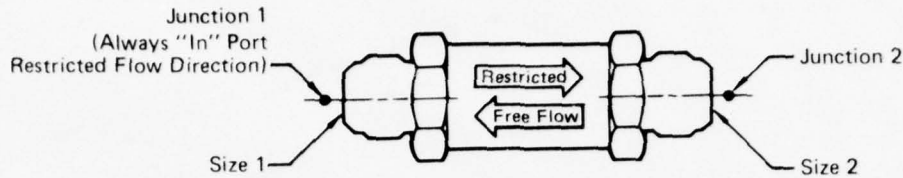

##### **Size 1 and Size 2**

Option 1 (Fitting End or Boss for Tube Size in 16ths of an in.)

Example:  $8 = 8/16$  in.)

or

Option 2 (Actual Fitting or Boss I.D.)

Example: 0.391 in.

GP74 0772-25

#### **ELEMENT TYPE 31 - ONE WAY RESTRICTOR**

The 1 way restrictor restricts flow in one direction and allows free flow in the other direction. The orifice flow is a function of orifice size, Reynolds number and the coefficient of discharge.

One card is required for input data. Junction 1 always starts at the restricted port for flow in the restricted direction. Size 1 and Size 2 correspond to junction 1 and junction 2 with options as noted. The orifice diameter is input along with a coefficient of discharge. If the coefficient of discharge is not input, the element model will select one.

CARD 1 FORMAT

COLUMNS	FORMAT	DATA	DIMENSIONS
1	I1	(NUMBER OF CARDS ) 2	--
2-8	7X	BLANK	--
9-16	F8.3	31. (ELEMENT TYPE)	--
17-24	F8.3	JUNCTION 1	--
25-32	F8.3	JUNCTION 2	--
33-40	F8.3	SIZE 1	IN. (SEE OPTIONS)
41-48	F8.3	SIZE 2	IN. (SEE OPTIONS)
49-56	F8.3	ORIFICE DIA OR RATED DP (RESTRICTED)	IN. OR PSI
57-64	F8.3	DISCHARGE COEF OR RATED Q (RESTRICTED)	-- OR GPM
65-72	F8.3	FREE FLOW CRACKING PRESSURE (OPTIONAL)	PSI
73-80	F8.3	F.F. RATED DP (OPTIONAL)	PSI

CARD 2 FORMAT

COLUMNS	FORMAT	DATA	DIMENSIONS
1-8	F8.3	F.F. RATED Q (OPTIONAL)	GPM
9-80	F8.3	BLANK	--





2.1.4.18 Type 32 - 2 Way Restrictor

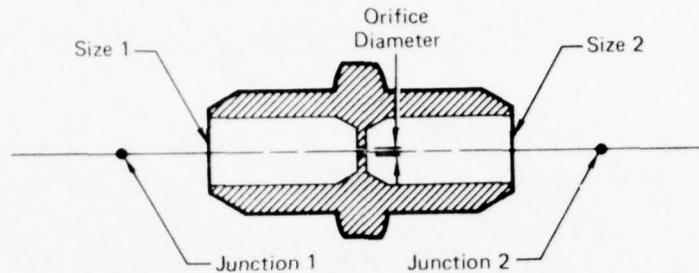

**Size 1 and Size 2**

Option 1 (Fitting End or Boss for Tube Size in 16ths of an in.)  
Example: 8 = 8/16 in.

or

Option 2 (Actual Fitting or Boss I.D.)  
Example: 0.391 in.

**ELEMENT TYPE 32 - TWO WAY RESTRICTOR**

GP74-0772-24

The two way restrictor restricts flow in both directions and is an orifice type element. The orifice flow is a function of the orifice diameter, Reynolds number and the coefficient of discharge.

One card is required for input data. Junctions 1 and 2 correspond to Size 1 and 2 respectively. The orifice diameter is input along with the coefficient of discharge. If no coefficient of discharge is input, the element model selects one.

CARD FORMAT

COLUMN	FORMAT	DATA	DIMENSIONS
1	I1	(NUMBER OF CARDS) 1	---
2-8	7X	BLANK	---
9-16	F8.3	(ELEMENT TYPE) 32.	---
17-24	F8.3	JUNCTION 1	---
25-32	F8.3	JUNCTION 2	---
33-40	F8.3	SIZE 1	IN. (See Options)
41-48	F8.3	SIZE 2	IN. (See Options)
49-56	F8.3	ORIFICE DIA.	IN.
57-64	F8.3	DISCHARGE COEFFICIENT	---
65-80		BLANK	---

EXAMPLE

TYPE 32 2 WAY RESTRICTOR INPUT DATA

MCDONNELL AUTOMATION COMPANY

MAC LISTEN

2.1.4.19 Type 33 - Relief Valve

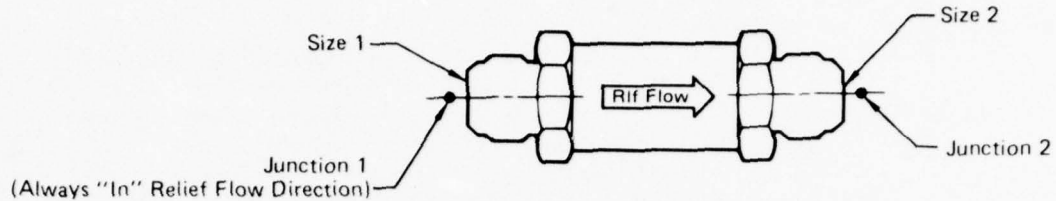

**Size 1 and Size 2**

Option 1 (Fitting End for Tube Size in 16ths of an in.)  
Example: 8 = 8/16 in.

or

Option 2 (Actual Fitting I.D. at End for Size 1 and Size 2)  
Example: 0.391 in.

**ELEMENT TYPE 33 - RELIEF VALVE**

GP74 0772-19

The relief valve acts in much the same manner as a Type 3 check valve. It is normally used to keep the system pressure or a component pressure from exceeding an upper limit.

One card is required for input data. Junction 1 is the "in" port to the relief flow direction. Junction 2 is the "out" flow port. Sizes 1 and 2 correspond to junctions 1 and 2. The nominal relief pressure is also input.

CARD FORMAT

COLUMNS	FORMAT	DATA	DIMENSIONS
1	I1	(NUMBER OF CARDS) 1	---
2-8	7X	BLANK	---
9-16	F8.3	(ELEMENT TYPE) 33.	---
17-24	F8.3	JUNCTION 1	---
25-32	F8.3	JUNCTION 2	---
33-40	F8.3	SIZE 1	IN. (See Options)
41-48	F8.3	SIZE 2	IN. (See Options)
49-56	F8.3	RELIEF VALVE PRESSURE SETTING	PSI
57-80		BLANK	---

EXAMPLE

TYPE 33 RELIEF VALVE INPUT DATA

1	33.	2400.	2420.	3.	3.	3750.
2						
3						
4						
5						
6						
7						
8						
9						
10						
11						
12						
13						
14						
15						
16						
17						
18						
19						
20						
21						
22						
23						
24						
25						
26						
27						
28						
29						
30						
31						
32						
33						
34						
35						
36						
37						
38						
39						
40						
41						
42						
43						
44						
45						
46						
47						
48						
49						
50						
51						
52						
53						
54						
55						
56						
57						
58						
59						
60						

MCDONNELL AUTOMATION COMPANY



2.1.4.20 Type 34 - Solenoid Valve (4W-3P)

Junction 1 (Always High Pressure Port)

Junction 2 (Always Return Port)

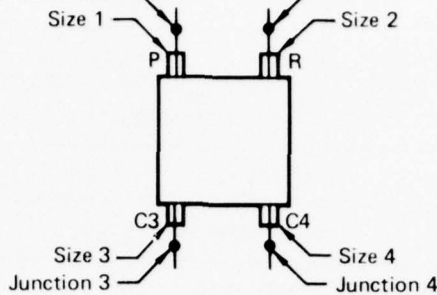

P - Pressure Port  
R - Return Port  
C3 - Cylinder Port  
C4 - Cylinder Port

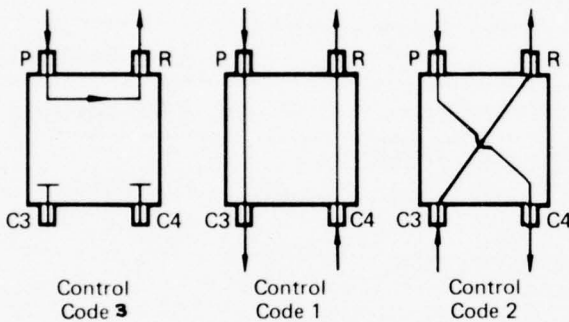

**Size 1, Size 2, Size 3 and Size 4**

- Option 1 (Fitting End or Boss for Tube Size in 16ths of an in.)  
Example: 8 = 8/16 in.
- or
- Option 2 (Actual Fitting or Boss I.D.)  
Example: 0.391 in.

GP74-0772-26

**ELEMENT TYPE 34 - SOL VALVE (4-WAY - 3 POSITION)**

The solenoid valve may be one of three different valves; Type 34-4 way 3 position, Type 35-3 way 2 position and Type 36-2 way 2 position. For a 4 way 3 position type valve the 3 positions are (1) pressure to C3 port with C4 ported to return - control code 1, (2) pressure to C4 port with C3 ported to return - control code 2, and (3) the valve in the null or closed position with leakage from high to low pressure - control code 3.

The 2 positions for a 3 way 2 position valve are (1) pressure to C3 port and the C4 port not connected - control code 1, (2) the valve in the null or closed position with leakage from high to low pressure - control code 3.

The 2 way 2 position valve has (1) direct path from pressure to return - control code 1 and (2) the valve in the null position with leakage from the high to low pressure - control code 2.

Two cards are required as input data for each type of valve. The junctions 1, 2, 3 and 4 ports are identified depending on the particular valve being used. Sizes 1, 2, 3 and 4 correspond with the same junction number with options as noted. Valve specifications usually give the internal pressure drops as a function of flow for a specific fluid and temperature. The viscosity for the fluid at these conditions has to be input to allow for other type fluids and different temperature operating conditions. The rated pressure drops at rated flows are input.

4 WAY - 3 POSITION  
CARD 1 FORMAT

COLUMNS	FORMAT	DATA	DIMENSIONS
1	I1	(NUMBER OF CARDS) 2	---
2-8	7X	BLANK	---
9-16	F8.3	(ELEMENT TYPE) 34.	---
17-24	F8.3	JUNCTION 1 (P)	---
25-32	F8.3	JUNCTION 2 (R)	---
33-40	F8.3	JUNCTION 3 (C3)	---
41-48	F8.3	JUNCTION 4 (C4)	---
49-56	F8.3	SIZE 1	IN. (See Options)
57-64	F8.3	SIZE 2	IN. (See Options)
65-72	F8.3	SIZE 3	IN. (See Options)
73-80	F8.3	SIZE 4	IN. (See Options)

CARD 2 FORMAT

COLUMNS	FORMAT	DATA	DIMENSIONS
1-8	F8.3	RATED FLOW FROM JCT 1 TO JCT 3 OR JCT 4	GPM
9-16	F8.3	RATED PRESSURE DROP FOR RATED FLOW	PSI
17-24	F8.3	VISCOSITY OF FLUID FOR RATED CONDITIONS	CENTISTOKES
25-32	F8.3	LEAKAGE FLOW FROM JCT 1 TO JCT 3	GPM
33-40	F8.3	PRESSURE DROP FOR LEAKAGE CONDITIONS	PSI
41-48	F8.3	OPERATING CONTROL CODE	---
49-80	F8.3	BLANK	---



3 WAY - 2 POSITION  
CARD 1 FORMAT

COLUMNS	FORMAT	DATA	DIMENSIONS
1	I1	(Number of Cards) 2	--
2-8	7X	Blank	--
9-16	F8.3	(Element Type) 34.	--
17-24	F8.3	Junction 1(P)	--
25-32	F8.3	Junction 2 (R)	--
33-40	F8.3	Junction 3 (C3)	--
41-48	F8.3	Blank	--
49-56	F8.3	Size 1	In. (See options)
57-64	F8.3	Size 2	In. (See options)
65-72	F8.3	Size 3	In. (See options)
73-80	F8.3	Blank	--

CARD 2 FORMAT

COLUMNS	FORMAT	DATA	DIMENSIONS
1-8	F8.3	Rated flow from JCT 1 to JCT 3	GPM
9-16	F8.3	Rated pressure drop for rated flow	PSI
17-24	F8.3	Viscosity of Fluid for rated conditions	Centistokes
25-32	F8.3	Leakage flow from JCT 1 to JCT 3	GPM
33-40	F8.3	Pressure drop for leakage conditions	PSI
41-48	F8.3	Operating control code	--
49-80	F8.3	Blank	--





2 WAY - 2 POSITION  
CARD 1 FORMAT

COLUMNS	FORMAT	DATA	UNITS
1	I1	(Number of cards) 2	--
2-8	7X	Blank	--
9-16	F8.3	(Element type) 34.	--
17-24	F8.3	Junction 1 (P)	--
25-32	F8.3	Junction 2 (R)	--
33-40	F8.3	Blank	--
41-48	F8.3	Blank	--
49-56	F8.3	Size 1	IN (See options)
57-64	F8.3	Size 2	IN (See options)
65-72	F8.3	Blank	--
73-80	F8.3	Blank	--

CARD 2 FORMAT

COLUMNS	FORMAT	DATA	UNITS
1-8	F8.3	Rated flow from JCT 1 to JCT 2	GPM
9-16	F8.3	Rated pressure drop for rated flow	PSI
17-24	F8.3	Viscosity of fluid for rated conditions	Centistokes
25-32	F8.3	Leakage flow from JCT 1 to JCT 2	GPM
33-40	F8.3	Pressure drop for leakage conditions	PSI
41-48	F8.3	Operating Control Code	--
49-80	F8.3	Blank	--



#### 2.1.4.21 Type 41 - Servo-Actuator

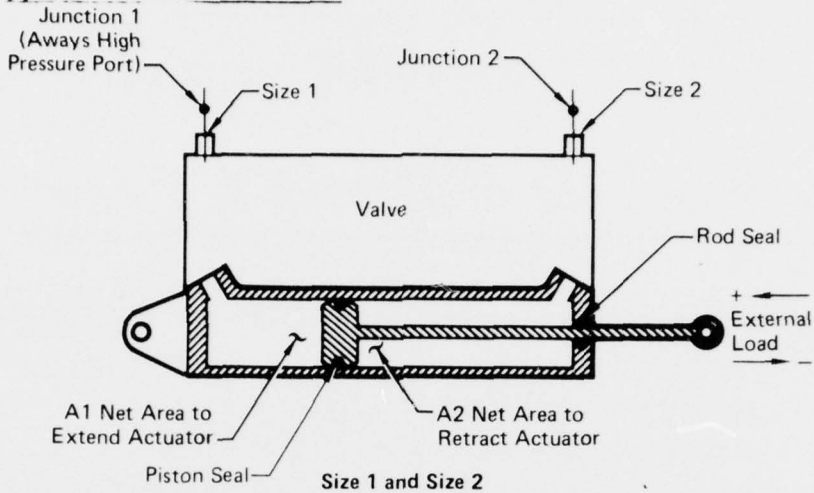

Option 1 (Fitting End or Boss for Tube Size in 16ths of an in.)

Example: 4 = 1/4 in.

Option 2 (Fitting End or Boss I.D. in in.)

Example: 0.172 in.

GP74-0772-20

### ELEMENT TYPE 41 - SERVO-ACTUATOR

The Type 41 servo-actuator is considered similar to a valve operation with a simple actuator except the valve is mounted directly on the actuator.

A separate model for the servo-actuator does not exist in the SSFAN program. To simulate a servo-actuator combine Type 34 (a four way three position valve) and Type 4 (a simple actuator) components into a servo-actuator model.

Under normal operating conditions the valve may be either wide open or completely closed (null position). The actuator may be a balanced (equal piston areas) or unbalanced type.

2.1.4.22 Type 91 - Appendix Reservoir

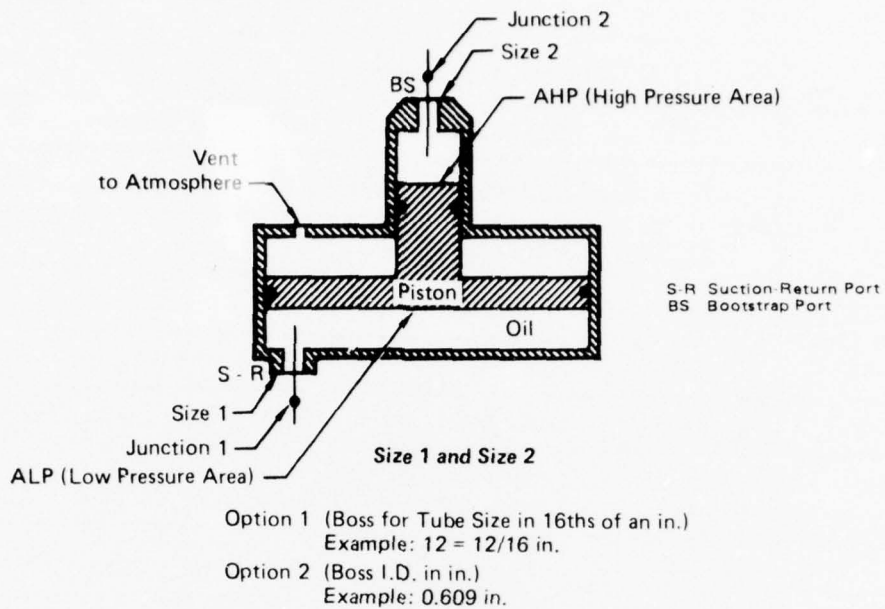

GP74-0772-21

**ELEMENT TYPE 91 - APPENDIX BOOTSTRAP RESERVOIR**

Type 91 reservoir is a bootstrap pressurized appendix type. Its purpose is to make up system volume differences that occur with fluid temperature changes and the volume exchange with differential area actuators in the sub-systems. The reservoir model is corrected for altitude using sea level as a 0 reference point.

One card is required for data input. The appendix port (S-R) and the bootstrap port must be input as junctions 1 and 2 respectively. The high pressure (bootstrap pressure) area of the reservoir piston along with the low pressure area are input. The seal friction force is calculated as shown for the type 9 reservoir.





2.1.4.23 Type 92 - Constant Pressure Reservoir

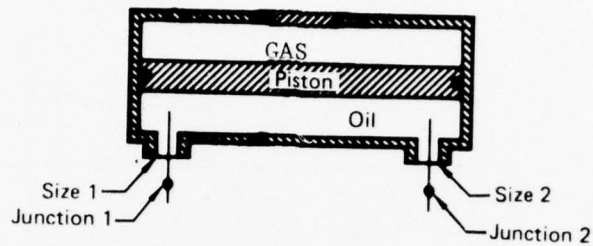

**Size 1, Size 2**

- Option 1 (Boss for Tube Size in 16ths of an in.)  
Example: 12 = 12/16 in.
- Option 2 (Boss I.D. in in.)  
Example: 0.609 in.

ELEMENT TYPE 92 - CONSTANT PRESSURE RESERVOIR

The Type 92 reservoir is a constant pressure flow through reservoir. Its purpose is to provide a constant reference pressure flow through reservoir. Its purpose is to provide a constant reference pressure regardless of the changing flow rate caused by a system demand.

One card is required for data input. The in and out junction numbers and port sizes are entered along with the constant pressure value on this card.





### 2.1.6 Program Deck and Input Data

The program deck and data cards are assembled as shown in Figure 2-6. The first six cards and the end card must be in order in the data deck. The element cards may be in random order.

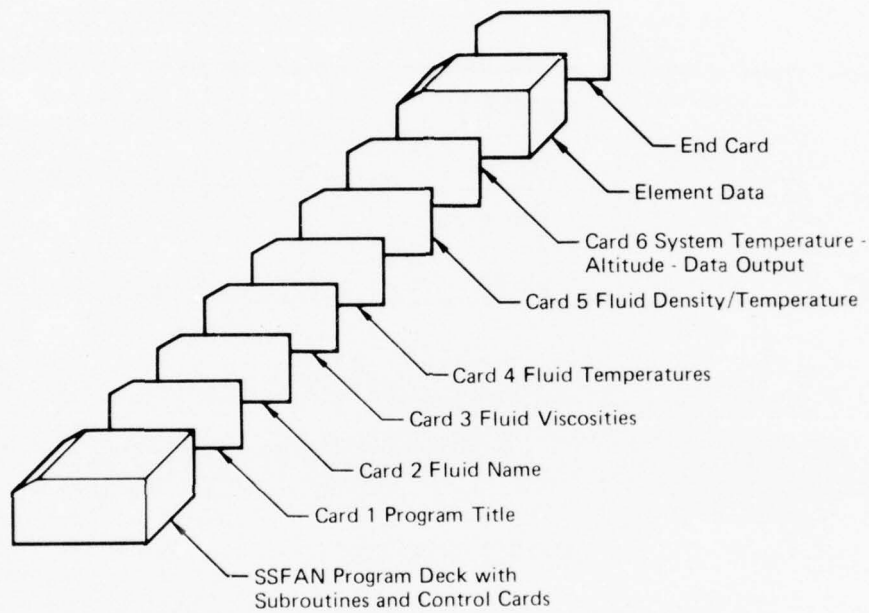

GP74-0772-10

**FIGURE 2-6**  
**SSFAN PROGRAM DECK AND INPUT DATA**



### 3.0 PROGRAM OUTPUT

For illustration, simple hydraulic systems of the types shown in Figures 3-1 and 3-8 are modeled to indicate the types of output which may be obtained with SSFAN. Normal input parameters set the system characteristics or resistances in each leg for the input conditions of fluid type and temperature and flight altitude. The network flow balance, pressures at branch points and leg pressure drops are calculated for this one set of conditions.

Program Output is of 4 basic types. Type 1 output is the individual element data that was input to the program. This may be used for reference when first setting up the system to ensure that the data was input correctly. Type 2 output prints the junction numbers at each end of a leg in the system with the calculated flow and pressure drop also printed for the legs. Type 3 output prints the pressures at each junction point or end point in the system along with the name of the junction point or end point element and its associated junction point number(s). Type 4 output is a special type output. There can be many variations of this output, many of which are not developed at the present. An example of type 4 output is to establish the system resistance characteristics, then vary one parameter such as altitude or fluid temperature by making multiple runs and study the pump and reservoir pressure and flow variations.

#### 3.1 SSFAN Sample Case Number 1

Sample case number 1 is the simple hydraulic system shown in Figure 3-1. This is a 2 actuator load system with the solenoid valve in position to extend the actuators each against a 1000 pound load. The actuators are the unbalanced area type and are of different sizes. The pump is a variable delivery type operating at 3750 RPM with a rated flow of 50 gpm at this RPM. The reservoir is a flow through type with bootstrap pressure.

Figure 3-2 shows a typical first page data output page giving the input title, fluid name, temperature, and altitude. The viscosity and density

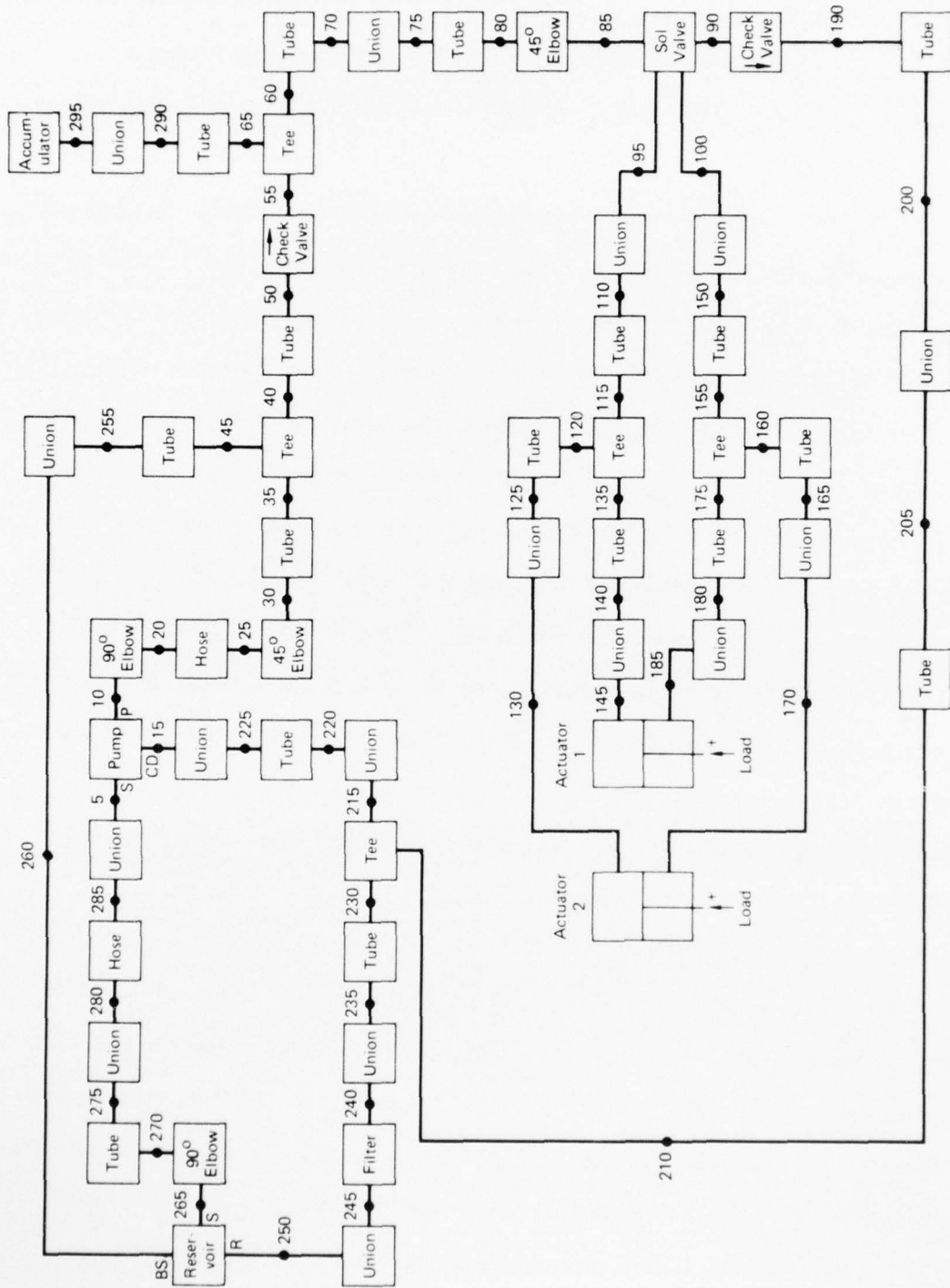

GP14-0712-23

**FIGURE 3-1**  
**SSFAN SAMPLE CASE NUMBER 1**  
 2 Actuator Subsystem



are the calculated atmospheric values at the input-temperature.

Figures 3-3 and 3-4 show the input data which was sorted and stored into the individual element arrays. This is output type 1. It may be noted in Figure 3-3 under Line array-Type 1 the individual input bend angles are not included. These were converted to equivalent length (EQLT), summed and stored to minimize required computer storage locations.

Figure 3-5 is an example of output type 2. The junction numbers at leg ends correspond to the numbers of Figure 3-1 block diagram. For example, for leg 10-35, this is the leg that starts at the pump pressure out port and ends at the downstream tee (reservoir bootstrap pressure tee). The pressure drop in this leg is 9.23 psi and the flow is 10.74 gpm. It may be noted that the bootstrap pressure line (45-260) and the accumulator line (65-295) have 0. flow and 0. pressure drop. Also, looking at the reservoir return line (230-250) and the pump suction line (265-5), system flow is being made up for the system from the reservoir because the unbalanced area actuators are extending.

Addition of flows will show that the flows are balanced within .01 gpm. Of course the flow changes across the pistons of the unbalanced area actuators.

The flow at the pump is balanced where the flow out the pressure port (10.74 gpm) plus the case drain flow (.82 gpm) equals the flow in the suction port (11.56 gpm).

Figure 3-6 gives pressure point data. The pump case pressure (junction 15) is seen to be 86.34 psi which is established at this level because of the return system flow gradient and the restricted case drain line. The overall effect is to increase the 3000 psi rated pump pressure out to 3027.50 because

77/02/02.

SSFAN -- SAMPLE CASE NUMBER 1

\*\*\*\* LINE ARRAY-TYPE 1 \*\*\*\*

JCT1	JCT2	SIZE	WALL	LENGTH	EQLT
40.000	30.000	8.000	.055	142.500	11.845
230.000	235.000	10.000	.028	63.200	4.554
205.000	210.000	8.000	.028	147.300	17.807
205.000	230.000	4.000	.028	178.200	4.774
175.000	200.000	8.000	.028	128.500	7.543
140.000	140.000	4.000	.020	85.600	3.808
155.000	150.000	4.000	.020	85.300	3.208
140.000	175.000	4.000	.020	95.700	2.924
135.000	175.000	4.000	.020	30.000	1.288
110.000	115.000	4.000	.050	75.000	3.086
175.000	70.000	6.000	.022	120.000	0.000
60.000	290.000	4.000	.020	170.000	2.969
65.000	35.000	4.000	.042	26.500	1.288
30.000	255.000	12.000	.042	85.300	9.788
45.000	275.000	4.000	.042	85.300	3.015
270.000	275.000	16.000	.042	85.300	8.441

77/02/02.

SSFAN -- SAMPLE CASE NUMBER 1

\*\*\*\* UNION ARRAY-TYPE 2 \*\*\*\*

JCT1	JCT2	SIZE1	SIZE2
245.000	250.000	10.000	10.000
215.000	215.000	4.000	4.000
205.000	205.000	8.000	8.000
170.000	165.000	4.000	4.000
150.000	160.000	4.000	4.000
140.000	145.000	4.000	4.000
125.000	130.000	4.000	4.000
75.000	149.000	4.000	4.000
290.000	295.000	4.000	4.000
255.000	260.000	4.000	4.000
275.000	280.000	4.000	4.000
275.000	285.000	16.000	16.000

FIGURE 3-3  
EXAMPLE SSFAN OUTPUT TYPE 1  
ELEMENT INPUT DATA



AD-A038 611

MCDONNELL DOUGLAS CORP ST LOUIS MO

AIRCRAFT HYDRAULIC SYSTEMS DYNAMIC ANALYSIS. VOLUME V. STEADY S--ETC(U)

FEB 77 R LEVEK, B YOUNG

F33615-74-C-2016

F/G 1/3

UNCLASSIFIED

AFAPL-TR-76-43-VOL-5

NL

2 of 2  
AD  
A038611

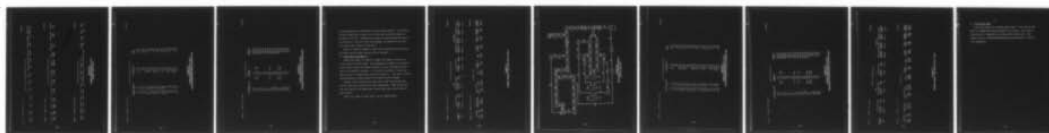

END

DATE  
FILMED  
5-77

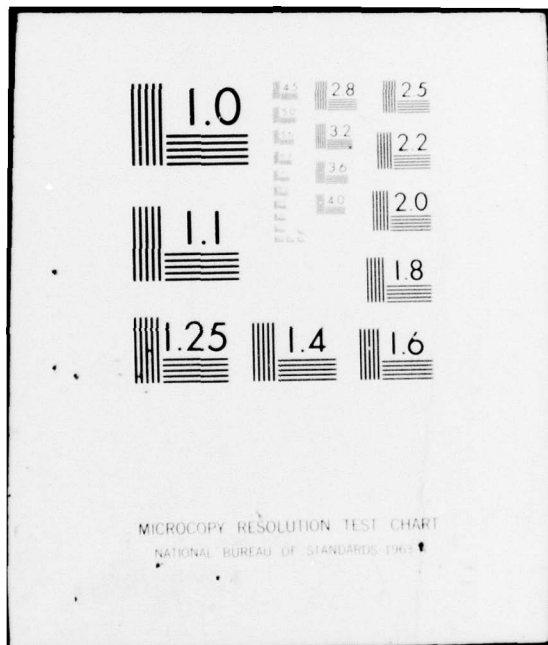

MICROCOPY RESOLUTION TEST CHART  
NATIONAL BUREAU OF STANDARDS-1963-A

77/02/02.

SSFAN -- SAMPLE CASE NUMBER 1

\*\*\*\*\* SOLENOID VALVE ARRAY-TYPE 34 \*\*\*\*\*

JCT1	JCT2	C3	C4	SIZE1	SIZE2	SIZE3	SIZE4	RFLW1-3/4	RDPI-3/4	RFLW1-2	RDPI-2	D/C
85.00	90.00	95.00	100.00	6.00	8.00	4.00	4.00	25.00	200.00	14.00	.10	3000.00

77/02/02.

SSFAN -- SAMPLE CASE NUMBER 1

\*\*\*\*\* ACTUATOR ARRAY-TYPE 4 \*\*\*\*\*

JCT1	JCT2	SIZE1	SIZE2	FXT AREA	RET AREA	FRICITION	LOAD	TOT STR	PISTON POS	PISTON DIA	C/V JCT1
145:	185:	4.000	4.000	4.500	3.250	35.000	1000.00	5.000	2.50	2.00	85:
140:	170:	4.000	4.000	3.850	2.900	25.000	1900.00	5.000	2.50	2.00	85:

SSFAN -- SAMPLE CASE NUMBER 1

\*\*\*\*\* PUMP ARRAY-TYPE 5 \*\*\*\*\*

JCT15	JCT2P	JCT3CD	SIZE1	SIZE2	SIZE3	RPH	RRPH	RATED 0	PI	PSMIN	RCDP	RCDL	PSET
5.00	10.00	15.00	16.00	12.00	4.00	3750.00	3750.00	50.00	3000.00	29.00	0.00	0.00	0.00

77/02/02.

FIGURE 3-4  
 EXAMPLE SSFAN OUTPUT TYPE 1  
 ELEMENT INPUT DATA

LFC FLOW AND PRESSURE DROPS

JUNCTION NUMBERS AT LEG ENDS	PPFSSURE DROP (PSIG)	FLOW (GPM)
10.- 35.	9.23	10.74
40.- 55.	114.66	10.74
45.- 260.	.00	.00
60.- 85.	.00	10.74
95.- 115.	970.39	10.67
135.- 145.	267.00	5.29
120.- 130.	100.57	5.38
65.- 205.	.00	- .00
145.- 175.	596.09	5.29
170.- 160.	762.51	5.38
90.- 210.	85.89	10.74
15.- 215.	6.62	.82
155.- 100.	826.34	10.67
230.- 250.	27.32	11.56
265.- 5.	1.81	11.56
85.- 90.	2738.02	.07
85.- 95.	39.10	10.67
95.- 90.	2698.91	.00
95.- 100.	2698.91	.00
100.- 90.	39.10	10.67

FIGURE 3-5  
EXAMPLE SSFAN OUTPUT TYPE 2  
FLOW AND PRESSURE DROP IN BRANCH LEGS

SSFAN -- SAMPLE CASE NUMBER 1

77/02/02.

BRANCH/END POINT ELEMENT	PRESSURE POINT DATA		PRESSURE (PSIG)
	JUNCTION NUMBERS		
PUMP	10.		3027.50
TEE	35.- 45.- 40.		3018.27
TEE	55.- 65.- 60.		2903.61
RESV	260.		3018.27
VLV	45.		2903.61
VLV	90.		165.59
VLV	95.		2864.50
VLV	100.		204.69
TEE	115.- 120.- 135.		1894.11
ACTR	145.		1627.11
ACTR	130.		1793.54
ACCUM	295.		2903.61
TEE	175.- 160.- 155.		1031.03
TEE	210.- 215.- 230.		79.71
PUMP	15.		86.34
RESV	250.		52.39
RESV	265.		52.39
PUMP	5.		50.58

FIGURE 3-6  
EXAMPLE SSFAN OUTPUT TYPE 3  
PRESSURES AT BRANCH POINTS AND END POINTS



the pump compensator is referenced to the case drain pressure. The reservoir internal pressure may be seen to be 52.39 psi and the suction pressure at the pump is 50.58 psi. Pressure point values are normally stored and output for actuators at the flow in port only; however, the pressure at the other port may be output under an output Type 4.

Figure 3-7 shows an example of output Type 4 which prints the pressures and flows around the pump, reservoir and all actuators.

### 3.2 SSFAN Sample Case Number 2

Sample case number 2 is similar to sample case number 1, except that a third actuator has been added. The configuration in Figure 3-8 illustrates a more complex circuit for analysis because it is not just another parallel load to the original 2 actuators. It tees into the actuator 2 return loop before actuator 2 completes its circuit with actuator 1. This type of network cross-branching is readily handled by the SSFAN solution technique.

Figures 3-9 and 3-10 show the output Type 2 flows and pressure drops and the output Type 3 pressure point data respectively. These results show data very similar to the sample case 1 data except there are more legs and branch points.

Figure 3-11 shows an output Type 4 for the example system.

SSFAN -- SAMPLE CASE NUMBER 1

77/02/02.

PUMP AND RESERVOIR DATA

PUMP PRESSURE PORT	PUMP		SUCTION PORT		RESERVOIR PRESSURES		RESERVOIR FLOWS			
	PRESSURE (PSIG)	FLOW (GPM)	PRESSURE (PSIG)	FLOW (GPM)	ADJUSTRAP (PSIG)	INTERNAL (PSIG)	FLOW-IN (GPM)	FLOW-OUT (GPM)		
10.	3027.50	10.74	56.34	.82	50.58	11.56	3018.27	52.39	11.56	11.56

SSFAN -- SAMPLE CASE NUMBER 1

77/02/02.

ACTUATOR DATA

ACTUATOR JCT1	JCT2	LOAD ON ROD (+COMP, -TENS)		PRESSURES		IN (GPM)	FLOWS		ROD VELOCITY (IPS)	TOTAL STROKE (IN)	PISTON POSITION (IN)	CONTROL VALVE JCT1-PDS
		(LPS)	(TENS)	IN (PSIG)	OUT (PSIG)		PISTON LEAK (GPM)	OUT (GPM)				
145:	170:	1000.00	1000.00	0.00	-318.46	10.000	.005	5.289	8.55	5.00	2.50	85.-1:
130:	170:	1000.00	1000.00	0.00	-353.45	10.000	.006	5.392	10.00	5.00	2.50	85.-1:

OT 3

FIGURE 3-7  
EXAMPLE SSFANL TEST CASE OUTPUT TYPE 4



LEG FLOW AND PPESSURE DRDPS		
JUNCTION NUMBERS AT LFG ENDS	PPESSURE DRDPS (PSTIG)	FLOW (GPM)
10.- 35.	11.20	11.94
40.- 55.	137.29	11.94
45.- 260.	.00	.00
60.- 85.	.00	11.94
95.- 96.	325.64	11.87
500.- 510.	228.05	5.03
110.- 115.	387.03	6.84
135.- 145.	275.97	5.37
120.- 130.	9.56	1.46
65.- 295.	.00	-.00
185.- 175.	610.58	5.37
170.- 170.	345.95	1.46
515.- 525.	514.49	5.03
90.- 210.	102.37	11.94
15.- 215.	5.54	.81
165.- 160.	-531.05	6.49
155.- 100.	998.97	11.87
230.- 250.	31.26	12.74
265.- 5.	2.16	12.74
85.- 90.	2694.90	.07
85.- 95.	48.36	11.87
95.- 90.	2646.55	.00
85.- 100.	2646.55	.00
100.- 90.	48.36	11.87

FIGURE 3-9  
EXAMPLE SSFAN OUTPUT TYPE 2  
FLOW AND PPESSURE DRDPS IN BRANCH LEGS



PRESSURE POINT DATA			
BRANCH/END POINT ELEMENT	JUNCTION NUMBERS		PRESSURE (PSIG)
PUMP	10.		3029.42
TEE	35.- 45.- 40.		3018.22
TEE	55.- 65.- 60.		2880.93
RESV	260.		3018.22
VLV	85.		2880.93
VLV	90.		186.02
VLV	95.		2832.57
VLV	100.		234.38
TEE	96.- 110.- 500.		2506.93
ACTR	510.		2278.89
TEE	115.- 120.- 135.		2119.91
ACTR	145.		1843.93
ACTR	130.		2110.35
ACCUM	295.		2880.93
TEE	175.- 160.- 155.		1233.35
TEE	170.- 525.- 165.		1764.40
TEE	210.- 215.- 230.		83.65
PUMP	15.		89.20
RESV	250.		52.39
RESV	265.		52.39
PUMP	5.		50.23

FIGURE 3-10  
 EXAMPLE SSFAN OUTPUT TYPE 3  
 PRESSURES AT BRANCH POINTS AND END POINTS



77/02/02.

SSFAN -- SAMPLE CASE NUMBER 2

PUMP AND RESERVOIR DATA

PRESSURE PORT	PUMP		SUCTION PORT		RESERVOIR PRESSURES		RESERVOIR FLOWS			
	PRESSURE (PSIG)	FLOW (GPM)	PRESSURE (PSIG)	FLOW (GPM)	BOOTSTRAP (PSIG)	INTERNAL (PSIG)	FLOW-IN (GPM)	FLOW-OUT (GPM)		
10.	3029.42	11.94	89.20	.81	50.23	12.74	3018.22	52.39	12.74	12.74

SSFAN -- SAMPLE CASE NUMBER 2

77/02/02.

ACTUATOR DATA

ACTUATOR JCT1	ACTUATOR JCT2	LOAD ON ROD (SCMPD-TENS)		PRESSURES (PSIG)		IN PISTON LEAK FLOWS (GPM)		OUT (GPM)	BOO VELOCITY (IPS)	TOTAL STROKE (IN)	PISTON POSITION (IN)	CONTROL VALVE JCT1-PDS
		(LBS)	(LBS)	IN	OUT	IN	OUT					
145.	185.	1000.00	1000.00	0.00	-318.46	10.000	0.05	5.373	8.55	5.00	2.50	85.-1.
170.	170.	1000.00	1000.00	0.00	-318.46	10.000	0.05	5.462	10.00	5.00	2.50	85.-1.
510.	515.	1000.00	1000.00	0.00	-318.46	10.000	0.05	5.031	8.55	5.00	2.50	85.-1.

3-14

FIGURE 3-11  
EXAMPLE SSFAN TEST CASE OUTPUT TYPE 4

### 3.3 Other Output Types

Other type outputs are currently being studied. SSFAN data has been output in computer plot form for specific case studies. This method is being studied for feasibility as a general SSFAN output type. These include studies of subsystem operating times with variations of load and fluid temperature.