

AD-A038 545

ARMY ELECTRONICS COMMAND FORT MONMOUTH N J  
REPETITIVE SERIES INTERRUPTER.(U)  
FEB 77 M WEINER

F/G 9/5

UNCLASSIFIED

ECOM-4469

NL

1 of 1  
AD  
A038545



END  
DATE  
FILMED  
5-77



12  
B.S.

AD A 038545

Research and Development Technical Report  
ECOM - 4469

REPETITIVE SERIES INTERRUPTER

Maurice Weiner  
Electronics Technology & Devices Laboratory ✓

February 1977

DISTRIBUTION STATEMENT  
Approved for public release;  
distribution unlimited.

DDC  
RECEIVED  
APR 22 1977  
RECEIVED  
D

AD NO. \_\_\_\_\_  
DDC FILE COPY,

**ECOM**

ARMY ELECTRONICS COMMAND FORT MONMOUTH, NEW JERSEY 07703

## NOTICES

### Disclaimers

The findings in this report are not to be construed as an official Department of the Army position, unless so designated by other authorized documents.

The citation of trade names and names of manufacturers in this report is not to be construed as official Government indorsement or approval of commercial products or services referenced herein.

### Disposition

Destroy this report when it is no longer needed. Do not return it to the originator.

UNCLASSIFIED

SECURITY CLASSIFICATION OF THIS PAGE (When Data Entered)

REPORT DOCUMENTATION PAGE		READ INSTRUCTIONS BEFORE COMPLETING FORM	
1. REPORT NUMBER ECOM-4469	2. GOVT ACCESSION NO.	3. RECIPIENT'S CATALOG NUMBER	9 Research and development
4. TITLE (and Subtitle) Repetitive Series Interrupter		5. TYPE OF REPORT & PERIOD COVERED Technical Report	9
7. AUTHOR(s) Maurice Weiner		6. PERFORMING ORG. REPORT NUMBER	17 E1
9. PERFORMING ORGANIZATION NAME AND ADDRESS US Army Electronics Command (ATTN: DRSEL-TL-BG) Fort Monmouth, NJ 07703		8. CONTRACT OR GRANT NUMBER(s)	
11. CONTROLLING OFFICE NAME AND ADDRESS Beam, Plasma and Display Technical Area US Army Electronics Technology and Devices Lab (ATTN: DRSEL-TL-B)		10. PROGRAM ELEMENT, PROJECT, TASK AREA & WORK UNIT NUMBERS 16 1ST 62705AH94 E1 01	
14. MONITORING AGENCY NAME & ADDRESS (if different from Controlling Office)		12. REPORT DATE Feb 1977	
12 21 p.		13. NUMBER OF PAGES 18	
		15. SECURITY CLASS. (of this report) Unclassified	
		15a. DECLASSIFICATION/DOWNGRADING SCHEDULE	
16. DISTRIBUTION STATEMENT (of this Report) Approved for public release; distribution unlimited.			
17. DISTRIBUTION STATEMENT (of the abstract entered in Block 20, if different from Report)			
18. SUPPLEMENTARY NOTES			
19. KEY WORDS (Continue on reverse side if necessary and identify by block number) Arc protector Thyratron Current interrupter Plasma Microwave tube			
20. ABSTRACT (Continue on reverse side if necessary and identify by block number) This work describes a novel approach for the protection of high power microwave tubes against arcs. The protective device is basically an electronically resettable fuse which is placed in series in the discharge circuit. Upon the sensing of an arc the device interrupts the current until the arc clears. This permits operation on the next pulse. The device consists of a thyratron with a long discharge region in series with a perforated anode. Current interruption is achieved by the application of a pulsed magnetic field			

DD FORM 1 JAN 73 1473

EDITION OF 1 NOV 65 IS OBSOLETE

037620

UNCLASSIFIED

SECURITY CLASSIFICATION OF THIS PAGE (When Data Entered)

over  
Y/B

UNCLASSIFIED

SECURITY CLASSIFICATION OF THIS PAGE(When Data Entered)

BLOCK #20 (Contd)

In the interaction region to vary the impedance of the discharge. Results of the investigation demonstrate overall feasibility and point out areas requiring further development.

APPROX FOR		
WTS	White Section	<input checked="" type="checkbox"/>
WTS	Buff Section	<input type="checkbox"/>
REPRODUCED		<input type="checkbox"/>
REPRODUCTION		
EXPLANATION/AVAILABILITY CODES		
MAIL and/or SPECIAL		
A		

DDC  
RECEIVED  
APR 22 1977  
D

UNCLASSIFIED

SECURITY CLASSIFICATION OF THIS PAGE(When Data Entered)

## CONTENTS

	<u>Page</u>
Summary	1
INTRODUCTION	1
DISCUSSION	3
Design Concept	3
Experimental Designs	4
Test Set-Up	5
Measurement Results	5
a. Tube Drop	5
b. Magnetic Fields Required for Interruption	6
c. Current Waveform	7
Physical Mechanisms of Current Interruption	7
CONCLUSIONS AND RECOMMENDATIONS	8
ACKNOWLEDGEMENTS	9
REFERENCES	9

## FIGURES

1. RSI Device in Discharge Circuit	10
2a. Device in Charging Circuit	10
2b. Resettable Crowbar	10
3. Schematic of RSI Device	11
4. RSI Device Design A	11
5. RSI Device Type A	12
6. RSI Device Type B	12
7. RSI Device Type B	13
8. Test Set-Up	13
9. Fault Current Simulation Set-Up	13
10. Variation of RSI Voltage Drop with Source Voltage, Design A Tube	14

CONTENTS (Continued)

	<u>Page</u>
11. Variation of RSI Voltage Drop with Source Voltage, Design B Tube	14
12a. Interrupted Fault Current and Field Current Waveforms in Type A Device	15
12b. Interrupted Normal Conduction Current and Field Current Waveforms in Type A Device	15
13. Variation of Turn-Off Field with Fault Current. Design A Tube. Source at 8.6 kV	16
14. Variation of Turn-off Field with Source Voltage. Design A Tube	16
15. Interrupted Normal Conduction Current and Field Current Waveforms in Type B Device	17
16. Variation of Turn-off Magnetic Field with Interaction Length Design B Tube	17
17. Current Waveform at 10.8 kV Type B Tube. Maximum Interaction Length	18

## REPETITIVE SERIES INTERRUPTER

Maurice Weiner

US Army Electronics Technology and Devices Laboratory (ECOM)  
Fort Monmouth, New Jersey 07703

Summary. Self modulated high power microwave tubes may be protected against arcs in at least two ways. One technique involves the use of a crowbar to divert the energy. Another approach is a high voltage fuse. In both cases a great deal of down time is involved. This work describes a third approach wherein a normally closed series device is placed in the discharge circuit. Upon the sensing of an arc the device interrupts the current until the arc clears. This permits operation on the next pulse. The device is basically a thyratron with a long discharge region in series with a perforated anode. Operation of the device depends on the application of a pulsed magnetic field in the interaction region to vary the impedance of the discharge. The interrupter device is described and measurement results of voltage tube drop, pulse shape, and magnetic fields needed for current interruption are given. The physical mechanisms underlying the current interruption are discussed. Results of the study demonstrate overall feasibility and point out areas requiring further development.

### INTRODUCTION

High power, self-modulated microwave tubes may be protected against arcs in two ways. One means for tube protection is the use of a high voltage fuse. When a tube arc occurs the increased current causes the fuse to open, thereby preventing further damage to the tube. The second technique involves a crowbar switch shunting the microwave tube. In the event of an occasional tube arc the switch is closed and energy is diverted from the tube to the crowbar circuit. In both these techniques the system shuts down and time is required to return the system to operation.



This paper discusses a protective device, the repetitive series interrupter (RSI), which is basically an electronically resettable fuse and therefore does not require system shut down. The RSI is placed in series with the microwave tube in the discharge circuit (Fig. 1). The RSI is normally closed. In the event of an occasional tube arc, however, a current sensor causes the RSI to temporarily interrupt the current allowing the tube arc to clear. The RSI then returns to its normally closed position during the interpulse time, allowing the next pulse to occur. As a result a continuous tracking capability may be maintained for a radar system. In the event of continual arcing, the logic for the RSI can be programmed to permanently open up the circuit after a specified number of consecutive interruptions (typically 5). This can be of particular importance in a radar using multiple microwave generators since the system can continue operation with diminished rf output. An RSI can also be used to immediately turn on a stand-by microwave generator if continuous full power operation is required.

The same basic device may be used in two other protective modes of operation, as shown in Figs. 2a and 2b. As in the previous mode of operation, these two modes serve to protect against the occasional arc without resorting to system shut-down. Figure 2A shows an RSI in the charging circuit. In the event of an arc a current sensor causes the RSI to interrupt the charging current. The advantage of this technique is that no pulse jitter, distortion or delay is introduced

because the protective device is not located in the discharge circuit. This mode assumes the microwave tube is capable of dissipating the stored energy in the capacitor without suffering permanent damage. This mode of operation also eliminates the necessity of resistively charging the secondary capacitor, thus enhancing the efficiency.<sup>1</sup> In Fig. 2b the device operates in a crowbar mode; the normally open protective device shunts the microwave tube. When arcing occurs the device is triggered into conduction, diverting the arc current from the tube and allowing the arc to clear. The protective device is then triggered back into the non-conducting state. The power supply need not be shut down unless the arc does not clear.

Longer life may be attained since the device does not operate continuously. The disadvantages are: (1) resistance in the capacitor circuit is required, thereby lowering efficiency, and (2) the device must be designed to handle higher currents.

In this paper experimental results will be presented on the RSI operating exclusively in the discharge circuit, as shown in Fig. 1. No experimental results were obtained on the protective modes of Figs. 2a and 2b. Previous experimental work, however, has been performed on the RSI device in the charging circuit.<sup>2</sup>

The principle of operation, the design, and measurements of tube drop, pulse wave form, and parameters necessary to interrupt the current are discussed.

## DISCUSSION

### Device Concept

The RSI is shown schematically in Fig. 3. The device consists of a thyratron section coupled, via a perforated anode, to a relatively long magnetic interaction column. The final anode is located at the end of the column. Current interruption is achieved by the application of a pulsed magnetic field directed transverse to the axis of the interaction column. The magnetic field effectively increases the impedance of the interaction region eventually causing complete interruption of the current. The magnetic field is removed before the start of the next pulse, thus preparing the RSI for conduction on the next pulse.

The thyratron section may be operated in either a keep-alive or triggered grid mode for a pulse system. The keep-alive mode is necessary for a CW system. In a pulse system, the advantage of the keep-alive is the elimination of a trigger for each rf pulse. The use of the grid mode on the other hand, allows for possibly a simpler way to permanently interrupt the current.

## Experimental Designs

Two designs of the RSI device were tested. The type A design is shown in Fig. 4 together with a photograph of the finished device in Fig. 5. The device was fabricated by C. Shackelford of ITT under Contract DAAB07-73-C-0320. The thyatron is an 8613 model

capable of 15 kV peak and 0.5 amps average current, and a peak current rating of 500 amps. The grid structure is modified to allow for the introduction of a separate keep-alive, which requires 140 volts and runs at 100 mA. The reservoir is set for a pressure of 0.45 torr hydrogen. The thyatron section is coupled to the magnetic interaction section by means of a wire mesh. The interaction region is folded back to reduce device length and facilitate magnetic field design. The length of the inner column is approximately 14" and that of the folded region is 10". The ID of the inner column is 3/8" and the folded annular region has an ID of 1/2" and an OD of 1.0". The design A model is discussed in more detail in Reference 2 where the device was developed for use in the charging line.

Design B is shown in Fig. 6 together with a photograph of the completed device in Fig. 7. The device was built by D. Turnquist of EG&G under Contract DAAB07-73-C-0274. The thyatron is a 7665 model capable of 16 kV peak, 0.5 amps average, and 350 amps peak. The grid element was operated as a keep-alive, running at 75 volts and 30 mA. The pressure is 0.425 torr hydrogen. The thyatron is coupled to the interaction region by means of a circular aperture. The interaction region is folded 3 times, thus providing 4 sections, each approximately 5 1/2" long. An electrode is provided at the end of each section, so that the effect of interaction length on the device behavior could be investigated. The ID of the interaction region is 0.181". The design criteria leading to the construction of the type B device is given in Reference 3.

### Test Set-Up

The set-up is shown in Fig. 8. Tube drop, waveforms and magnetic fields to interrupt normal conduction currents were measured. The microwave tube is simulated by a combined hard tube, the Machlett 6544, and a 600 ohm low inductance load resistor. The RSI is in series with the load. The pulse current is supplied by a 0.5  $\mu\text{f}$  capacitor charged to 15 kV. The pulse current was measured with a wide band transformer and pulse voltages were measured with a Tektronix P6015 probe. Measurements were obtained using a keep-alive mode of operation in the thyatron.

A 17 turn bifilar coil, ten inches long, produced approximately 1.64 gauss/amp. A single current pulse for the coil was supplied by a 75  $\mu\text{f}$  capacitor charged to 4 kV. Switching was accomplished by a triggered spark gap. The triggering of the spark gap was done after the start of the normal current pulse.

---

The test set-up for measuring the interruption behavior under fault current conditions (Fig. 9) is similar except for the addition of a thyatron switch, which shunts the load resistor and the hard tube. After the start of the normal conduction pulse the thyatron is triggered into conduction, effectively shorting the load and hard tube and providing a fault current to the RSI. The level of fault current thru the thyatron is varied by adjusting the tap on the series resistance of the hard tube.

### Measurement Results

a. Tube Drop. Tube drop measurements are shown in Figs. 10 and 11 for both designs. The hard tube was operated in the linear range. The conduction current increased with source voltage, reaching about 20 amps at 15 kV. It is noted that the tube drop decreases slightly as the source voltage and peak current are increased. The voltage drop in the thyatron section accounts for only a small part of the total

tube drop; the thyatron voltage drop in type A tube is 150 volts and in the type B tube it is 75 volts. The increase in tube drop as the interaction length increases is evident from Fig. 11. The tube drop is approximately proportional to the interaction length.

b. Magnetic Fields Required for Interruption.

Figure 12a shows, for the type A device, the interrupted fault current superimposed on the uninterrupted fault current (upper traces). The bottom trace shows the magnetic field current pulse. Because of the large coil inductance the field current reaches its peak (corresponding to 5000 gauss) at about 100  $\mu$ s. Figure 12b shows the results when interrupting normal conduction pulse under non-fault conditions. Based on previous work (Reference 3) the plasma reacts to turn-off fields in less than a microsecond. The turn-off times observed are not representative of those that can be achieved with magnetic field generators having smaller risetimes.

Figure 13 shows the variation of turn-off field as a function of the fault current for the type A model. The source voltage is fixed at 8.6 kV. The fault current was changed by varying the value of resistance shunted by the thyatron switch. The field was measured by noting the current flowing in the magnet coils at the time the fault current goes to zero. It is seen that the turn-off field changes little as the fault current increases.

Figure 14 shows the variation of the turn-off field, interrupting normal conduction currents, as a function of the source voltage. As noted from the figure the turn-off field increases linearly with source voltage. Comparison of Figs. 13 and 14 shows that the turn-off field is largely dependent on the source voltage, rather than the peak current.

Figure 15 shows typical waveforms, for the type B tube, of the interrupted and non-interrupted discharge currents (lower traces) and the magnetic field current pulse (upper traces). The current pulses interrupted here are for normal conduction pulses, i.e., no fault current was introduced. The magnetic field coil used was the one designated for the type A tube geometry.

Figure 16 shows the variation of the turn-off field as a function of the interaction length for the type B tube. The turn-off field decreases as the interaction length is increased. The tube drop, on the other hand, increases with interaction length. Comparison of Figs. 16 and 11 shows the kind of trade-off which may be made between the tube drop and turn-off magnetic field as the interaction length is varied.

c. Current Waveform. Figure 17 shows the current pulse in the cathode leg of the 6544 at 10.8 kV operated in series with the type B tube using 4 interaction lengths. The initial spike is the 6544 capacitance discharging. This is followed by a 1.0  $\mu$ s delay before full current conduction occurs, corresponding to full RSI conduction. The results are complicated by feedback to grid drive producing oscillation. Jitter, if present, is hidden in these oscillations. The observed delay decreases several tenths of a microsecond when the voltage is increased from 7 to 15 kV. No delay is observed when the magnetic interaction region is not used. The reduction in delay, by using one instead of four sections, is approximately 15%. The delay therefore can be attributed primarily to a formative time lag which involves the coupling aperture connecting the thyatron section and the magnetic interaction region.

#### Physical Mechanisms of Current Interruption

Two possible mechanisms which explain current interruption, caused by the magnetic field, are: (a) an increase in the transverse electron mobility, thereby increasing the discharge impedance, and (b) motion of the discharge against the tube wall, caused by  $\vec{J} \times \vec{B}$  forces, where  $\vec{J}$  is the current density and  $\vec{B}$  is the magnetic field. The proximity of the wall to the discharge enhances electron diffusion to the wall, as well as recombination, so that the discharge impedance is again increased.

The increase in the transverse mobility qualitatively explains certain features of the current interruption. In particular, for the type B tube, the change in turn-off field as a function of the interaction length, as well as the variation in discharge current with field (Fig. 15), may be qualitatively explained. However, wall effects arising from  $\vec{J} \times \vec{B}$  forces cannot be ruled out as a contributing factor, or even a predominant factor, to the current interruption, since (a) selective "scorching" of the tube walls have been observed in agreement with the  $\vec{J} \times \vec{B}$  direction, (b) the calculated time for the motion of the discharge against the wall is of the order of 1.0  $\mu$ s, which is much less than the time frames used in the measurements of current interruption, and (c) a complete model describing wall effects arising from  $\vec{J} \times \vec{B}$  force is not yet available, but may presumably explain the observed current interruption.

An observation concerning the current interruption is worth mentioning since it may provide a clue to the underlying physical mechanisms. From Figs. 12a and 12b, which apply to the type A tube, it may be seen that the current decreases rapidly at first, but at the end of 20  $\mu$ s or so the current decline becomes oscillatory and apparently more gradual. This behavior barely appears in the type B tube, and at that only for the single interaction length, and not in the cases where the interaction length is longer. In any event the change in the current decline, as the field increases, is probably indicative of a change in the mechanism controlling the current interruption.

#### CONCLUSIONS AND RECOMMENDATIONS

Test results of an RSI device operating in the discharge circuit have been presented. The device consists of a thyratron coupled to a magnetic interaction region. Current interruption is achieved when a pulsed magnetic field is directed perpendicular to the current flow. Measurements of tube drop, turn-off magnetic field, and pulse wave form were obtained.

Measurements showing the trade-off between tube drop and turn-off magnetic field amplitude, as a function of interaction length, are given. The measurements also show the strong dependence of the turn-off field on the applied voltage, in contrast to the weak dependence on discharge current.

The results obtained show that the RSI is a feasible concept. Additional studies have to be conducted at full average power to determine reliability and life. The various types of circuit applications have to be investigated more thoroughly. Because of system requirements the magnetic field generator must be compact. In this regard the use of ferromagnetic material for producing the field may be applicable.

#### ACKNOWLEDGEMENTS

Useful discussions with S. Schneider and J. Creedon, US Army Electronics Technology and Devices Laboratory (ECOM), are acknowledged.

#### REFERENCES

1. G. Taylor, S. Schneider, "Energy Control for Microwave Amplifier Arrays," IEEE Transactions on Aerospace and Electronic Systems, Vol. AES-4, No. 5, pp. 659-664, September 1968.
2. C. Shackelford, "Repetitive Series Interrupter," Final Report, ECOM Contract DAAB07-73-C-0320, September 1974.
3. J. Thomas, H. Vanden Brink, D. Turnquist, "New Switching Concepts," Final Report, ECOM Contract DA28-043 AMC-00123CE, October 1967.



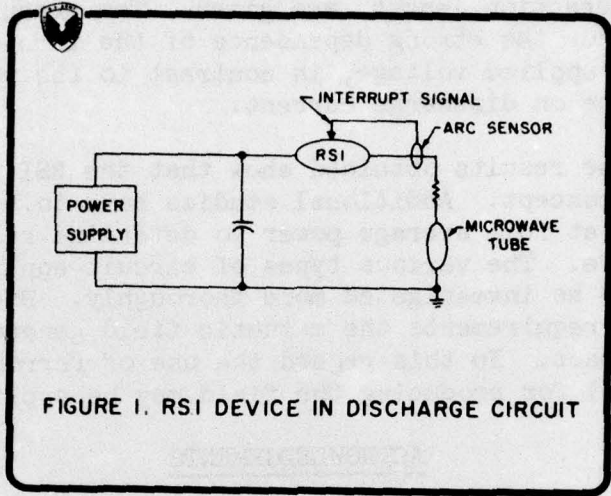

FIGURE 1. RSI DEVICE IN DISCHARGE CIRCUIT

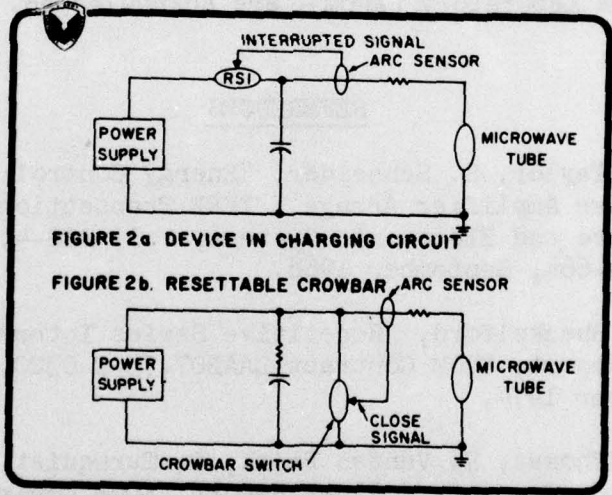
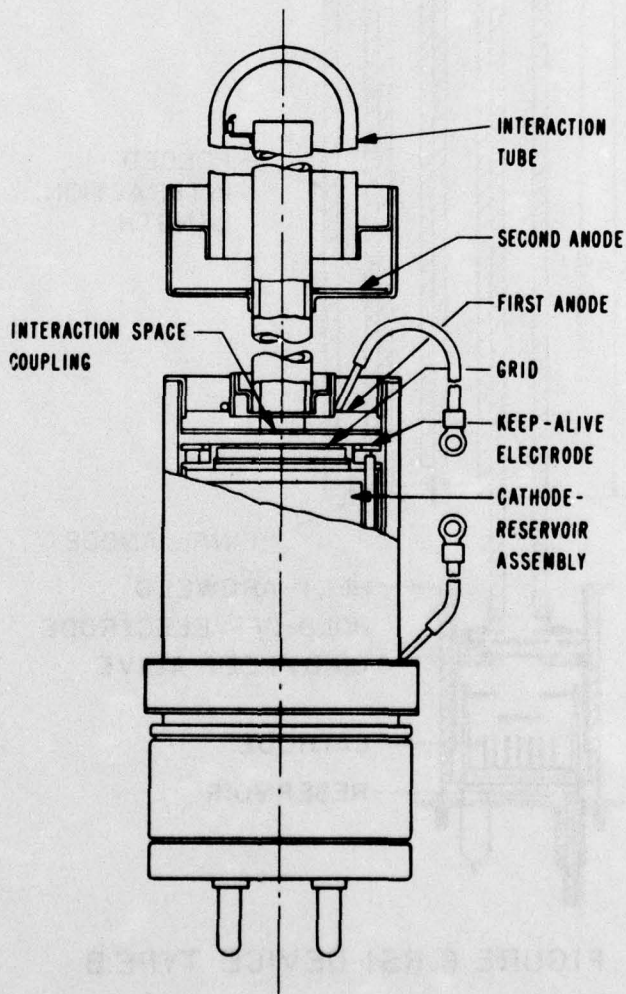
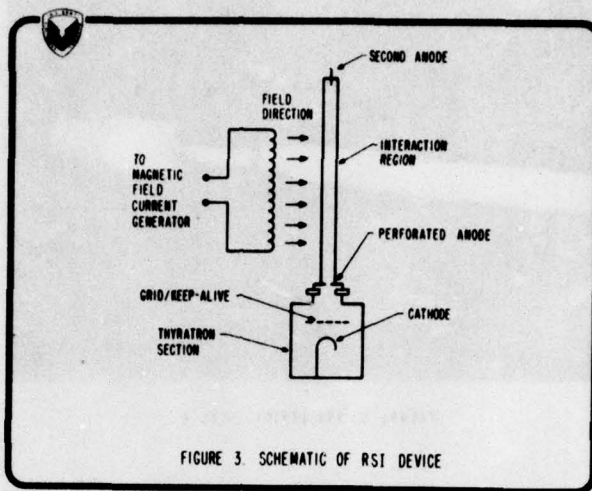

FIGURE 2a. DEVICE IN CHARGING CIRCUIT

FIGURE 2b. RESETTABLE CROWBAR



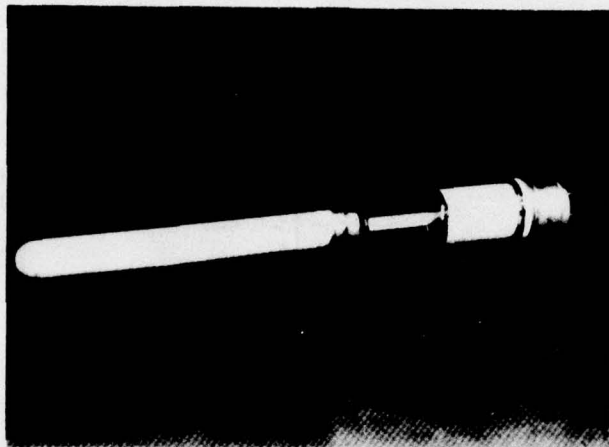

FIGURE 5. RSI DEVICE: TYPE A

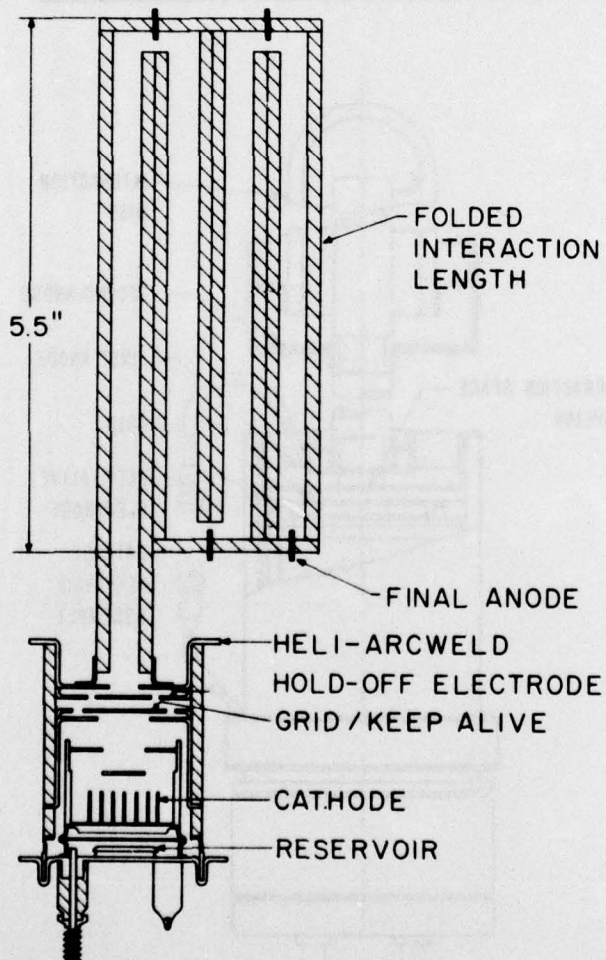

FIGURE 6. RSI DEVICE TYPE B

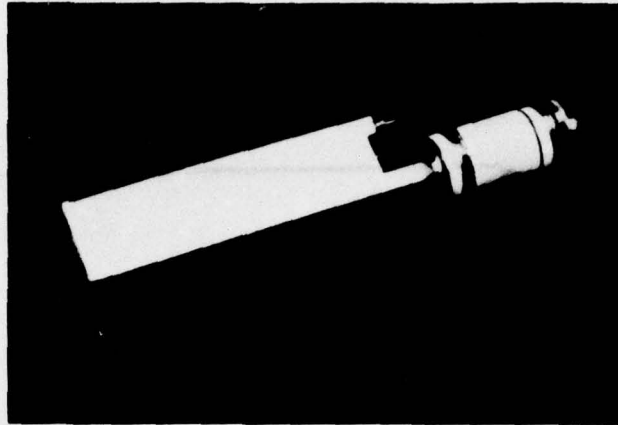

FIGURE 7. NSI DEVICE: TYPE D

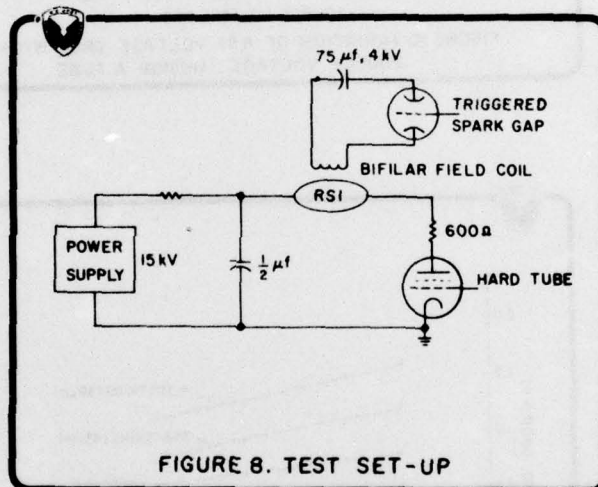

FIGURE 8. TEST SET-UP

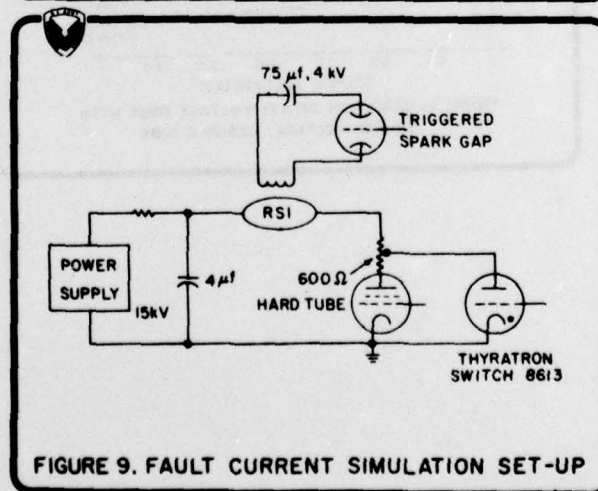
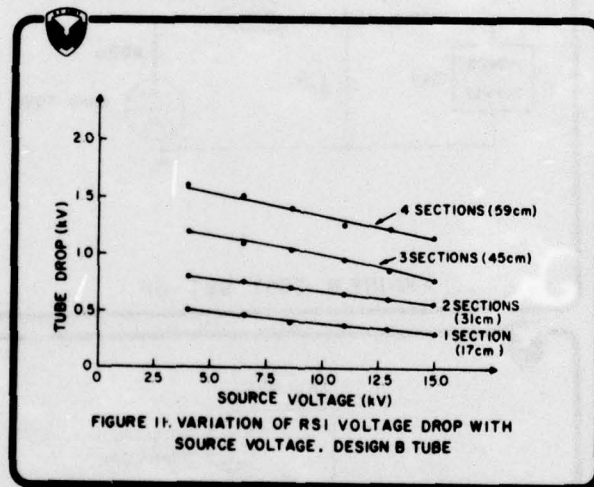
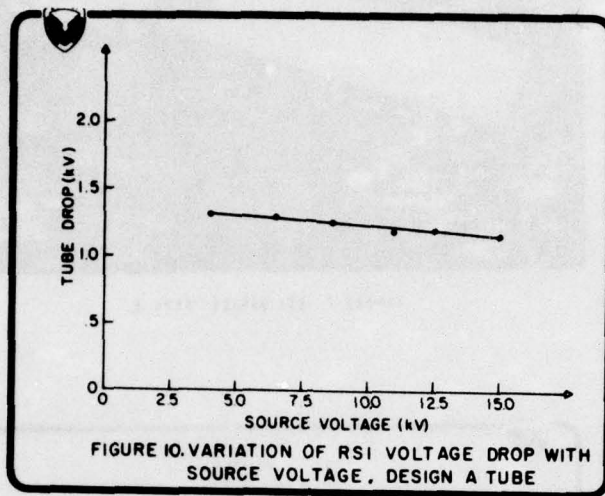

FIGURE 9. FAULT CURRENT SIMULATION SET-UP



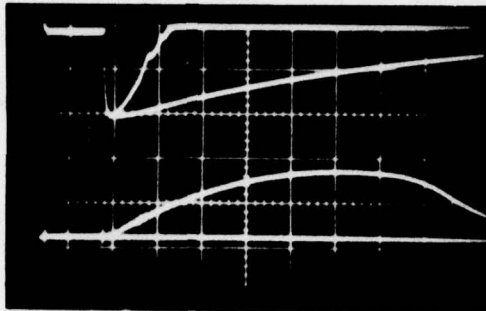

Figure 12a  
 Interrupted Fault Current and Field Current  
 Waveforms in Type A Device

Upper Traces: Interrupted current superimposed  
 on the uninterrupted current at 6.4 k  
 Horizontal = 20  $\mu$ s/cm  
 Vertical = 50 amps/cm

Lower Trace: Field Current  
 Horizontal = 20  $\mu$ s/cm  
 Vertical = 2000 amps/cm

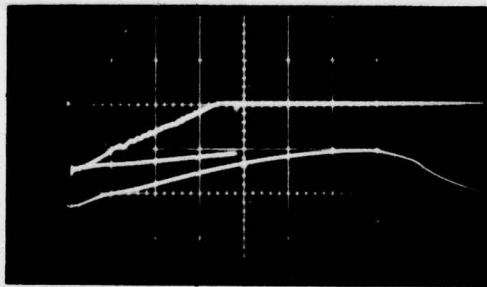
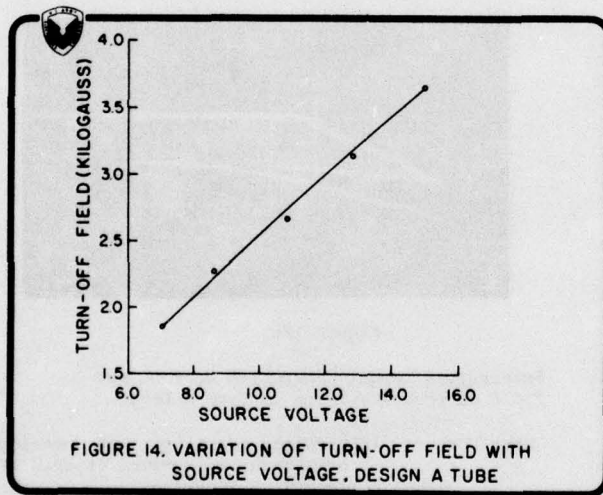
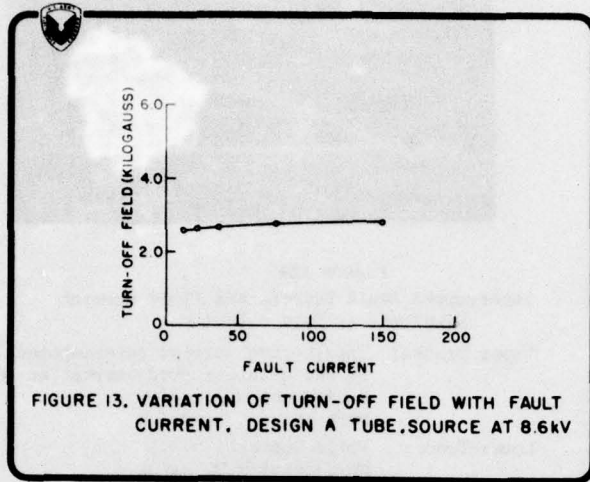

Figure 12b

Interrupted Normal Conduction Current and  
 Field Current Waveforms in Type A Device

Upper Traces: Interrupted normal current superimposed  
 on uninterrupted current at 12.8 kV  
 Horizontal = 20  $\mu$ s/cm  
 Vertical = 10 amps/cm

Lower Trace: Field Current  
 Horizontal = 20  $\mu$ s/cm  
 Vertical = 2000 amps/cm



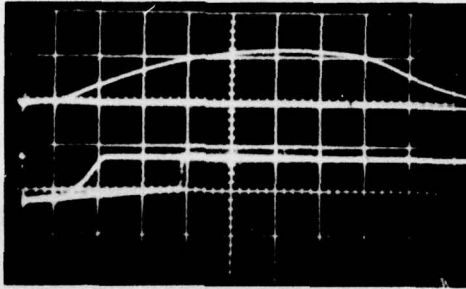
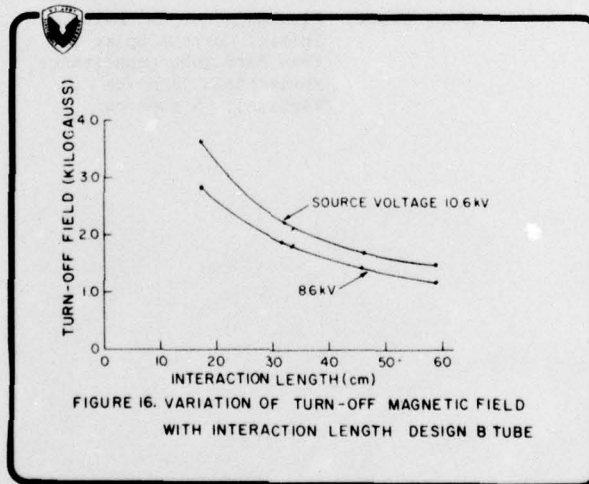

Figure 15

Interrupted Normal Conduction Current and Field Current Waveforms in Type B Device

- Lower Traces:** Interrupted normal current superimposed on uninterrupted current at 8.6 kV  
 Horizontal = 20  $\mu$ s/cm  
 Vertical = 10 amps/cm
- Upper Trace:** Field Current  
 Horizontal = 20  $\mu$ s/cm  
 Vertical = 2000 amps/cm





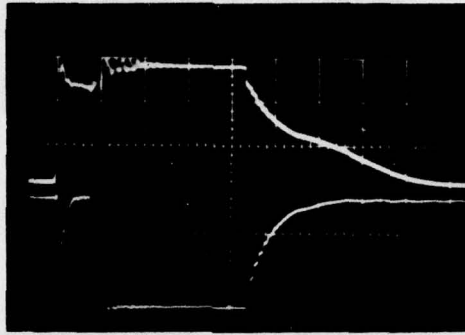

Figure 17

Current Waveform at 10.8 kV. Type B Tube.  
Maximum Interaction Length.

Upper Trace: Grid Pulse to Hard Tube  
Horizontal: 1  $\mu$ s/cm  
Vertical: 250 V/cm

Lower Trace: Discharge Current Pulse.  
Initial Current Spike is  
from Hard Tube Capacitance.  
Horizontal: 1  $\mu$ s/cm  
Vertical: 5 amps/cm