

12
B.S.

Technical Report PTR-1033-76-12
Contract No. MDA903-76-C-0241
December 31, 1976

AD A 038523

APPLICATION OF ADAPTIVE MODELS TO INFORMATION SELECTION IN C3 SYSTEMS

MICHAEL G. SAMET
GERSHON WELTMAN
KENT B. DAVIS

DISTRIBUTION STATEMENT A
Approved for public release;
Distribution Unlimited

AD NO.
DDC FILE COPY

Prepared for:

CYBERNETICS TECHNOLOGY OFFICE
Defense Advanced Research Projects Agency
1400 Wilson Boulevard
Arlington, Virginia 22209

DDC
APR 21 1977
LIBRARY

PERCEPTRONICS

6271 VARIEL AVENUE • WOODLAND HILLS • CALIFORNIA 91367 • PHONE (213) 884-7470

Technical Report PTR-1033-76-12
Contract No. MDA903-76-C-0241
December 31, 1976

APPLICATION OF ADAPTIVE MODELS TO INFORMATION SELECTION IN C3 SYSTEMS

**MICHAEL G. SAMET
GERSHON WELTMAN
KENT B. DAVIS**

Prepared for:

CYBERNETICS TECHNOLOGY OFFICE
Defense Advanced Research Projects Agency
1400 Wilson Boulevard
Arlington, Virginia 22209

PERCEPTRONICS

8271 VARIEL AVENUE • WOODLAND HILLS • CALIFORNIA 91387 • PHONE (213) 884-7470

TECHNICAL REPORT PTR-1033-76-12
For the Period March 1, 1976 to September 30, 1976
December 1976

APPLICATION OF ADAPTIVE MODELS
TO INFORMATION SELECTION IN C3 SYSTEMS

Michael G. Samet
Gershon Weltman
Kent B. Davis

*This research was supported by the Advanced Research
Projects Agency of the Department of Defense,
under Contract No. MDA 903-76-C-0241*

*The views and conclusions contained in this document
are those of the authors and should not be interpreted
as necessarily representing the official policies,
either expressed or implied, of the Advanced Research
Projects Agency or the United States Government.*

Approved for Public Release; Distribution Unlimited
Reproduction in whole or part is permitted for any purpose of the
United States Government

PERCEPTRONICS

6271 VARIEL AVENUE • WOODLAND HILLS • CALIFORNIA 91364 • PHONE (213) 884-7470

UNCLASSIFIED

SECURITY CLASSIFICATION OF THIS PAGE (When Data Entered)

REPORT DOCUMENTATION PAGE		READ INSTRUCTIONS BEFORE COMPLETING FORM
1. REPORT NUMBER PTR-1033-76-12	2. GOVT ACCESSION NO.	3. RECIPIENT'S CATALOG NUMBER
4. TITLE (and Subtitle) APPLICATION OF ADAPTIVE MODELS TO INFORMATION SELECTION IN C3 SYSTEMS		5. TYPE OF REPORT & PERIOD COVERED TECHNICAL REPORT 3-1-76 to 9-30-76
7. AUTHOR(s) Michael G./Samet Gershon/Weltman Kent B./Davis		6. PERFORMING ORG. REPORT NUMBER
9. PERFORMING ORGANIZATION NAME AND ADDRESS Perceptronics, Inc. 6271 Variel Avenue Woodland Hills, California 91367		8. CONTRACT OR GRANT NUMBER(s) MDA 903-76-C-0241
11. CONTROLLING OFFICE NAME AND ADDRESS Defense Advanced Research Project Agency Office of Human Resources 1400 Wilson Blvd., Arlington, VA 22209		10. PROGRAM ELEMENT, PROJECT, TASK AREA & WORK UNIT NUMBERS
14. MONITORING AGENCY NAME & ADDRESS (if different from Controlling Office) Technical rept. 1 Mar - 31 Sep 76		12. REPORT DATE 31 December 1976
		13. NUMBER OF PAGES
		15. SECURITY CLASS. (of this report) UNCLASSIFIED
		15a. DECLASSIFICATION DOWNGRADING SCHEDULE
16. DISTRIBUTION STATEMENT (of this Report) Approved for Public Release; Distribution Unlimited 12 104p.		
17. DISTRIBUTION STATEMENT (of the abstract entered in Block 20, if different from Report)		
18. SUPPLEMENTARY NOTES None		
19. KEY WORDS (Continue on reverse side if necessary and identify by block number) Adaptive Model Decision Aid Information Selection ASW Simulation Decision Making Man/Machine Interaction Command and Control Information Flow Multi-Attribute Utility Computer Aided Decisions Information Processing		
20. ABSTRACT (Continue on reverse side if necessary and identify by block number) This report describes research and development centered on the demonstration of an on-line adaptive model for automatically selecting information in a command, control, and communication (C3) system. Rationale for application of the model is built upon a review of psychological literature concerning human performance in specifying information requirements, and in acquiring and utilizing information for military decision making. Based on a multi-attribute decomposition of information messages, the model selects information		

14

6

10

15

14

9

DD FORM 1 JAN 73 1473

EDITION OF 1 NOV 65 IS OBSOLETE

UNCLASSIFIED

SECURITY CLASSIFICATION OF THIS PAGE (When Data Entered)

390 285

LB

20. Continued

for an individual user according to his observed information preferences in response to specific situational requirements. An additional algorithm reduces the size of a selected information set by dynamically pruning relatively low-utility items. The model was implemented for a simulated ASW tracking task, and was systematically evaluated in terms of both its intrinsic performance and the performance of an expert operator working with it. The results demonstrated the capability of the model to adapt to varied individualized information seeking strategies, and to subsequently automate the selection of information appropriate to those strategies. Empirical evaluations showed that an operator was able to perform the tracking task successfully and much more rapidly with automatic selection of information. Moreover, performance effectiveness was enhanced by the removal of messages which contributed little to the overall utility of an information set. The findings are discussed in terms of the advantages and implications of the adaptive, multi-attribute utility model and its potential application for improving information flow (e.g., pacing and routing) and utilization in computer-based C3 systems.

ACCESSION FOR

NTIS Write Section
DOC Buff Section
UNANNOUNCED
JUSTIFICATION

BY

INTRODUCTION, AVAILABILITY CODES
SYMBOL AVAIL. and/or SPECIAL

A

TABLE OF CONTENTS

	<u>PAGE</u>
1. SUMMARY	1-1
1.1 Objectives	1-1
1.2 Technical Approach	1-2
1.2.1 Rationale	1-2
1.2.2 System Concept	1-3
1.2.3 Demonstration and Evaluation	1-5
1.3 Findings	1-6
1.3.1 Model Performance	1-6
1.3.2 Operator Performance	1-7
1.4 Applications	1-8
1.4.1 Domain	1-8
1.4.2 Supervision of C3 Information Flow	1-8
2. SELECTIVE LITERATURE REVIEW	2-1
2.1 Purpose	2-1
2.2 Organization of Literature	2-1
2.3 Information Requirements	2-2
2.3.1 Specification of Information Requirements	2-2
2.3.2 Balancing the Information Supply	2-4
2.3.3 Individualized Adaptive Selection	2-5
2.4 Information Acquisition	2-7
2.4.1 Process Description	2-7
2.4.2 Experimental Studies	2-7
2.4.3 Rationale for Aiding Information Selection	2-11
2.5 Information Utilization	2-13
2.5.1 Information Quantity versus Decision Performance	2-13
2.5.2 Utilization Aiding Through User Modeling	2-17
2.5.3 ADDAM Decision Support System	2-18

TABLE OF CONTENTS (Continued)

	<u>PAGE</u>
3. MULTI-ATTRIBUTE MODEL FOR INFORMATION SELECTION	3-1
3.1 Overview	3-1
3.1.1 Concept	3-1
3.1.2 System Organization	3-1
3.1.3 Application Test Bed	3-1
3.1.4 Model Function	3-3
3.1.5 MAU Calculation	3-4
3.2 ASW Simulation	3-6
3.2.1 Operator's Task	3-6
3.2.2 Sensor Characteristics	3-8
3.2.3 Status and Intelligence Reports	3-8
3.3 Attribute Level Calculation	3-11
3.3.1 Information Attributes	3-11
3.3.2 Attribute Level Vector	3-12
3.3.3 Attribute Descriptions	3-12
3.4 Attribute Weights	3-17
3.4.1 Utility Estimator	3-17
3.4.2 Training Algorithm	3-19
3.5 Information Selection	3-21
3.5.1 One Message Per Location	3-21
3.5.2 Message Pruning	3-21
4. DEMONSTRATION AND EVALUATION	4-1
4.1 Approach	4-1
4.2 Differentiation of Attributes	4-1
4.2.1 Situation Specificity	4-1
4.2.2 Effect on Convergence	4-1
4.3 Adaptation of Attribute Weights	4-2
4.3.1 Definition of Selection Strategies	4-2
4.3.2 Model Performance with Consistent Strategy	4-6
4.3.3 Model Performance with Changes in Strategy	4-9
4.3.4 Size of Adjustment Step	4-14

TABLE OF CONTENTS (Continued)

	<u>PAGE</u>
4.4 Automatic Information Selection	4-15
4.4.1 Information Source Selection	4-15
4.4.2 Information Set Selection	4-17
4.5 Operator Performance with Automatic Information Selection	4-21
4.5.1 Purpose	4-21
4.5.2 Test Conditions	4-21
4.5.3 Performance Results	4-22
4.5.4 Information Acquisition Time	4-24
4.5.5 Information Filtering	4-26
5. DISCUSSION AND IMPLICATIONS	5-1
5.1 Generality of the Multi-Attribute Utility Model	5-1
5.1.1 Demonstration Approach	5-1
5.1.2 Replacement of Human Function	5-1
5.2 Advantages of the Multi-Attribute Utility Model	5-3
5.2.1 Generality	5-3
5.2.2 Parsimony	5-3
5.2.3 Robustness	5-4
5.2.4 Speed of Adaptation	5-4
5.2.5 Flexibility	5-4
5.2.6 Versatility	5-4
5.3 Supervision of Information Flow in C3 Systems	5-5
5.3.1 C3 System Description	5-5
5.3.2 Information Routing	5-8
5.3.3 Pacing and Load	5-10
6. REFERENCES	6-1

1. SUMMARY

1.1 Objectives

This report covers the first portion of a planned three-year program of research and development. The entire program is directed toward the use of adaptive supervisory computer programs to improve the acquisition and utilization of information by command personnel in large-scale systems for command, control and communication (C3). The work presented here deals specifically with the application of adaptive multi-attribute utility models to dynamically select information for a system user, on the basis of situational requirements and his observed information preferences. Specific objectives of the 7-month program included:

- (1) Analyze design principles and approaches for the dynamic control of information flow in C3 systems.
- (2) Develop and implement a prototype adaptive (individualized) information selection model.
- (3) Demonstrate and evaluate automatic information selection capabilities in a simulated C3-type task.
- (4) Establish guidelines for application of information selection models to higher-level, multi-man C3 systems.

These objectives were met by integrating the new system concept with adaptive modeling technology established by Perceptronics under previous ARPA-sponsored programs. In particular, the present adaptive multi-attribute utility model for information selection has at its core a trainable utility estimator previously developed for computer aiding of dynamic decision

processes. Similarly, the selection model was applied to and evaluated on a modified version of a simulated ASW submarine tracking task used in earlier experimental studies of decision aiding.

This approach allowed us to demonstrate successfully a prototype adaptive system for automatic information selection in a relatively realistic C3 situation. It is planned that the present model will be incorporated into a larger system of adaptive supervisory computer programs. Together, these computer programs will compose an integrated complex of man-computer models, procedures, and aids for real-time management of information flow, in concordance with specific information processing and decision making requirements. Our analysis and empirical results indicate that this approach can produce sizeable reductions in decision time, as well as improvements in the quality of the information-based decisions.

1.2 Technical Approach

1.2.1 Rationale. Technical advances have led to increases in the speed, mobility, and destructive power of military operations. The amount and rate of information acquisition has increased accordingly. Information must be processed more efficiently and more effectively for commanders to make tactical decisions responsive to the rapidly changing succession of events. To meet this need, new computer-based systems for command, control, and communications (C3) are being developed and implemented. These systems are intended primarily to aid in the collection, processing, and utilization of different types and amounts of military data. The overall process is cyclic -- as information is being used, other information is being processed, and new information is being sought and collected. The dynamics of information flow are, therefore, of critical importance and must be constantly monitored and directed.

The consensus concerning current computer-based military systems for C3 operations is that they have increased the rate and density of information flow to such an extent as to overwhelm a commander and his staff. New C3 techniques are required to control information flow so as to best match system capability with human characteristics in the man-computer interaction. Our review of previous research, presented in Chapter 2, suggests that a significant step in this direction would be to individualize and automate information selection. This would allow each system user continuously to obtain information that is both relevant and timely with regard to his individual processing characteristics and immediate decision making needs. Considering the large number of interrelated users in a typical C3 system, the effect on total system performance would be to substantially increase throughput while also improving decision making quality.

1.2.2 System Concept. The basic concept of the model-based selection system is illustrated in Figure 1-1. The message universe includes all information potentially available to the recipient, or system user. In the manual mode, the recipient continuously selects messages in accord with a selection strategy. A strategy represents individual preference for information in response to situational needs. In the automatic mode, an adaptive information selection mechanism automatically supplies the user with information on the basis of his individual selection strategy.

The factors which characterize an individual's strategy are incorporated in an adaptive multi-attribute utility model. In this model, incoming information is decomposed into measurable attributes. Attribute levels of a message are determined by vectors which include both situational requirements and source characteristics. The subjective weight, or utility, that the user places on each attribute is estimated on-line, by an adaptive technique, as the user manually selects information. The utilities, in combination with the measured attribute levels, permit calculation of a

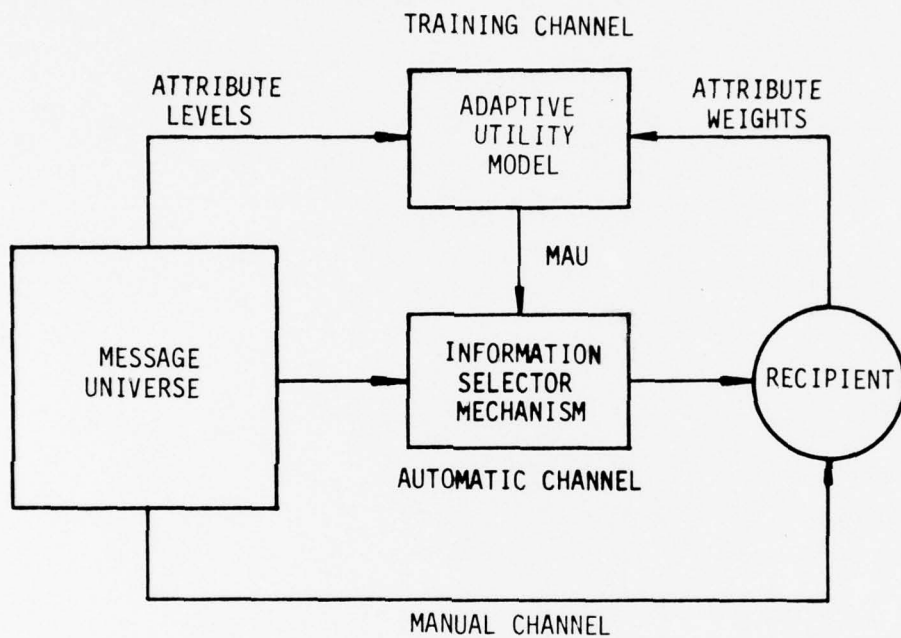

FIGURE 1-1
 INFORMATION SELECTION
 SYSTEM CONCEPT

PERCEPTRONICS

multi-attribute utility (MAU) value for each incoming message. The selector mechanism then passes to the recipient those messages with high MAU, that is, of high value to him. The selector can also use the MAU values to improve an individual's information gathering efficiency. For example, most users select more information than is actually necessary to reach a decision. The model-based selector can reduce the transmitted message set by eliminating those messages which contribute less than some criterion value of utility. In the present study, for example, we examined a pruning rule which ranked messages in order of decreasing MAU, and eliminated those messages for which the MAU was less than 15% of the total MAU of previously selected messages.

1.2.3 Demonstration and Evaluation. The methodology used to implement this system concept is described in Chapter 3. For purposes of demonstration and evaluation, the adaptive information selection model was applied to a simulated ASW tracking task. This task requires the operator to track continuously the movements of a submarine and a whale over a segmented expanse of ocean. The probable locations of the tracked objects are given by a computer-generated intelligence report. The operator uses this report to select a set of sensors, or information sources, for distribution over the ocean locations of interest. The available information sources differ in cost, reliability, discriminability, etc. On the basis of the information gathered, he reports the present location of the objects. His status report triggers a new intelligence report for the next cycle, and the task continues.

In the automatic mode, the process of source selection is taken over by the adaptive model, and the operator works entirely with this dynamically selected information. The task provides a realistic information environment, a large number of selection decisions, and objective measures of decision performance (tracking accuracy and information cost expenditure).

The model-based selection system, the simulated task, and the associated performance measurement programs were supported on an Interdata 70 minicomputer with 48K words of memory. The operator interacted with the system through a graphics terminal and keyboard.

1.3 Findings

System evaluation included a structured study of model performance and dynamic behavior, and a systematic empirical examination of operator task performance with varied types of automatic information selection. The results, presented in Chapter 4, are summarized below.

1.3.1 Model Performance. In brief, the use of an adaptive multi-attribute utility model for information selection was successfully demonstrated. Specific observations of model performance included:

- (1) Information Attributes. Seven attributes were sufficient to characterize the ASW information. These were arrived at through a reiterative process of analysis and empirical test.
- (2) Utility Convergence and Adaptation. Utilities for attributes converged rapidly to reflect consistent individual strategies of information selection. Typically, convergence took 10-20 adjustment cycles, spanning a few task trials. Changes in strategy produced corresponding changes in the selection behavior of the model.
- (3) Individualized Message Sets. Automatic selection of information yielded distinct message distributions for distinct individual strategies.

- (4) Information Filtering. Overall, the adaptive system was able to select automatically about 5 to 7 highly preferred messages from a potentially available universe typically in the order of 78,000 messages, a filtering ratio of over 15,000 to 1.

1.3.2 Operator Performance. Empirical evaluations showed that an operator was able to perform the tracking task successfully with automatic selection of information sources by the adaptive model. Comparison of different automatic selection modes revealed:

- (1) Preferential Strategies. ASW tracking performance was better when information selection included utility criteria (individualized attribute weights) than when utility criteria were eliminated from the selection procedure (uniform attribute weights).
- (2) Reduced Information Set. ASW tracking was further improved when relatively low-utility information was dynamically pruned from the individualized information set. The effectiveness ratio between performance with the reduced and with the non-reduced set was about 1.5 to 1. The effectiveness between performance with the best pruned strategy and with the uniform-weight strategy was 1.8 to 1.
- (3) Acquisition Time. Informal observation indicated that automatic information selection markedly reduced the time required for manual information acquisition in the simulated ASW task. Time reduction was in the order of 50 to 1.

1.4 Applications

1.4.1 Domain. The domain of application for the adaptive selection model developed here is a dynamic local environment, where new information of the same general type must be processed repeatedly. Such environments are ubiquitous in modern computer-based command and control operations. If the man and the computer can be considered as representing a single system, then the goal of the technique is to provide the man with information which will improve the overall decision output of the system.

Within its domain of application, the multi-attribute utility approach is highly generalizable. The present demonstration is indicative, since the ASW test bed was not specially tailored for the model, as is often the case. In addition to generality, other advantages of the multi-attribute utility formulation, discussed in Chapter 5, include parsimony, robustness, speed of adaptation, flexibility and versatility.

1.4.2 Supervision of C3 Information Flow. The present demonstration dealt with a single information user. However, we can consider the typical C3 system as a hierarchical, multi-level arrangement of users. People at one level process information for people at the next level, collecting and integrating data until a decision commensurate with their level can be made. Thus each person in the structure is at times a user of information, at times a source of unprocessed or processed information, and at times a source of decisions passed to higher levels of the hierarchy. A matrix analysis, presented in Chapter 5, suggests that optimum information flow in such a structure could be controlled by a supervisory program incorporating both heuristic control algorithms which are situation-dependent, and a set of behavioral models, which depend on psychological constructs and on individual user characteristics. Among the most significant models will be those which define:

- (1) Multi-Attribute Utility for Information
- (2) Information Routing
- (3) Information Pacing and Load

Feasibility of the first model has been demonstrated by the present study. The preliminary analysis of Chapter 5 indicates that the multi-attribute technique lends itself to important aspects of the other two models as well. It is planned to explore this approach in our extension of the current work to a supervisory system of information control, which will include the pacing and routing functions.

2. SELECTIVE LITERATURE REVIEW

2.1 Purpose

The purpose of this survey and analysis of relevant literature is to identify design principles for models of information flow in C3 systems. Many experiments have investigated information seeking and decision making in relatively well-structured situations. The results of these experiments provide much useful data on how people in C3 systems seek and use information. The review below attempts to demonstrate that these data support the development of on-line computer models, particularly adaptive ones, designed to help command personnel in the acquisition of appropriate, timely, and individually-suited information.

2.2 Organization of Literature

A crude but generally applicable schematic for information flow within a C3 system is provided below (adapted from Lin and Garvey, 1972).

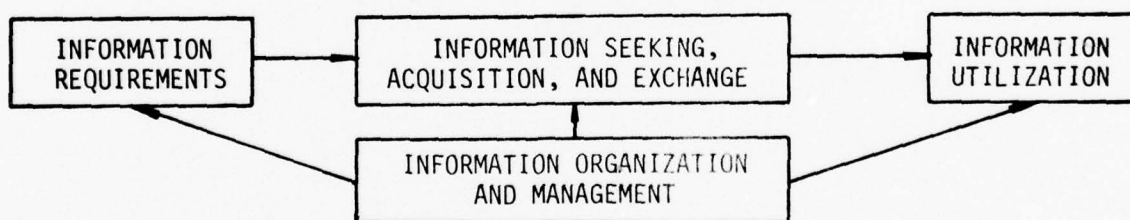

The diagram identifies the major phases of information communication and indicates an executive structure to govern the flow of information. The discussion of topics to follow focuses on human performance in specifying information needs, and in acquiring and utilizing information for decision

making. Throughout the review, emphasis is placed on the rationale for developing computer-administered procedures to adaptively present automatically selected information to decision makers.

2.3 Information Requirements

2.3.1 Specification of Information Requirements. In the context of management information systems, Ackoff (1967) has implied that the amount and type of information that a manager thinks he needs is often not in line with what he actually does need for effective decision making. In general, the more deficient the manager's "mental model" of the decision situation, the more information he will want. The result may be that the manager becomes overwhelmed from an overabundance of irrelevant information. Ackoff further states that "one cannot specify what information is required for decision making until an explanatory model of the decision process and the system involved has been constructed and tested".

A similar point of view, concerning military intelligence, has been expressed by Williams (1972):

"Information collectors must know what information the commander needs. Too often he does not tell them. Too often he does not know himself and too often the intelligence people are not qualified to anticipate for him. The commander's guidance is the vital pulse that should trigger a meaningful collection effort. Unfortunately, ... experience indicates that many commanders leave this responsibility almost entirely to their G2s."

Two important implications are evident from these remarks. First, a commander may be incapable or at least unwilling to accurately specify his information needs in a particular situations; for example, it would not be entirely uncommon for a commander to take the easy way out and tell his collectors to "get all the information you can get". Second, a commander's reliance on his collectors to supply the appropriate amount of relevant information may not be justifiable.

The hypothesis that potential users of information systems consider "everything" critical has received support from interesting empirical research conducted at ARI. In one study (McKendry, Wilson, Mace, and Baker, 1973), staff officers responded to survey questionnaires in which they were presented with a tactical mission and had to check-off items of information (combat events) which were perceived as most important to the successful completion of the mission. An important finding was that many subjects were unable to limit themselves to 30 crucial events (as instructed) from among a pool of 60 available events. In a second study, experienced field officers performed offensive and defensive tactical planning within a computer-controlled simulated scenario (Strub and McConnaughey, 1974). The officers were permitted to request information at will from a hierarchically-structured data base, and the computer kept track of each request noting the category of information (e.g., G-2 Intelligence) and level of detail (e.g., enemy situation) requested. In comparing results from the two research methods, Strub (1977) found that less information (in terms of amount and level of detail) was actually requested and used in laboratory exercises that was specified in questionnaires as being essential and of "should be requested" merit.

Because of the importance of this last finding by Strub, an attempt should be made to explain it. One possibility is that the information user, or supplier for that matter, does not want to be caught short and therefore overstates his information needs. The conservative bias is similar, in principle, with the typical observation that subjects, when performing in diagnostic tasks, purchase more information than recommended by normative Bayesian procedures (e.g., Levine, Samet, and Brahlek, 1975). Another possible explanation is suggested by the previously referenced remarks of Ackoff (1967). Since the user does not generally construct a model of the decision situation until he is actually engaged in it, he will be inclined to overstate his needs when asked to anticipate them prior to confronting the problem situation. Indeed, in the ARI studies, survey-questionnaire subjects (i.e., those who

expressed a need for relatively more information) projected needs across a problem context described in terms of a hypothetical tactical situation; whereas laboratory-experiment subjects (i.e., those who requested relatively less information) experienced actual needs while performing a realistic, although simulated, tactical exercise.

Additional support for the hypothesis that decision makers tend to overstate their information needs is available from Schroeder, Driver and Streufert (1967). They included a measure of information satisfaction within their studies of information processing in the Tactical and Negotiations Game (TNG). The TNG is a game simulation in which decision-making teams are given the task of directing the military, economic, intelligence, and negotiation activities of a small underdeveloped nation plagued by an internal revolution. In one experiment, the effects of information load (varied in terms of number of dimensions of information presented in a given time span, diversity of the information, and number of alternatives that each unit of information added) on the level of information processing and decision performance were assessed. At the conclusion of each game period, subjects were required to express their preferences for receiving a different amount of information relative to what was actually received in the previous session. All subjects showed a consistent but unjustifiable bias for having considerably more information. Subjects even ask for, or say they would prefer, more information following periods when their information processing level is already depressed by superoptimal information load. Apparently, people are not sufficiently sensitive to reverses in load which are detrimental to information processing.

2.3.2 Balancing the Information Supply. As a mechanism for summarizing the problem of information exchange in a field Army C3 system, Baker (1973) has employed the "economic man" concept:

"Observation of field exercises have led to the hypothesis that the G2 produces and stores more data than the G3 consumes in the normal course of operations. Likewise, G3's appear to ask for data that G2's have not yet produced. If one considers this situation from the standpoint of an economic analogy, it is not good business to use resources to produce items for which there is no buyer. Contrariwise, if a buyer desires something, it is good business to have it available to sell him. In the dynamics of the G2/G3 operations the G2 can be likened to a producer (of information) and the G3 as a consumer (information user)."

The trick, of course, is to maintain an appropriate, cost-effective balance of information supply and demand. Focusing upon the information consumer, it is clear that if too little information is disseminated to him, he cannot get the job done; on the other hand, if he gets too much information, he becomes overloaded and must expend valuable time screening items for relevant information.

The commander in many C3 systems appears to suffer more often from an overabundance of irrelevant information, much of which he did not ask for, and therefore two critical functions of the system become the filtration (or evaluation) and condensation of information. However, as Ackoff (1967) points out, the literature on information systems seldom refers to those functions let alone considers how to carry them out. If techniques can be developed to select information for individual users so that each gets the information that is most relevant and useful for his needs, then the techniques would simultaneously carry the potential to accomplish information filtration and condensation. In other words, the process would aid in weeding-out the information which is not desired by the user.

2.3.3 Individualized Adaptive Selection. As data come into a C3 system, it must be determined which of the separate users should be the recipients of messages containing specified classes of information. In a manual system, the selection procedures arise in response to specifically stated user requests and by the initiative of support personnel, who through training

and experience become aware of the information needs of various system users. In order to select information within an automated system, a set of programmable rules is necessary. However, as inferred from the research reviewed above, it is not sufficient -- because of inherent human biases -- to rely solely on direct user statements or on supplier judgments to determine selection specifications.

Fortunately, an automated C3 system lends itself to a more promising approach for determining routing procedures. Namely, an on-line computer model could be used to observe and track each individual's information processing behavior and thereby dynamically learn and assess his personal utilities for specific types of information. The overriding rationale here is that since the decision maker can attend to only a few information dimensions among many (Hayes, 1964), especially when under pressure (Wright, 1974), adaptive modeling can selectively choose and present those few dimensions that are most useful to him.

The notion of an adaptive system for providing information in a C3 system is further supported by writings of Thompson (1964, 1967). He dwells at length on the important role of situational context and command context in determining information relevance, as well as on their interaction and impact on command decision making. According to his conceptualization,

"... the data base is dynamic and responsive rather than inclusive. It is the embodiment of the current concerns of the particular headquarters. Thus, rather than striving for objective universality, it strives for relevance. This conception stems from the nature of the data itself and from the importance of change".

Thompson's theoretical framework has received empirical support from recent studies of information needs and priorities, as affected by such independent

variables as intensity of war (Coates and McCourt, 1976) and the user's staff element (e.g., G2, G3) and echelon of command (e.g., Army, Corps, Division) (McKendry, et al., 1973). It can be expected, therefore, that certain characteristics of the military situation and aspects of user identification could serve as useful input to any information selection model.

2.4 Information Acquisition

2.4.1 Process Description. In their recent, comprehensive review of the information processing and decision making literature, Nickerson and Feehrer (1975) identify "information gathering" as one of the principal tasks to be performed in a decision-oriented system. They describe the process as follows:

"From the point of view of the decision maker, most decision situations are characterized by some degree of uncertainty. This uncertainty may involve the current "state of the world", the decision alternatives that are available, the possible consequences of selecting any given one of them, and even the decision maker's preferences with respect to the possible decision outcomes. One of the major problems facing the decision maker, therefore, is that of acquiring information in order to reduce his uncertainty concerning such factors, thereby increasing his chances of making a decision that will have a desirable outcome.

"What makes the problem interesting, and nontrivial, is the fact that information acquisition can be costly, both in terms of time and money. Therefore, the decision maker must determine whether the value of the information that could be obtained through any given data-collection effort is likely to be greater than the cost of obtaining it. And therein lies a decision problem in its own right."

2.4.2 Experimental Studies. Much research has been done on information acquisition in decision tasks, but most studies have concentrated on information purchasing behavior. The latter have, for the most part, failed to capture the complexity of the problem that often faces the information

seeker in the real world. In the typical information purchasing experiment, information from a single source is presented to the subject, with his task essentially to decide whether it's worth what it will cost to acquire it. However, in many practical situations, the decision maker or commander must seek and locate the information he needs or wants, and he must often select from among alternatively available information sources of differential quality in terms of information diagnosticity and cost. A few relevant studies on information selection behavior have been conducted and their findings are reviewed below.

Kanarick, Huntington and Peterson (1969) studied performance in a simulated scenario in which the subject had to reach a binary decision about whether an enemy submarine was either present or absent in a given vicinity. On each trial the subject could purchase data, from one of three different information sources. The sources varied in both reliability and cost: the higher the reliability (diagnosticity) of the source, the greater the cost for consulting it. The penalties for incorrect decisions were also manipulated experimentally. Subjects' behavior was sensitive to the variations of the independent variables; however, performance was deficient when compared with an optimal Bayesian model. For example, they consulted the most reliable (and most costly) sources less frequently and the less reliable (less costly) sources more frequently than they should have. Also they generally purchased less information than required by the optimal model. This last result might be accounted for by the common finding of recent research that subjects tend to over-estimate the diagnostic impact of less than perfectly reliable data (e.g., Johnson, Cavanaugh, Spooner, and Samet, 1973).

Although Kanarick, et al., allowed subjects to choose among multiple information sources, the sources were presented in parallel. However, in real life situations, information from various sources is frequently sought, generated, and made available in a sequential, rather than in a parallel, mode. In a dynamic situation, furthermore, the uncertainty of the environment

may force the information seeker to perform under fluctuations and restrictions in the amount of available information and/or the level of resources needed to acquire the information. For example, the military commander can take advantage of all the patrol units that he can spare but still require more information about the enemy.

To study information seeking behavior under these kinds of conditions, an experiment was conducted by Levine, Samet, and Brahlek (1975). These investigators required subjects to determine which of four populations was being sampled in a multinomial Bayesian task. Each sequentially drawn datum was described on one of three dimensions which represented different levels of information source diagnosticity (high, medium, and low). On each trial, the subject purchased knowledge of the identity of the information source which was available on that trial, and he had the option to either purchase the associated datum at a fixed additional cost or pass it up at no additional cost. Using this paradigm, the amount of information potentially available and the percentage of it which could be purchased by the resources provided were varied factorially, and the effects on information selection and purchasing behavior were assessed. The principal relevant findings were that: (a) relative to the low diagnostic source, subjects purchased information about 5 times as often from the medium and high diagnostic sources; (b) when more information was potentially available, subjects were more efficient -- relative to an optimal Bayesian model -- in selecting from among information sources; (c) significantly more information was sought as both amount of available information and purchasing resources increased; and (d) across all experimental conditions, subjects generally purchased more information than was recommended by the normative model. With regard to the last finding, the subject was actually paying for information which had a negative value, i.e., information whose acquisition led to a decrease in expected payoff.

In another study involving the selection of information, Rapoport, Lissitz, and McAllister (1972) investigated the search behavior of subjects required to find a single object hidden in one of four distinguishable locations. For each location, they were given: (a) the *a priori* probability that the object would be detected there; (b) the probability that the object would not be found by a search (i.e., a random sampling); and (c) the per-trial cost of search. In agreement with the previous studies, the results indicated that subjects do not consult information sources in an optimal fashion. Of particular interest was a finding suggesting individual differences in search strategies; that is, some of the subjects deviated from the optimal policy in the direction of maximizing detection probability, whereas others deviated in the direction of minimizing search costs.

The results of experiments on information purchasing behavior also relate to man's capability as an information selector. The typical experimental paradigm allows the subject on each trial the option of either purchasing more data relevant to the decision that he is required to make, or to stop data collection and make a decision. Stopping data collection is also a decision and defines the selection of a predecisional information set. The various studies have shown that subjects are highly sensitive to informational and situational parameters, e.g., environmental variance (Schroeder and Benbasat, 1975), *a priori* probabilities for decision alternatives (Green, Halpert, and Minas, 1964), data diagnosticity (Snapper and Peterson, 1971), source reliability (Levine and Samet, 1973), and costs and payoffs (Pitz and Reinhold, 1968; O'Connor, Peterson, and Palmer, 1972), but their performance departs systematically from optimal performance. In general, it appears that too little information is purchased when much is required by a Bayesian Model and too much information is purchased when little is required. For example, subjects have been found to require from two to nine data observations to revise their opinions as much as Bayes' theorem would prescribe for one observation (Peterson, Schneider, and Miller, 1965; Phillips and Edwards, 1966).

2.4.3 Rationale for Aiding Information Selection. It is evident that when information quantity is held constant, an improvement in information quality leads to an improvement in decision performance (e.g., Levine and Samet, 1973; Snapper and Peterson, 1971). With regard to military information processing systems, the issue has been stated as follows:

"The key to competent decision making is the availability of current and accurate information. It is not the quantity of information which is important. Rather, it is the process of selecting the pertinent information, ascertaining its significance, and displaying it in a readily understood format which facilitates the decision-making process." (Albright, 1975)

Since one way to achieve an increase in information quality is to be more selective in collecting information, we can ask how well man does as an "information selector" or discriminator among alternative information sources. The basic conclusion reached by each of the experiments reviewed above is that although subjects are sensitive to the differences in information source quality, they perform poorly in selecting among information sources.

If man is sensitive to key informational and situational parameters, why does he consistently show systematic, stereotypical biases when choosing among available information for decision making? Apparently, because of his limited memory, attention, reasoning, and computational capabilities, he is unable to integrate/aggregate/combine various dimensions of information -- each with its associated graded level -- to arrive at a composite, subjective value for the information which is consistent and valid. Thus, for example, he is unable to appropriately trade off the reliability of information and its cost (Kanarick, et al., 1969). Therefore, it appears that a valuable type of aid for a decision maker would be one which helps him to assess and to apply consistently his own utility for the information provided by alternative sources.

The idea of utility-based aiding of information selection is strongly supported by a study of McKendry, Enderwick, and Harrison (1971). These investigators were interested in the effects on decision-making performance of using information which had been previously judged of low, medium, and high utility to the task by the decision makers themselves. The decision making task involved the tracking of a submarine by an airborne ASW aircrew under the direction of a tactical coordination officer (TACO) who had at his command all the sensor resources of the real aircraft.

Subjective information value (utility) ratings for various sensor returns were obtained off-line, by direct elicitation techniques, from a total of 39 experienced TACOs. Message content areas were judged separately, and the total subjective information value of a message was determined by a linear combination of the form:

$$b = \sum_{j=1}^n K_j a_j$$

where:

- b = worth of information in a message
- n = number of content areas in a message
- K_j = number of items in jth content area
- a_j = average utility of items in jth content area

(This formulation is very similar to the one derived independently by Perceptronics investigators for the multi-attribute utility of information items; see Section 3.1.5.) The total information value of N messages (B) was obtained by summation of individual message 'b' values.

In the experiment, aircrews began a tracking exercise with a package of information items totaling low, medium, or high information value. The

performance measure was the reduction in uncertainty of target location; uncertainty was taken as proportional to the ratio of remaining search area to original search area. Figure 2-1 shows the reduction in uncertainty with time when working with low, medium and high value information. The results indicated that performance was significantly better for the higher information-value conditions. That is, crews operating with the high-utility information were able to reach equivalent uncertainty levels much more rapidly than crews operating with medium or low utility data. In fact, the time improvement ratio for useful reductions of uncertainty lay in the range 2.0 to 3.5. Thus the findings of this highly relevant study imply that: (1) using information of higher subjective value results in significantly better decision-making performance; and (2) a linear model for multi-attribute utility appears to hold up well over various combinations of tasks and information items, that is, *"individual utilities can be summed to yield aggregate utilities -- at least up to mixtures of three things"*. As the authors state, the findings are of considerable importance to builders of decision-making models.

2.5 Information Utilization

2.5.1 Information Quantity versus Decision Performance. Does more information lead to better decision making? The psychological literature provides several instances where the answer is "no". For example, Schroeder and Benbasat (1975) found that increases in the level of information detail or in the historical time period covered by the information did not affect decision quality. This result is particularly significant since the subjects themselves determined how much information they would receive.

In an important experiment, Hayes (1964) studied choice decisions involving which of several airplanes should be dispatched to investigate a reported submarine sighting in a simulated tactical situation. The alternative planes differed with respect to their characteristics, such as

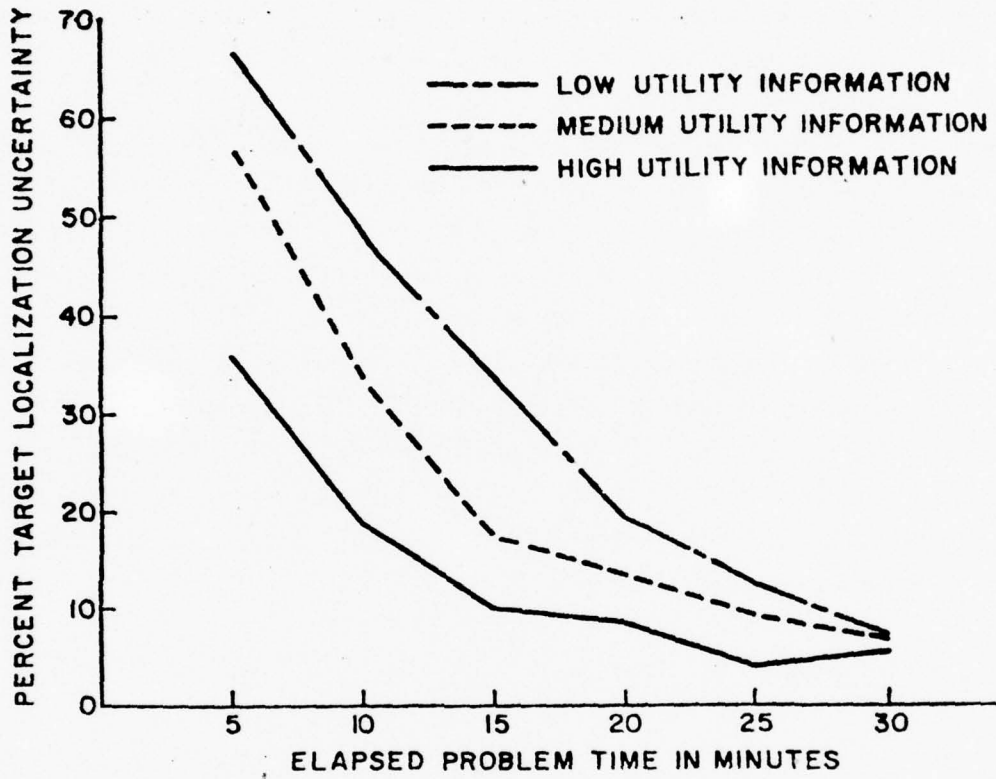

FIGURE 2-1
RESULTS OF AIRBORNE ASW PERFORMANCE RUNS
(McKendry, Enderwick, and Harrison, 1971)

PERCEPTRONICS

pilot quality, speed, radar quality, take-off delay, etc. Each characteristic could take on one of several "values" which could be ranked from best to worst. The independent variables involved the number of planes from which a choice had to be made (4 or 8) and the number of discriminating characteristics (2, 4, 6, or 8) on which to formulate a choice. Hayes conducted four experiments in all, and was able to examine the effects of time stress and training.

Hayes' principal findings can be summarized as follows: (1) decision quality was superior when a choice was required among 4 alternatives rather than among 8; (2) as the number of characteristics (i.e., information attributes) increased, decision time increased markedly but decision quality did not improve; that is, decisions based on only two characteristics were just as good as those based on 4, 6, or 8 characteristics; (3) when limited time (10 seconds) was available for a decision, increasing the number of information dimensions could actually degrade decision quality; (4) attempts at training the decision makers did not enable them to learn to make better decisions with increasing numbers of information dimensions. The important conclusion to be drawn from this research is that it is easy to provide a commander with more information than he can assimilate or use -- especially when he is operating under time pressure.

It is interesting to note that Hayes' result concerning time stress is consistent with a theory recently offered by Hogarth (1975). Applying to situations where a choice must be made among a given set of alternatives, the theory defines task complexity and cognitive strain as increasing functions of both the number of characteristics per alternative and difficulty of choice between alternatives. Because of human limitations on information processing, optimal decision time is proposed to be a concave (i.e., inverted-U) function of task complexity. The same idea was advanced earlier by Schroeder, Driver, and Streufert (1967), who support the theory with

empirical data which repeatedly demonstrate an inverted U relationship between environmental complexity (information load) and level of information processing. Thus, it is possible that when Hayes' subjects were given too many characteristics to process within ten seconds, they became cognitively "overloaded" and could not perform well.

Huber, O'Connell, and Cummings (1975) studied the effects of information specificity, information load, and group structure on perceived environmental uncertainty in an exercise using the Tactical and Negotiations Game. Examples of "low specificity" and "high specificity" messages are contrasted below.

High Specificity Message

Two carrier based F-2's on a routine patrol from NG-2A sighted and attacked an enemy truck convoy in sector G-3. Five trucks were completely destroyed, two partially damaged.

Low Specificity Message

Carrier based airplanes patrolling in Western Shamba sighted and attacked an enemy truck convoy. Damage determined.

The "low specificity" message can be considered a reduced information set derived from the "high specificity" message. Group decision performance was measured in terms of the uncertainty in a vector of subjective probabilities assigned to alternative "enemy" strategies represented in the game simulation. No significant main effect was obtained for information specificity, suggesting that a decrease in message detail need not affect decision uncertainty.

Additional evidence that reduction of information detail does not necessarily reduce performance levels comes from a recent study by Granda (1976) which investigated whether reduction of map detail reduces the efficiency of human information gathering and tactical decision making in a simulated tactical operations system (SIMTOS). The subjects were 20 mid-level Army officers that performed both planning and combat tasks during a SIMTOS offensive scenario. One group performed the task with standard Army

maps while the other group were only allowed access to maps of considerably reduced detail. Some of the performance measures evaluated were combat effectiveness scores, area captured, amount of information requested, and information processing time. No significant performance differences were found between users of the reduced detail maps and the standard maps despite the fact that some reduced-map users judged them to be inadequate.

2.5.2 Utilization Aiding Through User Modeling. A number of research groups have provided empirical support for the advantages of user modeling in aiding information utilization. In a series of experiments, Pask and Scott (1971, 1972) demonstrated that when information presentation techniques are matched with the information processing characteristics of the user (either a "serialist" or a holist"), cognitive performance is enhanced by a ratio of 2.0 as opposed to when there is a mismatch. Levit, Heaton, and Alden (1975) have succeeded in categorizing the decision styles of individuals according to three bipolar dimensions: active/passive, logical/intuitive, and abstract/concrete. In a laboratory experiment using a simulated, automated tactical environment, these researchers provided decision aids to each subject in accordance with his decision style. Although the results were not statistically conclusive -- apparently because of insensitivities in the system performance measures -- the soundness of individualized decision support in computer-based C3 systems was indicated.

Investigators at Perceptronics have developed and demonstrated the technology of adaptive utility assessment for modeling operators (users) in an on-line fashion. Decision support systems based on this technology have proved successful as an aid to information acquisition and related decision making in simulated tactical scenarios (Weisbrod, Davis and Freedy, 1977; Freedy et al., 1976) and in simulated electronic trouble shooting tasks (Freedy and Crooks, 1975). Since this work provides a direct background for the present project, its contributions and results are reviewed in more detail below.

2.5.3 ADDAM Decision Support System. Perceptronics' initial system for decision support, termed ADDAM, was developed under ARPA and ONR funding. Adaptive or goal-directed techniques were employed extensively in ADDAM for the acquisition of operator decision strategies. This dynamic modeling is closely related to the "on-line model matching" methods practiced in adaptive manual control (Gilstad and Fu, 1970) and to the adaptive linear models used to augment or replace the expert decision maker (Bowman, 1963; Kunreuther, 1969; Dawes and Corrigan, 1974). These techniques use pattern recognition or learning algorithms to estimate behavioral parameters. The ensuing models are then used to train, replace, or evaluate the operator. Perceptronics' development extends this field of work by placing the operator in a real-time interaction with his model, so that the system both descriptively models and proscriptively aids the operator.

The ADDAM decision support system is composed of a combination of three complementary elements -- a set of Bayesian probability aggregation programs, a dynamic model for tracking operator values for outcomes, and a strategy recommendation algorithm. The latter two elements are of particular interest here.

Utility Estimation. In ADDAM, utility estimation is realized through the use of a trainable multi-category pattern classifier, illustrated in Figure 2-2. As the operator performs the decision task, this on-line estimator observes the operator's choices among the various decision options. The estimator, using event probabilities as inputs, attempts to classify these probability patterns by adjusting utility weights according to an adaptive error correcting algorithm. In this manner, the utility estimator tracks the operator's decision making and learns his utilities. Such an approach has a number of advantages compared to off-line utility estimation. Dynamic estimation observes and models actual behavior rather than responses to hypothetical decisions. It does not interrupt or intrude on the process of decision making. And it responds to ongoing changes in task characteristics

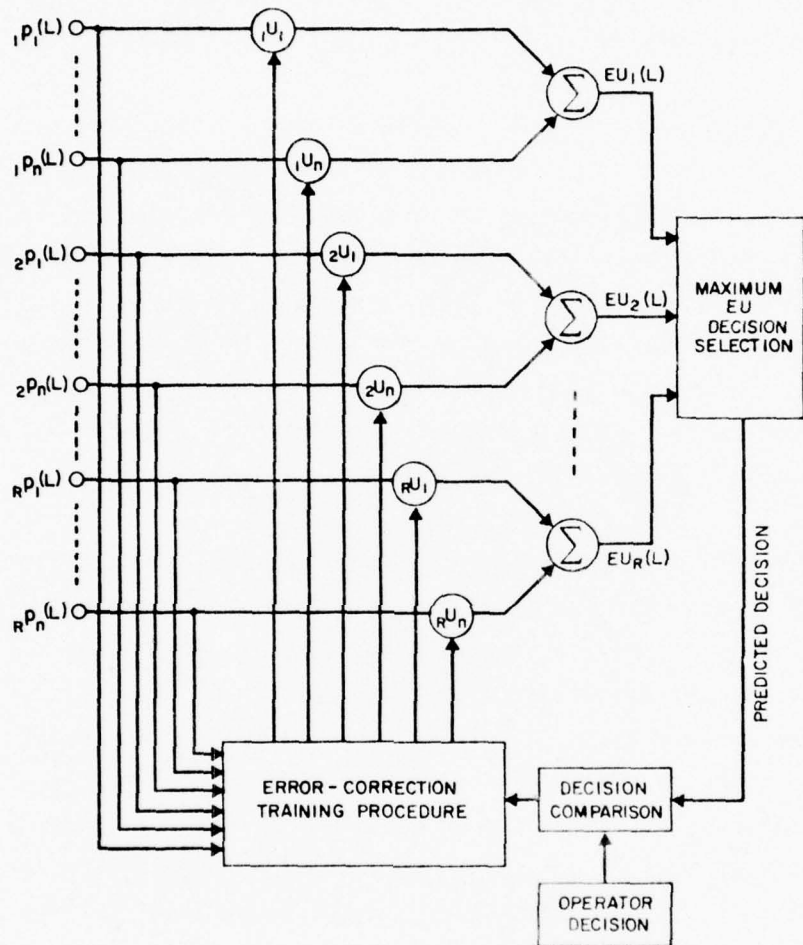

FIGURE 2-2
SCHEMATIC REPRESENTATION OF
DYNAMIC UTILITY ESTIMATOR FOR ADDAM

PERCEPTRONICS

and operator needs. The characteristics of the dynamic utility estimator have been evaluated in a variety of decision contexts. In all applications, the estimates of multiple dynamic utilities typically converged rapidly to stable and distinct values.

Strategy Recommendation. This element of the ADDAM system follows naturally from the probability and utility estimators. With these parameters defined, it is a simple matter to recommend individually optimal decisions. The choice with the greatest expected utility is determined and displayed to the operator. The recommendations given are thus based on the operator's own apparent values, and are organized into a normative framework. A certain generality is present in the normative processing, since the recommendations are not restricted to the identical circumstances used for training, but can be applied to other circumstances of the same structure.

Over the past three years, several experimental studies have been conducted to evaluate the decision support system in realistic but controlled circumstances. In one, a fishing fleet simulation task was used as the experimental vehicle (Weisbrod et al., 1977). The task involved the placement of diverse sensors to track and report the location of several components of a fishing fleet as they moved over an ocean expanse. The experiments focused on basic system validation and on how aiding (sensor recommendation) affected the "internal" quality of decision making. The experimental evidence studies indicated that (1) the adaptive model accurately predicted the operator's decisions, (2) aiding significantly improved decision consistency, (3) aiding significantly improved decision quality, (4) aiding reduced intersubject variability, and (5) aiding increased decision throughput.

A recent study showed that "external" measures of decision outcome, such as accuracy, errors, etc., are also improved by adaptive aiding (Freedy et al., 1976). The experimental task was a new ASW version of the fishing fleet simulation. Operators tracked the movements of a submarine and an

interfering object, using the same types of sensors (sonobuoys, helicopters, MAD's, etc.) available in Naval ASW exercises. The sensors varied in reliability, specificity, and cost. Unaided operators worked alone, using computer-generated intelligence reports. Aided operators received additional computer assistance in the form of (1) Bayesian sensor output evaluation, and (2) Utility-based sensor placement recommendations.

Results showed that the aided group performed significantly better than the control group, improving their mean score by almost a factor of two (88%). Improvement was partially attributed to a small but significant increase in the number of decision trials completed during the session. But most of it appeared due to the better overall quality of the aided decisions. That is, the aided operators incurred slightly higher costs, but received a much greater return in points, and a substantially lower number of penalties. Decision consistency, as measured by mean deviation from maximum expected utility, was significantly enhanced for the aided group, as in previous studies. Also, in replication of previous studies, the improved performance of the aided group was accompanied by decreased intragroup variability.

In most man-machine systems, objective performance criteria for the immediate task are not well defined, or are only indirectly related to long term system goals. This indeterminacy is particularly evident in systems operating in dynamic environments, where the results of earlier decisions affect later decisions. Such systems thus rely heavily on the operator's subjective evaluation of the situation at hand, and the decisions should be based on measurable subjective preferences (utilities) of the operator. Findings to date indicate that when these utilities are incorporated into an aiding system, significant improvements in performance can occur.

3. MULTIATTRIBUTE MODEL FOR INFORMATION SELECTION

3.1 Overview

3.1.1 Concept. Steeb (1975) suggested the use of an adaptive multiattribute model as a means for automatically selecting and distributing information in a generalized system for command and control. The present model (or model-based selection system) is based on that suggestion. Essentially, the model conceptualizes information as a multi-dimensional entity which can be decomposed into a set of measurable attributes. The model computes an aggregate multiattribute utility (MAU) as a weighted sum of each information attribute level (A_i) multiplied by the importance or utility of the attribute (U_i). The calculated MAU of an information item is used as the selection criterion.

3.1.2 System Organization. Figure 3-1 shows the major components of the selection system in block diagram form. Incoming information of potential utility to the recipient is parameterized in terms of both immediate situational factors (situation mask vector) and the intrinsic characteristics of its source (source characteristic vector). Together these two vectors contribute to the computation of the attribute levels associated with each item of information. The "information utility calculator" uses as inputs (1) the attribute levels of the incoming information, and (2) a vector of "attribute weights" which have been dynamically estimated for a given operator by an adaptive model. Based on these inputs, the overall multi-attribute utility of each information item is calculated. Information is then rank ordered along a scale of information utility, and a selection mechanism is applied to determine what specific information is presented to the operator.

3.1.3 Application Test Bed. The model-based selection system was implemented and tested for a simulated ASW intelligence-gathering and

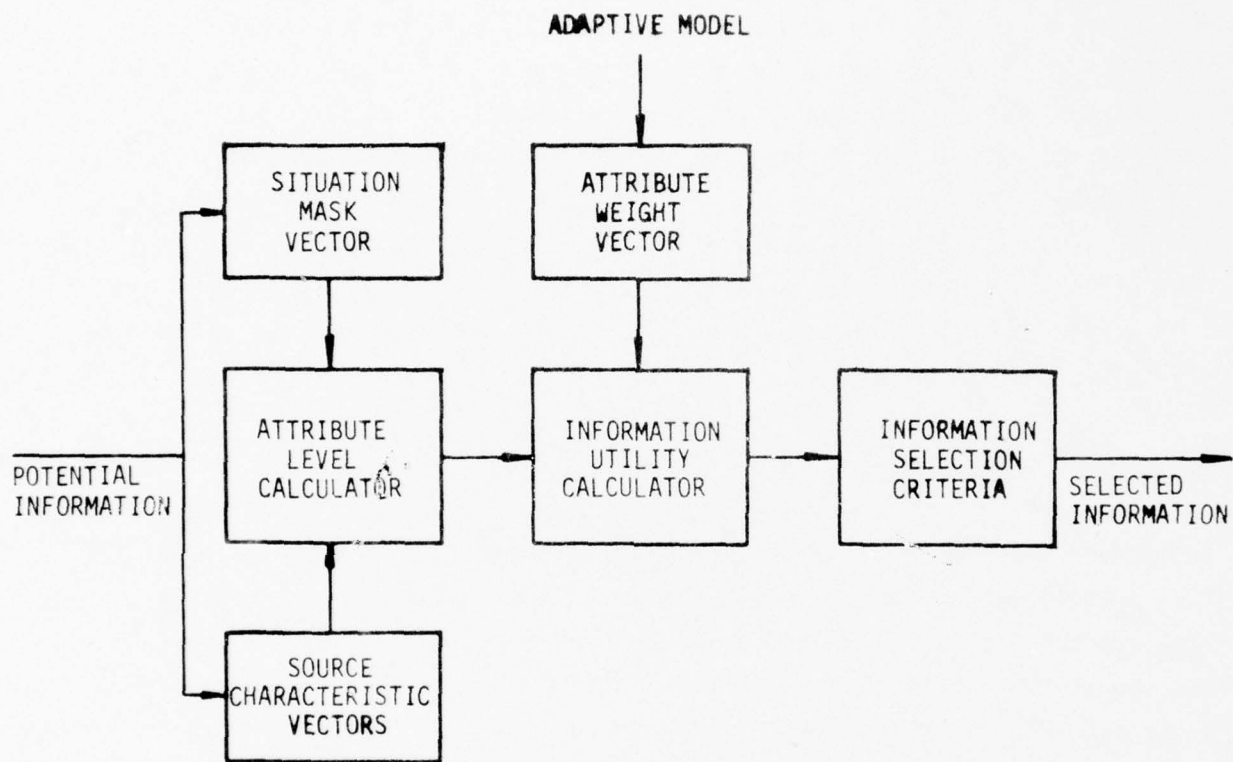

FIGURE 3-1
OVERVIEW OF INFORMATION SELECTION MODEL

PERCEPTRONICS

tracking task. This task, which is described further in Section 3.2, requires an operator to select among a wide variety of potential information sources (individual sensor deployments) in order to follow the movements of a hostile submarine and interfering non-hostile whale. The task itself was based on an existing computer simulation, used previously by Perceptronics in several studies of adaptive decision aiding. In order to adapt it to the present case, the existing simulation was modified considerably at the conceptual level, and concomitant changes were introduced into the task procedure. Only the features of the simulation that are germane to the present program are described in Section 3.2. For a more complete description of the original simulation, the reader is referred to Freedy, Davis, Steeb, Samet, and Gardiner (1976).

3.1.4 Model Function. The major function of the model is to relieve the operator of the need to choose among available information sources. That is, to automate his information selection task. The model accomplishes this by integrating two different types of knowledge. First, the model takes into account some basic features of the environment or state of the world; these features essentially define the operator's current information needs. In the ASW simulation, this information is expressed by an intelligence report, and takes the form of probability data about the location and status of the objects being tracked. The second type of knowledge involves a representation of the operator's own utilities for particular attributes of information, that is, his individual attribute weight vector. Included is the recognition that his preferences may depend upon the specific information requirements of the situation. With respect to the ASW task, the requirements break down to whether the operator is searching for a submarine, a whale, or both, in a particular location. Obviously, both types of knowledge are quite generalizable, and can be similarly applied to situations outside the present ASW context.

3.1.5 MAU Calculation. Calculation of the multi-attribute utility for information is central to the workings of the model. The MAU calculation is shown in Figure 3-2 as a two-step process. In Step 1, the cross-product of the situation mask vector and the source characteristic vector results in the attribute level vector. This calculation is described in Section 3.3. Definitions of the vectors themselves are provided below.

Situation Mask Vector. The purpose of this vector is to define, for a specific situation, the general information needs of the information recipient. The parameters reflect both the local environment and the task objective. For example, in the ASW tracking simulation, the content of the situation mask vector answers such questions as: Is the object of search a submarine, a whale, or both? If a submarine is being sought, is it necessary to discriminate between whether it is in a resting or floating state? etc.

Source Characteristic Vector. This vector describes the characteristics of a particular information source. These characteristics are properties which are assumed to affect the decisions of an operator when he selects among information items, or messages. For example, how much does the information cost? To what does it pertain? How reliable is it? In the case of the ASW simulation, for example, can the sensor discriminate between the presence of a submarine and a whale, or between a floating and resting submarine?

In Step 2 of the MAU calculation, the dot-product of the attribute level vector and the attribute weight vector provides the aggregate MAU value. Derivation of the attribute weights, or utilities, is described further in Section 3.4. In essence, the multiattribute representation of the operator's information preferences is built up during performance sessions in which the operator must make a series of choices among potential information sources in response to varying situational needs. Although the ASW task actually requires him to choose among sensors for deployment,

STEP 1:

Situation Mask Vector	X	Source Characteristic Vector	=	Attribute Level Vector
$\begin{bmatrix} M_1 \\ M_2 \\ M_3 \\ M_4 \\ M_5 \\ M_6 \\ M_7 \end{bmatrix}$	X	$\begin{bmatrix} C_1 \\ C_2 \\ C_3 \\ C_4 \\ C_5 \\ C_6 \\ C_7 \end{bmatrix}$	=	$\begin{bmatrix} A_1 \\ A_2 \\ A_3 \\ A_4 \\ A_5 \\ A_6 \\ A_7 \end{bmatrix}$

STEP 2:

Attribute Level Vector	.	Attribute Weight Vector	=	MAU
$\begin{bmatrix} A_1 \\ A_2 \\ A_3 \\ A_4 \\ A_5 \\ A_6 \\ A_7 \end{bmatrix}$.	$\begin{bmatrix} U_1 \\ U_2 \\ U_3 \\ U_4 \\ U_5 \\ U_6 \\ U_7 \end{bmatrix}$	=	$\sum A_i U_i$

FIGURE 3-2
CALCULATION OF INFORMATION UTILITY

PERCEPTRONICS

each deployed sensor can be viewed as a message, or as a multi-attribute item of information, and each choice as a selection among all alternative messages that could be generated and presented.

As the operator proceeds, an adaptive model performs in parallel with him, by predicting which information sources he will select. The model "learns" through an error correction procedure which dynamically adjusts estimates of the weights that the operator places on the relevant information attributes, and the predictions converge upon the actual information selection behavior of the operator. At this point, the model, which now accurately mimics the operator's information selection preferences, can take over the function of making the selection among available information. Thus, the system assumes a mode in which information is automatically selected for presentation to the operator, in accord with his own generalized preferences. The selection rules themselves can also be tailored to the situational needs and the operator's characteristics or desires. Those considered in the present study are discussed in Section 3.5.

3.2 ASW Simulation

The experimental simulation, although relatively primitive, includes the salient decision features of ASW localization and tracking. The simulation centers on an aircraft carrier, proceeding with a normal complement of ASW resources. It is assumed that the simulated ASW task begins after a hostile submarine and an interfering whale have been detected, and fixed-wing aircraft have deployed sono-buoys over the entire potential attack zone. The attack zone, displayed on a graphics terminal, is assumed to remain stationary with respect to the aircraft carrier. Figure 3-3 illustrates the configuration.

3.2.1 Operator's Task. The ASW simulation involves a single operator. His task is to allocate sensor resources in order to track and report on

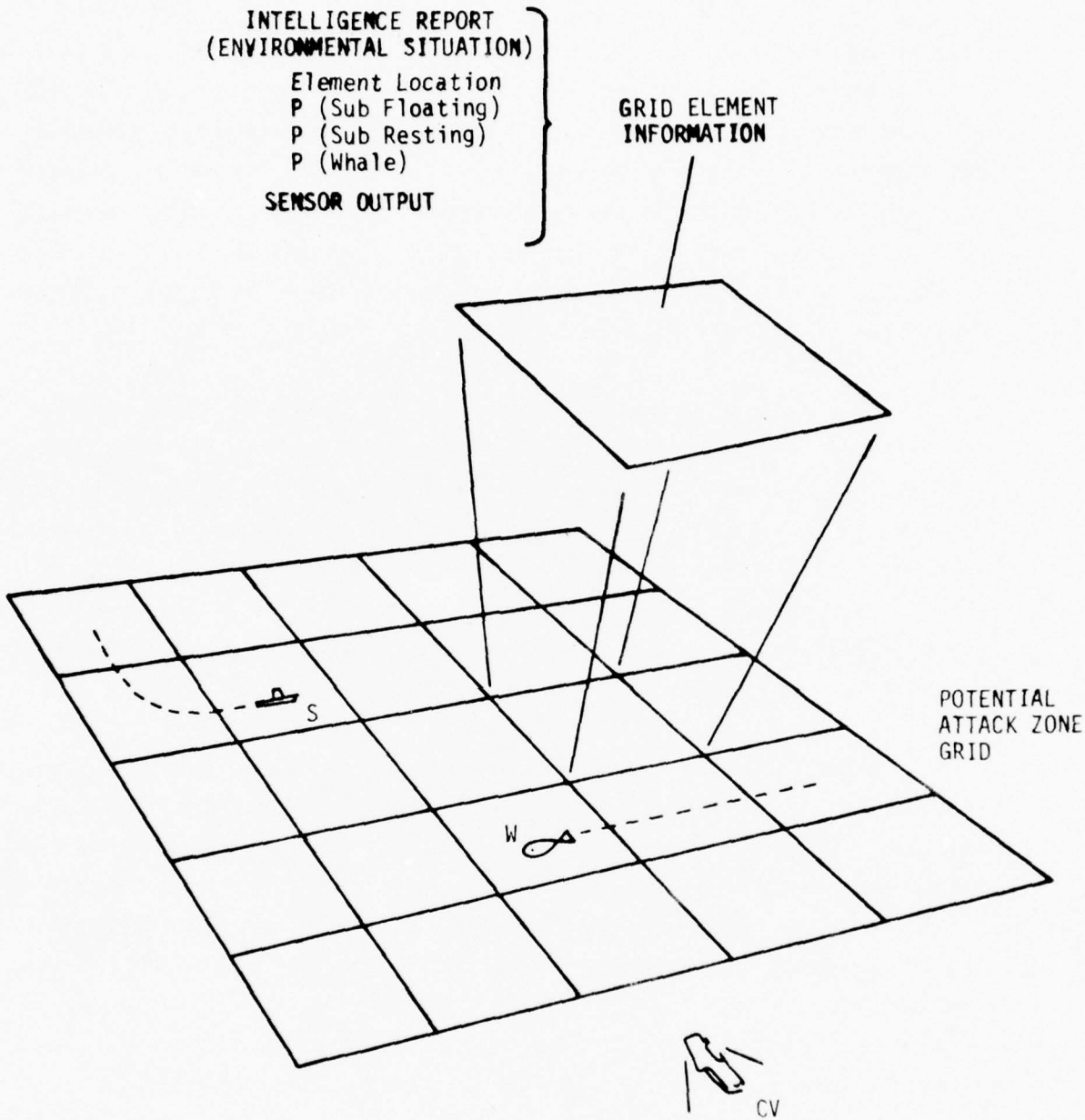

FIGURE 3-3
CONFIGURATION OF ASW SIMULATION

PERCEPTRONICS

the subsequent movements of the submarine and the whale in the well-defined ocean expanse. The basic cycle is illustrated in Figure 3-4. It begins with the deployment of sensors which report back what they have detected. The operator interprets these results and reports the status of the tracked objects. At this point in the performance of the task, the operator receives an intelligence report which aids him in the placement of new sensors, and so starts another task cycle. All previously deployed sensors are removed at the end of each status reporting cycle.

3.2.2 Sensor Characteristics. To monitor the movements of the objects, the operator deploys sensors which differ with respect to level of detection, reliability, and cost. The scenario allows the operator to deploy one of five types of sensors at each location; Table 3-1 lists the sensors and summarizes their properties. By evaluating the intelligence report obtained from the system as a result of his last report on the objects' location, the operator decides on the sensor-location combinations which will provide him with the information he needs to continue to track the objects.

After deploying the sensors the operator receives information about their output. An 'H' sensor, for example, can have one of two possible outcomes: "positive", indicating presence of a floating submarine in the sector, and "negative", indicating the absence of a submarine. Since sensors are not perfectly reliable, their response may be erroneous. The reliability (r) of the sensor is the probability that it will give a true report. The complement of reliability ($1-r$) is the likelihood that the sensor will give a false report. A false report may be one of two types, either failing to report a detectable object when it is actually there (false negative) or reporting the presence of the object when it is not actually there (false positive).

3.2.3 Status and Intelligence Reports. After receiving the sensor outputs, the operator is required to make a status report reflecting his

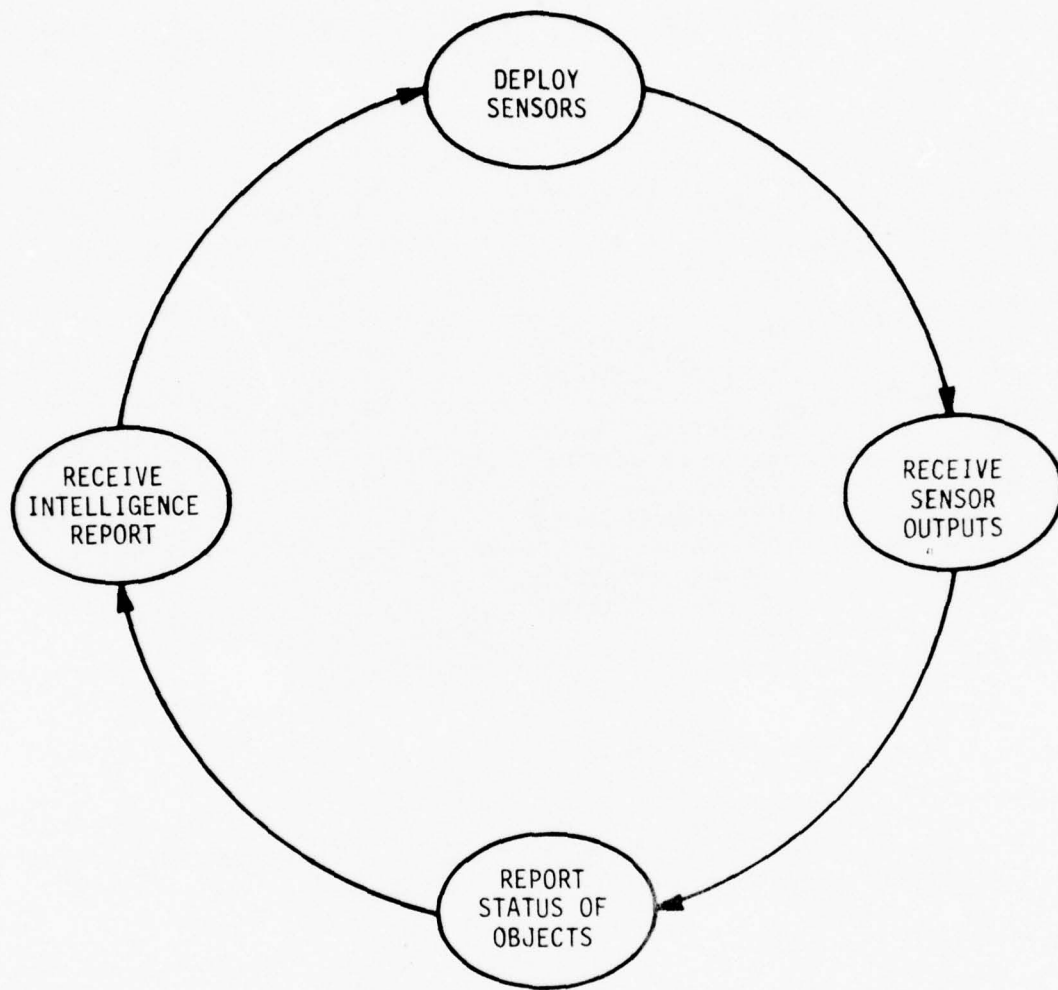

FIGURE 3-4
ASW TASK CYCLE

PERCEPTRONICS

TABLE 3-1

PROPERTIES OF ASW INFORMATION SOURCES

<u>SENSOR TYPE</u>	<u>LEVEL OF DETECTION</u>	<u>RELIABILITY</u>	<u>COST</u>
(B)	Object*	.60	1
(M1)	Submarine Floating Submarine Resting	.95	10
(M2)	Submarine Floating Submarine Resting	.80	5
(H)	Submarine Floating	.90	7
(D)	Submarine Floating Submarine Resting Whale	.70	4

* A Sono-Buoy reports only that an object has been detected but does not identify whether it is a whale or submarine.

best estimate of the present location of both the submarine and the whale. He bases his decisions on the prior probabilities of object location as determined by the intelligence report, and on the sensor outputs in light of the known error rates of the sensors deployed. Essentially, he must arrive at a posterior estimate by integrating the newly obtained sensor data with the prior data. Because the status decisions affect the subsequent intelligence report, the sensor deployment decisions are, in turn, dynamically influenced by the status decisions.

The intelligence report which aids the operator in deploying sensors, is derived from the operator's report on the status of the objects being tracked and from expert assessments of the behavior of these types of objects. The system assumes that the operator has correctly reported the location and heading of each object. By aggregating the conditional probabilities of state transformations (elicited from experts), it makes a Bayesian estimate of their next location. Thus, the intelligence report contains the probabilities that each object will be in each sector of the attack zone. The whale may move to an adjacent location or remain in the same location. The submarine may move likewise or remain in the same location, either floating in the ocean or resting on the bottom.

3.3 Attribute Level Calculation

3.3.1 Information Attributes. A set of seven attributes was required to model successfully the information preferences of an operator performing the simulated ASW task. These attributes were arrived at through an evolutionary, model-development process. Performance data and experience with the ASW simulation (Freedy, et al, 1976) provided an initial set of attributes for implementation. The flexibility of the model allowed this set to be iteratively tested for predictive sensitivity and to consequently be refined. The refinement procedure involved both the modification of existing attributes and the replacement of insensitive

ones with more promising ones. The development process was continued until a distinct set of attributes would satisfactorily predict information-selection behavior for different operator preference-strategies. Aspects of this process are illustrated in Chapter 4. Table 3-2 lists the final set of attributes.

TABLE 3-2. INFORMATION ATTRIBUTES FOR ASW TASK

- (1) Cost of Submarine Information
- (2) Cost of Whale Information
- (3) Expected Submarine Information Content
- (4) Expected Whale Information Content
- (5) Submarine Information Parsimony
- (6) Submarine/Whale Discriminability
- (7) Submarine Status Discriminability

3.3.2 Attribute Level Vector. The level of each attribute for a specific sensor source is determined by the multiplication of entries in the situation mask vector and the source characteristic vector. Table 3-3 defines the situation mask and source characteristic entries for each of the ASW attributes. The situation mask and source characteristic vectors are scaled so that each attribute level ranges from 0 to 1. Further, the orientation is arranged such that each attribute contributes positively to the overall aggregate MAU. That is, holding all other attribute levels constant, an increase in any attribute level increases the MAU. The individual entries should become more clear in the description of attributes given below.

3.3.3 Attribute Descriptions. Following are more detailed descriptions of the information attributes for the ASW simulation. They exemplify the use of the situation mask and the source characteristic to model information in a specific selection situation.

TABLE 3-3

DEFINITION OF MASK AND INFORMATION
CHARACTERISTIC FOR EACH ATTRIBUTE

<u>Attribute Number</u>	<u>Situation Mask</u>	<u>Information Characteristic</u>
1	1 when $P_S > 0$, 0 otherwise	Cost
2	1 when $P_W > 0$, 0 otherwise	Cost
3	P_S	Reliability
4	P_W	Reliability
5	1 when $P_R = 0$ and $P_W = 0$, 0 otherwise	1 when both F and R can be detected 0 otherwise
6	$H_{S,W}$	1 when S and W can be discriminated, 0 otherwise
7	$H_{F,R}$	1 when F and R can be discriminated, 0 otherwise

Notation: P = Probability

S = Submarine (either floating or resting)

F = Submarine Floating

R = Submarine Resting

W = Whale

$H_{S,W} = -(P_S \log_2 P_S + P_W \log_2 P_W)$, with probabilities normalized

$H_{F,R} = -(P_F \log_2 P_F + P_R \log_2 P_R)$, with probabilities normalized

- (1) Cost of Submarine Information. The cost of submarine information is the expenditure required to receive information from a sensor about the presence of a submarine. By virtue of the situation mask, the attribute comes into play (i.e., is non-zero) only when the submarine is being searched for (i.e., the probability of submarine presence is greater than zero). The source characteristic of cost used in the computation of the attribute is derived from the sensor properties listed in Table 3-1. The formula used to convert the absolute value of cost (c) into an appropriate relative quantity necessary for the attribute-level computation was $(11-c)/10$. This transformation was necessary to provide cost with a 0 to 1 range and to conform to the orientation standard of the model. Thus, a decrease in absolute cost (Table 3-1) leads to an increase in the source characteristic of cost which, assuming everything else equal, increases the MAU of the information. More simply, a decrease in information cost increases information utility.

- (2) Cost of Whale Information. The cost of whale information is the expenditure required to obtain information from a sensor about the presence of a whale. The situation mask activates the attribute only when the whale is being sought (i.e., the probability of whale presence exceeds zero). The source characteristic of cost is set and interpreted in the same way as for the cost of submarine information. Thus, the only difference between the first two attributes is that one is relevant when the submarine is being tracked and the other is relevant when the whale is being tracked. Of course, both are activated when both objects are searched for within the same location.

- (3) Expected Submarine Information Content. This attribute is the product of the prior probability that the submarine is present (situation mask, P_S , determined by the intelligence report) and the source characteristic value corresponding to the information reliability. The latter value is derived from the sensor properties (Table 3-1); as in the case of the cost attributes, a transformation was required to spread reliability (r) over a 0 to 1 scale. The formula used was $(R - .59)/.36$. The attribute is proportional to the likelihood of submarine detection (i.e., $P_S \times r$); when $P_S = 0$ within the location, there is no likelihood of finding a submarine there and the attribute does not contribute to the MAU calculation. An increase in P_S and/or r increases the chances of a true positive report of a submarine, thus increasing the utility of the information.
- (4) Expected Whale Information Content. This attribute is the product of the prior probability that the whale is present (situation mask, P_W , determined by the intelligence report) and the source characteristic value corresponding to the information reliability. The source characteristic of reliability is set and interpreted in the same way as for expected submarine information content. The attribute is proportional to the likelihood of whale detection (i.e., $P_W \times r$); when $P_W = 0$ within the sector, there is no likelihood of finding a whale there and the attribute does not contribute to the MAU calculation. An increase in P_W and/or r increases the chances of a true positive report of a whale, thus increasing the utility of the information. As in the case of the cost attributes, the two expected information content attributes differ only with respect to the object of search.

- (5) Submarine Information Parsimony. The attribute of parsimony reflects the use of a sensor whose capability matches the information requirements on hand. In the present case, parsimony refers to the deployment of a sensor which can detect only the precise object of search, i.e., a floating submarine.¹ The situation mask activates the attribute only when a floating submarine is the singular target being sought (i.e., the probabilities of a resting submarine (P_R) and a whale (P_W) are both zero). The source characteristic is set to 1 when both a floating and resting submarine can be detected and is set to 0 otherwise.² Only the H sensor is parsimonious with respect to the detection of a floating submarine since it cannot detect anything else. Ideally, an increase in information parsimony should increase information utility.
- (6) Submarine/Whale Discriminability. This attribute concerns the discrimination between a submarine and a whale. Discriminability reflects whether the information source can precisely identify a detected object. The property of discriminability is different from that of level of detection (Table 3-1). For example, the B sensor can detect both the submarine and the whale but it cannot discriminate between them. In fact, only the D sensor can discriminate between the two objects; thus it is assigned a 1 in the source characteristic vector whereas the other sensors

¹There was no need for a parsimony attribute with respect to a resting submarine because the characteristics of the ASW scenario were such that whenever there was some probability of a resting submarine there was also some probability of a floating submarine. That is, the very possibility of a resting submarine presence required discrimination between the two submarine states.

²Because of a programming error caught too late, the orientation of parsimony was reversed from what was originally intended. Thus, as modeled, when the attribute level for parsimony equaled 1, the information was actually the opposite of parsimonious. However, although this error makes the orientation of parsimony inconsistent with that of the other attributes, it does not affect the performance of the MAU model in any substantive way.

are assigned a 0. The situation mask contains the relative uncertainty associated with the simultaneous presence of the submarine and whale. In effect, the mask modulates the attribute level with respect to the need of the operator to discriminate between the two objects in the local environment; the more equal the prior probabilities of the respective objects being found in the same location, the higher the uncertainty level. As both the need to discriminate and the capability to do so increase so does information utility.

- (7) Submarine Floating/Submarine Resting Discriminability. This attribute concerns the discrimination between the states the submarine can assume -- either floating or resting. The M1, M2, and D sensors can make this discrimination but the H and B sensors cannot; the capability is reflected by a 1 or 0, respectively, in the source characteristic vector. The *mechanics* of the computation of this attribute and the impact of the *components* on information utility are identical to those for submarine/whale discriminability.

3.4 Attribute Weights

Estimates for an operator's attribute weights, or his utility for that attribute, are provided by the adaptive portion of the model. The weights are learned (or trained) during sessions where an operator performs the ASW tracking task by choosing freely among the five possible sensors for deployment in specific locations of interest. The model begins with equal weights assigned to each attribute and then dynamically adjusts them in accordance with a simple training rule.

3.4.1 Utility Estimator. The dynamic utility estimation technique is based on a trainable, multi-category pattern classifier. Figure 3-5

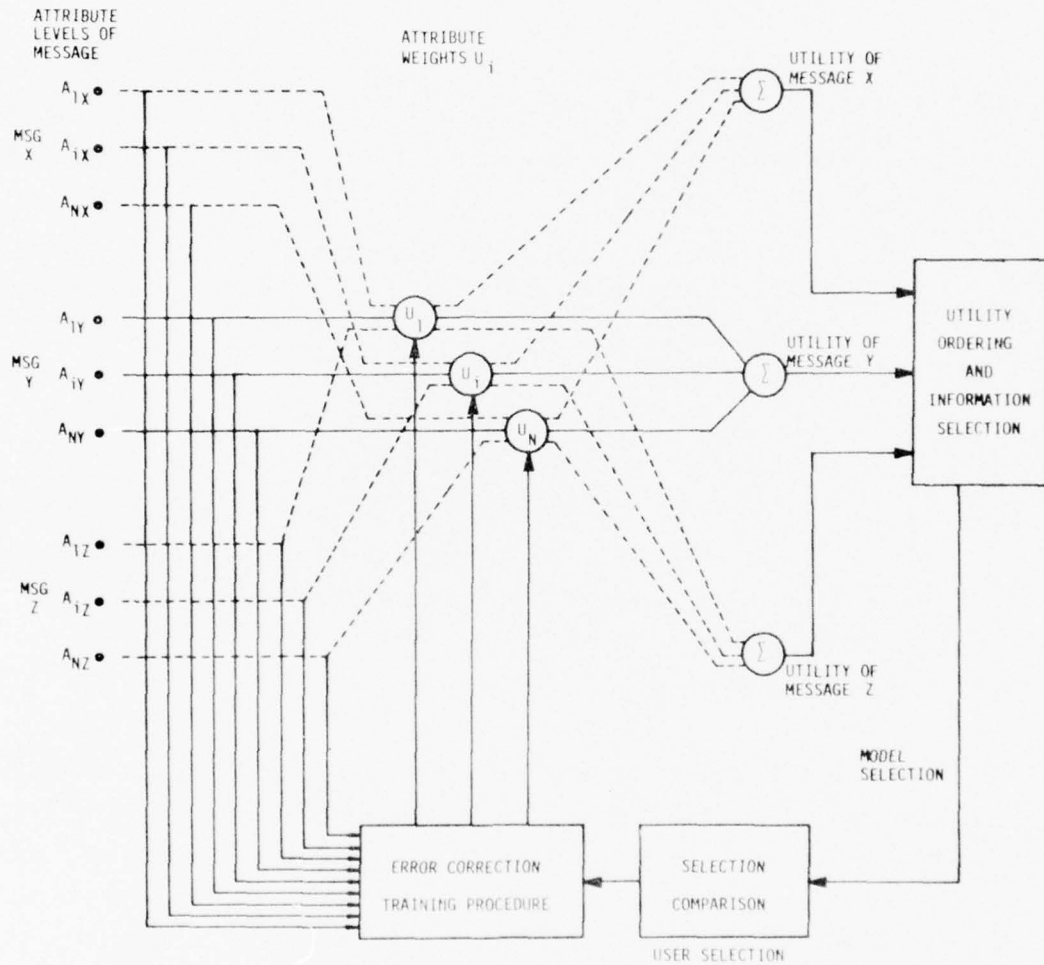

FIGURE 3-5
 SCHEMATIC REPRESENTATION OF ADAPTIVE
 MULTI-ATTRIBUTE INFORMATION UTILITY MODEL

PERCEPTRONICS

illustrates the mechanism. As the operator performs the task, the on-line utility estimator observes his choices among the available information sources (messages) at each location, and views his decision-making as a process of classifying patterns of information attributes. The utility estimator attempts to classify the attribute patterns by means of a linear evaluation (discriminant) function. These classifications are compared with the operator's choices. Whenever they are incorrect, an adaptive error-correction training algorithm is used to adjust the utilities. A comprehensive discussion of this technique can be found in Freedy, et al.(1976).

3.4.2 Training Algorithm. On each trial, the model uses the previous utility weights (U_j) for each attribute (j) to compute the multi-attribute utilities (MAU_i) for each sensor (i) in each plausible location of ocean (i.e., board square):

$$MAU_i = \sum_{j=1} A_{ji} U_j$$

For all squares where there is a non-zero probability of a submarine or whale, the model predicts that the operator will always prefer the information source with the maximum MAU value. If the prediction is correct (i.e., the operator chooses the sensor with the highest MAU), no adjustments are made to the utility weights. However, if the operator chooses a sensor having a MAU less than that of the predicted sensor, the model then adjusts the utility weights by pairing the chosen sensor with the predicted sensor and applying the error correction training algorithm. In this manner, the utility estimator "tracks" the operator's information selection behavior and learns his utilities or weights for information attributes. The training rule used to adjust the weights associated with each of the attributes is illustrated in Table 3-4.

TABLE 3-4

WEIGHT-TRAINING RULE*

Adjusted Weight (\hat{U}_j)	Previous Weight (U_j)	Adjustment Factor (λ)	CORRECTION DIFFERENCE					
			Chosen Information-Source Attribute Level (A_{jc})	Predicted Information-Source Attribute Level (A_{jp})				
\hat{U}_1	=	U_1	+	λ	·	(A_{1c})	-	(A_{1p})
\hat{U}_2	=	U_2	+	λ	·	(A_{2c})	-	(A_{2p})
\hat{U}_3	=	U_3	+	λ	·	(A_{3c})	-	(A_{3p})
\hat{U}_4	=	U_4	+	λ	·	(A_{4c})	-	(A_{4p})
\hat{U}_5	=	U_5	+	λ	·	(A_{5c})	-	(A_{5p})
\hat{U}_6	=	U_6	+	λ	·	(A_{6c})	-	(A_{6p})
\hat{U}_7	=	U_7	+	λ	·	(A_{7c})	-	(A_{7p})

* λ was set equal to .4

3.5 Information Selection

3.5.1 One Message Per Location. The final component of the multiattribute model involves the criteria for selecting information. The model as applied to the ASW simulation allowed for two types of selection processes. The first process was confined to the selection of a single item of information (i.e., sensor) for each grid element having a non-zero probability that either a submarine or whale would be present. By computing the MAU for each of the five possible sensors which could provide information on objects in a chosen element, the sensor with the highest utility is selected as providing the most preferred information for that element.

3.5.2 Message Pruning. The second selection process begins with the output of the first process. Given a set of messages representing information about locations where the objects might be found, utility-based criteria can be applied to select, for presentation only, the best messages among them. That is, once all useful messages have been ranked in order of decreasing utility, any number of selection algorithms or pruning rules can be applied. For example, a simple rule is to transmit some fixed number of the highest utility messages. Thus the operator would always receive four messages per cycle, or five, etc. Another possibility is to transmit only those messages whose MAU exceeds a certain threshold value. A more sophisticated rule is to successively transmit each next ranked message only if its utility exceeds some fixed percentage of the total utility of messages already transmitted. This rule results in a varying number of messages being selected, depending on operator preferences and the immediate situation. Within a given strategy (i.e., fixed set of attribute weights), the prior probabilities will influence the characteristics of the cumulative utility curve, and thus the number of sensors selected before the pruning cutoff point is reached. The latter pruning rule was implemented and evaluated in the present study, using 15% as the incremental criterion.

4. DEMONSTRATION AND EVALUATION

4.1 Approach

Because of the prototypical nature of the multi-attribute information utility model developed here, an exploratory research approach was taken to evaluate and demonstrate its properties and capabilities. This chapter reviews the main stages of the approach. These include certain aspects of the model-development process, a structured study of model dynamics and performance, and a systematic empirical demonstration of how the model contributes to human task performance. The experimental vehicle used throughout the evaluation and demonstration was the simulated ASW tracking task.

4.2 Differentiation of Attributes

4.2.1 Situation Specificity. As mentioned in Section 3.3.1, an iterative developmental process was employed to determine the set of information attributes for use in the systematic evaluation of the model's characteristics and capabilities. During this process, much was learned about the design requirements of a model intended to replace the information selection function of a human operator. In particular, it became immediately apparent that there was a need for the model to discriminate between the operator's preferences in one environmental situation as opposed to his preferences in another. The demonstration of this requirement is worthwhile because it led to the development of the general concept of the situation mask.

4.2.2 Effect on Convergence. The seven attributes used to model the operator's preferences (Table 3-2) include a pair of cost attributes and a pair of expected information content attributes. Each pair of attributes, whether for cost or for expected information content, is identical with respect to the information source characteristic. They differ, however,

with respect to the situation mask, which reflects whether the object of search is a submarine or a whale. The obvious question is why one cost attribute and one expected information content attribute doesn't suffice? Why are two separate attributes required in each case?

The answer to this important question can be simply illustrated. Suppose that the operator always preferred an expensive, high expected information content source when searching for a submarine, but that he always preferred a cheaper, lower expected information content source when searching for a whale. If a single, undifferentiated cost or expected information content attribute were implemented, the adaptive model would interpret the operator's behavior as inconsistent, and would repeatedly adjust the weight in opposing directions, resulting in an oscillating, nonconvergent weight-training curve, as shown in Figure 4-1. The operator is actually quite consistent, but only with respect to each search situation. When the attribute is differentiated into two situation-specific attributes, the attribute weights can be trained to convergent values as illustrated in Figure 4-2.

4.3 Adaptation of Attribute Weights

4.3.1 Definition of Selection Strategies. The next stage of evaluation was to demonstrate the general capability of the model to adapt to an individual operator's information selection strategy to the point of correctly predicting his information preferences. To accomplish this systematically, we identified logical information selection strategies which could be employed by an operator while he performed the ASW tracking task. These strategies are summarized in Table 4-1. Essentially the strategies differ with respect to the way the operator treats the information attributes relating to cost, information content, and parsimony. Within each strategy, it was assumed that the operator would always want to discriminate a submarine from a whale and a floating submarine from a resting submarine whenever the task situation required him to do so.

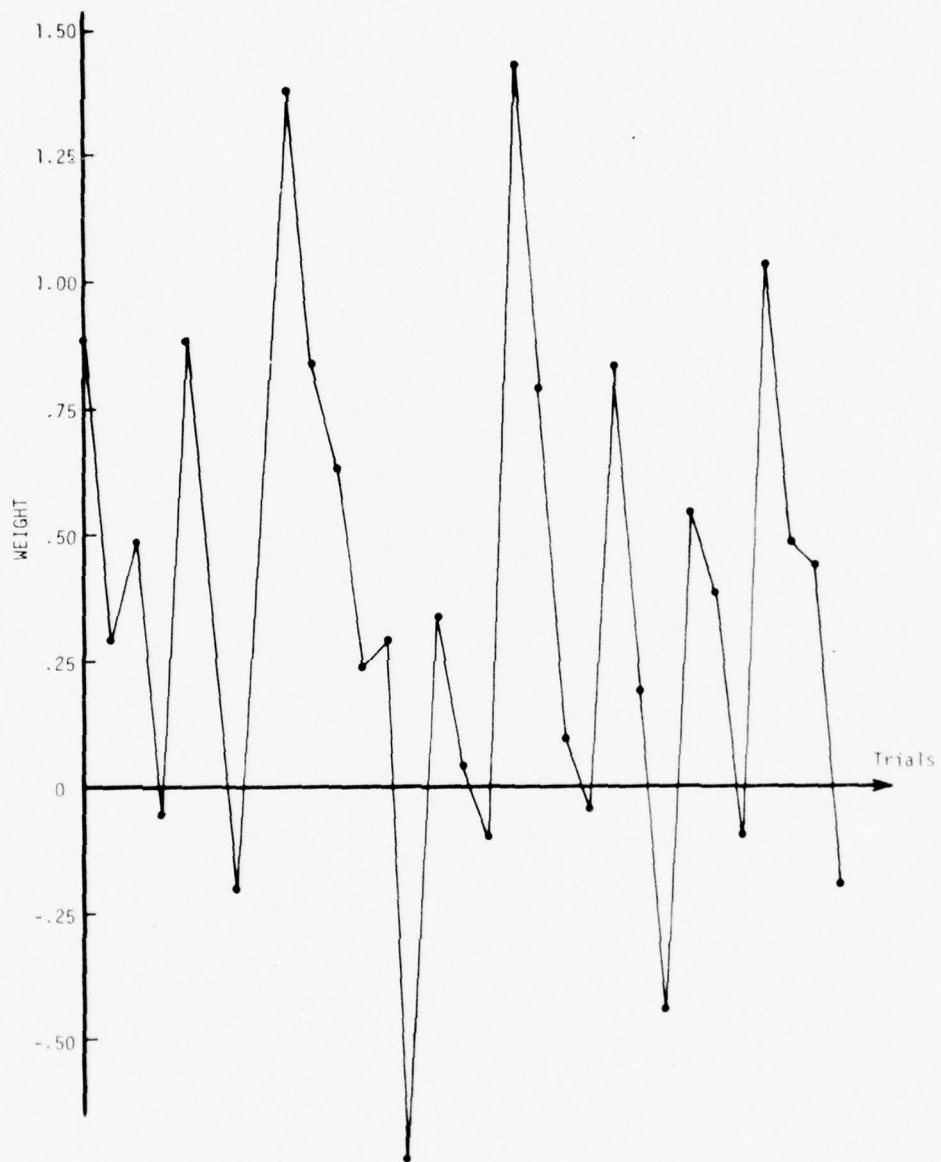

FIGURE 4-1
NONCONVERGENCE OF UNDIFFERENTIATED ATTRIBUTE

PERCEPTRONICS

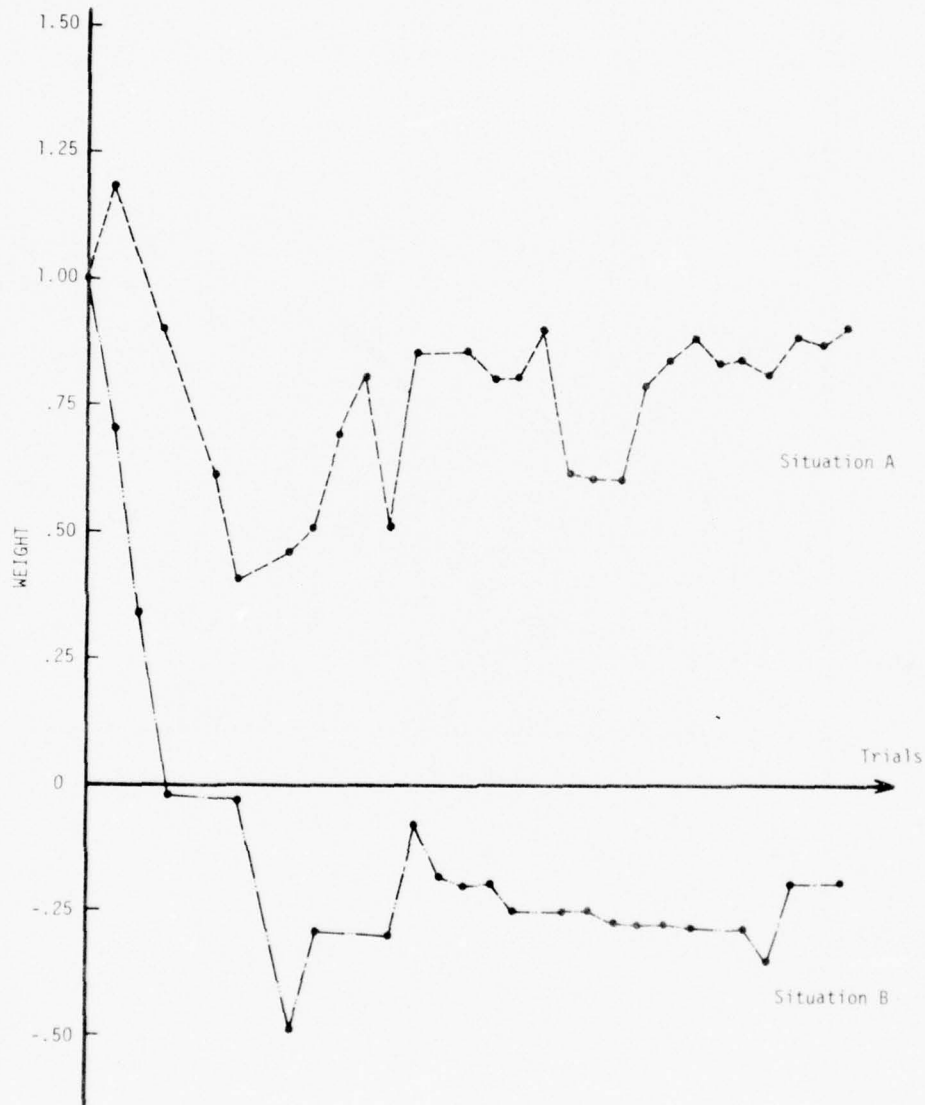

FIGURE 4-2
 CONVERGENCE OF A RELEVANT
 ATTRIBUTE IN TWO SITUATIONS

PERCEPTRONICS

TABLE 4-1

DEFINITION OF INFORMATION PREFERENCES
FOR SELECTION STRATEGIES TESTED

	<u>Strategy</u>	<u>Submarine</u>	<u>Whale</u>
I	Cost & Expected Information Content	Medium	Low
	Parsimony	Yes	--
	Submarine-Whale Discrimination	----- Yes -----	-----
	Submarine Status Discrimination	Yes	--
<hr/>			
II	Cost & Expected Information Content	High	High
	Parsimony	No	--
	Submarine-Whale Discrimination	----- Yes -----	-----
	Submarine Status Discrimination	Yes	--
<hr/>			
III	Cost & Expected Information Content	Low	Low
	Parsimony	Yes	--
	Submarine-Whale Discrimination	----- Yes -----	-----
	Submarine Status Discrimination	Yes	--
<hr/>			
IV	Cost & Expected Information Content	Low	High
	Parsimony	Yes	--
	Submarine-Whale Discrimination	----- Yes -----	-----
	Submarine Status Discrimination	Yes	--

4.3.2 Model Performance with Consistent Strategy. The predictive performance of the model with respect to each strategy was first tested under ideal conditions. That is, each strategy was carried out with perfect consistency throughout a sequence of tracking trials. During this sequence, which involved 24 trials, an expert operator performed the tracking task in a manual information-selection mode. A trial consisted of a set of information-selection decisions, each decision being associated with a particular location of search (i.e., the grid element of Figure 3-1). Based on the intelligence report of the probabilities of object presence in several locations, the operator selected, for each location, the one information source (among the five available) from which he most preferred to obtain output. For example, when searching for the submarine by itself under Strategy II, the operator would always prefer an M1 sensor because it had the highest cost, gave the highest expected information content, was not parsimonious, and could -- if necessary -- discriminate between a floating and resting submarine. Thus an operator's strategy decomposes into a set of consistent preferences which are associated with the relevant properties of potential information sources.

The model succeeded in adapting, i.e., arriving at correct predictions of operator information-selection choices, for each of the four distinct strategies. At the beginning of each learning session, each of the seven attributes were set to an arbitrary value of unity. As described in Section 3.4, the model immediately began to perform in parallel with the operator. The MAU was computed for each information source on the basis of the current attribute weights, and the model predicted that the operator would prefer the source with the highest MAU. If he did not, the error correction procedure was applied to adjust the weights. Since the course of adaptation of the attribute weights was similar for each of the four strategies evaluated, the typical adaptation pattern will be illustrated for only one of them, namely Strategy II. The adaptation of the weights for this strategy is depicted in Figure 4-3.

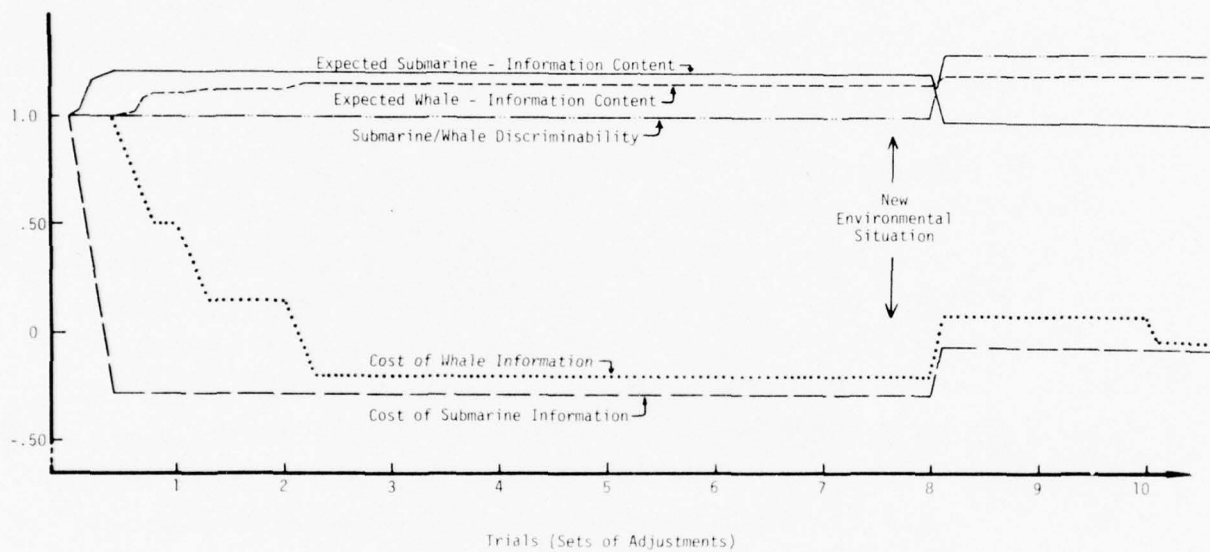

FIGURE 4-3
 ADAPTION OF ATTRIBUTE WEIGHTS
 FOR STRATEGY II (M1, D)

PERCEPTRONICS

As illustrated, the weights for only five of the seven attributes required adjustment according to this particular strategy. The weights for submarine information parsimony and for submarine status discriminability are not displayed since they remained at the initial value of unity throughout; that is, the information preferences in this strategy did not require their alteration. Among the five attribute weights that did adjust, the pattern is pretty much the same across trials. After considerable adjustment during the first few trials, the weights reach a plateau where they remain stable from trial 3 through 7. During this period of no adjustments there is perfect correspondence between the model and the operator in predicted and chosen information sources, respectively.

After the seventh trial a new environmental situation was encountered in the scenario, involving the potential collision of the submarine and whale. At that point it became necessary to discriminate between the detection of the two objects by the selection of a D sensor. Since this choice was not correctly predicted by the multi-attribute information utility model as it stood, the attribute weights were consequently adjusted by the model. From the 10th trial through the 24th no environmental situations occurred which had not been faced previously in the tracking session, and the model was again able to predict operator information-selection choices with perfect accuracy.

The general direction of movement of the attribute weights and their terminal, convergent values reflect their impact on the overall MAU of the selected information sources. In Strategy II, the operator's preferences for high expected information content maintain the associated attribute weights at high levels. Since higher attribute levels for cost indicate less expensive information, his preferences for higher information costs decrease the weights of the cost attributes (except when faced with a collision, where he prefers lower cost/reliability information which is more discriminatory -- i.e., a D sensor over an M1 sensor). When a need and

preference to discriminate between a submarine and a whale is invoked at trial 8 (i.e., collision situation) the corresponding attribute weight rises above its initial value of one; this heightened weight contributes to subsequent correct predictions of the operator's selection of information whenever a collision situation is re-encountered.

4.3.3 Model Performance with Changes in Strategy. In the previous section, it was demonstrated that the multi-attribute information utility model can rapidly learn a fixed, consistent operator strategy after starting from scratch. However, one of the major functions of an on-line adaptive model is to keep track of an operator's behavior. Such a model must be sensitive to behavioral changes and be able to adjust its parameters in order to remain in phase with the operator after a limited degree of lag. In the present case, behavioral changes take the form of shifts in information selection strategy that might occur in dynamic tracking environments.

The dynamic response of the model was tested by beginning with equal attribute weights and having the operator perform the tracking task according to a predefined, fixed strategy until steady state behavior of the model was observed. Once the model was accurately predicting (over several trials) the strategy actually being employed, that strategy was modified in some way. When the modified strategy was stably predicted, another change in information preferences was implemented. Thus, a total of three different information selection strategies were used in succession. These strategies, which are distinguished by the type of information preferred for tracking the submarine and the whale, are depicted in Table 4-2.

The attribute-weight training curves are displayed in Figures 4-4, 4-5, and 4-6. The curves plot the changes in specific attribute weights as a function of model adjustments. The points at which each new substrategy (either for tracking the submarine or the whale) is adopted are indicated by the arrows in the figures. The information source preferences annotating

TABLE 4-2. SENSORS PREFERRED ACCORDING TO STRATEGIES
UTILIZED IN DYNAMIC ADAPTATION EVALUATION

<u>Environmental Situation</u>	<u>Intelligence Report Characteristics</u>	<u>Strategy</u>		
		<u>1</u>	<u>2</u>	<u>3</u>
Submarine, floating or resting	$P_F > 0, P_R = 0$	M1	M2	M1
Submarine, floating only	$P_F > 0, P_R > 0$	H	H	M1

Whale, high probability	$P_W > .40$	B	D	B
Whale, low probability	$P_W > .40$	B	D	D

Submarine-Whale Collision	$P_F + P_R > 0, P_W > 0$	D	D	D

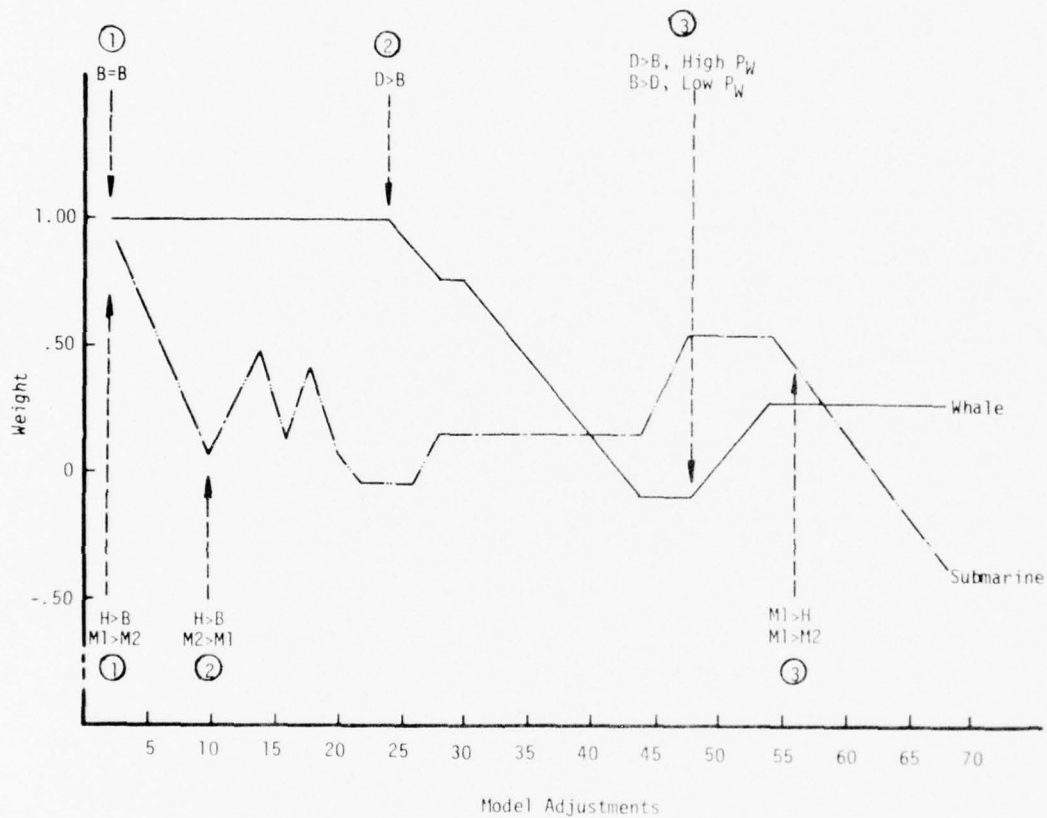

FIGURE 4-4
 SENSITIVITY OF COST WEIGHTS
 TO CHANGES IN STRATEGY

PERCEPTRONICS

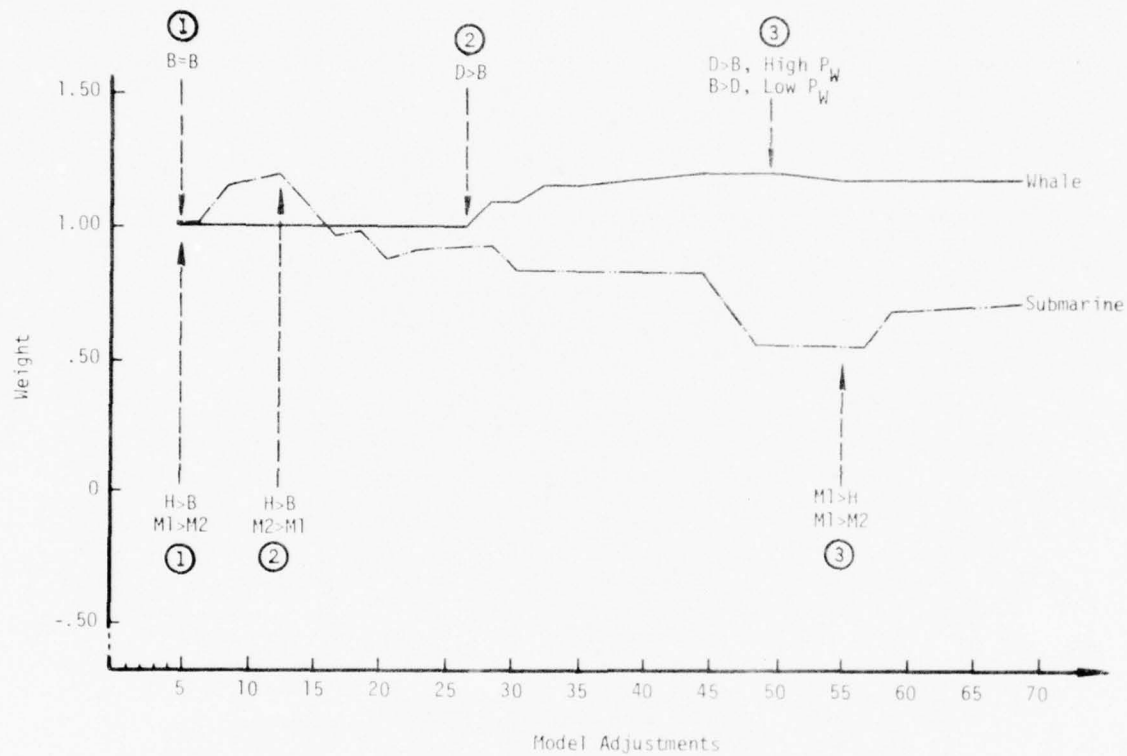

FIGURE 4-5
 SENSITIVITY OF EXPECTED INFORMATION-CONTENT
 WEIGHT TO CHANGES IN STRATEGY

PERCEPTRONICS

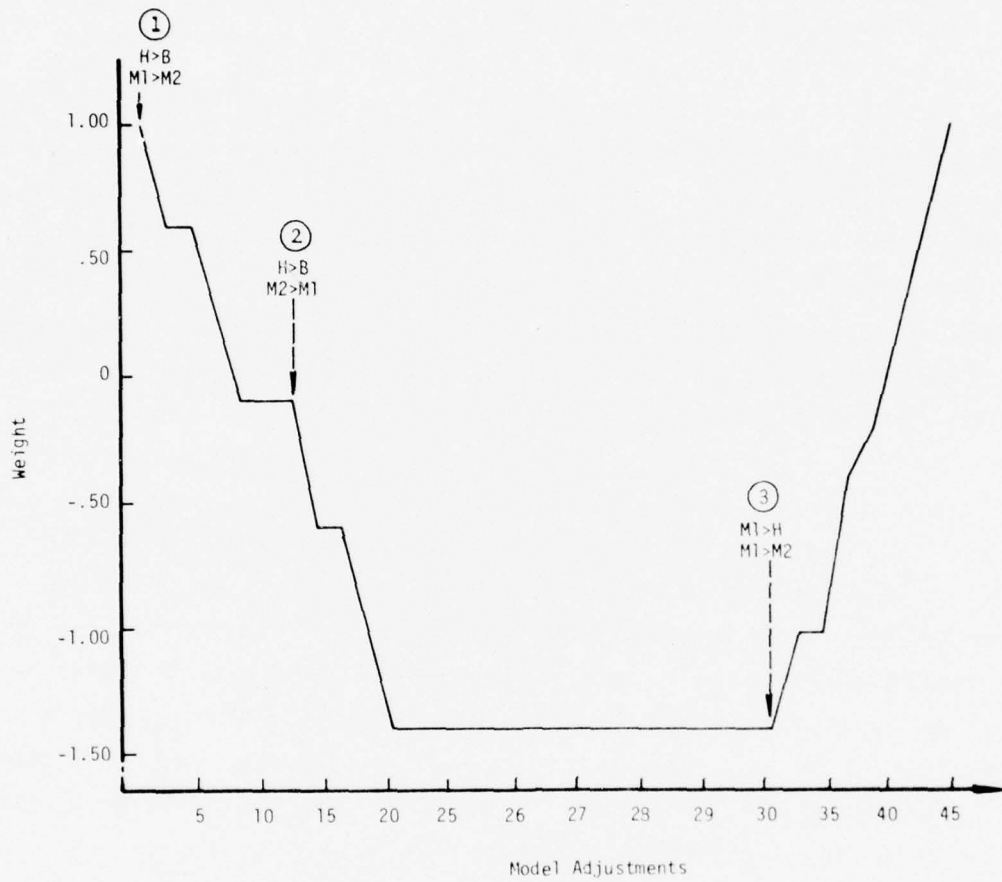

FIGURE 4-6
 SENSITIVITY OF SUBMARINE-INFORMATION
 PARSIMONY WEIGHT TO CHANGES IN STRATEGY

PERCEPTRONICS

these points are the operator preference versus the model prediction. For example, $H > B$ implies that the operator prefers an H sensor to the model prediction of a B sensor; $B = B$ means that the operator choice and model prediction start off equivalently.

Figure 4-4 shows the sensitivity of the cost weights to changes in strategy. To illustrate how the graph might be read, the adaptation of the weight for the submarine information cost attribute is considered. In Strategy 1 ($H > B$ when $P_F > 0$ and $P_R = 0$, $M1 > M2$ when $P_F > 0$ and $P_R > 0$), higher information cost is consistently preferred and thus the attribute weight declines from its initial value of 1 to close to 0. Then with Strategy 2, higher information cost is preferred in one submarine search situation ($H > B$ for $P_F > 0$ and $P_R = 0$), but lower cost is preferred in the other submarine search information ($M2 > M1$ for $P_F > 0$ and $P_R > 0$). Thus the attribute weight moves up and down until eventually stabilizing after about 55 adjustments. Finally, in the third strategy where the most expensive sensor ($M1$) is preferred in all submarine search situations, the weight level shows a steady decline. With respect to the other curves in Figures 4-4, 4-5, and 4-6, similar analyses can be made concerning the changes in information-selection strategy and their impact on the attribute weights. Overall, examination of the data reveals that it usually takes the model less than 20 adjustments to catch up with the operator in terms of correctly predicting his new information preferences.

4.3.4 Size of Adjustment Step. It is obvious from Figures 4-4, 4-5, and 4-6, as well as from Figure 4-3, that the size of the attribute weight adjustment step varies considerably across the different attributes. According to the weight-training rule (Table 3-4), the size of an adjustment depends upon λ (which is held equal to 0.4 across all attributes) and the difference in attribute levels between the operator-chosen information source and the model-predicted source. Thus, the variance within the levels that each attribute can assume impacts upon the size of weight adjustments.

Referring to Table 3-3, it is seen that the situation mask for the cost attributes, is either 0 or 1, but for the expected information content attributes, the mask is a probability or continuous number between 0 and 1. The information source characteristic levels are continuous (between 0 and 1) for each of these two types of attributes, but the difference in the scales for the situation mask account for the relatively steep adjustments for the cost attributes and relatively shallow adjustments for the expected information content attributes (Figures 4-3, 4-4, and 4-5). In contrast, the adjustments for the submarine information parsimony attributes are steepest of all. This is because both the situation mask and source characteristic for this attribute assume a discrete distribution -- either 0 or 1, consequently; the attribute level can take a value of only 0 and 1 resulting in the highest intra-attribute level variance.

4.4 Automatic Information Selection

Section 3.5 described two different levels of information selection. The first involves the selection of a single information source in each location of search having non-zero object probability. The second process relates to the further selection of an "optimum" set across a number of locations. As reported below, both selection processes were demonstrated in the empirical evaluation of the model.

4.4.1 Information Source Selection. The mechanism used to select among competing sources within each location of ocean was a straight-forward application of the MAU principle; namely, the source giving the highest computed MAU value was selected. Table 4-3 gives two examples of the computation taken from an actual performance run. The examples represent two different intelligence reports (i.e., object probabilities) regarding the subject location. The calculation is made during the latter part of the implementation of Strategy II, after the attribute weights had converged to

TABLE 4-3

TWO EXAMPLES OF COMPUTATION OF INFORMATION UTILITY FOR DIFFERENT SOURCES USING WEIGHTS FROM STRATEGY II

Intelligence Report (Environmental Situation)	Index	Situation Mask	Information Characteristic		Attribute Level		Attribute Weight	MAU		
			M1		M2			M1	M2	
			Example 1	1	1	.10		.10	.6	.6
$P_F = .75$	2	0	.10	0	.6	0	-.04	0	0	
	3	.75	1	.75	.58	.435	.99	.743	.431	
$P_R = .25$	4	0	1	0	.58	0	1.19	0	0	
	5	0	1	0	1	0	1.00	0	0	
$P_W = 0$	6	0	1	0	0	0	1.30	0	0	
	7	.91	1	.91	1	.91	1.00	.91	-.91	
								1.649	>	1.339

Intelligence Report (Environmental Situation)	Index	Situation Mask	D		B		Attribute Weight	D		B	
								D	B	D	B
			Example 2	1	1	.7		.7	1	1	-.04
$P_F = .50$	2	1	.7	.7	1	1	-.04	-.028	-.04	-.04	
	3	.50	.31	.155	.03	.015	.99	.153	-.0148	-.0148	
$P_R = 0$	4	.25	.31	.075	.03	.0075	1.19	.089	.0089	.0089	
	5	0	1	0	0	0	0	0	0	0	
$P_W = .25$	6	.91	1	.91	0	0	1.30	1.183	0	0	
	7	0	1	0	0	0	1.00	0	0	0	
								1.369	>	-.086	

stable values. Both examples show the entries for the situation mask vector corresponding to the given intelligence report, the information source characteristic vector and computed attribute level vector for two sources with the highest MAU values, the attribute weight vector, and the aggregate MAU or utility for the two competing sources considered. In Example 1, the M1 sensor was selected as the information source with the maximum MAU. In Example 2, the D sensor was similarly chosen.

One of the more important implications of employing the multi-attribute utility model to automatically select among competing information sources is that different strategies (i.e., attribute-weight vectors) will lead to different distributions of selected information. Figure 4-7 illustrates the relative frequency of selection for the five possible information sources after training on Strategy I and Strategy II. Each histogram is based on a total of about 150 separate information messages. Under Strategy I, more than 90% of the automatically selected messages consisted of H and B type sensors, each represented a little more than 45% of the time, with the remaining messages contributing a total of less than 7%. Under Strategy II, the frequency distribution is roughly the complement. The M1 and D sensor types are each selected about 50% of the time, while the H and B sensors, which are most frequently used in Strategy I, are almost never selected.

4.4.2 Information Set Selection. The second level of information selection was based upon the output from the first level of selection. The first-level output is a group of several sources (sensors), each providing the information message with the maximum MAU from a separate sector of search. Taken together for a single tracking trial, this group of sensors represents a full set of information messages covering all locations where the objects of search may actually be. Since some of these messages have much less information utility than others, the MAU principle can be used to prune away messages which contribute relatively little to the overall utility of the information set.

Relative Frequency of Selection

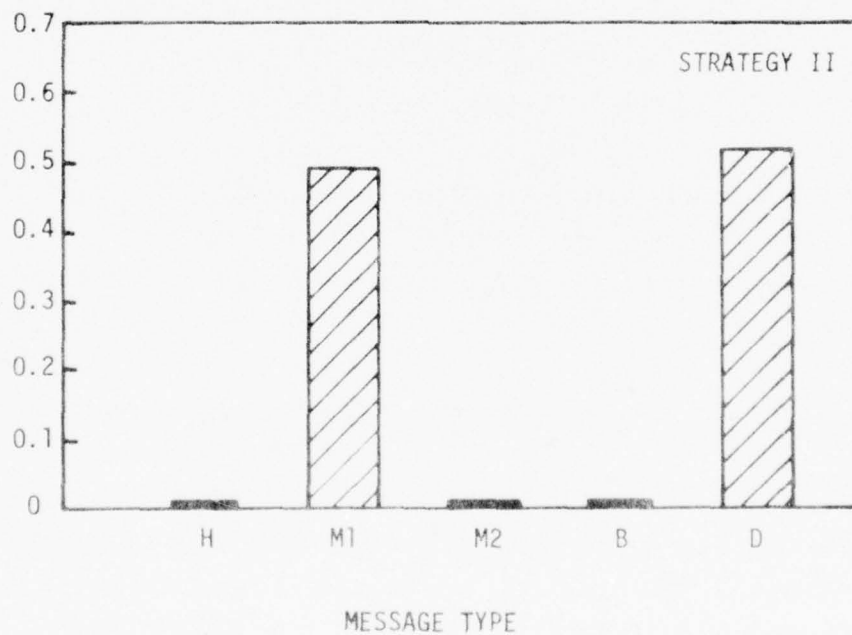
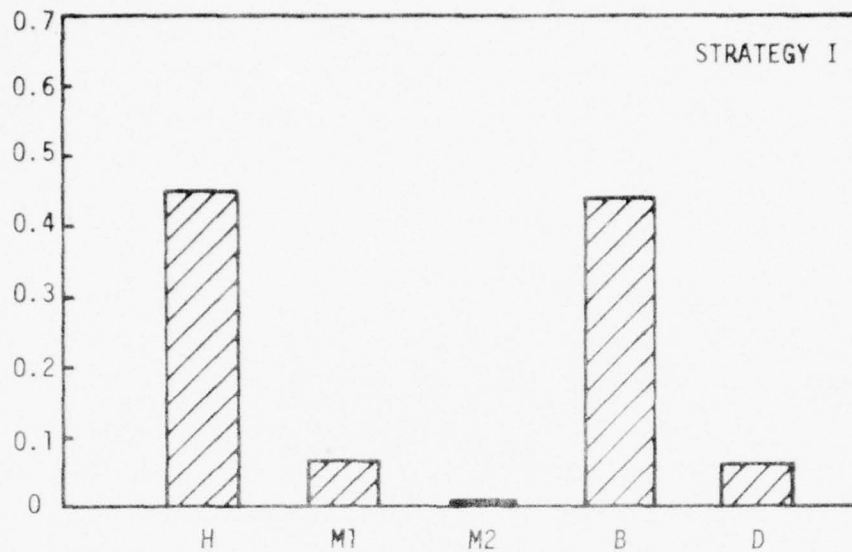

FIGURE 4-7
RELATIVE FREQUENCY OF AUTOMATIC MESSAGE
SELECTION FOR TWO INFORMATION ACQUISITION STRATEGIES

PERCEPTRONICS

In this way, the operator can be provided with a reduced set of the most valuable information.

The pruning rule implemented was as follows. First, all the members of the full information set for a trial were ordered according to decreasing MAU. It had been previously determined that because of the tracking task requirements, the three messages with the highest MAU must always be transmitted to the operator. The selection algorithm then added messages to this minimum set according to the following instruction: add each next highest ranked message only if its MAU exceeds 15% of the sum total MAU of the messages already in the set. Once the final set was determined all selected messages were transmitted simultaneously to the operator. The cut-off point of 15% was arrived at by analysis of previous data (Freedy et al., 1976) and through pilot experimentation.

Figure 4-8 demonstrates the effect of this pruning rule in reducing information sets generated by two different operator strategies. Strategies I and II were each run for 22 successive trials taken from an identical portion of the ASW tracking scenario (i.e., identical trial-by-trial movements of the submarine and whale). The convergent set of attribute weights were frozen for each strategy, and information messages were automatically selected and pruned according to the 15% rule. The results are plotted in terms of the median percentage of accumulated utility contributed by each additional ranked message.

For Strategy I, the 15% cut-off line hits the accumulated utility curve between the third and fourth ordered message. For Strategy II, the 15% line hits the curve between the fifth and sixth messages. Thus more information is pruned under Strategy II than under Strategy I. Taking into account the characteristic preferences of each strategy, the results are entirely reasonable. Strategy II emphasizes the use of high cost sensors with high expected information content. Therefore, under this strategy,

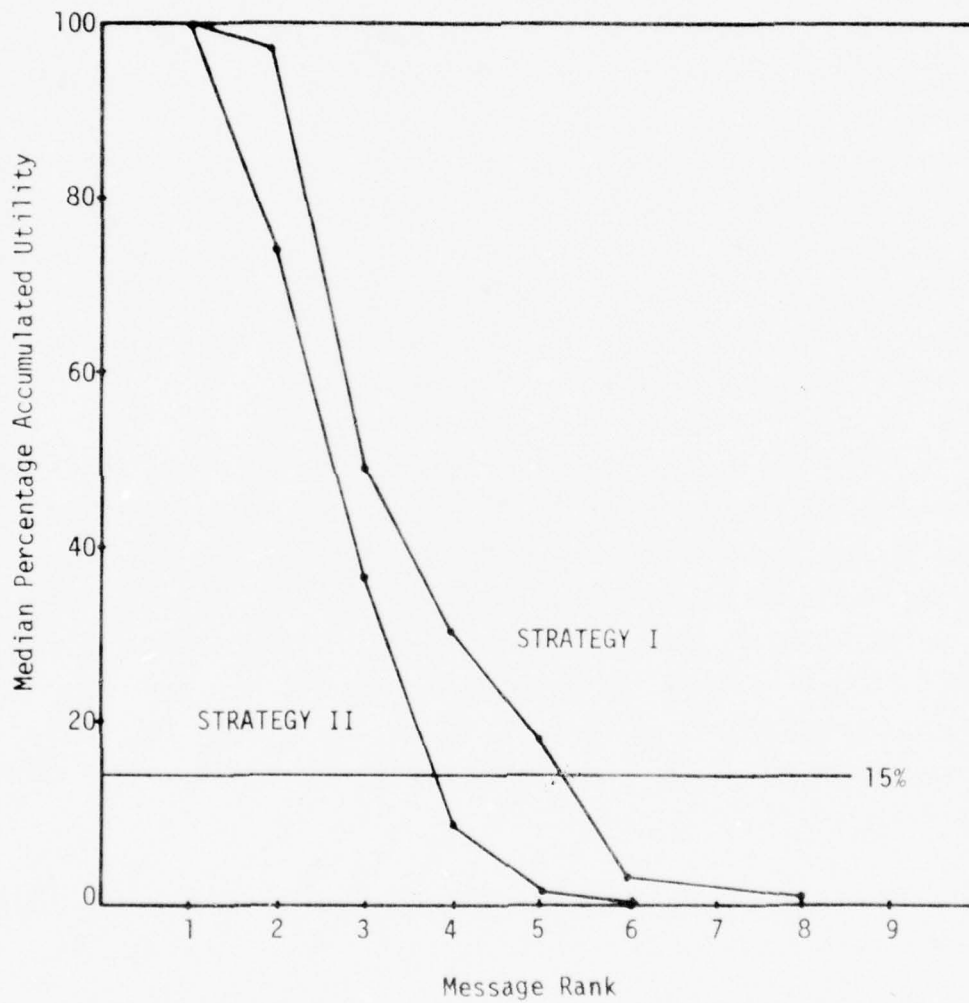

FIGURE 4-8
EFFECT OF 15% PRUNING RULE ON MESSAGES
SELECTION FROM TWO INFORMATION STRATEGIES

PERCEPTRONICS

most of the MAU in the full information set is concentrated in a few locations with the balance distributed in small amounts among the other locations. In contrast, Strategy I relies on sensors which are less costly and carry less expected information content; thus it generates a more homogeneous distribution of MAU across the different search locations. Under Strategy I, therefore, a larger set of information messages is required to provide approximately the same relative level of incremental utility as obtained under Strategy II.

4.5 Operator Performance with Automatic Information Selection

4.5.1 Purpose. The demonstrations described thus far focused on model performance. In sum, they illustrate that the model can select information on the basis of adaptively-estimated needs and preferences. It remains to be shown that an operator presented with information automatically selected in accordance with a stable preference model can successfully perform the ASW tracking task. This demonstration was accomplished using a single expert operator, who performed the ASW task under several conditions of automatic information selection.

4.5.2 Test Conditions. Information was automatically presented in accord with Strategies I and II. For each strategy, the convergent attribute weights, previously obtained from sessions run in the manual mode, were input into the multi-attribute information utility model. The model was then employed to select information and present it automatically to the operator over a set of 24 task trials; during these trials, movements of the objects were different than in the original model-training sessions. Two automatic selection modes were tested: (1) presentation of the full information set, and (2) presentation of a reduced set pruned according to the 15% rule. On each tracking trial, the operator simultaneously received the intelligence report and the information output of the automatic selector mechanism. On the basis of these data alone, he made an object status report, which generated a new intelligence report and new source selection, and so on.

In addition to the 2x2 combination of demonstration conditions, i.e., Strategy (I or II) x Information Set (Full or Pruned), a control treatment was introduced for performance comparison. The control strategy took into account the information needs of the operator (situation mask vector) and the differential properties of the sensors (source characteristic vector), but it did not include the operator-initiated, differential preferences for information attributes. That is, the MAU calculation utilized the same attribute level vector as did the other strategies, but the attribute weight vector was replaced by a unit vector. Thus, each attribute was accorded equal importance throughout the test session, and attribute weights remained equivalent to the initial state of the adaptive model. Data collected under automatic information selection governed by equal attribute weights was expected to reflect baseline performance with a strategy characterized by minimal cost, minimal expected information content. Because the information generated by the control strategy was of such low overall utility, it was not meaningful to apply the pruning rule to reduce further the information set.

4.5.3 Performance Results. The results of the performance evaluation are summarized in Table 4-4. For each strategy tested, the percentages of submarine and whale hits are listed together with the mean cost expenditure per trial. For Strategies I and II, the performance data is contrasted for the sessions under which a full or pruned information set was presented to the operator. In comparing any two conditions, performance in terms of the hit rate is generally better at the expense of higher costs.¹ For example, more than four times the costs were expended to achieve a 92% hit rate under Strategy II versus a 58% hit rate under the control strategy. Because of this trade-off between hits and costs, it was useful to assess overall or net performance in terms of an effectiveness index. The measure employed was:

¹A "hit" is a correct detection of a submarine or whale.

TABLE 4-4

OPERATOR TRACKING WITH
AUTOMATIC INFORMATION SELECTION

Selection Criterion	Utility-Based Strategies						Control Strategy		
	Strategy I			Strategy II			Sub Hits %	Whale Hits %	Mean Info Cost
	Sub Hits %	Whale Hits %	Mean Info. Cost	Sub Hits %	Whale Hits %	Mean Info Cost			
Full Info Set	75	42	25	92	92	44	58	58	10
Pruned Info Set	75	29	12	100	88	32	-	-	-

EFFECTIVENESS INDEX = $\frac{\text{TRACKING PERFORMANCE}}{\text{INFORMATION COST}}$, where

TRACKING PERFORMANCE = $2 [\text{ACCURACY}]_{\text{SUB}} + [\text{ACCURACY}]_{\text{WHALE}}$, and

ACCURACY = % HITS - % MISSES

The index is a benefit-to-cost ratio which has face validity because: (1) the operator was previously made aware that submarine tracking had twice the importance of whale tracking; and (2) accuracy in real-world ASW tracking tasks is often interpreted in terms of hits minus misses.

Since the effectiveness index averaged more than 1.7 times higher for tracking performance under Strategy II compared with Strategy I, only Strategy II was selected for further analysis (Table 4-5). Under Strategy II, operator performance with the pruned information set resulted in a 1.5 times better effectiveness index than obtained with a full information set. The Strategy II pruned condition represents performance under full model capability (i.e., where information is both selected and pruned in accordance with articulated operator preferences). It is thus desirable to compare performance in this condition with performance in the control condition (i.e., without specific information-attribute preferences and without pruning). These performance ratios are shown in the bottom part of Table 4-5. Although Strategy II with pruning expended more than 3 times the information costs of the control strategy, tracking performance was nearly 6 times better, resulting, overall, in an effectiveness improvement ratio of 1.8 to 1.

4.5.4 Information Acquisition Time. Informal observation indicated that automatic information selection markedly reduced the time normally required for information acquisition in the simulated ASW task. The time required by the operator to manually select and distribute information sources was about

TABLE 4-5

PERFORMANCE EFFECTIVENESS SUMMARY

EFFECTIVENESS MEASURES

	CONTROL STRATEGY	STRATEGY II	
		FULL SET	PRUNED
TRACKING PERFORMANCE	48	252	276
INFORMATION COST	10	44	32
EFFECTIVE INDEX	4.8	5.7	8.6

STRATEGY II PRUNED VS. CONTROL STRATEGY

PERFORMANCE RATIO	5.8:1
COST RATIO	3.2:1
EFFECTIVENESS RATIO	1.8:1

50 seconds. In contrast, the model automatically selected and distributed the sources in about 1 second. The throughput ratio of automatic to manual selection was thus on the order of 50 to 1.

4.5.5 Information Filtering. Overall, the adaptive system was able to select automatically about 5 to 7 highly useful messages from a potentially available universe typically in the order of 78,000 messages, a filtering ratio of over 15,000 to 1. This value was calculated as follows. Each trial yielded an average of 7 locations for which there was a non-zero probability of finding a submarine or whale, and information from each location could be obtained from one of five sources. Thus the potential message universe was $5^7 = 78,125$.

5. DISCUSSION AND IMPLICATIONS

5.1 Generality of the Multi-Attribute Utility Model

5.1.1 Demonstration Approach. More often than not, a specialized task scenario is designed whenever a newly developed decision aiding system must be implemented for experimental testing. In fact it has been said that a skeptic might argue that demonstrations of certain decision-aiding systems "merely show that one can design a simulated task in which it helps to have machine assistance" (Slovic, Fischhoff, and Lichtenstein, 1977). In the present work, however, a different course was taken; that is, the new multi-attribute information utility model was applied to an existing ASW simulation task. The ASW scenario had, in fact, been originally designed as a test bed for the outcome-based ADDAM model (described in Section 2.5.3) which is conceptually very different from the model developed here. The successful demonstration of the implementation of the new model to a scenario developed for another purpose endorses the generality of the model.

5.1.2 Replacement of Human Function. The model developed here provides another demonstration of how a simple linear model can be employed to replace an important human function within a decision system. Such models have proved successful in a variety of tasks (e.g., judgmental, decision making, attitudinal, perceptual) and applications (e.g., military, medical, social). In the present work, the application was extended to an information selection task within the context of ASW tracking. Furthermore, unlike the more commonly used methods of direct elicitation or regression analysis, the linear weights employed by the multi-attribute information utility model were adaptively estimated from on-line behavior. Certainly, the highly generalizable features of multi-attribute utility assessments (e.g., Brown, Kahr, and Peterson, 1974; Edwards, 1977) combined with an adaptive dynamic utility estimation technique which is growing in application depth (e.g., Felsen, 1976) provide a tool of far reaching potential.

Because of the generality and power of operator-based models or decision rules, it is important to ask why they can perform as well or better than the actual operator himself. Several investigators have suggested that the superior performance of the models, linear or otherwise, is due to their ability to eliminate or reduce "noise" effects in the subjective weighting of information and in erratic operator responses. For example, Bowman (1963) described the filtering process as follows:

"Man seems to respond to selective cues in his environment ... particular things seem to catch his attention at times ... (These random and particularistic components can be eliminated) through the use of decision rules incorporating coefficients derived from the operator's own recurrent behavior."

Dawes (1971) put it somewhat differently by stating that:

"A mathematical model, by its very nature, is an abstraction of the process it models; hence, if the decision maker's behavior involves following valid principles but following them poorly, these valid principles will be abstracted by the model -- as long as the deviations from these principles are not systematically related to the variables the decision maker is considering."

After a critical review and analysis of linear models in decision making, Dawes and Corrigan (1974) conclude that the success of these models is tied up with their inherent robustness and their appropriateness for many specific applications. It would seem from the results of the present investigation that the process of information selection in a C3 system has characteristics which lend themselves to this type of modeling approach. The trick, of course, in a C3 operation or any other, is to identify the attributes of information which can adequately model the operator's requirements and preferences in response to the situation.

5.2 Advantages of the Multi-Attribute Utility Model

The multi-attribute information utility model developed in this research is characterized by several attractive features. These features, which are itemized below, can be seen as advantages which endorse the application potential of the model. The advantages arise out of the theoretical structure of the model, especially the decomposition property. However, they have all been empirically illustrated to some degree in the demonstration and evaluation.

5.2.1 Generality. The adaptive, multi-attribute model for information selection holds a considerable amount of generality. It can be applied in situations where information messages can be decomposed into a small set of manageable, quantifiable attributes which have two critical characteristics. First, they must be logically related to the situation-specific information requirements, that is, their relevance to specific situations must be known. Second, they must directly impact upon a decision maker's choices among competing information sources or messages. Several military decision making environments have already been demonstrated to fit this paradigm (e.g., Coates and McCourt, 1976; Hayes, 1964; McKendry, Enderwick, and Harrison, 1971; Samet, 1975).

5.2.2 Parsimony. The model is parsimonious; it need only assess an operator's weights for a limited number of information dimensions or attributes. Besides significantly minimizing the model's computational needs and software complexity, this feature is in consort with the results of psychological experiments (e.g., Hayes, 1964; Slovic, 1975; Wright, 1974) and contemporary decision theory (e.g., Tversky and Kahneman, 1974); namely, that a decision maker can perform an intuitive conscious weighting and aggregation of only a relatively small number of what he considers to be the important dimensions common to the decision alternatives. Furthermore, when decisions are based

on a manageable number of information dimensions, they are easier to communicate and rationalize -- especially in group decision making situations (Gardiner and Edwards, 1975).

5.2.3 Robustness. Like other linear composition models, the multi-attribute information utility model is robust; that is, its performance (i.e., capability to mimic the information selection behavior of an operator) is not significantly degraded by proportionately small perturbations in the model's parameters (Dawes and Corrigan, 1974). Such robustness probably contributes to the finding that multi-attribute utility assessment techniques have proved, in certain instances, to be more reliable and valid than direct, holistic assessment procedures (Newman, 1975; Samet, 1976).

5.2.4 Speed of Adaptation. The adaptive model adjusts all parameters with each incorrectly predicted operator decision (i.e., information selection). Thus, weights (utilities) for specific information attributes can be trained rapidly during sessions in which the operator chooses information manually.

5.2.5 Flexibility. The multi-attribute utility model is inherently flexible. If accuracy of prediction of information selection behavior is not sufficient (i.e., if attribute weights cannot be trained to stable values), additional features or attributes can be added and inappropriate ones deleted. The response to dynamic changes in conditions is similarly flexible. In instances where conditions change rapidly and radically, new sets of weights trained for the conditions can be substituted. Such weight vectors could be previously trained either in actual operational situations or in step-through simulations.

5.2.6 Versatility. The model can be applied in a variety of situations, involving deterministic as well as probabilistic environments. In the probabilistic situation, an attribute might not be present at all in some information messages, or it might occur with some known probability.

Whatever the case, the modeling equation allows for any attribute level to either be zeroed out (i.e., be made irrelevant) or multiplied by the probability that the attribute will be present, giving a measure of expected attribute presence.

5.3 Supervision of Information Flow in C3 Systems

As stated in the Introduction, development of the present adaptive multi-attribute utility model represents one step toward development of a supervisory set of adaptive programs to control overall information flow in C3 systems. This section outlines a method for C3 system description, and suggests in brief how the present model might contribute to the supervisory control function. Further development of the supervisory concept will be the subject of subsequent project reports.

5.3.1 C3 System Description. We can consider the typical C3 system as a hierarchical, multi-level arrangement of users. Figure 5-1 illustrates the general configuration. People at one level process information for people at the next level, collecting and integrating data until a decision commensurate with their level can be made. Thus each person in the structure is at times a user of information, at times a source of unprocessed or processed information, and at times a source of decisions passed to higher levels of the hierarchy. The idea that information transmission in such a system could be expressed in matrix form was advanced by Thornton Roby (1968), whose untimely death prevented his further development of this concept. We can illustrate the methodology by considering a prototypical ASW command team, consisting of people (A, B, and C), each of whom tends to focus on information from the outside world relating to certain specific aspects of the ASW picture, and each of whom is responsible for certain types of ASW decisions.

PROCESSING AND COMMAND

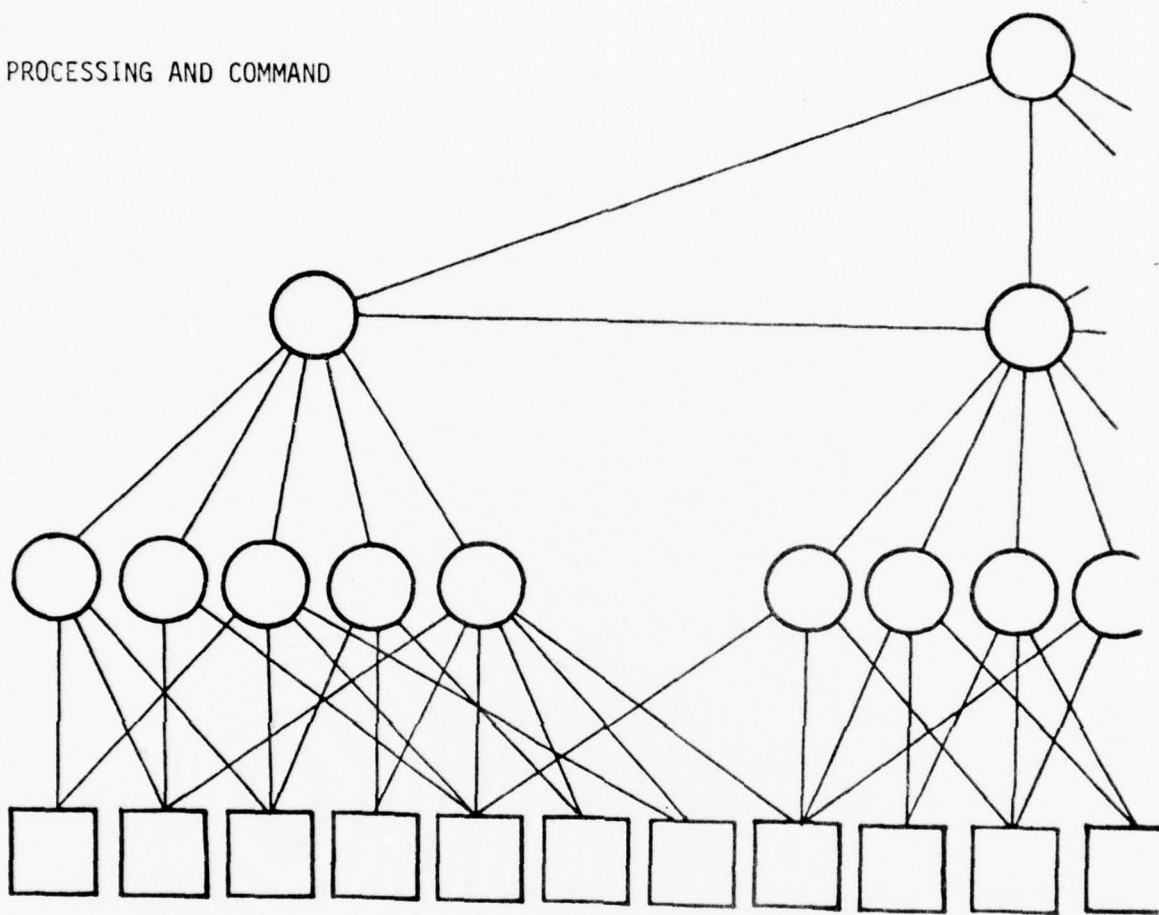

INFORMATION SOURCES

FIGURE 5-1
PARTIAL REPRESENTATION
OF A MULTI-LEVEL C3 SYSTEM

PERCEPTRONICS

Figure 5-2 exemplifies the steps involved in constructing the overall information transmission matrix (HRN) from the constituent matrices (H, R and N) for this illustrative situation. In matrix H, the column headings (i, j, k, ...) represent classes of information (e.g., intelligence, weapons characteristics, sensor returns, equipment availability, etc.), while the row headings (O, P, Q) represent information sources. A unit entry in any row indicates that the source is a producer of information in the associated class. Column headings (w, x, y, z) in matrix R represent classes of decisions (e.g., target location, sensor allocation, weapons readiness, etc.). Cell entries in R give the relevance of a given class of information to a certain decision. Finally, matrix N relates personnel to class of decisions; in this simple case, person A is responsible for w decisions, B for y decisions, and C for x and z decisions. Matrix multiplication of H and R yields matrix HR as an interim product, this matrix indicates the contribution of each information source to the output decisions. Matrices HR and N are multiplied to obtain the information transmission matrix HRN. This matrix relates sources of information to users of information, cell entries are information classes, as mitigated by the decision needs of the system.

In this simple example, only outside sources were considered, and users acted only as users. Since users can also act as sources to other users, the next step of complexity would add another dimensions to the transmission matrix, i.e., it would become a three-dimensional matrix, relating outside sources, users, and inside sources. Other dimensions are also possible, and the procedure would have to be adjusted to handle multiple sources for information items. Digital computers are well suited to manipulation of multi-dimensional matrices, and reasonable expansion of size should pose no immediate problems. The most important refinement, however, lies in replacing the basic 0 and 1 matrix entries with numerical weights which reflect the value of that connection in the information system. The overall value of a constituent C3 link, then, would be determined by a combination of weights through the matrix. Optimum information flow

through the system, i.e., maximum true value, would be achieved when the weights are adjusted in accord with the immediate requirements of the users and of the situation.

The supervisory computer program constitutes the mechanism by which the weights of the elements in the communications matrix are adaptively adjusted. It is suggested that the program contain both heuristic control algorithms, which are situation-dependent, and a set of behavioral models, which depend on psychological constructs and on individual user characteristics. Together, these determine the instantaneous element weights. Among the most significant models are those which define:

- (1) Multi-Attribute Utility
- (2) Information Routing
- (3) Information Pacing and Load

Feasibility of the first model has been demonstrated by the present work. Application of this work to realization of the other two models is discussed briefly below.

5.3.2 Information Routing. The multi-attribute utility model combines well with the communication matrix techniques suggested by Roby (1968) and described above. In essence, the matrices relate information sources to information classes or attributes, attributes to types of decisions, and decision types to users. By multiplying the matrices together, communication connections are enumerated between sources and users. To establish the strength of connections, the information attribute weights could be determined, and be adjusted on-line by an adaptive model. In this way, the model could be implemented to build upon the application of the communication matrix concept in order to provide a degree of automatic routing. In addition, since the model keeps track of a separate weight for each information

	H INFORMATION	R DECISION	
Source	$\begin{matrix} & i & j & k & l & m & n \\ \begin{matrix} O \\ P \\ Q \end{matrix} & \begin{bmatrix} 1 & - & 1 & - & - & - \\ - & 1 & - & - & - & 1 \\ - & - & - & 1 & 1 & - \end{bmatrix} \end{matrix}$	$\begin{matrix} & w & x & y & z \\ \begin{matrix} i \\ j \\ k \\ l \\ m \\ n \end{matrix} & \begin{bmatrix} i & i & - & i \\ - & j & - & - \\ - & - & k & k \\ l & l & - & l \\ - & - & m & - \\ n & n & - & - \end{bmatrix} \end{matrix}$	INFORMATION

	N USER	HR DECISION	
DECISION	$\begin{matrix} & A & B & C \\ \begin{matrix} w \\ x \\ y \\ z \end{matrix} & \begin{bmatrix} 1 & - & - \\ - & - & 1 \\ - & 1 & - \\ - & - & 1 \end{bmatrix} \end{matrix}$	$\begin{matrix} & w & x & y & z \\ \begin{matrix} O \\ P \\ Q \end{matrix} & \begin{bmatrix} i & i & k & i+k \\ n & j & - & - \\ l & - & l+m & - \end{bmatrix} \end{matrix}$	SOURCE

	HRN	USER
SOURCE	$\begin{matrix} & A & B & C \\ \begin{matrix} O \\ P \\ Q \end{matrix} & \begin{bmatrix} i & k & 2i+k \\ n & - & j \\ l & l+m & - \end{bmatrix} \end{matrix}$	

FIGURE 5-2
MATRIX REPRESENTATION OF A SIMPLE C3 NODE

PERCEPTRONICS

attribute, it has the capability to deliver rich feedback to the operator. For example, he could be informed of the relative weights he is placing on such attributes as information cost, reliability, relevance, and if desired, he could be given associated corrective instructions to influence his manual routing behavior.

5.3.3 Pacing and Load. According to the two information-selection strategies examined in the present study, the operator working with a pruned information set, as opposed to a larger information set, performed better in terms of his net effectiveness as a decision maker. Although this result was demonstrated for a single operator performing in only one session for each condition, it is consistent with previous findings that an increase in information density/detail/load is not necessarily accompanied by an improvement in decision quality (Granda, 1976; Hayes, 1964; Huber et al., 1975; Schroeder and Benbasat, 1975).

The consistency of experimental findings concerning the effects of information load on information processing performance have led investigators to postulate an inverted-U relationship between the variables (Hogarth, 1975; Schroeder, et al., 1967); that is, performance falls off both when information load is too low, and when information load is too high. The reasons for the fall-off are different, however. When load is too low, the operator has insufficient information to decide optimally. When load is too high, he has more information than he can handle mentally.

It would require systematic experimentation to define the optimal information load which would maximize ASW operator performance in the present task. However, performance results support the possibility that the full information set exceeded the amount of information that he could appropriately assimilate, especially in light of the fact that the sensor outputs were of imperfect reliability and often conflicting. In the present case, by applying

the 15% pruning rule, the size of the information set was apparently reduced to a more intellectually manageable size.

The important general implication that emerges is that if the optimal information load can be calibrated for a given operator, then an adaptive, on-line, multi-attribute information utility model such as developed here could be applied to select the appropriate amount of most useful available information. More specifically, one input to the multi-attribute model would be the immediate circumstances of the operator or recipient of information. That is, one attribute of incoming information would be defined as the current information load or message rate. If the load is high, the utility weight for load would act to devalue new information. On the other hand, if his load is low, the load weight would act to increase his overall utility for new information. By requiring information to exceed a certain utility threshold before being presented, the model could include the capability to adaptively pace information. It is planned to explore this approach in our future work.

AD-A038 523

PERCEPTRONICS INC WOODLAND HILLS CALIF
APPLICATION OF ADAPTIVE MODELS TO INFORMATION SELECTION IN C3 S--ETC(U)
DEC 76 M G SAMET, G WELTMAN, K B DAVIS
PTR-1033-76-12 MDA903-76-C-0241
NL

UNCLASSIFIED

2 of 2
AD-A038 523



END

DATE
FILMED
5 - 77

6. REFERENCES

- Ackoff, R.L. Management Misinformation Systems. Management Science, 1967, 14:B147-B156.
- Albright, A.F. Processing and Display of Information in the National Military Command Center (NMCC). U.S. Army War College (Carlisle Barracks, PA) AD A-012614, 23 May 1975.
- Baker, J.D. Human Performance Research in Military Information Systems: Quo Fuimus et Quo Vadimus? Paper presented at the NATO Defense Research Group Seminar on Man-Machine Relations, Utrecht, The Netherlands, May 1973.
- Bowman, E.H. Consistency and Optimality in Managerial Decision Making. Management Science, 1963, 9:310-321.
- Brown, R.V., Kahr, A.S., and Peterson, C. Decision Analysis for the Manager. New York: Holt, Rinehart & Winston, 1974.
- Coates, E.N., and McCourt, A.W. A Questionnaire-Based Analysis of Order-of-Battle Elements. U.S. Army Research Institute for the Behavioral and Social Sciences (Arlington, VA) Technical Report No. 271, January 1976.
- Dawes, R.M. A Case Study of Graduate Admissions: Application of Three Principles of Human Decision Making. American Psychologist, 1971, 26:180-188.
- Dawes, R.M., and Corrigan, B. Linear Models in Decision Making. Psychological Bulletin, 1974, 81:95-106.
- Edwards, W. How to Use Multi-Attribute Utility Measurement for Social Decision Making. IEEE Special Issue on Decision Making, May 1977 (in press).
- Felson, J. Decision Making Under Uncertainty: An Artificial Intelligence Approach. Hicksville, N.Y.: Exposition Press, 1976.
- Freedy, A., and Crooks, W.H. Use of An Adaptive Decision Model in Computer-Assisted Training of Electronic Troubleshooting. Proc. Conf. on New Concepts in Maintenance Training, Orlando, Florida, April 1975.
- Freedy, A., Davis, K.B., Steeb, R., Samet, M.G., and Gardiner, P.C. Adaptive Computer Aiding in Dynamic Decision Processes: Methodology, Evaluation, and Application. Perceptronics, Inc. (Woodland Hills, CA) Final Technical Report PFTR-1016-76-8/30, Contract N00014-73-C-0286/NR196-128, ARPA Order No. 2347, Code 455, Office of Naval Research, August 1976.

Gardiner, P.C., and Edwards, W. Public Values: Multi-Attribute Utility Measurement for Social Decision Making. In Schwartz & Kaplan (Eds.), Human Judgment & Decision Processes: Formal and Mathematical Approaches. New York: Academic Press, 1975.

Gilstad, D.W., and Fu, K.S. A Two-Dimensional Pattern Recognizing Adaptive Model of the Human Operator. Proc. Sixth Annual Conf. Manual Control, Wright-Patterson AFB, April 1970.

Granda, T.M. A Comparison Between a Standard Map and a Reduced Detail Map Within a Simulated Tactical Operations Systems (SIMTOS). U.S. Army Research Institute for the Behavioral and Social Sciences (Arlington, VA) Technical Paper 274, June 1976.

Green, P.E., Halbert, M.H., and Minas, J.S. An Experiment in Information Buying. Journal of Advertising Research, 1964, 4:17-23.

Hayes, J.R.M. Human Data Processing Limits in Decision Making. In Bennett, E. (Ed.), Information System Science and Engineering. Proceedings of the First Congress on the Information Systems Sciences. New York: McGraw-Hill, 1964.

Hogarth, R.M. Decision Time as a Function of Task Complexity. In Wendt, D. and Vlek, C. (Eds.), Utility Probability and Human Decision Making. Dordrecht-Holland: D. Reidel, 1975.

Huber, G.P., O'Connell, M.J., and Cummings, L.L. Perceived Environmental Uncertainty: Effects of Information and Structure. Academy of Management Journal, 1975, 18(4):725-740.

Johnson, E.M., Cavanagh, R.C., Spooner, R.L., and Samet, M.G. Utilization of Reliability Measures in Bayesian Inference: Models and Human Performance. IEEE Transactions on Reliability, 1973, R-22:176-183.

Kanarick, A.F., Huntington, J., and Peterson, R.C. Multi-Source Information Acquisition with Optional Stopping. Human Factors, 1969, 11:379-386.

Kunreuther, H. Extensions of Bowman's Theory on Managerial Decision Making. Management Science, 1969, 15(8):B415-B432.

Levine, J.M. and Samet, M.G. Information Seeking With Multiple Sources of Conflicting and Unreliable Information. Human Factors, 1973, 15(4):407-419.

Levine, J.M., Samet, M.G., and Brahlek, R.E. Information Seeking with Limitations on Available Information and Resources. Human Factors, 1975, 17(5):502-513.

Levit, R.A., Heaton, B.J., and Alden, D.G. Decision Support in a Simulated Tactical Operations System (SIMTOS). Honeywell, Inc. (Minneapolis, MI) Contract No. DAHC19-75-C-0008, November 1975.

Lin, N., and Garvey, W.D. Information Needs and Uses. In Caudra, C.A. (Ed.) Annual Review of Information Science and Technology, Vol. 7, Washington, D.C.: American Society For Information Science, 1972.

McKendry, J.M., Enderwick, T.P., and Harrison, P.C. A Subjective Value Approach to Information Utility. Human Factors, 1971, 13(6):503-509.

McKendry, J.M., Wilson, R.C., Mace, D.J., and Baker, J.D. Application of Method for Determining Information Requirements in a Field Army. U.S. Army Research Institute for the Behavioral and Social Sciences (Arlington, VA) Technical Paper 247, AD#767-262, August 1973.

Newman, J.R. Assessing the Reliability and Validity of Multi-Attribute Utility Procedures: An Application of the Theory of Generalizability. University of Southern California (Los Angeles, CA) SSRI Research Report 75-7, July 1975.

Nickerson, R.S., and Feehrer, C.E. Decision Making and Training: A Review of Theoretical and Empirical Studies of Decision Making and Their Implications for the Training of Decision Makers. Bolt, Beranek, and Newman (Cambridge, MA) Tech. Report NAVTRAEQUIPCEN 73-C-0128-1, July 1975.

O'Connor, M.F., Peterson, C.R., and Palmer, T.J. Stakes and Probabilities in Information Purchase. Organizational Behavior and Human Performance, 1972, 7:43-52.

Pask, G. and Scott, B.C.E. Learning and Teaching Strategies in Transformation Skill. British Journal of Mathematical and Statistical Psychology, 1971, 24:205.

Pask, G., and Scott, B.C.E. Learning Strategies and Individual Competence. International Journal of Man Machine Studies, 1972, 4:217.

Peterson, C.R., Schneider, R.J., and Miller, A.J. Sample Size and the Revision of Subjective Probabilities. Journal of Experimental Psychology, 1965, 69:522-527.

Phillips, L.D., and Edwards, W. Conservatism in a Simple Probability Inference Task. Journal of Experimental Psychology, 1966, 72:346-357.

Pitz, G.F., and Reinhold, H. Payoff Effects in Sequential Decision Making. Journal of Experimental Psychology, 1968, 77:249-257.

Rapoport, A., Lissitz, R.W., and McAllister, H.A. Search Behavior With and Without Optional Stopping. Organizational Behavior and Human Performance, 1972, 7:1-17.

Roby, T.B. Small Group Performance. Chicago: Rand McNally, 1968.

Samet, M.G. Quantitative Interpretation of Two Qualitative Scales Used to Rate Military Intelligence. Human Factors, 1975, 17:192-202.

Samet, M.G. Utility Assessment by "Interpolation Between Corners": An Application to the Evaluation of Drug Efficacy. U.S. Army Research Institute for the Behavioral and Social Sciences (Arlington, VA) Unpublished Manuscript, December 1976.

Schroder, H., Driver, M., and Streufert, S. Human Information Processing. New York: Holt, Rinehart and Winston, 1967.

Schroeder, R.G., and Benbassat, I. An Experimental Evaluation of the Relationship of Uncertainty in the Environment to Information Used by Decision Makers. Decision Sciences, 1975, 6(3):556-567.

Slovic, P. Choice Between Equally Valued Alternatives. Journal of Experimental Psychology: Human Perception and Performance, 1975, 1(3):280-287.

Slovic, P., Fischhoff, B., and Lichtenstein, S. Behavioral Decision Theory. Annual Review of Psychology, 1977 (in press).

Snapper, K.J., and Peterson, C.R. Information Seeking and Data Diagnosticity. Journal of Experimental Psychology, 1971, 87:429-433.

Steeb, R. Internal Memorandum, Perceptronics, Inc. (Woodland Hills, CA) September 8, 1976.

Strub, M.H. Tactical Planning (Offensive and Defensive) Information Requirements: Comparison of Survey Questionnaire and Laboratory Exercise Data. U.S. Army Research Institute for the Behavioral and Social Sciences (Arlington, VA) Technical Paper, 1977 (in preparation).

Strub, M.H., and McConnaughey, P. Tactical Planning (Offensive and Defensive) Minimal Essential Information Requirements. U.S. Army Research Institute for the Behavioral and Social Sciences (Arlington, VA) Research Memorandum 74-7, October 1974.

Thompson, F.B. Design Fundamentals of Military Information Systems. In Bennet, E., Degan, J., and Spiegel, J. (Eds.), Military Information Systems. New York: Praeger, 1964.

Thompson, F.B. Nature and Role of Data in Command and Control. In Uhlaner, J.E. (Ed.), Psychological Research in National Defense Today. U.S. Army Research Institute for the Behavioral and Social Sciences (Arlington, VA) Technical Report S-1, June 1967.

Tversky, A., and Kahneman, D. Judgment Under Uncertainty: Heuristics and Biases. Science, 1974, 185:1124-1131.

Weisbrod, R.L., Davis, K.B., and Freedy, A. Adaptive Utility Assessment in Dynamic Decision Aiding. IEEE Special Issue on Decision Making, May 1977 (in press).

Williams, R.W. Commanders and Intelligence. Army, 1972, 22(12):21-24.

Wright, P. The Harassed Decision Maker: Time Pressures, Distractions, and the Use of Evidence. Journal of Applied Psychology, 1974, 59(5):555-561.