

AD-A037 951

CIVIL ENGINEERING LAB (NAVY) PORT HUENEME CALIF
AN ICE EXCAVATION MACHINE. (U)
FEB 77 K D VAUDREY

F/G 13/3

UNCLASSIFIED

CEL-TR-851

NL

1 of 1
ADA037951

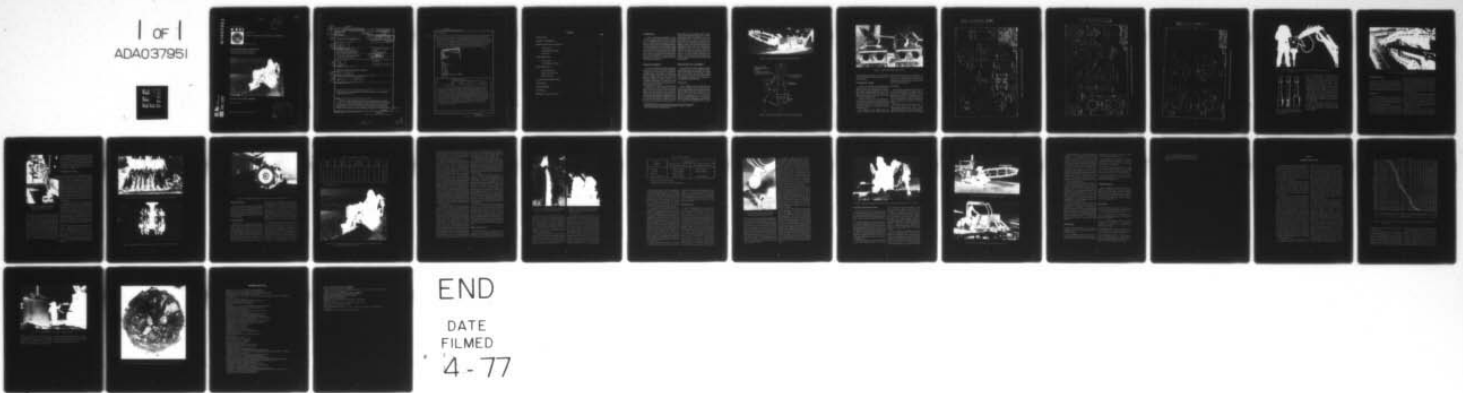

END

DATE
FILMED
4-77

ADA 037951

1

12

FL

Technical Report
R 851



Sponsored by
NAVAL FACILITIES ENGINEERING COMMAND

February 1977

CIVIL ENGINEERING LABORATORY
Naval Construction Battalion Center
Port Hueneme, California 93043



AN ICE EXCAVATION MACHINE

by K. D. Vaudrey

Approved for public release; distribution unlimited.

ADDC
RECEIVED
APR 11 1977
A

AD NO. _____
DDC FILE COPY

Unclassified

SECURITY CLASSIFICATION OF THIS PAGE (When Data Entered)

14

CEL

REPORT DOCUMENTATION PAGE		READ INSTRUCTIONS BEFORE COMPLETING FORM
1. REPORT NUMBER TR-851	2. GOVT ACCESSION NO. DN487008	3. RECIPIENT'S CATALOG NUMBER Rept.
4. TITLE (and Subtitle) AN ICE EXCAVATION MACHINE	5. TYPE OF REPORT & PERIOD COVERED Final Aug 1973 - Jun 1976	
7. AUTHOR(s) K. D. Vaudrey	8. CONTRACT OR GRANT NUMBER(s)	
9. PERFORMING ORGANIZATION NAME AND ADDRESS Civil Engineering Laboratory Naval Construction Battalion Center Port Hueneme, California 93043	10. PROGRAM ELEMENT PROJECT, TASK AREA & WORK UNIT NUMBERS 62759N; YF52.555.001.01.004	
11. CONTROLLING OFFICE NAME AND ADDRESS Naval Facilities Engineering Command Alexandria, Virginia 22332	12. REPORT DATE Feb 1977	13. NUMBER OF PAGES 26
14. MONITORING AGENCY NAME & ADDRESS (if different from Controlling Office)	15. SECURITY CLASS. (of this report) Unclassified	
16. DISTRIBUTION STATEMENT (of this Report) Approved for public release; distribution unlimited.	15a. DECLASSIFICATION/DOWNGRADING SCHEDULE	
17. DISTRIBUTION STATEMENT (of the abstract entered in Block 20, if different from Report) F52555		
18. SUPPLEMENTARY NOTES YF52555001		
19. KEY WORDS (Continue on reverse side if necessary and identify by block number) Ice, polar regions, excavating equipment, cold weather construction, snow, impacting, chipping, trenching, tools.		
20. ABSTRACT (Continue on reverse side if necessary and identify by block number) A review of operational requirements indicates a continuing need for equipment to excavate ice to facilitate polar construction. A 30-hp ladder-type trencher was selected and procured for its low ground pressure and versatility. The chain was outfitted with specially designed conical ice teeth, and a rotating ice chipper drum was designed and fabricated for the backhoe arm. Both modifications, along with an off-the-shelf hydraulic	continued	

12 28p.

16 F52555

18 YF52555001

→ next page

391111

Y/B

Unclassified

SECURITY CLASSIFICATION OF THIS PAGE(When Data Entered)

20. Continued

cont →

impactor attachment, were evaluated during a field test program after undergoing shakedown performance tests in the laboratory. A similar, but larger machine with identical teeth, procured under a separate task, was observed during an extended Antarctic ice-trenching operation. The CEL-designed conical teeth made both ice excavation machines very efficient trenchers, cutting over 3,000 lineal feet (900 m) of ice with an average specific energy of only 220 in.-lb/in.³ (1,500 kPa). Both backhoe attachments were effective for special applications, such as ice hummock removal and deadman anchor emplacement.

ACCESSION FOR
RTIS White Section
ODG
UNANNOUNCED
JUSTIFICATION
BY
DISTRIBUTION/AVAILABILITY
Dist. ANAL. W/OUT

Library Card

Civil Engineering Laboratory
AN ICE EXCAVATION MACHINE (Final), by K. D. Vaudrey
TR-851 26 pp illus February 1977 Unclassified

1. Ice - excavating equipment 2. Trencher - ladder type I. YF52.555.001.01.004

A review of operational requirements indicates a continuing need for equipment to excavate ice to facilitate polar construction. A 30-hp ladder-type trencher was selected and procured for its low ground pressure and versatility. The chain was outfitted with specially designed conical ice teeth, and a rotating ice chipper drum was designed and fabricated for the backhoe arm. Both modifications, along with an off-the-shelf hydraulic impactor attachment, were evaluated during a field test program after undergoing shakedown performance tests in the laboratory. A similar, but larger machine with identical teeth, procured under a separate task, was observed during an extended Antarctic ice-trenching operation. The CEL-designed conical teeth made both ice excavation machines very efficient trenchers, cutting over 3,000 lineal feet (900 m) of ice with an average specific energy of only 220 in.-lb/in.³ (1,500 kPa). Both backhoe attachments were effective for special applications, such as ice hummock removal and deadman anchor emplacement.

Unclassified

SECURITY CLASSIFICATION OF THIS PAGE(When Data Entered)

CONTENTS

	page
INTRODUCTION	1
EQUIPMENT DESCRIPTION	1
MODIFICATIONS AND ATTACHMENTS	1
Trencher Teeth	1
Ice Chipping Drum Assembly	3
Impact Device	3
LABORATORY TESTS	8
Trencher Teeth	8
Ice Chipping Drum Assembly	9
ARCTIC FIELD TESTS	11
Trenching Operations	11
Backhoe Attachment Tests	13
Hydraulic Impactor	15
ANTARCTIC FIELD OBSERVATIONS	17
CONCLUSIONS	19
ACKNOWLEDGMENT	19
REFERENCES	19
APPENDIX - Refrozen Trench Tests	21

INTRODUCTION

A review of operational requirements in both north and south polar regions indicates a continuing need for equipment that can excavate ice for (1) burial of hose and electrical power lines at vehicle road and aircraft taxiways; (2) building foundations to facilitate building erection and relocation; (3) melt water drainage control; and (4) trenching through annual sea ice for tide crack stabilization and forming of ice dock faces. It is believed that these requirements could be accomplished with suitable modification of small low-horsepower excavation equipment. References 1 and 2 present the results of FY-74 and FY-75 efforts on this project.

EQUIPMENT DESCRIPTION

A survey of commercial trenching and backhoe machines was conducted to determine the availability of equipment for ice excavation work. A ladder-type trenching machine with backhoe attachment was selected as having the greatest number of desirable features. Machines of this type were found to be commonly available in wheeled models, but one manufacturer (Davis Mfg. Co., a Division of J. I. Case Co.) was found to produce these machines also in high-flotation tracked models.*

Procurement of a Davis Model TF-700 trencher with backhoe was initiated in December 1973, and delivery was made in March 1974. This machine (Figure 1) has a basic length of 11 feet (3.3 m) and is 52 inches (133 cm) wide at the maximum point. The machine weighs approximately 4,400 pounds (19,500 N), and it has a ground pressure of approximately 5.1 psi (35 kPa). The trencher is powered by a 30-hp Wisconsin air-cooled engine with mechanical drive to

the trencher chain and hydraulic drive on tracks, backhoe and dozer blade operation. The maximum recommended depth for excavation in dirt is 72 inches (184 cm) for a 6-inch (15-cm) wide trench. This machine can be used for excavating wider trenches, but the recommended depth of cut is subsequently reduced. This trencher was equipped with standard 8-inch (20-cm) "frost-chain" with tungsten-carbide-tipped teeth. This chain is designed for excavation in frozen earth to a depth of 58 inches (148 cm). To increase the versatility of this particular machine two other standard attachments were purchased: (1) an alternate boom with a 6-foot (2-m) trenching capability, and (2) a 12-inch (30-cm) wide backhoe bucket.

MODIFICATIONS AND ATTACHMENTS

Upon delivery of the trencher, designs for modifications and attachments of the machine were begun. These included design and fabrication of ice-cutting teeth for the trencher and a revolving ice-cutting drum attachment for the backhoe. Another backhoe arm attachment considered for ice removal was a commercially available impact device.

Trencher Teeth

Various configurations for ice-cutting teeth were reviewed for maximum cutting rate and minimum horsepower requirements. It was concluded that teeth with a 30-degree conical point, developed by CEL in 1960 for use on an ice dozer, would be the most effective for excavating ice [3]. A conical tooth design was prepared (Figure 2) that is interchangeable with the commercial carbide-tipped tooth. Seventy-five of these teeth were fabricated for use on the

* Since the Davis trencher was purchased, another company now has a disc saw in a low-pressure tracked model. However, there is one major disadvantage to disc trenchers: to excavate a deep trench requires discs of enormous diameter.

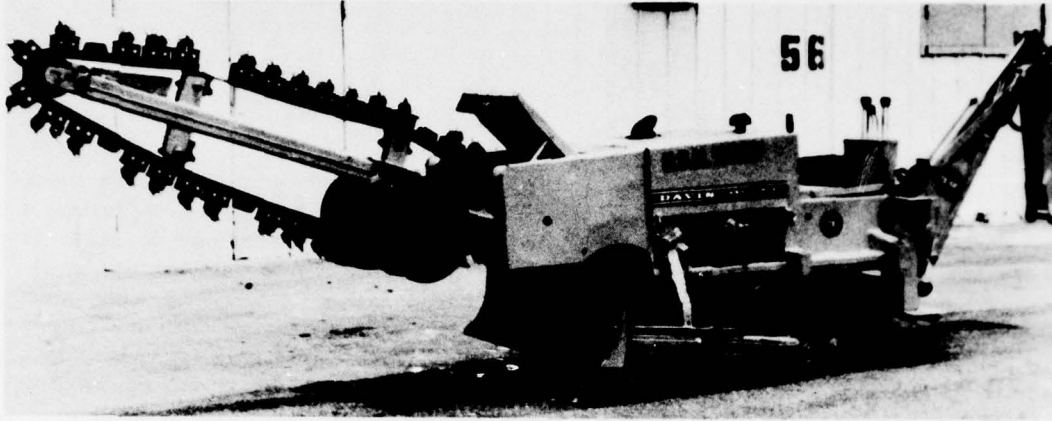

Figure 1. Thirty-hp ice excavation machine (Davis Model TF-700).

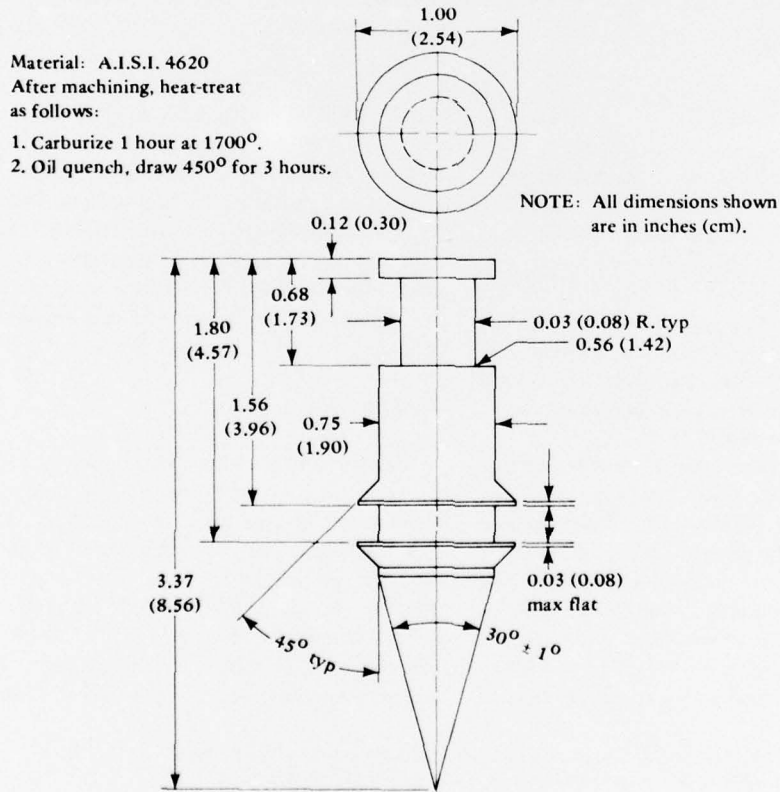

Figure 2. Conical ice trenching tooth used on ice excavation machine.

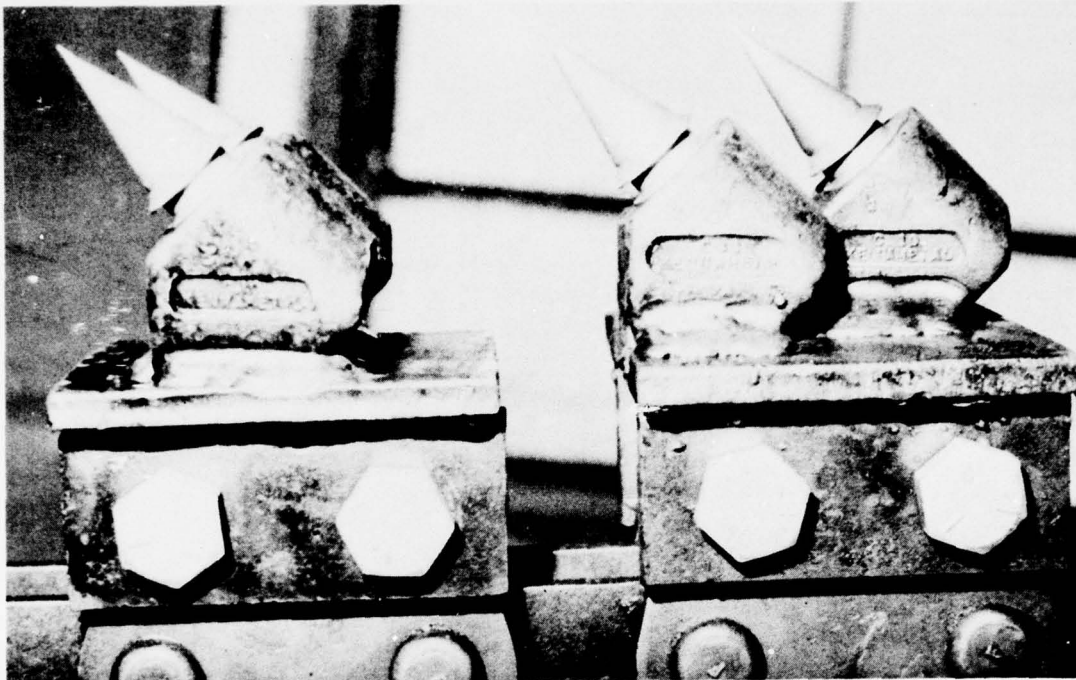

Figure 3. Conical teeth inserted in trencher chain.

trencher during testing (Figure 3). Twenty additional teeth were procured for the longer, 6-foot (2-m) boom attachment.

Ice Chipping Drum Assembly

A variety of concepts for reciprocating and rotating ice cutters for attachment to the backhoe arm was studied. It was concluded that the least complex and most promising configuration was a hydraulically driven revolving drum with conical teeth. Fabrication drawings for an attachment of this form were prepared (Figures 4 and 5).

The drum is 14 inches (36 cm) in diameter with 3-inch (8-cm) long teeth and a minimum width of 12.5 inches (31.8 cm). Drum extensions can be added to increase the width to 17.5 inches (44.5 cm). The attachment is designed for a maximum rotational speed of 500 rpm.

The fabrication of the chipping drum was completed in early December 1974. The initial test

results pointed out a deficiency in tooth spacing. The initial 2.5-inch (6.4-cm) spacing was reduced to 1 inch (2.5 cm) by refabricating the tooth-holder rings according to CEL Drawings 74-22-1F (Option Two) and 74-22-3F (Figures 4 and 6).

Impact Device

Another backhoe attachment with good potential for ice excavation and removal is an impact device. A high-energy, lightweight, hydraulically operated impactor was necessary for compatibility with the existing TF-700 trencher and D-100 backhoe arm. The only impactor found to meet all of these requirements is manufactured by Hughes Tool Company (Figure 7).

The Hughes Hydraulic Backhoe Impactor is a high-energy impact device which uses the tractor-backhoe hydraulic power source to deliver rapid, powerful blows to the top of the working tool. Each blow is released at a fixed (125 ft-lb) energy

BEST AVAILABLE COPY

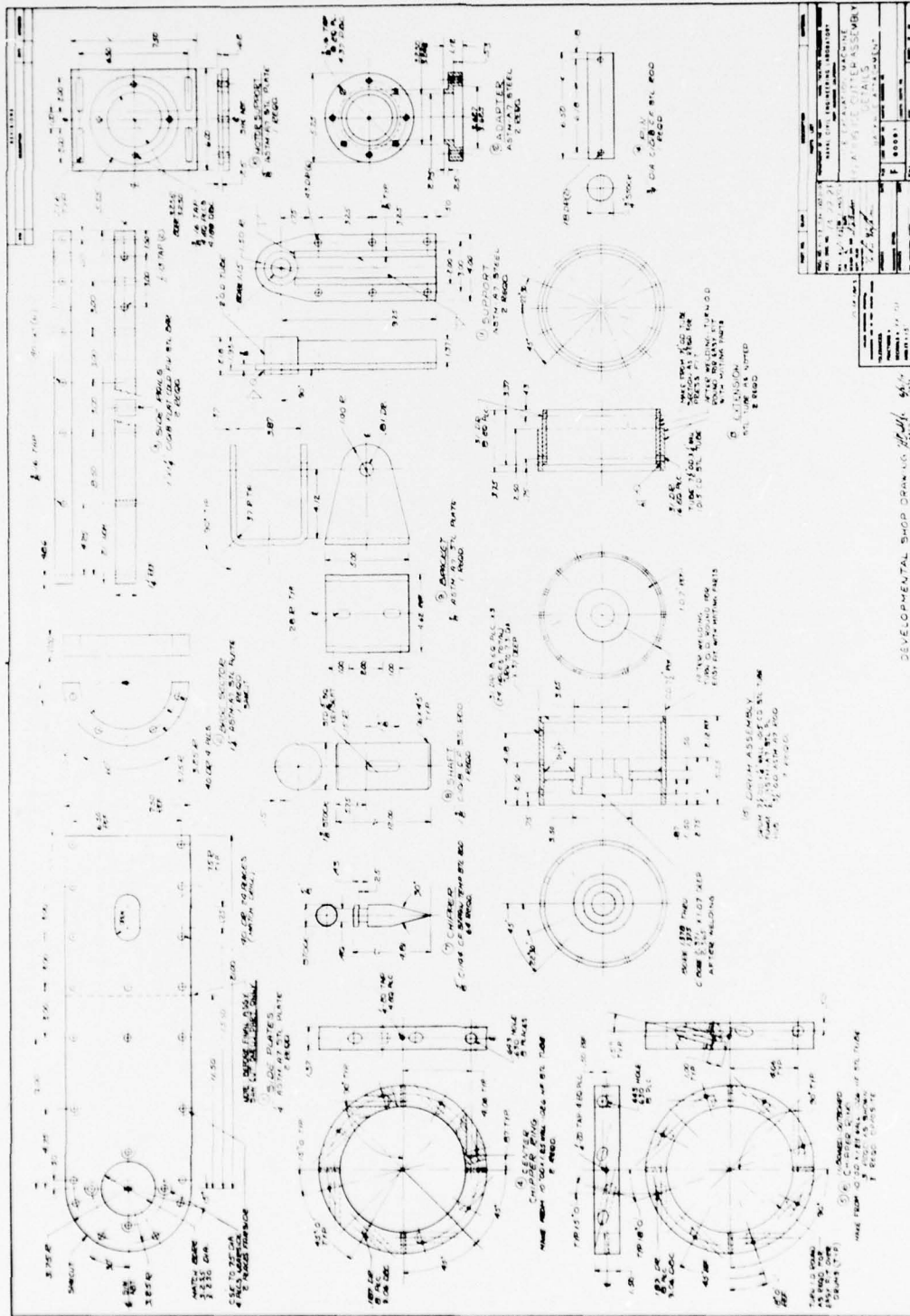

Figure 5. Fabrication Drawing 74-22-2F for rotating ice chipping drum assembly.

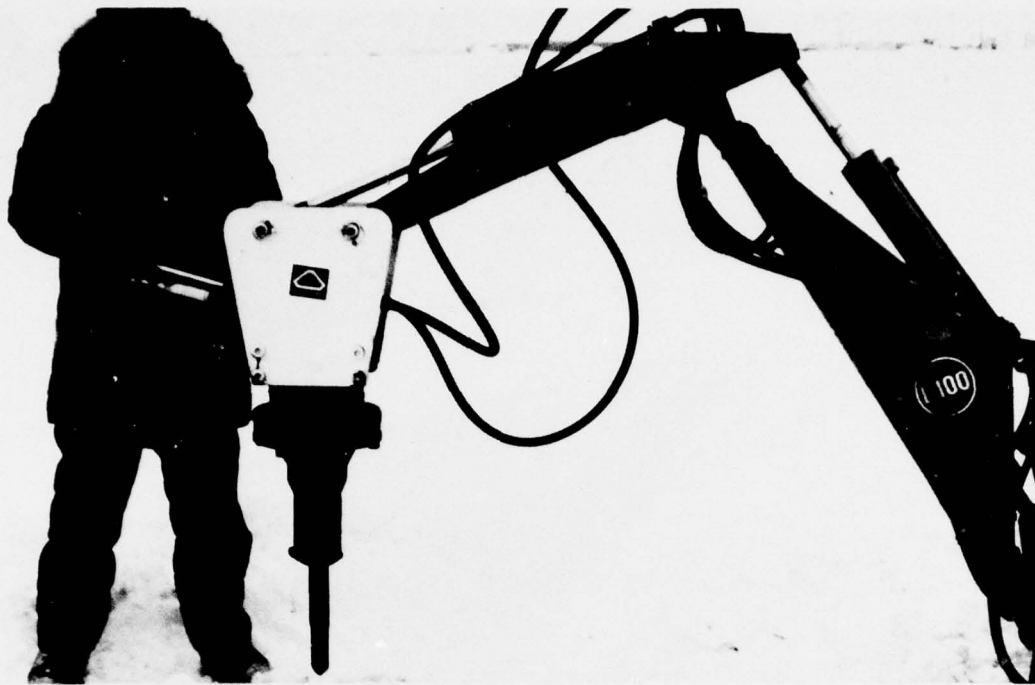

Figure 7. The impact device attached to backhoe arm with relieved moil working tool in place.

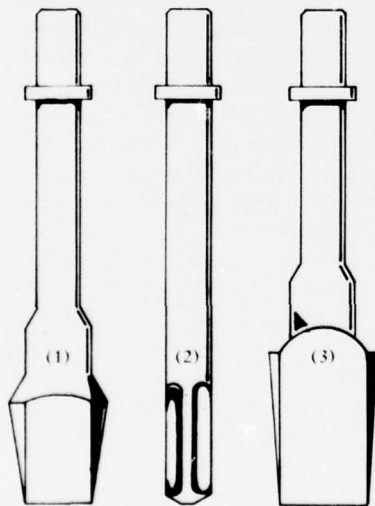

Figure 8. Three working tools for impactor: (1) 30-degree breaker, (2) relieved moil, and (3) frost spade.

level and is independent of the frequency of the blows. This impact frequency is determined by the volume of fluid available to drive the impactor hydraulic motor. Since the backhoe hydraulic circuit has already been modified with a diverter control valve and flexible hose lines to operate the ice chipping drum, it is a simple task to outfit the hoses with quick-disconnect couplings for rapid interchange between bucket, chipping drum, or impactor.

The impactor mounts on the backhoe by using adapter plates that fit the bucket linkage. The standard bucket pins are used to attach the impactor to the backhoe arm. Including the adapter plates for the D-100 backhoe, the weight of the entire impactor unit is 285 pounds.

Three working tools were selected for ice excavation: (1) 30-degree breaker [2-5/16-inch (7.5-cm) wide cutting edge]; (2) relieved moil; and (3) frost spade [3-3/4-inch (9.5-cm) wide cutting edge] (Figure 8).

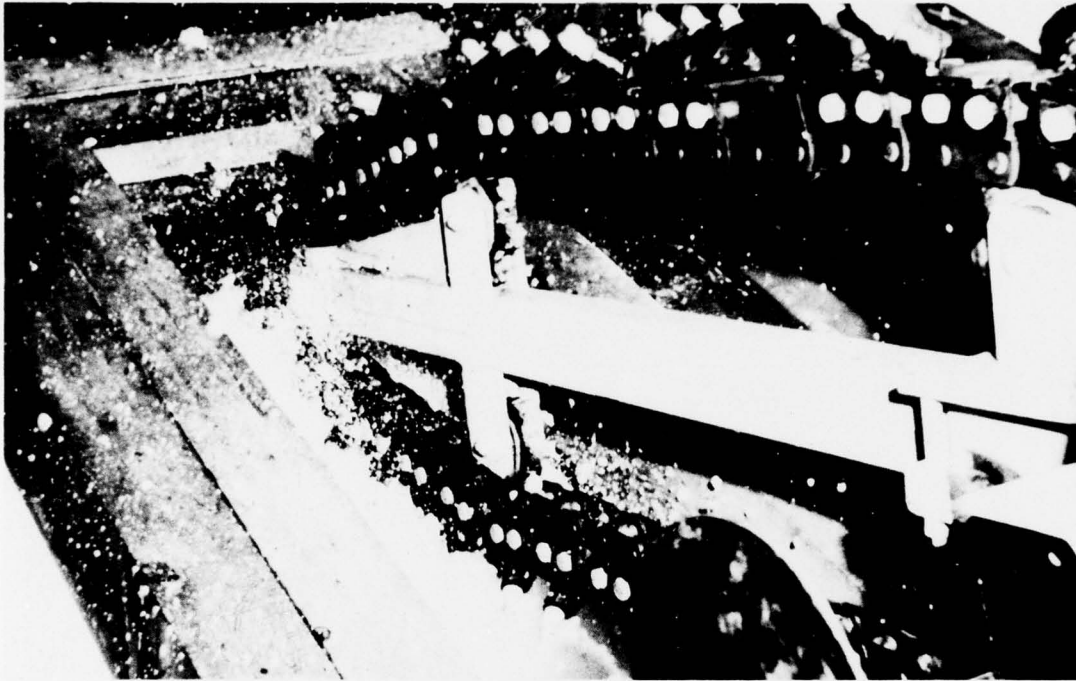

Figure 9. Trenching operation in cold chamber.

LABORATORY TESTS

Laboratory experiments were performed to compare the two sets of trencher teeth and assess the ice removal capability of the chipping drum assembly. The impactor attachment was selected as an off-the-shelf item and was received too late for inclusion in the laboratory testing of the ice excavation machine.

Trencher Teeth

In June 1974, laboratory tests were conducted on the ice excavation machine to compare the performance of the standard carbide-tipped frost teeth with the heat-treated conical teeth, and to determine its drawbar capacity on ice and sand.

The teeth comparison tests were conducted in the CEL cold chamber, using the 4.5-foot (1.4-m) wide by 16-foot (5-m) long by 3.5-foot (1.1-m) deep sub-floor tank filled with seawater. Seawater ice was grown to an average thickness of 31 inches (79 cm),

leaving 10 to 11 inches (25 cm) of briny water beneath it. The temperature of the ice was 23°F (-5°C). The cutting-chain speed of the trencher was maintained at about 90 fpm (27 m/min) during the tests. The maximum travel speed using the standard carbide-tipped teeth was 7.5 fpm (2.3 m/min) as compared to 13.9 fpm (4.2 m/min) for the conical teeth (Figure 9). Both types of teeth cut 8-inch (20-cm) wide trenches.

The travel speed using the standard carbide-tipped teeth was limited by the cutting characteristics of the teeth. At travel speeds faster than 7.5 fpm (2.3 m/min) the trencher would not cut through the 31 inches (79 cm) of ice, but instead was lifted until the carbide-tipped teeth supported the trencher. Using the conical teeth, the travel speed was limited by the horsepower of the trencher.

From the travel speeds and the volume of material removed it is possible to calculate the approximate specific energy consumption. Specific energy is found by dividing the power required to

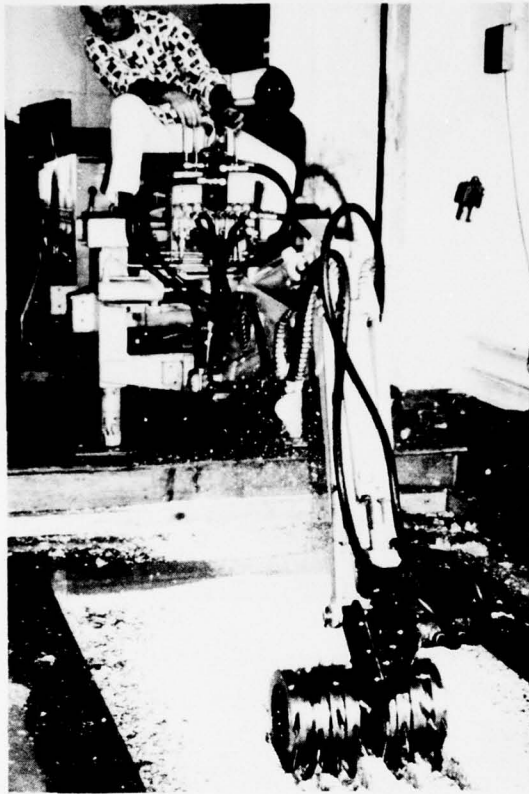

Figure 10. Ice chipping drum mounted on backhoe arm performing initial cold chamber tests.

excavate the ice by the volume rate of ice removed and has the units in.-lb/in.^3 (kPa). It is hard to define how much power is delivered to the trencher chain, but it is definitely less than the rated horsepower of the engine. A U. S. Army Cold Regions Research and Engineering Laboratory (CRREL) report [4] states that many types of excavating machines deliver only about 60% of the rated power to the cutting element. Using this figure, the ice trencher with carbide-tipped teeth had a specific energy of 319 in.-lb/in.^3 (2,200 kPa) compared to 172 in.-lb/in.^3 (1,186 kPa) for the conical ice teeth. These specific energy values compare favorably with a minimum value of 500 in.-lb/in.^3 (3,450 kPa) found from trenching frozen silt.

The maximum drawbar force of the trencher was found to be 1,500 pounds (6,700 N) on ice and 2,200 pounds (9,800 N) on beach sand. Additional tests showed that the drawbar capacity could be increased by placing 1/2-inch (1.3-cm) diameter bolts through existing holes in the tracks. With two bolts on every fifth track the drawbar capacity was increased to 2,900 pounds (12,900 N) on ice.

Ice Chipping Drum Assembly

In December 1974, laboratory tests were performed to evaluate the ice chipping drum attached to the backhoe arm (Figure 10). The hydraulic rotation control of the chipping drum was plumbed into the trencher circuitry. The rotation speed was calculated to be 400 rpm. The tests were conducted on 18 inches (46 cm) of seawater ice grown in the subfloor tank in the CEL cold chamber. The results of these performance tests identified two related limitations of the chipping drum. First, the 2-1/2-inch (6.4-cm) spacing between the planes formed by each ring of chipping teeth left ridges of ice (Figure 11). Second, the rotation drive housing prohibited the drum assembly from cutting more than 2 inches (5 cm) into the ice.

A second series of laboratory tests was conducted on manufactured blocks of ice. The chipping drum had been modified by simply reversing the order of tooth rings on the drum assembly to reduce the spacing to 1-3/4 (4.4 cm) and 1 inch (2.5 cm) (Figure 12). No discernible ridging occurred when the spacing was 1 inch (2.5 cm). If the operation is not constrained too severely by buildings or foundations, the second problem of limited penetration can be avoided. The chipping drum can be moved side-to-side while rotating to shave off the middle ridge, thereby allowing unrestricted cutting depth (Figure 13).

From these tests, a permanent modification to the ice chipping tooth-holding rings was designed — doubling the number of cutting circles of teeth to 16, while halving the number of teeth per circle to four. This redesign in effect reduces the tooth plane spacing to 1 inch (2.5 cm). This modification is clearly shown on CEL Drawing 74-22-1F as Option Two (Figure 4). Option One of the same drawing depicts the original fabrication for comparison.

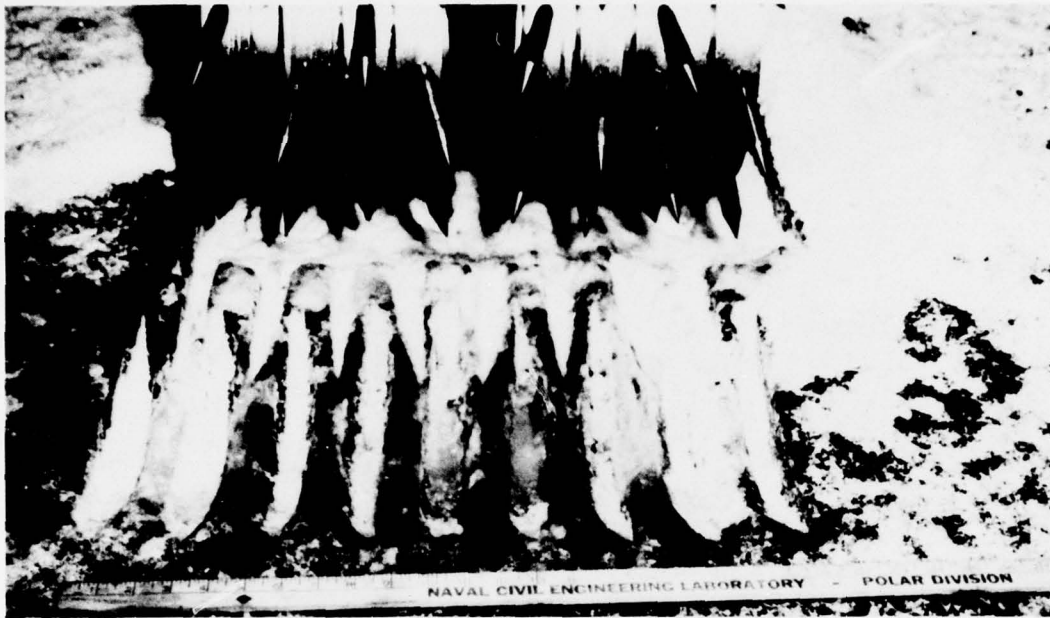

Figure 11. Chipping tests showing grooves left by 2-1/2-inch (6.4-cm) tooth spacing.

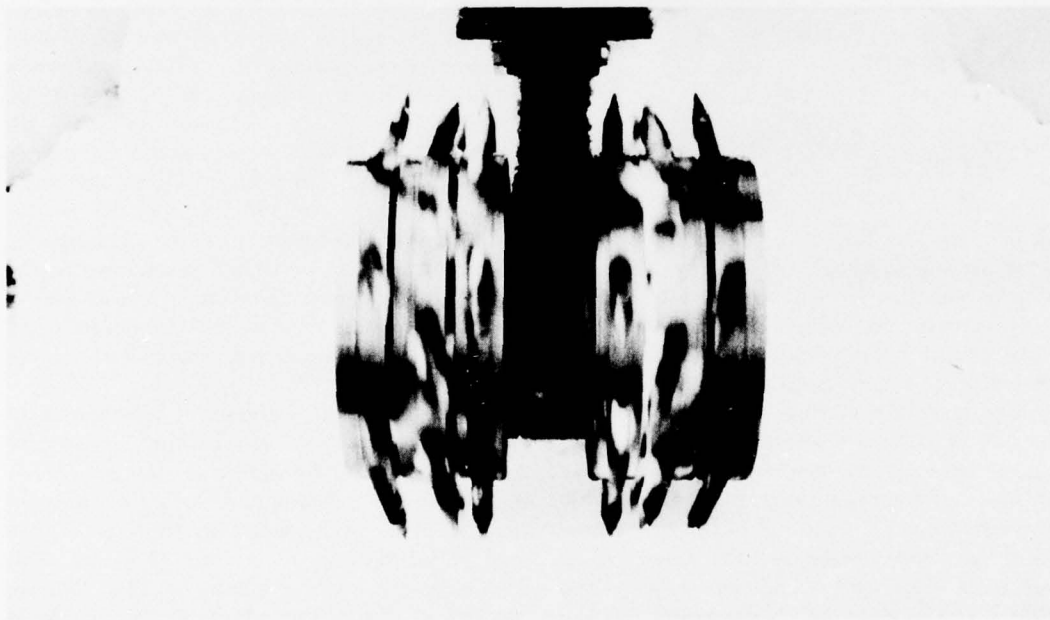

Figure 12. Chipping tests with tooth spacing reduced to 1-3/4 (4.4 cm) and 1 inch (2.5 cm).

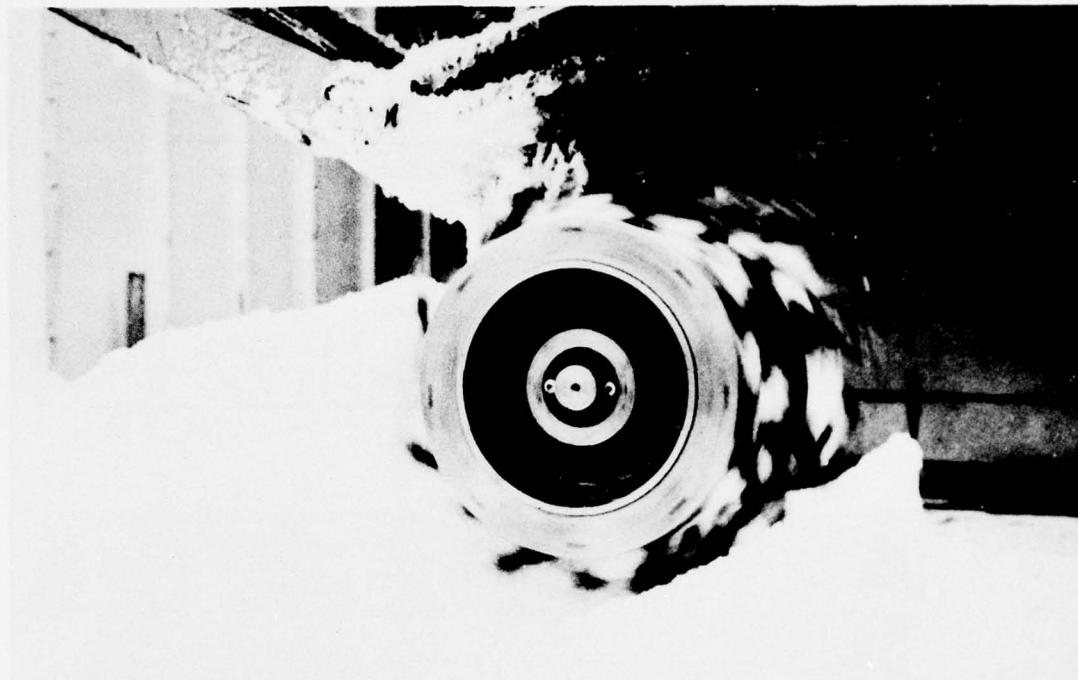

Figure 13. Chipping tests showing ice shape as drum moves across and through the ice.

ARCTIC FIELD TESTS

After the chain was outfitted with the special conical ice teeth and the rotating ice chipping drum was modified by closer tooth spacing, the ice excavation machine and its attachments were shipped by barge to Barrow, Alaska, for field evaluation experiments. The impactor attachment followed as a result of late procurement.

Trenching Operations

Initially, the ice excavation machine was used for cutting beams for the viscoelastic ice tests conducted under a separate task. Seven in-situ cantilever beams required approximately 700 lineal feet (213 m) of trench cut through the existing 75-inch (190-cm) ice sheet. Additional ice trenching operations during the test period brought the total trench length to over 1,000 feet (305 m) without any observable wear of the special conical ice teeth. Freeze-back of the trenches was a problem during long-term beam tests.

Any remaining ice chip aggregate accelerated trench refreezing. Therefore, all beam trenching operations were performed in two stages to reduce the amount of ice chip slurry. First, a 60-inch (152-cm) deep trench was cut and cleaned of all dry ice chips. Then a through trench was completed and the ice slurry removed from the surface. Figure 14 shows the ice excavation machine cutting a part-through trench, leaving ice chip berms on both sides. A through trench washes most of the ice spoilage back into the cut.

In order to trench through 75 inches (190 cm) of ice, it was necessary to use the alternate six-foot (2-m) boom, which means it can cut 6 feet (2 m) deep with the boom 30 degrees from vertical. Since the point of boom attachment on the treacher is 32 inches (81 cm) above the ice, the actual distance from attachment point to boom tip is 125 inches (318 cm). If the treacher is operated as a giant sabre saw with the boom almost vertical, the maximum ice trench depth with the "six-foot" boom is 93 inches (237 cm). However, a simple modification of the linkage

Table 1. Ice Trenching Field Test Results

Trench Depth		Trenching Speed		Ice Volume Removal Rate		Specific Energy	
in.	cm	fpm	m/min	ft ³ /min	m ³ /min	in.-lb/in. ³	kPa
26	66	9.4	2.9	13.5	0.38	305	2,100
40	102	7.7	2.3	17.2	0.49	240	1,655
48	122	6.6	2.0	17.7	0.50	233	1,607
60	152	4.3	1.3	14.4	0.41	286	1,972
75 ^a	191	4.5	1.4	18.8	0.53	219	1,510

^aCut through the ice sheet.



Figure 14. Ice excavation machine performing trenching operation, cutting 60-inch (150-cm) trench in 78-inch (200-cm) thick ice sheet.

between the boom hydraulic cylinder and axle must be made so the axle that raises and lowers the cutting boom can rotate into a vertical position. In addition, the dozer blade, both dirt augers, and back splash plate must be removed for such operation.

In addition to supporting the beam-cutting operation, several tests were conducted to qualitatively and quantitatively measure trencher performance on -10°F (-23°C) sea ice. A series of parallel trenches was cut to different depths to determine linear trencher speed and ice volume removal rates. Again, using the approximation that 60% of the rated machine power (30 hp) is delivered to the trencher teeth, specific energy values can be calculated. Trenching speeds, ice removal rates, and specific energies are shown in Table I. The relatively low specific energy determined for the through-trenching test is the result of the lubricating effect of seawater washing chips away from the trench face instead of dragging them up the slope of a dry trench. The revolution speed of the chain traveling around the boom was 300 fpm (90 m/min) for all tests. Qualitatively, one annoying feature that persisted during all trenching operations was the inability to maintain a straight trench because the machine kept drifting left (see Figure 15). Only through intermediate, but continual, braking could a straight trench be maintained. Of course, the braking operation reduced the forward speed of the trencher and, correspondingly, its cutting efficiency.

Since a limited comparison test between carbide-tipped and special conical ice teeth was performed in the laboratory, it was planned to duplicate the above series of trenching tests using the carbide teeth. However, after replacing the conical ice teeth with carbide ones, the results of the initial test indicated the futility of further testing. During the first attempt to dig a trench, the carbide-tipped teeth literally scraped their way to a depth of 5 feet (1.5 m), taking over 25 minutes. The resulting spoils were the consistency of fine sand, no chips present whatsoever. The tooth has a relatively flat 45-degree taper ending in a correspondingly blunt 90-degree carbide tip (see Figure 16) which caused it to slide and grind the bottom and up-slope of the trench without impacting or chipping the ice. Therefore, further field efforts with the carbide teeth in ice was abandoned with the thought: how did the carbide teeth perform as well as

they did during laboratory tests? During the laboratory tests the ice temperature was much higher, near melting, and the lower strength allowed the carbide-tipped teeth to trench reasonably well.

After the carbide teeth had failed to trench ice, a test was performed on frozen ground; first, in gravel, then in silt. The result was almost the same: the only difference was the frozen gravel remained almost impregnable to the trenching action, whereas a short 6-foot (2-m) trench, 16 inches (41 cm) deep, was cut in the frozen silt. This effort took almost 5 minutes, resulting in a high specific energy of $3,870 \text{ in.-lb/in.}^3$ ($2.67 \times 10^4 \text{ kPa}$).

The trenching test in frozen ground at a temperature of 10°F (-12°C) demonstrated that the machine was too light and the carbide-tipped teeth were ineffective. With the outriggers down and supplying maximum boom downpressure, the entire machine was supported by only the outriggers and the point of contact of the moving chain, yet no significant excavation occurred. What actual trenching did occur was again due to grinding rather than a chipping process, as in the ice test. This grinding action was the result of the angle between the axis of the tooth and the boom being almost equal to the 45-degree taper angle of the tooth tip. This means that the conical taper slides along the trench without the tooth tip striking or digging into the frozen ground.

After only a 5-minute operation in frozen gravel, inspection of the trencher teeth showed appreciable wear, not of the carbide tip, but of the metal surrounding and encasing the carbide. Of course, when most of the metal has worn away, the carbide tip will have lost its embedding matrix and will fall out. The 90-degree included tip angle should be reduced and the carbide button tip replaced by an entire carbide tooth point. A set of carbide teeth with a 75-degree included tip angle was purchased and will be tested during another field exercise in September 1976.

Backhoe Attachment Tests

Before presenting the results of the field evaluation tests of the ice chipping drum and impactor, it is appropriate to briefly discuss the backhoe itself and its operating functions. The Davis D-100 backhoe arm



Figure 15. Part-through trench in 78-inch (200-cm) thick ice sheet showing gradual curve to left.

is hydraulically operated and has the normal four degrees of freedom: (1) swing (180°); (2) boom up and down; (3) crowd in and out; and (4) bucket curl. For a given swing position, a lifting or pullout test was conducted using the other three movements. First, a chain toggle was attached to the underside of the ice sheet and frozen in. Distances of 4 feet (1.2 m) and 6 feet (1.8 m) were measured from the outriggers to the lift point for two separate tests. The results are tabulated in Table 2.

No value could be obtained for the bucket curl function at the 72-inch (183-cm) position because the governing hydraulic cylinder had reached maximum stroke. The entire hydraulic control system on the backhoe arm is jerky and makes any required precision movement very difficult to perform.



Figure 16. Carbide-tipped trencher teeth showing 45-degree inclusive tip angle and angle made with tooth holder.

The backhoe bucket was replaced with the ice chipping drum to perform field evaluation tests with the new 1-inch (2.5-cm) tooth spacing. The change-over operation took only 30 minutes including the connection of the hydraulic hose lines to the chipping drum. An ice removal rate test was performed with boom, crowd, and curl movements individually actuated. The chipping drum rotated freely at 610 rpm, while operating at a hydraulic pressure of 2,000 psi (13,800 kPa) and a flow rate of 11.5 gpm (43.5 l/min). Again, assuming only 60% of the hydraulic horsepower actually was used to chip the ice, the following specific energy values were attained: (1) boom, 730 in.-lb/in.³ (5,030 kPa); (2) crowd, 860 in.-lb/in.³ (5,930 kPa); and (3) curl, 780 in.-lb/in.³ (5,380 kPa). Consequently, the ice removal efficiency

Table 2. Backhoe Pullout Tests

Degree of Freedom	Pullout Forces for —	
	48-Inch Distance ^a (122 cm)	72-Inch Distance ^a (183 cm)
Boom only	1,600 lb (7,100 N)	1,000 lb (4,500 N)
Crowd only	4,100 lb (18,000 N)	3,400 lb (15,000 N)
Curl only	2,000 lb (9,000 N)	—
Boom + crowd + curl	3,600 lb (16,000 N)	3,300 lb (15,000 N) ^b

^aDistance from outrigger to lift point.

^bBoom and crowd only; no curl could be performed.

is about three times lower than the trenching operation, but still comparable to disc saws in permafrost. However, the major problem with the ice chipping drum is not entirely related to its low efficiency. The drum itself is simply too small to remove large quantities of snow and ice quickly. It was purposefully made small to reduce weight and increase maneuverability in limited-access areas, but as mentioned previously, the backhoe arm hydraulic controls are too sensitive for precision chipping.

A simulated foundation was made of small lumber and placed over a compacted snow and ice hummock. The chipping drum then cleared the ice and snow underneath the structure. The operation was slow due to the required careful movement of the chipping drum and its small size. If the drum was advanced too rapidly into the ice, the teeth would bite in and stop the drum. On the other hand, the drum functioned very well in high-density snow. However, as the drum worked its way underneath the simulated structure, it would become buried in powdery snow discharge and keep milling the same snow over and over. With the jerky hydraulics in a limited-access area where there was decreased visibility from flying snow and ice chips, it was only a matter of time before the chipping drum caught hold of the wood frame. If it had been heavy timber of a real foundation, the chipping drum would probably have been damaged.

Another experiment was conducted on removing ice hummocks that could block roadways or airfields

(Figure 17). In an open area the swing function of the backhoe arm was utilized for more effective and quicker ice removal, but still the size of the drum limited the quantity of ice removed. The ice chipping drum could perform effectively on leveling a road or runway ice surface if there were only a few, small hummocks to remove.

Hydraulic Impactor

After the ice chipping drum tests were completed, the drum was disconnected from the backhoe arm and the impact device connected in its place. The primary objective of the impactor tests was to evaluate how effective each of the working tools was in removing ice hummocks and irregular chunks and in constructing a pit for burying deadman anchors. Also, ice removal rates were to be found for later calculation of specific energy values. The first tool to be tested was the relieved moil; however, the 30-degree breaker and wider frost spade behaved similarly; therefore, only the overall test operations and evaluation will be presented. Initially, a test pit was attempted. After downpressure was applied to the tool and impacting commenced, the tool buried itself in a few seconds; however, a great deal of spalling occurred as horizontal ice platelets broke away from the ice sheet. The size of these tabular chips ranged from 1 to 2 inches (3 to 5 cm) about 4 inches (10 cm) away from the tool to giant 12-to-18-inch (30-to-45 cm) wide slabs about 2 feet (60 cm)



Figure 17. Removing ice hummock with ice chipping drum attached to backhoe arm.

from the tool. The ice immediately surrounding the tool was granulated, completely pulverized, while the average thickness of these larger slabs varied from 1 to 2 inches (3 to 5 cm). The pit crater looked roughly like an inverted cone with a depth at the tool almost equal to its penetration in the ice. Once the tool reached full penetration it was removed, moved over about one foot, downpressure applied again, and the procedure repeated. In about 5 to 10 minutes, a rough 18-inch (45-cm) deep by 4-foot (1-m) wide hole could be made for possible emplacement of deadman anchorages (see Figure 18). Most of that time was actually used in repositioning the tool and clearing away the ice rubble.

To calculate the specific energy for this ice impacting operation, approximate dimensions had to be assumed for a single-impacting event. Choosing a cone with a base diameter of 24 inches (60 cm) and a depth of 12 inches (30 cm) (the length of the exposed tool end), the ice removal rate becomes 70 cu in./sec (1,100 cc/sec). It has been mentioned previously that the energy release per blow is a constant 125 ft-lb (170 J). For a flow rate of 11.5 gpm (44 l/min) the impact rate was about 450 blows/min, giving an energy release rate of 900 ft-lb/sec (1,200 J/sec). Thus, the specific energy of the impactor during this operation was 150 in.-lb/in.³ (1,000 kPa). This relatively high efficiency is somewhat misleading since the impactor did not actually remove the ice, but broke it up into removable-sized chunks.

The above impacting operation was performed on the horizontal ice sheet. Another test was conducted on a 4-foot (1-m) high ice block where the impactor operated horizontally against one of the vertical faces. A reasonable preload was difficult to attain or maintain with only the hydraulic pressure; thus, it took considerable effort and time to demolish the block. For hummock removal, if the ice perturbation is 3 feet (1 m) or lower, the impactor can be positioned vertically so the weight of the trencher can assist in preloading the working tool for a more effective performance.

Tests were also conducted on frozen ground to attempt construction of a pit from a horizontal surface and enlarging a previously drilled 12-inch (30-cm) hole. During the pit tests at maximum preload downpressure, the two blunter spade-shaped working tools did not even penetrate the frozen soil, while the moil would penetrate the full tool depth, but only after heat buildup under the tool caused the soil to melt. No surficial spalling occurred as it did in the ice sheet tests. However, some spalling did occur during the hole enlargement tests with all the tools, provided they were placed within 6 inches (15 cm) of the edge of the hole. The largest of these frozen soil chunks was 6 inches (16 cm). It might be possible to combine trenching operations with impacting so a free, vertical face could be formed to aid spalling; however, this obviously tedious operation would be practical for only very limited excavation requirements.



Figure 18. Impactor attachment with frost spade working tool excavating anchor pit on ice sheet surface.

ANTARCTIC FIELD OBSERVATIONS

Part of the FY-75 effort of this work unit was devoted to observing the ice trenching performance of a similar machine during field tests in Antarctica [5]. A final report [6] covers the techniques used for sea-ice removal in greater detail than are presented here.

A 60-hp ladder-type trencher was purchased to excavate 8-inch (20-cm) wide trenches in the sea ice for a project sponsored by Naval Support Force, Antarctica (Figure 19). The objective was to assist the icebreaker in clearing ice from Winter Quarters Bay by a method that would prevent any breakup of the ice wharf from crack propagations during icebreaker operations. The plan was to operate this trencher as an ice saw, cutting large ice floes out of the sea-ice sheet (Figure 20).

While this operation is only one of the intended uses for an ice excavation machine, it was decided

that monitoring this Antarctic procedure would provide general operational characteristics for comparison with the 30-hp ice trencher. This larger ice trencher was equipped with the same conical ice teeth, but it did not have the dozer blade or backhoe arm of the smaller ice excavation machine. The larger ice trencher has a tilting operation capability to maintain a vertical trench over rough terrain, whereas the smaller machine does not. Besides the horsepower difference, the larger ice trencher is equipped with a Ford water-cooled diesel engine rather than the Wisconsin air-cooled gasoline engine of the smaller machine.

Sea-ice thickness measurements in Winter Quarters Bay ranged from 68 to 74 inches (173 to 188 cm) on 30 December 1974. Since the air temperatures were consistently above freezing, the ice-sheet temperature was essentially isothermal at about 26°F (-4°C). The mild temperatures, combined with many cloudless days, created an ice surface pock-marked with melt ponds as much as 18 inches (45 cm) deep.

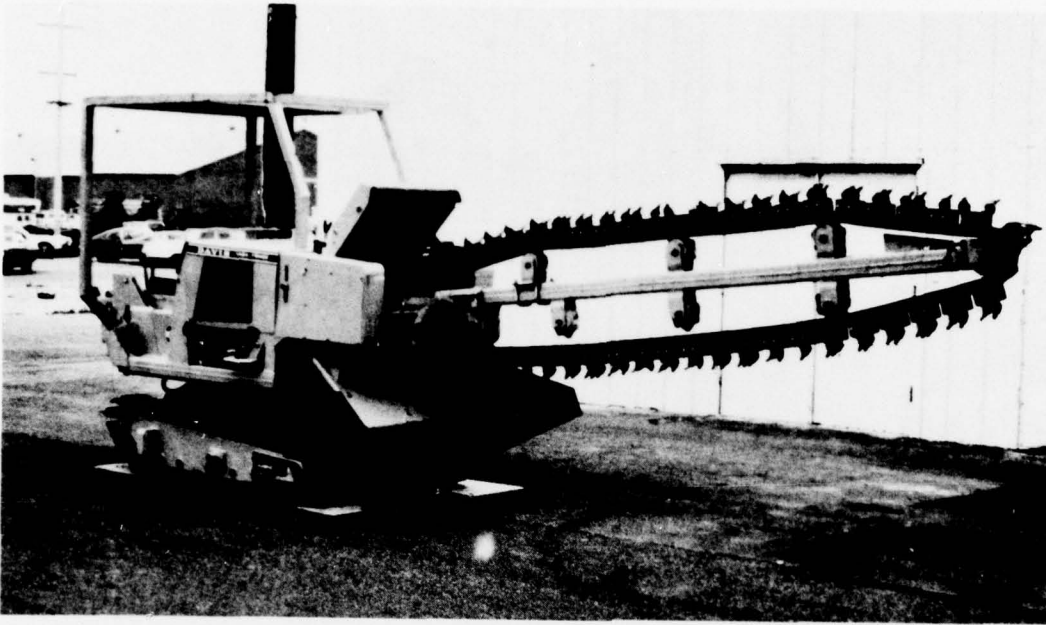

Figure 19. Sixty-hp ice trencher (Davis Model TF-1000).



Figure 20. Model TF-1000 during trenching operation in Antarctica.

Several problems were encountered during the operation: (1) a 24-inch (60-cm) layer of ice chips floating on the flooded trench caused rapid freeze-back; (2) with the 10-foot (3-m) boom the machine became nose-heavy; and (3) the uneven ice surface caused by severe ablation made it impossible to maintain a straight cut. The freeze-back problem was not solved, and it will remain during every trenching exercise unless the ice chips can be removed. The smaller 30-hp ice excavation machine should not have a balance problem, since the backhoe attachment provides better counterbalance and the machine itself has a lower center of gravity. Since there is no tilt capability on the smaller trencher to compensate for uneven ice, an ablated ice surface will be a serious, potential problem.

After operating the ice trencher for more than 25 hours, the teeth were inspected for wear, which was found to be imperceptible. However, should the teeth break or wear, they can be replaced easily and individually. The conical-shaped teeth showed their efficiency in cutting by allowing the trencher to go through 72 inches (183 cm) of sea ice at a travel speed of 10 fpm (3 m/min). The specific energy consumption was 206 in.-lb/in.³ (1,400 kPa), assuming 60% of the rated engine horsepower was delivered to the chain for trenching.

Overall, the trencher was easy to operate and quite simple to learn for the novice operator. From a human-factors standpoint, the machine was extremely noisy and, at times, exhaust fumes drifted back into the operator's face. Both of these problems could be corrected by extending the exhaust pipe. The ice trencher gave an overall maintenance-free performance during all phases of the operation. Cutting speeds equalled or exceeded the initial estimates.

CONCLUSIONS

1. The ice excavation machine was easy to operate, maintenance-free, and maneuverable during all ice trenching operations.
2. The CEL-designed conical teeth made the ice excavation machine an efficient trencher, cutting over 1,000 lineal feet (300 m) of ice with an average

specific energy of 250 in.-lb/in.³ (1,700 kPa), which is a relatively low value for excavation.

3. The ice chipping drum was effective on isolated small hummocks of ice or high-density snow, but in restricted access areas its operations were hampered by hydraulic system limitations.

4. The impactor was highly efficient at ice breaking with a specific energy around 150 in.-lb/in.³ (1,000 kPa), but the impactor required removing the ice spoils from the excavation as an additional function.

5. On frozen ground all excavating operations performed marginally because the machine was too lightweight and underpowered.

ACKNOWLEDGMENT

The author wishes to acknowledge and express his gratitude to CDR Richard H. Schaus, Commanding Officer, and his staff at the Naval Arctic Research Laboratory for their enthusiastic support of the CEL field team and the experiments performed using the ice excavation machine while in Barrow, Alaska, during the spring of 1976.

REFERENCES

1. Civil Engineering Laboratory. Progress Report 61-74-4: Ice excavation machine, by F. W. Brier and C. R. Hoffman. Port Hueneme, CA, Jun 1974.
- 2._____. Technical Note N-1415: Development of an Ice Excavation Machine, by K. D. Vaudrey. Port Hueneme, CA, Dec 1975.
- 3._____. Technical Report R-346: Ice grading equipment - Development of an experimental rotating-drum cutter, by S. E. Gifford. Port Hueneme, CA, Nov 1964.
4. Cold Regions Research and Evaluation Laboratory. Technical Note: Cutting frozen ground with disc saws, by M. Mellor. Hanover, NH, Jul 1972.
5. Civil Engineering Laboratory. Progress Report 61-75-7: Ice excavation machine - Characteristics of Antarctic ice trencher operations, by K. D. Vaudrey and F. W. Brier. Port Hueneme, CA, Feb 1975.

6._____. Technical Note: N-1416: Sea-ice removal techniques for Winter Quarters Bay, Antarctica, by F. W. Brier and K. D. Vaudrey. Port Huoneme, CA, Dec 1975.

Appendix

REFROZEN TRENCH TESTS

This test series of possible ice trencher application was a spinoff of an observation during the Antarctic operations. It was found that refrozen trenches containing ice chip aggregate could not be retrenched with the machine. Therefore, several separate tests were conducted at Barrow, Alaska, on a similar refrozen trench to determine if the ice strength or fracture toughness had increased and, if so, the possible cause for the increase.

Initially, a sieve analysis was performed on the dry ice chips cut with the conical teeth to determine the relative size and percentage of the aggregate pieces. A plot of two sieve analyses is shown in Figure A-1. Approximately 10% of the ice chips are larger than 1 inch (2.5 cm), 65% lie between 1 inch (2.5 cm) and 1/8 inch (0.3 cm), and 25% are smaller than 1/8 inch (0.3 cm).

A through trench was cut in the 78-inch (198-cm) ice sheet, and almost all of the ice chips washed back into the flooded trench. The trench was allowed to refreeze for 10 days at an average daily air temperature of -4°F (-10°C). While the slush-filled trench quickly (within 16 hours) reached freezing temperatures down to the 54-inch (137-cm) level, the thermal gradient was very gradual, being only 23°F (-5°C) at the 12-inch (30-cm) depth. However, after seven days the thermal gradient had stabilized, corresponding to that of the surrounding ice sheet. A 4-foot (1.2-m) by 6-foot (2-m) block, which contained the refrozen trench, was cut from the ice sheet (see Figure A-2) so that salinity and strength tests could be performed on the newly refrozen ice conglomerate. From Figure A-2 one can observe that the trench is much whiter than the surrounding blue-green ice sheet, which had a 5.5-inch (14-cm) "freeboard" over the refrozen trench. The trench ice extends down only 54 inches (137 cm), leaving an inverted V-notch, 17 inches (43 cm) deep, at the bottom of the trench. This reduced thickness is probably caused by some ice chips either collecting as spoils alongside the trench or washing out underneath the ice sheet.

A vertical salinity core was taken from the entire trench thickness. Salinities were measured for each

6-inch (15-cm) core section, and the average of 5.7 ppt for the entire core compares favorably to other salinity averages (ranging from 5.2 to 5.7) of cores taken from the ice sheet. Both horizontal and vertical thin sections were made to study any unusual petrographic features of the refrozen trench ice. It was difficult to tell the horizontal and vertical sections apart due to the random orientation of the large ice chip aggregate and small grain size of the cementing matrix. Figure A-3 shows a typical thin section containing several ice chips between 0.4 inch (1 cm) and 0.8 inch (2 cm) in size. These petrographic features are in sharp contrast to those of natural sea ice, which display the preferred vertical crystal growth bonded together at distinct grain boundaries. Similar ice characteristics in two orthogonal directions would indicate similar strength properties as well, which was confirmed during a series of compressive strength tests.

Compression specimens were cored from the trench ice, both vertically and horizontally. The horizontal cores were extracted at trench depths of 7 inches (18 cm), 16 inches (41 cm), and 26 inches (66 cm). Each specimen was cut 4 inches (10 cm) long and had a diameter of 2 inches (5 cm). The compressive loading was applied by a portable, 6,000-pound (27,000-N), electrically driven test frame with variable loadhead speeds. A loadhead setting was established that gave an applied stress rate range between 180 (1,240) and 200 psi/sec (1,380 kPa/sec) for the 10°F (-12°C) ice. The average compressive strength for nine horizontal specimens was 747 psi (5,150 kPa), while the average for eight vertical specimens was 750 psi (5,170 kPa). These essentially equivalent strengths bears out the previous prediction based on petrographic ice features. A comparison can be made with previous compressive strengths of natural sea ice at this temperature and salinity; the vertical compressive strength is found to be 1,220 psi (8,410 kPa), while the horizontal strength is 520 psi (3,590 kPa). Therefore, although cutting through an ice sheet and allowing the trench to refreeze does in fact strengthen the ice sheet

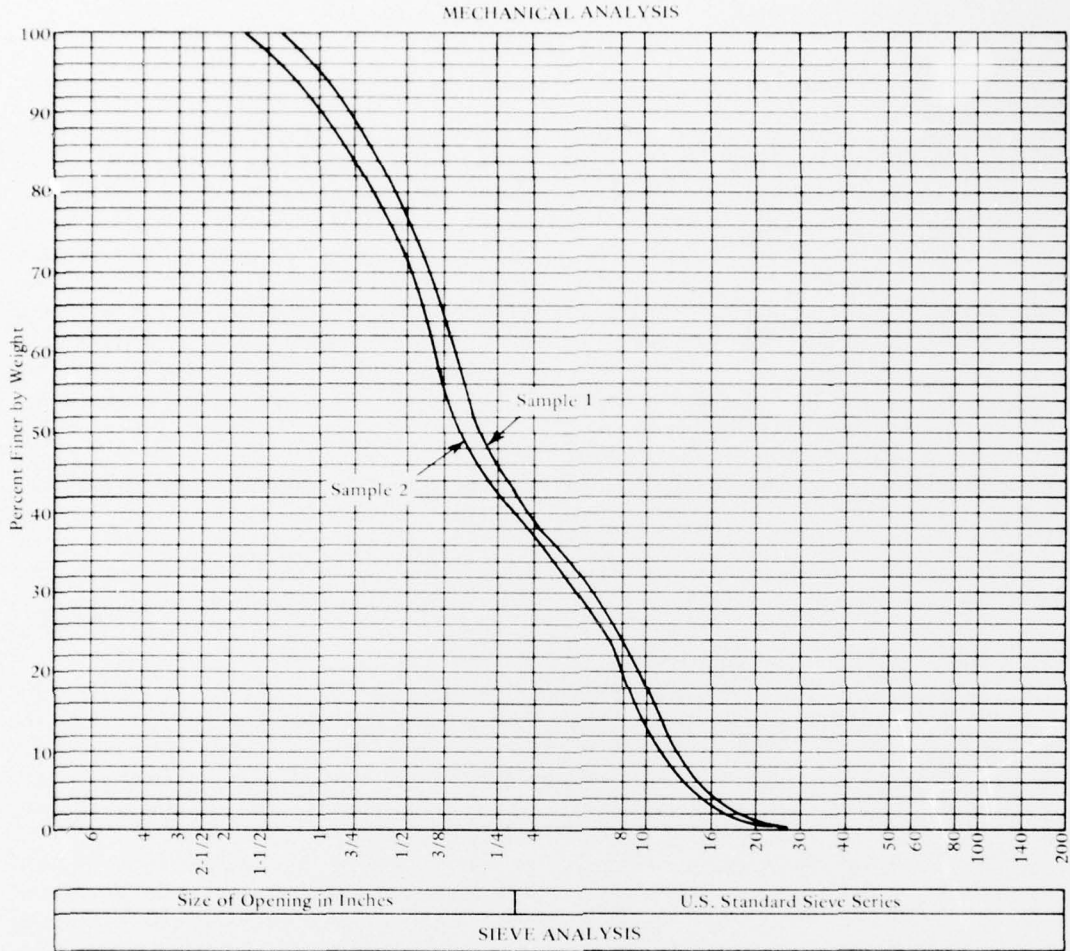

Figure A-1. Mechanical analysis of trenched sea ice chips showing sieve opening size versus percent finer by weight.

horizontally, it becomes significantly weaker in the vertical direction.

A flexural test series was also run on small ice beams with nominal dimensions, 2 x 2 x 18 inches (5 x 5 x 45 cm), containing the refrozen trench. These beams were simply supported with a span of 16 inches (40 cm) and subjected to a two-point loading with the refrozen trench lying within the maximum constant moment section. However, since the trench width was 8 inches (20 cm) and the two-point load

spacing was only 6 inches (15 cm), the boundary of the trench and natural sea ice was 1 inch (2.5 cm) outside the constant moment section. A loadhead speed was set to produce a stress rate between 10 to 15 psi/sec. The average flexural strength for nine beams was 75 psi (520 kPa), compared to 105 psi (725 kPa) for previous natural sea ice beam tests at the same ice temperature and salinity. This reduction in flexural strength is easily explained since seven of the nine beams failed directly on the boundary line



Figure A-2. Ice block showing refrozen trench being hoisted from ice sheet.

between the refrozen trench and ice sheet. The ice chip aggregate present in a cut trench possibly interferes with the establishment of a good bonding surface. It is pure speculation to infer that the boundary bonding strength may improve with time.

Further study of cracking behavior of ice sheets, refrozen crack strength, and preferentially controlling cracking away from over-ice structures or camps is being initiated under a separate work unit.



Figure A-3. Petrographic features showing large ice chip aggregate contained in refrozen trench.

DISTRIBUTION LIST

AFB AFCEC/Tech. Lib./Stop 21, Tyndall FL, CESCH, Wright-Patterson
ARMY DAEN-FEU, Washington DC, DAEN-MCE-D Washington DC
ARMY BALLISTIC RSCH LABS AMXBR-XA-LB, Aberdeen Proving Ground MD
ARMY CRREL A. Kovacs, Hanover NH, Library, Hanover NH
ASST SECRETARY OF THE NAVY Spec. Assist Energy (P. Waterman), Washington DC, Spec. Assist Submarines,
Washington DC
MCB ENS S.D. Keisling, Quantico VA
CNO Code NOP-964, Washington DC, OP987P4 (B. Petrie), Pentagon
DEFENSE DOCUMENTATION CTR Alexandria, VA
DTNSRDC Code 284 (A. Rufolo), Annapolis MD
MCAS PWO
NAS PWD (ENS E.S. Agonoy), Chase Field, Beeville TX, SCE, Barbers Point HI
NATL RESEARCH COUNCIL Naval Studies Board, Washington DC
NAVARCLAB Library, Pt Barrow AK
NAVCOASTSYS LAB Code 710 (R. Elliott), Code 710.5 (J. Quirk), Library
NAVEODFAC Code 605, Indian Head MD
NAVFACENGCOM Code 0433B, Code 0451, Code 101, PC-22 (E. Spencer)
NAVFACENGCOM - LANT DIV, RDT&ELO 09P2, Norfolk VA
NAVFACENGCOM - NORTH DIV, Code 1028, RDT&ELO, Philadelphia PA
NAVFACENGCOM - PAC DIV, Code 402, RDT&E, Pearl Harbor HI, Commanders
NAVFACENGCOM - WEST DIV, Codes 09PA, 09P/20
NAVFACENGCOM CONTRACTS ROICC (LCDR J.G. Leech), Subic Bay, R.P.
NAVMARCORESTRANCEN ORU 1118 (Cdr D.R. Lawson), Denver CO
NAVOCEANO Code 1600, Code 3412 (J. Dravitz)
NAVPETRES Director, Washington DC
NAVPGSCOL E. Thornton, Monterey CA
NAVPHIBASE Code S3T, Norfolk VA
NAVSHIPYD PWD (LT N.B. Hall), Long Beach CA
NAVSTA Utilities Engr Off. (LTJG A.S. Ritchie), Rota Spain
NAVWPNSUPPCEN PWO
NCBC CEL (CDR N.W. Petersen), Port Hueneme, CA, Code 10
NCR 20, Commander
NMCB THREE, Operations Off.
NTC Code 54 (ENS P. G. Jackel), Orlando FL
NUC Code 6565 (Tech. Lib.), San Diego CA
OCEANAV Mangmt Info Div., Arlington VA
PMTC Pat. Counsel, Point Mugu CA
PWC ENS J.A. Squatrito, San Francisco Bay, Oakland CA
SUBASE NEW LONDON LTJG D. W. Peck Groton CT
USCG R&D CENTER Tech. Dir.
USNA Sys. Engr Dept (Dr. Monney), Annapolis MD
LIBRARY OF CONGRESS WASHINGTON, DC (SCIENCES & TECH DIV)
MASSACHUSETTS INST. OF TECHNOLOGY Cambridge MA (Rm 10-500, Tech. Reports, Engr. Lib.), Cambridge
MA (Rm 14 E210, Tech. Report Lib.)
MICHIGAN TECHNOLOGICAL UNIVERSITY HOUGHTON, MI (HAAS)
NATL ACADEMY OF ENG. ALEXANDRIA, VA (SEARLE, JR.)
OHIO STATE UNIVERSITY COLUMBUS, OH (INST. OF POLAR STUDIES)
OREGON STATE UNIVERSITY CORVALLIS, OR (CE DEPT. BELL), Corvallis OR (School of Oceanography)
PURDUE UNIVERSITY LAFAYETTE, IN (ALTSCHAEFFL), LAFAYETTE, IN (CE LIB)
STANFORD UNIVERSITY STANFORD, CA (DOUGLAS)
TEXAS A&M UNIVERSITY COLLEGE STATION, TX (CE DEPT)
UNIVERSITY OF CALIFORNIA BERKELEY, CA (CE DEPT. GERWICK)
UNIVERSITY OF ILLINOIS URBANA, IL (NEWARK)
UNIVERSITY OF NEBRASKA-LINCOLN LINCOLN, NE (SPLETTSTOESSER)
UNIVERSITY OF WASHINGTON SEATTLE, WA (APPLIED PHYSICS LAB), SEATTLE, WA (OCEAN ENG
RSCH LAB. GRAY), Seattle WA (CE Dept. D. Carlson)
AEROSPACE CORP. Acquisition Group, Los Angeles CA

ATLANTIC RICHFIELD CO. DALLAS, TX (SMITH)
BECHTEL CORP. SAN FRANCISCO, CA (PHELPS)
CANADA Lockheed Petrol. Srv. Ltd., New Westminster BC, Mem Univ Newfoundland (Char), St Johns, Warnock
Hersey Prof. Srv Ltd, La Sale, Quebec
CHEVRON OIL FIELD RESEARCH CO. LA HABRA, CA (BROOKS)
CONCRETE TECHNOLOGY CORP. TACOMA, WA (ANDERSON)
DAMES & MOORE LIBRARY Los Angeles CA (T. Bullock)
DRAVO CORP Pittsburgh PA (Giannino)
MARATHON OIL CO Houston TX (C. Seay)
MARINE CONCRETE STRUCTURES INC. MEFAIRIE, LA (INGRAHAM)
NORWAY J. Creed, Ski
OFFSHORE DEVELOPMENT ENG. INC. BERKELEY, CA, Berkeley CA
SHELL OIL CO. Houston TX (R. de Castongrene)
SWEDEN VBB (Library), Stockholm
UNITED KINGDOM Cement & Concrete Assoc. (Lit. Ex), Bucks, Taylor, Woodrow Constr (014P), Southall,
Middlesex
WOODWARD-CLYDE CONSULTANTS Dr. J. Gaffey, Orange CA