

AD-A036 205

NAVAL PERSONNEL RESEARCH ACTIVITY SAN DIEGO CALIF
TRYOUT OF AN EXPERIMENTAL COURSE IN PROGRAMED INSTRUCTION TECHN--ETC(U)
APR 64 E N KEMP, W A KING
PRASD-232

F/G 5/9

UNCLASSIFIED

NL

| OF |

AD
A036205



END
DATE
FILMED
3-77

ADA 036205

COPY No. 2

(Handwritten marks: a circle with '1' and a signature)

6 TRYOUT OF AN EXPERIMENTAL COURSE IN
PROGRAMED INSTRUCTION TECHNIQUES

12 44 p.

10 Eugenia N./Kemp
William A./King

11 Apr 1964

D D C
MAR 1 1977
(Stamp with handwritten initials)

U. S. Naval Personnel Research Activity
San Diego, California 92152

14 Task 208.04-02
PRASD Report No. - 232

DISTRIBUTION STATEMENT A
Approved for public release;
Distribution Unlimited

USN PERSONNEL RESEARCH ACTIVITY
LIBRARY
SAN DIEGO, CALIFORNIA 92152

USN PERSONNEL RESEARCH ACTIVITY
LIBRARY
SAN DIEGO, CALIFORNIA 92152

251 250

mt

Submitted by

E. I. Jones, Ph.D., Director, Navy Training Research Laboratory
E. E. Dudek, Ph.D., Technical Director
CDR H. B. Boaz, USN, Officer in Charge

U. S. Naval Personnel Research Activity
San Diego, California

Approved by

S. Friedman
Head, Psychological Research Branch

CAPT R. M. Stuart, USN
Director, Personnel Research Division

Bureau of Naval Personnel
Washington, D. C.

205030502

BRIEF



An experimental workshop in programmed instruction was conducted to find whether naval personnel could be taught to produce usable programs in an actual Navy subject matter area during a two-week training period. The results of the study provide a positive answer to this question. This suggests that the Navy can reasonably expect to overcome one of the greatest barriers to its use of programmed instruction--the lack of programs for specific Navy courses-- by developing an "in-house" capability for program development.



CONTENTS

	Page
Brief	iii
A. Introduction	1
B. Procedure	1
C. Discussion	5
Appendix A - Objectives of a Workshop in Programed Instruction	7
Appendix B - Two Week Curriculum in Detail	8
Appendix C - The Language of Programed Instruction	10
Appendix D - Criteria for Selection of Material to Program	13
Appendix E - Summary of Rules for Linear Programs	14
Appendix F - Summary of Rules for Branching Programs	15
Appendix G - Proofreading Marks Used for Editing Programs	16
Appendix H - Examples of Defective Frames	18
Appendix I - Student Revision Procedures	24
Appendix J - Student History Form	25
Appendix K - Revision Sheet	26
Appendix L - Procedure for Final Test of Program	27
Appendix M - Objectives and Sample Frames from Programs	28

TABLE

1. Description of Programs and Results of Tryouts	4
---	---

ACCESSION for	
DTIC	Micro Service <input checked="" type="checkbox"/>
DDC	Dual Service <input type="checkbox"/>
UNCLASSIFIED	<input type="checkbox"/>
JUSTIFICATION <i>see file</i>	
BY <i>50 on file</i>	
CONTRIBUTOR/AVAILABILITY GROUP	
REF.	AVAIL. CODE/SPECIAL
A	

PRECEDING PAGE BLANK - NOT FILMED

TRYOUT OF AN EXPERIMENTAL COURSE IN
PROGRAMED INSTRUCTION TECHNIQUES

A. Introduction

A major problem in the use of programed instruction in the Navy is the lack of programs that satisfy the requirements of specific Navy courses. One way to fill this lack is to develop an "in-house" capability for program development by training naval personnel to write programs. The purpose of the present study was to find out whether such training could be accomplished under the following ground rules:

1. The duration of the course would be only two weeks.
2. The students would produce a tested program (covering one hour of conventional instruction in an area actually being taught in a Navy course) by the end of the workshop.

Previous workshops have shown that naval personnel can be trained to become programers, but these courses have lasted longer than two weeks and/or the programs developed have been "practice programs."

In line with the two ground rules, certain decisions were made about the type and amount of information that should be presented to the workshop students. Since the emphasis was to be on program production and the time was limited, it was decided to keep the amount of information on the psychological basis of programed instruction to a minimum. The greatest portion of the two weeks was to be spent in actual program production and the development of behavioral objectives and evaluative criteria.

B. Procedure

The Fleet Anti-Submarine Warfare School, San Diego, provided the physical facilities for the workshop.

Two instructors taught the workshop to eight students. The rank, present billet and Naval service of each student were as follows:

<u>RANK or RATE and RATING</u>	<u>BILLET</u>	<u>NAVAL SERVICE</u>
LCDR	NTDS Training Dept.	24 Years
AXCS	Instructor	20 "
ETC	"	22 "
FTC	"	16 "
SOC	"	14 "
SOCA	"	11 "
SOCA	"	8 "
SO1 (SS)	"	10 "

Two of the students had read some commercially developed programs. The other six students had had no experience in the area.

Upon their arrival for the course, the students were given a statement of the objectives of the workshop. These are presented in Appendix A. Briefly, they stated that the student would develop, revise, and test a program based on a subject area with which he was familiar. The curriculum followed for the two-week period is outlined below. A more detailed description of the curriculum and the materials used in the course are given in Appendices B through L.

TWO-WEEK CURRICULUM

<u>DAY</u>	<u>ACTIVITY</u>
1	Lecture on programmed instruction and review of published programs.
2	Lecture on preparation of objectives and criteria. Topic selection and development of objectives and criteria.
3	Lecture on program development and test construction.
4-9	Writing, editing, and testing of programs.
10	Review and critique.

From this outline it becomes obvious that the major portion of the time in the workshop was devoted to the students' writing and testing of the programs. The editing was done by the two instructors. The procedure used was to have each of the instructors review the programs every 10-30 frames. The programs were checked for logical sequence of information, informational accuracy, adherence to

programming rules, spelling, grammar, and to see that the information necessary to produce the required terminal behavior was presented. The amount of assistance required varied among the students, but by the third or fourth day of program writing comparatively little assistance was necessary. To the extent possible, the instructors attempted to keep their part in the development of the programs to a minimum so that the final product would reflect primarily the work of the students. The major problems in the editing were to keep the students from presenting too much information in one frame and to get them to provide sufficient repetition and practice of newly presented concepts and operations.

After the programs had been given a final editing, they were administered to selected Fleet Anti-Submarine Warfare School subjects who had the proper background for the particular program. The programs were given to one subject at a time so that the subject could tell the program writer when he was having problems, frame by frame. Upon completion of the program, the subject was given the criterion test. Program revision was based on the information obtained while the student was taking the program and on his test performance. The programs were revised after each subject tryout. Table 1 presents summary information on the eight programs. In this table, the subjects are listed in the order in which they took the programs. It should be noted that with one exception (An Introduction to the AN/SPS-37 Radar Receiver Program) the last subject to take the program met the required performance level. The objectives for each of the programs and representative frames from each of them are presented in Appendix M.

On the final day of the workshop, a review and a critique of the workshop were held. Students were asked what they felt should be added, deleted or changed in giving future workshops. Most of them indicated that more information about programmed instruction and the objectives of the workshop should be made available to students before they arrive to take the workshop. The suggestion was made that such information be programmed and sent to prospective students. No suggestions were made for additions or changes to the curriculum content. Students expressed the feeling that programmed instruction should have a real place in Navy instruction and several of them are revising and further testing the programs which they developed during the workshop. In addition, some plan to extend the programs to cover more material, when they can fit this in with their other duties.

TABLE 1
Description of Programs and Results of Tryouts

Student Rank or Rate and Rating	Program Topic	Program Format	No. of Frames	Number Questions on Test	Results of Experimental tryout of Program			
					Subj.	Time (Minutes)	Errors or Grade	Max. Errors Allowed or Acceptable Grade on a 4.0 Basis
LCDR	Naval Tactical Data System-Manual Air Detection	Linear	46	20	A	52	1	4 out of 20
					B	50	2	
AXCS	Physics of Sound	Branching	83	15	A	35	5	3 out of 15
					B	65	5	
					C	75	3	
					D	45	3	
ETC	An Intro. to the AN/SPS-37 Radar Receiver	Linear (Some Branching)	59	9	A	(Not Obtained)	4.0	2.5
					B			
FTC	Range Marker Generating Circuit	Branching (Some Linear)	37	10	A	88	2	3 out of 10
					B	55	1	
					C	51	1	
					D	50	1	
					E	62	6	
					F	89	4	
					G	27	3	
					H	48	3	
SOC	Operation of a Semiconductor diode	Linear (Some Branching)	76	8	A	60	0	2 out of 8
					B	56	0	
SOCA	Kircheff's Voltage Law	Branching	40	9	A	65	0	0 out of 9
					B	70	0	
SOCA	Cathode Bias	Branching (Some Linear)	61	10	A	24	3.2	2.5
					B	35	2.4	
					C	42	3.2	
SO1(SS)	Standard Navy Technical Manual for Sonar Equipment	Branching (Some Linear)	24	10	A	45	3.6	2.5
					B	40	3.2	
					C	45	3.2	

C. Discussion

As stated earlier, the purpose of presenting the workshop was to answer the question of whether naval personnel could be taught to develop usable programs of instruction (in areas actually being taught in the Navy) in a two-week period. The answer to this question, based on the results of this study, is--yes. Of course, this answer needs some qualifications, such as:

1. All but one of the sample of eight students were experienced instructors. Certainly, it is possible that with a different population different results might be obtained.

2. The students' ability to continue to write programs without editorial assistance is not certain. It is possible that periodic checks of programmed material developed after leaving the workshop would be necessary.

Even with these qualifications it appears that an "in-house" capability for developing programmed instruction can be obtained in the Navy in a reasonable time period, thus overcoming one of the major drawbacks to the use of programmed instruction--the lack of programs.

Students stated that programmed instruction would really answer some of their instructional problems. This, coupled with their continued efforts to produce and test programs after the conclusion of the workshop, suggests that it might be appropriate to introduce more information on programmed instruction (perhaps in the form of workshops) into the curriculum in instructor training schools.

APPENDIX A

OBJECTIVES OF A WORKSHOP IN PROGRAMED INSTRUCTION

The following three objectives define what you should be able to do at the completion of this workshop.

Given an area of instruction that you have previously taught (or had as a student) you will be able to:

1. Define specific objectives for the area so that they include all of the final behavior required of the student in the area.

2. Write and revise, on the basis of student tryout, a program of instruction that will produce the final behavior defined by the objectives.

3. Develop a criterion test that will measure the extent to which the students have met the objectives.

The criterion that will be used to find whether these objectives have been met will be:

1. The development of the objectives, program and criterion test, for approximately one hour of instruction.

2. Performance by the students on the criterion test at the level specified.

PRECEDING PAGE BLANK-NOT FILMED

APPENDIX B

TWO-WEEK CURRICULUM IN DETAIL

Day 1

A.M. Lecture covering the objectives of the course, what programmed instruction is and how it can help Navy instructors, specification of what the students would program, types of programmed instruction, development of programs, how to select programs, where program instruction would be of use to the Navy, and where programmed instruction has been used in the Navy.

P.M. Read Preparing Objectives for Programmed Instruction by Robert F. Mager, the Language of Programmed Instruction (See Appendix C for the latter), and a variety of programs.

Day 2

A.M. Lecture on why it is necessary to prepare objectives, how to prepare objectives, and statement of the criteria to be used by the students in selecting the material they would program. These criteria are presented in Appendix D.

A.M.-P.M. Students' selection of topic and development of objectives for their programs. The topic selection was approved and the objectives were reviewed on an individual basis by the instructors.

Lecture on the development of criterion tests.

Round-robin review by the students of each other's objectives.

Day 3

A.M. Lecture covering test construction, relation of tests to objectives, program technology, and frame construction. The students were given rules for linear programs (Appendix E), branching programs (Appendix F), and proofreading marks used for editing programs (Appendix G). These three hand-outs were used to edit a series of defective frames (Appendix H). The problems that the defective frames presented were discussed.

A.M.-P.M. Students began writing programs. The instructors requested that frames be written on 5 x 8 cards and that no more than 10 frames be written before they were reviewed by the instructors. The program format to be used was left to the students' discretion.

Days 4-9

Writing, editing, student testing, and revision of programs. Each student tried his program out on at least two subjects and revised the programs on the basis of these tryouts. Student revision procedure, student history, and revision sheets are given in Appendices I, J, and K.

Day 10

Review of principles of programmed instruction, development of objectives and criteria, and program development. Students wrote a critique of the workshop. Procedures to be used for program tryout after the workshop were given out (See Appendix L).

APPENDIX C

THE LANGUAGE OF PROGRAMED INSTRUCTION

When you first study any new subject you usually have to learn the language of that subject. This is true in mathematics, electronics, and, not surprisingly, in programed instruction. Learning the following words and their definitions will make it much easier for you to understand the concepts and operations that are used in programed instruction. Some of these words will already have meaning for you, but it is important that you learn what their meanings are when they are used in this new subject, programed instruction.

BEHAVIOR:

The activity of a student. When it is measurable, it is called overt behavior. If we can't measure it, it is called covert behavior.

STIMULUS:

A condition, event or change in the immediate surroundings of a person that produces a change in the person's behavior.

RESPONSE:

A unit of behavior. When it is measurable, that is when the instructor can see and record it, it is called an overt response. When only the student is aware of it, it is called covert.

RESPONSE REPERTOIRE:

Several responses that are logically or functionally related. For example, the set of responses we call typing, equation solution or poker playing are response repertoires.

RESPONSE SUBSTITUTION:

When a student learns to make a new response to a stimulus, he used to make a different response to. For example, in learning a foreign language we learn to make new responses to an object such as a book--in French we respond "livre," and in German "buch."

REINFORCEMENT:

To reward a response. When this is done, it makes it more probable that the response will be made again.

FEEDBACK:

The procedure of telling a student whether his response or answer is correct. Giving knowledge of results means the same thing as feedback. If the student is correct and he is rewarded by finding that he is correct, then feedback is reinforcing.

SHAPING:

Here the common meaning is partially correct, but in programmed instruction the shaping is used in reference to behavior. What we want to do is shape the students' behavior so that they give the correct responses. When we teach we are shaping behavior.

DISCRIMINATION:

This means to respond differently or to be able to tell the difference between stimuli.

GENERALIZATION:

This is the opposite of discrimination and means to make the same response to each stimulus in a group of stimuli. It is usually used where the group of stimuli have something in common like being colors or tones.

PROGRAMED INSTRUCTION:

Well, it's about time this one came up. It means a sequence of carefully constructed items of information that will lead a student to the mastery of a subject with minimal error and, hopefully, with maximum enjoyment.

LINEAR PROGRAM:

A program where the sequence of items is fixed and is the same for each student. All students answer all items.

BRANCHING PROGRAM:

A program that has built-in alternate sequences of items. If a student makes a mistake he is given an alternate sequence of items to correct his error.

FRAME:

A unit of material to which at least one response is required. Most frequently the student will be told if his response is correct and will be given the correct response before he goes on to the next frame. Item means the same as frame.

PANEL:

This is a section or paragraph of material, or a picture or diagram that a student uses to respond to a series of frames.

PROMPT:

Hints, suggestions or signals that help the student to make the correct response to a frame.

TERMINAL FRAME:

This is a frame where you find out whether the student has learned what you wanted him to. No prompts are used and a question is asked or a problem is given or the student has to fill in a blank.

TERMINAL BEHAVIOR:

This can be translated easily--it means what you expect the student to be able to do as a result of having gone through the program.

CRITERION TEST:

This is the test you use to find out whether you have been successful and the student can respond with the terminal behavior that you wanted him to.

PACING:

The rate at which a student responds to frames or items. When a student goes at the pace or rate he wants to, we call it self-pacing.

APPENDIX D

CRITERIA FOR SELECTION OF MATERIAL TO PROGRAM

1. The programer is a subject matter expert in the area.
2. Ease of treatment--the information can be given with words or pictures.
3. The topic can be covered in a period of not more than an hour.
4. The subject is presently being taught, so that a tryout of the program is possible.
5. The subject matter has a fairly apparent inherent logical structure.
6. If possible the topic should be one that has presented problems to students in the past or one that will meet special student needs (remedial or enrichment).

APPENDIX E

SUMMARY OF RULES FOR LINEAR PROGRAMS

1. Frames should be clearly written in good English.
2. The facts should be correct.
3. The sequence of frames should follow a logical order.
4. Each frame should have a purpose: To provide new information, to review information previously given, to give repetition or practice, or to test whether the information has been learned.
5. The response required should be relevant to the information in the frame, and also relevant to the goal of the program.
6. Sufficient practice should be given to provide discrimination and retention of the information.
7. Do not give information in a frame unless you ask the student to respond to it.
8. Don't use prompts in test frames.
9. Reduce the number of prompts in review frames from the number given in the original learning frames.

APPENDIX F

SUMMARY OF RULES FOR BRANCHING PROGRAMS

1. Frames should be clearly written in good English.
2. The facts should be correct.
3. The non-branching frames should present all the information necessary to produce the terminal behavior, in a logical order.
4. The question asked should test the student's understanding of the material covered.
5. The wrong alternatives should represent reasonable and non-trivial sources of misunderstanding.
6. If a wrong answer is chosen, state why the answer was wrong and give the student information to clear up his misunderstanding.
7. Repeat the answer and then tell the student whether it is right or wrong.
8. In the case of wrong answers assume the student is honestly trying.
9. Provide for sufficient practice to provide discrimination and retention of the information.

APPENDIX G

PROOF READING MARKS USED FOR EDITING PROGRAMS

In order to make it possible for you to get back your edited programs as quickly as possible, we'll use the following symbols to indicate frames where there are problems.

- ⊘ - a wrong response will probably be given to this frame.
- R - there are too many responses that will fit.
- ⊘ - the student has to guess and probably no response will be given.
- - most people have already learned a different response. Use more prompts.
- ☺ - add at least one example before you try to get this response.
- ∇ - give the rule for this example before you try to get this response.
- T - this should be a terminal frame. Take out all the prompts.
- ! - good use of the students' existing response repertoire.
- ? - subject matter seems questionable. Check your facts.
- > - split this frame into separate frames as marked.
- W - too wordy. Rewrite this frame with fewer words.
- RR - frame requires too many responses. Either limit this frame to one response or write separate frames.
- |RI| - unimportant response called for. Change so that the response required is relevant to the information presented.
- D - need to develop frames to make the student discriminate between correct responses and incorrect responses.
- RF - need to add review frames, to be sure the student can still give the previously learned responses.
- (a-n) - rewrite frames "a" through "n".
- C - make these frames into a chain by making the response from one frame the stimulus for the response to the next frame.

- U - underline.
- Cap - use capitals.
- E - check your English.
- P - present this material in a panel.
- IP - the responses required to these frames do not make use of the panel.
- IDP - use an illustration, diagram or picture with this frame.
- IDPI - the responses required do not make the student use the illustration, diagram or picture.

APPENDIX H

EXAMPLES OF DEFECTIVE FRAMES

Each of the following frames contains at least one major error. Read them carefully and state what you think the error (or errors) is in the space provided below the frame. In addition, when it is possible, use the proofreading symbols to indicate how the frame should be changed.

1. Used as a beginning frame

Write in what you think each of these symbols mean and then turn the page to see if you have done it correctly:

S^2 S SA A A^2

2. This frame and the following ones are from a program that is supposed to teach the rules for a card game called Chase the Ace.

Kings are the highest _____, Queens the next cards
highest and so on _____ to Aces which are down
the lowest _____ cards

3. Any one receiving a King places it face up on the table

Only _____ are placed face upward.

Kings

A player receiving a King and placing it face upward

cannot _____ a token on that particular hand. lose

4.

from p. 13

Page 9

Your answer: Paris is the capitol of Mexico. Let's look at this. Since everyone knows the capitol of Mexico is Mexico City, why did you say it was Paris? Return to p. 13 and re-read the question.

5.

A reinforcer is a _____ which _____ a _____ and
_____ the _____ of the _____ or _____
the _____ of the _____.

6.

from p. 18

Page 23

Your are correct. 4 is not the fourth component of the vector
(-1, 10, 4, 5, -7). The fourth component is 5. A vector with
two components is often called a "two-dimensional" vector, one
with three components is called a "three-dimensional" vector, etc.

Which of the following statements is incorrect?

1. Vector (a, b, c, d) has four components p. 17
 2. Vector (X, Y, Z, U, V) has six components p. 19
-
-

*7.

If a bill is _____ by the President, the bill doesn't become a law unless it goes back to Congress and is approved by a two-thirds majority of both houses. By the use of the veto, the President has a check on the Legislative Branch. Rarely can Congress get enough votes to pass a bill over a presidential veto.

8. This frame is from a program on telephone manners.

If you do not find the information as quickly as you had anticipated, return _____, use an _____ explain that _____, and ask if the caller still wishes to _____.

9.

You have some 206 bones making up your skeleton. At first the skeleton is made up of a soft substance called cartilage. Later, the bone cells begin to develop. First the skeleton is made up of a soft, substance called _____.

10.

from p. 34

Page 28

Your answer: 8. You are correct, $2 \times 2 \times 2 = 8$. The mathematical symbol meaning "form the product reached by using 2 as a factor three times is 2^3 ." It means use the number 2 as a factor 3 times. Similarly, $2 \times 2 \times 2 \times 2$ could be written 2^4 , 3×3 as 3^2 .

What would 3^4 be?

$$3^4 = 14$$

Page 24

$$3^4 = 81$$

Page 36

$$3^4 = .008$$

Page 31

11.

The President, sometimes called the _____
is at the head of the Executive Branch.

APPENDIX I

STUDENT REVISION PROCEDURES

1. Tell the student how to work with programmed instruction and why you're asking him to work through the program.
2. Tell the student to say when a frame confuses him. Mark down the number of the frame on your revision sheet and, if possible, give the reason for confusion.
3. Give the student the objectives and criteria--see if he has questions. Give the pretest and preliminary test, and then the program.
4. Be sure to keep a record of the student's responses. When errors are made, try to find the reason.
5. Be careful not to teach the student when he makes mistakes or is confused. The program should do this.
6. Give the criterion test. If the student wants you to, correct it and explain his errors, if any.
7. Ask the students for comments on the program. Write down their comments.
8. Keep the following records:
 - a. Student name, rate, rank, education, Navy courses.
 - b. Time start and stop for pretest, preliminary test, program and criterion test.
 - c. Errors--by frame number.
 - d. Questions--by frame number.
 - e. Errors on criterion test.
 - f. Student comments.

APPENDIX J
STUDENT HISTORY

Name _____

Rate or Rank _____

Years of Education _____

Years in Navy _____

Navy Course:

--- **NAME** ---

--- **YEAR TAKEN** ---

	TIME		
	START	FINISH	SCORE
Pretest	_____	_____	_____
Preliminary Test	_____	_____	_____
Criterion Test	_____	_____	_____

APPENDIX K
REVISION SHEET

Program Name _____

Student Name _____

FRAME NUMBER	ERROR	REASON
--------------	-------	--------

APPENDIX L

PROCEDURE FOR FINAL TEST OF PROGRAM

1. Get as many copies of revised program as there are students.
2. Provide sheets for students to make their responses if you want to re-use your programs.
3. Keep records of:

Student history

Responses--correct and errors both

Time start and finish program

Time start and finish test

Scores on tests--by item as well as total score.

APPENDIX M

OBJECTIVES AND SAMPLE FRAMES FROM PROGRAMS

For each of the programs, the title, objectives of the program, and representative frames are given so that some of the actual products may be seen.

NAVAL TACTICAL DATA SYSTEM

Objective: To be able to detect new raw video on the NTDS PPI display, enter this new raw video into the system as New Tracks, and correlate raw video with computer generated video to give accurate position and velocity information to the system. A score of 85 on the final test indicates successful completion of this program.

Sample frames:

To the left of the Track Ball in the lower right corner of the NTDS console is the Enable button. This button is used in conjunction with the Track Ball and is operated by momentarily pressing with your thumb while your fingers are on the Track Ball. The thumb of your right hand operates the _____ button.

ENABLE

While your fingers are on the _____ your thumb is free to operate the _____.

TRACK BALL

ENABLE BUTTON

PHYSICS OF SOUND

Objective: Chapter 1 gives a basic understanding of what sound is.

Upon completion of this chapter you must be able to:

1. Define by name the three basic ranges of sound frequency and identify the frequency of each range.
2. Define sound.
3. Identify by name and define the three basic requirements of sound.
4. Identify and define Compression and Rarefaction.
5. Identify Spreading, Wave Length, and Amplitude.
6. Write the speed of sound in the following mediums:
Air and Sea Water and give the cause of the change.
7. Write the three identifying characteristics of sound.

Sample frames

From page 19

Page 22

Your answer was: It is false. You cannot measure wave lengths between the peak of a crest and the bottom of a trough. You are correct. Using the same diagram again let's take up a new item.

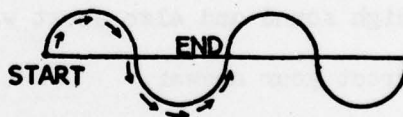

One cycle is a complete set of changes starting at the reference line and mounting through our compression wave to a crest and returning to the reference point, then descending our rarefaction wave to the bottom of the trough and back to the reference point. The frequency of the sound is the number of

cycles that occur per second. Fill in the blank with the correct answer.

If our sound source is vibrating fast and we have a short wave length, the frequency will be _____ ?

- a. High Turn to page 23
- b. Low Turn to page 24

From page 22

Page 23

Your answer was high frequency. You are correct.

Let us take a good look at some frequencies. The sounds an average person hears range in frequency from 20 cycles per second to approximately 15000 cycles per second. These are called SONIC FREQUENCIES or sounds in the audible range.

The sonic frequencies range between 20 and 1500 cycles

True Turn to page 25

False Turn to page 26

From page 22

Page 24

Your answer was low frequency. Nope, fast vibrations at the source will give us a high sound and also short wave length. Turn back to page 22 and correct your answer.

AN INTRODUCTION TO THE AN/SPS-37 RADAR RECEIVER

Objective: Upon completion of this program you will be tested on the following issues:

1. Frequency inversion--What it is and where it is used.
2. Compression filters--What they are and their use.
3. A generalized block diagram of the "37" radar receiver.

Sample Frames:

There is one factor to be made clear while talking about compression filters. This is that there is a definite time relationship between the entrance of two frequencies into a delay line and their leaving of it.

Q. A _____ exists between two frequencies upon entering and leaving a delay line.

Time relationship

For example: Suppose you leave San Diego for Los Angeles one hour ahead of a buddy, both of you traveling at 50 MPH. At this speed this is normally a two hour trip. You are delayed 30 minutes on the way due to a flat tire. You will then arrive in L.A. only _____ ahead of your friend.

30 minutes or $\frac{1}{2}$ hour

If it normally takes either of you two hours to make the trip, then a total of 3 hours was consumed from the time you left San Diego until your buddy arrived in L.A.

Since it took you $2\frac{1}{2}$ hours to make this trip because of the delay, your buddy is now only 3 less $2\frac{1}{2}$ or $\frac{1}{2}$ hour behind you in arriving. You can see that because of the delay, a time relationship of 1 hour departure times has been changed to $\frac{1}{2}$ hour arrival times.

Understand this point before going on--more examples will follow.

THE RANGE MARKER GENERATING CIRCUIT

Objective: To provide the student with the theory of operation of the Range Marker generating circuit; to enable him to recognize and identify the function of the components during normal operation. The student will be provided with a diagram of the Range Mark Generating Circuit to enable him to answer the questions contained in this program. A ten question multiple choice examination of the function of the components of the Range Mark Generating Circuit will be given at the completion of the program. The student must answer seven of the ten questions correctly to attain a passing score. The student will have 15 minutes in which to complete the examination.

Sample frames:

The AC oscillation is taken directly from the top part. (Refer to Figure 1) of the tuned circuit to the grid of V 1.

Question: The function of V 1 is to-

Amplify the AC oscillation	Go to page 10
Provide feedback to the AC oscillator	Go to page 11

Page 9

Your answer: Amplify the AC oscillation NO

Good try. Let us look at V1's circuit again. Check the cathode connection of V 1. You will see that it is connected to the center of L 1 in the tank circuit. The AC oscillation on the grid controls the current through the lower half of the L 1 to PROVIDE FEEDBACK to the oscillator.

Go back to page 9 and select another answer.

Page 10

Your answer: Provide feedback to the AC oscillator. Very good, you are correct. The AC oscillation on the grid of V 1 controls the current through the lower portion of L 1. This prevents the oscillator from damping out when V 2 is held cut-off for too long a period of time. The AC oscillation is also connected to the grid of V 3 through an R-C network consisting of R 5 and C 3.

Question: What is the function of V 3?

Grid Current Limiter

Go to page 13

Peaking Amplifier

Go to page 12

Page 11

OPERATION OF THE SEMI-CONDUCTOR DIODE

Objective: You have arrived at the beginning of our course. This is a course which deals with basic semi-conductor materials and the action of the majority carriers within the materials which make them useful as rectifiers. You have had atomic structure and the action of the valence electrons. Now we will begin using these valence electrons to produce semi-conductor materials. At the completion of the course, you will be able to define the majority carriers in "N" type material and the majority carriers in "P" type material. You will be able to bias a semi-conductor diode in both the forward and reverse directions.

Sample frames:

This electron moves into another valence band or into the crystal structure. However, these other valence bands are already

filled to the magic number of +8. Therefore, if one electron enters a full valence band and remains there, something must take place in that valence band.

The new electron must kick or repel another _____ out of its valence band.

Answer: Electron

Therefore, we can deduce from the material we have just covered that one electron is continuously moving about in the _____ structure.

Answer: Crystall lattice or crystal

KIRCHOFF'S VOLTAGE LAW

Objective: Like any course or lesson there are certain objectives that must be met if the course or lesson is to be effective. This lesson is no exception to this. The objective that you must meet for this lesson to be effective is:

You must be able to write Kirchoff's voltage law equations for simple D.C. circuits!

At the end of this lesson you will be given three simple D.C. series circuits for which you will write correctly the Kirchoff's voltage law equations.

Sample frames:

Page 13

(From Page 7)

Your answer: From negative to positive

How right you are. When we talk about current flow in a circuit we find it moves away from the negative terminal of the source through the circuit to the positive terminal of the source. Let's add an arrow to our circuit and indicate by using it the polarity that a voltage would have.

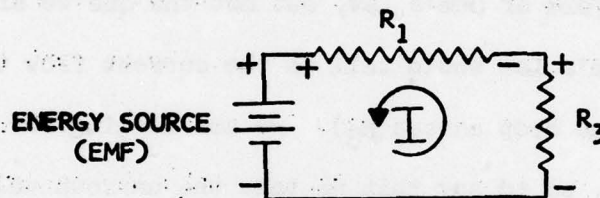

Using Ohm's Law if I is the amount of current flowing through R_3 then the voltage dropped (E) by R_3 is?

E/I Page 12

E/R_3 Page 15

IR_3 Page 19

Page 12

(From Page 13)

Your answer: E/I

NO SIR. This is one of the derivations of Ohm's Law, but it sure won't tell us how much voltage is dropped by R_3 . When we divide voltage by a current we will have for a quotient a resistance.

This will be true in all cases since it is by this that resistance is defined. If this quotient is a resistance, then for it to be a voltage drop we would have to say they are the same. But resistance and voltage are NOT the same. Return yourself forthwith to page 13 and try again.

Page 15

(From Page 13)

Your answer: E/R_3

Nope. This is a form of Ohm's Law, but not the one we are using. This derivation of Ohm's Law would tell us the current flow through R_3 (E being the voltage drop across R_3). We are looking for the voltage dropped by R_3 , so to say that we take the unknown voltage drop and divide it by the resistance is not very practical, I'm afraid. Also as I mentioned above our quotient of E/R_3 would be a current and therefore a little difficult to be a voltage drop at the same time.

Return to Page 13 and select another answer.

Page 19

(From Page 13)

Your answer: IR_3

Hello there. How right you are. Current flow times resistance does give us the voltage drop. Also since this current is flowing through a specific resistance, namely R_3 , it gives us specifically that voltage which is dropped across R_3 .

We have yet another resistance (R_1) across which there is a voltage drop. Apply Ohm's law to this we find the voltage drop to be IR_1 .

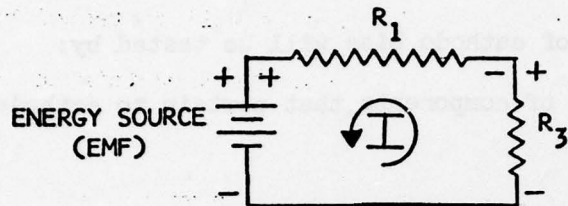

Now we found the voltage drop across each resistor by Ohm's Law.

Was Ohm's Law applied to:

- | | |
|---------------------|---------|
| A complete circuit? | Page 22 |
| A single component? | Page 25 |
| I'm not sure. | Page 18 |

CATHODE BIAS

Objective: This program is on cathode bias. Before it goes into cathode bias, it will review some of the basic circuits of a conventional amplifier. At the end of the program you will be expected to be able to do the following:

1. Identify components in the grid circuit that pertain to cathode bias.
2. Select the functions of components in the grid circuit that pertain to cathode bias.
3. Identify the components in the cathode circuit that pertain to cathode bias.

4. Select the functions of components in the cathode circuit that pertain to cathode bias.

5. Identify circuit configuration of cathode biasing in circuit application for future use.

6. Student knowledge of cathode bias will be tested by:

a. Identification of components that pertain to cathode bias.

b. Describing functions of components.

c. Describing theory of operation.

Sample frames:

#22

The function of R 1 is to return the grid to D.C. ground potential for bias application.

The D.C. voltage drop across R 1 is always zero.

There will be an A.C. voltage appearing across R 1 when a signal is applied from the left side of C 1 to ground.

The name of R 1 is:

1. Grid return capacitor

Turn to page 27

2. Grid return resistor

Turn to page 28

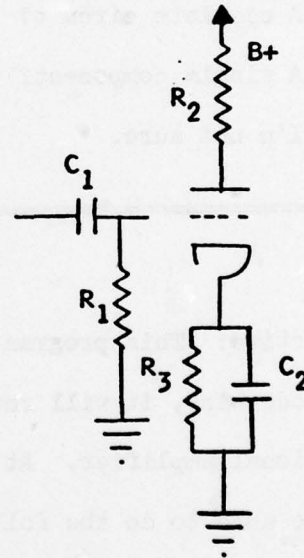

#27

The answer that you selected is not correct.

I believe that you read too fast.

The grid return part of your answer is correct. The third characteristic is wrong. R 1 is a resistor, not a capacitor.

Remember, components are named according to the following:

1. The electrode they are connected to.
2. The function they perform.
3. What they are.

Resistor symbol



Capacitor symbol

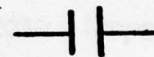

Turn to page 22

Select another answer

#28

The answer you chose is correct.

R 1 is a grid return resistor.

This satisfies the three requirements:

1. R 1 is in the grid circuit.
2. The function of R 1 is to return the grid to D. C. ground potential.
3. R 1 is a resistor.

Turn to page 26

THE STANDARD NAVAL TECHNICAL MANUAL FOR SONAR EQUIPMENT

Objective: Given any Standard Naval Technical Manual for sonar equipment, the student will complete the following in 30 minutes:

1. Write from memory the eight major sections of a standard naval technical manual.

2. Demonstrate the ability to identify the use of each of the eight major sections of a standard naval technical manual by completing a ten item multiple choice examination.

Sample frames:

Your answer: SECTION I, GENERAL DESCRIPTION

Very good! SECTION I, GENERAL DESCRIPTION would tell us the complement or number of tubes under the sub-section reference data.

TURN TO PAGE 9

Page 8

To see how well your memory is progressing, fill in the following by giving the titles of the sections. The answers may be found on the back of this page.

1. SECTION I _____
2. SECTION II _____

Check your answers with those on the back of this page and then continue to Page 10.

Page 9
