

AD-A036 153

CALSPAN CORP BUFFALO N Y
NORMAL STRESS, TEMPERATURE, AND PERFORMANCE PROPERTIES OF MILIT--ETC(U)
OCT 76 J R HAMPTON

F/G 1/3

F33615-75-C-0106

UNCLASSIFIED

CALSPAN-ZM-5689-T

AFFDL-TR-76-95

NL

1 OF 2
AD
A036153

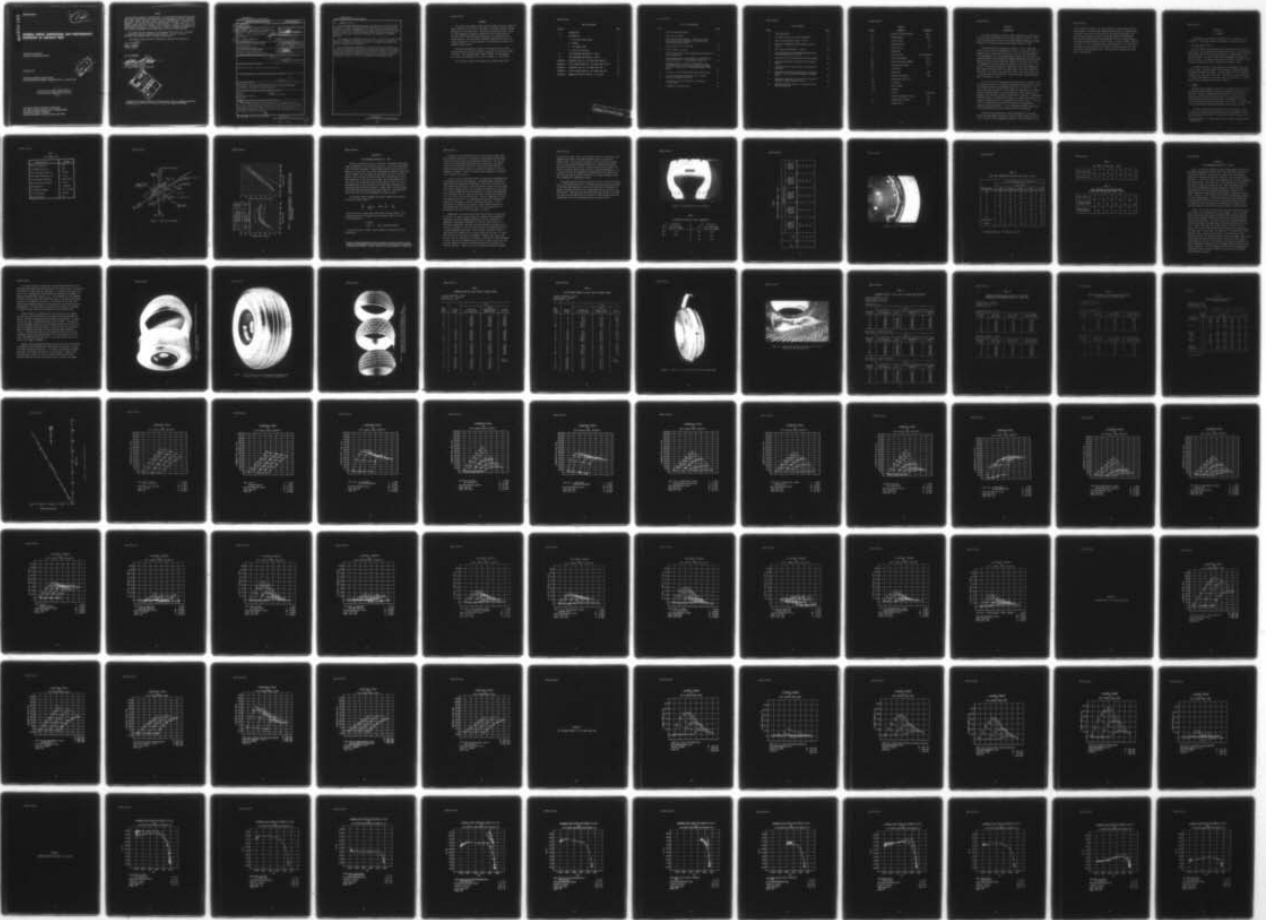

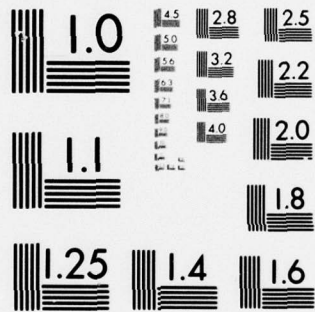

MICROCOPY RESOLUTION TEST CHART
NATIONAL BUREAU OF STANDARDS-1963-A

ADA 036 153

AFFDL-TR-76-95

12

NORMAL STRESS, TEMPERATURE, AND PERFORMANCE PROPERTIES OF AIRCRAFT TIRES

*MECHANICAL BRANCH
VEHICLE EQUIPMENT DIVISION*

OCTOBER 1976

TECHNICAL REPORT AFFDL-TR-76-95
FINAL REPORT FOR PERIOD 6 FEBRUARY 1975 - 11 AUGUST 1975

D D C
REGISTERED
MAR 1 1977
WRIGHT-PATTERSON AIR FORCE BASE

Approved for public release; distribution unlimited

AIR FORCE FLIGHT DYNAMICS LABORATORY
AIR FORCE WRIGHT AERONAUTICAL LABORATORIES
AIR FORCE SYSTEMS COMMAND
WRIGHT-PATTERSON AIR FORCE BASE, OHIO 45433

NOTICE

When Government drawings, specifications, or other data are used for any purpose other than in connection with a definitely related Government procurement operation, the United States Government thereby incurs no responsibility nor any obligation whatsoever; and the fact that the government may have formulated, furnished, or in any way supplied the said drawings, specifications, or other data, is not to be regarded by implication or otherwise as in any manner licensing the holder or any other person or corporation, or conveying any rights or permission to manufacture, use, or sell any patented invention that may in any way be related thereto.

This report has been reviewed by the Information Office (OI) and is releasable to the National Technical Information Service (NTIS). At NTIS, it will be available to the general public, including foreign nations.

This technical report has been reviewed and is approved for publication.

James R. Hampton

JAMES R. HAMPTON
Project Engineer

FOR THE COMMANDER

Ambrose B. Nutt

AMBROSE B. NUTT, Director
Vehicle Equipment Division
Air Force Flight Dynamics Laboratory

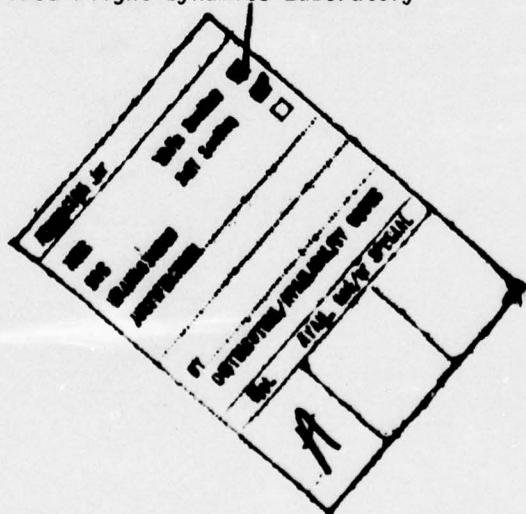

Copies of this report should not be returned unless return is required by security considerations, contractual obligations, or notice on a specific document.

UNCLASSIFIED

SECURITY CLASSIFICATION OF THIS PAGE (When Data Entered)

19 REPORT DOCUMENTATION PAGE		READ INSTRUCTIONS BEFORE COMPLETING FORM
1. REPORT NUMBER 18 AFFDL-TR-76-95	2. GOVT ACCESSION NO.	3. RECIPIENT'S CATALOG NUMBER
4. TITLE (and Subtitle) 6 NORMAL STRESS, TEMPERATURE, AND PERFORMANCE PROPERTIES OF MILITARY AIRCRAFT TIRES.		5. TYPE OF REPORT & PERIOD COVERED 8 Final Report - 6 Feb. - 11 Aug 75
7. AUTHOR(s) 10 James R. Hampton (AFFDL)		PERFORMING ORG. REPORT NUMBER CALSPAN-ZM-5689-T
9. PERFORMING ORGANIZATION NAME AND ADDRESS Calspan Corporation (TIRF Center) P. O. Box 235 Buffalo, New York 14221		8. CONTRACT OR GRANT NUMBER(s) 15 F33615-75-C-0106 new
11. CONTROLLING OFFICE NAME AND ADDRESS Mechanical Branch (AFFDL/FEM) Air Force Flight Dynamics Laboratory Wright-Patterson Air Force Base, Ohio 45433		10. PROGRAM ELEMENT, PROJECT, TASK AREA & WORK UNIT NUMBERS 16 Project No. 1369 Task No. 136901 Work Unit No. 13690146
14. MONITORING AGENCY NAME & ADDRESS (if different from Controlling Office) 12 105 p.		12. REPORT DATE 11 Oct. 1976
16. DISTRIBUTION STATEMENT (of this Report) Approved for public release; distribution unlimited		13. NUMBER OF PAGES 105
17. DISTRIBUTION STATEMENT (of the abstract entered in Block 20, if different from Report)		15. SECURITY CLASS. (of this report) Unclassified
18. SUPPLEMENTARY NOTES The Contract (F33615-75-C-0106) was monitored by Ben J. Brookman, Jr. (AFFDL/FEM). This report was prepared by James R. Hampton (AFFDL/FEM) from the data delivered by Calspan Corporation.		
19. KEY WORDS (Continue on reverse side if necessary and identify by block number) Tires Braking Aircraft Mechanical Properties Performance Properties Cornering		
20. ABSTRACT (Continue on reverse side if necessary and identify by block number) Measurements were made of the normal stress and temperature of the 20 x 4.4/12 PR Type VII military aircraft tire while rolled at various speeds. On one tire, normal stress was measured at five locations in the tread area at the carcass and tread interface. On the second tire, the contained air temperature, contained air pressure, and the carcass temperature at the carcass and tread interface was recorded.		

DD FORM 1 JAN 73 1473

EDITION OF 1 NOV 65 IS OBSOLETE

UNCLASSIFIED

SECURITY CLASSIFICATION OF THIS PAGE (When Data Entered)

409 727

mt

UNCLASSIFIED

SECURITY CLASSIFICATION OF THIS PAGE(When Data Entered)

20. ABSTRACT (Cont'd)

Force and moment measurements were also recorded for the 6.00-6 military aircraft tires under cornering and braking conditions for wet and dry surface conditions. Various configurations of the 6.00-6 Type III aircraft tire were used for these tests. Included were the standard production 6.00-6/8 ply rated Type III aircraft tire, 6.00-6 replaceable tread tires with various types of tread belts, and cast tires which are molded from thermoplastic elastomer materials.

The results of the temperature tests of the 20 x 4.4/12 PR tire demonstrated that tire temperature, contained air pressure, and contained air temperature generally increases with increasing velocity. The normal stress data on the 20 x 4.4/12 PR tire was inconclusive.

The force and moment measurements of the various types of 6.00-6 tires are shown to generally decrease with increasing surface wetness and increasing velocity and to generally increase with increasing tire loading and slip angle. Highly unusual results are demonstrated by the cast 6.00-6 tires. These tires are characterized by the behavior of providing large cornering forces while showing poor results for the tests in braking and self-aligning torque.

UNCLASSIFIED

SECURITY CLASSIFICATION OF THIS PAGE(When Data Entered)

FOREWORD

This report was prepared in the Vehicle Equipment Division, Mechanical Branch (FEM) of the Air Force Flight Dynamics Laboratory (AFFDL), Wright-Patterson Air Force Base, Ohio. The work was accomplished under Project No. 1369 "Mechanical Systems for Advanced Military Flight Vehicles," Task No. 136901 "High Performance Landing Gear for Advanced Military Flight Vehicles," Work Unit Number 13690146 "Laboratory Test and Technology Integration." The time period of the effort was 6 February 1975 through 11 August 1975.

The data was obtained by Calspan Tire Research Facility (TIRF), Calspan Corporation, Buffalo, New York, under Air Force Contract F33615-75-C-0106. TIRF submitted report number ZM-5689-T on the contract. The contract was monitored by Mr. Ben J. Brookman, Jr. (AFFDL/FEM).

This technical report was submitted by the author August 1976.

TABLE OF CONTENTS

SECTION		PAGE
I	INTRODUCTION	1
II	TEST MACHINE	3
	1. Tire Positioning System	3
	2. Roadway	3
	3. Tire Wheel Drive	4
	4. Facility Validation	4
III	TEST PROCEDURES AND RESULTS: PART I	9
IV	TEST PROCEDURES AND RESULTS: PART II	17
APPENDIX A	CORNERING FORCE VS. SLIP ANGLE AND VELOCITY	33
APPENDIX B	SELF-ALIGNING TORQUE VS. SLIP ANGLE AND VELOCITY	47
APPENDIX C	CORNERING FORCE VS. SLIP ANGLE AND LOAD	59
APPENDIX D	SELF-ALIGNING TORQUE VS. SLIP ANGLE AND LOAD	68
APPENDIX E	NORMALIZED TRACTIVE FORCE VS. SLIP RATIO	77

PRECEDING PAGE BLANK - NOT FILMED

LIST OF ILLUSTRATIONS

FIGURE		PAGE
1	TIRF Tire Research Machine	5
2	SAE Tire Axis System	7
3	Facility Validation Results: Cornering Stiffness and Aligning Torque Stiffness vs. Vertical Load for a G78-15 Tire at 28 psi	8
4	Cross Section of 20 x 4.4/12 PR	12
5	Tire B - Area of Failure	14
6	6.00-6 Rubber Carcass with Dismounted Circumferentially Grooved Tread Belt	21
7	6.00-6 Rubber Carcass with Mounted Circumferentially Grooved Tread Belt - The Replaceable Tread Tire	22
8	Replaceable Belts of Various Tread Designs: The Circumferentially and Laterally Grooved, the Knobby, and the Circumferentially Grooved Replaceable Tread Belts	23
9	Cast Tire: Failure Occurred During Cornering Tests	26
10	6.00-6/8 PR Standard Production Tire: Failure Occurred During Cornering Tests	27
11	Illustration of Slip Ratio Curve in Obtaining Traction Forces	34
12	Tachometer Calibration Curve	35

LIST OF TABLES

TABLE		PAGE
1	TIRF Capabilities	6
2	Calibration Factors of Stress Transducers	12
3	Values of Peak Normal Stress: Tire A	13
4	Final Tire Temperatures After Rolling 2 Miles: Tire B	15
5	Test Time of Two Mile Roll: Tire B	16
6	Tire Contained Air Pressure Measured Before and After Rolling 2 Miles: Tire B	16
7	Cornering Force of 6.00-6 Tires at Various Speeds	24
8	Self-Aligning Torque of 6.00-6 Tires at Various Speeds	25
9	Cornering Force of 6.00-6 Tires at Various Road Conditions	28
10	Mechanical Properties at 30 and 55 psi Inflation Pressure for the 6.00-6/8 PR Standard Production Tire	29
11	Mechanical Properties at 30 and 55 psi Inflation Pressure for the 6.00-6 Cast Tire	30
12	Normalized Tractive Force vs. Slip Ratio at Wet and Dry Conditions	31

SYMBOLS

SYMBOL	PARAMETER	DIMENSION
E_i	Bridge Excitation Voltage	volts
E_o	Voltage Output	volts
F_x	Tractive Force	lb
F_y	Cornering Force	lb
F_z	Vertical Load	lb
GF	Gage Factor	-
K	Stress Factor	microstrain/psi
M_x	Overturning Moment	ft-lb
M_y	Rolling Resistance Moment	ft-lb
M_z	Self-Aligning Torque	ft-lb
PR	Ply Rating	-
ΔR	Resistance	ohms
R	Variable Resistance	ohms
RTT	Replaceable Tread Tire	-
SR	Slip Ratio	-
S/N	Serial Number	-
Std.	Standard	-
ϵ	Strain	inches/inch
ω	Free Rolling Wheel Velocity	rpm
ω_b	Braked Wheel Velocity	rpm
σ	Normal Stress	psi

SECTION I
INTRODUCTION

This report summarizes results of tests conducted on aircraft tires at the Calspan Tire Research Facility (TIRF), Buffalo, New York. These tests were performed for the Air Force Flight Dynamics Laboratory, Wright-Patterson Air Force Base under Contract Number F33615-75-C-0106.

The test program was conducted in two parts. Part I comprised a series of tests of two instrumented 20 x 4.4/12 ply rating (PR) Type VII standard (std.) production aircraft tires. One tire was instrumented with thermocouples to indicate temperature build-up, while the other tire contained normal stress transducers imbedded between the tread and carcass. These tires were rolled at specified speeds for a distance of two miles for temperature tests and three tire revolutions for stress tests. Contained air pressure, contained air temperature, and carcass temperature were recorded from the first tire, while normal stress was recorded for the second. The normal stress measured in this test is the radial stress at the tread and carcass interface. These tests were conducted between March 26 and April 2, 1975.

Part II of this test program was conducted from May 5 to May 9, 1975. Various 6.00-6 aircraft tire designs were tested including the 8 ply rated std. production tire, the replaceable tread tire, and cast tire. The replaceable tread tire (RTT) is a two piece tire consisting of a separate textile reinforced rubber carcass and tread belt. When the carcass is deflated, the tread belt is easily slipped over the carcass's circumference. Then the carcass is inflated, which causes it to expand and results in an integral carcass/tread belt tire assembly (see Figures 6 and 7). The cast tire is a tire which was rotationally molded from a thermoplastic polyester elastomer material. It has a continuous toroidal construction with uniform thickness and does not have textile reinforcement.

The tests were accomplished to obtain measurements of the three forces and three moments generated in the tire contact patch (see Figure 2) as a function of six independent variables. These variables are the

AFFDL-TR-76-95

vertical load, slip angle, slip ratio, velocity, inflation pressure, and road condition. The tests were conducted such that three of these variables were held constant, while at least two of the remaining parameters were varied so as to obtain a family of curves describing the relationship between varying inputs and the corresponding tire force or moment output. The range of these parameters were as follows: vertical load 500 - 1500 lbs; slip angle 0° - 12° ; slip ratio from 0 (free rolling) to -1.0 (see Section IV, Figure 11) velocity from 5 to 100 mph; inflation pressure of 30 and 55 psi; and road conditions of dry, .050" water film thickness, and .200" water film thickness.

SECTION II
TEST MACHINE

A photograph of the Calspan Tire Research Facility (TIRF) is shown in Figure 1. The primary features of the machine are described below.

1. TIRE POSITIONING SYSTEM

The tire, wheel, force sensing balance, and hydraulic motor to drive or brake the tire are mounted in the movable upper head. The head provides steer, camber, and vertical motions to the tire. These motions, as well as vertical loading, are servo controlled and programmable for maximizing test efficiency. The ranges of the position variables, the rates at which they may be adjusted, and other information are shown in Table 1.

The wheel drive shaft is equipped with a six-component strain gage balance system. Three orthogonal forces and three corresponding moments are measured through this system. A fourth moment, torque, is sensed by a torque link in the wheel drive shaft. The tire axis system showing the tire forces and moments acting at the center of tire contact is in agreement with SAE convention and is shown in Figure 2.

2. ROADWAY

The 28-inch wide roadway is made up of a stainless steel belt covered with material that simulates the frictional properties of actual road surfaces. The belt is maintained flat to within 1 to 2 mils under the tire patch by the restraint provided by an air bearing pad which is beneath the belt in the tire patch region. The roadway is driven by one of the two 67-inch diameter drums over which it runs. The road speed is servo controlled and may be programmed to be constant or varied.

Surfaces usually used are commercial anti-skid coatings. These surfaces have excellent microtexture giving a wet skid number¹ of about 60 in the untreated condition. The surfaces are honed to reduce the wet

¹At 40 mph and 0.20 in. water depth using the ASTM E-501 Standard Pavement Traction Tire.

skid number to lower values (typically, surfaces of skid number 50 and 30 are used).

A unique feature of TIRF is the ability to carry out tests under wet road conditions. A water nozzle spans the width of the roadway. This nozzle has an adjustable throat which can be set to the desired water depth. The flow through the nozzle is then varied by controlling the water pressure. At each test condition the water film is laid on tangent to the belt with the water velocity equal to the belt velocity. The film thickness may be varied from as low as 0.005 inch up to 0.5 inch.

3. TIRE-WHEEL DRIVE

A drive system which is independent of the roadway drive is attached to the tire-wheel shaft. This separate drive allows full variation of tire slip both in the braking and driving modes. The tire slip ratio, which is the ratio of the braked to the unbraked wheel horizontal velocity, is under servo control.

4. FACILITY VALIDATION

It has generally become accepted by industry and government that data recorded from TIRF tests are valid, in the sense that forces, moments, and energy losses measured on the facility, are the same as would be experienced on the road under similar conditions. A validation program was sponsored by the Motor Vehicle Manufacturers Association and the Rubber Manufacturers Association in which identical bias belted and radial ply tires were run at various test conditions on the Calspan TIRF and eight other car and tire industry facilities. Three of these facilities were road testers (trailers or truck bed), two were circular drums (external) and three (in addition to TIRF) were flat bed laboratory machines. The road test data indicated significant spread, with the TIRF data falling near the center of this spread. Typical results are shown in Figure 3.

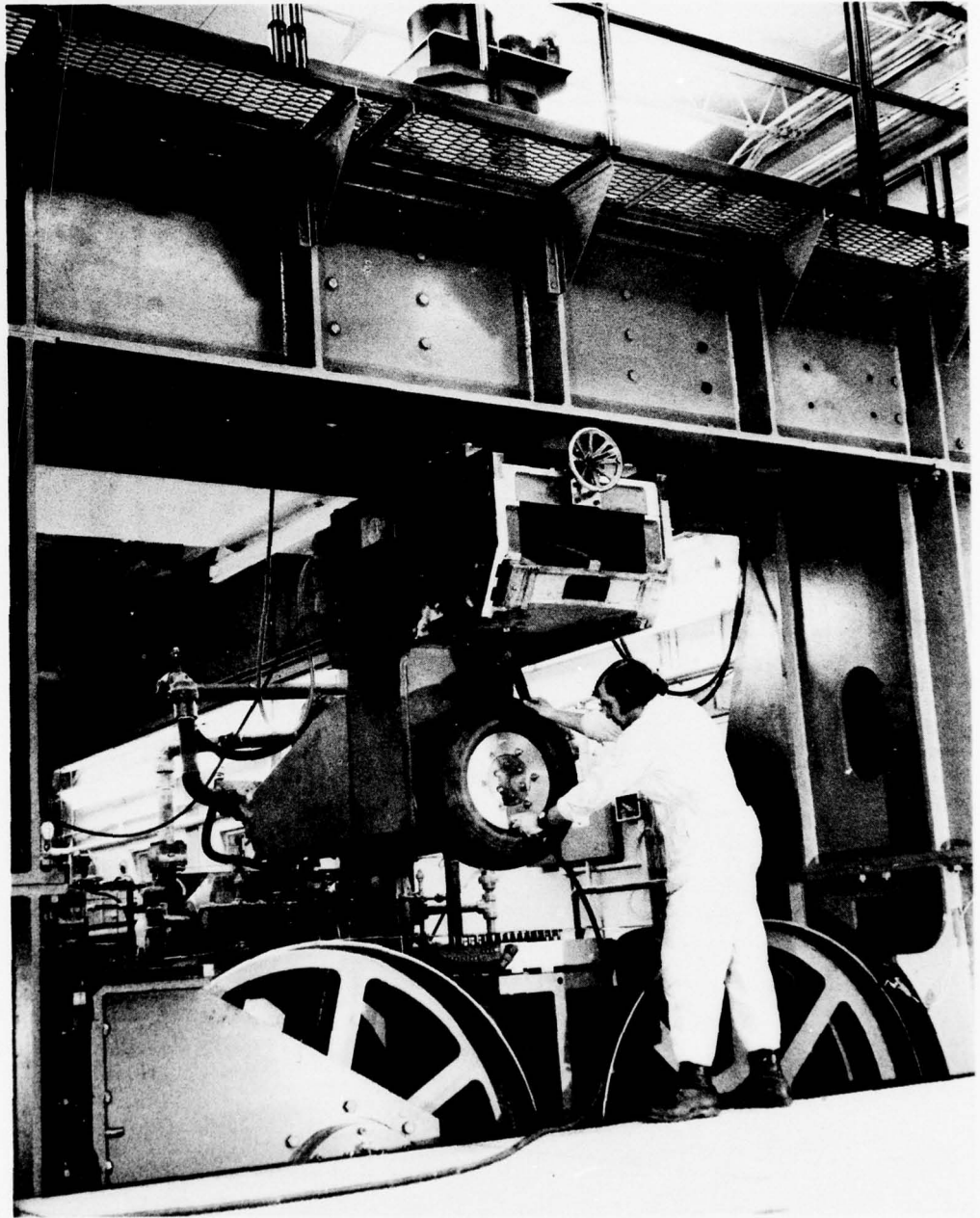

Figure 1. TIRF Tire Research Machine

TABLE 1
TIRF CAPABILITIES

Characteristic	Range
Tire Slip Angle (α)	$\pm 30^\circ$
Tire Camber Angle (γ)	$\pm 30^\circ$
Tire Slip Angle, Rate ($\dot{\alpha}$)	$10^\circ/\text{sec}$
Tire Camber Angle Rate ($\dot{\gamma}$)	$7^\circ/\text{sec}$
Tire Load Rate (Typical)	2000 lb/sec
Tire Vertical Positioning	2"/sec
Road Speed (V)	0-200 mph
Tire Outside Diameter	18.5" to 46"
Tire Tread Width	24" Max
Road Belt Width	28"

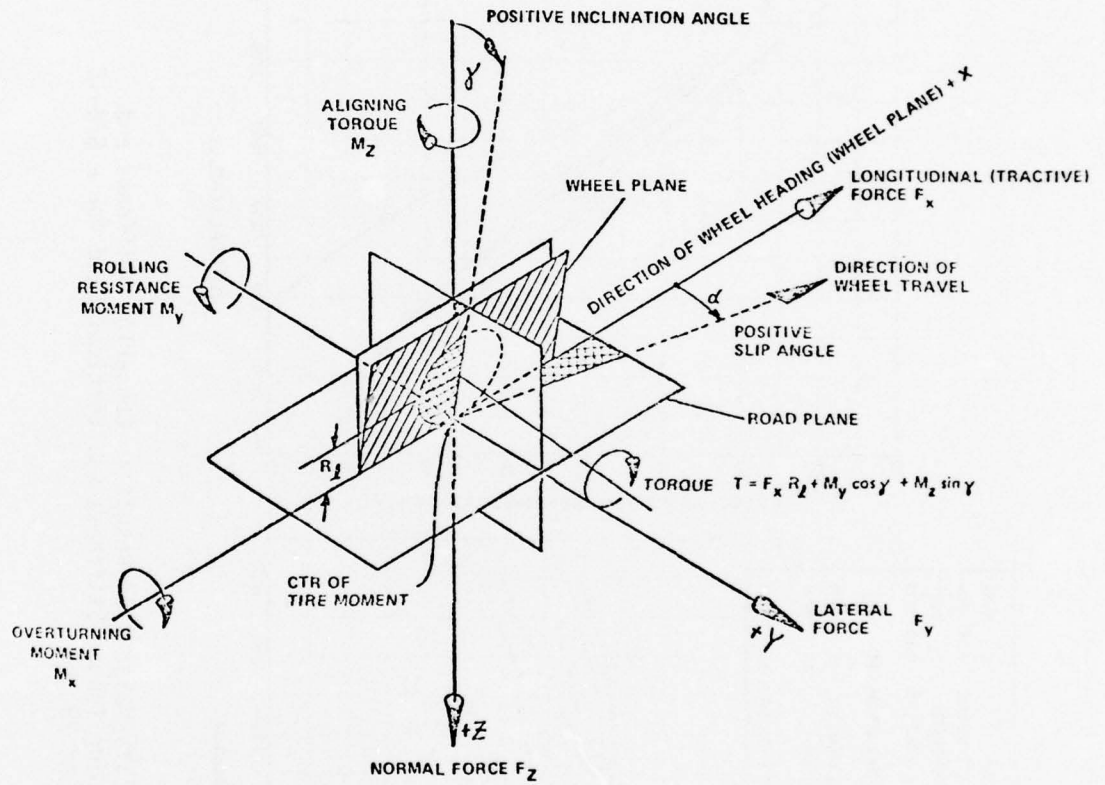

Figure 2. SAE Tire Axis System

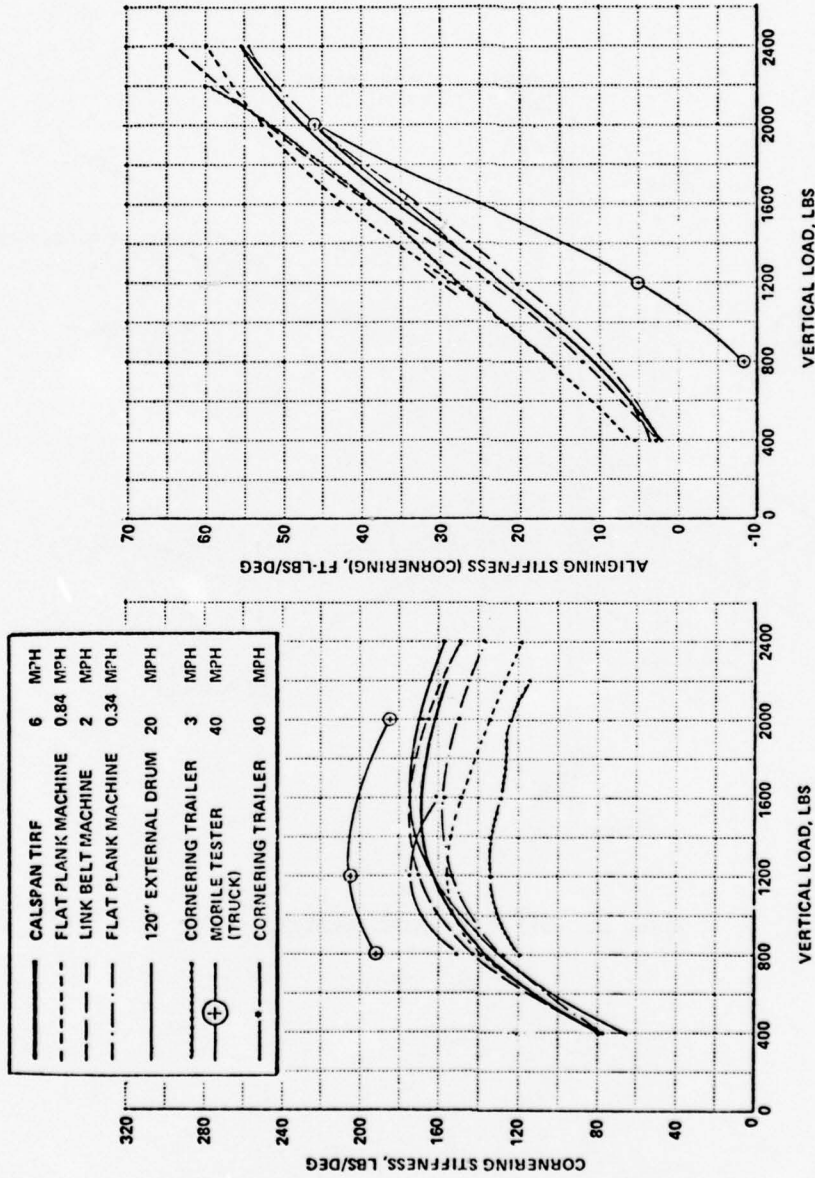

Figure 3. Facility Validation Results: Cornering Stiffness and Aligning Torque Stiffness vs. Vertical Load for a G78-15 Tire at 28 psi

SECTION III

TEST PROCEDURES AND RESULTS: PART I

The 20 x 4.4/12 PR aircraft tire which was instrumented with normal stress transducers will be denoted as tire "A". Tire A was instrumented with five stress transducers, three located one-half inch from the tire center line in an inner rib, and two located one and one-half inches from the tire center line in an edge rib (see Figure 4). All of the transducers in this tire and in the tire later to be referenced as tire "B" were placed only in the inner rib and edge rib of the outboard half of the tire so as to allow easy access to the lead-in wires. The stress transducers were of one active arm strain gage type, connected into a bridge with three volts DC excitation. Output signals from the bridges were conditioned by amplifiers whose gains were 100. The calibration factors for the five stress transducers are shown in Table 2.

The transfer function between the output voltage and the bridge excitation voltage (E_o/E_i) is:

$$\frac{E_o}{E_i} = \frac{1}{4R + 2}, \text{ where } \frac{R}{\Delta R} = \frac{1}{\epsilon GF},$$

ϵ being the strain (inches/inch) and GF being the gage factor.² The bridge output was then related to the tire normal stress (σ) by the following equation:

$$\sigma = \frac{2 \times 10^6}{k \left(\frac{E_i}{E_o} - 2 \right)} \text{ where } k(\text{microstrain/psi})$$

is the stress factor, unique to each transducer and specified by the manufacturer.

²Results of Tests Conducted on 6.00 x 6 and 20 x 4.4 Aircraft Tires at the Calspan Tire Research Facility for the Air Force Flight Dynamics Laboratory. Calspan Report ZM 5689-T, Calspan Corporation, Buffalo New York, July 1975.

The load on Tire A during the tests was approximately 3000 pounds which yielded a deflection of 31 percent of the unloaded section height at the inflation pressure of 100 pounds per square inch. The tire was rolled for at least three revolutions during recording of the normal stresses at the forward velocities of 5, 10, and 20 miles per hour. Values of the peak normal stress as a function of speed for Tire A are summarized in Table 3. Run 4 is a repeat of Run 2 because of a problem with a recorder pen on Run 2.

Tire B is a 20 x 4.4/12 PR aircraft tire which was instrumented with eight copper constantan thermocouples. The thermocouples were equally spaced around the outboard circumference of the tire in the tread, with four located one and one-half inches from the tire center line in an edge rib and four located one-half inch from the tire center line in an inner rib. Carcass temperature and the contained air pressure and temperature were recorded as the tire rolled for two miles at each of the velocities of 5, 10, 20, 50, and 75 miles per hour. The test conditions on Tire B were identical to Tire A; i.e. 3000 pounds at an initial contained air pressure of 100 pounds, yielding a 31 percent deflection. Tire B experienced a catastrophic cord rupture in the sidewall approximately ten seconds before the completion of the 75 mile per hour test. A photograph of the area of failure appears in Figure 5.

Temperature, time, and pressure data from the tests are summarized in Tables 4, 5, and 6. Table 4 contains a summary of the temperatures measured by the eight imbedded thermocouples and the contained air temperature thermocouple immediately at the end of each two mile run. The ambient temperature listed was that established at the beginning of each run. The data in this table indicates that the temperature build-up is highly dependent upon speed. This is further clarified in Table 5 which contains a tabulation of the time of each two mile test. It shows that the five mile per hour test consumed 24 minutes while the 75 mile per hour test was completed in 1.6 minutes. Even with the large difference in test time, the tire temperature after the 1.6 minute, 75 mile per hour test was roughly twice the tire temperature after the 24 minute, five mile per hour test. Table 6 lists the contained air pressures measured

AFFDL-TR-76-95

at the start and end of each run and shows that the air pressure is also dependent upon speed. Noticeable anomalies appear in the data of Tables 4 and 6. Particularly disturbing is the inconsistency between the final contained air temperature and final contained air pressure after each of the two mile rolls. Because the tire was a retread, the effects of carcass stretch cannot serve as a possible explanation. It is a possibility that the contained air thermocouple did not remain rigid and could have come in contact with the tire or wheel, thereby giving a false contained air temperature reading.

The rated load and inflation pressure of the 20 x 4.4/12 PR aircraft tire is 5150 pounds and 225 psi. The reason the tests were not performed at the rated load condition is due to the limitation of the loading in pounds per square inch which can be supported by the air bearing on the TIRF machine. Therefore, the load and pressure were adjusted to maintain the correct carcass deflection (31 percent) in order to approximate the same amount of flex and corresponding heat and stress levels.

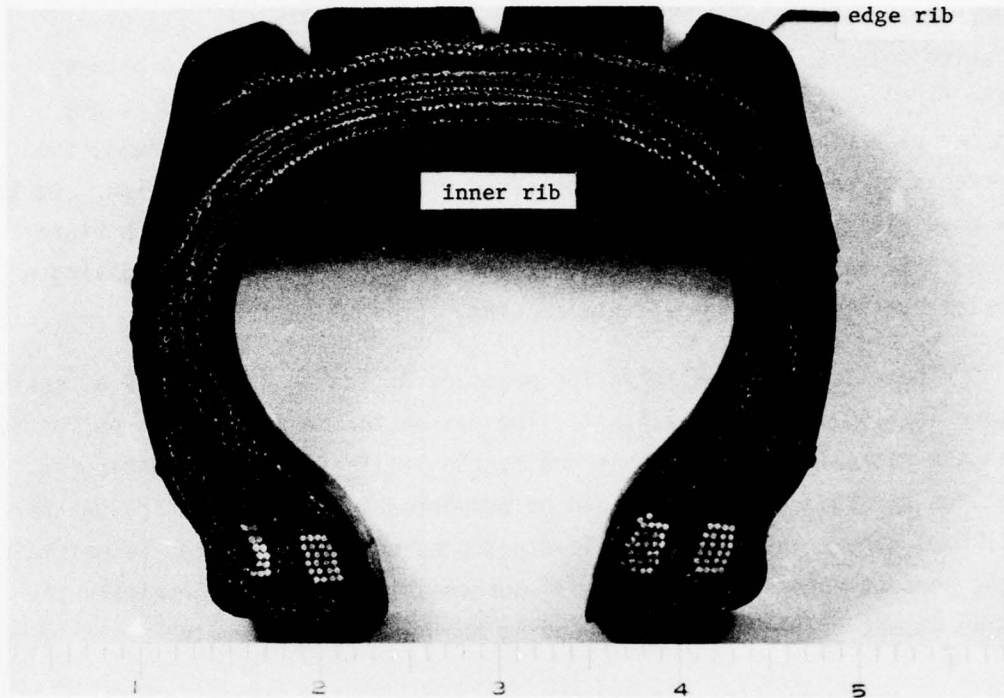

Figure 4. Cross Section of 20 x 4.4/12 PR

TABLE 2

CALIBRATION FACTORS OF STRESS TRANSDUCERS

120 Transducers		350 Transducers	
S/N	Micro-Strain/psi At GF = 2.00	S/N	Micro-Strain/psi At GF = 2.00
265	4.10	325	2.54
267	1.83	327	3.05
		328	2.16

TABLE 3
VALUES OF PEAK NORMAL STRESS: TIRE A

Run	V mph	Normal Stress (psi)				
		Stress Transducer S/N 325 Inner Rib	Stress Transducer S/N 327 Edge Rib	Stress Transducer S/N 328 Inner Rib	Stress Transducer S/N 265 Inner Rib	Stress Transducer S/N 267 Edge Rib
1	5	109	79	127	112	170
2	10	117	68	127	102	163
3	20	111	53	115	89	118
4	10	119	70	127	109	163

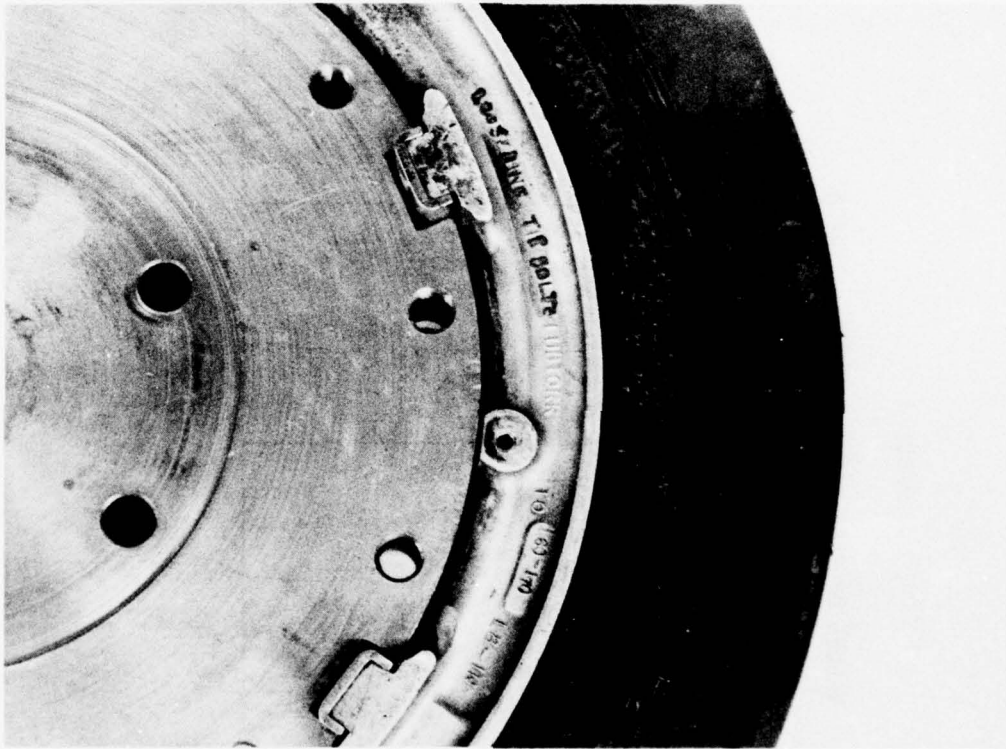

Figure 5. Tire B - Area of Failure

TABLE 4
FINAL TIRE TEMPERATURES AFTER ROLLING 2 MILES: TIRE B

Thermocouple	Tire Temperature After 2 Miles (°F)				
	Road Speed				
	5 mph	10 mph	20 mph	50 mph	75 mph
E1*	120	119	126	167	217
I2	107	121	145	199	250
E3	133	118	151	189	258
I4	118	110	139	192	252
E5	117	124	146	190	245
I6	96	101	138	189	234
E7	123	124	138	172	229
I8	94	107	126	184	230
Contained Air	92	70	83	107	146
Ambient	68	68	69	69	69

* "E" denotes edge rib; "I" denotes inner rib

TABLE 5

TEST TIME OF 2 MILE ROLL: TIRE B

Road Speed (mph)	5	10	20	50	75
Test Time (min)	24	12	6	2.4	1.6

TABLE 6

TIRE CONTAINED AIR PRESSURE MEASURED
BEFORE AND AFTER ROLLING 2 MILES: TIRE B

Road Speed (mph)	5	10	20	50	75
Initial Unloaded Pressure (psi)	100	100	100	100	100
Final Loaded Pressure (psi)	100	100	115	120	127

SECTION IV

TEST PROCEDURES AND RESULTS: PART II

Part II of the test program consisted of measurements of the forces and moments generated by 6.00-6 aircraft tires under the conditions of cornering and braking. Road speed, slip angle, load, and inflation pressure were varied during the tests under dry, wet, and flooded road conditions. A total of 32 tests were conducted, all at various conditions and configurations of the 6.00-6 tire. The configurations consisted of: the eight ply rated std. production tire, 6.00-6 replaceable tread tire (RTT) with circumferentially grooved tread belt, 6.00-6 RTT with a circumferentially and laterally grooved tread belt, 6.00-6 RTT with knobby tread belt, rubber carcass of RTT without a tread belt, and cast tires. Figures 6, 7, and 8 depict the RTT and the replaceable tread belt of various tread designs. The cornering and self-aligning torque data were generated with the tire rolling in one direction only while the slip angle was swept continuously from 0 degrees to 12 degrees with a sufficient pause at every even slip angle to obtain steady state data.

Tables 7 and 8 exhibit cornering force and self-aligning torque for three 6.00-6 tire configurations at various speeds. Table 7 indicates that the cornering force generally decreases with increasing velocity, while Table 8 indicates that no particular trend can be discerned for the self-aligning torque. The most significant information presented in these two tables is the magnitude of the forces created by the cast tire. At some conditions, the cornering force of the cast tire is found to be as high as 300 percent of that cornering force generated by the other tires. At the lower slip angles (0° - 8°) where most aircraft operation occurs, the cast tire excels in cornering force at each condition over the std. production 6.00-6 tire and the rubber carcass tire. On the other hand, the cast tire exhibits little or no self-aligning torque when the slip angle is increased to four degrees and beyond. No data is presented for the cast tire at 100 mph, due to the tire failure shown in Figure 9. The std. production 6.00-6 tire also experienced a catastrophic failure, shown in Figure 10, but the tire was replaced and testing was continued.

Cornering force of four 6.00-6 tire configurations is shown in Table 9 for several road conditions. It is shown in these charts that cornering force generally degrades as the surface becomes wet, especially at the higher slip angles. The cornering force of the cast tire, however, shows little change at the lower slip angles (up to 6°) with an increase at the higher slip angles as the surface becomes wet. This increase in cornering with an increase in water film thickness is highly abnormal and cannot be explained. Also, as demonstrated in Table 7 and 8, the cornering force of the cast tire exceeds that of the other 6.00-6 tire types up to eight degrees yaw and obviously becomes more predominant as the surface becomes wet. Another point of interest from these charts is the slip angle at which the peak cornering force is achieved. In general, the cornering force increases with increasing slip angle until a maximum slip angle is reached where the slope of the cornering curve will become negative. Typical values of the maximum slip angle are generally between 16° and 22° , depending on the tire type, size, and prescribed test conditions. However, the peak value of cornering force for the cast tire occurs around the slip angle of six degrees. Essentially, what this indicates is that the cornering force produced by the std. production 6.00-6 tire on a dry surface at approximately nine degrees of slip can be produced by the cast tire at a slip angle of only four degrees. On wet surfaces, Table 9 shows that the cornering force produced by the cast tire at two degrees of slip angle is comparable to the magnitude of cornering force produced by the std. production 6.00-6 tire at slip angles of eight to 12 degrees. Another important aspect, not shown in this table, but available in Appendix A is the cornering force dependency on speed. The cornering force diminishes at higher speeds, indicating no cornering ability at all for some of the tire configurations at a velocity of 100 miles per hour. However, the cornering stiffness (slope of the cornering force curve) of the cast tire is nearly independent of speed and thus is able to generate substantial cornering forces at large velocities under dry and wet conditions. Plots showing the self-aligning torque data for the various 6.00-6 tire types are shown in Appendix B at various speeds. Appendix C and D contains, respectively, plots of the cornering force and self-aligning torque as the tire loading is varied.

Table 10 and Table 11 present three mechanical properties for the cast tire and for the std. production 6.00-6 tire at inflation pressures of 30 and 55 pounds per square inch. These tables show that with increasing inflation pressure, cornering force increases, the unbraked drag force decreases, and the self-aligning torque decreases. These tables again indicate higher cornering force and lower self-aligning torque values of the cast tire at nearly every data entry. It also shows lower values of the unbraked drag force for the cast tire when compared to the std. production 6.00-6 tire, which indicates less power consumption. Table 10 shows there is a substantial loss of cornering force for the std. production 6.00-6 tire when the inflation pressure is reduced from the rated inflation pressure of 55 psi to 30 psi, where Table 11 shows less of a difference in the cornering force of the cast tire at the two inflation pressures. In fact, the cornering data of the cast tire is nearly identical for both inflation pressures at slip angles greater than five degrees.

Table 12 shows the normalized tractive force (tractive force divided by vertical load) for five 6.00-6 tire types at various slip angles. The peak value and the value at the slip ratio of 0.0 (free rolling) and at -1.0 (full braked skid) are provided at each slip angle. The peak value generally occurs around the slip ratio of -0.3, but may vary from -0.1 to -0.4. Figure 11 shows a typical slip curve (tractive force vs. slip ratio). On the dry surface, Table 12 shows that the RTT with the circumferentially grooved belt proved to be the best in brake force. In order, it was followed by the std. production 6.00-6 tire, the RTT with the circumferentially and laterally grooved belt, and the RTT with the knobby belt. The cast tire produced the lowest values of tractive force, with the force at the peak value comparable to the force produced at full skid. With a wet surface, Table 12 shows a rearrangement of the order of preference when selecting a tire for its braking ability. The RTT equipped with the circumferentially and laterally grooved belt or the knobby belt provided the most tractive force, followed by the RTT with the circumferentially grooved belt. The std. production 6.00-6 tire placed fourth, with the cast tire again showing the poorest tractive force performance.

The actual tractive or brake force can be obtained from Table 12 by multiplying the normalized tractive force by the vertical load. The vertical load during all brake stops was 1000 pounds. To obtain the tractive force curve, a d.c. tachometer was incorporated into the wheel hub assembly to measure the braked wheel velocity (ω_b). This parameter was then compared with the velocity of the TIRF road surface which is the free rolling wheel velocity (ω) to obtain the slip ratio. The velocity of the TIRF road surface was maintained constant at fifty miles per hour during the entire braking tests. A curve showing the tachometer calibration is presented in Figure 12 which relates the tachometer output to the wheel rpm.

Table 12 shows an incomplete set of data for three tires, namely the cast tire, and the RTT with the circumferentially grooved belt and the RTT with the circumferentially and laterally grooved belt. The data for the cast tire is incomplete because of tire failure. The data for the two replaceable tread tires are incomplete because the tires did not come to a complete stop under braking. Several of the tires would not come to a complete stop under the advised maximum brake pressure of 300 psi. The brake pressure was then increased to 450 psi but the two replaceable tread tires mentioned above still did not brake to a full stop. The normalized tractive force vs. slip ratio curves for all five 6.00-6 tires appear in Appendix E.

Another problem encountered during the brake tests was the inability of the brake to fully release after the pressure was removed. This did not affect the peak and skid (SR = -1.0) values, but may have increased the value of the freely rolling (SR = 0.0) drag force. However, this being the case, the data at zero slip remains significant for the relative comparison of free rolling drag force of one tire to another.



Figure 6. 6.00-6 Rubber Carcass with Dismounted Circumferentially Grooved Tread Belt



Figure 7. 6.00-6 Rubber Carcass with Mounted Circumferentially Grooved Tread Belt - The Replaceable Tread Tire



Figure 8. Replaceable Belts of Various Tread Designs: The Circumferentially and Laterally Grooved, the Knobby, and the Circumferentially Grooved Replaceable Tread Belts

TABLE 7

CORNERING FORCE OF 6.00-6 TIRES AT VARIOUS SPEEDS

Inflation Pressure: 55 psi
 Vertical Load: 1500 lbs
 Road Surface: Dry

Slip Angle (Deg)	Velocity (mph)	Tire		
		6.00-6/8 PR Std. Production	6.00-6 Rubber Carcass Without Belt	6.00-6 Cast Tire
0	5	31	3	- 14
2	5	-151	-133	-472
4	5	-332	-280	-703
6	5	-485	-426	-819
8	5	-632	-575	-809
10	5	-762	-713	-787
12	5	-892	-850	-769
0	20	44	9	-9
2	20	-141	-136	-453
4	20	-325	-286	-689
6	20	-488	-433	-759
8	20	-628	-584	-715
10	20	-757	-721	-653
12	20	-886	-845	-617
0	50	46	10	7
2	50	-135	-133	-420
4	50	-309	-283	-653
6	50	-454	-430	-658
8	50	-591	-578	-594
10	50	-708	-707	-557
12	50	-821	-813	-536
0	100	64	35	
2	100	-88	-94	(Tire Failed)
4	100	-228	-228	
6	100	-350	-355	
8	100	-452	-482	
10	100	-542	-601	
12	100	-625	-695	

TABLE 8

SELF-ALIGNING TORQUE OF 6.00-6 TIRES AT VARIOUS SPEEDS

Inflation Pressure: 55 psi
 Vertical Load: 1500 lbs
 Road Surface: Dry

Slip Angle (Deg)	Velocity (mph)	Tire		
		6.00-6/8 PR Std. Production	6.00-6 Rubber Carcass Without Belt	6.00-6 Cast Tire
0	5	-1.8	2.2	-8.4
2	5	38.6	33.0	38.7
4	5	73.6	57.2	19.6
6	5	92.6	75.2	1.5
8	5	107.3	83.5	-3.7
10	5	114.4	82.1	-4.5
12	5	114.0	73.8	-2.4
0	20	-4	0.4	-7.8
2	20	39.2	33.3	34.4
4	20	72.7	62.4	15.6
6	20	95.0	80.0	-1.9
8	20	104.6	87.2	-1.8
10	20	108.4	79.7	0.7
12	20	105.5	65.6	2.5
0	50	-2.4	0.1	-7.6
2	50	39.8	34.2	34.6
4	50	70.9	61.8	13.4
6	50	91.9	78.8	-2.3
8	50	101.5	85.9	1.9
10	50	101.3	77.6	1.1
12	50	96.8	59.4	1.0
0	100	-1.2	1.2	
2	100	34.8	34.7	(Tire Failed)
4	100	62.7	60.7	
6	100	81.3	82.4	
8	100	89.8	94.3	
10	100	90.9	97.3	
12	100	85.4	83.0	



Figure 9. Cast Tire: Failure Occurred During Cornering Tests

AFFDL-TR-76-95

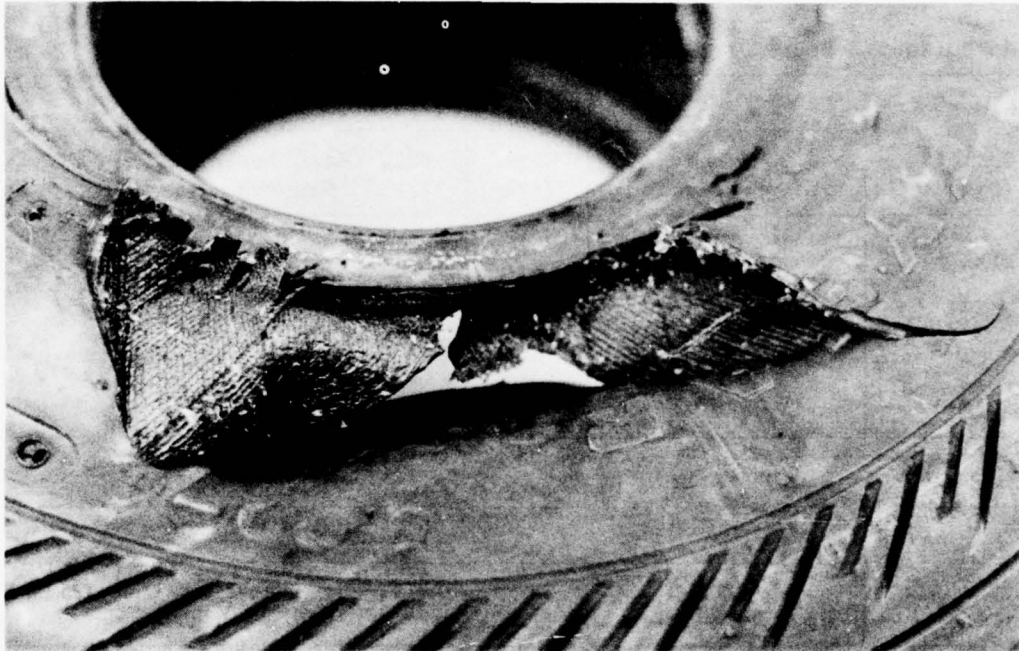

Figure 10. 6.00-6/8 PR Standard Production Tire: Failure Occurred During Cornering Tests

TABLE 9

CORNERING FORCE OF 6.00-6 TIRES AT VARIOUS ROAD CONDITIONS

Inflation Pressure: 55 psi

Vertical Load: 1500 lbs

Forward Velocity: 50 mph

Road Surface: Dry

Slip Angle (Deg)	Tire			
	6.00-6/8 PR, Std. Production	Cast Tire	RTT, Circumferential Grooves	RTT, Knobby Belt
0	46	7	38	41
2	-135	-420	-89	-86
4	-309	-653	-224	-221
6	-454	-658	-350	-351
8	-591	-594	-487	-485
10	-708	-557	-602	-609
12	-821	-536	-713	-713

Road Surface: 0.050" Water Film

Slip Angle (Deg)	Tire			
	6.00-6/8 PR, Std. Production	Cast Tire	RTT, Circumferential Grooves	RTT, Knobby Belt
0	59	-13	15	4
2	-120	-420	-117	-140
4	-273	-589	-244	-285
6	-366	-624	-345	-395
8	-423	-622	-413	-484
10	-438	-602	-456	-526
12	-441	-601	-474	-560

Road Surface: 0.200" Water Film

Slip Angle (Deg)	Tire			
	6.00-6/8 PR, Std. Production	Cast Tire	RTT, Circumferential Grooves	RTT, Knobby Belt
0	68	62	-3	-14
2	-120	-385	-112	-151
4	-254	-668	-185	-275
6	-325	-723	-216	-363
8	-366	-743	-226	-400
10	-380	-722	-237	-418
12	-380	-710	-226	-446

TABLE 10

MECHANICAL PROPERTIES AT 30 AND 55 PSI INFLATION
PRESSURE FOR THE STANDARD PRODUCTION 6.00-6/8 TIRE

Vertical Load: 1500 lbs
Forward Velocity: 50 mph
Road Surface: Dry

Inflation Pressure: 30 psi

Slip Angle (Deg)	Cornering Force (lbs)	Free Rolling Drag (lbs)	Self-Aligning Torque (ft-lbs)
0	28	-41	-0.9
2	-84	-41	46.4
4	-187	-51	83.8
6	-276	-64	111.0
8	-356	-81	124.9
10	-434	-94	132.4
12	-506	-106	132.7

Inflation Pressure: 55 psi

Slip Angle (Deg)	Cornering Force (lbs)	Free Rolling Drag (lbs)	Self-Aligning Torque (ft-lbs)
0	46	-28	-2.8
2	-135	-28	42.8
4	-309	-35	78.2
6	-454	-46	96.9
8	-591	-55	101.4
10	-708	-59	97.8
12	-821	-61	85.3

TABLE 11

MECHANICAL PROPERTIES AT 30 AND 55 PSI INFLATION
PRESSURE FOR THE 6.00-6 CAST TIRE

Vertical Load: 1500 lbs
 Forward Velocity: 50 mph
 Road Surface: Dry

Inflation Pressure: 30 psi

Slip Angle (Deg)	Cornering Force (lbs)	Free Rolling Drag (lbs)	Self-Aligning Torque (ft-lbs)
0	-13	-44	-15.1
2	-347	-36	29.8
4	-584	-32	27.7
6	-676	-27	3.3
8	-601	-28	3.9
10	-566	-29	0.4
12	-537	-30	0.0

Inflation Pressure: 55 psi

Slip Angle (Deg)	Cornering Force (lbs)	Free Rolling Drag (lbs)	Self-Aligning Torque (ft-lbs)
0	7	-30	-9.5
2	-420	-24	30.2
4	-653	-21	7.8
6	-658	-20	-0.4
8	-594	-20	0.5
10	-557	-19	1.6
12	-536	-20	-1.7

TABLE 12

NORMALIZED TRACTIVE FORCE VS. SLIP RATIO
AT WET AND DRY CONDITIONS

Vertical Load: 1000 lbs
Forward Velocity: 50 mph
Inflation Pressure: 55 psi

Tire	Slip Angle (Deg)	F_x/F_z : Dry			F_x/F_z : 0.50" Wet		
		SR = -1.0	SR = 0.00	Peak Value	SR = -1.0	SR = 0.00	Peak Value
6.00-6/8 PR, Std. Production	0°	0.760	0.020	0.810	0.180	0.030	0.370
	4°	0.810	0.030	0.850	0.180	0.040	0.305
	8°	0.895	0.035	0.900	0.180	0.050	0.300
	12°	0.730	0.040	0.800	0.180	0.055	0.265
Cast Tire	0°	0.310	0.025	0.340	0.200	0.025	0.260
	4°	0.310	0.020	0.290	0.240	0.025	0.260
	8°	*	*	*	0.230	0.030	0.250
	12°	*	*	*	0.240	0.025	0.270
6.00-6 RTT Circum. Grooved Belt	0°	*	0.020	1.150	0.230	0.030	0.400
	4°	*	0.025	1.050	0.220	0.030	0.305
	8°	0.700	0.035	0.800	0.215	0.040	0.325
	12°	0.710	0.035	0.750	0.210	0.050	0.295
6.00-6 RTT Knobby Belt	0°	0.600	0.020	0.810	0.280	0.025	0.455
	4°	0.640	0.025	0.740	0.280	0.030	0.450
	8°	0.650	0.030	0.700	0.280	0.040	0.410
	12°	0.620	0.030	0.650	0.280	0.045	0.355
6.00-6 RTT Circum. and Axially Grooved Belt	0°	*	0.020	0.800	0.290	0.025	0.475
	4°	*	0.025	0.800	0.280	0.030	0.430
	8°	*	0.030	0.750	0.275	0.040	0.390
	12°	*	0.030	0.650	0.275	0.040	0.385

*Data not available

AFFDL-TR-76-95

APPENDIX A
CORNERING FORCE VS. SLIP ANGLE AND VELOCITY

PRECEDING PAGE BLANK-NOT FILMED

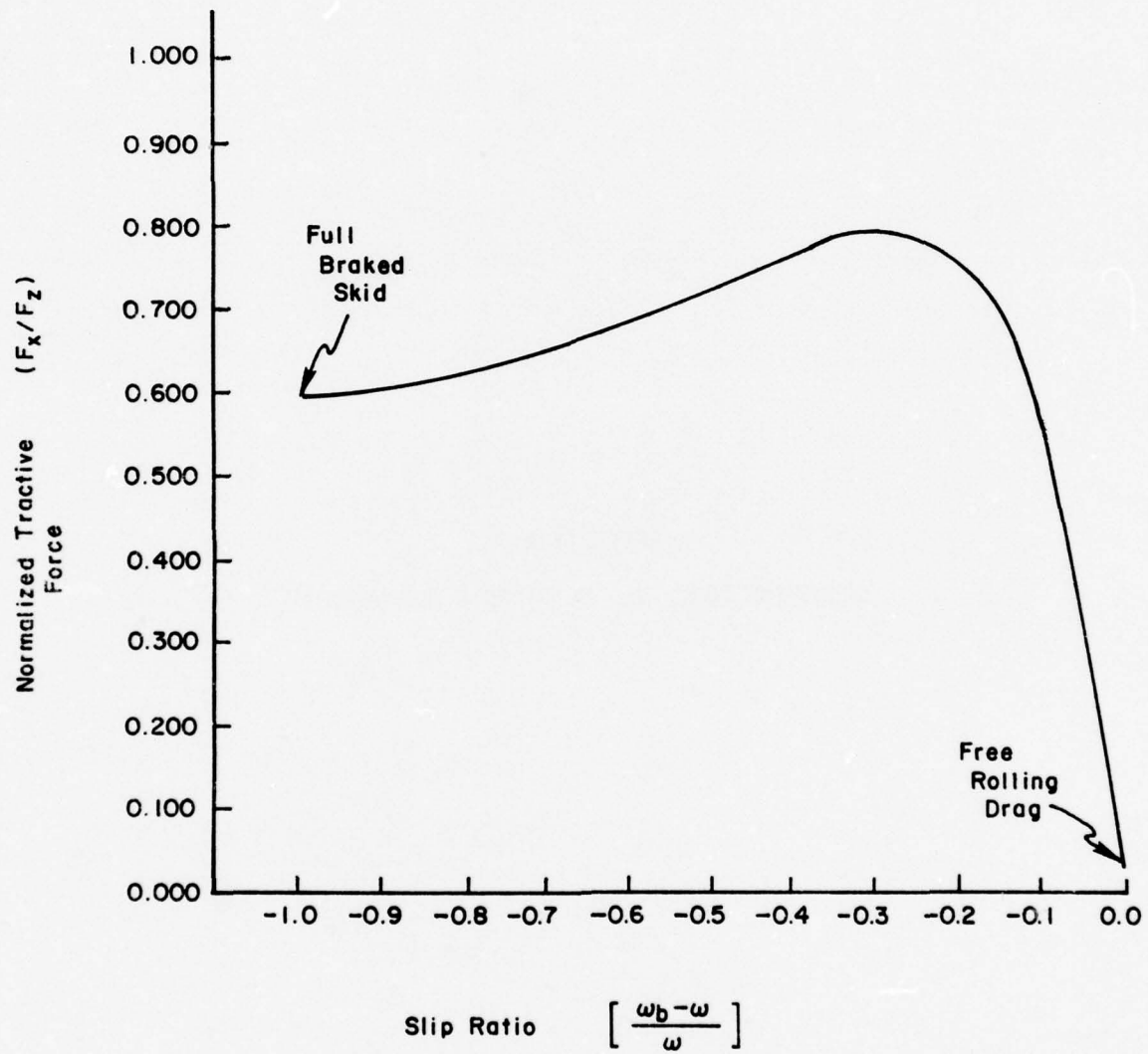

Figure 11. Illustration of Slip Ratio Curve in Obtaining Traction Forces

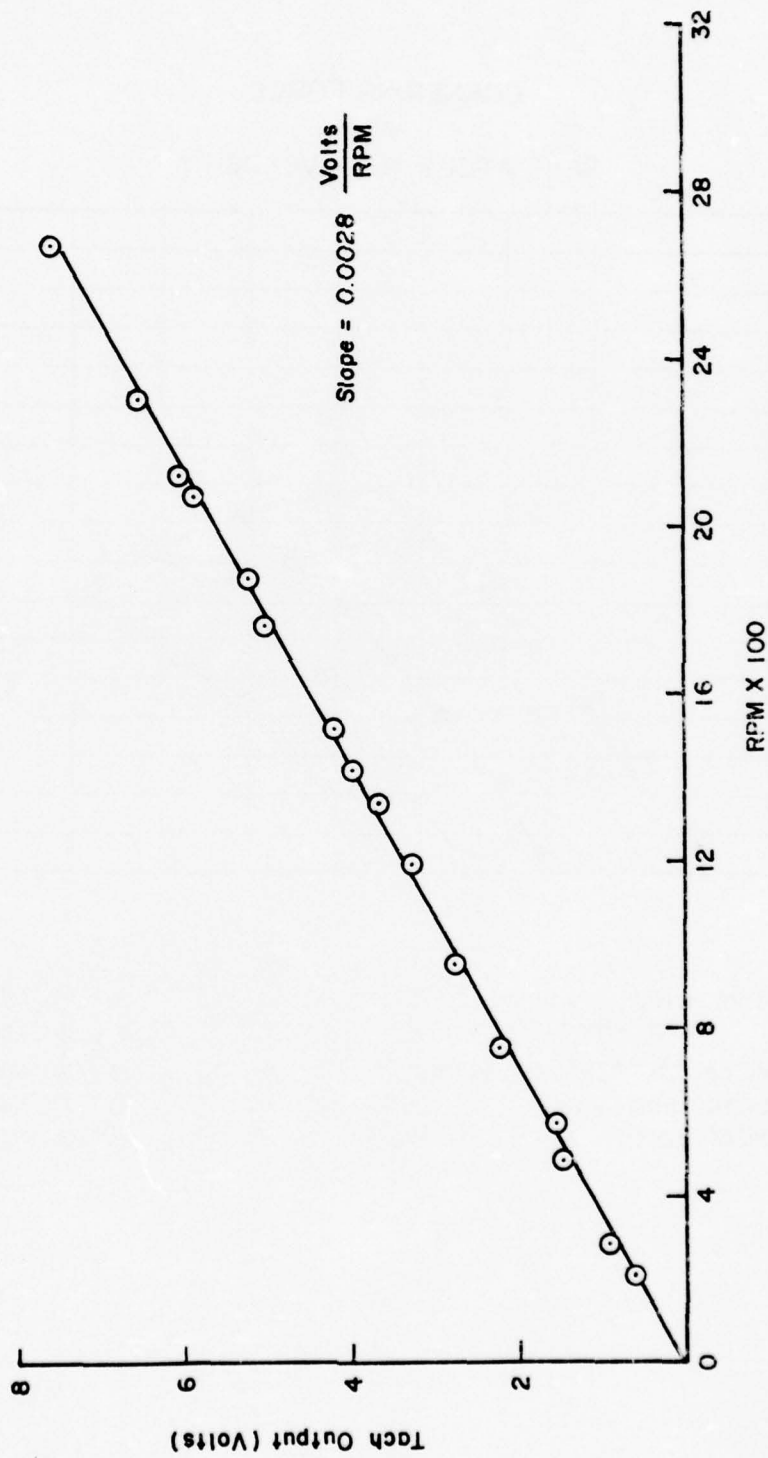
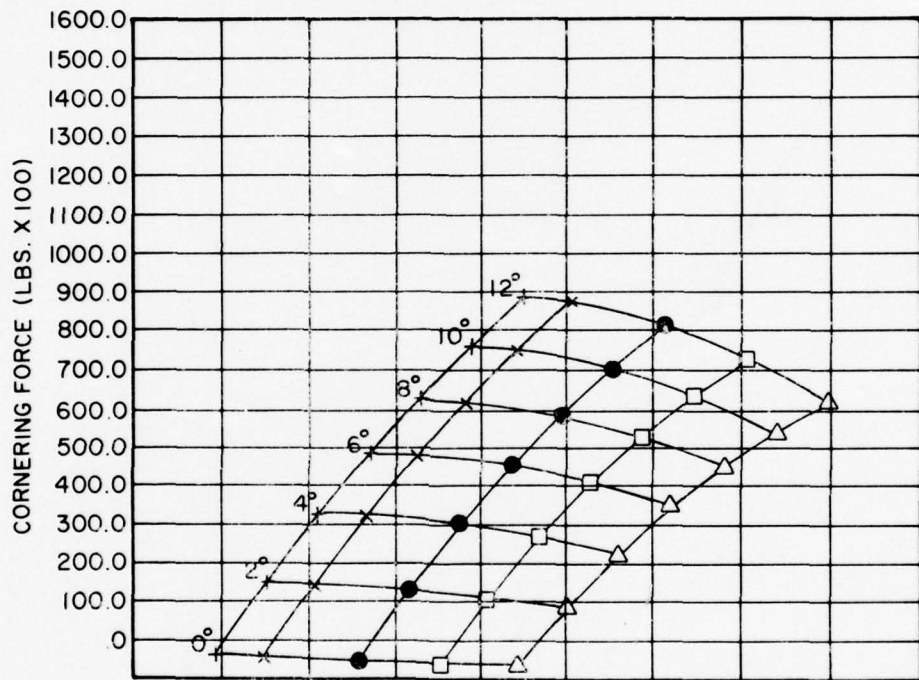

Figure 12. Tachometer Calibration Curve

CORNERING FORCE
VS
SLIP ANGLE AND VELOCITY



TIRE: 6 00 - 6 / 8 PR
STD. PRODUCTION
INFLATION PRESSURE: 55 PSI
LOAD: 1500 LBS.
ROAD: DRY

+ 5 MPH
x 20 MPH
● 50 MPH
□ 75 MPH
Δ 100 MPH

CORNERING FORCE
VS
SLIP ANGLE AND VELOCITY

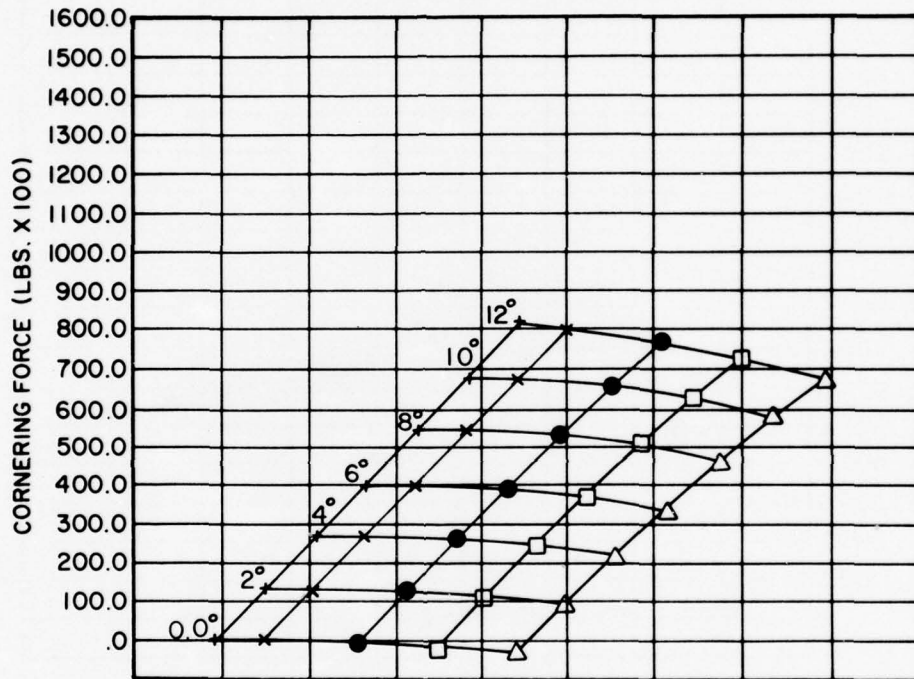

TIRE: 6.00 - 6
RUBBER CARCASS
INFLATION PRESSURE: 55 PSI
LOAD: 1500 LBS.
ROAD: DRY

+ 5 MPH
x 20 MPH
● 50 MPH
□ 75 MPH
△ 100 MPH

CORNERING FORCE
VS
SLIP ANGLE AND VELOCITY

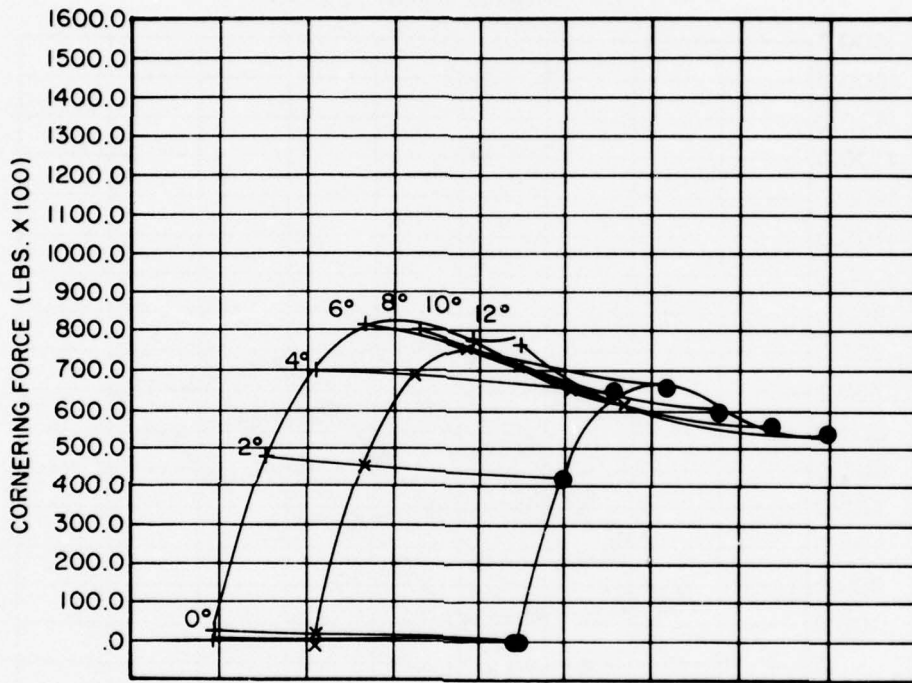

TIRE: 6.00 - 6 CAST TIRE
3000 GMS MATERIAL

INFLATION PRESSURE: 55 PSI

LOAD: 1500 LBS.

ROAD: DRY

+ 5 MPH

x 20 MPH

● 50 MPH

□ 75 MPH

△ 100 MPH

CORNERING FORCE
VS
SLIP ANGLE AND VELOCITY

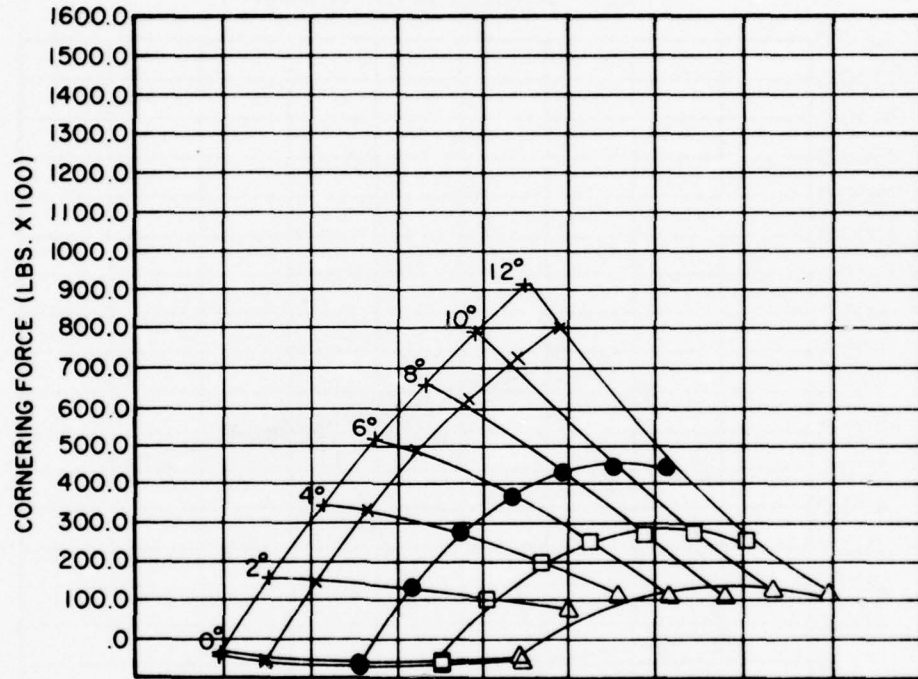

TIRE: 6.00 - 6 / 8 PR
STD. PRODUCTION
INFLATION PRESSURE: 55 PSI
LOAD: 1500 LBS.
ROAD: WET .050"

+ 5 MPH
X 20 MPH
● 50 MPH
□ 75 MPH
△ 100 MPH

CORNERING FORCE
VS
SLIP ANGLE AND VELOCITY

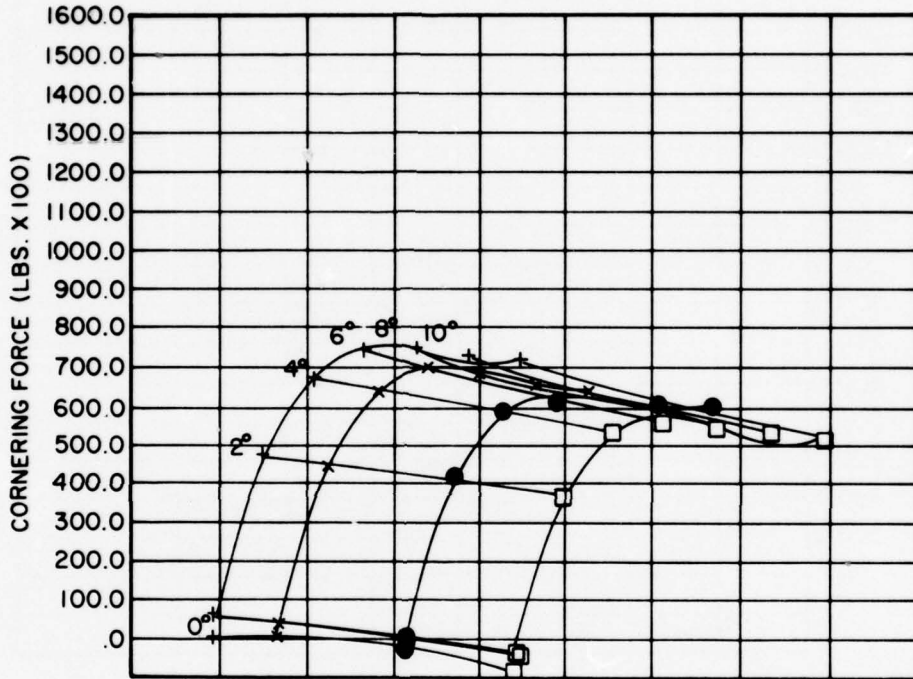

TIRE: 6.00 - 6 CAST TIRE
3000 GMS MATERIAL

INFLATION PRESSURE: 55 PSI

LOAD: 1500 LBS.

ROAD: WET .050"

+ 5 MPH

x 20 MPH

● 50 MPH

□ 75 MPH

Δ 100 MPH

CORNERING FORCE
VS
SLIP ANGLE AND VELOCITY

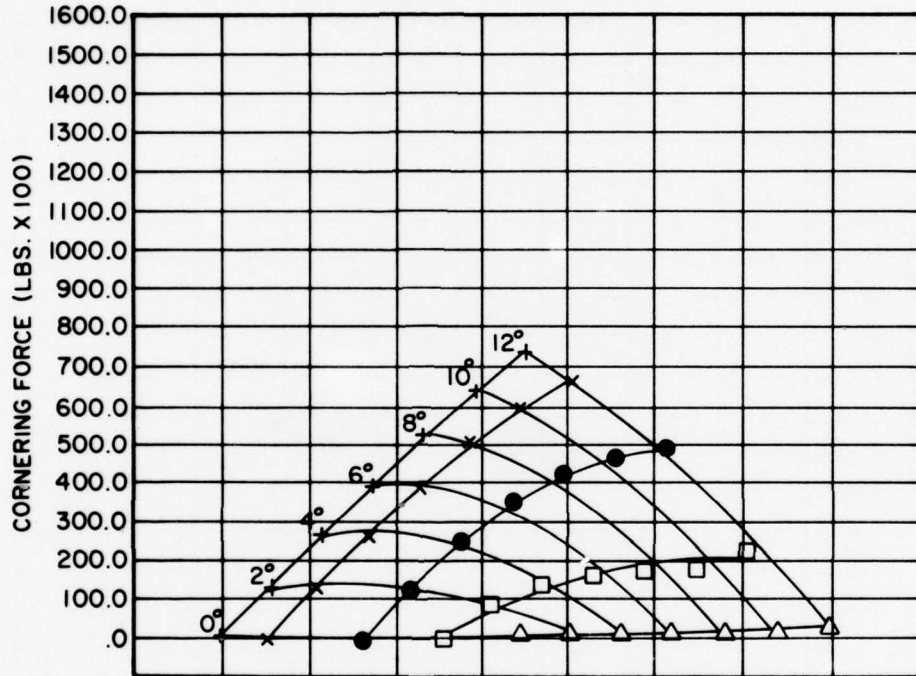

TIRE: 6.00-6 REPLACEABLE TREAD
(CIRCUMFERENTIALLY GROOVED)
INFLATION PRESSURE: 55 PSI
LOAD: 1500 LBS.
ROAD: WET .050"

+ 5 MPH
x 20 MPH
● 50 MPH
□ 75 MPH
△ 100 MPH

CORNERING FORCE
VS
SLIP ANGLE AND VELOCITY

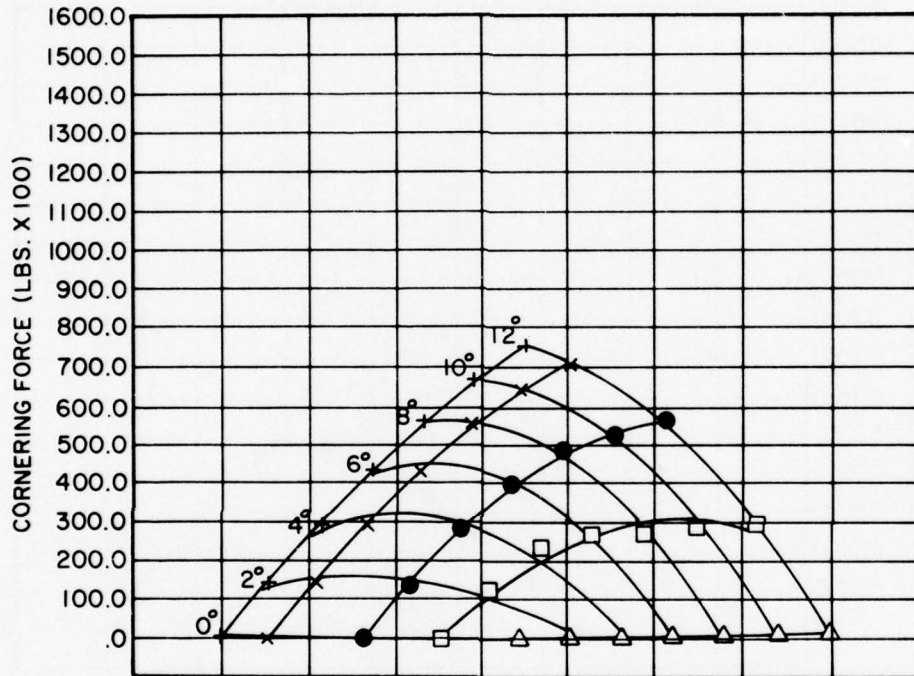

TIRE: 6.00 - 6 REPLACEABLE TREAD
(KNOBBY BELT)
INFLATION PRESSURE: 55 PSI
LOAD: 1500 LBS.
ROAD: WET .050"

+ 5 MPH
x 20 MPH
● 50 MPH
□ 75 MPH
Δ 100 MPH

CORNERING FORCE
VS
SLIP ANGLE AND VELOCITY

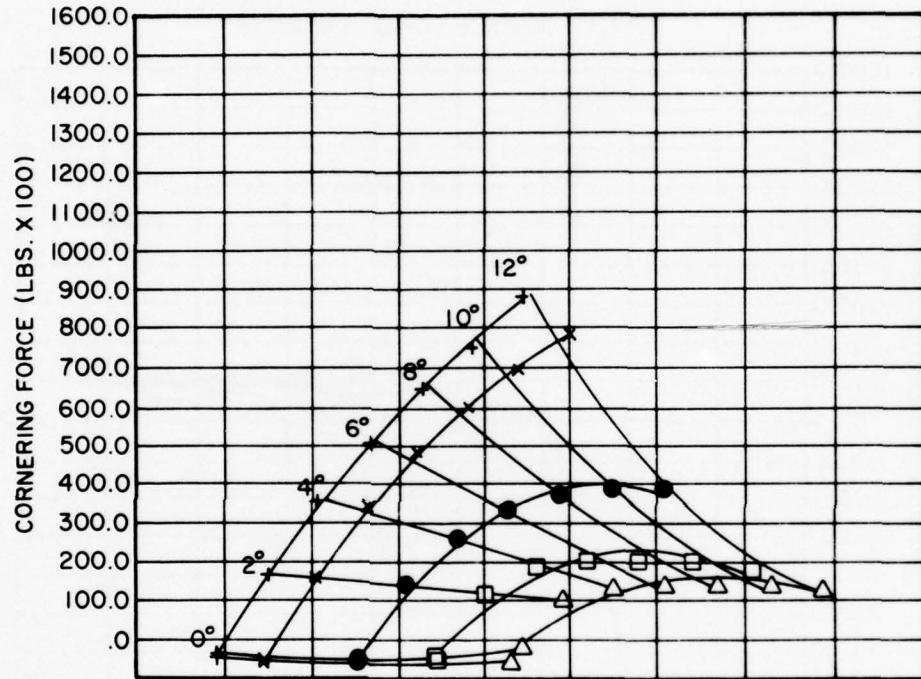

TIRE: 6.00 - 6 / 8 PR
STD. PRODUCTION
INFLATION PRESSURE: 55 PSI
LOAD: 1500 LBS.
ROAD: WET .200"

+ 5 MPH
X 20 MPH
● 50 MPH
□ 75 MPH
△ 100 MPH

CORNERING FORCE
VS
SLIP ANGLE AND VELOCITY

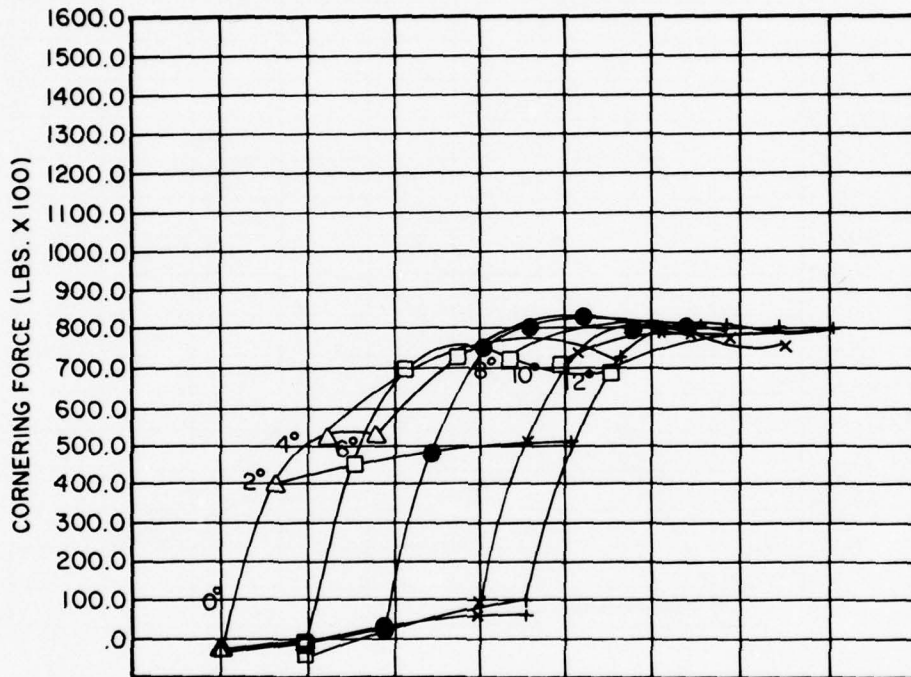

TIRE: 6.00 - 6 CAST TIRE
3000 GMS MATERIAL

INFLATION PRESSURE: 55 PSI

LOAD: 1500 LBS.

ROAD: WET .200"

+ 5 MPH

x 20 MPH

● 50 MPH

□ 75 MPH

Δ 100 MPH

CORNERING FORCE
VS
SLIP ANGLE AND VELOCITY

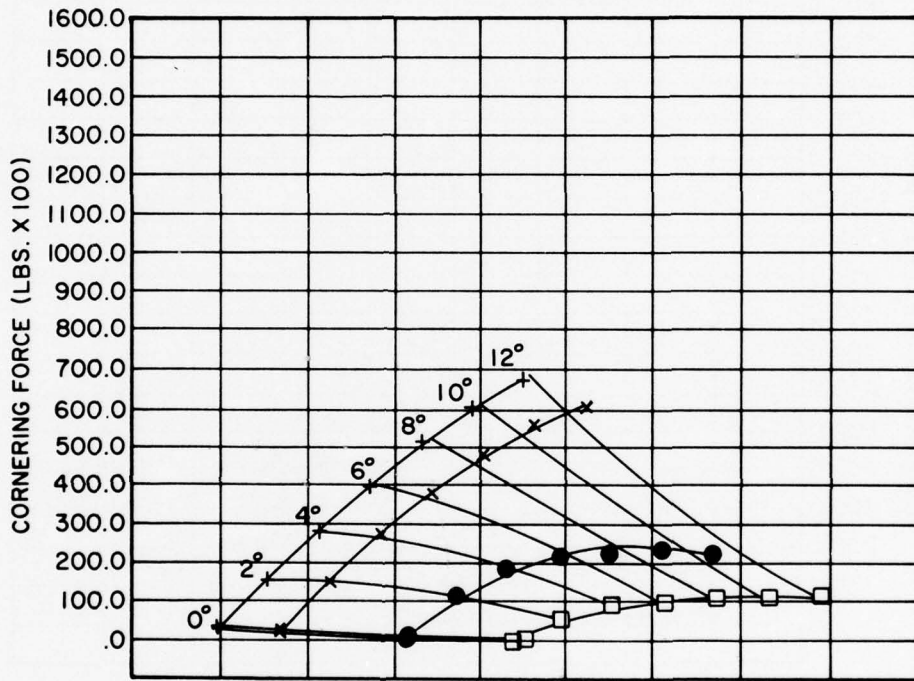

TIRE: 6.00-6 REPLACEABLE TREAD
(CIRCUMFERENTIALLY GROOVED)
INFLATION PRESSURE: 55 PSI
LOAD: 1500 LBS.
ROAD: WET .200"

+ 5 MPH
X 20 MPH
● 50 MPH
□ 75 MPH
△ 100 MPH

CORNERING FORCE
VS
SLIP ANGLE AND VELOCITY

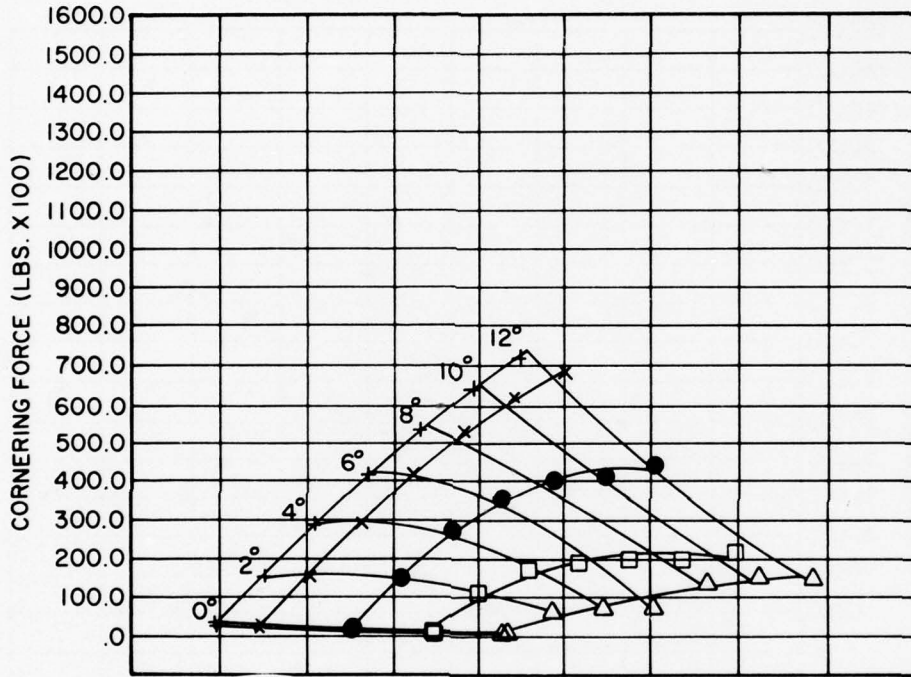

TIRE: 6.00 - 6 REPLACEABLE TREAD
(KNOBBY BELT)

INFLATION PRESSURE: 55 PSI

LOAD: 1500 LBS.

ROAD: WET .200"

+ 5 MPH

x 20 MPH

● 50 MPH

□ 75 MPH

Δ 100 MPH

AFFDL-TR-76-95

APPENDIX B

SELF-ALIGNING TORQUE VS. SLIP ANGLE AND VELOCITY

ALIGNING TORQUE
VS
SLIP ANGLE AND VELOCITY

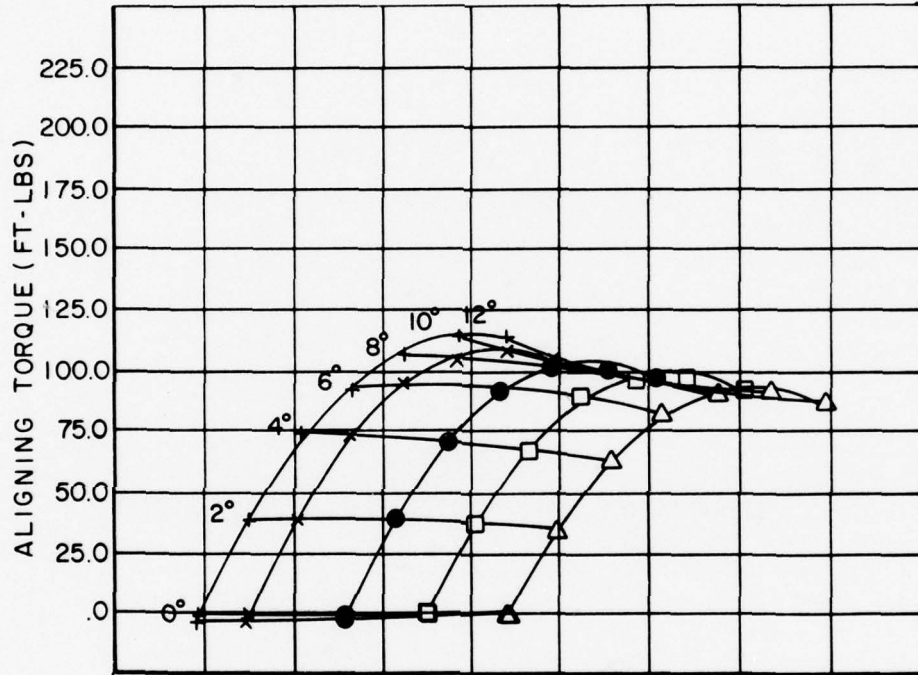

TIRE: 6.00 - 6 / 8 PR
 STD. PRODUCTION
 INFLATION PRESSURE: 55 PSI
 LOAD: 1500 LBS
 ROAD: DRY

+ 5 MPH
 x 20 MPH
 ● 50 MPH
 □ 75 MPH
 △ 100 MPH

ALIGNING TORQUE
VS
SLIP ANGLE AND VELOCITY



TIRE: 6.00 - 6
 RUBBER CARCASS
 INFLATION PRESSURE: 55 PSI
 LOAD: 1500 LBS
 ROAD: DRY

+ 5 MPH
 x 20 MPH
 ● 50 MPH
 □ 75 MPH
 △ 100 MPH

ALIGNING TORQUE
VS
SLIP ANGLE AND VELOCITY

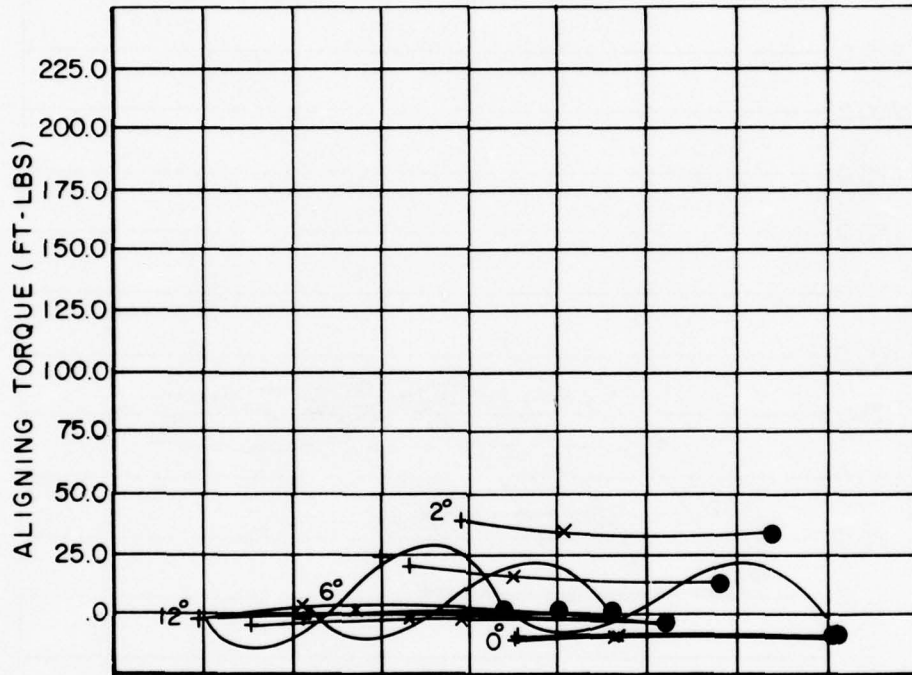

TIRE: 6.00 - 6 CAST TIRE
3000 GMS MATERIAL
INFLATION PRESSURE: 55 PSI
LOAD: 1500 LBS
ROAD: DRY

+ 5 MPH
x 20 MPH
● 50 MPH
□ 75 MPH
Δ 100 MPH

ALIGNING TORQUE
VS
SLIP ANGLE AND VELOCITY

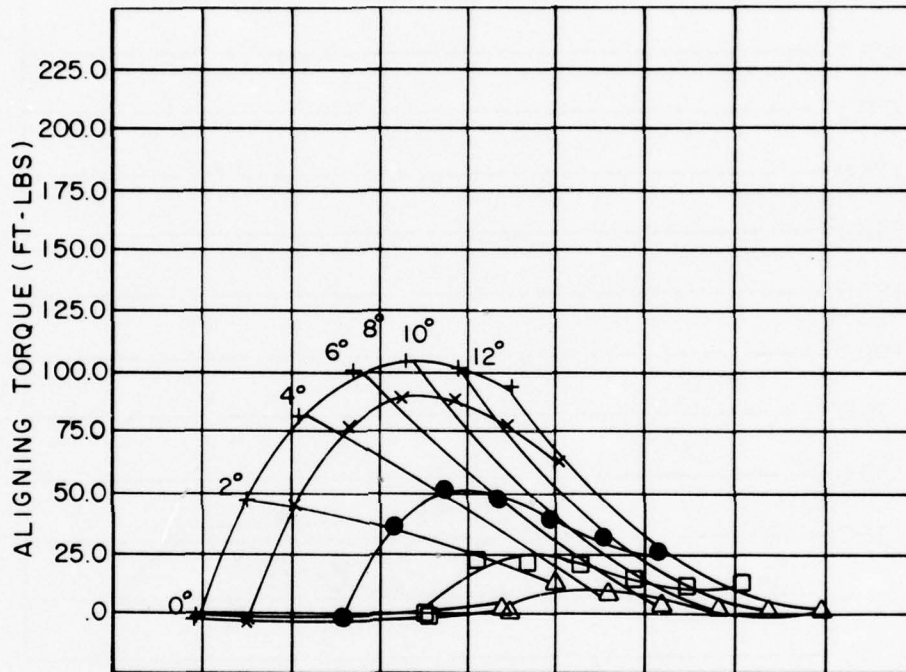

TIRE: 6.00 - 6 / 8PR
 STD. PRODUCTION
 INFLATION PRESSURE: 55 PSI
 LOAD: 1500 LBS
 ROAD: WET .050"

+ 5 MPH
 x 20 MPH
 ● 50 MPH
 □ 75 MPH
 △ 100 MPH

ALIGNING TORQUE VS SLIP ANGLE AND VELOCITY

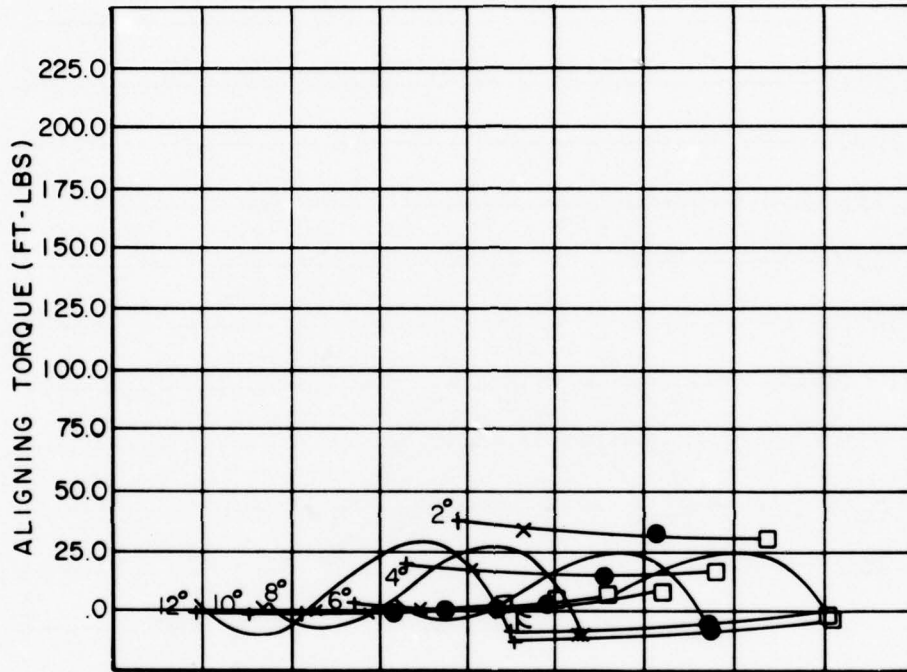

TIRE: 6.00 - 6 CAST TIRE
 3000 GMS MATERIAL
 INFLATION PRESSURE: 55 PSI
 LOAD: 1500 LBS
 ROAD: WET .050"

+ 5 MPH
 x 20 MPH
 ● 50 MPH
 □ 75 MPH
 △ 100 MPH

ALIGNING TORQUE
VS
SLIP ANGLE AND VELOCITY

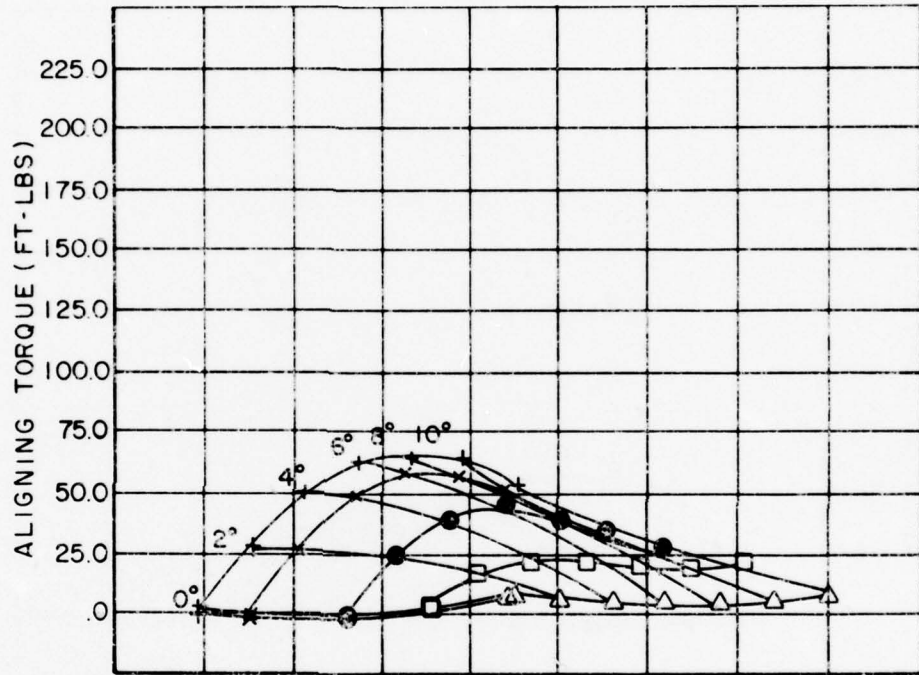

TIRE: 6.00 - 6 REPLACEABLE TREAD
(CIRCUMFERENTIALLY GROOVED)
INFLATION PRESSURE: 55 PSI
LOAD: 1500 LBS
ROAD: WET .050"

+ 5 MPH
x 20 MPH
● 50 MPH
□ 75 MPH
△ 100 MPH

ALIGNING TORQUE VS SLIP ANGLE AND VELOCITY

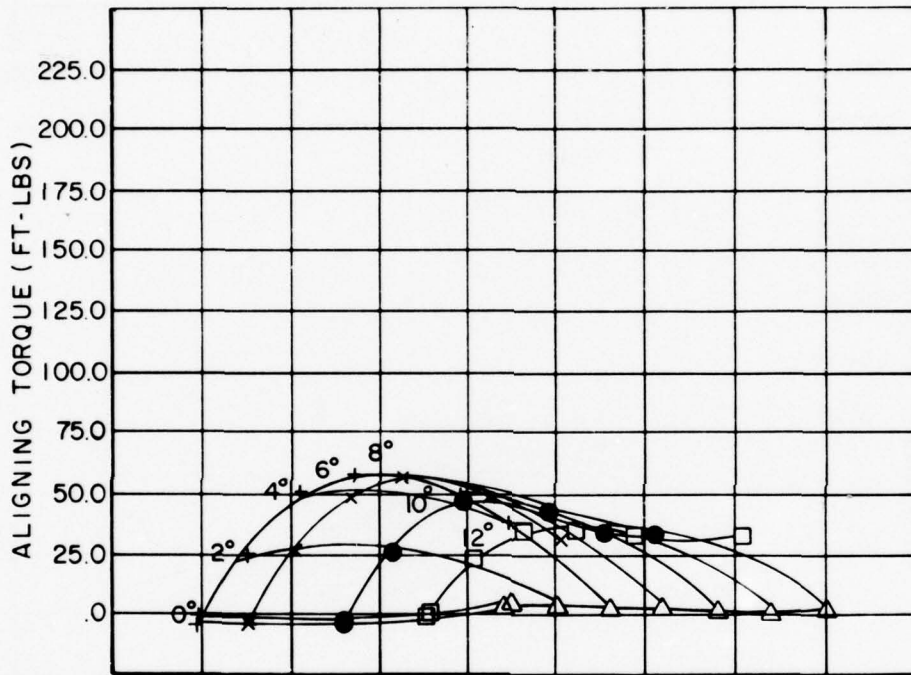

TIRE: 6.00 - 6 REPLACEABLE TREAD
(KNOBBY BELT)
INFLATION PRESSURE: 55 PSI
LOAD: 1500 LBS
ROAD: WET .050"

+ 5 MPH
x 20 MPH
● 50 MPH
□ 75 MPH
△ 100 MPH

ALIGNING TORQUE
VS
SLIP ANGLE AND VELOCITY

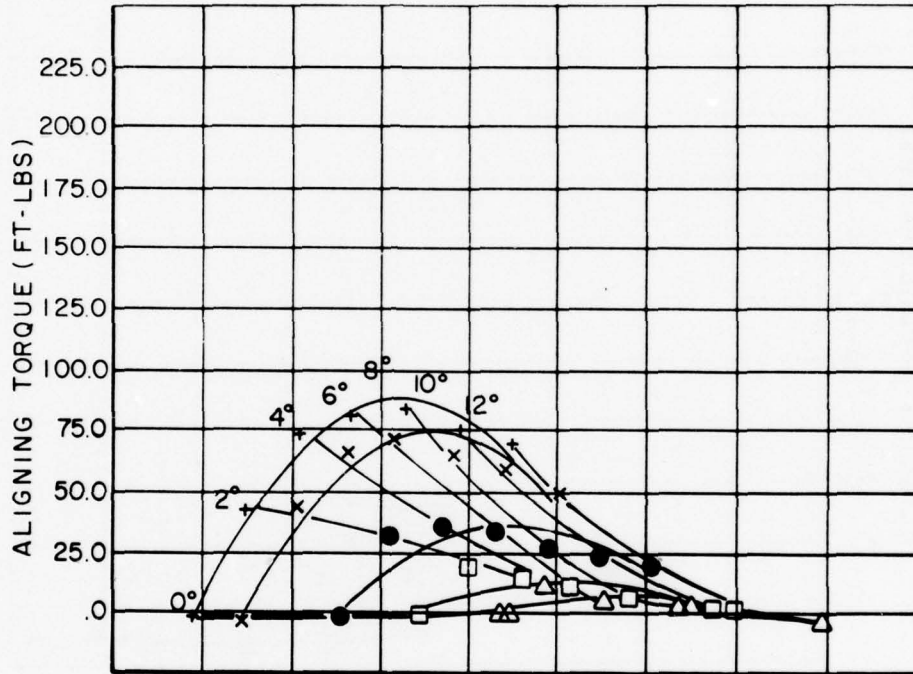

TIRE: 6.00 - 6 / 8 PR
STD. PRODUCTION
INFLATION PRESSURE: 55 PSI
LOAD: 1500 LBS
ROAD: WET .200"

+ 5 MPH
x 20 MPH
● 50 MPH
□ 75 MPH
△ 100 MPH

ALIGNING TORQUE
VS
SLIP ANGLE AND VELOCITY

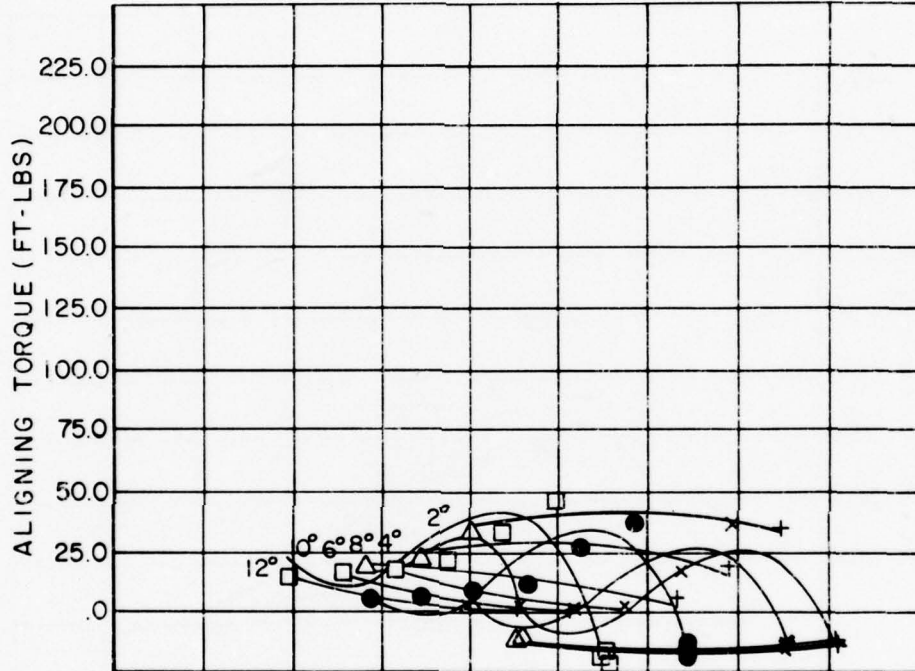

TIRE: 6.00 - 6 CAST TIRE
 3000GMS MATERIAL
 INFLATION PRESSURE: 55 PSI
 LOAD: 1500 LBS
 ROAD: WET .200"

+ 5 MPH
 x 20 MPH
 ● 50 MPH
 □ 75 MPH
 △ 100 MPH

ALIGNING TORQUE
VS
SLIP ANGLE AND VELOCITY

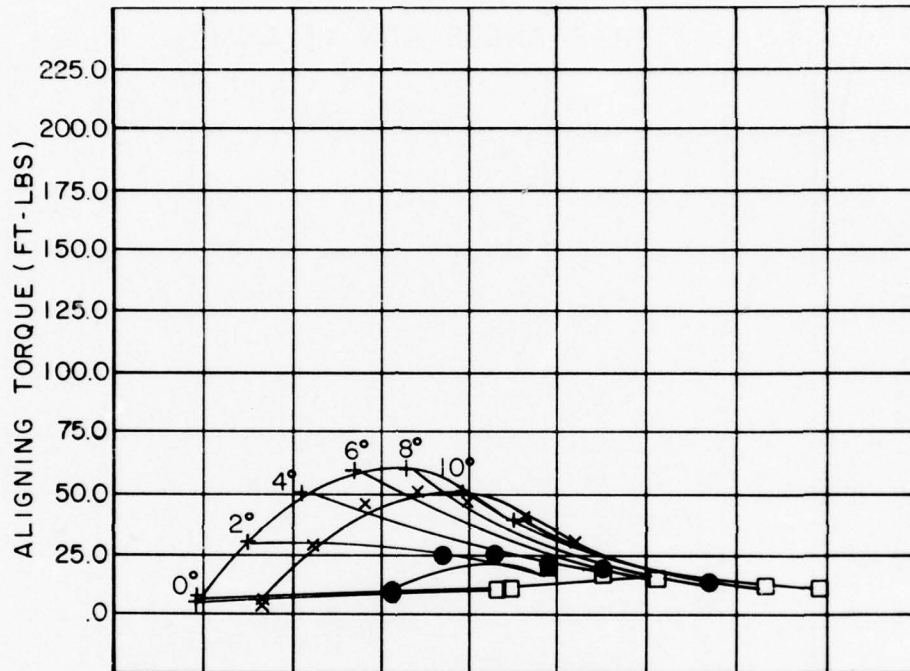

TIRE: 6.00-6 REPLACEABLE TREAD
(CIRCUMFERENTIALLY GROOVED)
INFLATION PRESSURE: 55 PSI
LOAD: 1500 LBS
ROAD: WET .200"

+ 5 MPH
x 20 MPH
● 50 MPH
□ 75 MPH
△ 100 MPH

ALIGNING TORQUE
VS
SLIP ANGLE AND VELOCITY

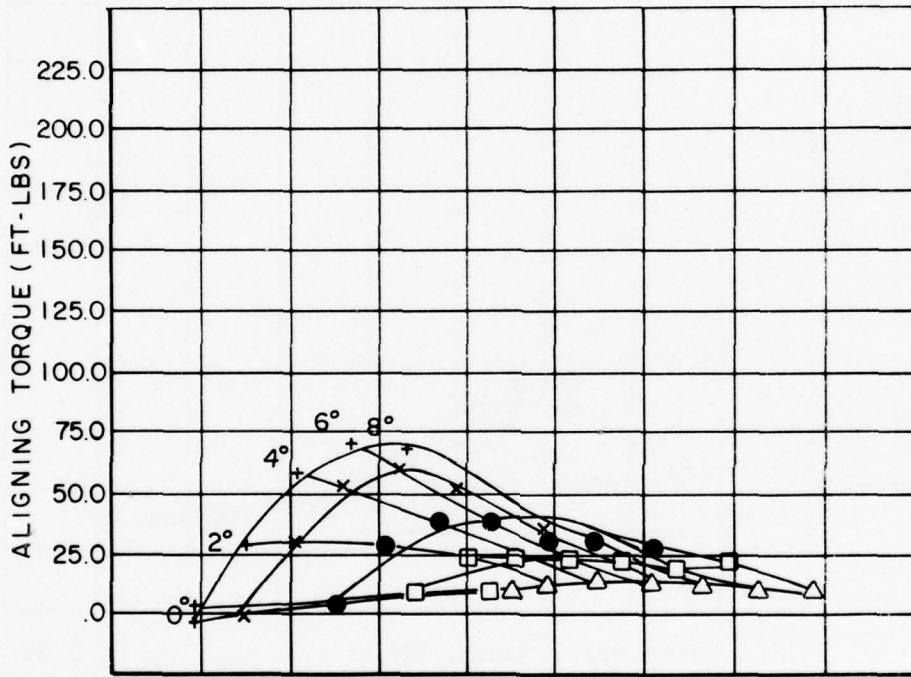

TIRE: 600 - 6 REPLACEABLE TREAD (KNOBBY) + 5 MPH
 x 20 MPH
 ● 50 MPH
 □ 75 MPH
 △ 100 MPH

INFLATION PRESSURE: 55 PSI
 LOAD: 1500 LBS
 ROAD: WET .200"

AFFDL-TR-76-95

APPENDIX C
CORNERING FORCE VS. SLIP ANGLE AND LOAD

CORNERING FORCE
VS
SLIP ANGLE AND LOAD

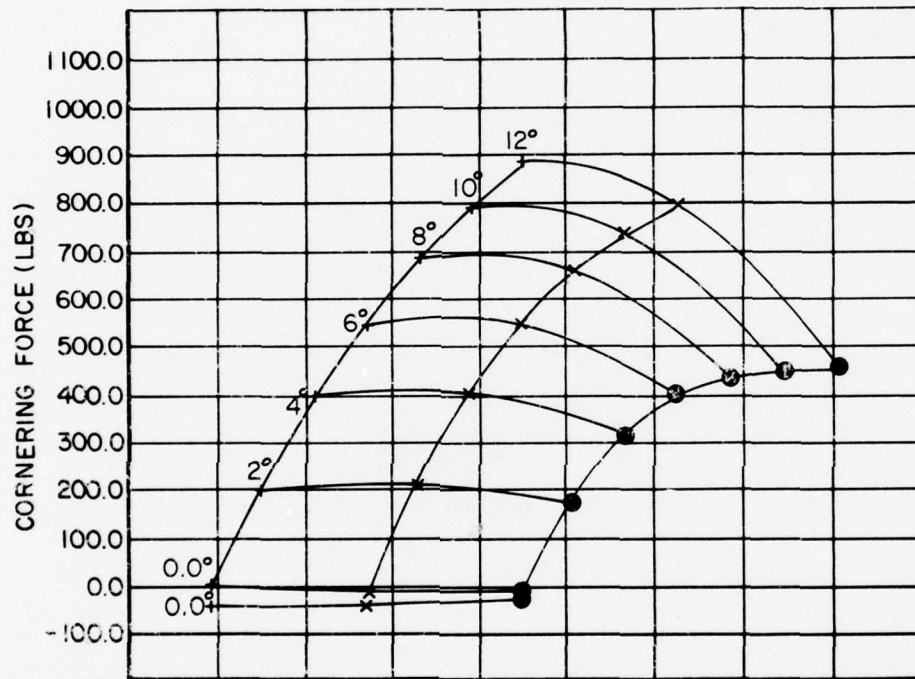

TIRE : 6.00 - 6/8 PR STD. PRODUCTION
 INFLATION PRESSURE : 55PSI
 VELOCITY : 50MPH
 ROAD : DRY

● 500 LBS
 × 1000 LBS
 + 1500 LBS

CORNERING FORCE
VS
SLIP ANGLE AND LOAD

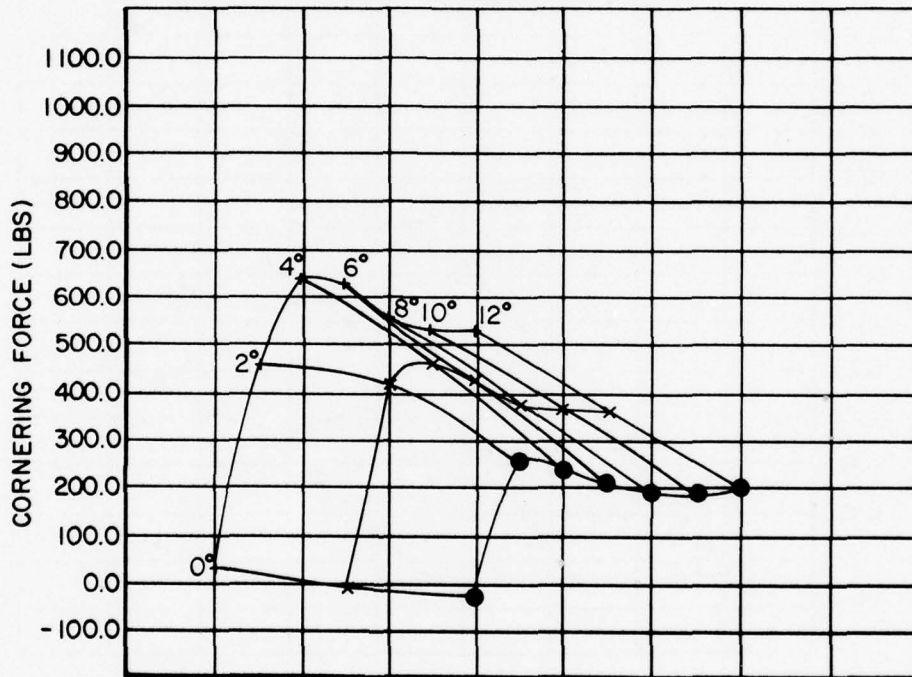

TIRE : 6.00-6 CAST TIRE, 3000 GMS MATERIAL
 INFLATION PRESSURE : 55 PSI
 VELOCITY : 50 MPH
 ROAD : DRY

● 500 LBS
 x 1000 LBS
 + 1500 LBS

CORNERING FORCE
VS
SLIP ANGLE AND LOAD

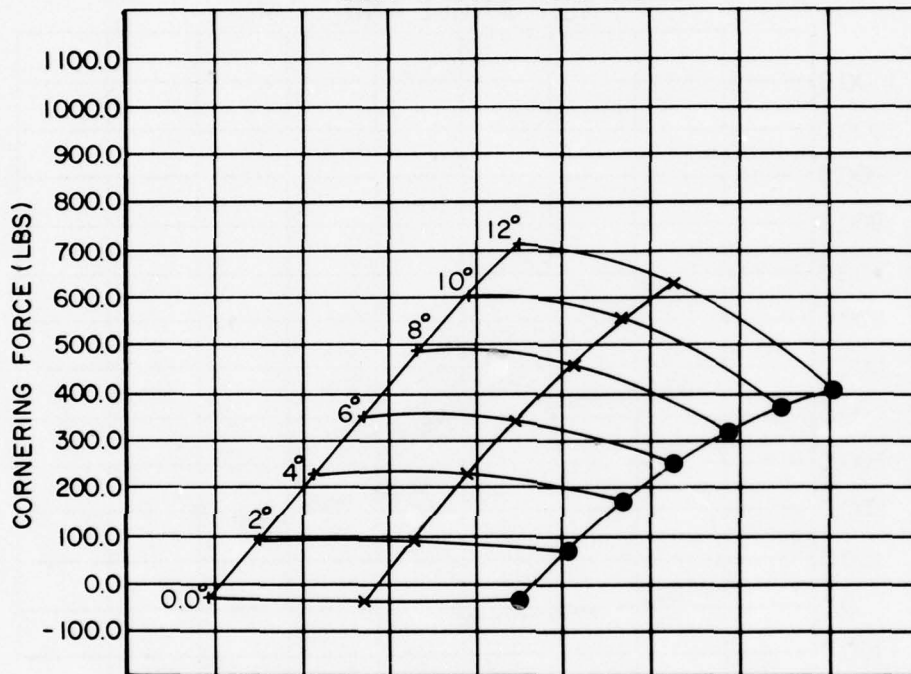

TIRE: 6.00-6 REPLACEABLE TREAD
(CIRCUMFERENTIALLY GROOVED)

INFLATION PRESSURE: 55 PSI

VELOCITY: 50 MPH

ROAD: DRY

● 500 LBS
x 1000 LBS
+ 1500 LBS

CORNERING FORCE
VS
SLIP ANGLE AND LOAD

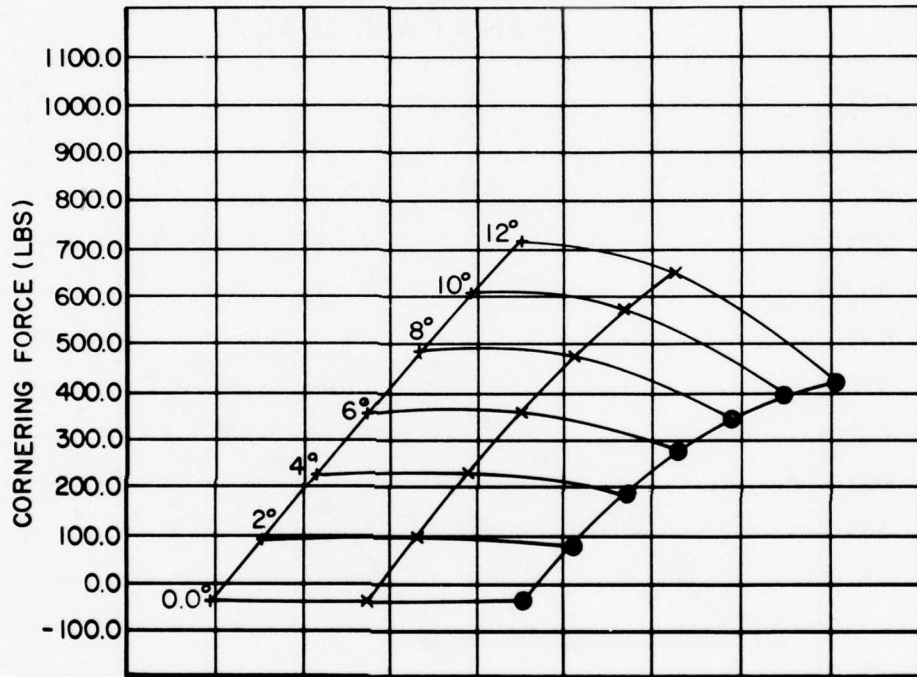

TIRE: 600-6 REPLACEABLE TREAD
(KNOBBY BELT)

INFLATION PRESSURE: 55 PSI

VELOCITY: 50 MPH

ROAD: DRY

● 500 LBS
x 1000 LBS
+ 1500 LBS

CORNERING FORCE
VS
SLIP ANGLE AND LOAD

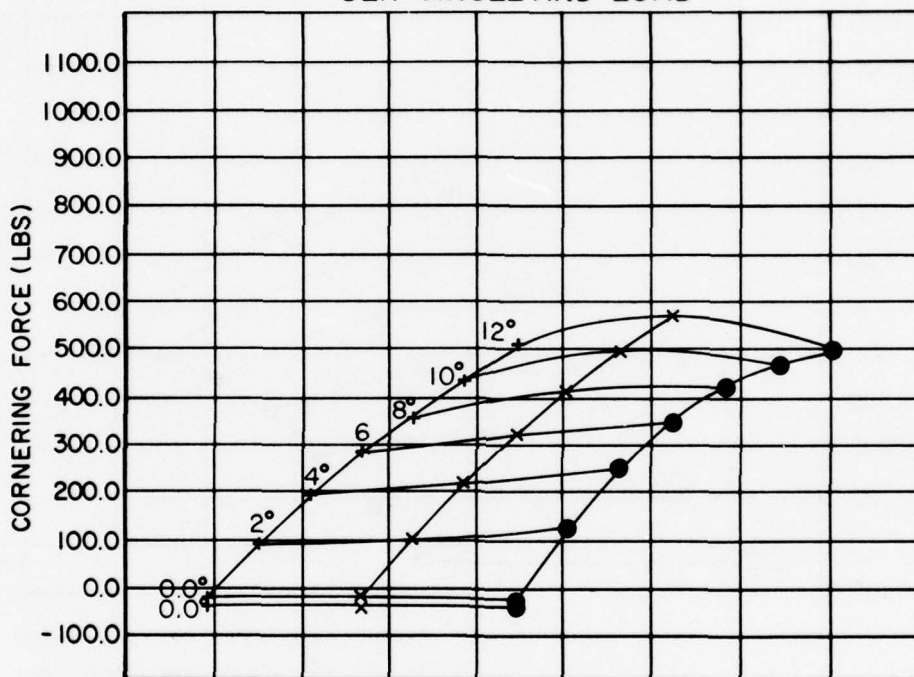

TIRE : 6.00 - 6 / 8 PR STD. PRODUCTION
 INFLATION PRESSURE : 30 PSI
 VELOCITY : 50 MPH
 ROAD : DRY

● 500 LBS
 × 1000 LBS
 + 1500 LBS

CORNERING FORCE VS SLIP ANGLE AND LOAD

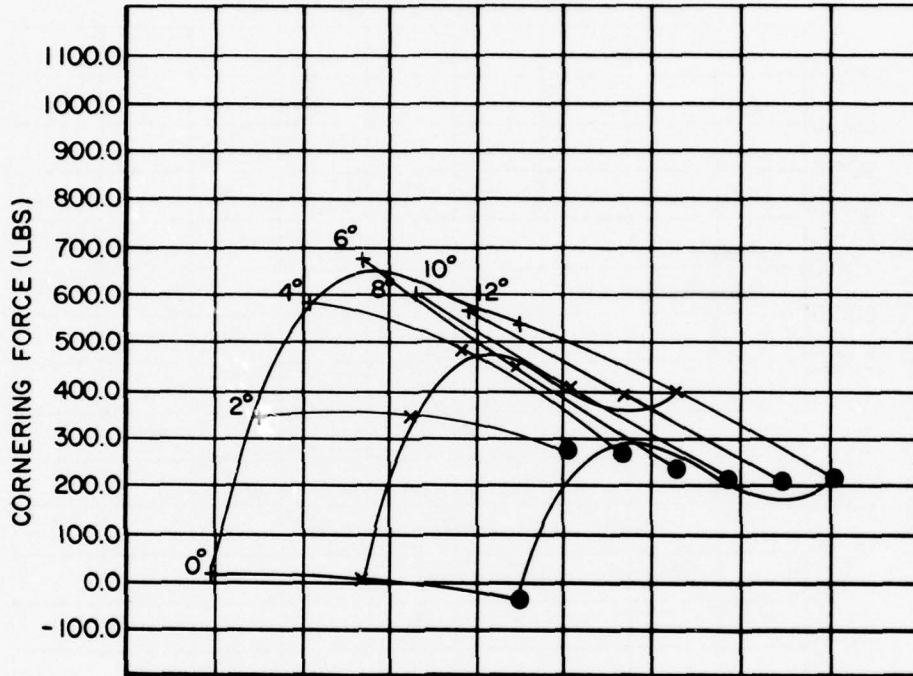

TIRE: 6.00 - 6 CAST TIRE, 3000 GMS MATERIAL
INFLATION PRESSURE: 30 PSI
VELOCITY: 50 MPH
ROAD: DRY

● 500 LBS
× 1000 LBS
+ 1500 LBS

CORNERING FORCE
VS
SLIP ANGLE AND LOAD

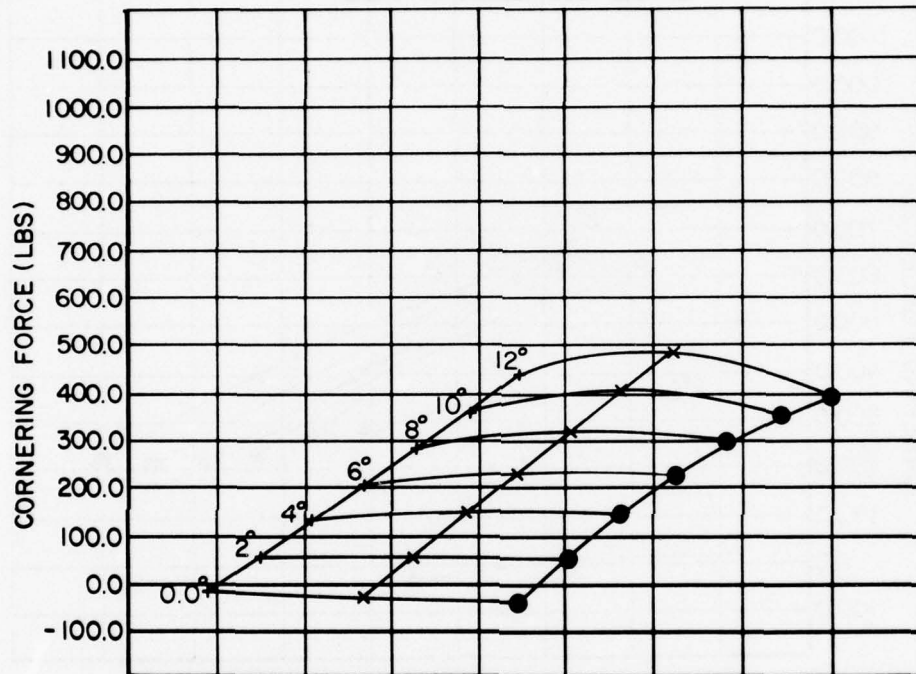

TIRE : 6.00 - 6 REPLACEABLE TREAD
(CIRCUMFERENTIALLY GROOVED)
INFLATION PRESSURE : 30PSI
VELOCITY : 50MPH
ROAD : DRY

● 500 LBS
× 1000 LBS
+ 1500 LBS

CORNERING FORCE
VS
SLIP ANGLE AND LOAD

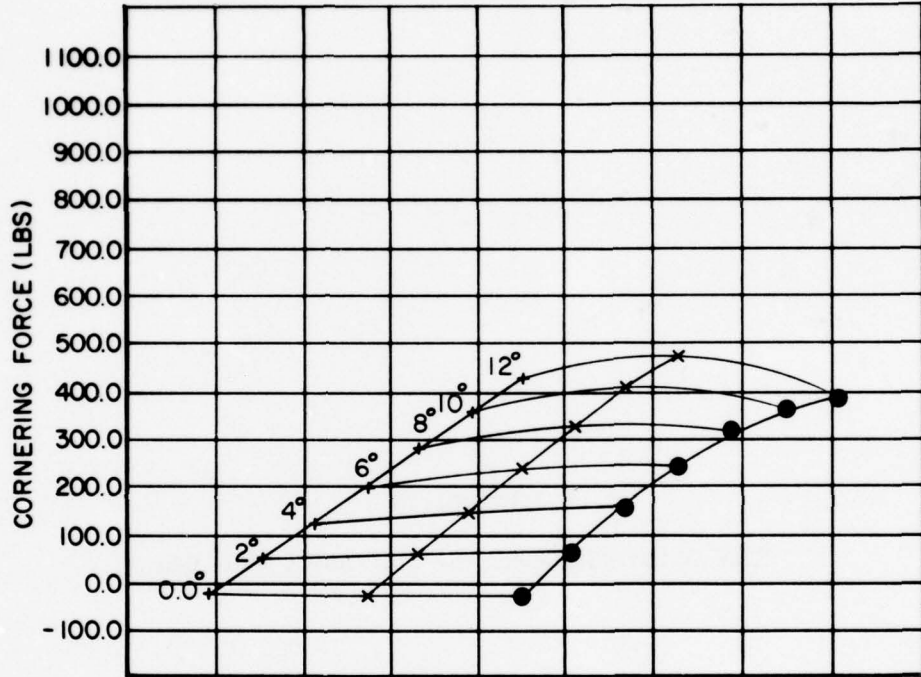

TIRE: 6.00-6 REPLACEABLE TREAD
(KNOBBY BELT)
INFLATION PRESSURE: 30 PSI
VELOCITY: 50 MPH
ROAD: DRY

● 500 LBS
× 1000 LBS
+ 1500 LBS

AFFDL-TR-76-95

APPENDIX D
SELF-ALIGNING TORQUE VS. SLIP ANGLE AND LOAD

ALIGNING TORQUE
VS
SLIP ANGLE AND LOAD

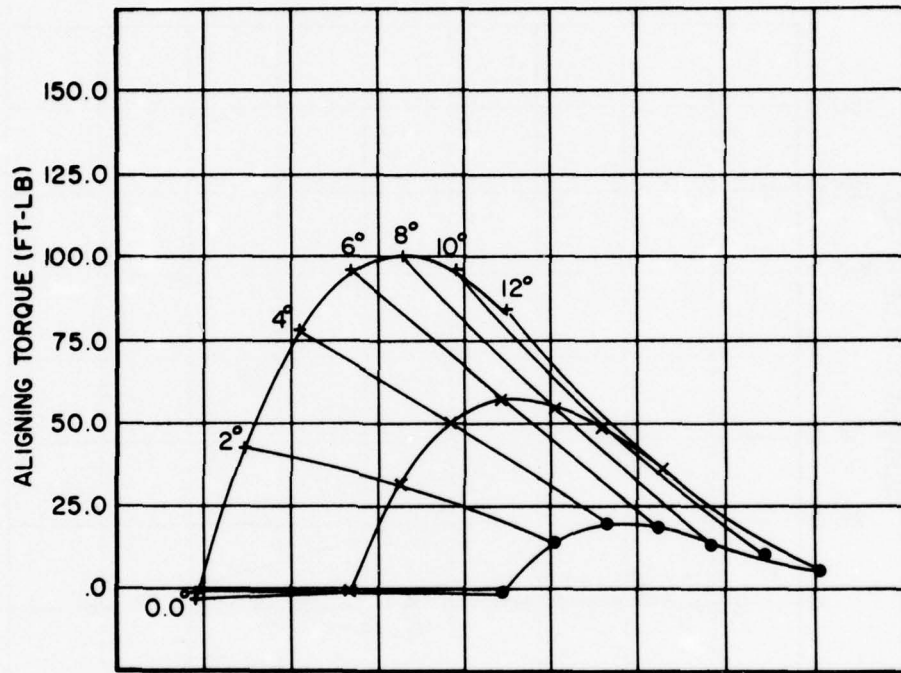

TIRE: 6.00 - 6/8 PR STD. PRODUCTION
INFLATION PRESSURE: 55 PSI
VELOCITY: 50 MPH
ROAD: DRY

● 500 LBS
x 1000 LBS
+ 1500 LBS

ALIGNING TORQUE
VS
SLIP ANGLE AND LOAD

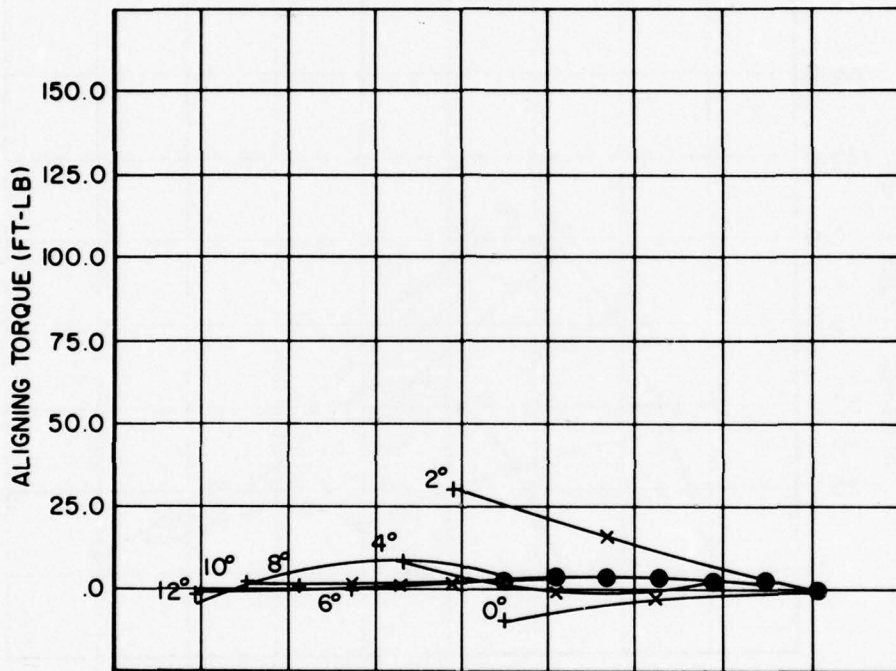

TIRE: 6.00 - 6 CAST TIRE, 3000 GMS MATERIAL

INFLATION PRESSURE: 55 PSI

VELOCITY: 50 MPH

ROAD: DRY

● 500 LBS
 × 1000 LBS
 + 1500 LBS

ALIGNING TORQUE
VS
SLIP ANGLE AND LOAD

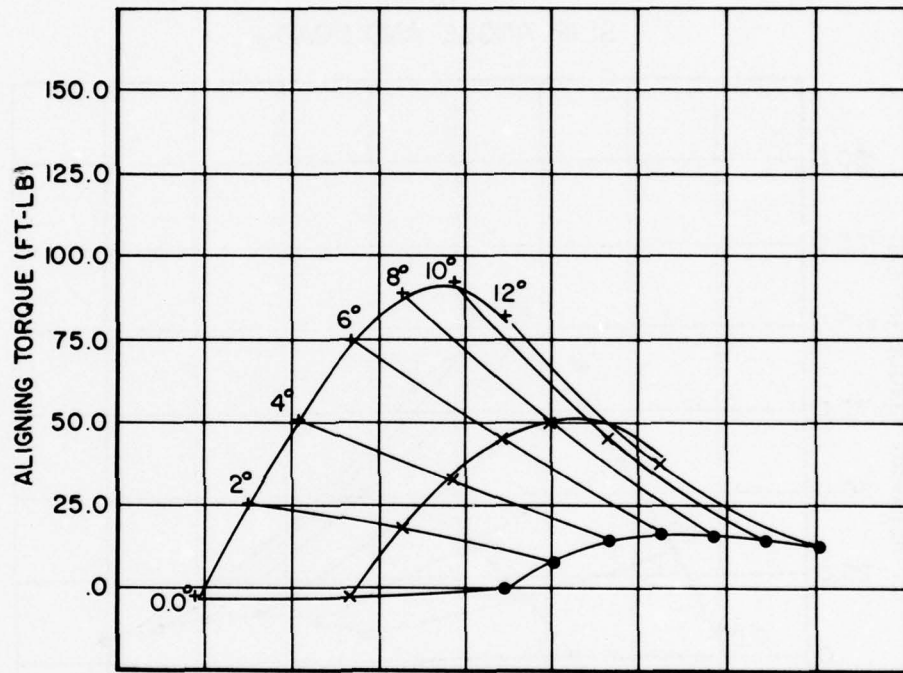

TIRE: 6.00 - 6 REPLACEABLE TREAD (Circumferentially Grooved)

INFLATION PRESSURE: 55 PSI

VELOCITY: 50 MPH

ROAD: DRY

● 500 LBS

× 1000 LBS

+ 1500 LBS

ALIGNING TORQUE VS SLIP ANGLE AND LOAD

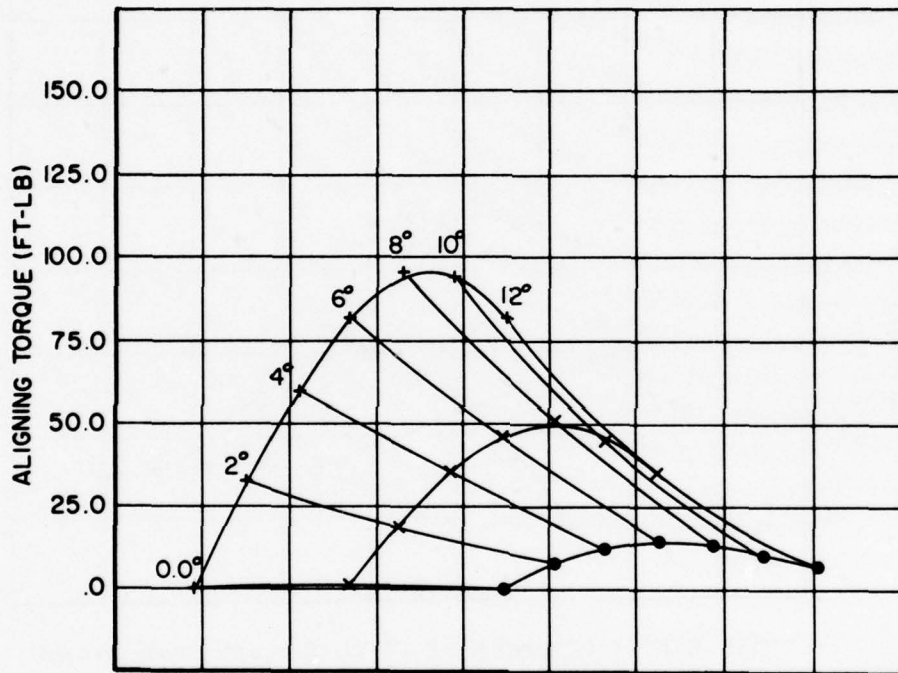

TIRE: 6.00 - 6 REPLACEABLE TREAD (Knobby Belt)

INFLATION PRESSURE: 55 PSI

VELOCITY: 50 MPH

ROAD: DRY

● 500 LBS

× 1000 LBS

+ 1500 LBS

ALIGNING TORQUE
VS
SLIP ANGLE AND LOAD

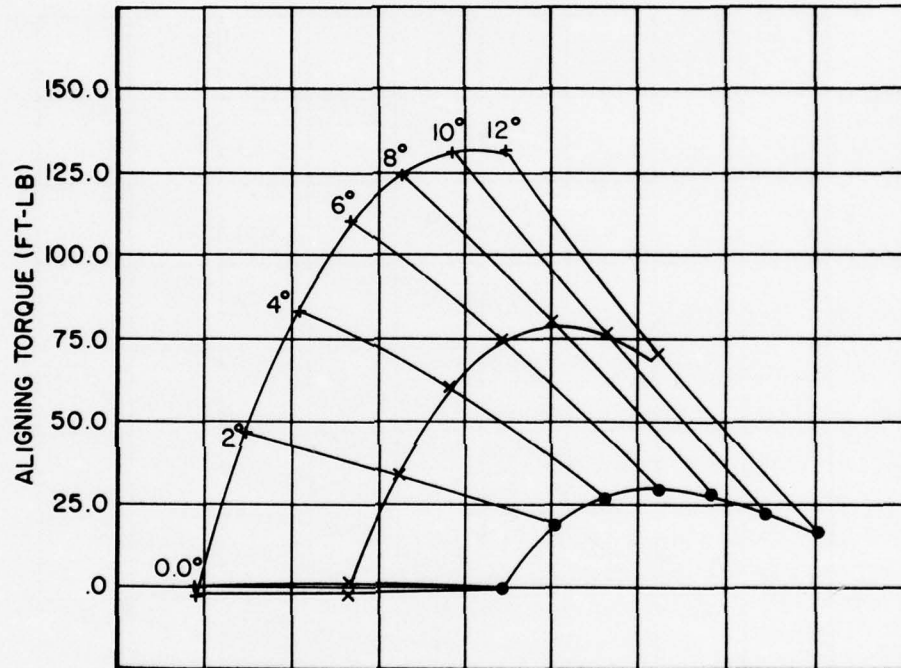

TIRE: 6.00 - 6/8PR STD. PRODUCTION
INFLATION PRESSURE: 30 PSI
VELOCITY: 50 MPH
ROAD: DRY

● 500 LBS
× 1000 LBS
+ 1500 LBS

ALIGNING TORQUE
VS
SLIP ANGLE AND LOAD

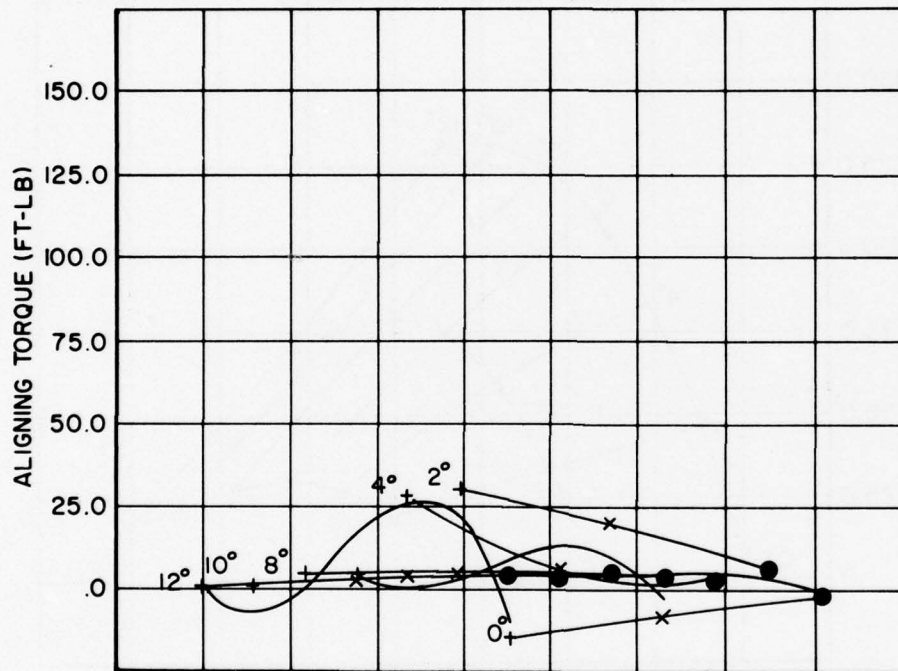

TIRE: 6.00 - 6 CAST TIRE, 3000 GMS MATERIAL

INFLATION PRESSURE: 30 PSI

VELOCITY: 50 MPH

ROAD: DRY

● 500 LBS

× 1000 LBS

+ 1500 LBS

ALIGNING TORQUE
VS
SLIP ANGLE AND LOAD

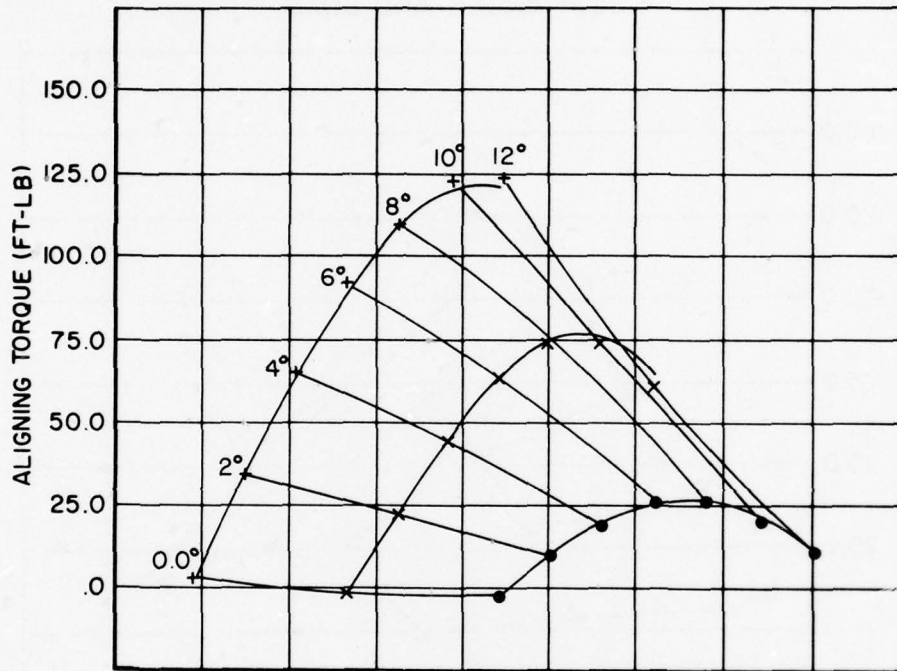

TIRE: 6.00-6 REPLACEABLE TREAD (Circumferentially Grooved)

INFLATION PRESSURE: 30 PSI

VELOCITY: 50 MPH

ROAD: DRY

● 500 LBS

× 1000 LBS

+ 1500 LBS

ALIGNING TORQUE
VS
SLIP ANGLE AND LOAD

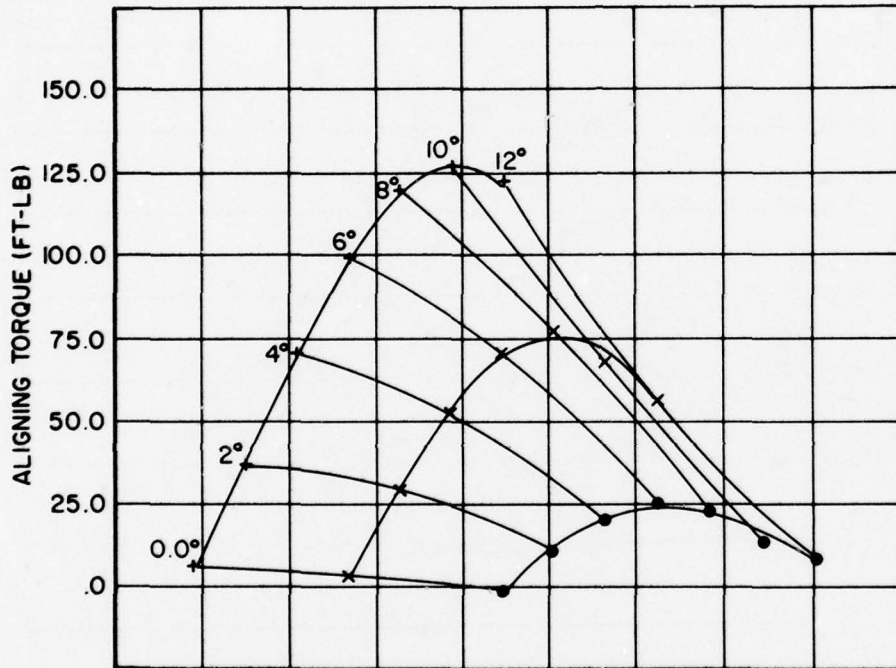

TIRE: 6.00-6 REPLACEABLE TREAD (Knobby Belt)

INFLATION PRESSURE: 30 PSI

VELOCITY: 50 MPH

ROAD: DRY

● 500 LBS

× 1000 LBS

+ 1500 LBS

AFFDL-TR-76-95

APPENDIX E
NORMALIZED TRACTIVE FORCE VS. SLIP RATIO

NORMALIZED TRACTIVE FORCE (F_x/F_z)
 VS
 SLIP RATIO (SR) AND SLIP ANGLE (α)

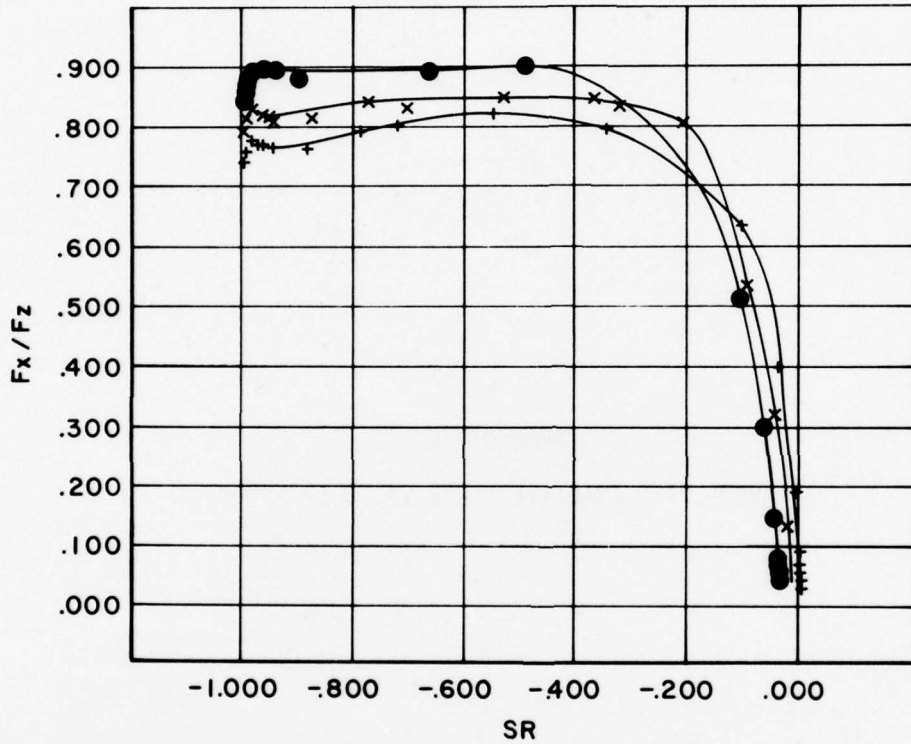

TIRE: 6.00 - 6 / 8 PR
 STD. PRODUCTION
 INFLATION PRESSURE: 55 psi
 VELOCITY: 50 mph
 LOAD: 1000 Lbs
 ROAD: DRY

+ $\alpha = 0^\circ$
 x $\alpha = 4^\circ$
 ● $\alpha = 8^\circ$
 □ $\alpha = 12^\circ$

NORMALIZED TRACTIVE FORCE (F_x/F_z)
VS
SLIP RATIO (SR) AND SLIP ANGLE (α)

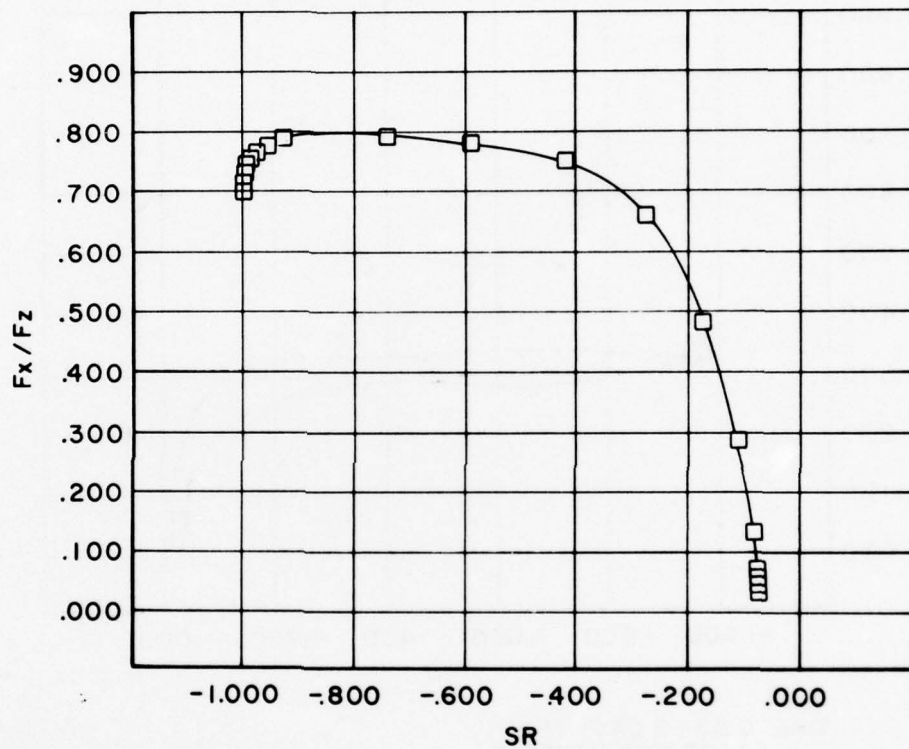

TIRE: 6.00 - 6/8 PR
STD. PRODUCTION

INFLATION PRESSURE: 55 psi

VELOCITY: 50 mph

LOAD: 1000 Lbs

ROAD: DRY

+ $\alpha = 0^\circ$
x $\alpha = 4^\circ$
● $\alpha = 8^\circ$
□ $\alpha = 12^\circ$

NORMALIZED TRACTIVE FORCE (F_x/F_z)
 VS
 SLIP RATIO (SR) AND SLIP ANGLE (α)

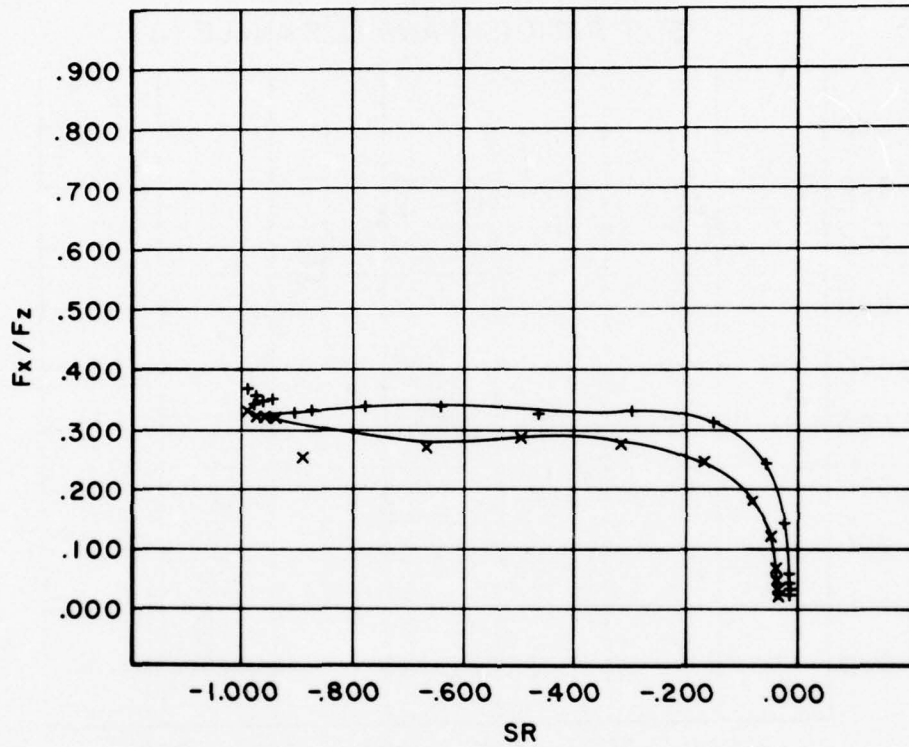

TIRE: 6.00-6 CAST TIRE
 2000 GMS MATERIAL

INFLATION PRESSURE: 55 psi

VELOCITY: 50 mph

LOAD: 1000 Lbs

ROAD: DRY

+ $\alpha = 0^\circ$
 x $\alpha = 4^\circ$
 ● $\alpha = 8^\circ$
 □ $\alpha = 12^\circ$

NORMALIZED TRACTIVE FORCE (F_x/F_z)
VS
SLIP RATIO (SR) AND SLIP ANGLE (α)

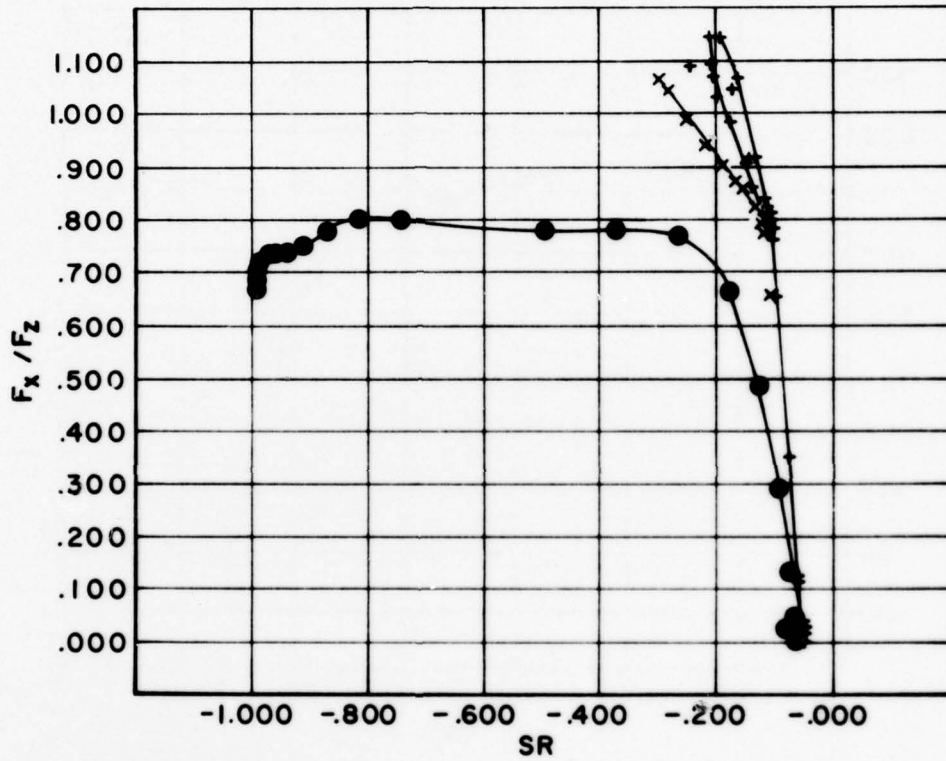

TIRE: 6.00 - 6/RT CIRCUMFERENTIALLY GROOVED BELT

INFLATION PRESSURE: 55 psi

VELOCITY: 50 mph

LOAD: 1000 Lbs

ROAD: DRY

- + $\alpha = 0^\circ$
- x $\alpha = 4^\circ$
- $\alpha = 8^\circ$
- $\alpha = 12^\circ$

NORMALIZED TRACTIVE FORCE (F_x/F_z)
VS
SLIP RATIO (SR) AND SLIP ANGLE (α)

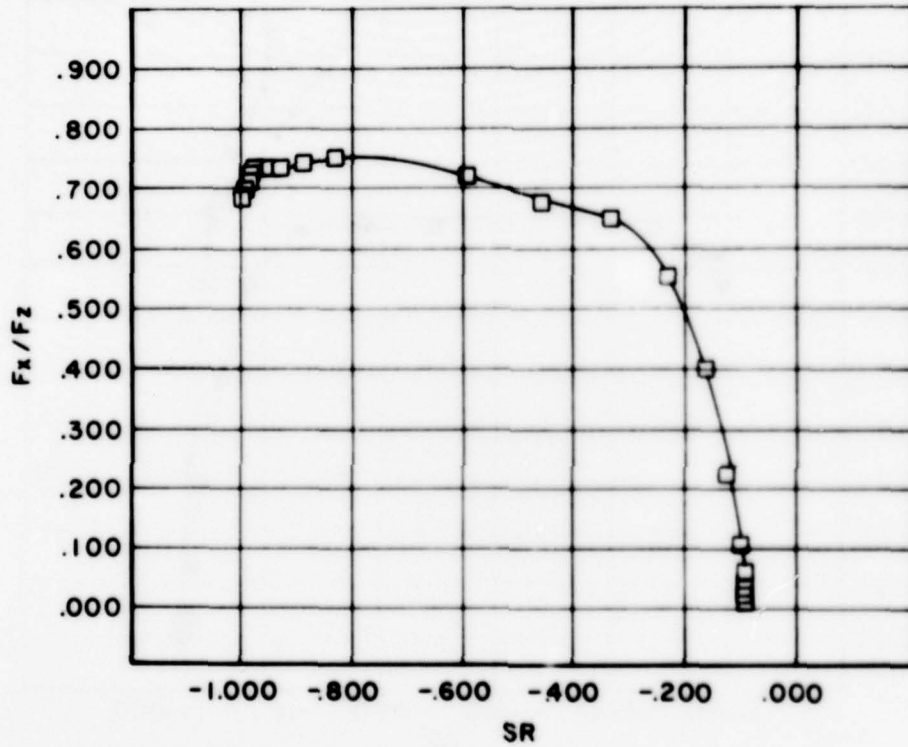

TIRE: 6.00-6/RT CIRCUMFERENTIALLY
GROOVED BELT

INFLATION PRESSURE: 55 psi

VELOCITY: 50 mph

LOAD: 1000 Lbs

ROAD: DRY

+ $\alpha = 0^\circ$

x $\alpha = 4^\circ$

● $\alpha = 8^\circ$

□ $\alpha = 12^\circ$

NORMALIZED TRACTIVE FORCE (F_x/F_z)
VS
SLIP RATIO (SR) AND SLIP ANGLE (α)

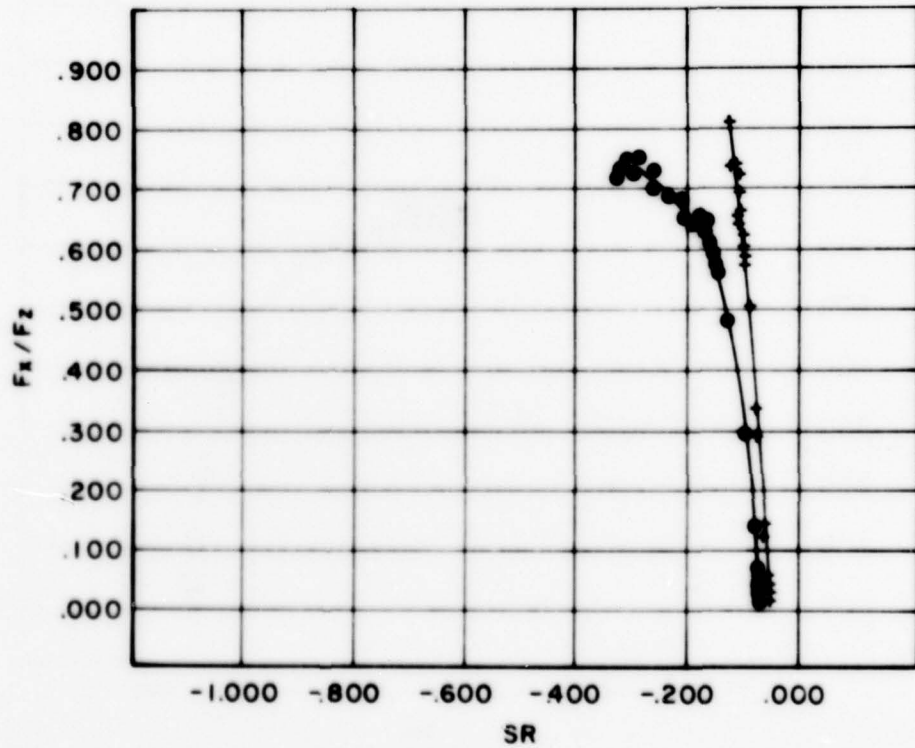

TIRE: 6.00-6/RT AXIALLY GROOVED
BELT

INFLATION PRESSURE: 55 psi

VELOCITY: 50 mph

LOAD: 1000 Lbs

ROAD: DRY

+ $\alpha = 0^\circ$

x $\alpha = 4^\circ$

● $\alpha = 8^\circ$

□ $\alpha = 12^\circ$

NORMALIZED TRACTIVE FORCE (F_x/F_z)
 VS
 SLIP RATIO (SR) AND SLIP ANGLE (α)

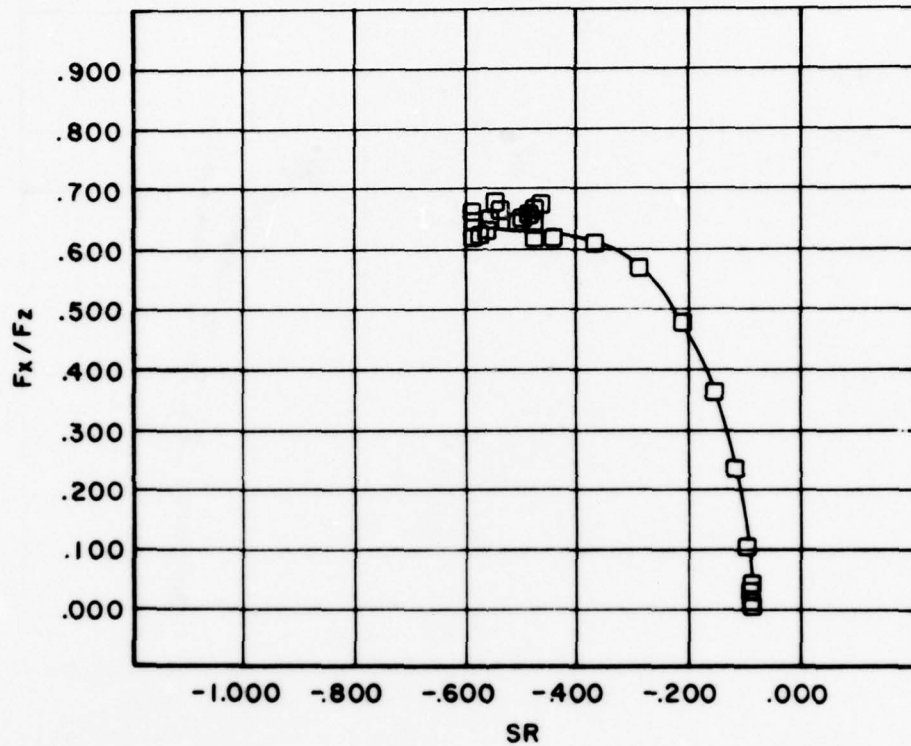

TIRE: 6.00 - 6/RT AXIALLY GROOVED
 BELT
 INFLATION PRESSURE: 55 psi
 VELOCITY: 50 mph
 LOAD: 1000 Lbs
 ROAD: DRY

+ $\alpha = 0^\circ$
 x $\alpha = 4^\circ$
 ● $\alpha = 8^\circ$
 □ $\alpha = 12^\circ$

NORMALIZED TRACTIVE FORCE (F_x/F_z)
VS
SLIP RATIO (SR) AND SLIP ANGLE (α)

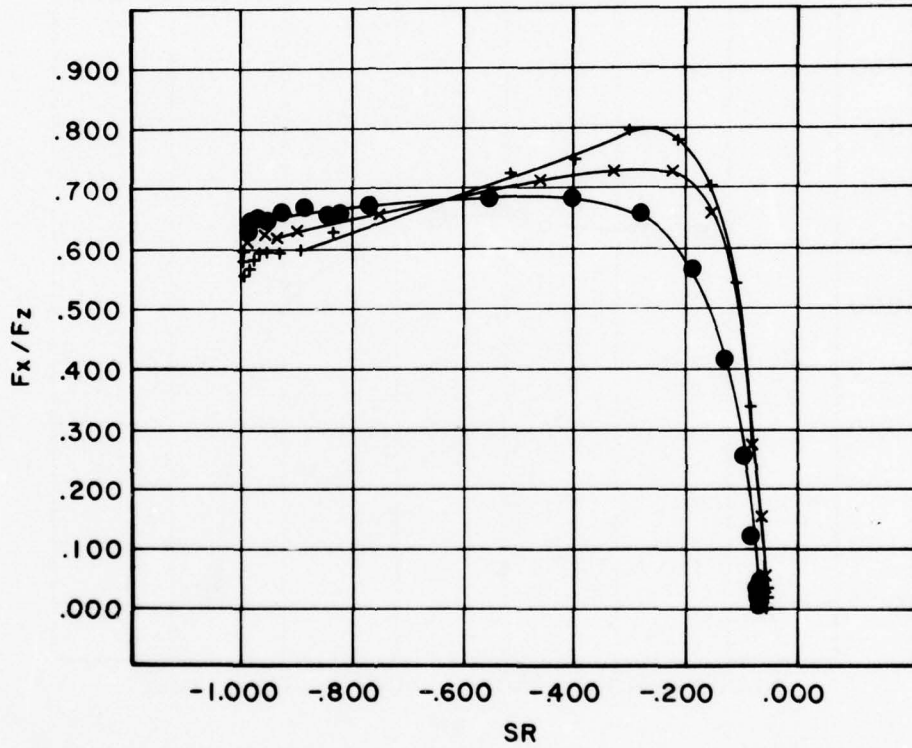

TIRE: 6.00-6/RT
KNOBBY BELT

INFLATION PRESSURE: 55 psi

VELOCITY: 50 mph

LOAD: 1000 Lbs

ROAD: DRY

+ $\alpha = 0^\circ$
x $\alpha = 4^\circ$
● $\alpha = 8^\circ$
□ $\alpha = 12^\circ$

NORMALIZED TRACTIVE FORCE (F_x/F_z)
VS
SLIP RATIO (SR) AND SLIP ANGLE (α)

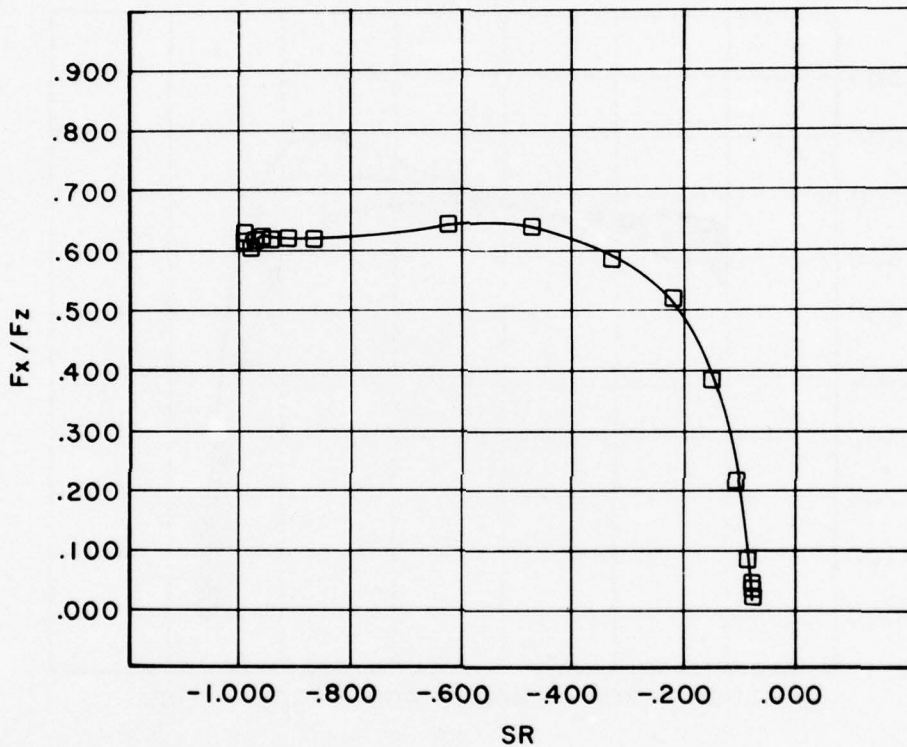

TIRE: 6.00 - 6 / RT
KNOBBY BELT
INFLATION PRESSURE: 55 psi
VELOCITY: 50 mph
LOAD: 1000 Lbs
ROAD: DRY

+ $\alpha = 0^\circ$
x $\alpha = 4^\circ$
● $\alpha = 8^\circ$
□ $\alpha = 12^\circ$

NORMALIZED TRACTIVE FORCE (F_x/F_z)
VS
SLIP RATIO (SR) AND SLIP ANGLE (α)

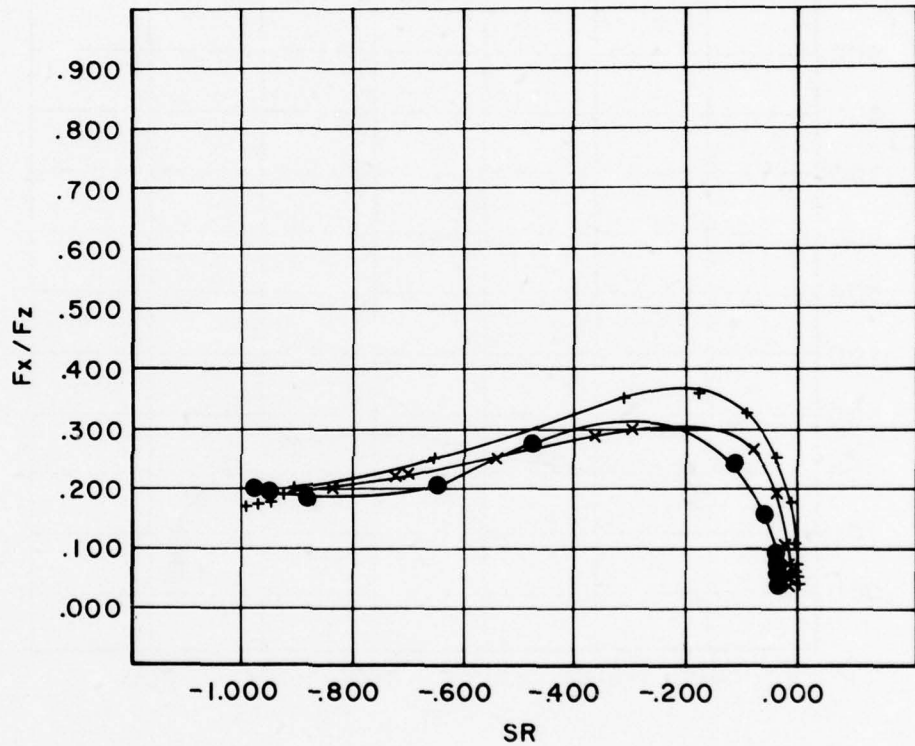

TIRE: 6.00 - 6/8 PR
STD. PRODUCTION

INFLATION PRESSURE: 55 psi

VELOCITY: 50 mph

LOAD: 1000 Lbs

ROAD: .050" WET

+ $\alpha = 0^\circ$

x $\alpha = 4^\circ$

● $\alpha = 8^\circ$

□ $\alpha = 12^\circ$

NORMALIZED TRACTIVE FORCE (F_x/F_z)
 VS
 SLIP RATIO (SR) AND SLIP ANGLE (α)

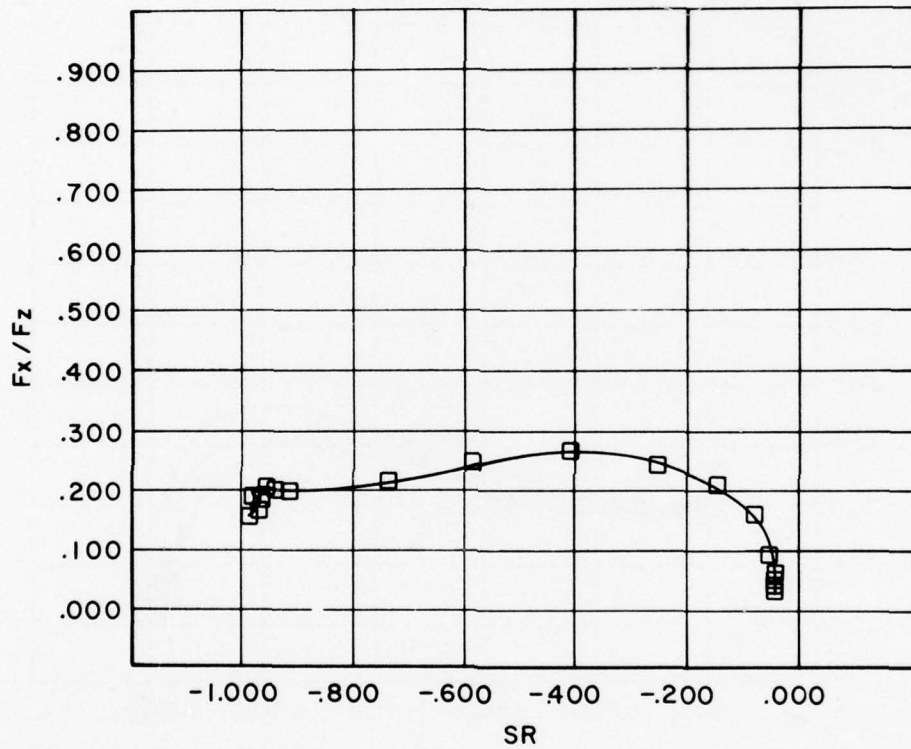

TIRE: 6.00 - 6 / 8 PR
 STD PRODUCTION
 INFLATION PRESSURE: 55 psi
 VELOCITY: 50 mph
 LOAD: 1000 Lbs
 ROAD: .050" WET

+ $\alpha = 0^\circ$
 x $\alpha = 4^\circ$
 ● $\alpha = 8^\circ$
 □ $\alpha = 12^\circ$

AD-A036 153

CALSPAN CORP BUFFALO N Y
NORMAL STRESS, TEMPERATURE, AND PERFORMANCE PROPERTIES OF MILIT--ETC(U)
OCT 76 J R HAMPTON

F/G 1/3

F33615-75-C-0106

UNCLASSIFIED

CALSPAN-ZM-5689-T

AFFDL-TR-76-95

NL

2 OF 2
AD
A036153

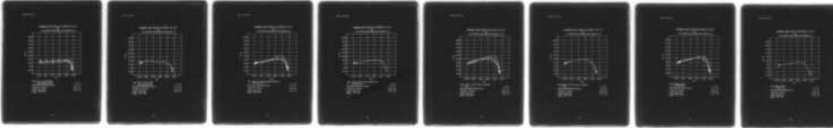

END

DATE
FILMED
3-77

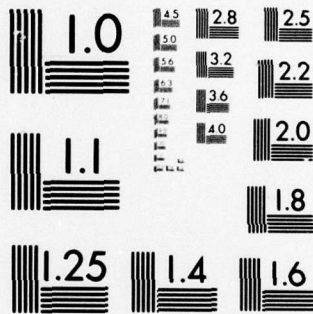

MICROCOPY RESOLUTION TEST CHART
NATIONAL BUREAU OF STANDARDS-1963-A

NORMALIZED TRACTIVE FORCE (F_x/F_z)
 VS
 SLIP RATIO (SR) AND SLIP ANGLE (α)

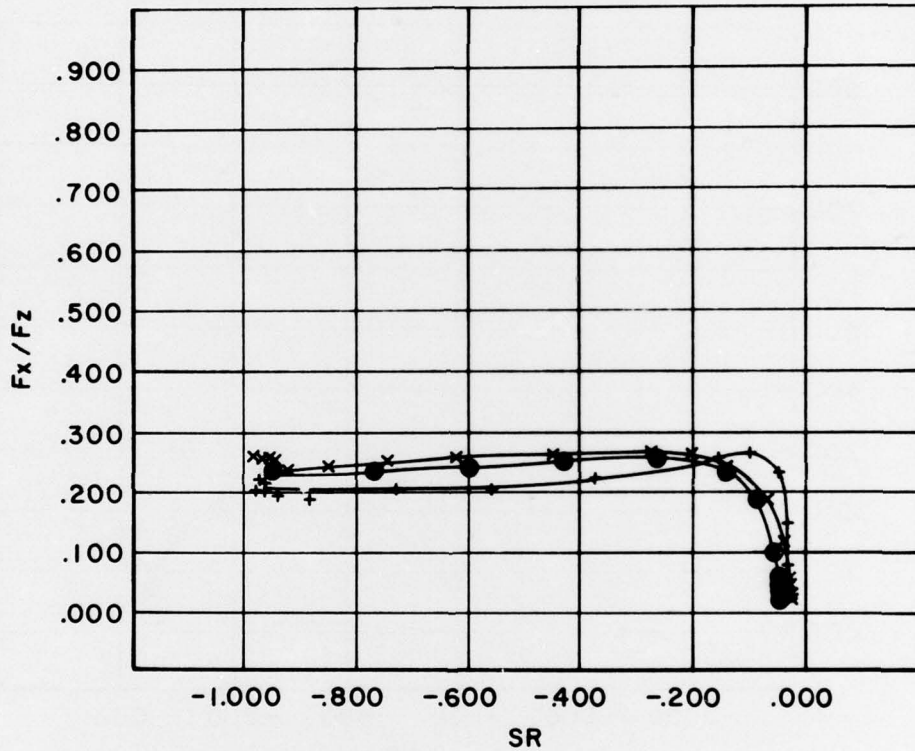

TIRE: 6.00 - 6 CAST TIRE
 2000 GMS MATERIAL
 INFLATION PRESSURE: 55 psi
 VELOCITY: 50 mph
 LOAD: 1000 Lbs
 ROAD: .050" WET

+ $\alpha = 0^\circ$
 x $\alpha = 4^\circ$
 ● $\alpha = 8^\circ$
 □ $\alpha = 12^\circ$

NORMALIZED TRACTIVE FORCE (F_x/F_z)
 VS
 SLIP RATIO (SR) AND SLIP ANGLE (α)

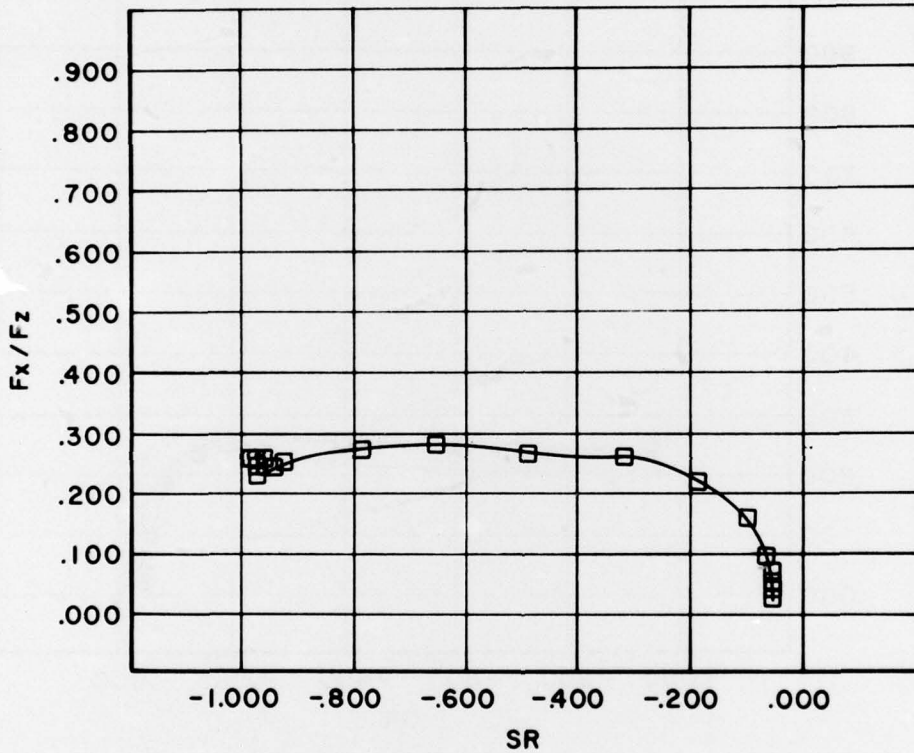

TIRE: 6.00-6 CAST TIRE
 2000 GMS MATERIAL
 INFLATION PRESSURE: 55 psi
 VELOCITY: 50 mph
 LOAD: 1000 Lbs
 ROAD: .050" WET

+ $\alpha = 0^\circ$
 x $\alpha = 4^\circ$
 ● $\alpha = 8^\circ$
 □ $\alpha = 12^\circ$

NORMALIZED TRACTIVE FORCE (F_x/F_z)
 VS
 SLIP RATIO (SR) AND SLIP ANGLE (α)

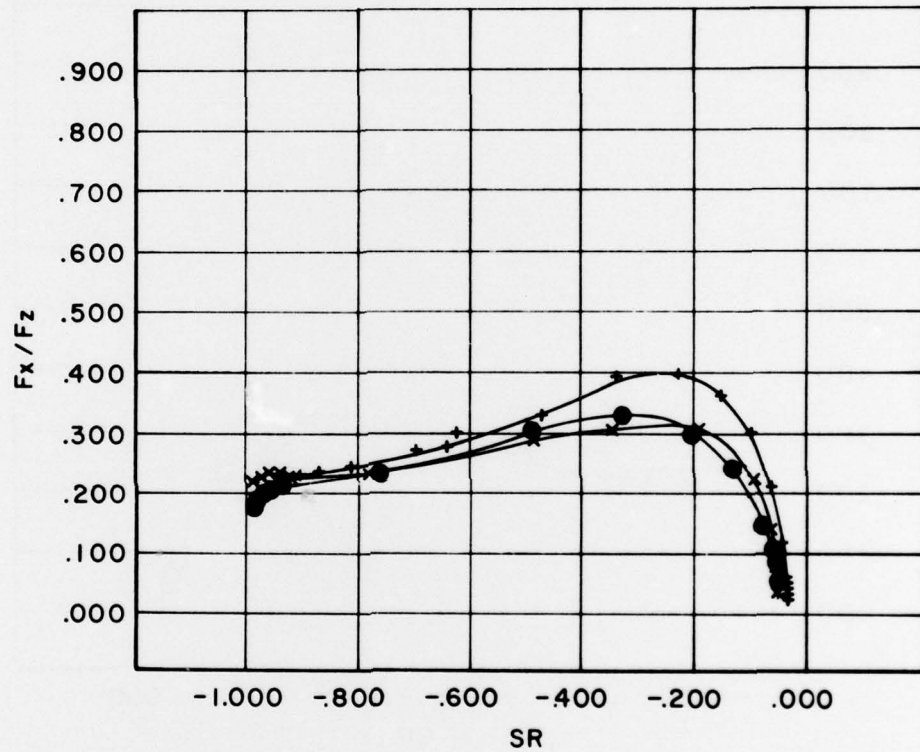

TIRE: 6.00 - 6 / RT CIRCUMFERENTIALLY GROOVED BELT

INFLATION PRESSURE: 55 psi

VELOCITY: 50 mph

LOAD: 1000 Lbs

ROAD: .050" WET

+ $\alpha = 0^\circ$

x $\alpha = 4^\circ$

● $\alpha = 8^\circ$

□ $\alpha = 12^\circ$

NORMALIZED TRACTIVE FORCE (F_x/F_z)
VS
SLIP RATIO (SR) AND SLIP ANGLE (α)

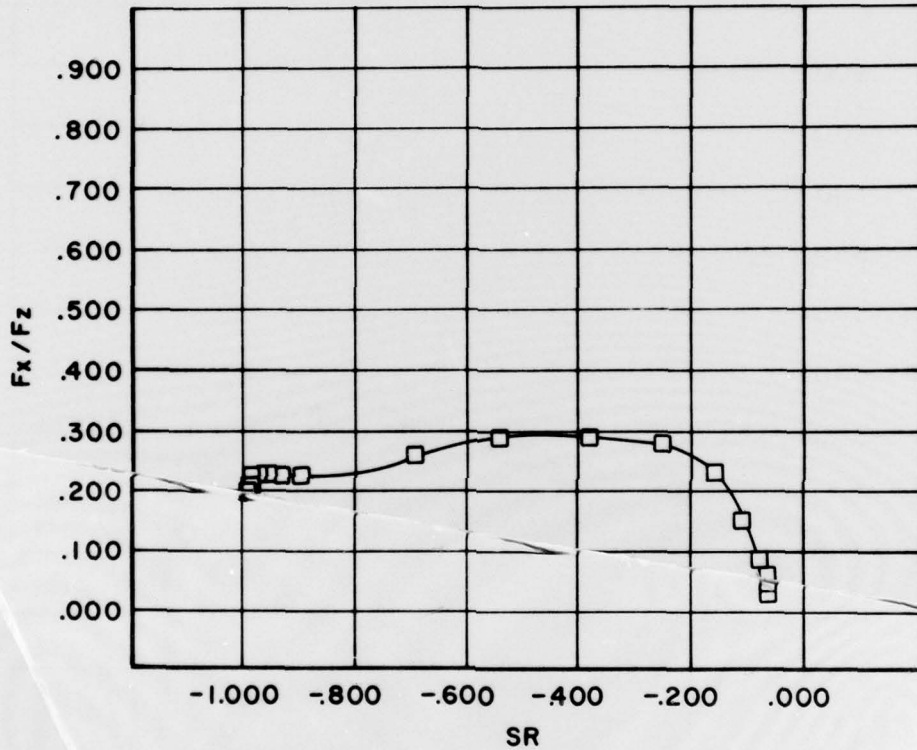

TIRE: 6.00-6/RT CIRCUMFERENTIALLY
GROOVED BELT

INFLATION PRESSURE: 55 psi

VELOCITY: 50 mph

LOAD: 1000 Lbs

ROAD: .050" WET

+ $\alpha = 0^\circ$

x $\alpha = 4^\circ$

● $\alpha = 8^\circ$

□ $\alpha = 12^\circ$

NORMALIZED TRACTIVE FORCE (F_x/F_z)
 VS
 SLIP RATIO (SR) AND SLIP ANGLE (α)

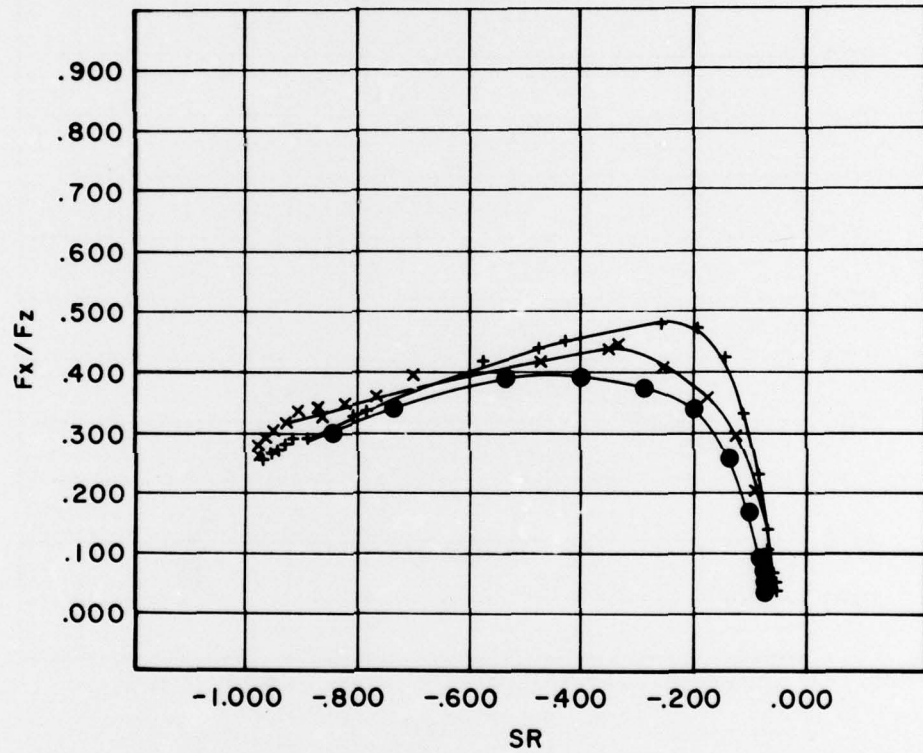

TIRE: 6.00 - 6 / RT AXIALLY GROOVED
 BELT

INFLATION PRESSURE: 55 psi

VELOCITY: 50 mph

LOAD: 1000 Lbs

ROAD: .050" WET

+ $\alpha = 0^\circ$

x $\alpha = 4^\circ$

● $\alpha = 8^\circ$

□ $\alpha = 12^\circ$

NORMALIZED TRACTIVE FORCE (F_x/F_z)
 VS
 SLIP RATIO (SR) AND SLIP ANGLE (α)

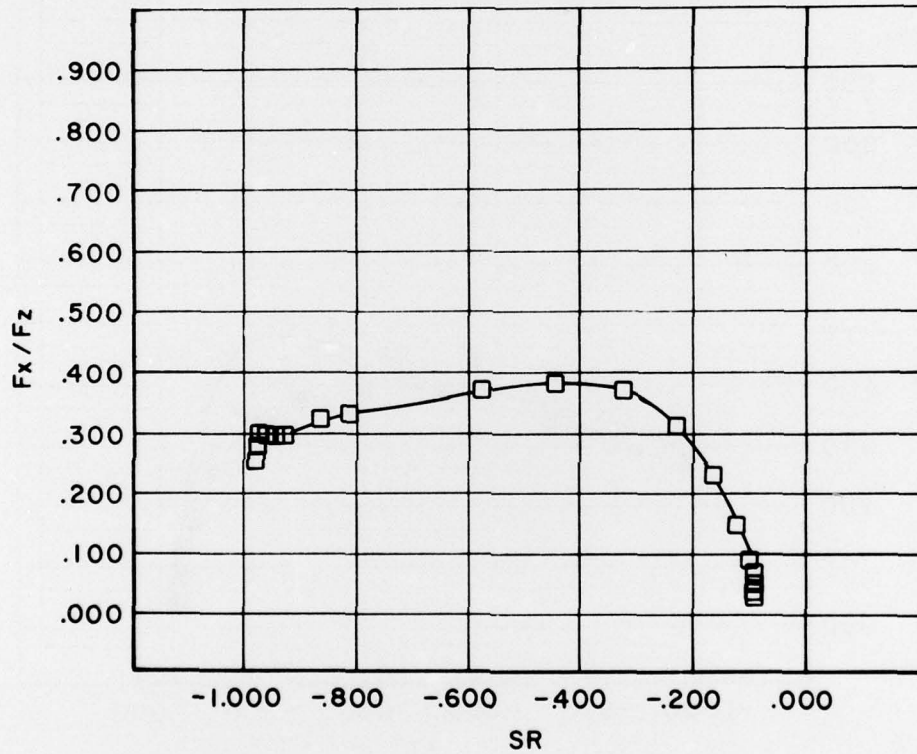

TIRE: 6.00 - 6 / RT AXIALLY GROOVED
 BELT

INFLATION PRESSURE: 55 psi

VELOCITY: 50 mph

LOAD: 1000 Lbs

ROAD: .050" WET

- + $\alpha = 0^\circ$
- x $\alpha = 4^\circ$
- $\alpha = 8^\circ$
- $\alpha = 12^\circ$

NORMALIZED TRACTIVE FORCE (F_x/F_z)
 VS
 SLIP RATIO (SR) AND SLIP ANGLE (α)

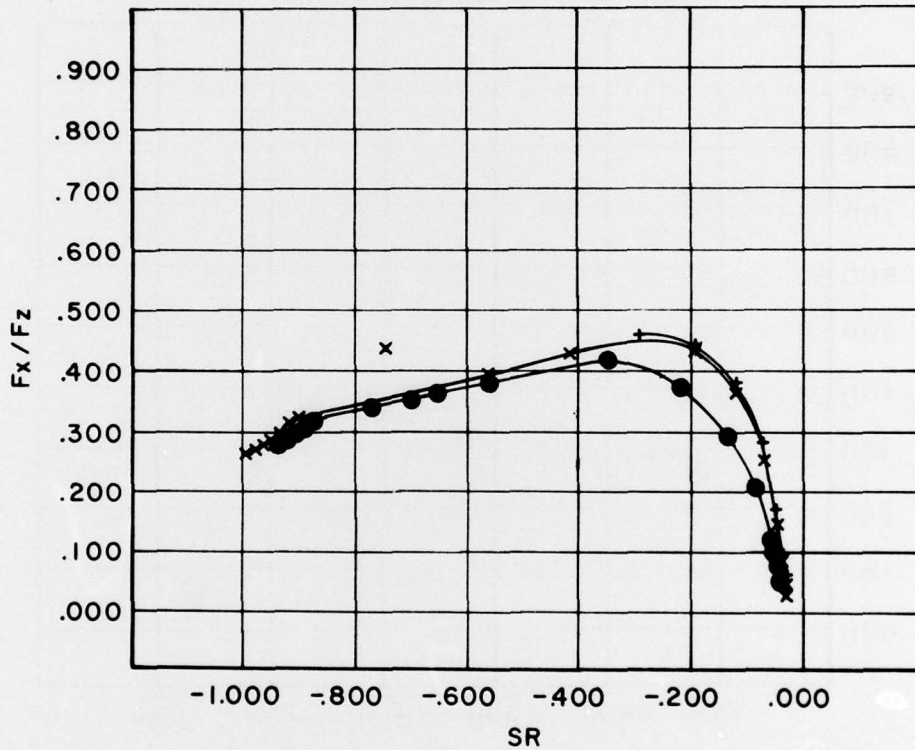

TIRE: 6.00 - 6 / RT
 KNOBBY BELT

INFLATION PRESSURE: 55 psi

VELOCITY: 50 mph

LOAD: 1000 Lbs

ROAD: .050" WET

+ $\alpha = 0^\circ$
 x $\alpha = 4^\circ$
 ● $\alpha = 8^\circ$
 □ $\alpha = 12^\circ$

NORMALIZED TRACTIVE FORCE (F_x/F_z)
 VS
 SLIP RATIO (SR) AND SLIP ANGLE (α)

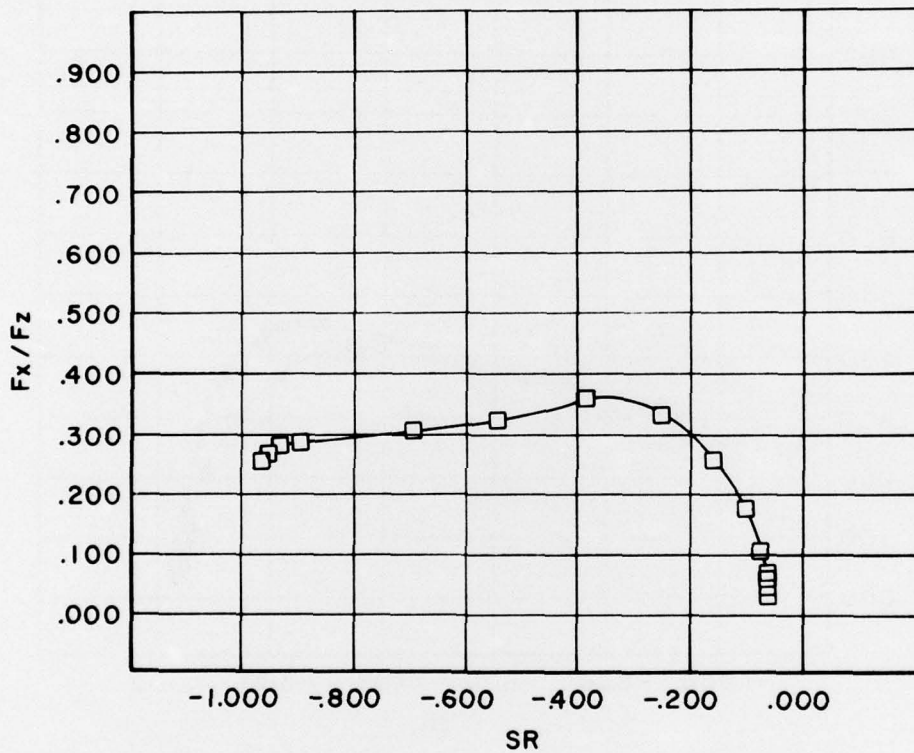

TIRE: 6.00 - 6/RT
 KNOBBY BELT
 INFLATION PRESSURE: 55 psi
 VELOCITY: 50 mph
 LOAD: 1000 Lbs
 ROAD: .050" WET

+ $\alpha = 0^\circ$
 x $\alpha = 4^\circ$
 ● $\alpha = 8^\circ$
 □ $\alpha = 12^\circ$