

AD-A036 085

TRI-CON ASSOCIATES INC CAMBRIDGE MASS

F/G 14/2

THE DESIGN DEVELOPMENT AND TEST OF SATELLITE, BALLOON AND ROCKE--ETC(U)

SEP 76 G P MURPHY

F19628-73-C-0192

UNCLASSIFIED

C-127

AFGL-TR-76-0214

NL

1 OF 1
AD
A036085



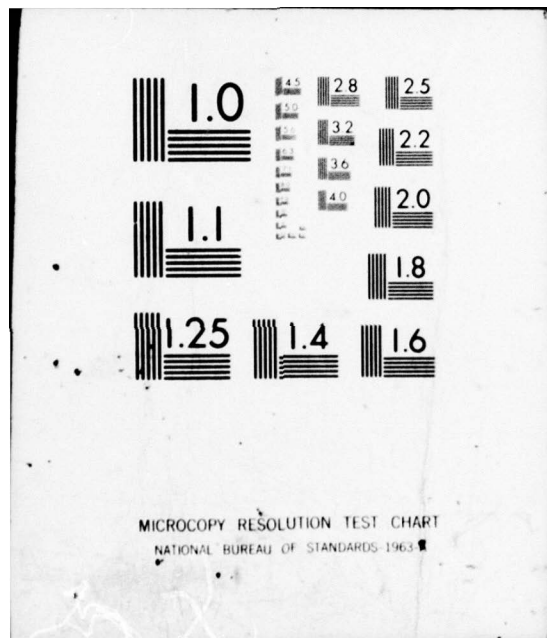

ADA 036085

AFGL-TR-76-0214

THE DESIGN DEVELOPMENT AND TEST OF
SATELLITE, BALLOON AND ROCKET BOURNE
MASS SPECTROMETER, ELECTRONIC ASSEMBLIES

George P. Murphy

TRI-CON ASSOCIATES, INC.
765 Concord Avenue
Cambridge, Massachusetts 02138

September 20, 1976

FINAL REPORT: Period Covered
1973 July to 1976 June

Approved for public release; distribution unlimited

AIR FORCE GEOPHYSICS LABORATORY
AIR FORCE SYSTEMS COMMAND
UNITED STATES AIR FORCE
HANCOCK AFB, MASSACHUSETTS 01731

DDC
RECEIVED
FEB 25 1977
RECEIVED

COPY AVAILABLE TO DDC DOES NOT
PERMIT FULLY LEGIBLE PRODUCTION

Qualified requestors may obtain additional copies from the Defense Documentation Center. All others should apply to the National Technical Information Service.

UNCLASSIFIED

SECURITY CLASSIFICATION OF THIS PAGE (When Data Entered)

19 REPORT DOCUMENTATION PAGE		READ INSTRUCTIONS BEFORE COMPLETING FORM	
18 1. REPORT NUMBER AFGL TR-76-0214	2. GOVT ACCESSION NO.	3. RECIPIENT'S CATALOG NUMBER	
6 4. TITLE (and Subtitle) THE DESIGN DEVELOPMENT AND TEST OF SATELLITE, BALLOON AND ROCKET BOURNE MASS SPECTROMETER, ELECTRONIC ASSEMBLIES.		5. TYPE OF REPORT & PERIOD COVERED Final Report 1973 July to 1976 June	
7. AUTHOR(s) 10 George P. Murphy		8. CONTRACT OR GRANT NUMBER(s) 15 F19628-73-C-0192	
9. PERFORMING ORGANIZATION NAME AND ADDRESS TRI-CON ASSOCIATES, INC. 765 Concord Avenue Cambridge, Massachusetts 02138		10. PROGRAM ELEMENT, PROJECT, TASK AREA & WORK UNIT NUMBERS 62101F 66870201	
11. CONTROLLING OFFICE NAME AND ADDRESS Air Force Geophysics Laboratory Hanscom AFB, Massachusetts 01731 Contract Monitor: Edmund Trzcinski LKD		12. REPORT DATE 11 30 Sept 1976	
14. MONITORING AGENCY NAME & ADDRESS (if different from Controlling Office) 9 Final rept. Jul 73 - Jun 76		13. NUMBER OF PAGES 49	
16. DISTRIBUTION STATEMENT (of this Report) Approved for Public Release, Distribution Unlimited		15. SECURITY CLASS. (of this report) Unclassified	
17. DISTRIBUTION STATEMENT (of the abstract entered in Block 20, if different from Report)		18. DECLASSIFICATION/DOWNGRADING SCHEDULE	
18. SUPPLEMENTARY NOTES			
19. KEY WORDS (Continue on reverse side if necessary and identify by block number)			
20. ABSTRACT (Continue on reverse side if necessary and identify by block number) This report reviews the design and development of the electronic assemblies used with Quadrupole Mass Spectrometers. The Mass Spectrometers are used by the Air Force Geophysics Laboratory to make composition studies of the upper atmosphere and the ionosphere. The first phase of work was directed toward a satellite instrument designed to measure both positive and neutral constituents in the range of 1 AMU to 44 AMU. → next page continued			

D D C
 FEB 25 1977
 A

DD FORM 1 JAN 73 1473 EDITION OF 1 NOV 65 IS OBSOLETE

UNCLASSIFIED
 SECURITY CLASSIFICATION OF THIS PAGE (When Data Entered)

390 416

mt

UNCLASSIFIED

SECURITY CLASSIFICATION OF THIS PAGE(When Data Entered)

Abstract continued

cont → Phase two was directed toward a balloon instrument which would be used to measure positive ions in the range of 10 AMU up to 400 AMU.

Phase three was directed toward the design of an instrument RMS-5 which could be used on either a rocket or satellite and measure both positive and neutral constituents. ↖

UNCLASSIFIED

SECURITY CLASSIFICATION OF THIS PAGE(When Data Entered)

TABLE OF CONTENTS

	Page
1. INTRODUCTION	1
2. SYSTEM DESIGN	1&2
2.1 Power Supply	2&3
2.2 Programmer.	4
2.2.1 Satellite Programmer.	4&5
2.2.2 Balloon Programmer.	5&6
2.2.3 RMS-5 Programmer.	7-9
2.3 DC Sweep Amplifiers.	9
2.3.1 Sweep Amplifier	9&10
2.4 RF Oscillator.	10-12
2.5 Data Amplifiers.	12-14
2.6 Emission Regulator	14
2.7 Monitor Circuits	14

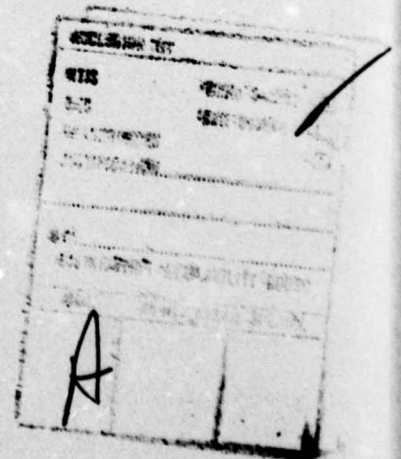

LIST OF DRAWINGS

	Page
D-865.	19
RMS-5 Timing Diagram	
D-639.	20
Emission Regulator Control (Satellite)	
D-645.	21
Mass Scan & DC Generator Satellite	
D-646.	22
Power Supply Satellite Mass Spectrometer	
D-647.	23
Programmer Satellite Schematic	
D-572.	24
Capacitor Electrometer Satellite Mass Spectrometer	
C-673.	25
High Voltage Satellite Schematic	
C-579.	26
RF Oscillator	
D-683.	27
Power Supply Balloon Mass Spectrometer	
D-684.	28
RF Oscillator	
D-686.	29
Programmer Sweep Generator	
D-690.	30
Electrometer & Pulse Amp	
D-692.	31
Console Schematic	
D-694.	32
Console Balloon	

	Page
D-845. Power Supply RMS-5	33
C-847. Emission Regulator RMS-5	34
C-848. Relay Control	35
D-850. Program Timer RMS-5	36
D-852. Telemetry Data RMS-5	37
C-854. Sweep Generator RMS-5	38
D-856. Wiring Diagram RMS-5	39
C-857. RF Oscillator RMS-5	40
D-858. Electrometers RMS-5	41

LIST OF ILLUSTRATIONS

	Page
B-735. Mode Outline Satellite	15
B-736. Program Timing Satellite	16
B-737. Electrometer Timing Satellite	17
FIGURE I. Balloon Sweep	18

1. INTRODUCTION

The objective of this contract was to design and fabricate the electronic assemblies for the AFGL Quadrupole Mass Spectrometer.

The mass spectrometers are used to make positive and neutral constituent measurements of the upper atmosphere and ionosphere. The first instrument that was developed is to be used on a satellite to measure positive and neutral species from 1 AMU to 44 AMU. A control console that is capable of generating the satellite command and data handling functions was designed to simplify laboratory testing.

The second instrument was designed to measure a wider range of masses, up to 400 AMU in a lower altitude balloon flight. A control console was also fabricated for testing of this instrument.

The third assembly (RMS-5) is designed to measure sixteen different masses in the range of 1 AMU to 50 AMU. The control console for the RMS-5 electronic package was fabricated at AFGL.

2. SYSTEM DESIGN

The system design for a Quadrupole Mass Spectrometer will include, with some variations:

- a) A DC to DC converter power supply.
- b) A programmer of sweep control circuit.
- c) DC sweep amplifiers with a plus and minus symmetrical sweep.
- e) An electrometer and/or pulse amplifier.
- f) Data handling circuits such as shift registers and counters.
- g) Monitors for temperature and vacuum.

The variations mentioned in the previous paragraph depend on the type of vehicle used such as satellite, rocket or balloon.

The satellite power converter has a switching regulator front end to improve the efficiency. The rocket and balloon experiments because of the short time of flight or payload capability do not require a switching regulator.

The satellite programmer is also different because the timing and data readout is determined by the satellite central processor. The RF oscillator, electrometer, and temperature monitors are similar in all three instruments.

2.1 Power Supply

All the power supplies that are designed for these mass spectrometer instruments use a square loop material in the main transformer.

The satellite converter D-646 has a switching regulator front end, a master oscillator for low power frequency determination, and a non

saturating slave transformer for efficient power conversion. The satellite converter frequency, is about 30 KC as compared to the rocket converters which operate at about 5 KC.

The switching regulator D-646 is comprised of Z_1 , Q_1 , and L_1 and is synchronized by the master oscillator Q_3 , Q_4 , T_1 from a feedback winding (10-11). The switching regulator reduces the power dissipation between the input (26 volts to 32 volts) and the main transformer center tap (+20 volts) by about 90%. This turns out to be about a 30% reduction of the total experiment power.

In DC to DC converter design, power is dissipated when the transformer goes into saturation and switching action occurs. At this time a large current spike occurs which causes heating in the switching transistor and the transformer. To reduce the amount of wasted power, a low power master oscillator is used to drive the main or slave transformer so that it never goes into saturation.

For satellite experiments the power is derived from solar cells recharging the batteries and the expected life time of the experiment is usually many months so that conservation of power is a primary consideration. For rocket and balloon experiments which have relatively short life times (10 to 20 minutes for rockets) or have greater payload capabilities, the power supply design is not as critical.

2.2 Programmer

2.2.1 Satellite Programmer

The satellite programmer D-647 contains the command relay logic, the mass scan advance logic and the data handling or electrometer readout logic.

The command relay logic is used to set the experiment in any one of five different modes. The relays are of the magnetic latching type and require a 28 volt 75 ms pulse to be activated. A single pulse is used on the desired mode input line to set the proper relay and reset all the others. Because of the limited number of commands allotted each experiment, the high voltage "low" command was also used to set the experiment into Mode I by resetting Mode Relays II to V.

The mass scan advance logic is used to determine the state of the mode relays, advance the mass scan counter and set the various bias levels in the ionizer.

An outline of the mode, submode, mass numbers and ionizer bias levels appears on Drawing B-735.

The data handling portion of the programmer is used to synchronize the

electrometer sample time and data read-out with the satellite telemetry system. The timing diagram for the electrometer and data handling appear on Drawing B-736 and B-737. A detail description of the circuit operation appears in previous reports, so it will not be included here.

2.2.2 Balloon Programmer

The balloon programmer is designed to generate a sweep which can be broken up into eight segments or modes. Each mode sweeps 50 masses so that the total sweep covers the spectrum of 1 AMU to 400 AMU. In addition to controlling the amplitude of DC amplifiers and RF oscillator, the programmer determines the oscillator frequency, by the state of the relays in secondary of the RF oscillator. A diagram of the resulting sweep appears on Figure I.

The reason for changing the frequency is to reduce the amplitude of the DC and RF voltage that is applied to the Quadrupole rods in order to reach mass 400. This is evident from the equation:

$$M = \frac{V_p}{7.219 f^2 r_o^2}$$

A high frequency improves the resolution of the instrument for low masses, but strains the stability of the oscillator, because of the high peak voltage, at high masses.

As an example if three frequency were used such as : $f_1 = 3.6$ mc, $f_2 = 2.4$ mc and $f_3 = 1.8$ mc, the peak RF voltage required to reach 400 AMU would be:

Single frequency

$$V_p = 7.219 (400)(3.6)^2 (.273)^2$$

$$V_p = 2789 \text{ volts}$$

Three frequencies with the lower frequency used for the higher masses:

$$V_p = 7.219 (400)(1.8)^2 (.273)^2$$

$$V_p = 697 \text{ volts}$$

The programmer controls the sweep such that a continuous sweep of 1 AMU to 400 AMU can be made or a particular mode can be selected, and the sweep will scan only in that mode. For example if it is desirable to look at only masses 100 AMU to 150 AMU, mode three is selected and the scanner starts at 100 AMU sweeps to 150 AMU then returns to 100 AMU and repeats the same sequence.

2.2.3 RMS-5 Programmer

The RMS-5 programmer has not been described in previous reports so a little more detail will be given here. The design philosophy was to include:

- a) Design the experiment so that it could be used on either a rocket or satellite with a minimum of modifications.
- b) Jump to selected masses instead of the usual linear scan.
- c) Include in the data readout a computer code and a mass number code so that automatic data reduction could be used.

The timer portion of the programmer D-850 is used to generate the timing function usually supplied by a satellite central processor, such as data gate, shift pulses and sync pulses. The scan control portion of the programmer C-854 contains the program advance counter U_1 , two programmable read only memories U_2 & U_3 and a 10 bit D/A converter U_5 .

The reason for this type of scan control is to eliminate the dead time between mass peaks which is inherent in a linear scan.

The use of a PROM also simplifies a change in the order in which a mass is sampled or the emphasis placed on any particular mass. The lower left hand portion of D-865 has a sample scan sequence in which mass 28 is selected on alternate mass steps so that a more accurate profile of mass 28 could be established during flight.

The counter U_4 on Drawing C-854 is used for laboratory calibration purposes and will be used to determine the outputs required from the PROMS to obtain the selected mass sequence. The counter can be used to provide a linear scan of all the masses from 1 AMU to 50 AMU in the laboratory and then will be removed before flight.

The data handling portion of the programmer D-852 includes the 40 bit shift register made up of U_4 , U_5 , U_6 , U_7 and U_{16} . The shift register accepts data from two different electrometer counters and the

mass scan PROM plus generating an eight bit computer code. The load and shift pulses are provided from the program timer and the register is designed to be self clearing.

2.3 DC Sweep Amplifiers

2.3.1 The DC sweep amplifiers for all three types of instruments are identical. The schematic for these amplifiers are on Drawings D-645, D-686, and C-854. The amplifiers are the same because there function is to supply a symmetrical plus and minus DC bias to the opposite pair of rods in the Quadrupole structure. The only difference in the amplifiers is the reference bias of the output and the amplitude, which will be a function of the mass range to be sampled. The amplifiers are designed around an integrated circuit operational amplifier such as the 741. The output stage is made up with two high voltage transistors operated in the common base mode which allows the output to swing well over one hundred volts, far exceeding the power supply limits of most integrated operational amplifiers.

The first transistor of each pair is used so that the rod bias is not restricted to operational amplifier

power supply limits of ± 15 volts. The transistors are operated in the common base mode so that no additional open loop gain is added to the already high gain of the 741. If a common emitter stage was used with a high gain transistor, stabilization of the amplifier would be difficult. The input and feedback resistors normally used are wire wound and matched to .01%.

2.4 RF Oscillator

The RF oscillator C-579 used in the three instruments is basically the same as far as circuit performance is concerned. The oscillator is a tuned secondary push pull Hartley oscillator whose frequency is determined by the resonance of the output winding and the quadrupole capacitance. The output is amplitude modulated by a control DC voltage so that a fixed ratio exists between the plus and minus DC sweep voltage and the peak RF voltage. The center tap of the output or resonant winding is DC open, and AC shorted so that the RF waveform can be superimposed on the DC sweep when it is applied to the quadrupole rods.

In order to close the loop and control the amplitude of the RF waveform an additional winding is added to the coil form whose output is peak detected and compared to the DC control voltage.

In the satellite and the RMS-5 instruments the frequency is fixed between 3 Mhz and 4 Mhz, the exact value being determined during laboratory calibration.

In the balloon instrument the frequency is changed as a function of mode or mass group being sampled such as:

Mode I	1	AMU to 50	AMU $f_1=3.6$ Mhz
Mode II	50	AMU to 100	AMU $f_2=2.4$ Mhz
Mode III	100	AMU to 150	AMU $f_2=2.4$ Mhz
Mode IV	150	AMU to 200	AMU $f_2=2.4$ Mhz
Mode V	200	AMU to 250	AMU $f_3=1.8$ Mhz
Mode VI	250	AMU to 300	AMU $f_3=1.8$ Mhz
Mode VII	300	AMU to 350	AMU $f_3=1.8$ Mhz
Mode VIII	350	AMU to 400	AMU $f_3=1.8$ Mhz

In order to obtain the different frequencies a multi tap coil is wound so that different inductances can be used to resonate with the quadrupole capacitance. An alternate approach for changing the frequency would be to use a single inductance and shunt the quadrupole capacitance with a fixed capacitance to lower the frequency.

The multi tap coil has two obvious advantages over the shunt capacitor approach and they are:

- 1) The power dissipated in the resonant tank for a fixed amplitude will increase with increasing capacitance.

- 2) The power supply on the primary side of the transformer can be a lower voltage with the multi tap coil approach.

In order to maintain a fixed ratio between the RF and DC sweep it is also necessary to change the amount of feedback to the peak detector from the "pick off" winding, when the output turns ratio is changed. This is accomplished by using relays K_4 , K_5 and K_6 , along with resistors R_{20} , R_{21} , R_{22} .

The multiplexer Z_2 D-684 is used as a fine trim or vernier adjustment of the ratio and can be programmed by control of inputs "A" and "B".

2.5 Data Amplifiers

The data amplifiers designed for the mass spectrometers are of the electrometer type which are used to measure currents from 10^{-13} amps to 10^{-5} amps. The two types of electrometers are the "capacitor integrating" and the "transistor logarithmic".

Detailed description of the circuit operation has been included in previous reports associated with this contract, such as AFGL-TR-C-0183, so it seems unnecessary to repeat it in this discussion.

The satellite experiment has two capacitor integrating electrometers, the first one has three ranges and measures the output of a Johnson secondary emission multiplier, with currents in the range of 10^{-11} to 10^{-5} amps. The range is determined by sampling the output of the multiplier for 4 ms prior to each data period. The timing diagram appears on Drawing B-737 and B-736.

The second satellite electrometer is used to measure the current of a grid which is placed in front of the electron multiplier, and is useful for detecting currents too large for the multiplier electrometers to handle.

Data in the balloon experiment will be handled by a capacitor amplifier or by a pulse amplifier using the same accumulator. The pulse amplifier will be used when the level of data with respect to time is so low that the capacitor electrometer does not respond in a reasonable time period.

An additional data card with two transistor logarithmic amplifiers can be substituted in the experimental package for use in laboratory testing.

The RMS-5 instrument contains two capacitor electrometers and a positive input transistor logarithmic electrometer. The capacitor electrometers are used to measure the multiplier and grid current in the same manner as the satellite amplifiers.

The transistor log amplifier is used to measure ion current at the electron impact ion source. The timing diagram for the RMS-5 is on Drawing D-865.

2.6 Emission Regulator

The emission regulator circuits are used to supply a heater current and bias voltages to an ionizer which is located between the entrance aperture and quadrupole rods. The ionizer which is used in the neutral mode to ionize particals, can be programmed on and off so that the instrument serves a dual purpose, and can measure positive ion or neutral species.

The RMS-5 emission regulator is slightly different from the satellite circuit in that the emitted current from the filament is controlled by a closed loop which includes an opto-isolator. The opto-isolator allows for large filament to anode voltages without putting undue stress on the anode amplifier transistors.

2.7 Monitor Circuits

Each of the instruments has a temperature monitor or two depending upon the number of packages required. The circuit is designed around a iso-curve thermistor and a 741 type operational amplifier. The components are selected to give a 0 to 5 volt output for a temperature change of 0 to 50 degrees centigrade.

Various voltages are monitored by using resistor dividers and are usually sampled on a subcommutator basis.

MODES SLIB MODES MASS (4RF STEP/MASS) VR GRID NPER G1 G4 ACCEL RODS BOX FIL HOLD ANODE

MODES	SLIB MODES	MASS (4RF STEP/MASS)	VR GRID NPER G1 G4 ACCEL RODS BOX FIL HOLD ANODE
I	5 ION 10 NEU HIGH 1 TOTAL ION	14, 16, 28, 30, 32 1, 2, 4, 15, 16, 20, 30, 32 3 TOTAL ION LEVELS & 1 CAL	0, -25, -150, -25, -25, -100, -15, -25, +10, +20, +30
II	5 NEU RETARD 10 NEU HIGH 1 TOTAL ION	SAME AS MODE I	-100, -100, -100, -100
III	5 NEU LOW 10 NEU HIGH 1 TOTAL ION	SAME AS MODE I	-20, -100
IV	RETARDING	16, (16 VR LEVELS/MASS STEP) 28, (16 VR LEVELS/MASS STEP)	-25, -25, % OF DC, -25
V	5/2 STEPS LINEAR SCAN	ALL MASSES 1-4-4	-25, -100

TEMPORARY MODE
OUTLINE
B-735
SATELLITE

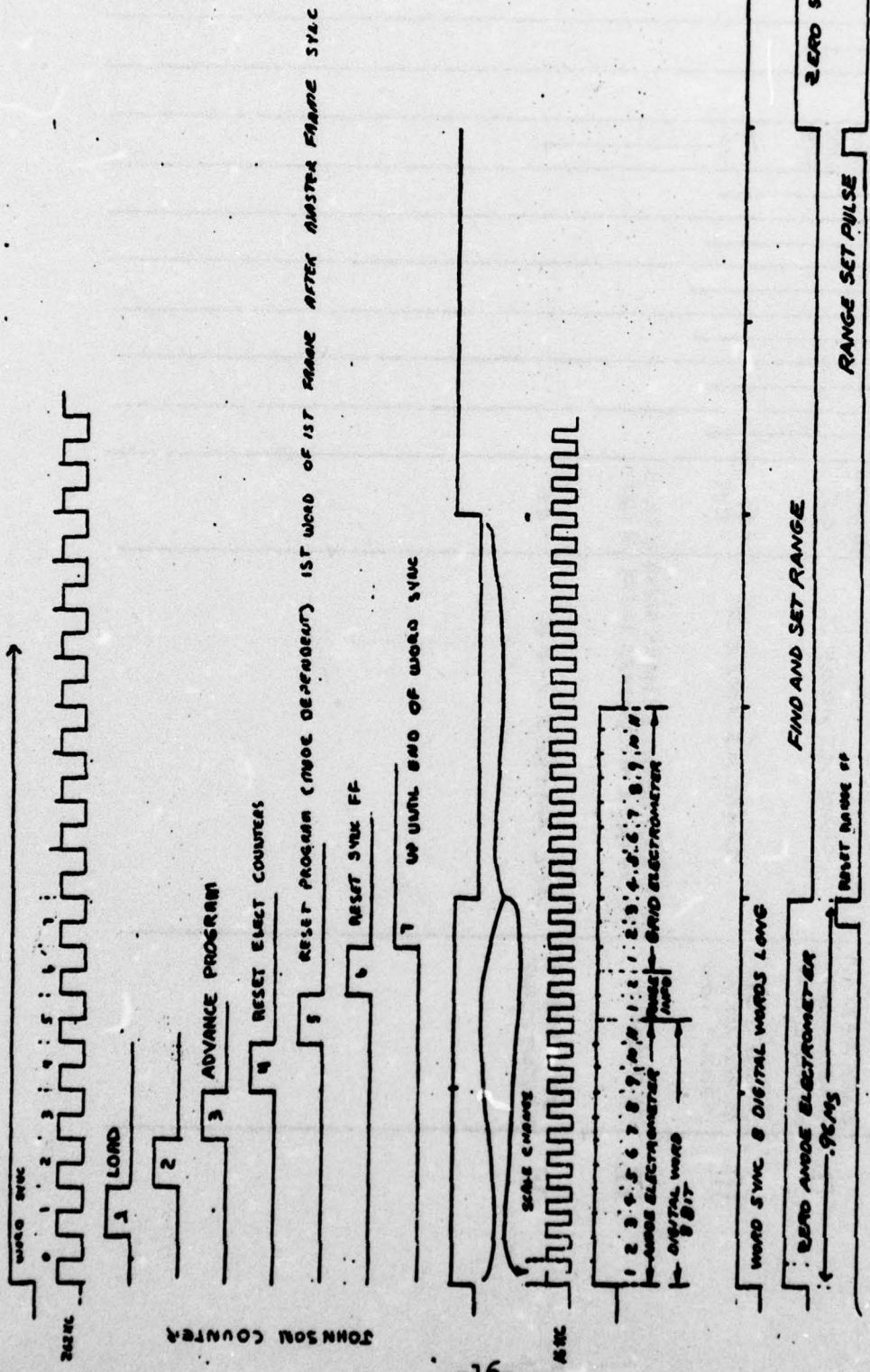

JOHNSON COUNTER

PROGRAM TIMING
B-736
 SATELLITE

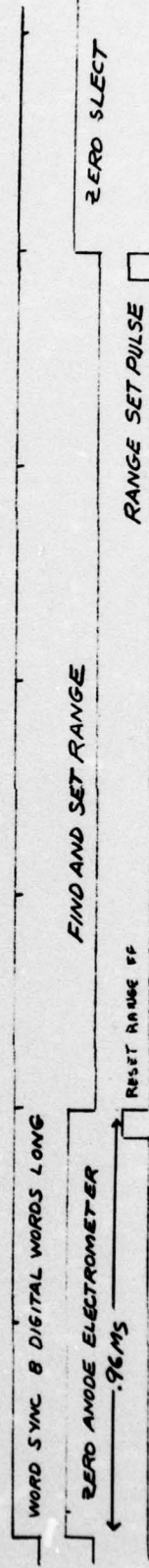
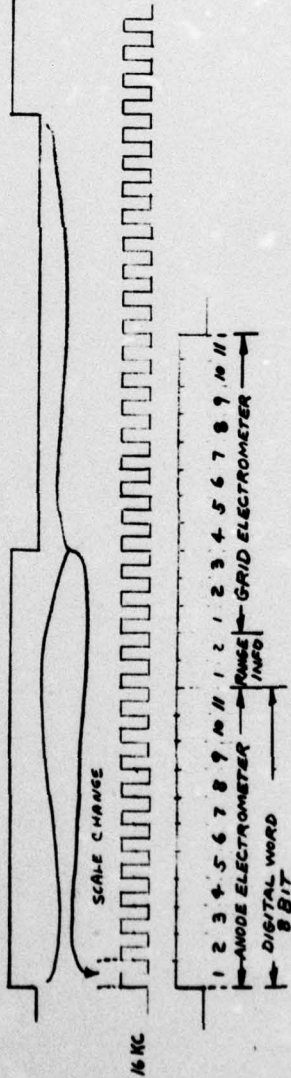
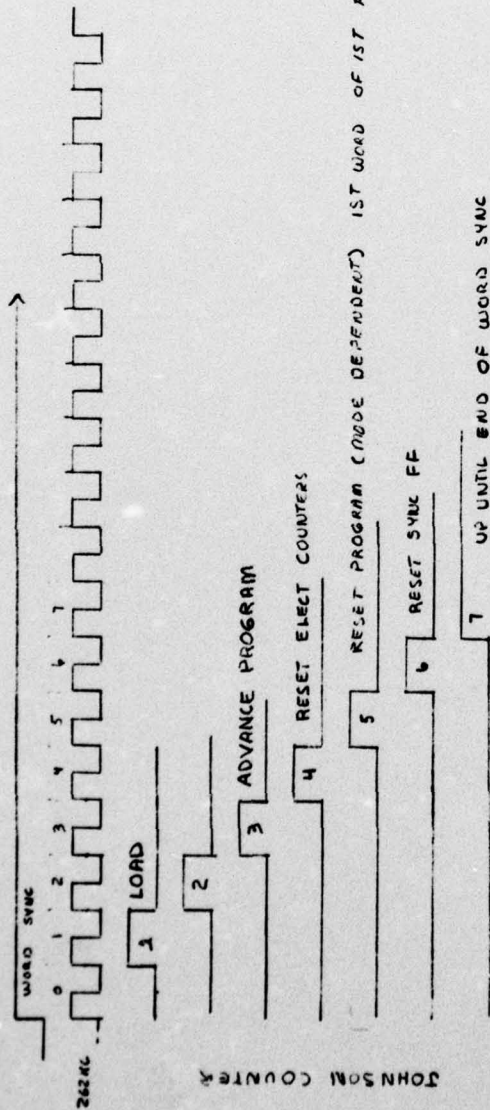

PROGRAM TIMING
B-736

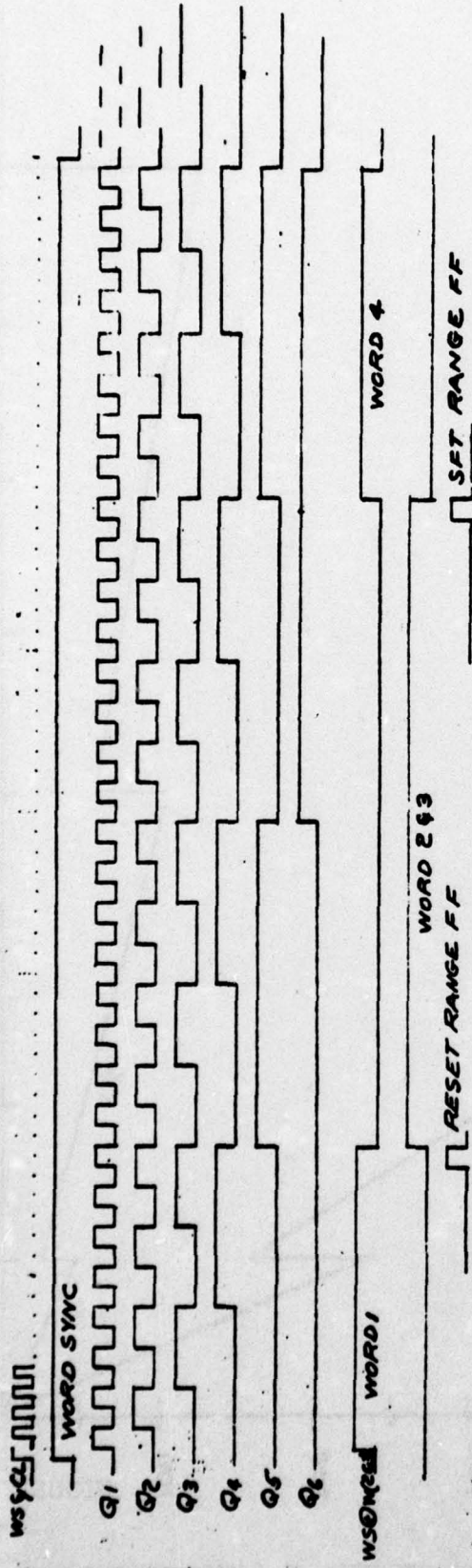

LOAD SHIFT R REGISTERS
 RESET ELECT COUNTERS
 WS ⊕ W(2+3)
 OCCURS IN 1ST 204 SEC OF WORD SYNC

ELECTROMETER TIMING
 SATELLITE
 B-737

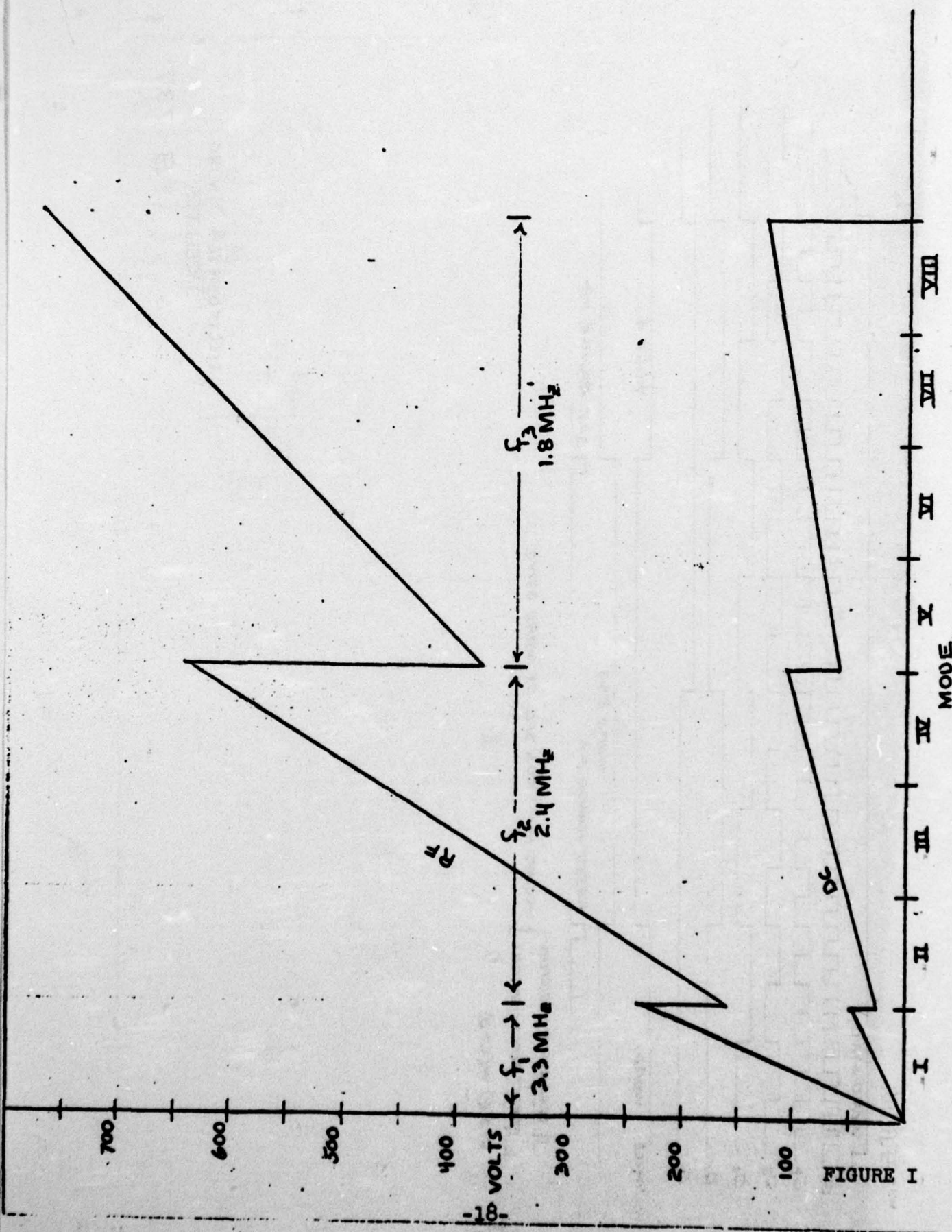
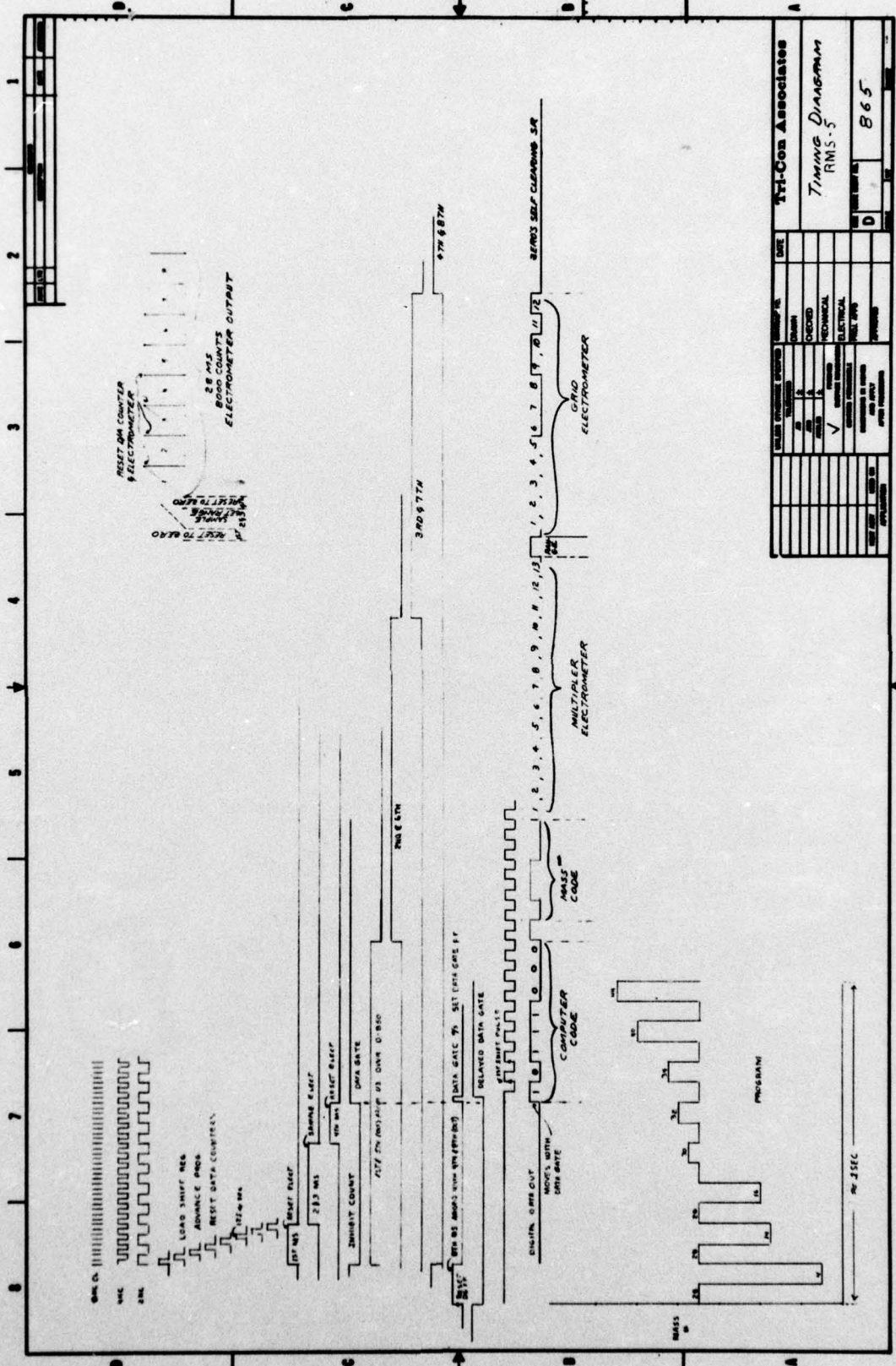
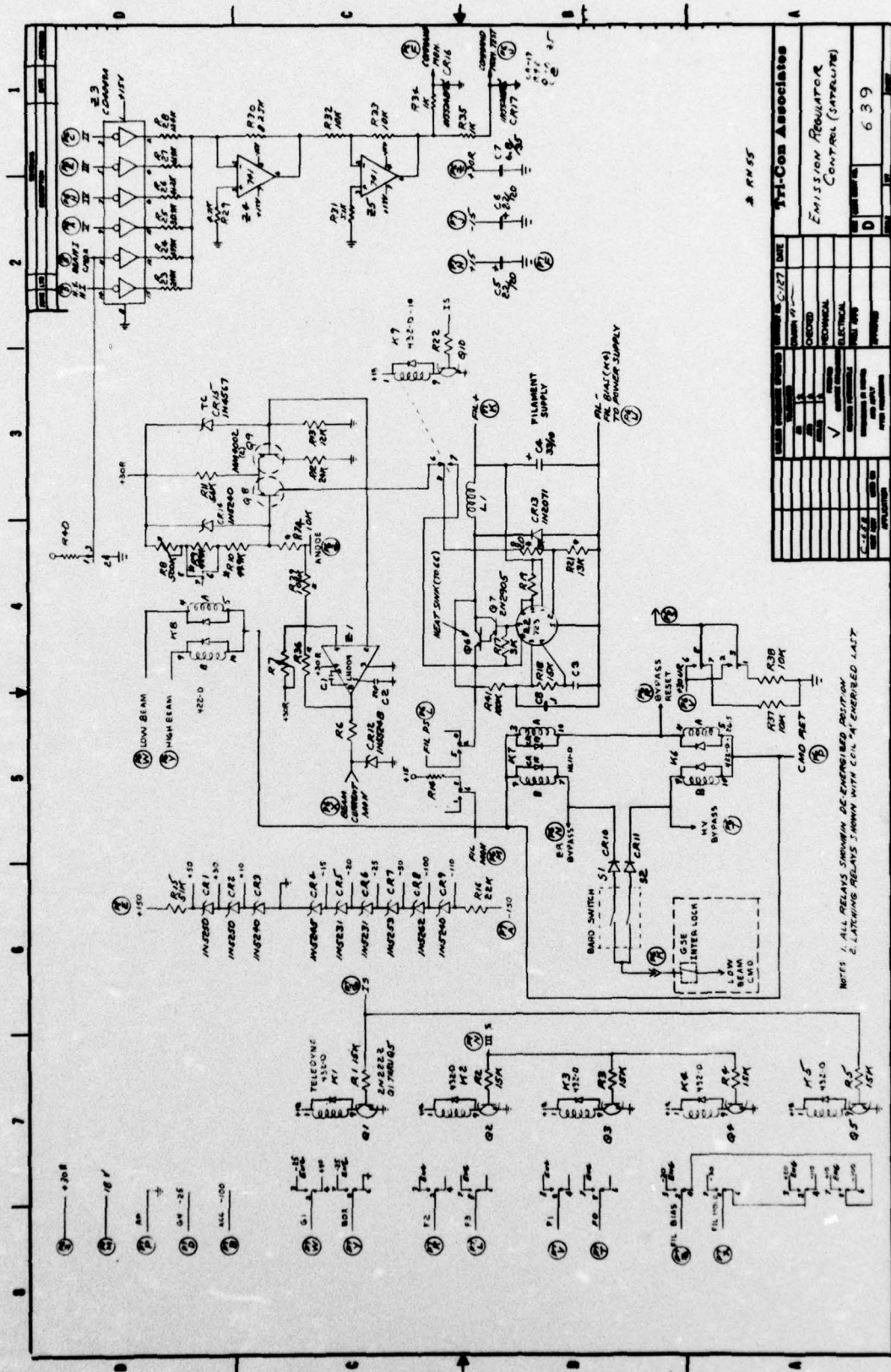

FIGURE I



Tri-Con Associates	
DATE	
DESIGNED BY	
CHECKED BY	
MECHANICAL	
ELECTRICAL	
TESTING	
APPROVED BY	
APPROVED DATE	
PROJECT NO.	865
REV.	0



Tri-Con Associates	
EMISSION REGULATOR CONTROL (SATellite)	
DATE	10/1/55
DRAWING NO.	639
REV.	
DESIGNED BY	
CHECKED BY	
APPROVED BY	
TESTED BY	
REVISIONS	
NO.	DESCRIPTION
1	REVISION
2	REVISION
3	REVISION
4	REVISION
5	REVISION
6	REVISION
7	REVISION
8	REVISION
9	REVISION
10	REVISION

NOTES: 1. ALL RELAYS SHOWN IN ENERGIZED POSITION.
2. LATCHING RELAYS SHOWN WITH COIL IN ENERGIZED STATE.

p.20

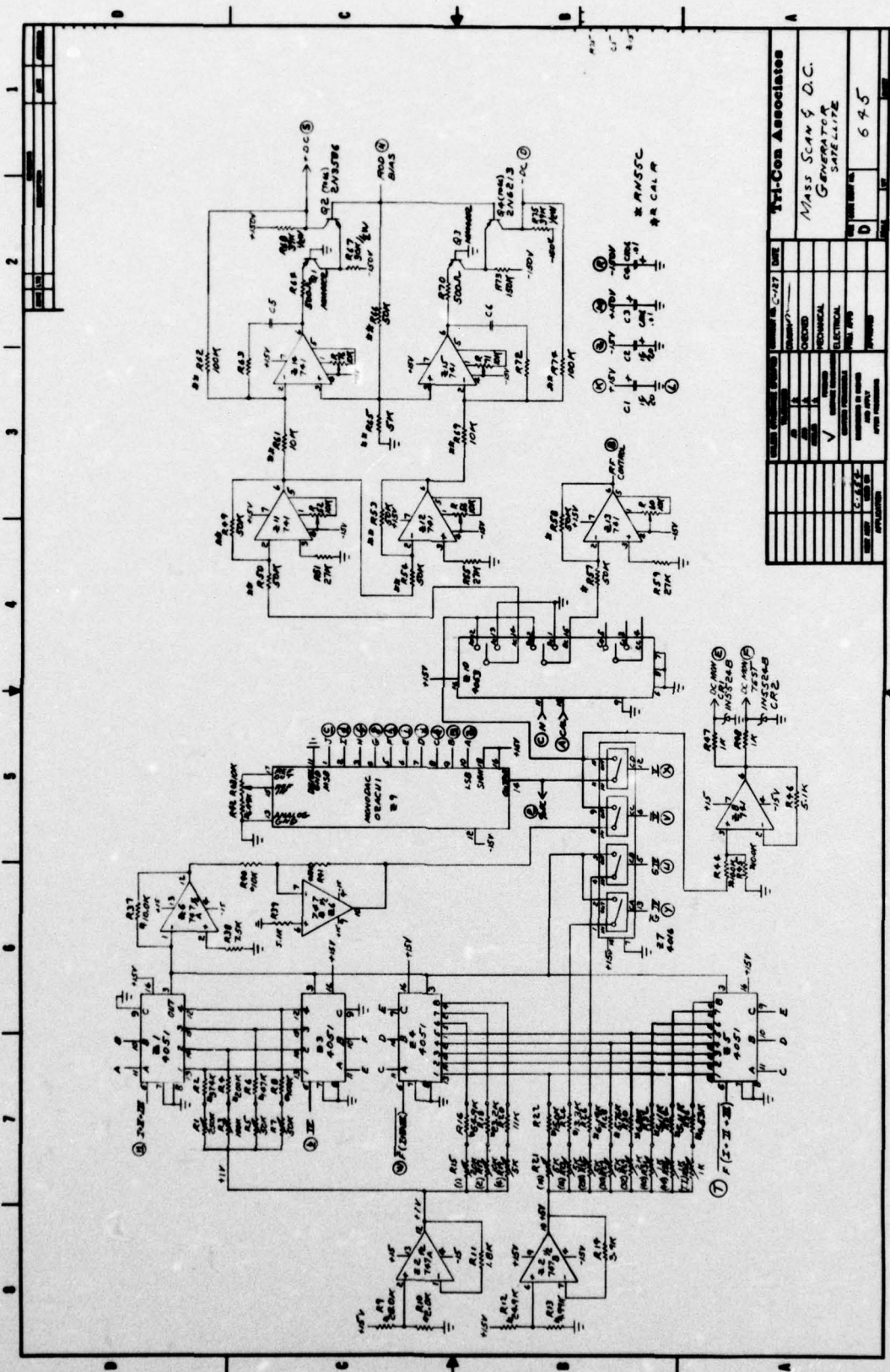

Tri-Con Associates MASS SCAN & D. C. GENERATOR SATELLITE	
DESIGNED BY: [] CHECKED BY: [] DRAWN BY: [] DATE: []	PROJECT NO.: [] SHEET NO.: [] TOTAL SHEETS: []
APPROVED BY: [] TITLE: []	DATE: [] TIME: []

p. 21

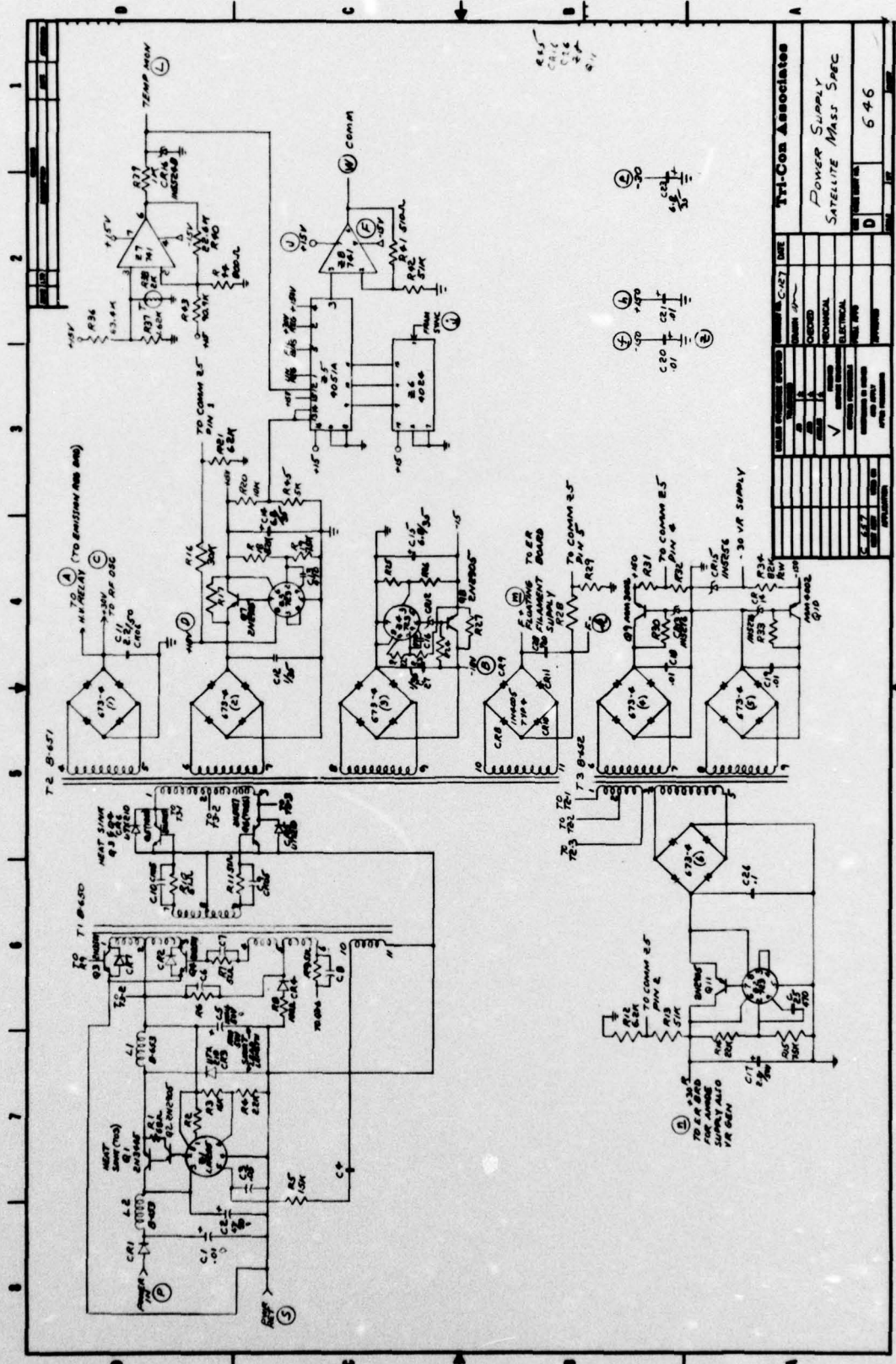

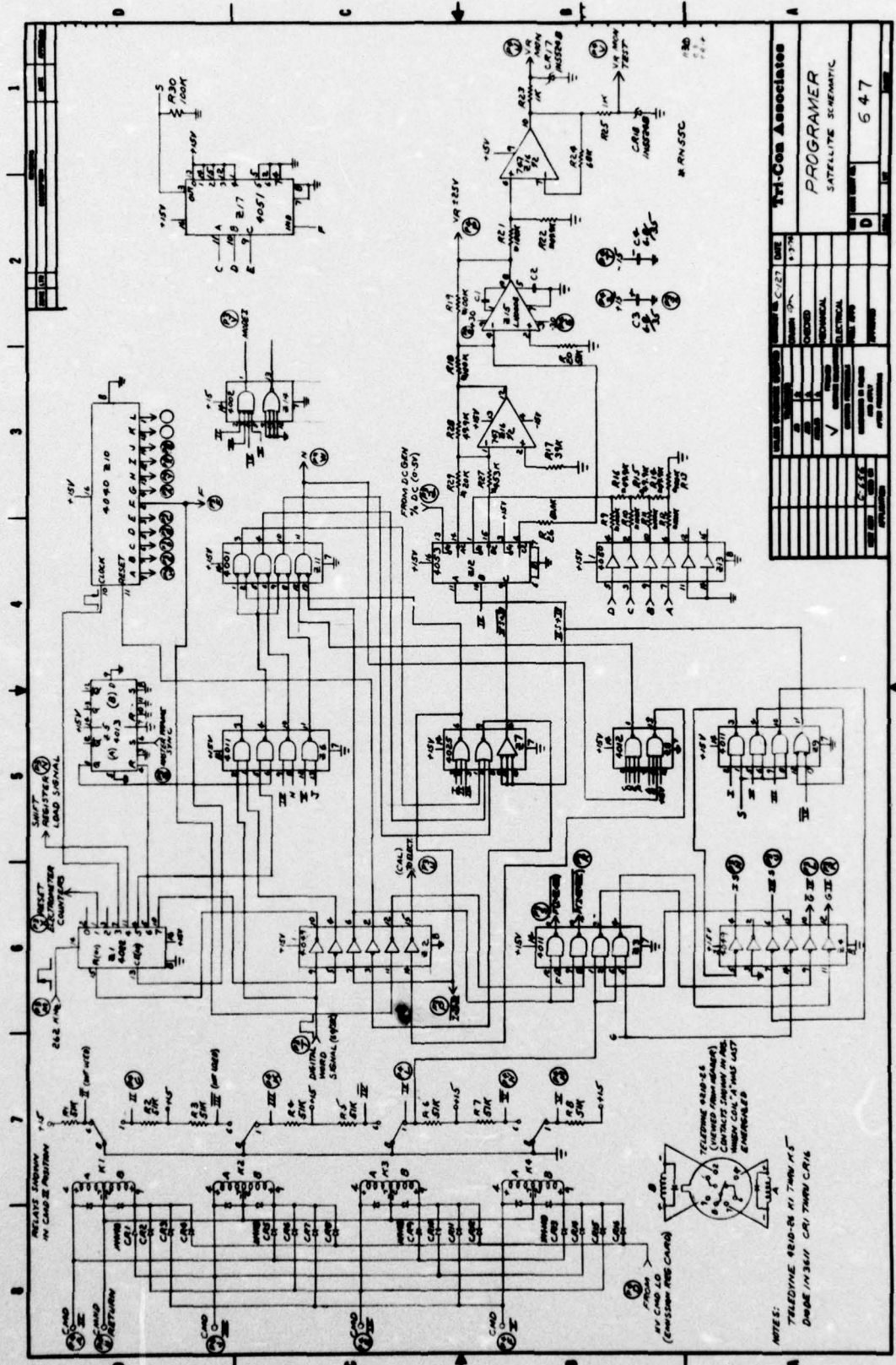

Tri-Con Associates	
PROJECT NO.	647
DATE	8-74
DESIGNED BY	W. J. ...
CHECKED BY	...
APPROVED BY	...
SCALE	...
REVISIONS	...
NO.	DESCRIPTION
1	...
2	...
3	...
4	...
5	...
6	...
7	...
8	...
9	...
10	...
11	...
12	...
13	...
14	...
15	...
16	...
17	...
18	...
19	...
20	...
21	...
22	...
23	...
24	...
25	...
26	...
27	...
28	...
29	...
30	...
31	...
32	...
33	...
34	...
35	...
36	...
37	...
38	...
39	...
40	...
41	...
42	...
43	...
44	...
45	...
46	...
47	...
48	...
49	...
50	...
51	...
52	...
53	...
54	...
55	...
56	...
57	...
58	...
59	...
60	...
61	...
62	...
63	...
64	...
65	...
66	...
67	...
68	...
69	...
70	...
71	...
72	...
73	...
74	...
75	...
76	...
77	...
78	...
79	...
80	...
81	...
82	...
83	...
84	...
85	...
86	...
87	...
88	...
89	...
90	...
91	...
92	...
93	...
94	...
95	...
96	...
97	...
98	...
99	...
100	...

p. 23

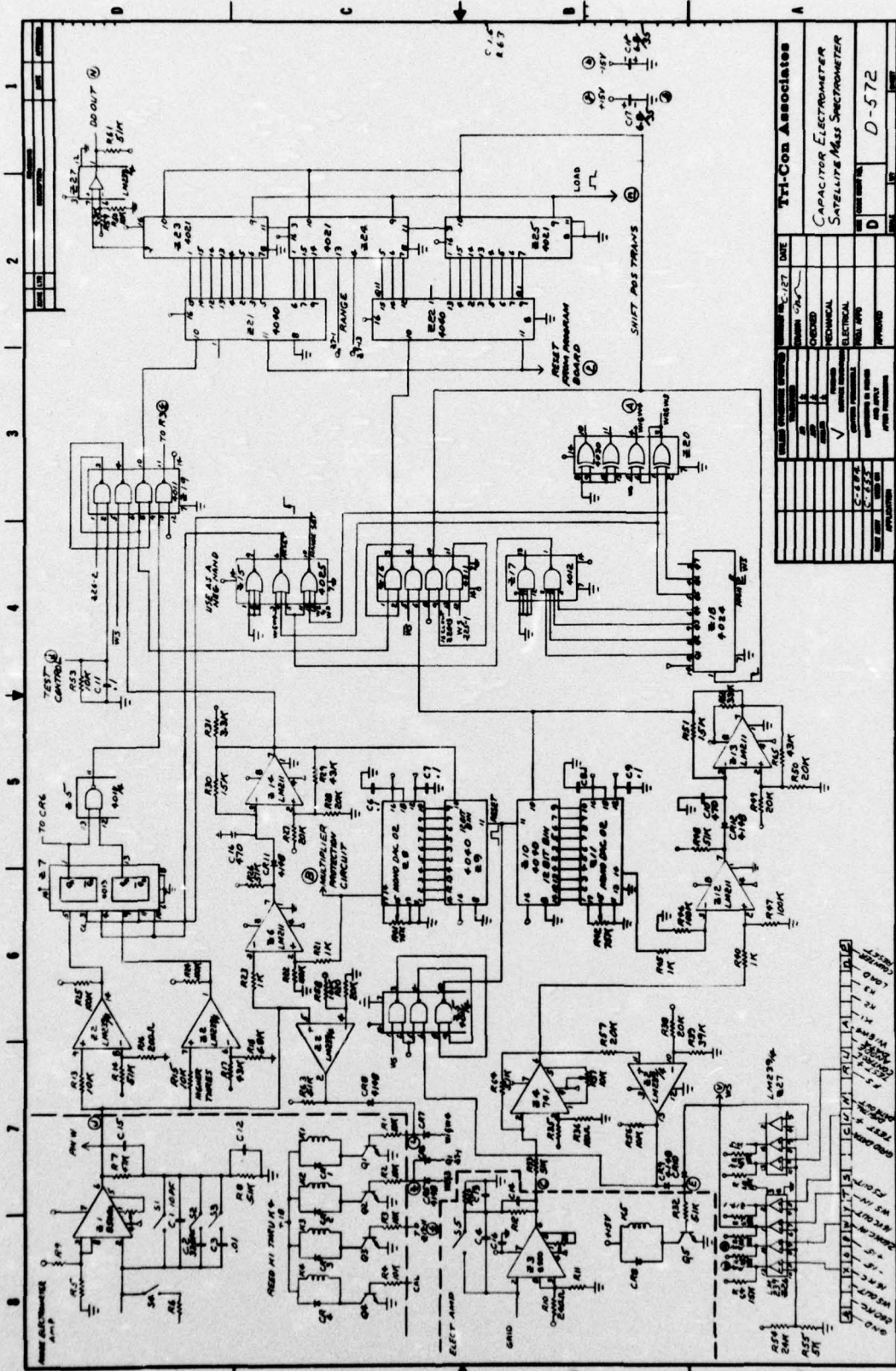

DESIGN REVISIONS		DATE
1	DESIGN	11-15-67
2	CHECKED	
3	MECHANICAL	
4	ELECTRICAL	
5	ASSEMBLY	
6	TESTING	
7	PRODUCTION	

DESIGNED BY	DATE
CHECKED BY	
MECHANICAL BY	
ELECTRICAL BY	
ASSEMBLY BY	
TESTING BY	
PRODUCTION BY	

Tri-Con Associates	
CAPACITOR ELECTROMETER	
SATELLITE MASS SPECTROMETER	
UNIT COST EST. NO.	D
UNIT COST EST. DATE	D-572

p.24

1	2	3	4
REVISION	DESCRIPTION	DATE	APPROVED

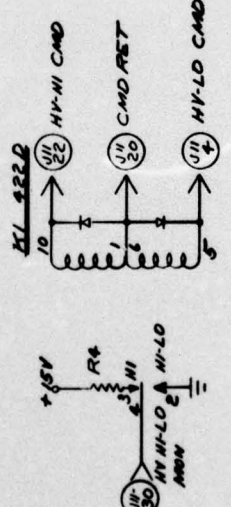
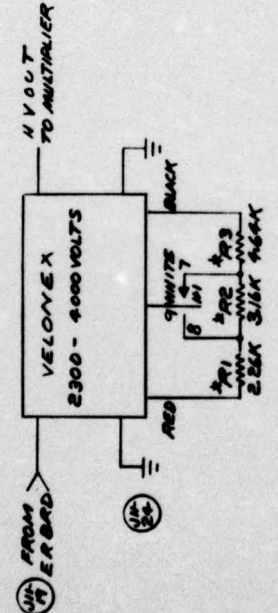
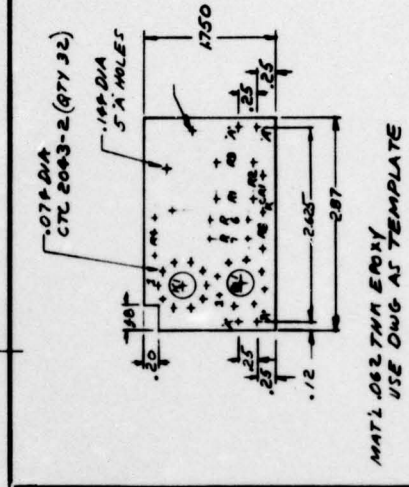
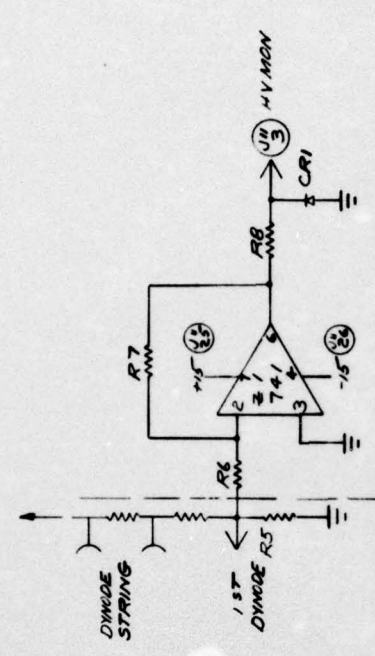

* RNS5

TTL-Con Associates	
HIGH VOLTAGE SATELLITE SCHEMATIC	
DATE	673
DESIGNER	
CHECKED	
MECHANICAL	
ELECTRICAL	
APPROVED	
DATE	
APPRECIATION	

p. 25

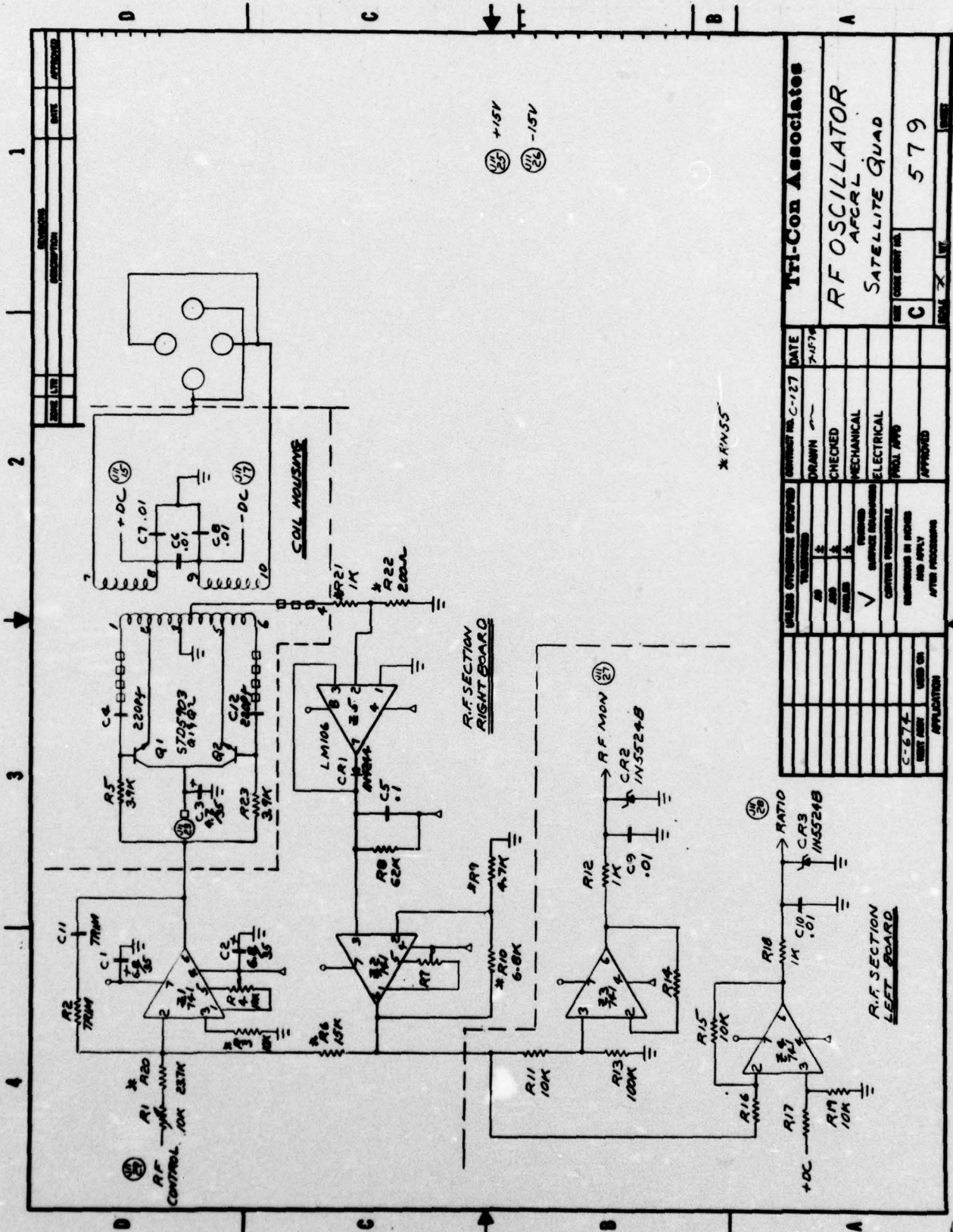

REV. NO.	DESCRIPTION	DATE	APPROVED

TTI-Con Associates		DATE	7-15-76
RF OSCILLATOR		DESIGNER	
SATELLITE QUAD		CHECKED	
		MECHANICAL	
		ELECTRICAL	
		PROD. APPR.	
		APPROVED	
		REVISIONS IN RECORDS	
		AND APPLY	
		AFTER PROCEEDING	
		APPLICATION	
		TEST APP.	
		USED ON	
		C-574	
		FORM NO. 1	
		579	

OK
OK
OK
OK
OK

CMD RET	1
PRD ON	2
PRD OFF	3
PRD MAN	4
RV ON	5
RV OFF	6
RV MAN	7
RF ON	8
RF OFF	9
+28 IN	10
PER RET	11
GND	12
+50	13
+15	14
-15	15
+5	16
+250	17
-250	18
	19
	20
	21
	22
	23
	24
	25

ALL RELAY MAN

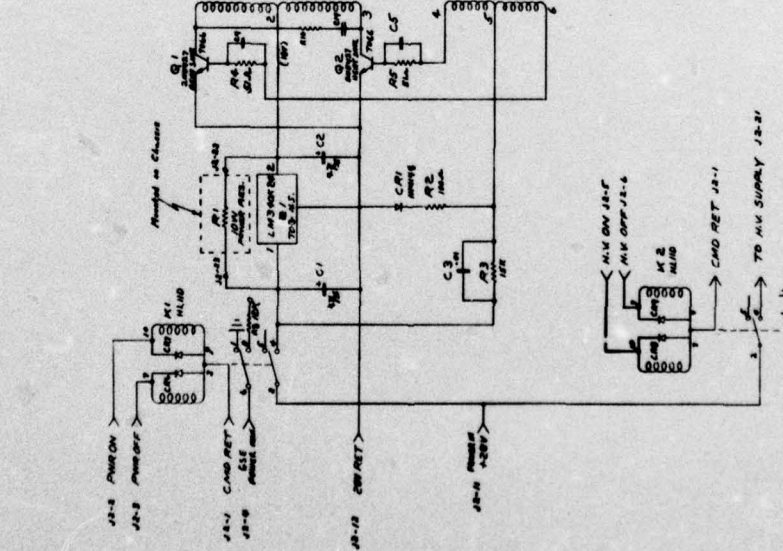
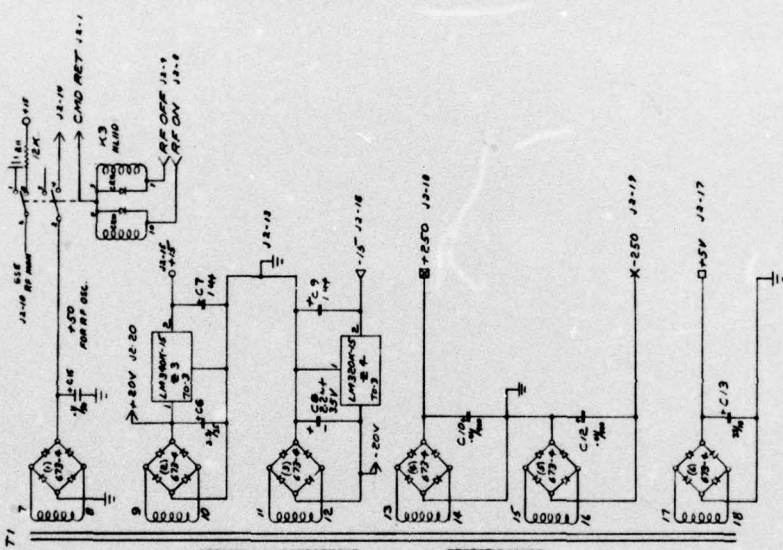

TTL-Con Associates	
POWER SUPPLY	
BALCON MASS SPEC	
D	683
REV	1
DATE	10-2-78
DESIGNED BY	
DRAWN BY	
CHECKED BY	
APPROVED BY	
COMPONENTS	
QUANTITY	
PRICE	
TOTAL	
REMARKS	
DATE ORDERED: 10-2-78	
QUANTITY: 1	
PRICE: \$100.00	
TOTAL: \$100.00	

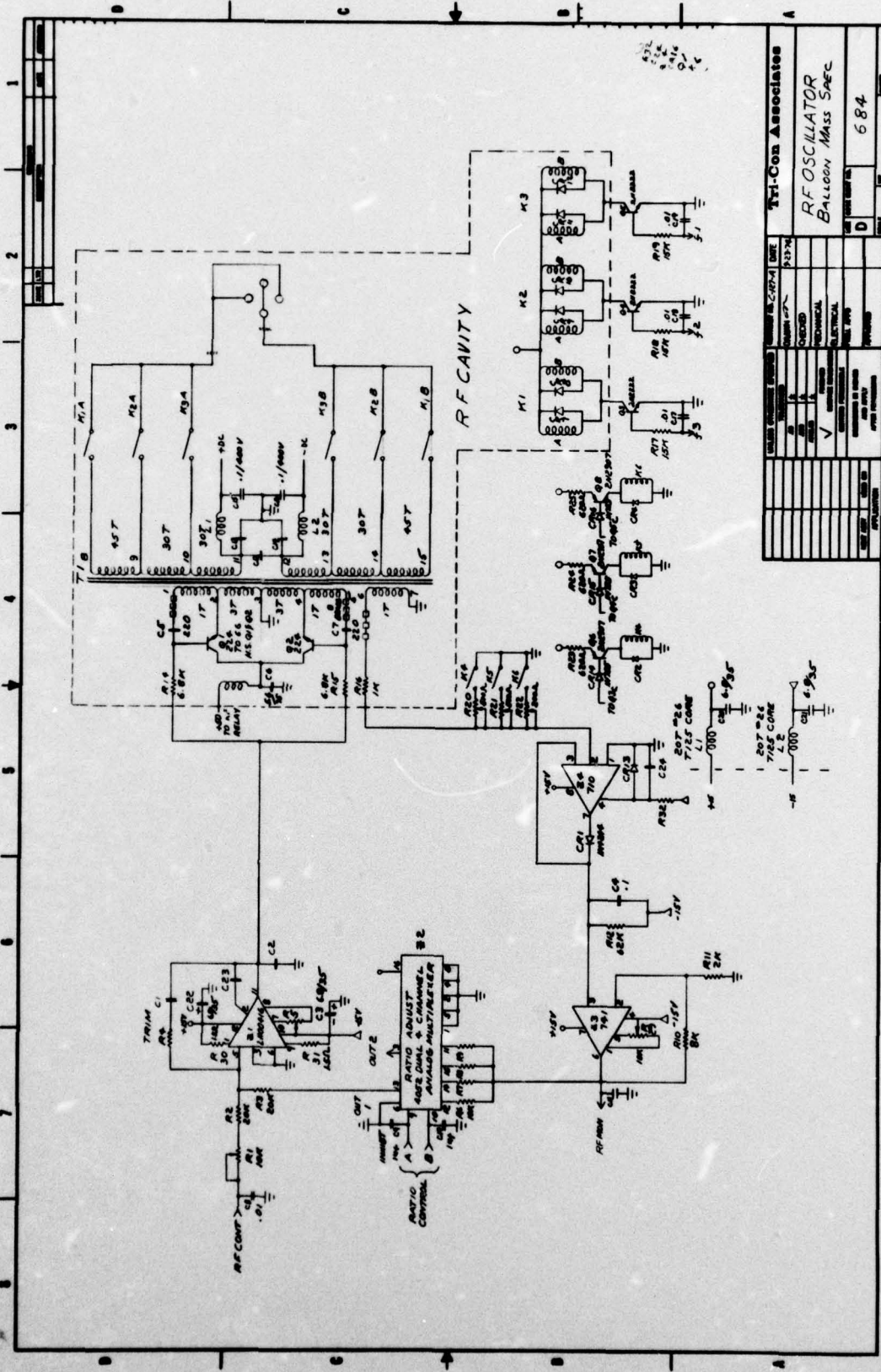

TEST POINTS		WAVEFORMS		MEASUREMENTS		EQUIPMENT	
1							
2							
3							
4							
5							
6							
7							
8							
9							
10							
11							
12							
13							
14							
15							
16							
17							
18							
19							
20							
21							
22							
23							
24							
25							
26							
27							
28							
29							
30							
31							
32							
33							
34							
35							
36							
37							
38							
39							
40							
41							
42							
43							
44							
45							
46							
47							
48							
49							
50							
51							
52							
53							
54							
55							
56							
57							
58							
59							
60							
61							
62							
63							
64							
65							
66							
67							
68							
69							
70							
71							
72							
73							
74							
75							
76							
77							
78							
79							
80							
81							
82							
83							
84							
85							
86							
87							
88							
89							
90							
91							
92							
93							
94							
95							
96							
97							
98							
99							
100							

Tri-Con Associates
 RF OSCILLATOR
 BALLOON MASS SPEC

684

8.28

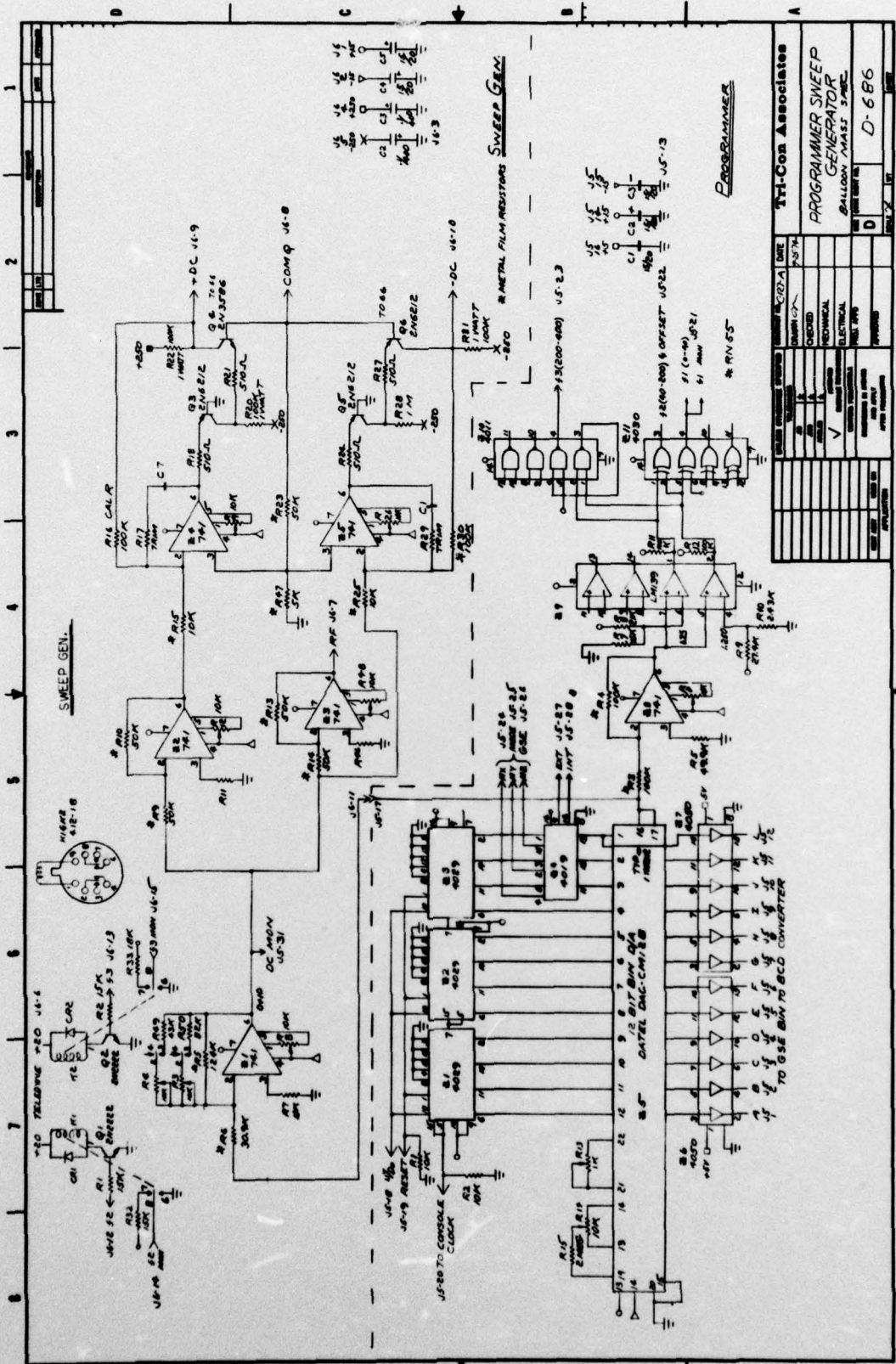

DATE	1-27-66
DESIGNED BY	J. L. WILSON
CHECKED BY	
APPROVED BY	
ELECTRICAL	
MECHANICAL	
PROGRAMMER	
TESTING	
REVISIONS	
REV	DESCRIPTION
1	INITIAL DESIGN
2	REVISED FOR PRODUCTION
3	REVISED FOR PRODUCTION
4	REVISED FOR PRODUCTION
5	REVISED FOR PRODUCTION
6	REVISED FOR PRODUCTION
7	REVISED FOR PRODUCTION
8	REVISED FOR PRODUCTION

Tri-Con Associates
PROGRAMMER SWEEP GENERATOR
BALLOON MASS 5-MFC
D-686

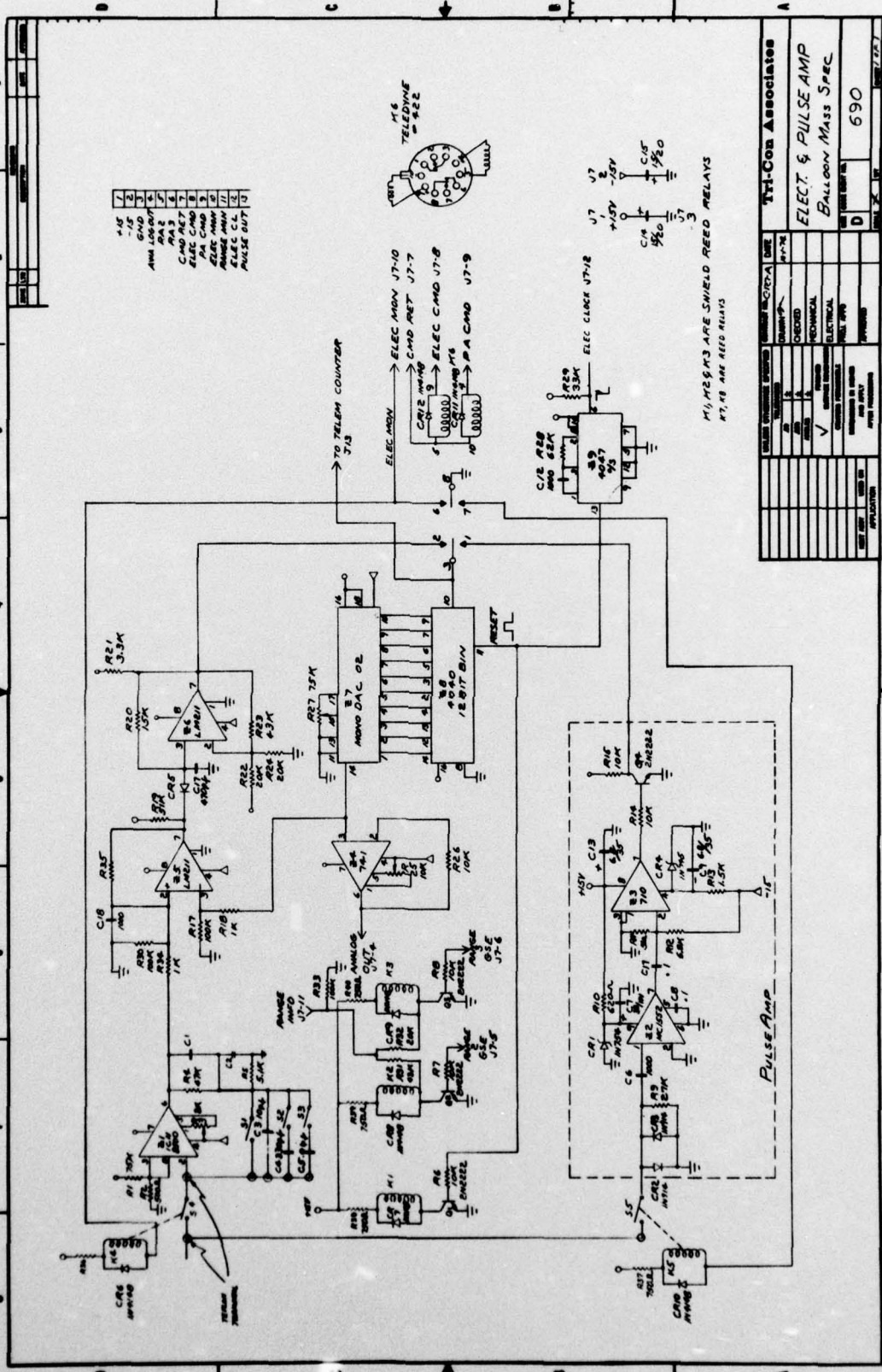

1	AM
2	15
3	GND
4	14
5	AM
6	AM
7	AM
8	AM
9	AM
10	AM
11	AM
12	AM
13	AM

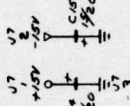
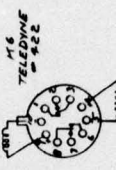

M1, M2, M3 ARE SHIELD REED RELAYS
M1, M2, M3 ARE REED RELAYS

TTL-CON Associates	
DATE	8-17-74
DESIGNED BY	...
CHECKED BY	...
REVISIONS	...
DESCRIPTION	ELECT. & PULSE AMP BALLOON MASS SPEC
QUANTITY	690

p. 30

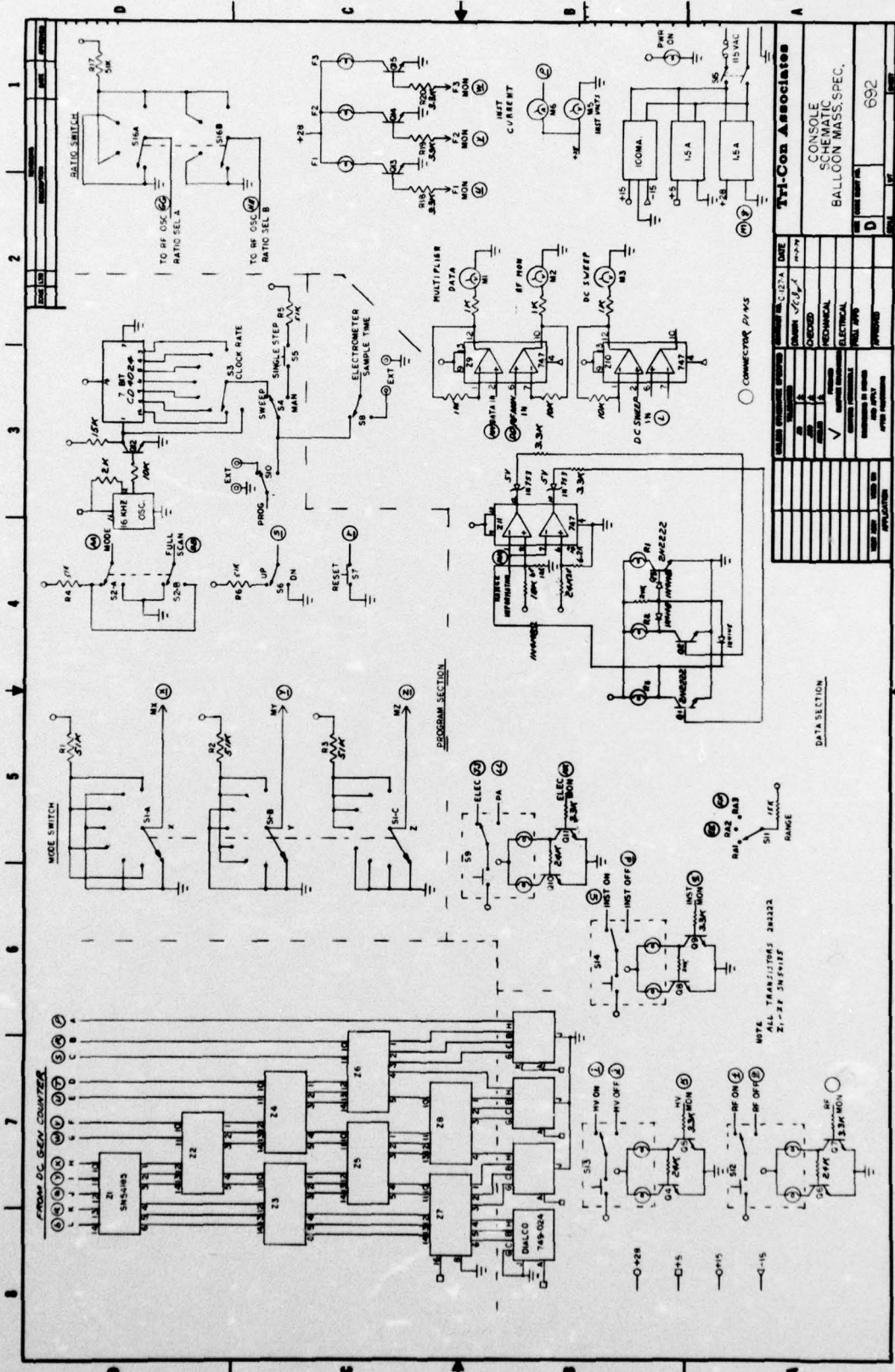

TTL-Con Associates	
DATE	10-27-62
DESIGNED BY	W.P.H.
CHECKED BY	
MECHANICAL	
ELECTRICAL	
APPROVED	
CONTRACT NO.	692
PROJECT	
REV.	

CONSOLE SCHEMATIC BALLOON MASS. SPEC.

692

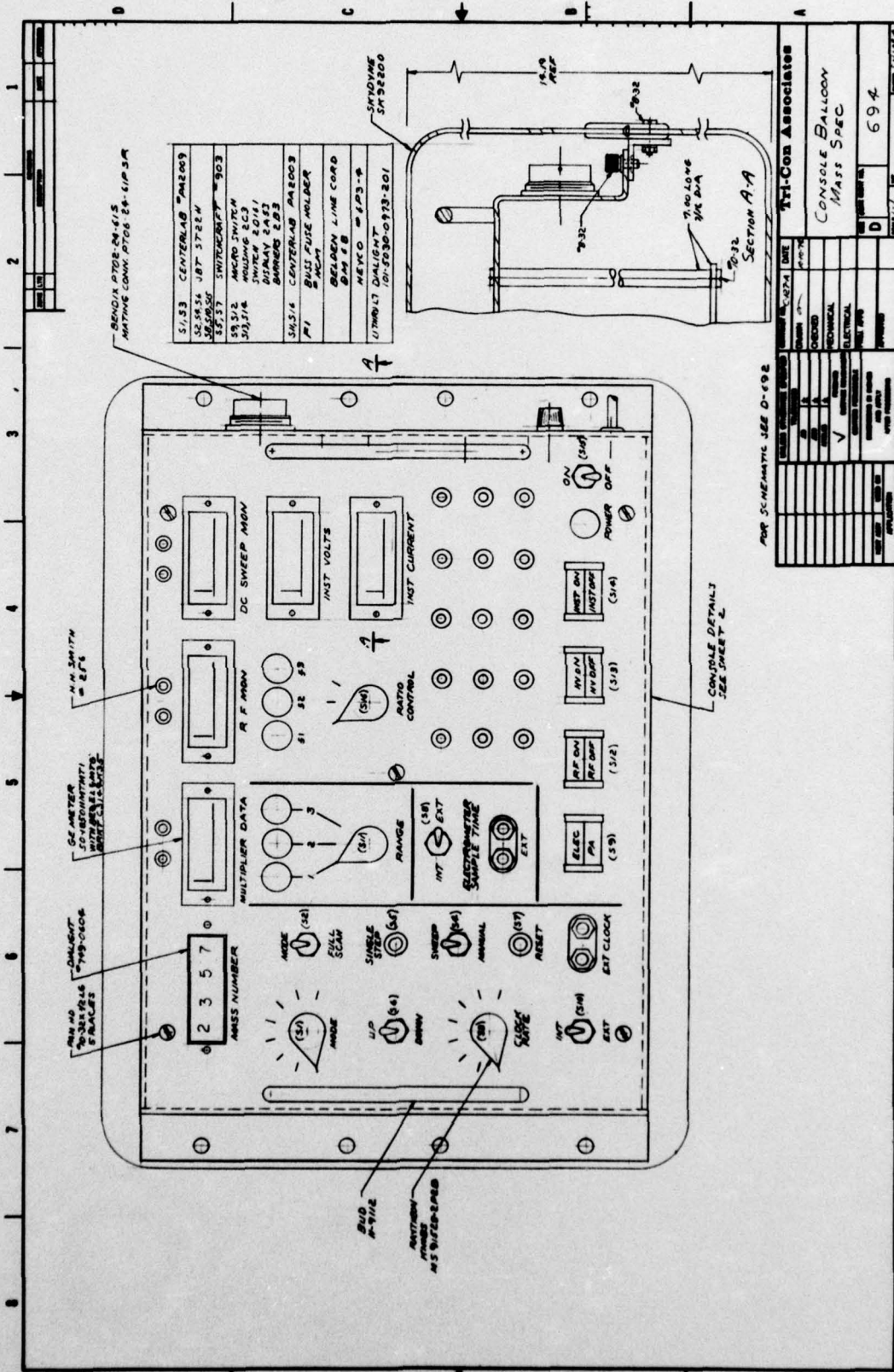

BENDIX P70E-24-615
MATING CONN. P706 28-61P3M

51/53	CENTERLAB	PAR009
52/54	187	5722M
53/55	SWITCH	903
54/56	MICRO SWITCH	
55/57	SHIMMING	2.0
56/58	DIMMAY	2A33
57/59	BARRERS	2.23
58/60	CENTERLAB	PAR003
59/61	BULLS FUSE HOLDER	
60/62	BEADEN LINE CORD	
61/63	MEVCO	5.293-9
62/64	1170AL7 DIALIGHT	
63/65	101-5030-0933-201	

Tri-Con Associates	
CONSOLE BALLOON MASS SPEC	
DATE	11-27-74
DESIGNED BY	W. J. H.
CHECKED BY	
APPROVED BY	
SCALE	
PROJECT NO.	694
REV.	
BY	
DATE	
DESCRIPTION	

FOR SCHEMATIC SEE D-692

CONSOLE DETAILS
SEE SHEET 2

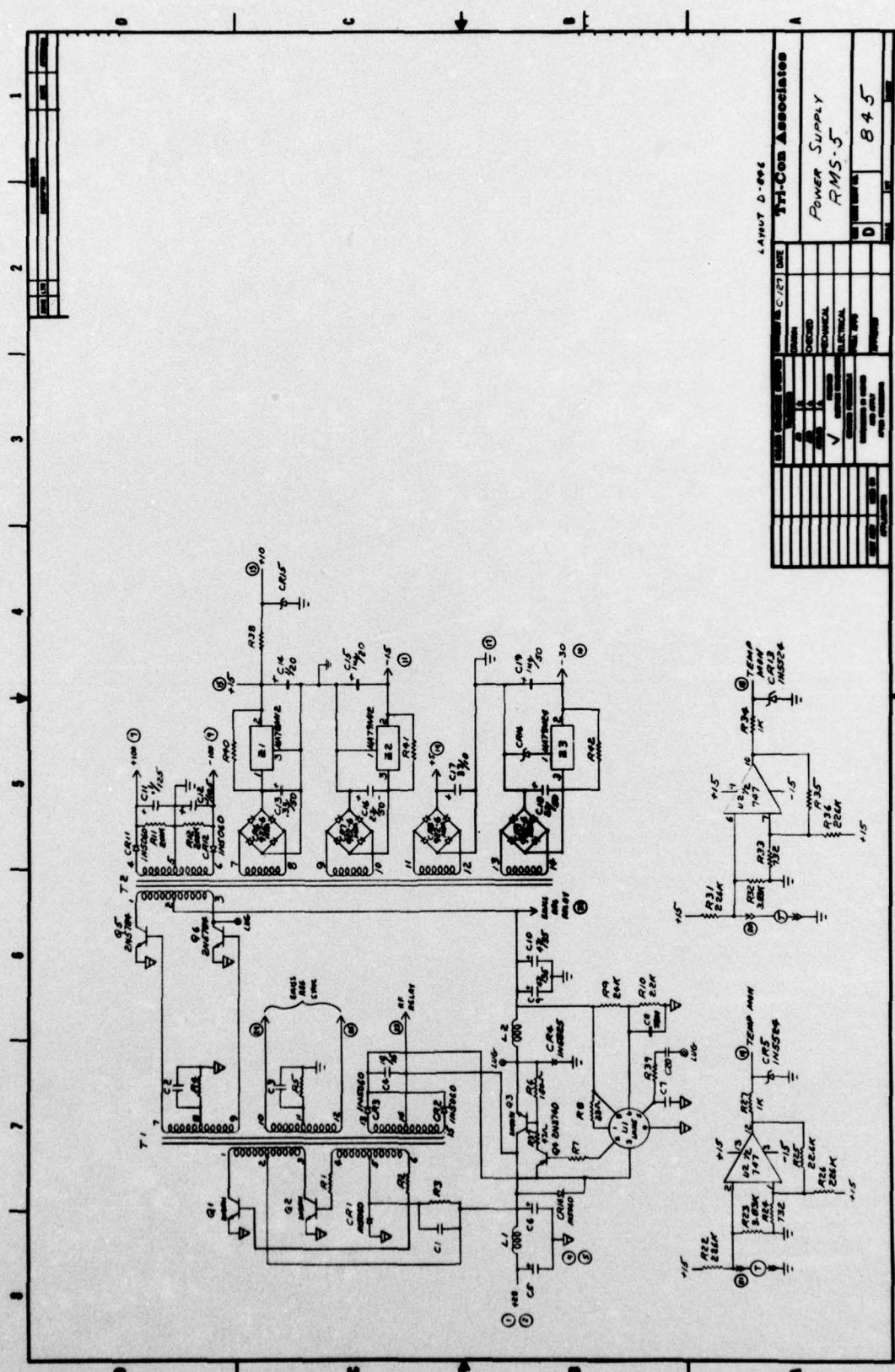

LAYOUT D-996

TyI-Con Associates

POWER SUPPLY
RMS-5

845

NO.	REV.	DATE	BY	CHK.	APP.
1					
2					
3					
4					
5					
6					
7					
8					
9					
10					
11					
12					
13					
14					
15					
16					
17					
18					
19					
20					

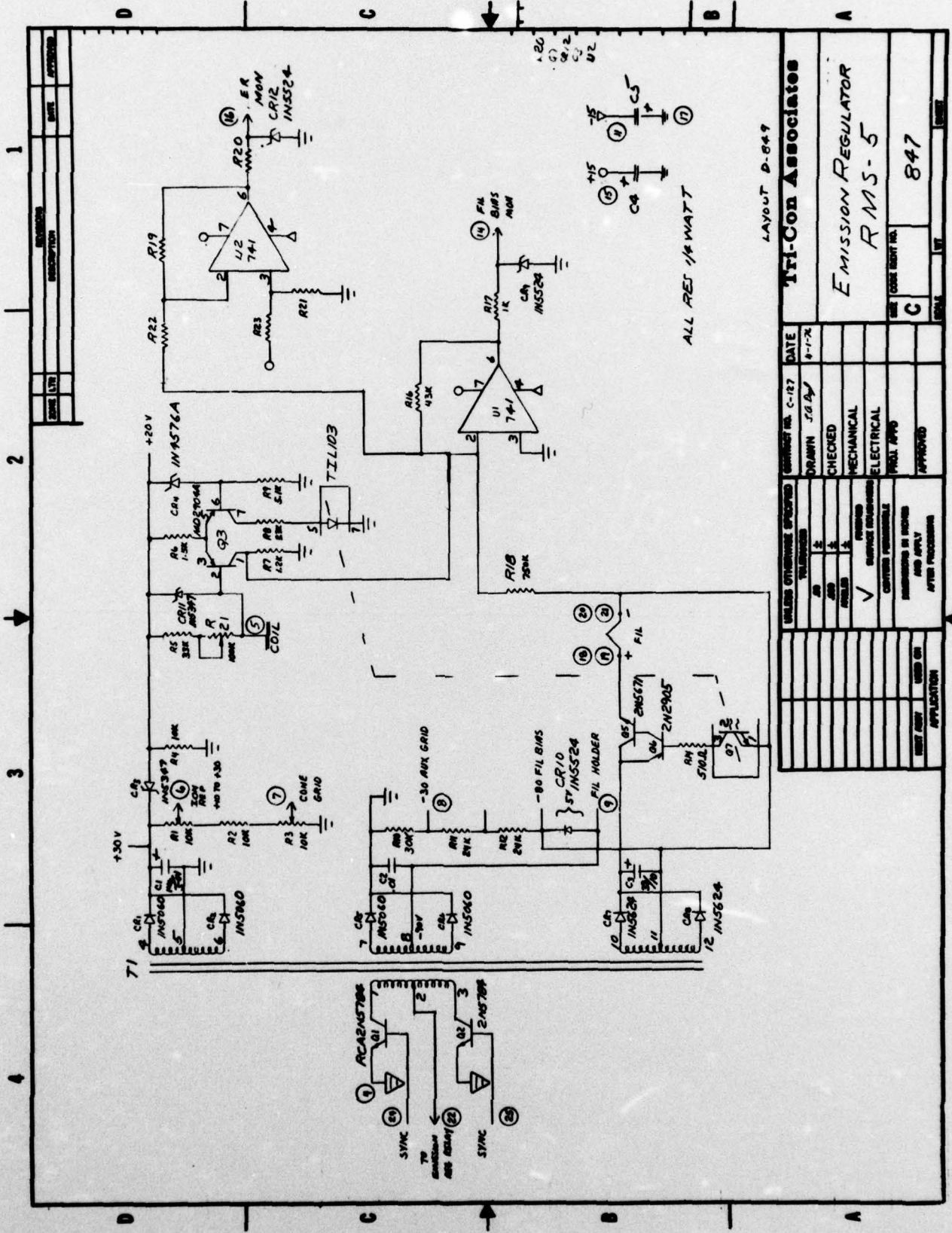

p.34

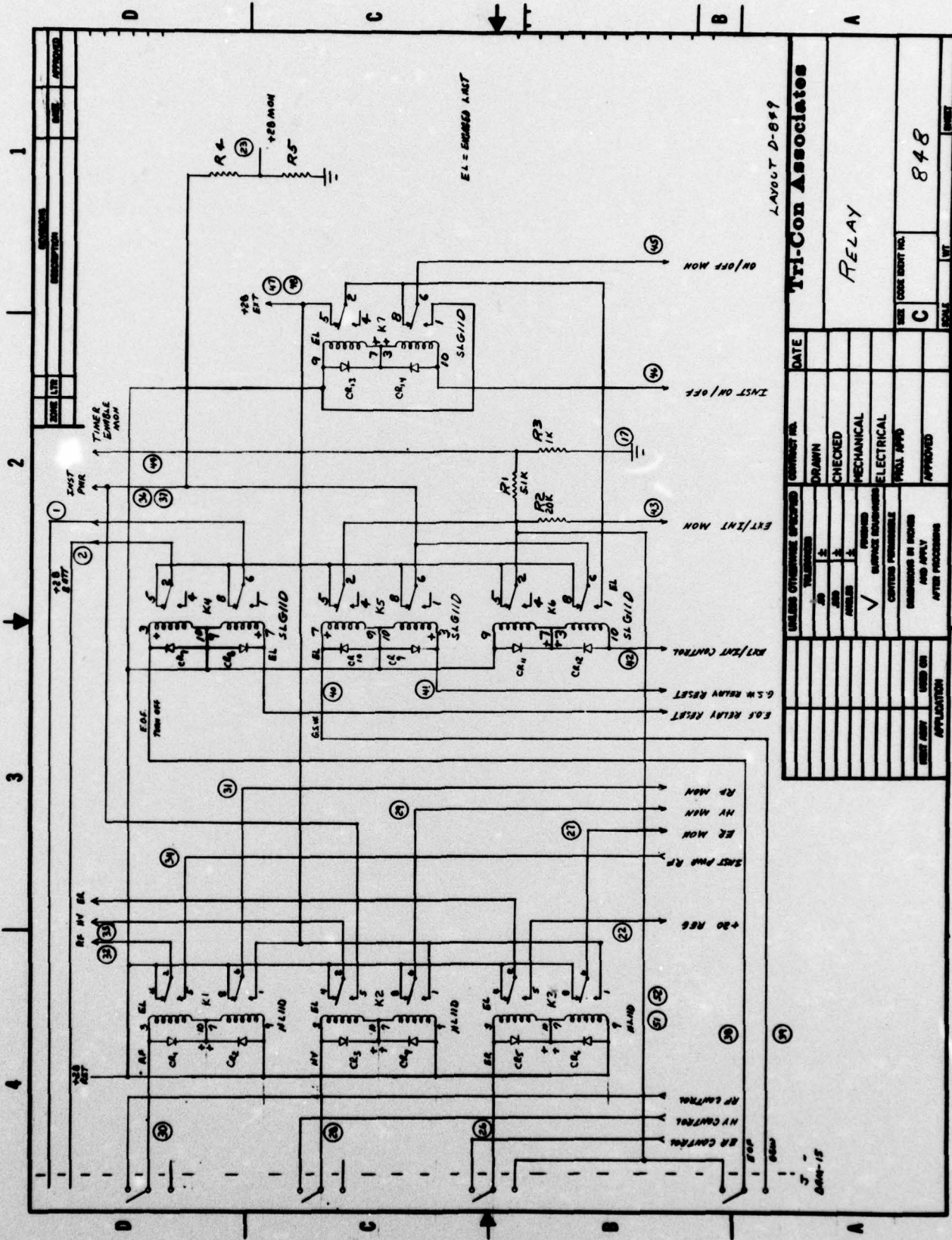

LAVOUT D-899

Tri-Con Associates	
RELAY	
DATE	SEE CODE BOOK NO. 848
DESIGNED BY	DATE
DRAWN BY	DATE
CHECKED BY	DATE
MECHANICAL BY	DATE
ELECTRICAL BY	DATE
TESTED BY	DATE
APPROVED BY	DATE
REVISIONS	DESCRIPTION
1	INITIALS
2	DATE
3	DATE
4	DATE
5	DATE
6	DATE
7	DATE
8	DATE
9	DATE
10	DATE
11	DATE
12	DATE
13	DATE
14	DATE
15	DATE
16	DATE
17	DATE
18	DATE
19	DATE
20	DATE
21	DATE
22	DATE
23	DATE
24	DATE
25	DATE
26	DATE
27	DATE
28	DATE
29	DATE
30	DATE
31	DATE
32	DATE
33	DATE
34	DATE
35	DATE
36	DATE
37	DATE
38	DATE
39	DATE
40	DATE
41	DATE
42	DATE
43	DATE
44	DATE
45	DATE
46	DATE
47	DATE
48	DATE
49	DATE
50	DATE
51	DATE
52	DATE
53	DATE
54	DATE
55	DATE
56	DATE
57	DATE
58	DATE
59	DATE
60	DATE
61	DATE
62	DATE
63	DATE
64	DATE
65	DATE
66	DATE
67	DATE
68	DATE
69	DATE
70	DATE
71	DATE
72	DATE
73	DATE
74	DATE
75	DATE
76	DATE
77	DATE
78	DATE
79	DATE
80	DATE
81	DATE
82	DATE
83	DATE
84	DATE
85	DATE
86	DATE
87	DATE
88	DATE
89	DATE
90	DATE
91	DATE
92	DATE
93	DATE
94	DATE
95	DATE
96	DATE
97	DATE
98	DATE
99	DATE
100	DATE

p.35

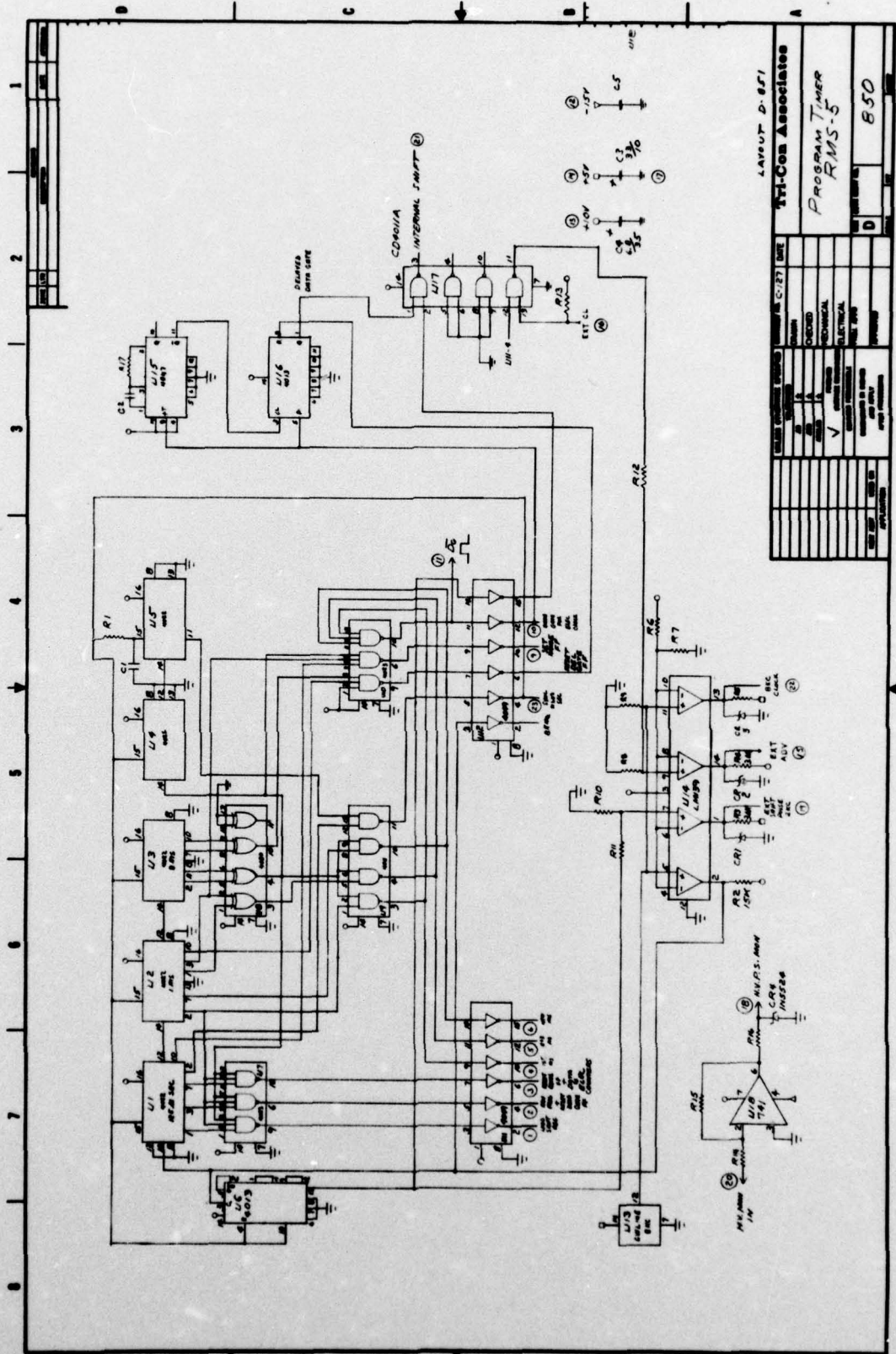

TTL-COR ASSOCIATES

PROGRAM TIMER
RMS-5

E50

DESIGNED BY	DATE
CHECKED BY	
APPROVED BY	
TESTED BY	
REVISIONS	
NO.	DESCRIPTION
1	INITIAL DESIGN
2	REVISED
3	REVISED
4	REVISED
5	REVISED
6	REVISED
7	REVISED
8	REVISED
9	REVISED
10	REVISED
11	REVISED
12	REVISED
13	REVISED
14	REVISED
15	REVISED
16	REVISED
17	REVISED
18	REVISED
19	REVISED
20	REVISED
21	REVISED
22	REVISED
23	REVISED
24	REVISED
25	REVISED
26	REVISED
27	REVISED
28	REVISED
29	REVISED
30	REVISED
31	REVISED
32	REVISED
33	REVISED
34	REVISED
35	REVISED
36	REVISED
37	REVISED
38	REVISED
39	REVISED
40	REVISED
41	REVISED
42	REVISED
43	REVISED
44	REVISED
45	REVISED
46	REVISED
47	REVISED
48	REVISED
49	REVISED
50	REVISED

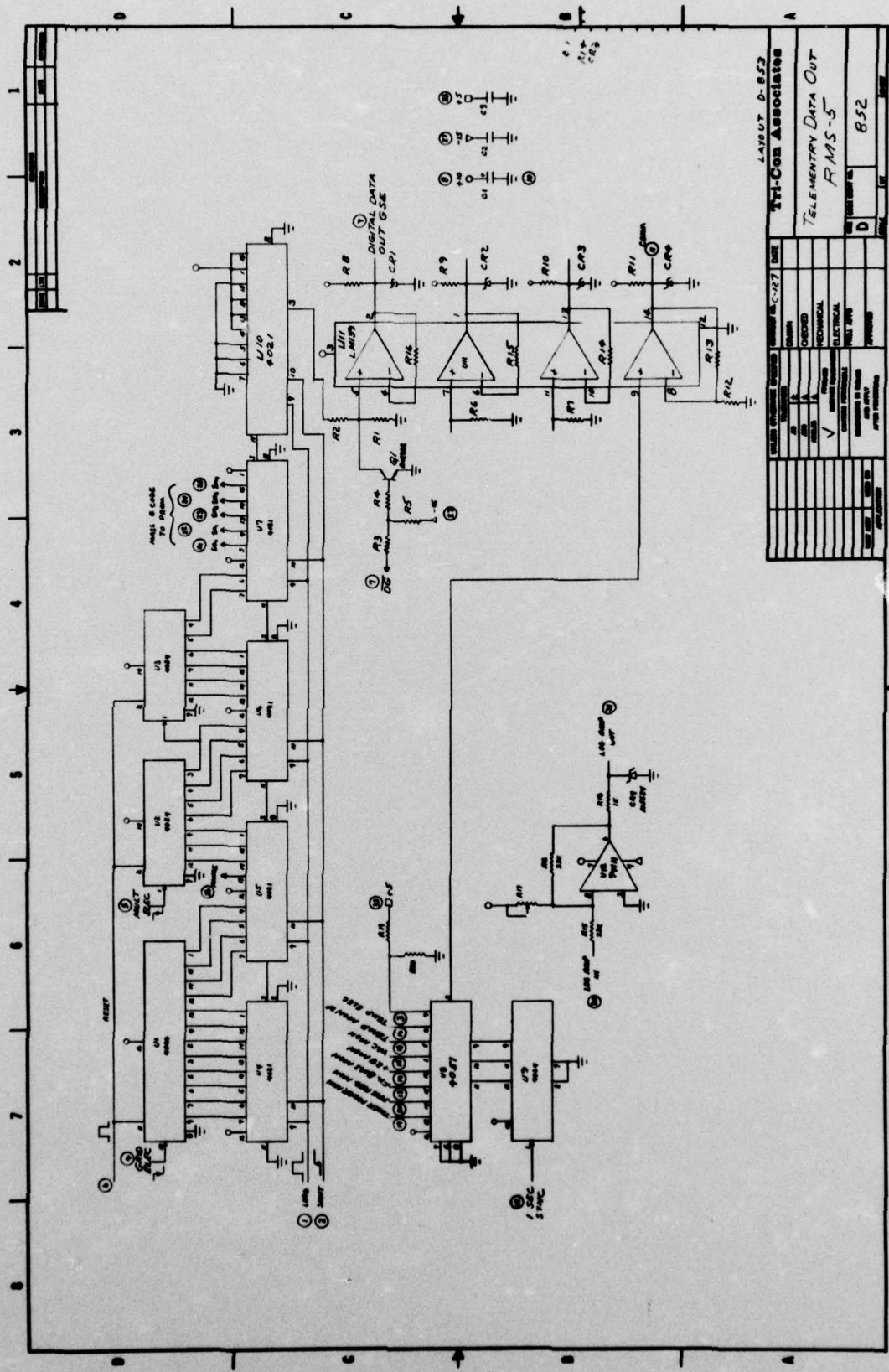

LAYOUT D-853
Tri-Coa Associates

DESIGNED BY	DATE
CHECKED BY	
APPROVED BY	
TESTED BY	
REVISIONS	
NO. OF SHEETS	852
TELEMETRY DATA OUT RMS-5	

p.37

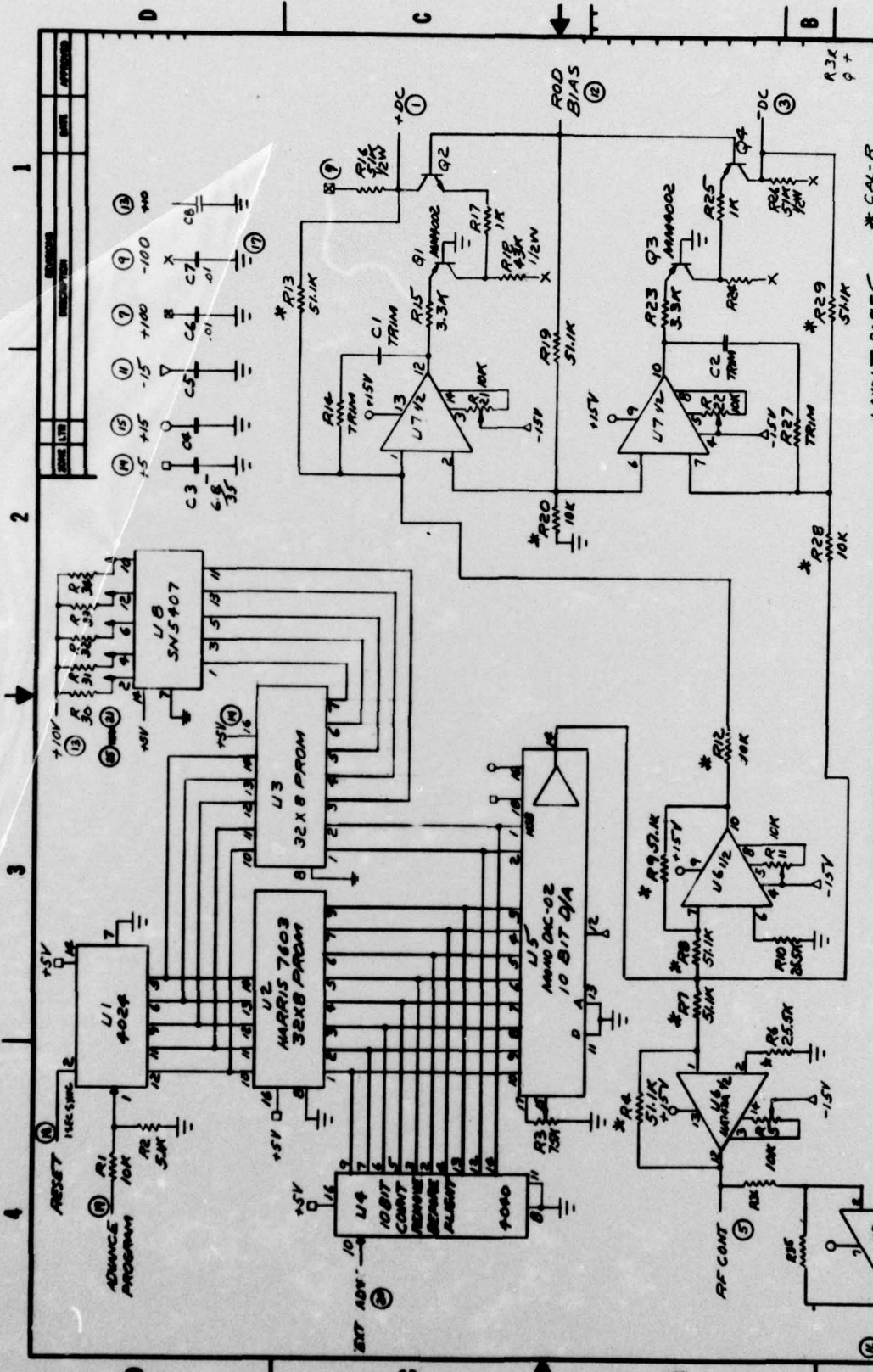

SIZE	UNIT	DESCRIPTION	QTY	REMARKS
100	Ω	R1, R2, R3, R4, R5, R6, R7, R8, R9, R10, R11, R12, R13, R14, R15, R16, R17, R18, R19, R20, R21, R22, R23, R24, R25, R26, R27, R28, R29		
100	μF	C1, C2, C3, C4, C5, C6, C7		

LAYOUT D-855 * CAL-R	
DESIGN NO.	C-127
DATE	9-9-76
DRAWN BY	MECHANICAL
CHECKED	ELECTRICAL
MECHANICAL	PROJ. ENG.
ELECTRICAL	APPROVED
PROJ. ENG.	
APPROVED	
DESIGNED BY	
CHECKED BY	
DATE	
SCALE	
VT	
854	

SWEEP GENERATOR
RMS-5

6-38

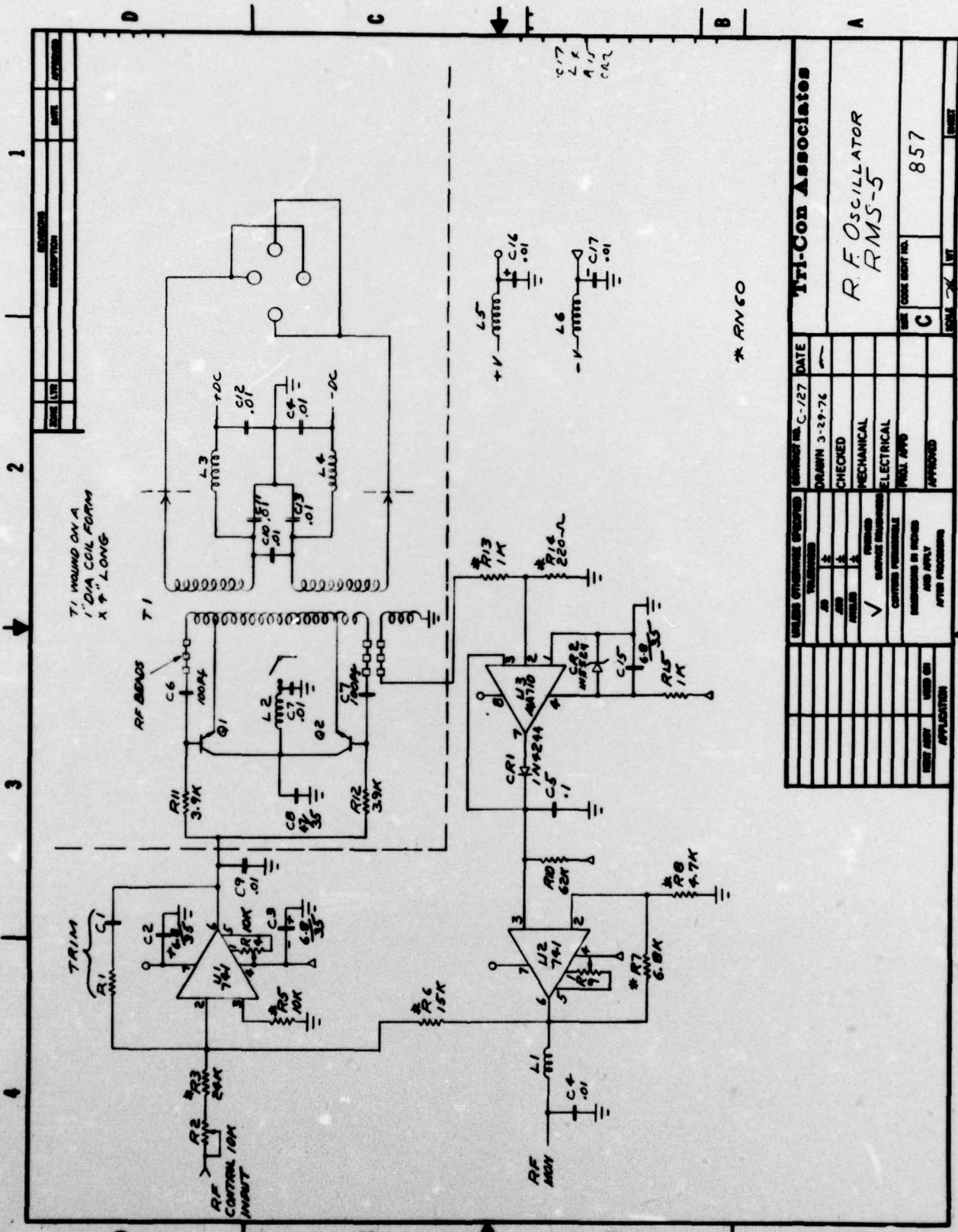

REV	DESCRIPTION	DATE	BY

TTI-Con Associates R.F. OSCILLATOR RMS-5	
ORDER NO. C-127 DRAWN 3-29-76 CHECKED MECHANICAL ELECTRICAL FINAL APP'D APPROVED	DATE
PART NO. C REV. 1 QTY. 1	WORK ORDER NO. 857 SHEET 1

p.40

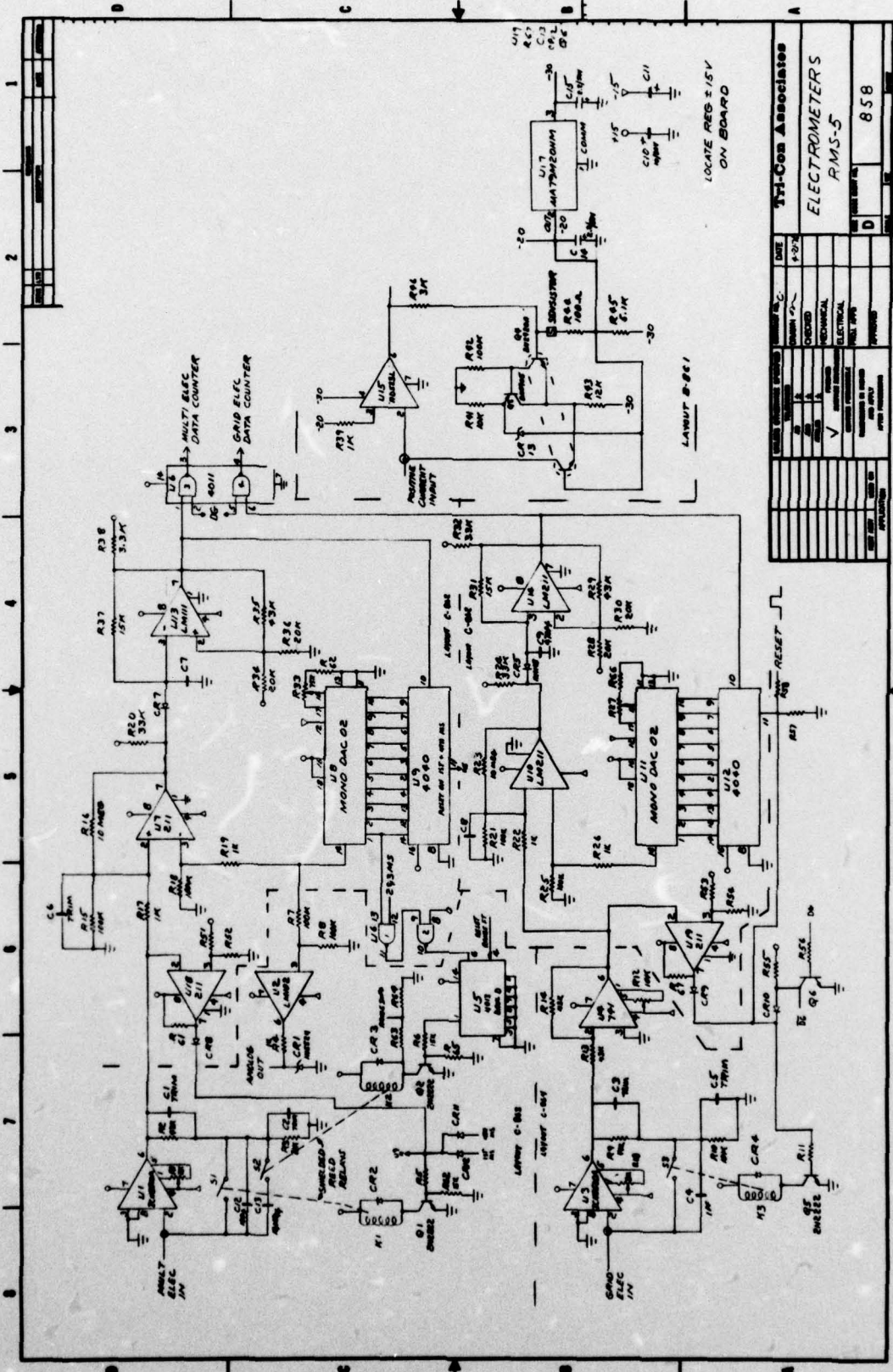

THI-Con Associates	
ELECTROMETERS	
RMS-5	
DATE	8 58
DESIGNED BY	
CHECKED BY	
MECHANICAL	
ELECTRICAL	
TEST DATA	
REVISIONS	
NO.	
DATE	
BY	
REASON	