

**U.S. DEPARTMENT OF COMMERCE  
National Technical Information Service**

**AD-A034 269**

**GAME WARDEN**

**CENTER FOR NAVAL ANALYSES, ARLINGTON, VIRGINIA**

**JANUARY 1976**

ADA 034269

CRC 284



**GAME WARDEN**

**CENTER FOR NAVAL ANALYSES**

1401 Wilson Boulevard  
Arlington, Virginia 22209

**Operations Evaluation Group**

**January 1976**

By: VICTORY DANIELS, JUDITH C. ERDHEIM

*Approved for public release; distribution unlimited.*

Prepared for:

**OFFICE OF NAVAL RESEARCH**  
Department of the Navy  
Arlington, Virginia 22217

**OFFICE OF THE CHIEF OF NAVAL OPERATIONS (Op03)**  
Department of the Navy  
Washington, D.C. 20350

**D D C**  
**RECEIVED**  
JAN 14 1977  
**REGULATORY**  
**C**

## THE OPERATIONS EVALUATION GROUP OF THE CENTER FOR NAVAL ANALYSES

The Operations Evaluation Group is charged with increasing the peacetime and wartime effectiveness of the Navy through operations research. It engages in studies dealing with current and near-future problems in tactics, strategy, logistics, force composition, and weapons employment. OEG provides scientific analysts and field representatives to the divisions in the Office of the Chief of Naval Operations and to operating commands ashore and at sea.

OEG, the Institute of Naval Studies, the Naval Warfare Analysis Group, Marine Corps Operations Analysis Group, and Systems Evaluation Group are the operating divisions of the Center for Naval Analyses. CNA conducts operations and systems research for the Chief of Naval Operations, the Commandant of the Marine Corps, and certain fleet and force commanders. CNA provides advice on operational problems susceptible of quantitative analysis, including the evaluation of new weapons, operational techniques, tactics, formulations of new requirements, technical aspects of strategic planning, and correlation of research and development programs with Navy and Marine Corps needs.

OEG publishes three principal types of reports of its research, in addition to many memoranda of limited distribution:

- A *Study* is a complete, self-substantiating analysis that provides the Navy with a quantitative basis for executive decisions or for recommendations to higher authority. Studies are endorsed by CNA and the operating division releasing the study, and represent the point of view held by CNA at the time of issue.
- A *Summary Report* is a resume of research originally published in another form. Summary Reports present results only, without substantiating analysis, and are designed for general information.
- A *Research Contribution* may be originated by any member of CNA when, in the opinion of the director of the issuing division, the subject is of interest to workers in operations research or in the author's own field. Research Contributions are also issued to increase the availability of analytical work performed in support of CNA research.

100-300000-1

SEARCHED	INDEXED
SERIALIZED	FILED
MAR 1964	
NAVY	
OPERATIONS RESEARCH	
CNA	

1

SECURITY CLASSIFICATION OF THIS PAGE (When Data Entered)

REPORT DOCUMENTATION PAGE		READ INSTRUCTIONS BEFORE COMPLETING FORM
1. REPORT NUMBER: CRC 284	2. GOVT ACCESSION NO.	3. RECIPIENT'S CATALOG NUMBER
4. TITLE (and Subtitle)  Game Warden	5. TYPE OF REPORT & PERIOD COVERED	
	6. PERFORMING ORG. REPORT NUMBER	
7. AUTHOR(s)  Victory Daniels, Judith C. Erdheim	8. CONTRACT OR GRANT NUMBER(s)  N00014-76-C-0001	
9. PERFORMING ORGANIZATION NAME AND ADDRESS Center for Naval Analyses 1401 Wilson Boulevard Arlington, Virginia 22209	10. PROGRAM ELEMENT, PROJECT, TASK AREA & WORK UNIT NUMBERS	
11. CONTROLLING OFFICE NAME AND ADDRESS Office of Naval Research Department of the Navy Arlington, Virginia 22217	12. REPORT DATE January 1976	
	13. NUMBER OF PAGES 176	
14. MONITORING AGENCY NAME & ADDRESS (if different from Controlling Office) Office of the Chief of Naval Operations (Op03) Department of the Navy Washington, D.C. 20350	15. SECURITY CLASS. (of this report)  Unclassified	
	15a. DECLASSIFICATION/DOWNGRADING SCHEDULE	
16. DISTRIBUTION STATEMENT (of this Report) Approved for public release; distribution unlimited.		
17. DISTRIBUTION STATEMENT (of the abstract entered in Block 20, if different from Report)		
18. SUPPLEMENTARY NOTES This Research Contribution does not necessarily represent the opinion of the Department of the Navy.		
19. KEY WORDS (Continue on reverse side if necessary and identify by block number) deltas, GAME WARDEN, infiltration (personnel), logistics, Mekong Delta, Naval operations, Navy, operation, operations, riverine warfare, rivers, South Vietnam, traffic, Vietnam, warfare		
20. ABSTRACT (Continue on reverse side if necessary and identify by block number) Game Warden, the U.S. Navy/Vietnamese Navy river patrol operation conducted in South Vietnam's Delta Region, is described. Enemy resupply and logistic routes and infiltration options are examined. Game Warden's response to the threat and limitations of that response are discussed.		

DD FORM 1473  
1 JAN 73

EDITION OF 1 NOV 65 IS OBSOLETE.  
S/N 0102-014-6601

SECURITY CLASSIFICATION OF THIS PAGE (When Data Entered)

1a

## TABLE OF CONTENTS

	Page
Foreword .....	iii
Introduction .....	1
Summary .....	3
Conclusions .....	5
Background .....	7
Mekong Delta and the RSSZ .....	7
Nature of the threat .....	9
U. S. Navy interdiction efforts .....	12
Setting up the operation--December 1965 through September 1968 .....	15
Acquisition of assets and bases .....	15
Coordination within TF 116 and with other commands .....	18
PBR operational tactics and techniques .....	20
Psychological operations .....	24
Game Warden in the RSSZ .....	26
Game Warden in the Mekong Delta .....	30
The situation in October 1968 .....	37
Appendix A - Distribution of enemy supplies to III and IV Corps .....	A-1 - A-12
Appendix B - VC/NVA base areas and Order of Battle in SVN .....	B-1 - B-4
Appendix C - Other military and quasimilitary forces operating in the Delta and RSSZ.....	C-1 - C-3
Appendix D - Game Warden task organization .....	D-1 - D-10
Appendix E - Characteristics of Game Warden assets .....	E-1 - E-4
Appendix F - Force levels.....	F-1 - F-4
Appendix G - Rules of engagement .....	G-1 - G-9
Appendix H - Mekong River merchant ship smuggling .....	H-1 - H-2
Appendix I - Game Warden chronology .....	I-1 - I-15
Appendix J - Bibliography (bound in separate volume)	

## FOREWORD

In addition to the documents listed in the bibliography, appendix J, this research contribution is based on: command histories; NavForV in-house working papers, memoranda, and drafts of briefings and studies; interviews; and information provided by the Central Intelligence Agency (CIA) and the Defense Intelligence Agency (DIA).

Appendix J has been bound separately and is available to qualified requestors. Requests should be addressed as follows:

Center for Naval Analyses  
1401 Wilson Boulevard  
Arlington, Virginia 22209

Attn: Management Information Office

Most of this information (except that provided by the intelligence agencies) can be found in the Vietnam Command Files and the NavForV Provenance Files at the Naval History Division Archives. The authors express their appreciation to Oscar Fitzgerald of the Naval History Division for his patience and help in using these files. The authors, of course, assume full responsibility for their interpretations of these documents.

## INTRODUCTION

Game Warden was the U.S. Navy/Vietnamese Navy (VNN) operation established in December 1965 to deny enemy movement and resupply on the major rivers of the Mekong Delta and the Rung Sat Special Zone (RSSZ) in South Vietnam (SVN). The U.S. considered river control to be an essential element in the overall plan to pacify SVN.

This research contribution examines the threat in the Mekong Delta and the RSSZ, specifically on the rivers. Game Warden's response to the threat and limitations on that response are discussed, and enemy resupply needs, logistic routes, and infiltration options are examined. Game Warden's full effect on the enemy remains unknown, but changing trends in his use of Delta and RSSZ waterways are noted.

The Game Warden concept was expanded with the beginning of Sea Lords in October 1968. Sea Lords is beyond the scope of this report, and the discussion of Game Warden in the Delta and the RSSZ ends with September 1968.

Figure 1 shows some of the key geographical locations highlighted in this report.

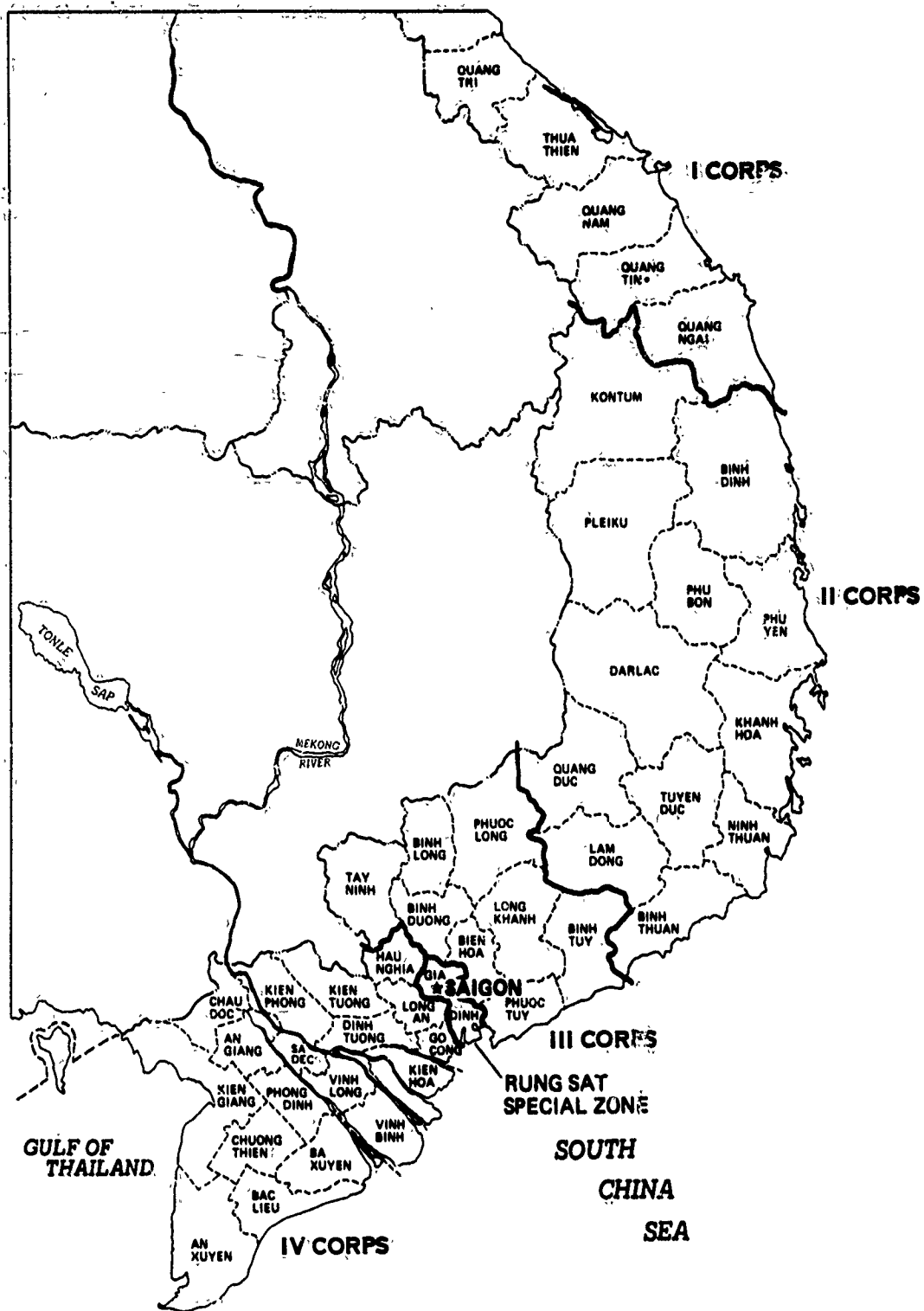

FIG. 1: SOUTH VIETNAM



## SUMMARY

During the early 1960s, the Viet Cong (VC) in southern SVN successfully undermined the SVN government's attempts to develop a sense of national responsibility among the population. Much of the southern half of the country--III and IV Corps<sup>1</sup>--was under VC control. But to maintain and increase this control, the VC had to infiltrate war materials into SVN.

Through the early part of 1965, the U.S. Military Assistance Command, Vietnam (MACV), considered the sea to be the main infiltration resupply route to southern SVN. Even before the major U.S. commitment in SVN in 1965, Cambodia was suspected to be a link in the resupply chain. There was, however, a question concerning the emphasis the communists placed on infiltrating supplies from Cambodia in relation to the emphasis on seaborne infiltration.

Before 1963, the Mekong/Bassac River complex was the major route from Cambodia to SVN used by the enemy for resupply. By 1966, additional enemy crossing points were located on the Cambodian/SVN border, and there were implications of high-level Cambodian military or government complicity in supplying the VC. MACV noted that Cambodia was the only area bordering SVN that could harbor communist forces with no threat of being countered by U.S. military action. Supplies from Cambodia were brought into SVN by inland waterways and overland routes.

Until 1966, the VC openly transited the major rivers of southern SVN and taxed the local population. The insurgents' use of the rivers for logistical movement was thought to be generally cross-stream rather than along-stream, especially in the lower Delta provinces fronting on the South China Sea. Lines of communication connecting VC base areas ran across major rivers. Near the Cambodian border, though, there was more along-stream traffic.

SVN military and civilian control of land, sea, and inland waterway routes was inadequate; the VNN River Force was particularly ineffective. Its main function was to furnish waterborne deployments and support for SVN army operations. But river patrol was given a low priority; consequently, the VNN River Force had inadequate resources with which to develop a significant capability for such patrols.

---

<sup>1</sup>To avoid confusion with the VC system of military regions in SVN (MR-1, etc.), this report uses the older designation of "Corps areas" for allied operations--that is, I Corps, etc.

The U.S. Navy made its first large commitment in SVN in March 1965 with the establishment of Market Time, a U.S. Navy/VNN coastal surveillance operation. Market Time was to sea! off the SVN coast from infiltrators. By mid-1966, MACV discounted seaborne infiltration as a major, workable resupply method for the VC.

Game Warden was established in December 1965 as a joint U.S. Navy/VNN operation to deny enemy movement and resupply on the major rivers of the Mekong Delta and the RSSZ. The rivers in the upper Delta in SVN are the Mekong and the Bassac. In the lower Delta, the Mekong splits into 3 smaller branches; in the RSSZ, the Long Tau River was the major shipping channel to Saigon.

Game Warden assets included shallow-draft river patrol boats (PBRs), armed UH-1B helicopters, and, in the RSSZ, minesweeping boats (MSBs). PBRs and helicopters were based ashore or on bases afloat. Three of the afloat bases were tank landing ships (LSTs) stationed on the 3 major rivers of the lower Delta. PBRs operating from an LST or one of the other afloat bases were much more flexible in meeting the threat than were those operating from shore bases.

Game Warden river patrols enforced SVN curfews, interdicted some VC logistical and tactical movements, and succeeded in influencing some of the Delta population in formerly VC-controlled areas to support the SVN government. In the RSSZ, MSBs swept mines along the main shipping channels and prevented the VC from closing off these vital links to Saigon.

Game Warden forces in the Mekong Delta were originally intended to give about equal coverage to the major rivers. By mid-1967, units in the upper Delta had reported only light contact with the enemy and were repositioned to give maximum concentration of forces on the lower Delta rivers, where extensive VC activity had been noted.

By spring 1968, the enemy was infiltrating supplies over the Cambodian border with impunity. In response, PBRs were again deployed to the upper Delta. But in July, PBRs in the upper Delta were, once again, experiencing only light contact with the enemy.

Evidence used in the planning of Sea Lords later in 1968 showed that the enemy generally crossed the border by canals or overland routes between the Bassac River and the Gulf of Thailand, or to the north of the Mekong River. Although the VC may have used the major rivers to cross the border before then, they probably changed their route to avoid PBR patrols. In the lower Delta, however, the VC were forced to cross major rivers to supply their base areas in the provinces between the rivers.

The concept of a static barrier on the major rivers of the Delta and RSSZ proved inadequate by 1968, and the Game Warden concept was expanded when Sea Lords began in October 1968. Sea Lords was a Delta-wide operation coordinating the combined assets

of the River Patrol Force, and 2 other U.S. Navy in-country task forces, and U.S. and SVN ground forces. Sea Lords would continually harass VC strongholds and interdict supplies infiltrated from Cambodia. The first Sea Lords barriers were established on canals 35 to 40 st. mi. from and parallel to the Cambodian border.

## CONCLUSIONS

Until more information becomes available concerning Game Warden's effect on enemy operations, it is unlikely that its total impact can be assessed.

Some analysts have pointed to trends in the numbers of enemy incidents on the rivers as indicating areas that were critical supply routes for the enemy. But basing patrols on the frequency and intensity of contact with the enemy could be misleading. For example, the few PBRs deployed to the upper Delta experienced far fewer incidents than did those in the lower Delta. This could have signified heavier enemy concentrations in the lower Delta. However, the more intensive PBR coverage in the lower Delta and comparable enemy concentrations in both areas could have resulted in the greater number of incidents in the lower Delta.

Some conclusions, however, can be drawn from available intelligence, from assessments of Game Warden participants, and from an examination of the evolution of the operation:

- Game Warden interrupted enemy movement on traditional routes across the major Delta rivers.
- Enemy efforts to close the sea lanes to Saigon--a major VC objective--were denied by U.S. Navy/VNN forces.
- Game Warden secured many sections of the major Delta and RSSZ rivers for commercial use.
- Coordination between Game Warden and ground force operations was inadequate.
- The mobile afloat base concept provided flexibility to river boat operations, enabling river forces to respond to a continually changing threat.
- Curfews proved to be absolutely crucial to fulfilling Game Warden's mission.
- Helicopters were essential to riverine operations in fire support, observation, and medical evacuation.
- PBRs were adequate for patrols on large major rivers, but smaller waterways required more armor and armament.

● The young U. S. Navy officers and enlisted men assigned to river patrols performed aggressively and responsibly on their own initiative.

● The enemy proved to be flexible in adapting to Game Warden in the Delta by continually finding new routes for his supply lines.

## BACKGROUND

### MEKONG DELTA AND THE RSSZ

To understand the nature of the enemy that Game Warden had to deal with, it is important to first understand the environment in which he operated. The Mekong Delta is a vast lowland plain laced with an intricate and extensive waterway system (see figure 2). Most of the Delta is less than 10 feet above sea level. There are 2 major rivers in the upper Delta: the Mekong and Bassac. The Mekong in the lower Delta has 3 branches: the Co Chien Ham Luong, and My Tho. The Delta is also veined with thousands of canals, streams, and ditches.

The wet season lasts from mid-May to early October because of the southwest monsoon, and the dry season lasts from November through mid-March during the northeast monsoon. During the wet season, the ground is inundated because of the heavy rains and poor surface drainage. Typhoons can also cause flooding from July through December. From June through November, most canals are navigable by ships with a draft of more than 6 feet, but the canals are subject to tidal influences from the South China Sea and the Gulf of Thailand, making navigation difficult.

The Rung Sat Special Zone is a mangrove swamp laced with an intricate network of canals southeast of Saigon. The 2 major rivers of the Rung Sat are the Long Tau and the Soirap. The Long Tau River is the critical shipping link to Saigon. During high tides, any part of the Rung Sat can be reached by sampan.

About 6 million people -- almost 40 percent of SVN's population -- lived in the area south of Saigon in 1967. The average population density in the Delta was 460 persons per square mile; near Saigon, population density was 1,000 persons per square mile.

The farm population in the Delta was concentrated in small hamlets. Marsh areas were uninhabited since they are unsuitable for growing rice, the main occupation of most of the Delta population. The most densely populated provinces were those along the major rivers. The South Vietnamese farmer relied on the rivers and other waterways not only to carry his rich rice crop to market, but as his main line of communication. In 1966, there were more than 45,000 registered watercraft and uncounted thousands of sampans that traveled the estimated 3,000 n.mi. of navigable rivers and canals.

Villagers in the Delta (except for those around the port cities) had very little contact with the outside world. Their knowledge and interest in areas beyond their immediate environment was extremely limited. For centuries, tight-knit families had been the center of small village social structures known as hamlets. They were socially conservative and strongly resisted external influences. This situation presented the SVN government with a difficult problem -- developing a sense of national responsibility.

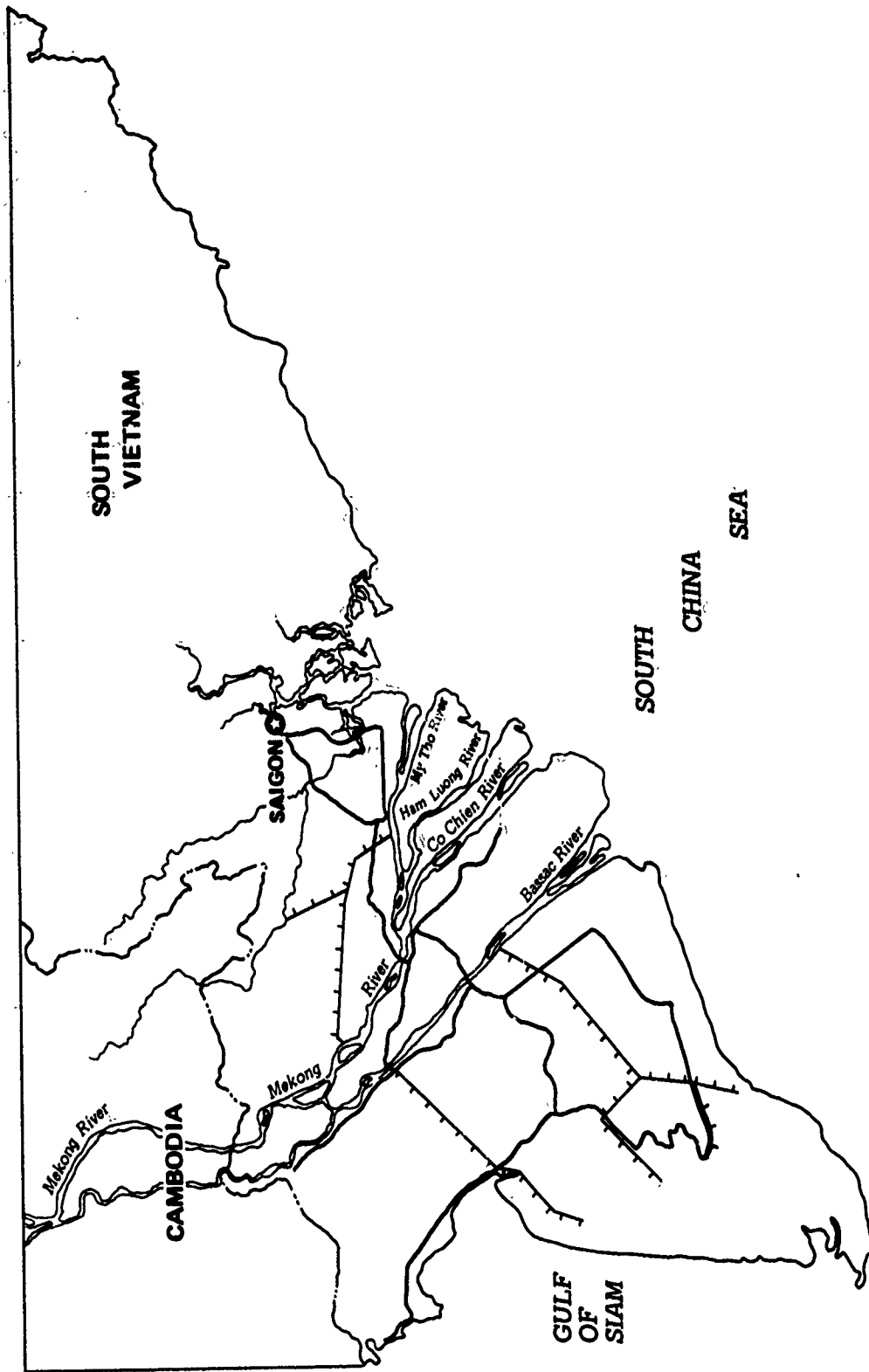

**FIG. 2: MEKONG DELTA AND RUNG SAT**

The enemy in SVN capitalized on this weakness. The VC, directed and supported by NVN, conducted a campaign of terror, propaganda, political subversion, economic sabotage, and military aggression. By 1964, according to DIA, VC objectives in SVN seemed to be to destroy and prevent establishment of pacified hamlets, consolidate liberated areas, and destroy government forces.

VC military successes during 1964 included gains in territory and population control as well as virtual isolation of government forces in many provincial and district capitals. Operations involving one or more battalions were carried out with relative impunity. Terrorism and propaganda efforts, particularly among the rural population, were successful in gaining either widespread cooperation with the VC or at least noncooperation with the SVN government.

#### NATURE OF THE THREAT

Documentation for 1965-1966 shows that the United States originally had an inadequate understanding of the intricate and detailed organization and in-country network used by the VC to transport supplies into SVN (see appendix A).

In about 1962, the Lao Dong Party in Hanoi established the Central Committee for SVN (COSVN). It was through this organization that NVN controlled the VC logistic supply system in SVN. After SVN President Diem's death in 1963, the enemy's logistic system began to evolve rapidly. The communications and liaison system (established about 1959) was virtually countrywide and furnished COSVN with a very efficient network of control down to the village level.

Through the beginning of 1965, MACV considered the sea to be the main infiltration route for VC resupply to southern SVN. Between 1963 and March 1965, up to 4,200 tons of arms and ammunition were delivered by communist trawlers to SVN. The destinations of the early trawlers were probably An Xuyen and Kien Hoa Provinces in IV Corps. By mid-1966, because of the buildup of Market Time, MACV discounted seaborne infiltration as a major VC resupply method.

Even before the major U.S. commitment in SVN during 1965, Cambodia was suspected of playing a role in the communist resupply effort to III and IV Corps. But there is some question as to the emphasis that was placed on infiltration from Cambodia in relation to the emphasis on seaborne infiltration.

Before 1963, the Mekong/Bassac River complex was the main route from Cambodia for resupply in SVN. By 1966, crossing points on the Cambodia/SVN border had been pinpointed, and there were implications of high-level Cambodian military or government complicity in the infiltration of supplies to the VC. MACV noted that Cambodia was the only area bordering SVN that could harbor communist forces with no threat of U.S. military action (see appendix A).

Supplies from Cambodia were brought into SVN by inland waterways and overland routes. They were transported by sampans, junks, ox carts, and porters. Supplies were moved in stages and handled through as many supply depots as were necessary to ensure security. No single unit carried supplies over an entire route. Supplies were shifted from one rear service area to another when needed or when a particular route and destination were not impeded by SVN or U.S. forces. Each rear-service area covered only one portion of a route.

Each communist military region had its own supply system and organization. VC base areas played an integral role in the resupply network (see appendix B). They served either as way-stations or as final destinations for supplies. The base areas on the South China Sea coast were originally the focus of major resupply efforts by sea. After 1965, rear service groups on the coast shifted their orientation to receiving supplies from Cambodia.

Game Warden had to cope with an enemy who controlled much of the RSSZ and Delta. The enemy knew the terrain and interconnecting waterways, allowing him considerable freedom of movement. The VC used the rivers overtly and covertly. They disguised themselves as civilians (with forged identification cards) or used someone with legitimate papers to smuggle for them. Smuggled goods were hidden in false bottoms, bulkheads or overheads of junks, or were buried under such hard-to-move cargo as rice, sugar cane, and fish. One smuggler of raw materials for explosives said that he concealed contraband in a false overhead of the junk's deckhouse and carried no other cargo. He discovered that junks appearing empty stood less chance of a thorough search than junks carrying an obviously full load.

In covert use of the rivers, the VC moved carefully to avoid contact with government representatives. They preferred to travel at night, usually between 2000 and 2200 hours and just before dawn. Game Warden Delta river patrols later forced the VC to attempt movements during the day.

The enemy also generally moved at or near high tide, since the tide opened areas closer to the brush for boats. When supplies were moved toward crossing points, harassing fire was used against SVN army outposts in the area. To make it more difficult for friendly forces to predict a crossing attempt, the VC did not maintain groups of watercraft at the crossing point; they procured sampans from the immediate area when needed.



The VC normally moved in groups of 4 or 5 per sampan, and the sampans traveled in pairs.

The VC transited the river as cross-stream instead of up- or downstream traffic in many areas, especially in the lower Delta provinces on the South China Sea. VC control in these provinces was extensive, and the enemy had large base areas in Go Cong, Kien Hoa, Vinh Binh, Bac Lieu, and Ba Xuyen Provinces. The lines of communication connecting these base areas ran across major rivers. In the provinces near the Cambodian border, there was more enemy along-stream traffic.

In addition to their extensive use of waterways for logistical and tactical movements, the VC frequently channeled and taxed legitimate civilian maritime traffic, especially in those areas where they had firm control along the river banks. In the SVN-controlled areas, mobile VC tax stations operated with no discernible patterns. Tax levies were usually extracted in the form of rice, salt, fish, livestock, and produce. Transportation taxes were also significant. Because tax collecting was an important source of VC revenue, it was almost a daily undertaking.

The largest VC threats to river patrols were ambushes and mines. Individual enemy craft fought PBRs with small arms and automatic weapons, and there were reports of suicide teams in sampans who had been trained to move alongside the PBRs in the best position to damage the boats with self-destruct charges.

Most mining incidents occurred when patrols were returning and security and surveillance were lax. Mining attempts were usually coordinated with small arms, automatic weapons, and, occasionally, recoilless rifle fire.

Ambushes usually took place in daylight and at low tide. They were mounted from protected firing positions along narrow parts of waterways. The enemy lured boats toward the shore or fired from one bank to drive a PBR toward the opposite bank, where the boat was ambushed.

In one incident, a PBR sighted a 1/4-inch wire leading into the brush from the river's edge just down stream from an RF/PF (Police and Regional Force and Popular Force) outpost. A platoon was dispatched to investigate and discovered a 10-kilo mine along with food and fresh water near the area. They traced the wire into the river and found a large mine, which was recovered by the explosive ordnance disposal team from Nha Be. The platoon also found a well-laid ambush site with 3 foxholes, aiming stakes,<sup>1</sup> a claymore mine facing the river, and 2 spools of wire.

---

<sup>1</sup>Wooden stakes stuck into the bottom of the river with the tops showing, providing exact range and line-of-sight information.

The enemy often had excellent intelligence on watercraft schedules and capabilities. As with minings, the VC preferred to carry out ambushes when craft were returning from an operation because the boat's route would be more predictable; 57mm. or 75mm. recoilless rifles supported by automatic weapons were often used instead of mines during an ambush. The rifles were more accurate than mines because the target did not have to be in one position to be attacked. Moreover, the recoilless rifles were more flexible and easier to set up than were mines.

The VC were generally patient enough to wait out patrols. If they were forced to move, they would begin sniper fire upstream or downstream from their crossing point to decoy the patrol away from the area. They needed an intricate warning system against patrols, using colored lights, gongs, bells, and shots.

At the end of 1965, the U.S. did not know the extent of VC use of the Delta and RSSZ. The first Game Warden operational order identified major known VC-controlled areas adjacent to the rivers and selected suspected enemy crossing points (see figure 3).

#### U.S. NAVY INTERDICTION EFFORTS

MACV made a significant effort to determine the nature of the threat in the Delta and the RSSZ and how to efficiently utilize SVN forces to meet this threat. In January 1964, a team of senior U.S. Naval officers was directed to study and analyze the nature of the threat and offer recommendations for improved control and prevention of infiltration of war supplies and personnel into SVN. The conclusions reached by this study group (documented in the "Bucklew Report") indicated that there was evidence of enemy infiltration, and that this infiltration was aided by inadequate SVN military and civilian control of the land, sea, and inland waterway routes. Although the report did not initiate any immediate direct U.S. involvement, it did point out South Vietnamese deficiencies in dealing with the situation.

U.S. advisors to the VNN were aware of the ineffectiveness of the River Force in addition to what was cited in the "Bucklew Report. VNN craft were slow and noisy and their crews unenthusiastic. Since the main role of the River Force was to provide capabilities for waterborne deployments and support for SVN army operations, the VNN paid relatively little attention to river control. The urgency of denying the VC use of Delta and RSSZ waterways was not recognized; therefore, river patrol was given a very low priority. As a result, the River Force had totally inadequate resources for river patrol.

The first large-scale U.S. in-country naval commitment in SVN came in February 1965 after a North Vietnamese trawler was discovered to have delivered arms and ammunition to the VC at Vung Ro Bay in II Corps. In response, the U.S. Navy established Market Time. Ships and aircraft patrolled the 1,000 n.mi. of SVN coast to counter sea-borne infiltration.

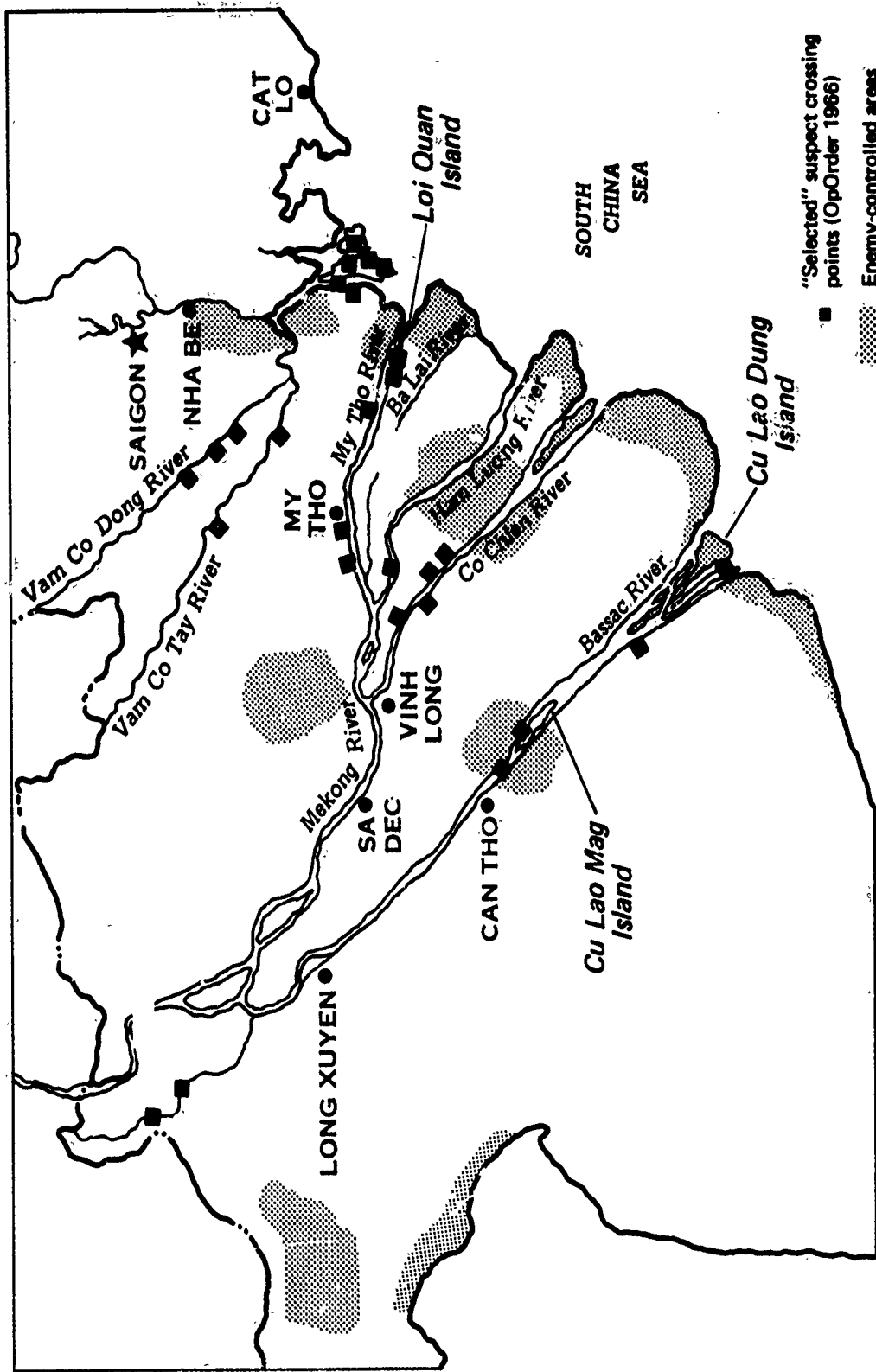

FIG. 3: KNOWN VC-CONTROLLED AREAS AND SUSPECTED ENEMY CROSSING POINTS, FEBRUARY 1966

The Chief of the Naval Advisory Group (CHNAG), MACV, who was responsible for Market Time, initiated studies to determine whether Market Time could be expanded into the Mekong Delta and the RSSZ. The possibility of assigning major rivers to the U.S. Army was discussed. It was finally decided that the U.S. Navy -- with its experienced boat personnel and close coordination with VNN River Assault Groups (RAGs, see appendix C) and Task Force (TF) 115 -- was better suited for the job.

Representatives from the Chief of Naval Operations (CNO), Commander in Chief, Pacific (CinCPac), Commander in Chief, Pacific Fleet (CinCPacFlt), MACV, and CHNAG met in Saigon in September 1965 to draft plans for the expanded Market Time force. They recommended that 120 suitable river boats be purchased for the Delta/RSSZ operation. Between September and December 1965, the Navy realized that the problem of the rivers was separate from that of the coast and warranted its own task force. On 18 December 1965, Game Warden, the river patrol force, was established as TF 116.

**SETTING UP THE OPERATION--DECEMBER 1965  
THROUGH SEPTEMBER 1968**

**ACQUISITION OF ASSETS AND BASES**

From December 1965 through March 1966, the Naval Advisory Group established the basic operational and logistical framework for Game Warden. The first OpOrder was issued in February 1966. Game Warden was divided into 2 task groups: TG 116.1 for the Mekong Delta and TG 116.2 for the RSSZ (see appendix D).

Finding a river patrol boat suitable for the Delta was an urgent requirement. The boat had to be fast, lightweight, maneuverable, equipped with a propulsion system that would operate in shallow waters infested with a variety of plant and animal life, and withstand a hot and humid environment. The boat also had to be selected from existing commercial designs. The PBR finally chosen had a glass-fiber hull and was powered by what was then a new propulsion system--a jet water pump (see appendix E).

In all, 120 PBRs were scheduled to be operational by the end of the year--40 in the RSSZ and 80 in the Delta. Each river patrol area was to be covered by a group of 10 PBRs.

Four inactive LSTs were recommissioned during 1966 to serve boating bases. Each LST would support 10 PBRs and a fire-support team of 2 helicopters. The LSTs provided both 24-hour-a-day support for the PBRs and 40mm. gunfire support.

The LSTs were extensively modified for Game Warden. They received new boat-handling booms, a helicopter deck equipped for day and night operations, and the newest electronic gear. Until the first of these specially configured LSTs arrived in SVN early in November 1966, 3 dock landing ships (LSDs) equipped with temporary helicopter decks provided the afloat support.

Original plans called for stationing the LSTs at the mouths of the Delta rivers, but heavy seas and changes in the focus of operations forced the LSTs inland. Earlier in 1966, an LSD had reported the loss of as much as half its operating time because of heavy winds and seas.

Game Warden shore bases in 1966 were at Cat Lo, Nha Be, My Tho, Vinh Long, Long Xuyen, Can Tho, and Sa Dec. Naval Support Activity at Saigon was responsible for base support. In mid-1966, an LSD was stationed between the mouths of the Co Chien and Bassac Rivers; and beginning in November, an LST was stationed on the Bassac. By September 1968, Game Warden forces were based at 4 shore bases at Nha Be, My Tho, Sa Dec, and Binh Thuy (figure 4); 3 on-station LSTs; and 5 other bases afloat.

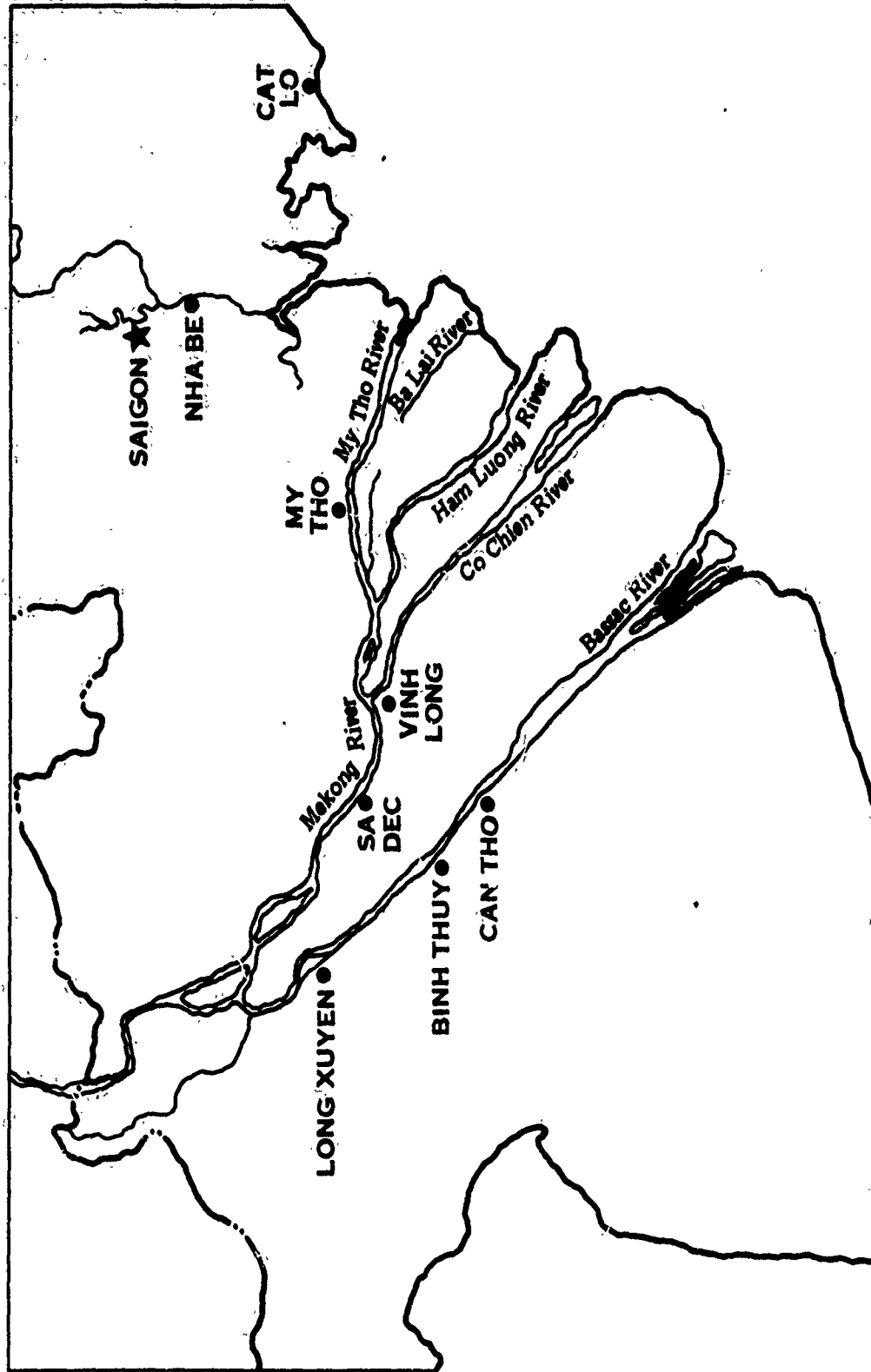

**FIG. 4: PBR SHORE BASES**

When the 4 Game Warden LSTs were operational, 3 remained on station on the Bassac, Co Chien, and Ham Luong Rivers; the fourth was out-of-country for maintenance. The LSTs were overcrowded and lacked the maintenance capabilities of the shore bases. Therefore, after being based on an LST for about 5 months, a PBR river section would rotate with a shore-based unit. PBRs found, however, that operating from an LST or one of the 5 other afloat bases offered much more flexibility in countering the threat.

By the end of 1966, it was obvious that more boats would be needed to respond to the growing number of enemy incidents in the Delta. On 28 February 1967, CNO approved a force level of 250 PBRs. By April 1968, the river patrol force had grown to 200 PBRs and, by late 1968, to 250 (appendix F).

Recognizing the need for increased force levels, ComNavForV recommended a second generation PBR, the Mk II, in September 1966. In March 1967, a contract to buy 80 Mk IIs was signed with United Boatbuilders; 60 of these new PBRs were to be assigned to the Delta, and 20 were to be used in a new river division in I Corps<sup>1</sup>.

Helicopters were the most suitable aircraft for PBR gunfire support. Since the Navy had no helicopter gunships of its own, the U.S. Army 197th Aviation Company furnished the armed UH-1B Iroquois helicopters used by Game Warden forces (see appendix E). In March 1966, SecDef/directed Navy crews to take over all Game Warden helicopter operations as soon as possible to free the Army of that responsibility. By the end of the year, Navy crews manned 8 Game Warden Army UH-1Bs; 6 of the helos operated in support of Game Warden while 2 were in the maintenance pool at Vung Tau.

By the end of 1967, 22 Game Warden helos were organized into 11 light helicopter fire teams. Three fire teams operated from the Game Warden LSTs, 4 teams from fixed bases at Nha Be, Dong Tam, Vinh Long, and Binh Thuy, and 8 helicopters remained in the maintenance pool at Vung Tau. By 1968, Vinh Long was also designated as a maintenance base.

Each detachment had 2 full crews so one crew could be kept on 24-hour alert. Helos could then be available to all PBRs within 20 minutes. The helicopter shore bases and the LSTs were located so that the maximum patrol distance from the base or ship was limited to 35 n.mi. or less from most incidents. Helo firepower helped PBRs carry out preplanned

---

<sup>1</sup>PBRs had first operated outside the Delta and RSSZ in September 1966. They were used to protect supplies moving north from Danang to Thua Thien and Quang Tri Provinces. Ultimately, this river division evolved into a task force called Clearwater.

attacks against fixed enemy positions, especially when these positions were located in areas that were not accessible to PBRs without unreasonable risk. As part of their secondary mission, the helicopters performed aerial reconnaissance and were involved in medical evacuation.

SEALs (sea, air, land, reconnaissance teams), highly specialized in counter guerrilla warfare, were first used in the RSSZ in 1966. By 1968, there were also SEAL teams attached to each Game Warden task group in the Delta.

About 90 percent of the SEAL effort was devoted to gathering intelligence. Most often, SEALs were carried into their area of operation at night either by PBRs or fast patrol craft of their own. SEAL operations usually consisted of ambushes, establishing listening posts, or raiding in VC territory.

#### Coordination within TF 116 and with other Commands

CTF 116 and subordinate commanders were served by Navy Operations Centers (NOC), the equivalent of Command Information Centers ashore. All NOCs could communicate with the operations centers of other commands in their areas. Helo support was requested through the NOC, and PBR operations were coordinated by the NOC.

CTF 116 headquarters was located at Can Tho or Binh Thuy, near Can Tho, for much of the operation. Can Tho, centrally located in IV Corps and the largest city in the Delta, was the headquarters of the SVN army's commanding general and the senior U.S. advisor for that corps. It was also the headquarters of the VNN Fourth Riverine Area.

Each task group commander--CTG 116.1 and 116.2--was also an advisor to the VNN. The locations of Game Warden bases at VNN bases eased the advisory duties of CTF 116.1 and 116.2.

Vietnamese liaison personnel worked with Game Warden crews to help in junk and sampan searches and to communicate with Vietnamese craft and shore units. They also advised U.S. crews on local conditions and customs. VNN officers and enlisted men generally handled liaison. At times, Game Warden authorities requested additional help from the National RF/PF boat companies (see appendix C).

By January 1968, TF 116 was reorganized, expanding from 2 to 4 task groups. The new river task groups had commands on the Bassac River (TG 116.1), Co Chien River (TG 116.2), My Tho River (TG 116.3), and in the RSSZ (TG 116.4). Although the RSSZ patrol group commander still functioned as an advisor, the 3 new Delta task group commanders did not have that responsibility. A new advisory billet for the IV Riverine Area (the post formerly held by CTG 116.1) was set up outside Game Warden's chain of command.



Each of the 4 new task group commands was assigned about the same number of PBRs, helos, and SEALs. MSBs were assigned in the RSSZ, and an LST was assigned to each Delta task group. The LSTs could operate as far upstream as the Bassac-Mekong crossover. In June 1968, another task group (TG 116.5) was established in the upper Delta.

The river patrol force had no precedents to rely on for guidance. Operational methods and concepts developed largely from immediate experience as the force evolved. The 1966 OpOrder encouraged task group and unit commanders to exercise their initiative and act fairly autonomously. They kept their superiors informed of their actions by daily situation reports and on-the-spot reports of significant incidents. They were authorized to arrange local joint operations with other U.S. and SVN armed forces and with SVN district and province government representatives.

There was actually little coordination between U.S. Game Warden forces and the VNN River Force. In addition, the mutual distrust between the VNN River Force and the SVN army limited the former to blocking operations and patrols. The U.S. Army occasionally used VNN RAGs in amphibious operations, but coordination was poor.

## PBR OPERATIONAL TACTICS AND TECHNIQUES

Game Warden forces were tasked to enforce SVN government curfews; interdict VC infiltration, movement, and resupply; and eliminate the VC insurgency in their areas of operations. To accomplish these goals, Game Warden forces performed harassment and interdiction operations, river patrols, and minesweeping operations, especially along the main Saigon shipping channels.

Game Warden forces were authorized to visit and search all river craft except foreign flag steel-hull merchant ships, warships, and military, police, or customs craft unless specifically authorized by CTF 116 (see appendix G). The Mekong River and its navigable branches were, by treaty, international waterways and open to those nations recognized diplomatically by SVN, Cambodia, and Laos.

By 1966, the Vietnamese Customs Agency enforced regulations governing transit by merchant ships (see appendix H). If merchant ships on international inland waterways offloaded cargo to watercraft, or if they dropped items overboard, Game Warden forces were supposed to make every effort to apprehend the craft upon their departure from alongside the ship and to recover items dropped overboard.

Game Warden PBRs noted one such incident. In July 1966, 2 PBRs on random patrol established radar contact with a ship that had 3 smaller boats alongside. When the PBRs approached them, the small craft headed for the river banks and the ship weighed anchor. The ship was identified as a tanker, the Mekong Phnom Penh of Cambodian registry, flying only a South Vietnamese flag aft. It was impossible to determine whether the tanker had been offloading contraband for VC forces in the area. But the ship's activity and the fact that it was anchored in a prohibited area made this a strong possibility.

PBR operations were based on 2-boat patrols, each boat within radar range of the other and normally in midstream. Each patrol lasted about 12 hours. The PBRs had neither the armor nor the firepower to attack the river banks. The OpOrder emphasized the need for random patrols to avoid mining and ambushes and the need to be alert against booby traps. It also pointed out that silence was crucial, especially at night, and recommended patrolling on a single engine when possible.

When a task unit began patrolling a new area, the commander gave an area indoctrination and familiarization for his men. Initial patrols in an area were made with local RAGs.

Before starting their patrols, PBR crews were briefed on any pertinent intelligence. Briefings also covered the scope and duration of the patrol, friendly forces in the area, recognition signals, available support, communications procedures, and special circumstances. Debriefs after a patrol included intelligence, results, and unusual activities noted by the participants.

Precautionary measures were taken to prevent the VC from determining the exact location of PBR patrols. There were the random midstream patrols; in addition, radio communications were restricted to a minimum. The enemy had captured U.S. equipment, and it was assumed that he could and would monitor U.S. circuits. If the PBRs were the victims of sniping by small-caliber, nonautomatic weapons, they would be warned against using automatic weapon fire in return unless they had pinpointed the source of the sniping to avoid disclosing the exact location and armament of the PBR.

All river traffic was considered suspect, especially during the nighttime curfew. During daytime, PBRs randomly searched watercraft when there were too many for all to be searched. About 60 percent of all junks and sampans detected were inspected or boarded, according to CinCPac in July 1967. This included a check of identification papers for all persons aboard. A South Vietnamese national policeman was usually on board one of the PBRs to provide an SVN "presence." He expedited the checking of papers and the questioning.

When suspects were detained during searches, U.S. forces maintained custody until the suspect was classified as prisoner of war (POW), returnee, civil defendant, or innocent. POWs were placed in camps by military police. Returnees were turned over to the nearest Chieu Hoi center.<sup>1</sup> Civil defendants were delivered to the national police or military units; and innocent Vietnamese were released and returned to where they were captured.

PBRs were warned to approach contacts at an angle that allowed the most weapons to bear on the target. Approach to a contact at night was made at high speed with the PBR darkened. The contact was illuminated at close range. When a PBR was within optimum range for illumination of a contact, it called for the boat to pull alongside. All occupants of the suspicious boat were ordered to make themselves visible before coming alongside the PBR. All searches were to be done in midstream if possible, and PBRs were instructed not to moor themselves to the boat being searched.

When a contact came alongside the PBR, the latter was vulnerable to hand grenades or mines. PBR crews were warned to be cautious of VC decoy tactics. The VC would station a boat with legitimate papers and no contraband in a position to be searched while another boat carrying contraband would evade search. The VC also took advantage of PBR medical aid by using a sampan to hail a PBR to evacuate a wounded person while a VC boat escaped detection.

---

<sup>1</sup> Chieu Hoi was the "open-arms" program in which VC who defected were rehabilitated and allowed to reenter South Vietnamese society.

While one PBR searched a contact, a second PBR covered the shore and positioned itself to have a clear line of fire to both sides of the river. The boat conducting the search was instructed to maintain a 50-caliber weapon and lookout covering the shore to the unengaged side of the boat.

Enforcing the curfews was a continuing problem. Curfews generally lasted from 2000 or 2100 hours to 0600 hours. Civilians in a patrol section were informed of the restrictions through leaflet drops and loudspeaker announcements. Curfew effectiveness depended largely on promulgation at the village and district level, and it varied from area to area.

For example, in April 1966, a fire team spotted 7 sampans in a restricted zone near Can Gio village in the RSSZ. The fire team requested permission to strike. Permission was granted after the VNN watch officer at Nha Be checked with Can Gio district headquarters. The helo strike was a success. But it was later discovered through the Can Gio advisors that the sampans held friendly fishermen fully aware of the curfew regulations. The village chief had granted the people permission to fish.

Curfew restrictions imposed financial hardship on the people by limiting their fishing time. Curfews were necessary, however, to successfully combat nighttime infiltration. In 1967, CinCPac determined that the curfew had not stopped VC river crossings, but it was being observed by the local people. This made the task of detecting VC river crossing attempts much simpler.

After PBR crews developed a familiarity with their patrol areas and the nature of the enemy, they developed several new tactics. One of these was a planned ambush to intercept a possible VC river crossing. Ambushes were based on intelligence reports or on the judgment of the boat commander.

The tactic was tested in one incident when Commander, River Patrol Section 531, reacted to intelligence reports of a probable enemy crossing. He took 4 PBRs to the suspected crossing to interdict enemy movements. The VNN RAG commander at My Tho sent 3 additional river patrol craft. The PBRs drifted silently into the crossing area and detected the enemy after about an hour. Although no large supply of weapons was detected, the enemy action was evaluated as an attempt by a tax collector to move under the protection of guerrilla troops.

PBRs at Can Tho used a new technique for sampan surveillance after receiving intelligence concerning a possible VC river crossing southeast of Can Tho. In addition to centering normal PBR patrols in the suspected area, Game Warden forces established an observation post on a sampan manned by one U.S. Naval officer and 3 enlisted men. The sampan was a former VC craft overhauled by Naval Support Activity Detachment at Can Tho. Communications to the PBRs on patrol and to Can Tho was by radio. This tactic

provided continuous surveillance of the entire suspicious area. This kind of surveillance was considered valuable when used with discretion periodically in areas where the river was wide enough to provide security for the sampans.

Because PBRs had been allowed to fire only warning shots to stop sampans and junks for visits or searches, many suspicious craft had evaded Game Warden searches. In October 1966, the rules of engagement (appendix G) were changed to permit PBRs to direct fire against evading junks or sampans after all other methods to stop them failed.

To counter the movement of contraband in small quantities, a new search procedure, code-named Ferret, was established in 1967 throughout the Delta. Ferret entailed randomly stationing PBRs twice a week in known VC crossing areas during the peak traffic hours of 0700, 1200, and 1700 hours. A South Vietnamese policeman and policewoman were embarked.

The patrols stopped and searched all river traffic. Inspections included a thorough probing of cargo, the passing of lines or poles under hulls to check for contraband suspended beneath keels, and the checking of passengers against lists of known VC. Each effort was coupled with civic action and psychological operations to ease the inconvenience to innocent travelers.

To frustrate and discredit PBR patrol methods, the VC confiscated identification cards of innocent civilians. This resulted in delays in searching and inconvenience to the civilians and local authorities.

By the end of 1967, the VC were using heavier weapons--recoilless rifles, mortars, rockets, and heavy machine guns. The upsurge in enemy activity culminated in the Tet offensive of January 1968. After that, CTF 116 noted that the enemy was using firing bunkers, which provided relative security from PBR suppressive fire. Continuous ground sweeps in enemy areas rarely returned significant results. To deal with increasing enemy capabilities, TF 116 used quick-reaction forces combining U.S. Navy, VNN, and RF/PF units. These forces were called on short notice.

Originally, it was standard procedure for PBRs when fired upon to return the fire and call for help while leaving the area of contact. After Tet, it was obvious that the PBRs were able to suppress enemy fire, and the procedure was changed to allow PBRs (at the discretion of the boat commanders) to remain and fight.

Improved intelligence became available to CTF 116 during 1968. A new and very quiet surveillance aircraft, the QT-2PC, proved its effectiveness in providing intelligence to Game Warden units by detecting 8 large junks at night near the mouth of the Bassac River. Two PBRs and a helicopter fire team responded and destroyed or heavily damaged all the junks.

From April to June 1968, TF 116 collected intelligence information on VC cadre in the Can Tho area for use in a blacklist. The names, ages, heights, weights, and activities of various VC cadre were compiled alphabetically. The first blacklist was published and distributed to River Division 51 during late June. After one month, the list had helped in capturing 4 confirmed VC in the Can Tho area.

## PSYCHOLOGICAL OPERATIONS

As a secondary mission, PBR crews participated in psychological operations to involve the people of the Delta in their own protection and to encourage potential sources of intelligence for Game Warden.

The psychological operations took many forms. PBRs and RAGs dropped leaflets and played taped broadcasts designed to meet situations in specific areas. The local population received, along with information distributed by the SVN government, items such as grain, salad oil, cigarettes, soap, cloth, needles, and thread. Distribution was from boats or, in VC-dominated regions, was air-dropped or packaged to float in with the tide.

One type of broadcast was directed against VC exploitation of South Vietnamese youth. (Game Warden forces had captured VC as young as 11 years old who had been in combat.) In their broadcasts, Game Warden crews stated that although the VC had promised South Vietnamese parents not to place their children into the front lines, the enemy had failed to honor his pledge. The effectiveness of surface broadcasts was best evidenced by the increased VC attacks on the broadcasting vehicles during spring 1968.

Game Warden psychological operations involved more than merely distributing goods and government propaganda. In flood and refugee relief operations, Game Warden crews helped build and repair bridges, schools, houses, and dispensaries. They also made deliveries of rice seed.

Psychological operations included dispensing medical aid and evacuating local Delta inhabitants and South Vietnamese military personnel. The South Vietnamese were helped to maintain individual and communal hygiene.

Local projects were undertaken by Game Warden crews. River Section 542 in the RSSZ "adopted" a village. Sailors visited the village with medical assistance, clothes, shoes, and toys. In the Can Tho area in the Delta, following the Tet offensive, Game Warden personnel built a school and bought classroom equipment and supplies for refugee children.

Special psychological campaigns were undertaken on important days of the Vietnamese calendar. During Tet 1967, special leaflet and broadcast appeals were made to the Delta population, stressing the traditional family nature of Tet. For the national election in September 1967, security was provided for voters. A campaign was begun a month before Tet 1968 to develop a sense of loyalty to the government. PBR crews gave parties and presented Vietnamese children with toys.

The VC were increasing emphasis on countering friendly psychological operations before Tet 1968. The enemy was reported to have ordered Delta inhabitants to destroy allied leaflets distributed in VC-controlled areas. Guerrillas had been ordered to fire on aircraft engaged in airdrops. The VC effort to counter psychological operations indicated the program was adversely affecting the enemy's ability to maintain control of the population.

Each PBR was considered to be a Chieu Hoi station. Many VC turned themselves into these stations, and some of them even taped broadcasts for the PBRs to play when patrolling areas where their former VC comrades would hear the broadcasts. Game Warden task unit commanders, district chiefs, and U.S. Navy psychological operations officers visited RF/PF outposts to explain PBR operations and win local acceptance of them.

Game Warden psychological operations convinced the population in some areas to help SVN government representatives fight the VC by providing information on enemy activities. An outstanding example of the kind of effect these operations often had on Delta inhabitants was a letter of appreciation received by the commander of the My Tho-based River Division 53 in August 1967. The letter was signed by members of a water taxi association in Kien Hoa Province.

The boatmen, who traveled daily on the Ham Luong River, used to have to pay the VC at check points established on the river. Payment was in money, rice, medicine (especially antibiotics), and occasionally sampan motors. Those who refused to pay the VC were often killed. The boatmen felt that the PBR crews were polite when they searched the watercraft, and Game Warden sailors were respected because they did not take bribes. The boatmen stated that the river was secured by the PBR patrols, and they promised to give PBR crews information on VC individuals and concentrations along the river banks.

Local inhabitants who had benefited from the humanitarian efforts of the PBRs provided intelligence that served as a basis for some Game Warden operations. The operations succeeded in thwarting VC mining and ambush attempts, destroying VC concentrations, and gaining defectors.

## GAME WARDEN IN THE RSSZ

Game Warden's early emphasis was on the RSSZ because of fears that the enemy would cut off the shipping lanes to Saigon. The first PBRs to become operational were assigned to the RSSZ in April 1966. By June, PBRs had replaced all the Market Time units there. Those units took part in operation Jackstay, which was directed against an estimated 1,000 VC in the RSSZ who frequently attacked military outposts and threatened the sea channel to Saigon. The operation, also supported by the VNN, lasted 12 days and resulted in 63 VC killed. More importantly, it disrupted a major base area consisting of an arms factory, a training area used to assemble river mines, and a large medical facility. This facility was so well built, special underwater demolition teams had to be flown in to destroy it.

Ten river patrol stations were established during Jackstay. When the operation ended, the stations were maintained by Game Warden PBRs to ensure that the VC would not re-infiltrate the area. As the Game Warden force expanded, more stations were added to the RSSZ patrol (figure 5).

MSBs that had served in Danang harbor since October 1965 sailed for the RSSZ on 2 March 1966. By June, there were 12 MSBs operating from Nha Be tasked with keeping the vital Saigon shipping channel open (see appendix F). The MSBs were from Mine Squadron 11's detachment Alpha, which operated as a task unit of the Game Warden force.

Before Game Warden reached its planned strength, one of the earliest problems was the need to reshuffle forces to meet emergencies. In April 1966, for example, there were several mining incidents at Nha Be. To help antiswimmer security patrols, 8 PBRs were transferred from Vung Tau to the Game Warden base at Nha Be. The PBRs remained at Nha Be assisting the U.S. Army patrol units through June.

Many times during the early months of the RSSZ patrols, the boats came under moderate to heavy small-arms and automatic-weapons fire from the banks. The Soirap River patrols noted stepped-up harassment through June and again in December. Most of the harassing fire was received near the Vam Sat River, a known infiltration route terminal.

The intense tempo of operations in the RSSZ taxed both the crews and their boats. And most river patrol sections were required to do their own maintenance. Most boats were used daily, allowing little time for preventive maintenance. This condition improved as more boats and crews became available and as the support bases developed better facilities.

In June, a NavForV assessment of the RSSZ indicated that patrols on the Long Tau and Soirap Rivers had effectively curtailed night movements. The VC were now crossing at sunrise or sunset, using seemingly innocent sampans stationed in midstream at river bends to notify other VC sampans of passing patrol units. To counter this activity, Game Warden forces established special daytime patrols.



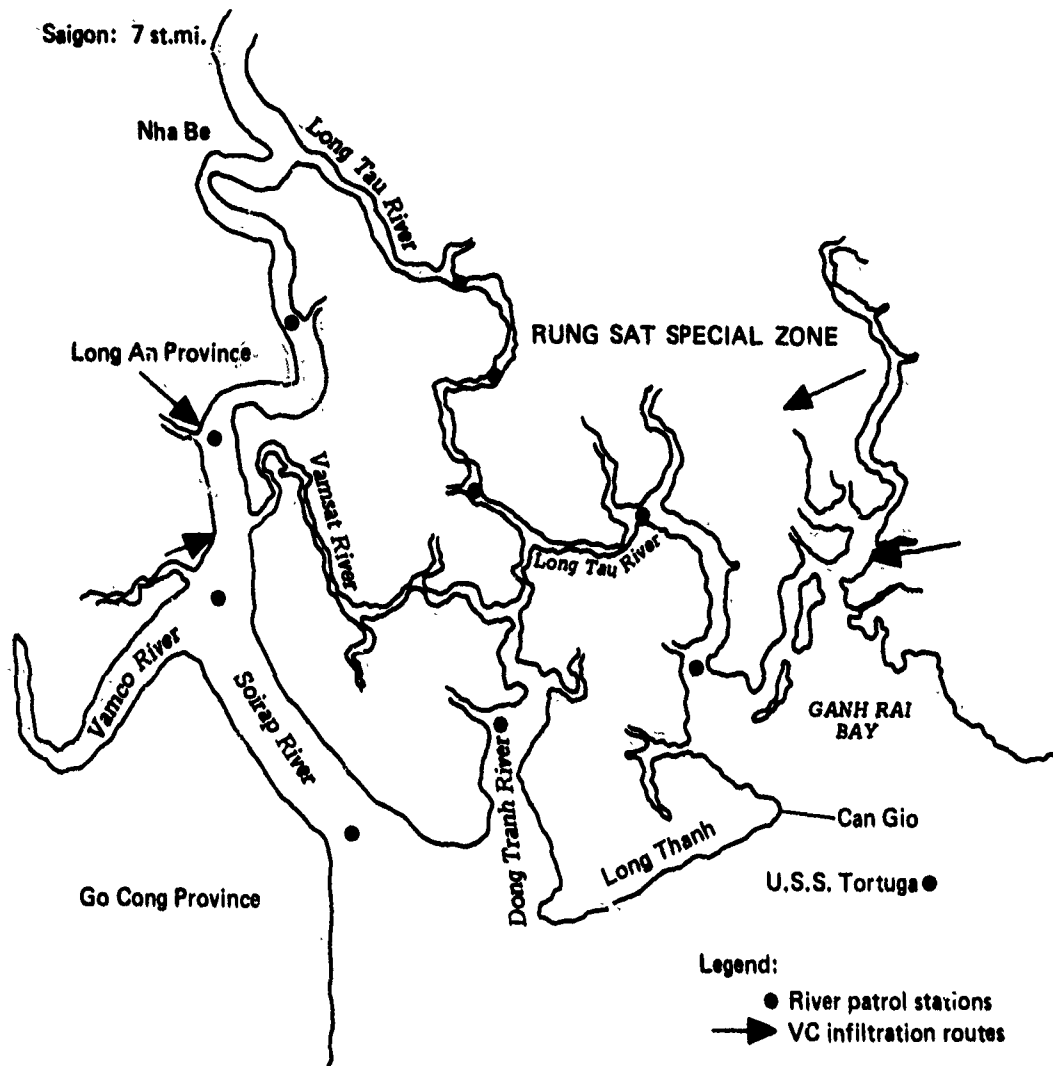

FIG. 5: RSSZ OPERATIONS

Previous studies had reported that the VC took advantage of dark phases of the moon to move supplies. The NavForV assessment noted, however, that a VC incident had taken place at low tide under full moon. This suggested the VC were flexible in adapting to hindrances imposed by Game Warden patrols.

In reaction to increased enemy activity, the USS Tortuga (LSD 26) was transferred to the mouth of the Long Tau River in August 1966 to provide an extra patrol section of 10 PBRs and 2 helos. Enemy activity in the RSSZ increased substantially toward the end of the year. Enemy documents discovered in November elaborated on the communist re-organization in the RSSZ; 3 scattered VC platoons reformed into one company-size element to attack RSSZ shipping in "quick-and-clean" operations. River minings and ambushes were emphasized.

The year 1966 ended on an ominous note with the 31 December discovery of a Soviet-type contact mine in Saigon's main shipping channel. It was the first time a contact mine had been detected on inland waterways.

At the beginning of 1967, enemy activity was especially heavy in the RSSZ. By the end of January, a reinforced U.S. Army battalion was assigned to the RSSZ to help deal with the increasing VC activity.

In March 1967, Game Warden units were faced with improved accuracy of VC sniper fire. An enemy document captured on 21 February in the RSSZ indicated that the VC RSSZ command received 5 sniper rifles the previous week. One participant stated that the VC were generally very poor shots.

There were indications by April 1967 that increased river patrols, additional armament for MSBs, and ground operations in the RSSZ were affecting VC ability to mount attacks against shipping in the Saigon channel. MSB armament was bolstered with 40mm. grenade launchers, enabling high-trajectory fire against VC positions on the river banks.

Despite daily channel sweeps by U.S. Navy and VNN craft by the end of 1967, enemy mining attempts continued. Investigation of one successful mining disclosed a new technique used by the VC to protect the electrical wires leading from the firing station to the mine. To prevent their being cut by minesweepers, the wires were enclosed in 2 sections of beetlenut logs, each about 6 inches in diameter and 15 feet long with about 10 feet of unprotected wire between the 2 sections. The effectiveness of this simple technique was proven. The area had been swept 15 minutes before the mining incident. The dual chain being used by the VNN minesweepers apparently passed over the logs without disturbing the command wire. A subsequent experimental sweep using the protective log coverings demonstrated that a conventional U.S. chain drag was effective.

Early in 1968, Game Warden forces noted increased use of enemy rockets, rifle grenades, recoilless rifles, and heavy automatic-weapons fire from ambush sites. In April, MSBs again noted a step-up in enemy mining efforts on the Long Tau shipping channel, as evidenced by many recoveries of electrical wires during sweep operations. In May and August, there were increased numbers of mining attacks against free-world shipping; 10 attacks occurred in May and 8 in August.

In June, the VNN assumed responsibility for clearing command-detonated mines out of the Long Tau shipping channel to Saigon; this was the type of mine most often used by the enemy on the Long Tau. U.S. MSBs retain responsibility for mine countermeasures against moored mines.

## GAME WARDEN IN THE MEKONG DELTA

The first river patrol units began operating in the Delta on 8 May 1966, when 10 PBRs moved up the Bassac River to Can Tho. Delta river patrol bases and support ships were established at locations that offered the requisite security and facilities while limiting the maximum patrol distance to be covered from a base or ship to about 35 n.mi. or less (figure 6).

Since there was inadequate intelligence during 1966, boat deployment was based on the availability of facilities. It turned out, though, that the first patrol areas covered--the lower Bassac and Co Chien, Ham Luong, and My Tho Rivers--were directly within VC supply corridors and probably caused the enemy serious resupply problems. At the end of 1966, Game Warden units in the Delta increased to 80 PBRs; they also patrolled the upper Bassac and Mekong Rivers.

River patrol units were repositioned to meet the elusive enemy throughout Game Warden. VC activity in the Mekong Delta rose sharply during November 1966, and 1967 began with a NavForV assessment that the enemy was seeking a major victory before the Vietnamese New Year truce (6 to 12 February). During January and February, VC activity was especially intense in the Delta west of the My Tho and Ham Luong Rivers.

Instead of spreading boats uniformly around the Delta, CTF 116 concentrated them in active VC areas during early 1967. Because the lower Bassac, Co Chien, and My Tho Rivers were active enemy areas, Game Warden boats assigned to the upper Delta were repositioned for high-density patrols on the lower Delta rivers, where intelligence indicated extensive enemy troop movements.

PBRs had been based at Long Xuyen, but contact with the enemy was lighter than had been expected. In response to an intelligence report that the enemy would try to concentrate forces in the Dong Tam area, 16 boats from Long Xuyen were deployed on 15 January to the lower Bassac and Co Chien Rivers. Meanwhile, Sa Dec-based PBRs concentrated their patrols in the lower portions of their assigned areas.

In April, the PBRs remaining at Long Xuyen were transferred to a floating base at Tan Chau near the Cambodian border. Because PBRs at Tan Chau had experienced only light contact with the enemy in mid-1967, the boats were transferred with the floating base to Binh Thuy, where there was considerable enemy activity. A few months later, the base and the PBRs were shifted closer to the coast at Ben Tre.

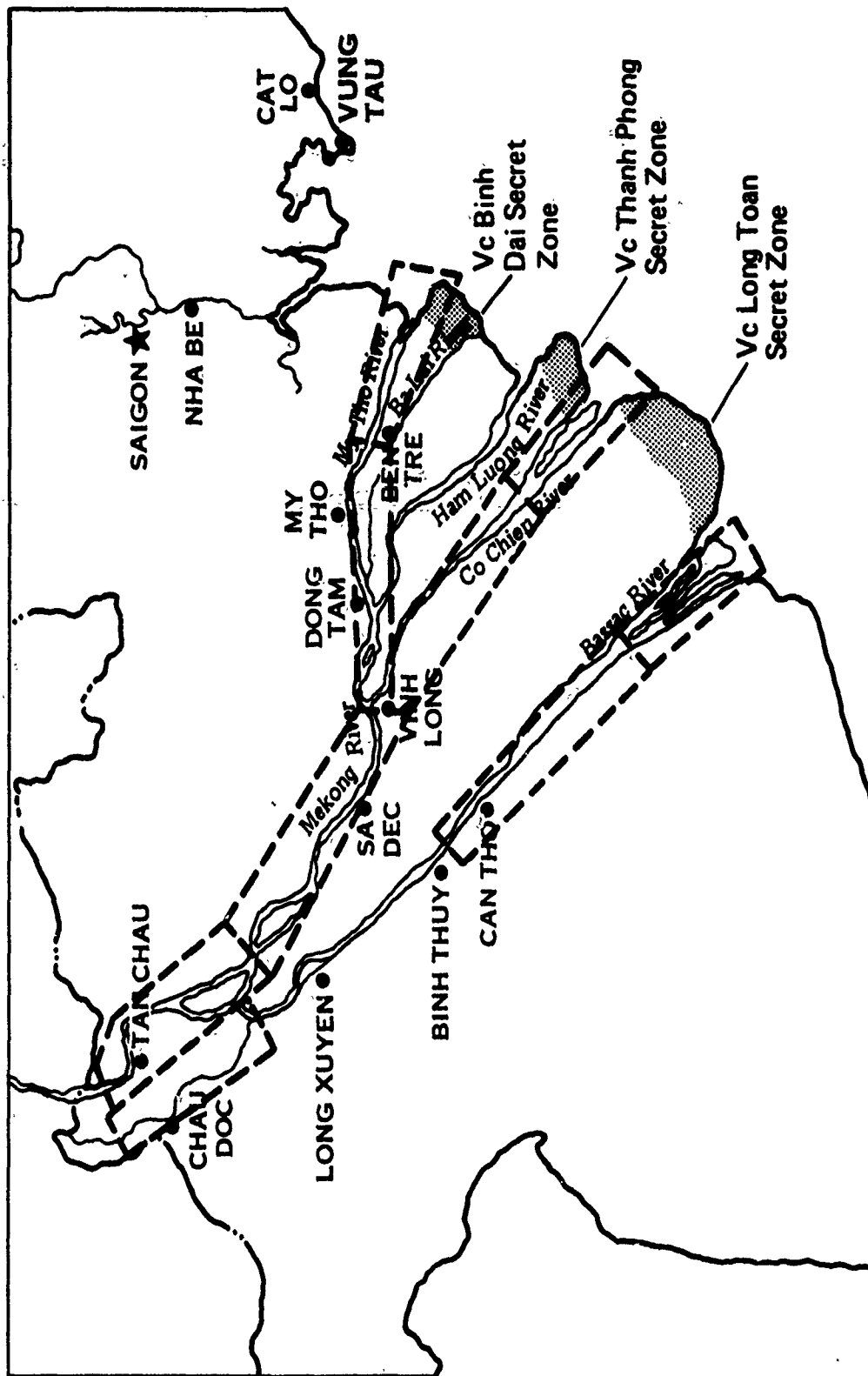

FIG. 6: PBR BASES AND RIVER SECTIONS, 1966

Upper Delta operations were eliminated by the end of 1967, since PBR contacts with the enemy had been so light (figure 7). There are some possible explanations for this lack of contact. Chau Doc and An Giang Provinces were under the control of the Hoa Hao, a religious sect. The VC erred in 1962 when they assassinated the head of the Hoa Hao. The Hoa Hao kept tight control over their own area, keeping the VC out; Game Warden forces found the area pacified. It may be, however, that the VC had simply found routes around the PBR patrols in the upper Delta. In any event, CTF 116 saw a need to concentrate forces in the lower Delta, drawing on assets patrolling the upper Delta.

CTF 116 redeployed some units to meet the growing threat in Kien Hoa Province, where parts of 3 VC battalions had been reported. By 6 May, about 3,000 main-force VC troops were in Kien Hoa. To interdict enemy lines of communication within that and adjacent provinces, Game Warden forces were again repositioned. PBRs made incursions into the Ham Luong River in Kien Hoa Province.

During the Ham Luong River operations, PBRs found increasing amounts of medicine on boat river traffic bound for Thanh Phu (a coastal district in Kien Hoa Province), where intelligence reports indicated a recent VC buildup. Large amounts of penicillin and streptomycin were discovered concealed on otherwise legitimate river traffic. To pave the way for incursions into the Ba Lai River in Kien Hoa Province, an LST was moved from the mouth of the Long Tau channel in the RSSZ to Dong Tam.

Random PBR patrols into canals and waterways off the major rivers began at the end of 1967. Incursions into the lesser waterways were left to the discretion of PBR commanders.

The boat commander in a patrol area would usually request information on enemy activity from the district chief. When the district chief felt that enemy troops were massing in some area, the PBR would investigate.

In April 1968, a new ComNavForV operational plan was promulgated. This plan emphasized the need for U.S. Navy/VNN reaction to infiltration of enemy supplies from Cambodia. Under the plan, when more boats became available, they would be assigned to the upper Mekong. (This official recognition of infiltration from Cambodia tends to discredit earlier assessments that little enemy activity was occurring in the upper Delta rivers.)

In May, PBRs began Game Warden operations on the upper Bassac and Mekong Rivers. These PBRs were assigned on a rotating basis from TG 116.1 (Bassac) and 116.2 (Co Chien) until June, when the Upper Delta River Patrol Group was established (figure 8). In July, PBRs from the afloat base at Tan Chau were experiencing only light contact with the enemy, reminiscent of their previous operations in the upper Delta in early 1967.

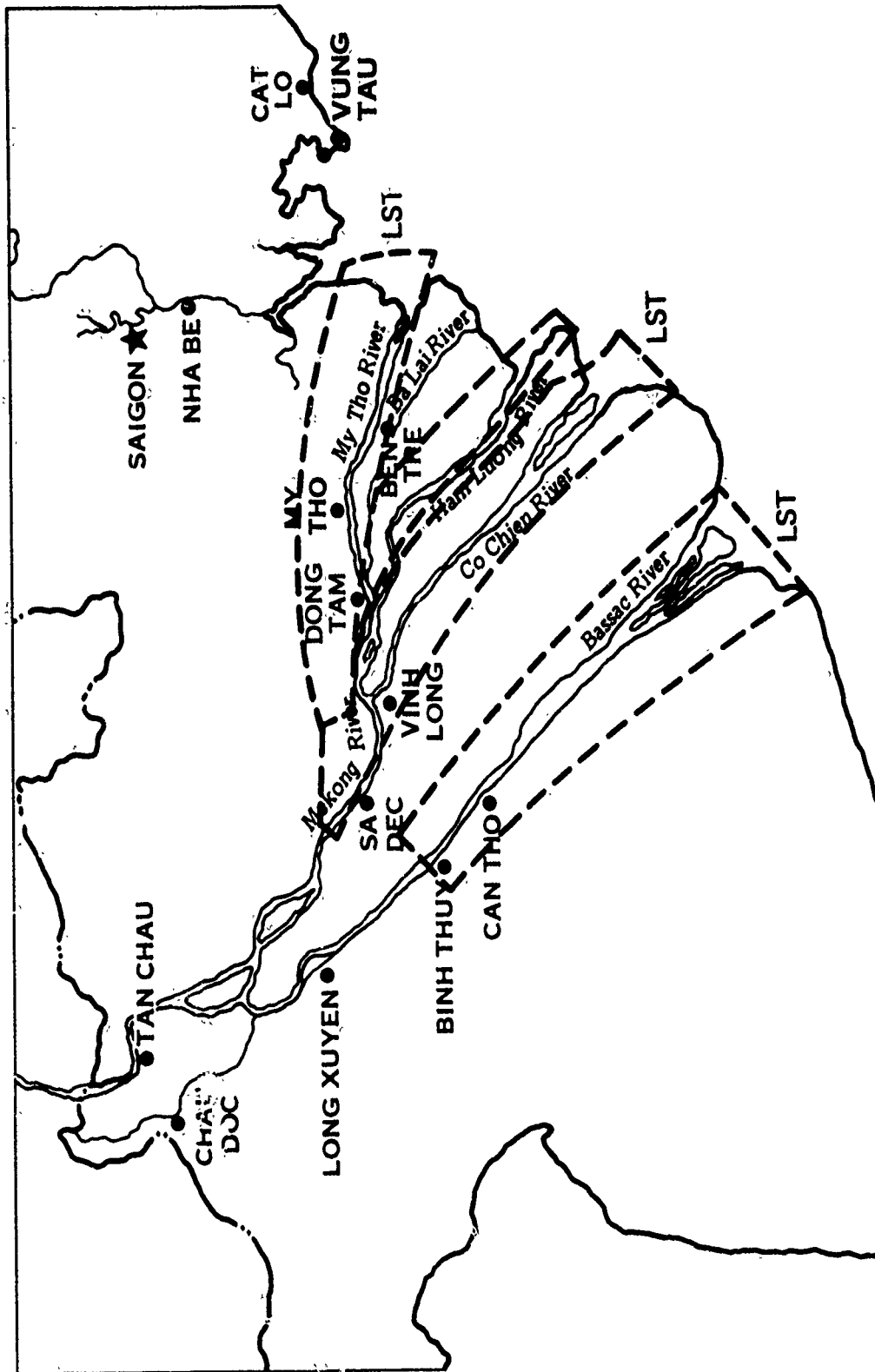

FIG. 7: GAME WARDEN AREA PATROLLED IN THE DELTA AT THE END OF 1967

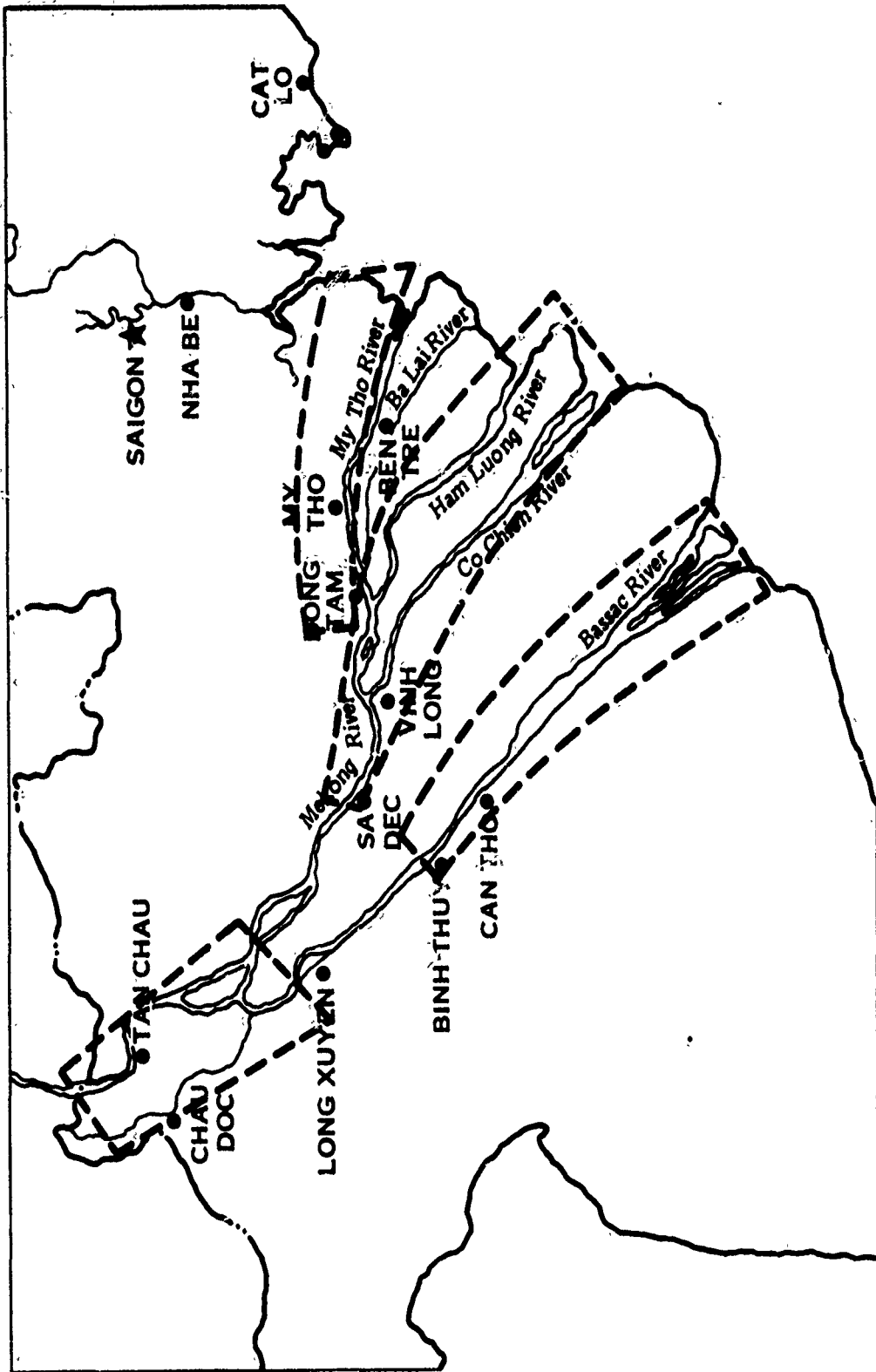

FIG. 8: 1968 GAME WARDEN AREAS PATROLLED IN DELTA



Evidence used in planning Sea Lords later in 1968 revealed that the enemy generally crossed the border by canals or overland routes between the Bassac River and the Gulf of Thailand or to the north of the Mekong. Although he may have used the major rivers to cross the border in the past, the enemy probably altered his route to avoid PBR patrols.

The 1968 Tet offensive saw simultaneous attacks on provincial capitals throughout the Delta. A study of enemy vulnerabilities, submitted by CTF 116 to ComNavForV on 18 February, included this assessment of Tet:

"The offensive...cost the enemy a high price in lives lost, but has not diminished his capability to continue the insurgency at pre-campaign intensity for an indeterminate period. SVN forces have been severely hampered by the necessity to defend the population centers. ...resources have been spread thin, thus permitting the VC a wide selection of targets. If the enemy objective was to demonstrate that (SVN and U.S. forces) could not effectively defend the people of the Delta, he must be judged successful.... There is no evidence, however, of the Vietnamese people rallying to the VC cause."

Game Warden forces saved Chau Doc and Ben Tre from falling to the VC during Tet, but the Game Warden base at Vinh Long had to be abandoned after the VC overran Vinh Long and PBR crews were cut off from their boats. An afloat base was established near Vinh Long.

An incident in March 1968 illustrates the effect Game Warden forces had on the enemy in the lower Delta. A Hoi Chanh<sup>1</sup> led a SEAL platoon to a large weapons cache and arms factory in Kien Hoa Province. This former enemy soldier related how he had been forced to go without food for 2 to 3 days at a time because PBRs prevented the VC from moving food supplies on the river. He added that river patrols had made it impossible for the VC to cross the river for the preceding 2 weeks.

In April 1968, a CNA analyst noted that the enemy appeared to be limiting his movements to lesser Delta waterways inaccessible to PBRs. The VC also continued to take advantage of the islands in the Bassac and My Tho Rivers to conceal their movement while minimizing exposure to PBR surveillance.

Intelligence reports in June indicated that the VC planned to move segments of their existing forces in IV Corps to support their continuing pressure and harassment on the Capital Military District of Saigon and its environs. Game Warden operations were

---

<sup>1</sup>A VC who has returned to government control.

extended to provide one river section of PBRs to patrol the Dong Nai River between Nha Be and a point about 2.4 st. mi. south of the Long Binh Bridge northeast of Saigon.

On 17 July 1968, Army LCU 1577 inadvertently crossed the SVN/Cambodia border on the upper Mekong. On 18 July, TF 116 assumed the responsibility for ensuring that all U.S./Allied shipping would be alerted as it approached the border. U.S. ships were not allowed to pass a point 4 n. mi. from the border, and all ships stopping at Tan Chau for customs inspection were alerted that U.S. personnel were not to cross the border. Liaison with the National Maritime Police was also established to prevent further inadvertent border crossings.

## THE SITUATION IN OCTOBER 1968

By October 1968, Game Warden forces had secured many sections of the major Delta and RSSZ rivers for commercial use. Routine VC tax collections had been interrupted along these major rivers. SVN government curfews were being enforced, and became effective weapons against the VC.

While it is probable that Game Warden denied the enemy overt control of the major rivers, it is far from clear whether Game Warden significantly denied the enemy use of the rivers as supply routes. ComNavForV, in October 1968, felt that Game Warden had effectively denied the VC use of the rivers for logistic movements. An intelligence analyst concerned with the period noted that, from 1966 to 1968, Game Warden failed to capture a single important shipment of war material. This did not imply the enemy was not making large shipments, however, since he had accumulated enough to mount the Tet offensive.

Intelligence in 1967 indicated there were other VC crossing points in addition to those covered by Game Warden patrols. These were located to the north and south of the Mekong/Bassac Rivers. (They later would be interdicted by Sea Lords barriers.)

It was clear by 1968 that the concept of a static barrier on the major rivers was inadequate. Evidence showed that the enemy was infiltrating supplies with impunity over the Cambodian border. In March 1968, NavForV analysts felt that massive infiltration over the Cambodian border was taking place, especially between Ha Tien on the Gulf of Thailand and Chau Phu on the Bassac River.

The Market Time task group commander in the Gulf of Thailand agreed with this assessment. He noted that enemy transshipment in the Gulf of Thailand from Cambodia to SVN had stopped, partly because of Market Time and partly because the VC could use the inland waterways without fear of disruption.

The SVN army, which should have been able to control IV Corps south of the Bassac, was ineffective. Not only were there not enough troops to interdict the enemy, but there were reports of SVN soldiers collaborating in VC smuggling across the border.

CTF 116 had earlier deployed PBRs to the upper Mekong and Bassac Rivers and had withdrawn them because of light contact with the enemy and the critical need for more support in the lower Delta. It is likely that if infiltration from Cambodia had been occurring across the entire border, the enemy could have successfully infiltrated supplies without using the upper Delta rivers. Another possibility is that there were never enough PBRs to effectively patrol the upper Mekong and Bassac Rivers.

Early in 1968, ComNavForV discussed the interdiction dilemma in a new OpOrder. He determined that the interdiction of resupply routes and river crossing points within SVN presented a more immediate problem to the VC than did interdiction of border crossing points. But the long-term effect would be far less significant, since the VC were known to alter their routes to adapt to hindrances. Interdiction of border crossing points would eventually exhaust the enemy's caches of modern weapons and would force him to use his older weapons. There were probably many caches of these weapons still available, especially in the older secret zones in An Xuyen Province.

Since it would obviously be more advantageous to interdict infiltration at the Cambodian border than to capture or destroy enemy material already within SVN, Game Warden was expanded into Sea Lords in October 1968. Sea Lords was a Delta-wide operation coordinating the combined assets of TF 115 (Market Time), TF 116, TF 117 (Mobile Riverine Force), and U.S. and Vietnamese ground forces. Sea Lords would continually harass VC strongholds and interdict supplies infiltrated from Cambodia.

The most logical place to set up a barrier against supplies entering SVN from Cambodia would have been on the canal that ran along the border. Because of the sensitive political situation, U.S. forces were not willing to risk border incidents. The first Sea Lords barriers were established on canals 35 to 40 n.mi. from and parallel to the Cambodian border.

The ultimate objective of in-country naval task forces was to support the extension of South Vietnamese control over the people and territory of the country. To reach this goal, naval operations had to complement the pacification programs. Sea Lords would extend SVN government influence into VC-controlled areas in conjunction with the accelerated pacification program begun in October 1968.

**APPENDIX A**

**DISTRIBUTION OF ENEMY SUPPLIES TO III AND IV CORPS**

## RESUPPLY FROM OUT OF COUNTRY

The key to the success of the enemy war effort was to satisfy the increasing demands for war materials and personnel to support the enemy objectives in the south. The enemy in the Mekong Delta of SVN depended heavily on infiltration of weapons and ammunition from NVN.

As early as 1960, evidence began accumulating on infiltration routes used by the enemy. Several options were available: direct seaborne infiltration; Cambodia (through Sihanoukville, Kampot, or Kep, then overland through Cambodia); and the overland route through Laos.

### Seaborne Infiltration

Seaborne infiltration of material and selected cadre into SVN probably started in the late 1950s. By 1962 (and possibly as early as 1960), the North Vietnamese were operating a maritime infiltration group that used ocean-going trawlers to transport munitions and some key personnel into SVN. Before 1963, the enemy used a variety of units ranging from small cargo junks to ships with a capacity of 100 tons. During this period, the enemy also relied on captured material and buried caches from earlier clashes with the French.

DIA believes that maritime infiltration reached its highest level in 1964 and early 1965. VC defectors had reported many seaborne deliveries from NVN to SVN. A CinCPac/CinCPacFlt study in 1967 concluded there had been as many as 20 trawler infiltrations in 1963, 15 in 1964, and perhaps 6 or 7 in 1965. NavForV estimated that these trawlers carried as much as 4,200 tons of arms and ammunition into SVN, enough to support 25 North Vietnamese Army (NVA) divisions for one year. The destinations of the early trawlers were probably An Xuyen or Kien Hoa Provinces in IV Corps.

Prompted by the discovery of an enemy trawler that had infiltrated II Corps, the U.S. Navy and the VNN initiated a coastal surveillance operation, Market Time, in March 1965. Because of the buildup of Market Time forces in 1965 and 1966, the enemy's ability to resupply his forces by seaborne infiltration decreased drastically. MACV estimated in 1965 that about 70 percent of VC/NVA resupply was accomplished by maritime infiltration. By mid-1966, MACV determined that not more than 10 percent of VC/NVA logistic support came by sea. By the end of 1966, MACV was able to say that there was no credible evidence of any significant infiltration of enemy troops or supplies by sea since November 1965.

During the first 3 years of Market Time, 12 NVN trawlers were detected heading for I, II, and IV Corps. III Corps was not used as a termination point because it failed to meet the security requirements of a sheltered, enemy-controlled beach. In early 1966,

in-country movement revealed that supplies destined for III Corps were probably landed in IV Corps, where facilities for receiving the cargo had been set up.

The nature of the trawler infiltration attempts during the first 3 years of Market Time suggested that the enemy would attempt seaborne infiltration to solve a short-term crisis. Trawlers were not inclined to abort their missions, and 8 of 12 trawlers were destroyed. The most drastic seaborne resupply attempt occurred immediately after the heaviest fighting of the Tet offensive in February 1968. During late February, 5 trawlers were detected attempting infiltration; this was the first time Market Time forces had observed an enemy attempt to saturate the coastal surveillance barriers. One trawler aborted its mission before entering SVN's contiguous waters. Several days later, 4 trawlers came under Market Time surveillance as they approached the coast of SVN off I, II, and IV Corps. Three of the trawlers were destroyed and the fourth aborted its mission. One of the trawlers carried a large quantity of medical supplies. This infiltration attempt had obviously been crisis-oriented in reaction to enemy casualties during Tet.

#### Infiltration from Cambodia through Sihanoukville

Cambodia played an increasingly important role in the resupply of war material to the VC in SVN (figure A-1). Official U.S. acceptance of Cambodia's role did not come until 1970, however, because of political implications.

CAS<sup>1</sup> reporting from Phnom Penh through the late 1950s reflected the evolution of an NVA-directed VC infrastructure in the Cambodian sanctuary. The enemy mission was to penetrate the lower and middle echelons of the bureaucracy and establish a base of support. War Zone D, the Parrot's Beak, and then War Zone C, appear successively as base areas for the VC (appendix B). By 1961-1963, the enemy established accommodations with middle-level Cambodian provincial officials along the borders of what became III and IV Corps. At the same time, supplies and funds from Phnom Penh and other urban centers were moved to these VC safe areas. There were also reports of outright logistic support of the VC by Cambodian military and civilian provincial authorities.

In January 1964, the Bucklew Report stated that Cambodia could be used for enemy infiltration into SVN. It was obvious to this study group that Cambodia offered the enemy great natural advantages -- proximity to SVN, the excellent inter-Cambodia/SVN waterway system of the Mekong-Bassac River complex, and direct access by sea. Communist-Bloc shipments could move through Sihanoukville and Kep. Had the Cambodian government been fiercely anticommunist, the enemy would not have been able to use many of these

---

<sup>1</sup> CIA term for Covert American Source.

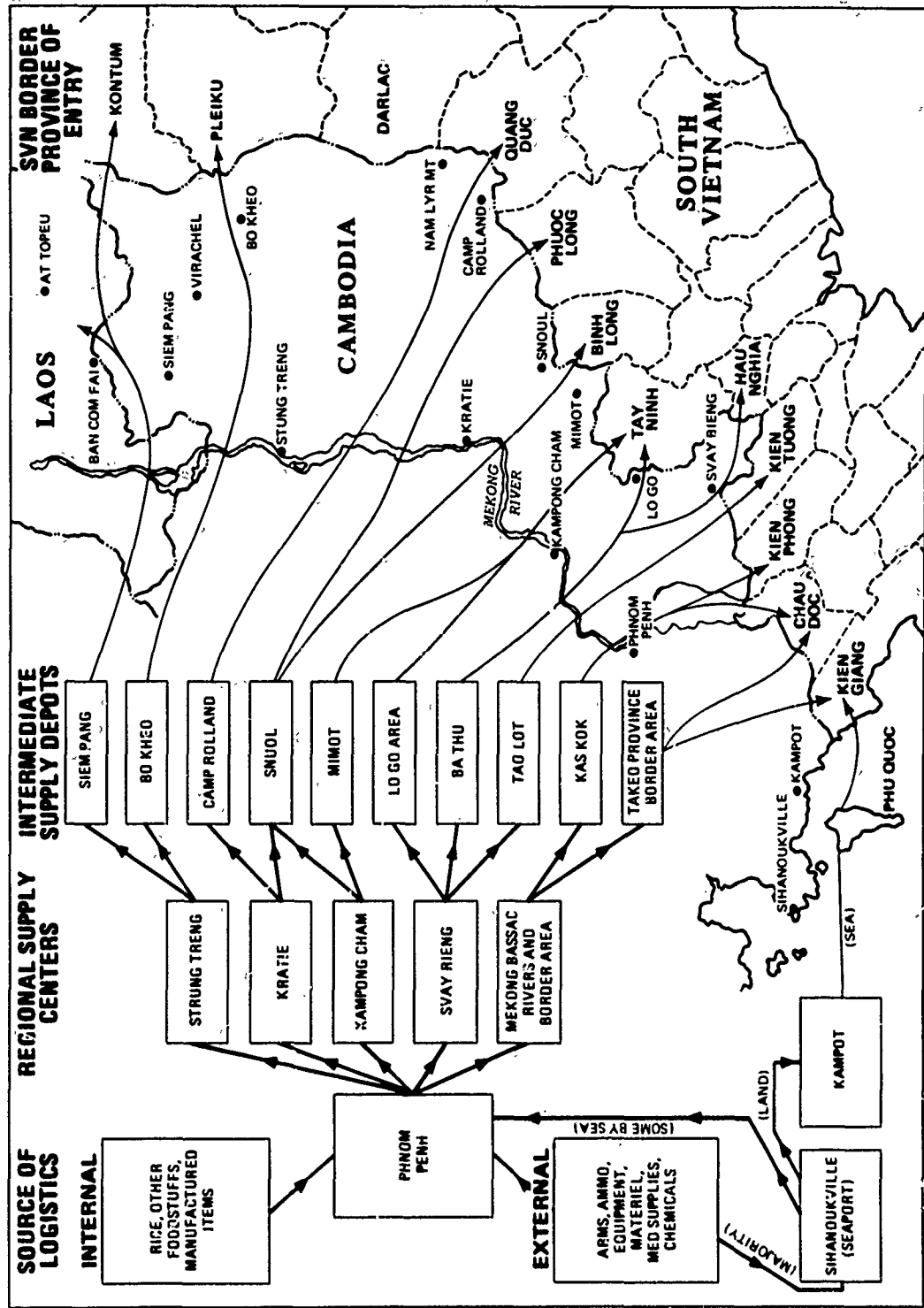

Source: MAC.

FIG. A-1: LOGISTICAL FLOW - CAMBODIA TO SVN (1966)



natural advantages with impunity. But the Cambodian government had close relationships with Hanoi, including a commercial air agreement and economic ties that permitted the stationing of key NVN economic representatives in Phnom Penh. Cambodia's foreign policy clearly showed favoritism to the communist bloc.

The VC headquarters of the "Committee for the Liberation of South Vietnam" in the early 1960s was located on the Cambodian/SVN border in Tay Ninh Province. Within Cambodia itself, North Vietnamese and Chinese elements were believed to be involved in the infiltration, with counterparts on the SVN side of the border.

The VC had taken advantage of Cambodian cooperation and would continue to do so until mid-1969. Supplies were moved by the enemy from Cambodia to SVN on inland waterways, on inland trails, or by sea in the Gulf of Thailand. There was substantial illegal trade for private profit between Cambodia and areas in SVN held by both the SVN government and the VC. Before 1963, the Mekong-Bassac River complex was the principal route from Cambodia for resupply in SVN.<sup>1</sup> Between 1963 and 1966, SVN's seizures of illegal supplies on the rivers almost ceased. Either SVN control of the border was deteriorating or the enemy had switched to land routes. By 1966, CIA had determined that VC resupply over the Cambodia/SVN border had been occurring for some time, and CIA determined the locations of many crossing points.

In 1964, a new family of Chinese communist weapons was discovered in the Delta. There were indications during late 1964 in IV Corps that VC cadre were going from main to local force units demonstrating the use of communist-bloc weapons. All-source reporting for 1964-1965 indicates massive equipping of enemy forces in III and IV Corps coinciding with shipments from Cambodian military warehouses. There were implications of high-level Cambodian military or government complicity.

It was obvious that these new weapons were being supplied from sources outside SVN. The Ho Chi Minh trail was not capable of handling this flow of material to the Delta. Although seaborne infiltration could account for the appearance of these weapons, intelligence information attests to Cambodia as their source.

In May 1965, Prince Sihanouk severed diplomatic relations with the U.S. and accepted Chinese military aid. He claimed that he was neutral. In October 1965, the U.S. Intelligence Board (USIB) concluded that the VC were using Cambodian territory with active Cambodian cooperation in some areas, a laissez-faire attitude in others, and the lack of Cambodian government patrol of frontiers. USIB added that the Cambodian government stopped short of military aid.

---

<sup>1</sup> Cambodian imports of potassium chlorate were very suspicious. The import of 10 metric tons in 1960 jumped to 107 metric tons for January-August 1963, far in excess of Cambodian needs.

MACV reported in 1965 that bases in Cambodia served as convenient transshipment points for supplies from NVN and China, and estimated that a minimum of 25 tons per day of all classes of supplies were entering SVN from Cambodia. In 1966, MACV concluded that, because of the increased effectiveness of Market Time and the continuation of friendly interdiction operations in Laos,

"Cambodia can figure prominently in all axes and methods except across the DMZ either as a source of supply or as a transit area for movement of enemy logistics. It is the only contiguous area and source of support for the NVA/VC forces in SVN against which no friendly military action is being taken. It could be developing into the principal transit area and source of supply for the logistical support of the NVA/VC war effort."

To substantiate this theory, NavForV was authorized to establish Sunshine Park, a program of collecting and assembling evidence to verify or deny Cambodia's role in the enemy resupply effort.

A 1966 Combined Intelligence Center, Vietnam (CICV), study on VC tactical use of inland waterways in SVN listed five major supply-infiltration routes from the Cambodian border area to SVN. The study noted that arms and ammunition moved from Cambodia south and east along these routes. By September, MACV's intelligence section presented a picture of the communist logistics flow within Cambodia and the destinations of supplies entering SVN from Cambodia.

At the end of 1967, the U.S. mission in Saigon noted an increase in the unconfirmed reports of shipments of communist arms and ammunition through Sihanoukville. In a 23 November message to the Secretary of State, the mission stated that: "If the enemy is to continue the war at the present levels, or expand it, a new main supply route will be required to augment present routes through the DMZ and Laos. Cambodia represents the real possibility for significant augmentation and improvement of enemy supply routes." CIA and MACV continued to reinforce this assessment.

In addition to low-level reports of Cambodia as a resupply route, communist use of Cambodia was further amplified by an examination of ordnance entering Sihanoukville on Chinese ships from October 1966 to July 1969. In spring and summer, 1969, Prince Sihanouk imposed an embargo on the delivery of communist arms and ammunition to Sihanoukville. Although the embargo was temporarily lifted, it was reimposed by late 1969. Communist use of Cambodia for distribution of supplies to SVN was halted permanently after the ouster of Sihanouk and the US/SVN cross-border operations in the spring of 1970.

Studies of goods entering Sihanoukville were made by MACV in November 1968, CinCPac in August 1969, and CIA in December 1970.<sup>1</sup> (See table A-1.)

An example of the magnitude of the supplies entering SVN from Cambodia was revealed by a communist border liaison cadre captured on 21 January 1968. The prisoner said that during the second half of 1967, 1500 tons of arms and ammunition were infiltrated from Ton Hon to the Seven Mountains and Tram Forest areas of Ha Tien District (BA 400). During the first half of 1967, 700 tons were infiltrated into this area. In April 1968, the intelligence staff at NavForV estimated that the infiltration of supplies, exclusive of food was 175 to 200 short tons per month. (The source for these figures stated that several years later it was decided that the actual infiltration tonnages were underestimated.) This infiltration rate was far greater than estimated requirements. The total monthly logistic requirement, exclusive of food, for the VC in IV Corps was about 28 short tons. Of this, 19 tons had to be infiltrated. The U.S. could not explain why infiltration exceeded the total requirements by such a large proportion. The VC tended to cache supplies, and U.S./SVN operations had uncovered many of these. Another factor may have been that infiltration depended on Cambodian cooperation; thus, it was important that the VC infiltrate as rapidly as possible, while the Cambodian government continued its collaboration with the VC.

The arms and ammunition delivered to Sihanoukville were in excess of the Cambodian armed forces' reasonable needs for the period. It was further determined that the excess supplies would have satisfied almost two-thirds of the enemy's needs in IV, III, and southern II Corps. In all, there were between 11,000 and 19,400 tons of arms and ammunition delivered to Sihanoukville from October 1966 to July 1969 destined for the VC/NVA in SVN.

Even though evidence accumulated from the early 1960s suggested that VC were using Cambodia as an infiltration route, it was not accepted at the national level until 1970. After Prince Sihanouk was ousted from power in mid-March, documentation became available describing the role of Sihanoukville and Cambodia in ordnance resupply for the communists in SVN.

#### Overland Route through Laos (Ho Chi Minh Trail)

The overland route through Laos was always considered a possible enemy infiltration route. In 1964, MACV had evidence that the land routes from NVN through Laos handled logistical traffic at least as far south as southern II Corps.

The Ho Chi Minh trail was upgraded to a truck route in 1964. When the new family of arms was discovered in the Delta, the trail was still under development and could not have handled the quantities of ordnance that appeared in III and IV Corps.

---

<sup>1</sup> CIA's 1970 assessment was an update of earlier studies.

TABLE A-1

**CHINESE DELIVERIES OF ARMS AND AMMUNITION  
TO SIHANOUKVILLE -- OCTOBER 1966-JULY 1969<sup>a</sup>**

Arrival date	Source in which arrival is cited <sup>b</sup>	Ship	Tonnes		
			MACV (probable)	PACOM (probable) (possible)	CIA
Oct 66	P	You Hao		250	
Dec 66	M, P, C	He Ping	450	450	1005
Jan 67	M	Hang Zou	2300		
Feb 67	C	Hang Zou			2102
Mar 67	M, P, C	He Ping	450	40	2964
Aug 67	M	Ji Ning	1000		0 <sup>c</sup>
Oct 67	M, P, C	You Yi	1400	805	1099
Dec 67	M, P	Fo Shan	10+	11	
Jan 68	M, P, C	You Yi	3348	3848	2344
Mar 68	M, P, C	Wu Xi	2000+	3000	2350
Aug 68	M, P, C	Fo Shan	2000	2000	2474
Jan 69	P, C	Li Ming		4500	2894
Mar 69	P	Huang Shi		2000	
Apr 69	C	Huang Shi			3689
Jul 69	P	You Yi			

<sup>a</sup> Cambodian Army's cut subtracted from total Chinese deliveries of arms and ammunition. CIA sets the cut at 1,679 tons with another 822 tons in legitimate aid.

<sup>b</sup> M = MACV  
P = PaCom  
C = CIA

<sup>c</sup> CIA believes the Ji Ning delivered 1,238 tons of foodstuffs and no ordnance in August 1967.

Through 1968, the enemy hardly used the overland route through Laos to resupply his forces in southern SVN. According to an Army study published in 1970, a total of 236 intelligence reports of varying reliabilities documented the flow of ordnance from Cambodia into II, III, and IV Corps from March 1967 to October 1968. Of these reports, only 14 indicated use of the overland route into Cambodia. Moreover, MACV stated in a message to JCS in December 1968 that in the Laotian panhandle below Base Area 610 (see figure B-2), the meager traffic flow recorded between December 1967 and December 1968 was considered insufficient to satisfy the needs of VC/NVA forces in southern SVN as well as those in I and II Corps.

#### IN-COUNTRY DISTRIBUTION

There is little documentation available even today describing the enemy supply system in SVN during 1965-1968. Many of the detailed maps of enemy routes that were used by NavForV during the war have been destroyed. Of the maps that survived, some are of a higher classification than this research contribution. In addition, pertinent CIA data is not readily available. The scenario presented here is based on a CinCPac Infiltration Study, NavForV and MACV in-house papers, a USIB study, and information provided by DIA.

The 1965 USIB study described the network of supply corridors used by the enemy in SVN as an interconnecting system of depots and way stations from provinces in NVN to the Ca Mau peninsula in SVN's Mekong Delta. The Tay Ninh Base Area in III Corps was thought to form the major connection between the corridors from the north and the network in the south.

A considerable part of the enemy transport system ran through VC-controlled territory. Some of this territory was controlled by the South Vietnamese during the day but not at night, when most of the enemy supplies were distributed. According to captured documents, supplies were moved in stages and handled through as many supply depots as necessary to ensure security. Transport units moved on secured routes protected by forces usually assigned from local guerrilla units. It was suspected that troops would conduct raids near the transport routes as a diversion to screen movements of supplies over more exposed sectors.

The routes generally followed the most direct waterways to base camps and enemy secret zones. Some areas, such as Kien Hoa province, offered many direct waterway routes, and the one selected certainly depended on the presence and frequency of U.S. and SVN army patrols in the area.

It is difficult to estimate the volume of supplies handled over internal VC supply routes. Figures A-2 and A-3 illustrate the possible major inland waterway routes used

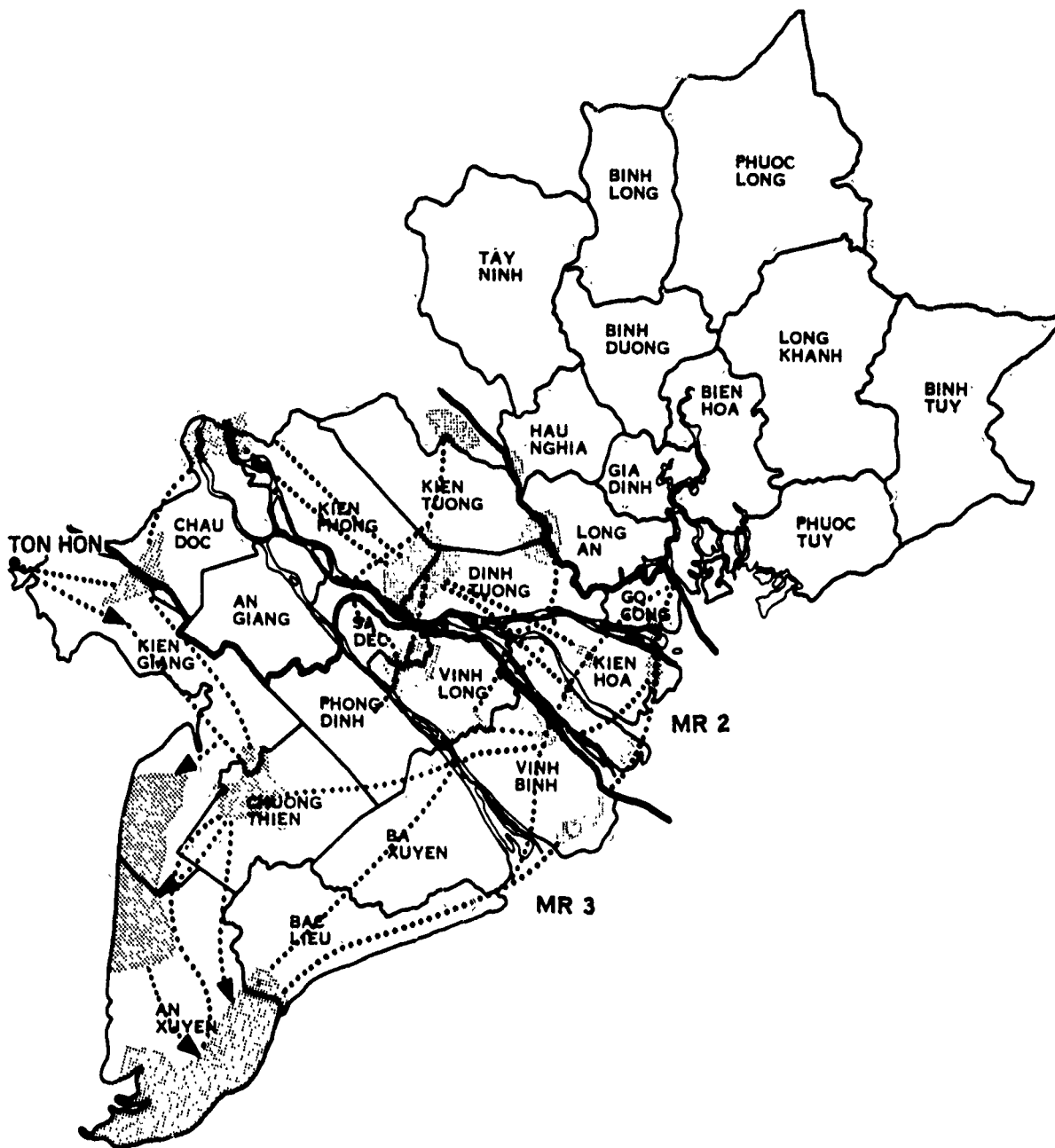

**FIG. A-2: SUSPECTED IV CORPS SUPPLY ROUTES**

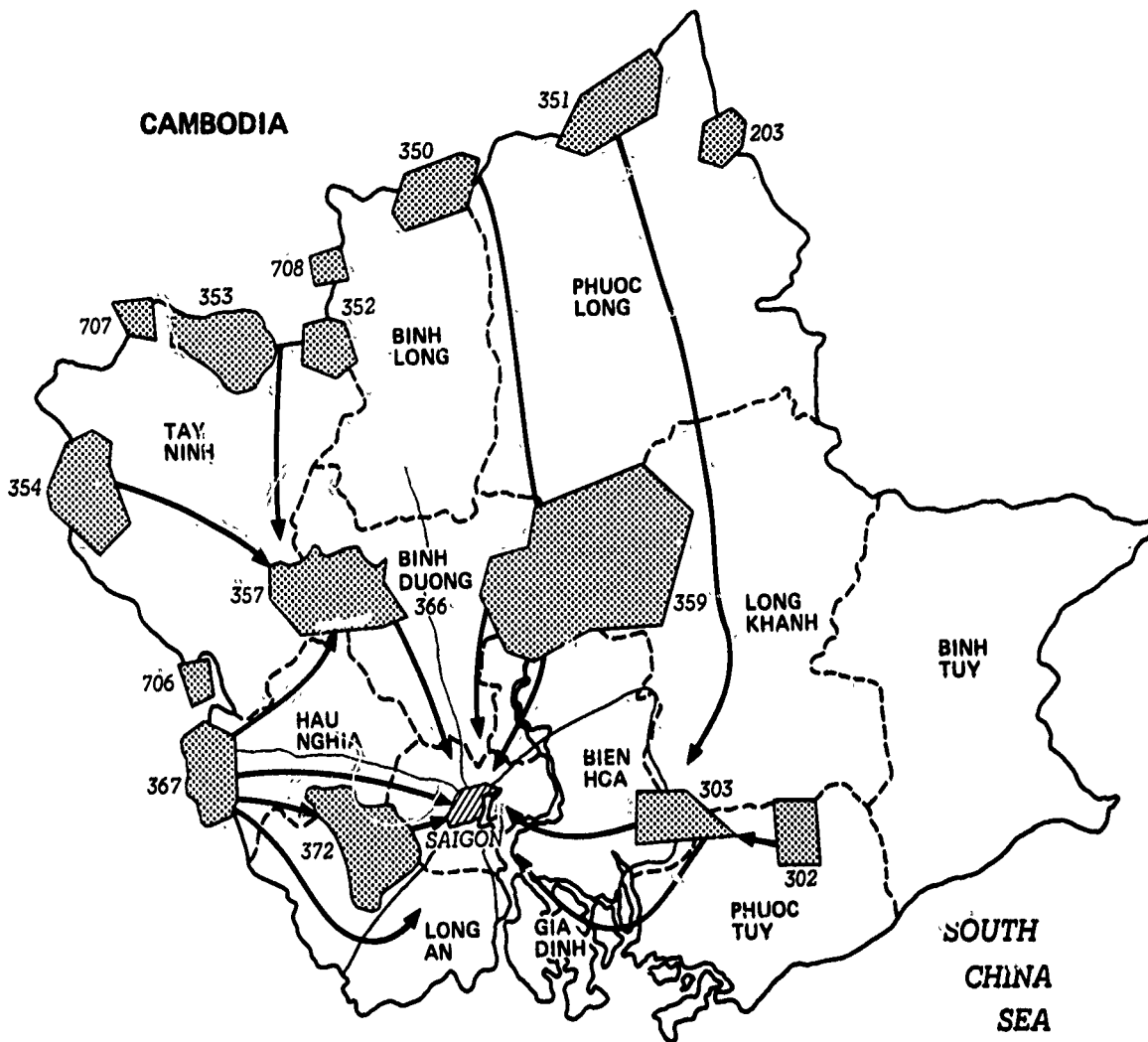

Before the TET offensive in 1968, in the areas of direct importance in the anticipated battle for Saigon, the military region surrounding Saigon was divided into subregions. DIA suggests this reorganization was prompted by the need for a more responsive supply system in the Capital district in view of the upcoming offensive.

**FIG. A-3: SUSPECTED III CORPS SUPPLY ROUTES**

by the VC between 1965 and 1968. It is impossible to determine when specific routes and base areas were abandoned and when they were used.

But it is possible to make some general assumptions about the nature of enemy dependence on certain routes. By 1966, the rear service groups geared to accepting those supplies that were delivered by sea had reoriented their focus to receiving supplies from Cambodia. Although the enemy probably had arms caches to be moved from his base areas on the South China Sea coast, it is likely that the traditional redistribution route from An Xuyen Province north to the lower Bassac River declined in importance after 1966. It is also probable that enemy transshipment from Cambodia to SVN in the Gulf of Thailand declined with the onset of Market Time patrols in the area.

The enemy did not have to cross the upper Mekong and Bassac Rivers, where Game Warden forces patrolled. He could supply his base areas to the north and south of the major rivers by crossing the Cambodia/SVN border by lesser waterways or overland routes on each side of the Mekong/Bassac River complex. To maintain his bases in Kien Hoa and Vinh Binh Provinces (located between major rivers), the VC would have been forced to cross major lower Delta rivers, which Game Warden patrolled. Intelligence has shown that the VC were flexible in their choice of routes to resupply their forces in southern SVN. With the vast network of waterways available to them in the Delta, they could switch their emphasis, depending on the tactical situation.

#### Distribution Organizations

A NavForV intelligence report in 1966 dealt with how the VC organization in the early 1960s received supplies by sea. Group 962 was probably the largest organization formed by the VC in IV Corps. Before becoming inactive in December 1966 when munitions began to arrive at Sihanoukville, Group 962 was responsible for receiving, distributing, and storing munitions sent to IV Corps by sea. These supplies were transshipped north into War Zones C and D.

After 1966, most infiltration into southern SVN originated from Cambodia. The distribution of war material infiltrated from Cambodia into IV Corps was apparently handled by two independent supply systems. The systems were maintained by MR-2 and -3 (VC designation) personnel. An interprovincial route served as the link between the two military regions. This route originated in the base area at the tip of An Xuyen province and went north to cross the Bassac River south of Can Tho. At the crossing, the route divided and continued until it ended in base areas north and northeast of the crossing point.

In III Corps, the enemy forces within the Saigon subregions were supported by 7 rear service groups -- subordinate to COSVN -- that were responsible for the support of all main force units operating in their area of responsibility. A deputy commander of the VC fifth front, who was captured in June 1968, said the rear service groups consolidated logistic requirements for all units operating in their areas of responsibility and submitted



the requirements to COSVN. COSVN provided the required supplies to the rear service groups quarterly. When COSVN planned operations in addition to those included in the original annual request for supplies, the rear service groups were informed of the extra supplies they would receive. The captured VC also revealed that the rear service groups generally had an abundance of munitions and experienced no trouble meeting the ammunition requirements of combat units.

## SUMMARY

Through the beginning of 1965, MACV considered the sea to be the main resupply route for the VC in southern SVN. By mid-1966, with the buildup of Market Time, MACV discounted seaborne infiltration as a major resupply method for the VC.

The overland route through Laos did not function as a resupply route for southern SVN through 1968.

Even before the major U.S. commitment in SVN in 1965, Cambodia was suspected to be playing a role in enemy resupply. There is some question as to the emphasis the communists placed on infiltration from Cambodia relative to seaborne infiltration.

By 1966, seaborne infiltration was restricted to crisis-oriented resupply attempts, and Cambodia gained in importance as the major communist resupply route to III and IV Corps. In late 1966, Chinese ships began to make deliveries destined for the VC/NVA in SVN to Sihanoukville. Between October 1966 and July 1969, these deliveries totaled between 11,000 and 19,400 tons of arms and ammunition. Until 1970, however, the U.S. did not have a complete picture of the network in Cambodia that began with the delivery of supplies to Sihanoukville and ended with their delivery over the border to forces in SVN.

Although MACV and the intelligence agencies seemed aware of these Chinese deliveries well before 1970, it was only after the ouster of Prince Sihanouk in March 1970 that documentation became available to prove the relation of the Chinese deliveries and the complicity of Cambodian officials with communist resupply in SVN.

Inadequate information is available describing the enemy supply system in southern SVN from 1965 through 1968. It is clear that, by 1966, enemy rear service groups had shifted their focus from receiving supplies delivered by sea to supplies infiltrated from Cambodia.

The enemy was flexible at adapting his supply routes to the changing tactical situation. Since he could infiltrate over the Cambodian border with impunity, he had access to many lesser waterways and land routes into the Delta. The only area in which he would have been forced to cross the rivers Game Warden patrolled was in the lower Delta. Enemy base camps in Kien Hoa and Vinh Binh Provinces were located between major rivers, which the enemy would have been forced to cross to accomplish resupply.

**APPENDIX B**

**VC/NVA BASE AREAS AND ORDER OF BATTLE IN SVN**

DIA was publishing maps of communist base areas in SVN when Game Warden began. Figures B-1, B-2, and B-3 are based on DIA's maps from July 1966 through July 1968.

B-1-a

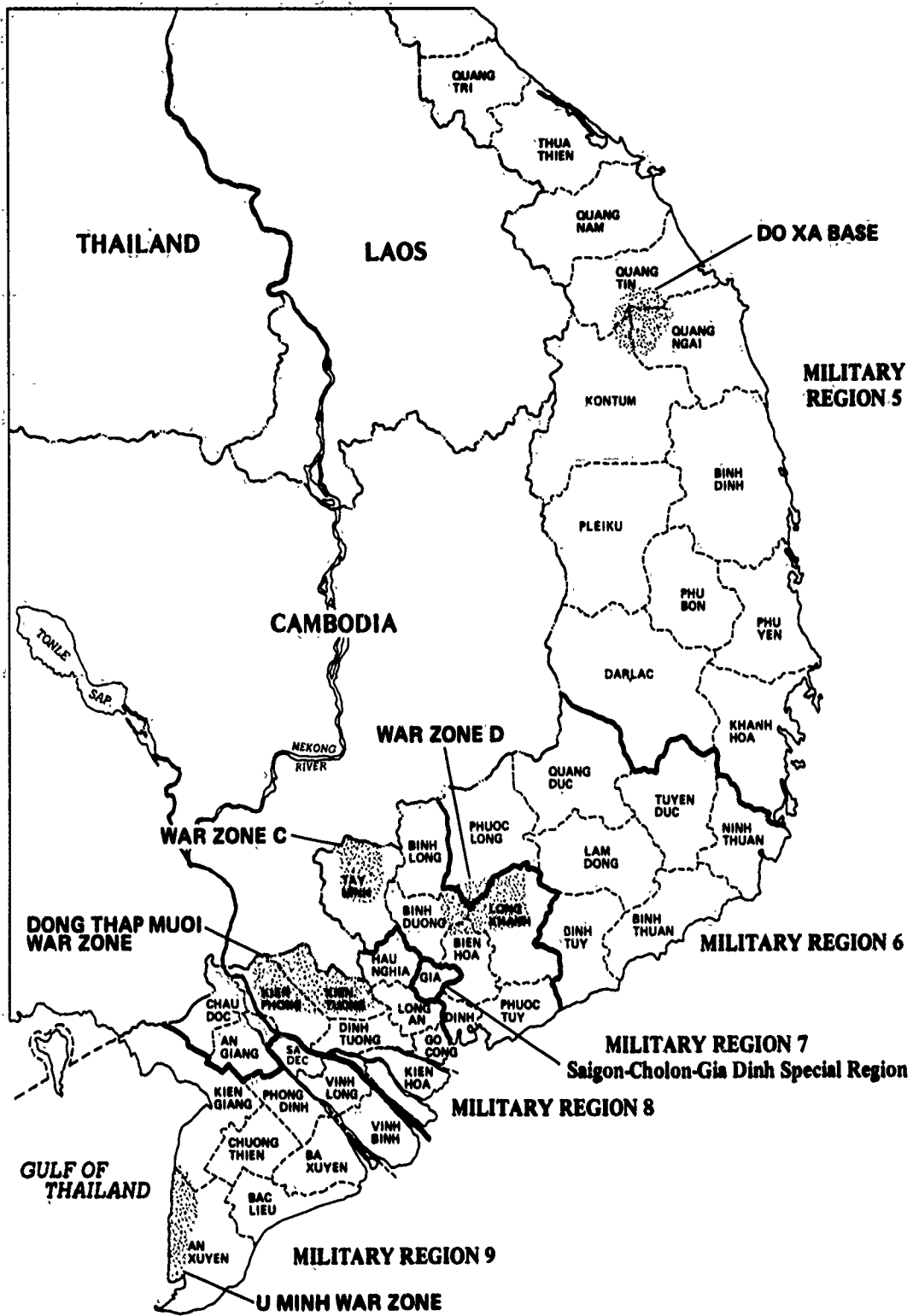
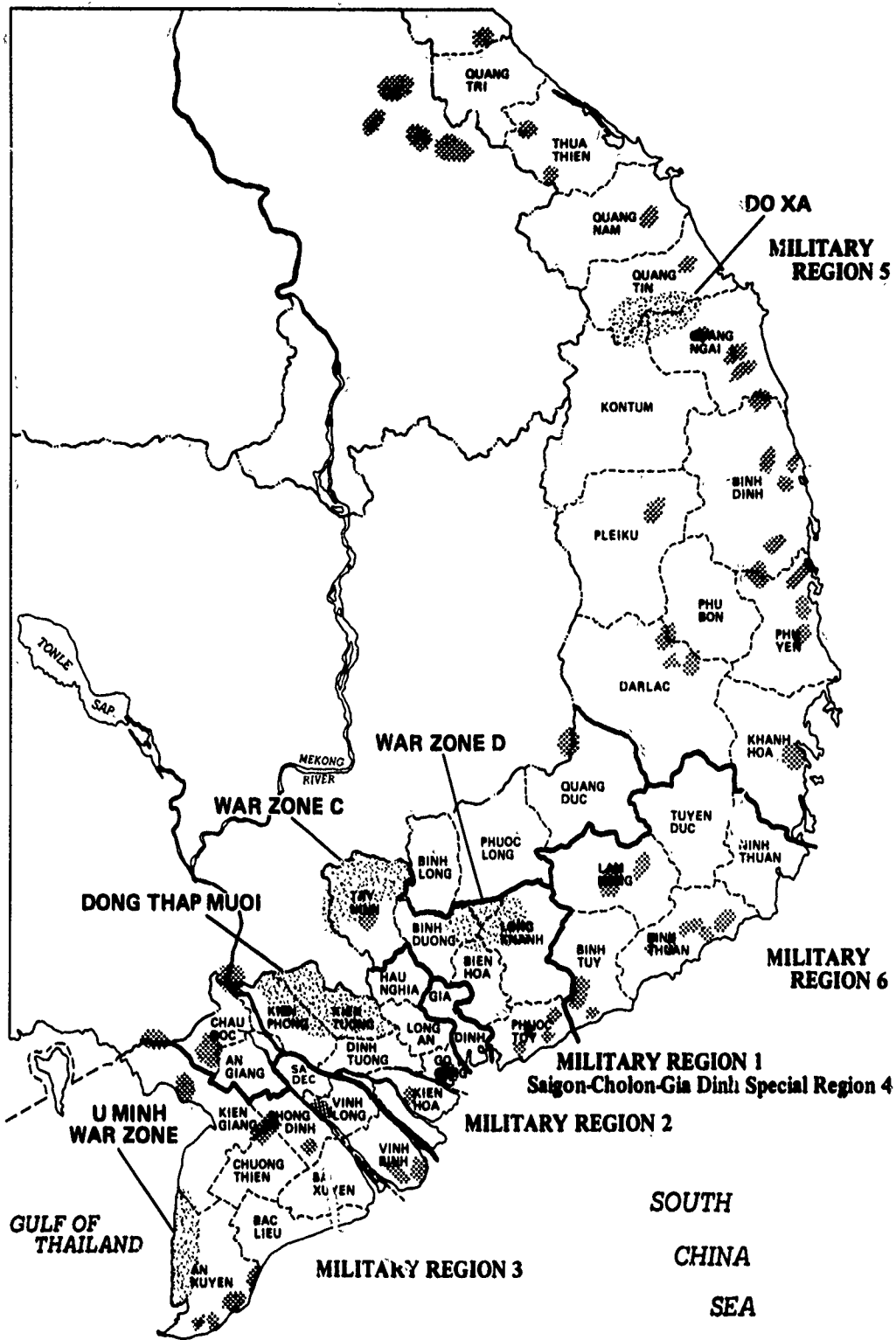
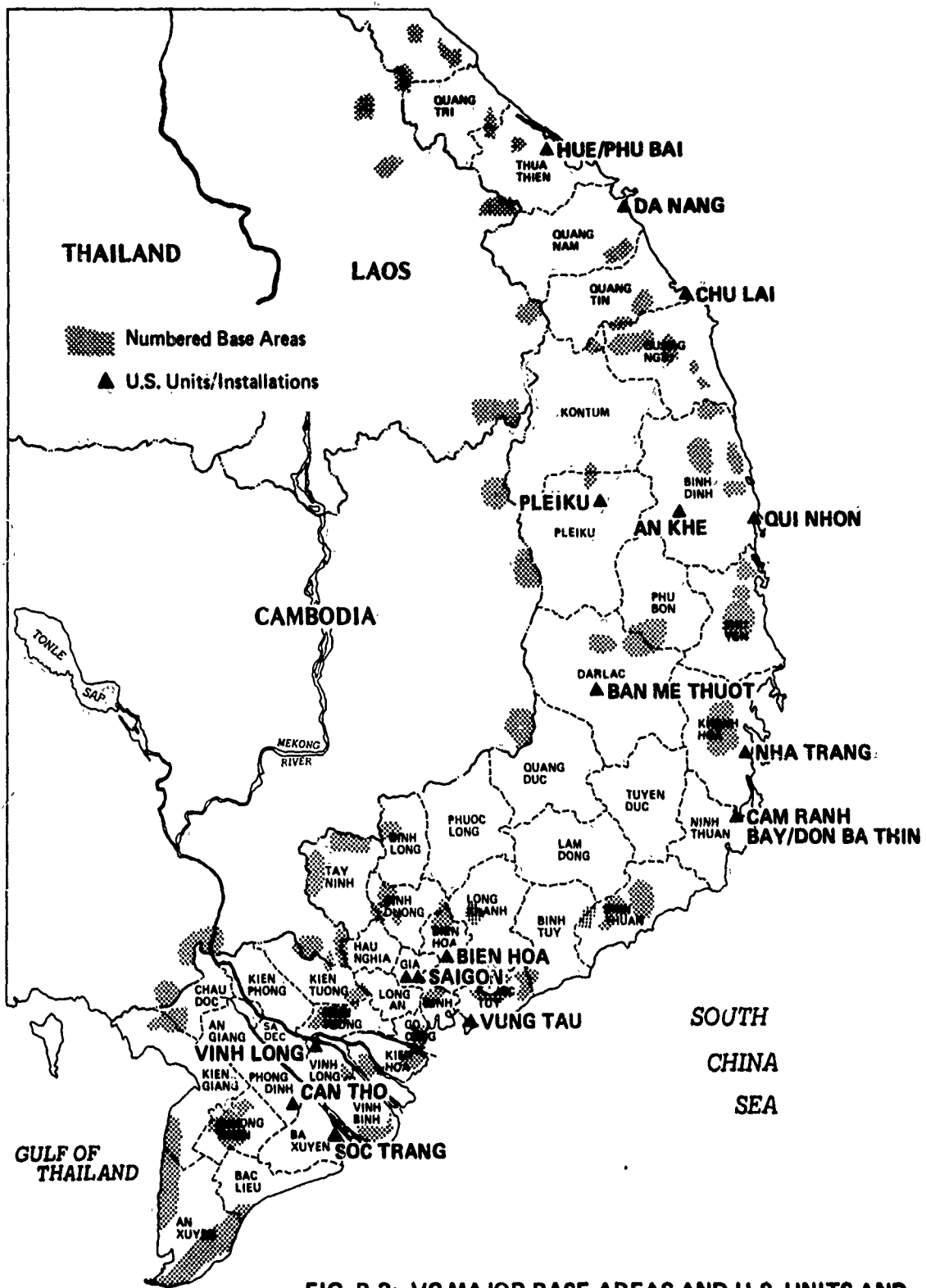

FIG. B-1: VC MILITARY REGIONS/WAR ZONES - 1966



**FIG. B-2: VC MAJOR BASE AREAS AND WAR ZONES – 1967**



**FIG. B-3: VC MAJOR BASE AREAS AND U.S. UNITS AND INSTALLATIONS - 1968**

**APPENDIX C**

**OTHER MILITARY AND QUASIMILITARY FORCES  
OPERATING IN THE DELTA AND RSSZ**

## VNN RIVER FORCE

The VNN River Force assigned river craft to the River Assault Groups (RAGs) and the River Transport and Escort Group (RTEG). In January 1967, the River Force averaged 225 boats assigned, 153 available, and 129 employed. The functions of the boats included command, communications, fire support, troop lift, and escort.

### RAGs

There were 13 RAGs deployed in III and IV Corps in mid-1967. The average RAG was about 20 boats, most of which were converted LCM troop carriers. Their primary mission was combat support for ground troops. Each RAG could carry a battalion of infantry. River patrol was a secondary mission. RAGs launched a psychological campaign in the Delta, using leaflets, loudspeakers, and airdrops to publicize the Chieu Hoi program. The local populace was encouraged, often successfully, to volunteer information about the VC.

### RTEG

In mid-1967, the RTEG had 28 RAG-type craft providing armed escort for the commercial river convoys between the Delta and Saigon. About 90 percent of Saigon's supply of rice and charcoal transited in these convoys. At times, the VC controlled part of the traditional route to market (the Mang Thit-Nicholai Canal), and the RTEG was forced to convoy 100 n.mi. out of the way by an alternate route. The Mang Thit-Nicholai Canal was temporarily cleared by a joint TF 116/117 operation during the counter-offensive following Tet. In October 1968, this canal was included in the Sea Lords area of operation.

## REGIONAL AND POPULAR FORCES

Regional forces (RFs) at the provincial level and popular forces (PFs) at the district government level had ground forces that made sweeps through areas near rivers that had been sites of enemy firing incidents against Game Warden. In addition to ground forces, the RFs had boat companies with one company generally assigned to each province. There were 24 of these companies in 1967.

A typical RF boat company consisted of 8 vehicle and personnel landing craft (LCVP) with 30- and 50-caliber machine guns; the company carried and supported one combat-equipped company of ground troops. RF boat companies were used to maintain security of the waterways within their assigned province by patrolling, ambushes, and small-scale amphibious assaults. They were also used for point defense and routine transportation. Utilization of RF boat companies varied widely from province to province. In 1967, they were not being used effectively because of the failure of province chiefs to assign them



to productive operations and because of fragmented command, coordination, and support arrangements.

#### NATIONAL POLICE RIVER PATROL FORCE

Under the director general of the National Police, the mission of the National Police River Patrol Force was to control river and inland waterway traffic by using mobile check-points. This force was built around USCG-type 40-foot police river patrol boats, which tow 2 small interceptor boats. This force was not fully used until 1968. During 1967, however, there were 56 boats stationed at 4 check points.

#### VIETNAMESE CUSTOMS BOAT FLEET

This organization primarily furnished boats to district customs offices to help them in their duties. In 1967, 37 lightly armed boats were operated. The customs officials were concerned chiefly with international movement of cargo and contraband control, with emphasis on coastal ports of entry, the Mekong, and the Cambodian border. Corruption and complicity with the Cambodians were acknowledged problems within the customs service.

#### ARMY OF THE REPUBLIC OF VIETNAM (ARVN)

The ARVN had 3 divisions operating in the Delta. ARVN officers generally lacked aggressiveness and motivation and VC were known to have infiltrated ARVN units.

Until 1967, the ARVN made no major efforts to disrupt the VC in the Delta. The Army was supposed to move into an area and maintain security after the Mobile Riverine Force (MRF) had struck a VC unit. In fact, however, the ARVN often did not remain until pacification measures made a solid impact on the population. ARVN activities were not often coordinated with operations conducted by the MRF or Game Warden forces, and ARVN offensive operations only temporarily displaced the enemy.

In 1968, the ARVN was given the responsibility to improve and maintain security on Route 4, the vital link between the Delta and Saigon and a major VC military objective.

#### MOBILE RIVERINE FORCE

The Mobile Riverine Force (MRF), a joint Army-Navy task force, was the first U.S. force specifically targeted against VC strongholds in the Mekong Delta and RSSZ. Its primary mission was to seek out and destroy VC main force units. Troop lift was via specially designed river assault craft.

MRF consisted of 3 battalions of the Second Brigade, Ninth Infantry division, U.S. Army, and Navy River Assault Flotilla One. River Assault Flotilla One consisted of 2 river assault squadrons and one support squadron, which were made up of a mixture of armored troop carriers, monitors, command/communication boats, and assault support patrol boats. The flotilla operated from afloat bases and a shore base at Dong Tam. The Navy transported troops from the mobile base to their area of operation, then provided direct and indirect gunfire support for those operations.

While VNN RAGs had not been armored sufficiently to sustain close contact with the enemy in small waterways, MRF boats were armored well enough to allow the Force to sustain contact with the VC for several days. MRF operations began in the RSSZ in February 1967 and in the Delta in April.

Besides strike operations in reaction to intelligence on the location of enemy forces in the Delta, improved security on the vital Route 4 was a MRF goal. This would allow a resumption of normal commerce. In strike operations, assault boats moved in quickly to block all waterway escape routes for the VC; helicopters and armored transports brought in troops to establish land blocks and to seek out the enemy; and assault boats furnished naval gunfire support.

During the 1968 Tet offensive, the MRF was credited with saving the major towns and cities of the Delta, which would have been otherwise captured or destroyed by the VC. Many times after the MRF left an area, however, security was not enforced and the VC returned.

By summer 1968, the MRF was concentrating on the pacification of Long An, Dinh Tuong, and Kien Hoa Provinces. In September, the primary focus of the MRF was the pacification of one province -- Kien Hoa.

APPENDIX D

GAME WARDEN TASK ORGANIZATION

(Source: CRR-5 Inst 05400.1)

## ORGANIZATION

### 2101 Squadron Organization

- 2101.1 This Squadron is a unit of the Amphibious Force, U.S. Pacific Fleet (PHIBPAC). Commander, Amphibious Force, U.S. Pacific Fleet (COMPHIBPAC) exercises Administrative and Type Commander's control.
- 2101.2 The Squadron consists of five River Divisions and twenty River Sections. The Squadron Commander exercises administrative control through regularly assigned Division Commanders.
- 2101.3 The administrative organization is illustrated in the following schematic:

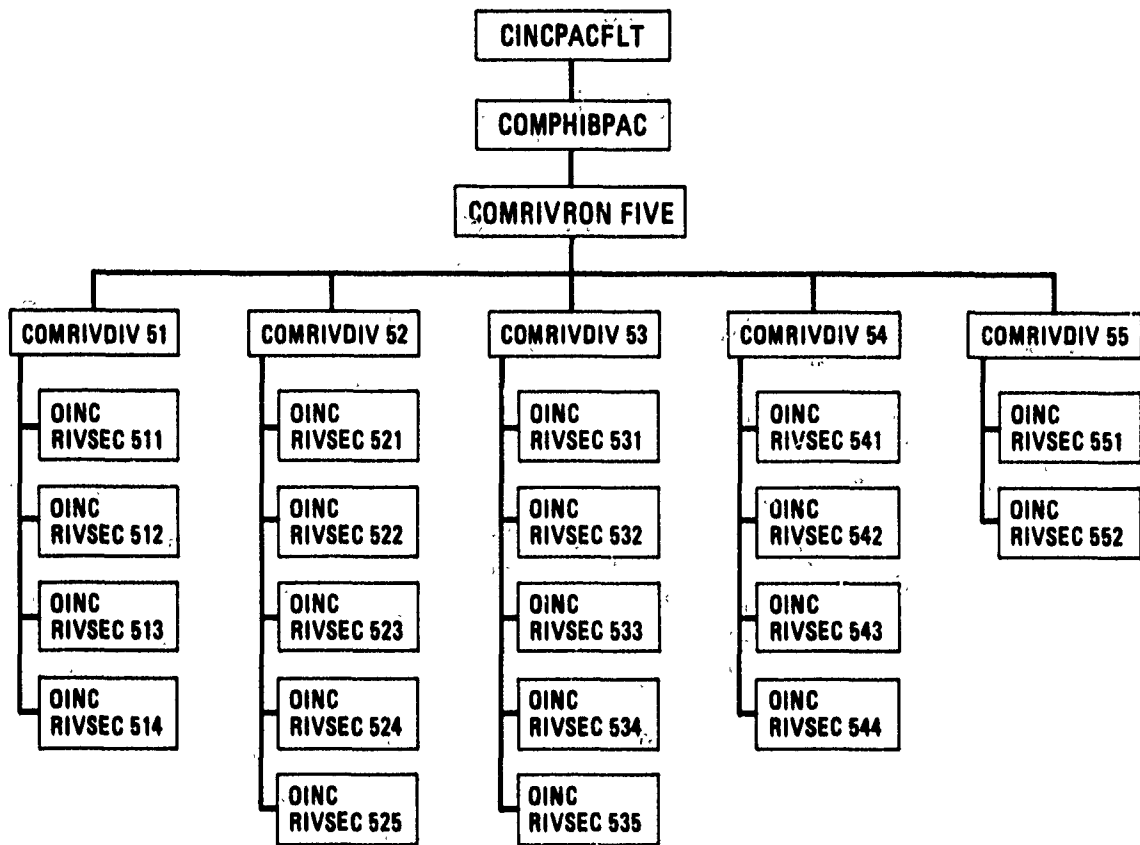

2102 Division Organization

2102.1 The River Divisions are organized as illustrated in the following schematic:

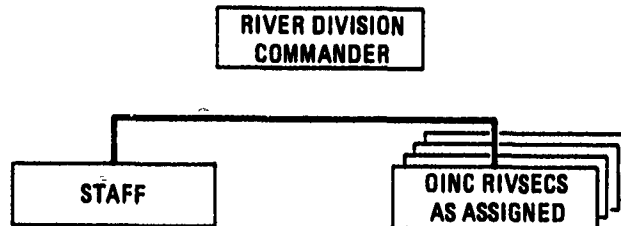

2103 River Section Organization

2103.1 Each River Section is under the control of an Officer in Charge and consists of six officers and fifty-nine enlisted men. Each River Section shall have as its normal boat allowance a total of ten boats.

2103.2 Each OINC will assign a Senior Petty Officer from the regularly assigned fifty-nine enlisted allowed to duty as training petty officer for seamanship. This petty officer will normally, but not necessarily, be selected from among the senior assigned BM, QM or GM.

2103.3 River Section boat crews are organized as illustrated in the following schematic:

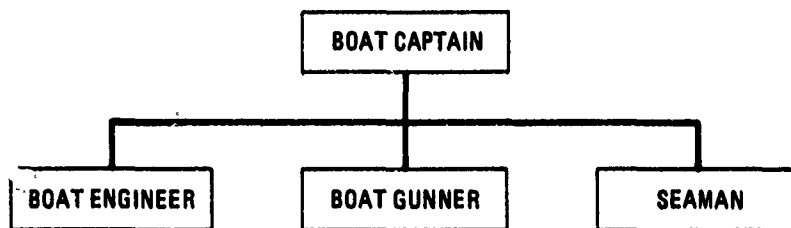

2104

Tactical Operations Control

2104.1

Commander in Chief, U.S. Pacific Fleet (CINCPACFLT) has directed that this Squadron will be under the tactical operational control of Commander River Patrol Force (CTF 116) during current hostilities in Vietnam. Tactical Operational control is illustrated in the following schematic:

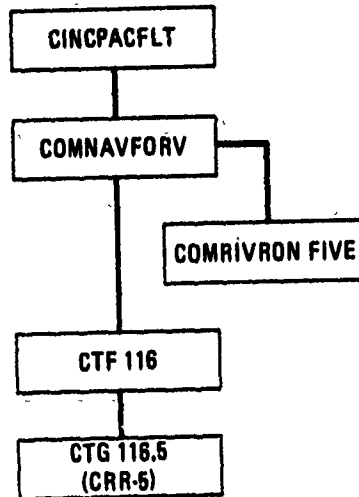

2104.2

CTF 116 exercises tactical operational control through his Task Group Commanders. River Division Commanders provide forces to CTF 116 or TF 116 group and unit commanders as directed.

2104.3

COMRIVRON FIVE, Division Commanders and River Section OINC's are assigned unit designations in TF 116.

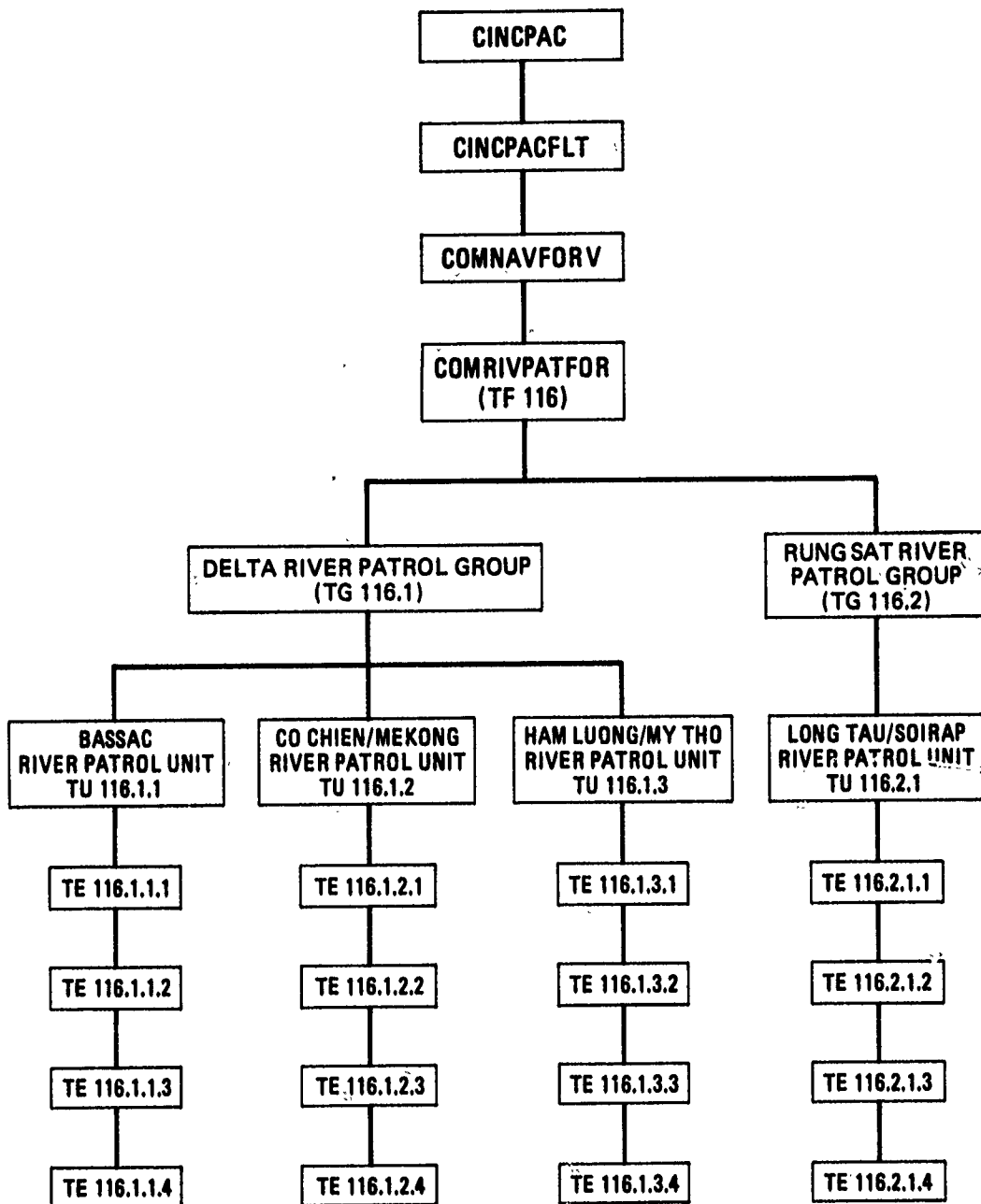

**OPERATIONAL ORGANIZATION  
OF  
RIVER PATROL FORCES**

On 3 January 1968, the task force organization was revised to obtain a greater responsiveness to the complex demands of the diverse elements of the force, and to enhance the capability for coordinating these elements regardless of location. Commanders of river patrol units were redesignated Task Group Commanders. Task Element Commanders were similarly upgraded to Task Unit Commanders in most cases. The task force was reorganized as follows:

<u>Task Organization</u>	<u>Operational Title</u>	<u>CDR/CO</u>
TF 116	River Patrol Force	COMRIVPATFOR
TG 116.1	Bassac River Patrol Group	COMRIVDIV 51
TU 116.1.0	Delta SEAL Support Unit A	OIC SEAL Team Det A Eighth Platoon
TU 116.1.1	Bassac River Patrol Unit A	OIC RIVPATSEC 511
TU 116.1.2	Bassac River Patrol Unit B	OIC RIVPATSEC 512
TU 116.1.3	Bassac River Patrol Unit C	OIC RIVPATSEC 535
TU 116.1.4	Bassac River Patrol Unit D	Not activated
TU 116.1.5	Not Assigned	
TU 116.1.6	Bassac River LST Support Unit	CO, USS JENNINGS CTY
TU 116.1.7	Not Assigned	
TU 116.1.8	Bassac River Helo Support Unit A	OIC HAL-3 DET 1
TU 116.1.9	Bassac River Helo Support Unit B	OIC HAL-3 DET 7
TG 116.2	Co Chien River Patrol Group	COMRIVDIV 52
TU 116.2.0	Delta SEAL Support Unit B	OIC SEAL Team Det A Sixth Platoon
TU 116.2.1	Co Chien River Patrol Unit A	OIC RIVPATSEC 513
TU 116.2.2	Co Chien River Patrol Unit B	Not Assigned
TU 116.2.3	Co Chien River Patrol Unit C	OIC RIVPATSEC 523
TU 116.2.4	Co Chien River Patrol Unit D	OIC RIVPATSEC 522
TU 116.2.5	Not Assigned	
TU 116.2.6	Co Chien River LST Support Unit	CO, USS GARRETT CTY
TU 116.2.7	Not Assigned	
TU 116.2.8	Co Chien River Helo Support Unit A	OIC HAL-3 DET 4
TU 116.2.9	Co Chien River Helo Support Unit B	OIC HAL-3 DET 3
TG 116.3	My Tho River Patrol Group	COMRIVDIV 53
TU 116.3.0	Delta SEAL Support Unit C	OIC SEAL Team Det A Seventh Platoon
TU 116.3.1	My Tho River Patrol Unit A	OIC RIVPATSEC 533
TU 116.3.2	My Tho River Patrol Unit B	OIC RIVPATSEC 532
TU 116.3.3	My Tho River Patrol Unit C	OIC RIVPATSEC 534
TU 116.3.4	My Tho River Patrol Unit D	OIC RIVPATSEC 531
TU 116.3.5	Not Assigned	
TU 116.3.6	My Tho River LST Support Unit	CO, USS HARNETT CTY



TU 116.3.7	Not Assigned	
TU 116.3.8	My Tho River Helo Support Unit A	OIC HAL-3 DET 5
TU 116.3.9	My Tho River Helo Support Unit B	OIC HAL-3 DET 6
TG 116.4	Rung Sat Special Zone Patrol Group	RSSZ Advisor
TU 116.4.0	Rung Sat Special Zone SEAL Unit	OIC SEAL Team Det G
TE 116.4.0.1	Rung Sat Special Zone Boat Support Element	OIC MST-3
TE 116.4.0.2	Rung Sat Special Zone SEAL Support Element A	OIC SEAL Team Det G ALFA Platoon
TE 116.4.0.3	Rung Sat Special Zone SEAL Support Element B	OIC SEAL Team Det G FOXTROT Platoon
TE 116.4.0.4	Rung Sat Special Zone SEAL Support Element C	OIC SEAL Team Det G BRAVO Platoon
TU 116.4.1	Rung Sat Special Zone Patrol Unit	COMRIVDIV 54
TE 116.4.1.1	Rung Sat Special Zone Patrol Element A	OIC RIVPATSEC 541
TE 116.4.1.2	Rung Sat Special Zone Patrol Element B	OIC RIVPATSEC 542
TE 116.4.1.3	Rung Sat Special Zone Patrol Element C	OIC RIVPATSEC 543
TE 116.4.1.4	Rung Sat Special Zone Patrol Element D	Not Activated
TU 116.4.2	Rung Sat Special Zone Minesweeping Unit	OIC MINRON 11 DET A
TU 116.4.3	Not Assigned	
TU 116.4.4	Not Assigned	
TU 116.4.5	Not Assigned	
TU 116.4.6	Rung Sat Special Zone LST Support Unit	Not Activated
TU 116.4.7	Not Assigned	
TU 116.4.8	Rung Sat Special Zone Helo Support Unit A	OIC HAL-3 DET 2
TU 116.4.9	Rung Sat Special Zone Helo Support Unit B	Not Activated
TG 116.5	Not Assigned	
TG 116.6	Delta SEAL Group	OIC SEAL Team Det A
TU 116.6.1	Delta Boat Support Unit	OIC MST-2
TG 116.7	Not Assigned	
TG 116.8	Helicopter Support Group	CO HAL-3
TG 116.9	Not Assigned	
Not Assigned	I Corps River Patrol Group	COMRIVDIV 55
Not Assigned	I Corps River Patrol Unit A	OIC RIVPATSEC 521

On 9 January River Section 521 commenced GAME WARDEN operations in I Corps Tactical Zone.

On 9 January River Section 534 (TU 116.3.3) commenced operations from APL-55 located near Dong Tam on the My Tho River.

On 10 January Commander Task Force 117 changed operational control of one Assault Support Patrol Boat (ASPB) to Commander Task Force 116 for a 30-day period to evaluate the suitability of the craft for GAME WARDEN operations. Commander Task Group 116.3 was assigned evaluation responsibility.

On 17 January River Section 524, based at My Tho, commenced operations on the My Tho River.

From 28-31 January, four PBRs from River Section 535 (TU 116.1.3) at Binh Thuy extended GAME WARDEN patrols to the upper Bassac River during the Tet holiday period to prevent an expected influx of enemy supplies from Cambodia. The PBRs were based at the U.S. Special Forces camp at Chau Doc.

From 29-31 January, five PBRs from River Section 513 (TU 116.2.1) the Rung Sat Special Zone to the APL-55 in the Ham Luong River. The platoon vacated task element designator 116.4.0.2 and assumed task element designator 116.3.0.2.

On 29 April USS JENNINGS COUNTY (LST846) changed to the operational control of CTF 116 and arrived on station in the Co Chien River. After embarking River Section 523 (TU 116.2.4) and HAL-3, Detachment Four (TU 116.2.8), JENNINGS COUNTY relieved GARRETT COUNTY (LST 786) as TU 116.2.6 and commenced GAME WARDEN operations.

On 29 April SEAL Team Detachment ALFA, Seventh Platoon, vacated TU 116.3.0 and was relieved by SEAL Team Detachment ALFA, Tenth Platoon, which assumed TE 116.3.0.1.

On 29 April River Section 525 assumed task element designator 116.4.1.4.

On 30 April USS GARRETT COUNTY (LST786) proceeded to Subic Bay, Philippines, for upkeep, changing to the operational control of CTF 76 enroute.

Task Force Organization End of April

<u>Task Designator</u>	<u>Unit</u>	<u>Location</u>
CTF 116	COMRIVPATRON	BINH THUY
CTG 116.1	COMRIVDIV 51	BINH THUY
CTU 116.1.0	SEAL TEAM DET ALFA, EIGHT PLT	BINH THUY
CTU 116.1.1	OIC RIVPATSEC 511	BINH THUY
CTU 116.1.2	OIC RIVPATSEC 512	BINH THUY
CTU 116.1.3	OIC RIVPATSEC 513	HARNETT COUNTY
CTU 116.1.4	OIC RIVPATSEC 514	BINH THUY
CTU 116.1.6	CO HARNETT COUNTY (LST821)	BASSAC RIVER
CTU 116.1.8	OIC HAL-3, DET ONE	HARNETT COUNTY
CTU 116.1.9	OIC HAL-3, DET 7	BINH THUY
CTG 116.2	COMRIVDIV 52	VINH LONG
CTU 116.2.0	OIC SEAL TEAM DET ALFA, NINTH PLTN	VINH LONG
CTU 116.2.1	OIC RIVPATSEC 524	SA DEC
CTU 116.2.3	OIC RIVPATSEC 522	VINH LONG
CTU 116.2.4	OIC RIVPATSEC 523	GARRETT COUNTY
CTU 116.2.6	CO JENNINGS COUNTY (LST846)	CO CHIEN RIVER
CTU 116.2.8	OIC HAL-3, DET 4	JENNINGS COUNTY
CTU 116.2.9	OIC HAL-3, DET 3	VINH LONG
CTG 116.3	COMRIVDIV 53	MY THO
CTU 116.3.0	OIC SEAL TEAM DET ALFA, TENTH PLTN	MY THO
CTE 116.3.0.1	OIC SEAL TEAM DET ALFA, TENTH PLTN	MY THO
CTE 116.3.0.2	OIC SEAL TEAM DET GOLF, MIKE PLTN	APL-55
CTU 116.3.1	OIC RIVPATSEC 533	MY THO
CTU 116.3.2	OIC RIVPATSEC 531	MY THO
CTU 116.3.3	OIC RIVPATSEC 534	APL-55
CTU 116.3.4	OIC RIVPATSEC 532	HUNTERDON COUNTY
CTU 116.3.5	OIC RIVPATSEC 535	APL-55
CTU 116.3.6	CO HUNTERDON COUNTY (LST838)	SPECIAL OPS II CTZ
CTU 116.3.8	OIC HAL-3, DET 5	DONG TAM
CTU 116.3.9	OIC HAL-3, DET 6	DONG TAM
CTG 116.4	COMRSSZRIVPATGRU	NHA BE
CTU 116.4.0	OIC SEAL TEAM DET GOLF	NHA BE
CTE 116.4.0.1	OIC MOBILE SUPPORT TEAM THREE	NHA BE
CTE 116.4.0.3	OIC SEAL TEAM DET GOLF, DELTA PLTN	NHA BE

CTE 116.4.0.4	OIC SEAL TEAM DET GOLF, BRAVO PLTN	NHA BE
CTU 116.4.1	COMRIVDIV 54	NHA BE
CTE 116.4.1.1	OIC RIVPATSEC 541	NHA BE
CTE 116.4.1.2	OIC RIVPATSEC 542	NHA BE
CTE 116.4.1.4	OIC RIVPATSEC 525	NHA BE
CTU 116.4.2	OIC MINRON 11 DET ALFA	NHA BE
CTU 116.4.8	OIC HAL-3, DET 2	NHA BE
CTG 116.5	COMRIVRON FIVE	BINH THUY
CTG 116.6	OIC SEAL TEAM DET ALFA	BINH THUY
CTU 116.6.0	SEAL TEAM DET ALFA, EIGHTH PLATOON	BINH THUY
CTU 116.8.1	OIC MOBSUPPORT TEAM TWO	BINH THUY
CTG 116.8	CO HAL-3	VUNG TAU

COMRIVDIV 55 and OIC RIVSEC 521 located Danang. Task designator unassigned these units.

On 1 June, River Section 551 assumed task element designator 116.4.1.6. and River Section 552 assumed task element designator 116.4.1.7. Also APL-55 was reclassified as the YRBM-18.

On 2 June, River Section 543 Detachment "B" vacated task element designator 116.4.1.3 and rejoined River Section 543 Detachment "A" in Danang.

Also on 2 June the PBR base at My Tho received 10-15 rounds of enemy mortar fire. One Navyman was slightly wounded.

On 5 June USS GARRETT COUNTY (LST786) changed to the operational control of CTF 116 and arrived on station in the lower Co Chien River and on 6 June embarked River Section 523 (TU 116.2.4) and Helicopter Attack (Light) Squadron THREE, Detachment FOUR (TU 116.2.8), and relieved USS JENNINGS COUNTY (LST846) TU 116.2.6 and commenced GAME WARDEN operations.

On 6 June USS JENNINGS COUNTY proceeded to Japan for overhaul, changing to the operational control of CTF 76 enroute.

On 11 June SEAL Team Detachment GOLF, JULIETT platoon relieved SEAL Team Detachment ALFA, Ninth Platoon at Vinh Long and assumed task unit designator 116.6.2. SEAL Team Detachment ALFA, Ninth Platoon relieved SEAL Team Detachment ALFA, Eighth Platoon at Binh Thuy and assumed task unit designator 116.6.1.

On 16 June River Section 543, under the operational control of CTF CLEARWATER relocated to Cua Viet from Danang.

On 23 June SEAL Team Detachment ALFA, Third Platoon under the operational control of CTG 116.4 became active in the Capital Military District for the defense of Saigon. This was the first use of SEALs in this area.

On 1 June LST-838 HUNTERDON COUNTY departed station on the Ham Luong River, proceeded to My Tho and debarked River Section 532, which vacated task unit designator 116.3.4 and assumed 116.3.1. After embarking River Section 533, which vacated task unit designator 116.3.1 and assumed 116.3.4, HUNTERDON COUNTY proceeded to station on the lower Ham Luong River.

On 1 June Task Force 116 realigned task organization as follows:

<u>Numerical Designator</u>	<u>Operational Title</u>	<u>Command</u>
TF 116	River Patrol Force	COMRIVPATFOR
TG 116.1	Bassac River Patrol Group	COMRIVDIV 51
TG 116.2	Co Chien River Patrol Group	COMRIVDIV 52
TG 116.3	My Tho River Patrol Group	COMRIVDIV 53
TG 116.4	Rung Sat Special Zone Patrol Group	RSSZ Advisor
TG 116.5	Upper Mekong Delta River Patrol Group	COMRIVDIV 55
TG 116.6	Special Operations Group	OINC SEAL Team Det ALFA
TG 116.7	PBR Support Group	COMRIVRON 5
TG 116.8	Helio Support Group	CO HA(L)-3
TG 116.9	Special River Support Group	COMRIVPATFOR

The task force organization was revised to establish the Upper Delta River Patrol Group (TG 116.5), the Special Operations Group (TG 116.6), the PBR Support Group (TG 116.7) and the Special Operations River Patrol Group (TG 116.9).

**APPENDIX E**

**CHARACTERISTICS OF GAME WARDEN ASSETS**

**This appendix describes the major boats and aircraft used in Game Warden operations.**

### **UH-1B HELICOPTER**

<b>Length</b>	<b>53 feet</b>
<b>Takeoff weight</b>	<b>8,500 pounds</b>
<b>Patrol speed</b>	<b>80 knots</b>
<b>Maximum gunship combat load speed</b>	<b>90 knots</b>
<b>Endurance at patrol speed</b>	<b>1½ hours</b>
<b>Armament</b>	<b>7-rocket pack of forward-firing 2.75-inch rockets on either side of aircraft</b>
	<b>7.62mm. machine guns mounted over rocket packs</b>
	<b>Freely trainable machine gun operated by each door gunner</b>
	<b>1-50-caliber and 1-M-60 (7.62mm.) in lead helo</b>
	<b>2-M60s in wing helo</b>
	<b>Grenades and small arms</b>
<b>Crew:</b>	<b>Pilot, copilot and 2 door gunners</b>

## GAME WARDEN AFLOAT BASES

In addition to the LSTs, there were 5 other Game Warden afloat bases:

- 3 YRBMs (nonself-propelled repair, berthing, and messing barge)
- 1 APL (nonself-propelled barracks craft) combined with a YR (nonself-propelled floating workshop)
- 1 mobile support base (a complex of Ammi barges designed to provide berthing, messing, repair, command, and control facilities for a section of 10 PBRs, and accommodations for 2 helicopters.

## TANK LANDING SHIP (LST)

**LENGTH:** 328 FEET  
**BEAM:** 50 FEET  
**DRAFT:** 14 FEET  
**DISPLACEMENT:** 1,653 TONS STANDARD, 2,366 TONS BEACHING  
(4,080 TONS FULL LOAD)  
**ARMAMENT:** 7-40mm. AA: 2-20mm. AA  
**DRIVE:** DIESEL, 2 SHAFTS  
**COMPLEMENT:** 119 (ACCOMMODATIONS FOR 266)





## EARLY PROBLEMS WITH PBRs (MK I)

After several months of operation, problems noted with the PBRs were premature aging, corrosion, and deterioration of the hull, pump drive shaft, and surface corrosion of the pump grill. Because of the long patrol hours, there was little time for maintenance. There were not many replacement parts, and crews were not experienced in repairing PBRs. By mid-1968, spare parts had caught up with the demand and maintenance crews had become skilled in working with glass fiber.

Speed was the PBR's best defense against the enemy, and speed was lost because of the deterioration of the Jacuzzi<sup>1</sup> pump and excessive weight. In September 1966, a modified Jacuzzi pump was installed in 3 PBRs by the manufacturer's technical representatives. A considerable improvement in speed resulted.

Because of the constant bottom fouling problems, it was recommended that swimmers be used to clean bottoms and intakes for PBRs. Divers cleared rice, grass, weeds, fish, and snakes from the pumps. This problem would continue to plague the PBRs.

Several PBRs experienced hull cracks resulting in absorption of water by the styro-foam hull reinforcement. The hull cracks were apparently caused by repeated hoisting and lowering in moderate seas and heavy weather. Up to 100 gallons of water had been drained from individual PBRs after operations.

Improved PBRs (Mk II), ordered early in 1967, had aluminum gunwalls installed to protect the sides when junks and sampans came alongside for inspection. The pump installed in the Mk II could be adapted for use in the Mk I PBR to provide greater speed.

---

<sup>1</sup>U.S. manufacturer of the pump assembly.

### RIVER PATROL BOAT (PBR)

**LENGTH:** 28 FEET  
**BEAM:** 12.5 FEET  
**DRAFT:** 10 INCHES  
**ARMAMENT:** 1-Mk 36 50-CALIBER TWIN MACHINE GUN  
1-30-CALIBER M1919AH  
1-40mm. (RAPID-FIRE) Mk 18 GRENADE LAUNCHES PIGGY-BACK  
PYROTECHNICS SMALL ARMS  
**DRIVE:** DIESEL (JET PUMPS)  
**COMPLEMENT:** ACCOMMODATIONS FOR 4 OR 5  
**HULL MATERIAL:** FIBERGLASS  
**RANGE:** 150 n.mi. AT 25 KNOTS (TOP SPEED, 35 KNOTS)



### MINE SWEEPING BOAT (MSB)

**LENGTH:** 57 FEET  
**BEAM:** 15 FEET  
**DRAFT:** 5.5 FEET (MAXIMUM)  
**DISPLACEMENT:** 45 TONS (FULL LOAD)  
**ARMAMENT:** 1-50-CALIBER MACHINE GUN  
4-30-CALIBER MACHINE GUNS  
2 Mk 18 GRENADE LAUNCHERS  
**DRIVE:** DIESEL REDUCTION  
**COMPLEMENT:** 6 OR 7 (NO ACCOMMODATIONS)  
**SPEED:** 11 KNOTS, 6.5 KNOTS SWEEPING

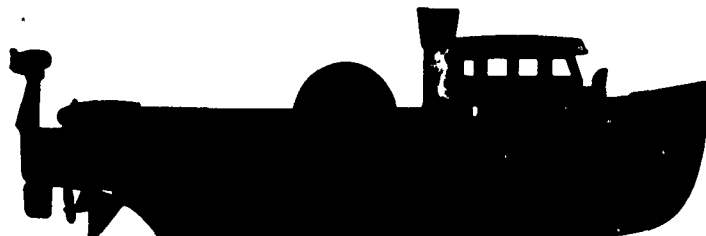

**APPENDIX F**  
**FORCE LEVELS**

Information has been obtained from the NASVA data base on the average number of U.S. Navy units assigned, available, and employed by Game Warden from the second quarter of 1966 through the third quarter of 1968.

NASVA omits mentioning the 4 LSTs committed to Game Warden; 3 of these were always on station after 1967. During the second and third quarters of 1967, the decrease in use of FBRs was because of damage.

There is a large discrepancy between the number of MSBs assigned and available and those employed after the second quarter of 1967, especially during the fourth quarter of that year. No explanation has been found for this discrepancy; it may be that there is an error in the program or data base.

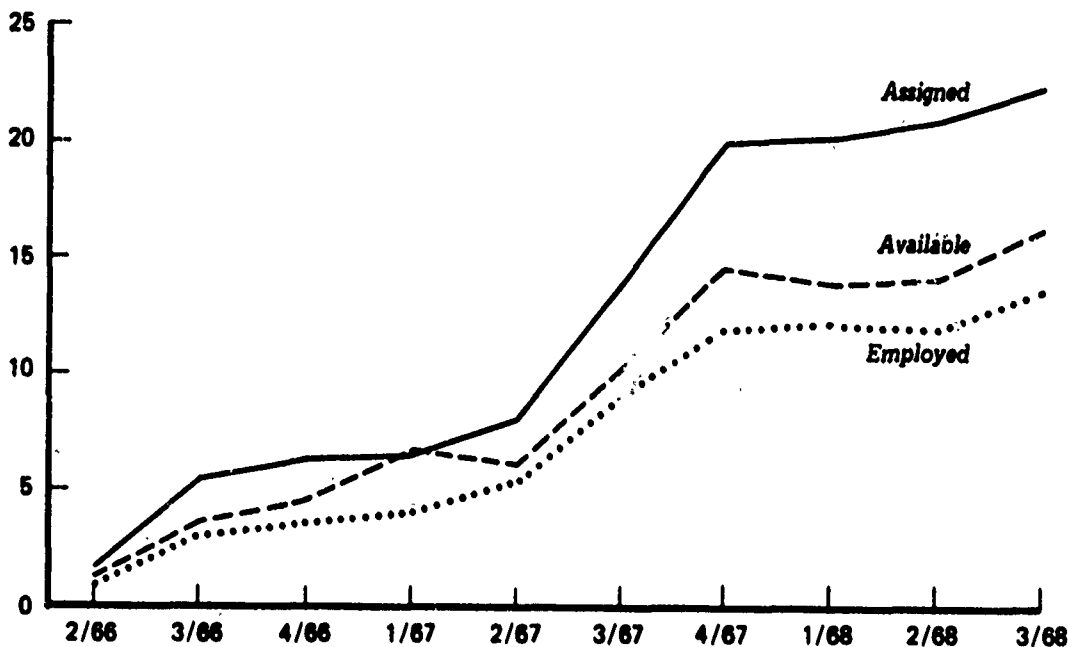

FIG. F-1: AVERAGE NUMBER OF UH-1s (U.S. ARMY)

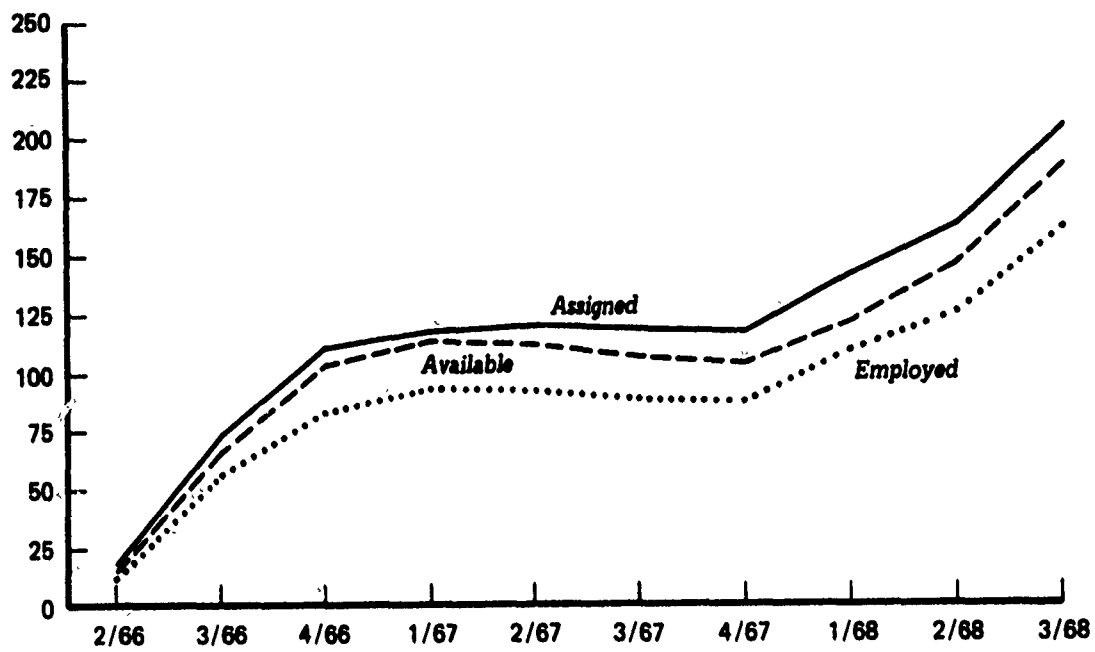

FIG. F-2: AVERAGE NUMBER OF PBRs (U.S. NAVY)

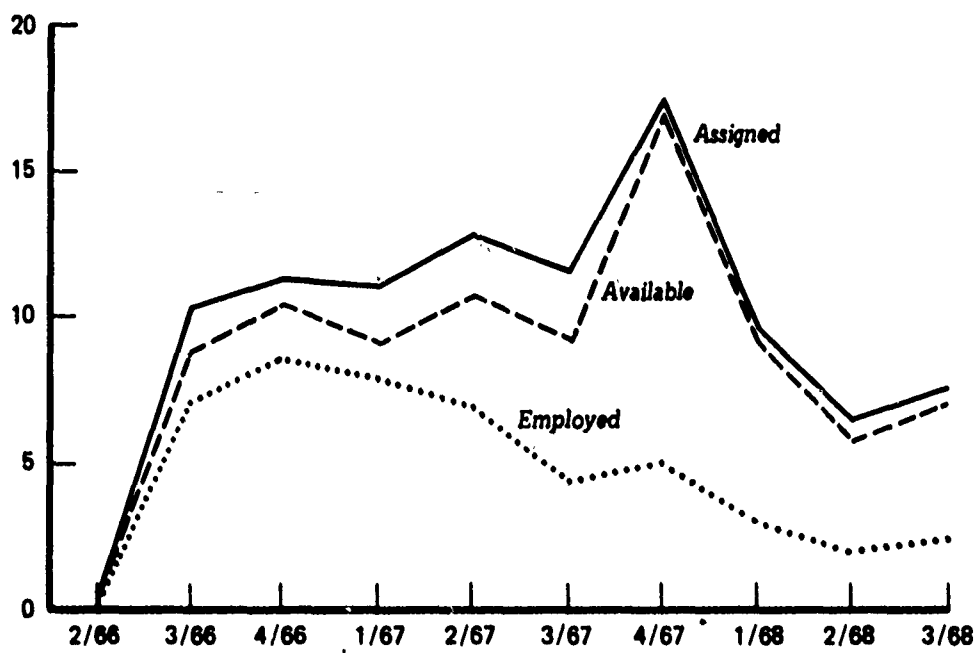

FIG. F-3: AVERAGE NUMBER OF MSBs (U.S. NAVY)

TABLE F-1

## AVERAGE NUMBER OF UNITS ASSIGNED

	Date									
	<u>2/66</u>	<u>3/66</u>	<u>4/66</u>	<u>1/67</u>	<u>2/67</u>	<u>3/67</u>	<u>4/67</u>	<u>1/68</u>	<u>2/68</u>	<u>3/68</u>
LCM					1.36	5.01	6.93	7.00	5.22	1.08
LCPL				0.9	1.89	2.00	2.00	2.00	1.73	1.23
LCVP					0.08					
LSM				0.9	.15					
MSB	0.40	10.04	11.35	11.11	12.89	11.68	17.48	9.78	6.54	7.61
MSC						1.72				
MSO						0.30				
PACV	0.45		0.84							
PBR	16.19	72.11	109.49	117.28	119.44	118.02	116.98	140.65	162.50	203.57
RPC			1.61	2.41	1.83					
UH-1	1.71	5.44	6.35	6.52	8.08	14.00	19.88	20.16	20.84	22.55

TABLE F-2

## AVERAGE NUMBER OF UNITS AVAILABLE

	Date									
	<u>2/66</u>	<u>3/66</u>	<u>4/66</u>	<u>1/67</u>	<u>2/67</u>	<u>3/67</u>	<u>4/67</u>	<u>1/68</u>	<u>2/68</u>	<u>3/68</u>
LCM					1.19	4.90	6.71	6.93	5.22	0.47
LCPL				0.74	1.89	2.00	2.00	1.86	1.73	0.24
LCVP					0.08					
LSM				0.90	0.15					
MSB	0.26	8.83	10.54	9.11	10.85	9.28	17.09	9.22	5.92	7.07
MSC						1.65				
MSO						0.30				
PACV	0.42		0.53							
PBR	13.83	64.4	102.39	113.34	111.44	105.34	102.86	121.6	145.83	187.19
RPC			1.4	2.19	1.53					
UH-1	1.32	3.6	4.51	6.63	6.17	10.25	14.59	13.86	14.11	16.37

TABLE F-3

## AVERAGE NUMBER OF UNITS EMPLOYED

	Date									
	<u>2/66</u>	<u>3/66</u>	<u>4/66</u>	<u>1/67</u>	<u>2/67</u>	<u>3/67</u>	<u>4/67</u>	<u>1/68</u>	<u>2/68</u>	<u>3/68</u>
LCM					0.56	3.39	3.92	4.34	3.20	0.08
LCPL				0.30	0.72	0.58	0.62	0.45	0.17	0.06
LCVP					0.02					
LSM				0.50	0.03					
MSB	0.13	7.11	8.6	7.93	6.99	4.14	5.05	3.01	2.07	2.58
MSC						0.30				
MSO						0.00				
PACV	0.22		0.31							
PBR	11.71	56.34	81.38	91.88	91.63	87.77	87.31	109.59	125.63	160.92
RPC			0.8	1.67	1.19					
UH-1	.81	3.00	3.64	3.99	5.38	9.04	11.91	12.24	12.00	13.71

APPENDIX G  
RULES OF ENGAGEMENT



This appendix was reprinted from the February 1967 TF 116 River Patrol Force OpOrder. After October 1966, the rules of engagement were revised to allow patrol craft commanders to direct fire against an evading watercraft.

Operation Order  
COMRIVPATFOR No. 201-YR

Naval Forces Vietnam  
Task Force 116  
River Patrol Force  
Can Tho, Vietnam  
DTG: 010001H FEB 1967  
Message Ref: TUS 025

APPENDIX II TO ANNEX B

RULES OF ENGAGEMENT

Reference: COMCOSURVFOR (CTF 115) OPOORDER NO. 201-YR

1. DEFINITIONS:

a. RVN Territorial Seas: A belt of sea adjacent to the RVN three miles in breadth measured from the low water mark along the coast.

b. Inland Waters: Waters to landward of the territorial seas.

c. Contiguous Zone: A zone of the high seas, contiguous to the territorial area of the RVN and extending to a maximum of 12 miles from the base line from which the territorial sea is measured.

d. Defensive Sea Areas (DSA): The territorial waters of RVN have been declared a Defensive Sea Area by the Government of Vietnam. Ships of any country operating within the territorial sea are subject to visit and search if not clearly engaged in innocent passage. The GVN has further proclaimed that within the contiguous zone (12 miles) vessels suspected of preparing to infringe upon the customs, fiscal, sanitary or immigration regulations (i.e., infiltrate) are subject to visit and search and possible arrest and disposition, and that the GVN has requested and received the assistance of the United States for the full cooperation of the U.S. Navy with the naval forces of the RVN to enforce the above measures.

e. International Inland Rivers: A term established by a treaty between Cambodia, Laos and Vietnam which declared that navigation is free upon the Mekong River and its navigable tributaries, issues and mouths situated within the territory of the contracting nations as well as upon all the waterways giving access to the ports of Saigon and the sea; that within the laws and customs regulations of each nation, navigation between Phnom Penh, Cambodia, and the sea by the waterways described above is considered maritime navigation. This freedom of navigation is granted freely to those nations recognized diplomatically by the contracting nations. Freedom of navigation by merchant ships of nations not recognized diplomatically by the contracting nations is subject to the agreement

Operation Order

COMRIVPATFOR No. 201-YR

of these nations. Vietnamese regulations currently prohibit passage by ships of nations, except Cambodia, not recognizing Vietnam. This prohibition includes ships of Indonesia, North Vietnam, Communist China and other Communist Bloc nations. The treaty further provides that to avoid any irregular debarkation on Vietnamese territory during passage of vessels between the mouths of the Mekong and the Cambodian borders, Vietnamese customs agents will escort the vessels between the Mekong mouths and the Cambodian border; that navigation of the Mekong as defined above must conform to the national laws and regulations, notably in matters of sanitation, police and customs and for the maintenance of general security; that each nation has the right to subject the transportation of persons and merchandise to certain conditions and that freedom of navigation will not be hindered by these conditions.

f. Immediate (HOT) Pursuit: Pursuit initiated in response to actions or attack by hostile aircraft or vessels as defined in these rules of engagement. The pursuit must be continuous and uninterrupted and may be extended as necessary and feasible over territorial and international air space and seas as prescribed herein.

g. Friendly Forces: (As defined in paragraph 1.b. of the basic OpOrder).

h. Hostile Aircraft: An aircraft in the air space of the RVN which:

(1) Is visually identified or is designated by the U.S. Director of the Tactical Air Coordination Center (TACC), and Air Force Control and Reporting Center (CRC), or their authorized representatives, as a hostile aircraft operating in RVN territorial air space without proper clearance from the government; or

(2) Is observed in one of the following acts:

(a) Attacking or acting in a manner which indicates within reasonable certainty an intent to attack U.S./friendly forces or installation.

(b) Laying mines, without the permission of the government concerned, within friendly territorial seas or inland waters.

(c) Releasing free drops, parachutes, or gliders over RVN territory without permission of the government and obviously not in distress. The foregoing includes the unauthorized landing of troops or material on RVN territory.

Operation Order

COMRIVPATFOR No. 201-YR

i. Hostile Vessel (Surface or sub-surface):

(1) A vessel in RVN inland waters and territorial seas or adjacent international waters which is engaged in one of the following acts:

(a) Attacking or acting in a manner which indicates within reasonable certainty an intent to attack U.S./friendly forces or installations, including the unauthorized landing of troops or material on friendly territory.

(b) Laying mines within RVN territorial seas or inland waters without permission of the government.

(c) Engaged in direct support of attacks against the RVN.

j. Hostile Ground Forces: Those ground forces which attack U.S. or friendly forces or installations.

k. Visit: Boarding a vessel with intent to search.

1. Search: Inspecting the vessel's papers and examination of the vessel and its cargo.

2. RULES OF ENGAGEMENT: The following Rules of Engagement cover those general situations expected to be encountered and will be observed by the River Patrol Force (SEALS withstanding):

a. River Patrol Force units are authorized:

(1) Within the rivers and contiguous zone of the RVN to demand the identification and a declaration of intent and to stop, visit and search vessels flying the RVN flag, or flying no flag (less foreign flag steel-hull merchant ships, warships and military, police or customs craft) which give a manifestly false response to the demand for identification and declaration of intent, or view other valid grounds for suspicion that all or part of their cargo or personnel is intended to be or has been taken directly into the RVN or is being transshipped within the RVN in violation of the customs, fiscal, immigration or sanitary laws of the RVN.

Operation Order

COMRIVPATFOR No. 201-YR

(2) Steel-hull merchant shipping of any foreign flag will not be stopped, visited and searched unless specifically authorized by CTF 116. TF 116 units will report to CTF 116 by immediate message a description of actions of foreign flag merchant ships providing a basis for suspicion of violation of innocent passage including time, position, type of suspicious activity, name, nationality and ship type of the vessel in question and will meanwhile shadow or maintain a radar plot of the suspected ship. In the case of merchant ships off-loading cargo to watercraft or dropping items over the side while on international inland waterways, every effort will be made to obtain photographs; to apprehend the watercraft upon departure from alongside the ship, and to recover items dropped overboard.

(a) River Patrol Force units will take particular care to ensure that their actions and maneuvers cannot be construed as harassing foreign flag merchant ships and that their actions in no way interfere with the transit of such shipping on the international inland waterways.

(3) To detain the following which have been intercepted pursuant to the above, until custody is assured by RVN forces:

(a) Vessels determined to have violated or to be preparing to violate laws and regulations of the RVN, including violation of curfew regulations, or which have engaged in hostile actions incident to interception.

(b) A vessel which refuses to permit visit, or having been visited, refuses to permit search.

(c) An intercepted vessel which fails to proceed as previously stated or directed.

(d) Personnel embarked on intercepted vessels who are without identification or who have improper identification or who have engaged in hostile action incident to interception.

(4) To return fire when fired upon by hostile ground forces, watercraft or aircraft as defined herein and to fire in support of friendly units receiving hostile fire.

(5) To fire warning shots in order to stop indigenous watercraft for visit and search. Due care must be exercised as to fall of shot.

Operation Order

COMRIVPATFOR No. 201-YR

(6) The minimum force necessary to accomplish patrol operations shall be exercised, up to and including destruction if required.

(a) Violators of curfew and prohibited zones (who may or may not be subjected to gunfire by the VNN) shall not be fired upon by River Patrol Force units unless the violator qualified as a hostile vessel in accordance with subparagraph 1.e. of this Appendix or attempts to evade and ignores warnings to stop.

(b) Every peaceful method at hand shall first be exhausted when attempting to stop a junk or sampan for boarding and searches. This failing, warning shots may be used as the next step. If it is obvious the junk or sampan is deliberately trying to evade, direct fire may be used as a last resort. Firing shall be ceased if the junk or sampan appears to be stopping.

(c) It is permissible to continue direct fire against an evading junk that beaches and against its fleeing occupants provided the firing is not in the vicinity of a hamlet or village. Any fire in the vicinity of a hamlet or village must be conducted strictly in accordance with Appendix IV to Annex B.

(7) To conduct immediate pursuit as necessary and feasible pursuant to the above rules over inland, contiguous and international waters and air spaces except that:

(a) No pursuit is authorized into the inland waters or the air spaces of Cambodia.

(b) River Patrol Force units will not approach the Cambodian border closer than three nautical miles at the points where the Mekong and Bassac Rivers enter Cambodia without the prior approval of CTF 116.

b. River Patrol Force units will

(1) Permit a vessel and embarked personnel not subject to detention to proceed to the stated port of destination.

(2) Recognize the possibility of language difficulties and allow sufficient time for vessel's master to fully realize the consequences for failure to properly respond.

Operation Order

COMRIVPATFOR No. 201-YR

(3) Not initiate any attack on ground forces or watercraft without the specific authority of CTG 116.1 or CTG 116.2, as appropriate, and the cognizant TOC. This does not limit firing in self-defense, firing in support of other friendly units requiring immediate assistance, firing of warning shots to stop watercraft for visit and search, or taking under direct fire junks and sampans that ignore warnings to stop and deliberately attempt to evade.

(4) Exercise the minimum force necessary to accomplish their mission.

(5) Display sound judgment in replying to fire from the vicinity of populated areas to ensure that unnecessary civilian casualties do not occur.

(6) Make an immediate report to CTG 116.1 or CTG 116.2, as appropriate, of incidents involving the talking under fire of hostile vessels, aircraft or ground forces. The task group commander will immediately report the incident to CTF 116 and the appropriate TOC and/or CSC.

c. Procedures for visit and search will be in accordance with the guidance of Appendix III to Annex B.

3. Rules of Engagement for SEAL

a. SEAL team detachments are now operating with GAME WARDEN forces in the Rung Sat Special Zone and the Delta. Due to the special nature of their operations, normal GAME WARDEN rules of engagement, as stated in the basic operation order, cannot, in their entirety, apply to SEAL operations. Consequently, these special rules of engagement are hereby promulgated and will be adhered to during all SEAL operations:

(1) All SEAL operations (ambush, reconnaissance, etc.) will be cleared by the appropriate Vietnamese authority through his U.S. counterpart. They will be cleared at the lowest echelon necessary, but it should not be necessary to clear lower than the district chief.

(2) Curfews and other restrictions imposed by GVN authority must be known by SEAL teams prior to any operation.

(3) SEAL teams must be intimately familiar with population patterns in the operating area to avoid inadvertent casualties to innocent persons.

**Operation Order**

**COMRIVPATFOR No. 201-YR**

(4) The decision to open fire at a target in a specific area will depend on whether or not that area has been designated a "Free Fire" area by GVN authorities.

(5) Offensive type actions will only be conducted in "Free Fire" areas or in areas specifically cleared by the District Chief or other GVN authority.

(6) Teams are permitted to return fire when fired upon and to fire in support of friendly units receiving hostile fire.

(7) Teams may conduct immediate pursuit as necessary and feasible; however, no pursuit is authorized across the borders into Cambodia.

**4. SUPPORTING RULES OF ENGAGEMENT**

a. Within assigned areas of responsibility, local tactical considerations may dictate the requirements for additional and more detailed Rules of Engagement for the Delta River and RSSZ River Patrol Groups. As operational experience is gained Commander Delta River Patrol Group (CTG 116.1) will develop jointly, with the Senior Advisor Fourth Corps, supporting Rules of Engagement for the Delta River Patrol Group (TG 116.1) and Commander RSSZ River Patrol Group (CTG 116.2) will develop supporting Rules of Engagement for the RSSZ River Patrol Group (TG 116.2). These rules will include the applicable Rules of Engagement cited herein and may further restrict these rules. All supporting Rules of Engagement and subsequent changes will be submitted to the Commander River Patrol Force (CTF 116) for approval prior to promulgation.

b. Commander Inshore Support Unit (CTU 116.8.5) will insure that embarked helicopters, when operating within IV CTZ, adhere to applicable IV Corps LOIs and other Rules of Engagement.

c. Annexes D and I to the reference establish Rules of Engagement and Visit and Search Procedures for Coastal Surveillance Force units and will be referred to by Commander Inshore Support Unit (CTU 116.8.5) for additional background information and guidance in the conduct of offshore surveillance and merchant ship visit and search operations. It should be noted that the Rules of Engagement established by this OpOrder provide restrictions in the case of foreign flag shipping in addition to the restrictions imposed by Annex D to the reference.



Operation Order

COMRIVPATFOR No. 201-YR

5. DEFENSIVE ACTION. Except for the limitations imposed by subparagraph 2.a.(6)(a) of this Appendix, nothing in these rules or in rules subsequently promulgated by task group commanders modifies or will modify in any manner the requirement of a military commander to defend his unit against armed attack with all means at his disposal. In the event of such attack, the commander concerned will take immediate aggressive action against the attacking force.

B. B. WITHAM, JR.  
Captain, U.S. Navy  
Commander River Patrol Force

Authenticated:

/s/

L. L. STINE, JR.  
Chief Staff Officer

APPENDIX H  
MEKONG RIVER MERCHANT SHIP SMUGGLING

Free-world shipping on the Mekong River, its tributaries, and waterway accesses to Saigon were guaranteed by a tripartite agreement between Laos, Cambodia, and SVN in December 1954. But little was done to monitor or regulate commercial transit on the rivers. The U.S. recognized the potential for shipping contraband to the VC and encouraged SVN to impose strict regulations on commercial shipping.

MACV examination of cargo manifests revealed that war materials had been shipped into Cambodia as early as 1964. Many items were those the VC could use. Responding to U.S. pressure, the South Vietnamese tightened Mekong River shipping control procedures. Authorization was required to transit the Mekong and ships from communist countries and those flying flags of countries that did not recognize SVN were denied access to the river.

Special procedures were imposed on merchant ships in transit. They could travel only from sunrise to sunset; a Vietnamese pilot had to be aboard at all times; small craft were prohibited from coming alongside commercial freighters; and South Vietnamese officials were authorized to inspect cargo and customs papers.

During the first few months of tightened controls, South Vietnamese confiscated a Japanese ship bound for Phnom Penh with a consignment of cartridge belts, and prevented 6 other free-world ships (mostly Japanese) from entering the river. Four of these ships were carrying cement from the USSR and China, and 2 were carrying chemicals that potentially had military significance.

The possibility that supplies were smuggled aboard merchant ships using the Mekong River was proposed to account for weapons and munitions acquired by the VC in southern SVN. These supplies could not be accounted for by seaborne infiltration or by shipments through Cambodia. Early in the war, there were intelligence reports that arms and munitions had been smuggled into the Delta on some of the free-world merchant ships that sailed up the Mekong.

In December 1965, MACV and CinCPac studied alternatives to gain control of contraband shipping. Because of the complex ramifications of international law, they decided against blockade and interdiction and decided that SVN must strictly enforce its existing regulations for commercial shipping. The South Vietnamese were encouraged to conduct cargo inspections with the threat of a complete offload, and the U.S. promised help with men and facilities. It was also recommended that military personnel should help customs officers inspect cargo, crosscheck the performance of customs officials and pilots, and provide additional intelligence. Surface and air patrols were planned to increase controls on the Mekong. MACV requested U.S. Embassy assistance in convincing SVN to enforce the controls.

Infiltration continued, but by the end of 1966, the South Vietnamese had taken some encouraging preparatory actions. These suggested acceptance of some of the control measures offered by the U.S.

Beginning in 1968, all merchant ships traveling on the Mekong River had to be escorted. The convoys were formed at Vung Tau and ended at Tan Chau (near the Cambodian border.) The convoys were generally very lax, as were the South Vietnamese customs inspections at Vung Tau. In addition, complicity of South Vietnamese and Cambodian officials in these cursory inspections is strongly suspected. Cleverly concealed secret compartments were discovered on several of the ships suspected of smuggling, and smuggling of commercial goods has been proven conclusively.

According to the Naval Ocean Surveillance Information Center (NOSIC), most of the merchant ships traversing the Mekong were not seaworthy, nor were their goods insured. Therefore, the cargo had to be lucrative to entice them to make the trip from Singapore or Hong Kong to Phnom Penh. The bills of lading listed expensive consumer goods as cargo rather than staples that a country as poor as Cambodia might be expected to import. The cargo generally filled less than the full capacity of the ship. It would not have been profitable for the owner to send an unseaworthy, underloaded ship on such a long trip unless it carried some other kind of profitable cargo, such as war supplies.

The materials to be smuggled, whether consumer or war goods, were loaded on a ship together with a legally consigned cargo for Phnom Penh. The merchant ships could load the contraband left by Soviet or Chinese ships in Hong Kong or Singapore for transshipment. As the ships were convoyed up the Mekong, they might take advantage of a lax escort and offload while still in SVN, or they could offload across the border in Cambodia. Another possibility was that the smuggled cargo was taken to a warehouse in Phnom Penh by a communist and distributed from there.

APPENDIX I  
GAME WARDEN CHRONOLOGY

This chronology includes the arrival of Game Warden units in SVN and major task unit shifts.

The chronology is not intended to list every river patrol operation. It highlights major Game Warden, Mobile Riverine Force, and ground operations in the Mekong Delta and RSSZ to illustrate the type and scope of friendly and enemy action in the Game Warden areas of responsibility.

The major sources for this chronology are the NavForV Monthly Supplements and Summaries.

1965

- Fall 1965 U.S. Navy begins riverine operations; 4 LCPL-4s control VC cross-channel traffic in RSSZ (using VNN facilities in Saigon)
- 18 December Game Warden (River Patrol Force) is established as Task Force 116

1966

- 11 February First Game Warden operation order is promulgated
- February SEAL Team-1 group of 3 officers and 15 enlisted men assigned to Game Warden
- 10 March 4 U.S. MSOs arrive at Vung Tau. First U.S. minesweeping units assigned to sweep Long Tau channel
- 15 March River Squadron Five (RivRon Five) established to administer newly arriving Game Warden units
- 21 March First 11 PBRs arrive in-country; USS Belle Grove (LSD 2) acts as interim support ship at Cat Lo
- 25 March UH-1B moves aboard USS Belle Grove
- 26 March Combined forces search and clean operation, Jackstay, begins in RSSZ
- 30 March 9 PBRs arrive in SVN
- 1 April NavForV established under RAdm. Norvell G. Ward. He is also Commander, River Patrol Force (CTF 116)
- 12 April USS Floyd County (LST-762) arrives in-country as the second interim inshore support ship
- 15 April River Section 541 begins patrol operations. Initial operations are nighttime patrols on Long Tau River in RSSZ
- 19 April USS Tortuga (LSD-26) relieves Belle Grove as interim support ship.
- 26 April 12 PBRs arrive at Cat Lo and begin shakedown cruises from USS Floyd County
- 8 May Units from the Tortuga move to Nha Be. First Game Warden river patrol units (River Section 511) move into the Delta (Can Tho)
- 18 May Capt. Burton B. Witham, Jr., relieves RAdm. Ward as Commander, River Patrol Force (CTF 116)

21 May - 9 June	U. S. Army operation Lexington III begins in RSSZ -- search and destroy operation conducted by Second Brigade, U. S. Army First Infantry Division
23 May	8 PBRs arrive in SVN
28 May	8 PBRs arrive in SVN
2 June	Game Warden River Section 543 moved to Cat Lo from Tortuga (LSD 26)
4 June	8 PBRs arrive in SVN
7 June	River Section 531 moves to Cat Lo from Tortuga
8 June	Daytime PBR patrols begin in RSSZ
9 June	8 PBRs arrive in SVN
10 June	River Sections 512, 542 shift from Cat Lo to Nha Be
10 June	Start of evaluation of patrol air cushion vehicles (PACVs) for Game Warden
13 June	River Section 512 (and 2 PACVs) deploy aboard Tortuga near mouths of the Co Chien and Bassac Rivers in first test of offshore support ship concept in Delta
20 June	River Section 531 transits from Cat Lo to My Tho
29 June	PACVs judged not suited for operations in Game Warden
23 July	First PBR use of a planned ambush at a possible river-crossing area
31 July	8 PBRs arrive in SVN
5 August	River Section 513 begins operations at Vinh Long
15 August	Start of 10-battalion SVN army operation Dan Chi 254, with 6 PBRs patrolling main channel of the Bassac River
16 August	8 PBRs arrive in SVN
17 August	8 PBRs arrive in SVN
19 August	8 PBRs arrive in SVN
20 August	River Section 521 begins operations at Sa Dec
25-26 August	River Sections 522 and 523 begin operations at Long Xuyen
29 August	Tortuga transferred from mouth of Bassac River to mouth of Long Tau River to provide extra patrol section for increased security of the shipping channel



30 August Navy crews begin operation of Game Warden fireteam helicopters aboard Tortuga

10 September USS Comstock (LSD-19) relieves Tortuga as Game Warden support ship

19 September Manufacturers' technical representatives install modified pumps on 3 Game Warden PBRs

26 September River Section 532 activated at Cat Lo

27 September 5 PBRs arrive in SVN

27 September - 17 October Game Warden/SVN troops conduct major flood operation in Plain of Reeds, resulting in many enemy killed

10 October CTF 116 shifts headquarters from Saigon to Can Tho

20 October My Tho-based PBRs begin random patrols on Ham Luong River, last of the major branches of the Mekong to be regularly patrolled by Game Warden forces

21 October Revised rules of engagement for river patrol forces go into effect (see appendix G)

1 November MSB 54 destroyed by VC mine on Long Tau River--first MSB destroyed

11 November USS Jennings County (LST-846), first specially configured LST, arrives at Vung Tau to relieve Comstock

14 November River Section 532 begins operations at My Tho

15 November Jennings County arrives on station at mouth of the Bassac River

18 November Jennings County is shifted to Can Tho because of difficulties in handling boats in heavy seas

22 November Sa Dec-based PBRs provide blocking force for operations of 13th SVN army battalion

23 November 6 PBRs arrive in SVN

12 December Jennings County returns to mouth of Bassac and again experiences difficulties in handling PBRs and helos because of monsoon winds and heavy seas.

29 December WHAMO 1-66, begins -- large-scale military civic action project in Kien Hoa province

31 December Discovery of a contact-detonated mine (500-pound charge) floating in Long Tau River; first of this type of mine discovered in inland waters

End December SEAL Team-1 RSSZ detachment has 3 platoons (7 officers and 30 enlisted men) at Nha Be

1967

6 January Operation Deckhouse V begins; Game Warden PBRs provide blocking force on the Co Chien and Ham Luong Rivers; first combined U.S./SVN amphibious landing in Delta; assault against Thanh Phu secret zone in Kien Hoa province

7 January First units of Riverine Assault Force arrive at Vung Tau (later renamed Mobile Riverine Force)

11 January Jennings County suffers severe damage to boat-handling equipment and PBR 30 is lost when high winds and material failure cause PBR to swamp

15 January PBRs from Long Xuyen augment forces at Vinh Long. Sa Dec-based River Section 521 concentrates patrols in lower portion of its area  
Long Xuyen-based River Section 522 deploys 8 PBRs to lower Bassac  
Long Xuyen-based River Section 523 stations 8 boats on Co Chien River

17 January Harnett County (LST-821), second Game Warden support ship, takes station off Dong Tam

20 January PBRs and VNN river patrol craft of Game Warden RSSZ patrol group support combined U.S./SVN operation that destroys VC quartermaster depot in Long An

26 January Game Warden units break up estimated 400-man enemy main force unit crossing attempt on lower Bassac

1 February River Patrol Force (TF 116) established as separate command under operational and administrative control of ComNavForV

15 February VC sink U.S. MSB and damage 2 others on Long Tau River in well-prepared series of attacks southeast of Nha Bex; MSB 45 sunk by controlled mine; MSB 49 hit by 3 rounds of 75mm. recoilless-rifle fire; MSB 51 damaged by heavy weapons fire

16 February Operation River Raider begins; series of sweeps and ambushes in the RSSZ by units of 9th Infantry Division (Riverine Assault Force)  
River Section 533 on Jennings County near mouth of the Long Tau River augments PBR patrols of Saigon channel

20-27 February VNN RAGs provide support for SVN army and regional force battalions during operation Cuu Long 55 in Binh Dai district of Kien Hoa Province

21 February Troops of 3/47 Infantry landed by River Assault Division 91 in RSSZ -- discover "extensive" VC base camp (Riverine Assault Force)

26 February Game Warden units deploy to meet growing enemy activity in Kien Hoa Province; River Section 523 moves from Long Xuyen to patrol Ham Luong; Jennings County shifted from mouth of Long Tau River to Dong Tam

27 February B-52 strike at the suspected headquarters area of RSSZ VC commander

28 February Riverine Assault Force activated as Task Force 117 under operational control of ComNavForV

February 2 platoons from Seal Team-2 based at Can Tho, begin Delta operations

7 March C Company, 3/47 infantry, supported by River Assault Squadron Nine, discovers VC munitions workshop area in lower RSSZ

PBRs provide blocking force for operation Overload II (U.S. 199th Infantry Brigade/25th SVN army division) on island south of Saigon, west of the Soi Rap River, in the RSSZ

17 March PBR patrol assists SVN outpost on Cu Lao May Island under attack by 200 VC

27 March USS Garrett County (LST-786), third specially configured support ship, is assigned to support Game Warden River Section 543 in RSSZ

28 March U.S. Naval support activity detachment set up at Tan Chau, 10 miles east of the Cambodian border, on the Mekong River; facilities to berth, mess, and provide necessary support for a 10-boat river patrol section

31 March Capt. Paul N. Gray, relieves Capt. Burton B. Witham, Jr. as Commander River Patrol Force (CTF 116)

USS Hunterdon County (LST-838), fourth specially configured Game Warden support ship, relieves Harnett County at mouth of the Co Chien River

1 April Helicopter-Attack (Light) Squadron Three (HA(L)-3) activated under the operational control of CTF 116. Squadron has 4 detachments composed of former detachments of Helicopter Combat Support Squadron One (HC-1):

- Detachment 1 based on Hunterdon County
- Detachment 2 based at Nha Be
- Detachment 3 based at Vinh Long
- Detachment 4 based on Jennings County

- Hunterdon County relieves Harnett County in support of River Section 512 and HA(L)-3, Det. 1, on Co Chien River
- 3 April Jennings County, with River Section 523 and HA(L)-3, Det. 4, relieves Hunterdon County, which shifts to mouth of Bassac River
- 8 April River Section 511 (based at Binh Thuy) and River Section 12 (based on an LST in the Co Chien River) exchange patrol areas and bases<sup>1</sup>
- 12 April MSBs 33 and 46 are delivered to MINRON ELEVEN, Det. A at Nha Be, bringing the number of MSBs in-country to 13
- 17 April Game Warden units begin operation Linebacker II in support of the SVN 9th Army Division's Operation Long Phi 999H, a search and destroy mission against the VC 306th Battalion in Vinh Long and Vinh Binh provinces
- 22 April Harnett County relieves Jennings County, which proceeds to Vung Tau for upkeep.
- 26 April River Section 512 (Based at Vinh Long) and River Section 523 (based on an LST on the Bassac River) exchange patrol areas and bases<sup>1</sup>
- 27 April RAdm. K.L. Veth relieves RAdm. Ward as ComNavForV and CHNAG, MACV
- 29 April Naval Support Activity detachment at Long Xuyen deactivated
- 30 April Game Warden sections and bases:

<u>River section</u>	<u>Base</u>
511	Hunterdon County
512	Binh Thuy <sup>1</sup>
513	Harnett County
521	Sa Dec
522	Tan Chau
523	Vinh Long <sup>1</sup>
531	My Tho
532	My Tho
533	Nha Be
541	Nha Be
542	Nha Be
543	Garrett County at mouth of Soi Rap

<sup>1</sup>There is a discrepancy in the source, NavForV Monthly Summary for April 1967. The April 1967 locations of River Sections 512 and 523 are not clear, since the text identifies their shore bases as both Binh Thuy and Vinh Long.

April PBRs begin new search procedure -- Operation Ferret

6 May Commander, Delta River Patrol Group (CTG 116.1) in Operation Overload, moves PBRs from upper rivers to increase patrol density in My Tho, Bassac, and Ham Luong Rivers

11 May Jennings County relieves Garrett County in support of River Section 543 at mouth of the Soi Rap River

Hunterdon County blows up VC ammunition cache in Long Toan Secret Zone, using night observation device

15 May Mobile Riverine Force (MRF) experiences first major contact with VC when elements of TF 117.2 engage enemy west of My Tho along Tra Tan Creek while supporting Operation Hop Tac XVIII

25 May Harnett County with River Section 513 and HA (L)-3, Det. 4 embarked, shifts to mouth of Ham Luong River from mouth of Co Chien

1 June Operational control of units patrolling Co Chien River shifted from CTU 116.1.3 (My Tho) to CTU 116.1.2 (Vinh Long)

3 July Naval Support Activity detachment at Tan Chau abandoned and YRBM-16 moved to Binh Thuy to provide interim support until facilities at that Game Warden base are operational

5 July CTF 116 and staff move from Can Tho to Binh Thuy, west of Can Tho

7 July PBRs act as blocking force for SVN army search and destroy operation in Long Toan Secret Zone in lower Vinh Binh province

25 July Navy helo fire team disrupts movement of 3 enemy companies along Ba Lai River, north of Ben Tre

29 July Sixth detachment of HA(L)-3 activated at Dong Tam

23 August Harnett County, with River Section 531 and HA(L)-3 Det. 5 embarked, relieves Jennings County as Game Warden support ship at mouth of Co Chien River

24 August River Section 533, which had been embarked on Jennings County, begins operations out of My Tho

August Third platoon from SEAL Team-1 platoons involved in special operations

5 September River Section 522, embarked on YRBM-16, moves from Bassac to the Ham Luong River

11 September River Section 534 activated at Nha Be

15 September Game Warden and RAG forces conduct search and destroy operation Crimson Tide against heavily fortified VC area along Bassac River opposite Culao Tan Dinh Island

18 September Hunterdon County with River Section 521 embarked leaves station on Ham Luong for trip to I Corps Tactical Zone to conduct river patrol operations

22 September Operation Bon Huu II (Friendship II), large-scale combined civic action program, begins on Thoi Son Island in My Tho River, adjacent to My Tho

25 September Garrett County with River Section 511 embarked shifts operations from lower to central Bassac River

28 September Hunterdon County shifts anchorage to mouth of Cua Dai River southeast of Danang for second phase of Operation Green Wave  
HA(L)-3 Det. 7 activated at Binh Thuy

30 September Boundary lines between Market Time and Game Warden operating areas shifted inland at the major Delta river mouths an average of 5 miles to take advantage of greater seaworthiness of Market Time craft.

7 October Termination of Game Warden I Corps Operation, Green Wave

13 October Hunterdon County with River Section 521 and HA(L)-3, Det. 4 embarked, resumed operations on lower Ham Luong River

15 October Jennings County with River Section 512 and HA(L)-3, Det. 1 embarked, relieves Garrett County at mouth of Bassac River  
River Section 511 relocates to Binh Thuy.

18 October Game Warden and SVN forces involved in blockade and clear operation of northern half of Cu Lao Nai Island on the Bassac downstream from Can Tho

November - December MRF engages in search and destroy Operation Coronado IX in area north of Mekong/My Tho River from Plain of Reeds east to the Soi Rap River.

9 November During Coronado IX, for the first time the Fifth Battalion, Vietnamese Marine Corps (VNMC) is used as the third maneuver battalion of the MRF

11 November River Section 534 relocates from Cat Lo to Nha Be and receives first MK II PBRs

14 November MRF conducts one day saturation patrol and search operation as part of Coronado IX in Dinh Tuong province "to enhance the security on Highway 4 and the Dong Tam base"

- 18-20 November MRF relocates to a position on the Mekong River near Sa Dec to continue Coronado IX in western Dinh Tuong and eastern Kien Phong provinces. This part of Coronado IX took the MRF to its deepest penetration of the Mekong Delta. The operation was coordinated with SVN Seventh and Ninth Divisions
- 26 November River Section 522 relocates from damaged YRBM-16 to My Tho
- 27 November MRF, continuing Coronado IX, begins a 4-day operation in the Cai Lay and Long Dinh districts of Dinh Tuong Province, primarily to clear 19 miles of the Xang Canal starting at Dong Tam to allow waterborne operations in northern Dinh Tuong province as far west as My Phouc Tay. The VC had kept the canal closed since 1964
- 1 December Harnett County with River Section 531 and HA(L)-3 Det. 5, embarked, shifts station from the Co Chien to the Ham Luong River  
Hunterdon County with River Section 521 embarked departs Ham Luong enroute to Danang
- 7 December Garrett County takes station on Co Chien River
- 11 December River Section 534 arrives at My Tho to begin first Mk II PBR patrols
- 14 December River Section 535 arrives at Binh Thuy with 5 Mk II PBRs  
MRF conducts operations in Cam Son Secret Zone. Penetration of Ba Rai stream sees first use of MRF Riverine Armored Reconnaissance Element (RARE). A RARE consisted of heavily armored MRF craft that protected troop carriers. The RARE preceded the troop carriers into an operational area to forestall attacks on the carriers.
- 18 December Game Warden units conduct Operation Preakness II along Ba Lai River, using units from River Sections 531, 532, 534, and helos from HA(L)-3 detachments 5 and 6 for collecting intelligence and destroying targets of opportunity
- 20 December MRF conducts operation in the Cai Lay district of northern Dinh Tuong Province in search of VC 514th provincial mobile battalion
- 21-23 December Game Warden PBRs conduct exfiltration blockade as part of operation Bold Carousel in support of SVN army sweep of Tan Dinh Island on lower Bassac  
River Section 524 activated at Nha Be
- 24-26 December MRF conducts Coronado IX in Long Dinh district of Dinh Tuong Province and the Giang Thom district of Kien Hoa Province to deny enemy forces their resupply routes during the Christmas truce

- 28 December MRF conducts operations in the Cam Son/BanLong Secret Zones, with saturation patrolling in the Ham Tuong district of western Kien Hoa Province and the Cai Be, Coi Lay, and Long Dinh districts of western Dinh Tuong Province
- 1968
- 3 January TF 116 reorganized (see appendix C)
- 9 January Game Warden forces begin operations in I Corps with River Section 521 operating from PBR Mobile Support Base I
- River Section 534 begins operations from APL-55 near Dong Tam on the My Tho River
- 10-12 January MRF begins Operation Coronado IX in Cai Be District, Dinh Tuong Province, and engages VC
- 261st Main Force Battalion.
- The River Patrol Group begins evaluating suitability of Assault Support Patrol Boats (ASPB) for Game Warden. (ASPB on loan from MRF)
- PBRs and 6 ASPBs from MRF begin operation Preakness III on Ba Lai River, concentrating on Thu Ba Lai village
- 17 January River Section 524 begins operations on My Tho River
- 18 January MRF begins Operation Coronado X, search-and-destroy operation in Giong Trom district of Kien Hoa Province
- 25 January ComRivDiv 52 conducts operation Windsong I against VC along the Thon and Mo Cay canals in Kien Hoa Province, using a combined force of Game Warden and MRF assets: 2 helo fire teams, 2 SEAL platoons, 8 PBRs, 2 monitors, and 4 ASPBs. This canal, linking the Co Chien and Ham Luong Rivers, furnished the sole route of commerce to Mo Cay district town
- 28 January 4 PBRs from River Section 535 at Binh Thuy extend Game Warden patrols to upper Bassac River during Tet holiday to prevent expected influx of enemy supplies from Cambodia. PBRs were based at the U.S. Special Forces camp at Chau Doc
- 29 January Start of Tet truce period
- River Section 535 PBRs begin patrols of upper Bassac River from Chau Doc to the Cambodian border (Operation Bold Dragon I)
- 5 PBRs from Sa Dec's River Section 513 begin patrols of upper Mekong to guard against infiltration of supplies during Tet. The PBRs operate from the U.S. Special Forces camp at Thuong Thoi during this operation



30 January ComUSMacV rescinds truce directive because of repeated VC truce violations

31 January Game Warden activity during Tet Offensive  
 SEALS, PBRs, and Helos support My Tho. PBRs and helos support Ben Tre and Vinh Long. PBRs provide a blocking force at Sa Dec. SEALS and PBRs engage in intense combat at Chau Doc. Helos support defense of the U.S. embassy in Saigon and Tan Son Nhut Air Base, and I Corps PBRs support defense of LCU ramp at Hue  
 River Section 531 shifts from Harnett County (LST 821) to My Tho. River Section 532 shifts from My Tho to Harnett County

1 February Game Warden forces aid in driving VC from Chau Doc  
 Navy personnel evacuate from Vinh Long to Garrett County

2 February 4 PBRs from Sa Dec rout 150 VC from the Cao Lanh ferry landing

3 February PBRs make repeated firing runs at about 200 VC along Sa Dec canal

4 February MRF relocates to Vinh Long  
 Game Warden forces interdict VC crossing attempt on Bassac south-east of Can Tho; capture 60 B-40 rockets  
 River Section 535 Mk II PBRs, operating from U.S. Special Forces camp at Thuong Thoi, heavily engaged with enemy on the Hong Ngu Canal just south of Cambodian border

7 February PBRs on the Ham Luong River east of Mo Cay sink a VC troop-laden sampan. Intelligence reports indicate 50 VC killed or wounded

9 February MRF forces begin Coronado X, search-and-destroy operation in Dong Tam

14 February Game Warden PBRs engage VC on Cu Lao May and Cu Lao Tan Dinh Islands in Bassac River

15 February CTF 116 directs TGs 116.1, 116.2, 116.3 to implement a proposal providing for a "ready-for-action" package force combining assets of USN/VNN and RF/PF for small-unit operations

19 February Hunterdon County embarks River Section 532 and HA(L)-3, Det. 5, and relieves Harnett County on station on the Ham Luong River.

20 February 3 PACVs of Coastal Division 17 transferred to operational control of CTF 116 to determine suitability for Game Warden patrols on major rivers (after about a week, they were judged unsuitable and returned to CTF 117).

22 February MRF, with SVN 21st division, begins operation in Phung Hiep district of Phong Dinh Province aimed against the VC MR III headquarters  
Harnett County changes to operational control of CTC 76.8.

24 February Task Force Clearwater becomes operational in I Corps

25 February River Section 521 becomes element of Clearwater

2 March MRF forms riverine armored reconnaissance element to transit Mang Thit/Nicholai canal between Bassac and Co Chien rivers, and proceeds to Dong Tam to await main body of MRF  
For the first time, 90mm. recoilless rifle used on a PBR.

7 March MRF begins Coronado XII, a search-and-destroy operation in the Cho Gao district, Kinh Tuong Province.

22 March River Section 514 activated at Nha Be

25 March PBRs of River Section 513 relocate from Sa Dec to Binh Thuy. River Section 522 debarks Garrett County at Vinh Long

26 March CTF 116 conducts combined GW/RAG operation Bold Dragon III against Cu Los/Tan Dinh Island in lower Bassac using RAG craft, 14 PBRs, armored LCPL and LCM-6, the Jennings County, 2 light helo fire teams, SEAL platoon, and RF/PF troops

3 April Capt. Arthur W. Price relieves Capt. Gray as Commander, River Patrol Force (CTF 116)  
River Section 535 relocates from Binh Thuy to APL 55; River Section 514 relocates from Nha Be to Binh Thuy

4 April MRF launches 3-day reconnaissance in Truc Giang and Giang Trom districts of Kien Hoa Province. MRB relocates from Dong Tam near My Tho to be near operations. Heavy contact with enemy around Ba Lai River northeast of Ben Tre  
U.S. and SVN forces conduct 4-day series of sweeps of Oc Island in Ham Luong River using PBRs and RAG craft as blocking and gunfire support forces.

8 April Through the 14th, 4 PBRs of River Section 511 conduct patrols on upper Bassac near Chau Doc to extend the U.S./SVN naval presence, collect intelligence, conduct psyops, and enforce curfews.

11 April Harnett County embarks River Section 513 and HA(L)-3, Det. 1, and relieves Jennings County on the Bassac. Jennings County changes to operational control of CTC 76 and sails to Subic Bay for upkeep

12 April ComRivDiv 51 conducts combined PBR/PF operation on Vong and Cu canals, southeast of Cau Tho, near VC concentration. PF troops overrun VC prison camp and free 24 prisoners

16 April APL 55 shifts location to the Ham Luong River near mouth of Ben Tre River

17 April CTF 116 activates new task group (TG 116.9) of 18 PBRs to conduct incursion of the Cho Gao canal (connecting Vam Co and My Tho Rivers) to extend U.S./SVN presence into an area of VC influence. No hostile incidents

24 April River Section 525 activated at Nha Be

25 April One of 3 SEAL Team-1 platoons in RSSZ moved to Delta

29 April Jennings County returns to operational control of CTF 116, embarks River Section 523 and HA(L)-3, Det. 4, and relieves Garrett County on station in Co Chien River

1 May 5 more PBRs assigned to CTF Clearwater for Cua Viet River operations  
River Section 544 activated at Nha Be

3 May APL 55 with embarked river sections shifts location to the Ham Luong/My Tho River junction  
PBRs from River Section 511 transit to Chau Doc and begin operations on upper Bassac

5 May PBRs from River Section 524 transit to Thuong Thoi Special Forces Camp and begin operations on upper Mekong near Tan Chau

15 May River Sections 551 and 552 activated at Nha Be

1 June CTF 116 realigns task organizations; see appendix D. APL-55 reclassified as LYRBM 18  
Hunterdon County leaves station on Ham Luong, debarks River Section 532 at My Tho, embarks River Section 533, and sails to station on the lower Ham Luong

5 June Garrett County changed to operational control of CTF 116 and stationed on lower Co Chien River, embarks River Section 523 and HA(L) 3 Det. 4 and relieves Jennings County

18 June Silent outboard motor used for the first time in Game Warden

10 June VNN takes command of 14 U.S. Navy river craft--6 LCM(M)s and 8 PBRs. With these craft, VNN assumes complete responsibility for minesweeping operations along the Long Tau river shipping channel to Saigon

11 July 6 PBRs provide blocking force in support of 400-man RF/PF sweep of the Cu Lao May Island in the Bassac

22 July PBR Mobile Base II, with ComRivDiv 55 and River Section 551 embarked, leaves Nha Be enroute to Thoug Thoi to begin operations as the Upper Mekong Patrol Group. Operations begin 28 July

29 July VNN receives first shipment of M-16 rifles from the USN

30 July HA(L)-3, Det. 3, relocates from Hunterdon County to PBR Mobile Base II

1 August VNN assumes partial responsibility for Dong Nai River patrol

26 September PBRs on upper Mekong take heavy automatic weapons fire from sampans retreating into Cambodia

September VAdm. E.R. Zumwalt, Jr., relieves RAdm. Veth as ComNavForV

8 October River Division 515 activated at Nha Be

19 October PBRs, MRF, and PF sweep northern half of Cu Lao May Island in the Bassac

22 October River Division 594 activated at Nha Be

end-October Operation Sea Lords begins, combining assets of CTF 115, CTF 116, and CTF 117 into single task force, TF 194. Initial operations would interdict flow of enemy supplies on the Rach Gia-Long Xuyen canal from Gulf of Thailand to the Mekong River

1 November River Squadron 51's PBRs begin intensified patrols on Can Tho crossing corridor

4 November VNN assumes full responsibility for the Dong Nai River patrols

10 November River Division 554 activated at Nha Be

15 November River Division 553 activated at Nha Be

end November Extension of Sea Lords to Vinh Te Canal area to close the Cambodian border

6 December Operation Giant Slingshot launched on Vam Co Tay and Cam Co Dong Rivers on either side of the "Parrots Beak" east into Saigon and south into the Delta