

AD-A034 139

DAVID W TAYLOR NAVAL SHIP RESEARCH AND DEVELOPMENT CE--ETC F/G 13/10
AN INVESTIGATION OF THE RELATIVE AND ABSOLUTE SHIP MOTIONS OF S--ETC(U)
NOV 76 S R GUNDERSON, L C RUTH

UNCLASSIFIED

SPD-515-01

NL

1 OF 1
AD
A034139
FBI

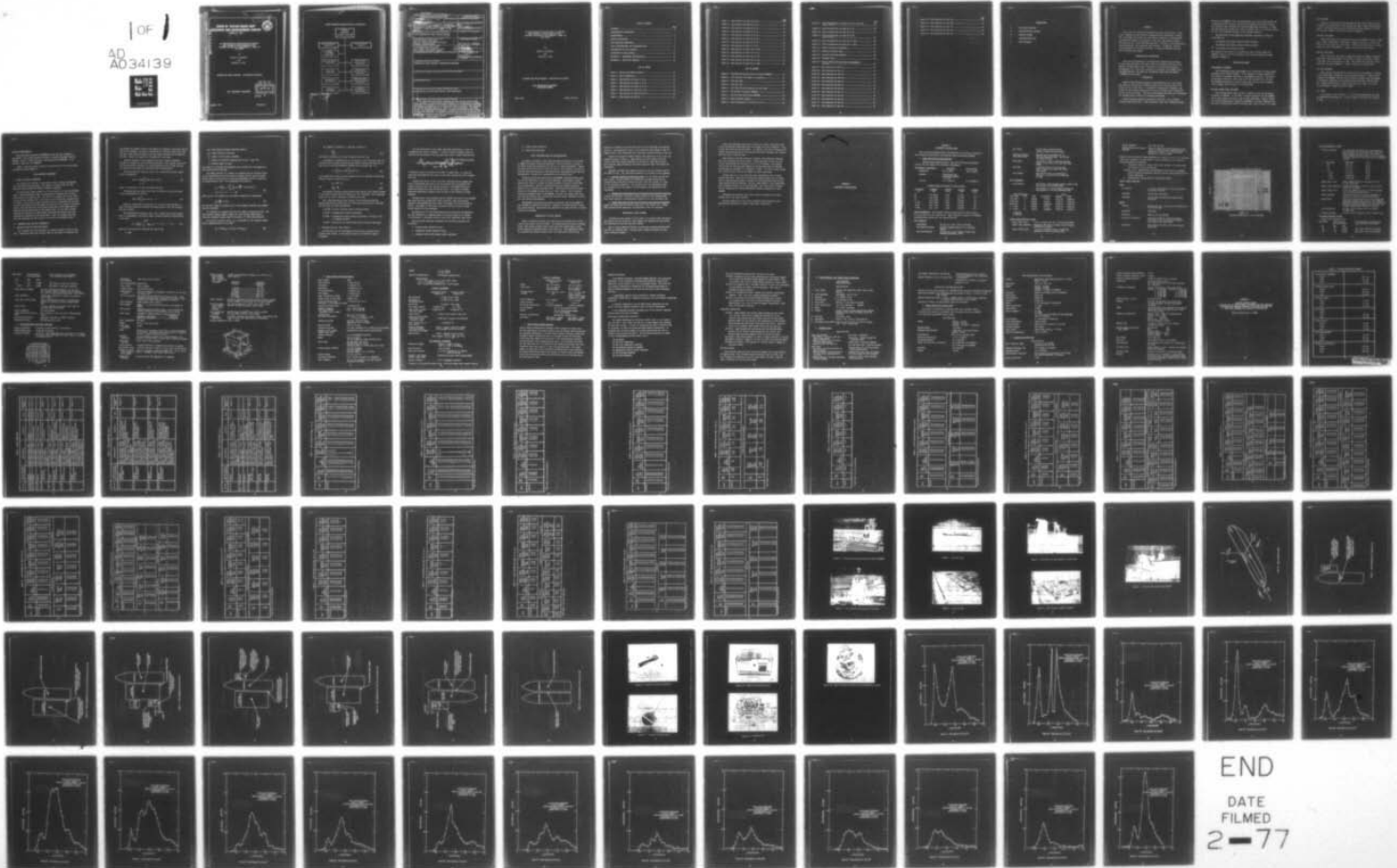

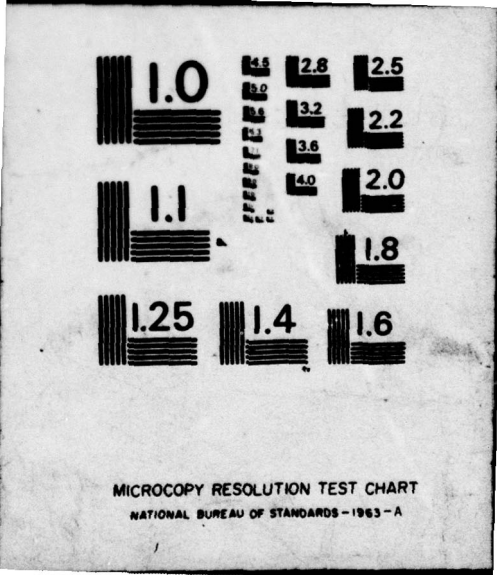

MICROCOPY RESOLUTION TEST CHART
NATIONAL BUREAU OF STANDARDS-1963-A

SPD-515-01

AN INVESTIGATION OF THE RELATIVE AND ABSOLUTE SHIP MOTIONS OF SHIPS INVOLVED IN THE "OFFSHORE DISCHARGE OF CONTAINERSHIP" (OSDOC II), SEA TRIALS

ADA 034139

12

DAVID W. TAYLOR NAVAL SHIP RESEARCH AND DEVELOPMENT CENTER



Bethesda, Md. 20084

AN INVESTIGATION OF THE RELATIVE AND ABSOLUTE
SHIP MOTIONS OF SHIPS INVOLVED IN THE
"OFFSHORE DISCHARGE OF CONTAINERSHIP" (OSDOC II)
SEA TRIALS

by

Steven R. Gunderson

and

Lawrence C. Ruth

APPROVED FOR PUBLIC RELEASE: DISTRIBUTION UNLIMITED

SHIP PERFORMANCE DEPARTMENT

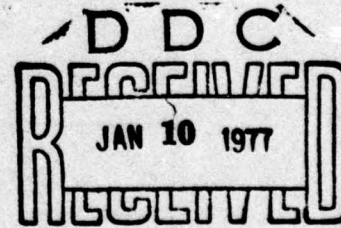

A

November 1976

SPD-515-01

MAJOR DTNSRDC ORGANIZATIONAL COMPONENTS

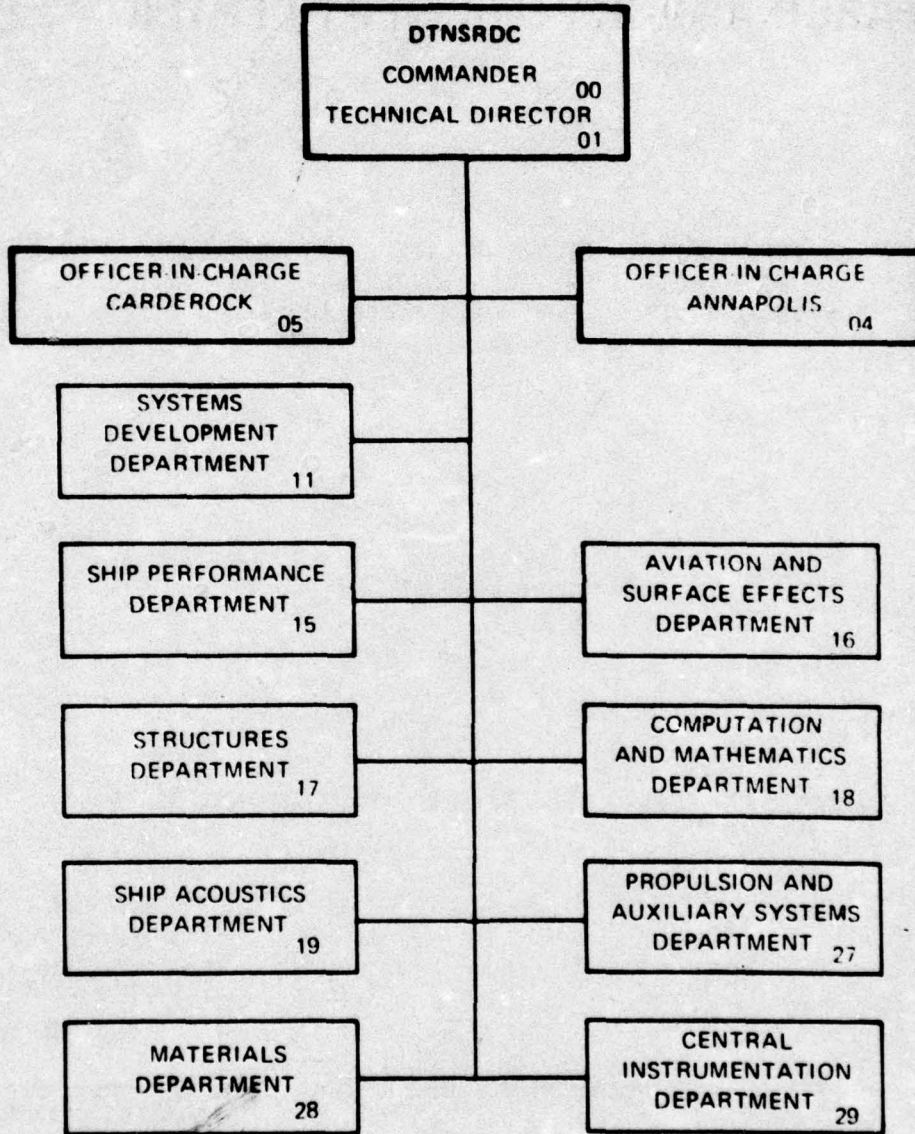

ACCESSION FOR

NTIS DTIC

ERIC SRI

ADONIS

BY

DATE

A

UNCLASSIFIED

SECURITY CLASSIFICATION OF THIS PAGE (When Data Entered)

REPORT DOCUMENTATION PAGE		READ INSTRUCTIONS BEFORE COMPLETING FORM
1. REPORT NUMBER SPD-515-01	2. GOVT ACCESSION NO.	3. RECIPIENT'S CATALOG NUMBER
4. TITLE (and Subtitle) AN INVESTIGATION OF THE RELATIVE AND ABSOLUTE SHIP MOTIONS OF SHIPS INVOLVED IN THE OFFSHORE DISCHARGE OF CONTAINERSHIP (OSDOC IT) SEA TRIALS		5. TYPE OF REPORT & PERIOD COVERED Final rept.
7. AUTHOR(s) Steven R. Gunderson and Lawrence C. Ruth		6. PERFORMING ORG. REPORT NUMBER
9. PERFORMING ORGANIZATION NAME AND ADDRESS Ship Performance Department David W. Taylor Naval Ship R&D Center Bethesda, Maryland 20084		8. CONTRACT OR GRANT NUMBER(s)
11. CONTROLLING OFFICE NAME AND ADDRESS Civil Engineering Laboratory Naval Construction Battalion Center Port Hueneme, California 93043		10. PROGRAM ELEMENT, PROJECT, TASK AREA & WORK UNIT NUMBERS Work Unit No. 1-1568-254
14. MONITORING AGENCY NAME & ADDRESS (if different from Controlling Office)		12. REPORT DATE November 1976
		13. NUMBER OF PAGES 93
		15. SECURITY CLASS. (of this report) Unclassified
16. DISTRIBUTION STATEMENT (of this Report) APPROVED FOR PUBLIC RELEASE: DISTRIBUTION UNLIMITED		
17. DISTRIBUTION STATEMENT (of the abstract entered in Block 20, if different from Report)		
18. SUPPLEMENTARY NOTES		
19. KEY WORDS (Continue on reverse side if necessary and identify by block number) Containership, Relative Ship Motions, Wave Measurement		
20. ABSTRACT (Continue on reverse side if necessary and identify by block number) Full scale ship trials were conducted one mile off the coast at Fort Story, Virginia, to both evaluate and determine the feasibility of equipment, procedures and systems for the offshore discharge of containerships including the movement of containers to the shore and across the beach. This exercise was a joint Army-Navy operation. Motions of the containership, unloading vessels, and lighterage were measured. In addition relative motions between the ships were measured. A Datawell Waverider buoy was used to measure wave height.		

AN INVESTIGATION OF THE RELATIVE AND ABSOLUTE
SHIP MOTIONS OF SHIPS INVOLVED IN THE
"OFFSHORE DISCHARGE OF CONTAINERSHIP" (OSDOC II)
SEA TRIALS

by

Steven R. Gunderson

and

Lawrence C. Ruth

APPROVED FOR PUBLIC RELEASE: DISTRIBUTION UNLIMITED

SHIP PERFORMANCE DEPARTMENT
EVALUATION REPORT

March 1973

Report 515-H-01

TABLE OF CONTENTS

	Page
ABSTRACT.....	1
ADMINISTRATIVE INFORMATION.....	1
INTRODUCTION.....	1
VEHICLE PARTICULARS.....	2
DATA REDUCTION TECHNIQUES.....	4
TRIAL CONFIGURATIONS AND INSTRUMENTATION.....	9
PRESENTATION OF TRIAL RESULTS.....	9
DISCUSSION OF TRIAL RESULTS.....	10
APPENDIX A - INSTRUMENT SPECIFICATIONS.....	12
APPENDIX B - RUN BY RUN PRINTOUT.....	30

LIST OF TABLES

Table 1 - Natural Ship Motion Periods.....	32
Table 2 - Trial Conditions.....	33
Table 3 - Ship Motions for Runs 1 to 15.....	36
Table 4 - Ship Motions for Runs 16 to 34.....	37
Table 5 - Ship Motions for Runs 35 to 39.....	38
Table 6 - Ship Motions for Runs 40 to 49.....	39
Table 7 - Ship Motions for Runs 50 and 51.....	40
Table 8 - Ship Motions for Run 52.....	41

	Page
Table 9 - Ship Motions for Runs 53 to 60.....	42
Table 10 - Ship Motions for Runs 61 to 64.....	43
Table 11 - Ship Motions for Runs 65 to 71.....	44
Table 12 - Ship Motions for Runs 72 to 77.....	45
Table 13 - Ship Motions for Runs 78 to 83.....	46
Table 14 - Ship Motions for Runs 84 to 89.....	47
Table 15 - Ship Motions for Runs 90 to 96.....	48
Table 16 - Ship Motions for Runs 97 to 99.....	49
Table 17 - Ship Motions for Runs 100 to 106.....	50
Table 18 - Ship Motions for Runs 107 to 111.....	51
Table 19 - Ship Motions for Runs 112 to 114.....	52
Table 20 - Ship Motions for Runs 115 to 126.....	53
Table 21 - Ship Motions for Runs 127 to 136.....	54

LIST OF FIGURES

Figure 1 - Floating Delong Barge Moored Alongside WARRIOR.....	55
Figure 2 - 7x15 Platform with Hopper in Operation.....	55
Figure 3 - Navy LCU 1659.....	56
Figure 4 - Army LCU 1524.....	56
Figure 5 - LST 1188 with Crane Mounted on Stern Deck.....	57
Figure 6 - ACV Voyageur Alongside WARRIOR.....	57
Figure 7 - Seatrain Ship Approaching WARRIOR.....	58
Figure 8 - Ship Coordinate System.....	59
Figure 9 - Ship Configuration for Runs 50 to 51.....	60

	Page
Figure 10 - Ship Configuration for Runs 53 to 64, 84 to 89, and 97 to 99.....	61
Figure 11 - Ship Configuration for Runs 65 to 71.....	62
Figure 12 - Ship Configuration for Runs 72 to 77.....	63
Figure 13 - Ship Configuration for Runs 78 to 83 and 90 to 96.....	64
Figure 14 - Ship Configuration for Runs 112 to 126.....	65
Figure 15 - Ship Configuration for Runs 127 to 136.....	66
Figure 16 - Wesmar Ultrasonic Transducer.....	67
Figure 17 - Datawell Waverider Buoy.....	67
Figure 18 - Datawell Waverider Receiver.....	68
Figure 19 - Honeywell Gyro.....	68
Figure 20 - Mark IV Stable Platform with Accelerometers in Place.....	69
Figure 21 - Wave Spectrum for Run 37.....	70
Figure 22 - Wave Spectrum for Run 45.....	71
Figure 23 - Wave Spectrum for Run 50.....	72
Figure 24 - Wave Spectrum for Run 52.....	73
Figure 25 - Wave Spectrum for Run 57.....	74
Figure 26 - Wave Spectrum for Run 63.....	75
Figure 27 - Wave Spectrum for Run 68.....	76
Figure 28 - Wave Spectrum for Run 75.....	77
Figure 29 - Wave Spectrum for Run 81.....	78
Figure 30 - Wave Spectrum for Run 86.....	79
Figure 31 - Wave Spectrum for Run 93.....	80
Figure 32 - Wave Spectrum for Run 98.....	81

	Page
Figure 33 - Wave Spectrum for Run 103.....	82
Figure 34 - Wave Spectrum for Run 109.....	83
Figure 35 - Wave Spectrum for Run 113.....	84
Figure 36 - Wave Spectrum for Run 121.....	85
Figure 37 - Wave Spectrum for Run 131.....	86

NOMENCLATURE

- E** Area under spectrum
- Q** Autocorrelation function
- S** Spectrol energy.
- τ** Autocorrelation lag
- ω** Wave frequency

ABSTRACT

Full scale ship trials were conducted one mile off the coast at Fort Story, Virginia, to both evaluate and determine the feasibility of equipment, procedures and systems for the offshore discharge of containerships including the movement of containers to the shore and across the beach. This exercise was a joint Army-Navy operation. Motions of the containership, unloading vessels, and lighterage were measured. In addition, relative motions between the ships were measured. A Datawell Waverider buoy was used to measure wave height:

ADMINISTRATIVE INFORMATION

This work was authorized by the Naval Civil Engineering Laboratory Project Order PO-3-0008 of 28 August 1972, and outlined in the Naval Ship Research and Development Center "Proposal for Unloading System Motion Measurements" of 11 July 1972, presented as enclosure (1) of NSRDC letter 1568:SRG/3900/7100. The work was accomplished under Work Unit Number 1-1568-254 at the Center.

INTRODUCTION

OSDOC II (The Offshore Discharge of Containerships) was a joint Army-Navy operation taking place between 4 October and 13 October 1972 off the Virginia coast at Fort Story. A commercial containership, "WARRIOR", was leased from the Sealand Corporation and used as the main base of operation for the at-sea activities. From this containership containers were discharged and reloaded using a variety of offloading mechanisms.

These offloading vehicles included the following: (1) a floating "Delong" barge fitted with a large commercial crane; (2) a commercial crane

fitted to the WARRIOR's deck; (3) helicopters; (4) an LST (1188) fitted with a commercial crane; and (5) a seatrain ship using its own on-board cranes. The containers were offloaded into various lighterages including: (1) Navy and Army LCU Class landing craft; (2) B.C. barges; (3) an air cushion vehicle; and (4) a 7x15 platform attached to the causeway sections.

The objectives of the NSRDC Ship Performance Department during the trials were to:

- (1) measure and analyze absolute vehicle motions;
 - (2) measure and analyze relative vehicle motions;
- and
- (3) measure and analyze sea state.

The purpose of the report is to provide this data in both tabular and graphical form, to aid the evaluation of the various offloading systems employed in OSDOC II.

VEHICLE PARTICULARS

CONTAINERSHIP (WARRIOR)

The containership used during OSDOC II is a converted C-2 Class vessel belonging to the Sealand Company. It was modified to accept standard 20 foot military containers just prior to the OSDOC II exercise. The length of the ship is 468 feet, with a beam of 63 feet and draft of 19.3 feet. The WARRIOR was moored in 41 feet of water just off Fort Story, Virginia using a single point, bow moor to a mooring buoy.

FLOATING DELONG BARGE AND CRANE

The floating Delong barge carried a commercial crane and was moored alongside the WARRIOR. It was used to unload containers from the WARRIOR and to place these containers on the various lighterages. Figure 1 shows the floating Delong barge alongside the WARRIOR. The barge dimensions are 300 feet in length with a width of 80 feet and a draft of from 2 to 3 feet.

7x15 PLATFORM

This was a floating platform measuring 90 feet long by 49½ feet wide. A "hopper" was constructed on the platform and used to feed containers onto trucks. The trucks drove onto the 7x15 platform from causeways at either end and were loaded by the hopper as shown in Figure 2.

NAVY LCU 1610 CLASS

These craft were used as lighterage during the OSDOC II exercise. They have a light displacement of 200 tons, a length of 139 feet, a beam of 29 feet and a mean light draft of 2.9 feet. LCU 1659 and LCU 1664 were instrumented for use during OSDOC II. Figure 3 shows one of these craft.

ARMY LCU 1466 CLASS

These craft were also used as lighterage during the OSDOC II exercise. They have a light displacement of 180 tons, a length of 119 feet, a beam of 34 feet, and a mean draft of 3 feet. LCU 1524 and LCU 1583 were instrumented for use during OSDOC II. Figure 4 shows one of these craft.

LST 1188 (SAGINAW)

This ship was used during the latter portions of the OSDOC II exercise. It was fitted with a commercial crane as shown in Figure 5. While moored alongside the WARRIOR, the LST crane offloaded containers from the WARRIOR to lighterage positioned on the opposite side of the LST. The LST 1188 has a length of 522.3 feet, a beam of 69.5 feet and a draft of 15 feet. Its displacement is 8384 tons fully loaded.

B.C. BARGE

This barge is seen in Figure 6. It is not self-powered and was used as lighterage during OSDOC II. It has a length of 111 feet and a beam of 32 feet.

SEATRAN CONTAINERSHIP

This ship came alongside the WARRIOR for the last day of OSDOC II operations. Its on-board cranes were used to offload containers from the WARRIOR. Figure 7 shows this ship coming alongside the WARRIOR. It is somewhat larger than the WARRIOR.

Table 1 lists the natural periods of oscillation for the various ships instrumented during OSDOC II.

DATA REDUCTION TECHNIQUES

I. ANALOG TO DIGITAL CONVERSION

All signals are recorded on both Sanborn direct writing oscillograph units and analog tape recorders. The signals on analog tapes are then digitized using the SDS 910 analog to digital converter.

The analog data tapes contain 0 to +1 volt and 0 to -1 volt calibrating steps. These calibration steps are digitized and inserted into the first three files on the digital tape. The first file contains the +1 volt level, the second file contains the -1 volt level and the third file contains the 0 volt level. The volts to counts conversion factor is computed from the data in these first three files and listed for each run on the computer "printout" sheets. All test data for a particular analog tape is then digitized and inserted into the fourth file on the digital tape. As the data is being digitized, a one-half volt level signal associated with each run is also digitized and inserted in this fourth file. Thus, for example, 200 test runs are represented by 200 one-half volt levels on the digital tapes.

II. IRREGULAR WAVE ANALYSIS (REFERENCE 1)

A. Spectral Analysis (Frequency Domain)

For irregular wave data analysis, two computer passes are made on the data. During the first pass the mean value of the signal is computed, and

the maximum and minimum values of the signal are obtained. During the second pass on the computer, the mean is subtracted on a point by point basis from the data, while spectral analysis and time domain analysis are performed on the data. Again, all results are obtained for a zero mean.

Spectral analysis of the irregular wave data is based on Wiener's theorem for analysis of time stationary processes. This theorem states that the autocorrelation function of a random function and the energy spectrum are related to each other by a Fourier cosine transformation.

The autocorrelation function, $Q(\tau)$, for a random time history signal, $X(t)$, is defined as

$$Q(\tau) = \lim_{T \rightarrow \infty} \frac{2}{T} \int_0^T X(t) X(t + \tau) dt \quad , \quad (1)$$

where τ is referred to as the autocorrelation lag.

The energy spectral density may then be defined as twice the Fourier cosine transformation of $Q(\tau)$ or

$$S(\omega) = \frac{2}{\pi} \int_0^{\infty} Q(\tau) \cos \omega \tau \cdot d\tau \quad . \quad (2)$$

Numerical integration of Equations (1) and (2) is then employed to obtain the autocorrelation function and energy spectra from the irregular wave test signals.

The autocorrelation function, $Q(\tau)$, for a random time history signal, $X(t)$, is programmed at the Center using a discrete numerical approximation of the form

$$Q_n = \frac{2}{(N_0 - n)} \sum_q^{N_0 - n} X_q X_{q+n} \quad (n = 0, 1, 2, \dots, m) \quad , \quad (3)$$

where Q_n = autocorrelation estimate for time or lag,

$$\tau = n\Delta t,$$

Δt = time interval between digitized points,

X_q = value of $X(t)$ at time $q\Delta t$,

N_0 = number of data points recorded,

n = number of intervals defining time or lag $\tau = n\Delta t$, and,

m = desired number of lags.

The number 2 is inserted into Equation (3) to account for the symmetry of the autocorrelation function.

The energy spectrum of a signal is estimated from the discrete values of the autocorrelation function using a discrete Fourier cosine transformation; which is equivalent to using the trapezoidal rule for integration to compute Equation (2). This approximation is given as

$$S_k = \frac{\Delta t}{\pi} \left[Q_0 + 2 \sum_{n=1}^{m-1} Q_n \cos \frac{nk\pi}{m} + Q_m \cos k\pi \right], \quad (4)$$

$(k = 0, 1, 2, \dots, m)$

where S_k are the estimates for the spectral densities at frequencies

$$\omega = \frac{\pi k}{m\Delta t} = k \Delta \omega. \quad (5)$$

The quantity, $\pi/m\Delta t$, in Equation (5) is the frequency interval, $\Delta \omega$, between spectral estimates.

For analysis of irregular wave data the number of lags used is 60. The time interval between digital samples is 0.599 seconds, which gives a frequency increment between spectral estimates of 0.088 radians/second.

The spectral ordinate values, S_k , are smoothed in the frequency domain using a Hanning process of the form

$$S_k = 0.25 S_{k-1} + 0.5 S_k + 0.25 S_{k+1}. \quad (6)$$

The degrees of freedom of a spectrum is given as

$$\frac{2N_0}{m}, \quad (7)$$

and value is printed out for each irregular wave test run.

An important characteristic of the spectrum is that the area under the spectrum curve is equal to twice the mean-square value of the function, or the value of the autocorrelation function for the zeroth lag, i.e.,

$$E = \int_0^{\infty} S(\omega) d\omega = \frac{2}{T} \int_0^T [X(t)]^2 dt. \quad (8)$$

For a signal with a zero mean this expression may be regarded as twice the variance, which is defined as Q_0 or

$$Q_0 = 2\sigma^2 = E, \quad (9)$$

and

$$\sqrt{Q_0} = \sqrt{E}. \quad (10)$$

The spectral analysis program yields power spectra with ordinate values in the form of single amplitude squared per unit frequency, versus abscissa values in the form of frequency in radians per second.

For a time-stationary process having a narrow band spectrum and Gaussian data point distribution, the following statistics may be obtained from the area, E , under the spectrum

1.414 \sqrt{E} = the most frequent double amplitude motion,

1.77 \sqrt{E} = average motion (double amplitude),

2.83 \sqrt{E} = "significant" motion (double amplitude) or average of the 1/3 highest motions,

3.60 \sqrt{E} = average of the 1/10th highest motion (double amplitude).

B. Histogram Analysis (Time Domain)

Concurrently with the performance of the spectral analysis for an irregular wave signal, a time domain analysis is performed to obtain histograms.

For the calculation of the double amplitude distribution, a cycle of information must first be defined. A cycle is defined as being three consecutive zero crossings of the zero mean data, while a double amplitude for

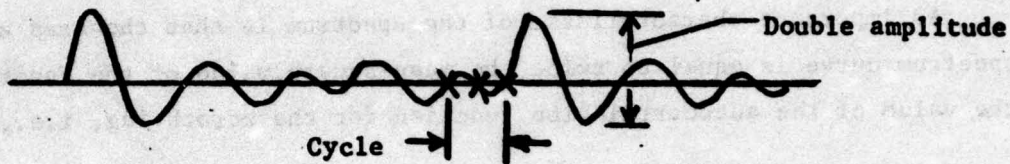

a particular cycle is defined as the peak to trough value. It should be noted that approximately 150 cycles of data were obtained for each irregular wave run.

Assuming 150 cycles of data the double amplitude values ranging from zero to the maximum data point minus the minimum point are grouped into thirty intervals, where the interval spacing is the maximum data point minus the minimum data point divided by thirty. The number of double amplitude occurrences falling in each of these thirty intervals is then obtained.

The data point values ranging from the minimum data point to the maximum data point are also grouped into thirty intervals, where the interval spacing is the maximum data point minus the minimum data point divided by thirty. The number of data point occurrences falling in each of these thirty intervals is also obtained.

Histogram plots for the double amplitude and data point distributions are then obtained for a reduced number of intervals based on the number of occurrences, a reasonable interval scale and a reasonable range scale.

From the double amplitude histograms the following statistics are calculated:

- a. average double amplitude value;
- b. significant double amplitude value;
- c. average of the 1/10th highest double amplitude;

d. median double amplitude;

e. mode double amplitude.

TRIAL CONFIGURATIONS AND INSTRUMENTATION

The ships and vessels listed under Ship Particulars were all involved in OSDOC II sometime during the exercises. Table 2 provides a listing of the ships being used during each run and the recorded measurements. Figure 8 defines the various motions listed in Table 2, while Figures 9 through 15 show the relative locations of each vessel with instruments during each test configuration. Vessels not instrumented are not always shown.

Absolute motions were measured for the WARRIOR, floating Delong barge, and the LST-1188 using a Mark IV stable platform. Three Donner accelerometers were fixed to the Mark IV stable platform to provide translational motion measurement. Relative translational motions between ships were measured using a Datawell Waverider buoy. This buoy was moored about 1000 yards from the WARRIOR mooring buoy in 41 feet of water. Data from this buoy were telemetered back to the WARRIOR. For LCU, B.C. barge, 7x15 platform and the seatrain ship, motions were measured using a Honeywell aircraft gyro and Donner accelerometers.

Photographs illustrating the various transducers used during OSDOC II are provided in Figures 16 through 20. Appendix A provides detailed instrument specifications. Motion data was recorded on two Ampex CP-100, 14 channel analog tape recorders.

PRESENTATION OF TRIAL RESULTS

Tables 3 through 21 present the significant and maximum values of the various ship motions and wave height. The maximum motion values are obtained using a time domain analysis which simply picks the largest peak to peak double amplitude occurring during a particular run. The significant values are obtained from response spectra where the significant values of the

response is defined as $2.83 \sqrt{E}$ with E equal to the area under the response spectrum. The significant value is also defined as the average of the 1/3 highest peak to peak excursions for a particular parameter during a test run.

Figures 21 through 37 present typical wave spectra for each of the test conditions given in Table 2. These spectra are point spectra and thus reflect total wave energy regardless of direction. These wave spectra were obtained using the methods previously described under "Data Reduction Techniques".

Appendix B presents the computer printout of all the analysis done on the OSDOC II data. The following information is provided in this appendix:

1. Spectral Ordinate and Abscissa Values for all vessel motions and wave height. For each channel of information recorded statistics are tabulated which have been obtained from area under the spectra, E. Some of the statistics listed are: the average value, the significant value, the average of the 1/10 highest, and the highest value expected in 100 encounters;
2. Response Amplitude Operations and Nondimensional Transfer Functions obtained by dividing a particular response spectra by the corresponding wave height spectra at corresponding frequencies are also tabulated; and
3. Double Amplitude and Data Point Frequency and Cumulative Distributions from which some statistical properties of the signal, i.e., median, mode, maximum double amplitude, and significant value are obtained.

DISCUSSION OF TRIAL RESULTS

Although the main purpose of this report is to provide other evaluators with motion and sea state data, some comments and observations made during the collection of this data may prove useful.

Due to a power generator failure, no data were collected between 0915 and 1740 on 9 October 1972. A starter motor failed and shorted out the entire electrical system.

Since the evaluation team had no control over actual operations, many of the instrumented lighterages were not brought into use on OSDOC II. Thus, no data were obtained for Navy LCU's. In addition, the lack of communication between operations personnel and evaluation personnel accounted for considerable lost data collection time.

With regard to the data that was collected, some additional observed ship motion information may be useful. During the power failure the roll of the containership was estimated to be 5° to 9° maximum. Also during this period the relative sway between the containership and the floating Delong barge was estimated at a maximum of 4 feet. All other motions during this time were small and did not appear to affect operations.

During runs 65 to 71 on 10 October some observations of B.C. barge motions were made. Essentially no relative surging between the B.C. barge and the floating Delong barge or between the floating Delong barge and the containership could be observed. The B.C. barge seemed to yaw considerably, with a maximum estimate of 5° being observed. The relative heave between the B.C. barge and the floating Delong was visually estimated at 2 feet maximum.

Throughout the exercise very little relative surging could be seen between any of the craft involved.

The data contained in this report provides system evaluators with quantitative information on which to base their evaluations.

Since the operations have had a successful record, many of the instruments mentioned here are brought into use on the 11. Thus, the lack of communication, in addition, the lack of communication between operations personnel and the instrument personnel is considered as one of the main reasons.

With regard to the data that was collected, some additional observations are that the data was not as accurate as it should have been. This is due to the fact that the data was collected during the operations and the data was not as accurate as it should have been. This is due to the fact that the data was collected during the operations and the data was not as accurate as it should have been.

During most of the operations, the data was not as accurate as it should have been. This is due to the fact that the data was collected during the operations and the data was not as accurate as it should have been. This is due to the fact that the data was collected during the operations and the data was not as accurate as it should have been.

APPENDIX A

INSTRUMENT SPECIFICATIONS

The data contained in this report provides system operators with information which is necessary for the operation of the system. The data is presented in a form which is easy to understand and use. The data is presented in a form which is easy to understand and use. The data is presented in a form which is easy to understand and use.

APPENDIX A
INSTRUMENT SPECIFICATIONS

The following paragraphs detail specifications for the major transducers and recording devices used in the Relative Motion Measurement Program

1. Ampex CP-100 Analog Tape Recorder

Minimum specifications require that the CP-100 Recording System operate over the range of the described environments.

ENVIRONMENTAL CONDITIONS	Operation	Non-Operation
Temperature	40° to 125°F	-20° to 160°F
Humidity	90% Relative non-condensing Humidity -5 to +0%	
Altitude	0 to 10,000 ft.	0 to 20,000 ft.

MAXIMUM CUMULATIVE FLUTTER (% PEAK-TO-PEAK)

TAPE SPEED IPS	BANDPASS CPS	FLUTTER % P-P	BANDPASS CPS	FLUTTER % P-P
60	0.2-10,000	0.50	0.2-312	.17
30	0.2- 5,000	0.55	0.2-312	.25
15	0.2- 2,500	0.60	0.2-312	.35
7-1/2	0.2- 1,250	0.60	0.2-312	.45
3-3/4	0.2- 625	1.00	0.2-312	.85
1-7/8	0.2- 3.2	1.00	0.2-312	1.00

POWER REQUIREMENTS. Will operate (without modification) on 28 volt dc or on 115 or 230 volt, 48 to 420 cps ac. Power required to operate a 14-channel record/reproduce system will not exceed 400 watts.

TAPE TRANSPORT

Tape Speeds	60, 30, 15, 7-1/2, 3-3/4, 1-7/8 ips.
Tape Speed Deviation	+0.25% of nominal speed at all recording speeds.
Tape Specification	1/2-inch or 1-inch, 0.001 or 0.0015 inch; maximum temperature, 140°F.

Reel Sizes 10 1/2-inches maximum diameter
(NARTB or AMPEX precision reels).

Cumulative Flutter (See table above) Measured when using AMPEX 741 1.0
MIL instrumentation tape. Low cut-off
frequency +0.2 cps.

Start Time 5 seconds to reach a stable 60 ips tape
speed. Faster start time with lower tape
speeds.

Stop Time 2 seconds maximum from 60 ips tape
speed. Faster stop times with lower
tape speeds.

Fast Forward Fast Forward Time (at approximately
250 ips). 3.15 minutes for 3,600 feet
of tape.

HEAD ASSEMBLIES

Head Geometry Gap Scatter, trailing edges within a band of 100
micro-inches wide (0.0001 inch).

Gap Azimuth, all stacks within ± 1 minute of
perpendicular to the head mounting plate.

Track Dimensions		Track			
Tape Width	Track	Type	Arrangement	Spacing	Width
*1/2-inch	4	Analog	In-line	0.110 in.	0.050 in.
*1/2-inch	4	Analog	In-line	0.140 in.	0.050 in.
**1/2-inch	7	Analog	Staggered	0.070 in.	0.050 in.
* 1-inch	14	Analog	In-line	0.070 in.	0.050 in.
** 1-inch	14	Analog	Staggered	0.070 in.	0.050 in.

* Special

** Standard

DIRECT RECORD/REPRODUCE SYSTEM

Signal Input Level 0.25 to 10 volts rms for 1.5 ma record current.

Signal Input Impedance Minimum 18,000 ohms in parallel with 275 μ fd,
unbalanced to ground.

Signal Output Level 1 volt rms (nominal) across a 10,000 ohm
impedance at normal recording level.

Output Impedance	Less than 100 ohms.
Dynamic Range and Frequency Response	Signal-to-noise ratio varies widely according to the defined limits between which it is measured, therefore it is best expressed graphically. See key below.

Signal-to-noise parameters shown graphically (in figure 1-7 thru 1-12) represent statistical averages of a large number of units tested and do not represent minimum guaranteed performance.

- A. Frequency response at normal record level maximum 1.4% 3rd-harmonic distortion at 30 ips and 500 cps.
- B,C,D,E, and F. System noise (rms measured at the output of a bandpass filter having an attenuation rate of 19 db per octave beyond the band limits indicated).
- G. Systems noise (rms) measured in half-octave bands.

CONTROL TRACK GENERATOR

Input

Sensitivity	1.75 volts rms minimum; 3 volts rms supplied by Capstan inverter.
Impedance	10,000 ohms, unbalanced.
Frequency	60 cps $\pm 0.02\%$ (obtained from capstan drive inverter).

Output

Voltage	Normally set for 5 volts (can be adjusted from 0 to 20 volt PP).
Impedance	1500 ohms.
Modulation	Normal set for 50% $\pm 5\%$.
Sub-Carrier Frequency	18,240 cps $\pm 0.05\%$ or 17,000 cps $\pm 0.05\%$, (selected at time of purchase by separate part numbers; see Parts List).
Distortion	Sub-carrier, less than 1.5% total harmonic distortion.

AVERAGE VALUES OF TYPICAL 14 TRACK CP-100 DIRECT SYSTEM

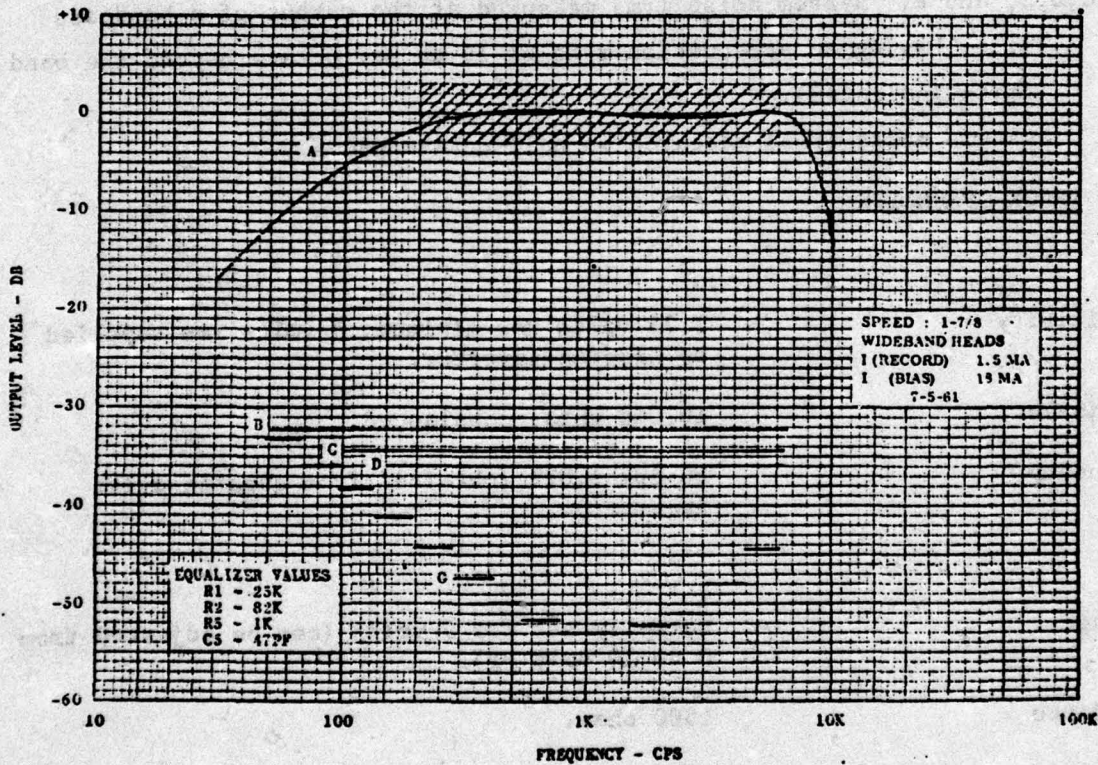

Frequency Response for 1-7/8 ips Operation

FM RECORD/REPRODUCE SYSTEM

Frequency Response

The following table gives the record/reproduce data bandwidth for all standard tape speeds with total harmonic distortion of no more than 2%. State passbands are flat within 1.0 db and signal-to-noise figures are rms values with an undeviated carrier.

Tape Speed	Band Width	S/N
60	0-20 kc	46 db
30	0-10 kc	46 db
15	0- 5 kc	46 db
7-1/2	0- 2.5 kc	45 db
3-3/4	0-1250 cps	42 db
1-7/8	0- 625 cps	42 db

Signal Input Level

Normal (+40%) deviation with inputs from 0.5 to 25.0 volts rms.

Signal Input Impedance

Minimum 18,000 ohms in parallel with 275 μ fd, unbalanced to ground.

Signal Output Level

1-volt rms (nominal) across a 10,000 ohm impedance at normal recording level.

Output Impedance

1000 ohms or less, dc to 20 kc; unbalanced to ground, (a function of gain potentiometer).

System Drift

Less than 1% after warm-up with line voltage and temperature constant for 8 hours. Less than 2% with line variations between 105 and 125 volts and temperature variations between 40° and 125° F for 8 hours. Warm-up time nominally 5 minutes.

Record/Reproduce

dc, \pm 1% of full deviation of a zero-based straight line.

Voltage Linearity

ac, \pm 1% of full deviation of best straight line.

PDM RECORD/REPRODUCE SYSTEM

System pulse characteristics:

Tape Speed	Pulse Duration (in microseconds)		Pulse accuracy in microseconds over specified pulse widths
	Min.	Max.	
Ips			
60	20	10,000	\pm 2.0 (50 to 900 usec duration)
30	40	10,000	\pm 2.0 (50 to 900 usec duration)

Tape Speed	Pulse Duration (in microseconds)		Pulse accuracy in microseconds over specified pulse widths
	Min.	Max.	
Ips			
15	80	10,000	± 3.0 (100 to 2,000 usec duration)
7-1/2	160	10,000	± 10 (200 to 3,000 usec duration)

Input Level and Range: 1.0 volt zero-to-peak nominal; 1 to 25 volts zero-to-peak (input attenuator must be adjusted to 1 volt for any input voltage from 1 to 25 volts).

Input Impedance: 20,000 ohms, unbalanced to ground, in parallel with 275 μf .

Input Rise and Fall Time: (10% to 90% amplitude level) 2.0 microseconds maximum (to maintain specified systems accuracy).

Output Level: 20 volts, minimum zero-to-peak into 1,000 ohm resistive load (AC coupled).

Output Impedance: 100 ohms maximum.

Output Pulse Rise and Fall Time: 2.0 μ seconds or less from 10% to 90% amplitude level.

Pulse Return Duration: Adjustable from 200 to 10,000 μ seconds.

Maximum Duty Cycle: 85% (900 pps data rate).

2. Gould Brush 260-6 Strip Chart Recorder

Number of channels 6 analog, 4 event markers 2 interchannel

Analog-channel span 40 mm (50 divisions)

Frequency response at 50 div.: flat within $\pm 2\%$ full-scale from d-c to 40 Hz;
at 10 div.: flat within $\pm 2\%$ full-scale from d-c to 100 Hz;
3 db down @ 125 Hz

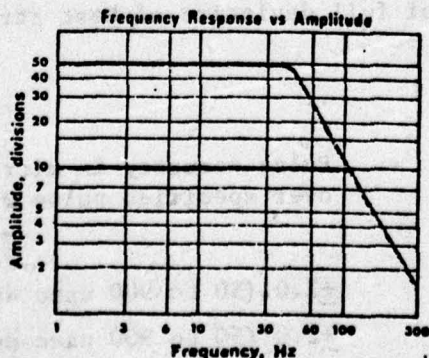

Deflection	Less than 0.5% full-scale
Non-linearity	
Trace presentation	Rectilinear
Trace width	0.01" nominal
Marking method	Pressurized fluid
Marking-fluid capacity	Two 1-oz. disposable cartridges (sufficient for one year of typical use)
Chart description	Six 40-mm grids graduated in 50 divisions each. 5-mm increments on time axis. Event-marker channels at both margins and between analog channels 2-3 and 4-5
Chart capacity	High-contrast paper: 225 ft
Chart-speeds	Eight: 1, 5, 25, and 125 mm/sec plus same speeds in mm/min
Event marker	Internally powered by 28-V source; to be activated by external switch with 50-mA minimum contact rating
Power input	115/230V a-c $\pm 10\%$; attached 3-conductor line cord Model No. 115V/60 Hz sinusoidal.....15-6367-00 230V/50 Hz sinusoidal.....15-6367-06
Power consumption	200 watts
Weight	65 lbs., less chart paper
Chart speed inaccuracy	$\pm 0.25\%$
Timer	Internal timer produces 1-sec pulses on left interchannel event marker. Rear-panel switch allows choice of timer or external, passive switching circuit.
Standard complement	6-analog-channel recorder with 4 event markers; 2 ink capsules installed full; 6 analog input connectors (plugs)
Input plug required	Cannon XLR-3-11C(6 supplied)
Input impedance	10 megohms balanced, 5 megohms each terminal to ground
Measurement range	1 mV/chart division to 500 V d-c full scale (50 divisions)
Maximum allowable input voltage to avoid damage	500 V d-c or peak a-c either terminal (No. 1 or No. 2) to ground. (Remember, 500 V peak = 354 V rms.)
Common-mode rejection	60 db @ 60 Hz @ 1mV range with 1 K unbalance

Maximum common-mode voltage, both terminals (No. 1 and No. 2) off ground

10,000 times attenuator setting, up to 500 V d-c or 500 V peak a-c.

Attenuator Setting	Maximum Common-mode Voltage
1 mV/div.....	10 V d-c
2 mV/div.....	20 V d-c
5 mV/div.....	50 V d-c
10 mV/div.....	100 V d-c
20 mV/div.....	200 V d-c
all others.....	500 V d-c

Signal limiters

Built-in, adjustable, instant-acting electronic limiters prevent damage to analog pens upon off-scale signals

Zero-line instability (drift) after 15-min. warm-up.

± 0.1 div/8 hours; ± 0.1 div/ $^{\circ}$ C from 15-35 $^{\circ}$ C; ± 0.05 div/volt for $\pm 10\%$ of nominal line voltage

Gain instability (maximum)

$\pm 0.1\%$ /8 hours; $\pm 0.05\%$ / $^{\circ}$ C from 15-35 $^{\circ}$ C; $\pm 0.05\%$ /volt for $\pm 10\%$ of nominal line voltage

Operating temperature

0 to 55 $^{\circ}$ C. Recorder will remain within specification over range of $\pm 10^{\circ}$ C from temperature of calibration

Storage temperature -40 $^{\circ}$ C to +85 $^{\circ}$ C

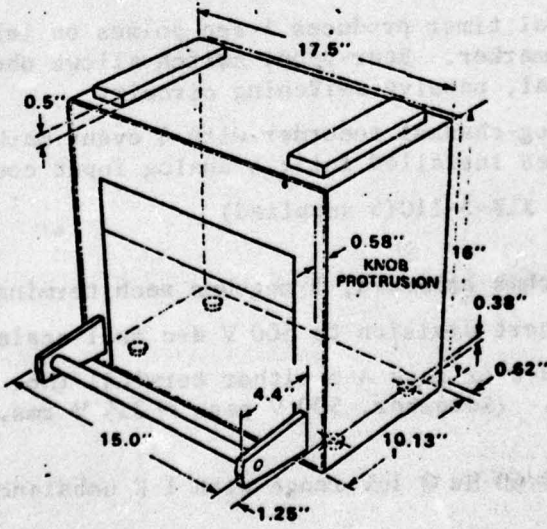

3. Donner Model 4310 Accelerometer

Model Number	4310
Non-linearity	< 0.05% of f.r.
Hysteresis	< 0.02% of f.r.
Resolution	> 0.0001% of f.r.
Non-repeatability	< 0.01% of f.r.
Zero Output	< 0.05% of f.r.
Temp. Coefficient of Null	3×10^{-5} G/°F
Output Noise in Volts RMS	0.05% of f.r.
Cross Axis Sensitivity (Referred to true sensitive axis)	< 0.002 G/G per f.s.i.
Temperature Sensitivity	< 0.01% per °F
Natural Frequency (90° Phase Shift) (Dependent upon G range)	E.D.: 150 to 250 cps F.D.: 70 to 150 cps
Damping Ratio (Customer Selectable)	E.D.: 0.4 to 0.7 ± 0.1 F.D.: (0.3 to 1.0 ± 0.1) (1.0 to 5.0 $\pm 10\%$) at 72°F
Temperature Range	Storage: --65°F to +200°F Operating: --40°F to +200°F
Shock Survival	100 G at 8 msec.
Vibration Survival	15 G rms, bandwidth 20 to 2000 cps (0.12 G ² /cps)
Humidity, Salt, Spray, Fungus, Sand, Dust	Hermetically sealed (meets MIL-E-5272 C)
Ambient Pressure	0 to 5 atmospheres absolute
Range	± 0.5 G to ± 35 G (or any asymmetric range totaling 70 G)
Input Power	± 15 VDC $\pm 10\%$, max. 8 ma ± 28 VDC $\pm 10\%$, max. 10 ma Telemetry Model: + 28 VDC $\pm 10\%$, max. 25 ma
Voltage Output--Nominal	± 7.5 VDC ($R_L = 5k\Omega$) ± 15 VDC ($R_L = 5k\Omega$) Telemetry Model: 0.2 to 4.8 VDC
Current Output	± 1.5 ma, ± 3.0 ma
Electrical Connector	6 or 7 solder terminals (6 standard)
Case Alignment	$\pm 1^\circ$ to true sensitive axis ($\pm \frac{1}{2}^\circ$ and $\pm \frac{1}{4}^\circ$ alignments optional)

Weight < 4 oz. (E.D.)
< 8 oz. (F.D.)

Physical Configuration Rectangular aluminum case

Abbreviations:

f.r. = full range; f.s.i. = full scale input;
v.s.f. = voltage scale factor;
E.D. = Electrically Damped; F.D. = Fluid Damped

ACCURACY PARAMETERS

	Symmetrical Output (Option A)	Telemetry Output (Option B)
Non-Linearity	< 0.05% of full range	
Hysteresis & Non-Repeatability	< 0.02% of full range	
Resolution	< 0.001% of full range	
Zero Output (Null)	< 0.05% of f.r.	2.5 v \pm 1%
Temp. Coeff. of Null (Of full range)	0.001% per $^{\circ}$ F.	0.006% per $^{\circ}$ F.
Output Noise	< 0.05% of full range in rms volts	
Cross Axis Sensitivity (Referred to true sensitive axis)	< 0.002 g/g of applied acceleration*	
Temp. Sensitivity of Scale Factor	< 0.01% per $^{\circ}$ F.	
Natural Frequency (90 $^{\circ}$ Phase Shift) (dependent on g range)	Electr. damped: 15-250 Hz at 25 $^{\circ}$ C. Fluid damped: 60-150 Hz at 25 $^{\circ}$ C.	
Damping Ratio	Electr. damped: 0.4 to 0.7 \pm 0.1 Fluid damped: (0.3 to 1 \pm 0.1) at 25 $^{\circ}$ C. (1 to 5 \pm 10%)	

ENVIRONMENTAL PARAMETERS

Temperature Range -60 $^{\circ}$ F to + 200 $^{\circ}$ F storage
-40 $^{\circ}$ F to + 200 $^{\circ}$ F operating*

Shock Survival 100 g 11 msec

Vibration Survival 15 g rms, bandwidth 20 to 2000 Hz
(0.12 g² per Hz)

**Humidity, Salt Spray,
Fungus, Sand, Dust** Hermetically sealed (meets MIL-E-5272C)

Ambient Pressure 0 to 5 atmosphere absolute

* Applies to electrically damped units. For fluid damped units consult factory.

PHYSICAL PARAMETERS

	Symmetrical Output (Option A)	Telemetry Output (Option B)
Range	± 0.5 g to ± 35 g	± 0.5 g to ± 30 g
Input Power	± 15 vdc $\pm 10\%$ at 10 ma maximum	28 vdc $\pm 10\%$ at 20 ma maximum
Voltage Output-- Nominal	± 7.55 vdc full scale $\pm 1\%$	0.2 to 4.8 vdc full range, nominal about 2.5 volt bias (symmetrical range)
Output Impedance	5 k Ω nominal	7.4 k Ω nominal
Output Current	3 ma f.r.	2 ma f.r.
Electrical Connections	6 solder terminals	7 solder terminals
Case Alignment	$\pm 1^\circ$ to true sensitive axis	
Weight	4.5 oz. electrically damped 6 oz. fluid damped	
Physical Configuration	Rectangular aluminum case	
Base Price	\$450 Electr. damped \$550 Fluid damped	\$475 Electr. damped \$600 Fluid damped

4. Mark IV MOD 0 Stable Platform

Overall System--Stabilization Equipment Mark 4 consists of three units: the Gyro Stabilizer, the Control Cabinet, and the Control Speed Transmitter. The equipment establishes a two-axis Stable Vertical reference system that transmits synchro information which is a measure of the roll and pitch of the ship with respect to the vertical. Two single-degree-of-freedom viscously damped, rate-integrating gyro units, one associated with pitch and the other with roll, are mounted on the stabilized platform with their respective input axes parallel to the roll and pitch axes. The output signals of these gyro units, with their associated servo loops, maintain the stabilized platform stable with respect to inertial space and thereby isolate the stabilized platform from arbitrary motions of the ship about the pitch and roll axes.

Component Functions

A two-degree-of-freedom, viscously damped pendulum, with associated amplifiers, is the reference maintaining the stabilized platform perpendicular to the vertical (i.e. in a horizontal plane). The pitch and roll angular correction is transmitted to the desired destination by synchro generators geared to the pitch and roll axes of the stabilized platform.

A temperature control circuit maintains a constant operating temperature (145°F) for all components mounted on the inner gimbal (stabilized platform).

A latitude compensation circuit (Mod 0 only) compensates for the effect of earth's angular velocity on the roll and/or pitch gyros.

A turn compensator permits continuous use of the vertical reference pendulum while the ship is turning.

Differences Between Mod 0 and Mod 1

The theory underlying the operation of Mark 4 Mod 1 is the same as that for Mod 0. Mod 1 makes the same kind of measurements and transmits the same kind of data. It does not compensate the effect of earth's rate on the gyros. It does not receive Own Ships Speed automatically. It transmits roll and pitch signals by 2-speed transmitters only and is slightly less accurate than Mod 0. The following components are common to (and interchangeable between) Mods 0 and 1:

- (a) the gyros
- (b) the servo amplifiers
- (c) the turn compensator amplifier
- (d) the pendulum amplifier assembly
- (e) temperature control system components
- (f) the reference pendulum
- (g) the alarm pendulum

The major differences between Mod 1 and Mod 0 are these:

- (a) Mod 0 transmits roll and pitch measurements as electrical signals from 2-speed and 36-speed synchro generators (type 23CX6). Mod 1 is equipped with only the 2-speed synchro generators (type 15CX4a).
- (b) Mod 0 is equipped with a latitude correction circuit that compensates for the effects of earth's rate on the gyros. Mod 1 has no latitude correction circuit.
- (c) Mod 0 is equipped with both a manual and automatic acceleration computer. Mod 1 has only a manual acceleration computer.
- (d) Mod 0 is equipped with switches S205 and S206 which close at roll angles greater than plus or minus 20 degrees and pitch angles greater than plus or minus 10 degrees respectively. Mod 1 does not have these switches.

Applicable Definitions

- (a) Roll - Angle between the vertical plane through own ship center line, and the normal plane through the intersection of the vertical plane through own ship center line and the deck plane, measured about the axis which is the intersection of the vertical plane through own ship center line and the deck plane. Positive direction is clockwise when viewed inward from own ship bow.
- (b) Pitch - Angle between the horizontal plane and the deck plane, measured in the vertical plane through own ship center line. Positive angle measured downward from the horizontal plane.
- (c) Torque - That which produces or tends to produce rotation or torsion.
- (d) Angular velocity - Speed of rotation in a given direction and sense.
- (e) Moment of Inertia - The property of a body to resist a change in rotational speed.

Operating Limits

The operating limits are plus or minus 40 degrees roll, plus or minus 20 degrees pitch. The allowable maximum operating errors for Mod 0 are plus or minus nine minutes in roll and pitch angles; for Mod 1, plus or minus 15 minutes in roll and pitch angles.

5. North Atlantic, Inc. Angle Position Indicator

API (Standard)
Model 8025 S-592

Specifications

1. Input signal synchro (one speed) 90 volts, line to line, 400 cps
2. Input impedance 5200 /80.6 line to line
3. Accuracy ± 6 minutes of arc
4. Repeatability ± 30 seconds of arc
5. Slew speed 180 deg. in less than 10 seconds
6. Power requirements 115 volts, 400 cps, 1 300 MA
7. Range 0° to 360° continuous
8. Display digital counter reading degrees and minutes, graduated each minute (readable within 30 seconds.)
9. Mounting half-panel, rack
10. Dimensions height 1 3/4", width 9 1/2", depth 9"
11. Retransmit Potentiometer 1K, zero of pot starts at zero of counter. 350° - 360° is dead zone.

6. Honeywell Gyro

Specifications

Power Requirements:

Gyro motor: 115 volts, 400 cps
±10%, single-phase
Erection motors: 26 or 30 volts,
400 cps, single-phase
Caging circuit: 28 volts dc.

Power Load:

Gyro motor: 50 watts starting; 20
watts running.
Erection motors: 6.5 watts each at
30 volts and 5.5 watts each at
26 volts.
Caging operation: 42 watts operating;
6 watts holding.

Roll Axis: Unlimited.

Pitch Axis: Limited at ±85° by
precession pins.

Caging Time: 10 seconds maximum.

Gyro Run-down Time: 5 minutes minimum.

Erection Rate: 2° to 8° per minute
(factory adjustable).

Scorgby Drift Rate: Does not exceed
0.5° per minute without erection.

Accuracy: 0.15° of true vertical
about each axis.

Gyro Speed: Approximately 22,000 rpm.

Angular Momentum: 6.33×10^6 gm-cm²/sec.

Pickoff Resolution: $1/8^\circ$ to $1/13^\circ$
each axis (dependent upon individual
requirements).

Potentiometer Linearity: 1% typical.

Weight: 6.5 lb.

Installation and Application Data

Facility for Electrical Connection: AN3102A-22-14S receptacle (AN3102C-18-1PonA-52).

Mounting Provisions: Four mounting holes are drilled in feet on $5 \frac{11}{32} \times 4 \frac{3}{4}$
inch centers.

Ambient Temperature Range: -65°F. to 160°F. (-54°C. to 71°C.) Can be operated
at higher temperatures for short periods.

Vibration and Shock: Per MIL-E-5272A except for frequency.

7. Wesmar SLM-10 Ultra Sonic Probe

The sensor is installed or supported with a $3/4$ inch NPT fitting.
A coaxial cable pigtail is furnished with the sensor and may be extended
up to 500 feet using RG62/U coaxial cable.

Specifications

Range:	Solids - 15 feet Liquids - 25 feet Liquids - 35 feet in standpipe
Minimum Range:	12 inches
Encapsulating Material:	LMS15 PVC - polyvinylchloride LMS15K - Kynar
Beam Pattern:	25° conical included angle
Operating Temperature:	-50° to $+250^\circ\text{F.}$
Operating Pressure:	Up to 100 PSI
Sensor to Electronics Separation:	Up to 200 feet with RG58A/U Up to 500 feet with RG62/U
Mounting:	$3/4$ inch NPT
Weight:	1 pound

SLM 10 Electronics' Specifications

Weight:	Electronics (including enclosure) - 15 lbs. Meter - 1/2 lb.
Enclosure:	JIC, 12" x 10" x 5"
Range:	Solids - 15 feet Liquids - 25 feet Liquids - 35 feet in standpipe
Accuracy:	Within 1% of Range (.5% in standpipe)
Resolution:	Within 1%
Repeatability:	Within 1%
Linearity:	Within 1%
Meter:	4-1/2" Rectangular (unmounted)
Meter Sensitivity:	0-1 MADC
Meter Scale:	0-100%
Output Signals:	0-5 VDC 0-1 MADC 1-5, 4-20, and 10-50 MADC into 600 ohms max. (may be floating)
Alarm Output:	3, independently adjustable
Alarm Adjustments:	100% of range
Alarm Contacts:	SPST 100 watts resistive at 125 VAC
Failsafe Output:	Zero Range
Input Power:	220/110 VAC, 5060 Hz., 10 watts
Operating Temperature	+30° to +120°F.

8. Datawell Waverider Buoy

Specifications

Wave frequency range	0.03 Hz-1.0 Hz (30°/o) 0.06 Hz-0.8 Hz (3°/o)
Maximum waveheight (H)	20 m (larger on request)
Resolving power	$\leq 3 \cdot 10^{-4}$ m/sec ²
Accelerometer linearity	Non linearity rectification $\leq 2 \cdot 10^{-3}$ /sec ² for 6m/sec ² amplitude of sinewave.
Cross sensitivity	$\leq 3\%$

Natural frequency accelerometer	45 Hz
Cutoff frequency high pass filter	0.03 Hz
Natural frequency platform	0.025 Hz. damping 0.8 of critical.
Modulation	am-fm, subcarrier 259 Hz am: 100%, square wave, rise time 0.25 msec. fm: 1.86 Hz/m
Transmitter frequency	Crystal stabilized, crystal type CR-77U Channel 1 27.505 MHz Channel 6 27.615 MHz 2 27.525 MHz 7 27.655 MHz 3 27.545 MHz 8 27.695 MHz 4 27.565 MHz 9 27.715 MHz 5 27.595 MHz 10 27.745 MHz
Radiated power in pulse	0,17 Watt \pm 20%
Antenna	Vertical $\lambda/4$ polyester glassfibre whip. In case of damage, the whip replacement is simple.
Range	50 km (30 miles) over seawater with phaselock demodulator and receiving antenna at least 100 m from traffic.
Effects of temperature	Operate $-5^{\circ}/+ 25^{\circ}\text{C}$ (watertemperature) Storage $-20^{\circ}/+ 40^{\circ}\text{C}$ Zero $0.03\text{m}/^{\circ}\text{C}$ Sensitivity $\leq 0.1\%/^{\circ}\text{C}$ Carrier frequency $\leq 500\text{ Hz}$
Battery life	≥ 9 months, batteries can be renewed through roof hatch.
Maximum changes during one year (20°C)	Sensitivity 1.0% Zero 1.0m Platform angle 1 Carrier frequency 300 Hz Radiated power 20 %
Buoy weight	90 kg (200 lbs)
Buoy hull	316 stainless steel, 2 mm (5/64")
Buoy handling	Two handgrips are provided for transporting the buoy.
Collision risk	Rubber fender 4 x 4cm ² . Antenna foot spring allows 90 ^o bending.
Transport risk	Platform is limited in rotation by stops.
Mooring	Special line is available to allow mooring in shallow water, providing sufficient range for maximum waveheight combined with a 2m sec. (4 knot) current.

APPENDIX B

**COMPUTER PRINTOUT SHEETS
PROVIDING SEA AND MOTION SPECTRA, RESPONSE AMPLITUDE OPERATORS,
NONDIMENSIONAL TRANSFER FUNCTIONS, AND DOUBLE AMPLITUDE AND
DATA POINT FREQUENCY AND CUMULATIVE DISTRIBUTIONS**

(Under Separate Cover to NCEL)

TABLE 1 - NATURAL SHIP MOTION PERIODS

Containership (WARRIOR)	
Heave	16.1 sec
Pitch	14.4 sec
Roll	9.0 sec
Floating DeLong Barge	
Heave	18.0 sec
Pitch	14.0 sec
Roll	14.4 sec
LCU 1524 (Army)	
Heave	4.8 sec
Pitch	6.5 sec
Roll	4.0 sec
B.C. Barge	
Heave	--
Pitch	6.0 sec
Roll	3.6 sec
7x15 Platform	
Heave	6.0 sec
Pitch	5.5 sec
Roll	4.0 sec
LST 1188 (SAGINAW)	
Heave	5.5 sec
Pitch	18.0 sec
Roll	9.0 sec
Seatrain Containership	
Heave	18.0 sec
Pitch	17.0 sec
Roll	18.0 sec



TABLE 2 - TRIAL CONDITIONS

Run No.	Ships Involved With Instruments	Measurements	Operation	Date	Configuration Figure
1 to 16	WARRIOR	Roll, Pitch, Heave, Sway	"Unrep"	10-4-72	--
17 to 34	WARRIOR	Roll, Pitch, Heave, Sway	"Unrep"	10-5-72	--
35 to 39	WARRIOR	Roll, Pitch, Heave, Surge, Sway, Wave Height	Mooring attempt	10-7-72	--
40 to 49	WARRIOR	Roll, Pitch, Heave, Surge, Sway, Wave Height	Mooring attempt	10-8-72	--
50 to 51	WARRIOR and Army LCU-1524	Roll, Pitch, Heave, Surge, Sway, Wave Height LCU Pitch, LCU Roll, LCU Heave	Off-load flat racks to LCU-1524	10-8-72	Figure 9
52	WARRIOR	Roll, Pitch, Heave, Surge, Sway, Wave Height	Prepare for helo operations	10-9-72	--
53 to 60	WARRIOR and Floating Delong	Roll, Pitch, Heave, Surge, Sway, Wave Height Delong Roll, Delong Pitch, Delong Heave	Helicopter dropping malivans on Floating Delong	10-9-72	Figure 10
61 to 64	WARRIOR Floating Delong	Roll, Pitch, Heave, Surge, Sway, Wave Height Delong Roll, Delong Pitch, Delong Heave, Delong Sway Relative to WARRIOR	Repositioning B.C. Barge and 7x15 Platform at side of Floating Delong	10-10-72	Figure 10
65 to 71	WARRIOR Floating Delong B.C. Barge	Roll, Pitch, Heave, Surge, Sway, Wave Height, Delong Roll, Delong Pitch, Delong Heave, Delong Sway Relative to WARRIOR, B.C. Barge Roll B.C. Barge Pitch, Relative Sway B.C. Barge to Delong	Offloading containers to B.C. Barge with Floating Delong crane	10-10-72	Figure 11

TABLE 2 - TRIAL CONDITIONS (Cont.)

Run No.	Ships Involved With Instruments	Measurements	Operation	Date	Configuration Figure
72 to 77	WARRIOR Floating Delong B.C. Barge	Roll, Pitch, Heave, Surge, Sway, Wave Height, Delong Roll, Delong Pitch, Delong Heave, Delong Sway Relative to WARRIOR, B.C. Barge Roll, B.C. Barge Pitch, B.C. Barge Heave, B.C. Barge Sway Relative to WARRIOR	Offloading containers to B.C. Barge using shipboard crane Dropped instrumented millivan	10-10-72	Figure 12
78 to 83	WARRIOR Floating Delong 7x15 Platform	Roll, Pitch, Heave, Surge, Sway, Wave Height, Delong Roll, Delong Pitch, Delong Heave, Delong Sway Relative to WARRIOR, 7x15 Platform Roll, 7x15 Platform Pitch, 7x15 Platform Sway Relative to Floating Delong	Loading containers through Hopper on 7x15 Platform	10-10-72	Figure 13
84 to 89	WARRIOR Floating Delong	Roll, Pitch, Heave, Surge, Sway, Wave Height, Delong Roll, Delong Pitch, Delong Heave, Delong Sway Relative to WARRIOR	Helicopters putting containers down on Delong bow	10-11-72	Figure 10
90 to 96	WARRIOR Floating Delong 7x15 Platform	Roll, Pitch, Heave, Surge, Sway, Wave Height, Delong Roll, Delong Pitch, Delong Heave, Delong Sway Relative to WARRIOR, 7x15 Platform Roll, 7x15 Platform Pitch, 7x15 Platform Heave, 7x15 Platform Sway Relative to Floating Delong	Attempting to mate causeway section to 7x15 Platform with winching operation. ACV on WARRIOR starboard side	10-11-72	Figure 13

TABLE 2 - TRIAL CONDITIONS (Cont.)

Run No.	Ships Involved With Instruments	Measurements	Operation	Date	Configuration Figure
97 to 99	WARRIOR Floating Delong	Roll, Pitch, Heave, Surge, Sway, Wave Height, Delong Roll, Delong Pitch, Delong Heave, Delong Sway Relative to WARRIOR	Toploader loading containers on trucks on 7x15 Platform	10-11-72	Figure 10
100 to 106	WARRIOR	Roll, Pitch, Heave, Surge, Sway, Wave Height	Moving Floating Delong	10-11-72	--
107 to 111	WARRIOR	Roll, Pitch, Heave, Surge, Sway, Wave Height	LST 1188 coming alongside WARRIOR	10-12-72	--
112 to 114	WARRIOR LST 1188 LCU 1524 (Army)	Roll, Pitch, Heave, Surge, Sway, Wave Height, LST Roll, LST Pitch, LST Heave, LCU Roll, LCU Pitch, LCU Heave, LCU Sway Relative to LST	Offloading containers from WARRIOR to LCU 1524 using LST 1188 crane	10-12-72	Figure 14
115 to 126	WARRIOR LST 1188	Roll, Pitch, Heave, Surge, Sway, Wave Height, LST Roll, LST Pitch, LST Heave	Offloading containers from WARRIOR to B.C. Barge and Navy LCU using LST 1188 crane	10-12-72	Figure 14
127 to 136	WARRIOR Seatrain	Roll, Pitch, Heave, Surge, Sway, Wave Height, Seatrain Roll, Seatrain Pitch, Sea- train Heave	Offloading containers from WARRIOR to Light- erage using Seatrain crane	10-13-72	Figure 15

TABLE 3 - SHIP MOTIONS FOR RUNS 1 TO 15*

Date	Run No.	E.D.T. Run Start Time	Run Length (Minutes)	Approximate Wave Height (Feet)	Significant WARRIOR Roll (Deg)	Maximum WARRIOR Roll (Deg)	Significant WARRIOR Pitch (Deg)	Maximum WARRIOR Pitch (Deg)	Significant WARRIOR Heave (Feet)	Significant WARRIOR Sway (Feet)
10/4/72	1	0930	9.72	4 to 5	0.95	2.05	0.85	1.20	1.13	0.60
	2	1006	23.33	4 to 5	1.81	2.76	1.52	3.76	2.05	1.86
	3	1030	15.00	4 to 5	0.91	1.58	0.76	1.15	0.59	--
	4	1050	15.00	5 to 6	1.57	2.45	0.61	0.94	--	--
	5	1110	20.00	4 to 5	1.92	2.73	1.14	2.21	1.19	0.89
	6	1300	15.00	↓	1.92	2.75	1.18	2.00	1.36	0.96
	7	1316	20.00		3.42	5.51	0.99	1.75	1.02	1.11
	8	1410	15.00		2.41	4.48	0.58	1.06	0.86	0.94
	9	1437	15.00		0.95	1.73	0.87	1.39	1.01	0.52
	10	1453	15.83		1.02	1.70	1.05	1.47	1.23	0.61
	11	1516	0.83		1.04	1.12	1.03	1.33	3.10	0.80
	12	1523	1.07		2.50	3.03	0.64	0.66	1.07	0.75
	13	1532	2.93		1.02	1.56	1.57	1.85	1.42	0.84
	14	1647	3.27		1.64	1.82	0.62	0.82	0.52	0.27
	15	1719	15.00		4 to 5	1.94	2.71	0.64	1.12	0.68

* See Table 2 for run conditions.

TABLE 4 - SHIP MOTIONS FOR RUNS 16 TO 34*

Date	Run No.	E.D.T. Run Start Time	Run Length (Minutes)	Approximate Wave Height (Feet)	Significant WARRIOR Roll (Deg)	Maximum WARRIOR Roll (Deg)	Significant WARRIOR Pitch (Deg)	Maximum WARRIOR Pitch (Deg)	Significant WARRIOR Heave (Feet)	Significant WARRIOR Sway (Feet)
10/5/72	16	0851	1.32	4 to 5	2.02	2.11	2.38	3.36	1.94	1.74
	17	0908	2.67	6 to 7	3.15	3.41	1.97	3.23	1.75	1.26
	18	0916	2.77	↓	2.39	3.23	1.64	2.16	1.87	1.47
	19	0941	1.23		2.40	2.55	2.91	3.32	--	1.51
	20	0950	3.23	6 to 7	2.50	2.81	2.60	3.74	2.53	1.18
	21	1006	5.60	4 to 5	3.28	5.51	3.06	4.19	3.81	1.76
	22	1014	0.88	↓	1.64	1.69	3.05	3.53	--	1.49
	23	1018	1.20		2.80	2.99	1.35	1.41	2.58	2.56
	24	1118	15.00	4 to 5	4.71	5.51	1.19	1.60	1.94	1.99
	25	1134	18.33	6 to 7	4.38	5.51	1.16	1.86	1.92	1.97
	26	1445	1.85	4 to 5	1.12	1.30	0.76	0.86	1.27	0.60
	27	1459	0.73	↓	2.70	2.75	1.86	2.06	2.25	0.85
	28	1507	1.48		1.65	2.33	1.27	1.49	1.58	2.25
	29	1510	1.52	6 to 7	4.13	4.21	1.75	1.87	2.45	1.58
	30	1514	1.47	4 to 5	5.20	5.41	1.70	1.88	2.81	--
	31	1603	2.23	4 to 5	8.70	10.80	1.06	1.29	0.76	1.17
	32	1611	1.60	↓	2.75	3.62	0.91	0.95	1.20	1.35
	33	1637	2.90		4.71	5.47	0.54	0.80	0.85	1.60
	34	1648	3.13	4 to 5	4.90	5.08	0.85	0.94	0.76	1.22

* See Table 2 for run conditions.

TABLE 5 - SHIP MOTIONS FOR RUNS 35 TO 39*

Date	Run No.	Run Start Time E.D.T.	Run Length (Minutes)	Significant Wave Height (Feet)	Significant WARRIOR Roll (Deg)	Maximum WARRIOR Roll (Deg)	Significant WARRIOR Pitch (Deg)	Maximum WARRIOR Pitch (Deg)	Significant WARRIOR Heave (Feet)	Significant WARRIOR Sway (Feet)	Significant WARRIOR Surge (Feet)
10/7/72	35	1128	15	4.65	7.61	10.50	1.11	1.49	0.00	3.84	1.24
	36	1145	15	4.59	7.58	10.01	1.09	1.77	0.00	3.63	1.22
	37	1201	15	4.78	8.95	10.96	1.04	1.47	0.00	4.08	1.23
	38	1600	15	4.51	6.36	10.89	1.03	1.72	0.00	2.15	1.23
	39	1616	15	4.23	7.93	10.96	0.95	1.56	0.00	2.98	0.99

* See Table 2 for run conditions.

TABLE 6 - SHIP MOTIONS FOR RUNS 40 TO 49*

Date	Run No.	Run Start Time E.D.T.	Run Length (Minutes)	Significant Wave Height (Feet)	Significant WARRIOR Roll (Deg)	Maximum WARRIOR Roll (Deg)	Significant WARRIOR Pitch (Deg)	Maximum WARRIOR Pitch (Deg)	Significant WARRIOR Heave (Feet)	Significant WARRIOR Sway (Feet)	Significant WARRIOR Surge (Feet)
10/8/72	40	0921	15	3.86	2.63	5.99	0.77	1.01	0.00	0.93	1.31
	41	0936	15	4.03	3.36	6.46	0.62	0.95	0.00	1.56	1.25
	42	0951	15	3.90	2.82	3.97	0.76	1.17	0.00	1.20	1.22
	43	1006	15	3.56	2.02	2.88	0.65	1.11	0.00	1.01	1.19
	44	1021	15	3.45	3.38	6.36	0.65	1.11	0.00	2.02	1.06
	45	1036	15	3.69	3.59	4.97	0.50	0.86	0.00	1.86	0.91
	46	1051	15	3.18	4.07	5.39	0.44	0.74	0.00	2.11	0.88
	47	1106	15	3.39	4.10	7.03	0.36	0.48	0.00	2.35	0.57
	48	1121	15	3.12	3.75	5.79	0.42	0.81	0.00	2.23	0.69
	49	1136	15	2.69	3.67	4.77	0.36	0.71	0.00	1.90	0.64

* See Table 2 for run conditions.

TABLE 7 - SHIP MOTIONS FOR RUNS 50 AND 51*

Date	Run No.	Run Start Time E.D.T.	Run Length (Minutes)	Significant Wave Height (Feet)	Significant WARRIOR Roll (Deg)	Maximum WARRIOR Roll (Deg)	Significant WARRIOR Pitch (Deg)	Maximum WARRIOR Pitch (Deg)	Significant WARRIOR Heave (Feet)	Significant WARRIOR Surge (Feet)
10/8/72	50	1503	15	2.07	1.52	2.07	0.57	0.81	0.81	0.89
	51	1518	15	2.15	1.71	2.73	0.60	0.90	0.85	0.90
Ligherage Motions and Seatrain										
Run No.	Significant LCU Roll (Deg)	Maximum LCU Roll (Deg)	Significant LCU Pitch (Deg)	Maximum LCU Pitch (Deg)	Significant LCU Heave (Feet)					
50	2.88	4.57	2.16	2.82	2.17					
51	3.02	4.62	2.04	3.52	2.10					

* See Table 2 for run conditions.

TABLE 8 - SHIP MOTIONS FOR RUN 52*

Date	Run No.	Run Start Time E.D.T.	Run Length (Minutes)	Significant Wave Height (Feet)	Significant WARRIOR Roll (Deg)	Maximum WARRIOR Roll (Deg)	Significant WARRIOR Pitch (Deg)	Maximum WARRIOR Pitch (Deg)	Significant WARRIOR Heave (Feet)	Significant WARRIOR Surge (Feet)
10/9/72	52	0855	15	2.67	4.72	8.09	0.43	0.71	1.74	0.42

* See Table 2 for run conditions.

TABLE 9 - SHIP MOTIONS FOR RUNS 53 TO 60*

Date	Run No.	Run Start Time Z.D.T.	Run Length (Minutes)	Signi- ficant Wave Height (Feet)	Signi- ficant WARRIOR Roll (Deg)	Maximum WARRIOR Roll (Deg)	Signi- ficant WARRIOR Pitch (Deg)	Maximum WARRIOR Pitch (Deg)	Signi- ficant WARRIOR Heave (Feet)	Signi- ficant WARRIOR Surge (Feet)
10/9/72	53	1741	15	2.22	2.59	3.84	0.69	0.74	1.02	0.65
	54	1756	15	2.37	2.59	4.65	0.73	0.92	1.05	0.72
	55	1811	15	2.64	3.26	4.86	0.72	0.74	1.01	0.63
	56	1826	15	2.56	3.30	4.76	0.69	0.81	1.08	0.60
	57	1841	15	2.77	3.71	4.55	0.68	0.70	1.25	0.54
	58	1856	15	2.96	4.01	5.92	0.72	0.73	1.23	0.56
	59	1911	15	2.98	3.43	4.39	0.67	0.66	1.27	0.49
	60	1926	10	2.92	4.21	6.91	0.59	0.61	1.18	0.39

Floating Delong										
Run No.	Signi- ficant Delong Roll (Deg)	Maximum Delong Roll (Deg)	Signi- ficant Delong Pitch (Deg)	Maximum Delong Pitch (Deg)	Signi- ficant Delong Heave (Feet)					
53	0.66	1.00	0.49	0.71	0.86					
54	0.67	0.99	0.53	0.95	0.88					
55	0.69	0.99	0.47	0.73	0.82					
56	0.71	1.08	0.45	0.70	0.87					
57	0.77	0.97	0.40	0.56	0.89					
58	0.90	1.28	0.42	0.63	1.00					
59	0.86	1.25	0.37	0.58	0.95					
60	0.86	1.33	0.29	0.37	0.95					

* See Table 2 for run conditions.

TABLE 10 - SHIP MOTIONS FOR RUNS 61 TO 64*

Date	Run No.	Run Start Time E.D.T.	Run Length (Minutes)	Significant Wave Height (Feet)	Significant WARRIOR Roll (Deg)	Maximum WARRIOR Roll (Deg)	Significant WARRIOR Pitch (Deg)	Maximum WARRIOR Pitch (Deg)	Significant WARRIOR Heave (Feet)	Significant WARRIOR Surge (Feet)
10/10/72	61	0839	15	3.96	4.87	7.41	0.76	0.91	1.65	0.35
	62	0854	15	3.76	4.20	6.42	0.78	0.88	1.42	0.39
	63	0909	15	3.88	4.60	7.32	0.78	0.85	1.33	0.33
	64	0924	15	4.07	3.40	4.97	0.68	0.80	0.97	0.36

Floating Delong						Delong & WARRIOR				
Run No.	Significant Delong Roll (Deg)	Maximum Delong Roll (Deg)	Significant Delong Pitch (Deg)	Maximum Delong Pitch (Deg)	Significant Delong Heave (Feet)	Significant Relative Sway (Feet)	Maximum Relative Sway (Feet)	Significant Relative Sway (Feet)	Maximum Relative Sway (Feet)	Significant Relative Sway (Feet)
61	1.16	2.02	0.44	0.66	1.05	6.55	7.64	6.55	7.64	6.55
62	1.14	1.69	0.45	0.60	1.07	7.01	7.67	7.01	7.67	7.01
63	1.02	1.80	0.40	0.59	0.93	5.14	7.36	5.14	7.36	5.14
64	0.81	1.16	0.47	0.70	0.73	4.93	5.89	4.93	5.89	4.93

* See Table 2 for run conditions.

TABLE 11 - SHIP MOTIONS FOR RUNS 65 TO 71*

Date	Run No.	Run Start Time E.D.T.	Run Length (Minutes)	Significant Wave Height (Feet)	Significant WARRIOR Roll (Deg)	Maximum WARRIOR Roll (Deg)	Significant WARRIOR Pitch (Deg)	Maximum WARRIOR Pitch (Deg)	Significant WARRIOR Heave (Feet)	Significant WARRIOR Surge (Feet)	Delong & WARRIOR														
											Significant Delong Heave (Feet)	Maximum Delong Pitch (Deg)	Significant Delong Pitch (Deg)	Maximum Delong Roll (Deg)	Significant Delong Roll (Deg)	Maximum Delong Sway (Feet)	Significant Delong Sway (Feet)	Maximum Delong Pitch (Deg)	Significant Delong Pitch (Deg)	Maximum Delong Roll (Deg)	Significant Delong Roll (Deg)	Maximum Delong Sway (Feet)			
10/10/72	65	1012	15	3.86	2.10	3.33	0.69	0.82	0.80	0.49	0.67	0.91	0.57	0.62	0.89	0.57	0.67	0.91	0.67	2.77	3.75	1.96	2.86	2.29	3.95
	66	1027	15	3.66	1.88	2.54	0.65	0.68	0.78	0.47	0.65	0.77	0.54	0.62	1.13	0.54	0.65	0.77	0.65	2.53	3.85	1.84	3.10	2.19	3.23
	67	1042	15	3.70	1.95	3.11	0.69	0.67	0.76	0.52	0.63	0.81	0.53	0.59	0.89	0.53	0.60	0.81	0.60	2.67	4.67	1.91	2.71	2.56	3.90
	68	1057	15	3.61	0.96	1.43	0.63	0.72	0.54	0.48	0.58	0.84	0.56	0.57	0.83	0.56	0.60	0.84	0.60	2.97	4.17	2.19	2.91	1.73	4.49
	69	1112	15	3.79	0.97	1.52	0.58	0.56	0.49	0.46	0.46	0.76	0.49	0.60	1.03	0.49	0.53	0.76	0.53	3.02	4.73	2.40	3.74	1.53	2.51
	70	1127	15	3.54	0.85	1.32	0.57	0.61	0.44	0.45	0.45	0.71	0.42	0.62	1.35	0.42	0.50	0.71	0.50	2.46	4.33	2.46	4.22	1.14	1.86
	71	1142	15	3.38	0.70	1.33	0.61	0.72	0.41	0.48	0.48	0.69	0.69	0.47	1.34	0.47	0.45	0.69	0.45	3.98	5.65	2.78	4.45	1.11	1.68

* See Table 2 for run conditions.

TABLE 12 - SHIP MOTIONS FOR RUNS 72 TO 77*

Date	Run No.	Run Start Time E.D.T.	Run Length (Minutes)	Significant Wave Height (Feet)	Significant WARRIOR Roll (Deg)	Maximum WARRIOR Roll (Deg)	Significant WARRIOR Pitch (Deg)	Maximum WARRIOR Pitch (Deg)	Significant WARRIOR Heave (Feet)	Significant WARRIOR Surge (Feet)	Significant WARRIOR Sway (Feet)
10/10/72	72	1302	17	3.22	2.33	2.67	0.63	0.67	1.07	0.39	0.85
	73	1323	15	3.06	2.32	4.55	0.72	0.89	1.20	0.27	1.03
	74	1338	15	2.97	2.77	5.32	0.70	0.99	1.36	0.25	1.20
	75	1353	15	2.83	2.80	4.02	0.67	0.68	1.36	0.26	1.14
	76	1408	11	2.82	2.76	4.84	0.69	0.84	1.25	0.27	1.17
	77	1436	9	3.04	2.79	3.95	0.60	0.57	1.34	0.10	1.06

Lighterage Motions (B.C. Barge)											
Run No.	Significant Roll (Deg)	Maximum Roll (Deg)	Significant Pitch (Deg)	Maximum Pitch (Deg)	Significant Heave (Feet)	Maximum Heave (Feet)	Significant Roll (Deg)	Maximum Roll (Deg)	Significant Pitch (Deg)	Maximum Pitch (Deg)	Significant Heave (Feet)
72	0.71	1.22	0.36	0.59	0.75	4.62	5.65	5.11	9.54	4.45	4.45
73	0.87	1.65	0.30	0.46	0.80	7.61	11.2	4.39	8.45	4.09	4.09
74	0.95	1.74	0.27	0.48	0.88	7.45	10.2	4.29	5.89	3.96	3.96
75	0.94	1.53	0.26	0.47	0.86	8.45	11.2	3.52	4.76	3.35	3.35
76	0.98	1.23	0.28	0.34	0.89	8.44	11.2	3.59	5.95	3.25	3.25
77	0.87	1.18	0.20	0.24	0.80	8.59	11.3	3.00	4.43	2.86	2.86

Floating Delong						Delong & WARRIOR					
Run No.	Significant Roll (Deg)	Maximum Roll (Deg)	Significant Pitch (Deg)	Maximum Pitch (Deg)	Significant Heave (Feet)	Maximum Heave (Feet)	Significant Roll (Deg)	Maximum Roll (Deg)	Significant Pitch (Deg)	Maximum Pitch (Deg)	Significant Heave (Feet)
72	3.96	3.96	0.36	0.59	0.75	4.62	5.65	5.11	9.54	4.45	4.45
73	4.38	4.38	0.30	0.46	0.80	7.61	11.2	4.39	8.45	4.09	4.09
74	5.39	5.39	0.27	0.48	0.88	7.45	10.2	4.29	5.89	3.96	3.96
75	6.30	6.30	0.26	0.47	0.86	8.45	11.2	3.52	4.76	3.35	3.35
76	5.12	5.12	0.28	0.34	0.89	8.44	11.2	3.59	5.95	3.25	3.25
77	5.16	5.16	0.20	0.24	0.80	8.59	11.3	3.00	4.43	2.86	2.86

* See Table 2 for run conditions.

TABLE 13 - SHIP MOTIONS FOR RUNS 78 TO 83*

Date	Run No.	Run Start Time E.D.T.	Run Length (Minutes)	Significant Wave Height (Feet)	Significant WARRIOR Roll (Deg)	Maximum WARRIOR Roll (Deg)	Significant WARRIOR Pitch (Deg)	Maximum WARRIOR Pitch (Deg)	Significant WARRIOR Heave (Feet)	Significant WARRIOR Surge (Feet)	Significant WARRIOR Sway (Feet)
10/10/72	78	1606	15	2.54	2.74	4.03	0.62	0.70	1.26	0.28	1.14
	79	1621	15	2.55	2.78	4.68	0.61	0.68	1.24	0.26	1.15
	80	1636	17	2.59	2.86	4.12	0.62	0.66	1.24	0.27	1.12
	81	1720	15	2.55	2.87	3.85	0.59	0.64	1.09	0.26	1.19
	82	1735	15	2.64	3.39	5.16	0.63	0.68	1.34	0.29	1.24
	83	1750	12	2.73	2.80	3.96	0.66	0.70	1.37	0.26	1.19

Lighterage Motions (7x15 Platform)											
Floating Delong						Delong & WARRIOR					
Run No.	Significant Roll (Deg)	Maximum Roll (Deg)	Significant Heave (Feet)	Significant Roll (Deg)	Maximum Roll (Deg)	Significant Pitch (Deg)	Maximum Pitch (Deg)	Significant Heave (Feet)	Significant Roll (Deg)	Maximum Roll (Deg)	Significant Relative Sway (Feet)
78	0.80	1.27	0.67	1.32	2.26	0.71	1.09	0.67	1.32	2.26	3.64
79	0.84	1.45	0.69	1.33	2.09	0.79	1.33	0.69	1.33	2.09	3.46
80	0.81	1.39	0.68	1.26	1.92	0.74	1.08	0.68	1.26	1.92	3.68
81	0.86	1.27	0.66	1.34	1.86	0.64	0.94	0.66	1.34	1.86	4.24
82	0.90	1.55	0.75	1.42	2.35	0.71	1.02	0.75	1.42	2.35	4.60
83	0.92	1.23	0.70	1.38	1.67	0.68	1.08	0.70	1.38	1.67	3.80
											5.73
											4.92
											4.76
											6.13
											7.22
											5.46

* See Table 2 for run conditions.

TABLE 14 - SHIP MOTIONS FOR RUNS 84 TO 89*

Date	Run No.	Run Start Time E.D.T.	Run Length (Minutes)	Significant Wave Height (Feet)	Significant WARRIOR Roll (Deg)	Maximum WARRIOR Roll (Deg)	Significant WARRIOR Pitch (Deg)	Maximum WARRIOR Pitch (Deg)	Significant WARRIOR Heave (Feet)	Significant WARRIOR Surge (Feet)	Significant WARRIOR Sway (Feet)
10/11/72	84	0830	15	2.77	2.53	3.79	0.46	0.74	1.11	0.19	1.03
	85	0845	15	2.70	3.75	4.81	0.50	0.68	1.30	0.17	1.54
	86	0900	15	2.90	2.86	3.75	0.51	0.82	1.32	0.19	1.24
	87	0915	15	2.89	1.82	2.41	0.43	0.64	0.85	0.24	0.71
	88	0930	15	2.71	1.21	2.33	0.37	0.65	0.47	0.19	0.36
	89	0945	15	2.78	0.60	0.93	0.28	0.35	0.29	0.19	0.20

Floating Delong

Run No.	Significant Roll (Deg)	Maximum Roll (Deg)	Significant Pitch (Deg)	Maximum Pitch (Deg)	Significant Heave (Feet)	Significant Relative Sway (Feet)	Maximum Relative Sway (Feet)
84	0.74	1.13	0.28	0.47	0.57	2.87	4.44
85	1.00	1.39	0.24	0.35	0.79	4.50	6.25
86	0.87	1.30	0.26	0.43	0.70	5.34	7.00
87	0.60	0.95	0.32	0.46	0.51	3.68	5.51
88	0.52	0.75	0.37	0.56	0.39	2.64	3.86
89	0.45	0.62	0.32	0.55	0.31	1.84	2.83

Delong & WARRIOR

* See Table 2 for run conditions.

TABLE 15 - SHIP MOTIONS FOR RUNS 90 TO 96*

Date	Run No.	Run Start Time E.D.T.	Run Length (Minutes)	Significant Wave Height (Feet)	Significant WARRIOR Roll (Deg)	Maximum WARRIOR Roll (Deg)	Significant WARRIOR Pitch (Deg)	Maximum WARRIOR Pitch (Deg)	Significant WARRIOR Heave (Feet)	Significant WARRIOR Surge (Feet)	Significant WARRIOR Sway (Feet)
10/11/72	90	1018	15	2.67	0.67	0.96	0.29	0.33	0.29	0.08	0.23
	91	1033	15	2.59	0.89	1.39	0.31	0.59	0.31	0.22	0.29
	92	1048	15	2.51	1.45	2.30	0.36	0.71	0.43	0.27	0.40
	93	1103	15	2.50	1.01	1.79	0.34	0.59	0.40	0.29	0.30
	94	1118	15	2.47	1.12	1.78	0.31	0.63	0.38	0.25	0.32
	95	1133	15	2.27	1.09	1.62	0.33	0.62	0.35	0.26	0.30
	96	1148	13	2.10	1.49	1.91	0.37	0.66	0.36	0.29	0.39
Delong & WARRIOR											
Floating Delong											
Run No.	Significant Roll (Deg)	Maximum Roll (Deg)	Significant Pitch (Deg)	Maximum Pitch (Deg)	Significant Heave (Feet)	Maximum Relative Sway (Feet)	Significant Relative Sway (Feet)	Maximum Relative Sway (Feet)			
90	0.72	1.06	0.44	0.64	0.38	1.74	1.74	2.45			
91	0.79	1.17	0.45	0.80	0.40	2.06	2.06	4.10			
92	1.26	2.01	0.50	0.85	0.54	3.01	3.01	5.14			
93	0.98	1.61	0.49	0.78	0.48	2.44	2.44	4.38			
94	0.82	1.21	0.44	0.74	0.41	2.20	2.20	2.57			
95	0.65	0.87	0.47	0.78	0.44	2.42	2.42	4.04			
96	0.79	1.25	0.56	0.91	0.53	3.78	3.78	5.53			
Delong & Lighterage											
Lighterage (7x15 Platform)											
Run No.	Significant Relative Sway (Feet)	Maximum Relative Sway (Feet)	Significant Roll (Deg)	Maximum Roll (Deg)	Significant Pitch (Deg)	Maximum Pitch (Deg)	Significant Heave (Feet)	Maximum Heave (Feet)	Significant Relative Sway (Feet)	Maximum Relative Sway (Feet)	Significant Maximum Pitch (Deg)
90	3.72	4.91	3.53	5.00	3.70	5.76	3.38	5.39	3.70	5.76	3.70
91	3.32	3.78	3.36	5.39	3.50	4.89	6.97	6.97	3.50	4.89	3.50
92	4.99	6.44	4.96	6.97	3.13	4.61	5.62	5.62	3.13	4.61	3.13
93	3.78	5.75	3.38	5.62	2.48	5.65	5.18	5.18	2.48	5.65	2.48
94	2.43	3.46	3.22	5.18	2.86	4.44	4.39	4.39	2.86	4.44	2.86
95	3.41	5.16	3.17	4.39	3.02	4.61	4.73	4.73	3.02	4.61	3.02
96	3.93	5.06	4.00	4.73	3.33	4.11			3.33	4.11	3.33

* See Table 2 for run conditions.

TABLE 16 - SHIP MOTIONS FOR RUNS 97 TO 99*

Date	Run No.	Run Start Time E.D.T.	Run Length (Minutes)	Significant Wave Height (Feet)	Significant WARRIOR Roll (Deg)	Maximum WARRIOR Roll (Deg)	Significant WARRIOR Pitch (Deg)	Maximum WARRIOR Pitch (Deg)	Significant WARRIOR Heave (Feet)	Significant WARRIOR Surge (Feet)	Significant WARRIOR Sway (Feet)
10/11/72	97	1442	15	1.84	0.62	1.18	0.23	0.53	0.24	0.04	0.41
	98	1457	13	1.79	2.48	2.67	0.33	0.64	1.10	0.19	--
	99	1514	17	1.81	3.38	5.96	0.31	0.59	0.97	0.17	0.65

Floating Delong & LST Motions						Delong & WARRIOR		
Run No.	Significant Delong Roll (Deg)	Maximum Delong Roll (Deg)	Significant Delong Pitch (Deg)	Maximum Delong Pitch (Deg)	Significant Relative Sway (Feet)	Maximum Relative Sway (Feet)		
97	0.34	0.45	0.26	0.41	1.20	1.58		
98	0.69	1.00	0.23	0.42	3.55	5.24		
99	0.67	1.28	0.20	0.34	3.36	8.46		

* See Table 2 for run conditions.

TABLE 17 - SHIP MOTIONS FOR RUNS 100 TO 106*

Date	Run No.	Run Start Time E.D.T.	Run Length (Minutes)	Significant Wave Height (Feet)	Significant WARRIOR Roll (Deg)	Maximum WARRIOR Roll (Deg)	Significant WARRIOR Pitch (Deg)	Maximum WARRIOR Pitch (Deg)	Significant WARRIOR Heave (Feet)	Significant WARRIOR Surge (Feet)	Significant WARRIOR Sway (Feet)
10/11/72	100	1804	15	1.88	2.58	3.34	0.49	0.76	0.80	0.21	0.46
	101	1819	15	1.96	2.87	4.43	0.43	0.65	-0.74	0.22	0.54
	102	1834	15	2.10	3.09	4.35	0.41	0.74	0.94	0.21	0.49
	103	1849	15	2.06	2.55	3.78	0.38	0.57	0.78	0.23	0.63
	104	1904	15	2.07	2.60	3.63	0.42	0.68	0.82	0.17	0.64
	105	1919	15	2.06	3.11	4.23	0.47	0.75	1.15	0.21	--
	106	1934	10	2.20	2.29	3.22	0.46	0.70	0.89	0.16	--

*See Table 2 for run conditions.

TABLE 18 - SHIP MOTIONS FOR RUNS 107 TO 111*

Date	Run No.	Run Start Time E.D.T.	Run Length (Minutes)	Significant Wave Height (Feet)	Significant WARRIOR Roll (Deg)	Maximum WARRIOR Roll (Deg)	Significant WARRIOR Pitch (Deg)	Maximum WARRIOR Pitch (Deg)	Significant WARRIOR Heave (Feet)	Significant WARRIOR Surge (Feet)	Significant WARRIOR Sway (Feet)
10/12/72	107	0902	15	2.00	0.91	0.96	0.38	0.77	0.42	0.16	0.29
	108	0917	15	2.08	0.72	--	0.37	--	0.41	0.10	0.16
	109	0932	15	2.12	0.96	--	0.43	--	0.49	0.11	0.13
	110	0947	15	2.18	0.61	--	0.42	--	0.38	0.10	--
	111	1002	11	1.97	0.58	--	0.45	--	0.41	0.16	--

*See table 2 for run conditions.

TABLE 19 - SHIP MOTIONS FOR RUNS 112 TO 114*

Date	Run No.	Run Start Time E.D.T.	Run Length (Minutes)	Significant Wave Height (Feet)	Significant WARRIOR Roll (Deg)	Maximum WARRIOR Roll (Deg)	Significant WARRIOR Pitch (Deg)	Maximum WARRIOR Pitch (Deg)	Significant WARRIOR Heave (Feet)	Significant WARRIOR Surge (Feet)	Significant WARRIOR Sway (Feet)
10/12/72	112	1052	15	1.96	0.61	1.04	0.38	0.60	0.35	0.10	0.22
	113	1107	15	1.98	1.11	2.65	0.35	0.55	0.47	0.19	0.50
	114	1122	4	1.81	2.52	2.68	0.37	0.43	1.00	0.16	1.20

LST Motions						Lighterage Motions						LCU & LST		
Run No.	Significant Roll (Deg)	Maximum Roll (Deg)	Significant Pitch (Deg)	Maximum Pitch (Deg)	Significant Heave (Feet)	Significant Roll (Deg)	Maximum Roll (Deg)	Significant Pitch (Deg)	Maximum Pitch (Deg)	Significant Heave (Feet)	Significant Relative Sway LCU (Feet)	Significant Relative Sway LST (Feet)	Significant Relative Sway LST (Feet)	
112	0.91	1.29	0.13	0.16	0.24	--	5.76	2.27	4.45	--	--	--	--	
113	1.85	4.11	0.26	0.43	0.64	3.43	5.67	1.79	2.89	1.72	3.36	6.66	6.66	
114	3.99	4.11	0.33	0.48	1.30	5.11	5.67	1.79	2.89	2.01	6.02	7.08	7.08	

*See Table 2 for run conditions.

TABLE 20 - SHIP MOTIONS FOR RUNS 115 TO 126*

Date	Run No.	Run Start Time E.D.T.	Run Length (Minutes)	Significant Wave Height (Feet)	Significant WARRIOR Roll (Deg)	Maximum WARRIOR Roll (Deg)	Significant WARRIOR Pitch (Deg)	Maximum WARRIOR Pitch (Deg)	Significant WARRIOR Heave (Feet)	Significant WARRIOR Surge (Feet)	Significant WARRIOR Sway (Feet)
10/12/72	115	1154	15	1.77	1.43	1.87	0.28	0.36	0.44	0.16	0.40
	116	1209	15	1.74	1.41	2.43	0.31	0.43	0.50	0.15	0.47
	117	1224	15	1.67	1.44	2.10	0.29	0.38	0.47	0.16	0.45
	118	1239	15	1.75	1.47	2.56	0.31	0.36	0.51	0.07	0.49
	119	1254	15	1.80	2.37	4.31	0.35	0.43	0.63	0.18	0.67
	120	1309	15	1.72	1.79	3.02	0.30	0.40	0.56	0.15	0.57
	121	1324	9	1.83	2.59	4.11	0.36	0.43	0.56	0.22	0.75
	122	1349	15	1.84	2.09	3.59	0.33	0.53	0.71	0.06	0.74
	123	1404	13	1.76	2.36	4.18	0.36	0.76	0.80	0.13	0.93
	124	1511	15	1.83	1.43	2.48	0.38	0.61	0.54	0.18	0.63
	125	1526	15	1.63	0.87	1.34	0.33	0.43	0.34	0.19	0.32
	126	1541	15	1.69	0.44	0.75	0.23	0.31	0.02	0.06	0.21

LST Motions

Run No.	Significant Roll (Deg)	Maximum Roll (Deg)	Significant Pitch (Deg)	Maximum Pitch (Deg)	Significant Heave (Feet)
115	1.95	2.76	0.20	0.32	0.39
116	2.64	3.86	0.19	0.26	0.47
117	3.80	4.86	0.26	0.39	0.51
118	3.01	4.41	0.20	0.30	0.49
119	3.49	5.81	0.19	0.36	0.61
120	3.78	5.74	0.23	0.42	0.56
121	4.42	6.13	0.29	0.46	0.77
122	3.70	6.09	0.16	0.40	0.74
123	5.37	7.38	0.34	0.63	1.06
124	3.21	5.79	0.27	0.48	0.79
125	1.88	3.64	0.16	0.24	0.42
126	0.54	0.87	0.11	0.11	0.21

*See Table 2 for run conditions.

TABLE 21 - SHIP MOTIONS FOR RUNS 127 TO 136*

Date	Run No.	Run Start Time E.D.T.	Run Length (Minutes)	Significant Wave Height (Feet)	Significant WARRIOR Roll (Deg)	Maximum WARRIOR Roll (Deg)	Significant WARRIOR Pitch (Deg)	Maximum WARRIOR Pitch (Deg)	Significant WARRIOR Heave (Feet)	Significant WARRIOR Surge (Feet)
10/13/72	127	0955	15	3.30	2.28	3.25	0.41	0.62	0.81	0.21
	128	1010	15	3.25	2.01	3.77	0.50	1.11	0.82	0.21
	129	1025	15	3.16	2.56	3.87	0.47	0.99	0.82	0.19
	130	1040	15	3.21	2.42	4.08	0.49	0.92	1.06	0.18
	131	1055	15	3.24	3.05	4.90	0.43	0.87	1.02	0.22
	132	1110	15	3.25	2.65	6.63	0.48	0.91	1.15	0.21
	133	1125	15	3.29	2.80	4.32	0.55	0.91	1.26	0.26
	134	1140	15	3.00	3.38	5.03	0.63	1.16	1.51	0.22
	135	1155	15	3.24	2.79	4.19	0.56	1.07	1.38	0.21
	136	1210	15	3.16	2.93	4.22	0.40	0.75	1.56	0.19

Sea Train

Run No.	Significant Roll (Deg)	Maximum Roll (Deg)	Significant Pitch (Deg)	Maximum Pitch (Deg)	Significant Heave (Feet)
127	1.99	3.90	0.53	1.15	0.81
128	2.61	4.05	0.47	1.02	0.89
129	2.50	4.25	0.51	1.03	1.00
130	3.18	5.00	0.43	0.89	1.09
131	2.70	3.77	0.50	0.90	1.13
132	2.98	4.47	0.54	0.94	1.23
133	3.29	5.20	0.70	1.11	1.25
134	2.79	4.49	0.58	1.12	1.22
135	2.96	4.38	0.40	0.83	1.51
136	3.22	5.20	0.42	0.78	1.22

*See Table 2 for run conditions.

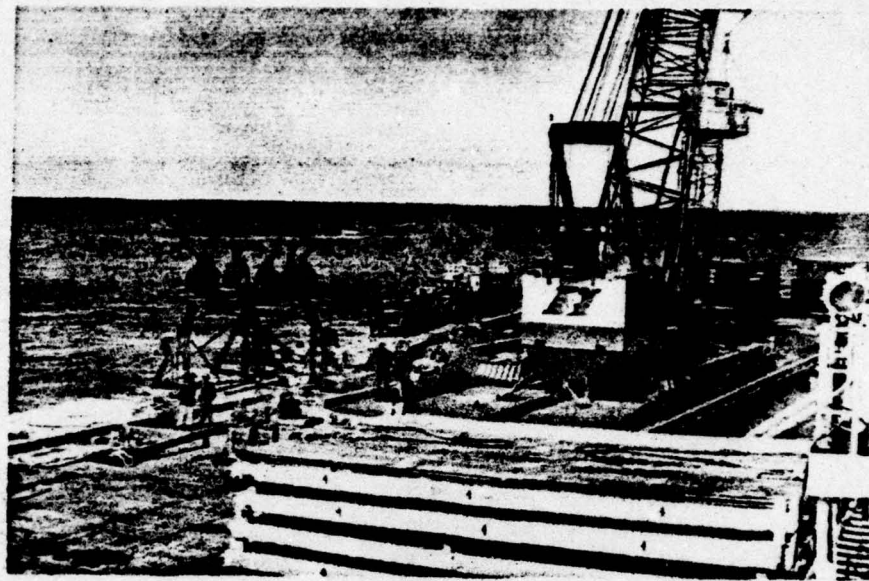

Figure 1 - Floating Delong Barge Moored Alongside WARRIOR

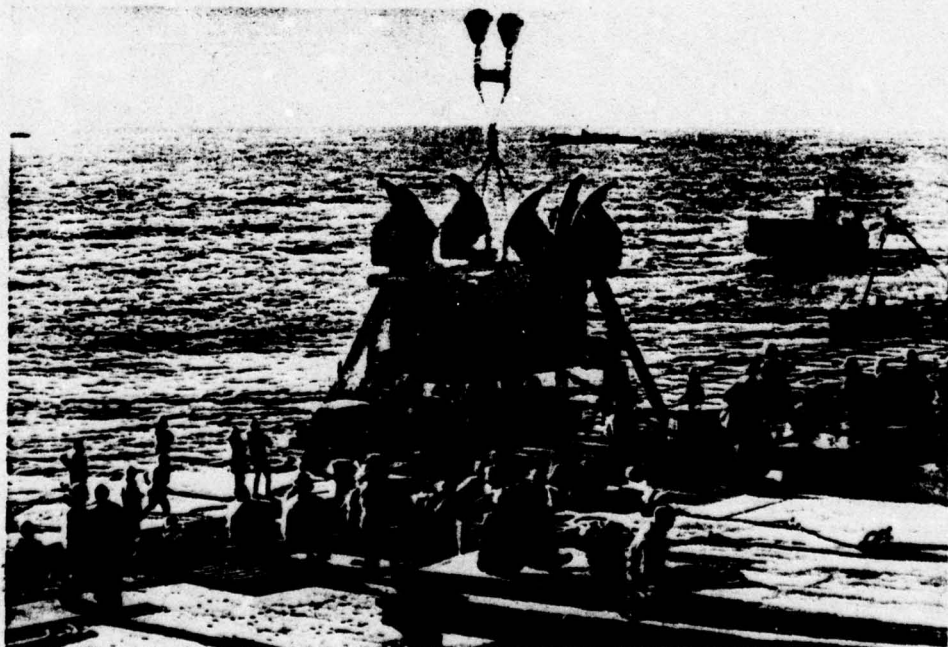

Figure 2 - 7x15 Platform with Hopper in Operation

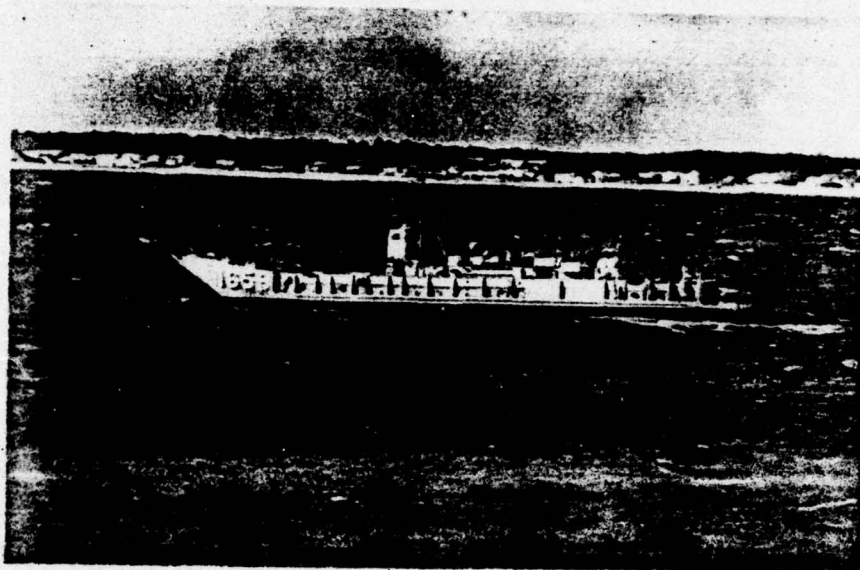

Figure 3 - Navy LCU 1659

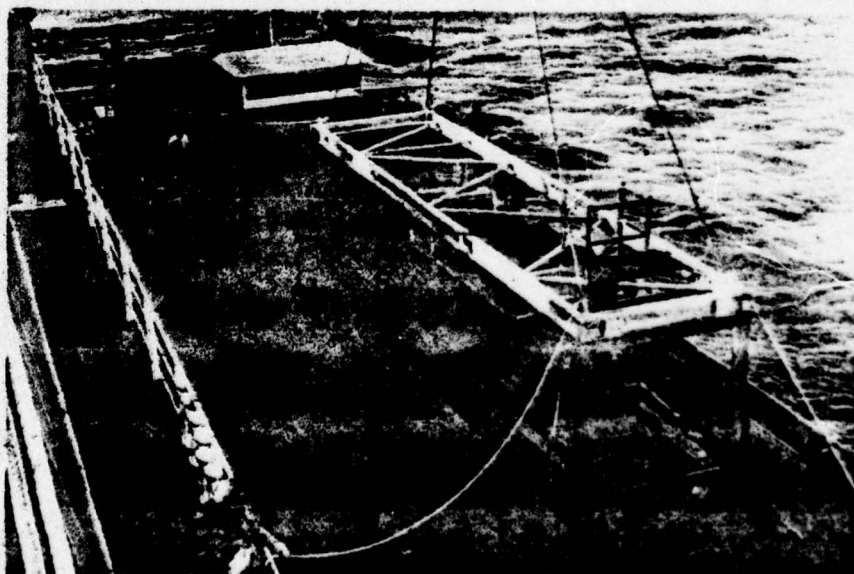

Figure 4 - Army LCU 1524

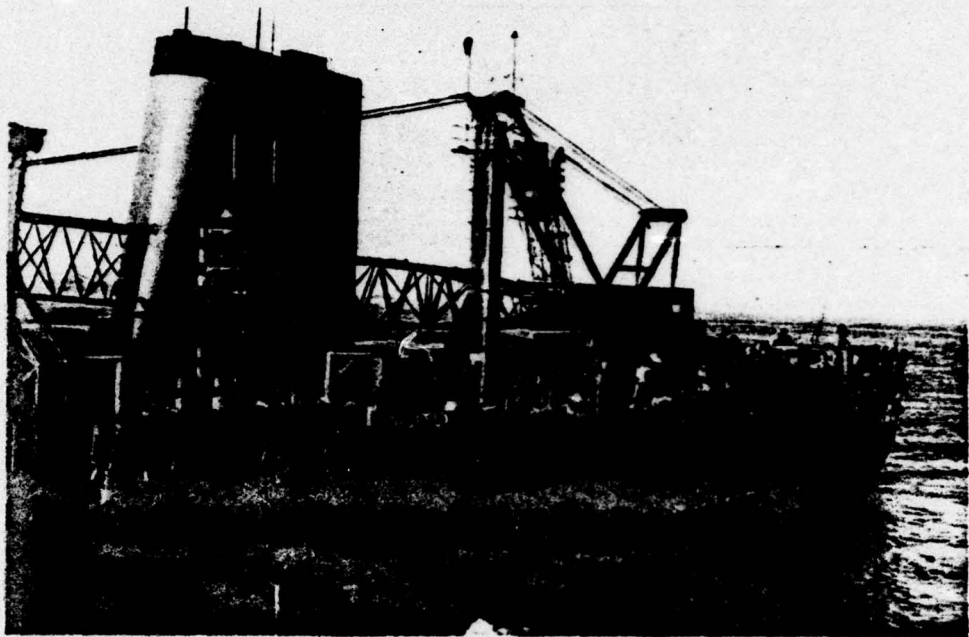

Figure 5 - LST 1188 with Crane Mounted on Stern Deck

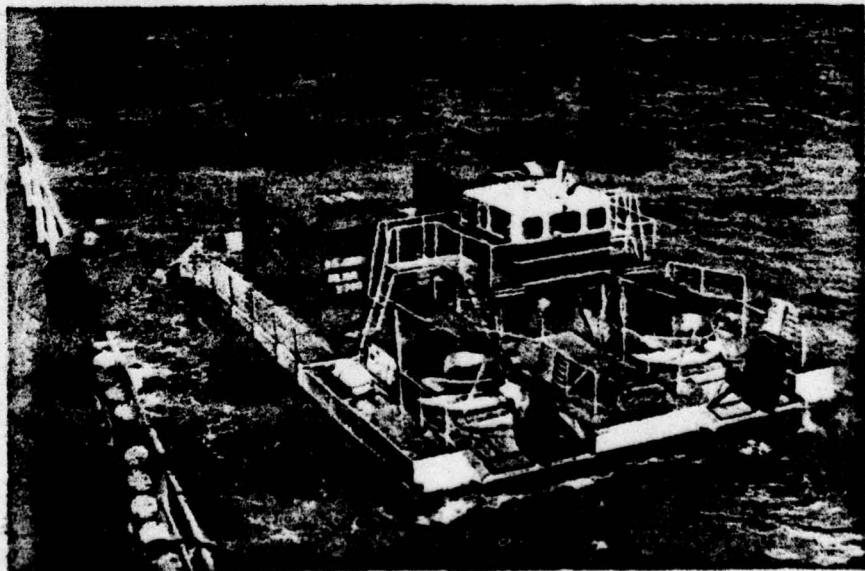

Figure 6 - ACV Voyager Alongside WARRIOR

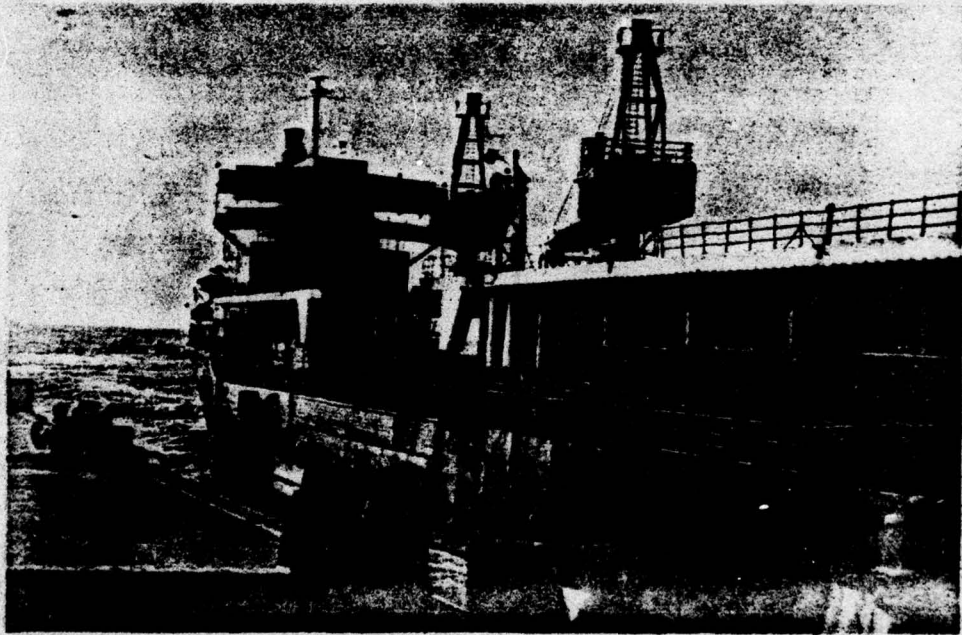

Figure 7 - Seatrain Ship Approaching WARRIOR

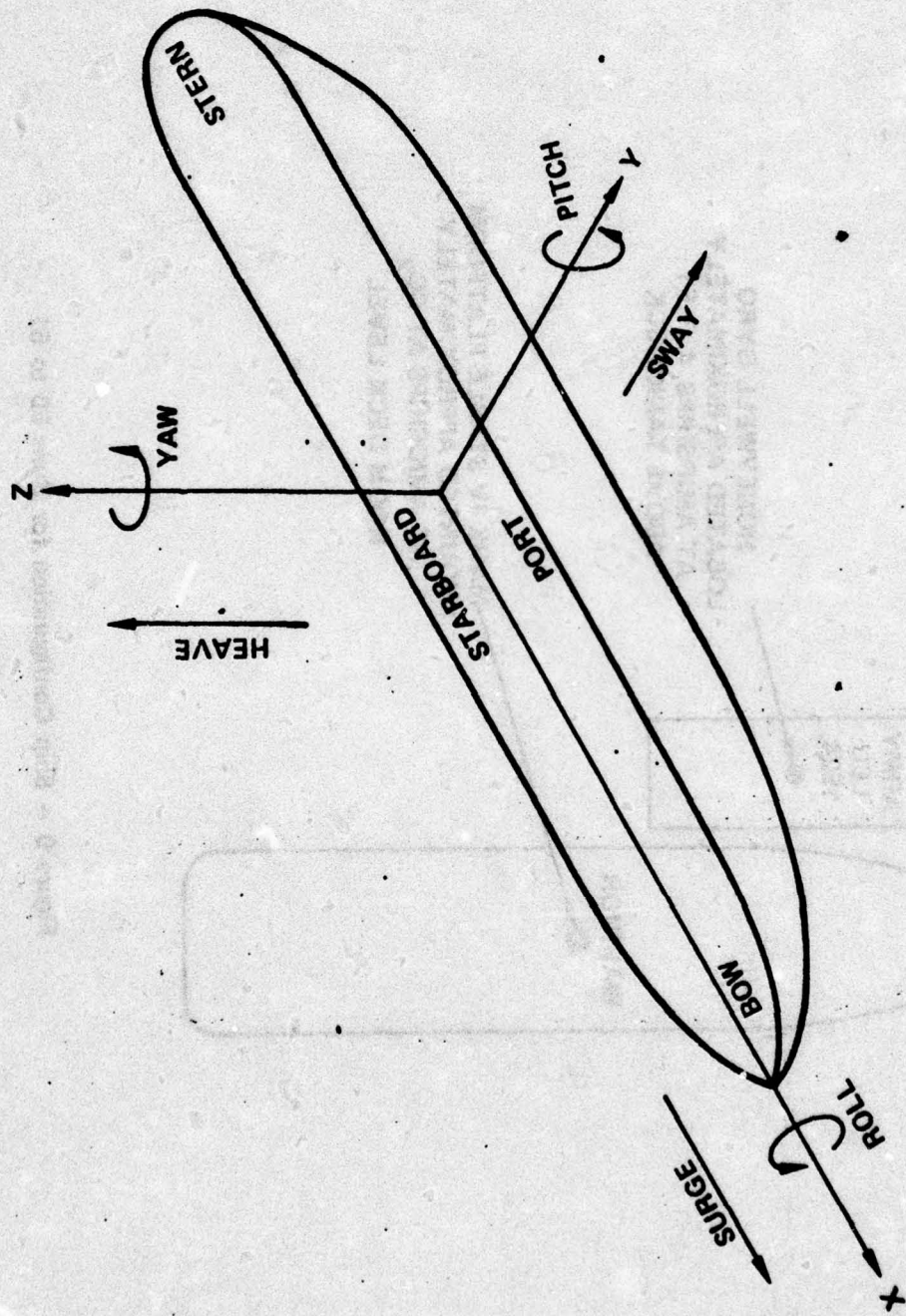

Figure 8 — Ship Coordinate System

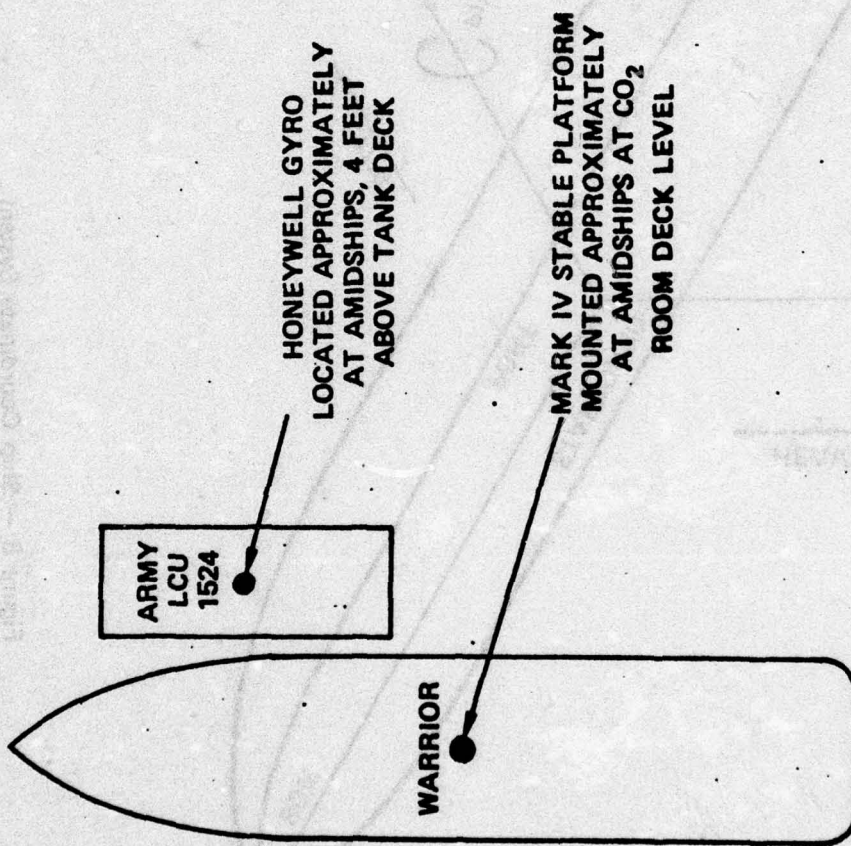

Figure 9 - Ship Configuration for Runs 50 to 51

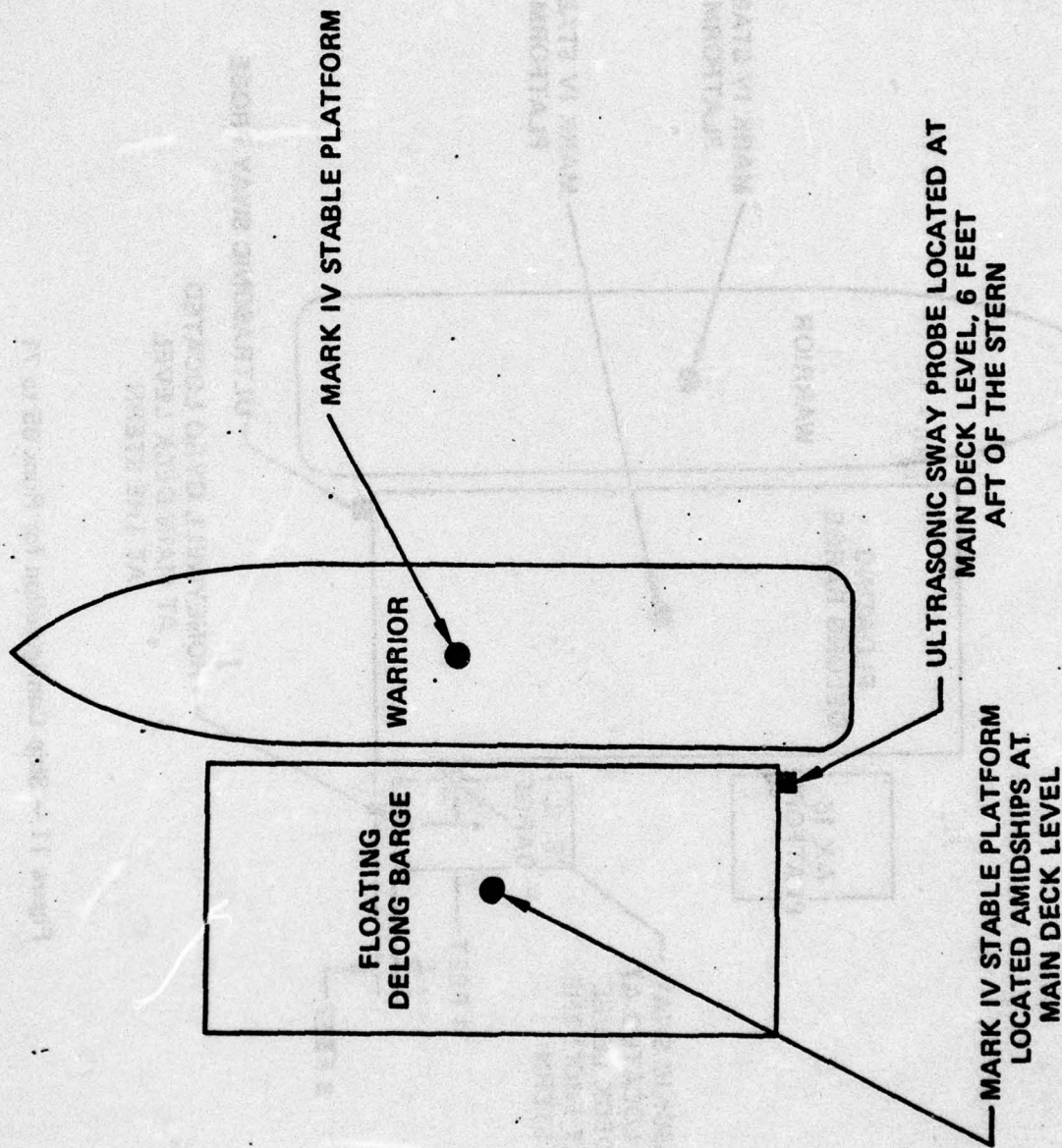

Figure 10 - Ship Configuration for Runs 53 to 64, 84 to 89, and 97 to 99

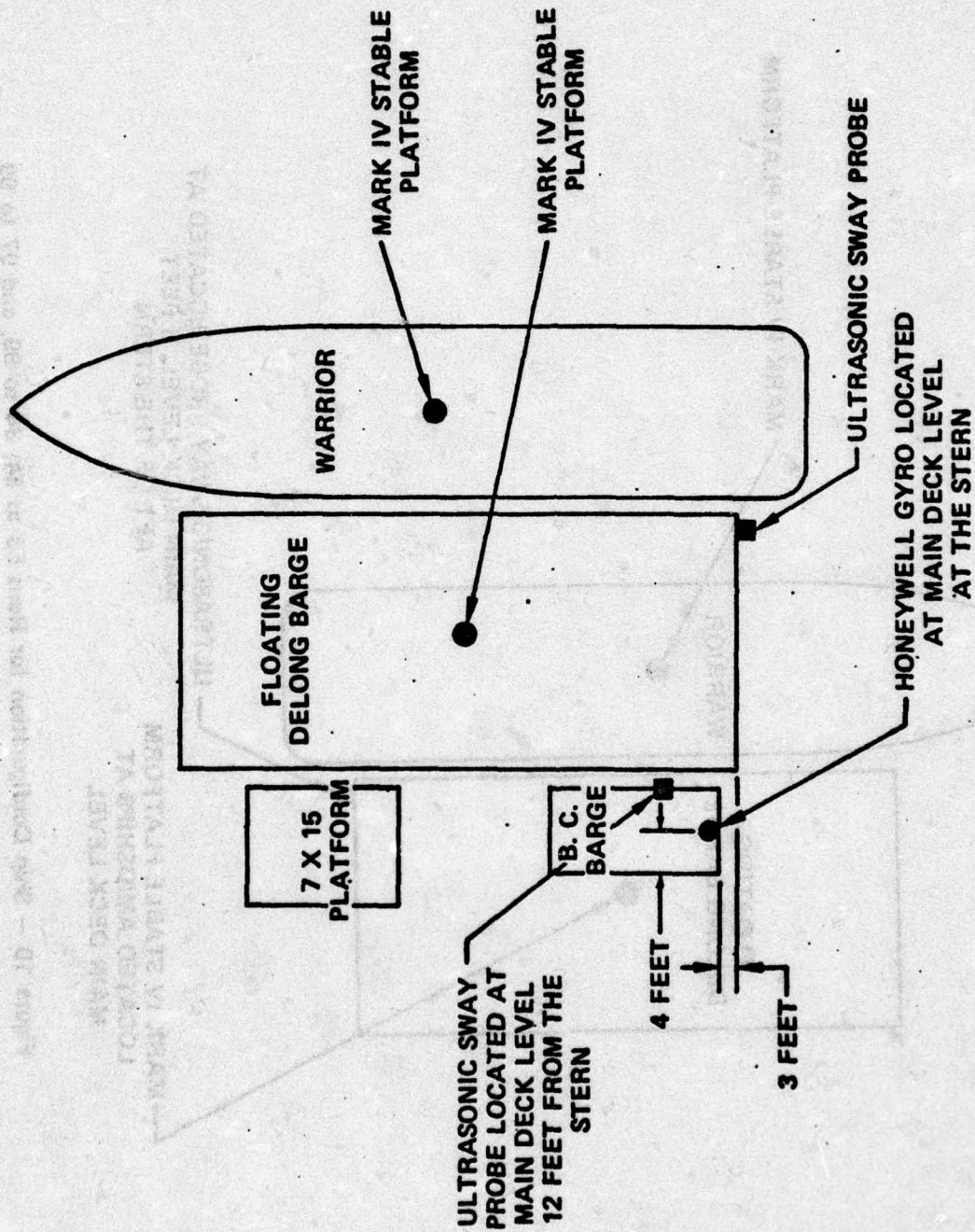

Figure 11 — Ship Configuration for Runs 65 to 71

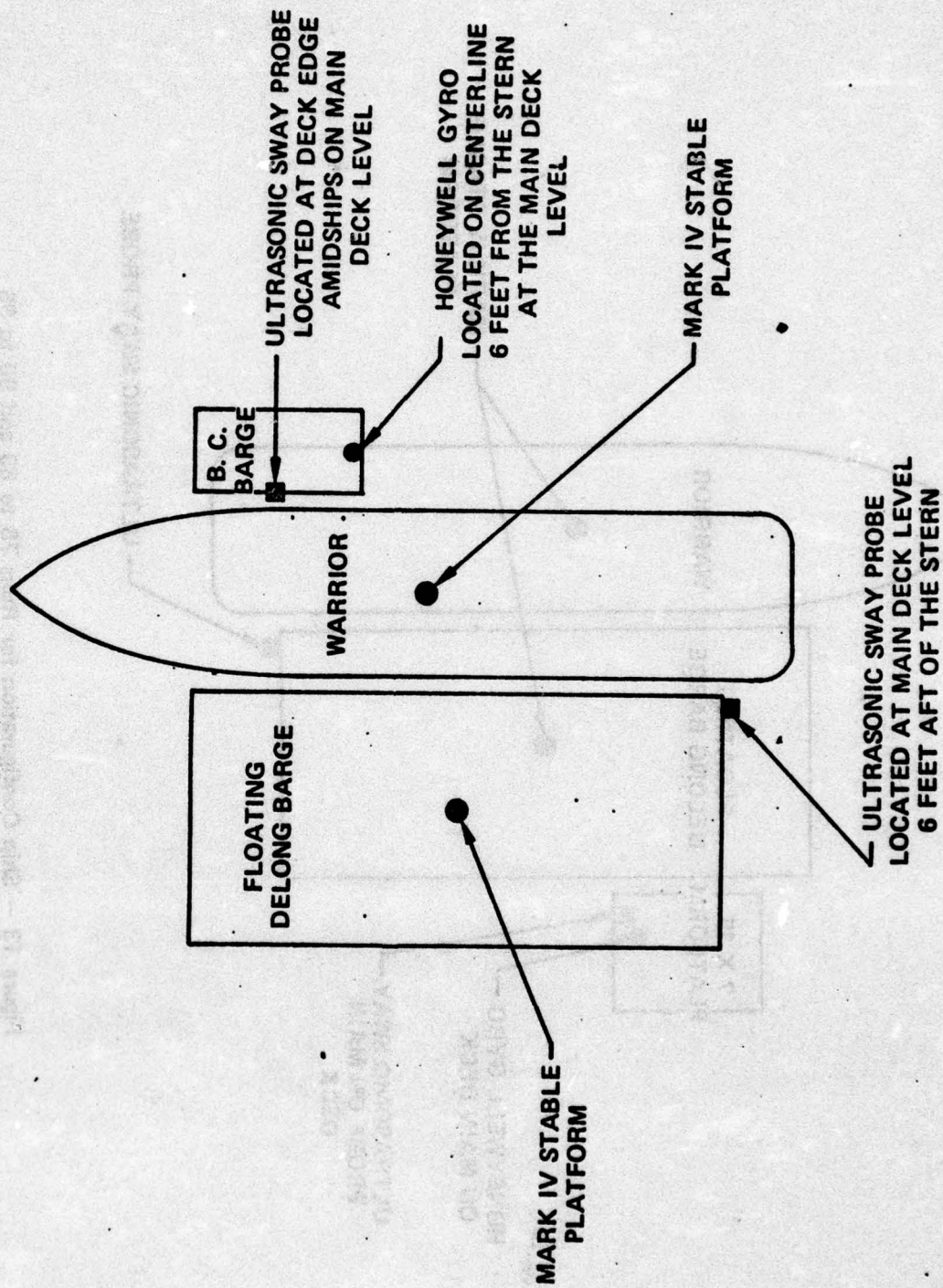

Figure 12 — Ship Configuration for Runs 72 to 77

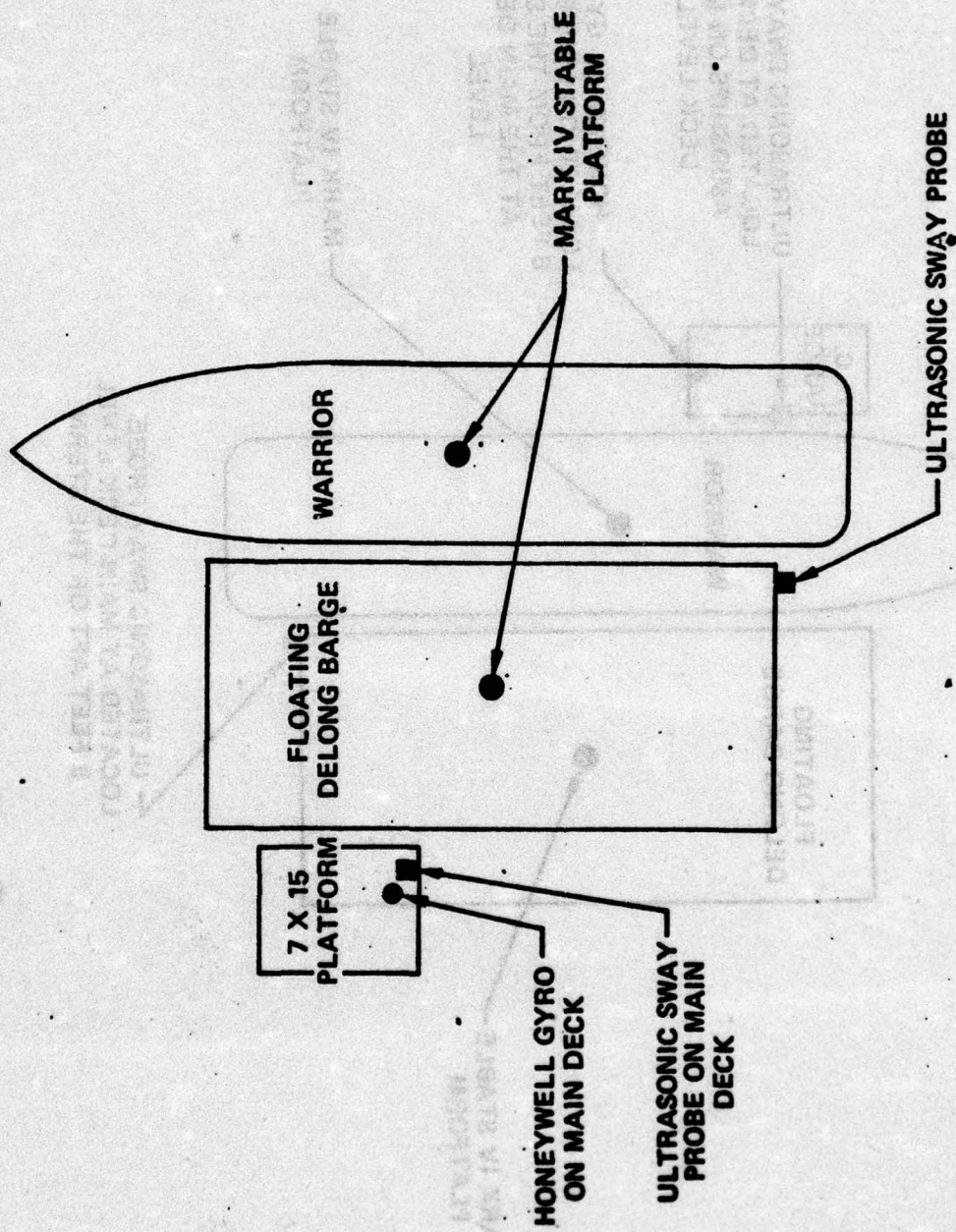

Figure 13 -- Ship Configuration for Runs 78 to 83 and 90 to 96

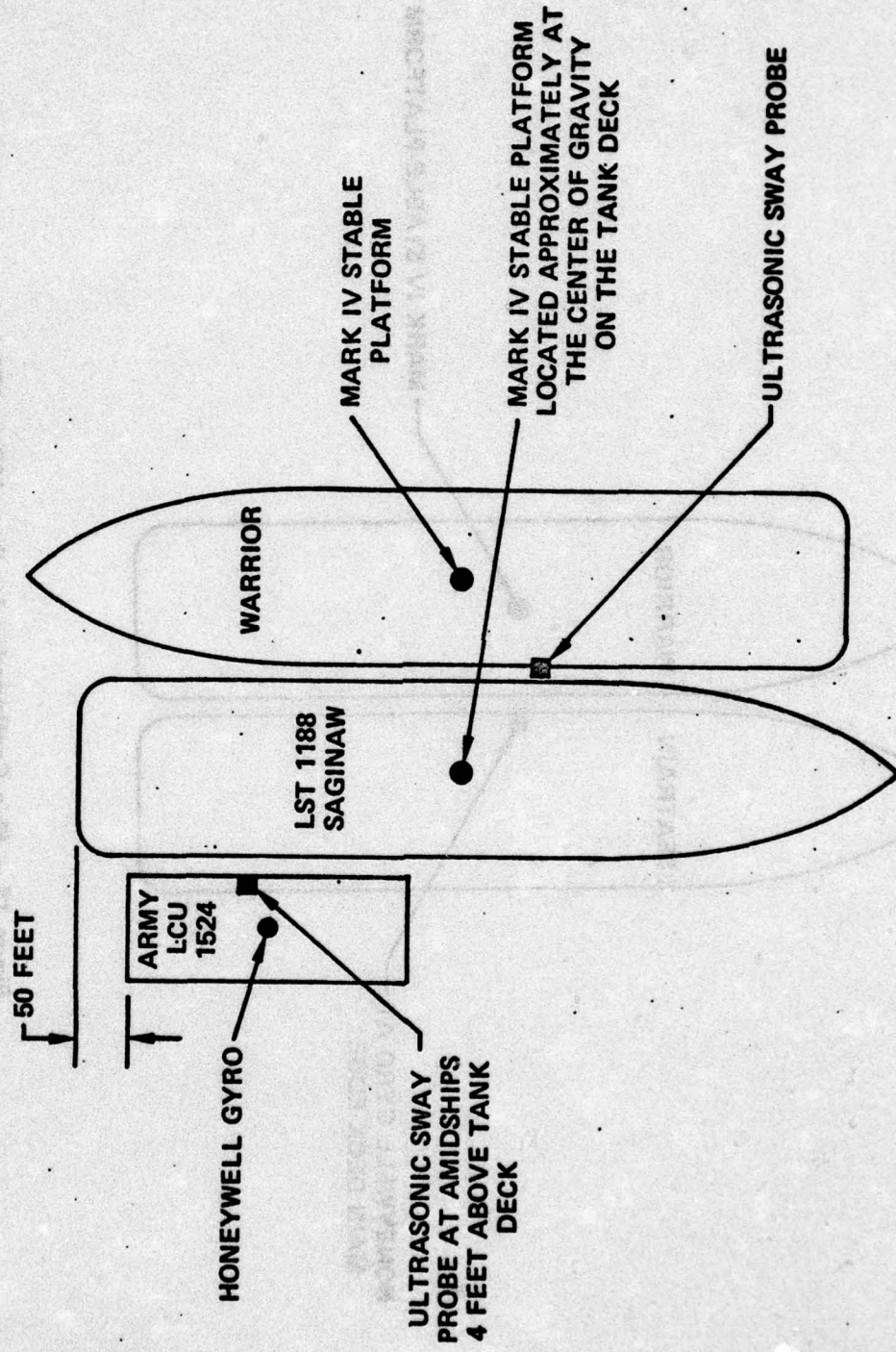

Figure 14 -- Ship Configuration for Runs 112 to 126

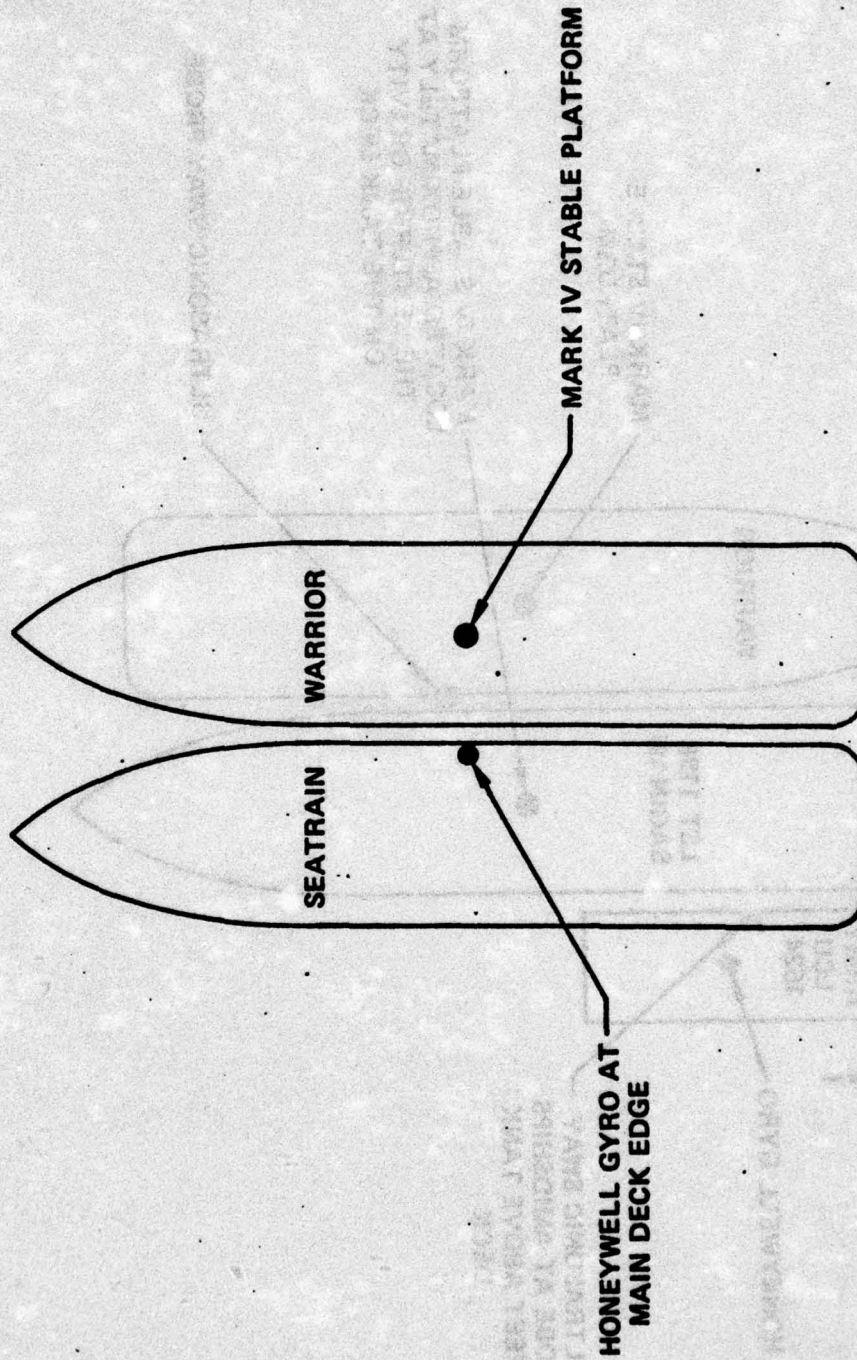

Figure 15 - Ship Configuration for Runs 127 to 136

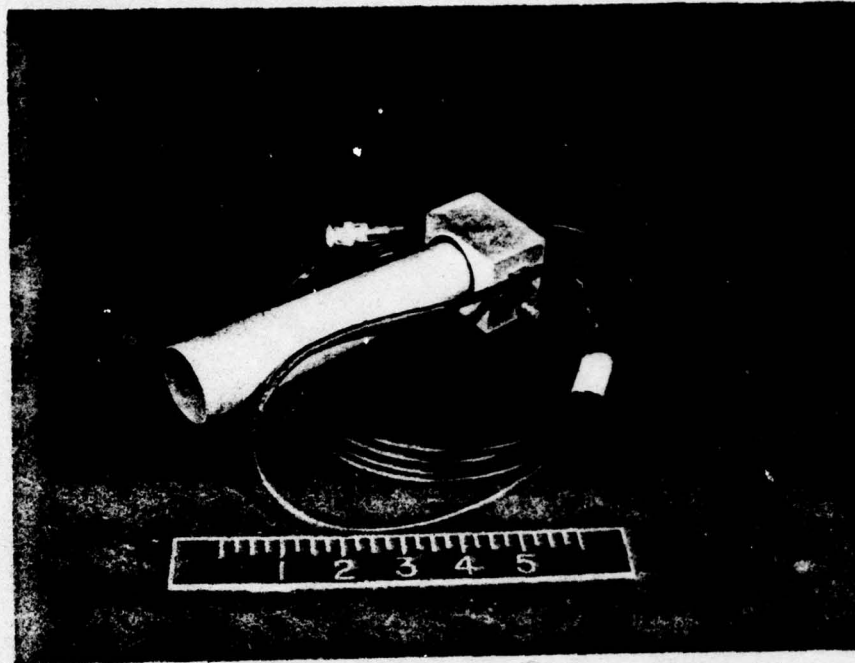

Figure 16 - Wesmar Ultrasonic Transducer

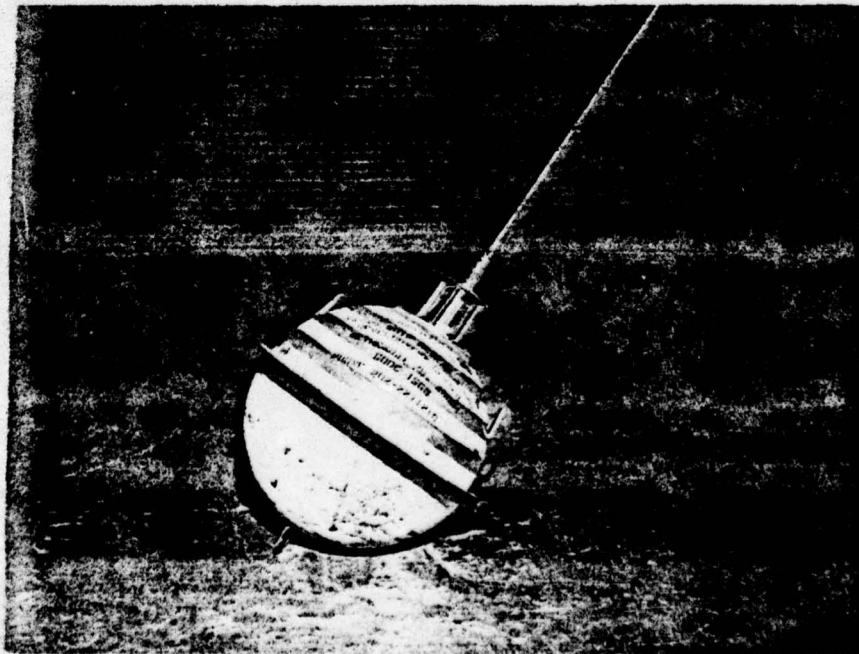

Figure 17 - Datawell Waverider Buoy



Figure 18 - Datawell Waverider Receiver

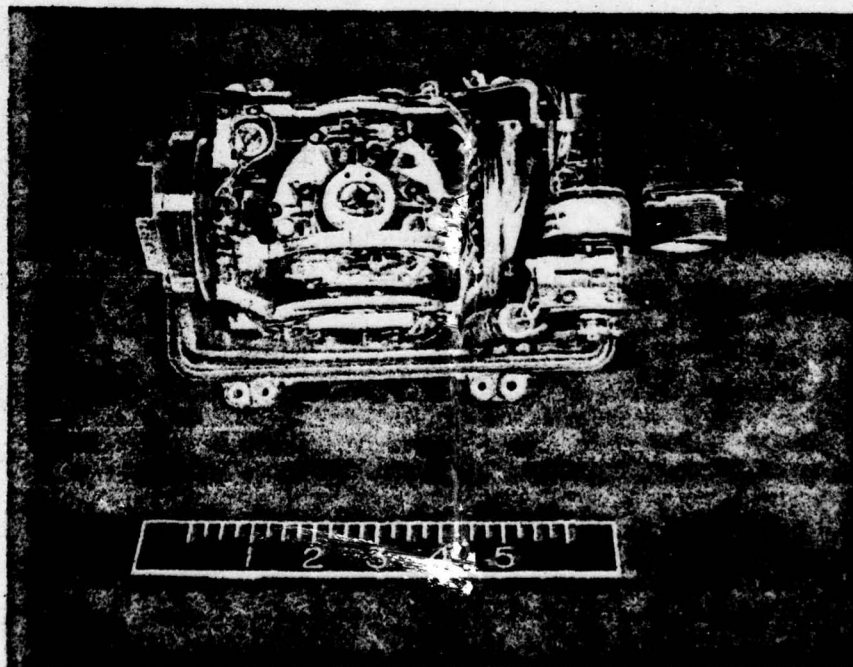

Figure 19 - Honeywell Gyro

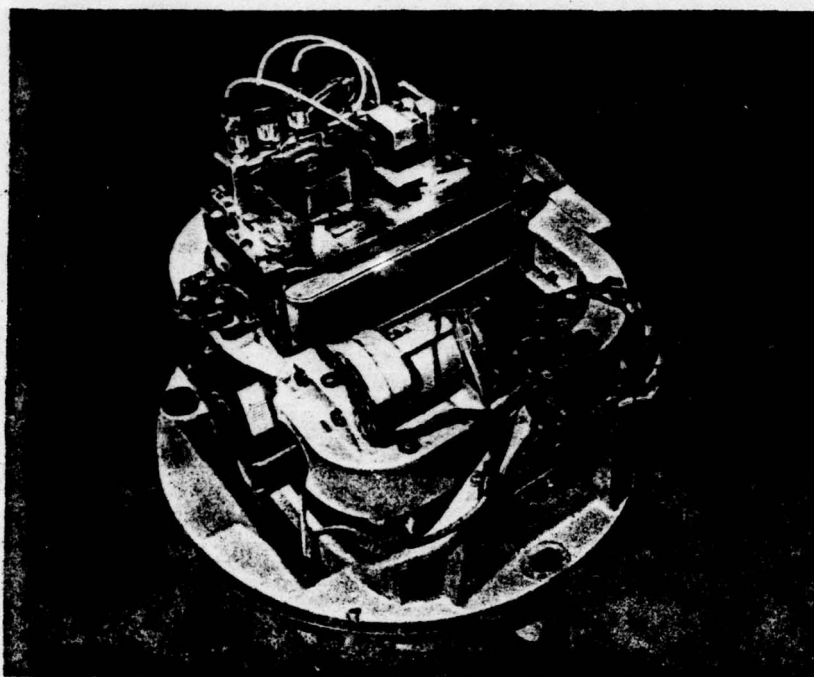

Figure 20 - Mark IV Stable Platform with Accelerometers in Place

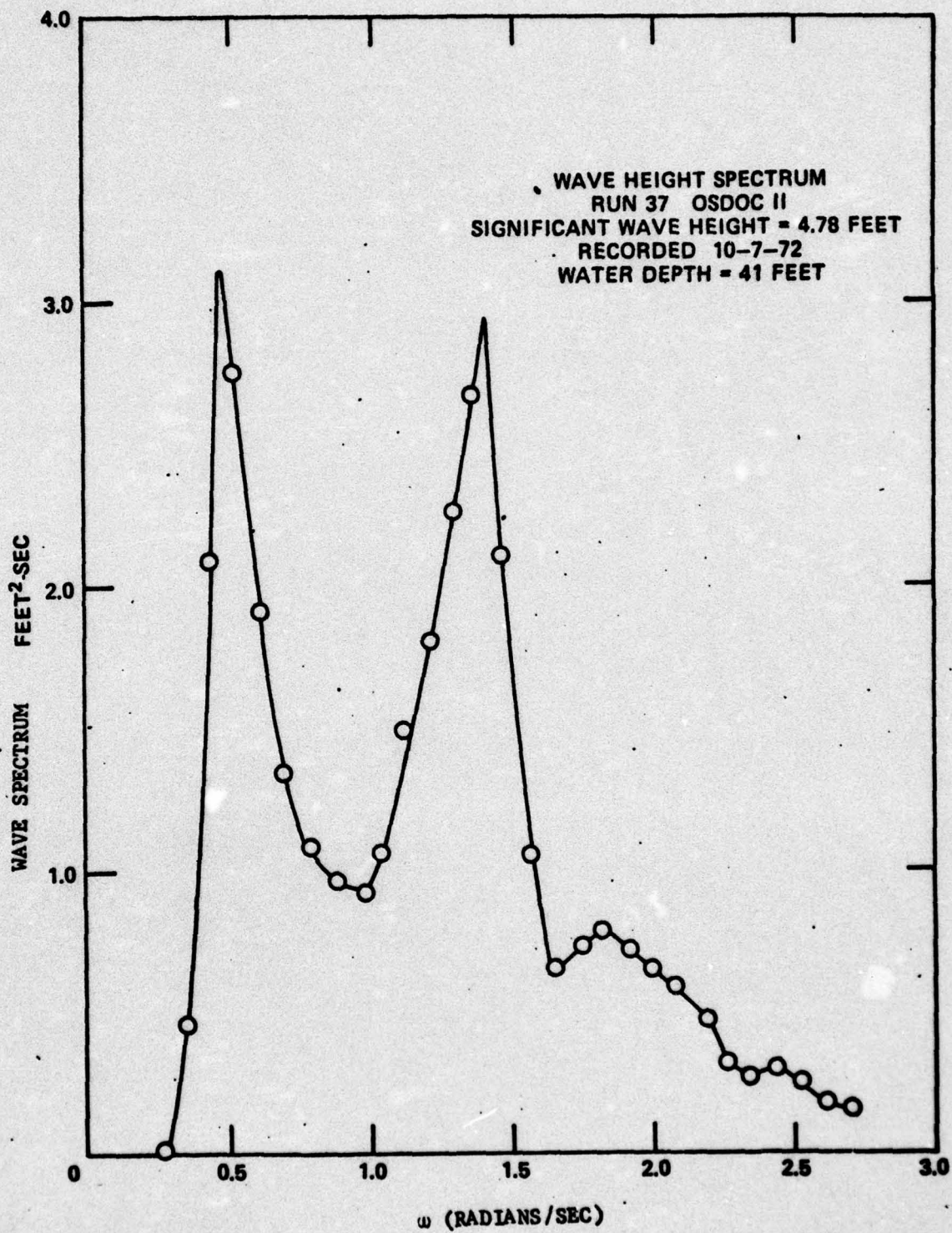

Figure 21 - Wave Spectrum for Run 37

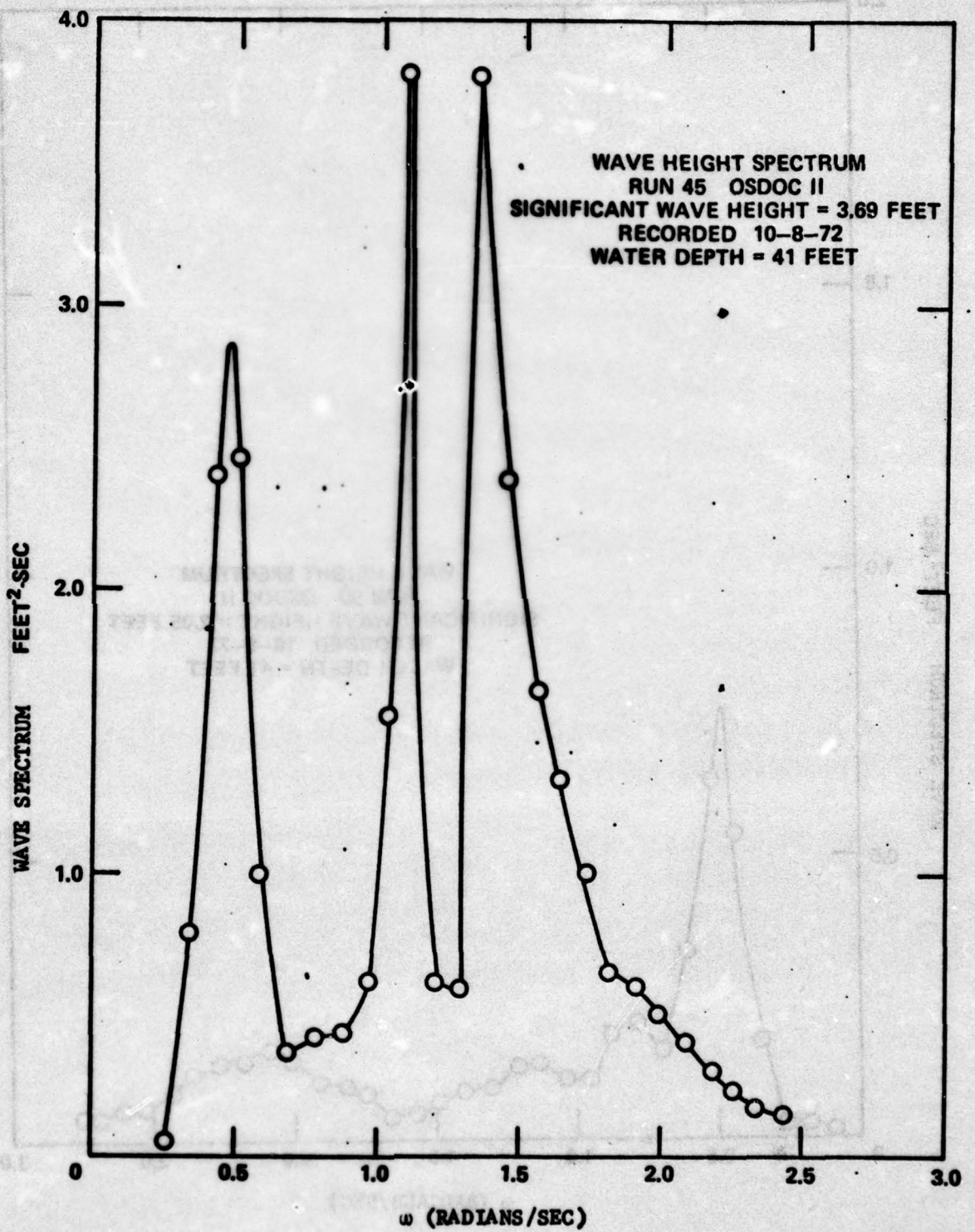

Figure 22 - Wave Spectrum for Run 45

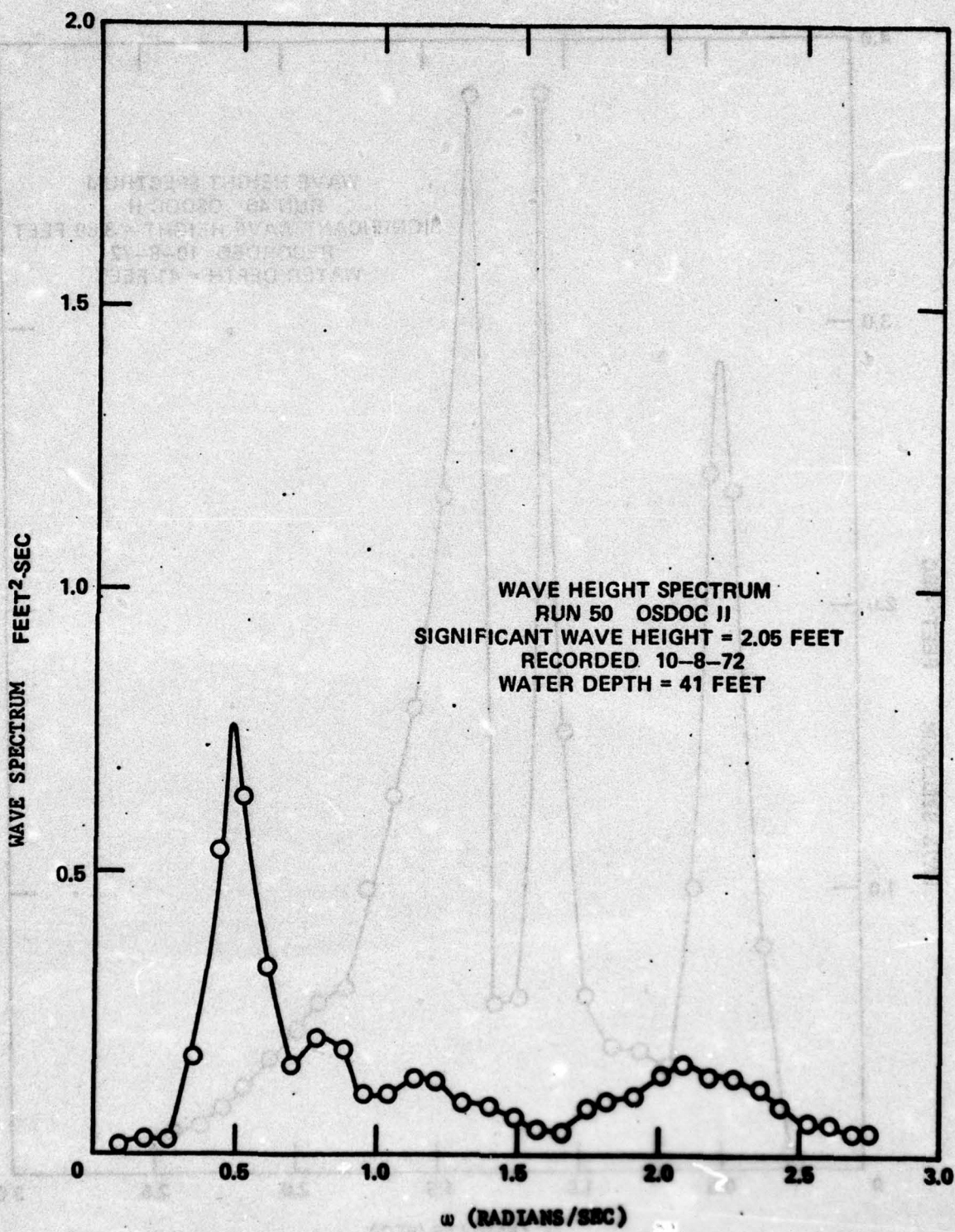

Figure 23 - Wave Spectrum for Run 50

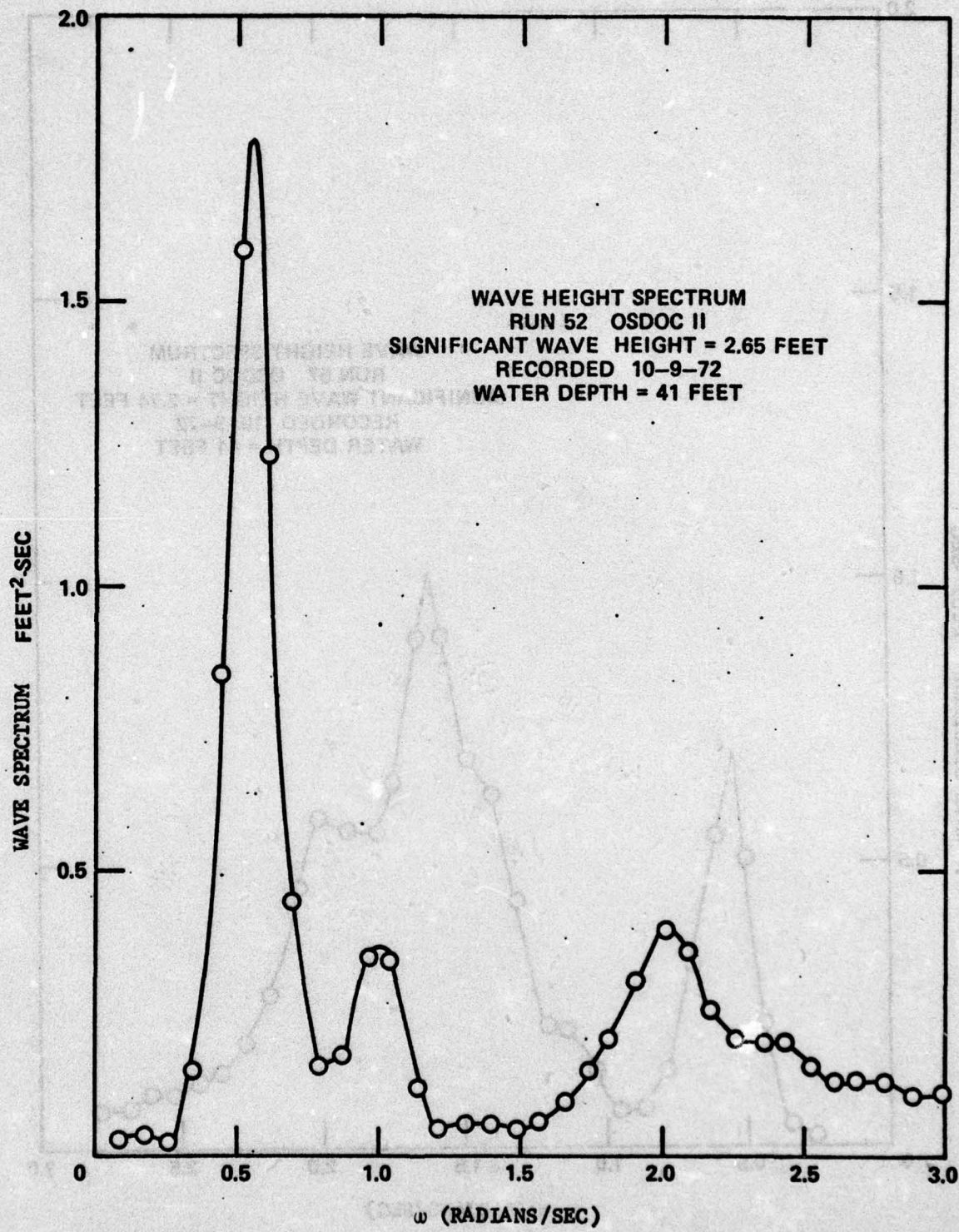

Figure 24 - Wave Spectrum for Run 52

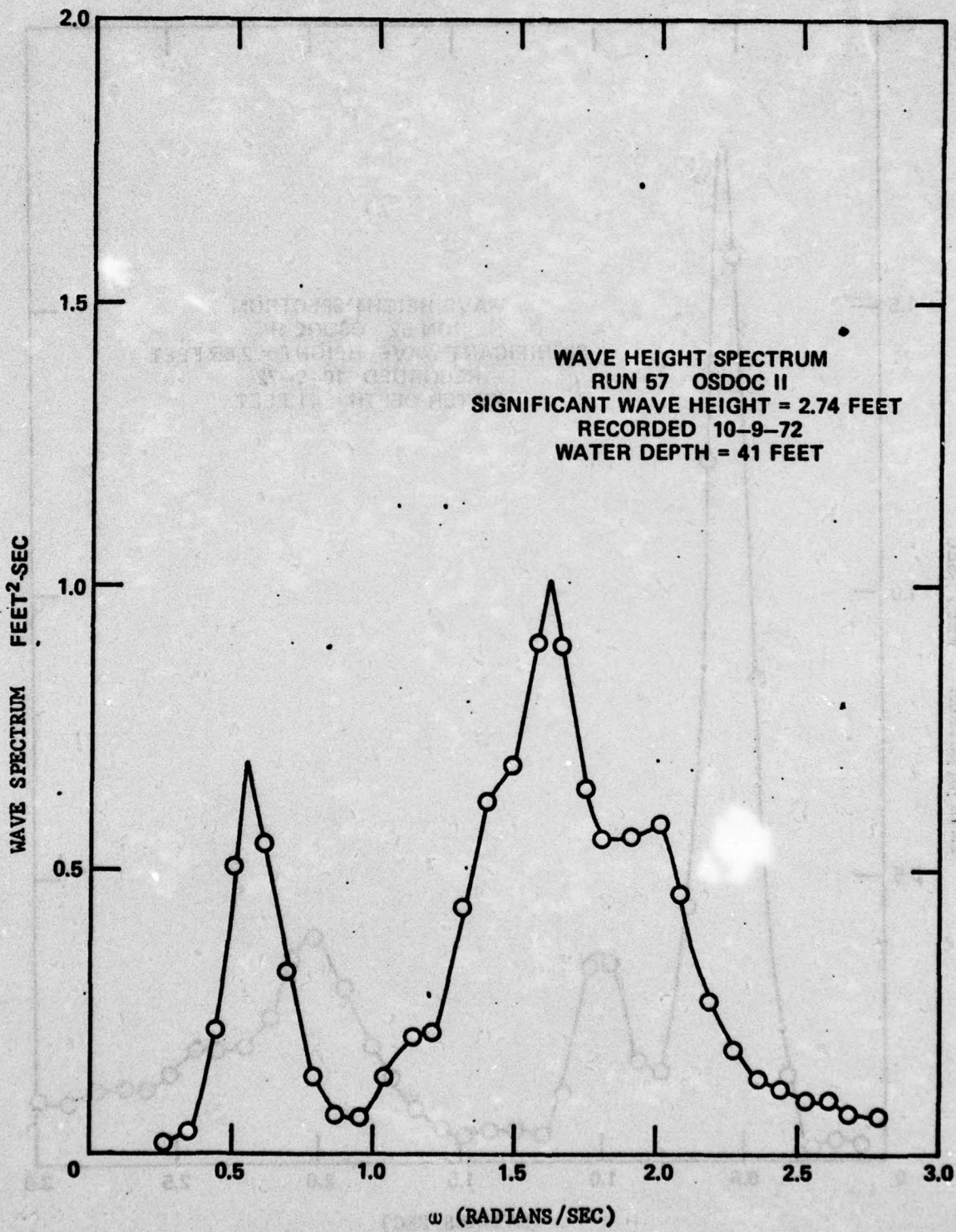

Figure 25 - Wave Spectrum for Run 57

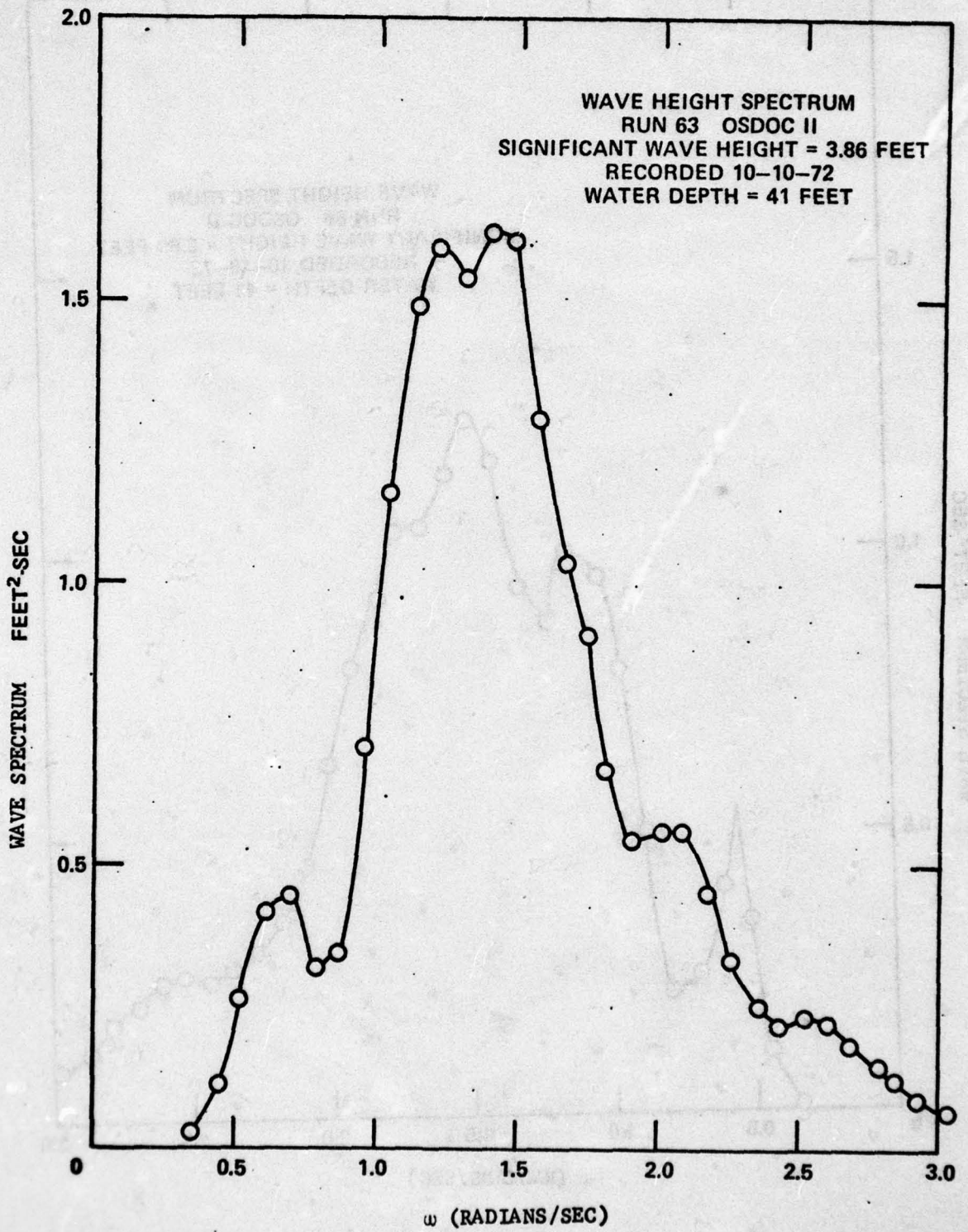

Figure 26 - Wave Spectrum for Run 63

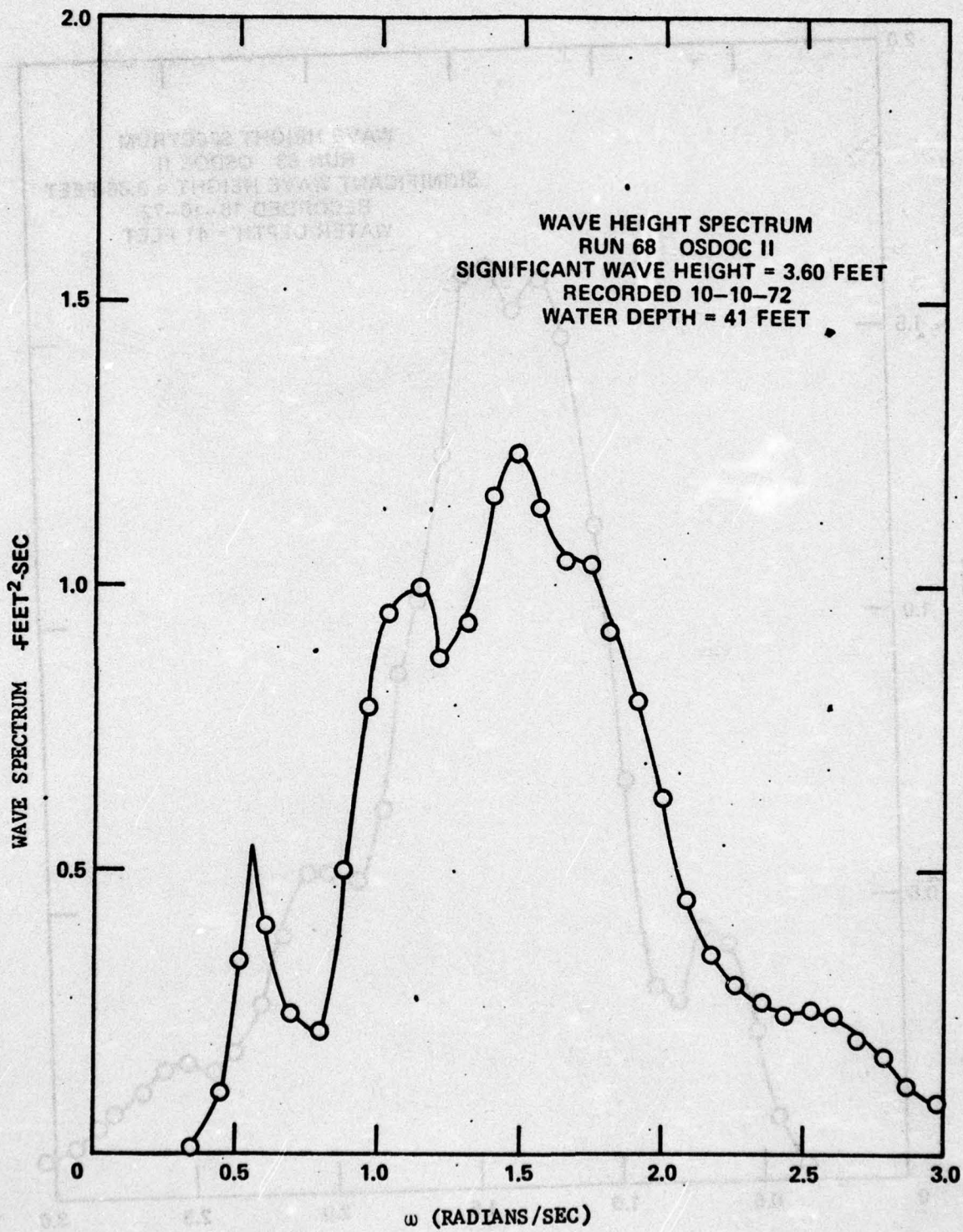

Figure 27 - Wave Spectrum for Run 68

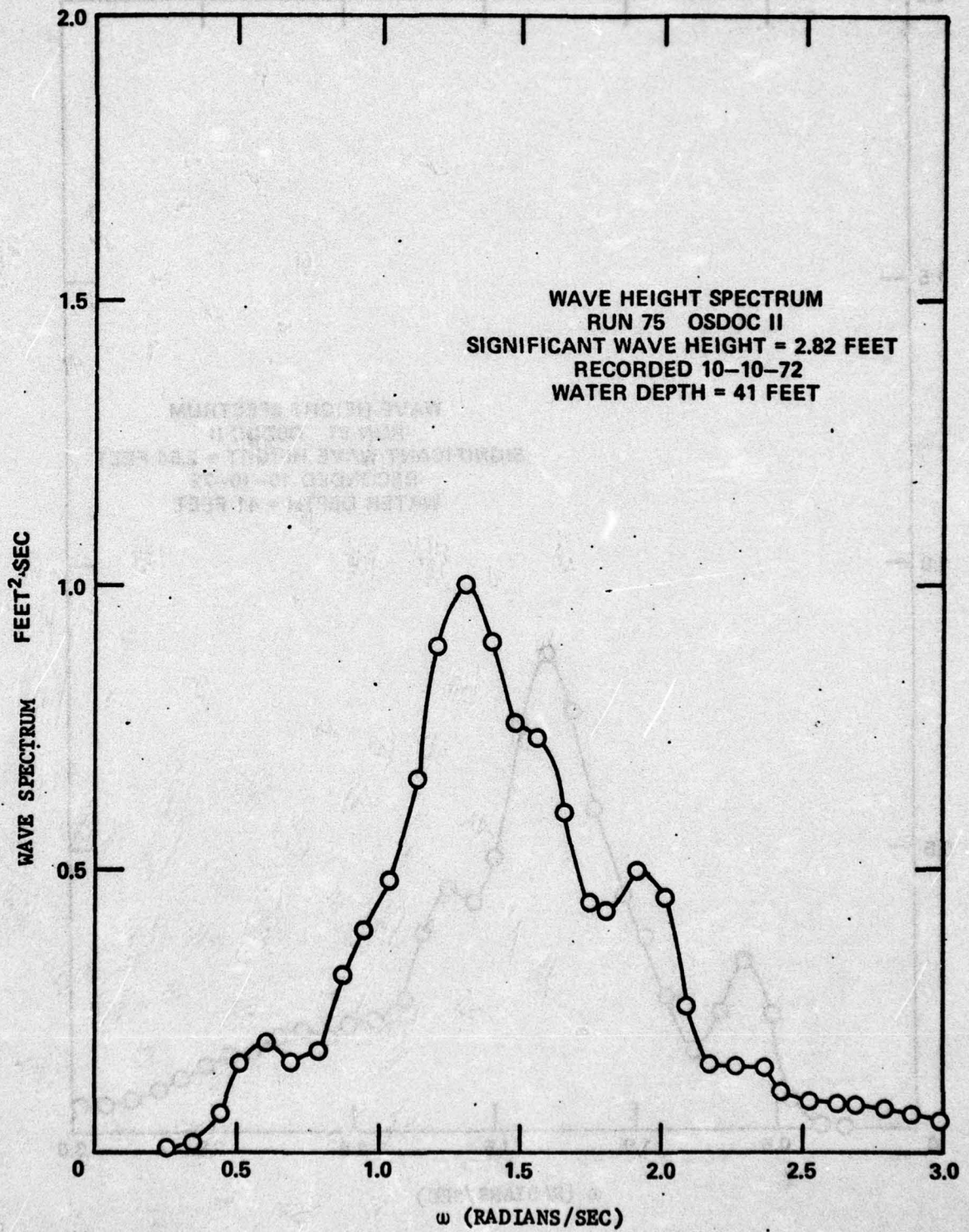

Figure 28 - Wave Spectrum for Run 75

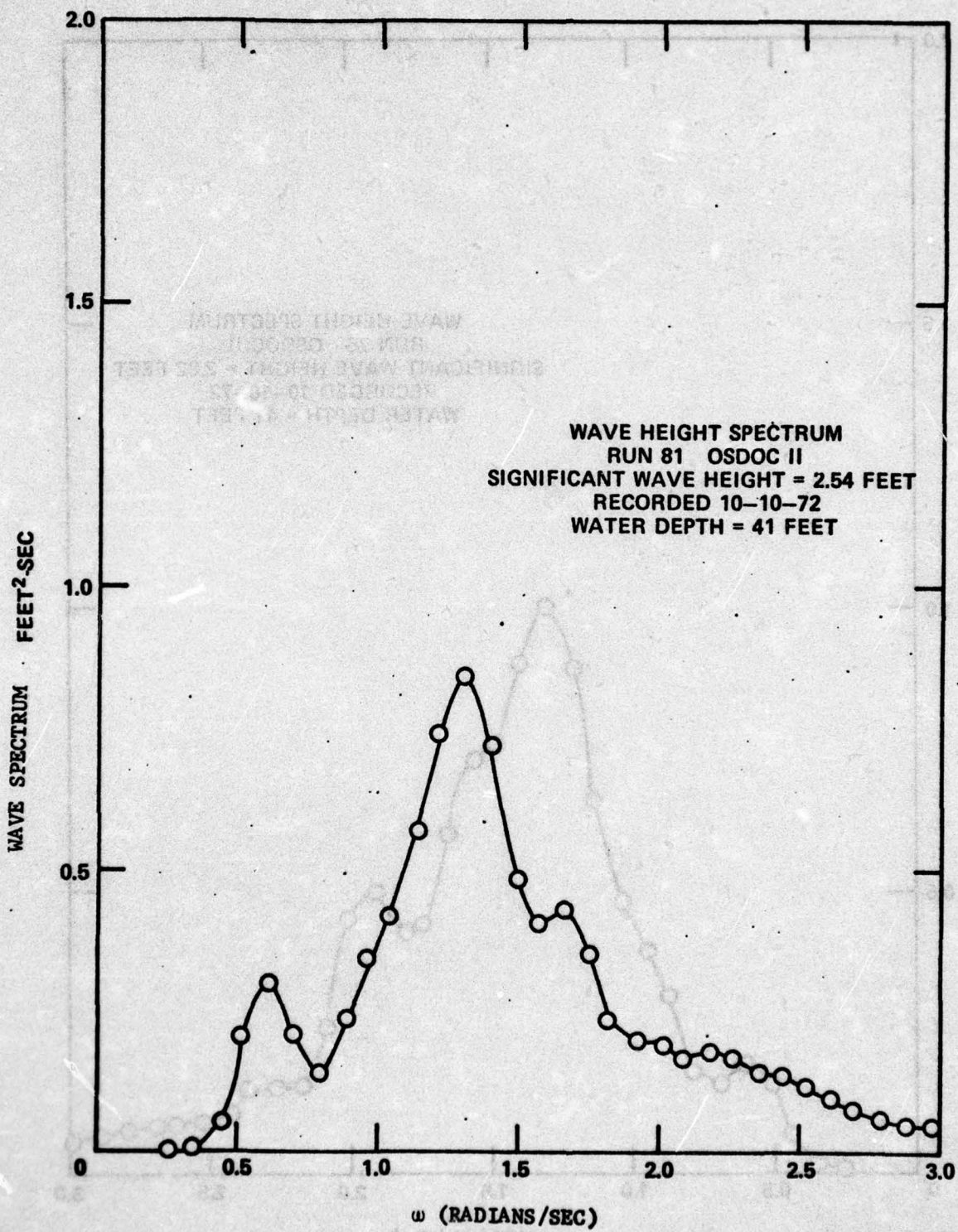

Figure 29 - Wave Spectrum for Run 81

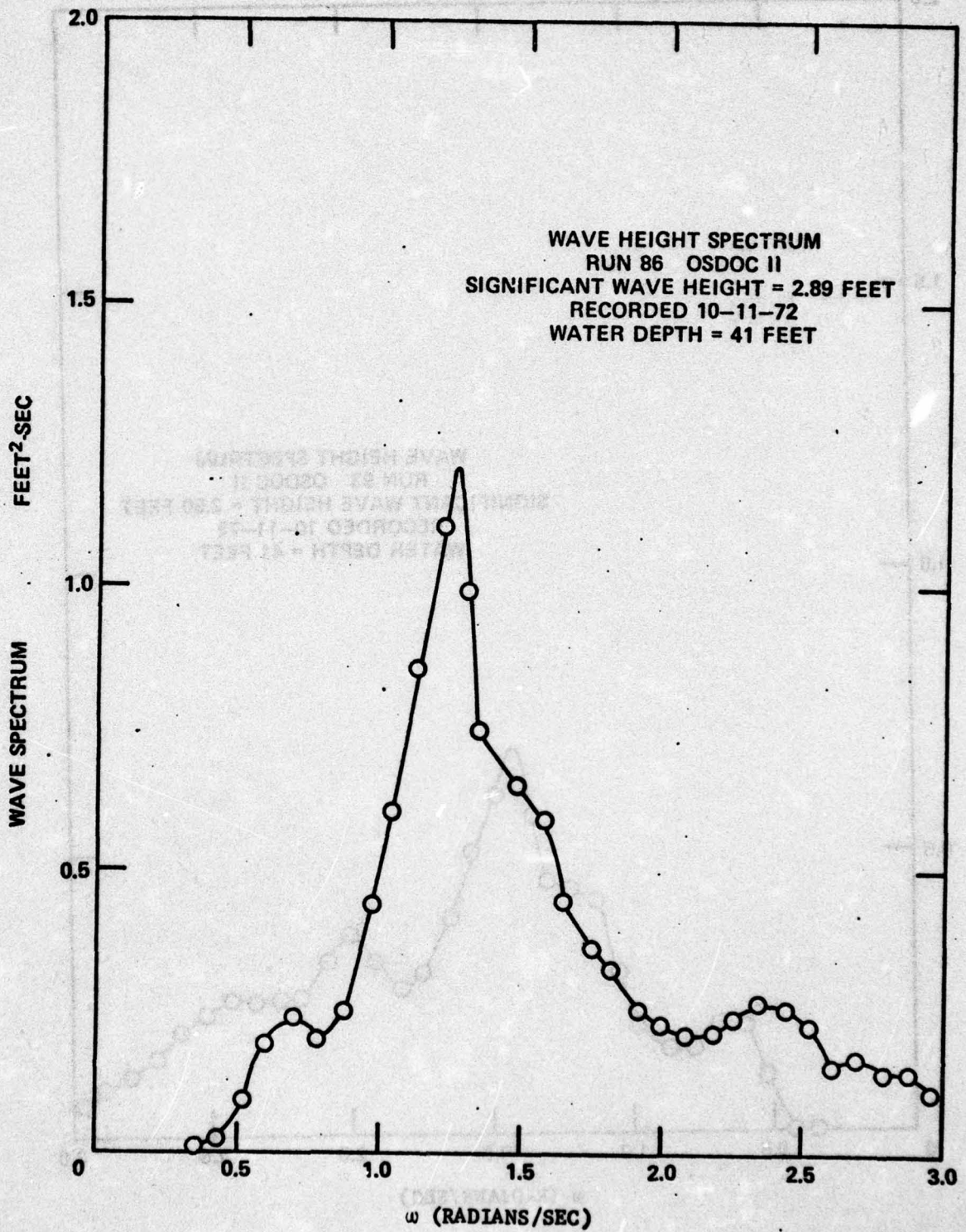

Figure 30 - Wave Spectrum for Run 86

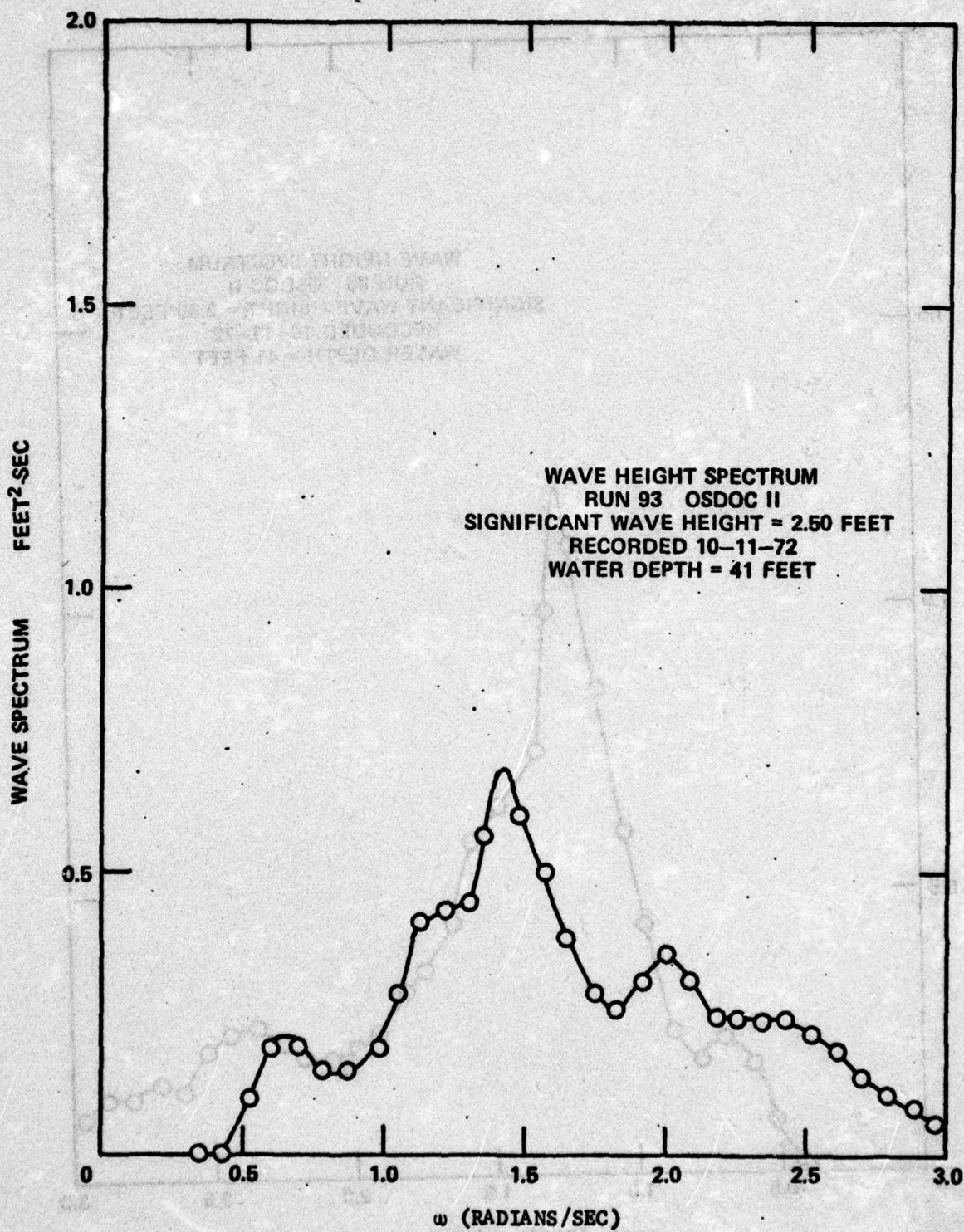

Figure 31 - Wave Spectrum for Run 93

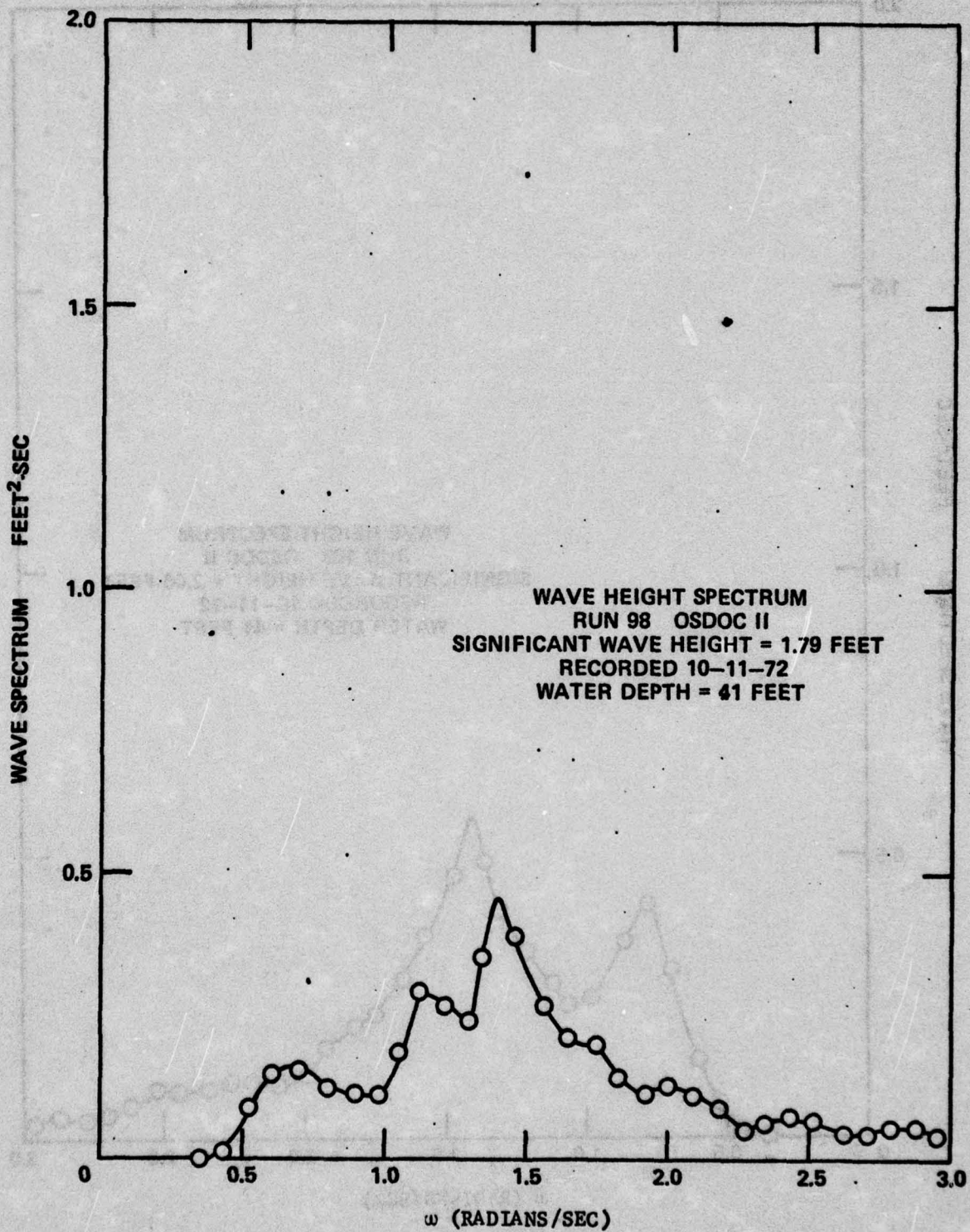

Figure 32 - Wave Spectrum for Run 98

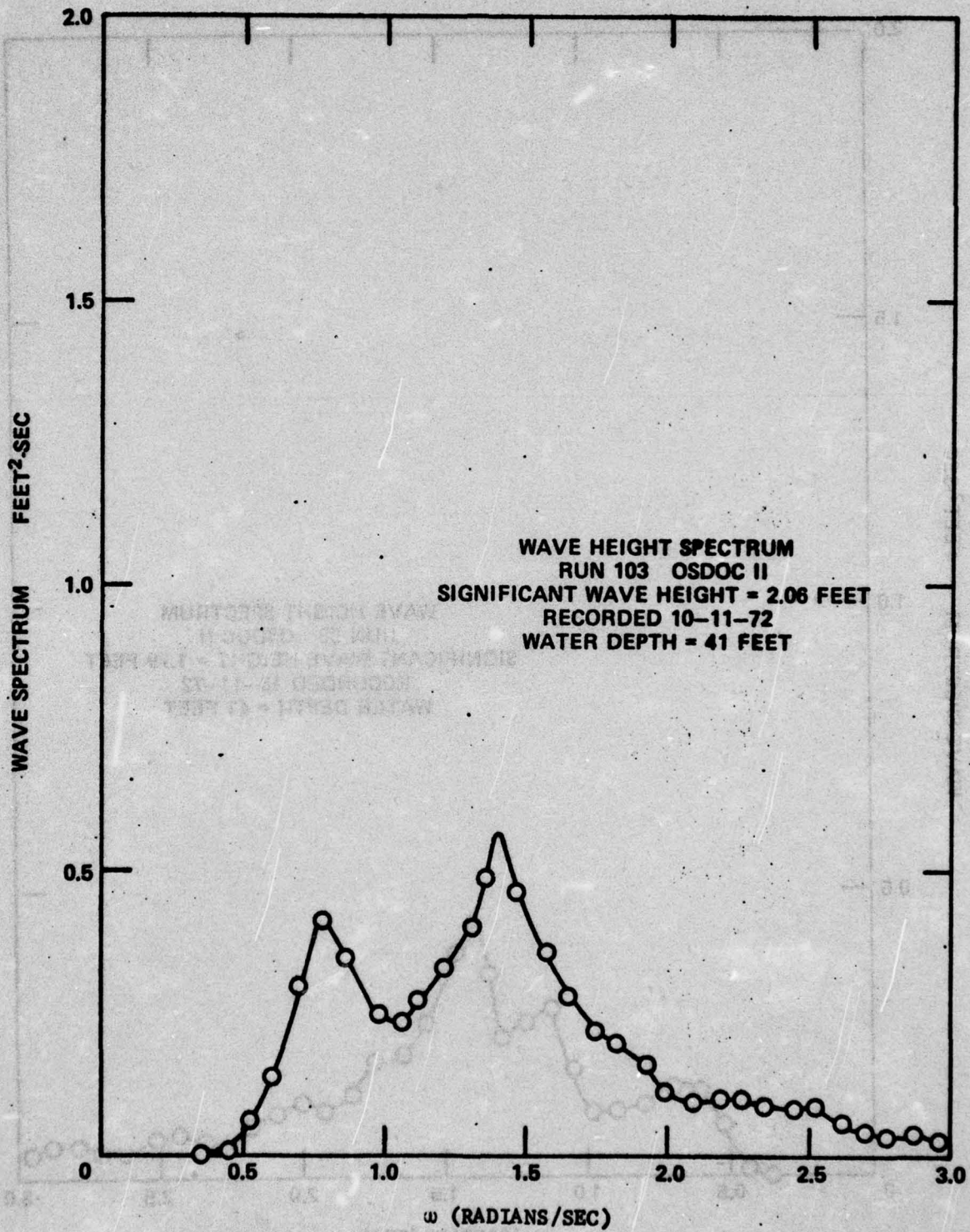

Figure 33 - Wave Spectrum for Run 103

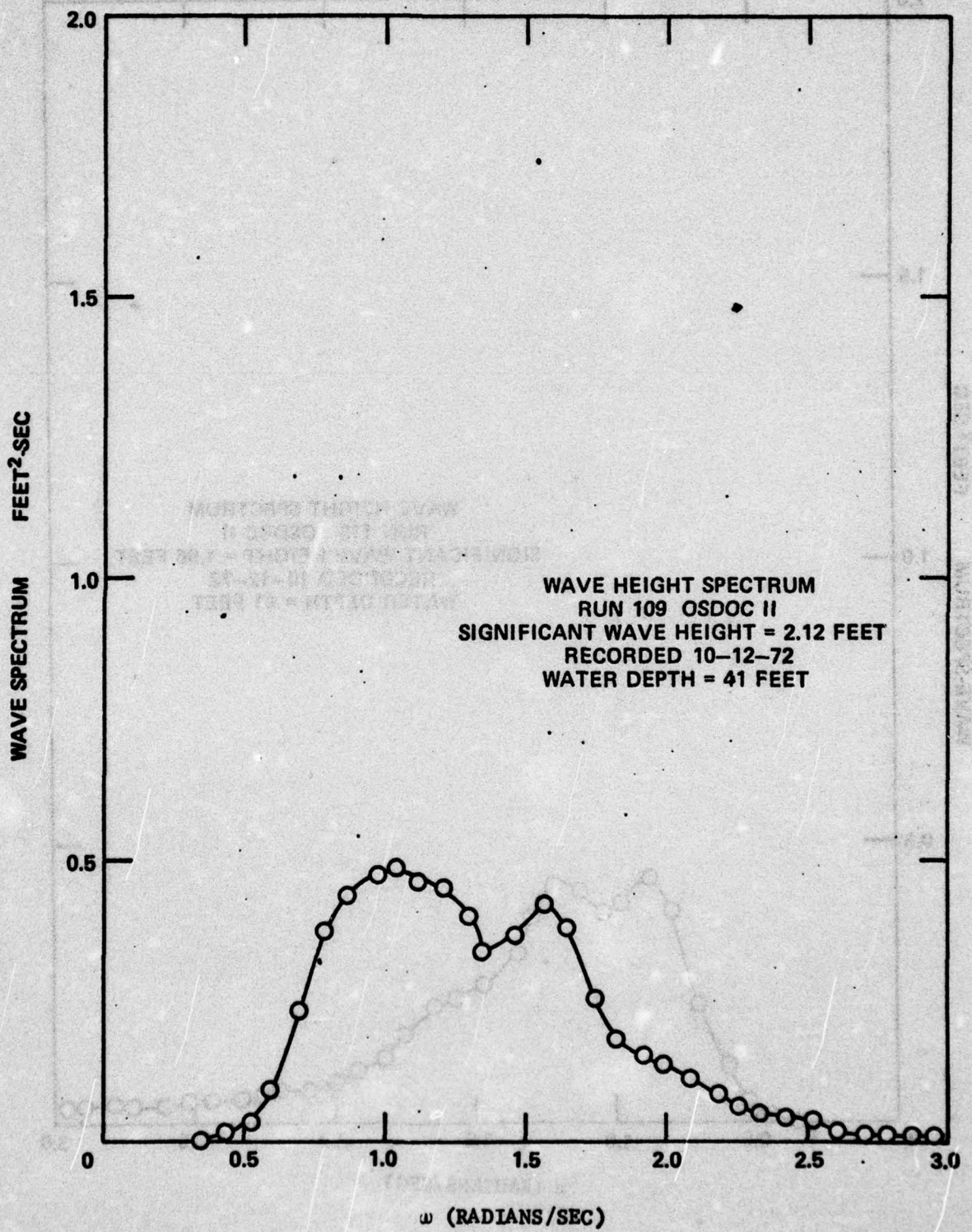

Figure 34 - Wave Spectrum for Run 109

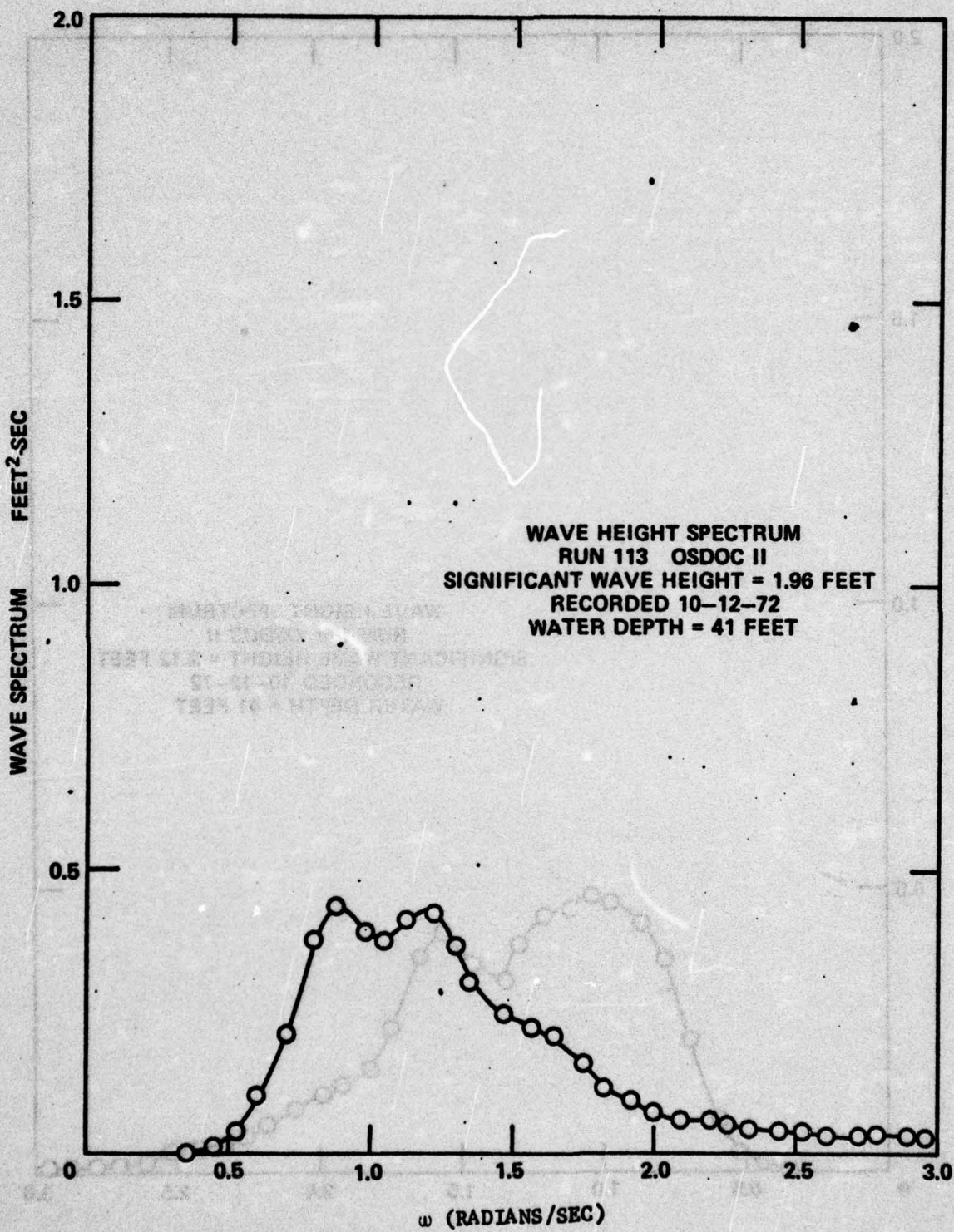

Figure 35 - Wave Spectrum for Run 113

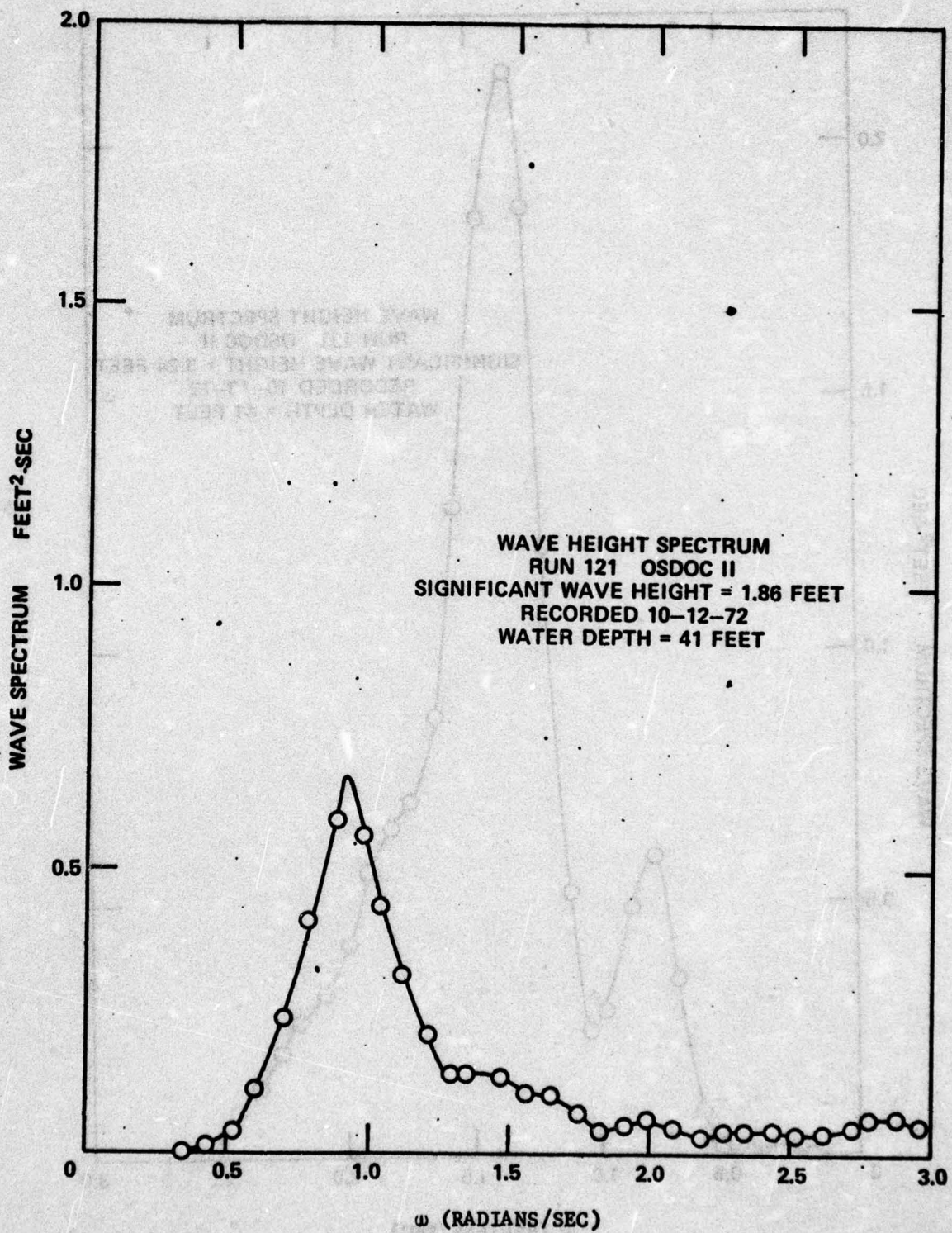

Figure 36 - Wave Spectrum for Run 121

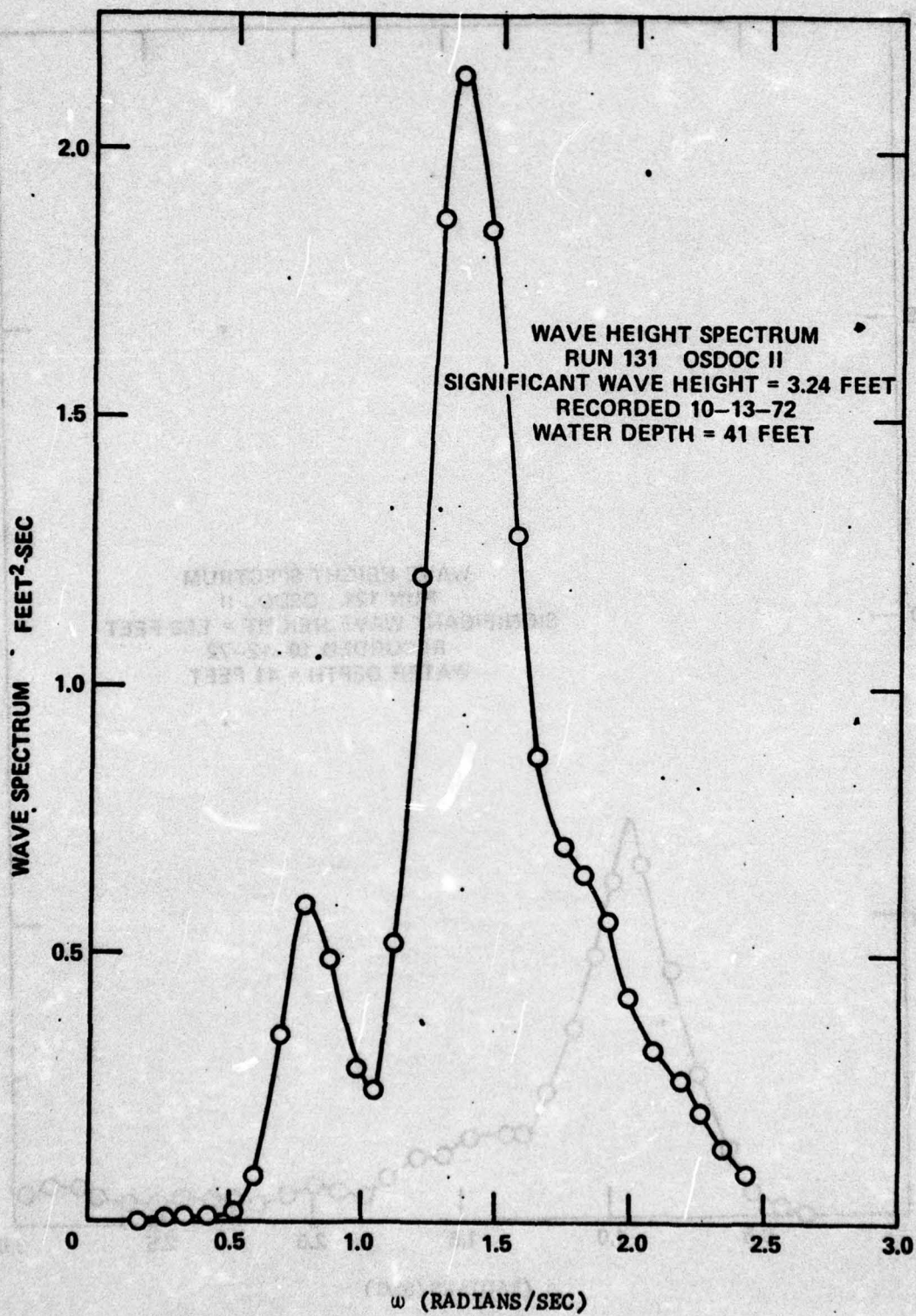

Figure 37 - Wave Spectrum for Run 131