

AD A 032062

12

COPY NO. 91

TECHNICAL REPORT 4937

SEAL INTEGRITY OF SELECTED FUZES AS
MEASURED BY THREE LEAK TEST METHODS

A. T. DEVINE
R. P. MUTCHLER

SEPTEMBER 1976

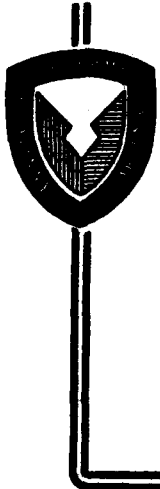

APPROVED FOR PUBLIC RELEASE; DISTRIBUTION UNLIMITED.

DDC
RECEIVED
NOV 16 1976
RECEIVED

PICATINNY ARSENAL
DOVER, NEW JERSEY

Handwritten initials

B

The findings in this report are not to be construed as an official Department of the Army position.

DISPOSITION

Destroy this report when no longer needed. Do not return to the originator.

UNCLASSIFIED

SECURITY CLASSIFICATION OF THIS PAGE (When Data Entered)

REPORT DOCUMENTATION PAGE		READ INSTRUCTIONS BEFORE COMPLETING FORM	
1. REPORT NUMBER Technical Report 4437	2. GOVT ACCESSION NO.	3. REPORTING ORGANIZATION'S CATALOG NUMBER MPA-TR-4137	
4. TITLE (and Subtitle) SEAL INTEGRITY OF SELECTED FUZES AS MEASURED BY THREE LEAK TEST METHODS		5. TYPE OF REPORT & PERIOD COVERED	
AUTHOR(s) A. T. Devine & R. P. Mutchler		6. PERFORMING ORG. REPORT NUMBER	
9. PERFORMING ORGANIZATION NAME AND ADDRESS Feltman Research Laboratory and Ammunition Development and Engineering Directorate Picatinny Arsenal, Dover, NJ 07801		8. CONTRACT OR GRANT NUMBER(s)	
11. CONTROLLING OFFICE NAME AND ADDRESS		10. PROGRAM ELEMENT, PROJECT, TASK AREA & WORK UNIT NUMBERS AMCMS No 4932.05 4204 1	
14. MONITORING AGENCY NAME & ADDRESS (if different from Controlling Office)		12. REPORT DATE Sep 1976	
		13. NUMBER OF PAGES 89	
		15. SECURITY CLASS Unclassified	
		15a. DECLASSIFICATION/DOWNGRADING SCHEDULE	
16. DISTRIBUTION STATEMENT (of this Report) Approved for public release, distribution unlimited.			
17. DISTRIBUTION STATEMENT (of the abstract entered in Block 20, if different from Report)			
18. SUPPLEMENTARY NOTES			
19. KEY WORDS (Continue on reverse side if necessary and identify by block number) Seal MIL STD 331, Test 108 Sealants Helium Mass Spectrometer Leak tests Fuzes			
20. ABSTRACT (Continue on reverse side if necessary and identify by block number) Ten different types of fuzes were leak tested. Two nondestructive methods were used: one employed commercial leak test equipment, while the other utilized internal pressurization of the fuze with the air-bubble indication. A third destructive type test, MIL STD 331, Test 108, required subsequent disassembly of the fuze and visual examination for evidence of moisture on the interior surfaces.			

282 900
by

UNCLASSIFIED

SECURITY CLASSIFICATION OF THIS PAGE(When Data Entered)

20. ABSTRACT (Continued)

The results of these tests indicate clearly those fuzes in which quality is poor and reveal where the problem lies. The results also show that the internal pressure-bubble indication test method is capable of detecting and locating leaks nondestructively

ACCESSION for	
NTIS	Write Section <input checked="" type="checkbox"/>
DDC	Best Section <input type="checkbox"/>
UNASSIGNED	<input type="checkbox"/>
JUSTIFICATION	
BY	
DISTRIBUTION/AVAILABILITY CODES	
Disc.	AVAIL. and/or SPECIAL
A	

UNCLASSIFIED

SECURITY CLASSIFICATION OF THIS PAGE(When Data Entered)

TABLE OF CONTENTS

	Page No.
Objective	1
Introduction	2
Discussion	2
Purpose and Impact of Program	2
Some Results of a Poorly Sealed Joint	4
Current Requirements	4
Analysis of Fuze Designs and Specified Leak Tests	5
Description of Leak Test Methods	8
MIL-STD-331, Test 108	8
Internal Pressurization- Bubble Indicator	8
Helium Mass Spectrometer	9
Production Lot Test Examples	9
Comparison of Leak Tests Employed by this Program	9
Level of Sealant (Seal) Effectiveness	13
Conclusions	14
Recommendations	15
References	16
Tables	
1 Examples of seals and sealants currently used in production	17
2 Summary of sealing practice (24 fuze types)	22
3 Current practice (24 fuze types)	23
4 Actual leak test results – M550	24
5 Actual leak test results – M219E1	26
6 Actual leak test results – M551	28
7 Actual leak test results – M423	31
8 Leak test results – M578	32
9 Leak test results –M577 (live)	34

10	Leak test results – M503 A2	35
11	Actual leak test results – M440	36
12	Leak test results – XM431	37
13	Actual leak test results – WDU 4A/A	39

Figures

1	Comparison of leak test methods	42
2	M423	43
3	M577	43
4	M578	44
5	M440	44
6	M431	45
7	M503A2	45
8	M219E1	46
9	M219E1	46
10	M550	47
11	Fuze, WDU-4A/A Whd	48
12	Fuze, M423, M427	49
13	Fuze, M577	50
14	Fuze, M578	51
15	Fuze, M440	52
16	Fuze, M431	53
17	Fuze, PD, M503A2	54
18	Fuze, PD, M551	55
19	Fuze, Grenade, M219E1	56
20	Fuze, PIBD, M550	57

Appendixes

A	Seal leakage test of WDU-4A/A	59
B	Seal leakage test of M423 M/P	63
C	Leak test of M577, Fuze, MT, Q	67

D	Seal leakage test of M578 fuze	71
E	Leak test of WDU-4A/A flechette warhead	75
F	Seal leak test of M578	87
	Distribution List	91

OBJECTIVE

General: To characterize fuze joints currently in production by means of seal quality and economics and to seek alternative sealants and application techniques which will yield higher integrity seals with reduced manufacturing difficulties and costs.

Specific. To examine current fuze joint designs, to evaluate the integrity of seal on selected fuzes by means of several leak-test methods, and to determine which of these methods is most sensitive and best suited for production.

INTRODUCTION

The Fuze Engineering Branch, Fuze Development and Engineering Division, of the Ammunition Development and Engineering Directorate of Picatinny Arsenal, was directed to develop techniques and equipment for producing better seals for fuzes under high production rates. This development work was carried out as part of an MTT program, project number 5754204. The Fuze Engineering Division requested the assistance of the Adhesives and Coatings Branch, Materials Engineering Division, Feltman Research Laboratory, in accomplishing this task.

The portion of the program with which this report deals was initiated for the purpose of assessing the utility of leak tests currently employed, to evaluate the integrity of specific types of fuze seals and to compare the reliability of three selected leak tests on the same fuzes to establish a reference base.

A summary outline, Table 1, of 24 fuze types was submitted to the Adhesives and Coatings Branch. This outline listed the fuze type, seal area, sealant, if any, method of leak testing employed, and some production-acceptance leak-test results. A review of this outline revealed that: (1) A program was needed to determine the basis for the acceptance or rejection of a joint based on the tests outlined because it raised the question of the multiplicity of leak tests that have been established using either external or internal pressures, water immersion, vacuum, and varying times of immersion. (2) Leak-test methods should be reduced to a few standard tests. (3) The choices of sealants seemed to have been restricted unnecessarily in view of the fact that there are now available a wide variety of polymeric types with sealant properties that are superior to those currently in use (Ref 1,2).

Based on these observations, a program was drafted to answer some of the questions. This report details the program and discusses the results obtained.

DISCUSSION

Purpose and Impact of Program

An important fuze requirement is long storage life, which can best be assured by assembly of the fuze with leak-proof seals at the various joints, thereby assuring a fuze free of the detrimental effects of moisture or other contaminants. This project is directed toward meeting this requirement as well as meeting prescribed procurement objectives brought about by automated fuze production rates.

The capability to produce better fuze-joint seals under high production rates is essential to the attainment of significant procurement advances and cost reduction. Procurement of quality items with improved shelf-life will be effected by this program. Engineering studies have shown that dud rates are directly proportional to storage time, and are attributed to deterioration of components due to improper seals which allow penetration of moisture into the fuze (Ref 3). When subjected to moisture metal components tend to oxidize causing (a) functional members to seize, thus preventing proper movement, and (b) structural weakness and breakage of components. Likewise, when subjected to moisture the explosive elements of a fuze may be degraded chemically resulting in smothering or non-functioning of the fuze. Thus, large savings would be attainable by significantly reducing the necessity to rework fuze items because of leakage resulting from long storage times. This would be possible if component integrity and functioning reliability could be consistently sealed into the items.

US Army munitions designers at present cannot pay proper attention to the sealing of various joints on munitions and other hardware due to lack of adequate sealant data. They must design to meet immediate performance requirements without giving necessary consideration as to how the item will retain its integrity upon subjection to a variety of storage and service environments.

The leak-proof requirements of Army ordnance may vary depending on intended use. It is, of course, most desirable to design all ordnance to be fully leak-proof; yet, satisfying such a requirement would be unjustifiably costly and compromise other desirable design features. However, in some instances, complete protection from hostile environments is a must to retain serviceability. Here, leak protection must not be compromised.

Water gains entrance to the interior of a joint in a number of ways. The first, and probably the most common, is water leakage under pressure through discontinuities, or flaws, in a joint. These flaws can appear as a poorly adhered sealant to a joint interface or a seam which allows water to pass between sealant and the joint surface intended for it have bonded to. There could be leak paths left by poor or shoddy sealant application techniques or by a highly porous sealant caused, very often, by void formation after solvent evaporation.

A second type of leak is that resulting from diffusion of water vapor through tiny flaws in the joint sealant which results in the joint actually "breathing". This occurs when variations in temperature and pressure cause air to be inhaled into the joint interior and then exhaled. If diurnal temperature variations are great enough, this situation can result in internal condensation of moisture.

A third type which occurs in the absence of the other two is permeation of water vapor and other gases through the sealant itself. Polysulfide sealants, for example, have been found to be much less permeable to water vapor than room temperature vulcanizable (RTV) silicones (Ref 4 to 6).

In all three types of leaks, flaws are present. They vary depending on whether the flaws are macroscopic, microscopic or molecular in size. All, however, are amenable to varying degrees of control by proper design and careful sealant selection. Selection of the correct sealant is dependent upon joint configuration and the service conditions likely to be encountered.

Some Results of a Poorly Sealed Joint

The impact of the environment on a poorly sealed joint manifests itself in a number of ways. The ingress of moisture to internal joint surfaces of ordnance can cause such reactions as sensitization or desensitization of explosives or propellants, failure of electrical circuits or fuze mechanisms. Bacterial or fungus growth may result which can rot fabrics and attack certain plastic materials.

Of course, other fluids, corrosive fumes, fuels, solvents and the like may also require exclusion from joint interiors, but water is generally the most damaging contaminant. Designers of Army ordnance must carefully consider how water can best be excluded from the items being designed.

Current Requirements

Table 1 outlines the types of seal employed on each of 24 different fuze types currently in production as well as the verification tests used and leak-test results, if any. This same information is summarized in Table 2 according to the number of fuze types using each type of seal and the test used to verify seal integrity.

Careful consideration of Tables 1 and 2 led to selection of 10 representative fuze designs to be incorporated into a comprehensive leak test and seal evaluation program (Fig 1). These fuze selections are indicated in Table 1 by an asterisk and are shown in Figures 2 to 10. Schematic depictions of the joint area are given in Figures 11 to 20.

It is interesting to note that in half of the fuze designs studied there was no test requirement specified to assure a seal had been effected. Where leak tests were employed, there was such diversity of methods that direct comparisons between fuze seals could not be made. For only three of the tested fuze types listed in Table 1 was a

Military Standard Waterproofness Test, MIL-STD-331, Test 108 specified; whereas, for the remainder different leak test methods were used. The various test criteria are presented in Table 1 and summarized in Table 3. Specific joint integrity verification test results for various fuzes are presented in Appendixes A to F.

Analysis of Fuze Designs and Specified Leak Tests

The following discussion requires reference to Table 1. It is evident that in many instances a sealing operation is to be carried out without any test specified to determine the seal quality. In those instances where the seal is subjected to testing, the test is often so ineffective as to provide almost no confidence in the ability of the joint to exclude moisture. The subject fuzes are evaluated in order of listing as follows:

M539

This fuze employs a threaded joint with Thiokol's LP-2 polysulfide used in the booster cavity seal. It is obvious that the exclusion of moisture from the booster was intended, and yet there is no verification testing. It is not known whether or not moisture has been excluded, nor under what conditions.

XM438

This fuze uses no sealant but a crimp over a flat, rubber ring. Again, no leak test is used to verify the leak resistance of the joint.

WDU4A/A

The design of this fuze depends upon ultrasonic welding to seal lid to case. The specified leak test merely requires the fuze to be submerged for two minutes and "observe for escaping air bubbles". No depth of immersion is specified; hence the pressure is unknown. Also the 2 minute duration does not seem adequate.

M423 and M427

Employs metal crimped over a square cut ring, slide fit over an O-ring, and RTV734 sealant as seals. Leak tests range from measured pressure drops of 2-5 Pa (.0003 to .00072 psi) at an applied 34.5 k Pa (5 psi) pressure. Unable to comment on the adequacy of the test.

M91A2

Thiokol LP-2 polysulfide sealant is used to seal the thread in two places. No verification testing specified on the joint.

M577

Plug-to-Body and Body-to-Ogive joints use RTV 732 to seal the threads. Verification test specifies MIL-STD-331, Test 108. This test is probably one of the better leakage tests from an effectiveness standpoint. However, from lot quantities of 690 and 480, reject rates of 20% were obtained.

M578

Thiokol's LP-2 polysulfide is used to seal threads in two locations. Testing requires that the fuze show no evidence of moisture on interior surfaces after 4 hours immersion in 15.24 cm (6 inches) of water. This test does not seem adequate in that 6 inches of water corresponds to only 1.48 kPa (0.215 psig). Also, if assembly is made under warm humid conditions 4 hours immersion may cool the fuze sufficiently to cause condensation of the moisture laden internal atmosphere depending on temperature of immersing water.

M440

Employs thread with O-ring on booster end and slide fit over O-ring on nose end. Pressure drop of 4.97 Pa (.00072 psi) in 10 sec allowed at a pressure of 34.47 kPa (5.0 psi). This requirement is considered to be an adequate test of joint integrity.

M431

A crimp of body over booster cap and seal ring is used. MIL-STD 331, Test 108 is used to verify joint integrity.

M503A2

Uses Thiokol's LP-2 to seal booster to body threaded joint. No verification testing is done on this joint although some kind of seal has obviously been intended. A 360° crimp over a closing disc is used to seal the nose to body joint in conjunction with a phenol formaldehyde varnish. A 103.4 kPa (15 psi) pressure is to be maintained for one minute allowing no more than .689 kPa (0.10 psi) pressure drop.

M557, M572, M65A1, M84

These fuzes employ threaded joints with no sealant or O-ring and undergo no verification testing for leak resistance. It is assumed that leak resistance is not a requirement in these items.

M524A6 and M525

RTV 734 or RTV 112 is used to seal threaded joints. No verification testing is specified although a seal was apparently intended.

M509A1

This fuze utilizes a slide fit and stake of booster cover to shield and shield to rotor housing. Since no sealant or leak test is called for, a good seal is apparently not a requirement on this item.

M431

A 360° crimp of the fuze body over the booster cap using a seal ring is called for. MIL-STD 331, Test 108 is required.

M551

On this fuze the fuze cover is crimped to housing over a closing disc seal. The leakage test specifies that the fuze is immersed in 7.62 cm (3 inches) of water in a closed glass container capable of being evacuated and a 39.47 kPa (5 psi) vacuum is applied for 15 seconds. A continuous stream of bubbles is considered to indicate a leak. This test is good although pressure and duration could be increased to make test more reliable. It is an internal pressure-bubble indication test.

M533

A 360° crimp around a molded polyethylene disc is employed to seal this fuze. The same leak test and comments apply here as for the M551.

M412E1

The booster is retained by a 360° crimped sealing disc. Since fuze is sealed into the round, no leak test is required on the fuze.

M219E1

A sealant bead is applied externally after crimping. Leakage test specifies that the fuze is to be immersed in 7.62 to 20.32 cm (3 to 8 inches) of water in a closed, glass vessel capable of being evacuated and held at a vacuum of 27.9 ± 3.8 cm (11 ± 1.5 inches) of mercury for one minute. A visible stream of bubbles indicates a leak. This is another internal pressure-bubble indication test and is quite discriminating.

M550

This fuze employs a 360° crimp over an O-ring. The joint must withstand an air pressure of 20.7 kPa (3 psi) for five seconds without leakage. The pressure and duration of this test are not considered to be very discriminating of leakage.

DESCRIPTION OF LEAK TEST METHODS

All methods of leak detection involve the passage of water or of a "tracer" fluid from one side of a presumed leak to the other, and the subsequent detection of the fluid on the latter side. Leaks may be detected by the submersion of the sample to a specified depth in water and observation of the escaping air bubbles. By pressurizing the interior atmosphere of the sample, the effect of this test becomes more discernible. Another waterproofness test involves the submersion of the test sample at a specified pressure head and time phase with subsequent visual inspection of the test sample interior for evidence of moisture. The approved military waterproofness test, MIL STD-331, Test 108, utilizes this procedure.

MIL-STD-331, Test 108

This method entails immersing the subject test specimen in a tank of water to which a fluorescein dye has been added. The tank is then pressurized to 103.42 kPa (15 psig) for a period of one hour after which the specimens are removed, opened, and examined under ultraviolet light for evidence of dye penetration which would indicate leakage.

Internal Pressurization-Bubble Indicator

The larger fuzes tested in this manner were first drilled and tapped to accommodate insertion of a pipe plug. In this version the method is semi-destructive. The fuzes were then immersed in water, pressurized to 103.4 kPa (15 psig) with air and the joint seams observed 30 seconds for escaping air bubbles. On smaller fuzes, such as the M219,

the fuze was immersed in a vessel of water and placed in a vacuum desiccator which was evacuated to 760 mm (30 inches) of water. As before, joints were observed for escaping air bubbles as evidence of leakage. This version of the test is non-destructive.

Helium Mass Spectrometer

Fuzes tested with this equipment were first evacuated for 2 hours and then back-filled with helium for an additional 2 hours. The fuzes, presumably containing helium if a leak path existed, were then placed in a vacuum chamber linked to the mass spectrometer and evacuated again. A sensing element in the mass spectrometer detects the helium gas and converts it to an electrical signal proportional to the leak rate. Frequent adjustments and standardization checks are required to keep this type inspection equipment in reliable condition. The use of the mass spectrometer for large volume production testing is therefore quite limited and is better suited for acceptance testing on limited quantities.

Production Lot Test Examples

Prior to the investigation, the production lot reports of the specified leakage tests for several fuze types were received for analysis. Each production lot report examined indicated an acceptable level of seal as rated against the specific test requirement shown on Table 3. A summary of the test specification and results of production lot acceptance tests are shown on Table 1. This information is given in more detailed form in Appendixes A through F.

The data indicate a wide deviation of level of inspection among the several types. While all these fuze types passed their respective test requirements, there is no evidence they would be acceptable under more stringent test criteria. The series of tests conducted on the several fuze types evaluated in this program display these variations of seal quality when tested by uniform test methods.

Comparison of Leak Tests Employed by this Program

Leak-test results (Tables 4 to 13) indicate that difficulties of interpretation are encountered when the helium-leak mass spectrometer is used. The instrument is so sensitive that leaks are indicated in all cases and the range of the rate of leakage indicated is such that the mass spectrometer could not be used to quantify the leaks detected by the other leak test methods. For example, in tests on the M423 (Table 7), the M440 (Table 11), and particularly the M503A2 (Table 10) leaks were detected both by the internal pressurization test and MIL-STD-331, Test 108 that appeared to be large enough to have caused "off-scale" readings on the mass spectrometer but did not.

In each instance leaks found to be minuscule when using the mass spectrometer turned out to be severe by one or both of the other leak test criteria. In short, the mass spectrometer results were too sensitive and inconsistent for a meaningful comparison to be made between the other methods or to quantify the other procedures.

The internal pressure-bubble indication test appears to be more discriminating than MIL-STD-331, Test 108 in that it detected leaks not found by MIL-STD-331, Test 108. For example, in testing the machined aluminum M503A-2 fuze (Table 10, numbers 1-16) two fuzes in thirteen were found with leaks that exceeded the meter limit of the mass spectrometer. The other eleven had such extremely small leak rates measured by the mass spectrometer that they should not have been detected on the other "less sensitive" tests. However, the internal pressure-bubble indication test revealed nine leakers in the same lot of thirteen and the MIL-STD-331, Test 108 uncovered four leaks in thirteen.

In a test on another set of M503A-2 fuzes using cast aluminum fuze bodies (Table 10, numbers 11-26), the helium mass spectrometer indicated leaks exceeding the meter limit on ten of eleven fuzes. Similarly MIL-STD-331, Test 108 found leaks on ten of eleven fuzes. One fuze found to leak on the mass spectrometer was not found to leak in MIL-STD-331, Test 108. Another, M503A-2 fuze, found to have a very low leak rate, showed up as a slight trace leak in MIL-STD-331, Test 108. By contrast the same eleven fuzes were all found to leak when tested by the internal pressure-bubble indicator technique.

In order of suitability, therefore, the internal pressurization-bubble indication appears most suitable for our application, followed by MIL-STD-331, Test 108, and lastly, helium-leak mass spectrometry. The mass spectrometer was found to have other drawbacks. The equipment used in this study was found to break down frequently and require constant adjustment and calibration checks. This type of equipment is definitely not recommended for production testing and should be used only to quantify leak rates in terms of cc/sec on small quantities.

MIL-STD-331, Test 108 was found to be reasonably sensitive but has the drawback of requiring disassembly of the item for visual examination. It is a destructive test, and is therefore limited to testing small sample quantities and could not be used on a 100% quality control test basis.

The internal pressure-bubble indication test has several features not available on the mass spectrometer or MIL-STD-331, Test 108. First, on both the other tests it is very difficult to determine where an item is leaking. If an item has two or more locations at which it may leak it is vital to know the leak location so that steps may be taken to

remedy the leak. The internal pressure-bubble indication test offers this as a built-in feature. The internal pressure-bubble indication test allows for versatile use of very simple equipment and for testing 100% of the production items. For example, instead of drilling and tapping the fuzes to receive pipe plugs as was done for this study, the same effect could be achieved by placing the fuze in a vacuum jar under water and pulling a vacuum. This procedure would work for test pressures up to about one atmosphere (103.4 kPa), a pressure more severe than any likely to be encountered in the normal life of a fuze; certainly more severe than any of the leak tests employed on the 24 fuzes considered in this study. Also, the leak-test fluid employed in the internal pressure-bubble indication test is ordinary air, a decided cost and convenience advantage over the helium used in the mass spectrometer. Additionally, the pumping time required to reach the vapor pressure of water at room temperature and the 30 seconds observation time offer considerable savings over the mass spectrometer. Air is also a better test medium than the water used in MIL-STD-331, Test 108. Air is a lower viscosity fluid whose molecules are not as tightly bonded as water and therefore is a more difficult material to provide a seal against. The test items may be either immersed in water or a tracer fluid such as aerosol OT, or any soapy solution may be applied to the area of interest and observations made for sudsing as evidence of a leak.

An inertial material such as a heavy viscosity oil should be evaluated as a possible substitute for water where repair of leakers is to be made. This eliminates the problem of water being sucked back into the fuze after the vacuum has been released which would make repair pointless. The high viscosity oil is unlikely to be drawn into the fuze due to the inability of the poor flowing oil to penetrate the joint flaw before the pressure in the test vessel has returned to ambient atmospheric pressure.

A still cleaner and more sophisticated means of detecting a leak may be to "listen" for it with special acoustical equipment. In this way the test medium (air) remains the same, only the means of detection (sound vs bubble indication) changes.

Vacuum chambers which permit the testing and observation of multiple items can be constructed to suit production needs. Those items found to leak can be recycled, reworked and retested before going into service.

M423

In testing the M423 fuze (Table 7), one leak was found in 20 tested. The internal pressure-bubble indication test found the same fuze to leak. MIL-STD-331, Test 108 did not detect leaks on any of these fuzes.

M440

Tests on the M440 fuze (Table 11) revealed no gross leaks present. This was confirmed by the internal pressure-bubble indication test. MIL-STD-331, Test 108 while confirming the no leak status of the rear O-ring seal did reveal some leakage around the forward O-ring seal on two of the 16 fuzes tested.

M578

No gross leaks were found by any of the test methods (Table 8).

M219E-1

Leak tests on this fuze (Table 5) revealed that, of 30 fuzes tested, 13 had gross leaks on the mass spectrometer. When tested by the internal pressure-bubble indication method, 20 fuzes were found to leak – the same 13 found by the mass spectrometer plus an additional seven others. MIL-STD-331, Test 108 detected 19 leaks – 10 of the 13 found by the mass spectrometer and 9 others. Two of these other 9 leaks were leaks not detected by the internal pressure-bubble indication test.

M551

No gross leaks were found by any of the three test methods employed on the 50 fuzes tested (Table 6).

XM431

Gross leaks were found in 8 (Table 12) out of 37 fuzes tested with the mass spectrometer. No leaks were detected by the internal pressure-bubble indication method. Eight leaks were found with the MIL-STD 331, Test 108 in the fore section of the fuze and none aft after disassembly. This fuze was somewhat unique in that O-rings and crimps effectively seal various fuze sections from each other. For this reason the air pressure applied to the center of the fuze never reached the fore section and consequently did not uncover any of the eight leaks in the fore section.

M577

Twelve gross leaks were found by means of the mass spectrometer (Table 9) but none were reported when tested by means of MIL-STD 331, Test 108 on 50 fuzes tested. The internal pressure-bubble indication test was omitted on these fuzes because

they contained live detonators, and energetic materials were not permitted in the area where the test facilities were available. This is the only instance in which the helium-leak mass spectrometer test unambiguously revealed leaks where none were detected by MIL-STD 331, Test 108. This could be the result of a seal which is more sensitive to leaks caused by pressure from an external rather than internal source, perhaps acting like a ball-check valve.

M550

The mass spectrometer (Table 4) results indicated gross leaks ($>1 \times 10^{-4}$ cc/sec) on 15 of these fuzes although there is reason to believe that these "leaks" may have been the result of helium detection from places other than the fuze interior. The fuzes supplied for this test came with a hole in the rear which was plugged with RTV-732 for test purposes. It is suspected, based on the other leak test method results, that in back filling these fuzes with helium, the helium may have been absorbed by the RTV sealant as well as detained in the crevice of the joint seam. When the fuze was placed in the vacuum chamber of the helium mass spectrometer the helium being detected could have been the helium absorbed by the RTV sealant as well as that sequestered in the joint seam crevice.

That this could be the case is supported by the fact that when the fuzes were immersed in water for the internal pressure-bubble test and the vacuum was first applied, small bubbles would appear, in many cases at the joint crevices and around the RTV sealant, but would soon cease, indicating that the source of the bubbles was external to the fuze and had been exhausted. In cases where there was a true leak (when the fuze interior was the bubble source), the bubbles would continue to emanate from the source of the leak.

When the same M550 fuzes were tested according to MIL STD 331, Test 108, the only two fuzes found to leak by this method were those determined to have large leaks as indicated with the internal pressure-bubble test. Those leaks reported as moderate, slight or very slight on the internal pressure-bubble test were not detected by MIL STD 331, Test 108.

LEVEL OF SEALANT (SEAL) EFFECTIVENESS

Based on the test results gathered in this program (Tables 4 through 13), it is evident that some fuzes are more leak resistant than are others. Undoubtedly the M503A-2 is the worst fuze from the seal standpoint. The M503A-2 fuze body is made from a cast aluminum alloy. The casting process leaves voids which, after machining the threads, present continuous paths through which leaks occur. No matter how well the threaded

joint is sealed with polysulfide, or any other sealant, the fuze body will leak. The same is true of the nose crimp over the sealing disc followed by an application of varnish. Even if no leaks occur at this point, the fuze still leaks. From a practical standpoint a tremendous cost savings could be gained by not sealing any of the joints on the M503A-2 since the fuze has this unremedied material defect which allows it to leak anyway.

The M219E-1 fuze was also found to leak excessively with approximately 2 of 3 fuzes leaking as detected by the internal pressure-bubble indication technique. It is evident that this fuze needs to be reviewed with regards to one or more of the following: (1) sealant used; (2) workmanship; and (3) design.

By contrast, the M423, M440, M578, XM431 and M551 appear well sealed as evidenced by the results of all three leak tests. Although 8 leaks were detected on the fore section of the XM431, out of 37 tested none of the moisture was found aft. This was the result of a compartmentalized situation designed into the fuze by using several crimps over flat rubber rings which essentially divided the fuze into 3 sections. This was the reason that the internal pressure-bubble indication test did not reveal the fore section leak, i.e., the pressure did not leak forward past the crimp from one section of the fuze into another. When the same test was used with pressure differential applied by vacuum over the entire fuze, the same 8 leaks were detected.

CONCLUSIONS

1. In most instances the internal pressure-bubble indication test proved to be very discriminating in the detection of leaks in the fuze items tested. Next was the MIL STD 331, Test 108 Waterproofness Test and finally, the helium-leak mass spectrometer.
2. The internal pressure-bubble indication leak test method has the advantage of being a nondestructive test capable of use on 100% of the production items and is capable of pinpointing the location of the leak.
3. MIL STD 331, Test 108, while being a good leak test, is destructive in nature and limited to verification testing or on a sample basis only.
4. The helium mass spectrometer has the capability of detecting leaks of extremely low level, and of providing a quantitative leak value. However, there are also a number of short-comings in the helium detection system:

First and foremost the helium-leak mass spectrometer is not readily adaptable to production-line use. It is designed as a research instrument and was found to have far greater sensitivity than was desirable or required for this application. It is applicable

to only one object at a time. It is necessary to make and test the connection to each test object and to differentiate between leaks in the connecting system and in the test object. It is difficult to precisely pin-point leaks especially on small items. It requires a skilled operator to maintain, calibrate, and interpret results.

5. Of fuzes tested the M503A2 is undoubtedly the worst from a leakage standpoint due to an inherent porosity in the fuze resulting from the use of a cast aluminum for the fuze body. The phenol-formaldehyde varnish-sealed crimp at the nose of the fuze also leaks severely in many cases.

6. The M219E1 is also a poorly sealed fuze as evidenced by the high percentage of leakers found by all leak test methods.

7. Most, but not all, of the fuze joint designs make some provisions for the addition of a sealing material to the joints but in instances where a sealant is employed the types used seem to have been restricted unnecessarily to room temperature-vulcanizing silicone rubbers, polysulfide rubbers and phenol-formaldehyde varnishes.

RECOMMENDATIONS

1. It is recommended that an internal pressure-bubble indication type test be employed to test all fuzes which require a positive seal. The sensitivity, ability to locate the source of the leak, and nondestructive nature of this test permit its use on 100% of the production items.

2. MIL STD 331, Test 108 is a good leak test method and has utility for testing on a sample basis.

3. The helium-leak mass spectrometer, as most generally used, is not considered as good a test as either the internal pressure-bubble indication test or MIL STD 331, Test 108 based on our test results and is therefore not recommended as a leak test for Army munitions. The helium-mass spectrometer was chosen for evaluation because it has been reported to be a sensitive test instrument against which other leak test methods could be evaluated.

4. Evaluate alternative sealant candidates in standard joint configurations using environments hostile to the maintenance of a good seal (e.g., temperature-humidity cycling and low-temperature impact).

5. Automated application methods for production-line use should be developed and their feasibility demonstrated using improved sealants.

6. Automated inspection techniques should be developed for production-line testing of sealed fuze joints utilizing the promising internal pressure-bubble indication test.

REFERENCES

1. Damusis, Adolfas, *Sealants*, Rheinhold Publishing Company, Copyright 1967
2. Devine, A. T., *Sealants: A Comparative Evaluation of Performance in Two Typical Joint Configurations*, Adhesives Age, November 1974, reprinted from 5th National Technical Conference Proceedings of SAMPE, Kiamesha Lake, N.Y., 9-11 October 1973
3. Production Engineering Measures (PEM) Project No. 5754204, *MMT - Automatic Production Sealing Equipment for Fuzes*, 2 July 1973
4. Schramm, E. C. and Levi, D. W., *Transmission of Water Vapor Through Sealants: VI Commercial Polyurethanes*, Picatinny Arsenal Technical Memorandum 2081, May 1973
5. Schramm, E. C. and Levi, D. W., *Transmission of Water Vapor Through Sealants: Part I, Commercial RTV Silicones*, Picatinny Arsenal Technical Report 4209, September 1971
6. Schramm, E. C., et al, *Transmission of Water Vapor Through Sealants: Part II, Commercial Polysulfide*, Picatinny Arsenal Technical Report 4267, December 1971

Table 1
Examples of seals and sealants currently used in production

<u>Item</u>	<u>Fuze</u>	<u>Seal</u>	<u>Sealant</u>	<u>Verification testing</u>
1	M539	Thread w/sealant booster Terminal post press fit and stake Ground screw thread	Polymer LP-2 100/15 Dwg 9204265 (PTA) None None	None
2	XM438	Slide fit & crimp over rubber flat ring	None	None
3	WDU4/A	Ultrasonic weld lid to case	None	Submerge fuze for 2 minutes "Observe Joint for Escaping Air Bubbles" <u>Production Test Results</u> From Contract for 117,119 units Tested: 312 Rejects: None
4	M423	Crimp booster housing over closing disc Crimp body assy over square-cut ring 9254747 (sub-assy) Slide fit w/"O" ring body assy to booster (fuze assy)	Silastic RTV 734 Dwg 9254736 None None	None Apply 5.0 ± .25 psig pressure drop allowed: .0003 psi in 10 sec Apply 5.0 ± psig pressure drop allowed: .00072 psi <u>Production Test Results</u> From (5) contracts for 10,194,015 units Tested: 10,368 Rejects: 12

Table 1 (Continued)

<u>Item</u>	<u>Fuze</u>	<u>Seal</u>	<u>Sealant</u>	<u>Verification testing</u>
5	M91A2	Thread w/sealant (2 places)	Polymer LP-2 90/10	None
6	M577	Thread w/sealant plug to body & body to ogive	Silastic RTV 731	MIL-STD-331, Test 108 - Submerge fuze at 15 psi for 60 min. Shall be no evidence of leakage. Fuze must function.
		Slide fit - Detonator to body nose to ogive w/"O" ring		
		Window to ogive slide fit w/adhesive	Adhesive Resin Epoxide 100/50 Dwg 9236514	To hold an air evacuated state for one minute with no pressure change
				<u>Test Results</u>
				From initial limited production
				<u>Lot Size</u> <u>Tested</u> <u>Rejects</u>
				690 5 1
				480 5 1
7	M509A1	Terminal post press fit & stake	None	None
		Slide fit & stake booster cover to shield & shield to rotor housing	None	None
8	M578	Thread w/sealant (2 places)	Polymer LP-2 90/10	Submerge fuze in water at depth of 6 inches for 4 hours. Shall show no evidence of moisture on the interior surfaces.
				<u>Production Test Results</u>
				From LSAAAP Contracts for 175,240 units
				Tested: 610
				Rejects: 1

Table 1 (Continued)

Item	Fuze	Seal	Sealant	Verification testing
9	M440	Thread w/"O" ring MS28775 (Booster end) Slide fit over "O" ring packing Dwg 926056	None Grease Dwg 9215603	Apply 5.0 + .25 psig Pressure drop allowed: .00072 psi in 10 sec MIL-STD-105 Insp Level II with AQL .40%
<p><u>Production Test Results</u> Contract DAAA09-72-C-0335, Quantity 114,000, no lot failure for leakage records not available</p>				
10	M423E1	Crimp 360° body over booster cap & seal ring	None	MIL-STD-331, Test 108 - Submerge fuze at 15 psi for 60 min. Shall be no evidence of leakage. Fuze must function.
<p><u>Production Test Results</u> From (3) Productivity Study Lots Tested: 36 Rejects: 0</p>				
11	M503A2	Thread w/sealant booster to body Slide fit & 360° crimp closing disc (nose) to body	Polymer LP-2 100/10 Phenol formaldehyde varnish Grade A or B Type IV, Spec MIL-V-13750	None Air pressure on nose crimped joint 15 psi for 1 minute pressure drop allowed 0.10 psi
12	M557	Thread booster assy to body	None	None
13	M572	Thread booster assy to body	None	None
14	M524A6	Thread w/sealant	Dwg 922086 2 Silastic RTV 734 or RTV 112	None

Table 1 (Continued)

Item	Fuze	Seal	Sealant	Verification testing
15	M65A1	Thread	None	None
16	M84	Thread	None	None
17	M525	Thread w/sealant booster to body	Dwg 9220862 Silastic RTV 734 or RTV 112	None
18	M572E2	Thread w/sealant	RTV Type II MIL-A-46146	MIL-STD-331, Test 108 - Submerge fuze at 15 psi for 60 min. Shall be no evidence of leakage. Fuze must function.
		"O" ring MS28775-013	Silicone Grease MIL-G-4343	
		Slide fit w/sealant	RTV Type II MIL-A-46146	
19	XM131 SAM-D			Leakage rate shall not exceed 1×10^{-5} standard cubic centimeters per second. <u>Production Test Results</u> No unit assembled-therefore, no leakage test performed.
20	M551	Crimp cover to housing over closing disc seal (rubber) Dwg 883 7967	None	Cover to withstand torque of 80 in lbs, then fuze immersed in water 3" deep at vacuum pressure 5 psi for 15 sec. "A continuous stream of bubbles shall not emerge from fuze." (4) Failures of 75 samples shall fail the lot. <u>Production Test Results</u> No lot failure for leakage. Records not available.

Table 1 (Continued)

Item	Fuze	Seal	Sealant	Verification testing						
21	M533	Crimp all around plastic molded disc (polyethylene Type 1 FED spec LP-394)	None	Fuze immersed in water 3" deep of vacuum pressure 5 psi for 15 sec. "A continuous stream of bubbles shall not emerge from fuze." (4) Failures of 80 samples shall fail the lot. <u>Production Test Results</u> No lot failure for leakage. Records not available.						
22	M412E1	Booster retained by disc w/360° crimp fuze assy by 2 screws	None	None (Protected by seal of round)						
23	M219E1	Crimp all around then apply sealant bead (automatic dispenser)	Compound spec MIL-C-450 Comp G Type II	Fuze immersed in water 3"-8" deep at 11 + 1.5 in. of mercury pressure for 1 min. "Fuze shall not emit a continuous stream of air bubbles." Sample: 50 units 5 fails the lot 3 or 4 failures requires retest. <u>Production Test Results</u> No lot failure for leakage. Records not available.						
24	M550	Crimp all around over "O" ring	None	Crimped joint must withstand without leakage an air pressure of 3 psi min. for 5 sec. Sample: 125-5 fails the lot. <u>Production Test Results</u> <table border="1"> <thead> <tr> <th>Contracts</th> <th>Quantity</th> </tr> </thead> <tbody> <tr> <td>DAAA-72-0852</td> <td>1,200,000</td> </tr> <tr> <td>DAA-73-0152</td> <td>6,200,000</td> </tr> </tbody> </table> No lot failure for leaks. Records not available.	Contracts	Quantity	DAAA-72-0852	1,200,000	DAA-73-0152	6,200,000
Contracts	Quantity									
DAAA-72-0852	1,200,000									
DAA-73-0152	6,200,000									

Table 2
Summary of sealing practice (24 fuze types)

Quantity Fuze types	Type of fuze joint	Verification specification
6	Threaded with no sealant	None
3	Threaded with sealant applied	None
1	Threaded with sealant applied	Submerge and inspect
2	Threaded with sealant applied	MIL-STD-331, Test 108
1	"O" ring in recess	MIL-STD-331, Test 108
2	"O" ring in recess	Measure pressure drop
2	Crimp over rubber	Measure pressure drop
3	Crimp over rubber	Submerge and observe bubbles
2	Stake w/no sealant	None
1	Crimp over "O" ring in recess	None
1	Ultrasonic weld	Submerge and observe bubbles

Table 3
Current practice (24 fuze types)
Leakproof test criteria

<u>Verification for leakproofness</u>	<u>Fuze types</u>
1. Submerge fuze and observe for escaping air bubbles.	M578, M551, M533, M219E1 WDU4A/A
2. Apply pressure to fuze exterior. Pressure drop shall not exceed specified limit.	
a. Apply 5.0 ± .25 psig. Pressure drop allowed: .00072 psi in 10 sec.	M423, M427 M440
b. Leakage rate shall not exceed 1×10^{-5} standard cubic centimeters per second.	XM131 SAM-D
c. Crimped joint must withstand, without leakage, an air pressure of 3 psi min for 5 sec.	M550
d. Air pressure on nose crimped joint 15 psi for 1 minute pressure drop allowed 0.10 psi	M503A2
3. MIL-STD-331, Test 108 – Submerge fuze at 15 psi for 60 minutes. Shall be no evidence of leakage. Disassemble fuze and examine under ultraviolet light. Fuze must be safe and operate after test.	M577, M431 M572E2
4. Submerge fuze minimum 6" for 4 hours. Shall show no evidence of moisture on the interior surfaces after disassembly of fuzes.	M578
5. None	M539, XM438, M91A2, M509A1 M557, M572 M524A6, M65A1 M84, M525 M412E1

Table 4
Actual leak test results
M550

Fuze No.	Helium mass spectrometer leak rate cc/sec	Internal pressure, 103.42 kPa (15 psig)	MIL-STD 331 Test 108
1	>1 x 10 ⁻⁴ (exceeds meter limit)	No leak	No leak
2	>1 x 10 ⁻⁴ (exceeds meter limit)	No leak	No leak
3	>1 x 10 ⁻⁴ (exceeds meter limit)	No leak	No leak
4	>1 x 10 ⁻⁴ (exceeds meter limit)	No leak	No leak
5	>1 x 10 ⁻⁴ (exceeds meter limit)	No leak	No leak
6	>1 x 10 ⁻⁴ (exceeds meter limit)	No leak	No leak
7	>1 x 10 ⁻⁴ (exceeds meter limit)	No leak	No leak
8	>1 x 10 ⁻⁴ (exceeds meter limit)	No leak	No leak
9	>1 x 10 ⁻⁴ (exceeds meter limit)	No leak	No leak
10	>1 x 10 ⁻⁴ (exceeds meter limit)	No leak	No leak
11	>1 x 10 ⁻⁴ (exceeds meter limit)	No leak	No leak
12	>1 x 10 ⁻⁴ (exceeds meter limit)	No leak	No leak
13	>1 x 10 ⁻⁴ (exceeds meter limit)	No leak	No leak
14	>1 x 10 ⁻⁴ (exceeds meter limit)	No leak	No leak
15	>1 x 10 ⁻⁴ (exceeds meter limit)	No leak	No leak
16	Test discontinued	No leak	No leak
17	Test discontinued	No leak	No leak
18	Test discontinued	No leak	No leak
19	Test discontinued	No leak	No leak
20	Test discontinued	No leak	No leak
21	Test discontinued	No leak	No leak
22	No test	No leak	No leak
23	No test	No leak	No leak
24	No test	No leak	No leak
25	No test	No leak	No leak
26	No test	No leak	No leak
27	No test	No leak	No leak
28	No test	No leak	No leak
29	No test	Slight leak	No leak
30	No test	Slight leak	No leak
31	No test	Very slight leak	No leak
32	No test	Slight leak	No leak
33	No test	Slight leak	No leak
34	No test	Slight leak	No leak

Table 4 (Continued)

<u>Fuze No.</u>	<u>Helium mass spectrometer leak rate cc/sec</u>	<u>Internal pressure 103.42 kPa (15 psig)</u>	<u>MIL-STD-331 Test 108</u>
35	No test	Very slight leak	No leak
36	No test	Slight leak	No leak
37	No test	Slight leak	No leak
38	No test	Slight leak	No leak
39	No test	Slight leak	No leak
40	No test	Slight leak	No leak
41	No test	Slight leak	No leak
42	No test	Slight leak	No leak
43	No test	Slight leak	No leak
44	No test	Large leak	Leak
45	No test	Large leak	Leak
46	No test	Moderate leak	No leak
47	No test	Moderate leak	No leak
48	No test	Moderate leak	No leak
49	No test	Moderate leak	No leak
50	No test	Moderate leak	No leak
51	No test	Moderate leak	No leak

Table 5

Actual leak test results

M219E-1

Fuze No.	Helium mass spectrometer leak rate α/sec	Internal pressure 103.42 kPa (15 psig)		MIL-STD/test 108 Crimp	Housing seal Foil
		Crimp	Foil		
1	2.8 x 10 ⁻⁷	Leak	No leak	Leak	No leak
2	> 1 x 10 ⁻⁴	Leak	No leak	Leak	No leak
3	1.8 x 10 ⁻⁷	No	No leak	No	No leak
4	1.6 x 10 ⁻⁷	No	No leak	No	No leak
5	> 1 x 10 ⁻⁴	Leak	No leak	Leak	No leak
6	> 1 x 10 ⁻⁴	Leak	No leak	Leak	No leak
7	> 1 x 10 ⁻⁴	Leak	No leak	No	No leak
8	> 1 x 10 ⁻⁴	Leak	No leak	No	No leak
9	1 x 10 ⁻⁷	No	No leak	No	No leak
10	4 x 10 ⁻⁷	No	No leak	Leak	No leak
11	1.2 x 10 ⁻⁶	Leak	No leak	Leak	No leak
12	> 1 x 10 ⁻⁴	Leak	No leak	Leak	No leak
13	2 x 10 ⁻⁶	Leak	No leak	Leak	No leak
14	3 x 10 ⁻⁸	No	No leak	No	No leak
15	> 1 x 10 ⁻⁴	Leak	No leak	Leak	No leak
16	> 1 x 10 ⁻⁴	Leak	No leak	Leak	No leak
17	> 1 x 10 ⁻⁴	Leak	No leak	Leak	No leak
18	7 x 10 ⁻⁸	Leak	No leak	Leak	No leak
19	> 1 x 10 ⁻⁴	Leak	No leak	Leak	No leak
20	> 1 x 10 ⁻⁴	Leak	No leak	Leak	No leak

Table 5 (Continued)

Fuze No.	Helium mass spectrometer leak rate		Internal pressure 103.42 kPa (15 psig)		MIL-STD/test 108		Housing seal	
	cc/sec		Crimp	Foil	Crimp	Foil	Foil	
21	> 1 x 10 ⁻⁴		Leak	No leak	Leak	No leak	No leak	No leak
22	1.4 x 10 ⁻⁶		Leak	No leak	Leak	No leak	No leak	No leak
23	4.0 x 10 ⁻⁸		No	No leak	Leak	No leak	No leak	No leak
24	7.0 x 10 ⁻⁸		No	No leak	No	No leak	No leak	No leak
25	> 1 x 10 ⁻⁴		Leak	No leak	No	No leak	No leak	No leak
26	5 x 10 ⁻⁸		No	No leak	No	No leak	No leak	No leak
27	3.4 x 10 ⁻⁵		Leak	No leak	Leak	No leak	No leak	No leak
28	3.8 x 10 ⁻⁸		No	No leak	No	No leak	No leak	No leak
29	2.5 x 10 ⁻⁸		No	No leak	No	No leak	No leak	No leak
30	2.0 x 10 ⁻⁸		Leak	No leak	Leak	No leak	No leak	No leak

Table 6
Actual leak test results
M551

Fuze No.	Helium mass spectrometer leak rate cc/sec	Internal pressure 103.42 kPa (15 psig)	MIL-STD 331/feet 109
1	3.9×10^{-6}	No leak	No leak
2	3.4×10^{-6}	No leak	No leak
3	1.4×10^{-6}	No leak	No leak
4	2.5×10^{-6}	No leak	No leak
5	2.4×10^{-7}	No leak	No leak
6	1.8×10^{-6}	No leak	No leak
7	2.0×10^{-6}	No leak	No leak
8	2.8×10^{-6}	No leak	No leak
9	1.4×10^{-6}	No leak	No leak
10	1.2×10^{-6}	No leak	No leak
11	1.2×10^{-6}	No leak	No leak
12	1.4×10^{-6}	No leak	No leak
13	7.0×10^{-7}	No leak	No leak
14	6.5×10^{-7}	No leak	No leak
15	3.5×10^{-6}	No leak	No leak
16	5.4×10^{-7}	No leak	No leak
17	3.0×10^{-6}	No leak	No leak
18	3.8×10^{-7}	No leak	No leak
19	2.4×10^{-7}	No leak	No leak
20	3.6×10^{-7}	No leak	No leak

Table 6 (Continued)

<u>Fuze No.</u>	<u>Helium mass spectrometer leak rate</u> cc/sec	<u>Internal pressure 103.42 kPa (15 psig)</u>	<u>MIL-STD 331/test 108</u>
21	2.0×10^{-7}	No leak	No leak
22	3.5×10^{-6}	No leak	No leak
23	1.6×10^{-6}	No leak	No leak
24	2.1×10^{-6}	No leak	No leak
25	1.8×10^{-6}	No leak	No leak
26	8.7×10^{-7}	No leak	No leak
27	7.5×10^{-7}	No leak	No leak
28	7.9×10^{-7}	No leak	No leak
29	1.8×10^{-6}	No leak	No leak
30	4.3×10^{-7}	No leak	No leak
31	1.4×10^{-7}	No leak	No leak
32	1.2×10^{-7}	No leak	No leak
33	1.2×10^{-6}	No leak	No leak
34	1.6×10^{-6}	No leak	No leak
35	1.4×10^{-6}	No leak	No leak
36	1.2×10^{-6}	No leak	No leak
37	2.0×10^{-6}	No leak	No leak
38	1.0×10^{-6}	No leak	No leak
39	1.0×10^{-6}	No leak	No leak
40	1.2×10^{-6}	No leak	No leak

Table 6 (Continued)

<u>Fuze No.</u>	<u>Helium mass spectrometer leak rate</u> cc/sec	<u>Internal pressure 103.42 kPa (15 psig)</u>	<u>MIL-STD 331/test 108</u>
41	1.1×10^{-6}	No leak	No leak
42	9.0×10^{-7}	No leak	No leak
43	1.6×10^{-6}	No leak	No leak
44	7.0×10^{-7}	No leak	No leak
45	1.0×10^{-6}	No leak	No leak
46	1.2×10^{-6}	No leak	No leak
47	6.0×10^{-7}	No leak	No leak
48	4.0×10^{-7}	No leak	No leak
49	1.0×10^{-6}	No leak	No leak
50	7.0×10^{-7}	No leak	No leak

Table 7
Actual leak test results
M423

Fuze No.	Helium mass spectrometer leak rate		Internal pressure, 103.42 kPa (15 psig)		MIL-STD 331/test 108 (15 psig)	
	cc/sec	Exceeds meter limit	Thread	Crimp	Thread	Crimp
1	> 1 x 10 ⁻⁴	Leak	No leak	No leak	No leak	No leak
2	7.0 x 10 ⁻⁶	No leak	No leak	No leak	No leak	No leak
3	3.5 x 10 ⁻⁶	No leak	No leak	No leak	No leak	No leak
4	5.0 x 10 ⁻⁶	No leak	No leak	No leak	No leak	No leak
5	2.0 x 10 ⁻⁶	No leak	No leak	No leak	No leak	No leak
6	1.4 x 10 ⁻⁶	No leak	No leak	No leak	No leak	No leak
7	3.2 x 10 ⁻⁶	No leak	No leak	No leak	No leak	No leak
8	1.9 x 10 ⁻⁶	No leak	No leak	No leak	No leak	No leak
9	1.3 x 10 ⁻⁶	No leak	No leak	No leak	No leak	No leak
10	1.1 x 10 ⁻⁶	No leak	No leak	No leak	No leak	No leak
11	1.2 x 10 ⁻⁶	No leak	No leak	No leak	No leak	No leak
12	7.5 x 10 ⁻⁷	No leak	No leak	No leak	No leak	No leak
13	8.2 x 10 ⁻⁷	No leak	No leak	No leak	No leak	No leak
14	6.2 x 10 ⁻⁷	No leak	No leak	No leak	No leak	No leak
15	6.2 x 10 ⁻⁷	No leak	No leak	No leak	No leak	No leak
16	8.0 x 10 ⁻⁷	No leak	No leak	No leak	No leak	No leak
17	7.7 x 10 ⁻⁷	No leak	No leak	No leak	No leak	No leak
18	4.4 x 10 ⁻⁷	No leak	No leak	No leak	No leak	No leak
19	8.0 x 10 ⁻⁷	No leak	No leak	No leak	No leak	No leak
20	5.6 x 10 ⁻⁷	No leak	No leak	No leak	No leak	No leak

Table 8
Leak test results
M578

Fuze No.	Helium mass spectrometer leak rate cc/sec	Internal pressure 103.42 kPa (15 psig)	MIL-STD 331/test 108
19	2.1×10^{-7}	No leak	No leak
13	8.8×10^{-8}	No leak	No leak
16	1.3×10^{-7}	No leak	No leak
18	2.1×10^{-7}	No leak	No leak
11	4.0×10^{-7}	No leak	No leak
20	2.1×10^{-7}	No leak	No leak
17	2.8×10^{-7}	No leak	No leak
10	1.5×10^{-6}	No leak	No leak
15	7.9×10^{-7}	No leak	No leak
12	9.5×10^{-7}	No leak	No leak
22	5.5×10^{-7}	No leak	No leak
6	1.3×10^{-6}	No leak	No leak
7	9.5×10^{-7}	No leak	No leak
8	6.8×10^{-7}	No leak	No leak
9	5.9×10^{-7}	No leak	No leak
14	3.9×10^{-7}	No leak	No leak
5	9.9×10^{-7}	No leak	No leak
4	4.7×10^{-7}	No leak	No leak
3	6.0×10^{-7}	No leak	No leak
2	6.8×10^{-7}	No leak	No leak
1	6.6×10^{-7}	No leak	No leak
21	1.9×10^{-7}	No leak	No leak
25	3.4×10^{-7}	No leak	No leak

Table 8 (Continued)

<u>Fuze No.</u>	<u>Helium mass spectrometer leak rate</u> cc/sec	<u>Internal pressure 103.42 kPa (15 psig)</u>	<u>MIL-STD 331/test 108</u>
90	6.6×10^{-7}	No leak	No leak
88	7.3×10^{-7}	No leak	No leak
89	2.8×10^{-7}	No leak	No leak
84	3.6×10^{-7}	No leak	No leak
83	2.8×10^{-7}	No leak	No leak
81	1.7×10^{-6}	No leak	No leak
85	3.4×10^{-7}	No leak	No leak
78	2.8×10^{-7}	No leak	No leak

Table 9
Leak test results
M577 (live)

Fuze No.	Helium mass spectrometer leak rate cc/sec	Internal pressure 103.42 kPa (15 psig)	MIL-STD 331/test 108
1	> 1×10^{-4} Exceeds meter limit	Omitted	No leak
2	> 1×10^{-4}	Omitted	No leak
3	6.8×10^{-6}	Omitted	No leak
4	5.2×10^{-6}	Omitted	No leak
5	3.0×10^{-6}	Omitted	No leak
6	1.6×10^{-6}	Omitted	No leak
7	> 1×10^{-4}	Omitted	No leak
8	> 1×10^{-4}	Omitted	No leak
9	8.8×10^{-6}	Omitted	No leak
10	3.4×10^{-6}	Omitted	No leak
11	5.1×10^{-6}	Omitted	No leak
12	3.4×10^{-6}	Omitted	No leak
13	3.1×10^{-6}	Omitted	No leak
14	> 1×10^{-4}	Omitted	No leak
15	2.0×10^{-6}	Omitted	No leak
16	2.6×10^{-6}	Omitted	No leak
17	> 1×10^{-4}	Omitted	No leak
18	2.0×10^{-6}	Omitted	No leak
19	1.6×10^{-6}	Omitted	No leak
20	3.3×10^{-7}	Omitted	No leak

Table 10
Leak test results
M1503 A2*

Fuze No.	Helium mass spectrometer leak rate cc/sec	Internal pressure 103.42 kPa (15 psig)	MIL-STD 331/test 108
5	—	—	—
6	—	—	—
7	1.6×10^{-7}	Leak (nose - small)	No leak
8	3.2×10^{-7}	Leak (nose - large)	No leak
9	$> 1 \times 10^{-6}$	Exceeds meter limit	Large leak
10	7.0×10^{-8}	No leak	No leak
11	4.2×10^{-7}	Leak (nose - large)	Moderate
1	1.7×10^{-7}	Leak (nose - medium)	No leak
12	1.9×10^{-7}	Leak (nose - large)	Trace
13	1.8×10^{-7}	Leak (nose - large)	No leak
14	1.7×10^{-7}	Leak (nose - large)	No leak
15	1.3×10^{-7}	No leak	No leak
16	$> 1 \times 10^{-4}$	Leak (nose - large)	Moderate
17	3.5×10^{-8}	Leak (nose - large)	No leak
18	4.4×10^{-8}	No leak	No leak
19	$> 1 \times 10^{-4}$	Leak (machined area)	Large
20	$> 1 \times 10^{-4}$	Leak (machined area)	Moderate
21	$> 1 \times 10^{-4}$	Leak (machined area)	Moderate
22	$> 1 \times 10^{-4}$	Leak (machined area & nose)	No leak
23	$> 1 \times 10^{-4}$	Leak (machined area)	Moderate
24	$> 1 \times 10^{-4}$	Leak (machined area)	Moderate
25	7.0×10^{-4}	Leak (machined area & nose)	Trace
26	$> 1 \times 10^{-4}$	Leak (machined area & nose)	Large
27	$> 1 \times 10^{-4}$	Leak (machined area & nose)	Moderate
28	$> 1 \times 10^{-4}$	Leak (machined area & nose)	Trace
29	$> 1 \times 10^{-4}$	Leak (machined area)	Moderate

*Nos. 1 - 16 had machined aluminum fuze bodies. Nos. 17 through 26 had cast aluminum fuze bodies.

Table 11
Actual leak test results
M440

Fuze No.	Helium mass spectrometer leak rate cc/sec	Internal pressure 103.42 kPa (15 psig)	MIL-STD 331/test 108	
			Fore	Aft
841	2.6×10^{-5}	No leak	No leak	No leak
833	1.7×10^{-5}	No leak	No leak	No leak
832	3.6×10^{-5}	No leak	No leak	No leak
831	1.2×10^{-5}	No leak	No leak	No leak
837	8.9×10^{-5}	No leak	No leak	No leak
4	4.0×10^{-5}	No leak	Trace	No leak
838	8.2×10^{-6}	No leak	No leak	No leak
847	1.0×10^{-5}	No leak	No leak	No leak
829	2.6×10^{-5}	No leak	No leak	No leak
5972	2.0×10^{-6}	No leak	Yes	No leak
828	7.4×10^{-6}	No leak	No leak	No leak
836	5.2×10^{-6}	No leak	No leak	No leak
834	5.7×10^{-6}	No leak	No leak	No leak
48	1.4×10^{-6}	No leak	No leak	No leak
839	6.0×10^{-6}	No leak	No leak	No leak
846	6.9×10^{-6}	No leak	No leak	No leak

Table 12
Leak test results
XM431

Fuze No.	Helium mass spectrometer leak rate	Internal pressure 103.42 kPa (15 psig)		MIL-STD 331/test 108	
	cc/sec	Fore	Aft	Fore	Aft
1	1.8×10^{-5}	No leak	No leak	No leak	No leak
2	1.0×10^{-5}	No leak	No leak	No leak	No leak
3	1.2×10^{-5}	No leak	No leak	No leak	No leak
4	1.0×10^{-5}	No leak	No leak	No leak	No leak
5	1.4×10^{-5}	No leak	No leak	No leak	No leak
6	6.5×10^{-6}	No leak	No leak	No leak	No leak
7	$> 1 \times 10^{-4}$	Yes	No leak	No leak	No leak
8	3.2×10^{-6}	No leak	No leak	No leak	No leak
9	4.6×10^{-6}	No leak	No leak	No leak	No leak
10	5.5×10^{-6}	No leak	No leak	No leak	No leak
11	$> 1 \times 10^{-4}$	Yes	No leak	No leak	No leak
12	$> 1 \times 10^{-4}$	Yes	No leak	No leak	No leak
13	$> 1 \times 10^{-4}$	Yes	No leak	No leak	No leak
14	1.8×10^{-6}	No leak	No leak	No leak	No leak
15	1.4×10^{-6}	No leak	No leak	No leak	No leak
16	2.6×10^{-6}	No leak	No leak	No leak	No leak
17	1.4×10^{-6}	No leak	No leak	No leak	No leak
18	1.4×10^{-6}	No leak	No leak	No leak	No leak
19	$> 1 \times 10^{-4}$	Yes	No leak	No leak	No leak
20	2.0×10^{-6}	No leak	No leak	No leak	No leak

Table 12 (Continued)

Fuze No.	Helium mass spectrometer leak rate	Internal pressure 103.42 kPa (15 psig)	MIL-STD 331/test 108	
	cc/sec		Fore	Aft
21	8.2×10^{-7}	No leak	No leak	No leak
22	1.0×10^{-6}	No leak	No leak	No leak
23	1.1×10^{-6}	No leak	No leak	No leak
24	6.2×10^{-7}	No leak	No leak	No leak
25	1.0×10^{-6}	No leak	No leak	No leak
26	4.3×10^{-7}	No leak	No leak	No leak
27	2.0×10^{-6}	No leak	No leak	No leak
28	$> 1 \times 10^{-4}$	No leak	Yes	No leak
29	5.2×10^{-7}	No leak	No leak	No leak
30	$> 1 \times 10^{-4}$	No leak	Yes	No leak
31	1.2×10^{-7}	No leak	No leak	No leak
32	3.3×10^{-7}	No leak	No leak	No leak
33	$> 1 \times 10^{-4}$	No leak	Yes	No leak
34	5.0×10^{-7}	No leak	No leak	No leak
35	2.8×10^{-7}	No leak	No leak	No leak
36	2.2×10^{-7}	No leak	No leak	No leak
37	3.0×10^{-7}	No leak	No leak	No leak

Table 13
Actual leak test results
WDU 4A/A

Fuze No.	Helium mass spectrometer leak rate cc/sec	Internal pressure 103.42 kPa (15 psig)	MIL-STD 331/test 108
1	1.0 x 10 ⁻⁴	Test omitted	No leak
2	1.0 x 10 ⁻⁴	Test omitted	No leak
4	1.0 x 10 ⁻⁴	Test omitted	No leak
4	1.0 x 10 ⁻⁴	Test omitted	No leak
5	1.0 x 10 ⁻⁴	Test omitted	No leak
6	1.0 x 10 ⁻⁴	Test omitted	No leak
7	1.0 x 10 ⁻⁴	Test omitted	No leak
8	1.0 x 10 ⁻⁴	Test omitted	No leak
9	1.0 x 10 ⁻⁴	Test omitted	No leak
10	1.0 x 10 ⁻⁴	Test omitted	No leak
11	1.0 x 10 ⁻⁴	Test omitted	No leak
12	1.0 x 10 ⁻⁴	Test omitted	No leak
13	1.0 x 10 ⁻⁴	Test omitted	No leak
14	1.0 x 10 ⁻⁴	Test omitted	No leak
15	1.6 x 10 ⁻⁵	Test omitted	No leak
16	9.2 x 10 ⁻⁶	Test omitted	No leak
17	3.8 x 10 ⁻⁶	Test omitted	No leak
18	2.7 x 10 ⁻⁶	Test omitted	No leak
19	1.3 x 10 ⁻⁶	Test omitted	No leak
20	1.2 x 10 ⁻⁶	Test omitted	No leak

Table 13 (Continued)

<u>Fuze No.</u>	<u>Helium mass spectrometer leak rate</u> <u>cc/sec</u>	<u>Internal pressure 103.42 kPa (15 psig)</u>	<u>MIL-STD 331/test 108</u>
21	1.7×10^{-6}	Test omitted	No leak
22	1.5×10^{-6}	Test omitted	No leak
23	1.4×10^{-6}	Test omitted	No leak
24	1.4×10^{-6}	Test omitted	No leak
25	1×10^{-4}	Test omitted	No leak
26	3.2×10^{-6}	Test omitted	No leak
27	1×10^{-4}	Test omitted	No leak
28	6.7×10^{-6}	Test omitted	No leak
29	4.3×10^{-6}	Test omitted	No leak
30	3.9×10^{-6}	Test omitted	No leak
31	6.0×10^{-5}	Test omitted	No leak
32	6.3×10^{-5}	Test omitted	No leak
33	4.8×10^{-5}	Test omitted	No leak
34	3.6×10^{-5}	Test omitted	No leak
35	2.8×10^{-5}	Test omitted	No leak
36	2.0×10^{-5}	Test omitted	No leak
37	1×10^{-4}	Test omitted	No leak
38	4.2×10^{-5}	Test omitted	No leak
39	3.2×10^{-5}	Test omitted	No leak
40	2.4×10^{-5}	Test omitted	No leak

Table 13 (Continued)

Fuze No.	Helium mass spectrometer leak rate cc/sec	Internal pressure 103.42 kPa (15 psig)	MIL-STD 331/test 108
41	1.2×10^{-5}	Test omitted	No leak
42	1.0×10^{-5}	Test omitted	No leak
43	1.3×10^{-5}	Test omitted	No leak
44	1.1×10^{-5}	Test omitted	No leak
45	8.0×10^{-6}	Test omitted	No leak
46	4.6×10^{-6}	Test omitted	No leak
47	7.2×10^{-6}	Test omitted	No leak
48	5.8×10^{-6}	Test omitted	No leak
49	3.3×10^{-6}	Test omitted	No leak
50	2.4×10^{-6}	Test omitted	No leak
51	2.5×10^{-6}	Test omitted	No leak
52	1.9×10^{-6}	Test omitted	No leak
53	8.0×10^{-7}	Test omitted	No leak
54	8.0×10^{-7}	Test omitted	No leak
55	8.2×10^{-7}	Test omitted	No leak
56	7.8×10^{-7}	Test omitted	No leak

TEST PLAN

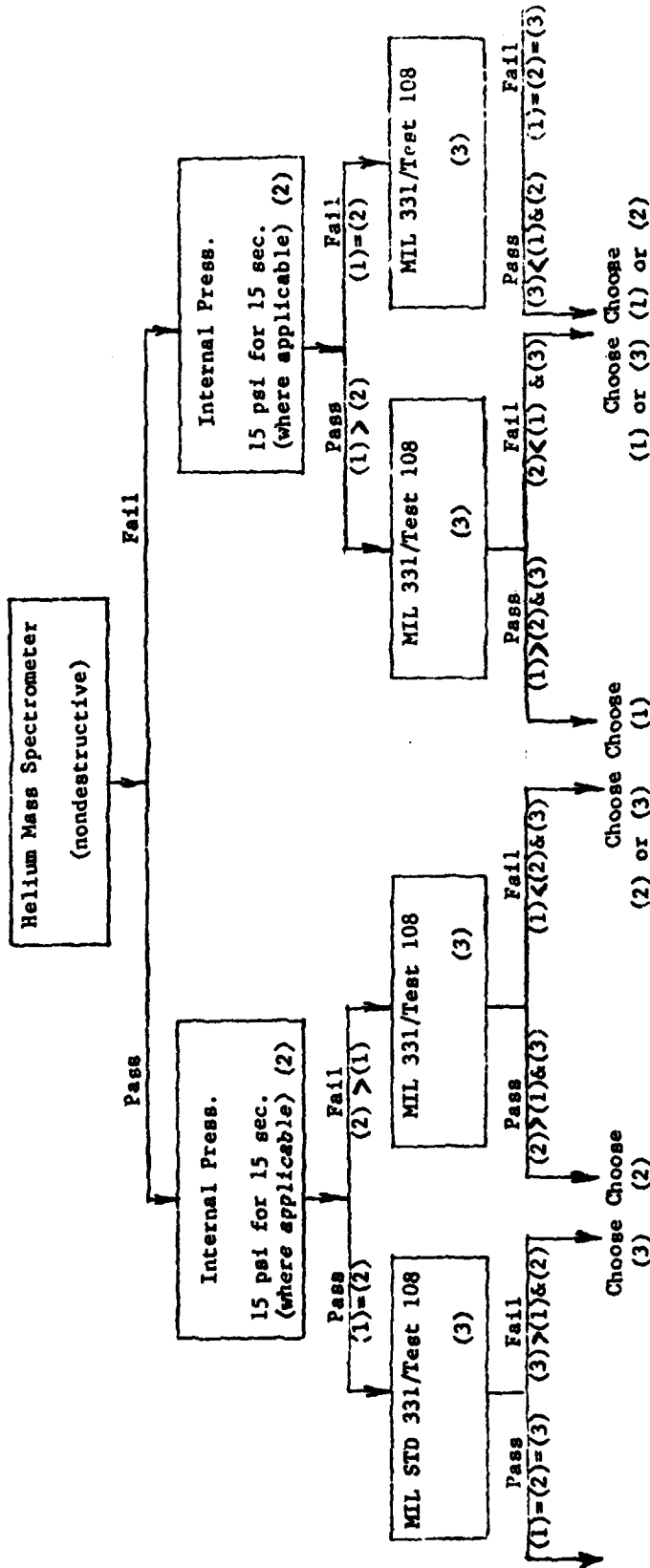

- (1) = Nondestructive Test (Helium Detection)
- (2) = Nondestructive Test (Bubble Indication)
- (3) = Destructive (Disassembly and examination of fuze interior)

> = More severe than
 < = Less severe than

Fig 1 Comparison of leak test methods

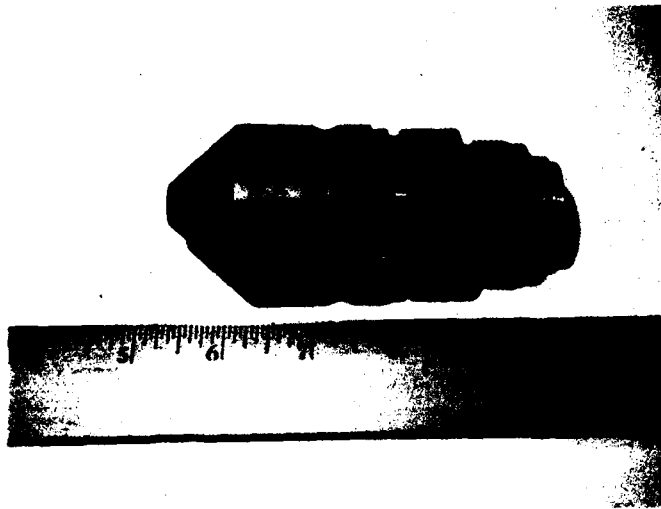

Fig 2 M423

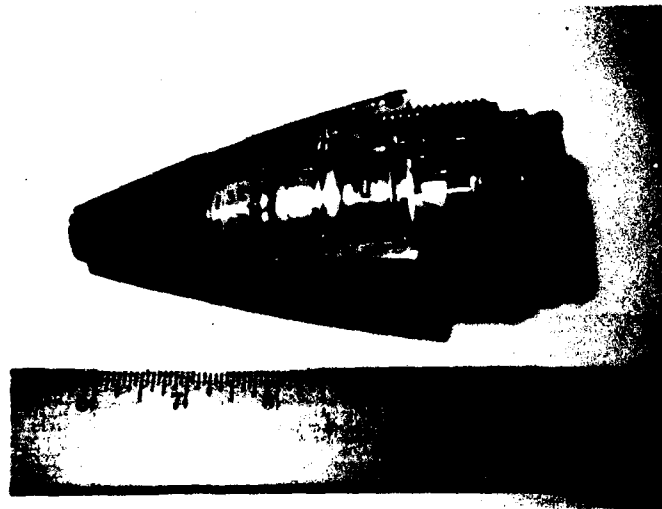

Fig 3 M577

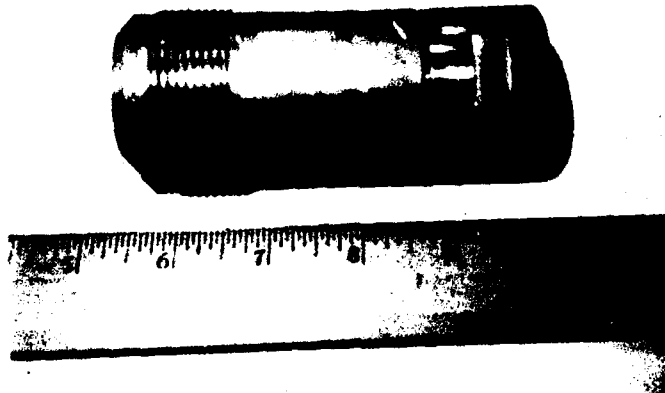

Fig 4 M578

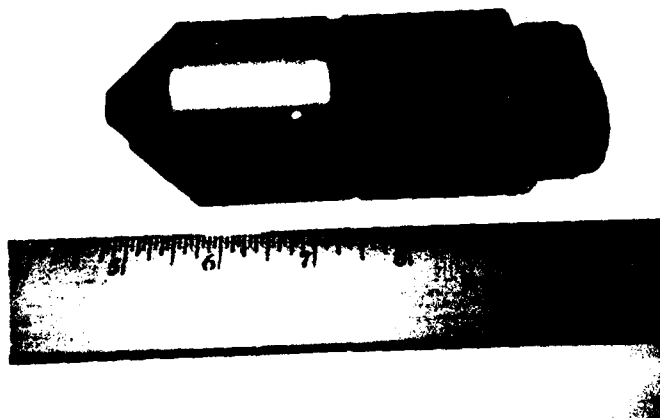

Fig 5 M440

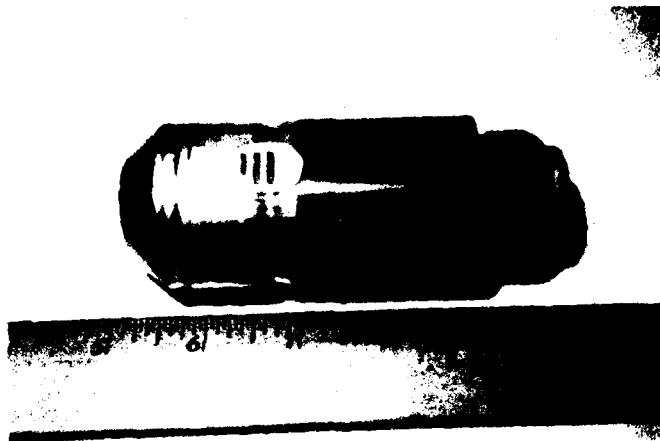

Fig 6 M431

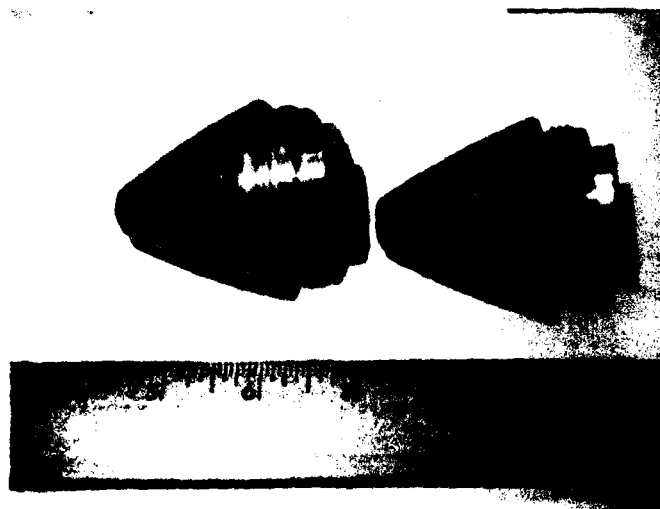

Fig 7 M503A2
Fuze on right is cast aluminum

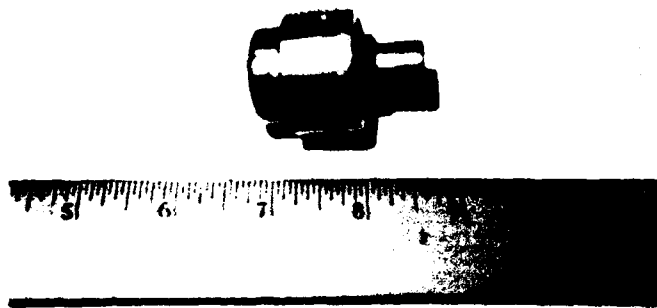

Fig 8 M551

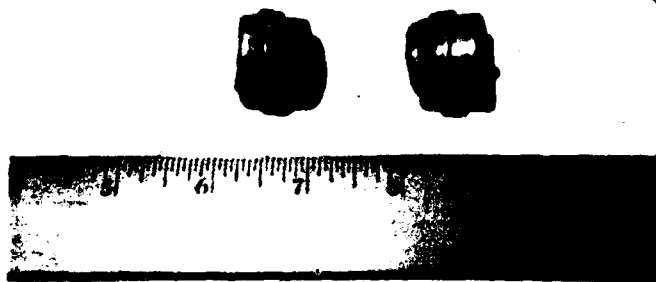

Fig 9 M219E1

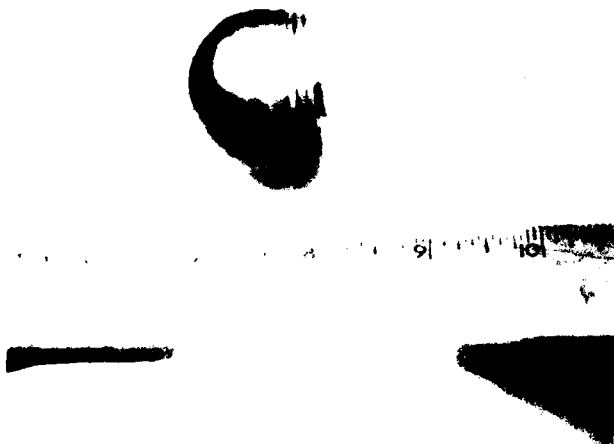
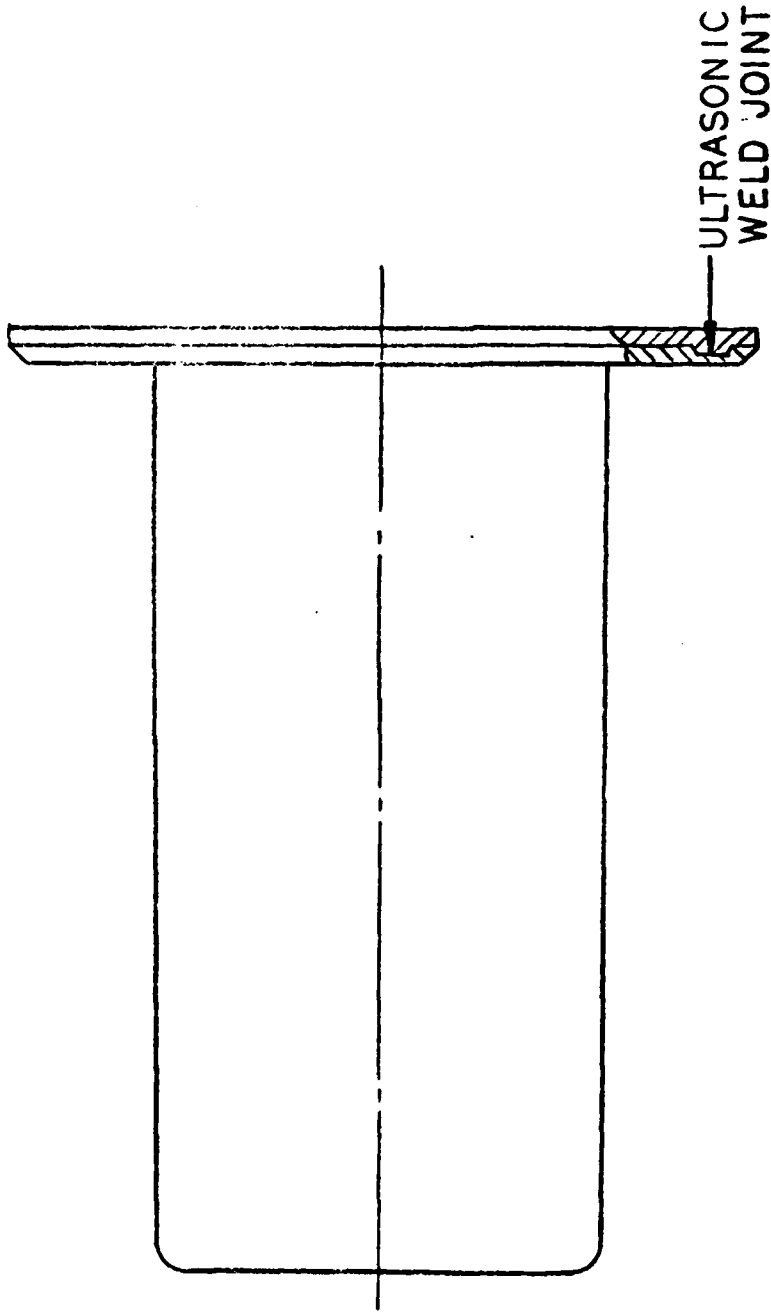
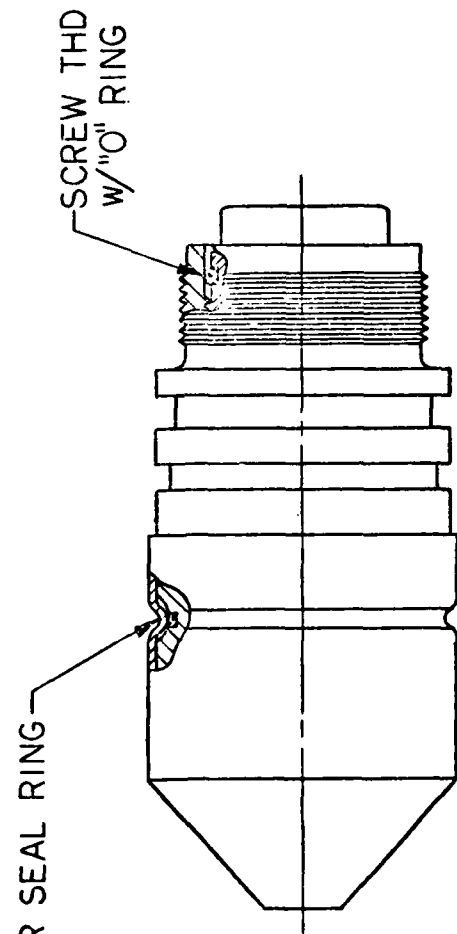

Fig 10 M550



JOINT MAT'L - PLASTIC SPEC L-P-393.

Fig 11 Fuze, WDU-4A/A Whd



SCREW THD JOINT MAT'L
 RUBBER, MS28775
 ALUMINUM, ASTM B210 & B211

CRIMP JOINT MAT'L -
 NITRILE RUBBER COMPOUND
 ALUMINUM, ASTM B210

Fig 12 Fuze, M423, M427

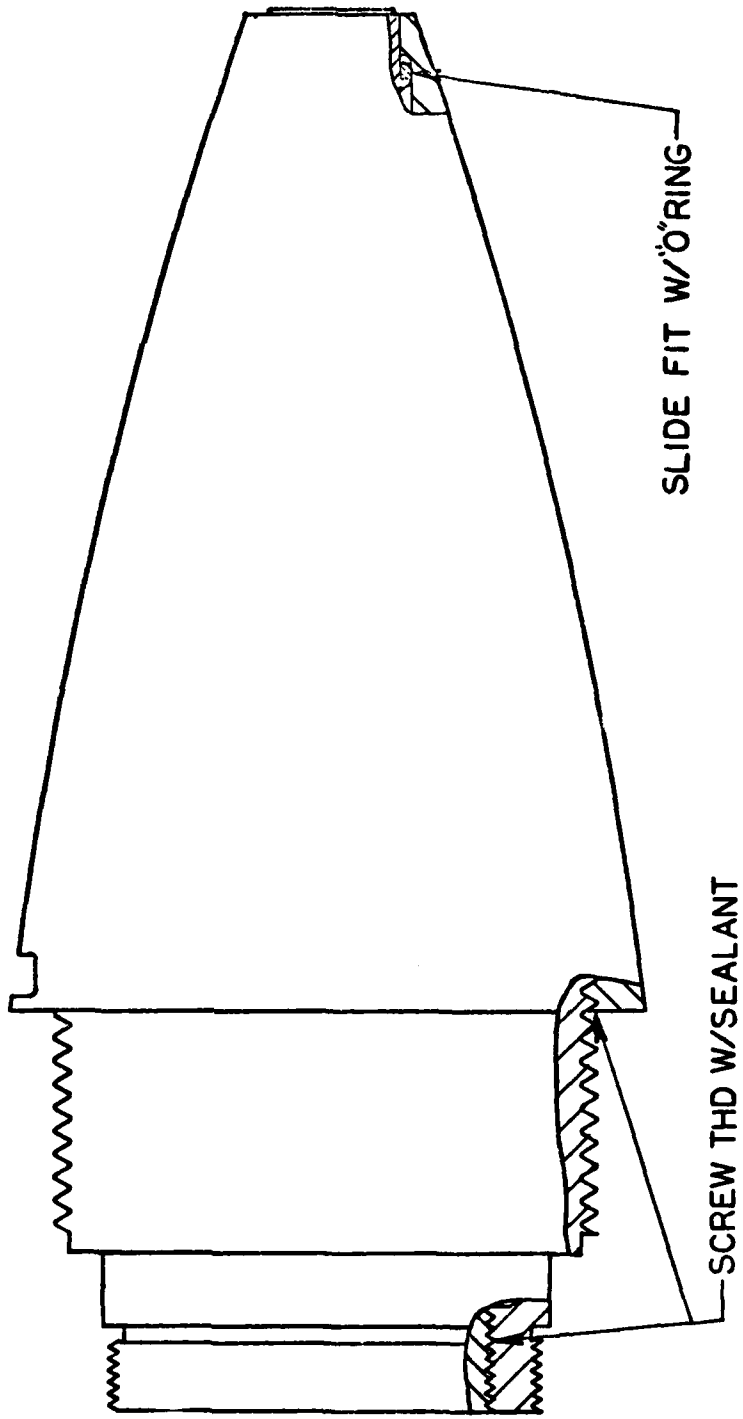

BOTH PLACES
 JOINT MAT'L -
 SILASTIC RTV 73I, DWG 9230886
 ALUMINUM, ASTM B211
 COR RES STEEL, ASTM A582

Fig 13 Fuze, M577

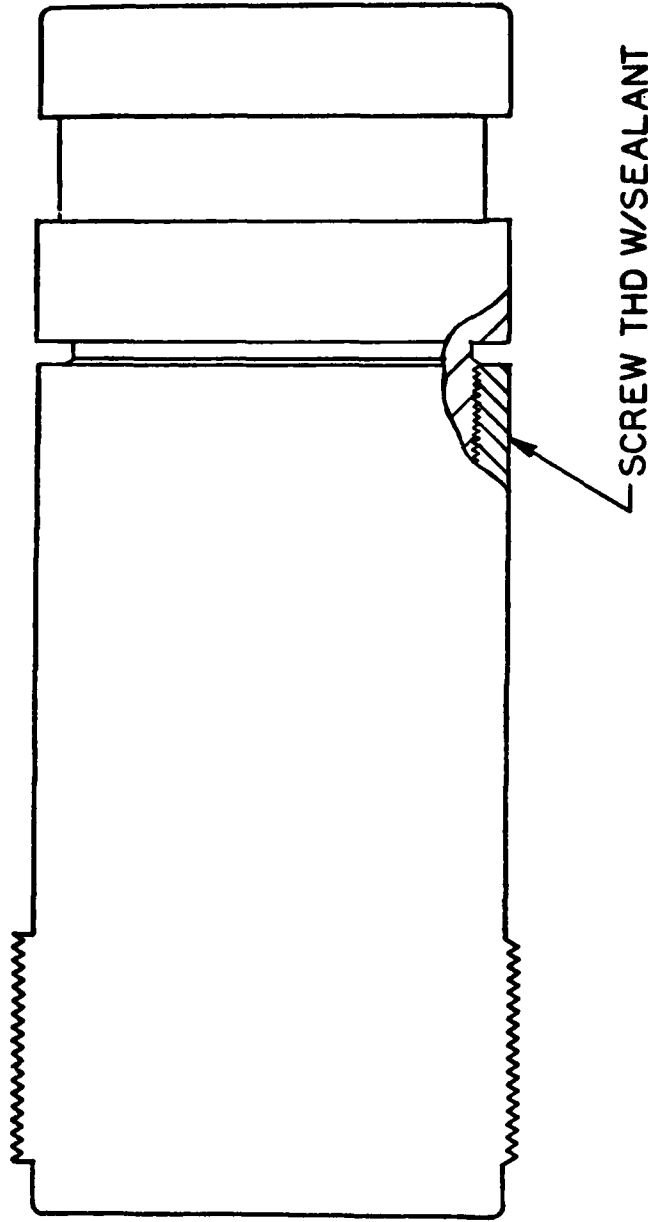

JOINT MAT'L -
POLYMER, LP-2
STEEL, 12L14

Fig 14 Fuze, M578

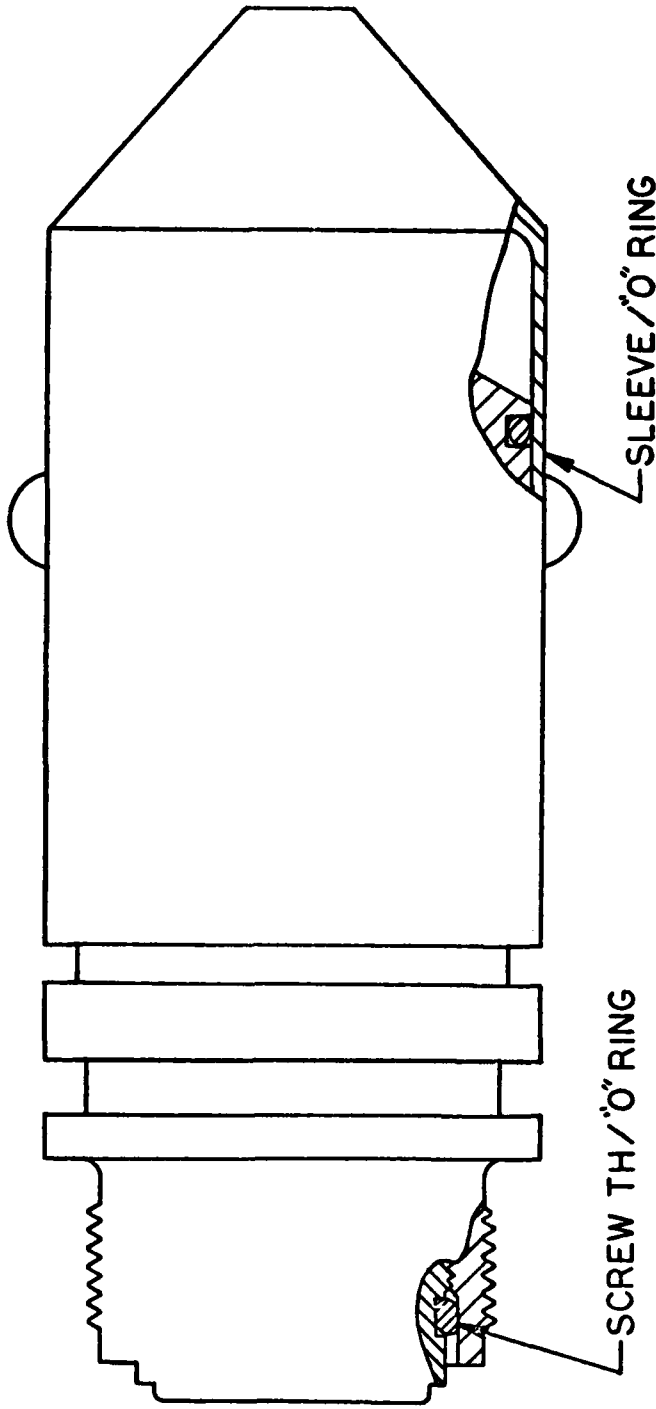

SCREW JOINT MAT'L -
 RUBBER, MS28775
 ALUMINUM, ASTM B210 & B211

SLEEVE JOINT MAT'L
 PACKING, 9269056
 ALUMINUM, ASTM B210 & B211

Fig 15 Fuze, M440

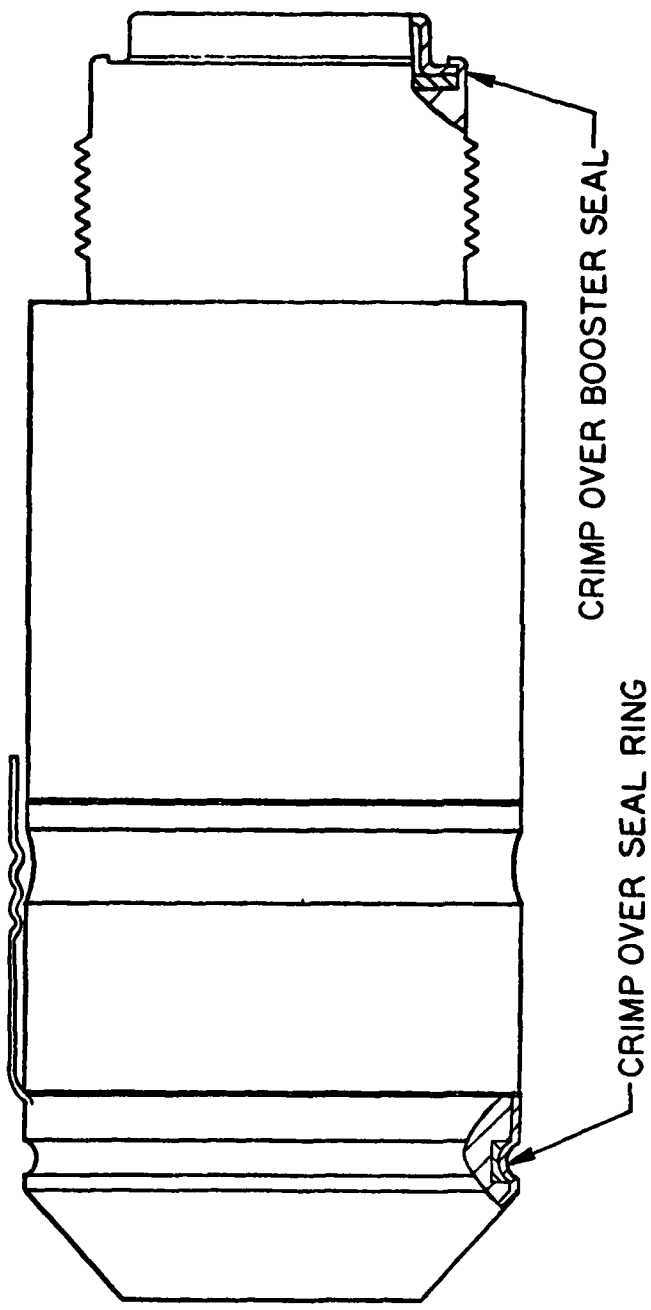

SEAL RING
JOINT MAT'L -

ALUMINUM, ASTM B209
RUBBER, SILICONE, CLASS 1b

CRIMP OVER SEAL RING

BOOSTER SEAL
JOINT MAT'L -
ALUMINUM, ASTM B209

CRIMP OVER BOOSTER SEAL

Fig 16 Fuze, M431

SCREW THD
W/SEALANT

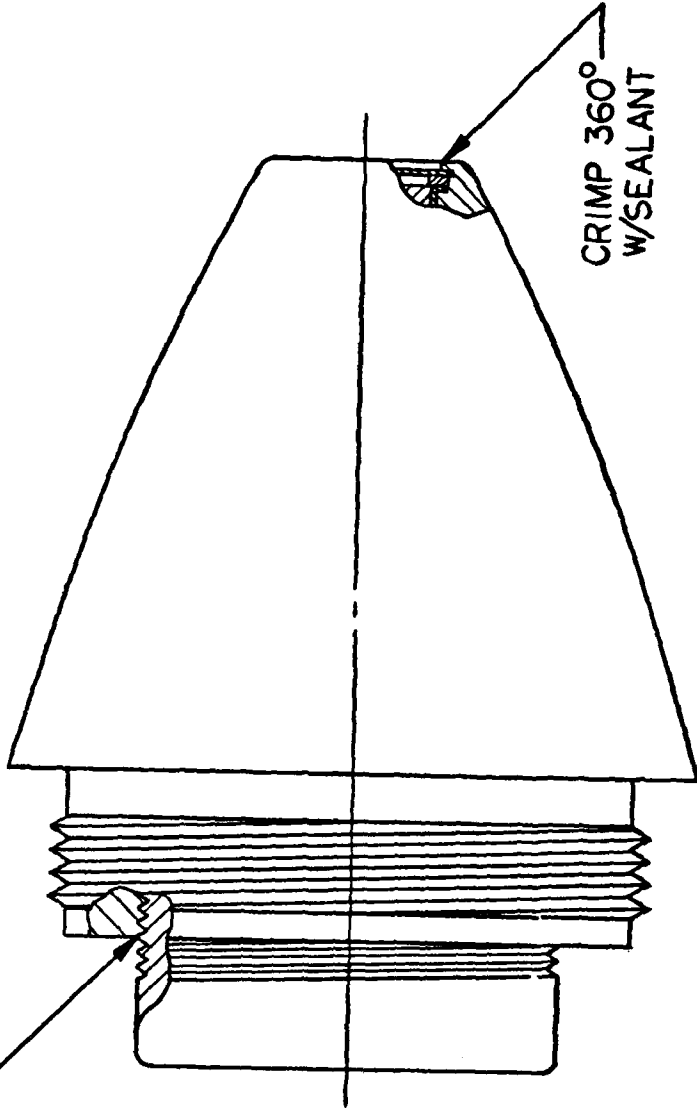

SCREW JOINT MAT'L -
POLYSULFIDE RUBBER, DWG 9215164 (LP-2)
ALUMINUM, ASTM B85

CRIMP JOINT MAT'L -
VARNISH, SPEC MIL-V-13750
ALUMINUM, ASTM B85 AND B209

Fig 17 Fuze, PD, M503A2

—CRIMP 360° OVER FLAT RUBBER SEAL

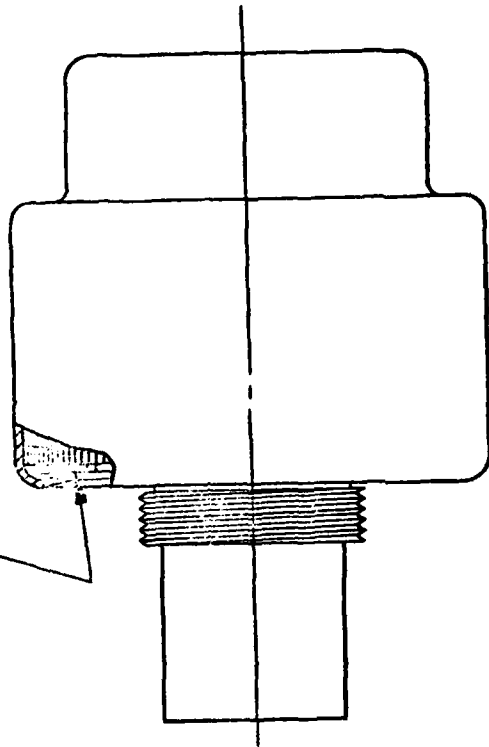

JOINT MAT'L -
RUBBER, SPEC MIL-R-3065
ALUMINUM, ASTM B209

Fig 18 Fuze, PD, M551

CRIMP 360° W/SEALANT ON EXTERIOR

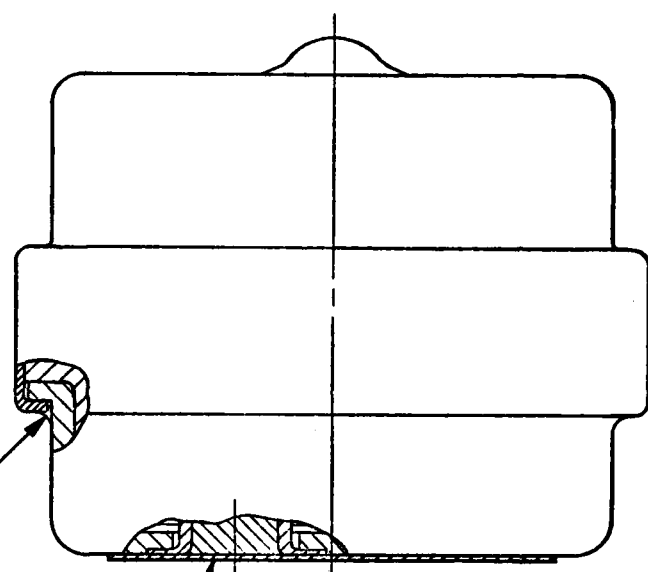

FOIL OVER
DET HOLE

CRIMP JOINT MAT'L -
COATING COMPOUND, SPEC MIL-C-450
ALUMINUM, ASTM B209
STEEL, SPEC QQ-S-698

TAPED JOINT MAT'L
ALUMINUM FOIL TAPE
ALUMINUM ASTM B209

Fig 19 Fuze, Grenade, M219E1

CRIMP 360° OVER "O" RING

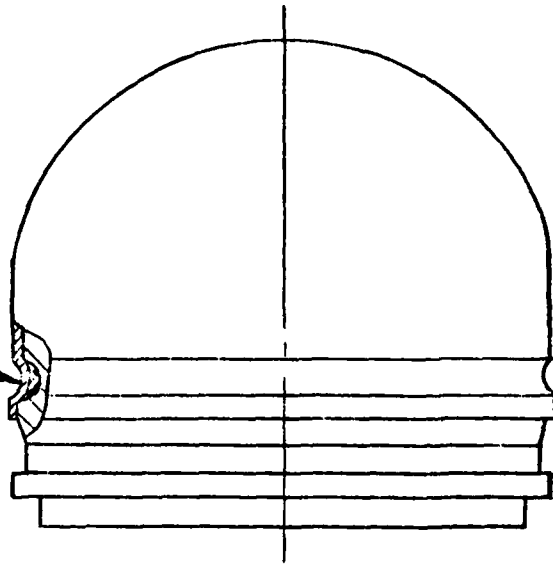

JOINT MAT'L -
NITRILE RUBBER (BUNA N)
ALUMINUM, ASTM B209 AND B211

Fig 20 Fuze, PIBD, M550

APPENDIX A
SEAL LEAKAGE TEST OF WDU-4A/A

SEAL LEAKAGE TEST OF WDU-4A/A

<u>CONTRACT NO.</u>	<u>PRODUCTION QUANTITY</u>	<u>SAMPLE SIZE</u>	<u>REJECTS</u>
71-C-0022	117,119	312	0

APPENDIX B

SEAL LEAKAGE TEST OF M423 M/P

SEAL LEAKAGE TEST OF M423 M/P

<u>CONTRACT NO.</u>	<u>PRODUCTION QUANTITY</u>	<u>SAMPLE SIZE</u>	<u>REJECTS</u>
69-C-0196	8,903,541	3,552	1
69-C-0175	457,062	3,072	6
70-C-0225	495,907	2,016	5
73-C-0072	133,255	1,056	0
73-C-0215	204,250	672	0
TOTAL	10,194,015	10,368	12

APPENDIX C
LEAK TEST OF M577, FUZE, MT, SQ

LEAK TEST OF M577, FUZE, MT, SQ

CONTRACT DAAA21-73-C-0368

<u>LOT NO.</u>	<u>TYPE OF TEST</u>	<u>TEST DATE</u>	<u>SAMPLE SIZE</u>	<u>REJECTS</u>
FAS 1-1	AIR LEAK (OGIVE)	Nov 73	80	NONE
FAS 1-1	WATERPROOFNESS (COMPLETE FUZE)	Nov 73	5	NONE

APPENDIX D

SEAL LEAKAGE TEST OF M578 FUZE

SEAL LEAKAGE TEST OF M578 FUZE

<u>CONTRACT NO.</u>	<u>PRODUCTION QUANTITY</u>	<u>SAMPLE SIZE</u>	<u>REJECTS</u>
LSAAP - 23	86,715	170	0
LSAAP - 24	72,485	140	1
LSAAP - 25	8,554	150	0
LSAAP - 26	7,486	150	0
TOTAL	175,240	610	1

APPENDIX E
LEAK TEST OF WDU-4A/A FLECHETTE WARHEAD

LEAK TEST OF WDU-4A/A FLECHETTE WARHEAD

Contract DAAA09-71-C-0022

KDI Precision Products Inc

<u>Lot No.</u>	<u>Lot Size</u>	<u>Test Date</u>	<u>Sample Size</u>	<u>Rejects</u>
NRT 6-2	20,000	2-12-71 2-19-71	12 12	None None
NRT 6-3	17,600	3-5-71 3-22-71	12 12	None None
NRT 6-5	15,000	5-14-71 5-24-71	12 12	None None
NRT 6-6	10,500	6-15-71 6-22-71	12 12	None None
NRT 6-11	10,900	11-4-71 12-1-71 12-14-71	12 4 8	None None None
NRT 6-12	3,000	2-2-72 2-10-72	12 12	None None
NRT 8-1	951	8-30-72 8-31-72	12 12	None None
NRT 8-2	3,072	9-5-72 9-8-72	12 12	None None
NRT 8-3	7,488	9-19-72 9-26-72	12 12	None None
NRT 8-5	7,680	11-1-72 11-16-72	12 12	None None
NRT 8-11	7,680	5-2-73 5-16-73	12 12	None None
NRT 8-12	7,680	5-31-73 6-14-73	12 12	None None
NRT 8-16	5,568	10-1-73 10-16-73	12 12	None None
Total	117,119		312	None

SEAL LEAKAGE TEST OF M123 M/P

Contract DAAA09-69-C-0196

KDI Precision Products, Inc.

<u>Lot No.</u>	<u>Lot Size</u>	<u>Test Date</u>	<u>Sample Size</u>	<u>Rejects</u>
KDI 13-10	20,812	2-28-69	96	0
KDI 13-11A	13,370	3-30-69	96	0
KDI 13-12	22,547	3-31-69	96	0
KDI 13-13	32,827	3-26-69	96	0
KDI 13-14	15,790	3-28-69	96	0
KDI 13-15	26,796	4-11-69	96	0
KDI 13-16	18,585	4-16-69	96	0
KDI 13-17	20,810	4-23-69	96	0
KDI 13-18	19,612	5-1-69	96	0
KDI 13-26	23,798	6-27-69	96	0
KDI 13-27	21,247	7-18-69	96	0
KDI 13-28	26,129	7-28-69	96	0
KDI 13-29	28,029	7-31-69	96	0
KDI 13-30	26,271	8-11-69	96	0
KDI 13-31	20,241	8-18-69	96	0
KDI 13-32	26,071	8-22-69	96	0
KDI 13-33	30,305	8-29-69	96	0
KDI 13-34	20,899	9-9-69	96	0
KDI 13-35	34,959	9-16-69	96	0
KDI 13-34	31,916	9-25-69	96	0
KDI 13-37	23,030	9-26-69	96	0

Seal Leakage Test of M423 M/P - Contract DAAA09-69-C-0196 Cont.

<u>Lot No.</u>	<u>Lot Size</u>	<u>Test Date</u>	<u>Sample Size</u>	<u>Rejects</u>
KDI 13-38	15,661	9-30-69	96	0
KDI 13-39	25,194	10-8-69	96	0
KDI 13-40	24,388	10-14-69	96	0
KDI 13-41	35,226	10-21-69	96	0
KDI 13-42	31,509	11-28-69	96	0
KDI 13-43	23,112	10-30-69	96	0
KDI 13-44	35,085	11-7-69	96	1
KDI 13-45	23,355	11-17-69	96	0
KDI 13-46	24,936	11-21-69	96	0
KDI 13-47	20,820	11-24-69	96	0
KDI 13-48	23,060	11-28-69	96	0
KDI 13-49	21,492	12-9-69	96	0
KDI 13-50	25,083	12-16-69	96	0
KDI 13-51	33,475	12-19-69	96	0
KDI 13-52	20,412	12-30-69	96	0
KDI 13-53	<u>16,689</u>	12-30-69	<u>96</u>	<u>0</u>
Total	8,903,541		3,552	1

SEAL LEAKAGE TEST OF M23 M/P

Contract DAAA09-69-C-0175

Bulova Watch Company

<u>Lot No.</u>	<u>Lot Size</u>	<u>Test Date</u>	<u>Sample Size</u>	<u>Rejects</u>
BWC-6-13	10,673	7-9-69	96	0
BWC-6-14	10,500	7-30-69	96	0
BWC-6-15	16,028	8-8-69	96	0
BWC-6-16	15,678	8-20-69	96	2
BWC-6-17	15,438	8-28-69	96	0
BWC-6-18	15,389	9-8-69	96	1
BWC-6-19	15,556	9-16-69	96	0
BWC-6-20	15,243	9-24-69	96	0
BWC-6-21	15,393	10-1-69	96	0
BWC-6-22	15,406	10-8-69	96	0
BWC-6-23	15,443	10-15-69	96	0
BWC-6-24	15,343	10-23-69	96	0
BWC-6-25	17,951	11-3-69	96	0
BWC-6-26	17,987	11-7-69	96	1
BWC-6-27	17,922	11-14-69	96	0
BWC-6-28	17,783	11-21-69	96	0
BWC-6-29	19,022	12-2-69	96	0
BWC-6-30	19,370	12-15-69	96	0
BWC-6-31	19,445	12-17-69	96	1
BWC-6-32	<u>18,848</u>	12-22-69	<u>96</u>	<u>0</u>
Total	324,468		1,920	5

Seal Leakage Test of M423 M/P - Contract DAAA09-69-C-0175 Cont.

<u>Lot No.</u>	<u>Lot Size</u>	<u>Test Date</u>	<u>Sample Size</u>	<u>Rejects</u>
BWC-10-1	9,588	4-7-69	96	1
BWC-10-2	10,331	4-16-69	96	0
BWC-10-3	11,430	4-21-69	96	0
BWC-10-4	10,950	4-25-69	96	0
BWC-10-6	10,783	5-6-69	96	0
BWC-10-7	10,483	5-12-69	96	0
BWC-10-9	10,680	5-21-69	96	0
BWC-10-10	9,624	5-21-69	96	0
BWC-10-11	10,494	6-6-69	96	0
BWC-10-12	10,712	6-13-69	96	0
BWC-10-13	10,702	6-20-69	96	0
BWC-10-14	<u>16,817</u>	6-30-69	<u>96</u>	<u>0</u>
Total	132,594		1,152	1
Contract Total	457,062		3,072	6

SEAL LEAKAGE TEST OF M123 M/P

Contract DAAA09-70-C-02225

KDI Precision Products, Inc.

<u>Lot No.</u>	<u>Lot Size</u>	<u>Test Date</u>	<u>Sample Size</u>	<u>Rejects</u>
KDI 14-12	30,092	5-14-70	96	0
KDI 14-13	21,468	5-14-70	96	1
KDI 14-14	19,305	5-27-70	96	0
KDI 14-16	<u>14,318</u>	6-20-70	<u>96</u>	<u>0</u>
Total	85,183		384	1
KDI 15-1	25,056	6-30-70	96	0
KDI 15-2	18,575	6-16-70	96	0
KDI 15-3	18,541	6-24-70	96	0
KDI 15-4	22,221	6-27-70	96	1
KDI 15-5	<u>20,577</u>	6-30-70	<u>96</u>	<u>0</u>
Total	104,970		480	1
KDI 16-1	24,732	8-13-70	96	0
KDI 16-2	25,842	8-22-70	96	1
KDI 16-3	26,559	8-27-70	96	1
KDI 16-4	21,211	8-29-70	96	0
KDI 16-5	<u>29,204</u>	9-9-70	<u>96</u>	<u>0</u>
Total	127,548		480	2

Seal Leakage Test of M423 M/P - Contract DAAA09-70-C-02225

<u>Lot No.</u>	<u>Lot Size</u>	<u>Test Date</u>	<u>Sample Size</u>	<u>Rejects</u>
KDI 17-1	24,646	9-16-70	96	0
KDI 17-2	25,830	9-23-70	96	0
KDI 17-3	<u>22,423</u>	9-26-70	<u>96</u>	<u>0</u>
Total	72,899		288	0
-				
KDI 18-1	32,265	10-7-70	96	0
KDI 18-2	30,556	10-15-70	96	1
KDI 18-3A	13,056	10-22-70	96	0
KDI 18-4	<u>29,430</u>	10-30-70	<u>96</u>	<u>0</u>
Total	105,307		384	1
Contract Total	495,907		2,016	5

SEAL LEAKAGE TEST OF M425 M/P

Contract DAAA09-73-C-0215
KDI Precision Products, Inc.

<u>Lot No.</u>	<u>Lot Size</u>	<u>Test Date</u>	<u>Sample Size</u>	<u>Rejects</u>
KDP 22-1	24,915	7-19-73	96	None
KDP 22-2	25,941	8-30-73	96	None
KDP 22-3	40,013	9-28-73	96	None
KDP 22-4	26,574	10-18-73	96	None
KDP 22-5	35,009	10-30-73	96	None
KDP 22-6	25,839	11-14-73	96	None
KDP 22-7	<u>25,959</u>	11-26-73	<u>96</u>	<u>None</u>
Total	204,250		672	None

SEAL LEAKAGE TEST OF M423 M/P

Contract DAAA09-73-C-0072
KDI Precision Products, Inc.

<u>Lot No.</u>	<u>Lot Size</u>	<u>Test Date</u>	<u>Sample Size</u>	<u>Rejects</u>
KDP 38-2	8,361	2-20-73	96	None
KDP 38-3	8,635	3-16-73	96	None
KDP 38-4	8,685	4-13-73	96	None
KDP 38-5	30,252	5-16-73	96	None
KDP 38-6	9,297	6-5-73	96	None
KDP 38-7	24,510	6-28-73	96	None
KDP 38-8	7,500	7-11-73	96	None
KDP 38-9	9,385	8-13-73	96	None
KDP 38-10	9,213	9-10-73	96	None
KDP 38-11	8,812	10-5-73	96	None
KDP 38-12	<u>8,605</u>	11-6-73	<u>96</u>	<u>None</u>
Total	133,255		1056	None

APPENDIX F
SEAL LEAK TEST OF M578

87

PRECEDING PAGE BLANK-NOT FILMED

SEAL LEAK TEST OF M578

Waterproofness of Loaded Fuze

Contractor: LSAAP

<u>Lot No.</u>	<u>Lot Size</u>	<u>Test Date</u>	<u>Sample Size</u>	<u>Rejects</u>
23-1	5,080	3-27-72	50	0
23-2	5,148	4-10-72	50	0
23-3	5,192	4-17-72	50	0
23-4	10,236	4-27-72	15	0
23-5	8,845	5-2-72	15	0
23-6	4,646	5-18-72	15	0
23-7	12,464	5-19-72	15	0
23-8	13,055	6-2-72	15	0
23-9	5,571	6-15-72	15	0
23-10	12,119	6-15-72	15	0
23-11	<u>4,359</u>	6-29-72	<u>15</u>	<u>0</u>
Total	86,715	6-29-72	170	0
24-1	4,475	12-8-72	50	0
24-2	5,094	12-14-72	50	1
24-3	9,688	12-29-72	50	0
24-4	9,625	1-17-73	15	0
24-5	9,946	2-1-73	15	0
24-6	9,764	2-20-73	15	0

Seal Leak Test of M578 - Contractor : LSAP cont.

<u>Lot No.</u>	<u>Lot Size</u>	<u>Test Date</u>	<u>Sample Size</u>	<u>Rejects</u>
24-7	9,825	2-21-73	15	0
24-8	11,108	3-21-73	15	0
24-9	<u>2,880</u>	3-29-73	<u>15</u>	<u>0</u>
Total	72,485		140	1
25-1	935	9-24-73	50	0
25-2	3,218	10-10-73	50	0
25-3	<u>4,401</u>	10-25-73	<u>50</u>	<u>0</u>
Total	8,554		150	0
26-1	1,871	1-22-74	50	0
26-2	2,504	1-24-74	50	0
26-3	<u>3,111</u>	1-23-74	<u>50</u>	<u>0</u>
Total	7,486		150	0
Contract Total	175,240		610	1

DISTRIBUTION LIST

	Copy No.
Commander Picatinny Arsenal	
ATTN: SARPA-TS-S	1-5
SARPA-FR-M-A	6-20
SARPA-ND	21-25
SARPA-AD	26-30
SARPA-QA	31-32
SARPA-IO	33-34
SARPA-QA-A	35
SARPA-QA-N	36
Dover, NJ 07801	
 Commander US Army Materiel Development and Readiness Command	
ATTN: DRCDE-R, Mr. J. Rivkin	37
DRCPP-PI	38
DRC-QA	39
5001 Eisenhower Avenue Alexandria, VA 22304	
 Commander US Army Missile Command	
ATTN: DRSMI-RLM, Mr. E. A. Verchot	40
Chief, Document Section	41
Redstone Arsenal, AL 35801	
 Commander US Army Armament Command	
ATTN: DRSAR-MP-PC	42
DRSAR-RDP	43
DRSAR-RDM, Mr. G. Chesnov	44
DRSAR-RDT, Dr. Daryl Penrod	45
DRSAR-RDT, Mr. J. Salamon	46
DRSAR-ASF, Mr. H. Wohlferth	47
Rock Island, IL 61201	

Commander
 US Army Electronics Command
 ATTN: DRSEL-TL-ME, Mr. Dan Lichenstein 48
 DRSEL-TL-ME, Mr. A. J. Raffalovich 49
 DRSEL-TL-ME, Mr. G. Platau 50
 DRSEL-PP-EM2, Sarah Rosen 51
 Fort Monmouth, NJ 07703

Commander
 US Army Aviation Systems Command
 ATTN: DRSAV-FET, Mr. J. Bramlet 52
 DRSAV-E-ER, Mr. W. McClane 53
 DRSAV-FEU, Mr. E. Dawson 54
 DRSAV-F-FE, Mr. C. Sims 55
 DRSAV-E-RE, Mr. G. Gorline 56
 P.O. Box 209, Main Office
 St. Louis, MO 63166

Director
 US Army Tank-Automotive Command
 ATTN: DRSTRA-KMD, Mr. Francis S. Lemmer 57
 Warren, MI 48090

Commander
 US Army Materials & Mechanics Research Center
 ATTN: DRXMR-FR, Dr. G. Thomas 58
 DRXMR-PL 59
 Technical Information Section 60
 Watertown, MA 02172

Director
 US Army Production Equipment Agency
 Rock Island Arsenal
 ATTN: DRXPE-MT, Mr. H. Holmes 61-62
 Rock Island, IL 61201

Commander
 Corpus Christi Army Depot
 ATTN: DRSAV-FES (STOP 55) 63-64
 DRSAV-FESA, Mr. T. Tullos 65-66
 DRSAV-FESP, Mr. Bulloch 67
 Corpus Christi, TX 78419

<p>Commander Aberdeen Proving Ground ATTN: Rosalie O. Forst, STEAP-TL, Bldg. 305 Aberdeen Proving Ground, MD 21005</p>	68
<p>Commander US Army Weapons Command Watervliet Arsenal ATTN: Dr. G. D. Andrea, SARWV-RDR-PS Watervliet, NY 12189</p>	69
<p>Commander US Army Engineer Waterways Experiment Station, P.O. Box 631 Corps of Engineers ATTN: Mr. Hugh L. Green - WE SSS1 Vicksburg, MS 39180</p>	70
<p>Commander US Army Medical Bio-Engineering Research and Development Laboratories Fort Detrick ATTN: Dr. C. Wade Frederick, MD 21701</p>	71
<p>Plastics Technical Evaluation Center ATTN: Mr. H. Pebly</p>	72
<p style="padding-left: 40px;">Mr. A. Landrock</p>	73
<p>Picatinny Arsenal Dover, NJ 07801</p>	
<p>Commander Harry Diamond Laboratories ATTN: Mr. N. Kaplan</p>	74
<p style="padding-left: 40px;">Mr. J. M. Boyd</p>	75
<p style="padding-left: 40px;">Library</p>	76
<p>Washington, DC 20438</p>	

Commander US Army Edgewood Arsenal ATTN: SAREA-DE-EP	77
SAREA-CL-CPM, Mr. Dave Schneck	78
SAREA-PA-PR, Mr. M. N. Timbs	79
SAREA-DME, Mr. M. A. Raun	80
Edgewood Arsenal, MD 21010	
 Commander Tobyhanna Army Depot ATTN: Mr. A. Alfano	81
Tobyhanna, PA 18466	
 Director US Army Ballistics Research Laboratories ATTN: Mr. Emerson V. Clark, Jr.	82
DRXBR-IB, Dr. Bruce Burns	83
Aberdeen Proving Ground, MD 21005	
 Commander US Army Materiel Development & Readiness Command ATTN: DRCPM-UA, Mr. C. Musgrave	84
DRCPM-LH, Mr. C. Cioffi	85
DRCPM-HLS-T, Mr. R. E. Hahn	86
P.O. Box 209 St. Louis, MO 63166	
 Commander	87
Natick Research & Development Command Natick, MA 01760	
 Commander	88
US Army Engineer Research & Development Labs Fort Belvoir, VA 22060	
 Department of the Navy Naval Air Systems Command ATTN: Mr. John J. Gurtowski (AIR 52032C)	89
Washington, DC 20360	

Naval Ordnance Station (NOSL) ATTN: Mr. W. J. Ryan, Code 5041 Southside Drive Louisville, KY 40214	90
Naval Avionics Facility ATTN: Mr. B. D. Tague, Code D/802 Mr. Paul H. Guhl, D/033.3 21st and Arlington Indianapolis, IN 46218	91 92
Commander US Naval Weapons Station ATTN: Research and Development Div Yorktown, VA 23491	93
Commander Aeronautical Systems Division ATTN: Mr. W. Scardino, AFML/MXE Mr. T. J. Aponyi Composite and Fibrous Materials Branch Nonmetallic Materials Division Wright-Patterson Air Force Base, OH 45433	94 95
Dr. Robert S. Shane, Staff Scientist National Materials Advisory Board National Academy of Sciences 2101 Constitution Avenue, N.W. Washington, DC 20418	96
Defense Documentation Center Cameron Station Alexandria, VA 22314	97-108
US Army Air Mobility R&D Laboratory, Headquarters Advanced Systems Research Office ATTN: Mr. F. Immen, MS 207.5 Ames Research Center Moffet Field, CA 94035	109

Naval Ship Engineering Center ATTN: Mr. W. R. Graner, SEC 6101E Prince George's Center Hyattsville, MD 20782	110
Mare Island Naval Shipyard Rubber Engineering Section ATTN: Mr. Ross E. Morris, Code 134.04 Vallejo, CA 94592	111
Hanscom Air Force Base ATTN: Mr. R. Karlson, ESD/DE, Stop 7 HQ, ESD Bedford, MA 01731	112
Naval Air Development Center Materials Laboratory ATTN: Mr. Coleman Nadler, Code 30221, Div, AVTD Warminster, PA 18974	113