

AD-A031 442

COLUMBIA UNIV NEW YORK DEPT OF CIVIL ENGINEERING AN--ETC F/G 13/13
STRAIN ENERGY EXPRESSIONS OF RINGS OF RECTANGULAR, T- AND I- SE--ETC
OCT 76 H H BLEICH

N00014-75-C-0695

NL

UNCLASSIFIED

1 OF 1
AD
A031442



END

DATE
FILMED
12-76

ADA031442

12

16

Columbia University
in the City of New York

DEPARTMENT OF CIVIL ENGINEERING
AND ENGINEERING MECHANICS



Final Report, Department of Civil Engineering, T- and T- Services,
Contract for the Dynamic Analysis of the Structural Cylindrical Shell

1973

See 1473

Office of Naval Research
Contract No. N00014-73-1-0001
Task Order No. 1001

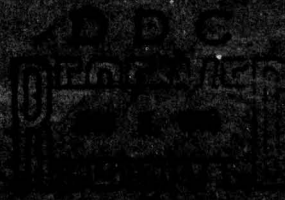

ACCESSION No.	
DTIC	White Section <input checked="" type="checkbox"/>
DDC	Buff Section <input type="checkbox"/>
UNANNOUNCED	<input type="checkbox"/>
JUSTIFICATION	
BY	
DISTRIBUTION/AVAILABILITY CODES	
DTIC	UNANNOUNCED/SPECIAL
A	

DEPARTMENT OF CIVIL ENGINEERING
AND ENGINEERING MECHANICS

Strain Energy Expressions of Rings of Rectangular, T- and I- Section,
Suitable for the Dynamic Analysis of Ring-Stiffened Cylindrical Shells.

by

Hans H. Bleich

Office of Naval Research
Contract N00014-75-C-0695
Technical Report No. 51

October, 1976

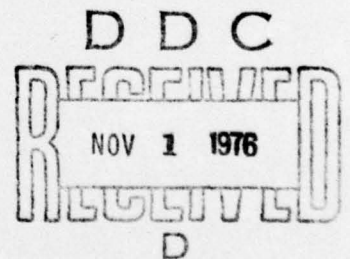

"Approved for public release; distribution unlimited."

ABSTRACT

Strain energy expressions are obtained for rings of rectangular, T- and I- section. The expressions are intended for use in the dynamic analysis of ring stiffened cylindrical shells. The approach is essentially a generalization of the conventional, approximate analysis of straight beams, i.e. the influence of shear stresses, and of direct stresses at right angles to the axis of the beams is neglected.

1. INTRODUCTION

The results obtained in this study will facilitate the determination of the modes of free vibration and/or of the dynamic response of ring-stiffened cylindrical shells. Expressions for the potential energy of the stiffeners in their most general state of displacement will be derived. The strain energies are obtained on the basis of "beam theory," i.e. the expressions are generalizations of those conventionally used for straight beams when shear effects and stresses at right angles to the axis of the beam are ignored. The approach is similar to the treatment of straight beams of thin-walled section in Ref. 1, Chapter 5, where the sections are considered to be built up from a number of flat plates for each of which the strain energy from elementary beam theory is known. Making the assumption that the shape of the cross section does not change, the energy in each plate can be expressed by the global coordinates of the bar. Allowing for the continuity of strains wherever two of the plates are jointed, strain energy expressions and the location of the shear center are obtained.

In the present treatment the elements of which the bars consist are either not flat, or not straight. The sections shown in Figs. 1a, b, and c will be treated. The ring in Fig. 1a is of simple rectangular cross section; it is really a flat plate of annular shape. In Fig. 1b the section is a T. The web is again an annular flat plate, while the flange is a short segment of a cylindrical shell. The third case, Fig. 1c, consists of three parts of similar nature. Expressions for the strain

energies of the elements are derived in the Appendices, using appropriately simplified relations available from plate and shell theories. For deformation of the entire bar in the plane of curvature a generalization of conventional beam theory is used, which assumes that plane sections remain plane, and also at right angles to the deformed center line.

The expressions in the Appendices could also be used to treat nonsymmetric cases like U- or L- stiffeners, Figs. 1d, e. These cases are not included because their use seems rather unlikely.

The strain energy expressions V obtained may be used in various, fairly obvious ways. They may be utilized to find the boundary conditions at the stiffeners for the a priori known partial differential equations for vibrations of the shell by using Hamilton's principle,

$$\int (V - T) dt = \text{extremum} \quad (1)$$

and applying calculus of variation with respect to the shell coordinates x and ϕ , Fig. 2. V and T are the strain energy and the kinetic energy, respectively.

As an alternative, one can use a Raleigh-Ritz approach and introduce appropriate approximation for the shell displacements u, v, w , Fig. 3, into Eq. (1).

As a further alternative, one may introduce into Eq. (1) the expressions

$$\begin{aligned}u &= U_n(x) \cos(n\phi + \alpha) \\v &= V_n(x) \sin(n\phi + \alpha) \\w &= W_n(x) \cos(n\phi + \alpha)\end{aligned}\tag{2}$$

where α is a phase angle. This substitution reduces the partial differential equations of the shell to three ordinary, simultaneous ones in U , V and W .

For either of the alternatives, a suitable expression for the strain energy of the cylindrical shell may be found in Ref. 2.

II. STIFFENING RINGS OF RECTANGULAR CROSS SECTION, FIG. 1a

Fig. 4a shows a portion of the shell of thickness t and radius a and an interior stiffener of depth d and thickness h . The depth d is a nominal one, measured from the center surface of the shell to the innermost edge of the stiffener, Fig. 4a. This figure also shows the centroid O of the stiffener cross section, and the radius R_O of the centroidal circle. Fig. 4b shows the original and the displaced center lines of shell and stiffener, and the displacements u_O, w_O of the centroid O as well as the rotation β . The out-of-plane displacement is v_O , but cannot be indicated in Fig. 4b.

Using Eqs. (A-13) and (A-22) for the portions of the strain energy of the stiffener in and out of the plane of curvature, respectively,

$$\begin{aligned}
 V = \frac{1}{2} \int \left[\frac{EZ}{R_O^3} \left(\frac{\partial^2 w_O}{\partial \phi^2} + w_O \right)^2 + \frac{EA}{R_O} \left(w_O + \frac{\partial v_O}{\partial \phi} \right)^2 + \right. \\
 \left. + \frac{EI_O}{R_O^3} \left(\frac{\partial u_O}{\partial \phi} + R_O \beta \right)^2 + \frac{GJ_O}{R_O^3} \left(\frac{\partial u_O}{\partial \phi} - R_O \frac{\partial \beta}{\partial \phi} \right)^2 \right] d\phi
 \end{aligned} \tag{3}$$

where

$$Z = \frac{hd^3}{12}, \quad A = hd, \quad I_O = \frac{h^3d}{12}, \quad J_O = \frac{h^3d}{3}, \quad R_O = a - \frac{d}{2} \tag{4}$$

The value of Z is approximate, but suitable if $d \ll a$. The displacements u_O, w_O and β can be expressed from geometry by the shell displacements at point A , Figs. 4a, 4b,

$$w_O = w_A, \quad \beta = -\frac{\partial w_A}{\partial x}, \quad u_O = u_A - \frac{d}{2} \beta \equiv u_A + \frac{d}{2} \frac{\partial w_A}{\partial x} \quad (5)$$

The quantity v_O appears in Eq. (3) only in the form $\frac{\partial v_O}{\partial \phi}$. To express this derivative, the equality of the strains in shell and stiffener at point A, Fig. 4a, is used

$$\frac{1}{a} \frac{\partial v_A}{\partial \phi} + \frac{1}{a} w_A = \frac{w_O}{R_O} + \frac{1}{R_O} \frac{\partial v_O}{\partial \phi} - \frac{d}{2aR_O} \left(\frac{\partial^2 w_A}{\partial \phi^2} + w_A \right) \quad (6)$$

The left hand side of this equation is the membrane strain in the shell at point A, while the right hand side is obtained from Eq. (A-15) for $\eta = d/2$. Noting the relation between a and R_O gives

$$\frac{\partial v_O}{\partial \phi} = \frac{d}{2a} \frac{\partial^2 w_A}{\partial \phi^2} + \frac{R_O}{a} \frac{\partial v_A}{\partial \phi} \quad (7)$$

Substitution into Eq. (3) gives the strain energy in the ring stiffener in terms of u_A , v_A and w_A ,

$$\begin{aligned} V = \frac{1}{2} \int & \left[\frac{EZ}{R_O^3} \left(\frac{\partial^2 w_A}{\partial \phi^2} + w_A \right)^2 + \frac{EA}{R_O} \left(w_A + \frac{d}{2a} \frac{\partial^2 w_A}{\partial \phi^2} + \frac{R_O}{a} \frac{\partial v_A}{\partial \phi} \right)^2 + \right. \\ & \left. + \frac{EI_O}{R_O^3} \left(\frac{\partial^2 u_A}{\partial \phi^2} + \frac{d}{2} \frac{\partial^3 w_A}{\partial x \partial \phi^2} - R_O \frac{\partial w_A}{\partial x} \right)^2 \right. \\ & \left. + \frac{GJ_O}{R_O^3} \left(\frac{\partial u_A}{\partial \phi} + a \frac{\partial^2 w_A}{\partial \phi^2} \right)^2 \right] d\phi \quad (8) \end{aligned}$$

If desired, one could introduce the approximation $R_O \approx a$, but the resulting simplification is hardly worthwhile.

III. STIFFENING RINGS OF T-SECTION, FIG. 1b

Figure 5a shows the shell and an interior stiffener and all dimensions. The centroid of the stiffener is at a distance e from the middle surface of the shell. Figures 5b and 5c show the web and flange in their original and in their displaced positions, respectively. Also shown are the centroids O_w and O_1 and their displacements.

The strain energy of the entire stiffener due to displacements w_0 and v_0 is

$$V(v_0, w_0) = \frac{1}{2} \int \left[\frac{EZ_0}{R_0^3} \left(\frac{\partial^2 w_0}{\partial \phi^2} + w_0 \right)^2 + \frac{EA_0}{R_0} \left(w_0 + \frac{\partial v_0}{\partial \phi} \right)^2 \right] d\phi \quad (9)$$

where $Z_0 = I_0$ and A_0 are the moment of inertia and the area of the section, respectively.

The strain energies due to the displacement in the x-direction and rotation for the web, V_w , and for the flange, V_1 , are according to Eqs. (A-22) and (A-32), respectively,

$$V_w(u_w, \beta) = \frac{1}{2} \int \left[\frac{EI_w}{R_w^3} \left(\frac{\partial^2 u_w}{\partial \phi^2} + R_w \beta \right)^2 + \frac{GJ_w}{R_w^3} \left(\frac{\partial u_w}{\partial \phi} - R_w \frac{\partial \beta}{\partial \phi} \right)^2 \right] d\phi \quad (10)$$

$$V_1(u_1, \beta) = \frac{1}{2} \int \left[\frac{EI_1}{R_1^3} \left(\frac{\partial^2 u_1}{\partial \phi^2} + R_1 \beta \right)^2 + \frac{GJ_1}{R_1^3} \left(\frac{\partial u_1}{\partial \phi} - R_1 \frac{\partial \beta}{\partial \phi} \right)^2 \right] d\phi \quad (11)$$

where the section properties are defined by

$$I_w = \frac{dh^3}{12}, \quad J_w = \frac{dh^3}{3}, \quad I_1 = \frac{t_1 b^3}{12}, \quad J_1 = \frac{bt_1^3}{3} \quad (12)$$

The displacements w_O , u_1 and u_w can be expressed by the equivalent quantities at point A. The relations are

$$w_O = w_A, \quad u_w = u_A - \frac{d}{2} \beta, \quad u_1 = u_A - d\beta, \quad \beta = - \frac{\partial w_A}{\partial x} \quad (13)$$

To express $\frac{\partial v_O}{\partial \phi}$, the strain in the shell at point A, and the strain in the web at the same point are equated

$$\frac{1}{a} w_A + \frac{1}{a} \frac{\partial v_A}{\partial \phi} = \frac{1}{R_O} (w_O + \frac{\partial v_O}{\partial \phi}) - \frac{e}{R_O(R_O+e)} (\frac{\partial^2 w_O}{\partial \phi^2} + w_O) \quad (14)$$

The right-hand side of this equation is Eq. (A-15) for $\eta = e$.

After simplification

$$\frac{\partial v_O}{\partial \phi} = \frac{e}{a} \frac{\partial^2 w_A}{\partial \phi^2} + \frac{R_O}{a} \frac{\partial v_A}{\partial \phi} \quad (15)$$

The total strain energy is the sum of Eqs. (9), (10) and (11). After substitution of Eqs. (13) and (15)

$$\begin{aligned}
 v = \frac{1}{2} \int & \left\{ \frac{EI_O}{R_O^3} \left(\frac{\partial^2 w_A}{\partial \phi^2} + w_A \right)^2 + \frac{EA_O}{R_O a^2} \left(a w_A + e \frac{\partial^2 w_A}{\partial \phi^2} + R_O \frac{\partial v_A}{\partial \phi} \right)^2 + \right. \\
 & + \frac{EI_W}{R_1^3} \left[\frac{\partial^2 u_A}{\partial \phi^2} + \frac{d}{2} \frac{\partial^3 w_A}{\partial x \partial \phi^2} - \left(a - \frac{d}{2} \right) \frac{\partial w_A}{\partial \phi} \right]^2 + \\
 & + \frac{EI_1}{R_1^3} \left[\frac{\partial^2 u_A}{\partial \phi^2} + d \frac{\partial^3 w_A}{\partial x \partial \phi^2} - (a - d) \frac{\partial w_A}{\partial \phi} \right]^2 + \\
 & \left. + G \left(\frac{J_W}{R_W^3} + \frac{J_1}{R_1^3} \right) \left(\frac{\partial u_A}{\partial \phi} + a \frac{\partial^2 w_A}{\partial x \partial \phi} \right)^2 \right\} d\phi
 \end{aligned} \tag{16}$$

This expression can be somewhat simplified, if desired, by noting that $d \ll a$, and that for thin-walled sections $I_W \ll I_1$. Using also

$$R_O \simeq R_1 \simeq R_W \simeq a \simeq d \simeq a - 2d \simeq a$$

one obtains

$$\begin{aligned}
 v = \frac{1}{2a^3} \int & \left\{ EI_O \left(\frac{\partial^2 w_A}{\partial \phi^2} + w_A \right)^2 + EA_O \left(a w_A + e \frac{\partial^2 w_A}{\partial \phi^2} + a \frac{\partial v_A}{\partial \phi} \right)^2 + \right. \\
 & + EI_1 \left(\frac{\partial^2 u_A}{\partial \phi^2} + d \frac{\partial^3 w_A}{\partial x \partial \phi^2} - a \frac{\partial w_A}{\partial \phi} \right)^2 + G (J_W + J_1) \left(\frac{\partial u_A}{\partial \phi} + a \frac{\partial^2 w_A}{\partial x \partial \phi} \right)^2 \left. \right\} a d\phi
 \end{aligned} \tag{17}$$

IV. I-BEAM STIFFENING RINGS, FIG. 1c

Figure 6a shows a cross section of the shell and of the stiffening ring inside the shell. The centroid of the web and of the entire stiffener is at O. The properties of the web and its displacements will carry the subscript O. The two flanges are of equal dimensions, b by t_1 , and their centroids are O_1, O_2 , respectively. The displacements of the two centroids carry the subscripts 1, 2, respectively.

Just as in Sections I and II, the portion of the strain energy $V(w_O, v_O)$ is given by Eq. (A-13),

$$V(w_O, v_O) + \frac{1}{2} \int \left[\frac{EZ}{R_O^3} \left(\frac{\partial^2 w_O}{\partial \phi^2} + w_O \right)^2 + \frac{EA}{R_O} \left(w_O + \frac{\partial v_O}{\partial \phi} \right)^2 \right] d\phi \quad (18)$$

where A and Z are the area, and the moment of inertia of the entire section.

The portion V_O of the strain energy of the web due to the displacements u_O and β is according to Eq. (A-22)

$$V_O(u_O, \beta) = \frac{1}{2} \int \left[\frac{EI_O}{R_O^3} \left(\frac{\partial^2 u_O}{\partial \phi^2} + R_O \beta \right)^2 + \frac{GJ_O}{R_O^3} \left(\frac{\partial u_O}{\partial \phi} - R_O \frac{\partial \beta}{\partial \phi} \right)^2 \right] d\phi \quad (19)$$

where

$$I_O = \frac{dh^3}{12}, \quad J_O = \frac{dh^3}{3}, \quad R_O = a - e - \frac{d}{2} \quad (20)$$

The portions of the strain energy due to the displacements of the two flanges u_i and β are, respectively, from Eq. (A-32)

$$V_1(u_1, \beta) = \frac{1}{2} \int \left[\frac{EI}{R_1^3} \left(\frac{\partial^2 u_1}{\partial \phi^2} + R_1 \beta \right)^2 + \frac{GJ}{R_1^3} \left(\frac{\partial u_1}{\partial \phi} - R_1 \frac{\partial \beta}{\partial \phi} \right)^2 \right] d\phi \quad (21)$$

$$V_2(u_2, \beta) = \frac{1}{2} \int \left[\frac{EI}{R_2^3} \left(\frac{\partial^2 u_2}{\partial \phi^2} + R_2 \beta \right)^2 + \frac{GJ}{R_2^3} \left(\frac{\partial u_2}{\partial \phi} - R_2 \frac{\partial \beta}{\partial \phi} \right)^2 \right] d\phi \quad (22)$$

where u_1, u_2 are the displacements of the flanges 1 and 2, respectively, and

$$I = \frac{t_1 b^3}{12}, \quad J = \frac{t_1^3 b}{3}, \quad R_1 = a - e, \quad R_2 = a - e - d \quad (23)$$

Referring to Fig. 6b, the displacements, except v_i , can be expressed by the displacements of the shell at point A,

$$\begin{aligned} w_O = w_A, \quad \beta = -\frac{\partial w_A}{\partial x}, \quad u_O = u_A - \left(\frac{d}{2} + e\right) \beta = u_A + \left(\frac{d}{2} + e\right) \frac{\partial w_A}{\partial x}, \\ u_1 = u_A - e\beta = u_A + e \frac{\partial w_A}{\partial x}, \quad u_2 = u_A - (d + e)\beta = u_A + (d + e) \frac{\partial w_A}{\partial x} \end{aligned} \quad (24)$$

The equality of the hoop strains at A in the shell and in the stiffener, with $\eta = e + d/2$ gives

$$\frac{1}{a} \left(w_A + \frac{\partial v_A}{\partial \phi} \right) = \frac{1}{R_O} \left(w_O + \frac{\partial v_O}{\partial \phi} \right) - \frac{d + ze}{R_O (2R_O + d + 2e)} \left(\frac{\partial^2 w_O}{\partial \phi^2} + w_O \right)$$

and after simplification

$$\frac{\partial v_O}{\partial \phi} = \frac{d + 2e}{2a} \frac{\partial^2 w_A}{\partial \phi^2} + \frac{R_O}{a} \frac{\partial v_A}{\partial \phi} \quad (25)$$

Using Eqs. (24) and (25), the four Eqs. (18), (19), (21) and (22) become

$$\begin{aligned}
 V(w_0, v_0) &= \frac{1}{2} \int \left[\frac{EZ}{R_0^3} \left(\frac{\partial^2 w_A}{\partial \phi^2} + w_A \right)^2 + \frac{EA}{R_0} \left(w_A + \frac{d+2e}{2a} \frac{\partial^2 w_A}{\partial \phi^2} + \frac{2a-d-2e}{2a} \frac{\partial v_A}{\partial \phi} \right)^2 \right] d\phi \\
 V_0(u_0, \beta) &= \frac{1}{2} \int \left[\frac{EI_0}{R_0^3} \left(\frac{\partial^2 u_A}{\partial \phi^2} + \frac{d+2e}{2} \frac{\partial^3 w_A}{\partial x \partial \phi^2} - R_0 \frac{\partial w_A}{\partial x} \right)^2 + \frac{GJ_0}{R_0^3} \left(\frac{\partial u_A}{\partial \phi} + a \frac{\partial^2 w_A}{\partial x \partial \phi} \right)^2 \right] d\phi \\
 V_1(u_1, \beta) &= \frac{1}{2} \int \left[\frac{EI}{R_1^3} \left(\frac{\partial^2 u_A}{\partial \phi^2} + e \frac{\partial^3 w_A}{\partial x \partial \phi^2} - R_1 \frac{\partial w_A}{\partial x} \right)^2 + \frac{GJ}{R_1^3} \left(\frac{\partial u_A}{\partial \phi} + a \frac{\partial^2 w_A}{\partial x \partial \phi} \right)^2 \right] d\phi \\
 V_2(u_2, \beta) &= \frac{1}{2} \int \left\{ \frac{EI}{R_2^3} \left[\frac{\partial^2 u_A}{\partial \phi^2} + (d+e) \frac{\partial^3 w_A}{\partial x \partial \phi^2} - R_2 \frac{\partial v_A}{\partial \phi} \right]^2 + \frac{GJ}{R_2^3} \left(\frac{\partial u_A}{\partial \phi} + a \frac{\partial^2 w_A}{\partial x \partial \phi} \right)^2 \right\} d\phi
 \end{aligned} \tag{26}$$

The entire strain energy V is the sum of the four terms, Eqs. (26). However, some approximations seem permissible. The first term in the relation for V_0 contains the factor $I_0 = dh^3/12$, which is very small in comparison to the similar terms in V_1 and V_2 , where $I = t_1 b^3/12$. For thin-walled sections the term multiplied by I_0 is negligible. Further $e = (t + t_1)/2$ is small compared to d or R . Using $e \simeq 0$ is thus a reasonable approximation. Assuming further that $d \ll a$, one may use approximately $R_0 \simeq R_1 \simeq R_2 \simeq a$. The end result is

$$\begin{aligned} V = \frac{1}{2a^3} \int [EZ \left(\frac{\partial^2 w_A}{\partial \phi^2} + w_A \right)^2 + Ea^2 A \left(w_A + \frac{d}{2a} \frac{\partial^2 w_A}{\partial \phi^2} + \frac{\partial v_A}{\partial \phi} \right)^2 + \\ + EI \left(\frac{\partial^2 u_A}{\partial \phi^2} - a \frac{\partial w_A}{\partial \phi} \right)^2 + EI \left(\frac{\partial^2 u_A}{\partial \phi^2} + d \frac{\partial^3 v_A}{\partial x \partial \phi^2} - a \frac{\partial w_A}{\partial x} \right)^2 + \\ + G(J_0 + 2J) \left(\frac{\partial u_A}{\partial \phi} + a \frac{\partial^2 w_A}{\partial x \partial \phi} \right)^2] d\phi \end{aligned} \quad (27)$$

V. SUMMARY

Strain energy expressions have been obtained for ring stiffeners of the types shown in Figs. 1a, b and c. The results are, respectively, given by Eqs. (8), (17) and (27). The stiffeners shown in Fig. 1 are all on the inside of the shell. However the results obtained are also applicable to stiffeners of the same type on the outside of the shell. In such cases the quantities d and e occurring in Eqs. (8), (17) and (27) must be replaced by $-d$, $-e$, respectively.

Possible applications for the strain energy expressions are indicated in the Introduction. The suggested uses require an expression for the strain energy of shell panels adjoining the stiffeners. Such an expression is available in Ref. 2. Defining the shell displacements u, v and w as shown in Fig. 3, the strain energy of a panel is

$$\begin{aligned}
 U = & \frac{E}{2(1-\nu^2)} \frac{h}{a} \iint [a^2 u_x^2 + (v_\phi + w)^2 + 2av u_x (v_\phi + w) + \frac{1-\nu}{2} (u_\phi + av_x)^2] dx d\phi \\
 & + \frac{E}{24(1-\nu^2)} \frac{h^3}{a^3} \iint [a^4 w_{xx}^2 + (w_{\phi\phi} + w)^2 + \frac{1-\nu}{2} ((aw_{x\phi} + u_\phi)^2 \quad (28) \\
 & + \frac{3(1-\nu)}{2} a^2 (v_x - w_{x\phi})^2 + 2va^2 w_{xx} (w_{\phi\phi} - v_\phi) - 2a^3 u_x w_{xx}] dx d\phi
 \end{aligned}$$

where t is the shell thickness, and the subscripts x or ϕ indicate partial derivatives with respect to x or ϕ . The double integrals extend over the area of the shell panel.

APPENDIX 1.

Strain energy of a circular curved bar due to deformation v, w
in the plane of curvature, Fig. A-1.

Consider an element of a curved bar, Fig. A-2, the cross section of which is symmetric to the plane of curvature. The element is stressed by a moment M and a direct force N , both in the plane of curvature. The small deflections of a point P in the location ϕ can be described by the radial component w and the tangential component v , Fig. A-1. Figs. A-1 and 2 show I-beams with unequal flanges, which are generalizations of the three specific cases, Figs. 1a, b and c, needed in the body of the report.

The approach used is a generalization of the simple Navier-Euler theory in straight beams, which assumes that only stresses in the axial direction contribute materially to the strain energy. Stresses in the radial direction and shear stresses, both of which must exist, are thus assumed to contribute only negligibly to the strain energy. The assumption that plane cross sections remain plane and at right angles to the deformed center line of the bar, leads to the distribution of bending stresses as obtained in the classical treatment of Winkler-Resal. The following is not concerned with a re-derivation of the equations for the stresses, but with the formulation of strain energy expressions in terms of derivatives of v and w . Such expressions seem not to be available in the literature.

Consider an element of the bar of length ds in its original and in its distorted shape, Fig. A-2. The centroidal axis of original length ds will be lengthened by Δds , and the angle between the two faces will change, as shown in the same figure, by $\frac{\Delta ds}{R} + \Delta d\phi$.

Considering an element dA at a radial distance η from the centroid, one can compute strain and stress in the element as function of Δds and $\Delta d\phi$

$$\sigma = E \left(\frac{1}{R} \frac{\Delta ds}{d\phi} + \frac{\eta}{R + \eta} \frac{\Delta d\phi}{d\phi} \right) \quad (A-1)$$

As usual, the quantity Z is introduced

$$Z = R \int \frac{\eta^2}{R + \eta} dA \equiv - R^2 \int \frac{\eta dA}{R + \eta} \quad (A-2)$$

If the depth of the bar is small compared to the radius R , the value of Z is practically identical to the moment of inertia I . In the body of the report, it will be assumed that $Z \approx I$. Comparing the resultants of the stresses given by Eq. (A-1), and M and N , one can determine Δds and $\Delta d\phi$,

$$\begin{aligned} \frac{\Delta d\phi}{d\phi} &= \frac{R^3 M}{EZ} \\ \frac{\Delta ds}{d\phi} &= \frac{R}{EA} \left(N + \frac{M}{R} \right) \end{aligned} \quad (A-3)$$

The strain energy dV in the element of length $ds = R d\phi$ being equal to the work done by the forces M and N during the distortion of the element, one finds

$$V = \int dV R d\phi = \frac{1}{2} \int \left[\frac{EZ}{R} \left(\frac{\Delta d\phi}{d\phi} \right)^2 + \frac{EA}{R} \left(\frac{\Delta ds}{d\phi} \right)^2 \right] d\phi \quad (A-4)$$

The quantities $\frac{\Delta d\phi}{d\phi}$ and $\frac{\Delta ds}{d\phi}$ are to be expressed in terms of v and w , which are the components of the displacement of the centroid O of the cross section. Figure A-3 shows the original and the distorted element superimposed on each other. Using polar coordinates, $\rho(\phi) = R + w(\phi)$, the curvature of the original center line is $1/R$, while the curvature $1/R_1$ of the distorted center line is, with $\rho = R + w$,

$$\frac{1}{R_1} = \frac{\rho^2 + 2 \left(\frac{d\rho}{d\phi} \right)^2 - \rho \frac{d^2\rho}{d\phi^2}}{\left[\rho^2 + \left(\frac{d\rho}{d\phi} \right)^2 \right]^{3/2}} \approx \frac{1}{R+w} - \frac{1}{(R+w)^2} \frac{d^2w}{d\phi^2} \quad (A-5)$$

The approximate result is obtained by using the fact that

$\left(\frac{dw}{d\phi} \right)^2 \ll (R+w)^2$. Forming the expression $1/R_1 - 1/R$, and allowing for $w \ll R$, and $ds \equiv R d\phi$, one finds

$$\frac{1}{R_1} - \frac{1}{R} = - \frac{w}{R(R+w)} - \frac{1}{(R+w)^2} \frac{d^2w}{d\phi^2} \approx - \frac{1}{R^2} \left(\frac{d^2w}{d\phi^2} + w \right) \quad (A-6)$$

In addition to above relation there is a geometric one between R , R_1 , Δds and $\Delta d\phi$, which can be read from Fig. A-3. The total length of the distorted axis, $ds + \Delta ds$, must equal the new radius R_1 multiplied by the angle α enclosed by the two faces of the deformed element. Thus

$$R_1 \alpha \equiv R_1 \left(\frac{ds}{R} + \Delta d\phi + \frac{\Delta ds}{R} \right) = \Delta s + \Delta ds \quad (A-7)$$

Rearranging and dividing by $R_1 R d\phi$ gives

$$\frac{1}{R_1} - \frac{1}{R} = \frac{1}{R} \frac{\Delta d\phi}{d\phi} + \frac{\Delta ds}{d\phi} \frac{R_1 - R}{R^2 R_1} \approx \frac{1}{R} \frac{\Delta d\phi}{d\phi} \quad (A-8)$$

The approximation in Eq. (A-8) is permissible because $(R_1 - R)/R$ is inherently a small quantity in comparison to unity. Equations (A-6) and (A-8) furnish

$$\frac{\Delta d\phi}{\phi d} = - \frac{1}{R} \left(\frac{d^2 w}{d\phi^2} + w \right) \quad (A-9)$$

In conjunction with Eq. (A-3) this relation leads to the well-known differential equation for the radial displacement w , see Ref. (3).

An additional geometric relation can be obtained from Fig. A-4. The end points A and B of the element ds displace to A' and B', respectively. The distances $\overline{CA'}$ and $\overline{CB'}$ follow from Fig. A-4, where quantities which are small of higher order are neglected.

$$\overline{CA'} = dw - v d\phi - dv d\phi \approx dw - \frac{1}{R} v ds \quad (A-10)$$

$$\overline{CB'} = R d\phi + w d\phi + dv + dw d\phi \approx ds + \frac{1}{R} w ds + dv$$

Further

$$\frac{1}{ds} \overline{A'B'} \equiv 1 + \frac{\Delta ds}{ds} = \sqrt{\left(1 + \frac{w}{R} + \frac{dv}{ds}\right)^2 + \left(\frac{dw}{ds} - \frac{v}{R}\right)^2} \quad (A-11)$$

Expanding the square root by the binomial law and neglecting higher order terms gives

$$\frac{\Delta ds}{d\phi} = w + \frac{dv}{d\phi} \quad (A-12)$$

Substitution into Eq. (A-4) gives finally the strain energy expression

$$V = \frac{1}{2} \int \left[\frac{EZ}{R^3} \left(\frac{d^2 w}{d\phi^2} + w \right)^2 + \frac{EA}{R} \left(w + \frac{dv}{d\phi} \right)^2 \right] d\phi \quad (A-13)$$

It is noted that the second Eq. (A-3) and Eq. (A-12) give the differential equation

$$\frac{w}{R} + \frac{dv}{ds} = \frac{1}{EA} \left[N + \frac{M}{R} \right] \quad (A-14)$$

Conventional texts contain only an approximation of the equation where the term M/R does not appear.

It will also be necessary to have an expression for the strain in a location η , Fig. A-2. Using Eqs. (A-1), (A-9) and (A-12) one finds

$$\epsilon_{\phi} = \frac{1}{R} \frac{\Delta ds}{d\phi} + \frac{\eta}{R+\eta} \frac{\Delta ds}{d\phi} = \frac{1}{R} \left(w + \frac{dv}{d\phi} \right) - \frac{\eta}{R(R+\eta)} \left(\frac{d^2 w}{d\phi^2} + w \right) \quad (A-15)$$

APPENDIX 2.

Strain energy of a thin annular plate, displaced at right angles to its middle plane, Fig. 5.

The web of a ring stiffener of a shell, Fig. 1a, b or c, may be considered as an annular plate. An expression for the strain energy of such a plate in polar coordinates can be found in Ref. (4 p. 346, Eq. (o)). This expression is a double integral over three major terms. The sum of the first two terms can be recognized as due to the direct stresses, while the third is due to the shear stresses. Let $V = V_1 + V_2$, and using the symbol \bar{u} for the normal displacements of the plate,

$$V_1 = \frac{D}{2} \iint \left[\left(\frac{\partial^2 \bar{u}}{\partial r^2} + \frac{1}{r} \frac{\partial \bar{u}}{\partial r} + \frac{1}{r^2} \frac{\partial^2 \bar{u}}{\partial \phi^2} \right)^2 - 2(1-\nu) \frac{\partial^2 \bar{u}}{\partial r^2} \left(\frac{1}{r} \frac{\partial \bar{u}}{\partial r} + \frac{1}{r^2} \frac{\partial^2 \bar{u}}{\partial \phi^2} \right) \right] r dr d\phi \quad (A-16a)$$

$$V_2 = \frac{D}{2} 2(1-\nu) \iint \left(\frac{1}{r} \frac{\partial^2 \bar{u}}{\partial r \partial \phi} - \frac{1}{r^2} \frac{\partial^2 \bar{u}}{\partial \phi^2} \right)^2 r dr d\phi \quad (A-16b)$$

Consistent with the assumption that the only stresses contributing materially to the strain energy V_1 of bending are direct stresses σ_ϕ , the term D in (A-16a) is to be evaluated for $\nu = 0$, while the value $\nu \neq 0$ is retained in Eq. (16-b) for shear effects. Further, as in elementary beam theory, it is assumed that the radial axis of the cross section remains a straight line

$$\bar{u}(r) \equiv \bar{u}(\eta) = u + \eta\beta \quad (\text{A-17})$$

where u is the displacement of the centroid and β the rotation of the cross section. Using $r = R + \eta$, $dr = d\eta$, and Eq. (A-17), one has the relations

$$\frac{\partial^2 \bar{u}}{\partial r^2} \equiv \frac{\partial^2 u}{\partial \eta^2} = 0, \quad \frac{\partial \bar{u}}{\partial r} \equiv \frac{\partial \bar{u}}{\partial \eta} = \beta \quad (\text{A-18})$$

$$\frac{\partial^2 \bar{u}}{\partial \phi^2} = \frac{\partial^2 u}{\partial \phi^2} + \eta \frac{\partial^2 \beta}{\partial \phi^2}, \quad \frac{\partial \bar{u}}{\partial \phi} = \frac{\partial u}{\partial \phi} + \eta \frac{\partial \beta}{\partial \phi}, \quad \frac{\partial^2 \bar{u}}{\partial r \partial \phi} = \frac{\partial \beta}{\partial \phi}$$

After substitution of these relations into Eqs. (A-16) one can integrate with respect to $\eta = r - R$. Using the fact that d/R is small compared to unity, the various integrals can be approximated

$$\int \frac{dr}{r} = \ln \frac{1+d/2R}{1-d/2R} \approx \frac{d}{R}, \quad \int \frac{dr}{r^2} = \frac{d}{R^2 - d^2/4} \approx \frac{d}{R^2},$$

$$\int \frac{dr}{r^3} = -\frac{1}{2(R+d/2)^2} + \frac{1}{2(R-d/2)^2} \approx \frac{d}{R^3} \quad (\text{A-19})$$

One obtains thus

$$V_1 = \frac{1}{2} \frac{Edh^3}{12} \int \frac{1}{R^3} \left(\frac{\partial^2 u}{\partial \phi^2} + R\beta \right)^2 d\phi \quad (\text{A-20})$$

and

$$V_2 = \frac{1}{2} \frac{Gdh^3}{3} \int \frac{1}{R^3} \left(\frac{\partial u}{\partial \phi} - R \frac{\partial \beta}{\partial \phi} \right)^2 d\phi \quad (A-21)$$

As a check on the adequacy of the simplifications made in Eqs. (19) consider a rigid body rotation of the annular plate with respect to the axis $\phi = +\pi/2, \phi = -\pi/2$, where $u = \Delta \cos \phi$, $\beta = \frac{\Delta}{R} \cos \phi$ and Δ is the displacement at $\phi = 0$. Substitution into Eqs. (A-20, 21) indicates that for this displacement $V_1 = V_2 \equiv 0$, as required for a rigid body displacement.

The total strain energy for out-of-plane displacements is thus

$$V = \frac{1}{2R^3} \int \left[\frac{Edh^3}{12} \left(\frac{\partial^2 u}{\partial \phi^2} + R\beta \right)^2 + \frac{Gdh^3}{3} \left(\frac{\partial u}{\partial \phi} - R \frac{\partial \beta}{\partial \phi} \right)^2 \right] d\phi \quad (A-22)$$

The two coefficients appearing in the integrand are the values EI and GJ appearing in the equivalent expressions for a straight beam. For $R \rightarrow \infty$, Eq. (A-22) thus furnishes the conventional value for V for a straight beam.

APPENDIX 3.

Strain energy stored in the flanges of rings of T- and I-Sections

Let the displacements of an arbitrary point P on the middle surface of a flange, Fig. 7, be designated by the symbols u_p, v_p, w_p while the displacements of the centroid O of the undeformable, rectangular cross section are u, v, w and the rotation is β .

Only sections which are symmetric to the plane of curvature are treated so that the strain energy separates into the sum of two terms

$$V = V_1(w, v) + V_2(u, \beta) \quad (A-23)$$

one term depending only on w and v , the other on u and β . The term V_1 has already been obtained in Appendix 1, Eq. (A-13) and the associated strain in Eq. (A-15).

The second term, V_2 , for T- or I-sections will be derived in the body of the report, using an expression for the web alone derived in Appendix 2, in conjunction with a relation to be derived here, treating flanges of rectangular cross section, $b \times t$, as short pieces of cylindrical shells. See Fig. A-7. Assuming that the cross section does not change its shape, the displacements of a point P in the location $\eta, z = 0$, Fig. A-7, are

$$w_p = -\eta\beta, \quad u_p = u \quad v_p = -\frac{\eta}{R} \frac{\partial u}{\partial \phi} \quad (A-24)$$

The strain energy $V_2(u, \beta)$ can be divided in a portion due to hoop strains ϵ_S , and one due to shear strains γ , $V_2 = V_{2\epsilon} + V_{2\gamma}$. Allowing again for the fact that direct stresses other than σ_S are negligible, the value of Poisson's ratio in $V_{2\epsilon}$ is assumed to vanish

$$V_{2\epsilon} = \frac{E}{2} \iiint \epsilon_S^2 d\eta dz (R + z) d\phi \quad (\text{A-25})$$

while the usual value of ν is retained in

$$V_{2\gamma} = \frac{G}{2} \iiint \gamma^2 d\eta dz (R + z) d\phi \quad (\text{A-26})$$

When evaluating Eq. (A-25) it is assumed that the bending strains do not vary significantly through the thickness, $t \ll d$, $t \ll R$, so that

$$V_{2\epsilon} = \frac{Et}{2} \iint \epsilon_S^2 d\eta (R + z) d\phi \simeq \frac{EtR}{2} \iint \epsilon_S^2 d\eta d\phi \quad (\text{A-27})$$

where the value ϵ_S at $z = 0$ is to be used. Reference [5, Eq. (5-b) on p. 209] gives for $z = 0$, after substitution of Eqs. (A-24)

$$\epsilon_S = \frac{1}{R} \frac{\partial v_p}{\partial \phi} + \frac{w_p}{R} = -\frac{\eta}{R^2} \frac{\partial^2 u}{\partial \phi^2} - \frac{\eta}{R} \beta$$

Equation (A-27) gives thus finally

$$V_{2\epsilon} = \frac{1}{2} \frac{Etd^3}{12} \int \frac{1}{R^3} \left(\frac{\partial^2 u}{\partial \phi^2} + R\beta \right)^2 d\phi \quad (\text{A-28})$$

The above integral vanishes, as required, for the rigid body motion $u = \Delta \cos \phi$, $\beta = \frac{\Delta}{R} \cos \phi$.

To evaluate the integral in Eq. (A-26) use is made of Ref. [5, Eq. (5-c)]. The value of the shear strain at an arbitrary point A, Fig. A-7, is expressed by the values at points P on the center plane

$$\gamma_A = \frac{1}{R+z} \frac{\partial u_P}{\partial \phi} + \frac{R+z}{R} \frac{\partial v_P}{\partial \phi} - \frac{\partial^2 w_P}{\partial x \partial \phi} \left(\frac{z}{R} + \frac{z}{R+z} \right) \quad (\text{A-29})$$

Substitution of Eqs. (A-24) gives

$$\gamma_A \equiv \gamma = -z \frac{2R+z}{R^2(R+z)} \frac{\partial u}{\partial \phi} + z \frac{2R+z}{R(R+z)} \frac{\partial \beta}{\partial \phi} \approx -2z \left(\frac{1}{R^2} \frac{\partial u}{\partial \phi} - \frac{1}{R} \frac{\partial \beta}{\partial \phi} \right) \quad (\text{A-30})$$

The approximation used utilizes the fact that $\max z = t/2 \lll a$.

The value of the integral in Eq. (A-26) becomes thus

$$V_{2\gamma} = \frac{1}{2} \frac{Gbt^3}{3} \int \frac{1}{R^3} \left(\frac{\partial u}{\partial \phi} - R \frac{\partial \beta}{\partial \phi} \right)^2 d\phi \quad (\text{A-31})$$

As necessary, this value vanishes for the rigid body motion tested on Eq. (A-28).

The total value of $V_2(u, \beta)$ is

$$V_2(u, \beta) = \frac{1}{2} \frac{Etd^3}{12} \int \frac{1}{R^3} \left(\frac{\partial^2 u}{\partial \phi^2} + R\beta \right)^2 d\phi + \frac{1}{2} \frac{Gbt^3}{3} \int \frac{1}{R^3} \left(\frac{\partial u}{\partial \phi} - R \frac{\partial \beta}{\partial \phi} \right)^2 d\phi \quad (\text{A-32})$$

In the limit, $R \rightarrow \infty$, Eq. (A-32) furnishes the usual expression for the strain energy of a straight bar.

REFERENCES

1. F. Bleich, Buckling Strength of Metal Structures, McGraw-Hill Book Co., 1952.
2. H. H. Bleich and F. DiMaggio, A Strain Energy Expression for Thin Cylindrical Shells, J. of Applied Mechanics, Sept. 1953, pp. 448-449.
3. S. Timoshenko, Strength of Materials, 3rd. ed., McGraw-Hill Book Co., 1958, p. 404.
4. S. Timoshenko and S. Woinowsky-Krieger, Theory of Plates and Shells, 2nd. ed., McGraw-Hill Book Co., 1959.
5. W. Flügge, Stresses in Shells, 2nd. ed., J. Springer 1973, pp. 208, 209, Eqs. (5.5 a-c).

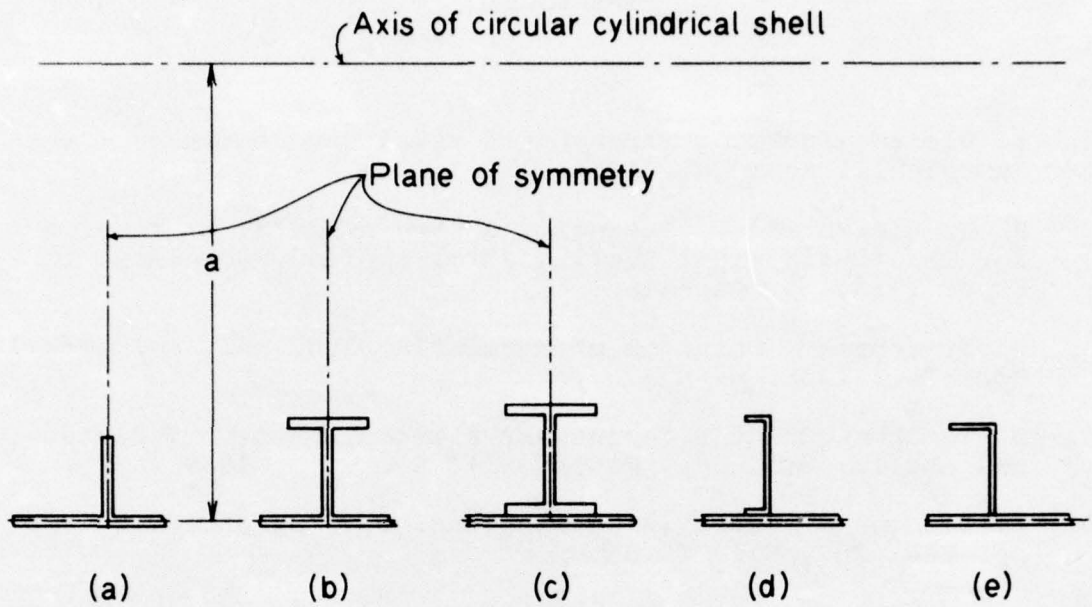

Fig. 1. Cross sections of ring stiffeners

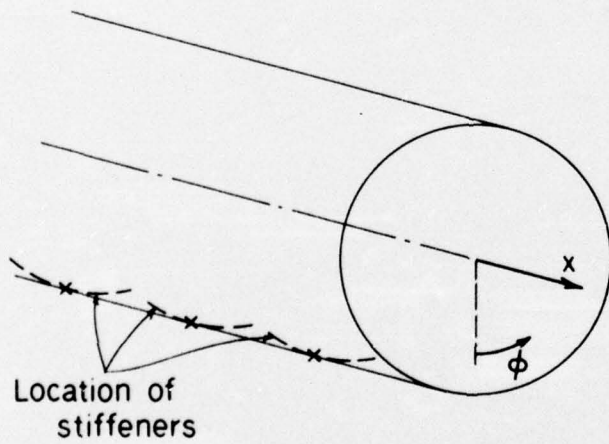

Fig. 2. Shell coordinates x, ϕ

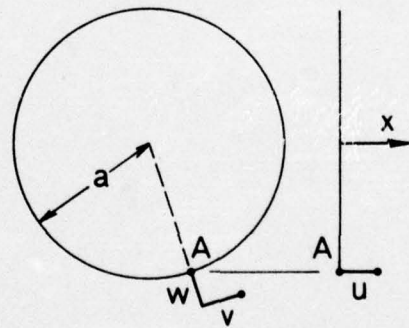

Fig. 3. Components u, v, w of shell displacements

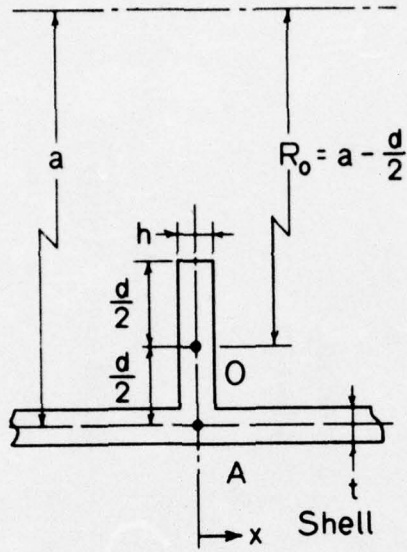

Fig. 4a

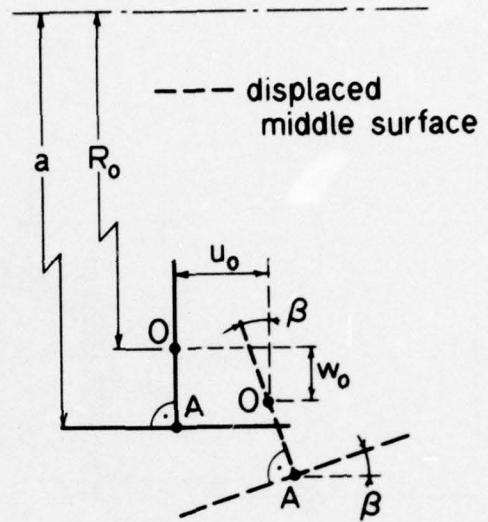

Fig. 4b

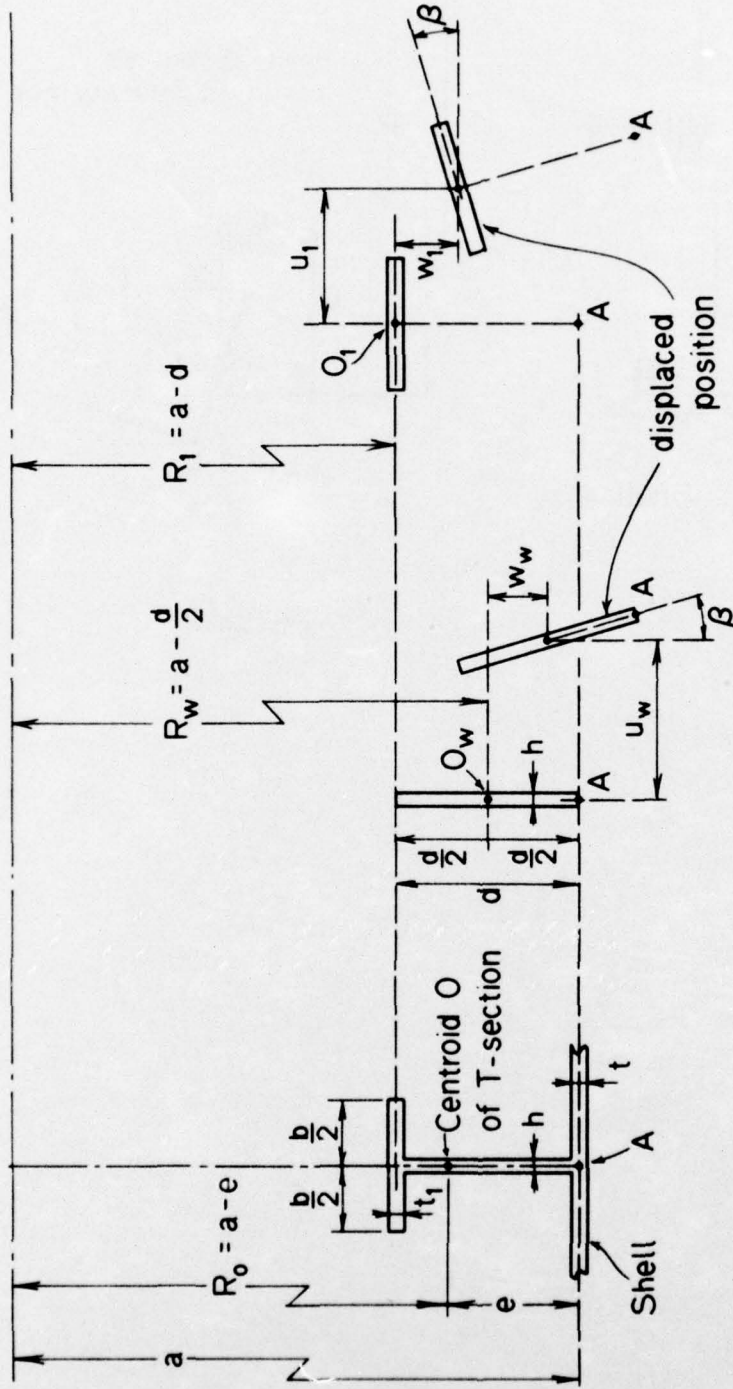

Fig. 5a

Fig. 5b

Fig. 5c

Displaced web

Displaced flange

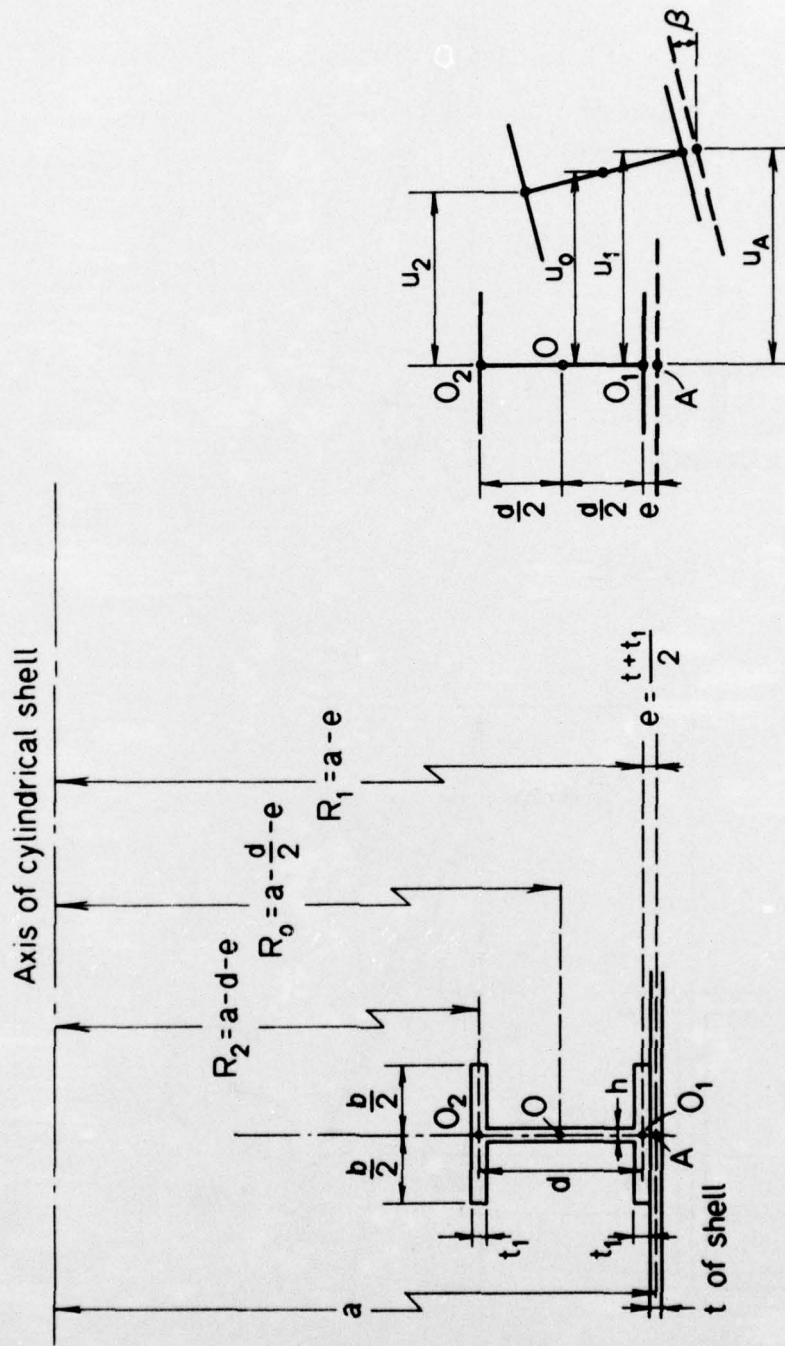

Fig. 6b

Displaced section

Fig. 6a

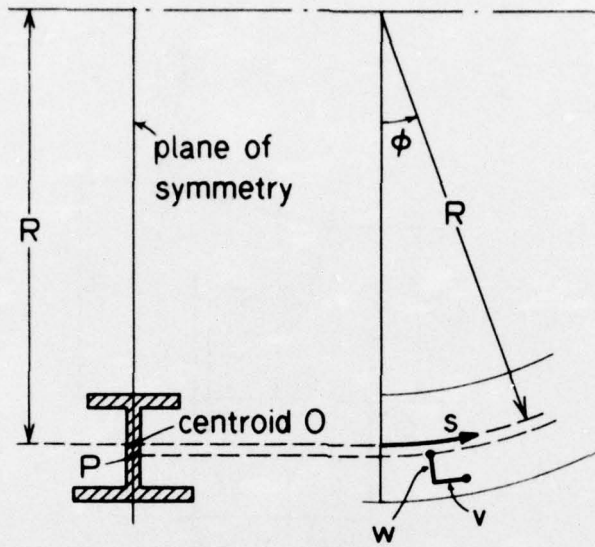

Fig. A-1

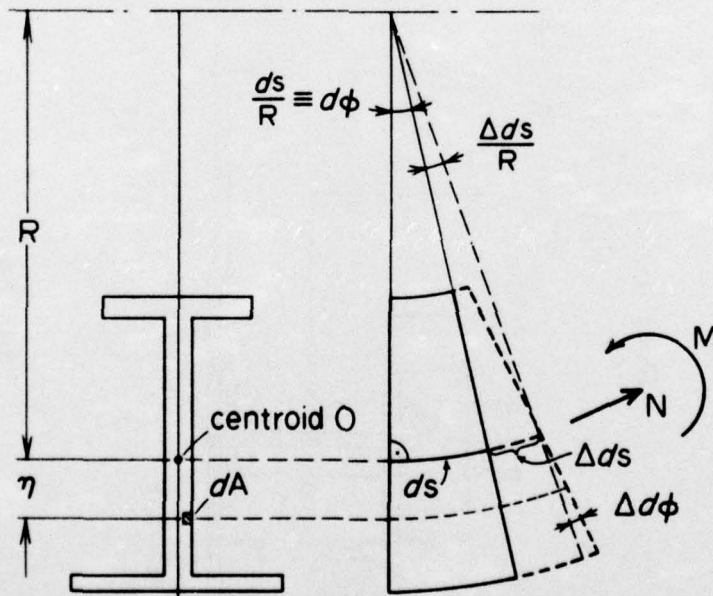

Fig. A-2

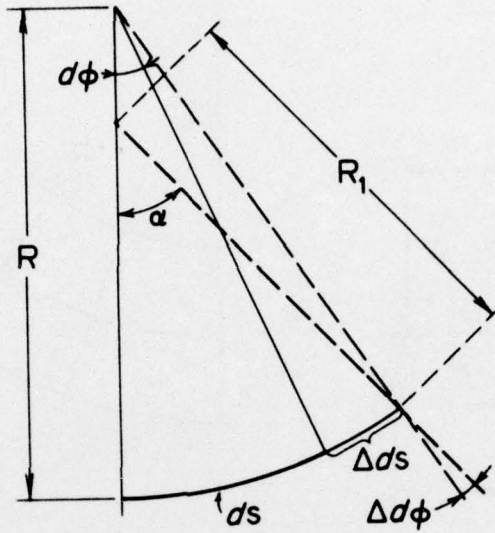

Fig. A-3

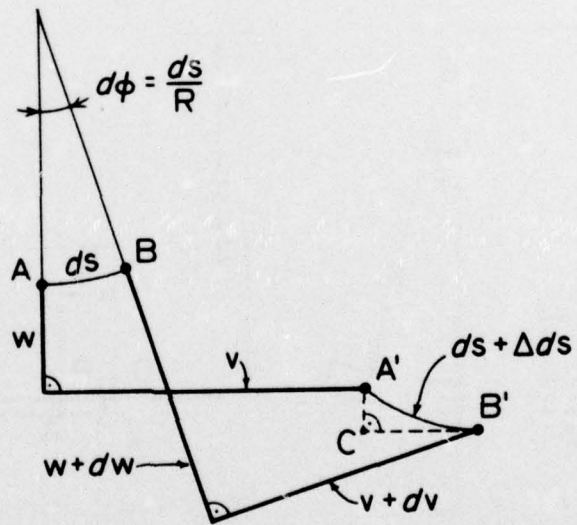

Fig. A-4

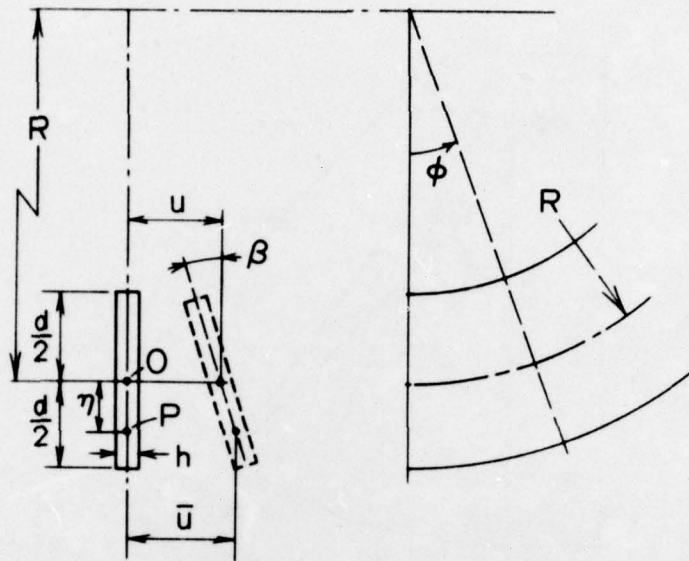

Fig. A-5

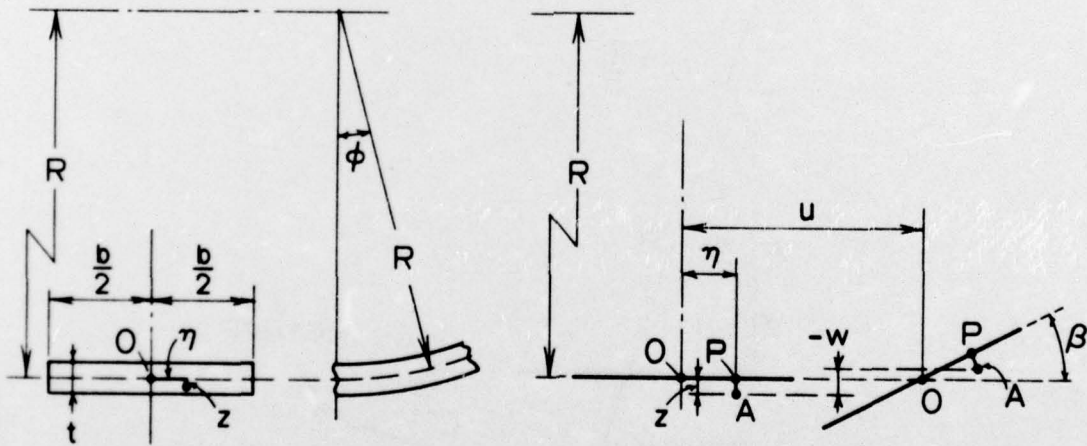

Fig. A-6

Fig. A-7

PART 1 - GOVERNMENT

Administrative & Liaison Activities

Chief of Naval Research
Department of the Navy
Arlington, Virginia 22217
Attn: Code 474 (2)
471
222

Director
ONR Branch Office
495 Summer Street
Boston, Massachusetts 02210

Director
ONR Branch Office
219 S. Dearborn Street
Chicago, Illinois 60604

Director
Naval Research Laboratory
Attn: Code 2629 (ONRL)
Washington, D.C. 20390 (6)

U.S. Naval Research Laboratory
Attn: Code 2627
Washington, D.C. 20390

Commanding Officer
ONR Branch Office
207 West 24th Street
New York, N.Y. 10011

Director
ONR Branch Office
1030 E. Green Street
Pasadena, California 91101

Defense Documentation Center
Cameron Station
Alexandria, Virginia 22314 (12)

Army

Commanding Officer
U.S. Army Research Office Durham
Attn: Mr. J. J. Murray
CRD-AA-IP
Box CM, Duke Station
Durham, North Carolina 27706 2

Commanding Officer
AMXMR-ATL
Attn: Mr. R. Shea
U.S. Army Materials Res. Agency
Watertown, Massachusetts 02172

Watervliet Arsenal
MAGGS Research Center
Watervliet, New York 12189
Attn: Director of Research

Technical Library

Redstone Scientific Info. Center
Chief, Document Section
U.S. Army Missile Command
Redstone Arsenal, Alabama 35809

Army R&D Center
Fort Belvoir, Virginia 22060

Navy

Commanding Officer and Director
Naval Ship Research & Development Center
Bethesda, Maryland 20034
Attn: Code 042 (Tech. Lib. Br.)
17 (Struc. Mech. Lab.)
172
172
174
177
1800 (Appl. Math. Lab.)
5412S (Dr. W.D. Sette)
19 (Dr. M.M. Sevik)
1901 (Dr. M. Strassberg)
1945
196 (Dr. D. Feit)
1962

Naval Weapons Laboratory
Dahlgren, Virginia 22448

Naval Research Laboratory
Washington, D.C. 20375
Attn: Code 8400
8410
8430
8440
6300
6390
6380

Undersea Explosion Research Div.
 Naval Ship R&D Center
 Norfolk Naval Shipyard
 Portsmouth, Virginia 23709
 Attn: Dr. E. Palmer
 Code 780

Naval Ship Research & Development Center
 Annapolis Division
 Annapolis, Maryland 21402
 Attn: Code 2740 - Dr. Y.F. Wang
 28 - Mr. R.J. Wolfe
 281 - Mr. R.B. Niederberger
 2814 - Dr. H. Vanderveldt

Technical Library
 Naval Underwater Weapons Center
 Pasadena Annex
 3202 E. Foothill Blvd.
 Pasadena, California 91107

U.S. Naval Weapons Center
 China Lake, California 93557
 Attn: Code 4062 - Mr. W. Werback
 4520 - Mr. Ken Bischel

Commanding Officer
 U.S. Naval Civil Engr. Lab.
 Code L31
 Port Hueneme, California 93041

Technical Director
 U.S. Naval Ordnance Laboratory
 White Oak
 Silver Spring, Maryland 20910

Technical Director
 Naval Undersea R&D Center
 San Diego, California 92132

Supervisor of Shipbuilding
 U.S. Navy
 Newport News, Virginia 23607

Technical Director
 Mare Island Naval Shipyard
 Vallejo, California 94592

U.S. Navy Underwater Sound Ref. Lab.
 Office of Naval Research
 P.O. Box 8337
 Orlando, Florida 32806

Chief of Naval Operations
 Dept. of the Navy
 Washington, D.C. 20350
 Attn: Code Op07T

Strategic Systems Project Office
 Department of the Navy
 Washington, D.C. 20390
 Attn: NSP-001 Chief Scientist

Deep Submergence Systems
 Naval Ship Systems Command
 Code 39522
 Department of the Navy
 Washington, D.C. 20360

Engineering Dept.
 U.S. Naval Academy
 Annapolis, Maryland 21402

Naval Air Systems Command
 Dept. of the Navy
 Washington, D.C. 20360
 Attn: NAVAIR 5302 Aero & Structures
 5308 Structures
 52031F Materials
 604 Tech. Library
 320B Structures

Director, Aero Mechanics
 Naval Air Development Center
 Johnsville
 Warminster, Pennsylvania 18974

Technical Director
 U.S. Naval Undersea R&D Center
 San Diego, California 92132

Engineering Department
 U.S. Naval Academy
 Annapolis, Maryland 21402

Naval Facilities Engineering Command
 Dept. of the Navy
 Washington, D.C. 20360
 Attn: NAVFAC 03 Research & Development
 04 " " " " " "
 14114 Tech. Library

Naval Sea Systems Command
 Dept. of the Navy
 Washington, D.C. 20360
 Attn: NAVSHIP 03 Res. & Technology
 031 Ch. Scientist for R&D
 03412 Hydromechanics
 037 Ship Silencing Div.
 035 Weapons Dynamics

Naval Ship Engineering Center
 Prince George's Plaza
 Hyattsville, Maryland 20782
 Attn: NAVSEC 6100 Ship Sys Engr & Des Dep
 6102C Computer-Aided Ship Des
 6105G
 6110 Ship Concept Design
 6120 Hull Div.
 6120D Hull Div.
 6128 Surface Ship Struct.
 6129 Submarine Struct.

Air Force

Commander WADD
 Wright-Patterson Air Force Base
 Dayton, Ohio 45433
 Attn: Code WWRMDD
 AFFDL (FDDS)
 Structures Division
 AFLC (MCEEA)

Chief, Applied Mechanics Group
 U.S. Air Force Inst. of Tech.
 Wright-Patterson Air Force Base
 Dayton, Ohio 45433

Chief, Civil Engineering Branch
 WLRC, Research Division
 Air Force Weapons Laboratory
 Kirtland AFB, New Mexico 87117

Air Force Office of Scientific Research
 1400 Wilson Blvd.
 Arlington, Virginia 22209
 Attn: Mechanics Div.

NASA

Structures Research Division
 National Aeronautics & Space Admin.
 Langley Research Center
 Langley Station
 Hampton, Virginia 23365

National Aeronautic & Space Admin.
 Associate Administrator for Advanced
 Research & Technology
 Washington, D.C. 02546

Scientific & Tech. Info. Facility
 NASA Representative (S-AK/DL)
 P.O. Box 5700
 Bethesda, Maryland 20014

Other Government Activities

Commandant
 Chief, Testing & Development Div.
 U.S. Coast Guard
 1300 E. Street, N.W.
 Washington, D.C. 20226

Technical Director
 Marine Corps Dev. & Educ. Command
 Quantico, Virginia 22134

Director
 National Bureau of Standards
 Washington, D.C. 20234
 Attn: Mr. B.L. Wilson, EM 219

Dr. M. Gaus
 National Science Foundation
 Engineering Division
 Washington, D.C. 20550

Science & Tech. Division
 Library of Congress
 Washington, D.C. 20540

Director
 Defense Nuclear Agency
 Washington, D.C. 20305
 Attn: SPSS

Commander Field Command
 Defense Nuclear Agency
 Sandia Base
 Albuquerque, New Mexico 87115

Director Defense Research & Engrg
 Technical Library
 Room 3C-128
 The Pentagon
 Washington, D.C. 20301

Chief, Airframe & Equipment Branch
 FS-120
 Office of Flight Standards
 Federal Aviation Agency
 Washington, D.C. 20553

Chief, Research and Development
 Maritime Administration
 Washington, D.C. 20235

Deputy Chief, Office of Ship Constr.
 Maritime Administration
 Washington, D.C. 20235
 Attn: Mr. U.L. Russo

Atomic Energy Commission
Div. of Reactor Devel. & Tech.
Germantown, Maryland 20767

Ship Hull Research Committee
National Research Council
National Academy of Sciences
2101 Constitution Avenue
Washington, D.C. 20418
Attn: Mr. A.R. Lytle

PART 2 - CONTRACTORS AND OTHER
TECHNICAL COLLABORATORS

Universities

Dr. J. Tinsley Oden
University of Texas at Austin
345 Eng. Science Bldg.
Austin, Texas 78712

Prof. Julius Miklowitz
California Institute of Technology
Div. of Engineering & Applied Sciences
Pasadena, California 91109

Dr. Harold Liebowitz, Dean
School of Engr. & Applied Science
George Washington University
725 - 23rd St., N.W.
Washington, D.C. 20006

Prof. Eli Sternberg
California Institute of Technology
Div. of Engr. & Applied Sciences
Pasadena, California 91109

Prof. Paul M. Naghdi
University of California
Div. of Applied Mechanics
Etcheverry Hall
Berkeley, California 94720

Professor P. S. Symonds
Brown University
Division of Engineering
Providence, R.I. 02912

Prof. A. J. Durelli
The Catholic University of America
Civil/Mechanical Engineering
Washington, D.C. 20017

Prof. R.B. Iesta
Columbia University
Dept. of Civil Engineering
S.W. Mudd Bldg.
New York, N.Y. 10027

Prof. H. H. Bleich
Columbia University
Dept. of Civil Engineering
Amsterdam & 120th St.
New York, N.Y. 10027

Prof. F.L. DiMaggio
Columbia University
Dept. of Civil Engineering
616 Mudd Building
New York, N.Y. 10027

Prof. A.M. Freudenthal
George Washington University
School of Engineering &
Applied Science
Washington, D.C. 20006

D. C. Evans
University of Utah
Computer Science Division
Salt Lake City, Wash 84112

Prof. Norman Jones
Massachusetts Inst. of Technology
Dept. of Naval Architecture &
Marine Engrng
Cambridge, Massachusetts 02139

Professor Albert I. King
Biomechanics Research Center
Wayne State University
Detroit, Michigan 48202

Dr. V. R. Hodgson
Wayne State University
School of Medicine
Detroit, Michigan 48202

Dean B. A. Boley
Northwestern University
Technological Institute
2145 Sheridan Road
Evanston, Illinois 60201

Prof. P.G. Hodge, Jr.
University of Minnesota
Dept. of Aerospace Engng & Mechanics
Minneapolis, Minnesota 55455

Dr. D.C. Drucker
University of Illinois
Dean of Engineering
Urbana, Illinois 61801

Prof. N.M. Newmark
University of Illinois
Dept. of Civil Engineering
Urbana, Illinois 61801

Prof. E. Reissner
University of California, San Diego
Dept. of Applied Mechanics
La Jolla, California 92037

Prof. William A. Nash
University of Massachusetts
Dept. of Mechanics & Aerospace Engng.
Amherst, Massachusetts 01002

Library (Code 0384)
U.S. Naval Postgraduate School
Monterey, California 93940

Prof. Arnold Allentuch
Newark College of Engineering
Dept. of Mechanical Engineering
323 High Street
Newark, New Jersey 07102

Dr. George Herrmann
Stanford University
Dept. of Applied Mechanics
Stanford, California 94305

Prof. J. D. Achenbach
Northwestern University
Dept. of Civil Engineering
Evanston, Illinois 60201

Director, Applied Research Lab.
Pennsylvania State University
P. O. Box 30
State College, Pennsylvania 16801

Prof. Eugen J. Skudrzyk
Pennsylvania State University
Applied Research Laboratory
Dept. of Physics - P.O. Box 30
State College, Pennsylvania 16801

Prof. J. Kempner
Polytechnic Institute of Brooklyn
Dept. of Aero. Engng. & Applied Mech
333 Jay Street
Brooklyn, N.Y. 11201

Prof. J. Klosner
Polytechnic Institute of Brooklyn
Dept. of Aerospace & Appl. Mech.
333 Jay Street
Brooklyn, N.Y. 11201

Prof. R.A. Schapery
Texas A&M University
Dept. of Civil Engineering
College Station, Texas 77840

Prof. W.D. Pilkey
University of Virginia
Dept. of Aerospace Engineering
Charlottesville, Virginia 22903

Dr. H.G. Schaeffer
University of Maryland
Aerospace Engineering Dept.
College Park, Maryland 20742

Prof. K.D. Willmert
Clarkson College of Technology
Dept. of Mechanical Engineering
Potsdam, N.Y. 13676

Dr. J.A. Stricklin
Texas A&M University
Aerospace Engineering Dept.
College Station, Texas 77843

Dr. L.A. Schmit
University of California, LA
School of Engineering & Applied Science
Los Angeles, California 90024

Dr. H.A. Kame1
The University of Arizona
Aerospace & Mech. Engineering Dept.
Tucson, Arizona 85721

Dr. B.S. Berger
University of Maryland
Dept. of Mechanical Engineering
College Park, Maryland 20742

Prof. G. R. Irwin
Dept. of Mechanical Engrg.
University of Maryland
College Park, Maryland 20742

Dr. S.J. Fenves
Carnegie-Mellon University
Dept. of Civil Engineering
Schenley Park
Pittsburgh, Pennsylvania 15213

Dr. Ronald L. Huston
Dept. of Engineering Analysis
Mail Box 112
University of Cincinnati
Cincinnati, Ohio 45221

Prof. George Sih
Dept. of Mechanics
Lehigh University
Bethlehem, Pennsylvania 18015

Prof. A.S. Kobayashi
University of Washington
Dept. of Mechanical Engineering
Seattle, Washington 98105

Librarian
Webb Institute of Naval Architecture
Crescent Beach Road, Glen Cove
Long Island, New York 11542

Prof. Daniel Frederick
Virginia Polytechnic Institute
Dept. of Engineering Mechanics
Blacksburg, Virginia 24061

Prof. A.C. Eringen
Dept. of Aerospace & Mech. Sciences
Princeton University
Princeton, New Jersey 08540

Dr. S.L. Koh
School of Aero., Astro. & Engr. Sc.
Purdue University
Lafayette, Indiana 47907

Prof. E.H. Lee
Div. of Engrg. Mechanics
Stanford University
Stanford, California 94305

Prof. R.D. Mindlin
Dept. of Civil Engrg.
Columbia University
S.W. Mudd Building
New York, N.Y. 10027

Prof. S.B. Dong
University of California
Dept. of Mechanics
Los Angeles, California 90024
Prof. Burt Paul
University of Pennsylvania
Towne School of Civil & Mech. Engrg.
Rm. 113 - Towne Building
220 S. 33rd Street
Philadelphia, Pennsylvania 19104
Prof. H.W. Liu
Dept. of Chemical Engr. & Metal.
Syracuse University
Syracuse, N.Y. 13210

Prof. S. Bodner
Technion R&D Foundation
Haifa, Israel

Prof. R.J.H. Bollard
Chairman, Aeronautical Engr. Dept.
207 Guggenheim Hall
University of Washington
Seattle, Washington 98105

Prof. G.S. Heller
Division of Engineering
Brown University
Providence, Rhode Island 02912

Prof. Werner Goldsmith
Dept. of Mechanical Engineering
Div. of Applied Mechanics
University of California
Berkeley, California 94720

Prof. J.R. Rice
Division of Engineering
Brown University
Providence, Rhode Island 02912

Prof. R.S. Rivlin
Center for the Application of Mathematics
Lehigh University
Bethlehem, Pennsylvania 18015

Library (Code 0384)
U.S. Naval Postgraduate School
Monterey, California 93940

Dr. Francis Cozzarelli
Div. of Interdisciplinary
Studies & Research
School of Engineering
State University of New York
Buffalo, N.Y. 14214

Industry and Research Institutes

Library Services Department
Report Section Bldg. 14-14
Argonne National Laboratory
9700 S. Cass Avenue
Argonne, Illinois 60440

Dr. M. C. Junger
Cambridge Acoustical Associates
129 Mount Auburn St.
Cambridge, Massachusetts 02138

Dr. L.H. Chen
General Dynamics Corporation
Electric Boat Division
Groton, Connecticut 06340

Dr. J.E. Greenspon
J.G. Engineering Research Associates
3831 Menlo Drive
Baltimore, Maryland 21215

Dr. S. Batdorf
The Aerospace Corp.
P.O. Box 92957
Los Angeles, California 90009

Dr. K.C. Park
Lockheed Palo Alto Research Laboratory
Dept. 5233, Bldg. 205
3251 Hanover Street
Palo Alto, CA 94304

Library
Newport News Shipbuilding &
Dry Dock Company
Newport News, Virginia 23607

Dr. W.F. Bozich
McDonnell Douglas Corporation
5301 Bolsa Ave.
Huntington Beach, CA 92647

Dr. H.N. Abramson
Southwest Research Institute
Technical Vice President
Mechanical Sciences
P.O. Drawer 28510
San Antonio, Texas 78284

Dr. R.C. DeHart
Southwest Research Institute
Dept. of Structural Research
P.O. Drawer 28510
San Antonio, Texas 78284

Dr. M.L. Baron
Weidlinger Associates,
Consulting Engineers
110 East 59th Street
New York, N.Y. 10022

Dr. W.A. von Rieseemann
Sandia Laboratories
Sandia Base
Albuquerque, New Mexico 87115

Dr. T.L. Geers
Lockheed Missiles & Space Co.
Palo Alto Research Laboratory
3251 Hanover Street
Palo Alto, California 94304

Dr. J.L. Tocher
Boeing Computer Services, Inc.
P.O. Box 24346
Seattle, Washington 98124

Mr. William Caywood
Code BBE, Applied Physics Laboratory
8621 Georgia Avenue
Silver Spring, Maryland 20034

Mr. P.C. Durup
Lockheed-California Company
Aeromechanics Dept., 74-43
Burbank, California 91503

Assistant Chief for Technology
Office of Naval Research,
Code 200
Arlington, Virginia 22217

14. KEY WORDS	LINK A		LINK B		LINK C	
	ROLE	WT	ROLE	WT	ROLE	WT
Stiffening Rings Strain Energy						

INSTRUCTIONS

1. **ORIGINATING ACTIVITY:** Enter the name and address of the contractor, subcontractor, grantee, Department of Defense activity or other organization (*corporate author*) issuing the report.
- 2a. **REPORT SECURITY CLASSIFICATION:** Enter the overall security classification of the report. Indicate whether "Restricted Data" is included. Marking is to be in accordance with appropriate security regulations.
- 2b. **GROUP:** Automatic downgrading is specified in DoD Directive 5200.10 and Armed Forces Industrial Manual. Enter the group number. Also, when applicable, show that optional markings have been used for Group 3 and Group 4 as authorized.
3. **REPORT TITLE:** Enter the complete report title in all capital letters. Titles in all cases should be unclassified. If a meaningful title cannot be selected without classification, show title classification in all capitals in parenthesis immediately following the title.
4. **DESCRIPTIVE NOTES:** If appropriate, enter the type of report, e.g., interim, progress, summary, annual, or final. Give the inclusive dates when a specific reporting period is covered.
5. **AUTHOR(S):** Enter the name(s) of author(s) as shown on or in the report. Enter last name, first name, middle initial. If military, show rank and branch of service. The name of the principal author is an absolute minimum requirement.
6. **REPORT DATE:** Enter the date of the report as day, month, year, or month, year. If more than one date appears on the report, use date of publication.
- 7a. **TOTAL NUMBER OF PAGES:** The total page count should follow normal pagination procedures, i.e., enter the number of pages containing information.
- 7b. **NUMBER OF REFERENCES:** Enter the total number of references cited in the report.
- 8a. **CONTRACT OR GRANT NUMBER:** If appropriate, enter the applicable number of the contract or grant under which the report was written.
- 8b, 8c, & 8d. **PROJECT NUMBER:** Enter the appropriate military department identification, such as project number, subproject number, system numbers, task number, etc.
- 9a. **ORIGINATOR'S REPORT NUMBER(S):** Enter the official report number by which the document will be identified and controlled by the originating activity. This number must be unique to this report.
- 9b. **OTHER REPORT NUMBER(S):** If the report has been assigned any other report numbers (*either by the originator or by the sponsor*), also enter this number(s).
10. **AVAILABILITY/LIMITATION NOTICES:** Enter any limitations on further dissemination of the report, other than those

imposed by security classification, using standard statements such as:

- (1) "Qualified requesters may obtain copies of this report from DDC."
- (2) "Foreign announcement and dissemination of this report by DDC is not authorized."
- (3) "U. S. Government agencies may obtain copies of this report directly from DDC. Other qualified DDC users shall request through _____."
- (4) "U. S. military agencies may obtain copies of this report directly from DDC. Other qualified users shall request through _____."
- (5) "All distribution of this report is controlled. Qualified DDC users shall request through _____."

If the report has been furnished to the Office of Technical Services, Department of Commerce, for sale to the public, indicate this fact and enter the price, if known.

11. **SUPPLEMENTARY NOTES:** Use for additional explanatory notes.
12. **SPONSORING MILITARY ACTIVITY:** Enter the name of the departmental project office or laboratory sponsoring (*paying for*) the research and development. Include address.
13. **ABSTRACT:** Enter an abstract giving a brief and factual summary of the document indicative of the report, even though it may also appear elsewhere in the body of the technical report. If additional space is required, a continuation sheet shall be attached.

It is highly desirable that the abstract of classified reports be unclassified. Each paragraph of the abstract shall end with an indication of the military security classification of the information in the paragraph, represented as (TS), (S), (C), or (U).

There is no limitation on the length of the abstract. However, the suggested length is from 150 to 225 words.
14. **KEY WORDS:** Key words are technically meaningful terms or short phrases that characterize a report and may be used as index entries for cataloging the report. Key words must be selected so that no security classification is required. Identifiers, such as equipment model designation, trade name, military project code name, geographic location, may be used as key words but will be followed by an indication of technical context. The assignment of links, roles, and weights is optional.

Unclassified

Security Classification

DOCUMENT CONTROL DATA - R&D

(Security classification of title, body of abstract and indexing annotation must be entered when the overall report is classified)

1. ORIGINATING ACTIVITY (Corporate author) Columbia University	2a. REPORT SECURITY CLASSIFICATION unclassified 2b. GROUP
---	--

3. REPORT TITLE
 6 Strain Energy Expressions of Rings of Rectangular, T- and I- Section, Suitable for the Dynamic Analysis of Ring-Stiffened Cylindrical Shells.

4. DESCRIPTIVE NOTES (Type of report and inclusive dates)
 9 Technical Report

5. AUTHOR(S) (Last name, first name, initials)
 10 BLEICH, HANS H. / Bleich

6. REPORT DATE 11 October, 1976	7a. TOTAL NO. OF PAGES 32	7b. NO. OF REFS 5
------------------------------------	------------------------------	----------------------

8a. CONTRACT OR GRANT NO. 15 N00014-75-C-0695 ✓ 8b. PROJECT NO. NR 64-428	9a. ORIGINATOR'S REPORT NUMBER(S) 14 TR-51 (12) 45p. 9b. OTHER REPORT NO(S) (Any other numbers that may be assigned this report)
--	--

10. AVAILABILITY/LIMITATION NOTICES
 approved for public release. Distribution unlimited

11. SUPPLEMENTARY NOTES	12. SPONSORING MILITARY ACTIVITY ONR
-------------------------	---

13. ABSTRACT
 Strain energy expressions are obtained for rings of rectangular, T- and I- section. The expressions are intended for use in the dynamic analysis of ring stiffened cylindrical shells. The approach is essentially a generalization of the conventional, approximate analysis of straight beams, i.e. the influence of shear stresses, and of direct stresses at right angles to the axis of the beams is neglected.

DD FORM 1 JAN 64 1473

088 920
Lpc

Security Classification