

~~FOR OFFICIAL USE ONLY~~

CLASSIFIED

COPY 34 of 53 COPIES

1

ADA030919

US ARMY TEST & EVALUATION COMMAND

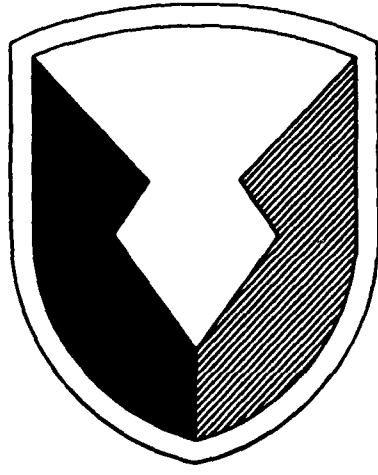

DDC
RECEIVED
A

6 9

FINAL REPORT.

OF

MILITARY POTENTIAL TEST

OF THE

MODEL PA23-250C FIXED-WING INSTRUMENT TRAINER.

DA PROJECT NO. NONE

16 USATECOM PROJECT NO. 4-5-1891-01

NOV 1964

11
30 Nov 64

12 46p.
15

~~FOR OFFICIAL USE ONLY~~

Re: National
USAMIA (PROV)

Approved for public release;
distribution unlimited

US ARMY

AVIATION TEST BOARD

FORT RUCKER, ALABAMA 036 500

14 APR 76
PR 340-16

DISCLAIMER NOTICE

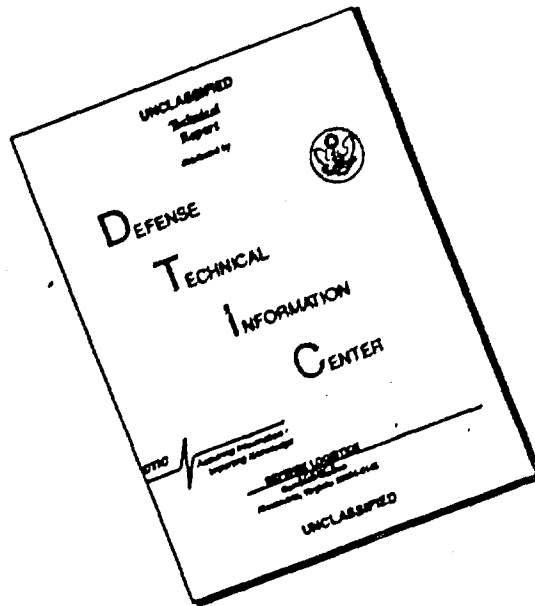

THIS DOCUMENT IS BEST QUALITY AVAILABLE. THE COPY FURNISHED TO DTIC CONTAINED A SIGNIFICANT NUMBER OF PAGES WHICH DO NOT REPRODUCE LEGIBLY.

34-57001ES

~~FOR OFFICIAL USE ONLY~~

DETAILED DESCRIPTION OF

MODEL PA23-250C AIRPLANE AS TESTED

1. General. The Model PA23-250C airplane is a low-wing, all-metal, tricycle-landing gear, twin-engine airplane. Each IO-540-C4B5 engine drives a 77-inch diameter, two-bladed, full-feathering, constant-speed HC-E2YK-2R propeller. The fuselage and constant chord cantilever wings are separate semimonocoque structures. The PA23-250C is certificated in the Standard-Normal Category by the Federal Aviation Agency (FAA), and the Approved Type Certificate is 1A10. The manufacturer's airplane serial number is 27-2506.

2. Cockpit. Side-by-side seating is provided for the instructor pilot and student in individual, adjustable seats. Entrance to the cockpit is gained by a side door located on the right side of the fuselage or from the cabin area. Rudder pedals and a wheel-type flight control are provided for the instructor pilot and student. The instrument panel provides space for engine and flight instruments, avionic control heads and indicators, and electrical switches and circuit breakers. The fuel selector panel, located between the instructor and student pilot's seats, contains a fuel selector valve for each engine and a cross-feed selector.

3. Cabin. Individual passenger seats are located in the cabin area behind the instructor pilot's and student pilot's seat. The seats are forward facing, adjustable fore and aft, reclining chairs. Entry into the cabin is accomplished through a side door located on the right side of the fuselage. The cabin has provisions for lighting, heating, and ventilation. The cabin floors are carpeted and the walls and ceiling are fitted with soundproofed appointments. The combined cockpit and cabin area has the following dimensions:

- Height - 52.5 inches (max.)
- Width - 50.0 inches (max.)
- Length - 111.5 inches (max.)
- Volume - 82 cu. ft.

encl 2

~~FOR OFFICIAL USE ONLY~~

*FE Malloy
USAAITA (PROV)
14 Apr 76
AR 340-16*

~~FOR OFFICIAL USE ONLY~~

4. Flight Controls. The PA23-250C airplane has dual flight controls affording control of the aircraft from either the instructor pilot or student pilot's station. A rotary movement of the control wheel controls the aileron travel. Fore-and-aft movement of the control column positions the stabilator (a movable horizontal stabilizer which eliminates the need for an elevator). The rudder travel is controlled by a dual set of rudder pedals mounted on the cabin floor forward of the pilot and copilot stations. The wing flap movement is hydraulically controlled by positioning the flap control lever mounted on the engine control pedestal. The ailerons, stabilator, and rudder are mechanically actuated through closed-circuit cable systems terminating in bell cranks. The stabilator and rudder trim-tab control cranks are located in the center of the forward cabin ceiling. Mechanical systems consisting of closed-circuit cables and jack shafts transmit trim control movements to the trim tabs. Indicators immediately to the rear of the trim-tab cranks show the trim-tab positions. No in-flight aileron tabs are provided. Fixed-position trim tabs are attached to the ailerons. A nose-up attitude is obtained by turning the elevator trim-tab control crank clockwise, and turning the crank counterclockwise gives a nose-down attitude. Additionally, a trim motor was incorporated in the system, providing longitudinal trim by actuating a spring-loaded switch attached to the control wheel. Turning the rudder trim-tab control crank clockwise provides left rudder trim, and turning the crank counterclockwise provides right rudder trim.

5. Engine. The PA23-250C is powered by two IO-540-C4B5 engines. The IO-540-C4B5 is a direct-drive, wet-sump, horizontally-opposed, six-cylinder, air-cooled, fuel injection engine. The engine displacement is 541.5 cubic inches, and the compression ratio is 8.5 to 1. The rated takeoff and rated maximum continuous brake horsepower is 250 at 2575 r. p. m. The FAA Type Certificate number for this engine is 1E4. The oil capacity is 12 quarts.

6. Engine Cowling. The engine cowling consists of five sections. To facilitate servicing the engine, a large cowl section on each side of the engine is removable. A cowling nose ring, a top cowl panel incorporating the oil filler and oil level indicator access, and the lower engine cowl complete the cowling assembly.

2
~~FOR OFFICIAL USE ONLY~~

~~FOR OFFICIAL USE ONLY~~

7. Engine Cooling. Cooling air enters the engine compartment through the openings in the cowling nose ring. A down-draft cooling system directs this cooling air down and around the engine cylinders and out through the lower engine nacelle openings equipped with cowl flaps adjustable from the cockpit.

8. Propellers. The Model PA23-250C is equipped with all-metal HC-E2YK-2R, controllable, full-feathering, constant-speed, two-bladed propellers. The propeller is controlled by a governor mounted on the left forward side of the engine. Oil pressure acting on the blade-actuating piston changes the propeller blade angle to low pitch. Internal air pressure in the propeller air dome reservoir rotates the propeller blades to a high-pitch angle. The governor regulates the oil pressure acting against the internal air pressure to position the propeller blades for a constant rotational speed selected by the pilot. The internal air pressure rotates the propeller blades to the feathered position when the oil pressure is relieved. A spring-loaded, high-pitch stop latch prevents the propeller from feathering when the airplane is on the ground and the engine is stopped. The latch is disengaged by centrifugal force when the propeller is rotating above 1000 r. p. m. Feathering the propeller is accomplished by moving the cockpit pedestal-mounted propeller control lever rearward through the detent into the feathering range. Unfeathering is accomplished in flight by starting the engine with the control lever just forward of the feathering detent.

9. Fuel System. The fuel is contained in four bladder-type fuel cells, two located in each wing. The four cells have a total usable fuel capacity of 144 US gallons. During normal operation each engine draws fuel from the adjacent wing fuel cells. However, a pressure crossfeed system permits either engine to consume the entire fuel supply of any or all cells. Each fuel cell is filled through its own filler opening located in the upper wing surface. Recesses in the wing covered by small hinged access doors house the filler openings. An individual electric auxiliary fuel pump is provided for each engine. The electric pumps can be used to provide pressure in the event of failure of the engine-driven pumps. The fuel on-off valves are manually actuated from the cockpit by the fuel selector handles. Fuel quantity is measured by float-type transmitter units which transmit signals to the fuel gauges on the instrument panel. Selection of the fuel tank determines the fuel cell to which each gauge is connected.

~~FOR OFFICIAL USE ONLY~~

10. Hydraulic System. The hydraulic system provides the power to operate the landing gear and flaps. The operation of these components is accomplished by the landing gear and flap selector valve unit which is housed within the engine control pedestal under the engine control levers. Hydraulic pressure is supplied to the control unit by an engine-driven hydraulic pump mounted on the left engine. The operating pressure of the system is 1150 p. s. i. To effect extension or retraction of the gear and flaps, the proper controls are moved to the desired position. When the selected component is fully extended or retracted, hydraulic pressure returns the control to the neutral position, which allows the hydraulic fluid to circulate freely between the pump and the control unit. Additionally, the activating cylinders and associated lines are isolated from the hydraulic fluid supply. This prevents complete loss of fluid in the event of a leak in the lines between the selector valve and the component or at the actuating cylinders. The return of the control handle to the neutral position is an indication that the components have reached full extension or retraction. An emergency hydraulic hand pump (figure 1), which is integral with the selector valve unit, is used to obtain hydraulic pressure in event of failure of the hydraulic pump on the left engine. The emergency pump handle is located between the flaps and landing gear control levers, and should be extended to its full length for operation.

11. Landing Gear. The Model PA23-250C airplane is equipped with a hydraulically-retractable, tricycle landing gear. The nose gear retracts rearward into the nose section. The main landing gear retracts forward into the engine nacelles. The landing gear is held in the full "up" position by hydraulic pressure. In the event of a complete hydraulic failure, the landing gear is extended by an independent carbon-dioxide system. A safety bypass valve on the left main gear prevents the landing gear retraction while the weight of the airplane is on the gear. A direct mechanical linkage between the rudder pedals and the nose wheel permits steering during ground operation.

12. Brake System. The main landing gear wheels are equipped with single-disc, hydraulically-actuated brakes. The brakes are actuated by individual master cylinders connected to the student pilot's rudder pedals and operated as toe brakes. No brakes are provided on the instructor pilot's rudder pedals. The hydraulic brake fluid reservoir is located inside the left nose access compartment. The parking brake is set by a push-pull control. Setting the control closes a valve in the brake lines so that pressure built up by pumping the toe pedals is retained and the brakes remain set. Pushing the control in or depressing the toe pedals opens the valve and releases the brakes.

~~FOR OFFICIAL USE ONLY~~

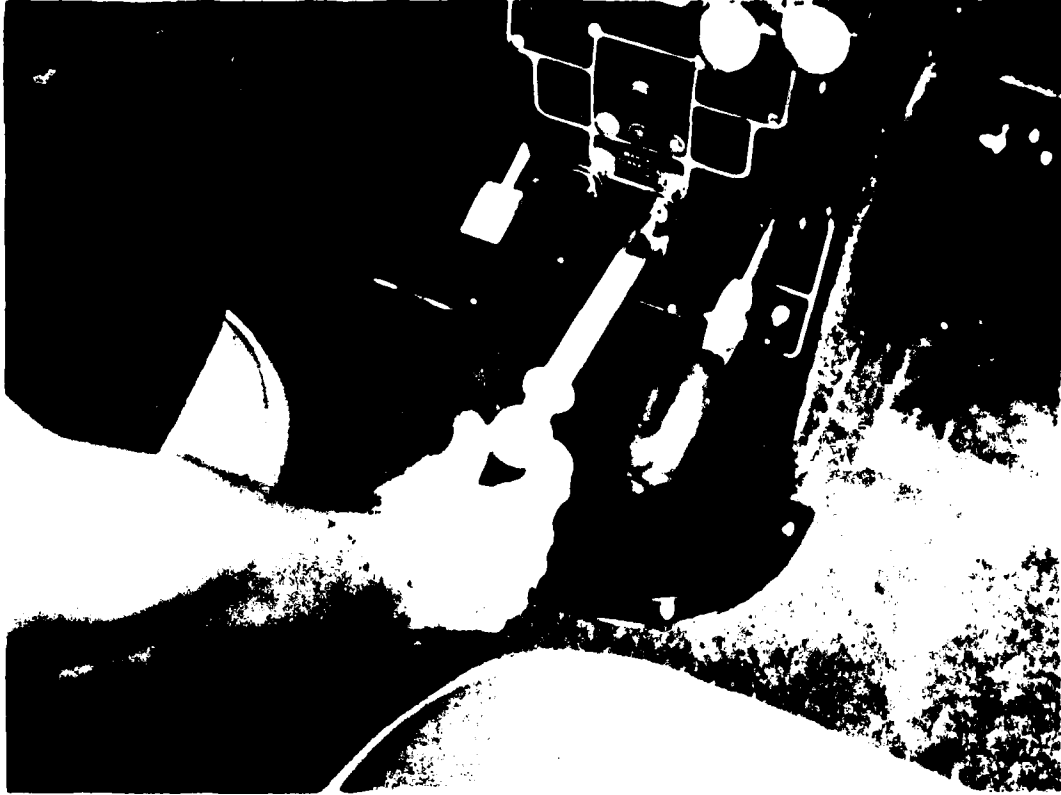

Figure 1. Emergency hydraulic hand pump.

13. Electrical Power Supply System. A 14-volt d. c. electrical system is the basic source of electrical power. Current for starting the engine is normally supplied from a 12-volt, 35 ampere-hour battery installed in the nose section (figure 2). Two 14-volt engine-driven generators provide electrical power. A plug-in receptacle under the nose is available in the event an external power source is desired.

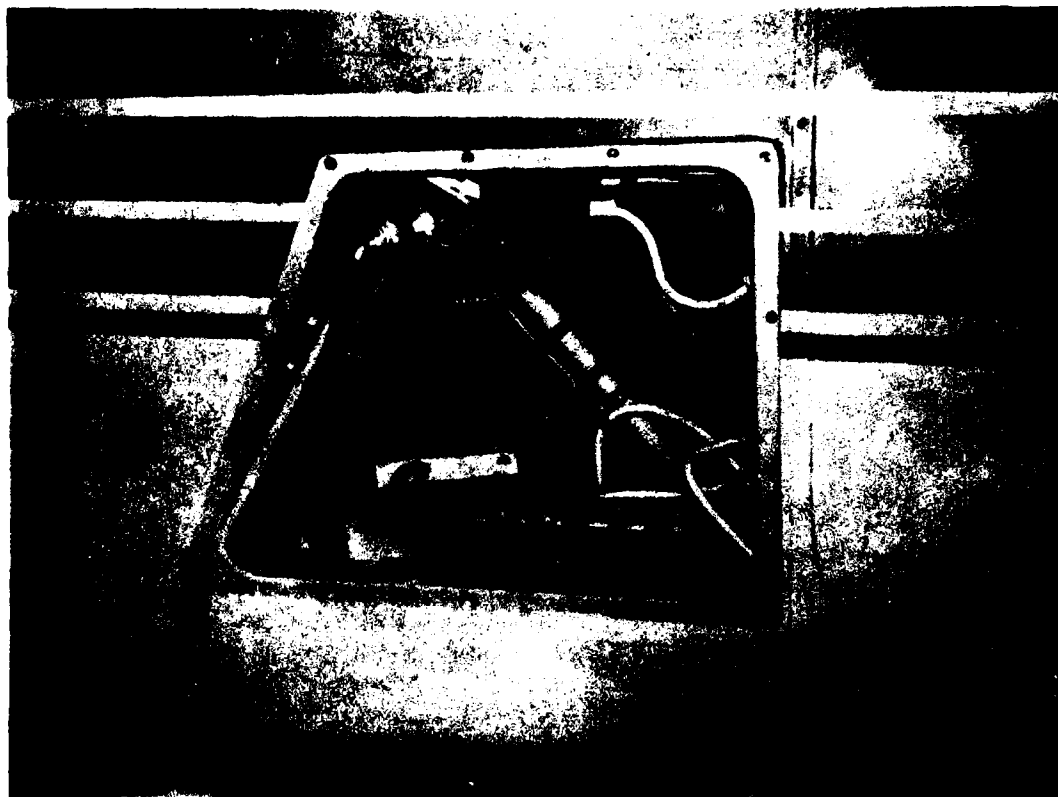

Figure 2. Battery installation.

14. Heating and Ventilating System. A forced air heating and ventilating system provides controllable cabin heat and ventilation. Blower air is furnished until the aircraft is in flight and the landing gear is retracted, and then ram air replaces blower air. In addition to the air supplied to the cabin through the heater fresh-air system, an air scoop on the dorsal fin conducts outside air to individual fresh air outlets above each seat. The outlets can be manually adjusted to control the quantity and direction of air flow. A cabin air exhaust vent completes the air circulation system. A 27,500-B.t.u. combustion-type heater provides heat for the cabin and the windshield defroster.

~~FOR OFFICIAL USE ONLY~~

15. Basic Aircraft Data. (See figure 3 for general dimensions.)

Aircraft serial No. 27-2506

Aircraft Type Certification No. 1A10

Engine serial No. (Left) L-747-48; (Right) L-746-48

Engine Type Certification No. 1E4

Areas.

Wing (total)	207.6 sq. ft.
Flaps (total)	16.7 sq. ft.
Ailerons (total)	16.8 sq. ft.
Tabs (Fixed - both wings)	0.11 sq. ft.
Horizontal tail (total)	37.0 sq. ft.
Elevators (incl. tabs)	None (stabilator)
Trim tab	6.2 sq. ft.
Vertical tail (incl. rudder)	14.8 sq. ft.
Rudder (incl. tab)	10.3 sq. ft.
Trim tab	2.6 sq. ft.
Dorsal fin	1.04 sq. ft.

General Data.

Wing

Airfoil section (root)	USA 35B
Airfoil section (tip)	USA 35B
Span	37 ft. 1.75 in.
Root chord	67 in.
Tip chord	67 in.

~~FOR OFFICIAL USE ONLY~~

Mean aerodynamic chord	56 in.
Taper ratio	0
Dihedral (outboard)	5 degrees
Aerodynamic washout (outboard)	2 degrees
Aspect ratio	6.62

Flaps

Span (total)	7 ft. 2.6 in.
Chord	20.7 percent

Ailerons

Span (total)	13 ft. 5.0 in.
Chord	20 percent

Stabilator

Airfoil section	NACA 0009
Span	12 ft. 6 in.
Mean aerodynamic chord	37 in.
Taper ratio	1.9
Aspect ratio	4.1
Elevator mean aerodynamic chord	None (stabilator)

Vertical Tail

Airfoil section	
Root	NACA 0009 (modified)
Tip	NACA 0007 (modified)
Height	69 in.

8
~~FOR OFFICIAL USE ONLY~~

~~FOR OFFICIAL USE ONLY~~

Height (ground line)	10 ft. 3.4 in.
Mean aerodynamic chord	53 in.
Taper ratio	2.3
Aspect ratio (geometric)	1.8
Rudder mean aerodynamic chord	20.0 in.
Maximum Fuselage Area Cross Section	
Height	5 ft. 6 in.
Width	4 ft. 2.5 in.
Landing Gear	
Tread on main wheels	11 ft. 4 in.
Wheel base	7 ft. 6 in.
Clearances	
Propeller to fuselage	9.38 in.
Propeller to ground (normal static position)	9.38 in.
Propeller to ground (flat struts and tires)	2.5 in.
Fuselage to ground (flat struts and tires)	13 in.
Control Surface Movements	
Wing flaps (maximum)	28 degrees down
Ailerons	20 degrees up
	20 degrees down

9
~~FOR OFFICIAL USE ONLY~~

~~FOR OFFICIAL USE ONLY~~

Rudder

25 degrees right

25 degrees left

Stabilator (elevator)

30 degrees up

15 degrees down

FOR OFFICIAL USE ONLY

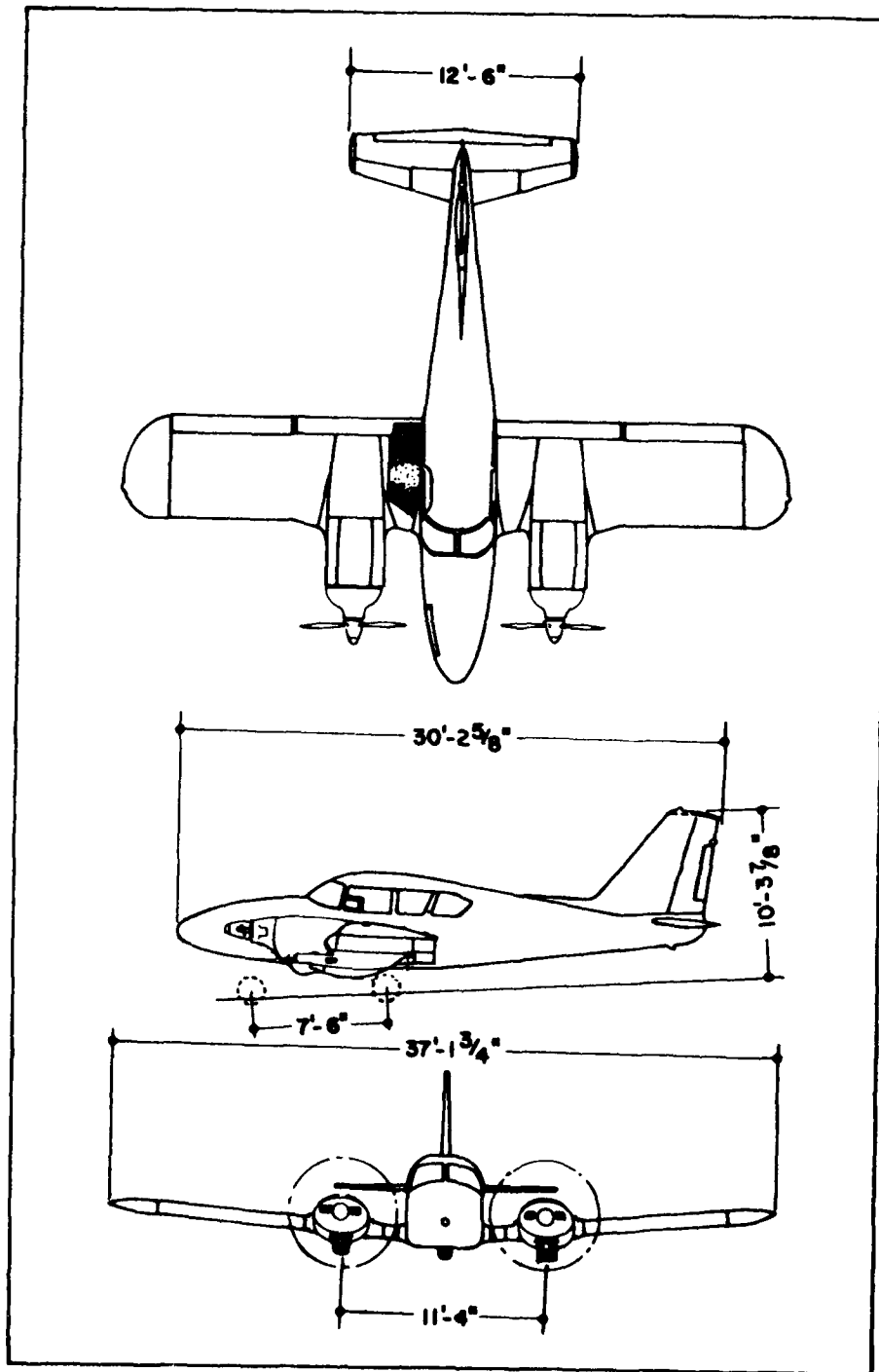

Figure 3.
General dimensions of M6del PA23-250C Airplane.

FOR OFFICIAL USE ONLY

~~FOR OFFICIAL USE ONLY~~

CARBON MONOXIDE INVESTIGATION OF THE OFF-THE-SHELF
FIXED WING INSTRUMENT TRAINERS

1. INTRODUCTION.

The US Army Aeromedical Research Unit was requested to determine the carbon monoxide concentration within the crew/passenger compartment of the five Off-the-Shelf Fixed Wing Trainers.

The aircraft submitted for the evaluation were:

- a. Aero Commander 500B.
- b. Beechcraft Baron B-55-B.
- c. Cessna 310"1".
- d. Piper Aztec "B".
- e. Piper Aztec "C".

2. METHODS AND MATERIALS.

a. Equipment used:

(1) Mine Safety Appliance Company Universal Testing Kit Model 2 with carbon monoxide detectors.

(2) A 250cc air sample was forced through a vial of carbon monoxide sensitive crystals (part no. 47134) using a manually operated "piston type" pump (part no. 83498). In the presence of carbon monoxide, the normally pale yellow indicating crystals turn green. The concentration of carbon monoxide is determined by comparing the color of the exposed vial to a standard color chart (part no. 994200). Sensitivity of the indicating crystals is .001 to 0.1% carbon monoxide.

b. Method.

(1) Samples of the crew/passenger compartment air were collected while the aircraft operated at normal cruise with all vents closed and the heater on.

Incl³

DE Malloy
US Army (PROV)
1406 76
PR 340-46

~~FOR OFFICIAL USE ONLY~~

~~FOR OFFICIAL USE ONLY~~

(2) The air samples were collected at the heater duct opening to readily detect the slightest amount of carbon monoxide.

3. RESULTS AND CONCLUSIONS.

No carbon monoxide was detected in any of the five aircraft while operating at a cruise with all vents closed and the heater on.

~~FOR OFFICIAL USE ONLY~~

UNITED STATES ARMY AVIATION TEST BOARD
Fort Rucker, Alabama 36362

FINAL REPORT
OF
MILITARY POTENTIAL TEST
OF THE
MODEL PA23-250C FIXED-WING INSTRUMENT TRAINER

DA PROJECT NO. NONE

USATECOM PROJECT NO. 4-5-1001-01

Raymond E. Rankin
for: A. J. RANKIN
Colonel, Armor
President

SEARCHED	INDEXED
SERIALIZED	FILED
SEP 19 1964	
FBI - FORT RUCKER	
A	

~~FOR OFFICIAL USE ONLY~~

~~FOR OFFICIAL USE ONLY~~



iii

~~FOR OFFICIAL USE ONLY~~

PRECEDING PAGE MISSING - NOT FILED

~~FOR OFFICIAL USE ONLY~~

ABSTRACT

↙ The Military Potential Test of the Model PA23-250C Fixed-Wing Instrument Trainer was conducted by the US Army Aviation Test Board during the period 5 October 1964 to 10 November 1964 at Fort Rucker, Alabama. Flight under actual and simulated instrument conditions and demonstrations to personnel representing the US Army Aviation Center and the US Army Aviation School were conducted during the test period. It was found that the Model PA23-250C test airplane as changed by the technical proposal will not meet all of the requirements contained in the Model Specification. It was recommended that a confirmatory test be performed on the initial production airplane if the Model PA23-250C airplane is selected as a fixed-wing instrument trainer.

v

~~FOR OFFICIAL USE ONLY~~

UNITED STATES ARMY AVIATION TEST BOARD
Fort Rucker, Alabama 36362

FINAL REPORT OF
MILITARY POTENTIAL TEST OF THE
MODEL PA23-250C FIXED-WING INSTRUMENT TRAINER

Table of Contents

	<u>Page No.</u>
SECTION 1 - GENERAL	1
1.1. References	1
1.2. Authority	1
1.3. Objectives	1
1.4. Responsibilities	2
1.5. Description of Materiel	2
1.6. Background	2
1.7. Findings	3
1.8. Conclusion	3
1.9. Recommendation	3
SECTION 2 - DETAILS AND RESULTS OF SUB-TESTS	5
2.0. Introduction	5
2.1. Physical Characteristics	5
2.2. Performance	15
2.3. Electronics Configuration	17
SECTION 3 - APPENDICES	19
I. List of References	I-1
II. Comparison with Model Specifications	II-1
III. Coordination	III-1
IV. Distribution List	IV-1

~~FOR OFFICIAL USE ONLY~~

UNITED STATES ARMY AVIATION TEST BOARD
Fort Rucker, Alabama 36362

USATECOM PROJECT NO. 4-5-1001-01
REPORT OF MILITARY POTENTIAL TEST
OF THE MODEL PA23-250C
FIXED-WING INSTRUMENT TRAINER

SECTION 1 - GENERAL

1.1. REFERENCES.

A list of references is contained in appendix I.

1.2. AUTHORITY.

1.2.1. Directive.

Letter, AMSTE-BG, US Army Test and Evaluation Command, 29 October 1964, subject: "Test Directive for USATECOM Project No. 4-5-1001-01, Military Potential Test of Fixed Wing Instrument Trainer Aircraft."

1.2.2. Purpose.

To determine whether the "off-the-shelf" Model PA23-250C airplane fulfills the Model Specifications for fixed-wing instrument trainers (reference 2).

1.3. OBJECTIVES.

To determine:

- a. Specified physical characteristics.
- b. Specified performance.
- c. The adequacy of the electronics configuration as proposed.

~~FOR OFFICIAL USE ONLY~~

1.4. RESPONSIBILITIES.

The US Army Aviation Test Board (USAAVNTBD) was responsible for developing, preparing, and publishing the plan of test and the report of test. Assistance during the test was provided by the US Army Aviation School (USAAVNS). Final approval of the plan and report of test is the responsibility of the US Army Aviation Materiel Command (USAAVCOM).

1.5. DESCRIPTION OF MATERIEL.

The proposed Model PA23-250C instrument trainer airplane is a low-wing, all-metal, tricycle-landing gear, twin-engine airplane. The fuselage and constant chord cantilever wings are separate semimonocoque structures. The airplane is powered by two IO-540-C4B5 direct-drive, wet-sump, horizontally-opposed, six-cylinder, air-cooled, fuel injection engines. The rated takeoff and rated maximum continuous brake horsepower is 250 at 2575 r. p. m. Each engine drives a 77-inch diameter, two-bladed, full-feathering, constant-speed propeller. The propellers are equipped with a blade unfeathering system. The cockpit provides individual, adjustable, side-by-side seats for the instructor and student pilot. Individual forward facing passenger seats are located in the cabin area behind the instructor pilot's and student pilot's seat. The fuel capacity is 144 US gallons. The gross weight of the proposed instrument trainer is 4800 pounds.

1.6. BACKGROUND.

1.6.1. In June 1962, the USAAVNS submitted to the Commanding General, US Continental Army Command (USCONARC), a requirement for a commercially produced, "off-the-shelf," fixed-wing instrument trainer to replace the tactical airplanes presently used by USAAVNS for instrument training. In February 1963, the Director of Army Aviation, Office, Deputy Chief of Staff for Operations (DCSOPS), submitted a Statement of Materiel Requirements to the Commanding General, US Army Materiel Command (USAMC), for an "off-the-shelf" fixed-wing instrument trainer. A two-step procurement program was established. The Model Specification, which was revised June 1964, accompanied the Request for Technical Proposals (Step One for the Invitation for Bid) which was prepared by the USAAVCOM and mailed to industry 16 July 1964. Each bidder was required to submit a written technical proposal and one unit of the version of the aircraft on which it proposed to submit a bid. The Step Two of the competition will be confined to the bidders whose airplanes and technical proposals are found acceptable. The second step consists of a formal procurement in which bid prices will be submitted.

~~FOR OFFICIAL USE ONLY~~

1.6.2. A Model PA23-250C test airplane possessing a Federal Aviation Agency (FAA) Standard-Normal Category Certificate was delivered to the USAAVNTBD for evaluation on 5 October 1964.

1.7. FINDINGS.

The Model PA23-250C test airplane as changed by the technical proposal will not meet all the requirements contained in the Model Specifications (appendix II).

1.8. CONCLUSION.

The Model PA23-250C airplane will not meet all of the requirements contained in the Model Specifications (appendix II).

1.9. RECOMMENDATION.

It is recommended that a confirmatory test be performed on the initial production airplane if the Model PA23-250C airplane is selected as a fixed-wing instrument trainer.

SECTION 2 - DETAILS AND RESULTS OF SUB-TESTS

2.0. INTRODUCTION.

2.0.1. During the period 5 October 1964 to 10 November 1964, the Model PA23-250C test airplane underwent a 25- to 50-hour flight test program conducted by the US Army Aviation Test Board (USAAVNTBD) at Fort Rucker, Alabama.

2.0.2. Flight under actual and simulated instrument conditions and flight demonstrations to personnel representing the US Army Aviation Center (USAAVNC) and the US Army Aviation School (USAAVNS) were conducted during the test period.

2.1. PHYSICAL CHARACTERISTICS.

2.1.1. Objective.

To determine the physical characteristics of the Model PA23-250C test airplane as contained in paragraphs 1.1.1, 3.2 - 3.4, 3.6, 3.7, and 3.9 - 3.11 of the Model Specification (appendix II).

2.1.2. Method.

2.1.2.1. The physical characteristics listed in Model Specification paragraph 1.1.1 were determined by visual study.

2.1.2.2. Determination of the physical characteristics listed in Model Specification paragraphs 3.2, 3.3, and 3.4 was made by measuring the airplane and weighing it with full oil and with fuel drained. Weight and balance computations were made for the proposed gross weight.

2.1.2.3. The physical characteristics listed in Model Specification paragraph 3.6 were determined by visual and physical studies. Instrument panel cutouts were used to study the panel proposal.

2.1.2.4. The requirements for interior and exterior lighting outlined in the Model Specification paragraph 3.7 were checked during night flights. The rotating beacon was checked for conformity with paragraph 3.705, Civil Aeronautics Manual 3.

~~FOR OFFICIAL USE ONLY~~

2.1.2.5. The heater was operated and an analytical study was made based on the Model Specification requirement paragraph 3.9.1 and the rated output of the heater.

2.1.2.6. The aircraft furnished for the test was not equipped with deicing and anti-icing equipment; therefore, a study was made from the description of the system in the FAA-Approved Flight Manual and Maintenance Manual to determine conformity with the provisions of Model Specification paragraph 3.9.2.

2.1.2.7. Oxygen equipment was not provided with the test aircraft. A study was made of the descriptive material of the equipment found in the FAA-Approved Flight Manual and Maintenance Manual to determine if the equipment offered in the technical proposal was capable of meeting Model Specification paragraph 3.9.3.

2.1.2.8. The area for stowage was measured and photographed to determine whether the space provided met the provisions of Model Specification paragraph 3.10.

2.1.2.9. A study was made of the publications that accompanied the test aircraft to determine whether the requirements of Model Specification paragraph 3.11 were met.

2.1.3. Results.

2.1.3.1. General Description, paragraph 1.1.1, Model Specification:

2.1.3.1.1. The Model PA23-250C test airplane was equipped with individual side-by-side seating for a student and instructor pilot in the cockpit (figure 1). Immediately to the rear in the cabin area, individual side-by-side seats were provided for two students.

2.1.3.1.2. Dual side-by-side flight controls were provided in the cockpit.

2.1.3.1.3. The Model PA23-250C test airplane was powered by two IO-540-C4B5 reciprocating engines. Each engine drive a two-bladed, full-feathering, constant-speed HC-E2YK-2R propeller. A positive propeller unfeathering system was not incorporated. The technical proposal listed the installation of unfeathering accumulators on the proposed instrument trainers.

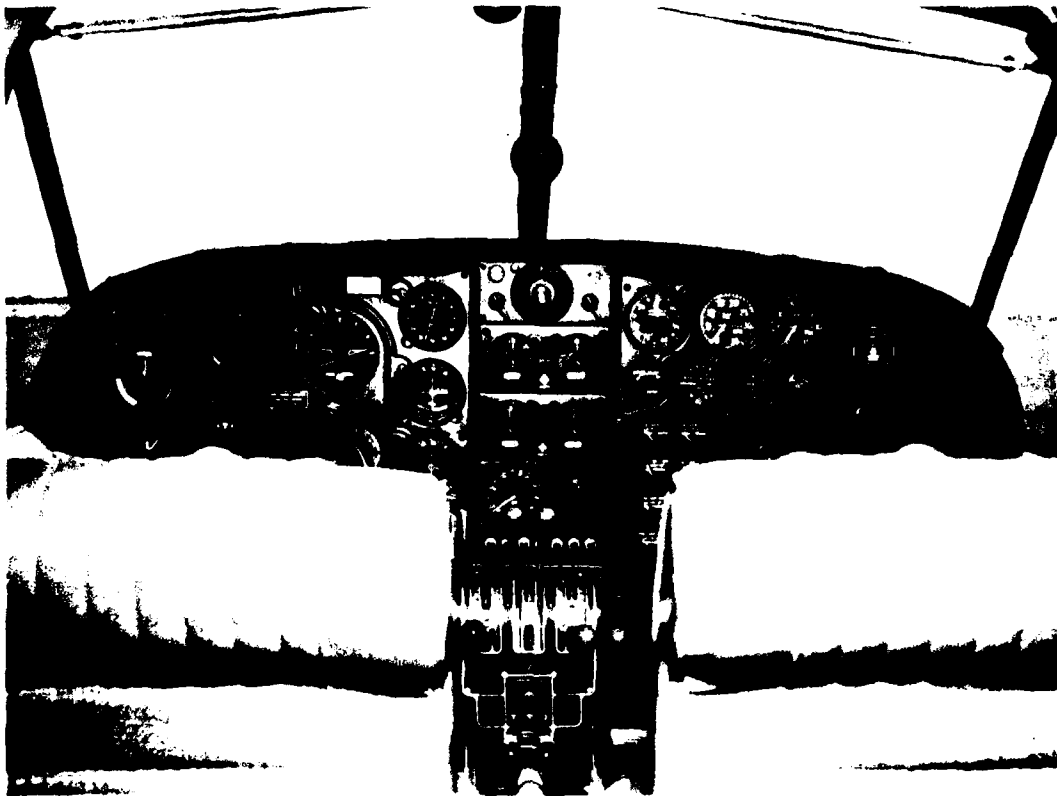

Figure 1. Seating arrangement

2. 1. 3. 1. 4. The Model PA23-250C test airplane featured an all-metal semimonocoque construction and was equipped with hydraulic retractable tricycle landing gear.

2. 1. 3. 2. Paragraph 3. 2, Model Specification: The basic weight of the test airplane was 3019 pounds. This weight did not include all of the equipment required by paragraph 3. 9 and the electronic equipment listed in appendix II of the Model Specification, which were not installed on the test airplane. No deletions were made from the basic weight for items installed on the test aircraft which were not required by the Model Specification. The technical proposal did not include a weight analysis for the proposed instrument trainer. The proposed basic weight of the instrument trainer is unknown.

~~FOR OFFICIAL USE ONLY~~

2.1.3.3. Paragraph 3.3, Model Specification: The center-of-gravity (c.g.) range was 98 inches (forward c.g. limit) to 100.5 inches (aft c.g. limit). No restrictions to mission payload or utility arose from constraints relating to the c.g. range.

2.1.3.4. Paragraph 3.4, Model Specification: In addition to fuel and oil necessary to accomplish the endurance mission (5.0 hours at 65% power at 7500 ft. MSL), the useful load of the test airplane was 1072 pounds. The technical proposal did not include a weight analysis; therefore, the useful load for the proposed trainer was unknown.

2.1.3.5. Paragraph 3.6.2.1, Model Specification: The Model PA23-250C test airplane featured an all-metal semimonocoque construction of the airframe.

2.1.3.6. Paragraph 3.6.2.2, Model Specification: The cabin interior arrangement provided individually adjustable side-by-side front seats. Two additional seats were provided immediately to the rear of the front seats. The seating arrangement permitted the exchange of the seating of the three students during flight. Shoulder harnesses were not provided in the test airplane and were not included in the technical proposal.

2.1.3.7. Paragraph 3.6.2.2.1, Model Specification: The fire extinguisher (4210-555-8837) and first-aid kit (9-196-650) are Government Furnished Aircraft Equipment (GFAE) and, therefore, were not present on the test aircraft.

2.1.3.8. Paragraph 3.6.2.3.1, Model Specification: The test airplane was equipped with dual flight controls including rudder pedals with toe-type brakes for the student pilot only (figure 2). However, the technical proposal provided toe brakes for the instructor pilot. The rudder pedals were not adjustable; however, the technical proposal provided for adjustable pedals.

2.1.3.9. Paragraph 3.6.2.3.2, Model Specification: The rudder and stabilator trim-tab control cranks were located in the center of the forward cabin ceiling. These controls were accessible to both the student and instructor pilot. No provisions existed in the test aircraft for in-flight aileron trim. The technical proposal included an in-flight aileron trim.



Figure 2. Model PA-28 dual engine controls.

2.1.3.10. Paragraph 3.0.2.3.3. Model specification: The engine control levers were mounted on the engine control pedestal located in front of, and between, the student and instructor pilot. The engine control levers controlled the throttle, propeller, fuel mixture, and alternate air. A friction lock knob on the right side of the engine control pedestal locked the engine control levers in any desired position. These control levers were easily accessible to the student and instructor pilot.

2.1.3.11. Paragraph 3.0.2.3.4. Model specification: No positive three-axis control surface lock was provided with the test aircraft. The technical proposal stated that positive control surface locks would be furnished with the proposed trainer.

FOR OFFICIAL USE ONLY

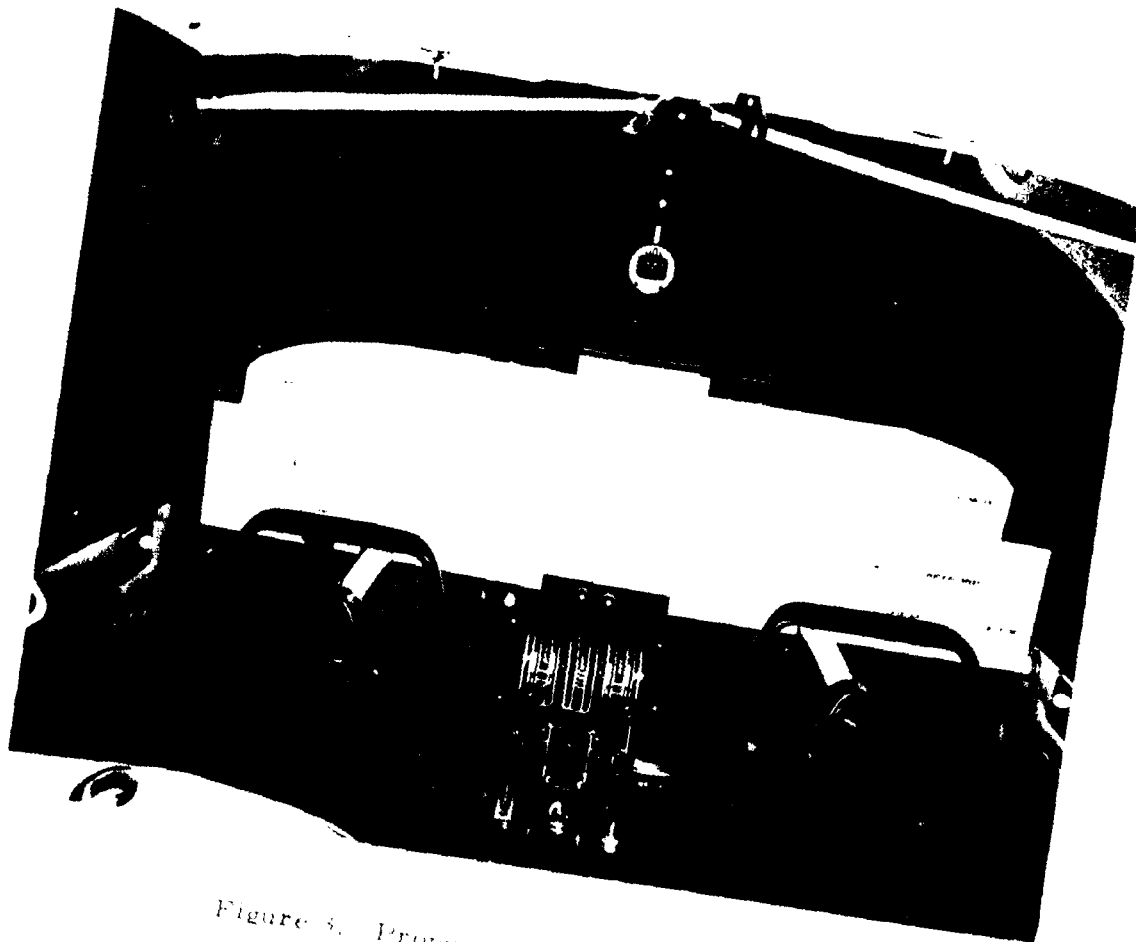

Figure 3. Proposed engine instruments

2.1.3.12. Paragraph 3.6.2.4.1. Model Specification: The test aircraft was delivered with a factory custom instrument panel which did not conform to the provisions of the Model Specification. The instrument panel proposed had the proper arrangement of instruments. The two proposed attitude indicators had separate power sources.

2.1.3.13. Paragraph 3.6.2.4.2. Model Specification: The proposed engine instruments were readable by both student and instructor pilot (figure 3).

FOR OFFICIAL USE ONLY

~~FOR OFFICIAL USE ONLY~~

2. 1. 3. 14. Paragraph 3. 7. 1, Model Specification: All of the instruments on the test aircraft were individually lighted and were compatible with night and instrument flight rule operations. A secondary lighting system consisting of red panel flood lights was located in the center of the cockpit ceiling. The intensity of the flood lights was controlled by a rheostat control knob. Two map lights with clear lenses were installed in the cabin ceiling just aft of the windshield. Each light was operated by a switch adjacent to the unit. An individual, white, reading spotlight was located over each rear seat.

2. 1. 3. 15. Paragraph 3. 7. 2, Model Specification: The Model PA23-250C test airplane was equipped with a rotating anticollision beacon faired into the top edge of the rudder. The installed beacon met the provisions of the FAA requirements as set forth in paragraph 3. 705 of the Civil Aeronautics Manual 3.

2. 1. 3. 16. Paragraph 3. 9. 1, Model Specification: A 27, 500-B. t. u. combustion-type cabin heater was installed in the test airplane. Existing climatic conditions precluded actual tests to determine the capability of the heater to meet the criteria of the Model Specification. However, using an estimated ventilating air flow rate and available combustion heater information (reference 4), the installed heater should amply fill the requirements of the Model Specification.

2. 1. 3. 17. Paragraph 3. 9. 2, Model Specification: The Model PA23-250C test airplane was not equipped with wing deicing and propeller anti-icing equipment. The technical proposal did not state that pneumatic deicer boots for the wing and tail surfaces, operated by engine-driven pumps, and propeller anti-icing equipment were available. The test airplane was equipped with pilot-controlled, heated alternate air for each engine induction system.

~~FOR OFFICIAL USE ONLY~~

~~FOR OFFICIAL USE ONLY~~

2.1.3.18. Paragraph 3.9.3. Model Specification: No oxygen equipment was installed in the Model PA23-250C test airplane. The technical proposal did not mention installation of oxygen equipment in the proposed trainer.

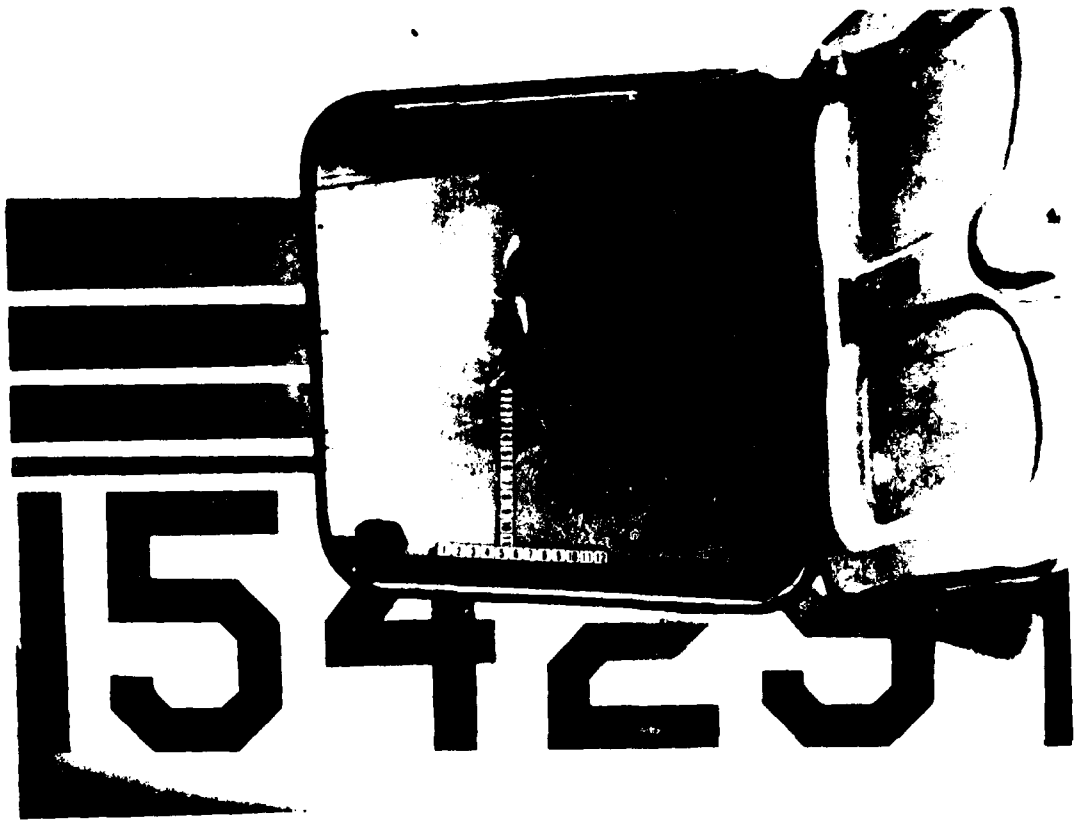

Figure 4. Baggage compartment aft of cabin

2.1.3.19. Paragraphs 3.10.1 and 3.10.2, Model Specification: The test airplane had the required baggage space for a minimum of 100 pounds of personal baggage. A baggage compartment aft of the cabin provided approximately 20 cubic feet of baggage space (figure 4). This compartment was placarded for a weight limit of 150 pounds. A door 22.5 inches wide by 22 inches high provided access to the baggage compartment from the outside. A nose compartment provided approximately 18 cubic feet of space and was placarded for a weight limit of 150 pounds (figure 5). There was ample storage space within the cabin for maps, charts, computers, and one TM 11-2557 (Jeppesen Case). A stowage area behind the rear seat measured 37 inches wide, 46 inches high, and 18 inches long (figure 6). The weight capacity of this area was limited only by the gross weight considerations of the aircraft.

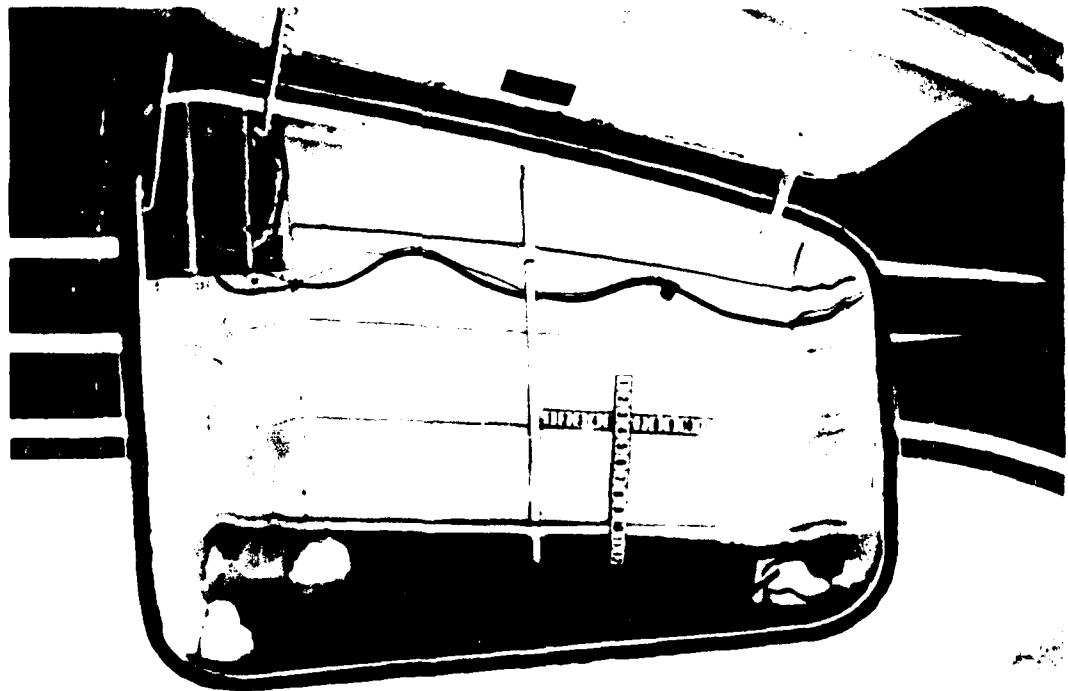

Figure 5. Nose compartment



Figure 1. Storage area behind rear seat

2.1.3.20. Paragraph 3.11, Model Specification: The Model PA-28-250C test airplane was delivered with an FAA-approved airplane flight manual and a maintenance and parts manual.

2.1.4. Analysis

Not applicable

2.2. PERFORMANCE.

2.2.1. Objective.

To determine the performance characteristics of the Model PA23-250C test airplane as related to the requirements specified in paragraph 3.5 of the Model Specifications.

2.2.2. Method.

2.2.2.1. The test airplane was flown at the gross weight outlined by the useful load requirement (paragraph 3.4, Model Specification), and tests were conducted to determine the cruise true airspeed (TAS), endurance, single-engine service ceiling (FAA requirement), and minimum safe single-engine speed (V_{mc}). Ballast was used to bring the gross weight of the test airplane up to the Standard-Normal Category gross weight of 4800 pounds. Data were tabulated in the National Aeronautical Space Administration Standard Day format.

2.2.2.2. The airspeed indicator from the test aircraft was calibrated. The airspeed position errors were obtained by the ground speed course method outlined in reference 3.

2.2.2.3. The factory engine cruise control chart and procedures outlined in the flight manual were used to determine the power settings for a series of stabilized level flight, 65-percent, cruise power runs. The data recorded were corrected to standard-day conditions.

2.2.2.4. The endurance data were obtained by use of the installed flow meters and verified by controlled flight profiles. The power was in accordance with recommended power charts and procedures. The mixture controls were set for best economy.

2.2.2.5. The single-engine service ceiling was determined by a series of saw-tooth climbs to substantiate the factory-recommended single-engine climb schedule. Using the climb schedule, climb data were obtained and reduced to standard-day conditions.

2.2.2.6. The minimum safe single-engine speed was investigated using the procedures and conditions described in paragraph 3.111, Civil Aeronautics Manual 3 (reference 5).

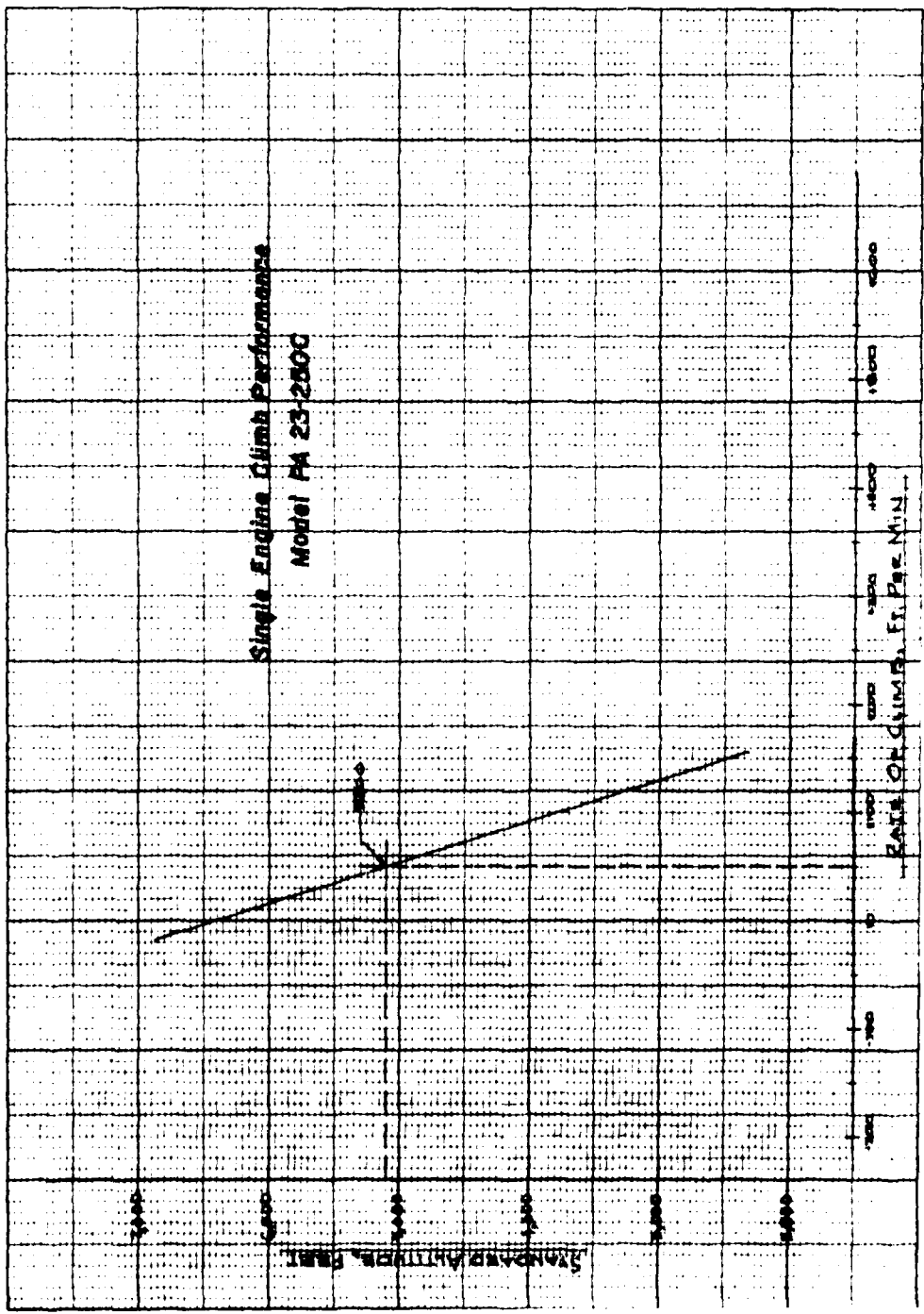

Figure 7

2.2.3. Results.

2.2.3.1. The cruise speed at 65 percent power, 7500 feet mean sea level was 167 knots TAS.

2.2.3.2. The Model PA23-250C test airplane consumed an average of 22.2 gallons of fuel per hour at 7500 feet altitude using a 65-percent best economy engine power setting. The test airplane basic weight was 3019 pounds. With the engine oil (45 pounds) and the 900-pound useful load required by the Model Specification, 836 pounds of fuel (139.3 gallons) may be added to meet the Standard-Normal Category gross weight of 4800 pounds. With this quantity of fuel, the test airplane will operate at the prescribed altitude and power settings for 6.3 hours. The endurance for the proposed instrument trainer is unknown because the technical proposal contained no weight analysis.

2.2.3.3. The Model PA23-250C test airplane had a single-engine service ceiling (climb rate of 50 f. p. m.) of 5200 feet (see figure 7).

2.2.3.4. The minimum safe single engine speed (V_{MC}) at sea level was 65 knots calibrated airspeed (CAS).

2.2.4. Analysis.

Not applicable.

2.3. ELECTRONICS CONFIGURATION.

2.3.1. Objective.

To study the technical proposal and determine the adequacy of the electronics configuration as related to paragraph 3.8 of the Model Specification.

2.3.2. Method.

The technical proposal was studied with regard to electronic equipment as listed in appendix II, Model Specification.

~~FOR OFFICIAL USE ONLY~~

2.3.3. Results.

Paragraph 3.8.1, Model Specification: The technical proposal did not contain any specifications for electronic equipment; therefore, the electronic configuration of the proposed instrument trainer could not be determined.

2.3.4. Analysis.

Not applicable.

~~FOR OFFICIAL USE ONLY~~

~~FOR OFFICIAL USE ONLY~~

SECTION 3

APPENDICES

~~FOR OFFICIAL USE ONLY~~

~~FOR OFFICIAL USE ONLY~~

APPENDIX I

LIST OF REFERENCES

1. Plan of Test, USATECOM Project No. 4-5-1001-01, "Military Potential Test of 'Off-the-Shelf' Airplanes as Fixed Wing Instrument Trainers," USAAVNTBD, dated 18 November 1964.
2. Letter, AMSTE-BG, USATECOM, 29 October 1964, subject: "Military Potential Test of Fixed Wing Instrument Trainer Aircraft," with inclosures.
3. AF-TR-6273, Flight Test Engineering Manual, Major Russel M. Herrington and Captain Paul E. Shoemaker, May 1951 (revised January 1953).
4. Kent's Mechanical Engineering Handbook (Power), Revised 1957.
5. Civil Aeronautics Manual 3, Airplane Airworthiness, Normal, Utility, and Acrobatic Categories, May 1962.
6. Model PA23-250 Service Manual, Piper Aircraft Corporation, 1 February 1963.
7. Aztec C Owner's Handbook, Piper Aircraft Corporation, April 1964.
8. Model Specification, Fixed Wing Instrument Trainer, Revised 26 June 1964, with Flight Instrumentation Appendix I and Table E, Appendix II.
9. Letter, SMOSM-PAIF-1, USAAVCOM, 16 July 1964, subject: "Invitation for Bid No. AMC(T)-23-204-64-459 (Step One)."
10. Technical Proposal, Piper Aircraft Corporation, 27 August 1964.

~~FOR OFFICIAL USE ONLY~~

~~FOR OFFICIAL USE ONLY~~

APPENDIX II

COMPARISON WITH MODEL SPECIFICATIONS

<u>Model Specification</u>	<u>Proposed Model PA23-250C Trainer Airplane Meets Mod Specs</u>	<u>Remarks</u>
<u>Fixed-Wing Instrument Trainer</u>		
1. <u>SCOPE</u>		
1.1 <u>Scope.</u> This specification covers the essential requirements for an instrument training airplane capable of performing the missions specified in 1.2.		
1.1.1 <u>Designation and General Description</u>		
Army Model Designation	Not yet assigned	
Number of Crew	1 Pilot (instructor)	Yes
Number of Passengers	3 Students	Yes
Flight Controls	Dual, side by side	Yes
Propulsion	Two reciprocating engines, feathering and positive unfeathering propellers	Yes

<u>Model Specification</u>	<u>Proposed Model PA23-250C Trainer Airplane Meets Mod Specs</u>	<u>Remarks</u>
Configura- tion and Construction	All metal with retract- able tricycle landing gear	Yes

1.2 Mission. The primary mission in which this airplane will be employed is the training of military pilots in instrument flying, in both day and night instrument flight rule operations.

1.2.1 Secondary Mission. Twin Engine Transition Trainer for single engine rated aviators.

1.3 Performance Information. Those items of performance stated as requirements herein which are not included in the FAA approved flight manual are subject to verification by the U. S. Army

2. APPLICABLE DOCUMENTS

2.1 The applicable documents shall be those necessary to fulfill the requirements of paragraph 3.10 Federal Aviation Agency Certification.

3. REQUIREMENTS

3.1 Federal Aviation Agency Certification. The airplane shall have a Part 3 (effective as of the date of issuance of the IFB) standard airworthiness certificate

Yes

The test airplane had an FAA Standard-Normal Category Certificate.

<u>Model Specification</u>	<u>Proposed Model PA23-250C Trainer Airplane Meets Mod Specs</u>	<u>Remarks</u>
for instrument flight operations, issued by the Federal Aviation Agency in the Utility Category.		
GFAE (electronics), contractor installed, shall be operationally verified by FAA.	Unknown	Not mentioned in technical proposal.
3.2 <u>Basic Weight.</u> The basic weight of the airplane shall include all required installed equipment including the items in Section 3.9 and the Electronic Equipment as stated in appendix II.	Unknown	No weight analysis in technical proposal.
3.3 <u>Center-of-Gravity Range.</u> No restrictions to mission payload or utility shall arise from constraints relating to center-of-gravity range, i.e. indiscriminate loading not to exceed useful load.	Unknown	No weight analysis in technical proposal.
3.4 <u>Useful Load.</u> The useful load shall be a minimum of 900 lb. of payload in addition to fuel and oil necessary to accomplish the endurance mission of paragraph 3.5.1.	Unknown	No weight analysis in technical proposal.
3.5 <u>Required Performance</u>		
3.5.1 <u>ICAO Standard Day Performance</u> (at certificated gross weight)		

~~FOR OFFICIAL USE ONLY~~

<u>Model Specification</u>		<u>Proposed Model PA23- 250C Trainer Airplane Meets Mod Specs</u>	<u>Remarks</u>
Cruise Speed (Minimum)	150 knots True Air Speed (TAS) at 65% Power at 7500 ft. Mean Sea Level (MSL)	Yes	
Endurance (Minimum)	5 hours at 65% Power at 7500 ft. MSL	Unknown	No weight analysis in technical proposal.
Single Engine Service Ceiling (minimum) - 7000 ft. MSL		No	Single-engine service ceiling was 5200 feet.
Minimum Safe Single Engine Speed at Sea Level, not to exceed 80 knots		Yes	
<u>3.6 Aircraft Structure</u>			
3.6.1 <u>Landing Gear.</u>	The landing gear shall be nose wheel type tri- cycle configuration and shall be retractable. The nosewheel shall be steerable.	Yes	
<u>3.6.2 Airframe</u>			
3.6.2.1	Construction shall be all metal.	Yes	
3.6.2.2	<u>Interior Arrangement.</u> Individual side-by-side adjustable	Yes	

<u>Model Specification</u>	<u>Proposed Model PA23- 250C Trainer Airplane Meets Mod Specs</u>	<u>Remarks</u>
front seats for the student on the left and the instructor on the right. Two additional seats immediately to the rear to accommodate two additional students. Seating arrangement must permit exchange of the three (3) students in flight.		
Shoulder harnesses shall be required for the front seats only.	No	There were no shoulder harnesses installed in test airplane and none were provided in technical proposal.
3.6.2.2.1 One (1) fire extinguisher and one (1) first aid kit shall be installed and shall be accessible in flight. (See appendix III.)	Yes	
3.6.2.3 <u>Flight and Engine Controls</u>		
3.6.2.3.1 Dual flight controls to include adjustable rudder pedals with toe-type brakes.	Yes	Test airplane had no adjustable rudder pedals and only one set of toe-brakes.
3.6.2.3.2 In-flight trim controls for elevator, aileron, and rudder are required and shall be easily accessible to both the student and instructor.	Yes	Test airplane had no in-flight aileron trim.
3.6.2.3.3 Engine controls shall be easily accessible to both the student and instructor.	Yes	

~~FOR OFFICIAL USE ONLY~~

<u>Model Specification</u>	Proposed Model PA23- 250C Trainer Airplane Meets Mod <u>Specs</u>	<u>Remarks</u>
3.6.2.3.4 Positive control surface locks will be provided for ramp use.	Yes	Test airplane had no positive control surface locks.
3.6.2.4 <u>Instrumentation</u>		
3.6.2.4.1 The instrument panel shall have dual instrumentation incorporating the "T" panel arrangement depicted in appendix I. Further, the two (2) attitude indicators shall have separate power sources.	Yes	
3.6.2.4.2 Engine instruments shall be readable by both student and instructor pilot.	Yes	
3.7 <u>Lighting</u>		
3.7.1 Cockpit and instrument lighting are required for night and instrument flight rule operations. (Fluorescent and/or red flood lighting not acceptable as primary lighting of instrument panel.)	Yes	
3.7.2 The aircraft shall have rotating beacon(s) per FAA requirements.	Yes	
3.8 <u>Electronic Equipment</u>		
3.8.1 Electronics shall be in accordance with appendix II.	Unknown	No electronic equipment was mentioned in technical proposal.

<u>Model Specification</u>	<u>Proposed Model PA23-250C Trainer Airplane Meets Mod Specs</u>	<u>Remarks</u>
3.8.2 Controls shall be easily accessible and readable to the student and instructor.	Unknown	No electronic equipment was mentioned in technical proposal.
2.8.3 Electronics controls shall be front panel mounted wherever possible. Overhead control panels are not acceptable.	Unknown	No electronic equipment was mentioned in technical proposal.
<u>3.9 Aircraft Systems</u>		
3.9.1 <u>Cabin Heating</u> . The aircraft shall have a heating system capable of maintaining a minimum of +40°F. cabin temperature with -25°F. outside air temperature.	Yes	
3.9.2 <u>Deicing Equipment</u> . Lightweight deicing and anti-icing equipment shall be installed on the aircraft as certificated. Deicing equipment must be capable of continuous operation for flight endurance of the aircraft.	No	No deicing or anti-icing equipment was provided on the test airplane or in technical proposal.
3.9.3 <u>Oxygen Equipment</u> . Equipment for four (4) persons for a minimum of 1.5 hours duration at 15,000 feet MSL. A liquid oxygen system is not acceptable.	No	No oxygen equipment was provided in test airplane or in the technical proposal.
<u>3.10 Stowage</u>		
3.10.1 Baggage space shall be provided for a minimum of 100 lb. of personal baggage.	Yes	

<u>Model Specification</u>	<u>Proposed Model PA23- 250C Trainer Airplane Meets Mod Specs</u>	<u>Remarks</u>
3.10.2 Storage space within the cabin shall be provided for maps, charts, computers, and one (1) TM 11-2557 (Jeppesen Case).	Yes	
3.11 <u>Manuals</u>		
3.11.1 The aircraft shall be furnished with a Flight Operator's Manual in accordance with FAA regulations and a Maintenance and Parts Manual.		

~~FOR OFFICIAL USE ONLY~~

APPENDIX III - COORDINATION

The following agencies participated in the review of the test report:

US Army Aviation School

US Army Combat Developments Command Aviation Agency

III-1

~~FOR OFFICIAL USE ONLY~~

APPENDIX IV - DISTRIBUTION LIST

REPORT OF USATECOM PROJECT NO. 4-5-1001-01

<u>Agency</u>	<u>No. Copies</u>
Commanding General US Army Aviation Materiel Command ATTN: SMOSM-EP St. Louis, Missouri 63166	10
Commanding General US Army Materiel Command ATTN: AMCMR-MC Washington, D.C. 20315	2
Commanding General US Continental Army Command ATTN: Colonel Greer Fort Monroe, Virginia	2
Commanding General US Army Test and Evaluation Command ATTN: AMSTE-BG Aberdeen Proving Ground, Maryland 21005	2
Commanding General US Army Mobility Command ATTN: AMSMO-M Warren, Michigan	2

AD _____ Accession No. _____
US Army Aviation Test Board, Fort Rucker, Alabama. Final Report
of USATECOM Project No. 4-5-1001-01, Military Potential Test of
the Model PA23-250C Fixed-Wing Instrument Trainer, 30 November
1964. DA Project No. None, 42 pp., 8 illus., FOR OFFICIAL USE
ONLY. The Military Potential Test of the Model PA23-250C Fixed-
Wing Instrument Trainer was conducted by the US Army Aviation
Test Board during the period 5 October 1964 to 10 November 1964
at Fort Rucker, Alabama. Flight under actual and simulated instru-
ment conditions and demonstrations to personnel representing the US
Army Aviation Center and the US Army Aviation School were conducted
during the test period. It was found that the Model PA23-250C test
airplane as changed by the technical proposal will not meet all of the
requirements contained in the Model Specification. It was recommended
that a confirmatory test be performed on the initial production airplane
if the Model PA23-250C airplane is selected as a fixed-wing instrument
trainer.

AD _____ Accession No. _____
US Army Aviation Test Board, Fort Rucker, Alabama. Final Report
of USATECOM Project No. 4-5-1001-01, Military Potential Test of
the Model PA23-250C Fixed-Wing Instrument Trainer, 30 November
1964. DA Project No. None, 42 pp., 8 illus., FOR OFFICIAL USE
ONLY. The Military Potential Test of the Model PA23-250C Fixed-
Wing Instrument Trainer was conducted by the US Army Aviation
Test Board during the period 5 October 1964 to 10 November 1964
at Fort Rucker, Alabama. Flight under actual and simulated instru-
ment conditions and demonstrations to personnel representing the US
Army Aviation Center and the US Army Aviation School were con-
ducted during the test period. It was found that the Model PA23-250C
test airplane as changed by the technical proposal will not meet all of
the requirements contained in the Model Specification. It was recom-
mended that a confirmatory test be performed on the initial produc-
tion airplane if the Model PA23-250C airplane is selected as a fixed-
wing instrument trainer.

~~FOR OFFICIAL USE ONLY~~