

**U.S. DEPARTMENT OF COMMERCE
National Technical Information Service**

AD-A028 714

Study of Anti-Distortion Jackets

Watervliet Arsenal

July 1976

REPORT DOCUMENTATION PAGE		READ INSTRUCTIONS BEFORE COMPLETING FORM
1. REPORT NUMBER WVT-TR-76028	2. GOVT ACCESSION NO.	3. RECIPIENT'S CATALOG NUMBER
4. TITLE (and Subtitle) STUDY OF ANTI-DISTORTION JACKETS		5. TYPE OF REPORT & PERIOD COVERED
7. AUTHOR(s) LT Arnold M. Manaker Paul J. Croteau		6. PERFORMING ORG. REPORT NUMBER
9. PERFORMING ORGANIZATION NAME AND ADDRESS Benet Weapons Laboratory Watervliet Arsenal, Watervliet, N.Y. 12189 SARWV-RT-TP		8. CONTRACT OR GRANT NUMBER(s)
11. CONTROLLING OFFICE NAME AND ADDRESS U.S. Army Armament Command Rock Island, Illinois 61201		10. PROGRAM ELEMENT, PROJECT, TASK AREA & WORK UNIT NUMBERS AMCMS No. 3110.15.1100 Pron No. M7-4-P4657-02-M7-M7
14. MONITORING AGENCY NAME & ADDRESS (if different from Controlling Office)		12. REPORT DATE July 1976
		13. NUMBER OF PAGES 50 55
		15. SECURITY CLASS. (of this report) UNCLASSIFIED
		15a. DECLASSIFICATION/DOWNGRADING SCHEDULE
16. DISTRIBUTION STATEMENT (of this Report) Approved for public release; distribution unlimited.		
17. DISTRIBUTION STATEMENT (of the abstract entered in Block 20, if different from Report)		
18. SUPPLEMENTARY NOTES		
19. KEY WORDS (Continue on reverse side if necessary and identify by block number) Anti-Distortion Jackets Guns Tanks (Combat Vehicles) Thermal Shrouds		
20. ABSTRACT (Continue on reverse side if necessary and identify by block number) An experimental investigation of the effects of various thermal and environmental conditions, such as sunlight, rain, wind, and internal heating resulting from firing, on the accuracy of tank cannons is undertaken. The approach taken in this report, is to shroud the tank cannon, thereby negating the environmental effects. The shrouds consist of high-strength filaments (S-glass) embedded into a low thermally conductive matrix (epoxy) and in some cases aluminum sheets are also embedded in the matrix. (See Other Side)		

20.

This study ascertains the usefulness of a composite shroud in negating the effects of solar radiation, internal heating and rain. Through the use of thermal shrouds, reduction in muzzle temperature gradients of 83% (solar radiation), 11% (internal heating), and 90% (solar radiation and rain) were achieved.

This study also reviews all of the past work, experimental and theoretical, and testing that has taken place to date.

ACQUISITION by
DTIC
C.G.
DISTRIBUTION STATEMENT
BY DISTRIBUTION STATEMENT
A

ia

239077

WVT-TR-76028

AD

ADA 028714

STUDY OF ANTI-DISTORTION JACKETS

DDC
RECEIVED
AUG 23 1976
C

July 1976

 **BENET WEAPONS LABORATORY
WATERVLIET ARSENAL
WATERVLIET, N.Y. 12189**

TECHNICAL REPORT

AMCMS No. 3110.15.1100

Pron No. M7-4-P4657-02-M7-M7

APPROVED FOR PUBLIC RELEASE: DISTRIBUTION UNLIMITED

REPRODUCED BY
NATIONAL TECHNICAL
INFORMATION SERVICE
U. S. DEPARTMENT OF COMMERCE
SPRINGFIELD, VA. 22161

DISCLAIMER

The findings in this report are not to be construed as an official Department of the Army position unless so designated by other authorized documents.

The use of trade name(s) and/or manufacturer(s) in this report does not constitute an official indorsement or approval.

DISPOSITION

Destroy this report when it is no longer needed. Do not return it to the originator.

WVT-TR-76028

AD

STUDY OF ANTI-DISTORTION JACKETS

LT Arnold M. Manaker
Paul J. Croteau

July 1976

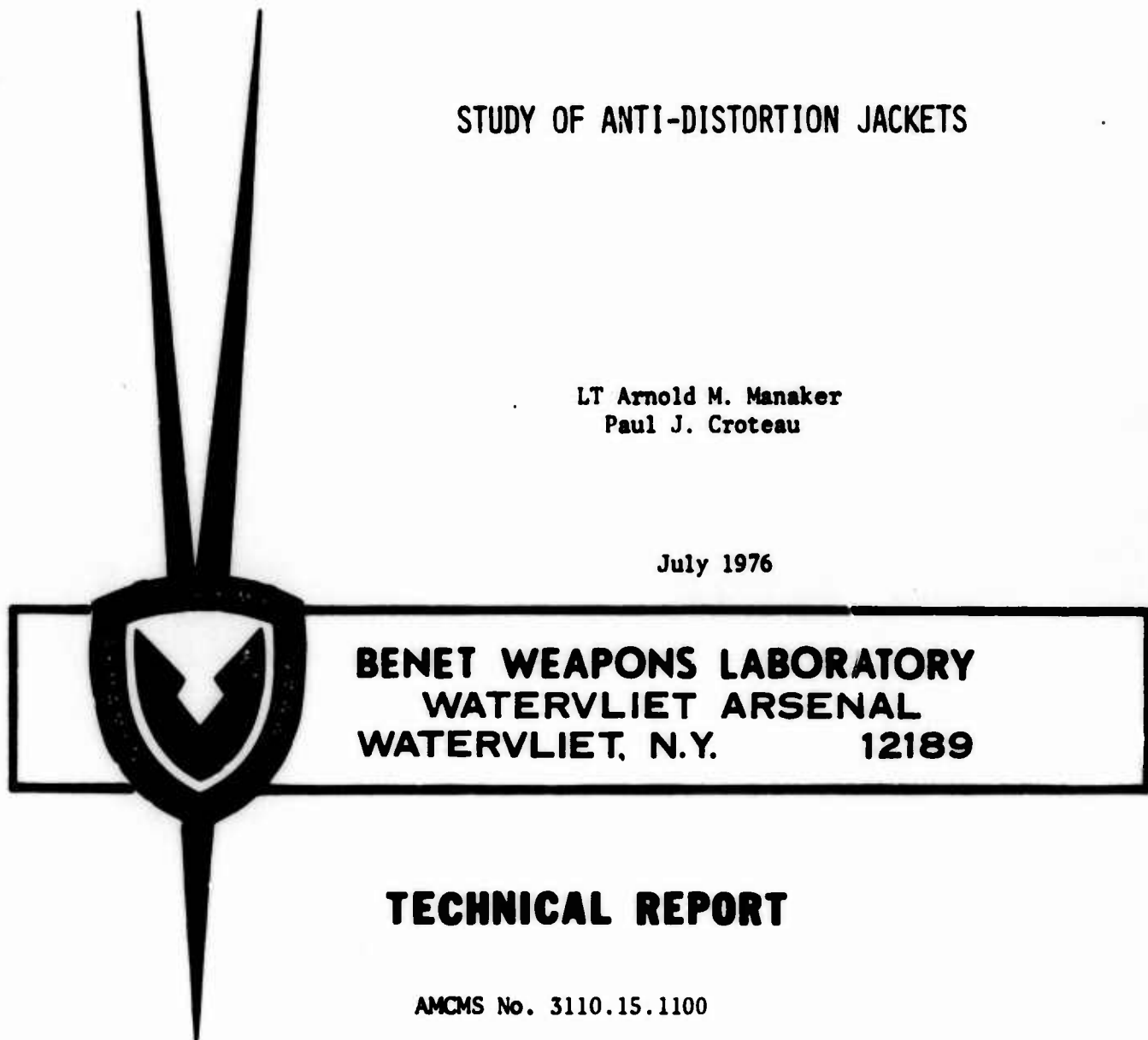

BENET WEAPONS LABORATORY
WATERVLIET ARSENAL
WATERVLIET, N.Y. 12189

TECHNICAL REPORT

AMCMS No. 3110.15.1100

Pron No. M7-4-P4657-02-M7-M7

APPROVED FOR PUBLIC RELEASE: DISTRIBUTION UNLIMITED

ib

ACKNOWLEDGEMENT

The authors gratefully acknowledge the technical assistance contributed by Dr. G. D'Andrea, Mr. R. Cullinan, Mr. H. Scheck and Mr. R. Peterson of the Watervliet Arsenal Research Directorate. The authors also wish to thank Product Development Division and the Research Directorate for providing funds for this project. Mrs. P. Clinton of the Research Directorate is to be commended for the fine typing in this report. Also thanks are due the Watervliet Arsenal Research Computer Center for use of their facilities in analyzing the data.

TABLE OF CONTENTS

	<u>Page</u>
REPORT DOCUMENTATION PAGE, DD FORM 1473	
ACKNOWLEDGEMENT	ii
LIST OF TABLES	iv
LIST OF FIGURES	v
INTRODUCTION	1
DESIGN AND FABRICATION	11
TESTING	13
DISCUSSION OF RESULTS	26
CONCLUSIONS	43
LITERATURE CITED	45
DISTRIBUTION LIST	47

LIST OF TABLES

	Page
Table I Thermal Test: Unpainted bare tube subjected to various solar fluxes ranging from 170 Btu/hr/ft ² to 260 Btu/hr/ft ² for 48 minutes	26
Table II Thermal Test: Unpainted tube with various unpainted thermal shrouds subjected to a solar flux of 270 Btu/hr/ft ² for 48 minutes	28
Table III Thermal Test: Unpainted tube and thermal shroud and painted thermal shroud subjected to a solar flux of 270 Btu/hr/ft ² for 48 minutes	32
Table IV Thermal Test: Painted tube and various thermal shrouds subjected to a solar flux of 270 Btu/hr/ft ² for 48 minutes.	34
Table V Thermal Test: Unpainted tube and various painted thermal shrouds subjected to internal heating for 30 seconds.	36
Table VI Thermal Test: Painted tube and various painted thermal shrouds subjected to internal heating for 30 seconds.	36
Table VII Thermal Test: Painted tube with a painted thermal shroud subjected to a solar flux of 270 Btu/hr/ft ² for 48 minutes and a heavy rain for 2 minutes.	40
Table VIII Thermal Test: Painted tube with a painted thermal shroud subjected to internal heating for 30 seconds and a heavy rain.	42

LIST OF ILLUSTRATIONS

	Page
Figure 1. Scaled model 105mm, M68 tube	14
Figure 2. S-glass/epoxy composite thermal shroud	15
Figure 3. S-glass/epoxy/aluminum insert composite thermal shroud	16
Figure 4. S-glass/epoxy/aluminum (one layer) composite thermal shroud	18
Figure 5. S-glass/epoxy/aluminum (three layers) composite thermal shroud	19
Figure 6. S-glass/epoxy/design 1 composite shroud	20
Figure 7. S-glass/epoxy/design 2 composite shroud	21
Figure 8. Overall view of solar radiation set-up which includes design 2 composite shroud and instrumentation	22
Figure 9. Overall view of internal heating set-up which includes S-glass/epoxy composite thermal shroud and instrumentation	23
Figure 10. Overall view of rain set-up which includes design 1 composite shroud and instrumentation	24
Figure 11. Deflection Vs Time, and Temperature Difference Vs Time of an unpainted bare tube subjected to various solar fluxes ranging from 170 Btu/hr/ft ² to 260 Btu/ hr/ft ²	27
Figure 12. Deflection Vs Time, and Temperature Difference Vs Time of an unpainted tube with various unpainted thermal shrouds subjected to a solar flux of 270 Btu/hr/ft ² for 48 minutes	29
Figure 13. Deflection Vs Time, and Temperature Difference Vs Time for an unpainted tube and thermal shroud and painted thermal shroud subjected to a solar flux of 270 Btu/hr/ft ² for 48 minutes	31
Figure 14. Deflection Vs Time, and Temperature Difference Vs Time of a painted tube and various thermal shrouds subjected to a solar flux of 270 Btu/hr/ft ² for 48 minutes	33

LIST OF ILLUSTRATIONS (Cont)

	Page
Figure 15. Deflection Vs Time, and Temperature Difference Vs Time for an unpainted tube and various painted thermal shrouds subjected to internal heating for 30 seconds.	35
Figure 16. Deflection Vs Time, and Temperature Difference Vs Time for a painted tube and various painted thermal shrouds subjected to internal heating for 30 seconds.	37
Figure 17. Deflection Vs Time, and Temperature Difference Vs Time for a painted tube with a painted thermal shroud subjected to a solar flux of 270 Btu/hr/ft^2 for 48 minutes and a heavy rain for 2 minutes. . .	39
Figure 18. Deflection Vs Time, and Temperature Difference Vs Time for a painted tube with a painted thermal shroud subjected to internal heating for 30 seconds and a heavy rain.	41

I. INTRODUCTION

Tank guns, such as the 105mm and 152mm, are subjected to various thermal and environmental conditions, such as sunlight, rain, wind and internal heating resulting from firing. These conditions cause a temperature gradient in the cannon, which results in cannon droop. The resultant of the cannon drooping is the shifting of the center of impact from occasion to occasion.

During the past several years, various approaches to the problem of tube droop have been attempted. One of the earliest theoretical and experimental investigations were undertaken by Gay and Elder (Reference 1) in 1959. Their objective was to evaluate the effect of tube droop on the overall accuracy of tank guns. Although their work does not include any thermal studies, it does outline the many problems associated with the "Lateral Motion of a Tank and Its Effect on the Accuracy of Fire."

In 1971 Watervliet Arsenal addressed the problem of tube distortion caused by solar radiation per the request of the MBT-70 Project Manager. It should be mentioned that at this time an asbestos blanket designed by the British for the 120mm Chieftain concept and an aluminum shroud designed by FRG for the Leopard Tank were considered. One should note that in terms of heat transfer characteristics the aluminum (high

¹Gay, H.P. and Elder, A.S., "The Lateral Motion of a Tank Gun and its Effect on the Accuracy of Fire", AD No. 217657, March 1959.

conductivity) is an excellent conductor whereas asbestos (low conductivity) is an excellent insulator. Watervliet's approach, at this time, was to substitute a high strength filament (S-glass) embedded into a low thermally conductive matrix (epoxy). The heat transfer characteristics of the composite (filament/epoxy) would be between that of aluminum and asbestos, however, structurally it would be an order of magnitude stronger than either of the other materials. In terms of US ARMY requirements, this last feature, that of high strength, was extremely important. From Watervliet's study (Reference 2), a shroud was designed and fabricated which reduced tube droop of a 152mm XM150E6 by as much as 89%, after 5 minutes exposure time, when subjected to solar loads of 250 to 300 Btu/hr/ft².

Due to the failure of the MBT-70 program, the thermal shroud program for the 152mm XM150E6 never really materialized, however, the PM-M60 showed some interest in a thermal cover for the 105mm M68 gun tube. A proposal was submitted by Watervliet to PM-M60 in January 1972 and accepted. Watervliet Arsenal was to build two shrouds, composed of high strength filaments (S-glass) embedded into a low thermally conductive matrix (epoxy)*. In the laboratory, reduction in gun tube droop of 76% after 5 minutes exposure to radiation was achieved with this type of shroud (Reference 3). It must be pointed out that the shrouding

*In total, Watervliet Arsenal has built about twenty thermal shrouds for the M60A1E3 project.

2D'Andrea, G., et al, "152mm G/L XM150E6 Thermal Shroud", WTV-7159, November 1971.

3D'Andrea, G., et al, "105mm M68 Thermal Shroud," WTV-7249, November 1972.

principal could not be optimized for the following reasons: (1) duration of the project (six months), (2) restrictions on the shroud dimensions (i.e. the shroud must fit into the present travel lock) and (3) funding was insufficient for any detailed analysis.

In the summer of 1973, the first live firing tests (Reference 4) were performed at Yuma Proving Ground to ascertain the effectiveness of the thermal shroud. The test consisted of firing one shot an hour from a tank with and without a thermal shroud at a target 1000 meters away. Generally the shot pattern followed the movement of the sun from east to west. About 50% reduction in the dispersion pattern was achieved with the shrouded tube, thus confirming the tests done at Watervliet Arsenal and ascertain the usefulness of the thermal shroud.

Based on the Yuma test, and results achieved in the laboratory at Watervliet Arsenal, the PM-M60 decided to use the thermal shroud on the M60A1E3 tank throughout its developmental phases.

At this time, Messrs Boylan, Deas and Riley of Ballistic Research Laboratory (Reference 5) took an interest in the thermal shroud problem. They developed a theoretical, 2-dimensional (r, θ) , steady state solution for a multi-layered cannon/shroud configuration. Their approach was to assume a product solution to the conduction equation which enables

⁴Unpublished Watervliet Arsenal data collected at the Yuma Proving Ground, Arizona, August 1973.

⁵Boylan, D.M., et al, "An Analytical Heat Transfer Model for Determining an Optimum Thermal Jacket for Tank Guns," BRL IMR 154, November 1973.

them to use the principal of separation of variables. The important effects of convection as well as internal heat generation are not considered. The environmental effect of solar radiation on a shrouded and unshrouded 105mm M68 tank is analyzed. The conclusions reached in their study were:

- (1) Ranking the performances of existing thermal shroud configurations accurately.
- (2) Design of candidate thermal shroud configurations which theoretically show marked improvements over the existing designs.

Many of the recommendations made in the report were proposed by D'Andrea and others (Reference 3) at Watervliet Arsenal but were not realized because of the earlier mentioned reasons of time, money and physical constraints.

In the winter of 1973-1974, unexplained shot patterns developed in the course of the developmental testing of the M60A1E3 tank at Fort Knox, Kentucky. What occurred was that the shot pattern dropped each successive round when the tank was firing at a rate of one round per minute. It was felt, by Fort Knox and PM-M60 personnel,

D'Andrea, G., et al. "105mm M68 Thermal Shroud," WTV-7249, November 1972.

that the round dropping problem was the result of excessive heat gradients that developed as a result of shrouding the gun tube.

In January 1974, an ammunition test (Reference 6) at Aberdeen Proving Ground was piggy-backed in order to evaluate the affect of the shroud on the tank gun, when the firing rate is of the order of one round per minute. The test consisted of firing 35 rounds without a shroud and 50 rounds with a shroud. Temperature data, at the 12 o'clock position on the tube, at various distances from the muzzle was recorded. Temperature gradients were not obtainable, however, because of insufficient data. No accuracy data was obtained because the cannon was muzzle sighted after each round therefore negating the effect of muzzle droop.

During this same time period (January 1974), Fort Knox instrumented one of the developmental tank (Reference 7) cannon with thermocouples. Analysis of the data reveals the fact that temperature gradients across the cannon fluctuate in magnitude as well as in sign. Therefore no significant, if any, conclusions could be reached on the effect the thermal shroud has on the cannon.

In January 1974, Watervliet Arsenal recommended to the PM-M60 that the initial test at Yuma (August 1973) be repeated because of the skepticism many had of the first test. The PM-M60 conducted the second

⁶O'Mara, K.J., "105mm, M68 Firing Test Both With and Without a Watervliet Thermal Shroud-Results of", Internal Watervliet Arsenal Report, 25 January 1974.

⁷Unpublished Fort Knox data collected at Fort Knox, Kentucky, 22 January 1974.

Yuma test (Reference 8) at the end of February 1974. The test consisted of firing five round shot groups every two hours from a shrouded tube and an unshrouded tube. Temperature as well as dispersion data was recorded during the test. Temperature results obtained were of a very suspicious nature, i.e., temperature differences from top to bottom at the muzzle end ranged from 19°F to 57°F. It was pointed out, after analysis of the test results, that the tanks were not re-sighted after each round therefore the movement of the tank in the sand invalidated the accuracy of the test.

Up to this point in time, ARMCOM did not actively participate in the thermal shroud program. In May 1974 they decided to become involved. They funded \$30K for two distinct phases: (1) a theoretical study to be undertaken by Clausing (Reference 9) and (2) environmental tests on the present thermal shrouds.

Clausing's work consisted of a theoretical, 2-dimensional transient conduction analysis of the cannon and shroud interaction. The analysis did not consider the effect of convection between the shroud and tube, thus ruling out any type of venting effects which could play a major role on the performance of the thermal shroud system. The study considers the effects of solar radiation as well as internal heat generation. A finite difference solution procedure is used. Results of his study are as follows:

⁸O'Mara, K.J., Trip Report No. 72-74, Watervliet Arsenal, 27 February 1974.

⁹Clausing, A.M., "The Influences of Asymmetric Heating and Cooling of Gun Tubes With and Without Thermal Shrouds", AMC TR 0074-4, June 1974.

a. The shrouds have a negligible influence on gun tube temperature buildup below temperature levels of 800°F.

b. The shrouds have a significant influence on the cooling rate, but the rate is only weakly influenced by shroud material selection.

c. A selective coating with a low ratio of absorption to emittance is effective in decreasing the diametrical temperature difference caused by solar heating.

d. An effective thermal shroud should have a high circumferential thermal conductivity. Again it must be pointed out that physical constraints (i.e., travel lock location, clamping the shroud to the tube, infrared detection and others) are not considered.

The second phase, environmental testing, consisted of the following sequence of events (carried out at APG in November 1974 (Reference 10):

a. Thermal shroud #1* (pre-located scratches, *Half the thickness of the shroud)

(1) Condition to -75°F and fire three rounds.

(2) Place in boiling tap water for 24 hours.

(3) Immediately after step b, 12 rounds were fired in 5 minutes and 20 seconds.

(4) Soak in boiling water for 24 hours.

(5) Immediately after step d, condition to -20°F.

(6) Remove from cold box and fire 5 rounds in 8 minutes.

*Watervliet Arsenal supplied the shrouds

¹⁰Friar, G.S., Trip Reports, Watervliet Arsenal, 14 November 1974 and 2 December 1974.

b. Thermal shroud #2 was taken through steps d, e and f.

Examination of both thermal shrouds, after the testing, revealed no deterioration in their structural integrity.

At about the same time the environmental testing was being performed, DT-OT-II phase of the M60A1E3 program was taking place. One phase of this testing was to evaluate the performance of the thermal shroud (Reference 11). During the thermal shroud testing phase, temperature as well as dispersion data was recorded. After prolonged firing, the surface temperature of the cannon varied from 192°F to 355°F. It should be noted that the reading of 192°F was recorded on top of the bore evacuator, which in effect acts as a shroud. Also upon analysis of the data one finds that at the muzzle section the cannon heats up faster on the bottom than on the top. This phenomenon is contrary to what one would expect to happen. This reverse heating occurs until the twenty-second round. At the middle section, ΔT 's of 46°F occur which is hard to believe. Also one notes that the bottom heats up faster than the top, at the mid-section, for about the first 20 rounds. Overall, the results are unacceptable.

During the first eight months of 1975, the Ballistic Research Laboratory published four technical reports (References 12 through 15)

¹¹Extract of DT II M60A1E3 Final Test Report, December 1974.

¹²Minor, T.C., et al, "Investigation of Variable Bias in Tank Guns: Heat Transfer and Deflection Calculations for Gun Tubes With Thermal Jackets", BRL IMR 349, February 1975.

¹³Minor, T.C., et al, "Cross-Tube Temperature Gradients Under the Watervliet Thermal Jacket on a 105mm, M68, Tank Gun", BRL IMR 375, Apr 75.

¹⁴Minor, T.C., et al, "Detailed Temperature-Time Data From Firing Test With the Watervliet Thermal Jacket on a 105mm M68 Gun", BRL IMR 391, June 75.

¹⁵Minor, T.C., et al, "Investigation of Variable Bias in Tank Guns: Heat Transfer and Deflection Calculations for Gun Tubes With Thermal Jackets (Part II)", BRL IMR 416, August 1975.

on their work involving thermal shrouds. In report BRL RP 349 (Feb 75), the results of analytical and experimental work are presented. The conclusions that were reached in their analytical study are:

a. The heat transfer model correctly predicts temperature profiles in gun tubes with and without thermal jackets under solar heating.

b. Radiation as well as conduction of heat across air gaps must be considered in the calculations of jacket performance.

c. The amount of gun tube distortion can be calculated from temperature differences along the gun.

Temperature differences across various tube locations are presented for a bare tube subjected to a solar flux of 961 watt/square meter. Also, muzzle deflection versus time for a German shroud (all aluminum) subjected to the previous mentioned solar flux are given. The accuracy of the deflection readings is questionable because it does not appear that the dial indicators are sufficiently insulated from the effects of the heat lamps.

Reports BRL RP 375 (April 75) and BRL RP 391 (June 75) detail the measurement of cross-tube temperature gradients under the muzzle section of a Watervliet Arsenal composite thermal jacket during the firing of groups of rounds from the 105mm M68, tank gun. Conclusions reached from the firing were that the maximum temperature gradient across the muzzle section was 4.1°F and the maximum temperature at the 12 o'clock position was 161.2°F. These results seem to disprove results obtained in the firing test at Yuma Proving Ground (Feb 74).

The final report, BRL RP 416 (August 75), summarizes their previous

three reports and also presents the results of a live firing test at APG. In this test, two M60A1E3 tanks, one with a bare 105mm M68 cannon and one with a BRL-jacketed cannon were used. Temperature data and dispersion data were recorded during the test. For the BRL shrouded tube the maximum temperature gradient at the muzzle end was 2.2°F. In terms of dispersion the thermal jacket reduced the circular dispersion to 39 percent of the bare tube value. In the report, a comparison is made between cross-tube temperature differences under the BRL and Watervliet Arsenal thermal jackets at a location 42 inches from the muzzle. The comparison is somewhat questionable in light of the fact that the two tests were not performed under the same conditions. Also the Watervliet Arsenal shroud was designed for the express purpose of negating the affect of solar radiation. The tests performed by BRL do not ascertain the performance of the thermal shroud under the previous mentioned condition.

To date the effects of internal heating and rain have not been considered. The objective of the study reported herein is to evaluate various thermal shroud configurations and compositions when subjected to the thermal condition of internal heating and the environmental conditions of solar radiation and rain.

The configurations considered are of a nature that they could be incorporated into the M60A1E3 thermal shrouds, without requiring extensive monetary investment or modification of the mounting hardware. It will become evident that slight modifications to the present thermal shroud will greatly increase its effectiveness.

II. DESIGN AND FABRICATION

A. Gun Tube

The tube was designed, so that for a given force, on a 105mm and scaled 105mm cannon, an equivalent deflection will result. Static deflection, which results from the weight of the tube, is not considered in the design because it can effectively be zeroed out in the environmental testing. Using the area-moment method, one can show that

$$D_{OD(M)} = \left\{ n^3 [D_{OD(105)}^4 - D_{ID(105)}^4] + D_{ID(M)}^4 \right\}^{1/4}$$

where

$D_{OD(M)} \equiv$ Outside diameter of model

$D_{ID(M)} \equiv$ Inside diameter of model

$D_{OD(105)} \equiv$ Outside diameter of 105mm cannon

$D_{ID(105)} \equiv$ Inside diameter of 105mm cannon

$n = (l_{(M)} / l_{(105)})$ ratio of length of model to length of a 105mm cannon

B. Thermal Shroud

The basic design considers the use of a high strength, low thermally conductive, lightweight "jacket" over the cannon. This "jacket" is wound on a mandrel, and later released and positioned onto the tube.

The thermal shrouds were fabricated on a filament winding machine which is electronically controlled, programmable, servo-driven unit with a high degree of winding flexibility. The fiberglass shroud was made of S-glass which was pre-impregnated with an epoxy/anhydride/amine

resin matrix. The curing cycle for this resin was 1 hour at 200°F for gelling followed by 2 hours at 350°F for final cure. This prepreg composite material was purchased from U.S. Polymeric, Inc. under their designation S-1014/E-787 20 end roving.

III. TESTING

The purpose of this testing is to evaluate the performance of various thermal shroud configurations, on a scaled 105mm M68 tank cannon, when subjected to the environmental condition of solar radiation, rain and the operating condition of firing ammunition. To accomplish this objective, the following types of tests were performed on a scaled model 105mm tank gun in the laboratory:

- a. Shade condition to solar radiation, to shade.
- b. Shade condition to sustained firing mode, to shade.
- c. Shade condition to solar radiation, to rain to shade.
- d. Shade condition to sustained firing mode, to rain to shade.

During each test the following data was recorded:

- a. Tube muzzle bend versus time.
- b. Temperature at predetermined tube locations versus time.
- c. Solar loading, when applied.

The equipment used in performing the experiments was:

- a. Scaled model 105mm, M68 gun tube (Figure 1).
- b. Various thermal shrouds:
 - (1) S-glass/epoxy composite shroud with an air space between the tube and shroud (Figure 2).
 - (2) S-glass/epoxy/aluminum insert composite shroud with an air space between the tube and shroud (Figure 3).

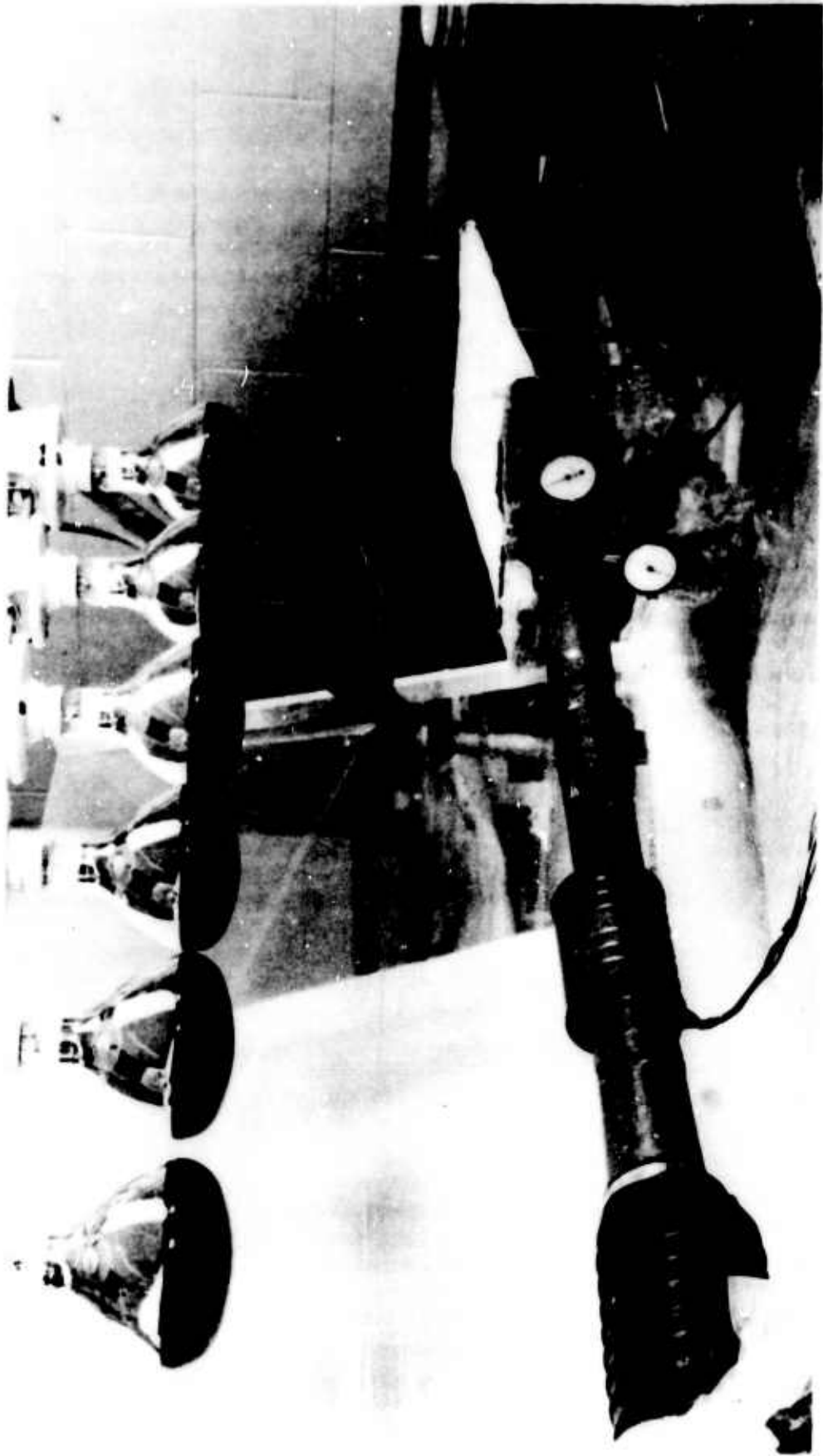
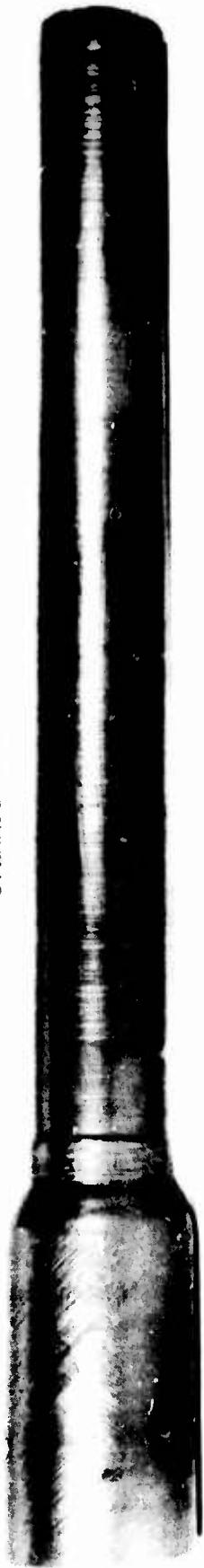
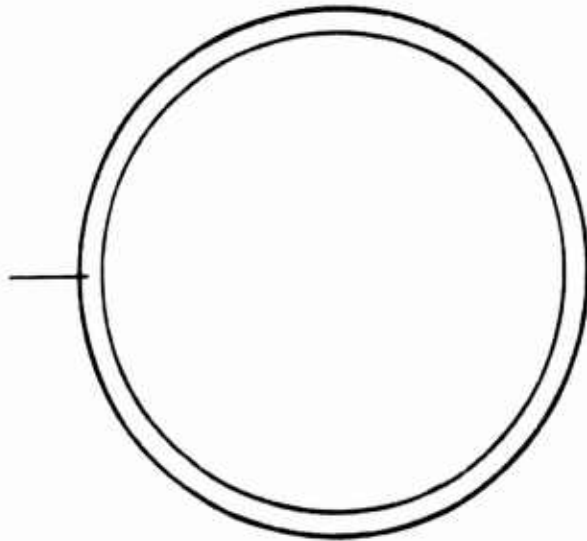

Figure 1. Scaled model 105mm, M68 tube.

OVERALL VIEW



S-glass/epoxy



CROSS SECTION (Not to scale)

Figure 2. S-glass/epoxy composite thermal shroud.

OVERALL VIEW



S-glass/epoxy

Aluminum

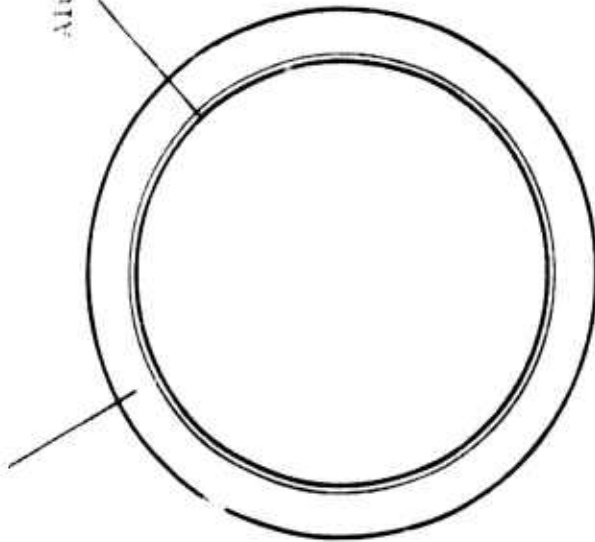

CROSS SECTION (Not to scale)

Figure 5. S-glass/epoxy/aluminum insert composite thermal shroud.

- (3) S-glass/epoxy/aluminum (one layer) composite shroud with an air space between the tube and shroud (Figure 4).
- (4) S-glass/epoxy/aluminum (three layer) composite shroud with an air space between the tube and shroud (Figure 5).
- (5) S-glass/epoxy/design 1 composite shroud with an air space between the tube and shroud (Figure 6).
- (6) S-glass/epoxy/design 2 composite shroud with an air space between the tube and shroud (Figure 7).

c. Simulation:

- (1) Solar radiation-infrared lights (Figure 8).
- (2) Sustained firing-propane gas supplied flame, through a 1" regulated nozzle (Figure 9).
- (3) Rain-water supplied through 1/8 HH 3.6 SQ fulljet nozzles, Water Cooling Corporation, Rosedale, New York (Figure 10).

d. Measurement and instrumentation:

Measurement	Instrumentation
(1) Temperature of gun tube.	<ul style="list-style-type: none"> (a) Nickel-Phenolic resistance thermometers. (b) Digitic multimeter model 269 and Digitic paper tape punch and control, models 672 and 625 respectively.
(2) Tube bend	<ul style="list-style-type: none"> (a) .001" Ames dial indicator (b) .0001" Standard number 241 dial indicator

OVERALL VIEW

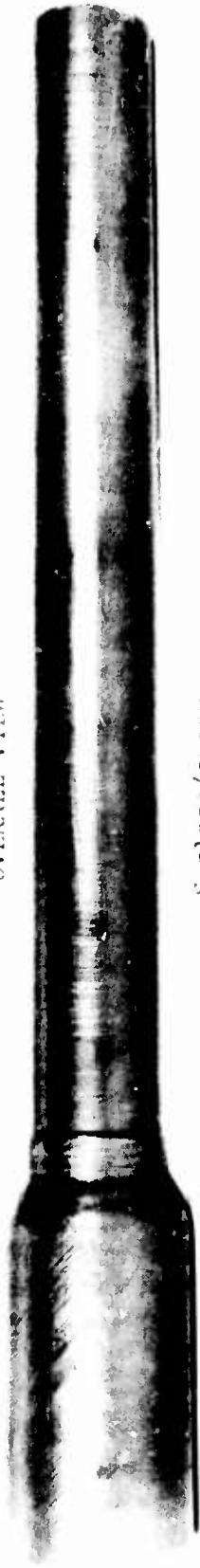

S-glass/epoxy

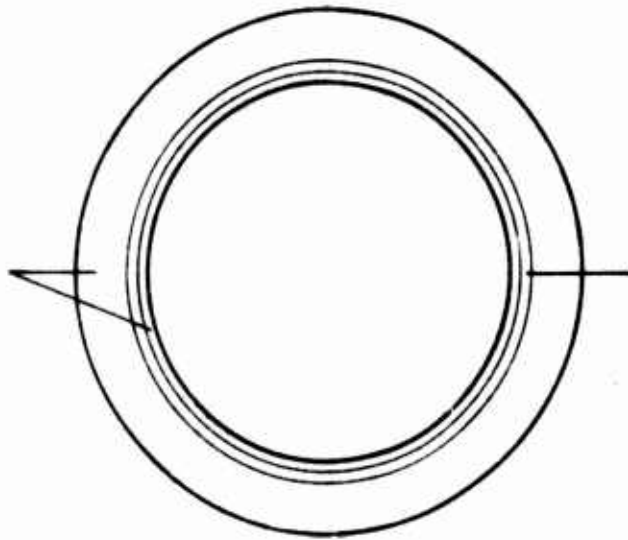

Aluminum

CROSS SECTION (Not to scale)

Figure 4. S-glass/epoxy/aluminum (one layer) composite thermal shroud.

OVERALL VIEW

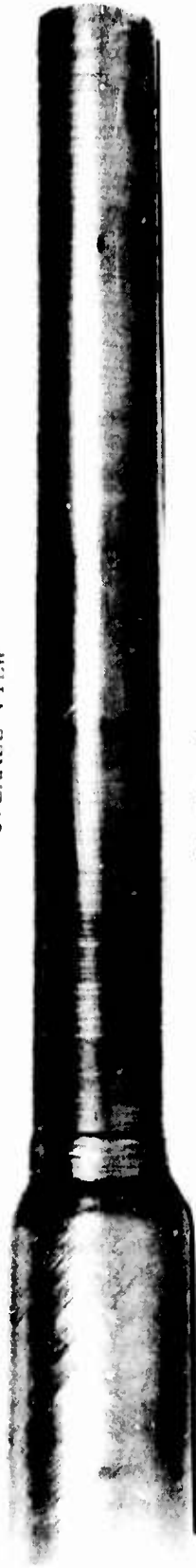

S-glass/epoxy

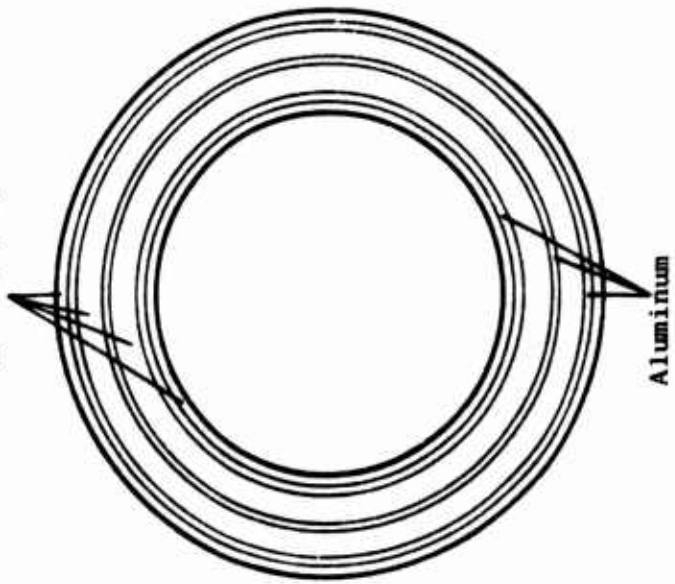

Aluminum

CROSS SECTION (Not to scale)

Figure 5. S-glass/epoxy/aluminum (three layers) composite thermal shroud.

Optical Micrograph



S-glass/epoxy

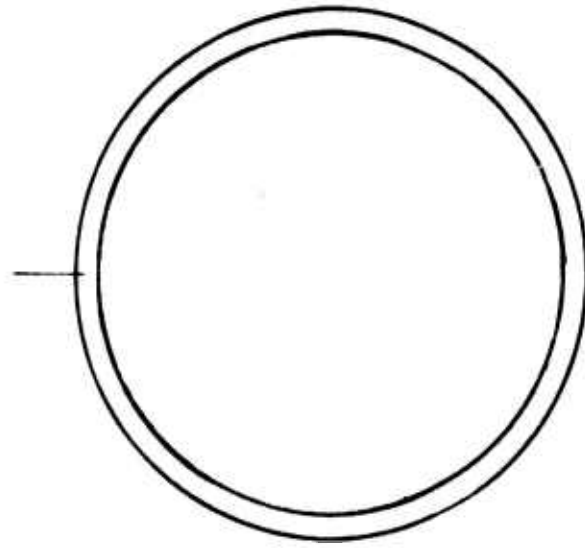

CROSS SECTION (Not to scale)

Figure 6. S-glass/epoxy/design 1 composite shroud.

OVERALL VIEW

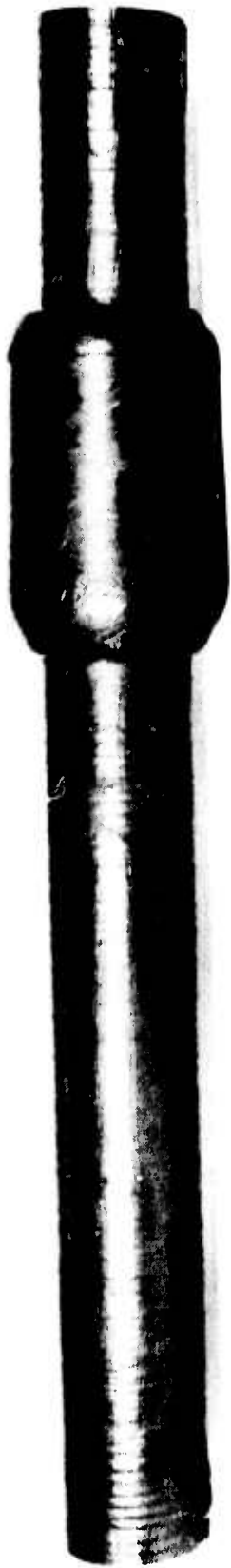

S-glass/epoxy

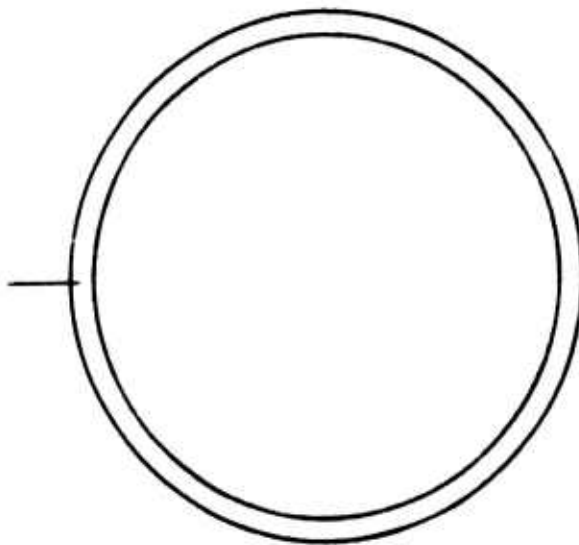

CROSS SECTION (Not to scale)

Figure 7. S-glass/epoxy/design 2 composite shroud.

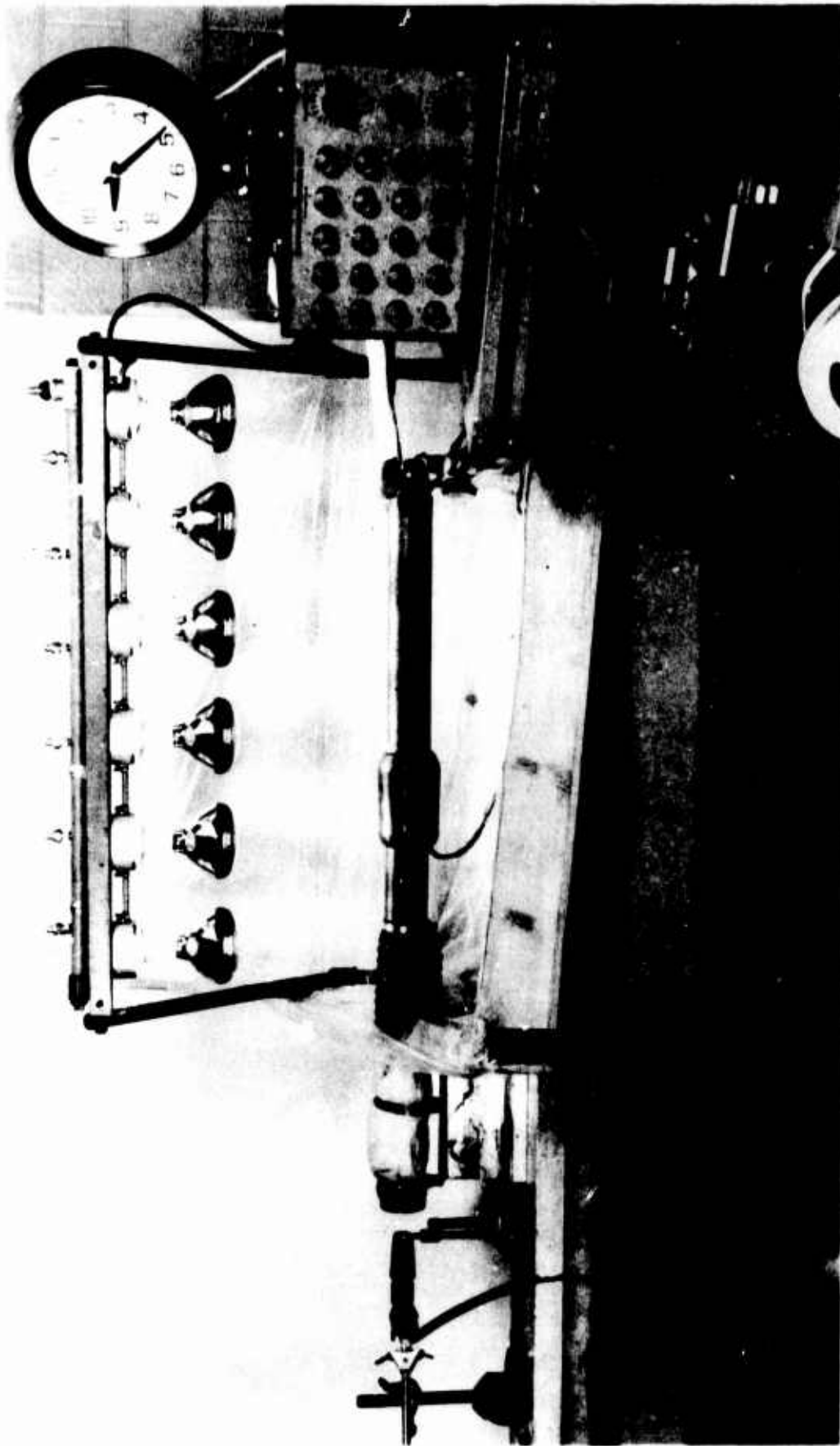

Figure 8. Overall view of solar radiation setup which includes design 2 composite shroud and instrumentation.

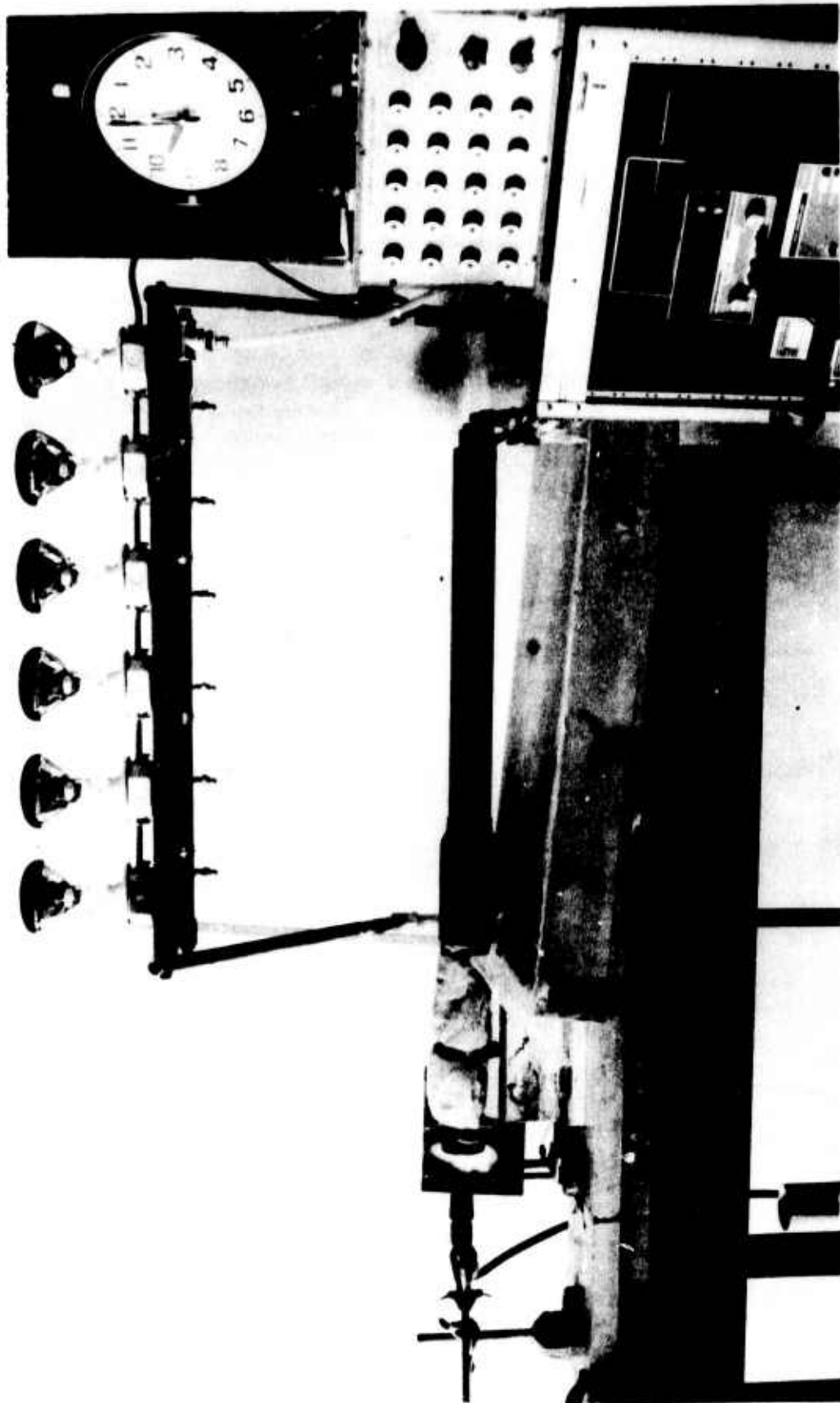

Figure 9. Overall view of internal heating setup which includes S-glass/epoxy composite thermal shroud and instrumentation.

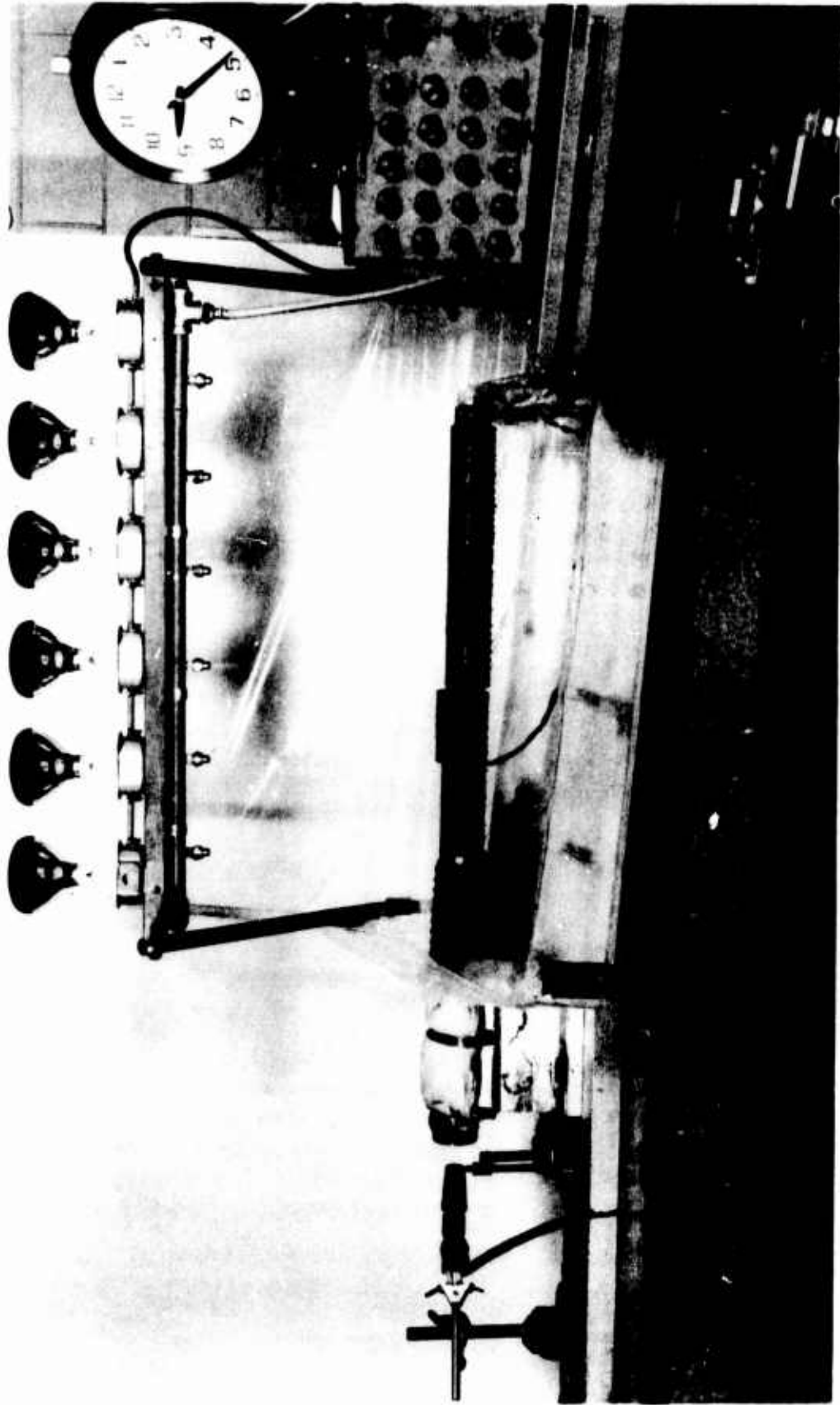

Figure 10. Overall view of rain setup which includes design 1 composite shroud and instrumentation.

(3) Solar loading
(Btu/hr/ft²)

(a) Sol-A-Meter Mark IV,
Matrix, Inc., Phoenix,
Arizona

IV. DISCUSSION OF RESULTS

A. Solar Radiation

The first test performed, summarized in Table 1 and Figure 11 was to subject an unpainted bare tube to various rates of solar flux for 48 minutes. The solar fluxes ranged from 170* Btu/hr/ft² (partially sunny) to 260* Btu/hr/ft² (sunny) in intensity. A gradual increase in the temperature gradient is observed for increased solar fluxes. The muzzle temperature gradients agree quite well with similar tests conducted on a full scale tube (References 3 and 12).

TABLE 1. UNPAINTED BARE TUBE SUBJECTED TO VARIOUS SOLAR FLUXES RANGING FROM 170 BTU/HR/FT² TO 260 BTU/HR/FT² FOR 48 MINUTES

Solar Flux (Btu/hr/ft ²)	Deflection (in)	Maximum (at muzzle) Temperature Difference (°F)
170	.0036	8.79
200	.0038	10.44
260	.0050	10.65

*The solar flux values are only approximate.

³D'Andrea, G., et al, "105mm M68 Thermal Shroud", WTV-7249, November 1972.

¹²Minor, T.C., et al, "Investigation of Variable Bias in Tank Guns: Heat Transfer and Deflection Calculations for Gun Tubes With Thermal Jackets", BRL IMR 349, February 1975.

Key

- 170 Btu/hr/ft²
- × 200 Btu/hr/ft²
- 260 Btu/hr/ft²

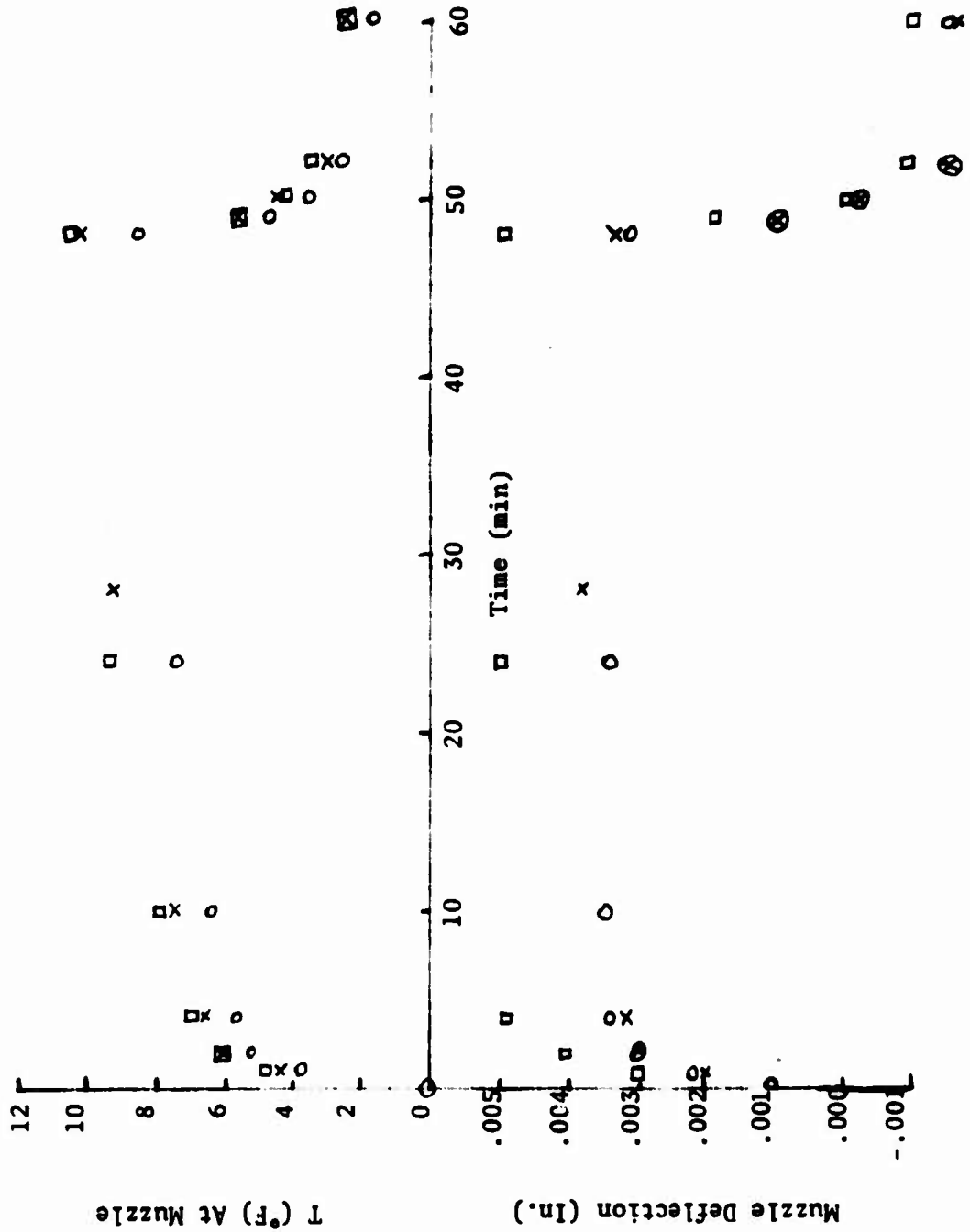

Figure 11. Deflection vs Time, and Temperature Difference vs Time of an unpainted bare tube subjected to various solar fluxes ranging from 170 Btu/hr/ft² to 260 Btu/hr/ft².

The purpose of the second set of tests performed, summarized in Table 2 and Figure 12, was to evaluate the effect of various unpainted thermal shroud configurations on an unpainted tube subjected to a solar flux of 270 Btu/hr/ft² for 48 minutes. Reduction in muzzle temperature gradients from 32% (S-glass/epoxy) to 83% (S-glass/epoxy/aluminum-three layers) is achieved.* Correspondingly similar reduction

TABLE 2. UNPAINTED TUBE WITH VARIOUS UNPAINTED THERMAL SHROUDS SUBJECTED TO A SOLAR FLUX OF 270 BTU/HR/FT² FOR 48 MINUTES

Shroud Composition	Maximum Deflection (in)	% Reduction	Maximum Temperature Difference (°F)	% Reduction
None (Bare tube)	.0089	-	10.88	-
S-glass/epoxy	.0054	39	7.36	32
S-glass/epoxy/ aluminum insert	.0032	64	2.19	80
S-glass/epoxy/ aluminum (one layer)	.0040	55	4.55	58
S-glass/epoxy/ aluminum (three layers)	.0023	74	1.88	83

* From the graph of temperature vs time (Figure 12), one observes that the rise time to 60% of steady state is 2 minutes for a bare tube, whereas for a shrouded tube, 60% of steady state is reached after 6 minutes. It is then evident that in considering improving first round hit probability, which is directly related to the temperature gradient across the muzzle, starting with the early stages of exposure to solar radiation, the thermal shroud contributes significantly not only in rise time, but also in reducing the magnitude of the temperature gradient across the muzzle.

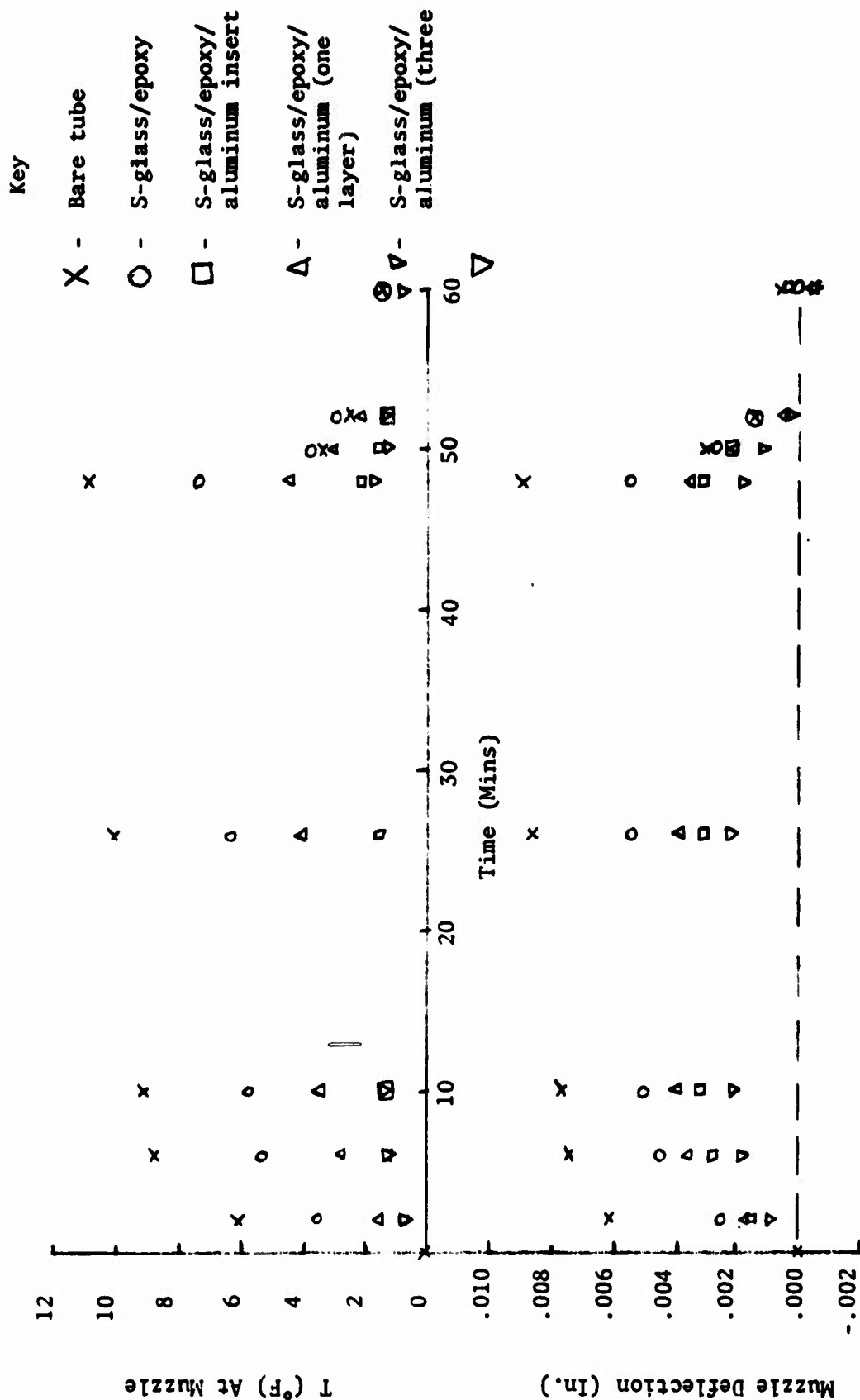

Figure 12. Deflection vs Time, and Temperature Difference vs Time of an unpainted tube with various unpainted thermal shrouds subjected to a solar flux of 270 Btu/hr/ft² for 48 minutes.

in muzzle droop is achieved. ** The reason for the reduction achieved by the S-glass/epoxy thermal shroud, is that it shields (insulates) the tube from a substantial amount of the solar radiation, thus reducing the temperature gradients. The vast improvement of the S-glass/epoxy/aluminum-three layers thermal shroud over that of the S-glass/epoxy thermal shroud, is that any solar radiation that penetrates the S-glass/epoxy is uniformly distributed around the tube by the aluminum layers, thus reducing the muzzle temperature gradients at the tube surface.

The purpose of the third set of tests performed, summarized in Table 3 and Figure 13, was to evaluate the effect of painting the thermal shroud, and subjecting the thermal shroud/tube combination to a solar flux of 270 Btu/hr/ft^2 for 48 minutes. Advantages of using reflective paint was pointed out by D'Andrea (Reference 3) and Clausing (Reference 9), to name a few. The thermal shroud, with the reflective olive drab (OD) painted, showed a reduction of 45% in muzzle temperature

** It should be pointed out that the temperature gradients are much more accurate than the muzzle deflections because of the instrumentation used. Therefore the muzzle deflections should be interpreted as trends and not as absolute values. It should also be noted that the resistance thermometer location was different from the dial indicator location therefore direct correlation between the measurements could not be made.

³D'Andrea, G., et al, "105mm M68 Thermal Shroud," WTV-7249, November 1972

⁹Clausing, A.M., "The Influences of Asymmetric Heating and Cooling of Gun Tubes With and Without Thermal Shrouds", AMC TR 0074-4, June 1974.

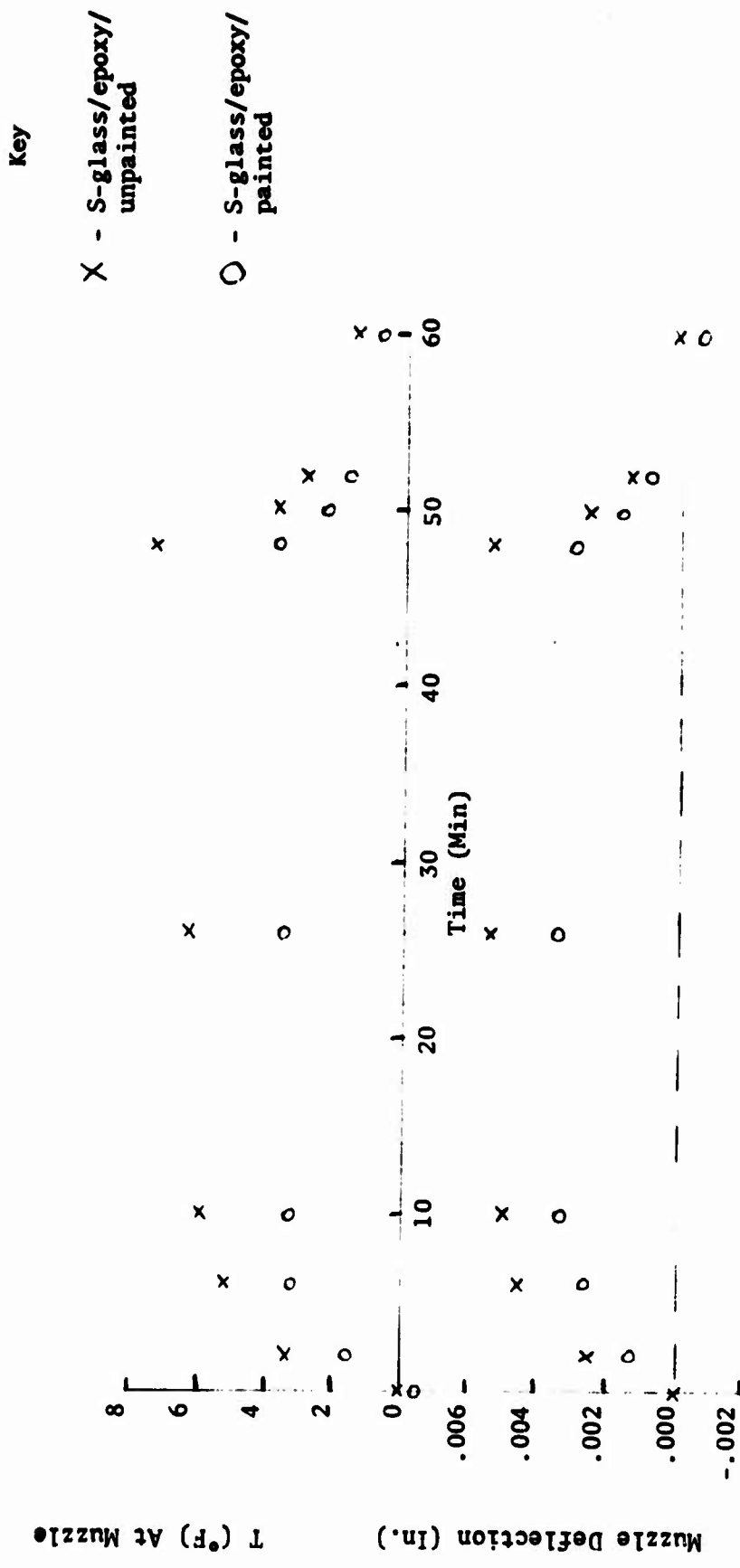

Figure 13. Deflection vs Time, and Temperature Difference vs Time for an unpainted tube and thermal shroud and painted thermal shroud subjected to a solar flux of 270 Btu/hr/ft² for 48 minutes.

gradient and a reduction of 33% in muzzle deflection over an unpainted thermal shroud thus ascertaining the usefulness of the paint.

TABLE 3. UNPAINTED TUBE AND THERMAL SHROUD AND PAINTED THERMAL SHROUD
SUBJECTED TO A SOLAR FLUX OF 270 BTU/HR/FT² FOR 48 MINUTES

Shroud Composition	Maximum Deflection (in)	% Reduction	Maximum Temperature Difference (°F)	% Reduction
S-glass/epoxy/ unpainted	.0054	-	7.36	-
S-glass/epoxy/ painted	.0036	33	4.06	45

Up to this point, all testing has been performed on an unpainted tube. Also the thermal shrouds used in the testing have only approximated the actual thermal shroud configurations. The fourth test, summarized in Table 4 and Figure 14, subjected a painted tube and various thermal shrouds to a solar flux of 270 Btu/hr/ft² for 48 minutes. A 50% reduction in the muzzle temperature gradient and a 52% reduction in muzzle deflection was achieved with the thermal shroud. These results are the same as reported by D'Andrea (Reference 3) in an earlier study done on a full scale tube. It should be pointed out that the approximate thermal shroud configurations used in tests 2 and 3 agree fairly well with the actual thermal shroud configurations used in this test.

³D'Andrea, G., et al, "105mm M68 Thermal Shroud," WTV-7249, November 1972.

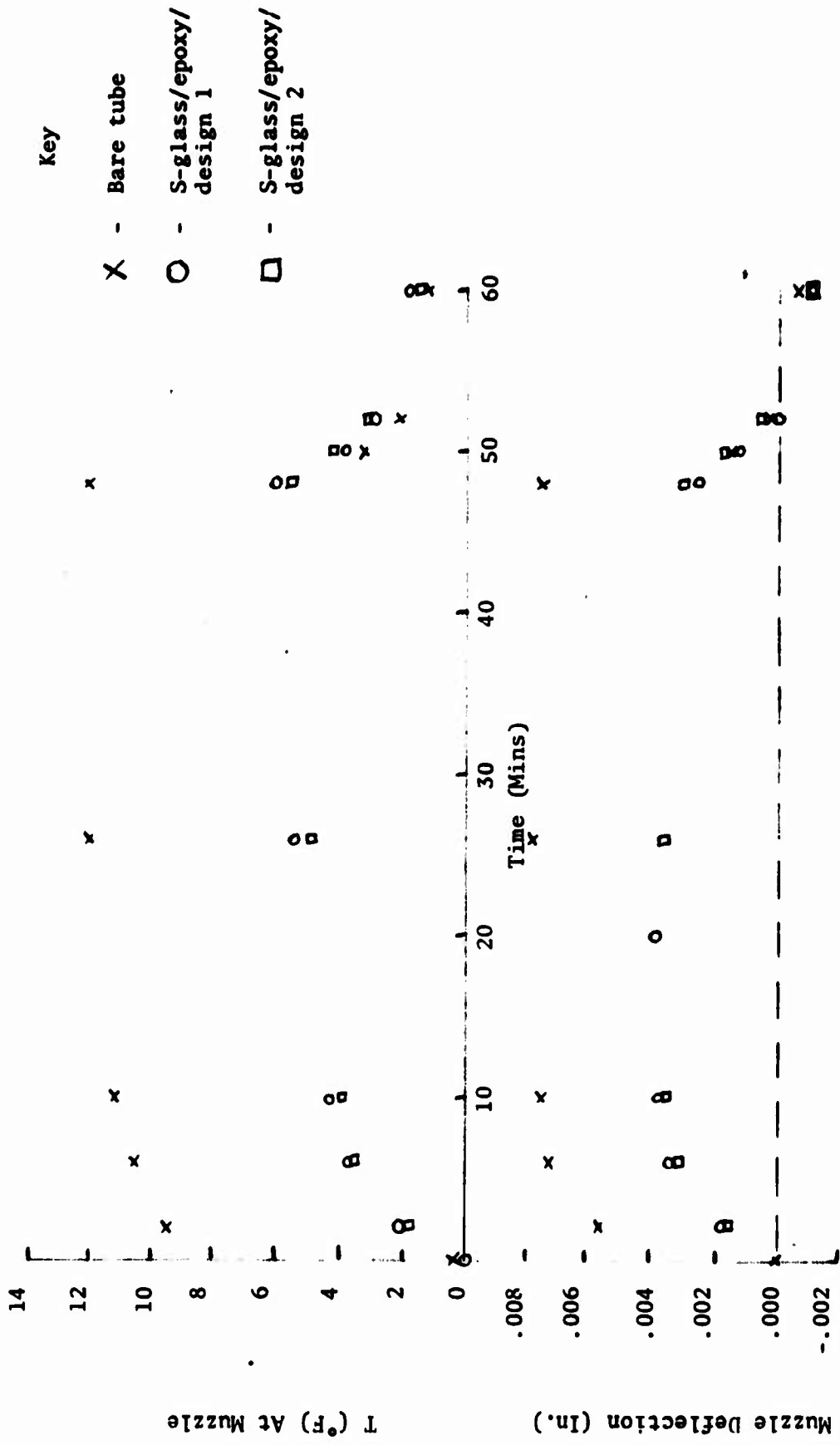

Figure 14. Deflection vs Time, and Temperature Difference vs Time of a painted tube and various thermal shrouds subjected to a solar flux of 270 Btu/hr/ft² for 48 minutes.

TABLE 4. PAINTED TUBE AND VARIOUS THERMAL SHROUDS SUBJECTED TO A SOLAR FLUX OF 270 BTU/HR/FT² FOR 48 MINUTES

Shroud Composition	Maximum Deflection (in)	% Reduction	Maximum Temperature Difference (°F)	% Reduction
None (Bare tube)	.0079	-	12.21	-
S-glass/epoxy/ design 1	.0038	52	6.06	50
S-glass/epoxy/ design 2	.0035	56	5.76	43

B. Sustained Firing

The first test performed, summarized in Table 5 and Figure 15, was to subject an unpainted tube and various thermal shrouds to internal heating for 30 seconds. An 11% reduction in the muzzle temperature gradient and a 19% reduction in muzzle deflection was achieved with an S-glass/epoxy/aluminum insert shroud. The reason for this was that the aluminum insert was of sufficient thickness to uniformly, to a certain extent, distribute the internal heat being generated. In the case of the S-glass/epoxy thermal shroud, the shroud acted as an insulator and not as a conductor thus deteriorating the performance. It was interesting to note that excessive temperature gradients did not develop as a result of shrouding the tube as observed in this test and in similar live firing tests that were done by BRL (Reference 13).

¹³Minor, T.C., et al, "Cross-Tube Temperature Gradients Under the Watervliet Thermal Jacket on a 105mm M68, Tank Gun", BRL IMR 375, April 1975.

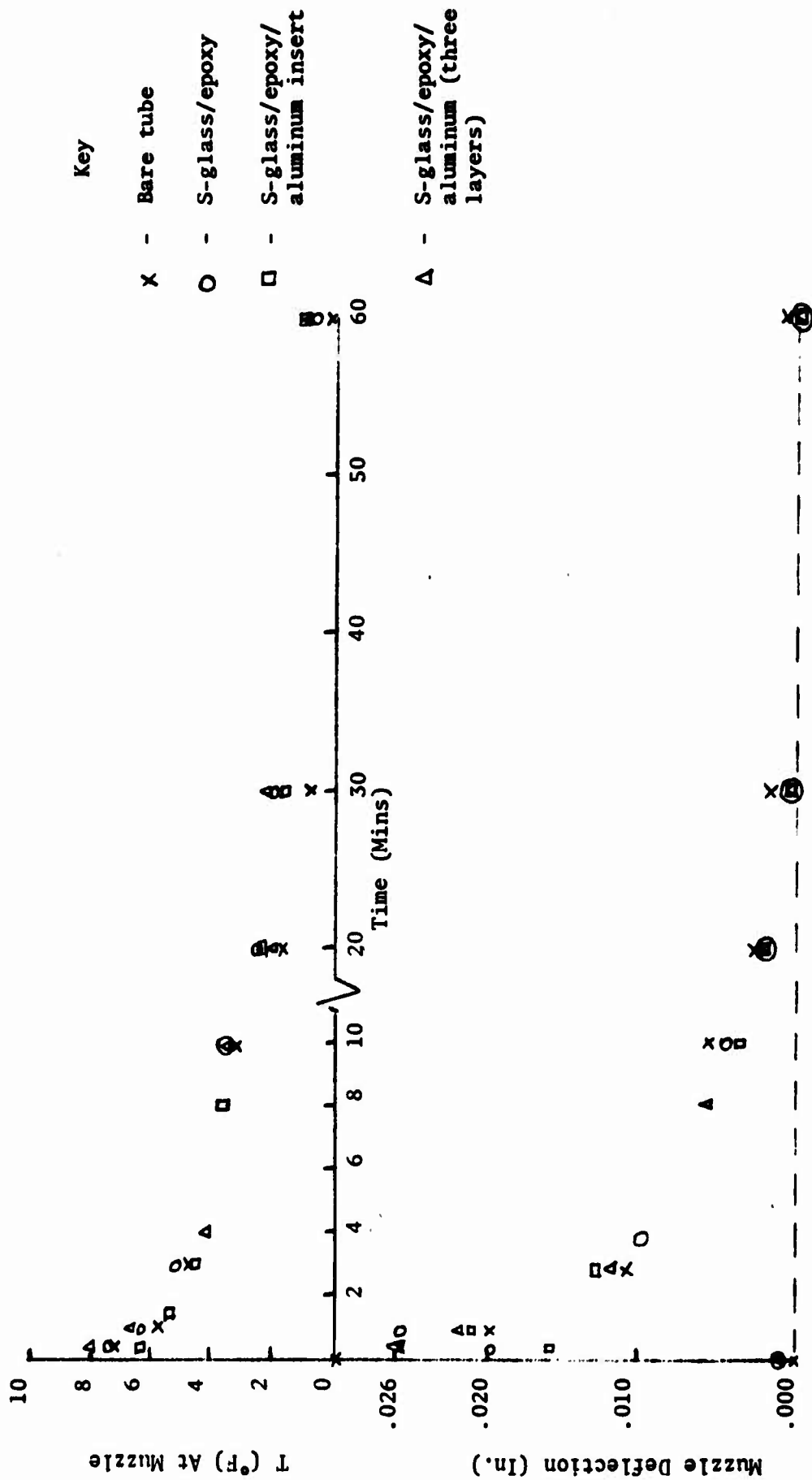

Figure 15. Deflection vs Time, and Temperature Difference vs Time for an unpainted tube and various painted thermal shrouds subjected to internal heating for 30 seconds.

TABLE 5. UNPAINTED TUBE AND VARIOUS PAINTED THERMAL SHROUDS SUBJECTED TO INTERNAL HEATING FOR 30 SECONDS

Shroud Composition	Maximum Deflection (in)	% Reduction	Maximum Temperature Difference (°F)	% Reduction
None (Bare tube)	.026	-	7.22	-
S-glass/epoxy	.026	0	7.50	-4
S-glass/epoxy/ aluminum insert	.021	19	6.44	11
S-glass/epoxy/ aluminum (three layers)	.026	0	8.06	-12

The second test performed, summarized in Table 6 and Figure 16, was similar to the first test, except that the tube and thermal shrouds were painted with reflective OD paint. The S-glass/epoxy/design 1/ with aluminum insert showed a very slight improvement over that of a bare tube, whereas the thermal shroud without aluminum did not perform as well.

TABLE 6. PAINTED TUBE AND VARIOUS PAINTED THERMAL SHROUDS SUBJECTED TO INTERNAL HEATING FOR 30 SECONDS

Shroud Composition	Maximum Deflection (in)	% Reduction	Maximum Temperature Difference (°F)	% Reduction
None (Bare tube)	.023	-	8.33	-
S-glass/epoxy/ design 1/with aluminum insert	.022	4	8.10	3
S-glass/epoxy/ design 2	.020	13	9.50	-14

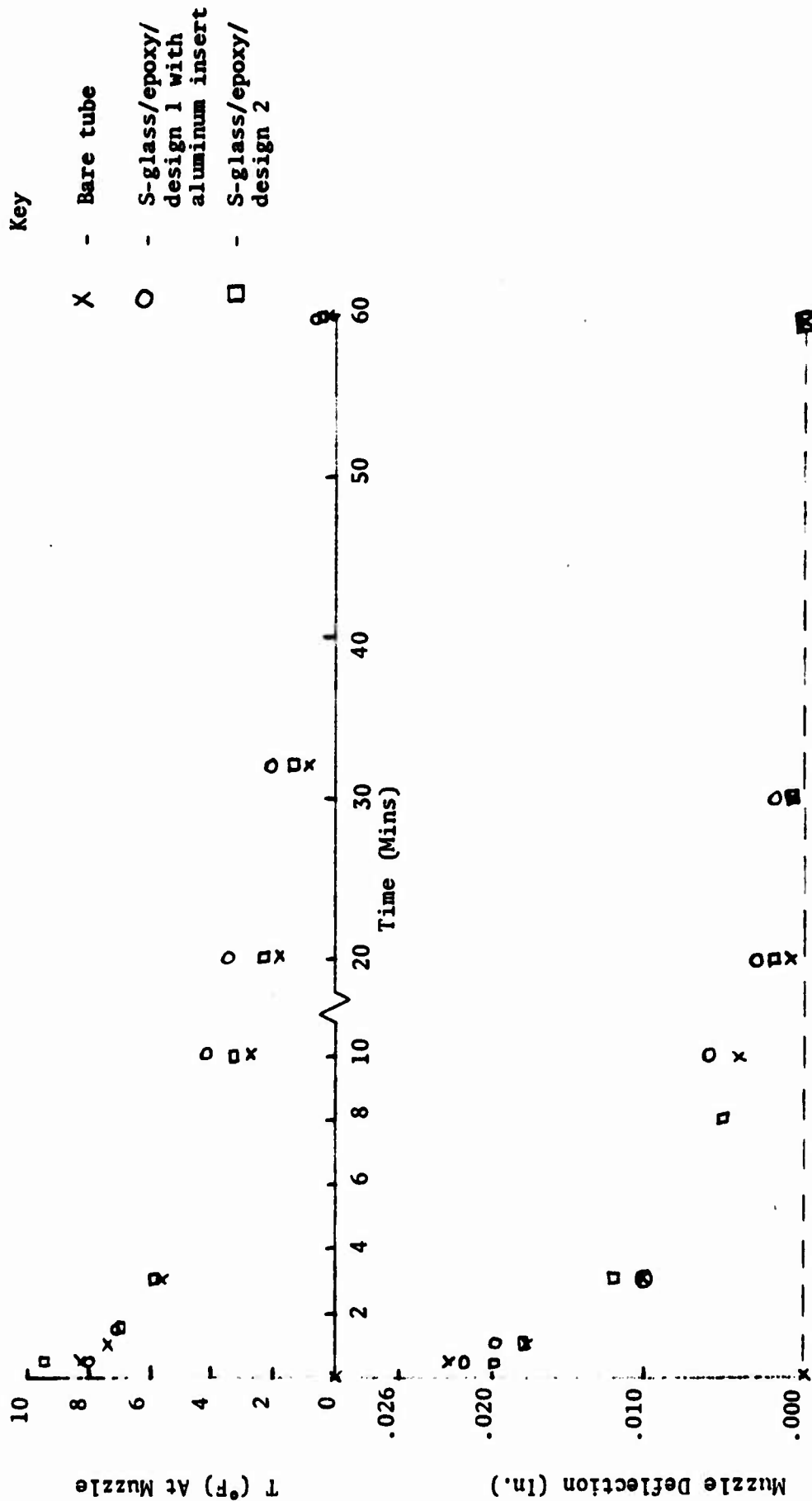

Figure 16. Deflection vs Time, and Temperature Difference vs Time for a painted tube and various painted thermal shrouds subjected to internal heating for 30 seconds.

C. *Solar Radiation and Rain

Only one test was performed, summarized in Table 7 and Figure 17, in which a painted tube with a painted thermal shroud was subjected to a solar flux of 270 Btu/hr/ft^2 for 48 minutes and a heavy rain for 2 minutes. Only the optimum thermal shroud, as was determined from limited previous results, was used in the test. As in past tests, the shrouded tube showed a 70% reduction in muzzle droop over that of a bare tube, when subjected to solar radiation. However, as the simulated rain started, the shrouded tube showed a 90% reduction in muzzle temperature gradient as well as in muzzle deflection over that of a bare tube. It should be noted that as the rain started, the magnitude of the muzzle temperature gradient on the bare tube increased substantially in the reverse direction (bottom hotter than top).**

*These tests were only preliminary and are given to show the adverse reaction a bare tube has to rain and how a thermal shroud substantially improves the performance.

**It is important to note that the rate of muzzle droop of the bare tube after exposure to the rain is so rapid that it is questionable whether a muzzle mirror could function under these conditions. However, a muzzle mirror in conjunction with a thermal shroud would be very effective in improving first round hit probability.

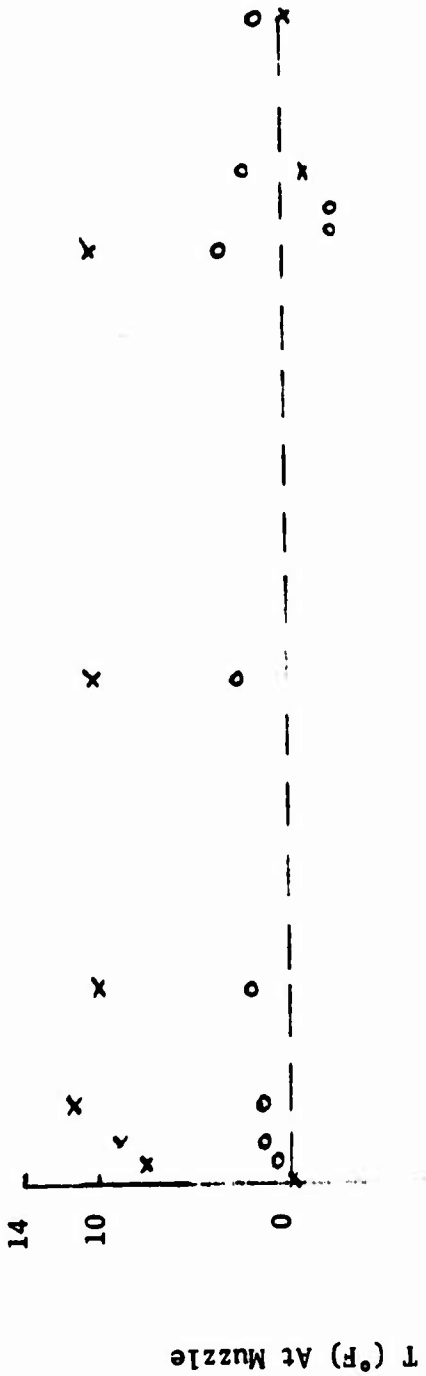

Key

X - Bare tube

O - S-glass/epoxy/
design 1 with
aluminum insert

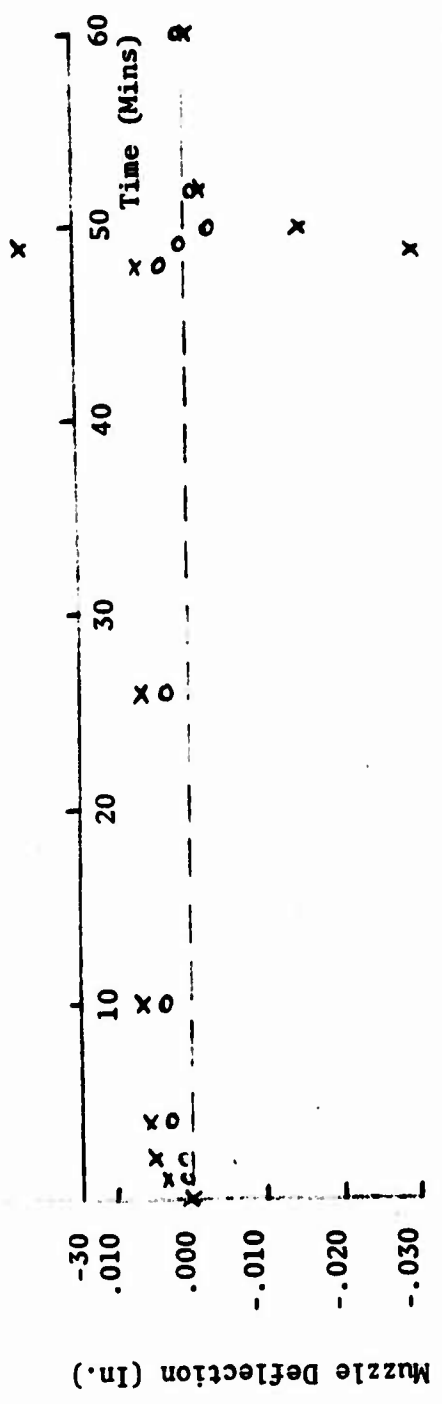

Figure 17. Deflection vs Time, and Temperature Difference vs Time for a painted tube with a painted thermal shroud subjected to a solar flux of 270 Btu/hr/ft² for 48 minutes and a heavy rain for 2 minutes.

TABLE 7. PAINTED TUBE WITH PAINTED THERMAL SHROUD SUBJECTED TO A SOLAR FLUX OF 270 BTU/HR/FT² FOR 48 MINUTES AND A HEAVY RAIN FOR 2 MINUTES

BEFORE RAIN				
Shroud Composition	Maximum Deflection (in)	% Reduction	Maximum Temperature Difference (°F)	% Reduction
None (Bare tube)	.007	-	11.4	-
S-glass/epoxy/ design 1 with aluminum insert	.0043	38	3.4	70
AFTER START OF RAIN				
Shroud Composition	Maximum Deflection (in)	% Reduction	Minimum Temperature Difference	% Reduction
None (Bare tube)	-.030	-	-27.0	-
S-glass/epoxy design 1 with aluminum insert	-.0029	90	-2.5	91

D. *Sustained Firing and Rain

The final test performed, summarized in Table 8 and Figure 18, was one in which a painted tube, with a painted thermal shroud, was subjected to internal heating for 30 seconds, and then a heavy rain. Even though the bare tube and shrouded tube experienced different durations of rain (2 minutes for the bare tube and 1 minute for the shrouded tube)

*These tests were only preliminary and are given to show the adverse reaction a bare tube has to rain and how a thermal shroud substantially improves the performance.

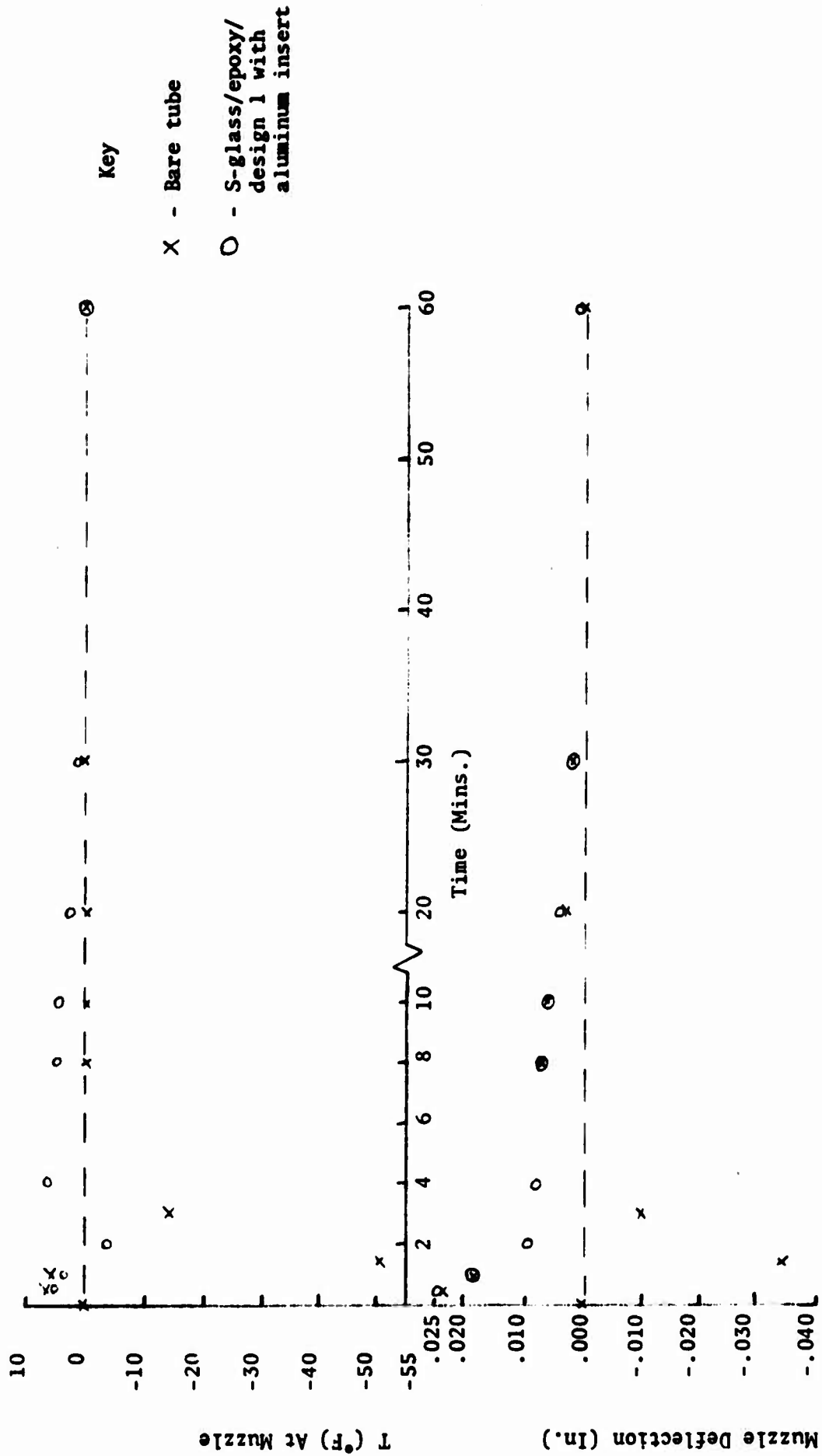

Figure 18. Deflection vs Time, and Temperature Difference vs Time for a painted tube with a painted thermal shroud subjected to internal heating for 30 seconds and a heavy rain.

one can note the substantial improvement of the shrouded tube over that of the bare tube.*

TABLE 8. PAINTED TUBE WITH PAINTED THERMAL SHROUD SUBJECTED TO INTERNAL HEATING FOR 30 SECONDS AND A HEAVY RAIN

Shroud Composition	Maximum Deflection (in)	Minimum Deflection (in)	Maximum Temperature Difference (°F)	Minimum Temperature Difference (°F)
None (Bare tube)**	.023	-.035	6.1	-51.6
S-glass/epoxy/ design 1 with aluminum insert***	.024	.001	5.8	-3.4

*It is important to note that the rate of muzzle droop of the bare tube after exposure to the rain is so rapid that it is questionable whether a muzzle mirror could function under these conditions. However, a muzzle mirror in conjunction with a thermal shroud would be very effective in improving first round hit probability.

**The bare tube was subjected to rain for 2 minutes.

***The shrouded tube was subjected to rain for 1 minute.

V. CONCLUSIONS

To evaluate the usefulness of a thermal shroud, an experimental program was undertaken in which various cannon/shroud configurations were subjected to a number of thermal shock loads. These thermal shock loads were of the following nature; shade to solar radiation, shade to internal heating, shade to solar radiation and then rain and shade to internal heating and then rain. The Watervliet Arsenal's test program ascertains the usefulness of a thermal shroud, when the cannon/shroud configuration is subjected to the previous mentioned thermal loads.

The following summarizes Watervliet Arsenal's findings:

- a. Modification of existing thermal shroud design, insertion of aluminum layers into the construction, will greatly increase its effectiveness when the cannon/shroud configuration is subjected to solar radiation of 270 Btu/hr/ft^2 . With the modified thermal shroud, the muzzle temperature is reduced by 80% over that of a bare tube, thus greatly increasing first round hit probability.
- b. The thermal shroud did not significantly affect the effectiveness of the cannon, when it was subjected to internal heating.
- c. The thermal shroud was exceedingly important in reducing the muzzle temperature gradient and ultimately the muzzle droop when the cannon/shroud configuration was exposed to rain after solar radiation or internal heating.

In summary, the thermal shroud will greatly improve first round

hit probability, when a tank is subjected to normal operating and environmental conditions. In view of the overall cost of a tank, dollar wise the thermal shroud is well worth its value in increasing the performance of the tank.

LITERATURE CITED

1. Gay, H.P. and Elder, A.S., "The Lateral Motion of a Tank Gun and its Effect on the Accuracy of Fire", AD No. 217657, March 1959.
2. D'Andrea, G., et al, "152mm G/L XM150E6 Thermal Shroud", WTV-7159, November 1971 .
3. D'Andrea, G., et al, "105mm M68 Thermal Shroud," WTV-7249, November 1972 .
4. Unpublished Watervliet Arsenal data collected at the Yuma Proving Ground, Arizona, August 1973.
5. Boylan, D.M., et al, "An Analytical Heat Transfer Model for Determining an Optimum Thermal Jacket for Tank Guns," BRL IMR 154, November 1973 .
6. O'Mara, K.J., "105mm, M68 Firing Test Both With and Without a Watervliet Thermal Shroud-Results of", Internal Watervliet Arsenal Report, 25 January 1974.
7. Unpublished Fort Knox data collected at Fort Knox, Kentucky, 22 January 1974 .
8. O'Mara, K.J., Trip Report No. 72-74, Watervliet Arsenal, 27 February 1974 .
9. Clausing, A.M., "The Influences of Asymmetric Heating and Cooling of Gun Tubes With and Without Thermal Shrouds", AMC TR 0074-4, June 74.

10. Friar, G.S., Trip Reports, Watervliet Arsenal, 14 November 1974 and 2 December 1974.
11. Extract of DT II M60A1E3 Final Test Report, December 1974.
12. Minor, T.C., et al, "Investigation of Variable Bias in Tank Guns: Heat Transfer and Deflection Calculations for Gun Tubes With Thermal Jackets", BRL IMR 349, February 1975.
13. Minor, T.C., et al, "Cross-Tube Temperature Gradients Under the Watervliet Thermal Jacket on a 105mm, M68, Tank Gun", BRL IMR 375, April 1975.
14. Minor, T.C., et al, "Detailed Temperature-Time Data From Firing Test With the Watervliet Thermal Jacket on a 105mm, M68, Gun", BRL IMR 391, June 1975.
15. Minor, T.C., et al, "Investigation of Variable Bias in Tank Guns: Heat Transfer and Deflection Calculations for Gun Tubes With Thermal Jackets (Part II)", BRL IMR 416, August 1975.