

AD-A027402

RIA-76-U426

Cy No. 1

TECHNICAL
LIBRARY

AD
A027402

DRSAR/SA/R-08



**COST/SCHEDULE UNCERTAINTY
ANALYSIS OF THE XMI/
ALTERNATIVE ARMAMENT PROGRAMS**

ROBERT C. BANASH

JAMES B. BEESON

JUNE 1976

Approved for public release; distribution unlimited.



**US ARMY ARMAMENT COMMAND
SYSTEMS ANALYSIS DIRECTORATE
ROCK ISLAND, ILLINOIS 61201**

DISPOSITION

Destroy this report when no longer needed. Do not return it to the originator.

DISCLAIMER

The findings in this report are not to be construed as an official Department of the Army position.

WARNING

Information and data contained in this document are based on input available at the time of preparation. Because the results may be subject to change, this document should not be construed to represent the official position of the US Army Development & Readiness Command unless so stated.

UNCLASSIFIED

SECURITY CLASSIFICATION OF THIS PAGE (When Data Entered)

REPORT DOCUMENTATION PAGE		READ INSTRUCTIONS BEFORE COMPLETING FORM
1. REPORT NUMBER DRSAR/SA/R-08	2. GOVT ACCESSION NO.	3. RECIPIENT'S CATALOG NUMBER
4. TITLE (and Subtitle) COST/SCHEDULE UNCERTAINTY OF XM1/ALTERNATIVE ARMAMENT PROGRAMS		5. TYPE OF REPORT & PERIOD COVERED Report - Final
		6. PERFORMING ORG. REPORT NUMBER
7. AUTHOR(s) Robert C. Banash James B. Beeson		8. CONTRACT OR GRANT NUMBER(s)
9. PERFORMING ORGANIZATION NAME AND ADDRESS US Army Armament Command Systems Analysis Directorate (DRSAR-SA) Rock Island, IL 61201		10. PROGRAM ELEMENT, PROJECT, TASK AREA & WORK UNIT NUMBERS
11. CONTROLLING OFFICE NAME AND ADDRESS US Army Armament Command Systems Analysis Directorate (DRSAR-SA) Rock Island, IL 61201		12. REPORT DATE April 1976
		13. NUMBER OF PAGES 91
14. MONITORING AGENCY NAME & ADDRESS (if different from Controlling Office)		15. SECURITY CLASS. (of this report) UNCLASSIFIED
		15a. DECLASSIFICATION/DOWNGRADING SCHEDULE
16. DISTRIBUTION STATEMENT (of this Report) Approved for public release; distribution unlimited.		
17. DISTRIBUTION STATEMENT (of the abstract entered in Block 20, if different from Report)		
18. SUPPLEMENTARY NOTES		
19. KEY WORDS (Continue on reverse side if necessary and identify by block number) Cost/Schedule Analysis TANK Armament Systems Armament Development Programs Risk Analysis Operations Research		
20. ABSTRACT (Continue on reverse side if necessary and identify by block number) A comparison was made of development cost/schedule burdens incurred by adopting either the US 105mm, the UK 110mm or the FRG 120mm armament systems into the US XM-1 Tank Program. These comparisons were made in terms of schedule delays and additional cost to the XM-1 Program. Programs were developed to produce US guns/ammunition from FRG/UK technical data packages. Modifications to the XM-1 Program were structured to account for vehicle redesign phase to accept the FRG/UK systems. Cost and schedule estimates for each program, that		

DD FORM 1 JAN 73 1473

EDITION OF 1 NOV 65 IS OBSOLETE

UNCLASSIFIED

SECURITY CLASSIFICATION OF THIS PAGE (When Data Entered)

UNCLASSIFIED

SECURITY CLASSIFICATION OF THIS PAGE(When Data Entered)

Block Number 20 - continued

is, US XM-1 with the US 105mm, the UK 110mm and the FRG 120mm armament systems, are presented and compared with the planned XM-1 105mm Program.

SECURITY CLASSIFICATION OF THIS PAGE(When Data Entered)

PREFACE

The analyses described in this note were prepared as part of the Tripartite Tank Armament Study and the XM1 Tank Program Cost/Schedule Analysis. Although the analyses were completed, documented and distributed in the summer of 1975, its publication as a Systems Analysis Note was not accomplished until a year after the study due to higher priority concerns. The distinctions between the concepts considered in the study and the current status must be recognized.

Next page is blank.

CONTENTS

	<u>Page</u>
INTRODUCTION	7
XM1/105MM PROGRAM	7
RESULTS	7
ANALYSIS OF RESULTS	8
XM1 PROGRAM COMPARISON	8
SUMMARY	9
APPENDIX US COST/SCHEDULE UNCERTAINTY ANALYSIS	
Section I. Gun/Ammunition in Isolation	27
Section II. Vehicle Development Including Gun Ammunition	33
ANNEX A CANNON COST/SCHEDULE UNCERTAINTY ANALYSIS	45
ANNEX B PROJECTILE SHELL METAL PARTS COST/SCHEDULE UNCERTAINTY ANALYSIS OBJECTIVE	53
ANNEX C AMMUNITION COST/SCHEDULE UNCERTAINTY ANALYSIS	73
DISTRIBUTION LIST	91

LIST OF FIGURES

	<u>Page</u>
Figure 1. XM1 Current Program	11
Figure A-1. XM1 Tank Program with Alternative Weapon System . .	36
Figure A-2. Development Program for the UK 110mm or the FRG 120mm Cannons (1 of 2)	49
Figure A-2. Development Program for the UK 110mm or the FRG 120mm Cannons (2 of 2)	51
Figure B-1. Tripartite Tank Armament Program -- Penetrator/ Metal Parts -- Frankford Arsenal	58
Figure B-2. Projectile Shell Metal Parts Network (1 of 5) . .	59
Figure B-2. Projectile Shell Metal Parts Network (2 of 5) . .	60
Figure B-2. Projectile Shell Metal Parts Network (3 of 5) . .	61
Figure B-2. Projectile Shell Metal Parts Network (4 of 5) . .	62
Figure B-2. Projectile Shell Metal Parts Network (5 of 5) . .	63
Figure C-1. Ammunition Development Network (1 of 4)	76
Figure C-1. Ammunition Development Network (2 of 4)	77
Figure C-1. Ammunition Development Network (3 of 4)	78
Figure C-1. Ammunition Development Network (4 of 4)	79

LIST OF TABLES

Table 1. XM1/US 105-mm Schedule	13
Table 2. XM1/US 105-mm Program-Schedule Slippage/Cost Increase	21
Table 3. XM1/Current Program Analysis	22
Table 4. XM1 Programs - Expected Schedule Slippage and Cost Increase	23
Table 5. XM1 Programs - Expected Schedule Slippage and Cost Increase to Full Production	24

LIST OF TABLES (CONT)

	<u>Page</u>
Table A-1. Candidate Armament Cost/Schedule Comparison Analyses	31
Table A-2. Current XM1/105mm Armament Schedule	35
Table A-3. XM1/Alternative Armament Cost/Schedule Comparison .	42
Table A-4. XM1/Alternative Armament Cost/Schedule Comparison .	42
Table B-1. Projectile Shell Metal Parts Network Activity . . .	64
Table B-2. Projectile Shell Metal Parts Network Activity Time and Cost for the UK-KE Round	65
Table B-3. Projectile Shell Metal Parts Network Activity Time and Cost for the FRG-KE Round	69
Table B-4. Tripartite Tank Armament Program - Frankford Arsenal Penetrator/Metal Parts	70
Table C-1. Arc Data for FRG and UK Networks	80
Table C-2. Picatinny Arsenal Needs - FRG Hardware	87
Table C-3. Picatinny Arsenal Needs - UK Hardware	87
Table C-4. Time Distributions to Milestones (FRG Round)	88
Table C-5. Time Distributions to Milestones (UK Round)	88
Table C-6. Expected Cost Intervals (FRG Round Translation) . .	89
Table C-7. Expected Cost Intervals (UK Round Translation) . . .	89
Table C-8. Expected Cost for FRG or UK Round Development . . .	90

Next page is blank.

INTRODUCTION

A determination will be made by US decision makers to adopt either the United Kingdom (UK) 110mm or the Federal Republic of Germany (FRG) 120mm armament system for the XM1 Tank or to continue with the current US 105mm armament system.

The objective of this report is to provide cost/schedule and technical risk information in support of the XM1 Tank Main Armament Decision.

An analysis was performed to compare the cost/schedule impacts of adopting the foreign systems with the official cost/schedule of the current XM1/105mm program. This analysis was published and is attached as US Cost/Schedule Uncertainty Analysis (see the Appendix). Potential cost overruns and schedule slippages of the current program are examined in this analysis, using the same procedures and guidelines as those described in the Appendix.

A description of the current XM1/US 105mm program is presented in the following section. The results of XM1/US 105mm analysis are then compared with programmed cost and the official XM1 schedule. These results are then compared with the cost/schedule estimates of the XM1/UK 110mm and XM1/FRG 120mm programs. The data for the XM1 program were furnished by the office of the XM1 Project Manager. Picatinny Arsenal furnished data on the XM735 projectile program.

XM1/105mm PROGRAM

The network presented in Figure 1 traces the flow of XM1/US 105mm program activities from the armament decision to the initiation of full scale production. It shows the major activities required under the Army Materiel Acquisition Guidelines (AR 1000.1) and highlights critical activities of the XM1 program, e.g., contractor tests. In addition to the planned activities, the network also considers activities which could arise as a result of testing at DT/OT I, II, and III -- program termination and redesign/retest. Key milestones of the official XM1 Program presented in Table 1 are measured from the armament decision, October 1975.

Point and interval time-to-completion estimates were obtained for individual activities. Due to the difficulties of obtaining cost estimates for each activity, only cost overruns were computed. These can occur if a planned activity is not completed within the scheduled time or if unplanned activities are required (e.g., redesign/retest). Data Lists I and II present a description of the activities and their estimated time and cost overruns.

RESULTS

The XM1/US 105mm program results, presented in Table 2, were

obtained for two sets of input data, differing only in regard to including or not including a Technical Transfusion activity. (Technical Transfusion is an unprogrammed activity which will occur or not occur--depending on an ASARC II/DSARC II decision. The purpose of Technical Transfusion is to incorporate the better components of both designs into the final design rather than select and build the design of one contractor.)

Schedule and cost results presented in Table 2 are increases over the planned schedule and programmed cost (Table 1). Upper (95%) and lower (5%) limits are presented, i.e., there is a 90% chance that the observed values will fall within these bounds.

In summary, the table shows that there is a 90% chance of a schedule slippage of 2 to 20 months in initiation of full production if a decision is made to incorporate Technical Transfusion. The expected slippage is about a year. If Technical Transfusion is not incorporated, then there is a 90% chance of a slippage of about 2 to 14 months in initiation of full production. The expected slippage is about one-half year. Expected cost increases are \$59M and \$10M, with and without Technical Transfusion, respectively. These estimates depend upon the availability of the XM735 projectile at DT/OT II. If production rounds are required, rather than engineering rounds, the program will be delayed an additional 4 to 6 months.

ANALYSIS OF RESULTS

There are three primary decisions which can be made at each of the XM1 program reviews (ASARC/DSARD): continue with present design, redesign, or terminate the program. Program termination can occur due to a wide variety of events not related to a successful development program and was, therefore, not quantified in this analysis. The requirement for system redesign was included by obtaining estimates of the probability of a decision for redesign at each of the three ASARC/DSARC. There are, therefore, eight combinations of decision outcomes. These outcomes and the cost/schedule overruns resulting from each combination are presented in Table 3.

The first data line in Table 3 shows that if no major modifications are required, the expected program slippage is 4 months and the expected cost overrun is \$2M. This combination of decisions is estimated to occur with about a 33% probability. If only Technical Transfusion is required, then the expected program slippage is 12 months with an expected cost overrun of \$52.8M. This combination of decisions is estimated with a 38% probability. The other combinations are less likely to occur than either of the two discussed.

XM1 PROGRAM COMPARISON

This section presents a side-by-side comparison of the cost/schedule results obtained for the three programs: XM1/US 105mm, XM1/UK 110mm, XM1/FRG 120mm. The first program will be referenced as the XM1

Current Program, the last two as the XM1 Alternative Programs. The data and results for the XM1 Alternative Programs used in the following sections were taken from the Appendix.

Table 4 summarizes the cost and schedule results for each of the three programs. The expected delays to the start of full production are 16 months for the UK 110mm system and 20 months for the FRG 120mm system; expected cost incurred is about \$55M with either system. These delays and costs are caused by the additional redesign activities and uncertainties in adopting the foreign armament systems to the vehicle. The results of the XM1 Current Program analysis indicated a 7 month slippage due to vehicle related problems; the expected cost overrun is \$10M (Technical Transfusion will add an additional 6 months).

The primary reason for the delays in the UK and FRG program is the 12-15 months required to redesign the vehicle to accept the heavier foreign armament after the armament decision. The redesign activities include contractor Engineering Design (ED) test being conducted simultaneously with prototypes production for DT/OT II. During this time period, the vehicle may or may not go through a Technical Transfusion activity, as indicated by the Current Program. Although the time required for Technical Transfusion is not significant, as the program is paced by the concurrent armament redesign activities, the cost will add \$4M-\$34M to the program.

From DT/OT II, both Alternative and Current Programs have identical activities. However, the data provided for these activities differ primarily due to the inclusion of vehicle uncertainties in the current program. The data for the Current Program contribute to greater schedule slippage and cost overruns than are caused by the foreign armament programs. This prompted us to obtain results from the viewpoint that the XM1 alternative armament programs will have at least the same level of uncertainty as the Current Program (i.e., time, cost, and probability levels) after the initiation of DT/OT II. These results are presented in Table 5.

Assuming that the cost/schedule problems of the XM1 program are comparable in magnitude regardless of armament, then a 2 year delay, rather than a 1-1/2 year delay, is expected. An expected cost increase of about \$70M, rather than \$50M, was computed for the XM1 Alternative Program.

SUMMARY

The published cost/schedule analysis in support of the Tripartite Tank Armament Study indicated a 1-1/2 year delay to full production at an expected cost increase of \$55M (FY74) (measured from October 75 to initiation of full scale production) if either the UK 110mm or the FRG 120mm armament system is adopted into the XM1 Program. The analysis considered armament and armament/vehicle interface problems. The cost/schedule analysis performed on the XM1/US 105mm program indicated an

expected scheduled slippage of 1/2 year and an expected cost overrun of \$10M (1 year and \$59M with Technical Transfusion). This analysis considered uncertainties in time and cost attributed to vehicle development and production.

Assuming that the XM1/UK 110mm and FRG 120mm programs have levels of uncertainty (beyond DT/OT II) comparable to the XM1/US 105mm program, then the expected schedule delay for either foreign armament systems is 2 years with an expected cost increase of \$71M.

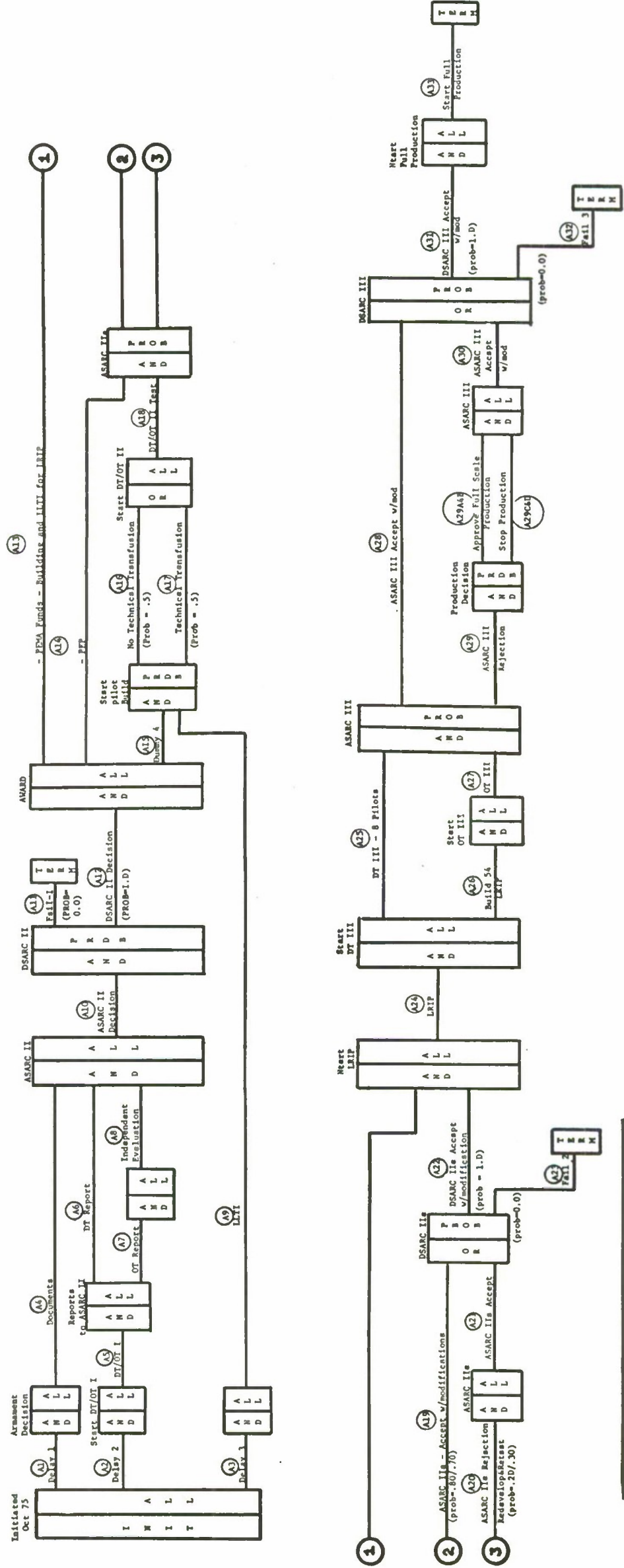

KEY

- IMIT - Initiates program
- AMND - Input activities must be completed
- ALL - All output activities are initiated
- OR - At least one input activity must be completed
- PROB - Initiates one activity based on probability of occurrence
- TERM - Terminates network

Figure 1. XMI Current Program

Next page is blank.

TABLE 1. XMI/US 105mm SCHEDULE

(From Armament Decision - October 1975)

Event (Start Of)	Scheduled Initiation (Mo/Date)
DT/OT II	25 (Nov 77)
DT/OT III	49 (Nov 79)
Full Production	58 (Aug 80)

DATA LIST I
XML/CURRENT PROGRAM ACTIVITY DESCRIPTION

<u>NUMBER</u>	<u>NAME</u>	<u>PROBABILITY OF OCCURRING</u>	<u>DESCRIPTION</u>
A1	Delay-1	1.0	Time delay to Armament Decision Selection is US 105mm
A2	Delay-2	1.0	Time delay to start DT/OT I on 1 Feb 75.
A3	Delay-3	1.0	Time Delay to 1 Jan 75
A4	Documents	1.0	Administrative work (e.g., RFP, D&F, SYS SPECS, DP, LCCE, RAM-D, DRA, COEA, Technical Task Force, Update - TOD, TOA, & BTA - Source Selection and PM negotiate.)
A5	DT/OT I	1.0	Development Test and Operational Test I
A6	DT I Report	1.0	Development Test Report to ASARC II
A7	OT I Report	1.0	Operational Test Report to ASARC II
A8	Independent Evaluation	1.0	Independent Evaluation Report to ASARC II
A9	LLTI	1.0	Long Lead Time Items
A10	ASARC II	1.0*	ASARC II Decision
A11	FAIL-1	0.0**	Terminate Program
A12	DSARC II	1.0*	DSARC II Decision
A13	PEMA Funds	1.0	PEMA funds must be available to renovate buildings, purchase tooling and other long lead time items for low rate initial production.

* Assumed to be 1.0

** Assumed to be 0.0

DATA LIST I (CONT)

<u>NUMBER</u>	<u>NAME</u>	<u>PROBABILITY OF OCCURRING</u>	<u>DESCRIPTION</u>
A14	PEP	1.0	Production Engineering & Planning. Supporting activity
A15	Dummy-4	1.0	Computer control arc
A16	No Technical Transfusion	0.5	ASARC/DSARC II accepted system with minor modifications if needed. Prototype vehicles are built and delivered to DT/OT II.
A17	Technical Transfusion	0.5	Major modification needed on vehicle system to continue program. Possible problem areas are: (1) Engine; (2) Fire control system; (3) Other (i.e., stored ammo load, armor design, coax, etc.). Major redesign and retesting must occur before prototypes are built and delivered to DT/OT II.
A18	DT/OT II	1.0	Development and Operation Tests II.
A19	ASARC IIa - acceptance	0.8/0.7	ASARC IIa acceptance of vehicle system with/without minor modifications. Probability of acceptance is 0.8 if there occurred a major Technical Transfusion after ASARC/DSARC II; Probability of acceptance is 0.7 otherwise.
A20	ASARC IIa-Rejection	0.2/0.3	Major modifications needed for acceptance by ASARC/DSARC IIa. See A19 for probability levels.
A21	Second ASARC IIa-Acceptance	1.0*	Second ASARC IIa accepted vehicle after redesign efforts.

* Assumed to be 1.0.

DATA LIST I (CONT)

<u>NUMBER</u>	<u>NAME</u>	<u>PROBABILITY OF OCCURRING</u>	<u>DESCRIPTION</u>
A22	DSARC IIa Acceptance	1.0*	DSARC IIa acceptance decision.
A23	FAIL-2	0.0**	Terminate program
A24	LRIP	1.0	Low Rate Initial Production and delivery 8 pilots for DT/OT III.
A25	DT III - 8 pilots	1.0	Development Test III.
A26	Build 54 - LRIP	1.0	Production of 54 Vehicles for OT III.
A27	OT III	1.0	Operational Test III.
A28	ASARC III Acceptance	0.95	ASARC III acceptance for full production.
A29	ASARC III Rejection	0.05	Major modifications are needed for ASARC III acceptance.
A29 A&B	Approve Full Scale Production	0.2	Full scale production will continue as scheduled with a retrofit program following. Probability of a fix in 6 months is 20%. Probability of a fix in 10 months is 80%.
A29 C&D	Stop Production	0.8	Full scale production is delayed until a fix is designed and tested. Probability of a 6 month slip is 20%. The probability of a 10 month slip is 80%.
A30	Second ASARC II	1.0*	Acceptance of vehicle full scale production.
A31	DSARC III	1.0*	DSARC III acceptance for full scale production.
A32	FAIL-3	0.0**	Terminate program.
A33	Start Full Scale Production	1.0	Full scale production of vehicle is started.

* Assumed to be 1.0.

** Assumed to be 0.0.

DATA LIST II

XM1/CURRENT PROGRAM ACTIVITY TIME AND COST INFORMATION

<u>ACTIVITY</u>		<u>SCHEDULED COMPLETION TIME</u>			<u>ACTIVITY COMPLETION TIMES</u>			<u>OVERRUN COST RATES</u> (IF SCHEDULE IS EXCEEDED)		
<u>Number</u>	<u>Name</u>	<u>Completion Time</u>	<u>Min</u>	<u>Max</u>	<u>Most Likely</u>	<u>COST RATE (\$M/MO)</u>	<u>Min</u>	<u>Max</u>	<u>Most Likely</u>	<u>FY</u>
A1	Delay-1	0 mo	0 mo (50%) ^a	4 mo	2 mo	2.1				76
A2	Delay-2	4 mo		4 mo (constant)		1.75				74
A3	Delay-3	3 mo		3 mo (constant)		2.1				76
A4	Documents	9 mo		No Impact		1.75				74
A5	DT/OT I	3 mo	3 mo (50%) ^a	4.5 mo	3 mo	2.1				76
A6	DT Report	5 wk	5 wk	8 wk	5 wk (80%) ^a	2.1				74
A7	OT Report	2 wk	2 wk	3 wk	2 wk	2.1				76
A8	Independent Evaluation	4 wk	4 wk	5 wk	4 wk	1.75				74
A9	LLTI			No Impact						
A10	ASARC II Decision	0	2 wk	4 wk	2 wk (20%) ^a	2.1				76
A11	FAIL-1					1.75				74

^aA mo(B%) - B is the probability that the activity is completed in A.

DATA LIST II (CONT)

XML/CURRENT PROGRAM ACTIVITY TIME AND COST INFORMATION

ACTIVITY Number	Name	SCHEDULED COMPLETION TIME	ACTIVITY COMPLETION TIMES			ESTIMATED TIME TO COMPLETION Most Likely	OVERRUN COST RATES (IF SCHEDULE IS EXCEEDED) COST RATE INCURRED COST (\$M)			FY
			Min	Max	Most Likely		(\$M/MO)	Min	Max	
A12	DSARC II Decision	0	0 mo	1 mo	2 wk		2.1			76
							1.75			74
A13	PEMA Funds	Supporting Activity	Unknown							Unknown
A14	PEP	Supporting Activity	No Impact							
A15	Delay-4		Computer Control Arc							
A16	No Technical Trans- fusion	16 mo	15 mo(10%) ^a	17 mo(30%) ^a	16 mo*		3.82			78
							2.84			74
A17	Technical Transfusion		19 mo	28 mo	25 mo		3.82			78
							2.84			74
	US Engine Change (Probability of occurrence-.4) Fire Control Problems (Probability of occurrence-.3) Other Major Problems (Probability of occurrence-.3) Engineering Support for Multiple Problems						1.0		11.0	78
							0.74		8.17	74
							1.0		5.9	78
							0.74		4.38	74
							1.0	2.0	4.0	78
							0.74	1.49	2.97	74
							1.0-2.4			78
							0.74-1.78			74
A18	DT/OT II Test	9 mo	9 mo	10 mo	9 mo(80%) ^a		0.6			79
							0.43			74
A19	ASARC IIa Acc.		2 wk	4 wk	2 wk(20%) ^a					

^a A mo (B%) - B is the probability that the activity is completed in A.

DATA LIST II (CONT)

XML/CURRENT PROGRAM ACTIVITY TIME AND COST INFORMATION

ACTIVITY Number	Name	SCHEDULED COMPLETION TIME	ACTIVITY COMPLETION TIMES			ESTIMATED TIME TO COMPLETION Most Likely	COST RATE (\$M/MO)	OVERRUN COST RATES (IF SCHEDULE IS EXCEEDED)			FY
			Min	Max	Most Likely			Min	Max	Most Likely	
A20	ASARC IIa Rej.		6 mo	12 mo	10 mo(80%) ^a	1.6	3.0	11.0	6.0	79	
						1.14				74	
A21	Second ASARC IIa		2 wk(20%)*	4 wk	2 wk	1.6				79	
						1.4				74	
A22	DSARC IIa		0 mo	1 mo	2 wk						
A23	FAIL-2										
A24	LRIP	15 mo	14 mo	15 mo	15 mo(90%) ^a						
A25	DT III Test	9 mo		9 mo(constant)							
A26	54 LRIP	8 mo		8 mo(constant)							
A27	OT III Test	1 mo		1 mo(constant)							
A28	ASARC III Acc.		2 wk	4 wk	2 wk(20%) ^a						
A29	ASARC III Rej.		2 wk	4 wk	2 wk(20%) ^a						
A29	A&B Continue Production		6 mo(20%)*	10 mo(80%) ^a			51.5(6 mo)	76.5(10 mo)		74	
A29	C&D Stop Production		6 mo(50%)*	10 mo(50%) ^a			49.0(6 mo)	56.8(10 mo)		74	
A30	Second ASARC III		2 wk	4 wk	2 wk(20%) ^a						
A31	DSARC III		0 mo	1 mo	2 wk						

^aA month (B%) - B is the probability that the activity is completed in A.

DATA LIST II (CONT)

XMI/CURRENT PROGRAM ACTIVITY TIME AND COST INFORMATION

<u>ACTIVITY</u>	<u>Number</u>	<u>Name</u>	<u>SCHEDULED COMPLETION TIME</u>			<u>ACTIVITY COMPLETION TIMES</u>			<u>OVERRUN COST RATES (IF SCHEDULE IS EXCEEDED)</u>				
			<u>Min</u>	<u>Max</u>	<u>Most Likely</u>	<u>Min</u>	<u>Max</u>	<u>Most Likely</u>	<u>COST RATE (\$M/MO)</u>	<u>Min</u>	<u>Max</u>	<u>Most Likely</u>	
	A32	FAIL-3											
	A33	Start Full Scale Production											
		Terminate Program											

TABLE 2. XML/US 105MM PROGRAM - SCHEDULE SLIPPAGE/COST INCREASE
(From Armament Decision to Full Production)

Event (Start Of)	WITH TECHNICAL TRANSFUSION				WITHOUT TECHNICAL TRANSFUSION						
	Schedule Slippage (mo)		Cost Increase \$M FY74		Schedule ^a Slippage (mo)		Cost Increase \$M FY74				
	5% Expected	95%	5% Expected	95%	5% Expected	95%	5% Expected	95%			
DT/OT II	4	9	11	-	-	0	1	2	-	-	
DT/OT III	7	12	21	-	-	1	5	13	-	-	
FULL PRODUCTION	8	13	23	23	59	2	7	14	0	10	49

^aAdd 6 months if XM735 production rounds are required at DT/OT II.

TABLE 3. XML CURRENT PROGRAM ANALYSIS

(From Armament Decision to Full Production)

<u>DECISION POINT</u>		<u>ASARC III</u>	<u>PROBABILITY OF OCCURRING</u>	<u>SCHEDULE SLIPPAGE</u>		<u>COST OVERRUN (\$M FY 74)</u>	
<u>ASARC II</u>	<u>ASARC IIa</u>			<u>MEAN (MO)</u>	<u>90% CONFIDENCE</u>	<u>MEAN</u>	<u>90% CONFIDENCE</u>
w/o TT	ACCEPT	ACCEPT	33.3%	4	+2	2.8	+ 2.0
w TT	ACCEPT	ACCEPT	38%	12	+3	52.8	+20.0
w/o TT	MMR	ACCEPT	14.3%	14	+2	19.6	+ 4.0
w/o TT	ACCEPT	MMR	1.7%	7	+4	70.8	+16.0
w TT	MMR	ACCEPT	9.5%	21	+4	69.5	+25.0
w TT	ACCEPT	MMR	2.0%	15	+6	121.6	+30.0
w/o TT	MMR	MMR	0.7%	17	+5	87.9	+20.0
w TT	MMR	MMR	0.5%	25	+7	138.5	+35.0

w/o TT - without Technical Transfusion
w TT - with Technical Transfusion
ACCEPT - No Modifications Required
MMR - Major Modifications Required

TABLE 4. XML PROGRAMS - EXPECTED SCHEDULE SLIPPAGE AND COST INCREASE^a
 (From Armament Decision to Full Production)

Program Alternative	Schedule Slippage		Cost Increase (\$M FY 74)	
	5% Expected	95%	5% Expected	95%
XM1/US 105mm	2	7	0	10
XM1/UK 110mm	11	16	48	54
XM1/FRG 120mm	14	20	48	55

^aDoes not include Technical Transfusion.

TABLE 5. XM1 PROGRAMS - EXPECTED SCHEDULE SLIPPAGE
AND COST INCREASE TO FULL PRODUCTION^a

(From Armament Decision to Full Production)

ARMAMENT	SCHEDULE DELAY (MO)		COST INCREASE (\$MFY74)	
	Expected	90% PI	Expected	90% PI
US 105mm	7	+ 6	10	+ 15
UK 110mm	22	+ 9	71	+ 40
FRG 120mm	25	+10	71	+ 41

^aAssumes Comparable uncertainties for XM1 System regardless of armament. Does not include Technical Transfusion.

APPENDIX

US COST/SCHEDULE UNCERTAINTY ANALYSIS

Next page is blank.

Section I. Gun/Ammunition in Isolation

OBJECTIVE

The objective of this analysis is to provide a comparison of cost and schedule burdens incurred by adopting each of the candidate armament systems.

INTRODUCTION

This section supports the following Measures and Indicators of Burden:

A.9 - Gun/Ammo development and production schedules, including uncertainty.

A.10 - Time phased life cycle cost of gun/ammo, including uncertainty.

As agreed, network* techniques were utilized to insure a common format for comparing and discussing national programs and to have a convenient format for the statistical procedures required for the uncertainty analysis.

The analysis presents a comparison of the current XM735 ammunition program with the gun/ammunition programs resulting from the decision to use the FRG or UK candidate armament. These programs show the cost and schedules of the engineering and test activities required to convert the FRG/UK technical data packages** (TDP) into US TDP's and to enter into full production. Major engineering and testing activities are considered from receipt of the TDP until initiation of full production.

APPROACH

Separate analyses were conducted for the cannon, shell metal parts, and propellant by those arsenals with mission responsibilities in these

*A network is a graphic representation of a program in which activities and decision points/milestones are interrelated according to sequence or concurrence.

**The technical data package should consist of (1) detailed component and assembly drawings with necessary notes to identify special requirements for manufacture and assembly, (2) material specifications and mechanical properties, and (3) specifications giving the inspection requirements and ballistic test requirements. Description of manufacture for special and/or unusual processes should be included.

The technical data package must reflect the ammunition submitted for performance and safety evaluation. The ammunition, in turn, must have demonstrated acceptable performance and have been accepted by the developing country for production initiation.

areas: Watervliet, Frankford, and Picatinny. The following guidelines were used for conducting these analyses:

- a. The networks would be initiated at receipt of the technical data package and terminated at initiation of full production.
- b. Off-shore hardware would be available for comparison purposes.
- c. Each arsenal would select one of the standard network analyzer computer techniques.
- d. Every effort would be made to obtain empirical data.
- e. Triangular distributions would be used to initially quantify subjective schedule uncertainty. (Estimates of the minimum, maximum, and most likely values would be used to define the distributions.)
- f. Cost uncertainty representation would be tailored to the activity. Cost dependence on activity time would be described if applicable, e.g.,

$$\text{Cost} = a + rt, \text{ a, r fixed}$$

$$\text{Cost} = A + rt, \text{ A, random} \\ \text{r, fixed}$$

$$\text{Cost} = A + Rt, \text{ A, R random}$$

The triangular distribution would be used for the random variables.

Although the standard network analyzers differ in certain respects, they are alike in those considerations pertinent to this study. With regard to network format:

- a. The lines (arcs) of the network are used to represent activities which consume time (e.g., testing) or carry information (e.g., test successfully completed).
- b. The boxes (nodes) of the network are used to represent milestones (e.g., initiation and termination of activities, decision points.) Logic features are contained in the nodes for the input and output arcs (e.g., "AND" input logic requires all input arcs to be completed before the output arcs are initiated. "PROB" output logic initiates one of several output arcs according to specified probabilities).

Minimum, maximum, and most likely estimates were obtained for cost and schedule data on those activities where uncertainty exists. In addition, a cost and time relationship was specified to account for cost increases due to slipped schedules, where applicable.

An iteration consists of statistically tracing the program flow and cumulating cost and time. Several hundred iterations were used to

obtain the cost/schedule mean values and confidence limits presented in this report.

The cannon, shell metal parts, and propellant networks were interfaced to obtain the armament cost/schedule for the UK and FRG candidates. Consideration was given to the situation that not all technical problems are resolvable by the expenditures of cost and time resources. Repeated or significant failures would lead to an early termination of the proposed program. The US candidate 105mm cannon is a production item and, therefore, not addressed.

ANALYSIS OF UK/FRG ARMAMENT SYSTEMS

The cannon, shell metal parts, propellant networks, data, and results are presented in Annexes A, B, and C, respectively. Differences between the networks representing the programs for the two rounds are minor; for example, additional time is incurred in translating the FRG technical data package into English. However, some schedule/cost differences were observed.

The networks indicate how the projects interface, e.g., Watervliet Arsenal must provide cannons for later Picatinny and Frankford Arsenal tests, while off-shore cannons will be used for early tests; the shell metal parts network (Frankford) is a subset of the propellant/load-and-pack network (Picatinny).

Assumptions on the availability of FRG or UK hardware were made for the analysis. The validity of these assumptions are crucial to the following schedule/cost estimates:

a. The estimated time from armament decision to receipt of the technical data package (TDP) is two to six months.

b. One FRG serviceable cannon will be available within the US four months from receipt of the TDP. One UK serviceable cannon will be available within six months from receipt of TDP. Another cannon will be available ten months after receipt of the TDP. (These requirements are described in Annexes A and B.)

c. FRG Ammunition will be available six months after receipt of the TDP; UK ammunition will be available four months after receipt of the TDP.

Four milestones are presented as follows:

a. XM1 System Test (DT/OT II), i.e., availability of hardware for DT/OT II acceptance testing of the XM1 System.

b. Complete Development, i.e., completion of the US Technical Data Package.

c. XM1 System Test (DT/OT III), i.e., availability of hardware for

DT/OT III acceptance testing of the XM1 System. Ammunition for DT/OT III will be produced prior to the start of DT/OT II and is not considered a critical interface point.

d. Full Production, i.e., the availability of first full production items. Cost of ammunition test rounds is included in total ammunition cost.

RESULTS

In Table A-1, the expected values of time and cost are displayed, together with 90% probability interval (PI)*, for the UK 110mm and FRG 120mm gun/ammunition systems. These values reflect development schedules and costs from the armament decision.

The expected times and 90% PI for the UK gun and ammunition systems to initiation of full production are 71 ± 5 months and 62 ± 6 months, respectively. Similarly, the cost of the gun is $\$6.2M \pm \$0.2M$ and the cost of the ammunition is $\$9.1M \pm \$1.1M$.

The expected times and 90% PI for the FRG gun and ammunition systems to initiation of full production are 70 ± 3 months and 66 ± 8 months, respectively. Similarly, the FRG gun cost is $\$6.7M \pm \$0.2M$; the ammunition cost is $\$9.1M \pm \$1.1M$.

The ammunition schedule results are applicable to both KE and CE projectiles. The cost results apply to the KE round and include development costs and rounds for the XM1 program ($\$2.8M$). CE development costs were estimated to be $\$4.8M$ and $\$5.0M$ for the UK and FRG rounds, respectively; CE rounds for the XM1 program were estimated to cost $\$1.6M$.

The probability of completing a successful development program is greater than 0.85 for either UK or FRG gun/ammunition systems.

*Ninety percent of the values (cost/time) observed in the thousand iterations of the networks were contained between the upper (95%) and lower (5%) values.

TABLE A-1. CANDIDATE ARMAMENT COST/SCHEDULE COMPARISON ANALYSES
(From Receipt of Technical Data Package to Specified Milestone)

Candidate Armament Subsystems Milestones	Schedule (Mo)			Cost (\$M)		
	5% ^a	Expected	95% ^b	5% ^a	Expected	95% ^b
US - 105mm Gun Ammo (XM735)						
XM1 System Test (DT/OT II)		25				
Full Production		33			1.6	
UK - 110mm Gun						
XM1 System Test (DT/OT II)	24	29	34			
Complete Development	37	42	47			
XM1 System Test (DT/OT III)	60	65	70			
Full Production	66	71	76	6.0	6.2	6.4
Ammo (KE) ^c						
XM1 System Test (DT/OT II) ^d	29	33	37			
Complete Development	36	40	44			
XM1 System Test (DT/OT III) ^d	-	-	-			
Full Production	58	62	68	8.0	9.1	10.2
FRG - 120mm Gun						
Tank System Test (DT/OT II)	26	28	30			
Complete Development	38	40	42			
XM1 System Test (DT/OT III)	61	64	67			
Full Production	67	70	73	6.5	6.7	6.9
Ammo (KE) ^c						
XM1 System Test (DT/OT II) ^d	31	37	43			
Complete Development	40	44	48			
XM1 System Test (DT/OT III) ^d	-	-	-			
Full Production	58	66	74	8.0	9.1	10.2

^a There is a 5% chance that the value will be less than displayed value.

^b There is a 95% chance that the value will be less than displayed value.

^c For CE (HEAT) Round the schedule is the same, development cost is \$4.8M for the UK 110 and \$5.0M for the FRG 120. CE hardware cost for XM1 test is \$1.6M.

^d Tank System Test Hardware - Hardware is available for tank system acceptance test DT/OT II and DT/OT III. Rounds for DT/OT III will be available from DT/OT II production. XM1 test cost is included in this analysis (\$2.8M).

Next page is blank.

Section II. Vehicle Development Including Gun Ammunition

OBJECTIVE

The object of this analysis is to compare the cost/schedule burdens incurred by the XM1 Tank System by selection of each candidate armament.

INTRODUCTION

This section supports the following Measures and Indicators of Burdens:

B.1 - Time phase life cycle cost, including uncertainty estimates.

B.2 - Vehicle development and production schedules, including uncertainty estimates.

The network procedures and guidelines described in the US Gun/Ammo Cost/Schedule Uncertainty Analysis were used for this analysis. This paper compares the current XM1 program schedule and cost with an XM1 program modified to incorporate the alternate armaments. The information obtained in the US Gun/Ammo Cost/Schedule Uncertainty Analysis (Section I) was input to this study. Uncertainty information (minimum, maximum, and most likely values) was estimated for the XM1 activities and was interfaced with the gun/ammo estimates to produce cost/schedule distributions of time-to-full production and cost-to-full production.

ANALYSIS

Current Program - XM1/XM735.

Table A-2 presents the current XM1/105mm schedule for selected key milestones. The cost of the program for the period from September 1975 to initiation of full production was not addressed in this analysis.

XM1/Alternative Armament Program.

Figure A-1 presents a network for the modified XM1 program to accommodate vehicle redesign and the alternative gun/ammo development programs. Data Lists A-I and A-II present a description of those activities and estimated program cost deviations from the Current Program.

This modified program differs from the current XM1 program in the following two respects.

1. Following the armament decision, the vehicle will undergo a major redesign phase to accommodate the heavier foreign armament. The contractor, after redesigning and building three prototypes, is given time to perform Engineering Design (ED) tests. Deficiencies

are corrected while pilot build (8 pilots) is continued. DT/OT II is then initiated and conducted in a similar manner to the original XM1 program.

2. The gun/ammunition programs are added. The network shows the critical gun/ammunition and vehicle interfaces: (a) at the start of DT/OT II, (b) at the start of DT/OT III, and (c) at the start of full production. Ammunition, guns, and vehicles must be available at these points with the appropriate lead time and stage of development and in the required quantities or program delays will result.

The assumption was made that the gun and ammunition technical data packages (TDPs) would be available within the same time period. Receipt of the TDPs is critical to the XM1 schedule as completion of these arcs initiates the US Gun/Ammo Development Programs. Initial estimates are that these packages would be available from 2 to 4 months after armament decision -- with 3 months as the most likely value. The armament decision was estimated to occur at the end of September 1975 at the earliest, but no later than the end of November 1975.

RESULTS

Results were obtained for three XM1 program milestones:

a. DT/OT II (acceptance test). The engineering and development tests required for the XM1 gun/ammo system to start Low Rate Initial Production.

b. DT/OT III (acceptance test). The development and operational test required for initiation of full production.

c. Full Production. Simultaneous full scale production of ammunition, guns, and vehicles.

The ammunition, KE/CE (HEAT), development program interfaces with the XM1 program at DT/OT II and the start of full production. No interface occurred at DT/OT III as engineering rounds would be available in advance of the milestone. The cannon development program interfaces with the XM1 program at DT/OT II, DT/OT III, and initiation of full scale production.

The XM1 Alternative Armament Program cost and schedule deviations from the XM1/105mm current schedule are presented in Table A-3. The expected values of time and cost are displayed, together, with a 90% probability interval*. The cost/schedule deviations are those incurred from September 1975 to initiation of full production and includes the

*Ninety percent of the values (cost/time) observed in the thousand iterations of the networks were contained between the upper (95%) and lower (.05%) values.

vehicle program, the cannon and ammunition (KE and CE) development programs, and cannon and ammunition hardware for the XM1 tests. The estimated delay and 90% probability interval to DT/OT II is 14 ± 4 months for the UK 110mm system and 18 ± 7 months for the FRG 120mm system. The estimated delay to DT/OT III and initiation of full scale production is 16 months for the UK 110mm system and 20 months for the FRG 120mm system with a ± 5 month 90% probability interval. The expected total cost increase and 90% probability interval incurred by the decision to adopt either the UK 110mm or FRG 120mm armament system is $\$54.6 \pm 8M$.

A major factor in the schedule delays is the timely availability of US-produced safety certified ammunition at DT/OT II. A schedule analysis was conducted assuming off-shore ammunition could be obtained for this test; the results are presented in Table A-4. The estimated delay and 90% probability interval to DT/OT II is 11 ± 2 months for UK or FRG systems. The delay to DT/OT III and initiation of full production is 14 ± 4 months for the UK 110mm system and 13 ± 3 months for the FRG 120mm system; the small difference observed is due to an estimated difference in the cannon development programs. Ammunition availability and cost for this alternative was not assessed. The expected time delay for the vehicle program in isolation is 13 ± 3 months.

TABLE A-2. CURRENT XM1/105mm ARMAMENT SCHEDULE

<u>EVENT</u> <u>(Start of)</u>	<u>SCHEDULED INITIATION</u> <u>(Mo/Date)</u>
DT/OT II	25 (Nov 77)
DT/OT III	49 (Oct 79)
Full Production	58 (Aug 80)

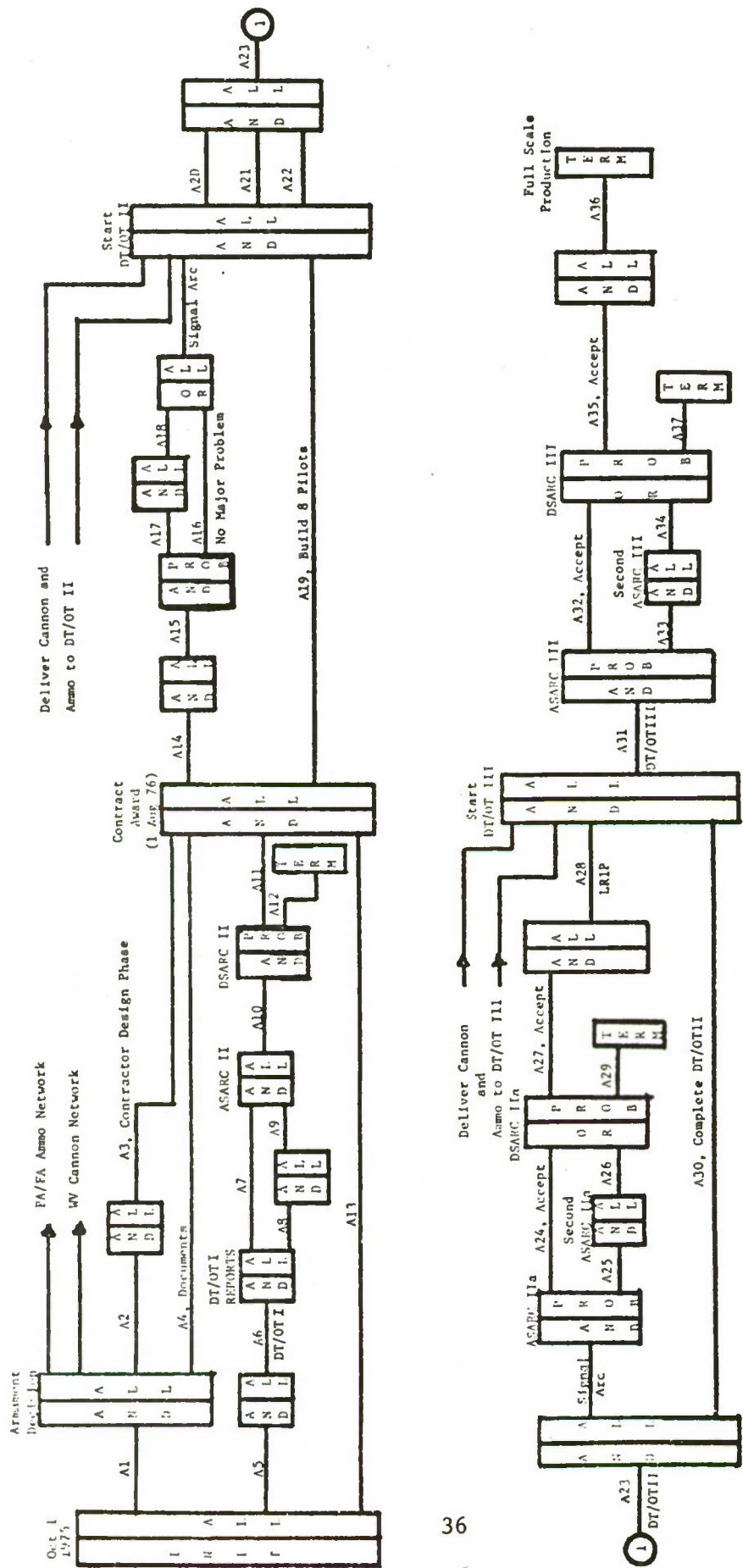

Figure A-1. XM1 Tank Program with Alternative Weapon System

DATA LIST A-I

XML/ALTERNATIVE PROGRAM ACTIVITY DESCRIPTION

<u>ARC NUMBER</u>	<u>NAME</u>	<u>PROBABILITY OF OCCURRING</u>	<u>DESCRIPTION</u>
A1	Delay - 1	1.0	Time delay to armament decision
A2	Contractor Rev. Lead Time	1.0	Administrative Lead Time
A3	Contractors (2) Initiate Design Revision	1.0	Begin Baseline Design Revision
A4	Documents	1.0	Administrative Work (i.e., RFP, D&F, Sys Specs, DT, LCC, RAM-D, DRA, COEA, TSSG, Update TOD, BTA and Source Selection and PM Contract Negotiate
37			
A5	Delay - 2	1.0	Time delay to start DT/OT I on 1 Feb 75
A6	DT/OT I	1.0	Development and Operational Test I
A7	DT I Report	1.0	Development Test Report to ASARC II
A8	OT I Report	1.0	Operational Test Report to ASARC II
A9	Independent Evaluation	1.0	Independent Report to ASARC II
A10	ASARC II Decision	1.0	ASARC II Decision
A11	DSARC II Decision	1.0	DSARC II Decision
A12	Fail	0.0	Terminate Program
A13	LLTI	1.0	Long Lead Time Items
A14	Design Build, 3 pilots	1.0	Design/Build 3 pilots for contractor test

DATA LIST A-I (CONT)

<u>ARC NUMBER</u>	<u>NAME</u>	<u>PROBABILITY OF OCCURRING</u>	<u>DESCRIPTION</u>
A15	Contractor ED Test	1.0	Contractor ED Test, 3 Pilots
A16	No Major Prob/Complete Test	0.9	No major problems, contractor ED Test completed
A17	Major Prob	0.1	Major problem uncovered
A18	Redesign/Retest	1.0	Problem corrected, remainder of Contractor ED Test completed
A19	Begin build, 8 pilots (deliver 2)	1.0	Begin build of 8 pilots, 2 delivered for start of DT/OT II.
A20	Refurbish, deliver 3 pilots	1.0	Refurbish 3 contractor pilots and deliver for DT/OT II
A21	Deliver 6 pilots	1.0	Complete delivery of 6 pilots for DT/OT II
A22	DT/OT II Buildup	1.0	DT/OT II started with 2 pilots, 9 remaining pilots delivered.
A23	DT/OT II Full Fleet	1.0	Continue DT/OT II with 11 pilots
A24	Accept w/Minor Mods	0.95	ASARC IIA acceptance of vehicle system with/without minor modifications.
A25	Reject, Redevelop, Retest	0.05	ASARC IIA rejection, major modification and retesting needed for acceptance.
A26	DSARC IIA Prep	1.0	Preparation time for DSARC IIA
A27	Accept	1.0	DSARC IIA Acceptance Decision

DATA LIST A-I (CONT)

<u>ARC NUMBER</u>	<u>NAME</u>	<u>PROBABILITY OF OCCURRING</u>	<u>DESCRIPTION</u>
A28	Pre-Rolloff LRIP	1.0	Initiate Low Rate Initial Production
A29	Fail	0.0	Terminate program
A30	Complete DT II	1.0	DT II Completion, independent of acceptance/rejection at ASARC IIa.
A31	Test 52 vehicles	1.0	Initiate testing (8 pilots for DT III, and 54 pilots for OT III)
A32	Accept w/Minor Mods	0.99	ASARC III acceptance of vehicle system with/without minor modifications
A33	Reject, redevelop, retest apply mods	0.01	ASARC III rejection, major modification and retesting needed for acceptance
A34	DSARC III Prep	1.0	Preparation time for DSARC III
A35	Accept	1.0	DSARC III Acceptance Decision
A36	Start Full Prod	1.0	Full Scale Vehicle Production Initiated
A37	Fail	0.0	Terminate program

DATA LIST A-II

XMI/ALTERNATE PROGRAM
ACTIVITY TIME AND COST RATE INFORMATION

ACTIVITY COMPLETION TIMES

<u>ARC NUMBER</u>	<u>MIN (t₁)</u>	<u>MAX (t₃)</u>	<u>MOST LIKELY (t₂)</u>	<u>COST RATE \$/MO</u>
A1	0	3	0	0.12
A2	3	4	3	0.12
A3			1 Aug 76	0.12
A4			1 Aug 76	
A5			1 Feb 76	
A6			3	
A7			2	
A8			1	
A9			1	
A10			1 Jul 76	
A11			1 Aug 76	
A12			0	
A13			1 Aug 76	
A14	16	19	18	2.3(t-15 Mo)
A15			5	2.3
A16	3	4	3	2.3
A17			0	
A18	4	10	6	2.3
A19			24	
A20	4	5	5	0.2
A21	4	5	5	

DATA LIST A-II (Cont)

ACTIVITY COMPLETION TIMES

<u>ARC NUMBER</u>	<u>MIN (t_1)</u>	<u>MAX (t_3)</u>	<u>MOST LIKELY (t_2)</u>	<u>COST RATE \$/MO</u>
A22			5	
A23			4	
A24			1	
A25	4	10	6	1.45
A26			1	
A27			0	
A28			15	
A29			0	
A30			6	
A31			8	
A32			1	
A33	6	12	10	
A34			1	
A35			0	
A36			0	

ACTIVITY COSTS (\$M)

<u>ARC NUMBER</u>	<u>MIN (c_1)</u>	<u>MAX (c_2)</u>	<u>MOST LIKELY (c_3)</u>
A14	0.4	0.4	0.4
A18	2.0 (.5) ^a	5.0-9.0 (.1) ^b	2.0-5.0 (.4) ^b
A25	1.0 (.5) ^a	3.0-5.0 (.1) ^b	1.0-3.0 (.4) ^b
A33	22.0	59.0	46.0

^aA(B%), B is the probability that activity cost will be A

^bA-B(c), c is the probability that activity cost will be between A and B.
In this range all values are equally likely. 41

TABLE A-3. XM1/ALTERNATIVE ARMAMENT COST/SCHEDULE COMPARISON

EVENT (Start Of)	Δ SCHEDULE ^a (Mo)			Δ COST (\$M)		
	5%	Expected	95%	5%	Expected	95%
FRG - 120mm gun/ammo ^b						
DT/OT II	12	18	25	--	--	--
DT/OT III	14	20	27	--	--	--
Full Production	14	20	27	47.9	54.7	63.3
UK - 110mm gun/ammo ^b						
DT/OT II	10	14	18	--	--	--
DT/OT III	11	16	21	--	--	--
Full Production	11	16	21	47.7	54.5	63.1

^aSchedule and cost values represent increases (Δ) in cost and time over the current XM1/105mm program.

^bFor KE and CE rounds only.

TABLE A-4. XM1/ALTERNATIVE ARMAMENT COST/SCHEDULE COMPARISON
(Assuming Ammo Does Not Delay DT/OT II)

EVENT (Start Of)	FRG 120mm Gun/Ammo ^a Δ SCHEDULE ^b (Mo)			UK 110mm Gun/Ammo ^a Δ SCHEDULE ^b (Mo)		
	5%	Expected	95%	5%	Expected	95%
DT/OT II	10	11	14	10	11	14
DT/OT III	11	13	17	11	14	19
Full Production	11	13	17	11	14	19

^aFor KE and CE rounds only.

^bSchedule values represent increases (Δ) in time over the current XM1/105mm program.

ANNEX A

CANNON COST/SCHEDULE UNCERTAINTY ANALYSIS

Next page is blank.

ANNEX A

CANNON COST/SCHEDULE UNCERTAINTY ANALYSIS

This analysis examines the cost and schedule uncertainties of the US cannon production of both the United Kingdom 110mm and the Federal Republic of Germany 120mm armament systems.

1. Assumptions:

- a. Program will start 3rd Qtr FY76.
- b. Existing cannon configuration will be used.
- c. Selected cannon has met requirements of DT I and is ready for Development.
- d. Six months after start date, manufacturing release (agreement) will be received from UK or FRG.
- e. Development phase will consist of:
 - (1) Review and Conversion of drawings.
 - (2) Minor changes only.
 - (3) Checking of fatigue and wear.
 - (4) Preliminary fatigue/wear data will be available.
 - (5) Planning of same time frame and quantity of weapons to support XM-1 DT II program.
- f. There will be approximately 125 component drawings per weapon.
- g. Major forging physicals are the same.
- h. Based on preliminary date, both weapons have approximately the same weight, size and length.
- i. Off shore-buy weapons will be available for analysis and firing evaluation w/recoil mount and rounds.
- j. Producibility, Engineering, and Planning (PEP) will occur during an 18 month duration; complete TDP, including only minor changes, is required.
- k. The TDP received will include development manufacturing drawings only, i.e., there will be no tool or gage design drawings, inspection procedures or component routing sheets.

2. Activity Rationale: The Cannon Program network is presented as Figure A-2 of ANNEX A. Following is a description of the program activities:

Activity
No.

- 2 Procure Forgings - Thirty tube forgings and twenty-one breech ring and breechblock forgings will be procured. This quantity will be sufficient to satisfy both the XM-1 and developers' requirements through DT/OT II. Time and cost is based on experience gained on similar cannon size and quantity procurement actions.
- 3, 4 & 5 Drawing Translation, Conversion and Material - These activities will cover the necessary conversion of the cannon drawing set for US manufacture.
- 7 Off-Shore Buy - One cannon, recoil mechanism and 100 rounds of slug ammunition is required by Watervliet (WVA) to confirm drawings received and to conduct preliminary and comparison firing tests. The time of one year to obtain this material is a judgment and may be reduced through negotiations of higher headquarters. Cost of this material has not been included.
- 8 Prepare Drawings - A complete set of US manufacturing drawings will be prepared.
- 9 Manufacture Cannon and Dynamic Hardware - Two cannons, one for Picatinny Arsenal (PTA) and one for Watervliet, plus one dynamic test specimen, will be fabricated from the US-converted drawings. Fabrication time and cost estimates are based on experience gained on similar configuration cannon.
- The following three test activities have been divided into two phases with an estimated risk assigned on success or failure. Dividing the tests allows early evaluation of test results and permits redesign early in the development cycle.
- 11 & 18 PTA-FFA Firing Tests - This activity is included only to indicate that firing data generated by PTA and Frankford Arsenal (FFA), including cannon incidents or failures, will be reported to Watervliet.
- 12 & 19 Watervliet Firing Tests - Conduct a 300-round test on the US-produced cannon to evaluate performance and function plus a comparison firing with the off-shore buy cannon.

Activity
No.

- 13 & 20 Dynamic Test - Perform a laboratory dynamic pressure test to determine preliminary breechblock, ring, and tube fatigue life. Establish areas of pressure components to be redesigned to increase fatigue life.
- 15 & 17 Redesign and Retrofit - This redesign consists of minor changes and retrofit of the test cannon and confirms the design change with a retest.
- 22 Redesign - This redesign activity carries a high risk, i.e., at this time in the development program the redesign necessary to correct the deficiency has to be minor; if it's major, it will take longer than the estimated activity time and will cause a termination of the program or return to start.
- 24 Manufacturing Cannons and Spare Tubes - The required quantity of cannons and spare tubes to support the XM-1 vehicle will be manufactured and delivered as indicated.
- 25 Manufacturing PA and Watervliet Cannons - Three cannons plus spare tubes, to the same configuration as the XM-1 hardware, will be fabricated--one for PTA and two for WVA.
- 27 Firing Test - This test will be to evaluate the final design configuration of the cannon; 500-slug rounds will be fired to evaluate the following:
- Breech function and performance
 - Bore evacuator performance
 - Tube and breech strain vs. pressure/time
 - System accelerations
 - Tube bore firing damage (heat checking)
 - Movie coverage
- 30 & 31 Redesign Retrofit - Again during Watervliet's test program a redesign and retrofit activity has been identified to allow for minor design changes that may be required to be incorporated into the XM-1 cannons prior to or during DT II.
- 33 Test Lead Time - This activity is included to provide the necessary cannon/vehicle assembly lead time prior to vehicle delivery, i.e., from delivery of first two cannons to initiation of DT II is six months.
- 35 Manufacturing Dynamic Hardware - Six breech mechanisms with stub tubes and fixtures will be fabricated to provide the required quantity of dynamic fatigue samples.

Activity
No.

36 Dynamic Test - This test, to be conducted by Watervliet Research Lab., will determine and confirm the safe breech ring and breechblock fatigue life. The established safe life value is required prior to or during OT II to provide an interim safety release for crew firing.

39 & 40 Producibility Engineering and Planning (PEP) - This activity is a normal PEP program to take the cannon development drawings and produce the necessary soft wear and drawings for production or a complete Tech Data Package (TDP).

41 IPF - This activity provides for the initiation of the long lead tooling, gages, etc. associated with Initial Production Facilities (IPF).

All engineering support activities covers the following normal support:

- Program engineering support
- Manufacturing support
- Test support
- Supervision and administration
- Maintenance of drawings

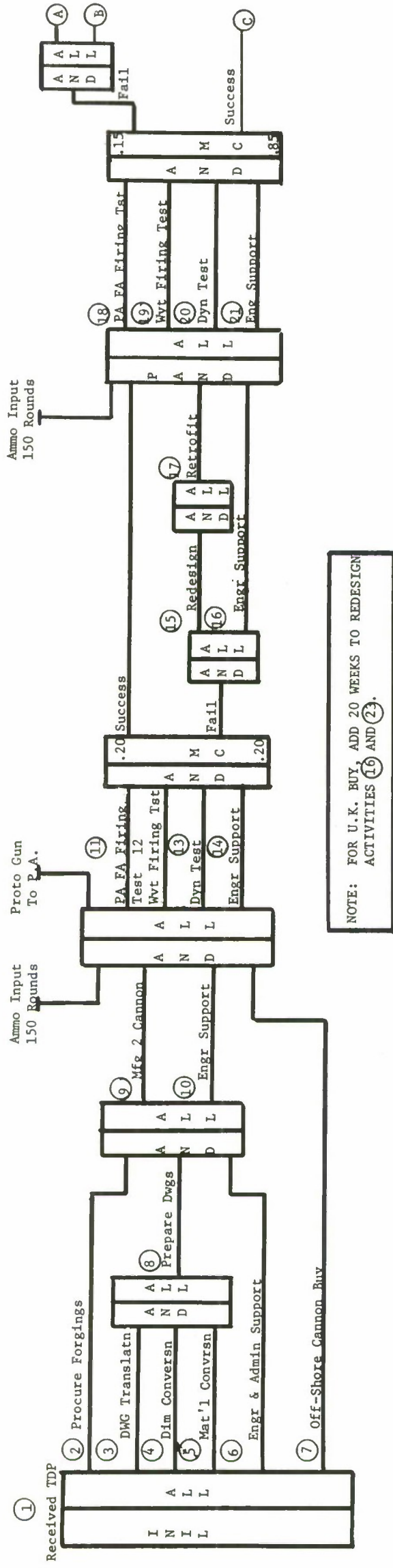

Figure A-2. Development Program for the UK 110MM or the FRG 120MM Cannons. (1 of 2)

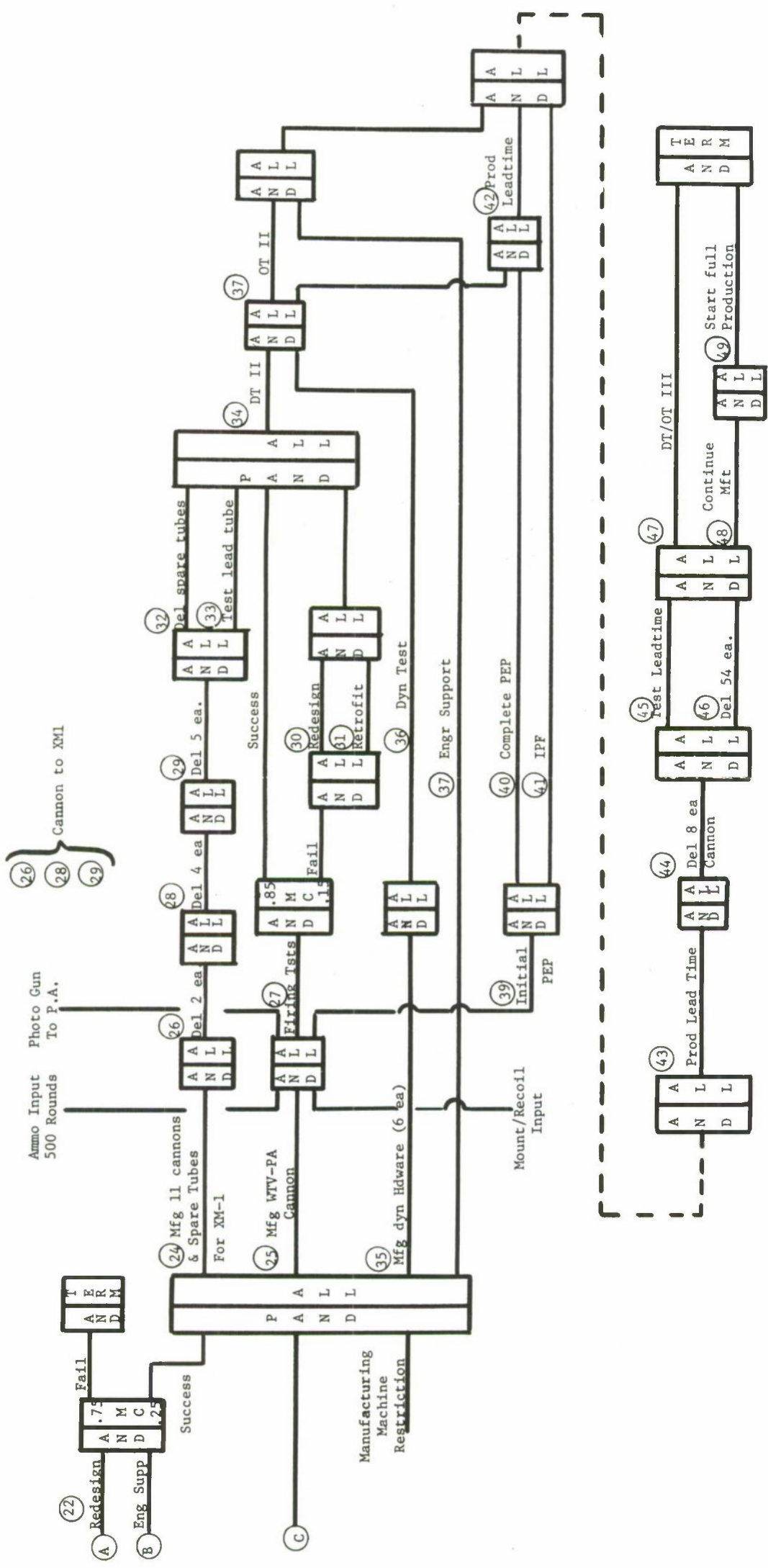

Figure A-2. Development Program for the UK 110MM or the FRG 120MM Cannons. (2 of 2)

ANNEX B

PROJECTILE SHELL METAL PARTS
COST/SCHEDULE UNCERTAINTY ANALYSIS OBJECTIVE

Next page is blank.

ANNEX B

PROJECTILE SHELL METAL PARTS COST/SCHEDULE UNCERTAINTY ANALYSIS

OBJECTIVE

This analysis examines the cost and schedule uncertainties of U.S. production of both the United Kingdom (UK) 110mm and the Federal Republic of Germany (FRG) 120mm K. E. projectile shell metal parts.

BACKGROUND

Presently, the U.S. Army is participating in the Tripartite Tank Armament Study with the United Kingdom and the Federal Republic of Germany concerning performance and cost effectiveness among three candidate tank weapon systems. These systems are the US 105mm cannon and associate projectiles, the UK 110mm system, and the FRG 120mm system.

In June 1974, the ARMCOM Systems Analysis Office (AMSAR-SAS) requested the Systems Analysis Division, Frankford Arsenal (SARFA-PAS) to initiate a Decision Risk Analysis in support of the Tripartite Tank Armament Study. Our risk analysis was to examine the cost and schedule uncertainties of U.S. production of projectile shell metal parts from the foreign technical data packages of the UK 110mm and FRG 120mm weapon systems.

In October 1974, a SARFA-PAS interim risk analysis report, as requested by AMSAR-SAS, was forwarded to both AMSAR-SAS and Plans and Analysis Office, Picatinny Arsenal (SARPA-PA-S) for inclusion into their consequential studies. The interim analysis was based upon data on the above foreign weapons systems then available to FFA engineers. Assessments made by the FFA Artillery Ammunition Production Office concerning materials order lead time, fabrication, and production costs and schedules reflected subjective estimates based upon the production of 3500 projectiles.

Subsequent program actions indicate that approximately 5000 projectiles need be fabricated, 1900 of which are for testing on the XM1 tank. To ascertain the effects on scheduling and costs due to the increased production quantity and to assess the impact of updated information, a revised risk analysis was prepared. This report represents our current penetrator/shell metal parts risk analysis input to the SARFA-PA-S tank ammunition cost/schedule uncertainty analysis as part of the above AMSAR-SAS study.

The penetrator/shell metal parts risk analysis for each foreign system consists of the review of the foreign technical data packages (TDP), the Frankford Arsenal In-House manufacture of proof slugs for initial propellant and weapon testing, the fabrication and assembly of approximately 5000 projectiles, and the testing of the projectiles

through TECOM DT II testing. Figure B-1 (Annex B) reflects the skeleton network.

PROGRAM ASSUMPTIONS

In order to assure a timely production schedule, our engineers have assumed that they will receive the highest possible DA project priority for funds, manpower, and contract award. This assumption underlies all time estimates in the schedule analysis.

The following engineering assumptions as to the character and risk of the program are made:

1. The TDP will arrive at Frankford Arsenal as a workable package with no important problems still to be resolved.
2. No product improvements to the basic TDP will be made during program execution.
3. Proof slugs will be fabricated in-house.
4. All contracts will be given priority in processing and sole source award.
5. Production rates will average approximately 500 projectiles per month.
6. Delivery of production quantities to Picatinny Arsenal for LAP will be made in a continuous manner.
7. Fabrication of 2200 projectiles for confirmatory by FFA, PTA, and WVA will be concurrent with the accuracy/security and penetration testing of the 1st pilot lot.
8. Fabrication of the TECOM quantity of 500 projectiles will be concurrent with Frankford Arsenal testing of rounds from the previous 2200 quantity.
9. The TECOM quantity will be released by Frankford Arsenal upon successful completion of testing in "8" above.
10. Fabrication of approximately 1900 projectiles for testing with the XM1 tank will immediately follow the TECOM quantity and will be concurrent with TECOM testing.
11. A minor failure in the accuracy/security test will imply that the test will be reevaluated.
12. A major failure in the accuracy/security test is assumed to be either a function of material problems or that the foreign designs are not adequate under our testing conditions.

NETWORK RISK ANALYSIS

Figure B-2 is the network used for analyzing both the UK 110mm and FRG 120mm weapon systems penetrator/shell metal parts program. Descriptions of network activities are presented in Table B-1. Table B-2 contains the time and cost data associated with the UK analysis. Table B-3 contains the time and cost data for the analogous FRG analysis. Time data is in the form of triangular distributions. However, arc A62 is in the form of a cumulative density function described by four points. Cost data is either in the form of fixed + variable (dependent upon time) costs or "fixed" costs given in terms of a random variable from distributions having their triangular distributions notated by 3 parameters in parentheses. Some network activity costs are dependent upon costs associated with other activities. A specific occurrence is the cost of remanufacturing items. The assumption is made that the remanufactured unit costs are equal to the original costs. Therefore, if 5000 items cost \$p, a random variable chosen from the estimated cost distribution of (\$4000-\$5000-\$6000), 100 more items would cost $(\$p/5000) \times 100$. This type data occurs in Table B-2. (All arcs and nodes not tabulated in Annex Tables B-2 and B-3 are signal arcs used for the network logic).

Major milestone activities, resulting from the network analysis, which must interface with the propellant risk analysis milestones of Picatinny are summarized in Table B-4. Based upon the assumption that all inputs needed by Frankford Arsenal are available, as required, the minimum time period to a final Frankford Arsenal-produced TDP for the UK 110mm is approximately 26 months, the mean time is 36 months, and the 80% certainty time is 37 months. Similarly, for the FRG 120mm, the minimum time is 26 months, the mean time is 41 months, and the 80% certainty time is 43 months.

CONCLUSIONS

For US production of projectiles for the UK 110mm weapon system, Frankford Arsenal estimates with 80% certainty that the 1st partial delivery of projectiles can be made within 19 months from receipt of the foreign TDP. The initial delivery of projectiles from the XM1 quantity of 1900 for LAP will be concurrent with TECOM testing. With a production rate of approximately 500 units per month, FFA estimates with probability of 0.8 that safety certification will be passed and fabrication of the total XM1 quantity will be complete within 30 months from receipt of the foreign TDP.

Similarly, 1st partial delivery of US produced FRG projectiles can be made within 25 months, estimated with 80% certainty. Safety certification should be passed and fabrication of the total XM1 quantity complete within 37 months on an 80% surety level.

Costs, similar for both programs, are less than \$7.5 million dollars on the 80% certainty level; the mean cost is \$7.1M. The probability of success is in excess of 0.98.

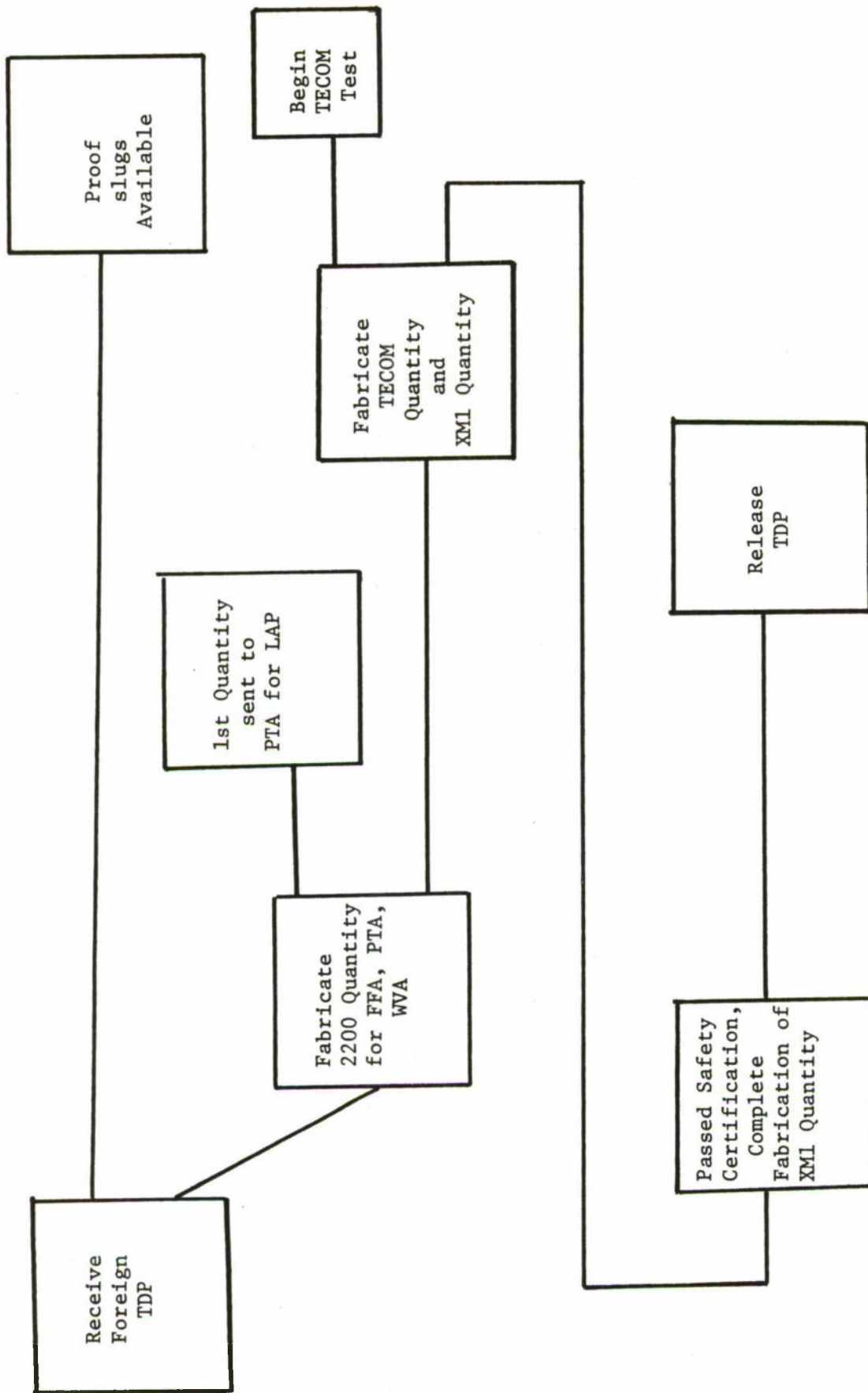

Figure B-1. Tripartite Tank Armament Program -- Penetrator/Metal Parts --
Frankford Arsenal

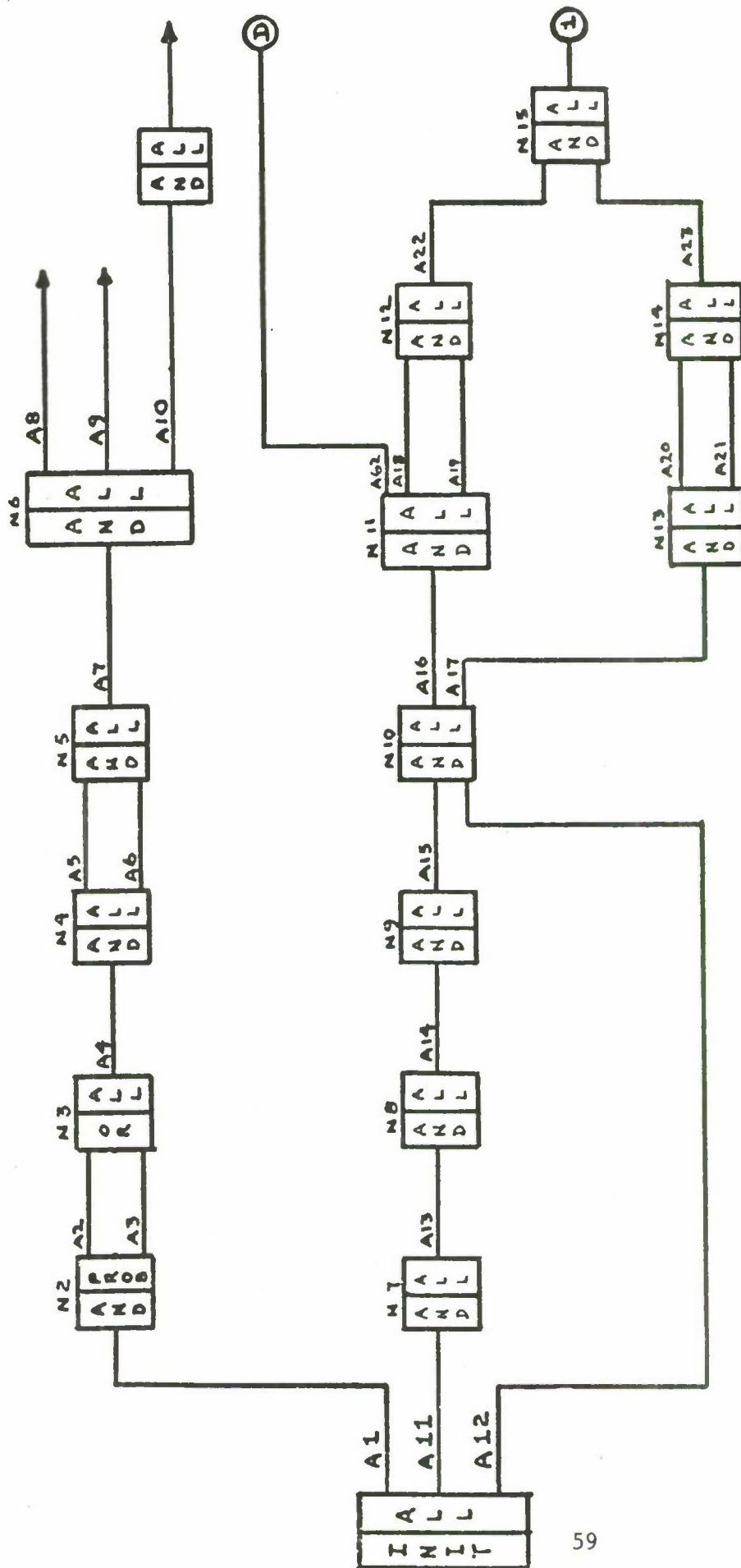

Figure B-2. Projectile Shell Metal Parts Network (1 of 5)

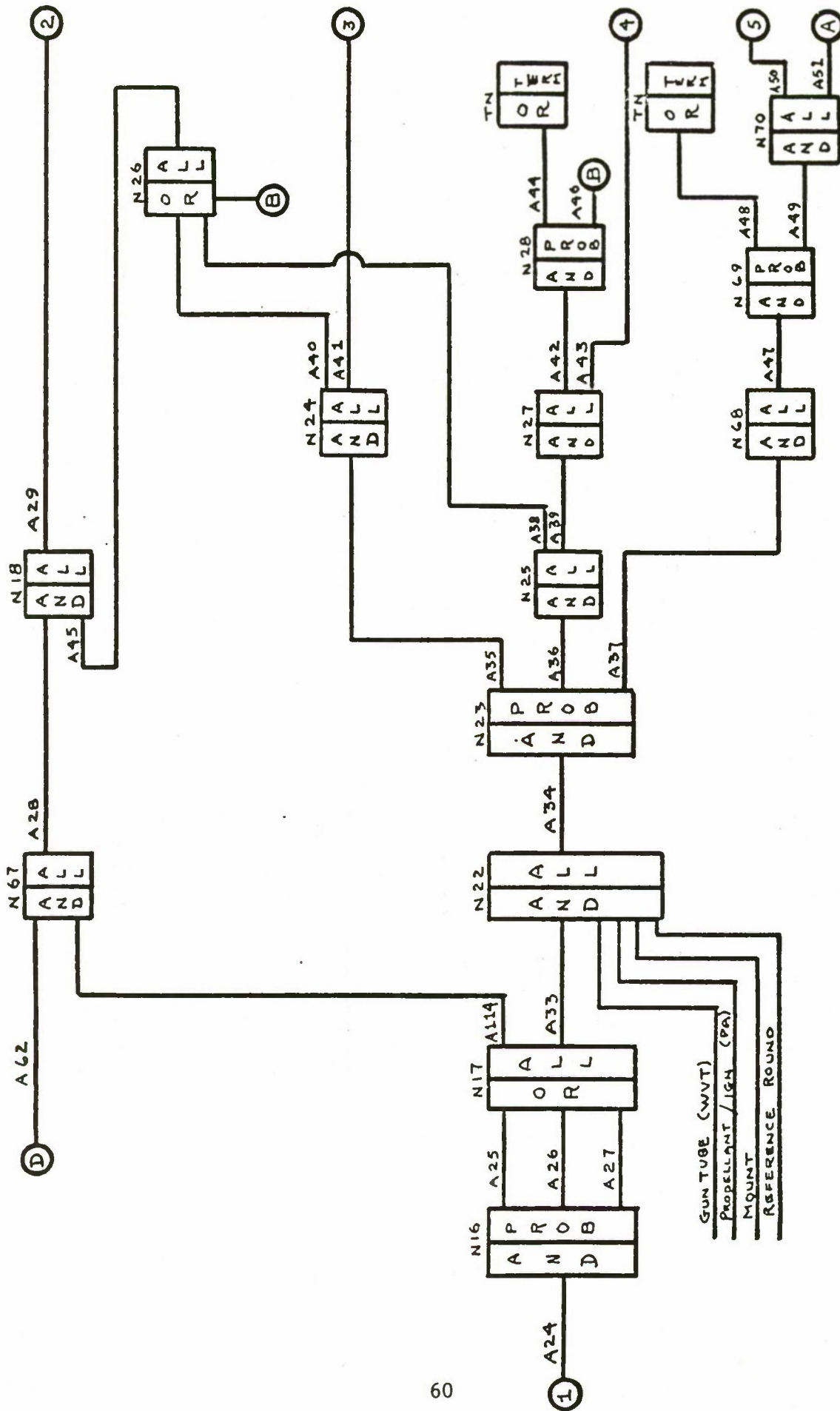

Figure B-2. Projectile Shell Metal Parts Network (2 of 5)

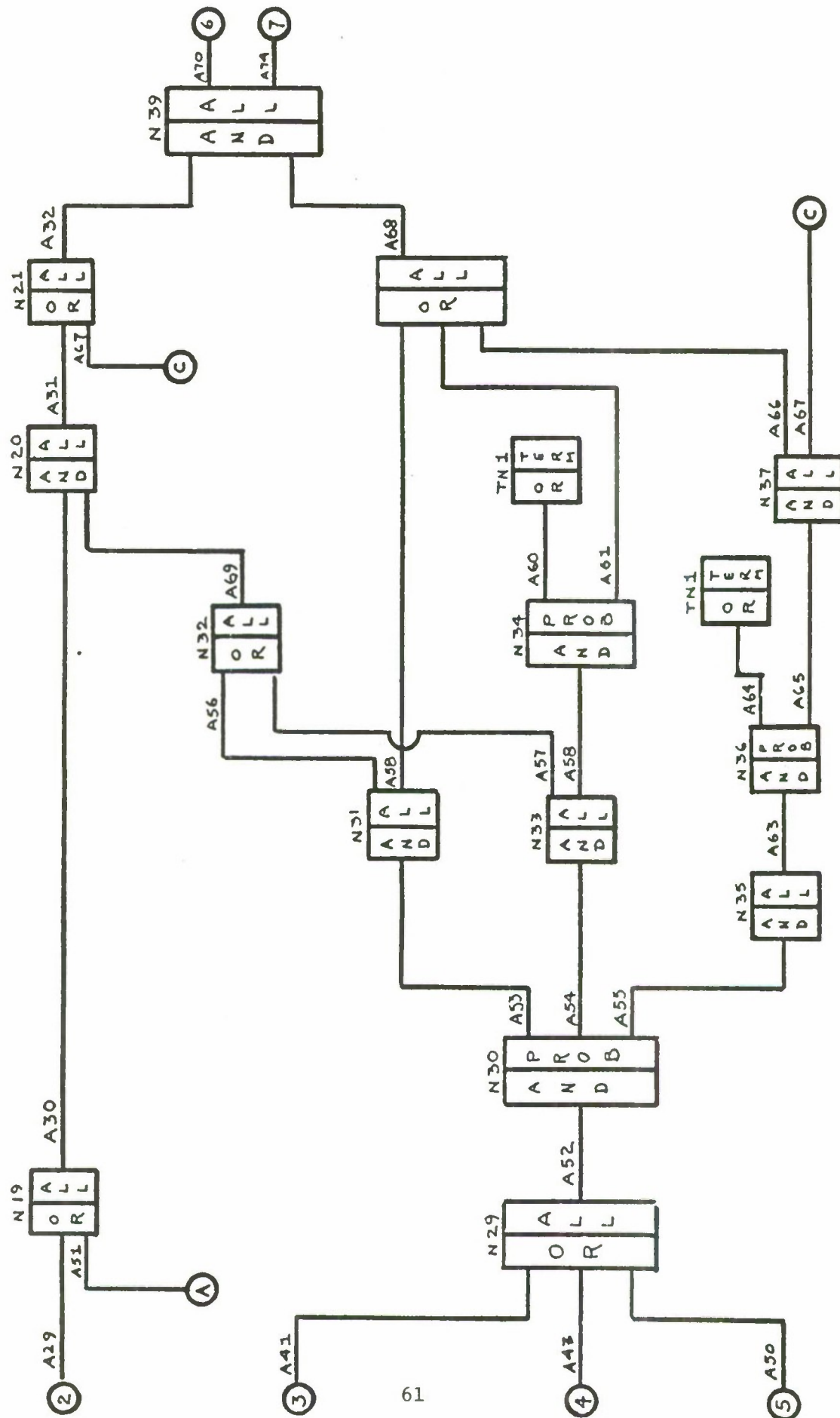

Figure B-2. Projectile Shell Metal Parts Network (3 of 5)

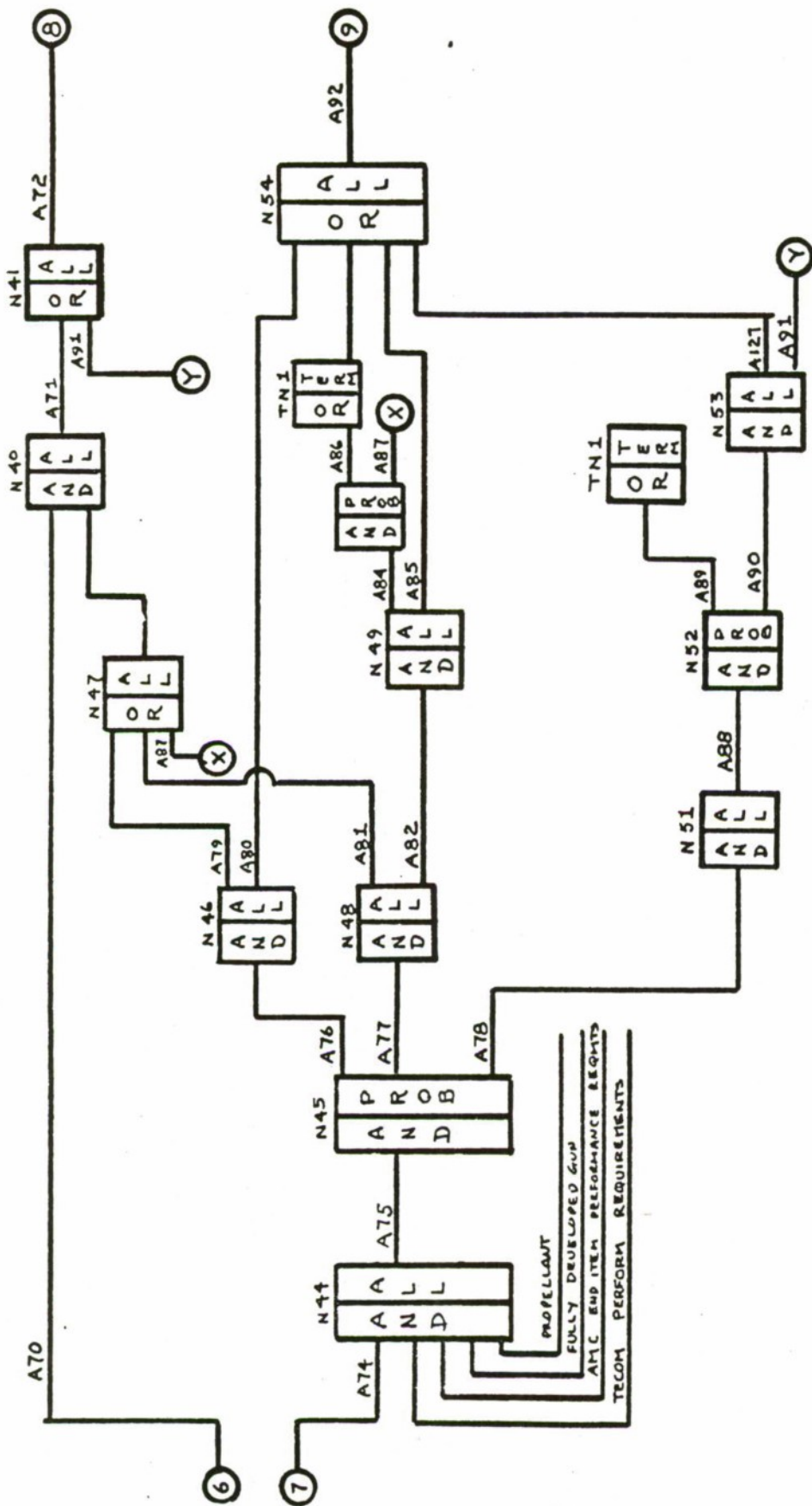

Figure B-2. Projectile Shell Metal Parts Network (4 of 5)

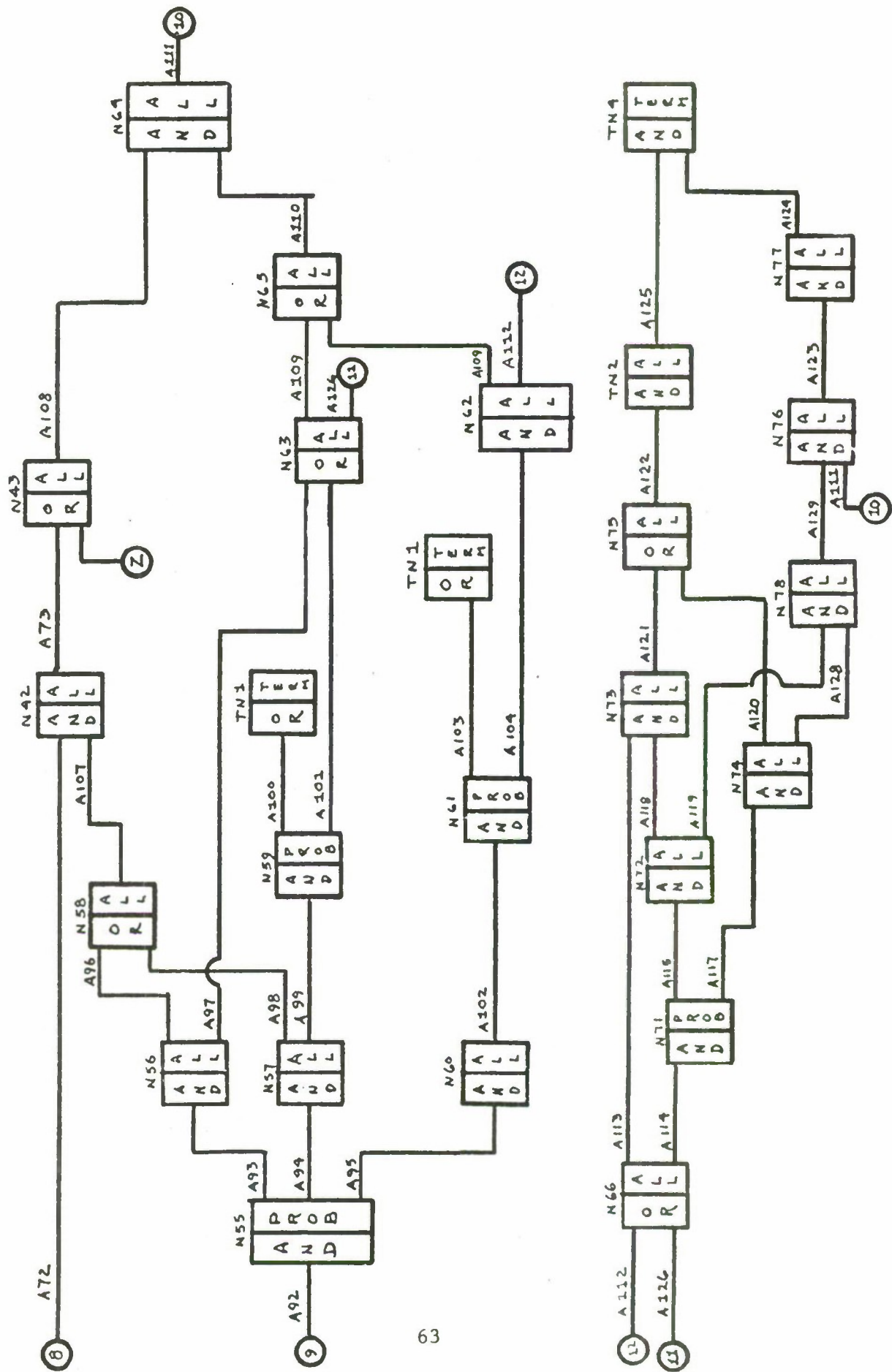

Figure B-2. Projectile Shell Metal Parts Network (5 of 5)

TABLE B-1. PROJECTILE SHELL METAL PARTS
NETWORK ACTIVITY DESCRIPTION

<u>Arc Number</u>	<u>Description</u>
A1	Review TDP for slugs
A2	Translate drawings
A3	Generate design drawings
A4	Preliminary methodizing in house
A5	Continue methodizing
A6	Order materials
A7	Fabricate & assemble initial quantity
A8	Proof slugs to WVA
A9	1st quantity proof slugs to PTA
A10	Fabricate and assemble final slug quantity for PTA
A11	Make foreign TDP into US TDP and prepare scope of work
A12	Review TDP - material char. & dim. analysis
A13	Contractor plan
A14	Negotiate and evaluate bids
A15	Award contract
A16	Metal parts preliminary methodizing
A17	Penetrator preliminary methodizing
A18	Continue methodizing
A19	Order materials
A20	Continue methodizing
A21	Receive material
A22	Fabricate
A23	Fabricate
A24	Assemble and inspect
A25	Fail - mech. prob.
A26	Fail - dim. prob.
A27	Pass
A28	Fabricate & assemble proof slugs
A29 thru A33	Signal arcs
A34	Accuracy & security tests
A35	Pass

TABLE B-1. PROJECTILE SHELL METAL PARTS
NETWORK ACTIVITY DESCRIPTION (CONT)

<u>Arc Number</u>	<u>Description</u>
A36	Minor failure
A37	Major failure
A38	Signal arc
A39	Reevaluate test
A40	Signal arc
A41	Signal arc
A42	Retest
A43	Signal arc
A44	Fail
A46	Pass
A47	Accuracy & security retest
A48	Fail
A49	Pass
A50	Signal arc
A51	Refabricate rounds
A52	Penetration test
A53	Pass
A54	Minor failure
A55	Major failure
A56 thru A58	Signal arcs
A59	Retest
A60	Fail
A61	Pass
A62	Penetrator test
A64	Fail
A65	Pass
A66	Signal arc
A67	Refabricate rounds
A68, A69	Signal arcs
A70	Fabricate rounds for TECOM & XM1
A71 thru A73	Signal arcs
A74	FFA design test
A75	Accuracy/security test

TABLE B-1. PROJECTILE SHELL METAL PARTS
NETWORK ACTIVITY DESCRIPTION (CONT)

<u>Arc Number</u>	<u>Description</u>
A76	Pass
A77	Minor failure
A78	Major failure
A79 thru A81	Signal arcs
A82	Reevaluate test
A83	Signal arc
A84	Retest
A85	Signal arc
A86	Fail
A87	Pass
A88	Accuracy/security retest
A89	Fail
A90	Pass
A91	Refabricate 4600 projectile
A92	Penetration test
A93	Pass
A94	Minor failure
A95	Major failure
A96 thru A98	Signal arcs
A99	Retest
A100	Fail
A101	Pass
A102	Penetration retest
A103	Fail
A104	Pass
A105	Signal arc
A106	Replace core 2400 quantity
A107 thru A112	Signal arcs
A113	Full test
A114	Safety certification
A115	Pass
A116	Signal arc
A117	Rebuild 2400 + 10%

TABLE B-1. PROJECTILE SHELL METAL PARTS
NETWORK ACTIVITY DESCRIPTION (CONT)

<u>Arc Number</u>	<u>Description</u>
A118 thru A125	Signal arcs
A122	Release TDP & TC action

TABLE B-2. PROJECTILE SHELL METAL PARTS NETWORK
ACTIVITY TIME AND COST FOR THE UK-KE ROUND

<u>ARC</u>	<u>PROB</u>	<u>TIME</u> (months)	<u>COST (\$K)</u> fixed + variable
A1		.25-.25-.5	8t
A2	.75	.25-.5-.5	12t
A3	.25	.5-.5-1	12t
A4		.25-.5-.5	(600-675-750) + 10t
A5		4-5-9	150 + 2t
A6		1-4-9	2t
A7		2-3-3	4t
A10		1-2-2	4t
A11		3-3-4	36t
A12		1-1.5-2	18 + 12t
A13		1-1.5-2	4t
A14		1-2-2	4t
A15		0	(4000-5000-6000) = P
A16		.5-.5-.75	2t
A17		.5-.5-.75	2t
A18		4-6-6	405 + 2t
A20		2-4-6	150 + 2t
A21		0-1-3	2t
A22		1-1.5-2	8t
A23		1-1.5-2	4t
A24		1-1-2	15 + 12t
A25	.03	4-5-6	4t
A26	.07	1-1-2	4t
A27	.9		
A62		P(t<3) = 0 P(t<6) = .6 P(t<7) = .9 P(t<10) = 1	
A28		5-6-9	4t
A34		1-1.5-2	27 + 4t
A35	.9		
A36	.09		
A37	.01	5-6-7	(P x 100/5000) + 8t
A39		.5-.5-.75	8t
A42		1-1.5-2	27 + 4t
A44	.05		
A46	.95		
A47		1-1.5-2	27 + 8t
A48	.05		
A49	.95		
A51		7-9-12	30 + 4t
A52		.5-.5-.75	38 + 4t
A53	.9		
A54	.09		
A55	.01	5-6-7	(P x 30/5000) + 8t
A59		.5-.5-.75	8 + 8t
A60	.05		

TABLE B-2. (CONT)

<u>ARC</u>	<u>PROB</u>	<u>TIME</u> (months)	<u>COST (\$K)</u> fixed + variable
A61	.95		
A63		.5-.5-.75	8 + 8t
A64	.05		
A65	.95		
A67		4-6-9	125 + 4t
A70		5-5-8	4 t
A75		1.25-1.75-2.25	66 + 4t
A76	.9		
A77	.09		
A78	.01	5-6-7	(Px300/5000) + 8t
A82		.5-.5-.75	8t
A84		1.25-1.75-2.25	66 + 8t
A86	.05		
A87	.95		
A88		1.25-1.75-2.25	66 + 8t
A89	.05		
A90	.95		
A91		10 + 12 + 15	30 + P + 4t
A92		1.25-1.5-1.75	24 + 4t
A93	.9		
A94	.09		
A95	.01	5-6-7	(P x 45/5000) + 8t
A99		1.25-1.5-1.75	24 + 8t
A100	.05		
A101	.95		
A102		1.25-1.5-1.75	24 + 8t
A103	.05		
A104	.95		
A106		6-8-11	(P x 2400/5000) + 4t
A66		2-2-2	
			500 rds if 6 mos. 1500 rds if 9 mos.
A112		2-2-2	+ 4t
A113		4-6-8	4t
A114		2-3-4	
A117		3-3-4	5 + 8t
A122		7-9-11	(Px 2400/5000) + 4t

TABLE B-3. PROJECTILE SHELL METAL PARTS NETWORK
ACTIVITY TIME AND COST FOR THE FRG-KE ROUND^a

<u>ARC</u>	<u>PROB</u>	<u>TIME</u> (months)	<u>COST (\$K)</u> fixed + variable
A1		.5-1-1.5	8t
A2	.5	.25-.5-.5	12t
A3	.5	.5-.5-1	12t
A5		5-6-10	150 + 2t
A11		3-4-6	36t
A12		1-1.5-2	18 + 12t
A13		1-3-6	4t
A18		4-7-8	405 + 2t
A20		2-5-6	150 + 2t
A25	.1	4-5-6	4t
A26	.1	1-1-2	4t
A27	.8		
A35	.85		
A36	.10		
A37	.05	5-6-7	(P x 100/5000) - 8t
A53	.85		
A54	.10		
A55	.05	5-6-7	(P x 30/5000) - 8t

^aFor Arcs A56 through A122 see Table B-2.

TABLE B-4. TRIPARTITE TANK ARMAMENT PROGRAM - FRANKFORD ARSENAL
 PENETRATOR/METAL PARTS
 (4570 Projectiles)

ACTIVITY	UK			FRG		
	OPT	MEAN	80%	OPT	MEAN	80%
1st Proof Slugs Available	7	10.2	11.2	8.5	11.7	12.7
Ready to Fabricate 2200 Quantity	11.5	15.5	16	11.5	19.4	21.2
1st Quantity of 500 sent to PTA	13	18	18.3	13	22.6	24.5
Ready to Fabricate TECOM and XML Quantity	16.5	22.4	23.5	16.5	27.3	29.4
Ready for TECOM Test (Includes LAP)	19	26	27	19	31	33
Safety Certification Passed and Fabrication of XML Quantity Complete	21.5	29.4	30	21.5	34.3	37
Release TDP	26	35.5	37	26	40.3	43
	DOLLARS (\$M)					
	UK			FRG		
	OPT	MEAN	80%	OPT	MEAN	80%
COST						
FFA TOTAL		7.1	7.3		7.1	7.5

Next page is blank.

ANNEX C

AMMUNITION COST/SCHEDULE UNCERTAINTY ANALYSIS

Next page is blank.

ANNEX C

AMMUNITION COST/SCHEDULE UNCERTAINTY ANALYSIS

PURPOSE

The purpose of this study is to develop a program plan and evaluate cost and schedule uncertainties for the US translation of the United Kingdom's (UK) and Federal Republic of Germany's (FRG) candidates for the armor-piercing, fin-stabilized, discarding sabot (APFSDS) round of the new Main Battle Tank.

GENERAL

Two program plans were developed, one for the FRG round and one for the UK round. The programs were developed, based on past history of translation of foreign munitions and some limited knowledge of the specific design details of each munition. The programs were assembled in network form and estimates of cost, time and success probabilities were gathered. The networks were then computer-simulated in order to determine the cost and time variabilities. The networks are presented in Figure C-1. Activity descriptions, cost and time are presented in Table C-1.

CONSTRAINTS

The following constraints bound the scope of the network simulations.

- a. The translation program will start with receipt of a foreign TDP and end with a round that has passed US qualification tests and a US TDP that is ready for production.
- b. No attempt will be made during the translation effort to improve round performance over that of the foreign round. Any such effort that may be required would be done in a subsequent product improvement program.
- c. Sufficient rounds will be produced in this translation effort to qualify the round and gun and to supply the XM-1 Project with rounds for their DT II/OT II program.

ASSUMPTIONS

The following assumptions were made in construction of the network logic and gathering of cost and time data.

- a. The foreign TDP to be furnished will be one of a round that has passed the FRG and UK version of our DT II/OT II tests.
- b. Any possible problems of proprietary data will be resolved prior to receipt of the TDP.

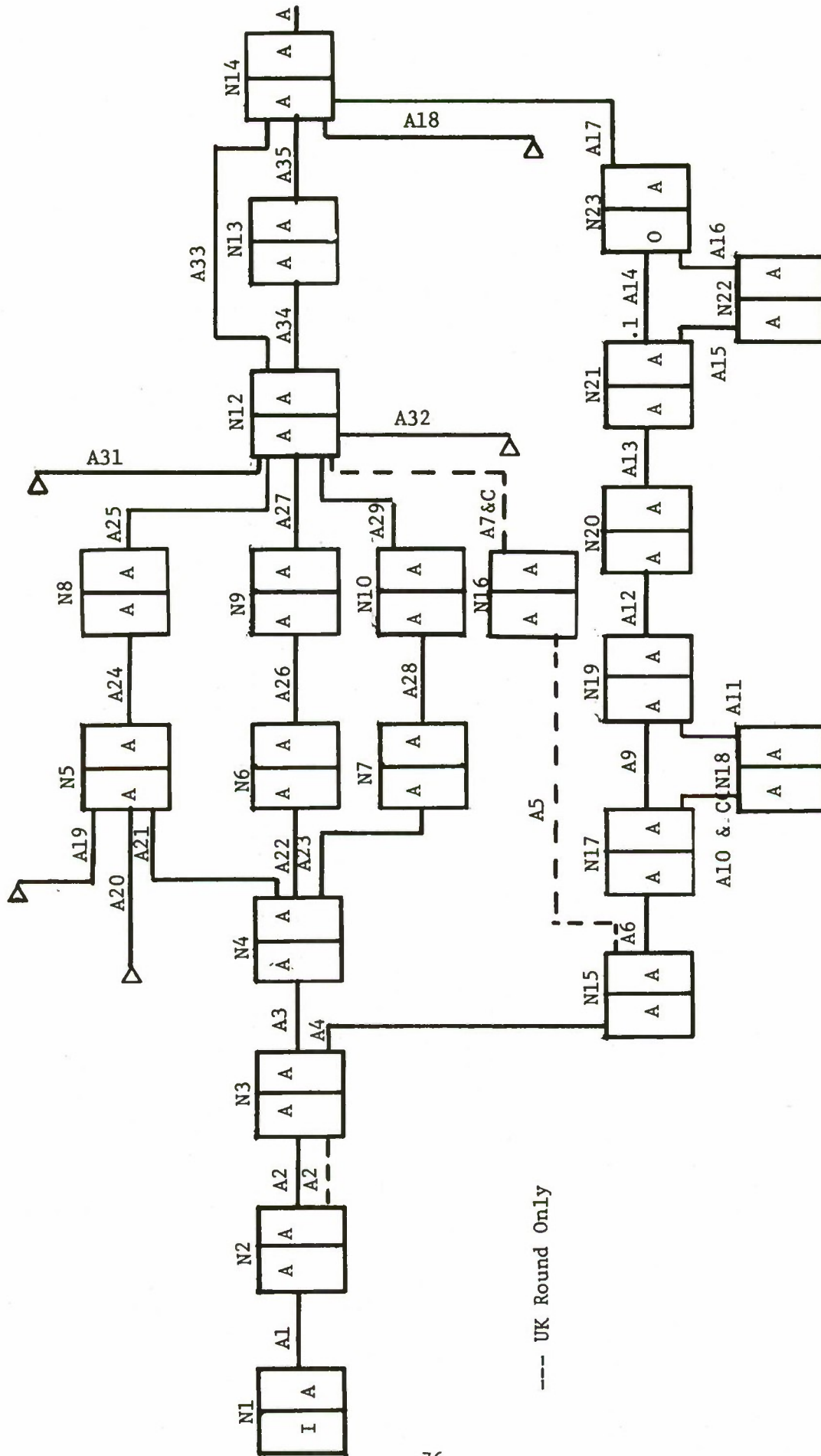

Figure C-1. Ammunition Development Network (1 of 4)

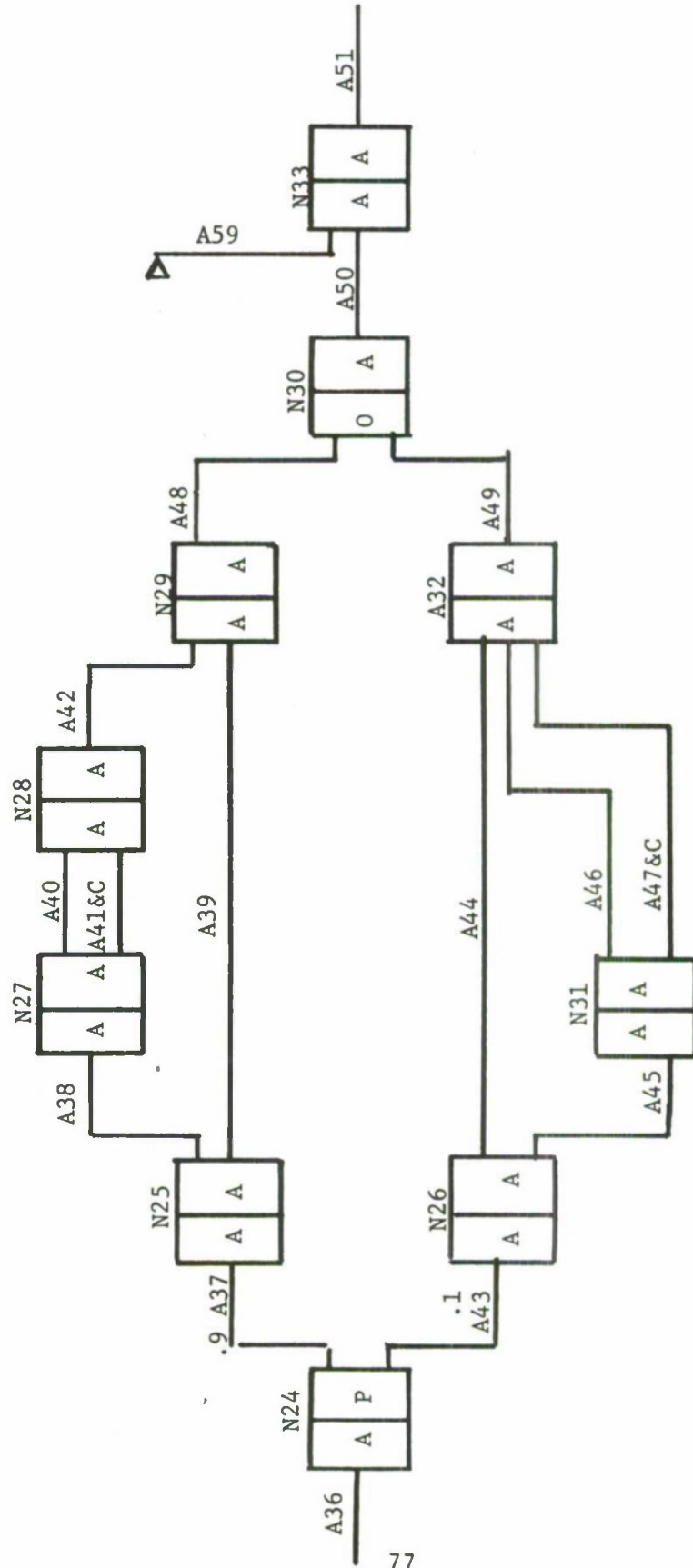

Figure C-1. Ammunition Development Network (2 of 4)

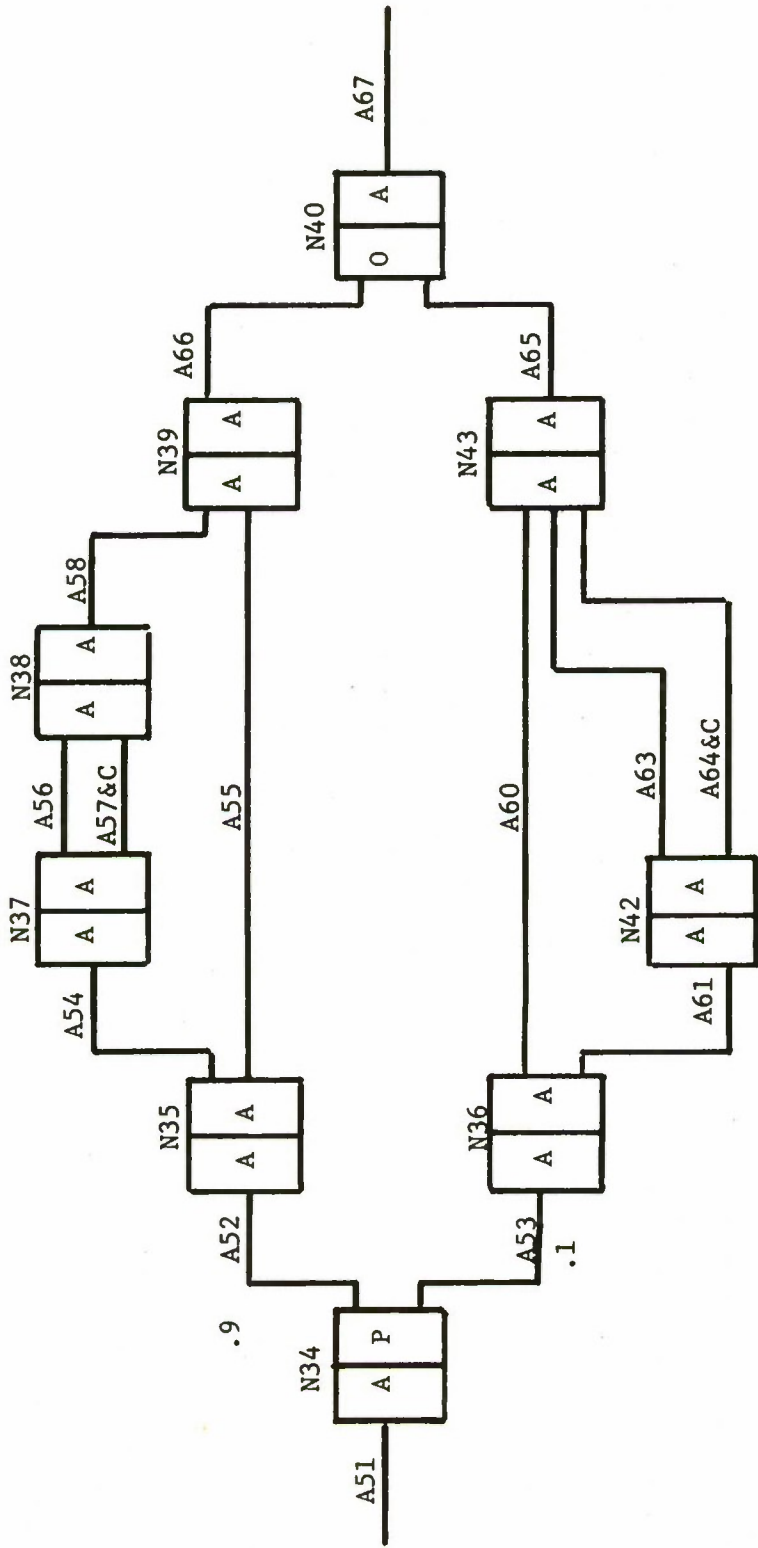

Figure C-1. Ammunition Development Network (3 of 4)

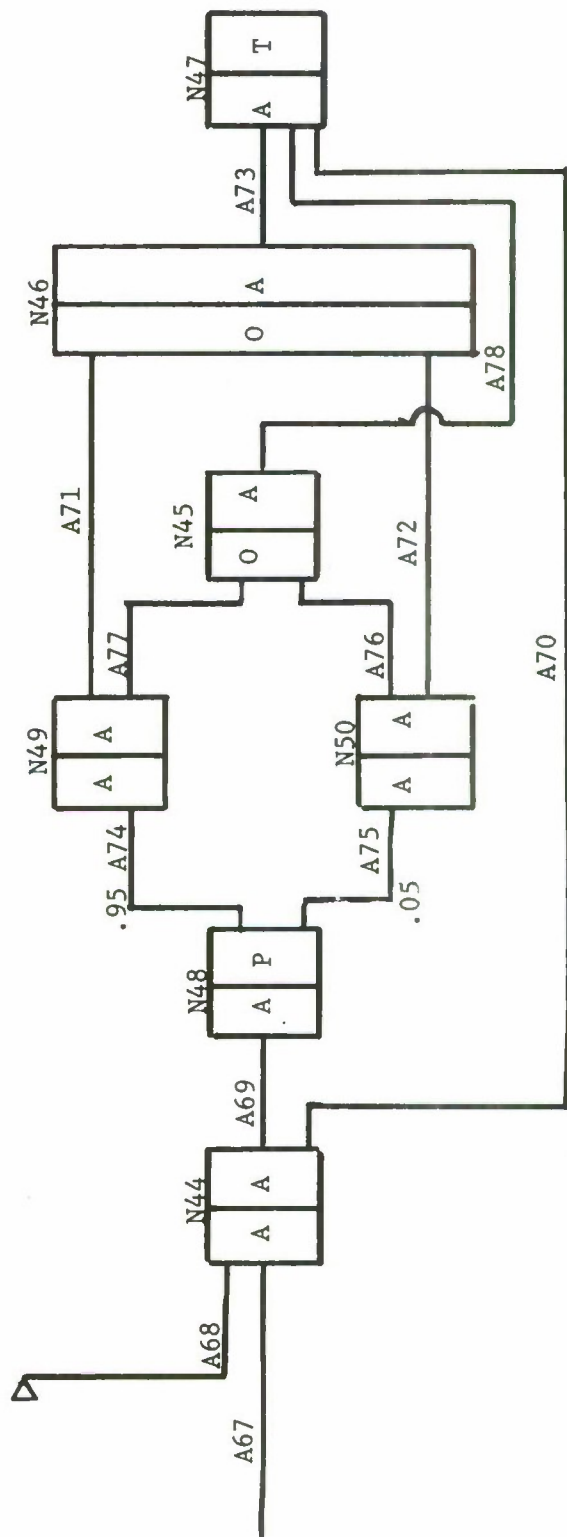

Figure C-1. Ammunition Development Network (4 of 4)

TABLE C-1. ARC DATA FOR FRG AND UK NETWORKS

<u>Arc Name</u>	<u>Description</u>	<u>Time (Months)</u>	<u>Cost (\$K)</u>		<u>From</u>	<u>To</u>
			<u>Fixed</u>	<u>Variable</u>		
A1	Receive TDP	0	0	0	N1	N2
A2	Translate TDP	1, 2, 3	25	0	N2	N3
*A2 (UK)	Signal	0	0	0	N2	N3
A3	Review TDP	1, 2, 4	0	8	N3	N4
A4	Stub Case to FA	0	0	0	N3	N15
*A5 (UK)	Acquire Cases to Modify	1, 1, 2	0	0	N15	N16
A6	Review TDP and Initial Setup	1.5, 2.5, 2.5	0	5	N15	N17
*A7 (UK)	Modify Cases	2, 3, 4	0	0	N16	N12
*A7C (UK)	Cost	.18, .22, .30	0	100	N16	N12
A8	Ammo Cases (Off-shore)	-	-	-	-	-
A9	Receive Cost M+1	0	40	0	N17	N19
A10	Fab Tooling	4, 7, 10	0	6	N17	N18
A10C	Cost	.50, .75, .90	0	100	N17	N18
A11	Setup Time	1, 2, 4	0	12	N18	N19
A12	Fab Pilot Lot (200)	.5, 1, 2	0	6	N19	N20
A12C	Cost	.15, .20, .25	0	100	N19	N20

*Pertains to UK network only

TABLE C-1. (CONT)

<u>Arc Name</u>	<u>Description</u>	<u>Time (Months)</u>	<u>Cost (\$K)</u>		<u>From</u>	<u>To</u>
			<u>Fixed</u>	<u>Variable</u>		
A13	Inspect	.25, .25, .25	0	16	N20	N21
A14	Signal (Good)	0	0	0	N21	N23
A15	Fail (Identify Prob)	0, .25, .25	0	16	N21	N22
A16	Fix	.25, .25, .75	0	4	N22	N23
A17	Signal	0	0	0	N23	N14
A18	Receive 60 Slugs from FA	-	-	-	-	-
A19	Receive One Gun (Off-shore)	-	-	-	-	-
A20	Received 30 Ammo Components (Off-shore)	-	-	-	-	-
A21	Prop Selection	1, 2, 4	0	2	N4	N5
A22	Sidewall Contract	2, 3, 5	0	6	N4	N6
A23	Mfg Primer	3, 5, 6	32	2	N4	N7
A24	Prop Test	1, 2, 3	20	4	N5	N8
A25	Prop Mfg and Del	2, 4, 6	75	1	N8	N12
A26	Mfg Dies	4, 5, 7	60	4	N6	N9
A27	Sidewall Deliver	1, 1, 1	0	2	N9	N12
A28	Static Test	1, 2, 3	10	2	N7	N10
A29	Primer Deliver	.25, .25, 1	0	2	N10	N12

TABLE C-1. (CONT)

<u>Arc Name</u>	<u>Description</u>	<u>Time (Months)</u>	<u>Cost (\$K)</u>		<u>From</u>	<u>To</u>
			<u>Fixed</u>	<u>Variable</u>		
A31	Receive 30 Ammo Components Off-shore	-	-	-	-	-
A32	Receive 60 Slugs from FFA	-	-	-	-	-
A33	Mfg Sidewall	1.5, 2, 3	20	4	N12	N14
A34	First Prop System Test	2, 3, 5	40K	2	N12	N13
A35	Signal	0		0	N13	N14
A36	LAP	1, 2, 3	10K	10	N14	N24
A37	Signal (Successful Design)	0		0	N24	N25
A38	Test Results Available	1/2 A39			N25	N27
A39	Second Prop System Test	1, 2, 4	30K	6	N25	N29
A40	Produce Sidewalls	1, 2, 3	66	4	N27	N28
A41	Produce Stub Cases FA	1, 2, 4	0	8	N27	N28
A41C	Cost	.6, .7, .9	0	100	N27	N28
A42	Signal	0		0	N28	N29
A43	Fail (Signal)	.5, 1, 2	15K	6	N24	N26
A44	Fix and Retest	3, 5, 8	40	6	N26	N32
A45	Wait for Fix	1, 2, 3		0	N26	N31

TABLE C-1. (CONT)

<u>Arc Name</u>	<u>Description</u>	<u>Time (Months)</u>	<u>Cost (\$K)</u>		<u>From</u>	<u>To</u>
			<u>Fixed</u>	<u>Variable</u>		
A46	Produce Sidewalls	1, 2, 3	60	4	N31	N32
A47	Produce Stub Cases	1, 2, 4	0	8	N31	N32
A47C	Cost	.6, .7, .9	0	100	N31	N32
A48	Signal	0	0	0	N29	N30
A49	Signal	0	0	0	N32	N30
A50	Signal	0	0	0	N30	N33
A51	LAP	1, 2, 3	55	10	N33	N34
A52	Signal (Success)	0	0	0	N34	N35
A53	Fail (Signal)	1, 1, 2	100	10	N34	N36
A54	Wait for Results	1/2 A55			N35	N37
A55	FDT	1.5, 2.5, 4	200	10	N35	N39
A56	Produce Sidewalls	1, 2, 3	47	4	N37	N38
A57	Produce Stub Cases (1500)	1, 2, 3	0	8	N37	N38
A57C	Cost	.71, .82, 1.0	0	100	N37	N38
A58	Signal	0	0	0	N38	N39
A59	-	-	-	-	-	-
A60	Fix and Retest (FDT)	3, 5, 8	300	14	N36	N43

TABLE C-1. (CONT)

Arc Name	Description	Time (Months)	Cost (\$K)		From	To
			Fixed	Variable		
A61	Wait for Fix	1, 2, 3	0		N36	N42
A62	Signal (Prototype to WVT)	-	-	-	-	-
A63	Produce Sidewalls	1, 2, 3	30	4	N42	N43
A64	Produce Stub Cases (1000)	1, 2, 3	0	8	N42	N43
A64C	Cost	.45, .52, .67	0	100	N42	N43
A65	Signal	0	0		N43	N40
A66	Signal	0	0		N39	N40
A67	Signal (FDT Comp)	0	0		N40	N44
A68	Receive Proj (FFA)	-	-	-	-	-
A69	LAP (DT II)	1, 1, 3	60	10	N44	N48
A70	Finalize TDP	4, 6, 8	0	12	N44	N47
A71	DT II Success	4, 6, 8	400	10	N49	N46
A72	DT II Fail Fix and Retest	6, 9, 14	650	14	N50	N46
A73	TC	2, 3, 6	0	5	N46	N47
A74	Signal (Success)	0	0		N48	N49
A75	Signal (Fail)	0	0		N48	N50
A76	Safety Release	5, 6, 7	0		N50	N45

TABLE C-1. (CONT)

<u>Arc Name</u>	<u>Description</u>	<u>Time (Months)</u>	<u>Cost (\$K)</u>		<u>From</u>	<u>To</u>
			<u>Fixed</u>	<u>Variable</u>		
A77	Safety Release	2, 3, 4	0	0	N49	N45
A78	Signal	0	0	0	N45	N47

c. Foreign hardware will be available in the quantities and at the times needed in the program.

d. Funds will be available on time and will not cause schedule slippages.

e. Testing facilities will be available when needed.

RESULTS

Foreign Hardware Requirements

The programmed network requires inputs of a foreign gun, complete rounds and components. The quantities and time from receipt of TDP for the foreign hardware required by Picatinny Arsenal are shown in Tables C-2 and C-3.

Time

Various milestones were chosen within the programs. The times to reach each milestone from receipt of the TDP are shown in Tables C-4 and C-5. The interval between the five percent and 95 percent column indicates a range in which completion of the milestone will occur 90 percent of the time. The start of DT II is when complete rounds will be available for the XM-1 Project. Safety release is when these rounds may be crew-fired. The resultant times are coordinated with Frankford Arsenal's network for availability of slugs and projectiles.

Cost

The costs shown in the Picatinny Arsenal networks do not include the following items:

1. The cost of any of the foreign hardware requirements.
2. The cost for engineering, testing, and hardware associated with slugs and projectiles.
3. The cost of engineering, testing, and hardware associated with translation of the new gun.

The costs shown in the Picatinny Arsenal networks do include the following:

1. The cost of engineering, testing, and hardware for the translation of the propellant, primer, combustible sidewall, and stub case (FFA input).
2. The cost of LAP for all rounds produced.

TABLE C-2. PICATINNY ARSENAL NEEDS -
FRG HARDWARE

<u>Type of Hardware</u>	<u>Quantity</u>	<u>Time (Mo.)</u>	
		<u>Minimum (5%)</u>	<u>Mean</u>
Gun	1	5.2	6.7
Ammo Components	30	5.2	6.7
Ammo Components	30	12.5	14.1
Stub Cases	60	12.5	14.1
Complete Rounds	30	17.7	19.6
Complete Rounds	200	23.5	26.7
Complete Rounds	100	29.9	34.4

TABLE C-3. PICATINNY ARSENAL NEEDS -
UK HARDWARE

<u>Type of Hardware</u>	<u>Quantity</u>	<u>Time (Mo.)</u>	
		<u>Minimum (5%)</u>	<u>Mean</u>
Gun	1	3.3	4.7
Ammo Components	30	3.3	4.7
Ammo Components	30	10.6	12.2
Complete Rounds	30	15.7	17.6
Complete Rounds	200	21.3	23.8
Complete Rounds	100	27.0	30.2

TABLE C-4. TIME DISTRIBUTIONS TO MILESTONES
(FRG ROUND)

<u>Milestone</u>	<u>Computer Ref</u>	<u>5%</u>	<u>Time</u> <u>95%</u>	<u>Mean</u>
1st Propellant Sys Test	N12	12.5	15.9	14.1
2nd Propellant Sys Test	N24	17.7	21.7	19.6
Confirmation Test	N34	23.5	32.0	26.7
Start DT II	(Estimated)	29.9	42.3	34.4
Complete Safety Rel	N45	32.9	45.3	37.4
TC & Prod. TDP Avail.	N47	39.1	52.3	44.1

TABLE C-5. TIME DISTRIBUTIONS TO MILESTONES
(UK ROUND)

<u>Milestone</u>	<u>Computer Ref</u>	<u>5%</u>	<u>Time</u> <u>95%</u>	<u>Mean</u>
1st Propellant Sys Test	N12	10.6	13.8	12.2
2nd Propellant Sys Test	N24	15.7	19.7	17.6
Confirmation Test	N34	21.3	27.2	23.8
Start DT II	(Estimated)	27.0	35.1	30.2
Complete Safety Rel.	N45	30.0	38.1	33.2
TC & Prod. TDP Avail.	N47	36.2	45.3	39.9

3. The cost to conduct the combined FFA/PTA confirmation test and DT II.

The cost to conduct the Picatinny Arsenal portion of the translation efforts for the FRG and UK rounds is shown in Tables C-6 and C-7. Total translation can be obtained by summing the costs of the Picatinny, Frankford and Watervliet networks.

The cost distribution is not continuous so two cost ranges are given as well as the overall mean. The first cost range can be expected if no major problems occur and the second if major problems do occur. The probability for being in each range is also given. The complete cost distributions are shown under N47 in the inclosed networks.

TABLE C-6. EXPECTED COST INTERVALS
(FRG Round Translation)

	<u>Cost Interval (\$K)</u>	<u>Probability</u>
No Major Problem	1850 - 2000	.85
Major Problems	2050 - 2500	.15
Overall Mean Cost - \$1,982		

TABLE C-7. EXPECTED COST INTERVALS
(UK Round Translation)

	<u>Cost Interval (\$K)</u>	<u>Probability</u>
No Major Problem	1868 - 2050	.86
Major Problems	2070 - 2500	.14
Overall Mean Cost - \$1,984		

The cost for translation of the FRG or KE round is shown as being approximately equal. It is expected that as design details of the two rounds become known, more accurate cost estimates can be made and differences will show up.

The cost figures will also vary as a function of the number of rounds produced. A total of 4,570 complete rounds will be produced as part of the translation effort. The cost is represented in Table C-8.

C-8. EXPECTED COST FOR FRG OR UK ROUND DEVELOPMENT

<u>TRANSLATION EFFORT</u>	<u>Quantity</u>
PTA and FFA Testing	500
WVA Gun Tests	1500
Complete Round DT II	<u>500</u>
Subtotal	2500
 <u>XM-1 PROJECT</u>	
XM-1 Component Acceptance	200
XM-1 DT II	1370
XM-1 OT II	<u>500</u>
Subtotal	2070
GRAND TOTAL	4570

DISTRIBUTION LIST

No. of Copies

15	Commander US Army Armament Command ATTN: DRSAR-SAS Rock Island, IL 61201
1	Commander Rock Island Arsenal ATTN: SARRI-LP-L Rock Island, IL 61201
12	Defense Documentation Center Cameron Station Alexandria, VA 22314

Next page is blank.