

AD A 024567

6

FC

D D C
RECEIVED
MAY 18 1978
476

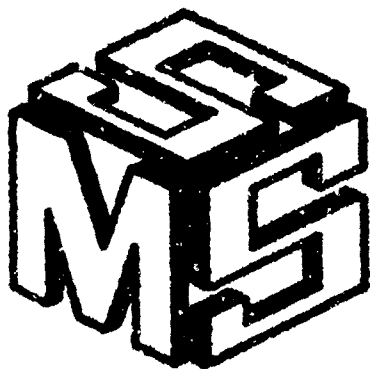

DISTRIBUTION STATEMENT A
Approved for public release;
Distribution Unlimited

MANNED SYSTEMS SCIENCES

8949 RESEDA BLVD. • NORTHRIDGE, CALIFORNIA 91324 • (213) 886-1193



DEPARTMENT OF THE NAVY
OFFICE OF NAVAL RESEARCH
ARLINGTON, VIRGINIA 22217

IN REPLY REFER TO

ONR 431:TJ:clf

From: Director, Naval Analysis Programs, Office of Naval Research
To: Distribution

Subj: Command and Control Systems Analysis & Evaluation Methods

1. The objective of the research project is to develop an analysis and evaluation methodology for addressing questions regarding the performance and effectiveness of operational command and control elements in manned systems. The final technical report for this effort is a document entitled "An Analysis and Evaluation Methodology for Command and Control: Final Technical Report". In addition, four other reports in support of the technical report are being issued. The titles of these supplemental reports are

- a. "Ergonomic Models of Human Performance: Source Materials for the Analyst"
- b. "A Computer Model for Command and Control Analysis"
- c. "A Handbook of Systems Descriptions Methods"
- d. "Human Factors Research and the Development of a Manned Systems Applications Science: The Systems Sampling Problem and a Solution"

2. Comments concerning all aspects of the reports are solicited; they should be addressed to

Director, Naval Analysis Programs
Office of Naval Research (Code 431)
Room 618
800 N. Quincy Street
Arlington, Virginia 22217



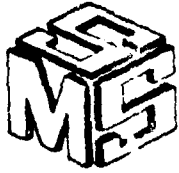

A COMPUTER MODEL
FOR
COMMAND AND CONTROL ANALYSIS (U)

November 1975

Approved for Public Release
Distribution Unlimited

DDC
RECEIVED
MAY 19 1976
A

Contract N00014-74-C-0324
NR 274-244 (formerly NR 364-090)

A COMPUTER MODEL
FOR
COMMAND AND CONTROL ANALYSIS (U)

Richard W. Obermayer

November 1975

Prepared for:

Naval Analysis Programs
Office of Naval Research
Department of the Navy
Arlington, Virginia 22217

Prepared by:

MANNED SYSTEMS SCIENCES, INC.
8949 Reseda Boulevard
Northridge, California 91324

Approved for Public Release
Distribution Unlimited

Reproduction in whole or in part is permitted
for any purpose of the United States Government

UNCLASSIFIED

SECURITY CLASSIFICATION OF THIS PAGE (When Data Entered)

REPORT DOCUMENTATION PAGE		READ INSTRUCTIONS BEFORE COMPLETING FORM
1. REPORT NUMBER None assigned	2. GOVT ACCESSION NO.	3. RECIPIENT'S CATALOG NUMBER
4. TITLE (and Subtitle) A Computer Model for Command and Control Analysis.		5. TYPE OF REPORT & PERIOD COVERED Technical Report.
7. AUTHOR(s) Richard W. Obermayer		8. CONTRACT OR GRANT NUMBER(s) N00014-74-C-0324
9. PERFORMING ORGANIZATION NAME AND ADDRESS Manned Systems Sciences, Inc. 8949 Reseda Blvd. Northridge, California 91324		10. PROGRAM ELEMENT, PROJECT, TASK AREA & WORK UNIT NUMBERS 65252N RTW31 (formerly R9109) 274-244 (formerly NR364-
11. CONTROLLING OFFICE NAME AND ADDRESS Naval Analysis Programs (Code 431) Office of Naval Research Arlington, Virginia 22217		12. REPORT DATE November 75
14. MONITORING AGENCY NAME & ADDRESS (if different from Controlling Office) 12 54p.		13. NUMBER OF PAGES 44
16. DISTRIBUTION STATEMENT (of this Report) Approved for public release; distribution unlimited. 16 RTW31 NR-274-244		15. SECURITY CLASS. (of this report) Unclassified
17. DISTRIBUTION STATEMENT (of the abstract entered in Block 20, if different from Report)		15a. DECLASSIFICATION/DOWNGRADING SCHEDULE
18. SUPPLEMENTARY NOTES		
19. KEY WORDS (Continue on reverse side if necessary and identify by block number) Command and Control, Computer Models and Programs, Crew Station Design and Evaluation, Human Factors Engineering, Human Performance Models, Manned and Man-Machine System Models, Systems Analysis		
20. ABSTRACT (Continue on reverse side if necessary and identify by block number) One approach to the evaluation of manned systems and their command and control elements is direct empirical observation. However, direct measurement, and especially the analytic study of system variables by systematically altering conditions within a manned system, are often either impractical or can be performed to only a limited degree. A model of the system which allows the variations needed for assessment of a command and control element may therefore be an effective alternative, and a computer model.		

DD FORM 1 JAN 73 1473

EDITION OF 1 NOV 65 IS OBSOLETE

UNCLASSIFIED

iii

SECURITY CLASSIFICATION OF THIS PAGE (When Data Entered)

381043

UNCLASSIFIED

SECURITY CLASSIFICATION OF THIS PAGE(When Data Ente d)

20 (Abstract - continued)

for such purposes is sought in this paper. The purpose of this paper is to report the development of this model, using the General Purpose System Simulator (GPSS) language in the construction of an example simulation of a Carrier Air Traffic Control Center (CATCC), and to present techniques and guidelines for constructing similar models of other manned systems.



FOREWORD

This report is one of several supporting documents to a final report to be issued under Contract N00014-74-C-0324. The final report will be entitled: "An Analysis and Evaluation Methodology for Command and Control: Final Technical Report" and will be issued in late 1975. The Scientific Officers for this program have been Dr. Toke Jayachandran, CDR William A. Arata and CDR Robert A. McCaffery of the Naval Analysis Programs division of the Office of Naval Research. The Principal Investigator has been Dorothy L. Finley of Manned Systems Sciences, Inc.

TABLE OF CONTENTS

<u>Section</u>	<u>Page</u>
FOREWORD	v
PREFACE	vii
I INTRODUCTION	1
II BACKGROUND	2
A Brief Introduction to GPSS	2
A Brief Introduction to the Carrier Air Traffic Control Center	4
III COMMAND AND CONTROL SIMULATION WITH GPSS	7
A Simple GPSS Simulation	7
Additional Modules for CATCC Simulation	14
IV GUIDELINES FOR COMPUTER MODEL DEVELOPMENT	17
System Information Needed	17
Amount of Model Detail and Complexity	18
Procedures	19
V ROLES OF COMPUTER MODELS IN COMMAND AND CONTROL ANALYSIS	24
System Effectiveness Questions	24
System Diagnostic Questions	24
System Performance Prediction Questions	25
Development of Measures	26
Role Within the Total Command and Control Analytic Process	26
Incorporation of Human Operator Models and Psychological Theory	26
VI DISCUSSION	28
VII REFERENCES	31
APPENDICES: A. Computer Program Listing: A Simplified GPSS Model of CATCC	32
B. Computer Program Listing: An Expanded GPSS Model of CATCC	37

PREFACE

This report is one output resulting from a program to develop an analysis and evaluation methodology for dealing with questions regarding operational Command and Control (C&C). As a prelude to the report it might be well to briefly describe our view of C&C and of program purpose, and to discuss how this report relates to the program. For more detailed discussions of C&C and a presentation of the overall methodology, the reader is referred to Reference 1 and, especially, Reference 2 (see page 31).

C&C can be defined most succinctly by saying that it is the unautomated, or human, management element of any system, responsible for enactment of that system's role and achievement of its goals. The overall C&C structure for any one system is being described as a hierarchical chain-of-command which links system-subsystem definitions, is responsible to higher links in the external chain-of-command, and which establishes and directs system mechanisms for the purposes of C&C information acquisition and utilization. Any one system, at whatever level of definition, is seen as being composed of at least the following: (1) a C&C Functional Model, (2) a system 'plant', (3) a system environment, and (4) the aforementioned information mechanisms. It is very important to note that what constitutes the system 'plant', or the controlled element, at one level of system definition may well constitute the command element at another level of system definition. All of the foregoing can be constituted of either men or men and machines, as appropriate to the problem under consideration.

The purpose of the overall program is to develop a methodology which will enable the Navy analyst to gain better status, predictive, and diagnostic information about operational C&C and, therefore, about the effectiveness and performance of manned systems. It has previously been the case that C&C has generally not been included as an integral part of most system design and operations analysis programs. Rather, if and when analyzed, it has been analyzed as a subject, or system, in and of itself; but as can be inferred from the above definition of C&C, this is a useless and often counter-productive exercise. C&C has meaning and purpose only as an integral element of a particular system; the purpose of the overall program is to provide a methodological framework for analyzing C&C from this viewpoint.

When C&C is viewed as the integral management element of a particular system, as that part responsible for system performance and effectiveness, then it can be evaluated only through careful analysis of system cause and effect variables which constrain and/or are the responsibility of the C&C element - e.g., the "plant" and "environment" variables. The implication here is that substantive questions regarding a complex operational system

or its command and control element will often require the development of a substantial model of that system and its components so as to reflect the effects of C&C strategies and tactics on the states and activities of system components and the consequence effects on their performances and on system effectiveness. The model developed of the system, its components, and its operations must be in a form which allows a compatible expression for human and equipment components and, further, allows the expression of C&C actions and the consequent effects on system behavior.

The purpose of the part of the program presented in this paper was to develop a way of modeling systems for computer analysis which would provide the foregoing capabilities of expression, analysis and evaluation. The approach taken was to review the techniques available for computer model development, select the most promising technique, to test out its capabilities through the modeling of a particular system with which we had had considerable experience, and to begin transforming this experience into a method for command and control analysis. This paper presents the work completed under this part of the program and, as a final comment, it appears that the simulation languages present capabilities for manned systems modeling which have not yet been fully exploited. Considerable potential remains untapped.

I. INTRODUCTION

One approach to the evaluation of manned systems and their command and control elements is direct empirical observation. However, direct measurement, and especially the study of system variables by systematically altering conditions within a manned system, are often impractical. A model of the system which allows variation and measurement may therefore be a cost effective alternative, and a computer model for such purposes is sought in this paper. Such a model must include computer representations of both human and machine components, so that subsystem and total system performance can be measured in terms of computer parameters.

The primary purpose of this report was to develop a method of computer modeling for command and control analysis. The method is called the Command and Control Analysis Model. A computer model was programmed at two levels of complexity, but since the emphasis was on the development and exposition of methods, as simple a model as possible was developed for test and evaluation. Complete detailed examples were not actually developed and tested, but sufficient direct programming experience was accumulated so as to provide a basis for the establishment of general procedures and some evidence of the workability of the approach.

The General Purpose System Simulator (GPS3) language was a convenient choice for this study but other computer simulation languages are available to serve similar purposes. The GPSS language was used to construct an example simulation based on the Carrier Air Traffic Control Center (CATCC). Both human and machine components are included, and the role of computer models in Command and Control analyses is discussed. Guidelines for the development of computer models are generated to guide future applications of this technique. An interesting side issue is that the computer simulation languages have such rich descriptive capabilities that for human task performance deficiencies in standard task analyses techniques are made apparent.

II. BACKGROUND

A BRIEF INTRODUCTION TO GPSS

The General-Purpose System Simulator (GPSS) is a computer language for modeling those systems which involve flows of transactions and events over time. The GPSS language also permits the collection of statistical records about system quantities. Some common examples of systems which can be simulated with GPSS are traffic flow (e.g., people, automobile or aircraft movements), factory assembly lines, distribution systems, and many aspects of man-machine systems. There are other simulation languages for computer modeling (e.g., SIMSCRIPT, SIMPAC, CSL, ESP, SIMON, GSP, MONTECODE, SIMULA, DYNAMO, and OPS), but GPSS will be presented here so as to allow concrete examples.

GPSS (Refs. 3 and 4) is a block-diagram-oriented language. When a system block diagram is prepared at a sufficiently molecular level using a GPSS-specific set of blocks, the computer program can be derived directly from the block diagram. Take for example the block diagram of a simple queue forming at a theatre ticket window as presented in Figure 1. In sequence, the block diagram indicates that the computer model should (1) GENERATE transactions (people) and cause them to be introduced at intervals according to a specified distribution, (2) form a QUEUE, or waiting line, for people waiting their turn and keep statistical records on the length of the line and waiting time, (3) SEIZE a facility (the ticket vendor) when an individual gets to the front of the line and the ticket vendor is not busy, (4) DEPART the queue, (5) ADVANCE the clock according to a specified distribution to account for the time needed for the ticket to be given and money exchanged, (6) RELEASE the facility or the next person in line, (7) TABULATE statistics (update frequency distributions) of system quantities for printout at the end of the computer run, and (8) TERMINATE the transaction (individual) from the system. This block diagram can be translated into a computer program along with specific system quantities. The computer model can then be exercised until a specified number of transactions are completed; subsequently the run would stop with a printout of requested statistics.

GPSS involves a number of entities which are included in a system model simply by referencing them by number (as there may be many of each). First, transactions are entities which flow through the system block diagram. Transactions may be thought of as people, automobiles, airplanes, mail, etc., as one wishes. Each transaction carries with it twelve or more numbered parameters. Values associated with each parameter can be used to characterize the transaction. Facilities are entities which simulate the processing of transactions, with as few as one transaction at a time being processed. Storages may process (or

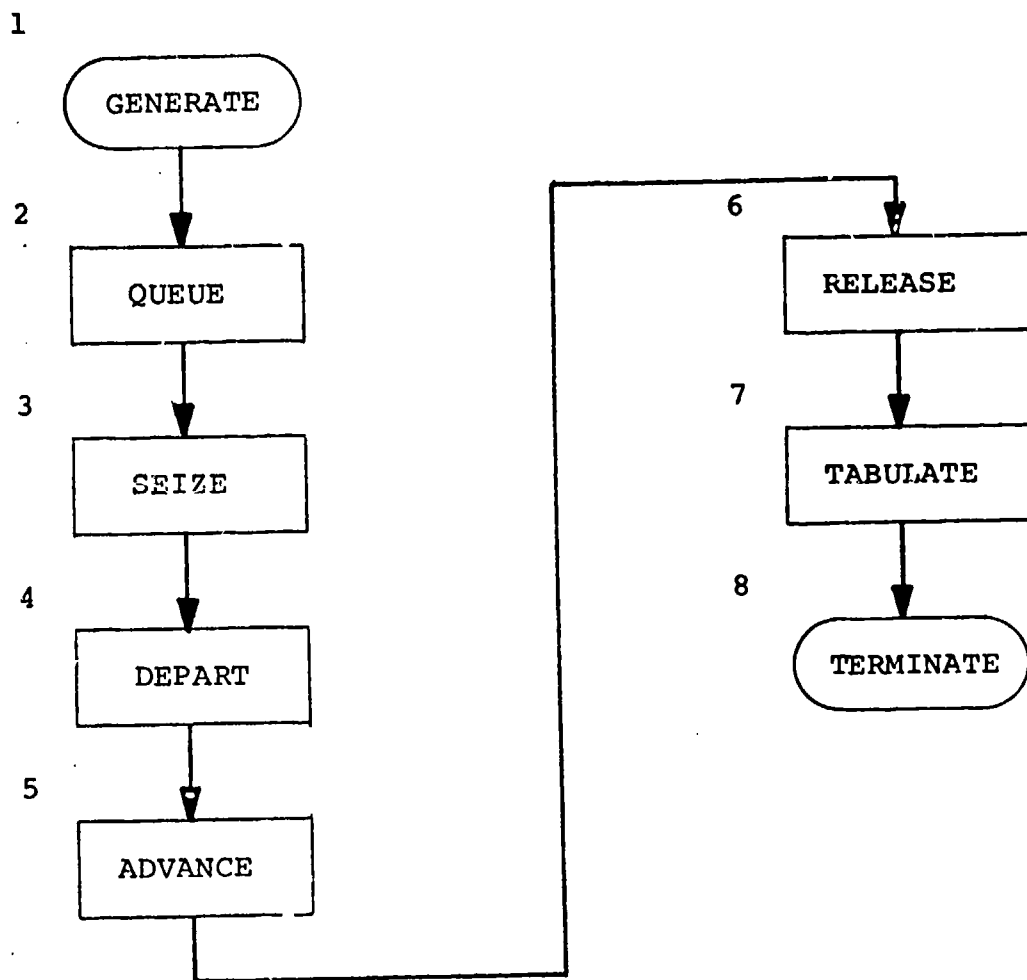

Figure 1. An Example GPSS Block Diagram (of Queue at a Theatre Ticket Window.

store) a number of transactions at a time, but a capacity for storage must be specified. Queues, as already indicated, are used to cause the GPSS system to maintain statistics on lines which form, Savevalues are numbered storage areas where special data may be kept until the end of a run. Standard Numerical Attributes (SNA) are system quantities which are automatically remembered. These and other entities are available to the GPSS programmer to create a computer model.

The GPSS language and the concepts included will be used in this report to develop a computer model of a specific man-machine system. This specific model has been constructed so as to serve as a vehicle for describing methods for developing models of other systems for command and control analysis purposes. The generic name for these types of models is the Command and Control Analysis Model.

The specific system to be modeled in this report is the Carrier Air Traffic Control Center. It controls the recovery of aircraft on an aircraft carrier and possesses a substantial command and control element. The essential characteristics of this system are outlined in the following section.

A BRIEF INTRODUCTION TO THE CARRIER AIR TRAFFIC CONTROL CENTER

The carrier air traffic control system (Ref. 1) consists of several agencies, each with specific control functions and responsibilities for coordinating with the other agencies. As one of these agencies, the Carrier Air Traffic Control Center (CATCC) has primary responsibility for aircraft requiring positive center control (e.g., under instrument flight conditions) within a one hundred mile radius of the ship for which that ship is either the destination or point of departure. For aircraft operating under other control conditions, CATCC interacts with other agencies for control purposes and/or monitors to ensure traffic safety.

One of the more difficult CATCC activities, and the one which requires the most complete and fullest utilization of CCA capabilities, is a Mode III recovery of a scheduled flight of aircraft. The number of aircraft per scheduled recovery commonly ranges from 7 to 18. CATCC recovery of a flight of aircraft is considered to be one of the more stressful air traffic control activities. The activity is stressful due to the task requirements for control within quite close position and time tolerances and for management of what can become a complex traffic pattern with many variables in operation. The level of stress is increased by the awareness of the extreme costs in terms of lives and aircraft that can be incurred by failing to meet task requirements.

The CCA control positions usually manned for these recovery operations are Marshal and Subteams A and B, with each subteam consisting of one Approach and one Final Controller. Other

personnel directly involved in support or supervisory roles include the Carrier Controlled Approach Officer (CCAO), the Supervisor, and Boardkeepers for the marshal and final status boards.

During recovery operations, the aircraft are initially under Marshal control. The Marshaller organizes aircraft within the marshalling configuration and ensures their individual entry into the approach pattern at the appropriate time. Aircraft handoffs from Marshal to Approach usually alternate between Subteams A and B, with subsequent handoffs from Approach to Final. The flow for CCA control and integration functions during scheduled Mode III recoveries is presented in Figure 2.

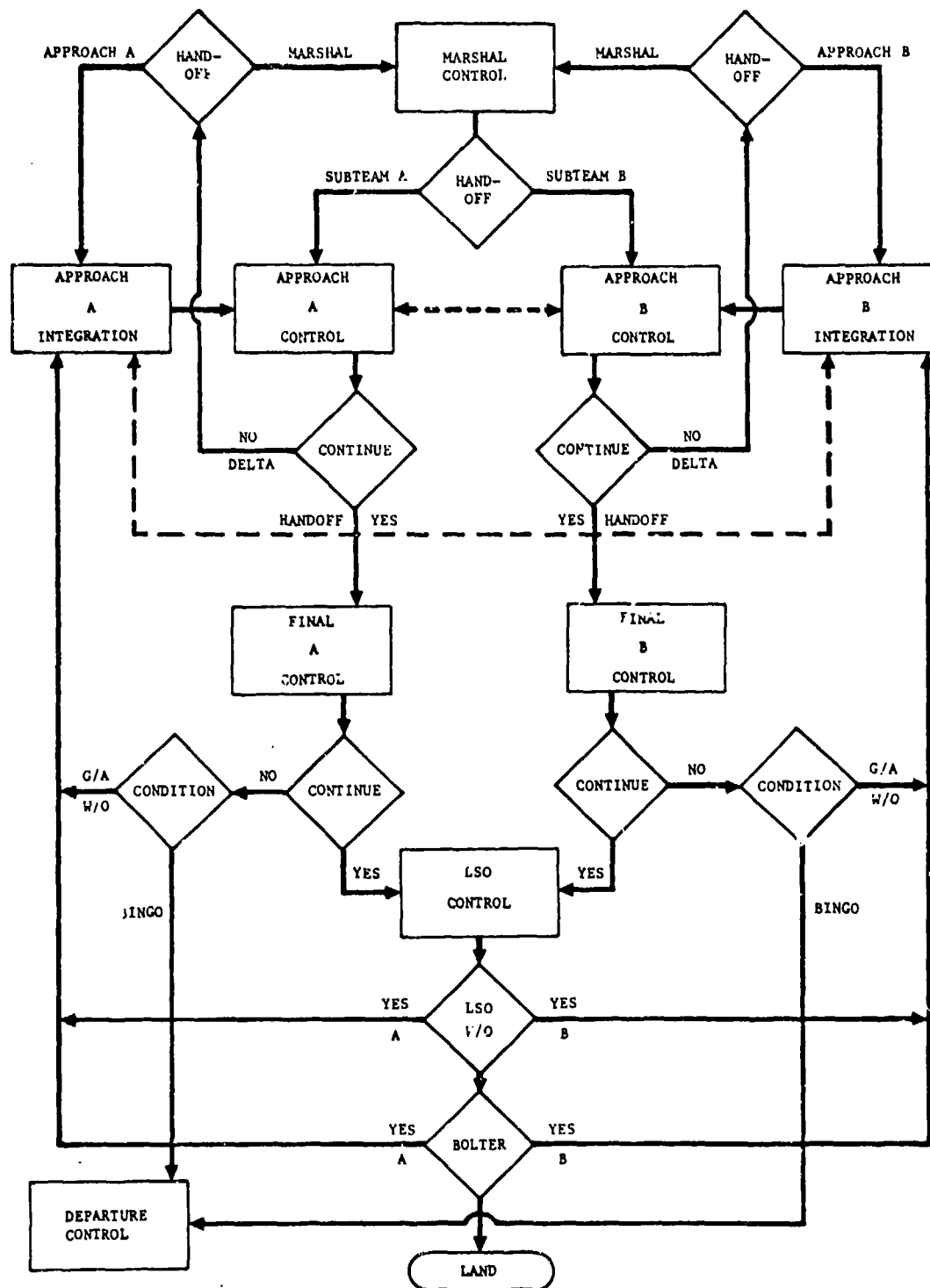

Figure 2. Carrier Case III Scheduled Recoveries: Air Traffic Control Function Flow (from Finley, et al, Ref. 1, Pg. 34).

III. COMMAND AND CONTROL SIMULATION WITH GPSS

Since GPSS produces models in which transactions flow through a system, the starting point in producing a simulation is the identification of the paths along which transactions flow, and, of course the different kinds of transactions. For a CATCC model, the following transactions and paths are appropriate as shown in Figure 3: (1) the flow of aircraft from the Marshal point down to the deck of the carrier, (2) data about the aircraft, flowing to the CATCC, (3) control instructions, flowing from CATCC to the various aircraft, (4) transformations of (2) to produce (3) flowing internally within CATCC, and (4) command information, flowing from external sources to CATCC.

When block diagrams are generated for each flow, programs generated and executed on a digital computer, all types of GPSS transactions flow "simultaneously" simulating an information-processing management system in which transformations and interactions occur in the same event/time relationships as the CATCC. The GPSS Software permits record keeping and the calculation of measures of effectiveness as the analyst desires.

For our purpose, which was the development and exposition of methods for developing computerized command and control analysis models, two versions of a GPSS CATCC model were produced. The first version was a very simple, and therefore unrealistic, model of CATCC while the second version was more complex and incorporated modules of interest in the analysis of manned systems. The development of two versions was a part of an iterative methods development, test, and evaluation process. Both versions are discussed in this chapter. Subsequent chapters will use the background provided by this chapter for exploring model development guidelines and uses.

A SIMPLE GPSS SIMULATION

A simple GPSS simulation for the control of a flow of aircraft is presented in Figure 4 in block diagram form (A complete listing of the GPSS program is presented in Appendix A). This model is oversimplified in at least two respects: (1) information and control related to the aircraft are updated at only one mile intervals, and (2) the controller is a simple unit which only tests spacing and sends aircraft back into line whenever the spacing is too close. This simple model will be used to develop methods and illustrate potential application to a system such as CATCC; additional modules for model sophistication will be discussed later.

The following comments apply to the block diagram of Figure 4:

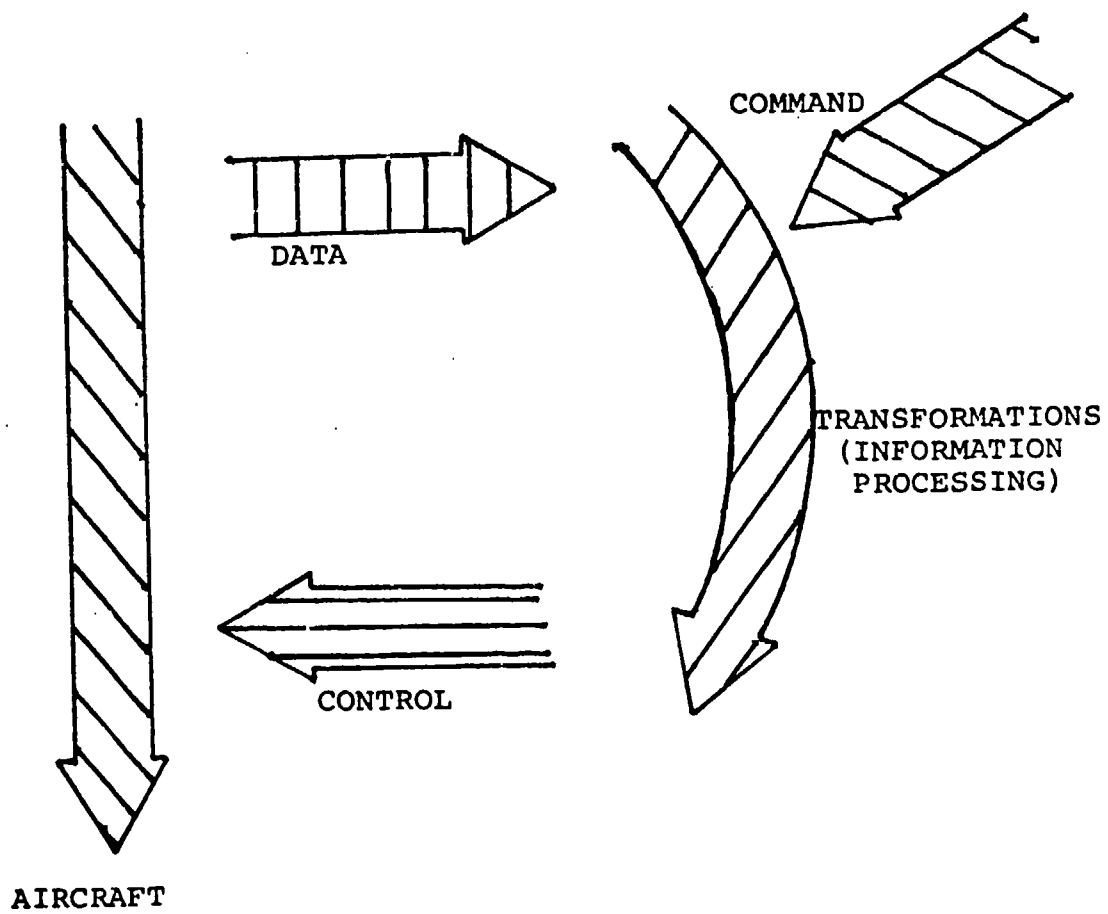

Figure 3. Information/Event Flow in a Simple GPSS Model of CATCC.

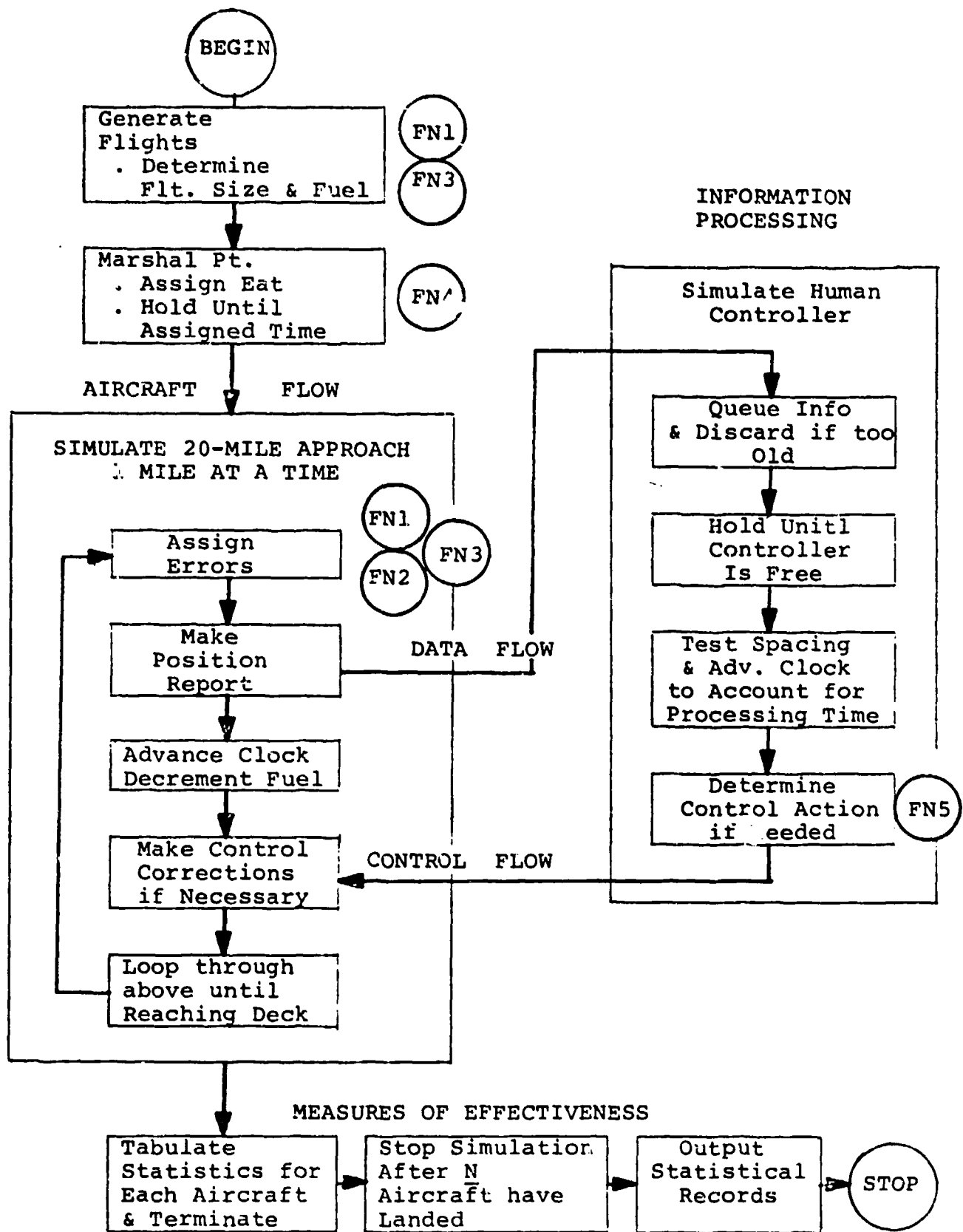

Figure 4. A Simple GPSS Simulation.
(General Block Diagram)

Parameters. Each transaction (aircraft) in the aircraft flow has associated with it a number of parameters as shown in Table 1. The value of each parameter characterizes each aircraft and becomes the basis for identifying and controlling information flowing in the system.

Generation of flights. Flights are generated at specified intervals (a constant interval, or a mean value with a specified distribution). As each flight is generated, the number of aircraft in each flight is determined as well as the parameters for each aircraft; each of these may be constants, computed values, or selected from a random generator with specified characteristics. Flight size and fuel remaining are determined through random distribution FN1 and FN3 (i.e., function one and function three).

Marshal point. Each arriving aircraft is assigned an estimated time to begin its approach to the carrier; each is separated by one minute. Subsequently, the time for each aircraft to begin approach is compared to the GPSS clock to determine when the aircraft can continue again.

Aircraft flow. As each aircraft flows through the system ("down the approach") the following occur: (1) glideslope, azimuth, and airspeed errors are introduced through specified random distributions identified in GPSS as functions (FN1, FN2, FN3), (2) each aircraft transaction is split into two duplicate transactions, one of which continues as an aircraft in the aircraft flow, and the other is sent as data along the data flow path, (3) the clock is advanced and fuel is decremented to reflect traveling one mile, and (4) if control is dictated, the aircraft is held and fuel decremented to simulate placing the aircraft at a new position in the approach line up. These events occur iteratively until each aircraft transverses the 20-mile path (20 times through the aircraft flow loop).

Information processing. The information processor in this simple example bears little resemblance to CATCC operations. Only one controller, with few human characteristics, is included; this controller tests the spacing between aircraft, and when an aircraft is following too closely it is sent to a pre-planned opening in the approach line up. As information in the form of position reports arrive at the controller, the number of items of information unprocessed is counted and additional information discarded to keep the queue sufficiently short so that exceptionally old information is not processed. When the controller is free, the time of arrival of each aircraft at a specific mile checkpoint is compared with the time the last aircraft arrived at the same checkpoint. If the time difference was less than 30 seconds, a control action is originated (split from the data transaction); otherwise, the data transaction would be terminated (discarded from the information processing subsystem). A control action consisted of computing the time for the aircraft to be

TABLE 1. PARAMETERS ASSOCIATED WITH EACH AIRCRAFT TRANSACTION

PARAMETER	CONTENTS
P1	Flight Number
P2	Flight Size
P3	Type Aircraft
P4	Serial Number
P5	Seconds of Fuel Remaining
P6	Clock Time Storage
P7	Airspeed (seconds per mile)
P8	Heading Error (degrees)
P9	Glideslope Error (feet)
P10	Checkpoint (miles to go)
P11	Holding Time (seconds to hold A/C)
P12	Clock Time Flt Arrives at Marshal

held, and allowing this information to be communicated to the aircraft-flow simulation.

Measures of effectiveness. As the system simulation proceeds, system quantities are automatically recorded. At specified points in the various flows, statistical tabulations are updated for summary printout at the end of the computer run. Statistical tabulations may include airspeed, heading and glideslope errors, fuel remaining after recovery, controller processing time, aircraft spacing, flight recovery time, and others. The computer run terminates after a specified number of aircraft have landed on the carrier deck.

Tables 2 and 3 present example statistical output for airspeed and spacing, respectively. The GPSS programmer defines intervals for each tabulated value, and then frequency counts are accumulated during the GPSS run. In each table, the following information is presented: the interval (in terms of the value at the upper limit of each interval), the observed frequency count in each interval, the frequency information in terms of the percent of the total number of entries in the table, cumulative percentages and 100% minus the cumulative percentage, the multiple of the mean, and the deviation from the mean.

TABLE 2. EXAMPLE GPSS STATISTICAL OUTPUT:
 FREQUENCY OF AIRSPEED VALUES (Seconds to Travel One Mile)

UPPER LIMIT	OBSERVED FREQUENCY	PERCENT OF TOTAL	CUMULATIVE PERCENTAGE	CUMULATIVE REMAINDER	MULTIPLE OF MEAN	DEVIATION FROM MEAN
10	0	0.00	0.00	100.00	.400	5.030
11	0	0.00	0.00	100.00	.400	4.695
12	0	0.00	0.00	100.00	.400	4.359
13	0	0.00	0.00	100.00	.520	4.023
14	0	0.00	0.00	100.00	.560	3.688
15	0	0.00	0.00	100.00	.600	3.352
16	0	0.00	0.00	100.00	.640	3.017
17	0	0.00	0.00	100.00	.680	2.681
18	1	1.00	1.00	99.00	.720	2.345
19	1	1.00	2.00	98.00	.750	2.010
20	4	4.00	6.00	94.00	.800	1.674
21	3	3.00	9.00	91.00	.840	1.339
22	7	7.00	16.00	84.00	.880	1.003
23	13	13.00	29.00	71.00	.920	.667
24	24	24.00	53.00	47.00	.950	.332
25	10	10.00	63.00	37.00	1.000	.000
26	10	10.00	73.00	27.00	1.040	.338
27	9	9.00	82.00	18.00	1.080	.674
28	3	3.00	85.00	15.00	1.120	1.010
29	7	7.00	92.00	8.00	1.160	1.345
30	3	3.00	95.00	5.00	1.200	1.681
31	1	1.00	96.00	4.00	1.240	2.016
32	3	3.00	99.00	1.00	1.280	2.352
33	1	1.00	100.00	.00	1.320	2.688

TABLE NUMBER 1
 ENTRIES IN TABLE
 100

MEAN ARGUMENT
 25.990

STANDARD DEVIATION
 2.379

SUM OF ARGUMENTS
 2499.000

TABLE 3. EXAMPLE GPSS STATISTICAL OUTPUT:
FREQUENCY OF SPACING VALUES (Seconds Between Aircraft)

UPPER LIMIT	OBSERVED FREQUENCY	PERCENT OF TOTAL	CUMULATIVE PERCENTAGE	STANDARD DEVIATION	SUM OF ARGUMENTS	MULTIPLE OF MEAN	DEVIATION FROM MEAN
41	5	.29	5.84	741.233	521.71.000	.137	.245
42	14	.79	7.63			.141	.344
43	11	.62	8.25			.144	.342
44	6	.34	8.59			.148	.341
45	18	1.02	9.61			.151	.340
46	13	.74	10.35			.154	.338
47	15	.85	11.20			.158	.337
48	13	.74	11.94			.161	.336
49	17	.96	12.90			.164	.334
50	14	.79	13.69			.168	.333
51	11	.62	14.31			.171	.332
52	17	.96	15.27			.174	.330
53	13	.74	16.01			.178	.329
54	21	1.19	17.20			.181	.328
55	18	1.02	18.22			.185	.326
56	24	1.36	19.58			.188	.325
57	35	1.99	21.57			.191	.324
58	57	3.25	24.82			.195	.322
59	51	2.90	27.72			.198	.321
60	190	10.83	31.55			.201	.320
61	53	3.02	41.57			.205	.318
62	39	2.22	43.79			.208	.317
63	41	2.33	45.12			.211	.316
64	36	2.05	48.17			.215	.314
65	27	1.54	49.71			.218	.313
66	22	1.25	50.96			.222	.311
67	23	1.31	52.27			.225	.310
68	20	1.14	53.41			.228	.309
69	19	1.02	54.43			.232	.307
70	10	.57	55.00			.235	.306
71	22	1.25	56.25			.239	.305
72	16	.91	57.16			.242	.303
73	7	.39	57.55			.245	.302
74	0	.45	58.00			.248	.301

The mean, standard deviation, sum of arguments, and the total number of entries in the table are also presented as summary information.

ADDITIONAL MODULES FOR CATCC SIMULATION

While the above model contains some characteristics desired in a CATCC model, it definitely lacks many others. Among these are the following, which may be considered as additional modules to be added or substituted in the previous simple model to achieve a more desirable model form (Appendix B contains a complete listing of the resulting expanded GPSS program):

MULTIPLE CONTROLLERS If a command and control analysis is to properly consider the man-machine problems encountered in CATCC, the individual workers and their communication channels must be identified. For example, the personnel "facilities" should minimally include the Marshal Controller, two Approach Controllers, two Final Controller, a status board keeper, and personnel from related command agencies.

Consider the following GPSS example (from Appendix B):

```
SEIZE 11      Seize a Communication channel
ADVANCE 100   Account for time for A/C to report in
SEIZE 2       Seize the Marshal Controller "facility"
ADVANCE 150   Account for time to assign an approach
              time
ASSIGN 6,V6   Assign an approach time to parameter 6
```

Two facilities are identified: a communication channel and the Marshal Controller. When an aircraft reports in a communication channel (facility #11) must first be available and time is taken for communicating the message. When the Marshal Controller (facility #2) is free and after sufficient time to determine the desired approach time, the approach time is assigned to the aircraft (information to be stored in parameter 6).

DISPLAYS To permit the simulation of individuals' tasks, display information must be provided in the model in a form required by each task. For example, information derived from a radar can be stored in specific computer storage areas (SAVEVALUES) which the mod 1 can access as needed. This permits radar information to be subsequently degraded or missing as appropriate to operational radar. Also, status boards can be similarly modeled, permitting realistic update intervals by the simulated status board keeper.

A method for storing display information for access as needed is to arrange a series of Savevalue locations to correspond to a matrix of aircraft numbers and all parameters for each

aircraft. When a data transaction is received GPSS variables are used to compute the proper place in the matrix for each associated parameter (see Radar/Display Information Updating in the program listing in Appendix B). When information is needed from a display for a human operator task, a similar computation can be performed to retrieve the latest information from the matrix. One can also insert additional display properties, such as loss of information during a specific range of distance by testing the distance before accessing the matrix and use the stored information only if outside the zone of radar loss.

CONTROL The control provided in the simple model does not reflect the full repertoire potentially available in the CATCC. A number of different maneuvers are used operationally to manage traffic flow, conflict, and emergency situations and could be added to the model.

In the current simulations, x-y position of each aircraft is not computed, only the position along the approach path. Control is exercised by halting motion along the path for a specified time, changing speed, or moving the aircraft back up the approach path (e.g., to the Marshal point). Consequently, within this simulation, the control actions can include: (1) delay aircraft advance by using an ADVANCE block and decrementing fuel by modifying parameter 5 with an ASSIGN block, (2) change speed by modifying the value stored in parameter 7, using an ASSIGN block or (3) send the aircraft back to a specific place in the flight path where a space in the approach sequence is available (using an ASSIGN block to change parameter 10 for distance to go and parameter 5 for fuel remaining, and an ADVANCE block to account for the time required).

TASKS Each task pertinent to information processing should be included in a CATCC simulation if it were to be used for detailed prediction and diagnosis analyses. Many tasks are initiated by specific stimuli; for example, a position report may initiate a task by a controller, which when completed may initiate another task, and so on. Other tasks may be rather continuous such as monitoring aircraft spacing on a radar screen, or others may be initiated as time permits; however, such tasks may be timeshared with other tasks, so that a task priority structure is clearly needed.

An example of a continuous activity is that of monitoring the radar screen for adequate spacing between aircraft. The rate of such activity can be controlled using a GENERATE block to create transactions which are used to cause radar information to be accessed, tested, and appropriate actions to be taken. For example:

```

GENERATE 10
:
SEIZE 4
TEST G V26, K13, CLOSE
:
ADVANCE 2
RELEASE 4
TERMINATE

```

In this case a transaction is created every 10 clock units, which causes the distance between aircraft to be computed (using variable 26 for computation) and if the distance is less than 13 distance units then the appropriate control actions will be taken (at address CLOSE). Other tests may be initiated by the transaction if inserted before the TERMINATE block.

Note the use of SEIZE, ADVANCE and RELEASE blocks in the above example to ensure that facility 4 (Approach Controller A) is available, account for his time occupied, and free him when completed. This member of the team may of course have other demands on his time simultaneously. GPSS and similar languages allow for a priority structure so that if more than one transaction attempts to seize a facility at the same time the facility can be devoted first to the more important one. Two cases can be directly implemented using GPSS: (1) when a given transaction must be serviced immediately, use of a PREEMPT block will obtain immediate use of a facility and permit the facility to then continue later by reconvening service of any previous transaction and (2) transactions may be assigned a priority which modifies the normal first-come first-served rule. Other priority structures may be implemented; for example, task A may be divided into segments (SEIZE-RETURN, SEIZE-RETURN,...) causing the facility seized to be entirely devoted to a transaction in segments, but free for other activities at predetermined intervals.

IV. GUIDELINES FOR COMPUTER MODEL DEVELOPMENT

The model explored in Chapter III of this paper used the CATCC as an example relevant to manned systems with a substantial command and control element. The specific procedures and problems encountered with that example are generalized as guidelines in this chapter so that the analyst may attempt to adapt these to his specific needs with other similar systems.

SYSTEM INFORMATION NEEDED

As the computer model is to be an analog of the operating real system, a great deal of information is needed about each facet of the system which is to be reflected in the model. Among the areas of system information needed are the following:

1. A description of the controlled element, the variables which specify the state of the controlled element, and variables which are used for control.
2. A specification of each channel of communication (various forms of electronic, visual, and auditory communication devices), and the capacities and manner of use for each channel.
3. Those machine elements of the system which share the information processing and control tasks with the human elements must be identified and described. They must be characterized (e.g., failure characteristics) so that they can be realistically represented in the computer model.
4. The information to be visually displayed within the system must be listed, along with display characteristics which may be of interest for model use such as rate of updating, method of accessing and display degradations (e.g., errors and missing information).
5. Incidents where human task requirements may occur simultaneously -- creating a need for human time-sharing -- must be identified. Methods for choosing between competing tasks, or methods for time-sharing tasks, must be defined in a manner permitting computer description.
6. The people in the system must also be modeled in a manner permitting the effect of human characteristics on human performance to be included in the computer model.
7. Scenarios are needed which describe the conditions and load under which the system will typically operate. The computer model must validly perform for each required scenario.

AMOUNT OF MODEL DETAIL AND COMPLEXITY

During computer model development the system programmer will face many decisions about model detail and complexity. Sufficient model detail is necessary for (1) proper model operation and output, (2) proper information processing within the model, (3) correct man-man and man-machine interface, (4) valid human and equipment performance, and (5) an adequate experimental design including all independent and dependent variables. (And what constitutes an "adequate" experimental design will vary as a function of whether the question being asked is one regarding system status, prediction, or diagnosis. This issue regarding model detail and complexity will be discussed again later.)

The programmer must consider all five of these needs during model construction. For example, a given communication may be of little importance for the scenario and therefore require only that the amount of personnel time consumed be accounted for. On the other hand, if the communications are relevant to scenario evolution then each item of information must be appropriately processed and stored.

Often computer programming for model development is turned over to a software specialist without adequate information on the foregoing. It should be clear that this could be disastrous, for the programmer must then make (often inadvertently or by default) many critical decisions about model details in order to develop a program which will answer the analysts questions. In the process of doing this the programmer must often generate considerable detail related to human performance models. The model developers, i.e., the programmers, must possess both command and control and programming expertise and, further, be given all the necessary and sufficient information about the system, its components, and its operations.

PROCEDURES

The steps listed below were used in developing a GPSS Model of CATCC and are offered as a general framework for the development of other models.

1. System Analysis. A description of the approaching aircraft the CATCC system, personnel tasks, system procedures, and measures of effectiveness was formulated. Scenarios were formed to specify the precise conditions under which the model would be used. Development of a scenario independent model was also attempted; however, it was found that descriptions of CATCC system operation were frequently a function of specific events occurring singly or in a specific sequence and under specific conditions. Consequently, the descriptions and therefore the model, derived for one scenario might not be valid for some events occurring at other times, in other sequences, or in unusual combinations. It became clear that models for command and control analysis are very scenario dependent and that the

selection of a representative set of scenarios for system description and, consequently, model development is critical.

2. Model Framework. A model framework was formed, based on the system analyses, including the following components: (1) the flow of approaching aircraft which provides information to CATCC and which responds to CATCC control, (2) displays, which are manually or automatically updated, (3) the man-machine system, including chains of events which are initiated by external stimuli, and events which are initiated internally, (4) measurement, and (5) external command inputs.

3. Task and Communication Analysis. The tasks were described using several formats, including a task analyses, operational sequence diagrams (OSD), and decision tree analyses. The analyses defined the sequence of occurrence for initiating stimuli (communications, or display of triggering information) and corresponding actions. Examples are presented in Figures 5 - 7. From these data GPSS flows were defined, with each flow initiated by the proper event or information. Other GPSS flows which resulted are those which are initiated within CATCC, or which are continuously performed (as time and events permit). The OSDs were constructed for selected task operations where the GPSS block diagram could result from a direct mapping from the OSD. Decision analyses were used to clarify the choice between alternatives, especially in the case of emergency events. The analyses were subsequently placed on a time line by listing tasks and, for a given scenario, assigning a nominal time to each task.

4. Scenarios and Experimental Design. Scenarios describing conditions under which the computer model was to be tested provided such information as the number of aircraft and mixes thereof. Since a number of random variables and unpredictable combinations of events will occur while exercising the computer model, experiments must be conducted with sufficient trials to achieve stable measurements of comparisons between alternative system configurations or inputs. Of course, the conditions under which the computer model will be used is valuable information for model development to ensure that desired experimental comparisons and measurements are designed into the model.

5. Programming and checkout. A computer program can be prepared based on the foregoing information. Normally, the programmer interacts between requirements, the program, and the results of trial program executions until he obtains what seems to be needed. The checkout of the program evolves in three stages: (1) correcting syntax, (2) getting the program to run, and (3) getting the program to run correctly.

6. Program verification. The last stage of program checkout, that of getting the program to run correctly, is, of course, the most critical stage. The programmer should personally possess both operational and system knowledge since it is

WAVE-OFF DECISIONS

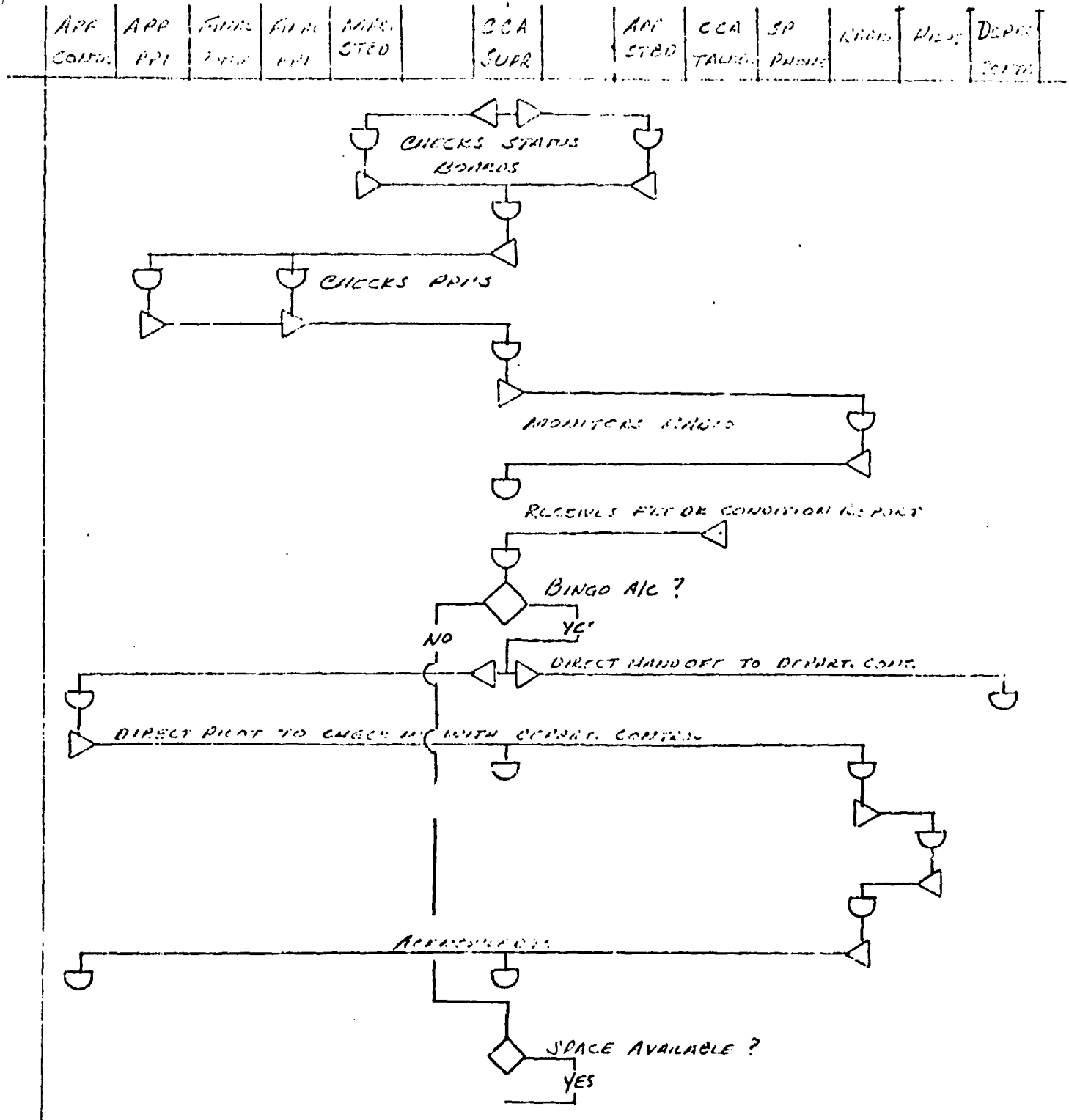

Figure 5. Example Operational Sequence Diagram.

A/C CHECK-IN - MONITOR MARSHAL PATTERN - PUSH TIME - HANDOFF TO APPROACH		
OPERATOR	EQUIP	DESCRIPTION
1. Marshal Controller	Marshal PPI	Verify Radar Contact with A/C at Check-in
2. Marshal Controller	Marsh. Cont. PPI	Shifts Aircraft Line up on Score Face
3. Marshal Controller	Radio, MC Freq.	Transmits Type of Recovery, Expected Approach Times, Approach Buttons (H or B), SIF Squawk, Altimeter, Weather, Time Check, Inbound Heading, Final Bearing and Bingo Field Information
4. Pilot	Radio, MC Freq.	Transmits A/C 1.0., Fuel Status, any Problems and Acknowledges Marshal Instructions
5. Status Board Keepers	Marsh. & Approach Status Boards	Update Boards: A/C 1.0. Fuel State, Push Time, EAT, Approach Controller Assigned.
6. CCA Supervisor	N/A	Monitors Status Boards, Marshal PPI, Radio Circuits
7. Marshal Controller	Marshal PPI	Monitor Marshal Pattern
8. Marshal Controller	Radio, MC Freq.	Transmit Time Check
9. Marshal Controller	Radio, MC Freq.	Verify Push Time with Pilot
10. Marshal Controller	N/A	Verify Assigned Approach Control has Contact
11. Marshal Controller	Marsh PPI	Monitor A/C Separation
12. Status Board Kpr.	App. Status Ed.	Updates Board Indicating Push Time
13. Marshal Controller	App. Status Ed. Status Bd.	Verifies Correct and Up-to-Date Information is on Board

Figure 6. Example Task Analysis.

BOLTER/WAVEOFF - ALTERNATE OPERATOR OPTIONS AND INFORMATION FLOW

Situation: LSO signals waveoff to aircraft at $\frac{1}{2}$ mile from ramp because of fouled deck. CCA, AirOps, PreFly and Bridge receives knowledge of same via monitoring activities.

ACTIVITIES

INFORMATION FLOW

- | ACTIVITIES | INFORMATION FLOW |
|---|--|
| 1. Bingo A/C | CCA Supr. reviews status board data and determines best solution is bingo.
CCA Supr. coordinates with AirOps for concurrence.
CCA Supr. instructs Approach Control to relay bingo information to pilot.
Approach Controller transmits bingo instructions to pilot and receives acknowledgement.
Status board keeps update status boards. |
| 2. Bring bolter A/C around for new approach ASAP | CCA Supr. reviews status board, notes A/C fuel state and instructs a new insertion ASAP.
Talker informs AirOps, PriFly, and Bridge.
App. Control coordinates with CCA Supr., Marshal Control and other Approach Controller to create space for bolter A/C.
App. Controller and Marshal Control Transmit speed, flight path changes, etc., as needed to affected A/C to accommodate bolter space creation.
Pilots acknowledge instructions.
App. Controller transmits insertion instructions to bolter A/C and handoff to Final Controller when appropriate.
Bolter A/C checks in with Final Control/LSO and completes landing.
Status board keeps maintain updated status boards. |
| 3. Reinsert bolter A/C at the end of the line after refueling | CCA Supr. reviews radars, status boards for recovery sequence details and determines bolter A/C will refuel and make new approach from marsnal.
Talker relays CCA Supr. action to AirOps, PriFly and Bridge.
CCA Supr. instructs Approach Controller to relay instructions to bolter pilot.
App. Control instructs bolter pilot to contact Departure Control for refuel instructions.
Bolter pilot acknowledges.
After refuel, bolter pilot re-enters marshal area and checks in with Marshal Control.
Status board keeps maintain board update. |

Figure 7. Example Decision Tree Analysis.

unlikely that he will be able to derive what he needs from other people in the form needed. However, the task will be expedited if specific check cases are constructed for which desired results are fully known. Also, highly detailed and redundant measurement printouts will help identify unanticipated problems. Aside from these few suggestions, it can only be said that checkout and debugging remains an art to be performed in a painstaking fashion.

V. ROLES OF COMPUTER MODELS IN COMMAND AND CONTROL ANALYSIS

Simulation language computer models, such as that represented by the GPSS CATCC model, can serve several roles in command and control analysis (cf, Ref. 1, 1974, pg. 64): (1) to answer questions about the status of systems effectiveness, (2) to diagnose system problems, and (3) to predict future system performance and effectiveness. In all of these roles, the computer model offers much more power and flexibility with regard to manipulating system parameters and reconfiguring the system than is possible when attempting to examine the operational system directly. On the other hand, it is not ordinarily possible to check the validity of each and every variation of the computer model, and often the validity of results is either estimated or is simply unknown. In the end, a blending of analytical techniques, including direct empirical testing, at critical points is probably necessary, giving some assurances but no overall guarantees of validity.

SYSTEM EFFECTIVENESS QUESTIONS

If only system-global or final status measures of effectiveness are needed, a computer simulation may need only represent the overall system and a detailed simulation of components or subsystems may be unnecessary. The performance of the system can be made to depend on the level of load or environmental conditions, which, in the case of CATCC, could include parameters such as: the number of aircraft in each flight, the rate of arrival of flights, mixes of aircraft types, pilot proficiency as evidenced in flight errors, and fuel condition. Specific events may also be pertinent, such as the turning of the carrier to a new heading or the bolter of an aircraft. Performance and effectiveness may be investigated as a function of these parameters or events if the design of the model included the appropriate features; for example, if parameters relating to number, type and arrival of aircraft are of interest, then the model must include entities which correspond to individual aircraft.

Given an appropriate computer model, the appropriate parameters may be varied as necessary, and resulting performance measured. Since GPSS permits multiple runs to be made with convenience, an experimental design may be implemented and sufficient data collected for statistical analysis. While large and costly computer runs may be involved for large numbers of iterations with a large model, it should be clear that performance data may be collected on situations which may be exceedingly difficult or impossible to collect during a field experiment involving an operational command and control system.

SYSTEM DIAGNOSIS QUESTIONS

Suppose that the measures of effectiveness for a given system indicate a deficient level of performance. How should one correct the situation? As suggested in Finley, et al (Ref. 1, P. 67), one may attempt to adjust the system, or failing in this, faulty components may be replaced. While the procedure may be basically trial-and-error, one must be guided by some prior and much more detailed knowledge of operational system response to specific changes if some degree of efficiency is to be achieved.

As pointed out in the preceding discussion, an iterative procedure will be difficult and costly, and often too dangerous or impossible to implement with an experimental approach using the operational system. A computer model is relatively simple and less expensive. Deficiencies may be systematically included in the model in varying degrees of severity and the effect on measures of effectiveness observed; however, this is limited to variation in the parameters provided in the model.

Through use of a more complete model than would be used to investigate a status question, the sensitivity of system performance to changes in parameters representing the more detailed and internal operations of the system can be found, allowing (1) the system characteristics to be identified which might cause a specific deficiency, and (2) a determination of the amount of adjustment which may be needed for correction. Of course, exercising the model in this manner should only be necessary to provide knowledge about system mis-operation and sensitivity to internal changes when such knowledge is not available or testable through operational experience. Ultimately, in any case, changes must be tried in the operational system, and measures of effectiveness collected to determine if the fix was appropriate.

SYSTEM PERFORMANCE PREDICTION QUESTIONS

The computer model may be used to predict system performance and effectiveness with much the same objective as the approach to system diagnoses. The question is put in the form: What will happen if...? If the model is constructed appropriately, variations in model parameters or configuration may be introduced. Since many inputs and parameters may be stochastic, multiple computer runs may be necessary to establish a sufficient statistical set of measures for evaluation. Based on this procedure, statements may be made to the effect that substitutions in either the man or machine components of the system (or ΔX change in a man or machine parameter) will make an average improvement ΔY in system performance. If such a prediction can be related to each change, then a regression equation may be formed with change variables and coefficients written on the left side of the equation and the equation and the predicted variable (measure of effectiveness) on the right-hand side.

It should be clear that while questions of system effectiveness status may be approached with a global model, questions about system effectiveness diagnoses or prediction require a model with much internal detail. For example, if man-machine performance is to be addressed, the people of the system must be modeled along with specific displays and man-machine and man-man interfaces. Consequently, model complexity is increased, requiring more model development and validation effort.

DEVELOPMENT OF MEASURES

The development and selection of a reliable, valid and useful measures set is often a difficult task. When measuring in the operational environment one should be certain that the measures set is the best possible. Consequently, there is reason to use the computer model as a testbed for measurement, so that alternative forms can be compared and combined in an environment which is conducive to measurement development. Further, many forms of measurement are so difficult to collect in the operational environment (e.g., those which require a large amount of information, reflect fast-happening events, or require extensive computation) that they are precluded from use in the operational environment unless the payoff can be demonstrated. The computer model will permit study of any mathematically expressible form of measurement whenever the model includes the quantities which are required for computing the measure.

ROLE WITHIN THE TOTAL COMMAND CONTROL ANALYTIC PROCESS

The computer model can be a powerful tool for the analysis of command and control systems; however, it should be used in context with other analytic methods and in conjunction with empirical tests. The computer model is based on other modeling efforts (e.g., models of the human components) and is used as a substitution for empirical tests. Consequently, the computer model is an outgrowth of other analytic methods, represented in a form which gives additional power, but which ultimately is an adjunct to empirical testing.

Normally, the computer model is neither used at the beginning or the end of the analytic process since prior analysis is usually needed to specify the computer model and the results of computer model computations are normally a preliminary to further analysis or empirical tests. Otherwise, of course, the role of the computer model within the total analytic process depends on the purpose to which it is applied. The computer model is truly a tool with many uses.

INCORPORATION OF HUMAN OPERATOR MODELS AND PSYCHOLOGICAL THEORY

The computer models discussed in this paper are basically task descriptive models wherein each action taken by human operators can be included as a system event. Of course, for the

computer model to work properly each event must be caused to occur for the proper combination of stimuli and at the proper time. In the most basic form, then, the computer model must include at least the characteristics for nominal and consistent human operators. The human operator can be readily embellished with some realistic operator characteristics by altering the event times, by including alternative stochastic distributions so as to allow for human variation as a function of conditions, and by incorporating known human errors which occur with defined probability. In this manner a human operator model can be developed for each workstation which will agree with observation and data.

The various parameters of the human operator model which control the distributions of time, error and alternative actions can also be variable. Consequently, to the extent that these factors are known, the model parameters can be changed to include the effects of fatigue, motivation, training, etc. Or, if one wishes, the model parameters can be changed systematically so as to reflect command actions and to determine their effect on the overall system performance, to infer the sensitivity of the system to the effects of fatigue, motivation, training, etc.

VI. DISCUSSION

One of the advantages provided by a computer model is the relative richness of the form of task description involved. Simulation language computer models incorporate timing of events, sequencing of tasks, interaction between task elements, and the competition of time-shared and over-loaded tasks. Further, task performance variables can be made to operate stochastically and alternate distributions can be used to reflect the effects of training, changed standards, motivation fatigue, etc.; that is, the effects of changes in factors that can be modified by command action. However, the richness of task description presents a problem to the analyst/programmer defining the computer model. The analyst/programmer has at his disposal a model which is capable of representing an operator's task at many descriptive level, from simple to highly detailed. As with any simulation development, the designer is faced with the difficult decisions associated with determining the necessary fidelity of simulation. A level of specificity must be determined which is adequate for model validity but which also restrains the cost of collecting information needed to fix model parameters. As the model becomes more complex, more information about the real system is needed. The analyst/programmer determines the mapping from the description of the system provided him (probably overly simple and incomplete) and the success of the model will depend on how well the analyst/programmer has done this mapping process. This at present is a complex creative process.

The type of computer model described in this report causes simulated events to occur in proper timing and sequence. This requires timing information for each operator activity to be assessed. The time (or distribution of times) for each operator activity requires detailed knowledge of operational task performance or the ability to make accurate estimates. Knowledge is also required of the tasks that are rather continuously performed or which are self-initiated; often only the tasks which are initiated by external events are clearly defined. Also, the computer model will be affected by the flexibility of the scenario provided: a simple constrained scenario will require only simulation for a highly-specific combination of circumstances; a more general scenario, or a set of scenarios, will require a more complex model and, correspondingly, much more information about parameters of the system. Similarly, information needed for the resultant model will depend on the specificity to be included about operator functions and decisions.

While the richness of description provided by the computer model may initially pose some problem due to insufficiency of information provided by the usual task analysis methods, the potential exists for advancing the state-of-the-art in human task description. If a task descriptive method is to be effective for systems in which task execution time, time-sharing of tasks, and

interdependencies between tasks are important, then the information required by the computer modelling method must be made available. In a sense, the computer model is a new task-analytic method and it must be formalized into a clear-cut set of task-analytic procedures. The procedures for describing the system operators, equipment displays and communications as given in Chapter III constitute, in fact, a new task/system description method which appears to be far richer than the methods presented in Figures 5 - 7. See Reference 2 for a further discussion of this issue.

Based on the examples developed and tested for this paper, it is believed that the C&C Analysis Model, using GPSS or a similar language, can serve an important role in the evaluation of manned systems and their command and control elements. A powerful technique results when the personnel and machine components of a total man-machine system are described both appropriately and in compatible terms: this is permitted by simulation languages like GPSS. Given a valid computer model which extends over both personnel and machine components, the analyst can address questions of systems effectiveness and performance status, diagnosis and prediction. From a composite view of the total man-machine system, enlightened analysis and design can proceed; and, when the model is in a working format such as with a GPSS computer model, innovations can be tested to determine their utility.

It is not contended, however, that the computer model approach will always be more cost effective than direct empirical assessment. It will often be practical to address difficult questions with a computer model instead of direct measurement on the system due to the difficulty and high cost of measurement in the operational environment. On the other hand, high costs for computer model development should be anticipated when: (1) high fidelity of simulation is necessary, or (2) information needs are very simple and easily obtainable. Of course, once data are collected and a model is constructed, many measurements under many model variations are possible, and the use of a model may greatly reduce costs compared to direct system measurement. But, it must be kept in mind that a computer model must be validated with some empirical tests prior to use. Consequently, if information needs can be easily satisfied by simple empirical tests (compared to those required for model validation), use of the computer model will not be cost-effective. It may also be seen that the overall effort required for model development is a combination of empirical and analytic efforts, and never purely an analytic effort.

Taking the above considerations into account, it is believed that the simulation-languages computer-model approach will often be cost-effective for the evaluation of command and control element in manned systems. Further, such models can integrate existing analysis methods which are now separate, provide an

advanced technique for task description, and provide a vehicle for the integrating of psychological theory into man-machine analysis.

VII. REFERENCES

1. Finley, D.L., Muckler, F.A., Gainer, C.A., and Roe, W.T. Development of an analysis and evaluation methodology for Command and Control: First technical report. Contract N00014-73-C-0095, Naval Analysis Programs, Office of Naval Research, Arlington, VA, March 1974. (AD 778 028)
2. Finley, D.L., Muckler, F.A., Gainer, C.A., and Obermayer, R.W. An analysis and evaluation methodology for Command and Control: Final technical report. Contract N00014-74-C-0324, Naval Analysis Programs, Office of Naval Research, Arlington, VA, November 1975. (AD)
3. International Business Machines Corporation. General Purpose Systems Simulator III: Introduction. White Plains, N.Y.: IBM Report No. GB20-0001-0, 1965.
4. General Purpose Systems Simulator III: User's Manual. White Plains, N.Y.: IBM Report No. GH20-0163-1, 1965.

APPENDIX A. COMPUTER PROGRAM LISTING:
A SIMPLIFIED GPSS MODEL OF CATCC
(VERSION 1)

SIMULATE

GPSS MODEL OF CATCC

THIS IS A VERY SIMPLE REPRESENTATION OF CATCC. IT IS INTENDED ONLY AS A STRAWMAN FOR DISCUSSION WITH REGARD TO FURTHER USE AND DEVELOPMENT. AT THIS POINT IN DEVELOPMENT, NO ATTEMPT IS MADE TO CONTROL A/C PARAMETER, BUT IF SPACING REDUCES TO 30 SEC. OR LESS, AN A/C IS DIVERTED TO AN OPEN SPACE FARTHER BACK IN THE APPROACH.

MOE INCLUDE FREQUENCY DISTRIBUTIONS OF THE FOLLOWING--

- (1) A/S, HDG, AND G/S ERRORS
- (2) FUEL REMAINING AFTER RECOVERY
- (3) CONTROLLER PROCESSING TIME
- (4) A/C SPACING
- (5) RECOVERY TIME

P. W. OBERMAYER 5/17/74 VERSION 1

PARAMETERS ARE ASSOCIATED WITH EACH TRANSACTION IN THE FLOW

PARAMETER DICTIONARY

- P1 - FLIGHT NUMBER (+50 IF BOLTER, +70 IF BOLTER LT 4 MI)
- P2 - FLIGHT SIZE
- P3 - TYPE A/C
- P4 - SERIAL NUMBER (CHANGED IF BOLTER)
- P5 - SECONDS OF FUEL REMAINING
- P6 - CLOCK TIME STORAGE
- P7 - AIRSPEED - SECONDS PER MILE
- P8 - HEADING ERROR - DEGREES
- P9 - GLIDESLPE ERROR - FEET
- P10 - CHECKPOINT - MILES TO GO
- P11 - HOLDING TIME (=10 IF PREV BOLTER)
- P12 - CLOCK TIME FLT ARRIVES AT MARSHAL

SAVEVALUES ARE STORAGE LOCATIONS FOR THE MEMORY OF SPECIFIC VALUES, AND TABLES OF INFORMATION (I.E. STATUS BOARD INFORMATION, AND OTHER OPERATOR DISPLAYS).

SAVEVALUE DICTIONARY

- X1-X20 - TIME LAST A/C REPORTED CHECKPOINT 1,2, ...20 MILES
- X21 - INCIDENT FLT NO BY 100
- X22 - TIME SEP FOR LAST REPORTING A/C
- X23 - SERIAL NO FOR A/C TO BE TESTED AND GIVEN COMMAND
- X24 -
- X25 -
- X27 - A/S CONTROL
- X28 - HDG CONTROL
- X29 - G/S CONTROL
- X30 - BOLTER A/C HOLDING TIME

- X40 - TIME FOR LAST A/C REPORTING IN AT SPECIFIC CHECKPOINT
- X41 - LAST CLOCK TIME TO START APPROACH ASSIGNED
- X42 - COUNTER FOR A/C LANDING WITHIN EA. FLT.
- X51-X70 - A/C NO. BY DIST. TO GO (PROGRESS DISPLAY)

***** BEGIN PROGRAM *****

* THE FOLLOWING ARE FUNCTIONS (I.E. DISTRIBUTIONS) USED IN THE GPSS
 * SIMULATION. FUNCTIONS 1-3 ARE NORMAL RANDOM DISTRIBUTIONS USED FOR
 * THE GENERATION OF FLIGHT ERRORS. FUNCTIONS 4 AND 5 ARE USED
 * IN THE ASSIGNMENT OF EAT AND FOR A/C BOLTER INTEGRATION.

1 FUNCTION FN1,C56

.0	-100.	.00003	-40.	.00023	-35.	.00135	-30.	.0026	-25.	.0047	-20.
.0002	-24.	.00139	-22.	.00227	-20.	.00287	-19.	.00359	-18.	.00446	-17.
.00548	-16.	.00668	-15.	.00808	-14.	.00958	-13.	.01151	-12.	.01357	-11.
.01587	-10.	.01841	-9.	.02119	-8.	.02420	-7.	.02743	-6.	.03095	-5.
.03446	-4.	.03821	-3.	.04207	-2.	.04602	-1.	.0500	0.0	.05398	1.
.05793	2.	.06170	3.	.06554	4.	.06915	5.	.07257	6.	.07580	7.
.07881	8.	.08159	9.	.08413	10.	.08643	11.	.08849	12.	.09032	13.
.09192	14.	.09332	15.	.09452	16.	.09554	17.	.09641	18.	.09713	19.
.09773	20.	.09801	22.	.09918	24.	.09953	26.	.09974	28.	.09985	30.
.09997	35.	.09997	40.								

2 FUNCTION FN1,C11

.0	-10.	.00003-4.	.00135-3.0	.00227 -2.	.01587 -1.	.0500	0.
.0413	1.	.09773 2.	.099973.0	.099974.	.0999910.		

3 FUNCTION FN1,C17

.00003-10.	.0026 -7.	.0082 -6.	.0227 -5.	.0548 -4.	.1151 -3.
.2119 -2.	.3446 -1.	.500 0.	.6554 1.	.7891 2.	.8849 3.
.944524.	.9773 5.	.9918 6.	.9974 7.	.9999710.	

* IN THE FOLLOWING FUNCTIONS FOR EAT ASSIGNMENT AND BOLTER INTEGRATION,
 * A SPACE IS LEFT IN THE APPROACH FOR ANOTHER A/C --(1-4) SPACE (5-9) SPACE
 * (10-15) SPACE (16-21) SPACE (22-27) SPACE (28-30)

4 FUNCTION P4,D30

1.	60.	2.	120.	3.	180.	4.	240.	5.	300.	6.	360.
7.	480.	8.	540.	9.	600.	10.	720.	11.	780.	12.	840.
13.	900.	14.	960.	15.	1020.	16.	1140.	17.	1200.	18.	1260.
19.	1320.	20.	1380.	21.	1440.	22.	1560.	23.	1620.	24.	1680.
25.	1740.	26.	1800.	27.	1860.	28.	1980.	29.	2040.	30.	2100.

5 FUNCTION P4,D30

1	4	2	3	4	2	4	1	5	5	6	4
7	3	3	2	9	1	10	6	11	5	12	4
13	3	14	2	15	1	16	6	17	5	18	4
19	3	20	2	21	1	22	6	23	5	24	4
25	3	25	2	27	1	28	3	29	2	30	1

* GENERATE FLIGHTS, TIME IN UNITS OF 1 SECOND.

- 1 GENERATE 3600.,0 ONE FLT EVERY HOUR
- 1 VARIABLE X21+K100
- 2 SAVEVALUE 21,V1 TEMP. STORE LAST FLT NO.
- 3 ASSIGN 1,X21 FLT NO IN P1
- 2 VARIABLE FN3+K15
- 4 ASSIGN 2,V2 FLT SIZE IN P2
- 5 MARK 12 RECORD START TIME FOR RECOVERY OF FLT
- 3 VARIABLE F2-K1
- 6 SPLIT V3,NEXT,4 CREATE INDIV. A/C AND SERIALIZE P4
- 7 NEXT ASSIGN 7,K24 VELOCITY IN P7
- 5 VARIABLE FN1*K5+K1+40
- 8 ASSIGN 5,V5 FUEL REMAINING (SEC) IN P5

* MARKSAL, ASSIGN TIME TO START APPROACH (1-MIN APART)

```

9      MARK                                RECORD START TIME FOR INDIV A/C TRANSIT TIME
6 VARIABLE FN4+C1
0 ASSIGN 6,V6                               START APPROACH TIME IN P6
1 TEST G P6,X41,MAPSH                       TEST TIME TO START SAVED IN X41
2 SAVEVALUE 41,P6                           SAVE LATEST EAT IN X41
3 MAPSH TEST LE P6,C1                       A/C HELD UNTIL TIME TO START APPROACH

```

.....

SIMULATE APPROACH ONE MILE AT A TIME

```

4      ASSIGN 10,K20                         P10 USED AS LOOP COUNTER, MILES TO GO
5 BEGIN ASSIGN 7+,FN2                       A/S ERROR IN P7
6      ASSIGN 8+,FN3                         L-R ERROR IN P8
7      ASSIGN 9+,FN1                         G/S ERROR IN P9
8      ASSIGN 6,C1                           ARRIVAL TIME RECORDED IN P6
9      SPLIT 1,DATA                          SEND XACT WITH DATA IN PARAMETERS TO DATA BELOW
0      ADVANCE P7                            ADV CLOCK TIME TO TRAVEL A MILE
1      ASSIGN 5-,P7                          DECREMENT FUEL REMAINING
2      GATE LS 1,SKIP                        LET XACT THRU IF CONTROL ACTIONS NEEDED
3      TEST E V11,X23,SKIP                   CONTROL ONLY PROPER A/C
4      SAVEVALUE 23,K0                       CLEAR A/C ID FLAG
5      LOGIC P 1                              RESET TO CLOSE GATE AGAIN
11 VARIABLE P1+P4
6      ASSIGN 7,X27                          CONTROL A/S
7      ASSIGN 8,X28                          CONTROL HEADING
8      ASSIGN 9,X29                          CONTROL GLIDE SLOPE
9      ASSIGN 11,X30                         HOLDING TIME IN P11
0      TEST NE P11,K0,SKIP                   TEST TO SEE IF BOLTER A/C
1      PRINT ,,P                             PRINT PARAMETER VALUES
2      PRINT 51,71,X                         PRINT PROGRESS DISPLAY
3      ADVANCE X30                           HOLD FOR THE TIME COMMANDED
4      SAVEVALUE 30,K0                       CLEAR BOLTER FLAG
5      ASSIGN 11,K10                         CLEAR FLAG, INDIC PREV BOLTER
6      ASSIGN 5-,X30                         DECREMENT FUEL
7      PRINT ,,P
8      PRINT 51,71,X                         PRINT PROGRESS DISPLAY
9 SKIP BUFFER
0      LOOP 10,BEGIN                         KEEP LOOPING UNTIL 20 MILES

```

.....

UPDATE STATISTICS

```

1      TEST LE P1,K100,TABUL                 PRINT AS EA A/C OF FIRST FLT LANDS
2      PRINT ,,P                             PRINT PARAMETERS AS EACH A/C LANDS
3      PRINT 1,71,X                         OUTPUT ALL SAVEVALUES
4 TABUL TABULATE 1                          UPDATE A/S TABLE
5      TABULATE 2                            UPDATE HDG TABLE
6      TABULATE 3                            UPDATE G/S TABLE
7      TABULATE 4                            UPDATE FUEL TABLE
8      TABULATE 7                            UPDATE TRANSIT TIME TABLE
19 VARIABLE X42+K1
9      SAVEVALUE 42,V19                      USE X42 AS A COUNTER
0      TEST GE X42,P2,JUMP                   IF X42 GE NO. IN FLT TAB RECOVERY TIME
1      TABULATE 4                            TABULATE RECOVERY TIME
2      SAVEVALUE 42,K0                       RESET COUNTER
3 JUMP TERMINATE 1

```

.....

SIMULATE CONTROL FUNCTIONS

```

4 DATA MARK
5      TEST LE 01,K20,TERM                   DO NOT PERMIT QUEUE TO BE LONGER THAN 20
6      QUEUE 1                               JOIN QUEUE 35

```

```

7 SEIZE 1 OBTAIN CONTROLLER
8 DEPART 1 DEPART FROM QUEUE
9 SAVEVALUE 40,X*10 TIME LAST A/C AT CHECKPT IN X40
0 SAVEVALUE P10,P6 STORE ARRIVAL TIME IN SAVEVALUE
14 VARIABLE P10+K60
1 SAVEVALUE V14,V11 UPDATE PROGRESS TABLE
2 SAVEVALUE 71,C1 RECORD TIME OF UPDATE
3 ADVANCE 5,2 DELAY 5+/-2 SECONDS
4 SAVEVALUE 22,V10 STORE SEP (LATER DIFF STORE FOR EA CHKPT)
5 TABULATE 6
10 VARIABLE P6-X40
6 TEST LE V10,K30,END TEST IF SPACING .LT. 30 SEC.
* BOLLTER CONTROL LOGIC
7 SAVEVALUE 23,V11 IDENTIFY A/C FOR BOLLTER
8 LOGIC S 1 SET FOR CONTROL GATE IN APPROACH LOOP ABOVE
9 SAVEVALUE 27,K24 AIRSPEED SET TO NOMINAL VALUE
0 SAVEVALUE 23,P8 NO CONTROL FOR NOW
1 SAVEVALUE 29,P9 NO G/S CONTROL FOR NOW
15 VARIABLE FN5*K60
2 SAVEVALUE 30,V15 X30 CONTAINS THE COMMANDED HOLDING TIME
3 ASSIGN ++,FN5 ASSIGN NO EQUAL TO A/C JUST BEHIND CLOSEST SPACE
4 ASSIGN 1+,K50
5 TEST LE P10,K4,PREV3 WITHIN 4 MI OF DECK, INTEGRATE FARTHER BACK
16 VARIABLE X30+FN5*K60+K60
6 ASSIGN ++,FN5
7 ASSIGN 1+,K20
8 SAVEVALUE 30,V16 HOLDING TIME TO GET TO NEXT FARTHER SPACE IN X30
9 PREV TEST G P11,K0,END
17 VARIABLE X30+K60
0 SAVEVALUE 30,V17
1 END RELEASE 1 RELEASE CONTROLLER FOR ANOTHER JOB
2 TABULATE 5 UPDATE INFO. PROC. TABLE
3 END TERMINATE

```

```

*****
* INSURE AN EVENT OCCURS EVERY 60 SEC.
4 GENERATE 60
5 TERMINATE
*****

```

* TABLE DEFINITIONS

* EACH TABLE IS A FREQUENCY DISTRIBUTION

```

* AIRSPEED (SEC/MI)
1 TABLE P7,10,1,30
* HEADING ERROR
2 TABLE P8,-50,1,101
* GLIDESLOPE ERROR
3 TABLE P9,-50,1,101
* FUEL REMAINING (SEC)
4 TABLE P5,0,10,30
* CONTROLLER INFO PROCESSING TIME
5 TABLE M1,0,1,120
* AIRCRAFT SPACING (SEC)
6 TABLE X22,C,1,122
* INDIVIDUAL A/C TRANSIT TIME
7 TABLE M1,360,10,100
RECOVERY TABLE
8 TABLE MF12,300,30,90

```

```

*****
* RUN SIMULATION FOR THE RECOVERY OF A NUMBER OF FLIGHTS TO COLLECT AN
* ADEQUATE SAMPLE FOR STATISTICAL ANALYSIS.

```

APPENDIX B. COMPUTER PROGRAM LISTING:

AN EXPANDED GPSS MODEL OF CATCC

(VERSION 2)

SIMULATE

GPSS MODEL OF CATCO

MGE INCLUDE FREQUENCY DISTRIBUTIONS OF THE FOLLOWING--
(1) A/S, HDG, AND G/S ERRORS
(2) FUEL REMAINING AFTER RECOVERY
(5) RECOVERY TIME

R. W. OBERMAYER 10/17/74 VERSION 2

PARAMETER DICTIONARY

P1 - FLIGHT NUMBER
P2 - FLIGHT SIZE
P3 - TYPE A/C
P4 - SERIAL NUMBER (CHANGED IF BOLTER)
P5 - SECONDS OF FUEL REMAINING
P6 - CLOCK TIME STORAGE
P7 - AIRSPEED - SECONDS PER MILE
P8 - HEADING ERROR - DEGREES
P9 - GLIDESLPE ERROR - FEET
P10 - CHECKPOINT - MILES TO GO
P11 - HOLDING TIME
P12 - CLOCK TIME FLT ARRIVES AT MARSHAL

SAVEVALUES ARE STORAGE LOCATIONS FOR THE MEMORY OF SPECIFIC VALUES,
AND TABLES OF INFORMATION (I.E. STATUS BOARD INFORMATION AND OTHER
OPERATOR DISPLAYS).

SAVEVALUE DICTIONARY

X1-X20 - LAST A/C REPORTED CHECKPOINT 1,2, ...20 MILES
X21 - INCREMENT FLT NO BY 100
X23 - SERIAL NO FOR A/C TO BE TESTED AND GIVEN COMMAND
X24 - A/S CONTROL
X25 - WAG

X42 - COUNT FOR A/C LANDING WITHIN EA. FLT.

X90, X901-X900 - STATUS BOARD DATA
X100, X101-X100 - RADAR/DISPLAY DATA
X95, X96 - SCAN COUNTERS
X96, X97 - DISTANCES FOR THE TWO A/C TO BE COMPARED

FACILITY ASSIGNMENTS

1 CCA
2 MC
3 STATUS RD UPKP
4 APPROACH A
5 APPROACH B
6 FINAL A
7 FINAL B

 ***** BEGIN PROGRAM *****

* THE FOLLOWING ARE FUNCTIONS (I.E. DISTRIBUTIONS) USED IN THE GPSS
 * SIMULATION. FUNCTIONS 1-3 ARE NORMAL RANDOM DISTRIBUTIONS USED FOR
 * THE GENERATION OF FLIGHT ERRORS. FUNCTIONS 4 AND 5 ARE USED
 * IN THE ASSIGNMENT OF EAT AND FOR A/C BOLTER INTEGRATION.

1 FUNCTION RN1,C56

.0	-100.	.00003	-40.	.00023	-35.	.00135	-30.	.0026	-28.	.0047	-26.
.0002	-24.	.0139	-22.	.0227	-20.	.0287	-13.	.0359	-18.	.0446	-17.
.0548	-16.	.0668	-15.	.0808	-14.	.0968	-13.	.1151	-12.	.1357	-11.
.1587	-10.	.1841	-9.	.2119	-8.	.2420	-7.	.2743	-6.	.3085	-5.
.3446	-4.	.3821	-3.	.4207	-2.	.4602	-1.	.500	0.0	.5398	1.
.5793	2.	.6179	3.	.6554	4.	.6915	5.	.7257	6.	.7580	7.
.7881	8.	.8159	9.	.8413	10.	.8643	11.	.8849	12.	.9032	13.
.9192	14.	.9332	15.	.94452	16.	.9554	17.	.9641	18.	.9713	19.
.9773	20.	.9861	22.	.9918	24.	.9953	26.	.9974	28.	.99865	30.
.99977	35.	.99997	40.								

2 FUNCTION RN1,C11

.0	-7.50	.00003	-3.0	.00135	-2.25	.0227	-1.5	.1587	-.75	.500	0.
.8413	.75	.9773	1.50	.9918	2.25	.99997	3.0	.999997	.50		

3 FUNCTION RN1,C17

.00003	-10.	.0026	-7.	.0002	-6.	.0227	-5.	.0548	-4.	.1151	-3.
.2119	-2.	.3446	-1.	.500	0.	.6554	1.	.7881	2.	.8849	3.
.944524.		.9773	5.	.9918	6.	.9974	7.	.99997	10.		

* IN THE FOLLOWING FUNCTIONS FOR EAT ASSIGNMENT AND BOLTER INTEGRATION,
 * A SPACE IS LEFT IN THE APPROACH FOR ANOTHER A/C -- (1-4) SPACE (5-9) SPACE
 * (10-15) SPACE (16-21) SPACE (22-27) SPACE (28-30)

4 FUNCTION P4,D30

1.	60.	2.	120.	3.	180.	4.	240.	5.	360.	6.	420.
7.	480.	8.	540.	9.	600.	10.	720.	11.	780.	12.	840.
13.	900.	14.	960.	15.	1020.	16.	1140.	17.	1200.	18.	1260.
19.	1320.	20.	1380.	21.	1440.	22.	1560.	23.	1620.	24.	1680.
25.	1740.	26.	1800.	27.	1860.	28.	1980.	29.	2040.	30.	2100.

5 FUNCTION P4,D30

1	4	2	3	3	2	4	1	5	5	6	4
7	3	8	2	9	1	10	6	11	5	12	4
13	3	14	2	15	1	16	6	17	5	18	4
19	3	20	2	21	1	22	6	23	5	24	4
25	3	26	2	27	1	28	3	29	2	30	1

 ***** VARIABLE DEFINITIONS *****

- 1 VARIABLE X21+K100
- 2 VARIABLE FN3+K10
- 3 VARIABLE P2-K1
- 5 VARIABLE FN1*K5+K14400
- 6 VARIABLE K10*FN4+P12+K12000
- 11 VARIABLE P1+P4
- 18 VARIABLE Y42+K1
- 20 VARIABLE K91+P4*K10+X100
- 21 VARIABLE X100+K1
- 22 VARIABLE X97+K25
- 23 VARIABLE K296+P4*K5+X90
- 24 VARIABLE X90+K1
- 25 VARIABLE X98+K10
- 26 VARIABLE X96-X97
- 28 VARIABLE X98-K6

29 VARIABLE X9A-K9
 30 VARIABLE Y*5+X*6
 31 VARIABLE K0-K4
 32 VARIABLE X98-K3
 33 VARIABLE K24-X*7

 * GENERATE FLIGHTS, TIME IN UNITS OF 1/10 SECOND
 *

1 GENERATE 30000,,0 ONE FLT EVERY HOUR
 2 SAVEVALUE 21,V1 TEMP. STORE LAST FLT NO.
 3 ASSIGN 1,X21 FLT NO IN P1
 4 ASSIGN 2,V2 FLT SIZE IN P2
 5 MARK 12 RECORD START TIME FOR RECOVERY OF FLT
 6 SPLIT V3,NEXT,4 CREATE INDIV. A/C AND SERIALIZE P4
 7 NEXT ASSIGN 7,K24 VELOCITY IN P7
 8 ASSIGN 5,V5 FUEL REMAINING (SEC) IN P5

 * MARSHAL, ASSIGN TIME TO START APPROACH (1-MIN APART)
 *

9 MARK RECORD START TIME FOR INDIV A/C TRANSIT TIME
 0 SEIZE 11 COMM CHAN
 1 ADVANCE 100 T1
 2 SEIZE 2 MC
 3 ADVANCE 150 T2
 4 ASSIGN 6,V6 START APPROACH TIME IN P6
 5 ADVANCE 20 T3
 6 SPLIT 1,SBD1
 7 RELEASE 2
 8 RELEASE 11
 9 TRANSFER ,MARSH

*****TIME LOOP -- MC CHECKS MARSHAL A/C PATTERN*****

0 GENERATE 1000,500 SIM T6 - T13
 1 SEIZE ?
 2 SEIZE 11
 3 ADVANCE 250
 4 RELEASE 11
 5 RELEASE 2
 6 TERMINATE

 * STATUS BOARD

SAVEVALUES LOCATION

	TD	DTG	FUEL	TIME	REMARKS
* AC1	301	302	303	304	305
* AC2	306	307	308	309	310
* AC3	311	312	-	-	315
* -	-	-	-	-	/
* AC20	396	397	398	399	400

*****STATUS BOARD UPDATING*****

7 SBD1 SEIZE 3
 8 SAVEVALUE 90,K0
 9 SAVEVALUE V23,V11 ID
 0 SAVEVALUE 90,V24
 1 SAVEVALUE V23,P10 DTG
 2 SAVEVALUE 90,V24
 3 SAVEVALUE V23,P5 FUEL REMAINING (SEC)
 4 SAVEVALUE 90,V24
 5 SAVEVALUE V23,C1 TIME OF REPORT
 6 SAVEVALUE 90,I24
 7 SAVEVALUE V23,K0 REMARKKS
 8 ADVANCE 250 40

```

9  RELEASE 3
0  SFIZF 1
1  ADVANCE 10 T5
2  RELEASE 1
3  TERMINATE

```

```

* STATUS BOARD UPDATE
4 PT SPLIT 1,SAD1
5 TRANSFER ,FET

```

*****RADAR/DISPLAY INFORMATION UPDATING*****

DISPLAY INFORMATION
SAVEVALUE LOCATIONS

```

* PARA ACRFT NUMBER
* NO. 1 2 3 4 5 6 --- 10 --- 20
* 1 101 111 121 131 141 191 291
* 2 102 112 --- --- --- 192 292
* 3 103 --- --- --- 193 293
* 4
* -
* -

```

```

* 10 110 120 130 --- 200 300

```

```

6 DISP SAVEVALUE 100,K0
7 SAVEVALUE V20,P1
8 SAVEVALUE 100,V21
9 SAVEVALUE V20,P2
0 SAVEVALUE 100,V21
1 SAVEVALUE V20,P3
2 SAVEVALUE 100,V21
3 SAVEVALUE V20,P4
4 SAVEVALUE 100,V21
5 SAVEVALUE V20,P5
6 SAVEVALUE 100,V21
7 SAVEVALUE V20,P6
8 SAVEVALUE 100,V21
9 SAVEVALUE V20,P7
0 SAVEVALUE 100,V21
1 SAVEVALUE V20,P8
2 SAVEVALUE 100,V21
3 SAVEVALUE V20,P9
4 SAVEVALUE 100,V21
5 SAVEVALUE V20,P10
6 TERMINATE

```

*****MARSHAL*****

```

7 MARSH TEST LF F6,C1 A/C HELD UNTIL TIME TO START APPROACH

```

*****SIMULATE APPROACH ONE TENTH MILE AT A TIME*****

```

8 ASSIGN 10,K200 P10 USED AS LOOP COUNTER, MILES TO GO
9 SPLIT 1,SAD1
0 BEGIN ASSIGN 7+,FN2 A/S ERROR IN P7
1 ASSIGN 8+,FN3 L-R ERROR IN P8
2 ASSIGN 9+,FN1 G/S ERROR IN P9
3 ASSIGN 6,C1 ARRIVAL TIME RECORDED IN P6
4 SPLIT 1,DISP UPDATE RADAR - DISPLAY INFO
5 TEST NE P10,K100,RPT 41

```

```

6 TEST NE P10,K70,RPT
7 TEST NE P10,K60,RPT
8 TEST NE P10,K5,RPT
9 RET ADVANCE P7 ADV CLOCK TIME TO TRAVEL 1/10 MILE
0 ASSIGN 5-,P7 DECREMENT FUEL REMAINING
1 TEST E V11,X23,SKIP CONTROL ONLY PROPER A/C (ID IN X23)
2 SAVEVALUE 23,K0 CLEAR A/C ID FLAG
3 ASSIGN 7+,X24 CONTROL A/S
4 ASSIGN 11,X25 TIME TO WAG
5 LOGIC R 1
6 TEST NE P11,K0,SKIP TEST TO SEE IF WAG
7 ADVANCE P11 HOLD FOR THE TIME COMMANDED
8 ASSIGN 5-,P11 DECREMENT FUEL
9 SKIP PUFFER
0 LOOP 10,REGIN KEEP LOOPING UNTIL 20 MILES
1 SPLIT 1,SR01

```

* UPDATE STATISTICS AS ACFT LAND

```

2 TEST LE P1,K100,TABUL PRINT AS EA A/C OF FIRST FLT LANDS
3 PRINT ,.P PRINT PARAMETERS AS EACH A/C LANDS
4 PRINT 1,500,X OUTPUT ALL SAVEVALUES
5 TABUL TABULATE 1 UPDATE A/S TABLE
6 TABULATE 2 UPDATE HDG TABLE
7 TABULATE 3 UPDATE G/S TABLE
8 TABULATE 4 UPDATE FUEL TABLE
9 TABULATE 7 UPDATE TRANSIT TIME TABLE
0 TEST E P4,K1,OTHR
1 SAVEVALUE 41,C1
2 HER SAVEVALUE 42,V1A USE X42 AS A COUNTER
3 TEST GE X42,P2,JUMP IF X42 GE NO. IN FLT TAB RECOVERY TIME
4 ASSIGN 12,X41
5 TABULATE 8 TABULATE RECOVERY TIME
6 SAVEVALUE 102,K0 SET FLT SIZE = 0
7 SAVEVALUE 42,K0 RESET COUNTER
8 JUMP TERMINATE 1

```

**** CHECK SEPARATION - ALL BY ONE OPERATOR ****

* PARAMETER ASSIGNMENTS FOR SEPARATION LOOP

```

* 1 110,120,130....
* 2 P1+K10
* 3
* 4 FLT SIZE
* 5 LOC. OF SER. NO.
* 6 LOC. OF FLT SIZE
* 7 LOC. OF A/S OF A/C UNDER CONTROL
* 8
* 9
* 10 0 = NO CONT., 1 = UNDER CONTROL

```

```

0 GENERATE 1,.,1
0 JAN TEST G X102,K0 NO SCAN UNLESS THERE IS A FLT
1 SEIZE 4
2 ASSIGN 4,X102 LOAD P4 WITH FLT SIZE
3 SAVEVALUE 98,K100
4 CHK1 SAVEVALUE 98,V25 START AT 110, INC BY 10
5 ASSIGN 5,V28 LOAD P5 WITH LOC OF SER NO
6 ASSIGN 6,V29 LOAD P6 WITH LOC OF FLT NO
7 TEST NE X*5,K1,JMP JUMP TO END FOR A/C NO 1

```

```

8 ASSIGN 1,X99 P1 HAS X WITH DIST OF A/C A
9 ADVANCE 1
0 TEST G X*1,K90,JMP NO SEPARATION CONTROL DURING THE LAST 8 MILES
1 ASSIGN 2,V25 P2 HAS X WITH DIST OF A/C B
2 ASSIGN 10,K0
3 RECK SAVEVALUE 96,X*1 MOVE CONTENTS P1 TO X96
4 SAVEVALUE 97,X*2 MOVE CONTENTS P2 TO X97
5 TEST G V26,K0,JMP NO SCAN IF A/C IS NOT IN FRONT
6 ADVANCE 10,5 TIME FOR THE COMPARISON
7 TEST G V26,K40,CONT
8 SAVEVALUE 97,V22
9 CONT TEST G V26,K13,CLOSE
0 TEST L V26,K30,FAR
1 TEST G P10,K0,JMP
2 TEST LE V26,K30,WATCH
3 TEST GE V26,K20,WATCH
4 SAVEVALUE 23,V30
5 ASSIGN 7,V32
6 SAVEVALUE 24,V33
7 SAVEVALUE 25,K0
8 PRINT 23,25,X
9 LOGIC S 1
0 GATE LR 1
1 JMP LOOP 4,CHK1
2 RELEASE 4
3 BUFFER
4 ADVANCE 10
5 TRANSFER ,SCAN
***** IF DIST IS WITHIN ROAD TOL. WAIT THEN CHECK AGAIN
6 WATCH ADVANCE 150
7 TRANSFER ,RECK
***** IF A/C IS TOO CLOSE TO THE ONE IN FRONT
8 USE ASSIGN 5,V28
9 ASSIGN 6,V29
0 ASSIGN 10,K10
1 SAVEVALUE 23,V30 10 OF A/C TO BE CONTROLLED
2 SAVEVALUE 24,K4 DECREASE A/S BY APPROX 25K
3 SAVEVALUE 25,K0
4 PRINT 23,25,X
5 LOGIC S 1
6 GATE LR 1
7 RELEASE 4
8 ADVANCE 300,100 WAIT 30+/-10 SEC, OPERATOR FREE
9 SEIZE 4
0 TRANSFER ,RECK
***** IF A/C IS TOO FAR FROM THE ONE IN FRONT
1 FAR ASSIGN 5,V28
2 ASSIGN 6,V29
3 ASSIGN 10,K10
4 TEST LF X*7,K32,NCON
5 SAVEVALUE 23,V30
6 SAVEVALUE 24,V31
7 SAVEVALUE 25,K0
8 PRINT 23,25,X
9 LOGIC S 1
0 GATE LR 1
1 NCON RELEASE 4
2 ADVANCE 300,100 WAIT 30+/-10 SEC, OPERATOR FREE
3 SEIZE 4
4 TRANSFER ,RECK

```

* INSURE AN EVENT OCCURS EVERY 60 SEC.

```

5 GENERATE 600
6 TERMINATE

```

*
* TABLE DEFINITIONS
*

* EACH TABLE IS A FREQUENCY DISTRIBUTION

* AIRSPEED (SEC/MI)

* 1 TABLE P7,10,1,30

* HEADING ERROR

* 2 TABLE P8,-50,1,101

* GLIDESLOPE ERROR

* 3 TABLE P9,-50,1,101

* FUEL REMAINING (SEC)

* 4 TABLE P5,0,10,30

* INDIVIDUAL A/C TRANSIT TIME

* 7 TABLE M1,3600,100,100

* RECOVERY TABLE

* 9 TABLE MP12,3000,300,90

* RUN SIMULATION FOR THE RECOVERY OF A NUMBER OF FLIGHTS TO COLLECT AN
* ADEQUATE SAMPLE FOR STATISTICAL ANALYSIS.
*

START 10

Distribution List for
"An Analysis and Evaluation Methodology
for Command and Control-Final Report"

	<u>No. of Copies</u>
Office of the Chief of Naval Operations Department of the Navy Washington, D.C. 20350 (OP-964)	1
(OP-966) CDR. McCaffery	1
Office of Naval Research 800 N. Quincy Street Arlington, Va. 22217 Code 200	1
Code 431	1
Code 455	3
Dr. E. E. Coyle Office of Naval Research Branch Office 1030 East Green Street Pasadena, California 91106	1
Navy Personnel Research and Development Center San Diego, California 92152 (Technical Library)	1
Center for Naval Analysis 1401 Wilson Boulevard Arlington, Va. 22209 (Library)	1
Defense Contract Administration Services 14450 Erwin Street Van Nuys, California 91408	1
Defense Documentation Center Cameron Station Alexandria, Va. 22314	12

Enclosure (1)