

12 FG



UNIVERSITY OF NEVADA - RENO - NEVADA - 89507

Mockoy School of Mines
Seismological Laboratory

FINAL REPORT

Telephone (702) 784-4975

10 April 1976

ADA024359

ARPA Order No.	2134
Program Code	2F10
Name of Contractor	University of Nevada, Reno
Contract Expiration Date	30 November 1975
Amount of Contract Dollars	\$309,291
Contract Number	F44620-72-C-0069
Principal Investigators	William A. Peppin, 702-784-4975 Alan Ryall, 702-784-4975
Program Manager	Alan Ryall, 702-784-4975
Short Title of Work	NEAR FIELD SMALL EARTHQUAKE LONG PERIOD SPECTRUM
Report Prepared By	William A. Peppin

See 1473

AIR FORCE OFFICE OF SCIENTIFIC RESEARCH (AFOSR)
 NOTICE OF TRANSMISSION TO DDC
 This technical report has been reviewed and is
 approved for release to the public under E.O. 11652 (7b).
 Distribution is unlimited.
 A. D. LADD
 Technical Information Officer

Sponsored by

Advanced Research Projects Agency

ARPA Order No. 2134

DDC
 RECORDED
 MAY 11 1976
 REGULATED
 B

TABLE OF CONTENTS

	Page
Introduction	1
I. SYSTEM DEVELOPMENT AND STATION DEPLOYMENT	1
<u>A. System Development</u>	1
<u>B. Station Deployment and Data Collection</u>	3
II. SIGNIFICANT RESULTS OBTAINED FROM THE NEVADA-WASHINGTON THEORY	3
<u>A. Long-Period Spectral Level</u>	4
<u>B. Explaining the Long-Period Spectrum</u>	5
III. RESEARCH AT NEVADA AND EARTHQUAKE SOURCE THEORY	6
<u>A. P-Wave Spectra of Nevada Test Site Events</u>	6
<u>B. Spectral Investigations of the Oroville Earthquake</u>	14
<u>C. P- and SV-Wave Corner Frequencies</u>	17
<u>D. A Scaling Law for Explosions in Tuff</u>	22
IV. ABSTRACTS OF OTHER RECENT PUBLICATIONS	26
V. SEISMIC SOURCE THEORY: CURRENT KNOWLEDGE	32
<u>A. What Has Been Learned of Earthquake Sources</u>	32
<u>B. What Remains Unknown of Earthquake Sources</u>	32
<u>C. What Data Remains to be Collected</u>	34
<u>D. Cause of the Ms:mb Discriminant</u>	34
VI. REFERENCES CITED	35
VII. PUBLICATIONS COMPLETED DURING THE NEAR-FIELD PROJECT	40

ACCESSION for	
NTIS	White Section <input checked="" type="checkbox"/>
DTIC	Red Section <input type="checkbox"/>
UNANNOUNCED	<input type="checkbox"/>
JUSTIFICATION	
BY	
DISTRIBUTION AVAILABILITY CODES	
Dist.	Avail. Code/Sec. Code
A	

INTRODUCTION

This document constitutes the final report covering participation of the University of Nevada in the Near Field Project (NFP) of Central California, sponsored by the Air Force Office of Scientific Research. We first summarize system development, station deployment, and data gathered by the Nevada-Washington long-period array. We then discuss significant results that have arisen from these data. The third section describes research done at Nevada aimed at understanding the earthquake source. The final section, based on what has been learned to date, addresses the following important questions: (1) what is known about earthquake sources? (2) what remains unknown about earthquake sources? (3) what data remains to be collected? (4) what causes the body wave-surface wave discriminant between earthquakes and underground nuclear explosions?

I. SYSTEM DEVELOPMENT AND STATION DEPLOYMENT

A. System Development

One major problem of the NFP was that earthquakes never occur at exactly the right spot. Thus, although numerous earthquakes occurred around the Hollister area during the operational time of the NFP, none was satisfactorily recorded by the near-field instruments operated by the University of California. Heloberger (1974), Bakun and Bufe (1975), and Heloberger and Malone (1975) have shown how strongly propagation effects modify observed seismograms in the Central California region (at the expense of information about the source). Thus, complete azimuthal coverage by the University of California close-in array was crucial in the study of several key points; how do spectral corner frequencies vary with azimuth? How do P- and S-wave corner frequencies relate?

This information is crucial if we are to evaluate any possible role of rupture propagation at the source (Peppin and Simila, 1976).

One way to avoid the problem of earthquakes not occurring in the ideal spot is to design maximum portability into field gear which is also capable of recording the necessary bandwidth and dynamic range. With self-contained stations, the recording sites could be moved in hours to the aftershock zone of an earthquake, and the required azimuthal coverage secured by knowledge of the aftershock epicenters. It was for this purpose that our technical staff has designed and built a three-component, digital, event-recording package. The electronics and tape recorder for this unit are contained in a small suitcase that weighs 25 pounds, and can be carried by rucksack. The unit is low power (50 ma at 12 volts), and can be driven by air cells for many weeks. The system response for very rapid field setups is 0.2 to 50 (or more) Hz, flat in either displacement or velocity (the latter the choice for small events: higher gain at higher frequencies). In more careful field setups, the LF passband can be extended to about .05 Hz. A trigger circuit continuously monitors ground motion and is activated by a sudden increase in 3-Hz ground motion. The trigger activates the tape recording mechanism. The three components are serially digitized (12-bit resolution, 1 to 16 gain ranging) and recorded, along with WWVB timing (filtered and passed through a Schmidt trigger) on tape. An 8-second shift register permits recording the onset of P and a noise sample preceding the event. A block diagram of the unit is shown in Figure 1. Unfortunately, the unit was not completed in time for its use by

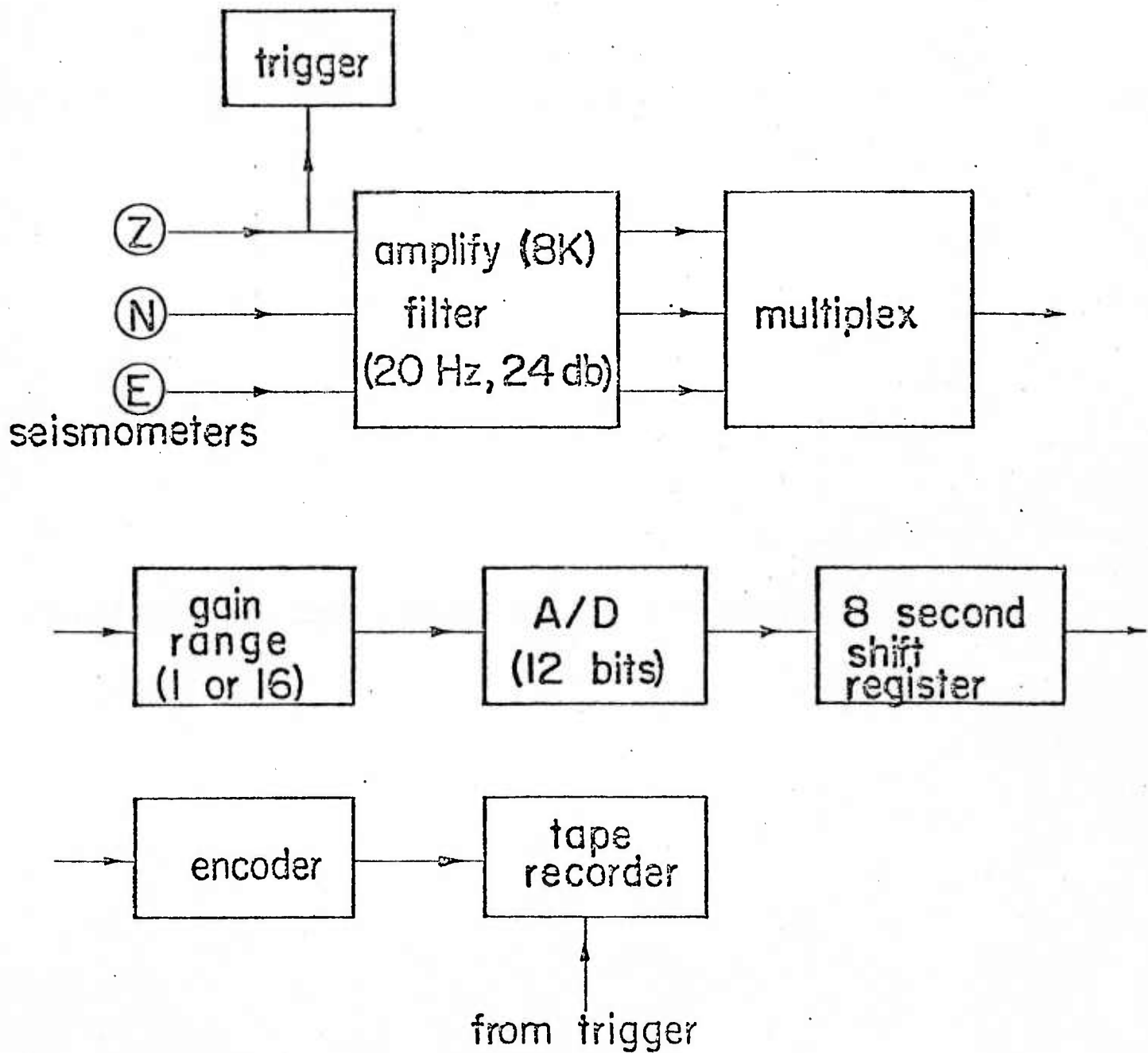

Figure 1. Block diagram of wideband digital seismic event recorder.

the NFP; but we plan to use it for source studies in the Nevada region, thus eventually carrying out the objectives of the NFP.

A concurrent development has been the general conversion of Laboratory facilities to permit processing of expected large volumes of digital data from the event recorders. Full analog/digital, digital/analog capability now exists in the Laboratory, including the capability of decoding the tapes written by the event recorders in the field. With funds from AFOSR, NSF, and the USGS we have invested considerably in software development for the laboratory mini-computer, and in a floppy disc. We plan to construct a batch processing line to the main University computer, giving high-volume, high-speed analysis capability: ideal for data analysis in connection with source studies. I believe this effort will result in very significant new data on the earthquake source within 12 months.

B. Station Deployment and Data Collection

The Nevada-Washington array operated at design specifications for the duration of the NFP. Station deployment and data collected are described in our previous technical reports. The Thanksgiving Day 1974 sequence, plus several other events in 1975 provided some additional data; however, since the change to the Kronos 2.1 system on the University computer, we have been unable to decode the tapes written by the Washington system. S. D. Malone carried out some preliminary analysis on these events, and therefore it was not thought profitable to pursue efforts to analyse these additional data.

II. SIGNIFICANT RESULTS OBTAINED FROM THE NEVADA-WASHINGTON ARRAY

The primary function of the NFP was to record successfully, over a range of distance and azimuth, a moderate, local earthquake. The Nevada-Washington array was to record the long-period (1-20 second) energy at 20-50 km. This it

successfully did for a number of earthquakes. The question is: are the long-period spectra flat as predicted by the commonly-accepted versions of dislocation theory, or are they peaked, as predicted by Archambeau's (1968) theory with R_s finite?

A. Long-Period Spectral Level

The long-period spectral level can be used to compute seismic moment M_0 if certain simplifying assumptions are made (Aki, 1966; Brune, 1970). This quantity measures directly the strength of the source. For a uniform, flat dislocation on a fault of area S , where the medium at the source has rigidity μ , we can estimate the fault offset Δu by the relation (Burridge and Knopoff, 1964) $M_0 = \mu \Delta u S$.

Moments have been computed for the events recorded, two of which (22 June, 1973 and 06 July 1974) were recorded by the close-in University of California array. A most significant result is this: moments for these events computed using the close-in data and Brune's (1970) theory are a factor of 2 to 3 higher than those computed from the Nevada-Washington array using the same theory (Turnbull, 1974; McEvilly, 1975, personal communication; see also Part III of this report). If the discrepancy holds up, it calls into question the basic assumption of flat spectra at long periods, first documented by Brune and King (1967); this is required by dislocation theory. Possible explanations for the discrepancy include: (1) failure of dislocation theory at close in distances; (2) domination and enhancement of the close-in, long-period spectra by near-field terms or ground tilt; (3) nonlinear ground amplification and response near the source due to strong ground motions. A mistake in the analysis is probably ruled out, as the phenomenon has been checked rather carefully by several members of the NFP. We disagree with Archambeau

(personal communication, 1975) that the moment discrepancy signals the invalidity of shear dislocation theory; far too many other seismic observations support this model, and it has a compelling physical basis that corresponds well to observed ground faulting. Moreover, spectra of seismograms recorded by the NFP appear flat in character, except possibly some rise to long periods due to near-field terms (i.e. no sign of Archambeau's overshoot anywhere). Work by Johnson and McEvilly (1974) indicates that the effect of ground tilt does not alter significantly the estimated long-period level. Therefore, we favor the third explanation of the discrepancy given above (nonlinear effects due to strong shaking). The problem wants careful study, but corroboration of this explanation comes from work by Aki et al. (1974). They find the same result when they compare close-in and far-field observations of underground nuclear explosions. Explosions and earthquakes are quite different seismic sources; therefore, an explanation of the near-field/far-field moment discrepancy in terms of non-source effects is indicated.

B. Explaining the Long-Period Spectra

Archambeau (personal communication, 1975) claims that the long-period, Nevada-Washington spectra admit no simple explanation such as Brune's (1970) theory. However, dislocation theory seems fully capable of explaining the character of these spectra. Malone (1974) and Helmberger and Malone (1975) have demonstrated how, using a simple dislocation model, severe modulation of the long-period spectrum can arise in spite of simplicity at the source. In the former paper the modulation is explained as interference of the near-field terms (which fall off as r^{-2}) with the far-field terms of the displacement field. In the latter paper, layer reverberations are taken as the cause of the modulation, again using a very simple dislocation source. We conclude that no

datum uncovered by the NFP compels rejection of the shear dislocation model for earthquakes, that is, we need not go to the more complex source theory of Archambeau (1968) to explain observations of earthquakes so far collected.

III. RESEARCH AT NEVADA INTO EARTHQUAKE SOURCE THEORY

My interest has been in elucidating details at the source of earthquakes. Because of my late entry into the NFP, and because the Washington group was well along in the analysis of the Nevada-Washington data, I did only minimal work with it. The main thrust of my research efforts have been aimed at the collection and analysis of spectral data in terms of seismic sources. This has led to a number of publications, including one manuscript within a week of completion. In this section we describe the principal results of these and then summarize the main points as they relate to seismic sources.

A. P-Wave Spectra of Nevada Test Site Events at Near and Very-Near

Distances: Implications for a Near-Regional Body Wave-Surface Wave

Discriminant (to appear: June 1976 Bulletin of the Seismological Society of America)

A detailed study of 140 P-wave spectra and their corner frequencies for events on Nevada Test Site (NTS) has been made using three data sets, denoted D1, D2, and D3. Set D1 includes close-in (2.4 to 13.7 km) seismograms written by three-component, 50-Hz accelerometers (at two gain levels with 32 db separation) of the large explosions JORUM (1430 GCT, 16 Sept 1969, 1100 ktons, $M_L = 6.2$), PIPKIN (1430 GCT, 08 October 1969, ca. 150 ktons, $M_L = 5.7$), and HANDLEY (1900 GCT, 26 Mar 1970, 1100 ktons, $M_L = 6.3$). Set D2 includes three-component, 50-Hz accelerometer data at 4 km from HANDLEY, and wideband (.1-20 Hz) velocity data at 18 and 29 km from HANDLEY and 30 km from PIPKIN. Set D3 includes wideband (.03-20 Hz) velocity data from 45 NTS events including earthquakes and

explosions, as recorded by the University of California Lawrence Livermore Laboratory (LLL) array at near-regional (200-300 km) distances. We first summarize the significant aspects of the data, and then discuss some possible inferences about earthquakes and explosions as seismic sources.

1. Significant Aspects of the Data

a. Data Set D1 (close-in accelerometer data)

Data set D1 (20 seismograms) has provided important information on the seismic source spectrum of underground explosions in tuff. The spectra, characterized by good signal-to-noise ratio, provide four important constraints on the seismic source spectrum: (1) they are flat from 0.1 Hz to the corner frequency, showing minimal spectral overshoot; (2) the corner frequencies are higher than predicted by any recently-published scaling curves at one megaton (1.5 to 2.0 Hz: Peppin, 1976, Table 1); (3) the corner frequencies scale with yield as $(\text{yield})^{-.100}$, far slower than for any recently-published scaling curves; and (4) the spectra decay to high frequency as least as frequency cubed.

b. Data Set D2 (close-in accelerometer and L-7 system data)

Data set D2 (15 seismograms) provides additional close-in data of the large explosions. These data corroborate the results of Data Set D1 above with its important implications for source theory.

c. Data Set D3 (near-regional, broadband data)

Several points have been well established by the spectral data taken from this data set (100+ seismograms), other less definitely so. Best established is the relation between 0.8 to 1.0-Hz Pg spectral amplitude and 12-second Rayleigh amplitude. Now the former quantity should be a measure of body wave magnitude m_b , while 12-second Rayleigh amplitude correlates well with yield

(Evernden and Filson, 1971). Plots of these quantities as determined at the three LLL stations Mina, Kanab, and Landers show linear scaling (with unit slope) over more than three orders of magnitude (Figure 2). As reported by Springer and Hannon (1973), who found similar results, it is very difficult to satisfy these data with conventional scaling laws which utilize cube-root scaling.

Some less definitive results

(i) Spectral overshoot

The most prominent of the less definitively-established results is spectral overshoot ratio. Most of the Pg spectra of this data set are strongly peaked due to layer reverberations (Peppin, 1976, Table 5). However, no variation in overshoot for different shot media could be seen. This supports Cherry et al. (1973), who, based on theoretical calculations of conditions close to the source, find flat source spectra for explosions in all media; it appears contradictory to the results of Werth and Herbst (1963), however.

(ii) Separation of explosions from NTS earthquakes

Of interest is the fact that, in Figure 2, explosions and earthquakes are indistinguishable. This is surprising, because we have plotted a "body-wave" quantity, 1-Hz Pg spectral amplitude, versus a "surface-wave" quantity. We should have expected separation based on the known effectiveness of the teleseismic Ms:mb discriminant (SIPRI, 1968). A similar result is found in Figure 3, where we plot spectral corner frequencies of explosions and earthquakes recorded at near-regional distances (200-350 km). In spite of published claims to the contrary (Wyss and Brune, 1970; Wyss et al., 1970) it is impossible to tell explosions from earthquakes based on gross differences in the spectral corner frequencies for events of comparable magnitude.

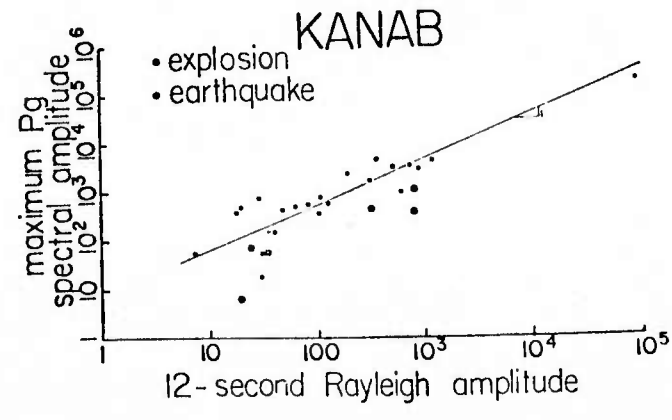
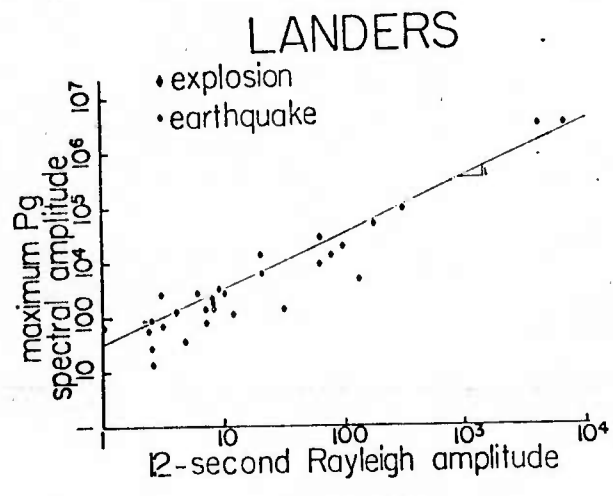
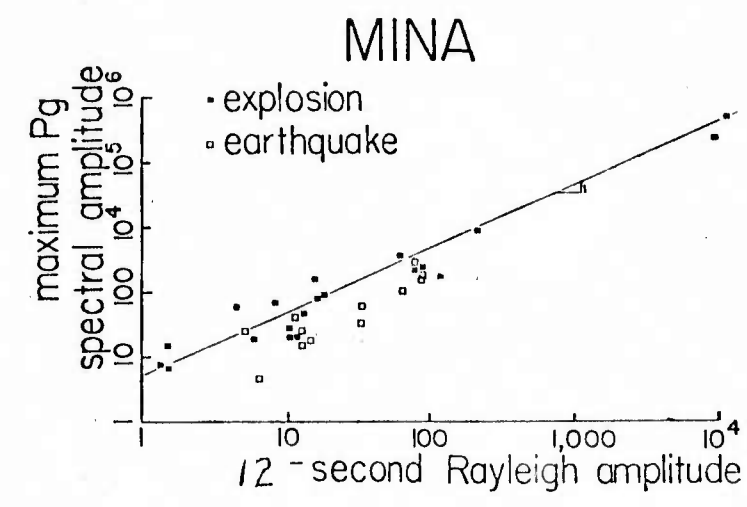

Figure 2. 0.8-1.0-Hz (averaged) P_g spectral amplitude versus 12-second Rayleigh wave amplitude as recorded at the LLL stations. The lines in the figures have unit slope.

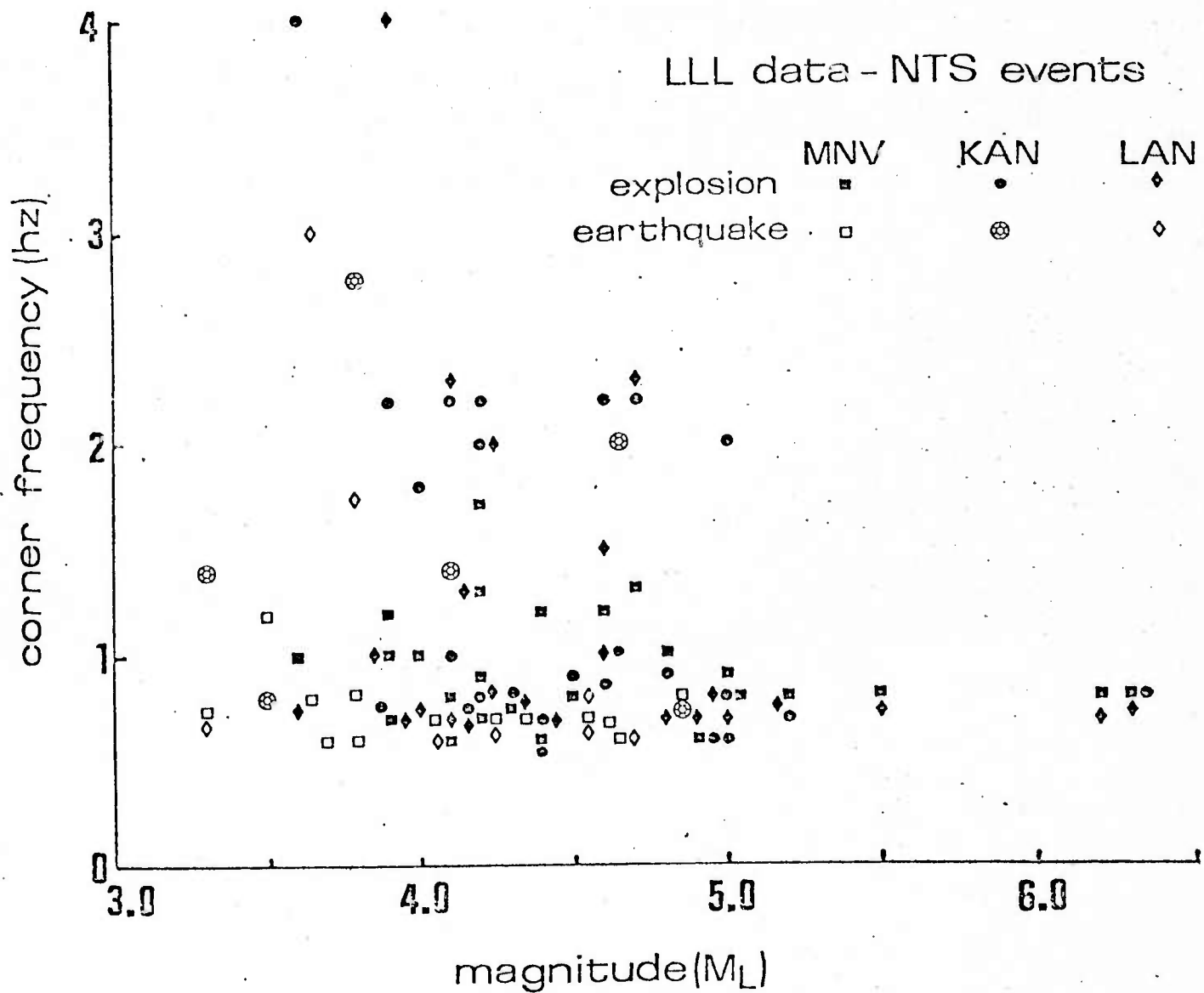

Figure 3. Spectral corner frequencies of explosions and NTS earthquakes as recorded by the LLL stations. Note that explosions and earthquakes are indistinguishable on this plot.

(iii) Contamination of whole-record spectra

Another result obtained from the LLL data is important. Many published spectra of explosions are computed from whole-record seismograms (Lynch, 1969). Thus, they are contaminated by surface waves. This contamination is evidently important, because while Lynch (1969) finds that spectral amplitudes cube-root scale, the data in my paper, which include P-only spectra, do not cube-root scale. This serves a warning to those who would use whole-record spectra (or event surface-wave ones) to construct scaling curves: These waves are probably much more influenced by the propagation path than are the body waves. In support of this claim, note that the depth of burial of NTS explosions cube-root scales to a good approximation (Murphy, 1975, personal communication). Thus, we have a ready explanation of the discrepancy between P-only and whole-record spectra: the cube root scaling of whole-record spectra, rather than showing cube root scaling of the source, is just measuring the shot depth. Based on recently-published papers on the effect of layers and shot depth on the spectra, such an explanation is reasonable.

2. Implications of These Data on the Ms:mb Discriminant

The data summarized here bear upon the question of what causes the body wave-surface wave, or Ms:mb discriminant between earthquakes and underground nuclear explosions (for a good review of this subject, see SIPRI, 1968). Presently seismologists disagree as to the cause of this discriminant. The theories that attempt to explain it can be broken into four groups. These four adopt as the cause of the discriminant either: (1) spatial source dimension, (2) the shape of the source spectrum, (3) source rise time, or (4) other causes. We discuss each of these in order.

a. Spatial source dimension

Suppose that source dimension is defined roughly as the maximum linear dimension of the surface that surrounds either the explosion or earthquake hypocenter outside of which elasticity theory applies. For earthquakes this might be related to the dimension of faulting and for explosions it is called the equivalent elastic radius. Those who believe that the source dimension causes the $M_s:m_b$ discriminant also believe that, for the same M_s , earthquakes have far larger source dimensions. Therefore, in analogy to electromagnetic radiation from quarter-wavelength antennas (Keylis-Borok, 1961), this theory would predict greater radiation of high frequency energy from explosions compared to earthquakes of similar M_s (Wyss and Brune, 1970; Wyss et al., 1971). The discriminant is thus explained as a corner frequency phenomenon, with explosions producing a higher corner frequency, thus higher value of m_b relative to M_s for sources of the same M_s . Some workers have found this explanation deficient, and have so stated in the literature (Molnar, et al., 1969; Tsai and Aki, 1971; McEvelly and Peppin, 1972; Peppin and McEvelly, 1974). The spectral data of Figure 3 in this study show no significant deviation of explosion from earthquake corner frequencies at the three LLL stations, so it appears that the $M_s:m_b$ discriminant found in Peppin and McEvelly (1974) cannot be explained by this idea.

Evernden (1975) also believes that the source dimension causes the discriminant, but on different grounds. He invokes Archambeau's (1968) source theory to show that the data demand very large source dimensions, even for small earthquakes (the whole world undergoes a stress change as a result of even a small earthquake). The problem with this idea is that it assumes small source dimensions for explosions when by the same reasoning, they should also cause a stress change over the whole world. That is, since both explosions and earthquakes can be represented as a combination of force dipoles, the stresses and

displacements suffer the same geometric decay respectively with distance for either source type.

6. Shape of the source spectrum

Some authors believe that the shapes of the far-field source spectra of explosions and earthquakes are different. In particular, explosion source spectra are thought to be peaked, earthquake ones flat at long periods with no peaking (Lieberman and Pomeroy, 1969; Molnar et al., 1969; Tsai, 1972; Aki et al., 1974). This implies a steplike time history for earthquakes, and an impulse-like one for explosions. Then the $M_s:mb$ discriminant arises as follows. We assume M_s and mb are, respectively, proportional to 20-second and 1-second spectral level of the source spectrum. Imagine an earthquake and an explosion of the same mb . Then the M_s values must differ because the spectral shapes are different (if they are normalized to have the same 1-second amplitude, the 20-second amplitude must differ). We have seen that the near field data for explosions in tuff show no overshoot. Yet Aki et al. (1974), based on data from the OSCURO and MONERO explosions, each in Yucca Flat tuff, inferred a peaked scaling law. The 37 close-in spectra of this study are self-consistent and show uniformly flat spectra with no overshoot, which is a strong argument against such an explanation of the $M_s:mb$ discriminant, at least for these explosions. A further objection to this explanation is that the proportionality between the 20-second source spectral amplitude and 20-second surface wave amplitude that gives M_s has been established neither theoretically nor empirically. In view of Tsai and Aki's work, where Rayleigh wave spectral amplitude is shown to be a fairly strong function of depth, it would appear that the relationship is not a simple one for many real cases.

c. Source rise time

Some authors believe that explosions have much shorter source rise times (SRT's) than earthquakes of the same magnitude (Davies and Smith, 1968; Marshall, 1970; McEvelly and Peppin, 1972; Peppin and McEvelly, 1974). This would result in discrimination even if the source spectra had exactly the same shape provided: (1) the spectral corner frequencies were caused by the SRT, (2) SRT's of earthquakes were of the order of seconds, and (3) SRT's of explosions were much shorter. Thus the discriminant could again arise as a corner frequency phenomenon, just as for the source dimension. The problems with this explanation are numerous. In the first place, current seismological thinking rejects the possibility that the SRT can be long compared to the ratio of the source dimension to the shear wave velocity (Brune, 1970)(in recent model experiments Archuleta and Brune (1975) have found that the SRT is of such an order that, based on Brune's (1970) theory the corner frequency caused by the SRT would be of the same order as that caused by the source dimension). Furthermore, there is no available evidence that the SRT of small (M_L near 3) earthquakes is anything like a second; just about all studies suggest smaller numbers (Johnson and McEvelly, 1974). In addition there is the data of Figure 3. The corner frequencies of explosions and earthquakes of the same magnitude can differ by little. There appears to be no way the SRT can be the cause of Peppin and McEvelly's (1974) Ms:mb discriminant, and this agrees with the findings of Tsai and Aki (1971).

d. Other explanations

Leet (1962), Douglas et al. (1971), Rodean (1971), and Tsai and Aki (1971) have given explanations of the Ms:mb phenomenon that involve gross differences between explosion and earthquake sources (the one an irrotational

pressure pulse, the other a shear dislocation). Then the discriminant arises because the earthquake generates far more S-wave energy relative to P than the explosion. These S-waves excite Rayleigh waves at the free surface above the source, so that M_s should be proportionately higher (by a factor of .7 to 1.0) for earthquakes of the same P amplitude (i.e. the same mb). This explanation is physically appealing and potentially of great significance, because it would indicate a considerable difficulty in any attempted evasion technique. However, as Douglas *et al.* (1971) point out, there is the problem that explosion sources are generally shallower (by a factor of at least three in the Western U. S.) than earthquakes, so that the depth of focus causes much of the separation predicted theoretically between the two source types to disappear. This occurs because the nearer is the source to the free surface the more energy is transmitted as Rayleigh waves (Peppin, 1974, Figures 12(a), (f)). This and related problems, as yet unresolved, are discussed in Peppin (1974), and will be the subject of another paper. The results of that work indicate that there is presently no theory based on infinitesimal elasticity that definitively explains the M_s :mb discriminant at near-regional distances documented by Peppin and McEvelly (1974).

3. Conclusions

Some 140 spectra of 45 events on Nevada Test Site have been studied. The close-in (3-30 km) data for explosions in tuff give 37 stable, good-quality P-wave spectra that exhibit no overshoot and which decay at least as frequency cubed to high frequency. The corner frequencies are quite high for the explosions compared with those predicted by several recent scaling theories, viz. $1.62 \pm .38$ Hz for 1.1 megaton vertical data (14 observations), and $2.08 \pm .38$ Hz for 150 kton data (5 observations), as compared to .7 and 1.1 Hz predicted

by Murphy and Mueller (1971). The variation with yield is less than would be expected for these events based on existing scaling theories. The near-regional (190-300 km) spectra are less easy to interpret; they admit some definitive and other less certain conclusions. The scaling of $\log 0.8$ to 1.0 Hz Pg spectral amplitude with \log 12-second Rayleigh wave amplitude (and therefore \log yield) is well established as linear with unit slope for $3.6 \leq M_L \leq 6.3$ (ca. 5 to 1100 ktons). On such a plot explosions and earthquakes cannot be distinguished, which suggests a basic similarity in the way these events scale with magnitude. Observed corner frequencies of explosions and earthquakes at near-regional distances are indistinguishable, but due to strong propagation effects no such strong statement can be made about the source spectra of these events; we can say that, for $3.0 \leq M_L \leq 4.8$, the source corner frequencies of explosions and earthquakes can differ by little. Based on these data, it appears that the near-regional Ms:mb discriminant of Peppin and McEvilly (1974) cannot be explained as a spectral corner frequency phenomenon, nor in terms of different source spectral shapes for explosions versus earthquakes. Therefore, the following factors cannot explain this discriminant: (1) the source dimension, (2) the source rise time, or (3) the source time history.

C. Spectral Investigations of the 01 August, 1975 Oroville earthquake sequence, W. A. Peppin, in Oroville, California, Earthquake 1 August 1975, California Division of Mines and Geology Special Report 124, Sherburne and Hauge Ed.

The occurrence of the Oroville earthquakes of 01 August, 1975 and its abundant aftershock sequence provided another excellent source of data of relevance to the NFP. The Seismological Laboratory made a major effort at

obtaining data from this sequence, including the deployment of high-gain epicenter-location gear from 02 August 2300 GCT) to 28 August, 1975 (4 to 7 stations) and of broadband, self-triggering, 50-Hz SMA-2 accelerometers, which operated from 08 to 20 August, and which produced 45 useable accelerograms.

The near-regional University of California broadband array at WDC (150 km NW), BRK (175 km SW) and JAS (175 km SSE) provided an opportunity to follow the same earthquakes out to near-regional distances. Ground displacement spectra were determined for the 16 August, 0548 GCT aftershock ($M_L = 4.0$) using both the close-in accelerometers (epicentral distance 5 km) and the near-regional data. Some interesting information relevant to earthquake source theory was uncovered. This is summarized below.

1. Long-period discrepancy

The close-in data provided a value for the seismic moment of the 16 August event which is three times higher than the value obtained at the near-regional stations, a discrepancy similar to that found between the close-in and near-regional records of the 22 June 1973 and 06 July 1974 Bear Valley events (see above this report). The result is surprising, because all of the spectra we computed were flat at frequencies below a "corner frequency". Thus, there is no easy explanation of this discrepancy in terms of multiple spectral corner frequencies. More data is needed to corroborate this finding, and is in possession of T. C. Hanks of the U. S. G. S.

2. Spectral corner frequencies.

Spectral corner frequencies of the SV and SH-phases recorded on the close-in accelerometers were quite high for events of this magnitude (3.0 to 4.3), falling in the range 10-20 Hz. These values are right at the upper side of spectral parameters obtained by Tucker and Brune (1975) for the San Fernando

aftershocks, indicating relatively high stress drops. This observation might be of importance, because there is some reason to believe that the Oroville earthquake was triggered by the filling of Oroville reservoir in the months March-August 1975. It would be significant if high (relative to other California events) stress drops are associated with man-caused events.

3. Comparison of close-in and near-regional corner frequencies

There is evidence that the Oroville earthquakes were complex events. For example, a partial accelerogram of the Oroville mainshock, obtained by the California Department of Water Resources, shows a duration of not more than a few seconds, with spectral corner frequency near 1.0 Hz. This is totally unlike the clearly-defined corner frequencies (for the P-phase) of .1-.2 Hz found on the JAS and WDC broadband systems. Hart, et al. (1975) have suggested that the Oroville mainshock was characterized by rapid slip on a small section of the fault (causing the close-in accelerometer duration observed) superimposed upon a slow creep over the larger faulting surface (giving the near-regional corner frequencies). If true, the suggestion implies that we are not so close to "routine" estimation of fault parameters as we might hope, at least for these earthquakes.

Data I have collected on a large ($N_L = 5.00$) Oroville aftershock are also suggestive of complex faulting. In Figure 4 we see the P- and SH-ground displacement spectra of this earthquake at Berkeley. The SH-corner frequency is ten times higher than the P-wave one, which is less than .2 Hz. On the other hand, while we were in the field, at a distance of a few km from the epicenter of this earthquake, we experienced the following sensations: a loud, clearly-audible explosion lasting about a second (the P-wave) followed by inaudible motion of the ground for a few seconds (the S-phase). To explain the total

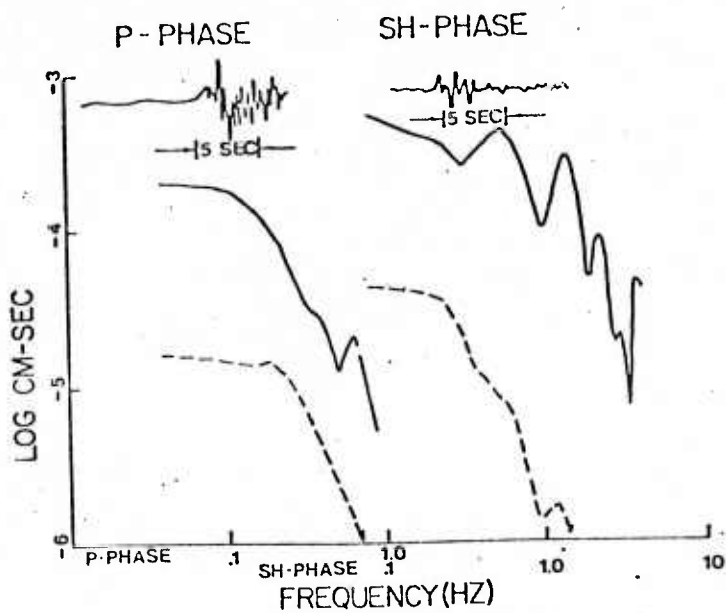

Figure 4. The 02 August 2023 GCT event as recorded at Berkeley vertical (P) and N45W (SH) instruments. Noise spectrum given by dashed line.

inconsistency of duration of P and S at close-in as compared with near-regional distances, a more complex model of faulting than a simple, uniform dislocation seems required.

D. P- and SV-wave Corner Frequencies over Low-Loss Paths: A Discriminant for Earthquake Source Theories? W. A. Peppin and G. W. Simila, submitted to Journal of Physics of the Earth.

One aim of the NFP was to study earthquakes at a wide range of azimuths, so that the details of fault rupture could be inferred. In the absence of adequate data from the Bear Valley arrays, we attempted to find another data set with which to conduct such a study. We selected the University of California broadband system at Jamestown, California (JAS), because: (1) it supplies continuously-recorded data over a wide band (.025 to 10 Hz) at two gain levels, either flat in displacement or velocity, and (2) it provides seismograms of events travelling in and around the Sierra batholith, a known high-velocity, homogeneous body of granites with presumed small attenuation properties. Each of the above qualities is essential if meaningful spectra, capable of providing seismic source parameters, are to be computed.

In this paper we study the relationship between P- and SV-wave spectral corner frequencies in an attempt to resolve apparently contradictory investigations of these which have appeared (Molnar et al., 1973; Stump, 1974; Bakun et al., 1975). We first present the data and method of analysis. We then discuss the implications of these data on recent earthquake source theories.

1. The Data

The events selected for analysis include all well-recorded trans-Sierra Nevada events from 06 July 1974 to 31 August, 1975, and a representative sampling of the many Oroville earthquake aftershocks. Epicenter and magnitude

information is given in Table 1 (Event nos. 1-18). The nature of the travel paths to JAS can be seen in Figure 5, which also shows the distribution of exposed granites. Fault-plane solutions could be constructed only for Events 8-10 (one nodal plane poorly constrained) and Event 17. The mechanism for Event 16 was supplied by Karen McNally (personal communication, 1975), while the mechanisms for Events 3, 4, 5, and 18 are assumed to be represented by the composite solutions of Pitt and Steeples (1975), one of which is shown in Figure 5.

2. Spectral Analysis

The JAS seismograms were digitized at 25 or 50 samples per second after analog alias filtering. A 10% cosine taper was applied and spectral moduli were computed for the entire vertical Pg or Sg phase, then smoothed (3-point triangle window). The instrument response was removed, but not the 10-Hz alias filter response. Identical processing was applied to a noise sample (different for P than for SV) preceding each event. Corner frequencies for all spectra were estimated by overlaying the spectra with a template, flat at long period and decaying to high frequency as frequency squared or cubed (whichever fit the individual spectrum better). The corner frequencies selected are given together with an estimate of their uncertainty in Table 1.

3. Results

The corner frequencies were used to compute \underline{R} , and these values are given in Table 1. The observed value of \underline{R} for all 18 earthquakes is $.96 \pm .17$. The earthquakes represent at least four distinct source areas at widely varying azimuths from JAS; thus, we can safely say that these values, showing equal P- and S-wave corner frequencies to a precision of 20%, are representative of earthquakes in the Sierra Nevada province. The values of \underline{R} are plotted in

TABLE 1

Event no.	Date-Time	Location	Δ JAS (km)	M_L (4)	f_{cP} (5) (Hz)	f_{cS} (5) (Hz)	R	$Q_{\beta} \geq$ (7)
1	06 July 1974	38.77 N 119.63 W	114	3.7	3.8 (G)	5.0 (E)	.76	710
2	13 Aug 1974	38.69 N 119.10 W	137	3.3	2.8 (F)	2.9 (E)	.97	495
3	14 Nov 1974	37.77 N 118.30 W	174	3.3	2.9 (G)	2.8 (G)	1.04	610
4	18 Nov 1974	37.72 N 118.72 W	160	3.2	4.8 (G)	4.3 (G)	1.12	860
5	21 Nov 1974	37.77 N 118.25 W	180	3.4	2.1 (F)	2.3 (G)	.91	515
6	07 Dec 1974	37.99 N 118.79 W	149	3.3	3.0 (G)	3.2 (E)	.94	595
7	25 Feb 1975	37.1 N 117.9 W (1)	251	4.0	2.7 (G)	2.7 (G)	1.00	845
8	05 May 1975	38.61 N 119.73 W	97	3.6	4.3 (G)	3.9 (E)	1.10	(470)
9	05 May 1975	38.61 N 119.73 W	97	3.2	4.0 (G)	4.7 (G)	.85	570
10	07 May 1975	38.61 N 119.73 W	97	3.6	3.7 (F)	3.5 (E)	1.06	(425)
11	01 Aug 1975	39.45 N 121.55 W (2)	175	3.6	3.0 (F)	3.1 (G)	.97	680
12	02 Aug 1975	39.48 N 121.51 W (2)	175	3.8	2.4 (P)	2.5 (G)	.96	545
13	02 Aug 1075	39.47 N 121.49 W (2)	175	3.7	1.5 (P)	2.1 (G)	.71	460
14	04 Aug 1975	39.42 N 121.52 W (2)	175	3.5	2.3 (G)	2.8 (F)	.82	610
15	06 Aug 1975	39.50 N 121.53 W (2)	175	3.6	2.0 (G)	1.4 (G)	1.42	305
16	10 Aug 1975	37.37 N 119.99 W (2)	77	3.8	2.3 (G)	3.0 (E)	.77	(290)
17	16 Aug 1975	39.47 N 121.52 W (2)	175	4.0	2.5 (F)	2.2 (G)	1.14	480
18	17 Aug 1975	37.53 N 120.40 W (2)	160	3.7	2.7 (F)	3.4 (G)	.79	680
A	10 Sept 1965	38.00 N 121.83 W (3)	35 (6)	2.6	4.0 (G)	3.2 (G)	1.25	140
B	11 Sept 1965	38.00 N 121.85 W (3)	35 (6)	2.8	4.0 (F)	3.1 (G)	1.29	135
C	11 Sept 1965	38.01 N 121.85 W (3)	35 (6)	2.4	4.6 (G)	3.2 (F)	1.5	140

- (1) PDE location
- (2) Berkeley locations
- (3) McEvilly and Casaday (1967)
- (4) Berkeley Wood-Anderson magnitudes
- (5) reproducibility of measurements (estimate)
 - E: 5%
 - G: 10%
 - F: >10%
 - P: not well-defined
- (6) distance to Berkeley
- (7) estimate presumed low if included in parentheses

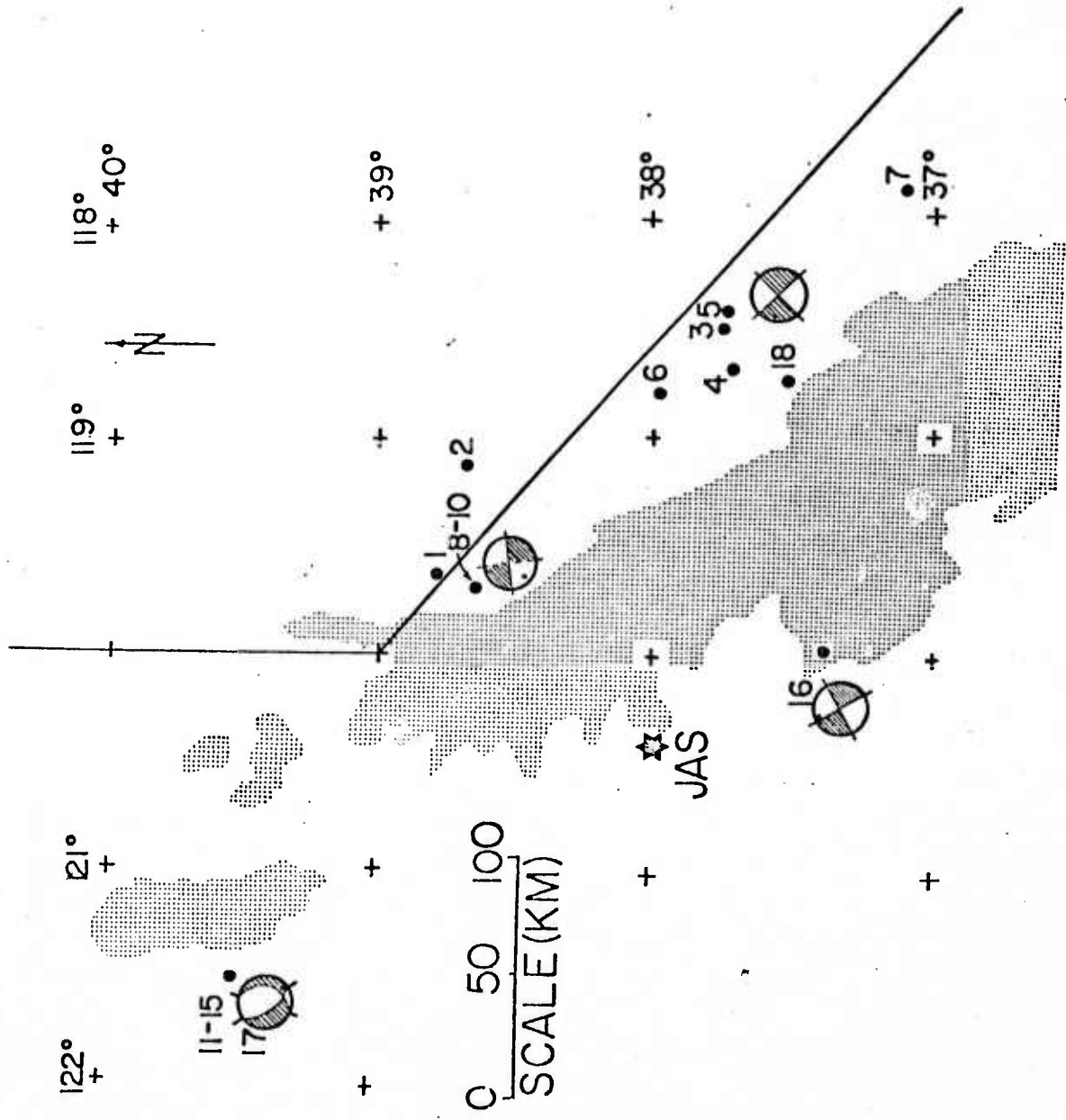

Figure 5. Map of the area around Jamestown showing exposed granites (stippled areas) and the earthquake travel paths from the earthquakes studied. The travel paths from the earthquakes pass through these granites.

Figure 6 along with data from Molnar et al. (1973) and Bakun et al. (1975). The main point of this paper is that these three studies, each based on excellent data, give quite different and distinctive patterns for R in the three source regions represented.

4. Implications for Earthquake Source Theory

In the following discussion, we will assume that propagation effects have not significantly altered the observed corner frequencies presented in Table 1, so that these corner frequencies measure directly some source parameters. The discussion is aimed at deducing what these source parameters might be.

In all of the recently-published source theories, the dimension of faulting controls the P- and S-wave corner frequencies, and in all but two the predicted variation with azimuth amounts to a factor of 2 or more. Thus, the resolution of the data in Table 1 is adequate to discriminate between source models (subject to the assumption above). Berckhemer and Jacob (1968) employ subsonic rupture propagation velocity, but concentration of energy from the center of a circular dislocation to find equal P- and S-wave corner frequencies. Brune (1970, 1971) and Hanks and Wyss (1972) employ an infinite rupture speed on a circular fault to find higher corner frequencies for P than for S by the ratio of the P- and S-wave velocities. Molnar et al. (1973) use uniform rupture at high propagation velocity on a circular dislocation to find higher values for P- than for S-wave corner frequencies. Sato and Hirasawa (1973) use subsonic rupture propagation on a circular dislocation with greater slip near the center to find higher (> 50%) corner frequencies for P than for S. Burridge (1975) considers self-similar rupture on a circular fault lacking cohesion at the P-wave velocity. His formula (59) for the ratio of the P- to SV-phase corner frequency is 1.2 averaged over the focal sphere, but the ratio is 2 or more

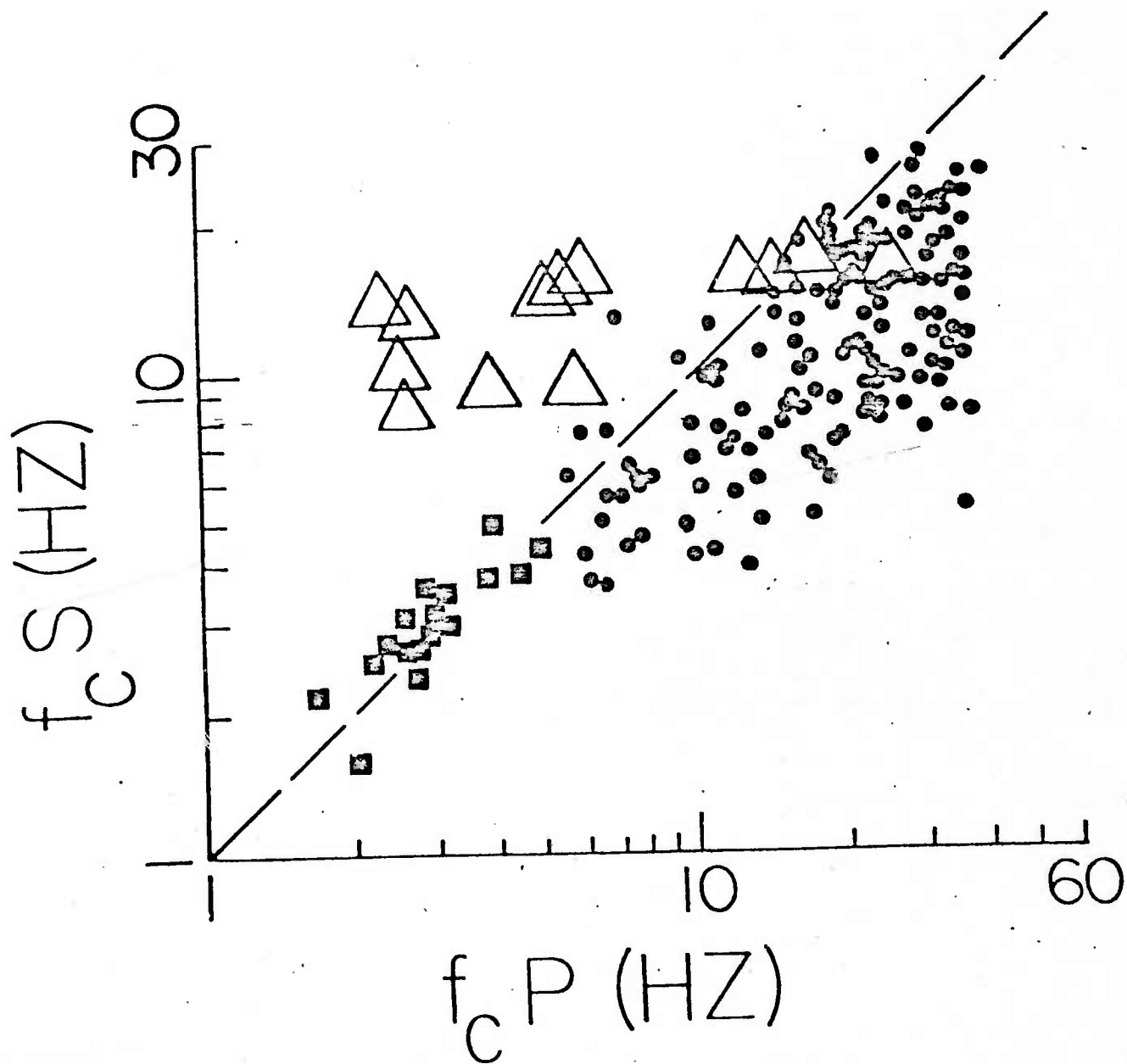

Figure 6. S-wave spectral corner frequency versus P-wave spectral corner frequency for different source regions. Solid circles: Molnar et al. (1973), representing the San Fernando aftershocks; open triangles: Bakun et al. (1975), representing earthquakes in the Cabilan granites of Central California; solid squares: this study.

on 50% of the focal sphere. Madariaga (1976) solves the problem of slip on a circular crack when stress drop is specified. The slip is concentrated near the center of the crack, and gives slightly higher (10-20%) P-corner frequencies for subsonic rupture propagation. In contrast, Savage (1972) uses a Haskell fault model with uniform, bilateral, subsonic rupture propagation at 90% of the S-wave speed and uniform fault slip; he finds higher primary corner frequencies for S than for P by a ratio (averaged over the focal sphere) of 1.65 to 1. Similarly, Dahlen (1974) uses a combined dislocation and self-similar crack model at subsonic rupture propagation with uniform fault slip; he finds higher corner frequencies for S than for P (averaged over the focal sphere) by the ratio 2.38 to 1 or 1.75 to 1, depending on whether the rupture propagation velocity is 90% or 80% of the S-wave velocity. In summary, models which have uniform slip and subsonic rupture propagation on circular or bilateral faults predict higher corner frequencies for S than for P at all azimuths, while models which employ supersonic rupture propagation velocity or slip concentrated near the fault center predict higher corner frequencies for P than for S at all azimuths (on the average); Table 2. Of the above-mentioned models, only those of Berckhemer and Jacob (1968) and Madariaga (1976) cannot be excluded by the data of Table 1; but note that the former authors employ what may be an unrealistic assumption, namely rupture propagation velocity decreasing as the faulting front moves out.

The quantity R , then, appears to be a rather sensitive source-model discriminant. Our data could be explained by the models of Berckhemer and Jacob (1968) or Madariaga (1976), but not, for example, by the model of Savage (1972). Bakun *et al.* (1975) find the opposite: Savage's model can describe their data quite well. None of these three seems capable of explaining the high values

TABLE 2. Essentials of Recent Source Theories

Author	Fault Shape	Rupture Propagation Velocity	Direction of Fault Rupture	Nature of Slip	Predicted R	Reference
Berckhemer and Jacob (1968)	circular	subsonic, variable	radial	uniform	near 1	Savage (1972) p. 3792
Brune (1970, 1971)	circular	instantaneous	simultaneous	uniform	1.7	Brune (1971)
Hanks and Wyss (1972)	circular	instantaneous	simultaneous	uniform		equation (7)
Molnar et. al. (1973)	circular	supersonic	radial out, then radial in	uniform or concentrated near center	1.7	p. 2099
Sato and Hirasawa (1973)	circular	subsonic	radial	concentrated near center	>1.5	Table 2
Burridge (1975)	circular	supersonic	radial	uniform	1.25-1.5	equation (59)
Madariaga	circular	subsonic	radial	concentrated near center	1.0-1.2	Figure 10
Savage (1972)	rectangular	subsonic	bilateral	uniform	.61	equation (13)
Dahlen (1974)	circular or elliptical	subsonic	radial	uniform	.42-.57	equation (41)

of \underline{R} found by Molnar et al. (1975), but Brune's (1970, 1971) model with a modification by Hanks and Wyss (1972) can. We saw in Table 2 that \underline{R} depends largely upon the rupture propagation velocity on the fault; it is physically reasonable that this quantity might vary in different source regions (e.g. slower in areas of great heterogeneity, faster on smooth, well-developed fault traces like the San Andreas). That is, we should not be surprised to find that no one model can accurately predict the totality of earthquake phenomena (but note in Table 2 the features common to the models: each can be formulated as a specific case of Haskell dislocation theory).

The results of this investigation can be explained by another model. If the corner frequency is determined by the time history of motion at the source for these events, then equal and non-varying corner frequencies for P and S would result at all azimuths. This particular model seems physically reasonable for small-to-moderate earthquakes; it implies a source time duration that is long compared with the rupture propagation time across the source. This explanation was considered by Johnson and McEvilly (1974) for Central California earthquakes, and would be consistent with the findings of Archuleta and Brune (1975) based on model experiments in foam rubber. More complete azimuthal coverage would be needed to test such a model.

CONCLUSIONS

P- and SV-wave spectral corner frequencies for 18 trans-Sierra earthquakes give a ratio \underline{R} of P-wave to SV-wave corner frequency of $.96 \pm .17$. These values appear to be independent of propagation effects, and thus are indicative of conditions at the source of the earthquakes. The SV-wave spectra permit a minimum estimate of 480 for Q, which is high compared with other California crustal paths previously studied. The precision with which we have determined

R allows us to eliminate all but two of the recently-published source models as applicable to these earthquakes; in this way we find that R is a successful discriminant among competing source models.

E. A Scaling Law for Explosions in Tuff, W. A. Peppin, manuscript near completion.

Considerable disagreement exists in the literature on the nature of underground nuclear explosions as seismic sources. As a result, authors disagree on the exact cause of the surface wave-body wave, or Ms:mb discriminant between earthquake and underground nuclear explosions. In this paper we have studied data which seem incapable of explanation by existing source models for explosions. We have accordingly constructed a model which does satisfy these data, but which differs from existing models in several important respects. We summarize the paper in three parts as follows: (1) the relevant data, (2) the construction of theoretical seismograms, and (3) the construction of scaling curves for explosions in tuff.

1. The relevant data

Of the large amount of data I have investigated, there are six classes of observations that appear to be crucial in the construction of a source model for explosions: (1) the ratio between body- and surface-wave amplitude is consistently higher (by a factor of 5 to 20) for explosions than for earthquakes of the same body-wave magnitude (SIPRI, 1968; Evernden et al., 1971; McEvelly and Peppin, 1972; Peppin and McEvelly, 1974); (2) at near-regional distances, 0.8 to 1.0-Hz P-wave amplitudes scale linearly (unit slope) with 12-second Rayleigh-wave amplitude from ca. 5 to 1100 ktons (Springer and Hannon, 1973, Figure 3; Peppin, 1976, Figures 5a-5c); (3) the observed close-in spectra of explosions fired in tuff are flat in displacement from 0.2 to 1.5 Hz, showing not more than 1.5-to-1 spectral overshoot (Rodean, 1971, p. 61; Peppin, 1976 Figures 2, 3);

(4) the surface waves of explosions and their hole collapses are almost always very similar in form, but 180° out of phase (Smith, 1963; McEvelly and Peppin, 1972, Figure 2); (5) close-in accelerometer data for explosions show that considerable SV energy leaves the source; and (6) close-in displacement spectra of explosions decay to high frequency as frequency cubed or (frequency)⁴.

Observation (1) is satisfied by modelling an explosion in large part as a center of dilatation which injects volume into the medium (a pure source of compression). Observations (2), (3), and (6) are crucial in the construction of scaling curves. Observations (4) and (5) appear to require that the explosion source consist in part of an upward force impulse; a center of dilatation alone cannot satisfy these data using (possibly inapplicable) elasticity theory.

2. Construction of theoretical seismograms

In Figure 7 we show the average product of radial and vertical acceleration as recorded 8 km from the one-megaton explosions JORUM and HANDLEY. On such a plot a positive ordinate indicates longitudinal (P-type) motion, while a negative ordinate indicates transverse (SV-type) motion. Note the considerable SV energy shown by Figure 6. Sources of pure compression produce no SV, so we include as part of the explosion source an upward force impulse. We scale the two source constituents to give the observed ratio of P to SV in Figure 6: 6×10^{13} cc of volume injection plus an upward force impulse of 2×10^{19} dyne-seconds. The wave propagation from source to receiver is accomplished by exact Cagniard-de Hoop theory for sources in a homogeneous, isotropic, elastic halfspace. The theoretical ground motion is passed through the instrument and compared with the data in Figure 8. The fit of the whole record, P, S, and Rayleigh waves, is adequate. Spectra of either the P or the whole record, taken from the theoretical seismograms, agree very well with comparable spectra

FIVE SUMMED EXPLOSIONS

VERTICAL x RADIAL
15-POINT SMOOTHING

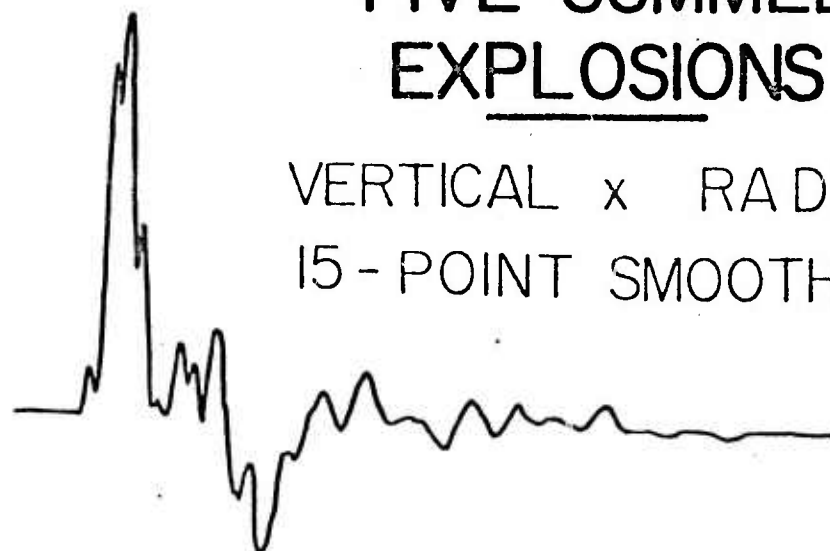

0 2 4 6 8 10
TIME (SEC)

Figure 7. Product of radial times vertical acceleration from five stacked accelerograms of the one megaton explosions JORUM and HANDLEY. Positive ordinate shows longitudinal motion, and negative ordinate shows transverse motion. This figure shows that a sizeable amount of S-wave energy leaves the source of these explosions.

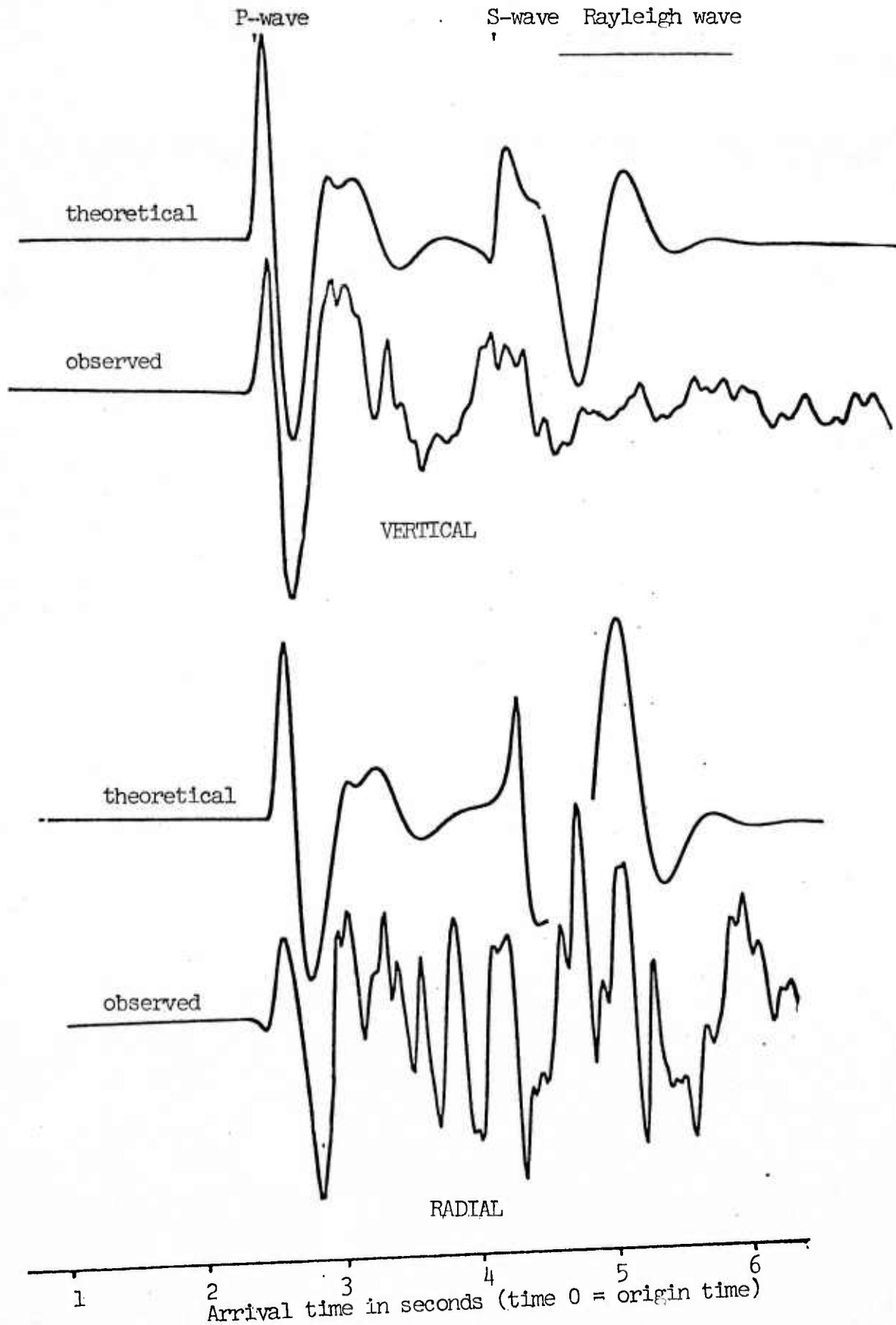

Figure 8. Comparison of observed accelerometer data with theoretical seismograms using source model described in text.

of the data. It was crucial in obtaining even the fit shown in Figure 7 that the far-field source spectrum of the explosion decay to high frequency as frequency cubed; this has important consequences in the construction of the scaling curves, shown in the next section.

3. Construction of the scaling curves.

The following features were built into the scaling curves we present in this section: (a) decay as frequency cubed to high frequency; (b) relatively slow shifting of the spectral corner frequency with yield (as $(\text{yield})^{-.10}$), in agreement with the data of Peppin (1976), but in disagreement with other published scaling curves; (c) a secondary corner frequency, thought to measure source radius, that scales according to the results of Mueller and Murphy (1971); (d) the primary spectral corner frequencies at 1100 and 150 kt agree with observations by Peppin (1976) for JORUM, HANDLEY, and PIPKIN, and with the data of Werth and Herbst (1963) at 1.7 kt for RAINER. We present the scaling curves in Figure 9.

Consider a plot of 12-second Rayleigh amplitude versus 4.0-Hz Pg spectral amplitude. This is shown in Figure 10, for explosions which range from 5 to 1100 kt in yield. Unlike all other scaling curves published, only those of Figure 8 can satisfy these data (the predicted relation is shown also in Figure 9, together with predicted relations from two other recently-published studies for comparison). On the other hand, a significant objection can be raised against these curves, namely the following fact: at teleseismic distances, explosion spectra--both P and Rayleigh wave--appear to diminish toward long periods (Molnar, et al., 1969). Some recently-collected data on the University of California long-period displacement system at Jamestown is of interest here (Figure 11). These show flat spectra from 40 seconds to the corner frequency for both P and Rayleigh waves. Aside from the fact that these spectra corroborate the scaling curves of Figure 8, they are the only such spectra ever published for explosions.

SOURCE MODEL FOR TUFF

source dimension time function corner
corner

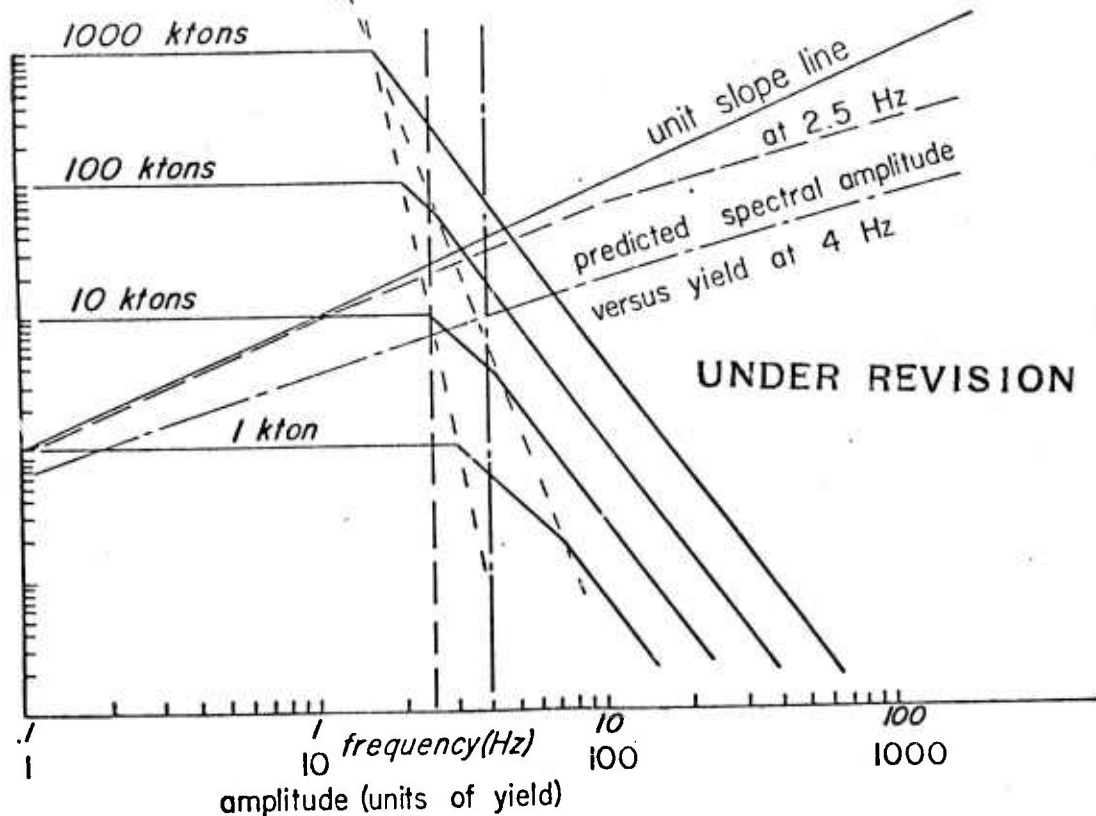

Figure 9. Scaling curves intended to be specific to explosions fired in tuff. Primary corner frequency scales with the source time duration, and the secondary one scales with the source dimension according to Murphy and Mueller (1971). Warning: no claim is made here that these curves are generally valid; they are based on only four explosions.

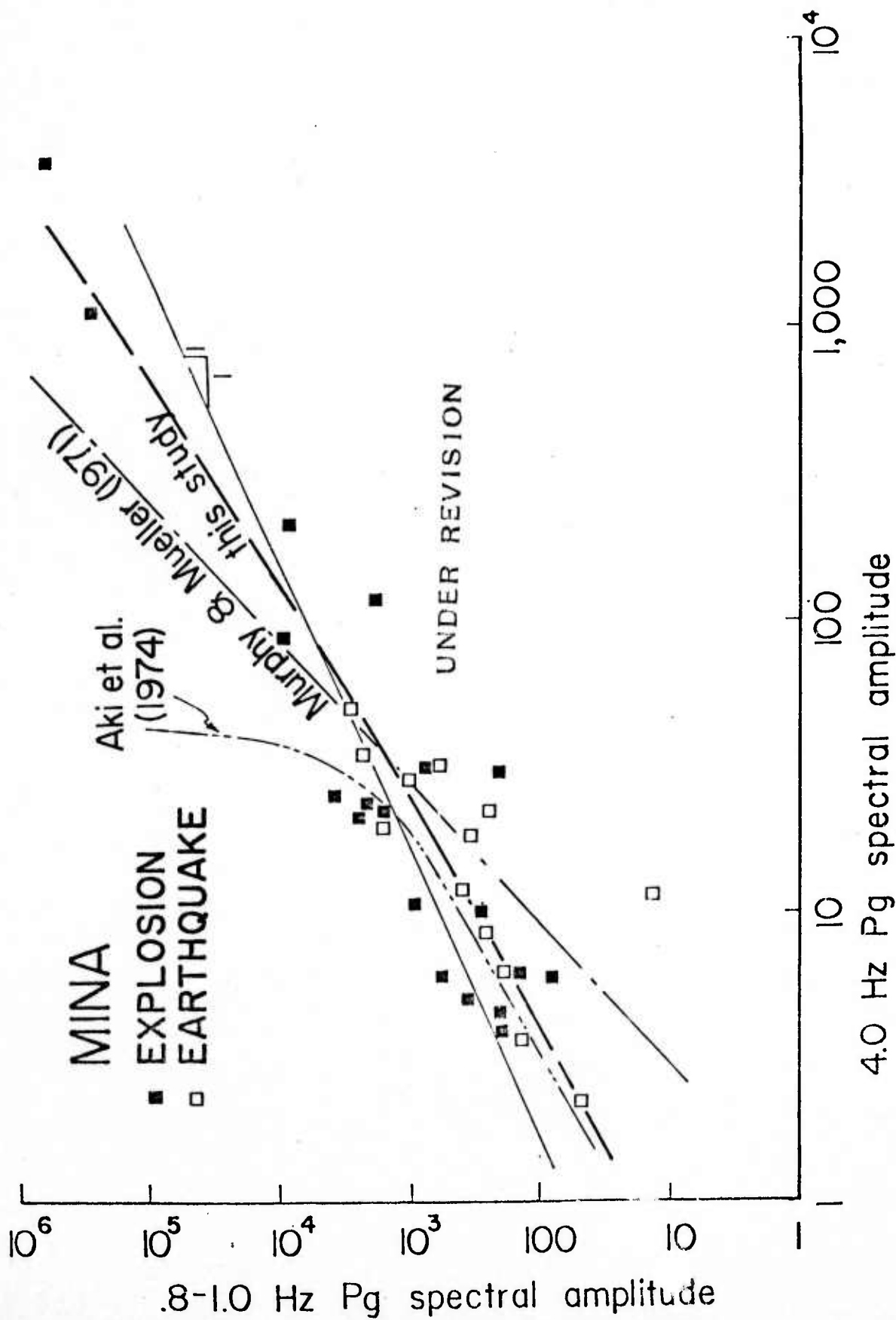

Figure 10. A plot of 0.8-1.0-Hz Pg spectral amplitude (the maximum spectral amplitude) versus 4.0-Hz Pg spectral amplitude. The line labelled "this study" is the relation predicted by the scaling curves of Figure 9. The predicted relations are made by assuming that the smallest event has 5 kt yield. Note: the curves are offset for best comparison with the data.

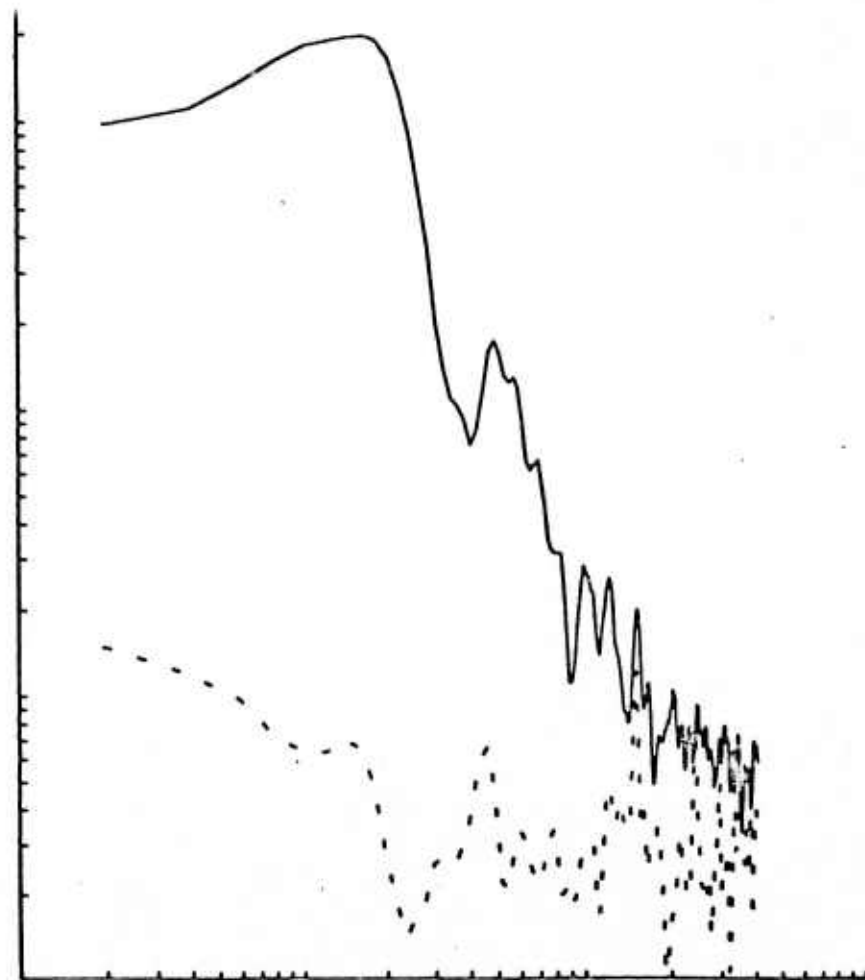
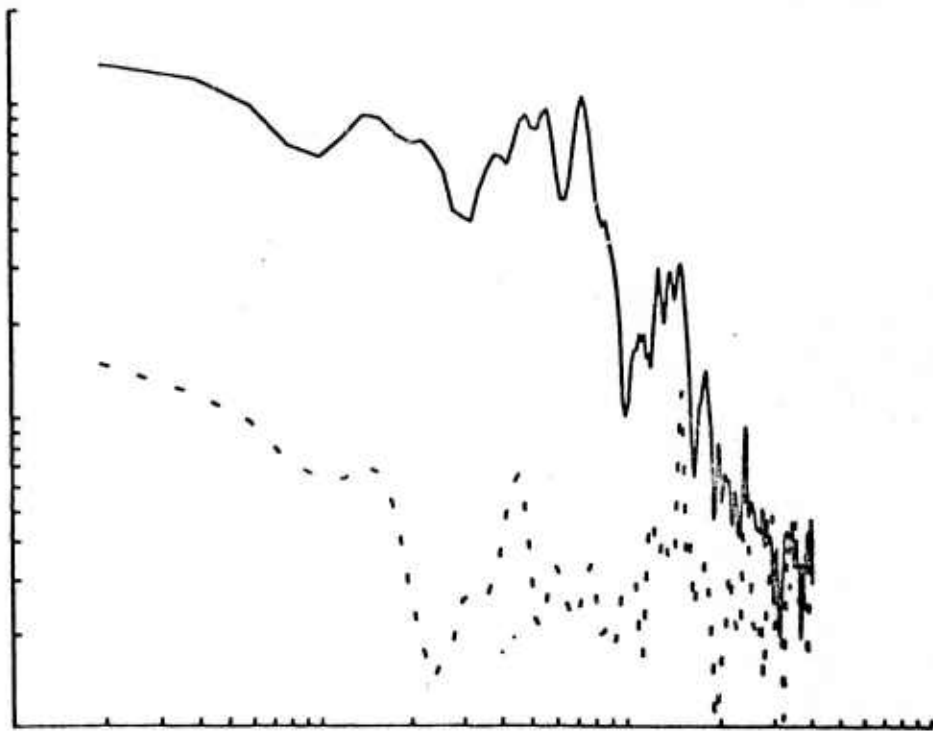

Figure 11. Displacement spectra of the 12 February 1976 explosion (one megaton). Top figure: P-wave only; bottom: Rayleigh wave. The dashed line is an estimate of the noise.

This provides clear evidence that the discrepancy between near-field data of explosions (which show flat source spectra of explosions in tuff) and the teleseismic data is a propagation effect. Perhaps the combination of pP reflection and slapdown conspire to annihilate the long periods which propagate to teleseismic distances. The new spectral data will provide perhaps the last crucial stimulus needed to pin down the complex circumstances which give rise to the Ms:mb discriminant at near and at teleseismic distances.

Conclusions

We have studied a broad class of close-in and near-regional data. These data appear to demand a seismic source model for a one megaton explosion consisting of: (1) the steplike (.6 second rise time) injection of 6×10^{13} cc of volume into the medium (with reasonable elastic moduli specified) and (2) an upward force impulse of duration .6 second that imparts 2×10^{19} dyne-second of momentum to the medium. The slow scaling of the primary corner frequency with yield implies that this spectral parameter cannot be a measure of the equivalent source dimension, as this latter quantity is observed to scale more rapidly with yield. Such a source model implies scaling curves for tuff different from other published ones in that: (1) the primary corner frequency scales slowly, as $(\text{yield})^{-.100}$, (2) the high frequency fall-off is as frequency cubed, (3) the long-period spectrum is flat from .025 to 1.0 Hz, showing slight or no overshoot. This source model can satisfy our close-in and near-regional data as no other can. The model contradicts investigations of teleseismic distances of explosion seismograms. We believe that the discrepancy is caused by some unaccounted-for near-source effect such as the surface reflection; however, previous studies indicate that the pP reflection alone cannot resolve the problem.

IV ABSTRACTS OF OTHER RECENT PUBLICATIONS

The following papers, all of which appeared in the last year, represent work partly funded by AFOSR at the University of Nevada.

Ryall, A. and J. D. VanWormer, 1975. Field-seismic investigation of the Oroville, California earthquakes of August, 1975, Oroville, California, Earthquake of 1 August, 1975, California Div. Mines and Geology, Special Report 124, R. Sherburne and C. Pauge Ed.

ABSTRACT. The Oroville earthquake of August 1, 1975 ($M_L = 5.7$) occurred in an area of relatively low seismicity, 10 km from Lake Oroville (height of dam 210 meters, $4,364 \times 10^6 \text{ m}^3$ capacity), seven years after initial filling of the lake but only a month after the most rapid filling since 1968 (L. Fredrickson, personal communication). The main shock occurred eight seconds after a magnitude 4.5 foreshock, and according to T. V. McEvelly (personal communication), the two events were collocated ($39^\circ 26.3'N$, $121^\circ 31.7'W$, depth 8 km). This location is on the eastern edge of the Great Valley of California, in a zone separating valley sediments to the west from Tertiary volcanics, Mesozoic intrusives, metavolcanics, and Paleozoic marine deposits of the Sierra Nevada foothills to the east. In general, lineaments in the vicinity of Lake Oroville trend about $N 15^\circ W$, and those to the west trend $N. 35^\circ W - N 40^\circ W$. One lineament on the skylab photograph coincides with ground cracking observed just south of Wyandotte ($39^\circ 25.9'N$, $121^\circ 28.1'W$), and passes within 2 kilometers of the lake.

Ryall, A. and Priestley, K., 1975. Seismicity, secular strain, and maximum magnitude in the Excelsior Mountains area of western Nevada and eastern California, Bull. Geol. Soc. Am., 86, 1585-1592.

ABSTRACT. Seismicity in the Excelsior Mountains area appears to have been an order of magnitude higher for at least several decades than that which preceded great earthquakes in central Nevada in 1915 and 1954. A high degree of crustal fracturing is indicated for the area by complex geology and by a scattered distribution of epicenters. A composite fault-plane solution is similar to those for large shocks at Fairview Peak and Rainbow Mountain in 1954, which shows the the same regional stress field is acting to produce earthquakes in both areas. The slope of the recurrence curve, or b value, is higher than average for the Nevada region. Crustal strains recorded at Mina indicate that periods of strain build-up alternate with periods of strain release. Comparison of these characteristics with results of laboratory experiments and observations in other regions suggests that the area is one in which a moderate level of tectonic stress combined with a high degree of crustal fracturing leads to strain release by a continuing series of small-to-moderate earthquakes and fault creep. If so, the magnitude of 6 1/4 for the 1934 Excelsior Mountains earthquake may represent a maximum magnitude for this area.

Douglas, B. M. and Ryall, A., 1975. Return periods for rock acceleration in western Nevada, Bull. Seism. Soc. Am., 65, #6, 1599-1611.

ABSTRACT. A method is described for determining expected acceleration return periods, based on calculations involving magnitude, fault length and distance to the causative fault. The method permits earthquake magnitude and duration of strong motion to be associated with these return periods. In addition, because attenuation equations are in terms of distance to the causative fault, instead of focal distance, sites can be considered which are in the immediate vicinity of potential faults. Results of calculations indicate that for an average site in the western Nevada region

maximum-amplitude, maximum-duration ground motion has a recurrence time of the order of thousands of years. This result, based on a relatively brief sample of instrumental data, is entirely consistent with geological field data representing time periods two to three orders of magnitude longer. Smaller ground motions have correspondingly smaller return periods, down to about a decade for accelerations greater than 0.1 g, when caused by all earthquakes with magnitude 5 or greater. Our results indicate that evaluation of seismic risk in terms of a single peak ground-motion parameter may lead to risk estimates which are several times too high.

Savage, W. U. 1975. Earth Probability Models: Recurrence Curves, Aftershocks and Clusters, University of Nevada-Reno Ph.D. Dissertation; 137 pp.

ABSTRACT. The application of the one-dimensional Poisson probability model to magnitude- and time-series of earthquakes can be an important aid in further understanding of the physics of earthquake occurrence, yet there are many features of earthquake sequences that are not described by the simple Poisson model. From a detailed examination of the axiomatic basis of the Poisson process in the context of observed earthquake magnitude-frequency and occurrence-frequency distributions, specific non-Poisson earthquake behavior patterns are identified and isolated for further study. Emphasis is placed on understanding the process of earthquake occurrence rather than on the determination of accurate mathematical models.

The frequency distribution of magnitude has been extensively discussed in terms of the linear relationship $\log N = a - bM$. The Poisson basis of the law is reviewed so as to apply proper statistical procedures to evaluate data samples consistently and accurately. In studying the Poisson behavior of magnitude distributions, three non-Poisson elements

must be considered in order to perform a mathematically valid analysis of b-values: determination of the minimum magnitude cutoff needed to define a complete catalog, possible non-random characteristics of the largest events, and magnitude-value biases or other sources of nonlinear magnitude-frequency distributions. Close examination of the cumulative magnitude-frequency plot combined with use of the maximum likelihood estimator of b is the best b value analysis technique. In the analysis of specific samples of foreshocks and aftershocks, it is found that the proposed dependence on compressive stress level within a fracture zone is not statistically supported at a high confidence level.

For earthquake time-series, three processes based on the Poisson model appear to describe earthquake behavior. The first is a simple Poisson occurrence of independent earthquakes that has a stationary or slowly time-varying occurrence rate. The second is the triggered process of aftershock occurrence, in which one of the independent events in the simple Poisson process initiates a single sequence or multiple sequences of aftershocks. Each aftershock sequence is composed of Poisson-distributed independent events that follow an approximately hyperbolically decaying rate law, with the trigger event generally of magnitude 4.0 or larger. The third process is that of microearthquake clustering, occurring among earthquakes of magnitude up to between 3.0 and 4.0. Clustering is defined by spatial and temporal relatedness among earthquakes and is identified in the seismically active regions of Nevada and central California. A cluster is not characterized by a trigger event, but each cluster is composed of events with magnitudes independent of one another. The cluster-size frequency distribution is described by an inverse power law with

with exponent near 3.5. Spatial and temporal statistical features of clustering are analogous to those of the aftershock process in most respects, but the pattern of energy release is symmetric about the center of the cluster in contrast to the major energy release occurring with the trigger event of an aftershock sequence. Comparisons with laboratory experiments suggest that the predominant occurrence of clusters of earthquakes containing events differing by less than one-half magnitude unit is associated with the small size of the source volumes of the clustered events and apparent rapid viscoelastic reloading of the initial slip surface.

Ryall, A., Peppin, W. A. and J. D. VanWormer, 1976. Field-seismic investigation of the August, 1975 Oroville, California earthquake sequence, submitted to Engineering Geology.

ABSTRACT. Several thousand aftershocks of the August 1, 1975 Oroville, California earthquake ($M_L = 5.7$) were recorded by an 8-station field-seismic network. Focal coordinates of 104 of these events were fit by least-squares to a plane striking $N 07^\circ W$ and dipping $59^\circ W$; the strike (but not the dip) of this plane is in good agreement with that ($N 69^\circ W$) obtained from a faultplane solution for a large foreshock 8 seconds before the main shock, and it agrees fairly well with the trend ($N 15^\circ W$) of structural lineaments in the vicinity of Lake Oroville. The surface trace of the plane of foci passes through the Oroville Dam, as well as through surface cracking 12 km south of the dam. The main shock occurred 7 years after the filling of Lake Oroville, but only a month after the most rapid filling since 1968. The rate of aftershock occurrence during the first month decayed approximately as $1/t$. Event duration was measured for more than 2,000 aftershocks during August and September; average log-duration, taken

over samples of 100 events, decreased gradually during this period. Close-in spectra obtained from strong-motion recordings of several of the larger aftershocks have corner frequencies that are quite high compared to other western U. S. earthquakes of similar magnitude. The Oroville earthquakes had several features in common with another Sierra Nevada earthquake sequence, near Truckee, California, in September, 1966.

Richins, W. D. and Ryall, A., 1976. Earthquake swarm near Denio, Nevada, February to April, 1973 and possible relation of northwest Nevada earthquakes to geothermal activity, submitted for publication.

ABSTRACT. Historic seismicity in northwest Nevada has been lower by an order of magnitude than that in the west-central part of the region. During the last century no earthquake with magnitude greater than $5 \frac{3}{4}$ has occurred in the northwest part of the state, and shocks with $M > 5$ have generally been associated with swarms. In addition, the earthquake swarms are spatially correlated with geothermal activity. One such swarm occurred during February, March, and April, 1973, twenty kilometers south of Denio on the Nevada/Oregon border. The largest event of the sequence was a magnitude 5.3 shock on 3 March. Fault plane solutions indicate right-lateral oblique-slip motion on a plane striking $N 11^\circ W$ and dipping $60^\circ E$. This mechanism is very similar to those of the 1954 Fairview Peak and other earthquakes in the western Basin and Range, and is consistent with regional extension in a $WNW-ESE$ direction. During March and April, a small tripartite array recorded more than 1,500 events of this sequence, and 221 of them were selected for detailed analysis. Epicenters of these events fall in a north-south trending zone, 8 kilometers in length and 2 kilometers wide; focal depths range from $5 \frac{1}{2}$ to $8 \frac{1}{2}$ kilometers. The b -value for this sequence

is 1.00 which is higher than 0.81 found for northwest Nevada as a whole. High b -values have been found in laboratory experiments for heterogeneous materials and for rocks under low to moderate stress.

V. SEISMIC SOURCE THEORY: CURRENT KNOWLEDGE

This section is intended as a summary of what we have learned about seismic source theory during the NFP. We discuss: (1) what has been established about earthquake sources, (2) what remains unknown about earthquake source, (3) what data remains to be collected, and (4) what causes the body wave-surface wave discriminant between earthquakes and underground nuclear explosions.

A. What Has Been Learned of Earthquake Sources

The most important finding of the NFP is that Haskell (1964) dislocation theory serves as an adequate model of the earthquake source. That is, long-period spectra of earthquake appear to be flat, not peaked, so that we need not invoke a more complex theory depending upon tectonic stress (Archambeau's (1968) theory with R_s finite). The more complex recent theories such as Madariaga (1976) also predict flat source spectra. For all its complexity, such theory has really told us nothing of first-order importance. According to Madariaga, the displacement on the fault tapers off to zero at the edges, a much more physically plausible model than the uniform slip of Haskell (1964). However, Haskell theory is easily modified to incorporate this feature (see Sato and Hirasawa, 1973). This detail does not affect the long-period spectrum, but profoundly influences the estimated stress drop. This latter parameter has not proved to be informative so far.

B. What Remains Unknown of Earthquake Sources

A constant theme runs through all the above-described work on source theory. We still cannot be certain that we understand what is causing the observed spectral corner frequency of seismic sources. All published papers on source theory infer

or utilize a direct, linear scaling of faulting length with spectral source corner frequency (although it is certainly true that the constant of proportionality varies quite widely among different theories). Cogent arguments are advanced as to why this should be true. They usually conclude that the source rise time is shorter than the transit time of elastic waves across the zone of faulting, and thus cannot itself be the cause of the observed corner frequencies. However, these arguments are dependent on several assumptions suspected to be invalid near the source, e.g. that elasticity theory holds, that viscoelastic or viscous creep effects do not control the corner frequencies. If earthquakes consist in large part of creep events (as appears to be the case for some recent Central California earthquakes), then the rise time might be much longer than is now believed. Significantly, this point can be investigated by seismic methods. Almost any model of faulting in which the rise time is short will predict an azimuthal variation in spectral corner frequency due to the geometry of the zone of faulting. In contrast, if the corner frequency is caused by the rise time, it would be invariant at all azimuths of observation, consistent with the data of Peppin and Simila (1976). A primary goal for future work should be to make the required observations; we now have NSF support to carry out precisely this task.

A deeper and more fundamental gap in our knowledge is just what an earthquake consists of. Our usual models employ equivalent elastic wave theory on idealized, planar faults. The real situation is almost certainly more complicated (e.g. en echelon, multiple, parallel cracking in a volume around the fault). Therefore, we have no real understanding of why or when earthquakes occur, or even if this information is itself of potential interest. The NFP has, in many respects, carried the seismic observations of particular earthquakes to an extreme. If we are to answer these more fundamental questions, it is likely that expensive in situ experiments will be needed.

C. What Data Remains to be Collected

In my opinion, the NFP failed in two respects to acquire the best possible seismic data. First, the Central California region is one characterized by quite severe attenuation and highly variable geology. Thus, one is never sure when variations in the data are caused by some unaccountable propagation effect. Second, we were never able to record a suitable earthquake which would permit P- and S-waves to be studied at all azimuths. Thus, since the variation of these quantities is intimately related to rupture propagation, we were not able to pinpoint the fault motions for the earthquakes we recorded.

D. Cause of the Ms:mb Discriminant

Our work indicates rather unequivocally that explosions fired in tuff possess flat source spectra with spectral corner frequencies similar to those of nearby earthquakes of the same body wave magnitude. Since earthquakes also have flat spectra, we cannot explain the clear discrimination of these events based on the shape of the source spectrum, nor differences in the source dimension or source rise time. We have found that near-regional data disagree with teleseismic data in this regard. We suggest that, if we are to explain the Ms:mb discriminant at all distances, that different explanations will be needed at very-near and at far-teleseismic distances. This results from the fact that seismic waves leaving the explosion source upward may be entirely different from those leaving downward, due to different seismic coupling, etc. The implications for rendering seismic discrimination ineffective are not clear and perhaps not accessible by seismic methods.

Discrimination must be applied at teleseismic distances in a practical application. Thus, we might be content to rely on the oft-stated basis for discrimination: explosions act like pressure pulses, and earthquakes like shear dislocations.

- Brune, J. N., 1971. Correction, Jour. Geophys. Res., 76, no. 20, 5002.
- Brune, J. N. and King, C., 1967. Excitation of mantle Rayleigh waves of period 100 seconds as a function of magnitude, Bull. Seism. Soc. Am., 57, no. 6, 1355-1365.
- Burridge, R., 1975. The effect of sonic rupture velocity on the ratio of S to P corner frequencies, Bull. Seism. Soc. Am., 65, #3, 667-676.
- Burridge, R. and Knopoff, L., 1964. Body force equivalents for seismic dislocations, Bull. Seism. Soc. Am., 54, no. 6, 1875-1888.
- Cherry, J. T., Bache, T. C. Savino, J. M., and Archambeau, C. B., 1973. A Deterministic Approach to the Prediction of Teleseismic Ground Motion from Nuclear Explosions, ARPA semiannual technical report, Systems, Science, and Software Corp.
- Dahlen, F. A., 1974. On the ratio of P-wave to S-wave corner frequencies for shallow earthquake sources, Bull. Seism. Soc. Am., 64, #4, 1159-1180.
- Davies, J. B. and Smith, S. W., 1968. Source parameters of earthquakes, and discrimination between earthquakes and nuclear explosions, Bull. Seism. Soc. Am., 58, no. 5, 1503-1517.
- Douglas, A., Hudson, J. A. and Kembhavi, V. K., 1971. The relative excitation of seismic surface and body waves by point sources, Geophys. J. R. A. S., 23, 451-460.
- Evernden, J. F., 1975. Further studies in seismic discrimination, Bull. Seism. Soc. Am., 65, no. 2, 359-392.
- Evernden, J. F. and Filson, J., 1971. Regional dependence of surface-wave versus body-wave magnitude, Jour. Geophys. Res., 76, 3303-3308.

PRECEDING PAGE BLANK-NOT FILMED

- Hart, R. S., Butler, R. and Kanamori, H., 1975. Surface wave and ultra long period body wave constraints on the August 1, 1975 Oroville earthquake, EOS, Trans. Am. Geophys. Un., 56, no. 12, 1023.
- Haskell, N. A., 1964. Total energy and energy spectral density of elastic wave radiation from propagating faults, Bull. Seism. Soc. Am., 54, #6, 1811-1842.
- HelMBERGER, D. V., 1974. Generalized ray theory for shear dislocations, Bull. Seism. Soc. Am., 64, no. 1, 45-64.
- HelMBERGER, D. V. and Malone, S. D., 1975. Modeling local earthquakes as shear dislocations in a layered half space, Jour. Geophys. Res., 80, no. 35, 4881-4888.
- Johnson, L. R. and McEvilly, T. V., 1974. Near-field observations and source parameters of Central California earthquakes, Bull. Seism. Soc. Am., 64, no. 6, 1855-1886.
- Keylis-Borok, V. I., 1961. The difference in the spectrum of surface waves in earthquakes and explosions, Seismic Effects of Underground Explosions, O Yu. Schmidt Institute of Geophysics Transactions, 182, no. 15.
- Leet, L. D., 1962. The detection of underground explosions, Sci. Am., 206, no. 6, 55-59.
- Liebermann, R. C. and Pomeroy, P. W., 1969. Relative excitation of surface waves by earthquakes and underground explosions, Jour. Geophys. Res., 74, no. 6, 1575-1590.
- Lynch, R. D., 1969. Response spectra for Pahute Mesa nuclear events, Bull. Seism. Soc. Am., 59, no. 6, 2295-2310.
- Madariaga, R., 1976. Dynamics of an expanding circular crack, Bull. Seism. Soc. Am., June, in press.

- Malone, S. D., 1974. Observations of the static displacement field from a medium sized nearby earthquake, EOS, Trans. Am. Geophys. Un., 56, no. 12, 1148.
- Marshall, P. D., 1970. Aspects of the spectral differences between earthquakes and underground explosions, Geophys. J. R. A. S., 20, 397-416.
- McEvelly, T. V. and Peppin, W. A., 1972. Source characteristics of earthquakes, explosions, and after-events, Geophys. J. R. A. S., 31, 67-82.
- Molnar, P., Savino, J., Sykes, L. R., Liebermann, R. C., Hade, G., and Pomeroy, P. W., 1969. Small earthquakes and explosions in Western North America recorded by new high gain, long period seismographs, Nature, 224, 1268-1273.
- Molnar, P., B. E. Tucker, and J. N. Brune, 1973. Corner frequencies of P and S waves and models of earthquake sources, Bull. Seism. Soc. Am., 63, #6, 2091-2104.
- Murphy, J. R., and Mueller, R. A., 1971. Seismic characteristics of underground nuclear detonations. Part II. Elastic energy, Bull. Seism. Soc. Am., 61, no. 6, 1693-1704.
- Peppin, W. A., 1974. The Cause of the Body Wave-Surface Wave Discriminant between Earthquakes and Underground Nuclear Explosions at Near-Regional Distances, Ph.D. Thesis, University of California at Berkeley.
- Peppin, W. A. and McEvelly, T. V., 1974. Discrimination among small magnitude events on Nevada Test Site, Geophys. J. R. A. S., 37, no. 2, 227-244.
- Peppin, W. A., 1976. P-wave spectra of Nevada Test Site events at near and very-near distances: implications for a body wave-surface wave discriminant, Bull. Seism. Soc. Am., 66, June, in press.
- Peppin, W. A. and Simila, G. W., 1976. P- and SV-wave corner frequencies over low-low paths: a discriminant for earthquake source theories? Jour. Phys. Earth, submitted for publication.

- Pitt, A. M. and Steeples, D. W., 1975. Microearthquakes in the Mono Lake-Northern Owens Valley, California Region from September 28 to October 18, 1970, Bull. Seism. Soc. Am., 65, no. 4, 835-844.
- Rodean, H. C., 1971. Nuclear Explosion Seismology, U.S.A.E.C. Division of Technical Information.
- Sato, T. and Hirasawa, T., 1973. Body wave spectra from propagating shear cracks, Jour. Phys. Earth, 21, #4, 415-432.
- Savage, J. C., 1972. The relation of corner frequency to fault dimensions, Jour. Geophys. Res., 77, 3788-3795.
- SIPRI, 1968. Seismic Methods for Monitoring Underground Explosions, Int. Inst. for Peace and Conflict Research, (SIPRI), David Davies Ed.
- Smith, S. W., 1963. Generation of seismic waves by underground explosions and collapse of cavities, Jour. Geophys. Res., 68, no. 5, 1477-1483.
- Springer, D. L. and Hannon, W. J., 1973. Amplitude-yield scaling for underground explosions, Bull. Seism. Soc. Am., 63, 477-500.
- Stump, B. E., 1974. P and S wave corner frequencies observed in the near field and the effect of attenuation, EOS, Transactions, American Geophys. Union, 56, no. 12, 1148.
- Tsai, Y., 1972. Utility of Tsai's Method for Seismic Discrimination, semiannual technical report, Texas Instruments Corp.
- Tsai, Y. and Aki, K., 1971. Amplitude spectra of surface waves from small earthquakes and underground nuclear explosions, Jour. Geophys. Res., 76, no. 17, 3940-3952.
- Tucker, B. E. and Brune, J. N., 1975. Source mechanism and surface wave excitation for aftershocks of the San Fernando earthquake, unpublished manuscript.

Werth, G. C. and Herbst, R. F., 1963. Comparison of amplitudes of seismic waves from nuclear explosions in four mediums, Jour. Geophys. Res., 68, no. 5, 1463-1475.

Wyss, M. and Brune, J. N., 1970. Dimensions of nuclear explosions and small, shallow earthquakes, Wood's Hole Conference on Seismic Discrimination, July 20-23, 1970, Proceedings, 2.

Wyss, M., Brune, J. N., Hanks, T. C., and Tucker, B. E., 1970. Source dimensions of nuclear explosions and small shallow earthquakes, Wood's Hole Conference on Seismic Discrimination, July 20-23, 1970, Proceedings, 2.

VII. PUBLICATIONS COMPLETED DURING THE NEAR-FIELD PROJECT

Douglas, B. M. and A. Ryall (1975). Return periods for rock acceleration in the Nevada seismic zone, Bull. Seism. Soc. Am., 65 (6), 1599-1611.

Gupta, I. N. (1973a). Dilatancy and premonitory variations of P, S travel times, Bull. Seism. Soc. Am., 63, 1157-1161.

Gupta, I. N. (1973b). Premonitory changes in shear velocity anisotropy in Nevada, Proc. Conf. on Tectonic Problems of the San Andreas Fault System, Stanford Univ., 479-488.

Gupta, I. N. (1973c). Premonitory variations in S-wave velocity anisotropy before earthquakes in Nevada, Science, 182, 1129-1132.

Gupta, I. N. (1973d). Discussion on "Elastic velocity anisotropy in the presence of an anisotropic initial stress" by F. A. Dahlen, Bull. Seism. Soc. Am., 63 (3), 1174.

Koizumi, C. J., A. Ryall and K. F. Priestley (1973). Evidence for a high-velocity lithospheric plate under northern Nevada, Bull. Seism. Soc. Am., 63, 2135-2144.

- Peppin, W. A. (1975). Spectral investigations of the 1 August 1975 Oroville earthquake sequence, Calif. Div. Mines and Geology, Spec. Report 124, 109-114.
- Peppin, W. A., 1976a. P-wave spectra of Nevada Test Site events at near and very-near distances: implications for a near-regional body wave-surface wave discriminant, Bull. Seism. Soc. Am., 66, June, in press.
- Peppin, W. A., 1976b. An explosion source model for tuff, in preparation.
- Peppin, W. A. and Simila, G. W., 1976. P- and SV-wave corner frequencies over low-loss paths: a discriminant for earthquake source theories? Jour. Physics Earth, submitted for publication.
- Priestley, K. F. (1975). Possible premonitory strain changes associated with an earthquake swarm near Mina, Nevada, Pure and Appl. Geophys., 113, 251-256.
- Richins, W. D. (1974). Earthquake Swarm Near Denio, Nevada, February to April, 1973, Univ. Nevada MS Thesis, 57 pp.
- Richins, W. D. and A. Ryall (1976). Northern Nevada earthquake swarm, February to April, 1973, and possible relation to geothermal activity, submitted to Bull. Seism. Soc. Am.
- Ryall, A., W. U. Savage and C. J. Koizumi (1974). Seismic potential in the western Nevada/eastern California region, Proc. Fifth World Conf. Earthquake Engineering, 2, 1729-1732.
- Ryall, A. and W. U. Savage (1974). S-wave splitting: key to earthquake prediction? Bull. Seism. Soc. Am., 64 (6), 1943-1951.
- Ryall, A. and K. F. Priestley (1975). Seismicity, secular strain and maximum magnitude in the Excelsior Mountains area, western Nevada and eastern California, Bull. Geol. Soc. Am., 86, 1585-1592.

19 REPORT DOCUMENTATION PAGE

READ INSTRUCTIONS BEFORE COMPLETING FORM

1. REPORT NUMBER AFOSR TR-76-0502 2. GOVT ACCESSION NO. 3. RECIPIENT'S CATALOG NUMBER

4. TITLE (and Subtitle) NEAR FIELD SMALL EARTHQUAKE LONG PERIOD SPECTRUM. 5. TYPE OF REPORT & PERIOD COVERED FINAL 04/01/73 - 11/30/75 6. PERFORMING ORG. REPORT NUMBER

7. AUTHOR(s) William A. Peppin Alan Ryan 8. CONTRACT OR GRANT NUMBER(s) F44620-72-C-0069, VVARPA Order-2134

9. PERFORMING ORGANIZATION NAME AND ADDRESS Seismological Laboratory Mackay School of Mines University of Nevada, Reno, NV 89507 10. PROGRAM ELEMENT, PROJECT, TASK AREA & WORK UNIT NUMBERS AO 2134-6 2F10

11. CONTROLLING OFFICE NAME AND ADDRESS ARPA 1400 Wilson Blvd. Arlington, VA 22209 12. REPORT DATE 11 Apr 1976

13. NUMBER OF PAGES 42 14. MONITORING AGENCY NAME & ADDRESS (if different from Controlling Office) Air Force Office of Scientific Research (NPG) Bolling AFB, Bldg. 410 Washington, DC 20332 15. SECURITY CLASS. (of this report) UNCLASSIFIED 15a. DECLASSIFICATION/DOWNGRADING SCHEDULE

16. DISTRIBUTION STATEMENT (of this Report) Approved for public release; distribution unlimited (12) 45p.

17. DISTRIBUTION STATEMENT (of the abstract entered in Block 20, if different from Report) (9) Final rept. 1 Apr 73 - 30 Nov 75.

18. SUPPLEMENTARY NOTES TECH, OTHER

19. KEY WORDS (Continue on reverse side if necessary and identify by block number) SOURCE THEORY NEAR-FIELD STUDIES DISCRIMINANT SOURCE SPECTRUM SPECTRUM NEAR-FIELD SPECTRUM SOURCE SEISMIC DISCRIMINATION Ms:mb DISCRIMINANT

20. ABSTRACT (Continue on reverse side if necessary and identify by block number) We compute displacement spectra of explosion and earthquake seismograms in an attempt to study source parameters. The explosion data are at odds with several recent source theories for explosions (e. g. flat P-wave spectra from .025 to 1.5 Hz). These data are consistent with a study of trans-Sierra earthquakes in that the spectral corner frequency appears to be controlled by the source time duration. These data should stimulate the investigation of source models for which the corner frequency measures the source time duration and not the source dimension.

18

15

Ryall, A. and J. D. VanWormer (1975). Field-seismic investigation of the Oroville, California, earthquakes of August, 1975, Calif. Div. Mines and Geol., Spec. Report 124, 139-145.

Ryall, A., W. A. Peppin and J. D. VanWormer (1976). Field-seismic investigation of the August, 1975 Oroville, California earthquake sequence, submitted to Engineering Geol.

Ryall, A. and B. M. Douglas (1976). Seismicity of northern Nevada related to nuclear power plant siting, in preparation.

Savage, William U. (1975). Earthquake Probability Models: Recurrence Curves, Aftershocks, and Clusters, Univ. Nevada PhD Dissertation, 137 pp.