

Technical Paper 265

AD

ADA018368

TACTICAL ORDER OF BATTLE: A STATE-OF-THE-ART SURVEY

(Handwritten signature)
B.S.

Russell J. Bowen, Jeanne A. Halpin,
Peter T. Russell, and Bruce J. Staniforth
Bolt Beranek and Newman, Inc.

SYSTEMS INTEGRATION & COMMAND/CONTROL TECHNICAL AREA



U. S. Army

DEC 12 1975
RECEIVED
(Handwritten signature)

Research Institute for the Behavioral and Social Sciences

October 1975

Approved for public release; distribution unlimited.

**Best
Available
Copy**

U. S. ARMY RESEARCH INSTITUTE FOR THE BEHAVIORAL AND SOCIAL SCIENCES

A Field Operating Agency under the Jurisdiction of the
Deputy Chief of Staff for Personnel

J. E. UHLANER
Technical Director

W. C. MAUS
COL, GS
Commander

Research accomplished under contract to the Department of the Army

Bolt Beranek and Newman Inc.

ACCESSION for	
NOTICES	

DISTRIBUTION: Primary distribution of this report has been made by ARI. Please address correspondence concerning distribution of reports to: U. S. Army Research Institute for the Behavioral and Social Sciences, ATTN: PERI-P, 1300 Wilson Boulevard, Arlington, Virginia 22208.

FINAL DISPOSITION: This report may be destroyed when it is no longer needed. Please do not return it to the U. S. Army Research Institute for the Behavioral and Social Sciences.

NOTE: The findings in this report are not to be construed as an official Department of the Army position, unless so designated by other authorized documents.

Unclassified

SECURITY CLASSIFICATION OF THIS PAGE (When Data Entered)

18 ART REPORT DOCUMENTATION PAGE		READ INSTRUCTIONS BEFORE COMPLETING FORM	
19 1 REPORT NUMBER Technical Paper 265 ✓	2. JOVT ACCESSION NO.	3. RECIPIENT'S CATALOG NUMBER	
6 4 TITLE (and Subtitle) TACTICAL ORDER OF BATTLE: A STATE-OF-THE-ART SURVEY,		5. TYPE OF REPORT & PERIOD COVERED Final Nov 72 - Jan 74	
7. AUTHOR(s) Russell J. Bowen, Jeanne A. Halpin, Peter T. Russell, Bruce J. Staniforth		14 6 PERFORMING ORG. REPORT NUMBER 2662	8. CONTRACT OR GRANT NUMBER(s) 15 DAHC 29-73-C-0019 New
9. PERFORMING ORGANIZATION NAME AND ADDRESS Bolt Beranek and Newman Inc. 1701 N. Fort Myer Drive Arlington, VA 22209		10. PROGRAM ELEMENT, PROJECT, TASK AREA & WORK UNIT NUMBERS 16 DA-20621-1A754	
11. CONTROLLING OFFICE NAME AND ADDRESS U.S. Army Intelligence Center and School Fort Huachuca, Arizona 85613		11 12 REPORT DATE October 1975	13. NUMBER OF PAGES 120 12 120 p.
14. MONITORING AGENCY NAME & ADDRESS (if different from Controlling Office) U.S. Army Research Institute for the Behavioral and Social Sciences 1300 Wilson Boulevard Arlington, VA. 22209		15. SECURITY CLASS. (of this report) Unclassified	
16. DISTRIBUTION STATEMENT (of this Report) Approved for public release; distribution unlimited		15a. DECLASSIFICATION/DOWNGRADING SCHEDULE	
17. DISTRIBUTION STATEMENT (of the abstract entered in Block 20, if different from Report)			
18. SUPPLEMENTARY NOTES			
19. KEY WORDS (Continue on reverse side if necessary and identify by block number) Order of battle (OB) Combat Effectiveness Intelligence Information Processing OB Factors			
20. ABSTRACT (Continue on reverse side if necessary and identify by block number) This report provides a state-of-the-art survey of tactical order of battle (OB) intelligence, concentrating on the division OB section and based on official documentation, authoritative reference material, and the results of an informal questionnaire and interview program with experienced combat intelligence and operations personnel. The survey includes: Historical development of OB; role, function, and operations of the division CB section; examination of the OB factors; and the results of a brief survey of military opinions on OB.			

DD FORM 1 JAN 73 1473

EDITION OF 1 NOV 68 IS OBSOLETE

Unclassified

406 454 ✓ SECURITY CLASSIFICATION OF THIS PAGE (When Data Entered)

Next page 113

Unclassified

SECURITY CLASSIFICATION OF THIS PAGE(When Data Entered)

20. OB analysis requires more varieties of detailed information processing than any other single area of combat intelligence. However, the procedures and techniques available are not standardized or well developed, and the OB section tends to provide historical reference information rather than current intelligence. Specific findings and recommendations are presented after each section of the survey.



Unclassified

SECURITY CLASSIFICATION OF THIS PAGE(When Data Entered)

TACTICAL ORDER OF BATTLE: A STATE-OF-THE-ART SURVEY

**Russell J. Bowen, Jeanne A. Halpin,
Peter T. Russell, and Bruce J. Staniforth
Bolt Beranek and Newman Inc.**

Robert S. Andrews, Supervisory Project Director

**SYSTEMS INTEGRATION & COMMAND/CONTROL TECHNICAL AREA
Cecil D. Johnson, Chief**

**Submitted By:
Joseph Zeidner, Director
ORGANIZATIONS AND SYSTEMS
RESEARCH LABORATORY**

**Approved By:
J. E. Uhlener
TECHNICAL DIRECTOR**

U. S. ARMY RESEARCH INSTITUTE FOR THE BEHAVIORAL AND SOCIAL SCIENCES

**Office, Deputy Chief of Staff for Personnel
Department of the Army
1300 Wilson Boulevard, Arlington, Virginia 22209**

October 1975

**Army Project Number
20062101A754**

**Intelligence Systems
DAHC 19-73-C-0019**

ARI Research Reports and Technical Papers are intended for sponsors of R&D tasks and other research and military agencies. Any findings ready for implementation at the time of publication are presented in the latter part of the Brief. Upon completion of a major phase of the task, formal recommendations for official action normally are conveyed to appropriate military agencies by briefing or Disposition Form.

FOREWORD

The Systems Integration & Command/Control Technical Area of the U.S. Army Research Institute for the Behavioral and Social Sciences (ARI) is concerned, in part, with human information analysis and interpretation functions and the subsequent utilization of the products thereof in intelligence systems. The objective is to provide both technological advances in human/machine-aided tactical intelligence information processing and the translation of these advances in support of intelligence systems requirement and design decisions, and formulation of doctrine and procedures. One facet of military intelligence addressed within this program is tactical Order of Battle (OB). This report presents a state-of-the-art survey of OB intelligence and its components in the Army, in order to provide a basis for improving the processing techniques and methods of estimation used in OB analysis. The survey covers both historical development and current status and embraces virtually all aspects of tactical OB, with emphasis on OB factor composition, especially the factor of Combat Effectiveness. It supports the proposition that Order of Battle should serve as the initial integrator of all information about the enemy in direct support of targeting and decision making, as the most important analytical activity of the G2 section in the field.

This report is one of two ARI Technical Papers on tactical OB. It is part of a larger research effort responsive to requirements of RDTE Project 20062101A754, Intelligence Information Processing, FY 1974 Work Program, and to special requirements of the U.S. Army Training and Doctrine Command. ARI research in this area is conducted as an in-house effort augmented by contracts with organizations selected as having special capabilities for specific research tasks. The present study was conducted jointly by personnel of the Army Research Institute and of Bolt Beranek and Newman Inc., particularly Colonel R. J. Bowen, MI-USAR, Retired.



J. E. UHLANER
Technical Director

TACTICAL ORDER OF BATTLE: A STATE-OF-THE-ART SURVEY

BRIEF

Requirement:

To survey the state-of-the-art of tactical order of battle (OB) intelligence, with emphasis on the division OB section, in order to provide a basis for both the evaluation of current procedures for processing OB intelligence information and for the development of improved procedures. The scope included: historical development of OB; role, function, and operations of the division OB section; an examination of the OB factors; and a survey of military opinions on OB.

Procedure:

Data were obtained from official documentation, authoritative reference material, contacts with seven divisional headquarters and other appropriate commands and agencies, and an interview and survey program conducted with experienced intelligence and operations combat personnel.

Findings:

OB analysis requires more varieties of detailed information processing than any other single area of combat intelligence. However, the procedures and techniques for processing OB intelligence information are not standardized or well developed, and the OB section tends to provide historical reference information rather than current intelligence.

Utilization of Findings:

Problem areas have been identified and a basis provided for research designed to improve the processing of OB intelligence information. The information obtained was helpful in the development of an experimental test bed designed to obtain research data on which to base new or improved OB procedures and methodologies.

TACTICAL ORDER OF BATTLE: A STATE-OF-THE-ART SURVEY

CONTENTS

	Page
INTRODUCTION	1
General	1
Procedure	1
HISTORY OF ORDER OF BATTLE	3
Background	3
Order-of-Battle Terminology: Historical Origins	6
Order-of-Battle Terminology: United States Army	9
Discussion of Order-of-Battle Elements (Factors)	11
Discussion of Combat Effectiveness Element	14
Current Status of OB Intelligence	16
Summary of History of OB	17
THE ORDER OF BATTLE SECTION	17
Role and Function of the OB Section	18
Organization and Staffing of an OB Section	20
OB Section Operations	26
OB Section Personnel	35
Key OB Section Problems	42
EXAMINATION OF ORDER OF BATTLE FACTORS	43
Composition	45
Disposition	47
Strength	48
Training	50
Tactics	51
Logistics	53
Combat Effectiveness	54
Miscellaneous	56
Relationships Between OB Factors	59
Key Problems of OB Factors	59
SURVEY OF MILITARY OPINION	60
Interviews of OB Specialists	61
G2/S2 Questionnaire	73
G3/S3-Field Commander Questionnaire	82

	Page
SUMMARY	85
OB Processing Concepts	87
OB Support Requirements	88
CONCLUSIONS	89
Proper Role of OB	90
Wartime vs. Peacetime Role	90
Timeliness of Information	91
Information Processing Aids	91
REFERENCES	93
ADDITIONAL REFERENCES	97
APPENDIXES	99
DISTRIBUTION LIST	119

TABLES

Table	1. Variants of division A&P sections	23
	2. OB Analyst concerns	33
	3. Traditional OB factors and sub-elements	44
	4. Combat effectiveness	55

FIGURES

Figure	1. Diagram of Order of Battle	6
	2. Order of Battle definitions --A chronology	10
	3. Order of Battle elements--A chronology	12
	4. Relationship of Order of Battle factors	13
	5. Some current examples of OB Section TOE's	22
	6. Utilization of intelligence analyst in Vietnam	28
	7. OB analysis flow scheme	37
	8. Possible tactical combinations	52

TACTICAL ORDER OF BATTLE: A STATE-OF-THE-ART SURVEY

INTRODUCTION

General

This report is a state-of-the-art survey of Army tactical Order of Battle (OB) intelligence in general and of the OB factors in particular. Its scope is dictated by the fact that OB analysis encompasses more varieties of information processing than any other single area of combat intelligence. This arises from the fact that OB involves the integration of all information concerning the enemy that can be assembled by every collection means available to the command. OB intelligence is produced by one element of a complex G2 Section which has responsibilities for a wide range of intelligence collection and production activities embracing Counter-Intelligence (CI), Imagery Interpretation (II), Interrogation of Prisoners of War (IPW), Signal Intelligence (SIGINT), captured documents analysis, and other specialized functions. Whereas the other functions embrace both collection and production of intelligence, OB is almost entirely a user of information supplied by others which it uses to create integrated products designed to support the command decision-making and planning process.

Traditionally, OB analysis has revolved around a small number of so-called OB factors, which, taken together, are assumed to be the net characteristics and capabilities of an opposing enemy force. At present, some eight factors are recognized by OB doctrine as useful in describing various aspects of an enemy force. Potentially, the most important of these is Combat Effectiveness, which represents the net capability of an enemy force to engage in combat operations. In practice, neither field commanders nor intelligence analysts tend to place much reliance on estimates of Combat Effectiveness. Aside from the fact that insufficient data are usually available in the field on which to base reliable estimates of the elements of Combat Effectiveness, there are no standardized or formalized procedures for integrating those elements to produce a reliable estimate of the factor of Combat Effectiveness itself.

The present survey attempts to determine the status of the OB factors and in particular, that of Combat Effectiveness, with a view to the discovery of possible areas for improvement in OB doctrine and procedures.

Procedure

In order to assess the state-of-the-art of OB intelligence, structured interviews were held with 14 individuals at the Army Intelligence Center and School (AICS) at Fort Huachuca, Arizona. Subsequently, a questionnaire was administered to 12 former G2's, G2 advisors, and S2's (i.e., users of the product of OB intelligence). Supplemental interviews were also conducted with about half of these individuals as well as with a number of experienced OB officers. A third questionnaire was prepared and circulated to individuals who must depend on

estimates of Combat Effectiveness: G3/S3's and field commanders. This involved some 14 colonels and lt. colonels at the Army War College, as well as five general officers with field command experience and several officers with either field command or operations experience assigned to the Deputy Chief of Staff for Operations or to the Office of the Assistant Chief of Staff for Intelligence.

In addition to structured interviews and questionnaires, informal visits and phone calls were made to individuals and organizations with either OB backgrounds or experience related to the estimation of Combat Effectiveness. Among the other organizations contacted were:

- Army Security Agency (Combat Developments Activity)
- Concepts Analysis Agency (formerly STAG)
- Continental Army Command Intelligence Agency (CONTIC)
- Defense Intelligence Agency
- JFK Military Institute
- The Armor School
- The Army War College
- The Command and General Staff College
- The Infantry School
- The Industrial College of the Armed Forces

The G2 sections of seven divisional headquarters were also approached for information concerning the current operating procedures in OB sections. The following divisions were contacted:

- 1st Infantry Division - Fort Riley, Kansas
- 4th Infantry Division - Fort Carson, Colorado
- 9th Infantry Division - Fort Lewis, Washington
- 82nd Airborne Division - Fort Bragg, North Carolina
- 101st Airborne Division - Fort Campbell, Kentucky
- 2nd Armored Division - Fort Hood, Texas¹
- 1st Cavalry Division - Fort Hood, Texas

¹ Also, the 163d MI Bn which provides OB support to the G2 sections of 2nd Armored and 1st Cavalry Divisions, Fort Hood.

A history of the concept of Order of Battle in the U.S. Army is presented as background for the survey; next, the discussion of the development of the Order of Battle Section from World War I to the present includes variations in field experience and problems encountered. The nature of the OB factors is examined, from their definition to the way they are determined and used. Finally, the main findings of the Survey of Military Opinion are presented. The detailed results of that survey, together with a discussion of the findings, are in a supplemental document, "Survey of Military Opinion on Tactical Order of Battle: Supporting Data and Commentary." ²

HISTORY OF ORDER OF BATTLE

Background

Prior to World War I, the United States, in its political and physical isolation behind two great oceans, did not seriously contemplate land warfare with other highly civilized nations. It is not surprising, therefore, that in 1885 when the Secretary of War requested from the War Department certain information concerning a foreign army, he was told that there was no office or officer charged with the collection or supply of foreign military intelligence.³ To meet this need, he created a Military Information Division in the office of the Adjutant General, and, in 1889, instituted what became a small military attache system.

In 1903 when the War Department General Staff was created, the Military Information Division was transferred to the Office of the Chief of Staff and later became the Second Division of the General Staff. However, in 1908, a reorganization of the General Staff placed the intelligence function, primarily information-gathering on foreign armies, with the War College. As a consequence of this action, except for a Military Information Committee of the War College, the embryonic intelligence service essentially disappeared as a separate activity.

Prior to World War I the military establishment had little conception of an intelligence service that, with specially trained personnel,

² Bowen, R.J. Survey of military opinion on tactical Order of Battle: Supporting data and commentary. Arlington, Virginia: Bolt Beranek and Newman Inc. consulting Research Memorandum on file with ARI. January 1974.

³ The Military Intelligence Division, War Department General Staff. The Functions of the Military Intelligence Division. 1 October 1918.

would make a systematic and continuing effort to collect and record data concerning the characteristics of foreign armed forces. Nor did the U.S. Army appreciate the need for all commanders to have and to use detailed intelligence. Instruction as to the disposition of information about the enemy in time of war taught that messages and reports concerning the enemy were to be sent to higher headquarters if deemed of sufficient importance. Commanders of troops in the field were generally expected to seek information of the enemy for their own use. Higher commanders would obtain information from their own agencies or would send specific requests to subordinate commanders for particular pieces of information.⁴ Information about the enemy was gained primarily through reconnaissance and secondarily from spies, deserters, prisoners, newspapers, etc. Curiously, Regulations for Troops in Campaign prescribed in 1903 that "the provost-marshal-general shall superintend the Secret Service," including spying activities.⁵

Following the entry of the United States into World War I in April 1917, the Chief of Staff directed the War College to organize a military intelligence section. On 7 February 1918, the Secretary of War reorganized the General Staff and made the Military Intelligence Section a branch of the Executive Division of the General Staff. It was not until August 1918, three months before the Armistice in France, that Military Intelligence was raised to a separate Division of the War Department General Staff.

General Headquarters of the American Expeditionary Force (GHQ AEF), prior to arriving overseas, decided on a tentative intelligence organization based on that of the British and modified by the best of what the French had to offer. The British had had to solve problems similar to that of the AEF. They had been forced to organize the intelligence service of their expeditionary army during the war; they were operating in an Allied country, albeit but one day's travel from their own capital; and they were subject to the same language difficulties as the AEF. The Regulations for the Intelligence Section, GHQ AEF were published on 31 August 1917. Many new concepts, techniques, and organizations were adopted and developed by the new Military Intelligence Service. Among them was the study of battle order."the location of all of the enemy's units, in line and in reserve."⁶

⁴ Sweeney, W. C. Military Intelligence, A New Weapon in War. New York: Frederick A. Stokes, 1924.

⁵ Wagner, A. L. The Service of Security and Information (12th Ed.). Kansas City, Kansas: Hudson-Kimberly Publishing Company, 1903.

⁶ Assistant Chief of Staff G2. Final Report of Assistant Chief of Staff G2. General Headquarters, American Expeditionary Force, 15 June 1919.

Following World War I, the United States dismantled not only its army of two and a half million troops, but also its capability to produce OB intelligence. In 1939, authorized strength of the Army was 165,000 men and 12,800 officers, including Air Corps. As late as January 1939, there were only four Training Regulations relating to the subject of intelligence: Scouting and Patrolling, Visual Signaling, Aerial Photo Mapping, and Tactical Interpretation of Aerial Photographs.⁷ "Combat Intelligence" was covered in Part I, Volume X of the Basic Field Manual. Its 27 paragraphs were printed on 24 small pages, while "Order of Battle" was covered in a bibliographic reference to Final Report of Assistant Chief of Staff G2, GHQ AEF, 15 June 1919. In 1940, just two months before the fall of France, the field manual FM 30-5, Combat Intelligence, first appeared; it was classified RESTRICTED. The heading "Order of Battle" did not appear either in the Table of Contents or the Index, and only passing reference was made to the subject.⁸

With the coming of World War II, the United States again rebuilt its intelligence service and, with it, its OB capability. This time, however, it had the experience from World War I, in addition to the tested methods of the British. Selected personnel were trained in OB functions in special courses at various military schools. The Order of Battle School, which began functioning in the European Theater of Operations in January 1944, passed a total of 1,271 officers and men through its regular courses up to the end of March 1945, while its mobile field unit gave familiarization courses to many hundreds more.⁹ OB development in the Southwest Pacific followed a similar course.

By the end of World War II, OB specialist teams, together with other specialists teams (PW interrogator, photo interpreter) had been organized as Military Intelligence companies and battalions to be attached as separate units at all echelons from theater down to division. Since World War II, the United States has maintained and improved its OB capability, both in organization and technique, profiting along the way from its experiences in Korea and Vietnam.

⁷ Koch, O.W. and Hays, R.G. G2: Intelligence for Patton. Philadelphia: Whitmore, 1971.

⁸ Pershall, W. R. Enemy Order of Battle in Sixth Army, Southwest Pacific Area. The Ground General School, 1949.

⁹ (ETO) Report of the General Board. Military Intelligence in the European Theater of Operations. United States Forces, ETO, 1945.

The term "Order of Battle" (OB), sometimes used interchangeably with "Battle Order", dates from early writings on military tactics. The expression has, however, meant different things to different people. Military writers, on occasion, have felt constrained to define Order of Battle to suit their own particular purposes (most dictionaries do not even list the expression Order of Battle). These definitions range from "the general or geometrical disposition of troops for battle"¹⁰ to "all intelligence concerning all foreign military forces."¹¹ Although the term was in wide vogue during World War I, it was not until 1941 that the U.S. Army, in Change 1 to FM 30-5 (April 1940), gave official sanction to a specific definition of Order of Battle. Even that definition has undergone several changes, the present official version having been introduced in 1964. Moreover, as has become clear during the present study, confusion (or imprecision) still exists regarding Order of Battle, even among experienced operational and intelligence officers.

In 1747, in his highly confidential and limited-distribution (30 copies) Instructions for his generals, Frederick the Great wrote, "When you are accustomed to the size of your army, you soon form your 'coup d'oeil' [i.e., mental picture--ed.] with reference to it, and habit teaches you the ground that you can occupy with a certain number of troops... within a single square mile, a hundred different orders of battle can be formed." Later, in his discussion of battle in the open field, Frederick the Great writes and diagrams: "Here is my order of battle:"

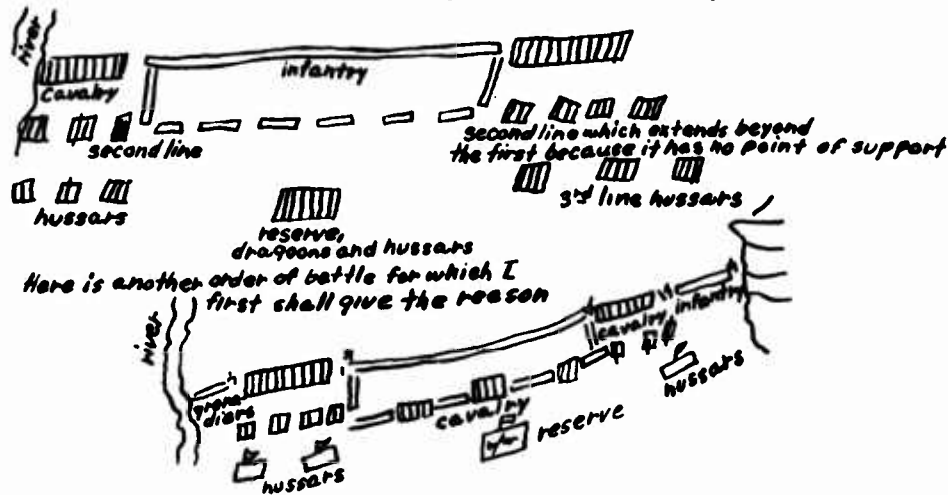

Figure 1. Diagram of Order of Battle

¹⁰ Bond/Garber. A modern Military Dictionary. Washington, D.C. PS Bond Publishing Co., 1942.

¹¹ Instruction Folder IF 66012 (D/NRI), U.S. Army Intelligence School. Introduction to Order of Battle and Order of Battle Factors. September 1968.

During the American Revolution, General Washington's principal drillmaster and tactician was Baron von Steuben, a former officer in the army of Frederick the Great. From Steuben's references to Order of Battle in his Regulations, it is clear that his use of the term remained essentially unchanged from that of his former chief.¹² This is confirmed by William Duane, Lt. Colonel in the Army of the United States and author of The American Military Library. In Duane's Military Dictionary¹³, published in 1810 after his death, Order of Battle was defined as: "The arrangement or disposition of the different component parts of an army in one or more lines, according to the nature of the ground, for the purpose of engaging an enemy, by giving or receiving an attack, or in order to be reviewed, &c." This same definition is repeated in A Military Dictionary and Gazetteer¹⁴ printed in 1881.

Mentions of Order of Battle or Battle Order are found in Battles and Leaders of the Civil War¹⁵, a four-volume comprehensive compilation of documents and eyewitness accounts of that war. "Jomini's Summary of the Art of War was carried in the saddlebags of most generals and colonels of the Civil War."¹⁶ In that work, Baron de Jomini, an eminent military writer of Swiss nationality and former staff officer and ardent chronicler of Napoleon, wrote: "Article XXXI - Offensive Battles and Different Orders of Battles... As soon as it is determined to attack the enemy, some order of attack must be adopted; and that is what I have thought ought to be called order of battle...At least twelve orders of battle may be enumerated, viz: (1) The simple parallel order. (2) The parallel order with a defensive or offensive crotchet. (3)..."¹⁷

Carl von Clausewitz (1780-1831), contemporary of Napoleon and Jomini and famed as the father of the modern German Army, wrote in his well known treatise On War: "Chapter V. Order of Battle of an Army.

¹²Riling, J. R. Baron von Steuben and His Regulations. Philadelphia: Ray Riling Arms Books Co., 1966.

¹³Duane, W. Military Dictionary. Philadelphia: William Duane, 1810.

¹⁴Wilhelm, T. A Military Dictionary and Gazetteer. Philadelphia: L. R. Hammersly and Co., 1881.

¹⁵Battles and Leaders of the Civil War, Grant-Lee Edition. New York: The Century Co., 1888.

¹⁶Ney, Virgil. The Evolution of Military Unit Control - CORG M217. Combat Operations Research Group (CORG), 10 September 1965.

¹⁷Jomini, A. H. Summary of the Art of War. Harrisburg: Military Service Publishing Co., 1952.

The order of battle is that division and formation of the different arms into separate parts or sections of the whole Army, and that form of general position or disposition of those parts which is to be the norm throughout the whole campaign or war."¹⁸

In 1894, writing on Organization and Tactics ("Officially recommended from Headquarters of the Army to Officers subject to Examination for Promotion"), Arthur L. Wagner said: "By the term 'order of battle' is meant the relative tactical position of the opposing forces in preparation for battle or during the encounter. The subject has been treated by some military writers with a wealth of diagrams and an infinitude of pedantic detail calculated to make scientific matter out of a subject which really pertains to plain common sense."¹⁹ Colonel E.S. Farrow, in A Dictionary of Military Terms published in 1918, reduced the pedantic detail to 4 items. "Order of Battle - The combination which is made to attack one or more points of an army in position. The four principal orders of battle are the parallel, the oblique, the concave, and the convex."²⁰

Describing the Roman art of war under the Republic, F.E. Adcock in 1960 made an interesting observation on order of battle: "With the requirement that both armies be deployed into position, it was necessary that an order of battle be devised. This requirement was essentially the beginning of unit control of large masses of troops. The disposition of the troops upon the ground and facing the enemy line constituted the order of battle."²¹ And in a 1965 report on The Evolution of Military Unit Control for the Combat Operations Research Group (CORG), Virgil Ney concluded: "The Greeks had the first important tactical formation - the phalanx...it should be noted that battles at this period of history (about 500 BC) were rather set piece affairs. Pre-combat arrangement of the contending armies was the common practice and thus the order of battle became a basic form of unit control."²²

¹⁸ Clausewitz, C. V. On War (1827). Harrisburg: Kegan Paul, Trench, Tribner and Co., 1952.

¹⁹ Wagner, A. L. Organization and Tactics. Kansas City, Kansas: Hudson-Kimberly Publishing Co., 1894.

²⁰ Farrow, E. S. A Dictionary of Military Terms. New York: Crowell, 1918.

²¹ Adcock, F. E. Roman Art of War Under the Republic. New York: Barnes and Noble, 1960.

²² Ney, 1965, op.cit.

During World War I, the American Expeditionary Force G2 copied the British terminology:²³ "Battle Order: By battle order is understood the location of all of the enemy's units, in line and in reserve." This definition, while simple and straightforward in statement, took on a new meaning in interpretation. The intensive study of the enemy was apportioned among nine subsections of the AEF G2. One of these subsections, G2A1-Battle Order, "collected, classified, scrutinized, appreciated and collated all information of the enemy army which would assist in determining what the enemy's intentions were, his capacity for battle, the time and place of his projected operations and the means available with which to carry them out." This sounds like the current definition of combat intelligence itself.

Between World War I and World War II, little attention was paid to Order of Battle in any official publication except to refer the reader to the Final Report of G2 GHQ AEF, 15 June 1919. As new situations and new needs arose during and after World War II, the term acquired new meanings. As an example, FM 30-5, February 1946, p. 4 describes Order of Battle as: "the manner in which the enemy has organized and disposed his military forces." On p. 27 it continues: "(c) Proper examination of prisoners of war, deserters, repatriates, and inhabitants furnished valuable and accurate information concerning the enemy order of battle, organization, dispositions, plans and preparations, morale and numerous other subjects." FM 30-19, October 1955, p. 2 states: "Order of Battle is defined as the manner in which military forces are organized and disposed. Throughout this manual, the term has further connotation of denoting enemy military forces."

In 1964, by Change 1 to FM 30-5, a new definition was given to Order of Battle: "Order of Battle is defined as the identification, strength, command structure, and disposition of the personnel, units, and equipment of any military force." This definition is the one in use by the United States today. By Standardization Agreement (STANAG) 2077, members of the North Atlantic Treaty Organization have adopted not only this definition of Order of Battle and Elements of Order of Battle Intelligence, but also many forms and procedures for processing and disseminating Order of Battle information/intelligence.

The evolution of OB definitions is shown in Figure 2.

²³Assistant Chief of Staff G2, 1919, op.cit.

FIELD MANUALS AND THEIR DEFINITIONS OF "ORDER OF BATTLE"

- G2 Report 1919 - The location of all the enemy's units, in line and in reserve.
- Basic FM 1923 - (None, refer to G2 Report 1919)
- Basic FM 1938 - (None, refer to G2 Report 1919)
- FM 30-5 1940 - Enemy manpower, location, strength, composition, training, and morale of all enemy troop units, both in line and in reserve.
- Change 1 1941 - The location, strength, composition, combat value of all units, in line and in reserve.
- FM 30-5 1946 - The manner in which the enemy has organized and disposed his military forces.
- FM 30-5 1951 - The manner in which the enemy has organized and disposed his military forces.
- FM 30-19 1952 - (Defined in FM 30-5)
- FM 30-19 1955 - The manner in which military forces are organized and disposed.
- FM 30-5 1956 - (Defined in FM 30-19)
- FM 30-19 1959 - The manner in which military forces are organized, disposed, maneuvered and supplied.
- FM 30-5 1960 - (Defined in FM 30-19)
- FM 30-5 1963 - (Defined in FM 30-19)
- Change 1 1964 - Identification, strength, command structure and disposition of the personnel, units and equipment of any military force.
- FM 30-5 1967 - Identification, strength, command structure and disposition of the personnel, units and equipment of any military force.
- FM 30-5 1971 - Identification, strength, command structure and disposition of the personnel, units and equipment of any military force.

Figure 2. Order of Battle definitions--A chronology

Discussion of Order-of-Battle Elements (Factors)

Although Order of Battle was studied in detail during World War I, it was not until World War II that official practice divided Order of Battle into elements or factors. In 1946, doctrine divided the definition into component parts for detailed examination and reporting. This first partition established three factors - strength, disposition, and organization - plus a catch-all category entitled "Additional Factors," which among other elements included: training, logistics, tactics, unit history, and military personalities. Each of these designated "Additional Factors" came in time to be a separate factor, although some were eventually regrouped under a new catch-all renamed "Miscellaneous Factors."

In current military doctrine, eight OB elements (factors) are listed. A description of each OB element is given in Appendix A and discussed in detail in a later section. The eight elements are related to OB in the following definition:

"Order of Battle (OB) is the identification, strength, command structure, and disposition of the personnel, units, and equipment of any military force....OB consists of evaluated information regarding the following elements: composition, disposition, strength, training status, tactics, logistics, combat effectiveness and miscellaneous."

[FM 30-5, 1973]

A chronology of Order of Battle elements (Figure 3) clearly indicates the changing emphasis on different factors and subfactors of Order of Battle. It is interesting to note in FM 30-31, however, that for stability (insurgency) operations, the factor of personalities is once again treated as a separate (i.e., ninth) factor. This exception demonstrates that in certain situations, subfactors may be given special prominence. It also suggests that a new look should be taken at the methodology for processing OB intelligence and at the interrelationships among the elements of OB intelligence as currently promulgated in official Army doctrine.

"The elements of OB intelligence (OB factors) are not independent of one another; they are closely related and must be considered as a whole. Information on any one element will often lead to a reevaluation or alteration of information previously received on another element" (FM 30-31, Stability Operations-Intelligence, January 1970). Intelligence concerning Composition, Training, and Logistics may give important clues as to strength, while intelligence on Strength, Composition, and Disposition, with the addition of intelligence regarding Training and Logistics, may well suggest the tactics that the enemy will adopt. Miscellaneous data include various types of supporting information needed by an analyst to contribute to the other OB elements.

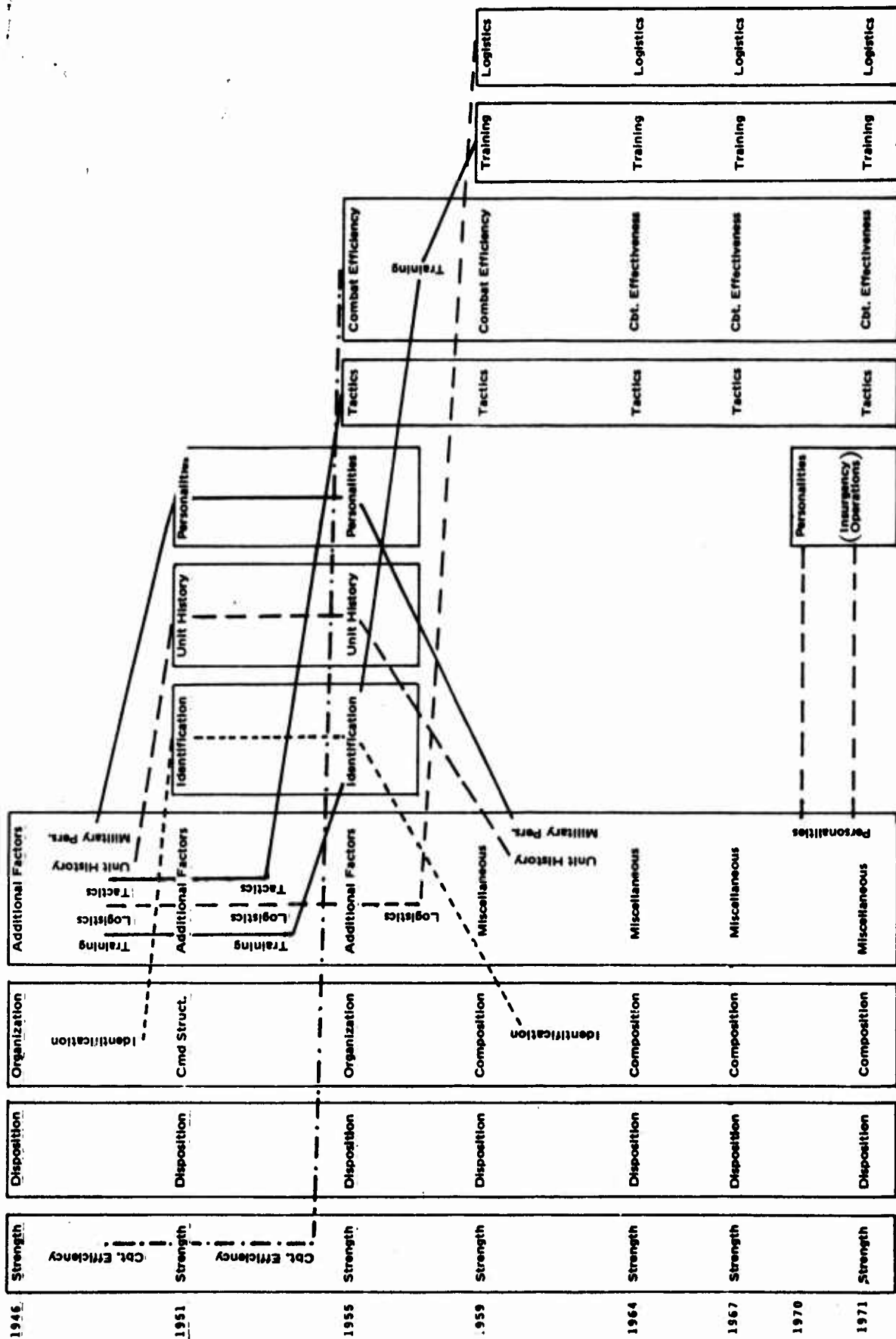
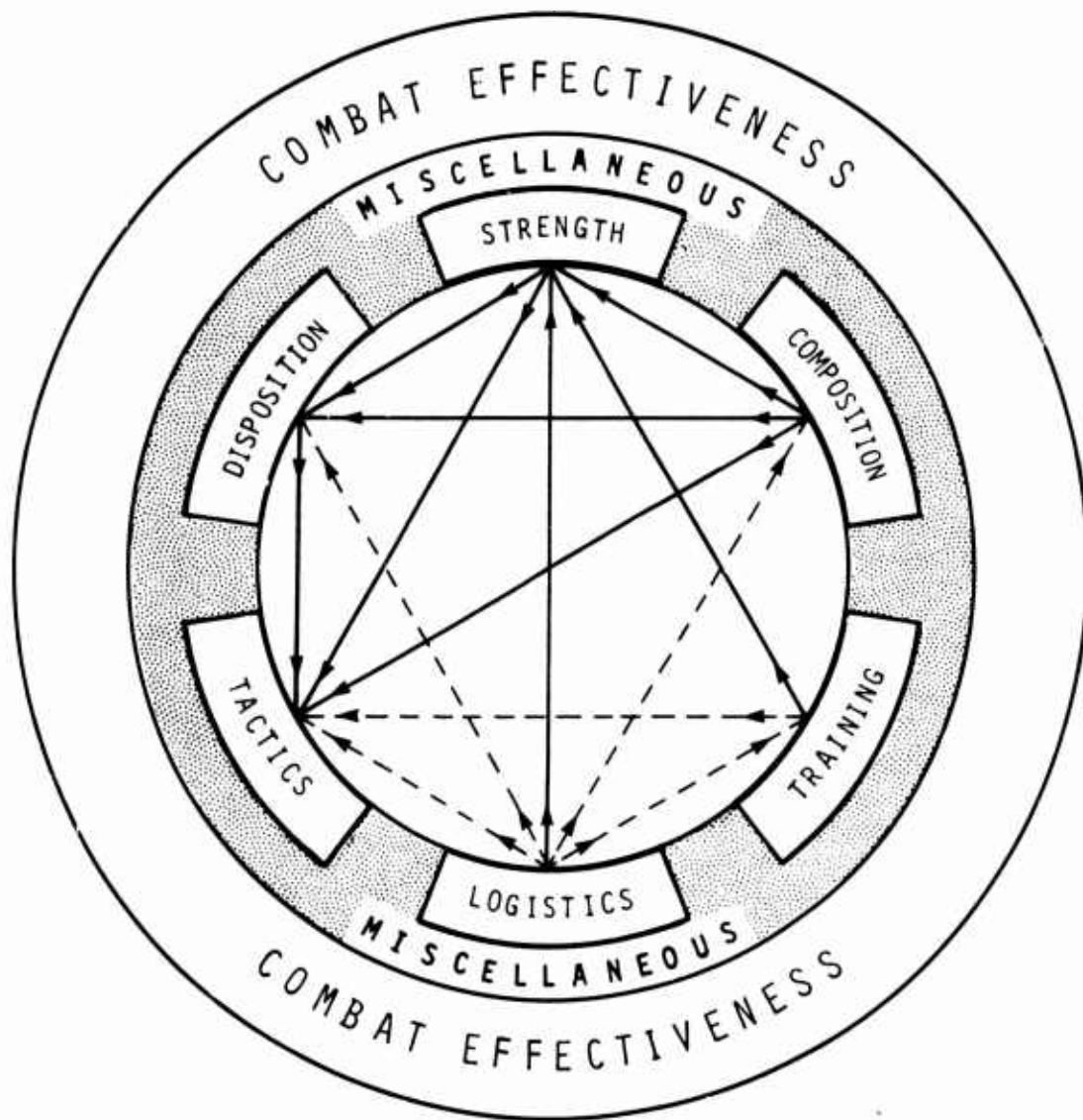

Figure 3. Order of Battle elements--A chronology

Relationships between and among various OB factors are shown in Figure 4. Because Miscellaneous data may include or add to other elements, it is shown surrounding the other factors. Combat Effectiveness is judged from a consideration of the other elements including miscellaneous data; it is, therefore, shown encompassing all other elements. Combat Effectiveness is of major interest in this report.



PRIME RELATIONSHIPS

INFLUENCING RELATIONSHIPS

Figure 4. Relationship of Order of Battle factors

Discussion of Combat Effectiveness Element

As long as man has struggled against an adversary, prime among his questions has been: "How good is my opponent?" The question has been asked in many ways and with many different adjectives and adverbs: fighting value, fighting quality, battle worth, capacity for battle, combat efficiency, combat effectiveness. Essentially, the object of the question remains the same, to judge the enemy's capability relative to one's own.

U.S. Military documents published prior to World War II often mentioned "battle worth," "combat effectiveness," etc., but not until 1946 was an official doctrinaire definition attempted.

"Combat efficiency is the fighting value of the represented strength and is determined by a consideration of the organization, weapons and equipment, strength, supply, losses, wastage, leadership, training, combat experience, personnel, and morale."

[FM 30-5, 1946]

Inexplicably, the edition of FM 30-5 dated February 1951 made no attempt to define either "combat efficiency" or "combat effectiveness" except to indicate parenthetically "combat effectiveness (quality)." In 1955, FM 30-19 elliptically defined the enemy's battle value as: "Combat efficiency is that degree of effectiveness which an enemy unit can achieve in a fighting engagement." The explanation did not go on, however, to list the characteristics, qualities, and circumstances which affect a unit's combat efficiency. In 1964, the United States adopted the definition and analysis of combat effectiveness which was subsequently accepted by the NATO Standardization Group, and which remains current in U.S. intelligence doctrine.

7-9. Combat Effectiveness.

Combat effectiveness is a term used to describe the abilities and fighting quality of an enemy unit, element, or entire national army. Combat effectiveness affects the capabilities of a unit or an army. How well a unit will perform in combat may be predicted by analyzing:

- a. Personnel strength.
- b. Amount and condition of weapons and equipment.
- c. Status of training.
- d. Efficiency of the officer and non-commissioned officer corps.

- e. Length of time a unit has been committed in combat.
- f. Traditions and past performance.
- g. Personality traits of the unit commander.
- h. Geographical area in which committed.
- i. Morale, health, discipline, and political reliability (or belief in the cause for which they fight).
- j. Status of technical and logistic support of the unit.
- k. Adequacy of military schooling at all levels.
- l. National characteristics of the people.

[FM 30-5, 1973]

Little attempt has been made to describe the manner in which an appraisal of combat effectiveness is to be presented to the commander or his staff. Some explanation is presented in an appendix to FM 30-5, first as a format and then as a sample (see Appendix B). An extract of the format is shown below:

COMBAT EFFECTIVENESS: This paragraph includes data on the combat effectiveness of enemy units: either of the entire force or of a major tactical unit. Items indicating morale, spirit, quality of troops and commanders are listed. The ability of the enemy unit to accomplish its expected mission is expressed.

The accompanying example (Appendix B) demonstrates the approved manner of preparing an Order of Battle Annex; an extract paragraph is shown below:

6. COMBAT EFFECTIVENESS

a. PW from 16 Mech Div and 30 Mech Div state morale is high but senior officers are disgruntled because their units always receive difficult missions while the 32 Mech Div and 56 Tk Div have, until recently, been assigned less hazardous missions. (F-6)

COMMENT: Analysis of unit history and recent operations of Aggressor 2d CAA indicates it has usually been highly successful in combat. This, and the fact that 2d CAA has always had fine commanders, would account for high morale in units. This is first indication of dissatisfaction among officer personnel. Report seems cogent, however, since 32 Mech Div has not been engaged in combat with U.S. Forces in this campaign.

b. PW reports 30 Mech Div to be redesignated 30 "Fusilier" Mech Div for superior combat record. (F-6)

COMMENT: 3 U.S. Corps rates combat effectiveness of 30 Mech Div from excellent to outstanding in comparison to other Aggressor divisions in same sector. 30 Mech Div casualties have been comparatively small; no deserters have been apprehended and its operations have been executed with determination.

Of the eight OB elements, combat efficiency is the most complicated to analyze. Its dozen factors listed above (more under special situations) are largely descriptive or judgmental. Because of a common tendency to visualize units in terms of personality factors, a considerable amount of intuition may be involved in the analysis of combat effectiveness. As a result, presentation of an analysis in meaningful terms introduces a complicated problem in human communication. Is an adjectival rating and comparison with a known quality adequate? Examples of the problem and of different approaches to the estimation of combat effectiveness are shown in Appendix C of this report.

Current Status of OB Intelligence

In announced U.S. Order of Battle doctrine, no significant change in guidance or methodology has occurred since the publication of FM 30-19 in June 1959, except for a change in the definition of Order of Battle. For comparison purposes, the two definitions are quoted:

FM 30-19, June 1959

Order of Battle is defined as the manner in which military forces are organized, disposed, maneuvered, and supplied.

FM 30-5, October 1973

Order of Battle is the identification, strength, command structure and disposition of the personnel, units and equipment of any military force.

There are only minor differences in the stated component parts of Order of Battle in definitions and in terminology (indicated below by underscore):

FM 30-19, June 1959 Order of Battle Factors

1. Composition
2. Disposition
3. Strength
4. Training
5. Tactics
6. Logistics
7. Combat Efficiency
8. Miscellaneous

FM 30-5, October 1973 Order of Battle Elements

1. Composition
2. Disposition
3. Strength
4. Training
5. Tactics
6. Logistics
7. Combat Effectiveness
8. Miscellaneous

Of the major aids and files in Order of Battle reporting (OB Annex, usually attached to the Periodic Intelligence Report [PERINTREP]) and recording (situation map, unit workbook, OB Workbook, military installation file, personality file), there are but slight differences. Some additional aids, formerly described only as to purpose, now have standardized formats.

Summary of History of OB

Current OB doctrine for the U.S. Army is the product of evolutionary negotiation, primarily with allied countries of the North Atlantic Treaty Organization (NATO). In fact, the entire chapter dealing with Order of Battle in the current field manual, FM 30-5, Combat Intelligence, October 1973, is in full conformance with NATO Standardization Agreement (STANAG) 2077. Many significant forms, files, reports, and procedures have been standardized for simplicity and ease in exchanging information among the military forces of the different nations of NATO. For the U.S. Army in the field, with minor exceptions, the same doctrine and technique extant 14 years ago are in effect today.

THE ORDER OF BATTLE SECTION

The present discussion is focused on the status and evolution of the OB section at divisional level, now known in some divisions as the Analysis and Production (A&P) Section. Passing reference is made to the corresponding changes which are taking place at field army and corps levels or at brigade and battalion when they relate to divisional-level changes. Special intelligence sources are not considered beyond noting that they provide significant support to the OB function.

Despite the extensive background of practical experience derived from Vietnam, when analyzing the OB function as it might operate in a tactical combat environment of the future it is necessary to depend heavily on recent peacetime developments, since they form the main basis for an understanding of division-level OB operations at the present time. Personnel training and experience are considered with respect to both conventional and unconventional warfare. Trends in the development of the OB function are viewed from several standpoints; that of the field practitioner of OB; that of the OB instructor; and that of the individual responsible for developing policy and doctrine in this area.

Role and Function of the OB Section

The role of the OB section of a combat unit in the field is to provide the commander with intelligence concerning the enemy, as opposed to intelligence concerning the tactical environment. While it could be maintained that any information concerning the enemy is Order of Battle, the scope of interest of the OB section tends in practice to be somewhat more restricted. For example, enemy activities analysis is often treated as a current intelligence function with OB being responsible for following general trends in enemy activities.

The creation of OB teams for division-level and higher headquarters during World War II provided the first specialized augmentation (for OB functions) of the G2 sections of forces in the field. The three-man division-level teams (a captain, a master sergeant, and a Tech grade 3)^{24,25} concerned themselves mainly with enemy unit locations, identifications, and frontal strengths. The teams relied heavily on higher echelon OB support for more detailed analysis of enemy forces, such as estimates of combat effectiveness. Currently, each G2 section of a division or higher-level headquarters is provided with an integral element responsible for performance of the entire OB function.

While the role of OB at division level now embraces a far wider scope of responsibility than it once did, there is still a flavor of recent history to the product of some OB sections. OB sections in Vietnam operated as a somewhat longer-range analytical backup to the current intelligence function of the G2 section, tending to produce dated material more suitable for planning the next battle than for supporting the operations of the present one. Vietnam was a proving ground for OB doctrine and procedures, requiring that its practitioners adapt themselves to the complexities of unconventional warfare with little advance preparation. As a result of its Vietnam experience, the Army is increasing its emphasis on the training of combat intelligence personnel. OB is being recognized as the field commander's main source of targeting and capabilities intelligence required for decision-making.

In Vietnam, practical necessity tended to give OB the responsibility for integrating the products of other methods that have evolved over the years for providing information about the enemy. In some respects the nature of the OB function (despite its less sophisticated level of

²⁴ Military Intelligence Service in the European Theater of Operations.
The General Board, United States Forces, European Theater, Study
Number 12, 1946, UNCLASSIFIED.

²⁵ Organization and Operation of a Corps G-2 Section in Combat V Corps-ETO.
The Intelligence School, Fort Riley, Kansas, 1946, UNCLASSIFIED.

development) was more clearly defined during World War II, when individual OB teams were attached to G2 sections of divisions and corps in the field. Today, at the division level, the OB function is a somewhat ad hoc operation carried out as an integral part of the G2 section, with the OB personnel formally assigned to the MI company.

One result of the lack of definition of the OB role at present has been a series of personnel problems. One of the key problems of the OB section, particularly at division level, has been the modest rank and the high mobility of the personnel professionally engaged in this specialty. Warrant officer OB technicians and senior OB NCO's have been a source of continuity of expertise over the years. OB officers, often with no specific background in OB, come and go. Analyst personnel seldom remain in the OB field beyond part of a single tour of duty. This has made it difficult for senior officers to accept the concept of the OB section as the main source of command information on the enemy. OB personnel, instead of being viewed as competent analysts, have often been regarded as file clerks and treated accordingly. Thus, OB sections have found it difficult to maintain the level of proficiency needed due to frequent turnover of personnel, changes in TOE's, insufficiencies of staffing, inadequacy of training opportunities during peacetime, limited clearance levels, etc.

As the pace of war has increased in recent years the current intelligence function, through activities analysis, has tended to dominate the support of command decision-making. OB sections until recently have frequently merited characterization as historical reference bureaus providing bits of information on the enemy to sustain analyses performed by other portions of the G2 section.

Recognition of the vital contributions of OB to both targeting and command decision-making in Vietnam is leading toward a greater responsibility for analysis of current activities in the OB section. The OB function is evolving into an integral element of intelligence operations with respect to current enemy activities. For example, the Battlefield Information Coordination Center (BICC) concept envisages the exercise of the OB function at brigade and perhaps as low as maneuver battalion level. While the situation is still in flux, resolution may occur through development of all-source operational centers in direct support of the commander. This would enhance OB intelligence as the end result of analysis which depends on inputs from most of the other elements of the G2 section to provide an integrated product that is vital to the command decision-making process. However, whether OB evolves into a provider of current intelligence at the division level must await the outcome of developments still in progress.

A Schematic View. In view of the fact that at present there is no such thing as a "typical OB section" at any echelon of command, it is somewhat difficult to describe such an entity. There are Tables of Organization and Equipment (TOE) of OB sections, but these are unrealistic and designed mainly for peacetime organizational requirements with their limited missions and severe restrictions on assigned personnel. (It may also be argued that OB section TOE's are designed to meet the needs of only the combat phase of battle.) During combat, OB section organization in the past has tended to be somewhat ad hoc. A division G2, for example, acquires personnel from a variety of sources, both within the division and outside, to meet the extremely high information processing needs of combat situations. Frequently, assigned strengths of such sections in Vietnam were two or three times greater than their TOE values, OB sections of 20 or more not being uncommon. In view of the somewhat nebulous character of the staffing, we shall first describe what are believed to be the minimum requirements of a division-level OB section and suggest how these would probably expand under a combat situation.

First, consider the personnel requirements of a single shift. Whether it is a twelve-hour peacetime shift or an eight-hour wartime shift need not concern us particularly here, since the basic staffing requirements of the shift would not be affected. To begin with, there must be a Shift Officer, an Officer in Charge (OIC) or Noncommissioned Officer in charge (NCOIC). This may be a captain or lieutenant (the OB officer), a warrant officer (the OB technician), or an E7 or E6 (the senior NCO of the team). Although it is not always the case, we will assume that there is a Logger in the OB section, presumably an E2 or E3, whose prime task is the recording of incoming messages before routing them to the OIC/NCOIC for action determination. He can also serve as a clerk-typist. We will further assume that there are at least two E4 or E5 96B Intelligence/OB analysts on duty in the section during any shift. The main duty of one analyst is the maintenance of the OB Situation Map and the card files, and that of the other analyst, maintenance of statistical data and filing of documents. The file function carries with it the responsibility of determining the required extracts to go into the files. In addition, each analyst will be given responsibility for subjects that are of interest to the section, such as OB factors, areas of terrain or enemy units (i.e., pages of the OB and unit workbooks). Both analysts, together with the OIC/NCOIC, participate in the preparation of section products, such as OB inputs to INTSUM's, PERINTREP's, etc.

Each analyst will have a field desk (i.e., a table), a chair, a telephone, and space in a safe for files. Beyond that, he is usually on his own to operate within the limitations of his professional training, the section Standard Operating Procedure (SOP), and his own general competence. It is clear that one cannot restrict particular individuals to narrow areas of interest, however much the interests of efficiency might seem to indicate the desirability of such a procedure. There are

just too few people allocated to an OB section to permit this under any but the most freewheeling combat situations in which augmentation personnel may be attached. The BICC concept, if implemented, would provide additional personnel, particularly below division level.

A "typical" current division-level OB section under combat conditions consists of an OIC/NCOIC, a Logger, and an unspecified number of 96B analysts. Each analyst is capable of: maintaining an OB Sit Map, maintaining OB file cards, extracting information from messages, maintaining any portion of an OB workbook or unit workbook, conducting liaison with personal sources of information, and providing inputs to any of the many products of the OB section. In addition, the analysts must be prepared to participate in all of the housekeeping tasks of the section and of the administrative unit to which they are assigned in the headquarters. The working conditions of the OB section generally tend to be cramped and noisy. In the field, OB personnel will usually work in a van-type setup as part of a larger intelligence operations activity--i.e., near or part of a Tactical Operations Center (TOC).

Current Status. Divisions based in the continental United States (CONUS) are in the process of transition from the TOE of an OB Section of the division MI company to that of an A&P Section of the company with the same responsibilities for OB production. As a result, various organizational arrangements for performing the OB function are found in these units and, presumably, in other similar units as well as in the OB elements of other echelons, such as corps and field army.

Some current examples of division-level OB section TOE's are shown in Figure 5. It is clearly a rapidly changing situation with the OB sections reporting themselves unable to staff more than a single shift operation under current peacetime conditions and estimating a need for at least twofold augmentation for 24-hour operation under conventional wartime conditions.

Under the Integrated Battlefield Control System (IBCS) and Battlefield Information Coordination Center/Battlefield Information Center (BICC/BIC) concepts currently being studied by Project MASSTER at Fort Hood, Texas, a number of variants of the G2 staff and BICC augmentation elements of an MI company supporting a division G2 section have been evaluated in field tests. Consideration is also being given to the possibility of assigning an MI battalion to a division in place of the conventional MI company, as the source of personnel for BICC/BIC augmentation of G2 and S2 sections. In Table 1 may be seen the personnel makeup of four variants of A&P sections of MI companies which have been evaluated and one BICC concept that is to be tested. This experimentation has already led to provisional changes in the TOE's of divisional OB (or A&P) sections, and it may safely be assumed that further changes will be forthcoming as the matter receives additional study. The evolutionary nature of the makeup of the OB section is clear from the data for three CONUS-based divisions presented in Figure 5; each is operating under a different TOE for its OB section. Moreover, each has an actual organizational arrangement that is quite different from its TOE and would like to have something else again as a TOE for proper execution of its mission.

	1st Inf Div(Mech) Fort Riley, Kansas	4th Inf Div(Mech) Fort Carson, Colorado	82nd Airborne Div Fort Bragg, North Carolina
Section Designation	Analysis & Production	Analysis & Production	Order of Battle
TOE	30-017HCA04	30-017HCA021	30-17GV01 (modified)
Date:			
of TOE	21 March 1973	"late 1972"	30 April 1970
of Info.	18 April 1973	21 May 1973	16 May 1973
PERSONNEL:	TOE Actual Desired	TOE Actual Desired	TOE Actual Desired
CPT (MOS 9301) Sect. Chief	1 1 1	1 - 1	- - -
WO (MOS 964A) OB Tech.	1 1 1	1 2 2	2 1 4
E7 (MOS 96B) OB SGT.	- - 1	- - -	- - -
E6 (MOS 96B) OB SGT.	- 1 1	- - -	1 3 2
E5 (MOS 96B) Intel Analyst	3 2 2	3 3 3	2 2 4
E4 (MOS 96B) Intel Analyst	1 2 1	1 1 1	1 - 2
E3	- - -	- - -	- 1 -
E2	- - -	- - -	- 1 -

Figure 5. Some current examples of OB Section TOE's.

Table 1

VARIANTS OF DIVISION A&P SECTIONS^a

Personnel	Baseline Analysis TOE 30-17H	C3 Concept ^b	IBCS Phase 1 ^c	Preferred Alternative	Tactical SOP G2/BICC ^d
CPT	1 (MOS 9301) Sect. Chief	-	-	-	-
LT	-	-	-	1 (MOS 9301) Intel. Officer	3 (MOS 9301) Intel. Officer
2LT	-	-	1 (MOS 9318) OB officer	-	-
WO	1 (MOS 964A0) OB Tech.	1/2 (MOS 964A) OB Tech.	-	1 (MOS 964A0) OB Tech.	1 (MOS 964A0) OB Tech.
E6	-	-	1 (MOS 96B20) OB SGT	2 (MOS 96B40) Intel. SGT	2 (MOS 96B40) Intel. SGT
E5	1 (MOS 96B20) Intel. Anal. OB	4/3 (MOS 96B20) OB Analyst	1 (MOS 96B20) Intel. Anal.	2 (MOS 96B20) Intel. Anal.	2 (MOS 96B20) Intel. Anal.
E4	1 (MOS 96B20) Intel. Anal.	-	2 (MOS 96B20) Intel. Anal.	-	-

^aBased on MI Company organization. As of August 1970, a suggested Combat Intelligence Battalion for the mechanized division had the following A&P Section staffing:

2LT(9301), Intel. Staff Officer - OB; 1 E6(96B40), OB Sergeant; 1 E5(96B20), Intel. Analyst - OB; 2 E5(96B20), Intel. Analyst; 2 E4(96B20), Intel. Analyst; Total: 8. (Source: Combat Intelligence Battalion (CBTI BN), Mechanized Division - Training Text, ACN 17496, TT 30-7, USACDCINTA, Fort Holabird, Maryland, 10 August 1970, UNCLASSIFIED.)

^bAuthorized/Test 113 at Project MASSTER

^cSame personnel for Type C and Test 113

^dProjected/Test 119 at Project MASSTER: (Source: Tactical Standard Operating Procedures, G2/BICC, Division Level, Extract from Plan of Test 119 of Project MASSTER, 1973, UNCLASSIFIED.)

Source: First Submission, IBCS Division Level Definition, USACDCINTA, Fort Huachuca, Arizona, 8 June 1972, UNCLASSIFIED.

The officer in charge of the OB section is usually a captain or a lieutenant. Unfortunately, these officers, while usually holding some MI Military Occupational Specialty (MOS), frequently are not experienced in OB. Then there are four EM's holding the 96B MOS, generally E4's or E5's, who serve as the working analytical staff of the section. There is frequent turnover in OIC's and in EM's, often with the need to use E2's and E3's fresh from the Intelligence school to replace E4's and E5's who have been transferred out. In this connection, it is worth noting that a real problem faced by the MI community, and by OB in particular, is an excessive turnover of qualified enlisted personnel, whether through transfer or completion of minimum duty tours.

The most frequent complaint from those responsible for OB sections is lack of sufficient personnel with which to staff three (or even two) shifts under peacetime CONUS conditions. If a division has 7 or 8 people in its A&P section, and wishes to operate three shifts, only two individuals can be used per shift, clearly a minimal capability for performance of even a training function. Unfortunately, this situation is not likely to be rectified in the near future. During peacetime, OB has no responsibilities comparable to those which it must exercise in wartime. As a consequence, staffing shrinks to a level commensurate with garrison duties. Thus, a task of G2's and MI personnel planners is to provide realistic OJT training for available OB staff and to plan for rapid augmentation in times of emergency.

A variety of speculation is heard concerning the rationale behind current OB section staffing policies. Some feel that it is simply a failure to appreciate the importance of the OB function for success in battle. Some attribute it to an assumption that eventually, under the BICC concept, corps will be feeding more OB intelligence to lower echelons. Others suggest that it is a reflection of a "CPX attitude" in which one thinks in terms of current intelligence play in the solution of problems. It may be noted that, in order to carry out proper play of the OB function, it is necessary to have available historical data gathered over a period of time as a basis for OB judgments. Most field exercises are simply not geared to this type of play; message sets are generally concerned only with current activities. The generation of historical OB data files is usually not considered by those preparing the exercises. There is, of course, the Aggressor Handbook (which is in the process of being automated at AICS); it permits some consideration of the OB factors, but in a static rather than a dynamic fashion. A clear need exists to give more attention to the reality aspect of peacetime OB training and operations. However, even where proper exercises are available, the limited staffing of OB sections would still severely limit the potential for realistic OB play.

Various suggestions have been made for dealing with the OB staffing and training problem in peacetime. One is that OB analysts be kept active through regular assignment to a high-level HQ such as USAREUR, where there is a continuing mission, albeit a strategic one. Another approach is used by the 9th Infantry Division at Fort Lewis, Washington.

There, analysts are being trained in an Information Analysis Center to deal with the complex peacetime problems of post, camp, and station security, using the analytical tools of OB and, in particular, pattern analysis.²⁶ Finally, the current assignment of responsibility for contingency planning for operations in certain regions of the world to specific CONUS-based units may result in improved staffing and training of OB sections during peacetime.

Vietnam Experience. The crucial importance of the OB function in combat is attested to by the fact that OB sections of divisions typically balloon to two or three times their peacetime strength under combat conditions. In Vietnam, the staffs of such sections were as large as 15 to 20 or more, and of corps at times in excess of 50. (For both divisions and corps, the TOE of the OB section was 6.) Initial staffing of the OB functions in Vietnam took place in 1965 with personnel of the 519th MI Bn from Fort Bragg and the 319th MI Bn from USARPAC (the 319th was moved from Fort Bragg to Hawaii in May of that year). At Fort Bragg the 519th MI Bn had been stripped of OB personnel to staff the MI Detachments of units like the 1st, 4th, and 25th Infantry Divisions (the 1st Infantry Division also received the 55th OB Det as augmentation at that time). Late in 1965 from the OB Branch of USARPAC in Hawaii the 319th MI Bn sent a provisional unit to Vietnam. This unit consisted of seven OB teams (K-type: 1 officer and 4 enlisted men), a control detachment, and an Area Analysis team to serve as the cadre for the OB Branch of Combined Intelligence Center Vietnam (CICV). In the 1966-67 period the respective strengths of the OB Branches of USARPAC and MACV were about 115 and 150 officers, enlisted men, and civilians.

Some idea of the changing personnel requirements of theater and combat-level OB section operations in Vietnam may be gained from the fact that, in 1967, the following MI detachments were activated within the regular Army at Fort Bragg, North Carolina, transferred to Vietnam for G2 section augmentation purposes, and subsequently inactivated there during the period from early in 1970 to late in 1972, according to TAGO.

<u>Detachment</u>	<u>Initial Strength</u>	<u>Deactivation Date</u>
628th MID (OB)	(O)1-(EM)3	Feb. 1970
629th MID (OB)	(O)4-(EM)4	Oct. 1970
634th MID (OB Aug)	(EM)8	Mar. 1971
636th MID (OB)	(O)1-(EM)3	Feb. 1970
202nd MID (OB)	(O)1-(WO)1-(EM)3	Feb. 1970
204th MID (OB)	(O)6-(WO)3-(EM)11	Nov. 1972

²⁶Information Analysis Center (IAC), 9th Infantry Division. Fort Lewis, Washington, 1973, UNCLASSIFIED.

In addition to G2/S2 augmentation drafts (e.g., in 1967, the 4th Infantry Division received a G2/S2 augmentation of 54 individuals), another mechanism for providing trained OB personnel to Vietnam units was their assignment from other intelligence activities. Presumably, deactivation of the above-listed augmentation detachments indicates absorption of their personnel into regular units or their rotation from the theater without replacement. As indicated by Figure 6, some 467 individuals holding the 96B20 MOS were on duty in Vietnam as of mid-1968.

Given the past experience of a greatly expanded requirement for OB personnel in combat, one might argue that it is a bit short-sighted to worry about whether the TOE of the OB section of a division should provide for 5, 6, or 8 people. Nor can one reasonably argue that the real requirement cannot be estimated until the nature of the situation has become evident, as past experience can serve as a considerable guide in this area. However, stringent peacetime personnel limitations have often been met by cutting back in those areas having low peacetime responsibilities; and it cannot be denied that OB is one such area.

OB Section Operations

General. The operation of an OB section is subject to unexpected change, as it is dependent on the availability of personnel and on the situation. Around-the-clock coverage in all circumstances is necessary so that the commander's need for information, including his requirement for continuity of operations during displacements, can always be met by spot briefings. However, the manner in which this is done varies greatly from unit to unit. Each unit attempts to standardize its own procedures by drawing up an OB (or A&P) section SOP covering most of the likely eventualities. The following discussion is based on current information on: the shift operation of three CONUS-based divisions (the 1st and 4th Infantry Divisions, and the 82d Airborne Division); an outline of a new concept being tested by the 9th Infantry Division; and comments of G2 personnel as to how seven division OB sections (representing four divisions) operated in Vietnam.

The 82nd Airborne Division, with 8 individuals assigned to its OB section, operates two 12-hour shifts in a Tactical Intelligence Center (TIC) associated with the TOC, which includes ASA, IPW, CI and OB activities. A thirty-minute overlap is provided for briefing the new shift. Shifts correspond to the INTSUM output (a weekly task, at present) in order that a break in personnel will not occur at the time the INTSUM is being prepared. Three to four OB personnel are available during each of the 12-hour periods. Each shift is supervised by an OB OIC or NCOIC. At least two analysts perform prescribed tasks, with the NCOIC available to provide additional analytical assistance. In combat, the OB section would expect to be augmented by 100 percent in order to man three 8-hour shifts.

The 1st Infantry Division, with 7 individuals assigned to its A&P Section, operates three 8-hour shifts, starting at midnight. After each 8-hour shift, the members of that shift take about an hour to brief the new shift and then proceed to a quiet location for another three hours to prepare formal products, such as OB annexes or other specified items. There is an OIC or NCOIC for each shift plus either one or two analysts, who spend most of each shift with procedural matters. The section is capable of operating either three shifts, as at present, or a two-shift jump. In the latter case, two 2-man teams (each consisting of an OIC/NCOIC and an analyst) would move up with the commander, the teams working 12-hour shifts plus four hours of overlap. The remaining section members would move up with the G2 section. The A&P Section normally works in the G2 Operations area of the TOC. Considerable augmentation of the A&P Section (2 to 3 fold) would be necessary during wartime to permit adequate shift-manning under combat workloads. Present staffing is considered to be about adequate for CPX play.

The 4th Infantry Division, with six individuals assigned to its A&P Section, normally operates two 12-hour shifts, starting at midnight. Each shift is composed of an officer, an NCO and a clerk/typist. Depending on the tactical situation, teams may work three 8-hour shifts. Each team coming off duty takes about 30 minutes to brief its replacement (i.e., until the incoming team is satisfied and releases the previous team). The A&P Section is normally located in a separate van in conjunction with the G2/DSEC. Employment depends on the tactical situation and the desires of the G2/DSEC. Present staffing is about satisfactory for operation of a single shift. Wartime operation would require considerable augmentation.

The 9th Infantry Division, at Fort Lewis, Washington, has departed significantly from traditional combat intelligence doctrine and operational procedure; in their concept, the Target Development Center (TDC) is the focal point of control, coordination and processing of intelligence at division headquarters, and at each subordinate headquarters to include brigades, maneuver battalions, division artillery, the air cavalry squadron, and direct support artillery battalions. In essence, the TDC replaces the G2 section at division level. Many of the ideas embraced by TDC are derived from the BICC concept.^{27,28,29}

²⁷
Target Development Center (TDC), 9th Infantry Division. Fort Lewis, Washington, G2 Section, 9th Infantry Division, 1973, UNCLASSIFIED.

²⁸
Annex B (Intelligence) to TAC SOP, 9th Infantry Division, Fort Lewis, Washington, August, 1973, UNCLASSIFIED.

²⁹
TDC Training Program, 9th Infantry Division. Fort Lewis, Washington, June, 1973, UNCLASSIFIED.

Total 96B20 Assigned within MACV: 13
 Total 96B20 Assigned within USARV: 454

1 Echelon Assigned	2 Area or Task	3 Estimated % of Total Time Spent in Area/Task	4 Desired Level of Proficiency in Indicated Task
Sep Bde	OB	45%	High Proficiency
Division	OB	11%	High Proficiency
FFV	OB	43%	High Proficiency
HQ USARV	OB	85%	High Proficiency
HQ MACV	OB	20%	High Proficiency
CICV	OB	28%	High Proficiency
Intel Adv (CTZ-Sector)	OB	45%	High Proficiency
Sep Bde	CI	0%	Familiarity
Division	CI	5%	Working Knowledge
FFV	CI	1%	Working Knowledge
HQ USARV	CI	0%	Familiarity
HQ MACV	CI	0%	Familiarity
CICV	CI	0%	Familiarity
Intel Adv (CTZ-Sector)	CI	0%	Familiarity
Sep Bde	Rpt Writing	15%	Working Knowledge
Division	Rpt Writing	10%	Working Knowledge
FFV	Rpt Writing	5%	Working Knowledge
HQ USARV	Rpt Writing	5%	Working Knowledge
HQ MACV	Rpt Writing	20%	High Proficiency
CICV	Rpt Writing	10%	High Proficiency
Intel Adv (CTZ-Sector)	Rpt Writing	10%	Working Knowledge
Sep Bde	Censorship	0%	Familiarity
Division	Censorship	0%	Familiarity
FFV	Censorship	0%	Familiarity
HQ USARV	Censorship	0%	Familiarity
HQ MACV	Censorship	0%	Familiarity
CICV	Censorship	0%	Familiarity
Intel Adv (CTZ-Sector)	Censorship	0%	Familiarity
Sep Bde	Filing, Collating and Editing Information	15%	High Proficiency
Division		45%	High Proficiency
FFV		20%	High Proficiency
HQ USARV		15%	High Proficiency
HQ MACV		15%	High Proficiency
CICV		27%	High Proficiency
Intel Adv (CTZ-Sector)		11%	High Proficiency
Sep Bde	Typing	7%	Working Knowledge
Division	Typing	15%	Working Knowledge
FFV	Typing	15%	Working Knowledge
HQ USARV	Typing	15%	Working Knowledge
HQ MACV	Typing	15%	High Proficiency
CICV	Typing	15%	High Proficiency
Intel Adv (CTZ-Sector)	Typing	9%	Working Knowledge
Sep Bde	Map Reading	8%	High Proficiency
Division	Map Reading	1%	High Proficiency
FFV	Map Reading	5%	Working Knowledge
HQ USARV	Map Reading	0%	Working Knowledge
HQ MACV	Map Reading	15%	Working Knowledge
CICV	Map Reading	8%	Working Knowledge
Intel Adv (CTZ-Sector)	Map Reading	10%	High Proficiency
Sep Bde	Maint Sit Map	10%	High Proficiency
Division	Maint Sit Map	13%	High Proficiency
FFV	Maint Sit Map	10%	High Proficiency
HQ USARV	Maint Sit Map	10%	High Proficiency
HQ MACV	Maint Sit Map	15%	High Proficiency
CICV	Maint Sit Map	10%	High Proficiency
Intel Adv (CTZ-Sector)	Maint Sit Map	10%	High Proficiency
Sep Bde	Air Surv/Recon	0%	Familiarity
Division	Air Surv/Recon	0%	Familiarity
FFV	Air Surv/Recon	1%	Familiarity
HQ USARV	Air Surv/Recon	0%	Familiarity
HQ MACV	Air Surv/Recon	0%	Familiarity
CICV	Air Surv/Recon	2%	Familiarity
Intel Adv	Air Surv/Recon	5%	Familiarity

Figure 6. Utilization of Intelligence Analyst in Vietnam, August 1968.

Note: Intelligence analysts assigned to HQ MACV and CICV should have the capability to type 36 words per minute. Intelligence analysts should have the capability to type 20 words per minute before assignment to the other echelons of command in RVN.

Source: Duberstein, CPT George E. *Intelligence Analyst Training, Staff Study, MIOAC 68-A-2, U. S. Army Intelligence School, Fort Holabird, Maryland, August 1968, UNCLASSIFIED.*

The division TDC is located within the DTOC and is composed of a Receipt and Dissemination Section, an Analysis and Production Section, a Plans and Estimates Section, a TDC Air Section and a SIGINT Liaison Officer. The mission of the A&P Section of the division TDC is to record, evaluate, analyze, and integrate information; formulate conclusions; and produce intelligence (including prediction of targets). It may also task collection agencies. The shift manning of the A&P Section is two officers (MOS 9301) and two enlisted men (MOS 96B). Also within the DTOC is a combined G2/G3 operational element known as Current (Operations and Estimates, where estimates of probable enemy course of action are prepared and tactical decisions are made concerning the deployment of the division. Subordinate TDC Teams OPCON, each composed of an intelligence officer and a combat intelligence analyst, are eventually to be provided to all of the above-noted elements of the command.

Individuals experienced in the operations of OB sections in Vietnam have indicated that, instead of the present manning of about six people, there were normally anywhere from 12 to 25 individuals in division OB sections. Sometimes, these were obtained from outside the division (i.e., as augmentation), but frequently were drawn from portions of the G2 section where workloads were less (i.e., II, IPW, CI). Moreover, there was a tendency to work only two shifts in some units in Vietnam. In one extreme case there was an 0730 to 2230 hours shift, plus a 2230 to 0730 hours shift manned by only a couple of people. This uneven allocation of time and personnel within OB sections is consistent with the image of OB as a long range, analytical function, rather than a current, quick-reaction capability.

Three examples of the ad hoc character of the organization of an OB section are available from the case of the 4th Infantry Division in Vietnam during the late 1960's. As of early 1968, this division was responsible for the largest area of operations in Vietnam, about 12,000 square miles embracing three provinces. The G2, in allocating personnel for the OB function, assigned a three-man team to be responsible for each province. The teams, each consisting of an officer and two enlisted men, worked a single 12-hour shift in the Operations Branch of the G2 Section. (By contrast, most division OB sections in Vietnam were located with the MI company.) When fighting was heavy in a particular region, the teams would double up on areas of responsibility in order to be able to operate two shifts. Three OB specialists were used on each 12-hour shift in the TOC. The 4th Division, therefore, at the time in question, had about fifteen people working on OB, as opposed to their TOE allocation of six.

The next person to take over the Fourth Division's G2 section in 1968 had a different approach to staffing the OB function. He preferred to concentrate on enemy units rather than areas requiring the allocation of OB personnel. He also operated his OB section in the Operations Branch of the G2 section, but as two 12-hour shifts of six individuals each. He placed no OB people in the TOC, but maintained one SI-cleared OB analyst in the SSO, together with an ASA and an SSO representative, to handle current intelligence (i.e., anything needing action within four hours). These people were prepared to sanitize material instantly

for operational use. As a result, all-source material, while still somewhat of a hindrance at times, was no barrier to OB operations. Actually, non-SI-cleared OB specialists responsible for in-depth analysis of enemy activities seldom, if ever, lacked an understanding of the practical import of all-source data coming into the G2 section. As such, they were frequently in a better position than the battalion commanders for access to incoming information about the enemy. However, no battalion commander ever lacked ready access to available information on his prime concerns, i.e., where the enemy was and how many of them were out there.

It is worth noting in passing the high regard in which OB analysts were held by the Commanding General (CG) of the Fourth Division at this time. Since the OB specialist on a particular enemy unit soon became the most knowledgeable individual on that unit in the headquarters, both the G2 and the CG made it a practice to hold frequent discussions with the individual OB analysts. In addition, the CG often took an OB analyst with him in his helicopter during an operation, using the latter's skills in pattern recognition to help spot enemy activities that were difficult for battalion commanders to discern on the ground. The same CG also frequently had a POW interrogator with him during operations to facilitate rapid acquisition of information on enemy activities. The OB unit specialists in this division were encouraged to learn to think like the unit they were studying and were relied on for estimates of enemy unit combat effectiveness.

A third G2 of the Fourth Division, who served from mid-1968 to mid-1969, had his own approach to the organization of OB section operations, dictated largely by the fact that the division was now responsible for four sparsely inhabited provinces in the Central Highlands. Multiple-overlay pattern analysis, based on SIGINT and aerial surveillance and reconnaissance took precedence over the analysis of IPW and documents information that had been so important previously. There were still about 15 people in the OB section. Three SI-cleared members of the section were located in the SSO, where they reviewed incoming information which they were prepared to sanitize rapidly for use by the remainder of the OB section, who were located in the MI Company. The SI-cleared Operations Officer coordinated the operations of the SSO, OB section, IPW, etc. In addition to his other duties, he served, together with the G2, as the conduit and reviewer for collateral and all-source analyses prepared by the G2 section. The OB section served as the focal point for all intelligence on the enemy, performing the analysis and integration of information contained in INTSUM's and PERINTREP's issued by operations. Analysts were assigned areas of responsibility, for the most part, rather than units per se. However, some units were followed regularly and an area analyst would be responsible for all units in his area at any given time.

The 25th Infantry Division in the spring of 1968 was heavily engaged with about 45 enemy battalions in its very active area of operations, Tainin Province, a region of both heavy jungle and open terrain. The OB officer built up the OB activity from a marginally effective staff of six or seven which had existed under his predecessor to a highly

productive group of 12 to 15. He, as the SI-cleared member, maintained liaison with the SSO and the TOC. The OB section, functioning as part of the MI Detachment, operated on a single-shift basis from 0700 hours to 1730-1800 hours. The OB Officer edited and wrote reports for about three hours in the evening and one man slept overnight in the section. This highly coordinated OB shop was responsible for integrating all information on the enemy and for preparing most of the content of the daily INTSUM's and biweekly PERINTREP's issued by the Operations Section. The G2 placed heavy responsibilities on the OB section for the support of targeting and command decision-making.

The 25th Infantry Division from late 1968 to late 1969 was located in roughly the same area of operations as before. The G2 section continued some of the procedures developed previously and initiated some new ones. In particular, they began to operate an all-source Tactical Intelligence Center (TIC) as part of the TOC. The OB section, which grew in size to some 19 people, operated on a single 18-hour shift. A night crew was maintained in the TOC. The OB Officer and the OB representative in the TIC were SI-cleared, as well as one enlisted man in the OB section who received SI messages. OB was the production section that integrated all information of the enemy, being mainly concerned, however, with the support of targeting and, to a lesser degree, with direct support of decision-making. The OB section provided inputs for the weekly G2 estimate and prepared the monthly PERINTREP's. Daily INTSUM's were produced in the TOC on the basis of inputs from the OB section. A SIGINT OB report was prepared for the commander each day as a compartmentalized OB function. Considerable OB section effort went into the production of research aids in the form of handbooks and special reports.

The First Infantry Division represents yet another mode of organization and operation of an OB section during their period of activity around Lai Khe, about 40 miles north of Saigon, from mid-1967 to mid-1968. They made extensive use of POW interrogation and documents in support of the OB operations, with SIGINT and aerial surveillance/reconnaissance also making significant contributions, the latter being more important to the G2 and Operations Officer. Multiple-overlay pattern analysis was the main information-processing technique of the OB section. (The G2 section was fortunate to have a platoon of Mohawk aircraft supporting it.) Two OB analysts were maintained in the SSO to provide quick access to SIGINT.

The OB section itself consisted of about six analysts, and was usually under the direction of a lieutenant. They operated two twelve-hour shifts, the night shift being more lightly manned. They were supported by five II's from the II Section who prepared some 17 kinds of overlays for them, only about half of which were based on imagery. The G2 and Operations Officer served as the final integrators of the analytical product from the OB section. The First Infantry Division was chosen to carry out a two-month field test in 1968 which was the forerunner of the BICC concept. For this purpose, a provisional MI Bn was created as augmentation of the G2 section. Two OB analysts were attached to each battalion, 6 to 10 to each brigade, and 20 to the division G2 section. The results of this test were generally favorable.

A final example of OB operations is provided by the 101st Airborne Division in Vietnam in 1970 and early 1971. They maintained an all-source OB activity in the SSO area and a collateral OB operation in the MI Company, both of which were coordinated by the Operations Officer. The whole OB operation was organized on a two-shift, 24-hour basis. The OB section consisted of a captain, two warrant officers and about 15 enlisted men. The SSO element, aside from screening all-source material, had responsibility for the preparation of material with which to brief the commander. It was manned by two combat arms captains, a lieutenant and a warrant officer OB technician; only the latter was formally a member of the OB section. The main OB section was part of what they called a Tactical Intelligence Center. Responsibility for preparation of PERINTREP's, SITREP's and estimates of enemy capabilities, as well as for requests for supporting collection, fell on the OB activity, under the supervision of the Operations Officer.

So far, we have considered the general operations of an OB section with regard to allocation of personnel to shifts, as well as the location and attachment of the sections in various units. However, nothing has been said about equipment, facilities, working conditions, communications, etc., which varied from unit to unit and were the source of numerous complaints and criticisms from the individuals interviewed. The extreme variability of the individual situations represented renders generalization difficult. However, a comment on one point is in order: lack of access by some OB sections in Vietnam to current, all-source information rendered their products somewhat historical in nature--suitable for planning future operations, perhaps, but of less utility to the support of operations in progress.

Specific Operations. It is instructive to consider the physical entities with which the OB analyst must deal in the performance of his duties. These are: Incoming Messages and Documents; Recording Aids; and Products of the OB Section (Table 2).

Let us look a bit more closely at the process involved in their generation by following a message from its entry into the OB section until it comes to rest in one or more files of the section or is otherwise disposed of.

1. The message enters the OB section, going either to the Shift Officer (OIC or NCOIC) or, in some cases, to a Logger or Recorder, and then to the Shift Officer.
2. It is reviewed by the Shift Officer for pertinence, currency, and required action.
3. If immediate action is called for, the Shift Officer takes it (usually, by calling it to someone's attention within or outside of the G2 section).

Table 2

OB ANALYST CONCERNS

Incoming Messages and L ments

Spot Reports
Information Reports
Intelligence Reports
Draft OPLAN
Requests/Directives

Recording Aids

Unit Workbook
OB Workbook
OB Sitmap
OB Card File
Personality File
Military Installation File
Organizational File
Strength File
Topical File

Products of the OB Section

Evaluation Reports
Spot Reports
Directives and Requests for Information
OB Studies
OB Annex to PERINTREP
INTSUM
Estimates
Intel Annex to OPLAN
Analyses of OB Factors and Elements

^a A detailed list of such reports is available from the Functional Area Description for Order of Battle, Vols. I & II, Final Draft. USACDCINTA, Fort Holabird, Maryland, November 1968, CONFIDENTIAL.

4. If it involves the location of a unit or an incident or action, the analyst-plotter is furnished with a copy of the information (or is shown the message directly, its immediacy of interest determining this last to a certain extent).

5. It then goes to the OB analyst responsible for the OB factors(s) to which it relates.

6. The analyst will introduce it into the appropriate portions of the OB Workbook and/or Unit Workbook if it concerns a current matter, after which, he will file it under all appropriate headings in the Recording Aids. (In addition to the above list, these may include activity, problem, and area files.)

7. If the message requires immediate analyst action, such as collation, initiation of request for additional data, initiation of request for confirmation, assignment of new evaluation, etc., he will take such action, generating any appropriate messages.

8. When action has been taken by the analyst, the message is filed under all appropriate headings, including pending action files of requests for further information or files on incomplete pattern analysis.

Among the questions the analyst should consider while processing the information contained in this message are the following:

- Do we already have anything on this subject?
- Does it add to or otherwise alter what we already have on the subject?
- What problems does it answer or suggest?
- What is our net evaluation of this item? (Is it consistent with what we know? Is it basically reasonable - plausible? Does it confirm something we already know?, etc.)
- What products are affected by the contents of the message? For example, how is the status of relevant OB factors and elements affected by the information?
- Is some immediate action suggested by this message?

In addition to these questions, additional inquiries will be suggested by the specific requirements of the special products that the analyst is required to produce. While much of the activity just described is fairly routine, each formal product will require a fairly complex process of analysis involving many pieces of additional information.

In all of this the analyst will be pursuing operations within the following list of categories:

Processing

Reviewing

Evaluation and Analysis

Updating/File Maintenance

Requesting Further Information

Report Preparation

Briefing--Including Presentation of Recommendations

The implications of computer-based support for OB operations have been explored in detail in recent years in conjunction with development activity related to the Tactical Operations System (TOS). A Functional Area Description (FAD) was created for Order of Battle Intelligence by USACDINTA at Fort Holabird, in 1968.³⁰ While that study concentrated on the requirements of an optimized manual operation--examining input data types, output products, data handling rates, organization, and related matters--it was designed to provide a basis for a later assessment of the feasibility of automating the OB function (i.e., providing it with computer-based support.)³¹ Figure 7 is a condensation of the manual scheme of organization of the OB function presented in the FAD.

OB Section Personnel

Role of OB Personnel. At least four separate roles are distinguishable in a division-level OB section: (1) the OB Officer, a captain, lieutenant or warrant officer (WO); (2) the OB Technician, a WO or senior NCO; (3) the analyst, a middle-grade NCO (all members of the section, save very junior clerk-typists, are supposedly capable of serving as analysts); and (4) clerk-typists. For all practical purposes, analyst and supervising analyst or shift officer are the chief functional roles. Individuals who might serve as shift officers are the OB Officer, the OB Technician and the senior NCO.

The OB Officer has the following duties (in addition to any others which the G2, the BICC Chief or the MI Company Commander may specify): (1) administers the OB section; (2) is responsible for operation of the OB section; (3) represents the OB section formally; (4) supervises creation of the OB section SOP (may draw it up himself; (5) is shift officer on one shift. As shift officer: (1) takes action on incoming messages; (2) routes data to analysts, including individual maintaining SITMAP (the shift officer will seldom maintain the SITMAP himself, but will consult it frequently); (3) manages the workload of the section, unless there is a senior shift NCO available (as there would be in wartime); (4) coordinates products (may merely edit, but may also integrate analyst products or produce material himself); (5) provides professional judgment on uncertain points; (6) serves as liaison with the G2 and the rest of the HQ; (7) gives briefings; and (8) assists in emergencies to meet deadlines or provide special expertise.

³⁰ Functional Area Description for Order of Battle, Vols. I & II, Final Draft. USACDCINTA, Fort Holabird, Maryland, November 1968, CONFIDENTIAL.

³¹ Allen, D. O. Feasibility Analysis of Order of Battle Functional Area. Bunker-Ramo Corporation report for The Computer System Command ADSAF Project, Fort Belvoir, Virginia, April 1969, CONFIDENTIAL.

NON - AUTOMATED FILES/NO UPDATE CAPABILITY

AUTOMATED F

- G2/S2 JOURNAL FILE** RECORD OF ALL SIGNIFICANT EVENTS, ACTIVITIES, MESSAGES RECEIVED/ TRANSMITTED, ETC. WITHIN THE G-2 SECTION DURING A GIVEN PERIOD OF TIME
- REQUEST FOR INFO FILE** COLLECTION REQUESTS, DIRECTIVES AND SRI WHICH HAVE BEEN PASSED TO THE COLLECTION FUNCTIONAL AREA
- INTELLIGENCE FILE** INTELLIGENCE DOCUMENTS CONTAINING FINISHED INTELLIGENCE.
A. SPECIFIED FILES - INTSUM & INTEL ESTIMATE
B. INDEX OF MANUAL FILES
- SPOT INFORMATION REPORT FILE** SPOT REPORTS WHICH CONTAIN NORMALLY URGENT AND/OR PARTICULARLY SIGNIFICANT INFORMATION EXTRACTED FROM INFORMATION REPORTS OR FORMAL INTELLIGENCE DOCUMENTS
- INFORMATION REPORT FILE** INDEX OF INFORMATION REPORTS, IPW, II, ETC.

- OB DATA FILE** ANY HOSTILE UNIT (S TO AFFECT CURRENT OF CONSIDERED CONFIRMED VALIDATING IDENTIFIC FIRMED AND UNIDENTIF
- OB PERSONALITY FILE**
- OB STRENGTH/ ORGANIZATION FILE** RUNNING NUMERICAL TA PERSONNEL + EQUIPMEN CONTAINS COMPLETE BR ALL ECHELONS INCLUDI MENT. DELINEATES ENT
- TOPICAL FILE** DETAILED INFORMATION MENT, CHANGES OR CLA DOCTRINE OR ANYOTHER
- OB INTELLIGENCE FILE** REPOSITORY (SCRATCH) BE USED AS OB INPUT SUMMARIES AND OB SPE (TAKES PLACE OF OB/U
- "SUSPENSE" WORK FILE** SENDS MSG TO IO DEVI LISHED TIME MEASURE

INPUTS

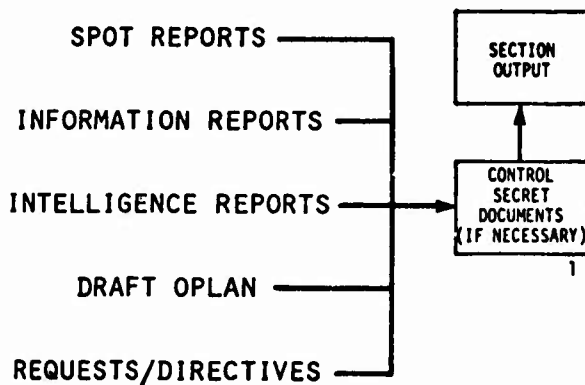

SPECIFIC EXAMPLES OF INPUTS

- SPOT REPORT
- INTELLIGENCE REPORT
- SUPPLEMENTARY INTEL REPORT
- SITUATIONS REPORT
- BOMBING REPORT
- MISSILE REPORT
- TOXIC REPORT
- MORTARING REPORT
- SHELLING REPORT
- NBC 1
- NBC 3
- IN-FLIGHT REPORT
- HOT REPORT
- SEVERE WEATHER WARNING
- ASA REPORTS

- INTELLIGENCE SUMMARY
- PERIODIC INTELLIGENCE REPORT
- INTELLIGENCE ANNEX
- CIVIL AFFAIRS MILITARY GOV SUMMARY
- SPECIAL STUDIES
- TERRAIN STUDY
- TRAFFICABILITY STUDY
- SOIL STUDY
- INTELLIGENCE ESTIMATE

- WEATHER FORECAST:
 - SHORT
 - EXTENDED
 - LONG
- CURRENT WEATHER
- WEATHER SUMMARY
- CLIMATIC SUMMARY
- MISSION REPORT
- AGENT REPORT (CI)
- SUMMARY OF INFORMATION (CI)
- LETTER REPORT (CI)

- REQUEST FOR INFORMATION
- COLLECTION DIRECTIVES
- AIR RECONNAISSANCE REQUEST
- PREPLANNED IMMEDIATE
- ITEMS WANTED LIST

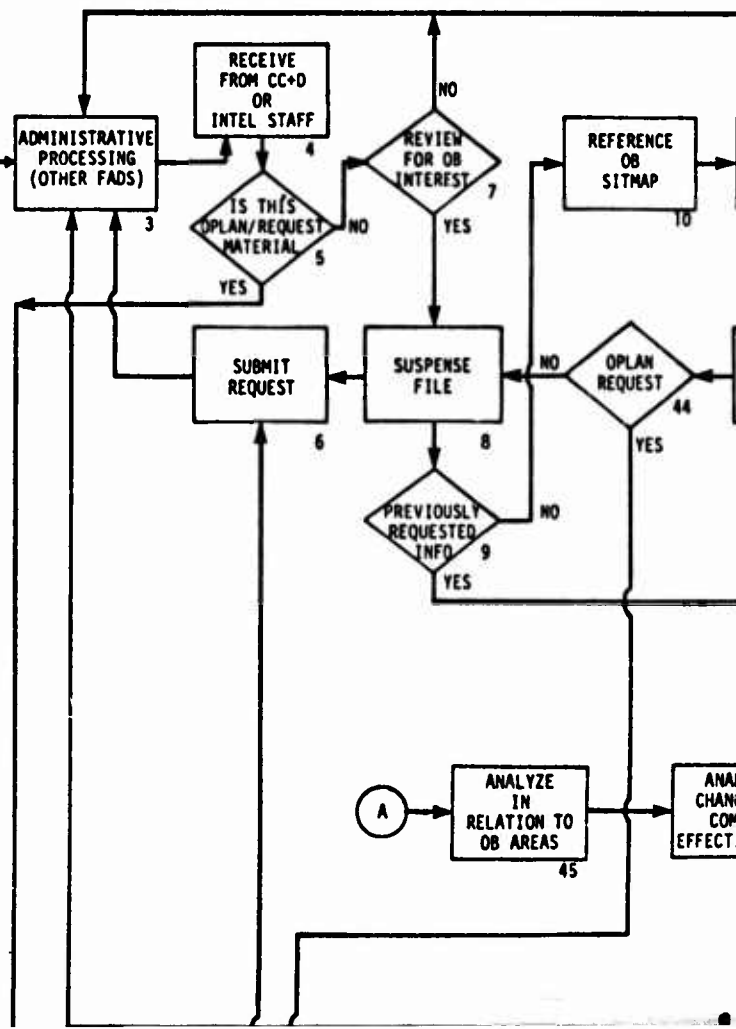

2

WEATHER FORECAST
 SHORT
 EXTENDED
 LONG
 CURRENT WEATHER
 WEATHER SUMMARY
 CLIMATIC SUMMARY
 MISSION REPORT
 AGENT REPORT (CI)
 SUMMARY OF INFORMATION (CI)
 LETTER REPORT (CI)
 REPORT OF INVESTIGATION (CI)
 NAME TRACE REQUEST (CI)

COLLECTION DIRECTIVES
 AIR RECONNAISSANCE REQUEST
 PREPLANNED
 IMMEDIATE
 ITEMS WANTED LIST

IPIR IIR
 GPIR GIIR
 PILOT TRACE
 INITIAL INTERROGATION REPORT
 DETAILED INTERROGATION REPORT
 KNOWLEDGEABILITY BRIEF
 SPECIAL INTERROGATION REPORT
 DOCUMENT TRANSLATION REPORT
 NBC 2
 NBC 4
 NBC 5
 AFTER ACTION REPORT
 LESSONS LEARNED
 ASA REPORTS
 INTEL INFORMATION REPORT (DD 1396)

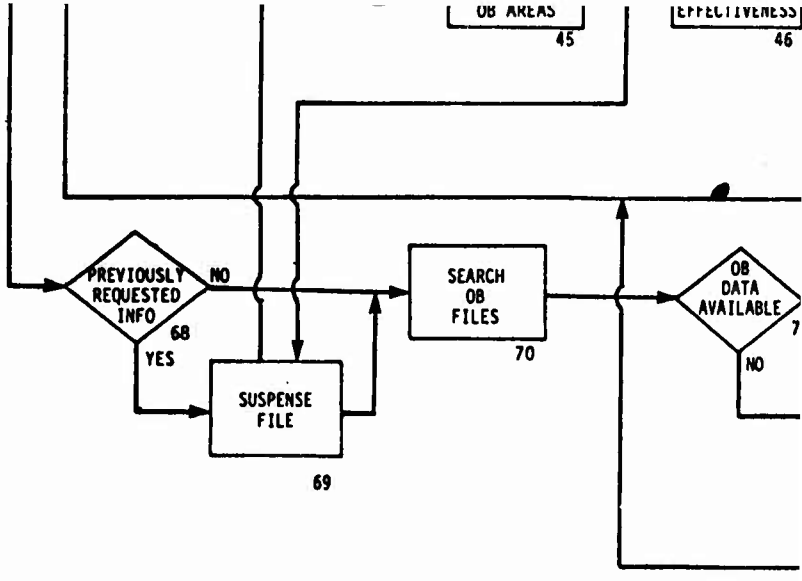
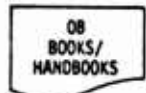

Figure 7. OB analysis flow scheme

ANY HOSTILE UNIT (\leq DIVISION) IN A POSITION TO AFFECT CURRENT OPNS. DESCRIBES THOSE UNITS CONSIDERED CONFIRMED BY TWO OR MORE REPORTS VALIDATING IDENTIFICATION, AS WELL AS UNCONFIRMED AND UNIDENTIFIED UNITS



COPIES OF OB GENERATED INTELLIGENCE REPORTS + STUDIES



RUNNING NUMERICAL TABULATION OF HOSTILE PERSONNEL + EQUIPMENT STRENGTHS ORGANIZATION CONTAINS COMPLETE BREAKOUT OF ALL UNITS AT ALL ECHELONS INCLUDING PERSONNEL AND EQUIPMENT. DELINEATES ENTIRE ENEMY FORCE.

DETAILED INFORMATION ON NEW ITEMS OF EQUIPMENT, CHANGES OR CLARIFICATION OF BATTLE DOCTRINE OR ANY OTHER PERTINENT DATA

REPOSITORY (SCRATCH) FILE FOR INTELLIGENCE TO BE USED AS OB INPUT TO VARIOUS INTEL REPORTS, SUMMARIES AND OB SPECIAL STUDIES (TAKES PLACE OF OB/UNIT WORKBOOKS)

SENDS MSG TO IO DEVICE BASED ON SOME ESTABLISHED TIME MEASURE

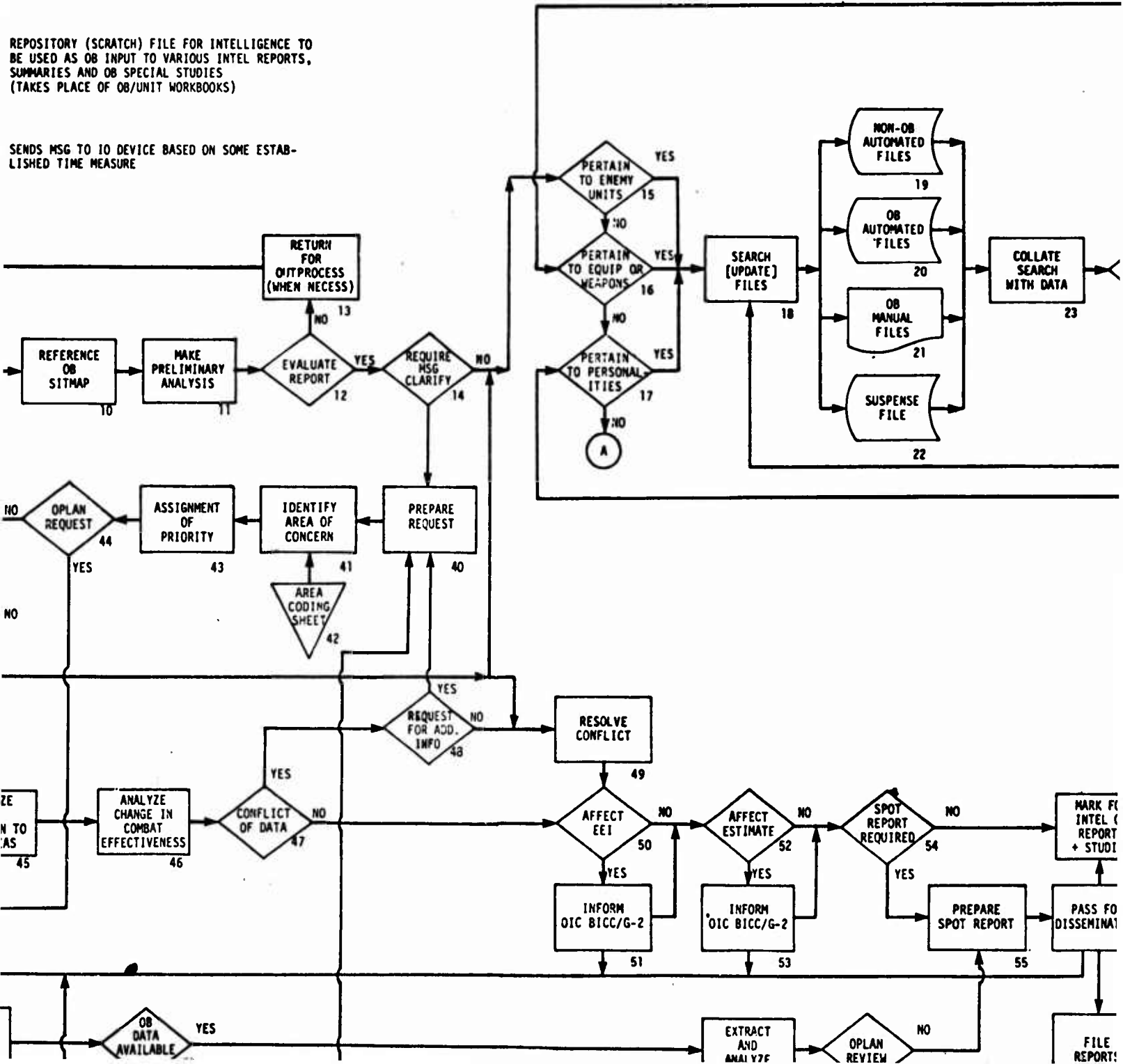

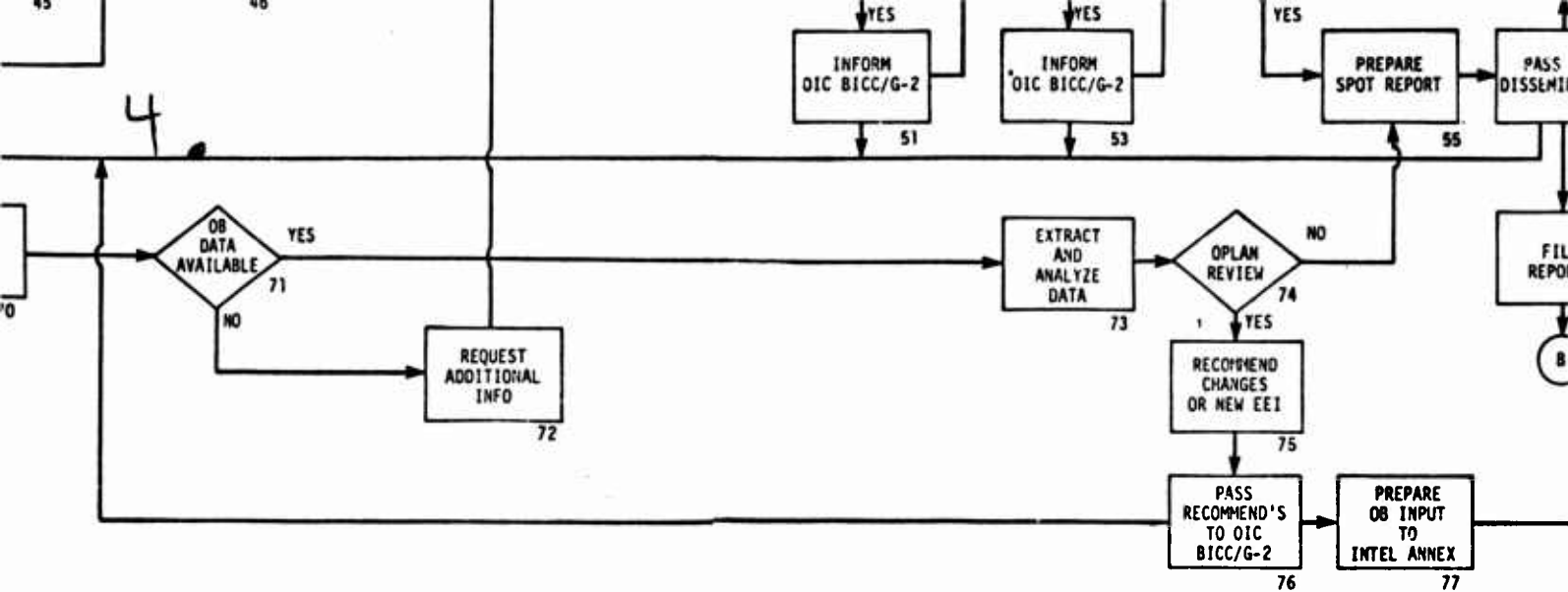

5

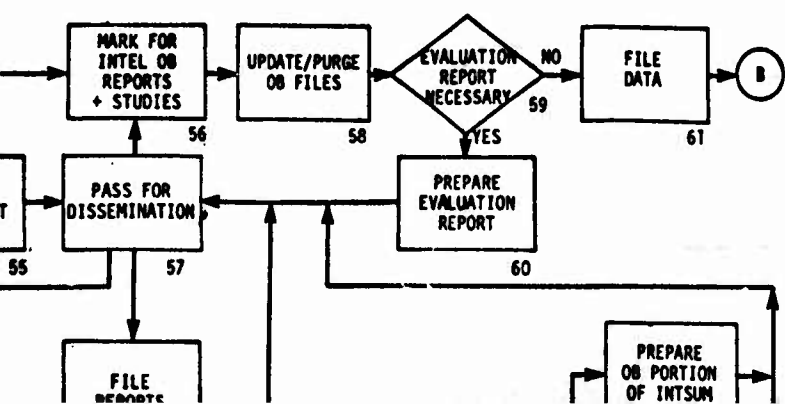
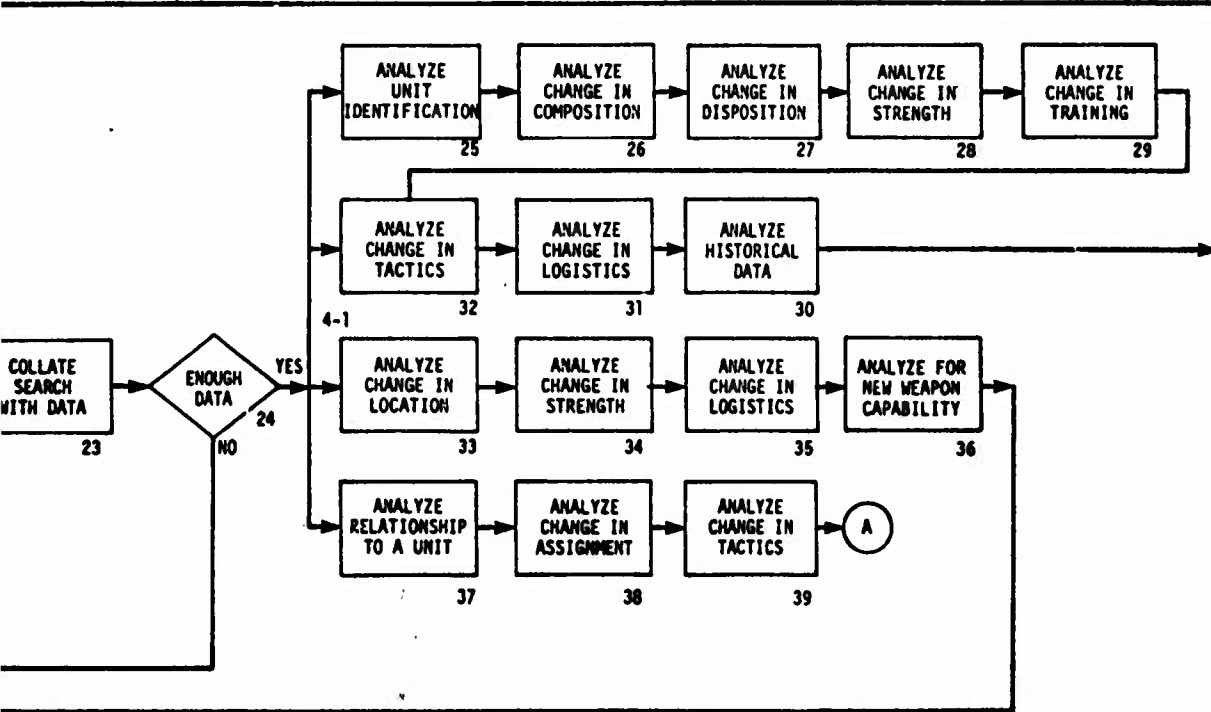

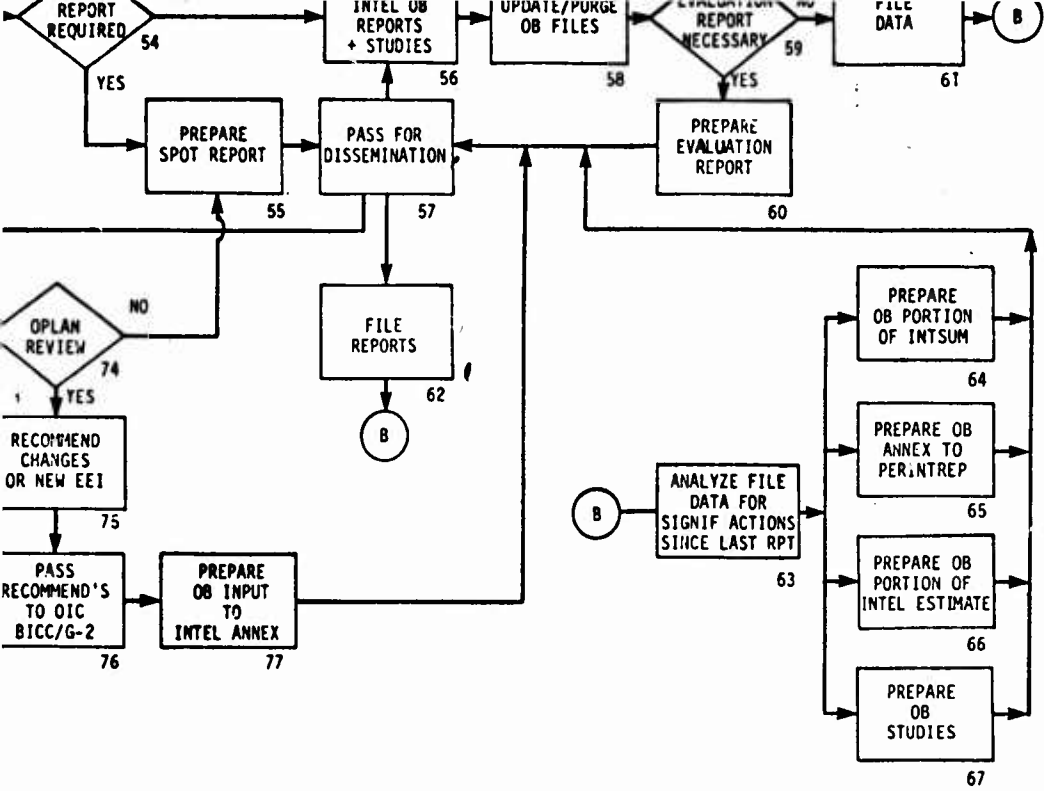

6

The WO OB Technician and senior NCO have the same duties as the OB Officer when serving as shift officer. They are more likely than the OB Officer to be competent OB analysts if, as often happens, the OB Officer is a specialist in some other area of MI.

The analyst is responsible for all of the substantive products of the OB section if he is properly used. (In many cases, however the analyst is used as a high-grade file clerk to supply the WO OB Technician, the NCOIC, or the OB Officer with material with which to create the products of the section.) Where the analyst is being properly used, he will have been given specific responsibilities in the section, such as maintenance of certain pages of the OB Workbook (i.e., particular OB factors), one or more Unit Workbooks, plus supporting reference aids (files, maps etc.). In addition, experienced analysts normally maintain a personal set of maps and working files. Moreover, the analyst is occasionally even made responsible for portions of products of the OB section.

Traditionally, there have been few clerks on the rolls of OB sections. This requirement has been met by using analysts in routine clerical tasks. Generally, even the E2's and E3's now being assigned to OB sections as clerks hold the 96B MOS; they would tend to be assigned the clerical tasks that were not so closely related to analyst work as to require that an analyst perform them. Thus, maintenance of certain analyst files of an individual nature, such as files relating to uncompleted pattern analyses, would probably be better done by the analyst himself. In some situations in the past, the G2 section's journal clerk has maintained the only record of incoming messages; however, the semi-independent character of the new A&P Section suggests the need for a separate OB logger. Another clerical job would be, on occasion, maintenance of the OB SITMAP.

As indicated earlier, we are probably safe in thinking in terms of two skill levels of analysts, the working analysts who maintain the data base of the section and make inputs to products, and the senior analysts who feed material to and coordinate the product of the working analysts and on occasion prepare completed products themselves.

What generally distinguishes senior analysts from working analysts is experience. Analysts will usually have been selected for training as 96B's because of a higher-than-average intelligence and perhaps some useful academic or professional specialty. They will then have received a superficial exposure to the elements of the 96B MOS through attendance at AICS or through correspondence courses, in the case of Reservists. However, little will have been done to test their analytical capacities or to add to them, and their knowledge of combat arms tactics and techniques may be minimal. Thus, the average middle-grade working analyst in an OB section is intelligent, may or may not possess analytical capabilities, and may or may not be able to make sound judgments about tactical alternatives. In cases of analyst deficiency, the senior analyst can supplement the capabilities of the working analyst and assure that satisfactory products leave the OB section.

Selection and Training of Intelligence Analyst/OB Personnel. Selection of personnel for OB duties has presented many problems as the nature of the OB function has changed, particularly since World War II. In general, it has been recognized that OB specialists have less need for language qualification and more need for broad, analytical skills than do many other types of tactical intelligence personnel. As one result, OB sections have tended to receive a mixture of types of people, usually not language-qualified, who did not fit into the other areas of intelligence that require some kind of technical specialization. Usually, while they might be above average in intelligence, little else indicated any particular competence for OB. Moreover, a good intelligent bookkeeper could have performed most of the tasks, since the level of analysis carried out in OB sections was frequently not very sophisticated.

The relatively "unglamorous" OB function has provided few unique attractions for either officer or enlisted personnel. OB analysis is performed at division level by middle grade sergeants, supervised by a warrant officer, or senior sergeant OB technician, with a captain or lieutenant in overall charge of the section. Until recently, most of these people were not cleared above the collateral level, making it difficult for the OB section to function as an integral part of a G2 operation working with the most current, all-source information.

Some idea of the basic requirements of an OB analyst may be gained by reference to Figure 6. This rather detailed breakdown of the allocation of time of personnel with MOS 96B20 assigned to Vietnam was prepared in mid-1968, in response to an inquiry from the MI School concerning training requirements for intelligence analysts. Eight major headquarters were queried concerning the specialists of this type under their control. Of 467 MOS-qualified individuals reported on, a large proportion of them were actually engaged in OB duties. A great disparity existed between the allocation of the time of 96B20's at different echelons, for example, divisions, separate brigades, and Headquarters, U.S. Army Republic of Vietnam (HQ USARV.) A high utilization of OB personnel for clerical tasks at division level left little time for analysis; in the case of separate brigades a greater allocation of specialist time to OB probably resulted from a need to make optimum use of very scarce personnel; at HQ USARV there was a greater allocation of time to OB perhaps due to the availability of clerical personnel.

The current selection process for intelligence analysts (the 96B MOS now refers to an Intelligence/OB analyst, rather than to an OB analyst per se) provides a flow of personnel with above average intelligence for training at the Army Intelligence Center and School at Fort Huachuca. During the Vietnamese conflict, the graduates of this training program had an opportunity for additional on the job training (OJT) through service with active units in the field.

Personnel selected for this training were generally highly qualified, and few felt impelled to remain in the army; this contributed to a constant turnover of OB analysts in the field. In addition, company

grade officers selected to supervise OB sections in the field had usually not been trained as OB specialists but had been co-opted from some other branch of MI. The warrant officers and senior NCO's served to provide a continuity of experience and competence in the OB function. However, there are only a few dozen warrant officer OB technicians in the Army today, and no more are being created. While there is certainly little opportunity to train OB specialists on the job in a peacetime environment, focused contingency planning for specific major units should tend to concentrate the interests and capabilities of their intelligence personnel on specific regions of the world and contribute to development of some OB expertise. Moreover, some units, such as the 9th Infantry Division, have instituted quite realistic training programs for their OB analysts. Unfortunately, at present there is almost no basis for OJT of OB specialists in the MI Reserve Program of the Army, although a good selection of correspondence courses is offered by AICS.

A more detailed look at the requisite characteristics of the OB analyst in the modern Army is needed. The OB analyst will have to be knowledgeable in all of the requisite military specialties, will have to possess basic analytical skills (in addition to the prime requisite of common sense), and will have to be able to use automation to advantage as current developments gradually are implemented. The time is past when the OB (or the Intelligence/OB) analyst can be regarded as little more than a file clerk providing information for someone else to analyze. He must become an active member of the G2 team, participating on a real-time basis in the intelligence effort being carried out in support of the command decision-making process. Whether the elimination of the OB specialist MOS and career paths for EM and officers in favor of the more general Intelligence/OB analyst and staff intelligence officer classifications was a step in the right direction remains to be demonstrated. Certainly the problem existed which it was designed to correct, namely, the lack of military breadth of many former OB specialists.

Analytical Methodology. Traditional OB analysis uses the workbook concept, in which all incoming information is filed under topics of interest (e.g., enemy units, operational areas, OB factors) and periodically summarized. It is really little more than the standard G2 Workbook approach applied to the field of OB. It entails, however, the maintenance of manifold supporting files against which new items of information can be checked, so that changes in the status or condition of particular elements of a situation may be detected and significant trends may be estimated.

Many experienced observers associate OB with the maintenance of voluminous files about enemy forces and the consultation of thick reference works, such as OB handbooks. The timeliness of the OB product, however, still depends to a considerable extent on the speed with which the OB section can process the information provided to it. It is all very well to speak of high-speed computerized storage-and-retrieval systems and automated displays as future means for solving the timeliness problem; however, such means are not yet at hand.

One way to aid rapid production of OB intelligence has been through the technique of multiple-overlay pattern analysis. This entails plotting significant types of enemy activity or environmental circumstances for particular periods of time, and seeking to discern interrelationships between activity types and trends in enemy capabilities that point to specific probable enemy courses of action. The 1st Infantry Division was very successful in the use of this technique in Vietnam, regularly preparing some 17 types of overlays--nine derived from imagery and the rest from other types of intelligence inputs such as SIGINT, IPW, documents, and agent reports. The 4th Infantry Division found an overlay technique indispensable for the detection of enemy intentions in sparsely settled areas of the Central Highlands of Vietnam, in situations where SIGINT and aerial surveillance and reconnaissance had to be relied upon as the main sources of information. Other combat units also made some use of the overlay pattern-analysis approach in Vietnam with varied success.

The above examples refer to the use of overlays in addition to conventional analytical procedures of the OB section, including the traditional filing systems. At present, the 82nd Airborne Division is experimenting with a concept in which overlays will replace conventional OB workbooks and files in the interests of speed of operation. Thus, overlays are to be prepared in advance, on a contingency basis against anticipated operations, and will serve as working documents for the recording and analysis of information. The effectiveness of this procedure remains to be demonstrated.

Pattern analysis, and more specifically overlay-based pattern analysis, would appear to be the most powerful new tool available for OB analysis.³² Long a mainstay of SIGINT analysis, this technique is relatively new to OB analysis. Some preliminary training in pattern analysis is already being offered at AICS, based mainly on study of enemy vehicle traffic patterns, but much more fundamental training in pattern analysis is needed. As one experienced G2 has observed, "OB is pattern analysis".

Key OB Section Problems

The following problem areas are crucial to the OB Section:

1. Excessive Turnover of OB Personnel: particularly of OIC's and middle-grade NCO analysts.
2. Clearance Levels of Personnel and Classification of Information:
 - (a) analysts need all-source clearance to handle raw current intelligence inputs; and
 - (b) rapid downgrading of content of all-source

³² Bowen, R.J., Fehrer, G. E., Nickerson, R.S., and Triggs, T. G., Bolt Beranek & Newman. Computer based displays as aids in the production of Army tactical intelligence. ARI Technical Paper 258. February 1975.

material is required to support collateral intelligence operations and permit release of information to combat elements.

3. Adequacy of Staffing and Peacetime Training: (a) at least double the present TOE level of analysts is required to permit adequate shift operation in peacetime if a realistic OB training mechanism is available; (b) wartime operation requires 50-100 percent more than that; (c) more clerical support is required to permit use of analysts in their proper OB function; (d) OIC's should be OB-trained; (e) CPX's should be structured to permit realistic OB play; (f) more provision should be made for OJT; (g) advanced training at AICS should be facilitated on a regular basis, in order to disseminate the latest doctrine and experience to the field.

4. Volume of Material Handled: methods should be provided or procedures developed to lessen the workload of processing large volumes of material in combat; additional clerical personnel would help, but if exploitation of collected material is to take place on a reasonably current basis, technical means are more pertinent--such as overlay techniques, graphic displays, automated storage, retrieval and cross-referencing of data, etc.

5. Role and Function: the OB function should be integrated with the rest of the G2 section in a manner and to a degree commensurate with its role as a focal point for the analysis and integration of information on enemy forces in support of targeting and command decision-making.

EXAMINATION OF ORDER OF BATTLE FACTORS

This section examines in detail the so-called OB factors, those elements of OB intelligence with which the members of the OB section concern themselves in preparing their inputs to the decision making process. Doctrine defines eight OB factors: Composition, Disposition, Strength, Tactics, Training, Logistics, Combat Effectiveness, and Miscellaneous. Miscellaneous is not a true factor but a series of files of supporting information related to the other factors.

The OB factors are highly interdependent. Composition and Strength are closely related, particularly for full-strength units; both are also related to Logistics. Disposition and Tactics are likewise related, and both tend to be related to Training. Combat Effectiveness reflects the total combat potential of an opposing force. However, the doctrinal definition of Combat Effectiveness makes no mention of Composition, Disposition or Tactics per se. Unit History, under Miscellaneous, provides information concerning Composition and Tactics, but not Disposition. A historical overview of the eight OB factors and their sub-elements (Table 3) has already been presented. However, they will be presented individually here, their basic nature described and their manner of derivation and their interrelationships examined. We should thereby become better able to understand the true contribution that each factor and sub-element makes to the combat intelligence process. While it is

Table 3

TRADITIONAL OB FACTORS AND SUB-ELEMENTS

-
-
- **Composition**
 - Unit Identification
 - Unit Organization
 - Basic, Self-Sufficient Tactical Unit
 - **Disposition**
 - Location
 - Tactical Deployment
 - Movement
 - **Strength**
 - Men
 - Weapons
 - Equipment
 - Number of Type Units
 - **Tactics**
 - Defensive Tactical Doctrine
 - Offensive Tactical Doctrine
 - Special Operations
 - Nuclear Warfare
 - **Training**
 - **Logistics**
 - Storage
 - Transportation and Distribution
 - **Combat Effectiveness**
 - Strengths
 - Weaknesses
 - **Miscellaneous Data**
 - Personalities
 - Unit History
 - Uniform and Insignia
 - Code Names and Numbers
 - Weapons and Equipment
 - Administration
-

clear that few of the OB factors have an intrinsic importance of their own, each contributes to the understanding of the opposing forces on which command decision-making and planning is based. Particular attention will be paid to the factor of Combat Effectiveness, since, conceptually at least, this much misunderstood element of OB intelligence should be the composite which best summarizes an opposing force's fighting capacity.

Each OB Factor is defined in terms of a number of information elements which indicate the kind of data required to describe the status of that factor in narrative terms. No specific rules exist, either formal or heuristic, for the evaluation of factors or elements, or their combination. In examining the relative importance of a factor or element, consideration will also be given to whether it is merely an indicator or descriptor of a potential attribute or capability or whether it constitutes a concrete attribute or capability.

Composition

The OB factor of Composition defines the general magnitude and type of opposition one is facing, providing a starting point and standard of comparison (through TOE data) for more detailed estimates of enemy force characteristics (in particular, Strength and Combat Effectiveness). Together with Strength, Composition indicates the theoretical firepower potential (FPP) of a unit being rated. In the absence of detailed information for an estimate of Strength, the TOE provided by Composition is the presumptive basis for the Strength estimate, which in such cases will almost always tend to be conservative. In using the OB factor of Composition, one must remember that by itself, it bears the dimensions of a descriptor or an indicator, and only by implication those of an attribute or capability.

Since Composition defines a unit, it bears at least some relationship to each of the other OB factors and to many of the sub-factors, particularly those listed under Miscellaneous. Other factors may relate to Composition on at least three levels, as descriptors, as indicators, or as capabilities. For example, many of the sub-elements of Miscellaneous are indicators or descriptors of Composition (or of its sub-elements), while most of the other OB factors may be regarded as capabilities or attributes of Composition.

The elements of Composition are "identification" and "organization." Unit identification consists of the complete designation of a specific unit. It identifies the unit, indicates the type of unit, and gives its relative size or strength. In essence, identification involves the information normally contained in the military symbol designating the unit: size, branch or duty performed, parent unit or higher echelons of command, echelon relationship to parent unit, and any necessary additional information required to describe the unit's nature and purpose. Organization, on the other hand, is the structure of the unit and the relationship of the various echelons within the structure.

Combined with organization, the identification of a specific unit alerts the analyst to the possible presence of other unidentified units of the same parent organization. This can become somewhat confusing during stability operations when insurgent elements may operate without apparent support from logistical bases, relying for their support on either the local populace or base areas in third countries.

The capabilities of an enemy are difficult to assess accurately without knowledge of organization; moreover, the organization of all types of armies is constantly changing. Thus, when considering Composition, the basic self-sufficient tactical unit must be the focal point of attention. In the U.S. Army the combat division is the basic self-sufficient unit. In some countries it is the field army. In the case of insurgency, it may be the battalion or guerrilla detachment. An awareness of the requirements of self-sufficiency can aid the analyst in estimating enemy organizational needs to carry out particular kinds of missions and can serve to alert him to the possibilities inherent in particular situations. In estimating organization the analyst must take account of three kinds of force elements: organic, attached, and coordinate.

As a hypothetical illustration, The Handbook on Aggressor Military Forces (FM 30-102) provides a list of major combat arm unit types against which information about enemy organization can be compared in training exercises:

Army Group	Tank Division	Mechanized Regiment
Combined Arms Army	Airborne Division	Tank Regiment (mdm or hv)
Tank Army	Rifle Division	Antitank Regiment
Air Army	Artillery Division	Airborne Regiment
Mechanized Division	SSM Division	Mechanized Battalion
Tank Battalion (mdm or hv)	SSM Brigade	SAM Brigade
Artillery Brigade	HV SSM Brigade	Guerrilla Units (gp, reg't, bn)

The TOE's for these units provide the analyst with a basis for pattern analysis in which fragmentary information may be used to develop both the identification and organization of the OB factor of Composition.

In essence, Composition is a designator on which to base an analysis of Combat Effectiveness or some other capability. It points the way to the standard TOE to be used in estimating actual capabilities. As already noted, Composition can serve as the basis for an idealized estimate of Strength.

Composition also may be inferred from identification alone if it is known that a standard type of unit is present, whose TOE has already been determined. Actually, then, identification and organization say the same thing when a known type of unit is involved, except that identification also includes unit designation. When an unknown type of unit is involved, organization is necessary to complete the picture of identification.

Disposition

The OB factor of Disposition concerns the location, deployment, and movement of enemy forces within a particular region or sector. In essence, it means the enemy's "battle array" and physical activities. As such, Disposition carries with it much of the historical meaning of Order of Battle. Today, the term implies a knowledge of the general area of responsibility of the enemy force and the location of each force element within that area, and an understanding of what the various force elements are doing. Thus the basic questions of the commander--Who is out there? Where are they? What are they doing?--are epitomized in the OB factor of Disposition. The wide-ranging scope of Disposition is also evident from the fact there is overlap between it and the factor of Composition and, to some extent, the factors of Strength, Tactics, Logistics, Training, Miscellaneous and Combat Effectiveness. For example, there are accepted rules of procedure for the employment of infantry, armor and artillery in particular situations for optimum effectiveness. In addition to the related OB factors, mission, terrain, and opposing force characteristics are also related to Disposition. However, for purposes of analysis, Disposition is usually assumed to be an independent OB factor definable in terms of the elements of location, deployment, and movement, which in turn are susceptible to description through discrete items of information.

By "location" is meant the specification of the general geographic area of responsibility of the enemy force, including frontage and depth. A key location within the enemy's area of operations will be the site of the unit's command post.

By "deployment" is meant the pattern of locations of major striking-force elements, whether the locations are forward, middle or rear with respect to the front and rear boundaries of the zone of responsibility (including whether or not there is contact with friendly forces), as well as the lateral location (right, left or mid-position with respect to the longitudinal axis of the zone). Disposition of forces relative to natural or man-made obstacles, terrain features, etc., should be noted, as should the tactical pattern of the striking-force elements (noting indicators of attack, defense, or withdrawal, as well as special indicators for insurgency operations and ad hoc indicators developed out of individual situations). Deployment of logistical elements should be considered.

Deployment should also be related to friendly force Disposition and to the apparent mission of the enemy force. Ideally, deployment should be reducible to a few standard patterns that become known as characteristic of the enemy force with which one is dealing. Thus, FM 30-102

notes that Aggressor traditionally uses a two-up and one-back pattern of deployment for attack. However, the greatly increased mobility of modern armed forces makes possible rapid changes in troop deployments at the last minute, and renders somewhat unreliable traditional indicators based on deployment alone. In the absence of precise information concerning unit identity and organization, it may be necessary to fall back on estimates of strength concentrations (with or without specific knowledge as to types of forces) within particular zones or sectors of the fighting area. This problem is encountered frequently in unconventional warfare situations.

Movement, the somewhat euphemistic term for enemy activity, has many dimensions. Thus, all types of striking-force activity, from armor, artillery, and APC activity, to truck traffic, patrol activity, air activity, logistical activity, communications activity, and movement of soldiers by foot, become important for estimating this aspect of Disposition. Patterns of activity can normally be associated with different types of deployment and Disposition, making enemy activity an important confirmatory element of Disposition.

Information related to the OB factor of Disposition is essential to the estimation of enemy capabilities. Capabilities are normally expressed as answers to What? When? Where? and In What Strength?, each of which involves an element of Disposition, the answer to Where? being the most closely related. However, if one thinks of the commander as creating in his mind some kind of vector of enemy striking force momentum, then he must concern himself with mass, rate of movement, direction of movement and concentration of forces on the ground--all elements of the factor of Disposition. It is worth noting that enemy activity estimation has normally been not a function of the OB section but the responsibility of the Current Intelligence element of the G2 section. As a consequence, while enemy activity is theoretically part of OB intelligence, it has been defined as a sub-element of movement under the factor of Disposition. In practice the Current Intelligence people usually deal with the immediate consequences of observed enemy activity, while OB concerns itself with the longer-range consequences of patterns of enemy activity. Moreover, communications activity is estimated quite separately by the ASA element of the headquarters. Disposition, then, is a most important OB factor, serving as a catch-all for the most important inputs to both the targeting and enemy-capabilities-estimation process for intelligence analysts, G2's, and field commanders.

Strength

The OB factor Strength describes a unit or force in terms of men, weapons, and equipment. It is formally categorized in terms of: committed forces, reinforcements, air and capability to employ nuclear weapons and CBR agents. Information concerning Strength provides the commander with an indication of enemy capabilities and helps him determine the options open to the enemy commander. In conventional warfare, enemy Strength estimates are generally related to particular sectors of a front, although versatile transport capabilities make changes of

disposition relatively easy for a modern, sophisticated force. In unconventional warfare, where there is no well-defined front between opposing forces, it is necessary when estimating Strength to consider all personnel potentially available to the enemy commander.

The relationship of Strength to the other OB factors is similar to that of Composition; the constituent elements of Strength tend to be unique to particular types of organizations. However, relationships are both more and less direct. Relationships are more direct with Combat Effectiveness, Composition, Disposition, and Logistics, and less direct with Training, Tactics, and Miscellaneous. Strength relates to Combat Effectiveness, Logistics, and Disposition as a concrete attribute and the other factors relate to it as descriptors or indicators.

The following terminology is employed in Strength estimates:

1. Numerical Strength is the description of a unit or force in terms of numbers of personnel, weapons, and equipment.

2. Initial Strength of an enemy unit or force comprises the number of personnel, weapons, and equipment authorized by TOE.

3. Effective Strength of an enemy unit or force consists of that part, including logistic components, of its Initial Strength which is currently capable of combat employment.

4. Strength by type unit is the expression of units or forces in terms of numbers of units by type, such as infantry, armor, artillery, and air.

The most important of these is, of course, Effective Strength, which is defined as: TOE Strength minus losses plus replacements.

Enemy Strength computation has been standardized throughout NATO (see Appendix K of 1971 edition of FM 30-3). At the outset of conflict, Effective Strength is estimated as the TOE value, unless there is specific information to the contrary. Further estimates are based on the incidence of casualties, reinforcements, and replacements. A percentage attrition rate is deducted from Initial Strength estimates when experience has permitted the establishment of such a rate.

Personnel Strength must take account of enemy killed, prisoners of war, and wounded noneffectives. Weapons and Equipment Strength must take account of items destroyed, captured, or damaged to an extent requiring workshop repair. Personnel reinforcement and replacement of weapons and equipment is added in accordance with a standard estimation scale or a scale justified by reliable intelligence. In the absence of other guidance, and where the enemy has secure lines of communication to his main base, it is assumed that:

1. Personnel reinforcement can be completed within 72 hours.

2. Small weapons and light equipment can be replaced within 72 hours; other weapons and equipment can be replaced within 6 days.

Resultant calculations are expressed as percentages of TOE Strength where possible; however, use of numerical values may be necessary to present a better understanding of the combat capability of a force and to provide the commander with a basis for comparison.

Strength by type of unit includes the total number of enemy units listed by category and type. Normally, OB analysts account for units down to and including two echelons below their own.

Training

FM 30-5 presents the following description of the OB factor of Training:

"Training is closely related to combat effectiveness in times of peace and war. Each type or phase of training analyzed (individual or unit) contributes to the overall picture of potential or actual enemy capabilities. Units usually are engaged in field exercises and in maneuvers during the latter part of the training cycle. Thus, the combat efficiency and capabilities of units at the peak of proficiency can be appraised. The thoroughness, degree and quality of specialist, NCO, and officer training determine to a large extent the overall efficiency of the armed force."

Training can be either indicative or descriptive of special unit capabilities or general unit capabilities. Thus, the ability of a unit to overcome particular problems with which they may be faced, such as river crossing, night fighting, or counter guerrilla operations, can be indicated by the degree to which these matters have been stressed during training. Where highly realistic training has demonstrated a particular capability, that Training may be regarded as a descriptor.

The overlap between the factors of Training and Combat Effectiveness may be appreciated from a consideration of the following sub-elements of the latter:

- Status of Training
- Efficiency of the Officer and NCO Corps
- Adequacy of Military Schooling at All Levels
- Geographical Area in Which Committed
- National Characteristics of the People

It is important to note, however, that Training is most important as an indicator of the possible behavior patterns of a fresh unit that has been newly introduced into combat. After a unit has been in combat for a certain period of time, there will have been a turnover in personnel and the remaining original manpower will have acquired a certain amount of experience in carrying out their duties, both as individuals and as a unit. The following elements of Combat Effectiveness must be taken into

consideration when assessing both Training and Experience:

Length of Time a Unit Has Been Committed in Combat
Traditions and Past Performance

The second of these is provided by the Miscellaneous element of Unit History.

It is also important to note that the OB factor of Tactics may be indicated by particular types of Training to which a unit has been subjected, particularly if that Training was performed just prior to commitment of the unit.

Tactics

FM 30-5 covers the OB factor of Tactics in the following paragraph:

"Tactics in order of battle intelligence include tactical doctrine as well as tactics employed by specific units. Tactical doctrine refers to the enemy's accepted principles of organization and employment of forces for the conduct of operations. Tactics, on the other hand, describe the manner in which the enemy conducts an operation. From a knowledge of tactical doctrine, the OB analyst knows how the enemy may employ his forces under various conditions and in certain type situations or special operations. Conventional enemy forces normally can be expected to perform according to certain patterns within the framework of tactical doctrine. There are established principles and patterns for the employment of infantry, mechanized, armor, and artillery in the offense and defense. Any predetermination of the probable patterns of employment and enemy action or reaction is extremely important in the planning phase of an operation as well as in the execution phase."

Tactics is clearly an important indicator of enemy capabilities and probable courses of action. Thus, in a given situation, an enemy commander can be expected to employ certain types of tactics, making due allowance for his ingenuity and capacity for deception. In any situation, there should be a strong relationship between the OB factors of Disposition and Tactics. Likewise, Tactics are related to both Composition and Training, and depend to a considerable degree on Strength, Combat Effectiveness and Logistics. Tactics even relates to Miscellaneous through Commander Characteristics and Unit History. Moreover, firepower potential as an element of enemy capabilities analysis must be regarded as dependent on Tactics, if only as a modifier of Strength.

In a more general sense, Tactics embraces a very wide range of possibilities. In essence, it includes all of the What? When? and in What Strength? capability combinations shown in Figure 8.

<u>WHAT?</u>	<u>WHEN?</u>	<u>WHERE?</u>	<u>IN WHAT STRENGTH?*</u>
1. Attack	1. Immediate (1-3 hrs)	1. Frontal	1. Detachment
a. frontal		a. left	2. Company
b. penetration	2. within 6 hrs	b. right	3. Battalion
c. envelopment		c. center	4. Regiment
i. single	3. within 12 hrs	2. Flank	5. Brigade
ii. double		a. left	6. Division
iii. encirclement	4. within 24 hrs	b. right	7. Corps
iv. turning movement		3. Rear (specify depth)	8. Army
d. infiltration	5. within 48 hrs	4. Point or Area Objective (specify)	9. Combat Team (specify)
e. meeting engagement	6. within 72 hrs	5. Combinations (specify)	10. Other (specify)
f. movement to contact	7. other (specify)		
g. pursuit			
h. spoiling			
i. reconnaissance in force			
2. Defense			
a. mobile			
b. area			
3. Withdrawal			
a. local			
b. general			
4. Delaying Action			
5. Retirement			
6. Reinforcement			
7. Combinations (specify)			

Figure 8. Possible tactical combinations

* Specify type of force and armament (viz., combined arms force, air borne battalion) including nuclear, chemical and air delivery capability.

Logistics

Adequate logistical support is recognized as a key element of success in battle. Failure of Logistics can exert a powerful negative influence on Combat Effectiveness, although adequacy of Logistics is no guarantee of success. Logistics, therefore, should be regarded as a necessary but not sufficient element of success in battle. Logistical limitations can powerfully influence enemy force capabilities and can even actually determine the course of action adopted. Under any circumstances, the ability of a fighting force to continue in action depends directly on its resupply capabilities.

FM 30-5 lists the following nine types of logistical information as of interest to OB:

1. All classes and types of supply
2. Requirements
3. Procurement
4. Distribution
5. Transportation
6. Installations
7. Terminals
8. Evacuation and salvage
9. Maintenance

These may be compressed into four descriptors of Logistics:

1. Supply Stocks
2. Transport Capability
3. Storage & Distribution Capability
4. Technical Service Capability

The status of Logistics may then be treated in terms of the status of the above four elements.

Logistics relates directly to Combat Effectiveness and Strength and indirectly to Composition, Disposition, Tactics, Training, and Miscellaneous. One might even say that the relationship of Composition to Logistics is fairly direct. Certainly, when Composition must stand in place of Strength for lack of data on the latter, the relationship can be considered a direct one.

In an actual battlefield situation where the enemy's ability to sustain himself over a protracted period is monitored, the factor of Logistics would be very important in estimating enemy capabilities. The search for key supply shortages is a customary form of pattern analysis carried out by intelligence analysts. Interference with the enemy's

logistical support is a prime mission of friendly tactical air. Vehicle traffic analysis is, therefore, a very important aspect of current intelligence activity in a divisional G2 section, although the ease with which logistical movements can be carried out at night renders analysis of this type of traffic quite uncertain. Thus, the logistics aspect of combat is comparable in magnitude to the striking force elements and requires a corresponding level of analysis for proper consideration. Detailed treatment for Logistics has not been customary at the divisional level, largely due to the difficulties in analyzing the normally available data.

Combat Effectiveness

Conceptually, at least, the most important OB factor is Combat Effectiveness. This factor, frequently expressed as a percentage of an ideal value, is a composite of many OB elements and is presumed to indicate the potential battle capability of an enemy force. If it could be estimated with accuracy, it would be one of the most important inputs to the commander's decision-making process. Unfortunately, the lack of standardization and of formalized procedures for its determination, or even of any objective way to demonstrate its utility in predicting enemy capabilities, has relegated it to the background in OB analysis. Instead, the more directly measurable or observable enemy characteristics, such as personnel strength, numbers of vehicles, or weapons have been emphasized. While undoubtedly useful in filling out the picture of an opposing enemy force, the latter approach falls far short of providing an estimate of potential enemy capabilities for battle.

The traditional list of elements of the Combat Effectiveness factor of OB analysis is shown in Table 4. The origins of this rather "mixed bag" of items are obscure. Certainly, each element listed has some relevance to a unit's combat capabilities. However, they are by no means equal in importance nor is the manner of their estimation and combination anywhere described.

Moreover, some of the traditional OB factors are not represented among these elements--for example, Composition or Disposition, two important determinants of a unit's effectiveness, are omitted. Nor are the important matters of intelligence or command, control and communications capability included in the Combat Effectiveness concept, to say nothing of the failure to include any mention of such aspects as: mission, level of conflict, or characteristics of the area of operations.

The manner of combination of OB elements is a matter of particular uncertainty. One could readily work up schemes for estimating each of the traditional elements of Combat Effectiveness. But what would an analyst do with these elements? Should he average them? Should he try to assign relative weights to them and then average them? No methodology is available at present, nor are there any good guidelines for the development of such a methodology. (Some OB analysts have worked up their own schemes for this type of estimation as noted in Appendix C.)

Table 4

COMBAT EFFECTIVENESS

-
-
- Strength in Personnel
 - Amounts and Condition of Weapons and Equipment
 - Status of Training
 - Efficiency of the Officer and NCO Corps
 - In Combat, the Length of Time that a Unit has been Committed
 - Traditions and Past Performance
 - Personality traits of a Unit's Commander
 - Geographical Area in Which Committed
 - Morale, Discipline, and Political Reliability (or belief in the cause for which they fight)
 - Status of a Unit's Technical and Logistical Support
 - Adequacy of Military Schooling of All Levels
 - National Characteristics of the People
-

The traditional elements of Combat Effectiveness are little more than indicators of various aspects of the ability of a combat unit to perform its function. Their weakness as estimators lies in the fact that, except for the aspects of Strength and Logistics, they generally do not relate to any conceptual model or mental image of a unit's fighting ability from which an index of Combat Effectiveness could be derived by the average OB analyst. Rather, there seems to be an implicit assumption that an analyst, after staring for a long enough time at a set of estimated values of these elements, should somehow be able to conjure up a value for the corresponding Combat Effectiveness index. Intelligence analysts (as well as operations officers and commanders) need a sound basis from which to view the elements of Combat Effectiveness in a more realistic light.

In view of the inherent complexity of the problem of estimating the true Combat Effectiveness of an enemy force, the current procedures must be considered as little more than ad hoc schemes based on a wide variety of indicators. Personal experience plays a major role in selecting the methodology used in any individual case. In a way, this resembles the problem of defining a methodology for "sizing up" a person on first encounter. Very little unanimity would be found among individuals on this point, despite the fact that roughly the same qualities are being evaluated: friendliness, integrity, capability, etc. The main difference, of course, is that if an individual misjudges another person, he may be the one to suffer; if an enemy's Combat Effectiveness

is misjudged and plans made accordingly, the battle could be lost. Experienced commanders do not rely much on Combat Effectiveness estimates when making their decisions. A reliable methodology is required in this area. This might be done by considering all variables having any significant bearing on Combat Effectiveness as possible indicators. Then, one could attempt to develop patterns of indications that would permit estimation of Combat Effectiveness with sufficient reliability for practical purposes, given the normal limitations of data in combat situations. Functional capabilities such as Firepower; Mobility; Command, Control, and Communications; Logistics; and Intelligence might be considered and suitably modified to reflect pertinent surrounding circumstances.

Surrounding circumstances should include such matters as: area of operations; type of conflict; mission; exploitable vulnerabilities; unusual threat capabilities; human factors (motivation plus physical and technical capabilities); past unit performance; and the quality, quantity, and age of data. Estimated Combat Effectiveness could be related to that of an ideal unit of the same type (the present approach) or to the needs of the mission. Any new methodology for estimating Combat Effectiveness, in addition to indicating time of preparation and individuals responsible, should provide for reporting the time frame to which the rating applies (data decay rate), the trend of the rating (direction and rate), the range of variation (confidence limits) of the rating, and the standard of comparison used in making the assessment.

Miscellaneous

The OB factor of Miscellaneous covers several types of supporting data relating to the other OB factors, including descriptors, indicators, qualifiers of OB factors, and simple files of supporting information. The following file categories are under Miscellaneous:

- Personality Files
- Unit History
- Uniform and Insignia Data
- Unit Code Designations
- Technical Characteristics of Weapons and Equipment
- Personnel Administration

Three of these seem worth further specification: Personality Files; Unit History; and Personnel Administration.

At one time, the MI School included the following types of information under the heading of Personalities:

PERSONALITIES

Date and Place of Birth
Civil Education
Political Affiliations
Physical Peculiarities
Schools
Qualifications
Awards and Decorations
Chronology of Assignments
Campaigns
Character Traits

At present, FM 30-5 merely notes that Personality Files contain information on the characteristics and attributes which describe individual members of an enemy force, and observes that a knowledge of personalities is important as an aid to identifying units and, in some cases, to predicting the course of action a unit will take. From this standpoint, Personality Files are most important in support of the OB factors of Composition, Tactics, and Combat Effectiveness.

Likewise, the MI School once included under Unit History:

UNIT HISTORY

Historical and Honorific Names
Combat Record
Major Reorganizations
Resignations
Outstanding Personalities
Specific Qualifications
Reputation

At present, FM 30-5 notes that Unit History includes information and intelligence on component elements of a specific unit, on present and past parent units, on personalities who have commanded the unit, and on other details such as past performance and activities which describe, limit, or clarify the capabilities of the unit concerned. The point is made that military or paramilitary units, like individuals, develop certain characteristics which distinguish them from other units. It is recommended that OB personnel consider an enemy unit as a "personality" when analyzing its capabilities and limitations.

A number of the elements listed in FM 30-5 under Combat Effectiveness may be supported by information included under Unit History:

Length of Time a Unit Has Been Committed in Combat
Traditions and Past Performance
Morale, Health, Discipline, and Political Reliability
National Characteristics of the People
Efficiency of the Officer and NCO Corps

Such information might be more sensibly stored under Unit History than under Combat Effectiveness since everyone has his own way of estimating Combat Effectiveness anyway.

The MI School once included under Personnel Administration the following types of information:

PERSONNEL ADMINISTRATION

Administrative Procedures
Rates of Pay
Promotions and Demotions
Enforcement of Discipline
Clubs, Messes, PX's
Assignments and Transfers
Retirement, Leaves and Passes
Relief from Active Duty
Conscription and Enlistment
Personnel Classification
Efficiency Reports

FM 30-5 does not even mention Personnel Administration as an OB topic of interest today. Some of these topics are useful for background information on a unit and a few, such as Promotions and Demotions and Enforcement of Discipline, might at times have a bearing on combat-level OB analysis.

The OB factor of Miscellaneous may be viewed as general storage and retrieval support for the analysis of the OB factors. Uniform scales are needed to relate the levels of some of the elements of Miscellaneous to the other OB factors and elements that they may be related to.

Relationships Between OB Factors

We have examined the individual OB factors in some detail and mentioned their qualitative interdependences. A few general observations remain, based mainly on the definitions of the factors.

Doctrine does not give the relative importance of the OB factors beyond a rank ordering implicit in the order of listing the factors. Certainly Composition, Disposition, and Strength are key descriptors of an enemy force from a common-sense standpoint. Listing Combat Effectiveness next to last may reflect its dependence on all of the preceding factors rather than imply low status. However, most OB analysts would agree that Combat Effectiveness is of little importance because of its low reliability in practice. Placing Miscellaneous last is reasonable, as it primarily contains supporting data for the other factors.

The traditional ordering of the factors agrees roughly with the rank ordering observed in a large-scale survey of 1456 MI, combat arms, and other officers reported in 1972.³³ In that study, Disposition ranked first, with Composition and Strength a close second, and Combat Effectiveness and Tactics somewhat behind and close together in third place. Training and Logistics were close together in fourth place somewhat further back, while Miscellaneous was uniformly last.

The interactions of the OB factors have been discussed and depicted schematically in Figure 4. It is clear that they are not independent. In fact, Combat Effectiveness is frequently said to be a combination of all of the other factors, although the twelve elements in its formal definition only involve four other OB factors--Strength, Training, Logistics and Miscellaneous (i.e., Characteristics of Enemy Commander and Unit History).

Key Problems of OB Factors

1. There are no standardized methodologies for estimating OB factors (except for a generalized NATO procedure for Strength reporting). There is a requirement for standard units and forms for reporting of OB factors and elements, either in absolute terms or relative to norms. Composites (or data structures) for the OB factors and elements which are more representative than current descriptors of the state of enemy forces should be developed. For example, Combat Effectiveness at present fails to take adequate account of the interactions between the inherent capabilities of the enemy unit being evaluated and related circumstances deriving from the tactical situation.

³³ Coates, E. N. and McCourt, A. W. Analysis of Order of Battle Data Base. ARI Technical Paper, in press.

2. There are no standardized methodologies for incorporating OB factors into the products of OB intelligence.
3. There is no methodology for estimating and reporting reliabilities of OB factor estimates nor the significance of levels of OB factors and their elements relative to general descriptors of the state of enemy forces, such as Combat Effectiveness.
4. There is no realistic and generally accepted definition of the OB factor of Combat Effectiveness. A serious ambiguity of rationale about estimating enemy Combat Effectiveness derives from the point of view of the estimator. (A G2 thinks in terms of the enemy force, while the commander or G3 is concerned with the enemy's net potential effectiveness relative to friendly forces in the existing circumstances.)
5. There is no indication in doctrine of the relative importance of the OB factors, or of their interrelationships.
6. There are no consistent, validated indicators, data aggregates, or data elements for the various OB factors and their elements.
7. There is no methodology for relating the elements of an OB factor to each other, or to the factor itself.

SURVEY OF MILITARY OPINION

A major source of information for this state-of-the-art survey of tactical Order of Battle has been a questionnaire and interview program involving OB practitioners (current or former OB specialists), direct users of the product of OB analysis (G2/S2's and intelligence operations officers), and ultimate users of OB intelligence (G3/S3's and field commanders). The detailed results of that program are presented in the form of opinion, comment, and findings in a supplemental report, "Survey of Military Opinion on Tactical Order of Battle: Supporting Data and Commentary."³⁴

The initial portion of the program consisted of a series of structured interviews with fourteen OB specialists at AICS. The 57 interview questions concerned information received in the OB section, Combat Effectiveness, opinions of OB in general, and operations of the OB section. The collated responses are discussed in the supplemental report. This preliminary effort focused attention on the most fruitful problem areas for further survey activity.

³⁴ Bowen, 1974, op. cit.

In the next stage a questionnaire emphasizing Combat Effectiveness was completed by twelve former G2's, S2's, and intelligence operations officers. Supplemental comment was obtained through interviews with nine of these as well as with a number of former OB officers, to elicit opinion on a variety of broader questions and issues concerning OB section operations. The main focus was on the division-level OB section.

A third questionnaire, also devoted mainly to Combat Effectiveness, was prepared for ultimate users of OB intelligence and was completed by 23 former G3/S3's and field commanders: 14 colonels and lt. colonels at the Army War College, four colonels and lt. colonels in DCSOPS and OACSI, and five general officers with recent field command experience.

The replies to the questionnaires and the results of the interview sessions are discussed in detail in the supplemental report; only the findings are presented in this section. The results of informal discussions on Combat Effectiveness with former senior field commanders are presented in the form of a set of general opinions which show the basic attitudes of responsible ultimate users of Combat Effectiveness information. These are presented after the findings from the first phase of data collection.

Results are presented by listing under each phase of the data collection (Interviews of OB Specialists; G2/S2 Questionnaires; G3/S3-Field Commander Questionnaire) the main topics considered and appending to each the findings derived for that subject. Individual opinion on a variety of OB-related topics is summarized at the end of each section. Where analogous topics appear under different portions of the program, the findings presented were derived independently. The reader should consult the supplemental report³⁵ for detailed summaries of opinion and comment on particular topics.

The findings reported here are derived from the considered judgments of several dozen highly competent and knowledgeable individuals, whose views of OB are heavily conditioned by experience in responsible positions in the field in Vietnam, and represent the consensus of opinions between the respondents.

Interviews of OB Specialists

During the course of this survey, there was an opportunity to interview a number of former G2's, OB Officers and G2 Operations Officers to obtain informed opinion on several topics not covered in detail by the questionnaires. The group of interviewees consisted of six COL's, one LTC, three MAJ's two CPT's and one SFC. Six former U.S. infantry division

³⁵ Bowen, 1974, op. cit.

G2's were included, one G2 advisor to a Vietnamese infantry division and corps, one G2 advisor to a Vietnamese airborne division, one G2 Operations Officer of a U.S. airborne division, a corps OB Officer, an infantry division OB Officer, a district team OB Officer, and a senior NCO OB instructor with extensive field experience.

Findings:

OB ANALYST CHARACTERISTICS

1. The characteristics of a good OB analyst include: intelligence; motivation; industry; attention to detail; a good understanding of military organization and tactics; a good memory; flexibility of thought; and good, solid common sense. The primary requirements, however, are imagination, a capacity for creative thought, and a cognitive ability for the recognition of patterns of event and circumstance in complex bodies of data. This implies a capability for inductive and deductive reasoning and a probabilistic rather than a deterministic manner of thinking. It would also seem to favor the Gestalt or informed holistic thinker who strives to see things in terms of an interconnected whole, rather than the atomistic thinker who patiently builds a logical structure out of bits and pieces of fact.
2. Insufficient attention is, at present, being devoted to the discovery and isolation of individuals possessing high creative thought capability for development as key OB analysts.
3. OB sections require both creative thinkers and individuals of average intellectual capability. A few of the former should be supported by many of the latter.
4. No particular civilian occupations guarantee capability as an OB analyst. Undergraduate students, in general, and law candidates, in particular, frequently make good analysts, but then so do intelligent farm boys. Intellectual flexibility, an inquiring mind, and common sense are not unique to any particular field of endeavor. It is generally easier to train individuals as OB analysts who have not become firmly committed to a professional area of specialization, unless that area happens to require a similar analytical approach, as, for example, may be the case for political science majors or news analysts.

INFORMATION RECEIVED BY THE OB SECTION

1. IPW and documents continue to be the best sources of OB information at the divisional level with their importance being about equal in Vietnam. However, every effort must be exerted to

overcome the inherent untimeliness of their exploitation. The next most useful are reports of troops in contact, particularly in fast-moving situations.

2. SIGINT is very useful at division level for targeting and early-warning purposes. This is generally of more interest to the G2 and the Operations Officer than to the OB section. It can be very useful for focusing intelligence collection resources for targeting purposes. It may also be very useful to OB for pattern analysis, particularly where troops are not in contact.
3. Aerial surveillance and reconnaissance is of considerable interest to the G2 and Operations Officer at division level, but is limited by the nature of the terrain, by enemy air-defense capabilities, and by delays in the processing and transmission of information.
4. Ground surveillance and reconnaissance for detecting unspecified enemy activity is of greatest utility at battalion level, less so at brigade level, and has limited utility to OB at division level.
5. Patrol activity tends to have limited utility for division-level OB purposes although it can provide confirmatory evidence.
6. Agent reports are frequently somewhat untimely. As a source in Vietnam, they tended not to be useful to OB. However, on occasion they were very important, so that their utility is somewhat unpredictable.
7. One cannot emphasize too much the need to exploit every source available for information concerning both friendly and enemy forces that could have a bearing on OB. This calls for extensive liaison with friendly force tactical unit personnel and exploitation of both the operations and the intelligence communications networks.
8. Imagery interpretation capabilities can be utilized to good purpose in support of the OB operation, for example, by the production of enemy activity overlays based on all available information inputs to the OB section.
9. Depending on the availability of timely collection resources, the relative importance of sources of information may vary greatly for OB teams operating apart from major military units, as in the case of district teams in Vietnam.
10. Direct aerial observation, with its capability for reporting targets of opportunity, may be a very valuable source of information.

ROLE OF OB

1. Division-level OB sections in Vietnam varied in their role from the provision of information concerning the identification and location of enemy units to the complete integration of all information concerning the enemy, the preparation of INTSUM's and PERINTREP's and provision of most of the contents of intelligence estimates.
2. The level of responsibility assigned to the OB section depended considerably on the level of confidence which the G2 had in the OB Officer and his staff of analysts. While it tended to be higher than specified in OB doctrine, few G2's used their OB sections as more than supporting elements for the Operations Officer and themselves.
3. Some OB Sections were concerned more with targeting than with support of the decision-making process. However, others were relied on heavily for enemy capabilities information.
4. OB sections perform an important role in the supply of collateral information to the operational troops. When forced to operate on an all-source basis, as in the first BICC-like test in 1968, their ability to support the operational elements with collateral information from divisional level suffered. However, the lower echelon headquarters were able to make use of their augmentation OB personnel to produce a certain amount of collateral intelligence for themselves.
5. In some units, the OB section tailored its production effort quite specifically to the known interest of its customers to the exclusion of less interesting information. For example, in one division, the focus was on body, gun and food locations, because that was what the operational leaders were concerned with.
6. The amount of responsibility delegated by the G2 to the OB Officer depends greatly on the rapport established between them and the degree of confidence of the G2 in the latter's capability to produce the type of intelligence estimates required by the command. Occasional instances of a G2 giving wide responsibilities to the OB Officer, because of the latter's proven abilities, probably can not serve as the norm of the future in view of the variability of OB section capabilities that results from mobility of personnel, unevenness of analyst training and other contributing factors.
7. The occasional outstanding performance of a division-level OB section may, however, be taken as an indication of what it is possible to achieve through competence, dedication, and effort. Study of the examples provided by such operations should result in greater understanding of ways of achieving improvement in the average OB section.

8. As a result of the Vietnam experience, many G2's came to see OB as the heart of combat intelligence; the core of the estimative process. As such, it embraced all elements supporting the decision-making process, including: targeting, activities analysis, and estimation of enemy capabilities and probable courses of action.
9. There was no uniformity in the organization, staffing, or roles played; or as to type, format, content, or rate of issue of products among division OB sections in Vietnam.

COMBAT EFFECTIVENESS

1. There is no uniformity of understanding among G2's and among OB Officers as to the definition, utility and manner of estimation and utilization of estimates of enemy Combat Effectiveness.
2. The use of numerical percentages as a means of expressing enemy Combat Effectiveness is frowned on by most G2's and OB Officers.
3. Most G2's and OB Officers are not overly concerned with a breakout of enemy Combat Effectiveness as an element in itself, but prefer to regard its components as inputs to the estimation of enemy capabilities and probable courses of action.
4. Some G2's and OB Officers prefer not to introduce friendly force Combat Effectiveness until considering probable enemy courses of action, preferring to deal with enemy capabilities in isolation from friendly force considerations.
5. Very few G2's try to visualize enemy capabilities for all conceivable missions within a given situation as a basis for Combat Effectiveness estimation.
6. Most G2's and OB Officers see enemy capabilities in terms of the real situation and desire to have Combat Effectiveness estimated in that manner as well. OB doctrine, on the other hand, makes no provision for relating Combat Effectiveness to the details of the situation, except as the elements of Combat Effectiveness are integrated into estimates of enemy capabilities and probable courses of action.

Individual OB-Related Opinions of Experienced G2 Personnel

In this section, we shall present without comment a collection of individual opinions, divided only by whether they were expressed by G2's and/or G2 Operations Officers or by OB Officers.

OPINIONS OF G2's AND G2 OPERATIONS OFFICERS

1. The essential factor in all aspects of the G2 operation is speed. Constant and repeated emphasis on the need for speed is a major management problem of the G2.
2. There is a lack of timeliness of the products of most means of collection, from II to SIGINT and agent reports, that could be corrected either through proper application of existing technology (i.e., quick readout of aerial sensors) or improved management of the data transmission process to eliminate unnecessary delays. In the past, it has been necessary to improvise field expedients to bring about timely operation in combat. Proper attention to data handling procedures beforehand would obviate the need for much of this improvisation.
3. Intelligence is the "detection of change." In order to be effective at this, you must focus on significant change before the fact. SIGINT and, potentially, aerial surveillance and reconnaissance, provide useful "sieves" for the selection of targets against which to deploy the limited collection resources of the division in support of the intelligence production process.
4. Division commanders differ greatly in their manner of utilization of intelligence information. Some are more analytically minded and others are more operationally minded. The latter type may simply want his G2 to tell him where the enemy is so that he can attack. The former may want to participate in the analytical process. Each type of individual must be accommodated by his G2 section.
5. Where both G2's and S2's are MI Branch, it is often possible to carry out a professional combat intelligence operation to a degree not feasible when combat arms personnel occupy positions of responsibility in the G2/S2 system.
6. In the long run, the most successful maneuver unit is the one that reacts quickly to all timely information that is possibly true.
7. A useful philosophy for intelligence operations at division level is that it be both target-oriented and user-oriented and that intelligence personnel participate actively in the field

exploitation of the information that they develop. One of the problems of a target orientation is that it may produce a conflict of interest in the utilization of collection assets controlled by higher headquarters. It also requires rapid integration of all information and continuous coordination of everyone producing information. While being target-oriented also implies being user-oriented, the latter requires as much or more emphasis on support of subordinate units for providing division staff and higher headquarters with the information they need. In order to round out this process, participation in the field use of their intelligence product can help intelligence personnel to learn what the ground troops need and what they do with the information that they get, and can assist in the immediate exploitation of further leads developed during the operation. Timeliness is the key to target and user orientation, since intelligence produced at division level may frequently be exploited by line companies.

8. Division-level publications must be designed for use by brigades and battalions. Material published in the INTSUM must include G2 evaluation and comments, since there is little capability for analysis below division level. Estimates presented in INTSUM's and PERINTREP's must tie together the "big picture" for the brigade and battalion S2's. The morning intelligence briefing prepared for the CG should be transmitted to the brigades.
9. Despite frequent turnover of OB Officers and their lack of specialization in OB, they can learn to do their job fairly quickly if they have the basic skills and they receive proper OJT.
10. There is a continuing need for collateral communication by a division OB section. Lower-echelon personnel, in particular, require ease of access at the collateral level.
11. Despite frequent dire predictions, there is no real problem of between-echelon communication in the BICC system. Such communication is done regularly in combat. Where there is a "headquarters position" on a particular issue, the matter is handled so as not to embarrass the parties involved.
12. In combat, some G2 sections keep a draft estimate available to go to press on a few hours notice. It is usually updated on a daily basis.
13. In combat, some G2 sections keep available potential targets of company-, battalion- and brigade-size against the possible availability of friendly forces to undertake such mission on short notice.

14. The G2 is the only staff officer who does not deal in a measurable commodity of some kind. He deals in confidence, the confidence that the CG has in his word. He must preserve this confidence and make every effort to ensure that the estimates which his section comes up with are reliable. For this, he must rely heavily on his OB section.
15. Better visual aids are needed for briefings. The man with a pointer, fumbling with charts while trying to describe a graphic situation in words for his commander, is hopelessly out of date. One way to meet this need would be some kind of display board on which the information being described could be automatically depicted in a manner calculated to transmit the briefing message most effectively.
16. A problem in pattern analysis is frequently best carried out by a small group of individuals who can focus on the subject matter intensively. It does not lend itself as well to the bureaucratic team approach.
17. There are three levels of probability in combat intelligence: confirmed, probable, and possible. One can construct lists of indicators for any given eventuality and set standards for decision-making based on patterns of confirmed indicators derived from recent enemy activity data. A decision will amount to a conclusion to make a recommendation to the commander on, for example, an enemy course of action.
18. One must avoid letting computers drive the intelligence system by putting information only potentially useful into them that only clutters up the system. Thus, one cannot always come up with a viable program to exploit certain kinds of data. Simple programs permit you to save time on storage and retrieval. Computers are not to let you reach a decision sooner but to save time in hunting for information; the time saved can then be applied to additional analysis.
19. The OB section and G2 Operations at the division level should be integrated in order to optimize exploitation of SIGINT and other special intelligence inputs.
20. Pattern analysis should be greatly emphasized in the training of MI officers.
21. Pattern analysis is a technique whereby all known enemy information is categorized, placed on overlays, and analyzed. It includes special intelligence. The result is a dynamic display of enemy activity which is continually updated and under constant evaluation, and is also an excellent briefing graphic and a highly effective intelligence tool.

22. Pattern analysis, based on SIGINT and aerial surveillance and reconnaissance inputs, can provide a reliable means of estimating enemy campaigns, intentions, capabilities and objectives weeks in advance even of establishment of contact. It can permit more effective utilization of long-range reconnaissance patrols, air strikes, artillery fire and sensors, and it permits quick comparisons to be made with past enemy operations. Pattern analysis can continue to supplement analysis based on traditional OB sources, such as IPW and documents, after contact with the enemy has been established.
23. Battalion commanders should be cleared for access to special intelligence. Denial of this information (except in sanitized form) sometimes proved counterproductive in Vietnam.

OPINIONS OF OB OFFICERS

1. In looking at the OB factors, your first consideration should be a toss-up between Strength and Disposition, depending on the situation, particularly the influence of terrain. Disposition is usually as important as Strength. In general, however, because Composition has traditionally been called "the Key to Order of Battle," it tends to be considered first in the list of factors. Although you would like to know the identification of a unit and how it is organized, the real analysis does not begin until after you have some enemy unit coordinates and can start to relate units to one another in terms of type and deployment.
2. The situation will limit the usefulness of some of the OB elements. Thus, Disposition is very important during the combat phase, while some of the items under Miscellaneous may be very important in the planning phase.
3. While the vast majority of OB analysts encountered in the field had been through the intelligence school, they still had to pick up certain skills through OJT, one such skill being communications.
4. Given the ad hoc nature of the average OB section, the ability of NCO's to channel the skills and strengths of analysts into specific jobs for which they are best suited is a very important supervisory qualification.
5. The most valuable type of supplemental study in Vietnam was that which attempted to relate enemy activity to time and space factors for purposes of pattern analysis. An example of this was an indicator manual for the location of VC tunnel complexes that related terrain, time, and enemy activity for a particular region.

6. The enemy also learned pattern recognition. OB can be helpful in pointing out evidence of enemy abilities in this regard. An example would be the rapid recognition by the VC of no-fire zones which they could employ as sanctuaries. Patterns of fire preparation for certain types of attacks also came to be recognized by the VC. In general, it must be considered that any kind of military activity will leave some kind of trail that can serve as a recognition pattern. We must consider the enemy's ability to identify and exploit such patterns. (This might be considered as "counter-OB.")
7. There is no specific doctrine or standard format for the keeping of OB files. Retention of information is based solely on the needs of the unit concerned. Thus, some analysts think they are operating commendably if they can fill their file cabinets with information, while others have an aversion to files unless absolutely necessary. Clearly, information filed should have some potential for being used and filing discipline should be enforced by the OB Officer.
8. One cannot stress too much the need to sell the capability of the OB section to users, from the CG, G2 and G3 and their staffs down to lower unit commanders and up to higher HQ. This can only be done by consistently producing timely, reliable products and making them available to those who need them.
9. One way to train analysts in the field is to have them write histories of opposing units from the earliest available reference material up to current acquisitions. In this way, the analyst rapidly becomes immersed in his subject and learns to recognize and understand change.
10. Turnover of OB personnel is not that important per se. It is the loss of good people that hurts. One can teach a new man to do a functional job in an OB shop in a week. However, there will be little job satisfaction for him in that. On the other hand, if you give him broad responsibilities and lose him, a serious hole may develop. Achieving a proper balance in this matter is a fundamental management problem that must be faced by the OB Officer. If he takes too much of the responsibility for coordination into his own hands, then he becomes the vulnerable point in the system.
11. OB analysts should not be trained in standard methods but in what they are expected to do later in the field. They should be trained to ask questions and go after the answers until they find them. There is no standard list of items that one is looking for. In recognition of this, very little training time should be devoted to such matters as file concepts. Rather, most training time should be devoted to applications.
12. One way to retain OB skills during peacetime would be to rotate all OB analysts through high command echelons, such as USAREUR, where there is a live mission. OB sections or personnel could be sent on tactical level assignments for specific training purposes, perhaps to the infantry just to learn what the operating level is all about.

13. It would be nice to be able to indicate the weaknesses in analyses by specific reference to the quality of the input elements. To do this with machine assistance would require considerable specialized formatting, but it conceivably could be accomplished.
14. It would be extremely useful to have mechanisms to develop indications that were specific to particular situations. Whenever you establish a pattern you in fact establish an indicator. Thus, when you pick up any item that is essential to a pattern it becomes an indicator for the rest of the pattern. To be able to reduce patterns to other patterns which are more readily recognizable by the analysts would be very advantageous. However, the main problem in this lies with the analyst making predictions too soon through inexperience.
15. While it is not always possible to keep individuals working on OB analysis in peacetime, they should be given jobs requiring at least some kind of analytical skill. Then, when required to perform as OB analysts in real situations, they would be able to bring themselves up to speed again within a few weeks time. In any event, one should allow two weeks to a month of overlap before any new analyst takes over from an old one on a particular OB job.
16. All manual file-keeping will probably not be replaced even if machines become available. The analyst is always going to be on the lookout for the new and unusual. He may, on occasion, have to develop a file that does not yet exist just to produce a particular piece of intelligence. It sometimes happens that from a certain kind of file, "it just stands up and hits you in the eye" that something is a pattern. However, many standard files could be formatted for machine.
17. While it is possible to do a satisfactory OB job in association with a TOC, the two are separate functions and should be kept apart organizationally even if they are located close to one another physically.
18. Recognizing indicators is a learned response, much of which must be based on experience. As an analyst fresh out of school begins working in an OB assignment, he will start to learn the relative reliability of sources and the normal patterns of his problem area. He will become able to recognize the disturbances of these normal patterns that warn him that "something is up". However, until he learns the normal patterns he cannot be of much use.
19. The average analyst becomes quite uncomfortable when he has a lot of information dumped on him at once. Normally, an analyst likes to have a starting base from which he can build up a picture gradually over a period of time. Sometimes, he really does not even know what he is looking for until the picture begins to take shape. Any computer-aided storage and retrieval system should be designed to take account of this preferred manner of analyst functioning.

Field Commander Interviews

Discussions with experienced combat commanders revealed that the majority, when making combat decisions, take into account an evaluation of enemy Combat Effectiveness, but in an overall sense, i.e., good, fair, poor. Within this context, commanders were more interested in such specifics as Disposition, Composition, Strength and threats, vulnerabilities, Tactics, and techniques than in over-all ratings of Combat Effectiveness. The consensus was that Combat Effectiveness ratings, in a broad sense, are useful in that they are cautionary. That is, all enemy forces are dangerous in that they are armed, hostile and intend to defeat or thwart friendly forces.

Except in low-intensity operations, divisional commanders seldom originate their own missions. Missions which they do originate that will involve a significant commitment of personnel, materiel, and/or effort are closely controlled, supervised, or monitored by higher headquarters. Thus, most divisional operations are not of the independent-decision or free-maneuver type, but are part of a larger scheme and are subject to influences and restrictions that may bear little relationship to the local situation. Most often, decisions concerning significant divisional operations are not "whether," but "in what manner."

Recognition of this apparent anomaly in judging the value of precise ratings of enemy Combat Effectiveness led to the survey of the opinions of several officers who had served in combat at division and separate brigade level.

Opinions:

1. All agreed that higher headquarters kept a tight rein on significant operations to avoid over-commitment, both militarily and diplomatically.
2. While destruction of enemy forces was the objective in most operations, the method was to attack in coordinated fashion that terrain in which the enemy was believed to be located.
3. While it can be accepted that certain enemy units are definitely within an operational area, it is dangerous to assume that no other units are present.
4. No foresighted commander is going to expose his command to enemy surprise. The cost of defeat is so great that caution and boldness are relative degrees of conservatism. Thus, knowledge of enemy Combat Effectiveness may increase or decrease the degree of risk a commander is willing to accept.
5. None of the interviewed senior officers made conscious use of a definite Combat Effectiveness score, except in reports or briefings designed to give "ballpark" evaluations to those unfamiliar with

particular units. When conscientiously used operationally, enemy Combat Effectiveness was subjectively evaluated with reference to the particular operational situation.

6. All agreed that they sought from knowledgeable commanders and staff officers not only specific information of the enemy, but also judgments, intuition, and "gut feeling." All placed judgmental values not only on the source of the information, but also on their evaluation of the reporter's judgment.
7. All agreed that they would look with great suspicion on any mathematical formula; and that, however precisely elements of a formula were derived, the result to be at all usable would still have to be expressed in gross terms, i.e., good, fair, poor, 100%, 90%, 80%, etc.
8. Ultimately, commanders are fully responsible for all that their commands do or fail to do. They make their own judgments, and these judgments are based on multitudinous bits of information and influenced by personal experience and training.
9. For broad, high-level planning and force development Combat Effectiveness ratings scientifically arrived at have usefulness, but for combat situations there is no substitute for the subjective human judgment of the responsible field commander--he simply will accept no other.
10. The tendency to give collective personification to an enemy force was evident in these discussions.

G2/S2 Questionnaire

Introduction

As a means of sampling opinion of users of OB section products, a questionnaire was created for individuals with G2/S2 experience. Responses were received from twelve subjects: eight colonels, one lt. colonel, and three majors, all MI Branch and all having had Vietnam experience. The range of field experience represented varies from sector S2 advisor to corps G2 advisor. Seven former U.S. division G2's and two G2 advisors to Vietnamese divisions are included. Because of their recent Vietnamese experience, their comments and suggestions may be oriented toward unconventional warfare.

Definition of Combat Effectiveness

Findings:

G2/S2's differ greatly in their understanding of the meaning of Combat Effectiveness, from "the ability of an enemy unit to perform its TOE mission" to "the ability of an enemy unit to perform any assigned mission."

Desired Content of Combat Effectiveness Contribution of OB Section

Findings:

1. G2/S2's desire quite different Combat Effectiveness reporting by the OB section. Some prefer detailed analytical reports treating every factor with any conceivable bearing on Combat Effectiveness; others prefer reports on a few key indicative factors that they feel reflect the status of Combat Effectiveness. Still others want summary reviews of enemy capabilities and probable courses of action based on Combat Effectiveness considerations.
2. The only point of consistency among G2/S2's concerning the elements of Combat Effectiveness is that Strength is a primary consideration.

Desired Format of Combat Effectiveness Contribution of OB Section

Finding:

The majority of G2/S2's desire a fairly detailed analytical presentation from the OB section on Combat Effectiveness, including a summary statement, and with backup material available for examination. Some want only notes containing the latest information on the unit being evaluated so that they can make their own judgment concerning Combat Effectiveness. A small proportion will settle for oral briefings.

Desired Format of Combat Effectiveness Contribution of G2 Section to Commander

Findings:

1. Oral briefing is the favored manner of presentation of estimates of enemy Combat Effectiveness to the commander. Most commanders want supporting evidence available in the form of overlays, notes, or detailed formal submissions. Some will want bibliographic supporting

evidence available to back up estimates. Some will want to know the reasons for estimates.

2. Some commanders will be satisfied to have the Combat Effectiveness factor incorporated into summary statements of enemy capabilities and probable courses of action.

Suggestions for Improvement in the Determination of Combat Effectiveness

Findings:

1. A fundamental review of Combat Effectiveness doctrine is needed to demonstrate the validity of such suggestions as the following:
 - (a) There should be a complete, total integration of timely collateral and all-source information at the Order of Battle desk.
 - (b) There should be more emphasis on total integration and analysis of all-source information during training.
 - (c) There should be more education of commanders and their operations staffs on the value of all-source information to operations.
 - (d) There should be more control by the G2 over reconnaissance and surveillance units and methods.
 - (e) There should be better feedback from theater level of political, economic, sociological and military factors that would tend to influence enemy units.
2. Combat Effectiveness should not be allowed to overshadow other OB factors, particularly Disposition and Strength, in the determination of enemy capabilities and probable courses of action. (Perhaps Combat Effectiveness should be expanded to incorporate all OB related factors.)

Utility of Knowledge of Enemy Combat Effectiveness

Findings:

1. An accurate knowledge of enemy Combat Effectiveness can serve as a prime determinant of friendly courses of action through its indication of the limits of enemy capabilities and the corresponding possibilities for economy of force and risk limitation in disposition of friendly forces.

2. As a practical matter, the factor of enemy Combat Effectiveness per se has small-to-limited impact on friendly force operational planning. Rather, it is the data which relate to Combat Effectiveness that are employed in estimates of enemy capabilities and probable courses of action.

Role of OB Factors in Analysis of the Situation

Opinion:

A great variety of opinion was expressed by the respondents. The more important comments are summarized as follows:

1. One subject added "leadership" as a category of Miscellaneous and noted that Combat Effectiveness depends on all of the OB factors for each of the units you are facing. For battalion-sized units from the same parent organization such factors as Training, Logistics and Tactics may be roughly equal from unit to unit.
2. OB is important when other factors are considered, such as the environment in which Training was obtained, or the comparative combat power of each side.
3. Disposition and Strength are the most important. Logistics and Composition are next. Mission is as important as Disposition and Strength.
4. All the OB factors are part of the Combat Effectiveness factor. To these should be added: type unit, authorized strength, actual strength, morale, caliber of leadership, past performance, training of troops, number of old-timers and number of recent replacements, illnesses, subordination, most recent operations, recent losses suffered, desertions, food supply, ammunition supply, weapons, and any recent deserter or PW interrogation reports and captured documents relating to the unit.
5. All of the OB factors are essential elements in determining enemy effectiveness. Combat Effectiveness is an analytical judgment based on all-source material which includes: location of the unit, identification, intentions, capabilities, and sources used for the analysis. Capability should consider: strength, weapons, motivation morale, leadership, mobility (unit and terrain), Logistics, recent history (including recent movement) and an analysis of the effects on the unit of weather, terrain, other enemy units, operational guidance and effectiveness of higher headquarters, potential support, and probable reaction to our operations based on past actions. In short, an assessment of strengths and weaknesses.

6. As a set, the OB factors allow the G2 to assist the commander in determining where to employ the combat strength of the division.
7. In Vietnam, Disposition, Strength and Logistics were important elements of Combat Effectiveness. Strength was critical, both quantitative and in terms of quality of leadership. Disposition provided a repetitive pattern and thus an indicator of certain unit operational intentions. Logistics, particularly food supply, became a larger problem to the enemy in 1969.
8. There is a dichotomy in the eight OB factors, in that the first six will have an impact on the seventh (Combat Effectiveness); they are, in effect, integral parts of the process of determining Combat Effectiveness. They are also some of the major factors that the G2 uses in determining the Combat Effectiveness of friendly forces.
9. Composition and Disposition provide the "address" of the enemy, with Disposition also providing indications of intent. Strength indicates what you are up against. All the rest is "nice to know." In a fast-moving situation there isn't time to play with the rest. In a slow-moving situation, where deliberate planning or detailed planning is necessary, the other factors become important.
10. The OB factors enable one to analyze the enemy's capabilities and judge his most probable course of action.
11. Each member of the following set of factors plays an integral role in the determination of Combat Effectiveness and in advising the commander of its effect on his courses of action.

Strength/Organization/Location
 Equipment/Equipment Status
 Morale
 Logistics Situation
 Operational Capability
 Intelligence-Gathering Capability
 Training/Tactics

One subject discussed the OB factors in detail, as follows:

1. Composition. Force composition is important. Knowing the designations of sub-units of the enemy's organizations is vital. Detecting a battalion of a division which is not supposed to be in your area is a pretty good indication that the enemy is reinforcing or relieving in place. This is particularly true if his tactical doctrine does not permit cross-attacking at regimental level.

2. Disposition. How the enemy disposes his forces will indicate his intention to attack or defend.
3. Strength. The strength of his units will tell you something about his capability to attack or defend. It is not the whole answer though, for he may mass understrength units to make an attack succeed. Hence, Disposition is also a part of the estimate.
4. Tactics. Quite important. Small (division and below) units are fairly well tied to tactical doctrine. Knowing the enemy's tactical doctrine will assist the G2 in forecasting the enemy's next move. Of course, the Composition and Disposition of his forces interact here as he composes and disposes his forces according to tactical doctrine. For example, during map exercises at the Army's Command and General Staff College, U.S. officers playing the Red forces usually are quite effective against the Blue (or U.S.) force because they know U.S. tactical doctrine thoroughly--so thoroughly, in fact, that they can usually pinpoint the Blue headquarters, artillery position and supply points on the map without relying on intelligence.
5. Training. The level of unit Training of an enemy unit is important if the unit has not been committed to combat before; however, once "seasoned" in combat, unit Training is not very important. The type of Training the unit has received or is receiving is important (e.g.: amphibious, airmobile, stay-behind, etc.). The Training level of replacements is important because poorly trained replacements are more likely to desert or surrender under heavy pressure.

Finding:

Many G2/S2's see the OB factors in terms of the contribution that they make to an understanding of enemy Combat Effectiveness. Others see them in terms of a sample listing of enemy strengths and weaknesses.

Role of OB Factors in Commander's Evaluation of Situation

Finding:

G2/S2's see the OB factors as providing the basis for the G2 estimate of the situation on which the prudent commander should base his course of action.

Timeliness of Products of OB Section for Current Operations

Findings:

1. G2/S2's see timely OB section products as essential to the planning and execution of current operations. They seem to assume that somehow OB products can be made timely because they have to be.
2. Despite the fundamental need for timeliness in OB section products, it is clear that they do not always meet this criterion. For one thing, the OB section does not always receive information rapidly enough to turn it into timely products. This, then becomes a collection problem as well.
3. One method of improving on the timeliness problem is to create a quick-reaction unit within the G2 section whose only task is to provide adequate, if somewhat superficial, answers to questions of great immediacy. More detailed treatment of such problems is then left to the OB section to carry out as more information becomes available. It is necessary to give such a quick-reaction unit access to all sources of information in the command through appropriate communications and transport facilities.
4. The fundamental problem of the G2 is sometimes described as the need to develop a sufficient sense of urgency in his section to assure that the timeliness of products is achieved and maintained.
5. Various technical suggestions for improving timeliness of product include: hot lines, dedicated intelligence communications, and an automated data base which can be rapidly queried and rapidly updated.
6. If the OB section fails to produce a timely product, the CG and G3 will improvise their own product, with whatever consequences that may entail.

Effect of Situational Factors on OB Analysis

Findings:

1. All pertinent situational factors should be taken into account in OB analysis. The standard OB factors do not provide for such matters as phase of combat or type of combat, for example. The emphasis given to various OB factors will also vary with the situation.
2. Combat Effectiveness should be examined in the light of all potential enemy missions, rather than of merely the TOE mission for which a particular unit was designed.

3. One needs to be skeptical of OB analyses that may be influenced by preconceptions of enemy intentions generated by specific events. Thus, one may tend to attribute greater enemy Combat Effectiveness during periods of expected enemy offensive action and lesser Combat Effectiveness following a period of heavy contact. There is a role for a devil's advocate in an OB shop.
4. OB analysis encounters problems during the attack phase when the situation is fluid and fast-moving. Initially, there will be numerous sketchy or erroneous reports on enemy units. It is not until the consolidation or defensive phase, usually, that more accurate information filters back from front-line units, prisoners, or captured documents or equipment. In the defense, the collection and reporting system is more stable and the OB section has time to "sort the wheat from the chaff."
5. It might be useful to include in OB doctrine or methodology some kind of check list of intrinsic and extrinsic factors to be taken into account when estimating enemy Combat Effectiveness or preparing other types of OB analytical products.

Contribution of OB Section to Production of Combat Intelligence

Finding:

The OB section should serve as the primary contributor to combat intelligence production, i.e., the central coordinating function for information concerning the enemy. Most respondents saw this as an analytical and integrating function, a few as only the provision of a data base concerning the enemy. In the majority view, the OB section should be the most important element of the G2 shop, the core of analysis and estimation, the place where all information concerning the enemy is analyzed, integrated, and assembled into the combat intelligence product required by the commander. As such, it is:

- (a) The critical integrating element for estimates of enemy capabilities and intentions.
- (b) The identifier of lucrative objectives (enemy units and operational areas) for major combat operations.
- (c) The producer of aids for use in field operations (such as OB handbooks).

Suggestions for Improvement of Contribution of OB Section

All but one of the respondents had his own set of ideas for improvements, with little overlap between subjects. Therefore individual suggestions and comments are listed:

Opinion:

1. Improve data storage, retrieval and manipulation.
2. Develop standardized procedures which analysts can use to rapidly chart OB factors and hopefully also give some type of Combat Effectiveness rating.
3. Investigate the feasibility of using the probabilistic methods of systems analysis for evaluating enemy effectiveness and capabilities.
4. Give OB section leaders experience with tactical unit command problems during training exercises.
5. The value of the OB section contribution will be in direct relationship to the commander's opinion of the value of his G2 and the whole G2 shop. The value of the OB section contribution depends on the degree of professionalism existing in the G2 section and the degree of trust and confidence the commander has in his G2 based on past performances. If the G2 shop has demonstrated great credibility in the past and the commander knows he can rely on his G2, the OB contribution is invaluable. If all they have produced is "historical data" without sound analysis (as many do), a commander usually will ignore the data and analysis or read the data and attempt to do his own analysis on whatever information is presented.
6. Unless an OB section forces its members to learn everything possible about enemy units and personalities by reviewing past performance from the day the units were created (all major engagements, successes and failures and tactics), the analysts are not likely to be prepared to react rapidly and soundly to requirements. They must prepare themselves to be able to recognize the significance and potential value of a piece of information by just looking at it in the light of their understanding of the enemy.
7. An OB section is not just there to put data down on paper but also to analyze and make bold assumptions as to the enemy's intentions, based on an in-depth knowledge of the enemy and detailed study of all information coming in daily from all sources. A good OB section, knowing the enemy intimately, can frequently determine the enemy's future courses of action even before he does himself.
8. Less restriction on the distribution of COMINT.
9. Let professional MI Officers become G2's and keep the combat arms professionals out of the job.

10. More emphasis on combat intelligence training and less narrow specialization during the early years of a career in MI.
11. Integrate SIGINT and collateral intelligence in the OB shop.
12. Educate commanders and operations staff officers as to the value of OB work.
13. Maintain a cadre of professional OB analysts and a continuing school training program.
14. Establish a central automated data base which can be up-dated and retrieved from brigade level. This would reduce the time-lag associated with transmission of OB information between echelons.
15. Assure that TOE's of OB sections are adequate. This may mean division-level OB sections of 15-20 people, since that is the normal size to which such shops expand in combat.
16. Employ improved means of displaying Combat Intelligence to the commander and staff at all echelons. Maps, overlays and pointers should be supplanted by 3-D, computer-driven mural screens for briefings.

G3/S3-Field Commander Questionnaire

Introduction

The G3/S3-Field Commander Questionnaire, containing 10 questions on the subject of Combat Effectiveness, was completed by 30 individuals. These included 14 COL's and LTC's from a recent class at the Army War College, 1 COL and 2 LTC's from ODCSOPS and OACSI in the Pentagon, 1 LTC from the Industrial College of the Armed Forces, 2 MG's and 3 BG's with combat experience. The sample contained 23 individuals of the rank of LTC or higher having G3/S3 and/or Field Commander experience, most of whom had seen combat in Vietnam (6 had not had occasion to make use of the concept of Combat Effectiveness).

Detailed discussions of the responses to the questionnaire may be found in "Survey of Military Opinion on Tactical Order of Battle: Supporting Data and Commentary." The finding for each key topic is presented below.

Definition of Combat Effectiveness

Findings:

Perceptions varied of the meaning of the term "Combat Effectiveness." Many associate it with relative combat power of own and enemy forces or with the enemy's capability to accomplish a particular mission.

Philosophical Basis

Finding:

Combat Effectiveness estimates should be made in terms of the potential capability of an enemy force to meet a specific situation at hand, rather than in terms of the capabilities of a TOE unit in an assumed average type of situation, as is the normal practice of OB estimates.

Responsible Estimator

Finding:

The commander preferably makes the ultimate judgment concerning enemy Combat Effectiveness, rather than relying on the G2/S2 to do it, as is normal OB practice.

Desired Format

Finding:

A variety of methods of presenting Combat Effectiveness estimates were preferred, including listing of enemy force strengths and weaknesses and narrative descriptions involving all attendant circumstances, as opposed to the customary OB approach of relating enemy Combat Effectiveness to that of a TOE unit.

Primary Factors

Finding:

Opinions varied on the most important factors to be used in estimating enemy Combat Effectiveness. There was considerable unanimity concerning the primary role of Strength. Other factors mentioned frequently were: Training, experience, morale, and leadership, with a sprinkling of references to a multitude of other factors. Individual groups of factors were often used as indicators or patterns to represent the complex function of Combat Effectiveness, but with no uniformity as to the groups of factors to be employed nor their manner of employment.

Functional Parameters

Finding:

The capability elements--Command, Control and Communication; Firepower; Intelligence; Logistics; and Mobility--were agreed to be necessary but not sufficient descriptors of Combat Effectiveness. However, there was wide disagreement as to what additional factors should be included, or how they should be included. Morale was mentioned frequently as an important additional consideration.

Elements of Success in Battle

Finding:

Roughly equal relative weight was given to the functional parameters--Command, Control and Communication; Firepower; Intelligence; Logistics; and Mobility--insofar as their contributions to success in battle are concerned. However, the equality of weights may have been either a true indication of opinion or merely a randomized reflection of ignorance.

Effect of Changing Situation

Finding:

The relative contributions of the functional parameters of Combat Effectiveness to success in battle are believed to change with the situation, although there is no agreement as to the nature of this change or how to estimate it.

Qualification of Estimates

Finding:

Estimates of Combat Effectiveness should be accompanied by a qualifying statement as to probable accuracy.

SUMMARY

An overview of the current state-of-the-art of tactical Order of Battle intelligence in the Army and of the status of the OB factors should provide a basis for improving both the processing techniques and methods of estimation used in OB analysis.

The survey has embraced all aspects of tactical OB, with emphasis on OB factor estimation at the division level and in particular the factor of Combat Effectiveness. It has presented both the historical development and a current status report on OB in the U.S. Army. It was based on official documentation, other authoritative reference material, and the findings of an informal questionnaire and interview program involving experienced combat personnel with backgrounds in intelligence, operations, and field command.

Order of Battle is defined as the identification, strength, command structure, and disposition of the personnel, units and equipment of any military force, by FM 30-5. This definition has been adopted by all members of NATO, by STANAG 2077. The fundamental role of tactical OB is to inform the commander of the detailed nature of enemy forces with which the command is in contact or may reasonably expect to be. OB intelligence includes both descriptive information on enemy activities and estimates of the capabilities of enemy forces.

OB intelligence is produced by one sub-element of a complex G2 Section which has responsibilities for a wide range of intelligence collection and production activities. Whereas the other functions embrace both collection and production of intelligence, OB is almost entirely a user of information supplied by others; it employs this information to create integrated products designed to support the command decision-making and planning process.

The scope of OB intelligence as taught at AICS is currently based on FM 30-5. For example, current activities analysis is treated as an OB function, even though, in the past, it was often carried out by the Current Intelligence section of the Operations Branch in a divisional G2 section. The somewhat academic distinction between current intelligence and OB is currently being erased at the basic analyst level by training all 96B MOS personnel as Intelligence/OB analysts instead of merely as OB specialists. Likewise, OB specialization for officers has been eliminated in favor of intelligence staff officer (MOS 9301) training.

The scope of OB intelligence as practiced in the field has normally been much more limited. Current intelligence personnel of the division G2 section are customarily cleared for access to all-source information whereas normally OB section personnel have not been. Thus, the OB section has often been regarded as a historical reference operation producing long-range output of limited interest to the current situation.

In Vietnam G2 Operations current intelligence personnel concerned themselves with the immediate consequences of enemy activities, while the OB section examined trends and patterns of enemy activity in an attempt to discern their longer-range implications.

The experience of Vietnam brought about a recognition of the importance of the OB function as the principal source of intelligence for targeting, command decision-making and operational planning. G2's in Vietnam had some success with the OB function, using a variety of improvised organizational and procedural techniques. Efforts are now being made to develop new doctrines and procedures designed to make the OB section a current intelligence production activity based on all-source material.

Doctrine defines eight OB factors: Composition, Disposition, Strength, Tactics, Training, Logistics, Combat Effectiveness, and Miscellaneous (Table 3). Miscellaneous is not a true factor but a series of files of supporting information relating to the other OB factors. The OB factors are highly interdependent. Composition and Strength are closely related, particularly for full-strength units, and both are related to Logistics. Disposition and Tactics are similarly related, and both tend to be related to training. Combat Effectiveness reflects the total combat potential of an opposing force. However, the doctrinal definition of Combat Effectiveness does not mention Composition, Disposition or Tactics as such. Unit History, under Miscellaneous, provides information concerning Composition and Tactics, but not Disposition.

Each OB factor is defined in terms of a number of information elements which indicate the type of data required to describe the status of that factor in narrative terms. There are no specific rules, either formal or heuristic, for the evaluation of factors or elements, or their combination. The normal lack of definitive battlefield data requires the use of pattern and indications analysis in estimating the status of any particular factor.

There is no formal guidance for the use of OB factors or their elements in estimating any particular enemy capability or in making military judgments. The estimator is assumed to have enough military awareness to make such judgments for himself. High enemy capability in all military areas is generally considered indicative of high Combat Effectiveness. However, to estimate intermediate levels of enemy capability each analyst must develop his own approach. For factors where items of equipment or numbers of personnel can be counted, as in Strength estimation, high-quality estimates can be achieved. There also is a common-sense awareness that Strength estimates are a necessary, if not sufficient, element of enemy capabilities estimation. The utility of a Strength estimate in this regard cannot be demonstrated.

OB Processing Concepts

Most products of OB intelligence are incorporated in other products of the G2 section, designed to support targeting and command decision-making, such as the PERINTREP's, INTSUM's, Estimates, and the OPLAN. As such, they frequently appear in the form of estimates of enemy capabilities, vulnerabilities, and probable courses of action. In the case of the PERINTREP and OPLAN, they may remain distinguishable as OB products, such as the OB Annex. Aside from OB studies, other purely OB items generated include: evaluation reports, spot reports, directives and requests for information, analyses of OB factors and elements, and briefings. Conceptually, the inherently most important OB factor for consumers of OB intelligence is enemy Combat Effectiveness. In current practice enemy Strength reports are the most important factor.

The variety of procedures used in different OB sections precludes discussion of a standardized methodology beyond noting that incoming information (i.e., messages) is logged in, examined by the OIC/NCOIC for action and/or routing, and processed and filed by analysts. Data processing is almost entirely manual, although various forms of computer-based support are currently under development. The following basic procedural techniques are employed: review, evaluation and analysis, updating/file maintenance, requesting further information, preparation of reports and briefings. An increasingly important analytical technique is multiple-overlay pattern analysis.

Individuals are generally responsible for posting the OB SITMAP, maintaining specific files and analytic aids such as unit workbooks, and/or following particular OB factors. Some OB section products require group effort supervised by the shift officer, but individual analysts are usually responsible for reporting on specific specialties (e.g., enemy units, areas of operation, OB factors). Analysts may be assigned whatever activity is important on their particular shift. In wartime, when staffs are augmented, it may be possible to assign narrower responsibilities to certain individuals on a continuing basis.

The key member of an OB section is the warrant officer OB technician. He and the senior NCO provide the continuity of experience of the section. The OIC, a captain or lieutenant, is normally not OB trained and is subject to frequent transfer, as are the middle-grade sergeant OB analysts. Enlisted personnel of an OB section will almost always be trained in the 96B MOS, which now denotes Intelligence/OB analyst instead of OB analyst. Analysts are generally selected for above-average intelligence. However, the best qualities for an analyst are common sense and a knowledge of combat arms tactics and techniques. Analysts who possess the requisite knowledge and skills without having undergone extensive OJT are reportedly rare.

OB Support Requirements

The OB section of a division has no direct collection responsibilities or capabilities; it depends on the division for its information and places its requirements through the Operations Branch of the G2 section. Under the Battlefield Information Coordination Center (BICC) concept, the BICC would manage collection. Individual analysts would have access to the data base of the division under the automated conditions planned for the future. However, analysts would still depend on their own liaison contacts with other sections for informal access to information not yet in the data base.

Traditionally, UPW and captured documents have been the most important sources of OB intelligence. SIGINT, an important and inherently timely form of intelligence which lends itself well to pattern analysis, has been only partly useful to OB because of security restrictions. Aerial surveillance and reconnaissance is an important means of following enemy dispositions and activities. However, in a fast-moving situation, reports of troops in contact remain the primary source of OB intelligence. Depending on circumstances, almost any source of information can be of some use to OB.

Using manual procedures with current TOE staffing, division OB sections in combat tend to be periodically so swamped with data that much information remains unprocessed or is processed too late. Information filing and retrieval in the OB section needs simplifying, particularly at the divisional level, possibly through specialized automated filing systems, which would let analysts spend more of their time on analysis. The utility of an automated system will be determined by the rate at which collected information can be incorporated into the system, the competence of initial screeners, and the adequacy of the file structures of the data bank. Development of standardized techniques for estimation of OB factors and their related elements would facilitate the analytical process under either manual or automated conditions.

Basic training of Intelligence/OB analysts at AICS uses the case method approach and is quite comprehensive. However, more time could be spent on training in analytic thought processes, particularly pattern analysis.

In peacetime the normal division operations and the occasional CPX or field exercise do not provide adequate training in the general OB functions. Even in exercises in which OB is played, messages tend to reflect only current activities rather than what has been taking place over an extended period of time. More efficient OJT is needed during peacetime as well as ways of bringing the latest developments to the attention of field personnel.

Periodic OB refresher training of active-duty personnel is needed at AICS or through correspondence courses. Reservists should also receive OB training in order to maintain and extend existing OB skills

and to develop new OB specialists. Careful consideration should be given to the possibility of reintroducing OB as an MOS skill specialty for both officers and enlisted men.

Excessive turnover of combat unit OB analysts and OIC's during peacetime results in inefficient and discontinuous OB section operation and the failure of many junior (i.e., operational) personnel to obtain adequate OJT in their specialties. Moreover, the peacetime staffing of division OB sections on the basis of existing TOE's has in the past needed to be doubled or tripled during wartime. Peacetime training is needed for tactical OB sections or for the personnel who may have to staff them in combat, so that such OB sections can better meet emergency situations.

CONCLUSIONS

OB is an important form of intelligence for both targeting and command decision-making, since it encompasses all information concerning the enemy. In practice, OB at the division level has often provided more background reference material than current intelligence. As such, the OB input has frequently been more useful in planning the next operation than in guiding decisions on the current one. Efforts are underway to improve the capabilities and status of OB in tactical units and particularly the timeliness of OB products, by integrating OB with current intelligence.

The individual OB factors seldom play a role in themselves; they tend to appear as elements of the OB products. Conceptually, the one OB factor which tends to stand alone is Combat Effectiveness. However, because it is poorly understood and has no standard method for its estimation it plays little significant part in the estimation of enemy capabilities. By default, identifications and Strength estimates tend to be the most important role of OB analysis.

Some specific problems in OB are:

1. Lack of standardized and proven techniques for the estimation of OB factors and associated confidence levels (particularly for Combat Effectiveness)
2. Lack of all-source access of personnel
3. Excessive rates of turnover of analysts and OIC's
4. Lack of sophisticated information-processing capability
5. Limited analytical capability of OB specialists (particularly in combat tactics and techniques and the employment of pattern analysis)

6. Lack of realistic OB section training in peacetime
7. Lack of planning for wartime

This survey has produced four major areas of findings: (1) The proper role of OB in a combat situation, (2) reconciliation of the wartime and peacetime roles of the divisional OB section, (3) the timeliness of information available to the OB section in combat, and (4) the need for information-processing aids for the OB analyst.

Proper Role of OB

OB doctrine should be reviewed thoroughly in the light of field experience in Vietnam where the central role assigned to many OB sections for the coordination and integration of all information concerning the enemy considerably exceeded the doctrinal OB function. For example, a division OB section in Vietnam was often called on to provide the daily G2 briefing material for the CG and prepare most of the contents of INTSUMS, SITREPS and even PERINTREPS, whereas their nominal responsibility was only to provide information inputs to these products, prepare OB annexes, and issue an occasional special OB report. The degree to which these added duties were assumed varied with the unit, the G2, and the OB officer. However, the unique importance of knowledge of the enemy and his location to success in battle in Vietnam focused attention on the OB section. OB sections grew to two or three times their normal TOE strength and served as direct extensions of the Commander's and of the G2's analytical capabilities.

In viewing OB doctrine it should be remembered that the Vietnam experience represents an unconventional warfare situation and that any changes made in OB should not detract from the primary conventional warfare capability.

Wartime vs. Peacetime Role

Tactical OB has no functional peacetime role. The OB section is primarily an institutionalization of the analysis and interpretation of information about an enemy contacted in combat. Manning levels of OB sections shrink in peacetime, training is sporadic and often unrealistic, and personnel shift frequently in and out of OB sections.

Assuming that wartime OB staffing levels cannot be realistically sustained in peacetime, some mechanism is required for maintaining and formally institutionalizing an OB capability, in order to have available a corps of experienced OB analysts who can in an emergency fill this vital staff need of combat forces. If an augmentation of division G2 and S2 staffs such as BICC develops, an even greater need will arise for meaningful training of large numbers of OB analysts in a peacetime setting.

Timeliness of Information

Those aspects of intelligence collection and preliminary field processing which delay information should be examined. Available technology and management techniques should then be applied to developing methods for minimizing the time required for information to reach the OB analyst from various sources.

G2 sections in the field have traditionally needed to improvise ways to transmit information quickly from source to user. While one cannot foresee the delays inherent in every possible field situation, experience from Vietnam may suggest technical changes and management procedures to meet particular problems which arise frequently.

The potential importance to OB of pertinent information available from friendly troop and staff elements must be recognized. Access to such information may require OB personnel to establish special liaison procedures, which is clearly feasible. If the OB section is to serve as the center of information about the enemy forces, it must operate on a near real-time basis.

Information Processing Aids

The OB analyst himself needs improved information processing aids, such as automated storage and retrieval systems and computerized displays. Drudgery that claims much of the OB analyst's time and prevents him from concentrating on creative analysis impels a consideration of any possible assistance in handling and processing information. While recognizing the need for help in coping with the volume of information to be processed, many analysts are skeptical of the technical support now under development, pointing out that automation has been somewhat oversold in the past.

Storage and retrieval of information is potentially the most profitable application of automation. Automated displays for analysis and for briefings would also be useful. However, better use of what is already available arouses the greatest interest among analysts. Some OB sections in the field in Vietnam were able to forecast enemy intentions through pattern analysis with multiple overlays of enemy activity information. This improved the timeliness of analysis over the old file-card and workbook approach and permitted very rapid reproduction and transmission of information to users at all echelons. Clearly, the use of conventional techniques could be improved while looking forward to more sophisticated aids to analysis.

The findings of this survey are tentative and deserve further examination from the standpoint of doctrinal requirements and the realities of field operations. Thus, they should be regarded, not as analytically accurate, but as representing the opinions of a few highly responsible and knowledgeable individuals, whose views of OB have been heavily influenced by the Vietnam combat experience. Two points,

however, seem inescapable:

1. There is a need to study in detail the procedures followed by OB analysts in producing OB intelligence and in preparing the formal products of the OB section. An effort should be made to determine those procedures which are susceptible to standardization and to select (or develop) methodologies which are most suitable for training Intelligence/OB analysts. The minimum goal should be the achievement of a level of standardization of OB section procedures consistent with the anticipated needs of computerized support with its associated common data base and file structure.
2. A standardized definition and methodology for the estimation of Combat Effectiveness should be developed in order to permit this highly important descriptor of an enemy force's fighting potential to be estimated with confidence in combat situations.

REFERENCES

Adcock, F. E. Roman Art of War Under the Republic. New York: Barnes and Noble. 1960.

Allen, D. O. Feasibility Analysis of Order of Battle Functional Area. Bunker-Ramo Corporation report for The Computer System Command ADSAF Project, Fort Belvoir, Virginia. April 1969. CONFIDENTIAL.

Annex B (Intelligence) to TAC SOP, 9th Infantry Division. Fort Lewis, Washington. August 1973. UNCLASSIFIED.

Assistant Chief of Staff G2. Final Report of Assistant Chief of Staff G2. General Headquarters, American Expeditionary Force. 15 June 1919.

Battles and Leaders of the Civil War. Grant-Lee Edition. New York: The Century Co. 1881.

Bond/Garber. A Modern Military Dictionary. Washington, D.C.: PS Bond Publishing Co. 1942.

Bowen, R. J. Survey of military opinion on tactical Order of Battle: Supporting data and commentary. Arlington, Virginia: Bolt Beranek & Newman, Inc., consulting Research Memorandum on file with ARI. January 1974.

Bowen, R. J., Feehrer, C. E., Nickerson, R. S., and Triggs, T. G., Bolt Beranek & Newman, Inc. Computer based displays as aids in the production of Army tactical intelligence. ARI Technical Paper 258. February 1975.

Clausewitz, C. V. On War (1827). Harrisburg: Kegan Paul, Trench, Tribner & Co. 1952.

Coates, E. N. and McCourt, A. W. Analysis of Order of Battle Data Base. ARI Technical Paper, in press.

Combat Intelligence Battalion (CBTI BN), Mechanized Division - Training Text, ACN 17496, TT 30-7. USACDCINTA, Fort Holabird, Maryland. 10 August 1970. UNCLASSIFIED.

Duane, W. Military Dictionary. Philadelphia: William Duane. 1810.

Duberstein, CPT George E. Intelligence Analyst Training. Staff Study, MIOAC 68-A-2, U.S. Army Intelligence School, Fort Holabird, Maryland. August 1968. UNCLASSIFIED.

(ETO) Report of the General Board. Military Intelligence in the European Theater of Operations. United States Forces, ETO. 1945.

Farrow, E. S. A Dictionary of Military Terms. New York: Crowell, 1918.

First Submission, IBCS Division Level Definition. USACDCINTA, Fort Huachuca, Arizona. 8 June 1972. UNCLASSIFIED.

Functional Area Description for Order of Battle, Vols. I & II, Final Draft. USACDCINTA, Fort Holabird, Maryland. November 1968. CONFIDENTIAL.

Information Analysis Center (IAC), 9th Infantry Division. Fort Lewis, Washington. 1973. UNCLASSIFIED.

Instruction Folder IF 66012 (D/NRI), U.S. Army Intelligence School.
Introduction to Order of Battle and Order of Battle Factors. September 1968.

Jomini, A. H. Summary of the Art of War. Harrisburg: Military Service Publishing Co. 1952.

Koch, O. W., and Hays, R. G. G2: Intelligence for Patton. Philadelphia: Whitmore. 1971.

Military Intelligence Service in the European Theater of Operations. The General Board, United States Forces, European Theater, Study Number 12. 1946. UNCLASSIFIED.

Ney, Virgil. The Evolution of Military Unit Control - CORG M217. Combat Operations Research Group (CORG). 10 September 1965.

Organization and Operation of a Corps G-2 Section in Combat V Corps-ETO. The Intelligence School, Fort Riley, Kansas. 1946. UNCLASSIFIED.

Pershall, W. R. Enemy Order of Battle in Sixth Army, Southwest Pacific Area. The Ground General School. 1949.

Riling, J. R. Baron von Steuben and His Regulations. Philadelphia: Ray Riling Army Books Co. 1966.

Sweeney, W. C. Military Intelligence, A New Weapon in War. New York: Frederick A. Stokes. 1924.

Tactical Standard Operating Procedures, G2/BICC, Divisional Level. Extract from Plan of Test 119 of Project MASSTER. 1973. UNCLASSIFIED.

Target Development Center (TDC), 9th Infantry Division. Fort Lewis, Washington, GS Section, 9th Infantry Division. 1973. UNCLASSIFIED.

TDC Training Program, 9th Infantry Division. Fort Lewis, Washington. June 1973. UNCLASSIFIED.

The Military Intelligence Division, War Department General Staff. The Functions of the Military Intelligence Division. 1 October 1918.

Wagner, A. L. Organization and Tactics. Kansas City, Kansas: Hudson-Kimberly Publishing Co. 1894.

Wagner, A. L. The Service of Security and Information (12th Ed.). Kansas City, Kansas: Hudson-Kimberly Publishing Co. 1903.

Wilhelm, T. A Military Dictionary and Gazetteer. Philadelphia: L. R. Hammersly & Co. 1881.

Additional References

Instructional Materials, Curriculum for Order of Battle, U.S. Army Intelligence School

Field Manuals (Department of Army)

Title: Combat Intelligence
 FM 30-5 dated 1940 (initialed)
 Change 1 " 1941
 FM 30-5 " 1946
 " " " 1951
 " " " 1956
 " " " 1960
 " " " 1963
 Change 1 " 1964
 FM 30-5 " 1967
 " " " 1971
 " " " 1973 (last issue)

Title: Battle Order
 FM 30-19 dated 1952 (initialed)
 " " " 1955
 " " " 1959 (discontinued)

Title: Stability Operations-Intelligence
 FM 30-31 dated 1970
 Change 1 " 1972

Other Manuals

Training Regulations No. 210-5, "Combat Intelligence Regulations (Provisional)," 1923

Training Regulations No. 210-5, Military Intelligence, "Combat Intelligence Regulations," 1926

Basic Field Manual, Volume X, Military Intelligence, Part 1, "Combat Intelligence," 1938

APPENDIXES

Appendix	Page
A. Elements of Order Of Battle Intelligence	101
B. Format and example of Order of Battle Annex to PERINTREP (STANAG 2014, SOLOG 17R)	105
C. Examples of different approaches to the estimation of Combat Effectiveness	109
Tables: C-1. Answers to Question 9 of Fort Huachuca Survey	115
C-2. Answers to Question 6 of G3/S3:Field Commander Questionnaire	116

APPENDIX A

Section II. ELEMENTS OF ORDER OF BATTLE INTELLIGENCE**7-3. Composition**

Composition is the identification and organization of units. It applies to specific units or commands as opposed to type units.

a. Unit identification is often called the key to order of battle intelligence because it leads to the answers to many questions concerning the enemy. Unit identification consists of the complete designation of a specific unit by name or number, type, relative size or strength, and usually subordination. Through identification, the order of battle analyst is able to develop a history of the composition, training, tactics, and combat effectiveness of an enemy unit. Combined with organization, the identification of a specific unit alerts the analyst to the possible presence of other unidentified units of the same organization.

b. Organization is the structure of a unit and the relationship of the various echelons within the structure. Knowledge of the organization of a military force aid in developing accurate intelligence concerning strength, tactics, training, logistics, and combat efficiency. Enemy capabilities are difficult to assess accurately without knowledge of his current organization.

c. The basic, self-sufficient, tactical unit (in the US Army a combat division) must be considered when developing intelligence concerning composition. In some countries the field army is considered the basic, self-sufficient, tactical unit. The importance of this concept lies in the term self-sufficient. Units subordinate to self-sufficient tactical units, although capable of limited independent action, cannot sustain themselves over relatively long periods of time. They are dependent upon their self-sufficient headquarters or upon that unit which by design is self-sufficient. Subordinate units are seldom employed independently or separately from the basic, self-sufficient tactical unit. For example, a new enemy mechanized regiment is reported in the area of operations. Knowing that the mechanized division is the basic, self-sufficient, tactical unit and its three mechanized regiments are seldom employed independently, the presence not only of a new regiment but of a new mechanized division is tentatively

accepted. When one of these regiments is located it may be reasonably assumed that the remaining elements of the division are also in the area.

7-4. Disposition

Disposition consists of the location of enemy units and the manner in which these units are tactically (or administratively in times of peace) deployed. In addition, disposition includes the recent, current, and proposed (or probable) movements of enemy units.

a. Location refers to a geographical area or position occupied by a unit or units. Knowledge of the strength and location of an enemy assists the intelligence officer in determining the capabilities of this force and its effect upon the accomplishment of the mission. Data of this type are also collected during times of peace; however, knowledge of foreign military forces is severely limited due to limitations on collection elements.

b. Tactical deployment is the relative position of units with respect to one another or to the terrain. Tactical formations are designed for executing the various tactical maneuvers. If this deployment can be predetermined, it may lead to an accurate appraisal of probable enemy courses of action. The knowledge of how enemy units are echeloned may indicate (if the enemy assumes the offensive) which units will be used in the initial attack and which units will be employed in supporting and reserve roles. Tactical deployment with respect to terrain is also important. A study of dispositions, coupled with an analysis of the area of operations leads to conclusions concerning enemy capabilities, vulnerabilities, and probable courses of action.

c. Movement of enemy units is another subelement of disposition. Movement is the physical relocation of a unit from one geographical point to another. Patrol activity may be an indication of planned movement but, in itself, is not movement. Movement is significant because it automatically changes the tactical deployment of the opposing forces. When an enemy has moved, is moving, or will possibly move in the future, it may become capable of a number of actions which affect the

order of battle situation. Such a unit may be moving into an attack position, or moving to reinforce, or to replace a unit, or to perform other missions unknown to friendly forces. In view of these possibilities, movement of an enemy unit becomes important and units must be monitored at all times in order for the OB analyst to provide correct and detailed data on enemy dispositions.

7-5. Strength

The term "strength" covers the description of a unit or force in terms of men, weapons, and equipment. Information concerning strength provides the commander with an indication of enemy capabilities, and assists him in determining the probable courses of action or options open to enemy commanders. A lack of strength or a preponderance of strength has the effect of lowering or raising the estimate of the capabilities of an enemy force. Likewise, a marked concentration or buildup of units in an area gives the commander certain indications of enemy objectives and probable courses of action. During peacetime, changes in the strength of potential enemy forces are important factors which indicate the enemy's intention to wage war. Strength computations are discussed in appendix K.

7-6. Tactics

Tactics in order of battle intelligence include tactical doctrine as well as tactics employed by specific units. Tactical doctrine refers to the enemy's accepted principles of organization and employment of forces for the conduct of operations. Tactics, on the other hand, describe the manner in which the enemy conducts an operation. From a knowledge of tactical doctrine, the OB analyst knows how the enemy may employ his forces under various conditions and in certain type situations or special operations. Conventional enemy forces normally can be expected to perform according to certain patterns within the framework of tactical doctrine. There are established principles and patterns for the employment of infantry, mechanized, armor, and artillery in the offense and defense. Any predetermination of the probable patterns of employment and enemy action or reaction is extremely important in the planning phase of an operation as well as in the execution phase.

7-7. Training

Individual and unit training can significantly contribute to the combat effectiveness of any military

organization. The thoroughness, degree and quality of individual training received by the recruit, specialist, NCO, and officer are major factors in determining the overall efficiency of an armed force. Unit training, normally conducted in seasonal cycles from small unit exercises to large-scale maneuvers, is an essential part of the training necessary for a unit to operate at its full potential. Each type or phase of training accomplished by a unit adds to its capabilities and effectiveness. Therefore, the combat effectiveness of an enemy unit is more easily appraised when the degree and quality of its training are known.

7-8. Logistics

Logistics also is closely related to combat effectiveness. The adoption of a course of action is influenced by the ability of the logistical system to support that action. Knowledge of the enemy's logistics facilitates a more accurate evaluation of enemy capabilities, strength, combat efficiency, and disposition. Types of logistic information include—

- (1) All classes and types of supply.
- (2) Requirements.
- (3) Procurement.
- (4) Distribution
- (5) Transportation.
- (6) Installations.
- (7) Terminals.
- (8) Evacuation and salvage.
- (9) Maintenance.

7-9. Combat Effectiveness

Combat effectiveness is a term used to describe the abilities and fighting quality of an enemy unit. Combat effectiveness affects the capabilities of a unit or army and may be predicted by analyzing—

- a. Personnel strength.
- b. Amount and condition of weapons and equipment.
- c. Status of training.
- d. Efficiency of the officer and noncommissioned officer corps.
- e. Length of time a unit has been committed in combat.
- f. Traditions and past performance.
- g. Personality traits of the unit commander.
- h. Geographical area in which committed.

i. **Morale, health, discipline, and political reliability (or belief in the cause for which they fight).**

j. **Status of technical and logistical support of the unit.**

k. **Adequacy of military schooling at all levels.**

l. **National characteristics of the people.**

7-10. Miscellaneous Data

Miscellaneous data include various types of supporting information needed by an analyst to contribute to the development of the other order of battle elements. Miscellaneous data include basic intelligence that can be described as "know your enemy."

a. **Personality files contain information on certain characteristics and attributes which describe individual members of an enemy military force. A knowledge of personalities is important as an aid to identifying units, and, in some cases, predicting the course of action the unit will take. Personality data, therefore, is valuable because the tactics and combat efficiency of particular units are closely related to key individuals.**

b. **Unit history includes information and intelligence on component elements of a specific unit; on present and past parent units; personalities who have commanded the unit; and other details such as past performance and activities which describe, limit, or clarify the capabilities of the unit con-**

cerned. The development of unit history is important because it aids in determining the capabilities and limitations of a unit. Military or paramilitary units, like individuals, develop characteristics which distinguish them from other units. Just as they consider the various qualifications and traits of enemy personalities, order of battle personnel must also consider an enemy unit as a "personality" in analyzing its capabilities and limitations.

c. **Information on uniforms and insignia is an important part of know-your-enemy intelligence. This information assists in establishing unit identification and organization and in determining morale and esprit de corps.**

d. **Some foreign armies use systems of code numbers (and names) to conceal true designations (or affiliation) of units, field post numbers and vehicles. These code number systems, when properly analyzed, are valuable sources of information related to composition and disposition.**

e. **The order of battle analyst must be able to recognize and appreciate the capabilities and limitations of foreign weapons and equipment. Although technical intelligence agencies are primarily concerned with the determination of weapons and equipment characteristics and capabilities, the analyst uses this intelligence to analyze the effects of these items on the organization, disposition, tactics, and combat effectiveness of the military force.**

APPENDIX B

**FORMAT AND EXAMPLE OF ORDER OF BATTLE ANNEX TO PERINTREP
(STANAG 2014)**

1. Format of Order of Battle Annex

- Notes.*
1. Omit items not applicable and renumber remaining paragraphs.
 2. All entries are followed by a comment.
 3. Evaluation of source and information, including type of source, accompanies each entry.

(Classification)

ORDER OF BATTLE

Annex _____, (OB) to PERINTREP NO. _____, _____, Corps, _____

1. **COMPOSITION AND DISPOSITION** (see appendix 1, overlay). An overlay is usually attached to present the graphic display of enemy units. The initial subparagraphs always consist of identification and disposition; the remaining subparagraphs contain information pertaining to organization. Information concerning identification and disposition is listed by mentioning the highest echelons first, followed by subordinate units from left to right, or top to bottom, as displayed on the overlay. Related items may be combined and presented in a single entry.
2. **STRENGTH.** This paragraph contains information pertaining to enemy personnel, weapons, and equipment losses during the period. Replacement rates and strength figures of individual units may be listed.
3. **TACTICS.** Only new tactics and deviations from prescribed tactical doctrine are reported.
4. **TRAINING.** New development and recent changes in training programs or methods of special training undertaken by the enemy since the initiation of hostilities are reported.
5. **LOGISTICS.** Enter data concerning those items which will affect current enemy operations such as supply status, supply systems, and locations of supply facilities.
6. **COMBAT EFFECTIVENESS.** This paragraph includes data on the combat effectiveness of enemy units, either of the entire force or of a major tactical unit. Items indicating morale, esprit, quality of troops and commanders are listed. The ability of the enemy unit to accomplish its expected mission is expressed.

(Classification)

(Classification)

7. MISCELLANEOUS DATA. Personalities, unit history, field post numbers (FPO), code numbers and names, order of battle changes, and any other item of order of battle intelligence that cannot be properly inserted in preceding paragraphs are listed.

Acknowledge.

(SIGNATURE)

Appendixes:

Distribution:

OFFICIAL

(NAME OF G2)

2. Example of Order of Battle Annex

Annex E (OB) to PERINTREP 29, 3 Corps, 201800 August 19_____

ORDER OF BATTLE

1. COMPOSITION AND DISPOSITION (see appendix 1, Overlay).

a. All PW captured during period are from Aggressor 2d Combined Arms Army. Unit identification include: (C-1)

<u>17 Mech Div</u>	<u>30 Mech Div</u>	<u>32 Mech Div</u>
282 Mech Regt	141 Mech Regt	132d Mdm Tk Regt
290 Mech Regt	142 Mech Regt	
	130 Mdm Tk Regt	
	130 Recon Bn	

COMMENT: 32 Mech Div accepted as being organic to 2d CAA. 52 Tk Div previously accepted, completing organization of 2d CAA.

b. Two large missile-type weapons mounted on large amphibious armored carriers and several smaller vehicles identified in position vic MP 420513. (B-2)

COMMENT: Probably elements of Free Rocket Regt, 2d CAA, previously unlocated.

c. Captured Aggressor field order reveals plan to attach 40 TK Div to 2d CAA effective 22 Aug. (B-1)

COMMENT: PW previously reported 40th Tk Div moving to reinforce 2d CAA. Aggressor main effort probably planned for this area.

2. STRENGTH.

En losses reported during period:

	<u>PW</u>	<u>KIA</u>	<u>ARTY</u>	<u>ARMOR</u>	<u>AIR</u>	<u>VEH</u>
16 Mech Div	37	302	2	4	1	21
30 Mech Div	16	52	8	1	—	16
32 Mech Div	8	12	—	—	—	4
Total III US Corps Sector	61	366	10	5	1	41

COMMENT: The marked increase in personnel losses during the period have been sustained primarily by Aggressor combat patrols. Aircraft loss was H1, Observation Helicopter equipped with AERO radar. Overall strength of 2d CAA is generally not affected.

(Classification)

(Classification)

3. TACTICS.

a. PW from 16 Mech Div and 30 Mech Div state they have been instructed in the event their units are cut off to continue fighting as guerrilla units or in small groups, live off the land, and destroy as much US Army property as possible before gradually infiltrating back to friendly lines. (C-6)

COMMENT: Intensive guerrilla activity in our rear areas can be expected if elements of these units are cut off.

b. Enemy documents captured 07 Aug included a training pamphlet for battalion, company and platoon commanders, written by G/D GRIBOY-EDOV entitled "Tanks Out Front," (appendix 3). It advocates tactics permitting US patrols and advancing forces to pass through Aggressor lines. A coordinated tank-infantry attack is then made on open flanks and rear elements with tanks continuing momentum of attack to destroy remaining US forces. (B-2)

COMMENT: Considering Aggressor doctrine that tanks are the decisive arm, the above tactic is possible, particularly in view of reports of probable employment of 40 Tk Div (para 1).

4. TRAINING.

a. Reference paragraph 3b.

b. Indications of Aggressor concern for COMSEC is noted in document captured from 2d CAA dated 10 Aug, directing all subordinate units to immediately initiate intensive training in radio security and communications procedures. (B-2)

COMMENT: ASA confirms Aggressor lack of radio discipline and states that security violations increase during reinforcement and relief operations. Numerous Aggressor security violations have been noted since 17 Aug, further substantiating reinforcement or relief of 2d CAA units.

5. LOGISTICS.

a. PW state Aggressor supply personnel have recently contacted local merchants, farmers, and fishermen for supplies of most Class I items. (C-6)

COMMENT: Aggressor either has critical shortage of Class I items or has a bottleneck in the supply system requiring local procurement of Class I items.

b. Air and ground reconnaissance patrols have reported Aggressor stockpiling large quantities of supplies and equipment in rear areas of frontline divisions. (B-2)

COMMENT: Not normal supply procedures. Significance as yet undetermined. Would indicate Aggressor may be planning major offensive soon.

6. COMBAT EFFECTIVENESS.

a. PW from 16 Mech Div and 30 Mech Div state morale is high but senior officers are disgruntled because their units always receive difficult missions while the 32 Mech Div and 56 Tk Div have, until recently, been assigned less hazardous missions. (F-6)

(Classification)

(Classification)

COMMENT: Analysis of unit history, and recent operations of Aggressor 2d CAA indicates it has usually been highly successful in combat. This, and the fact that 2d CAA has always had fine commanders, would account for high morale in units. This is first indication of dissatisfaction among officer personnel. Report seems cogent, however, since 32 Mech Div has not been engaged in combat with US Forces in this campaign.

b. PW reports 30 Mech Div to be redesignated 30 "Fusilier" Mech Div for superior combat record. (F-6)

COMMENT: III US Corps rates combat effectiveness of 30 Mech Div from excellent to outstanding in comparison to other Aggressor divisions in same sector. 30 Mech Div casualties have been comparatively small; no deserters have been apprehended and its operations have been executed with determination.

7. MISCELLANEOUS DATA.

a. Personalities Identified by PW: (C-1)

CG, 40th Tk Div	G/D GRIBOYEDOV, Semyon P. (Ref 3b)
CO, 282 Mech Regt	Col CARDUCCI, Gherardo S.
CO, 283 Mech Regt	Col UNSET, Bjornstjerne (Acting CO)
CO, 130 Mdm Tk Regt	Col STEENWYK, Martin J.
CO, 132 Mdm Tk Regt	Col Mattea, Mario

COMMENT: Confirms previously obtained information.

b. Unit History: Officer PW stated his unit (32 Mech Div) trained extensively during 1965 and 1966 in special tactics for assault of river lines. (F-6)

COMMENT: Special training received by 32 Mech Div should increase its overall effectiveness when employed in river-crossing operations. No evidence of other units so trained.

c. Field Post Numbers: Captured document reveals Aggressor field post numbers being used as identification symbols on documents and messages. First two and last three digits are transposed. Field post number of 46 Mech Div will appear as 75031 instead of 31750. (B-1)

COMMENT: Aggressor has employed this system previously as a security measure. Expect this system of transposing digits will occur in different patterns during future operations.

Acknowledge.

LEE
LTG

Appendixes: 1-En Disp Overlay
2-Aggressor Army Org Chart
3-Aggressor Training Pamphlet

Distribution: Same as PERINTREP 29

OFFICIAL
GRANT
G2

Note: In joint service operations, the Order of Battle Annex to the PERINTREP will be replaced by the Order of Battle Annex to the PERINTSUM as contained in Chapter V, JCS Publication 12.

(Classification)

APPENDIX C

EXAMPLES OF DIFFERENT APPROACHES TO THE ESTIMATION OF COMBAT EFFECTIVENESS

Of all the OB factors, Combat Effectiveness is subject to the widest range of interpretation by experienced military personnel. Each individual has his own personal approach to its estimation, an approach that generally bears little resemblance to the doctrinal definition of Combat Effectiveness contained in FM 30-5.¹ Many, despairing of being able to obtain sufficient information on which to base a really valid appraisal of an enemy force's fighting capabilities, fall back upon a superficial numerical approach, such as equating enemy percent of TOE Strength to his Combat Effectiveness. While thoughtful military analysts generally deplore this practice, it occurred frequently in division G2 sections in Vietnam.

Estimation of Combat Effectiveness in the field is examined by presenting a few actual examples from the literature and interviews of this survey. In this way, certain common practices or favored approaches can serve as a basis for further analysis.

A starting point is an example from Vietnam, about 1966, which involves an estimate by Combined Intelligence Center Vietnam (CICV) of the relative Combat Effectiveness of the VC and the NVA.² The official list of Combat Effectiveness elements from FM 30-5, which has been the standard since 1959, can be compared with the list of elements used by CICV.

ELEMENTS OF COMBAT EFFECTIVENESS

FM 30-5

Personnel Strength
Amount and Condition of Weapons and Equipment
Status of Training
Efficiency of Officer/NCO's
Time Unit in Combat
Traditions and Past Performance
Personality of CO
Geographic Area of Commitment
Morale, Health, Discipline, Politics
Status of Technical and Logistical Support
Adequacy of Military Schooling at all Levels
National Characteristics

CICV

Personnel Strength
Weapons and Equipment
Training
Tactics
Leadership
Morale
Logistics
National Characteristics

¹ FM 30-5, Combat Intelligence, Department of the Army, October 1973.

² Combat Effectiveness: VC vs NVA. Order of Battle Study 66-54, Combined Intelligence Center Vietnam, 2 June 1966.

Despite considerable similarity between the two sets of elements, there are significant differences, such as the inclusion of Tactics on the CICV list. There are probably also differences in the way that the various elements are actually estimated. Thus, newspapers have reported extensive discussions of the basically different ways in which major U.S. intelligence agencies have estimated enemy Strength in Vietnam. 3.4

Brig. Gen. Oscar W. Koch, G2 to General Patton in World War II, has discussed in some detail the difficulty that he encountered in estimating German unit Combat Effectiveness during Third Army's push beyond the Rhine.⁵ His situation map usually carried so many fragmentary divisional identifications that it was impossible to judge the actual fighting capabilities of the forces facing Third Army. His solution was to estimate the number of effective maneuver battalions and to report this as the enemy Combat Effectiveness. Several persons interviewed in the present study have indicated their preference for this approach even in a relatively stable situation, since it permits the analysts (and the commander) to get a picture of the maneuver possibilities open to the enemy commander. This is not possible with mere Strength estimates.

Another approach was being advocated in training material of the U.S. Army Intelligence School in 1966.⁶ Noting the limited value of Combat Effectiveness expressed in terms of a percentage, they recommended the listing of enemy force strengths and weaknesses as a basis for the estimation of his Combat Effectiveness. Incidentally, they also indicated that the list of Combat Effectiveness elements presented in

³The Washington Post, 7 and 8 March, 1973.

⁴New York Times, 7 and 8 March, 1973

⁵Koch, O. W., and Hays, R. G. G-2: Intelligence for Patton. Philadelphia: Whitmore, 1971.

⁶Order of Battle Tactics and Combat Efficiency Exercise. IF 67150, U.S. Army Intelligence School, Fort Holabird, Maryland, December 1966.

FM 30-5 should not be considered all-inclusive. Although FM 30-5 is currently considered the official doctrine of AICS, the Order of Battle Card (STANAG 2078) used at the school today treats Combat Effectiveness in terms of strengths and weaknesses.⁷

In recognition of the importance of being able to make accurate assessments of enemy Combat Effectiveness, investigations of the problem have been in progress since the early 1960's under the sponsorship of DCSOPS, first at the Army Institute of Advanced Studies (IAS) and, later, at the Strategy and Tactics Analysis Group (STAG) (now the Concepts Analysis Agency--CAA). The immediate purpose of the research has been to support war gaming. The work at IAS attempted to use five factors: Firepower; Mobility; Command, Control and Communications; Logistics; and Intelligence. They restricted consideration to only these factors and attempted to estimate the relative Combat Effectiveness of two opposing forces in terms of ratios of powers of the five factors.⁸ This approach has been abandoned and subsequent efforts at STAG/CAA have concentrated on the estimation of enemy firepower potential scores (FPP's) based on numbers and characteristics of weapons in lieu of Combat Effectiveness.⁹ The technique has been refined to a high degree through their Weapons Effectiveness Index - Weapons Utility Value (WEI/WUV) concept and research is still in progress to find a better methodology. While STAG/CAA admit the undesirability of basing Combat Effectiveness completely on firepower, no better methodology is available. Related conceptual work on Combat Effectiveness, carried out under the auspices of U.S. Army Combat Developments Command and reported in 1967, focused on the factors of firepower potential and weapon battlefield mobility.¹⁰ It is clear from these examples that there remains a requirement for the development of a valid means for the estimation of Combat Effectiveness.

An interesting recent study¹¹ presents a methodology for the analysis of historical battle data by estimating the relative "combat power" of opposing military forces in terms of all attendant circumstances and

⁷ Order of Battle Card (STANAG). USAINTS Form 52, Revised 1 April 1968.

⁸ Assessment of Combat Effectiveness, Part II. Final Report, Institute of Advanced Studies, Carlisle Barracks, Pennsylvania, United States Army Combat Developments Command, 1 December 1966.

⁹ Basic FPP Briefing. U.S. Army Strategy and Tactics Analysis Group (STAG), Bethesda, Maryland (now Concepts Analysis Agency), February 1973.

¹⁰ Behrns, V. N. and Backus, G. R. Measuring Combat Effectiveness, Vol. IV, Firepower/Mobility Measures. Combat Operations Research Group (CORG) Memorandum, CORG-M-272, August 1967 (SECRET).

¹¹ Dupuy, COL. T. N. The Quantified Judgment Method of Analysis of Historical Combat Data. 3 May 1972 (unpublished study).

force characteristics. Detailed analysis of some 60 engagements in the Italian Campaign in World War II is claimed to predict the outcome with more than 90 percent success. The method correlates battle outcome with weapons effectiveness, force strength, and operational variables to arrive at a means of estimating relative combat power. It is a rational approach to the historical analysis of engagements which could illuminate certain aspects of the Combat Effectiveness estimation problem. However, the difficulty of obtaining reliable estimates of the kind of data needed to apply it as an OB estimation tool makes it of more academic than practical interest at the present time, although a sensitivity analysis of this multivariable system might provide some idea of its ability to tolerate the kind of limited-reliability data which one encounters in a field situation.

Some OB sections have attempted to reduce the estimation of Combat Effectiveness to a standardized procedure and formula. Such a methodology is suggested in the current Procedures for Internal Operations of the Analysis and Production Section of the First Infantry Division, Fort Riley, Kansas. Their recommended initial approach for the evaluation of the elements of Combat Effectiveness employs a 300-point rating scheme:

I. Past Performance

- a. Training (0-30 points)
- b. Combat Experience (0-40 points)
- c. Unit Esprit-de-Corps and Leadership (0-30 points)

II. Physical Resources

- a. Personnel Strength (0-40 points)
- b. Weapons and Equipment (0-30 points)
- c. Logistical Support (0-30 points)

III. Psychological Conditioning

- a. Fighting in Defense of Homeland or For Cause (0-50 points)
- b. Leadership and Esprit-de-Corps (0-30 points)
- c. Attitude and Characteristics of the people (0-20 points)

In using the above formula, the analyst must make subjective judgments concerning the status of each factor. A unit with a rating of 200-300 points should be rated as Category I, one with 100-200 points, Category II, and one with less than 100 points, Category III, or "combat ineffective." It is assumed that a complete lack of any of the elements of the Physical Resources sector would be sufficient to merit a rating of "combat ineffective." It should be emphasized that the proponents of this approach are fully aware of its potential limitations and recommend that it be employed with judgment and discretion.

The OB Section of the 82d Airborne Division, at Fort Bragg, North Carolina, made a number of suggestions concerning Combat Effectiveness when reviewing the most recent edition of FM 30-5. It was recommended that the following computer-oriented enemy unit combat readiness rating be established:

- C-1 - Combat Effective
- C-2 - Marginally Combat Effective
- C-3 - Limited Combat Effective
- C-4 - Non-Effective

where,

C-1 is defined as any unit or force at 80-100% TOE in a high state of morale and intensely trained.

C-2 is defined as any unit or force at 70-80% TOE, with an acceptable state of morale and marginally trained in offensive/defensive tactics.

C-3 is defined as any unit or force at 50-70% TOE with poor morale and/or only partially trained in offensive/defensive tactics.

C-4 is defined as any unit or force below 50% TOE and lacking a ratable degree of training. Under these conditions morale is not deemed a factor for consideration.

The above ratings do not take into consideration unit leadership but acknowledge that it is an extremely important factor. Thus, the two lower ratings might reflect poor leadership, but might also imply either a unit buildup or, after repeated engagements in wartime, combat ineffectiveness due to losses.

It was noted that the above ratings generally applied to conventional warfare, and the following supplemental nuclear capability ratings also were suggested:

- N-1 - Possesses Strategic and/or Tactical Nuclear Weapons
- N-2 - Possesses Tactical Nuclear Weapons
- N-3 - Maintains a Nuclear Weapons Delivery Capability but Probably Not a Nuclear Weapons Inventory
- N-4 - Unit Is Nuclear Non-Capable or Is Not a Nuclear Threat

A third example is to be found in the procedures under consideration by a senior military intelligence activity responsible for both strategic and tactical evaluations of enemy forces. This group acknowledges the great complexity of the concept of Combat Effectiveness and singles out the following factors as having particular significance for its estimation (in the order of their assumed relative importance):

1. Character and Personality of the Commander
2. Quality of Leadership at All Levels
3. Morale, Discipline and Personal Traits of Troops

4. Unit Mission
5. Command and Control Institutions and Procedures
6. Quality of Training
7. Quality and Quantity of Equipment
8. Logistic Support
9. Size and Strength of the Unit

There is no certainty that a consensus can be achieved concerning the relative importance of any of the above elements, since they clearly would have different weights in different circumstances. It was noted that an absolute deficiency in even the least important factor could render a unit useless for combat. It is also assumed that Factors 1-6 and 8 would probably be unknown in any real situation, making it necessary to rely on Factors 7 and 9 for estimative purposes.

The methodology assigns weights to Factors 7 and 9 in the following manner. The score for Trained Manpower (Factor 9) is estimated on the basis of one point for each one-tenth of unit strength, to give a maximum of ten points. Combat Equipment (Factor 7) is estimated by allocating the percentage of nominal firepower potential present in terms of tanks, artillery, and APC's for the particular type of unit under consideration, and expressing the total potential on a scale with a norm of ten points. The artillery score is based on the theoretical weight of HE in pounds per minute which could be delivered by the unit's weapons of larger than 100mm. All other equipment is compared on the basis of numbers held. The overall score is obtained by multiplying the Trained Manpower score by the Combat Equipment score; a standard unit would score 100. The method seems to be more appropriate for strategic intelligence than for tactical intelligence.

A final example consists of the wide variety of means suggested by the 14 subjects of the Fort Huachuca interview program and the first 13 respondents to the G3/S3 - Field Commander Questionnaire from the Army War College. These are summarized in Tables C-1 and C-2, respectively. There, one can see the range of factors regarded by experienced personnel as important for the estimation of Combat Effectiveness. About the only common items are Strength and Morale. However, the total number of items mentioned is not so great as to preclude the possible development of sets of indicators for use with a functional diagram for the estimation of Combat Effectiveness.

Despite the many approaches to estimating Combat Effectiveness, methods can be resolved into the following categories:

- A percentage of a norm.
- A listing of effective enemy maneuver elements present.
- A listing of enemy force strengths and weaknesses.
- Various lists of key enemy characteristics.

A functional diagram (or checklist) showing the status of all factors affecting Combat Effectiveness.

A narrative description of the characteristics of the opposing force and its tactical setting, including the status of all internal and external factors bearing on Combat Effectiveness.

Respondents expressed considerable interest in these last two approaches, particularly the narrative description. Indicating the importance that they attach to Combat Effectiveness estimation, many stated that they would want "all of the above, plus anything else one can think of" as a means of reporting this factor to the commander.

Table C-1

ANSWERS TO QUESTION 9 OF FORT HUACHUCA SURVEY

Subject	Factors Cited
1	Composition, Disposition, Strength
2	Composition, Disposition, Strength
3	Training
4	Well-trained Replacements
5	Composition, Disposition, Strength
6	Motivation might be strongest (see also answer to Question 8)
7	Ability of Commander (Strength, which is used most often, is not necessarily right)
8	Strength
9	Strength, Morale, Status of Equipment, Adequate Resupply
10	Strength, Logistics, Composition
11	Ability to Fight (Status of Training)
12	Weapons and Equipment, Strength, Personnel
13	Disposition, Strength
14	Strength

Note. Question 9: Which of the factors making up Combat Effectiveness do you consider to be most important?

Table C-2

ANSWERS TO QUESTION 6 OF G3/S3:FIELD COMMANDER QUESTIONNAIRE

Subject 1

Leadership
 Personnel Strength
 Training and Experience
 in Area
 Equipment Strength
 Supply

Subject 2

Strength
 Experience
 Leadership
 Morale
 Discipline
 Firepower
 Mobility
 Logistics

Subject 3

Strength
 Training/Experience
 Morale
 Esprit

Subject 4

(No answer)

Subject 5

The five factors stated.*

Subject 6

Force Size	Arms
Strength	Morale
Leadership	Combat Exposure
Configuration	Time on Line
Equipment	Logistics Backup

Subject 7

Strength
 Equipment (fire-
 power, mobil-
 ity, etc.)
 Motivation (morale)
 and esprit)
 Geographical
 Advantages
 Command and Con-
 trol System

Subject 8

The Result

Subject 9

Physical and Men-
 tal Condition
 Supply and Re-
 supply Capa-
 bility
 Recent Record
 Combat Record
 Strength (manpower)
 Intelligence Capa-
 bility
 Equipment Status Habits
 Anything Else We
 Can Find Out

Subject 10

Strength
 Weapons, Equipment
 and Munitions
 Morale
 Leadership
 Mobility (depending on circumstances)

Subject 11

CCC
 Strength (personnel)
 Combat Experience
 Training
 Firepower (relative)
 Mobility
 Logistics
 Morale

Subject 12

In addition to the
 five factors:^a
 Strength
 Intelligence
 Capability
 Mobility
 Experience

Subject 13

Leadership
 Strength
 Training
 Combat Experience
 Leadership
 Morale/Esprit

* Firepower, CCC, Mobility, Intelligence and Logistics capabilities

Note. Question 6: What factors do you consider to be the most important in estimating combat effectiveness?

References

Assessment of Combat Effectiveness, Part II, Final Report, Institute of Advanced Studies, Carlisle Barracks, Pennsylvania, United States Army Combat Developments Command, 1 December 1966.

Basic FPP Briefing, U.S. Army Strategy and Tactics Analysis Group (STAG), Bethesda, Maryland, (now Concepts Analysis Agency), February 1973.

Behrns, V.N. and Backus, G.R., Measuring Combat Effectiveness, Vol. IV, Firepower/Mobility Measures, Combat Operations Research Group (CORG) Memorandum, CORG-M-272, August 1967 (SECRET). ✓

Combat Effectiveness: VC vs NVA, Order of Battle Study 66-54, Combined Intelligence Center Vietnam, 2 June 1966.

Dupuy, Col. T.N., The Quantified Judgement Method of Analysis of Historical Combat Data, 3 May 1972 (unpublished study).

FM 30-5, Combat Intelligence, Department of the Army, October 1973.

Koch, O. W., and Hays, R. G. G-2: Intelligence for Patton. Philadelphia: Whitmore, 1971.

New York Times, 7 and 8 March, 1973.

Order of Battle Card (STANAG), USAINiS Form 52, Revised 1 April 1968.

Order of Battle Tactics and Combat Efficiency Exercise, IF 67150, U.S. Army Intelligence School, Fort Holabird, Maryland, December 1966.

The Washington Post, 7 and 8 March, 1973.

DISTRIBUTION

ARI Distribution List

- 4 OASD (M&RA)
- 2 HQDA (DAMI-CSZ)
- 1 HQDA (DAPE-PBR)
- 1 HQDA (DAMA-AR)
- 1 HQDA (DAPE-HRE-PO)
- 1 HQDA (SGRD-ID)
- 1 HQDA (DAMI-DOT-C)
- 1 HQDA (DAPC-PMZ-A)
- 1 HQDA (DACH-PPZ-A)
- 1 HQDA (DAPE-HRE)
- 1 HQDA (DAPE-MPO-C)
- 1 HQDA (DAPE-DW)
- 1 HQDA (DAPE-HRL)
- 1 HQDA (DAPE-CPS)
- 1 HQDA (DAFD-MFA)
- 1 HQDA (DARD-ARS-P)
- 1 HQDA (DAPC-PAS-A)
- 1 HQDA (DUSA-OR)
- 1 HQDA (DAMO-ROR)
- 1 HQDA (DASG)
- 1 HQDA (DAGFI)
- 1 Chief, Consult Div (DA-OTSG), Adelphi, MD
- 1 Mil Asst. Hum Res, ODDR&E, OAD (E&LS)
- 1 HQ USARAL, APO Seattle, ATTN: ARAGP-R
- 1 HQ First Army, ATTN: AFKA-OI-TI
- 2 HQ Fifth Army, Ft Sam Houston
- 1 Dir, Army Stf Studies Ofc, ATTN: OAVCSA (DSP)
- 1 Ofc Chief of Stf, Studies Ofc
- 1 DCSPER, ATTN: CPS/OCF
- 1 The Army Lib, Pentagon, ATTN: RSB Chief
- 1 The Army Lib, Pentagon, ATTN: ANRAL
- 1 Ofc, Asst Sect of the Army (R&D)
- 1 Tech Support Ofc, OJCS
- 1 USASA, Arlington, ATTN: IARD-T
- 1 USA Resch Ofc, Durham, ATTN: Life Sciences Dir
- 2 USARIEM, Natick, ATTN: SGRD-UE-CA
- 1 USATTC, Ft Clayton, ATTN: STETC-MO-A
- 1 USAIMA, Ft Bragg, ATTN: ATSU-CTD-OM
- 1 USAIMA, Ft Bragg, ATTN: Marquet Lib
- 1 US WAC Ctr & Sch, Ft McClellan, ATTN: Lib
- 1 US WAC Ctr & Sch, Ft McClellan, ATTN: Tng Dir
- 1 USA Quartermaster Sch, Ft Lee, ATTN: ATSM-TE
- 1 Intelligence Material Dev Ofc, EWL, Ft Holabird
- 1 USA SE Signal Sch, Ft Gordon, ATTN: ATSO-EA
- 1 USA Chaplain Ctr & Sch, Ft Hamilton, ATTN: ATSC-TE-RD
- 1 USATSCH, Ft Eustis, ATTN: Educ Advisor
- 1 USA War College, Carlisle Barracks, ATTN: Lib
- 2 WRAIR, Neuropsychiatry Div
- 1 DLI, SDA, Monterey
- 1 USA Concept Anal Agcy, Bethesda, ATTN: MOCA-WGC
- 1 USA Concept Anal Agcy, Bethesda, ATTN: MOCA-MR
- 1 USA Concept Anal Agcy, Bethesda, ATTN: MOCA-JF
- 1 USA Artic Test Ctr, APO Seattle, ATTN: STEAC-MO-ASL
- 1 USA Artic Test Ctr, APO Seattle, ATTN: AMSTE-PL-TS
- 1 USA Armament Cmd, Redstone Arsenal, ATTN: ATSK-TEM
- 1 USA Armament Cmd, Rock Island, ATTN: AMSAR-TDC
- 1 FAA-NAFEC, Atlantic City, ATTN: Library
- 1 FAA-NAFEC, Atlantic City, ATTN: Hum Engr Br
- 1 FAA Aeronautical Ctr, Oklahoma City, ATTN: AAC-44D
- 2 USA Fid Arty Sch, Ft Sill, ATTN: Library
- 1 USA Armor Sch, Ft Knox, ATTN: Library
- 1 USA Armor Sch, Ft Knox, ATTN: ATSB-DI-E
- 1 USA Armor Sch, Ft Knox, ATTN: ATSB-DT-TP
- 1 USA Armor Sch, Ft Knox, ATTN: ATSB-CD-AD
- 2 HOUSACDEC, Ft Ord, ATTN: Library
- 1 HOUSACDEC, Ft Ord, ATTN: ATEC-EX-E-Hum Factors
- 2 USAEEC, Ft Benjamin Harrison, ATTN: Library
- 1 USAPACDC, Ft Benjamin Harrison, ATTN: ATCP-HR
- 1 USA Comm-Elect Sch, Ft Monmouth, ATTN: ATSN-EA
- 1 USAEC, Ft Monmouth, ATTN: AMSEL-CT-HDP
- 1 USAEC, Ft Monmouth, ATTN: AMSEL-PA-P
- 1 USAEC, Ft Monmouth, ATTN: AMSEL-SI-CB
- 1 USAEC, Ft Monmouth, ATTN: C, Fac Dev Br
- 1 USA Mater's Sys Anal Agcy, Aberdeen, ATTN: AMXSY-P
- 1 Edgewood Arsenal, Aberdeen, ATTN: SAREA-BL-H
- 1 USA Ord Ctr & Sch, Aberdeen, ATTN: ATSL-TEM-C
- 2 USA Hum Engr Lab, Aberdeen, ATTN: Library/Dir
- 1 USA Combat Arms Tng Bd, Ft Benning, ATTN: Ad Supervisor
- 1 USA Infantry Hum Resch Unit, Ft Benning, ATTN: Chief
- 1 USA Infantry Bd, Ft Benning, ATTN: STEBC-TE-T
- 1 USASMA, Ft Bliss, ATTN: ATSS-LRC
- 1 USA Air Def Sch, Ft Bliss, ATTN: ATSA-CTD-ME
- 1 USA Air Def Sch, Ft Bliss, ATTN: Tech Lib
- 1 USA Air Def Bd, Ft Bliss, ATTN: FILES
- 1 USA Air Def Bd, Ft Bliss, ATTN: STEBD-PO
- 1 USA Cmd & General Stf College, Ft Leavenworth, ATTN: Lib
- 1 USA Cmd & General Stf College, Ft Leavenworth, ATTN: ATSW-SE-L
- 1 USA Cmd & General Stf College, Ft Leavenworth, ATTN: Ed Advisor
- 1 USA Combined Arms Cmbt Dev Act, Ft Leavenworth, ATTN: Dep Cdr
- 1 USA Combined Arms Cmbt Dev Act, Ft Leavenworth, ATTN: CCS
- 1 USA Combined Arms Cmbt Dev Act, Ft Leavenworth, ATTN: ATCASA
- 1 USA Combined Arms Cmbt Dev Act, Ft Leavenworth, ATTN: ATCACO-E
- 1 USA Combined Arms Cmbt Dev Act, Ft Leavenworth, ATTN: ATCACO-CI
- 1 USAECOM, Night Vision Lab, Ft Belvoir, ATTN: AMSEL-NV-SD
- 3 USA Computer Sys Cmd, Ft Belvoir, ATTN: Tech Library
- 1 USAMERDC, Ft Belvoir, ATTN: STSFB-DQ
- 1 USA Eng Sch, Ft Belvoir, ATTN: Library
- 1 USA Topographic Lab, Ft Belvoir, ATTN: ETL-TD-S
- 1 USA Topographic Lab, Ft Belvoir, ATTN: STINFO Center
- 1 USA Topographic Lab, Ft Belvoir, ATTN: ETL-GSL
- 1 USA Intelligence Ctr & Sch, Ft Huachuca, ATTN: CTD-MS
- 1 USA Intelligence Ctr & Sch, Ft Huachuca, ATTN: ATS-CTD-MS
- 1 USA Intelligence Ctr & Sch, Ft Huachuca, ATTN: ATSI-TE
- 1 USA Intelligence Ctr & Sch, Ft Huachuca, ATTN: ATSI-TEX-GS
- 1 USA Intelligence Ctr & Sch, Ft Huachuca, ATTN: ATSI-CTS-OR
- 1 USA Intelligence Ctr & Sch, Ft Huachuca, ATTN: ATSI-CTD-DT
- 1 USA Intelligence Ctr & Sch, Ft Huachuca, ATTN: ATSI-CTD-CS
- 1 USA Intelligence Ctr & Sch, Ft Huachuca, ATTN: DAS/SRD
- 1 USA Intelligence Ctr & Sch, Ft Huachuca, ATTN: ATSI-TEM
- 1 USA Intelligence Ctr & Sch, Ft Huachuca, ATTN: Library
- 1 CDR, HQ Ft Huachuca, ATTN: Tech Ref Div
- 2 CDR, USA Electronic Prvg Grd, ATTN: STEEP-MT-S
- 1 CDR, Project MASSTER, ATTN: Tech Info Center
- 1 Hq MASSTER, USATRADO, LNO
- 1 Research Institute, HQ MASSTER, Ft Hood
- 1 USA Recruiting Cmd, Ft Sheridan, ATTN: USARCPM-P
- 1 Senior Army Adv., USAFAGOD/TAC, Elgin AF Aux Fid No. 9
- 1 HQ USARPAC, DCSPER, APO SF 96568, ATTN: GPPE-SE
- 1 Stimson Lib, Academy of Health Sciences, Ft Sam Houston
- 1 Marine Corps Inst., ATTN: Dean-MCI
- 1 HOUSMC, Commandant, ATTN: Code MTMT 51
- 1 HOUSMC, Commandant, ATTN: Code MPI-20
- 2 USCG Academy, New London, ATTN: Admission
- 2 USCG Academy, New London, ATTN: Library
- 1 USCG Training Ctr, NY, ATTN: CO
- 1 USCG Training Ctr, NY, ATTN: Educ Svc Ofc
- 1 USCG, Psychol Res Br, DC, ATTN: GP 1/82
- 1 HQ Mid-Range Br, MC Det, Quantico, ATTN: P&S Div

1 US Marine Corps Liaison Ofc, AMC, Alexandria, ATTN: AMCGS-F
 1 USATRADO, Ft Monroe, ATTN: ATRO-ED
 6 USATRADO, Ft Monroe, ATTN: ATRP-AD
 1 USATRADO, Ft Monroe, ATTN: ATTS-EA
 1 USA Forces Cmd, Ft McPherson, ATTN: Library
 2 USA Aviation Test Bd, Ft Rucker, ATTN: STEBG-PO
 1 USA Agcy for Aviation Safety, Ft Rucker, ATTN: Library
 1 USA Agcy for Aviation Safety, Ft Rucker, ATTN: Educ Advisor
 1 USA Aviation Sch, Ft Rucker, ATTN: PO Drawer O
 1 HOUSA Aviation Sys Cmd, St Louis, ATTN: AMSAV-ZDR
 2 USA Aviation Sys Test Act., Edwards AFB, ATTN: SAVTE-T
 1 USA Air Def Sch, Ft Bliss, ATTN: ATSA TEM
 1 USA Air Mobility Resch & Dev Lab, Haffetz Fld, ATTN: SAVDL-AS
 1 USA Aviation Sch, Res Tng Mgt, Ft Rucker, ATTN: ATST-T-RTM
 1 USA Aviation Sch, CO, Ft Rucker, ATTN: ATST-D-A
 1 HQ, USAMC, Alexandria, ATTN: AMXCD-TL
 1 HQ, USAMC, Alexandria, ATTN: CDR
 1 US Military Academy, West Point, ATTN: Serials Unit
 1 US Military Academy, West Point, ATTN: Ofc of Milt Ldrshp
 1 US Military Academy, West Point, ATTN: MAOR
 1 USA Standardization Gp, UK, FPO NY, ATTN: MASE-GC
 1 Ofc of Naval Resch, Arlington, ATTN: Code 452
 3 Ofc of Naval Resch, Arlington, ATTN: Code 458
 1 Ofc of Naval Resch, Arlington, ATTN: Code 450
 1 Ofc of Naval Resch, Arlington, ATTN: Code 441
 1 Naval Aerosp Med Res Lab, Pensacola, ATTN: Acous Sch Div
 1 Naval Aerosp Med Res Lab, Pensacola, ATTN: Code L51
 1 Naval Aerosp Med Res Lab, Pensacola, ATTN: Code L5
 1 Chief of NavPers, ATTN: Pers-OR
 1 NAVAIRSTA, Norfolk, ATTN: Safety Ctr
 1 Nav Oceanographic, DC, ATTN: Code 6251, Charts & Tech
 1 Center of Naval Anal, ATTN: Doc Ctr
 1 NavAirSysCom, ATTN: AIR-5313C
 1 Nav BuMed, ATTN: 713
 1 NavHelicopterSubSqs 2, FPO SF 98601
 1 AFHRL (FT) William AFB
 1 AFHRL (TT) Lowry AFB
 1 AFHRL (AS) WPAFB, OH
 2 AFHRL (DOJZ) Brooks AFB
 1 AFHRL (DOJN) Lackland AFB
 1 HOUAF (INYSO)
 1 HOUAF (DPXXA)
 1 AFVTG (RD) Randolph AFB
 3 AMRL (HE) WPAFB, OH
 2 AF Inst of Tech, WPAFB, OH, ATTN: ENE/SL
 1 ATC (XPTD) Randolph AFB
 1 USAF AeroMed Lib, Brooks AFB (SUL-4), ATTN: DOC SEC
 1 AFOSR (NL), Arlington
 1 AF Log Cmd, McClellan AFB, ATTN: ALC/DPCRB
 1 Air Force Academy, CO, ATTN: Dept of Bel Scn
 5 NavPers & Dev Ctr, San Diego
 2 Navy Med Neuropsychiatric Resch Unit, San Diego
 1 Nav Electronic Lab, San Diego, ATTN: Res Lab
 1 Nav TrngCen, San Diego, ATTN: Code 9000-Lib
 1 NavPostGraSch, Monterey, ATTN: Code 55Aa
 1 NavPostGraSch, Monterey, ATTN: Code 2124
 1 Nl. TrngEquipCtr, Orlando, ATTN: Tech Lib
 1 US Dept of Labor, DC, ATTN: Manpower Admin
 1 US Dept of Justice, DC, ATTN: Drug Enforce Admin
 1 Nat Bur of Standards, DC, ATTN: Computer Info Section
 1 Nat Clearing House for MH-Info, Rockville
 1 Denver Federal Ctr, Lakewood, ATTN: BLM
 12 Defense Documentation Center
 4 Dir Psych, Army Hq, Russell Ofcs, Canberra
 1 Scientific Advsr, Mil Bd, Army Hq, Russell Ofcs, Canberra
 1 Mil and Air Attache, Austrian Embassy
 1 Centre de Recherche Des Facteurs, Humaine de la Defense
 Nationale, Brussels
 2 Canadian Joint Staff Washington
 1 C/Air Staff, Royal Canadian AF, ATTN: Pers Std Anal Br
 3 Chief, Canadian Def Resch Staff, ATTN: C/CRDS(W)
 4 British Def Staff, British Embassy, Washington

1 Def & Civil Inst of Enviro Medicine, Canada
 1 AIR CRESS, Kensington, ATTN: Info Sys Br
 1 Militærpsykiologisk Tjeneste, Copenhagen
 1 Military Attache, French Embassy, ATTN: Doc Sec
 1 Medecin Chef, C.E.R.P.A.-Arsenal, Toulon/Naval France
 1 Prin Scientific Off, Appl Hum Engr Resch Div, Ministry
 of Defense, New Delhi
 1 Pers Resch Ofc Library, AKA, Israel Defense Forces
 1 Ministeris van Defensie, DOOP/KL Afd Sociaal
 Psychologische Zaken, The Hague, Netherlands