

AD-A018 034

AIRBORNE MEASUREMENTS OF VOR/LOCALIZER SIGNAL STRENGTH
AND DESIRED TO UNDESIRE SIGNAL RATIOS. VOLUME II. LOVE
FIELD, DALLAS, TEXAS: WESTMORELAND FIELD, LATROBE,
PENNSYLVANIA: 8-LOOP, V-RING AND TWIN T LOCALIZER
ANTENNA TYPES

Robert E. Everhart

Federal Aviation Administration
Washington, D. C.

November 1975

DISTRIBUTED BY:

NTIS

National Technical Information Service
U. S. DEPARTMENT OF COMMERCE

Report No. FAA-RD-75-165, II

343121

AIRBORNE MEASUREMENTS OF VOR/LOCALIZER SIGNAL STRENGTH AND DESIRED TO UNDESIRED SIGNAL RATIOS

Volume II

Love Field, Dallas, Texas; Westmoreland Field, Latrobe, Pa.;
8-Loop, V-Ring and Twin T Localizer Antenna Types.

Robert E. Everhart
Spectrum Management Staff



November 1975
Final Report

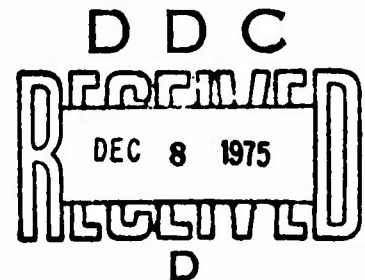

Document is available to the Public through the
National Technical Information Service,
Springfield, Virginia 22161

Reproduced by
NATIONAL TECHNICAL
INFORMATION SERVICE
U.S. Department of Commerce
Springfield VA 22151

Prepared by

U.S. DEPARTMENT OF TRANSPORTATION
FEDERAL AVIATION ADMINISTRATION
Systems Research & Development Service
Washington, D.C. 20590

ADA 018034

DECISION for		
ETIS	White Section	<input checked="" type="checkbox"/>
DBS	Diff Section	<input type="checkbox"/>
UNANNOUNCED		<input type="checkbox"/>
JUSTIFICATION.....		
BY.....		
DISTRIBUTION/AVAILABILITY CODES		
Dist.	AVAIL. and/or SPECIAL	
A		

NOTICE

This document is disseminated under the sponsorship of the Department of Transportation in the interest of information exchange. The United States Government assumes no liability for its contents or use thereof.

ic.

Technical Report Documentation Page

1. Report No. FAA-RD-75-165, II		2. Government Accession No.		3. Recipient's Catalog No.	
4. Title and Subtitle Airborne Measurement of VOR/Localizer Signal Strength and Desired to Undesired Signal Ratios Volume II				5. Report Date November 1975	
				6. Performing Organization Code	
7. Author(s) Robert E. Everhart, Project Engineer				8. Performing Organization Report No.	
9. Performing Organization Name and Address U.S. Department of Transportation Federal Aviation Administration Systems Research and Development Service Spectrum Management Staff, ARD-60 ATC Spectrum Engineering Branch, ARD-62				10. Work Unit No. (TRAIS)	
				11. Contract or Grant No.	
12. Sponsoring Agency Name and Address Department of Transportation Federal Aviation Administration Systems Research and Development Service Washington, D. C. 20591				13. Type of Report and Period Covered Final Report	
				14. Sponsoring Agency Code ARD-60	
15. Supplementary Notes Spectrum Management Staff ATC Spectrum Engineering Branch					
16. Abstract <p>This report contains the results of airborne measurements of signal strengths and select facility flyability recordings at Love Field, Dallas, Texas and Westmoreland Field, Latrobe, Pa. These measurements were conducted on three types of ILS arrays. Tests were conducted before and after conversion from 8-Loop to the specialized array by FAA flight inspection/facility installation teams.</p> <p>Volume I - VOR and Localizer Free Space Interactions, Chickasha Oklahoma.</p> <p>Volume II - Love Field Dallas, Texas, Westmoreland Field Latrobe, Pa., 8-Loop, V-Ring and Twin-T Localizer Antenna Types.</p>					
17. Key Words VOR Localizer, Field Strength, Signal Ratios, Spectrum Management			18. Distribution Statement Document is available to the public through the National Technical Information Service, Springfield, Virginia 22151 COPIES SUBJECT TO CHANGE		
19. Security Classif. (of this report) Unclassified		20. Security Classif. (of this page) Unclassified		21. No. of Pages 140	22. Price \$6.00-2.25

D D C
RECEIVED
 DEC 8 1975
REGISTERED
 D

METRIC CONVERSION FACTORS

Approximate Conversions to Metric Measures

Symbol	When You Know	Multiply by	To Find	Symbol
LENGTH				
in	inches	2.5	centimeters	cm
ft	feet	30	centimeters	cm
yd	yards	0.9	meters	m
mi	miles	1.6	kilometers	km
AREA				
m ²	square inches	6.5	square centimeters	cm ²
ft ²	square feet	0.09	square meters	m ²
yd ²	square yards	0.8	square meters	m ²
mi ²	square miles	2.6	square kilometers	km ²
	acres	0.4	hectares	ha
MASS (weight)				
oz	ounces	28	grams	g
lb	pounds	0.45	kilograms	kg
	short tons (2000 lb)	0.9	tonnes	t
VOLUME				
teap	teaspoons	5	milliliters	ml
fl oz	fluid ounces	30	milliliters	ml
c	cups	0.24	liters	l
pt	pints	0.47	liters	l
qt	quarts	0.95	liters	l
gal	gallons	3.8	liters	l
ft ³	cubic feet	0.03	cubic meters	m ³
yd ³	cubic yards	0.76	cubic meters	m ³
TEMPERATURE (exact)				
°F	Fahrenheit temperature	5/9 (after subtracting 32)	Celsius temperature	°C

Approximate Conversions from Metric Measures

Symbol	When You Know	Multiply by	To Find	Symbol
LENGTH				
mm	millimeters	0.04	inches	in
cm	centimeters	0.4	inches	in
m	meters	3.3	feet	ft
m	meters	1.1	yards	yd
km	kilometers	0.6	miles	mi
AREA				
cm ²	square centimeters	0.16	square inches	in ²
m ²	square meters	1.2	square yards	yd ²
km ²	square kilometers	0.4	square miles	mi ²
ha	hectares (10,000 m ²)	2.5	acres	ac
MASS (weight)				
g	grams	0.035	ounces	oz
kg	kilograms	2.2	pounds	lb
t	tonnes (1000 kg)	1.1	short tons	st
VOLUME				
ml	milliliters	0.03	fluid ounces	fl oz
l	liters	2.1	pints	pt
l	liters	1.06	quarts	qt
l	liters	0.26	gallons	gal
m ³	cubic meters	35	cubic feet	ft ³
m ³	cubic meters	1.3	cubic yards	yd ³
TEMPERATURE (exact)				
°C	Celsius temperature	9/5 (then add 32)	Fahrenheit temperature	°F

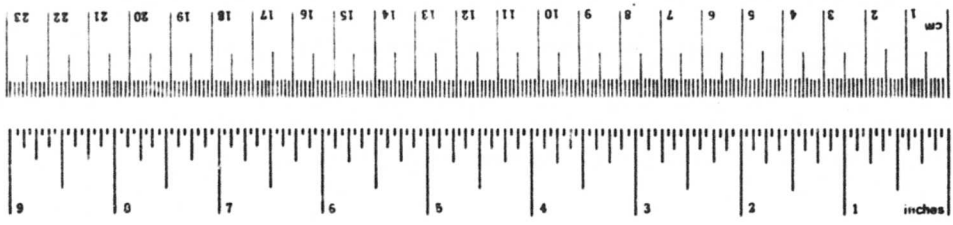

100

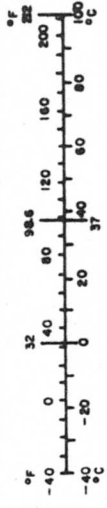

*1 in. = 2.54 exactly. For other exact conversions and more data, see tables, see NBS Visc. Publ. 236, Units of Weights and Measures, Pt. 1, 2, 3, SD Catalog No. C13.1, 2, 3, 6.

TABLE OF CONTENTS

DESCRIPTION	PAGE
Introduction	1
Background	2
Test Procedures	3
Description	
(1) General	4-5
Test Results	
(A) Love Field R/W 13L 8-Loop Antenna (Orbital)	6-11
(B) Love Field R/W 13L 8-Loop Antenna (Radial)	12-19
(C) Love Field R/W 13L V-Ring Antenna (Orbital)	20-25
(D) Love Field R/W 13L V-Ring Antenna (Radial)	26-32
(E) Love Field R/W 31L V-Ring Antenna (Orbital)	33-38
(F) Love Field R/W 31L V-Ring Antenna (Radial)	39-42
(G) Latrobe R/W 23 Twin-T Antenna (Orbital)	43-46
(H) Latrobe R/W 23 Twin-T Antenna (Radial)	47-52
Receiver Level Test	53-57
Conclusions	
(A) Gain	58-60
(B) Directivity	61-62
Supplemental Data	63
(A) Boston vs Laconia D/U Ratio	64-68
(B) Boston vs Nantucket D/U Ratio	69-73
(C) Receiver Calibrations	74-82

Appendix (Illustrations)

	Page
(A) Receiver Calibrations & Transmission Line Loss	A-1 to A-4
(B) Love Field 8-Loop Antenna R/W 13L (Orbital Pattern)	B-1 to B-6
(C) Love Field 8-Loop Antenna R/W 13L (Radial Pattern)	C-1 to C-8
(D) Love Field V-Ring Antenna R/W 13L (Orbital Pattern)	D-1 to D-6
(E) Love Field V-Ring Antenna R/W 13L (Radial Pattern)	E-1 to E-7
(F) Love Field V-Ring Antenna R/W 31L (Orbital Pattern)	F-1 to F-6
(G) Love Field V-Ring Antenna R/W 31L (Radial Pattern)	G-1 to G-4
(H) Latrobe Twin-T Antenna R/W 23 (Orbital Pattern)	H-1 to H-4
(I) Latrobe Twin-T Antenna R/W 23 (Radial Pattern)	I-1 to I-6

INTRODUCTION

With the ever increasing number of Instrument Landing System (ILS) both installed and planned, spectrum management is finding it extremely difficult to assign frequencies. The present distance separation criteria which determine frequency assignments between co-channel ILS's is determined by the function (localizer, glide slope, distance measuring equipment) requiring the greatest separation. At present this geographical separation criteria is determined by the 200W 8-Loop localizer which has an essentially omnidirectional radiation pattern. In an effort to further refine this separation criteria it will be necessary to make use of both the antennas directivity and gain, of all localizer type antenna systems (8-Loop, V-Ring, Twin t, VOR LOC).

Another area of concern for spectrum management is the localizer airborne receiver. In the past little if any information has been available to receiver manufacturers in determining the dynamic range an airborne receiver will actually encounter. As a result, various receivers under a strong signal may tend to deteriorate with rejection. In an effort to correct this situation it is hoped that we will be able to furnish data so that they can more precisely write future specifications for the next generation of airborne receivers.

This report is the second of two reports that reflect Airborne Measurements of VOR/Localizer signal Strength and Desired to Undesired Signal Ratios Report No. FAA-RD-75-165 Vol. I and Vol. II.

BACKGROUND

Airborne measurements were made on a facility presently an 8-Loop localizer that was scheduled to be upgraded to a V-Ring antenna system. Since the radiation pattern and gain of the 8-Loop are well established facts it is possible to compare a known (8-Loop) to an unknown quantity (in this case V-Ring).

In this manner the gain of the antenna system can be accurately determined. Unfortunately no 8-Loop localizers were scheduled for replacement by Twin-T antennas so this type of antennas directivity and gain are measured separately.

At each site, terrain permitting, a 25 Nm orbit was flown at 1000', 2000', 3000', 4000', 5000' and 6250' AGL. Radial flights were flown starting 25 Nm out and ending 25 Nm beyond the antenna system. The two radials are 0° and 90° and were flown at 1000' and 6250' AGL. In essence this gave us four radials, 0° and 90° to the facility and 180° and 270° from the facility. The SAFI equipment aboard the aircraft enabled the exact azimuth and distance to the localizer antenna's to be determined.

The only measurements that will be made by the plane will be R.F. signal level. This measurement was done by using the aircrafts #2 and #3 VHF navigation receivers (Modified Bendix NA26C) these receivers both share the front VHF antenna (Collins 37J-3) on the aircraft. The AGC of these receivers recorded on the aircrafts CEC recorders with proper calibration along with the SAFI sequence numbers. All AGC values were converted to uV and sequence numbers were converted to azimuth and distance to the localizer antennas.

Unfortunately the aircraft was not flying a perfect circle therefore all the orbital data has been corrected for 25 NM, experimently it has been determined that the 180° point is 6 dB down from 0° and 270° is the same as 0° , but there are not corrections made in the data. In all cases it was necessary to add attenuation to the aircraft receivers so that the saturation point of the receiver is not reached. At this point there is an indication of expected input levels that are encountered in the normal approach of an aircraft to an ILS.

TEST PROCEDURES

These procedures were conducted by the same national flight inspection SAFI Convair 580 based at Oklahoma City, Oklahoma. The aircraft was in no way altered from its normal state. All measurements were made using the aircrafts normal receivers. These receivers were calibrated either before or after each test flight. When making receiver input signal level runs a variable attenuator was added to the receiver input and varied so that it would not drive the AGC to saturated values.

The sites where antenna gain and directivity were measured a series of 25 NM orbits were flown. The altitudes ranged from 1000' - 6250', with readings taken at 0° (Front Course), 90°, 180° (Back Course), & 270°, and SAFI equipment was used to determine the aircrafts position, radials were flown also at 25 Nm TO and FROM the facility.

DESCRIPTION

1. GENERAL

A. 8 Loop - Love Field Runway (R/W) 13L Dallas, Texas

This facility was a normal 8 Loop array with a small screen in back. The antennas are 5.5' above ground and 1100' from the end of the R/W, the carrier power to the antenna distribution unit is 150 watts (21.8 dBW).

Data: The following flying was done in clear weather on August 26-27, 1969.

Orbits 1000', 2000', 3000', 4000', 5000', 6250' Above Ground Level (AGL)
Radials 1000' AGL - 0°, 90°, 180°, 270°
6250' AGL - 0°, 90°, 180°, 270°

B. V-Ring Localizer Love Field R/W 13L Dallas, Texas

The V-Ring installation is typical of the FAA standard localizer for CAT II runways. The antennas were manufactured by the Antenna Products Corp. and are installed within 5' of the original 8 Loop array. The antennas are 5.5' high above ground and 1100' from the runway and unscreened the measured carrier power at the antenna distribution unit is 118W (20.7 dBW).

Data: The following flying was done in clear weather on January 2&3, 1970.

Orbits 1000', 2000', 3000', 4000', 5000', 6250' AGL
Radials 1000' AGL - 0°, 90°, 180°, 270°
6250' AGL - 0°, 90°, 180°, 270°

No data will be found on the 90° 1000' radials due to terrain conditions.

C. V-Ring Love Field R/W 31L Dallas, Texas

This is a standard FAA V-Ring antenna system which has been elevated one wavelength above ground. The carrier power to the antenna distribution unit is 140 watts (21.5 dBW).

Data: The flying was done in clear weather on January 2&3, 1970.
The 1000' radials were omitted from the flight test due to terrain.

Orbits 1000', 2000', 3000', 4000', 5000', 6250' AGL
Radials 6250' AGL, 0°, 90°, 180°, 270°

D. Twin-T R/W 23 Latrobe, Pa.

This is a non-federal facility with an Airborne Instruments Twin-T antenna system. The antennas are 9.33' high and have approximately 2W (3 dBW) carrier power to the antennas distribution unit.

Orbits 3000', 4000', 5000', 6250' AGL

Radials 1000' AGL - 0°, 180°

6250' AGL - 0°, 90°, 180°, 270°

The 1000' & 2000' orbits as the 90° & 270° 1000' radials were not flown because of terrain conditions.

Note: Polar plots reflect the FAA's 5 uV usable distance criteria. When the curve touches this circle it indicates a R.F. signal level of less than 5 uV at the antenna output.

TEST RESULTS A

LOCALIZER SIGNAL MEASUREMENTS

Love Field Dallas, Texas
Runway 13L
8-Loop Localizer
Frequency 110.3 MHz
8/27/69
1000' AGL 25 NM Orbit

<u>Azimuth (degrees)</u>	<u>uV</u>	<u>Azimuth (degrees)</u>	<u>uV</u>
223.0	4.2	43.0	**
219.0	8.7	32.0	5.7
213.0	8.4	27.0	6.1
208.0	8.8	22.0	8.5
203.0	8.2	18.0	5.6
197.0	**	13.0	12.1
192.0	7.4	7.0	12.4
187.0	6.5	3.0	11.8
182.0	4.6	358.0	12.9
177.0	6.4	352.0	12.4
172.0	6.3	347.0	12.5
167.0	4.8	342.0	11.2
162.0	**	337.0	10.3
157.0	**	332.0	12.1
152.0	**	327.0	11.4
148.0	**	322.0	12.1
142.0	**	318.0	8.5
137.0	**	314.0	7.9
133.0	**	307.0	9.4
127.0	**	302.0	12.0
122.0	**	297.0	10.1
118.0	**	293.0	8.4
112.0	**	287.0	13.2
107.0	**	282.0	10.5
102.0	**	278.0	8.8
97.0	**	272.0	10.3
92.0	**	268.0	14.1
87.0	**	262.0	9.7
83.0	**	257.0	5.0
77.0	**	253.0	4.6
73.0	**	248.0	**
67.0	**	243.0	4.0
63.0	**	237.0	4.3
57.0	**	232.0	5.0
52.0	**	228.0	5.0
48.0	**		

** Receiver input less than 3.3 microvolts

LOCALIZER SIGNAL MEASUREMENTS

Love Field Dallas, Texas
 Runway 13L
 8-Loop Localizer
 Frequency 110.3 MHz
 8/27/69
 2000' AGL 25 NM Orbit

<u>Azimuth (degrees)</u>	<u>uV</u>	<u>Azimuth (degrees)</u>	<u>uV</u>
223.0	13.2	42.0	11.3
218.0	18.2	37.0	17.6
212.0	19.0	32.0	15.8
207.0	21.1	28.0	14.4
202.0	14.1	23.0	19.3
198.0	13.3	17.0	22.1
193.0	10.5	13.0	26.0
187.0	13.8	7.0	30.8
182.0	10.4	2.0	26.1
177.0	7.9	352.0	37.7
173.0	9.7	348.0	38.4
167.0	11.8	342.0	29.5
163.0	8.3	338.0	21.8
158.0	9.5	332.0	32.5
153.0	8.9	327.0	34.6
147.0	7.7	322.0	28.3
142.0	7.8	318.0	21.5
137.0	6.1	313.0	22.0
132.0	7.0	308.0	26.7
127.0	4.7	302.0	29.9
123.0	5.9	298.0	20.0
118.0	5.4	293.0	19.5
112.0	5.0	287.0	25.2
108.0	5.9	282.0	22.4
102.0	4.1	278.0	20.7
98.0	4.5	272.0	22.0
93.0	**	268.0	17.4
88.0	7.3	263.0	25.9
82.0	5.3	258.0	23.1
78.0	6.7	253.0	11.7
72.0	8.3	247.0	18.0
67.0	8.0	242.0	17.3
63.0	8.7	238.0	15.3
57.0	12.5	232.0	19.7
52.0	13.3	228.0	11.6
47.0	8.4		

** Receiver input less than 3.3 microvolts

LOCALIZER SIGNAL MEASUREMENTS

Love Field Dallas, Texas
Runway 13L
8-Loop Localizer
Frequency 110.3 MHz
8/27/69
3000' AGL 25 NM Orbit

<u>Azimuth(degrees)</u>	<u>uV</u>	<u>Azimuth(degrees)</u>	<u>uV</u>
224.0	20.6	43.0	27.6
217.0	23.1	38.0	32.6
212.0	25.9	32.0	34.2
207.0	28.3	27.0	30.6
202.0	32.3	22.0	33.5
197.0	25.1	18.0	33.5
188.0	26.2	12.0	39.0
182.0	20.5	7.0	47.8
177.0	14.9	2.0	51.6
172.0	20.9	355.0	52.8
168.0	24.2	352.0	53.3
162.0	21.0	348.0	58.7
157.0	20.3	342.0	35.0
152.0	18.3	337.0	40.0
147.0	16.3	332.0	42.5
142.0	23.0	327.0	49.1
137.0	13.5	323.0	52.4
132.0	14.4	317.0	39.4
127.0	12.1	314.0	32.9
122.0	10.8	308.0	44.1
116.0	12.2	303.0	51.5
112.0	12.1	297.0	28.5
108.0	11.8	293.0	29.3
102.0	12.5	288.0	40.2
98.0	12.9	283.0	36.7
92.0	10.1	278.0	28.0
87.0	14.1	273.0	33.8
82.0	11.5	267.0	47.6
78.0	15.3	262.0	34.0
72.0	15.4	258.0	29.1
68.0	17.5	252.0	23.6
62.0	19.1	248.0	34.3
57.0	25.9	243.0	30.3
52.0	26.7	237.0	29.3
47.0	18.8	233.0	23.1
		228.0	18.4

LOCALIZER SIGNAL MEASUREMENTS

Love Field Dallas, Texas
 Runway 13L
 8-Loop Localizer
 Frequency 110.3 MHz
 8/27/69
 4000' AGL 25 NM Orbit

<u>Azimuth(degrees)</u>	<u>uV</u>	<u>Azimuth(degrees)</u>	<u>uV</u>
217.0	24.2	27.0	44.7
211.0	36.5	22.0	38.5
207.0	41.7	18.0	47.3
202.0	40.7	12.0	57.5
197.0	43.6	7.0	74.5
192.0	37.5	2.0	83.2
186.0	38.5	357.0	70.7
182.0	35.0	352.0	66.3
177.0	33.5	347.0	70.2
172.0	26.9	342.0	64.7
166.0	23.6	337.0	47.3
162.0	26.5	332.0	60.4
156.0	25.3	327.0	78.2
152.0	21.6	322.0	74.5
147.0	15.5	317.0	43.5
142.0	21.2	310.0	38.6
137.0	19.2	307.0	52.7
132.0	17.7	302.0	43.6
127.0	16.7	297.0	37.1
122.0	12.8	292.0	43.0
117.0	19.6	287.0	48.5
112.0	17.4	282.0	43.8
107.0	13.9	276.0	42.2
102.0	18.8	272.0	42.4
97.0	15.1	267.0	36.5
93.0	14.8	263.0	43.4
87.0	24.8	257.0	41.1
82.0	18.7	252.0	27.9
77.0	21.3	247.0	36.4
72.0	21.8	242.0	36.9
66.0	26.9	237.0	39.6
62.0	25.5	233.0	37.3
56.0	32.3	226.0	30.5
52.0	31.8		
47.0	25.5		
43.0	32.2		

LOCALIZER SIGNAL MEASUREMENTS

Love Field Dallas, Texas
 Runway 13L
 8-Loop Localizer
 Frequency 110.3 MHz
 8/27/69
 5000' AGL 25 NM Orbit

<u>Azimuth (degrees)</u>	<u>uV</u>	<u>Azimuth (degrees)</u>	<u>uV</u>
217.0	26.8	37.0	52.3
212.0	40.6	33.0	61.9
207.0	42.5	27.0	49.9
203.0	39.5	22.0	39.2
197.0	53.3	17.0	55.9
192.0	37.5	12.0	57.5
187.0	36.7	7.0	73.5
182.0	39.5	2.0	76.1
177.0	22.1	359.0	68.0
172.0	42.8	352.0	77.6
167.0	31.8	348.0	69.7
162.0	34.2	343.0	78.9
157.0	31.9	337.0	48.8
153.0	33.0	332.0	74.6
148.0	29.4	327.0	83.3
143.0	30.7	322.0	85.6
137.0	22.9	317.0	72.6
132.0	22.6	312.0	52.9
127.0	26.4	307.0	61.9
122.0	21.6	301.0	56.1
118.0	22.6	297.0	42.9
112.0	24.3	292.0	45.9
108.0	24.3	287.0	55.9
102.0	24.0	282.0	52.5
97.0	27.0	277.0	55.7
92.0	19.0	272.0	40.3
88.0	22.1	267.0	40.9
82.0	23.4	262.0	48.4
77.0	29.5	257.0	51.0
72.0	30.4	252.0	33.3
68.0	30.6	247.0	44.0
62.0	31.3	242.0	40.2
58.0	39.6	238.0	35.5
52.0	39.7	232.0	33.5
47.0	24.2	227.0	37.0
42.0	36.9	224.0	26.2

LOCALIZER SIGNAL MEASUREMENTS

Love Field Dallas, Texas
 Runway 13L
 8-Loop Localizer
 Frequency 110.3 MHz
 8/27/69
 6250' AGL 25 NM Orbit

<u>Azimuth (degrees)</u>	<u>uV</u>	<u>Azimuth (degrees)</u>	<u>uV</u>
222.0	43.0	42.0	46.8
217.0	37.3	37.0	73.5
212.0	51.8	32.0	74.0
208.0	64.0	27.0	75.1
203.0	50.7	23.0	55.2
197.0	63.7	17.0	77.0
193.0	50.2	13.0	90.3
187.0	61.2	7.0	113.0
182.0	47.2	2.0	85.0
177.0	35.8	358.0	116.0
172.0	57.3	353.0	111.0
168.0	41.1	347.0	110.0
162.0	50.2	342.0	78.7
158.0	44.1	337.0	94.8
152.0	42.7	333.0	98.3
148.0	39.2	327.0	101.0
142.0	33.0	322.0	102.0
138.0	30.4	318.0	82.9
133.0	22.7	312.0	68.1
128.0	34.5	307.0	77.0
122.0	28.4	303.0	67.2
118.0	28.8	298.0	56.1
112.0	33.3	293.0	54.5
107.0	31.0	287.0	77.4
102.0	31.1	282.0	54.5
97.0	34.0	277.0	56.8
92.0	28.1	273.0	48.0
88.0	32.3	267.0	63.8
82.0	38.0	262.0	58.6
77.0	47.9	257.0	43.7
73.0	46.2	253.0	57.0
67.0	39.6	248.0	51.4
63.0	40.0	243.0	50.8
57.0	60.3	238.0	49.3
52.0	53.7	233.0	52.0
48.0	27.7	227.0	50.0

TEST RESULTS B

LOCALIZER SIGNAL MEASUREMENTS

Love Field Dallas, Texas
Runway 13L
8-Loop Localizer
Frequency 110.3 MHz
8/26/69
1000' AGL 0° (F.C.) Radial

<u>Distance (NM)</u>	<u>uV</u>	<u>Distance (NM)</u>	<u>uV</u>
23.6	11.4	3.8	858.0
23.0	13.0	3.3	1265.0
22.5	13.8	2.7	1545.0
21.9	14.3	2.2	2250.0
21.4	16.0	1.7	6875.0
20.8	17.9	1.0	3800.0
20.2	18.7		
19.7	20.1		
19.1	19.8		
18.6	21.8		
18.1	22.6		
17.5	24.0		
17.0	24.8		
16.4	26.4		
15.9	28.4		
15.3	31.7		
14.8	33.0		
14.2	36.6		
13.7	35.8		
13.3	37.8		
12.6	41.3		
12.1	49.0		
11.5	55.2		
11.0	65.5		
10.5	79.3		
9.9	92.5		
9.4	114.0		
8.9	135.0		
8.3	157.0		
7.7	184.0		
7.1	248.0		
6.6	270.0		
6.1	309.0		
5.5	358.0		
4.9	463.0		
4.4	595.0		

LOCALIZER SIGNAL MEASUREMENTS

Love Field Dallas, Texas
 Runway 13L
 8-Loop Localizer
 Frequency 110.3 MHz
 8/26/69
 6250' AGL 0° (F.C.) Radial

<u>Distance (NM)</u>	<u>uV</u>	<u>Distance (NM)</u>	<u>uV</u>
23.6	116.0	3.8	1678.0
23.0	128.0	3.3	1843.0
22.5	138.0	2.7	1875.0
21.9	150.0	2.2	1884.0
21.4	155.0	1.7	1595.0
20.8	157.0	1.0	1375.0
20.2	163.0	.5	2640.0
19.7	174.0	.04	1623.0
19.1	193.0		
18.6	215.0		
18.1	195.0		
17.5	215.0		
17.0	226.0		
16.4	240.0		
15.9	267.0		
15.3	240.0		
14.8	269.0		
14.2	284.0		
13.7	308.0		
13.2	328.0		
12.6	385.0		
12.1	311.0		
11.5	341.0		
11.0	391.0		
10.5	429.0		
9.9	457.0		
9.4	517.0		
8.9	556.0		
8.3	618.0		
7.7	671.0		
7.1	825.0		
6.6	781.0		
6.1	897.0		
5.5	1018.0		
4.9	1210.0		
4.4	1513.0		

LOCALIZER SIGNAL MEASUREMENTS

Love Field Dallas, Texas
Runway 13L
8-Loop Localizer
Frequency 110.3 MHz
8/26/69
1000' AGL 90° Radial

<u>Distance (NM)</u>	<u>uV</u>	<u>Distance (NM)</u>	<u>uV</u>
23.4	**	2.2	1815.0
22.8	**	1.6	4570.0
22.2	**	1.0	3885.0
21.6	**	.4	3885.0
21.0	**		
20.4	**		
19.8	**		
19.3	**		
18.7	**		
18.1	5.6		
17.5	7.6		
16.9	5.4		
16.4	9.4		
15.8	7.5		
15.2	7.7		
14.6	9.8		
14.0	10.7		
13.4	12.0		
12.8	14.3		
12.2	17.1		
11.7	15.7		
11.1	20.7		
10.5	24.0		
9.8	29.7		
9.3	29.5		
8.6	34.2		
8.0	42.1		
7.5	49.5		
7.0	54.4		
6.3	70.4		
5.7	79.8		
5.1	100.0		
4.6	160.0		
3.9	270.0		
3.3	424.0		
2.7	930.0		

** Receiver input less than 3.3 microvolts

LOCALIZER SIGNAL MEASUREMENTS

Love Field Dallas, Texas
Runway 13L
8-Loop Localizer
Frequency 110.3 MHz
8/26/69
6250' AGL 90° Radial

<u>Distance (NM)</u>	<u>uV</u>	<u>Distance (NM)</u>	<u>uV</u>
23.4	41.0	2.2	2420.0
22.8	48.0	1.6	1254.0
22.2	51.0	1.0	3520.0
21.6	52.0	.4	2393.0
21.0	59.0		
20.4	61.0		
19.8	66.0		
19.3	71.0		
18.7	75.0		
18.1	84.0		
17.5	86.0		
16.9	90.0		
16.4	105.0		
15.8	108.0		
15.2	117.0		
14.6	143.0		
14.0	149.0		
13.4	155.0		
12.8	177.0		
12.2	193.0		
11.7	212.0		
11.1	256.0		
10.5	286.0		
9.8	297.0		
9.3	347.0		
8.6	396.0		
8.0	484.0		
7.5	545.0		
7.0	600.0		
6.3	699.0		
5.7	869.0		
5.1	1062.0		
4.6	1452.0		
3.9	2035.0		
3.3	1749.0		
2.7	2393.0		

LOCALIZER SIGNAL MEASUREMENTS

Love Field Dallas, Texas
Runway 13L
8-Loop Localizer
Frequency 110.3 MHz
8/26/69
1000' AGL 180° (B.C.) Radial

<u>Distance (NM)</u>	<u>uV</u>	<u>Distance (NM)</u>	<u>uV</u>
.05	7260.0	20.0	7.3
.6	2145.0	20.5	6.5
1.2	1100.0	21.1	6.3
1.7	649.0	21.6	5.1
2.3	385.0	22.2	4.9
2.8	275.0	22.7	4.2
3.4	174.0	23.3	3.6
3.9	134.0	23.8	3.8
4.5	98.0	24.4	3.6
5.0	68.8	24.9	3.5
5.6	52.3		
6.1	37.7		
6.7	36.9		
7.2	32.8		
7.8	25.3		
8.3	25.8		
8.9	23.7		
9.4	22.0		
10.0	20.1		
10.6	13.5		
11.1	13.5		
11.7	12.2		
12.2	11.5		
12.8	11.0		
13.4	10.0		
13.9	8.8		
14.5	9.2		
15.0	7.9		
15.6	8.5		
16.1	8.1		
16.7	8.3		
17.2	8.8		
17.8	8.9		
18.4	7.1		
18.9	6.9		
19.4	7.4		

LOCALIZER SIGNAL MEASUREMENTS

Love Field Dallas, Texas
Runway 13L
8-Loop Localizer
Frequency 110.3 MHz
8/26/69
6250' AGL 180° (B.C.) Radial

<u>Distance (NM)</u>	<u>uV</u>	<u>Distance (NM)</u>	<u>uV</u>
.6	935.0	20.5	43.0
1.2	1375.0	21.1	43.0
1.7	1045.0	21.6	41.0
2.3	567.0	22.2	39.0
2.8	402.0	22.7	36.0
3.4	317.0	23.3	36.0
3.9	297.0	23.8	34.0
4.5	270.0	24.4	32.0
5.0	262.0	24.9	31.0
5.6	231.0		
6.1	209.0		
6.7	242.0		
7.2	229.0		
7.8	209.0		
8.3	191.0		
8.9	182.0		
9.4	168.0		
10.0	149.0		
10.6	138.0		
11.1	131.0		
11.7	131.0		
12.2	119.0		
12.8	100.0		
13.4	107.0		
13.9	101.0		
14.5	90.0		
15.0	85.0		
15.6	80.0		
16.1	79.0		
16.7	76.0		
17.2	66.0		
17.8	65.0		
18.4	61.0		
18.9	58.0		
19.4	50.0		
20.0	47.0		

LOCALIZER SIGNAL MEASUREMENTS

Love Field Dallas, Texas
 Runway 13L
 8-Loop Localizer
 Frequency 110.3 MHz
 8/26/69
 1000' AGL 270° Radial

<u>Distance (NM)</u>	<u>uV</u>	<u>Distance (NM)</u>	<u>uV</u>
.3	11,000+ **	21.4	8.4
.8	2805.0	22.1	7.0
1.4	1392.0	22.7	6.6
2.0	627.0	23.2	6.5
2.6	445.0	23.8	5.3
3.2	325.0	24.4	5.0
3.8	256.0		
4.4	240.0		
4.9	204.0		
5.6	177.0		
6.2	152.0		
6.7	98.0		
7.3	76.0		
8.0	72.0		
8.6	51.0		
9.2	42.0		
9.7	38.0		
10.3	35.0		
10.9	32.0		
11.5	30.0		
12.0	30.0		
12.7	28.0		
13.3	26.0		
13.9	23.0		
14.4	21.0		
15.0	19.0		
15.6	16.0		
16.2	16.0		
16.8	14.0		
17.3	13.0		
17.9	12.0		
18.5	11.0		
19.1	11.0		
19.7	10.0		
20.3	9.4		
20.9	8.9		

** Receiver AGC curve not calibrated above this value

LOCALIZER SIGNAL MEASUREMENTS

Love Field Dallas, Texas
Runway 13L
8-Loop Localizer
Frequency 110.3 MHz
8/26/69
6250' AGL 270° Radial

<u>Distance (NM)</u>	<u>u v</u>	<u>Distance (NM)</u>	<u>u v</u>
.3	1953.0	21.4	37.0
.8	1452.0	22.1	36.0
1.4	1144.0	22.7	33.0
2.0	520.0	23.2	32.0
2.6	616.0	23.8	32.0
3.2	490.0	24.4	31.0
3.8	457.0		
4.4	396.0		
4.9	347.0		
6.2	308.0		
6.7	275.0		
7.3	253.0		
8.0	237.0		
8.6	212.0		
9.2	176.0		
9.7	164.0		
10.3	153.0		
10.9	138.0		
11.5	131.0		
12.0	125.0		
12.7	117.0		
13.3	115.0		
13.9	97.0		
14.4	80.0		
15.0	74.0		
15.6	65.0		
16.2	59.0		
16.8	55.0		
17.3	52.0		
17.9	49.0		
18.5	47.0		
19.1	45.0		
19.7	42.0		
20.3	39.0		
20.9	38.0		

TEST RESULTS C

LOCALIZER SIGNAL MEASUREMENTS

Love Field Dallas, Texas
 Runway 13L
 V-Ring Localizer
 Frequency 110.3 MHz
 1/3/70
 1000' AGL, 25 NM Orbit

<u>Azimuth (degrees)</u>	<u>uV</u>	<u>Azimuth (degrees)</u>	<u>uV</u>
223	3.5	42	7.2
218	8.1	38	6.6
212	5.0	33	12.3
208	5.4	27	11.7
202	7.1	23	16.5
197	4.4	18	20.3
193	6.8	12	28.0
187	8.8	7	35.4
182	14.0	3	53.8
177	16.3	358	63.5
172	7.6	353	34.8
167	4.6	347	40.5
163	4.1	343	21.5
157	**	337	25.5
152	**	332	23.5
148	**	328	23.5
142	**	322	13.0
137	**	317	14.4
133	**	312	11.6
128	**	307	9.1
122	**	302	8.6
117	**	297	10.7
112	**	292	7.5
107	**	288	5.7
102	**	282	5.3
99	**	277	4.9
93	**	272	**
87	**	268	4.7
81	**	262	**
77	**	257	**
73	**	253	**
66	**	247	**
63	**	243	**
57	**	238	**
53	3.5		
47	5.4		

** Values at these points are less than 3.3 microvolts

LOCALIZER SIGNAL MEASUREMENTS

Love Field Dallas, Texas
 Runway 13L
 V-Ring Localizer
 Frequency 110.3 MHz
 1/3/70
 2000' AGL, 25 NM Orbit

<u>Azimuth (degrees)</u>	<u>uV</u>	<u>Azimuth (degrees)</u>	<u>uV</u>
222	19.3	42	24.4
218	13.5	38	17.7
212	10.5	32	27.9
207	12.9	27	33.2
202	13.7	23	42.7
198	11.5	17	50.8
192	11.2	12	60.9
188	19.3	7	72.6
182	38.4	2	145.0
178	27.6	357	158.0
172	14.2	353	102.0
167	10.3	347	87.5
162	8.8	342	65.0
158	8.0	337	69.5
152	5.9	332	57.0
148	6.4	327	60.9
142	5.6	322	38.4
138	3.6	317	37.2
132	**	313	29.2
127	**	308	18.6
122	**	302	22.0
118	**	298	25.0
112	**	293	17.0
107	**	287	10.7
103	**	282	10.2
97	**	277	7.4
93	**	272	5.4
87	**	268	9.9
82	3.3	263	3.4
77	**	258	3.5
73	3.6	252	3.5
67	5.1	248	5.2
62	8.1	242	9.5
58	12.0	238	10.2
53	10.4	232	10.4
47	14.9		

** Values at these points are less than 3.3 microvolts

LOCALIZER SIGNAL MEASUREMENTS

Love Field Dallas, Texas
 Runway 13L
 V-Ring Localizer
 Frequency 110.3 MHz
 1/3/70
 3000' AGL, 25 NM Orbit

<u>Azimuth(degrees)</u>	<u>uV</u>	<u>Azimuth(degrees)</u>	<u>uV</u>
222	24.2	42	50.0
216	9.5	38	37.2
212	14.7	32	43.7
207	14.4	27	50.4
203	21.6	22	67.0
197	14.9	17	69.0
192	25.5	13	86.3
187	26.8	8	120.0
183	46.8	2	204.0
177	60.0	357	284.0
172	23.6	353	167.0
168	18.2	348	131.0
162	15.7	343	79.0
157	14.3	338	86.4
153	10.5	332	75.5
147	11.3	327	81.0
143	10.3	322	56.0
137	6.0	317	69.0
131	3.4	313	71.5
127	3.8	307	35.2
123	**	302	29.3
118	**	297	31.2
113	**	292	21.0
107	**	287	15.8
103	**	282	13.3
97	**	278	9.7
93	**	272	6.7
87	5.0	267	11.4
83	6.0	262	3.6
77	6.8	257	4.9
72	6.0	252	5.1
67	9.8	248	9.8
62	13.9	242	11.9
57	18.7	237	13.4
52	18.4	233	14.8
47	26.9	227	14.7

** Values at these points are less than 3.3 microvolts

LOCALIZER SIGNAL MEASUREMENTS

Love Field Dallas, Texas
 Runway 13L
 V-Ring Localizer
 Frequency 110.3 MHz
 1/3/70
 4000' AGL, 25 NM Orbit

<u>Azimuth(degrees)</u>	<u>u V</u>	<u>Azimuth(degrees)</u>	<u>u V</u>
222	28.3	37	62.5
217	18.1	32	86.5
213	21.8	28	75.0
207	22.6	22	85.0
203	28.9	17	98.5
198	30.5	12	136.0
192	42.5	7	174.0
187	40.0	2	292.0
183	73.4	358	330.0
177	80.3	352	210.0
173	44.6	347	142.0
167	33.2	342	135.0
163	24.4	337	108.0
156	17.5	332	104.0
152	17.5	327	112.0
147	17.8	322	78.0
141	14.0	318	67.0
137	11.9	312	94.6
132	7.6	307	44.0
127	6.3	302	36.4
122	6.0	297	37.0
117	**	293	28.0
111	**	287	19.0
107	**	283	14.2
102	3.8	277	10.9
97	5.4	272	8.3
92	7.2	267	16.1
87	8.8	261	3.9
82	10.1	257	7.0
77	10.0	253	7.5
72	13.3	247	10.7
67	20.2	242	16.9
62	25.6	238	16.9
57	44.7	232	16.6
54	48.2	228	19.2
42	85.5		

** Values at these points are less than 3.3 microvolts

LOCALIZER SIGNAL MEASUREMENTS

Love Field Dallas, Texas
 Runway 13L
 V-Ring Localizer
 Frequency 110.3 MHz
 1/3/70
 5000' AGL, 25 NM Orbit

<u>Azimuth (degrees)</u>	<u>uV</u>	<u>Azimuth (degrees)</u>	<u>uV</u>
223	33.0	42	94.6
218	23.7	37	52.1
213	28.2	32	90.0
208	23.2	27	96.5
202	37.6	23	96.8
198	45.0	17	107.0
192	45.7	13	142.0
187	53.2	7	170.0
183	102.0	3	273.0
178	127.0	358	287.0
172	53.6	353	223.0
167	31.4	348	261.0
162	27.2	343	117.0
157	25.4	337	128.0
152	22.6	332	128.0
148	22.5	327	116.0
143	19.3	322	89.5
137	13.3	317	92.5
132	10.7	312	81.0
128	8.4	308	45.0
122	7.2	302	54.2
118	5.3	297	46.2
113	**	292	15.1
108	**	288	22.5
102	4.0	282	18.4
97	6.4	277	17.3
93	6.6	272	11.2
88	11.1	268	4.7
83	10.4	263	5.9
78	13.8	257	7.9
72	15.3	252	9.1
67	17.5	248	10.0
61	22.8	242	14.7
57	32.3	238	18.3
52	29.0	232	18.9
47	39.0	228	24.4

** Values at these points are less than 3.3 microvolts

LOCALIZER SIGNAL MEASUREMENTS

Love Field Dallas, Texas
Runway 13L
V-Ring Localizer
Frequency 110.3 MHz
1/3/70
6250' AGL 25 NM Orbit

<u>Azimuth (degrees)</u>	<u>uV</u>	<u>Azimuth (degrees)</u>	<u>uV</u>
222	35.0	42	102.0
218	21.3	37	90.5
213	26.0	33	123.0
207	36.0	27	122.0
203	45.2	23	137.0
197	54.4	17	137.0
192	58.5	13	203.0
188	55.1	7	229.0
182	130.0	3	292.0
177	132.0	358	273.0
172	61.3	352	292.0
168	52.0	347	232.0
163	30.5	343	168.0
158	33.5	336	180.0
153	25.4	331	165.0
148	25.7	327	137.0
142	22.3	323	114.0
137	16.5	317	118.0
133	13.7	313	111.0
128	8.0	307	58.3
122	6.0	302	64.0
117	5.2	298	55.0
112	**	292	33.5
107	**	287	26.4
102	5.5	283	22.1
97	7.9	277	18.9
93	8.3	272	15.0
87	12.8	267	18.0
82	13.0	262	7.9
77	17.8	258	9.3
73	18.3	252	12.5
68	21.4	247	15.2
62	30.5	242	16.8
57	50.8	238	21.8
53	35.5	232	26.3
48	36.8	227	33.9

** Values at these points are less than 3.3 microvolts

TEST RESULTS D

LOCALIZER SIGNAL MEASUREMENTS

Love Field Dallas, Texas
Runway 13L
V-Ring Localizer
Frequency 110.3 MHz
1/3/70
1000' AGL 0° (F.C.) Radial

<u>Distance (NM)</u>	<u>u V</u>	<u>Distance (NM)</u>	<u>u V</u>
24.8	112.0	4.7	3795.0
24.2	112.0	4.2	4675.0
23.6	132.0	3.7	7450.0
23.1	132.0	3.1	11,000+**
22.6	143.0	2.5	11,000+**
22.0	163.0	2.1	11,000+**
21.5	163.0	1.5	11,000+**
20.9	171.0	1.0	11,000+**
20.4	187.0	.5	11,000+**
19.8	207.0	.03	11,000+**
19.3	217.0		
18.6	240.0		
18.1	252.0		
17.6	262.0		
17.0	275.0		
16.4	275.0		
15.9	278.0		
15.3	292.0		
14.8	336.0		
14.2	352.0		
13.7	391.0		
13.1	412.0		
12.5	468.0		
12.0	501.0		
11.4	553.0		
10.8	638.0		
10.2	638.0		
9.7	737.0		
9.2	858.0		
8.7	919.0		
8.1	1056.0		
7.6	1155.0		
7.1	1375.0		
6.5	1375.0		
5.9	2228.0		
5.3	3135.0		

** Receiver AGC curve not calibrated for higher values

LOCALIZER SIGNAL MEASUREMENTS

Love Field Dallas, Texas
 Runway 13L
 V-Ring Localizer
 Frequency 110.3 MHz
 1/3/70
 6250 AGL 0° (F.C.) Radial

<u>Distance (NM)</u>	<u>uv</u>	<u>Distance (NM)</u>	<u>uv</u>
24.9	517.0	2.0	11,000+**
24.3	517.0	1.4	2255.0
23.6	537.0	.7	11,000+**
23.0	556.0	.1	11,000+**
22.4	556.0		
21.7	611.0		
21.1	710.0		
20.5	836.0		
19.8	946.0		
19.2	979.0		
18.5	1023.0		
18.0	1188.0		
17.2	1227.0		
16.7	1469.0		
16.1	1469.0		
15.4	1661.0		
14.8	1738.0		
14.1	2145.0		
13.5	2695.0		
12.8	2695.0		
12.2	2860.0		
11.6	3190.0		
10.9	3988.0		
10.2	3988.0		
9.6	4758.0		
9.0	5253.0		
8.3	5253.0		
7.7	6498.0		
7.1	7370.0		
6.5	11,000+**		
5.8	11,000+**		
5.2	11,000+**		
4.5	11,000+**		
3.9	11,000+**		
3.3	11,000+**		
2.6	11,000+**		

** Receivers AGC not calibrated for higher values

LOCALIZER SIGNAL MEASUREMENTS

Love Field Dallas, Texas
Runway 13L
V-Ring Localizer
Frequency 110.3 MHz
1/3/70
6250' AGL 90° Radial

<u>Distance (NM)</u>	<u>u V</u>	<u>Distance (NM)</u>	<u>u V</u>
25.1	10.0	3.8	396.0
24.4	7.5	3.1	369.0
23.8	7.7	2.6	396.0
23.3	8.4	2.0	611.0
22.7	8.6	1.4	396.0
22.1	10.4	.8	2255.0
21.5	9.0	.2	2002.0
20.9	10.5		
20.3	11.8		
19.8	18.9		
19.1	12.4		
18.5	14.6		
17.9	17.9		
17.4	24.5		
16.7	26.7		
16.2	29.4		
15.6	29.4		
14.9	30.9		
14.4	33.0		
13.8	39.9		
13.2	44.6		
12.7	49.5		
12.0	54.5		
11.5	56.7		
10.9	67.8		
10.3	75.4		
9.7	95.7		
9.1	116.0		
8.5	126.0		
7.9	149.0		
7.3	182.0		
6.7	204.0		
6.1	234.0		
5.5	281.0		
5.0	344.0		
4.3	355.0		

LOCALIZER SIGNAL MEASUREMENTS

Love Field, Dallas Texas
Runway 13L
V-Ring Localizer
Frequency 110.3 MHz
1/3/70
1000' AGL 180° (B.C.) Radial

<u>Distance (NM)</u>	<u>uV</u>	<u>Distance (NM)</u>	<u>uV</u>
.5	11,000+**	20.3	6.3
1.1	11,000+**	20.9	5.9
1.7	9185.0	21.5	5.9
2.2	4675.0	22.0	6.0
2.8	2778.0	22.6	5.4
3.3	1375.0	23.1	9.2
3.9	979.0	23.7	8.6
4.4	688.0	24.2	11.6
5.0	561.0		
5.5	418.0		
6.1	314.0		
6.6	248.0		
7.2	196.0		
7.8	163.0		
8.3	138.0		
8.8	138.0		
9.4	112.0		
9.9	94.0		
10.4	72.0		
11.0	65.0		
11.5	47.0		
12.0	50.0		
12.6	46.0		
13.2	45.0		
13.7	45.0		
14.3	36.0		
14.8	27.0		
15.4	26.0		
15.9	28.0		
16.5	25.0		
17.0	20.0		
17.6	16.0		
18.1	14.0		
18.7	15.0		
19.3	13.0		
19.8	10.1		

** Receiver AGC curve not calibrated for higher values

LOCALIZER SIGNAL MEASUREMENTS

Love Field Dallas, Texas
Runway 13L
V-Ring Localizer
Frequency 110.3 MHz
1/3/70
6250' AGL 180° (B.C.) Radial

<u>Distance (NM)</u>	<u>uV</u>	<u>Distance (NM)</u>	<u>uV</u>
.6	11,000+**	23.4	92.0
1.2	3575.0	24.1	82.0
1.8	2063.0	24.7	81.1
2.5	3218.0		
3.1	3218.0		
3.7	2970.0		
4.4	2145.0		
5.1	2063.0		
5.6	1452.0		
6.3	1232.0		
6.9	979.0		
7.5	912.0		
8.2	655.0		
8.8	572.0		
9.5	446.0		
10.1	413.0		
10.7	413.0		
11.3	396.0		
11.9	352.0		
12.6	352.0		
13.2	317.0		
13.9	273.0		
14.5	259.0		
15.1	251.0		
15.8	226.0		
16.4	193.0		
17.0	187.0		
17.7	171.0		
18.3	163.0		
18.9	152.0		
19.6	138.0		
20.3	133.0		
20.9	116.0		
21.5	112.0		
22.2	109.0		
22.8	94.0		

** Receiver AGC curve not calibrated for higher values

LOCALIZER SIGNAL MEASUREMENTS

Love Field Dallas, Texas
Runway 13L
V-Ring Localizer
Frequency 110.3 MHz
1/3/70
1000' AGL 270° Radial

<u>Distance (NM)</u>	<u>u V</u>	<u>Distance (NM)</u>	<u>u V</u>
.3	3025.0	18.8	**
.9	748.0	19.2	4.9
1.4	550.0	19.8	4.9
1.9	330.0	20.3	4.5
2.4	251.0	20.8	4.3
2.9	152.0	21.3	**
3.5	100.0	21.9	**
4.0	63.3	22.4	**
4.5	64.9	22.8	**
5.0	56.7	23.4	**
5.5	40.8	23.8	**
6.0	41.9	24.4	**
6.5	36.3		
7.0	29.5		
7.6	25.3		
8.1	21.8		
8.6	19.0		
9.1	19.0		
9.6	16.5		
10.1	13.8		
10.6	12.3		
11.1	11.1		
11.6	10.6		
12.2	9.8		
12.7	8.1		
13.2	7.4		
13.8	7.8		
14.2	7.1		
14.7	6.8		
15.3	6.2		
15.8	5.7		
16.3	4.7		
16.7	4.3		
17.2	3.9		
17.8	4.5		
18.3	4.3		

** Receiver input less than 3.3 microvolts

LOCALIZER SIGNAL MEASUREMENTS

Love Field Dallas, Texas
Runway 13L
V-Ring Localizer
Frequency 110.3 MHz
1/3/70
6250' AGL 270° Radial

<u>Distance (NM)</u>	<u>uV</u>	<u>Distance (NM)</u>	<u>uV</u>
.5	5170.0	22.2	13.1
1.0	537.0	22.8	11.2
1.7	354.0	23.4	10.5
2.3	383.0	24.1	10.2
2.9	297.0	24.6	10.6
3.5	187.0		
4.1	182.0		
4.7	165.0		
5.3	143.0		
5.9	127.0		
6.5	127.0		
7.2	112.0		
7.7	81.4		
8.4	67.7		
9.0	56.7		
9.6	50.6		
10.2	47.1		
10.8	45.4		
11.5	43.5		
12.0	40.7		
12.7	35.2		
13.2	32.2		
13.9	32.2		
14.4	30.3		
15.0	28.6		
15.6	25.1		
16.3	23.1		
16.9	21.2		
17.4	20.6		
18.1	17.9		
18.6	16.1		
19.2	16.0		
19.8	16.1		
20.4	15.2		
21.0	13.9		
21.6	12.7		

TEST RESULTS E

LOCALIZER SIGNAL MEASUREMENTS

Love Field Dallas, Texas
Runway 31L
V-Ring Localizer
Frequency 111.7 MHz
1/3/70
1000' AGL 25 NM Orbit

<u>Azimuth(degrees)</u>	<u>uV</u>	<u>Azimuth(degrees)</u>	<u>uV</u>
37	43.8	217	5.4
32	71.5	212	6.8
28	67.5	207	9.3
22	76.5	202	12.0
18	108.0	197	14.2
12	103.0	192	14.9
7	47.3	188	20.6
2	116.0	183	43.6
357	189.0	177	42.5
353	60.4	172	36.0
348	69.0	168	26.8
342	52.8	162	14.4
337	52.3	157	12.8
333	38.5	152	15.7
327	33.4	147	20.2
322	21.4	143	9.5
317	16.1	138	14.5
312	16.7	133	8.1
307	7.2	127	6.3
303	10.0	122	6.9
297	9.6	117	5.7
292	10.2	112	4.9
287	6.4	107	4.1
282	6.7	103	4.2
278	7.4	97	6.5
272	**	92	7.8
267	**	87	8.6
263	3.8	83	17.4
257	**	77	24.2
253	6.8	72	27.4
247	3.5	67	14.2
243	**	62	16.2
238	**	58	24.4
232	5.1	54	25.0
227	4.5		
222	4.2		

** Receiver input less than 3.3 microvolts

LOCALIZER SIGNAL MEASUREMENTS

Love Field Dallas, Texas
Runway 31L
V-Ring Localizer Frequency 111.7 MHz
1/3/70
2000' AGL 25 NM Orbit

<u>Azimuth</u> (degrees)	<u>uV</u>	<u>Azimuth</u> (degrees)	<u>uV</u>
37	103.0	217	10.2
32	167.0	212	23.0
27	207.0	208	16.5
21	242.0	203	20.1
17	239.0	197	36.9
13	220.0	193	28.8
7	128.0	187	44.0
2	418.0	182	91.3
357	341.0	177	110.0
352	124.0	172	63.7
347	143.0	167	61.5
341	138.0	162	41.7
337	120.0	157	36.2
333	99.0	152	39.8
327	80.0	147	53.0
322	50.6	142	26.8
318	45.0	138	40.2
312	43.0	132	21.6
307	23.3	127	17.3
302	23.9	123	15.9
298	22.0	118	14.5
293	17.1	112	11.5
287	15.2	108	10.7
282	17.6	102	7.7
277	6.8	97	16.4
272	5.0	92	24.4
268	5.3	87	20.6
262	5.9	82	42.0
257	7.4	77	61.0
252	7.1	72	69.8
246	8.9	68	61.9
243	13.2	62	56.8
237	7.0	58	88.4
233	10.4	53	64.3
227	9.5	47	98.0
223	15.1		

LOCALIZER SIGNAL MEASUREMENTS

Love Field Dallas, Texas
Runway 31L
V-Ring Localizer
Frequency 111.7 MHz
1/3/70
3000' AGL 25 NM Orbit

<u>Azimuth(degrees)</u>	<u>u v</u>	<u>Azimuth(degrees)</u>	<u>u v</u>
37	110.0	218	24.0
32	259.0	213	30.8
28	245.0	207	26.8
22	272.0	202	41.2
17	234.0	198	41.2
12	286.0	192	43.1
8	262.0	187	78.5
3	432.0	182	120.0
358	641.0	177	113.0
353	296.0	172	83.4
347	228.0	167	68.9
342	223.0	163	57.8
338	207.0	158	41.6
332	171.0	153	41.1
328	132.0	147	51.0
323	95.7	142	31.6
317	109.0	137	54.5
312	57.5	132	51.3
307	37.2	127	30.5
302	45.6	122	25.5
297	47.3	118	34.5
292	29.7	112	15.6
288	29.9	108	19.2
282	21.2	102	21.8
278	10.2	98	32.4
272	22.0	92	41.0
267	8.0	87	32.7
263	9.9	82	53.8
258	16.1	77	74.8
252	8.6	72	86.3
247	9.9	66	80.0
242	13.7	62	85.0
237	13.4	57	81.2
232	14.5	52	89.5
227	19.2	48	118.0
223	23.4	43	123.0

LOCALIZER SIGNAL MEASUREMENTS

Love Field Dallas, Texas
Runway 31L
V-Ring Localizer
Frequency 111.7 MHz
1/3/70
4000' AGL 25 NM Orbit

<u>Azimuth (degrees)</u>	<u>uv</u>	<u>Azimuth (degrees)</u>	<u>uv</u>
37.0	185.0	207.0	41.7
33.0	297.0	203.0	56.9
27.0	322.0	197.0	72.8
21.0	467.0	192.0	71.8
17.0	360.0	186.0	113.0
13.0	478.0	182.0	154.0
7.0	372.0	177.0	203.0
3.0	705.0	172.0	87.0
357.0	1106.0	167.0	83.4
352.0	490.0	162.0	58.4
347.0	412.0	158.0	57.4
343.0	310.0	152.0	60.3
337.0	333.0	147.0	71.2
332.0	266.0	142.0	57.5
327.0	248.0	137.0	60.6
322.0	197.0	132.0	32.8
317.0	190.0	127.0	43.1
312.0	144.0	122.0	39.5
307.0	74.0	116.0	33.0
302.0	103.0	112.0	30.7
297.0	106.0	107.0	19.1
292.0	66.2	102.0	20.8
287.0	56.4	97.0	51.9
282.0	41.3	92.0	37.0
276.0	14.9	87.0	64.1
273.0	37.7	81.0	65.6
267.0	18.0	77.0	103.0
262.0	12.0	71.0	122.0
257.0	13.2	67.0	105.0
252.0	11.0	62.0	96.0
247.0	19.0	56.0	105.0
242.0	17.5	52.0	128.0
238.0	28.0	47.0	131.0
222.0	37.2	41.0	126.0
217.0	31.5		
212.0	43.0		

LOCALIZER SIGNAL MEASUREMENTS

Love Field Dallas, Texas
Runway 31L
V-Ring Localizer
Frequency 111.7 MHz
1/3/70
5000' AGL 25 NM Orbit

<u>Azimuth (degrees)</u>	<u>uV</u>	<u>Azimuth (degrees)</u>	<u>uV</u>
37.0	270.0	218.0	31.3
32.0	385.0	212.0	75.6
27.0	354.0	207.0	64.1
21.0	505.0	203.0	63.5
18.0	516.0	196.0	75.8
13.0	565.0	192.0	86.2
7.0	546.0	187.0	87.2
2.0	1080.0	183.0	183.0
357.0	1650.0	177.0	154.0
352.0	635.0	172.0	98.0
347.0	401.0	166.0	135.0
342.0	468.0	163.0	77.0
337.0	533.0	158.0	69.5
333.0	446.0	152.0	64.0
328.0	330.0	148.0	83.5
322.0	225.0	143.0	67.0
317.0	236.0	137.0	81.2
312.0	196.0	133.0	75.0
307.0	132.0	128.0	40.5
302.0	143.0	122.0	39.4
297.0	144.0	118.0	38.5
292.0	85.0	112.0	20.8
287.0	71.2	107.0	22.0
282.0	61.4	102.0	16.0
278.0	27.0	98.0	46.5
273.0	49.5	92.0	61.6
267.0	19.7	88.0	66.3
262.0	15.4	83.0	57.2
258.0	18.5	77.0	122.0
252.0	11.2	72.0	128.0
247.0	11.3	68.0	113.0
243.0	20.0	62.0	104.0
238.0	27.5	58.0	120.0
232.0	14.5	52.0	160.0
227.0	32.6	47.0	242.0
222.0	46.6	43.0	278.0

LOCALIZER SIGNAL MEASUREMENTS

Love Field Dallas, Texas
 Runway 31L
 V-Ring Localizer
 Frequency 111.7 MHz
 1/3/70
 6250' AGL 25 NM Orbit

<u>Azimuth (degrees)</u>	<u>uV</u>	<u>Azimuth (degrees)</u>	<u>uV</u>
38.0	284.0	218.0	92.0
32.0	418.0	212.0	82.4
27.0	458.0	207.0	65.3
21.0	593.0	203.0	72.0
17.0	538.0	198.0	72.0
12.0	690.0	192.0	86.3
7.0	550.0	187.0	107.0
3.0	955.0	183.0	159.0
357.0	1320.0	177.0	254.0
353.0	738.0	172.0	108.0
347.0	557.0	167.0	116.0
343.0	369.0	162.0	75.8
337.0	468.0	158.0	73.2
332.0	468.0	152.0	64.4
328.0	369.0	147.0	79.6
322.0	212.0	142.0	62.4
318.0	216.0	138.0	78.4
313.0	219.0	132.0	78.0
308.0	114.0	128.0	50.0
302.0	138.0	122.0	48.3
298.0	144.0	118.0	38.0
293.0	95.7	111.0	30.5
287.0	72.3	107.0	27.1
282.0	59.0	102.0	20.6
278.0	30.8	97.0	47.5
272.0	42.4	93.0	69.7
267.0	22.3	87.0	72.4
262.0	18.7	83.0	57.6
257.0	19.8	78.0	128.0
252.0	13.0	72.0	134.0
248.0	14.0	67.0	132.0
242.0	26.8	62.0	132.0
237.0	31.5	57.0	168.0
232.0	17.2	53.0	147.0
227.0	44.7	47.0	226.0
222.0	43.0	42.0	253.0

TEST RESULTS F

LOCALIZER SIGNAL MEASUREMENTS

Love Field Dallas, Texas
Runway 3L
V-Ring Localizer
Frequency 111.7 MHz
1/2/70
6250' AGL 00 (F.C.) Radial

<u>Distance (NM)</u>	<u>uV</u>	<u>Distance (NM)</u>	<u>uV</u>
24.8	2090.0	5.9	8250.0
24.2	2420.0	5.4	8250.0
23.7	2420.0	4.9	11,000+**
23.2	2420.0	4.3	11,000+**
22.7	2420.0	3.8	11,000+**
22.1	2888.0	3.2	11,000+**
21.6	2888.0	2.7	11,000+**
21.1	2888.0	2.2	11,000+**
20.6	3740.0	1.7	6270.0
20.1	3520.0	1.1	11,000+**
19.5	3740.0	.6	11,000+**
19.0	3740.0	.1	11,000+**
18.5	3740.0		
17.9	4565.0		
17.4	4895.0		
16.9	4895.0		
16.4	4895.0		
15.9	4895.0		
15.3	6380.0		
14.8	7150.0		
14.3	7150.0		
13.8	7150.0		
13.2	7160.0		
12.7	9075.0		
12.2	11,000+**		
11.7	11,000+**		
11.2	11,000+**		
10.7	11,000+**		
10.1	11,000+**		
9.6	11,000+**		
9.1	9075.0		
8.6	7150.0		
8.1	5940.0		
7.5	3575.0		
7.0	4565.0		
6.5	7810.0		

** Receiver AGC curve not calibrated for higher values

LOCALIZER SIGNAL MEASUREMENTS

Love Field Dallas, Texas
Runway 31L
V-Ring Localizer
Frequency 111.7 MHz
1/2/70
6250' AGL 90° Radial

<u>Distance (NM)</u>	<u>uV</u>	<u>Distance (NM)</u>	<u>uV</u>
25.9	51.0	7.0	226.0
25.6	59.0	6.5	341.0
25.1	62.0	6.0	370.0
24.6	69.0	5.4	452.0
24.0	73.0	4.9	627.0
23.5	88.0	4.4	897.0
23.0	91.0	3.8	1056.0
22.5	96.0	3.3	1056.0
22.0	91.0	2.8	1056.0
21.5	94.0	2.1	1007.0
21.0	103.0	1.6	1007.0
20.4	103.0	1.2	853.0
19.9	97.0	.7	2723.0
19.4	94.0	.4	3273.0
18.8	94.0		
18.3	94.0		
17.8	96.0		
17.3	97.0		
16.7	99.0		
16.2	107.0		
15.7	99.0		
15.1	91.0		
14.6	102.0		
14.1	139.0		
13.8	122.0		
13.0	122.0		
12.4	154.0		
11.9	193.0		
11.4	193.0		
10.8	226.0		
10.3	226.0		
9.7	193.0		
9.2	193.0		
8.6	193.0		
8.1	201.0		
7.6	207.0		

LOCALIZER SIGNAL MEASUREMENTS

Love Field Dallas, Texas
Runway 31L
V-Ring Localizer
Frequency 111.7 MHz
1/2/70
6250' AGL 180° (B.C.) Radial

<u>Distance (NM)</u>	<u>u v</u>	<u>Distance (NM)</u>	<u>u v</u>
.5	11,000+**	19.4	278.0
1.0	6270.0	19.9	259.0
1.5	3300.0	20.4	248.0
2.1	4290.0	21.0	248.0
2.6	3053.0	21.5	245.0
3.2	2860.0	22.0	229.0
3.7	2090.0	22.5	215.0
4.2	1980.0	23.1	207.0
4.8	1458.0	23.6	190.0
5.3	1248.0	24.1	182.0
5.8	1248.0	24.6	182.0
6.3	1248.0		
6.9	1248.0		
7.4	1248.0		
7.9	1188.0		
8.4	1001.0		
8.9	1001.0		
9.5	1051.0		
10.0	1051.0		
10.6	1051.0		
11.1	891.0		
11.6	891.0		
12.1	847.0		
12.7	704.0		
13.2	671.0		
13.7	671.0		
14.2	644.0		
14.7	556.0		
15.3	556.0		
15.8	449.0		
16.3	429.0		
16.8	385.0		
17.4	372.0		
17.9	332.0		
18.4	306.0		
18.9	306.0		

** Receiver AGC curve not calibrated for higher values

LOCALIZER SIGNAL MEASUREMENTS

Love Field Dallas Texas
Runway 3L
V-Ring Localizer
Frequency 111.7 MHz
6250' AGL 270° Radial

<u>Distance (NM)</u>	<u>uV</u>	<u>Distance (NM)</u>	<u>uV</u>
.7	5300.0	20.0	24.5
1.2	201.0	20.5	19.6
1.7	278.0	21.1	20.0
2.2	154.0	21.6	19.0
2.7	125.0	22.2	18.5
3.3	95.0	22.7	15.2
3.8	73.2	23.2	16.3
4.4	77.0	23.8	17.7
4.9	44.3	24.3	17.7
5.4	75.4		
6.0	75.4		
6.5	40.1		
7.1	53.7		
7.6	64.9		
8.1	44.0		
8.7	28.1		
9.2	30.3		
9.7	29.2		
10.2	29.2		
10.8	43.2		
11.3	38.0		
11.9	39.6		
12.4	39.6		
12.9	47.3		
13.4	44.3		
14.0	44.3		
14.5	46.2		
15.0	45.0		
15.6	38.5		
16.2	31.4		
16.7	29.7		
17.2	29.2		
17.8	28.6		
18.3	28.0		
18.9	28.0		
19.5	28.0		

TEST RESULTS G

LOCALIZER SIGNAL MEASUREMENTS

Westmoreland - Latrobe Airport Latrobe, Pa.
Runway 23
Twin-T Localizer
Frequency 110.9 MHz
10/29/69
3000' AGL 25 NM Orbit

<u>Azimuth (degrees)</u>	<u>u v</u>	<u>Azimuth (degrees)</u>	<u>u v</u>
129.0	**	308.0	10.9
123.0	**	304.0	6.9
119.0	**	298.0	6.9
113.0	**	294.0	6.8
109.0	**	288.0	4.4
103.0	**	284.0	3.9
98.0	**	278.0	**
93.0	**	274.0	**
88.0	**	269.0	**
84.0	**	263.0	**
79.0	**	258.0	**
73.0	**	254.0	**
68.0	**	248.0	**
63.0	**	244.0	3.5
58.0	**	238.0	5.0
53.0	**	234.0	4.5
48.0	**	229.0	4.4
43.0	**	224.0	4.0
38.0	4.2	218.0	10.9
33.0	5.9	213.0	8.5
28.0	5.5	208.0	10.7
23.0	4.4	204.0	12.3
18.0	3.7	199.0	6.1
13.0	13.8	193.0	13.4
8.0	30.1	188.0	27.3
3.0	54.8	184.0	29.8
358.0	63.8	178.0	34.1
353.0	49.9	174.0	32.2
348.0	28.3	168.0	20.2
344.0	20.6	163.0	9.5
338.0	20.4	158.0	12.3
333.0	19.9	154.0	16.6
329.0	21.3	149.0	9.4
323.0	14.6	143.0	4.4
318.0	12.0	138.0	4.6
314.0	13.8	134.0	**

** Receiver input less than 3.3 microvolts

LOCALIZER SIGNAL MEASUREMENTS

Westmoreland - Latrobe Airport Latrobe, Pa.
 Runway 23
 Twin-T Localizer
 Frequency 110.9 MHz
 10/29/69
 4000' AGL 25 NM Orbit

<u>Azimuth (degrees)</u>	<u>uV</u>	<u>Azimuth (degrees)</u>	<u>uV</u>
129.0	3.7	308.0	17.4
123.0	**	304.0	11.6
119.0	**	298.0	12.0
113.0	**	293.0	13.9
108.0	**	289.0	8.4
104.0	**	283.0	6.3
98.0	**	279.0	5.5
93.0	**	273.0	4.4
88.0	**	269.0	4.7
84.0	**	263.0	**
79.0	**	258.0	**
73.0	**	254.0	5.1
69.0	**	248.0	5.4
63.0	**	244.0	6.3
59.0	**	238.0	8.3
53.0	**	234.0	8.9
49.0	**	228.0	6.6
44.0	**	221.0	10.1
38.0	7.0	219.0	11.0
33.0	12.2	214.0	11.1
12.0	57.9	209.0	11.0
8.0	74.3	203.0	14.2
3.0	101.0	198.0	17.3
357.0	117.0	194.0	18.9
353.0	83.1	188.0	42.0
348.0	49.3	183.0	69.6
344.0	36.3	178.0	73.8
338.0	38.2	173.0	67.1
333.0	32.2	169.0	34.0
329.0	36.3	164.0	16.6
323.0	20.2	158.0	19.8
319.0	16.5	153.0	27.2
313.0	20.4	149.0	25.7
		143.0	13.1
		138.0	9.6

** Receiver input less than 3.3 microvolts

LOCALIZER SIGNAL MEASUREMENTS

Westmoreland - Latrobe Airport Latrobe, Pa.
 Runway 23
 Twin-T Localizer
 Frequency 110.9 MHz
 10/29/69
 5000' AGL 25 NM Orbit

<u>Azimuth (degrees)</u>	<u>uv</u>	<u>Azimuth (degrees)</u>	<u>uv</u>
134.0	8.0	313.0	23.7
129.0	5.8	309.0	19.6
124.0	4.2	303.0	16.0
118.0	**	298.0	15.5
113.0	**	294.0	16.9
109.0	**	288.0	12.2
104.0	**	283.0	8.7
98.0	**	278.0	7.2
93.0	**	274.0	6.9
89.0	**	268.0	6.1
84.0	**	263.0	4.6
79.0	**	259.0	4.8
75.0	**	253.0	5.9
69.0	**	248.0	8.5
64.0	3.7	243.0	11.8
59.0	**	238.0	12.4
54.0	**	234.0	12.4
48.0	**	228.0	9.5
43.0	6.2	224.0	10.2
38.0	9.7	218.0	15.0
34.0	18.2	213.0	22.7
28.0	34.0	208.0	17.5
23.0	32.0	203.0	18.4
18.0	31.0	199.0	15.8
13.0	43.0	193.0	23.9
9.0	64.0	188.0	46.2
3.0	125.0	183.0	81.1
358.0	171.0	178.0	90.8
353.0	120.0	173.0	64.0
349.0	61.0	168.0	31.8
342.0	35.0	162.0	22.7
338.0	36.7	159.0	22.9
333.0	38.4	153.0	28.9
328.0	37.6	148.0	32.3
323.0	31.5	144.0	27.8
319.0	21.2	139.0	20.6

** Receiver input less than 3.3 microvolts

LOCALIZER SIGNAL MEASUREMENTS

Westmoreland - Latrobe Airport Latrobe, Pa.
 Runway 23
 Twin-T Localizer
 Frequency 110.9 MHz
 10/29/69
 6250' AGL 25 NM Orbit

<u>Azimuth (degrees)</u>	<u>uV</u>	<u>Azimuth (degrees)</u>	<u>uV</u>
123.0	14.7	303.0	17.1
119.0	11.0	298.0	18.7
113.0	7.9	293.0	19.8
109.0	9.7	289.0	14.9
103.0	**	282.0	10.9
99.0	4.4	278.0	8.1
93.0	**	273.0	7.3
88.0	**	268.0	7.6
84.0	**	263.0	6.5
78.0	**	259.0	6.3
73.0	**	253.0	6.3
69.0	4.0	248.0	10.8
63.0	6.6	243.0	14.3
58.0	6.6	238.0	14.3
53.0	5.8	233.0	15.5
49.0	6.3	228.0	12.3
44.0	10.6	224.0	14.0
38.0	19.4	218.0	20.2
34.0	33.7	213.0	22.9
28.0	44.2	209.0	24.6
23.0	32.1	203.0	22.9
18.0	29.2	199.0	27.0
13.0	49.2	193.0	47.0
7.0	93.5	188.0	74.1
3.0	119.0	183.0	86.1
359.0	174.0	178.0	124.0
353.0	158.0	173.0	83.9
349.0	69.3	169.0	49.6
342.0	45.5	163.0	30.6
338.0	44.2	158.0	32.0
333.0	44.7	154.0	36.5
328.0	42.7	148.0	37.3
323.0	38.9	143.0	32.7
319.0	25.3	139.0	20.0
313.0	27.7	134.0	13.5
308.0	19.4		

** Receiver input less than 3.3 microvolts

TEST RESULTS H

LOCALIZER SIGNAL MEASUREMENTS

Westmoreland-Latrobe Airport Latrobe, Pa.
Runway 23
Twin-T Localizer
Frequency 110.9 MHz
10/28/69
1000' AGL 0° (F.C.) Radial

<u>Distance (NM)</u>	<u>u v</u>	<u>Distance (NM)</u>	<u>u v</u>
	18.0	11.2	165.0
27.5	18.0	10.8	167.0
26.9	19.0	10.3	187.0
26.5	20.0	9.9	171.0
26.0	20.0	9.4	178.0
25.5	22.0	8.9	220.0
25.1	25.0	8.5	231.0
24.6	25.9	8.0	240.0
24.2	27.0	7.6	275.0
23.7	30.0	7.0	314.0
23.3	35.0	6.6	314.0
22.8	36.0	6.1	341.0
22.4	37.0	5.6	363.0
22.0	34.0	5.1	363.0
21.6	36.0	4.7	435.0
21.2	45.0	4.2	473.0
20.6	44.0	3.6	553.0
20.2	59.0	3.2	627.0
19.7	61.0	2.7	814.0
19.3	65.0	2.2	1045.0
18.8	64.0	1.7	1472.0
18.3	80.0	1.2	2008.0
17.9	78.0	.7	4510.0
17.6	74.0	.2	1650.0
17.2	70.0		
16.7	92.0		
16.3	92.0		
15.7	94.0		
15.3	109.0		
14.8	116.0		
14.4	116.0		
13.9	120.0		
13.5	135.0		
13.0	138.0		
12.6	143.0		
12.1	149.0		
11.7			

LOCALIZER SIGNAL MEASUREMENTS

Westmoreland-Latrobe Airport Latrobe, Pa.

Runway 23

Twin-T Localizer

Frequency 110.9 MHz

10/28/69

6250' AGL 0° (F.C.) Radial

<u>Distance (NM)</u>	<u>uy</u>	<u>Distance (NM)</u>	<u>uy</u>
24.7	130.0	3.0	1706.0
24.1	130.0	2.4	1293.0
23.6	124.0	1.8	506.0
22.9	132.0	1.2	2228.0
22.4	154.0	.6	1238.0
21.7	154.0		
21.1	160.0		
20.6	160.0		
19.9	174.0		
19.3	176.0		
18.7	182.0		
18.1	201.0		
17.5	207.0		
16.9	215.0		
16.3	229.0		
15.7	252.0		
15.1	256.0		
14.5	289.0		
13.9	300.0		
13.3	303.0		
12.7	336.0		
12.1	361.0		
11.5	369.0		
10.9	396.0		
10.3	396.0		
9.7	440.0		
9.1	490.0		
8.4	534.0		
7.8	594.0		
7.2	638.0		
6.6	748.0		
6.0	847.0		
5.4	968.0		
4.8	1205.0		
4.2	1485.0		
3.6	1815.0		

LOCALIZER SIGNAL MEASUREMENTS

Westmoreland-Latrobe Airport Latrobe, Pa.

Runway 23

Twin-T Localizer

Frequency 110.9 MHz

10/28/69

6250' AGL 90° Radial

<u>Distance (NM)</u>	<u>uV</u>	<u>Distance (NM)</u>	<u>uV</u>
.3	176.0	21.9	**
.8	130.0	22.4	**
1.3	50.0	23.0	**
1.9	15.0	23.7	**
2.5	25.0	24.3	**
3.1	31.0		
3.6	30.0		
4.2	29.0		
4.8	26.0		
5.4	23.0		
5.9	21.0		
6.5	19.0		
7.1	18.0		
7.6	15.0		
8.3	13.0		
8.9	13.0		
9.4	10.5		
10.0	8.7		
10.6	8.3		
11.2	7.2		
11.8	6.7		
12.4	6.4		
13.0	5.4		
13.6	4.8		
14.2	5.3		
14.8	5.1		
15.4	4.7		
16.0	4.3		
16.6	3.6		
17.2	3.5		
17.7	**		
18.0	**		
19.0	**		
20.1	**		
20.7	**		
21.3	**		

** Receiver input less than 3.3 microvolts

LOCALIZER SIGNAL MEASUREMENTS

Westmoreland-Latrobe Airport Latrobe, Pa.

Runway 23

Twin-T Localizer

Frequency 110.9 MHz

10/28/69

1000' AGL 180° (B.C.) Radial

<u>Distance (NM)</u>	<u>u v</u>	<u>Distance (NM)</u>	<u>u v</u>
.3	1040.0	18.0	21.0
.8	1513.0	18.6	20.0
1.2	1045.0	19.1	18.0
1.7	825.0	19.5	17.0
2.2	605.0	20.3	15.0
2.7	407.0	20.9	15.0
3.2	325.0	21.3	14.0
3.6	248.0	21.8	15.0
4.2	209.0	22.4	14.0
4.7	165.0	22.9	13.0
5.1	141.0	23.1	11.0
5.7	122.0	23.4	11.0
6.2	110.0	23.9	9.0
6.7	101.0	24.3	9.0
7.3	92.0	24.9	8.0
7.8	83.0		
8.3	77.0		
8.9	67.0		
9.4	66.0		
9.9	59.0		
10.4	54.0		
10.8	51.0		
11.3	45.0		
11.9	42.0		
12.4	39.0		
12.9	37.0		
13.3	39.0		
13.8	37.0		
14.3	36.0		
14.8	32.0		
15.3	32.0		
15.7	31.0		
16.2	28.0		
16.6	26.0		
17.1	24.0		
17.6	21.0		

LOCALIZER SIGNAL MEASUREMENTS

Westmoreland-Latrobe Airport Latrobe, Pa.

Runway 23

Twin-T Localizer

Frequency 110.9 MHz

10/28/69

6250' AGL 180° (B.C.) Radial

<u>Distance (NM)</u>	<u>uV</u>	<u>Distance (NM)</u>	<u>uV</u>
.1	190.0	22.5	58.0
.7	633.0	23.0	54.0
1.3	616.0	23.7	53.0
1.9	168.0	24.3	51.0
2.5	413.0		
3.1	451.0		
3.7	446.0		
4.4	468.0		
5.0	462.0		
5.6	424.0		
6.2	432.0		
6.8	396.0		
7.4	325.0		
8.0	292.0		
8.6	267.0		
9.3	273.0		
9.9	267.0		
10.5	245.0		
11.1	231.0		
11.7	207.0		
12.3	193.0		
12.9	174.0		
13.6	157.0		
14.3	146.0		
14.9	135.0		
15.5	124.0		
16.2	113.0		
16.8	107.0		
17.4	101.0		
18.0	89.0		
18.7	84.0		
19.3	78.0		
19.9	70.0		
20.6	68.0		
21.2	64.0		
21.8	63.0		

LOCALIZER SIGNAL MEASUREMENTS

Westmoreland-Latrobe Airport Latrobe, Pa.
 Runway 23
 Twin-T Localizer
 Frequency 110.9 MHz
 10/28/69
 6250' AGL 270° Radial

<u>Distance (degrees)</u>	<u>uV</u>	<u>Distance (degrees)</u>	<u>u V</u>
24.4	6.3	4.5	65.0
23.9	6.4	3.9	76.0
23.3	6.4	3.4	90.0
22.8	6.6	2.8	85.0
22.2	7.3	2.2	46.0
21.7	7.5	1.6	75.0
21.1	7.8	1.0	124.0
20.6	8.1	.5	87.0
20.0	8.0		
19.5	8.5		
19.0	10.7		
18.4	10.8		
17.8	11.3		
17.3	11.3		
16.8	12.7		
16.2	13.8		
15.7	13.2		
15.1	13.5		
14.6	15.2		
14.0	16.5		
13.5	17.1		
12.9	18.2		
12.3	20.9		
11.8	22.9		
11.2	23.7		
10.7	20.9		
10.1	23.4		
9.6	20.7		
9.0	26.2		
8.5	26.7		
7.9	30.3		
7.4	36.6		
6.8	39.4		
6.2	43.5		
5.7	50.1		
5.1	53.4		

RECEIVER SIGNAL LEVEL TESTS

On August 26, 1969 two approaches were made on the Runway 13L 8-Loop Localizer at Love Field Dallas, Texas. The first approach the N-102 made was a normal ILS approach from the outer marker to the runway threshold at which point the plane flew at a height of 50' along the centerline of the runway to the localizer antennas at which point the test was broken off. In order to avoid RF saturation of both receivers a 30 dB attenuator was inserted in Receiver #3's RF input. The N-102 made a normal ILS approach and landing. Once on the ground the plane rolled out to the end of the runway before turning off. Again in order to avoid saturation of both receivers a 40 dB attenuator was inserted in Receiver #3's RF input. In order to establish distance to the localizer antennas, various ground check points were noted on the chart recorder when they were flown over. Later these checkpoints were converted to distance from the antennas. For altitude, the plane's altimeter was used. The receiver signal level tests curves illustrate the back and front course of the flights with corrections. The Back Course data has not been placed in tabular form due to receiver difficulty.

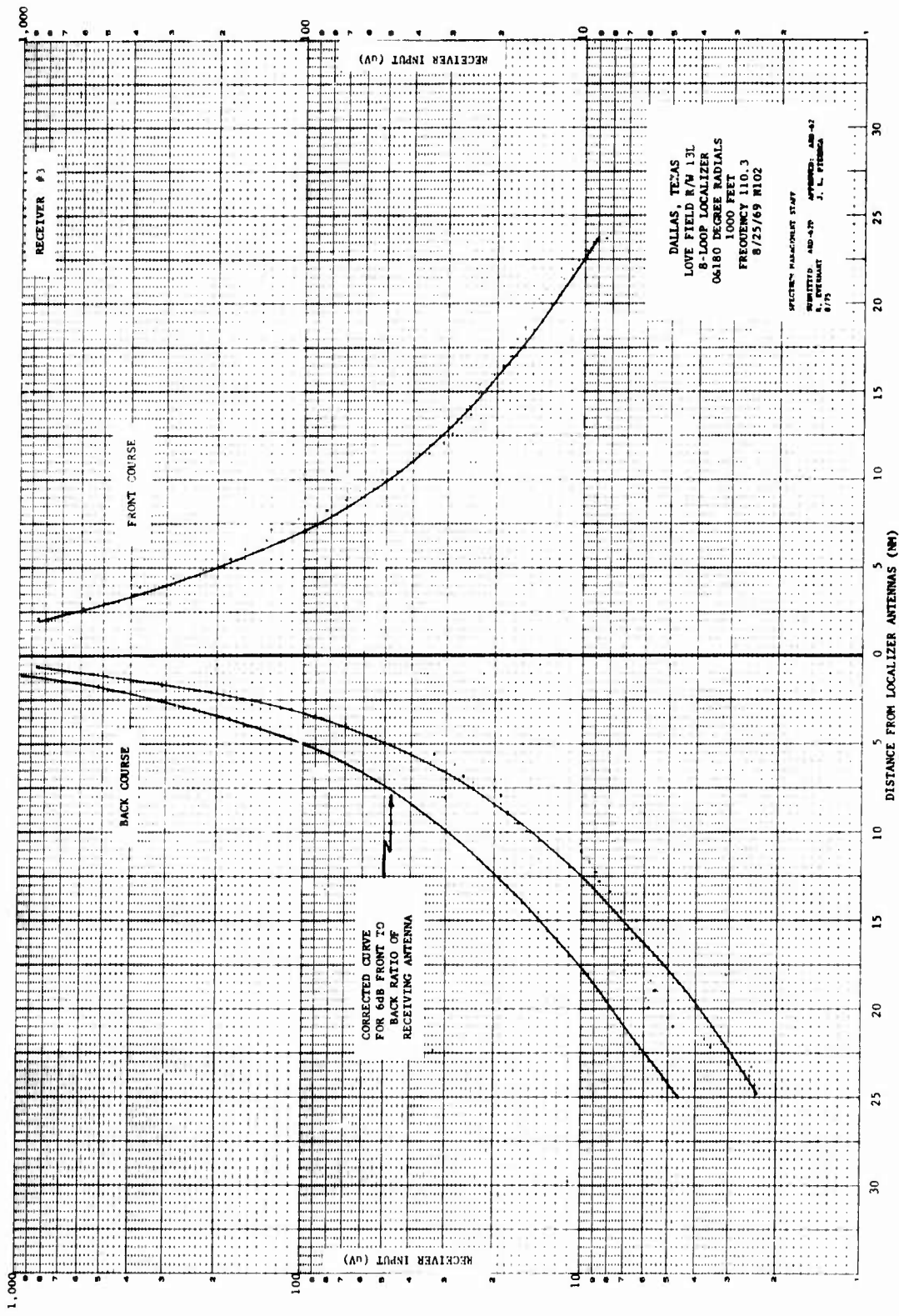

ALTITUDE FLOWN 1000 FEET - 8-LOOP LOCALIZER

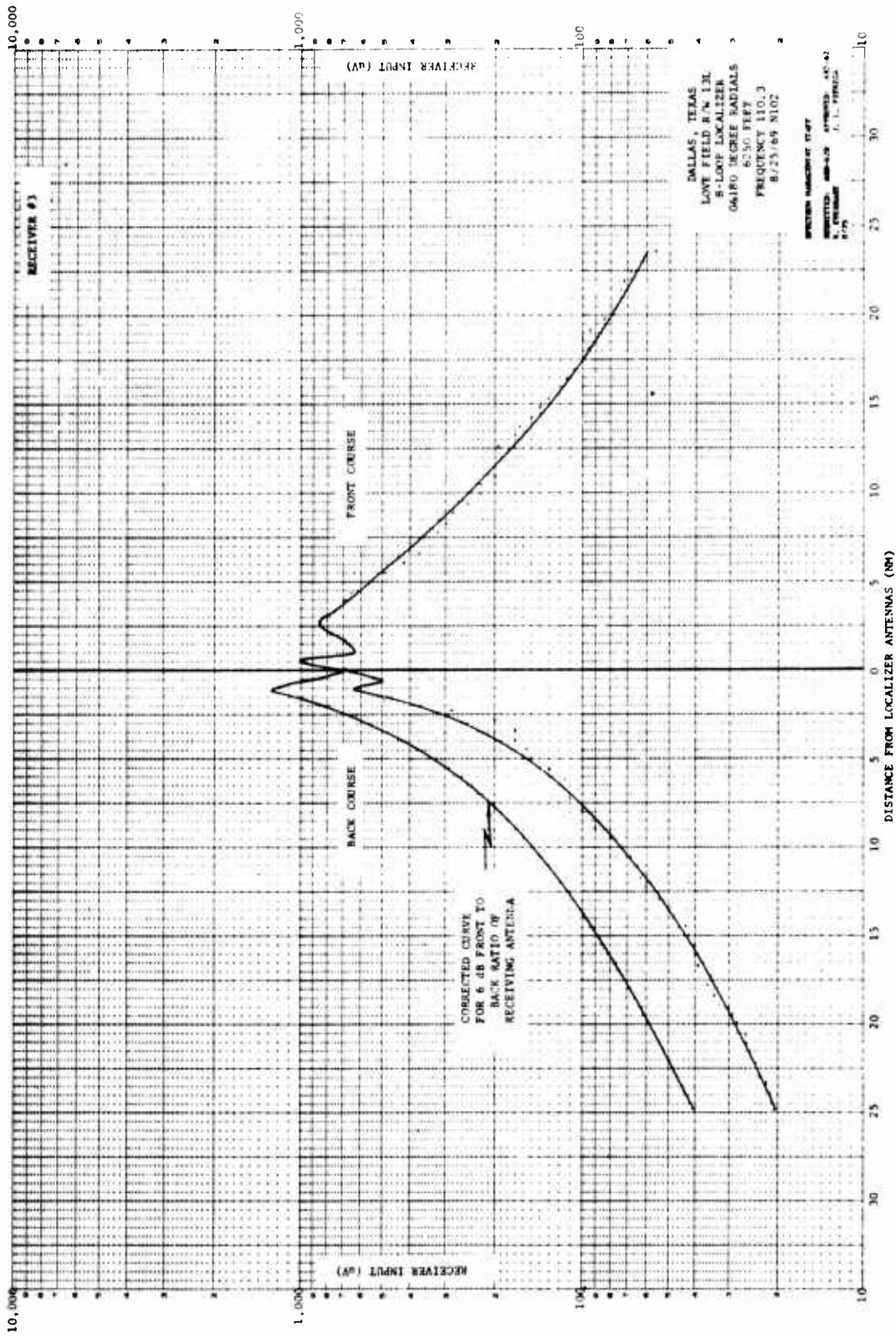

ALTITUDE FLOWN 6250 FEET - 8-LOOP LOCALIZER

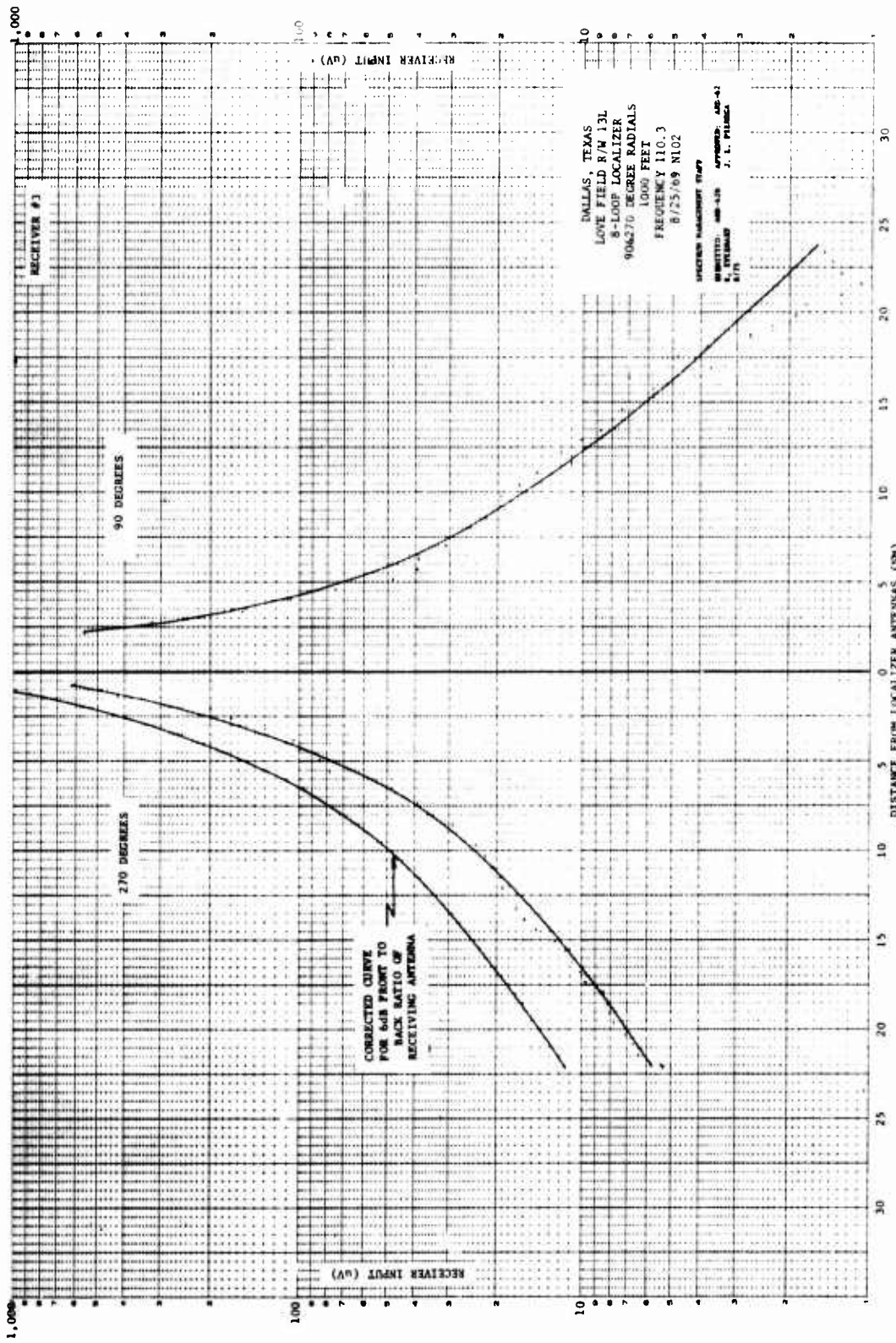

ALTITUDE FLOWN 1000 FEET - 8-LOOP LOCALIZER

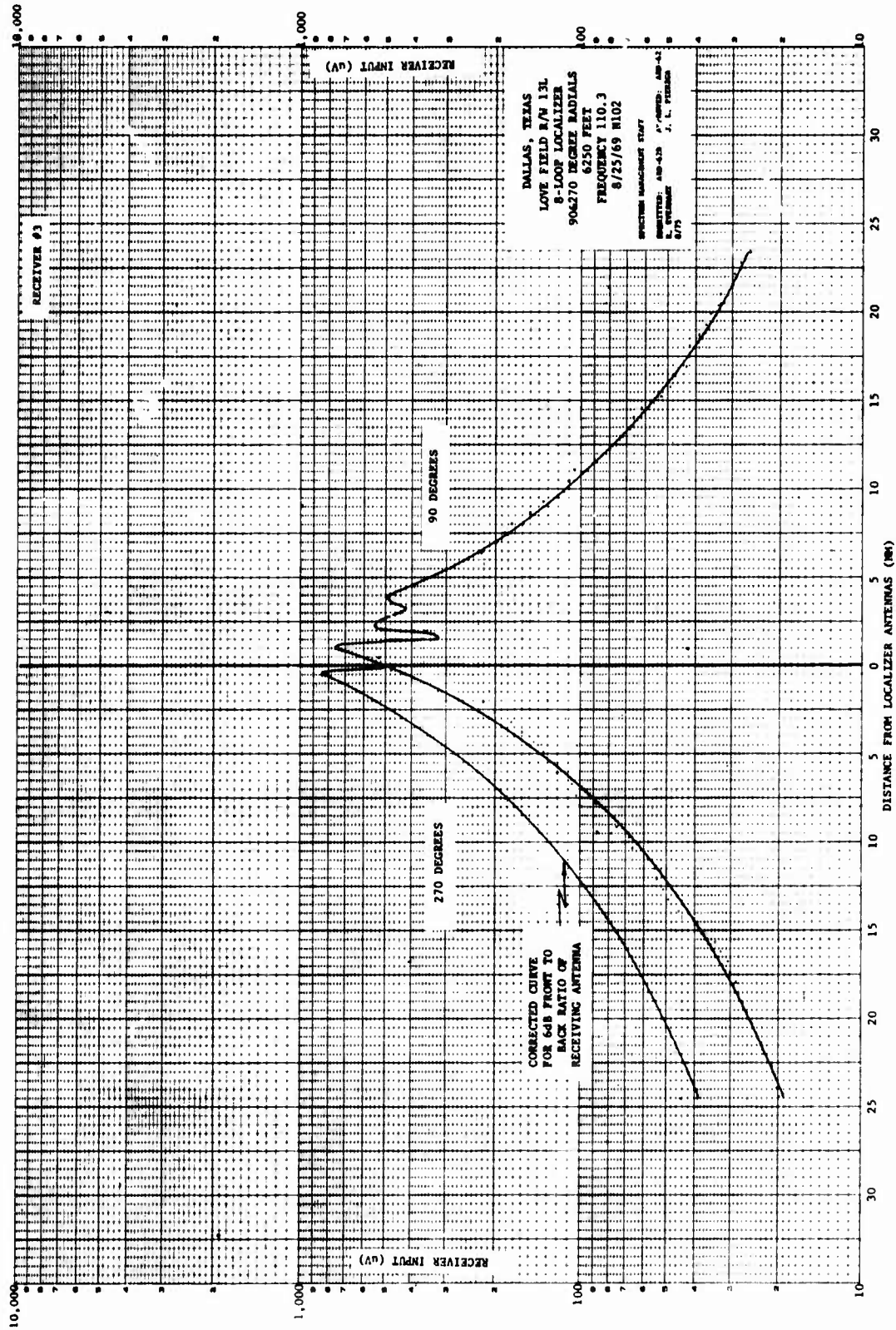

ALTITUDE FLOWN 6250 FEET - 8-LOOP LOCALIZER

CONCLUSION

- A. Antenna Gain - From the orbital data the gain of the various antenna systems was determined using the following formula.

$$ERP_u \text{ (dB)} - ERP_k \text{ (dB)} = 10 \text{ Log } (P_{tu}/P_{tk})$$

where P_t = Power Transmitted

$$\text{since } P_t = \frac{E^2 r^2}{30} \quad \begin{array}{l} E = \text{Field intensity (v/m)} \\ r = \text{distance from facility (meters)} \end{array}$$

$$ERP = A_g + P \quad \begin{array}{l} A_g = \text{antenna gain (dB)} \\ P = \text{carrier power to antenna (dB)} \end{array}$$

The equation becomes the following

$$(A_{gu} + P_u) - (A_{gk} + P_k) = 10 \text{ Log } \frac{\frac{E_u^2 r^2}{30}}{\frac{E_k^2 r^2}{30}} \quad r = \text{constant}$$

$$A_{gu} = 20 \text{ Log } \frac{E_u}{E_k} + P_k + A_{gk} - P_u$$

Our known antenna system will be the Dallas 13L 8-Loop Localizer. The gain of this antenna system is 4 dB and the Carrier Power to the antennas was 37.5 watts (15.8 dBW). Substituting these values into the above equation we have

$$A_{gu} = 20 \text{ Log } \frac{E_u}{E_k} + 19.8 - P_u$$

The above formula will have to be modified to allow us to use Receiver Input (E) values instead of Field Intensity (E). Below is the rational for the new formula using Receiver input.

$$P_r \text{ (dBw)} = P_d \text{ (dBw)} - 10 \text{ Log } \frac{d^2}{4} \quad \frac{d^2}{4} = K$$

$$10 \text{ Log } \frac{E^2}{R} = 10 \text{ Log } \frac{E^2}{120} - 10 \text{ Log } K$$

$$\frac{E^2}{R} = \frac{E^2}{120}$$

$$E = \frac{120 \text{ K}}{R} E \quad \frac{120 \text{ K}}{R} = K_1$$

$$E = K_1 E$$

$$A_{gu} = 20 \text{ Log } \frac{K_1 E_u}{K_1 E_k} + 19.8 - P_u$$

$$A_{gu} = 20 \text{ Log } \frac{E_u}{E_k} + 19.8 - P_u$$

By substituting the appropriate carrier power for each system tube evaluated we get the following results.

Dallas 13L V-Ring

$$A_g = 20 \text{ Log } \frac{E_u}{E_k} + 19.8 - 20.7 \text{ (118w)}$$

$$A_g = 20 \text{ Log } \frac{E_u}{E_k} - .9$$

Dallas 31L V-Ring

$$A_g = 20 \text{ Log } \frac{E_u}{E_k} + 19.8 - 21.5 \text{ (140w)}$$

$$A_g = 20 \text{ Log } \frac{E_u}{E_k} - 1.7$$

Latrobe 23 Twin-T

$$A_g = 20 \text{ Log } \frac{E_u}{E_k} + 19.8 - 4 \text{ (2.5w)}$$

$$A_g = 20 \text{ Log } \frac{E_u}{E_k} + 15.8$$

ANTENNA GAIN

FACILITY	1000' AGL		2000' AGL		3000' AGL		4000' AGL		5000' AGL		6250' AGL		AVG	
	E uV	A _g dB	E uV	A _g dB	E uV	A _g dB	E uV	A _g dB	E uV	A _g dB	E uV	A _g dB	E uV	A _g dB
8 Loop Dallas 13L	12.5	4.0	29.3	4.0	51.4	4.0	82.7	4.0	70.7	4.0	100.5	4.0	57.8	4.0
V-Ring Dallas 13L	59.6	12.7	150.2	13.3	236	12.4	311	10.6	281	11.1	281	8.1	219.8	11.4
V-Ring Dallas 31L	145	19.6	387	20.7	557	19.0	906	19.1	1308	23.6	1137	19.4	740.0	20.2
Twin-T Latrobe 23	NA	NA	NA	NA	60.2	17.2	109	18.2	152.6	22.5	160	19.8	120.4	19.4

Notes: 1 - Elevated V-Ring
2 - Antenna Gain above an isotropic

B. Antenna Directivity - The directivity of each of the four antenna systems has been calculated for $\pm 10^\circ$ and $\pm 35^\circ$. These azimuths were chosen because of their use by ICAO (Annex 10) as the azimuth limits of the localizer coverage sector. Also the ratio of the front course signal to the back course signal was calculated. All numbers were taken from the respective orbits involved. The formulas used were as follows.

$$\text{Directivity (dB)} = 20 \text{ Log (Receiver Input (E) at } 0^\circ / \text{Receiver Input (E) at desired azimuth)}$$

$$\text{Front/Back (dB)} = 20 \text{ Log (Receiver Input (E) at } 0^\circ / \text{Receiver Input (E) at } 180^\circ)$$

DIRECTIVITY

	1000' AGL	2000' AGL	3000' AGL	4000' AGL	5000' AGL	6250' AGL	AVG
Dallas 13L	+350	7.8 dB	4.8 dB	3.7 dB	6.7	1.9 dB	2.7 dB
	+100	.2 dB	.3 dB	2 dB	2.2 dB	2.8 dB	0 dB
	-350	.6 dB	-0.9	0 dB	.7 dB	-1.5 dB	0 dB
8 Loop	-100	0 dB	-2.2 dB	-8 dB	1.7 dB	-0.3 dB	-0.4 dB
	Front	7.5 dB	9.9 dB	9 dB	7.6 dB	6.8 dB	7.2 dB
	Back						8 dB
Dallas 13L	+350	15.5	11.3	10.6	12.6	12.5	10.0
	+100	7.3 dB	6.9 dB	5.0 dB	4.1 dB	2.3 dB	2.3 dB
	-350	9.7	10.2	10.5	9.3 dB	10.0	7 dB
V-Ring	-100	4 dB	6.6 dB	4.7 dB	2.9 dB	1.5 dB	1.6 dB
	Front	12 dB	13.1 dB	12.9 dB	12.1 dB	7.6 dB	6.6 dB
	Back						10.7 dB
Dallas 31L	+350	8.4 dB	9.6	10.3	11.5	12.3	10.2
	+100	5.1 dB	6.5 dB	6.2 dB	6.6 dB	7.5 dB	5.1 dB
	-350	14.1	15.2	14.1	12 dB	13.5	11.8
V-Ring	-100	6.9 dB	9.4 dB	6.6 dB	5.9 dB	7.7 dB	4.9 dB
	Front	10.6 dB	11.9 dB	13.6 dB	14.3 dB	17.8 dB	14.8 dB
	Back						13.8 dB
3	+350	2	2	21.3	20.7	19.6	19.3
	+100			8.1 dB	4.4 dB	8.3 dB	7 dB
	-350			10.9	12.3	13.1	12 dB
Latrobe 23	-100	2	2	4.2 dB	4.8 dB	6 dB	0.9 dB
	Front			5.3 dB	3.6 dB	4.9 dB	3.4 dB
	Back						4.3 dB

- Notes 1 - Screened back course
- 2 - Data not taken due to terrain
- 3 - Elevated V-Ring

SUPPLEMENTAL DATA

This information is additional orbital data on a Boston V-Ring (110.3 MHz) and a Laconia VOR LOC (108.5 MHz) both facilities are located in Massachusetts, also a Nantucket 8 loop (109.1 MHz) in New Hampshire. The altitudes recorded were 2000', 3000', 4000', 5000' and 6250'. 1000' recordings were not made due to terrain conditions. Both 4165.3A Bendix receivers were calibrated at uV values of 1, 2, 3, 5, 10, 15, 20, 25, 50, 100, 200, 300, 500, 1000, 2000, 5000 and 10,000 and were plotted for comparison.

LOCALIZER SIGNAL MEASUREMENTS

LOCATION Boston vs Laconia
 DATE 6/9/70
 ALTITUDE 2000 feet
 DIRECTION C.C.W. Orbit
 FLIGHT #167
 AIRCRAFT #N-102

FREQUENCY Boston - 110.3 MHz
 RECEIVER #1010
 ANTENNA TYPE Boston - V-Ring
 FREQUENCY Laconia - 108.5 MHz
 RECEIVER #1009
 ANTENNA TYPE Laconia - VOR LOC

<u>BOSTON</u>			<u>LACONIA</u>			<u>Total Dist (NM)</u>	<u>D/U</u>
<u>Az</u>	<u>Dist (NM)</u>	<u>uV</u>	<u>Az</u>	<u>Dist</u>	<u>uV</u>		
055.7°	24.5	10.4	161.3°	63.0	1.3	87.5	18.1
050.6°	23.8	9.0	162.5°	61.2	1.3	85.0	16.8
045.1°	23.4	14.5	163.8°	59.3	1.4	82.7	20.3
040.9°	23.3	19.5	164.8°	58.0	1.4	81.3	22.9
035.5°	23.2	55.0	166.2°	56.3	1.2	79.5	33.2
030.2°	23.3	23.3	167.7°	54.7	1.5	78.0	23.8
024.9°	23.5	12.4	169.3°	53.1	1.5	76.6	18.4
020.9°	23.9	8.9	170.5°	52.0	-	75.9	-
014.9°	24.7	8.1	172.8°	50.1	1.4	74.8	15.2
010.0°	24.2	5.5	175.3°	50.0	1.4	74.2	11.9
005.2°	23.5	5.2	177.7°	50.3	1.1	73.8	13.5
359.8°	23.2	5.6	180.2°	50.5	*	73.7	-
355.8°	23.0	4.2	182.0°	50.8	*	73.8	-
350.8°	23.0	3.5	184.3°	51.2	*	74.2	-
345.2°	23.2	2.7	186.7°	51.6	1.3	74.8	6.3
339.9°	23.7	1.8	189.1°	52.1	1.4	75.8	2.1
334.9°	24.3	1.6	191.4°	52.7	1.3	77.0	1.8
330.5°	25.0	1.3	193.4°	53.5	1.4	78.5	-0.6
330.5°	24.2	*	194.2°	55.4	1.8	79.6	-
319.9°	23.5	1.0	195.2°	57.8	2.0	81.3	-6.0
315.9°	23.2	1.8	195.8°	59.3	2.1	82.5	-1.3
310.5°	23.0	3.3	196.6°	61.4	3.4	84.4	-0.2
304.8°	23.1	5.0	197.4°	63.5	4.0	86.6	1.9
300.7°	23.2	6.4	197.9°	65.0	4.1	88.2	3.8
295.4°	23.6	7.4	198.5°	67.1	2.1	90.7	10.9
290.1°	24.1	6.7	199.1°	69.3	2.4	93.4	8.9
285.1°	24.8	9.4	199.6°	71.4	2.0	96.2	13.4
280.5°	24.3	9.7	199.0°	73.3	3.3	97.6	9.4
275.7°	23.8	13.3	198.5°	74.6	2.4	98.4	14.9
270.6°	22.8	20.7	197.2°	76.9	1.6	99.7	22.2
265.0°	22.6	19.7	196.5°	78.9	2.5	101.5	17.9
260.9°	22.6	23.6	196.1°	80.5	2.1	103.1	21.0
255.3°	23.0	19.7	195.6°	82.6	1.8	105.6	20.8
250.0°	23.5	27.0	194.5°	84.6	*	108.1	-

* uV Values Less Than 1 are not Recorded

LOCALIZER SIGNAL MEASUREMENTS

LOCATION Boston vs Loconia
 DATE 6/9/70
 ALTITUDE 3000 feet
 DIRECTION C.C.W. Orbit
 FLIGHT #167
 AIRCRAFT #N-102

FREQUENCY Boston - 110.3 MHz
 RECEIVER #1010
 ANTENNA TYPE Boston - V-Ring
 FREQUENCY Laconia - 108.5 MHz
 RECEIVER #1009
 ANTENNA TYPE Laconia - VOR LOC

<u>BOSTON</u>			<u>LACONIA</u>			<u>Total</u>	<u>D/U</u>
<u>Az</u>	<u>Dist (NM)</u>	<u>uV</u>	<u>Az</u>	<u>Dist</u>	<u>uV</u>	<u>Dist (NM)</u>	
059.0°	25.4	14.2	160.2°	64.3	*	89.7	-
054.6°	24.4	13.5	161.5°	62.6	*	87.0	-
049.7°	23.8	11.5	162.7°	60.9	*	84.7	-
044.3°	23.4	9.5	164.0°	59.1	1.0	82.5	19.6
040.2°	23.2	26.0	165.0°	57.8	*	81.0	-
034.9°	23.2	56.0	166.4°	56.1	*	79.3	-
029.9°	23.4	31.0	167.8°	54.4	1.4	77.8	27.0
024.5°	23.6	17.1	169.1°	53.2	1.1	76.8	23.8
020.4°	24.2	14.2	170.7°	51.6	1.3	75.8	20.8
015.4°	24.9	11.5	172.5°	50.1	1.3	75.0	18.9
010.5°	24.2	8.5	175.0°	50.0	1.4	74.2	15.7
005.6°	23.6	8.9	177.4°	50.2	1.7	73.8	14.4
000.5°	23.3	10.4	179.9°	50.4	1.6	73.7	16.3
355.1°	23.1	8.2	182.3°	50.7	1.5	73.8	14.8
349.7°	23.1	5.2	184.7°	51.1	1.6	74.2	10.2
344.4°	23.3	2.7	187.0°	51.6	1.7	74.9	4.0
340.4°	23.6	2.6	188.8°	52.1	2.0	75.7	2.2
335.3°	24.2	2.1	191.1°	52.7	2.4	76.9	6.8
330.5°	24.9	3.1	193.3°	53.5	2.4	78.4	6.6
325.2°	24.1	1.1	194.4°	55.6	4.4	79.7	7.3
320.2°	23.5	1.5	195.2°	57.7	2.3	81.2	7.8
314.7°	23.2	3.2	196.0°	59.7	3.2	82.9	8.2
310.4°	23.1	4.1	196.7°	61.4	2.6	84.5	8.5
304.6°	23.0	5.3	197.4°	63.5	2.6	86.5	8.8
300.4°	23.2	9.1	197.9°	65.2	3.4	88.4	8.9
294.9°	23.6	9.2	198.5°	67.3	2.5	90.9	9.1
289.5°	24.2	9.2	199.1°	69.5	2.7	93.7	9.2
285.6°	24.8	12.3	199.6°	71.2	3.9	96.0	9.2
280.5°	24.0	16.1	198.8°	73.3	2.1	97.3	9.6
275.0°	23.3	19.7	197.9°	75.4	1.7	98.7	10.2
269.4°	22.9	31.8	197.1°	77.5	1.7	100.4	10.6
264.9°	22.8	35.0	196.6°	79.1	2.1	101.9	10.8
260.7°	22.8	33.5	195.6°	80.6	2.1	103.4	11.0
255.0°	23.1	52.0	194.6°	82.8	1.8	105.9	11.1

*uV Values Less Than 1 are not Recorded

LOCALIZER SIGNAL MEASUREMENTS

LOCATION <u>Boston vs Laconia</u>	FREQUENCY <u>Boston - 110.3 MHz</u>
DATE <u>6/9/70</u>	RECEIVER <u>#1010</u>
ALTITUDE <u>4000 feet</u>	ANTENNA TYPE <u>Boston - V-Ring</u>
DIRECTION <u>C.C. W. Orbit</u>	FREQUENCY <u>Laconia - 108.5 MHz</u>
FLIGHT <u>#167</u>	RECEIVER <u>#1009</u>
AIRCRAFT <u>#N-102</u>	ANTENNA TYPE <u>Laconia - VOR LOC</u>

<u>BOSTON</u>			<u>LACONIA</u>			<u>Total</u>	
<u>Az</u>	<u>Dist (NM)</u>	<u>uV</u>	<u>Az</u>	<u>Dist</u>	<u>uV</u>	<u>Dist (NM)</u>	<u>D/U</u>
044.7°	23.4	15.4	164.0°	59.3	1.6	82.7	19.6
039.5°	23.1	30.8	165.3°	57.6	1.5	80.7	26.2
035.5°	23.1	62.4	166.3°	56.4	1.7	79.5	31.3
030.2°	23.2	38.0	167.7°	54.8	1.9	78.0	26.0
025.0°	23.5	23.1	169.3°	53.2	1.8	76.7	22.1
020.0°	24.0	16.6	170.9°	51.6	1.9	75.6	16.3
015.2°	24.6	14.2	172.7°	50.2	1.9	74.8	15.2
010.3°	24.0	11.0	175.2°	50.2	1.2	74.2	19.3
005.3°	23.5	11.9	177.6°	50.3	1.5	73.8	18.0
000.0°	23.2	13.1	180.1°	50.5	1.5	73.7	16.3
354.6°	23.1	7.9	182.5°	50.7	1.6	73.8	13.9
350.6°	23.0	6.8	184.3°	51.1	1.7	74.1	12.1
345.4°	23.2	4.8	186.6°	51.5	1.9	74.6	8.2
340.2°	23.6	3.7	188.9°	52.1	2.4	75.1	3.8
335.3°	24.3	2.2	191.2°	52.7	3.1	77.0	-3.0
330.4°	24.8	3.1	193.3°	53.6	2.4	78.4	2.2
325.6°	23.9	1.5	194.1°	55.7	2.5	79.6	-4.5
320.4°	23.3	2.0	195.0°	57.7	2.1	81.0	-.4
314.9°	23.1	4.6	195.9°	59.7	1.7	82.8	8.6
310.6°	23.0	5.6	196.6°	61.3	1.5	84.3	11.4
305.2°	23.0	7.9	197.3°	63.3	1.7	86.3	13.3
299.7°	23.3	13.7	198.0°	65.4	1.4	88.7	19.8
295.9°	23.6	14.1	198.5°	66.9	1.9	90.5	17.4
290.0°	24.3	13.0	199.2°	69.3	1.3	93.6	20.0
285.3°	24.8	18.2	199.6°	71.4	1.5	96.2	21.7
280.4°	24.0	24.1	198.7°	73.3	1.7	97.3	23.0
275.3°	23.3	38.5	197.9°	75.3	2.2	98.6	24.9
269.6°	23.0	43.2	197.2°	77.4	2.2	100.4	25.9
265.3°	22.9	45.7	196.7°	79.0	2.4	101.9	25.6
259.7°	22.9	74.4	196.1°	81.0	2.1	103.9	30.1
255.4°	23.1	66.0	195.6°	82.6	1.4	105.7	33.5
249.9°	23.5	66.0	195.0°	84.7	*	108.2	-
245.9°	24.0	83.6	194.6°	86.3	*	110.3	-
239.8°	24.6	78.6	-	-	-	-	-

* uV Values Less Than 1 are not Recorded

LOCALIZER SIGNAL MEASUREMENTS

LOCATION Boston vs Laconia
 DATE 6/9/70
 ALTITUDE 5000 feet
 DIRECTION C.C.W. Orbit
 FLIGHT #167
 AIRCRAFT #N-102

FREQUENCY Boston - 110.3 MHz
 RECEIVER #1010
 ANTENNA TYPE Boston - V-Ring
 FREQUENCY Laconia - 108.5 MHz
 RECEIVER #1009
 ANTENNA TYPE Laconia - VOR LOC

<u>BOSTON</u>			<u>LACONIA</u>			<u>Total</u>	
<u>Az</u>	<u>Dist (NM)</u>	<u>uV</u>	<u>AZ</u>	<u>Dist</u>	<u>uV</u>	<u>Dist (NM)</u>	<u>D/U</u>
205.0°	24.9	23.6	256.0°	64.6	1.6	89.5	23.4
200.0°	24.1	24.6	257.0°	62.8	1.3	86.9	25.5
195.0°	23.6	16.5	258.0°	61.1	1.4	84.7	21.4
190.0°	23.2	30.5	259.0°	59.1	1.3	82.3	27.4
185.0°	23.1	54.0	260.0°	57.7	1.2	80.8	33.1
181.0°	23.1	113.0	261.0°	56.5	1.1	79.6	40.3
176.0°	23.2	66.0	263.0°	54.9	1.2	78.1	34.8
166.0°	24.1	26.6	266.0°	51.8	1.2	75.9	26.9
151.0°	23.5	16.8	272.0°	50.3	1.2	73.8	22.9
140.0°	23.1	10.3	277.0°	50.7	1.4	73.8	15.1
136.0°	23.0	10.8	279.0°	51.1	1.4	74.1	15.4
131.0°	23.3	6.3	282.0°	51.5	1.4	74.8	13.1
126.0°	23.6	4.9	284.0°	52.0	1.5	74.8	13.1
120.0°	24.2	3.0	286.0°	52.8	1.2	75.6	10.3
116.0°	24.9	3.7	288.0°	53.5	1.3	77.0	8.0
110.0°	23.9	2.4	289.0°	55.9	2.0	78.4	9.1
105.0°	23.4	3.6	289.0°	55.9	2.0	79.8	15.8
100.0°	23.0	6.0	290.0°	57.8	2.1	81.2	4.7
096.0°	22.9	7.4	291.0°	59.8	2.4	82.8	8.0
090.0°	22.9	12.0	291.0°	61.3	2.0	84.2	11.4
085.0°	23.2	19.8	292.0°	63.3	2.4	86.2	14.0
080.0°	23.6	16.5	293.0°	65.3	1.9	88.5	20.4
075.0°	24.1	21.2	294.0°	67.2	2.5	90.8	16.5
071.0°	23.7	26.6	294.0°	69.2	2.8	93.3	17.6
066.0°	23.9	31.0	295.0°	71.2	2.0	95.9	22.5
061.0°	23.3	54.0	294.0°	73.1	1.8	97.0	24.7
055.0°	22.9	60.0	293.0°	75.1	2.0	98.4	28.6
050.0°	22.9	65.0	292.0°	77.1	2.6	100.0	27.3
046.0°	22.9	87.0	292.0°	79.2	2.2	102.1	29.4
040.0°	23.2	128.0	291.0°	80.8	1.5	103.7	35.3
			291.0°	82.8	1.5	106.0	38.7

LOCALIZER SIGNAL MEASUREMENTS

LOCATION Boston vs Laconia
 DATE 6/10/70
 ALTITUDE 6250 feet
 DIRECTION C.C.W. Orbit
 FLIGHT #167
 AIRCRAFT #N-102

FREQUENCY Boston - 110.3 MHz
 RECEIVER #1010
 ANTENNA TYPE Boston - V-Ring
 FREQUENCY Laconia - 108.5 MHz
 RECEIVER #1009
 ANTENNA TYPE Laconia - VOR LOC

BOSTON

LACONIA

<u>Az</u>	<u>Dist (NM)</u>	<u>uV</u>	<u>Az</u>	<u>Dist</u>	<u>uV</u>	<u>Total Dist (NM)</u>	<u>D/U</u>
205.0°	24.8	21.7	256.0°	64.7	1.3	89.5	24.5
200.0°	24.4	23.6	256.0°	63.0	1.4	87.7	24.6
195.0°	23.7	23.3	258.0°	60.9	1.5	84.6	23.8
190.0°	23.4	23.3	259.0°	59.4	1.1	82.8	26.5
196.0°	23.1	47.2	260.0°	58.0	*	81.1	-
179.0°	23.2	74.4	262.0°	56.0	*	79.2	-
175.0°	23.4	132.0	263.0°	54.5	1.1	77.9	41.6
170.0°	23.8	70.2	264.0°	53.0	1.6	76.8	32.9
165.0°	24.4	46.5	266.0°	51.3	1.4	75.7	30.4
160.0°	25.0	20.7	267.0°	49.9	1.9	74.9	20.4
155.0°	24.3	22.5	270.0°	49.5	2.8	73.8	18.1
150.0°	23.7	17.8	273.0°	50.1	2.7	73.8	16.4
146.0°	23.3	23.6	275.0°	50.4	2.0	73.7	21.4
139.0°	23.0	16.4	278.0°	50.8	2.5	73.8	16.3
135.0°	23.0	11.3	280.0°	51.2	2.1	74.2	14.6
130.0°	23.2	7.1	282.0°	51.7	1.7	74.9	12.5
125.0°	23.5	6.9	284.0°	52.2	2.0	75.7	10.8
121.0°	24.1	4.5	286.0°	52.7	2.5	76.8	5.1
115.0°	24.8	4.8	288.0°	53.7	1.6	78.5	9.6
110.0°	24.3	4.8	289.0°	55.5	1.9	79.9	8.1
105.0°	23.6	5.8	290.0°	57.8	2.1	81.4	8.8
100.0°	23.4	7.8	291.0°	59.6	3.2	83.0	7.8
095.0°	23.2	9.2	292.0°	61.4	2.9	84.6	10.0
090.0°	23.2	13.6	292.0°	63.2	3.0	86.4	13.1
086.0°	23.4	17.4	293.0°	65.0	2.2	88.4	18.0
079.0°	23.8	20.0	294.0°	67.5	3.1	91.3	16.2
075.0°	24.4	25.4	294.0°	69.3	2.8	93.7	19.1
069.0°	25.2	39.0	295.0°	71.7	3.8	96.9	20.2
065.0°	24.7	49.3	294.0°	73.6	3.1	98.3	24.0
059.0°	24.0	70.2	293.0°	75.8	2.8	99.8	28.0
055.0°	23.5	63.6	293.0°	77.5	2.0	101.0	30.1
050.0°	23.2	95.6	292.0°	79.3	1.8	102.5	34.6
045.0°	23.2	115.6	291.0°	81.0	1.4	104.2	38.4
040.0°	23.3	132.0	291.0°	82.1	1.5	105.4	38.9
035.0°	23.6	134.6	290.0°	84.6	1.1	108.2	41.7
030.0°	24.4	101.8	290.0°	87.0	*	111.4	-

*uV Values Less Than 1 are not Recorded

LOCALIZER SIGNAL MEASUREMENTS

LOCATION <u>Boston vs Nantucket</u>	FREQUENCY <u>Boston - 110.3 MHz</u>
DATE <u>6/9/70</u>	RECEIVER <u>#1010</u>
ALTITUDE <u>2000 feet</u>	ANTENNA TYPE <u>Boston - V-Ring</u>
DIRECTION <u>C.C.W Orbit</u>	FREQUENCY <u>Nantucket - 109.1</u>
FLIGHT <u>#167</u>	RECEIVER <u>#1009</u>
AIRCRAFT <u>#N-102</u>	ANTENNA TYPE <u>Nantucket - 8 Loop</u>

<u>BOSTON</u>			<u>NANTUCKET</u>			Total	
<u>Az</u>	<u>Dist (NM)</u>	<u>uV</u>	<u>Az</u>	<u>Dist</u>	<u>uV</u>	<u>Dist (NM)</u>	<u>D/U</u>
240.0°	24.8	25.8	325.8°	77.9	*	102.7	-
234.7°	24.1	30.8	326.3°	75.6	*	99.7	-
230.0°	23.5	23.6	326.8°	73.9	1.0	97.4	27.0
225.1°	22.9	71.6	327.6°	71.7	1.1	94.7	36.3
220.5°	22.7	97.8	328.1°	70.0	1.1	92.7	38.9
216.0°	22.7	232.0	328.6°	68.4	1.0	91.1	47.3
209.8°	22.9	127.0	329.3°	66.0	*	88.9	-
205.5°	23.2	71.6	329.9°	64.4	*	87.6	-
199.7°	23.9	-	330.7°	62.1	-	86.0	-
195.8°	24.5	59.0	331.3°	60.4	1.0	84.9	35.4
190.0°	24.1	45.7	333.4°	59.1	1.1	83.2	32.4
185.6°	23.6	47.2	335.2°	58.6	1.2	84.2	31.9
179.4°	23.1	58.0	337.6°	57.8	1.3	80.9	32.9
174.5°	22.9	45.7	339.5°	57.4	1.1	80.3	32.4
169.7°	22.9	46.5	341.4°	56.9	1.1	79.8	32.5
164.9°	23.2	23.1	343.3°	56.5	*	79.7	-
160.1°	23.5	23.1	345.3°	56.2	1.6	79.7	23.2
155.7°	24.0	15.3	347.2°	55.9	1.5	80.2	20.2
150.3°	24.8	16.8	349.7°	55.7	*	80.6	-
145.6°	24.4	10.1	351.4°	56.9	*	81.3	-
139.6°	23.8	6.3	353.3°	58.6	1.1	82.5	15.2
135.1°	23.4	7.5	354.6°	60.0	1.2	83.5	15.9
130.5°	23.2	6.9	355.8°	61.4	1.1	85.3	15.9
125.8°	23.3	8.5	357.0°	62.8	1.0	86.1	18.6
119.4°	23.6	4.1	358.6°	64.8	1.0	88.4	12.3
114.9°	23.8	3.8	359.6°	66.3	1.0	90.2	11.2
110.4°	24.4	3.2	000.6°	67.8	1.0	92.2	9.7
104.8°	25.5	2.8	001.8°	59.9	*	95.4	-
100.7°	25.6	3.3	002.5°	71.6	1.0	97.2	10.4
095.6°	24.8	5.2	002.1°	73.9	1.0	98.8	14.3
090.6°	23.9	6.5	001.4°	76.1	*	100.0	-
085.4°	23.3	6.8	000.9°	78.2	*	101.6	-
079.7°	23.2	9.3	000.6°	80.5	*	103.8	-
075.2°	23.4	12.0	000.4°	82.3	*	105.7	-
069.5°	23.7	12.5	000.2°	84.6	*	108.4	-
065.6°	24.2	7.3	000.1°	86.3	*	110.6	-
060.5°	24.9	11.5	359.9°	88.6	*	113.6	-

*uV Values Less Than 1 are not Recorded

LOCALIZER SIGNAL MEASUREMENTS

LOCATION <u>Boston vs Nantucket</u>	FREQUENCY <u>Boston - 110.3 MHz</u>
DATE <u>6/9/70</u>	RECEIVER <u>#1010</u>
ALTITUDE <u>3000 feet</u>	ANTENNA TYPE <u>Boston - V-Ring</u>
DIRECTION <u>C.C.W. Orbit</u>	FREQUENCY <u>Nantucket - 109.1</u>
FLIGHT <u>#167</u>	RECEIVER <u>#1009</u>
AIRCRAFT <u>#N-102</u>	ANTENNA TYPE <u>Nantucket - 8 Loop</u>

<u>BOSTON</u>			<u>NANTUCKET</u>			<u>Total</u>	
<u>Az</u>	<u>Dist (NM)</u>	<u>uV</u>	<u>Az</u>	<u>Dist</u>	<u>uV</u>	<u>Dist (NM)</u>	<u>D/U</u>
235.4 ⁰	24.0	58.0	326.4 ⁰	75.8	1.4	99.8	32.3
229.7 ⁰	23.2	61.0	327.1 ⁰	73.6	1.7	96.8	31.1
225.0 ⁰	23.0	98.0	327.5 ⁰	71.7	1.5	94.7	36.3
220.3 ⁰	22.8	132.0	328.0 ⁰	69.9	1.8	92.8	37.3
215.6 ⁰	22.8	276.0	328.6 ⁰	68.1	1.9	91.0	43.2
209.4 ⁰	23.1	127.0	329.3 ⁰	65.8	2.4	88.9	34.5
204.9 ⁰	23.4	87.0	329.9 ⁰	64.0	2.6	87.5	30.5
200.5 ⁰	23.9	72.0	330.5 ⁰	62.3	2.9	86.2	27.9
195.0 ⁰	24.7	77.0	331.5 ⁰	60.0	1.6	84.8	33.6
190.6 ⁰	24.2	57.0	333.1 ⁰	59.1	3.0	83.4	25.6
184.5 ⁰	23.6	62.0	335.5 ⁰	58.3	2.8	81.9	26.9
179.9 ⁰	23.3	60.0	337.3 ⁰	57.7	2.4	81.0	27.9
175.1 ⁰	23.2	60.0	339.2 ⁰	57.1	2.1	80.3	29.1
170.3 ⁰	23.1	44.9	341.1 ⁰	56.7	2.2	79.9	21.2
165.6 ⁰	23.2	29.0	343.0 ⁰	56.4	2.2	79.7	22.4
159.3 ⁰	23.7	31.3	345.6 ⁰	56.0	2.3	79.8	22.7
155.1 ⁰	24.2	17.4	347.5 ⁰	55.8	2.6	80.0	16.5
150.7 ⁰	24.8	20.0	349.6 ⁰	55.6	1.7	80.5	21.4
144.9 ⁰	24.4	12.6	351.7 ⁰	57.0	*	81.4	-
140.2 ⁰	24.0	7.0	353.2 ⁰	58.3	*	82.4	-
135.8 ⁰	23.7	8.5	354.5 ⁰	59.6	*	83.4	-
130.0 ⁰	23.5	8.3	356.1 ⁰	61.4	1.1	84.9	17.5
125.4 ⁰	23.5	8.6	357.2 ⁰	62.8	1.2	86.3	17.1
119.4 ⁰	23.6	3.9	358.6 ⁰	64.8	1.2	88.4	10.2
114.9 ⁰	23.8	4.1	359.5 ⁰	66.3	1.1	90.1	11.4
110.5 ⁰	24.2	4.6	000.5 ⁰	67.8	1.1	92.1	12.4
100.5 ⁰	24.9	3.4	001.6 ⁰	69.9	*	94.9	-
100.5 ⁰	24.7	3.8	001.8 ⁰	71.8	1.0	96.5	11.6
095.2 ⁰	24.2	5.4	001.6 ⁰	74.1	1.0	98.3	14.6
089.5 ⁰	23.6	8.4	001.2 ⁰	76.5	*	100.2	-
085.3 ⁰	23.2	7.4	000.8 ⁰	78.2	*	101.4	-
080.7 ⁰	23.0	9.6	000.6 ⁰	80.0	*	103.1	-
074.7 ⁰	23.3	17.5	000.4 ⁰	82.5	*	105.8	-
070.6 ⁰	23.7	18.0	000.3 ⁰	84.2	*	107.9	-
064.8 ⁰	24.4	11.7	000.1 ⁰	86.7	*	111.2	-
060.6 ⁰	25.1	12.4	359.9 ⁰	88.6	*	113.7	-

*uV Values Less Than 1 are not Recorded

LOCALIZER SIGNAL MEASUREMENTS

LOCATION Boston vs Nantucket
 DATE 6/9/70
 ALTITUDE 4000 feet
 DIRECTION C. C. W. Orbit
 FLIGHT #167
 AIRCRAFT #N-102

FREQUENCY Boston - 110.3 MHz
 RECEIVER #1010
 ANTENNA TYPE Boston - V-Ring
 FREQUENCY Nantucket - 109.1
 RECEIVER #1009
 ANTENNA TYPE Nantucket - 8 Loop

<u>BOSTON</u>			<u>NANTUCKET</u>			<u>Total</u>	
<u>Az</u>	<u>Dist (NM)</u>	<u>uV</u>	<u>Az</u>	<u>Dist</u>	<u>uV</u>	<u>Dist (NM)</u>	<u>D/U</u>
239.8 ⁰	24.6	78.6	326.0	77.7	1.5	102.3	34.4
234.3 ⁰	23.7	62.4	326.5	75.3	1.8	99.1	30.8
230.2 ⁰	23.2	85.4	327.0	73.7	1.8	97.0	33.5
225.8 ⁰	22.9	134.6	327.5	72.0	2.0	95.0	36.6
219.9 ⁰	22.7	176.2	328.1	69.8	2.3	92.5	37.7
215.4 ⁰	22.8	332.0	328.6	68.1	2.3	90.9	43.2
209.5 ⁰	23.0	172.4	329.3	65.9	2.9	88.9	35.5
205.3 ⁰	23.4	107.2	329.8	64.2	3.0	87.7	31.1
199.9 ⁰	24.0	80.0	330.6	62.1	3.5	86.1	27.2
195.9 ⁰	24.6	107.2	331.2	60.4	3.6	85.0	29.5
190.5 ⁰	24.1	67.4	333.2	59.2	3.6	83.4	25.4
184.9 ⁰	23.5	67.4	335.4	58.4	4.7	82.0	23.1
180.4 ⁰	23.3	68.8	337.1	57.8	3.9	81.2	24.9
174.2 ⁰	23.1	62.4	339.5	57.1	2.4	80.5	28.3
169.6 ⁰	23.1	47.2	341.3	56.7	2.4	79.9	25.9
164.8 ⁰	23.2	28.6	343.3	56.4	2.4	79.9	21.5
160.4 ⁰	23.5	31.3	345.1	56.1	2.6	79.7	21.6
154.8 ⁰	24.2	22.5	347.6	55.8	2.6	80.1	18.7
150.5 ⁰	24.8	24.8	349.6	55.7	1.8	80.6	22.8
145.8 ⁰	24.3	13.3	351.3	56.9	1.0	81.3	22.4
140.8 ⁰	23.9	9.5	352.9	58.3	1.0	82.2	19.6
134.8 ⁰	23.5	11.7	354.7	60.0	1.1	83.6	20.5
130.5 ⁰	23.4	9.5	355.8	61.3	1.2	84.7	17.9
124.7 ⁰	23.3	10.4	357.2	63.1	1.3	86.5	18.1
120.2 ⁰	23.4	4.3	358.3	64.6	1.4	88.0	9.7
115.8 ⁰	23.6	3.7	359.2	66.0	1.3	89.7	9.1
110.3 ⁰	24.2	6.2	000.5	67.9	1.2	92.1	14.3
104.9 ⁰	25.0	3.6	001.7	69.8	1.1	94.9	10.3
100.9 ⁰	24.8	4.8	001.9	71.6	1.2	96.5	12.4
095.8 ⁰	24.4	4.9	001.8	73.9	1.1	98.3	12.9
090.3 ⁰	24.2	9.6	001.7	76.2	1.1	100.4	18.8
084.8 ⁰	24.3	11.9	001.6	78.5	1.1	102.9	20.7
080.8 ⁰	24.2	8.5	001.3	80.2	1.1	104.4	17.7
075.5 ⁰	23.8	14.1	000.7	82.3	1.0	106.2	22.9

LOCALIZER SIGNAL MEASUREMENTS

LOCATION <u>Boston vs Nantucket</u>	FREQUENCY <u>Boston - 110.3 MHz</u>
DATE <u>6/9/70</u>	RECEIVER <u>#1010</u>
ALTITUDE <u>5000 feet</u>	ANTENNA TYPE <u>Boston - V-Ring</u>
DIRECTION <u>C.C.W. Orbit</u>	FREQUENCY <u>Nantucket - 109.1</u>
FLIGHT <u>#167</u>	RECEIVER <u>#1009</u>
AIRCRAFT <u>#N-102</u>	ANTENNA TYPE <u>Nantucket - 8 Loop</u>

BOSTON			<u>NANTUCKET</u>			Total	
<u>Az</u>	<u>Dist (NM)</u>	<u>uV</u>	<u>Az</u>	<u>Dist</u>	<u>uV</u>	<u>Dist (NM)</u>	<u>D/U</u>
020.0 ⁰	24.2	102.0	261.0 ⁰	75.8	2.0	100.0	34.2
015.0 ⁰	23.5	109.0	262.0 ⁰	73.6	2.4	97.1	33.1
010.0 ⁰	23.2	176.0	262.0 ⁰	71.8	2.5	95.0	37.0
006.0 ⁰	23.0	176.0	263.0 ⁰	70.1	2.6	93.1	36.6
000.0 ⁰	23.0	440.0	264.0 ⁰	67.9	3.3	90.9	42.5
356.0 ⁰	23.1	325.0	264.0 ⁰	66.2	3.3	89.3	39.9
350.0 ⁰	23.6	142.0	265.0 ⁰	64.0	3.9	87.6	31.2
346.0 ⁰	23.1	113.0	265.0 ⁰	62.3	4.4	86.4	28.2
340.0 ⁰	24.8	138.0	266.0 ⁰	60.1	3.6	84.9	31.7
335.0 ⁰	24.0	73.0	269.0 ⁰	59.2	5.0	83.2	32.9
330.0 ⁰	23.6	89.0	270.0 ⁰	58.5	5.5	82.1	24.2
324.0 ⁰	23.4	84.0	273.0 ⁰	57.6	4.7	81.0	25.1
320.0 ⁰	23.3	84.0	274.0 ⁰	57.0	3.5	80.3	27.6
315.0 ⁰	23.3	71.0	276.0 ⁰	56.6	4.5	79.9	24.0
311.0 ⁰	23.4	43.0	278.0 ⁰	56.3	4.1	79.7	20.4
305.0 ⁰	23.8	45.5	280.0 ⁰	55.9	3.8	79.7	21.6
300.0 ⁰	23.4	36.5	282.0 ⁰	55.8	4.0	80.1	19.2
295.0 ⁰	25.0	28.2	285.0 ⁰	55.7	2.6	80.7	20.7
275.0 ⁰	23.5	12.5	291.0 ⁰	61.4	1.3	84.9	19.9
270.0 ⁰	23.4	10.6	292.0 ⁰	63.2	1.7	86.6	15.9
265.0 ⁰	23.5	5.2	293.0 ⁰	64.6	1.7	88.1	9.6
260.0 ⁰	23.8	7.3	295.0 ⁰	66.5	1.7	90.3	12.7
255.0 ⁰	24.3	5.7	296.0 ⁰	67.9	1.5	92.2	11.6
250.0 ⁰	24.9	5.2	297.0 ⁰	69.9	1.0	94.8	13.9
245.0 ⁰	23.5	6.4	297.0 ⁰	72.2	1.0	96.7	16.2
240.0 ⁰	23.9	11.9	296.0 ⁰	74.5	1.4	98.4	18.6
234.0 ⁰	23.2	15.8	296.0 ⁰	76.6	1.0	99.8	24.0
224.0 ⁰	22.9	17.0	295.0 ⁰	80.6	1.0	103.5	24.6
215.0 ⁰	23.7	29.0	295.0 ⁰	84.6	1.0	108.3	29.3
206.0 ⁰	24.8	20.0	295.0 ⁰	88.5	1.0	113.3	26.0

LOCALIZER SIGNAL MEASUREMENTS

LOCATION <u>Boston vs Nantucket</u>	FREQUENCY <u>Boston - 110.3 MHz</u>
DATE <u>6/10/70</u>	RECEIVER <u>#1010</u>
ALTITUDE <u>6250 feet</u>	ANTENNA TYPE <u>Boston - V-Ring</u>
DIRECTION <u>C.C.W. Orbit</u>	FREQUENCY <u>Nantucket - 109.1</u>
FLIGHT <u>#167</u>	RECEIVER <u>#1009</u>
AIRCRAFT <u>#N-102</u>	ANTENNA TYPE <u>Nantucket - 8 Loop</u>

BOSTON

NANTUCKET

<u>Az</u>	<u>Dist (NM)</u>	<u>uV</u>	<u>Az</u>	<u>Dist</u>	<u>uV</u>	<u>Total Dist (NM)</u>	<u>D/U</u>
021.0°	24.6	134.6	261.0°	75.9	3.6	100.5	31.5
015.0°	23.9	109.0	262.0°	73.5	3.4	97.4	30.0
010.0°	23.5	200.0	262.0°	71.7	4.4	95.2	33.2
005.0°	23.4	300.0	263.0°	69.7	4.2	93.1	37.0
000.0°	23.4	564.0	263.0°	67.9	4.1	9.13	42.8
356.0°	23.5	332.0	264.0°	66.1	4.7	89.6	37.0
349.0°	23.8	180.0	265.0°	63.7	5.8	87.5	29.8
345.0°	24.3	137.2	265.0°	61.9	7.1	86.2	25.7
340.0°	24.8	176.4	266.0°	60.2	5.4	85.0	30.3
335.0°	24.2	113.4	268.0°	59.0	7.2	83.2	23.9
330.0°	23.8	107.2	270.0°	58.3	8.1	82.1	22.5
326.0°	23.5	127.2	272.0°	56.0	6.0	80.5	26.5
319.0°	23.5	139.6	274.0°	56.9	5.4	80.4	28.2
315.0°	23.4	134.6	276.0°	56.5	5.5	79.9	27.8
310.0°	23.6	70.2	278.0°	56.2	5.8	78.8	21.7
305.0°	23.8	64.8	280.0°	55.9	6.0	79.7	20.7
301.0°	24.3	63.6	282.0°	55.8	7.0	80.1	19.2
295.0°	25.1	45.7	285.0°	55.6	4.6	80.6	19.8
290.0°	24.2	41.1	287.0°	57.3	3.0	81.5	22.7
286.0°	22.4	23.3	287.0°	59.2	3.6	81.6	16.2
281.0°	21.9	22.5	289.0°	61.1	3.1	83.0	17.2
276.0°	22.0	17.8	290.0°	62.3	2.0	84.3	19.0
269.0°	22.6	14.5	292.0°	63.7	1.9	86.3	17.7
265.0°	23.0	12.2	293.0°	65.0	1.5	88.0	18.2
260.0°	23.6	9.1	294.0°	66.3	*	-	-
256.0°	24.2	9.2	295.0°	67.8	2.0	92.0	13.3
250.0°	25.0	6.2	297.0°	70.0	1.0	95.0	15.4
245.0°	24.6	8.9	297.0°	71.9	1.2	96.5	17.4
240.0°	23.7	14.1	296.0°	74.4	1.3	98.1	20.7
235.0°	23.3	20.7	296.0°	76.3	1.2	99.6	24.7
231.0°	23.1	21.5	296.0°	78.2	1.0	101.3	26.6

*uV Values Less Than 1 are not Recorded

BOSTON LOCALIZER PROJECT
AGC Calibrations N-102
4165.3A Bendix VOR Receiver

Boston, Mass. V-Ring
Frequency 110.3 MHz

System #2 S/N 1010

1 uV	3.50 ma
2 uV	4.15 ma
3 uV	4.75 ma
5 uV	5.70 ma
10 uV	6.70 ma
15 uV	7.15 ma
20 uV	7.45 ma
25 uV	7.65 ma
50 uV	8.10 ma
100 uV	8.45 ma
200 uV	8.80 ma
300 uV	8.90 ma
500 uV	9.10 ma
1,000 uV	9.25 ma
2,000 uV	9.40 ma
5,000 uV	9.65 ma
10,000 uV	9.85 ma

System #3 S/N 1009

1 uV	2.60 ma
2 uV	3.60 ma
3 uV	3.95 ma
5 uV	4.85 ma
10 uV	6.10 ma
15 uV	6.70 ma
20 uV	7.05 ma
25 uV	7.25 ma
50 uV	7.85 ma
100 uV	8.30 ma
200 uV	8.70 ma
300 uV	8.85 ma
500 uV	9.10 ma
1,000 uV	9.35 ma
2,000 uV	9.50 ma
5,000 uV	9.75 ma
10,000 uV	9.85 ma

Receiver Calibration Date: 6/12/70

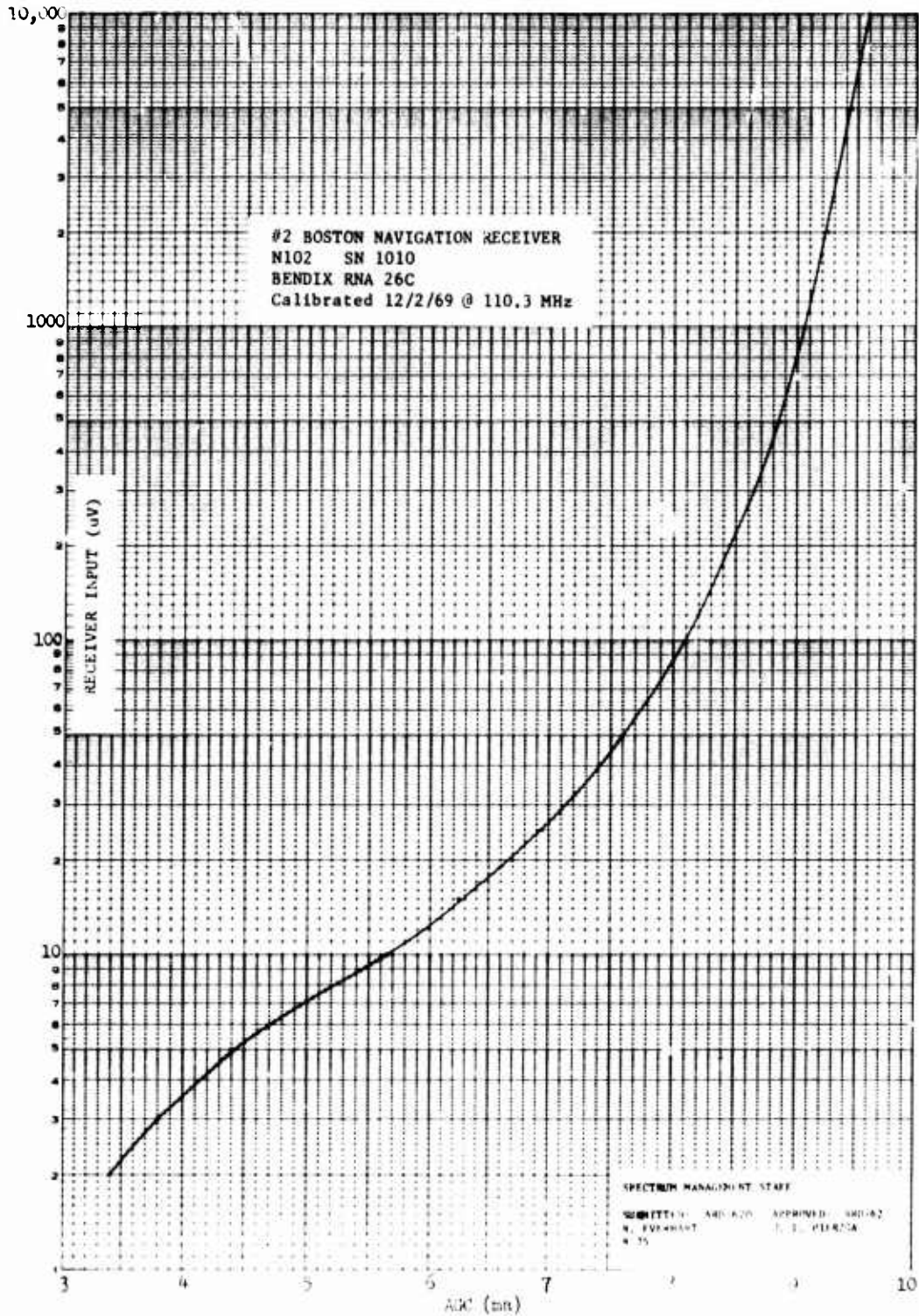

Boston Navigation Receiver

8/75

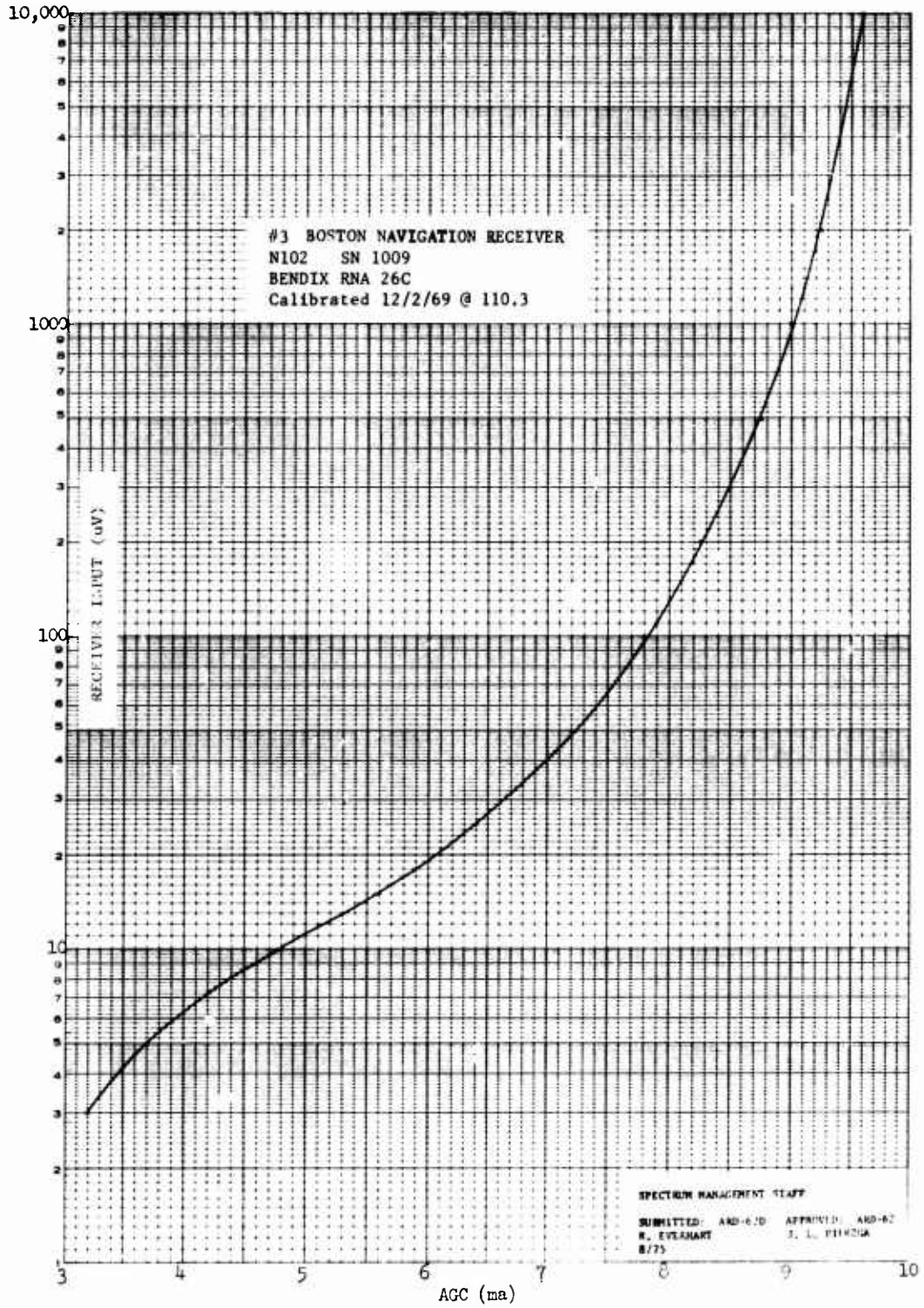

Boston Navigation Receiver

BOSTON LOCALIZER PROJECT
AGC Calibrations N-102
-165.3A Bendix VOR Receiver

Laconia, N. H. VORLOC
Frequency 108.5 MHz

System #2 S/N 1010

1 uV	3.10 ma
2 uV	3.85 ma
3 uV	4.20 ma
5 uV	5.20 ma
10 uV	6.35 ma
15 uV	6.85 ma
20 uV	7.20 ma
25 uV	7.40 ma
50 uV	7.90 ma
100 uV	8.40 ma
200 uV	8.60 ma
300 uV	8.75 ma
500 uV	9.00 ma
1,000 uV	9.20 ma
2,000 uV	9.40 ma
5,000 uV	9.60 ma
10,000 uV	9.80 ma

System #3 S/N 1009

1 uV	2.70 ma
2 uV	3.55 ma
3 uV	3.85 ma
5 uV	4.78 ma
10 uV	6.05 ma
15 uV	6.60 ma
20 uV	7.00 ma
25 uV	7.25 ma
50 uV	7.85 ma
100 uV	8.35 ma
200 uV	8.75 ma
300 uV	8.95 ma
500 uV	9.15 ma
1,000 uV	9.35 ma
2,000 uV	9.55 ma
5,000 uV	9.75 ma
10,000 uV	9.90 ma

Receiver Calibration Date: 6/12/70

8/75

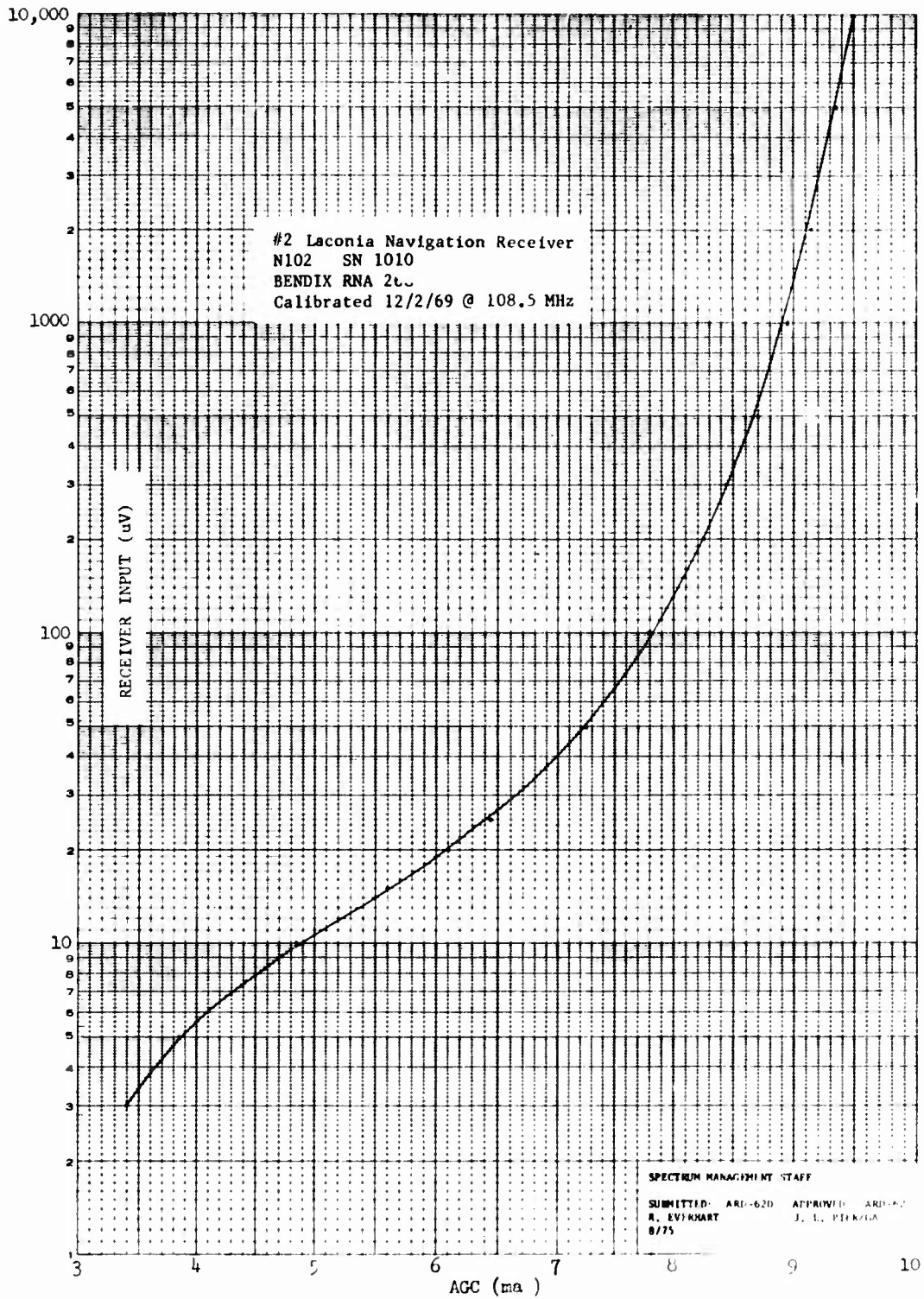

Laconia Navigation Receiver

8/75

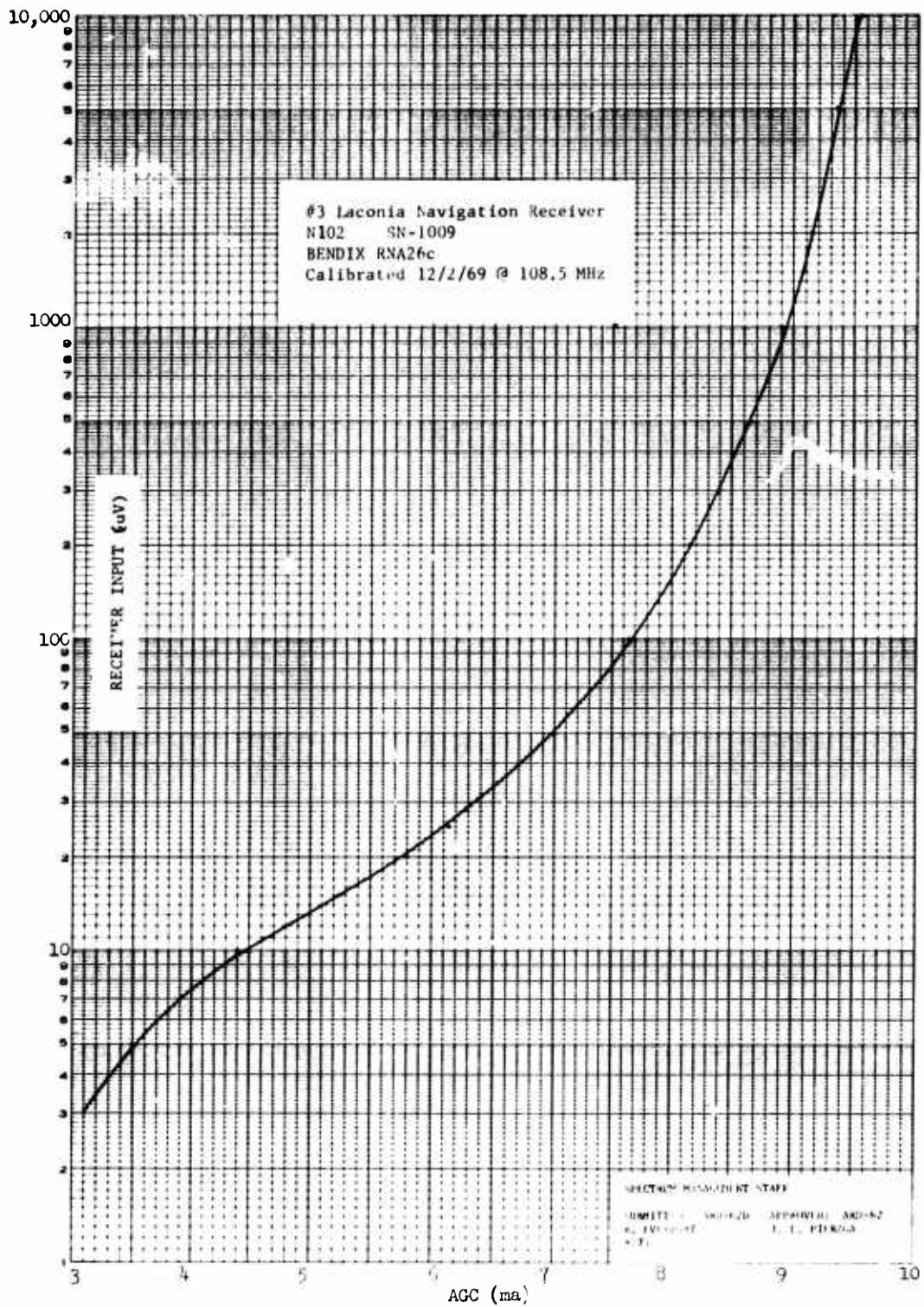

Laconia Navigation Receiver

BOSTON LOCALIZER PROJECT
AGC Calibrations N-102
4165.3A Bendix VOR Receiver

Nantucket, Mass. 8 Loop
Frequency 109.1 MHz

System #2 S/N 1010		System #3 S/N 1009	
1 uV	3.30 ma	1 uV	2.65 ma
2 uV	4.00 ma	2 uV	3.50 ma
3 uV	4.40 ma	3 uV	3.80 ma
5 uV	5.40 ma	5 uV	4.55 ma
10 uV	6.50 ma	10 uV	5.85 ma
15 uV	7.00 ma	15 uV	6.45 ma
20 uV	7.30 ma	20 uV	6.85 ma
25 uV	7.50 ma	25 uV	7.10 ma
50 uV	8.00 ma	50 uV	7.75 ma
100 uV	8.45 ma	100 uV	8.25 ma
200 uV	8.75 ma	200 uV	8.65 ma
300 uV	8.90 ma	300 uV	8.85 ma
500 uV	9.10 ma	500 uV	9.05 ma
1,000 uV	9.25 ma	1,000 uV	9.30 ma
2,000 uV	9.45 ma	2,000 uV	9.50 ma
5,000 uV	9.65 ma	5,000 uV	9.75 ma
10,000 uV	9.80 ma	10,000 uV	9.85 ma

Receiver Calibration Date: 6/12/70

8/75

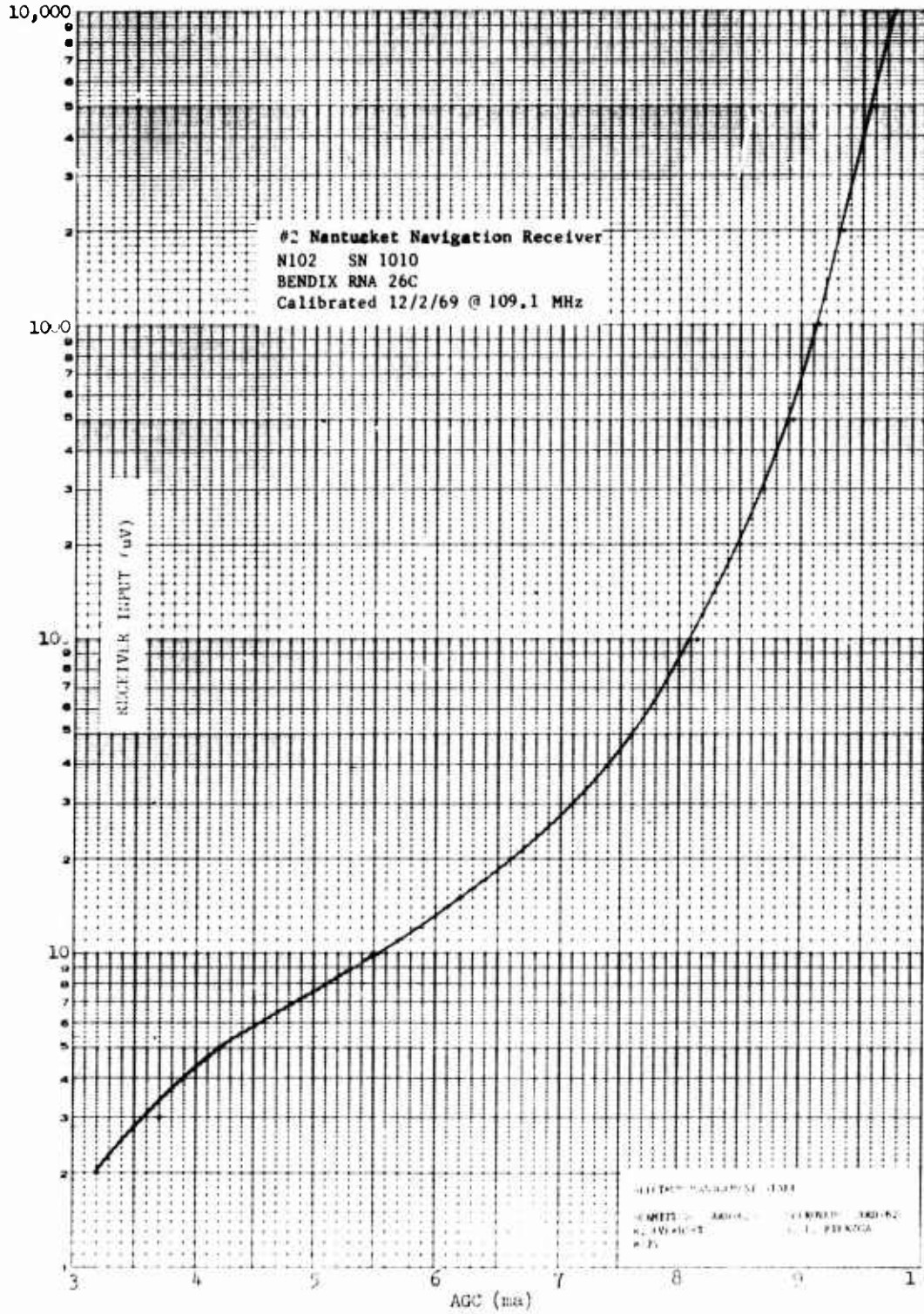

Nantucket Navigation Receiver

8.75

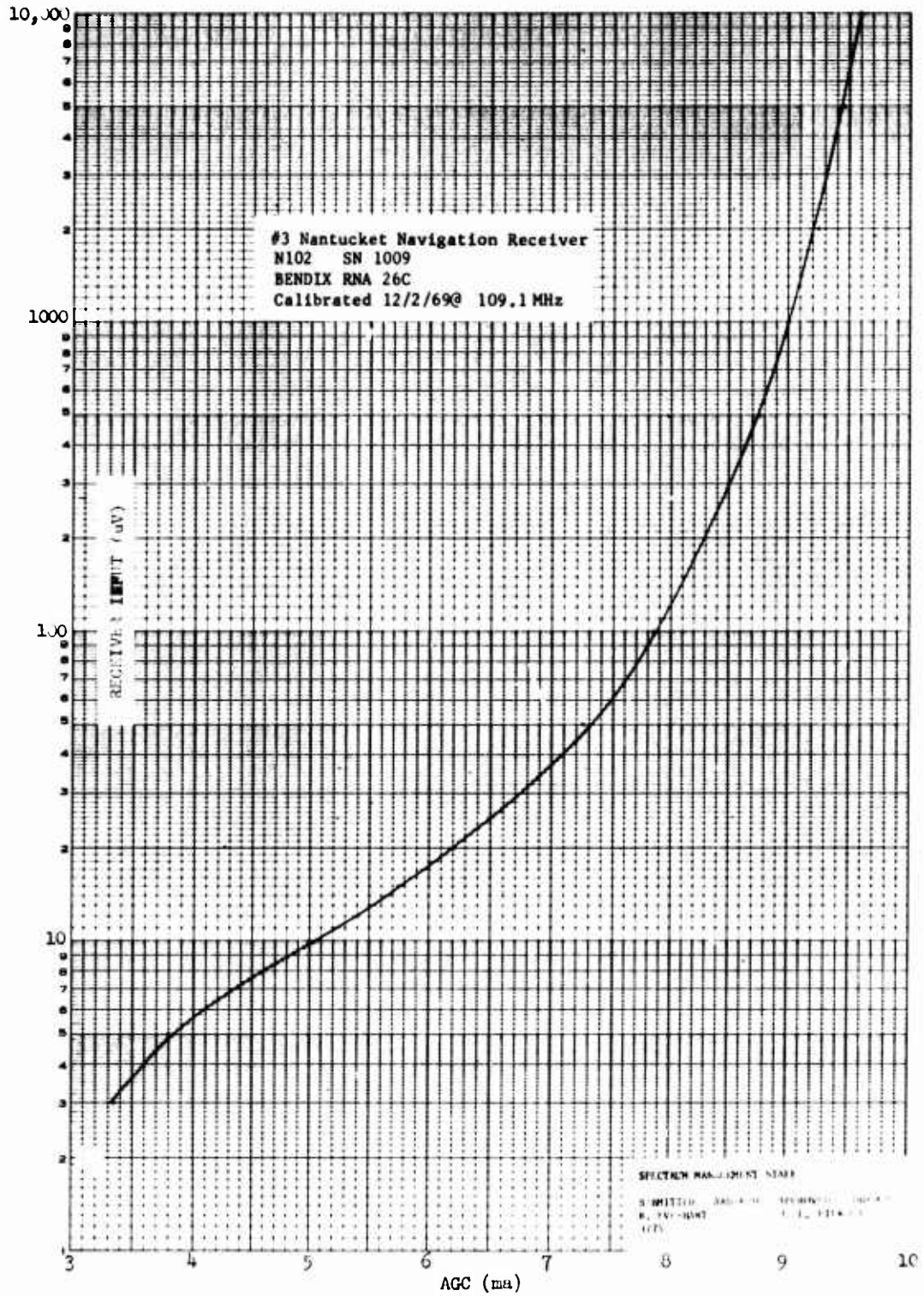

Nantucket Navigation Receiver

APPENDIX A

RECEIVER CALIBRATION/TRANSMISSION LINE LOSS

The receivers were calibrated in such a manner that it was possible to predict what the RF signal level was at the output terminals of the antenna. This was accomplished by calibrating the receivers AGC, in the craft, with the RF calibrating voltage being introduced at the antenna connector. Although the receivers transmission line loss's were calibrated out, it was felt that a determination of these loss's would still be made. Below is a detailed account of the receiver calibration and transmission line loss measurement techniques employed.

RECEIVER AGC CALIBRATION

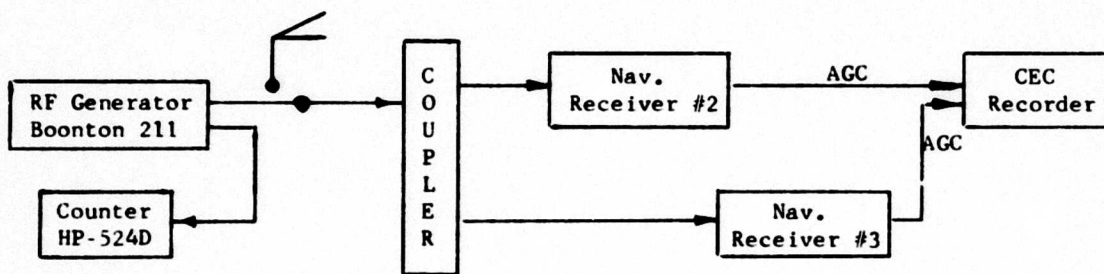

Procedure 1 - Initial Conditions: receivers inside the aircraft in their normal operating position, craft powered by auxiliary ground power unit, all test equipment commercially powered.

- Procedure 2 - Boonton 211 signal generator properly calibrated and inserted at the antenna connector.
- Procedure 3 - Counter used to set the Frequency of the Boonton generator to the Frequency that the AGC curve was run.
- Procedure 4 - CEC recorder calibrated for $4'' = 8 \text{ ma}$ and set up to record the AGC level of both #2 and #3 VHF Nav receivers simultaneously.
- Procedure 5 - The RF control on the Boonton generator was set, and the AGC recorded at each of the following levels for each Frequency of interest 3, 5, 10, 15, 20, 25, 50, 100, 200, 300, 500, 1,000, 2,000, 5,000, and 10,000 μV .

TRANSMISSION LINE LOSS

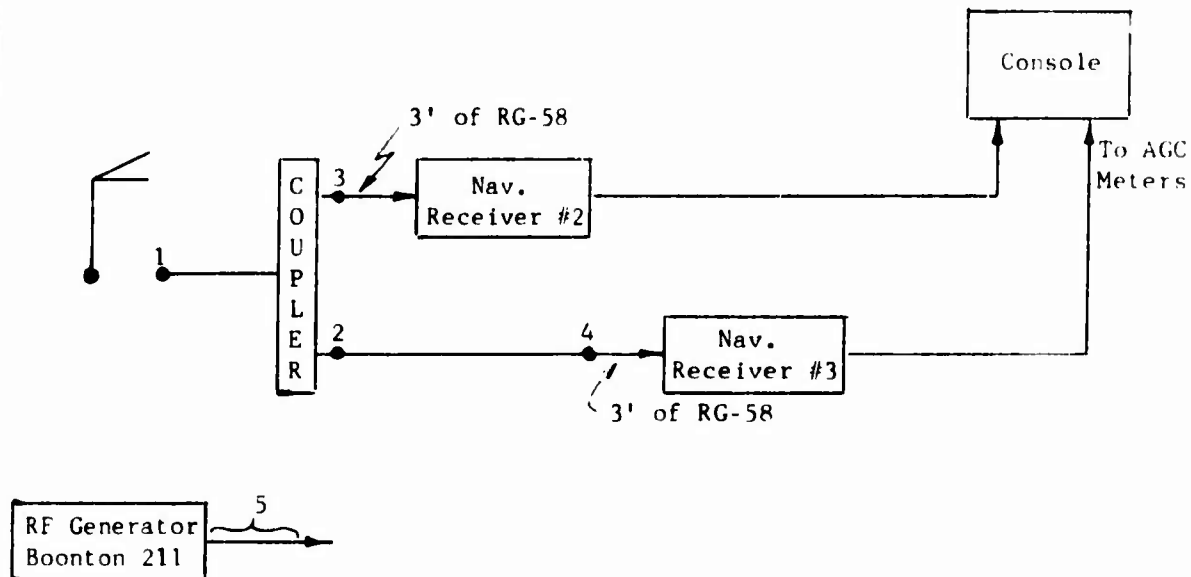

- Procedure 1 - Initial Conditions: receivers inside the aircraft in there normal operating position, craft powered by auxiliary ground unit, all test equipment commercially powered.
- Procedure 2 - The AGC meters on the console for #2 and #3 VHF Nav. receivers to be kept at 6.2 ma (this value was chosen because it: 1- represents a point on the receivers AGC curve where the current changes relatively fast for a change in the RF input; 2- is close to the center of the meters range).
- Procedure 3 - Insert the Boonton 211 at point 1 and set the AGC panel meters at 6.2 ma for both receivers. The RF reading on the front of the Boonton 211 was recorded for each receiver.
- Procedure 4 - Insert the Boonton 211 at point 2. Set the AGC panel meters for receiver #3 at 6.2 ma. RF level of the 211 was recorded.
- Procedure 5 - Insert the Boonton 211 at point 3. Set the AGC panel meters for receiver #2 at 6.2 ma. RF level of the 211 was recorded.
- Procedure 5 - Insert the Boonton 211 at point 4. Set the AGC panel meters for receiver #3 at 6.2 ma. RF level of the 211 was recorded.
- Procedure 7 - Steps 2-6 repeated for verification of numbers.

TEST POINTS

	<u>1</u>	<u>2</u>	<u>3</u>	<u>4</u>
Receiver #2	17 uV		11.5 uV	
Receiver #3	20 uV	13.25 uV		11.5 uV
Calculated losses from pts		1-3	3.4 dB	
		1-4	4.8 dB	
		1-2	3.6 dB	
		2-4	1.2 dB	

Procedure 8 - The loss of cable #5 was ascertained on the bench to be
 .87 dB (55/50 uV).

The AGC curves that were taken on N102 on December 2, 1969 at Oklahoma City, Oklahoma were curves that didn't take into account the additional loss of the calibration cable (.87 dB). All microvolt readings extracted from these curves must be multiplied by 1.1 to give a true reading of the RF signal level at the antenna output.

8/75

Appendix B

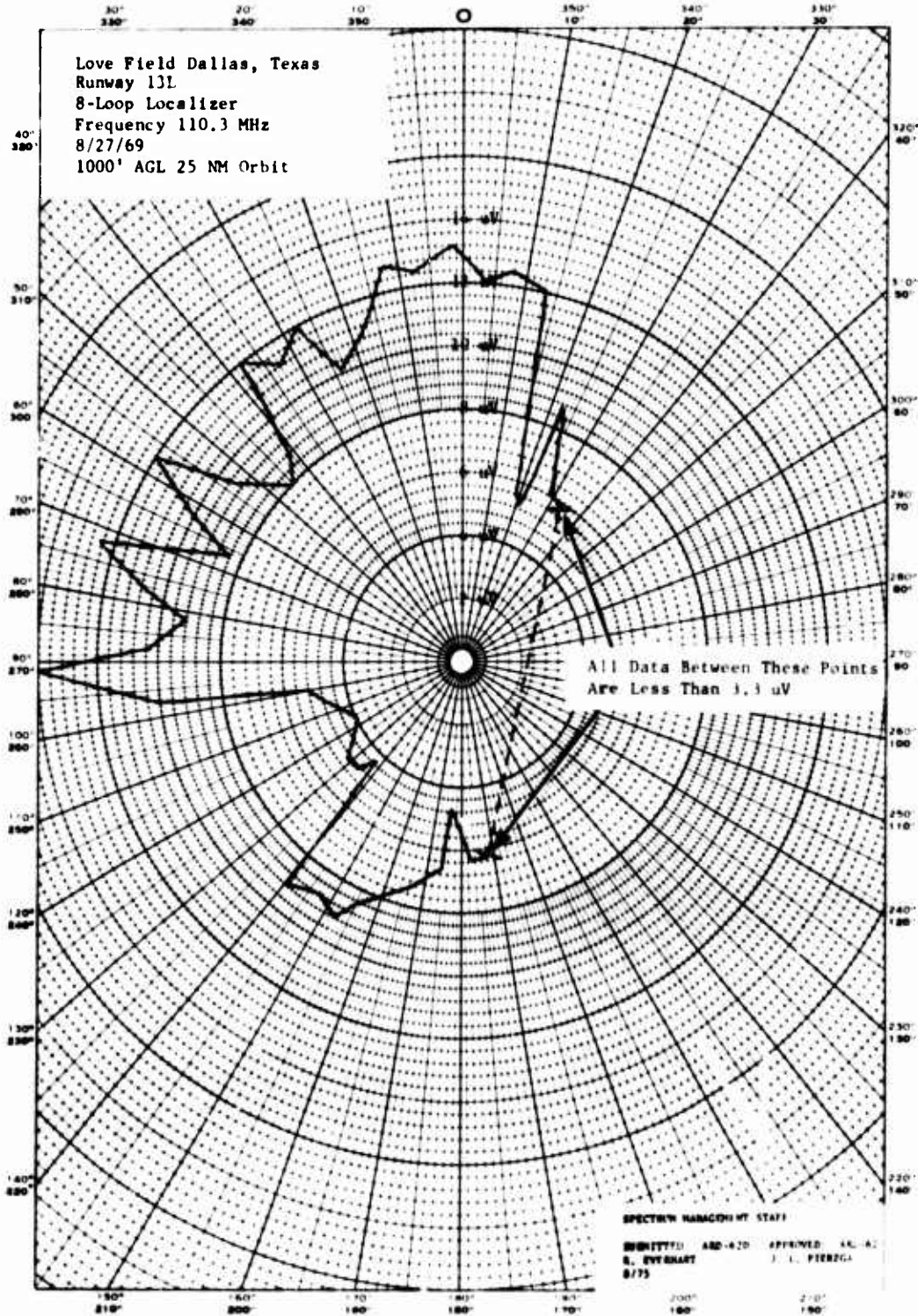

Altitude Flown - 1000 ft.

B-1

8/75

Appendix B

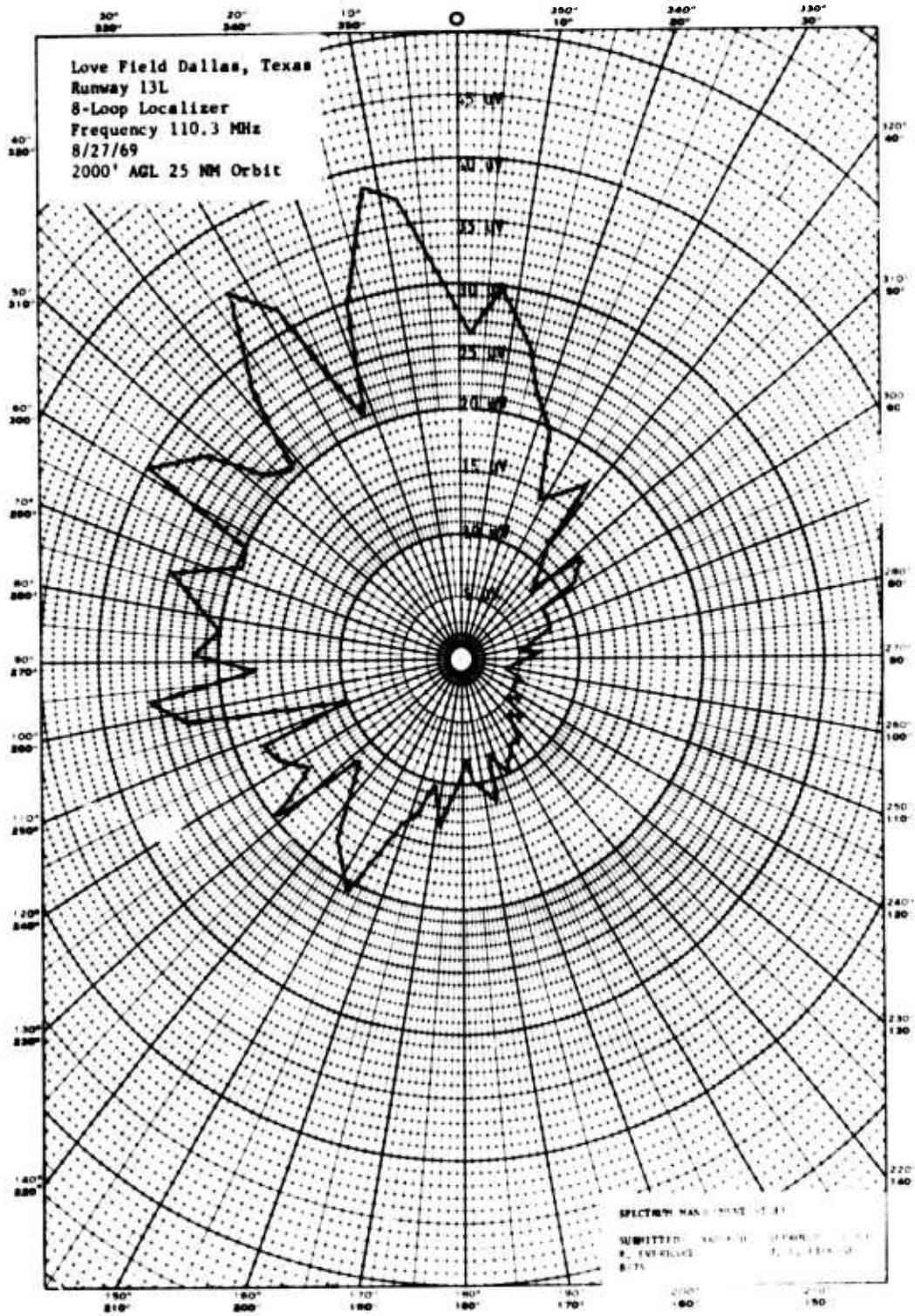

Altitude Flow - 2000 ft.

8/75

Appendix B

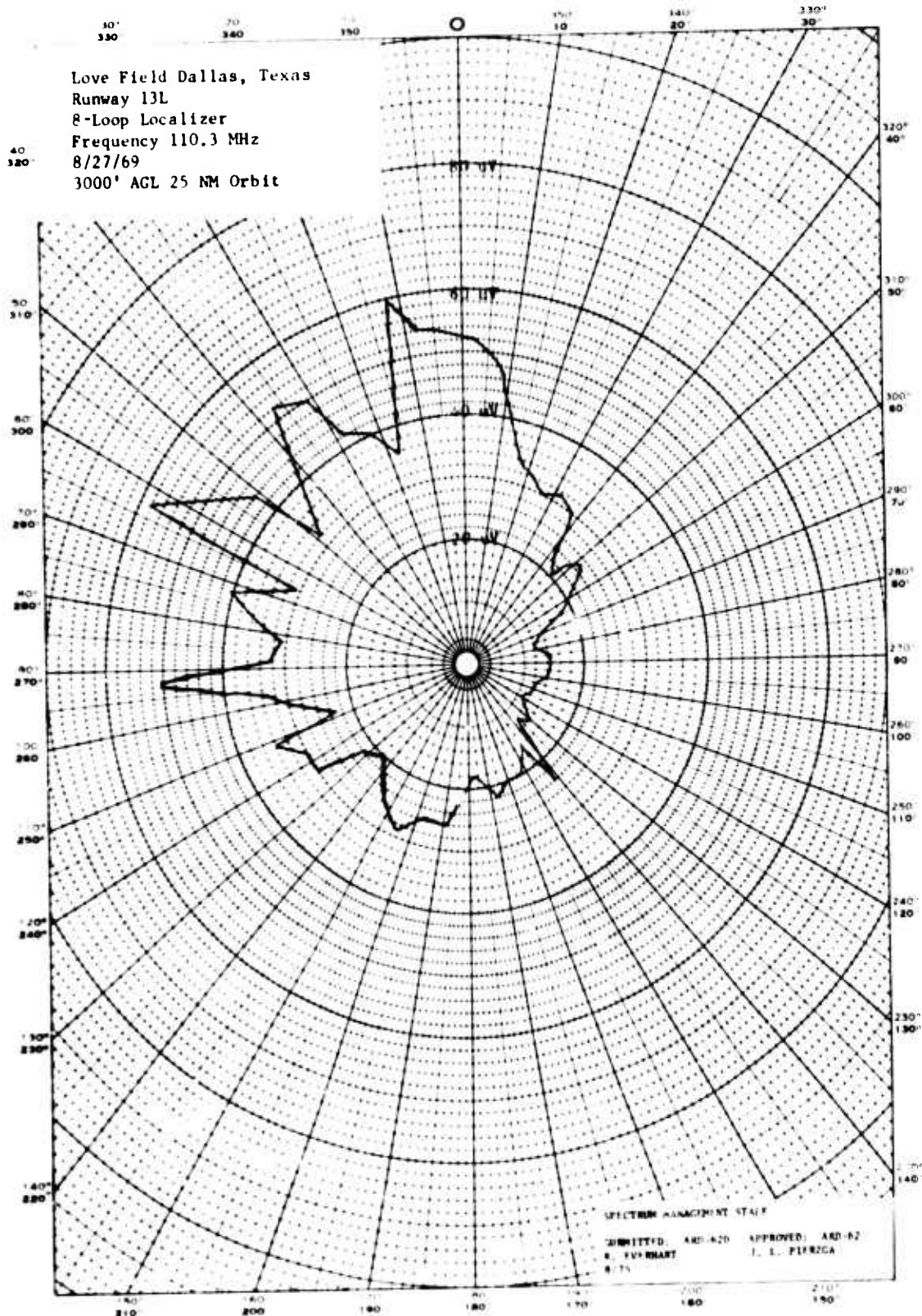

Altitude Flown - 3000

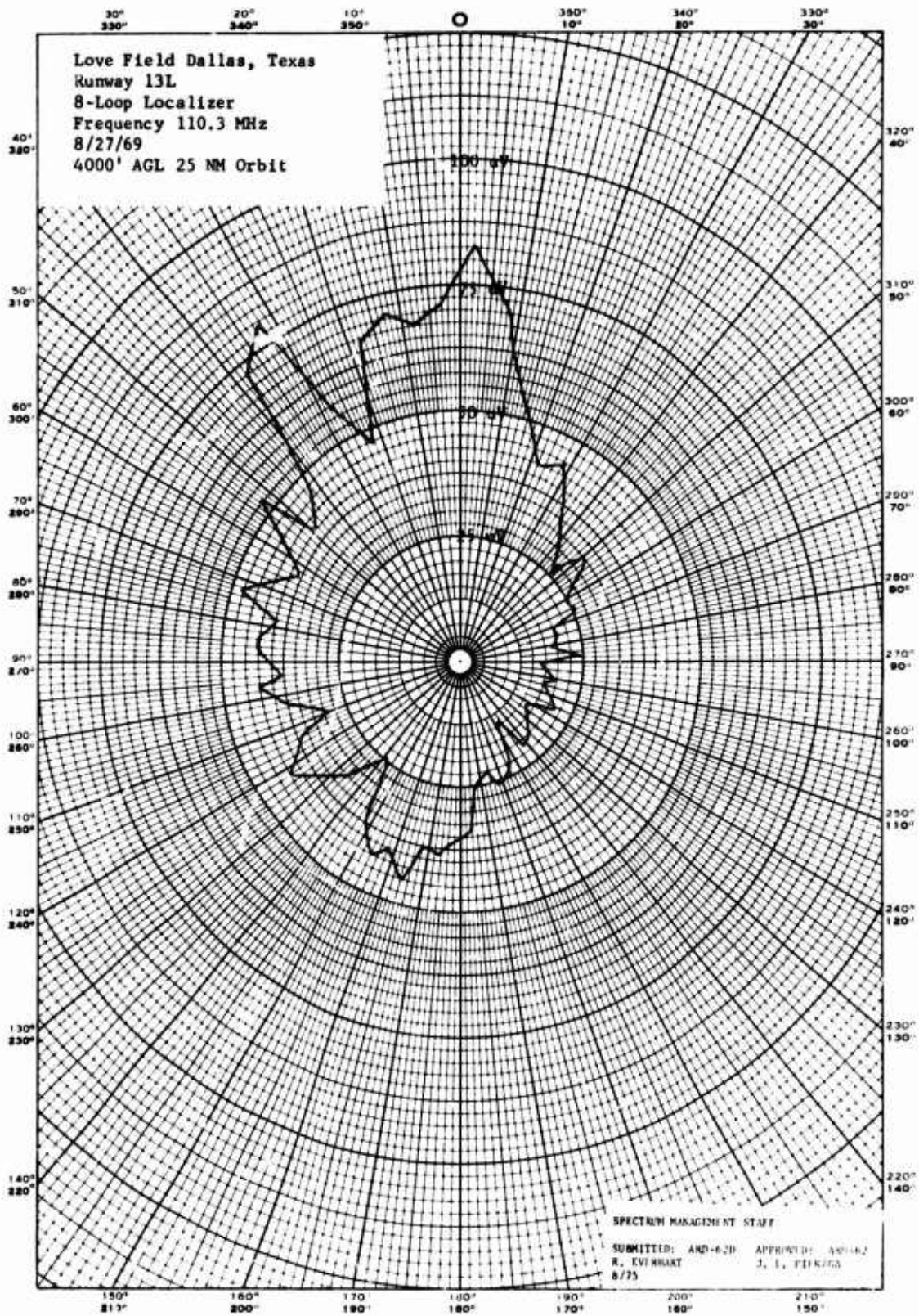

Altitude Flown - 4000 ft.

8/75

Appendix B

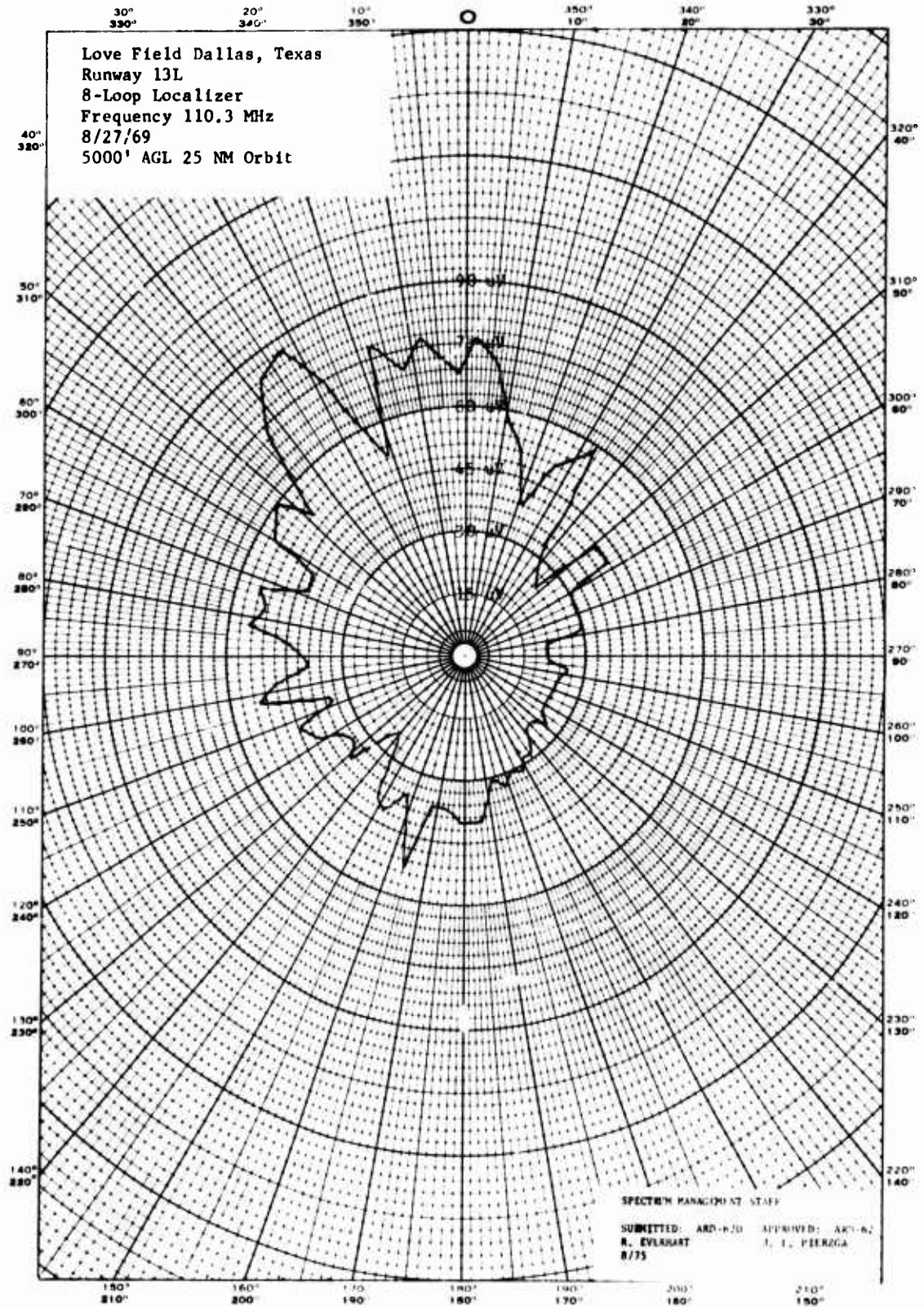

Altitude Flow - 5000 ft.

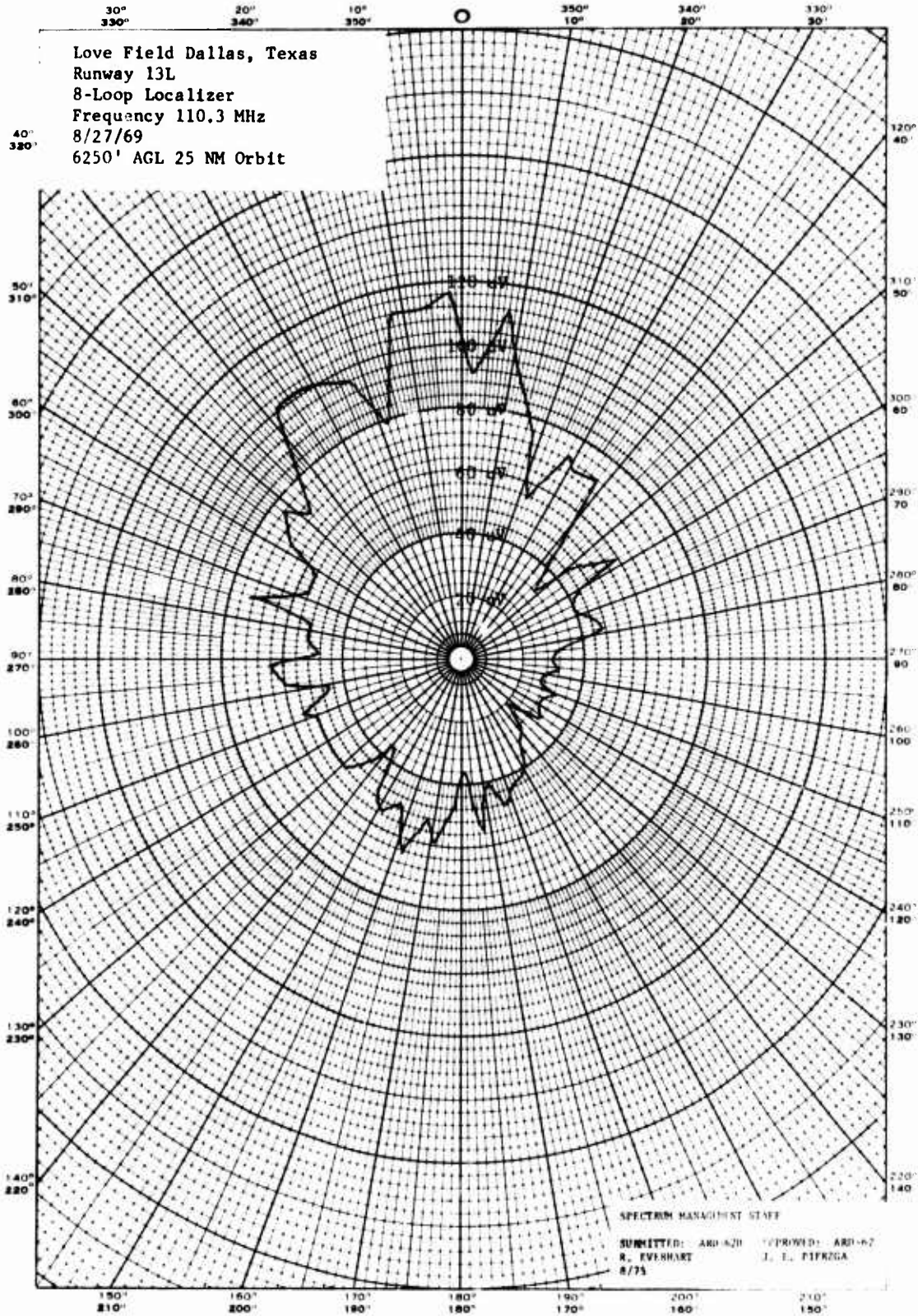

Altitude Flown - 6250 ft.

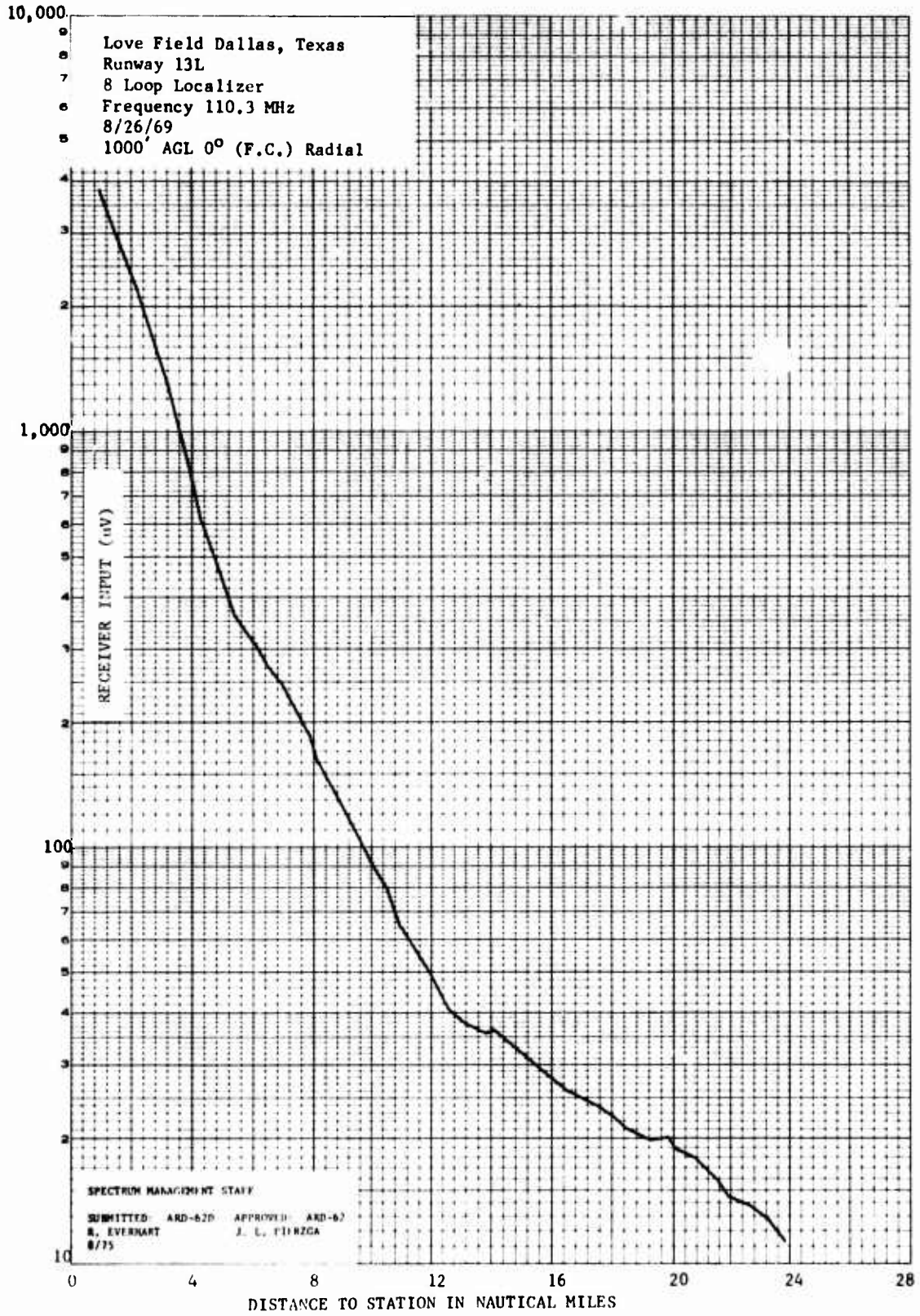

Altitude Flown - 1000 ft.

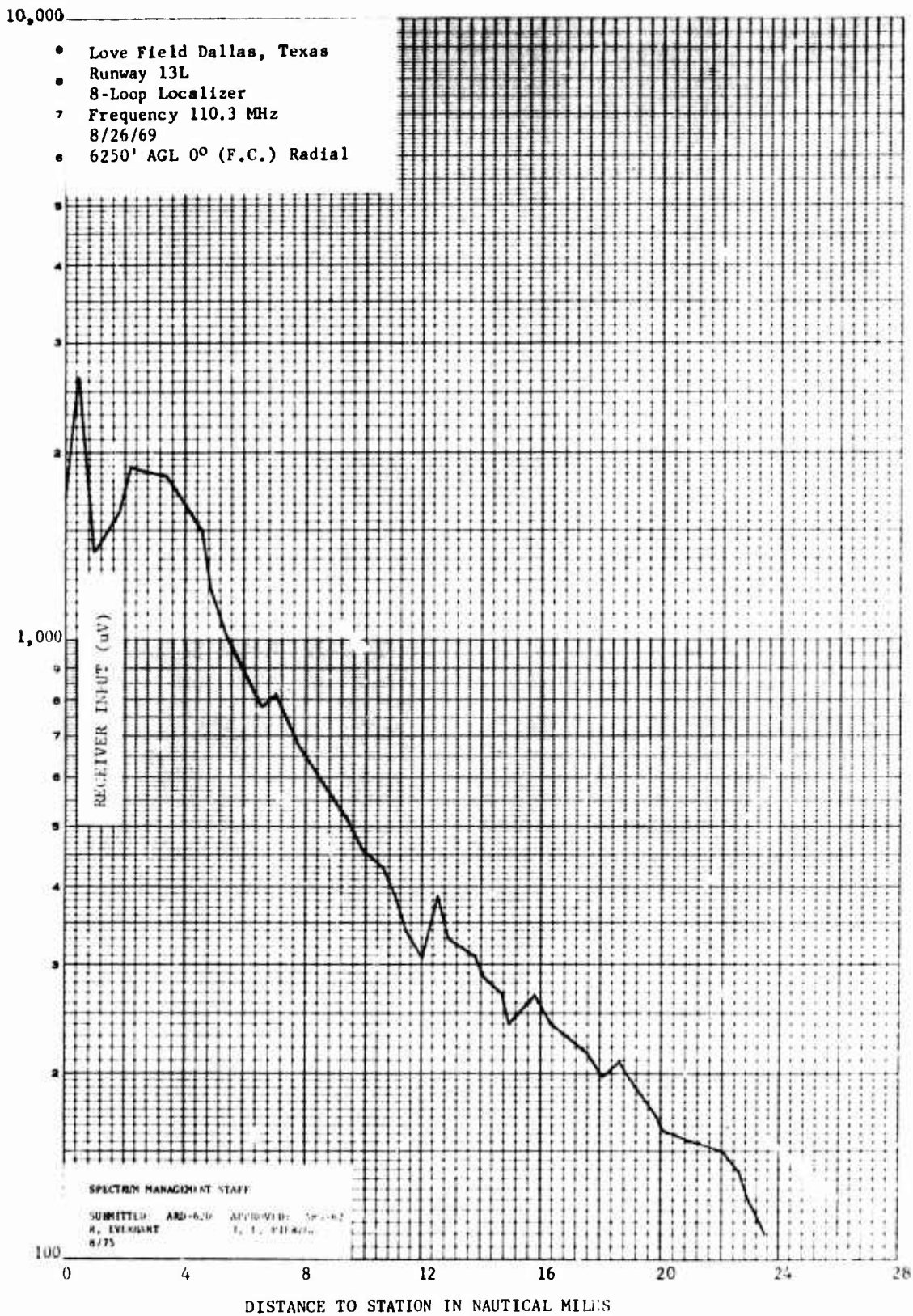

Altitude Flown - 6250 ft.

8/75

Appendix C

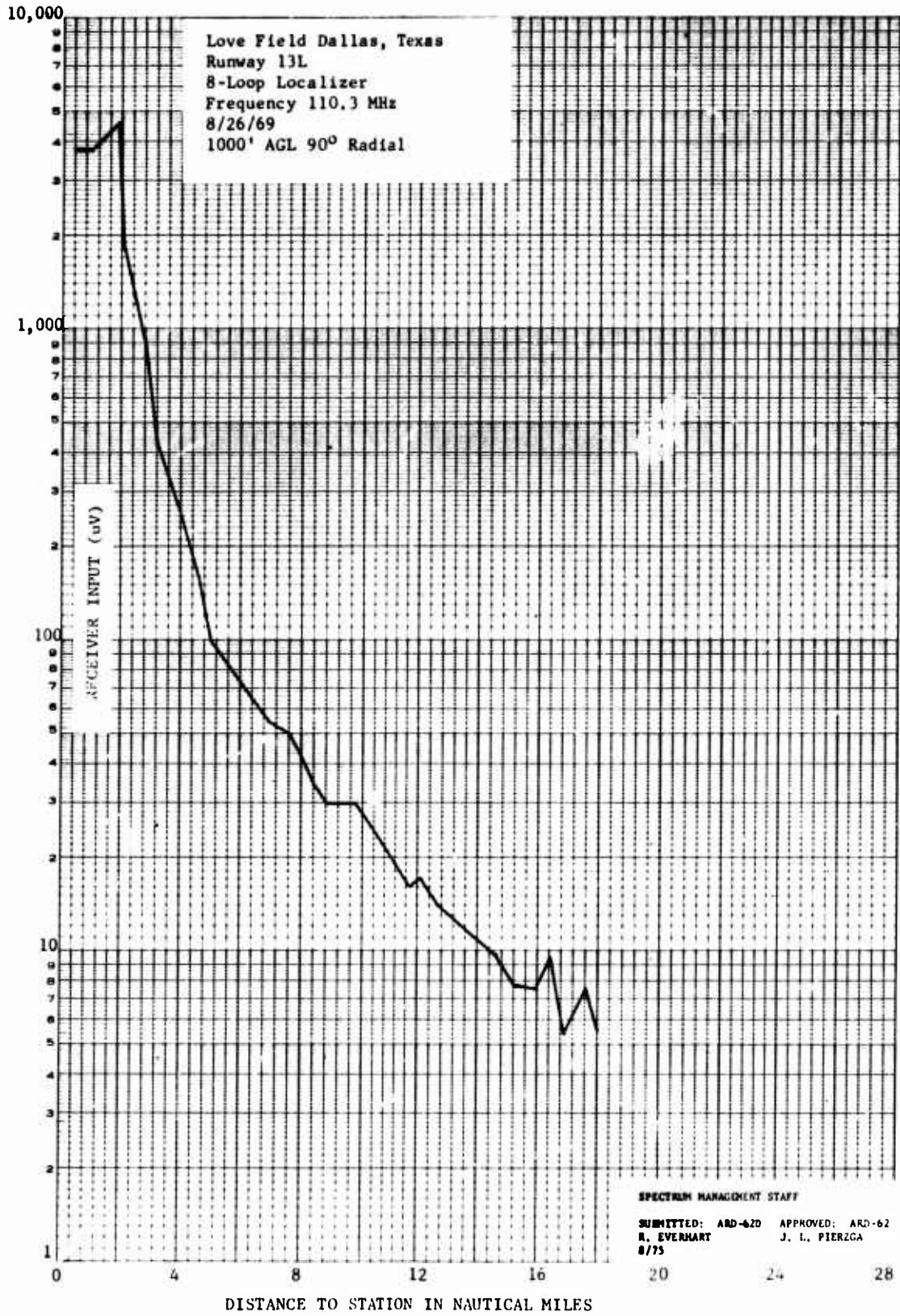

Altitude Flown - 1000 ft.

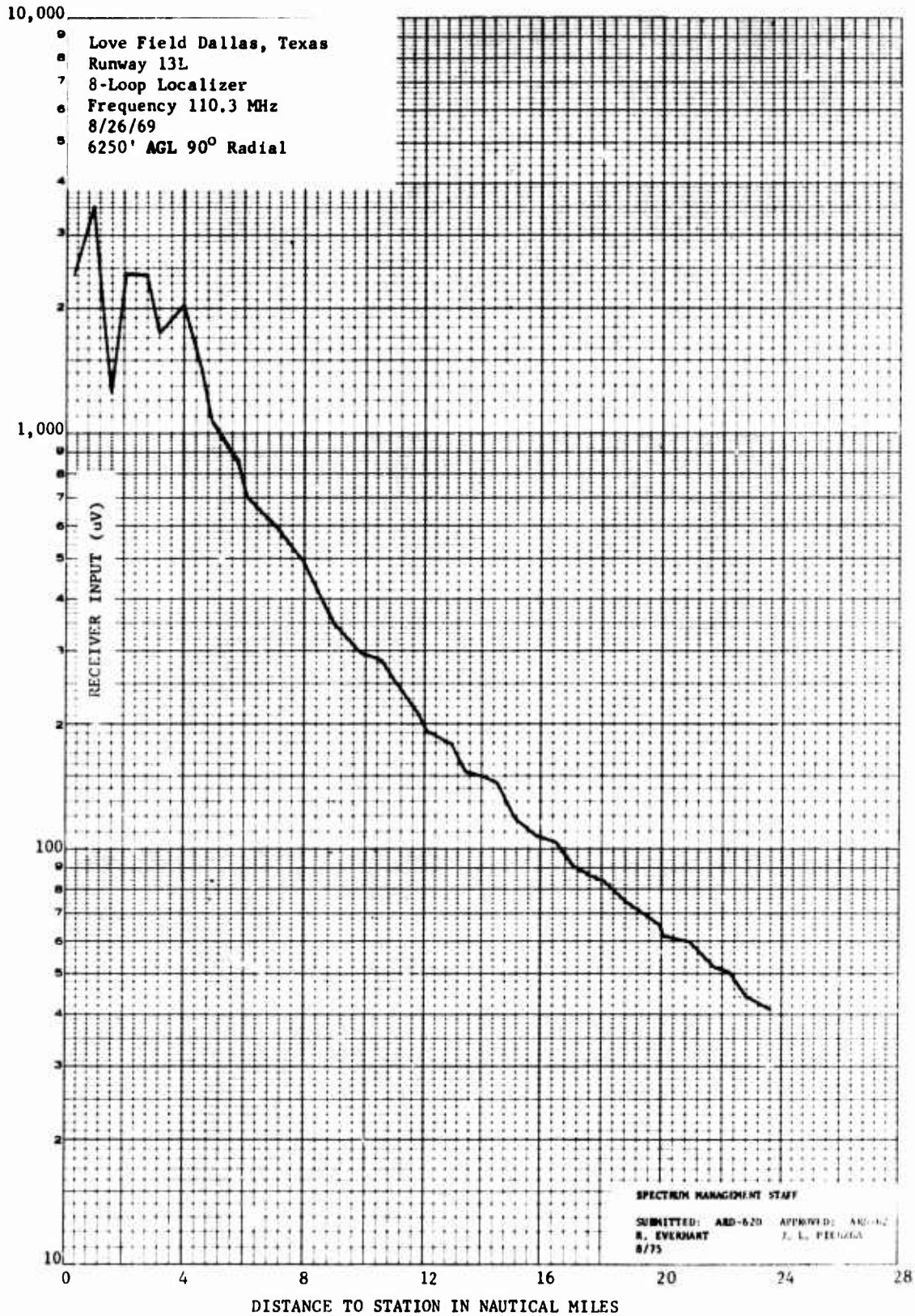

Altitude Flown - 6250 ft.

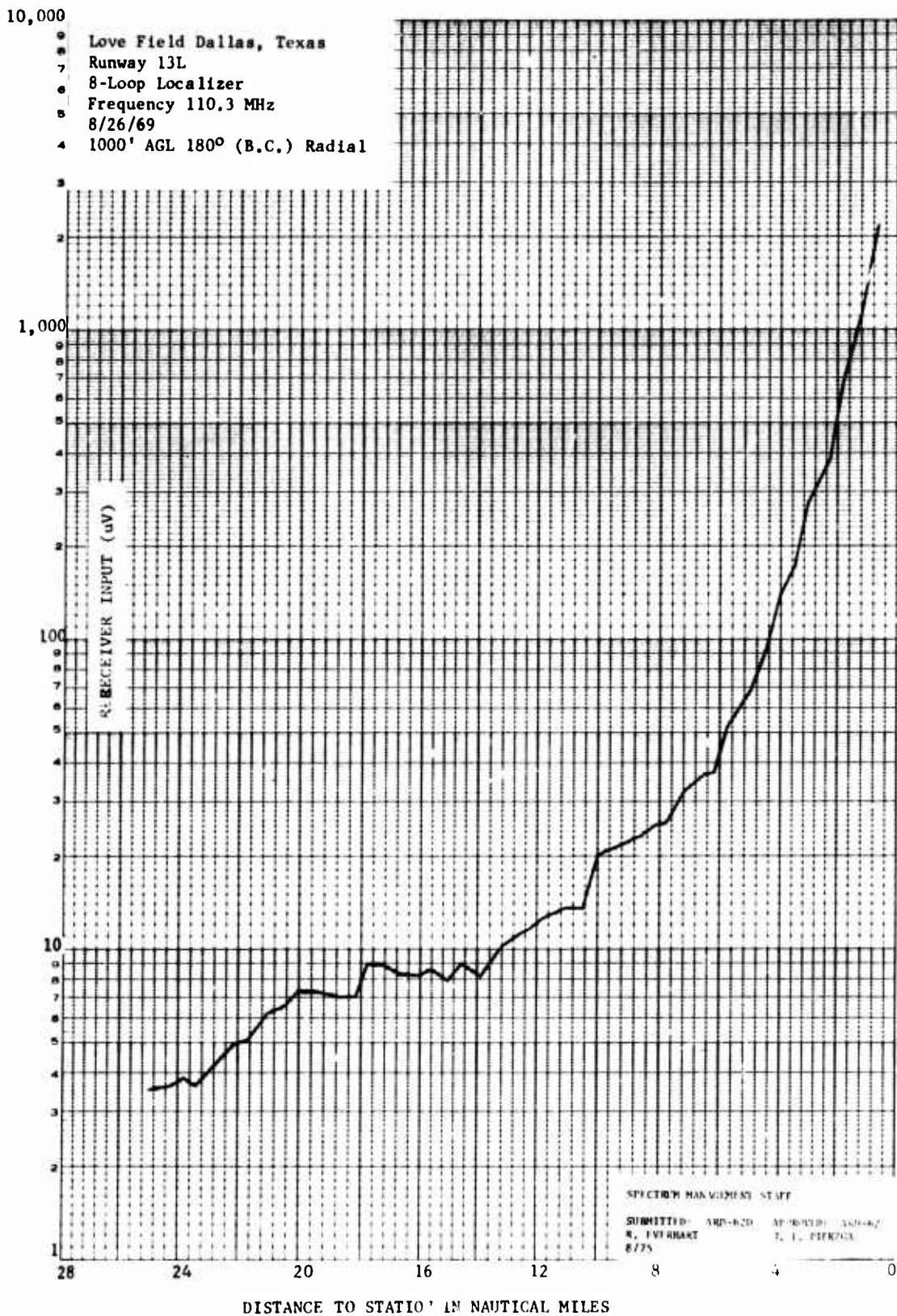

Altitude Flown - 1000 ft.

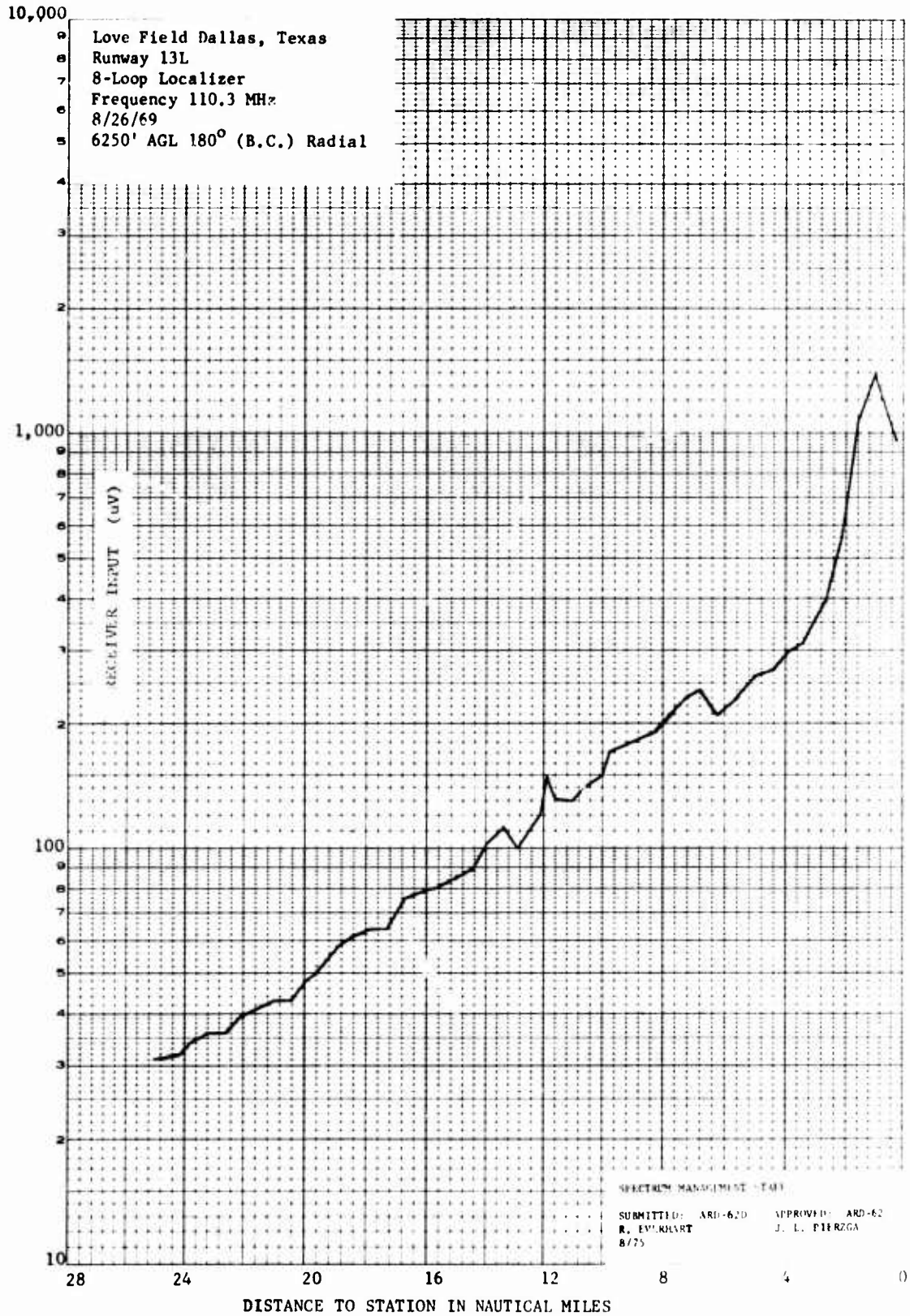

Altitude Flow - 6250 ft.

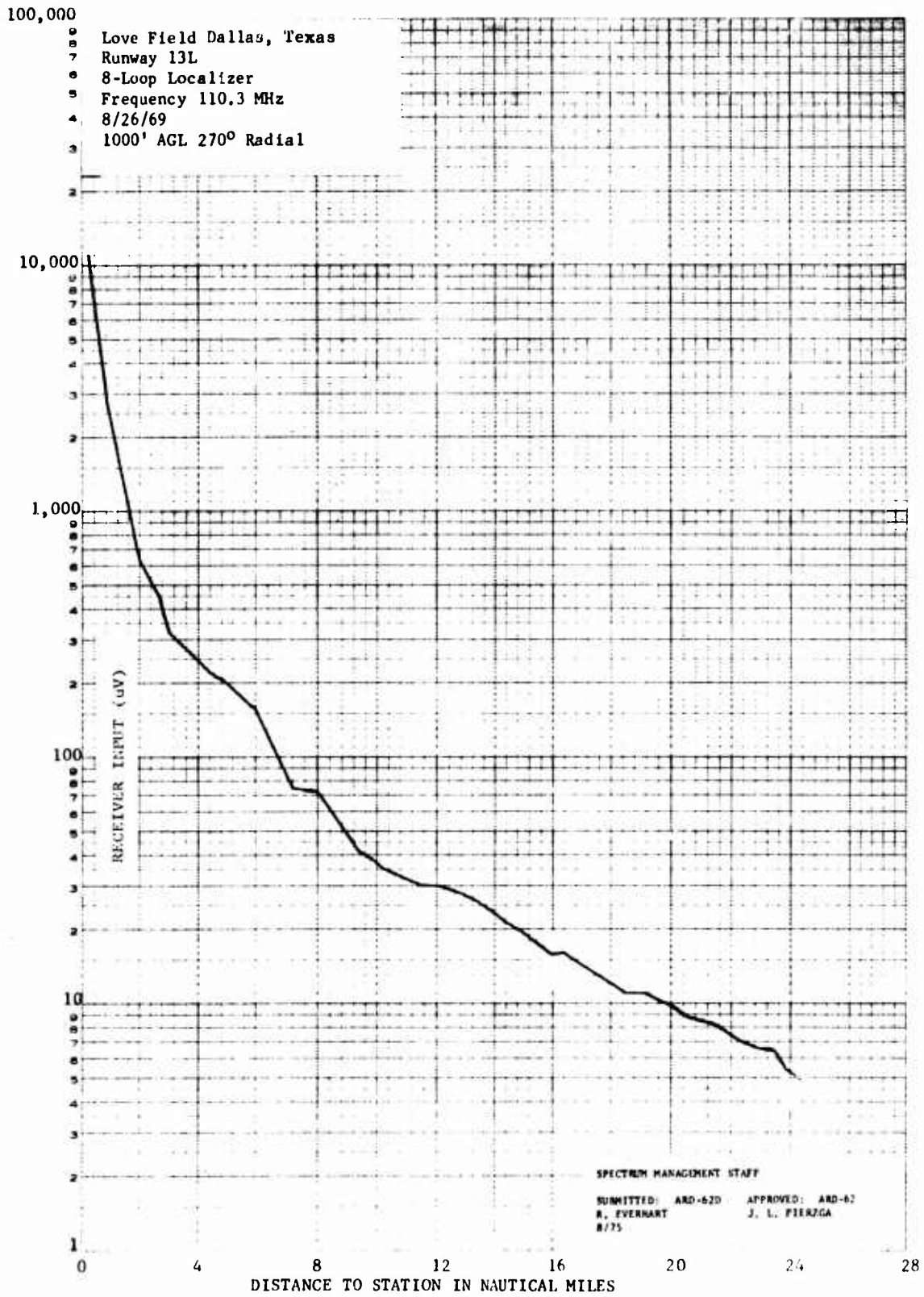

Altitude Flown - 1000 ft.

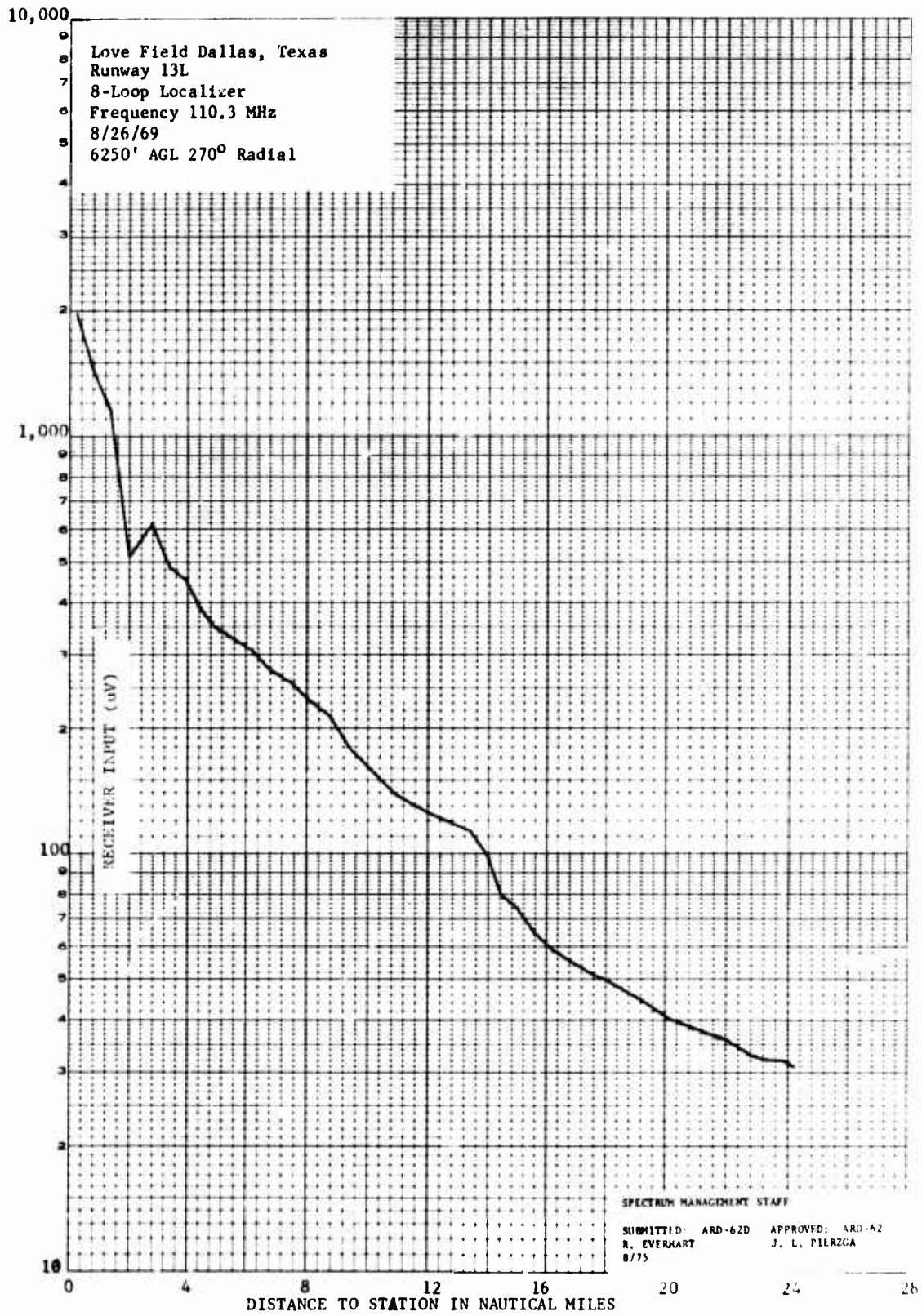

Altitude Flown - 6250 ft.

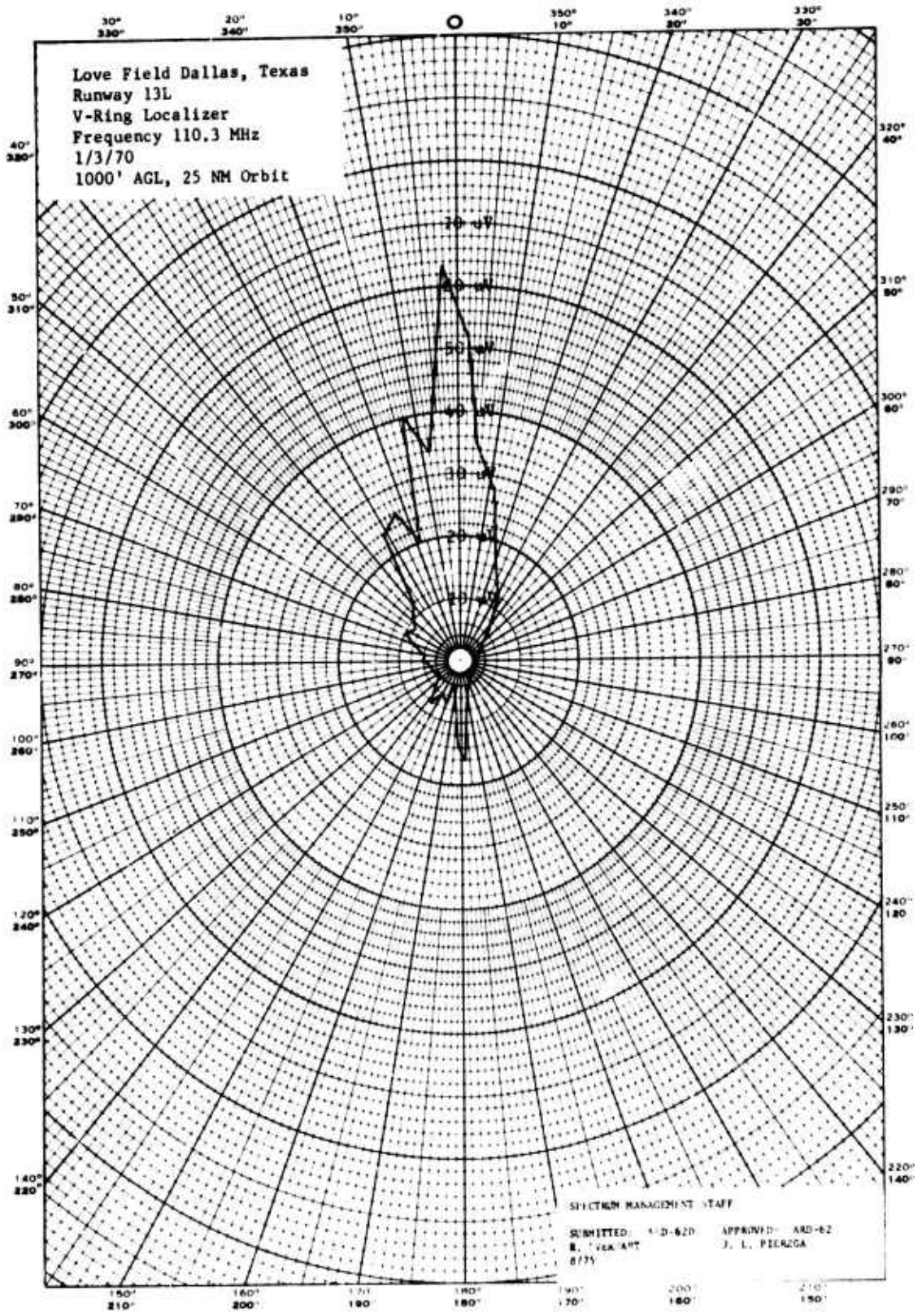

Altitude Flown - 1000 ft.

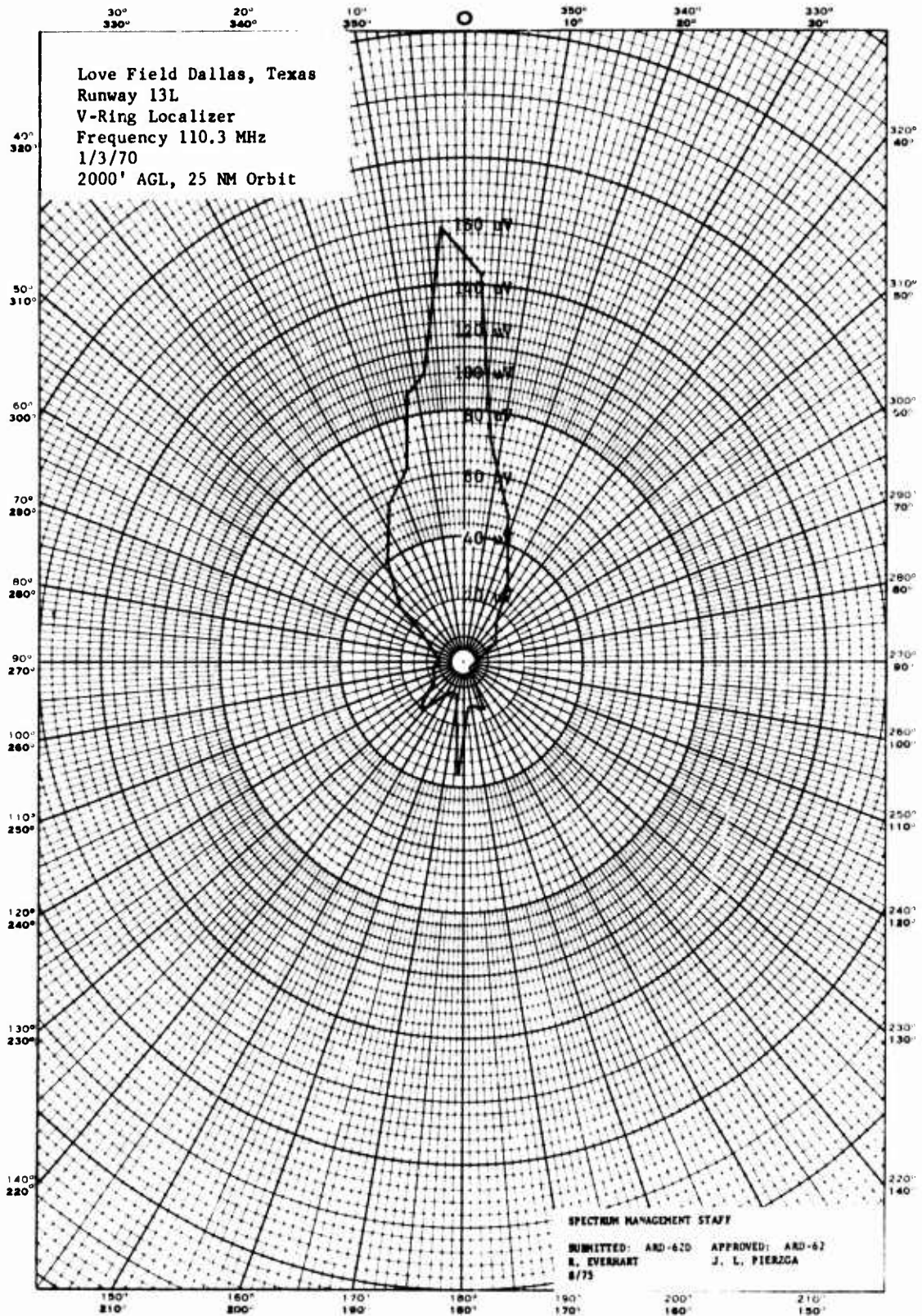

Altitude Flown - 2000 ft.

8/75

Appendix D

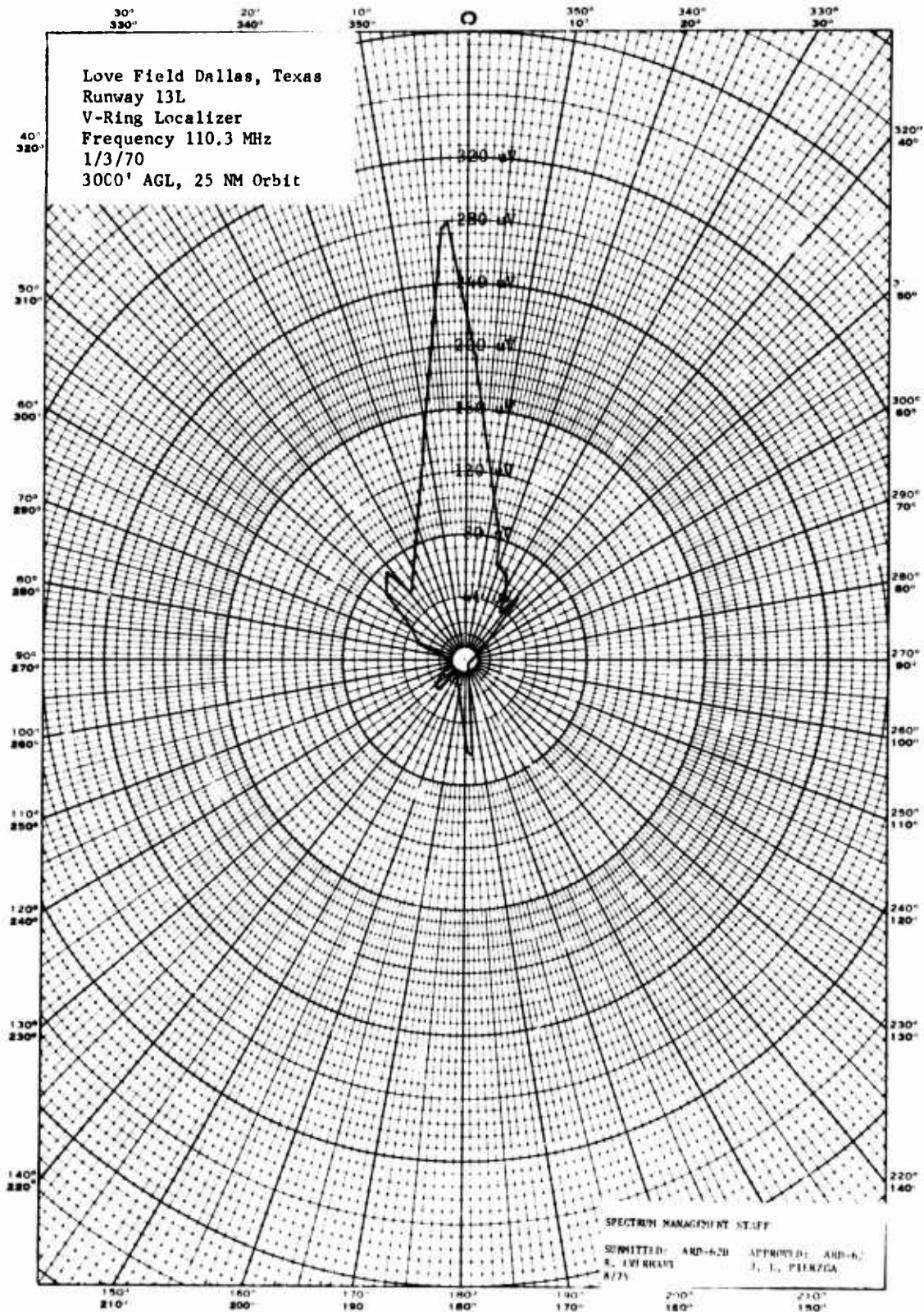

Altitude Flow - 3000 ft.

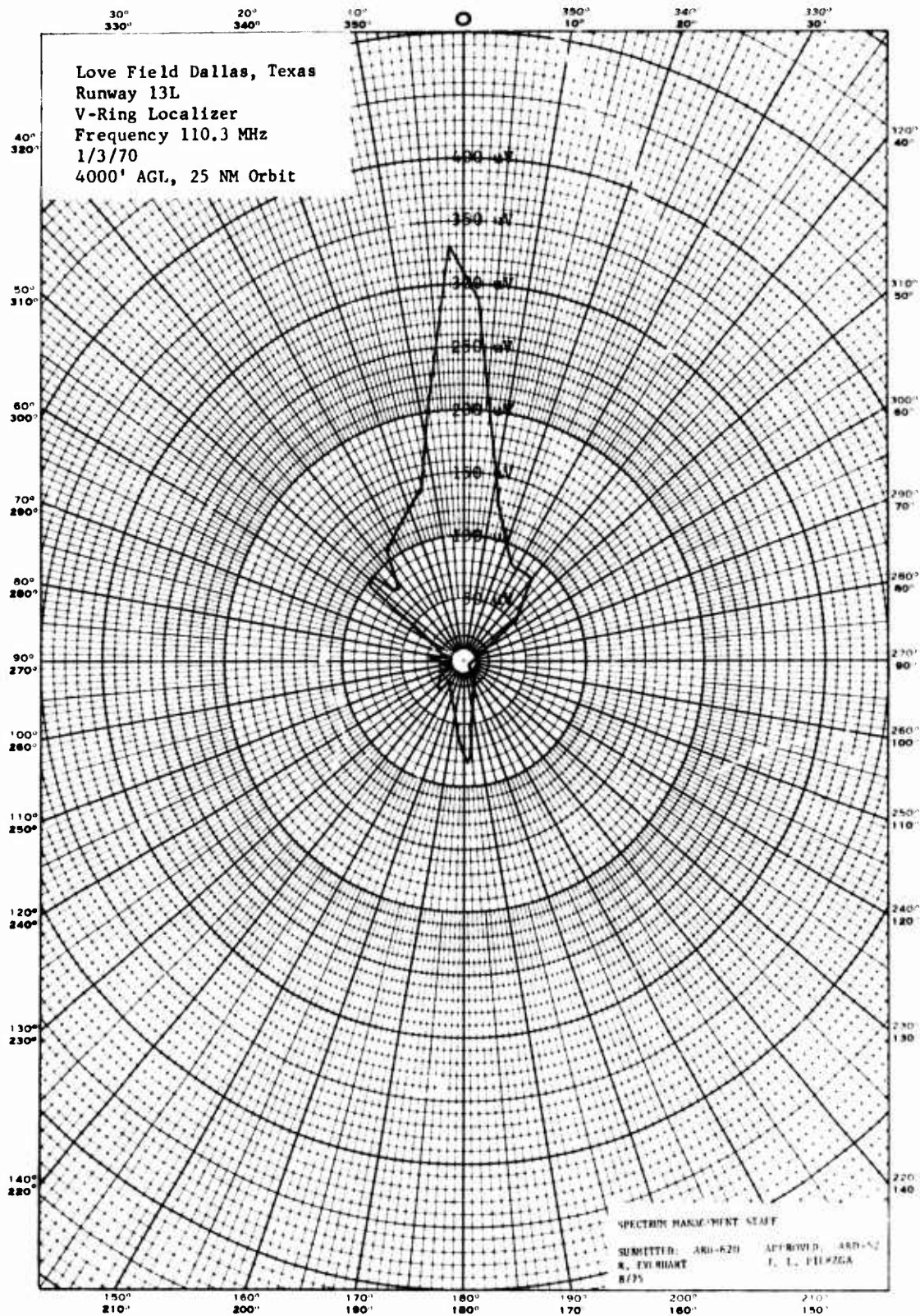

Altitude Flown - 4000 ft.

8/75

Appendix D

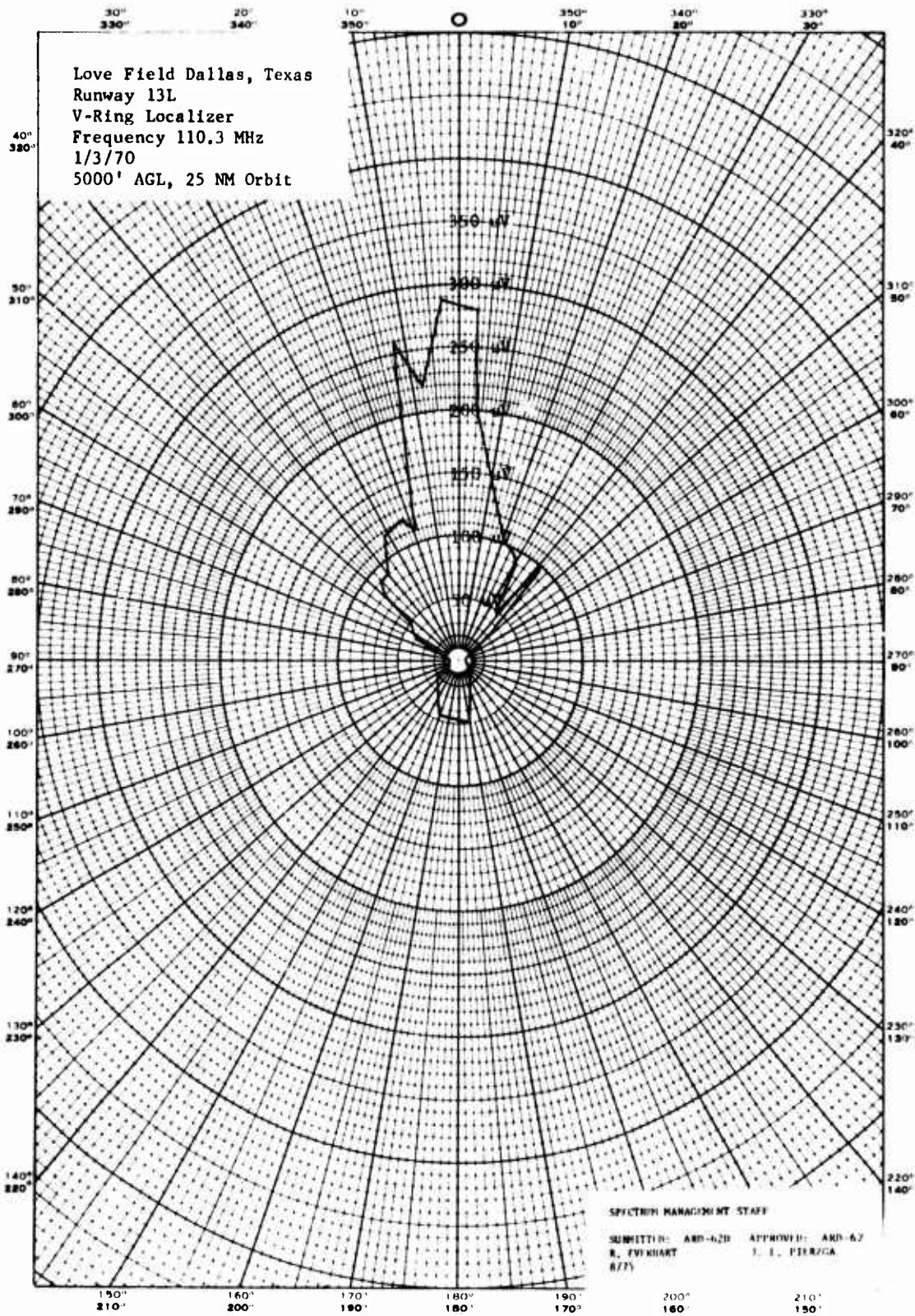

Altitude Flown - 5000 ft.

8/75

Appendix D

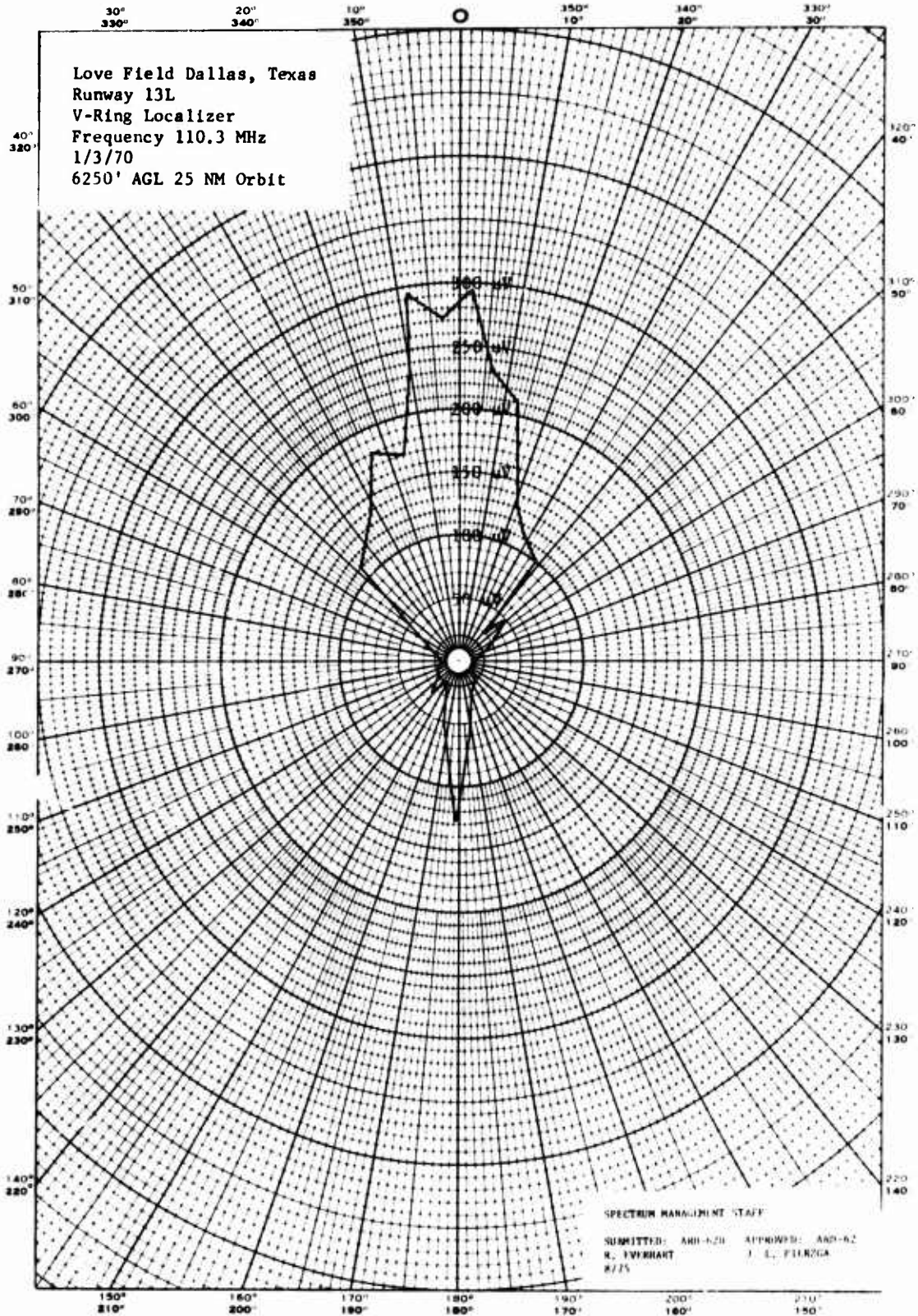

Altitude Flown - 6250 ft.

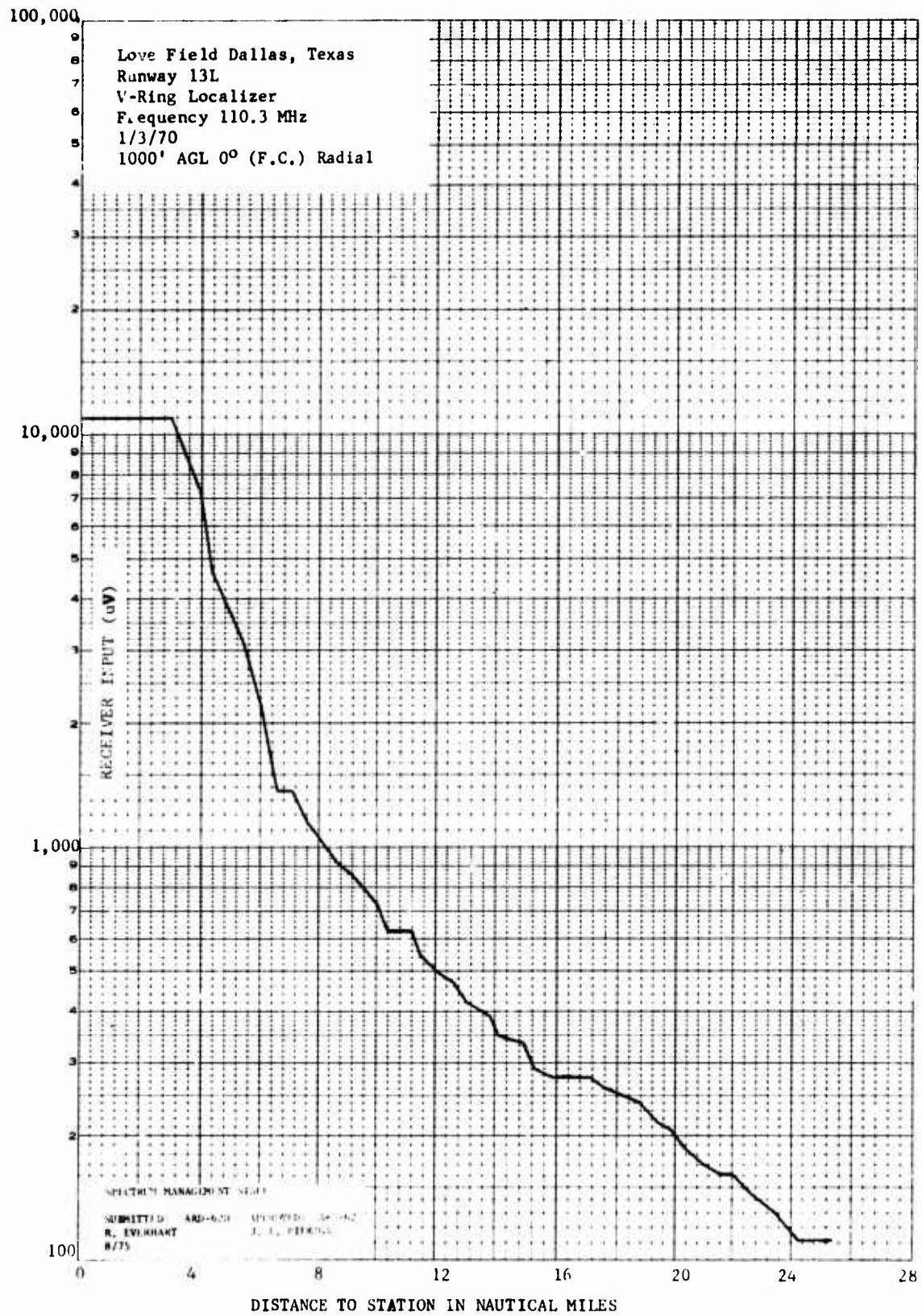

Altitude Flown - 1000 ft.

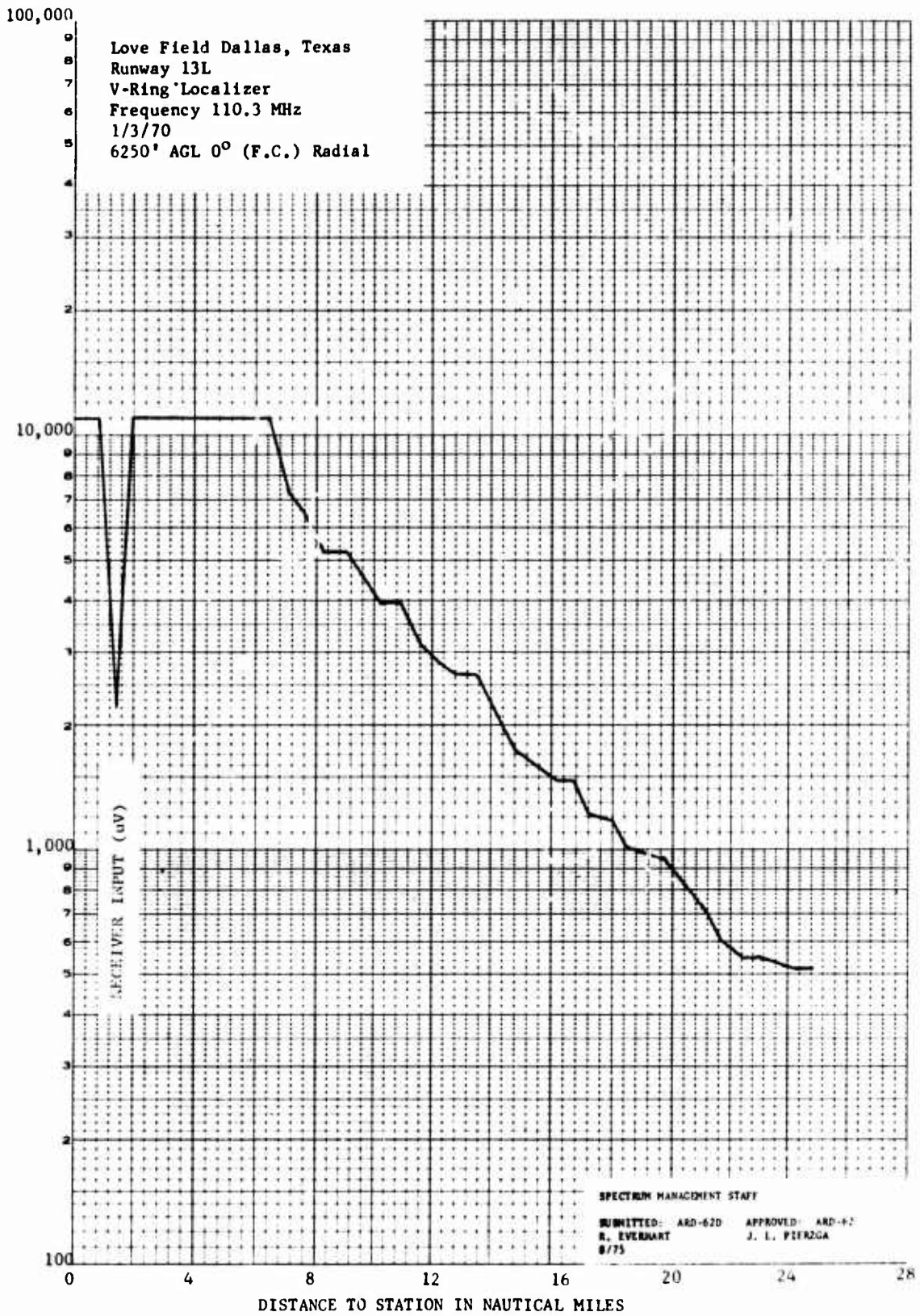

Altitude Flown - 6250 ft.

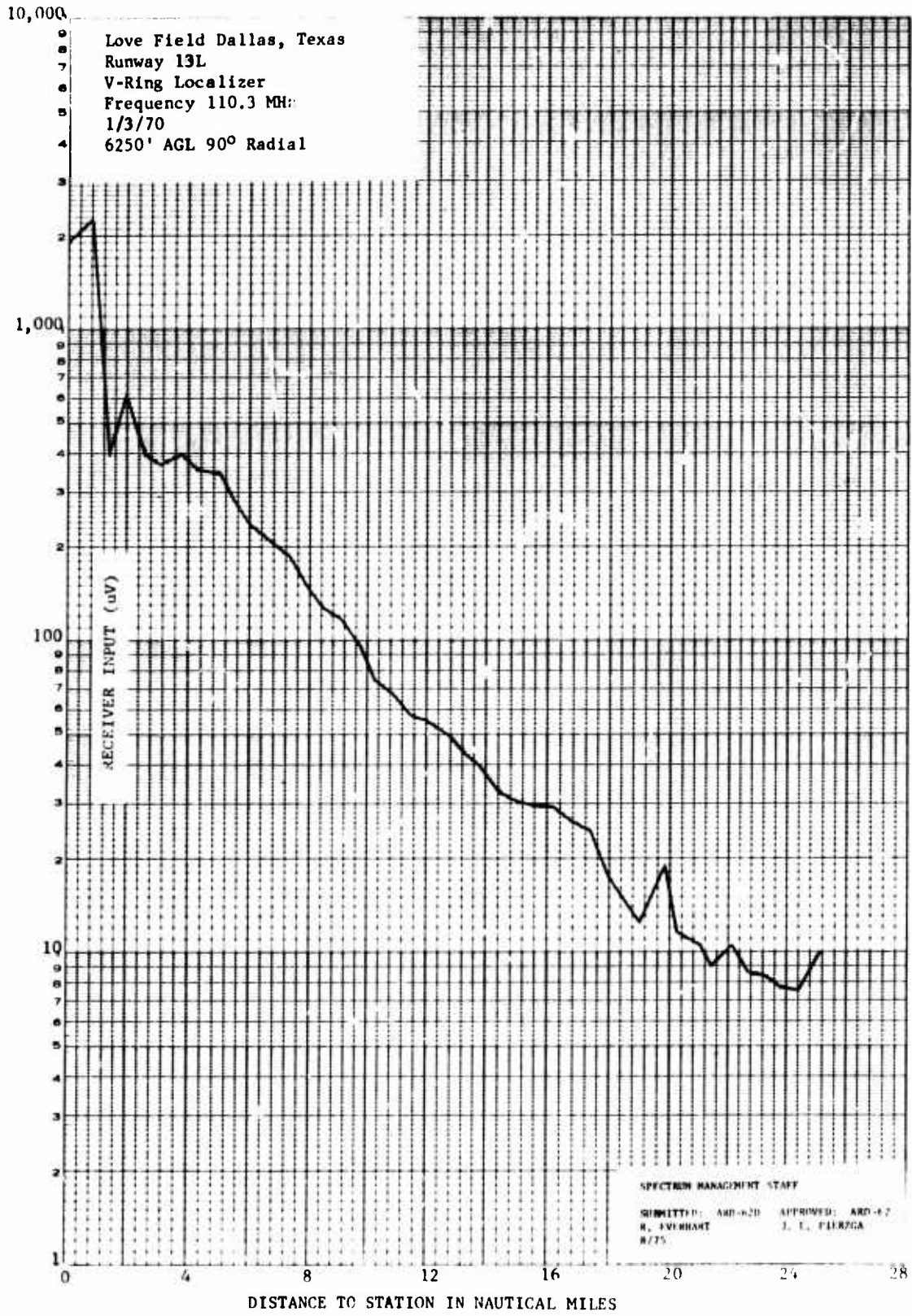

Altitude Flown - 6250 ft.

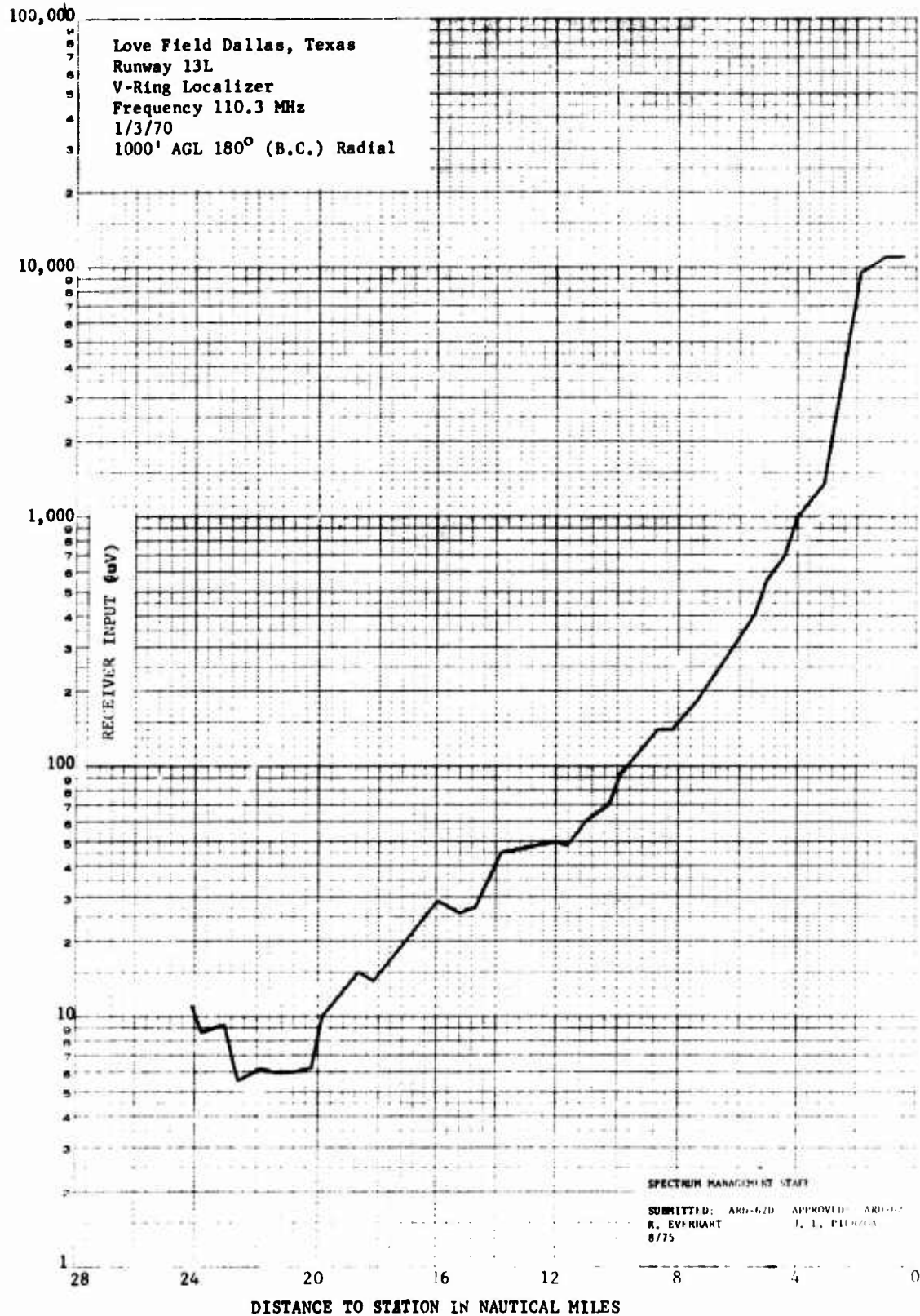

Altitude Flow - 1000 ft.

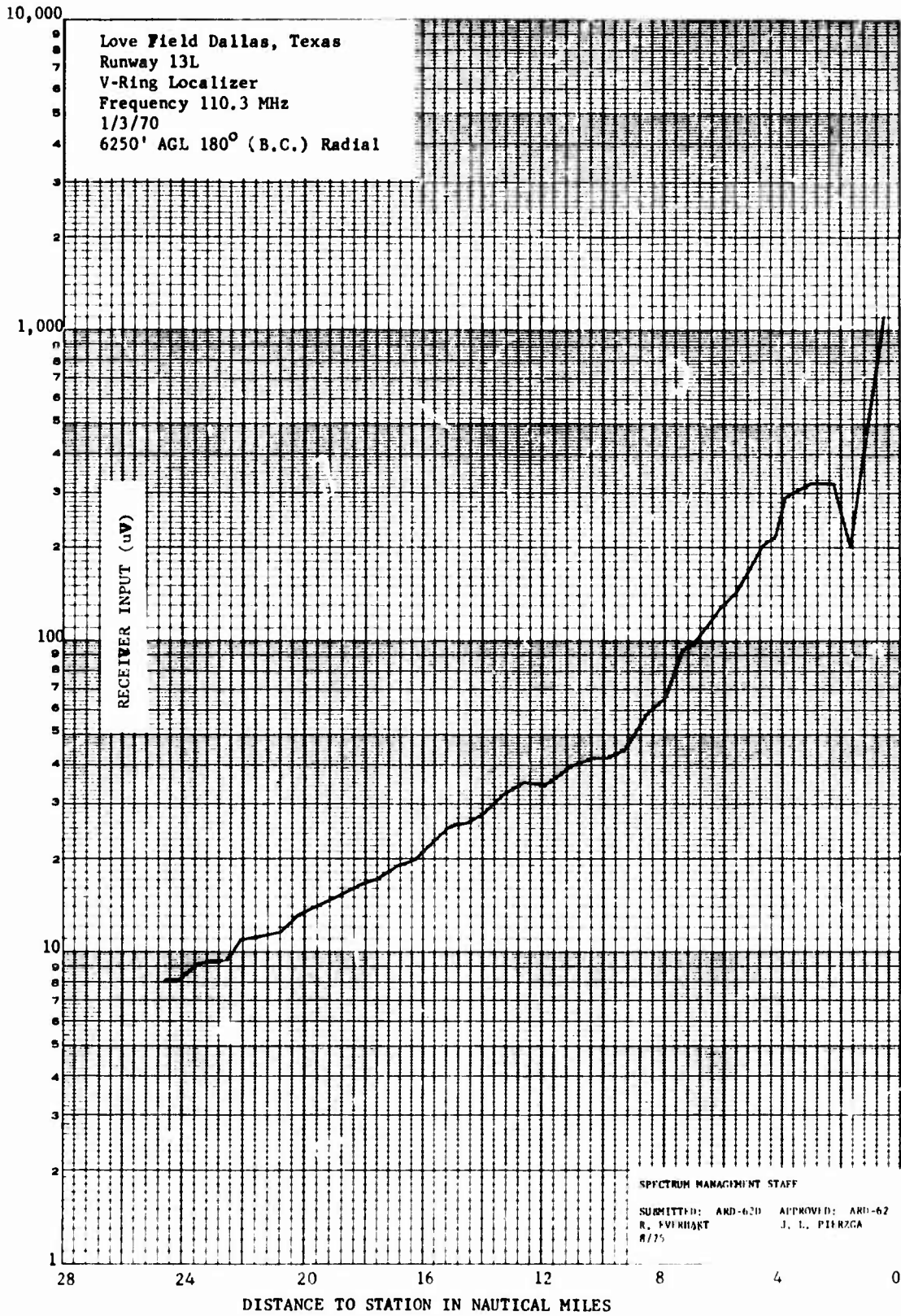

Altitude Flown - 6250 ft.

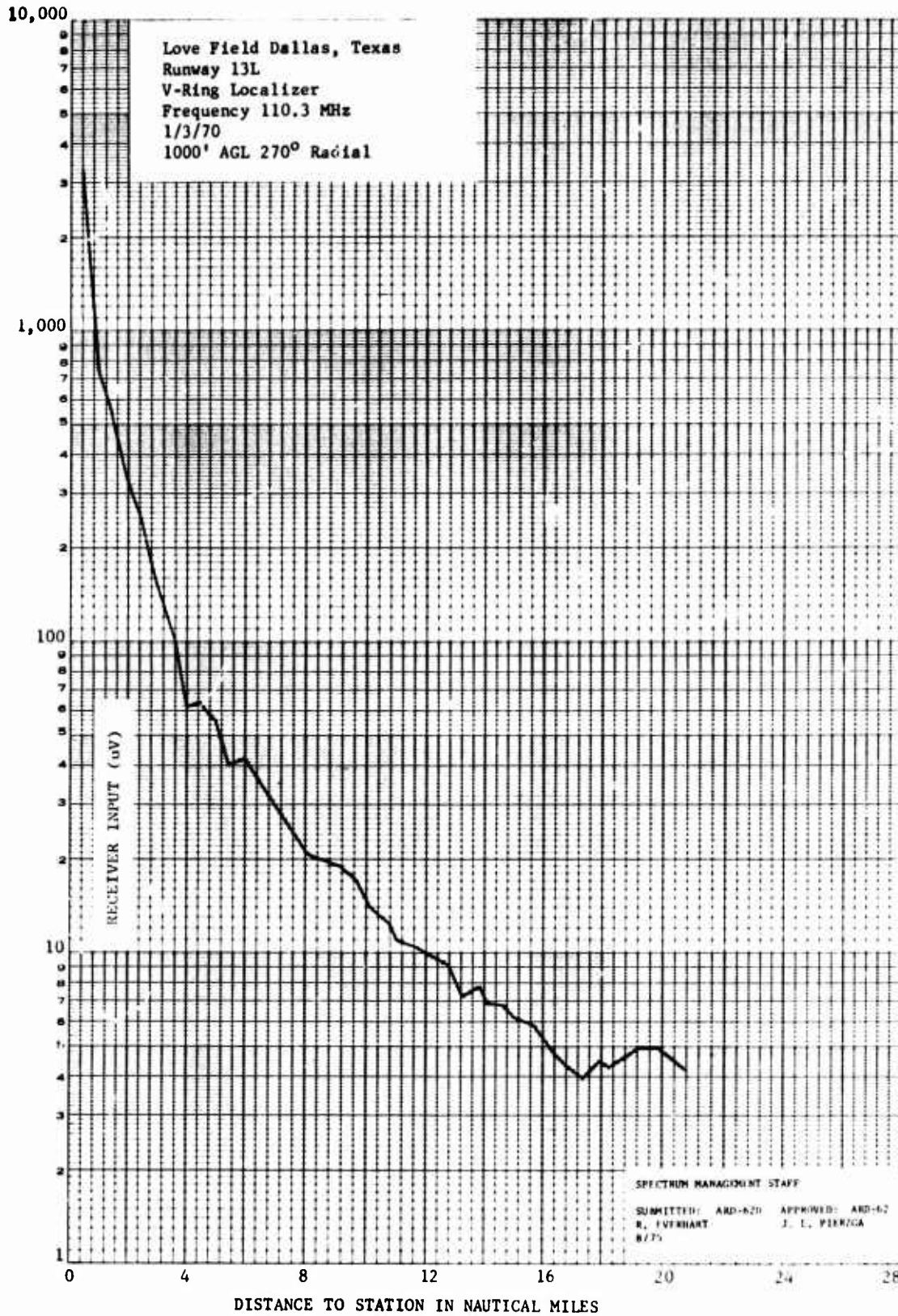

Altitude Flown - 1000 ft.

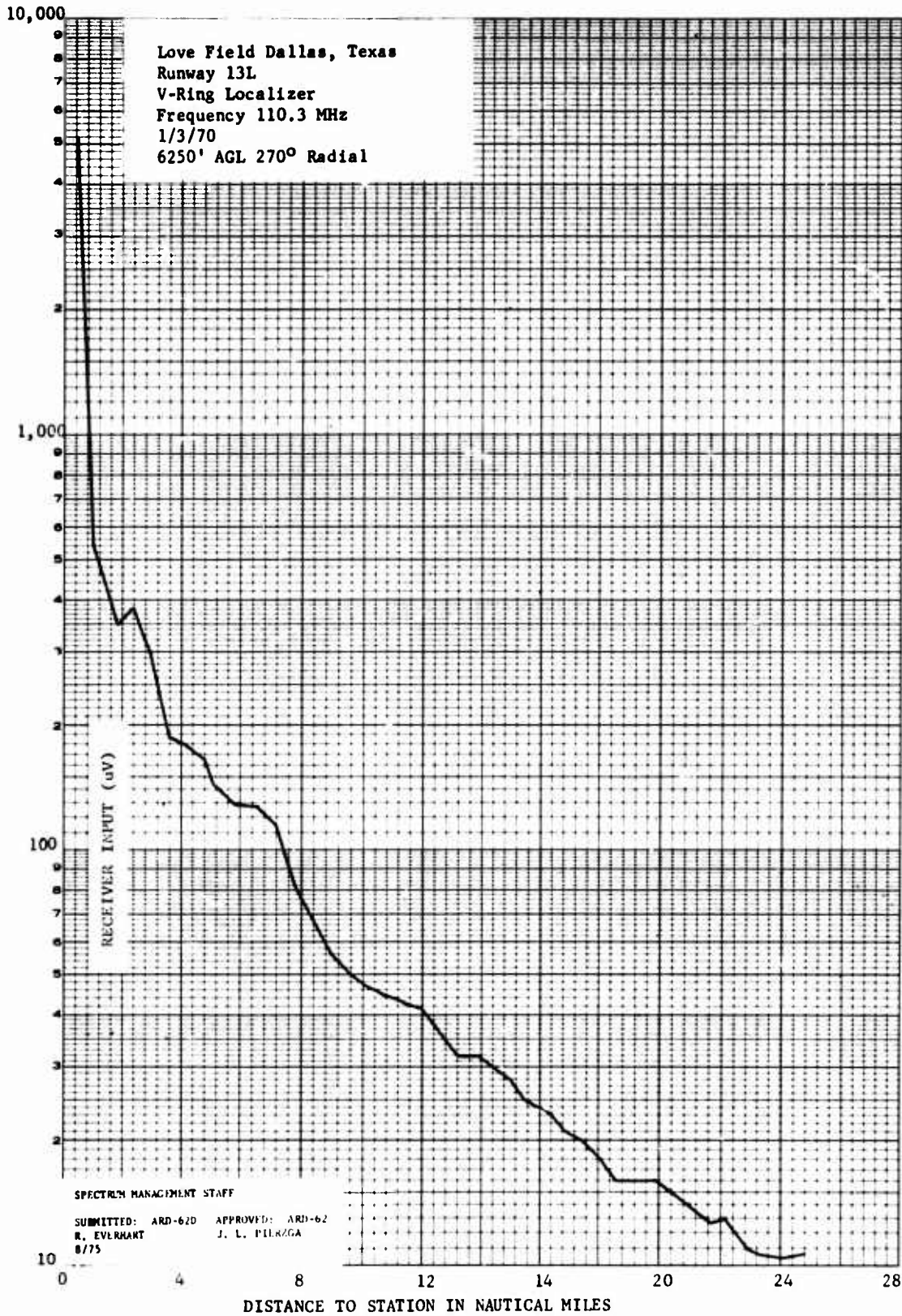

Altitude Flown - 6250 ft.

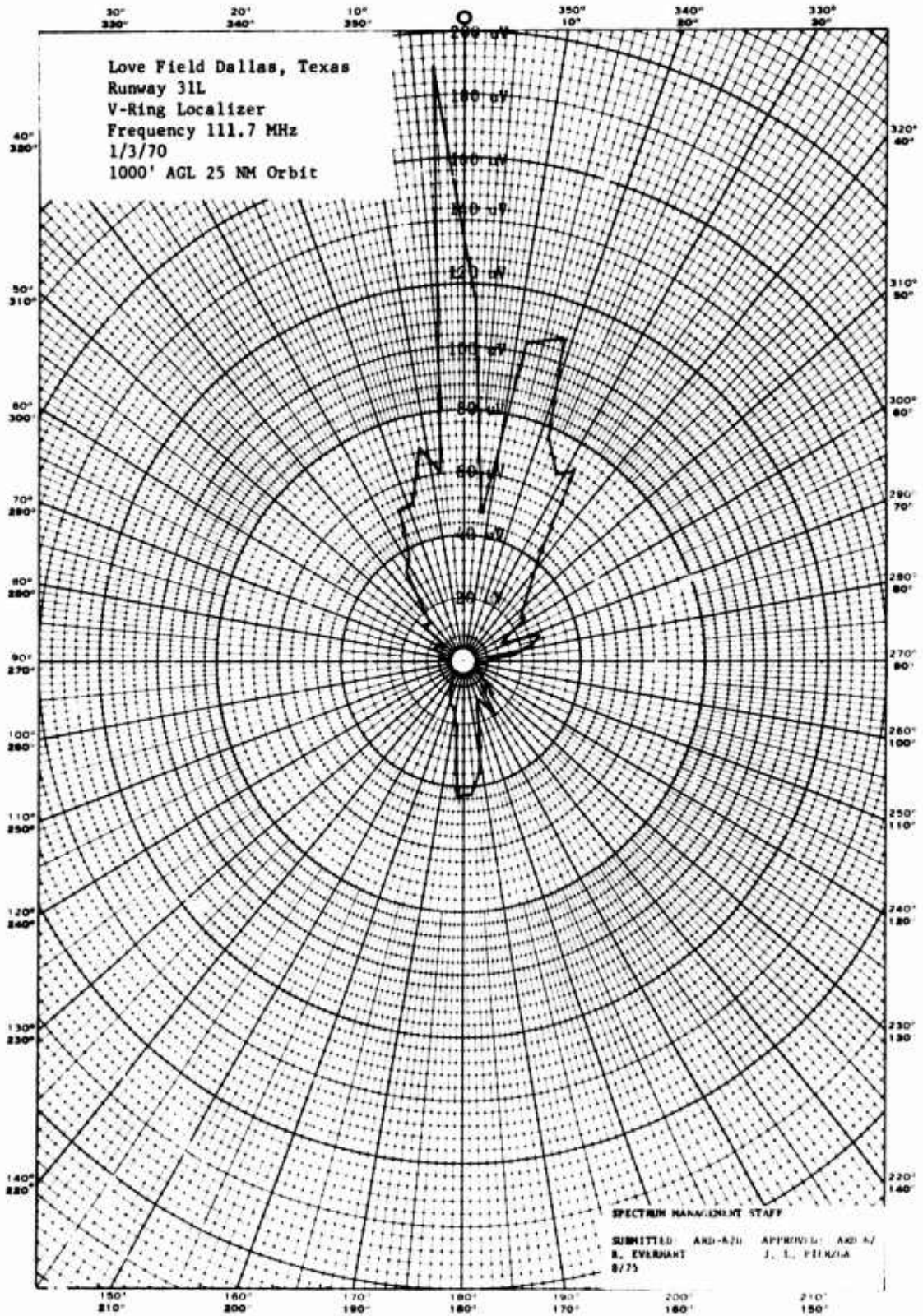

Altitude Flown - 1000 ft.

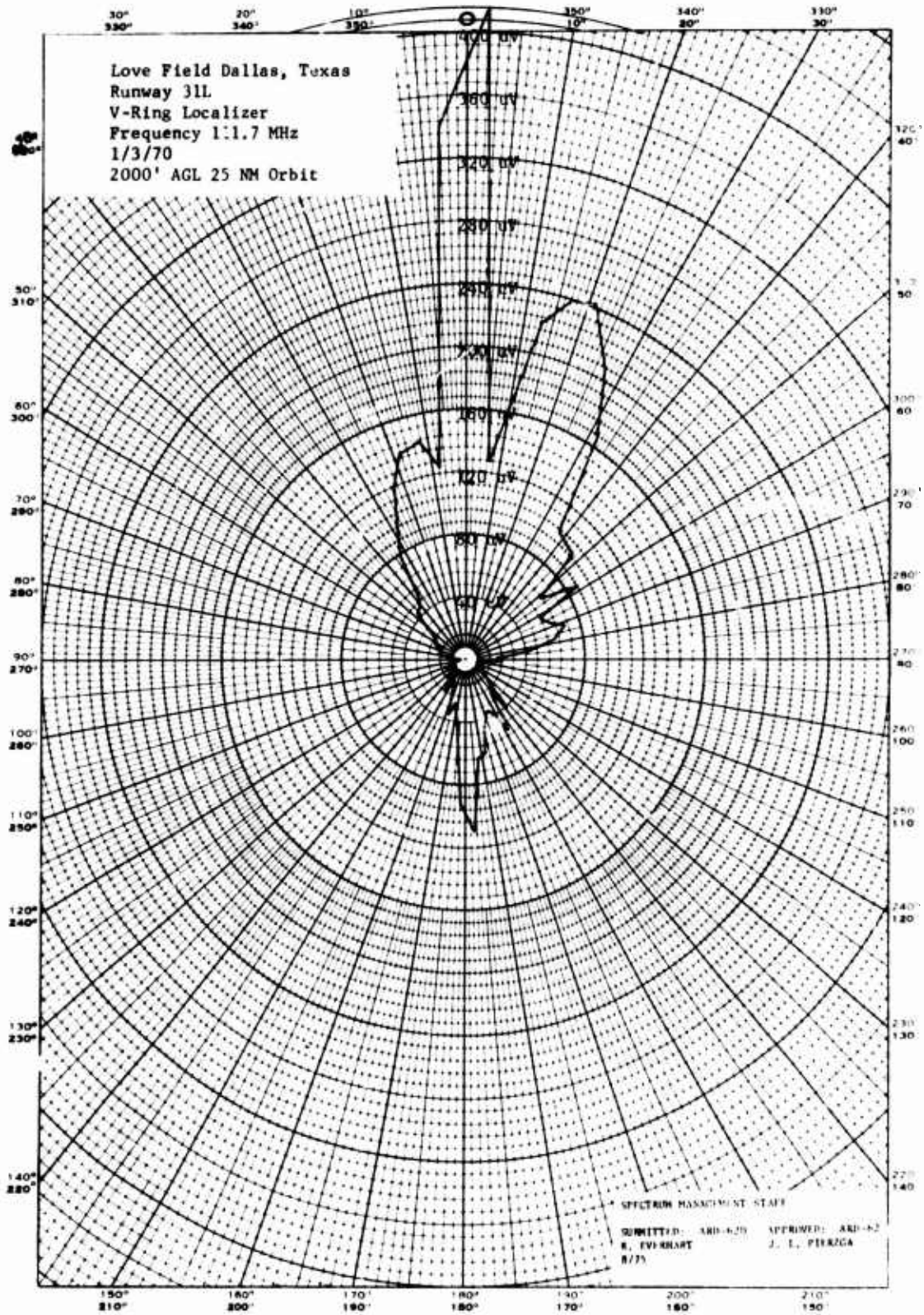

Altitude Flown - 2000 ft.

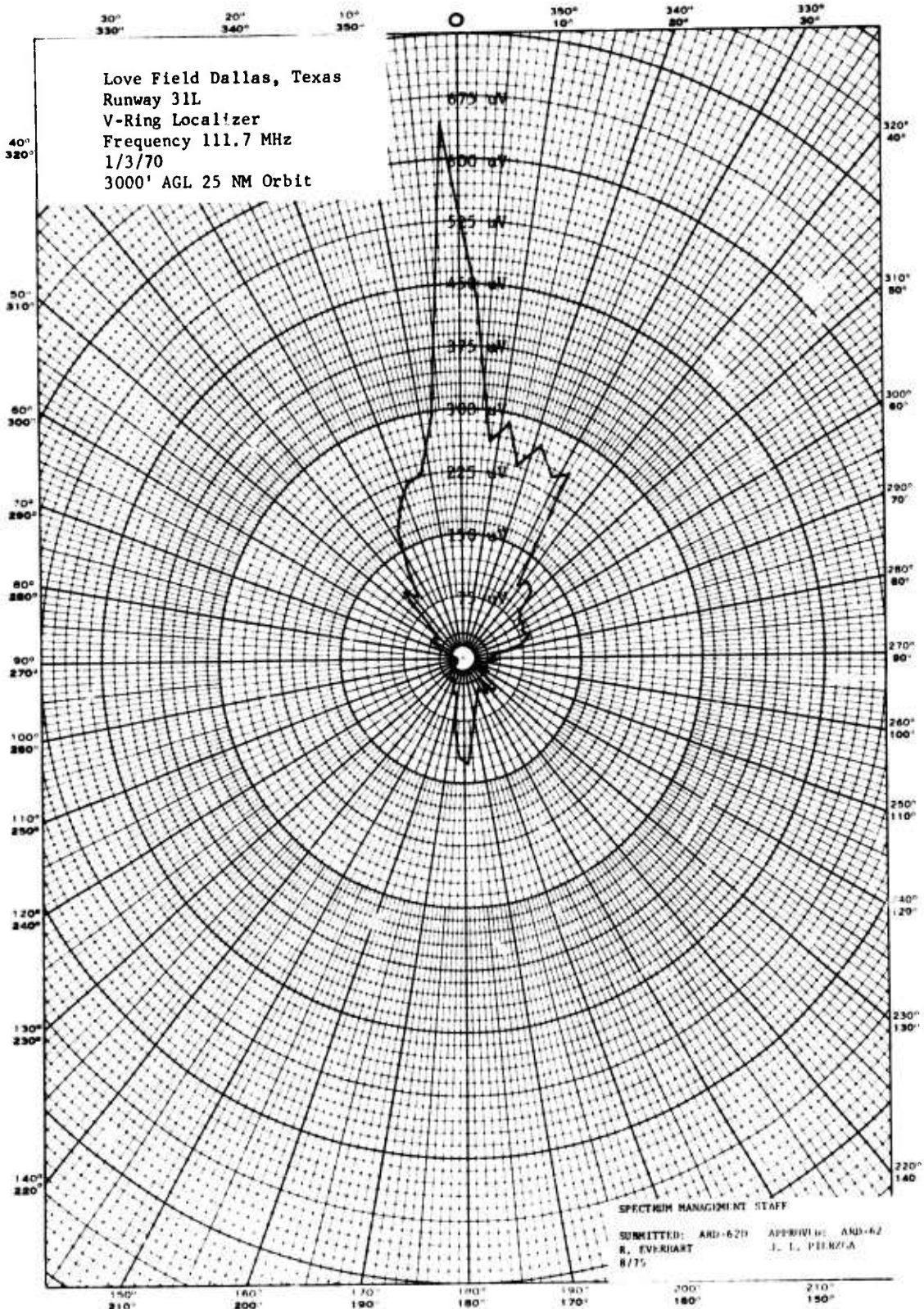

Altitude Flown - 3000

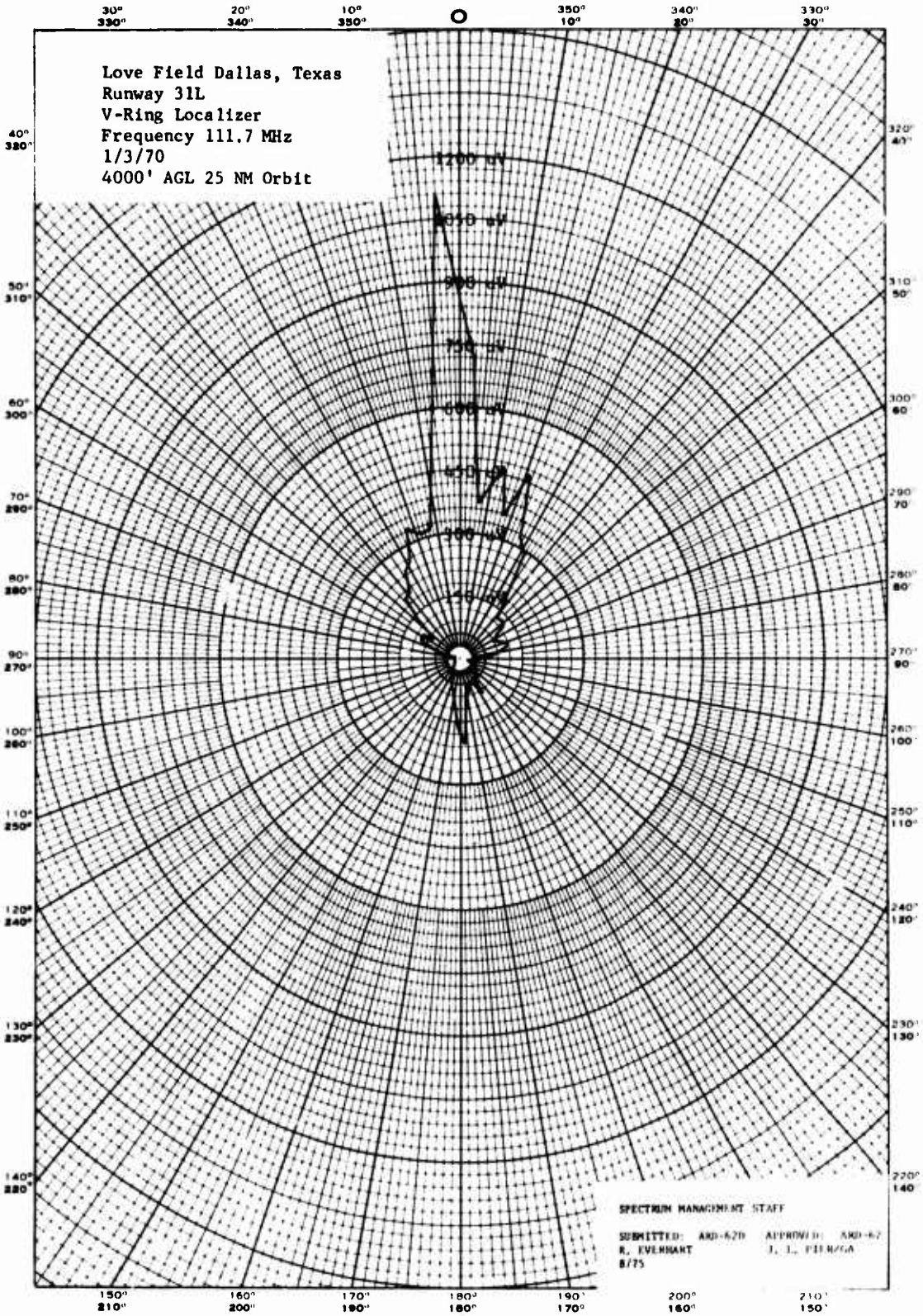

Altitude Flown - 4000 ft.

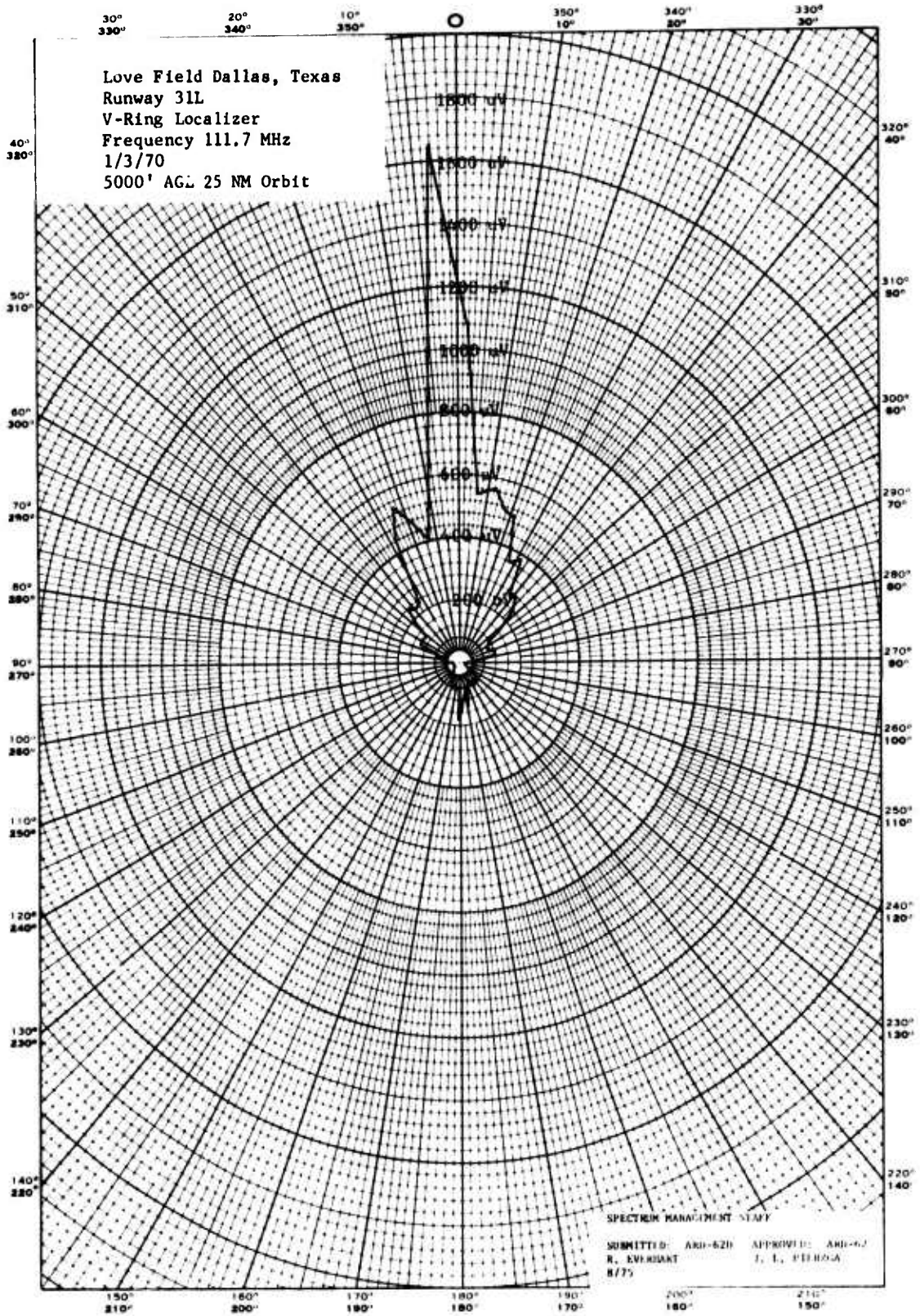

Altitude Flown - 5000 ft.

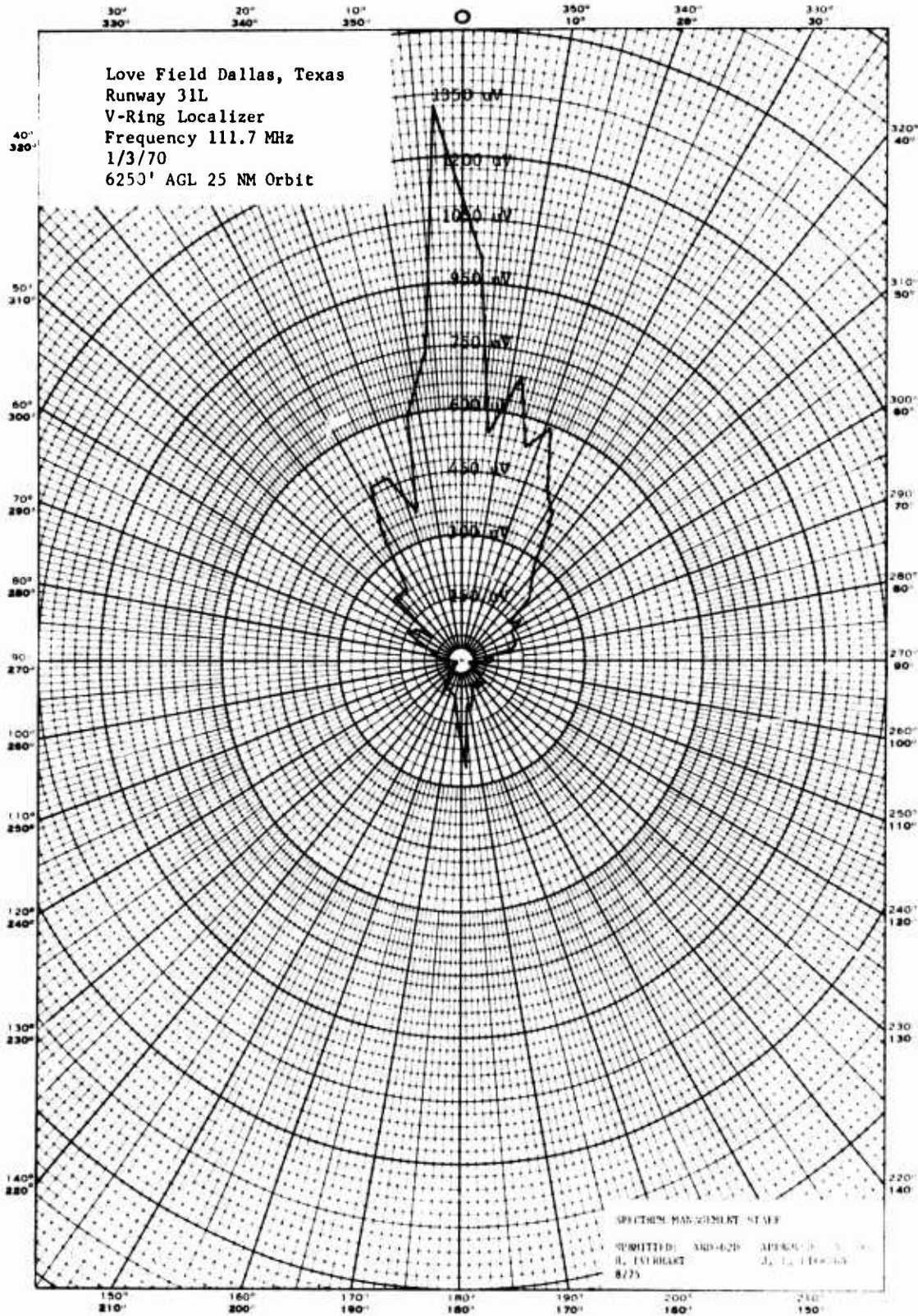

Altitude Flown - 6250 ft.

100,000

- Love Field Dallas, Texas
- Runway 31L
- V-Ring Localizer
- Frequency 111.7 MHz
- 1/2/70
- 6250' AGL 0° (F.C.) Radial

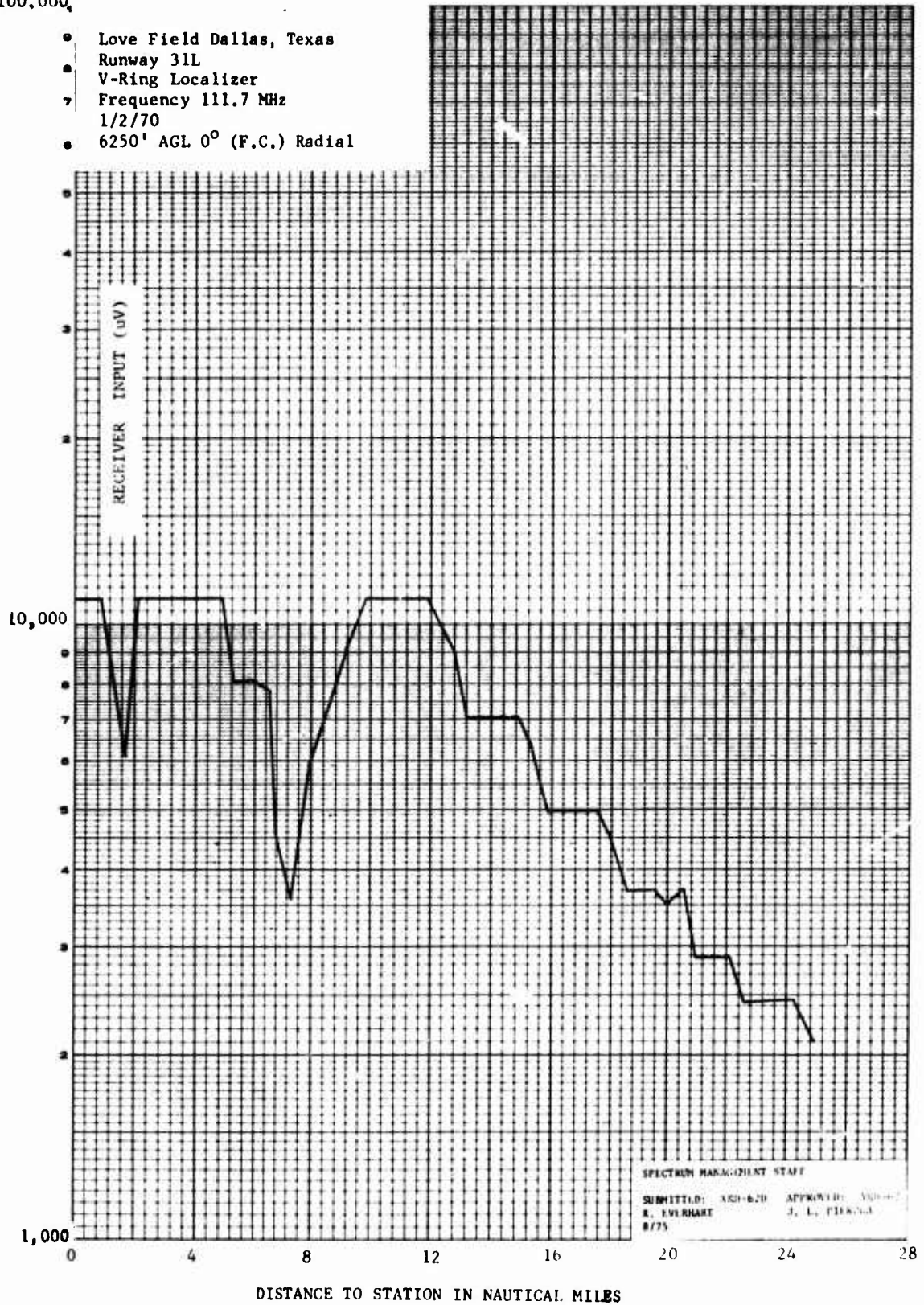

Altitude Flown - 6250 ft.

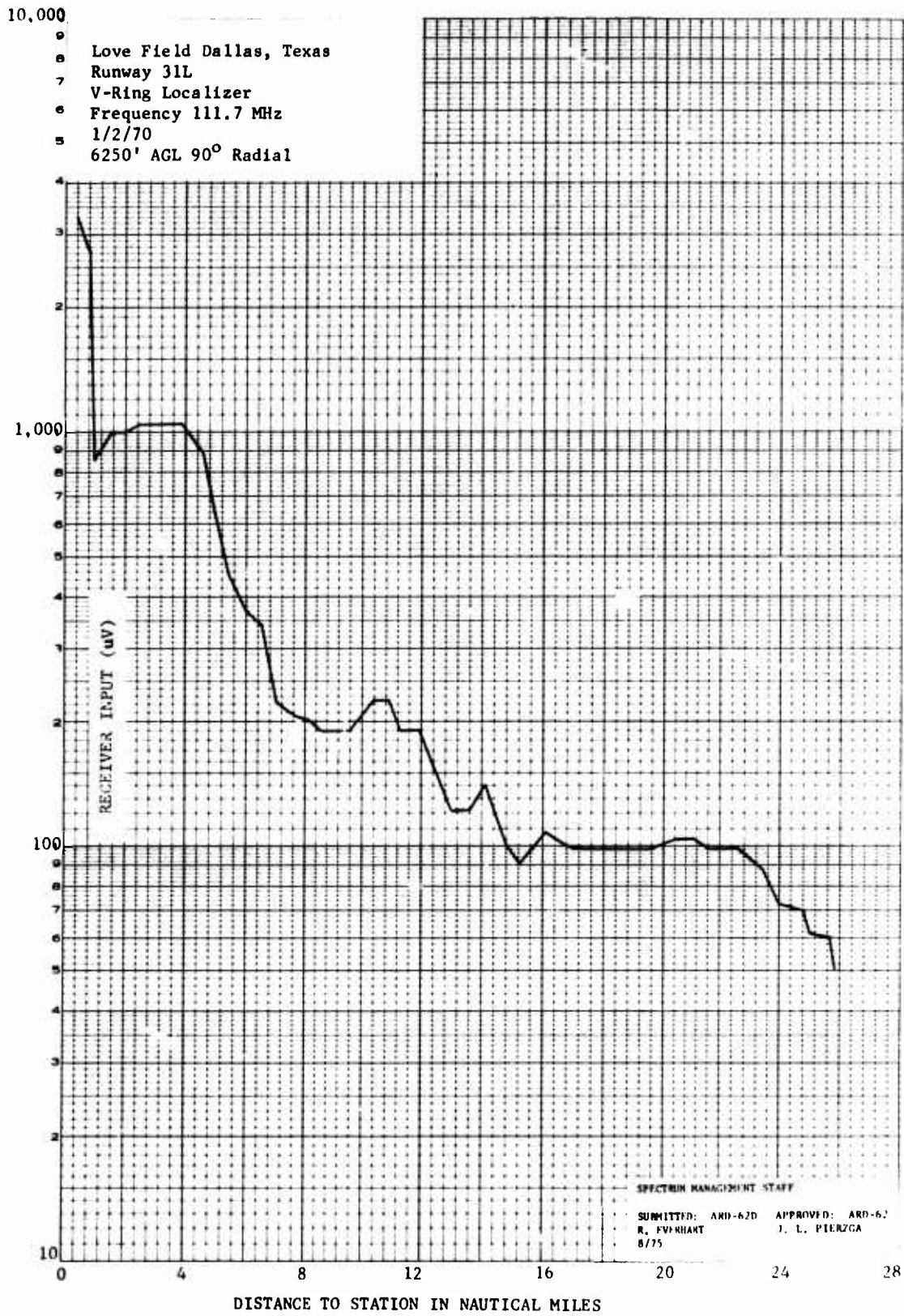

Altitude Flown - 6250 ft.
G-2

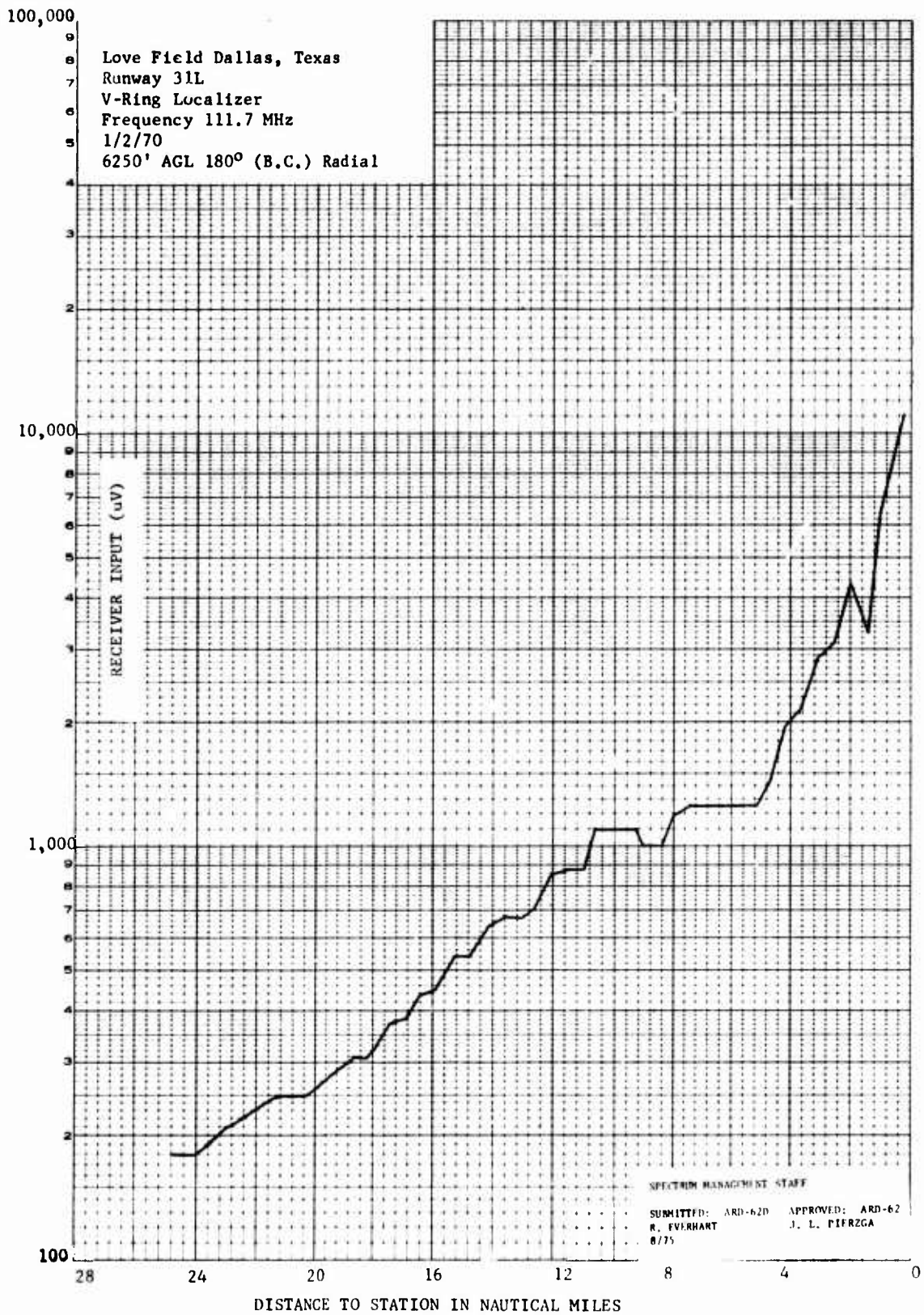

Altitude Flown - 6250 ft.

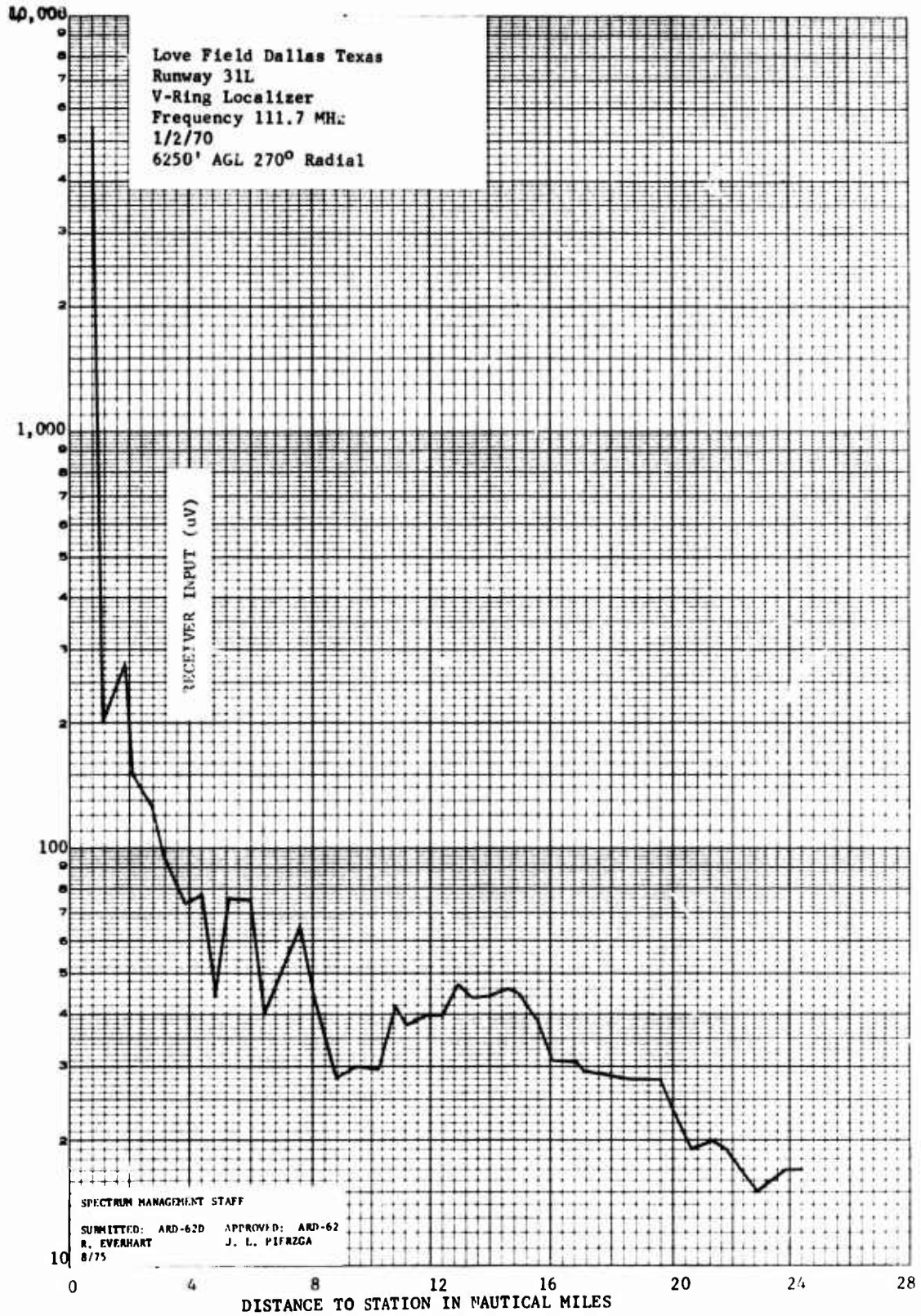

8/75

Appendix H

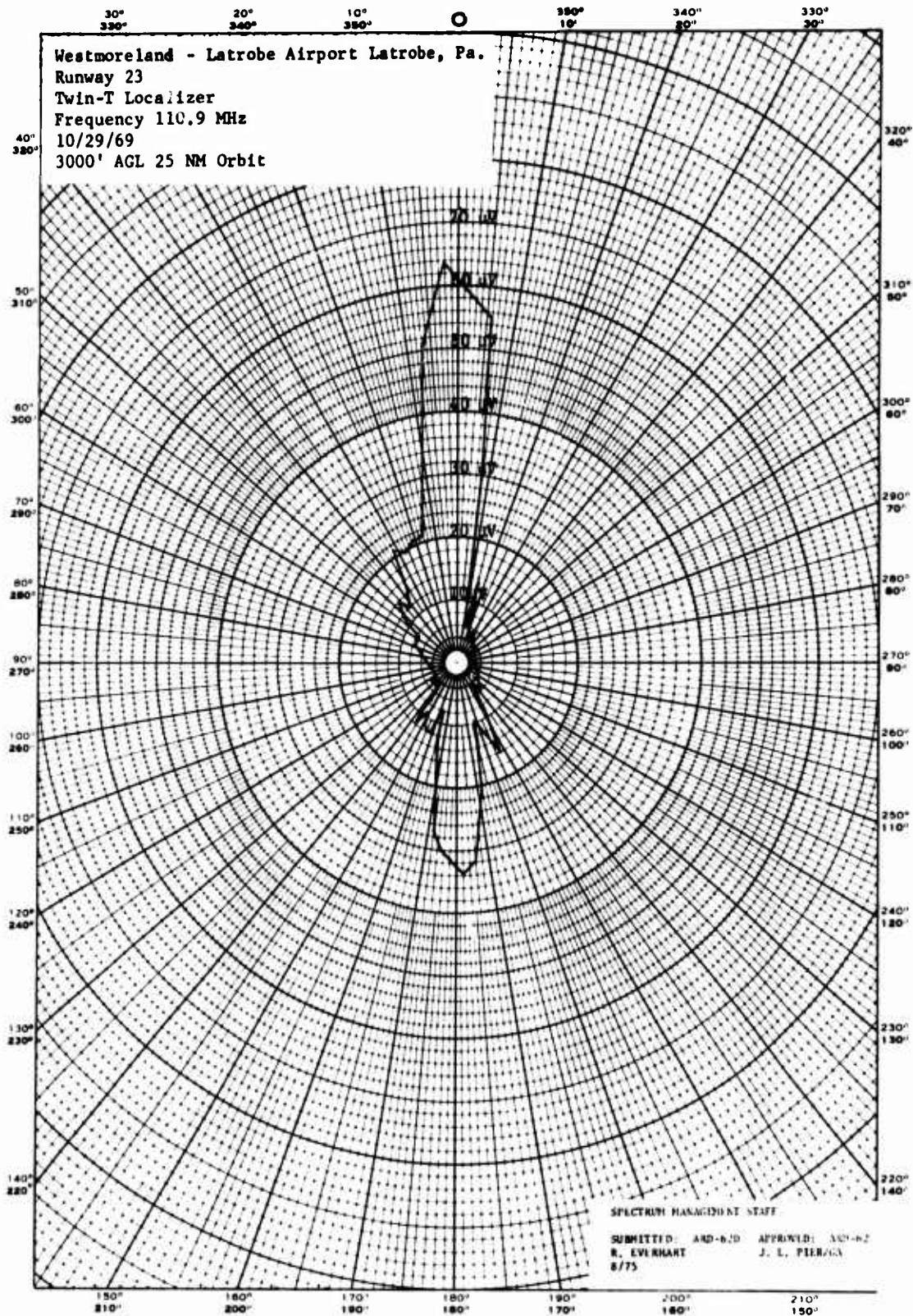

Altitude Flown - 3000 ft.
H-1

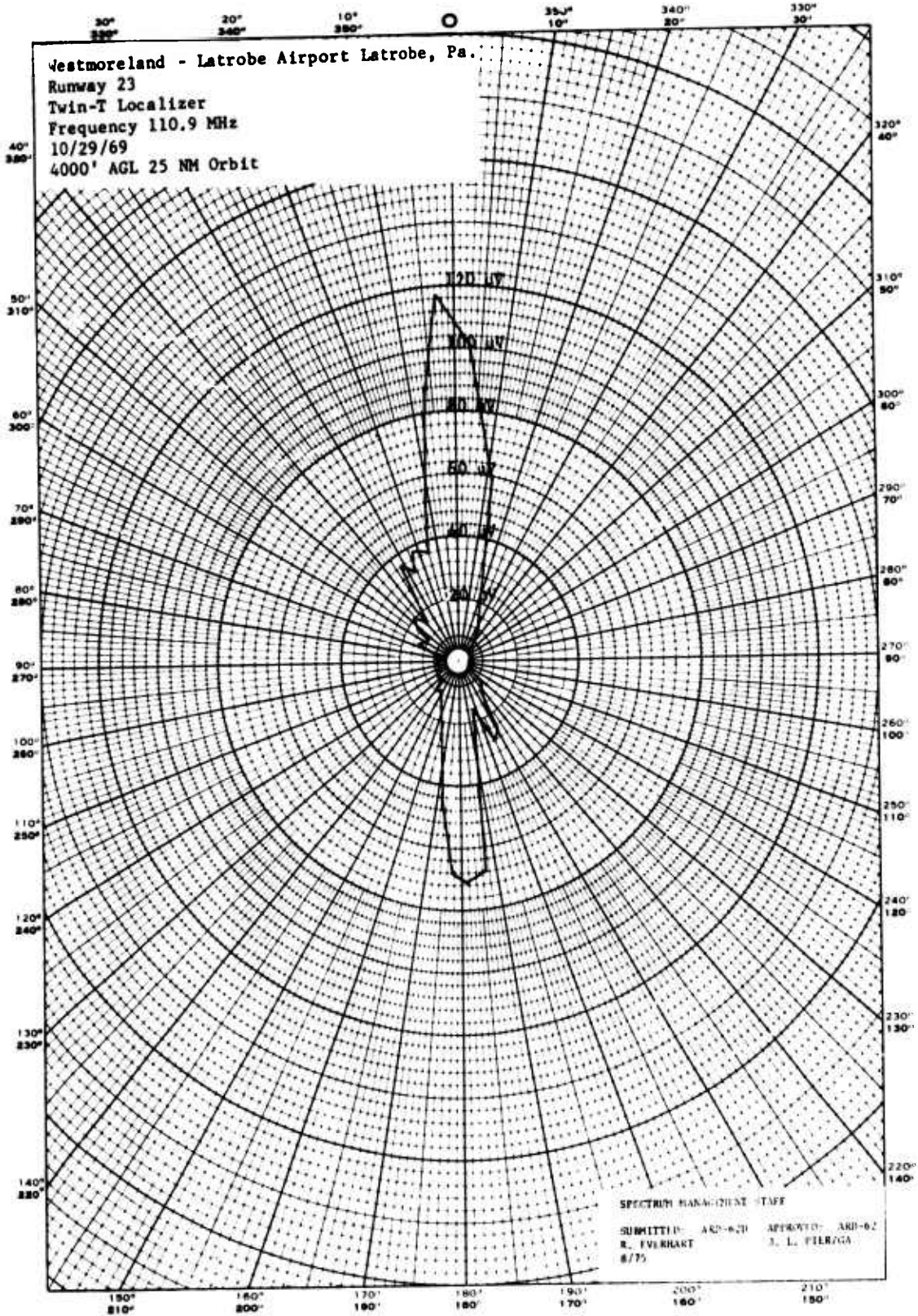

Altitude Flown - 4000 ft.

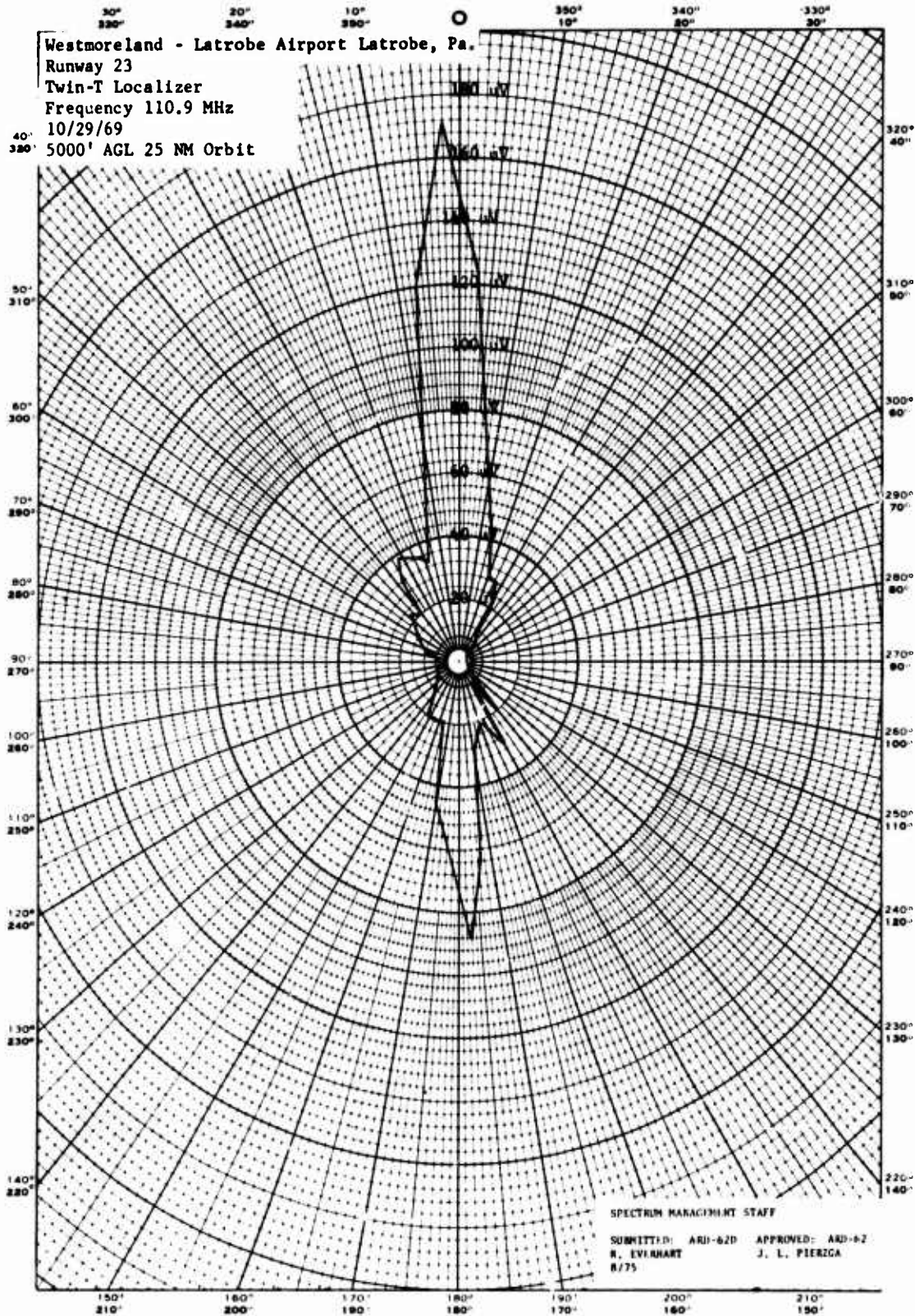

Altitude Flown - 5000 ft.
H-3

8/75

Appendix H

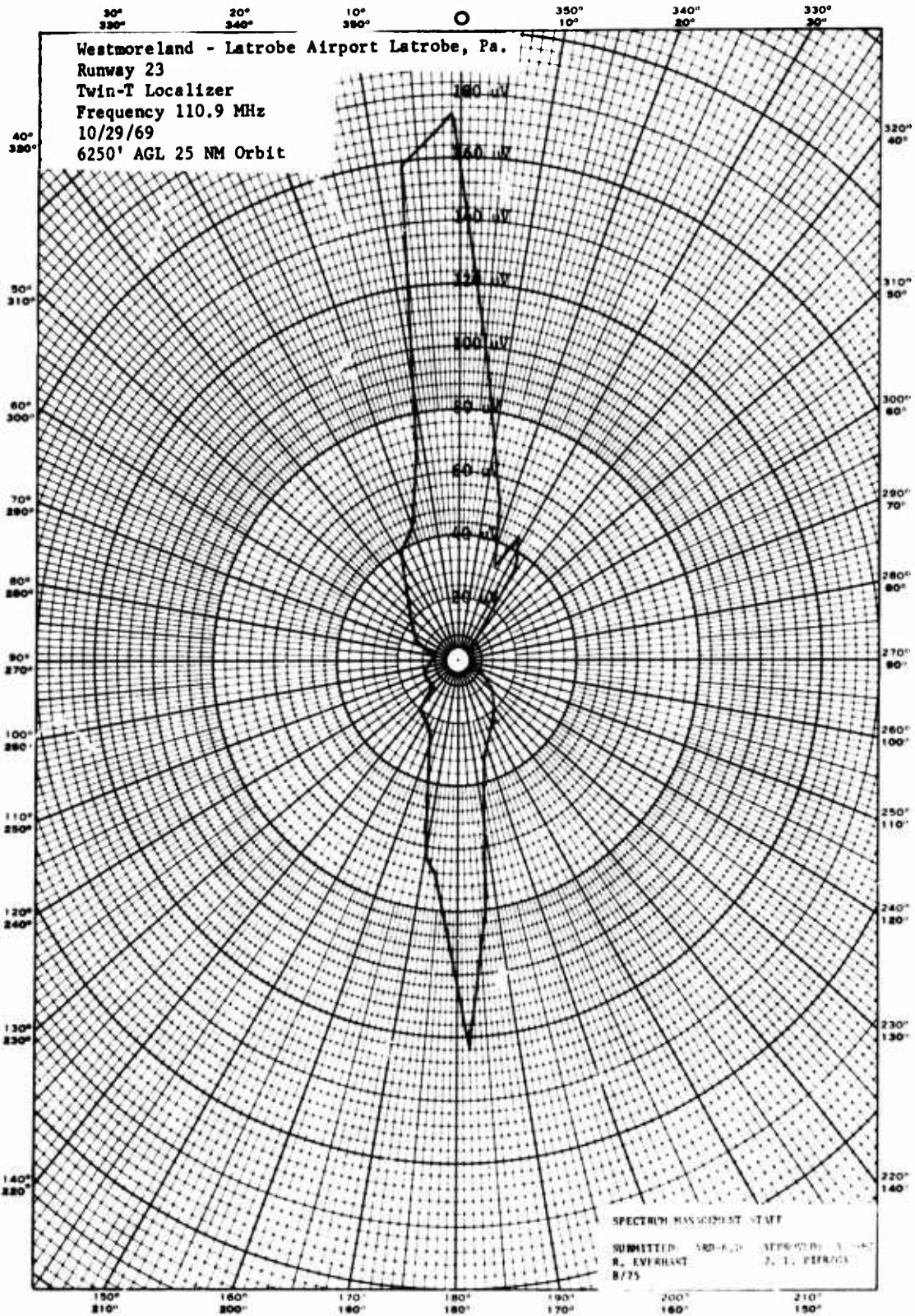

Altitude Flown - 6250 ft.
H-4

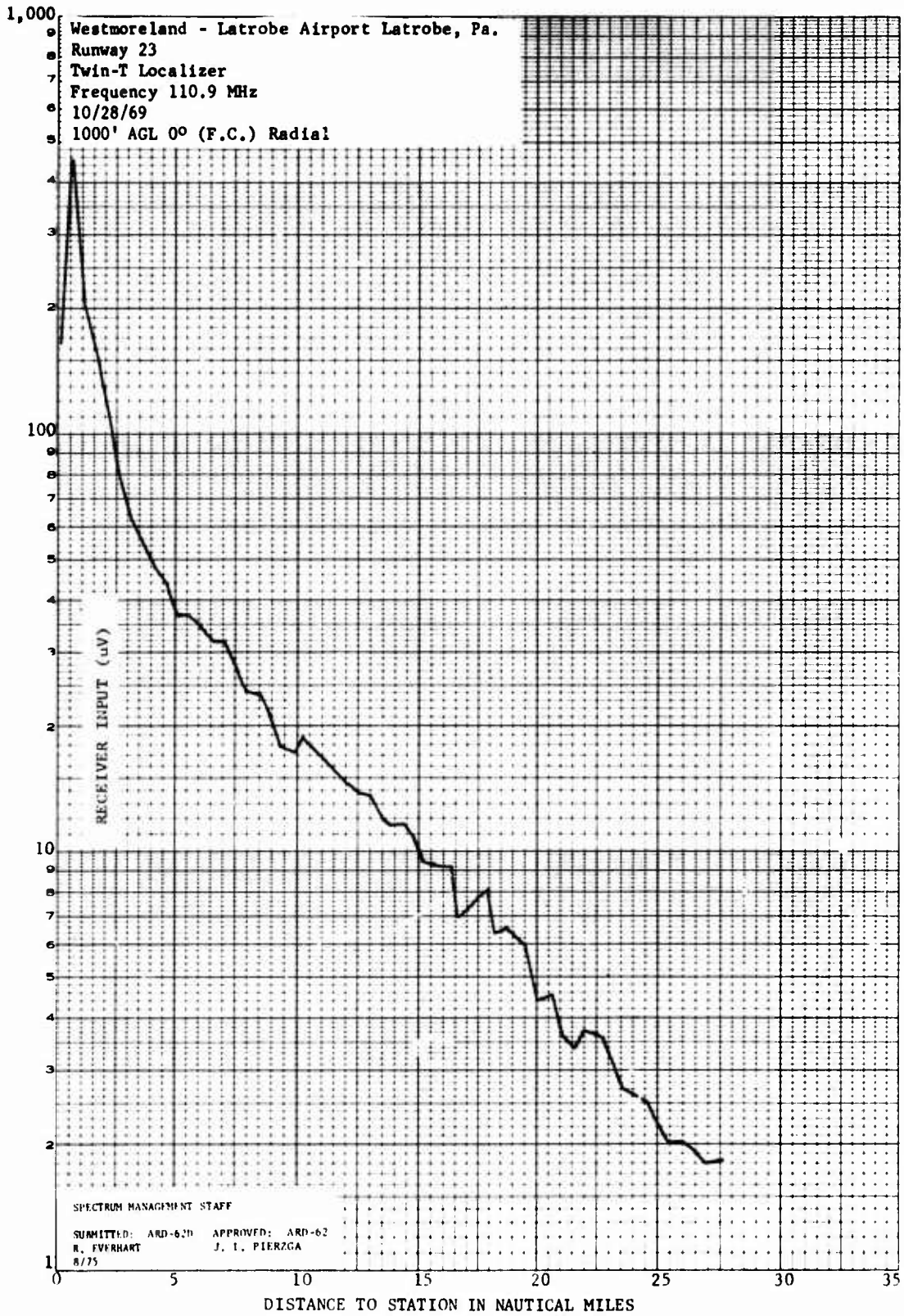

Altitude Flown - 1000 ft.

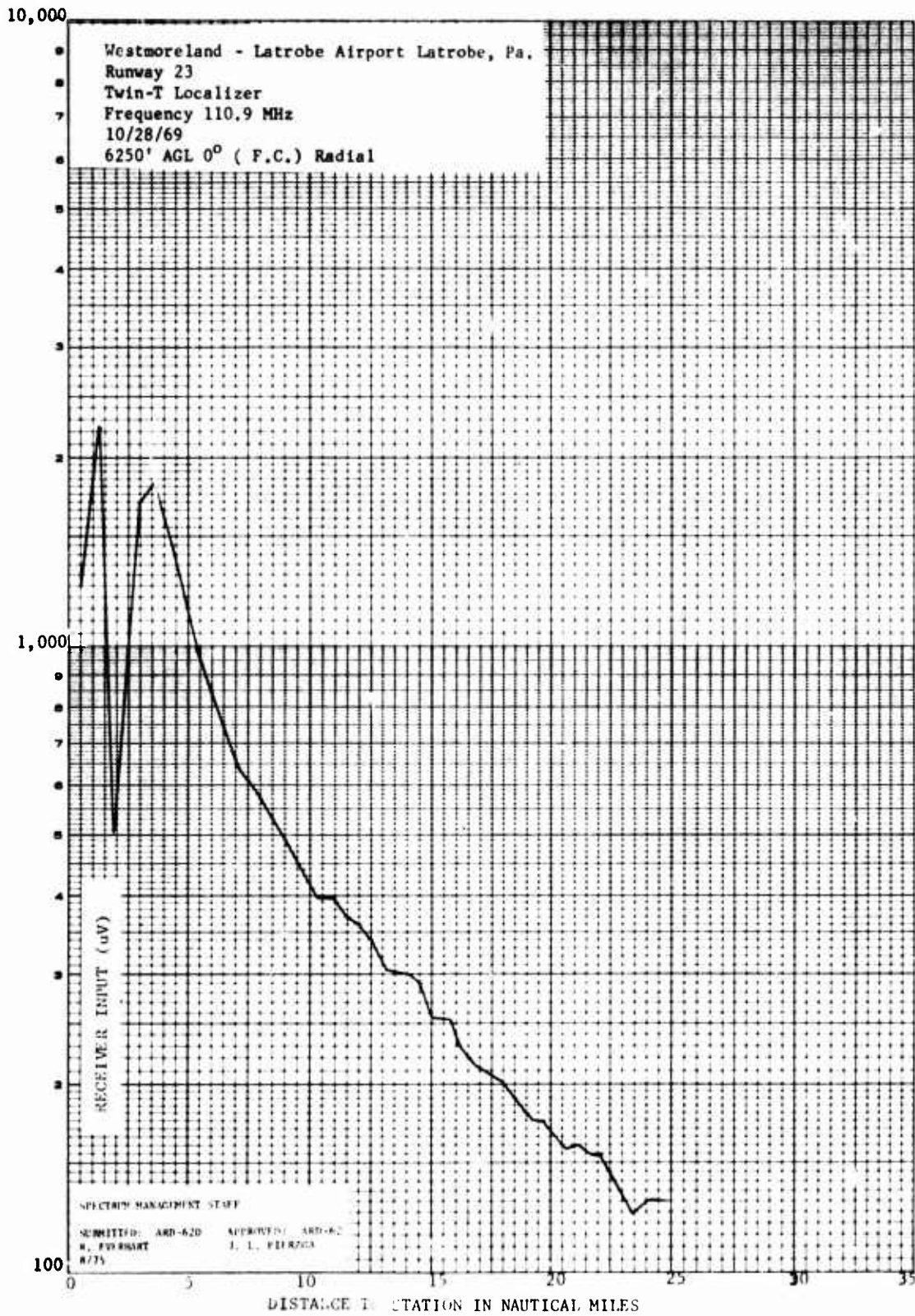

Altitude Flown - 6250 ft.
I-2

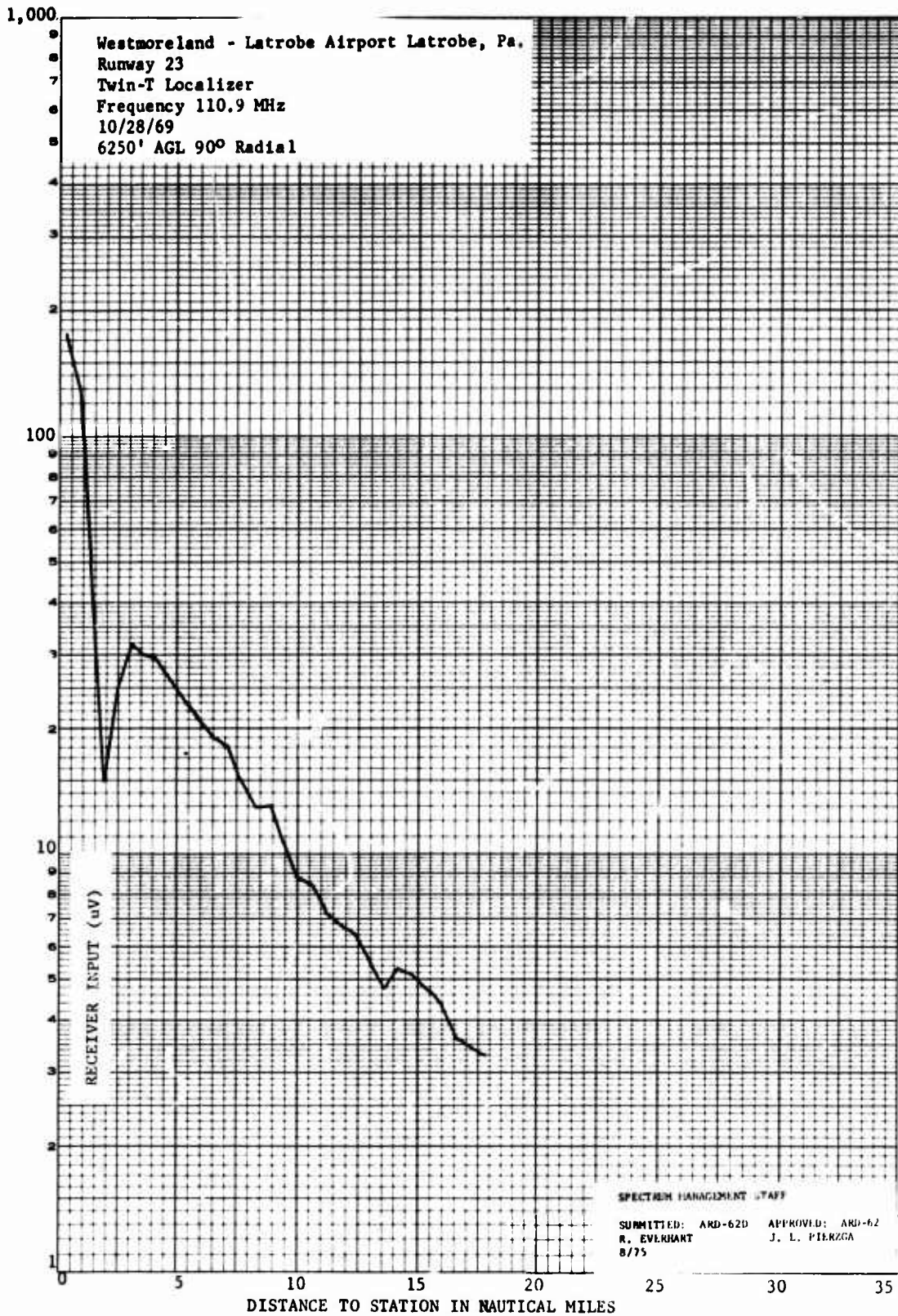

Altitude Flown - 6250 ft.

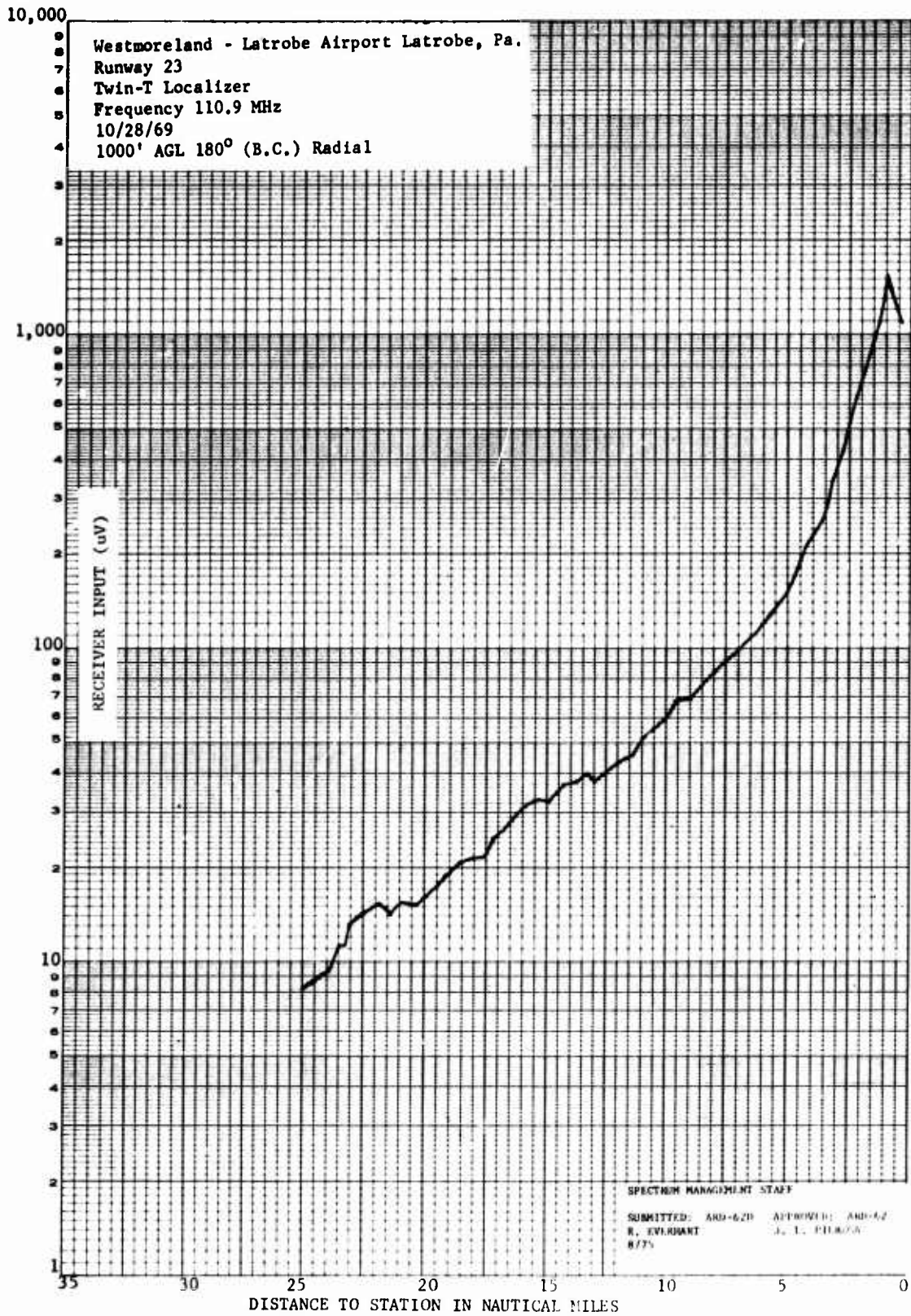

Altitude Flown - 1000 ft.

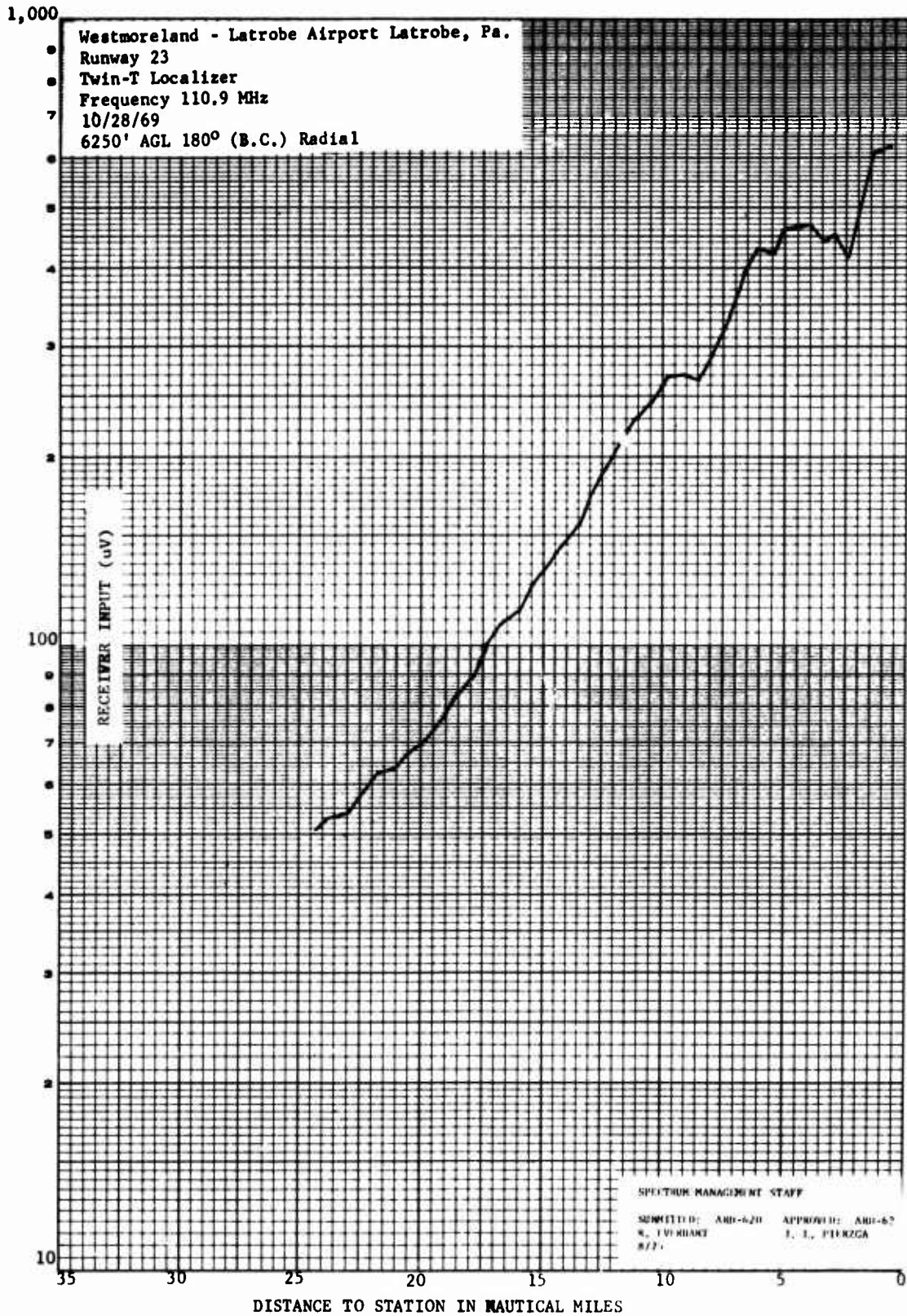

Altitude Flown - 6250 ft.
I-5

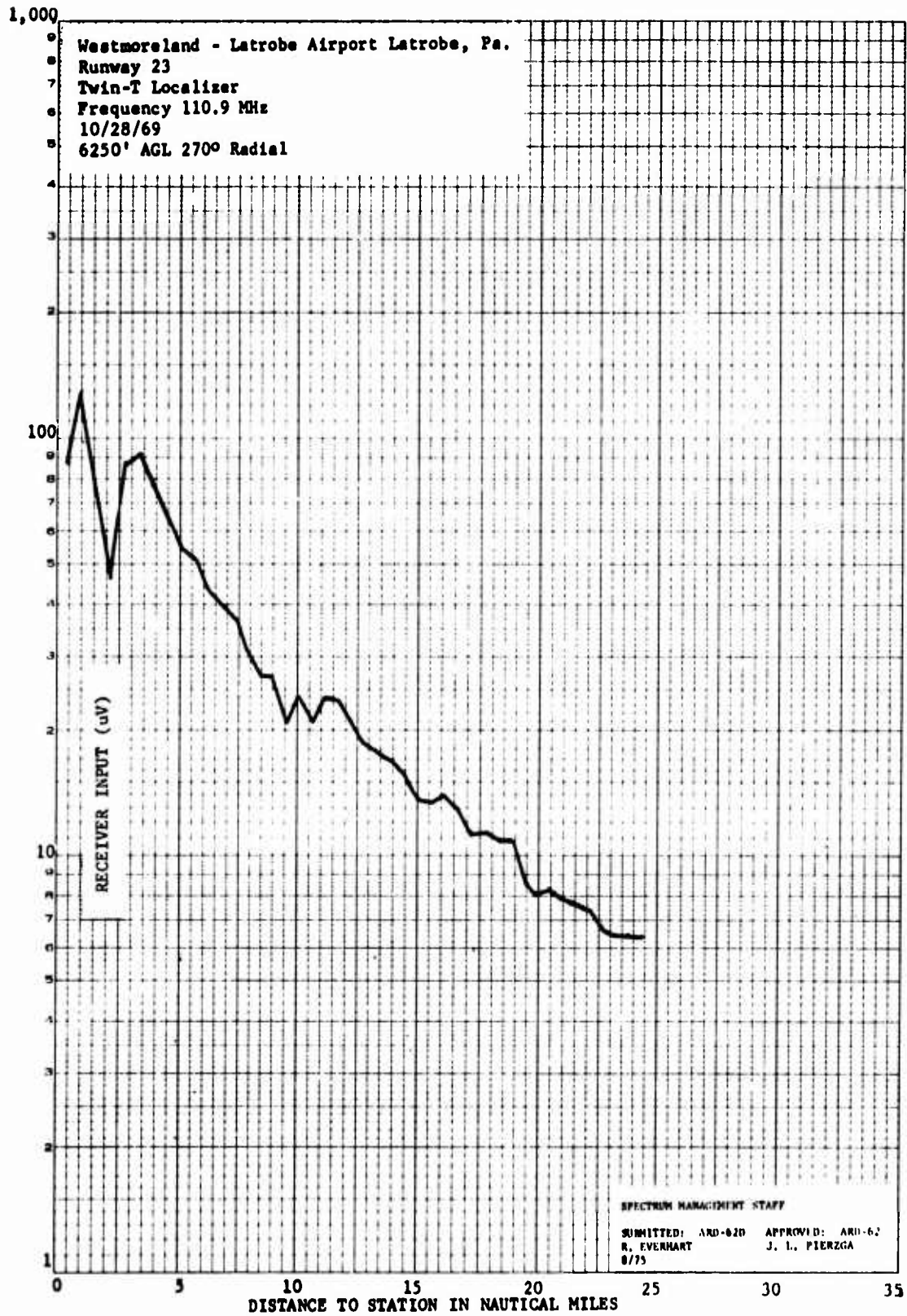

Altitude Flown - 6250 ft.