

AD-A014 574

PRESSED TNT AS A STANDARD FOR THE ASSESSMENT OF  
UNDERWATER EXPLOSIVES. PART 1

J. A. Hicks, et al

Explosives Research and Development Establishment  
Waltham Abbey, England

February 1974

DISTRIBUTED BY:

**NTIS**

National Technical Information Service  
U. S. DEPARTMENT OF COMMERCE

COPYRIGHT ©

CONTROLLER HMSO LONDON

1974

Reproduced by  
**NATIONAL TECHNICAL  
INFORMATION SERVICE**

US Department of Commerce  
Springfield, VA. 22151

National Technical Information Service is authorized to  
reproduce and sell this report.

**Best  
Available  
Copy**

DOCUMENT CONTROL SHEET  
(Notes on completion overleaf)

Overall security classification of sheet .....

(As far as possible this sheet should contain only unclassified information. If it is necessary to enter classified information, the box concerned must be marked to indicate the classification eg (R),(C) or (S)).

1. DRIC Reference (if known)	2. Originator's Reference <b>ERDE TR 164</b>	3. Agency Reference	4. Report Security Classification <b>UNLIMITED</b>
5. Originator's Code (if known)	6. Originator (Corporate Author) Name and Location		
5a. Sponsoring Agency's Code (if known)  445050	6a. Sponsoring Agency (Contract Authority) Name and Location <b>Explosives Research and Development Establishment Waltham Abbey Essex England</b>		
7. Title <b>PRESSED TNT AS A STANDARD FOR THE ASSESSMENT OF UNDERWATER EXPLOSIVES. PART 1</b>			
7a. Title in Foreign Language (in the case of translations)			
7b. Presented at (for conference papers). Title, place and date of conference			
8. Author 1. Surname, initials  <b>HICKS J A</b>	9a. Author 2  <b>KENDREW E L</b>	9b. Authors 3, 4...  <b>PEMBER W J</b>	10. Date pp ref  <b>2.1974 57 -</b>
11. Contract Number	12. Period	13. Project	14. Other References
15. Distribution statement			
Descriptors (or keywords)  <b>Trinitrotoluene, Standards, Underwater explosions, Explosives, Shock Waves</b>  <p style="text-align: right;">(TEST) continue on separate piece of paper if necessary</p>			
Abstract <b>A need exists for an internationally agreed underwater explosive charge as a reference standard in shock wave parameter measurements.</b> <b>The reference explosive selected is 80.4 crystal TNT isostatically pressed to a density of 1600 kg/m<sup>3</sup> and machined into 1:1 right circular cylinders.</b> <b>The performance of charges in weights, from 3.6 kg down to 0.05 kg is examined and the shock wave parameters <math>P_m</math>, <math>\theta/W^3</math>, <math>I/W^3</math> and <math>E/W^3</math> presented in graphical form.</b> <b>The results are discussed and a recommendation given that the standard charge be a 1:1 right cylinder 0.45 kg in weight centrally initiated.</b>			

EXPLOSIVES RESEARCH AND DEVELOPMENT ESTABLISHMENT

Technical Report No 164

February 1974

Pressed TNT as a Standard for the Assessment  
of Underwater Explosives  
Part 1

by

J A Hicks  
E L Kendrew  
W J Pember

SUMMARY

A need exists for an internationally agreed underwater explosive charge as a reference standard in shock wave parameter measurements.

The reference explosive selected is 80.4 crystal TNT isostatically pressed to a density of  $1600 \text{ kg/m}^3$  and machined into 1:1 right circular cylinders.

The performance of charges in weights from 3.6 kg down to 0.05 kg is examined and the shock wave parameters  $P_m$ ,  $\theta/W^{1/3}$ ,  $I/W^{1/3}$  and  $E/W^{1/3}$  presented in graphical form.

The results are discussed and a recommendation given that the standard charge be a 1:1 right cylinder 0.45 kg in weight centrally initiated.

Further copies of this technical report can be obtained from Technology  
Reports Centre, Orpington, Kent. BR5 3RF

## CONTENTS

	<u>Page No</u>
1 INTRODUCTION	5
2 CHARGE DESCRIPTION	6
2.1 Material	6
2.2 Configuration	6
2.3 Manufacture	7
3 SENSITIVENESS AND HANDLING PROPERTIES	7
4 FIRING RIG CONFIGURATION	8
5 INSTRUMENTATION	9
5.1 Gauges	9
5.2 Calibration	9
5.3 Recording	9
6 DATA ANALYSIS	
6.1 Trace Reading and Data Processing	9
6.2 Regression Analysis and Confidence Limits	10
7 RESULTS	11
7.1 Comparison of Centre-Initiated Cylinder with Sphere	11
7.2 Comparison of Centre and End-Initiated Cylinders	11
7.3 The Effect of Charge Size; Centre-Initiated Cylinders	12
7.4 The Effect of Charge Size; End-Initiated Cylinders	12
8 CONCLUSIONS	13
9 RECOMMENDATIONS	14
APPENDIX A: Draft Specification. TNT for Reference Charges for Underwater Measurements	16
APPENDIX B: Regression Analysis and Confidence Limits	20
Figures 1 to 40	

1 INTRODUCTION

In the field of assessment of underwater explosives it has been apparent for some time now that there is an urgent need for an agreed, close tolerance, explosive charge which can be used as a standard. There is, for example, the problem of comparison of past and present UK and US underwater explosives when not only do different establishments obtain considerable differences in free field measurements on a given explosive, but a given establishment also finds that its own absolute values of the shock wave parameters appear to vary over a period of time. A standard charge would not only be invaluable for inter-laboratory comparisons but would also be useful as an instrumentation check.

This matter was discussed by representatives of NOL, NSRDC, AWRE, NCRE and ERDE at a TTCP meeting held in London, 6 to 10 May 1968, and was agreed upon as an item for collaboration between the UK and US.

It was further agreed that a reference explosive should be a single chemical compound, readily available and easily fabricated into charges, with adequate pick-up sensitivity and handling properties. Various possibilities were discussed but it was decided initially to examine the properties and performance of pressed TNT in cylindrical charges of various densities, covering the weight range of 0.1 kg up to 150 kg and having minimal boosting systems. Some doubts existed as to whether pressed TNT has sufficient sensitiveness, also concerning the limits of charge size which can be made in a reproducible manner and give a reproducible output. However, it is probable that most of these doubts were based on experience with cast TNT and no major difficulties could be foreseen, even for charges less than 0.1 kg in weight, using cold pressed TNT of uniform density.

This report, Part 1, is concerned with the effect on the underwater shock parameters of charge size (scaling) and with a comparison of end-initiated and centre-initiated cylindrical charges; the charge density throughout is  $1590 \text{ kg/m}^3$ .

A second report, Part 2, will be concerned with the effect of variation of charge density on the parameters for 0.45 kg end-initiated cylindrical charges.



## 2 CHARGE DESCRIPTION

### 2.1 Material

The material used in charge manufacture was 80.4 TNT crystal. A complete specification is included in Appendix A.

### 2.2 Configuration

Charge weights, shape and initiation points are given in the following table:

Weight, kg	Shape	Nominal Dimensions, cm	Initiation Point	No of charges fired
12.25 (27 lb)	Cylinder	22 x 22	End	5
3.6 (8 lb)	Cylinder	14.5 x 14.5	Centre	4
			End	4
0.45 (1 lb)	Cylinder	7.4 x 7.4	Centre	9
			End	4
0.45 (1 lb)	Sphere	8.1 x 8.1	Centre	8
0.11 ( $\frac{1}{4}$ lb)	Cylinder	4.6 x 4.6	Centre	8
			End	4
0.05 ( $\frac{1}{8}$ lb)	Cylinder	3.5 x 3.5	Centre	9
			End	9
			Total	64

Apart from the spheres all charges were right cylinders of length equal to the diameter.

The question of boosting was discussed by representatives of NOL, NCRE, AWRE and ERDE at a meeting held at NCRE on 15 September 1969 and it was agreed that initiation should be minimal and, if possible, confined to detonator alone. However subsequent experience showed that pick-up sensitivity from detonator alone was marginal, particularly in the end-on mode of charge initiation, and to obviate any possibility of misfires minimal boosting by tetryl pellets was employed. The exact number and configurations is shown in Figures 1 and 2. The detonator used was the standard low tension No 8 Briska manufactured by ICI Ltd (0.7 g tetryl charge).

The protective discs shown are cut from a soft fibre-board known commercially as Tentest and serve to protect the edges of the charge from possible damage, having no detectable effect on the measurements reported.

### 2.5 Manufacture

All the TNT charges were made at ROF Burghfield, starting from the 80.4 crystal TNT raw material. This was pressed isostatically in a 60 cm press into cylindrical billets of approximate dimensions 22 cm x 22 cm, or, for the larger charges, 50 cm x 50 cm. All charges were pressed at room temperature and, for the three main densities examined, the pressing conditions were as given.

Density, kg/m <sup>3</sup>	Pressure, MN/m <sup>2</sup>	Duration, min
1600	140	20
1560	70	15
1520	42	15

The billets were then sectioned and machined into cylinders or spheres by conventional techniques. Dimensional tolerances were better than 1 per cent; the charges were free from major defects and had a turned finish.

Charge densities (overall) were specified to within  $\pm 20$  kg/m<sup>3</sup>. Cylinders were tested for uniformity of density by sectioning into 24 cubes and measuring the densities of the cubes. The homogeneity was found to be very good, the maximum deviation within the cylinders being not greater than  $\pm 0.4$  per cent.

### 3 SENSITIVENESS AND HANDLING PROPERTIES

The isostatically pressed TNT at various densities was tested for shock sensitiveness (the ERDE Scale VI Gap Test), drop sensitiveness (the AWRE Oblique Impact Test) and compressive strength. Results for the gap test and the compressive strength are summarised in Figure 3 and compared with results for end-pressed flake TNT; end-pressed Atlas crystal TNT and cast Composition B.

It is interesting to note that the shock sensitiveness of isostatically pressed TNT is comparable with that of cast Composition B, but is somewhat lower than that of end-pressed flake or crystal TNT and less dependent on density, presumably because of its greater uniformity of density.

The compressive strength of pressed TNT charges is adequate at the higher densities and no fragility problems have been encountered in handling bare

charges of up to 12.25 kg in the density range 1500 to 1600 kg/m<sup>3</sup>.

Sensitiveness to dropping on a hard surface is low, as shown by the completely negative results on the oblique impact test. 2.5 kg charges of iso-statically pressed TNT (density 1595 kg/m<sup>3</sup>) in JABROC vehicles were dropped on to a standard sand/Araldite/steel surface from the maximum height of the test machine (6 m). At 45° impact angle the charges were cracked and lumps broken off, whilst at 76° to the normal there were radial cracks and some abrasion, but in neither case was there any ignition.

#### 4 FIRING RIG CONFIGURATION

The basic firing rig shown in Figure 4, is made up of standard aluminium scaffold tube held together with screw type clamps for ease of maintenance and modification. This in turn supports the explosive charge and gauges via terylene cording (Figure 5), the charge axis being vertical with the gauges lying on the central equatorial plane. The whole rig is suspended from a steel cable catenary and can be winched out and into the firing pool.

Eight gauges are used arranged in pairs radiating out from the charge at set stand off distances (Figure 6). Minimum stand off is dictated by the need to prevent gauge damage and maximum stand off by the physical dimensions of the firing rig and depth of water.

The firing pool itself is approximately 43 metres in diameter with a maximum depth of 5.8 metres. This allows charges of up to 12.25 kg weight to be fired consistent with the requirement for a minimum free water record of 6.7 s duration.

A table of stand off distances vs charge weight is given below.

Charge Weight, (W) kg	Stand off D				Reduced Stand off $D/W^3$			
	Min		Max		Min		Max	
	m	ft	m	ft	m	ft	m	ft
0.05	0.61	2.0	2.44	8.0	1.22	4.0	4.88	16.0
0.11	0.92	3.0	4.58	15.0	1.46	4.8	7.35	24.0
0.45	0.92	3.0	4.58	15.0	0.92	3.0	4.58	15.0
3.6	1.22	4.0	4.58	15.0	0.61	2.0	2.29	7.5
12.25	1.85	6.0	6.10	20.0	0.61	2.0	2.04	6.7

## 5 INSTRUMENTATION

### 5.1 Gauges

For shock wave recording tourmaline piezo-electric gauges are employed of a type commonly used for underwater pressure measurements (Figure 7). They are of four-disc pile form, each disc 6.2 mm ( $\frac{1}{4}$  inch) in diameter, the nominal output being  $0.5 \mu\text{C}/\text{kNm}^{-2}$ . The gauges are of commercial origin (Crystal Research Inc USA) made up and sealed to a working length of anti-microphonic co-axial cable.

### 5.2 Calibration

The gauges are calibrated in the laboratory by the "pressure off" technique.

The gauge is sealed in an hydraulic chamber pressurised to  $6.9 \text{ MN/m}^2$  (1000 psi) via a dead weight press. A mechanical release valve, with an operating time of 2 ms, is actuated and the resulting transient fed via a charge amplifier to a Tektronix oscilloscope and camera. By comparing the amplitude of this transient with that given by a known test electrical charge the gauge is calibrated.

### 5.3 Recording

Gauge signals are recorded by twin channel Tektronix 555 and 556 oscilloscopes and Polaroid cameras (Figure 8). Triggering of the oscilloscopes is by a closed circuit wire loop, taped to the charge base. The fracture of this on detonation operates a multi-channel delay unit, which in turn triggers each oscilloscope at the appropriate time for each gauge (related to its stand-off distance).

## 6 DATA ANALYSIS

### 6.1 Trace Reading and Data Processing

At present all pressure/time data are in Polaroid print form and as such are manually digitized using a desk-type trace reader. The number of points read varies with the complexity of the trace and is currently between 100 and 150. The output of the series of x-y values is in the form of paper tape which, together with data and program tapes is fed into an Elliott 903 digital computer. It is hoped that in the future the method of reading and format of computer analysis will be standardized, as far as possible, between laboratories in the United Kingdom.

At present the computer analysis involves the following procedure:

Since the gauges and equipment have finite time responses the pressure as shown by the pressure-time record is somewhat lower than the true peak pressure,  $P_m$ . This is derived by computing a best straight line through log (pressure) vs time data (by the method of least squares) over a range of approximately one time constant and extrapolating this back to zero time. The dimensions of the gauge element and shock wave velocity determine the initial time  $t = 0$  which, for the gauges in use and a shock velocity of 1520 m/s (5000 ft/s), is approximately 2  $\mu$ s from the onset of the pulse on to the leading edge of the gauge.

Two "time constants" are computed, the negative reciprocal slope of the above best straight line ( $\delta$ ) and the time at which pressure falls to  $P_m/e$  ( $\theta$ ). ERDE's practice is to accept  $\theta$  as the practical time constant for comparison with the results of other laboratories.

Impulse I and the Work Done Function E are computed by summing values of average pressure (or pressure squared for E) multiplied by the time interval between successive data points. This is done for recording times up to both 5  $\theta$  and 6.7  $\theta$ .

## 6.2 Regression Analysis and Confidence Limits

The pressure range of our free field shock measurements is from 1 kbar down to about 50 bar. Over this range it is found that straight line regressions

$$y = \alpha x + \beta$$

may be used for  $Y = \log P, \log I/W^{1/3}$  and  $\log E/W^{1/3}$  ( $E = \int p^2 dt$ ) against  $x = \log D/W^{1/3}$ .

However, for  $\log D/W^{1/3}$  against  $\log D/W^{1/3}$  a quadratic regression

$$y = ax + bx^2 + c$$

is often found to give a better fit than the linear regression.

In this report the results are presented in the form of a regression line together with two sets of associated confidence curves,

- a the confidence limit curves between which 95% of all future individual measurements should lie, and
- b the limit curves between which there is 95% confidence that future sets of measurements (regression lines) should lie.

The former reflects the variance of the experimental point, the latter the variance of the mean values of the data.

Essential elements of the statistical analysis used are given in Appendix B.

## 7 RESULTS

Results are presented in graphical log/log form. These indicate regression analyses for  $P_m$ ,  $I(6.70)/W^{1/3}$ ,  $E(6.70)/W^{1/3}$ , and  $\theta/W^{1/3}$ , together with their associated 95% confidence curves (Section 6.2). All measurements refer to a charge density of 1590 kg/m<sup>3</sup>.

Units are given in both Metric and Imperial form. The figures adjacent to the axes are in the following dimensions:

Log $D/W^{1/3}$	Log P	Log $\theta/W^{1/3}$	Log $I(6.7)/W^{1/3}$	Log $E(6.7)/W^{1/3}$
ft/lb <sup>1/3</sup>	lb in <sup>-2</sup>	$\mu\text{s}/\text{lb}^{1/3}$	lb in <sup>-2</sup> $\mu\text{s}/\text{lb}^{1/3}$	(lb in <sup>-2</sup> ) <sup>2</sup> $\mu\text{s}/\text{lb}^{1/3}$

The outer figures are in metric units as follows:

Log $D/W^{1/3}$	Log P	Log $\theta/W^{1/3}$	Log $I(6.7)/W^{1/3}$	Log $E(6.7)/W^{1/3}$
m/kg <sup>1/3</sup>	MN m <sup>-2</sup>	$\mu\text{s}/\text{kg}^{1/3}$	MN m <sup>-2</sup> $\mu\text{s}/\text{kg}^{1/3}$	(MN m <sup>-2</sup> ) <sup>2</sup> $\mu\text{s}/\text{kg}^{1/3}$

### 7.1 Comparison of Centre-Initiated Cylinder with Sphere

Results for the spherical charges (not included in this report for the sake of brevity) show that (at the 95% confidence level) for 0.45 kg charges of density 1590 kg/m<sup>3</sup> and within the given working range it is not possible to distinguish between the free field shock wave from a spherical-charge and that from a centre-initiated 1:1 cylinder (in the equatorial plane). There was no detectable difference in the scatter of results for the two types of charge.

### 7.2 Comparison of Centre and End-Initiated Cylinders

The impulse values for centre and end-initiated 0.45 kg cylinders (Figs 19 and 35) are indistinguishable within the working range considered here. However, close in, the peak pressures for centre-initiated charges appear to be approximately 5 - 10 higher than for end-initiated charges (Figs 11 and 27); the time constants are correspondingly smaller (Figs 15 and 31). These differences diminish as the stand off is increased, so that at  $D/W^{1/3} = 5.95$  m/kg<sup>1/3</sup> (15 ft/lb<sup>1/3</sup>) they are down to less than 4 for peak pressure and 7% for  $E(\int p^2 dt)$  (Figs 23 and 39).

The scatter on results for end-initiated charges is somewhat greater than for centre-initiated charges.

Similar conclusions can be drawn for 3.6 kg (Figs 12, 16, 20, 24 and 28, 32, 36, 40) and 0.1 kg (Figs 10, 14, 18, 22 and 26, 30, 34, 38) charges, using the two modes of initiation.

In contrast the results for 0.05 kg charges (Figs 9, 13, 17, 21 and 25, 29, 33, 37) present a rather confused picture. As before there is reasonable compatibility between the impulse lines but close in the end-initiated cylinders give a 25% higher output than centre-initiated and the centre-initiated apparently give up to 50% higher energy flux at large stand off distances.

These results, combined with the high degree of scatter, are almost certainly due to the difficulty in alignment inherent in using such a small charge.

### 7.3 The Effect of Charge Size; Centre-Initiated Cylinders

Again it was found that the reduced impulse values for centre-initiated 0.05, 0.1, 0.45 and 3.6 kg charges were indistinguishable over the working range (Figs 17 - 20).

There appears to be some evidence that close-in to the charge the peak pressure at a given reduced stand-off decreases as the charge size increases (Figs 9 - 12). The reasons for this are not known but the effect diminishes as the reduced stand-off is increased (from about 10% at  $0.8 \text{ m/kg}^{1/3}$  to 5% at  $5.95 \text{ m/kg}^{1/3}$ ). With the compensatory factor of  $\theta$  the overall effect of charge size on reduced  $E$  ( $\int p^2 dt/W^3$ ) is not significant.

The scatter on results increases very significantly as the charge size is reduced, but this is less true of the impulse and  $E$  values than for pressure and time constant.

### 7.4 The Effect of Charge Size; End-Initiated Cylinders (Figs 25 - 40)

Again reduced impulse values for end-initiated 0.05, 0.1, 0.45 and 3.6 kg charges were in close agreement over the working range.

From the results obtained for peak pressure there does not appear to be any significant trend. The 3.6 kg results agree quite well with those for 0.45 kg charges. Close-in pressures from 0.1 kg charges coincide with the results for 0.45 kg charges, but are up to 25% higher further out.

The worst correlation is between 0.05 kg and 0.45 kg charges, the former being at least 25% higher.

To complete the picture four 12.25 kg charges were fired, end-initiated, and the results agreed closely with those from the 5.6 kg charges. The curves are not reproduced in this report.

The scatter on results increases as the charge size is reduced and is significantly greater than for the centre-initiated charges.

## 8 CONCLUSIONS

For the range of charges and reduced stand off distances covered we conclude:

- a The reduced impulse/stand off relationship appears to be the same, no matter the size, shape or mode of initiation. This is probably our most important observation.
- b The other parameters measured (peak pressure, time constant, E) for the cylindrical charges are dependent on the charge size and initiation geometry at the smaller stand off distances. These effects are small for centre-initiated charges, significantly worse for end-initiated, but in the former case diminish at the larger distances.

It was not possible to distinguish between the parameters for 0.45 kg centre-initiated cylinders and 0.45 kg spheres.

- c The reproducibility of the results for the 0.45 kg and larger charges is good (by underwater shock data standards), indicating the reliability of the manufacture and output of pressed TNT charges and the adequacy of the small booster systems (less than 1 per cent by weight). The 0.1 and 0.05 kg charges showed a larger scatter in their data, being greatest for the end-initiated charges, although the means values agreed well with those of the larger charges.
- d The consistency of the data from centre-initiated charges is better than from end-initiated cylinders and the experimental scatter is less.
- e The effect of charge density on shock parameters is small but just detectable. Concurrent work (Part 2 of this report) shows that the density should be specified to within 1 per cent.
- f The sensitiveness of isostatically pressed TNT charges is adequate and roughly constant for the density range covered ( $1500 - 1620 \text{ kg/m}^3$ ); it is comparable with that of cast Composition B.



- g The mechanical strength of bare charges in the above density range is satisfactory, provided the precautions described are taken to prevent damage by the suspension system. With central initiation of charges there is less of a handling problem than with end-initiated systems.
- h The isostatically pressed charges are easy to press cold in a reproducible manner and to machine. They have very uniform density.

## 9 RECOMMENDATIONS

It is apparent from the conclusions listed in Section 8 that even with a homogeneous, single compound explosive charge such as isostatically pressed TNT there are several factors which have to be taken into account if such a charge is to be used as a standard for underwater work. The variations in output with charge sizes, mode of initiation, etc we have reported are small but, we believe real. However, we find it difficult to visualise any standard charge which does not suffer from these minor defects and the overall reproducibility and ease of manufacture and use of isostatically pressed TNT leads us to recommend its adoption.

Summarising, we recommend:

- a The use of 80.4 crystal TNT (specification attached), cold pressed isostatically to a uniform density of  $1600 \pm 20 \text{ kg/m}^3$ . (The high density is specified mainly to give high mechanical strength.)
- b The use of 1:1 cylindrical charges, initiated centrally (as described), with output measured in the equatorial plane through the centre of the charge. Central initiation gives better reproducibility and the results for 1:1 cylinders are indistinguishable from those for spherical charges.
- c Minimal boosting (1 per cent, or less), avoiding the necessity of correcting output data for the effect of the booster charge.
- d The use of light charge supports with protection of the bare charge against the supports (as described).
- e The charges should be 0.45 kg in weight. We see no advantage in using larger charges and if smaller charges are used then a greater number of firings would be required because of the increased scatter in the output.

If Where pressed TNT charges of other than the recommended weight, mode of initiation, etc are used, or a different range of stand off distances, then comparisons of data are best performed using the reduced shock impulse because this appears to be insensitive to these variations.

Copyright © Controller HMSO, London, 1974

Draft Specification  
TNT for Reference Charges  
for Underwater Measurements

1 SCOPE

This specification covers a grade of TNT suitable for the production of pressed charges for use as reference standards in underwater assessment work.

The material consists of TNT of high purity prepared as crystal and maintained in that form. "Flake" or "crushed flake" will not be acceptable.

2 RELATED DOCUMENTS

a Reference is made in this specification to:

British Standard 410, 'Test sieves'.

b Reference in this specification to a British Standard undated, means, in any tender or contract, the edition current at the date of such tender or contract.

3 DESCRIPTION

The TNT shall consist essentially of alpha-trinitrotoluene. It shall be produced only by the direct nitration of toluene, and shall not contain any material derived from the recovery and/or purification of TNT previously used in munitions.

4 INFORMATION TO BE SUPPLIED BY THE PURCHASER

The purchaser shall state clearly in his order that the material is to comply with this specification.

5 METHOD OF MANUFACTURE

The TNT shall be produced by a process which has received authoritative approval. The Inspection Authority shall be informed regarding the process used and shall be given prior notification of any proposed change therefrom.

6 TESTING

a Samples taken from any portion of the supply shall be free from gritty particles, visible impurities and foreign matter and shall comply with the following test limits:

TEST	LIMIT
Setting point .....	TNT 80.4
..... °C	80.4 min
Acidity as H <sub>2</sub> SO <sub>4</sub> .....	80.9 max
..... per cent	
Vacuum stability .....	0.005 max
..... ml of gas	
(applicable only to supplies containing recovered TNT)	
Moisture .....	0.10 max
..... per cent	
Sulphated ash .....	0.05 max
..... per cent	
Organic matter insoluble in toluene:	
i Total matter insoluble in toluene minus the	
sulphated ash .....	0.05 max
..... per cent	
ii Gritty particles retained on No 60 BS sieve*	Nil
Melting test:	
i Scum, suspended matter and deposit .....	Nil
ii Colour of freshly melted material .....	Not darker than
	Colour Standard No 2 <sup>†</sup>
iii Darkening on heating for 2 hours .....	Not appreciable
Total sodium, calculated as Na .....	0.001 max
..... per cent	

\* Particulars of the BS sieve referred to in this clause will be found in BS 410, Table 1.

<sup>†</sup> Colour Standard No 2 will be prepared by the method described in the Appendix.

The whole of the material shall be capable of passing a No 25 BS sieve and not less than 20 per cent shall be capable of passing a No 52 BS sieve.\*

## 7 SAFETY OPERATIONS

Nothing in this specification shall relieve the contractor of his responsibility for the safety of his operations.

## 8 PACKAGING

The TNT shall be packed in sound, clean bags of an approved type, containing an approved quantity, and each bag shall be enclosed within a sound, clean container of approved pattern.

The packages constituting a consignment shall each be legible marked with the full description of the contents, including quality and physical form. The markings shall include also the contract or extract number, a distinctive lot number, a consecutive package number, the tare and net weight, the date of supply and the manufacturer's initials or recognised trade mark.



The paint or other material used for marking and also the paint for packages, when required, shall be of good quality and to the satisfaction of the Inspection Authority.

The inclusion of any foreign matter or impurities in any of the packages will render the whole consignment liable to rejection.

9 INSPECTION

Samples of the TNT and of the materials used in its manufacture may be taken at any stage of manufacture. For this purpose the authorised representatives of the Inspection Authority shall have free access, subject to the Contractor's safety regulations, to all parts of the factory in which the TNT is manufactured.

After manufacture, the TNT and the packages in which it is contained will be subject to inspection by, and final approval of, the Inspection Authority.

If on examination, any sample be found not to conform to this specification, the whole consignment may be rejected.

Method for the preparation of Colour Standards1 Reagents

- a Potassium dichromate solution. Dissolve 80 g of 'analytical reagent' quality potassium dichromate in water and dilute to 1 litre.
- b Potassium permanganate solution. Dissolve 3.16 g of 'analytical reagent' quality potassium permanganate in water and dilute to 1 litre.
- c Copper sulphate solution. Dissolve 200 g of 'analytical reagent' quality cupric sulphate ( $\text{CuSO}_4 \cdot 5\text{H}_2\text{O}$ ) in water and dilute to 1 litre.

2 Colour standards

The colour standards are to be freshly prepared daily and filtered before use if cloudy.

a Colour Standard No 1

Potassium dichromate solution	35	ml
Copper sulphate solution	15	ml

b Colour Standard No 2

Potassium dichromate solution	35	ml
Potassium permanganate solution	1.25	ml
Copper sulphate solution	13.75	ml

c Colour Standard No 3

Potassium dichromate solution	32.5	ml
Potassium permanganate solution	3.75	ml
Copper sulphate solution	13.75	ml

REGRESSION ANALYSIS AND CONFIDENCE LIMITS1 Linear Regressions

If the  $n$  pairs of observations  $(x_1, y_1)$  are best fitted to a straight line, then putting

$$x_1 = x_1 - \bar{x}$$

$$\text{and } y_1 = y_1 - \bar{y}$$

$$\text{we have } Y = \alpha X + \beta,$$

$$\text{where } \alpha = \frac{\sum X_1 Y_1}{\sum X_1^2} \quad \text{and} \quad \beta = \frac{\sum Y_1 - \alpha \sum X_1}{n}$$

The confidence limit curves (a) and (b) are given by

$$Y \pm \delta Y = \alpha X + \beta,$$

where  $\delta Y$  is

(a) for Point estimates,

$$(\delta Y)^2 = t^2 s^2 \left( 1 + \frac{1}{n} + (X - \bar{x})^2 V(\alpha) \right)$$

(b) for estimates from regression line

$$(\delta Y)^2 = t^2 s^2 \left( \frac{1}{n} + (X - \bar{x})^2 V(\alpha) \right),$$

where  $t$  = Student's  $t$  factor,

$$s^2 = \frac{1}{(n-2)} \sum (y_1 - Y)^2, \text{ for } (n-2) \text{ degrees of freedom,}$$

$$V(\alpha) = \text{variance coefficient of } \alpha = \frac{1}{\sum X_1^2}$$

2 Quadratic Regressions

If the quadratic,  $Y = aX + bX^2$   
is expressed in the form  $z = ax + by,$

$$\text{where } z = Y - \bar{Y},$$

$$x = X - \bar{X},$$

$$y = X^2 - \bar{X}^2,$$

$$\text{then } a\Delta = \sum y^2 \sum xz - \sum xy \sum yz$$

$$\text{and } b\Delta = \sum x^2 \sum yz - \sum xy \sum xz,$$

$$\text{where } \Delta = \sum x^2 \sum y^2 - (\sum xy)^2$$

The confidence limit curves (a) and (b) are given by

$$Y \pm \delta Y = aX + bX^2$$

where  $\delta Y$  is

(a) for Point estimates,

$$(\delta Y)^2 = t^2 s^2 \left[ 1 + \frac{1}{n} + (x - \bar{x})^2 v(a) + 2(x - \bar{x})(x^2 - \bar{x}^2) \text{co.}v(a,b) + (x^2 - \bar{x}^2)^2 v(b) \right]$$

(b) for estimates from the regression line,

$(\delta Y)^2 =$  as for (a), without the first term in the bracket,

where  $s^2 = \frac{1}{(n-3)} \Sigma (Y_i - aX_i - bX_i^2)^2$ , for  $(n-3)$  degrees of freedom,

and the variance coefficients are

$$v(a) = \Sigma y^2 / \Delta$$

$$v(b) = \Sigma x^2 / \Delta$$

$$\text{co } v(a,b) = -\Sigma xy / \Delta$$



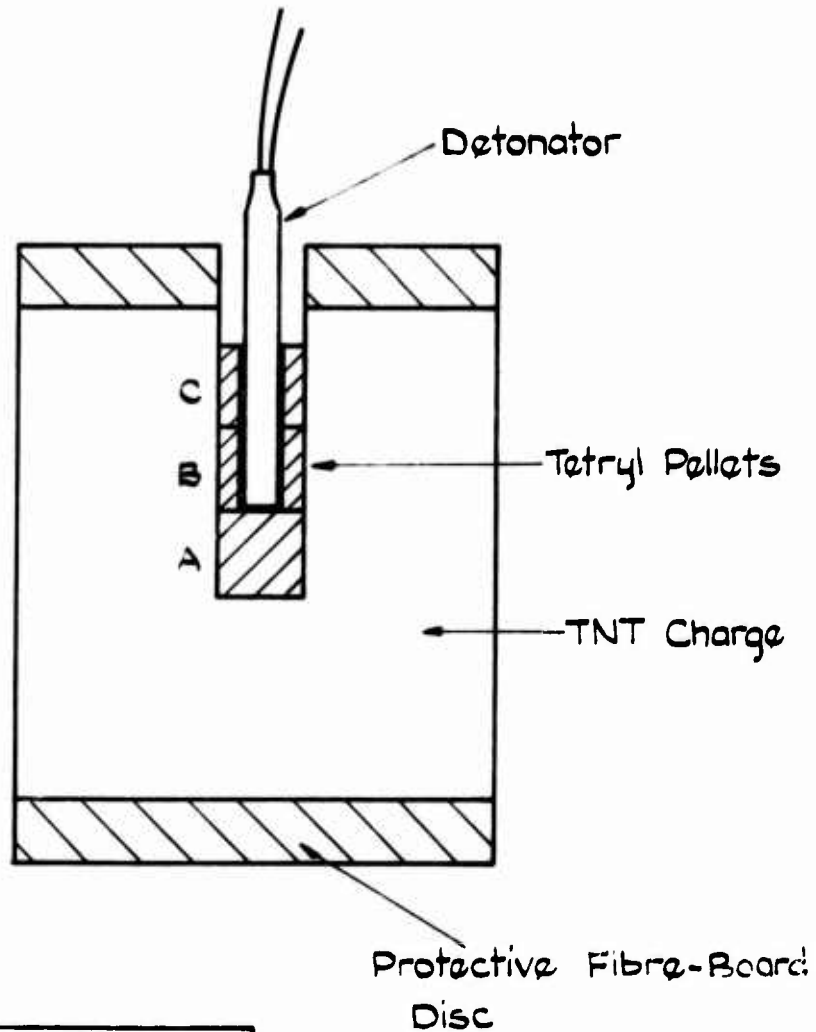

CHARGE WEIGHT	BOOSTER	
	PELLETS	WEIGHT
0.05 kg	Nil	Nil
0.1	A+B	4.25 g
0.45	A+B+C	6.00
3.6	A+B+C	6.00

FIG. 1 CENTRE INITIATION.

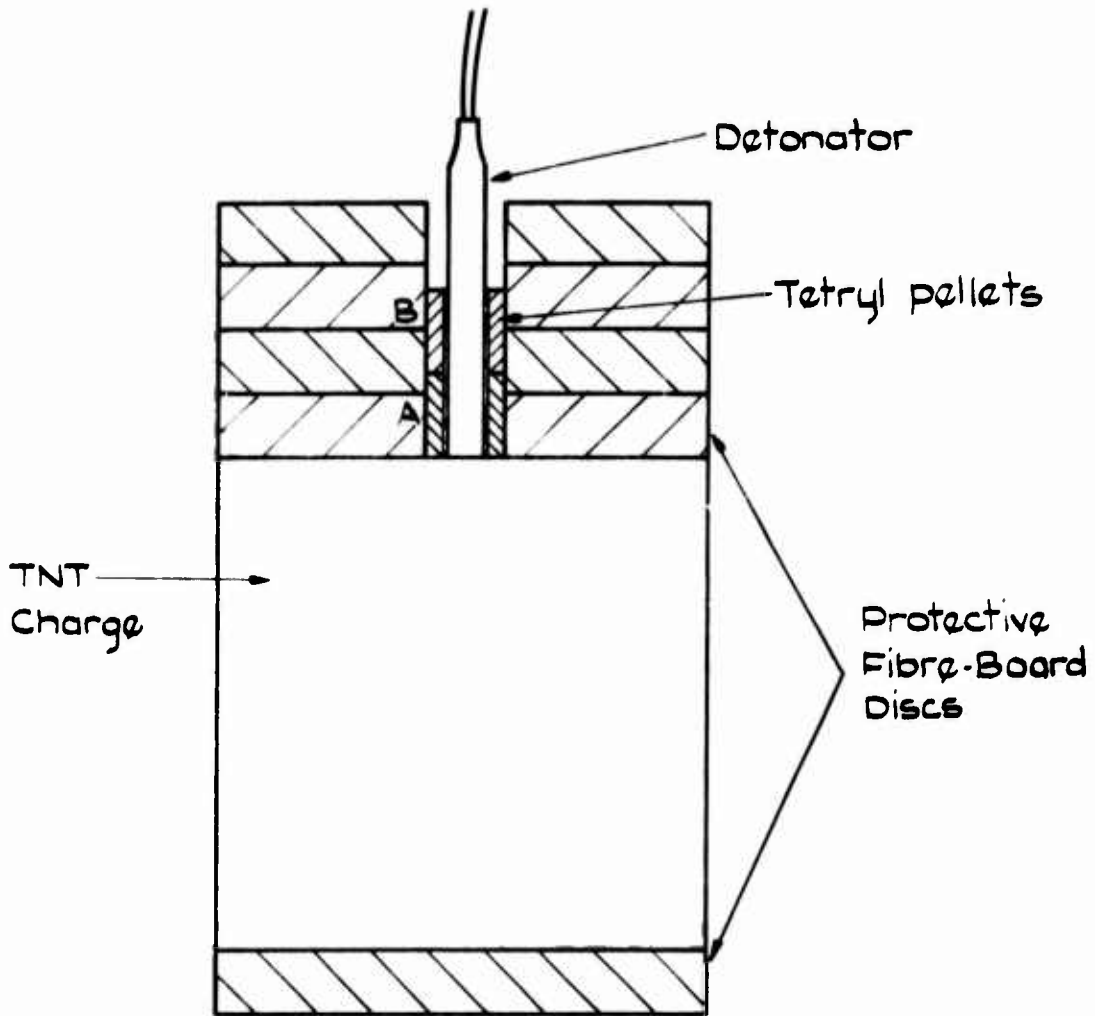

CHARGE WEIGHT	BOOSTER	
	PELLETS	WEIGHT
0.05 kg	Nil	Nil
0.1	A	1.75g
0.45	A	1.75
3.6	A+B	3.5
12.3	A	10.0

FIG. 2 END INITIATION.

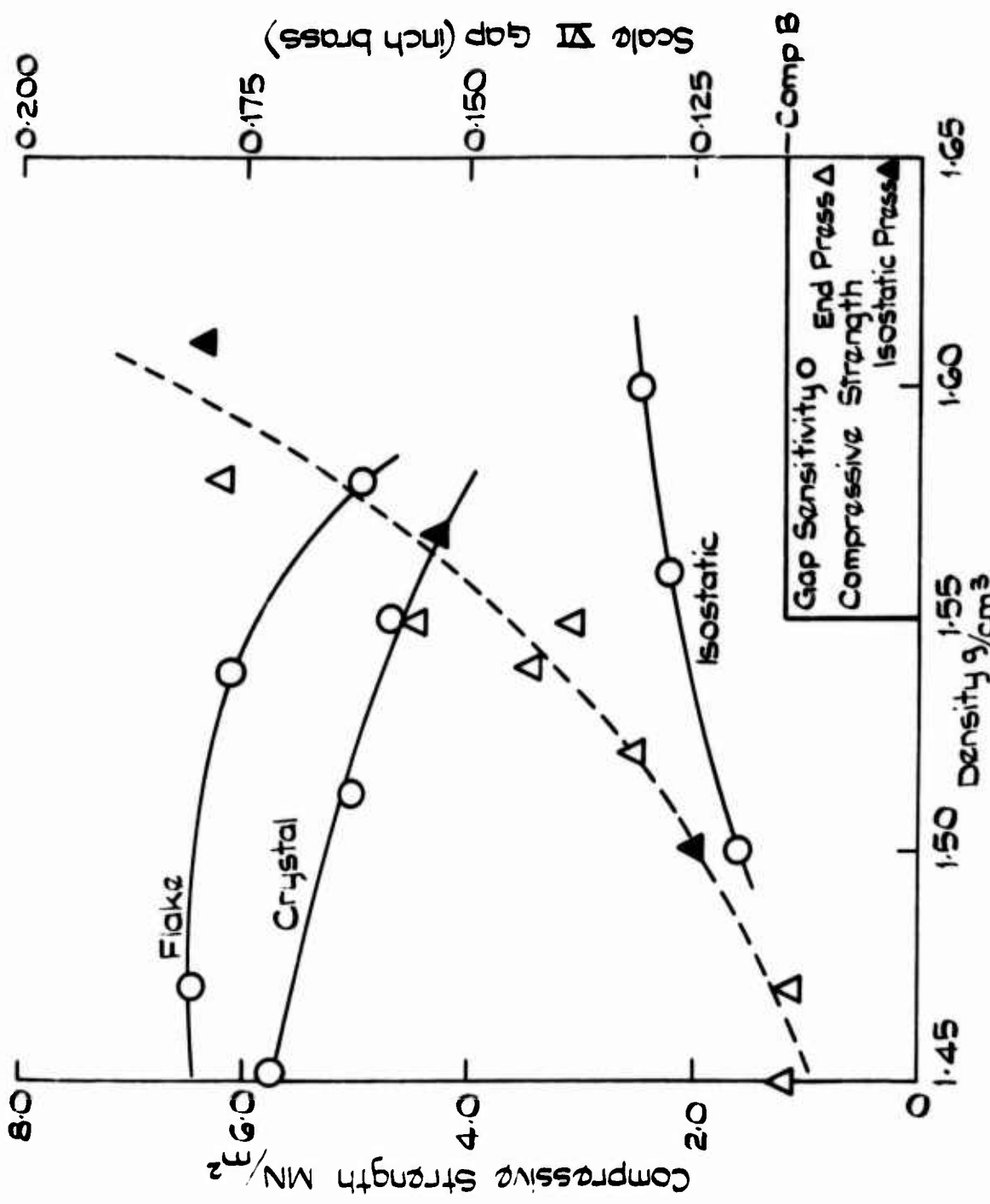

FIG. 3 DENSITY VS SENSITIVITY AND COMPRESSIVE STRENGTH FOR  
 PRESSED TNT.

TR 164  
Fig. 4

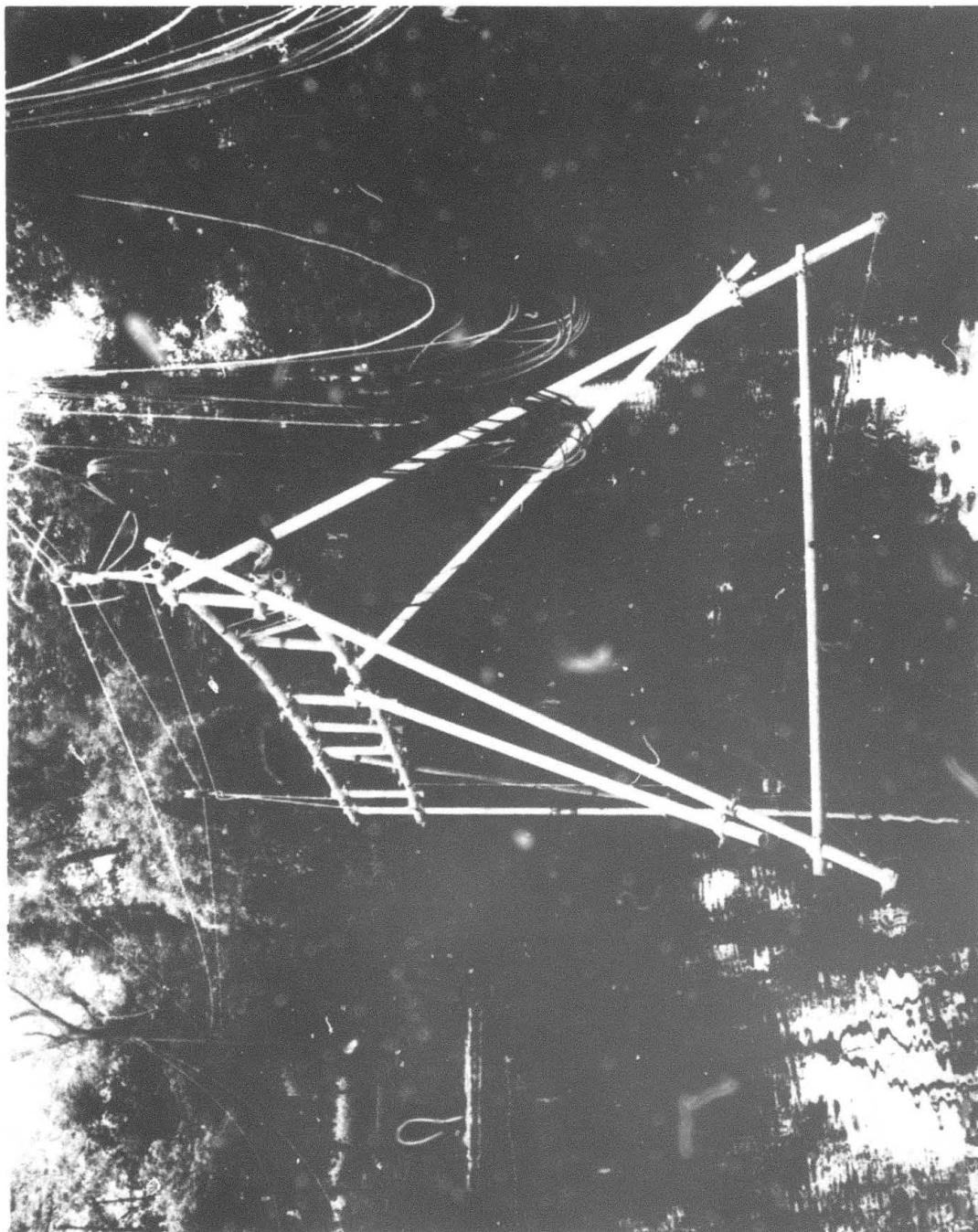

FIG. 4 FIRING RIG.

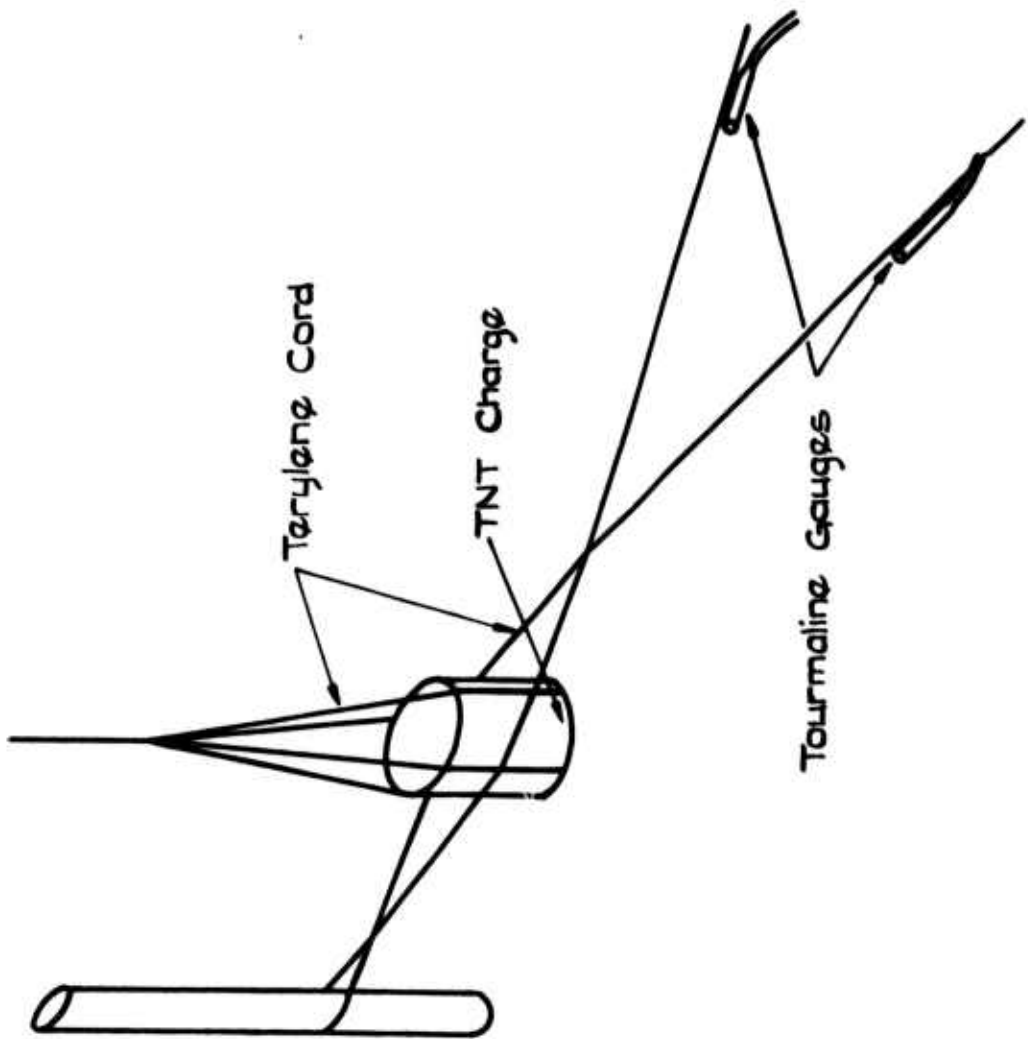

FIG. 5 CHARGE SUPPORT.

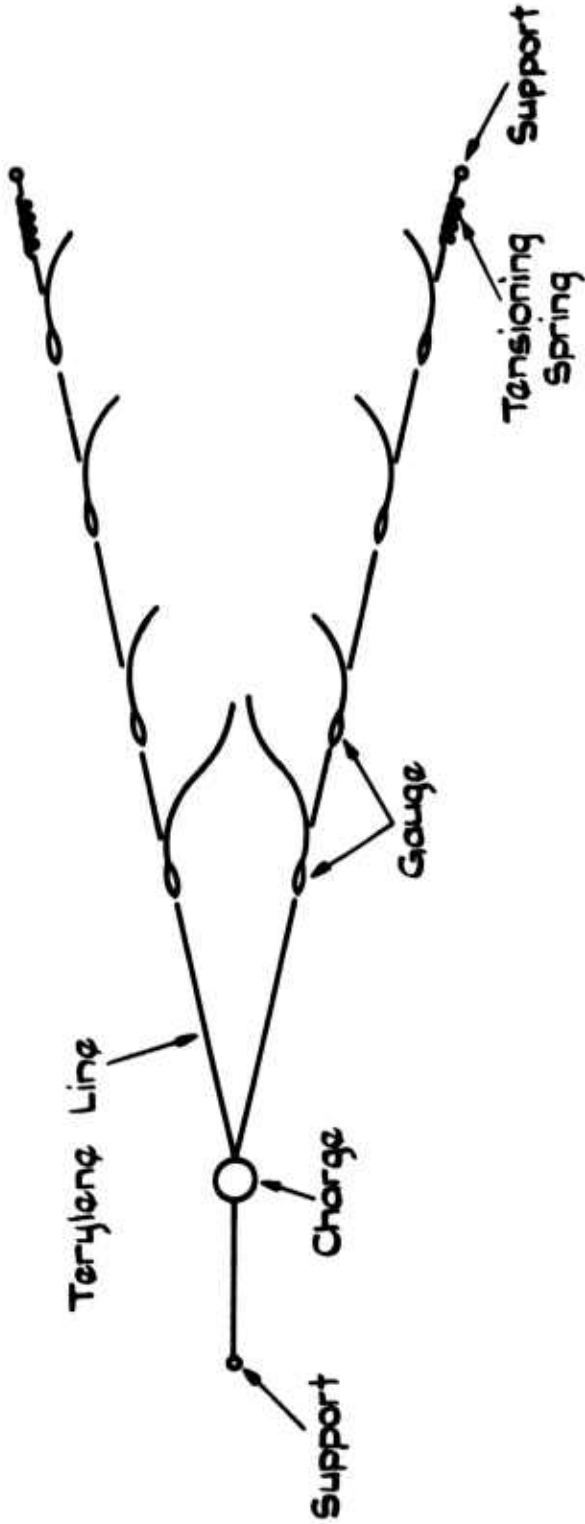

FIG. 6 CHARGE GAUGE GEOMETRY.

TR 164  
Fig. 7

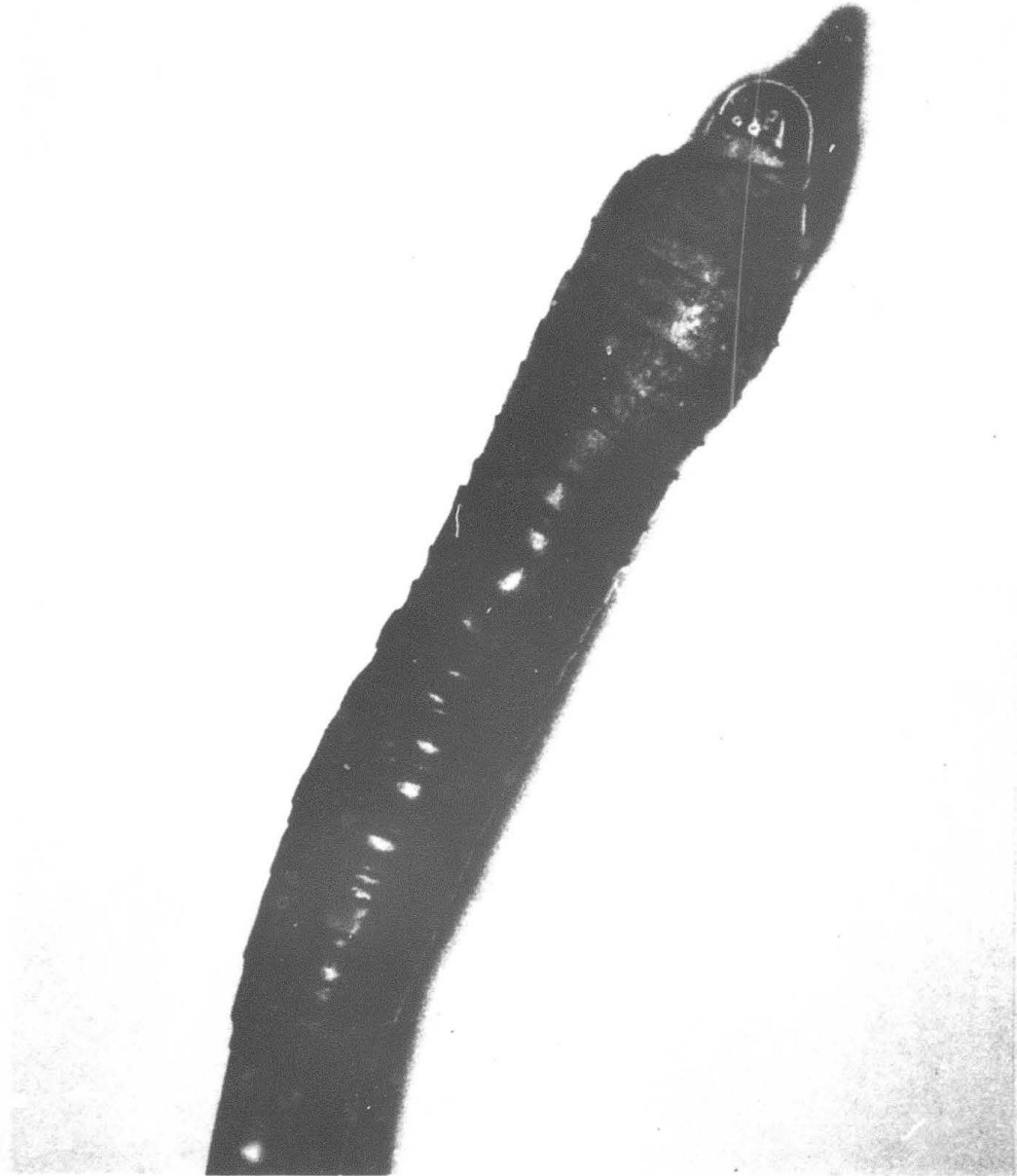

FIG. 7 UNDERWATER GAUGE.

TR 164  
Fig. 8

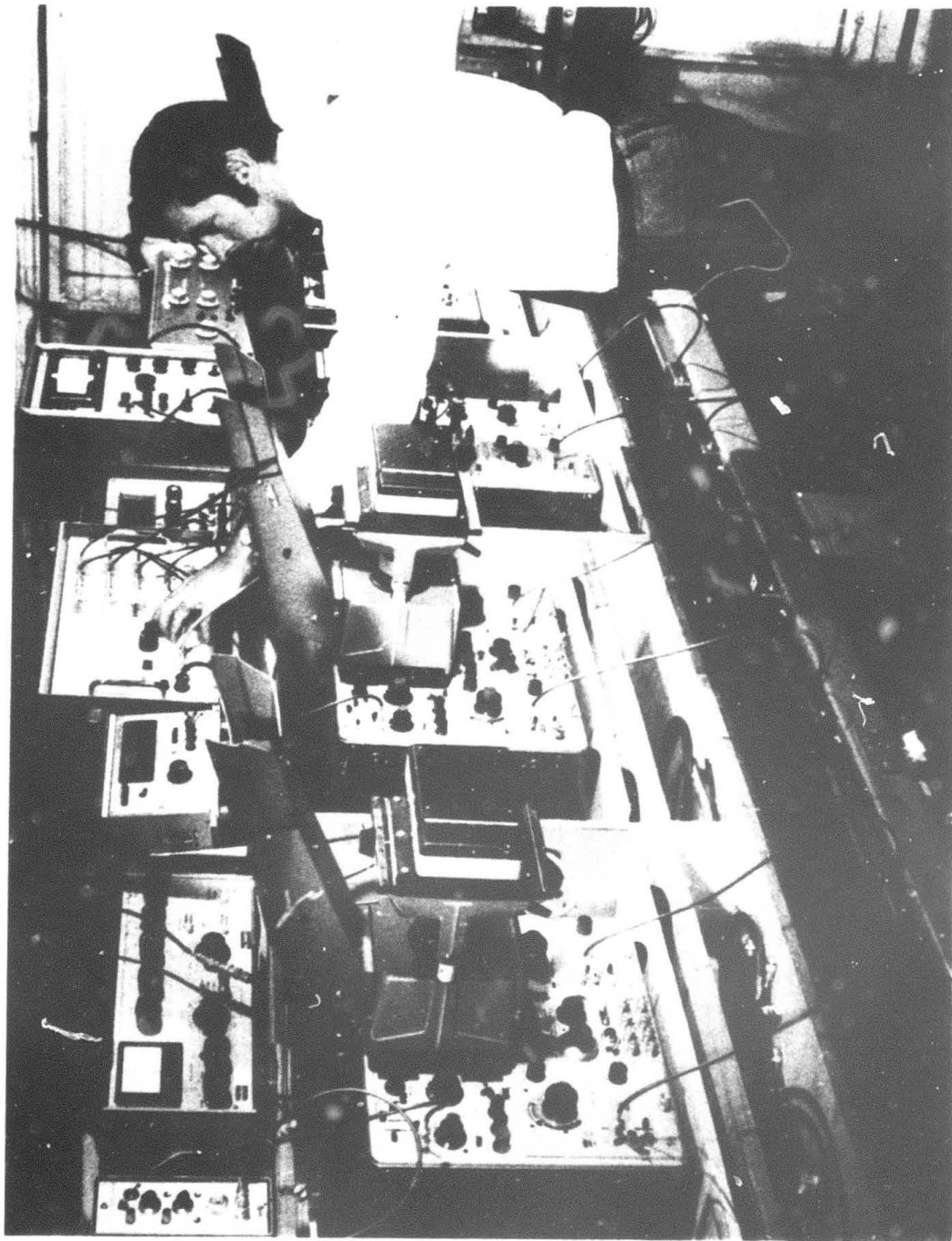

FIG. 8 INSTRUMENTATION.



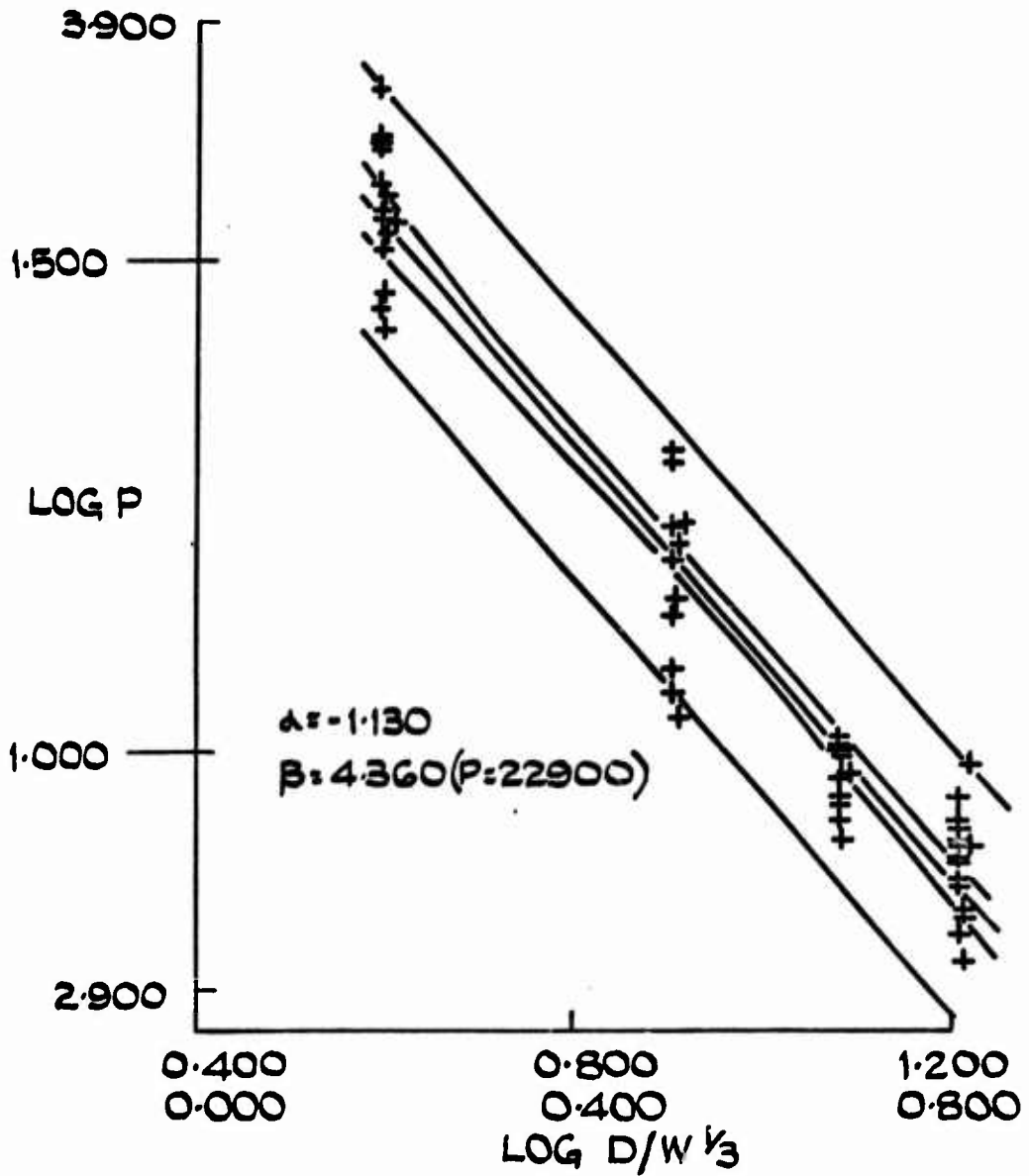

FIG. 9 PEAK PRESSURE - 0.05 kg CYLINDER CENTRE INITIATED.

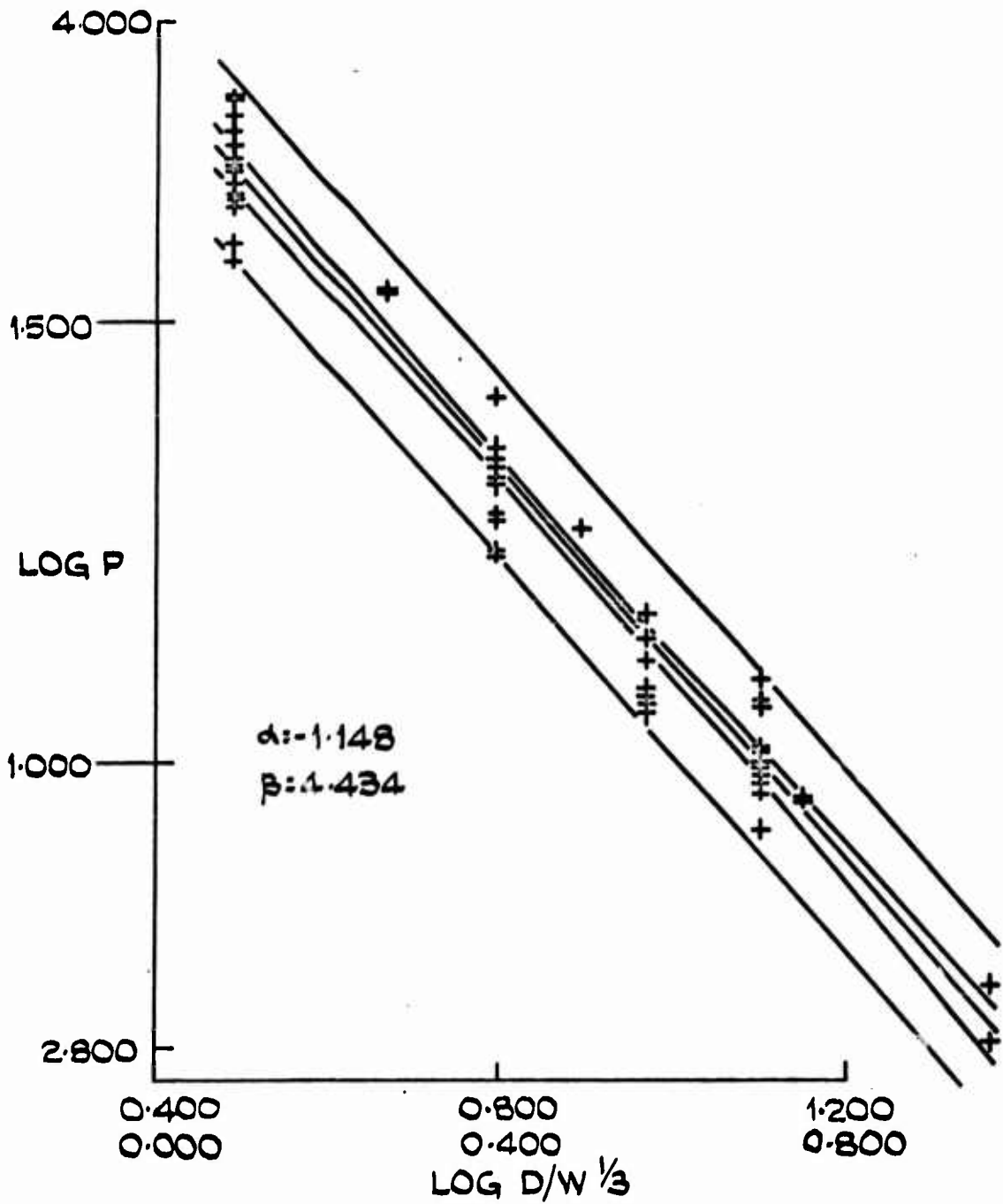

FIG. 10 PEAK PRESSURE -0.1 kg CYLINDER CENTRE INITIATED.

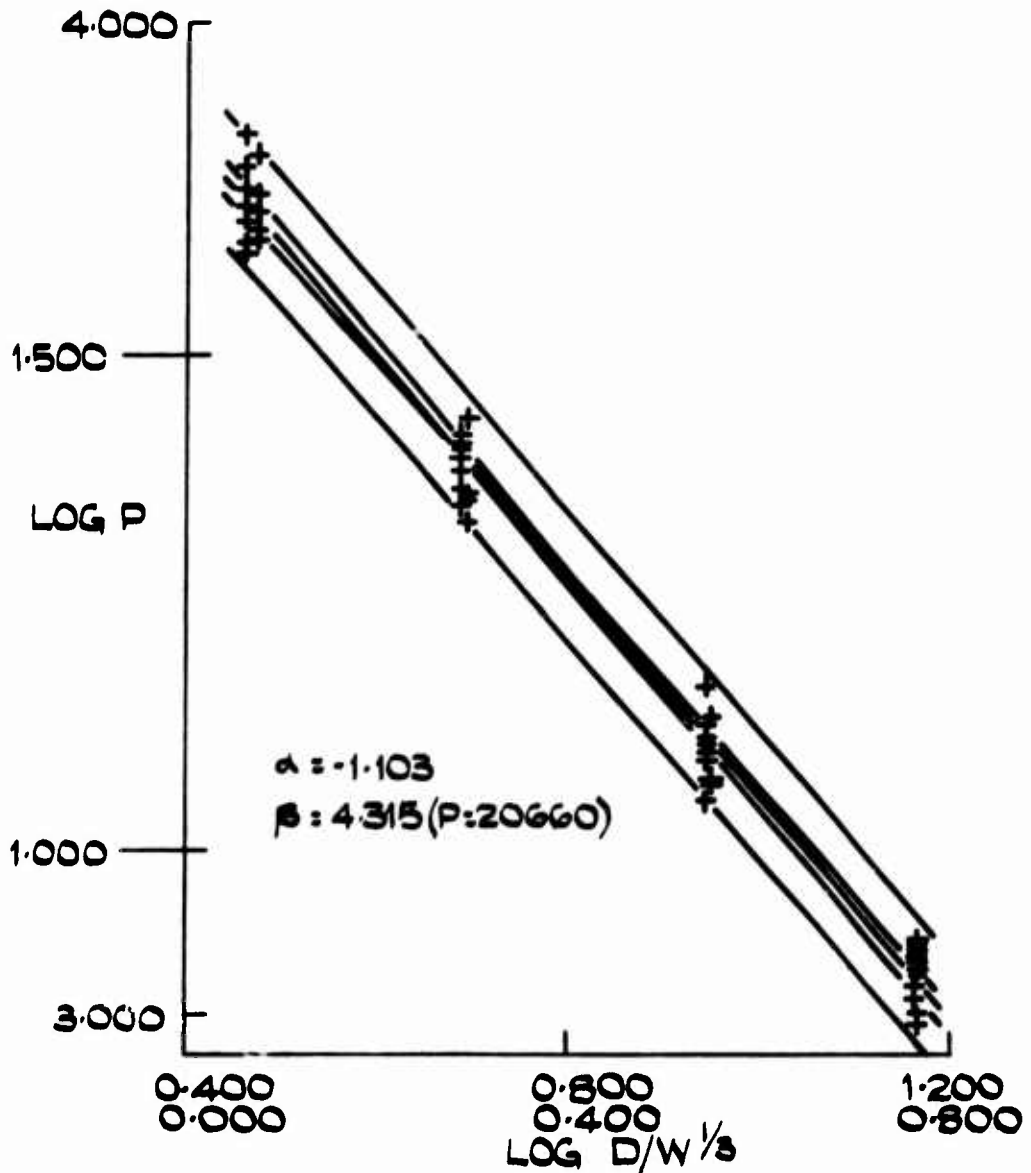

FIG. 11 PEAK PRESSURE -0.45 kg CYLINDER  
CENTRE INITIATED.

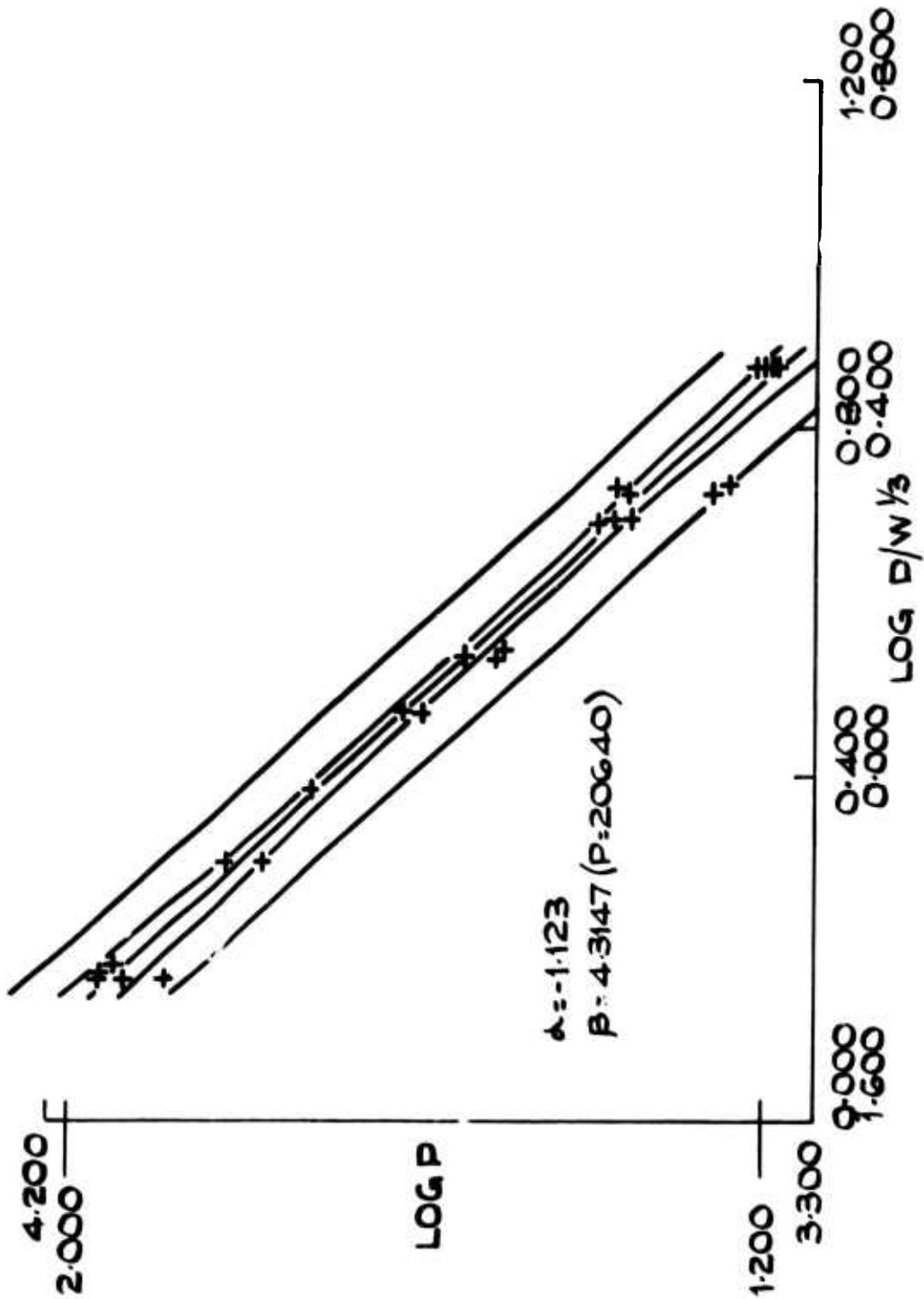

FIG.12 PEAK PRESSURE -3.6 kg CYLINDER CENTRE INITIATED.

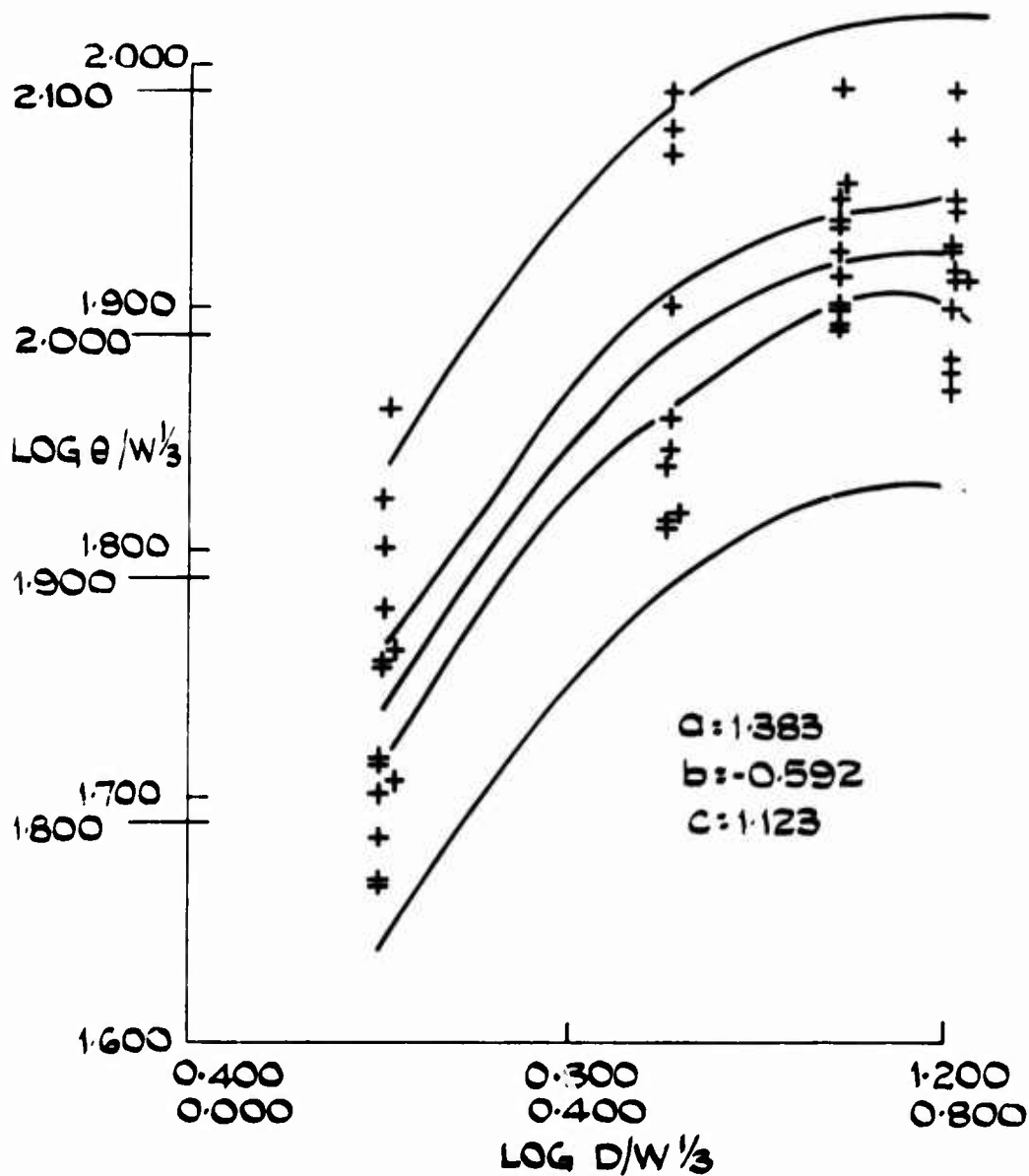

FIG.13 THETA -0.05 kg CYLINDER CENTRE INITIATED.

TR 164

Fig. 14

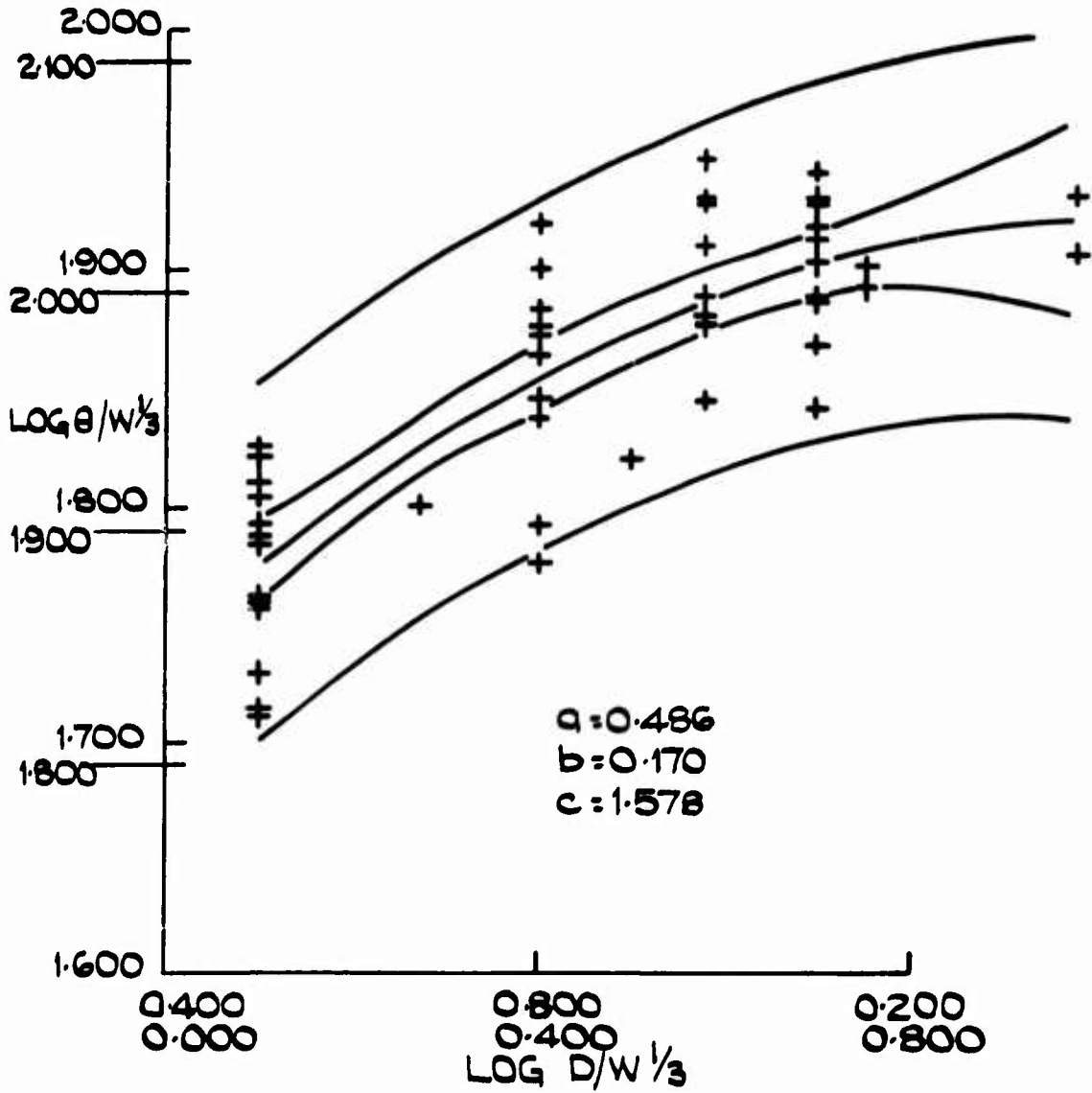

FIG. 14 THETA - 0.1 kg CYLINDER CENTRE INITIATED.

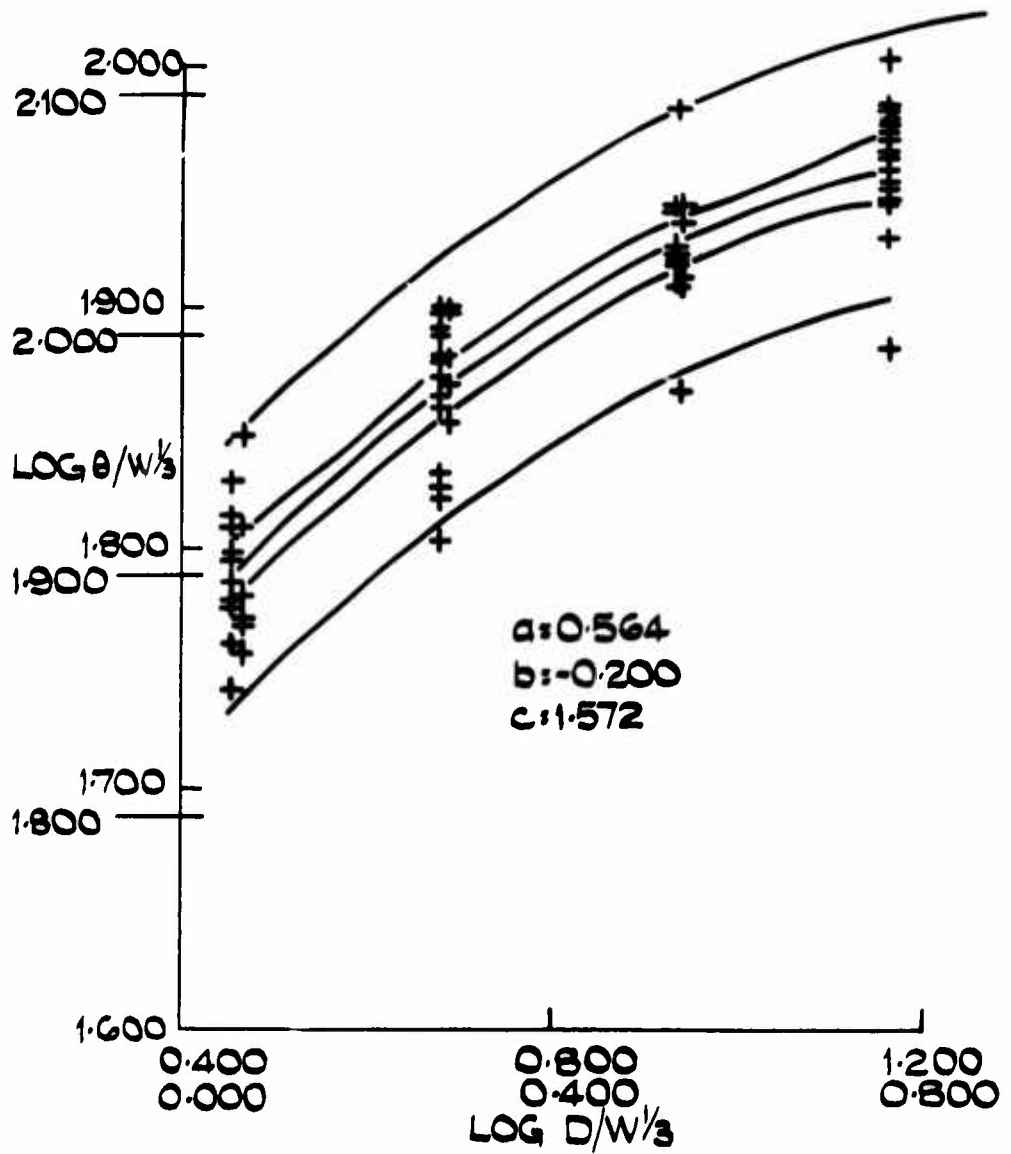

FIG. 15 THETA - 0.45 kg CYLINDER CENTRE INITIATED.

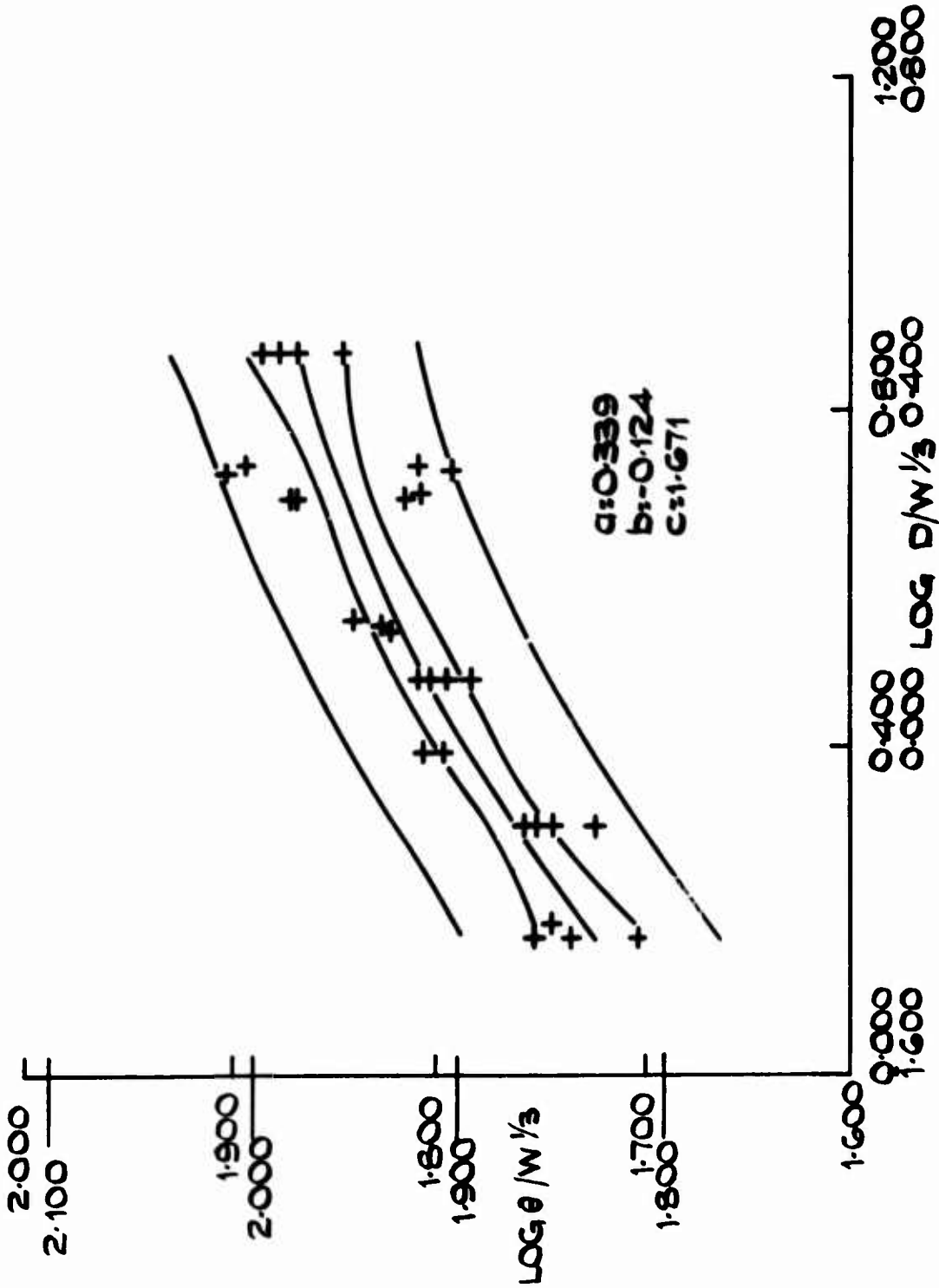

FIG. 16 THETA -3.6 kg CYLINDER CENTRE INITIATED.



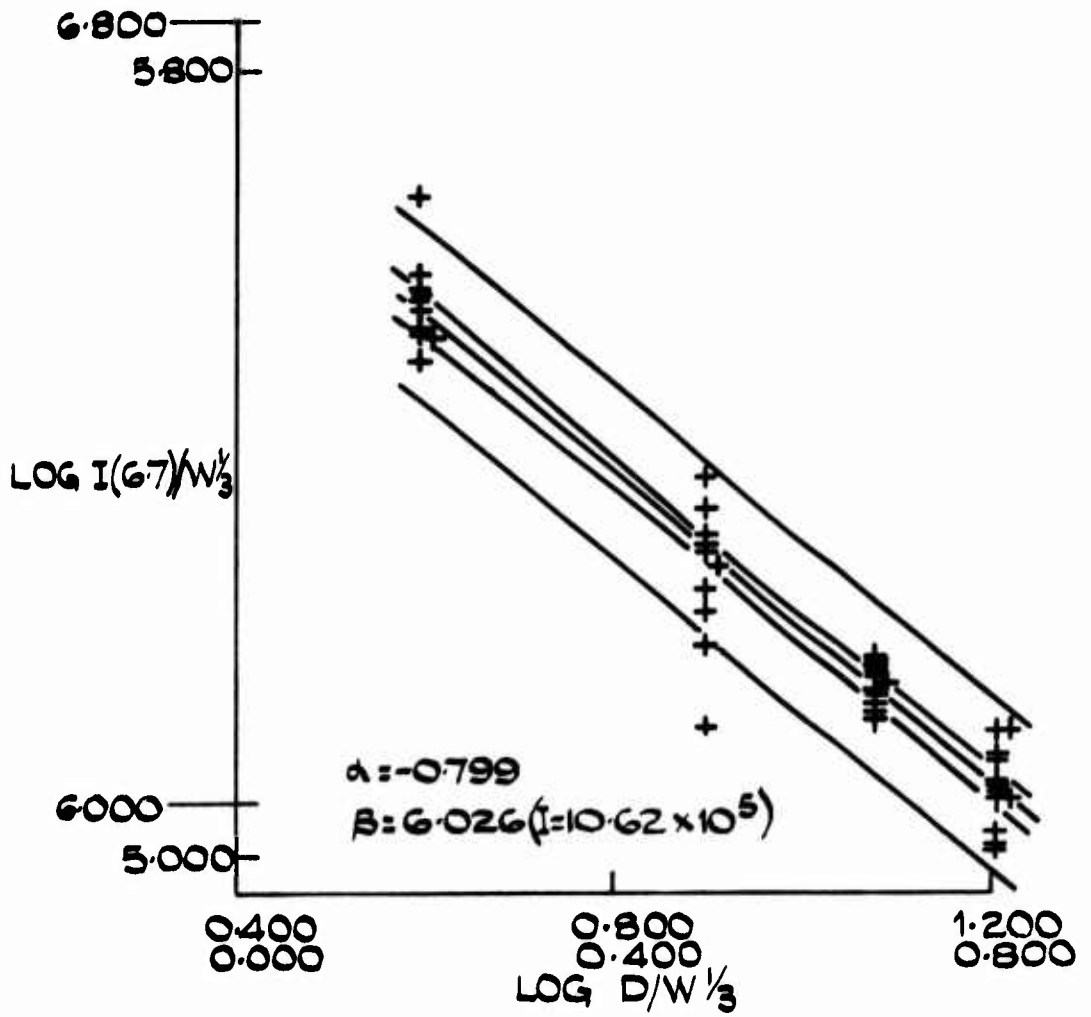

FIG. 17 IMPULSE -0.5 kg CYLINDER CENTRE INITIATED.

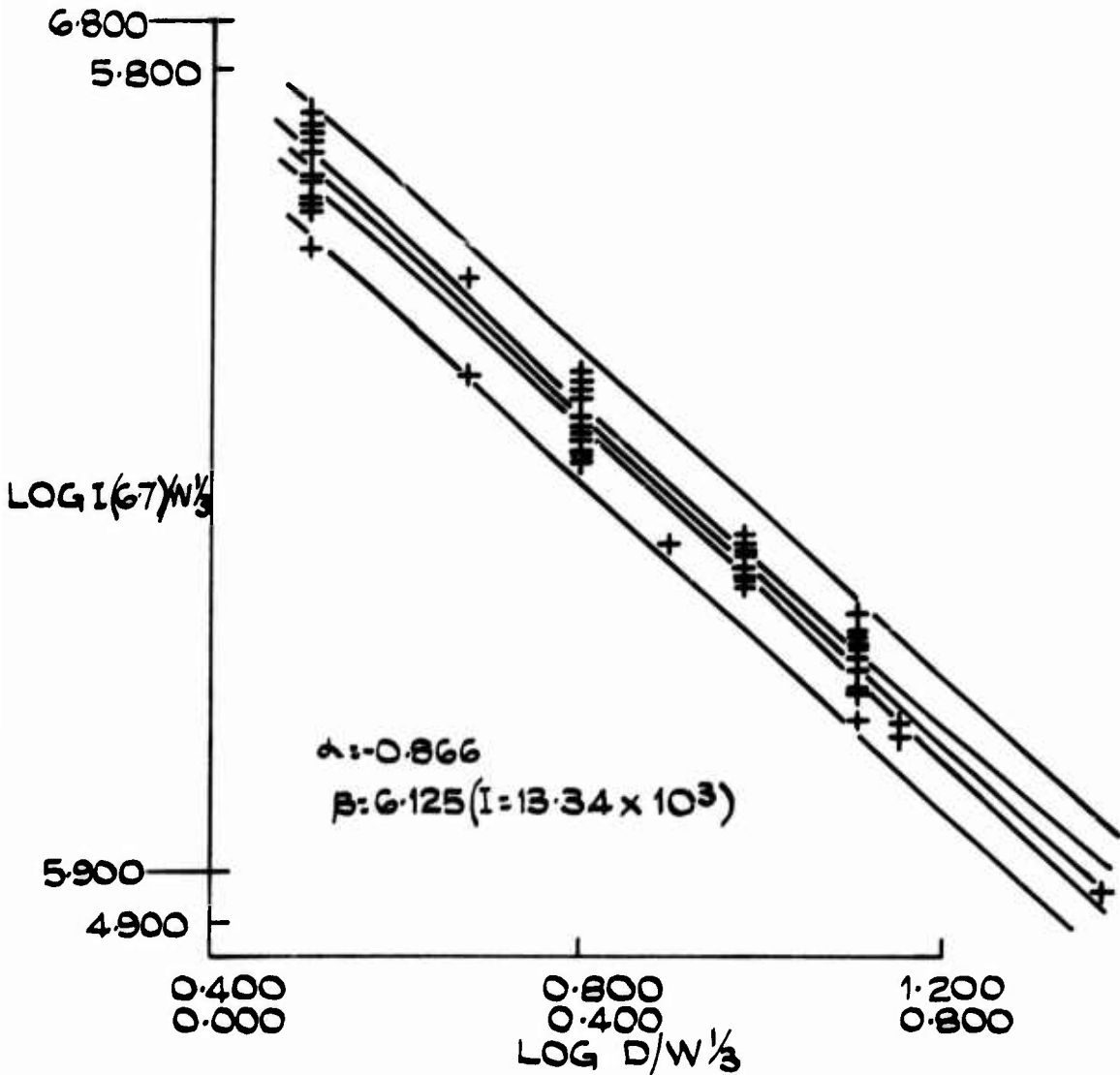

FIG. 18 IMPULSE -0.1 kg CYLINDER CENTRE INITIATED.

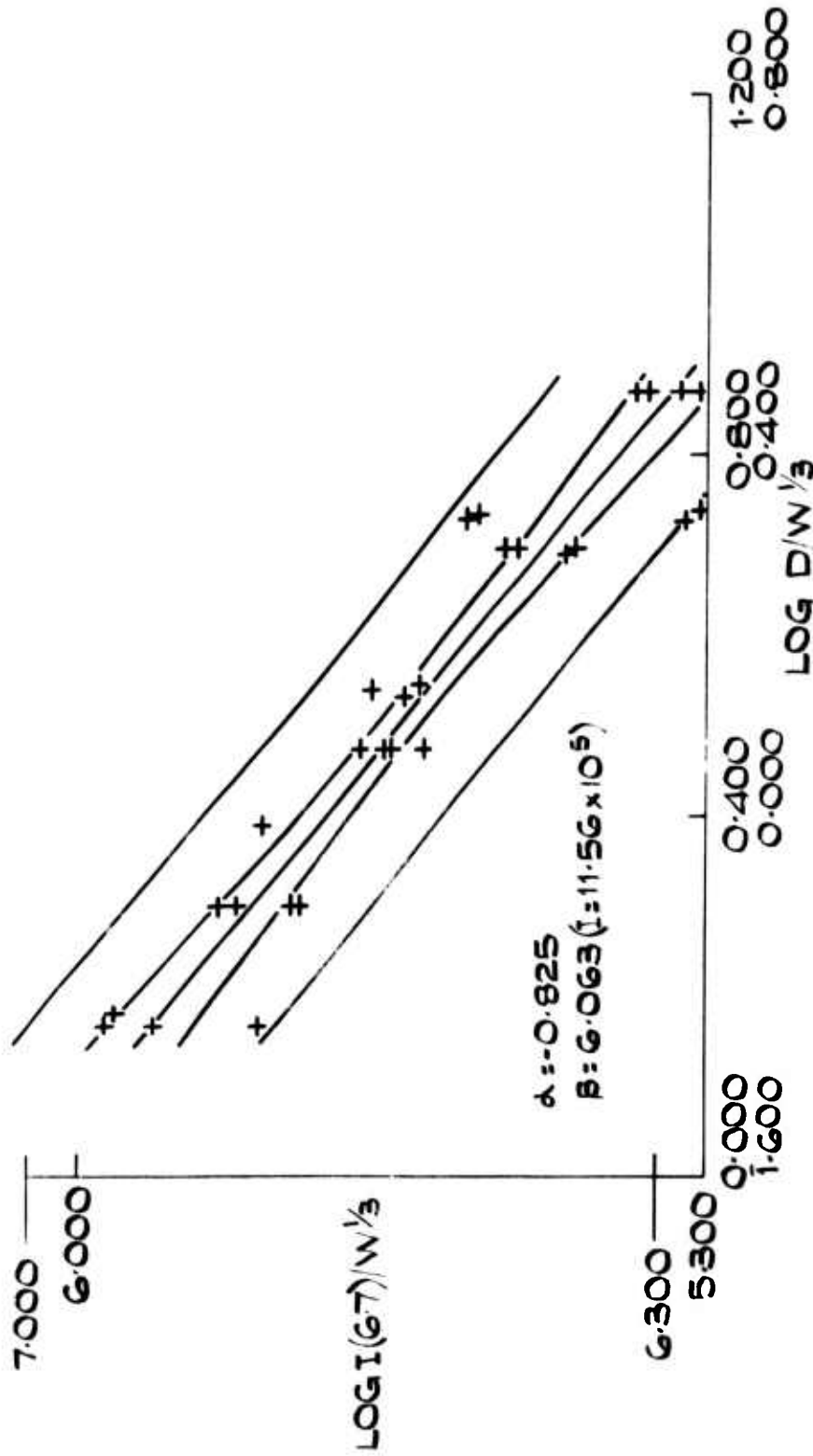

FIG. 20 IMPULSE - 3.6 kg CYLINDER CENTRE INITIATED.

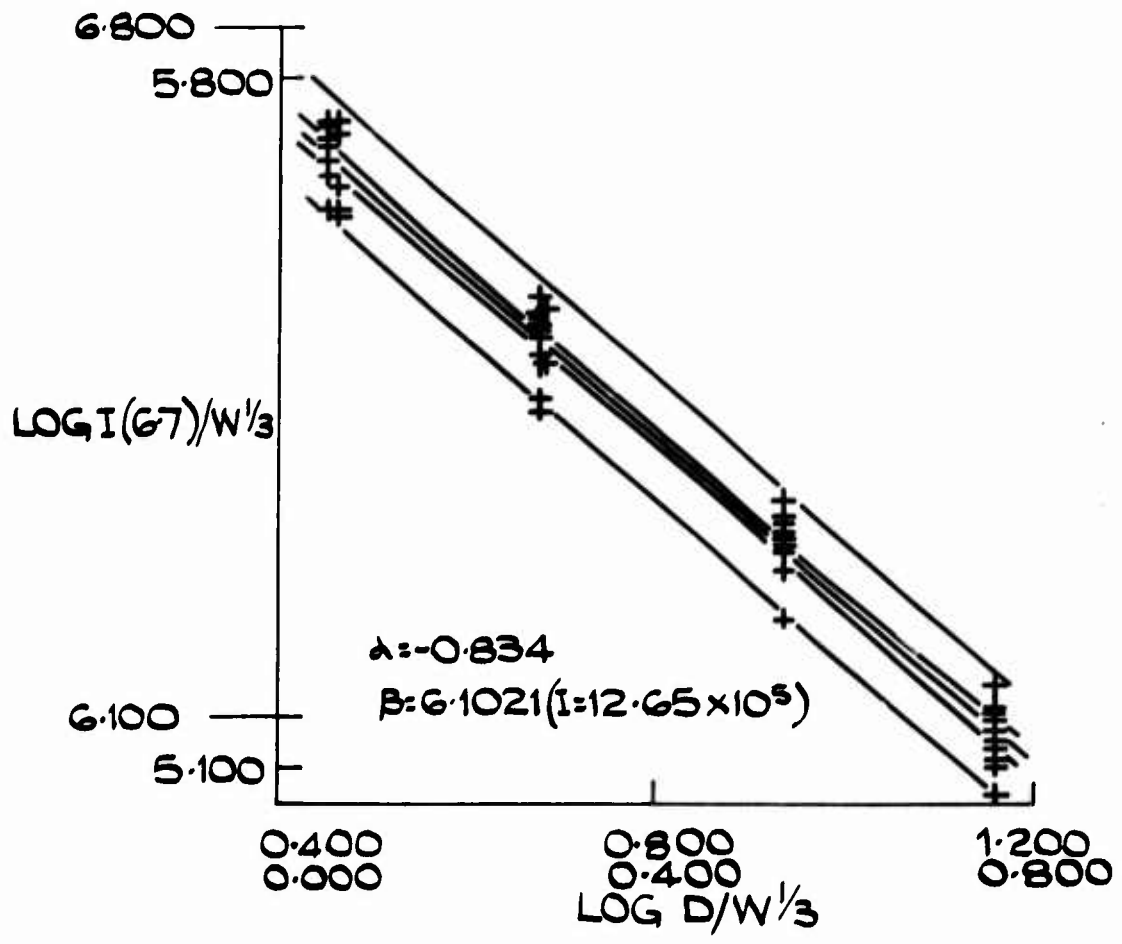

FIG. 19 IMPULSE -0.45 kg CYLINDER CENTRE INITIATED.

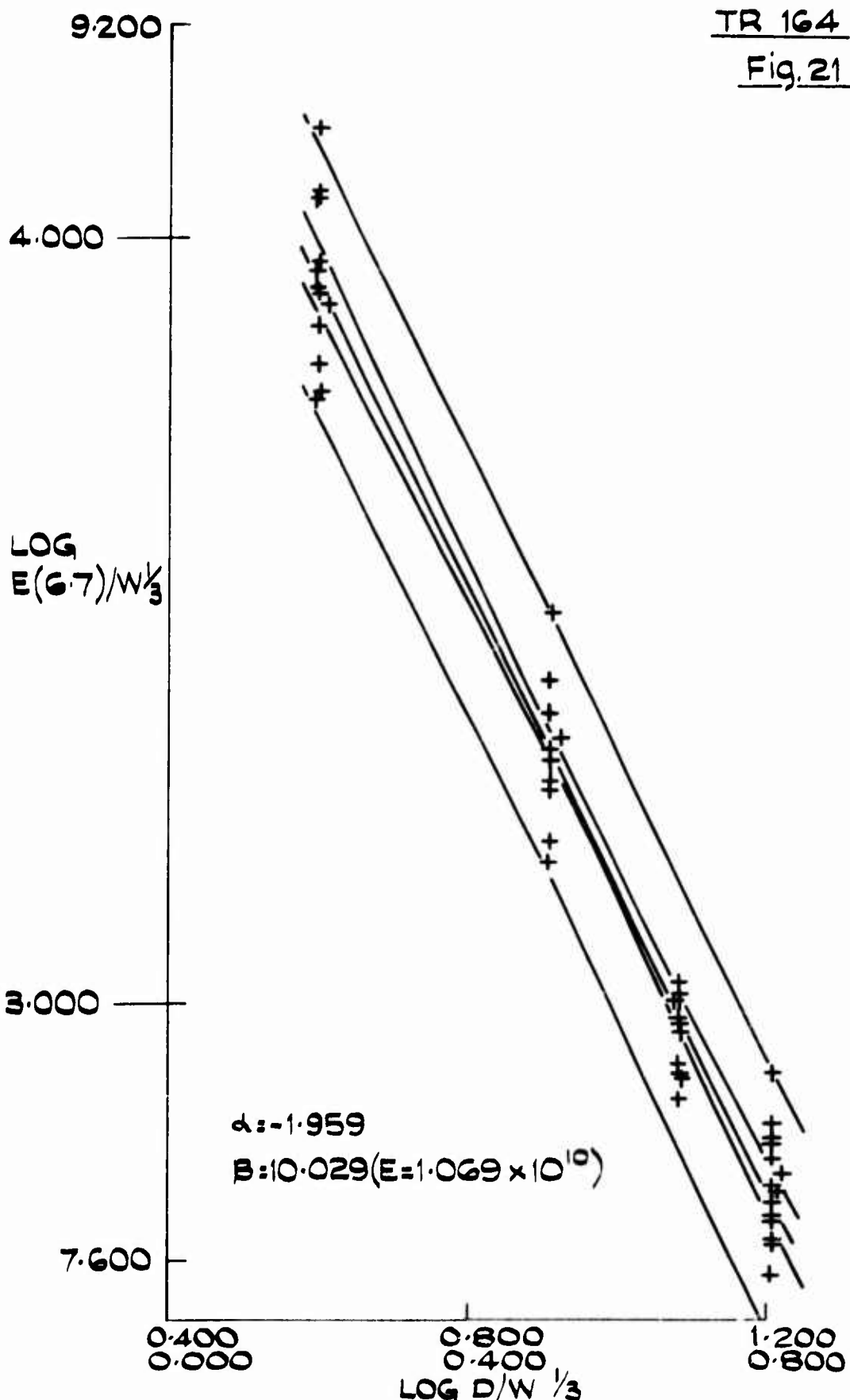

FIG. 21 E-0.05 Ra CYLINDER CENTRE INITIATED

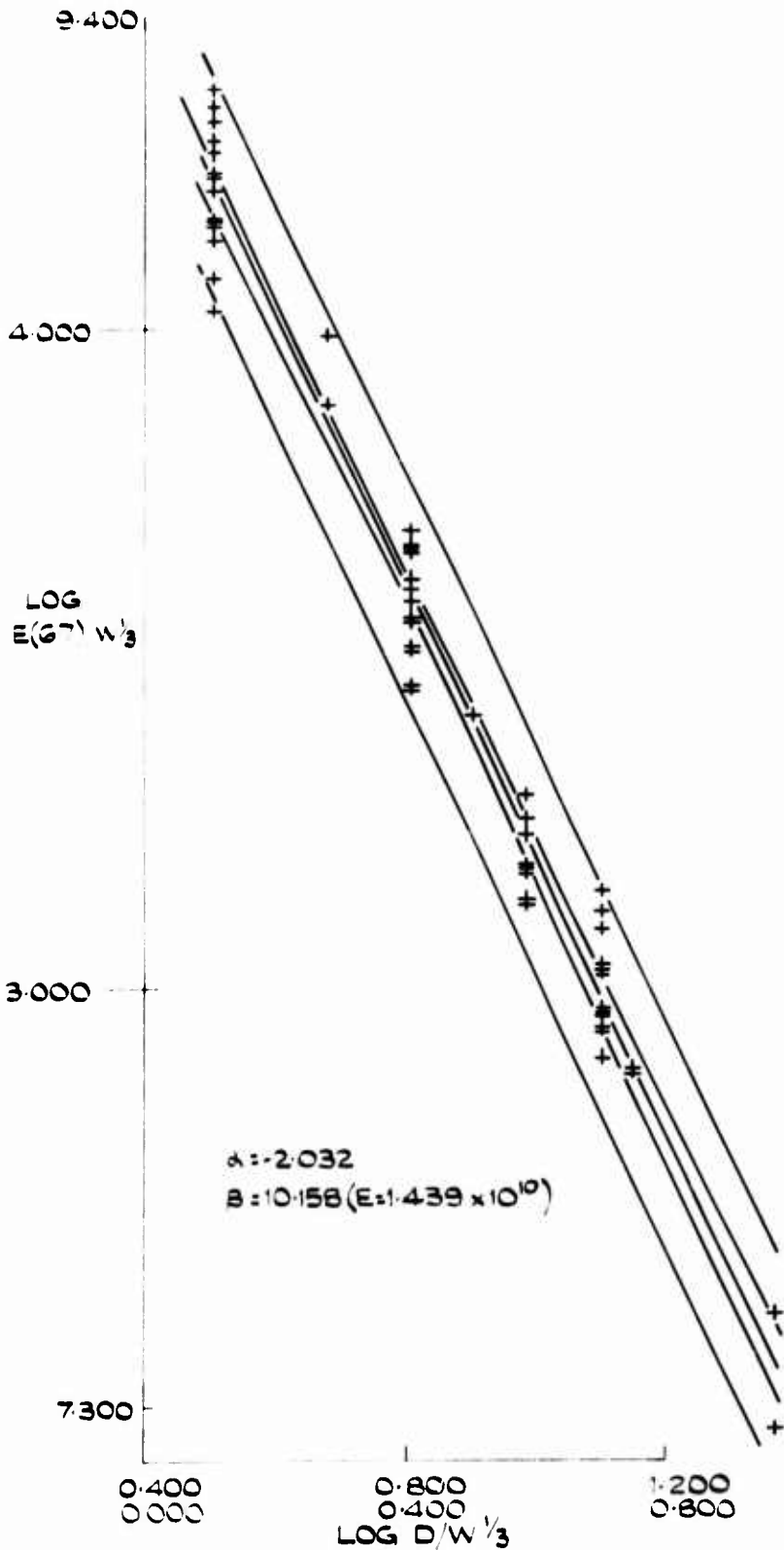

FIG 22 E=0.1 R<sub>g</sub> CYLINDER CENTRE INITIATORS.

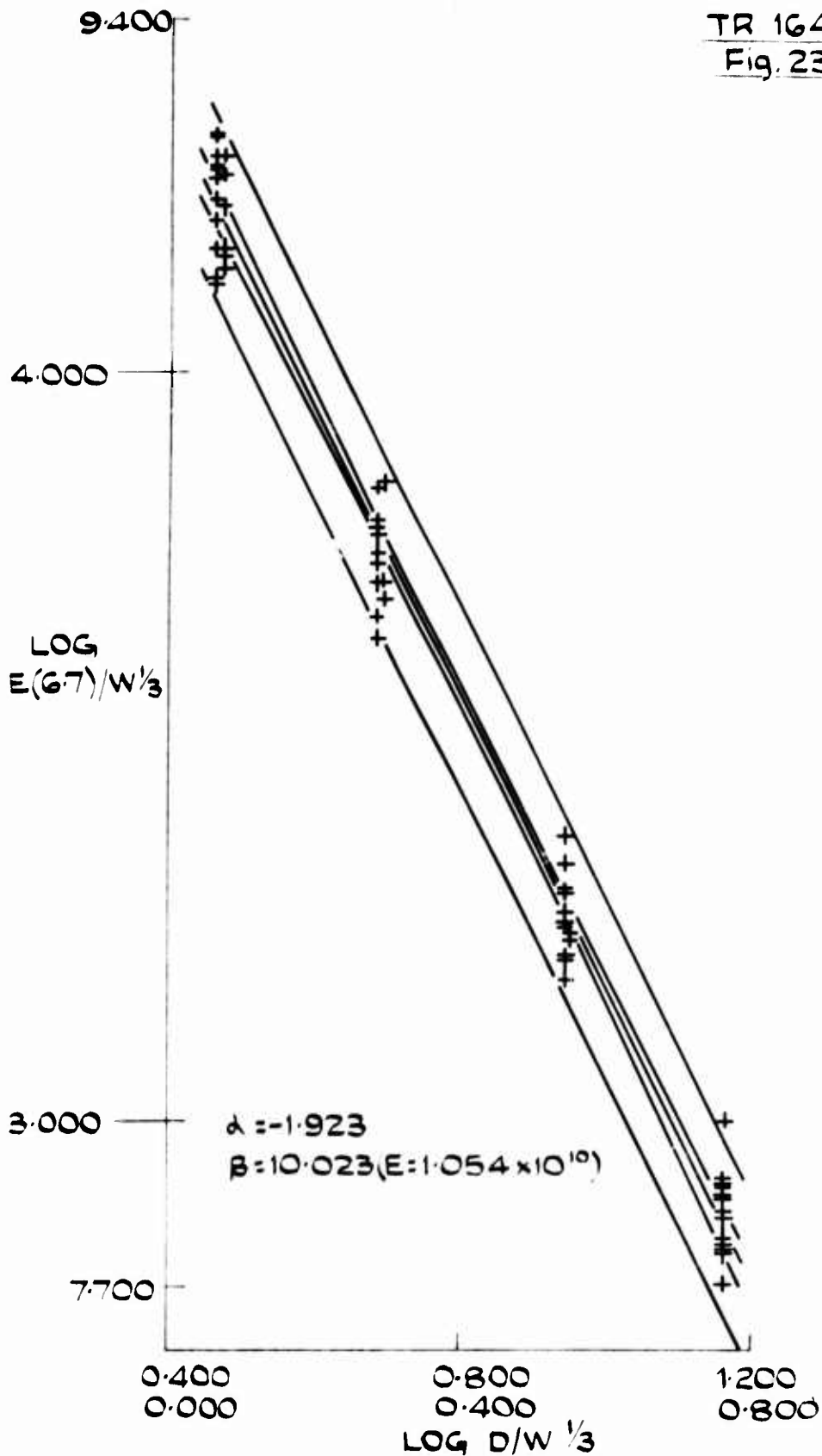

FIG.23 E-0.45 kg CYLINDER CENTRE INITIATED.

TR 164  
Fig. 24

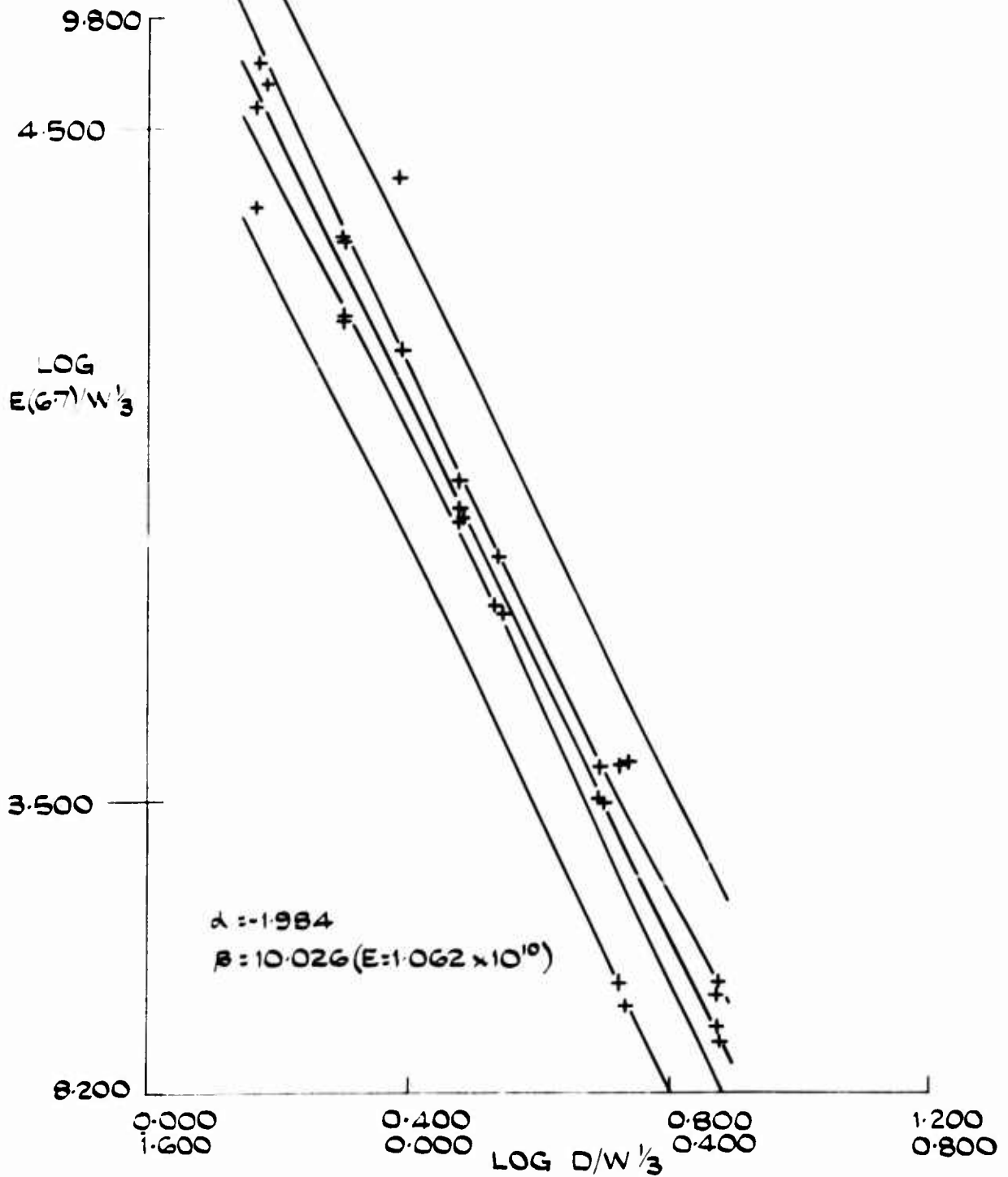

FIG. 24 E-3.6 kg CYLINDER CENTRE INITIATED.



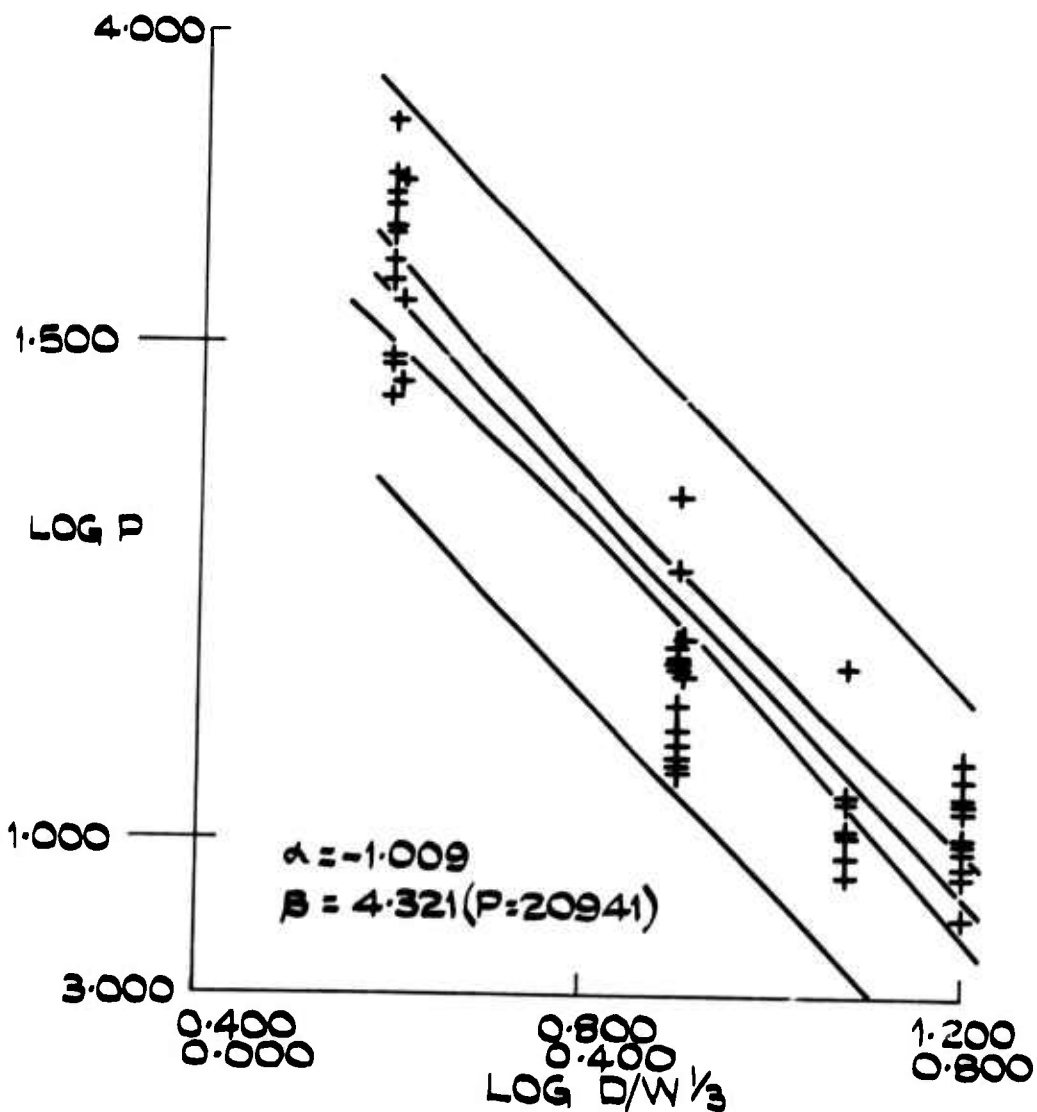

FIG. 25 PEAK PRESSURE -0.05 kg CYLINDER END INITIATED.

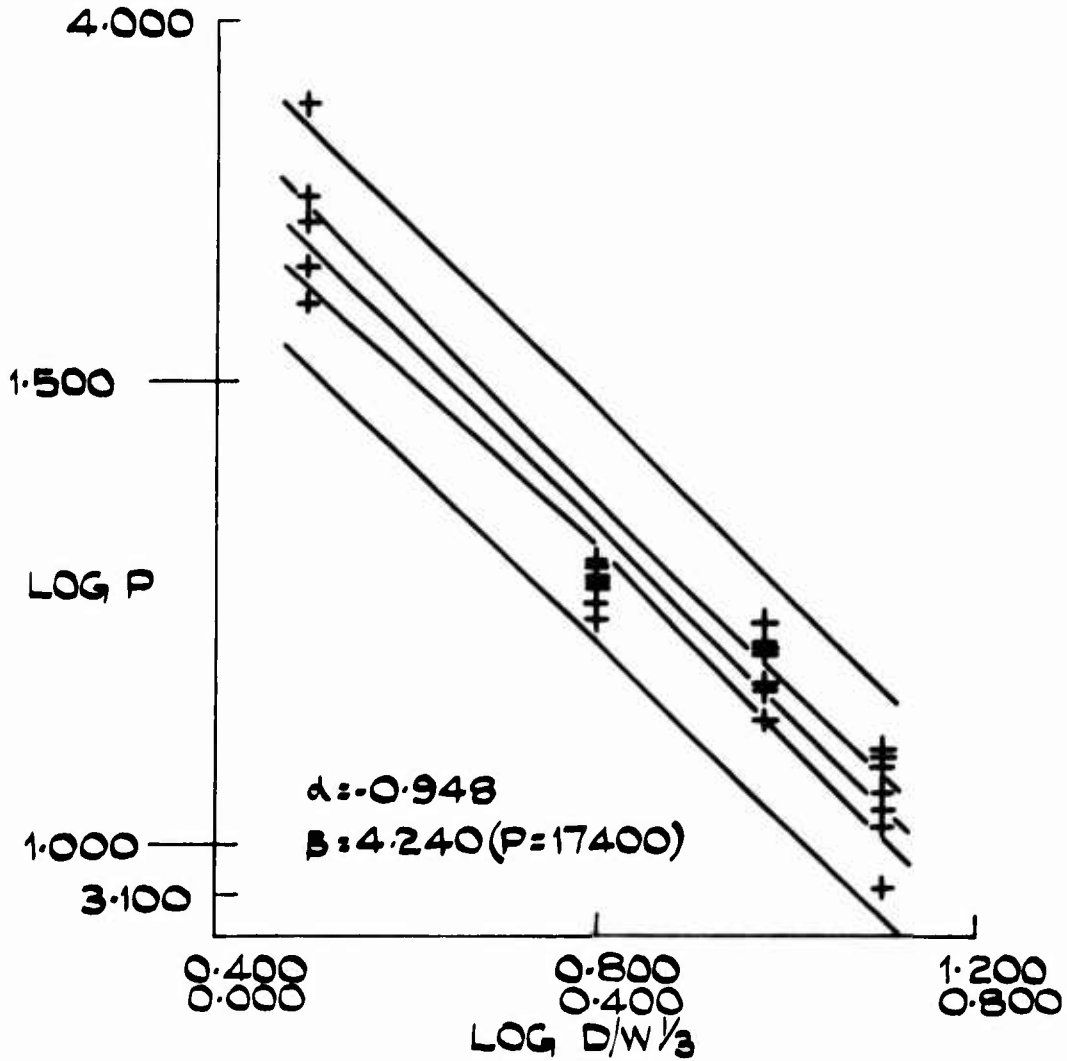

FIG. 26 PEAK PRESSURE - 0.1 kg CYLINDER END INITIATED.

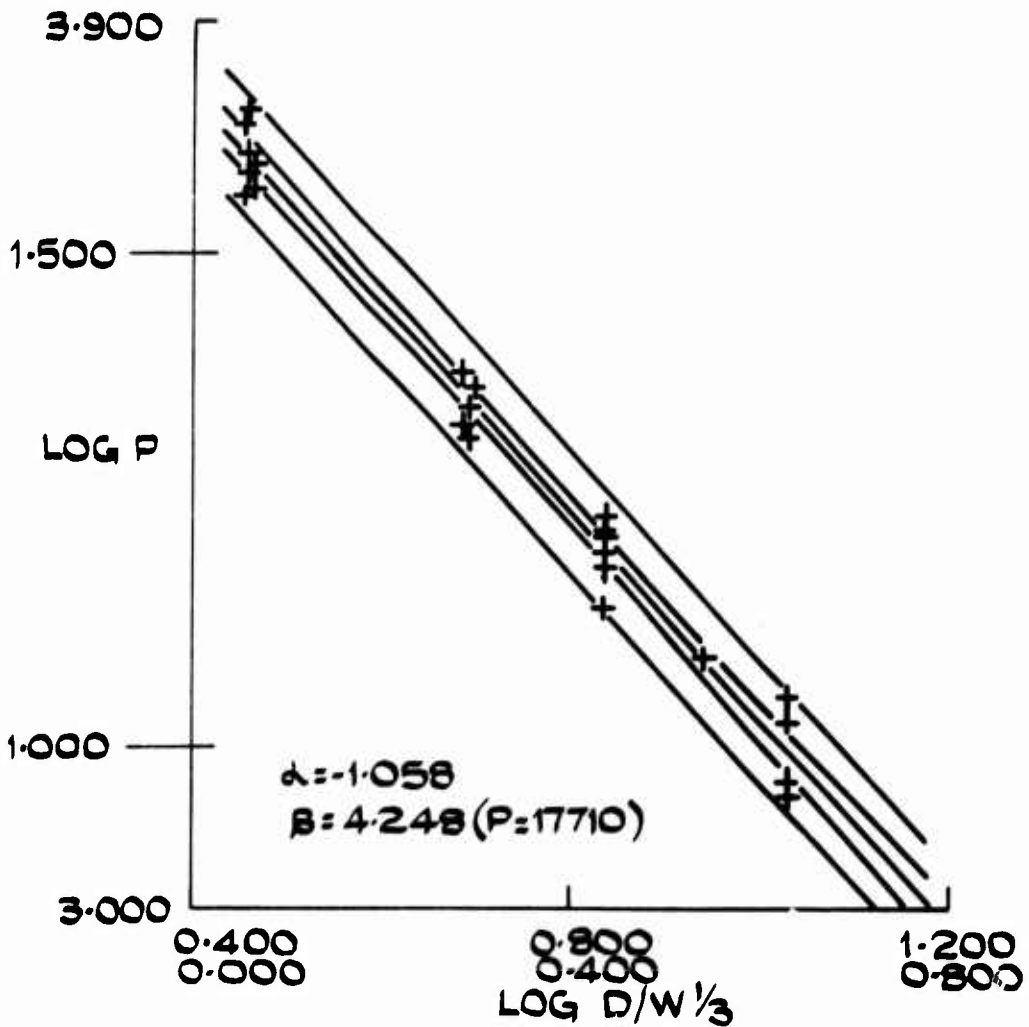

FIG. 27 PEAK PRESSURE -0.45 kg CYLINDER  
END INITIATED.

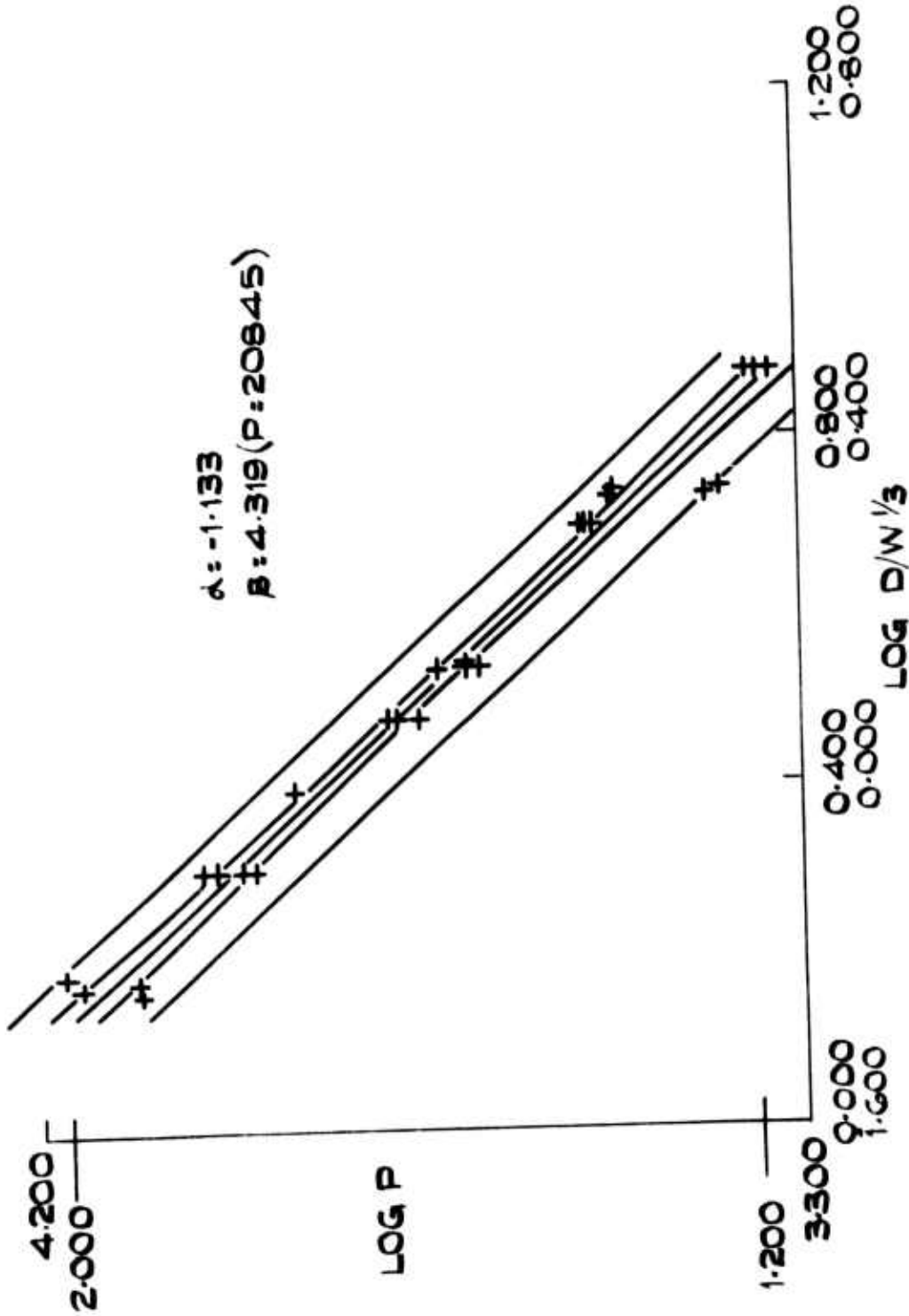

FIG. 28 PEAK PRESSURE - 3.6 kg CYLINDER END INITIATED.

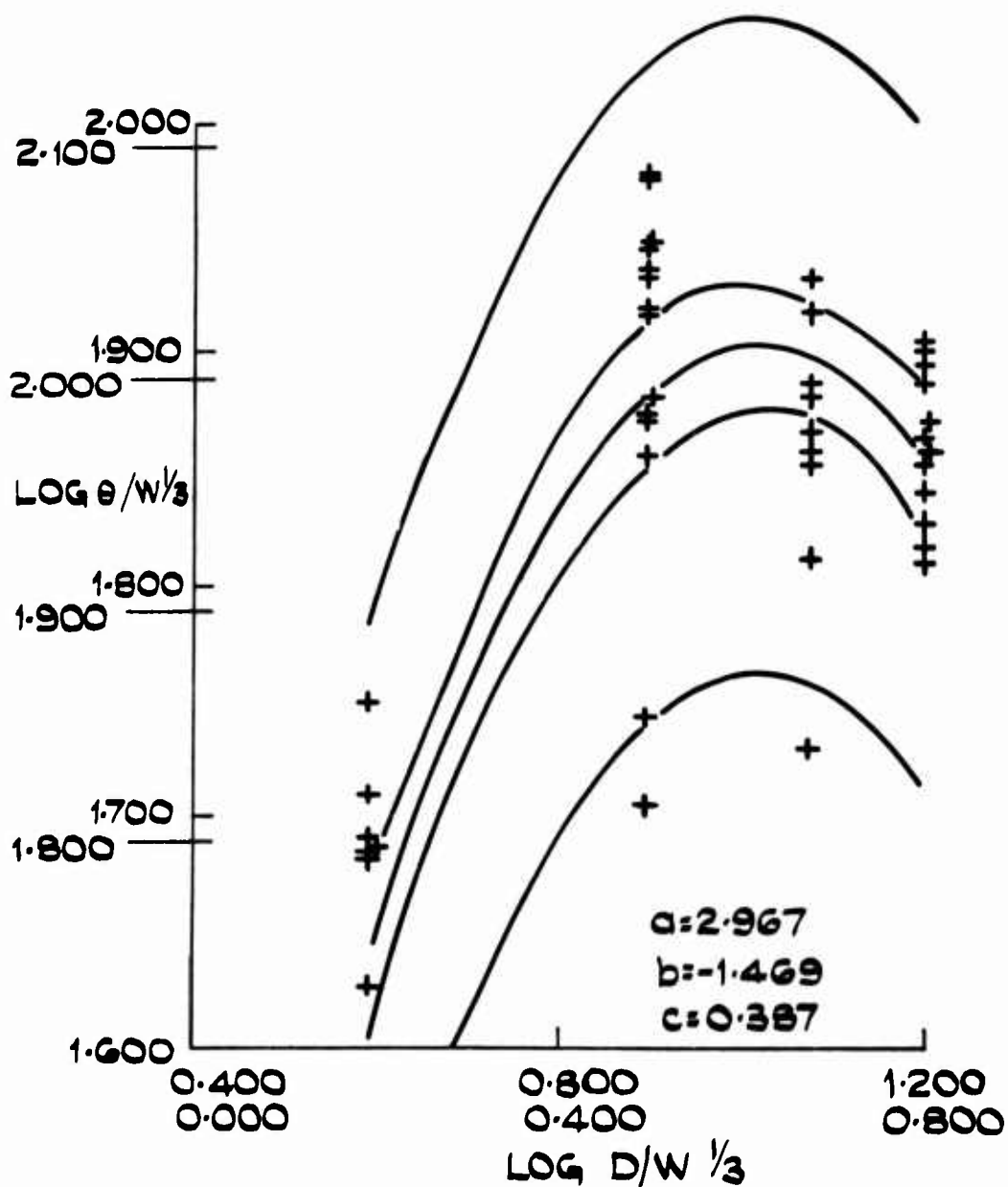

FIG. 29 THETA - 0.05 kg. CYLINDER END INITIATED.

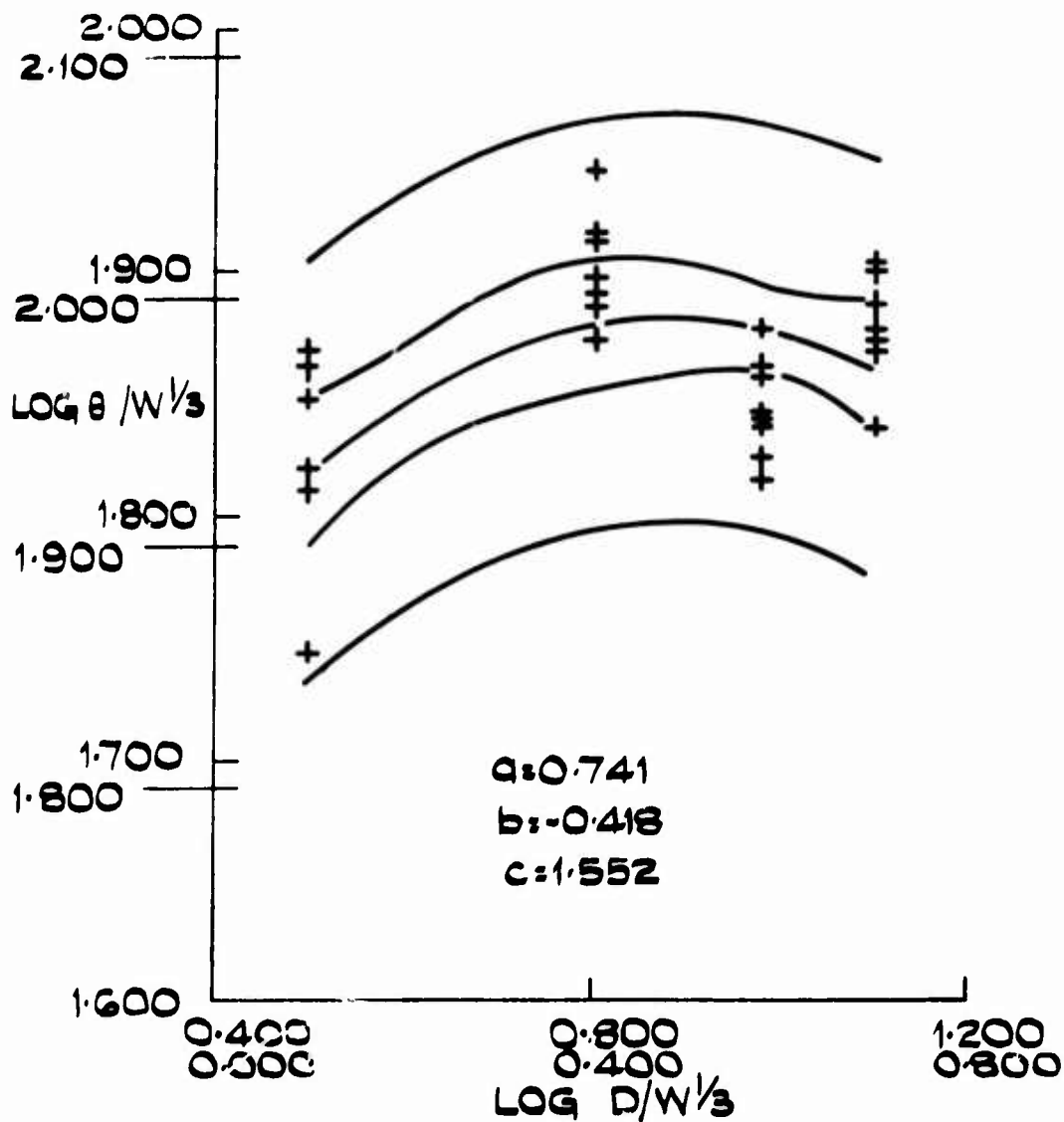

FIG. 30 THETA - 0.1 kg CYLINDER END INITIATED.

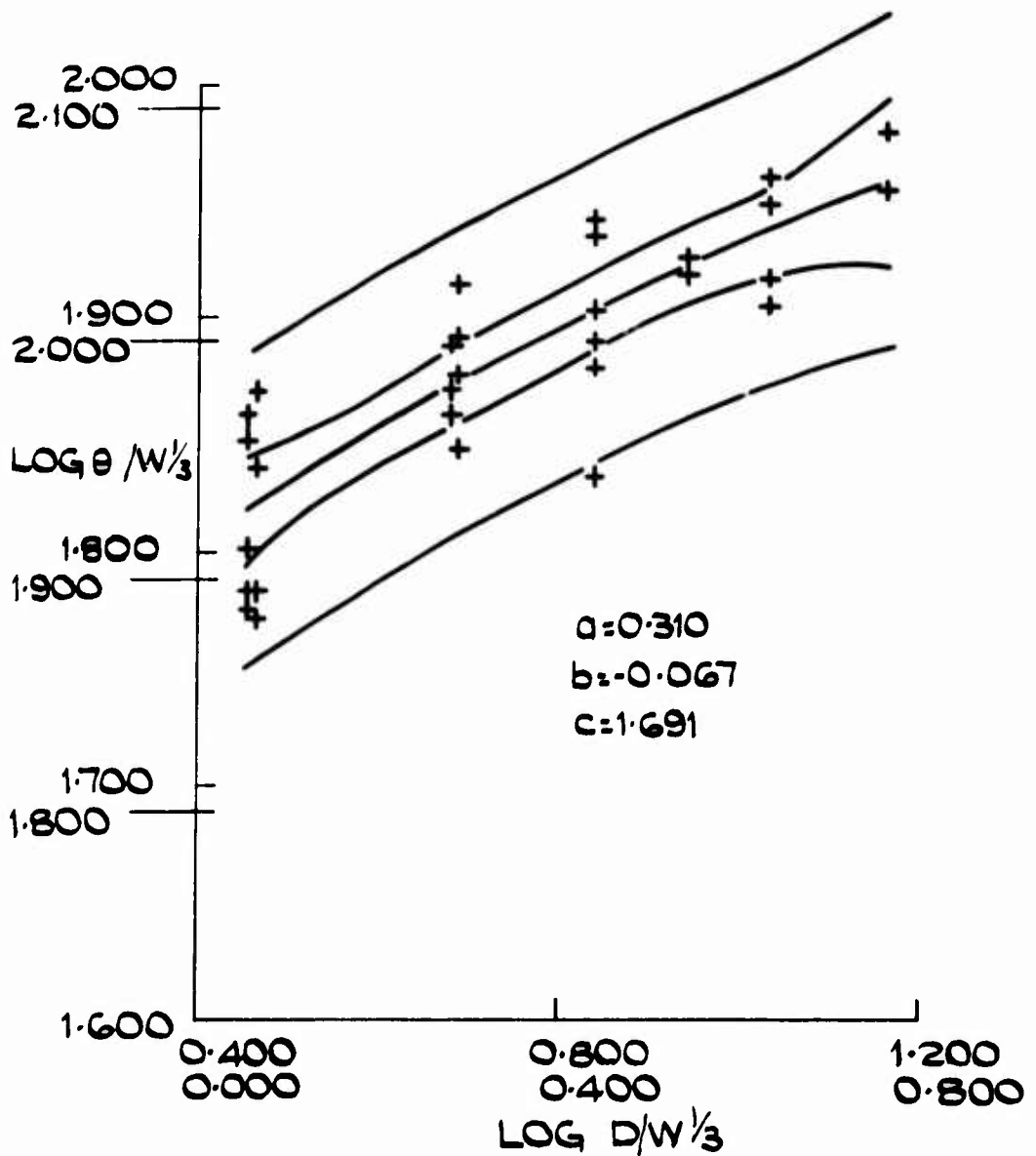

FIG. 31 THETA - 0.45 kg CYLINDER END INITIATED.

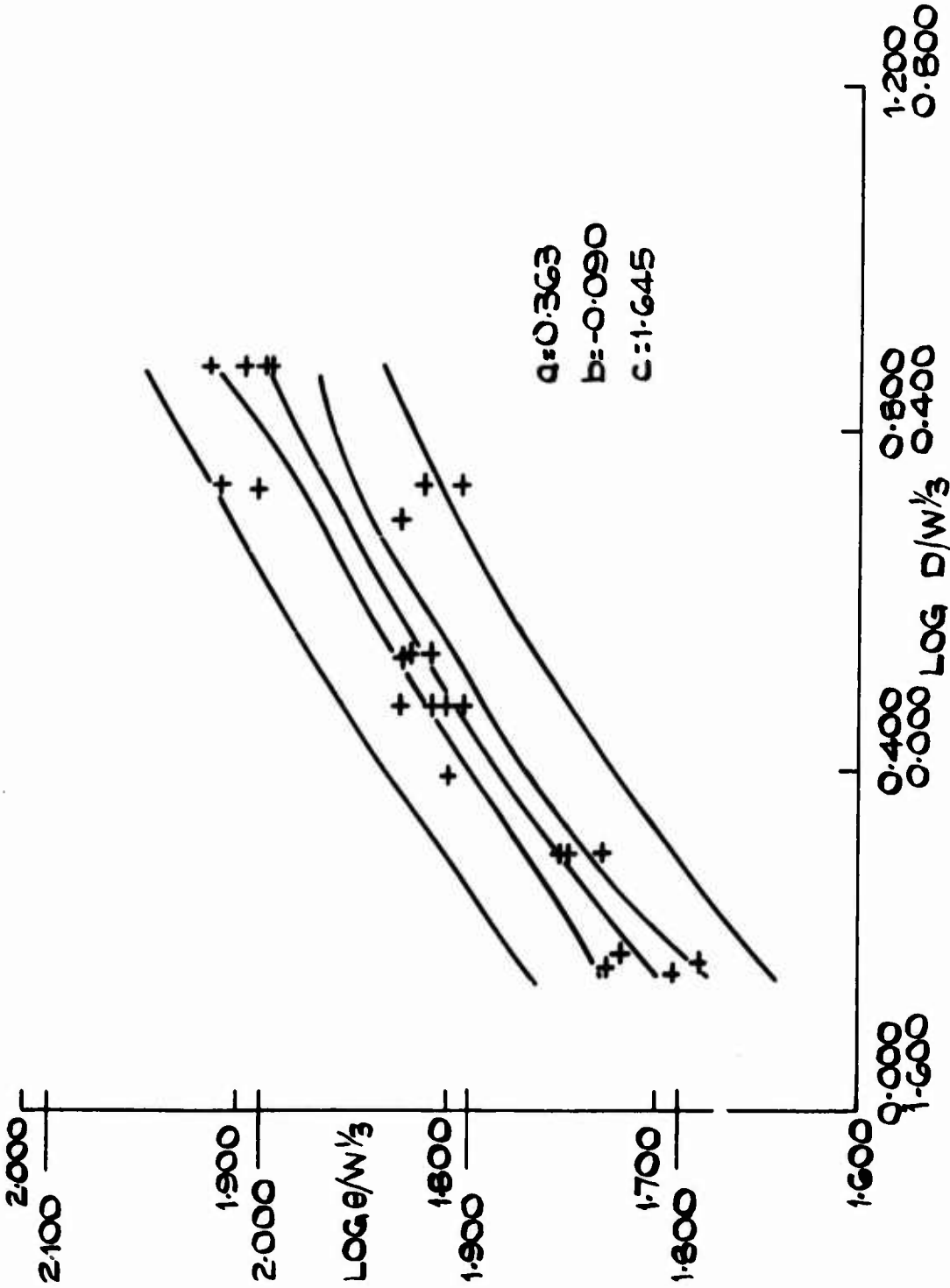

FIG. 32 THETA -3.6 kg CYLINDER END INITIATED.



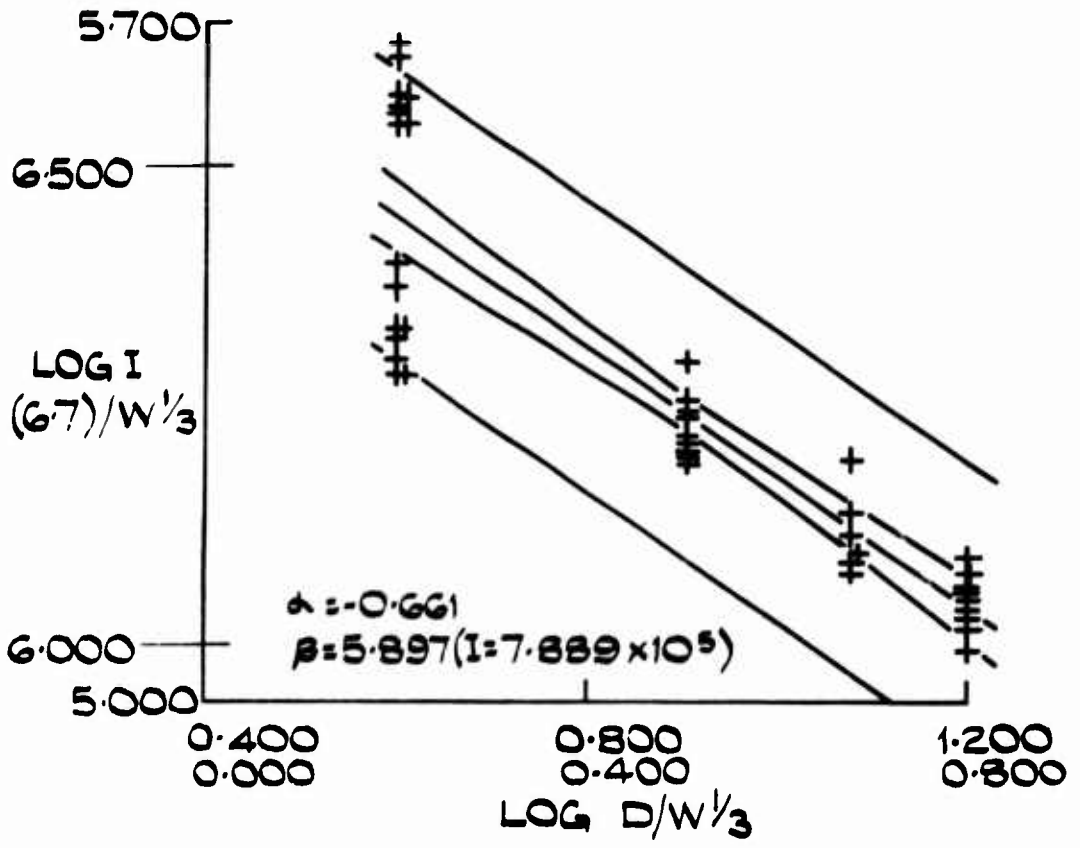

FIG. 33 IMPULSE - 0.05 kg CYLINDER END INITIATED.

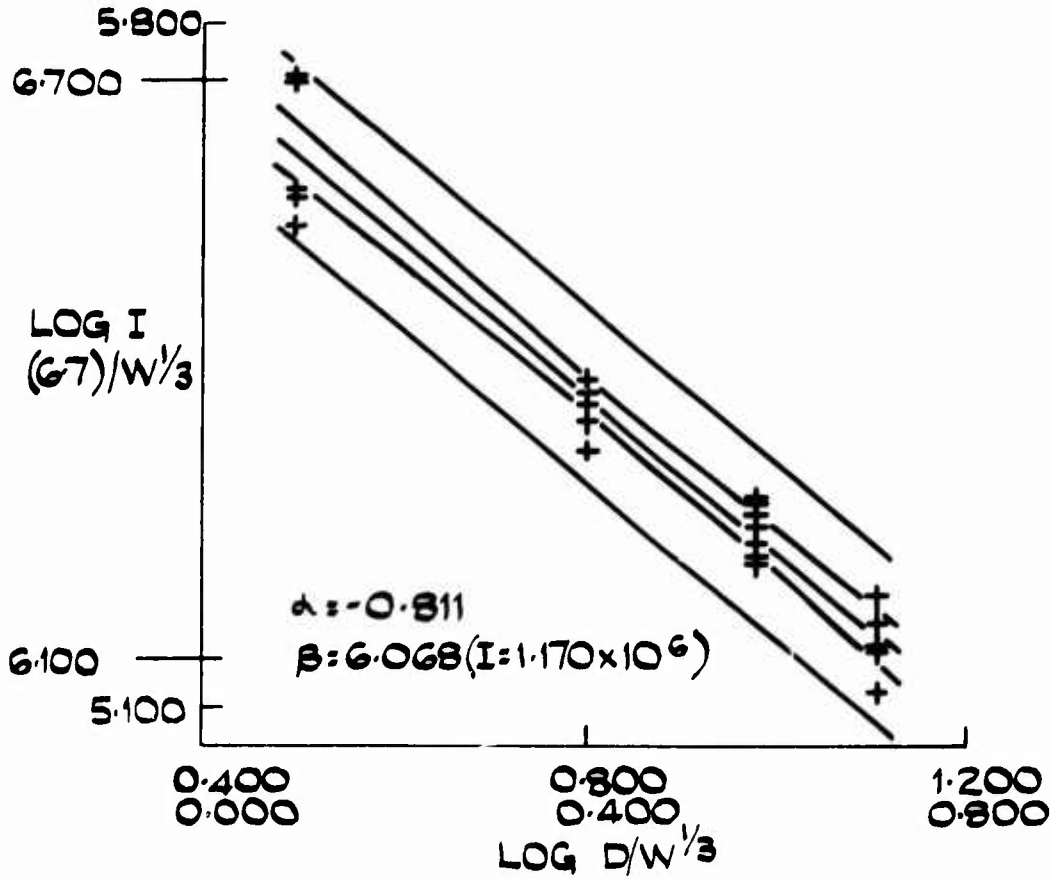

FIG. 34 IMPULSE 0.1 kg CYLINDER END INITIATED.

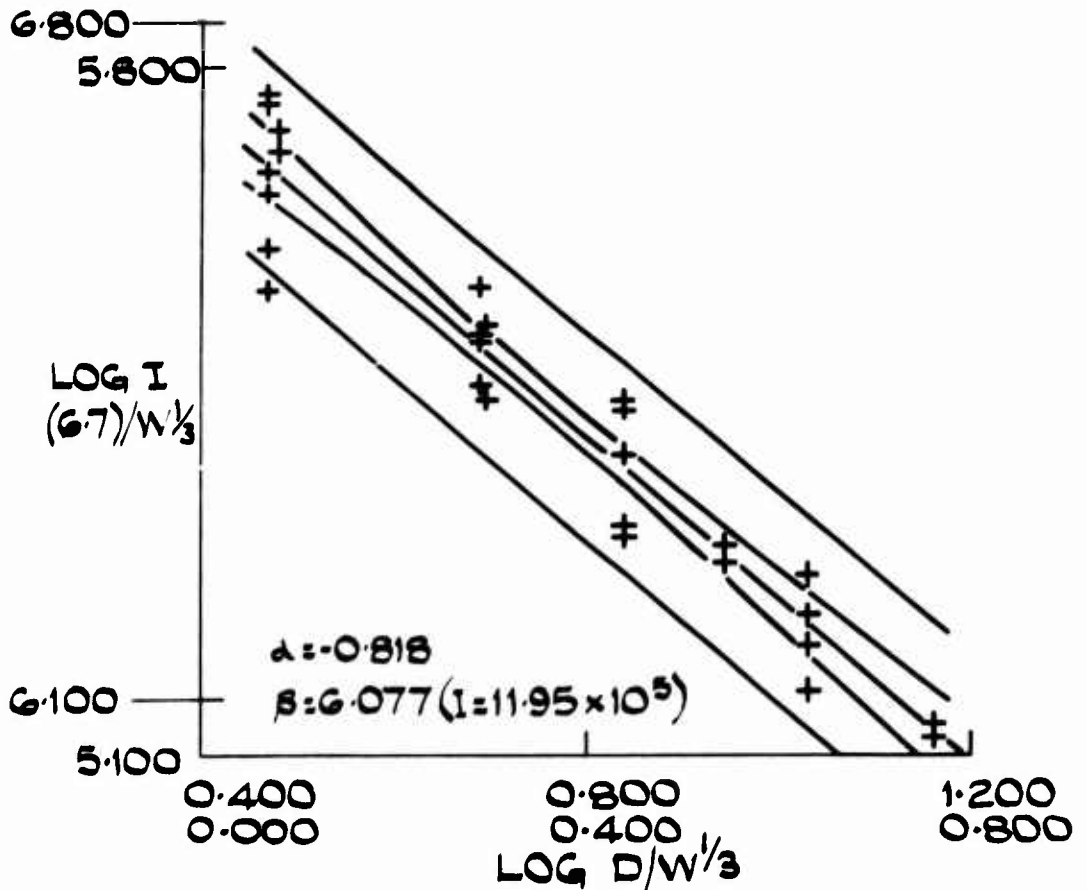

FIG.35 IMPULSE -0.45 kg CYLINDER END INDICATED.

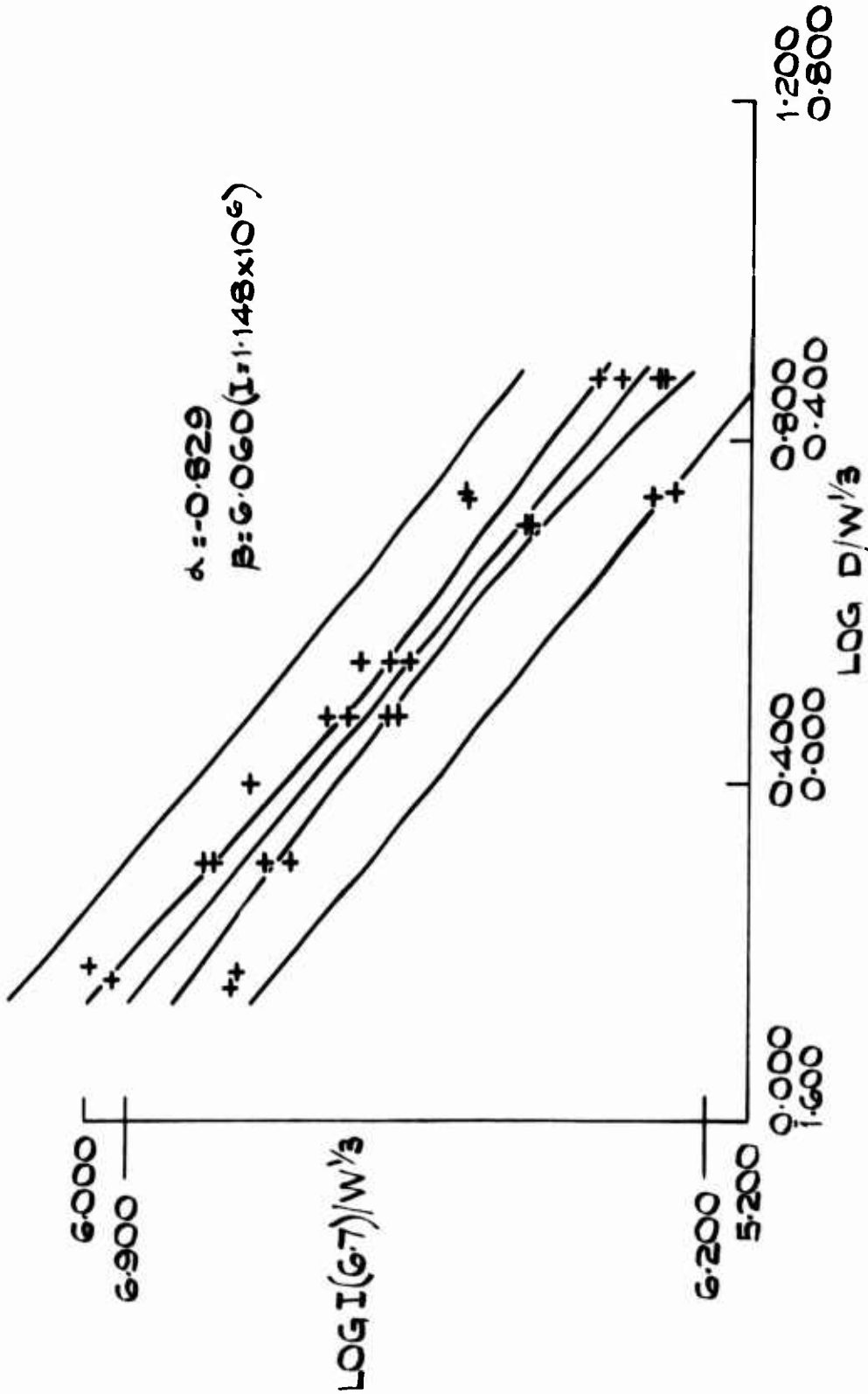

FIG. 36 IMPULSE -3.6 Rq CYLINDER END INITIATED.

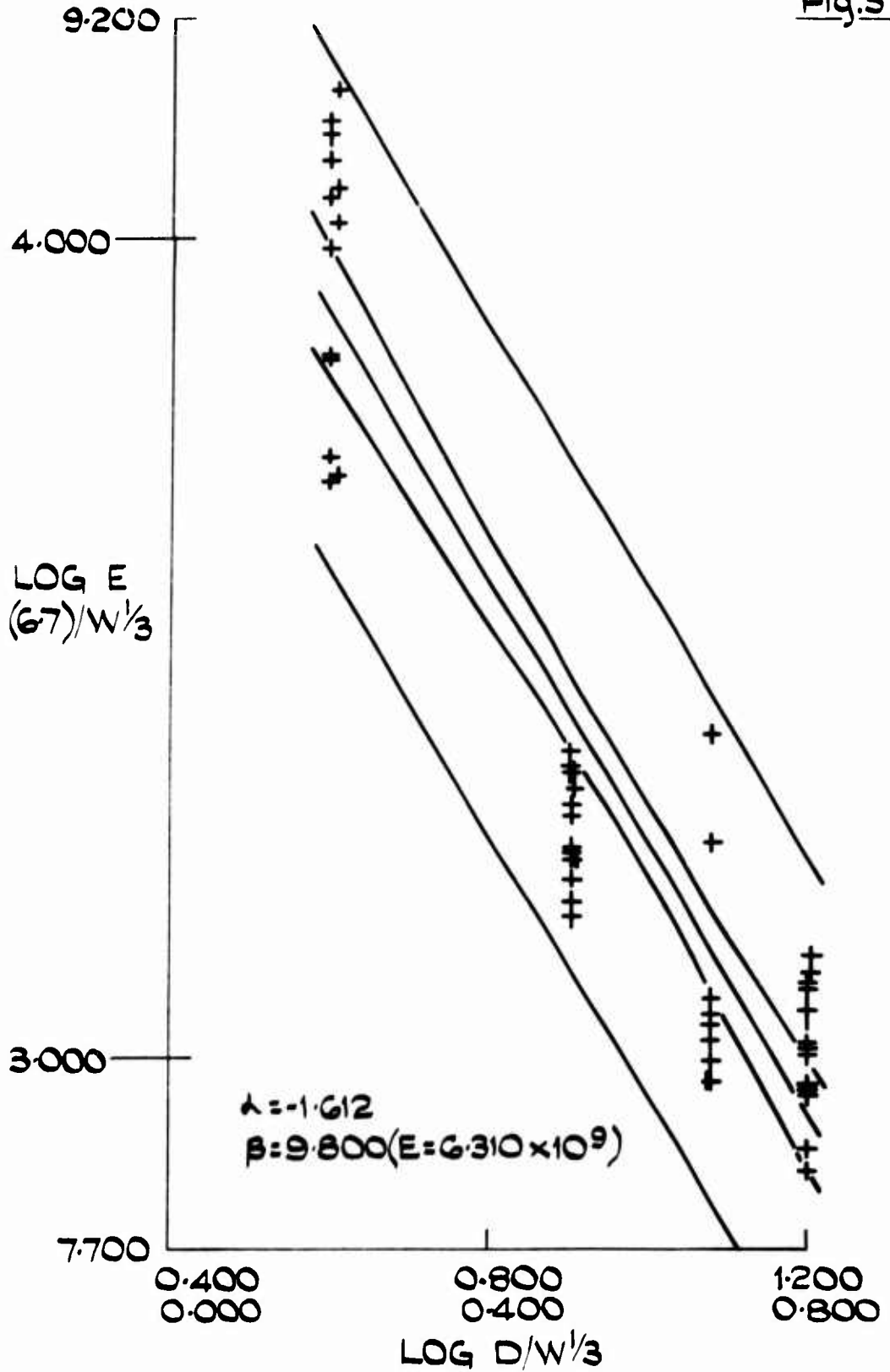

FIG.37 E-0.05 kg CYLINDER END INITIATED.

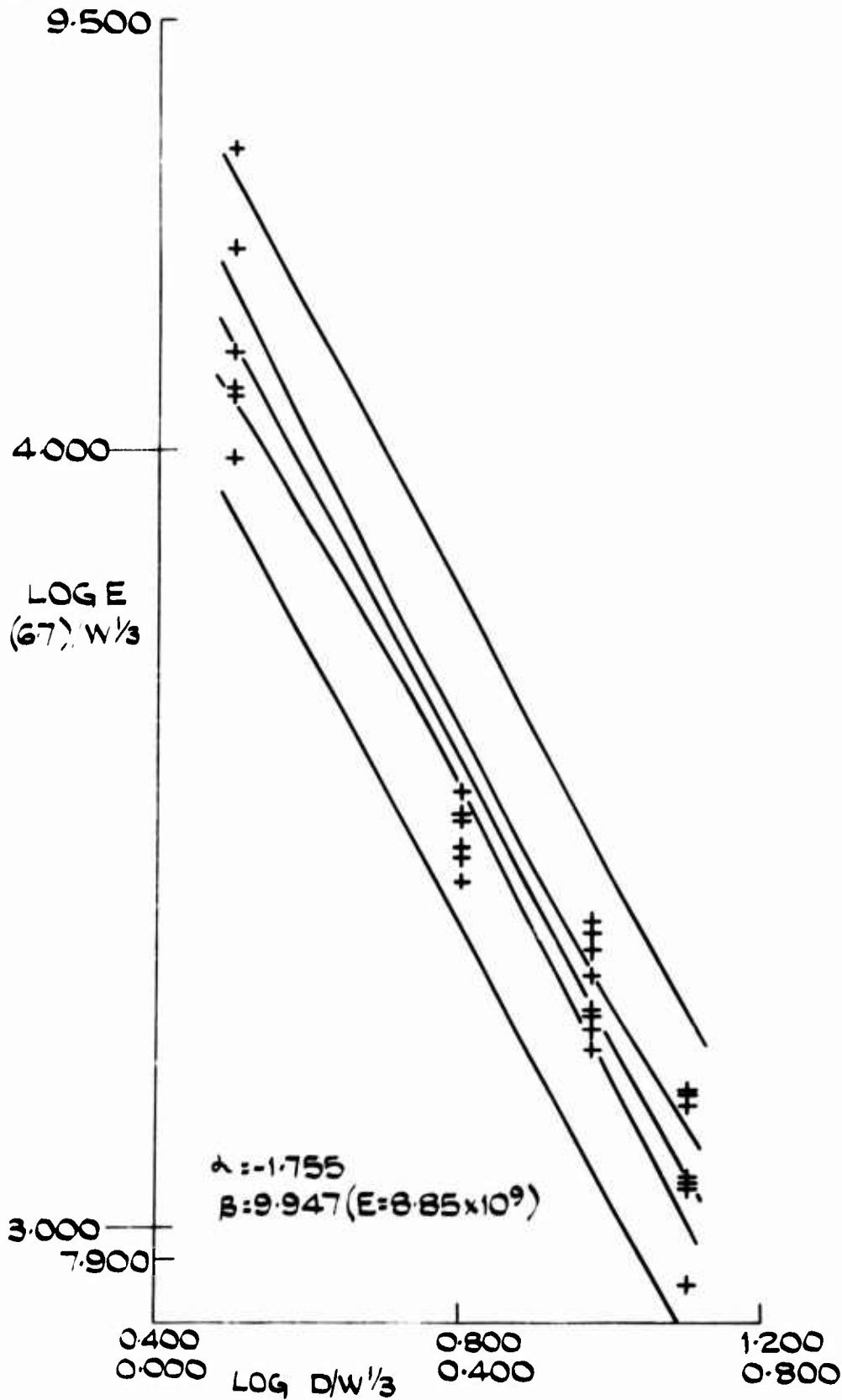

FIG. 38 E-0.1 kg CYLINDER END INITIATED.

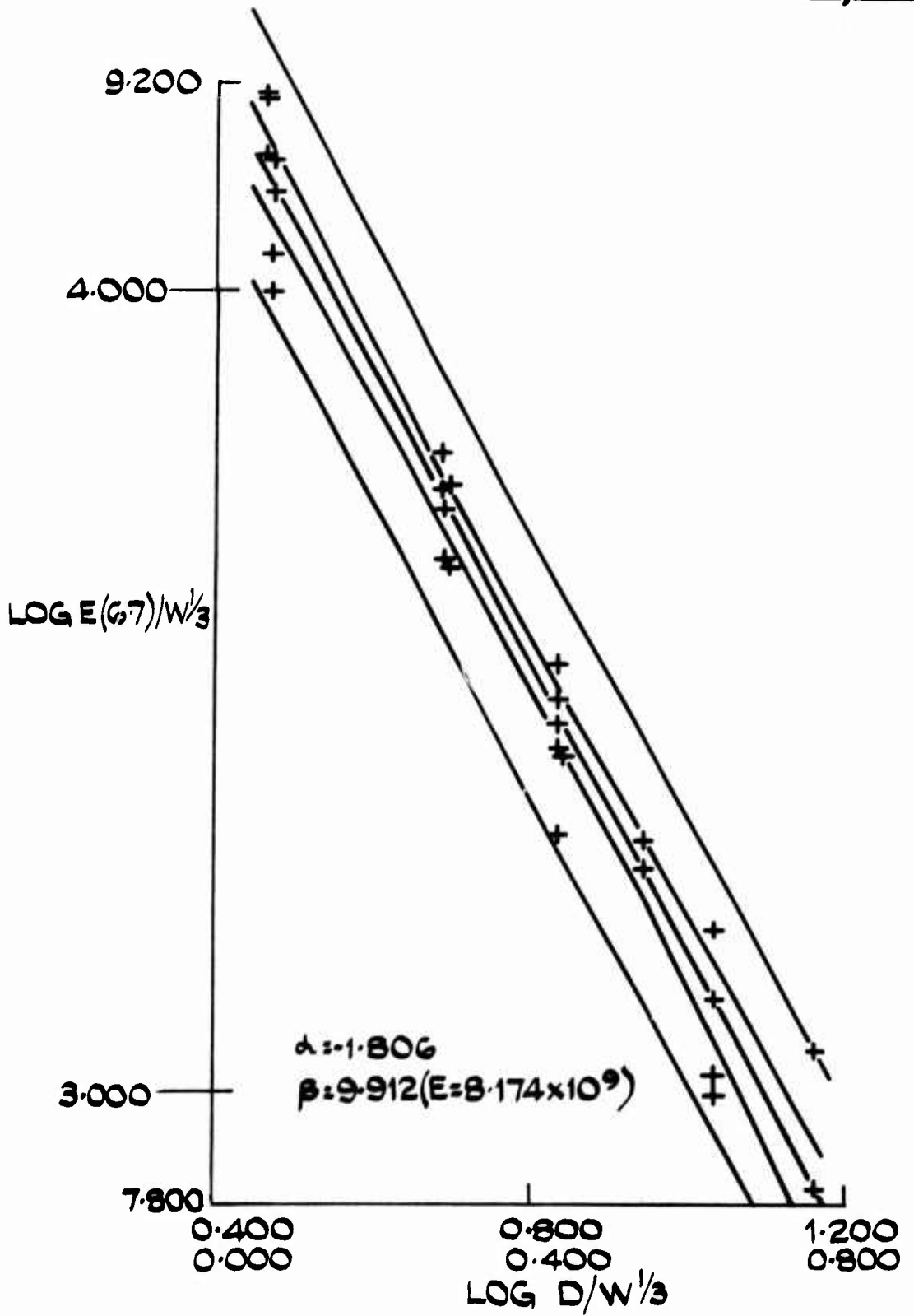

FIG. 39 E-0.45 Rg CYLINDER END INITIATED.

Fig. 40

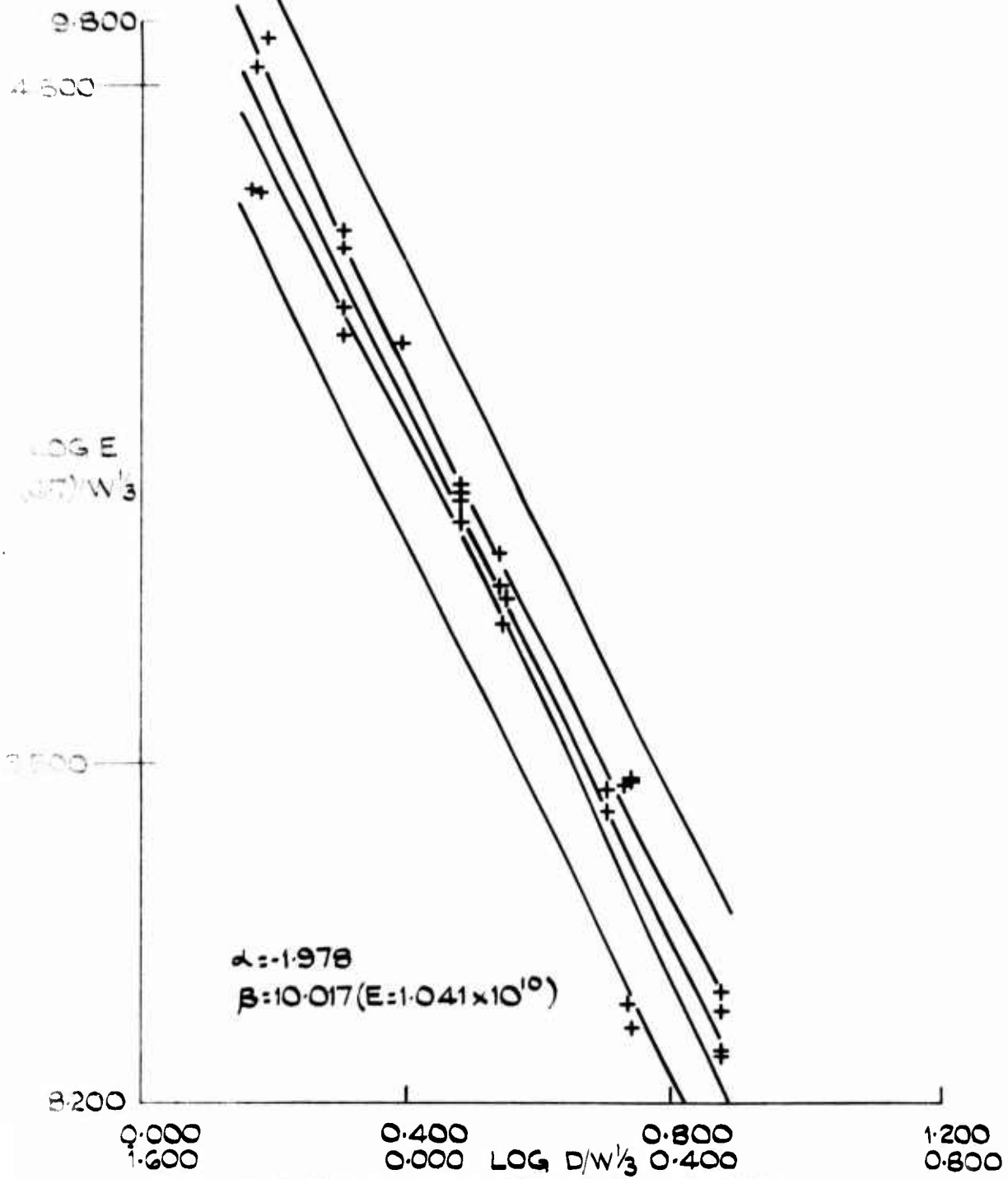

FIG. 40 E-3.6 Rg CYLINDER END INITIATED.