

AD-A014 099

BOATING ACCIDENT INVESTIGATIONS 1974, FIRE AND
EXPLOSION

Robert Loeser

Underwriters' Laboratories,
Incorporated

Prepared for:

Coast Guard

15 April 1975

DISTRIBUTED BY:

NTIS

National Technical Information Service
U. S. DEPARTMENT OF COMMERCE

251071

Report No. CG-D-119-75

BOATING ACCIDENT INVESTIGATIONS 1974

FIRE AND EXPLOSION

ROBERT LOESER



Reproduced by
NATIONAL TECHNICAL
INFORMATION SERVICE
US Department of Commerce
Springfield, VA. 22151

FINAL REPORT

APRIL 1975

Document is available to the public through the
National Technical Information Service,
Springfield, Virginia 22161

Prepared for

**DEPARTMENT OF TRANSPORTATION
UNITED STATES COAST GUARD**

Office of Research and Development
Washington, D.C. 20590

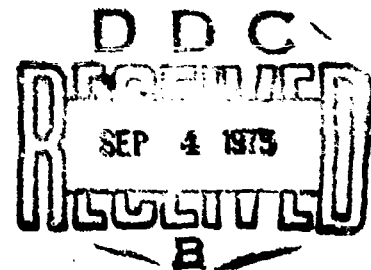

ADA014099

11 JUL 1975

The work reported herein was accomplished for the U. S. Coast Guard's Office of Research and Development, Marine Safety Technology Division, as part of its program in Recreational Boating Safety.

The contents of this report reflect the views of Underwriter's Laboratories, Tampa, Florida, who are responsible for the facts and accuracy of the data presented herein. The contents do not necessarily reflect the official views or policy of the Coast Guard. This report does not constitute a standard, specification, or regulation.

R. D. Erwin

Reviewed by: R. D. ERWIN, LTJG, USCGR
Project Officer

J. M. Cece

Submitted by: J. M. CECE, Commander, USCG
Chief, Marine Safety Projects Branch

W. D. Markle, Jr.

Released by: W. D. MARKLE, JR., CAPT., USCG
Chief, Marine Safety Technology Division
Office of Research and Development
U. S. Coast Guard Headquarters
Washington, D. C. 20590

ACCESSION for	
NTIS	White Section <input checked="" type="checkbox"/>
DCC	Dist. Section <input type="checkbox"/>
UNANNOUNCED	<input type="checkbox"/>
JUSTIFICATION	
BY	
DISTRIBUTION/AVAILABILITY CODES	
Dist.	AVAIL. and/or SPECIAL
A	

1. Report No. CG-D-119-75	2. Government Accession No.	3. Reporting Catalog No. AD-A014 099
4. Title and Subtitle Boating Accident Investigations 1974 Fire and Explosion		5. Report Date 15 April 1975
7. Author(s) Robert Loeser		6. Performing Organization Code
9. Performing Organization Name and Address Underwriters Laboratories Marine Department 2602 Tampa East Blvd. Tampa, Florida 33619		8. Performing Organization Report No.
12. Sponsoring Agency Name and Address U.S. Coast Guard Headquarters Office of Research & Development 400 Seventh St. SW Washington, D.C. 20590		10. Work Unit No. (TRAIS) 745210.0
		11. Contract or Grant No. DOT-CG-23200-A
		13. Type of Report and Period Covered Final Report Summer 1974
		14. Sponsoring Agency Code
15. Supplementary Notes In-depth studies of Recreational Boat Fires & Explosions #AD 717955 for 1970, AD773778 for 1972 and AD785598 for 1973, dated 15 March '74		
16. Abstract The U.S. Coast Guard Boating Statistics (CG357) reveal that in a recent 5 year period there were a total of 1882 fire and explosion accidents with a monetary loss of over 15 million dollars. In these accidents, there were 95 fatalities and 677 injuries. This program is aimed at determining the cause of such losses and this Report is the result of 4 years of work conducting in-depth investigations of fire and explosion accidents. The Report includes the individual case reports for 11 in-depth investigations conducted in 1974, plus an analysis of 38 cases investigated in 1970, 1972 and 1973. The in-depth study was initially started in 1970 by Ford & Beck, two Coast Guard officers, and the case reports by Ford & Beck are included in the 49 cases which constitute the basis of this Report. The analysis section includes a complete set of data tables for the 4 years and an analysis for the same period. The basic data is covered in 5 separate tables for each year. The Report indicates that the major causes for explosions and fires on boats are: (1) Fuel tank failures (including fuel tank installation problems), (2) Failures of the fuel fill pipe system, (3) Siphon action of fuel and (4) Failures of fuel lines and fittings. Electrical system failures constitute a major cause, but the likelihood of a total loss appears to be substantially less. The study indicates that areas deserving special attention include the consistent lack of adequate fire extinguishing equipment.		
17. Key Words Fire Explosion Boating Accidents Primary Cause Secondary Factors		18. Distribution Statement Document is available to the public through the National Technical Information Service, Springfield, Virginia 22161.
19. Security Classif. (of this report) Unclassified	20. Security Classif. (of this page) Unclassified	21. No. of Pages 280
		22. Price \$ 3.75



UNDERWRITERS' LABORATORIES, INC.

2002 TAMPA EAST BLVD. TAMPA, FLORIDA 33619 - PHONE 813-621-3004

an independent, not-for-profit organization testing for public safety

PROJECT CG-23, 200-A

BOATING ACCIDENT INVESTIGATIONS

1974

April 1975

By

ROBERT LOESER



FINAL REPORT

TABLE OF CONTENTS

Preface	1
Introduction.	2
Method of Investigation	6
Summary of Individual Cases in 1974	12
Discussion - General.	15
Significance of Results	44
Indicated Trends	47

LIST OF TABLES

<u>Table Number</u>		
Table 1A	<u>Basic Data on Boat and Equipment 1970</u>	21
	Key to Table 1A on page	41
Table 2A	<u>Primary Cause - Source of Fuel 1970</u>	22
	Key to Table 2A on page	42
Table 3A	<u>Ignition of Primary Vapor Source 1970</u>	23
Table 4A	<u>Secondary Factors - Source of Fuel 1970</u>	24
	Key to Table 4A on page	43
Table 5A	<u>Fire Extinguishing Efforts and Explosion Relief- 1970.</u>	25
Table 1B	<u>Basic Data on Boat and Equipment 1972</u>	26
	Key to Table 1B on page	41
Table 2B	<u>Primary Cause - Source of Fuel 1972</u>	27
	Key to Table 2B on page	42
Table 3B	<u>Ignition of Primary Vapor Source 1972</u>	28
Table 4B	<u>Secondary Factors - Source of Fuel 1972</u>	29
	Key to Table 4B on page	43
Table 5B	<u>Fire Extinguishing Efforts and Explosion Relief- 1972</u>	30

LIST OF TABLES (CONT.)

<u>Table Number</u>		
Table 1C	<u>Basic Data on Boat and Equipment 1973</u>	31
	Key to Table 1C on page	41
Table 2C	<u>Primary Cause Source of Fuel 1973</u>	32
	Key to Table 2C on page	42
Table 3C	<u>Ignition of Primary Vapor Source 1973</u>	33
Table 4C	<u>Secondary Factors - Source of Fuel 1973</u>	34
	Key to Table 4C on page	43
Table 5C	<u>Fire Extinguishing Efforts and Explosion Relief- 1973</u>	35
Table 1D	<u>Basic Data on Boat and Equipment 1974</u>	36
	Key to Table 1D on page	41
Table 2D	<u>Primary Cause - Source of Fuel 1974</u>	37
	Key to Table 2D on page	42
Table 3D	<u>Ignition of Primary Source 1974</u>	38
Table 4D	<u>Secondary Factors - Source of Fuel 1974</u>	39
	Key to Table 4D on page	43
Table 5D	<u>Fire Extinguishing Efforts and Explosion Relief- 1974</u>	40
Table 7	<u>Fuel Tank Service Life Table Based On Data From 1970, 1972, 1973 & 1974 Investigations.</u>	63

LIST OF FIGURES

Figure 1	<u>Frequency of Primary Causes Providing Fuel In 49 Fire and Explosion Cases</u>	60
Figure 2	<u>Frequency of Primary Ignition Sources in 49 Cases</u>	61
Figure 3	<u>Frequency of Secondary Factors Contributing Fuel To the Fires on 49 Boats</u>	62

LIST OF CASES

Case
Number

Case No. 1	64
Case No. 2	80
Case No. 3	99
Case No. 4	122
Case No. 5	140
Case No. 6	156
Case No. 7	177
Case No. 8	195
Case No. 9	211
Case No. 10.	232
Case No. 11.	250

PREFACE

This Report has been prepared for the U. S. Coast Guard by Underwriters Laboratories under an extension of Contract DOT CG-23, 200A. The Report covers the in-depth investigation of 11 fire and explosion cases during the 1974 boating season and an analysis of the in-depth investigations conducted in 1970, 1972, 1973 and 1974. The investigations in 1970 were conducted by Ford and Beck, two Coast Guard Officers.

INTRODUCTION

The safety standards that exist in the boating field today have evolved mainly as the result of deliberations by broad based committees of the National Fire Protection Association (NFPA) and the American Boat and Yacht Council (ABYC) with additional contributions by such industry groups as the Boating Industry Association and the Society of Automotive Engineers. The decisions which resulted in those standards have, for the most part, been based on the technical knowledge of the individuals serving on the committees and often tend to be more empirical than factual. Personal experience is a reflection of the particular situations and conditions to which an individual is repeatedly exposed. Those experiences and the decisions that result, may or may not be supported by statistical data and are sometimes greatly influenced by local problems or conditions. In brief, it must be recognized that personal experience can easily be weighted one way or the other on any given question. It is the fundamental reason why a committee of several individuals with varying backgrounds has a better chance of reaching a sound decision than any single individual. Notwithstanding the inherent limitations of personal experience, it is also considered an irreplaceable asset, vital to any standard writing effort. It simply cannot be used totally apart from the counter-balancing realism of statistical fact, assuming the statistical data is sound.

History

The need for safety standards dealing with fire and explosion hazards on boats was initially recognized in 1925 when the "Regulations Governing Marine Fire Hazards" was first adopted by the NFPA. That Standard, which dealt only with the fire peril, was revised and modified through the years and is now the "Fire Protection Standard for Motor Craft", NFPA 302. The 1968 edition of NFPA 302 was approved as an ANSI Standard by the American National Standard Institute on September 9, 1968. It is designated Z120.1.

The Motor Craft Standard of the NFPA has for many years included the statement, "There are few other uses of petroleum fuels by the public in which the fire and explosion hazards parallel those possible in inboard powered motor craft." It is quite evident that this statement is equally valid today. The problem facing each committee is to determine how best to avoid hazardous conditions without becoming unnecessarily restrictive.

The Motor Craft Standard did not receive any meaningful recognition by the boating industry until the late 40's when the standard was used in several court cases and was upheld by the Courts as representing good marine practice. This period coincided with a

very rapid growth period for the pleasure boat industry and it was soon apparent that standards were also needed for safety factors outside the fire hazard areas. Accordingly, in 1954, after considerable discussion, the American Boat and Yacht Council was organized as a non-profit standard-writing body. The new organization had no restrictions on its coverage and project technical committees were set up to develop standards for helm visibility, steering systems, and through-hull fittings, as well as the fire peril areas already covered by the NFPA. The justification given for the duplication of effort was that the industry desired a single standard that included all requirements.

The problem associated with two standards covering the same areas was immediately recognized, and an agreement was worked out whereby proposals developed by the ABYC that overlapped the NFPA were automatically referred to the NFPA Committee for review. This system worked well and although the two standards used different words to cover specific points, the two standards did not actually conflict.

At the same time that the NFPA and ABYC were developing broad based safety standards, the Boating Industry Association, a trade association, developed and issued an "Engineering Manual of Recommended Practices". The manual was initially confined to outboard boats, but later was expanded to include all motorboats under 26 feet as well as sailboats. The recommended practices were developed by a BIA engineering committee and therefore were industry rather than broad based standards such as those of the NFPA or ABYC. The BIA recognized the NFPA as the logical body to establish fire protection standards for boats; with the permission of the NFPA, the BIA reproduced the NFPA 302 Standard as part of the BIA manual, but then went on to include substitution paragraphs for the NFPA Standard where the BIA Engineering Committee did not agree with the NFPA requirements.

In 1968 the BIA inaugurated a boat certification program using parts of the Engineering Manual as the basis for the issuance of the BIA Certification Label. Certification Labels were issued on a model year basis.

In the early 70's the problems of four standard writing bodies, all independently developing safety and engineering standards for the same boats, became manifold; the BIA together with the National Association of Engine and Boat Manufacturers made a decision to technically and economically back the ABYC program. The shift to the ABYC was to coincide with a phase-out of the BIA Standards. The BIA no longer issues its "Engineering Manual of Recommended Practices", but

continues to issue its requirements for the BIA Boat Certification Program. The certification requirements are issued as the "BIA Certification Handbook". The certification handbook is now based on the ABYC safety standards, but differs in some details and does not require conformity with all ABYC Standards. At the time the BIA and the National Association of Engine and Boat Manufacturers decided to back the ABYC, a conflict developed that resulted in the withdrawal of the members of the National Association of Marine Surveyors. The withdrawal of the insurance company representation from the ABYC had the result of destroying the broad base balance of several important project technical committees, but the broad base balance of the organization was maintained at the Technical Board and Board of Directors levels.

The Federal Boat Safety Act of 1971 greatly changed the potential relationship of the requirements being developed by the broad-based standard writing organizations and the boat and equipment manufacturers. Many of the requirements previously proposed by those organizations for voluntary compliance were now being proposed as regulations by the U.S. Coast Guard to implement the Boat Safety Act. In essence, having established the need for regulations in certain areas, the Coast Guard turned as much as possible to existing voluntary standards for guidance in what was considered good marine practice.

In the process of developing both the voluntary standards and proposed Regulations, technically sound data was and will continue to be needed. This fact was initially recognized in 1949 by the Yacht Safety Bureau, a small non-profit organization sustained by the marine insurance industry. A system was established at that time to collect and analyze fire and explosion loss reports from about 20 insurance companies and issue an annual report. Approximately 70 cases were added each year and the program continued for about 16 years. The data collected was of great value to the NFPA and ABYC Committees concerned with Fire Peril Standards, but was not usually sufficiently detailed to answer specific questions. Since the data was based entirely on boats covered under "marine" insurance policies and did not cover those insured under homeowner policies or those that were not insured, the boats in the analysis were better boats than the overall average. The insurance company data tended to be more reliable than other sources of information (such as newspaper clipping services or the Coast Guard Statistical Data in CG 357) because the reports were usually prepared by professional marine surveyors. Unfortunately, it was not always economically feasible for the insurance company to underwrite the cost of a detailed investigation, so that the reports varied from such statements as "Fuel leakage in the bilge was ignited when the engine was started "

to a complete in-depth study. The simple report of a fire or explosion will indicate that a problem exists, but will not specifically pin-point the cause. In the case of a fuel tank failure, it is necessary to know the specific alloy and thickness, how long the tank was in service before the failure occurred and the specific nature of the failure. For instance, in Case No. 6 included in the addendum of this Report, the terneplate fuel tank failed in the eighth year due to external corrosion, but perhaps the most important factor is that the corrosion was accelerated by the method of installation. The Report also confirmed that it was not practical to properly inspect the tank to detect the pending failure. The Report identified the terneplate coating as a 9 pound type, which is lower than the 12 pound coating specified in both the NFPA and ABYC Standards. For committee purposes, this data is far more useful than a statement that "The fuel tank failed."

The U.S. Coast Guard in-depth fire and explosion study by Ford and Beck was the first meaningful attempt to accumulate in-depth data on the causes of fire and explosion cases and served as a pilot program for the in-depth study covered by this Report. The current program was developed by Underwriters Laboratories in 1972 and this Report now summarizes the results of 4 years' work.

The program as started in 1972 was specifically designed to be used on a continuous basis and is considered to be of very limited value on a short term basis. The program will gain in value in proportion to the number of cases investigated where the cause is determined.

METHOD OF INVESTIGATION

The fire and explosion investigation procedures used in 1974 were substantially identical to the methods used in 1972 and 1973, except for the initial reporting and screening procedures. Each investigation involved the following parts:

Reporting and Screening

As in previous years, Coast Guard Headquarters notified all Coast Guard Stations throughout the continental United States to report all fire and explosion accidents. In 1974, the stations reported the accidents directly to U. S. Coast Guard Headquarters where the reports were pre-screened to determine if the cases fit the basic parameters established for cases to be investigated. As in previous years, these were:

- (1) The boat should be less than 15 years old.
- (2) The boat must be inboard powered.
- (3) The boat must be available for the investigation.
- (4) The owner must agree to the investigation.
- (5) The boat should not have been disturbed to an extent that would destroy the evidence needed to ascertain the cause.

The prescreening of the calls at Coast Guard Headquarters covered items 1 through 3 when the information was available, but the follow-up calls reconfirmed the data with respect to those items and determined the status with respect to items 4 and 5. Generally, the follow up additionally provided data on what happened, who was involved, the make of the boat, information on injuries and whether or not the insurance company had been notified.

On the whole, it appeared that the prescreening operation did not work as well as intended because Coast Guard Headquarters did not usually receive sufficient data to make the initial decisions.

During the 1974 program, a total of 79 calls were received from Coast Guard Headquarters and 8 of those cases were investigated. Information with respect to 3 of the cases investigated came from other sources. The following is a summary of the locations, date, and sources of information on the cases investigated.

<u>Location</u>	<u>Boat</u>	<u>Information From</u>	<u>Date</u>
1. Warwick, R.I.	30 foot	Coast Guard Htqrs.	7/8/75
2. New Orleans, La.	20 foot	" " "	7/22/74
3. Kent, Md.	38 foot	" " "	7/29/74
4. St. Ignace, Mich.	18 foot	" " "	8/3/74
5. Tacoma, Wash	19 foot	" " "	8/19/74
6. Amityville, N.Y.	16 foot	ABYC	8/26/74
7. Atlantic City, N.J.	16 foot	Coast Guard Htqrs.	8/27/74
8. Tampa, Fla.	24 foot	St. Petersburg USCG	9/30/74
9. Deale, Md.	25 foot	Coast Guard Htqrs.	10/14/74
10. Tampa, Fla.	45 foot	" " "	8/26/74
11. Dunedin, Fla.	23 foot	Insurance Company	2/18/75

Although every effort is made to obtain adequate information on the boats before an investigation is conducted, it is not infrequent that the data obtained during the screening process is found to be inaccurate. Boats claimed to be 2 or 3 years old turn out to be 12 or 14 years old and boats that were supposedly accessible, have on a couple of occasions, been found on the bottom. Fortunately, the errors with respect to the accessibility of the boat are rare and the errors with respect to the age of the boat or other details have not affected the investigations.

On-Site Investigations

The method of conducting the on-site investigations in 1974 remained substantially identical to the procedures followed in 1972 and 1973, except that an effort was made to take color slides and a 16 mm documentary film. The 16 mm film was prepared for the Coast Guard for the purpose of explaining the in-depth accident investigation program to Coast Guard personnel in the field.

Each on-site investigation was of a moderately detailed type, involving one or two men, in one or two days. Within the limitations of time and man-power, the investigations were as detailed as conditions would permit. When the investigation involved a boat that was obviously completely destroyed beyond repair, fuel tanks, fuel lines, wiring and hull structure were removed without concern, but this was not true when the boat was repairable. When a boat still has value, it is necessary to obtain specific permission to do what would be automatic in a totally destroyed boat. In Case No. 6 1974, for instance, it

was necessary to obtain the owner's permission to remove the entire deck of the boat and to remove the foamed-in fuel tank. In the three years the program has been operating, the cooperation received from the boat owners, boat yards and local Coast Guard Stations has been exceptionally good. No difficulty has been experienced in obtaining boat parts for laboratory study or in getting data on the boat itself.

The general procedures followed in conducting on-site investigations follow a general pattern but must be varied depending on the type and size of the boat, the extent of the damage and the location of the boat. Some boats are investigated at a Coast Guard Station with access to some equipment and assistance, while others are in the owner's back yard. In investigating the source of fuel leakage in a boat, it is desirable to follow the system from one end to the other, but in practice the theoretical approach cannot be followed. The danger in approaching the investigation in check list fashion is that when items are removed or disturbed in order to gain access to some specific part, other valuable information may be destroyed. Every bit of evidence is important and there is no way of backtracking once the evidence is lost. When investigating a fuel system, the physical position of an item can be very important. In Case No. 4 1974 the fuel filter bowl, which was found on the cockpit deck just forward of the engine, could not have gotten into that position as a result of the fire. The position of the filter bowl, together with other information, confirmed the fact that the owner had removed the bowl and placed it in that position. In a totally burned boat a bilge pump that is not burned will help establish the height of the bilge water prior to the fire. The straight check list approach to an investigation is not normally possible and must actually be avoided. If anything in the boat is moved for any reason, notes must be made of all data in that area even though the information is not related to the specific information being sought. Because of this fact it is standard practice in conducting investigations to take photographs before anything is disturbed, as well as after.

The recording of all field findings is absolutely vital to a good investigation because the quantity of information accumulated necessitates the use of a reliable system to retaining the detailed data. Copious notes are desirable, but not practical under normal field conditions. When a boat has burned to the waterline it is necessary to manually sift through the evidence and it is not unusual for written notations to sometimes become almost unreadable. Occasionally they must be rewritten even in the notation stage. The problem is compounded in rain or drizzle and in unlit boats when working below deck. At times, the problem

is as simple as finding a level safe place to lay the notebook while physically investigating the evidence.

A tape recorder is often useful but it too has its limitation. In Case No. 3 1974 the tape recorder being used slid off a burned deck beam and was totally submerged in black bilge water before the first notation was made. A more serious limitation is that the tape recorder does not permit simple diagrams or sketches which are often used and normally more effective than written descriptions.

Numerous photographs coordinated with written notations constitute the most valuable form of recording details. The old adage that a single photograph is worth a thousand words is particularly valid in the case of accident investigation work. There are many situations that must be recorded that would defy description by field notations but can easily be recorded on film.

Witness Interviews

In each case, the narrative account of the incident is obtained and recorded on the basis of witness interviews, with the major data usually coming from either the boat operator or on-board guests. Other sources include dock attendants, the Coast Guard, boat yard personnel and other local witnesses. The human factors involved in the cases investigated have been determined only to the extent necessary to establish what occurred, with no attempt to analyze the psychological factors and their relationship to the accident. It is not uncommon, for instance, for a boat operator to fuel the boat and then, without making any attempt to check the bilge for vapors, to press the starter button. Under these conditions it is self evident that a proper check might have revealed fuel leakage and it follows that the accident might have been avoided. The investigations have simply recognized that the potential to avoid the accident existed, but to seek in the investigation only the engineering factors. Most of the accidents in this investigation could have been prevented by either engineering changes or by the actions of the boat operator.

If possible, the witness interviews are conducted in the evening after the initial physical investigation. Since time does not permit interviews to be conducted before and after the investigation of the boat, it has been found best to conduct the interviews after the first day of checking the boat. By so doing, the investigation is not conducted with any preconceived ideas and when the interviews are conducted, the investigator has a better basis for the questions asked.

Individual Case Reports

The individual case reports covering the findings of each investigation are not only extremely important to the accident analysis conducted for that year, but accumulatively have value in the future. The reports follow the same format each year and have been prepared to make a recheck of any case as simple as possible. Each report includes the following sections:

- (1) Description of the Boat - This section generally serves to classify the type of boat and power, with some data on arrangement or construction.
- (2) Photographs - Each report includes several photographs to supplement the written section of the report.
- (3) Narrative Report of Incident - This section is intended to describe the conditions and sequence of events that led up to the fire and/or explosion, and is normally based on eye witness reports. The narrative account can have an important bearing on efforts to pinpoint the cause. How long a boat was underway will, for instance, help establish the fuel quantity aboard at the time of the accident.
- (4) Known Changes to Original Design - Since one of the purposes of these studies is to determine the relationship of industry design practices to accidents, it is vital to know what modifications were made by the owner or repair yards and if they affected the accident.
- (5) Facts Established from Witnesses - A separate section is provided for information obtained from witnesses to separate it from the data based on physical evidence. In some instances, the physical evidence will confirm information obtained from witnesses and in others, it may not.
- (6) Observations and Findings - This section of the report contains all of the pertinent information and evidence determined from the physical evidence during the on-site investigation. Since the investigation usually involves the fuel system, the engine, the electrical and other systems, the report attempts to group the information under those headings. The names of various component parts of the system are used as subheadings to permit specific details to be checked quickly.

- (7) Laboratory Tests - Laboratory tests conducted to confirm some hypothesis, to check ignition-proofing or tests conducted to classify or identify any material are included in this section.
- (8) Opinion - Based on all of the evidence available, the opinion section attempts to indicate how the accident occurred and if possible, provide justification for the opinion stated. In essence, the opinion section summarizes the findings.

SUMMARY OF INDIVIDUAL CASES INVESTIGATED IN 1974

The complete in-depth case reports covering the 11 accidents investigated in 1974 are included in the addendum of this Report with photographs; however, the following summaries of each case report have been prepared for completeness of the Report itself.

Case No. 1

The 14 year old 30 foot flying bridge cruiser involved in this low order explosion and fire had taken on 25 gallons of fuel, but remained at the fueling dock for about 20 minutes before an attempt was made to start the single engine. After 20 minutes, without checking the bilge, the passenger on the boat attempted to start the engine while the owner was standing on the dock. The boat did not have a blower. As the starter was energized, there was a mild explosion followed by fire. It was determined that the fire was caused by a missing pipe plug from a tee fitting for the tank vent. The original pipe plug was fitted with a tee handle and was apparently used to check fuel level in the tank. Ignition was probably at the starter or ignition distributor.

Case No. 2

This accident occurred on the first trip the owner and his family took in the 20 foot single engine I/O they purchased a month before. The boat was 11 years old. The boat was fueled, the engine was started without incident and the boat proceeded out of the marina. When the boat was about 1/4 mile out of the marina, an explosion occurred in the engine space that severely burned a woman and her daughter who were seated on the stern seat. The investigation revealed a split seam in the terneplate steel fuel tank as the source of fuel. The ignition distributor was the most probable source of ignition.

Case No. 3

The 5 year old 38 foot flying bridge cruiser involved in this explosion and fire was in the process of being fueled and had taken on 6 gallons of gasoline when the explosion occurred. The investigation revealed that the gasoline taken aboard was discharged on the top of the port tank because the fuel fill hose had slipped off at the tank connection. The failure occurred because a bonding wire was improperly clamped to the tank connection, providing too short a connection for the hose. It was also established that the port engine was running while the boat was being fueled, providing a source of ignition.

Case No. 4

The inboard/outdrive boat in this explosion and fire was a five year old 18 foot open sport fisherman that had been underway for about 25 minutes when the engine gradually died. When the owner checked the engine, he detected a fuel leak. The investigation indicated that the owner removed the fuel filter bowl to check the gasket and that siphon action from the bow tank caused a continuous flow of fuel. The fuel was ignited when a tool struck an exposed live terminal at the engine.

Case No. 5

The 19 foot inboard/outdrive sport fisherman involved in this explosion/fire was at the fueling dock when a guest on the boat attempted to start the engine without checking the bilge or operating the blower. After the engine ran for about 30 seconds, there was an explosion and fire that ignited the owner's jacket as he stepped on board. He jumped overboard to extinguish the burning jacket and then climbed back on board and extinguished the fire in the engine space with one extinguisher from the boat and one from the dock. The investigation determined that fire was caused by a split vent line hose at the tank. Ignition was most probably caused by the ignition distributor.

Case No. 6

The explosion and fire on this 16 foot high-powered inboard/outdrive speedboat occurred after about 25 minutes of operation. Ignition occurred when the engine was throttled back. The fire was extinguished by the operator with 12 extinguishers obtained mostly from other boats. The investigation revealed a massive failure of the fuel tank due to corrosion of the tank along the aft edge and of the fuel feed pick-up tube connection. Ignition was attributed to either a backfire or the ignition distributor.

Case No. 7

This case involved the same type 16 foot high-powered speedboat that was involved in Case No. 6, except that it had a water jet outdrive. The boat had been out for over an hour when it witnessed a capsizing and was standing by waiting for the Coast Guard. The boat drifted while waiting and after running the blower, the operator restarted the engine to move the boat further off shore. When the starter was cranked, there was an explosion in the engine space that severely burned the operator's daughter who was holding the engine cover open to ventilate the space. The investigation indicated that the cause was probably a rich mixture from the engine carburetor and not a component failure. Ignition was from either the starter or the ignition distributor.

Case No. 8

The one year old 24 foot inboard/outdrive boat involved in this explosion and fire was anchored off a channel for fishing, when the operator decided to move to a better location and attempted to start the engine. After operating the blower for about 10 seconds, the engine was cranked and started. Within seconds of starting, smoke was observed at the engine and an explosion occurred that blew the box open. The exact point of failure could not be pinpointed, but the evidence indicated that the failure was in the engine space and that siphon action caused a considerable quantity of fuel to accumulate in the engine well before ignition. Ignition was probably from the starter motor.

Case No. 9

The 25 foot 4 year old boat twin screw I/O boat involved in this fire had just been fueled and burst into flame when the engines were being started. The port engine had actually started, but when the owner could not start the starboard engine, he opened the engine cover to check the engine and fire immediately broke out in the engine space. The investigation revealed that the 10 foot long fuel fill hose failed at the foamed-in-tank connection. The failure was attributed to corrosion of the reinforcing wire which had punctured the hose. It was also determined that the hose was not resistant to gasoline. Ignition was from the operating engine.

Case No. 10

This fire case involved a 10 year old 45 foot twin diesel cruiser which burned due to an electrical fire that occurred while the boat was unattended. The exact cause was not determined, but the evidence indicated that the fire did not involve fuel and was apparently due to a short circuit.

Case No. 11

This case involved a double explosion on an 8 year old single screw inboard/outdrive boat immediately after fueling. After both saddle tanks were filled, the engine box was opened and the operator started and ran the single engine for about 5 minutes. When everything appeared to be operating properly, the operator replaced the engine cover in preparation to casting off when the explosion occurred. The initial explosion blew the engine box off and was followed almost immediately by a second explosion in the tank space and in the inner bottom. The investigation revealed a leak in the 3 year old starboard 304 stainless steel fuel tank at the threaded fuel feed flange which was brazed to the tank shell. Ignition was attributed to the ignition distributor.

DISCUSSION - GENERAL

One of the primary objectives of a continuous program of in-depth investigations is to seek trends and patterns and, over a longer range period, to be able to extract statistically significant information that may be pertinent to the review and development of safety requirements. To do this, it is necessary to create a means of summarizing the key information from each investigation into tables and charts that will reveal patterns when they develop. In 1972 a data recording system was devised that involved the use of four tables. Table 1 was developed to record basic descriptive data on the boat, Table 2 the cause as related to the source of fuel, Table 3 the source of ignition and Table 4 the secondary factors. In 1973 a separate table was added to summarize information on how the fire was extinguished. The 1973 Report uses the same 5 Tables, but Table 1 has been expanded to provide additional details on fuel tanks. Although the data from each investigation is transferred to the 5 Tables for analysis, the complete Report of each case investigated is retained and can always be reviewed when specific data is sought.

Because the five data Tables are so important to the final analysis, the method of using each Table is reviewed:

Table 1 - Basic Data on Boat and Equipment

Although the very purpose of the 5 Tables being discussed is to summarize and simplify the mass of data from the individual cases, over-simplification can tend to distort the data and the truths being sought. In part, the function of Table 1 is to help keep the data in the other 4 Tables in proper perspective. In Case No. 11, 1974, for instance, Table 1 shows that the tank that failed was 3 years old, that it was fabricated of Type 304 stainless steel and that the boat was 8 years old. From the last fact, it is apparent that the original tanks were replaced after 5 years.

Most of the Table is self-explanatory, but a review of some of the columns and their relationship to the analysis as a whole will permit the Tables to be used more effectively.

- (1) Column 6 "Material" - In accordance with the key to the basic data Table, this column lists the tank material. The column has now been expanded so that if the boat has more than one tank, all tanks are listed. In Case 11, 1974 it is noted that the boat had one stainless steel tank and one fiberglass tank.

- (2) Column 8 "Base Alloy" - This column has been added to supplement Column 6 by recording the actual alloy designation. In the case of terneplate and hot-dipped galvanized steel tanks, the basic alloy is listed as steel since the material is coated.
- (3) Column 9 "Years Service" - This column has been added to indicate the age of the tanks and can be compared to column 5 which lists the age of boat. By checking the two Columns, it is easy to determine if the tanks had been replaced.
- (4) Column 10 "Years to Failure" - This column is particularly useful, but must be used in conjunction with the other columns. If no failure is indicated, the "Years Service" column may provide useful data on the service life of the material. Since the program is limited to boats less than 15 years of age, the upper limit of Column 9 is 15 years. If the tank does fail, Column 9 will indicate its age at the time of failure and Column 5 will indicate whether or not the tank was original equipment.
- (5) Column 11 "Installation" - Because installation methods often affect corrosion, this column is provided to indicate the general type of installation used. The designations are given in the key to the chart.
- (6) Column 14 "Fuel Metering" - In 1972 the column now marked "Fuel Metering" was marked "Type Carburetor". The broader term was adopted so that the column could more correctly be used to cover diesel engines and fuel injection systems. The code designations still cover the various types of carburetors.
- (7) Columns 22 Through 30 - The columns under headings of "Modifications to Boat by Owner" and "Marine Repairs" are provided primarily to indicate when the cause of an accident is related to modifications or repairs to the boat, rather than to its original design. The last column in each section indicates whether or not the modification or repair was a factor.

This Report includes Table 1 for the investigations conducted by Ford and Beck in 1970 and the investigations by Underwriters Laboratories in 1972, 1973 and 1974. The Tables are identified as Tables 1A, 1B, 1C and 1D respectively.

Table 2 - Primary Cause - Source of Fuel

From the outset of the in-depth accident investigation program, starting with the study by Ford and Beck* in 1970, the prime objective of every investigation has been to determine the "Primary Cause" of the accident. Specifically, what failed or occurred to allow fuel vapors to accumulate in sufficient quantity to cause a fire or an explosion? The need for specific information on the primary cause is obvious, but the degree to which an in-depth study is carried out is a distinct variable that must be established. In this study, each accident was investigated in a one or two day period by one or two men. In 1973 the investigations were sufficient to establish the probable cause of the accidents in 8 out of the 11 cases.

The primary failures in boat fire and explosion cases are usually associated with such factors as corrosion, mechanical failures, chemical deterioration, and installation errors.

Table 2 covering the "Primary Cause - Source of Fuel" is identical to Table 2 in 1973. It is noted that in addition to a column marked "Undetermined", a separate column marked "Other" is provided. The column marked "Other" is used when the cause has been determined, but the cause does not correspond to the listed causes in the Table. By providing the two columns, it will be possible at some future time to recheck all of the cases under the heading of "Other" and determine if any cause is repeated sufficiently to warrant a new column in the Table. The column has been used for such causes as an overheated vee-drive and a canvas cockpit cover ignited by a cigarette.

The "Primary Cause-Source of Fuel" Table serves as a means of accumulating data on the source of fuel that was initially ignited to cause the explosion or start the fire. The degree of certainty that the particular cause was determined to be responsible for the accident is indicated by using unity (or 100 percent) when, in the opinion of the investigator, the cause was positively established. Where the single cause was not determined, two or more entries are made with the degree of likelihood that each was the source as a proportion of unity. In some instances, the cause of the accident can be specifically determined, but the cause is related to more than one factor. In Case 9, 1974, the cause of the accident was the failure of the fuel fill hose, but the cause is not entered as unity in the Table. The reason is that the failure was partially due to corrosion of the reinforcing wire, partially because the hose was not resistant to gasoline and partially because of the foamed-in installation.

*Project 705105/001" An In-Depth Study of Recreational Boat Fires and Explosions" by LCDR A.B. Ford and LTJG R. E. Beck. AD 717 955.

This Report includes Table 2 for the investigations conducted by Ford and Beck in 1970 and the investigations by Underwriters Laboratories in 1972, 1973 and 1974. The Tables are identified as Tables 2A, 2B, 2C and 2D respectively.

Table 3 - Ignition of Primary Source

The consistency with which the primary source of fuel is usually isolated in an investigation is not possible with ignition source. In most of the boats investigated, there are a number of possible sources of ignition and usually no physical evidence remains to indicate which item actually ignited the fuel vapors.

An electric starter, for instance, will not leave any evidence of an internal flash that can be detected in a field investigation. An arc from a wet ignition wire will leave no trace and the same is true of an arc across the ceramic surface of a spark plug. Other items such as mechanical voltage regulators and ignition distributors may leave clues. In Case 2, 1974 for example, the ignition distributor showed no evidence of external fire damage (see Photo 2), but the wire inside the distributor (Photo 5), was completely burned. The engine was running and the distributor is listed as the source of ignition.

Although, at this time, it is not normally possible to isolate the specific ignition source responsible for an explosion or fire, this should change within the next couple of years when the Coast Guard "ignition-proofing" requirements become effective. When all items in the engine space are "ignition-proofed", it should then be possible, if sufficient evidence remains, to determine which of the enclosures failed. In determining the figures entered in Table 3, careful consideration must be given to the narrative account, the position of switches and in the case of an explosion, evidence of the source of pressure. By means of the narrative and position of various switches, it is sometimes possible to eliminate some of the ignition sources and narrow down the possibilities. It is noted that in all 11 cases conducted in 1974, the source of ignition was established in only 1 case.

In most of the cases covered in this Report, the failure of some part of the fuel system created the probability for an explosion and fire and the ignition source established the time of the accident. In Cases 2, 5, 6 and 11, 1974 the source of fuel was present and could have been ignited by any source of ignition. The difference would simply be in the timing of the accident. In Cases 5 and 6 the fuel leakage had been present for an extensive period of time.

This Report includes Table 3 for the investigations by Ford and Beck in 1970 and the investigations by Underwriters Laboratories in 1972, 1973 and 1974. The Tables are identified as Tables 3A, 3B, 3C and 3D respectively.

Table 4 Secondary Factors - Source of Fuel

The fire resistance of items in the fuel system, siphon action and flammability of various items in the boat may have no bearing on the cause of the fire, but are likely to determine whether or not a fire can be extinguished or the boat burns to the waterline.

Table 4, when filled out for any case, is a simple analysis of why the boat burned to the extent it did. In essence, what burned and quantitatively how much? In each case, unity represents the total fire damage so that if an item is marked .3, it indicates that the particular factor contributed to 30 percent of the loss. The breakdown is an estimate of how much fuel each item contributed to the total fire. The last column under the heading "Extent of Damage to Boat" establishes the extent of the loss in terms of value of the boat.

The secondary factors ultimately determine the recovery potential of the boat and if the boat is off shore may be a determining factor in the recovery of the people on board. In time it should be possible to look for patterns that cause total losses, or conversely, how losses can be limited.

The secondary factors in Table 4 are based on a pure judgement factor, since there is no available means of measuring the degree of involvement for each item. Although the values are nothing more than an educated guess, they should over a period of time indicate the major areas of fire spread.

This Report includes Table 4 for the investigations by Ford and Beck in 1970 and the investigations by Underwriters Laboratories in 1972, 1973 and 1974. The Tables are identified as Tables 4A, 4B, 4C and 4D respectively.

Table 5 Fire Extinguishing Efforts and Explosion Relief

The analysis of fire fighting equipment and effort on boats involved in fire and explosion accidents was started in 1973 and has revealed some interesting data. Probably the most interesting and obvious fact revealed is that very few boats are equipped with any form of fixed fire extinguishing system and in almost every case, such a system might have helped.

Most of the Table is self explanatory but the columns indicating whether or not (1) a fixed fire extinguishing system, (2) an access hole or (3) explosion vents would help, are based on judgement of the available facts. In the case of a major initial explosion for instance, a standard CO² fixed fire extinguisher would not react fast enough to prevent the damage and an access hole for a portable fire extinguisher is of no value if the engine box or hatch is open. This also applies to explosion vents. In Case 15, 1970, an extinguisher access hole would not have helped since the boat was abandoned with no attempt to use portable extinguishing equipment. In Case No. 4, 1974, the explosion occurred with the engine box removed so the answer to all three questions was negative. In Case 3, 1974 the single occupant on the boat was badly burned by the initial explosion so an access hole would not have been used. Had other passengers been on-board to man the extinguishers, an access hole might have been of value. In this sense, the Table is based on the facts related to the specific accident.

This Report includes Table 5 covering the investigations by Ford and Beck in 1970 and the investigations by Underwriters Laboratories in 1972, 1973 and 1974.

DATA	BOAT		FUEL TANKS				ENGINE				METALLIC FUEL LINES		FLEXIBLE FUEL LINES		MODIFICATIONS TO BOAT BY OWNER (16)					MARINE REPAIRS (17)								
	TYPE BOAT	L.O.A.	AGE	(2) MATERIAL	(3) YEARS SERVICE	(4) YEARS TO FAILURE	(5) INSTALLATION	(6) TYPE ENGINE	(7) FUEL PUMP	(8) FUEL METERING	(9) FLAME ARRESTER	(10) DRIP COLLECTOR	(11) MATERIAL	(12) FITTINGS	(13) TYPE HOSE	(14) FIRE RESISTANCE	(15) FITTINGS	FUEL TANKS	ENGINES	STRUCTURAL	FUEL SYSTEM	ELECTRICAL SYSTEM	CONTRIBUTED TO ACCIDENT	FUEL SYSTEM	ELECTRICAL SYSTEM	ENGINES	CONTRIBUTED TO ACCIDENT	
1	I/O	16	-	T	-	-	F	4G4	SD	-	-	-	-	-	-	-	-	-	-	-	-	-	-	F	-	-	F	Yes
2	I/O	23	4	-	-	-	-	-	SD	-	-	C	-	MB	-	S	-	-	-	-	-	-	-	F	-	-	F	Yes
3	I	-	7	-	-	-	-	4G8	-	-	PA	NR	-	-	-	-	-	-	-	-	-	-	-	-	-	-	-	-
4	I	38	30	SS	-	-	-	-	-	-	-	-	-	-	-	-	-	-	-	P	I	-	-	-	-	-	-	-
5	I	35	-	S	-	-	-	4G6	-	-	-	C	-	-	-	-	-	-	-	-	-	-	-	-	-	-	-	-
6	I	26	-	SG	-	-	CF	4G8	SD	DD	CA	NR	C	C	-	-	-	-	-	-	-	-	-	-	-	-	-	-
7	I	27	-	-	-	-	-	4G6	-	SD	NA	NO	C	C	-	-	-	-	-	-	-	-	-	-	-	-	-	-
8	A	31	9	-	-	-	-	4G4	-	-	-	-	-	-	-	-	-	-	-	-	-	-	-	-	-	-	-	-
9	H	34	-	-	-	-	-	4G8	-	-	-	-	-	-	-	-	-	-	-	-	-	-	-	-	-	-	-	-
10	H	35	-	-	-	-	-	-	-	-	-	-	-	-	-	-	-	-	-	-	-	-	-	-	-	-	-	-
11	I/C	20	-	T	-	-	-	4G8	SD	DD	CA	NR	-	-	-	-	-	-	-	-	-	-	-	-	-	-	-	-
12	I	18	13	-	-	-	CS	4G8	E	SD	-	-	-	NR	I	-	-	-	-	-	-	-	-	-	-	-	-	-
13	I	36	-	-	-	-	-	4G6	-	-	CA	-	-	-	-	-	-	-	-	-	-	-	-	-	-	-	-	-
14	I/O	16	1	-	-	-	P	4G8	-	-	-	-	-	-	-	-	-	-	-	-	-	-	-	-	-	-	-	-
15	I	38	15	SC	-	-	CS	-	E	UD	-	C	CH	-	-	-	-	-	-	-	-	-	-	-	-	-	-	-
15	I/O	25	-	-	-	-	-	4G8	-	DD	CA	-	-	NR	I	S	-	-	-	-	-	-	-	-	-	-	-	-
17	H	38	-	GS	3	-	CS	4G6	SD	-	-	-	-	FR	1 1/2	S	-	-	-	-	-	-	-	-	-	-	-	-

BASIC DATA ON BOAT AND EQUIPMENT - 1970

TABLE 1A

CATEGORY	ENGINE						D C ACCESSORIES										115/230 VAC ACCESSORIES						NON ELECTRICAL										
	EXHAUST	IGN. DISTRIB.	H.V.IGN.WIRE	ALT. OR GEN.	VOLT. REGUL.	BACKFIRE	STARTER	ENG.WIRING	BATT.SWITCH	SWITCH	BATT.CONNec.	BATT.CHRG.	VAPOR DETECT	SIGNAL ALARM	BIGE PUMP	BLOWER	WATER PUMP	INSTALLATION	CIRCUIT PROT.	DC WIRING	HOT WATER HTR.	REFRIGERATOR	AIR COND.	HEATER	STOVE/OVEN	CIRCUIT PROT.	AC WIRING	PILOT LIGHT	GALLEY STOVE	HEATER	OTHER	UNDETERMINED	
1		.6																															.4
2		.6		.2	.1																												.1
3																																1.0	
4																																1.0	
5																																	
6																																	1.0
7		.2	.2	.2																	.1												
8																																	1.0
9																																	1.0
10																												1.0					
11		.5	.1	.1																													.3
12			.5																														.1
13											.6																						.4
14			.3	.1	.1	.2	.3																										
15			.2			.4																											.4
16		.2	.1	.1	.1	.4																											.1
17		.3																													.5	.2	

IGNITION OF PRIMARY VAPOR SOURCE - 1970

TABLE 3A

SECONDARY FACTORS - SOURCE OF FUEL - 1970

TABLE 4A

CAUSE	Category	Fuel Fill System	Fuel Tank	Portable Container or Tank	Metallic Feed & Vent Lines	Flexib. Feed & Vent Lines	Fuel Pump	Fuel Valve	Fuel Filter	Carburetor	Construction Materials	Cooking Fuel	Other Sources	Secondary Explosion	Primary Failure	Extent of Damage to Boat
1		Fire Resist					Fire Resist			Other	Hull	Storage Cyl				TL
2											Joiner Work	Dispos Cyl				TL
3											Insulation					100
4											Decorative					TL
5																TL
6											Other					200
7																TL
8																TL
9	.2															TL
10																TL
11																TL
12																TL
13																600
14	.1															800
15																TL
16																TL
17																TL

TL - TOTAL LOSS

CASE NUMBER	FIXED SYSTEM	FIXED SYSTEM USED	EFFECTIVENESS OF FIXED SYSTEM	WOULD FIXED SYSTEM HAVE HELPED	USE OF ON-BOARD PORTABLE EXTINGUISHERS	EFFECTIVENESS OF PORTABLE EXTINGUISHERS	WOULD PORTABLE EXTINGUISHER ACCESS HOLE HAVE HELPED	MARINA FIRE EQUIPMENT USED	EFFECTIVENESS OF MARINA EQUIPMENT	PORTABLE EXTINGUISHERS FROM OTHER BOATS USED	EFFECTIVENESS OF EXTINGUISHERS FROM OTHER BOATS	EXTINGUISHED BY USCG HARBOR POLICE OR F.D.	WOULD EXPLOSION VENTS HAVE HELPED	NO FIRE FIGHTING INFORMATION AVAILABLE	EXTENT OF LOSS	COMMENT
1	No	-	-	No	U	NE	Yes	NA	-	NU	-	NA	-	-	TL	Severe Explosion
2	No	-	-	Yes	U	NE	Yes	U	NE	NU	-	NA	Yes	-	TL	Severe explosion
3	Yes	U	E	-	U	E	Yes	NA	-	NA	-	NA	No	-	10%	Boat saved by fixed system
4	Yes	NU	-	-	NU	-	No	NU	-	NA	-	Yes	No	-	TL	Fixed system control inaccessible
5	No	-	-	Yes	NU	-	No	NU	-	NA	-	Yes	No	-	TL	Severe explosion
6	No	-	-	Yes	NU	-	No	U	-	NA	-	Yes	Yes	-	20%	Severe explosion
7	No	-	-	Yes	NU	-	No	NA	-	NA	-	NA	No	-	TL	Starting engine with boat speed
8	No	-	-	No	NU	-	-	-	-	-	-	-	No	NA	20%	Propane explosion
9	No	-	-	Yes	-	-	-	-	-	-	-	-	-	NA	10%	Ignited by pilot light
10	No	-	-	-	-	-	-	-	-	-	-	-	-	NA	TL	Severe explosion ignited by pilot light
11	No	-	-	-	-	-	-	NA	-	-	-	Yes	-	NA	TL	Explosion when put in reverse
12	No	-	-	-	-	-	-	-	-	-	-	Yes	Yes	NA	TL	Explosion venting would have helped
13	No	-	-	-	-	-	-	-	-	-	-	Yes	No	NA	60%	Trouble evident before accident
14	No	-	-	Yes	NU	-	No	-	-	U	E	-	Yes	-	80%	Ignited by backfire
15	Yes	U	NE	-	NU	-	No	NA	-	NA	-	NA	No	-	TL	Fire only when underway
16	Yes	NU	-	-	-	-	-	-	-	NU	-	-	Yes	-	TL	Explosion underway
17	No	-	-	Yes	U	E	Yes	NA	-	NA	-	No	No	-	20%	Explosion underway

NE - NOT EFFECTIVE
 E - EFFECTIVE
 NU - AVAILABLE BUT NOT USED
 NA - NOT AVAILABLE
 U - USED
 TL - TOTAL LOSS

FIRE EXTINGUISHING EFFORTS AND EXPLOSION RELIEF - 1970

TABLE 5A

DATA	BOAT		FUEL TANKS			ENGINE					FUEL LINES			FLEXIBLE FUEL LINES			CONDITIONS TO OCCUR BY OWNER (16)					MARINE REPAIRS (17)											
	(1)	I.O.A.	AGE	(2)	(3)	(4)	(5)	(6)	(7)	(8)	(9)	(10)	(11)	(12)	(13)	(14)	(15)	FUEL TANKS	ENGINES	STRUCTURAL	FUEL SYSTEM	ELECTRICAL SYSTEM	CONTRIBUTED TO ACCIDENT	FUEL SYSTEM	ELECTRICAL SYSTEM	ENGINES	CONTRIBUTED TO ACCIDENT						
1	I/C	23	7	AL	4	4	P	4G6	SD	DD	CA	NR	-	-	NR	1	P	F	-	-	-	-	-	-	-	-	-	-	-	-	-		
2	I	33	5	S	5	-	CF	4G6	DD	DD	NA	NR	-	-	NR	1	C	-	-	-	-	-	-	-	-	-	-	-	-	-	-		
3	I	30	15	SG	15	15	CS	4G6	SD	DD	NA	NO	C	P	FR	1	S	-	-	-	-	-	-	-	-	-	-	-	-	-	-		
4	I/C	23	6	T	6	-	P	4G6	SD	DD	CA	NR	-	-	FR	1	C	-	-	-	-	-	-	-	-	-	-	-	-	-	-	Yes	
5	I	22	13	GS	13	-	CF	4G8	SD	SD	NA	NO	C	F	-	-	-	-	-	-	-	-	-	-	-	-	-	-	-	-	-	-	
6	I	23	3	SG	3	-	CS	4G8	SD	DD	CA	NR	C	P	MB	1	S	-	-	-	-	-	-	-	-	-	-	-	-	-	-	-	
7	I/C	23	7	FG	2	-	P	4G8	SD	DD	NA	NR	-	-	NR	1	C	F	I	I	I	-	-	-	-	-	-	-	-	-	-	-	-
8	I	22	12	C	12	-	CF	4G8	E	DD	NA	NR	C	H	FR	1	C	-	-	-	-	-	-	-	-	-	-	-	-	-	-	-	
9	I/C	24	5	AL	1	-	P	4G6	SD	DD	-	NR	-	-	NR	1	C	P	I	-	-	-	-	-	-	-	-	-	-	-	-	-	Y
10	I	36	10	NC	10	-	CF	4G8	SD	DD	CA	NR	C	F	FR	1	P	-	-	-	-	-	-	-	-	-	-	-	-	-	-	-	Y

BASIC DATA ON BOAT AND EQUIPMENT - 1972

TABLE 1B

CATEGORY	ENGINE						D C ACCESSORIES											115/230 VAC ACCESSORIES						NON ELECTRICAL										
	EXHAUST	IGN. DISTRIB.	H.V. IGN. WIRE	ALT. OR GEN.	VOLT. REGUL.	BACKFIRE	STARTER	ENG. WIRING	BATT. SWITCH	SWITCH	BATT. CONNFC.	BATT. CHRGC.	VAPOR DETECT	SIGNAL ALARM	BIDGE PUMP	BLOWER	WATER PUMP	INSTALLATION	CIRCUIT PROT.	DC WIRING	HOT WATER HTR.	REFRIGERATOR	AIR COND.	HEATER	STOVE/OVEN	CIRCUIT PROT.	AC WIRING	PILOT LIGHT	GALLEY STOVE	HEATER	OTHER	UNDETERMINED		
1		.7	.1																	.2														
2					.8	.1																												
3		.2			.5	.3																												
4		.7																		.3														
5																																	1.0	
6		.9																															.1	
7	.5	.4		.1																														
8		.2			.5	.3																												
9																																		
10																				1.0													1.0	

IGNITION OF PRIMARY VAPOR SOURCE - 1972

TABLE 3B

CASE NUMBER	FIXED SYSTEM	FIXED SYSTEM USED	EFFECTIVENESS OF FIXED SYSTEM	WOULD FIXED SYSTEM HAVE HELPED	USE OF ON-BOARD PORTABLE EXTINGUISHERS	EFFECTIVENESS OF PORTABLE EXTINGUISHERS	WOULD PORTABLE EXTINGUISHER ACCESS HOLE HAVE HELPED	MARINA FIRE EQUIPMENT USED	EFFECTIVENESS OF MARINA EQUIPMENT	PORTABLE EXTINGUISHERS FROM OTHER BOATS USED	EFFECTIVENESS OF EXTINGUISHERS FROM OTHER BOATS	EXTINGUISHED BY USCG, HARBOR POLICE OR F.D.	WOULD EXPLOSION VENTS HAVE HELPED	NO FIRE FIGHTING INFORMATION AVAILABLE	EXTENT OF LOSS	COMMENT
1	No	-	-	Yes	NU	-	Yes	NA	-	U	NE	NC	Yes	-	TL	Owner considered fighting fire
2	No	-	-	No	NU	-	No	U	NE	NA	-	Yes	Yes	-	TL	Severe explosion prevented effort
3	No	-	-	No	NU	-	No	U	E	NU	-	No	Yes	-	20%	Severe explosion prevented effort
4	No	-	-	Yes	U	NE	Yes	NA	-	NA	-	No	Yes	-	TL	Fixed system or access hole needed
5	No	-	-	Yes	NU	-	Yes	NA	-	U	NE	Yes	Yes	-	TL	Fixed system or access hole needed
6	No	-	-	Yes	NU	-	No	NA	-	NU	-	Yes	Yes	-	TL	No attempt was made to fight the fire
7	No	-	-	No	NU	-	No	NA	-	NA	-	Yes	No	-	TL	Owner threw the gas can overboard
8	No	-	-	Yes	U	NE	Yes	NA	-	NU	-	Yes	Yes	-	TL	Fixed system or access hole needed
9	No	-	-	Yes	U	NE	Yes	NA	-	NU	-	No	Yes	-	TL	Fixed system or access hole needed
10	No	-	-	No	U	E	No	NA	-	NU	-	No	No	-	10%	Electrical Fire

NE - NOT EFFECTIVE
 E - EFFECTIVE
 NU - AVAILABLE BUT NOT USED
 NA - NOT AVAILABLE
 U - USED
 TL - TOTAL LOSS

PIRE EXTINGUISHING EFFORTS AND EXPLOSION RELIEF - 1972

TABLE 5B

DATA	BOAT		FUEL TANKS				ENGINE				METALLIC TUBES			FLOORING TUBES			MODIFICATIONS TO BOAT BY OWNER (1.6)					NO. OF DEVIATIONS (1.7)				
	TYPE BOAT	L.O.A.	MA	MATERIAL	YEARS SERVICE	YEARS TO FAILURE	INSTALLATION	TYPE ENGINE	FUEL PUMP	FUEL HEATING	FLAME ARRESTER	DRIP COLLECTOR	MATERIAL	FITTINGS	TYPE HOSE	FIRE RESISTANCE	FLOORING TUBES	FUEL TANKS	ENGINES	STRUCTURAL	FUEL SYSTEM	ELECTRICAL SYSTEM	FUEL SYSTEM	ELECTRICAL SYSTEM	ENGINES	CONTINUED TO ACCIDENT
(1)				(2)	(3)	(4)	(5)	(6)	(7)	(8)	(9)	(10)	(11)	(12)	(13)	(14)	(15)									
1	I	29	10	SG	10	-	CS	4CS	SD	DD	FA	NR	C	P	CA	2A	B	-	-	-	-	-	-	-	-	-
2	I	33	1	S	1	-	CF	4CS	SD	D	NR	NR	-	-	FR	1A	S	-	-	-	-	-	-	-	-	-
3	I	25	2	SG	2	-	CF	4CS	SD	DD	CA	NR	C	P	FR	2	R	-	-	-	-	-	-	-	-	-
4	I	33	15	C	15	15	CF	4CS	SD	SD	FA	DD	C	P	-	-	-	-	-	-	-	-	-	-	-	-
5	I/O	17	11	T	11	-	CF	2CA	PO	SD	CA	Z	C	P	FR	1	S	-	-	-	-	-	-	-	-	-
6	I	25	9	SG	9	-	CS	4CS	SD	DD	FA	NR	C	P	MB	2	R	-	-	-	-	-	-	-	-	-
7	I	53	3	FG	3	-	P	4CS	CF	D	NR	NR	-	-	MB	2	R	-	-	-	-	-	-	-	-	-
8	I	28	13	SG	13	13	CF	4CS	SD	SD	FA	DD	C	P	FR	1	S	-	-	-	-	-	-	-	-	-
9	I	24	6	CS	6	6	P	4CS	SD	DD	FA	NR	C	P	FR	1	P	-	-	-	-	-	-	-	-	-
10	I	40	4	S	4	-	CF	4CS	CF	D	NR	NR	C	P	FR	1	P	-	-	-	-	-	-	-	-	-
11	I	32	5	SG	4	-	CS	4CS	SD	SD	FA	DD	C	P	FR	1	S	I	-	-	-	-	-	-	-	-

BASIC DATA ON BOAT AND EQUIPMENT - 1973

TABLE 1C

CAUSE	FILL FILL SYSTEM			FILL TANK			PORTABLE FILL CONTAINER OR TANK			RIGID FILL PIPE & VENT LINES			FLEXIBLE FILL PIPE & VENT LINES			FUEL PUMP			FUEL VALVE			FUEL FILTER			CARBURETOR			CONSTRUCTION MATERIALS			L.P.G. SYSTEM			ELECTRICAL SYSTEM			EXPLOSION	
	CORROSION	MECHANICAL	INSTALLATION	CORROSION	MECHANICAL	GENERAL	INSTALLATION	CORROSION	MECHANICAL	GENERAL	INSTALLATION	CORROSION	MECHANICAL	GENERAL	INSTALLATION	CORROSION	MECHANICAL	INSTALLATION	CORROSION	MECHANICAL	INSTALLATION	CORROSION	MECHANICAL	INSTALLATION	CORROSION	MECHANICAL	INSTALLATION	CORROSION	MECHANICAL	INSTALLATION	WIRE	INSTALLATION	OTHER	EXPLOSION				
1																																			Y			
2																																				D.O.M.		
3																																					N	
4																																					Y	
5																																					Y	
6										.8																										Y		
7																																					D.O.M.	
8																																					N	
9																																					Y	
10																																					Y	
11																																					D.O.M.	
																																						Y

PRIMARY CAUSE - SOURCE OF FUEL - 1973

TABLE 2C

CATEGORY	ENGINE							D C ACCESSORIES										115/230 VAC ACCESSORIES						NON ELECTRICAL										
	EXHAUST	IGN. DISTRIB.	H.V.IGN.WIRE	ALT. OR GEN.	VOLT.REGUL.	BACKFIRE	STARTER	ENG.WIRING	BATT.SWITCH	SWITCH	BATT.CONNec.	BATT.CHRG.	VAPOR DETECT	SIGNAL ALARM	BILGE PUMP	BLOWER	WATER PUMP	INSTALLATION	CIRCUIT PROT.	DC WIRING	HOT WATER HTR.	REFRIGERATOR	AIR COND.	HEATER	STOVE/OVEN	CIRCUIT PROT.	AC WIRING	PILOT LIGHT	GALLEY STOVE	HEATER	OTHER	UNDETERMINED		
1		.5			.3										.2																			
2																															1.0			
3							1.0																											
4		.2		.3	.2	.3																												
5		.2				.8																												
6																															1.0			
7																											.5							
8						.7																												
9		.4																															.2	
10																																	1.0	
11		.6		.2	.2																													

IGNITION OF PRIMARY VAPOR SOURCE - 1973

TABLE 3C

CAUSE	FUEL FILL SYSTEM	FUEL TANK	PORTABLE CONTAINER OR TANK	METALLIC FEED & VENT LINES	FLEXIBLE FEED & VENT LINES	FUEL PUMP	FUEL VALVE	FUEL FILTER	CARBURETOR	CONSTRUCTION MATERIALS	COOKING FUEL	EXTENT OF DAMAGE TO BOAT
1	FIRE RESIST									HULL	STORAGE CYL	NO .30
2	LIVID FUEL									JOINER WORK	DISPOS CYL	NO .20
3	FIRE RESIST									INSULATION	FUEL CANS	NO .40
4	OTHER									DECORATIVE		NO .70
5										OTHER		NO .20
6										OTHER		NO .25
7										OTHER		NO .1
8										OTHER		NO .2
9										OTHER		NO .3
10										OTHER		Yes .3
11										OTHER		Yes .2

TL - TOTAL LOSS

SECONDARY FACTORS SOURCE OF FUEL - 1973

TABLE 4C

CASE NUMBER	FIXED SYSTEM	FIXED SYSTEM USED	EFFECTIVENESS OF FIXED SYSTEM	WOULD FIXED SYSTEM HAVE HELPED	USE OF ON-BOARD PORTABLE EXTINGUISHERS	EFFECTIVENESS OF PORTABLE EXTINGUISHERS	WOULD PORTABLE EXTINGUISHER ACCESS HOLE HAVE HELPED	MARINE FIRE EQUIPMENT USED	EFFECTIVENESS OF MARINA EQUIPMENT	PORTABLE EXTINGUISHERS FROM OTHER BOATS USED	EFFECTIVENESS OF EXTINGUISHERS FROM OTHER BOATS	EXTINGUISHED BY USCG, HARBOR POLICE OR P.D.	WOULD EXPLOSION VENTS HAVE HELPED	NO FIRE FIGHTING INFORMATION AVAILABLE	EXTENT OF LOSS	COMMENT
1	No	-	-	Yes	NU	-	No	NA	-	NU	-	Yes	Yes	-	TL	Experienced operator went overboard
2	No	-	-	Yes	U	NE	No	NA	-	NU	-	Yes	No	-	30%	Fire alarm system might have helped
3	No	-	-	No	U	NE	No	NA	-	NU	-	Yes	No	-	50%	Electrical Fire
4	No	-	-	Yes	NU	-	No	U	E	NA	-	No	Yes	-	TL	Severe explosion prevented effort
5	No	-	-	Yes	NU	-	No	NU	-	NA	-	No	Yes	-	TL	Fire spread outside boat by bilge pump
6	No	-	-	No	NU	-	No	NA	-	U	E	No	No	-	40%	Fire above cockpit deck
7	No	-	-	Yes	NU	-	No	NU	-	NU	-	Yes	No	-	TL	Electrical fire
8	No	-	-	Yes	U	NE	Yes	NA	-	NU	-	Yes	Yes	-	TL	Fire too much for portable extinguisher
9	No	-	-	Yes	NU	-	No	NJ	-	NA	-	No	Yes	-	TL	Severe explosion prevented effort
10	No	-	-	Yes	U	NE	No	NA	-	NU	-	Yes	No	-	TL	Fire not accessible
11	No	-	-	Yes	NU	-	Yes	NA	-	NA	-	Yes	Yes	-	TL	Vapor detector might have helped

NE - NOT EFFECTIVE
 E - EFFECTIVE
 NU - AVAILABLE BUT NOT USED
 NA - NOT AVAILABLE
 U - USED
 TL - TOTAL LOSS

FIRE EXTINGUISHING EFFORTS AND EXPLOSION RELIEF - 1973

TABLE 5C

CAUSE	CATEGORY	CORROSION	MECHANICAL	CHEMICAL	INSTALLATION	FUEL TANK	PORTABLE FUEL CONTAINER OR TANK	METALLIC FUEL FEED & VENT LINES	FLEXIBLE FUEL FEED & VENT LINES	FUEL PUMP	FUEL VALVE	FUEL FILTER	CARBURETOR	CONSTRUCTION MATERIALS	L.P.G. SYSTEM	ELECTRICAL SYSTEM	NOT DETERMINED	OTHER	EXPLOSION
1																			
2			1.0																
3				.8															
4																			
5																			
6																			
7																			
8																			
9																			
10																			
11																			

— PRIMARY CAUSE - SOURCE OF FUEL - 1974 —
TABLE 2D

CATEGORY	ENGINE						D C ACCESSORIES											115/230 VAC ACCESSORIES						NON ELECTRICAL									
	EXHAUST	IGN. DISTRIB.	H.V. IGN. WIRE	ALT. OR GEN.	VOLT. REGUL.	BACKFIRE	STARTER	ENG. WIRING	BATT. SWITCH	SWITCH	BATT. CONNEX.	BATT. CHRG.	VAPOR DETECT	SIGNAL ALARM	BILGE PUMP	BLOWER	WATER PUMP	INSTALLATION	CIRCUIT PROT.	DC WIRING	HOT WATER HTR.	REFRIGERATOR	AIR COND.	HEATER	STOVE/OVEN	CIRCUIT PROT.	AC WIRING	PILOT LIGHT	GALLEY STOVE	HEATER	OTHER	UNDETERMINED	
1		.7					2																										.1
2		1.0																															
3		.5																				.1										.1	.3
4																		.6														.4	
5		.8	.1																													.1	
6		.8				.2																											
7		.5				.1	.3	.1																									
8				.1			.4																								.1	.4	
9		.5				.2	.3																										
10																		.1	.2	.5													.2
11		.6																															.2

--- IGNITION OF PRIMARY SOURCE - 1974 ---
TABLE 3D

CAUSE	CATEGORY	FUEL FILL SYSTEM	FUEL TANK	PORTABLE CONTAINER OR TANK	METALLIC FEED & VENT LINES	FLEXIBLE FEED & VENT LINES	FUEL PUMP	FUEL VALVE	FUEL FILTER	CARBURETOR	CONSTRUCTION MATERIALS	COOKING FUEL	EXTENT OF DAMAGE TO BOAT
1		FIRE RESISTANCE			FIRE RESISTANCE	FIRE RESISTANCE	FIRE RESISTANCE	FIRE RESISTANCE			JOINER WORK	STORAGE CYLINDER	OTHER SOURCES
2		LIQUID FUEL			SIPHON	SIPHON	INSTALLATION	INSTALLATION	OTHER		INSULATION	DISPOSABLE CYLINDER	SECONDARY EXPLOSION
3		OTHER			OTHER	OTHER	OTHER	OTHER			DECORATIVE	FUEL CANS	PRIMARY FAILURE
4											OTHER		
5													
6													
7													
8													
9													
10													
11													

— SECONDARY FACTORS - SOURCE OF FUEL - 1974 —
TABLE 4D

CASE NUMBER	FIXED SYSTEM	FIXED SYSTEM USED	EFFECTIVENESS OF FIXED SYSTEM	WOULD FIXED SYSTEM HAVE HELPED	USE OF ON-BOARD PORTABLE EXTINGUISHERS	EFFECTIVENESS OF PORTABLE EXTINGUISHERS	WOULD PORTABLE EXTINGUISHER ACCESSIBLE HAVE HELPED	MARINA FIRE EQUIPMENT USED	EFFECTIVENESS OF MARINA EQUIPMENT	PORTABLE EXTINGUISHERS FROM OTHER BOATS USED	EFFECTIVENESS OF EXTINGUISHERS FROM OTHER BOATS	EXTINGUISHERS BY USCG, MARINE POLICE, P.D.	WOULD EXPLOSION VENTS HAVE HELPED	NO FIRE FIGHTING INFORMATION AVAILABLE	EXTENT OF LOSS	COMMENT
1	NO	-	-	YES	U	U	U	U	-	NO	-	YES	NO	-	TL	FIXED SYSTEM NEEDED
2	NO	-	-	YES	U	U	YES	U	-	NO	-	YES	YES	-	10%	ONE PORTABLE EXTINGUISHER ALMOST ENOUGH
3	NO	-	-	YES	U	U	NO	U	-	NO	-	YES	YES	-	TL	FIXED SYSTEM NEEDED
4	NO	-	-	NO	U	U	NO	U	-	NO	-	YES	NO	-	TL	ONE PORTABLE EXTINGUISHER ALMOST ENOUGH
5	NO	-	-	YES	U	U	YES	U	E	NO	-	NO	YES	-	10%	EXTINGUISHER WITH 2 PORTABLE EXTINGUISHERS
6	NO	-	-	YES	U	U	NO	U	-	U	E	NC	YES	-	15%	12 PORTABLE EXTINGUISHERS WERE USED
7	NO	-	-	YES	U	U	NO	U	-	NO	-	YES	YES	-	20%	EXTINGUISHER BY USCG
8	NO	-	-	YES	U	U	NO	U	-	NO	-	NO	YES	-	TL	ARMORED WHEN FIRE FONE AND APT
9	NO	-	-	YES	U	U	NO	U	-	NO	-	YES	NO	-	TL	ONE PORTABLE EXTINGUISHER
10	NO	-	-	YES	NO	U	NO	U	-	NO	-	YES	NO	-	TL	NOT SET AHEAD
11	NO	-	-	YES	NO	U	YES	U	E	NO	-	NO	YES	-	TL	EXPLOSION VENTS NEEDED

NE - NOT EFFECTIVE
 E - EFFECTIVE
 NU - AVAILABLE BUT NOT USED
 MA - NOT AVAILABLE
 U - USED
 TL - TOTAL LOSS

FIRE EXTINGUISHING EFFORTS AND EXPLOSION RELIEF - 1974

TABLE 50

<u>Note</u>	<u>Data</u>	<u>Abbreviation</u>	<u>Notes</u>	<u>Data</u>	<u>Abbreviations</u>
(1) "Type Boat"	Inboard Outboard Inboard/Outboard Auxiliary Houseboat	I O I/O A B	(8) "Fuel Metering"	Carburetors Downdraft Updraft Slide-draft	BD DD ED FD GD
(1a) "No. of Engines"	Single Gasoline Twin Gasoline Single Diesel Twin Diesel	SG TG SD TD	(9) "Flame Arrestor"	Current Approval (162.041) Past Approval (162.015) Not Approved or Inoperative Not Required	CA PA NA NR
(2) "Material"	Copper Nickel Steel, Hot Dip Galvanized Steel, Galv. Sheet Steel, Anneplate Steel, (Plain, Pickled & Oiled Painted) Fiberglass Reinforced Plastic Aluminum Stainless Steel Plastic	C NC SG CS T S FG AL SS P	(10) "Drip Collector"	Effective and Self Stripping None or Not Effective Not Required	E ND NR
"Base Alloy"	Aluminum - Insert Aluminum Assoc. No. Stainless Steel - Insert ASTM No. Coated Materials - Insert Base material		(11) "Material"	Copper Nickel Copper Steel	C NC SC S
(3) "Years Service"	Insert Number To Correspond With Service Life		(12) "Type Fittings"	Flare Compression Clamped Hose Hose Without Clamps	F C CS d
(4) "Years To Failure"	Insert Number To Correspond With Service Life If Tank Fails Prior To Fire or Explosion		(13) "Type Hose"	Metallic Braids Reinforced Fabric Reinforced Not Reinforced Corrugated Metal With Braids	ND FR NR CS
(5) "Installation"	Chocks and Framing Chocks and Straps Foamed in Place Flat Surfaces (Plywood etc.)	CF CS F P	(14) "Fire Resistance"	Reason or estimated fire resistance in minutes	S B C R P D
(6) "Type Engine"	Gasoline 2 Cycle Gasoline 4 Cycle Diesel 2 Cycle Diesel 4 Cycle Suffix 4, 6 or 8 indicates number of cylinders	2G 4G 2D 4D	(15) "Fittings"	Swept Reamable Clamped Push-On Brazed or Silver Solder	
(7) "Fuel Pump"	Single Diaphragm Dual Diaphragm Electric Add "S" For Safety Circuit Pressure Operated Gear Pump	SD DD E FO GP	(16) "Fuel Tanks" "Reservoirs" "Structural" "Fuel System" "Electrical System" "Tank Material"	Replacement of item that failed or was a pending failure System or item changed or replaced for improvement purposes. Tank material reason	F I D
			(17) "Fuel System" "Electrical System" "Engines"	Replacement of item that failed or was a pending failure System or item changed or replaced for improvement purposes Unknown reason	F I D

TABLE I

BASIC DATA ON BOAT AND EQUIPMENT

KEY TO TABLE 2 - PRIMARY CAUSE - SOURCE OF FUEL

"Corrosion" - Includes any form of corrosion that results in fuel leakage.

"Mechanical Stress" - Includes vibration and shock failures (fatigue), failures due to hydraulic pressure, failures resulting from the application of stress levels exceeding the material limits, and any form of breakage due to object impact or rough usage.

"Chemical" - Would apply to the deterioration of non-metallic materials due to contact with gasoline, oil or other liquids.

"Installation" - Applies to leakage resulting from a loose fitting, clamp or thread, where the failure would not have occurred had the components been properly assembled or installed. It could apply to a fuel tank installed so as to create a gravity feed fuel supply to the engine. In essence, the tank and fittings are not at fault and the cause of the leakage can be corrected by installing the tank at a lower level. Under the "Fuel Pump", installation would include an electrical fuel pump installed without an oil pressure cut-off switch to prevent pump operation when the engine is stopped. It could apply to an electric pump installed at the tank end of the line instead of at the engine, creating a long pressurized fuel line.

"Fuel Gauge" - The separate category for a fuel gauge (or fuel gauge transmitter) is included to distinguish gauge problems from basic tank problems. It would only be used where the source of leakage is because of the design or construction of the device itself and would not be used if the tank design was the reason for leakage.

"Fitting" - Would apply to the failure of a tube fitting used with metallic fuel lines or swaged or reusable fittings on flexible fuel lines. A cracked flare or leakage at a compression fitting would be listed as a fitting failure. A clamped hose connection that leaks would normally be an installation failure, but if the barbed fitting used with push-on hose failed, the failure would be listed as a fitting failure.

"Diaphragm" - External fuel leakage of any mechanical fuel pump due to diaphragm failure. It would apply to both single and dual diaphragm pumps.

"Valve Seal" - Would be used to indicate leakage due to failure of an "O" ring, valve packing or leakage at a tapered plug.

"Gasket" - Would be used to record any leakage of a gasket or seal at a fuel filter. It would apply to an "O" ring seal.

"Carburetor Drip" - Would apply to liquid fuel discharged from a carburetor due to the lack of adequate drip-collecting provisions. In a down-draft carburetor, where the liquid is collected inside the manifold, the resulting vapor discharge would be listed under "Vapors", not carburetor drip.

"Vapors" - Would be used to indicate any fire or explosion caused by the ignition of vapors discharged from the carburetor, such as when flooded. It would not include liquid leakage or the discharge of liquid fuel covered under carburetor drip.

"Leakage" - Carburetor leakage would cover any fuel leakage around the float chamber, through shafts or through any of the gasketed joints, etc.

"Construction Materials" - The four items listed provide a means of breaking down the available sources of combustible materials. Joiner work includes all cabinets, coamings, the superstructure and other structure not part of the hull.

"LPG System" - The breakdown under LPG system would serve to indicate the source of fuel leakage was at the appliance, in the distribution system or at the storage cylinders. If the leakage was due to a loose fitting, the cause would be listed as an "installation" error.

"Electrical System" - The electrical system is divided into two parts to indicate if wire insulation was ignited or if some piece of electrical equipment caught fire.

"Not Determined" - Would be used where there was no reasonable data available to indicate where the fire started.

"Other" - The column is used to cover items such as an overheated gear box, the ignition of a canvas cover or mattress, etc. where the item has been pinpointed but is not covered in the other causes and categories listed.

"Explosion" - The column marked "explosion" is used to indicate whether or not an explosion occurred immediately. An explosion that occurred as a result of the initial fire would be listed as a "Secondary Explosion" in the "Secondary Factor Table".

KEY TO TABLE 4 - SECONDARY FACTORS SOURCE OF FUEL

"Fire Resistance" - Is without question the major secondary factor with respect to any part of the fuel system. Fire resistance as a separate factor, however, must often be considered in relation to other factors in determining the degree of contribution. Under the category of "Flexible Fuel Lines", for instance, the fire resistance of a hose may cause it to fail, but the amount of fuel that is released will depend on whether or not siphon action is involved, or if because of a bottom tank feed, the entire contents of the tank will be dumped.

"Liquid Fuel" - The liquid fuel is to be used to indicate whether or not liquid fuel is present in the fill pipe and, quantitatively, how much. If the fill pipe burns through and there is no liquid fuel, the fill pipe will become a torch fed only by fuel vapors. If the pipe is long and contains an appreciable quantity of fuel, it could become an important secondary factor.

"Fitting Location" - This factor is used to indicate the existence of bottom or side openings in a tank where a failure of a fill, vent or feed pipe would permit an appreciable quantity of fuel to be added to the fire. With a fire-resistant fuel tank and all fittings off the top, it is not unusual for a tank to retain most of the fuel present at the start of the fire.

"Installation" - This factor could be used if a non-metallic fuel tank intended to be buried for fire resistance is exposed to full flame impingement. It could also be used to cover a suspended bow tank that dropped when the suspending straps failed due to fire. In the case of fuel lines or a fuel pump, etc., installation could be used to indicate any installation condition that contributed to the secondary fuel supply. A loose connection that was not part of the primary cause could be covered under installation.

"Siphon Action" - When it can be determined that siphon action provided a secondary source of fuel, it would be used, but consideration must be given to the fact that when the fire causes the flexible fuel line to burn through at or above fuel level, siphon action ceases. It would normally follow that siphon action with a metallic line will exist for a longer period than with flexible tubing.

"Construction Materials" - The items listed provide a breakdown of the sources of fuel that contribute to the fire.

"Cooking Fuel" - The 3 items listed provide a means of recording the presence of containers of various cooking fuels involved in the fire.

"Secondary Explosion" - The column is used to indicate whether or not an explosion occurred as a result of fire exposure, as opposed to an initial explosion due to primary ignition of vapors.

"Primary Failure" - The primary failure column is used to indicate the quantitative contribution of the primary source of fuel to the total fire.

"Extent of Damage to Boat" - This column provides an indication of the total extent of damage so that the breakdown of contributing factors can be reviewed in proper perspective.

SIGNIFICANCE OF RESULTS

The system of collecting and analysing the data in this Report has been devised to be objective and complete, but it must be recognized that the system used or any other will contain certain inherent fallacies that cannot be avoided. Some are directly related to the limited depth of the field investigations and others would continue to exist with the most sophisticated type of investigation. If these factors, that tend to weigh the results are understood, the charts and tables presented will become more meaningful. Factors to be considered include:

Overall Statistical Significance

The 49 investigations which constitute the base of this Report are considered insufficient to establish any meaningful statistical significance to the findings presented. The absence of statistical significance is compounded by the wide variety of boat types, by a variety of boat sizes and ages and because the cause is determined in only 80 percent of the investigations conducted. It is recognized, however, that if the program is continued good representation of the boating population should come about automatically. How quickly this occurs will depend largely on how many investigations are conducted, and providing the degree of in-depth study is maintained or improved. It can also be expected that the data will become useful in some areas faster than others.

The Numerical Values In the Tables

When numerical values are assigned to the various factors in the Tables of "Causes" and "Secondary Factors", each entry is related to unity or 100 percent for that particular case. However, the resultant percentages under any given cause cannot be assumed to be true indicators of the degree of involvement for that item or factor at this stage. When, for instance a particular cause has been determined on one boat and entered into the appropriate Table, it is automatically given a certain weight in relation to all other causes and the total number of cases covered in the analysis. It is important to realize that not all of the boats in the analysis are equipped with that item or type of equipment. The statistical analysis takes on a different meaning when only one or two boats are equipped with an item as opposed to all boats. In order to minimize the effects of this anomaly, it is necessary to determine and statistically take into account what equipment is used on each boat and to create an analysis method that is flexible enough to relate the cause to either the total number of boats or to the number of boats with that type of component. Table 7, for instance, will in time permit aluminum tank failures to be compared to tanks of all materials, or just to the other aluminum alloys. Table 1 of "Basic Data on Boat and Equipment" was created for this purpose.

Self-Destruct Evidence

In conducting an investigation after a severe fire of long duration, the relative fire resistance of the various component parts plays a very important part in the ability of the investigator to determine what occurred and how each part contributed to the accident. This self-destruct characteristic of some equipment will create an imbalance in the meaning of the tabulated results that must be considered.

In a major fire, it is normal to find the engine carburetors melted beyond recognition while at the same time the fuel tanks remain half full of fuel. Because of the good fire resistance of most fuel tank materials, the tank can be examined in great detail for corrosion, cross threaded joints, evidence of internal water and other physical or chemical damage. This is not true of the less fire resistant items. In the case of the carburetor, the only data possible would be identification of the alloy used and possibly the position of the throttle and choke. It is not possible to check for throttle shaft leakage, to determine if the flame arrester assembly was securely in place or similar details. The differences in available detail is reflected in the individual covering reports and finally in the tables that serve as the basis for the statistical analysis. The chances of pinpointing the fuel tank as a cause is substantially greater than the carburetor, hence the causes listed cannot be accepted on a one-to-one basis.

This same factor applies to wiring, non-reinforced fuel hose and other items to various degrees and the relative susceptibility of each must be considered as it relates to each case. In general, Table 6 places various equipment items in what is considered to be their general or normal order of fire resistance as related to the ability of an investigator to extract usable detail data from the remains of a boat after a fire. The table is presented as a means of conveying the general nature of the problem and not as factual data. The relationships shown will not hold true in all situations.

Age of Components

First, because one of the guidelines established in the selection of boating accidents is a limitation of 15 years on boat age, the resultant statistics will not reveal the life expectancy of fuel tank materials such as nickel copper, some hot dipped galvanized tanks and other materials that are known to last over 20 years.

From the outset of the program, the value of being able to relate failures to boat age was recognized and was the primary

reason for creating Table 1. The fact that a fuel tank of a given material fails and causes an accident is considered relatively useless information without the paralleling information on the age of the tank. Without the age data provided in Table 1, the tabulation of "causes" in Table 2 could be quite misleading.

Sampling Procedure

Because of the very limited number of cases investigated under this program, an attempt was made through the screening procedures to carefully select the particular accidents investigated. While the selection process is relatively effective in making the field time of value, it does not provide any assurance that the accidents investigated reflect the entire boating population. Within the established guidelines, an effort was made to include various boat sizes and types, but not to the extent of following any pre-established pattern.

TABLE 6

GENERAL FIRE RESISTANCE OF MARINE EQUIPMENT AS RELATED TO THE LOSS OF DETAILED INFORMATION IN AN INVESTIGATION AFTER A FIRE

Carburetor	}	Items capable of being destroyed in 10 minutes or less.
Non Reinforced Fuel Hose		
Wiring		
Non-Metallic Air Ducts		
Glass Bowl Filters	}	Items capable of being destroyed in a period of about 10 to 30 minutes.
Fabric Reinforced Fuel Hose		
Fuse Panels		
Fuel Fill System		
Blowers		
Battery Switches		
Instrument Panel		
Batteries		
Mechanical Fuel Pumps	}	Items that will remain substantially intact after exposure to a fire for long periods.
Bilge Pumps		
Marine Fuel Filters (bronze)		
Electric Fuel Pumps		
Engine Controls		
Exhaust System		
Fuel Tanks	}	
Metallic Fuel Lines (copper-steel)		

INDICATED TRENDS

The data accumulated as the result of the 49 in-depth investigations covered in this Report is not considered adequate to justify proposing conclusions, but there are indicated trends and patterns developing that warrant discussion and further observation. The observations are made on the basis of accumulated facts and are listed in the order of their importance and the degree of documentation.

Fuel Above Tank Top Level

Failures of component parts of the fuel system that lie between the tank top and the hull or deck have been involved as primary cause factors in a number of accidents. They are recognized as a major area of concern. Reference is made to the following specific cases:

- (a) Case 1 1970 - The fuel leakage was traced to a fuel gauge. The tank was filled to a level above the fuel gauge mounting plate.
- (b) Case 6 1970 - The fuel leakage was traced to a broken vent line connection (compression fitting) at the tank. The tank had been topped off prior to the accident.
- (c) Case 9 1970 - The fuel for the fire was from the port fuel fill line. The tank had just been topped off and was still at the fueling dock.
- (d) Case 10 1970 - The source of fuel was traced to a leak at the fuel gauge sender. The tank had just been topped-off and was at the fueling dock.
- (e) Case 14 1970 - It was concluded that the fuel leakage was from an improperly fastened fuel gauge sending unit. The boat had just been fueled.
- (f) Case 2 1972 - The investigation traced the leakage to a plastic fuel fill fitting that cracked. The boat had just been fueled and was at the fueling dock.
- (g) Case 6 1972 - The fuel leakage was traced to a fuel tank vent connection that was disconnected. The boat had just been fueled.
- (h) Case 4 1973 - The fuel leakage was traced to a corrosion failure of the port fuel fill pipe. The boat had just been fueled.

- (i) Case 5 1973 - The source of fuel was traced to the failure of a fuel line vent fitting on the port tank. The boat had just been fueled.
- (j) Case 8 1973 - The investigation revealed a corrosion failure of the fuel fill pipe connection at the tank. The boat had just been fueled.
- (k) Case 1 1974 - The fuel leakage was traced to a missing pipe plug in the fuel tank vent system. The boat had just been fueled.
- (l) Case 3 1974 - The fuel leakage was traced to a fuel fill hose that slipped off at the tank. The boat was being fueled.
- (m) Case 5 1974 - The investigation revealed a split vent hose at the tank. The boat had just been fueled.
- (n) Case 9 1974 - The source of fuel was traced to a fuel fill hose failure caused by a corroded spiral reinforcing wire and lack of resistance of the hose to gasoline. The boat had just been topped off.
- (o) Case 11 1974 - The source of fuel was traced to a corrosion failure of the fuel pick-up tube connection at the tank. The boat had just been fueled.

The failures can be summarized as follows:

(1) Fuel fill and vent line fitting failures	6
(2) Fuel gauge mounting problems	3
(3) Corrosion failures	3
(4) Fill and vent hose failures	3

The obvious common denominator in all 15 cases was the fact that the boat was either being fueled or had just been fueled prior to the accident. Although the specific causes varied, the leakage of liquid fuel was in each case present because the tanks were filled to capacity and in most cases well above capacity, making the fuel fill pipe and vent line serve as fuel storage containers. It is noted that in some boats, the fuel fill pipe alone can contain about a gallon of fuel. A standard 1½ inch ID hose can contain about .09 gallons of fuel per foot and a ½ inch ID vent line .012 gallons per foot. The Motor Craft Standard of the NFPA includes the following requirement which is rarely applied at the fuel dock.

"§33(e) Tanks shall not be completely filled. Allow a minimum of 2 per cent of tank space for expansion. The space allowance should be 6 per cent if the fuel being taken aboard is 32°F or below in temperature."

The standards for marine fuel tanks have always been quite rigid, requiring welded or brazed seams, corrosion resistant materials, 2½ minute fire resistance, shock and fatigue resistance and controlled installation. At the same time the standards have tended to become more relaxed for the fuel fill and vent system on the basis that the fill and vent are not intended to serve as fuel storage containers. There would appear to be three possible directions to take in order to solve this problem.

- (1) Educate the public and marina attendants at the fueling dock.
- (2) Apply the same rigid standards developed for fuel tanks to the fill and vent.
- (3) Install an automatic shut-off device that would prevent the tank from being filled to capacity.

Siphon Action

The conditions that permit fuel to be siphoned from the fuel tank exist in most boats and were present in virtually every boat covered in this Report. The siphoning of fuel is most commonly associated with the secondary factors in a fire rather than the primary cause, but the validity of this assumption is gradually being eroded.

Siphon action is definitely one of the major factors involved in the spread of fire and was specifically cited in 10 of the cases included in this Report. In most cases, the evidence indicated that a non-fire resistant hose burned through at the engine and because of siphon action fuel continued to feed the fire. The action will continue until the fire burns through the line above the level of fuel in the tank. At that point, it can be expected that the fuel fill and vent hose will also burn through and the openings will torch at tank top level.

The relationship of siphon action to the primary cause is not as clear cut, since in each case something mechanical must fail to permit the siphon action and the mechanical failure is listed as the cause. In Case No. 11 of 1973, for instance, the primary cause was found to be a distorted gasket on a fuel filter and the cause is so listed, but it was siphon action that permitted or caused the fuel to flow.

In connection with the investigation of Case No. 4 in 1972, a laboratory test was conducted to document the fact that it was possible to simultaneously sustain siphon leakage from a fuel feed line while the engine on the line is running. The test clearly demonstrated that it was possible and that there would be no indication of a problem as long as the engine was operating at low RPM. In the test, the 125 HP engine was operated at 1500 RPM under some load while sustaining a siphon action leak of 300 milliliters per minute. The interesting fact was that the siphon head was only a couple of inches. When the throttle was advanced, the engine RPM increased to 3400 RPM and then the engine quit due to fuel starvation. At the lower RPM there was no evidence of a problem and the engine operated normally.

The current safety standards of the ABYC and the NFPA, as well as the proposed Coast Guard Regulations, all require some form of anti-siphon protection and, as previously noted, the need appears to be more than justified. Accepted methods of anti-siphon protection include automatic anti-siphon valves, electric shut-off valves, keeping all parts of the fuel distribution system above tank top level and the use of an air bleed hole in the tank fuel pick-up tube. A brief review of each method, based on information gathered in the four years of this study, seems in order. The following is noted:

- (1) Anti-Siphon Valves - Although it was determined that several of the boats involved in this study were initially equipped with anti-siphon valves at the time they were manufactured, the valves were not in place when the investigations were conducted. It was found that it is almost standard procedure for boat dealers and service yards to remove the valves at the first indication of a fuel problem. In some cases the valves are removed before the boat is delivered to the customer. The reason involves two problems. First, the standard anti-siphon valves available on the market introduce enough restriction to fuel flow and impose enough load on the fuel pump that the pump cannot deliver the required fuel at full power. Second, it was found that when two tanks were used and one ran dry, the engine fuel pump would not pick up the fuel from the full tank when the tanks were switched. It would appear that the level of technical development in anti-siphon valve design is not equal to the field requirements at this time. There are reportedly some new designs under development, but field data was not available to judge their performance.

- (2) Electric Fuel Shut-Off Valves - The use of a positive automatic shut-off valve, if properly sized, provides a positive control of the problem whenever the engines are not operating. Valves are relatively expensive and rarely used. None of the boats investigated were equipped with electric valves. The electric solenoid valve is not really an anti-siphon device in the normal sense of the word.
- (3) Keeping Fuel Distribution System Above Tank Top Level - The sloping of all fuel lines up from the tank is the most positive and simplest method of anti-siphon protection; however, the investigations indicate that the condition is rarely achieved in actual practice. It was found that in order to properly position the propeller with respect to the hull bottom, inboard-outdrive engines are invariably installed in an engine well with the engine crankshaft at or slightly below the cockpit deck level. Since mechanical fuel pumps and flexible fuel lines are often positioned below the crankshaft, siphon action is possible even when the fuel tank is located below the cockpit deck.
- (4) Air Bleed In Tank - An air bleed hole in the fuel pick-up tube in the tank has been used for many years. It appears to be effective when the correct size bleed hole is used and as long as the hole does not clog. There are no figures available to properly assess the clogging problem, but when several boats were checked a number of years ago in connection with an NFPA Committee discussion, some were found to be clogged. As in the case of an anti-siphon valve, the size of the hole is vital and must be determined by both the engine requirements and the potential height of the fuel above the lowest part of the system. If the bleed hole is too small, siphon action is still possible.

Fuel Tanks - Design and Installation

Every component in a boat fuel system must be considered very carefully, but from a quantitative standpoint the fuel tank obviously poses the greatest single problem. Since corrosion remains as the major concern with respect to tank failures and corrosion is directly influenced by installation conditions, installation warrants special attention. The available in-depth data is still weak, but the following observations are suggested by the data collected in the 4 year period:

- (1) Internal Corrosion - The susceptibility of a fuel tank to internal corrosion is largely determined by the material, but it is also evident that tank design and installation play an important part in what occurs. Based on the 49 investigations, the materials found most susceptible to internal corrosion were (1) terneplate steel, (2) galvanized sheet steel and (3) the aluminum alloys. Specific reference is made to the following cases where information was obtained on internal corrosion:
- (a) Case No. 1 1972 - The 4 year old 3004 aluminum alloy tank corroded through from the inside and was determined as the primary cause of that accident. The nature of the failure suggested that a particle of brass, probably from a threaded fitting dropped into the tank and caused a local cell to be created.
 - (b) Case No. 9 1973 - The fiberglass covered galvanized sheet metal tank was very badly corroded internally, below the level of the fuel pick-up tube. Failure of the tank was established as the cause of the accident. When the tank was sectionalized for study, it was very clearly evident that the heavy corrosion in the tank started at the exact level of the fuel pick-up tube. The pick-up tube length was such that the last 7/8 of an inch of liquid was never removed. Since water is heavier than gasoline the salt water always remained in the tank. The tank was 6 years old.
 - (c) Case No. 6 1974 - Although the 9 pound terneplate fuel tank in this boat failed due to external corrosion, scattered internal corrosion to a depth of 18 thousands of an inch or 1/3 the material thickness was found. The tank was 8 years old when it failed.
 - (d) Case No. 9 1974 - The 5052 aluminum tank in this case was not the cause of the fire, but the investigation revealed internal corrosion pitting to a depth of .030 inches or 1/3 of the material thickness. The investigation revealed the fact that the boat had sunk several years prior to the accident and it was not possible to evaluate to what extent the sinking contributed to the corrosion. External pitting with pit depths of .040 were found and a sheet metal screw had been installed in one end of the tank to stop a leak that developed after the sinking, 1-1/2 years before the accident.

- (2) External Corrosion - Except for the normal corrosion of a given metal alloy in a marine environment, the accelerated corrosion found on tanks in service is inevitably associated with the accumulation or entrapment of water somewhere on the surface. Water accumulation results from either the tank design or water traps created by the method of installation.

Both the NFPA and ABYC Standards include a general requirement that fuel tanks shall be constructed so that exterior surfaces will not hold moisture, but it is apparent that many fuel tanks do not comply. The problem, as it relates to the tank itself, is almost entirely restricted to light gauge materials which deform around tank-top fittings and fuel gauge openings. This form of localized corrosion, due to water pockets, is evident in Photograph No. 3, Case No. 2, 1974, in the addendum of this Report.

The problem of corrosion due to water entrapment can, and often is, compounded by the method of installation of the tank. NFPA Standard 302 states that "Contact between metallic fuel tanks and other structure should be limited to the necessary supports in order to permit free circulation of air." Reference is made to the installation of the tank in Case No. 2, 1974 and Case No. 4, 1974. Both are examples of tanks secured to flat platforms with no air circulation below the tanks. (See photographs in addendum of Report.) Although neither of the tanks referred to failed, because of the installation method, the bottom surfaces did show evidence of local accelerated corrosion due to water entrapment.

The number of foamed-in fuel tanks encountered in this study is relatively small, but it appears evident from the investigation of Case 4, 1970 and Cases 6, 7 and 9 in 1974, that the foaming in of the tanks was directly responsible for accelerated corrosion of the tank in each case.

In Cases 4 of 1970 and 6 of 1974, the tanks involved were terneplate steel construction and there would appear to be little, if any, debate with the fact that terneplate steel should never be foamed in place. It is noted that both the ABYC and the proposed Coast Guard regulations restrict foamed-in installations to non-metallic tanks and certain aluminum alloys. Notwithstanding the material itself, Photograph No. 3 of Case No. 6, 1974 and Photograph No. 3 of Case No. 7, 1974 illustrate the fact that the installations

did cause water to be trapped on the tank top. It seems axiomatic, that if water is trapped, even the acceptable materials will experience accelerated corrosion.

Although the foamed-in installations are theoretically intended to prevent water from reaching the tank bottom and sides, the evidence available to date would indicate that the protection is not actually achieved in practice. Photograph No. 3 of Case 7, 1974 illustrates how the foam has separated from the tank, leaving a gap to channel water to the lower surfaces. In Case No. 6, 1974, it was clearly evident that water had migrated past the foam to the entire tank bottom. It was interesting to note that the foamed-in tank bottom in Case No. 6, 1974 did look relatively clean, although scattered pits with depths of .018 inch were found. While it is entirely possible that the corrosion on the tank bottom was less than that of a standard chock installation, the corrosion along the top edges and on the tank was considered to be greatly accelerated.

- (3) Accessibility - In conducting any fire and explosion investigation, it is very important to completely check the fuel tank and whenever possible, the tank is removed from the boat and returned to the laboratory for detailed examination. The need to check tanks after a fire has tended to graphically illustrate the difficulty any boat owner or service yard would have attempting to check the tanks as part of routine service. Some are, of course, quite accessible, but it is becoming increasingly evident that many are either difficult to inspect or completely inaccessible. In conducting the 11 investigations in 1974, the following examples of this condition were found:

- (a) Case 5 1974- In this case the fuel tank was "accessible", but because it was necessary to remove about 10 screws and a molded fiberglass seat, the boat operator was not aware of the failure of a vent tube at the tank. The evidence clearly showed that the leakage was present over a long period of time, since the fuel had effected the paint coating on the tank. In this instance a hinged seat would have made the tank "readily accessible" and increased the chances of detecting the failure.

Case 6 1974 - The fuel tank in this boat was completely inaccessible for inspection and it became necessary to remove the entire deck to gain adequate access to the tank. Since the aft edge of the tank was perforated in at least 26 places and the fuel pick-up tube connection was corroded out and supported by the fuel line, the leakage had to be present for an extended period of time. It was again probable that accessibility would have increased the likelihood of detecting the failure.

Case 7 1974 - This installation was identical to that in Case 6, and although the 1 year old tank had not failed, the problem will probably exist in a couple of years.

Case 9 1974 - In order to check this tank after the fire, it was necessary to remove the cockpit deck with an ax since no hatch had been provided. The tank was very badly corroded, but the boat owner had no way of determining the fact that the tank was on the verge of failing or that the fuel fill hose had failed. The fuel fill hose was foamed-in.

Electrical System Problems

Over the 4 year period only a few electrical fires have been investigated so that the basis for any comment is statistically weak. Notwithstanding the absence of good statistical data, three possible areas of concern have emerged from the 49 investigations that deserve specific consideration. They are reviewed in what is considered to be the order of their importance.

- (1) Unprotected Ignition and Alternator Circuits - In a number of the boats investigated in this program, it has been found that the ignition circuit and alternator circuits are often completely without overcurrent protection. Usually, the battery is connected directly to the starter solenoid on the engine and a heavy conductor, such as a number 4 Awg wire, is connected from the solenoid to the ignition switch. When the switch is "on", the battery is connected directly to the engine ignition circuit and alternator through the switch.

The absence of overcurrent protection can and has been determined as the mechanism which can trigger secondary fires. While a small engine space fire might be controlled with on-board extinguishers, secondary fires are usually beyond the capability

of the small portable extinguishers usually carried on boats. This is particularly true of electrical fires, which will tend to reignite until the source of power is disconnected. In the circuit described, when the original fire softens the insulation of either the ignition system power feed or alternator leads and the wires short to the engine block, a dead short condition then exists from the engine to the ignition switch and back to the engine solenoid. This condition was definitely established as the cause in Case 3, 1973, and was a major factor in Case 7, 1974.

- (2) Ignitability of Boat Wiring - In a number of cases it has been evident that wire insulation used on boats is very easily ignited by a very short duration flame front. In the same general area, rubber hose, wood and paint will show no evidence of fire damage, but the wiring will ignite and burn. Spark plug wires are apparently particularly susceptible to this type of flash ignition.

The ready ignitability of wiring is often used to help analyze a fire. The burn pattern on the cylindrical wires can help determine the direction of the flame front in a given area and also provide an indication of the flame duration.

- (3) Master Battery Switch - The need for a master battery switch has been the subject of much debate in the standard writing committees and although the 49 cases investigated do not shed much light on the subject, the following observations were made:
- (a) Out of 32 cases investigated from 1972 to 1974, 10 boats were equipped with master battery switches.
 - (b) In the 10 boats with switches, 3 switches were completely inaccessible under fire conditions.
 - (c) In Case 10, 1972, the electrical short involved jumper cables to the batteries. The jumper cables would have by-passed any master battery switch, if one has been provided.
 - (d) An accessible master battery switch would have undoubtedly greatly minimized the damage in Case 3, 1973. No fuel was involved.
 - (e) In Case 4, 1974, an accessible master battery switch might have prevented the ignition of the fuel. The ignition was caused by a tool shorting against a live electrical terminal during repairs.

- (f) In Case 7, 1974, the owner shut off the fuel supply and probably would have used an accessible master switch, if provided. The fire damage at the instrument panel was attributed to secondary short circuits.
- (g) The electrical fire in Case 10, 1974 was attributed to a short in the DC system. Since the boat was unattended, it is possible that a master switch could have prevented the fire.

Histograms

In order to graphically reveal any possible patterns in the three cause and effect tables, each table has been prepared in histogram form. In each case the basic histogram represents the results of the 49 cases investigated between 1970 and 1974. Each bar represents the total frequency that each cause was responsible for the 49 fire and explosion cases or, in the case of the secondary factors how much each factor quantitatively contributed to the fires. The results for 1974 are superimposed on the results of the 4 year study.

Frequency of Primary Causes Providing Fuel in 49 Fire and Explosion Cases - Figure 1.

The histogram of "Primary Causes" represents the frequency that each cause was responsible for releasing the fuel that caused the accident when ignited. All causes which cumulatively contributed the equivalent of 20 percent or less of one accident in the 4 years were eliminated from the histogram. The superimposed black bar represents the results in 1974 only.

It is noted that in 1974 the results did not follow the four year pattern but no significance is attached to this departure. In 1974 both fuel tank corrosion and fuel tank installation were the major factors and it is noted that the number of undetermined causes was lower than normal.

Frequency of Primary Ignition Sources in 49 Cases - Figure 2.

The histogram of "Primary Ignition Sources" represents the frequency that each cause was judged to be responsible for igniting the primary source of fuel. All causes which cumulatively contributed the equivalent of 20 percent or less of one accident in the 4 year period were eliminated. The superimposed black bar represents the results of the investigations in 1974 only.

The results of the 1974 investigations appear to be reasonably consistent with the four year totals. The two major problem areas indicated are the ignition distributor and the engine starter.

Frequency of Secondary Factors Contributing Fuel To the Fires On 49 Boats - Figure 3.

The histogram represents the quantitative contribution of each factor in 49 cases fuel sources which were judged to contribute the equivalent of less than 20 percent of the fuel in one case over the 4 year period were not included in the histogram. The superimposed black bar represents the results in 1974.

Fuel Tank Service Life

Information pertinent to the suitability of various fuel tank materials in marine service can be one of the most valuable contributions of a program of this type, although the information will develop slowly. Table 7 is a summary of the data collected in the 49 cases.

Summary of Unusual Causes

The following is a brief summary of unusual causes that are not likely to be repeated. The summary of unusual causes is based on a review of the 49 cases covered in this analysis.

Case 1 1974

A pipe tee fitting was installed in the vent connection of each fuel tank with a 1/8 inch tee-handle pipe plug installed, apparently for the purpose of checking fuel level in the tank. The 3/8 inch diameter opening was too small for a normal dip-stick. The accident was caused by the tee plug falling out.

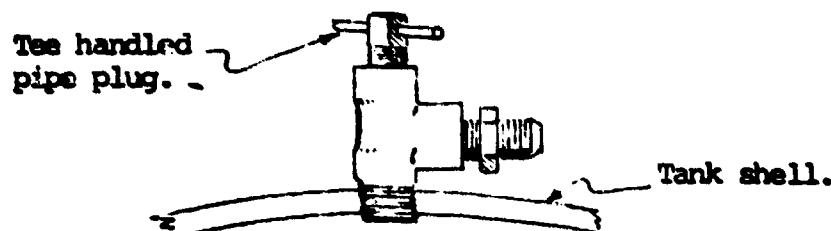

Case 3 1974

In this case, a bonding wire was clamped to the short pipe provided for attachment of the fill hose. Because of the very limited length of pipe left for clamping, the hose slipped off and when the tank was filled, the fuel was pumped onto the tank top instead of into the tank.

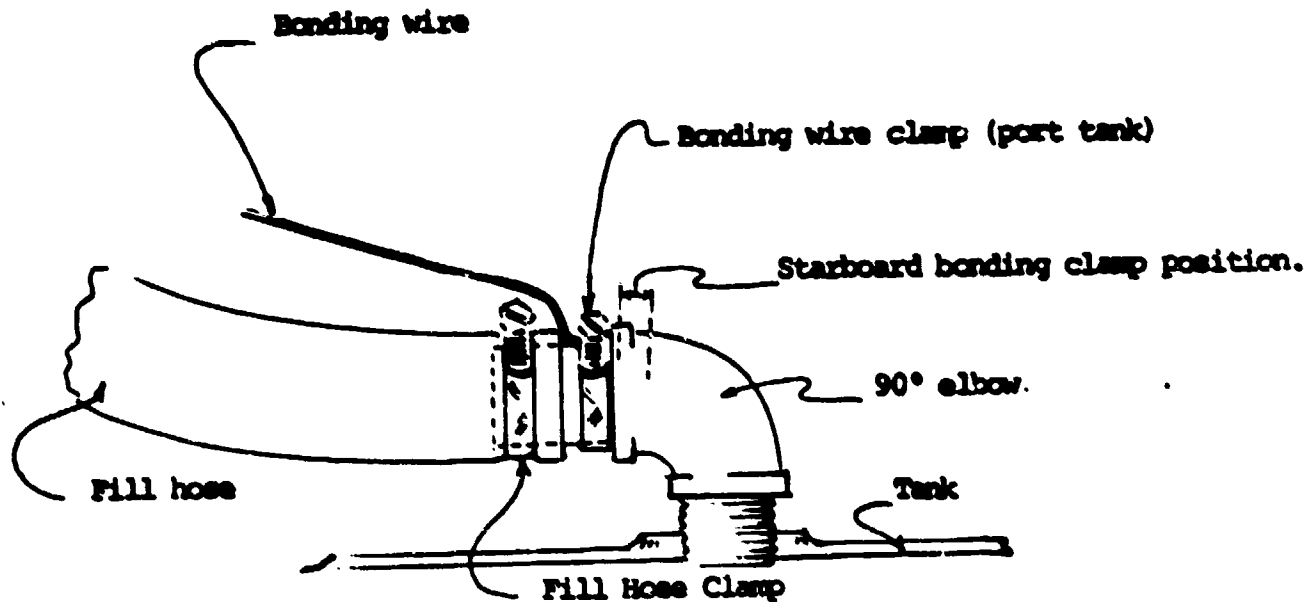
Case 10 1972

The electrical fire on this boat was caused by battery jumper cables that were left connected to the port battery, with the free end clamped to a taped metallic tachometer table. The battery clamp cut through the plastic tape, resulting in a direct short to ground.

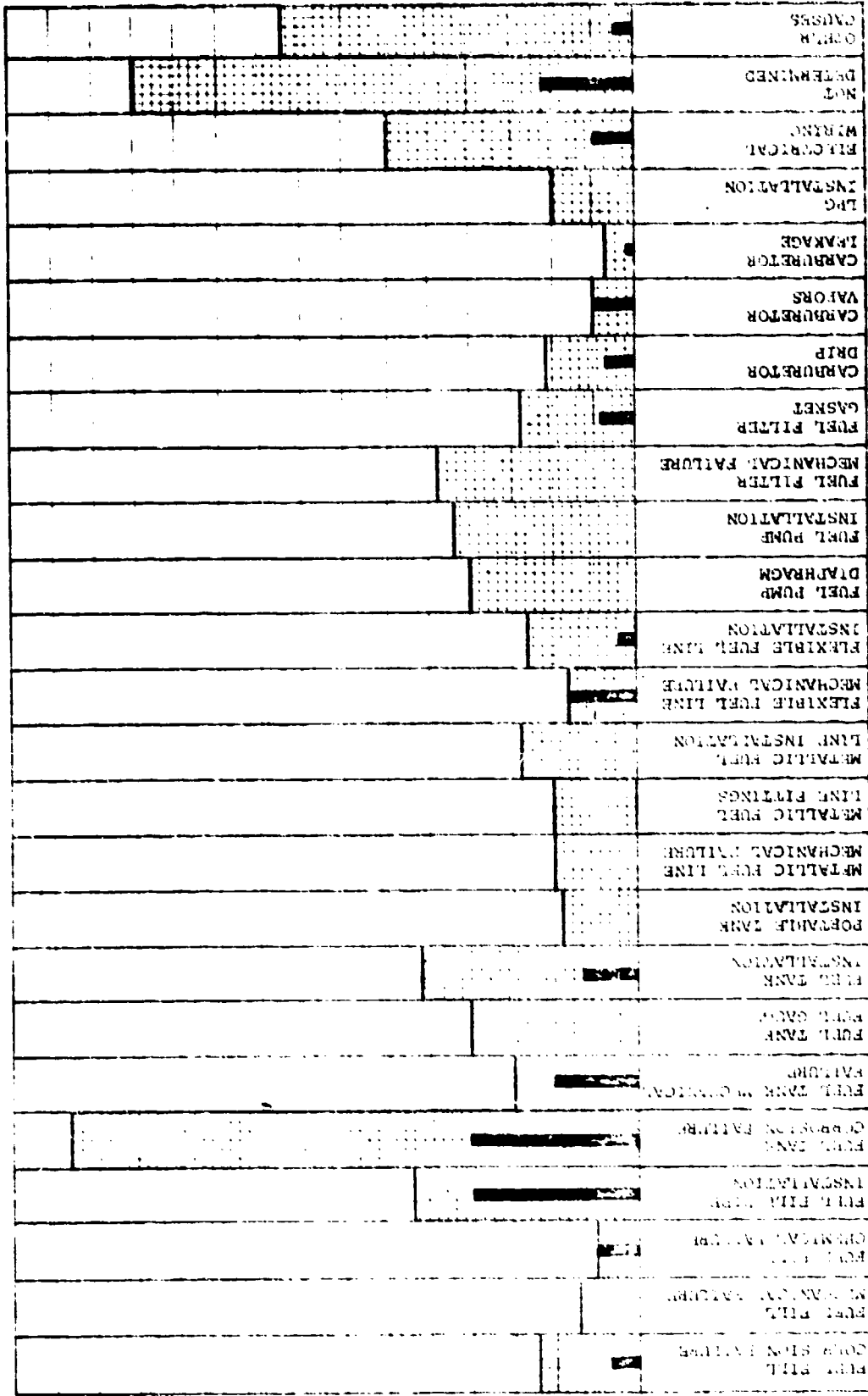

Total 1970, 1972, 1973 and 1974
 1974
 FREQUENCY OF PRIMARY CAUSES PROVIDING FUEL
 IN 49 FIRE AND EXPLOSION CASES

FIGURE 1

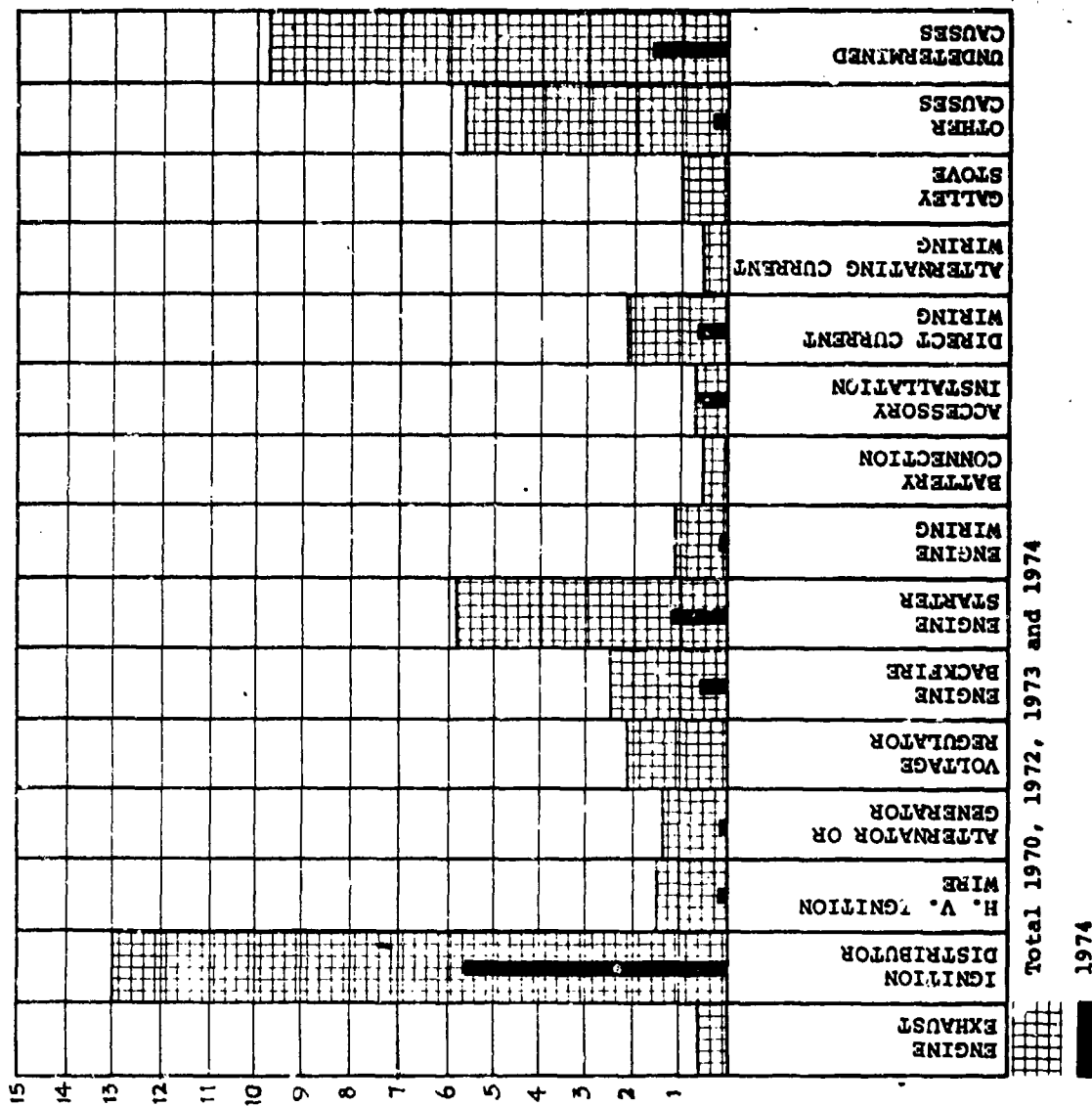

**FREQUENCY OF PRIMARY IGNITION SOURCES
IN 49 CASES**

FIGURE 2

Total 1970, 1972, 1973 and 1974

1974

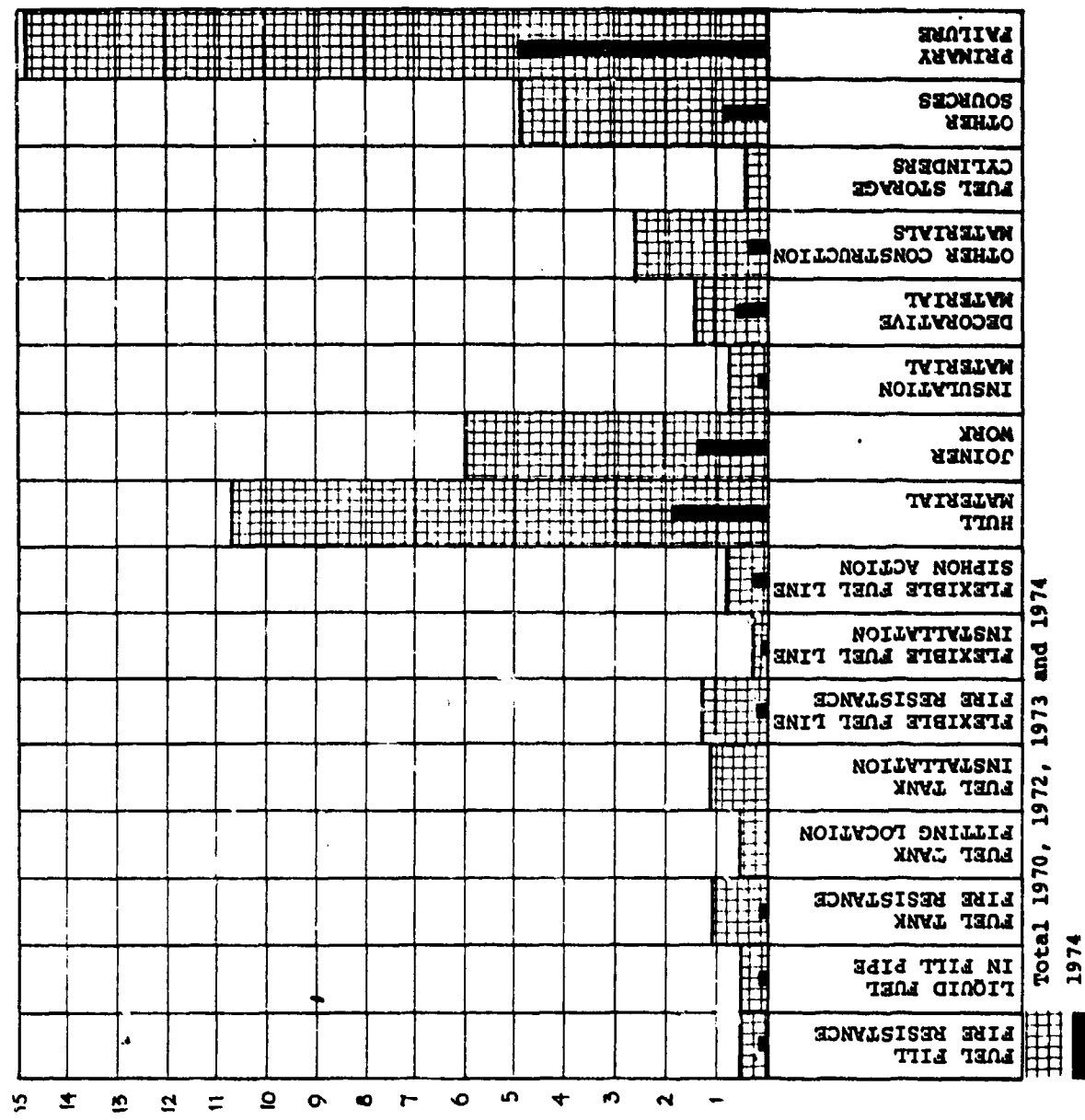

FREQUENCY OF SECONDARY FACTORS CONTRIBUTING
FUEL TO THE FIRES ON 49 BOATS

FIGURE 3

**FUEL TANK SERVICE LIFE TABLE BASED
ON DATA FROM 1970, 1972, 1973 & 1974
INVESTIGATIONS**

		1	2	3	4
	Abbreviation Used in Table	Tanks With Service Life of 10 Years Or More	Tank Failures With Service Life Of 1 to 4 Years	Tank Failures With Service Life Of 5 to 9 Years	Tank Failure With Service Life * Of 10 to 15 Years
Copper	C	2	-	-	1
Nickel Copper	NC	3	-	-	-
Hot-Dipped Galvanized Steel	SG	5	-	-	2
Galvanized Sheet Steel	GS	1	-	1	-
Terneplate Steel	T	1	-	1	1
Steel	S	-	-	-	-
Fiberglass Reinforced Plastic	FG	-	-	-	-
Aluminum 3004	AL	-	1	-	-
Stainless Steel 304	SS	-	-	-	-
Plastic	P	-	1	-	-

*Tanks listed in column 4 that fail after 10 years are also included in column 1.

TABLE 7

APPENDIX

RECREATIONAL BOATING ACCIDENT INVESTIGATIONS FOR 1974

C A S E N O. 1

DESCRIPTION OF BOAT

The boat involved in this fire was a 30 foot Flying Bridge Sport Fisherman built by Henry Luhrs Sea Skiff Inc. of Morgan, New Jersey in 1960. The boat was of wooden lapstrake construction with steam bent oak frames and copper riveted seams.

The 14 year old boat was single screw, with an engine box at the forward end of the open cockpit and two fuel tanks under the aft cockpit deck on the port and starboard sides. The tanks were positioned fore and aft. The boat had vee bunks forward, an enclosed head aft of the bunks on the port side and the helm console on the starboard side. A small galley sink was located aft of the helm. The boat was not equipped with a galley stove or dinette. See Figure No. 1.

The boat was powered by a 220 HP Gray marine engine with a fresh water cooling system. The engine was in fair condition.

The port cylindrical hot-dipped galvanized fuel tank was 14 inches in diameter and 65 inches long with a capacity of about 42 gallons. The starboard hot-dipped galvanized steel tank was 14 inches in diameter and 78 inches in length with a capacity of approximately 50 gallons. Both tanks were supported by two form-fitting chocks.

The boat had a 4-cowl 4-duct natural ventilating system that apparently was installed to comply with the U.S.Coast Guard rules on ventilation. The ducts were 4 inches in diameter.

PHOTOGRAPHS

No. 1 - Bow view of burned hull. In the photograph both the port and starboard fuel tanks are visible aft of the engine.

No. 2 - View of engine looking forward on starboard side. The generator is visible forward below the starboard water-cooled manifold and the melted carburetor is visible aft of the expansion tank. The backfire flame arrester is on the starboard manifold facing forward. (It was found in the bilge.)

No. 3 - Photograph of starboard tank vent connection showing tee fitting at tank with pipe plug fitted with a tee handle.

No. 4 - Photograph of port tank vent connection showing tee fitting with pipe plug missing.

No. 5 - Photograph of port fuel tank fuel feed connection, shown with hose connected to pressurize the tank. The port exhaust pipe, which dropped on the fuel line is visible at the arrow. The valve below the tee connection is the cross feed valve.

NARRATIVE REPORT OF INCIDENT

The boat owner, with one male adult passenger, had been out for a couple of hours in the evening prior to the accident and during that period the boat operated normally. They found a fueling dock still open and decided to fill the tank. At the fuel dock, the boat took on about 25 gallons (\$14.50) in the port tank, using sound as the means of determining when the tank was full. The starboard tank was not used by the owner in order to keep the boat in better trim. When the tank was full, the boat remained at the dock for about 20 minutes before an attempt was made to start the engine.

The boat did not have a blower and no attempt was made to check the bilge for fumes prior to starting. The boat owner was on the fueling dock when the passenger attempted to start the engine. As the starter button was depressed, there was a mild puff and flame was immediately visible on the port side. The owner did not know if the engine started but indicated that he did not hear the engine backfire.

The boat owner used one hand portable extinguisher on the fire but it was not effective. After the owner and passenger got off, the boat was cut loose and was shoved into the open water. The boat was taken in tow by another boat yard and towed to the opposite shore where the fire was extinguished by the Fire Department with water. The boat was then hauled.

FACTS ESTABLISHED FROM WITNESSES

1. The boat owner purchased the boat 2 years prior to the accident and had owned other boats.
2. The boat owner indicated that he did not use the starboard fuel tank, because the boat would trim better with just the port tank.
3. The boat owner indicated that he determined when the tank was full by sound.
4. Yardman that took boat in tow (before the fire was extinguished) indicated the presence of a blow torch fire at the port vent fitting.

KNOWN CHANGES TO ORIGINAL DESIGN

1. An extra belt-driven water pump had been added forward of the engine on the port side.

2. The exhaust system had been modified but is classified as a repair.

OBSERVATIONS AND FINDINGS.

1. Boat Fuel System - When the investigation was conducted, the fuel system was not tight and would not hold pressure. The starboard fuel tank was empty and shut-off which confirmed the owner's statement that the tank was not used.

- a. Fuel Fill - The port fuel fill pipe was badly burned but was apparently still liquid tight after the fire. Only part of the fill system could be pressure checked. The multilayer fabric reinforced hose was double clamped and was provided with a bonding strap to the deck plate. The system could hold a maximum of 2/10 gallons, based on the location of the vent discharge.
- b. Vent System - Both fuel tanks were vented with 1/2 inch OD copper tubing through the hull side just below the sheer line. The vent discharge was about 18 inches above the tank top. The vent line was connected with a flare fitting to a tee fitting at the tank. See Figure No. 2.

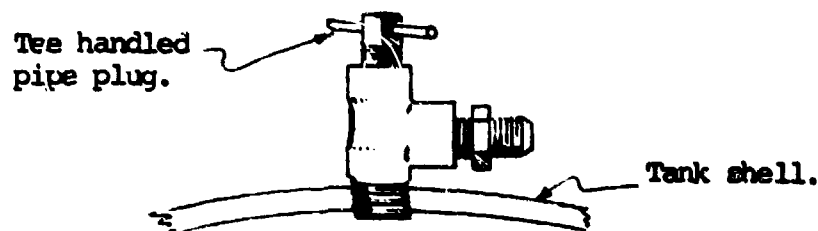

Figure No. 2

When inspected, the tee handle plug was missing from the port fuel tank and is considered to be the source of fuel for the fire. The missing plug could not be located.

At the discharge end, the copper tubing was pressed through the hull planking and flared on the outside. A sheet metal cover was provided with no flame screen.

(c) Fuel Feed System - The layout of the fuel feed system is shown in Diagram No. 1. The following was noted:

- (1) The fuel tank shut-off valves were external spring loaded cocks which are not recommended for use in fuel systems. The valves were not independently supported. The valve could not comply with UL 1106 "Manually Operated Valves For Use With Flammable Liquids".
- (2) The flare nut connecting the distribution line to the port tank shut-off valve was split. It is probable that the nut split as a result of thermal shock when it was hit by cold water by the Fire Department.
- (3) The fabric reinforced push-on hose used between the copper fuel distribution line and the engine would not comply with the 2-1/2 minute fire resistance requirement of the NFPA or ABYC. The system had no

antisiphon protection and therefore could not comply with the ABYC requirements for systems not required to have 2-1/2 minutes fire resistance.

- (4) The cross feed valve was not independently supported. The valve could not comply with UL 1106.
- (5) The fuel feed system was routed under the engine exhaust pipe. As installed, a failure of the exhaust pipe would permit the exhaust-pipe to fall on the fuel distribution line and automatically cause the fuel system to fail. If the fuel system was routed high as recommended, this could not occur.

(d) Fuel Tanks - Both tanks were hot dipped galvanized steel and appeared to be fabricated of 14 gauge material with welded seams. The tanks had been painted and did not show evidence of any advanced corrosion. The port fuel tank was found liquid tight and contained approximately 34 gallons after the fire (3/4 full). It is believed that all of the fuel loss (approximately 8.5 gallons) was lost through the open vent by expansion and direct combustion.

2. Engine - Gray Marine 220 HP No. 3158242 - R18889A.

- (a) Backfire Flame Arrester - The Barr backfire flame arrester with Zenith grid did not have a USCG Approval Number and could not have been approved because of the 1/2 inch pipe nipple out of the housing. See Photograph Number 2. The owner stated that there was no backfire.
- (b) Distributor - The Delco Remy ignition distributor was completely burned. See Photograph Number 2. Since the housing was vented in 3 places with a 1/4 inch and two 1/8 inch openings, it was a likely source of ignition for fuel vapors. The distributor had a vacuum advance.
- (c) Generator - The engine was equipped with an enclosed generator that appeared tight and a mechanical voltage regulator. Since a generator does not cut in at very low RPM it is not likely that the ignition spark was from the generator or voltage regulator. Had the engine "revved up" when ignition occurred, the boat owner probably would have recalled the engine starting.
- (d) Oil Level - The engine oil level and the transmission oil level were normal and all drive belts were in place.
- (e) Controls - Both the engine helm control and the carburetor and transmission confirmed that the engine was in neutral and at idle RPM.

- (f) Exhaust System - The exhaust pipes had a slight downward slope but the water injection elbow was almost horizontal. (The point of water injection was above the lower edge of the exhaust manifold opening.) The ABYC Standards require a drop of 4 inches to the point of water injection.

3. Electrical

- (a) Main Switch - The boat was equipped with an open knife switch but the switch was not used at the time of the ignition. The insurance company had recommended that the knife switch be removed 2 years prior to the accident. All connections were tight.
- (b) Wiring - The wiring was completely burned, throughout the boat. Wiring was of the flexible and 7 strand type.
- (c) Batteries - The boat had two separate batteries but only one was connected.
- (d) Overcurrent Protection - The fuse panel was not located.
- (e) Bonding System - The boat had a 1 inch copper bonding strap and the fill pipes were electrically bonded.

4. Miscellaneous

- (a) PFD's - Type AK-1 kapok buoyant device was found on forward bunk.

(c) Two spray cans had exploded and signal flare kit burned. The spray cans and flare kit were in the sink cabinet behind the helm.

(d) An automotive battery charger was found loose in the bilge.

OPINION

All of the facts and findings in this case tend to confirm that the source of fuel for the fire was from the missing vent plug from the port 42 gallon tank. The boat was filled until the sound indicated the fuel had reached the fill pipe. Although the exact amount is not known, the horizontal section of the fuel fill would fill up quickly and the major sound level change would occur when the fuel reached the vertical pipe. At that point the fuel would be pouring out of the missing vent opening to the bilge. The boat did not move for about 20 minutes which would allow additional fuel to be discharged due to the gradual increase in the temperature of the fuel. The fuel was delivered from an underground tank and the temperature of the engine compartment was probably about 50° C (122F) since the fresh water cooled engine would operate at about 82° C (180F).

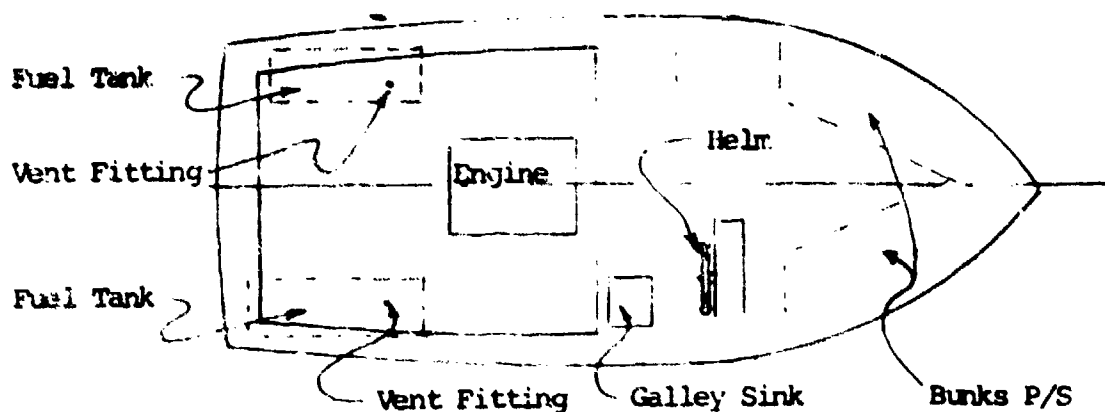
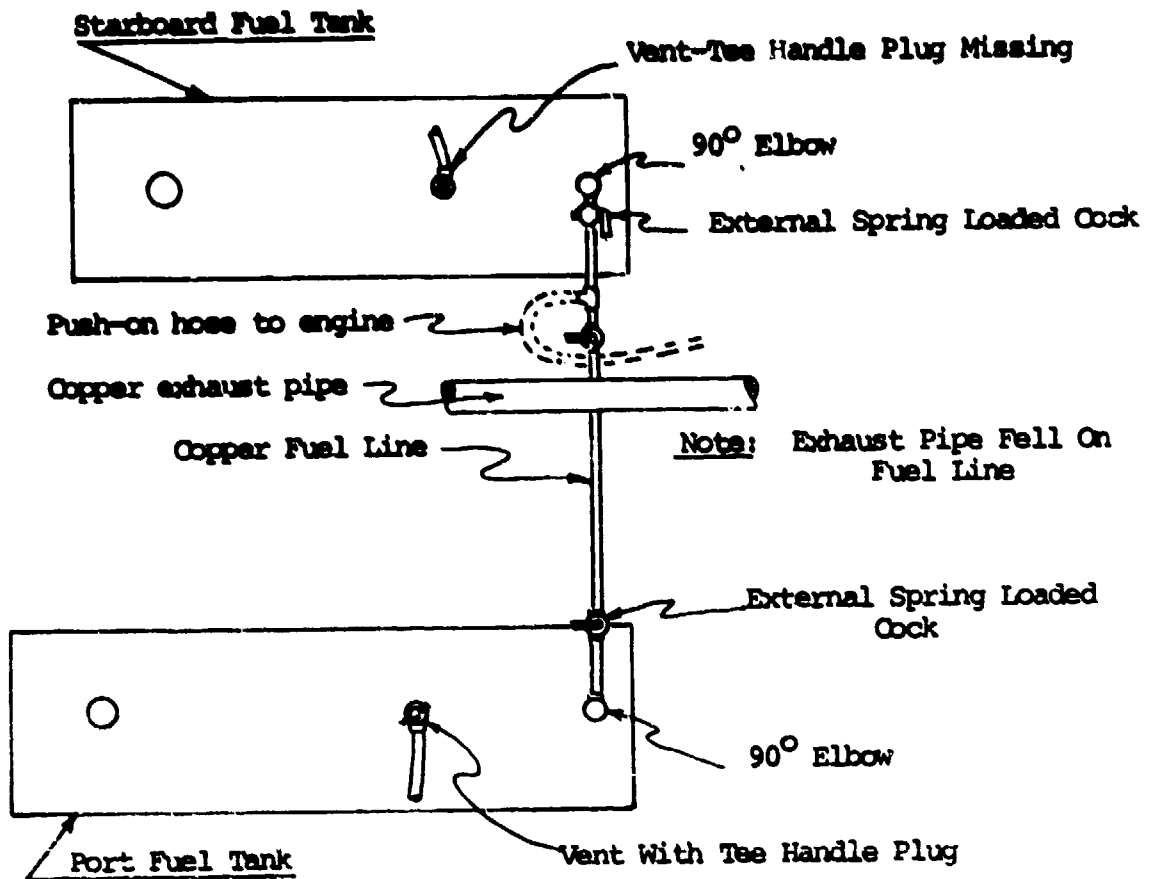

Figure No. 1



Fuel Feed System Layout

Diagram No. 1

NO	DESCRIPTION	DATE	UNIT	QTY	PRICE	TOTAL	TAX	AMOUNT	STATUS
1	FIXED SYSTEM								NO
2	FIXED SYSTEM UNIT								NO
3	EFFECTIVENESS OF FIXED SYSTEM								NO
4	WOULD FIXED SYSTEM HAVE HELPED								YES
5	USE OF OTHER EQUIPMENT								U
6	EFFECTIVENESS OF OTHER EQUIPMENT								NE
7	WOULD OTHER EQUIPMENT HAVE HELPED								NO
8	USE OF OTHER EQUIPMENT								NO
9	EFFECTIVENESS OF OTHER EQUIPMENT								NO
10	WOULD OTHER EQUIPMENT HAVE HELPED								NO
11	EFFECTIVENESS OF OTHER EQUIPMENT								NO
12	WOULD OTHER EQUIPMENT HAVE HELPED								NO
13	EFFECTIVENESS OF OTHER EQUIPMENT								NO
14	WOULD OTHER EQUIPMENT HAVE HELPED								NO
15	EFFECTIVENESS OF OTHER EQUIPMENT								NO
16	WOULD OTHER EQUIPMENT HAVE HELPED								NO
17	EFFECTIVENESS OF OTHER EQUIPMENT								NO
18	WOULD OTHER EQUIPMENT HAVE HELPED								NO
19	EFFECTIVENESS OF OTHER EQUIPMENT								NO
20	WOULD OTHER EQUIPMENT HAVE HELPED								NO
21	EFFECTIVENESS OF OTHER EQUIPMENT								NO
22	WOULD OTHER EQUIPMENT HAVE HELPED								NO
23	EFFECTIVENESS OF OTHER EQUIPMENT								NO
24	WOULD OTHER EQUIPMENT HAVE HELPED								NO
25	EFFECTIVENESS OF OTHER EQUIPMENT								NO
26	WOULD OTHER EQUIPMENT HAVE HELPED								NO
27	EFFECTIVENESS OF OTHER EQUIPMENT								NO
28	WOULD OTHER EQUIPMENT HAVE HELPED								NO
29	EFFECTIVENESS OF OTHER EQUIPMENT								NO
30	WOULD OTHER EQUIPMENT HAVE HELPED								NO
31	EFFECTIVENESS OF OTHER EQUIPMENT								NO
32	WOULD OTHER EQUIPMENT HAVE HELPED								NO
33	EFFECTIVENESS OF OTHER EQUIPMENT								NO
34	WOULD OTHER EQUIPMENT HAVE HELPED								NO
35	EFFECTIVENESS OF OTHER EQUIPMENT								NO
36	WOULD OTHER EQUIPMENT HAVE HELPED								NO
37	EFFECTIVENESS OF OTHER EQUIPMENT								NO
38	WOULD OTHER EQUIPMENT HAVE HELPED								NO
39	EFFECTIVENESS OF OTHER EQUIPMENT								NO
40	WOULD OTHER EQUIPMENT HAVE HELPED								NO
41	EFFECTIVENESS OF OTHER EQUIPMENT								NO
42	WOULD OTHER EQUIPMENT HAVE HELPED								NO
43	EFFECTIVENESS OF OTHER EQUIPMENT								NO
44	WOULD OTHER EQUIPMENT HAVE HELPED								NO
45	EFFECTIVENESS OF OTHER EQUIPMENT								NO
46	WOULD OTHER EQUIPMENT HAVE HELPED								NO
47	EFFECTIVENESS OF OTHER EQUIPMENT								NO
48	WOULD OTHER EQUIPMENT HAVE HELPED								NO
49	EFFECTIVENESS OF OTHER EQUIPMENT								NO
50	WOULD OTHER EQUIPMENT HAVE HELPED								NO

SUMMARY OF DATA
 BOAT 30 FT F. A. SPORT FISHERMAN, WOOD LAPSTRAKE
 MANUFACTURER HENRY LUIRS SEA SKIFF INC
 YEAR 1974 CASE NO. 1

Reproduced from
best available copy.



1974 CASE No. 1 PHOTO No. 1



1974 CASE No 1 PHOTO No



PHOTO No 3



1974 CASE

Reproduced from
best available copy.



1974 CASE No. PHO 01

RECREATIONAL BOATING ACCIDENT INVESTIGATIONS FOR 1974C A S E N O. 2DESCRIPTION OF BOAT

The 20 foot, single engine, inboard-outdrive boat involved in this explosion and fire had been purchased by the owner as a used boat about a month before the accident. The boat is an 11 year old Crestliner.

The boat is of fiberglass reinforced plastic construction with a trunk cabin forward and open cockpit aft. The hull is a standard hard chine design but with rounded bilges aft below the chine forming a built-in spray rail. See Photograph No. 1.

The boat has a 4 cylinder in-line Mercruiser inboard engine with an inboard/outdrive propulsion unit. The engine was located aft at the transom. The aft deck is hinged at the transom and the engine box is hinged at the forward edge. The hinged deck aft is 24 inches deep and the engine box extends into the cockpit approximately 13 inches. The latter is 24 inches wide. See Diagram No. 1.

The single 18 gallon terneplate fuel tank was located outboard of the engine on the port side below the aft deck. See Photograph No. 3. The tank was set on a flat surface and secured by a metal strip that clamped the tank flange. See Figure No. 1.

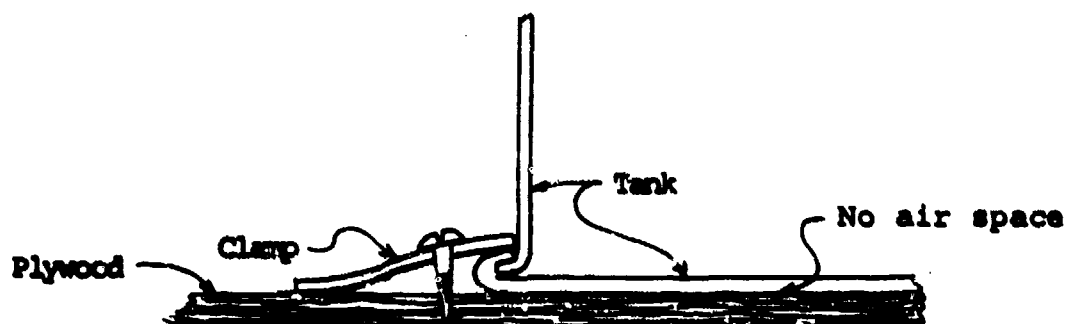

Figure No. 1

Although the boat was an inboard outdrive, the boat name plate indicated that the boat was designed for an outboard engine of no more than 100 OBC certified horsepower and a maximum weight capacity of 2500 pounds (persons, motor and gear).

The boat was marked as Model 2341-5, serial number 55660.

PHOTOGRAPHS

No. 1 - View of boat after the fire from the starboard side with the aft hinged deck closed.

No. 2 - Overall view of cockpit from starboard side with the aft hinged deck open and the engine box removed. The fuel tank (item 1) is visible behind the engine. The small diameter hose is the fuel tank vent and the larger hose, the fuel fill. The unburned ignition distributor (item 2) and unburned flexible fuel line (item 2) are visible on the engine. The exhaust ventilating clam shells (P/S) (item 3) are visible on the side deck.

The unburned fuel hose and a plastic fuel filter between the fuel pump and carburetor are visible forward and behind the valve cover.

No. 3 - View of fuel tank installation from starboard side. The photograph shows the fuel fill and fuel gage transmitter (inoperative) on the outboard aft corner, the vent connection at the forward inboard corner and the fuel feed connection at the aft inboard corner. The bonding ground tab is just forward of the fuel gage transmitter. The plastic hose just aft of the tank was for the bilge pump. The arrow points to the area of the side deck blackened by the flame front when the aft hinged deck lifted.

No. 4 - Photograph of engine and engine compartment from starboard side. The battery box (white) is visible at the bottom of the photograph. The battery was disconnected and removed to prevent a reignition of the fire due to many shorted wires. The single diaphragm mechanical fuel pump and connecting flexible fuel line are visible just above the battery box. The lack of support for the connection between the copper fuel line and flexible fuel line is noted at the left. The mechanical voltage regulator is secured to the transom aft of the battery box.

No. 5 - Close-up photograph of ignition distributor showing the burned primary wire inside the unburned housing.

No. 6 - Photograph of fuel tank after it was removed for examination. The fill opening was taped closed to permit a pressure check. The bonding wire is still connected and the fuel feed pet-cock at the lower right is the fuel feed shut-off valve. Prior to taking the photograph the tank was tilted forward and the fuel leakage at the seam is visible between the arrows.

NARRATIVE ACCOUNT OF ACCIDENT

The boat had been purchased by the owner about a month before the accident and because the boat had been laid up for service and repairs, this was the first time the owner and his family were taking the boat out. On the day of the accident (Saturday) the owner planned to fill the fuel tank in preparation for a cruise the following day. The total repair bill was approximately \$400.00 and included the installation of new fuel lines on the engine, the installation of a new electric shift and general engine service work.

The boat operated without difficulty between the boat's permanent slip and the fuel dock. At the fuel dock, the boat took on about 4 gallons of fuel. The boat did not have a blower but the owner stated that he ventilated the engine space and then ran the engine in the slip for about 5 minutes. The engine cowl was closed and the boat proceeded out of the area at a slow speed heading toward the boat's permanent slip. When the boat was approximately 1/4 mile (within 10 minutes) from the fuel dock, an explosion occurred that lifted the hinged rear deck and the engine box deflecting the flame into the aft cockpit. The witnesses described the sound of the explosion to be similar to the sound of a metal folding chair hitting a hard floor. Both the owner's wife and 1 year old daughter who were sitting on either side of the engine box were severely burned by the flame. See Diagram No. 1.

An 11 year old daughter who was in the cockpit opposite the helm was slightly burned. The owner inadvertently hit the starter switch when he tried to shut the engine down. The owner's 15 year old son attempted to extinguish the fire with a 5 pound CO₂ and almost succeeded. The fire was extinguished by the USCG and the boat was towed back to its slip.

FACTS ESTABLISHED FROM WITNESSES

1. The boat owner had installed new copper fuel lines but the lines on the engine were changed by the boat yard to a fabric reinforced type with hose clamp connections. The boatyard also installed the plastic in-line fuel filter. See Photograph No. 2.
2. The accident occurred almost in front of the Coast Guard Station and a boat was at the scene within a couple of minutes. The fire was almost extinguished with the on-board extinguisher but had reignited and was extinguished by the Coast Guard.

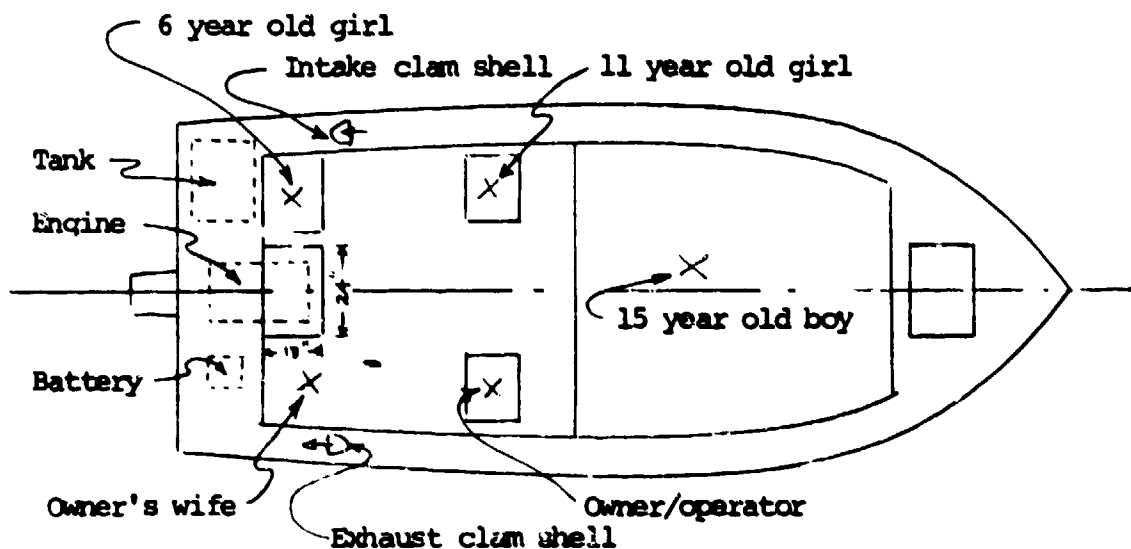

Diagram No. 1

KNOWN CHANGES TO ORIGINAL DESIGN

There were no known changes to the original design.

OBSERVATIONS AND FINDINGS

1. Boat Fuel System - The boat fuel system had sustained only minor damage from the fire but showed evidence of leakage when aerostatically pressure checked. The following was found.

- (a) Fuel Fill - The fuel fill hose was slightly blistered but found liquid tight and vapor-tight. The hose was of a multilayer non-metallic reinforced type with a single hose clamp. The tank connection was beaded.
- (b) Tank Vent - The 7/8 inch O.D. non-metallic reinforced hose was found burned through at the bend just above the tank connection, but was otherwise undamaged. The damage is considered to be a result of the fire, not a cause.
- (c) Tank Shut-Off Valve - The valve was found open and liquid tight but would probably not comply with UL Standard 1106 covering "Manually Operated Valves For Use With Flammable Liquids." The valve was supported by a pipe thread and was connected to the fuel feed line with a flare fitting. The flare connection was tight.
- (d) Fuel Tank - The aerostatic pressure test of the tank revealed a slow leak and upon removal of the tank

8.

a 6 inch long leak along the horizontal shell seam was revealed. When the tank was installed in the boat, the leak was detectible by sound but the source of the leak could not be pinpointed. The tank leak is considered the source of fuel for the explosion and fire. See Photograph No. 6. The tank contained 11 inches of fuel after the fire, which placed it about at the tank seam. The fuel tank was not labeled.

- (e) Fuel Distribution Line - The fixed copper fuel line between the tank and engine was found liquid tight and both flares were well made with no evidence of cracking.
- (f) Flexible Fuel Lines - The non-metallic reinforced hose with swaged fittings was blistered at one end but was liquid tight. Since the fuel level was well above the flexible fuel line, the flexible section should have been of the 2-1/2 minute fire resistant type, to meet the requirements of NFPA 302, the Standards of the American Boat & Yacht Council or the proposed Coast Guard Regulations. The Gates 3225 SS hose used has a fire resistance of approximately 1 minute.
- (g) Fuel Filter - The boat was not equipped with a hull mounted fuel filter.
- (h) Fuel Gauge - The fuel gauge transmitter was inoperative and had been disconnected.

(1) Installation

- (1) The fuel tank was installed on a flat plywood surface providing no air circulation under the bottom surface. The installation did result in some overall accelerated corrosion of the bottom surface. See Figure No. 1.
- (2) The fixed fuel line was not supported at the point of connection to the flexible fuel line. This condition will result in an increase in the vibration amplitude reaching the fixed fuel line rather than a decrease as intended. See Photograph No. 4.
- (3) The fixed fuel line between the tank and engine was inadequately supported.

2. Engine - The MerCruiser in-line engine was not badly damaged and had not seized or overheated. The oil level was well above the low level mark.

- (a) Fuel Pump - The fuel pump was of the externally vented single diaphragm type. The pump and diaphragm were found liquid tight. The externally vented pump would not comply with the ABYC Standard since liquid fuel would be discharged directly to the engine space in case of diaphragm failure. The pump was marked as a rebuilt unit (No. 6790R0).

- (b) Flexible Fuel Lines - The Gates Type 3225 hose used between the fuel pump and carburetor was not of the 2-1/2 minute fire resistant type as required by the NFPA, ABYC and proposed Coast Guard Regulations. The hose and fittings were liquid tight.
- (c) Fuel Filter - The automotive plastic in-line fuel filter ahead of the carburetor was liquid tight and undamaged but would not meet the 2-1/2 minute fire resistance requirements of the NFPA or ABYC or the requirements of UL 1105. The filter contained approximately 2 ounces of fuel.
- (d) Carburetor - The carburetor was not damaged by the fire and there was no indication of fuel leakage. A check indicated that the throttle was in a low rpm position. The carburetor float valve was still operative.
- (e) Backfire Flame Arrester - The backfire flame arrester was found in place and in serviceable condition but was loose. The device had a current 162.041 Approval Number.
- (f) Alternator and Voltage Regulator - The C.E. Niehoff alternator was Listed by the Yacht Safety Bureau and was still tight and ignition proof. The C.E. Niehoff Mechanical Voltage Regulator was enclosed and revealed no indication of internal flame. The alternator and regulator are not considered a likely source of ignition. The voltage regulator is shown in Photograph No. 4, as found, with the cover in place.

(g) Ignition Distributor - The ignition distributor was found externally undamaged by the fire but internally the insulation of the breaker point wire was totally burned. See Photograph No. 5. Since the molded wire gripper where the wire passes into the housing was still intact the evidence would indicate that the insulation was ignited by an internal flash, not by the external fire. The distributor is considered the most probable source of ignition for the fire. The distributor was a Delco Remy marked 1112620 2G25.

3. Electrical

- (a) Battery - The battery was not burned and there was no evidence of an internal explosion. The battery is visible in Photograph No. 6.
- (b) Battery Switch - The boat was not equipped with a battery switch. In this instance, a battery switch, if accessible from outside the engine compartment, would have provided a means of controlling secondary electrical shorts.
- (c) Wiring - Although the fuel fire was of short duration, the fire did ignite the engine space wiring insulation in several areas and contributed to the fire spread. All electrical connections were found tight. The wiring was an SAE stranded type.
- (d) Overcurrent Protection - The boat had a single 14 ampere fuse in the helm console protecting all circuits. The circuit protection would not comply with NFPA 302 or the electrical standards of the

ABYC. The wiring between the battery and engine and the main electrical panel at the helm was without overload protection.

4. Miscellaneous

(a) Bilge Pump - The boat was equipped with a Crowell non-automatic electric bilge pump located in the engine well. The upper portion of the pump and the wires were burned but the pump was tight.

(b) Fire Pattern - The charred surfaces and burned wiring confirm that the source of the fire was from the engine well and that the primary draft in the engine space was aft toward the transom. The blackened vertical section of the deck on the port side shows that the hinged aft deck blew open and confirms little burning at the forward end of the engine.

(c) Blower - The boat did not have a blower.

(d) Galley - The boat did not have a galley stove.

OPINION

In conducting the investigation it was noted that the extent of fire damage was not consistent with the amount of fuel missing from the tank. The 6-1/2 to 7 gallons of fuel missing from the tank would have caused more extensive damage. There are two possible explanations for this inconsistency. First, it is possible that the fuel was pumped overboard with the

bilge pump, or second, that the explosion and fire occurred after a small amount had leaked out and that the rest of the fuel leaked out after the fire was extinguished.

All of the evidence indicates that the source of leakage for the explosion and fire was from the sheet metal lock seam, on the back side of the terneplate fuel tank. It is noted that since the tank took on only a little over 4 gallons of fuel, the seam failure must have occurred during the last fueling operation. The seam was probably on the verge of failure and finally failed as a result of the slight pressures created during the filling process. Had the leak developed prior to that time, the boat would have taken on more than 4 gallons. The faulty seam was located at a level that would have required about 7 gallons of fuel had the seam leaked prior to fueling.

It is noted that while a 3 psi pressure test of the system could possibly have revealed the problem, a visual examination of the system would not have revealed the leak until the tank was full and the leakage present.



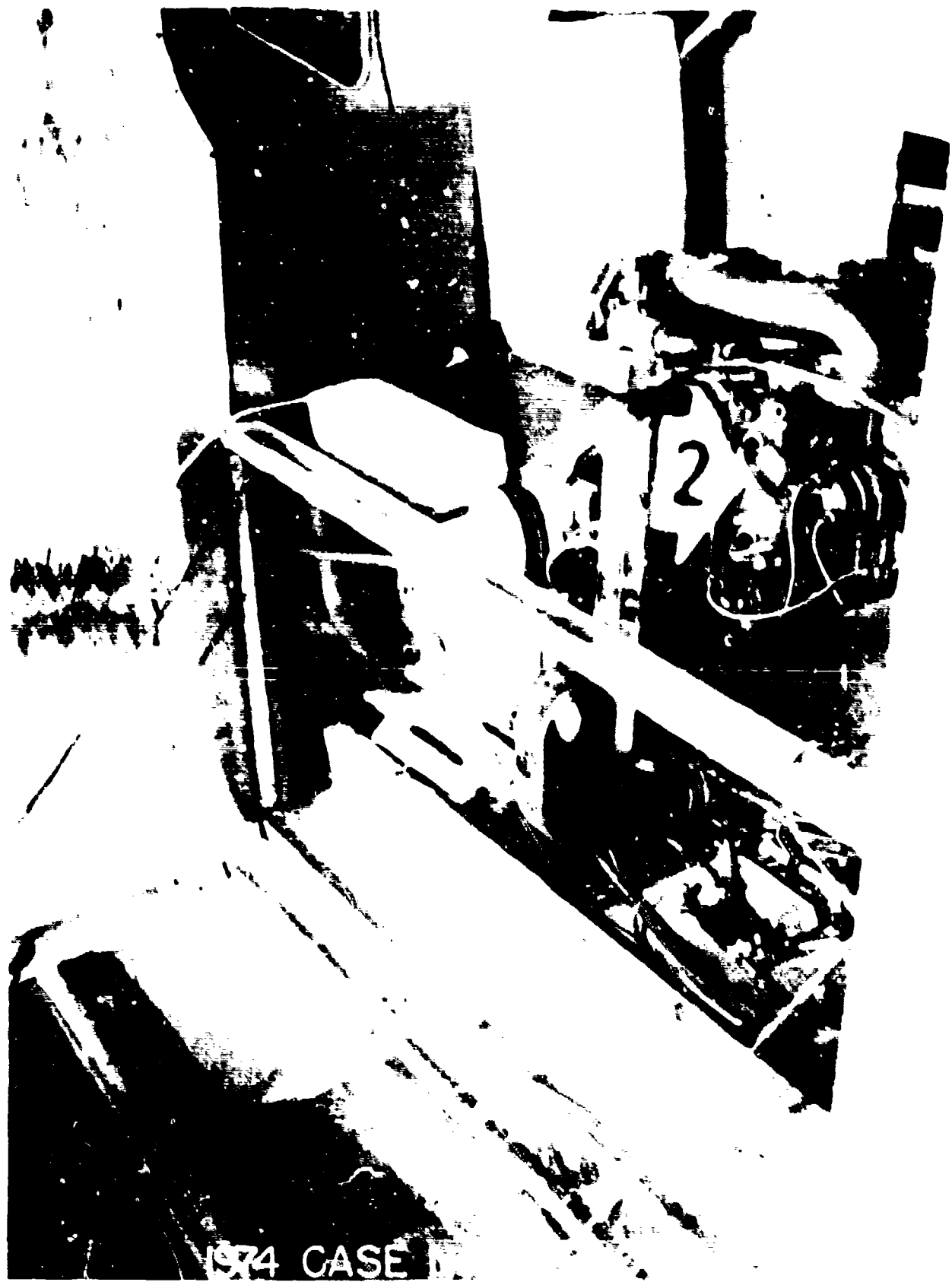

1974 CASE



1974 CASE No. 2 PHOTO No. 3

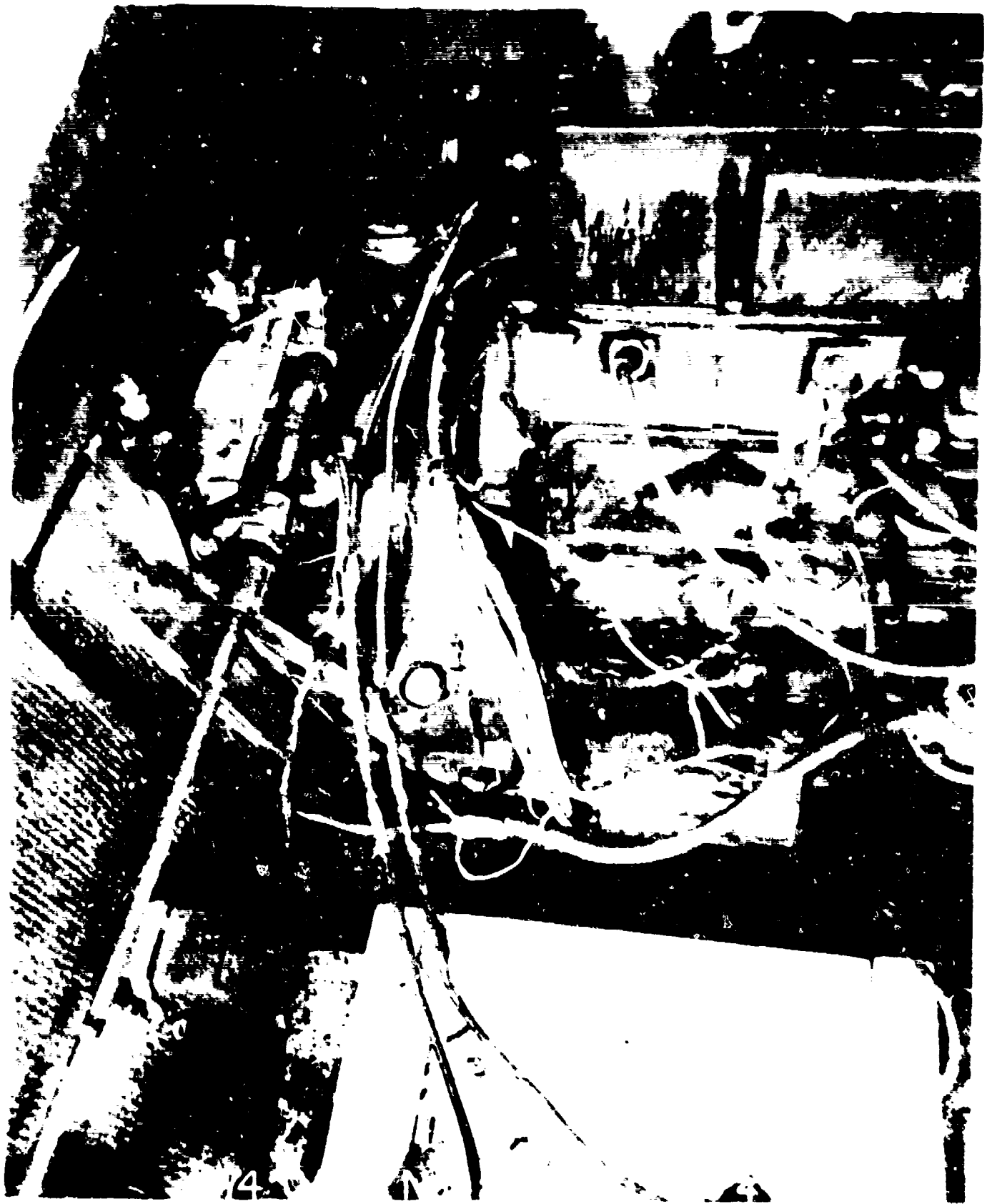

14

Reproduced from
best available copy.

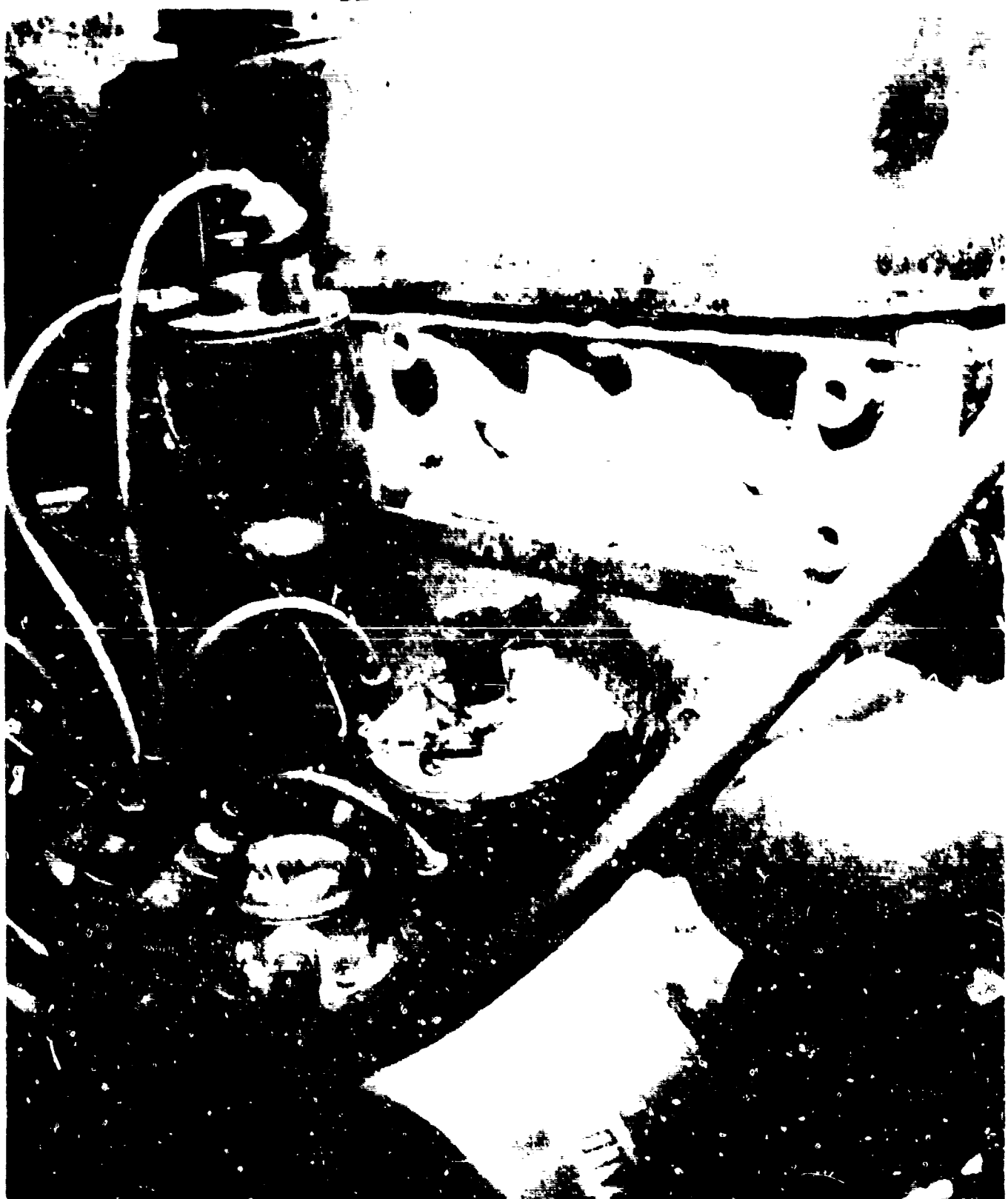

1974 CASE No. 2 PHOTO No 5

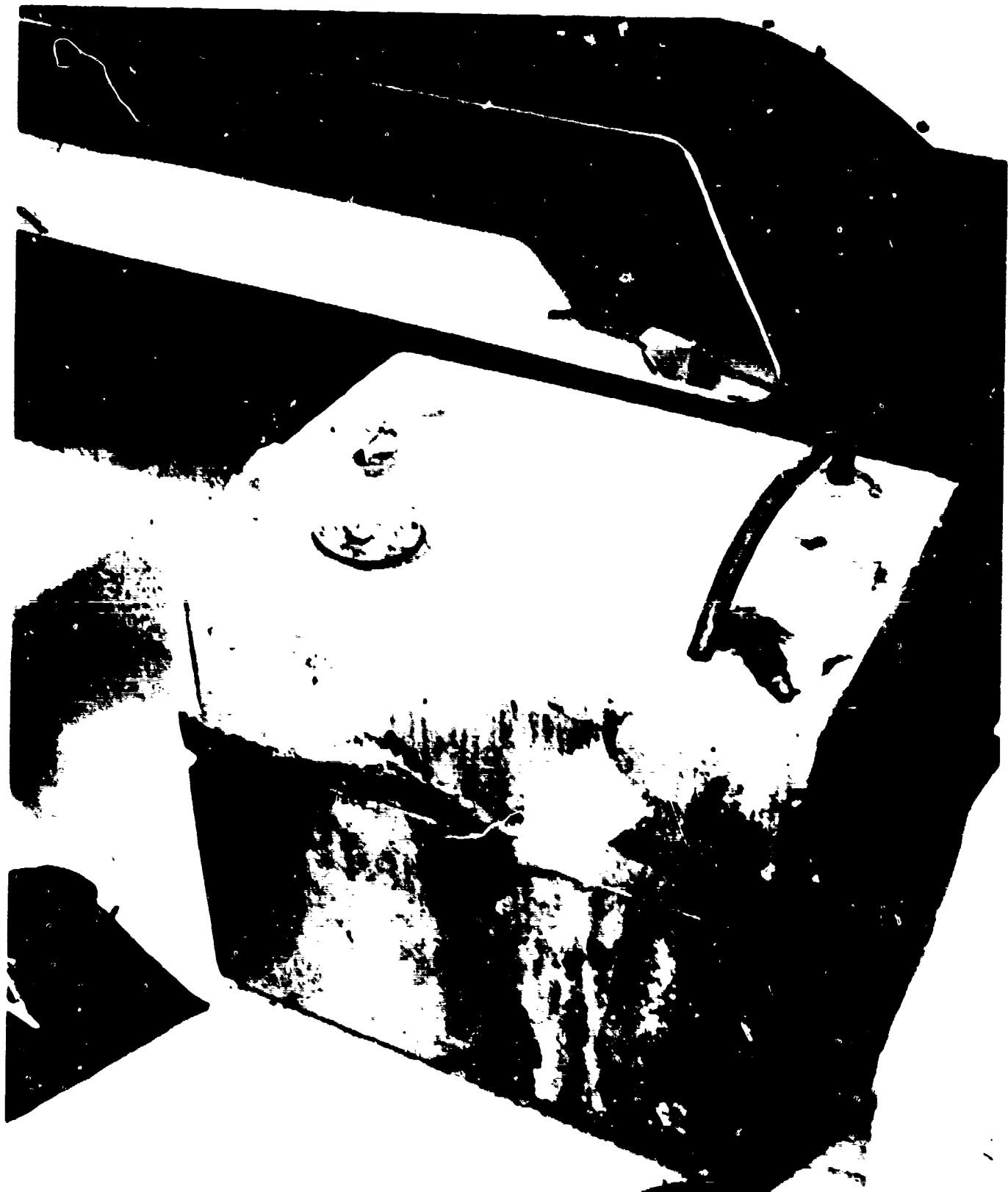

OTO No 6

40

RECREATIONAL BOATING ACCIDENT INVESTIGATIONS FOR 1974C A S E N O. 3DESCRIPTION OF BOAT

The 38 foot, flying bridge, sport sedan cruiser involved in this fire and explosion was of wooden, lap strake construction with steam bent oak frames. The 5 year old boat was built by the Pembroke Yacht Corporation and was powered with two 265 HP International Marine Engines (Model M392) with vee-drives. The engines were fresh water cooled. See Photographs Nos. 1 and 2.

The boat had two 120 gallon welded Monel fuel tanks located below the sedan cabin floor directly forward of the engines. The tanks were 4 feet long, 2 feet 10 inches wide and 17 inches high with the deck fill and outboard vent connections directly outboard of the respective tank fittings. The boat was equipped with a 115 volt Kohler auxiliary generator that was fueled from the starboard feed line with a separate valve. The generator was located between and just forward of the engines.

The boat layout included an open cockpit aft approximately 8 feet long, a salon cabin and wheelhouse approximately 9 feet long and a forward cabin with a head, galley and sleeping accommodations. The head was on the starboard side and a large refrigerator was located between the head and helm console at the companionway step. See Figure No. 1 and Photograph No. 7.

The ventilating system consisted of two 3 inch ventilating ducts (P/S) outboard of the fuel tanks and two 3 inch ducts aft of the engines. The aft louvers were trimmed as intakes and the forward as exhausts. See Photograph No. 2 of a similar model.

The fuel distribution system used copper fuel lines, flare fittings and non-mettalic push-on flexible hose at the engines and the generator. The tank vents were copper with a compression fitting at the tank and two sweat fittings to the hull discharge.

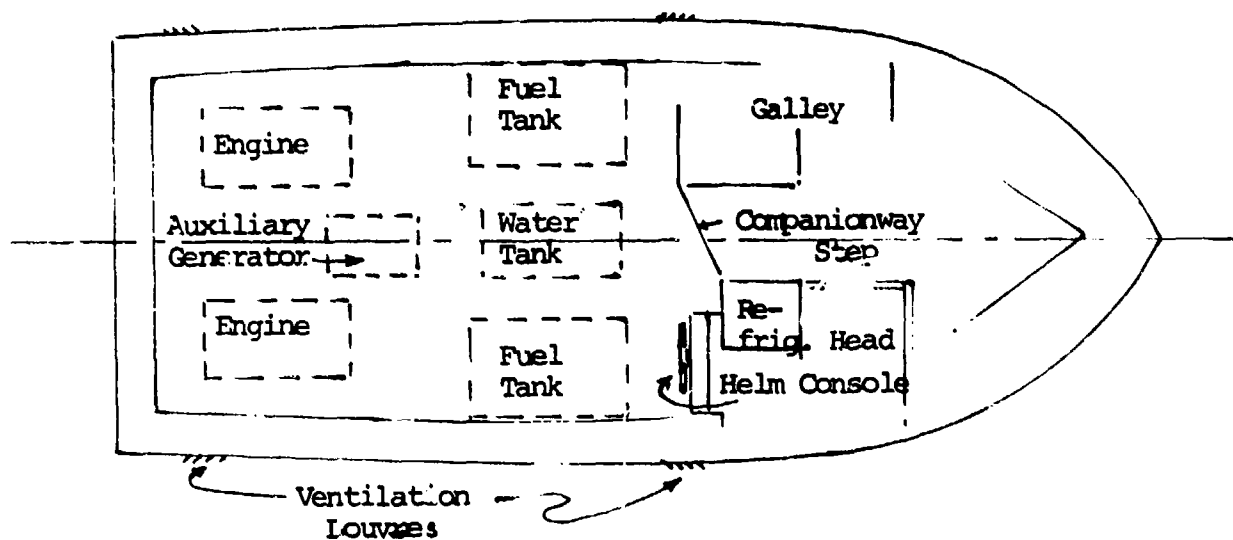

FIGURE NC. 1

PHOTOGRAPHS

No. 1 - Bow view of boat after explosion and fire.

No. 2 - Stern view of similar model. The ventilating louvers are visible on the port side of the hull.

No. 3 - View of port engine from above. The flame arrestor on this engine was Coast Guard Approved. The deeply charred deck beam indicates that the fire burned for an extended period.

No. 4 - View of starboard engine from the port side.

No. 5 - Photograph shows the Kohlar generator and starboard engine from a position at the port engine. The boat batteries are visible aft of the auxiliary generator.

No. 6 - View No. 6 shows the instrument panel and throttle controls for the engines. Both ignition keys were in the on position, but the starboard key fell out before the photo was taken. All of the instruments and the throttle levers indicate the engines were operating. The P/S oil pressure gauges are at upper corners of the panel outboard of the large tachometers, the engine temperature gauges are directly below the oil pressure gauges and the alternator ammeters are below the tachometers. The controls from left to right are: (1) Port throttle (above normal idle position). (2) Port gear control (neutral). (3) Starboard gear control neutral and starboard throttle (fast idle position).

No. 7 - View of control console on sistership showing instruments and switches.

NARRATIVE ACCOUNT OF ACCIDENT

On the afternoon of the accident the boat was moved from its slip at a marina to a fueling dock approximately 1/2 mile away. The boat was normally used for charter purposes, but at the time of the accident was being operated by the boat yard owner, an experienced operator. When the boat was being fueled, the port engine was apparently left running and the starboard engine may have been running. The operator had intended to top off the tanks which were about half full. The dock attendant started filling the port tank and when he had pumped \$3.20 worth of gasoline into the tank (approximately 6 gallons), an explosion occurred which set the boat on fire. The owner was the only one on the boat and had trouble getting off. The dock assistant went on board and pulled the owner off. The fire ignited the fueling dock, so the boat was cut loose and set adrift. It drifted to a point on the shore approximately 300 yards from the initial spot of the incident.

The 5 year old boat was used for charter purposes and was well maintained. The owner of the boat was also the owner of the marina where the boat was kept at a slip. The owner and the dock attendant were burned as a result of the fire. The owner received burns on his face and arms and was rushed to a nearby hospital by a rescue helicopter. The fire was extinguished by the local fire department.

FACTS ESTABLISHED FROM WITNESSES

1. The yard manager, who was not present at the accident, said the boat was at the gas stop for fuel and the port tank was in the process of being fueled at the time of the explosion. Only \$3.20 worth of fuel had been pumped into the port tank when the explosion occurred. It was his understanding that the engines were off when the boat was being fueled. Immediately following the explosion, the boat broke out into flames. The owner was still aboard. He had trouble getting off the boat so the dock attendant assisted him and was slightly hurt.
2. Two witnesses in the vicinity said that they did not actually see the explosion or fire, but came over to the accident scene just after the boat fire was extinguished. They indicated that someone had told them that the owner had driven the boat to the fueling docks and started taking on fuel with one or both engines running. The explosion occurred while fueling and while the engines were running.
3. A restaurant owner who had heard people talk about the fire said that both engines were running while the owner was taking on fuel.

KNOWN CHANGES TO ORIGINAL DESIGN

There were no known changes to the original design.

OBSERVATIONS AND FINDINGS

1. Boat Fuel System - The fuel system of the boat was in tact with the exception of the fuel fill hoses. The boat had

two 120 gallon fuel tanks mounted forward of the engines at the same level as the engines. The fuel lines leading to the engines were all copper with a short flexible fuel line to the engine fuel pumps. The copper lines were all in good shape with the exception of the starboard line. The starboard line had one hole approximately 1/8 in. in diameter where the phenomenon called eutectic action had taken place as a result of the fire. The tanks were hydrostatically pressure checked at approximately 2 psig after the accident. There was no evidence of liquid leakage or vapor from the tanks.

- (a) Fuel Fill- The fuel fill consisted of a filler cap on the side deck and approximately 40 in. of neoprene, fabric reinforced flexible fill hose. The flexible fill hose was connected to the fitting on deck and the 2-5/8 inch long pipe at the tank with a single hose clamp. A piece of the starboard tank hose and both the hose clamps were found. They seemed to be in the tightened position. On the port tank, the hose clamp at the deck fitting was found in position and the hose clamp at the tank was found near the connection on top of the tank. Both the port and starboard tanks were grounded by means of a separate hose clamp which secured a bonding wire to the tank fill connection. See Figure No. 2 showing the grounding arrangement for the port fuel tank. The starboard tank was similar except that the grounding wire clamp was secured to the elbow instead of the short horizontal pipe as shown.

This allowed a better purchase for the starboard fill hose. The port tank installation could not comply with the NFPA or ABYC Standards with respect to the clamping of fill pipe hose. Although the actual physical evidence was destroyed by the fire, the evidence would indicate a failure of the port fuel fill pipe.

- (b) Vent - A 30 inch piece of copper tubing was connected to the tank by compression fitting. The tubing ran horizontally to the side of the boat where it was connected to a vertical 16 inch pipe by means of a 90° sweated elbow. The vertical pipe was in turn connected to a short horizontal pipe and the external vent fitting with another sweated elbow. The clamshell vent on the outside was designed with the opening toward the rear to prevent the intake of water. The vent systems were intact on both tanks. Sweated copper connections are not prohibited by the standards, but are not considered acceptable marine practice since they provide no flexibility and create a galvanic cell that will cause accelerated corrosion of the solder joints.
- (c) Shut-Off Valves - Both the port and starboard tanks had shut-off valves, but the valves were not at the tank connections and were not accessible from outside the compartment. All shut-off valves were of the solid bottom type that were all in working order and did not leak. Because

the tank shut-off valves were not accessible from outside the engine compartment, they would not comply with the present safety standards or with the NFPA Standard that was in effect at the time the boat was built. The valves were not independently supported.

- (d) Feed Line - Both port and starboard fuel feed lines were copper with flare fittings throughout the system. The flares all seemed to be well made and no cracks were apparent. One place in the fuel feed line from the starboard tank had a 1/8 inch hole that is believed to have been caused by eutectic action as a result of the fire. The fuel lines were very poorly supported.
- (e) Flexible Fuel Line - The flexible fuel lines at the engine were fabric-reinforced neoprene with push-on hose connections. The hose would appear to have about 1 minute fire resistance and would not comply with the required 2-1/2 minute fire resistance of NFPA 302 or the ABYC. The system would be subject to syphon action with the tanks near full.
- (f) Tank - The port and starboard tanks of the boat were welded monel and identical in every respect. The 120 gallon tanks were 48 in. long by 17 in. high by 34 in. long. At the time of the investigation, the port tank contained 9-1/4 inches of fuel (65 gallons) and the starboard tank 7-1/2 inches (52 gallons). The fill pipes and the fuel gauge transmitter were steel, but the tank spuds were of non-

magnetic material (probably brass or bronze).

There was no evidence of corrosion or deterioration of the tanks and no indication of an internal explosion. Both tanks had electric fuel gauges. The gaskets for the electric fuel gauge sending unit were burned and leaked after the fire. The tank installation would permit inspection and appeared to comply with the NFPA/ABYC Standards.

2. Engine - The evidence would tend to indicate that the engines were both running when the explosion/fire occurred. The engines had about 1700 hours total time.

- (a) Fuel Pump - The engine fuel pumps were of the single diaphragm mechanical type. The combination fuel pumps and filter (glass bowl) were not UL Approved and would result in fuel leakage to the bilge in case of a diaphragm failure. The fuel pump diaphragms were found liquid-tight.
- (b) Feed Fuel Lines - All the fuel lines from the fuel pump on were neoprene covered by copper braid that would not have 2-1/2 minute fire resistance. The copper braid portion of the line was still in tact, but the inside neoprene was burned to a stiff char.
- (c) Carburetor - The port and starboard engines both had down-draft carburetors that would not require drip collectors. The starboard carburetor was starting to melt around the air horn. The choke was half closed and the throttle butterfly was in the idle position. The port engine carburetor

was more severely melted than the starboard carburetor and the choke was fully open. The top of the flame arrestor had melted completely away and portions of it settled down into the throat of the carburetor. Both port and starboard engines had the Fisher type B175-36A flame arrestors. They were both Coast Guard Approved under the Coast Guard Approval Number 162.041/74.

- (d) Generators - Both of the Motorola alternators on the engines were Listed by the old YSB. The brush housings on both alternators were melted open by the fire, but the YSB Listing indicates they were originally "ignition-proof". It is not likely that the generators on either engine were the ignition source.
- (e) Engine Instruments and Controls - When the engine instruments and controls were lifted from the remains, all of the engine instruments confirmed that the engines were running when the boat was being fueled. See Photograph No. 6 showing the instruments and controls as found. (The instrument cover glasses were carefully broken and removed for the photograph). It is noted that although the temperature and pressure gauges would react to a short at the engine (with the switches on), the tachometers depend on voltage pulses and would normally return to 0. The engine controls

confirm that the boat was in neutral and both engines were running above minimum idle. It is normal to pull both throttles to their idle positions before stopping the engines.

- (f) Oil Levels - When checked, the port engine oil level and the port vee drive oil level were normal. No oil was found in the starboard engine, but the vee-drive oil level was normal. There was no evidence of engine seizure and it is probable that the oil leaked out as a result of the failure of a gasket or fitting during the fire.
- (g) Distributors - The engine distributors were of the vent type with spring clip caps that were not "ignition-proof" and are considered one possible source of ignition.
- (h) Starters - The engine starters were not considered as a possible source of ignition since both main engines were apparently running.

3. Electrical

- (a) Auxiliary Generator - The auxiliary generator was not "ignition-proof" and contained several potential sources of ignition including open relays, hot resistors, the magneto ignition system and the generator itself. Whether or not the generator was operating was not determined. Because of the absence of "ignition-proofing", the auxiliary generator would not comply with the NFPA or ABYC Standards.

- (b) Wiring - Because of the long fire, most of the wire insulation was burned away, but it was determined that most of the wire was of the stranded type and all electrical connections checked were tight. No short circuited wires were found.
- (c) Master Switch - The boat was not equipped with a master battery switch at the batteries (3), but apparently did have a battery switch in the load line to the electrical distribution panel.
- (d) 115 VAC System - The 115 VAC system was wired as a two wire system with no grounding wire. The system would not comply with the current NFPA or ABYC Standards.
- (e) Bilge Pumps - The boat was equipped with a UL Listed Lovett submersible automatic bilge pump (No. AM198350) and a non-listed Rule automatic pump. Both pumps were totally submerged and not considered as potential sources of ignition.

4. Miscellaneous

- (a) Fire Extinguishing System - The boat was not equipped with a built-in fixed fire extinguishing system.
- (b) Portable - Two portable USCG Approved extinguishers were found in the boat, but as far as could be determined, they were not used.

OPINION

The facts obtained in this case leave little doubt that the primary source of fuel was a failure of the fill pipe on the port tank. More specifically, it is most probable that the fill hose became disconnected at the short tank connection. Because the hose was almost totally destroyed by the fire, the suspected cause could not be documented. However, the following factors are considered as supporting the suspected cause.

(1) The immediate major fire that followed the initial explosion indicated the presence of a reasonable quantity of liquid fuel. A class A fire, involving wire insulation, wood and other combustible materials would develop more slowly than indicated in this case. Since the investigation revealed that the fuel distribution system was intact and in fact could not have had any major leakage since the engines were running, the fuel leakage source is not likely to have been in the distribution system. (2) The fuel pumps checked out as being tight and since the glass bowl filters at the engines were not cracked or melted, it does not appear likely that the major accumulation of fuel was below the engines. A sustained fire below the engines would quickly affect the glass bowls. (3) The available facts would indicate that the fuel accumulated during the filling process. Since it only takes about 12-15 seconds to deliver about 6 gallons and ignition was immediate, the fuel leakage was more likely at the fill than through any of the small fuel feed lines. If, as suspected, the connection at the port tank

came off, the 6 gallons would spread out over the tank top surface so as to accelerate fuel vaporization. The remaining liquid fuel would flow down the tank sides to the bilge. (4) Both fuel tanks were found liquid-tight and since the tanks were only half full, leakage at the fuel gauge or the fuel tank vent system can be eliminated.

Although the actual source of ignition could not be pinpointed, it seems highly probable that the ignition occurred at the engines, which were apparently running. It is noted that electrical temperature and pressure gauges are not in themselves positive indicators that the engines were running, but the engine tachometers in combination with the other gauges constitute strong evidence for that supposition. It is important to recognize that the tachometers depend on voltage pulses rather than a ground. The evidence was, as indicated in the foregoing report, supported by the fact that both keys were on and the position of the controls and carburetor butterflies all confirm engine operation. It would not be natural to turn the key off and then back on without starting the engines. It is noted that although the temperature and pressure gauges can give false readings due to electrical shorts, they will not register unless the switches are on.

The fact that the major concentration of the fire was forward near the tanks is supported by the fact that the engine instruments show engine operation. In essence, for the conditions to exist as found, it was necessary for the instruments to become

jammed by the fire or explosion before the engines themselves shut down as a result of the fire. If the major fire was initially at the engines, the engines would stall out for lack of oxygen and the tachometers, etc. would fall to near 0 before the fire seized the instruments forward.

The actual probable cause was most likely the very short (2-5/8 inch) connection for the port fuel fill hose at the port tank. Since approximately 3/4 inch was used for the ground connection, only 1-7/8 of pipe remained for the fill hose connection.

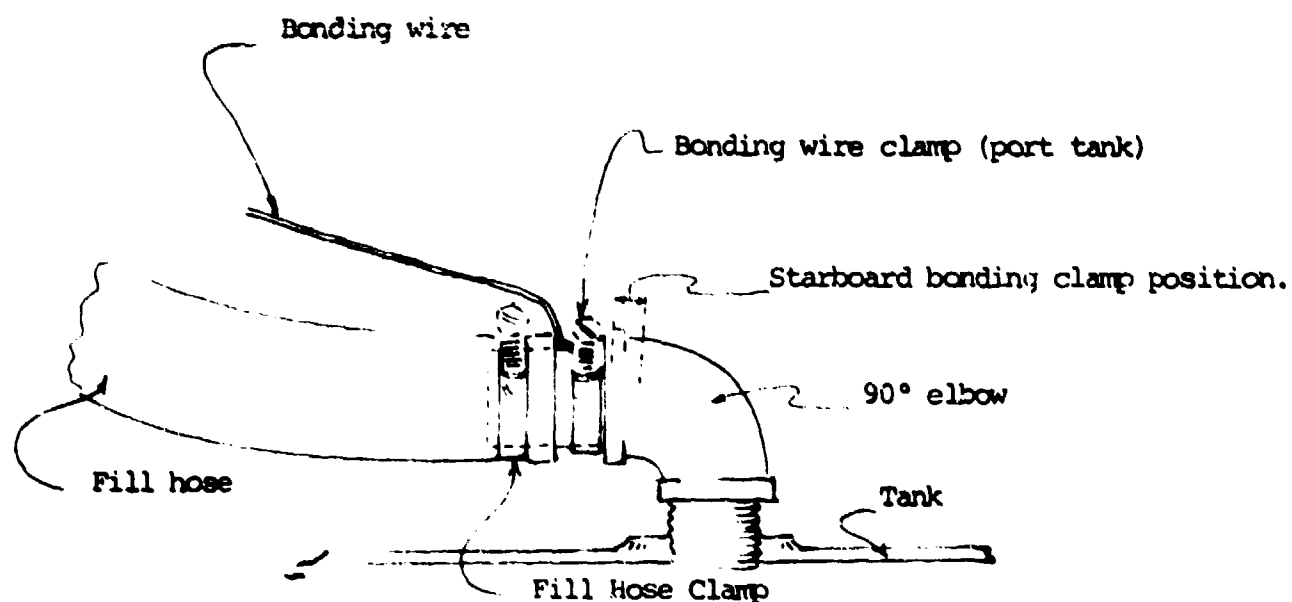
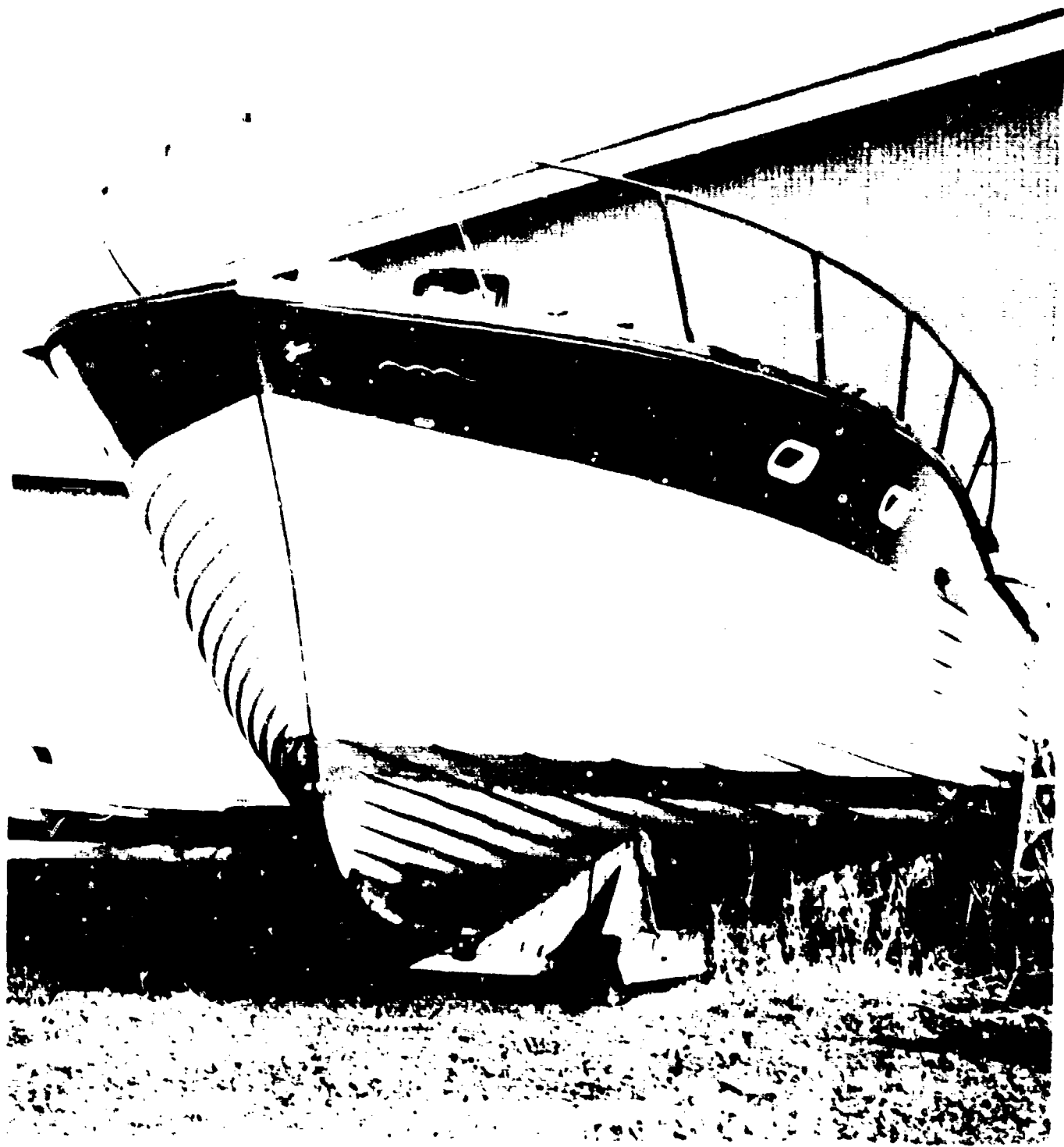

Figure 2





1974 6100 3 PHOTO No 2



246

PHOTO

3



1974 CAS 3 PHOTO No 4

Reproduced from
best available copy.

6

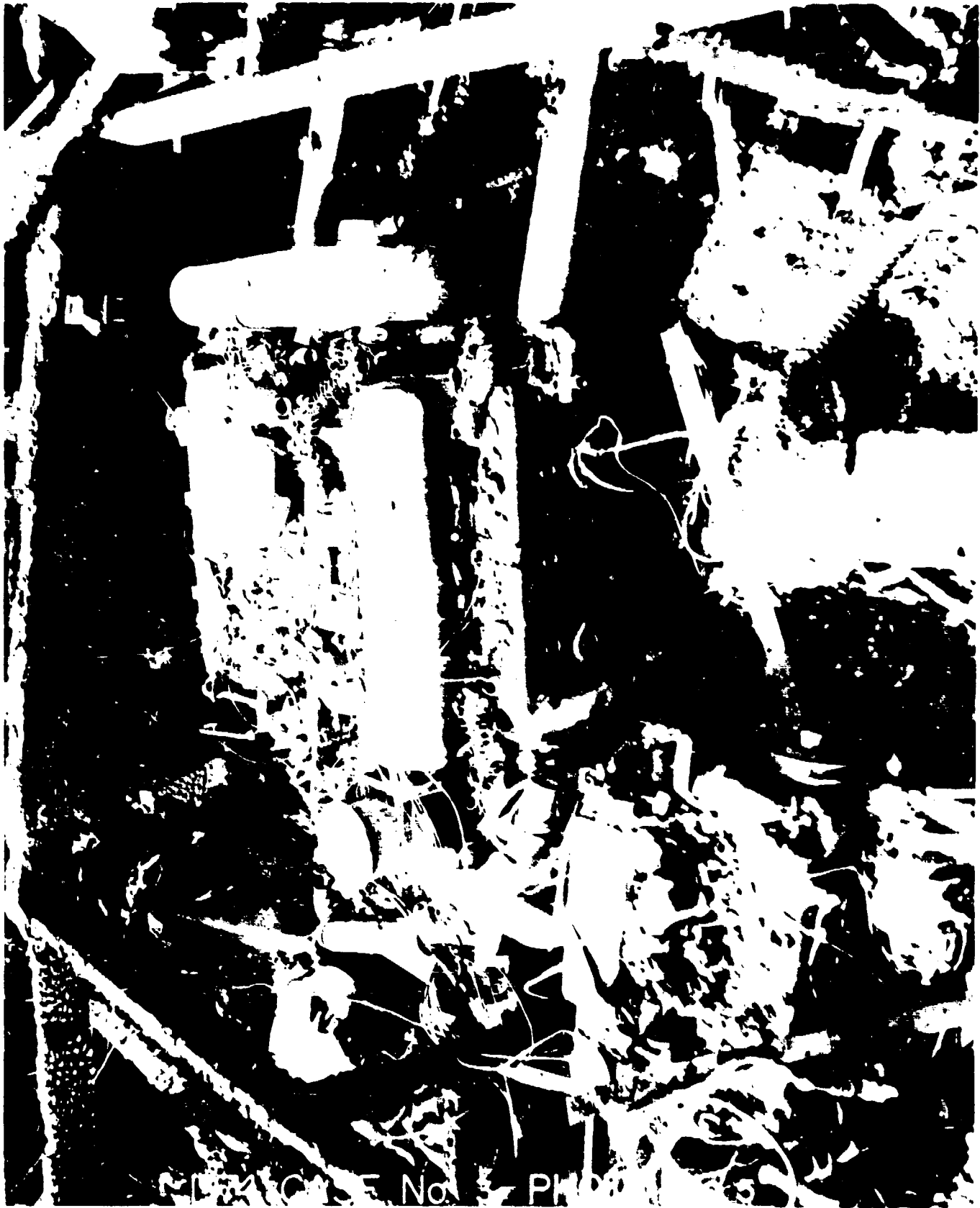

NIA CASE No. PH 100 100

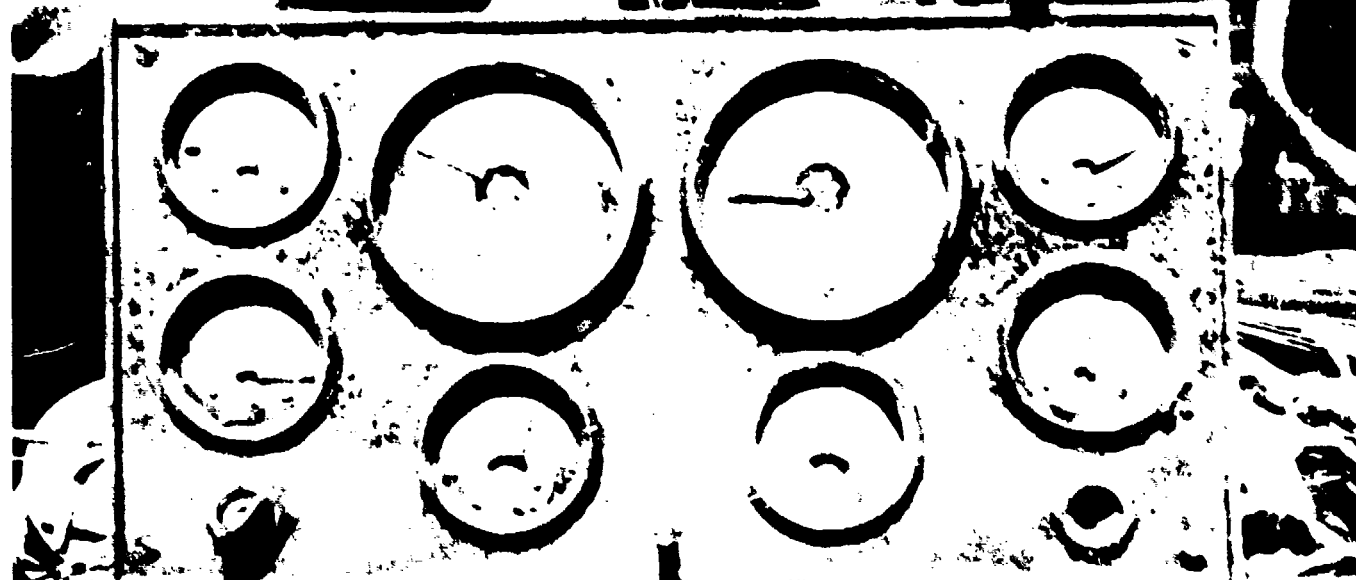

CASE No. 3 PHOTO No. 6

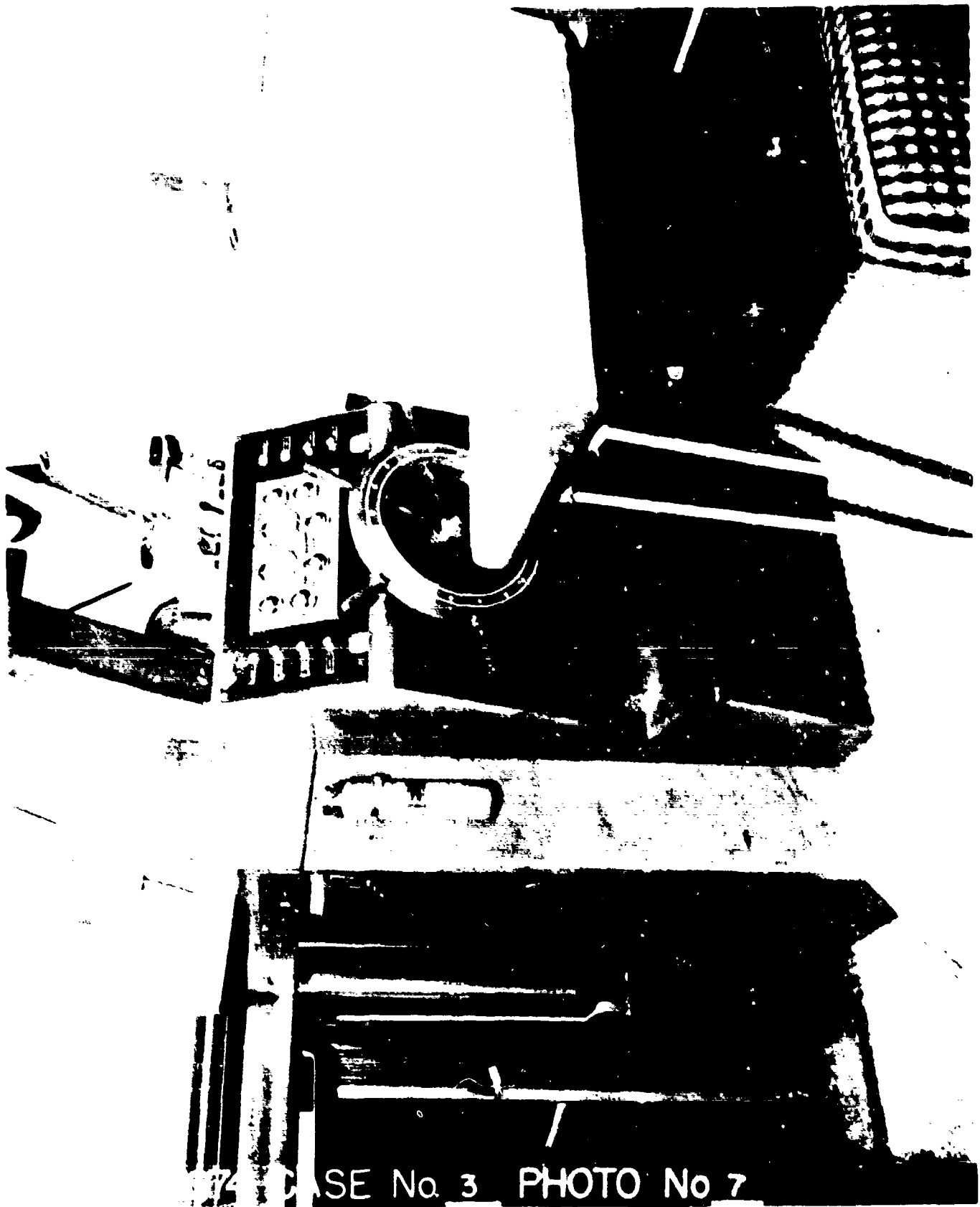

74 CASE No. 3 PHOTO No 7

RECREATIONAL BOATING ACCIDENT INVESTIGATIONS FOR 1974

C A S E N O. 4DESCRIPTION OF BOAT

The inboard/outdrive boat involved in this flash fire was an 18 foot open Sport Fisherman built by "New Man" of Maimi, Oklahoma. It was built in 1969 and purchased by the owner in 1972.

The boat was of fiberglass reinforced plastic construction, of conventional design, with a short bow deck and large open cockpit aft. It had a short aft deck with a fiberglass engine box that projected into the cockpit about 2 feet. The boat was equipped with a navy top that was in use at the time of the accident.

Engine fuel was supplied from a single 20 gallon terneplate fuel tank that was located on a raised platform under the bow deck. The platform, on which the tank was located, was approximately 1 foot above the keel and would result in the fuel level being above the fuel pump and carburetor when the tank was near full. No anti-siphon protection was provided. The fuel distribution line from the tank to the engine was copper with flare fittings and was routed under the deck on the port side. The helm was on the starboard side just aft of the bow deck and the boat was equipped with two seats, port and starboard, approximately amidships. See Photograph No. 1 and Figure No. 1. The boat ventilating system consisted of two 3-1/2 inch ducted vents forward, on either side of the tank, and two exhaust cowls aft with one duct to the bilge. A bilge blower was mounted on the transom (starboard side).

PHOTOGRAPHS

No. 1 - View of burned hull from star side.

No. 2 - View of bow fuel tank installation with deck removed. The metal strip securing the tank flange at the aft end of the tank is visible and the liquid level in the tank after the fire is discernible along the tank side and on the end. The fuel feed line flare fitting connection is visible on the port side. There was no provision for air circulation under the tank.

No. 3 - View of engine from starboard side. The T-fittings on the fuel pump were for a fuel pump pressure relief valve which was not located. The aluminum fuel filter bowl shown in place was initially found in an upright position on the edge of the engine well. The hydraulic pump solenoid is visible outboard and near the aft end of the engine.

No. 4 - View of engine from port side. The bilge pump is visible directly below the engine in the engine well.

No. 5 - View of engine from starboard side. The aluminum bowl filter is visible at the arrow.

NARRATIVE REPORT OF INCIDENT

On the day of the accident, the wind was from the west northwest at 5 MPH, the visibility was 10 miles and the seas about 1/2 foot. At the time, there was approximately 8 to 10 gallons of fuel in the 20 gallon tank. The boat, with the owner, his wife, 13 year old son and two adult guests had been underway for about 25 minutes at about 3000 RPM (15 MPH) when the engine RPM gradually dropped off and the engine stalled. Just prior to the time when the engine stalled, the owner's wife

smelled gasoline vapors and told her husband. The bilge blower was started at this point. The owner went aft and lifted the hatch to determine why the engine had stalled and indicated that he did see fuel leakage on the starboard side of the engine. He was not clear as to specifically what was leaking. There appears to be a conflict in the physical evidence and the owner's recollection of the incident from this point on. The owner recalled seeing the leakage and indicated that he had one hand on the engine and one on a tool box on the starboard side of the engine when the explosion occurred with no indication of having attempted to make a repair. The owner reported seeing a spark or flash on the starboard side but again was not clear as to what arced. The physical evidence revealed that the aluminum bowl filter had been removed prior to the fire and had been placed on the edge of the engine well, forward of the engine. The evidence would appear to indicate that the owner found leakage at the fuel bowl and then removed the bowl in an attempt to stop the leakage. Immediately after the flash, the owner's 13 year old son attempted to extinguish the fire with a portable extinguisher and apparently almost succeeded. When the portable extinguisher did not work, everyone went overboard and were picked up by a ferry boat which was close by when the fire started. The accident was reported to the U. S. Coast Guard by the ferry boat and the fire was extinguished by the U. S. Coast Guard. The boat was towed ashore.

When the owner was in the water the outboard drive unit was observed raising due to an electrical short in the control wiring.

The owner received 1st and 2nd degree burns and the owner's wife lost 1 finger as a result of the accident.

FACTS ESTABLISHED FROM WITNESSES

1. The original owner of the boat had some difficulty with the boat on its first run that reportedly almost resulted in a fire. Details were not available.
2. The boat had been operating properly prior to the accident.

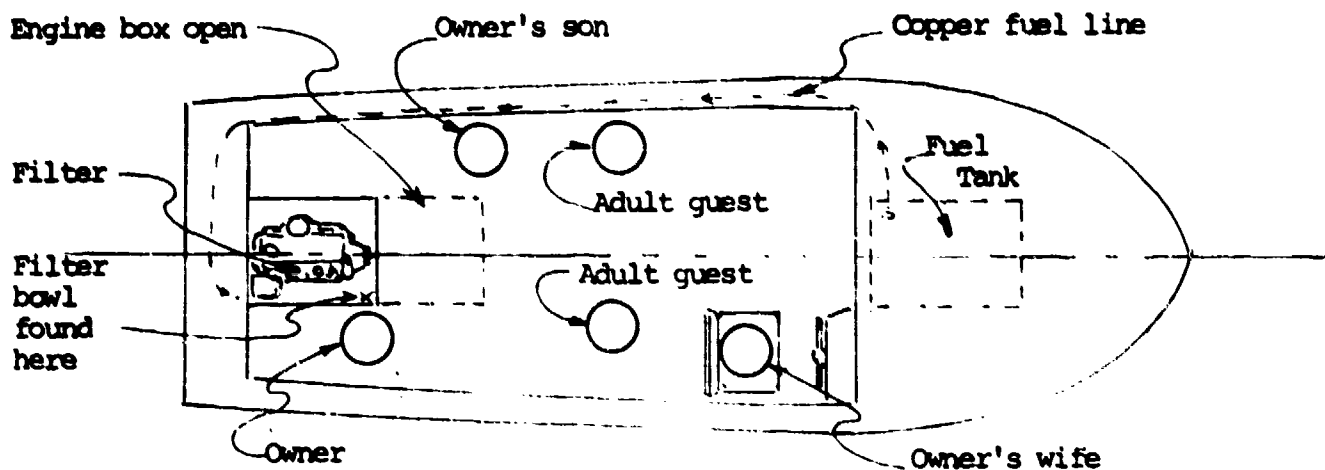

Figure 1

KNOWN CHANGES TO ORIGINAL DESIGN

There were no known changes to the original boat.

OBSERVATIONS AND FINDINGS

1. Boat Fuel System - When the investigation was conducted, the fuel system, from the tank to the engine was found tight except for the fuel fill, vent and flexible section at the engine. The fuel tank was approximately 1/2 full. Because of the tank installation, the lack of a shut-off valve and the fact that the system did not have 2-1/2 minute fire resistance, the system would not comply with the NFPA or ABYC Standards in affect when the boat was built or the current Standards.

- (a) Fuel Fill - The fuel pipe was a short straight fabric reinforced hose that was destroyed by the fire. The hose was single clamped and a bonding wire was provided between the fuel fill deck fitting and the tank. The hose would have less than 2-1/2 minutes fire resistance.
- (b) Vent System - The fuel vent system was of a light fabric reinforced type and would have less than 1 minute fire resistance. The hose was clamped at both ends with strap clamps.
- (c) Fuel Feed System - The fuel distribution system was a single length of copper tubing with flare fittings between the fuel tank and the flexible fuel line to the engine. The flares were well made and revealed no cracking.

- (d) Fuel Tank - The 20 gallon fuel tank was welded terneplate steel, 16-1/4 inches wide, 26-1/2 inches long and 11-3/4 inches high. The tank was liquid tight after the fire except for minor leakage at the fuel gauge transmitter gasket. The tank was approximately 1/2 full and was set on a solid plywood platform with no provision for air circulation below the tank, other than the beaded ribs on the bottom surface. No advanced corrosion was found on the tank bottom but some pitting was evident around the tank top fittings. The tank was secured by the tank flange with a strip of metal. See Photograph No. 2.
- (e) Valve - No shut-off valve was provided in the system and the system did not have any form of anti-siphon protection. Since the fuel tank was mounted on a raised platform, the system could siphon if a leak developed anywhere between the flexible fuel line connection and the carburetor.
- (f) Flexible Fuel Line At Engine - The flexible fuel line was of the fabric reinforced type with swaged fittings. The fabric reinforced hose would have a fire resistance of about 1 minute.

2. Engine - The engine was a 120 HP 4 cylinder Merc Cruiser inboard/outdrive No. V11031BA.

- (a) Backfire Flame Arrester - The Fisher Model 1125 backfire flame arrester was USCG Approved under 162.041/20/0 and was found loose but in good condition. The arrester assembly was not physically damaged by the fire. See Photograph No. 3. The slight loosening can result from the fire and does not indicate that it was loose prior to the fire.
- (b) Ignition Distributor - The Delco ignition distributor was still intact and appeared to be in good operating condition. The points were in good condition and all of the ignition wires were tight. The ignition wires were burned. See Photograph No. 3. The distributor was not UL Listed and was not "ignition-proof". It would not meet the NFPA/ABYC requirements.
- (c) Alternator - The engine was equipped with a Delco marine alternator that was not a UL Listed device. The collector ring housing appeared to be enclosed. The voltage regulator was a solid state device.
- (d) Oil Level - The engine oil level was normal and there was no evidence of any malfunction of the engine or outdrive. The belt drives were burned but in position indicating no belt failure.
- (e) Starter - The Delco starter, located at the aft end of the engine low on the starboard side, was apparently tight but not "ignition-proof". The wire connections were tight. The terminals were fully exposed.

(f) Carburetor - The carburetor was still in-tact indicating that the temperatures at the engine were below 1000°F. The throttle butterfly and throttle control were found in the idle position with the drive in neutral. This tends to confirm the owner's account that the engine switch was turned off and the control was put in neutral before he checked the engine.

(g) Fuel Pump - The engine fuel pump was of the single diaphragm type that was vented to the engine crankcase. An AC fuel filter with metal (aluminum) bowl was attached to the fuel pump with a short nipple and a pressure relief by-pass valve was provided between the pump outlet and the inlet side of the filter. See Photograph No. 3. The fuel filter bowl was found forward of the engine at the edge of the engine well in an upright position. The fire had fused the bowl to the deck covering material but the metal bowl itself was not distorted or melted. The wire bail used to attach the bowl was found directly below the fuel pump under the engine. It was not distorted or damaged. Because of the condition and position of the parts, it seems evident that the filter had been disassembled prior to the fire. It was noted that the mating edges of the filter housing, the edge of the metal bowl and the contact surfaces of the bail were covered with soot. The fuel pump diaphragm itself was found

in tact after the fire.

- (h) Engine Controls - The single throttle gear shift lever was found in a neutral/idle position. The carburetor choke was found closed and the throttle butterfly in idle position.

3. Electrical - The wiring system in this boat was generally in a state of poor repair with many wire splices in the harness system. The electrical system has a number of wires not protected by overcurrent protection that could cause secondary short circuits and result in secondary fires remote from the location of any original short caused by the fire. The following was noted:

- (a) Master Battery Switch - The system did not have a master battery switch or a main switch in the battery lead to the instrument panel and fuse block. A master battery switch is required by NFPA 302 but not required by the current ABYC proposal or the proposed U.S. Coast Guard Regulations.
- (b) Overcurrent Protection - The only fuse found was for the navigation light circuit. The navigation light switch was off.
- (c) Unprotected Terminals - There were several unprotected live terminals in the engine compartment that could have accidentally caused a short circuit when working on the fuel filter. The starter solenoid terminals were directly below the fuel filter and the hydraulic pump solenoid terminals about a foot aft of the fuel filter. See Photograph No. 3.

4. Miscellaneous

- (a) Fire Extinguisher - A single USCG/UL Approved 5 BC dry chemical extinguisher, manufactured by Fire Control of Linden, New Jersey was found (No. AF795217)
- (b) Blower - The boat was equipped with a bilge blower that was mounted on the transom with a direct discharge. The natural ventilating system was completely burned but the remains indicated that it was set up to comply with the current U.S. Coast Guard requirements for ventilation.

OPINION

The facts in this instance, and the physical evidence did not support the owner's account of the accident and although there was, what might be considered a human error, the cause is primarily attributed to the absence of any anti-siphon protection. Notwithstanding the human element that was involved, it seems highly likely that when the engine slowed down and finally stalled, that a siphon action leak had developed at the fuel filter and either stalled the engine due to lack of fuel or because of an overly rich mixture in the compartment, due to the leakage. Since the drop off was gradual rather than abrupt, the later is more likely. The owner did indicate that he saw liquid leakage which would tend to support the fact that siphon action was present. Since the filter is on the intake side of the pump, the operating engine would tend to minimize the leakage due to the reduced pressure at the inlet of the

pump. It has been proven by laboratory test that an engine can continue to run with a substantial siphon leak on the inlet side of the pump. Reference is made to laboratory tests conducted in connection with Case No. 4 in 1972. After the engine stopped and the owner opened the engine box and removed the filter bowl, it is quite probable that the siphon action continued since there was no shut-off valve or anti-siphon valve to stop the flow. As previously noted, the tank itself was elevated and even when it was only half full a head of fuel would exist at fuel pump/fuel filter level.

In addition to not being able to cut off the fuel flow when working on the engine, the owner could not cut off the electrical power since the boat did not have any form of master disconnect. The source of ignition could not be established but since the engine was not operating, a momentary short circuit to one of the exposed live terminals on the hydraulic pump solenoid is the most likely. In a situation such as this, it should have been possible to shut off both the fuel supply at the tank and the electrical power at the battery while repairs were made and until all vapors were dissipated by natural ventilation.

The lack of adequate overcurrent protection is considered a probable major factor in not being able to extinguish the fire with portable equipment. The wire insulation materials are easily and quickly ignited by any fire and it can be expected that secondary short circuits will and must occur.

In this particular boat if the lead between the alternator battery terminal and the ammeter shorts to ground, the red and white wire from the engine space all the way to the instrument panel would probably ignite and burn since it is not protected. The resulting fire would then cause a second short in the unprotected lead from the ammeter to the starter, in the hot leads to all instruments and in the unprotected conductors to the power trim control. See Figure No. 2.

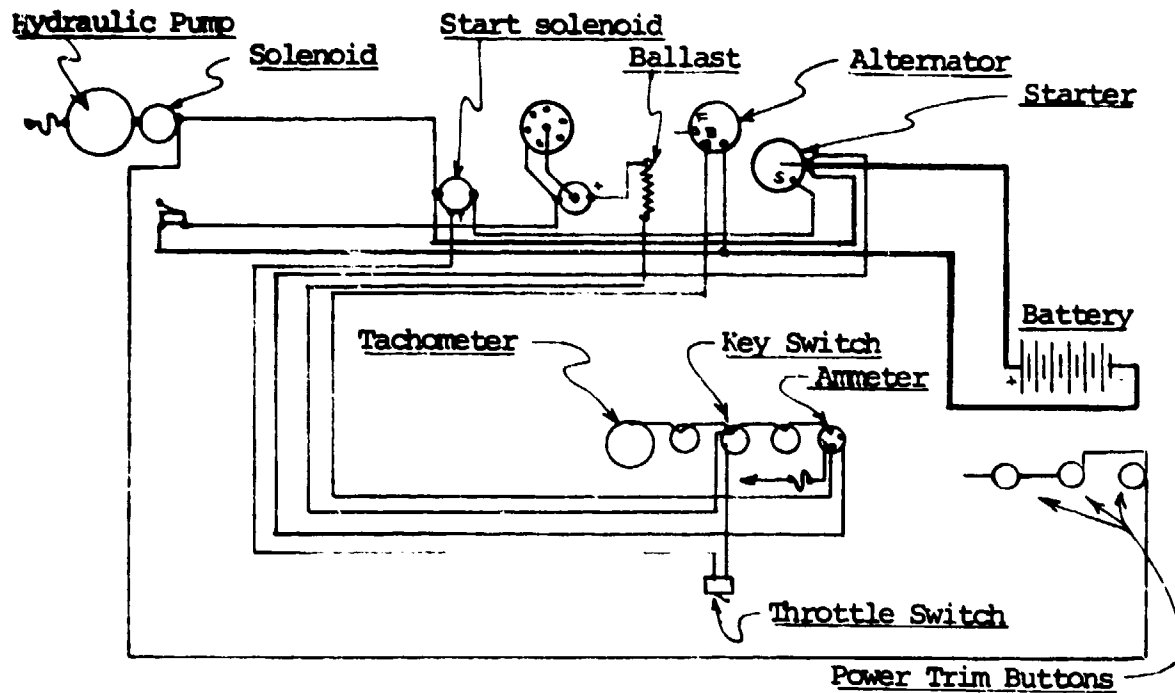

Approximate Diagram of Wiring Without Overcurrent Protection

Figure 2



4 PHOTO



MAPAS No. 10

Reproduced from
best available copy.

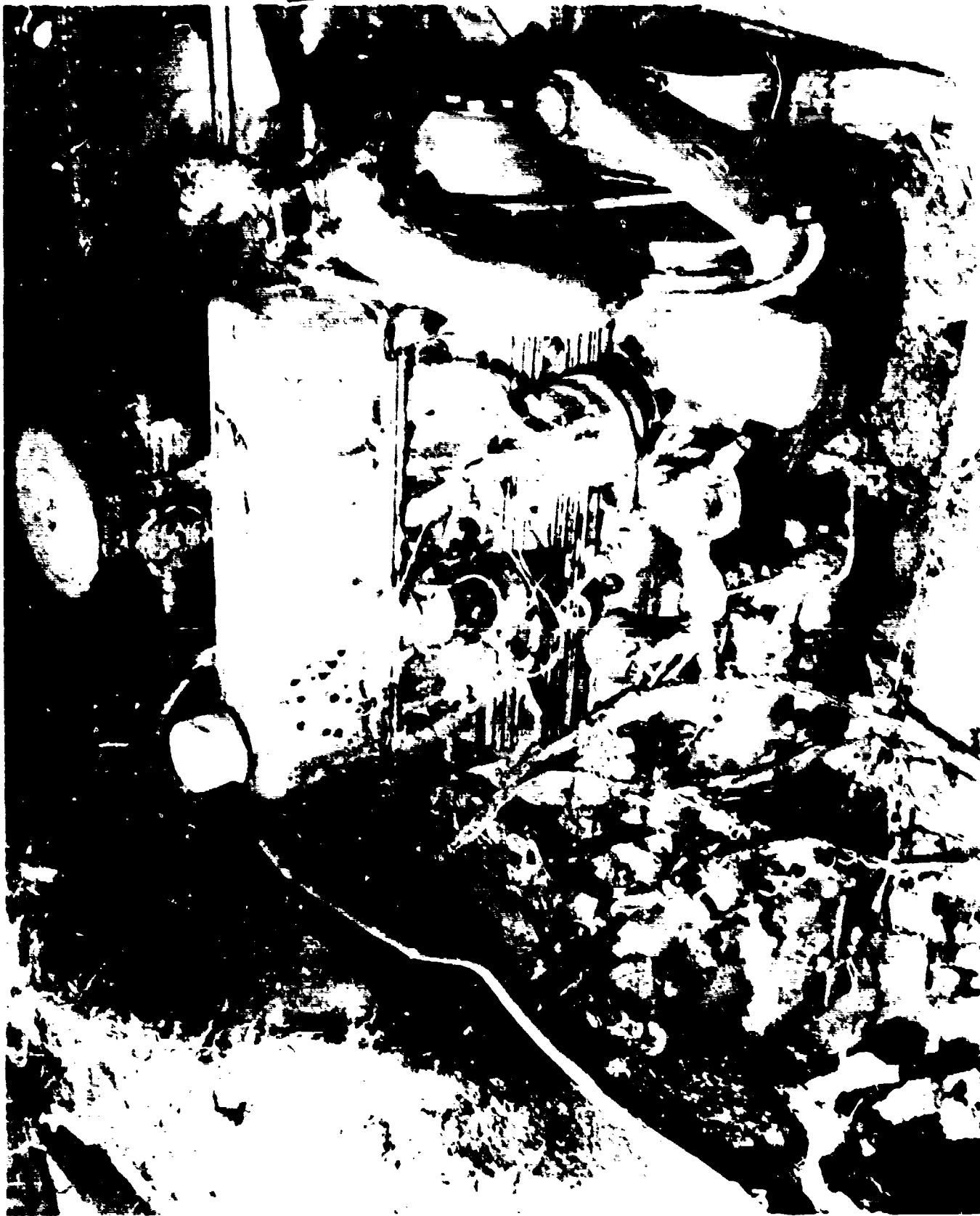



APR 24 1965 NO. 1 PHOTO NO.



1974 CASL 4 PHOTO NOV

RECREATIONAL BOATING ACCIDENT INVESTIGATIONS FOR 1974C A S E N O. 5DESCRIPTION OF BOAT

The 19 foot boat involved in this explosion and fire was a 1966 Johnson "Surfer". The boat was an open cockpit sport fisherman model with a tri-hull bottom and 150 horsepower inboard/outdrive engine. The boat was used for fishing and was equipped with a homemade fish well which the owner bolted to the stern deck. See Photograph No. 1.

The boat was of molded fiberglass reinforced plastic construction with a foamed bottom and had no living accommodations. The boat was equipped with a Navy top that was in use at the time of the fire.

The 150 HP V-8 engine was positioned at the stern with a close fitting engine box that extended into the cockpit 32 inches. The stern deck was 12 inches wide and the clearance on either side of the engine box approximately 17 inches to the cockpit coaming. The main fuel tank was located aft on the port side between the engine box and hull. See Photograph No. 2. The 20 gallon terneplate fuel tank measured 17 by 32 by 10 inches and was original equipment (8 years old).

The boat owner had installed a second fuel tank in the bow cockpit which projected above the bow deck level. The location was such that the tank could completely siphon if a leak developed anywhere in the fuel distribution system. When full, the tank

would place a hydrostatic pressure on the fuel pump and carburetor. The tank contained about 10 gallons and was shut-off with a valve in the engine box.

The boat tag indicated that the boat was designed for 9 persons of 170 pounds or 2000 pounds combined weight.

PHOTOGRAPHS

No. 1 - View of boat stern from port side. The box on the stern deck is a fish well added by the owner. The engine box cover was removed for the photograph. The opening in the deck mold at the transom are natural ventilating openings. The larger hole is for a 3 inch diameter duct to the engine space and the small hole for a 2 inch diameter duct to the tank space. The fuel tank vent fitting is visible below the rub rail about 16 inches forward of the transom.

No. 2 - View of engine from above. The main fuel tank is located below the molded cockpit seat on the port side. Arrow No. 1 points to the bow tank shut-off valve and arrow No. 2 to the stern tank valve. The flexible fuel line to the engine is connected to the tee fitting between the two valves. The white coating on the engine is the dry powder extinguishing agent.

No. 3 - View of terneplate fuel tank looking aft along port side. The flexible fuel line forward of the tank is from the bow tank. The arrow points to the split in the non-metallic vent line just above the hose clamp.

No. 4 - Close-up photograph of tank fitting plate with split vent hose removed. The arrow points to the grounding screw where the tank leaked when pressurized. The peeled and alligatored paint surface is attributed to fuel leakage over a period of time.

NARRATIVE ACCOUNT OF ACCIDENT

The boat involved in this explosion/fire had been operated the day before without any indication of trouble. On the day of the accident the engine was started and the boat proceeded about 500 feet to the fueling dock where the main 20 gallon tank was topped off with about 5 gallons of fuel. The tank was filled by one of the guests and the filling operation was continued until fuel was discharged at the fuel fill. No fuel was added to the bow tank. While the tank was being filled, the boat owner was on the dock. After fueling, the owner stepped back aboard and one of the guests started the engine. The engine was started without the blower, and without first checking the bilge for vapors. The engine ran for about 30 seconds at about 500 RPM and had drifted in neutral about 8 feet from the dock when an explosion occurred in the engine space. The force of the explosion lifted the engine box cover and the flame front ignited the owners jacket. The owner jumped overboard to extinguish the flames on his clothing and then immediately climbed back on board and used the boat's 4 pound dry powder extinguisher to fight the fire. The boat's portable extinguisher helped but was inadequate to extinguish the blaze. A 5 pound dry powder extinguisher was passed to the boat owner from the dock and used to extinguish the remaining fire. There were no injuries and the resulting fire damage was relatively minor.

FACTS ESTABLISHED FROM WITNESSES

1. The boat owner had installed the external fish well shown in Photograph No. 1 on the stern deck and had installed the bow fuel tank.
2. The boat owner did not know for sure if the guest, who was operating the boat, had put the boat in gear but thought it was still in neutral. He was sure that the blower was not operated and that the bilge was not checked for vapors.

KNOWN CHANGES TO ORIGINAL DESIGN

1. The boat owner had installed the external fish well on the stern deck.
2. The boat owner installed the spare fuel tank in the bow cockpit and the fuel distribution system.
3. There were no other known changes to the boat.

OBSERVATIONS AND FINDINGS

1. Boat Fuel System - When the investigation was conducted, the fuel system would not hold pressure. When a slight aerostatic pressure applied to the system at the engine flexible fuel line connection, the leak was audible and gasoline vapors were immediately evident although it was not possible to see the source of the vapors.

- (a) Fuel Fill - The shaped, non-reinforced fuel fill pipe was still liquid tight but slightly charred by the fire. The hose would probably have about 1 minute or less fire resistance. It was clamped with a single clamp at both ends. See Photographs 3 and 4.

- (b) Vent System - The fuel tank vent was a molded non-reinforced neoprene hose that was single clamped at the tank spud and at the plastic through-hull fitting. The hose was found split about 1/4 inch from the tank spud connection.

The split in the vent hose was the cause of the fuel leakage that resulted in the fire. See Photographs Nos. 3 and 4. The hose would have less than 1 minute fire resistance. The tank vent spud was not beaded to prevent the hose from slipping off but the connection was tight.

- (c) Fuel feed Line - The fuel distribution line from the aft tank was copper with flare fittings. The line was routed from the tank 90° fitting to a fuel shut-off valve inside the engine box. The line was liquid tight but poorly supported. It was secured only by the flare fitting at the tank and by a bracket at the valve in the engine box, approximately 38 inches apart. See Photograph No. 2 and 3.

The fuel feed line from the bow tank was non-reinforced PCV 5/16-inch hose (Gates 3225). The bow tank installation would not comply with the ABYC or NFPA Standards since it did not have an external fill connection and the vent could discharge vapors back into the hull

- (d) Bonding - The fuel tank was electrically bonded to the deck fill fitting with an insulated wire. When, in the course of the investigation, the fuel tank was pressurized with air, leakage was detected at the machine screw securing the bonding wire to the tank fitting plate. See Photograph No. 4. The arrow points to the grounding wire connection.
- (e) Fuel Tank - The 20 gallon fuel tank was welded terne-plate steel and measured approximately 17" x 32" x 10". The tank was liquid tight except for leakage at the bonding wire connection. The paint on the top surface of the tank in the area of the fitting plate was peeled in a manner that would indicate that the fuel leakage had been present for an extended length of time. The alligator finish was localized and not the result of the flash fire. See Photograph Nos. 3 and 4. The fuel tank was set on two longitudinal chocks and secured with a single clamp. Some advanced corrosion was evident around the fitting plate (within 1/4 inch) and along the bottom edges. See Photograph NO. 3.

The bow fuel tank was high and would place a hydrostatic head of fuel on the fuel pump and carburetor whenever the bow tank valve was open. The aft tank was low but the fuel would siphon at the fuel pump or if a break occurred in the lower part of the flexible fuel line.

Although the fuel tank was technically accessible, access was difficult and the owner of the boat had not removed the port seat to check the tank since the bow tank was installed a couple of years prior to the accident. See Photograph No. 2. The molded seat was secured in position with about 8 screws and bolts and was not easily removed.

(f) Shut-Off Valves - The boat was not equipped with fuel tank shut-off valves or with anti-siphon protection, but did have two solid bottom plug cocks inside the engine box. The valves were used to select the bow or stern tank as needed. The installation would not comply with either the NFPA or ABYC Standards in effect at the time, or the current Standards.

(g) Flexible Fuel Line At Engine - The 26 inch long flexible fuel line section was 1/4 inch ID non-reinforced hose with swaged fittings. The hose would have about 30 seconds of fire resistance and was made up of 2 sections joined in the center with a 4 inch length of 9/32 inch ID copper tubing. The copper tubing splice was secured with 2 strap clamps. The hose was blistered by the fire but still liquid tight.

2. Engine - The engine was Johnson 150 HP V6 (225 cu. in. displ.) engine with an OMC stern drive.

- (a) Backfire Flame Arrester - The Fisher Model 6100 Backfire Flame Arrester was approved under 162.041/41/0 and was found in position in good condition. It is not considered a likely source of ignition.
- (b) Ignition Distributor - The distributor was an externally vented type with a "trap door" distributor cap. Because the wiring inside the unburned cap was slightly blistered, the distributor is considered the source of ignition for this flash fire. All high voltage wires were in position and were not badly burned or swollen indicating the presence of little open flame in that area.
- (c) Alternator - The Prestolite alternator was not listed by UL or the YSB but appeared to be an "ignition-proof" type. The metal collector ring cover was in position and there was no evidence of internal fire. The mechanical voltage regulator was not "ignition-proof", but the cover gasket was tight and there was no evidence of internal fire. The voltage regulator is visible in Photograph No. 2 outboard of the distributor (starboard side).
- (d) Starter - Since the engine was operating the time of the fire, the starter is not considered a source of ignition. The wiring connections were tight at the starter and at the starter solenoid.

- (f) Oil Level - The engine oil level was normal and there was no evidence of any engine malfunction. The drive belt for the alternator and water pump was intact.
- (g) Carburetor - The carburetor was completely intact with no indication of sustained fire in the area.
- (h) Fuel Pump - The fuel pump was of the single diaphragm type that was either vented to the crankcase of the bilge. The diaphragm was liquid tight when pressure checked.
- (i) Control - The boat had a single lever control for the throttle and gear box.

3. Electrical - The electrical wiring was found substantially undamaged by the fire and there was no evidence of any electrical short circuits.

- (a) Master Battery Switch - The boat did not have a master battery switch or switch in the battery lead to the instrument panel.
- (b) Overcurrent Protection - The boat was equipped with a fuse block at the instrument panel with fuses for the bilge pump (14 amp), cigarette lighter (14 amp), windshield wiper (14 amp), instrument lights (7.5 amps), running lights (7.5 amps) and accessories (7.5 amps). None of the fuses were blown.

4. Miscellaneous

- (a) Fire Extinguisher - The boat had a single pound dry powder extinguisher that ran out before the fire was extinguished. The fire was extinguished with a 5 pound dry powder extinguisher from the dock.
- (b) Ventilation - The boat had two 3 inch diameter flexible ventilating ducts (P/S) with ventilating louvers recessed in the deck mold near the transom. See Photograph No. 1. Since both ducts were excessively long and had two 90° bends the efficiency of the system had to be very poor. In addition to the duct losses, ventilating louvers are the least effective type of ventilation fitting.
- (c) Blower/Bilge Pump - The boat was equipped with a combination blower/bilge pump that was melted. The blower/bilge pump was not UL Listed but, being a submersible type, was probably "ignition-proof".

OPINION

The basic cause of this accident was the failure of the non-reinforced tank vent hose with ignition by the open ignition distributor. Although the vent hose failure is classified as the cause for the presence of fuel, the inaccessibility of the tank for inspection must be recognized as a major contributing factor. This factor is substantiated in this instance by the fact that the fuel leakage was present over a period of time long enough to cause the paint on the tank top surface to become alligatored from leaking fuel. If this tank were readily accessible, it is most probable that the leakage might have been

detected before the fire occurred.

It is considered highly probable that the lack of fire spread and minimal evidence of sustained fire in the tank compartment was due to poor ventilation in that space. In essence, it is believed that the fire was to a great extent self-extinguished due to a lack of adequate oxygen. This fact tends to support the concept that the Standards should not attempt to require ventilation where fuel vapors can only be present from liquid fuel leakage.

In this boat, because the top of the engine box is hinged at the aft end, the explosion was directed at, rather than away from the boat occupants. The normal front latch did not hold under the pressures exerted by the explosion.

It is noted that when this flash fire occurred, the boat owner could neither shut off the main fuel supply or cut the electrical power. If the flash fire, which was of sufficient duration to melt the bilge pump/blower, had caused an electrical short circuit, reignition of the fire after the 5 lb. extinguisher was used would have been likely.



Reproduced from
best available copy.



1974 CASE NO 5 PHOTO NO 2 4



1974 CASE No. 5 PHOTO No. 3



CASE No 5

4

RECREATIONAL BOATING ACCIDENT INVESTIGATIONS FOR 1974C A S E N O. 6DESCRIPTION OF BOAT

The Donzi, 16 foot ski sport runabout involved in this explosion and fire was built in 1966 and was purchased as a used boat by the owner, 2 years before the accident.

The boat was of molded fiberglass reinforced plastic construction with a 165 HP Interceptor 1/0 engine that had been modified with high lift cams and heavy valve springs for added power. The boat used a 12 x 25 cupped prop. The hull was of a deep vee design with a ribbed bottom. Longitudinal stiffness was provided by two fore and aft stringers 22 inches apart running from the transom to a point slightly forward of the bow fuel tank. The longitudinal stringers were about 8 inches deep.

The boat had a conventional speedboat layout, with a midship cockpit, bow deck and engine compartment aft. See Photograph No. 1. The 1/0 engine was below the aft deck with a large flush engine hatch. The hatch was hinged at the aft end and latched at the forward edge. The engine space was inter-connected to the fuel tank space by openings between the cockpit ceiling and hull. Limber holes in the engine space bulkhead and the floors would permit the free flow of bilge water between the engine and fuel tank space. See Figure No. 1.

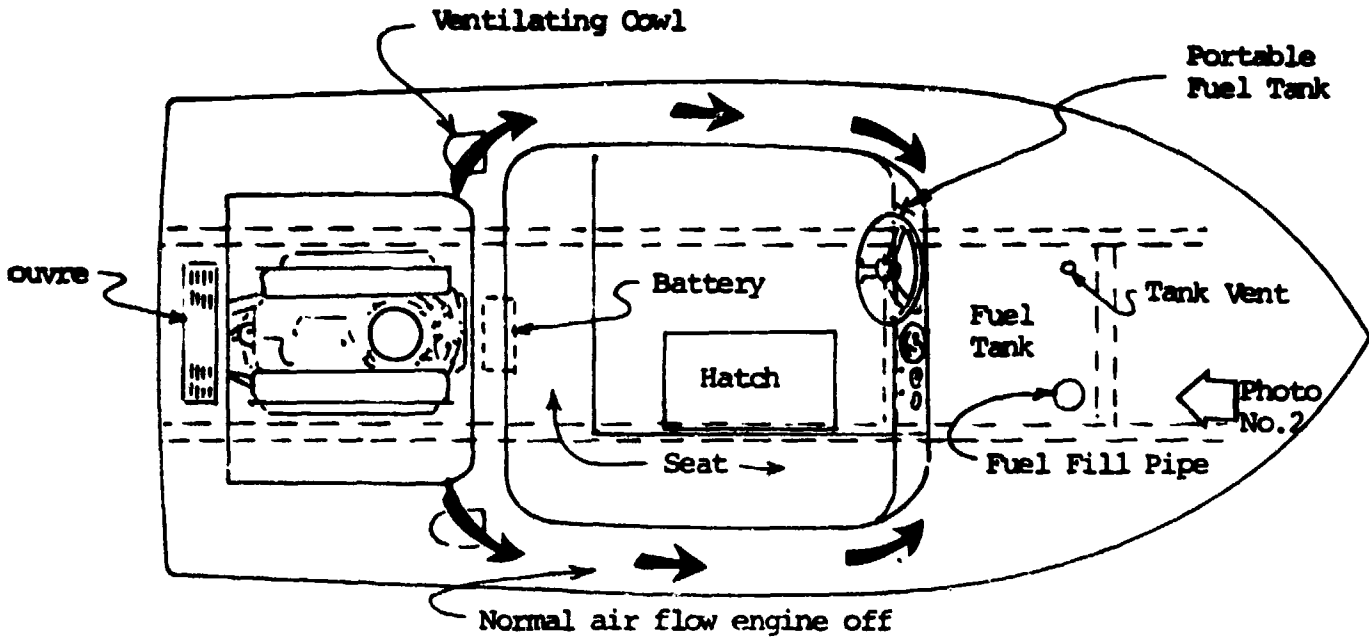

FIGURE 1

The ventilating system consisted of a louvre aft of the engine in the deck mold and two ducted clam shells facing forward at the forward end of the engine space. The major ventilation in this boat would be from the air flow created by the pressure differential under the instrument panel. The air flow would be as shown in Figure No. 1 when the engine was not operating. When the engine was running the major flow of air to the carburetor would be from the same source with the flow opposite to that shown.

The boat fuel tank was foamed in place under the bow deck between the two fore and aft stringers. Photograph No. 2, was taken from the position indicated in Figure 1. The photograph shows the exposed surface of the fuel tank.

PHOTOGRAPHS

No. 1 - View of boat after the fire from a position 1 point on the starboard quarter. A small cockpit hatch was removed and the engine hatch is missing. The small round opening in the cockpit deck below the instrument panel is for access to the fuel tank shut-off valve.

No. 2 - Photograph of the fuel tank as viewed from the bow. The position is indicated in Figure No. 1. The vertical rod at the left connects the forward lifting eye to the hull, the fuel fill pipe is directly behind the lifting rod and the fuel tank vent hose is on the right. The tank fuel gauge (direct reading) is barely visible below the cockpit deck. The burned wiring at the top of the photograph is the back of the instrument panel. The photograph shows the ridge around the tank created by the foam that causes water to collect on the tank top.

No. 3 - View of foamed-in fuel tank with the entire deck and cockpit mold removed. The photograph is from the starboard side looking forward. The fuel feed line is visible aft of the fuel gauge and the non-metallic vent line is visible at the forward end of the tank. The dark ring around the spud, at the arrow, is where the material has corroded away. The fitting is supported by the fuel line.

No. 4 - View of engine from port side looking forward after deck was removed. The fuel filter is at approximately 8:30 in the photograph. The photograph shows that the wires inboard of the engine stringer are burned and that the wiring outboard of the stringer were protected from direct flame exposure.

No. 5 - Photograph of fuel tank after removal from hull being checked for leakage. The fuel feed connection had fallen out and was plugged with putty before the photograph was taken. The entire tank edge between the three arrows was perforated.

No. 6 - Photograph of burned plastic fuel container and kapok cushions.

NARRATIVE ACCOUNT OF ACCIDENT

The boat involved in this accident was to be the lead boat in a sailing regatta and the single fuel tank had been topped off that morning. Only the owner and his wife were aboard the boat at the time. After being fueled, the boat was operated for about 25 minutes and the owner/operator indicated that the engine was operating better than it had since he bought the boat two years before. The owner's wife wanted to light a cigarette and the operator, after increasing power to change trim (put the boat on step), throttled the engine back to about 2500 rpm. Without warning, or prior indication of a problem, an explosion occurred in the engine space that was of sufficient force to break the engine hatch latch and blow the hatch off. The flame front then moved forward to the open space under the dash board at the fuel tank and burned the ankles of the owners wife who was sitting on the starboard side.

A number of boats came to the assistance of the stricken boat and the owner used about 12 portable extinguishers to extinguish the fire.

The fire caused moderate damage in the engine space and to the deck mold around the engine hatch, completely burned the battery forward of the engine and most of the wiring in the boat. A plastic portable fuel container clamped to the foot board below the dash board was burned through but did not explode. It was not thrown overboard. See Photograph No. 6.

FACTS ESTABLISHED FROM WITNESSES

1. The boat owner who is an experienced small boat operator did not know he was required under Section 37(d) of the Federal Boat Safety Act to report the accident to the U. S. Coast Guard and was not advised of this requirement by the local Marine Police.
2. The engine in the boat had been modified by a local shop with high lift cams and heavy valve springs and was not original equipment.

KNOWN CHANGES TO ORIGINAL DESIGN

1. The engine in the boat was modified by a local shop and is not considered original equipment. The engine was originally a 165 HP Interceptor but with the modifications was about 400 HP.
2. The portable fuel container and bracket were added.

OBSERVATIONS AND FINDINGS

1. Boat Fuel System - The boat had a single 25 gallon foamed-in terneplate steel fuel tank under the bow deck with a single non-metallic flexible fuel line between the tank and a bronze fuel filter at the engine. The system was physically in tact but would not hold pressure.

- (a) Fuel Fill Pipe - The fuel fill pipe was a straight length of multi-layer fabric reinforced hose that was single clamped to the deck fitting and at the tank. See Photograph No. 2. The hose was singed and blistered by the fire but apparently still liquid tight. The clamps were tight.
- (b) Fuel Tank Vent - The tank vent was a fabric reinforced hose with a single strap clamp at the tank and at the hull connection. The hose was partially blistered by the fire but liquid tight after the fire.
- (c) Fuel Feed Line - The full length non-metallic fuel line between the fuel tank and bronze "Groco" fuel filter was singed but still intact. The cotton braid hose was Aeroquip 1525-6 and was used with push-on fittings.
- (d) Fuel Tank - The 16 gauge 25 gallon terneplate fuel tank was manufactured by "Fabco" and was the original tank. The tank was 38 inches long, 22 inches wide and 12 inches deep at the vee. The Model 125 tank was foamed in place between the main fore and aft stringers with a fiberglass floor fore and aft making a five sided enclosure. Only the top surface of the tank was exposed. The tank vee bottom was set on wooden blocks so as to be supported independently of the foam as required by current standards. Examination of the tank revealed the following:

- (1) The fuel pick-up tube had corroded out and was supported by about 1/2 inch of paper thin metal. See Photograph No. 3.
 - (2) The entire aft top edge of the tank and the first 9 inches of the top edge along the right side was totally perforated. All other top edges were badly corroded but had not yet corroded through.
 - (3) The tank bottom and side surfaces that were in contact with the foam did not initially show evidence of advanced corrosion but when the surfaces were cleaned off in the laboratory hundreds of pits were found that varied in depth from a few thousandths of an inch to 18 thousandths or approximately 1/3 the material thickness. The pits were scattered over the entire surface but in some areas were concentrated. When the tank was removed, the bedding foam surface was brown with iron oxide and likewise showed evidence of greater corrosion in some areas. See Laboratory test results.
 - (4) The fuel tank and deck fill were electrically bonded to ground.
- (e) Fuel Filter - The boat was equipped with a "Groco" bronze fuel filter that was Listed by the Yacht Safety

Bureau. The filter which was secured to the port stringer forward of the engine was liquid tight after the fire.

2. Engine - The V8 engine was an Interceptor 165 HP gasoline engine that had been modified for increased horsepower.

(a) Backfire Flame Arrestor - The down-draft carburetor had a Barbron 162.015/98/0 backfire flame arrestor approved under the old 162.015 Coast Guard Specification. The USCG 162.015 specification was superseded by specification 162.041 in August of 1965, hence this boat should have been equipped with a device complying with the new specification. The backfire flame arrestor cover plate was found cocked to one side indicating the possibility of severe backfire. See Photograph No. 1.

(b) Carburetor - The Holley down-draft carburetor was in good mechanical condition after the fire. It was noted that the installation included a large diameter breather hose connection to the starboard valve rocker box cover that could permit flame to by-pass the backfire flame arrestor if the hose slipped off or split. In this case the hose was totally intact.

(c) Alternator - The 38 ampere alternator and the engine mounted mechanical voltage regulator were not UL or YSB Listed ignition-proofed units but both appeared totally enclosed. They were not considered likely sources of ignition.

- (d) Ignition Distributor - The Mallory YL vented distributor was not "ignition-proof" and is considered a possible source of ignition. Both the distributor body and cap were vented directly to the engine space.
- (e) Starter - Since the engine was running at the time of ignition the starter was eliminated as an ignition source.
- (f) Oil Level - The oil level in the engine was normal and there was no evidence of an engine or transmission seizure.
- (g) Fuel Pump - The single diaphragm externally vented pump was found liquid tight.

3. Electrical - Most of the electrical wiring in the boat was destroyed by the fire.

- (a) Master Battery Switch - The boat was not equipped with a master battery switch. Although a master switch might have helped, the secondary fire at the instrument panel was not attributed to secondary short circuits.
- (b) Overcurrent Protection - The engine wiring was such that there were unprotected wires between the battery, the instrument panel and back to the engine. Since the wires in the harness were not melted, the wiring damage at the instrument panel is attributed in this case to the secondary flame front. See Photograph No. 2.

4. Miscellaneous

- (a) Ventilating System - The boat ventilating system would comply with the ABYC, NFPA and U.S. Coast Guard requirements. The major air flow in an engine-off condition would be due to the air pressure differential created under the dash board not due to the ventilators. With the engine operating, the main air supply would again be from the openings forward.

LABORATORY TEST OF FUEL TANK MATERIAL

Objective - To determine the gauge of the steel used for the tank, the weight of the terne coating and the degree of corrosion by laboratory analysis.

Result -

- (1) Steel Gauge - The tank material was determined to be 16 gauge steel.
- (2) Terne Coating - Weight of coating tests according to ASTM method A309 indicated a coating weight (total both sides) by the triple spot test to be 0.28 oz. per sq. ft. The coating weight (total both sides) by the single spot test (the one sample of the three with the lightest coating) was found to be 0.27 oz. per sq. ft. These coating weights correspond to a coating designation of LT25 per ASTM A308-69 which corresponds to what is known as a 9 lb. coating. The current NFPA and ABYC Standards require a 12 lb. coating with a minimum .35 oz. lead per square foot. See Table 1 for test results.

(3) Corrosion Pitting

- (a) The tank exhibited severe internal and external corrosion and was perforated 27 times along the aft top edge. The holes varied from pin holes to holes 1/16" by 3/8". The corrosion of the aft edge was from the outside and is attributed to the periodic accumulation of water between the tank and the foam in which the tank was bedded. The perforated edge was corroded internally as well and the corrosion pattern would indicate that water entered one or more of the perforations from the outside and migrated along the seam. This would indicate that the tank had been leaking for a period of time before the accident.
- (b) The fuel feed pipe spud connection corroded out completely due to thinning of the metal within 1/2 inch of the spud. The corrosion was due to the accumulation of water on the tank top surface around the spud.
- (c) The exterior surface of the tank that had been in contact with the foam looked reasonably clean when the tank was removed except for the loss of about 1/2 of the original paint coating. When cleaned and checked, the external surface revealed scattered spots of pit-type corrosion with several pits being approximately .018 in. deep.

(d) The internal surfaces revealed scattered spots of pit-type corrosion but generally less than the exterior. The pits were as deep as .015 in and were mostly on upper surfaces above normal fuel level. In addition to the surface corrosion, all of the tank seams and corner bends showed evidence of internal corrosion probably due to disruption of the terne coating during fabrication.

T A B L E I

Results of Coating Weight Tests
(Terne Coating Steel From Marine Fuel Tank)

<u>Specimen</u>	<u>Coating Weight, Oz. Per sq Ft</u>		
	<u>Outside</u>	<u>Inside</u>	<u>Both Sides</u>
1	0.13	0.15	0.28
2	0.13	0.15	0.28
3	0.12	0.15	0.27
Average	0.13	0.15	0.28

These results align with ASTM A308 specifications as follows:

<u>ASTM 308-63T</u> <u>Old Coating Class</u>	<u>ASTM 308-69</u> <u>New Corresponding</u> <u>Coating Designation</u>	<u>Minimum Coating</u> <u>Triple Spot Test</u> <u>Total Both Sides</u>	<u>Weights, Oz/ft²</u> <u>Single Spot Test</u> <u>Total Both Sides</u>
0.35	LT25	0.25	0.20

This coating class (0.35), new coating designation LT25 corresponds to a nominal coating of 9.00 lbs/double base box. Results of tests on Terne coated steel from Marine fuel tank:

<u>Coating Weights, Oz/Ft²</u>	
<u>Triple Spot Test</u> <u>Total Both Sides</u>	<u>Single Spot Test</u> <u>Total Both Sides</u>
0.28	0.27

OPINION

The direct cause for the low grade explosion and fire on this boat was the corrosion penetration of the bow fuel tank. Although the fuel tank leak was the direct cause, the foaming-in of the fuel tank must be recognized as the proximate cause. The evidence clearly indicates that the method of installation caused water to be trapped around the top aft surface of the tank setting up a condition for accelerated corrosion. As installed, the installation would not comply with NFPA302, Para. 312(c) which states, "Tanks shall be so constructed that, as installed, exterior surfaces will not hold moisture."

It is interesting to note that the tank had numerous leaks and the potential for a fire and explosion accident existed for some indefinite period of time. Considering this factor, it is then also a fact that ready accessibility to the tank to permit easy inspection could easily have prevented the accident. The installation in this instance was such that reasonable inspection of the tank was not possible. Both the fuel feed spud that corroded out and the aft edge of the tank were completely inaccessible for inspection. The fact that the tank was not accessible for inspection as required by NFPA 302, Para. 313(a), is considered a contributing factor to this accident.

The cause of ignition was considered to be either the vented ignition distributor or a backfire that dislodged the backfire flame arrester cover.

The burning of the electrical wiring behind the instrument panel is primarily attributed to the flash fire that occurred at the fuel tank and possibly the portable fuel container. Since the wires in the harness were not melted, the fire at the panel was apparently not due to secondary short circuits, although it is noted that all of the wiring was not protected with fuses.

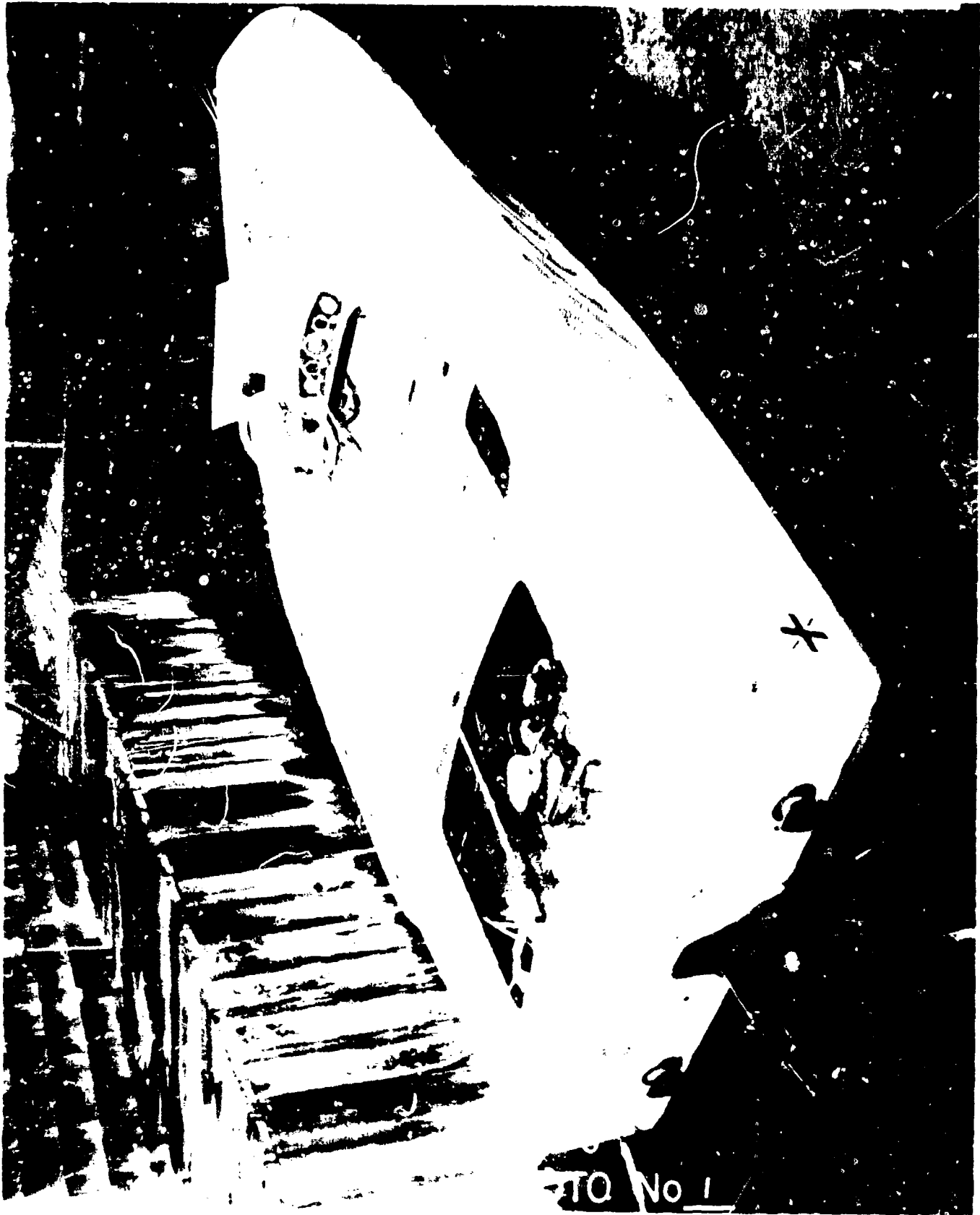



Reproduced from
best available copy. 



6 PHOTO



CAS

OTC/NO



49

5



PHOTO No. 6

RECREATIONAL BOATING ACCIDENT INVESTIGATIONS FOR 1974C A S E N O. 7DESCRIPTION OF BOAT

The boat involved in this explosion and fire was a 16 foot high speed, single screw, inboard jet drive speedboat, built by "Donzi Marine" of Miami, Florida. The boat was a 1973 model.

The deep-V, stern jet drive was powered with a 390 HP Oldsmobile engine, converted for marine use by Kingcruiser Engine Corporation. The drive unit was a "Berkeley" jet drive manufactured in Berkeley, California.

The fiberglass reinforced plastic hull has two full length stringers, which in addition to providing longitudinal stiffness, serve as engine beds and to enclose the bow fuel tank. The fiberglass deck and cockpit is molded as one piece and is screw-fastened to the hull along the sheer.

The engine and jet drive unit are located aft of the cockpit under the stern deck. The engine compartment is the full width of the boat with access through a single hatch. The hatch is hinged at the aft end and latched at the forward edge. See Photograph No. 1.

The boat has a conventional speedboat center cockpit layout. A bench seat is provided across the aft end of the cockpit and there are two individual seats forward by the dash board.

The engine space is interconnected with the bow fuel tank space by tunnel spaces between the cockpit ceiling and the hull along the port and starboard sides. See Figure 1.

The boat has a single 25 gallon hot-dipped galvanized fuel tank, foamed in place in the bow. The tank is positioned between the two fore and aft stringers below the foot rest under the dash board. The fuel tank shut-off valve is accessible through an access plate directly below the dash. See Photograph No. 2.

The boat's natural ventilating system consists of two clam shells forward and outboard of the engine. The cowls are fitted with wire reinforced plastic ducting to the bilge. The starboard clam shell is trimmed as an exhaust and the port clam shell as an intake. A power blower is located under the starboard clam shell. Although the boat has deck cowls, the major ventilating air flow would be through the tunnel spaces along the sides of the cockpit due to the differential pressure created under the dash.

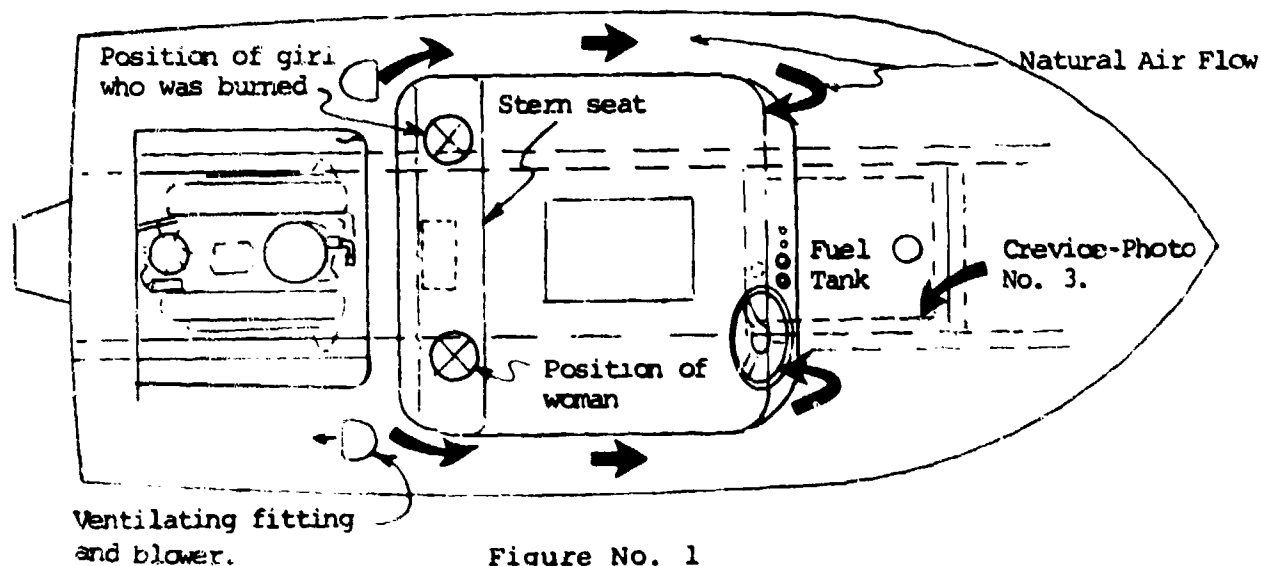

Figure No. 1

PHOTOGRAPHS:

No. 1 - View of boat after the fire from the port quarter.

No. 2 - Photograph of cockpit with the two forward seats removed. The electrical fire under the dash caused the three instruments on the left of the panel to fall out. The access hole for the fuel tank shut-off valve is visible at arrow No. 1 and the fuel tank vent hose is at arrow No. 2. The hose was pulled out for the photograph.

No. 3 - Photograph looking down at fuel tank, showing a crevice between the foam and tank. The starboard stringer is on the right, outboard of the tank. Arrow No. 1 points to the foam and arrow No. 2, to the crevice.

No. 4 - Photograph of aft end of the engine. The distributor cap was removed for the photograph. The DC wiring to the alternator and starter is visible as it crosses the control cable.

No. 5 - Photograph of engine carburetor after the integral carburetor fuel filter was removed.

NARRATIVE ACCOUNT OF ACCIDENT

On the day of the accident, the boat owner/operator with two other adults and one child had been out fishing. Shortly before the incident, they had witnessed another boat capsize and the boat owner called the Coast Guard with a citizen band two-way radio. While waiting for the Coast Guard, the boat slowly drifted west-south-west toward a boardwalk. When the owner thought he had drifted too far, he decided to start the engine and move further off shore. He turned the power blower on and told his daughter, who was seated aft on the port side, to lift the engine cover. The little girl lifted the forward end of the

hinged engine hatch and held it for about 30 seconds before the owner attempted to start the engine. In line with his normal practice, the owner pumped the throttle several times and then turned the key to start the engine. The starter cranked the engine and there was an immediate rich mixture explosion that caused a large bolt of flame and black smoke to mushroom out of the partially open hatch. The flame almost immediately also mushroomed out under the dash. The girl was in the direct path of the flame at the engine hatch and was burned on the face, arm and neck. The woman sitting on the starboard side of the same stern seat was also slightly burned, but escaped the full flame. The owner immediately shut off the fuel tank valve at the access hole under the dash and, after snuffing out the flame in his daughter's hair, helped everyone overboard. Using the 2-1/2 pound Stempel dry powder extinguisher, he attempted to extinguish the blaze, but was unsuccessful. The fire was extinguished by the U. S. Coast Guard who were nearby because of the other accident.

FACTS ESTABLISHED FROM WITNESSES

1. At the time of the accident, the 25 gallon fuel tank was approximately 1/2 full.
2. The boat owner cut off the fuel supply by means of the tank shut-off valve which was accessible through the access hole forward.
3. The boat owner did not know how the vent hose became disconnected, but thought the Coast Guard might have pulled it loose when fighting the fire.

4. When the fire started, the owner instructed the occupants to don their personal flotation devices which were accessible.

5. The boat owner removed the fuel filter at the carburetor prior to the investigation. He stated that the filter was tight; however, since the system between the fuel pump and carburetor was not pressure checked, before it was disturbed, the indicated conclusion may or may not be valid.

KNOWN CHANGES TO ORIGINAL DESIGN

There were no known changes to the original design.

OBSERVATIONS AND FINDINGS

1. Boat Fuel System - The fuel system was partially in tact and, with the vent plugged, was able to withstand a pressure of approximately 2 pounds up to the engine fuel pump. The following was noted:

- (a) Fuel Fill Pipe - The fuel fill pipe was a straight length of multi-layer fabric reinforced hose that was single clamped at the deck and at the tank. The line was still tight and held pressure.
- (b) Fuel Tank Vent - The tank vent hose was a common red garden hose and was found disconnected. An examination revealed that the inside diameter of the garden hose was larger than the outside diameter of the thru-hull vent fitting and would be difficult to clamp. Since there was no indication of fire at the fitting or in the immediate area of the disconnected hose, it is probable that the hose was accidentally disconnected by the Coast

Guard after extinguishing the fire. The connection would not comply with the NFPA, ABYC or proposed Coast Guard regulations.

- (c) Fuel Feed Line - The full length non-metallic fuel line between the fuel tank and engine was Aeroquip, Type 2568, dated the second quarter of 1972. The clamped-on hose was liquid-tight after the fire and had not been exposed to much fire.
- (d) Fuel Tank - The 25 gallon fuel tank was a 14 gauge hot-dipped galvanized steel tank produced by Taylor and Gaskin in July of 1972. The tank was pressure checked and found liquid-tight. The top surface of the tank revealed an overall general corrosion due to water accumulation.
- (e) Installation - The installation would not comply with NFPA, ABYC or new proposed U. S. Coast Guard regulations which do not permit the foaming in of ferrous metal tanks. The tank was not Listed by UL for marine use. Photograph No. 3 shows a crevice between the tank and foam that was found full of water. The entire top surface of the tank was a water trap with no effective means of draining of any accumulated water.
2. Engine - The boat was powered with a Oldsmobile 390 HP V8 engine that was converted for marine use by Kingscruiser Engine Corporation.

- (a) Backfire Flame Arrestor - The down-draft carburetor had a Bendix Zenith backfire flame arrestor with Approval Number 162.041/94/0. The assembly was in good operating condition, but was found loose.
- (b) Carburetor - The down draft carburetor was found blackened, but had not been subject to any intense heat. The integral fuel filter had been removed by the owner.
- (c) Alternator - The "Delco" alternator and voltage regulator were an ignition-proof type and were found in good condition. All wiring connections were tight, but several wires at the aft end of the engine were burned, including the alternator field lead. The alternator B+ lead was connected directly to the starter solenoid.
- (d) Ignition Distributor - The ignition distributor was not damaged by the fire, but is considered a possible source of ignition. There was no internal evidence of fire when the distributor was opened; however, this fact does not eliminate the distributor as the source of ignition. A stoichiometric or lean mixture will not usually leave evidence of burning.
- (e) Starter - The starter was completely inaccessible and could not be checked in detail. The wiring connections to the starter solenoid were tight. The starter solenoid wires were burned and had shorted to the steel bowden wire aft of the engine. The starter is considered a potential source of ignition.

- (f) Fuel Pump - The single diaphragm fuel pump was not damaged by the fire and was found liquid-tight when pressure checked.
- (g) Engine Fuel Lines - The fuel line from the pump to the carburetor was partially steel and part SAEJ30 hose (Gates 3225). When found, the hose clamp used to secure the hose to the short steel line had slipped off the hose. The loose connection is not believed to be the result of the owner removing the filter after the fire.

3. Electrical - Almost all of the wiring in the boat was destroyed.

- (a) Master Battery Switch - The boat was not equipped with a master battery switch. Since the boat operator shut off the fuel valve almost immediately, it is quite probable that he would also have shut off a master switch if one had been provided. The master switch might have prevented the electrical fire behind the instrument panel.
- (b) Overcurrent Protection - The engine wiring was such that there were several unprotected wires. The power lead from the starter solenoid to the ignition switch and panel was unprotected. A short circuit in the ignition, alternator or the starter solenoid circuit could result in a dead short that could ignite the electrical harness from the engine compartment to the instrument panel. See Figure No. 2.

TYPICAL WIRING DIAGRAM

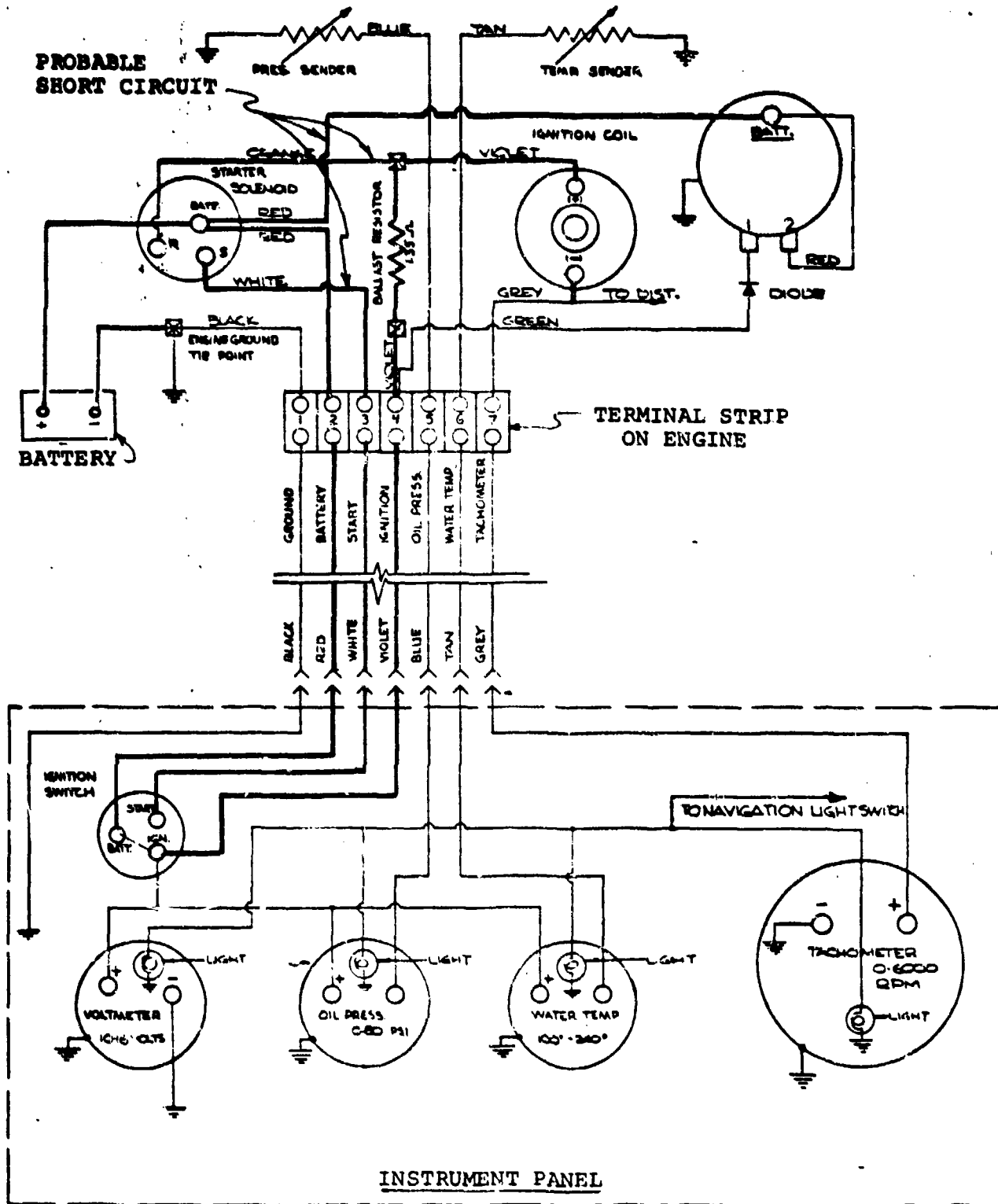

FIGURE 2

4. MISCELLANEOUS

- (a) Ventilating System - The boat ventilating system would comply with the ABYC, NFPA and U.S. Coast Guard requirements. The major air flow in the engine compartment in an engine-off condition would be due to the air pressure differential created under the dash board. The power blower would be relatively efficient due to the short direct ducting. The blower was completely melted.
- (b) Bilge Pump - The automatic-manual Rule bilge pump was not damaged and had been removed by the owner.
- (c) Personal Flotation Devices - The boat had several PFD's. One was still wrapped in plastic.

OPINION

The specific item that failed and caused this explosion and fire was not determined, but sufficient data is available to isolate the engine fuel system as the only logical source of the fuel. A review of the facts will reveal the basis of the hypothesis:

- (a) Except for the fuel tank vent, the fuel tank and fuel system were liquid-tight up to the engine, including the engine fuel pump.
- (b) The fuel tank vent system was eliminated because open flame was present in the bow compartment, but there was no evidence that the vent was burning at the end of the hose or outside the hull at the vent fitting. The absence of charring at the end of the hose would indicate that the line was disconnected after the fire was extinguished. The tank was only

1/2 full eliminating leaks at tank top fittings.

- (c) There was no evidence of prolonged burning of liquid fuel either below the engine or on the engine near the carburetor. Photographs 4 and 5 show the absence of open flame damage to rubber hoses and ignition wires. The burned spot on the intake manifold is normal.
- (d) The fuel vapors that ignited as a rich mixture either accumulated in the carburetor after the previous shut-down or accumulated outside the carburetor due to a leak somewhere between the fuel pump and the carburetor. The accumulation of excess fuel inside the intake manifold, with manifold heat causing immediate vaporization, is considered the most probable source of the rich mixture. Any residual liquid fuel would continue to burn after the initial explosion. With the hatch open, any breeze over the bow of the boat would cause the vapor cloud to move forward through the tunnel spaces to the fuel tank space, as it did. It is noted that the owner always pumped the throttle prior to starting the engine. This action would add additional fuel to any already accumulated.

Note: Since the boat owner had removed the integral carburetor fuel filter before the investigation was conducted, these items could not be checked. The owner stated that the filter was tight but since the connections were not pressure checked before the filter was removed, the conclusion cannot be confirmed.

(e) The explosion of the rich mixture vapor cloud ignited the blower on the starboard side, outboard of the engine, and also softened the insulation of the wires at the aft end of the engine. The softened insulation caused a short between either the ignition wire or the starter solenoid wire and a grounded control cable on the aft end of the engine. This would result in an overheated wire all the way from the engine space to the instrument panel. The short caused a secondary fire forward, totally burning the wiring behind the instrument panel.

Note: Since the engine did crank it is not probable that the electrical short occurred first.

- (f) Although the power blower was used, prior to starting the engine, it was only on for a short period (30 seconds) and if the vapors were generated at the carburetor as suggested, the low blower pick-up was simply ineffective.
- (g) The source of ignition was probably either the starter or the distributor.





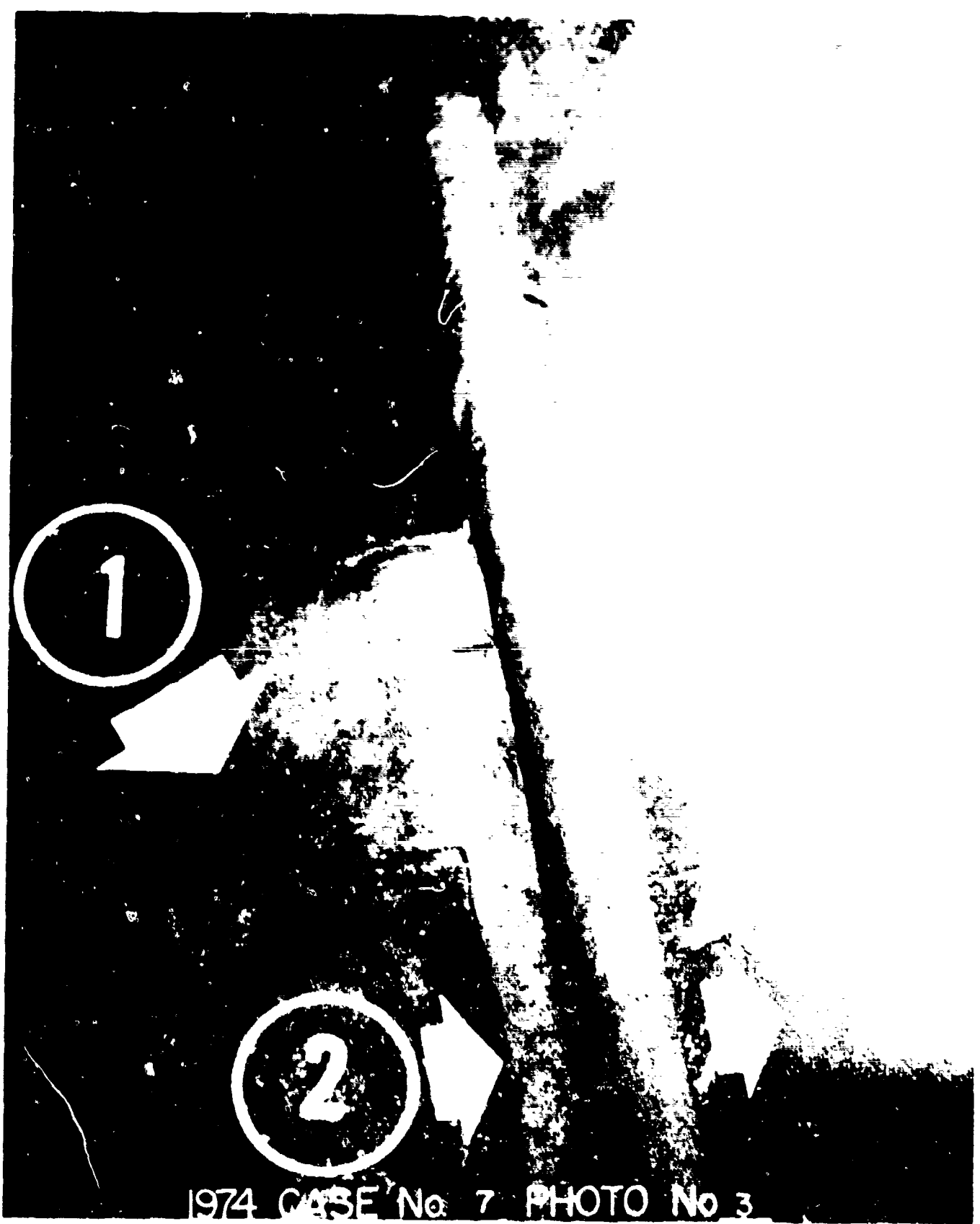

1974 CASE No. 7 PHOTO No 3

Reproduced from
best available copy.



CASEIN

7



1974 GAS-

7

5

RECREATIONAL BOATING ACCIDENT INVESTIGATIONS FOR 1974C A S E N O. 8DESCRIPTION OF BOAT

The 24 foot single screw inboard-outdrive boat involved in this low order explosion and fire was a 1973 Wellcraft, built in Sarasota, Florida. The boat was an open cockpit, sport fisherman model with a cathedral hull. The fire resulted in a constructive total loss.

The hull and deck were of molded fiberglass construction with three full length fore-and-aft wooden stringers, glassed in from the transom to the bow. Flotation foam was provided in the form of blocks at the transom and between the stringers below the plywood cockpit deck. The bilge was sufficiently open to permit liquid gasoline to flow fore and aft if it accumulated in the bilge.

The boat was powered with an OMC 225 HP inboard-outdrive engine installed in a conventional manner just forward of the transom. The engine box served as a seat. The compartment was ventilated by means of 4 large clam shells on the stern deck with the two outboard clam shells trimmed aft as exhaust, and the center two clam shells forward as intakes. The starboard outboard clam shell served as the power blower discharge. The ventilators were fitted with plastic flexible air ducting.

The boat was fitted with two 5052 welded aluminum alloy fuel tanks installed as saddle tanks above the cockpit deck. The tanks were positioned approximately amidships with the fuel

fill fittings on the side deck outboard of the coaming. Both tanks were of 28 gallon capacity.

PHOTOGRAPHS:

No. 1 - View of burned boat from starboard quarter.

No. 2 - Photograph of port fuel tank after fire.

No. 3 - Photograph of engine from the port side. The engine mounts had failed and the engine dropped. The port battery is visible outboard of the engine.

No. 4 - View of engine from starboard side. The starter and starter solenoid are visible below the manifold and the starboard battery is visible outboard of the engine.

No. 5 - Photograph of engine and boat stern from starboard side.

NARRATIVE ACCOUNT OF ACCIDENT

The owner of the boat involved in this fire was an avid fisherman and was out fishing alone on the day of the accident. Prior to the fire, the boat operated well with no indication of any malfunction. The fuel tanks were about 1/2 full. Prior to the accident, the boat was anchored about 12 feet off a channel in protected waters. When the fish did not bite, the owner-operator turned the power blower on for about 10 seconds and then started the engine in preparation for a move. After the engine started, he went aft to pull the anchor and noticed smoke coming through the ventilators and around the engine box. He immediately moved forward to get the boat's single portable extinguisher and as he did so, an explosion occurred in the engine space that blew the engine box open. He attempted to extinguish the fire, but when he saw smoke in the forward cabin, decided to abandon the boat. The attempt to extinguish the blaze was not successful

and the boat continued to burn.

FACTS ESTABLISHED FROM WITNESSES

1. The two 28 gallon fuel tanks were about 1/2 full and at the time of the accident, the valves to both tanks were open so the single engine could draw fuel from either or both tanks.
2. When the fire started, the engine was idling and the out-drive was in neutral.

KNOWN CHANGES TO ORIGINAL DESIGN

There were no known changes to the original design.

OBSERVATIONS AND FINDINGS

1. Boat Fuel System - Almost the entire fuel system was consumed by the fire and a pressure test was not possible.

(a) Fuel Fill - The fuel fill was a short straight length of 1-1/4 in ID wire reinforced hose, single clamped at the tank and at the deck fitting.

The clamps were still in place. Since the tanks were well below full, failure of the fuel fill can be eliminated as the source of fuel. The fuel fill bonding wire was tucked under the hose, which is not good practice.

- (b) Tank Vent - The port fuel tank vent discharge fitting was located forward of the tank and 4 inches below the tank top surface. The installation was not in accordance with the intent of the ABYC or NFPA Standards, but is not considered a factor in this accident, since the fuel level was approximately 10 inches below the tank top. The fuel vent hose

was a fabric-reinforced type. It was secured with hose clamps. It was noted that both vent discharges had ignited and burned outside the hull, indicating that both were connected and substantially intact prior to the fire.

- (c) Tank Shut-Off Valve - The fuel system was not equipped with a shut-off valve at the tank or an anti-siphon valve. Since the fuel tanks were mounted above deck, the tanks could almost completely siphon in case of a break in the line. Since the builder claims to install anti-siphon valves on all tanks, it is believed the valves were removed by the dealer or service yard.
- (d) Fuel Tanks - The two 28 gallon saddle tanks were manufactured by Aluminum Fabricated Products, Inc. of .090 in. thick 5052 aluminum. The tanks, which were a little over a year old were examined for corrosion with the following findings. The port tank had scattered spots of pit-type corrosion on the exterior surface with an average depth of about .003 inches, but two pits measured .010 and .013 inches. The interior surface had two small areas of corrosion with a maximum depth of about .002 inch. The starboard tank was relatively free of any pit-type corrosion except for two spots on the back and one pit on the inside surface. The external pits were .002 inch deep and the pit on the inside surface was .002 inch. The boat was operated in salt and brackish water. The tanks were secured directly to the deck with self-

tapping screws through two welded flanges at the tank ends. No ventilation was provided between the deck and tank bottom as recommended by the NFPA.

- (e) Fuel Feed Line - The fuel feed line was a full length section of SAEJ30 type hose from the tank to a selector valve assembly, aft of the engine. The unsupported flexible fuel line was installed as shown in Figure 1 and would siphon the tank if a break or leak occurred at point A or B. In this instance, it is believed that a leak occurred in Section A and that the initial small fire caused a total failure of the line permitting a continuous siphon feed of fuel.

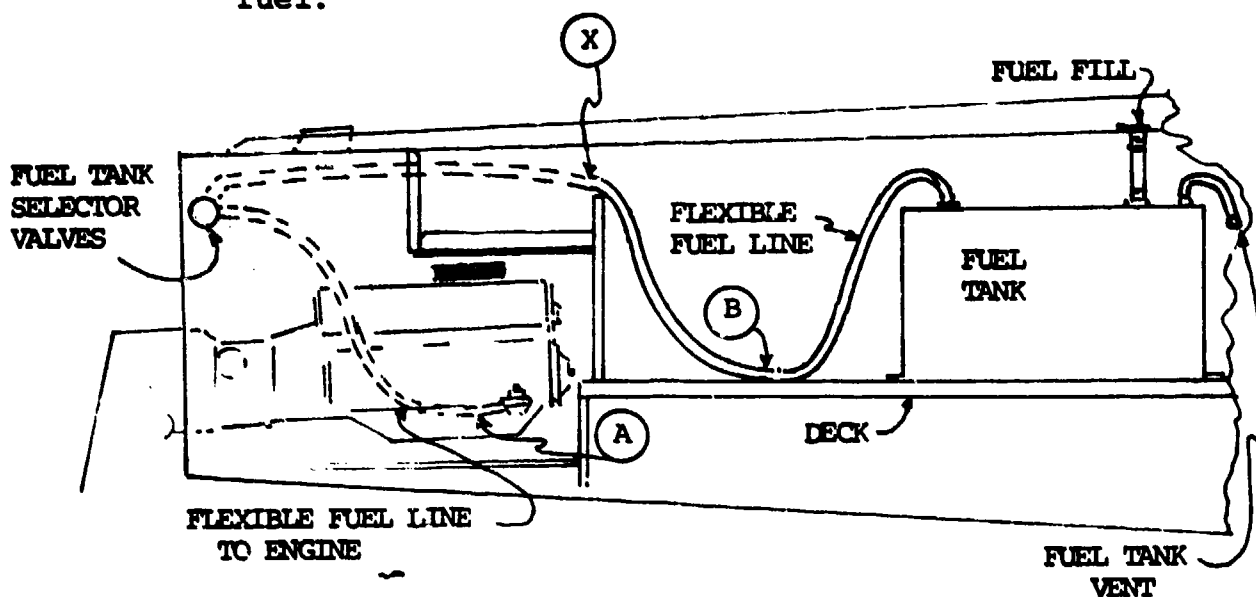

PLAN VIEW SHOWING GENERAL LOCATION OF TANK AND ROUTING OF FUEL LINE

Figure 1

(f) Fuel Valves - The boat was equipped with "tee" assembly of two Anderson Brass (series 600) UL Listed solid bottom shut-off cocks. They were used to select the port or starboard fuel tank. The valves were located aft of the engine, inside the engine compartment and were not accessible for emergency use. Both valves were found open and liquid-tight, but the flexible fuel lines had burned off at the clamped hose connections with the clamps still in position.

2. Engine - The OMC 225 engine had been subject to extensive heat, causing a total failure of the engine mounts and all engine mounted accessories. The engine was number 990211F-WC2981.

(a) Fuel Pump - The engine was equipped with a dual diaphragm UL Listed fuel pump with an SAEJ30 type hose connected to the inlet and a steel fuel line between the pump and engine mounted fuel filter. The fuel pump was equipped with an integral fuel filter.

(b) Fuel Lines - The engine fuel lines were steel with reverse flare fittings.

(c) Backfire Flame Arrester - The down-draft carburetor was equipped with a Fisher flame arrester approved under USCG Specification 162.041. The arrester was in position.

- (d) Alternator - The engine was equipped with a Presolite alternator that appeared to be an ignition-proof construction, but the ALK 6210 is not Listed for Marine use by UL. The engine mounted solid state voltage regulator was a Presolite regulator number VSH 6201. The regulator is not UL Listed, but is inherently ignition-proof. The alternator was completely destroyed by the fire.
- (e) Ignition Distributor - The engine was equipped with a Mallory YL520 CV distributor with screw fastened cap. The distributor is an ignition-proof type currently Listed by UL.
- (f) Starter -The starter was a Delco solenoid engage unit that was not certified as ignition-proof. The wiring terminals were tight.
- (g) Oil Level - The engine oil level was normal and there was no indication of engine seizure.
- (h) Controls - The investigation revealed the throttle butterfly to be in an idle RPM position, the choke was open and the engine control was in neutral.

3. Electrical - All wiring insulation was completely destroyed by the fire.

- (a) Circuit Protection - The small fuse panel at the helm included fuse protection for the bilge pump, the blower, the windshield wipers and the horn. The ignition and alternator circuits were not protected.

- (b) Batteries - The boat had two separate batteries located under the stern deck outboard of the engine on the port and starboard sides. See Photograph No. 5.
- (c) Main Switch - The boat was not equipped with a main battery disconnect switch or main switch in the panel lead.
- (d) Wiring - SAE stranded type wire was used throughout the boat. No specific evidence of a short circuit was found.

4. Miscellaneous

- (a) Buoyant Devices - The buoyant devices on the boat were stored under the forward port bunk and were not used.
- (b) Power Blower - A Wilcox Crittenden electric blower was mounted on the inside of the transom and discharged through the outboard clam shell. The blower installation would be relatively efficient, but as previously indicated, the blower was only operated for about 10 seconds before the engine was started.
- (c) Natural Ventilation - The 4 cowl 4 duct system would comply with US Coast Guard requirements and the NFPA and ABYC Standards.

OPINION

The intense heat of the fire on this boat destroyed all component parts of the fuel system to an extent that it was not possible to pin-point the specific cause. However, the available data would indicate a fuel leak in the engine space with

siphon action causing a continuous source of fuel to feed the fire. The following is specifically noted. The fire apparently started in the engine compartment and the failure of the engine mounts and all components would confirm the accumulation of a considerable quantity of fuel in the engine well below the engine. The sequence of events would seem to suggest that the leak occurred prior to the attempt to start the engine. It is probable that the initial mixture was excessively rich causing the initial smoke and that a thermal draft created by the initial fire introduced sufficient oxygen to cause the explosion that followed. It is noted that the initial ignition did not result in any audible explosion or swooshing noise characteristic of most explosions. The absence of any noise is far more likely with a rich mixture than a lean mixture. The starter was the probable source of ignition. The fire would burn through the soft hose in a minute or less, providing full siphon action fuel flow. The siphon action feeding the fire is believed to have continued until the fire burned the hose off at tank top level at the tank fitting, but by the time this occurred, the fire would engulf the two tanks and burn through the tank walls, as it did. The fire in this boat spread very rapidly because the liquid fuel in the engine well ran forward, immediately spreading the fire to the small accommodation space forward. The fire was also spread by the partial bulkhead between the engine space and the tank compartment. Fire in the engine space would immediately mushroom

over the bulkhead and burn the fuel feed line at point X
(Figure 1).



7 CASE No. 8



1974 CASEY 8 PHOTO No. 2



1974 CASE No. 8 PHOTO No 3

Reproduced from
best available copy.



PHOTO: News



1974 CA

5

RECREATIONAL BOATING ACCIDENT INVESTIGATIONS FOR 1974

C A S E N O. 9

DESCRIPTION OF BOAT

The 25 foot "Malibue", open sport fisherman involved in this fire was built in 1970 and was purchased from an insurance company 1-1/2 years before the accident. The 4 year old boat was purchased after it sank.

The inboard/outdrive boat was powered with two 130 HP Volvo Penta engines that were installed by the present owner. Both engines were purchased as used equipment including all accessories. The engine crankshafts were a few inches below the cockpit deck.

The hard chine hull was of fiberglass reinforced plastic construction with a molded fiberglass weather deck and fiberglass covered plywood cockpit deck. The boat was of conventional design and construction. See Figure No. 1.

The boat's single 75 gallon aluminum fuel tank was foamed in place below the cockpit deck, just forward of the engines. The tank, which measured 35 x 10 x 52 inches was manufactured by Certified Industries of Hialeah, Florida of .090 inch thick 5052 H32 aluminum. The tank had two baffles and all seams were heliarc welded.

The boat did not have a power blower and the natural ventilating system consisted of two clam shells on the stern deck with 3 inch diameter ducting to the turn of the bilge.

PHOTOGRAPHS

No. 1 - Bow view of boat after fire.

No. 2 - View of engines from cockpit. The deck and fuel tank were removed before the photograph was taken. The fuel tank was located just forward of the partial bulkhead, between the fore and aft stringers, outboard of the engines. The cutouts were provided for the fuel fill pipe and the engine controls.

No. 3 - View of the aft cockpit before the deck was removed. The fuel tank was located below the deck in the area of the lower arrow. The short straight arrow at the upper right points to the fuel fill fitting.

No. 4 - Photograph of foam that was installed between the deck and the tank top. The fiberglass tube at the arrow was to support wiring and control cables.

No. 5 - Photograph of the bottom surface of the fuel tank. Some of the major areas of corrosion are circled. The long line of corrosion across the width of the tank occurred at the edge of the plywood platform which supported the tank.

No. 6 - Macro photograph of fuel fill hose at the point where it failed. The needle point end, caused by corrosion of the spiral wire reinforcement, is visible.

No. 7 - Macro photograph of two areas of corrosion on the aluminum fuel tank. The right half of the photograph shows a corroded area on the bottom, aft end of the tank. The photograph shows the head of a sheet metal screw that had been installed by the present owner. The

left half of the Macro photograph is of a section of the line of corrosion that occurred on the tank bottom just forward of the plywood platform on which the tank was supported. See Figure No. 2.

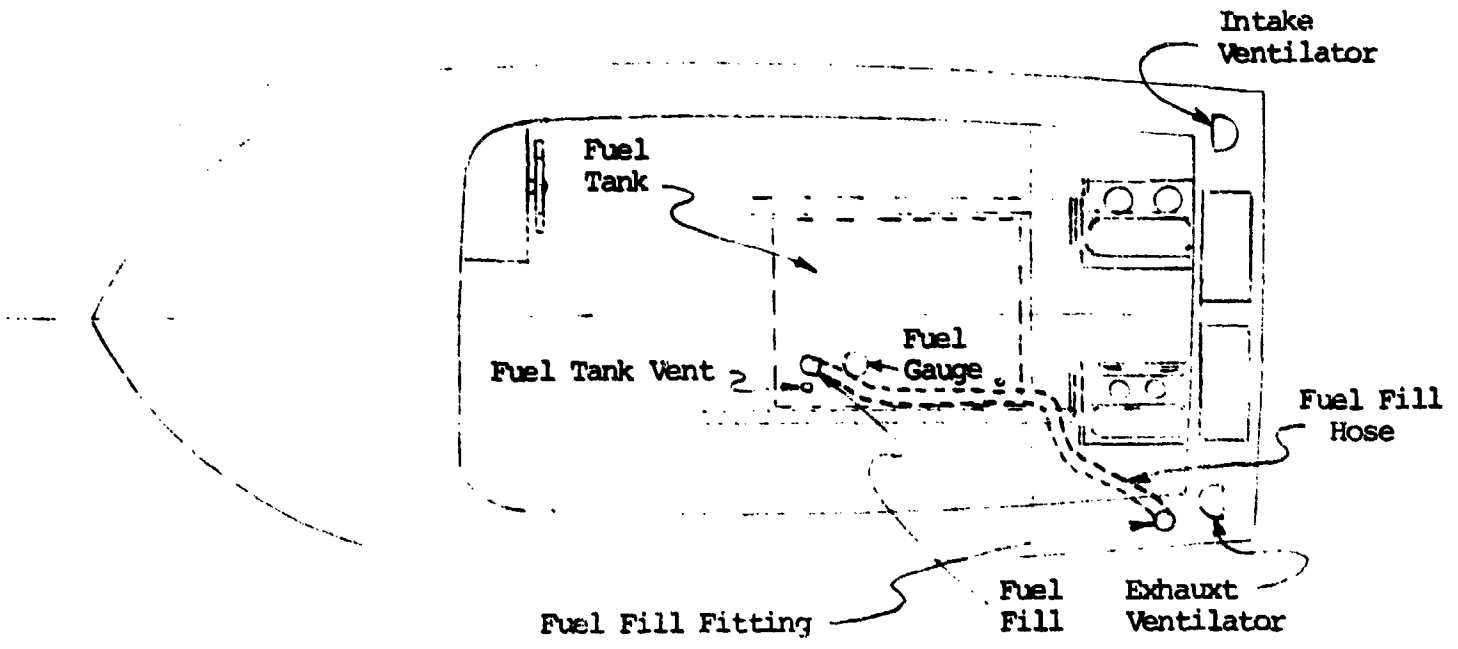

Figure 1

left half of the Macro photograph is of a section of the line of corrosion that occurred on the tank bottom just forward of the plywood platform on which the tank was supported. See Figure No. 2.

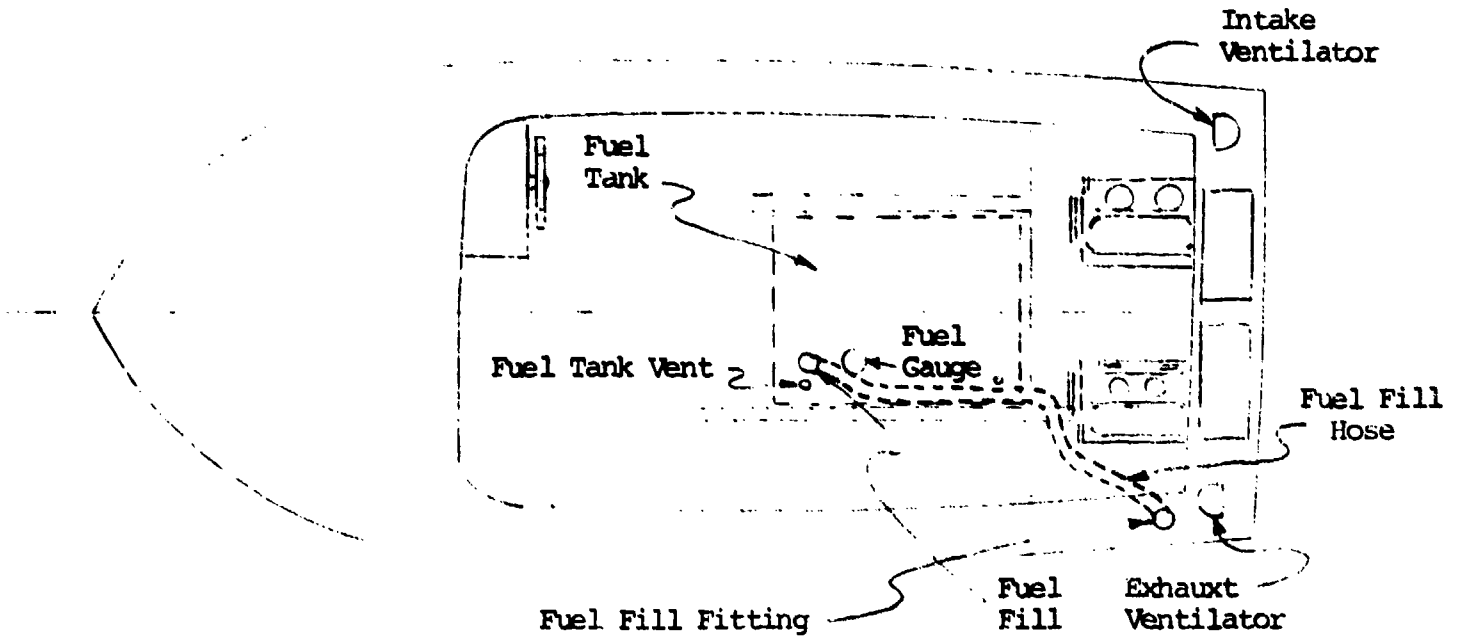

Figure 1

NARRATIVE ACCOUNT OF ACCIDENT

The boat had just been fueled by the boat owner/operator and burst into flames when the engines were being started to move the boat away from the fueling station. The boat had taken on approximately 50 gallons of fuel and the tank was filled until the fuel backed up in the fuel pipe. The boat owner was alone on the boat at the time and was not aware of the accumulation of fuel in the engine and tank space. The boat did not have a power blower and the owner did not check the engine space for vapors before attempting to start the engines.

After fueling, the port engine started but the starboard engine would not turn over. The owner opened the engine box preparing to jump start that engine, but apparently did not actually do so. Fire broke out in the engine space when it was opened. The owner was not able to extinguish the fire with the boat's single 4 pound extinguisher.

The boat was abandoned and pushed away from the fuel dock. The fire was extinguished by the local fire department.

FACTS ESTABLISHED FROM WITNESSES

1. The boat owner had two second-hand Volvo engines installed after he purchased the boat from the insurance company. The starboard engine was considerably older than the port engine but both apparently operated reasonably well during the 1-1/2 year period.
2. The aluminum fuel tank was original equipment.

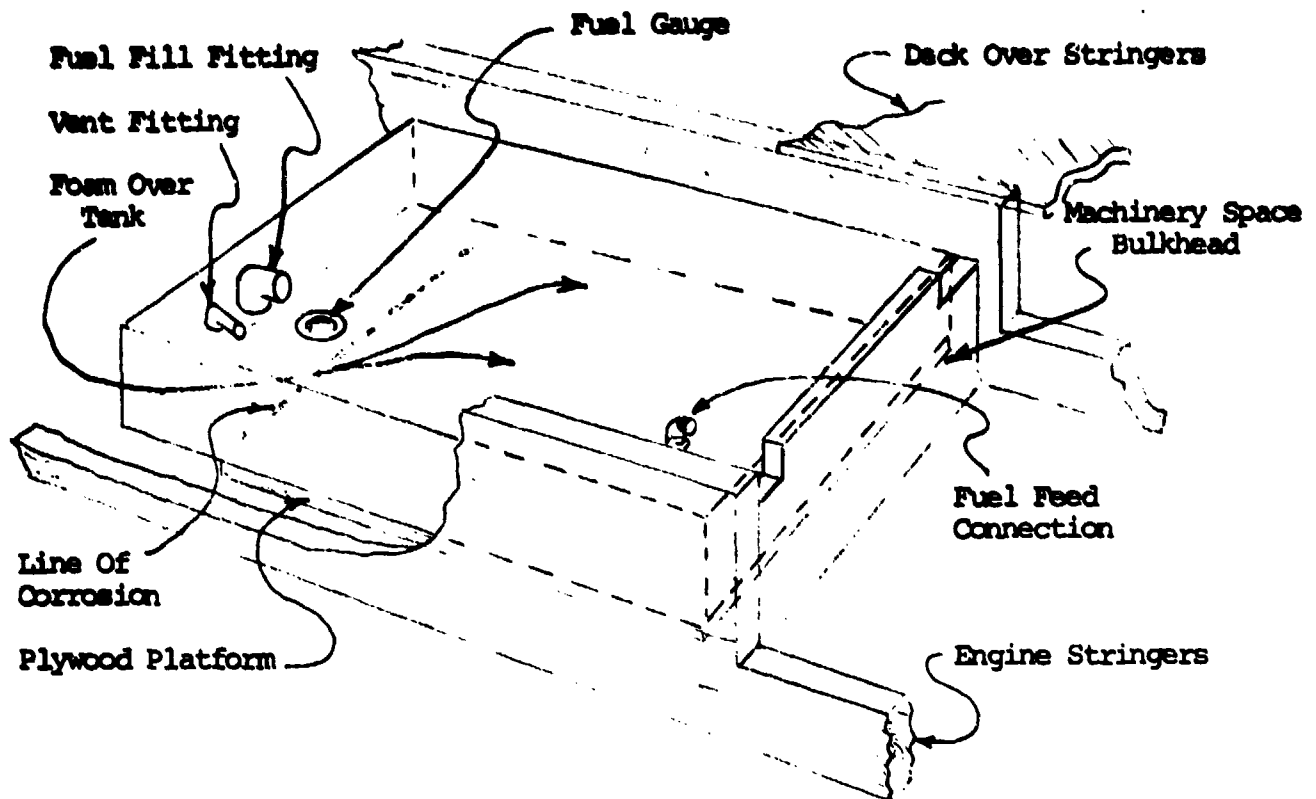

Figure 2

KNOWN CHANGES TO ORIGINAL DESIGN

1. The engines had been replaced by the present owner.
2. There were no other known changes to the boat.

OBSERVATIONS AND FINDINGS

1. Boat Fuel System - When the investigation was conducted, the fuel system would not hold pressure. When pressure was applied at the starboard engine connection with the vent plugged, no pressure could be built up. An examination revealed the following:

(a) Fuel Fill - The fuel fill pipe installation was found to be a hazardous installation and considered responsible for the fuel leakage that caused the fire. The following is noted:

- (1) The fuel fill pipe was approximately 10 feet long and would normally contain about .8 of a gallon of fuel. Until the fuel is consumed, the fill pipe is functionally part of the fuel tank.
- (2) The Tempo 1-1/2 inch ID hose was constructed to SAEJ30 specifications with a steel spiral wire reinforcement.
- (3) Because the fuel fill hose was foamed-in for approximately 50 inches, it was not accessible for inspection and the foam had, in fact, caused water to be entrapped around the hose near the tank fill pipe connection. See Figures 1 and 2.
- (4) The fill hose was spliced in the engine space with a short length of PVC plastic pipe and clamps. The clamps were tight but the plastic section had melted.
- (5) A laboratory test on the hose revealed that gasoline caused the hose to expand approximately 30 percent in a period of 10 days. The inadequate resistance of the material to gasoline is considered a contributing factor.

- (b) Vent - The non-metallic vent line was almost toally destroyed by the fire and could not be checked. The hose was a fabric reinforced type with a fire resistance of less than 1 minute. The tank was externally vented as required but the 1/2 inch ID hose was smaller than the 9/16 inch ID required.
- (c) Shut-Off Valves - No shut-off valve was provided at the tank connection but two service valves were provided in the engine space for the engine feed lines. The service valves would not be accessible in case of fire in the machinery space. When investigated, both valves were open and both were liquid tight. Since the fuel line, the valves and the engine fuel pump were positioned below the top of the fuel tank, the system could siphon. The system would not comply with the fuel system requirements in effect at the time the boat was built or the present requirements. No anti-siphon valve was provided.
- (d) Flexible Feed Line - The fuel feed lines were a fabric reinforced push-on hose, secured with strap clamps. All connections were in position and tight but the lines were destroyed by the fire.
- (e) Tank - The .090 inch thick 5052 aluminum alloy fuel tank was very badly corroded, but still contained

about 63 gallons after the fire. The tank top was only mildly pitted, but the tank bottom and ends were extensively covered with both pit type corrosion and galvanic or stray current corrosion. The corrosion had penetrated the tank to a depth of .040 or almost 1/2 of the tank thickness. The tank was not considered the cause but is considered very close to a point of failure.

Because of the foam between the tank top and deck, it is noted that deck loads (walking on deck) would be transmitted directly to the tank top. When the tank was opened for examination it was noted that the fuel feed pick-up tube had, in fact, bottomed on the tank and scored the bottom surface.

2. Engines - The boat had two 4 cylinder Volvo Penta 130 HP engines that were second-hand replacements installed by the present owner. The older starboard engine was a 1960 model, the port engine was a later model. The fire did not create sufficient heat to melt the carburetor or the plastic distributor cap.

(a) Fuel Pump - Both engines had single diaphragm mechanical fuel pumps with manual primers. The pumps were intact and apparently liquid tight. Since the pumps were externally vented to the engine space, they would not comply with the present ABYC requirements or the proposed USCG Regulations.

- (b) Engine Feed Lines - The engine fuel lines were fabric reinforced hose with swaged brass fuel line connections. The lines were still intact.
- (c) Flame Arresters - The starboard backfire flame arresters were marked with USCG Approval Number 162.015/45/0 and should not have been installed in 1972, since the 162.015 specification was superceded in 1965 with specification 162.041. The port engine dual flame arrester was marked with current Approval Number 162.041 16/0. The machine screw for the clamp of the aft starboard flame arrester was missing and the arrester was loose.
- (d) Carburetors - The side draft carburetors were still intact and appeared to be liquid tight. The starboard choke was open and the throttle closed. The port engine throttle was open 1/3 and the choke was open.
- (e) Alternators - The alternator on the starboard engine was a Motorola MA12N, 45 ampere unit, with a solid state voltage regulator. The alternator was not a UL Listed model, but appeared to be of an ignition-proof design. The alternator was missing from the port engine but the solid state regulator was still in place.

Based on marks on the port alternator bracket and the fact that if the alternator were missing before the fire, it would have been logical to start the

starboard engine first; it is probable that the alternator was removed after the fire.

- (f) Oil Level - When checked, the oil levels were normal and there were no indications of engine seizure or malfunction.
- (g) Ignition Distributors - Both ignition distributors were externally vented. Since the port engine was running, the port distributor is considered as a potential source of ignition.
- (h) Starters - The starter on the port engine is eliminated since the engine was running, but the starboard starter is considered a possible source of ignition. The starter apparently did not work and could have overheated if the starter button were held in. This could not be confirmed at the investigation.
- (i) Engine Controls and Gauges - The control console was consumed by the fire and it was not possible to determine the throttle positions.

3. Electrical -The wiring in the boat was completely destroyed by the fire thereby limiting the data that could be obtained.

The following was noted:

- (a) Battery Switch - The boat was not equipped with a master battery switch or a switch in the power feed to the instrument panel.
- (b) Overcurrent Protection - Two fuses were found in the

area of the instrument panel, but no determination was made with respect to the circuits covered. Since one wire ran forward from the control station, it was probably in the navigation light circuit.

- (c) Batteries - The boat had two batteries that were not secured in any way and did not have covers. The battery installation would not comply with the NFPA, ABYC or proposed USCG Regulations. One unsecured battery is visible in Photograph No. 2.
- (d) Unprotected Terminals - The boat had several unprotected live terminals at the engine and outdrive unit, but all connections appeared tight.

4. Miscellaneous

- (a) Fire Extinguisher - The boat had a single 4 pound dry chemical extinguisher that was used but proved inadequate.
- (b) Power Blower - The boat was not equipped with a power blower.

OPINION

Both the sequence of events and the physical evidence indicate that a failure of the fuel fill hose was the direct cause of this fire and over filling the tank the proximate cause. The ignition source was not pinpointed, but could have been the starboard starter, the port ignition distributor (or ignition system) or a backfire of the port engine in that order. The following facts are noted with respect to the indicated cause for the presence of fuel:

- (a) The fuel tank had just been filled and a considerable quantity of fuel would be in the fuel pipe. It was established that the owner was in the habit of filling the tank until fuel backed up into the fill.
- (b) Because the fuel fill hose at the tank was partially encased in foam, it sustained practically no fire damage. Accordingly, the condition of the hose, as shown in Photograph No. 6, occurred before the fire. It is believed that the water, entrapped by the foam, penetrated the 4 outer fabric layers of the hose and corroded the steel spiral wire reinforcement. The corrosion rate gradient caused the corroding wire to form a fine needle point which eventually punctured the neoprene inner liner. This resulted in fuel leakage whenever the tank was overfilled. Based on the advanced state of hose degradation, it is believed that the leakage initially occurred some time before the accident. After fueling, the .8 gallons of fuel in the fill would be discharged to the tank top over some given period of time. The approximate fuel leakage rate could not be established.
- (c) Liquid leakage from the fuel fill line would tend to run aft on the top surface of the tank and under the foam. Being spread out, the liquid fuel would vaporize and the vapors would drift into the machinery space

since the port engine was running and would create a slight reduced pressure in that space. Since the port engine did start and run, the mixture in the compartment at that carburetor was not too rich, but the mixture could have been rich at the port ignition distributor or the starboard starter. Opening the engine box could easily have provided sufficient fresh air to bring the mixture at the ignition source into the explosive range.

- (d) The laboratory chemical exposure test conducted on the fuel fill hose that was removed from the boat, revealed that the hose material was not resistant to regular leaded gasoline. The entire hose swelled by approximately 30 percent. The swelling could have been the factor that caused the spiral reinforcing wire to puncture the inner hose. The swelling would cause the overall diameter of the hose to increase but the diameter of the spiral wire would remain constant.

It is recognized that the sinking of the boat may have contributed to the extensive corrosion of the fuel tank, but since the boat was raised and hauled almost immediately, the degree of contribution of that factor cannot be established.



1974 CASE No. 9 PHOTO No. 1



1974 CASE No. 7 PHOTO No. 2

Reproduced from
best available copy.



1974 AS E W PHOTO No 3



1974 CASE No. 9 PHOTO No. 1

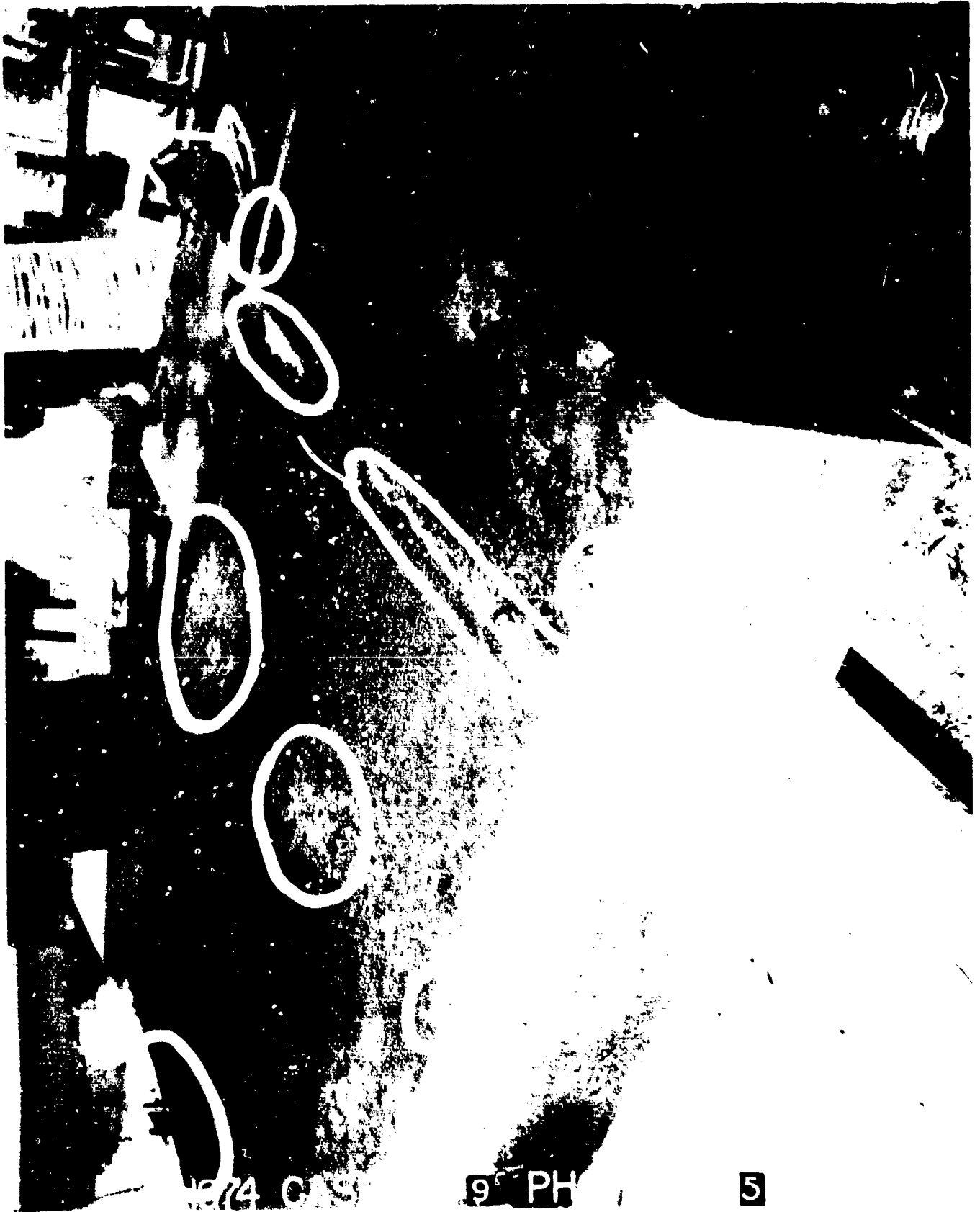

1974 CAS

9 PH

5

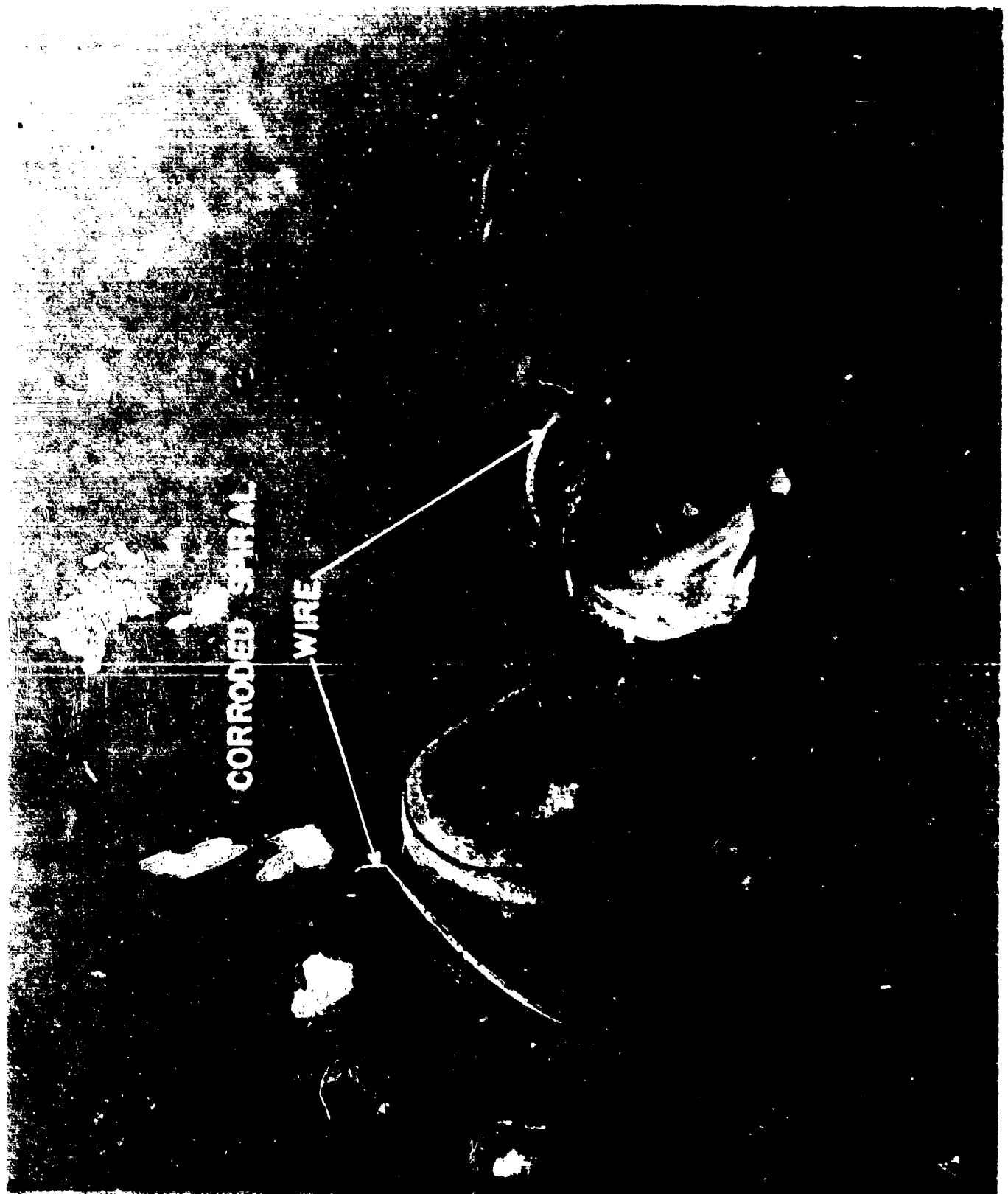

CORRODED SPIRAL

WIRE

CASE No. 1 PHOTO No 6

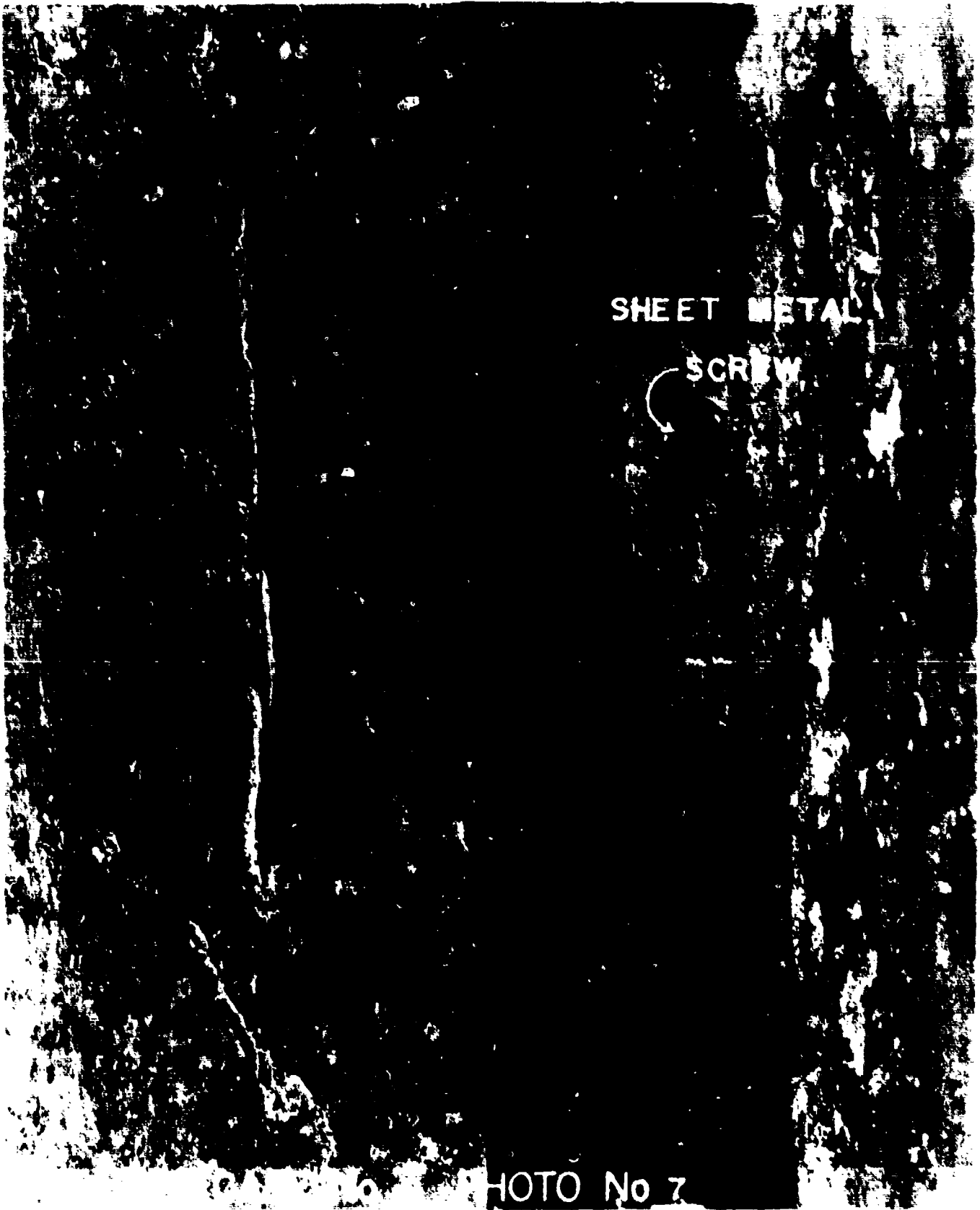

SHEET METAL

SCREW

PHOTO No 7

RECREATIONAL BOATING ACCIDENT INVESTIGATION FOR 1974C A S E N O. 1 0DESCRIPTION OF BOAT:

The 45 foot flying bridge cruiser involved in this accident was a Pacemaker built in 1964. The boat was powered by twin 6V-53 General Motors diesels. The 110 volt diesel generator, by Onan was used for powering the A-C electrical system.

The boat was of carvel plank construction with steam bent oak frames. The engines were located slightly aft of amidship with conventional direct drive propeller shafts from the transmissions. Two fuel tanks, approximately 130 gallons each were mounted aft of the engines on the port and starboard sides. The tanks were mounted under the salon deck with no means of inspection to the tops, back sides and bottoms of the tanks.

PHOTOGRAPHS:

No. 1 - Side view of boat involved. The ventilating louver is at the forward end of the engine compartment.

No. 2 - Stern view of boat involved. The vertical flame pattern in Photograph No. 1 and 2 indicate that at the time of the fire there was virtually no wind.

No. 3 - Bow anchor electric winch and bow lights. This picture is representative of the wiring throughout the boat.

No. 4 - Photograph of water tank looking outboard at hull side. The unsupported wiring is from the helm console and flying bridge. The wiring on the tank was apparently bunched to take up excess wire.

No. 5 - View of power leads to starter, alternator, and voltage regulator. The plumbers valve on the left was the engine cooling water intake.

No. 6 - Close up view of 125 volt circuit breaker box with panel removed for the photograph. Note the insulation is still on most of the wires in the box. The unsupported wiring on the left is in the helm console.

No. 7 - Cockpit view before investigation.

NARRATIVE REPORT OF INCIDENT

The owner and three friends had been boating on the day of the incident. Approximately four o'clock in the afternoon, the owner secured the boat to the dock at his house and connected the 115 volt shore power cord set. He then left the boat unattended. Late that night, the owner discovered flames coming from the boat forward of amidship. He attempted to extinguish the fire with a garden hose. After fighting the fire for a few minutes he realized it was out of control and called the fire department. The fire department responded within ten minutes to extinguish the fire.

The fire had already burned through the salon deck before it was detected. The owner stated that the engine or engines started as a result of the fire and that he pushed the boat from under its shed. There were no injuries from the accident.

KNOWN CHANGES TO ORIGINAL DESIGN

The boat had been rewired two times in the last two years. The boat was partially rewired by the previous owner about two years before when the wiring in the helm console shorted and burned

the console. The electrical work was done by the previous owner himself but the console was rebuilt by a boat yard. The present owner also experienced electrical problems and likewise had attempted to rewire some of circuits.

FACTS ESTABLISHED FROM WITNESSES

1. Boatyard personnel confirmed the fact that the two boat owners had electrical problems and that neither owner would permit the boatyard to do a complete repair job.
2. There were no witnesses to the starting of the fire other than the boat owner. He indicated that the fire started somewhere forward of amidships.
3. The owner indicated that he started to extinguish the fire with a garden hose but was unable to bring it under control. The fire department of the city in which he was living was called and extinguished the fire.
4. Owner stated that the engine(s) in the boat started sometime during the fire that he pushed the boat from under its shelter.
5. The owner indicated that the refrigerator was not being used and was electrically turned off.
6. The owner of the boat indicated that he did not touch or disturb any portion of the boat after the fire had taken place. The boat was pumped out on the following day and towed over to a marina where it was hauled.

OBSERVATIONS AND FINDINGS

1. Fuel System - The fuel system was completely intact and liquid tight.

- (a) Fuel Tanks - The two monel tanks were completely intact and liquid-tight but the soldered joints were not in accordance with NFPA 302 or the ABYC Standards. The fuel fill, vent and fuel feed were off the top most portion of the surface as required by the NFPA and ABYC Standards. The tanks were mounted aft of the engines on the port and starboard side under the salon deck. Each tank had a capacity of 130 gallons. No corrosion was evident on the tanks.
- (b) Fuel Shut-Off Valves - Both tanks had fuel shut-off valves mounted directly to the fuel tanks. The solid bottom plug cock type valves were not readily accessible. Independent support and accessibility are a requirement of the ABYC and NFPA fuel system Standards. The valves incurred no damage from the fire.
- (c) Fuel Lines - The lines were copper with flare fittings from the tank shut-off valves to the point of connection to the flexible fuel line at the engines. There was no damage to the fuel lines.
- (d) Flexible Fuel Lines - The flexible fuel lines were of the non-metallic reinforced type and were still intact. The flexible sections would not comply with the 2-1/2 minute fire resistance requirement of the NFPA or ABYC.

3. Electrical Systems

General - The method of supporting and splicing of wires would not comply with any of the existing safety standards. Photo No. 3 shows the typical procedure used for supporting the wires. The wires in the aft portion of the bilge ran 4 to 5 feet between supports. Plastic wire nuts were used throughout the boat without a junction box. Wires were found to be entangled with one another and pushed in corners to take up the slack. Refer to Photo No. 4.

- (a) Circuit Breaker Panel - The AC breaker panel was poorly wired. Wires were pushed and jammed to where chafing could take place. The incoming leg from the shore power inlet to the breaker box would not meet the ABYC requirements because it does not have a breaker within 72 in. of the shore power inlet. There was not much evidence of wires overheating in the panel due to a shorted condition. Refer to Photo No. 6.
- (b) AC Wiring - The AC system was 125 volts throughout the boat. The wires were solid copper instead of flexible stranding as required by the NFPA and ABYC. Frayed and globular ends of wires were prevalent throughout the system. The system would not comply with ABYC or NFPA requirements for alternating current systems on boats. The wires connecting the shore power inlet with the breaker panel were not burned from the inlet to the box (about 3') indicating that overheating did not occur in the power feed circuit.

(c) Twelve Volt Electrical System - The system used all stranded wire. The low voltage system ran with the 110 volt system in several places. ABYC and NFPA prohibit high and low voltage systems from running together. Improper supporting methods were used throughout the system. Tracing wires to the inside console and up the guide tube (approx 3 inches in diameter by 4 feet long) leading to the flying bridge uncovered wires that were jammed into the tube. Many of the wires showed signs of shorting. By tracing the wires back past the portion that was damaged, two 12 volt wires were found to be overheated. The wires were under water for about 3 feet then immersed back up to the hot lead on the starter motor on the starboard engine. These wires were without any type of overcurrent protection. The over heated wires interlaced with approximately 25 more wires which ran into the console from various places in the boat.

4. Miscellaneous

(a) Refrigerator - The boat contained a full size 115 volt refrigerator. The refrigerator is not considered an ignition source because the refrigerator circuit breaker was in the off position as indicated by the owner. The fact that the refrigerator contained no food reasonably confirms the owner's statement that the refrigerator was not operating.

- (b) Galley Stove - The galley stove was installed on the starboard side of the boat just forward of the refrigerator (approx 3 feet). The stove was a four burner 115 volt electric. The stove is of some interest in the report because the owner had just (according to the boat yard) finished wiring some electrical work in the boat and the stove was part of this wiring. The name plate was burned off of the stove so identification was not possible. The cabinets under the stove were closed and did not indicate that fire had been in them. All the cabinets along the floor of the boat were smoked filled but were not burned.
- (c) 115 Volt Auxiliary Generator - The boat was equipped with a 115 volt diesel powered Onan generator. The control box was not ignition-proof but since the auxiliary generator was not operating it was not considered a source of ignition in this instance.
- (d) Fire Extinguishers - The boat contained two fire portable fire extinguishers. One Amway Model 275R-5C fire extinguisher was found to be in good shape. It had not been used and was stored in a drawer. One Kidde fire extinguisher was down but had not been used in the fire. It was a 2-1/2 pound extinguisher.
- (e) Bilge Pump - The boat contained one bilge pump listed by the old Yacht Safety Bureau. The pump was below bilge water level and was not burned.

- (f) Ventilation - The natural ventilating system consisted of two large louvers facing aft at the forward end of the engine space and openings (3/4 inch) in the aft cockpit ceiling. The louvers were ducted to the bilge by boxing in a single frame space to a distance of about 10 inches below the deck and the 3/4 inch opening aft was through the frame space openings. The system would be very inefficient.
- (g) Optional Lights - The boat had three florescent lights, one under the salon deck in the engine compartment, one on the port side in the living area and one forward over the sink in galley area. The boat also had two docking lights mounted in the bow section of the boat.

OPINION

The exact cause of the fire was not found, but all the facts confirm that the original fire was electrical. The probable cause of the fire is believed to be a short in the 12 volt DC electrical system. After examining the wires coming into the console it was found that there were some wires that were not clearly broken but had melted ends. The melted ends indicate that a short had taken place whether before or after the fire. This point could not be determined by the ends of the wire at the console. After tracing each wire from the console tube back into the unburned portion of the bilge, several wires leading to the starboard starter motor were burned. The over heated wires were under the bilge of the boat where no fire was apparent.

They were interlaced with four more wires leading to the positive side of the starter solenoid which received no damage from the fire. The AC circuit, although very poorly wired, could probably be ruled out as a cause of the fire, because the wires leading into the breaker box were intact and not badly burned or over heated. Refer to Photo No. 6. This would indicate the AC electrical system did not cause the short. The 12 volt DC system in the boat was not properly fused or supported. The facts about the wires and lack of fusing in the 12 volt system points to this as a probable cause. Because of the very poor wiring leading up to the console, it is reasonable to assume that the short originated somewhere in the console panel (the amount of fire supports the fact that the fire had been burning longer in this portion in the boat) and ignited the wood console. After one short occurred in the DC circuit (without the proper fusing) the shorted wires would burn the insulation on the surrounding wires that were so closely housed in the tube. When this occurred it caused enough wires to short to produce a hot enough electrical fire to ignite the surrounding wood. Once the wood started to burn it traveled throughout the forward portion of the boat. The fact that the engine started also indicates that the electrical short was in the console and that the wires that shorted were connected with the ignition or starting circuit of the engines.

If the boat had been properly fused, the fuse system would have

taken care of the short and rendered the wires leading to the bridge console dead. The only thing that probably would have happened at this point would have been a rewiring of the shorted wire and new fuses.

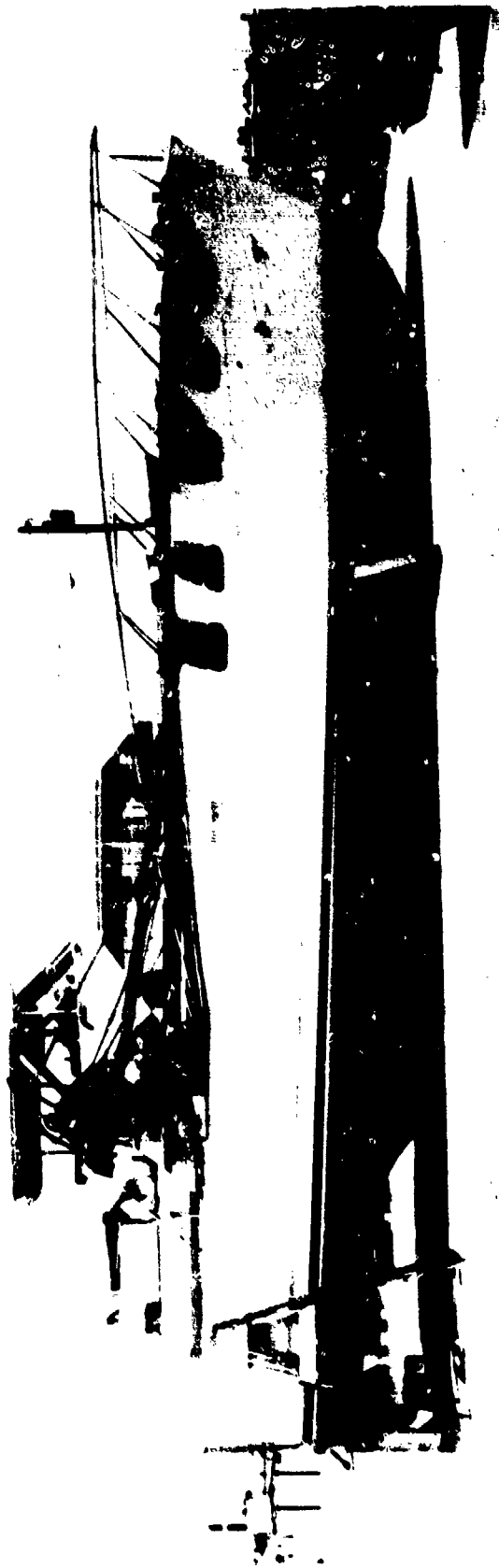

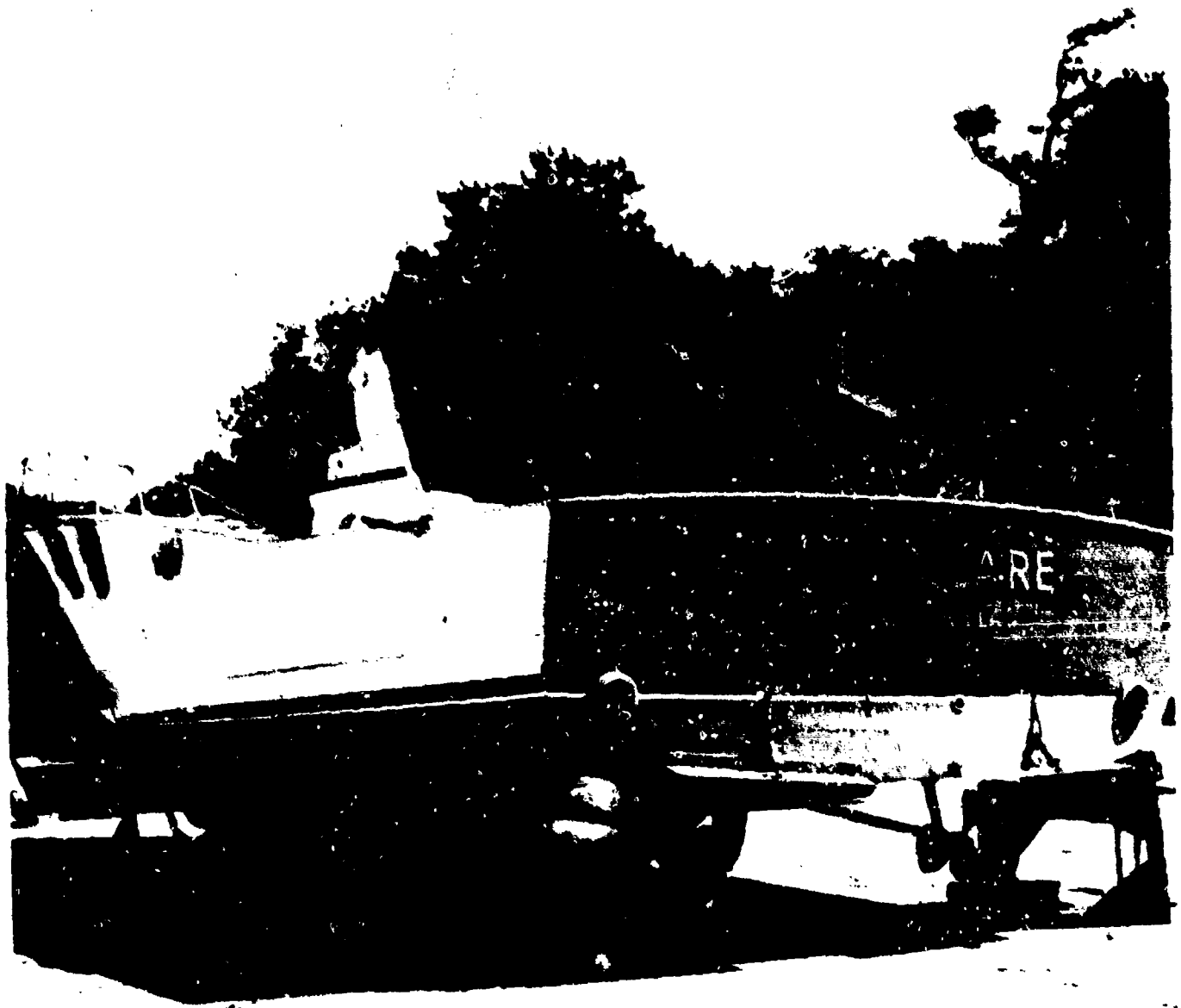

Reproduced from
best available copy.



1974 CASE No. 19 PHOTO No. 3



AS 100-105-100 No. 10 No. 4

Reproduced from
best available copy.



No 10

5





19 SE 10 10

RECREATIONAL BOATING ACCIDENT INVESTIGATIONS FOR 1974C A S E N O. 1 1DESCRIPTION OF BOAT

The 23 foot single screw inboard-outdrive boat involved in this double explosion was built by Allmand Boats in 1966. The conventional deep-vee hull was of fiberglass reinforced construction. The nameplate indicated that the boat was designed for a maximum horsepower of 250 and a passenger load of 6 persons.

The eight year old boat was a sport fishing model with a large open cockpit aft, a small trunk cabin and a flying bridge. A small sink and ice box unit was located aft of the helm seat on the starboard side and the boat had vee berths forward with an escape hatch to the forward deck. Back-to-back seats were installed on the port side opposite the galley unit. The boat was not equipped with a galley stove. A manual head was located forward between the vee berths. The boat was powered with an OMC 155 HP V8 engine and outboard drive. The engine was located in a 28 by 32 inch well about 10 inches deep with a fiberglass engine box that doubled as a stern seat. See Figure No. 1 and Photograph No. 1.

The boat was equipped with two saddle tanks, 7 feet long, 1 foot 8 inches high and 4-1/4 inches wide. The starboard tank was fabricated of 304 stainless steel and the port tank of fiberglass reinforced plastic. The starboard tank was fitted

with an external spring loaded drain-cock at the aft end and with a solid-bottom tank shut-off valve at the fuel pick-up connection. The port tank did not have a shut-off valve. The tanks were set on small aligning blocks and were secured to the hull with fiberglass. See Photograph No. 5. The copper fuel distribution lines from the port and starboard tanks were routed aft of the engine to a fuel selector valve. A single fuel feed line to the engine was installed between the valve and the engine fuel pump.

The boat had a single ventilating clam shell located on the aft deck with a 3 inch flexible duct routed below the engine. Two small clam shells without ducting were located 2 inches aft of the fuel fill fittings on the cabin side. The side ventilators were intended to ventilate the fuel tank space.

The boat was called a "Ticonderoga 23" and was taken in as a trade a couple of months before the accident.

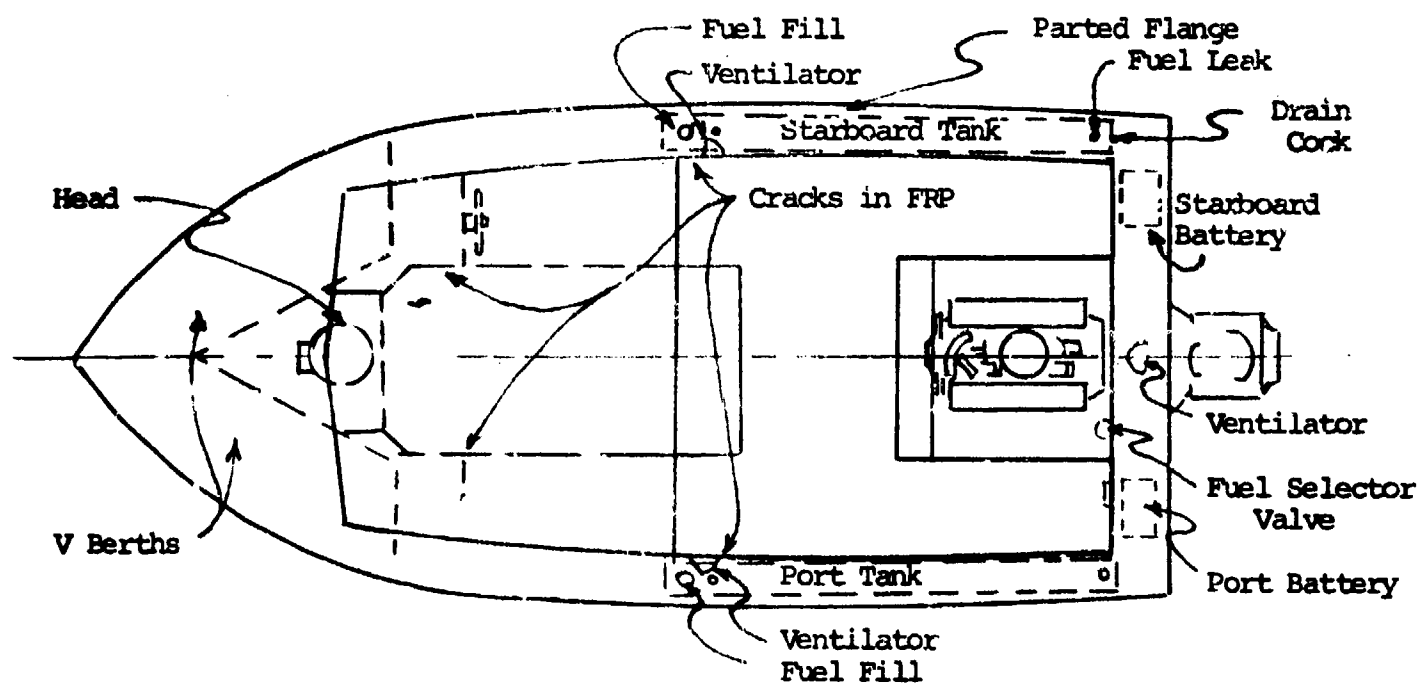

Figure No. 1

PHOTOGRAPHS

No. 1 - Photograph of boat.

No. 2 - Photograph looking forward from cockpit at explosion and fire damage. The marine head which was blown out, is visible in the center of the picture. The arrows point to structural cracks from the explosion.

No. 3 - View looking aft to port battery. The battery selector switch is directly above the battery on the deck skirt. The unsupported battery wires are visible below the switch and the burned engine belt is visible at the alternator pulley. The fuel selector valve and both fuel filters are visible just below the deck skirt aft of the engine.

No. 4 - View looking aft to starboard battery and the aft end of the starboard 304 stainless steel fuel tank. The fuel leakage stains are visible on the tank directly below the fuel feed connection. The loose control cables and #4 conductors draped over the tank are visible. The cockpit ceiling panel was removed for the photograph.

No. 5 - Close up photograph of forward end of starboard stainless steel tank showing the fuel fill and the method of securing the tank with a fiberglass strip. The fuel fill clamp shown was found loose.

No. 6 - Close-up photograph of aft end of starboard fuel tank showing tank shut off valve and drain cock. The arrow points to the leaking spud.

No. 7 - View of unsupported flexible fuel line.

NARRATIVE REPORT OF ACCIDENT

The boat was in a marina and had topped off both fuel tanks with 12 to 14 gallons in each tank prior to a planned cruise. After fueling, the operator lifted the engine box off the engine and ran the engine for about 5 minutes. The boat was not equipped with a blower. At the time of the accident, 2 men and young boy were on board. After the engine was operating for the five minutes, the operator put the engine box in place in preparation to casting off. Approximately 5 seconds after the engine box was replaced, an explosion occurred in the engine space. That explosion was followed within a couple of seconds by a second more powerful explosion forward on the starboard side. At the instant of the explosions the operator and passengers were apparently forward near the helm and were not injured.

Because the boat was still at the dock, the fire was extinguished with marina portable extinguishers with a minimum of fire damage to the boat.

The initial explosion was apparently in the machinery space and blew the engine box off, the second explosion was in both the tank space above the cockpit deck and in the inner bottom on both the port and starboard sides. The explosion in the inner bottom blew the marine head completely out and broke the water intake connection causing the boat to start to sink. The boat was immediately hauled by the yard to prevent it from sinking.

FACTS ESTABLISHED FROM WITNESSES

1. The boat owner indicated that fuel had been removed from the starboard tank after the fire, hence, the exact quantity of fuel remaining in the tank was not significant.
2. The boat was taken as a trade-in a couple of months prior to the accident and was used as a rental boat by the boat yard.
3. The boat yard extinguished the fire and immediately hauled the boat to prevent it from sinking.

KNOWN CHANGES TO ORIGINAL DESIGN

1. The previous boat owner changed both fuel tanks because of leakage when the boat was between 4 and 5 years old. The replacement starboard fuel tank was fabricated of 304 stainless steel and was fabricated by Central Florida Machine Co. Because of the cost, the owner had the port tank fabricated of fiberglass in Sarasota.
2. There were no other known changes.

OBSERVATIONS AND FINDINGS

1. Boat Fuel System - When the investigation was conducted, the fuel system would not hold pressure but the fuel tanks still contained fuel. It is noted that some fuel had been removed following the fire.

(a) Fuel Fill - The starboard fuel fill flexible hose was found loose and was initially considered as a possible source of fuel leakage. An examination of the hose revealed that the bottom was cut on a bias making one

side of the hose 7/8 inch shorter than the other. The top end had a ragged cut. Since the hose was single clamped on a straight tubular section, the amount of purchase was limited. No bonding wire was provided across the flexible section. The deck fitting was loose.

- (b) Tank Vent - The tank vent on the starboard side was found tight. The vent consisted of a single clamped green garden hose that was so installed that it could conduct liquid spray into the tank. It did not incorporate an inverted "U" to prevent the intake of water. There was no evidence of fire at the hull vent fitting.
- (c) Fuel Feed System - The fuel distribution system consisted of a copper fuel line from the aft end of each fuel tank to a fuel selector valve located aft of the engine on the port side. A single line connected the valve to the engine fuel pump. The following was noted:
- (1) The copper fuel distribution lines with short nut flare fittings were unsupported between the tanks and selector valve. The fuel lines were still liquid tight but in poor condition with flattened areas and poor flares. The lines were routed at tank top level but because of the absence of support would not comply with the ABYC or NFPA Standard in effect at the time or the current Standard.

- (2) An unsupported glass bowl filter was provided in the line to the port tank and a small metal bowl filter in the starboard fuel tank feed line. The latter was also unsupported. Both filters were liquid tight. The filters would not have 2-1/2 minute fire resistance to comply with the NFPA or ABYC Standards.
- (3) The copper fuel line between the fuel selector valve and the flexible fuel line below the engine, was completely unsupported. Because of the lack of support, the lines would be subject to an increased amplitude of vibration at any resonant frequency. The installation would not comply with the safety standards of the NFPA or ABYC.
- (4) The fabric reinforced flexible fuel line with swaged fittings would have a fire resistance of about 1 minute or less. Since the boat did not have any form of anti-siphon protection, the flexible fuel line should have had 2-1/2 minute fire resistance to comply with the NFPA, ABYC or proposed US Coast Guard Regulations.

(5) The starboard fuel tank was provided with a shut-off valve at the tank but the valve would not be accessible under fire conditions.

(d) Fuel Tanks - Both fuel tanks in the boat had been replaced by the previous owner of the boat approximately 3 years before the accident. Both tanks measured 7 feet by 1 foot 8 inches by 4-1/4 inches with a capacity of approximately 28 gallons. The two original galvanized steel fuel tanks failed shortly after the previous owner purchased the boat.

(1) The starboard fuel tank was fabricated of 304 stainless steel by Central Florida Machine Co. of Auburndale, Florida. The tank had no baffles. It was a failure of the brazed fuel feed pick-up threaded flange on the welded stainless steel tank that caused the fuel leakage that resulted in the explosion. The leak at the spud is attributed to an insufficient amount of brazing material and an unfavorable galvanic couple between the brazing alloy

and 304 stainless steel. When the tank was checked, the hole at the spud discharged approximately 200 to 300 milliliters of fuel per minute under a head of approximately 6 inches. This was done by tilting the tank after removal from the boat.

- (2) The starboard fuel tank had an external spring petcock drain valve at the aft bottom end of the tank that showed evidence of some minor seepage at the tapered plug and at the threaded nipple that was brazed to the tank. The connection at the tank was found loose. The drain petcock on the tank is in a direct conflict with the NFPA, ABYC Standards in affect at the time and the current Standards.
- (3) The port fuel tank was fabricated of fiberglass reinforced resin of very light construction. The tank was still liquid tight and was not equipped with a drain cock.
- (4) Both fuel tanks were secured in position with strips of fiberglass. The installation would not comply with the NFPA or ABYC Standards in affect at the time.

2. Engine - The boat was powered with an OMC 155 HP V8 engine.

- (a) Backfire Flame Arrester - The engine was equipped with a Fisher flame arrester with Approval Number 162.015/94/0. Since subpart 162.015 was superseded by 162.041 in August 1965 the particular flame arrester should not have been installed on a boat built in 1966.
- (b) Ignition Distributor - The ignition distributor was fully vented to the engine space with a "trap door" distributor cap and openings in the body at the vacuum advance slide. The distributor is a like source of ignition since the engine was running and the distributor will draw in vapors when in operation. There was evidence of a flash in the distributor cap but the internal wiring was not burned.
- (c) Fuel Pump - The engine was equipped with single diaphragm externally vented fuel pump. The pump was equipped with an integral fuel filter but neither the filter or the pump were damaged by the fire. The single diaphragm, externally vented fuel pump would not comply with either the current NFPA or ABYC Standards.
- (d) Oil Level - The engine and transmission oil levels were normal and there was no evidence of engine seizure.
- (e) Controls - At the time of the investigation the controls and carburetor butterfly positions would indicate that the engine was in a fast idle condition

but in this instance the controls could have been changed.

- (f) Starter - The starter was a solenoid engage type that has not been ignition-proofed but because the engine was running it can be eliminated as a source of ignition. All of the wire to the starter ignition system and alternator were badly burned near the starter, but there was no evidence of electrical short circuits.
- (g) Alternator and Voltage Regulator - The alternator was a UL Listed ALE5203 model with a Listed solid state voltage regulator. Both were ignition-proof and all connections and covers were found in place and tight.
- (h) Exhaust System - The exhaust system was found tight and totally intact.

3. Electrical - The wiring harness was found intact except in the engine space where it had been exposed to open flame. The harness was burned on the starboard side of the engine near the starter, at the alternator and voltage regulator and adjacent to and aft of the starboard fuel tank. The wiring forward of the fuel tank up to the instrument panel was not damaged. No evidence of short circuits was found except for three blown fuses.

- (a) Battery Switch - The boat had a Perko model 85A battery selector switch located aft just outboard of the engine on the port side. The switch was

connected to the port and starboard batteries with the output connected directly to the starter solenoid. The switch was found in the off position and could have been the reason why no evidence of secondary short circuits was found.

- (b) Wiring - The wiring harness and the No. 4 Awg conductors to the switch panel (helm console), were totally unsupported. The wires were draped over the fuel tank and over the engine. The wiring installation would not comply with the NFPA or ABYC Standards. Wiring was stranded SAE type except the No. 4 conductors, which were 7 strand THW 75C and TW NEC wire.
- (c) Circuit Protection - The boat was equipped with a 9 fuse panel at the helm console but no protection was provided for the No. 4 Awg conductors from the starter solenoid to the helm distribution panel. The fire did cause 3 of the fuses to blow.
- (d) Batteries - The boat was equipped with two separate batteries located aft on the port and starboard side of the engine. The batteries were restricted from sliding by wooden blocks but did not have battery covers.

4. Miscellaneous

- (a) Ventilation - The ventilation provisions were very poor from the standpoint of ducts and cowls; however, because of the openings in the cockpit ceiling the actual ventilation was probably quite good on a

- (1) The boat was fitted with clam shell fittings at the forward end of the tank space that were installed almost on top of the fuel fill opening. It can be expected that the fitting would normally pick up vapors generated during filling depending on the wind direction at the time. The installation would not comply with either the NFPA or ABYC Standards.
- (2) The engine compartment had a single 3 inch clam shell facing aft with a flexible duct routed from the fitting to a position below the engine. The duct had three 90 degree bends and would be very inefficient.
- (3) The molded cockpit deck had parted from the hull along the starboard side and probably provided the path for the fuel vapors to reach the inner bottom.

OPINION

The physical evidence and the witness accounts in this case indicate that the leaking spud at the starboard fuel pick-up connection was responsible for the double explosion. Both fuel tanks had just been filled up into the fuel fill pipes. It is estimated that the fuel level would place the leaking spud connection under a head of approximately 6 to 10 inches of fuel. This considers

length of the fill hose, the position of the vent discharge fitting and the trim of the boat. A check of the leak indicated a probable leakage rate of about 200 milliliters per minute under a 6 inch head of fuel. Because the fuel tank still had value and was to be repaired, the exact nature of the failure could not be checked but the following is noted with respect to the failure:

- (a) The brazed joint showed an insufficient amount of filler material around the forward edge of the pipe thread flange.
- (b) The brazed on non-ferrous metal flange was a drilled type designed for attachment with countersunk machine screws. The leakage was through one of the flange mounting holes.
- (c) Standard brazing filler alloys create an unfavorable galvanic couple with alloy 304 stainless steel. Since the unfilled holes in the flange would hold moisture, it is probable that a galvanic cell was created between the stainless steel and brazing filler material that either caused or contributed to the failure.
- (d) The stains on the stainless steel would tend to indicate that the leakage existed for a period of time and did not occur just prior to the accident.

If, as indicated, the leakage occurred some time before the accident, then the relative inaccessibility of the fuel tank behind a solid panel must be considered as a contributing factor to this

accident. The tank was accessible in that the panel could be removed with tools but was not readily accessible, as with a hinged panel and latches not requiring tools.

In this instance two additional potential sources of leakage were found and although they are not listed as contributing factors because of a lack of supporting evidence, they did present serious hazards. The first was the external spring loaded drain-cock at the base of the tank and the second the loose fuel fill hose. The installation of a drain-cock is against all safety standards and presents an obvious hazard. If the valve were inadvertently knocked open or vibrated open, the entire tank would drain into the machinery space. The valve itself is not suitable for use with gasoline and the pipe thread connection was found very loose.







E. No. 1. PHOTO No 3



PICTURE NO. 1



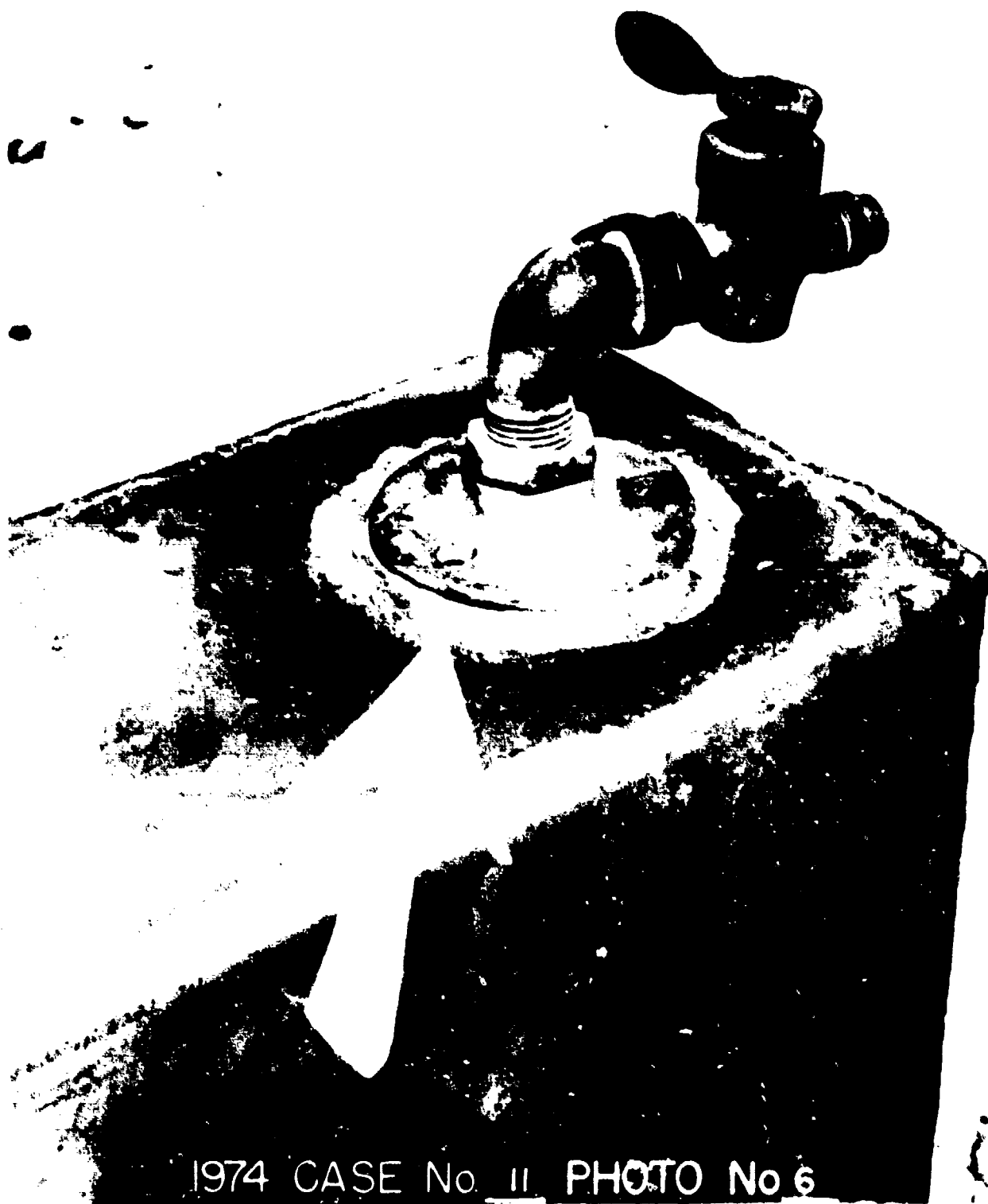

1974 CASE No. 11 PHOTO No. 6

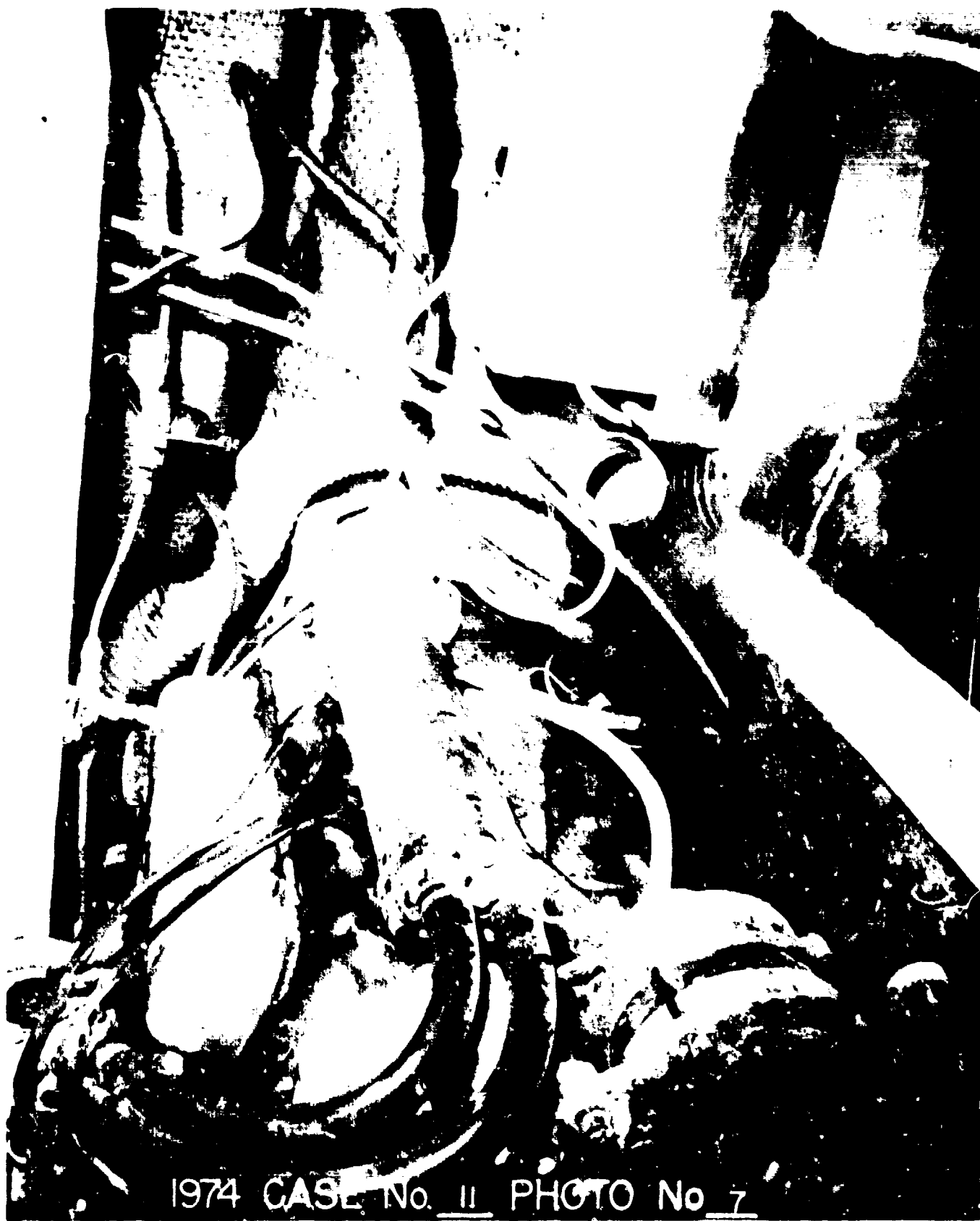

1974 CASE No. 11 PHOTO No 7