

TR 265



Technical Report 265

ADA013831

THE RESPONSE OF FROZEN SOILS TO VIBRATORY LOADS

Henry W. Stevens



June 1975

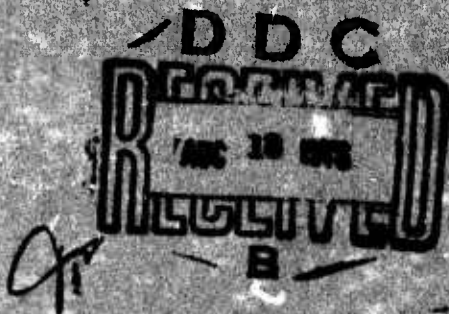

PREPARED FOR
DIRECTORATE OF MILITARY CONSTRUCTION
OFFICE, CHIEF OF ENGINEERS
DA PROJECT 4A162121A894

BY
CORPS OF ENGINEERS, U.S. ARMY
COLD REGIONS RESEARCH AND ENGINEERING LABORATORY
HANOVER, NEW HAMPSHIRE

APPROVED BY	
BY	DATE
BY	DATE
BY	DATE
BY	
BY	
BY	DATE
BY	DATE
BY	DATE

The findings in this report are not to be construed as an official Department of the Army position unless so designated by other authorized documents.

Unclassified

SECURITY CLASSIFICATION OF THIS PAGE (When Data Entered)

REPORT DOCUMENTATION PAGE		READ INSTRUCTIONS BEFORE COMPLETING FORM
1. REPORT NUMBER 9 Technical Report 165 ✓	2. GOVT ACCESSION NO. 14 CKREL-TR-165	3. RECIPIENT'S CATALOG NUMBER
4. TITLE (and Subtitle) 6 THE RESPONSE OF FROZEN SOILS TO VIBRATORY LOADS		5. TYPE OF REPORT & PERIOD COVERED
7. AUTHOR(s) 12 Henry W. Stevens		6. PERFORMING ORG. REPORT NUMBER
8. CONTRACT OR GRANT NUMBER(s)		
9. PERFORMING ORGANIZATION NAME AND ADDRESS U.S. Army Cold Regions Research and Engineering Laboratory Hanover, New Hampshire 03755		10. PROGRAM ELEMENT, PROJECT, TASK AREA & WORK UNIT NUMBERS DA Project 4A162121A894 Task 23 Work Unit 002
11. CONTROLLING OFFICE NAME AND ADDRESS Directorate of Military Construction Office, Chief of Engineers Washington, D.C.		12. REPORT DATE 11 June 1975
14. MONITORING AGENCY NAME & ADDRESS (if different from Controlling Office)		13. NUMBER OF PAGES 103 13 104
		15. SECURITY CLASS. (of this report) Unclassified
16. DISTRIBUTION STATEMENT (of this Report) Approved for public release; distribution unlimited.		15a. DECLASSIFICATION/DOWNGRADING SCHEDULE
16 DA-4A-162121-A-894		
17 4-A-162121-A-894		
18. SUPPLEMENTARY NOTES		
19. KEY WORDS (Continue on reverse side if necessary and identify by block number) Frozen soils Nonfrozen soils Soil properties Soil tests Viscoelastic theory		
20. ABSTRACT (Continue on reverse side if necessary and identify by block number) This study was conducted to provide reliable values of the stiffness and damping properties of frozen soils subjected to vibratory loads and to define the significant factors affecting these parameters. A laboratory test was conducted on prepared specimens of frozen soils wherein a right circular cylinder was subjected to steady-state sinusoidal vibration. The material was considered to be linearly viscoelastic. Analysis of test data based on one-dimensional wave propagation yielded the complex Young's modulus, the complex shear modulus, the phase velocity of wave propagation, the shear velocity, the damping property expressed as the angle representing time lag between stress and strain, an attenuation coefficient, and a complex Poisson's ratio. The frequency of vibration was varied from 500 to Next Page		

20. Abstract (cont'd)

10,000 Hz, and the peak dynamic stress was varied from 0.1 to 5.0 psi. Specimens were remolded or cored in-situ, frozen, and tested at temperatures of 0, +15 and +25° F. A few tests were conducted on identical soils nonfrozen. Test results from a limited number of tests on selected soils indicate that the stiffness of these soils varies with the volume of ice/volume of soil ratio, and that ice is less stiff than saturated frozen soils. Frozen soils have stiffnesses up to 100 times those of identical soils nonfrozen. Depending upon the degree of ice saturation, the stiffness of non-saturated frozen soils varies from that of the saturated soils to nearly that of the nonfrozen soils. Stiffness increases with decreasing temperature but the rate is relatively low. As temperature rises and approaches the freezing point, stiffness abruptly decreases. Damping, as a property of the material, does not differ greatly for frozen soil versus nonfrozen soil. This indicates that the mechanism influencing damping for frozen soil is quite different from that for nonfrozen soil. In the range of frequencies and stresses studied, the use of *linear* viscoelastic theory appears to be adequate for frozen soils, as only slight evidence of *nonlinearity* was observed.

PREFACE

This report was prepared by H.M. Stevens, Research Civil Engineer, of the Foundations and Materials Research Branch, Experimental Engineering Division, U.S. Army Cold Regions Research and Engineering Laboratory (USA CRREL). The study was conducted and the report was prepared under DA Project 4A162121A894, *Engineering in Cold Environment*; Task 23, *Cold Regions Earth Materials and Foundations Systems for Military Facilities*; Work Unit 002, *Stress, Strain, Time Relationships of Frozen Ground Pertinent to Military Construction*.

The report was technically reviewed by Dr. Y. Nakano of USA CRREL, and A.F. Muller of the Office of Chief of Engineers. Their suggestions are gratefully acknowledged. Dr. P. Lillienthal reviewed the mathematical equations and relationships and his suggestions are greatly appreciated.

A number of U.S. Army enlisted men contributed to the development of the test procedure and conducted the tests. Some of the more recent ones are B.I.S. Helme, Jr., M.J. Dabney III, F. Berrego, R.N. Lachenmaier and D.J. Coombes. Dr. T.M. Lee, Dr. D.M. Norris, Jr. and Dr. Y. Nakano gave valuable advice and assistance in developing the theory and analysis of test data.

The contents of this report are not to be used for advertising, publication, or promotional purposes. Citation of trade names does not constitute an official endorsement or approval of the use of such commercial products.

CONTENTS

	Page
Preface	iii
Nomenclature	vi
Conversion factors, British to metric units	viii
Introduction	1
Method of analysis	2
Definitions	2
Equations	4
Discussion of stress-strain computation	8
Poisson's ratio and the compression (dilatational) velocity	9
The damping property	9
Sample length - diameter ratio	13
Test apparatus and procedures	13
General	13
Test apparatus	14
Test procedures	16
Procedure for data computation	16
Test program	17
Soils	17
Ice	21
Test results	21
Discussion of test results	22
Analysis of test results	23
General	23
Effect of ice content	23
The effect of void ratio	24
Effect of temperature	27
Effect of frequency and dynamic stress	30
Effect of dynamic stress and strain	32
Poisson's ratio	34
Relation of complex modulus to compression strength	36
Conclusions	36
Literature cited	37
Appendix A. Computer program for nonresonant condition of specimen	39
Appendix B. Computer program for resonant condition of specimen	47
Appendix C. Preparation of frozen soils	53
Appendix D. Measurement of density and degree of ice saturation	57
Appendix E. Auxiliary computer programs	59
Appendix F. Summary of test data	65

ILLUSTRATIONS

Figure	Page
1. Strain distribution at specimen resonance	8
2. Diagram of stress-strain relationship for one cycle of steady-state vibration	9
3. $\tan \delta$ vs frequency for various rheological models	11
4. Relationship of $\tan \delta$ to amplitude ratio and frequency	11
5. Graphical representation of energy stored and dissipated per cycle	12
6. Laboratory test apparatus for applying vibratory loads to frozen soils and ice	14
7. Schematic of laboratory test apparatus	15
8. Schematic of control and readout system of dynamic test apparatus	15
9. Gradation curves for frozen soils	18
10. Manchester silt compaction test results	18
11. Crystal structure of laboratory molded ice	22
12. The effect of ice saturation on complex shear modulus and shear velocity	24
13. The effect of void ratio on complex Young's modulus	25
14. The effect of void ratio on complex shear modulus	26
15. The effect of void ratio on $\tan \delta$ (torsional mode)	27
16. The effect of temperature on complex Young's and shear moduli	28
17. The effect of temperature on shear velocity of ice, saturated sand and silt	29
18. The effect of temperature on $\tan \delta$	30
19. The effect of frequency on complex shear modulus and on shear velocity at a dynamic stress of 0.1 psi	31
20. The effect of frequency on shear velocity and $\tan \delta$ at a dynamic stress of 5 psi	32
21. The effect of frequency and dynamic stress on complex shear modulus	33
22. The effect of dynamic stress and frequency on shear velocity	33
23. The effect of frequency and dynamic stress on $\tan \delta$ (torsional mode)	34
24. Relationship of complex Young's modulus to maximum compression strength	36

TABLES

I. Unconfined compression test of 20-30 Ottawa sand	17
II. Unconfined compression test of Hanover silt	19
III. Unconfined compression strengths of Suffield clay	19
IV. Specimen properties	20
V. Poisson's ratio for several soils	35

NOMENCLATURE

As used in this list, L = length, F = force,
T = time, De = angle, D = dimensionless, % = percent.

A = single amplitude of sine wave; also area	L
A_B = single amplitude at base (input) of specimen	L
A_T = single amplitude at top (output) of specimen	L
c = dashpot coefficient (Voigt model)	FTL^{-1}
C_c = critical dashpot coefficient (Voigt model)	FTL^{-1}
c/C_c = damping ratio (Voigt model)	D
D = damping ratio; actual damping to critical damping	D
E = Young's modulus (elastic)	FL^{-2}
E^* = complex Young's modulus	FL^{-2}
En = energy	LFL^{-3}
e = void ratio = vol. voids/vol. solids	D
f = frequency	T^{-1}
f_r = resonant frequency	T^{-1}
g = acceleration of gravity	LT^{-2}
G = shear modulus (elastic)	FL^{-2}
G^* = complex shear modulus	FL^{-2}
G_s = specific gravity (soil solids)	D
K = spring constant	FL^{-1}
\mathcal{L} = longitudinal mode (used as subscript); also hysteresis loop	D
L = length of specimen	L
LL = liquid limit	%
M = mass = W/g	$FL^{-1}T^2$
n = resonance number (fundamental resonance = 1)	D
PI = plasticity index	%
PL = plastic limit	%
Q = mass ratio = ratio of mass of cap to mass of specimen	D
Q = ratio of total energy input to energy dissipated (other authors)	D
$Q_{\mathcal{L}}$ = mass ratio, longitudinal mode	D

Q_t = mass ratio, torsional mode	D
R = amplitude ratio = A_T/A_B	D
S_i = saturation, ice = vol. ice/vol. voids $\times 100$	%
S_w = saturation, water = vol. water/vol. voids $\times 100$	%
t = time	T
t = torsional mode (used as subscript)	
U = displacement	L
V_l = phase (rod) velocity	LT^{-1}
V_c = compressional (dilatational) velocity	LT^{-1}
V_s = shear velocity	LT^{-1}
W = total weight	F
wc = water content = weight water/weight solids $\times 100$	%
α = attenuation coefficient	L^{-1}
γ_d = unit dry weight	FL^{-3}
γ_w = unit wet weight	FL^{-3}
Δ = log decrement	D
δ = lag angle between stress vector and strain vector	De
ϵ = strain	LL^{-1}
ϵ_d = dynamic strain (peak)	LL^{-1}
η = dashpot coefficient in compression	
λ = wavelength	L
μ = dashpot coefficient in shear	
ν = Poisson's ratio	D
ν^* = complex Poisson's ratio	
ξ = frequency ratio = $\omega l/v$	D
ρ = mass density, γ/g	$FL^{-4}T^2$
σ = stress	FL^{-2}
σ_0 = static confining pressure, $(\sigma_1 + 2\sigma_3)/3$	FL^{-2}
σ_1 = axial (vertical) static pressure	FL^{-2}
σ_3 = lateral static pressure	FL^{-2}
σ_d = dynamic stress (peak)	FL^{-2}
ϕ = phase shift between end accelerations	De
$\psi = \xi \tan \delta/2$	D
ω = angular frequency	T^{-1}

CONVERSION FACTORS, BRITISH TO METRIC UNITS

British units of measurement are usually used in this report. They can be converted to metric units as follows:

<i>Multiply</i>	<i>By</i>	<i>To obtain</i>
inches (in.)	2.54	centimeters (cm)
feet (ft)	0.3048	meters (m)
inches per second (in./sec)	2.54	centimeters per second (cm/sec)
feet per second (ft/sec)	0.3048	meters per second (m/sec)
feet per second squared (ft/sec ²)	0.3048	meters per second squared (m/sec ²)
pounds (lb)	0.45359	kilograms (kg)
pounds per square inch (psi)	0.07031	kilograms per square centimeter (kg/cm ²)
pounds per square inch (psi)	68947.6	dynes per square centimeter (D/cm ²)
pounds per square foot (lb/ft ²)	4.88243	kilograms per square meter (kg/m ²)
pounds per cubic foot (lb/ft ³)	16.0185	kilograms per cubic meter (kg/m ³)
kips per square inch (ksi)	70.407	kilograms per square centimeter (kg/cm ²)
tons per square foot (tons/ft ²)	9764.86	kilograms per square meter (kg/m ²)

THE RESPONSE OF FROZEN SOILS TO VIBRATORY LOADS

by

Henry W. Stevens

INTRODUCTION

Foundations for structures incorporating vibratory loads (e.g. providing support for heavy machinery such as turbines) present special problems to the designer. Magnifications of motions due to structural resonances, fatigue, consolidation, and similar effects result from vibratory loading. A knowledge of the response of the soil to this type of load is essential in the cold regions. The normal layered soil system is further complicated by the presence of frozen and/or thawing soils. As soils in such a state have a response to vibratory loads significantly different from that of normal nonfrozen soils, this response needs definition so that foundation design methods and technical procedures used in the Temperate or Tropic Zone may be equally feasible in the cold regions.

A laboratory test was adopted which subjects a right cylinder (i.e., with upright axis perpendicular to base) of frozen soil to steady-state sinusoidal vibration in the longitudinal or compressional mode and, again, in the torsional or shear mode. Testing is conducted in a walk-in coldroom where temperatures can be controlled to $\pm 1^{\circ}\text{C}$. Specimens are prepared by molding to a given density and water content and are frozen in special refrigerator cabinets which allow freezing of the specimens from the tops down. After tempering to test temperature, the specimens are tested in an unconfined state.

The objective of this study was to provide reliable values of the stiffness and damping properties of frozen soils subjected to vibratory loads and to define the significant factors affecting these parameters. This report describes in detail the test method used to obtain the pertinent parameter values. Test results for selected frozen soils are presented and their relations to stress and strain level, frequency, temperature, soil type and condition, are analyzed and summarized.

Test results published by Kaplar (1969), Nakano et al. (1971), Nakano and Arnold (1972), Sayles and Epanchin (1966), Sayles (1968), and Sayles and Haines (1972) are frequently used to round out and augment the data reported here. Not only do these results help to complete the presentation of relationships, but as the test methods used are quite different from those described here, they aid in evaluating the authenticity of the various values. Apparently all the results used agree in a general way since the relationships developed are logical.

METHOD OF ANALYSIS

Definitions

1. *Viscoelastic material* – A material (solid) in which time is an essential parameter in the stress-strain relationship. In general, the constitutive equation for a viscoelastic material includes the time derivatives of stress and strain. In a viscoelastic material, when the stress σ_d varies sinusoidally with time at an angular frequency ω , the strain ϵ_d varies with time t at the same frequency but there is a phase lag δ between stress and strain.

2. *Complex moduli* – Adopting the following nomenclature:

$E^*, G^*, \epsilon^*, \sigma^*$ = complex numbers

$|E^*|, |\epsilon^*|, |\sigma^*|$ = moduli of complex numbers.

Then

$$\sigma^* = \sigma_1 + i\sigma_2 = |\sigma^*|e^{i\omega t}$$

$$\epsilon^* = \epsilon_1 + i\epsilon_2 = |\epsilon^*|e^{i[\omega t - \delta(i\omega)]}$$

$$E^* = E_1 + iE_2 = |E^*|e^{i\delta(i\omega)}$$

$$G^* = G_1 + iG_2 = |G^*|e^{i\delta(i\omega)}$$

and
$$\frac{\sigma^*}{\epsilon^*} = \frac{|\sigma^*|e^{i\omega t}}{|\epsilon^*|e^{i(\omega t - \delta)}} = \frac{\sigma^*}{\epsilon^*} e^{i[\omega t - \omega t + \delta(i\omega)]} = \frac{\sigma^*}{\epsilon^*} e^{i\delta(i\omega)}$$

where $\delta = \tan^{-1} \frac{E_2}{E_1}$ and is a function of ω .

Then $\frac{\sigma^*}{\epsilon^*} = |E^*(i\omega)|$.

E^* = complex Young's modulus as used here and, analogously, G^* = complex shear modulus. (For simplicity, the vertical bars denoting modulus of complex number are hereafter omitted.)

E_1 or G_1 = component of stress in phase with strain

E_2 or G_2 = component of stress 90° out of phase with strain.

3. *Angle of phase lag δ* – The angle whose tangent = E_2/E_1 or G_2/G_1 , representing the frequency-dependent phase shift between stress σ and strain ϵ . Hereafter subscripts l and t refer to longitudinal and torsional respectively; δ_l is not necessarily equal to δ_t . (δ_t is designated δ_s when used in conjunction with G , the shear modulus, or V_s , the shear velocity.)

4. *Complex Poisson's ratio ν^** – Assuming that the relationship among the elastic constants applies to the viscoelastic moduli, $\nu^* = (E^*/2G^*) - 1$, then by substitution and arrangement of terms (Thomson 1966):

$$\begin{aligned} \nu^* &= \frac{E^*}{2G^*} - 1, |\nu^*| = (\nu_1^2 + \nu_2^2)^{1/2} \\ |\nu^*| &= \frac{E_1 + iE_2}{2(G_1 + iG_2)} - 1 \\ &= \frac{(E_1 + iE_2)(G_1 - iG_2)}{2(G_1 + iG_2)(G_1 - iG_2)} - 1 \\ &= \frac{E_1G_1 + E_2G_2}{2(G_1^2 + G_2^2)} - 1 + \frac{i(E_2G_1 - E_1G_2)}{2(G_1^2 + G_2^2)} \\ &= (\nu_1^2 + \nu_2^2)^{1/2} \end{aligned}$$

where

$$\begin{aligned} \nu_1 &= \frac{E_1G_1 + E_2G_2}{2(G_1^2 + G_2^2)} - 1 \\ \nu_2 &= \frac{E_2G_1 - E_1G_2}{2(G_1^2 + G_2^2)} \end{aligned}$$

5. *Dynamic stress* σ_d - The stress imposed by the peak sinusoidal drive force.
6. *Dynamic strain* ϵ_d - The natural strain corresponding to the stress as defined under 5.
7. *Damping* $\tan \delta$ - The property of the material which causes the strain to lag in time behind the stress.
8. *Attenuation coefficient* a - If a plane wave is passed through a solid, the displacement amplitude at a distance from the source is A_1 , and at a distance x farther along is A_2 ; then $A_2 = A_1 e^{-ax}$, and a = attenuation coefficient.
9. *Amplitude ratio* R - The ratio of the output (top) amplitude of the energy wave to the input (bottom) amplitude.
10. *Specimen resonant frequency* f_r - The frequency at which the amplitude ratio R is a maximum. As the frequency is increased from zero, a series of maximum ratios occurs indicating the fundamental resonance and succeeding harmonics.
11. *Static confining pressure* σ_0 - Isotropic component of the ambient state of stress around a test specimen.
12. *Mass ratio* Q - The ratio of the mass of the cap = W_c/g , to the mass of the specimen = W_s/g (W = total weight). In the torsional mode, this is the ratio of the polar mass moment of inertia of the cap to the polar mass moment of inertia of the specimen.

Recalling that $\tan \delta$, the loss angle, $= E_2/E_1$, the real and imaginary parts of the complex modulus, and defining the frequency ratio as $\xi = \omega L/V_p$, where the phase velocity $V_p = \sqrt{E^*/\rho}$ $\sec \delta/2$, eq 2 can be written as:

$$\frac{1}{R^2} = \frac{1}{2} [Q^2(\xi^2 + \psi^2)(\cosh 2\psi - \cos 2\xi) + 2Q(\psi \sinh 2\psi - \xi \sin 2\xi) + (\cosh 2\psi + \cos 2\xi)] \quad (3)$$

where $\psi = \xi \tan \delta/2$

and $Q =$ ratio of cap mass to specimen mass.

Equation 2 can also be written in the form of real and imaginary parts as follows:

$$\frac{U(0, t)}{U(L, t)} = \text{Re} + i\text{Im} \quad (4)$$

where $\text{Re} = (\cosh \psi)(\cos \xi - Q\xi \sin \xi) + Q\psi \cos \xi \sinh \psi$ (5)

and $\text{Im} = (\sinh \psi)(\sin \xi + Q\xi \cos \xi) + Q\psi \sin \xi \cosh \psi$. (6)

From eq 4 the phase angle ϕ between the displacement at the driven end and that at the free end of the specimen is equal to:

$$\phi = \tan^{-1} \frac{\text{Im}}{\text{Re}} \quad (7)$$

Combining eq 5, 6 and 7

$$\phi = \tan^{-1} \frac{\sinh \psi (\sin \xi + Q\xi \cos \xi) + Q\psi \sin \xi \cosh \psi}{\cosh \psi (\cos \xi - Q\xi \sin \xi) + Q\psi \cos \xi \sinh \psi} \quad (8)$$

A value for the velocity of wave propagation V can be obtained if the frequency ratio $\xi = \omega L/V$ is known from the known quantities of ω and L . Likewise, a value for $\tan \delta/2$ can be obtained if the frequency ratio ξ and the term $\psi = \xi \tan \delta/2$ can be evaluated. Equations 3 and 8 can be solved simultaneously for ξ and ψ if the test yields values for R and ϕ . The frequency can be set at any desired value within the limits of the drive motors.

A computer program has been developed to accomplish the solution of eq 3 and 8. The iteration is accomplished using the Newton-Raphson method (Scarborough 1950). To accomplish the iteration in an efficient manner, approximate values for ξ and $\tan \delta/2$ are obtained using simplified relationships which do not account for the effect of the end mass. The equations used are as follows (Stevens 1970):

$$\sin^4 \xi (-R^2 \sec^2 \phi) + \sin^2 \xi \sec^2 \phi (R^2 - 1) + \tan^2 \phi = 0. \quad (9)$$

Equation 9 is of the form $ax^2 + bx + c = 0$ and can be solved by the usual solution:

$$x = \frac{-b \pm \sqrt{b^2 - 4ac}}{2a}$$

Then

$$\psi = \text{arc tanh} (\tan \phi / \tan \xi) \quad (10)$$

$$\tan \delta/2 = \psi / \xi. \quad (11)$$

The computer program with explanatory text for the *nonresonant condition* of the specimen is given in Appendix A.

The desired parameters can also be determined for the *resonant condition* of the specimen. In this case it is not necessary to measure the phase angle ϕ . It has been shown that the specimen is at resonance when the amplitude ratio R is a maximum (Lee 1963, Brown and Serway 1964). As the frequency is increased, the first maximum is the fundamental resonance and successive maximums indicate the harmonics. For the condition of resonance where R is a maximum and $1/R^2$ is a minimum, eq 3 is differentiated with respect to ξ and set equal to zero:

$$\frac{\partial}{\partial \xi} \left(\frac{1}{R^2} \right) = 0$$

as follows:

$$\begin{aligned} Q^2 \xi (1 + \psi^2 / \xi^2) (\cosh 2\psi - \cos 2\xi + \xi \sin 2\xi + \psi \sinh 2\psi) \\ + \frac{1+Q}{\xi} (\psi \sinh 2\psi - \xi \sin 2\xi) \\ + \frac{2Q}{\xi} (\psi^2 \cosh 2\psi - \xi^2 \cos 2\xi) = 0. \end{aligned} \quad (12)$$

where Q is the ratio of mass of cap to mass of specimen. Equations 12 and 3 may be solved simultaneously with an iterative process such as the Newton-Raphson method for ξ and ψ and values established for V , the phase velocity, and $\tan \delta$, the loss factor.

The computer program with explanatory text for the *resonant condition* of the specimen is given in Appendix B.

With known values of V and $\tan \delta/2$, the complex moduli E^* and G^* can be computed using the mass density ρ as follows:

$$E^* = \frac{V_l^2 \rho}{1 + \tan^2 \delta_l/2} \quad (13)$$

As the torsional case is perfectly analogous, then:

$$G^* = \frac{V_s \rho}{1 + \tan^2 \delta_s/2} \quad (14)$$

where V_s = shear velocity

δ_s = shear phase lag angle between stress and strain

δ_l = longitudinal phase lag angle between stress and strain.

For convenience, and to obtain the modulus in units of kips, the following equations are used:

$$E^* = \frac{(2.15934 \times 10^{-7}) \gamma_w V_d^2}{(1 + \tan^2 \delta_d/2)} \quad (15)$$

or

$$G^* = \frac{(2.15934 \times 10^{-7}) \gamma_w V_s^2}{(1 + \tan^2 \delta_s/2)} \quad (16)$$

where γ_w = unit wet weight in pounds per cubic foot.

Equations describing the values of σ_d , the peak stress, and ϵ_d , the peak strain, are wave equations in the variable X , the distance along the specimen from the end chosen as an origin. The values vary in a damped, sinusoidal manner as a function of X . Furthermore, σ_d is a maximum at the same position as the maximum ϵ_d , and σ_d and ϵ_d reach that maximum at the node in the standing wave nearest the driven end of the specimen ($X = 0$). At a resonance, this node is very close indeed to the driven end. As most testing to date has been with the specimen resonating, σ_d and ϵ_d have been computed at the driven end of the specimen ($X = 0$). Thus, if the specimen is at resonance or fairly close to it, the stress and strain computed and used for correlation purposes are close to the maximums in the specimen.

From Norris and Young (1970)

$$\sigma_d = E^* e^{i\delta} \epsilon_d$$

and

$$\epsilon_d = U_p \left[\left(\frac{\tan pL + \Gamma}{1 - \Gamma \tan pL} \right) \cos px - \sin px \right] e^{i\omega t} \quad (17)$$

where p and Γ are as previously defined.

If the expressions for p and Γ are substituted in eq 17 and the right-hand side is separated into real and imaginary parts, the complex result represents the magnitude of the strain at any point X along the specimen.

If $X = 0$, eq 17 becomes:

$$\epsilon_d = U_0 p \left[\left(\frac{\tan pL + \Gamma}{1 - \Gamma \tan pL} \right) e^{i\omega t} \right] \quad (18)$$

Substituting the expressions for p and Γ , after some algebraic rearrangement, eq 18 assumes the form:

$$\epsilon_d = \frac{U_0}{L} (\xi - i\psi) \left[\frac{\tan(\xi - i\psi) + Q(\xi - i\psi)}{1 - Q(\xi - i\psi) \tan(\xi - i\psi)} \right] \quad (19)$$

With the input amplitude A_B substituted for U_0 , eq 19 is used to compute the strain ϵ_d . The corresponding stress σ_d is computed from:

$$\sigma_d = E^* \epsilon_d \quad \text{or} \quad \sigma_d = G^* \epsilon_d \quad (20)$$

Again, in order to solve eq 19, the right-hand side must be separated into the real and imaginary parts, and the complex result evaluated. The computer program (App. B) solves eq 19 in this manner.

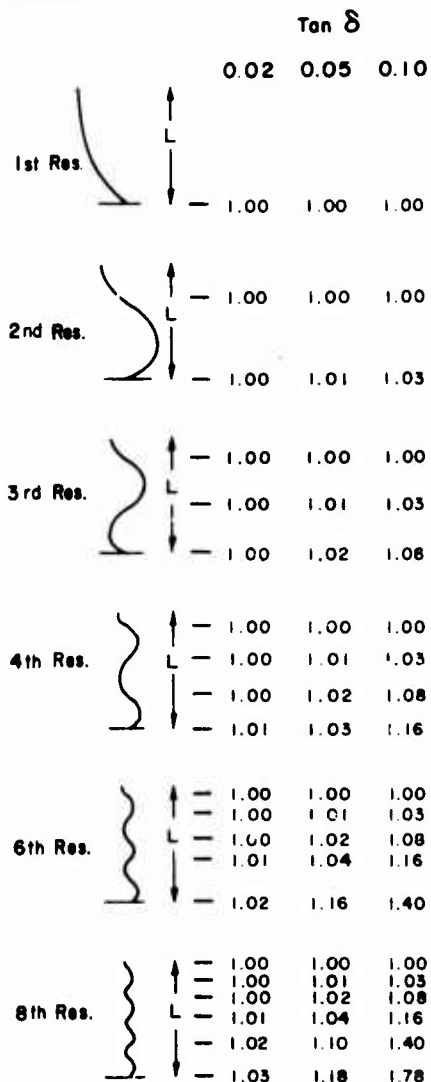

Figure 1. Strain distribution at specimen resonance. Curves represent amplitude distribution.

An error may be introduced here in that the modulus is computed from wave velocity and represents an average or total response modulus of the entire specimen. If the response is nonlinear with strain, it is possible that comparing the maximum strain in the specimen with the modulus is not strictly valid, the error depending upon the degree of nonlinearity with strain and the range of strain employed. However, as the entire concept is based on an assumption of linear viscoelasticity and the range of strains involved is small, the error is assumed to be slight. Lachenmaier (1969) showed that linear theory applied to a nonlinear phenomenon can approximate the nonlinear constitutive relationships, at least for soil and within a limited range of strain.

Discussion of stress-strain computation

Figure 1 shows the distribution of amplitude along the length of the specimen for various resonances with an arbitrary value for strain shown for each node in the standing wave. The simplified equation used considers the top end of the specimen to be completely free, that is, with no end cap or mass. Note that the maximum strain does, indeed, occur at the node nearest the driven end. Note also that the sinusoidal wave distribution of the motion results in strain reaching a maximum at the nodes and minimum, close to zero, at the antinodes. Therefore, strain approaches zero at the free end of the specimen where amplitude is greatest (at resonance) and is large at the nodes where amplitude approaches zero.

At the *first* resonance, strain is a maximum at the node close to the driven end of the specimen and decreases according to the quarter sine wave distribution to close to zero at the top or free end. The addition of an end mass on the free end modifies the values of strain somewhat but the principle remains the same. If the end mass has substantial length and weight, only a portion of the quarter sine wave representing amplitude distribution is included within the specimen and this portion of the curve can approach a straight line or strain approaches a constant value along the length of the specimen. In this case, and assuming the bottom end is truly fixed, dividing the top amplitude by the length of the specimen gives a rough approximation of the average strain. However, for the test conditions reported here, the end mass is only a small, light plate and the other end is not truly fixed, but driven.

A linear distribution of strain cannot be assumed. The average strain could be computed assuming the sine wave distribution, but as the length of the wave included in the sample varies with frequency, this becomes complicated, and there is some question as to the significance of the average. Accordingly, the maximum strain in the specimen is computed and used for correlation purposes.

In the torsional mode, the stress-strain distribution in the horizontal plane through the cylindrical specimen must be considered. As the stress and/or strain varies from the center axis to the periphery, it is computed for the 1-in. radius in the 3-in.-diam specimen, assuming a linear distribution. Thus an approximate average is used. It is recognized that this is not entirely satisfactory, but the remedy is 1) use of a more sophisticated analysis to account for the true distribution, or 2) use of a hollow cylinder specimen. To date, neither of these remedies has been attempted.

Poisson's ratio and the compression (dilatational) velocity

Although a complex Poisson's ratio, which allows comparison of the complex moduli, is used, the relationship remains the same as for elastic materials. Furthermore, the value of Poisson's ratio is difficult to obtain accurately because it is wholly dependent upon accurate values of E^* and G^* . The compressional velocity V_c is related to the rod or phase velocity V_d through complex Poisson's ratio as follows:

$$V_c = V_d \left[\frac{1 - \nu^*}{(1 + \nu^*)(1 - 2\nu^*)} \right]^{1/2}$$

The above relationship holds fairly well for an elastic material, but may not hold for viscoelastic materials, especially since Poisson's ratio may not fall between 0 and 0.5 for the latter materials. It can be seen that as ν^* approaches 0.5, V_c approaches infinity, and as ν^* approaches zero, V_c approaches 1. As either value is ridiculous, the values of compressional velocity obtained using Poisson's ratios greater than about 0.45 or less than 0.10 must be considered unreliable.

The damping property

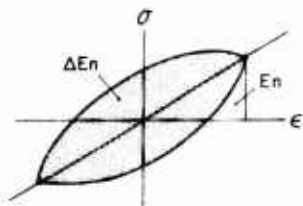

Figure 2. Diagram of stress-strain relationship for one cycle of steady-state vibration.

When the response to dynamic (vibratory) load is such that the strain lags the stress, the stress-strain curve for one cycle of a steady-state vibration is a closed (hysteresis) loop (Franklin and Krizek). The work done or, reciprocally, the energy dissipated ΔEn is given by Kennedy (1962) as the integral of $\sigma(t)\epsilon$ over the stress cycle, or:

$$\Delta En = \int_0^{2\pi/\omega} \sigma_d \cos \omega t \epsilon_d \sin \delta \, dt$$

or

$$\Delta En = \pi \epsilon_d \sigma_d \sin \delta. \tag{21}$$

One value for the damping property is called the "specific damping capacity" and is defined as the ratio of energy dissipated per cycle to total energy carried En , or $\Delta En/En$ (Kolsky 1964 and Richart et al. 1970). If En is $\epsilon_d \sigma_d \cos \delta/2$, then:

$$\frac{\Delta En}{En} = \frac{\pi \epsilon_d \sigma_d \sin \delta}{\epsilon_d \sigma_d \cos \delta/2} = 2\pi \tan \delta. \tag{22}$$

A slightly different version is frequently used (Nakano and Arnold 1972, Weissman 1971, and Kolsky 1964):

Q = ratio of energy carried by the wave to energy dissipated per radian of phase shift

or

$$\frac{2\pi En}{\Delta En} = \frac{1}{\tan \delta} \quad (23)$$

Nakano and Arnold (1972) reason that, since energy is proportional to the square of the amplitude and amplitude is proportional to $e^{-\alpha x}$, Q can be expressed as:

$$Q = \frac{\pi}{a\lambda} = \frac{1}{\tan \delta} \quad (24)$$

Q is also used in the form $1/Q$ and called the specific dissipation function (Richart et al. 1970):

$$1/Q = 2V a/\omega = \tan \delta \text{ (if } \delta \text{ is small)}$$

where

λ = wavelength of propagating wave and a = attenuation coefficient.

A very common method of evaluating the energy absorbing or damping property of a material is to represent the response by a model in which viscous elements (dashpots) are introduced into an elastic (spring) network. The Voigt or Kelvin model has been widely used. In this model the spring and dashpot components are parallel. If η is the dashpot coefficient in compression and μ is that in shear

$$\eta = \frac{E_1 \tan \delta}{\omega} \quad (25)$$

and

$$\mu = \frac{G_1 \tan \delta}{\omega} \quad (26)$$

or

$$c = \frac{K \tan \delta}{\omega} \quad (27)$$

where K = spring constant and c = dashpot coefficient.

Note that the dashpot coefficient varies inversely with frequency, or apparently the coefficient decreases with increasing frequency (see Fig. 3). However, it is not possible to generalize in this manner, as the modulus and $\tan \delta$ may also vary with frequency. Two other models frequently considered are the Maxwell model in which the components are in series and the standard linear model in which the Voigt and Maxwell models are combined (Fig. 3). Finally, it is apparent that springs and dashpots can be assembled to represent the response of many materials but the shear mass of calculations required is such as to make this a less desirable approach (Kolsky and Shi 1958).

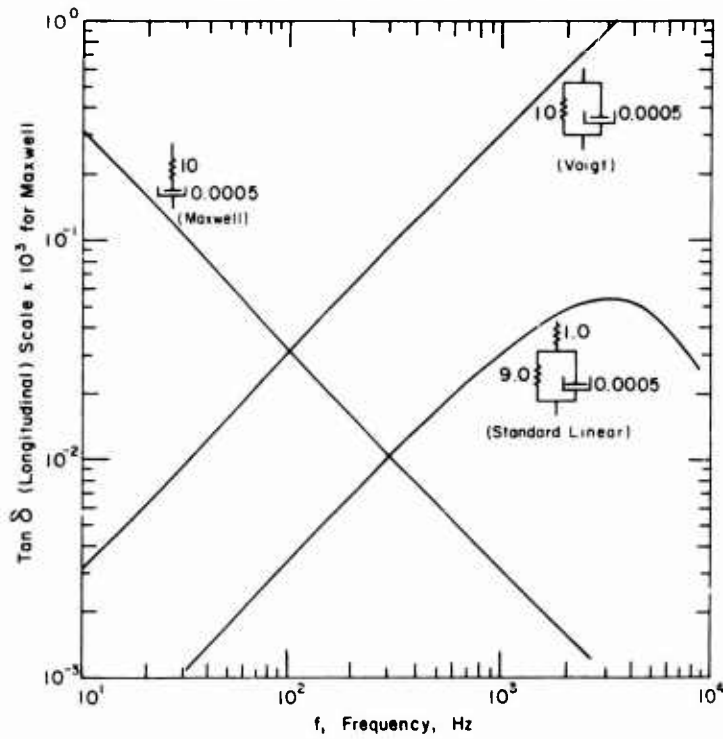

Figure 3. $\tan \delta$ vs frequency for various rheological models. (Arbitrary values assigned to spring and dashpot elements.)

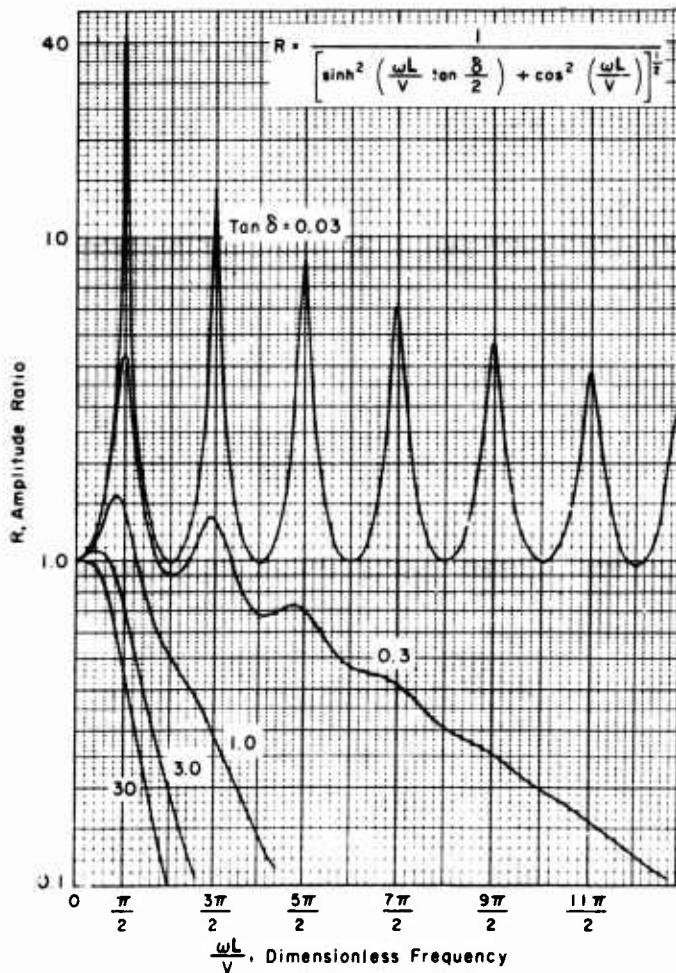

Figure 4. Relationship of $\tan \delta$ to amplitude ratio and frequency.

Another evaluation of the damping property is the "damping ratio" D . In general this refers to the ratio of actual damping c to critical damping C_c , defined as the amount of damping which prevents an oscillation. Using the Voigt model, assuming a single degree of freedom and, generally, that K , the spring constant, and c , the dashpot coefficient, are not functions of frequency, it can be shown (Harris and Crede 1961) that:

$$D = c/C_c = \sin \delta/2 \quad (28)$$

where $C_c = 2\sqrt{KM}$, $c = K \tan \delta/\omega$, and $M = \text{mass}$.

On the other hand, if a multiple degree of freedom is allowed and the modulus is allowed to vary with frequency, it can be shown that the value of critical $\tan \delta$ which prevents an oscillation approaches infinity (Fig. 4).

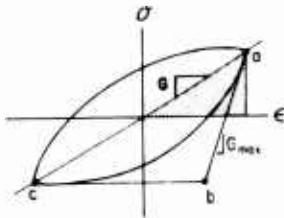

Figure 5. Graphical representation of energy stored and dissipated per cycle.

Hardin and Drnevich (1970) obtain a value for the damping ratio by a somewhat different approach (Fig. 5): the damping ratio D is given by:

$$D = A_g/4\pi A_r \quad (29)$$

where A_g = area of stress-strain loop

A_r = area of a right triangle with a base of the peak strain and height of peak stress (see cross-hatched area)

$4\pi A_r$ = total energy stored in elastic material.

If the area of the loop, or total energy dissipated, is $A_g = \pi\sigma_d\epsilon_d \sin \delta$ and $A_r = \sigma_d\epsilon_d/2$, then:

$$D = \frac{\pi\sigma_d\epsilon_d \sin \delta}{4\pi(\sigma_d\epsilon_d/2)} = \sin \delta/2. \quad (30)$$

Hardin and Drnevich (1970) also show that D , the damping ratio, is equal to:

$$D = 2K_i/\pi(1 - G/G_{\max})$$

where K_i = a constant (A/A_r)

and G_{\max} = maximum shear modulus.

For a propagating stress wave, it is convenient to express the damping property in the form of the attenuation coefficient α (see definitions). Kennedy (1962) and Kolsky (1964) show that:

$$\alpha = \frac{\delta\omega}{2V}$$

where $V = \sqrt{E/\rho}$, δ is assumed to be small, and $\tan \delta \cong \delta$.

A more general relationship is used here to allow $\tan \delta$ to be any value:

$$\alpha = \frac{\omega}{V_l} \tan \delta_l/2 \quad (31)$$

where

$$V_l = \sqrt{E^*/\rho} \sec \delta_l/2.$$

There are at least two other methods of measuring the damping property. The first takes advantage of the dependence of the bandwidth of the peak amplitude-frequency plot at resonance to the damping property of the material. The bandwidth is defined as $\Delta f/f_r$, where f_r is the resonance frequency and $\Delta f = f_1 - f_2$; f_1 and f_2 are frequencies at which the value of ϵ falls to $\epsilon_{\max}/\sqrt{2}$. The bandwidth is controlled by the damping property. A simple Voigt model relationship is: $\Delta\omega = \eta/M$, with $\Delta\omega = 2\pi\Delta f$. The second method uses the fact that the rate of decay of the natural oscillations of a mechanical system is a measure of damping. The log decrement Δ is defined as the ratio of the log of successive amplitudes. The log decrement relates to loss angle as follows:

$$\Delta = \frac{2\pi(1 - \sqrt{1 - \tan^2 \delta})}{\tan \delta} \quad (32)$$

If damping is small:

$$\Delta = \frac{2\pi D}{1 - D^2} = \frac{2\pi \sin \delta/2}{1 - \sin^2 \delta/2} = \pi \tan \delta \quad (33)$$

$$\Delta = \pi/Q = 2\pi\nu a/\omega = \lambda a.$$

The foregoing relationships are given to correlate the loss factor $\tan \delta$ with other commonly used values to evaluate the damping property. Most of the relationships given are simplified versions of the rigid equations but have been found adequate for most situations. It is considered, however, that the damping property should be evaluated by the loss factor $\tan \delta$ or by an expression of energy dissipation, as the use of these parameters allows fairly rigid relationships to be made without simplifying or limiting assumptions.

Sample length — diameter ratio

A specimen, usually cylindrical in shape, presents boundary conditions to the propagation of a stress wave such that assumption of an infinitely long rod without lateral dimensions (a one-dimensional plane wave) is not sufficiently valid. The error in the assumption varies depending upon Poisson's ratio, the length/diameter ratio, and wavelength, a function of frequency. The situation was studied by Bancroft (1941), assuming an elastic material. The elastic condition is an extreme case and the introduction of the effect of damping would modify the findings somewhat; but for choosing a proper specimen length, the elastic solution is very useful. Using Bancroft's equations and taking a specimen having a length/diameter ratio of 3.75, it can be shown that the true velocity of wave propagation is reduced to 99.8% at the first resonance, but to 90.0% at the fourth resonance. Accordingly it can be concluded that a minimum ratio of about 3.0 is required if only the first resonance is used, but as much as 6.0 is required if the fourth or fifth resonance is used. As coarse soils are frequently tested, a 3-in.-diameter specimen is used which requires a length of 18 in. considering that the fourth or fifth resonance is often used at frequencies to 10 or 12 kHz.

TEST APPARATUS AND PROCEDURES

General

A vertical cylinder of soil is subjected to steady-state sinusoidal vibration at its lower or base end with the other end free except for a light, relatively rigid cap. The input and output stress

waves are observed and measured with piezoelectric accelerometers attached to the base plate and cap plate at each end of the specimen. The peak acceleration and the frequency are recorded. The drive frequency may be any value above the so-called "rigid body frequency" and within the limits of the drive motors, if the phase angle between input and output waves can be accurately measured; otherwise, the specimen must be excited at a known resonance. The ratio of output to input amplitudes, and the frequency, together with the specimen properties of density and length, are required to compute the desired parameters.

Test apparatus

The complete test apparatus includes the device for applying vibration as pictured in Figure 6, and shown schematically in Figure 7; the control and readout apparatus shown schematically in Figure 8; and the molds and auxiliary equipment required for specimen preparation described and pictured in Appendixes C and D.

A steel drive base, having suitable provisions for attaching accelerometers for measuring longitudinal and torsional motion in g 's is bolted to a steel drive shaft. The shaft is supported in a heavy steel framework through wagon-spoke-type springs and is attached to the electromagnetic motors. A light steel cap has provision for attaching accelerometers, one on the longitudinal axis and two on the circumference, to measure the torsional motion.

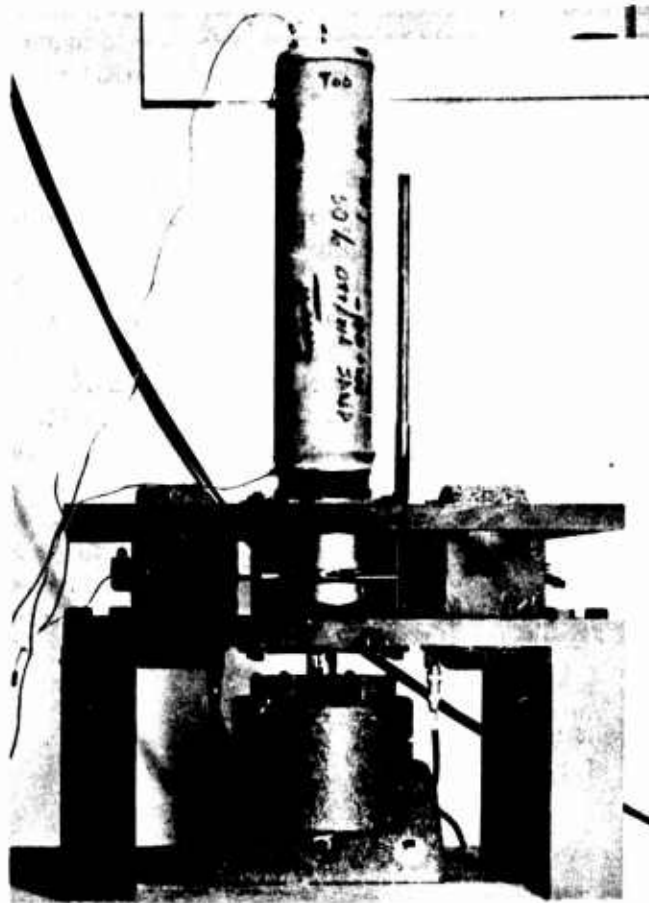

Figure 6. Laboratory test apparatus for applying vibratory loads to frozen soils and ice.

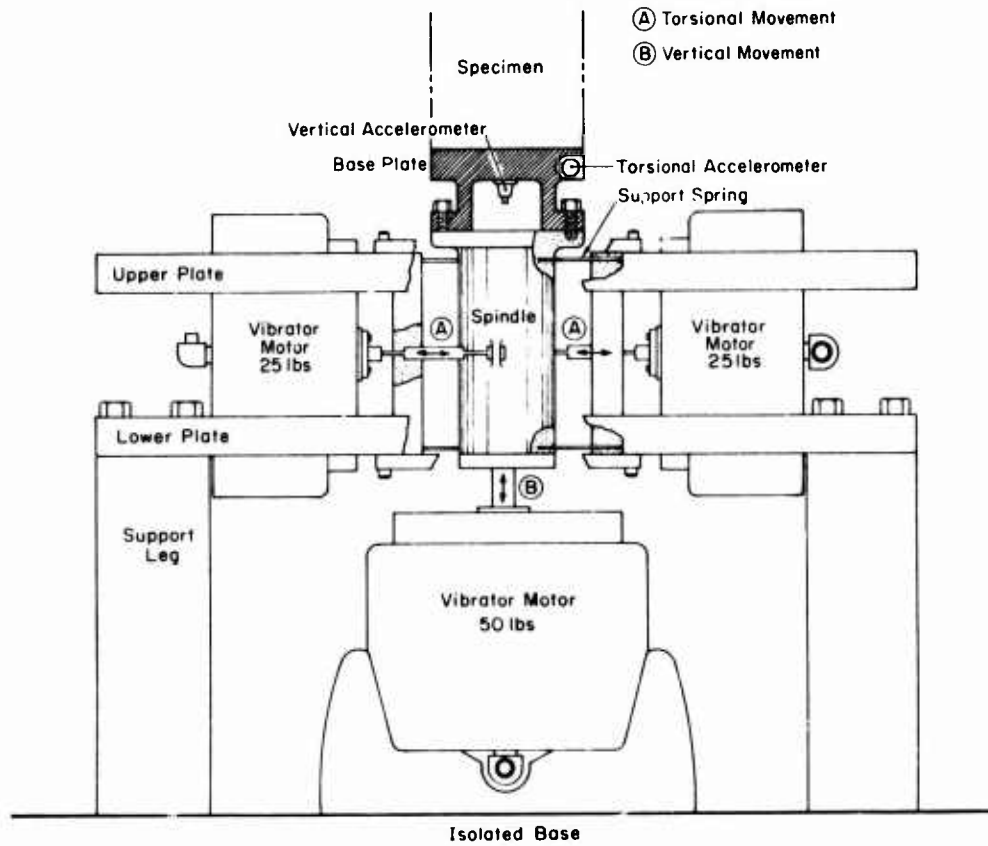

Figure 7. Schematic of laboratory test apparatus.

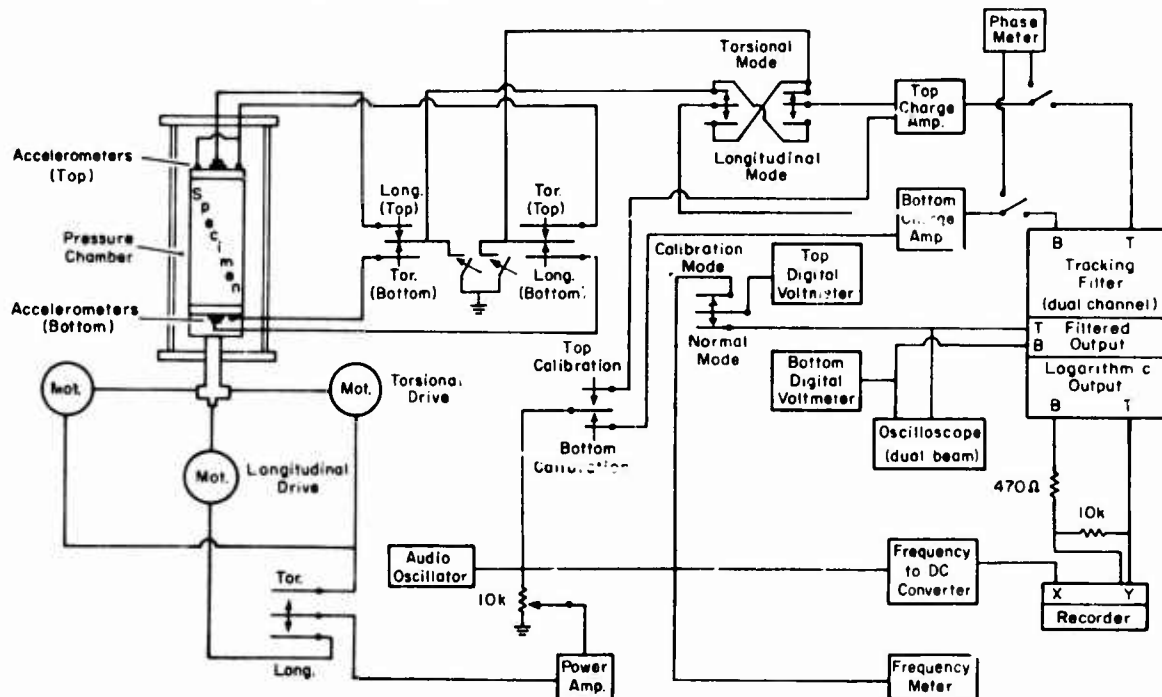

Figure 8. Schematic of control and readout system of dynamic test apparatus.

The readout instrumentation receives the two accelerometer signals from the top and bottom of the sample and, after amplification of the signals, feeds them through a phase meter, a dual-channel tracking filter, a dual beam oscilloscope, digital voltmeters, an electronic counter (frequency meter), a logarithmic converter, and an X-Y recorder, as shown in Figure 8.

Appendix C also describes the equipment and procedures for preparing frozen specimens.

Test procedures

The specimen (prepared as described in App. C) is carefully weighed and measured before freezing to the baseplate and cap of the test apparatus. The calibration of the voltmeters is accomplished as follows: the sensitivity of the particular accelerometer (in pico coulombs/g) is set on the sensitivity dial of the variable gain charge amplifier (the amplifier should have this capability such as the Kistler Model 503). A 1.00-peak volt signal [0.707-volt root-mean-square (rms) as read on the voltmeter] at approximately 5000 Hz is applied at the CAL INPUT connector. The OUTPUT is monitored on the sensitive voltmeter. This output, which corresponds to 1 g, can be adjusted by the gain on the charge amplifier. Thus, depending on the accelerometer sensitivity and on the operating range, the gain can be set such that 1 g = 1 v, or 1 g = 0.1 v, etc.

Most of the tests to date have been conducted using a resonating specimen and, although the off-resonance method using the phase meter is currently in use, data are still taken at the resonant frequencies. The procedure is as follows: the operator applies the vibration in either the longitudinal or torsional mode with the drive force at a low level (top acceleration of 1 g or less) and sweeps the frequency upward. As the frequency is swept, attention is directed to the X-Y recorder. The outputs from the charge amplifiers and tracking filter are then fed through the logarithm converter. The log of the bottom acceleration is subtracted from the log of the top acceleration. The difference (acceleration - amplitude ratio) is applied to the Y-axis of the X-Y recorder. The "Record" output of the frequency meter is applied to the X-axis of the recorder. Thus, a printed record is obtained of acceleration ratio vs frequency. The frequency of maximum amplitude ratio (or acceleration ratio) can be easily located and the resonances enumerated, since the second, third and fourth resonances are approximately multiples of 3, 5 and 7, respectively, of the first resonance. With the pen of the plotter set on the first resonance point, the frequency is recorded together with the two g values from the voltmeters. The drive force is increased a significant amount and the procedure is repeated. The frequency is then changed to the second resonance, the readings at the various drive forces are repeated, etc, through the fourth and fifth resonances. The drive mode is changed, longitudinal to torsional, or vice versa, and the series of readouts is repeated.

To employ the nonresonance method, the procedure is the same except that the phase is measured and the X-Y recorder is not required. The operator selects an initial frequency and applies the vibration, in either mode, with the drive force again at a low level. The outputs from the charge amplifiers are switched into the phase meter, measuring the phase lag between the bottom and top accelerations. The frequency is recorded together with the two g values and the phase angle. A range of drive forces is applied and the readings are recorded for each force, after which the next required frequency is set, etc. until the range of frequency desired is covered.

Procedure for data computation

The test procedures, therefore, yield values for the resonant frequency or drive frequency, the amplitude or acceleration ratio, and the phase angle, together with the density, void ratio or porosity, water or ice content, and soil type of the specimens; and, finally, values for the test environment characterized by such parameters as temperature and static pressures. From these data the desired properties of modulus, wave velocity, and damping must be computed for the given

stress, strain and frequency conditions. The equations and computer programs described in section *Method of Analysis* accomplish this. The Young's modulus, shear modulus, longitudinal and shear velocities, $\tan \delta$ and attenuation coefficient, with the corresponding stress, strain, amplitude and g level, are computed and tabulated by the appropriate computer program (App. A or B). Next, these values are combined to show the relationships of the material properties to stress, strain and frequency. The computer plots modulus and $\tan \delta$ versus stress. After smooth curves are drawn through the computer-plotted points, values for modulus and $\tan \delta$ are read for several given stresses. For each given stress, then, a plot is made of frequency versus modulus or $\tan \delta$. Again values are read for selected frequencies. Upon completion of the foregoing procedure, values of Young's modulus, shear modulus, longitudinal $\tan \delta$ and torsional $\tan \delta$ for a range of stresses and frequencies are available. The final data tabulation is made after a computer computation (see App. E-3) which back-computes (i.e., computes backwards from modulus, $\tan \delta$, stress and frequency rather than vice versa as was done in first computation) the values of velocity, Poisson's ratio, strain, and attenuation coefficient for each given group of modulus, $\tan \delta$, stress and frequency.

TEST PROGRAM

Soils

The majority of tests conducted to date were performed using two USA CRREL stock soils, 20-30 Ottawa sand and Manchester silt. The properties of 20-30 Ottawa sand are well known and are not repeated here. The properties of 20-30 OWS in the frozen state are, perhaps, not so well known. Table I lists strengths in unconfined compression at a constant strain rate (Sayles 1968). Manchester silt is a rock flour (nonplastic). The gradation is given in Figure 9, and the compaction properties are given in Figure 10. Strengths in unconfined compression are given in Table II (Sayles 1972) for Hanover silt, a local silt very similar to Manchester silt. A third USA CRREL stock soil, Goodrich clay, has been designated for testing, but to date only a few tests have been conducted. The gradation and other pertinent properties are given in Figure 9. Goodrich clay is a brick clay, classified as a silty clay, CL, almost in the CH category, with a liquid limit (LL) of 45 and a plasticity index (PI) of 21. Twenty-three Ottawa sand and Manchester silt were remolded (see App. C) and Goodrich clay was used in the undisturbed state. Specimens in the undisturbed state are cored in the in-situ, nonfrozen state and frozen without access to water to prevent ice segregation.

Table I. Unconfined compression test of 20-30 Ottawa sand [after Sayles (1968)].

Constant rate of strain = 0.033 in./in./min.

Temp (°F)	Specimen no.	Ice saturation (%)	Void ratio	Max stress (ksi)	Avg stress (ksi)
25	OWS 130	99.4	0.606	1.447	1.460
	158	97.3	0.572	1.471	
	164	97.9	0.579	1.491	
	166	98.2	0.575	1.449	
	171	98.5	0.566	1.446	
15	OWS 67	98.6	0.601	2.694	2.531
	69	97.1	0.592	2.612	
	70	98.7	0.593	2.410	
	74	98.8	0.600	2.438	
	76	98.8	0.584	2.503	

THE RESPONSE OF FROZEN SOILS TO VIBRATORY LOADS

Design		G_s	LL	PL	PI
1	20-30 Ottawa Sand	2.65	-	-	NP
2	Minus 100-200 Ottawa Sand	2.65	-	-	NP
3	Hanover Silt	2.74	-	-	NP
4	Fairbanks Silt	2.70	-	-	NP
5	Manchester Silt	2.73	-	-	NP
6	Suffield Clay	2.69	45.0	24.0	21.0
7	Goodrich Clay	2.82	41.0	23.0	18.0
8	Thetford Till	2.64	-	-	NP
9	Minus 100 Lebanon Till	2.86	-	-	NP

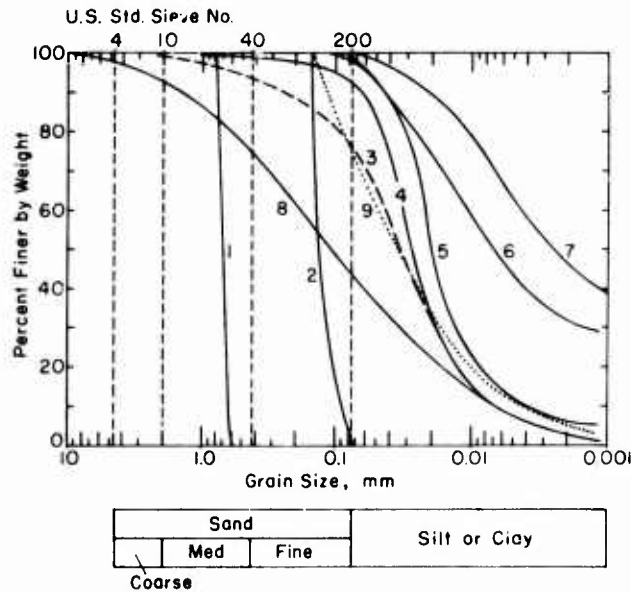

Figure 9. Gradation curves for frozen soils.

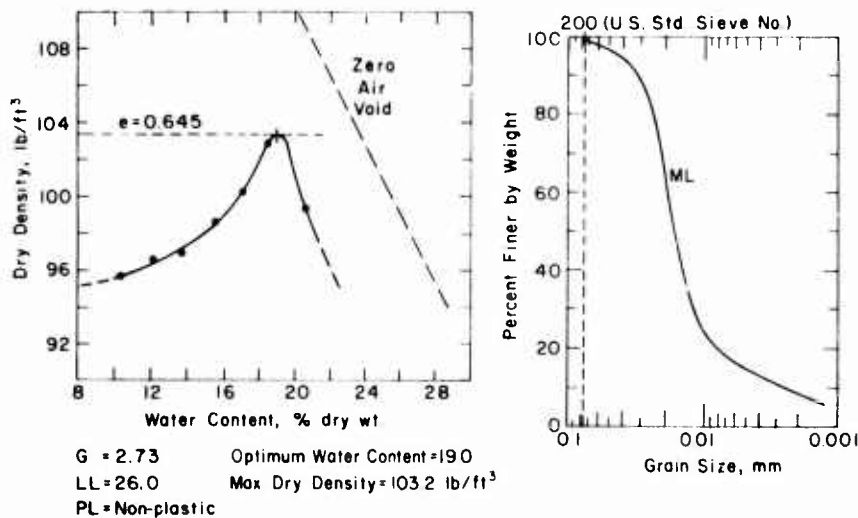

Figure 10. Manchester silt compaction test results.

Table II. Unconfined compression test of Hanover silt (Sayles and Haines 1972).

Temp (°F)	Specimen no.	Tan mod* (ksi)	Ice saturation (%)	Measured rate of applied strain† (in./in./min)	Void ratio	Max stress (ksi)
15	HAS 1	200	98.9	0.098	0.903	1.39
	2	160	99.9	0.067	0.915	1.42
	3	160	99.5	0.074	0.904	1.37
	Avg	173	99.4	0.08	0.907	1.39
25	HAS 108	156	99.2		0.968	0.821
	109	160	99.3	0.10	0.973	0.822
	112	160	99.2	0.12	1.007	0.828
	114	160		0.12		0.772
Avg	159		0.11		0.811	
29	HAS 116	112	100.0	0.19	0.984	0.504
	118	112	100.0	0.19	1.022	0.522
	119	113	100.0	0.18	1.014	0.531
	Avg	112	100.0	0.19	1.006	0.519
31	HAS 77	50	100.0	0.21	1.019	0.282
	95	47	98.8	0.27	0.974	0.292
	113	115	98.3	0.18	1.030	0.290
	117	100	98.4	0.18	1.008	0.307
Avg	78	98.9	0.21	1.008	0.293	

* Tangent modulus at 50% max stress.

† Average rate of applied strain = 14.1%/min.

Table III. Unconfined compression strengths of Suffield clay [after Sayles and Haines (1972)].

Temp (°F)	Specimen no.	Tan mod* (ksi)	Ice saturation (%)	Measured rate of applied strain† (in./in./min)	Void ratio	Max stress (ksi)
15	SFC 22	100	100.0	0.15	1.078	0.691
	23	113	100.0	0.11	1.089	0.711
	17	131	100.0	0.08	1.109	0.731
	Avg	115	100.0	0.11	1.092	0.711
25	SFC 3	90	100.0	**	0.999	0.452
	12	80	100.0	0.09	1.084	0.443
	8	82	100.0	0.06	1.099	0.451
	Avg	84	100.0	0.075	1.060	0.448
29	SFC 17A	50	**	0.31	**	0.334
	11	54	100.0	0.10	1.105	0.344
	16	55	99.9	0.13	1.105	0.321
	Avg	53		0.18		0.333
31	SFC 24	33	99.3	0.20	1.096	0.197
	14	30	99.2	0.29	1.095	0.212
	19	24	98.6	0.15	1.086	0.208
	Avg	29	99.0	0.21	1.092	0.206

* Tangent modulus at 50% max stress.

† Average rate of applied strain = 15.2%/min.

** Data unavailable.

Table IV. Specimen properties.

OS = 20-30 Ottawa sand HS = Hanover silt GC = Goodrich clay
 FOS = 100-200 Ottawa sand FS = Fairbanks silt I = Ice
 MS = Manchester silt SC = Suffield clay TT = Thetford till

Specimen no.	Soil type	Unit wet weight (lb/ft ³)	Water content (%)	Unit dry weight (lb/ft ³)	Porosity (%)	Void ratio	Water saturation (%)	Ice saturation (%)	Length (in.)	Diam (in.)
1005	OS	122.6	22.0	101.0	35.8	0.636	91.8	100.9	15.24	3.947
1006	OS	123.2	21.9	100.9	38.8	0.636	91.0	100.2	15.03	3.952
1030	OS	127.7	17.9	108.3	34.5	0.528	89.8	99.9	13.14	2.000
1032	OS	121.1	20.9	100.1	39.5	0.654	85.2	93.0	11.90	1.980
1036	OS	127.5	18.3	107.9	34.9	0.536	91.1	98.3	19.75	3.192
1051	OS	127.1	17.7	108.0	34.7	0.532	88.2	98.0	20.39	3.005
1052	OS	128.2	17.5	109.2	34.0	0.516	90.2	100.2	20.30	3.020
1056	OS	127.7	18.1	108.2	34.6	0.529	91.0	99.8	20.12	2.955
1062	OS	127.8	18.1	108.2	34.5	0.528	90.8	100.8	18.70	2.984
1064	OS	126.4	18.8	106.4	35.7	0.556	89.8	99.7	20.19	2.999
1068	OS	128.6	17.5	109.5	33.8	0.509	90.3	100.3	20.31	2.994
1070	OS	122.4	21.0	101.9	38.3	0.622	89.6	99.5	20.09	3.023
1074	OS	127.0	18.3	107.3	35.6	0.553	88.4	98.1	19.37	3.010
1014	FOS	122.7	22.0	100.6	39.2	0.645	90.4	98.7	15.27	3.961
1013	FOS	123.3	21.3	101.6	38.5	0.627	90.2	98.5	15.21	3.968
1017	FOS	109.4	10.2	99.3	40.0	0.666	40.6	45.1	15.29	3.955
1033	MS	122.3	24.6	98.2	42.1	0.729	90.7	100.8	13.46	1.985
1037	MS	123.1	22.7	100.4	41.1	0.697	88.9	97.0	18.75	3.000
1038	MS	122.3	23.4	99.1	41.7	0.714	88.9	98.8	19.63	3.075
1039	MS	107.5	36.4	78.9	53.7	1.163	85.0	93.5	18.10	2.941
1040	MS	121.1	24.3	97.5	43.3	0.743	89.1	98.8	17.35	3.066
1041	MS	121.9	23.2	98.9	42.5	0.723	86.7	96.7	18.75	3.080
1042	MS	121.7	22.7	99.2	41.8	0.718	86.6	96.1	19.62	3.070
1043	MS	106.9	37.1	78.1	54.0	1.279	95.8	95.3	19.55	2.942
1045	MS	103.1	7.1	96.2	46.0	0.852	22.7	25.0	19.00	2.995
1048	MS	114.9	33.5	86.1	57.3	1.340	68.2	75.0	20.62	2.988
1053	MS	121.5	22.9	98.6	41.9	0.719	86.7	96.1	19.78	3.015
1053A	MS	121.5	22.9	98.6	41.9	0.719	86.7	96.1	19.10	3.015
1054	MS	121.9	22.6	99.7	41.4	0.709	86.2	95.8	19.35	3.018
1055	MS	123.2	22.4	100.7	40.9	0.689	88.5	96.7	20.61	3.020
1059	MS	107.9	29.1	96.0	43.8	0.823	101.0	110.1	19.75	3.005
1063	MS	121.5	22.2	99.6	41.7	0.717	85.2	92.8	20.47	3.180
1067	MS	121.0	24.1	97.6	42.8	0.748	88.0	98.3	20.31	3.026
1069	MS	119.6	25.0	95.7	42.3	0.765	87.3	96.9	20.53	3.028
1071	MS	112.9	32.1	85.5	50.0	0.993	88.3	98.0	20.06	3.015
1072	MS	113.0	31.7	85.7	49.7	0.988	87.6	97.3	20.41	3.013
1076	MS	118.8	25.4	95.3	44.1	0.794	88.1	97.6	20.37	3.027
1025	HS	118.8	28.5	92.1	46.1	0.855	91.3	102.4	15.84	4.000
1026	FS	98.9	46.0	66.3	60.7	1.545	80.3	87.6	16.83	2.964
1027	FS	77.1	130.0	33.5	80.2	4.030	86.8	94.7	20.25	2.974
1028	FS	89.4	66.0	53.8	68.1	2.130	83.6	91.2	16.22	2.977
1007	SC	101.7	18.6	85.5	50.0	0.962	51.6	56.8	15.05	3.952
1008	SC	100.7	17.5	85.3	48.0	0.962	49.2	54.2	15.75	3.959
1010	SC	111.4	36.0	81.9	51.2	1.050	92.1	102.3	15.00	4.000
1012	SC	116.3	30.6	89.1	46.9	0.885	92.9	101.5	15.00	4.000
1082	SC	130.6	17.3	111.3	33.5	0.505	92.3	100.0	17.75	3.025

Table IV (Cont'd).

Specimen no.	Soil type	Unit wet weight (lb/ft ³)	Water content (%)	Unit dry weight (lb/ft ³)	Porosity (%)	Void ratio	Water saturation (%)	Ice saturation (%)	Length (in.)	Diam (in.)
1075	GC	121.2	27.3	95.3	45.2	0.853	92.7	102.2	9.035	2.762
1079	GC	119.6	26.2	94.8	45.4	0.833	88.3	96.9	15.625	3.139
1077	TT	116.6	24.9	93.5	44.6	0.803	83.6	93.0	15.85	2.922
1022	I	56.43							15.00	4.000
1023	I	56.79							13.90	4.000
1024	I	56.63							15.93	4.000
1057	I	54.75							19.938	3.005
1058	I	56.75							19.80	3.010
1073	I	56.10							18.72	3.009
1080	I	56.4							12.10	2.975
1081	I	55.39							18.56	3.004

A number of other soils have been tested using two to four specimens mostly at a temperature of +15°F. They include 100-200 Ottawa sand, Hanover silt, Fairbanks silt (undisturbed), Suffield clay (remolded), Thetford till, and Lebanon till. The gradations for these soils are also given in Figure 9. Unconfined compression strengths for Suffield clay are given in Table III (Sayles and Haines 1972). All remolded soils contained no segregated ice, as they were frozen without access to water. The Goodrich clay, while undisturbed, was nonfrozen when cored and frozen without access to water, and hence contained no ice lenses. However, the undisturbed Fairbanks silt was cored from frozen ground and did contain segregated ice. The properties of all individual specimens tested are given in Table IV. A detailed description of the specimen preparation procedure and equipment is given in Appendix C.

Ice

An attempt was made to prepare ice specimens having multiple small crystals representative of the ice contained in the pores of frozen soil. Rapid freezing of distilled deaired water was one method used. Snow saturated with deaired water and quick-frozen was another method. Neither method was satisfactory. Figure 11 shows the crystal size in a typical 20-in.-long 3-in.-diam specimen. The lack of uniform size is apparent. In any case, no concerted effort to test ice has yet been made. However, a few tests have been conducted for comparison purposes.

Test results

A summary of the measured values of the complex Young's modulus and shear modulus, the (compressional) dilational, phase and shear velocities, the $\tan \delta$ for the longitudinal and torsional modes, the attenuation coefficient for both modes, and Poisson's ratio, is given in Appendix F. The values are grouped according to soil type, temperature, frequency and dynamic stress level, so that all results for each of the four categories are gathered together. Each specimen is identified by number, percentage of ice saturation, and void ratio, so that auxiliary information on a particular specimen may be found by reference to other tables. Adequate information is available in the tabulation to compute values for other parameters, if desired. For example, strain for a particular test may be computed by dividing stress by modulus. Damping may be expressed in other forms by computation using $\tan \delta$, frequency, modulus, or other given values as necessary. Such

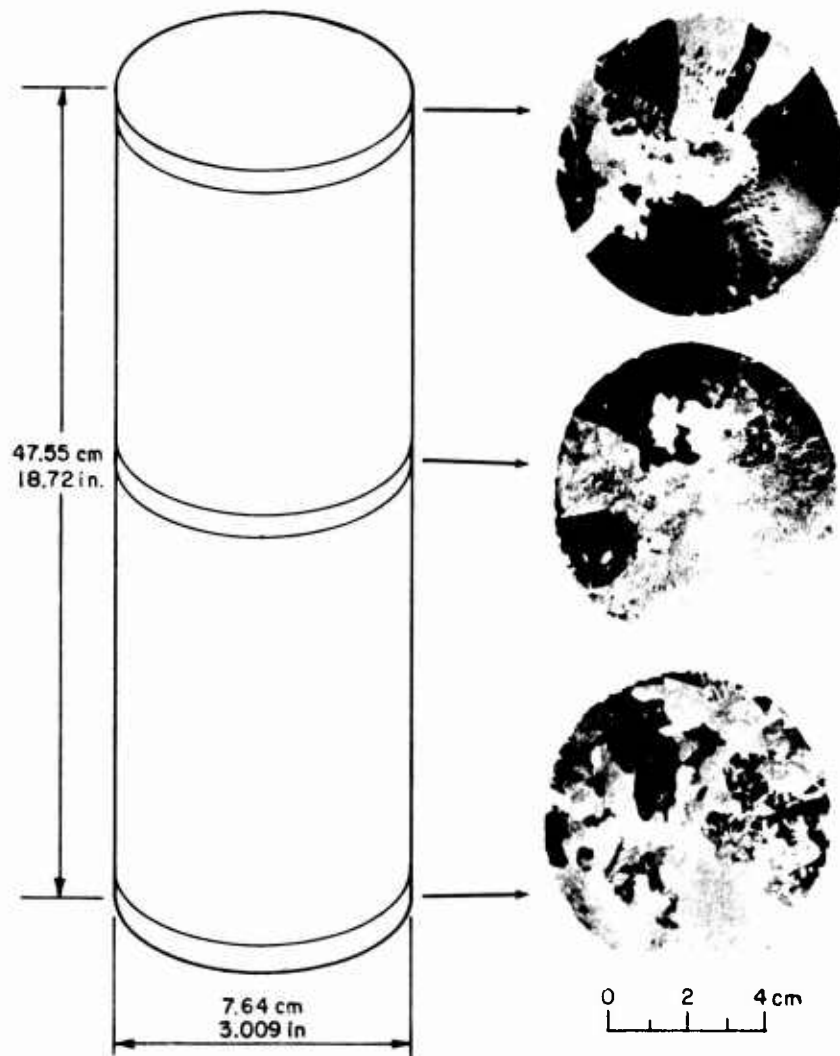

Figure 11. Crystal structure of laboratory molded ice.

values as drive amplitudes and g level are available in USA CRREL records or may be computed from the listed data, although a computer program is desirable.

Discussion of test results

Tests of frozen soils have been conducted over the past three years, during which time the test procedure and equipment have been continually revised and updated to increase accuracy and versatility. Therefore, the earlier test results (lower numbers) are less dependable, with larger error range, than later (higher numbers) test results. In some cases, this may be the reason for anomalies in the data. In general, too few reliable tests have been completed to allow establishment of firm (mathematical) relationships. However, results of earlier tests using simpler apparatus and analysis procedures give values surprisingly in agreement with those using current, more sophisticated techniques. If a trend is to be observed, it is that the more accurate current method tends to give higher values of modulus and velocity than the older method. The random spread of

values is also less. It is obvious that a considerable amount of testing and study has yet to be accomplished before the complete picture of the response of frozen soils to vibratory load is established.

ANALYSIS OF TEST RESULTS

General

The test results to date show that the response of a frozen soil to vibratory load depends upon the following parameters, in the order of their importance:

1. Ice content, usually expressed as percentage of saturation
2. Void ratio of soil
3. Temperature
4. Frequency of imposed vibratory load
5. Stress or strain imposed by vibratory load.

The first two parameters can be combined and expressed as the ratio of volume of ice to volume of soil. However, in this report the two are considered separately. Frozen soils having segregated ice masses and lenses have not been especially considered, and the effect of maximum and minimum void ratios for a given soil is apparently of some significance. In any case, void ratio and ice content are obviously insufficient parameters to completely identify the response of all frozen soils to vibratory loads and the real basic parameters are more subtle and extensive. A more detailed study of natural soils is required to identify these basic parameters. Likewise, the effect of temperature has been studied, so far, by simply measuring the response of specimens subjected to the various temperatures. This response has not been related to the cause of temperature effects, such as the percentage of nonfrozen water present, and the effect of temperature on ice rigidity and adhesion strength.

Effect of ice content

Only a few tests have been conducted on frozen soils having ice contents less than about 90% saturation because the occurrence of such soil conditions in nature is relatively rare. Sufficient tests have been conducted to show that, as would be expected, the modulus decreases radically as the volume of ice in the voids available to cement the soil grains together decreases. Figure 12a shows the complex shear modulus versus ice saturation for a sand, silt and remolded clay. Figure 12b shows the same relationship for the shear velocity. Also shown for zero ice saturation are values for the same soil in a nonfrozen state. The completely dry condition would be most accurate, but only the 20-30 Ottawa sand has been tested in this condition. Also, a confining pressure is necessary for nonfrozen specimens, at least for the sands and silts, and the values of modulus and velocity given are for an ambient static pressure of 5.0 psi.

It is shown that the shear velocity decreases by more than an order of magnitude (8500 to 600 ft/sec for Ottawa sand) as the ice saturation varies between 100% and 0%. The shear modulus decreases from 2×10^6 psi to 8×10^3 psi for Ottawa sand, or more than two orders of magnitude. The rate of decrease, however, is quite different depending upon soil type. The coarser grained, nonplastic soils, typified by 20-30 Ottawa sand, show little decrease in modulus or velocity until ice saturation is less than about 50%. On the other hand, the decrease in modulus with decreasing ice saturation for Suffield clay is nearly constant, approaching a straight line between the maximum at 100% and the minimum at 0%. Manchester silt, a fine-grained, nonplastic soil, falls between the two. It can be stated, therefore, that the degree of ice saturation between 50% and 100% has a very

THE RESPONSE OF FROZEN SOILS TO VIBRATORY LOADS

Curve	Frozen soils	f kHz	Temp °F	Non-frozen soils			
				Point	$\sigma_0 = 5$ psi	Water content	e
A	Suffield clay	1	15	A'	Suffield clay	12.7	0.94
B	Manchester silt	1	25	B'	Manchester silt	18.3	0.80
C	20-30 Ottawa sand	1000	14	C'	20-30 Ottawa sand	Dry	0.50

[Nakano and Arnold (1972)]

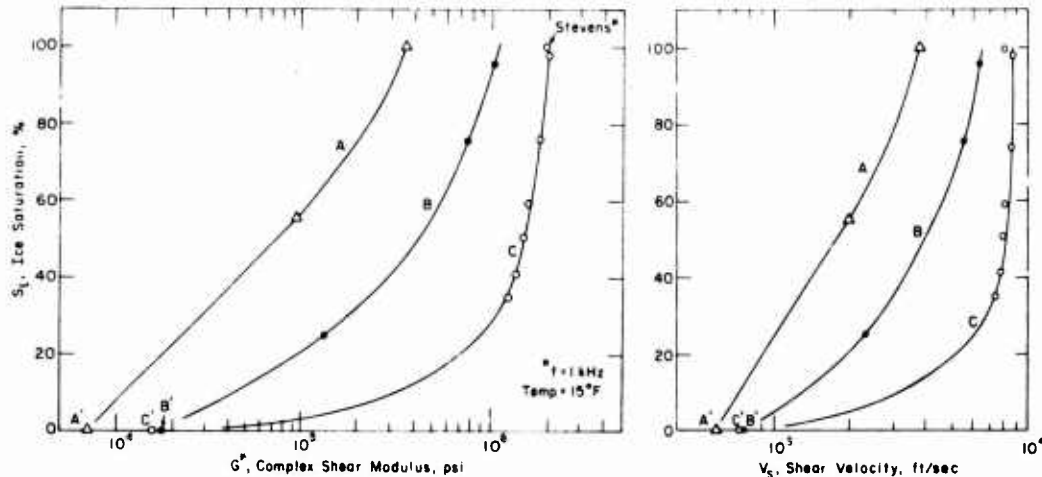

Figure 12. The effect of ice saturation on complex shear modulus and shear velocity.

significant effect on the stiffness of fine-grained frozen soils, but is a relatively insignificant factor in the stiffness of coarse-grained soils such as sand. This is logical for several reasons. The lack of strong adhesive bond between grains furnished by the ice is not as important for the already cohesive soils as for the coarse-grained noncohesive soils. It is relatively common to find spherically grained sands with a coating of ice on the grains which, in the total matrix, produces a low percentage of ice saturation. Nevertheless, the bond between grains can be quite strong.

The effect of void ratio

Figures 13 and 14 show that, in general, the moduli increase as the void ratio decreases, provided the voids are essentially (90% or better) filled with ice; that is, the ratio of volume of ice to volume of soil increases as modulus decreases. Following this trend to its ultimate conclusion, the stiffness of frozen soils is greater than that of ice alone. It is logical, therefore, to conclude that the stress wave would pass through the ice matrix when the soil grains do not touch or are more or less imbedded in the ice. When the soil grains touch, however, and are held together by the adhesive force of the ice, the stress wave would tend to pass through the soil matrix. This would not be an abrupt change because the ice structure would vary between a light structure to solid ice, depending upon the volume of soil per volume of ice. Nevertheless, the rate of increase in stiffness should be rather abrupt when the void ratio decreases below about 1.0 and this seems to be born out by Figures 13 and 14. Again, however, this can be no firm criterion because of the variation in the shape, size and strength of soil grains.

In general, soils in the dry state have a maximum and minimum void ratio; that is, they can be tightly packed together or loose, held together only by their shape, weight and natural cohesive or frictional properties, or some outside pressure. When the voids are filled (but not overfilled) with ice, it is apparent that the stiffness of a given soil varies only within the limits of its void ratio

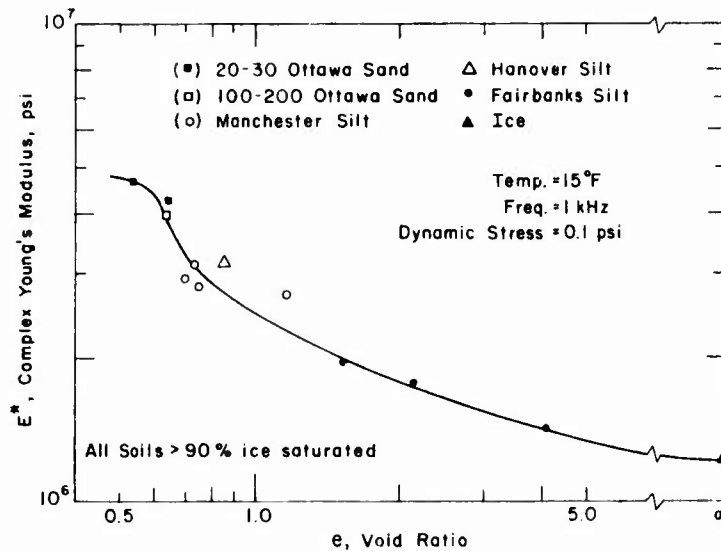

Figure 14. The effect of void ratio on complex Young's modulus.

and depends upon the adhesive strength of the ice to the particular soil grain, as well as the stiffness of the soil grain itself. Therefore, a plot of void ratio versus modulus for a wide range of saturated soils shows the soil types grouped together in bands along the plot (see Fig. 13). Coarse, strong-grained soils (gravels and sands) show the highest modulus, followed by silts and then clays with overlapping areas between each soil type. Although insufficient tests at a wide range of void ratios have not been conducted to show conclusive evidence, it is fairly obvious that the stiffness of each type of frozen soil varies with void ratio from a maximum value at its minimum void ratio to the stiffness of ice, with the most rapid and abrupt decrease occurring between the minimum and maximum void ratio of the particular soil.

In contrast to coarse, free-draining soils, fine-grained soils in nature tend to develop segregated ice in lenses or chunks. The volume of ice may considerably exceed the volume of soil. In any case the void ratio tends to approach 1.0. Therefore, the stiffness of frozen fine-grained soils, particularly undisturbed specimens, tends to approach the stiffness of ice, whereas the coarse-grained soils generally have a stiffness considerably in excess of that of ice.

Figure 13 also shows that nonplastic soils such as gravel, sand and nonplastic silts have a higher modulus than do the soils containing clay sizes. A single curve could be drawn to represent fairly well the variation of modulus with void ratio for all the nonplastic soils (see Fig. 14). The tills containing clay sizes and the clays themselves relate stiffness to void ratio in an increasingly less sensitive manner.

The effect of void ratio on the damping property, $\tan \delta$, is shown in Figure 15. In spite of considerable scatter of test values, it is evident that $\tan \delta$ is not greatly affected by void ratio. This is interpreted as evidence that the $\tan \delta$ of ice governs the degree of damping in the frozen soil, at least, until the volume of ice/volume of soil ratio becomes relatively small or less than 1.0. The coarse-grained, noncohesive soils show a tendency for a decreasing $\tan \delta$ with decreasing void ratio, but the fine-grained cohesive soils have an increasing $\tan \delta$ with decreasing void ratio. The damping or attenuation value for frozen soils can be much higher than would be expected for such a stiff material, where the modulus can be as high as that of concrete. Generally, the $\tan \delta$ of frozen soils is equal to or higher than that of ice.

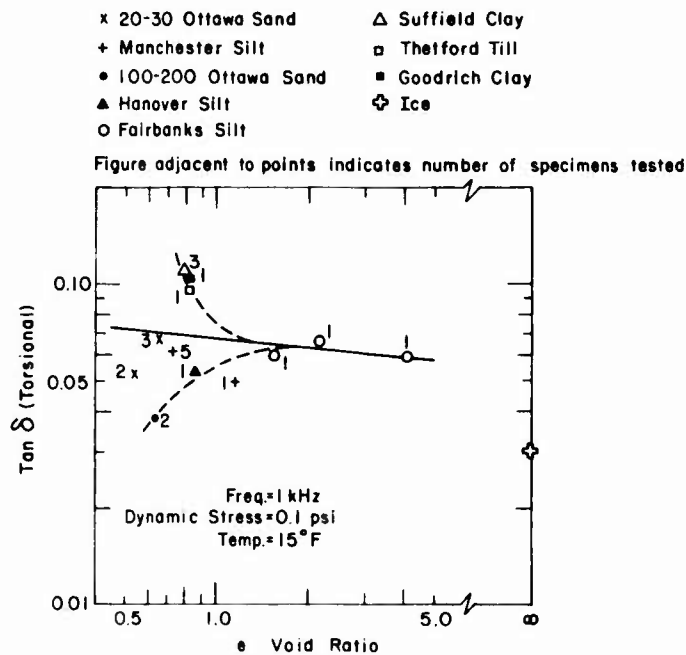

Figure 15. The effect of void ratio on $\tan \delta$ (torsional mode).

Effect of temperature

The relation of complex Young's and complex shear modulus to temperature is shown in Figure 16. Tests of frozen soils were conducted at 0° , $+15^\circ$ and $+25^\circ\text{F}$ and of nonfrozen soils at room temperature. The decrease in modulus between 0° and $+25^\circ\text{F}$ is relatively small, although varying depending upon soil type. The Ottawa sand decreases in modulus less than 10%, the Manchester silt a little over 20%, and the Thetford till about 50%. As discussed previously under *Effect of Ice Content*, the decrease in modulus from the solid frozen state at $+25^\circ\text{F}$ to the nonfrozen state, say at room temperature, is more than two orders of magnitude, or the modulus of nonfrozen soil is less than 1% of the modulus of the same soil frozen. Specifically, Young's modulus of saturated Ottawa sand at $+25^\circ\text{F}$ is 4.5×10^6 psi and E^* of saturated nonfrozen Ottawa sand is 1.55×10^4 psi or about 0.3% when confined under 5 psi. Dry Ottawa sand has a higher modulus than "saturated" sand in the nonfrozen state and Young's modulus is about 0.6% of that in the frozen state. Manchester silt has about the same relationship. In this test series, $+25^\circ\text{F}$ is the closest test temperature to $+32^\circ\text{F}$; therefore, the effect of temperature change between $+25^\circ$ and $+32^\circ\text{F}$ is uncertain. However, assuming the static tangent modulus is related to the vibratory Young's modulus, there is shown in Figure 16 the static tangent modulus for Hanover silt at temperatures from $+15^\circ\text{F}$ to $+31^\circ\text{F}$ (Sayles and Haines 1972). The decrease in modulus is quite large in this temperature range, and it can be assumed that the vibratory modulus of Manchester silt would follow the same trend.

The effect of temperature on the shear stress wave velocity of ice, saturated sand and silt is shown in Figure 17a and b. Data for these plots were obtained from the literature as well as from test results of this study. There is agreement that the effect of temperature on velocity of stress waves in ice is small, almost negligible, at least for temperatures less than about $+25^\circ\text{F}$. Therefore, the presence of ice in frozen soil has only a small effect on the variation of modulus with temperature. When a considerable effect occurs, as for clays, the reason must be connected with the properties of the soil grains or the adhesive bond strength of the ice with that particular soil.

THE RESPONSE OF FROZEN SOILS TO VIBRATORY LOADS

Design.	S_s %	S_w %	e	Description
1a	99.1	—	0.53	Ottawa Sand
1b	—	93.8	0.60	
1c	Dry	Dry	0.50	
2a	97.2	—	0.73	Manchester Silt
2b	—	91.4	0.73	
3a	96.9	—	0.83	Goodrich Clay
3b	—	99.4	0.95	
4a	93.0	—	0.80	Thetford Till
4b	—	100	0.44	
5	—	—	—	Ice
6	99.1	—	0.97	Hanover Silt Static Tangent Modulus 50% max stress (Soyles and Haines, 1972)

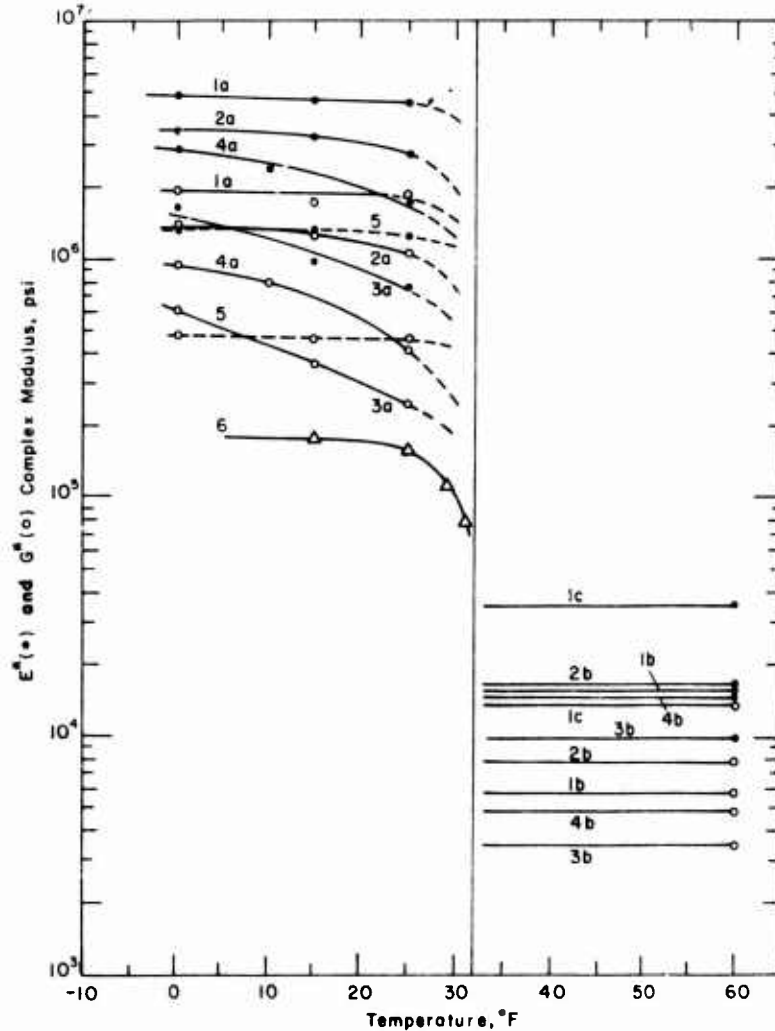
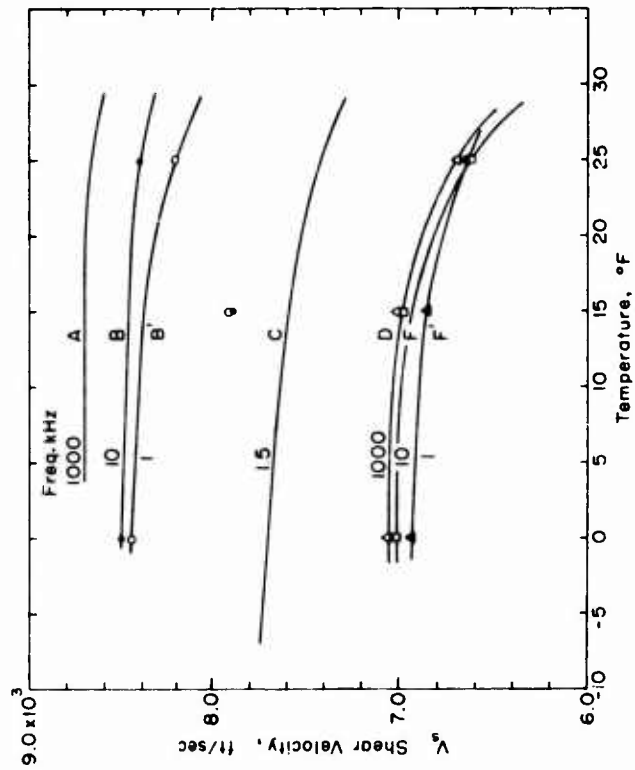
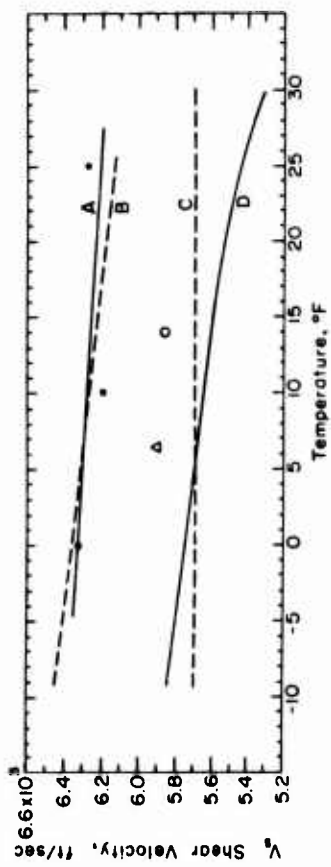

Figure 16. The effect of temperature on complex Young's and shear moduli. Frequency = 1 kHz, dynamic stress = 0.1 psi.

Design	Description	e
A	20-30 Ottawa sand (Nakano and Arnold 1972)	0.647
B and B'	Ottawa sand (Stevens App. F)	0.522-0.557
C	McNamara conc sand (Kaplar 1969)	0.503
D	Hanover silt (Nakano et al. 1971)	1.065
F and F'	Manchester silt (Stevens App. F)	0.823-1.163



- (A) Stevens (App. F), laboratory molded and frozen ice, $f = 5$ kHz
- (B) Roethlisberger (1972), compilation of values from seismic measurements on glacier ice
- (C) Stevens - Tizzard (1969), lake ice cored in-situ, 3.3 kHz
- (D) Kaplar (1969), laboratory molded and frozen ice, 3.0-3.3 kHz
- (Δ) N. Smith (1969), laboratory compacted snow, 1.4 kHz
- (o) J. Smith (1965), glacier ice cored in-situ, sonic pulse



a. Ice. b. Saturated sand and silt. B' and F' indicate different void ratios.

Figure 17. The effect of temperature on shear velocity of ice, saturated sand and silt.

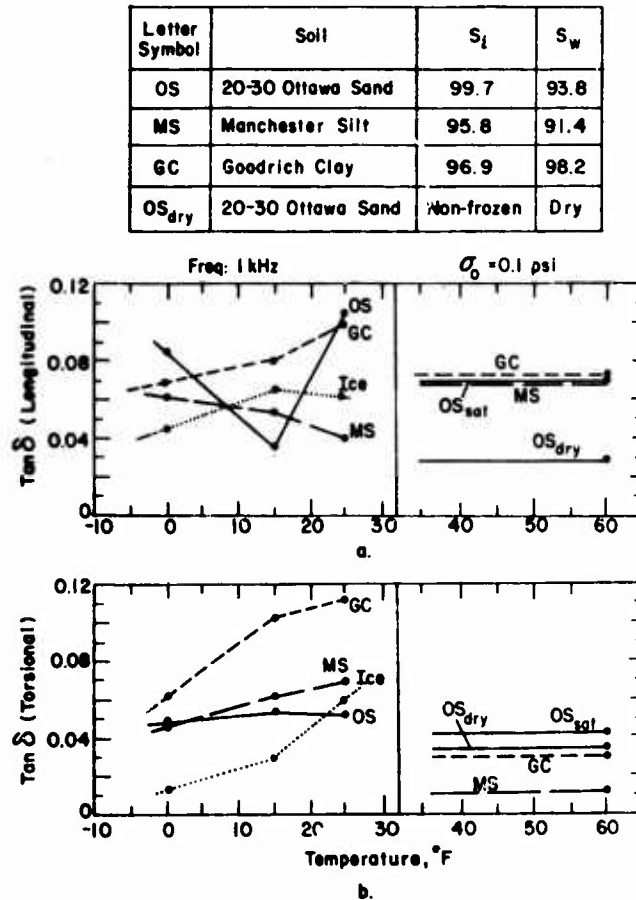

Figure 18. The effect of temperature on $\tan \delta$.

Figure 18 shows the relationship of temperature to $\tan \delta$ in both modes. Although the scatter of values prevents a proper evaluation of the relationship, it can be concluded that $\tan \delta$ for frozen soils is not significantly different from that of nonfrozen soils. A stress wave is attenuated in frozen soil to the same extent that it is in nonfrozen soil although the stiffness (modulus) is 100 times that of the nonfrozen soil. This is contrary to the usual relationship where $\tan \delta$ decreases when modulus increases. Damping in frozen soil must be the result of a mechanism quite different from that in nonfrozen soil and, as the presence of ice in the voids rather than air and/or water is the principal physical difference, it may be assumed that the ice in frozen soil governs the damping property.

Effect of frequency and dynamic stress

The frequency and dynamic stress are characteristics of the vibratory load rather than material properties or other outside influences. As for static loads, the forces and rate of loading influence the response. The test procedure limits the range of frequencies and stress levels. The maximum frequency is of the order of 10 kHz and the minimum about 100 Hz. The maximum drive force of the motors is 50 lb, which translates into a maximum peak stress of about 5 psi in most frozen soils. For the frozen soils, when the resonant column method is used, the frequency range for frozen soils ranges from 1000 Hz to 10 kHz and test values were determined for 1000, 5000 and 10000 Hz. Nakano et al. (1971) and Nakano and Arnold (1972) provide values for complex shear modulus and shear velocity at frequencies of 1000 Hz for nearly identical soils tested at the same

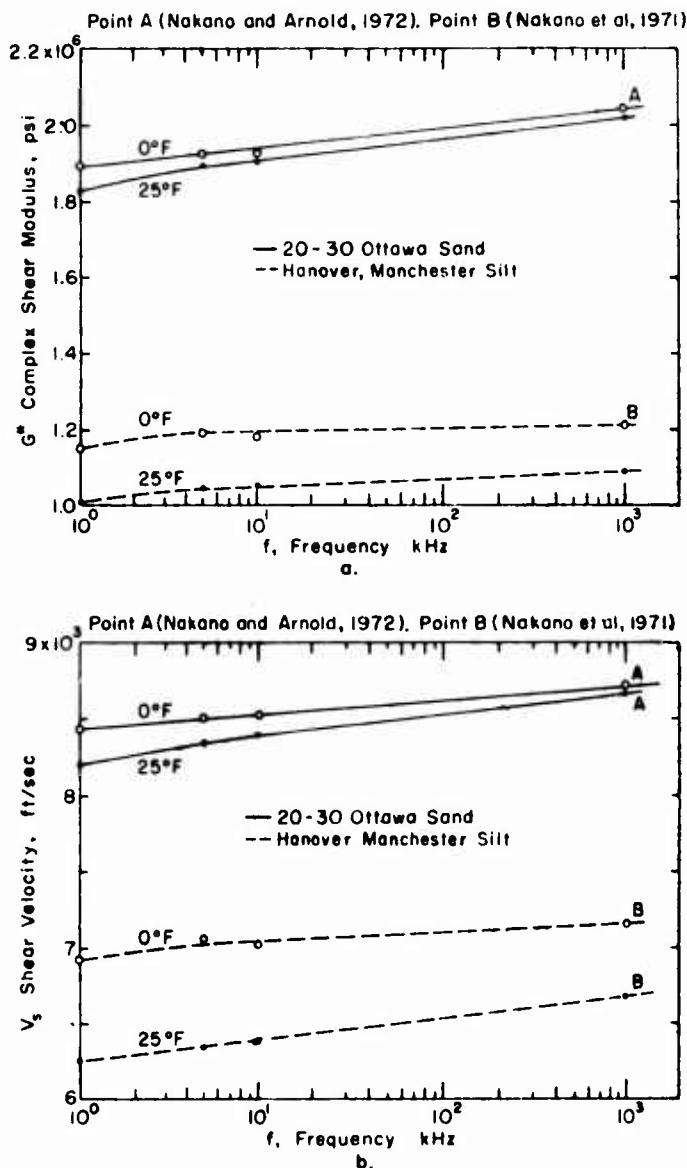

Figure 19. The effect of frequency on complex shear modulus and on shear velocity at a dynamic stress of 0.1 psi.

temperature. Figure 19a shows the effect of frequency from 1 kHz to 1000 kHz on the complex shear modulus of 20-30 Ottawa sand and Hanover-Manchester silt and Figure 19b shows the effect on the shear velocity. Velocity increases with increasing frequency. The rate of increase is fairly constant from 5 kHz to 1000 kHz and relatively flat, so that an investigator considering only a portion of this range might fail to observe a significant variation. Indeed, the test results from these tests show little to no discernible increase in shear velocity between 5 kHz and 10 kHz, although a greater increase is apparent at +25°F than at 0°F. Only when the results of Nakano and Arnold (1972) at 1000 kHz are added is an appreciable increase in velocity noted. Between 1 kHz and 5 kHz, these test results show some increase although still small; again the greater amount is noted at 25°F. It must be concluded, therefore, that frequency has small effect on the response of frozen soil in the range 1 to 1000 kHz and at a dynamic stress of 0.1 psi.

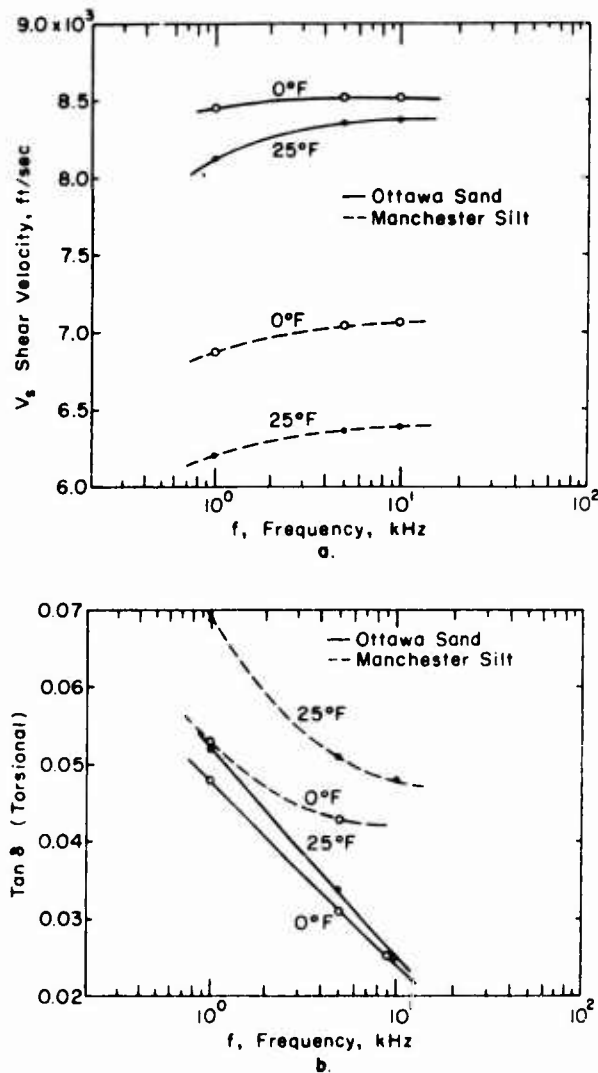

Figure 20. The effect of frequency on shear velocity and $\tan \delta$ at a dynamic stress of 5 psi.

Figure 20a shows shear velocity versus frequency for a dynamic stress of 5 psi. The variation with frequency is somewhat greater than at 0.1 psi as would be expected. Figure 20b shows $\tan \delta$ versus frequency. Damping is obviously much more sensitive to frequency than is the modulus or velocity, decreasing with increasing frequency at a steep rate. The trend indicates a viscous type of damping mechanism; that is, a strong dependence on frequency or rate of strain indicates viscous response.

Effect of dynamic stress and strain

Figures 21 and 22 show the effect of increasing dynamic stress on the complex shear modulus and shear velocity, respectively, from 0.1 to 5.0 psi. It is evident that the modulus is nonlinear with stress beyond some threshold stress. The threshold of stress and the rate of decrease of modulus with increasing stress vary depending upon frequency, temperature and other variables; but, in general, the threshold is close to 1.0 psi and the rate of decrease is small. Thus it can be concluded that, for frozen soils, nonlinearity need not be a matter of concern for most situations

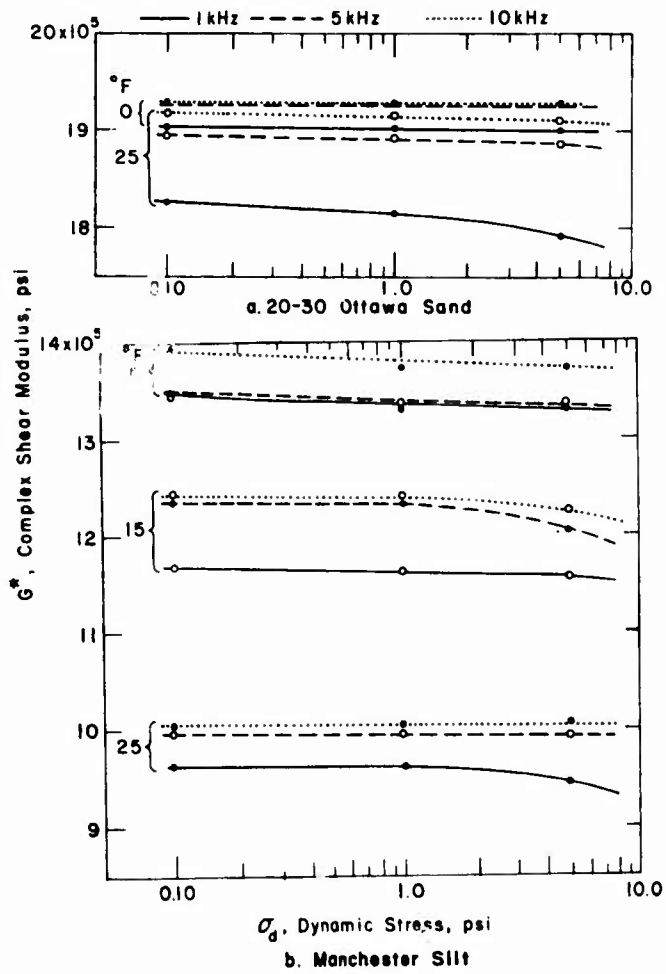

Figure 21. The effect of frequency and dynamic stress on complex shear modulus.

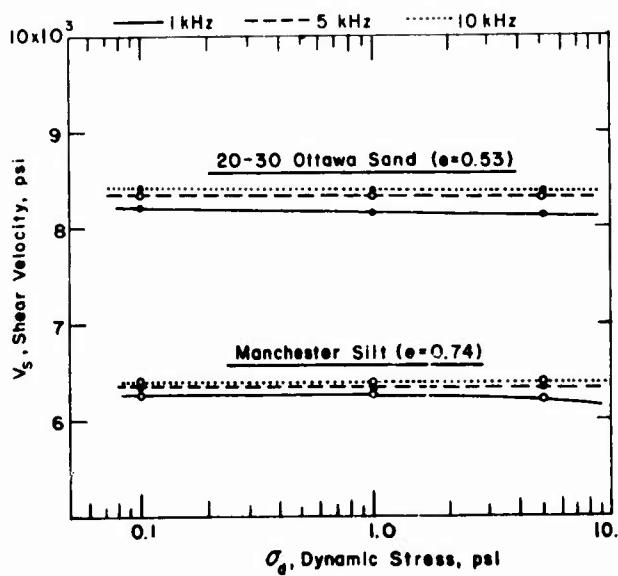

Figure 22. The effect of dynamic stress and frequency on shear velocity.

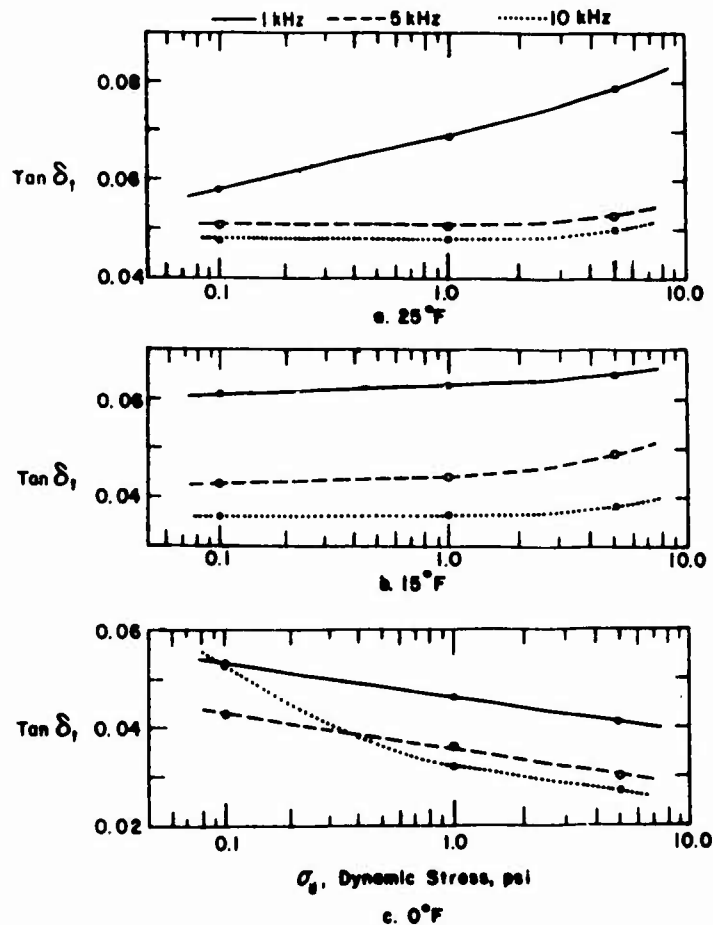

Figure 23. The effect of frequency and dynamic stress on $\tan \delta$ (torsional mode).

involving stress waves of low amplitude and frequencies of the order of 1000 Hz or more. However, many foundation problems are concerned with vibratory loads, imposing stresses of 5 psi or greater, and at frequencies of 100 Hz, or perhaps 5 Hz or even less. It is indicated that tests should be conducted under the loads having such frequencies, to determine the extent and significance of the depressed modulus.

Figure 23 shows the effect of dynamic stress and frequency of $\tan \delta$ (torsional mode). $\tan \delta$ increases with increasing stress at the higher frequency and with the rate increasing with lower frequency. Again, however, the change is not great and there is some uncertainty, as $\tan \delta$ decreases slightly with increasing stress at 0°F. As the measurement of $\tan \delta$ is less accurate than that of the modulus, it can only be concluded that the effect of stress on damping, at least from 0.1 to 5.0 psi, is not great and is certainly not enough to be a significant factor in the nonlinearity of the modulus in its response to increasing stress.

Poisson's ratio

Table V lists the measured Poisson's ratios versus temperature, dynamic stress and frequency for various soils. The values of Poisson's ratio cannot be considered as accurate as the directly measured parameters, because their accuracy is wholly dependent upon the accuracy of the modulus values, and small errors in either modulus results in a very sizeable error in Poisson's ratio. Moreover, the application of Poisson's ratio to a viscoelastic material may be stretching the concept.

Table V. Poisson's ratio for several soils.

Frequency, Hz	Temperature		
	+25°F	+15°F	0°F
20-30 Ottawa sand			
$\sigma_d = 0.1$ psi			
1000	0.25	0.34	0.28
5000	0.28	0.38	0.26
10000	0.33	0.33	0.28
$\sigma_d = 1.0$ psi			
1000	0.25	0.34	0.28
5000	0.28	0.37	0.25
10000	0.32	0.36	0.35
$\sigma_d = 5.0$ psi			
1000	0.28	0.30	0.27
5000	0.29	0.38	0.25
10000	0.27	0.34	0.24
Manchester silt			
$\sigma_d = 0.1$ psi			
1000	0.25	0.27	0.25
5000	0.27	0.26	0.22
10000	0.30	0.29	0.26
$\sigma_d = 1.0$ psi			
1000	0.25	0.28	0.25
5000	0.29	0.27	0.24
10000	0.30	0.29	0.22
$\sigma_d = 5.0$ psi			
1000	0.26	0.29	0.24
5000	0.30	0.31	0.23
10000	0.30	0.29	0.21
Goodrich clay			
$\sigma_d = 0.1$ psi			
1000	0.72	0.35	0.51
5000	0.54	0.38	0.36
10000	0.52	0.40	0.32
$\sigma_d = 1.0$ psi			
1000	0.59	0.37	0.47
5000	0.52	0.40	0.34
10000	0.47	0.41	0.32
$\sigma_d = 5.0$ psi			
1000	0.58	0.40	0.46
5000	0.47	0.42	0.32
10000	0.42	0.43	0.32

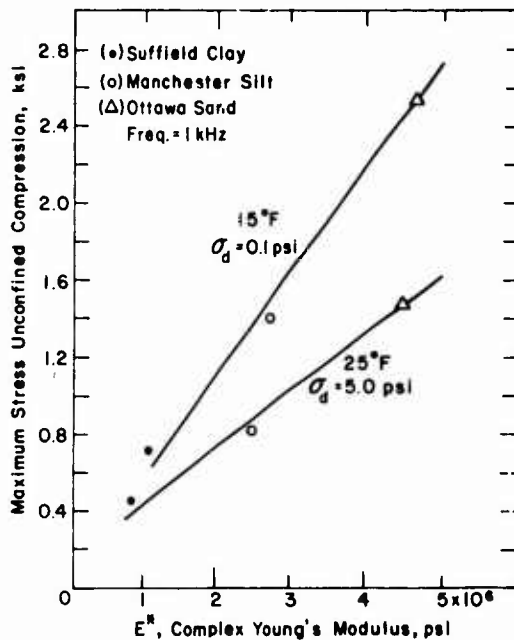

Figure 24. Relationship of complex Young's modulus to maximum compression strength.

variables must be taken into account in establishing a useful relationship. Figure 24 indicates a linear relationship, but it would be premature to make this assumption on the basis of the scant test data now available.

However, the results as presented in the table show little to no variation with temperature, dynamic stress or frequency for 20-30 Ottawa sand and Manchester silt. For Goodrich clay, Poisson's ratio decreases with decreasing temperature, increasing dynamic stress, and increasing frequency. As the values are mostly greater than 0.5, however, and only two specimens were tested, it is not certain that these trends are reliable.

Relation of complex modulus to compression strength

Figure 24 relates the maximum unconfined compression strength (Sayles 1968, Sayles and Haines 1972) to the complex Young's modulus. A strong relationship is indicated and it is probable that the unconfined compression test would be an excellent index test for approximating the vibratory load modulus. Obviously, the effect of temperature, magnitude of stress, rate of load application (frequency), and similar significant

CONCLUSIONS

1. The viscoelastic properties relating stress, strain and time under vibrating loads may be determined by subjecting a cylinder of soil to steady-state vibration and measuring the amplitude ratio at a given frequency. Using the mass density and the length of the cylinder, and applying linear viscoelastic theory and the applicable boundary conditions, the parameters describing the stiffness, damping property and stress wave propagating capability can be evaluated.
2. The Young's modulus and shear modulus of saturated frozen soil decrease with increasing void ratio. A void ratio of infinity, for solid ice without soil, tends to have a lower modulus than any saturated frozen soil. The maximum modulus for a given frozen soil depends upon its minimum void ratio and the soil type. The complex shear modulus varies from about 2.4×10^6 psi for a clean gravelly sand to 0.46×10^6 psi for ice at a temperature of $+15^\circ\text{F}$, a dynamic stress of 0.1 psi and a frequency of 5 kHz. The damping property, represented by $\tan \delta$, of saturated frozen soil does not vary significantly with void ratio. For void ratios less than 1.0, $\tan \delta$ decreases with increasing modulus and vice versa. In general, the $\tan \delta$ of frozen soil is equal to or higher than that of ice.
3. The degree of ice saturation has maximum effect on the modulus as maximum modulus occurs in soils with 100% saturation and minimum modulus occurs in soils with no ice in the voids or in nonfrozen dry soils. However, the coarser-grained soil (e.g. 20-30 Ottawa sand) shows only a small decrease in modulus as saturation decreases from 100% to about 50% and an abrupt decrease from 50% to approaching 0%. Fine-grained plastic soils (e.g. Suffield clay) have an almost constant rate of decrease in modulus as saturation decreases from 100% to 0%.

4. The modulus of a soil in the frozen state is about two orders of magnitude greater than the modulus of the same soil in the nonfrozen state. It follows that the velocity of wave propagation in frozen soil is about one order of magnitude greater than that in nonfrozen soil.

5. The damping coefficient, $\tan \delta$, for frozen soil is approximately equal to or slightly higher than that for nonfrozen soil.

6. The modulus of frozen soil decreases with increasing temperature. The rate of decrease varies with the soil type: almost flat for 20-30 Ottawa sand to fairly steep for Goodrich clay. As temperature increases above about 25°F, the decrease in modulus is rapid, but the actual amount has not been determined.

7. Test results, to date, indicate that $\tan \delta$ is relatively independent of temperature.

8. The modulus increases and $\tan \delta$ decreases with increasing frequency. The rate of increase (in modulus) is small in the frequency range 5-1000 kHz and greater in the range 1 to 5 kHz. A substantial decrease in modulus may take place at frequencies less than 1 kHz.

9. Within the limits of the test procedure (0.1-5.0 psi), the effect of stress level is small on the modulus and velocity and almost flat at temperatures less than about +15°F with a frequency of 5 kHz or greater. For design purposes, it appears that the moduli of sand, gravel, well-compacted silt, etc. subjected to vibratory loads as limited above can be considered independent of stress and frequency.

10. Poisson's ratio for noncohesive soils does not vary significantly with temperature, dynamic stress or frequency and averages 0.28. The cohesive soils, represented by Goodrich clay, have a Poisson's ratio approaching 0.5, which tends to decrease with increasing frequency and decreasing temperature.

11. The unconfined compression test appears to be a good index test to estimate the stiffness of frozen soil. However, more test values are required to fully establish the correlation.

LITERATURE CITED

- Bancroft, D. (1941) The velocity of longitudinal waves in cylindrical bars. *Physical Review*, vol. 59, April.
- Brown, G.W. and D.R. Selway (1964) Frequency response of a photoviscoelastic material. *Experimental Mechanics*, vol. 4, no. 3, p. 57-63.
- Franklin, A.G. and R.J. Krizek, Hysteresis in soft clay. (Publisher and date of publication unknown.)
- Hardin, B.O. and V.C. Drnevich (1970) Shear modulus and damping in soils, 1. Measurement and parameter effects; 2. Design equations and curves. Office of Research and Engineering Services, College of Engineering, University of Kentucky, Technical Report UKY 26-70-CE2, July.
- Harris, C.M. and C.E. Crede (1961) *Shock and vibration handbook*. New York: McGraw-Hill Book Co.
- Kaplar, C.W. (1969) Laboratory determination of dynamic moduli of frozen soils and of ice. U.S. Army Cold Region Research and Engineering Laboratory (USA CRREL) Research Report 163 (AD 686282).
- Kennedy, A.J. (1962) *Processes of creep and fatigue in metals*. Edinburgh, Scotland: Oliver and Boyd.
- Kolsky, H. and Y.Y. Shi (1958) The validity of model representation for linear viscoelastic behavior. Dept. of the Navy Office of Naval Research, Contract, Jan.

- Kolsky, H. (1964) Stress waves in solids. *Journal of Sound Vibration*, vol. 1.
- Lachenmaier, R.N. (1969) Nonlinear stress wave propagation in a soil column. Thesis submitted to Thayer School of Engineering, Dartmouth College, in partial fulfillment of degree of Master of Science.
- Lee, T.M. (1963) Method of determining dynamic properties of viscoelastic solids employing forced vibration. U.S. Army Snow, Ice and Permafrost Research Establishment (USA SIPRE) Research Report 122 (AD 434085).
- Nakano, Y. and R. Arnold (1972) Effect of water content on acoustic properties of frozen granular soils. Prepared for the Advanced Research Projects Agency, ARPA Order 1525. USA CRREL (unpublished).
- Nakano, Y., M. Smith, R. Martin, H. Stevens and K. Knuth (1971) Determination of the acoustic properties of frozen soils. Prepared for the Advanced Research Projects Agency, ARPA Order 1525. USA CRREL (unpublished).
- Norris, D.M., Jr. and W. Young (1970) Longitudinal forced vibration of viscoelastic bars with end mass. University of New Hampshire, Report No. 67-102, Grant No. DA-AMC-27-021-67-621; USA CRREL Special Report 135 (AD 707925).
- Richart, F.E., Jr., J.R. Hall, Jr. and R.D. Woods (1970) *Vibrations of soils and foundations*. Prentice-Hall International Series in Theoretical and Applied Mechanics. Englewood Cliffs, N.J.: Prentice-Hall, Inc.
- Roethlisberger, H. (1972) Seismic exploration in cold regions. USA CRREL Science and Engineering Monograph II-A2a (AD 752111).
- Sayles, F.H. (1968) Creep of frozen sands. USA CRREL Technical Report 190 (AD 680902).
- Sayles, F.H. and N.V. Epanchin (1966) Rate of strain compression tests on frozen Ottawa sand and ice. USA CRREL Technical Note (unpublished).
- Sayles, F.H. and D. Haines (1972) Creep of frozen silt and clay. USA CRREL Technical Note (unpublished).
- Scarborough, J.B. (1950) *Numerical mathematical analysis*. Second Edition. Baltimore, Maryland: Johns Hopkins Press.
- Smith, J.L. (1965) The elastic constants, strength and density of Greenland snow as determined from measurements of sonic wave velocity. USA CRREL Technical Report 187 (AD 632357).
- Smith, N. (1969) Determining the dynamic properties of snow and ice by forced vibration. USA CRREL, Technical Report 216 (AD 694376).
- Stevens, H.W. (1970) Suggested method of test for some viscoelastic properties of materials, especially frozen and nonfrozen soils under vibratory loads. In *Special procedures for testing soil and rock for engineering purposes*. American Society of Testing Materials, Special Technical Publication 479.
- Stevens, H.W. and W.J. Tizzard (1969) Traffic tests on lake ice, Portage Lake, Maine. USA CRREL Technical Report 99 (AD 700130).
- Thomson, K.C. (1966) On the complex Poisson's ratio of a urethane rubber compound. Air Force Cambridge Research Laboratories, Physical Sciences Research Paper no. 269.
- Weissman, G.F. (1971) Torsional vibrations of circular foundations. American Society of Civil Engineers, SM 9, Sept.

APPENDIX A. COMPUTER PROGRAM FOR NONRESONANT CONDITION OF SPECIMEN*

Nomenclature of dynamic soils test of nonresonant specimen, main program

<u>Fortran symbol</u>	<u>Math symbol</u>	<u>Units</u>	<u>Definition</u>
A, XB, XC, DISC			Terms in quadratic equation for the solution of ξ
AA, CPXTERM, GAMMA, P, TANPL			Dummy variables used to compute strain
AB	A_B	in.	Amplitude of peak-to-peak bottom vibration of specimen
AFUNC	$A(\xi_0, \tan \delta_0/2)$		Value of $A(\xi, \tan \delta/2)$ at $\xi = \xi_0$ and $\tan \delta/2 = \tan \delta_0/2$
BFUNC	$B(\xi_0, \tan \delta_0/2)$		Value of $B(\xi, \tan \delta/2)$ at $\xi = \xi_0$ and $\tan \delta/2 = \tan \delta_0/2$
CP	σ_0	psi	Static confining pressure
CPXTERM			See AA
DADTAN	$\frac{\partial A(\xi, \tan \delta/2)}{\partial \tan \delta/2}$		Value of the partial derivative of $A(\xi, \tan \delta/2)$ with respect to $\tan \delta/2$ at $\xi = \xi_0$ and $\tan \delta/2 = \tan \delta_0/2$
DADX1	$\frac{\partial A(\xi, \tan \delta/2)}{\partial \xi}$		Value of the partial derivative of $A(\xi, \tan \delta/2)$ with respect to ξ at $\xi = \xi_0$ and $\tan \delta/2 = \tan \delta_0/2$
DBDTAN	$\frac{\partial B(\xi, \tan \delta/2)}{\partial \tan \delta/2}$		Value of the partial derivative of $B(\xi, \tan \delta/2)$ with respect to $\tan \delta/2$ at $\xi = \xi_0$ and $\tan \delta/2 = \tan \delta_0/2$
DBDX1	$\frac{\partial B(\xi, \tan \delta/2)}{\partial \xi}$		Value of the partial derivative of $B(\xi, \tan \delta/2)$ with respect to ξ at $\xi = \xi_0$ and $\tan \delta/2 = \tan \delta_0/2$
DISC			See AA

* The computer programs are in Fortran II and are compatible with the Honeywell DDP-24 computer used at USA CRREL. Input data are on punched paper tape in tabular form. Results are line printer outputted, also in tabular form. Input for each specimen consists of a specimen heading, and a number of sets of data, each consisting of a set heading and a table. Each set comprises the measurements made at a single static confining pressure and mode of vibration.

<u>Fortran symbol</u>	<u>Math symbol</u>	<u>Units</u>	<u>Definition</u>
EORG	E^*, G^*	ksi	Complex Young's modulus and complex shear modulus, respectively
EPS			Dummy variable used to stop the iteration process when the solutions for ξ , $\tan \delta/2$ are exact enough
FREQ	f	Hz	Frequency
GAMMA			See AA
GLB	U_b	g	Bottom peak acceleration
GLT	U_t	g	Top peak acceleration
H	L	in.	Length of specimen
I			Dummy variable used to index the number of data sets
ISN			Specimen number
J			Dummy variable used to index the different frequencies
JUNK			Dummy variable used in the input data after the date
KKK			Dummy variable used to index input data for a particular frequency
MODE		1, 2	1 for longitudinal mode, 2 for torsional mode
MTC			Dummy variable used as an index on the output punch tape
ND			Dummy variable used to correct the input phase angle
NFREQS			Number of different frequencies
NNN			Dummy variable used to correct ξ to its proper quadrant value
NQUAD			Dummy variable used to determine the proper correction formula for ξ
NRC			Dummy variable equal to the quadrant value of Φ
NROWS			Number of data rows in a frequency set
NSETS			Number of data sets in input data

<u>Fortran symbol</u>	<u>Math symbol</u>	<u>Units</u>	<u>Definition</u>
P			See AA
PI	π		π
PHI	Φ	deg	Phase angle between top and bottom waves
PSI	ψ		$\xi \tan \delta/2$
Q	Q		Dummy variable equal to mass ratio
QL	Q_l		Longitudinal mass ratio
QT	Q_t		Torsional mass ratio
R			U_t/U_b
RB, RT	r_b, r_t	in.	Distance of top and bottom torsional accelerometers, respectively, from axis of specimen
SOIL			Dummy variable equal to date
S2PHP			$\text{Sec}^2 \Phi$
STRAIN	ϵ_d	in./in.	Dynamic strain, single amplitude average of all modes, computed at 1-in. radius in torsional case
STRESS	σ_d	psi	Dynamic stress = modulus $\times \epsilon_d \times 1000$
TANCORR			Correction factor for $\tan \delta/2$
TAND	$\tan \delta$		$\tan \delta$
TAND2	$\tan \delta/2$		$\tan \delta/2$
TANPHI	$\tan \Phi$		$\tan \Phi$
TANPL			See AA
TANNUM			Dummy variable
VEL	V_l, V_s	ft/sec	Phase velocity and shear velocity of wave, respectively
W	ω		$2\pi f$
WD	γ_w	lb/ft ³	Unit wet weight of specimen
XB			See AA
XC			See AA
XENON			Dummy variable
XI	ξ		ξ

<u>Fortan symbol</u>	<u>Math symbol</u>	<u>Units</u>	<u>Definition</u>
XICORR			Correction factor for ξ
XINUM			Dummy variable
XPHI	Φ	rad	Phase angle Φ expressed in radians
XS			Dummy variable equal to $\sin^2 \xi$
XX			Dummy variable equal to $\tan \Phi / \tan \xi$
ZRB			Dummy variable equal to RB
ZRT			Dummy variable equal to RT

Input for main program (nonresonant specimen)

Specimen no.	No. of data sets	
Date (Print 24 characters)		
QL	QT	
1.5	1.625 - (for frozen specimens)	
1.5	1.5 - (for unfrozen specimens)	
Confining pressure	Height of specimen	Wet density
Mode (1-Long) (2-Tors)	Number of frequencies	
Frequency	Number of rows of data	Nearest resonance
GT	GB	phi (deg)
GT	GB	phi
ETC	ETC	etc
Frequency	Number of rows of data	Nearest resonance
GT	GB	phi
GT	GB	phi
ETC	ETC	etc

REPEAT SEQUENCE AS REQUIRED

C	DYNAMIC SCILS T, MAIN PROGRAM, NON-RESONANT CASE, M. J. DABNEY	0001
C		0002
	DIYENSTON AA(2),S(2),P(2),GAMMA(2),TANPL(2),SCIL(6),XS(2)	0003
	I,C,CMPLFY(2),XNUM(2),PROD(2),DENCM(2),FRAC(2),C(2),D(2)	0004
	ASINH(A)=ELCGF(A+SQRT(A*A+1.))	0005
	CCSH(A)=.5*(EXPF(A)+EXPF(-A))	0006
	SINH(A)=.5*(EXPF(A)-EXPF(-A))	0007
	TANF(A)=SINF(A)/COSF(A)	0008
	TANH(A)=SINH(A)/COSH(A)	0009
	ATANHF(A)=0.5*ELCGF((1.+A)/(1.-A))	0010
	ASINF(A)=ATANF(SQRT(A*A/(1.-A*A)))	0011
	PI=3.14159265	0012
C		0013
	READ PAPER TAPE 1,ISN,NSETS	0014
	PUNCH TAPE 90,ISN,NSETS	0015
	READ PAPER TAPE 2,(SOIL(1),L=1,6),JUNK	0016
	READ PAPER TAPE 3,QL,QT	0017
	READ PAPER TAPE 3,RT,RB	0018
	DO 400 I=1,NSETS	0019
	MTC=0	0020
	READ PAPER TAPE 4,CP,H,WD	0021
	READ PAPER TAPE 1,MODE,NFREQS	0022
	PUNCH TAPE 91,CP,MODE,NFREQS	0023
	GO TO (1CC,101),MODE	0024
100	PRINT 50,ISN,(SOIL(L),L=1,6)	0025
	PRINT 53,(F,H,WD	0026
	PRINT 54	0027
	PRINT 55	0028
	Q=QL	0029
	ZRB=1.	0030
	ZRT=1.	0031
	GO TO 102	0032
101	PRINT 51,ISN,(SOIL(L),L=1,6)	0033
	PRINT 53,CP,H,WD	0034
	PRINT 54	0035
	PRINT 57	0036
	Q=QT	0037
	ZRB=RB	0038
	ZRT=RT	0039
C		0040
C	READING IN THE DATA	0041
C		0042
102	DO 300 J=1,NFREQS	0043
	READ PAPER TAPE 6,FREQ,NRCWS,NRC	0044
	MTC=MTC+1	0045
	PUNCH TAPE 92,MTC,NRCWS	0046
	DO 200 KKK=1,NRCWS	0047
	READ PAPER TAPE 5,GLT,GLB,PHI	0048
	GLT=GLT/ZRT	0049
	GLB=GLB/ZRF	0050
	AR=19.55C9356*GLB/FREQ/FRFC	0051
	R=GLT/GLB	0052
C		0053
C	COMPUTING APPROXIMATE VALUES OF XI AND TAND2	0054
C		0055
	XPHI=PHI+PI/180.	0056
	GO TO (6C0,600,601,601,6C2,602),NRC	0057
600	ND=0	0058
	GO TO 790	0059
601	ND=1	0060
	GO TO 790	0061
602	ND=2	0062
790	PHI=PHI+(360.*ND)	0063
	PHI=PHI+PI/180.	0064
	S2PHI=(1./COSF(PHI))**2.	0065
	A=-1.*(R**2.)*S2PHI	0066
	XB=S2PHI*(R**2.-1.)	0067
	XC=(TANF(PHI))**2.	0068
	DISC=XF**2.-4.*A*XC	0069
	IF (DISC) 717,718,718	0070
717	PHI=PHI+180./PI-360.*(1+(PHI/2./PI))	0071
	PRINT 55,NRC,CLB,FREQ,PHI,R,AR	0072
	STRESS=1CC.	0073
	ECRG=.1	0074
	TAND=1.	0075
	PUNCH TAPE 93,STRESS,FREQ,TAND,FRFC	0076

	GC TC 200	0077
71A	DISC=SQRT(DISC)	0078
	XS(1)=(-XG+DISC)/(2.*A)	0079
	XS(2)=(-XF-DISC)/(2.*A)	0080
	DC 791 K=1.2	0081
	IF (XS(K)) 791,791,792	0082
792	IF (XS(K)-1.) 793,793,791	0083
791	CONTINUE	0084
	GC TC 717	0085
793	XI=ASINF(SQRT(XS(K)))	0086
	NGUAT=XPHI*2./PI+1.	0087
	NNN=NRC-1	0088
	NGUAT=2-NQUAD+NQUAD/2.*	0089
	GO TO (721,722),NGLAD	0090
721	XI=PI+ANN+XI	0091
	GO TC 723	0092
722	XI=PI*(ANN+1)-XI	0093
723	XX=TANF(PHI)/TANF(XI)	0094
	IF (XX-1.) 727,724,724	0095
724	GC TC 717	0096
727	PSI=ATANHF(XX)	0097
726	TAND2=PSI/XI	0098
	PHI=PHI+180./PI	0099
	TANPHI=TANF(XPHI)	0100
C		0101
C	COMPUTING EXACT VALUES OF XI AND TAND2 BY NEWTON-RAPHSON METHOD	0102
C		0103
	EPS=0.00001	0104
11	AFUNC=SINH(XI+TAND2)*(SINF(XI)+COSF(XI))*Q*XI*(1.-TANPHI+TAND2))+	0105
	ICCSH(XI+TAND2)*(SINF(XI)*Q*XI*(TAND2+TANPHI)-COSF(XI)*TANPHI)	0106
	BFUNC=SINH(2.*XI+TAND2)*2.*Q*XI+TAND2+COSH(2.*XI+TAND2)*	0107
	I(Q**2.*XI**2.*(1.+TAND2**2.)*+1.)-SINF(2.*XI)*2.*Q*XI+CCSF	0108
	I(2.*XI)*(1.-Q**2.*XI**2.*(1.+TAND2**2.))-2./R**2.	0109
	DAEXI=STNH(XI+TAND2)*(SINF(XI)*XI*(TAND2**2.+2.*TAND2	0110
	TANPHI-1.)*COSF(XI)*(Q-Q*TAND2+TANPHI-TAND2+TANPHI+1.))	0111
	ICCSH(XI+TAND2)*(SINF(XI)*(TAND2+TANPHI)+Q*TAND2+C*TANPHI)+	0112
	ICCSF(XI)*Q*XI*(2.*TAND2+TANPHI-TAND2**2.*TANPHI))	0113
	DAETAN=SINH(XI+TAND2)*(SINF(XI)*C*XI**2.*(TAND2+TANPHI)-	0114
	ICCSF(XI)*XI*TANPHI*(1.+C))+COSH(XI+TAND2)*(COSF(XI)*XI*(1.+Q)	0115
	+COSF(XI)*Q*XI**2.*(1.-TANPHI+TAND2))	0116
	DRDXI=SINH(2.*XI+TAND2)*2.*TAN(2*(C**2.*XI**2.+C**2.*XI**2.*TAN	0117
	2**2.+Q*1.)*COSH(2.*XI+TAND2)*2.*C*XI*(Q+Q*TAN(2**2.+2.*TAND2**	0118
	2.)*SINF(2.*XI)*2.*(Q**2.*XI**2.+C**2.*XI**2.*TAND2**2.-C-1.)*CC	0119
	1SF(2.*XI)*2.*C*XI*(-Q-Q*TAND2**2.-2.)	0120
	DRDTAN=SINF(2.*XI+TAND2)*2.*XI*(Q**2.*XI**2.+C**2.*TAND2**2.	0121
	+XI**2.	0122
	1+Q*1.)*COSH(2.*XI+TAND2)*2.*Q*XI**2.*(C*TAN(2.+2.*TAN(2))-CCSF	0123
	I(2.*XI)*2.*Q**2.*XI**2.*TAND2	0124
	XENOM=DADX1*DRDTAN-DAETAN*DRDX1	0125
	XINUM=RFLAC*DAETAN-AFUNC*PECTAN	0126
	TANNUM=AFUNC*DRDX1-BFUNC*PADX1	0127
	XICCOR=XINUM/XENOM	0128
	TANCCRR=TANNUM/XENOM	0129
	IF (ABSF(XICCOR/XI)-EPS) 15,15,20	0130
15	IF (ABSF(TANCCRR/TAND2)-EPS) 16,16,20	0131
20	XI=XI+XICCOR	0132
	TAND2=TAND2+TANCCRR	0133
	GO TC 11	0134
16	CONTINUE	0135
C		0136
C	COMPUTING PHASE VELOCITY, TANGENT DELTA, AND MODULUS	0137
C		0138
	VEL=.5235988*FREQ*H/XI	0139
	TAND=TANF(2.*ATANF(TAND2))	0140
	ECRG=2.15934E-7*WD*VEL**2./(1.+TANF2**2.)	0141
		0142
C	COMPUTING STRAIN AND STRESS	0143
	W=2.*PI*FREQ	0144
	PSI=XI+TANF2	0145
	AA(1)=1.	0146
	AA(2)=0.0	0147
	P(1)=W/(VEL*12.)	0148
	P(2)=-1.*L+TAND27/(VEL*12.)	0149
	GAMMA(1)=Q*XI	0150
	GAMMA(2)=-1.*Q*PSI	0151
	TANPL(1)=SINF(2.*XI)/(COSF(2.*XI)*COSH(2.*PSI))	0152

	TANPL(2)=-1.*SINH(2.*PSI)/(COSF(2.*XI)+COSH(2.*PSI))	0153
	CALL CMPXA (TANPL,GAMMA,XNUM)	0154
	CALL CMPXM (GAMMA,TANPL,FROD)	0155
	CALL CMPXS (AA,FROD,DENOM)	0156
	CALL CMPXD (XNUM,DENOM,FRAC)	0157
	CALL CMPXM (P,FRAC,COMPLEX)	0158
	CPXTERM=SQRTF(COMPLEX(1)**2.+COMPLEX(2)**2.)	0159
	STRAIN=AF/2.*CPXTERM	0160
	STRESS=EORG*STRAIN*1000.	0161
	PRINT 58,NFC,CLB,FREQ,PHI,R,AE,VEL,TAND,STRESS,STRAIN,EORG	0162
	PUNCH TAPF 93,STRESS,EORG,TAND,FREQ	0163
200	CONTINUE	0164
300	CONTINUE	0165
400	CONTINUE	0166
C		0167
C	FORMAT STATEMENTS	0168
1	FORMAT (2I5)	0169
2	FORMAT (6A4,I10)	0170
3	FORMAT (2F10.0)	0171
4	FORMAT (3F10.0)	0172
5	FORMAT (3F10.0)	0173
6	FORMAT (F8.0,2I5)	0174
50	FORMAT (1H115HSAMPLE NUMBER 15,3X6A4,10X17HLONGITUDINAL MODE14X 117HNCN-RESONANT CASE)	0175 0176
51	FORMAT (1H115HSAMPLE NUMBER 15,3X6A4,10X14HTORSIONAL MODE17X 117HNCN-RESONANT CASE)	0177 0178
53	FORMAT (1HC20CCNFINING PRESSURE =F6.1,5H PSI/1H 12X8HHEIGHT =F6. 12,7H INCHES/1H 7X13HWFT DENSITY =F5.1,5H PCF/)	0179 0180
54	FORMAT (1H 11HNFC PK-G5X19HFREQ PHASE AMP6X4CHBOT AMP P PHASE VEL TALENT STRESS6X6HSTRAIN5X7HMODULUS)	0181 0182
55	FORMAT (1H 6X6HSINGLE5X2HH74XSHANGLE3X18HRATIO PK-PK INS6X3HF IPS7X5HDELT46X7HF518X5FK/IN8X3HKST/)	0183 0184
57	FORMAT (1H 6X6HSINGLE5X2HH712X18HRATIO PK-PK RAD6X3HFPS7X5HDELT IA4X2IHH=1, PSI R=1, IN/IN5X3HKST/)	0185 0186
58	FORMAT (1H 13,F9.3,F8.0,F8.1,F8.2,F13.8,F10.0,F11.3,F11.4,F14.8, IF9.2)	0187 0188
59	FORMAT (1H 13,F9.3,F8.0,F8.1,F8.2,F13.8,5X17HHAS NO REAL VALUE)	0189
60	FORMAT (14,1H ,13)	0190
61	FORMAT (F5.1,1H ,13,1H ,13)	0191
62	FORMAT (12, 1H ,12)	0192
63	FORMAT (F7.4,1H ,F7.2,1H ,F5.3,1H ,F7.0)	0193
	END	0194
	SUBROUTINES REQUIRED	
	F3MV ELOGF SQRTF F3FM F3FA EXPF	
	SINF COSF F3FD F3FS ATANF SQRT	
	F3T1 F3RT F3T0 F3FL F3PT F3SE	
	F3T3 F3LL F3C1 F3X2 F3C4 F3X3	
	ARSF CMPXA CMPXM CMPXS CMPXD F3I	
	F3RS F3A F3F F3HD F3X F3CR	
	END	0194

APPENDIX B. COMPUTER PROGRAM FOR RESONANT CONDITION OF SPECIMEN

Explanation of program

<i>Line</i>	<i>Explanation</i>
6- 10	Establish function identities
13- 22	Read in soil parameters
23- 38	Print parameters and set up acceleration conversion values to adjust to radius
41- 45	Read in data
46- 47	Convert accelerations so that (torsional case) they correspond to readings at 1 in. from specimen axis
48	Convert bottom acceleration to peak-to-peak amplitude in inches
49	Compute ratio GT/GB
53- 56	Compute approximate values of ξ and $\tan \delta/2$ (see eq 9 and 10)
58- 88	Solve by Newton-Raphson method, eq 3 and 12 <ol style="list-style-type: none"> 59-61. Take partial derivatives of the exact solutions necessary to find ξ and $\tan \delta/2$ 78-82. Combine partial derivatives into the Newton-Raphson format, arriving at new change (i.e. DELX, DELY) for the given iteration 83-84. Check to see if solution has converged within the preset limits 85-86. Complete individual iteration if convergence has not been met
92	Calculate velocity, from value of FREQ and H. The first number converts units.
93	Calculate $\tan \delta$ from $\tan \delta/2 = \psi/\xi$
94	Calculate E^* or G^* , eq 15 or 16
97-106	Commence solving equation for ϵ , eq 19, by dividing up various sections into real (subscript 1) and imaginary (subscript 2) parts
107-112	Perform operations on the various sections of the strain equation and combine into one complex term (CPXTERM)
113	Calculate strain
114	Calculate stress from strain and modulus
116-118	Iterate sign of R_{\max} values (change quadrants of wave) and print values calculated
123-148	Format statements

PRECEDING PAGE BLANK NOT FILMED

Newton-Raphson theorem

$$F(x, y) = 0 \quad \text{where } x = \xi$$

$$G(x, y) = 0 \quad y = \tan \delta/2$$

$$J(x_n, y_n) = \frac{\partial F}{\partial x}(x_n, y_n) \frac{\partial G}{\partial y}(x_n, y_n) - \frac{\partial F}{\partial y}(x_n, y_n) \frac{\partial G}{\partial x}(x_n, y_n)$$

$$\xi_{n+1} = \xi_n - \frac{\frac{HX}{F(x_n, y_n) \frac{\partial G}{\partial y}(x_n, y_n) - G(x_n, y_n) \frac{\partial F}{\partial y}(x_n, y_n)}}{\frac{J(x_n, y_n)}{HD}}}{DELX}$$

$$\tan \delta/2_{n+1} = \tan \delta/2_n + \frac{\frac{HY}{F(x_n, y_n) \frac{\partial G}{\partial x}(x_n, y_n) - G(x_n, y_n) \frac{\partial F}{\partial x}(x_n, y_n)}}{\frac{J(x_n, y_n)}{HD}}}{DELY}$$

Input for main program (resonant condition of specimen)

Specimen no.	No. of data sets	
Date (Print 24 characters)		
QL	QT	
1.5	1.625 - (for frozen specimens)	
1.5	1.5 - (for unfrozen specimens)	
Confining pressure	Height of specimen	Wet density
Mode 1-Long 2-Tors	No. of resonance in mode	
No. of resonance	No. of data groups in resonance	
GT	GB	Frequency
GT	GB	Frequency
ETC	ETC	etc
No. of resonance	No. of data groups in resonance	

GT	GB	Frequency
GT	GB	Frequency
ETC	ETC	etc
Confining pressure	Height of specimen	Wet density
Mode 1-Long 2-Tors	No. of resonance in mode	
No. of resonance	No. of data groups in resonance	
GT	GB	Frequency
GT	GB	Frequency
ETC	ETC	etc

REPEAT SEQUENCE AS REQUIRED

		CC01
C	DYNAMIC SCALE TEST, MAIN PROGRAM, RESONANT CASE, M.J. DAHNEY	CC02
C		CC03
	DIMENSION AA(2), B(2), C(2), D(2), P(2), GAMMA(2), TANPL(2), XNUM(2),	CC04
	IPCC(2), FFMOM(2), FRAC(2), COMPLEX(2), SOIL(6)	CC05
	ASINH(A)=ELCCF(A*SQRT(A*A+1.))	CC06
	CCSH(A)=.5*(EXPF(A)+EXPF(-A))	CC07
	SINH(A)=.5*(EXPF(A)-EXPF(-A))	CC08
	TANF(A)=SINF(A)/COSF(A)	CC09
	TANH(A)=SINH(A)/COSH(A)	CC10
	PI=3.14159265	CC11
C		CC12
	READ PAPER TAPE 1, ISN, NSETS	CC13
	PUNCH TAPE 90, ISN, NSETS	CC14
	READ PAPER TAPE 2, (SOIL(L), L=1,6), JUNK	CC15
	READ PAPER TAPE 3, CL, OT	CC16
	READ PAPER TAPE 3, RT, RB	CC17
	DO 400 I=1, NSETS	CC18
	READ PAPER TAPE 4, CP, H, VE	CC19
	READ PAPER TAPE 1, MODE, NRES	CC20
	PUNCH TAPE 91, CP, MODE, NRES	CC21
	GO TO (100, 101), MODE	CC22
100	PRINT 50, ISN, (SOIL(L), L=1,6)	CC23
	PRINT 53, CP, H, VE	CC24
	PRINT 54	CC25
	PRINT 55	CC26
	O=CL	CC27
	ZRB=1.	CC28
	ZRT=1.	CC29
	GO TO 102	CC30
101	PRINT 51, ISN, (SOIL(L), L=1,6)	CC31
	PRINT 53, CP, H, VE	CC32
	PRINT 54	CC33
	PRINT 55	CC34
	O=CT	CC35
	ZRB=NB	CC36
	ZRT=RT	CC37
C		CC38

C	READING IN THE DATA	0036
C		0040
102	DC 700 J=1,NRES	0041
	READ PAPER TAPE 1,NRN,NRCWS	0042
	PUNCH TAPE 92,NFN,NROWS	0043
	DO 700 K=1,NROWS	0044
	READ PAPER TAPE 5,GLT,CLF,FREQ	0045
	GLT=GLT/2PT	0046
	GLB=GLB/ZRB	0047
	AR=19.5509356*GLF/FREQ/FRFQ	0048
	RMAX=GLT/CLR	0049
C		0050
C	COMPUTING APPROXIMATE VALUES OF XI AND TAND2	0051
C		0052
	XARN=NRN	0053
	XI=F1*(2.0*XARN-1.)/2.	0054
	PSI=ELCGF((1.0+SQRT(1.0+RMAX**2.0))/RMAX)	0055
	TANF2=PSI/XI	0056
C		0057
C	COMPUTING EXACT VALUES OF XI AND TAND2 BY NEWTON-RAPHSON METHOD	0058
	EPS=0.0001	0059
	DO 700 TC (11,22,11,22,11,22,11,22),NRN	0060
22	RMAX=RMAX	0061
11	F1=CCSH(XI*TAND2)=(COSF(XI)-Q*XI*SINF(XI))+C*XI*TAND2*	0062
	ICCSF(XI)*SINH(XI*TAND2)	0063
	F2=SINH(XI*TAND2)*(SINF(XI)+Q*XI*CCSF(XI))+COSH(XI*TAND2)*	0064
	I0*XI*TAND2*SINF(XI)-1./RMAX	0065
	F1XT2=COSH(XI*TAND2)*I-(1.0+Q)*SINF(XI)-Q*XI*(1.-TAND2**2.0)*	0066
	ICCSF(XI)	0067
	F2XT2=COSH(XI*TAND2)*((1.0+Q)*TAND2*SINF(XI)+2.0*C*XI*TAND2*	0068
	ICCSF(XI)	0069
	F1X=SINH(XI*TAND2)*((1.0+Q)*TAND2*CCSF(XI)-2.0*C*XI*TAND2*	0070
	ISINF(XI))+F1XT2	0071
	F2X=SINH(XI*TAND2)*((1.0+Q)*COSF(XI)-Q*XI*(1.-TAND2**2.0)*SINF(XI)	0072
	I+F2XT2	0073
	F1Y=SINH(XI*TAND2)*((1.0+Q)*XI*CCSF(XI)-Q*XI**2.0*SINF(XI))+	0074
	ICOSH(XI*TAND2)*C*XI*XI*TAND2*CCSF(XI)	0075
	F2Y=COSH(XI*TAND2)*((1.0+Q)*XI*SINF(XI)+Q*XI**2.0*COSF(XI))+	0076
	ISINH(XI*TAND2)*Q*XI*XI*TAND2*SINF(XI)	0077
	HD=F1X+F2Y-F1Y-F2X	0078
	HX=F1-F2Y-F2-F1Y	0079
	HY=F2-F1X-F1-F2X	0080
	DFLX=-HX/HD	0081
	DELY=-HY/HD	0082
	IF (ABSF(DELY/XI)-EPS) 15,15,20	0083
15	IF (ABSF(DELY/TAND2)-EPS) 16,16,20	0084
20	XI=XI+DFLX	0085
	TAND2=TAND2+DELY	0086
	GO TO 11	0087
16	CCATIME	0088
C		0089
C	COMPUTING PHASE VELOCITY, TANGENT DELTA, AND MODULUS	0090
C		0091
	VEL=.5235988*FREQ*H/XI	0092
	TANF=TANF(2.0*ATANF(TAND2))	0093
	ECRG=2.15934E-7*VD*VEL**2.0/(1.0+TAND2**2.0)	0094
		0095
C	COMPUTING STRAIN AND STRESS	0096
	W=2.0*PI*FREQ	0097
	PSI=XI*TANF2	0098
	AA(1)=1.	0099
	AA(2)=0.0	0100
	PI(1)=W/(VEL*12.)	0101
	PI(2)=-1.0*W*TAND2/(VEL*12.)	0102
	GAMMA(1)=C*XI	0103
	GAMMA(2)=-1.0*Q*PSI	0104
	TANFL(1)=SINF(2.0*XI)/(CCSF(2.0*XI)+COSH(2.0*PSI))	0105
	TANFL(2)=-1.0*SINH(2.0*PSI)/(COSF(2.0*XI)+COSH(2.0*PSI))	0106
	CALL CPMX (TANFL,GAMMA,XALM)	0107
	CALL CPMX (GAMMA,TANFL,PROD)	0108
	CALL CPMX (AA,PROD,DENOM)	0109
	CALL CPMX (XNUM,DENOM,FRAC)	0110
	CALL CPMX (F,FRAC,COMPLEX)	0111
	CPXTERM=SQRT(CCMPLX(1)**2.0+CCMPLX(2)**2.0)	0112
	STRAIN=AF/2.0*CPXTERM	0113
	STRESS=ECRG*STRAIN*1000.	0114

	GC TC (33,44,33,44,33,44,33,44),NRN	0115			
44	RMAX=RPAY	0116			
33	PRINT 58,ARN,GLE,FREQ,RPAY,AB,VFL,TAND,STRESS,STRAIN,ECHG	0117			
	PUNCH TAFF 93,STRESS,FORG,TAND,FREQ	0118			
200	CONTINUE	0119			
300	CONTINUE	0120			
400	CONTINUE	0121			
F		0122			
C	FORMAT STATEMENTS	0123			
1	FORMAT (215)	0124			
2	FORMAT (6A4,110)	0125			
3	FORMAT (2F10.0)	0126			
4	FORMAT (3F10.0)	0127			
5	FORMAT (3F10.0)	0128			
50	FORMAT (11I15HSAMPLE NUMBER 15,3X6A4,10X17HLONGITUDINAL MODE18X 113+RESCANT CASE)	0129 0130			
51	FORMAT (11I15HSAMPLE NUMBER 15,3X6A4,10X14HTORSIONAL MODE21X 113+RESCANT CASE)	0131 0132			
53	FORMAT (11C20HCCNFINING PRESSURE =F6.1,5H FSI/1H 12X8HHEIGHT =F6. 12,7H 1ACHFS/1H 7X13HMET [FASITY =F5.1,5H PCF/)	0133 0134			
54	FORMAT (1H 11HRES PK-C5X19HPEE APP6X4CH90T APP 1HASF VEL TANGCAT STRESS6X6HSTRAIN5X7HMCDULUS)	0135 0136			
55	FORMAT (1H 6X6FSINGLE5X2H712X13HRATIO PK-PK 1N6X3HFPS7X5HPELT 1A6X3HPS18X5HIN/1A8X3HKS1/)	0137 0138			
57	FORMAT (1H 6X7FSINGLE5X2H712X13HRATIO PK-PK 1N6X3HFPS7X5HPELT 1A4X2HHR=1, PSI R=1, 1N/1A5X3HKS1/)	0139 0140			
5A	FORMAT (1H 13,F9.3,F8.0,F16.2,F13.8,F10.0,F11.3,F11.4,F14.6,F9 1.2)	0141 0142			
61	FORMAT (1H 13,F9.3,F8.0,F16.2,F13.8,5X15HMAX LESS THAN F6.2,3 10X1H*)	0143 0144			
60	FORMAT (14,1H ,13)	0145			
91	FORMAT (F5.1,1H ,13,1H ,13)	0146			
92	FORMAT (12,1H ,12)	0147			
93	FORMAT (F7.4,1H ,F7.2,1H F5.3,1H ,F7.0)	0148			
	END	0149			
SUBROUTINES REQUIRED					
FSHV	ELCGF	CORTF	FSFM	FSFA	EXPF
SINF	COSF	FSFD	FSFD	FST1	FERT
FST0	FSEL	FSFT	FSSR	FST3	FRUL
FSCI	FSFS	FSX2	FSX3	AESF	ATANF
CMPXA	CMPXP	CMPXS	CMPXD	FST	FERS
FSA	FSF	FSFD	FSX	FSCR	

APPENDIX C. PREPARATION OF FROZEN SOILS

by

Alan R. Greatorex

Introduction

This Appendix describes the procedures used in the preparation of specimens 3 in. in diameter and having a length-to-diameter ratio equal to or greater than 6, as required for a test to measure the response of frozen soils to vibratory loads using a resonant column technique. The preparation procedure depends upon the desired density and water content as well as the type of soil to be tested.

Material

The mold consists of a split Synthane* tube and two aluminum end plugs (Fig. C1). The base plug serves as a compaction base and also has fittings for the attachment of a hose to supply water. There are two top plugs: one provides the necessary fittings for attaching a hose to supply a vacuum, or water; and the other provides for the rapid transfer of heat through fins into circulated cold air. The second plug is used for quick-freezing partially saturated samples.

A modified Proctor hammer is used to compact fine-grained soils. The hammer has a 3-in.-diam face on the hammer head. The number of blows per layer is varied to produce a uniform dry unit weight of the specimen from top to bottom; for example: to achieve a dry unit weight of 112 lb/ft^3

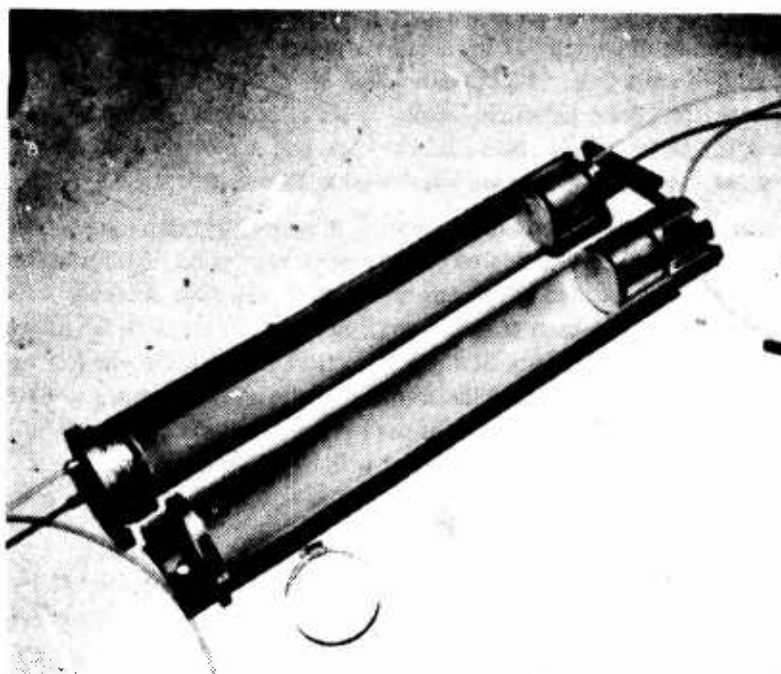

Figure C1. Specimen mold showing two types of top end plugs.

* Trade name.

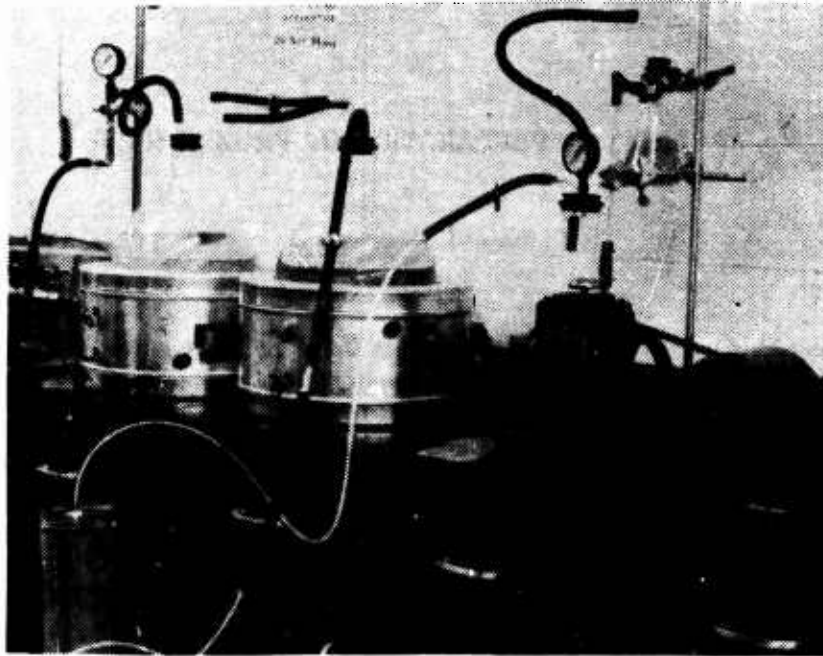

Figure C2. Saturation apparatus.

with a nonplastic silt at 25% ice saturation, soil containing the proper volume of water is compacted with 15 blows/layer for the first 4 layers, 20 blows/layer for the following 3 layers, 25 blows/layer for the following 3 layers, and 30 blows/layer for the remaining 5 layers.

Saturated silt specimens are compacted in 10 layers, 2 at 35 blows/layer, 6 at 40 blows/layer, and 2 at 45 blows/layer. The silt is compacted at an "optimum" water content. The samples are then saturated using a constant head water supply 6 ft above the sample base, and a constant vacuum to support a column of mercury 22 in. above its reservoir, applied at the top. Coarser-grained, uniformly-graded soils (e.g. 20-30 Ottawa sand) are compacted using a fixed-frequency, variable-amplitude vibrator. Some judicious tapping of the filled mold during the evacuation and saturation process with the top plug in place aids in obtaining a uniform density. The vacuum pump and deaired water supply apparatus are illustrated in Figure C2.

After the specimens are compacted (and saturated, if necessary), they are placed in freezing devices. The type of device used depends on the degree of saturation. To maintain a uniform distribution of ice, partially saturated specimens are quick-frozen from one end, with a closed system (i.e., water unavailable at base of specimens), in about 16 hours in the rotating device shown in Figure C3. This device is kept in a -30°F ambient temperature and has forced circulation across the finned plug that extends beyond the insulation. Saturated specimens are frozen in a cold box with an open system (i.e., water available at base of specimens). Insulation is placed around the sides of the specimens and a cold cell, supplied with -73°F brine, is set on the base plug of the inverted mold (Fig. C4). The temperature at the bottom end of the specimen is monitored by a thermocouple to ensure that the sample is completely frozen.

Completed samples are tempered to the desired temperature in the test coldroom for at least 24 hours. The actual temperature of each specimen at the time of test is measured by a thermocouple embedded about $\frac{1}{2}$ in. in the center of the bottom of the specimen.

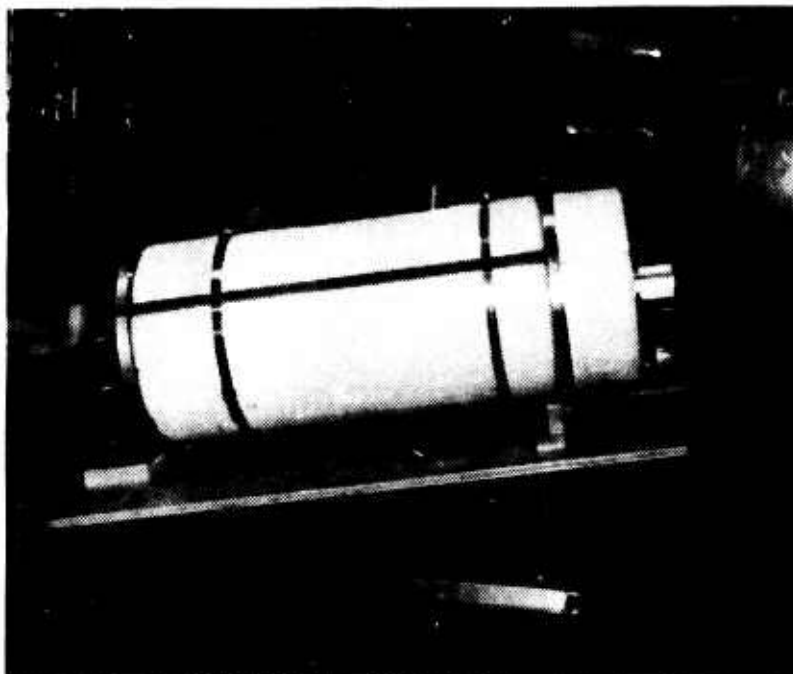

Figure C3. Device for insulating and rotating partially saturated specimens during freezing.

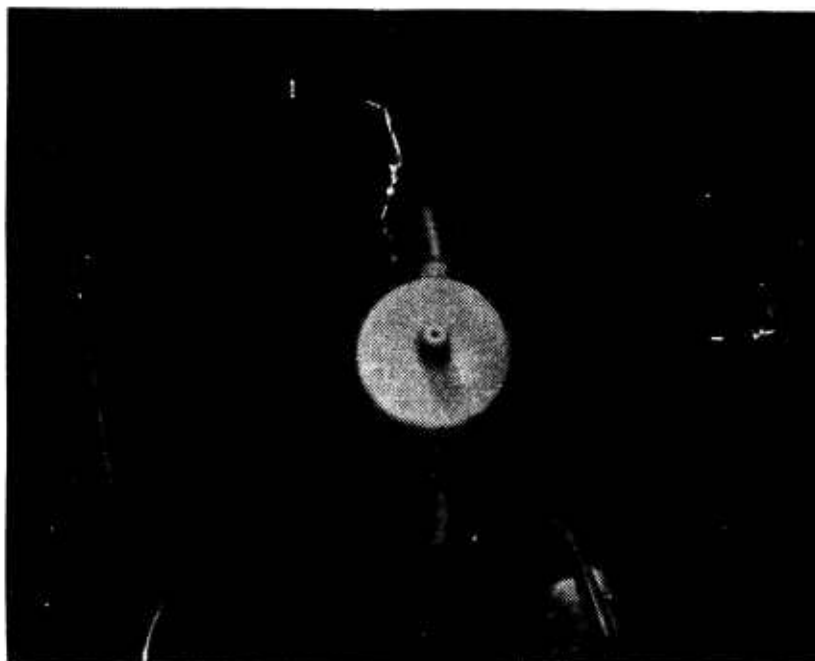

Figure C4. Cold box and cold cell for freezing saturated specimens.

APPENDIX D. MEASUREMENT OF DENSITY AND DEGREE OF ICE SATURATION
(Isooctane Displacement Method)

by

Jonathan E. Ingersoll

Procedure for determining volume of ice saturated soil sample

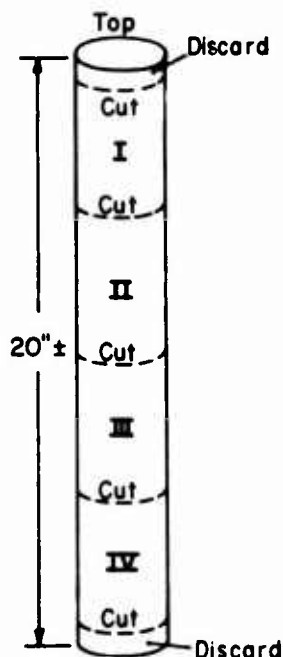

1. Trim top and bottom (½ in.) approx.
2. Use wire brush to remove sublimated loose soil (if present) on remaining sample.
3. Cut remaining sample into 3-4 segments and label top to bottom.
4. Use wire brush on segment ends to remove any loose particles.
5. Weigh each segment in air and record, ± 0.1 g.
6. Record tare of "basket" immersed.
7. Weigh segments immersed, in basket, in isooctane and record.*
8. Place segments in oven for moisture determination.

* If the sample is not ice saturated, the segments must be coated using a fine spray of ice water, coating surface several times. The weight after spraying is recorded. The difference in weight in grams $\times 1.10$ = the volume of ice added, which is deducted from the total volume.

Example: Calculation of a saturated segment. Segment no. II, SN 1040, Manchester silt, 6 June 1970, $G_s = 2.73$

Weight in air = 798.0 g
 Soil and tare immersed = 810.7
 Basket, tare = 349.0
 Weight of soil immersed = $810.7 - 349.0 = 461.7$ g
 Fluid displacement = $798.0 - 461.7 = 336.3$ g
 $G(\text{Isooctane @ } +25^\circ\text{F}) = 0.710$

Volume of sample* = $\frac{336.3}{0.710} = 473.7 \text{ cm}^3$

$\gamma_w = \frac{798.0}{473.7} = 1.685 \text{ g/cm}^3$

$\% w = \left(\frac{\text{wt in air} - \text{dry wt}}{\text{dry wt}} \times 100 \right) = 44.2$

Weight of dry soil = 553.3 g (this should be used for γ_d calculation)

$\gamma_d = \frac{553.3}{473.7} = 1.168 \text{ g/cm}^3$.

* Volume of "ice spray" would be deducted.

Degree of ice saturation

$$\text{(For 100\% water saturation)} \quad S_{100} = \frac{e}{G} \times 100$$

$$V_s = \frac{1.168}{2.73} = 0.428 \quad e = \frac{0.572}{0.428} = 1.336 \quad (n = 57.2\%)$$

$$S_{100} = \frac{1.336}{2.73} \times 100 = 48.9\%$$

$$S_{\text{water}} = \frac{44.2}{48.9} = 90.4\%$$

$$S_{\text{ice}} = \frac{44.2 \times 1.10}{48.9} = 99.4\%$$

Moisture migration

Several of the original samples were further checked for horizontal moisture migration by slicing the outside edges of the segments, and comparing the unit weights and percentage of water with those of the central sections. The migration proved negligible in the rotary, quick, one-directional freeze method.

Cutting frozen silts

After trying several saws and blades, it was decided that an inexpensive 55-in. bandsaw blade, $\frac{3}{8}$ in. in width, claw, racker set, 3 to 5 teeth/in. was very satisfactory. It is important to use a gear reduction device to slow the blade speed. This reduces or eliminates soil melting and is necessary because melted soil clogs the space between the blade teeth and makes the blade ineffective.

APPENDIX E. AUXILIARY COMPUTER PROGRAMS

Table E1. Computer plotting program for modulus and $\tan \delta$ vs stress.

C	DYNAMIC SOILS TEST PLOTTING PROGRAM, D. COOMBS	0C01
	LOGICAL XPRINT, PAFGN	0C02
	DIMENSION XLGST(5,20), XLGMD(5,20), XLGTD(5,20), KDARW(5), AXH(11),	0C03
	IAXT(11), XPRINT(100), FREQ(5,20)	0C04
	MCCF=C	0C05
	READ PAPER TAPE 102, ISN, NSETS	0C06
103	READ PAPER TAPE 32, CP, MODE, NRES	0C07
	GMINP=10000.	0C08
	GMINI=1000.	0C09
	GMAXP=-1000.	0C10
	GMAXI=-1000.	0C11
	DC 3 I=1, NRES	0C12
	READ PAPER TAPE 4, NRN, NRCUS	0C13
	READ PAPER TAPE 5, (XLGST(NRN,J), XLGMD(NRN,J), XLGTD(NRN,J),	0C14
	IFREQ(NRN,J), J=1, NROWS)	0C15
C	CHECK FOR INCORRECT DATA POINTS-TAKE THE AVERAGE MOD AND USE	0C16
C	ONE THIRD OF THE AVERAGE FOR THE DEVIATION	0C17
	AV=0.0	0C18
	DC 10 N=1, NROWS	0C19
	AV=AV+XLGME(NRN,N)	0C20
10	CONTINUE	0C21
	XRCLE=APOLS	0C22
	AV=AV/XRCUS	0C23
	NFCLET=NFCUS	0C24
	HV=AV/1.5	0C25
	NETK=0	0C26
	DC 11 N=1, NRCUS	0C27
271	IF (AV-PV-XLGMT(NRN,N)) 12, 13, 13	0C28
12	IF (AV+PV-XLGMD(NRN,N)) 13, 11, 11	0C29
13	NETK=NETK+1	0C30
	DC 14 J=N, NRCUS-1	0C31
	IF (J-NROWS) 272, 273, 273	0C32
272	XLGME(NRN,J)=XLGMD(NRN,J+1)	0C33
	XLGTE(NRN,J)=XLGTD(NRN,J+1)	0C34
	XLGST(NRN,J)=XLGST(NRN,J+1)	0C35
14	CONTINUE	0C36
	NRCUST=NROWS-1	0C37
	IF (NETK+1-NRCUST) 271, 275, 275	0C38
11	CONTINUE	0C39
	GO TO 275	0C40
273	NRCUST=NROWS-1	0C41
275	NRCUS=NFCLET	0C42
	KDARW(1000)=APOLS	0C43
C	CONTINUATION OF PRGGR4 AFTER SETTING LIMITS	0C44
C	FIND LIMITS FOR MOD AND TAN δ GRAPHS	0C45
	DC 3 J=1, NROWS	0C46
	IF (XLGME(NRN,J)-GMINM) 16, 17, 17	0C47
16	GMINM=XLGME(NRN,J)	0C48
17	IF (XLGTD(NRN,J)-GMINI) 18, 19, 19	0C49
18	GMINI=XLGTE(NRN,J)	0C50
19	IF (GMAXM-XLGME(NRN,J)) 20, 21, 21	0C51
20	GMAXM=XLGMD(NRN,J)	0C52
21	IF (XLGTE(NRN,J)-GMAXI) 15, 15, 22	0C53
22	GMAXI=XLGTE(NRN,J)	0C54
C	TAKING LOGARITHMS OF INPUT DATA	0C55
15	XLGST(NRN,J)=FLOG10(XLGST(NRN,J))	0C56
	XLGME(NRN,J)=FLOG10(XLGMD(NRN,J))	0C57
3	XLGTE(NRN,J)=FLOG10(XLGTD(NRN,J))	0C58
	GMINM=FLOG10(GMINM)	0C59

	GMINT=FLOCIOF(GMINT)	0C60
	GMAXM=FLOCIOF(GMAXM)	0C61
	GMAXT=FLOCIOF(GMAXT)	0C62
C	SET LIMITS FOR MOD AND TAN D GRAPH	0C63
	MAXP=GMAXM*100.	0C64
	GMAXP=MAXM*1	0C65
	GMAXP=GMAXM/100.	0C66
	MINM=GMINM*100.	0C67
	GMINM=MINM	0C68
	GMINM=GMINM/100.	0C69
	MAXM=GMAXT*100.	0C70
	GMAXT=MAXM	0C71
	GMAXT=GMAXT/100.	0C72
	MINM=GMINM*100.	0C73
	GMINM=MINM*1	0C74
	GMINM=GMINM/100.	0C75
C	GENERATION OF AXES NUMBERS FOR YOUNGS MODULUS+ TAN D	0C76
	AXP(1)=GMINM	0C77
	AXT(1)=GMINT	0C78
	A=(GMAXP-GMINM)/10.	0C79
	B=(GMAXT-GMINM)/10.	0C80
	DO 31 I=2,11	0C81
	AXP(I)=AXP(I-1)+A	0C82
	AXT(I)=AXT(I-1)+B	0C83
31	CONTINUE	0C84
	STLV=-1.00	0C85
C	GENERATION OF GRAPH TITLE	0C86
	IF (MCEE-1) 25,25,26	0C87
25	PRINT 27,1,SN,CP	0C88
	GO TC 29	0C89
26	PRINT 28,1,SN,CP	0C90
29	PRINT 30,(AXP(I),I=1,11)	0C91
	PRINT 33,STLV	0C92
C	PRINT OUT CF GRAPH	0C93
	JGRT=1	0C94
75	SLCT=-1.505	0C95
76	MTENS=1	0C96
67	DO 50 I=1,100	0C97
	XPRINT(160)=*J3565656	0C98
50	CONTINUE	0C99
	DO 47 K=1,NRES	0100
	KIT=K*ARL(K)	0101
	DO 48 KTRY=1,KIT	0102
	IF (SLCT-XLGST(K,KTRY)) 43,43,48	0103
43	IF (XLGST(K,KTRY)-(SLCT+.03)) 44,44,47	0104
44	IF (JGRT-1) 76,76,77	0105
76	XLETP=XLGNE(K,KTRY)-GMINM	0106
	LETP=(XLETP/(GMAXM-GMINM))*100.	0107
	GO TC 79	0108
77	XLETP=XLGTE(K,KTRY)-GMINT	0109
	LETP=(XLETP/(GMAXT-GMINT))*100.+1.	0110
79	IF (XPRINT(LETP)+*J3565656) 58,78,58	0111
58	XPRINT(LETP)=*0C565656	0112
	GO TC 47	0113
78	IF (K-2) 49,52,53	0114
53	IF (K-4) 54,57,56	0115
49	XPRINT(LETP)=*C1565656	0116
	GO TC 47	0117
52	XPRINT(LETP)=*02565656	0118
	GO TC 47	0119
54	XPRINT(LETP)=*C3565656	0120
	GO TC 47	0121
55	XPRINT(LETP)=*04565656	0122
	GO TC 47	0123
56	XPRINT(LETP)=*05565656	0124
48	CONTINUE	0125
47	CONTINUE	0126
	SLCT=SLCT+.03	0127
60	IF (PTFNS-2) 62,65,65	0128
62	MTENS=PTFNS+1	0129
	MARGN=*-J3565656	0130
	PRINT 61,MARGN,(XPRINT(JT),JT=1,100)	0131
	GO TC 63	0132
65	STLV=STLV+.06	0133
	MARGN=*2C65656	0134
	PRINT 64,STLV,MARGN,(XPRINT(JT),JT=1,100)	0135
	IF (STLV-1.09) 66,66,67	0136

67	JGRT=JERT+1	0137			
	IF (JGRT-2) 90,90,91	0138			
90	IF (MGPE-1) 92,92,93	0139			
92	PRINT 94,ISN,CF	0140			
	GO TO 95	0141			
93	PRINT 96,ISN,CF	0142			
95	PRINT 97,(AXT(1),I=1,11)	0143			
	STLV=-1.60	0144			
	PRINT 98,STLV	0145			
	GO TO 75	0146			
91	MCCF=MCCF+1	0147			
	IF (INSETS-MCCF) 105,103,103	0148			
C	FCRMATS	0149			
61	FCRMT (1H 8X1A1,10CA1)	0150			
64	FCRMT (1H F6.2,2X1A1,10CA1)	0151			
94	FORMAT (/////2H\$N15,38X17HLONGITUDINAL MODE/1H 20HCONFINING PRESS	0152			
	IURE =F6.2,4H PSI40X17HLOGARITHMIC GRAPH//1H 7HDYNAMIC23X9HTAN D	0153			
	IFLTA)	0154			
96	FCRMT (/////2H\$N15,38X14HTORSIONAL MODE/1H 20HCONFINING PRESSUR	0155			
	IE =F6.2,4H PSI40X17HLOGARITHMIC GRAPH//1H 7HDYNAMIC23X9HTAN DE	0156			
	IFLTA)	0157			
97	FCRMT (1H 6HSTRESS/1H 3HPSIF7.3,10F10.3)	0158			
98	FCRMT (1H F6.2,2X,20(5H*....),1H*)	0159			
102	FCRMT (2I5)	0160			
32	FORMAT (F6.6,2I5)	0161			
4	FORMAT (2I5)	0162			
5	FORMAT(4F12.0)	0163			
27	FCRMT (/////2H\$N15,38X17HLCNGITUDINAL MODE/1H 20HCONFINING PRESS	0164			
	IURE =F6.2,4H PSI40X17HLOGARITHMIC GRAPH//1H 7HDYNAMIC23X34HCOMP	0165			
	ILEX YOUNGS MODULUS,E*,10**3PSI)	0166			
28	FCRMT (/////2H\$N15,38X14HTORSIONAL MODE/1H 20HCONFINING PRESSUR	0167			
	IE =F6.2,4H PSI40X17HLOGARITHMIC GRAPH//1H 7HDYNAMIC23X33HCOMPL	0168			
	IEX SHEAR MODULUS,G*,10**3PSI)	0169			
30	FORMAT (1H 6HSTRESS/1H 3HPSIF7.3,10F10.3)	0170			
33	FORMAT (1H F6.2,2X,20(5H*....),1H*)	0171			
105	END	0172			
SUBROUTINES REQUIRED					
FSC4	FSTG	FSRT	FSEL	FST3	FST1
FSSR	FSFA	FSC1	FSFD	FSFS	FLOG10F
FQFM	FSUL	FST2	FSMD	FSX	FSA
FRRS	FSF	FSCR	FBI	FSTT	FSSR
FSCR					
105	END	0172			

Table EII. Computer plotting program for frequency vs stress.

C	DYNAMIC SOILS TEST, FREQUENCY VS STRESS PLOTTING PROGRAM, D, COCMFES	0C01
	LOGICAL XPRINT, MARGN	0C02
	DIMENSION XPRINT(100), FREQ(5,20), XLGST(5,20), XLGMD(5,20),	0C03
	XLGTD(5,20), AXT(11), KDFW(5)	0C04
	MCCF=0	0C05
	READ PAPER TAPE 1, ISN, NSETS	0C06
103	READ PAPER TAPE 2, CP, MODE, NRES	0C07
	GMIN=10000.	0C08
	GMAX=-1000.	0C09
	DO 3 ICUN=1, NRES	0C10
	READ PAPER TAPE 4, NRN, NRCUS	0C11
	READ PAPER TAPE 5, (XLGST(NRN,J), XLGMD(NRN,J), XLGTD(NRN,J),	0C12
	IFREQ(NRN,J), J=1, NRCUS)	0C13
C	NORMALIZE EACH RESONANCE TO THE FIRST RESONANCE	0C14
	XNRN=2+NRN-1	0C15
	DO 6 I=1, NRCUS	0C16
6	FREQ(NRN,I)=FREQ(NRN,1)/XNRN	0C17
C	CHECK FOR INCORRECT DATA POINTS- TAKE THE AVERAGE FREQUENCY AND	0C18
C	USE ONE-THIRD OF THE AVERAGE FOR THE DEVIATION	0C19
	AV=0.0	0C20
	DO 7 N=1, NRCUS	0C21
7	AV=AV+FREQ(NRN,N)	0C22
	XRCUS=NRCUS	0C23
	AV=AV/XRCUS	0C24
	NRCUS=NRCUS	0C25
	BV=AV/3.	0C26
	DO 8 N=1, NRCUS	0C27
	IF (AV-BV-FREQ(NRN,N)) 9,10,10	0C28
9	IF (AV+BV-FREQ(NRN,N)) 10,6,8	0C29
10	DO 11 J=N, NRCUS-1	0C30
11	FREQ(NRN,J)=FREQ(NRN,J+1)	0C31
	NRCUS=NRCUS-1	0C32
8	CONTINUE	0C33
	NRCUS=NRCUS	0C34
	KDFW(ICUN)=NRCUS	0C35
C	FIND LIMITS FOR GRAPH	0C36
	DO 3 J=1, NRCUS	0C37
	XLGST(NRN,J)=FLOG10F(XLGST(NRN,J))	0C38
	IF (FREQ(NRN,J)-GMIN) 12,13,13	0C39
2	GMIN=FREQ(NRN,J)	0C40
3	IF (GMAX-FREQ(NRN,J)) 14,3,3	0C41
4	GMAX=FREQ(NRN,J)	0C42
	CONTINUE	0C43
	SET LIMITS FOR GRAPH	0C44
	MAX=GMAX	0C45
	MAX=(MAX/10)*10*20	0C46
	GMAX=MAX	0C47
	MIN=GMIN	0C48
	MIN=(MIN/10)*10*20	0C49
	GMIN=MIN	0C50
	AXT(1)=GMIN	0C51
	SPRD=GMAX-GMIN	0C52
	IF (100.-SPRD) 15,16,16	0C53
15	XNTV=10.	0C54
	SPRD=100.	0C55
	GO TO 17	0C56
16	XNTV=20.	0C57
	SPRD=200.	0C58
17	DO 18 I=2,11	0C59
18	AXT(I)=AXT(I-1)+XNTV	0C60
	GENERATION OF GRAPH TITLE	0C61
	STLV=-1.4	0C62
	IF (MCCF-1) 19,19,20	0C63
19	PRINT 21, ISN, CP	0C64
	GO TO 22	0C65
20	PRINT 21, ISN, CP	0C66
22	PRINT 24, (AXT(I), I=1,11)	0C67

	PRINT 25,STLV	0068
C	PRINT OUT OF GRAPH	0069
	SLOT=-1.375	0070
6A	MTENS=1	0071
6B	DO 25 IVD=1,100	0072
20	XPRINT(IVD)=-*33565656	0073
	DC 47 K=1,WRSS	0074
	KIT=KDRV(K)	0075
	DO 31 KYKY=1,KIT	0076
	IF (SLET-XLST(K,KTRY)) 43,43,31	0077
43	IF(XLST(K,KTRY)-(SLOT+.05)) 44,44,47	0078
44	XLETF=FREQ(K,KTRY)-GMIN	0079
	LETF=(XLETF/SFRD)=100.*1.	0080
	IF (XPRINT(LETF)*33565656) 45,46,45	0081
45	XPRINT(LETF)*00565656	0082
	GO TO 47	0083
46	IF (K-2) 49,52,53	0084
53	IF (K-4) 54,55,56	0085
49	XPRINT(LETF)*01565656	0086
	GO TO 47	0087
52	XPRINT(LETF)*02565656	0088
	GO TO 47	0089
54	XPRINT(LETF)*03565656	0090
	GO TO 47	0091
55	XPRINT(LETF)*04565656	0092
	GO TO 47	0093
56	XPRINT(LETF)*05565656	0094
31	CCONTINUE	0095
47	CCONTINUE	0096
	SLOT=SLOT+.05	0097
	IF (MTENS-2) 62,65,63	0098
62	MTENS=MTENS+1	0099
	MARGN=-*33565656	0100
	PRINT 61,MARGN,(XPRINT(JT),JT=1,100)	0101
	GO TO 63	0102
65	STLV=STLV+.1	0103
	MARGN=*20565656	0104
	PRINT 64,STLV,MARGN,(XPRINT(JT),JT=1,100)	0105
	IF (STLV-.99) 66,66,67	0106
67	MCCP=MCCP+1	0107
	IF (MSETS=POOP) 105,103,102	0108
1	FCRMT (2F5)	0109
2	FCRMT (F6.0,2F5)	0110
4	FCRMT (2F5)	0111
5	FCRMT (4F12,0)	0112
21	FCRMT (/////NF SN15,36X17HLONGITUDINAL MODE/1H 20HCCNFING PRESS	0113
	IURE *F6.2,4H PS140X22*SFPI-LOGARITHMIC GRAPH//1H 7HDYNAMIC	0114
	123X2GHNORMALIZED FREQUENCY)	0115
23	FCRMT (/////NF SN15,36X14HTOPSTONAL MODE/1H 20HCCNFING PRESS	0116
	IURE *F6.2,4H PS140X22*SFPI-LOGARITHMIC GRAPH//1H 7HDYNAMIC	0117
	123X2GHNORMALIZED FREQUENCY)	0118
24	FCRMT (1H 6*STFESS/1H 3*PS12XF7.1,10F10.1)	0119
25	FCRMT (1H F6.2,2X20(5*.....),1F*)	0120
61	FCRMT (1H 8X1A1,100A1)	0121
64	FCRMT (1H F6.2,2X1A1,100A1)	0122
105	END	0123
	SUBROUTINES REQUIRED	
	FST0 F8RT FSEL F8T3 F8T1 F8S9	
	F8SB F8CT F8FD F8FA F8FS FLOG10F	
	F8C4 F8LL F8T2 F8FM F8I F8RS	
	F8F F8CR F8HD F8X F8ST F8SR	
	F8GR F8A	
105	END	0123

Table EIII. Velocity, Poisson's ratio, strain, attenuation coefficient for modulus, $\tan \delta$, frequency, stress, and density.

C	DYNAMIC SOILS TEST, SUMMARY PROGRAM, M. J. TARNEY III	0001
	DIMENSION SOIL(6), CONFP(10), HT(10), WTDEN(10), CP(10), E(10)	0002
	IG(10), TDL(10), TDT(10), XAL(10), EVEL(10), NCFCP(10)	0003
	TANF(C)=SINF(C)/COSF(C)	0004
	READ PAPER TAPE 1, (SOIL(1), I=1,6), ICMH	0005
	READ PAPER TAPE 2, ISN, IUNITS, NFREQS, NCPS, QL, CT	0006
	READ PAPER TAPE 3, (CONFP(1), HT(1), WTDEN(1), I=1, NCPS)	0007
	DC 100 J=1, NFREQS	0008
	READ PAPER TAPE 4, FREQ, NSLVLS	0009
	DC 200 K=1, NSLVLS	0010
	READ PAPER TAPE 5, STRESS, NCP	0011
	PRINT 50, ISN, (SCIL(1), I=1,6)	0012
	PRINT 51, FREQ	0013
	PRINT 52, STRESS	0014
	PRINT 54	0015
	PRINT 55	0016
	PRINT 56	0017
	PRINT 57	0018
	PRINT 58	0019
	DC 300 L=1, NCP	0020
	READ PAPER TAPE 6, CP(L), NCFCP(L), E(L), G(L), TDL(L), TDT(L)	0021
	E1=F(L)*COSF(ATANF(TDL(L)))	0022
	E2=F(L)*SINF(ATANF(TDL(L)))	0023
	G1=G(L)*COSF(ATANF(TDT(L)))	0024
	G2=G(L)*SINF(ATANF(TDT(L)))	0025
	XNU1=.5*(F1*G1+E2*G2)/(G(L)*.2)-1.	0026
	XNU2=.5*(E2*G1-E1*G2)/(G(L)*.2.)	0027
	XNL(L)=SCRTF(XNU1*.2+.XNU2*.2.)	0028
	CALL SURRY(E(L), TDL(L), QL, STRESS, WTDEN(NCFCP(L)), FREQ,	0029
	HT(NCFCP(L)), STRAIN, VEL, EA, ALPHA, PKG)	0030
	CCL=SINF(ATANF(TDL(L)/2.))	0031
	DVFL(L)=VFL*SCRTF((1.-XNU(L))/(1.+XNU(L))+(1.-2.*XNU(L)))	0032
300	PRINT 61, CP(L), F(L), TEL(L), BA, PKG, DVFL(L), VEL, STRAIN, ALPHA,	0033
	ICCL, XNL(L)	0034
	PRINT 59	0035
	PRINT 60	0036
	DC 400 M=1, NCP	0037
	CALL SURRY(G(M), TDT(M), CT, STRESS, WTDEN(NCFCP(M)), FREQ, HT(0038
	NCFCP(M)), STRAIN, VEL, FA, ALPHA, PKG)	0039
	CCT=SINF(ATANF(TDT(M)/2.))	0040
400	PRINT 62, CP(M), G(M), TDT(M), PA, PKG, VEL, STRAIN, ALPHA,	0041
	ICCT, XNL(M)	0042
200	CCNTINF	0043
100	CCATINF	0044
C		0045
1	FORMAT(6A4,110)	0046
2	FORMAT(4E,2FA,C)	0047
3	FORMAT(3F,0)	0048
4	FORMAT(FE,C,1F)	0049
5	FORMAT(FE,C,1F)	0050
6	FORMAT(FE,C,12,4FE,0)	0051
50	FORMAT(11F,15,SAMPLE NUMBER IS,2X6A4)	0052
51	FORMAT(11F,16,FREQUENCY =F6,0,3H WZ)	0053
52	FORMAT(11F,5X1F,DYNAMIC STRESS =F6,2,4H PSI)	0054
54	FORMAT(11F,1X4HCONF3X7H,DYNAMIC2X4HLCSS4X8HROT AMPL4X4HPEAK1X12H	0055
	ILATATIONAL3X7HPAR7X6H,CTICP5X5HATTEN4X7H,DAMPING2X7HCCMPLEX)	0056
55	FORMAT(11F,1X5HPRESS2X7H,CDLLUS2X5H,ANGLE4X5HPK-PK7X1H,65X6HVELO	0057
	ICITY3X2H,VFLOCITY4X6H,STRAINEX5H,CEFFEX5H,RATIC2X4H,PCISSONS)	0058
56	FORMAT(11F,2X3HPSI5X3H,MSI3X6H,INCHES13X6H,FT/SECS5X6H,FT/SECS5X6H	0059
	11N/16X4H1/FTX4HC/CC5X5H,RATIC)	0060
57	FORMAT(11F,045X17H,LCNGITIDINAL PCPE)	0061
58	FORMAT(11F,02X2H,CFEX2H,EX5H,ETAN EX2H,EA8X4H,PK-G4X4H,VEFL7X3H,VEL	0062
	18X6H,STRAIN5X5H,ALPHA5X4H,CC6X3H,NU=)	0063
59	FORMAT(11F,046X14H,TORSIONAL MODE)	0064
60	FORMAT(11F,02X2H,CFEX2H,EX5H,ETAN EX2H,EA8X4H,PK-G4X4H,VEFL7X3H,VEL	0065
	18X6H,STRAIN5X5H,ALPHA5X4H,CC6X3H,NU=)	0066
61	FORMAT(11F, F5,1,F9,2,F7,3,1FE12,7,OFF9,3,F9,C,F11,C,1FE13,3,	0067
	1E11,3,OFF9,4,F9,4)	0068
62	FORMAT(11F, F5,1,F9,2,F7,3,1FE12,7,OFF9,3,14X,F11,C1PF13,3,	0069
	1E11,3,OFF9,4,F9,4)	0070
	ENC	0071
	SUBROUTINES REQUIRED	
	FSMV SIN FCSF F3FD FSRT FSSP	
	FST1 FSYG FSEL FSUL ATANF FSPM	
	FSX2 FSFA FSFS SCRTF SURRY FST3	
	FSA FSJ F3RE FSF FSH	
	FSP FSE	

APPENDIX F. SUMMARY OF TEST DATA

Table FI. Frozen 20-30 Ottawa sand.
Frequency = 1000 Hz, dynamic stress = 0.1 psi.

Spec no.	E* (psi)	G* (psi)	v* -	V _c	V _l (ft/sec)	V _s	tan δ _l -	tan δ _s -	α _l (1/ft)	α _s (1/ft)	S _l (%)	e -
Temperature = +25°F (-3.9°C)												
1051	4110000	1817000	0.13	12443	12199	8111	0.033	0.030	0.008	0.012	98.0	0.532
1052	4620000	1990000	0.16	13342	12928	8486	0.023	0.049	0.006	0.018	100.0	0.516
1056	4430000	1670000	0.35	16140	12739	7792	0.190	0.069	0.046	0.028	99.8	0.529
1062	4820000	1890000	0.28	15385	13615	8525	0.028	0.019	0.006	0.007	100.8	0.528
1064	4520000	1780000	0.31	15273	12976	8091	0.248	0.102	0.560	0.040	99.7	0.556
Avg.	4500000	1829400	0.25	14121	12891	8201	0.104	0.052	0.025	0.021	99.7	0.532
Temperature = +15°F (-9.4°C)												
1005	4250000	1620000	0.31	14900	12680	7830	0.003	0.055	0.001	0.022	100.0	0.636
1006	4150000	1750000	0.18	13120	12580	8152	0.012	0.050	0.003	0.019	100.0	0.636
1030	4370000	1640000	0.32	15030	12591	7714	0.055	0.060	0.007	0.012	99.9	0.528
1032	4270000	1510000	0.42	20400	12787	7607	0.065	0.099	0.008	0.020	93.0	0.654
1036	4900000	1803000	0.36	17300	13347	8098	0.014	0.046	0.003	0.018	98.3	0.536
Avg. 1	4635000	1721500	0.34	15875	12969	7906	0.035	0.053	0.005	0.015	99.1	0.532
Avg. 2	4223300	1626700	0.30	14714	12682	7868	0.027	0.068	0.006	0.020	98.0	0.642
Temperature = 0°F (-17.7°C)												
1068	4500000	1880000	0.22	13915	13029	8401	0.160	0.077	0.039	0.029	100.3	0.509
1070	4700000	1840000	0.28	13419	11900	8399	0.074	0.063	0.017	0.024	99.5	0.622
1074	5350000	1993000	0.34	17400	14037	8567	0.017	0.003	0.004	0.001	98.1	0.553
Avg.	4850000	1904340	0.28	14686	12989	8456	0.084	0.048	0.020	0.018	99.3	0.557

Table FI (cont'd). Frozen 20-30 Ottawa sand.
Frequency = 5000 Hz, dynamic stress = 0.1 psi.

Spec no.	E* (psi)	G* (psi)	ν^* -	V_c	V_l (ft/sec)	V_s	$\tan \delta_l$ -	$\tan \delta_s$ -	α_l (1/ft)	α_s (1/ft)	S_i (%)	e -
Temperature = +25°F (-3.9°C)												
1051	4550000	1817000	0.25	14059	12834	8110	0.013	0.023	0.016	0.045	98.0	0.532
1052	5170000	2010000	0.29	15654	13675	8528	0.019	0.037	0.022	0.068	100.2	0.516
1056	4720000	1850000	0.29	15005	13108	8197	0.100	0.026	0.120	0.050	99.8	0.529
1062	4880000	1910000	0.28	15489	13699	8570	0.028	0.031	0.032	0.057	100.8	0.528
1064	4850000	1900000	0.28	17137	15157	8352	0.110	0.056	0.129	0.105	99.7	0.556
Avg.	4834000	1897400	0.28	15483	13694	8351	0.082	0.034	0.064	0.065	99.7	0.532
Temperature = +15°F (-9.4°C)												
1005	4175000	1620000	0.29	14387	12568	7830	0.003	0.020	0.004	0.020	100.9	0.636
1006	4150000	1620000	0.28	14224	12580	7860	0.012	0.041	0.015	0.082	100.2	0.636
1030	4630000	1640000	0.41	19760	12960	7714	0.053	0.060	0.064	0.122	99.9	0.528
1032	4270000	1510000	0.42	20427	12785	7607	0.039	0.099	0.048	0.204	93.0	0.654
1036	4935000	1830000	0.35	16970	13395	8157	0.009	0.013	0.010	0.025	98.3	0.536
Avg. 1	4782500	1735000	0.38	18029	13177	7935	0.031	0.036	0.037	0.073	99.1	0.532
Avg. 2	4198330	1583300	0.33	15391	12644	7766	0.018	0.080	0.022	0.102	98.0	0.642
Temperature = 0°F (-17.7°C)												
1068	4500000	1883000	0.20	13698	12995	8404	0.065	0.046	0.078	0.086	100.3	0.509
1070	4700000	1840000	0.28	15166	13413	8392	0.045	0.036	0.053	0.067	99.5	0.622
1074	5350000	2060000	0.30	16286	14037	8710	0.010	0.012	0.011	0.021	98.1	0.553
Avg.	4850000	1927667	0.26	14913	13482	850.2	0.040	0.031	0.047	0.058	99.3	0.557

Table FI (cont'd).
 Frequency = 10000 Hz, dynamic stress = 0.1 psi.

Spec no.	E* (psi)	G* (psi)	v* -	V _c	V _l (ft/sec)	V _s	tan δ _l -	tan δ _s -	α _l (1/ft)	α _s (1/ft)	S _f (%)	e -
Temperature = +25°F (-3.9°C)												
1051	5350000	1817000	0.47	-	13916	8110	0.013	0.023	0.029	0.089	98.0	0.532
1052	5190000	2020000	0.29	15688	13701	8549	0.014	0.032	0.032	0.118	100.2	0.516
1056	4745000	1920000	0.24	14265	13135	8350	0.076	0.019	0.182	0.071	99.8	0.529
1064	5200000	1900000	0.37	24354	18312	8350	0.050	0.037	0.114	0.139	99.7	0.556
1062	4940000	1940000	0.28	15380	13791	8637	0.072	0.013	0.164	0.047	100.8	0.528
Avg.	5085000	1919400	0.33	17732	14571	8400	0.045	0.025	0.104	0.093	99.7	0.532
Temperature = +15°F (-9.4°C)												
1005	4150000	1620000	0.28	14190	12530	7830	0.003	0.061	0.006	0.032	100.9	0.636
1006	4150000	1520000	0.36	16280	12580	7612	0.012	0.040	0.024	0.132	100.2	0.636
1036	4980000	1863000	0.34	16700	13456	8230	0.003	0.006	0.007	0.023	98.3	0.536
Avg.	44626700	1667340	0.33	15647	12855	7891	0.006	0.016	0.007	0.023	98.3	0.563
Avg.	44150000	1575000	0.31	14750	12555	7721	0.008	0.020	0.015	0.082	100.0	0.636
Temperature = 0°F (-17.7°C)												
1068	4500000	1885000	0.19	13711	12988	8406	0.008	0.012	0.019	0.045	100.3	0.509
1070	4700000	1840000	0.28	15162	13410	8390	0.010	0.009	0.023	0.034	99.5	0.622
1074	5350000	2060000	0.30	16285	14036	8710	0.005	0.023	0.011	0.083	98.1	0.553
Avg.	4850000	1928340	0.28	15239	13478	8502	0.007	0.015	0.018	0.054	99.3	0.557

Table FI (cont'd). Frozen 20-30 Ottawa sand.
 Frequency = 1000 Hz, dynamic stress = 1.0 psi.

Spec no.	E* (psi)	G* (psi)	v*	V _c	V _t (ft/sec)	V _s	tan δ _t	tan δ _s	α _t (1/ft)	α _s (1/ft)	S _t (%)	e
Temperature = +25°F. (-3.9°C)												
1051	4110000	1806000	0.14	12487	12199	8086	0.033	0.031	0.008	0.012	98.0	0.532
1052	4620000	1970000	0.18	13471	12928	8444	0.023	0.051	0.006	0.019	100.0	0.516
1056	4340000	1670000	0.33	15349	12609	7792	0.190	0.071	0.047	0.029	99.8	0.529
1062	4820000	1870000	0.29	15586	13615	8480	0.028	0.018	0.006	0.007	100.0	0.528
1064	4520000	1760000	0.33	15793	12976	8046	0.248	0.102	0.060	0.040	99.7	0.556
Avg	4482000	1815200	0.25	13655	12465	8169	0.104	0.055	0.026	0.021	99.7	0.532
Temperature = +15°F. (-9.4°C)												
1005	4250000	1620000	0.31	14928	12680	7830	0.011	0.153	0.027	0.061	100.0	0.636
1006	4150000	1750000	0.18	13109	12580	8168	0.022	0.108	0.005	0.041	100.0	0.636
1030	4320000	1640000	0.32	14976	12519	7714	0.058	0.06	0.014	0.024	99.9	0.528
1032	4270000	1510000	0.42	20430	12787	7606	0.059	0.092	0.014	0.038	93.0	0.654
1036	4900000	1803000	0.36	17303	13347	8098	0.014	0.046	0.003	0.018	98.3	0.536
Avg1	4610000	1721500	0.34	16020	12933	7906	0.036	0.026	0.007	0.023	98.3	0.563
Avg2	4223300	1626700	0.30	14700	14700	7868	0.031	0.118	0.015	0.082	100.0	0.636
Temperature = 0°F. (-17.7°C)												
1068	4500000	1880000	0.22	13895	13004	8395	0.100	0.015	0.024	0.006	100.0	0.509
1070	4700000	1840000	0.28	15172	13419	8394	0.074	0.063	0.017	0.024	99.5	0.622
1074	5290000	1993000	0.33	16990	13958	8567	0.016	0.005	0.004	0.002	98.1	0.553
Avg	4830000	1904340	0.28	15210	13460	8452	0.063	0.024	0.015	0.011	99.3	0.557

Table FI (cont'd).
Frequency = 5000 Hz, dynamic stress = 1.0 psi.

Spec no.	E* (psi)	G* (psi)	ν^* -	ν_c	ν_l (ft/sec)	ν_s	$\tan \delta_l$ -	$\tan \delta_s$ -	α_l (1/ft)	α_s (1/ft)	S_1 (%)	e -
Temperature = +25°F. (-3.9°C)												
1051	4550000	1806000	0.26	14196	12834	8086	0.012	0.024	0.016	0.047	98.0	0.532
1052	5170000	1990000	0.30	15866	13675	8486	0.019	0.041	0.022	0.076	100.0	0.516
1056	4710000	1850000	0.28	14805	13094	8197	0.100	0.028	0.120	0.054	99.8	0.529
1062	4880000	1910000	0.28	15489	13699	8570	0.028	0.024	0.032	0.044	100.0	0.528
1064	4820000	1900000	0.27	16737	14973	8352	0.110	0.056	0.130	0.105	99.7	0.556
Avg.	4826000	1891200	0.28	15420	13655	8338	0.054	0.035	0.064	0.065	99.7	0.532
Temperature = 15°F. (-9.4°C)												
1005	4175000	1620000	0.29	14387	12568	7830	0.009	0.010	0.011	0.020	100.9	0.636
1006	4150000	1620000	0.28	14224	12580	7860	0.021	0.085	0.026	0.169	100.0	0.636
1030	4570000	1640000	0.39	18185	12876	7714	0.053	0.060	0.065	0.122	99.9	0.528
1032	4270000	1510000	0.42	20427	12785	7606	0.039	0.092	0.048	0.190	93.0	0.654
1036	4935000	1830000	0.35	16969	13395	8157	0.009	0.013	0.011	0.025	98.3	0.536
Avg 1	4752500	1735000	0.37	17490	13135	7935	0.031	0.036	0.038	0.073	99.1	0.532
Avg 2	4198300	1583000	0.33	15370	12644	7765	0.023	0.062	0.025	0.126	99.8	0.642
Temperature = 0°F. (-17.7°C)												
1068	4500000	1883000	0.20	13690	12988	8403	0.015	0.036	0.018	0.067	100.3	0.509
1070	4700000	1840000	0.28	15166	13413	8392	0.045	0.036	0.053	0.067	99.5	0.622
1074	5290000	2060000	0.28	15782	13958	8710	0.010	0.014	0.011	0.025	98.1	0.553
Avg	4830000	1927670	0.25	14720	13453	8502	0.023	0.029	0.027	0.053	99.3	0.557

Table FI (cont'd). Frozen 20-30 Ottawa sand.
 Frequency = 10000 Hz, dynamic stress = 1.0 psi.

Spec no.	E* (psi)	G* (psi)	v* -	V _c	V _l (ft/sec)	V _s	tan δ _l -	tan δ _s -	α _l (1/ft)	α _s (1/ft)	S _i (%)	e -
Temperature = +25°F. (-3.9°C)												
1051	5350000	1806000	0.48	—	13916	8086	0.013	0.024	0.029	0.093	98.0	0.523
1052	5190000	2010000	0.29	15684	13701	8528	0.014	0.037	0.032	0.136	100.0	0.516
1056	4745000	1920000	0.24	14260	13135	8350	0.076	0.021	0.182	0.079	99.8	0.529
1062	4940000	1940000	0.28	15593	13791	8637	0.072	0.012	0.164	0.044	100.0	0.528
1064	4940000	1900000	0.30	18137	15632	8350	0.050	0.037	0.117	0.139	99.7	0.556
Avg.	5033000	1915200	0.32	16760	14035	8390	0.045	0.026	0.105	0.098	99.7	0.532
Temperature = +15°F. (-9.4°C)												
1005	4150000	1620000	0.28	14167	12530	7830	0.007	0.001	0.014	0.003	100.0	0.636
1006	4150000	1520000	0.36	16309	12580	7612	0.021	0.014	0.042	0.046	100.0	0.636
1030	4570000	1640000	0.39	18185	12876	7714	0.053	0.060	0.065	0.122	99.9	0.528
1036	4980000	1863000	0.34	16694	13456	8230	0.003	0.006	0.007	0.023	98.3	0.536
Avg 1	4775000	1751500	0.36	16920	13166	7972	0.028	0.033	0.036	0.073	99.1	0.532
Avg 2	4150000	1570000	0.32	14900	12555	7721	0.014	0.008	0.028	0.025	100.0	0.636
Temperature = 0°F. (-17.7°C)												
1068	4500000	1885000	0.19	13609	12988	8406	0.008	0.012	0.019	0.045	100.3	0.509
1070	4700000	1840000	0.28	15162	13410	8309	0.010	0.009	0.023	0.034	99.5	0.622
1074	5290000	2060000	0.28	15782	13958	8710	0.005	0.023	0.011	0.083	98.1	0.553
Avg	4830000	1928300	0.35	17050	13485	8475	0.008	0.022	0.018	0.056	99.3	0.557

Table FI (cont'd).
 Frequency = 1000 Hz, dynamic stress = 5.0 psi.

Spec no.	E* (psi)	G* (psi)	ν^* -	V_c	V_L (ft/sec)	V_S	$\tan \delta_L$ -	$\tan \delta_S$ -	α_L (1/ft)	α_S (1/ft)	S_i (%)	e -
Temperature = +25°F. (-3.9°C)												
1051	4110000	1791000	0.17	12669	12220	8053	0.122	0.041	0.031	0.016	98.0	0.532
1052	4620000	1960000	0.19	13546	12928	8430	0.027	0.097	0.007	0.036	100.0	0.516
1056	4230000	1670000	0.38	17239	12600	7803	0.380	0.127	0.092	0.051	99.8	0.529
1062	4820000	1810000	0.33	16572	13615	8342	0.028	0.019	0.006	0.007	100.0	0.528
1064	4520000	1730000	0.35	16439	12976	7977	0.248	0.060	0.102	0.040	99.7	0.556
Avg	4446000	1792200	0.28	14549	12868	8121	0.161	0.069	0.048	0.030	99.7	0.532
Temperature = +15°F. (-9.4°C)												
1005	4250000	1620000	0.31	14928	12680	7830	0.052	0.309	0.013	0.120	100.	0.636
1006	4150000	1750000	0.18	13108	12580	8168	0.070	0.320	0.017	0.119	100.	0.636
1030	4280000	1640000	0.30	14459	12462	7714	0.063	0.060	0.016	0.024	99.9	0.528
1032	4270000	1510000	0.41	19496	12787	7606	0.059	0.090	0.014	0.037	93.0	0.654
Avg 1	4280000	1640000	0.30	14459	12462	7714	0.063	0.060	0.016	0.024	99.9	0.528
Avg 2	4223000	1627000	0.30	14714	12682	7868	0.060	0.139	0.015	0.092	98.0	0.642
Temperature = 0°F. (-17.7°C)												
1068	4500000	1880000	0.22	13895	13004	8395	0.100	0.015	0.024	0.006	100.	0.509
1070	4700000	1840000	0.28	15172	13419	8394	0.074	0.063	0.017	0.024	99.5	0.622
1074	5200000	1993000	0.30	16056	13839	8567	0.016	0.010	0.004	0.004	98.1	0.553
Avg	4800000	1904300	0.27	15002	13421	8452	0.063	0.029	0.013	0.011	99.3	0.557

Table FI (cont'd). Frozen 20-30 Ottawa sand.

Frequency = 5000 Hz, dynamic stress = 5.0 psi.

Spec no.	E* (psi)	G* (psi)	v*	V _c	V _t (ft/sec)	V _s	tan δ ₁	tan δ _s	α ₁ (1/ft)	α _s (1/ft)	S ₁ (%)	e
Temperature = +25°F. (-3.9°C)												
1051	4510000	1791000	0.26	14133	12778	8052	0.021	0.029	0.026	0.057	98.0	0.532
1052	5170000	1980000	0.31	16100	13675	8467	0.021	0.063	0.034	0.117	100.0	0.516
1056	4690000	1850000	0.30	15189	13091	8197	0.160	0.032	0.191	0.061	99.8	0.529
1062	4880000	1880000	0.30	15894	13699	8503	0.028	0.030	0.032	0.055	100.0	0.528
1064	4820000	1900000	0.27	16737	14973	8352	0.110	0.056	0.130	0.105	99.7	0.556
Avg	4814000	1880200	0.29	15618	13643	8314	0.068	0.042	0.042	0.080	99.7	0.532
Temperature = +15°F. (-9.4°C)												
1005	4175000	1620000	0.29	14387	12568	7830	0.034	0.010	0.042	0.020	100.0	0.536
1006	4150000	1620000	0.28	14224	12580	7880	0.069	0.073	0.086	0.146	100.0	0.636
1030	4520000	1640000	0.38	17521	12806	7714	0.058	0.060	0.071	0.122	99.9	0.528
1032	4270000	1510000	0.42	20427	12785	7606	0.039	0.090	0.048	0.018	93.0	0.654
Avg	4520000	1640000	0.38	17521	12806	7714	0.058	0.060	0.071	0.122	99.9	0.528
Avg	4198300	1583000	0.33	15390	12644	7765	0.047	0.058	0.059	0.061	98.0	0.642
Temperature = 0°F. (-17.7°C)												
1068	4500000	1883000	0.20	13690	12988	8403	0.015	0.036	0.018	0.067	100.3	0.509
1070	4700000	1840000	0.28	15166	13413	8392	0.045	0.036	0.053	0.067	99.5	0.622
1074	5200000	2060000	0.26	15307	13838	8710	0.010	0.017	0.011	0.031	98.1	0.553
Avg	4800000	1928000	0.25	14693	13413	8502	0.035	0.030	0.041	0.055	99.3	0.557

Table F1 (cont'd).
 Frequency = 10000 Hz, dynamic stress = 5.0 psi.

Spec no.	E* (psi)	G* (psi)	ν^* -	V_c	V_t (ft/sec)	V_s	$\tan \delta_l$ -	$\tan \delta_s$ -	α_l (1/ft)	α_s (1/ft)	S_d (%)	e -
Temperature = +25°F. (-3.9°C)												
1051	5320000	1791000	0.26	15350	13877	8052	0.019	0.029	0.043	0.113	98.0	0.532
1052	5190000	2000000	0.30	15899	13701	8507	0.014	0.041	0.032	0.151	100.0	0.516
1056	4745000	1920000	0.24	14260	13135	8350	0.076	0.028	0.182	0.105	99.8	0.529
1062	4940000	1940000	0.28	15593	13791	8637	0.072	0.013	0.164	0.047	100.0	0.528
1064	4890000	1900000	0.29	17495	15283	8350	0.050	0.037	0.117	0.139	99.7	0.556
Avg.	5017000	1910200	0.27	15378	13757	8379	0.046	0.030	0.107	0.111	99.7	0.532
Temperature = +15°F. (-9.4°C)												
1036	4980000	1863000	0.34	16694	13456	8230	0.003	0.006	0.007	0.023	98.3	0.536
Temperature = 0°F. (-17.7°C)												
1068	4500000	1885000	0.19	13609	12988	8406	0.008	0.012	0.019	0.045	100.	0.509
1070	4700000	1840000	0.28	15162	13410	8390	0.010	0.009	0.010	0.034	99.5	0.622
1074	5200000	2060000	0.26	15307	13838	8710	0.005	0.023	0.011	0.083	98.1	0.553
Avg.	4800000	1928300	0.24	14561	13412	8502	0.011	0.022	0.020	0.081	99.3	0.557

Table FII. Frozen Manchester silt.
Frequency = 1000 Hz, dynamic stress = 0.1 psi.

Spec no.	E* (psi)	G* (psi)	v* -	V _c	V _l (ft/sec)	V _s	tan δ _l -	tan δ _s -	α _l (1/ft)	α _s (1/ft)	S _i (%)	e -
Temperature = +25°F (-3.9°C)												
1041	3120000	1110000	0.40	15956	10899	6501	0.062	0.060	0.018	0.029	96.7	0.723
1042	2720000	1124000	0.21	10805	10184	6544	0.065	0.035	0.020	0.017	96.1	0.718
1043	2102000	761000	0.38	13071	9555	5748	0.064	0.049	0.021	0.027	95.3	1.279
1053	2295000	974000	0.18	9753	9360	6101	0.023	0.067	0.008	0.034	96.1	0.719
1053*	2310000	943000	0.24	10199	9391	6009	0.026	0.114	0.009	0.059	96.1	0.719
1054	2275000	959000	0.21	9871	9304	6050	0.031	0.115	0.010	0.060	95.8	0.709
1055	2460000	1060000	0.16	9930	9622	6317	0.022	0.048	0.007	0.048	96.7	0.689
1059	2695000	1025000	0.32	12869	10760	6643	0.030	0.096	0.009	0.045	100.1	0.823
1063	2570000	950000	0.35	13240	10450	6347	0.050	0.046	0.015	0.023	92.8	0.717
1048	2150000	760000	0.42		9318	5539	0.054	0.027	0.018	0.015	75.0	1.340*
1045	250000	117500	0.06	3366	3353	2299	9.082	0.048	0.038	0.033	25.0	0.852*
Avg.	2535700	1015700	0.25	10831	9887	6267	0.040	0.069	0.016	0.035	95.8	0.713
									*Omit from average			
Temperature = +15°F (-9.4°C)												
1037	2905000	1210000	0.21	11110	10462	6757	0.028	0.085	0.004	0.085	97.0	0.697
1038	3175000	1226200	0.29	12520	10974	6803	0.050	0.043	0.007	0.010	98.8	0.714
1039	2735000	1087000	0.26	12000	10866	6849	0.061	0.049	0.009	0.049	93.5*	1.163
1033	3045000	1100000	0.38	14800	10769	6469	0.136	0.115	0.040	0.056	100.0	0.729
1040	2825000	1213000	0.17	10790	10401	6816	0.017	0.040	0.005	0.018	98.8	0.743
1041	3580000	1350000	0.33	14190	11671	7166	0.034	0.023	0.009	0.010	96.7	0.723
Avg.	3106000	1219840	0.27	12136	10857	6802	0.053	0.061	0.013	0.036	97.6	0.721
									*Omit from average			
Temperature = +0°F (-17.7°C)												
1067	3270000	1410000	0.16	11510	11175	7342	0.046	0.080	0.013	0.034	98.3	0.748
1069	3460000	1390000	0.25	12780	11660	7358	0.088	0.026	0.024	0.011	96.9	0.765
1071	3090000	1173000	0.42	16690	11426	6983	0.257	0.012	0.071	0.005	98.0	0.993
1072	2766000	1136000	0.30	12571	10820	6881	0.212	0.018	0.062	0.008	97.3	0.998
1074	3500000	1320000	0.33	14197	11737	7206	0.048	0.029	0.013	0.013	97.6	0.794
Avg 1	3410000	1373000	0.25	12620	11527	7302	0.061	0.046	0.017	0.019	97.6	0.769
Avg 2	2928000	1154500	0.36	14420	11123	6932	0.234	0.015	0.066	0.007	97.8	0.995

Table FII (cont'd).
 Frequency = 5000 Hz, dynamic stress = 0.1 psi.

Spec no.	E* (psi)	G* (psi)	v* -	V _c	V _t (ft/sec)	V _s	tan δ _t -	tan δ _s -	α _t (1/ft)	α _s (1/ft)	S _i (%)	c -
Temperature = +25°F (-3.09°C)												
1041	3130000	1120000	0.40	16007	10914	6528	0.045	0.029	0.065	0.070	96.7	0.723
1042	2890000	1126000	0.28	11685	10454	6550	0.040	0.035	0.060	0.084	96.1	0.718
*1043	2108000	807000	0.31	11282	9566	5918	0.043	0.041	0.071	0.109	95.3	*1.279
1053	2543000	1021000	0.25	10793	9853	6245	0.022	0.045	0.053	0.223	96.1	0.719
1053A	2470000	970000	0.28	10980	9711	6089	0.023	0.075	0.037	0.183	96.1	0.719
1054	2660000	1024000	0.30	11673	10061	6246	0.042	0.080	0.066	0.201	95.8	0.709
1055	2810000	1082000	0.30	11932	10284	6382	0.030	0.046	0.197	0.011	96.5	0.689
*1059	2695000	1020000	0.32	12871	10760	6620	0.023	0.024	0.034	0.057	100.0	*0.823
1063	2537000	994000	0.28	11726	10371	6492	0.036	0.046	0.054	0.111	92.8	0.717
Avg	2720000	1648100	0.27	11448	10241	6347	0.052	0.051	0.061	0.126	95.8	0.713
Temperature = +15°F (-9.4°C)												
1033	3060000	1155000	0.33	13114	10774	6621	0.048	0.064	0.070	0.152	100.0	0.729
1037	3000000	1380000	0.09	10727	10631	7212	0.028	0.048	0.041	0.104	97.0	0.697
1038	3296000	1250000	0.32	13374	11180	6886	0.034	0.046	0.048	0.105	98.8	0.714
*1039	2815000	1125000	0.25	12072	11020	6967	0.026	0.037	0.037	0.083	93.5	*1.163
1040	3192000	1303000	0.22	11814	11057	7064	0.030	0.035	0.034	0.156	98.8	0.743
1041	3678000	1350000	0.36	15335	11829	7166	0.025	0.021	0.033	0.046	96.7	0.723
Avg	3245200	1287600	0.26	12271	11094	6990	0.033	0.043	0.045	0.112	97.6	0.721
Temperature = 0°F (-17.7°C)												
1067	3300000	1410000	0.17	11636	11224	7339	0.015	0.052	0.021	0.011	98.3	0.748
1069	3460000	1390000	0.24	12603	11609	7358	0.033	0.033	0.045	0.070	96.9	0.765
1071	3090000	1206000	0.28	12826	11344	7083	0.087	0.054	0.121	0.120	98.0	0.993
1072	2960000	1183000	0.25	12170	11110	7022	0.054	0.030	0.076	0.067	97.3	0.988
1076	3500000	1355000	0.29	13475	11736	7301	0.038	0.019	0.051	0.041	97.6	0.794
Avg 1	3420000	1385000	0.22	12080	11314	7240	0.034	0.034	0.039	0.041	97.6	0.769
Avg 2	3025000	1194000	0.26	12550	11227	7053	0.070	0.042	0.038	0.094	97.6	0.990

*Omit from average

*Omit from average

Table FII (cont'd). Frozen Manchester silt.
 Frequency = 10000 Hz, dynamic stress = 0.1 psi.

Spec no.	E* (psi)	G* (psi)	v* -	V _c	V _l (ft/sec)	V _s	tan δ _l -	tan δ _s -	α _l (1/ft)	α _s (1/ft)	S _i (%)	e -
Temperature = +25°F. (-3.9°C)												
041	3145000	1127000	0.40	16015	10939	6548	0.033	0.025	0.095	0.120	96.7	0.723
042	2925000	1150000	0.27	11241	10557	6620	0.030	0.035	0.089	0.166	96.1	0.718
043	2114000	832000	0.27	10708	9578	6009	0.040	0.041	0.131	0.214	95.3	1.279
053	2565000	1028000	0.25	10839	9895	6266	0.017	0.045	0.053	0.226	96.1	0.719
053A	2510000	973000	0.30	11359	9789	6098	0.021	0.071	0.067	0.365	96.1	0.719
054	2660000	1030000	0.29	11516	10060	6264	0.033	0.074	0.103	0.371	95.8	0.709
055	2925000	1038000	0.34	12842	10492	6400	0.026	0.043	0.078	0.211	96.7	0.689
059	2670000	1019000	0.31	12613	10710	6616	0.018	0.012	0.053	0.057	100.0	0.823
063	2518000	1000000	0.26	11559	10450	6512	0.030	0.046	0.091	0.222	92.8	0.717
Avg.	2749710	1056571	0.30	11965	10311	6385	0.027	0.048	0.090	0.240	95.8	0.713
*Omit from average												
Temperature = +15°F. (-9.4°C)												
1033	3070000	1220000	0.26	11934	10789	6803	0.020	0.051	0.058	0.235	100.0	0.729
1040	3260000	1303000	0.25	12239	11173	7064	0.012	0.035	0.034	0.156	98.8	0.743
1041	3686000	1350000	0.36	15351	11841	7166	0.017	0.021	0.045	0.092	96.7	0.723
Avg.	3338670	1291000	0.39	12899	11268	7011	0.016	0.036	0.046	0.161	98.8	0.732
Temperature = 0°F. (-17.7°C)												
1067	3340000	1500000	0.12	11481	11292	7570	0.010	0.052	0.028	0.022	98.3	0.748
1069	3460000	1390000	0.25	12682	11608	7360	0.023	0.054	0.062	0.230	96.9	0.765
1071	3090000	1173000	0.42	18256	11426	6983	0.007	0.025	0.071	0.005	98.0	0.993
1072	2970000	1190000	0.25	12174	11125	7043	0.018	0.037	0.051	0.165	97.3	0.988
1076	3500000	1380000	0.27	13093	11734	7368	0.026	0.018	0.070	0.077	97.6	0.794
Avg 1	3433000	1423300	0.21	13410	11545	7439	0.020	0.041	0.053	0.110	97.6	0.769
Avg 2	3030000	1181500	0.33	13724	11275	7013	0.013	0.031	0.061	0.035	97.6	0.990

Table FII (cont'd).
 Frequency = 1000 Hz, dynamic stress = 1.0 psi.

Spec no.	E* (psi)	G* (psi)	v* -	V _c	V _g (ft/sec)	V _s	tan δ _g -	tan δ _s -	a _g (1/ft)	a _s (1/ft)	S _i (%)	e -
Temperature = +25°F. (-3.9°C)												
1041	3120000	1110000	0.40	15954	10899	6501	0.062	0.060	0.018	0.029	96.7	0.723
1042	2795000	1125000	0.21	10805	10184	6544	0.065	0.035	0.020	0.017	98.1	0.718
*1043	2082000	753000	0.38	13010	9509	5718	0.064	0.049	0.021	0.027	95.2	1.279
1053	2290000	972000	0.18	9743	9350	6095	0.023	0.067	0.008	0.035	98.1	0.719
1053A	2307000	937000	0.25	10281	9385	5990	0.026	0.114	0.009	0.114	98.1	0.719
1054	2275000	959000	0.21	9871	9304	6050	0.031	0.115	0.010	0.068	98.8	0.709
1055	2450000	1052000	0.17	9955	9602	6293	0.023	0.048	0.008	0.024	96.7	0.689
*1059	2695000	1025000	0.32	12871	10760	6643	0.030	0.096	0.009	0.045	100.0	*0.823
1063	2575000	950000	0.35	12819	10450	6347	0.050	0.046	0.015	0.023	92.8	0.717
Avg.	2544428	1015000	0.25	10810	9868	6260	0.040	0.069	0.013	0.043	95.8	0.73
1045	230000	105000	0.10	3254	3218	2174	0.081	0.075	0.039	0.054	25.0	0.852
1048	1880000	720000	0.31	10258	8713	5391	0.052	0.027	0.019	0.016	75.0	1.340
*Omit from average												
Temperature = +15°F. (-9.4°C)												
1033	3045000	1095000	0.39	15211	10770	6455	0.138	0.119	0.040	0.058	100.0	0.729
1037	2875000	1205000	0.20	10970	10407	6744	0.028	0.088	0.008	0.041	97.0	0.697
1038	3171000	1225300	0.29	12553	10966	6817	0.031	0.043	0.009	0.020	98.8	0.714
*1039	2730000	1080000	0.26	12008	10856	6828	0.057	0.054	0.016	0.025	93.5	*1.163
1040	2820000	1190000	0.19	10889	10392	6751	0.017	0.040	0.005	0.019	98.8	0.743
1041	3530000	1350000	0.31	13645	11590	7167	0.040	0.026	0.011	0.011	96.7	0.723
Avg.	3088200	1213060	0.28	12239	10825	6787	0.051	0.063	0.024	0.032	97.6	0.721
*Omit from average												
Temperature = 0°F. (-17.7°C)												
1067	3270000	1370000	0.19	11713	11179	7233	0.061	0.038	0.017	0.016	98.3	0.748
1069	3460000	1390000	0.25	12728	11619	7358	0.088	0.026	0.024	0.011	96.9	0.765
1071	3090000	1169000	0.33	13808	11343	6971	0.081	0.012	0.022	0.005	98.0	0.993
1072	2766000	1136000	0.23	11572	10748	6881	0.093	0.018	0.027	0.008	97.3	0.988
1076	3440000	320000	0.30	13574	11636	7206	0.048	0.029	0.013	0.013	97.6	0.794
Avg 1	3390000	1360000	0.25	12610	11511	7266	0.066	0.031	0.018	0.013	97.6	0.769
Avg 2	2928000	1152500	0.28	12488	11045	6926	0.087	0.015	0.024	0.007	97.6	0.930

Table FII (cont'd). Frozen Manchester silt.
 Frequency = 5000 Hz, dynamic stress = 1.0 psi.

Spec no.	E* (psi)	G* (psi)	v* -	V _c	V _l (ft/sec)	V _s	tan δ _l -	tan δ _s -	α _l (1/ft)	α _s (1/ft)	S _i (%)	e -
Temperature = +25°F. (-3.9°C)												
1041	3130000	1120000	0.40	15976	10914	6528	0.045	0.029	0.065	0.070	96.7	0.723
1042	2890000	1126000	0.28	11865	10494	6550	0.040	0.035	0.060	0.082	96.1	0.718
1043	2096000	796000	0.32	11410	9538	5878	0.043	0.041	0.071	0.109	95.3	*1.279
1053	2541000	1019000	0.25	10789	9849	6238	0.022	0.045	0.034	0.113	96.1	0.719
1953	2470000	967000	0.28	10980	9711	6080	0.023	0.075	0.037	0.194	96.1	0.719
1054	2660000	1024000	0.30	11673	10061	6248	0.042	0.080	0.066	0.201	95.8	0.709
1055	2800000	1082000	0.29	11752	10266	6382	0.031	0.046	0.047	0.113	96.7	0.689
1059	2695000	1020000	0.32	12871	10760	6620	0.023	0.024	0.034	0.057	100.0	0.823
1063	2537000	994000	0.28	11726	10371	6492	0.036	0.046	0.054	0.111	92.8	0.717
Avg	2718280	1047427	0.29	11720	10238	6331	0.034	0.051	0.052	0.126	95.8	0.713
*Omit from average												
Temperature = +15°F. (-9.4°C)												
1033	3060000	1150000	0.33	13114	10774	6607	0.049	0.066	0.071	0.157	100.0	0.729
1037	2945000	1375000	0.07	10589	10533	7199	0.028	0.052	0.042	0.113	97.0	0.697
1038	3287000	1249500	0.32	13356	11165	6885	0.031	0.050	0.044	0.114	98.8	0.714
*1039	2810000	1125000	0.25	12061	11010	6967	0.026	0.037	0.037	0.083	93.5	*1.163
1040	3190000	1297000	0.23	11901	11053	7048	0.030	0.035	0.043	0.078	98.8	0.743
1041	3655000	1350000	0.35	14939	11792	7166	0.030	0.023	0.040	0.050	96.7	0.723
Avg	3227400	1284380	0.27	12367	11063	6981	0.034	0.045	0.048	0.102	97.9	0.715
*Omit from average												
Temperature = 0°F. (-17.7°C)												
1067	3300000	1375000	0.20	11832	11225	7246	0.027	0.038	0.038	0.082	98.3	0.748
1069	3460000	1390000	0.24	12603	11609	7358	0.033	0.033	0.045	0.070	96.9	0.765
1071	3090000	1200000	0.29	12974	11334	7066	0.026	0.060	0.036	0.133	98.0	0.993
1072	2960000	1183000	0.25	12167	11107	7022	0.030	0.030	0.042	0.067	97.3	0.988
1076	3440000	1355000	0.27	12996	11633	7301	0.025	0.019	0.034	0.041	97.6	0.794
Avg 1	3400000	1373300	0.24	12480	11489	7635	0.028	0.030	0.039	0.064	97.6	0.769
Avg 2	3027500	1191500	0.27	12542	11220	7044	0.028	0.045	0.039	0.100	97.6	0.990

Table FII (cont'd).
 Frequency = 10000 Hz, dynamic stress = 1.0 psi.

Spec no.	E* (psi)	G* (psi)	v*	V _c	V _l (ft/sec)	V _s	tan δ _l	tan δ _s	α _l (1/ft)	α _s (1/ft)	S _i (%)	e
Temperature = +25°F. (-3.9°C)												
1041	3145000	1127000	0.40	16013	10939	6548	0.033	0.025	0.095	0.120	96.7	0.723
1042	2925000	1150000	0.27	11801	10557	6620	0.030	0.035	0.089	0.166	96.1	0.718
1043	2105000	822000	0.28	10808	9559	5973	0.040	0.040	0.131	0.215	95.3	*1.279
1053	2563000	1026000	0.25	10836	9892	6260	0.017	0.045	0.053	0.226	96.1	0.719
1053A	2510000	970000	0.30	11357	9789	6089	0.021	0.071	0.067	0.366	96.1	0.719
1054	2660000	1030000	0.29	11516	10060	6264	0.033	0.074	0.103	0.371	95.8	0.709
1055	2880000	1087000	0.33	12672	10411	6397	0.027	0.043	0.080	0.211	96.7	0.689
1059	2670000	1019000	0.31	12609	10710	6616	0.018	0.012	0.053	0.057	110.1	*0.823
1063	2518000	1000000	0.26	11429	10332	6512	0.030	0.046	0.091	0.222	92.8	0.717
Avg	2743000	1055710	0.30	11931	10283	6384	0.024	0.048	0.083	0.240	95.8	0.713
									*Omit from average			
Temperature = +15°F. (-9.4°C)												
1033	3070000	1210000	0.27	12060	10789	6776	0.020	0.053	0.058	0.246	100.8	0.729
1040	3203000	1290000	0.24	12004	11057	7048	0.012	0.035	0.034	0.156	98.8	0.743
1041	3686000	1300000	0.36	15351	11841	7166	0.017	0.023	0.045	0.101	96.7	0.723
Avg	3319670	1285670	0.29	12854	11229	6997	0.016	0.037	0.046	0.168	98.8	0.732
Temperature = 0°F. (-17.7°C)												
1067	3340000	1455000	0.15	11603	11292	7454	0.018	0.038	0.050	0.160	98.3	0.748
1069	3460000	1390000	0.25	12716	11608	7360	0.023	0.054	0.062	0.230	96.9	0.765
1071	3090000	1200000	0.29	12973	11333	7065	0.009	0.025	0.025	0.111	98.0	0.993
1072	2970000	1190000	0.25	12187	11125	7043	0.018	0.037	0.051	0.165	97.3	0.988
1076	3440000	1380000	0.25	12701	11633	7368	0.013	0.018	0.035	0.077	97.6	C.794
Avg 1	3413000	1408300	0.22	12320	11511	7394	0.018	0.036	0.049	0.156	97.6	0.769
Avg 2	3030000	1195000	0.27	12552	11229	7054	0.014	0.031	0.038	0.138	97.6	0.990

Table FII (cont'd). Frozen Manchester silt.
 Frequency = 1000 Hz, dynamic stress = 5.0 psi.

Spec no.	E* (psi)	G* (psi)	v* -	V _c (ft/sec)	V _l	V _s	tan δ _l -	tan δ _s -	α _l (1/ft)	α _s (1/ft)	S _i (%)	e -
Temperature = +25°F. (-3.9°C)												
1041	3120000	1110000	0.40	15954	10899	6501	0.062	0.060	0.018	0.029	96.7	0.723
1042	2720000	1124000	0.21	10805	10184	6544	0.065	0.035	0.020	0.017	96.1	0.718
1053	2120000	912000	0.17	9327	8996	5904	0.023	0.067	0.008	0.036	96.1	0.719
1053A	2224000	931000	0.24	10004	9215	5978	0.026	0.148	0.009	0.077	96.1	0.719
1054	2220000	943000	0.22	9820	9191	6005	0.033	0.148	0.011	0.077	95.8	0.709
1055	2420000	1004000	0.21	10125	9543	6148	0.025	0.048	0.008	0.025	96.7	0.689
1059	2695000	1025000	0.32	12871	10760	6643	0.030	0.096	0.009	0.045	100.0*	0.823
1063	2575000	950000	0.35	13239	10450	6347	0.050	0.046	0.015	0.023	92.8	0.717
Avg	2485570	996290	0.26	10821	9783	6204	0.041	0.079	0.013	0.038	95.8	0.713
									*Omit from average			
Temperature = +15°F. (-9.4°C)												
1033	3045000	1080000	0.41	16424	10772	6411	0.144	0.125	0.042	0.061	100.0	0.729
1038	3126000	1218000	0.29	12464	10888	6799	0.035	0.068	0.010	0.031	98.8	0.714
1040	2800000	1183000	0.19	10850	10355	6732	0.017	0.040	0.005	0.019	98.8	0.743
1041	3460000	1350000	0.28	12974	11475	7167	0.044	0.028	0.012	0.012	96.7	0.723
Avg	3107750	1207750	0.29	12446	10872	6777	0.060	0.065	0.017	0.031	98.8	0.727
Temperature = 0°F. (-17.7°C)												
1067	3270000	1370000	0.19	11710	11176	7232	0.052	0.028	0.015	0.012	98.3	0.748
1069	3460000	1390000	0.25	12728	11619	7360	0.088	0.026	0.024	0.011	96.9	0.765
1071	3030000	1150000	0.32	13429	11226	6914	0.050	0.012	0.014	0.001	98.0	0.993
1072	2766000	1136000	0.22	11476	10740	6881	0.056	0.018	0.016	0.008	97.3	0.988
1076	3240000	1320000	0.29	13391	11602	7206	0.048	0.029	0.013	0.013	97.6	0.794
Avg 1	3383300	1360000	0.24	12420	11466	7266	0.063	0.028	0.017	0.012	97.6	0.769
Avg 2	2898000	1143000	0.27	12277	10983	6897	0.053	0.015	0.015	0.005	97.6	0.990

Table FII (cont'd).
 Frequency = 5000 Hz, dynamic stress = 5.0 psi.

Spec no.	E* (psi)	G* (psi)	ν^* -	V_c	V_L (ft/sec)	V_S	$\tan \delta_L$ -	$\tan \delta_S$ -	α_L (1/ft)	α_S (1/ft)	S_i (%)	e -
Temperature = +25°F. (-3.9°C)												
1041	3130000	1120000	0.40	15976	10914	6528	0.045	0.029	0.065	0.070	96.7	0.723
1042	2890000	1126000	0.28	11865	10494	6550	0.040	0.035	0.060	0.084	96.1	0.718
1053	2538000	1011000	0.26	10888	9843	6214	0.022	0.045	0.034	0.114	96.1	0.719
1053A	2465000	964000	0.29	11105	9701	6072	0.023	0.086	0.037	0.222	96.1	0.719
1054	2620000	1020000	0.29	11430	9985	6235	0.042	0.087	0.066	0.219	95.8	0.709
1055	2785000	1082000	0.29	11720	10238	6382	0.034	0.046	0.052	0.113	96.7	0.689
1059	2695000	1020000	0.32	12871	10760	6620	0.023	0.024	0.034	0.057	110.1	0.823
1063	2537000	994000	0.28	11726	10371	6492	0.036	0.046	0.054	0.111	92.8	0.717
Avg	2709300	1045286	0.30	11859	10221	6353	0.035	0.053	0.053	0.133	95.8	0.713
Temperature = +15°F. (-9.4°C)												
1033	3060000	1120000	0.37	14330	10775	6520	0.051	0.069	0.074	0.166	100.8	0.729
1038	3285000	1249300	0.32	13352	11162	6886	0.035	0.066	0.049	0.150	98.8	0.714
1040	3165000	1295000	0.22	11764	11010	7043	0.030	0.035	0.043	0.078	98.8	0.743
1041	3620000	1350000	0.34	14560	11736	7167	0.032	0.025	0.043	0.055	96.7	0.723
Avg	3376700	1253575	0.31	13152	11171	6904	0.037	0.049	0.037	0.112	98.8	0.727
Temperature = 0°F. (-17.7°C)												
1067	3300000	1375000	0.20	11831	11224	7246	0.022	0.028	0.031	0.061	98.3	0.748
1069	3460000	1390000	0.24	12603	11609	7358	0.033	0.033	0.045	0.070	96.9	0.765
1071	3090000	1196000	0.29	12974	11334	7054	0.020	0.060	0.028	0.134	98.0	0.993
1072	2960000	1183000	0.25	12167	11107	7022	0.024	0.030	0.034	0.067	97.3	0.988
1076	3420000	1355000	0.26	12857	11599	7301	0.025	0.020	0.019	0.041	97.6	0.794
Avg 1	3393300	1373300	0.23	12320	11477	7302	0.027	0.027	0.032	0.057	97.6	0.769
Avg 2	3025000	1188500	0.27	12542	11220	7038	0.022	0.045	0.031	0.100	97.6	0.990

Table FII (cont'd). Frozen Manchester silt.
 Frequency = 10000 Hz, dynamic stress = 5.0 psi.

Spec no.	E* (psi)	G* (psi)	v* -	V _c	V _l (ft/sec)	V _s	tan δ _l -	tan δ _s -	a _l (1/ft)	a _s (1/ft)	S _i (%)	e -
Temperature = +25°F. (-3.9°C)												
1041	3145000	1127000	0.40	16013	10939	6548	0.033	0.025	0.095	0.120	96.7	0.723
1042	2925000	1150000	0.27	11801	10557	6620	0.030	0.035	0.089	0.166	96.1	0.718
1053	2560000	1020000	0.26	10935	9886	6241	0.017	0.045	0.053	0.226	96.1	0.719
1053A	2507000	967000	0.30	11351	9783	6081	0.021	0.081	0.067	0.418	96.1	0.719
1054	2620000	1028000	0.28	11290	9985	6258	0.038	0.077	0.120	0.386	95.8	0.709
1055	2850000	1090000	0.31	12194	10357	6406	0.029	0.043	0.088	0.211	96.7	0.689
1059	2670000	1019000	0.31	12609	10710	6616	0.018	0.012	0.053	0.057	100.0	0.823
1063	2518000	1000000	0.26	11429	10332	6512	0.030	0.046	0.091	0.222	92.8	0.717
Avg	2732100	1054570	0.30	11907	10263	6381	0.030	0.050	0.086	0.250	95.8	0.713
									*Omit from average			
Temperature = +15°F. (-9.4°C)												
1033	3070000	1180000	0.30	12518	10789	6691	0.021	0.054	0.061	0.253	100.0	0.729
1040	3193000	1295000	0.23	11905	11057	7043	0.012	0.035	0.034	0.156	98.8	0.743
1041	3650000	1350000	0.35	14927	11753	7166	0.017	0.024	0.045	0.105	96.7	0.723
Avg	3304300	1275000	0.29	12833	11210	6967	0.017	0.038	0.047	0.171	98.8	0.732
Temperature = 0°F. (-17.7°C)												
1067	3340000	1455000	0.15	11603	11292	7453	0.015	0.028	0.042	0.118	98.3	0.748
1069	3460000	1390000	0.25	12616	11608	7360	0.023	0.054	0.062	0.230	96.9	0.765
1071	3090000	1200000	0.29	12973	11333	7063	0.009	0.025	0.025	0.111	98.0	0.993
1072	2970000	1190000	0.25	12187	11125	7043	0.018	0.037	0.051	0.165	97.3	0.988
1076	3420000	1380000	0.24	12584	11599	7368	0.048	0.029	0.035	0.077	97.6	0.794
Avg 1	3406670	1408300	0.21	12220	11500	7394	0.029	0.030	0.046	0.142	97.6	0.769
Avg 2	3030000	1195300	0.27	12563	11239	7053	0.014	0.031	0.038	0.138	97.6	0.990

Table FII. Miscellaneous soils.
 Frequency = 1000 Hz, dynamic stress = 0.1 psi.
 Temperature = +15°F (-9.4°C).

Spec no.	E* (psi)	G* (psi)	v* -	V _c	V _l (ft/sec)	V _s	tan δ _l -	tan δ _s -	α _l (1/ft)	α _s (1/ft)	S _i (%)	e -
100-200 Ottawa Sand												
1013	4000000	1400000	0.43	20683	12258	7257	0.030	0.046	0.008	0.020	98.5	0.627
1014	3820000	1520000	0.26	13282	12008	7575	0.029	0.030	0.007	0.012	98.7	0.645
1017	1465000	720000	0.02	7878	7875	5521	0.024	0.023	0.010	0.013	45.1	0.666*
Avg	3910000	1460000	0.35	13590	10713	7416	0.027	0.038	0.008	0.015	98.6	0.636
*Omit from average												
Hanover Silt												
1025	3174000	1199500	0.32	13314	11130	6841	0.039	0.053	0.011	0.024	100.0	0.855
Fairbanks Silt (Undisturbed)												
1082												
1026	1964000	719000	0.37	12888	9691	5864	0.023	0.060	0.007	0.032	87.6	1.545
1027	1415700	516200	0.37	12254	9221	5568	0.023	0.059	0.008	0.033	94.7	4.030
1028	1758000	621500	0.42	15244	9541	5674	0.030	0.066	0.010	0.037	91.2	2.130
Suffield Clay												
1082	954000	285000	0.67	-	5867	3211	0.126	0.160	0.067	0.160	100.0	0.505
1010	1160000	400000	0.45	-	6992	4106	0.096	0.095	0.043	0.095	100.0	1.050
1012	1101000	389500	0.43	11179	6625	3940	0.090	0.076	0.043	0.061	100.0	0.885
Avg	1072300	358200	0.52	-	6495	3752	0.104	0.110	0.051	0.105	100.0	0.797
1007	272000	103000	0.32	4213	3522	2168	0.105	0.130	0.093	0.187	56.8	0.962
1008	252000	85000	0.48	-	3408	1969	0.130	0.170	0.119	0.268	54.2	0.962
Avg	262000	94000	0.40	4620	3465	2068	0.118	0.150	0.106	0.227	55.5	0.962
Goodrich Clay												
1079	830000	308000	0.35	7294	5778	3521	0.080	0.103	0.043	0.092	96.9	0.833
Thetford Till												
1077	2320000	792000	0.46	-	9614	5618	0.086	0.095	0.028	0.053	93.0	0.803
Ice												
1023	1288000	420500	0.53	-	10250	5856	0.055	0.017	0.017	0.009	-	-
1080	1420000	484000	0.47	-	10815	6309	0.107	0.066	0.031	0.033	-	-
1081	1222000	466000	0.31	11955	10115	6246	0.032	0.007	0.010	0.035	-	-
Avg	1310000	456830	0.43	17600	10393	6137	0.065	0.030	0.019	0.026	-	-

Table FIII (cont'd). Miscellaneous soils.
 Frequency = 5000 Hz, dynamic stress = 0.1 psi.
 Temperature = +15°F (-9.4°C).

Spec no.	E* (psi)	G* (psi)	v* -	V _c	V _g (ft/sec)	V _s	tan δ _g -	tan δ _s -	α _g (1/ft)	α _s (1/ft)	S _i (%)	e -
100-200 Ottawa Sand												
1031	4000000	1535000	0.30	14222	12258	7593	0.025	0.022	0.032	0.045	98.5	0.627
1014	3820000	1520000	0.26	13282	12008	7575	0.029	0.024	0.038	0.050	98.7	0.645
1017	1830000	818000	0.12	8950	8802	5885	0.040	0.022	0.071	0.059	45.1	0.666
Avg	3910000	1527500	0.28	13710	12133	7584	0.027	0.023	0.035	0.047	98.6	0.636
										*Omit from average		
Hanover Silt												
1025	3176000	1250000	0.27	12445	11133	6984	0.028	0.030	0.039	0.067	100.0	0.855
Fairbanks Silt (Undisturbed)												
1026	1964000	728000	0.35	12277	9691	5902	0.043	0.043	0.070	0.011	87.6	1.545
1027	1450000	527000	0.37	12412	9333	5631	0.051	0.044	0.088	0.123	94.7	4.030
1028	1799000	643500	0.40	14130	9653	5773	0.065	0.040	0.106	0.110	91.2	2.130
Suffield Clay												
1082	1032000	322000	0.60		6098	3406	0.100	0.094	0.258	0.434	100.0	0.505
1010	1210000	430000	0.41	10888	7141	4259	0.090	0.124	0.198	0.456	100.0	1.050
1012	1185000	431500	0.38	9410	6878	4153	0.146	0.170	0.322	0.638	100.0	0.885
Avg	1142300	394500	0.46		6706	3939	0.112	0.129	0.259	0.509	100.0	0.797
Goodrich Clay												
1079	970000	351000	0.38	8682	6247	3755	0.090	0.047	0.226	0.197	96.9	0.833
Theftord Till												
1077	2320000	792000	0.46		9606	5612	0.027	0.021	0.044	0.059	93.0	0.803
Ice												
1023	1288000	425500	0.51		10250	5891	0.041	0.013	0.025	0.035	-	-
1080	1420000	486000	0.45		10805	6345	0.060	0.031	0.082	0.077	-	-
1081	1275000	477000	0.31	12146	10332	6319	0.019	0.020	0.029	0.049	-	-
Avg.	1328000	461800	0.42	15290	10462	6185	0.040	0.021	0.045	0.054	-	-

Table FIII (cont'd).

Frequency = 1000 Hz, dynamic stress = 1.0 psi.

Temperature = +15°F (-9.4°C).

Spec no.	E* (psi)	G* (psi)	v*	V _c	V _t (ft/sec)	V _s	tan δ _t	tan δ _s	α _t (1/ft)	α _s (1/ft)	S ₁ (%)	e
100-200 Ottawa Sand												
1013	4000000	1400000	0.49	—	12315	7253	0.280	0.058	0.070	0.025	98.5	0.627
1014	3820000	1520000	0.26	13286	12011	7581	0.074	0.120	0.019	0.050	98.7	0.645
1017*	1440000	716000	0.01	—	7809	5506	0.060	0.053	0.024	0.053	45.1	0.666*
Avg.	3910000	1460000	0.38	16610	12163	7417	0.177	0.089	0.044	0.038	98.6	0.636
*Omit from average												
Hanover Silt												
1025	3174000	1183000	0.35	14104	11133	6804	0.073	0.156	0.021	0.072	100.0	0.855
Fairbanks Silt (Undisturbed)												
1026	1964000	719000	0.37	12888	9691	5865	0.037	0.066	0.012	0.035	87.6	1.545
1027	1413000	516200	0.37	11423	9213	5569	0.032	0.059	0.011	0.033	94.7	4.030
1028	1755500	620500	0.42	15231	9533	5670	0.031	0.069	0.010	0.038	91.2	2.130
Suffield Clay												
1082	954000	285000	0.67	—	5866	3211	0.117	0.160	0.063	0.157	100.0	0.505
1010	1160000	400000	0.45	—	6992	4106	0.103	0.102	0.046	0.078	100.0	1.050
1012	1101000	389500	0.43	11182	6627	3941	0.121	0.105	0.057	0.083	100.0	0.885
Avg.	1071700	358170	0.52	—	6495	3756	0.114	0.122	0.055	0.106	100.0	0.797
1007	255000	103000	0.24	3704	3412	2170	0.148	0.148	0.135	0.247	56.8	0.962
1008	246000	84000	0.46	—	3367	1969	0.133	0.170	0.123	0.269	54.2	0.962
Avg	250000	93500	0.35	4510	3390	2070	0.140	0.154	0.129	0.258	55.5	0.962
Goodrich Clay												
1079	830000	302000	0.37	7793	5778	3487	0.080	0.103	0.080	0.103	96.9	0.833
Thetford Till												
1077	2120000	792000	0.34	11368	9191	5618	0.089	0.095	0.030	0.053	93.0	0.803
Ice												
1023	1280000	413000	0.55	—	10221	5804	0.079	0.037	0.024	0.020	—	—
1080	1350000	477000	0.41	16431	10532	6260	0.032	0.033	0.009	0.017	—	—
1081	1209000	466000	0.30	11649	10061	6246	0.029	0.005	0.009	0.025	—	—
Avg	1279700	452000	0.42	16410	10271	6103	0.047	0.025	0.014	0.021	—	—

Table FIII (cont'd). Miscellaneous soils.
 Frequency = 5000 Hz, dynamic stress = 1.0 psi.
 Temperature = +15°F (-9.4°C).

Spec no.	E* (psi)	G* (psi)	v* -	V _c	V _l (ft/sec)	V _s	tan δ _l -	tan δ _s -	α _l (1/ft)	α _s (1/ft)	S _i (%)	e -
100-200 Ottawa Sand												
1012	4000000	1535000	0.30	14226	12261	7593	0.070	0.029	0.089	0.060	98.5	0.627
1013	3820000	1520000	0.26	13286	12011	7575	0.074	0.024	0.097	0.050	98.7	0.645
1017*	1820000	813000	0.12	8926	8779	5867	0.060	0.028	0.107	0.075	45.1	0.666
Avg	3935000	1527500	0.28	13756	12136	7584	0.072	0.027	0.093	0.055	98.6	0.636
									*Omit from average			
Hanover Silt												
1025	3176000	1197000	0.33	13553	11134	6835	0.050	0.036	0.070	0.083	10	0.855
Fairbanks Silt (Undisturbed)												
1026	1964000	728400	0.35	12277	9691	5902	0.044	0.043	0.071	0.114	87.6	1.545
1027	1446700	527000	0.37	12399	9323	5627	0.052	0.044	0.088	0.123	94.7	4.030
1028	1791000	642500	0.39	13604	9632	5768	0.070	0.041	0.114	0.112	91.2	2.130
Suffield Clay												
1082	1032000	322000	0.60		6098	3406	0.100	0.094	0.258	0.434	100.0	0.505
1010	1210000	430000	0.41	10888	7141	4259	0.092	0.130	0.202	0.477	100.0	1.050
1012	1185000	431500	0.38	9410	6878	4153	0.146	0.170	0.312	0.638	100.0	0.885
Avg	1142300	394500	0.46		6706	3939	0.112	0.131	0.257	0.516	100.0	0.797
Goodrich Clay												
1079	970000	346000	0.40	9323	6247	3728	0.090	0.047	0.226	0.168	96.9	0.833
Thetford Till												
1077	2320000	792000	0.46	-	9607	5612	0.034	0.021	0.056	0.059	93.0	0.803
Ice												
1023	1280000	425000	0.51	-	10217	5887	0.027	0.014	0.041	0.037	-	-
1080	1350000	490000	0.38	14305	10531	6344	0.017	0.020	0.025	0.049	-	-
1081	1234000	477000	0.30	11942	10295	6385	0.026	0.007	0.029	0.049	-	-
Avg	1288000	464000	0.40	15150	15150	6205	0.023	0.014	0.032	0.045	-	-

Table FIII (cont'd).
 Frequency = 1000 Hz, dynamic stress = 5.0 psi.
 Temperature = +15°F (-9.4°C).

Spec no.	E* (psi)	G* (psi)	v* -	V _c	V _l (ft/sec)	V _s	tan δ _l -	tan δ _s -	α _l (1/ft)	α _s (1/ft)	S _i (%)	e -
100-200 Ottawa Sand												
1013	3900000	400000	0.41	18696	12262	7256	-	0.099	-	0.043	98.5	0.627
1014	3820000	1520000	0.39	17009	12043	7685	0.220	0.520	0.057	0.200	98.7	0.645
1017*	1380000	712000	0.21	8183	7713	5499	0.400	0.166	0.157	0.094	45.7	0.666
Avg	3860000	1460000	0.40		12153	7470	-	0.309	-	0.121	98.6	0.636
Hanover Silt												
1025	3174000	1123000	0.43	18834	11163	6666	0.225	0.374	0.062	0.158	100.0	0.855
Fairbanks Silt (Undisturbed)												
1026	1913000	718100	0.33	11651	9572	5862	0.122	0.090	0.040	0.048	87.6	1.545
1027	1411500	512600	0.38	12605	9213	5550	0.100	0.100	0.034	0.034	94.7	4.030
1028	1753000	618250	0.42	15225	9529	6660	0.061	0.061	0.020	0.043	91.2	2.130
Suffield Clay												
1082	948000	285000	0.66	-	5847	3211	0.117	0.160	0.063	0.160	100.0	0.505
1010	1160000	400000	0.45	-	6992	4106	0.134	0.125	0.060	0.095	100.0	1.050
1012	1101000	389500	0.43	11214	6646	3944	0.250	0.160	0.116	0.127	100.0	0.885
Avg	1069670	358170	0.51	-	6495	3754	0.167	0.148	0.080	0.127	100.0	0.797
1007	231000	99000	0.17	3387	3263	2136	0.360	0.320	0.336	0.459	56.8	0.962
1008	241000	82000	0.47	-	3334	1947	0.149	0.202	0.140	0.323	54.2	0.962
Avg	236000	90500	0.32	-	3299	2041	0.255	0.261	0.238	0.391	55.5	0.962
Goodrich Clay												
1079	830000	297000	0.40	8401	5778	3458	0.080	0.103	0.043	0.094	36.9	0.833
Thetford Till												
1077	1890000	792000	0.19	9112	8680	5618	0.100	0.095	0.036	0.053	93.0	0.803
Ice												
1023	1275000	405000	0.66	-	10263	5748	0.333*	0.065	0.099*	0.035	-	-
1080	1330000	476000	0.40	15139	10453	6254	0.026	0.033	0.008	0.017	-	-
1081	1209000	466000	0.30	11634	10661	6246	0.018	0.005	0.006	0.025	-	-
Avg	1271300	449000	0.45	-	10459	6083	0.022	0.034	0.007	0.026	-	-
*Omit from average												

Table FIII (cont'd). Miscellaneous soils.
 Frequency = 5000 Hz, dynamic stress = 5.0 psi.
 Temperature = +15°F (-9.4°C).

Spec no.	E* (psi)	G* (psi)	v* -	V _c	V _l (ft/sec)	V _s	tan δ _l -	tan δ _s -	α _l (1/ft)	α _s (1/ft)	S ₁ (%)	e -
100-200 Ottawa Sand												
1013	3900000	1535000	0.55	-	12262	7593	0.490	0.029	0.089	0.060	98.5	0.627
1014	3820000	1520000	0.33	14659	12043	7575	0.220	0.030	0.284	0.062	98.7	0.645
1017*	1800000	806000	0.13	8912	8737	5842	0.118	0.053	0.211	0.142	45.1	*C.666
Avg	3860000	1530000	0.44	21900	12152	7584	0.355	0.030	0.186	0.061	98.6	0.636
									*Omit from average			
Hanover Silt												
1025	3176000	1194000	0.34	13822	11141	6827	0.114	0.059	0.160	0.136	100.0	0.855
Fairbanks Silt (Undisturbed)												
1026	1948000	723200	0.35	12228	9652	5881	0.045	0.043	0.073	0.114	87.6	1.545
1027	1441500	527200	0.37	12377	9307	5628	0.060	0.054	0.101	0.151	94.7	4.030
1028	1759000	640000	0.38	13065	9549	5757	0.099	0.041	0.162	0.113	91.2	2.130
Suffield Clay												
1082	1026000	322000	0.59	-	6080	3406	0.100	0.094	0.258	0.434	100.0	0.505
1010	1210000	418000	0.42	11409	7141	4197	0.105	0.104	0.230	0.155	100.0	1.050
1012	1185000	431500	0.38	9408	6876	4155	0.124	0.195	0.282	0.730	100.0	0.885
Avg	1140300	390500	0.46	-	6699	3919	0.110	0.131	0.257	0.440	100.0	0.797
Goodrich Clay												
1079	970000	342000	0.42	10044	6247	3707	0.090	0.047	0.226	0.199	96.9	0.833
Thetford Till												
1077	2320000	792000	0.46	-	9608	5612	0.046	0.021	0.075	0.059	93.0	0.803
Ice												
1023	1275000	423000	0.52	-	10207	5873	0.131*	0.017	0.201*	0.049	-	-
1080	1330000	488000	0.36	13643	10452	6331	0.014	0.020	0.021	0.050	-	-
1081	1266000	487000	0.30	11943	10295	6385	0.012	0.020	0.012	0.049	-	-
Avg	1290000	466000	0.39	14580	10318	6196	0.013	0.019	0.017	0.049	-	-
									*Omit from average			

Table FIV. Miscellaneous soils and ice.
 Frequency = 1000 Hz, dynamic stress = 0.1 psi.

Spec no.	E* (psi)	G* (psi)	v*	V _c	V _l (ft/sec)	V _s	tan δ _l	tan δ _s	α _l (1/ft)	α _s (1/ft)	S _i (%)	e
Goodrich Clay, +25°F (-3.9°C)												
1079	735000	214000	0.72	-	5447	2936	0.148	0.112	0.085	0.120	96.9	0.833
Suffield Clay, +25°F (-3.9°C)												
1082	772000	253000	0.52	-	5282	3025	0.148	0.159	0.088	0.165	100.0	0.505
Thetford Till, +25°F (-3.9°C)												
1077	1455000	413000	0.76	-	7609	4053	0.051	0.035	0.020	0.027	93.0	0.803
Ice, +25°F (-3.9°C)												
	500	465000	0.31	11856	10070	6232	0.033	0.035	0.010	0.018	-	-
	9000	470000	0.29	11476	9738	6075	0.038	0.081	0.012	0.042	-	-
1080	1350000	452000	0.49	-	10536	6101	0.063	0.089	0.019	0.046	-	-
1081	1240000	463000	0.30	11548	9962	6226	0.138	0.031	0.043	0.016	-	-
Avg.	1233300	464000	0.36	13050	10078	6158	0.063	0.059	0.021	0.030	-	-
Goodrich Clay, 0°F (-17.7°C)												
1075	1836000	574000	0.60	-	8532	4771	0.021	0.036	0.008	0.024	100.0	0.853
1079	1180000	412000	0.43	11779	6891	4071	0.095	0.087	0.043	0.067	96.9	0.833
Avg.	1508000	493000	0.51	-	7711	4421	0.053	0.061	0.025	0.045	98.4	0.843
Suffield Clay, 0°F (-17.7°C)												
1082	1201000	333000	0.90	-	6576	3469	0.082	0.144	0.044	0.130	100.0	0.505
Thetford Till, 0°C (-17.7°C)												
1077	2710000	934000	0.45	-	10389	6095	0.079	0.035	0.024	0.018	93.0	0.803
Ice, 0°F (-17.7°C)												
1073*	2212000	1190000	0.07	-	13562	9947	0.156	0.155	0.036	0.049*	-	-
1080	1355000	479000	0.41	15750	10352	6154	0.043	0.023	0.013	0.016	-	-
1081	1245000	475000	0.31	12060	10212	6306	0.046	0.003	0.014	0.001	-	-
Avg.	1300000	477000	0.36	13320	10282	6230	0.045	0.013	0.013	0.009	-	-
* = omit from average												

Table FIV (cont'd). Miscellaneous soils and ice.

Frequency = 5000 Hz, dynamic stress = 0.1 psi.

Spec no.	E* (psi)	G* (psi)	v*	V _c	V _t (ft/sec)	V _s	tan δ _t	tan δ _s	a _t (1/ft)	a _s (1/ft)	S _i (%)	e
Goodrich Clay, +25°F (-3.9°C)												
1079	766000	249000	0.54	-	5553	3164	0.099	0.067	0.280	0.333	96.9	0.833
Suffield Clay, +25°F (-3.9°C)												
1082	875000	308000	0.42	9108	5622	3332	0.140	0.103	0.391	0.486	100.0	0.505
Thetford Till, +25°F (-3.9°C)												
1077	1745000	413000	1.11	-	8332	4053	0.036	0.028	0.068	0.109	93.0	0.803
Ice, +25°F (-3.9°C)												
1057	1320000	446000	0.48	-	10499	6232	0.022	0.035	0.033	0.018	-	-
1080	1350000	481000	0.40	15629	10533	6287	0.045	0.036	0.067	0.090	-	-
1081	1252000	476000	0.32	12172	10240	6313	0.041	0.019	0.063	0.047	-	-
Avg.	1307300	468000	0.40	15210	10424	6277	0.036	0.030	0.054	0.052	-	-
Goodrich Clay, 0°F (-17.7°C)												
1075	1844000	683000	0.35	10841	8552	5206	0.046	0.060	0.084	0.181	100.0	0.853
1079	1408000	514000	0.37	10036	7527	4545	0.090	0.063	0.188	0.218	96.9	0.833
Avg.	1626000	598500	0.36	10400	8039	4875	0.068	0.061	0.136	0.199	98.4	0.843
Suffield Clay, 0°F (-17.7°C)												
1082	1240000	358000	0.73	-	6684	3589	0.096	0.071	0.225	0.311	100.0	0.505
Thetford Till, 0°F (-17.7°C)												
1077	2860000	934000	0.53	-	10666	6095	0.032	0.027	0.047	0.070	93.0	0.803
Ice, 0°F (-17.7°C)												
1080	1355000	494000	0.37	13823	10350	6249	0.026	0.019	0.039	0.048	-	-
1081	1293000	496000	0.30	12150	10404	6445	0.019	0.042	0.029	0.102	-	-
Avg.	1324000	495000	0.34	12880	10377	6337	0.023	0.030	0.034	0.075	-	-

Table FIV (cont'd).
 Frequency = 10000 Hz, dynamic stress = 0.1 psi.

Spec no.	E* (psi)	G* (psi)	ν^* -	V_c	V_L (ft/sec)	V_S	$\tan \delta_L$ -	$\tan \delta_S$ -	α_L (1/ft)	α_S (1/ft)	S_i (%)	e -
Goodrich Clay, +25°F (-3.9°C)												
1079	776000	256000	0.52	-	5588	3207	0.096	0.058	0.540	0.568	96.9	0.833
Suffield Clay, +25°F (-3.9°C)												
1082	891000	321000	0.39	8095	5671	3399	0.129	0.074	0.715	0.684	100.0	0.505
Thetford Till, +25°F (-3.9°C)												
1077	1800000	413000	1.18	-	8461	4053	0.025	0.019	0.093	0.147	93.0	0.803
Ice, +25°F (-3.9°C)												
1080	1350000	488000	0.38	14566	10531	6331	0.023	0.009	0.069	0.045	-	-
1081	1272000	487000	0.31	12076	10319	6385	0.013	0.014	0.040	0.069	-	-
Avg.	1311000	487500	0.34	12920	10425	6358	0.018	0.012	0.054	0.057	-	-
Goodrich Clay, 0°F (-17.7°C)												
1075	1855000	715000	0.30	9936	8582	5326	0.081	0.057	0.297	0.336	100.0	0.853
1079	1422000	526000	0.35	9631	7562	4598	0.080	0.061	0.332	0.417	96.9	0.833
Avg.	1638500	620500	0.32	9690	8072	4962	0.080	0.059	0.314	0.376	98.4	0.843
Suffield Clay, 0°F (-17.7°C)												
1082	1250000	358000	0.74	-	6710	3589	0.092	0.063	0.431	0.551	100.0	0.505
Thetford Till, 0°F (-17.7°C)												
1077	2860000	934000	0.53	-	10665	6095	0.079	0.035	0.047	0.082	93.0	0.303
Ice, 0°F (-17.7°C)												
1080	1355000	502000	0.35	13100	10350	6299	0.016	0.016	0.048	0.080	-	-
1081	1302000	500000	0.30	12156	10440	6470	0.007	0.022	0.021	0.107	-	-
Avg.	1328500	501000	0.33	12690	10395	6385	0.012	0.019	0.039	0.093	-	-

Table FIV (cont'd). Miscellaneous soils and ice.

Frequency = 1000 Hz, dynamic stress = 1.0 psi.

Spec no.	E* (psi)	G* (psi)	v* -	V _c	V _l (ft/sec)	V _s	tan δ _l -	tan δ _s -	α _l (1/ft)	α _s (1/ft)	S _i (%)	e -
Goodrich Clay, +25°F (-3.9°C)												
1079	667000	210000	0.59	-	5190	2909	0.151	0.112	0.091	0.121	96.9	0.833
Suffield Clay, +25°F (-3.9°C)												
1082	772000	249000	0.55	-	5279	3001	0.133	0.159	0.079	0.166	100.0	0.505
Thetford Till, +25°F (-3.9°C)												
1077	1370000	413000	0.66	-	7388	4054	0.086	0.047	0.036	0.024	93.0	0.803
Ice, +25°F (-3.9°C)												
1057	1214000	465000	0.31	11856	10070	6232	0.033	0.035	0.010	0.018	-	-
1058	1195000	470000	0.28	10945	9681	6075	0.038	0.081	0.012	0.042	-	-
1080	1324000	481000	0.47	-	10432	6082	0.054	0.089	0.016	0.046	-	-
1081	1180000	460000	0.29	11327	9945	6206	0.070	0.031	0.022	0.016	-	-
Avg.	1228250	469000	0.34	12420	10032	6149	0.049	0.059	0.015	0.030	-	-
Goodrich Clay, 0°F (-17.7°C)												
1075	1744000	574000	0.52	-	8316	4773	0.040	0.064	0.015	0.042	100.0	0.853
1079	1180000	412000	0.43	11769	6890	4071	0.087	0.087	0.040	0.067	96.9	0.833
Avg.	1462000	493000	0.47	-	7603	4422	0.063	0.077	0.027	0.054	98.4	0.843
Suffield Clay, 0°F (-17.7°C)												
1082	1170000	331000	0.77	-	6490	3459	0.082	0.152	0.040	0.152	100.0	0.505
Thetford Till, 0°F (-17.7°C)												
1077	2650000	934000	0.42	16751	10276	6095	0.091	0.035	0.028	0.018	93.0	0.803
Ice, 0°F (-17.7°C)												
1080	1342000	472000	0.42	16599	10300	6109	0.016	0.023	0.005	0.012	-	-
1081	1245000	472000	0.32	12240	10211	6286	0.037	0.003	0.011	0.002	-	-
Avg.	1293500	472000	0.37	13720	10255	6197	0.027	0.013	0.008	0.007	-	-

Table FIV (cont'd).
 Frequency = 5000 Hz, dynamic stress = 1.0 psi.

Spec no.	E* (psi)	G* (psi)	ν^* -	V_c	V_l (ft/sec)	V_s	$\tan \delta_l$ -	$\tan \delta_s$ -	α_l (1/ft)	α_s (1/ft)	S_i (%)	e -
Goodrich Clay, +25°F (-3.9°C)												
1079	746000	246000	0.52	-	5480	3145	0.100	0.067	0.287	0.335	96.9	0.833
Suffield Clay, +25°F (-3.9°C)												
1082	875000	305000	0.43	9824	5620	3315	0.131	0.103	0.366	0.484	100.0	0.505
Thetford Till, +25°F (-3.9°C)												
1077	1720000	413000	1.08	-	8272	4053	0.042	0.040	0.080	0.155	93.0	0.803
Ice, +25°F (-3.9°C)												
1057	1320000	446000	0.48	-	10499	6103	0.022	0.032	0.033	0.082	-	-
1080	1324000	477000	0.39	14626	10430	6260	0.035	0.036	0.053	0.090	-	-
1081	1252000	474000	0.32	12266	10239	6299	0.029	0.019	0.045	0.047	-	-
Avg.	1298670	465670	0.40	15170	10389	6221	0.029	0.029	0.044	0.073	-	-
Goodrich Clay, 0°F (-17.7°C)												
1075	1815000	683000	0.33	10305	8486	5206	0.058	0.060	0.011	0.181	100.0	0.853
1079	1400000	514000	0.36	9789	7504	4545	0.082	0.063	0.172	0.218	96.9	0.833
Avg.	1607500	598500	0.34	-	7995	4875	0.070	0.061	0.091	0.199	98.4	0.843
Suffield Clay, 0°F (-17.7°C)												
1082	1237000	356000	0.73	-	6676	3579	0.098	0.071	0.231	0.312	100.0	0.505
Thetford Till, 0°F (-17.7°C)												
1077	2830000	934000	0.52	-	10613	6095	0.056	0.027	0.083	0.070	93.0	0.803
Ice, 0°F (-17.7°C)												
1080	1342000	488000	0.38	13891	10300	6211	0.013	0.019	0.020	0.048	-	-
1081	1293000	492000	0.31	12351	10404	6419	0.013	0.038	0.020	0.093	-	-
Avg.	1317500	490000	0.35	13150	10352	6315	0.013	0.029	0.020	0.070	-	-

Table FIV (cont'd). Miscellaneous soils and ice.
Frequency = 10000 Hz, dynamic stress = 1.0 psi.

Spec no.	E* (psi)	G* (psi)	ν^*	V_c	V_L (ft/sec)	V_S	$\tan \delta_L$	$\tan \delta_S$	α_L (1/ft)	α_S (1/ft)	S_i (%)	e
Goodrich Clay, +25°F (-3.9°C)												
1079	748000	254000	0.47	-	5487	3195	0.096	0.058	0.550	0.570	96.9	0.833
Suffield Clay, +25°F (-3.9°C)												
1082	891000	318000	0.41	8504	5671	3383	0.129	0.074	0.715	0.687	100.0	0.505
Thetford Till, +25°F (-3.9°C)												
1077	1780000	413000	1.15	-	8414	4053	0.030	0.031	0.120	0.240	93.0	0.803
Ice, +25°F (-3.9°C)												
1080	1324000	488000	0.36	13414	10429	6331	0.017	0.009	0.057	0.009	-	-
1081	1272000	484000	0.31	12226	10319	6365	0.012	0.014	0.036	0.069	-	-
Avg.	1298000	486000	0.34	12650	10374	6348	0.014	0.017	0.043	0.039	-	-
Goodrich Clay, 0°F (-17.7°C)												
1075	1855000	715000	0.30	9936	8582	5326	0.081	0.057	0.297	0.336	100.0	0.853
1079	1414000	526000	0.34	9448	7541	4598	0.080	0.061	0.333	0.417	96.9	0.833
Avg.	1634500	620500	0.32	-	8061	4962	0.080	0.059	0.315	0.376	98.4	0.843
Suffield Clay, 0°F (-17.7°C)												
1082	1250000	352000	0.77	-	6710	3559	0.092	0.063	0.431	0.556	100.0	0.505
Thetford Till, 0°F (-17.7°C)												
1077	2840000	934000	0.52	-	10628	6095	0.019	0.016	0.056	0.082	93.0	0.803
Ice, 0°F (-17.7°C)												
1080	1342000	494000	0.36	13300	10300	6249	0.011	0.016	0.033	0.080	-	-
1081	1302000	496000	0.31	12339	10400	6944	0.007	0.010	0.021	0.049	-	-
Avg.	1322000	495000	0.34	12650	10370	6597	0.009	0.013	0.027	0.065	-	-

Table FIV (cont'd).
 Frequency = 1000 Hz, dynamic stress = 5.0 psi.

Spec no.	E* (psi)	G* (psi)	v*	V _c	V _g (ft/sec)	V _s	tan δ _g	tan δ _s	α _g (1/ft)	α _s (1/ft)	S _i (%)	e
Goodrich Clay, +25°F (-3.9°C)												
1079	648000	205000	0.58	-	5116	2873	0.153	0.112	0.094	0.122	96.9	0.833
Suffield Clay, +25°F (-3.9°C)												
1082	752000	236000	0.59	-	5211	2922	0.133	0.159	0.080	0.171	100.0	0.505
Thetford Till, +25°F (-3.9°C)												
1077	1370000	413000	0.65	-	7388	4056	0.086	0.083	0.036	0.064	93.0	0.803
Ice, +25°F (-3.9°C)												
1080	1304000	449500	0.45	-	10353	6082	0.049	0.089	0.015	0.046	-	-
1081	1180000	463000	0.29	11367	9945	6199	0.070	0.031	0.022	0.016	-	-
Avg.	1242000	456250	0.37	13500	10149	6140	0.059	0.060	0.018	0.031	-	-
Goodrich Clay, 0°F (-17.7°C)												
1075	1714000	574000	0.49	-	8248	4773	0.073	0.070	0.028	0.046	100.0	0.853
1079	1180000	412000	0.43	11769	6890	4071	0.087	0.087	0.040	0.067	96.9	0.833
Avg.	1447000	493000	0.46	-	7569	4421	0.080	0.078	0.034	0.056	98.4	0.843
Suffield Clay, 0°F (-17.7°C)												
1082	1124000	326000	0.73	-	6362	3433	0.082	0.152	0.040	0.139	100.0	0.505
Thetford Till, 0°F (-17.7°C)												
1077	2590000	834000	0.39	14449	10159	6095	0.091	0.035	0.028	0.018	93.0	0.803
Ice, 0°F (-17.7°C)												
1080	1342000	467000	0.44	18151	10300	6076	0.016	0.023	0.005	0.012	-	-
1081	1240000	470000	0.32	12221	10190	6272	0.037	0.003	0.011	0.002	-	-
Avg.	1291000	468500	0.38	14020	10245	6174	0.027	0.013	0.008	0.007	-	-

Table FIV (cont'd). Miscellaneous soils and ice.
 Frequency = 5000 Hz, dynamic stress = 5.0 psi.

Spec no.	E* (psi)	G* (psi)	v*	V _c	V _l (ft/sec)	V _s	tan δ _l	tan δ _s	α _l (1/ft)	α _s (1/ft)	S _i (%)	e
Goodrich Clay, +25°F (-3.9°C)												
1079	715000	243000	0.47	-	5365	3125	0.105	0.067	0.307	0.337	96.9	0.833
Suffield Clay, +25°F (-3.9°C)												
1082	862000	286000	0.55	-	5578	3210	0.131	0.103	0.369	0.504	100.0	0.505
Thetford Till, +25°F (-3.9°C)												
1077	1720000	413000	1.08	-	8272	4055	0.042	0.072	0.080	0.280	93.0	0.803
Ice, +25°F (-3.9°C)												
1080	1304000	477000	0.37	13653	10351	6260	0.032	0.036	0.048	0.090	-	-
1081	1252000	472000	0.33	12384	10239	6286	0.029	0.019	0.029	0.047	-	-
Avg.	1278000	474500	0.35	13070	10295	6273	0.030	0.028	0.038	0.069	-	-
Goodrich Clay, 0°F (-17.7°C)												
1075	1780000	683000	0.30	9806	8406	5206	0.078	0.060	0.146	0.181	100.0	0.853
1079	1390000	514000	0.35	9532	7477	4545	0.082	0.063	0.172	0.218	96.9	0.833
Avg.	1585000	598500	0.32	9530	7941	4875	0.080	0.061	0.159	0.199	98.4	0.843
Suffield Clay, 0°F (-17.7°C)												
1082	1234000	352000	0.75	-	6668	3559	0.098	0.071	0.231	0.313	100.0	0.505
Thetford Till, 0°F (-17.7°C)												
1077	2830000	934000	0.52	-	10613	6095	0.056	0.027	0.083	0.070	93.0	0.803
Ice, 0°F (-17.7°C)												
1080	1342000	480000	0.38	14122	10300	6198	0.013	0.019	0.017	0.040	-	-
1081	1285000	487000	0.32	12419	10372	6386	0.013	0.038	0.020	0.093	-	-
Avg.	1313500	483500	0.35	13140	10366	6292	0.013	0.029	0.018	0.067	-	-

Table FIV (cont'd).
 Frequency = 10000 Hz, dynamic stress = 5.0 psi.

Spec no.	E* (psi)	G* (psi)	v*	V _c	V _l (ft/sec)	V _s	tan δ _l	tan δ _s	a _l (1/ft)	a _s (1/ft)	S _i (%)	e
Goodrich Clay, +25°F (-3.9°C)												
1079	716000	252000	0.42	8718	5368	3182	0.097	0.058	0.568	0.573	96.9	0.833
Suffield Clay, +25°F (-3.9°C)												
1082	885000	297000	0.49	-	5652	3270	0.129	0.074	0.717	0.711	100.0	0.505
Thetford Till, +25°F (-3.9°C)												
1077	1780000	413000	1.15	-	8414	4054	0.030	0.060	0.120	0.465	93.0	0.803
Ice, +25°F (-3.9°C)												
1080	1304000	488000	0.33	12744	10350	6331	0.016	0.009	0.048	0.045	-	-
1081	1272000	480000	0.32	12450	10319	6339	0.012	0.014	0.036	0.069	-	-
Avg.	1288000	484000	0.32	12410	10334	6335	0.014	0.012	0.042	0.057	-	-
Goodrich Clay, 0°F (-17.7°C)												
1075	1855000	715000	0.30	9936	8582	5326	0.081	0.057	0.297	0.336	100.0	0.853
1079	1410000	526000	0.34	9361	7530	4598	0.080	0.061	0.334	0.417	96.9	0.833
Avg.	1632500	620500	0.32	9660	8056	4962	0.080	0.059	0.315	0.376	98.4	0.843
Suffield Clay, 0°F (-17.7°C)												
1082	1250000	352000	0.77	-	6710	3559	0.092	0.063	0.431	0.556	100.0	0.505
Thetford Till, 0°F (-17.7°C)												
1077	2840000	934000	0.52	-	10628	6095	0.019	0.016	0.056	0.082	93.0	0.803
Ice, 0°F (-17.7°C)												
1080	1342000	486000	0.38	14122	10300	6198	0.011	0.016	0.033	0.081	-	-
1081	1292000	490000	0.32	12408	10400	6405	0.007	0.004	0.021	0.020	-	-
Avg.	1317000	488000	0.35	13150	10350	6301	0.009	0.010	0.025	0.050	-	-

