

AD-A012 399

ON THE DEVELOPMENT OF A UNIFIED THEORY FOR VORTEX FLOW
PHENOMENA FOR AERONAUTICAL APPLICATIONS

Thomas K. Matoi

Massachusetts Institute of Technology

Prepared for:

Office of Naval Research

14 April 1975

DISTRIBUTED BY:

NTIS

National Technical Information Service
U. S. DEPARTMENT OF COMMERCE

**Best
Available
Copy**

206074

ADA012399

ON THE DEVELOPMENT OF A UNIFIED THEORY FOR VORTEX FLOW
PHENOMENA FOR AERONAUTICAL APPLICATIONS

Thomas K. Matoi
Massachusetts Institute of Technology
Department of Aeronautics and Astronautics
Fluid Dynamics Research Laboratory
Cambridge, Massachusetts 02139

Technical Report
1 November 1973 - 31 October 1974

Approved for public release; distribution unlimited

[April 14, 1975]

Reproduced by
NATIONAL TECHNICAL
INFORMATION SERVICE
US Department of Commerce
Springfield, VA. 22151

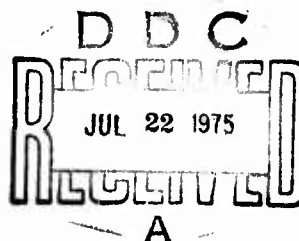

This investigation was supported by the Office of Naval Research, Code 211, Arlington, Virginia 22217, under Contract N 00014-67-A-0204-0085 (NR215-230).

Reproduction in whole or in part is permitted for any purpose of the United States Government.

UNCLASSIFIED

SECURITY CLASSIFICATION OF THIS PAGE (When Data Entered)

REPORT DOCUMENTATION PAGE		READ INSTRUCTIONS BEFORE COMPLETING FORM
1. REPORT NUMBER	2. GOVT ACCESSION NO.	3. RECIPIENT'S CATALOG NUMBER
4. TITLE (and Subtitle) ON THE DEVELOPMENT OF A UNIFIED THEORY FOR VORTEX FLOW PHENOMENA FOR AERONAUTICAL APPLICATIONS		5. TYPE OF REPORT & PERIOD COVERED TECHNICAL November 1973-October 1974
7. AUTHOR(s) Thomas K. Matoi		6. PERFORMING ORG. REPORT NUMBER
9. PERFORMING ORGANIZATION NAME AND ADDRESS Massachusetts Institute of Technology Cambridge, Massachusetts 02139		8. CONTRACT OR GRANT NUMBER(s) N00014-67-A-0204-0085
11. CONTROLLING OFFICE NAME AND ADDRESS Office of Naval Research Vehicle Technology, Code 211 Arlington, Virginia 22217		10. PROGRAM ELEMENT, PROJECT, TASK AREA & WORK UNIT NUMBERS NR 215-230
14. MONITORING AGENCY NAME & ADDRESS (if different from Controlling Office) Office of Naval Research Resident Representative E19-628 Massachusetts Institute of Technology Cambridge, Massachusetts 02139		12. REPORT DATE April 14, 1975
		13. NUMBER OF PAGES -140 / 45
		15. SECURITY CLASS. (of this report) Unclassified
		15a. DECLASSIFICATION/DOWNGRADING SCHEDULE
16. DISTRIBUTION STATEMENT (of this Report) Approved for public release; distribution unlimited.		
17. DISTRIBUTION STATEMENT (of the abstract entered in Block 20, if different from Report)		
18. SUPPLEMENTARY NOTES		
19. KEY WORDS (Continue on reverse side if necessary and identify by block number) Leading-edge vortex Vortex Flow Phenomena		
20. ABSTRACT (Continue on reverse side if necessary and identify by block number) ON THE DEVELOPMENT OF A UNIFIED THEORY FOR VORTEX PHENOMENA FOR AERONAUTICAL APPLICATIONS The low-speed performance of a high span loading aircraft depends critically on the structure and stability of the vortex flow field created by the wing. Conventional formulation of lifting surface theory is not		

DD FORM 1473
1 JAN 73

EDITION OF 1 NOV 68 IS OBSOLETE
S/N 0102-014-6601

UNCLASSIFIED
SECURITY CLASSIFICATION OF THIS PAGE (When Data Entered)

adequate to handle the low-aspect-ratio-wing problem since the leading-edge vortices add several complications. Specifically, the nonplanar nature of the vortex sheet may have to be considered explicitly, the leading-edge loading is altered, and vortex breakdown is a rotational phenomenon. Due to those additional difficulties, a study was made of the state of the art in vortex-wing interactions. Namely, 1) a critical review was made of existing models for the individual flow field elements; 2) a critical review was made of existing models of leading-edge separation (summarized in Table 3); and 3) areas where further research is necessary were identified. The study concludes that additional effort must be made to develop a lifting-surface-theory model to include the high span loading phenomena.

ON THE DEVELOPMENT OF A UNIFIED THEORY FOR VORTEX FLOW
PHENOMENA FOR AERONAUTICAL APPLICATIONS

Thomas K. Matoi
Massachusetts Institute of Technology
Department of Aeronautics and Astronautics
Fluid Dynamics Research Laboratory
Cambridge, Massachusetts 02139

Technical Report
1 November 1973 - 31 October 1974

Approved for public release; distribution unlimited

[April 14, 1975]

This investigation was supported by the Office of Naval Research, Code 211, Arlington, Virginia 22217, under Contract N 00014-67-A-0204-0085 (NR215-230).

Reproduction in whole or in part is permitted for any purpose of the United States Government.

ON THE DEVELOPMENT OF A UNIFIED THEORY FOR VORTEX FLOW
PHENOMENA FOR AERONAUTICAL APPLICATIONS

TABLE OF CONTENTS

LIST OF ILLUSTRATIONS	3
INTRODUCTION	5
Historical Development	7
VORTEX FLOW ELEMENTS	12
Vortex Sheets	14
Vortex Core	17
Vortex Breakdown	21
Instability	22
Separation Phenomenon	25
Standing Wave Phenomenon	26
Finite Transition	28
Trapped Wave Model	29
Smooth Development	
Simplified Analysis	
CONTINUOUS SLENDER-BODY MODELS	
Method of Legendre (I)	34
Method of Brown and Michael	37
Method of Mangler and Smith	42
Method of Smith	48
Method of Legendre (II)	57
DISCRETE SLENDER-BODY MODELS	
Fundamentals	62
Method of Sacks	71
LIFTING SURFACE THEORY	
Method of Belotserkovskii	82
Method of Polhamus	87
CONCLUSION	94
BIBLIOGRAPHY	97
SYMBOLS AND ILLUSTRATIONS	109

ACKNOWLEDGMENTS

The author would like to thank Professors Sheila E. Widnall and Eugene E. Covert for their supervision and guidance during the period of research. The contributions of fellow investigators John Keesee and Ping Wong are also acknowledged.

The investigation described in this report was supported by the Office of Naval Research, Code 211, under Contract N 00014-67-A-0204-0085.

LIST OF ILLUSTRATIONS

- Figure 1. Diagrams of the flow over triangular wings [Wilson & Lovell (1947)].
- Figure 2. Schematic sketches showing the (suggested) flow on the suction side of a flat plate delta wing [Ornberg (1954)].
- Figure 3. Axial filaments of dye [Lambourne & Bryer (1961)].
- Figure 4. Stages in behavior of axial filament [Lambourne & Bryer (1961)].
- Figure 5. Vortex sheet shape and azimuthal velocity [Küchemann & Weber (1965)].
- Figure 6. Experimental & theoretical profiles of axial velocity and circumferential velocity [Hall (1961)].
- Figure 7. Stable and unstable regions in the \tilde{c}_w, \tilde{c}_v plane [Ludwig (1961)].
- Figure 8. Vortex breakdown flowfield regions [Bossel (1969)].
- Figure 9. Coordinate systems for the potential flow problem [Legendre (1952)].
- Figure 10. Lift Curves for various sweep angles. Dashed lines represent Jones' result [Legendre (1952)].
- Figure 11. Coordinate system notation [Brown & Michael (1954)].
- Figure 12. Pressure distributions [Brown & Michael (1954)].
- Figure 13. Coordinates for cross-section [Mangler & Smith (1957)].
- Figure 14. Approximation to vortex sheet [Mangler & Smith (1957)].
- Figure 15. Notation in transformed plane [Mangler & Smith (1957)].
- Figure 16. Normal force - Theory and experiment [Mangler & Smith (1957)].
- Figure 17. Shape of vortex sheet and position of core center for $\alpha/K = .4, .8, 1.2, 1.6, 2.0$ [Mangler & Smith (1957)].
- Figure 18. Configuration in transformed plane, $Z^* = y^* + iz^*$ [Smith (1968)].
- Figure 19. Vortex sheet shapes and isolated vortex positions for $a = .91$ [Smith (1968)].
- Figure 20. Sheet shape and strength compared with asymptotic solutions [Smith (1966a)].

- Figure 21. Calculated sheet shape and vortex core location [Pullin (1973)].
- Figure 22. Vortex axis locus comparison of theories with test results [Legendre (1966)].
- Figure 23. Model of vortex separation on a 3-D body [Angelucci (1971)].
- Figure 24. Vortex sheet, pressure and non-linear force increment [Fink & Soh (1974)].
- Figure 25. Calculation for a delta wing by progressive deformation of a rectangular wing [Rehbach (1973b)].
- Figure 26. Verification of the conicality of the flow [Rehbach (1973b)].
- Figure 27. Vortex sheet at the trailing edge for $\alpha = 1$ (top) and normal force coefficient (bottom) [Rehbach (1973b)].
- Figure 28. Variation of K_p and K_r with \mathcal{R} for delta wings [Polhamus (1966)].
- Figure 29. Comparison of theory with experimental lift of delta wings [Polhamus (1971)].

INTRODUCTION

The low speed performance, safety and handling qualities of high span loading aircraft depend on the structure and stability of the vortex flow created by the wing. The development of a unified theory of vortex flow phenomena near the wing would permit one to predict the lift distribution on such a wing as well as the structure and stability of the free vortex flow field. In principle, such knowledge would allow one to tailor the wing-vortex interaction to achieve good handling qualities and a stable flow over the wing. At least, detailed knowledge of the vortex phenomena might enable the designer to reduce their possible detrimental effect on the aerodynamic characteristics of the aircraft. For example, consider the adverse effects of breakdown of the leading-edge vortices, studied by Hummel and Redeker (1967). Another example is the effect of vortex filaments on yawed aircraft, as examined by Landahl and Widnall (1971).

The flow field of high aspect ratio wings have been handled fairly well by existing lifting-surface theories. [For more detail, see the recent surveys by Landahl and Stark (1968) and Ashley and Rodden (1972).] Linear lifting surface theories fail, however, when strong vortex flows are created near the wing. This failure is particularly evident for the case of the small aspect ratio wing, where the pressure distribution is strongly effected by the near flow field.

Hummel, D., and Redeker, G., "Über den Einfluss des Aufplatzens der Wirbel auf die aerodynamischen Beiwerte von Deltaflügeln mit kleinem Seitenverhältnis beim Schiebefluss," Jahrbuch 1967 of WGLR, pp. 232-240.

Landahl, M. T. and Widnall, S. E., "Vortex Control," M.I.T., Supported by the Air Force Office of Scientific Research under Contract Nos. AF49(638)-1622 and F44620-69-C-0900, in Olsen, Goldberg & Rogers, 1971.

Landahl, M. and Stark, V., "Numerical Lifting Surface Theory-Problems and Progress," "AIAA J.", 6, No. 11, pp. 2049-2060, Nov. 1968.

Ashley, H. and Rodden, W., "Wing-Body Aerodynamic Interaction," Annual Review of Fluid Mechanics, Vol. 4, pp. 431-472.

The delta wing of low aspect ratio is of primary interest in modern aerodynamics for transonic and low supersonic speed flight, because of its flight properties which include a fairly smooth transition from the subsonic to the supersonic flight regime. Furthermore, the flat plate delta wing has been more amenable to theoretical consideration and consequently much of the recent research on low-aspect-ratio wings with regions of concentrated vorticity has been restricted to delta-wing-type geometries. The delta wing configuration also demonstrates most of the characteristics of vortex flow phenomena near the wing and it is hoped that eventually the results for the delta wing will lead to extensions to more general planforms. Thus, because of its role as a practical wing planform and its simplicity, this planform will be the primary subject in the following report.

The following general procedure will be used to accomplish this background study for a unified theory of vortex flow phenomena.

- 1) Review existing theories and mathematical models for the individual elements in the vortex-wing flow field. This will include models for the roll-up of a vortex sheet, the development of axial gradients, and the occurrence of vortex breakdown.
- 2) Review existing models for their ability to predict the response of the flow field elements to external influences, which is necessary to construct a theory involving interactions between wings and free vortices. This would include a discussion of existing models for wings with free vortices based on slender-body theory as well as existing models for their ability to predict response of a vortex to external pressure gradients.
- 3) Identify areas where further research is necessary to complete the theory and to suggest methods of approach to these problems.

Historical Development

When attempting to devise a unified theory of vortex flow phenomena, one realizes that the actual flow is governed by the Navier-Stokes equations of motion, which are both nonlinear and elliptic. Their solution proves to be an impossible task except in the simplest of flows. Thus, one is forced to search for a simplified form for the governing equations and one resorts to experiment to discover the important parameters governing the flow. Early experiments demonstrated the need for a theory which applied to low aspect ratio wings with strong vortex flows, in place of the linear lifting surface theory for high aspect ratio wings.

Winter (1936) conducted an extensive series of tests on low aspect ratio wings, including the delta wing, and noted the appearance of leading-edge vortices and the nonlinear character of the lift. Wilson and Lovell (1947) gave a more detailed picture of the flow field over a triangular wing and compared this flow to that over the standard attached flow model of linear lifting surface theory, which only occurs at relatively low angles and with rounded leading edges, while the separated flow field occurs at higher angles of attack and sharp leading edges. [See Figure 1.] However, their primary concern were the forces on the wing, rather than a detailed flow description.

A fairly complete physical description of the flow field was given by Örnberg (1954). [See Figure 2.] He considered the separation at the leading edge and included the form of both the primary separated vortices (d) and of the secondary vortices (e) in a schematic sketch of the flow over a flat plate delta wing.

Winter, H., "Flow Phenomena on Plates and Airfoils of Short Span," NACA TM No. 798, 1936.

Wilson, H. and Lovell, J., "Full-Scale Investigation of the Maximum Lift and Flow Characteristics of an Airplane Having Approximate Triangular Planform," NACA RM No. L6K20, 1947.

Örnberg, T., "A Note on the Flow around Delta Wings," KTH Aero TN 38, R.I.T., 1954.

G. H. Lee (1958) conducted oil flow tests on the upper surface to study the boundary layer flow picture, including secondary separation and reattachment.

Elle (1958) conducted extensive flow visualization studies involving air-bubble suspension in a water tank and smoke in a wind tunnel. For the water tunnel results, slender delta wings were tested and showed a "nearly linear vortex center-line from the apex downstream to somewhere near the trailing edge, at which point it bent off rather sharply" in the direction of the free stream, which indicated that trailing-edge effects might be limited to a small region. However, these early results are qualitative rather than quantitative.

Early attempts to define the flow field were made by Fink and Taylor (1967) who carried out some total head traverses to describe the vortex core position and the nature of the leading-edge separation at low speeds. For a 20° angle delta wing with sharp leading edges, they obtained unseparated flow for an angle of attack of 3° ; for angles of attack greater than 5° , the flow was clearly separated. According to Fink and Taylor, the principal features of the cross flow (viewed at a constant chordwise station on the wing), are:

- 1) Separation of the boundary-layer flow from the pressure side at the leading edges.
- 2) Formation of vortex cores in the stream from the boundary-layer fluid which has left both surfaces of the wing upstream of the transversed station.
- 3) Secondary separation of suction-side boundary-layer a little outboard of the main vortex position.
- 4) Reattachment of the cross-flow outboard of the secondary separation points.

Lee, G. H., "Note on the Flow around Delta Wings with Sharp Leading Edges," ARC R&M 3070, Sept. 1958.

Elle, B. J., "An Investigation at Low Speed of Flow Near the Apex of Thin Delta Wings with Sharp Leading Edges," ARC R&M 3176, 1958.

Fink, P. T. and Taylor, J., "Some Early Experiments on Vortex Separation," ARC R&M 3489, 1967.

They found that increasing the angle of attack led to:

- 1) A movement of the main vortex cores away from the leading edges.
- 2) A progressive reduction of the total pressure in the vortex cores.
- 3) An increased intensity of the vortex sheets which spring from the primary separation points.
- 4) Progressive reduction of the boundary layer thickness on the central portion of the suction side of the wing.

They also investigated the static pressure along seven rays passing through the apex to determine whether there were stations at which the pressure distribution might be taken to be approximately conical. However, their results indicate that even for an 80° sweep wing, the flow cannot be described as conical, although the pressure did change slowly over the middle third of the wing. The trailing edge was found to have a considerable effect on the upstream flow. The lift was shown to be greater by Fink and Taylor for the delta wing with separated flow than would have been predicted by linear theory.

In 1957, Peckham and Atkinson (1957) noted that when the incidence was increased above 25° for a gothic wing of aspect ratio one, the "condensation trail representing the vortex core appeared to 'bell-out' before disappearing -- as though the core was becoming more diffuse."

Elle (1958) noticed the same phenomena and described it more completely. He coined the term "breakdown" since the pattern broke down. The centerline became "wavy in front of the breakdown point (Figure 3). This slight waviness very soon becomes unstable with the result that the vortex center-line changes shape into a low pitched spiral." After this, the fluid appeared to spread out rapidly.

He noted that the breakdown occurred at higher incidences the higher the leading-edge sweep and that it first occurred far downstream of the trailing edge and moved upstream as the angle of attack was increased.

Peckham, D. H. and Atkinson, S. A., "Preliminary Results of Low Speed Wind Tunnel Tests on a Gothic Wing of Aspect Ratio 1.0," ARC CP No. 508, 1957.

Again, early descriptions were fairly qualitative and only later were quantitative descriptions of the vortex core obtained.

Earnshaw (1961) attempted to obtain the small-scale structure of the velocity field of the vortex layer spiraling into the core. He obtained his results with a five-tube yawmeter for a delta wing of unit aspect ratio. He concluded from his experiments that the leading-edge vortex can be divided into three regions:

- 1) A vortex core of approximately 30% of the local semispan in diameter wherein traces of the vortex sheet are small. The flow here was essentially conical except for a slender region along the axis.
- 2) A viscous sub-core of approximately 5% semispan in diameter in which the gradients of total head, static pressure and velocity are high, and consequently viscosity cannot be neglected. Within the sub-core, circumferential velocities were found to be almost equal to the free stream velocity and axial velocities of 2.3 times the uniform velocity were recorded at 15° angle of attack.
- 3) A region where the trace of the vortex sheet is still clear, between the leading edge and the vortex core.

Lambourne and Bryer (1961) described the vortex breakdown in detail. When vortex bursting occurred, there was an expansion of the fluid flow along the axis of the laminar vortex which resulted in the formation of a large turbulent core. [See Figure 3.]

They found two possible ways in which the vortex could burst. One was an asymmetrical spiral arrangement in which the dye remained in a discrete filament after the expansion of the core. The other possibility was an axisymmetrical arrangement in which the dye is diffused over a bell-shaped region; this latter form was only occasionally observed according to Lambourne and Bryer.

Earnshaw, P. B., "An Experimental Investigation of the Structure of a Leading-Edge Vortex," ARC R&M 3281, 1961.

Lambourne, N. C. and Bryer, D. W., "The Bursting of Leading-Edge Vortices-Some Observations and Discussion of the Phenomena," ARC R&M 3282, 1961.

They considered the more common asymmetric breakdown to occur in three successive stages [See Figure 4]:

- 1) A sudden deceleration of the fluid along the axial filament.
- 2) An abrupt kink where the axial filament was deflected into a spiral configuration, which persisted for a few turns.
- 3) A breakdown to large-scale turbulence.

Their experiments showed that the burst position was sensitive to the pressure distribution along the vortex. They concluded that:

- 1) An essential feature for bursting to occur was believed to be a low total pressure region at the axis of the laminar vortex.
- 2) A positive pressure gradient was required which could, for example, be furnished by viscous action within the core of the vortex or the deceleration of the flow external to the core due to the presence of the trailing edge.

They also found that the bursting caused a loss of suction locally at the surface.

These are the basic phenomena observed over the delta wing at moderate angles of attack when the flow separates at the leading edge. Some of the phenomena still require some clarification. For example, Bergesen and Porter (1960) conceded that opinion on the effect of secondary vortices was quite diverse. This is because of their small scale which makes accurate measurement of the flow properties difficult. Also, experimental evidence of the effect of viscosity on bursting of the vortex is small. A qualitative indication from comparison of water tunnel [Elle (1958)] and wind tunnel experiments suggest the bursting phenomena is not strongly Reynolds number dependent. However, it is difficult to separate out the other effects which might have caused the differences between experiments with delta wings of similar aspect ratio. These other effects include the thickness and roughness of the planform. More will be said on this later when experimental results are compared with theory.

Bergesen, A. J. and Porter, J. D., "An Investigation of the Flow around Slender Delta Wings with Leading Edge Separation," Princeton Rep. 510, 1960.

VORTEX FLOW ELEMENTS

As described in the introduction, an attempt will be made to study the individual elements in the vortex flow field. The first element to be considered are the spiral sheets from the leading edges which terminate in a core region of rotational flow. Recently, Smith (1966b) published an article on the formation of vortex sheets which includes historical as well as fairly recent contributions. As is seen from the experiments on delta wings with sharp leading edges, the primary separation occurs along them at relatively small angles of attack. The separated flow forms a spiral vortex on each wing half under the influence of its own vorticity. In such a flow, viscosity is important only in regions of large velocity gradients, i.e., in the boundary layer, at the point of separation and in a small viscous sub-core at the center of the spiral. Since the primary vortex creates a suction peak on the wing below it, the boundary-layer flow after passing under it towards the leading edge encounters an adverse pressure gradient and separates to form the secondary vortex. Smith reports that outside of those regions, the effect of Reynolds number appears small.

This implies that one can construct an inviscid model to describe the large-scale features of the flow. Although the model would have to include rotational regions, the vorticity is negligible in most of the flow field, and he argues that it is attractive to regard the vorticity to be concentrated on vortex sheets. Thus, the entire flow field, outside of the sheets is considered irrotational and consequently, a velocity potential exists.

Due to the difficulty in handling the remaining nonlinear problem, further assumptions are often made. First, the flow can be considered conical. This is strictly true over a supersonic flat plate delta wing and has been seen to be approximately true away from the trailing edge for subsonic flow. To further simplify the problem, Legendre (1956) attempted

Smith, J. H. B., "Theoretical Work on the Formation of Vortex Sheets," in Progress in Aeronautical Sciences, Vol. 7, D. Küchemann, ed., pp. 35-51, 1966b.

Legendre, R., "Écoulement subsonique transversal à un secteur angulaire plan," C. R. Acad. Sci., 243, p. 1716, Nov. 1956.

to construct conical incompressible models of the flow and discovered that this led to the appearance of singularities in the flow field. In view of this difficulty of constructing a conical, incompressible, flow model, the nonlinear character of the governing equations without the compressibility assumption, and the occurrence of leading-edge separation only for slender delta wings, Smith argues it is reasonable to employ the slender body theory of Munk (1924), Jones (1946), and Ward (1949), to calculate the properties of the model. Unfortunately, slender-body theory only applies to flow in which the streamwise gradient of the streamwise velocity component is small compared to transverse gradients. However, in the slender conical vortex sheet, wound into the appropriate spiral, the velocity component along the axis will later be shown to tend to infinity logarithmically. Thus, the slender body theory is violated.

Some of the objections to the use of an indefinitely rolled-up vortex sheet as a model of the flow and to the use of slender-body theory to describe an incompressible flow are made by Roy (1966).

Munk, M. M., "The Aerodynamic Forces on Airship Hulls," NACA Rep. 184, 1924.

Jones, R. T., "Properties of Low Aspect Ratio Pointed Wings at Speeds Below and Above the Speed of Sound," NACA Rep. 835, 1946.

Ward, G. N., "Supersonic Flow Past Slender Pointed Bodies," *Quart. Journ. Mech. and Appl. Math.*, 2, p. 75, 1949.

Roy, M., "On the Rolling-Up of the Conical Vortex Sheet Above a Delta Wing," in Progress in Aeronautical Sciences, Vol. 7, D. Küchemann, ed., pp. 1-5, 1966.

Vortex Sheets

Some of the works on the form of the rolled-up sheet will now be considered. Küchemann and Weber (1965) published a review of the available models. Following Mangler and Weber (1966), they consider two methods of analysis. The sheet can be assumed to be shed and then roll up as a function of time; or the sheet can be assumed to be rolled up from the start of the analysis. The first method of analysis will be considered further in the section on the vortex models using discrete elements of vorticity. The second method has been used to develop theories for continuous spiral sheets.

The following development of the problem can be found in Mangler and Weber. They consider a steady three-dimensional flow past a body which sheds a thin vortex sheet. Two conditions must be satisfied by the vortex sheet. It must be a stream surface and it cannot sustain a pressure difference across it. Thus, the velocity vector on either side of the sheet must lie in the sheet. For zero total pressure difference, the vorticity vector must lie along the mean flow direction.

For the two dimensional case, they obtain the result that the flow must be unsteady to satisfy the pressure condition. Then the vorticity is along the generators of the cylinder and the sheet grows to satisfy the pressure condition.

For the delta wing leading-edge core problem, one is primarily interested in a three-dimensional growing vortex with axial velocity. Mangler and Weber model this phenomenon by assuming that the flow is steady, incompressible, conical and homentropic. The governing equation becomes the continuity equation. They use a change of variables to simplify the boundary conditions by mapping the region between turns of the spiral onto a strip. They then assume an asymptotic expansion in the new variables for the inner part of the core to avoid the singularities mentioned earlier for conical,

Küchemann, D. and Weber, J., "Vortex Motions," ZAMM, 45, No. 7-8, pp. 457-474, Dec. 1965.

Mangler, K. W. and Weber, J., "Flow Field near Centre of a Rolled-Up Vortex Sheet," RAE TR No. 66324, 1966.

incompressible flow. They obtain an asymptotic solution by using terms of equal order in the differential equation. However, they note "the present approach of term by term evaluation of the asymptotic expansion cannot provide information about its convergence." Although convergence cannot be proved, additional terms in the approximation can be generated by this scheme. Mangler and Weber find for the velocity components in cylindrical coordinates (x, r, θ) in the neighborhood of the axis

$$w = c(k - \ln \bar{r}) \pm \pi c \bar{r} (1/2 + k - \ln \bar{r})^{1/2} + \dots = \text{axial velocity} \quad (1)$$

$$u = -1/2 c \bar{r} \pm \pi c \bar{r}^2 (1 + k - \ln \bar{r}) (1/2 + k - \ln \bar{r})^{1/2} + \dots = \text{radial velocity} \quad (2)$$

$$v = c(1/2 + k - \ln \bar{r})^{1/2} \pm \pi c \bar{r} (k - \ln \bar{r}) + \dots = \text{circumferential velocity} \quad (3)$$

where c and k are free constants and $\bar{r} = r/x$. The shape of the sheet is obtained by integrating

$$\frac{d\theta}{d\bar{r}} = \frac{1}{\bar{r}^2 (1/2 + k - \ln \bar{r})^{1/2}} + O(\ln \bar{r}) \quad (4)$$

They similarly derive the results for the unsteady two-dimensional case. As a special case of the unsteady problem, one can derive the conical, slender-body result. They obtain for the sheet shape

$$\frac{d\theta}{d\bar{r}} = -c/\bar{r}^2 \quad (5)$$

which Mangler and Weber note is the result obtained by Mangler and Smith (1959). They also find the radial and circumferential velocities

Mangler, K. W. and Smith, J. H. B., "A Theory of Flow past a Slender Delta Wing with Leading Edge Separation," Proc. Roy. Soc. London, Ser. A, 251, p. 200, 1959.

$$u = \pm \frac{\pi}{C} \bar{r}^2 \quad (6)$$

$$v = C \pm \pi \bar{r} \quad (7)$$

where C is a constant. There is no mean flow for the second result in the radial direction since there is no place for the flow to go. This is a common failing of two-dimensional theories. Furthermore, the azimuthal velocity approaches a constant near the axis. Since the potential is two-dimensional in the conical sense, it is possible to obtain the axial velocity as

$$w = C^2(1 + k - \ln \bar{r}) + O(\bar{r}) \quad (8)$$

which blows up at the axis and so the slenderness assumption is violated by the slender, conical solution, while the radial and tangential velocities also differ from the nonslender results. Thus, Küchemann and Weber concluded, "It is therefore, difficult to see what physical significance it (slender core) has." By suitable choosing, the two constants for the non-slender core to match the experimental spiral of Earnshaw (unpublished at the time of Küchemann and Weber), they obtain fairly good agreement between experiment and theory. [See Figure 5.] A closer inspection of the experimental data of Earnshaw shows the swirl component falls to zero at the axis. This represents the small viscous sub-core. Also, the axial velocity is finite at the core axis.

These are the primary results for infinite sheets. In connection with more complete models of the flow field, additional representations of the vortex sheet will be presented.

Vortex Core

The core structure shall be treated next. Hall (1966b) presents a summary of the state of the art and also includes a brief description of vortex breakdown. [There are a considerable number of works devoted to the trailing edge vortex, e.g., Moore and Saffman (1971, 1973), Newman (1959), Rott (1958), Batchelor (1964), Widnall and Bliss (1971). Although this is a different phenomenon, possibly some of these techniques to handle regions of concentrated vorticity can be extended to the leading edge vortex.]

One of the first theoretical analyses on the leading-edge vortex core was by Hall (1961) and Ludwig (1962). They both assume an axisymmetric, conical, incompressible, inviscid, rotational flow in the core. The flow then depends on a single parameter $\bar{r} = r/x$. They obtain the following differential equations for the three velocity components (u, v, w) in cylindrical coordinates (r, θ, x) from the Euler equations of motion

Hall, M. G., "The Structure of Concentrated Vortex Cores," in Progress in Aeronautical Sciences, Vol. 7, D. Küchemann, ed., Pergamon Press, pp. 53-110, 1966b.

Moore, D. W. and Saffman, P. G., "Axial Flow in Laminar Trailing Vortices," Proc. Roy. Soc., Ser. A., 333, pp. 491-508, 1973.

Moore, D. W. and Saffman, P. G., "The Motion of a Vortex Filament with Axial Flow," Phil. Trans. Proc. Roy. Soc., Ser. A, 272, pp. 403-429, Oct. 1971.

Newman, B. G., "Flow in a Viscous Trailing Vortex," Aeron. Quart., 10, pp. 149-162, 1959.

Rott, N., "On the Viscous Core of a Line Vortex," CR Acad. Sci. pp. 543-553, 1958.

Batchelor, G. K., "Axial Flow in Trailing Line Vortices," JFM, 20, pp. 645-658, 1964.

Widnall, S. E. and Bliss, D. B., "Slender-Body Analysis of the Motion and Stability of a Vortex Filament Containing an Axial Flow," JFM, 50, pp. 335-353, 1971.

Hall, M. G. "A Theory for the Core of a Leading Edge Vortex," JFM, 11, pp. 209-228, 1961.

Ludwig, H., "Zur Erklärung der Instabilität der über angestellten Deltaflügeln auftretenden freien Wirbelkerne," Z. Flugw., 10, pp. 242-249, 1962.

$$\bar{r}u u' - v^2 - \bar{r}^2 w u' = -\frac{1}{\epsilon} \bar{r} p' \quad (9)$$

$$\bar{r}u v' + uv - \bar{r}^2 w v' = 0 \quad (10)$$

$$\bar{r}u w' - \bar{r}^2 w w' = \frac{1}{\rho} \bar{r}^2 p' \quad (11)$$

$$\bar{r}u' + u - \bar{r}^2 w' = 0 \quad (12)$$

where ()' represents differentiation with respect to \bar{r} . They assume a slender core $\bar{r} \ll 1$, which implies $u \ll v$, $u \ll w$. They solve the resulting differential equations and after applying the boundary condition that u is not infinite at the axis, they obtain

$$u = -1/2c\bar{r} \quad (13)$$

$$v = c\sqrt{-\ln\bar{r} + 1/2 + k} \quad (14)$$

$$w = c(-\ln\bar{r} + k) \quad (15)$$

which is seen to be identical to the lowest order solution given by Mangler and Weber. The effect of the discrete vortex sheet does not enter until the next higher term.

Hall notes that this solution is not valid near the axis where viscosity becomes important to prevent the velocity from becoming infinite. By an order of magnitude estimate, Hall finds that for

$$r/x = 0 \left[\frac{w_c}{v_c} \left(\frac{v}{w_c x} \right)^{1/2} \right] \quad (16)$$

where the subscript refers to the value at the outer edge of the core, viscous effects become important. For this inner viscous sub-core, the flow is no longer conical since viscous dissipation precludes the existence of a conical flow. He employs a fairly involved calculation of the boundary-layer type and obtains a solution for the viscous sub-core which is presented in Hall (1961). He matches the two solutions at an intermediate point to obtain a

composite solution. He compares the results with experiment [see Figure 6] and notes that there is good agreement for the outer solution, but for the inner solutions, there is only qualitative agreement. The theoretical velocity and pressure gradients are too large and the peaks are too pronounced. He suggests that a possible error was the fact that the theory is laminar while the actual vortex core flow might be turbulent, and notes that the use of an eddy viscosity would have improved agreement by increasing the diffusion of the core.

Later, Stewartson and Hall (1963) obtain a more acceptable inner solution. Instead of matching at a finite point, the new solution can be matched asymptotically from the inner solutions. However, the solution is found by numerical method, and although additional terms can be obtained from the asymptotic expansion, it is fairly complicated and is not discussed here. The solution is obtained partly in terms of universal functions which are tabulated.

Brown (1965) considers another possibility. It is known from the theoretical analysis that there is a low pressure region in the core. Thus, the incompressible solution of Hall and others is open to question. To allow the problem with compressibility to be solved, the core flow is assumed to be inviscid and consequently, conical everywhere. The flow is still considered axisymmetric and by assuming slenderness, $\bar{r} \ll 1$, the governing equations become

$$\rho^{\gamma-1} \left(1 - \frac{\gamma-1}{2} \beta \frac{d\rho}{dw} \right) = \frac{\gamma-1}{2} M_c^2 (A^2 - w^2) \quad (17)$$

$$- \bar{r} \frac{dw}{d\bar{r}} = \beta \rho \quad (18)$$

Stewartson, K. and Hall, M. G., "The Inner Viscous Solution for the Core of a Leading-Edge Vortex," JFM, 15, pp. 306-318, 1963.

Brown, S. N., "The Compressible Inviscid Leading-Edge Vortex," JFM, 22, pp. 17-32, 1965.

after some manipulation; where ρ is the density, w is the axial velocity, where both have been normalized by their value at the edge of the core, γ = ratio of specific heats, and the other terms are constants. A is related to the energy, M_c is the Mach number at the edge, and B incorporates constants from the edge of the core.

The boundary conditions used are similar to Hall for the inviscid model and both swirl, v/w , and Mach number M_c can be specified at the outer edge of the core. The equations are solved numerically for a range of constants. It is seen that the effect of compressibility is confined to a sub-core near the axis. In the compressible case, the circumferential velocity goes to zero while the axial velocity tends to a constant when the axis is approached. She remarks on the similarity between her results and the solution of Stewartson & Hall (1963) and obtains, using a boundary-layer type of approximation, a uniform solution for low Mach numbers with an incompressible outer core and a compressible sub-core. It was previously mentioned that the model of Hall and Ludwig agreed to lowest order with the irrotational model of Mangler and Weber (1965). Similarly, Brown and Mangler (1967) later extend the Mangler and Weber solution to include the Brown model of the incompressible sub-core, as the first approximation for the irrotational flow.

Brown, S. N. and Mangler, K. W., "An Asymptotic Solution for the Centre of a Rolled-up Conical Vortex Sheet in Compressible Flow," *Aeron. Quart.*, 18, Part 4, pp. 354-366, Nov. 1967.

Vortex Breakdown

The next element to be considered is the vortex breakdown phenomenon. [See Hall (1972) for a criticism of available vortex models.]

The study of the breakdown of vortex core has been studied in vortex tubes as well as over the leading-edge of the delta wing. The reason for this is two-fold. First, delta wings are not the only phenomena which incorporate vortex breakdown. Secondly, the breakdown in a tube is much easier to control. It is noted by Hall (1966b) that a difference between the observations of Harvey in a tube and of Lambourne and Bryer (1961) over a wing, which may be important, is that while Harvey's flow in the vicinity of the stagnation points appears to be axially symmetric while that of Lambourne and Bryer usually shows a spiral disturbance. Also, Jones (1960) believed that "there is no great similarity between this (vortex tube) instability and vortex breakdown but it is hardly to be expected since the boundary conditions are so different. Because of the presence of the walls, viscosity is likely to have a much larger effect in disturbances in the tube than in a free vortex." Lambourne and Bryer (1961) also commented similarly on the differences and similarity of the two phenomena. Although vortex breakdown of the leading-edge vortices is of primary concern, the continuous growth of the vortex as a function of the distance from the apex increases the complexity of the problem. The vortex tube offers a simpler flow field and many theories are originally derived for a vortex tube. It is to be hoped that the theory can be extended to the leading-edge vortex later. An experimental contribution to this area was made by Sarpkaya (1970), who found spiral breakdown in a vortex tube as well as the axisymmetric breakdown found by earlier investigators. Thus, this eliminates one of the primary differences between the two flow fields although the difference of the relative effect of viscosity is still unclear.

Hall, M. G., "Vortex Breakdown", in Annual Review of Fluid Mechanics, Vol. 4, Annual Reviews, Inc., Palo Alto, pp. 195-218, 1972.

Jones, J. P., "The Breakdown of Vortices in Separated Flow," Univ. of Southampton, Rep. 140, 1960.

Sarpkaya, T., "Experimental Investigation of the Vortex-Breakdown Phenomenon," NASA Accession No. N71-11955, 1970.

Vortex breakdown has elicited a number of plausible explanations. They can be divided into attempts to describe vortex breakdown as

- 1) A result of hydrodynamic instability
- 2) A separation phenomenon
- 3) A standing wave phenomenon
- 4) A finite transition between conjugate flow states
- 5) A trapped wave phenomenon
- 6) A normal development of the flow.

Instability

An early explanation of breakdown as an instability phenomenon was presented by Jones (1960). He considers axisymmetric disturbances as a function of downstream distance superposed on a cylindrical base flow that is incompressible and inviscid. The equations are simplified forms of the Navier-Stokes equations. Assuming a disturbance of the form $u = u_1(r) e^{i(\lambda x - \sigma t)}$, he obtains for the radial perturbation equation

$$\frac{d}{dr} \left\{ \frac{du_1}{dr} + \frac{u_1}{r} \right\} - \left\{ \lambda^2 + \frac{r}{w-c} \cdot \frac{d}{dr} \left(\frac{1}{r} \frac{dw}{dr} \right) - \frac{2v(v/r + dv/dr)}{r(w-c)^2} \right\} u_1 = 0 \quad (19)$$

where w is the axial base flow and v is the tangential base flow and $c = \sigma/\lambda$.

He obtains the following condition for instability, when radial gradients of the radial flow are small at the inner and outer boundary values r_{ax} and r_0 and when the radial velocity is zero. For unstable flows, the function

$$r \frac{d}{dr} \left(\frac{1}{r} \frac{dw}{dr} \right) - \frac{4\tau v}{r} \frac{\left[\frac{v}{r} + \frac{dv}{dr} \right]}{\tau^2 + \beta^2} \quad (20)$$

changes sign between r_{ax} and r_0 , where $c = \alpha + i\beta$, $\tau = w(r) - c$.

His theory cannot be, in general, simplified and thus has limited usefulness. It can only be applied in specific examples. Furthermore, he only considers axisymmetric disturbances.

Ludwig (1960, 1961) developed a theory for the study of the stability of the helical flow in a narrow cylindrical annulus based on the stability criterion of Rayleigh for rotating fluids. Rayleigh showed for the flow in an annulus, that the flow is unstable if the circumferential velocity falls off more rapidly than $1/r$ for the inviscid, axisymmetric case with zero axial flow. Ludwig adds axial flow to the model to study helical flow. Again he assumes inviscid, axisymmetric flow in a cylindrical annulus. He assumes no radial velocity and a circumferential and axial velocity which are linear in r .

$$v = v_0 + c_v(r - r_0) \quad (21)$$

$$w = w_0 + c_w(r - r_0) \quad (22)$$

where r_0 is the mean radius of the annulus.

He nondimensionalizes by the average radius and circumferential velocity v_0 .

$$\tilde{c}_v = \frac{c_v r_0}{v_0} \quad \tilde{c}_w = \frac{c_w r_0}{v_0} \quad (23)$$

and obtains a necessary and sufficient stability criterion by employing perturbation vortices. Ludwig finds that the flow is stable to helical disturbances for

$$(1 - \tilde{c}_v)(1 - \tilde{c}_v^2) - \left(\frac{5}{3} - \tilde{c}_v\right) \tilde{c}_w^2 > 0 \quad (24)$$

For $c_w = 0$, the Rayleigh criterion is recovered [see Figure 7]. He notes (1960) that the previous results only held for a narrow annulus. He suggests

Ludwig, H., "Stabilität der Strömung in einem zylindrischen Ringraum," Z. Flugw., 8, No. 5, pp. 135-140, 1960.

Ludwig, H., "Ergänzung zu der Arbeit: Stabilität der Strömung in einem zylindrischen Ringraum," Z. Flugw., 9, No. 11, pp. 359-361, 1961.

that a broader annulus could be considered by dividing it into many smaller rings of small thickness Δr . Although not proved, he surmises that the flow would be stable if for each radius, the stability criterion is satisfied.

Hummel (1965) compares the experimental results he obtained over a slender delta wing (aspect ratio = .78) with the predictions of Ludwig for a station before the breakdown and notes "a comparison of measurements with Ludwig's stability theory furnishes good agreement."

Ludwig (1962) later applies his stability criterion to the Hall-Ludwig vortex model. He finds, for this case, that the flow is most unstable at the outer edge, so the fact that this leading-edge model is not applicable at the core is of no concern. He obtains the result that the flow is unstable for $\alpha = \tan^{-1} v/w$ greater than 48° .

Ludwig (1965) further argues that his model provides for the asymmetric breakdown of the originally axisymmetric leading-edge vortex. He supports such a contention by referring to the experimental work of Hummel (1965), which shows such asymmetry.

He explains that the instability theory can predict the violent nature of breakdown due to the low velocity and total pressure region which accompanies the vortex. Hall (1972) criticizes Ludwig's explanation on the basis it failed to explain the axisymmetric [Ludwig (1965) considered the axisymmetric and asymmetric breakdown distinct, while experiments by Sarpkaya (1970) have shown for the vortex tube that they are aspects of the same problem]. Finally, Hall argues that the theory is difficult to test since there are always velocity gradients of the required magnitude somewhere in the flow. Also, Hall questions the explanation of the suddenness of the transition and concludes that "the abruptness of the change in core structure is explained by the existence of a critical state."

Hummel, D., "Untersuchungen über das Aufplatzen der Wirbel an schlanken Deltaflügeln," *Z. Flugw.*, 13, No. 5, pp. 158-168, 1965.

Ludwig, H., "Erklärung des Wirbelaufplatzens mit Hilfe der Stabilitätstheorie für Strömungen mit schraubenlinienförmigen Stromlinien," *Z. Flugw.* 13, p. 437-442, 1965.

Hall, M. G., "A New Approach to Vortex Breakdown," in Proc. of 1967 Heat Transfer and Fluid Mechanics Institute, P. A. Libby, ed., Stanford U. Press, pp. 319-340, 1967.

Jones (1960) suggests that compressibility may be another factor which should not be left out due to the analogy with supersonic jets.

Separation Phenomenon

Hall (1967) drew an analogy with the boundary-layer separation, which separates near the value where the boundary-layer approximations fail. He observed from experiments involving leading-edge vortices, that the flow upstream only varied slowly in the axial direction, the axial gradients were small compared to the radial gradients and the stream surfaces were approximately cylindrical. By assuming that the flow is steady, laminar, incompressible and axisymmetric, and assuming the flow is quasi-cylindrical, as above, he obtains

$$\frac{\partial u}{\partial r} + \frac{u}{r} + \frac{\partial w}{\partial x} = 0 \quad (25)$$

$$\frac{r^2}{r} = \frac{1}{\rho} \frac{\partial p}{\partial r} \quad (26)$$

$$u \frac{\partial v}{\partial r} + \frac{uv}{r} + w \frac{\partial v}{\partial x} = v \left(\frac{\partial^2 v}{\partial r^2} + \frac{1}{r} \frac{\partial v}{\partial r} - \frac{v}{r^2} \right) \quad (27)$$

$$u \frac{\partial w}{\partial r} + w \frac{\partial w}{\partial x} = - \frac{1}{\rho} \frac{\partial p}{\partial x} + v \left(\frac{\partial^2 w}{\partial r^2} + \frac{1}{r} \frac{\partial w}{\partial r} \right) \quad (28)$$

from the Navier-Stokes equations.

The boundary conditions are 1) those to be satisfied on the axis of symmetry, 2) one condition -- e.g., pressure is supplied at $r = r_c(x)$ of the vortex core, where the shape must then be unprescribed -- and finally 3) an initial velocity distribution is given at some starting point. Since the problem is now parabolic, rather than elliptic, one can calculate the solution by proceeding step by step in the axial direction. The numerical method is outlined in Hall (1967).

Breakdown is noted whenever the axial gradients become large and violate the quasi-cylindrical approximation. He says his results are consistent with observations concerning breakdown as a function of Reynolds numbers and of pressure gradients. He concludes that 1) breakdown depends on the stream surface (pressure) and on the swirl in the usual manner, and

2) for an increase in Reynolds number, the breakdown moves upstream, although he said this is a smaller effect than swirl or pressure. He compares his results with Benjamin (1962) and Ludwig (1962) for a vortex tube breakdown. Ludwig's criterion is not in agreement in predicting this breakdown while Benjamin's is. Hall (1972) criticizes the theory on the basis that it can only describe the flow up to the breakdown of the quasi-cylindric approximation. It is of merit though since it includes the effects of Reynolds number and of pressure, although the onset of Hall's results (1967) fail to agree with the actual abruptness of the phenomena.

Standing Wave Phenomena

An early theory was that of Squire (1960) who developed the theory of long standing waves on a cylindrical vortex flow. Although he was investigating the breakdown of leading-edge vortices, for simplicity, he considered only cylindrical vortices and symmetrical disturbances. He formulates the critical condition as follows: The minimum condition for the possible existence of a standing wave is sought. Because if it exists, he postulates disturbances which are generally downstream will spread upstream and cause the breakdown. He considers an inviscid, steady, incompressible flow, which is cylindrical. As a result, the unperturbed velocities w and u are functions of r only. It is supposed that this base flow has a steady disturbance of small amplitude superposed on it. Then, the stream function ψ satisfies the single equation derived from continuity and momentum equations by Squire (1956)

$$\left(\frac{\partial^2}{\partial x^2} + \frac{\partial^2}{\partial r^2} - \frac{1}{r} \frac{\partial}{\partial r} \right) \psi = D^2 \psi = \frac{r^2}{\rho} \frac{dH}{d\psi} - \frac{d(\kappa^2)}{2d\psi} \quad (29)$$

Benjamin, T.B., "Theory of the Vortex Breakdown Phenomenon," JFM, 14, pp. 593-629, 1962.

Squire, H. B., "Analysis of the 'Vortex Breakdown' Phenomenon, Part I," Imperial College, Aero. Dept., Rep. 102, 1960.

Squire, H. B., "Rotating Fluids," in Surveys in Mechanics, Batchelor and Davis, ed., 1956.

where H is the total head and $2\pi\kappa = \text{circulation}$. Letting $\psi = \psi_0 + \psi_1$ where ψ_0 is the unperturbed stream function and ψ_1 is the stream function of the disturbance, ψ_0 satisfies

$$D^2\psi_0 = \frac{r^2}{\rho} \frac{dH}{d\psi_0} - \frac{d(\kappa^2)}{2d\psi_0} \quad (30)$$

For ψ_1 , one obtains

$$D^2\psi_1 = \psi_1 \left[\frac{r^2}{\rho} \frac{d^2H}{d\psi_0^2} - \frac{d^2(\kappa^2)}{2d\psi_0^2} \right] \quad (31)$$

Assuming a periodic disturbance

$$\psi_1 = f(r) \cos \alpha x \quad (32)$$

implies the following form of the differential equation

$$f_{rr} - \frac{1}{r} f_r + f \left[\frac{2\kappa\kappa_r}{r^3 w^2} + \frac{w_r - r w_{rr}}{r w} - \alpha^2 \right] = 0 \quad (33)$$

The criticality condition is determined by the case when standing waves first become possible.

Squire first considers the simple case of

$$v = \begin{cases} v_c r & \text{for } r \leq 1 \\ v_c / r & \text{for } r \geq 1 \end{cases} \quad (34)$$

$$w = w_c = \text{constant} \quad (35)$$

He solves this explicitly and finds that the smallest value of v_c/w_c which allows standing waves to exist is

$$\frac{v_c}{w_c} = 1.20 = \frac{\max v}{w_c} \quad (36)$$

for which $\alpha = 0$. Furthermore, he considers two other swirl values for constant axial flows also. He obtains from the three cases for $\alpha = 0$, that

$$1.00 \leq \frac{\max v}{w} \leq 1.20 \quad (37)$$

$$45^\circ \leq \phi = \tan^{-1} \left(\frac{\max v}{w} \right) \leq 50^\circ \quad (38)$$

He concludes that vortex breakdown may occur when the ratio of maximum swirl to axial velocity is slightly greater than one.

Experimental research was reported by Harvey (1960) over a thin delta wing for a 20° apex angle delta wing with breakdown at approximately 45°. He reports a swirl angle of 51°. He does not state the location of breakdown nor the precise angle of attack.

This theory is criticized by Benjamin (1962) because from a similar analysis he obtains the result that the group velocity of the standing wave is directed downstream, thus Squire's belief that disturbances would propagate upstream breaks down. Ludwig (1965) criticizes the theory since the Hall-Ludwig vortex is always stable according to it. Nevertheless, as Hall (1972) noted, the theory does have the advantage of simplicity.

Finite Transition

Benjamin (1962, 1967) went on to develop a theory of vortex breakdown that was consistent with this observation. He proposes that breakdown is a transition between two conjugate steady states of axisymmetric swirling flows being analogous to hydraulic jumps in open-channel flow.

The stream function in inviscid cylindrical flow can be described by

$$\frac{d^2 \psi}{dr^2} - \frac{1}{r} \frac{d\psi}{dr} = -\kappa \frac{d\kappa}{d\psi} + \frac{r^2}{\rho} \frac{dH}{d\psi} \quad (39)$$

Harvey, J., "Analysis of the Vortex Breakdown Phenomenon, Part II," Aero. Dept., Imperial College, Rep. 103, 1960.

Benjamin, T. B., "Theory of the Vortex Breakdown Phenomenon," JFM, 14, pp. 593-629, 1962.

Benjamin, T. B., "Some Developments in the Theory of Vortex Breakdown," JFM, 28, pp. 65-84, 1967.

where $H = \text{total head}$, and $\kappa = \nu r$, where only Squire's (1956) axial derivative has been dropped. A pair of flow stream functions ψ_A and ψ_B are defined as conjugates of one another if they satisfy the same equation and same boundary conditions at the endpoints $\psi(0) = 0$, $\psi(r_c) = 0$, and if the two curves do not intersect at any points other than their endpoints. Benjamin (1962) shows that if one is subcritical, the other is supercritical, where the critical condition is the same as Squire's (1960). The transition considered is from a supercritical flow which cannot support waves to a subcritical one that can. However, he finds that this subcritical flow has a greater momentum flux

$$2\pi \int_0^{r_c} (\rho w^2 + p) r dr \quad (40)$$

than the supercritical one.

To conserve the momentum flux, he hypothesizes the existence of small standing waves on the subcritical flow to balance the momentum flux for infinitesimal differences. For more violent transitions, Benjamin proposes that turbulence accomplishes this same purpose. Hall (1972) criticizes Benjamin on the basis of the fact that it is only applicable to small perturbations, while actual breakdown observed by Harvey (1962), for example, is marked. However, in this case, the flow is not turbulent. Furthermore, it says nothing about the structure of the breakdown. Also, Benjamin, like Squire, only considers cylindrical flows which is appropriate only for certain vortex tube flows. Finally, although he extends the analysis for infinite radius, he does not consider the more complicated problem of leading-edge vortices.

Trapped Wave Model

Due to Hall's criticisms that Benjamin's analysis cannot predict the location and mechanism of breakdown, Randall and Leibovich (1973) present

Harvey, J., "Some Observations of the Vortex Breakdown Phenomenon," JFM, 14, pp. 585-592, 1962.

Randall, J. D. and Leibovich, S., "The Critical State: A Trapped Wave Model of Vortex Breakdown," JFM, 58, pp. 495-515, 1973.

a similar theory for vortex tube flows, which eliminates some of these limitations. Their theory will only be treated briefly since extension to leading-edge vortices appears complicated. The model is centered on a theory of long, weakly nonlinear axisymmetric waves in tubes of slowly variable cross sections.

They note the theory is limited to small amplitude as Benjamin's (1962), but suggest that it can possibly be used as a model, rather than as a theory of breakdown. They consider a flow at the critical condition and obtain the following results:

- 1) The flow is supercritical upstream and subcritical below.
- 2) A stationary wave may occur only if the tube diverges in the direction of the flow, i.e., adverse pressure gradient.
- 3) They obtain a bubble representing the boundary of the trapped wave.
- 4) The calculated wall pressure is similar to that found by Sarpkaya (1971).
- 5) The calculated position of the breakdown depends on Reynolds number and is in accord with the experiments of Sarpkaya (1971); the breakdown is driven upstream for increasing Reynolds numbers.

Bilanin (1973) has considered a similar problem to model vortex breakdown in a vortex filament.

Smooth Development

Bossel (1967) considers two special cases of the governing differential equations for the vortex flow phenomenon with respect to vortex breakdown. Starting from the Navier-Stokes equations, he assumes incompressible, axisymmetric motion. Furthermore, he considers the case of:

- 1) slender vortex flows, with swirl approximately one, and viscosity important, similar to the quasi-cylindric assumption of Hall; and 2) expanding (or contracting) flows, with viscosity important, swirl approximately

Sarpkaya, T., "On Stationary and Travelling Vortex Breakdowns," JFM, 45, pp. 545-559, 1971.

Bilanin, A. J., "Wave Mechanics of Line Vortices," Ph.D. Thesis, M.I.T., 1973.

Bossel, H. H., "Inviscid and Viscous Models of the Vortex Breakdown Phenomenon," Ph.D. Thesis, U. of C., Berkeley, 1967.

one, and expansion $u/w = \text{order } 1$. Bossel (1969) clarifies the model of breakdown in the vortex tube where he breaks the vortex flow into four regions (see Figure 8). He applies his second model involving the expanding flows to obtain flow shapes of the bubble which appear qualitatively similar to the results of Harvey (1962). He concludes "vortex breakdown is a necessary feature of symmetric flows having high swirl close to the critical and some flow retardation at and near the axis, perhaps caused by the exterior pressure gradient or by an object on the axis itself. Vortex breakdown is fully explainable and describable by the supercritical solutions to the inviscid equations to which the Navier-Stokes equations approximate in the breakdown region. Neither the explanation of vortex breakdown as a finite transition (analogous to the hydraulic jump) from supercritical to the subcritical nor as the result of hydrodynamic instability appear justified." Later, he extends his views on vortex breakdown for higher swirl ratios (Bossel, 1972). Considering Bossel's (1967) thesis, Hall agrees that Bossel seems to give a representation of the axisymmetric bubble, for properly adjusted parameters. Because Bossel's form of the equations are elliptic near the breakdown bubble, he has to furnish a downstream boundary condition on the bubble. And Hall notes his breakdown "depends very much on the form assumed for the downstream distribution of $\psi(r)$ (the stream function)." Secondly, as with most theories, this is primarily a model for the axisymmetric breakdown in a vortex tube. Bossel does not consider the problem of the leading-edge vortex.

Simplified Analysis

Since vortex breakdown criterion are fairly complicated, it is difficult to see that breakdown actually develops from the form of the equations. Thus, Bossel (1968) presents a simplified stagnation model to show

Bossel, H. H., "Vortex Breakdown Flowfield," *Physics of Fluids*, 12, pp. 498-508, 1969.

Bossel, H. H., "Vortex Equations: Singularities, Numerical Solution, and Axisymmetric Vortex Breakdown," NASA CR-2090, July 1972.

Bossel, H. H., "Stagnation Criterion for Vortex Flows," *AIAAJ*, 6, pp. 1192-1193, 1968.

the significance of both the high swirl and the adverse pressure gradient.

He considers a rigid body rotation from $0 \leq r \leq r_c$ in an inviscid, quasi-cylindrical and incompressible flow. If the initially constant axial velocity w_0 is changed by the amount Δw , to first order, by continuity

$$r_c^2 w_0 = (r_c + \Delta r)^2 (w_0 + \Delta w) \quad (41)$$

$$\rightarrow \frac{\Delta r}{\Delta w} = - r_c / 2w_0 \quad (42)$$

By conservation of angular momentum and (42)

$$r_c v_c = (r_c + \Delta r)(v_c + \Delta v) \quad (43)$$

$$\rightarrow \frac{\Delta v}{\Delta w} = v_c / 2w_0 \quad (44)$$

Centrifugal balance at r_c implies that the pressure changes from r_c to $r_c + \Delta r$

$$\Delta p = \rho v_c^2 \frac{\Delta r}{r_c} \quad (45)$$

Substituting (42) gives the change of pressure

$$\Delta p = - \rho v_c^2 \Delta w / 2w_0 \quad (46)$$

Finally, the axial momentum balance for this pressure difference requires a new change of the axial velocity $\Delta \bar{w}$ at $r_c + \Delta r$

$$\frac{\Delta \bar{w}}{\Delta w} = v_c^2 / 2w_0^2 \quad (47)$$

The initial velocity disturbance is thus amplified at $r_c + \Delta r$ for $v_c / w_0 > \sqrt{2} = \tan \phi$

$$\phi = \tan^{-1}(\sqrt{2}) = 54.8^\circ \quad (48)$$

He then combines this with a result given by Hall (1966b). For incompressible, quasi-cylindrical flow, the centrifugal force balance with Kelvin's theorem and Bernoulli's theorem yields

$$\frac{dw_{ax}^2}{dx} = \frac{dw_c^2}{dx} - 2 \int_0^{r_c} \frac{u(d\kappa^2/dr)}{r^2 w} dr \quad (49)$$

with $\kappa = vr$. Hall thus found that a change in the axial velocity along the outside is accompanied by a more pronounced change along the axis.

Specifically, in a retarded flow, Bossel states that the integrand is positive, while $\frac{dw_c^2}{dx}$ is negative and therefore

$$\left| \frac{dw_{ax}^2}{dx} \right| > |dw_c^2/dx| \quad (50)$$

Thus, one finds if the initial axial velocity disturbance at the core is decelerating, that stagnation will eventually result if the initial maximum swirl parameter $v/w > \sqrt{2}$.

In another effort to illustrate the conjugate flow states in a simpler manner, Landahl and Widnall (1971) devise a simplified "one-dimensional" model of breakdown similar to the example of Bossel by extending the analysis of Barcilon (1967) to include a rotating flow field. They obtain transitions similar to those of Benjamin by energy considerations. For solid body rotation, they obtain the criticality condition that $v/w = \sqrt{2}$.

Hall, M. G., "The Structure of Concentrated Vortex Cores," in Progress in Aeronautical Sciences, Vol. 7, D. Kuchemann, ed., Pergamon Press, pp. 53-110, 1966b.

Landahl, M. T. and Widnall, S. E., "Vortex Control," M.I.T., supported by the Air Force Office of Scientific Research under Contract Nos. AF 49(638)-1622 and F44620-69-C-0009, in Olsen, Goldberg & Rogers, 1971.

Barcilon, A., "Vortex Decay above a Stationary Boundary," JFM, 27, pp. 155-175, 1967.

CONTINUOUS SLENDER-BODY MODELS

Method of Legendre (I)

One of the earliest works on a mathematical formulation of the leading-edge vortex sheet problem was proposed by Legendre (1952). He considers the simple case of an infinite, conical flat plate delta wing, strongly swept, Mach number near one, at incidences of approximately 10 degrees. The flow outside of the wing and the vortex sheets emanating from the leading edges is considered irrotational. He neglects the effect of viscosity except at the leading edge where he applies the Joukowsky condition, reasoning that there is only an arbitrary distinction between the leading and trailing edges when the edges are sufficiently sharp so that the flow separates. As a result of these simplifications and restrictions, he is able to obtain a rough approximation for the separated flow field on a delta wing. He admits that the restrictions are considerable and not particularly applicable to the real practical problem -- sharp leading edges, and infinitesimal aspect ratio. However, it appears to be an improvement over R. T. Jones (1946) attached flow model when the flow separates at moderate angles of attack. As a result of the simplifications, the velocity can be divided into a uniform free stream and perturbation velocity and the governing equation becomes Laplace's equation in the cross-flow plane. This is a result of slender body theory (SBT).

Legendre comments that the SBT assumptions of small perturbations of the velocity are violated near the leading-edge vortex cores where the velocity goes to infinity as $1/r$. He cites justifications for proceeding in light of this violation to the basic assumption. First, he claims that the error introduced should be local and should not affect global results, citing the analogous condition at the leading edge for the attached flow model of Jones, where the velocity goes to infinity as $1/r^{1/2}$. Secondly, he also notes that the use of point singularities is only a mathematical artifice and in reality the velocity does not approach infinity, although it does become several factors larger than the free stream near the core. He suggests that the point singularities could be replaced by viscous regions

Legendre, R., "Écoulement au voisinage de la pointe avant d'une aile à forte flèche aux incidences moyennes," Recherche Aeronautique, No. 30, 3-8, 1952.

of finite dimensions to alleviate this violation of the assumptions, if necessary. These regions, of course, would not satisfy Laplace's equation. Only the region outside of the vortices would be considered as the region of interest. More importantly, the conformal transformation of such shapes would further complicate the problem. The actual formulation of Legendre follows.

With the above assumptions, the continuity equation becomes the governing equation and for the perturbation velocity potential takes the form

$$(1 - M^2) \phi_{xx} + \phi_{yy} + \phi_{zz} = 0 \quad (51)$$

For "slender" wings near Mach number = 1,

$$(1 - M^2) \phi_{xx} \ll \phi_{yy}, \phi_{zz} \quad (52)$$

and the governing equation becomes Laplace's equation in two dimensions.

$$\phi_{yy} + \phi_{zz} = 0 \quad (53)$$

Thus ϕ is a harmonic function. For conical flow

$$\phi = R_e[xF_1(\eta)] \quad (54)$$

where F_1 is an analytic function of $\eta = \frac{z + iy}{b}$, where $b = \text{local semispan} = x \cot \lambda$. He separates out a free stream component

$$F_1 = U \cos \alpha + U \sin \alpha \cot \lambda F(\eta) \quad (55)$$

For moderate incidences at which leading-edge separation occurs and the linearization of the velocity is still valid, he models the flow by placing two isolated vortices above the wing [see Figure 9]. Since the flow is conical, the strength of the vortices grows linearly with x , and as a result, Helmholtz' theorem of conservation of circulation is violated.

Thus, the model cannot be rigorously justified, but it does seem to be more accurate than the Jones attached flow model.

The η -plane is difficult to use since image vortices are required in the slit representing the wing to satisfy the no-flow condition through the wing. Therefore, Legendre suggests making a conformal transformation to the S -plane or the ζ -plane.

$$\zeta^2 = 1 + \eta^2 \text{ or } 2\eta = S - 1/S \quad (56)$$

In the S -plane, the potential becomes

$$2F = S + 1/S + \frac{i\gamma}{2} \ln \frac{(S - S_0)(S - 1/\bar{S}_0)}{(S - \bar{S}_0)(S - 1/S_0)} \quad (57)$$

where S_0 is the location of the point vortex in the upper right hand quadrant and γ is the intensity of that vortex. The $(\bar{\quad})$ stands for the complex conjugate of the quantity in question. The Joukowski condition of finite velocity at the wing tips furnishes one equation for the three unknowns, γ and the real and imaginary parts of S_0 . The remaining two equations used by Legendre are that the cross-flow velocity is zero at S_0 so that there are no forces on the point vortices, in the y and z directions. With these three equations, Legendre obtains a C_L curve after calculating the pressure distribution on the wing [See Figure 10]. The lift is a fairly complicated function of λ and α . For small angles of attack, the lift is negative and remains less than the attached flow lift ($C_L = \frac{\pi}{2} R \sin \alpha$) for angles of attack less than about 10° . Eventually, the lift for the Legendre model exceeds that for the attached flow model; this occurs at lower angles of attack for the lower aspect ratios. Legendre concludes that this model is not valid at low angles of attack where the flow remains attached. This model is primarily of historical interest and it has since been supplanted.

Later, Legendre (1953b) revises this method upon the instigation

Legendre, R., "Écoulement au voisinage de la pointe avant d'une aile à forte fleche aux incidences moyennes," Recherche Aeronautique, No. 35, pp. 7-8, 1953.

of Mac C. Adams (1953). In his first work, he notes that he had implicitly assumed a cut joining the two vortices. However, Adams noted that as a result the lift was multivalued, since the region was no longer simply connected. In the second form, Legendre includes a cut between the vortices and their respective leading edges to roughly account for the feeding sheets. However, this formulation allows a pressure difference across the sheet, and the force on the wing depends on whether or not one calculates the pressure force on the wing, or whether one takes a contour integral around the wing-vortex combination.

Method of Brown and Michael

Edwards (1954) and later Brown and Michael (1954, 1955) further pursue this slender body model of conical flow for the delta wing. Edwards and Brown and Michael both include a no-force condition on the vortex-cut combination so that the lift is single-valued and the pressure distribution on the wing gives the same result as the contour integration for the momentum flux. Edwards furnishes the small angle of attack result

$$C_L = \frac{\pi}{2} R \alpha + \pi (R)^{1/3} \alpha^{5/3} \quad (58)$$

where the first term is identical to that of the slender body theory of Jones and the second term is the additional term due to the leading-edge vortices. Brown and Michael (1954) note that Jones' result was obtained using a special irrotational flow pattern; since, by Kelvin's theorem, the irrotational flow yields the least kinetic energy and hence the least apparent mass, where $L = \alpha U^2 m'$ (m' = apparent mass of the two-dimensional flow at the trailing edge), they conclude that the lift in all other cases must always be greater than that computed by Jones. Since Brown and Michael formulated it in much more detail in their publications, their derivation

Edwards, R. H., "Leading-Edge Separation from Delta Wings," JAS, 21, pp. 134-135, Feb. 1954.

Brown, C. E. and Michael, W. H., "Effect of Leading-Edge Separation on the Lift of a Delta Wing," JAS, 21, No. 10, pp. 690-694, Oct. 1954.

Brown, C. E. and Michael, W. H., "On Slender Delta Wings with Leading-Edge Separation," NACA TN 3430, 1955.

shall be followed here, although the results of Edwards are identical to those of Brown and Michael.

They make the standard slender body assumption of Jones and obtain

$$\phi_{yy} + \phi_{zz} = 0 \quad (59)$$

as the governing equation. They use the coordinate system shown in Figure 11, where they approximate the flow by two point vortices above a flat plate.

As with Legendre (1952), there are three unknowns here, the location of the vortices and their strength. The three equations used by Brown and Michael are the no-force condition on the vortex-cut combination on each side and the Joukowski condition at the leading edge.

The vortices are connected to the leading edges by cuts across which a pressure jump exists. The vector force on the sheet due to this pressure discontinuity is given by

$$i\rho U \left(\frac{dy}{dx} \right) (\sigma_0 - b) \quad (60)$$

The force on the vortex is $-\rho v^* \gamma$ where v^* is the net velocity at σ_0 . Since the flow is assumed conical, the vortex strength increases linearly and thus the circulation is given by

$$\gamma = \frac{dy}{dx} x \quad (61)$$

The zero net-force condition requires that

$$v^* = \frac{U(\sigma_0 - b)}{x} \quad (62)$$

By using the transformation $\theta = \sqrt{\sigma^2 - b^2}$, it is easy to satisfy the no-flow consideration on the plate and obtain in the θ -plane [see Figure 11] the potential

$$W(z) = \frac{-i\gamma}{2\pi} \ln \frac{(\theta - \bar{\sigma}_0)}{(z + \bar{\sigma}_0)} - iU\alpha\theta \quad (63)$$

In the θ -plane, a stagnation point at $\theta = 0$ corresponds to the Joukowski condition since this is a singular point of the transformation. This gives the third relation and one obtains

$$\frac{i\gamma}{2\pi} \left[\frac{\sigma_0}{(\sigma_0^2 - b^2) + \sqrt{\sigma_0^2 - b^2} \sqrt{\bar{\sigma}_0^2 - b^2}} - \frac{\bar{\sigma}_0}{\sqrt{(\sigma_0^2 - b^2)(\bar{\sigma}_0^2 - b^2)}} - \frac{\sigma_0}{\sigma_0^2 - b^2} + \frac{1}{2} \frac{b^2}{\sigma_0(\sigma_0^2 - b^2)} \right] = U \frac{b}{X} \left[2 \frac{\bar{\sigma}_0}{b} - 1 \right] \quad (64)$$

where the real and imaginary parts furnish two equations for the real and imaginary parts of σ_0 which give the locations of the vortices. γ may be eliminated by the Joukowski condition, to get the solution in terms of the aspect ratio and angle of attack.

$$\gamma = 2\pi U\alpha \left(\frac{1}{\sqrt{\sigma_0^2 - a^2}} + \frac{1}{\sqrt{\bar{\sigma}_0^2 - a^2}} \right) \quad (65)$$

Brown and Michael calculate the lift by computing the flow of momentum at the trailing edge through a contour including the wing. Thus,

$$L = -\rho U \iint (\phi_z - U\alpha) dz dy$$

$$= -\rho U \int_c \phi dy \quad (66)$$

$$C_L = \frac{2\gamma\epsilon}{Ub} \frac{\theta_0 + \bar{\theta}_0}{b} + 2\pi\alpha\epsilon \quad (67)$$

where $\epsilon =$ semiapex angle, $R \approx 4\epsilon$, and to the lowest 2 orders, this corresponds to the result of Edwards.

Several problems occur with this type of formulation. First, even at relatively low Mach numbers, Brown and Michael note that the absolute pressure can be negative (unphysical) at moderate angles of attack [see Figure 12]. For example, the pressure becomes negative for 75° sweep at approximately 12° angle of attack for a Mach number of 1. This is due

to the fact that the velocity becomes infinite at the point vortices. As a result, this violates the condition of linearized velocity. Secondly, Brown and Michael comment that they did not consider the possibility of more than one pair of stationary vortices. That is, they neglect to consider the possibility of secondary vortices. The basic model also allows a pressure discontinuity across the model of the sheet as well as allowing normal velocities across the sheet. As a result, Bryson (1959) argues there is a resulting moment even though the force is zero on each vortex sheet, although over the entire flow, the left and right symmetry causes this to vanish. Furthermore, the assumption that $(1 - \gamma^2)\phi_{xx}$ is small is violated by experimental results, where there are large axial velocities. Thus, the flow near the point vortices cannot hope to be well-represented. Finally, in the real flow, both the vortex sheet and the end of the spiral should be located on stream surfaces, and they should be force-free at every point instead of being globally so.

Thus, comparison with experiment cannot be perfect. Elle (1958) compares the theory with his experimental results and finds the vortex cores are actually farther inboard than predicted by Brown and Michael. Also, the experimental lift is always less than the theoretical prediction. He concludes that from his analysis that the "concept of a discrete vortex with a feeding sheet is basically sound," but the assumed model of the flow pattern is not suitable and must be replaced by another one.

The primary value of this theory of Brown and Michael is not its correctness or completeness, but its simplicity. For example, one can consider the case of secondary separation. Even early experiments, Peckham (1958) and Earnshaw and Lawford (1966), indicate the presence of secondary vortices as well as the primary vortices. Bergeson and Porter (1960) report

Bryson, A. E., "Symmetric Vortex Separation on Circular Cylinders and Cones," Journ. of Applied Mech., pp. 643-648, Dec. 1959.

Peckham, D. H., "Low Speed Wind Tunnel Tests on a Series of Uncambered Slender Pointed Wings with Sharp Edges," ARC R&M 3186, 1958.

Earnshaw, P. B. and Lawford, J. A., "Low-Speed Wind-Tunnel Experiments on a Series of Sharp-Edged Delta Wings," ARC R&M 3424, 1966.

that the strength of the secondary vortices relative to that of the primary vortices is not negligible. Hence, they conclude, no mathematical treatment which fails to include the effect of secondary vortices on the flow field can accurately predict the lift curve. Smith (1966a) says he tried unsuccessfully to include the presence of the secondary vortices in a Brown-and-Michael-type model. He does not present details of his attempt there. The governing equations would seem to be the same as before. One would have three additional unknowns which determine the location and strength of the secondary vortices. One needs to specify three additional boundary conditions, as a result, to determine these unknowns. One would probably have to resort to a boundary layer argument to find the separation point induced on the wing for the pressure distribution given by the primary vortex, using the Brown and Michael model for simplicity. The no-force condition on the secondary vortex-cut configuration would be similar to the one for the primary vortex. Now, one would have six equations for six unknowns. It would help to perform such a calculation as it would help answer the question concerning the importance of secondary separation on the entire flow field.

Nangia and Hancock (1968) attempt to include the trailing edge effect by incorporating the shed vorticity into the Brown and Michael model with the more standard lifting surface theory using bound and trailing vorticity to describe the planform and two isolated vortices to describe the leading-edge vortices, which are joined to the leading edges by cuts. The model is no longer conical. The Joukowski condition at the trailing edge is satisfied by a collocation method, and the problem is solved by an iterative procedure.

This model no longer requires a center of pressure at the $2/3$ chord point, and for the delta wing considered (angle of attack = .25 radians, aspect ratio = 1), they obtain the center of pressure at .6 chord, compared to then unpublished experimental results which placed it at .61 chord. They

Smith, J. H. B., "Improved Calculations of Leading-Edge Separation from Slender Delta Wings," RAE TR 66070, March 1966a.

Nangia, R. and Hancock, G. J., "A Theoretical Investigation for Delta Wings with Leading-Edge Separation at Low Speeds," ARC CP No. 1086, 1968.

do mention that the question which needs recognizing before proceeding further is whether it is worthwhile to incorporate large expenses in utilizing large amounts of computer time when the results will still contain the inherent faults of the Brown and Michael method.

Portnoy and Russell (1971) consider another extension and add rhombic thickness to the Brown and Michael model using a conformal transformation. Their results show a decrease in lift and the outboard trend as the thickness increases, but their results for the vertical displacement are inconclusive.

A final example is provided by Smith (1957), who considers curved leading edges. Applying the conical model at the apex and then using slender body theory to march from the apex downstream, he applies the Brown and Michael no-force condition to each vortex location and obtains vortex core locations which follow the leading edge fairly well.

Another important use of the Brown and Michael method is for initial approximations for iterative procedures. For example, Pullin (1973) uses the Brown and Michael scheme to provide the initial configuration for a more sophisticated model considered later.

Method of Mangler and Smith

In an effort to improve the agreement between experiment and theory, Mangler and Smith (1957) propose a slightly different model. They consider a rough approximation of the vortex sheet in the cross-flow plane, as well as the concentrated vortex core. Again they assume a conical, slender flow

Portnoy, H. and Russell, S. C., "The Effect of Small Conical Thickness Distributions on the Separated Flow past Slender Delta Wings," ARC CP1189, 1971.

Smith, J. H. B., "A Theory of the Separated Flow from the Curved Leading Edge of a Slender Wing," ARC R&M No. 3116, Nov. 1957.

Pullin, D. I., "A Method for Calculating Inviscid Separated Flow about Conical Slender Bodies," ARL/A14, Australian Defense Scientific Service, Rep. 140, May 1973.

Mangler, K. W. and Smith, J. H. B., "Calculation of the Flow past Slender Delta Wings with Leading Edge Separation," RAE Rep. Aero. 2593, May 1957.

and obtain the two-dimensional Laplacian as the governing equation. Since they now attempt to represent the outer part of the sheet, near the leading edge, the following notation must be considered [see Figure 13].

The boundary conditions are given as follows. Far from the body $\phi_x = U$, $\phi_z = \alpha U$. On the surface of the body or on a vortex sheet, the normal velocity vanishes. If the equation of the surface is

$$S = r - bF(\theta) \quad (68)$$

where $b = Kx = x \tan \epsilon$; $\epsilon =$ semiapex angle, the normal velocity condition becomes

$$\phi_n = -(KU/b)r \sin \phi \quad (69)$$

The condition that the vortex sheet cannot support a pressure difference becomes

$$\Delta \phi = \Delta \dot{\phi} \left(r \dot{r} - \frac{b \phi_{\sigma m}}{KU} \right) \quad (70)$$

where $(\dot{})$ indicates differentiation along the arc, σ , where Δ is the difference of the value across the vortex sheet and $\phi_{\sigma m}$ is the mean value of ϕ_{σ} across the sheet.

Arguing that the vortex sheet nearest the wing will have the greatest effect on the wing loading, they approximate the rolled up sheet by the approximation shown in Figure 14, where the inner part of the spiral has been replaced by an isolated vortex located at point D which contains all of the vorticity inside the circle of radius R.

The derivation for this is fairly involved and is summarized below. By a geometrical asymptotic derivation, Mangler and Smith (1959) relate the distance to a point on the spiral to its relative angle and

Mangler, K. W. and Smith, J. H. B., "A Theory of Flow past a Slender Delta Wing with Leading Edge Separation," Proc. Roy. Soc. London, Ser. A, 251, p. 200, 1959.

the location of its center. For large angle θ_1 , i.e., many turns of the spiral, they obtain the relation for the spiral radius as a function of θ_1 as

$$r_1 = a\mu\theta_1^{-m} + \text{higher order terms } (m > 0) \quad (71)$$

where μ , m characterize the spiral. By applying boundary conditions of the fact that the sheet is a stream surface and supports no pressure difference, they derive two equations. By applying various lowest order approximations, continuity equation, geometric construction, and equating the coefficients of the resulting equalities, they obtain the flow characteristics in the inner part of the spiral. The effect of the vorticity in the small circle on the remainder of the flow field is shown to be the same as that from an isolated vortex of strength $\Delta\phi = 2\pi\mu KU \frac{a}{b} R$ at its center (see Figure 14 for notation), as they produce the same velocity on the boundary and have the same total circulation. Their calculations also specify the strength of the vortex sheet where it is tangent to the small circle. These calculations also specify some of the boundary conditions applied at the point vortex to calculate the flow field.

There is a cut similar to the one employed by Brown and Michael between the point C, the point of the sheet tangent to the circle at point D, and the point D. However, due to the relative shortness of this cut, the forces should be reduced.

To simplify the normal condition on the flat plate, they make use of the standard transformation [see Figure 15].

$$z^{*2} = z^2 - b^2 \quad (72)$$

Mangler and Smith assume that R is sufficiently small that the circle of radius R can be considered to transform into a circle of radius R^* . As before, the point $Z^* = 0$ becomes a stagnation point to satisfy the Joukowski condition. The other boundary conditions become

$$\psi_n^* = \frac{-kU}{b} r^* \sin \phi \quad (73)$$

$$\Delta\psi = \gamma^* \left(\frac{r}{r^*}\right)^2 \left(\frac{s\psi}{Ku} - r^* \cos \psi\right) \quad (74)$$

where

$$\gamma^* = -\frac{\partial}{\partial s^*} (\Delta\psi) \quad (75)$$

To find an approximate configuration, they introduce a finite set of parameters to define the sheet shape and strength. Then the boundary conditions are satisfied at a finite number of points to find the unknown parameters. The parametrization chosen first is the following. The curve in the Z-plane is assumed to be defined by a circular arc of radius r_1 and length $2r_1 \theta$. For the function γ^* , the following is chosen

$$\gamma^* = \gamma_0 + \gamma_r \cos \theta - \gamma_i \sin \theta \quad (76)$$

The system depends on the seven parameters, θ , r_1 , $r_2 = R^*$, γ_0 , γ_r , γ_i , and μ , where μ characterizes the strength of the isolated vortex. The seven conditions to determine the unknowns are

- 1) By symmetry, $\gamma^* = 0$ at A^* .
- 2) γ^* must equal $\frac{2\pi Ku}{b} R \left| \frac{dZ}{dZ^*} \right|$ at C^* to match the isolated vortex properly.
- 3) A^* must be a stagnation point.
- 4) The nonsingular part of the velocity at D must be $\frac{Ku a}{b}$ along OD . This likewise follows from the representation of the tip of the vortex sheet and provides two conditions.
- 5) The normal velocity condition is applied at B^* , midpoint of A^*C^* .
- 6a) The pressure condition is applied at A^* , or
- 6b) The pressure condition is applied at B^* .

They neglect the forces on the cut from D to C at times and at other times, they use the method of Brown and Michael to eliminate this force. However, this shall not be considered further as it does not greatly affect the form of the solution.

The actual mathematical formulation for these boundary conditions is given in their Appendix. The equations are nonlinear and simple expressions cannot be written down for the location of the vortex sheets and the vortices

as a function of angle of attack and aspect ratio. Because of this non-linearity of quadratic equations, they consider the possibility of double roots. They note that there is little difficulty in choosing the correct root on the basis of the fact that the vorticity and the angle of attack must be positive. They end up solving simultaneously a pair of nonlinear equations by an interpolation method.

Once these equations are solved, all of the unknowns can be calculated for the flow field. The pressure distribution is obtained from Bernoulli's equation while the normal force coefficient can be obtained in either of two ways. First, they integrate the pressure over the entire wing. Alternately, they use a momentum integral in the plane at the trailing edge of the wing [see Figure 16]. The results are slightly different since the first method only considers the forces on the wing, while the latter method includes the forces on the sheet-source system as well. The force is not identically equal to zero on the sheet-vortex system, since the no-pressure and normal flow condition are only satisfied at one point. There are some differences, therefore, between the various methods used to calculate the shape of the sheet. These depend on the location of the point at which the pressure condition is satisfied and whether a no-net force condition is applied to the vortex only or to the vortex-cut combination. However, all four results are grouped near a line corresponding to the choice of pressure satisfied at the leading edge of the wing and the use of the Brown and Michael no-force condition. An attempt is made to curve fit the line for moderate values of α/K which turns out to be the crucial parameter in their calculations. They obtain

$$C_N = \frac{\pi}{2} R \alpha + 4\alpha^2 \text{ for } \left| \frac{\alpha}{K} \right| < 1.6 \quad (77)$$

where the choice of constants is probably guided by experience, i.e., note that the first term gives the slender body limit of Jones. Again, as in the case of Brown and Michael, the force is always greater than the R. T. Jones case, unlike Legendre's early model. They also give the representation of the vortex core and the sheet shape [see Figure 17]. Their results are in better agreement with experiment than those of Brown and Michael, but it

still leaves the question of justified assumptions unanswered. They note that unlike Jones' attached flow model, there is vorticity of the opposite sense in the trailing edge vorticity. See the following Table from Mangler and Smith (1957).

Table 1. Vorticity Origin

Origin and Sense of Vorticity	2.5	1.0	.5	.25	Jones
Leading Edge	86%	76%	57%	57%	0%
T. E. Normal Sense	1	1	6	15	100
T. E. Opposite Sense	13	23	37	28	0

After Mangler and Smith complete their calculations, they check their assumptions. They check the error in the normal velocity and pressure on the sheet due to the different treatments for the circle containing the core region and the circular arc representing the sheet; there is a logarithmic singularity in the normal velocity at the junction of the two models, no matter how far the model of the sheet is extended. This occurs wherever the sheet is terminated. Roy (1957) has suggested in a similar problem that a finite core of vorticity be used to replace the end of the spiral sheet in order to limit the velocity. Mangler and Smith suggest that this singularity may be acceptable, so they do not suggest any means of alleviating this problem, although they do attempt to justify its existence. The pressure difference on the sheet is also given and is always less than .8 of the wing center line pressure difference. The difference is far less than this on the average.

They state that the similarity of the lift forces for the various calculations indicate that representing the core by an isolated vortex is not a serious modification. Although the proportion of total vorticity on the sheet is small for small ratios of α/K and only rises to about 20% for $\alpha/K = 1$, it is important because it occurs closer to the leading edge than

Roy, M., "Sur la Théorie de l'aile en delta: Tourbillons d'apex et nappes en cornet," Recherche Aeronautique, No. 56, pp. 3-12, Feb. 1957.

that of the isolated vortex. This is borne out by their better agreement with experiment than Brown and Michael. At large α/K , there is increasing divergence between theory and experiment. At the same time, there is considerable scatter in the data. Part of the scatter in the data can be explained by the fact that different methods were used to calculate the normal force and different cross-sectional models were employed, different amounts of wind tunnel wall effects were included, and different Reynolds numbers were encountered in the experiments. Mangler and Smith suggest that the discrepancy between experiment and theory can be possibly explained by the presence of secondary vortices. This would reduce the pressure peaks and consequently, the lift, giving better agreement with experiment. They do not consider viscous effects as a possible culprit and do not include Reynolds numbers with the experimental data that they present.

Method of Smith

Due to the limitations of the preceding model and the advent of greater computing power, Smith (1966a, 1968) later proposed a better representation of the leading-edge vortex sheet. The problem is formulated in the same manner as the earlier Mangler and Smith problem except when it comes to representing the outer part of the spiral sheet [see Figure 18]. The unknowns chosen are the polar distances of the sheet segments, the values representing the sheet strength, and the strength of the isolated vortex and its two coordinates which furnishes $2n + 3$ unknowns.

To solve for these unknowns, he chooses the following set of equations. The Kutta-Joukowski condition of finite velocity at the leading edge, the no-force condition for the vortex-cut combination, the no-pressure difference condition across the sheet, and the conical normal velocity condition on the sheet, which is equivalent to the stream surface condition of the three-dimensional flow, are employed. Since the pressure condition is nonlinear, Smith does not try to solve the equations explicitly for the

Smith, J. H. B., "Improved Calculations of Leading-Edge Separation from Slender Delta Wings," RAE TR 66070, March 1966a.

Smith, J. H. B., "Improved Calculations of Leading-Edge Separation from Slender, Thin Delta Wings," Proc. Roy. Soc., Ser. A, 306, pp. 67-90, 1968.

shape and strength of the sheet. Rather he uses an iterative approach. From a known solution, either from a simpler model or a nearby condition, he adjusts the shape and the strength of the vortex sheet to satisfy the governing equations. The nonlinear pressure condition is handled by the method of steepest descent, which has the difficulty, that the mathematical region near the solution is fairly oblate and convergence is consequently slow. From the dimensionless form of the equations, it is found that the quantity characterizing the flow field is $a = \alpha/K$. Also, one must specify the extent of the sheet shape, since this cutoff is arbitrary. Also, one has to furnish tolerances of what constitutes a satisfactory solution and one must finally furnish that initial guess to represent the leading-edge sheet. In order to justify the different treatment of the inner and outer regions of the spiral sheet, Smith (1968) examines the effect of changing the extent of the sheet.

Table 2. Effect of Sheet

Source	θ_{max}	y/b	z/b	Circulation		Lift
				Total	Sheet Fraction	
Brown & Michael (1954)	0	.871	.220	4.45	0	11.22
Smith (1968)	157°	.722	.225	4.22	.23	9.93
Smith (1968)	517°	.744	.215	4.22	.47	9.88
Smith (1968)	877°	.738	.227	4.22	.60	9.87
Mangler & Smith (1959)	157°	.803	.171	3.77	.19	9.12

Thus, the importance of correctly representing the outer sheet is seen. Compared to the Brown and Michael model, the new vortex position is 13% of the semispan further inboard, the overall circulation is 5% lower and the lift is 12% lower. There are also discrepancies with the Mangler and Smith model even when identical sheet extents ($\theta_{max} = 157^\circ$) are compared. This may either be due to the application of the pressure and the normal velocity conditions at only one point or may be due to the fact that the sheet was poorly approximated by a circular arc in the transformed plane, or that the sheet strength was inadequately specified by three constants. For the different extents, the sheet shapes are compared [see Figure 19] and there

is little discrepancy between the results and he suggests that even the shortest sheet extent is probably adequate while there is little justification for carrying the calculation further than the intermediate value.

Noting that there is an infinite singularity at the end of the sheet, he says that the shape of the sheet is relatively independent of the extent of the sheet, since even when this singularity is not alleviated, the sheet shapes for the various extents are closely similar. This implies that although there was some question earlier about the singularity, it does not appear to be responsible for the difficulty.

Smith compares his sheet shape with the asymptotic results of Mangler and Weber (1965) [see Figure 20]. He also plots the sheet strength $\frac{d\Delta\psi}{d\sigma}$ versus the arc length and obtains the following solution in the physical plane which shows remarkable agreement to the asymptotic solution of Mangler and Weber for large θ [see Figure 20]. Although the analysis would seem to be most valid as $a = \alpha/K$ tends towards zero, as it is a perturbation solution, Smith does not carry out the problem for a less than .20. This is due to a variety of reasons which he considers.

- 1) The calculations took longer as a was reduced.
- 2) The sheet shape developed an inflection point suggesting a larger value of θ_{\max} .
- 3) The agreement between theory and experiment was poor.

The first condition may be the result of the closeness of the isolated vortex to the wing for small a . Smith tried to alleviate the second problem by extending the sheet, but the sheet came close to crossing itself near the end, which would have been unphysical, so he discontinued that approach. Finally, the third problem could be due to the failure of the physical model. For small a , the curvature at the leading edge may become important and the flow may not be fully separated, or may not separate at exactly the leading edge. Also, the boundary layer thickness becomes larger with respect to the height of the isolated vortex above the wing, and here the model would be inadequate.

As before, the lift may be calculated by two different methods. Either the pressure on the wing may be integrated over the surface or a momentum analysis can be used at the "trailing edge". Since the pressure

condition is satisfied at only a finite number of points, there are discrepancies between the two methods, which should disappear as the number of points per arc length are increased. After plotting the curve of the normal force coefficient versus the parameter a , Smith obtains the curve fit for $.25 \leq a \leq 2.5$

$$C_N = \frac{\pi}{2} R \alpha + 3.2 \alpha^{1.7} (R)^3 \quad (78)$$

which may be compared to the Brown and Michael solution of

$$C_N = \frac{\pi}{2} R \alpha + \pi (R)^{1/3} \alpha^{5/3} \quad (79)$$

Finally, one must compare this result with experiment to discover if it can be justified. Before this can be done, a few notes must be made to partially explain the discrepancy between experimental models.

- 1) Wind tunnel corrections should be considered; at high angles of attack and for larger aspect ratios, wind tunnel effects become important but are often neglected.
- 2) Reynolds number affects the boundary layer transition. For example, when Earnshaw (1961) induced turbulence by roughening the wing, this resulted in the vortex core moving outward and upward. Also, Smith notes an intensification of the suction peak after the transition.
- 3) Furthermore, Smith considers the effect of wing thickness, since it is impossible to build a flat plate delta wing without thickness, due to structural reasons. On a thick wing, the vortex tends to be higher up and further outboard than on a thin wing.
- 4) One must consider the effect of the trailing edge on the nonconicality of the subsonic flow which is often used for these experiments. Experimental agreement would probably be most satisfying if the lift were obtained by integrating the pressure (assumed conical) at a chordwise station sufficiently far from the trailing edge. As the trailing edge is approached, the vortex moves higher and further inboard, while the pressure difference falls to zero.
- 5) The Reynolds number also affects the boundary layer thickness. Smith suggests the possibility that at low Reynolds numbers, the vortex would be

further inboard and higher due to the boundary layer displacement effect.

Thus, it was concluded that the size of the vortex model was well described by the theoretical model of Smith and that its shape differs in a manner closely related to the lateral displacement of its core from the calculated position of the isolated vortex. This is confirmed by plots of the low pressure region and by flow visualization techniques. Due to the displacement of the isolated vortices due to the boundary layer effects, the model is less successful in predicting the size and shape of the suction peak beneath the vortex on the wing. There is a definite difference between experimental results for laminar and turbulent secondary separation and it is impossible for an inviscid theory to adequately model both phenomena. The disagreement between experiment and theory is especially severe at low α , where the boundary layer displacement thickness becomes noticeable with respect to the height of the isolated vortex above the wing. The measurements of the integrated pressure -- sectional lift -- appear adequate for the approximately conical flow. The agreement between theory and experiment is everywhere reasonable and seems to justify the use of slender body theory. Most of the remaining discrepancy seems to be explained in terms of Reynolds number effects rather than in terms of high axial velocity gradients that would invalidate the theory.

Pullin (1973) formulates the problem for the flat plate delta wing in a manner similar to Smith. However, he departs in the method of numerical treatment of the governing integro-differential equation. While Smith uses a more or less trial and error procedure for finding the solution, Pullin obtains a gradient matrix with respect to the $2N + 3$ variables describing the outer sheet and the isolated vortex in terms of the governing equations. The formulation is slightly different and one must specify the per cent of vorticity in the sheet, instead of the extent of the sheet.

Pullin, D. I., "A Method for Calculating Inviscid Separated Flow about Conical Slender Bodies," ARL/A14, Australian Defense Scientific Service, Rep. 140, May 1973.

The problem becomes one of the following $2N + 3$ unknowns

Position of the vortex sheet	$2N$
Position of the isolated vortex	2
Overall Vorticity	1

The $2N + 3$ equations are

Joukowsky condition	1
The no-force condition on the cut-vortex	2
The tangency condition on the sheet	N
The pressure condition on the sheet	N

Instead of considering the strength of the sheet at isolated points as unknowns, he allows the vortex sheet two degrees of freedom and allows the vorticity to be distributed according to an initial guess. Smith, on the other hand, assumes an angular distribution and left the radial distance of the sheet and the strength at those points as the $2N$ unknowns. Instead, following the early work of Legendre (1953a), Pullin assumes that the sheet strength to be a dummy variable of integration. Smith had previously shown that the sheet strength $\Delta\phi$ was a monotonic function of the angular extent of arc length, so this is justified.

One other comment is noteworthy. Using the Biot-Savart Law for calculating the induced velocity, one obtains an integral of the form of a Cauchy-Principal Value. Both Smith and Pullin linearize the integrand near that point and consequently simply neglect the singularity.

Since Pullin's analysis is based on an iterative method, albeit more rational than Smith's, it requires an initial approximation. Pullin obtains an initial approximation by using Brown and Michael's no sheet solution for one control point. Then, this solution is used to furnish an initial approximation for the two-control point problem, etc., until the desired number of control points is obtained. Since this method will produce an approximate solution and not an exact one, it is necessary to determine when

Legendre, R., "Écoulement au voisinage de la pointe avant d'une aile à forte flèche aux incidences moyennes," Recherche Aeronautique, No. 31, pp. 3-6, 1953a.

when a sufficiently accurate solution is found. Pullin uses two parameters to describe the convergence of the method. First, he uses the mean error of the unknowns in satisfying the governing difference equations, and secondly, the modulus of the total force acting on the cut-vortex system for that approximation. After formulating the problem, Pullin goes on to calculate some examples for both the flat plate and the flat plate-circular cone problem. For 45% of the vorticity in the outer sheet, the Newton-Raphson scheme for $N = 20$ breaks down (fails to converge) for $a = .5$. For only 20% of the vorticity in the sheet and $N = 10$, Pullin was able to obtain solutions for a down to $.2$. This is similar to the difficulty encountered by Smith. Pullin suggests that the problem may be due to the behavior of the strongly nonlinear finite difference equations, since the onset of divergence occurs quite suddenly; near the point of breakdown, there is no appreciable increase in the time required for the computation. Physically, this is no explanation; however, as previously noted, this type of formulation is not very applicable for small a , and, consequently, it is probably not worth too much additional effort to clarify this difficulty. However, if it were to turn out to be a manifestation of the nonlinear behavior of the equation, this may indicate the need for a greater understanding of the governing equation. The question of existence, uniqueness and stability of the solution are of primary consideration if one is to have faith in the results. He compares his solutions with Smith for a comparable number of points and the agreement between the two is reasonable as it should be. He furthermore compares his method with Sacks' (1967) method employing finite elementary vortices [see Figure 21]. The outer sheet shape is approximately given and the overall lift is in good agreement. The vortex sheet is further outboard for Sacks' representation. However, the position of the vortex core is outboard and lower for Sacks' method. This can possibly be attributable to the fact that different criteria have been used to determine the vortex core position. Smith and Pullin use the

Sacks, A. H., Lundberg, R. and Hanson, C., "A Theoretical Investigation of the Aerodynamics of Slender Wing-Body Combinations Exhibiting Leading-Edge Separation," NASA CR-719, 1967.

the position of the isolated vortex to mark the vortex core location. This is justified since this position appears to be relatively independent of the sheet extent for the extent of 517° of the rolled-up sheet.

Sacks et al, on the other hand, use a center of gravity [see Figure 21] calculation to calculate the location of the vortex center. Although they do not go into detail of how they calculate the vortex center, its location would differ depending on what extent of the outer sheet they include in the center of gravity calculation. Inclusion of the outer part of the sheet near the leading edge would mean that one would obtain a center of gravity position which is lower and farther outboard. Possibly, a more reasonable way to locate the vortex core using the discrete vortex model would be to search for some type of convergence by just using the vortices outside the first 90° to 180° of the sheet. Since the shift of the entire sheet and the core are in the same direction for the comparison between the two methods, it is probable that they have already used such a method. Also notable is the outboard displacement of Sacks' sheet shape. This could possibly be accounted for by the suppression of vertical velocities near the leading edge in Sacks' model or the handling of the Cauchy Principal Value in Smith and Pullin models.

Included in Pullin's report is much of the computer program necessary to obtain the solution for the problem. However, he leaves several subroutines unspecified and not even all of the parameters are defined.

Pullin (1973) says in lieu of the representation of the core by an isolated vortex, he tried to incorporate one of the available asymptotic solutions for the sheet structure in the core region into the vortex sheet model in order to construct the sheet shape from an "inner" and "outer" solution. This attempt failed due to the difficulty in properly formulating the problem. He gives no additional details on this attempt.

Smith (1971) later extends his method to a body with a rhombic cross-section by using a Schwarz-Christoffel transformation. With increasing

Smith, J. H. B., "Calculations of the Flow over Thick, Conical, Slender Wings with Leading-Edge Separation," ARC R&M 3694, March 1971.

thickness, the vortex cores move upwards and outwards and the circulation falls off accordingly. Experimental agreement decreases with increasing thickness, possibly due to secondary separation, according to Smith.

Levinsky and Wei (1968) extend the results of Smith by using a more general conformal transformation to study conical wing-body combinations, where strakes are used to fix the separation point. The basic difference in their numerical approach is that of satisfying the force balance condition on the vortex-cut; Smith uses a steepest descent method, while Levinsky uses a procedure devised by Warner (1957).

For the problem of the cone with strakes, they find a multi-valued lift for intermediate values of α/ϵ . They suggest that the multi-valued lift may be a result of their assumptions, such as neglecting secondary vortices, etc. Later, they publish with Maki [Levinsky, Wei, Maki (1969)] a further development of this theory. They use the same system of $2N + 3$ unknowns and governing equations as did Smith.

In the multi-valued region, three possible theoretical solutions exist for the same α/ϵ . A "weak" solution gives a weak vortex near the wing tip, and progressively stronger solutions locate vortices farther from the wing. In an accompanying discussion, Levinsky notes that for the case of the conical body with small strakes, three different solutions appear to satisfy all of the boundary conditions. In order to check this method, they used the Brown and Michael approach and obtained the same result. They consider it to be the consequence of the fact that there may be more than a single solution to a set of nonlinear equations. An alternate possibility is the location of a false solution due to the nature of the problem and error limit which "determines a solution." Examples of this type are often given

Levinsky, E. S. and Wei, M. H., "Nonlinear Lift and Pressure Distribution of Slender Conical Bodies with Strakes at Low Speeds," NASA CR-1202, 1968.

Warner, F. J., "On the Solution of 'Jury' Problems with Many Degrees of Freedom," Math. Tables and Other Aids to Computation, 11, pp. 268-271, 1957.

Levinsky, E. S., Wei, M. H. and Maki, R. L., "Theoretical Studies of Vortex Flow on Slender Wing-Body Combinations," NASA Accession No. N70-21358, also in NASA SP-228, pp. 113-129, 1969.

in books on computing techniques as possible pitfalls of numerical methods.

The nonlinear theory is also extended by Levinsky, et al, to non-conical transformations. The Joukowski and the tangential flow conditions remain unaltered while the remaining boundary conditions are no longer algebraic as for the conical flow case. The same boundary conditions are used, but their form is considerably more complex and is listed in this reference.

Method of Legendre (II)

Soon after Legendre proposed his original simplified model with two isolated vortices, he (1953a) also formulated the problem for the leading-edge vortex sheets. Again, making the same assumption about the flow field, Legendre obtains the governing equation

$$\nabla_{2D}^2 \phi = 0 \quad (80)$$

Instead of just point vortices, he now formulates the problem for sheets of distributed vorticity. As before,

$$\phi = \text{Re}[x(U \cos \alpha + U \sin \alpha \cot \lambda F(\eta))] \quad (81)$$

where

$$\eta = \frac{z + iy}{x \cot \lambda} \quad (82)$$

Using the transformation $\zeta^2 = 1 + \eta^2$

$$F = \zeta - \int_0^1 \ln \frac{\zeta - \xi}{\zeta + \xi} d\xi \Big/ \int_0^1 \frac{\xi - \bar{\xi}}{\xi \bar{\xi}} d\xi \quad (83)$$

Legendre, R., "Écoulement au voisinage de la pointe avant d'une aile à forte flèche aux incidences moyennes," Recherche Aeronautique, No. 21, pp. 3-6, 1953a.

where $\bar{\eta}(c)$ determines the shape of the sheet and c is proportional to the intensity of the shed vorticity, which varies from 1 at the leading edge to zero at the free end, where the Joukowski condition has already been applied to eliminate the vorticity constant.

To determine the location of the sheet, two additional conditions are required. First, there is the condition that the pressure difference across the sheet is zero.

$$2c - \frac{\eta}{\eta_c} - \frac{\bar{\eta}}{\eta_c} + \tan\alpha \tan\lambda \left[\frac{F_{\eta}}{\eta_c} + \frac{F_{\bar{\eta}}}{\eta_c} \right] = 0 \quad (84)$$

where subscripts refer to partial differentiation. Secondly, there is the condition that the sheet is convected by the fluid, the so-called normal velocity condition.

$$x \frac{\eta_x}{\eta_c} = -\eta + \frac{\tan\alpha \tan\lambda}{\eta_c} \bar{F}_{\bar{\eta}} \equiv A(c) \quad (85)$$

After these conditions are applied, the governing equation becomes

$$\frac{\bar{\eta} - c\bar{\eta}_c}{\eta} = \tan\alpha \tan\lambda \frac{\int_0^1 \frac{1}{\xi(\xi - \zeta)} - \frac{1}{\bar{\xi}(\bar{\xi} - \zeta)} d\zeta}{\int_0^1 \frac{\xi - \bar{\xi}}{\xi\bar{\xi}}} \quad (86)$$

Legendre suggests the following method for solving this equation. An initial form for the sheet is chosen. This can, for example, be based on the flow field for the model with two isolated vortices. The integral on the right hand side is performed to give a first approximation for η_c . Once this is known, it can be integrated as a function of c to obtain a second approximation for the shape of the sheet. This process can be iterated until the solution converges to an acceptable degree. Legendre notes in 1953 that the application of this method and its theoretical justification have yet to be accomplished. In a later report, Legendre (1963) considered a slightly different formulation of the same problem.

Legendre, R., "Tourbillons en cornet des ailes delta," C. R. Acad. Sci., 257, pp. 3814-3817, Dec. 1963.

Due to the violation of slender body theory at the core of the axis for all flows and specifically for the case of the finite aspect ratio wing, Roy (1966) and Legendre (1959, 1964, 1966) have considered the possibility and form of a conical, incompressible, nonslender flow field.

According to Mangler and Weber (1966), it was proven by Germain that "the assumption of a wholly conical incompressible flow must lead to the existence of singularities outside the wing and the vortex sheet originating at the wing; as a consequence, the solution is not uniquely defined." Legendre (1959) has explicitly demonstrated this. However, to obtain some type of nonslender conical solution, Legendre (1966) assumes the potential of the form

$$\phi = \text{Re}(xf - iRf_{\omega}) \quad (87)$$

where

$$\zeta = e^{i\omega} = \frac{y + iz}{R + x}; \quad R^2 = x^2 + y^2 + z^2 \quad (88)$$

He attempts a derivation for the conical flow over a plane angular sector, determined by its edges at $\pm \zeta_0$. By assuming no singularities upstream, the singularities of f are at the location of the point vortices and their images. Also, the imaginary part of f must be the imaginary part of an eigensolution for the conical flow.

The eigensolutions are i , $\cos \omega = 1/2(\zeta + \frac{1}{\zeta})$, $\sin \omega = -\frac{i}{2}(\zeta - \frac{1}{\zeta})$.

Roy, M., "On the Rolling-Up of the Conical Vortex Sheet above a Delta Wing," in Progress in Aeronautical Sciences, Vol. 7, D. Küchemann, ed., pp. 1-5, 1966.

Legendre, R., "Nappes en cornets aux bords d'attaque d'une aile en delta," Recherche Aeronautique, No. 70, pp. 3-10, May 1959.

Legendre, R., "Nappes de tourbillons en cornets," C. R. Acad. Sci., 258, pp. 429-432, Jan. 1964.

Legendre, R., "Vortex Sheets Rolling-Up along Leading-Edges of Delta Wings," in Progress in Aeronautical Sciences, Vol. 7, D. Küchemann, ed., pp. 7-33, 1966.

Finally, $G_\omega = g_\beta - ig_\tau$ must be tangent to the plate and to the axis of symmetry, where $\omega = \beta + i\tau$, and $G = f \tanh \tau - if_\omega$.

He builds the following set of functions which satisfy the above restrictions.

$$\begin{aligned}
 f_1 &= 1 \\
 f_2 &= \eta \\
 f_3 &= i \ln \left(\frac{t - t_1}{t - \bar{t}_1} \times \frac{t\bar{t}_1 - 1}{t\bar{t}_1 - 1} \right) \\
 f_4 &= i(\zeta + 1/\zeta) \ln \left(\frac{tt_1 - 1}{t - t_1} \times \frac{t\bar{t}_1 - 1}{t - \bar{t}_1} \right) \\
 f_5 &= (\zeta - 1/\zeta) \ln \left(\frac{t - t_1}{t - \bar{t}_1} \times \frac{t\bar{t}_1 - 1}{t\bar{t}_1 - 1} \right)
 \end{aligned} \tag{89}$$

where $t_1, \bar{t}_1, 1/t_1, 1/\bar{t}_1$ represent the locations of the vortex singularities and

$$\frac{\zeta}{\zeta_0}{}^2 = 1 + \eta^2 \tag{90}$$

$$\eta = \frac{1}{2} (t + 1/t) \tag{91}$$

Due to the condition that the coefficient of $\ln(t - t_1)$ must be zero for $t = t_1$, he obtains the linear combination for the solution

$$f = c + D\eta + i(1 - \zeta_1\bar{\zeta}_1)f_3 - \frac{\zeta_1 + \bar{\zeta}_1}{2} f_4 - \frac{\zeta_1 - \bar{\zeta}_1}{2i} f_5 \tag{92}$$

where D is determined by the condition that f and f_ω are finite for $\zeta = \pm \zeta_0$ or $\eta = 0$

$$D = i(\eta_1 - \bar{\eta}_1) \tag{93}$$

He then attempts to satisfy the Joukowski condition at the leading edges, f_{∞} , finite for $t = \pm i$. This cannot be done for this example. He then applies a global condition for the forces on the axis of the core, $g_{\pm} = g_{\mp} = 0$ for $\zeta = \zeta_1$. He obtains for the position of the isolated vortices, with $\rho^2 = \eta_1 \bar{\eta}_1$

$$\left(\frac{\eta_1 - \bar{\eta}_1}{2i} \right)^2 = \frac{1}{4} \frac{\rho^2 (1 + \rho^2)}{1 + 2\rho^2 + 2\rho^4}; \quad \left(\frac{\eta_1 + \bar{\eta}_1}{2} \right)^2 = \frac{1}{4} \rho^2 \frac{(3 + 7\rho^2 + 8\rho^4)}{(1 + 2\rho^2 + 2\rho^4)} \quad (94)$$

He plots the solution for this in Progress in Aeronautical Sciences [see Figure 22].

DISCRETE SLENDER-BODY MODELS

Fundamentals

In this investigation of vortex sheet roll-up from the leading edge and its effect on the near field, occasional reference will be made to wake roll-up analysis. However, this is not the primary concern of the paper. For more detailed information on the wake roll-up, see Spreiter and Sacks (1951) and McMahon (1967).

Due to the difficulty in handling the general problem as described in the preceding section, an alternate development has been followed by others. This development concerns the replacement of the continuous vortex sheet by discrete arrays of two-dimensional vortices. To put this method in proper perspective, a little history will be presented before the actual application is made to leading-edge separation.

Fundamental to the theory of discrete arrays is the list of the invariants of the discrete vortex flow phenomena in an infinite medium where there are no external forces and where the velocities go to zero at infinity [e.g., see Batchelor (1967) for details].

The Center of Gravity Invariant:

$$\sum \Gamma_i y_i = \bar{y} \sum \Gamma_i \quad (95)$$

$$\sum \Gamma_i x_i = \bar{x} \sum \Gamma_i \quad (96)$$

The Moment of Inertia Invariant:

Spreiter, J. R. and Sacks, A. H., "The Rolling Up of the Trailing Vortex Sheet and Its Effect on Downwash behind Wings," JAS, 18, p. 21-32, 1951.

McMahon, T. A., "Review of the Vortex Wake Rollup Problem," M.I.T. ASRL TR 145-1, June 1967.

Batchelor, G. K., An Introduction to Fluid Dynamics, Cambridge University Press, 1967.

$$\sum \Gamma_i (x_i - \bar{x})^2 + (y_i - \bar{y})^2 \quad (97)$$

The Energy Invariant:

$$-\frac{\rho}{4\pi} \sum_{\substack{i,j \\ i \neq j}} \Gamma_i \Gamma_j \log r_{ij} \quad \text{where } r_{ij} = \sqrt{(x_i - x_j)^2 + (y_i - y_j)^2} \quad (98)$$

These can also be given in integral form for continuous distributions of vorticity. All methods considered are open to question, if these invariants are not preserved.

Rosenhead (1931) was one of the first to use the discrete vortex model; he studied the stability of an infinite two-dimensional vortex sheet. Westwater (1935) used an array of two-dimensional line vortices to study the deformation of the vortex sheet behind an elliptic wing. This was the first attempt found to analytically describe the roll-up of the vortex sheet behind a wing of finite span. Earlier, Kaden (1931) had considered the rolling up of a semi-infinite wake, but his similarity solution was based on the fact that there was no reference length. However, it is felt that the Kaden model can model the initial roll-up when the radius of curvature of the sheet is small compared to the span. Westwater suggests the use of the Kaden model for the tip of his sheet even for large times.

To handle the three-dimensional problem, Westwater uses the simplification of treating the vortex sheet as consisting of an array of two-dimensional vortices lying in a plane. This consists of neglecting the bound vorticity and of considering the additional effect of the semi-infinite array in the direction of upstream infinity to be negligible. Since the array has been assumed flat initially, while the bound vorticity is being neglected at the same time, i.e., far away, this implies that this procedure is

Rosenhead, L., "The Formation of Vortices from a Surface of Discontinuity," Proc. of Roy. Soc., A, 134, pp. 170-192, 1931.

Westwater, F. L., "The Rolling Up of the Surface of Discontinuity behind an Airfoil of Finite Span," ARC R&M 1692, Aug. 1935.

Kaden, H., "Augwicklung einer unstablen Unstetigkeitsfläche," Ingenieur-Archiv, 2, pp. 140-168, 1931.

applicable only to cases where the wake roll-up proceeds slowly, i.e., light wing loading.

Instead of calculating the three-dimensional roll-up, he calculates the unsteady problem (where the x-axis becomes the pseudo-time in the standard unsteady cross-flow analysis) of two-dimensional roll-up. He calculates the velocities induced by the vortex field of discrete vortices and then uses the Euler method of integration to obtain the new vortex locations. He continues this process until the vortex roll-up becomes pronounced. In employing such a scheme, he neglects the self-induced velocities which occur for curved vortices.

An easy check of the validity of such a discrete vortex array is the vorticity theorems in Batchelor (1967) and Betz (1933). The easiest condition to apply is that with the absence of external forces the center of gravity of the vortex system must remain constant. Since there are no external forces in the lateral direction, the lateral position of the center of gravity for each half of the sheet must remain constant. This is satisfied approximately by the model, but Westwater notes that it would be satisfied approximately even if the entire sheet strength were placed in two vortices. The discrepancy as a function of time is explained by Westwater, "The errors are due solely to the finite time intervals. It is certain that the source of error in this connection is the set of vortices whose velocities undergo rapid changes, i.e., those at the end of the sheet."

He argues that the photographs taken by Kaden give confirmation to the view that the numerical method gives a good approximation to the motion. He finds that for flat wakes several spans behind the wing, the error ignored by the two-dimensional approximation is negligible. However, he assumes the effect of self-induced velocity due to the curvature to be small and does not discuss it further. From this analysis, it would be assumed that the sheet would be better represented for smaller step sizes and equi-strength vortices. Contrary to this supposition, Hackett and Evans (1971) note that Betz, A., "Behavior of Vortex Systems," NACA TM 713, 1933.

Hackett, J. E. and Evans, M. R., "Vortex Wakes behind High-Lift Wings," JA, 8, No. 5, pp. 334-340, 1971.

one obtains a more uniform spiral if one uses longer time steps for equal strength vortices in the case of the elliptic distribution of two-dimensional vortices. Also, one obtains a smoother spiral if one uses equally-spaced vortices.

Many people accepted the calculations using discrete vortex models of Rosenhead and of Westwater for 30 years, before the advent of greater computing capacity encouraged investigators to recalculate the results obtained. After an analysis of this approximation, Birkhoff and Fisher (1959) say, "Our view is that continuous vortex sheets in inviscid fluids are extremely unstable and will soon break up. Viscosity is essential to stabilize the rolling up of real vortex sheets, which will only roll up smoothly by diffusion for one or two complete turns at most." However, they realize that investigators resorted to the discrete array representation because of the difficulty in handling the actual continuous problem. They concentrate on the Helmholtz instability problem of the sinusoidally perturbed infinite vortex sheet, which was treated originally by Rosenhead. Since then many people have considered the use of the discrete vortex approximation. However, almost all encountered some sort of difficulty and an attempt will be made to discuss the difficulties as well as to describe the application of the method.

Extensive numerical work has been done by Moore (1971, 1974) in this area. In 1971, Moore states, "It must be emphasized that the purpose of this work is not to deny that the vortex sheets roll-up -- the analytical work of Kaden (1931) and Stern (1956) on the semi-infinite sheet suggest very strongly that roll-up will occur in the finite case also -- but is to assert

Birkhoff, G. and Fisher, J., "Do Vortex Sheets Roll Up?" *Circolo Matematico Di Palermo Reconditi*, 8, Series 2, pp. 77-89, 1959.

Moore, D. W., "The Discrete Vortex Approximation of a Finite Vortex Sheet," NASA Accession No. N72-24005, 1971.

Moore, D. W., "A Numerical Study of the Roll Up of a Finite Vortex Sheet," *JFM*, 63, Part 2, pp. 225-235, 1974.

Stern, M., "The Rolling-Up of a Vortex Sheet," *ZAMP*, 7, pp. 326-342, 1956.

that useful quantitative information about the process cannot be found by the type of numerical procedure proposed by Westwater." He formulates the problem as Westwater had done for the elliptic distribution and employs vortices of equal strength placed at the vorticity centroid of each segment. Instead of using the Euler integration scheme for the timewise integration of velocity as did Westwater, Moore uses the mathematically more accurate fourth-order Runge-Kutta method with double precision arithmetic.

Moore considers the shortest time scale as the orbital period of the two closest vortices (the tip vortices) and obtains the characteristic time as $t = \pi^2 b / M^3 v$, where M = number of segments on each half of the sheet. v is the downward velocity at the time $t = 0$ and b = semi-span.

Westwater fails to discuss the nondimensional time he used, stating simply that his "t is a factor proportional to the time that has elapsed since the sheet was straight." Using his notation where his initial sheet strength is described by

$$\Gamma_0 y / b^2 \sqrt{1 - y^2 / b^2} \quad (99)$$

where $v = \Gamma_0 / 2b$, relating this to the velocity used by Moore, the obvious choice for a time would be

$$\frac{b^2}{\Gamma_0} = 10 \text{ sec} \quad (100)$$

His initial time step is given as .008, corresponding then to

$$\Delta t = \left(\frac{b^2}{\Gamma_0} \right) .008 \quad (101)$$

where Moore has said that the time step should be for Westwater's choice of parameters

$$dt(v/b) = dt^* \ll .01 \quad (102)$$

In terms of Moore's nondimensional time step, Westwater's result becomes

$$\Delta t^* = .004$$

(103)

If the time given by Westwater is actually .008 seconds, then the initial step size would be smaller by a factor of 10 and it would be well within the criterion of Moore. However, this can probably be easily clarified by examining the work of authors who have reproduced the results of Westwater.

Although .004 is less than .01, Moore decreases dt^* to .00001 for his finest mesh. The tip vortices are shown by him to orbit each other as an almost linear function of time. Westwater stated that although the tip vortices would not represent the sheet properly, the central portion of the sheet would be little affected by approximating the infinite spiral by a handful of vortices. He also contended that the main source of error would be from the large step size in time. Even with Moore's smaller step size, Moore (1971) notes, "This orbiting motion of the tip vortices rapidly affects the neighboring vortices and ruins the whole calculation." He then increases the number of vortices to 40 and 60 vortices, but no smooth spiral structure emerges, while the "vortices originally near the tip tend to collect into a roughly circular patch." Since decreasing the time and increasing the number of vortices fails to result in any improvement, this suggests to Moore that the method of discretization is responsible for the problems.

In a later paper (1974), Moore elaborates on this discussion. He notes that a possible reason for the "success" of Westwater's calculation may be that the large step size increases the separation between vortices near the tip beyond their true value. This would suppress problems associated with the singular nature of the flow field as the separation distance goes to zero, and would prevent the outer vortices from orbiting about each other. More will be said of this in connection with the work of Hackett and Evans (1971) and others.

Moore also notes that the Euler integration results in a cumulative error and cannot possibly be valid for large times. He finds two additional difficulties with the finite array of vortices. If the distance between turns is much less than the typical distance between neighboring vortices on the sheet, then there will be instances when vortices on neighboring turns will come close together and one can hardly expect such a representation

to model a continuous sheet. He suggests that this problem had been suppressed by various methods of introducing pseudo-viscosity. For example, one can lump vortices together if they become closer than a certain distance. A second method is to employ a nonsingular velocity field for each discrete vortex. The second difficulty noted is that since the spiral of Kaden is infinite, any attempt to replace the sheet by a finite number of point vortices will cease to be adequate sufficiently near the center of the spiral.

Thus, he suggests replacing the spiral center by a more orderly arrangement in terms of a discrete vortex array than the chaotic distribution obtained by earlier researchers. Thus, he uses the condition that each turn of the spiral must be determined by a sufficient number of vortices to determine the non-chaotic motion. Starting with the vortices near the tip of the sheet, the vortices are amalgamated if there is insufficient description of the spiral turn, where Moore concludes that four per turn were sufficient. He notes that for the discrete array, that the energy invariant is not preserved in his amalgamation of the tip vortices.

In this second paper, he starts with an equi-distant array, since this gives him a better description of the inner part of the sheet and allows longer step sizes to be used since the scale of the smallest time is notably increased. With these changes, he is able to obtain $2\frac{1}{2}$ turns of what appears to be a reasonably well-defined spiral for $t^* = 7$. From his Figure 4, it can be seen that the distance between spirals is less than the arc lengths between neighboring vortices and this may cause difficulty. However, Moore notes that this did not cause trouble, and suggests that this could be due to the fact that the tip vortex provides the dominant contribution to the velocities of the individual vortices. From Kaden's similarity analytic solution, one would expect the fraction of vorticity to be rolled up as a function of time to be proportional to the one-third power of time. This is approximately true for Moore's example when $t^* < .1$.

Another early work on the discrete vortex model is by Hama and Burke (1960). They primarily study the Helmholtz instability problem,

Hama, F. R. and Burke, E. R., "On the Rolling-Up of a Vortex Sheet," Maryland U., BN-220, 1960.

originally studied by Rosenhead using a distribution of discrete vortices.

Following the criticisms of Birkhoff and Fisher (1959), they decide to study the problem in detail. By using smaller time steps, they do not get Rosenhead's smooth roll up. Since vortex sheets actually do roll up, they suggest several possible explanations for the discrepancy between experiment and the inviscid theory. First, the viscosity reduces the high velocities and prevents the existence of infinitely thin sheets. Secondly, the substitution of discrete vortices itself may be inappropriate. From the energy invariant, Birkhoff and Fisher conclude that any decrease between certain pairs of vortices must be accompanied by an increase of other distances. For vortices which have equal strength as is used in the Rosenhead problem, this theorem is determined by the product of all mutual distances. In consequence, no two vortex lines can approach each other indefinitely, and if the possibility of a lost vortex is disregarded, coalescence in terms of concentration of the vorticity in a point cannot occur. However, they do not agree with Birkhoff and Fisher, who believe that randomization has to occur; they hypothesize the possibility of smooth roll up for some intermediate time. They then note that the vortex sheet will deform due to the Helmholtz instability. They represent the deformed sheet by unequal strength vortices and they then obtain smooth roll up. This reinforces their belief that the results of the calculation are sensitive to the initial condition assumed. Thus, although they are unable to obtain smooth roll up with Rosenhead's method and small time step, they are able to obtain smooth roll up by changing the initial distribution slightly. It is apparent by now that this area of research has caused a great deal of concern.

Kawahara and Takami (1973) cite several examples of discrete array computations and note that such calculations appear to give the solution qualitatively. They note that in many cases irregularity appeared in the solution so they introduced an "artificial viscosity" to suppress such irregularity. Instead of assuming a velocity field of a point vortex for their discrete vortex elements,

Kawahara, K. and Takami, H., "Numerical Studies of Two-Dimensional Vortex Motion by a System of Point Vortices," Journ. of Phys. Soc. of Japan, 34, No. 1, pp. 247-253, Jan. 1973.

$$v = \frac{\Gamma}{2\pi r} \quad (105)$$

they assume

$$v = \frac{\Gamma}{2\pi r} (1 - e^{-r^2/4\nu t}) \quad (105)$$

which is the result given in Lamb (1945) by means of the analogy with the heat equation for a special form of the Navier-Stokes equation. However, they mention that a superposition of vortices of this type no longer satisfies the governing Laplace's equation in two dimensions. However, they consider this simply as an artifice to obtain a more regular solution, and they do not provide additional justification for its use. In order to test the validity of such an approximation, it is necessary to have a problem for which an exact solution is known. The case considered here is a vortex tube of inviscid, incompressible fluid whose cross section is an ellipse and with uniform vorticity while the outer flow field is irrotational. It is known that such a tube rotates with a constant angular velocity and without changing its external shape [Lamb (1945), p. 232].

They model this continuous vortex distribution by uniformly distributed vortices of unequal strength and obtained fairly good agreement with theory. They note that the vortices near the boundary deviated slightly due to the fact that the discrete grid did not accurately model the curves of the boundary. The approximation becomes more accurate as the number of vortices increases. They also allow the minor axis to go to zero and obtain a Helmholtz instability problem. They then consider the wake roll-up problem using equi-strength vortices and they show a progression of regularity as the artificial viscosity is increased. This only affects those vortices near the tip. They thus state that the use of discrete vortices as an approximation to a continuous distribution could provide quantitative as well as qualitative solutions if the artificial viscosity is used to force the solution to remain regular.

Others have attempted to use similar artifices to promote regularity, but do not attempt to elaborate on their justification. For

Lamb, H., Hydrodynamics, Dover Publications, 6th edition, 1945.

example, Clements and Maul (1973) in considering the rolling up of a trailing vortex sheet in an effort to study methods of reducing the tip vortex strength basically use Westwater's method, but if the induced velocity becomes too large, they combine the two tip vortices at the centroid of vorticity. Thus, from the work of Moore, caution must be used in order to model discrete vortex flows, especially when vortices become close together. However, the work of Kuwahara and Takami suggests that quantitative results can be obtained. Thus, combined flow will next be studied using discrete vortex models.

Method of Sacks

For slender bodies, Sacks (1954) employs the extension of the Blasius formula developed by Milne-Thomson (1950) for unsteady flow to calculate the forces and moments in a steady 3-dimensional incompressible flow. He finds that the forces and moments (except drag) are linear in the velocity potential and thus is later able to extend these results to include free vortices.

Sacks (1955) extends the analysis of his earlier work to include the effect of vorticity shed from a wing on a tail. Due to the linearity of the calculations from the previous work, one need only add the effect of the shed vortices. He finds that the potential of the point vortices in the cross flow plane is

$$F(\sigma) = -\frac{i}{2\pi} \sum_{k=1}^m \Gamma_k \ln(\sigma - \sigma_k) + \frac{i}{2\pi} \sum_{k=1}^m \Gamma_k \ln\left(\sigma - \frac{r_0^2}{\sigma_k}\right) \quad (106)$$

where σ is the complex plane where the airplane cross-section has been transformed to a circle of radius r_0 .

Now, it remains to find the distribution of Γ_k , σ_k to completely determine the problem. Enroute to his solution, he notes the following

Clements, R. R. and Maul, D. J., "The Rolling Up of a Trailing Vortex Sheet," *Aeron. Journ.*, 77, No. 745, pp. 46-51, Jan. 1973.

Sacks, A. H., "Aerodynamic Forces, Moments & Stability Derivatives for Slender Bodies of General Cross Section," NACA TN 3283, 1954.

Sacks, A. H., "Vortex Interference on Slender Airplanes," NACA TN 3525, 1955.

theorem for calculating the force due to such vortices.

Theorem: The lateral force $Y + iL$ due to each vortex of strength Γ shed from a forward wing of a slender wing-body-tail combination in steady straight flight is equal to the change, from the wing trailing edge to the base of the airplane, of the quantity $i\rho U\Gamma\sigma_r$ where σ_r is the (complex) distance between the vortex and its image in the plane in which the body cross section is mapped onto a circle while leaving the flow field at infinity unchanged.

In his first calculation, he assumes the sheet of the wing to be completely rolled up at the tail and replaces the wake by two point vortices of unknown strength and location. He obtains the strength and the location of the vortices from Rogers (1954), where Rogers obtains the circulation distribution at the trailing edge from the span loading,

$$\Gamma(y) = \frac{U}{2} \int_0^c \frac{\Delta p}{q} dx \quad (107)$$

and then replaces the circulation by point vortices in the manner of Westwater. [Rogers (1954) contains a list of references on attempts to model the wake structure.] In addition, if there is a body extending beyond the trailing edge, he simply adds the velocity induced by the body to the velocity induced by the vortices before applying the Euler integration method to discover the new location of the vortices in the streamwise direction.

As it became apparent that leading-edge separation was important, Sacks, Lundberg and Hanson (1967) finally included leading-edge vortices. Many of the early representations of shed vorticity, even from the leading edge, fail to allow the free vortex sheets to roll up and assumed that they are planar. The authors aimed at removing this restriction and extending the theory to nonconical flows. Also, the models of Mangler and Smith (1959)

Rogers, A., "Application of Two-Dimensional Vortex Theory to the Prediction of Flow Fields behind Wings of Wing-Body Combinations at Subsonic and Supersonic Speeds," NASA TN 3227, 1954.

Sacks, A. H., Lundberg, R. and Hanson, C., "A Theoretical Investigation of the Aerodynamics of Slender Wing-Body Combinations Exhibiting Leading-Edge Separation," NASA CR-719, 1967.

and Brown and Michael (1954) allow the fluid to support non-zero forces, and are only force-free in the mean.

Sacks et al extend the earlier work of Sacks (1955) to include leading-edge separation. They assume that the two contributions, linear lift and separated lift, are separable and additive. Although they use slender body theory to calculate the nonlinear portion of the lift, they use the lifting surface results of Lawrence (1951) to obtain the linear portion of the lift for a low aspect ratio wing, since they note that Jones' approximation is only valid as the aspect ratio goes to zero.

For the separated flow contribution, they utilize slender body theory and assume that a pair of discrete vortices are shed at chord-wise stations just outside of the leading-edge. The strengths and positions are fixed by the following boundary conditions. The normal velocity condition requires that the vortex leaves the wing edge tangentially. Hence, the initial position is described by only a lateral coordinate. The Kutta condition furnishes a second condition and the third condition is obtained from the shedding rate. Although they obtain an empirical shedding rate from water tank experiments, which give better experimental agreement for the lift calculations, the theoretical derivation will be of interest here since it has more general applicability.

The lateral velocity at the edge of the wing is calculated. This velocity is used to calculate the lateral growth of the flat vortex sheet being shed in the plane of the wing, whose strength must satisfy the Kutta condition. The sheet is then replaced by a vortex of the same strength which is located to satisfy the Joukowski condition. From an upstream location, one knows the complex potential for a wing and the shed vorticity [see Sacks (1954), for example]. To obtain the potential at the station in question, one calculates the new locations as previously described in the discrete line-vortex methods and adds a term to account for the vorticity shed in the sheet.

Lawrence, H. R., "The Lift Distribution of Low Aspect Ratio Wings at Subsonic Speeds," JAS, 18, No. 12, pp. 683-695, 1951.

$$-\frac{j}{2} \int_{r_i = r_0}^{r_i = r_0 + \delta_i} \gamma dy \ln \frac{(\sigma - \sigma_i)(\sigma + \frac{r_0^2}{\sigma_i})}{(\sigma + \bar{\sigma}_i)(\sigma - \frac{r_0^2}{\bar{\sigma}_i})} \quad (108)$$

The length δ_i is found by the Euler method of integration. To reduce Equation (108) to a form that can be easily handled, γ is assumed to be constant. Then the vortex strength becomes $\Gamma_n = \gamma \Delta s$, where Δs is its length in the physical plane. Now the vorticity is replaced by a point vortex of strength Γ_n and of unknown lateral displacement and the Joukowski condition is again used to determine the location of the newly shed vortex. This process can be continued downstream for small step sizes to obtain a representation of the leading-edge separation. Since they use slender body theory, they terminate their calculations at the "trailing edge" of the body; however, it is to be noted that the load in general will not be zero there. This initial work only allows monotonically increasing span in the chord-wise direction. [Fink and Soh (1974) say that Sacks et al do not account for the chord-wise variation in span, but Finkleman (1972) later includes the increase in span in his formulation.] The problem would also be complicated by the appearance of a vortex wake from the trailing edge.

As developed in Sacks (1954), they use the change in impulse to calculate the force on the wing. Since they know the pressure distribution for every chord-wise station, they are also able to obtain the pitching moment and the center of pressure. In their discussion, they note several areas of concern. First, to obtain the location of the sheet vortex requires an induced velocity at the leading-edge from other vortices. For the first shedding station, there are no vortices to induce the required field, so they assume that the first vortex is shed with a downwash velocity $U\alpha/2$

Fink, P. T. and Soh, W. K., "Calculation of Vortex Sheets in Unsteady Flow and Applications in Ship Hydrodynamics," for Tenth Symposium in Naval Hydrodynamics, July 1974.

Finkleman, D., "Nonlinear Vortex Interactions on Wing-Canard Configurations," JA, 9, No. 6, pp. 399-406, June 1972.

following Gersten (1961) and Bollay (1939). More will be said about this later.

The solution is obtained by using a fourth order Runge-Kutta numerical integration technique with the Gill variation. The method is approximate in that it only satisfies the Joukowski condition at the leading edge at only a finite number of stations. Other approximations are apparent in the derivation of this method. They hypothesize that as the number of vortices increases, the discrete vortex model would converge to the continuous sheet. For their program, the convergence is slowest at high aspect ratios and low angles of attack. For lift, a rough rule of thumb for convergence is $n = 30 + 30 AR$ for $.5 < AR < 2.0$.

A comparison between Mangler and Smith (1957) and Sacks et al for $AR = 1.0$ and 1.5 , shows that both lift predictions are higher than the experimental results of Bartlett and Vidal (1955); Sacks' method starts out lower, but surpasses Mangler and Smith at high angles of attack. It is noted by the authors that they modified Mangler and Smith results by using the same attached flow lift of Lawrence after subtracting the Jones' slender body lift for the attached flow model. As a further check on the present analysis, the vortex position above a delta wing is compared with experiment. They represent the vortex position by its center of gravity, but fail to mention which vorticity they consider to be relevant in their calculations.

Finally, in their conclusion, Sacks et al (1967) say that "it appears that the overprediction of the normal force due to separation stems from an overprediction of the shedding rate (theoretical result is greater than experimental result) and is largely due to three-dimensional effects as in the case for the attached flow," i.e., the discrepancy grows for

Gersten, K., "Calculation of Non-linear Aerodynamic Stability Derivatives of Aeroplanes," AGARD Rep. 342, April 1961.

Bollay, W., "A Non-Linear Wing Theory and Its Application to Rectangular Wings of Small Aspect Ratio," ZAMM, 19, pp. 21-35, Feb. 1939.

Bartlett, G. E., and Vidal, R. J., "Experimental Investigation of Influence of Edge Shape on the Aerodynamic Characteristics of Low Aspect Ratio Wings at Low Speed," JAS, 22, pp. 517-533, 1955.

increasing aspect ratio as the difference between Lawrence and Jones.

They note that the Lawrence method is not really applicable to the separated-flow problem since it is based upon a linear relationship between the local pressure and the velocity potential. The pressure due to the separated flow, however, contains quadratic terms which do not cancel. Thus, this is only considered to be a correction term rather than a universally valid theory.

The development of the feeding rate appears to be one of the most important concerns for the unsteady finite element method. An alternate method is presented next.

Following the development of Sacks, Angelucci (1971, 1973) describes a slender-body model using discrete vortices. Notably, he differs from Sacks et al (1967) in the mathematical definition of the elementary vortex sheet at the point of separation. He applies the approximation for the streamline condition as: 1) the vortex sheet is oriented in the direction of the total velocity induced at a specific point of interest and, 2) the vorticity distribution is such that the average velocity normal to the sheet and induced by the sheet itself is zero.

He states the simplest distribution that satisfies these conditions is $k|\sigma_a - \sigma_i||\sigma_i - \sigma_s|$, where σ_i is a point on the sheet (e.g., the center of vorticity) and σ_s and σ_a are the end points of the sheet in the transformed plane where the body is represented by a circle [see Figure 23]. He then makes the final assumption that due to the local conical nature of the slender problem, the segment length should be linear as a function of the x-direction. The circulation then becomes

$$\gamma(s) = k(\sigma_a - \sigma_i)(\sigma_i - \sigma_s)e^{-i2\phi_s} \quad (109)$$

where ϕ_s represents the orientation of the sheet at the point of separation with respect to the real axis, and s denotes the arc parameter on the sheet.

Angelucci, S. B., "A Multivortex Method for Axisymmetric Bodies at Angles of Attack," JA, 8, pp. 959-966, Dec. 1971.

Angelucci, S. B., "Multivortex Model for Bodies of Arbitrary Cross-Sectional Shapes," AIAA Paper No. 73-104, Jan. 1973.

The sheet is then replaced by a concentrated vortex of equivalent strength in the manner of Sacks et al. Similarly, the rest of the problem is derived according to Sacks et al. He does consider axisymmetric bodies without strakes for the case where the location of the viscous separation is considered as given. He also calculates the nonlinear and linear lift separately. He obtains the nonlinear lift contribution from the change of impulse and suggests obtaining the linear portion of the lift from the best possible source available, while he obtains it by extrapolating the experimental lift for small angles of attack.

A more recent development along the same lines is included in a paper by Fink and Soh (1974). Fink and Soh start with a critical survey of some of the papers published using the discrete two-dimensional vortex arrays. They agree in principal with the findings of Moore (1971) and others that the tip vortices become random, but they then go on to demonstrate how such randomness can be avoided.

To discover such a scheme, they start with the governing integral equation for the continuous sheet and then formulate a finite difference scheme to approximate this equation. As a result, they are also able to formulate the errors involved.

The complex conjugate velocity induced by a segment of a sheet from s_a to s_b of strength $\gamma(s)$ is

$$\bar{q}(Z) = u - iv = \frac{1}{2\pi} \int_{s_a}^{s_b} \frac{\gamma(s_1) ds_1}{Z - Z_1} \quad (110)$$

where the Cauchy Principal Value must be applied to evaluate the singular integral.

In transforming the integral to a complex one, they use the identity

$$dZ_1 = e^{i\theta} ds_1 \quad (111)$$

Fink, P. T. and Soh, W. K., "Calculation of Vortex Sheets in Unsteady Flow and Applications in Ship Hydrodynamics," for Tenth Symposium in Naval Hydrodynamics, July 1974.

where θ is the angle between the tangent of the sheet at the point $Z(s)$ and the real axis. Then, they are able to develop the complex potential for the flow field. From the time derivative of the complex potential, they obtain the rate of change of circulation $\dot{\Gamma}$ related to the vorticity density γ and the velocity at the shedding point

$$\dot{\Gamma} = \text{Re}[(q_{vs} - V) \gamma e^{-i\theta}]_{\text{edge}} \quad (112)$$

where V denotes the velocity of the point and q_{vs} denotes the average complex velocity across the sheet, while θ has been defined previously. They then develop a numerical method to follow the shedding vorticity. The integral becomes

$$\bar{q}(Z) = \frac{1}{2\pi i} \sum_{k=1}^n \int_{s_{k-1/2}}^{s_{k+1/2}} \frac{\gamma(s_1) ds_1}{Z - Z_1} = \frac{1}{2\pi i} \sum_{k=1}^n \frac{\Gamma_k}{Z - Z_k} \quad (113)$$

where the sum is well behaved for a point off the sheet. For a point on the sheet, Z_j , by assuming that the segment is straight and the vorticity may be taken as a constant, they obtain approximately

$$\bar{q}(Z_j) = \frac{1}{2\pi i} \sum_{k \neq j} \frac{\Gamma_k}{Z_j - Z_k} - \frac{1}{2\pi i} \frac{\Gamma_j e^{-i\theta_j}}{|s_{j+1/2} - s_{j-1/2}|} \ln \left| \frac{Z_j - Z_{j+1/2}}{Z_j - Z_{j-1/2}} \right| \quad (114)$$

It is noted that for Z_j located at the midpoint of the segment, the last term vanishes and one obtains the result that is normally used in discrete approximations by ignoring the singularity in the first place.

However, they note that the vortex has to be placed at the midpoint for this to be valid at all times during the process of roll up. On the other hand, they state that the original sheet segments are deformed and thus the discrete vortices will no longer be located at the midpoints. Thus, they explain that as the number of vortices is increased, the number of logarithmic terms which were formerly neglected increases and consequently it is not surprising that increasing the number of vortices does not lead to improved roll up.

Instead of retaining the logarithmic term for calculations as a function of time, they suggest an alternate possibility. Instead, at each step, they "represent the vorticity by an entirely new set of equidistant discrete vortices whose strengths are adjusted to give a good representation of that density."

Because of the fact that the centroid and the midpoint will rarely fall together, this scheme can only be considered to be reasonable in conserving the invariants if the step size is small.

To reduce the computer time needed by the small steps, they use the simpler Euler method of integration. To calculate the pressure distribution over a body with vorticity being shed according to the previously derived result for $\dot{\Gamma}$, the discrete approximation will misrepresent the actual flow near the shedding point. They thus approximate the vorticity near the edge by a straight segment attached to the edge with constant vorticity density and assume that the mean velocity of the sheet is the mean velocity at the edge. They suggest calculating the force both from Blasius' theorem for unsteady motion and from the pressure distribution to check for consistency. It is to be noted that they only resorted to the special treatment at the shedding point, after their original calculations failed to provide good agreement with experiment.

They then do a partial error analysis for their discretization of the vortex sheet integral for the induced velocity. They consider the effect of approximating the vorticity density as constant for a summation term and the deviation of the sheet from the assumed straight segment. The vortices adjacent to the point on the sheet are shown to have the greatest contribution to the error, and it can be reduced by considering additional terms in the approximation.

They suggest that in the timewise integration it may be advantageous to consider simpler schemes like the Euler method they use rather than the Runge-Kutta method, since each additional point at which the flow field must be evaluated allows the creation of further logarithmic terms. They end up performing the calculations using the cruder Euler method of integration and using equi-spaced vortices, which two methods have both resulted in improved regularity of the wake roll up. Thus, although their error analysis

of the Cauchy Principal Value is laudable, their actual application is reminiscent of other earlier methods. They repeat the calculations of Rosenhead and Westwater and obtain much more regular behavior.

They also consider other unsteady problems including the model essentially developed by Sacks et al. They compare their results with Smith and Sacks et al for $\alpha/K = 1.0$ for a delta wing [see Figure 24]. The vortex spiral of Fink and Soh is more uniform than Sacks', while Smith's result is considerably rounder than that of Fink and Soh although Smith's curve is slightly higher by the nature of its greater eccentricity. Fink and Soh and Smith give almost identical results for the pressure distribution while their lift results are lower than Smith's and agree more closely with the results of Sacks et al. In general, they seem to have developed a general method for calculating vortex sheet shapes in the unsteady two-dimensional problem using a discrete vortex model which does not suffer from the irregularities which plagued early workers.

A further outgrowth of the discrete vortex method is the treatment of trailing vorticity. Finkleman (1972) considers the canard-wing configuration using Sacks' method. He includes the vorticity from the trailing edge in the leading-edge vortex system of Sacks et al. The trailing edge vortices correspond to a spanwise loading which maintains the discontinuity in potential across the surface.

At the trailing edge, the Joukowski condition is violated due to the violation of slender body theory. That is, slender body theory does not allow the pressure difference at the trailing edge to go to zero for a sharp change in span, since it is basically a theory in which all of the information is transmitted only in the rearward direction. As noted by Sacks et al, the method is not self-starting. Finkleman tries several methods including using conical flow models near the apex and notes that the starting process is rapidly forgotten. Also, he notes that if the vortex is even an infinitesimal

Finkleman, D., "Nonlinear Vortex Interactions on Wing-Canard Configurations," JA, 9, No. 6, pp. 399-406, June 1972.

distance away from the edge of the wing, it will experience a velocity component normal to the plane of the wing.

To expedite computations, the canard leading-edge vortices are combined in pairs as soon as the trailing edge is reached. Also, he comments that he encountered difficulties on the trailing wing of the canard-wing combination. The first difficulty is the tendency of the vortices to pierce the wing surface at high angles of attack. To prevent this, when the vortices are sufficiently close to the wing, their normal velocity is suppressed. However, this appears to be just a stopgap measure, and it would be preferable to be able to understand this problem in greater detail.

The second problem encountered is the one studied by Moore (1971), of vortices close together creating unphysical flow patterns, so he simply lumps the two vortices together when they come within a "small fraction of the local span" to each other. These results are one of the first to consider the combined effect of leading-edge and trailing-edge separation.

LIFTING SURFACE THEORY

Method of Belotserkovskii

The previous discrete models were applied to slender bodies. The next step will be to look at discrete lifting-surface theories, not restricted to slender bodies. First, the lifting-surface theory developed by Belotserkovskii (1968) will be considered. Although he only considers vortices from the side edges and trailing edge in the presentation, he suggests that the method could be used to solve the leading-edge problem. The theory is a three-dimensional lifting surface theory where the wing is replaced by a bound-vortex network and the wake and other shed vorticity is replaced by free vortex lines. Earlier theories based on discrete vortex elements also had similar bound and trailing vortices. A notable difference employed by Belotserkovskii is the fact that he allows his free vortex elements to become nonplanar and roll up. He accomplishes this by segmenting the trailing vortices a finite number of times downstream of the shedding point. He then calculates the induced velocities according to the Biot-Savart law from the vortex network and satisfies the no-flow condition at a finite number of points to find the strengths of the bound vortices in the normal manner. With the extra degree of freedom provided by the unknown orientation of the free vortex segments, he satisfies the convection condition at a point on each segment and thus assures that they would be force free. Once the entire flow is determined, the lift is calculated using the Kutta-Joukowski theorem. Also, more detailed information, about the flow everywhere, can be calculated if desired as with a normal lifting-surface model.

There are several problems with this method that should be noted. First, he divides the wing into a network of boxes and the vortex element is placed at the quarter chord point and he satisfies the normal flow condition at the 3/4 chord point. This method follows from the flat plate result and was developed extensively by Weissinger. However, there has been some

Belotserkovskii, S. M., "Calculation of the Flow Around Wings of Arbitrary Planform over a Wide Range of Angles of Attack," *Mekhanika Zhidkosti i Gaza*, Vol. 3, No. 4, pp. 32-44, 1968, translated in *Fluid Dynamics Consultants Bureau*, pp. 20-27.

debate on its validity [Thwaites (1960, p. 341)].

Furthermore, Ashley and Landahl (1965) note that with the advent of high speed computers, "there is an element of irrationality in clinging to any questionably consistent approximation that embodies the numerical work inherent in all of the traditional lifting-surface theories." Another difficulty is the problem of vortex curvature. As is obvious from the form of the velocity induced by the vortex element, any time there is a kink in the vortex element, there is an infinite self-induced velocity and this cannot possibly be a good representation of the flow, i.e., even as the number of segments increases, the singularities [see Hama (1962), for example for some repercussions of this line vortex problem] continue to exist. Finally, because it is a discrete vortex model with singularities, it can only approximate the flow field at a distance at best, since singularities are excluded in the actual flow field; although this is not a serious handicap when the desired flow field is far from the vortex elements, this method cannot hope to give information about the flow in the vortex cores, even discounting the effect of neglecting the viscosity in the sub-core. Of course, as in the two-dimensional problems, there remains the question of whether or not it is valid to approximate a continuous vortex sheet by discrete vortex elements.

Despite these objections, the inherent difficulty of handling the nonlinear lifting surface problems with leading-edge separation made it inevitable that this method would be extended to the delta wing and other planforms with leading-edge separation.

This method has also been used by Perrier and Vitte (1971) and

Thwaites, B., Incompressible Aerodynamics, Clarendon Press, 1960.

Ashley, H. and Landahl, M., Aerodynamics of Wings and Bodies, Addison-Wesley Publishing Co., Inc., 1965.

Hama, F. R., "Progressive Deformation of a Curved Vortex Filament by its own Induction," Phys. of Flids., 5, pp. 1156-1162, 1962.

Perrier, P. and Vitte, W., "Calculation Procedures for Three Dimensional Aerodynamics in Perfect Fluids," NACA TT E-14, 074, 1971.

C. Renbach (1973a) for the problem without leading-edge separation. Renbach made some refinements, which are notable. First, instead of starting at an incidence of zero lift and gradually increasing the angle of attack to obtain the desired configuration, using the previous result as the initial guess for the subsequent problem, Renbach found faster convergence by using the simpler method of Butter and Hancock (1971) who only used a single bound vortex. He calculates the local tangential velocity to obtain the loading on the wing, which requires less computational effort than the Kutta-Joukowski law, which he also uses to verify the solution and obtained good agreement between the two methods. He indicates that he encountered a few difficulties, yet he seems to have solved all problems that he encountered as the roll up of the trailing vorticity appears fairly uniform. He notes that for low angles of attack, the greatest number of problems are found in trying to calculate the equilibrium position of the sheet, as far as the numerical applications are concerned. These difficulties are primarily due to the fact that the shed vortices are close to each other at small incidences for the rectangular planform. However, he does not clarify how he solved this problem. He notes that for convergence it is important to have a good initial approximation for the sheet shape.

Renbach (1973b) extends the work to include the leading-edge separation from the delta wing. As he noted in the previous work, he encountered difficulty in convergence unless a good approximation of the ~~v~~act shape of the sheet was available for small aspect ratios. Thus, he considers the following scheme to provide a good approximation of the leading-edge sheet for the slender delta wing. He starts with a rectangular wing of aspect ratio A^* . Then, in increments tempered by experience, he decreases the leading edge of the rectangular wing while leaving the trailing edge

Renbach, C., "Calculation of Flows around Zero Thickness Wings with Evolutive Vortex Sheets," NASA TT F-15, 183, 1973a.

Butter, J. J. and Hancock, G. J., "A Numerical Method for Calculating the Trailing Vortex System behind a Swept Wing at Low Speed," Aeron. Journ., 75, pp. 564-568, Aug. 1971.

Renbach, C., "Étude Numérique de nappes tourbillonnaires issues d'une ligne de Decollement près du Bord d'attaque," Rech. Aerosp., No. 6, pp. 225-330, 1973b.

constant. This process is shown in the accompanying illustration [see Figure 25].

As a result of this process, he obtains convergence for the delta wing problem which might have caused numerical difficulty due to the concentration of vorticity at the apex. This is especially worrisome since the modeling of the apex often requires considerable care to produce useful results.

He compares the theoretical shape of the rolled-up sheet with the experimental results and seems to obtain reasonable agreement. He also checks his rolled-up sheet for conicality [see Figure 26]. As one progresses from the apex to the trailing edge, there is a trend for the sheet to move downwards and become tighter. This result must be evaluated with caution since this preliminary result could be the product of the numerical approximations as well as the actual description of the real flow. He then compares the results he obtained with those of Smith (1968) and with Sacks et al (1967), for $\alpha = 15^\circ$, $\delta = \text{semi-apex angle} = 15^\circ$. There is considerable discrepancy between the three results and the experimental center of the vortex given by Werle [see Figure 27]. The result of Rehbach is more inboard and higher and tends to agree better with the experimental result. He obtains a similar result for the normal force [see Figure 27]. Rehbach suggests a possible reason for the discrepancy is the fact that the apex angle and the angle of attack considered may be outside the range of validity for the slender body analysis of both Sacks et al and of Smith. This is, of course, the advantage of a scheme such as Rehbach's. He also notes a certain vagueness of the velocity field near the apex, probably as a result of the calculation using a fairly concentrated network of discrete singularities in that region. He suggests that this problem can be alleviated by utilizing the conicality of the flow in that region.

Probably working at the same time, Mook and Maddox (1974) published their results using a similar model based on the lifting surface theory of

Mook, D. T. and Maddox, S. A., "Extension of a Vortex-Lattice Method to Include the Effects of Leading-Edge Separation," *JA*, 11, pp. 127-128, Feb. 1974.

Belotserkovskii. They do not furnish many details of their calculation. They do note difficulty in convergence for angles of attack of less than 5°.

However, in a later paper, Kandil, Mook and Nayfeh (1974) claim that the Mook and Maddox method "is subject to the same limitations regarding camber, etc., as the KRG (Kalman, Geising and Rodden) program and cannot account for wing-tip and trailing vortex sheets being free of forces." Neither group seems to be aware of the work of Rehbach. They then claim to follow Belotserkovskii and obtain force free trailing line segments. Their manner of solution is as follows:

- 1) They assume an initial orientation of the vortex elements.
- 2) For the given vortex network, they calculate the circulation distribution by satisfying the normal flow condition on the wing.
- 3) They calculate the local velocity in the wake.
- 4) They then align the upstream end of each free segment with the velocity.
- 5) They now iterate between 3) and 4) until the method converges.
- 6) Now the normal flow condition is no longer satisfied and they iterate between two and five until the method converges. This furnishes the answer for the number of elements initially chosen.

They consider convergence in two aspects. The shape of the wake must converge as a function of iterations. Secondly, the predicted air loads must converge as the number of elements is increased. They calculate the force on the wing using the Kutta-Joukowski theorem and obtain reasonable agreement with the experiments of Bartlett and Vidal (1955) and of Peckham (1958) for the normal force and center of pressure calculations. They note that their figures are similar to those determined by Mook and Maddox for the rolling up of the leading-edge vortices. They do not seem to have encountered any difficulty and claim that the method of iteration they use converges. In conclusion,

Kandil, O. A., Mook, D. T. and Nayfeh, A. H., "Nonlinear Prediction of Aerodynamic Loads on Lifting Surfaces," AIAA Paper No. 74-503, June 1974.

Peckham, D. H., "Low Speed Wind Tunnel Tests on a Series of Uncambered Slender Pointed Wings with Sharp Edges," ARC R&M 3186, 1958.

they admit that the present method has the disadvantage of long computation time if a large number of elements are used. They reduce the time for convergence by using good initial guesses for the sheet shape and only considering a few vortices in the trailing edge sheet.

Method of Polhamus

Finally, one arrives at the leading-edge-suction analogy of Polhamus. Polhamus (1966, 1971) was dissatisfied with the usual means of treating the problem for they failed to consider the trailing-edge Kutta condition. The method that he developed does not give the local distribution of the lift on the wing and consequently cannot give pitching moments in its originally derived form.

The approach assumes that if the flow reattachment occurs on the upper surface, the total lift can be calculated as the sum of a vortex lift associated with the existence of the leading-edge vortices and of a potential flow lift for attached flow. The potential lift is considered to be that lift obtained from the wing in the normal manner using a lifting surface theory, but subtracting out the contribution of the leading-edge suction, since with separation, there is no longer a leading-edge suction force.

This is accomplished by modifying a lifting surface program by applying a Joukowski condition to the leading edge. He uses a modification of the Multhopp lifting surface theory to accomplish this. He finds for this potential lift

$$C_{L_p} = K_p \sin\alpha \cos^2\alpha \quad (115)$$

where K_p is only a function of aspect ratio for delta wings and this is plotted in Figure 28.

For the nonlinear vortex lift, he assumes that the total force on

Polhamus, E. C., "A Concept of the Vortex Lift of Sharp-Edge Delta Wings Based on a Leading-Edge-Suction Analogy," NASA TN D-3767, 1966.

Polhamus, E. C., "Predictions of Vortex-Lift Characteristics by a Leading-Edge-Suction Analogy," JA, 8, pp. 193-199, April 1971.

the wing, associated with the pressure required to maintain equilibrium of the flow over the separated spiral vortex sheet, is essentially the same as the leading-edge suction force associated with the leading-edge pressure required to maintain attached flow around a large leading-edge radius.

For the delta wing, the component of leading-edge suction force which is pertinent is the force normal to the leading edge. He obtains the suction contribution as

$$C_{L_V} = (K_p - K_p^2 K_i) \frac{\cos \alpha}{\cos \lambda} \sin^2 \alpha \quad (116)$$

where $\lambda =$ sweep and

$$K_i = \frac{\partial C_{D_i}}{\partial C^2} \quad (117)$$

which he rewrites in terms of a suction lift coefficient

$$C_{L_V} = K_V \cos \alpha \sin^2 \alpha$$

For the delta wing, K_V is again only a function of aspect ratio having been calculated from lifting surface theory [see Figure 28]. He compares his results with experiments and obtains good agreement for lift [see Figure 29]. He concedes that a rigorous proof of the concept has yet to be established; and that it does not appear to have been published yet at the time of this writing.

Later this method is applied by Bradley, Smith and Bhatley (1973) to more complex planforms of a general nature, while Snyder and Lamar (1972) extend the method to give chordwise load distributions and consequently pitching moment variations.

This concludes the discussion on existing models for vortex flow phenomena. A chronological listing of the models is included in Table 3 for the reader's convenience.

Bradley, R. G., Smith, C. W., Bhatley, I. C., "Vortex-Lift Prediction for Complex Wing Planforms," *JA*, 10, No. 6, pp. 379-381, June 1973.

Snyder, M. and Lamar, J., "Application of the Leading-Edge-Suction Analogy to Prediction of Longitudinal Load Distribution and Pitching Moments for Sharp-Edged Delta Wings," NASA TN D-6994, 1972.

TABLE 3
TABLE OF MODELS

Author	Legendre (1952)	Legendre (1953a)
Type of Model	Slender Body; Vortex Pair	Slender Body Theory; Vortex Sheets
Assumptions	Conical Flow; Kutta Condition; no force on vortices	Conical; Normal Velocity Condition and No-Pressure Condition on Sheet; Kutta Condition
Results	Numerical (See Figure 10)	None
Remarks	Lift negative for small α ; Violates Helmholtz Conserva- tion Theorem	Formulates problem for continuous vortex sheet; does not solve
Author	Edwards (1954) Brown and Michael (1954)	Smith (1957)
Type of Model	Slender Body; Vortex Pair; Feeding Cut	Slender Body Theory; Vortex Pair; Feeding Cut
Assumptions	Conical Flow; Kutta Condition; no net force on vortex-cut	Kutta Condition; no net force on vortex-cut
Results	$C_L = \frac{\pi}{2} R\alpha + \pi(R)^{1/3} \alpha^{5/3}$ (See Figure 16)	Numerical
Remarks	Pressure discontinuity across cut; net moment on vortex-cut; overpredicts lift	Extends Brown & Michael to planform with curved leading edges

Author	Mangler & Smith (1957)	Smith (1966a)
Type of Model	Slender Body Theory; Vortex Pair; Feeding Sheet; Feeding Cut	Slender Body Theory; Vortex Pair; Feeding Sheet; Feeding Cut
Assumptions	Conical; Kutta Condition; approximate sheet shape & strength near leading edge; apply boundary condition for vortex sheet at single point	Conical; Kutta Condition; approximate sheet by n segments; apply boundary conditions for sheet at n points
Results	Numerical (See Figure 16)	Numerical; curve fit $C_N = \frac{\pi}{2} AR\alpha + 3.2(AR)^{.3} \alpha^{1.7}$ (Figure 27)
Remarks	Formulates general boundary conditions on feeding vortex sheet, wing, and at infinity; better agreement with experi- ment than Brown and Michael	Extends Mangler and Smith; solved using 3 nested iterations; better agreement with experiment than simpler models.
Author	Polhamus (1966)	Legendre (1966)
Type of Model	Lifting Surface Theory; Leading-Edge Suction Analogy	Vortex Pair; Nonslender
Assumptions	Incompressible; leading-edge suction force becomes lead- ing-edge vortex force	Conical; incompressible; singularities at vortex locations & images only; global force condition
Results	$C_{L_V} = K_V \cos\alpha \sin^2\alpha$ (Figures 28 & 29)	Analytical; only vortex location given
Remarks	Modifies linear lifting surface theory to calculate both linear & nonlinear lift; obtains good agreement with experiment	Formulates nonslender prob- lem to remove contradiction at vortex axis; unable to satisfy Kutta condition at leading edge.

Author	Sacks, Lundberg & Hanson (1967)	Nangia & Hancock (1968)
Type of Model	Slender Body Theory; Incompressible; Array of pt. vortices	Lifting Surface Theory; Vortex Pair; Feeding Cut; Trailing Edge
Assumptions	Separated and linear lift separable and additive; Kutta Condition; vortices convected; vortices shed tangent to wing	Kutta Condition; no net force on vortex-cut; "flat" wake until roll up
Results	Numerical (See Figure 27)	Numerical
Remarks	Removes restriction of conical flow; question of discrete vortex representation of sheet; use impulse to calculate forces; results comparable to Smith (1966a)	Numerical collocation method to obtain vorticity of wing and wake; adds Brown & Michael vortex-cut to linear lifting surface theory, computations lengthy
Author	Levinsky, Wei & Maki (1969)	Portnoy & Russel (1971)
Type of Model	Same as Smith (1966a)	Slender Body Theory; Vortex Pair; Feeding Cut; Rhombic Body
Assumptions	Same as Smith; also extends to nonconical case	Same as Brown & Michael
Results	Numerical	Numerical
Remarks	Extends Smith to conical wing-body combinations; found multi-valued lift for intermediate values of α/ϵ . Extends results to nonconical problem.	Extends Brown & Michael to rhombic body by conformal transformation; predicts outward movement of vortices with increased thickness.

Author	Angelucci (1971)	Finkleman (1972)
Type of Model	Same as Sacks et al	"Slender body theory"
Assumptions	Separated and linear lift separable & additive; Kutta condition; assumes sheet strength to be quadratic at shedding	Same as Sacks; trailing edge
Results	Numerical	Numerical
Remarks	Results similar to Sacks et al; extends to cylindrical body by using experimental results to fix shedding point.	Includes effect of trailing edge by placing vortices corresponding to spanwise loading at trailing edge; violates slender body assumption.
Author	Pullin (1973)	Rehbach (1973b)
Type of Model	Same as Smith (1966a)	Lifting Surface Theory; bound and trailing vortices
Assumptions	Same as Smith	Incompressible; no flow through wing; no force on wake; Kutta condition
Results	Numerical	Numerical (Figure 27)
Remarks	Formulation slightly different than Smith; similar results.	Replaces wing, wake & leading vortices by vortex line segments; obtains lift by integrating pressure distribution.

Author	Fink & Soh (1974)
Type of Model	Same as Sacks et al
Assumptions	Same as Sacks et al
Results	Numerical (Figure 24)
Remarks	Includes error analysis; more uniform rollup than Sacks et al due to use of equi-distant vortices.

CONCLUSION

The present state of the art for small aspect ratio wings with external vortex flow has been described. Although controversy still exists over the exact nature of the vortex breakdown, it is felt that the fundamental behavior of the flow elements are reasonably well understood.

The slender body theories are well-developed and represent the flow within their limitations. However, the limitations in the existing theories suggest that one should consider a more general problem. First, it would be desirable to obtain results for moderate aspect ratio delta wings which are more like the practical aircraft shapes. Secondly, considering the importance of the adverse pressure gradient near the trailing edge on vortex bursting, it would be desirable to include the trailing edge condition in a unified theory. Finally, it would be advantageous to obtain a more detailed flow picture near the vortex core than can be provided by means of a discrete vortex model.

Thus, it is suggested that a lifting surface theory of the kernel-function type should be used rather than the discrete vortex type. Normal lifting surface theory [Ashley and Landahl (1965)] of the kernel-function type fails to consider vortex sheet roll-up in obtaining the kernel-function formulation. This is significant, since the study would extend to infinity for the steady problem, and it is this simplification that allows the contribution of the sheet to be neglected.

Lifting surface theory has generally been applied to attached flow models where the roll-up of the trailing wake only contributes as α^3 and thus can be ignored, since the theories are linear in lift. To extend existing lifting surface theory to the separated flow problem, however, does not appear impossible, although it may be necessary to settle for a solution which is not as rigorous as the original development.

Two possible approaches immediately suggest themselves. First, one could consider an unsteady lifting-surface theory of the type developed by Djojodihardjo and Widnall (1969) following a suggestion by

Djojodihardjo, R. H., and Widnall, S. E., "A Numerical Method for the Calculation of Nonlinear, Unsteady Lifting Potential Flow Problems," AIAAJ, 7, No. 10, pp. 2001-2009, Oct. 1969.

Ashley (1966) which allows the consideration of nonlinear lifting problems. The assumptions are similar to most lifting surface theories with respect to inviscid, irrotational, and incompressible flow outside the wing and wake. They are able to consider the wake roll-up because at their initial time, they start with no wake and for any finite time, the wake remains finite and therefore its effect can be explicitly considered.

To attack the present problem of a steady vortex sheet, it may be possible to study the problem for some finite time and, if the solution approaches a constant value, this can possibly be used as a steady-state solution.

Alternatively, one could develop a model based on the idea of Mangler and Smith (1959) that only the flow field near the wing has to be modeled exactly, and farther away simplifying assumptions could be made. This suggests the possibility that the flow field can be constructed of a wing and a finite portion of the rolled-up vortex sheet near the leading edge while the contribution of the far wake could be considered to be similar to the case for the lifting surface problem and it may be possible to eliminate it from the evaluation of the integral if the solution shows convergence as the segment of the roll-up sheet which is explicitly represented is increased. Also, it may be possible to replace the core of the leading-edge vortex in the manner of Mangler and Smith by an asymptotic representation. For a first approximation, one might consider the models of Mangler and Weber (1966) or that of Hall (1961) and Ludwig (1962).

Such a combined flow field should adequately model all of the fundamental phenomena of the vortex flow field. Viscosity and compressibility has been shown to have negligible effects outside of a small core region and the boundary layer. From agreement between linear lifting-surface theory and experiment, the neglecting of the boundary layer thickness on the wing and the finite thickness of the wake seems justified.

Once the basic vorticity elements have been modeled, all the aerodynamic characteristics can be obtained and that would provide a unified

Ashley, H., "Machine Computation of Aerodynamic Loads in Linear and Nonlinear Situations," AFOSR 66-1440, M.I.T. FDRL Rept. 66-5, 1966.

theory for the vortex flow phenomena on this simplified platform. The next step would be to extend the model to include the effects of control surfaces and of yaw and roll where the vortex flow phenomena are also important.

BIBLIOGRAPHY

- Adams, M. C., "Leading-Edge Separation from Delta Wings at Supersonic Speeds," JAS, 20, p. 430, June 1953.
- Adams, M. C. and Sears, W. R., "Slender-Body Theory - Review and Extension," JAS, 20, pp. 85-98, Feb. 1953.
- Angelucci, S. B., "A Multivortex Method for Axisymmetric Bodies at Angles of Attack," JA, 8, pp. 959-966, Dec. 1971.
- Angelucci, S. B., "Multivortex Model for Bodies of Arbitrary Cross-Sectional Shapes," AIAA Paper No. 73-104, Jan. 1973.
- Anton, L., "Formation of a Vortex at the Edge of a Plate," NACA TM 1398, March 1956, translation of "Ausbildung eines Wirbels an der Kante einer Platte," Ingenieur-Archiv, 10, pp. 411-427, 1939.
- Ashley, H., "Machine Computation of Aerodynamic Loads in Linear and Non-linear Situations," AFOSR 66-1440, M.I.T. FDRL Rept. 66-5, 1966.
- Ashley, H. and Landahl, M., Aerodynamics of Wings and Bodies, Addison-Wesley Publishing Co., Inc., 1965.
- Ashley, H. and Rodden, W., "Wing-Body Aerodynamic Interaction," Annual Review of Fluid Mechanics, Vol. 4, pp. 431-472, 1972.
- Ashley, H., Widnall, S. and Landahl, M., "New Directions in Lifting Surface Theory," AIAAJ, 3, p. 3-16, Jan. 1965.
- Barcilon, A., "Vortex Decay above a Stationary Boundary," JFM, 27, pp. 155-175, 1967.
- Barsby, J. E., "Calculations of the Effect of Blowing from the Leading Edges of a Slender Delta Wing," ARC R&M 3692, 1971.
- Bartlett, G. E. and Vidal, R. J., "Experimental Investigation of Influence of Edge Shape on the Aerodynamic Characteristics of Low Aspect Ratio Wings at Low Speed," JAS, 22, pp. 517-533, 1955.
- Batchelor, G. K., "Axial Flow in Trailing Line Vortices," JFM, 20, pp. 645-658, 1964.
- Batchelor, G. K., An Introduction to Fluid Dynamics, Cambridge University Press, 1967.
- Belotserkovskii, S. M., "Calculation of the Flow around Wings of Arbitrary Planform over a Wide Range of Angles of Attack," Mekhanika Zhidkosti i Gaza, Vol. 3, No. 4, pp. 32-44, 1968, translated in Fluid Dynamics, Consultants Bureau, pp. 20-27.

- Belotserkovskii, S. M., Theory of Thin Wings in Subsonic Flow, Plenum Press, New York, 1967.
- Benjamin, T. B., "Significance of the Vortex Breakdown Phenomenon," Trans. ASME, J. of Basic Eng., pp. 518-524, 1965.
- Benjamin, T. B., "Some Developments in the Theory of Vortex Breakdown," JFM, 28, pp. 65-84, 1967.
- Benjamin, T. B., "Theory of the Vortex Breakdown Phenomenon", JFM, 14, pp. 593-629, 1962.
- Bergeson, A. J. and Porter, J. D., "An Investigation of the Flow around Slender Delta Wings with Leading Edge Separation," Princeton Rep. 510, 1960.
- Betchov, R., "On the Curvature and Torsion of an Isolated Vortex Filament," JFM, 22, pp. 471-479, 1965.
- Betz, A., "Behavior of Vortex Systems," NACA TM 713, 1933.
- Bilanin, A. J., "Wave Mechanics of Line Vortices," Ph.D. Thesis, M.I.T., 1973.
- Bilanin, A. J. and Widnall, S. E., "Aircraft Wake Dissipation by Sinusoidal Instability and Vortex Breakdown," AIAA Paper No. 73-107, Jan. 1973.
- Birkhoff, G. and Fisher, J., "Do Vortex Sheets Roll Up?", Circolo Matematico Di Palermo Reconditi, 8, Series 2, pp. 77-89, 1959.
- Bliss, D. B., "Dynamics of Flows with High Concentrations of Vorticity," Ph.D. Thesis, M.I.T., 1973.
- Bollay, W., "A Non-Linear Wing Theory and Its Application to Rectangular Wings of Small Aspect Ratio," ZAMM, 19, pp. 21-35, Feb. 1939.
- Bollay, W., "A Theory for Rectangular Wings of Small Aspect Ratio," JAS, 4, pp. 294-296, 1937.
- Bossel, H. H., "Inviscid and Viscous Models of the Vortex Breakdown Phenomenon," Ph.D. Thesis, U. C., Berkeley, 1967.
- Bossel, H. H., "Stagnation Criterion for Vortex Flows," AIAAJ, 6, pp. 1192-1193, 1968.
- Bossel, H. H., "Vortex Breakdown Flowfield," Physics of Fluids, 12, pp. 498-508, 1969.
- Bossel, H. H., "Vortex Computation by the Method of Weighted Residuals using Exponentials," AIAAJ, 9, No. 10, pp. 2027-2034, 1971.

- Bossel, H. H., "Vortex Equations: Singularities, Numerical Solution, and Axisymmetric Vortex Breakdown," NASA CR-2090, July 1972.
- Bradley, R. G., Smith, C. W., and Bhatley, I. C., "Vortex-Lift Prediction for Complex Wing Planforms," JA, 10, No. 6, pp. 379-381, June 1973.
- Brown, C. E. and Michael, W. H., "Effect of Leading-Edge Separation on the Lift of a Delta Wing," JAS, 21, No. 10, pp. 690-694, Oct. 1954.
- Brown, C. E. and Michael, W. H., "On Slender Delta Wings with Leading-Edge Separation," NACA TN 3430, 1955.
- Brown, S. N., "The Compressible Inviscid Leading-Edge Vortex," JFM, 22, pp. 17-32, 1965.
- Brown, S. N. and Mangler, K. W., "An Asymptotic Solution for the Centre of a Rolled-Up Conical Vortex Sheet in Compressible Flow," Aeron. Quart., 18, Part 4, pp. 354-366, Nov. 1967.
- Bryson, A. E., "Symmetric Vortex Separation on Circular Cylinders and Cones," Journ. of Applied Mech., pp. 643-648, Dec. 1959.
- Butter, D. J. and Hancock, G. J., "A Numerical Method for Calculating the Trailing Vortex System behind a Swept Wing at Low Speed," Aeron. Journ., 75, pp. 564-568, Aug. 1971.
- Clements, R. R. and Maul, D. J., "The Rolling Up of a Trailing Vortex Sheet," Aeron. Journ., 77, No. 745, pp. 46-51, Jan. 1973.
- Coe, P., "Stationary Vortices behind a Flat Plate Normal to the Freestream in Incompressible Flow," AIAAJ, 10, p. 1701, Dec. 1972.
- Coe, P., "A Vortex Entrainment Model Applied to Slender Delta Wings," AIAAJ, 12, No. 1, pp. 110-112, Jan. 1974.
- Cone, C. D., "Theoretical Investigation of Vortex-Sheet Deformation Behind a Highly Loaded Wing and Its Effect on Lift," NASA TN D-657, April, 1961.
- Crow, S. C., "Stability Theory for a Pair of Trailing Vortices," Boeing SRL Document D-1-82-0918, Sept. 1969.
- Das, A., "Zum Anschwellen von Aufgerollten Wirbelflächen und Aufplatzen des Wirbelkerns bei schlanken Tragflugeln," Z. Flugwiss., 15, No. 10, pp. 355-362, Oct. 1967.
- Dixon, C. J., Thiesen, J. G., Scruggs, R. M., "Theoretical and Experimental Investigation of Vortex Lift Control by Spanwise Blowing: Volume I, Experimental Research," Lockheed-Georgia Company, LG73ER-0169, Sept. 1973.

- Djojodihardjo, R. H., "A Numerical Method for the Calculation of Nonlinear, Unsteady Lifting Potential Flow Problems," Sc.D. Thesis, M.I.T., 1969.
- Djojodihardjo, R. H. and Widnall, S. E., "A Numerical Method for the Calculation of Nonlinear, Unsteady Lifting Potential Flow Problems," AIAAJ, 7, No. 10, pp. 2001-2009, Oct. 1969.
- Earnshaw, P. B., "An Experimental Investigation of the Structure of a Leading-Edge Vortex," ARC R&M 3281, 1961.
- Earnshaw, P. B. and Lawford, J. A., "Low-Speed Wind-Tunnel Experiments on a Series of Sharp-Edged Delta Wings," ARC R&M 3424, 1966.
- Edwards, R. H., "Leading-Edge Separation from Delta Wings," JAS, 21, pp. 134-135, 1954.
- Elle, B. J., "An Investigation at Low Speed of Flow Near the Apex of Thin Delta Wings with Sharp Leading Edges," ARC R&M 3176, 1958.
- Ermolenko, S. D. and Barinov, M. T., "Calculation of the Angles of Downwash of Flow behind Rectangular Wings of Small Aspect Ratio at Subsonic Velocities According to Non-Linear Theory," RAE LT No. 1247, Aug. 1967.
- Fink, P. T., "Wind Tunnel Tests on a Slender Delta Wing at High Incidence," Z. Flugw., 4, No. 7, pp. 247-249, July 1956.
- Fink, P. T., and Soh, W. K., "Calculation of Vortex Sheets in Unsteady Flow and Applications in Ship Hydrodynamics," for Tenth Symposium in Naval Hydrodynamics, July 1974.
- Fink, P. T. and Taylor, J., "Some Early Experiments on Vortex Separation," ARC R&M 3489, 1967.
- Finkleman, D., "Nonlinear Vortex Interactions on Wing-Canard Configurations," JA, 9, No. 6, pp. 399-406, June 1972.
- Fraenkel, L. E., "On Benjamin's Theory of Conjugate Vortex Flows," JFM, 28, pp. 85-96, 1967.
- Gartshore, I. S., "Some Numerical Solutions for the Viscous Core of an Irrotational Vortex," NRC Aero. Rep. LR-378, 1963.
- Gersten, K., "Calculation of Non-linear Aerodynamic Stability Derivatives of Aeroplanes," AGARD Rep. 342, April 1961.
- Govindaraju, S. and Saffman, P., "Flow in a Turbulent Trailing Vortex," Phys. of Fluids, 14, No. 10, pp. 2074-2080, Oct. 1971.

- Hackett, J. E. and Evans, M. R., "Vortex Wakes behind High-Lift Wings," JA, 8, No. 5, pp. 334-340, 1971.
- Hall, M. G., "A New Approach to Vortex Breakdown," in Proc. of 1967 Heat Transfer and Fluid Mechanics Institute, P. A. Libby, ed., Stanford U. Press, pp. 319-340, 1967.
- Hall, M. G., "On the Occurrence and Identification of Vortex Breakdown," RAE TR 66283, 1966a.
- Hall, M. G., "The Structure of Concentrated Vortex Cores," in Progress in Aeronautical Sciences, Vol. 7, D. Kuchemann, ed., Pergamon Press, pp. 53-110, 1966b.
- Hall, M. G., "A Theory for the Core of a Leading-Edge Vortex," JFM, 11, pp. 209-228, 1961.
- Hall, M. G., "Vortex Breakdown," in Annual Review of Fluid Mechanics, Vol. 4, Annual Reviews, Inc., Palo Alto, pp. 195-218, 1972.
- Hama, F. R., "Progressive Deformation of a Curved Vortex Filament by its own Induction," Phys. of Fluids, 5, pp. 1156-1162, 1962.
- Hama, F. R., "Progressive Deformation of a Perturbed Line Vortex Filament," Phys. of Fluids, 6, pp. 526-539, 1963.
- Hama, F. R. and Burke, E. R., "On the Rolling Up of a Vortex Sheet," Maryland U., BN-220, 1960.
- Hancock, G. J., "On the Rolling Up of a Trailing Vortex Sheet," Aeron. Journ. of Roy. Aero. Soc., 74, pp. 749-752, Sept. 1970.
- Harvey, J., "Analysis of the Vortex Breakdown Phenomenon, Part II," Aero. Dept., Imperial College, Rep. 103, 1960.
- Harvey, J., "Some Observations of the Vortex Breakdown Phenomenon," JFM, 14, pp. 585-592, 1962.
- Hawkes, J. W., "Simple Model for Vortex Breakdown Phenomenon," M.I.T., M.S. Thesis, 1969.
- Hoffman, E. R. and Joubert, P. N., "Turbulent Line Vortices," JFM, 16, pp. 395-411, July 1963.
- Hummel, D., "Untersuchungen über das Aufplatzen der Wirbel an schlanken Deltaflügeln," Z. Flugw., 13, No. 5, pp. 158-168, 1965.
- Hummel, D., and Redeker, G., "Über den Einfluss des Aufplatzens der Wirbel auf die aerodynamischen Beiwerte von Deltaflügeln mit kleinem Seitenverhältnis beim Schiebefluss," Jahrbuch 1967 of WGLR, pp. 232-240.

- Mei, D. and Srinivasan, P. S., "Vortex Breakdown Effects on the Low-Speed Aerodynamic Characteristics of Slender Delta Wings in Symmetrical Flow," J. Roy. Aeron. Soc., 71, No. 676, pp. 319-322, April 1967.
- Jones, J. P., "The Breakdown of Vortices in Separated Flow," Univ. of Southampton, Rep. 140, 1960.
- Jones, R. T., "Properties of Low Aspect Ratio Pointed Wings at Speeds Below and Above the Speed of Sound," NACA Rep. 835, 1946.
- Jordan, P. F., "Structure of Betz Vortex Cores," JA, 10, p. 691-693, Nov. 1973.
- Kaden, H., "Aufwicklung einer unstablen Unstetigkeitsfläche," Ingenieur-Archiv, 2, pp. 140-168, 1931.
- Kandil, O. A., Mook, D. T. and Nayfeh, A. H., "Nonlinear Prediction of Aerodynamic Loads on Lifting Surfaces," AIAA Paper No. 74-503, June 1974.
- Kirkpatrick, D. L., "Analysis of Static Pressure Distribution on a Delta Wing in Subsonic Flow," ARC R&M 3619, 1970.
- Kirkpatrick, D. L., "Experimental Demonstration of the Similarity of Leading Edge Vortices above Slender Wings in the Subsonic Conical Flow," WGLR 1967 Jahrbuch, pp. 223-231.
- Küchemann, D., ed., Progress in Aeronautical Sciences, Vol. 7, Pergamon Press, 1966.
- Küchemann, D., "Report on IUTAM Symposium on Concentrated Vortex Motions in Fluids," JFM, 21, pp. 1-20, 1965.
- Küchemann, D. and Weber, J., "Vortex Motions," ZAMM, 45, No. 7-8, pp. 457-474, Dec. 1965.
- Kuwahara, K. and Takami, H., "Numerical Studies of Two-Dimensional Vortex Motion by a System of Point Vortices," Journ. of Phys. Soc. of Japan, 34, No. 1, pp. 247-253, Jan. 1973.
- Lamb, H., Hydrodynamics, Dover Publications, 6th Edition, 1945.
- Lambourne, N. C. and Bryer, D. W., "The Bursting of Leading-Edge Vortices - Some Observations and Discussion of the Phenomena," ARC R&M 3282, 1961.
- Lampert, S., "Aerodynamic Force Characteristics of Delta Wings at Supersonic Speeds," Caltech JPL Rep. No. 20-82, Sep. 1954.
- Landahl, M. and Stark, V., "Numerical Lifting Surface Theory - Problems and Progress," AIAAJ, 6, No. 11, pp. 2049-2060, Nov. 1968.

- Landahl, M. T. and Widnall, S. E., "Vortex Control," M.I.T., Supported by the Air Force Office of Scientific Research under Contract Nos. AF 49 (638)-1622 and F44620-69-C-0900, in Olsen, Goldberg & Rogers, 1971.
- Lawrence, H. R., "The Lift Distribution of Low Aspect Ratio Wings at Subsonic Speeds," JAS, 18, No. 12, pp. 683-695, 1951.
- Lee, G. H., "Note on the Flow around Delta Wings with Sharp Leading Edges," ARC R&M 3070, Sept. 1958.
- Legendre, R., "La condition de Joukowski en écoulement tri-dimensionnel," Recherche Aérospatiale, No. 5, pp. 241-248, 1972.
- Legendre, R., "Écoulement au voisinage de la pointe avant d'une aile à forte flèche aux incidences moyennes," Recherche Aeronautique, No. 30, 3-8, 1952, Nos. 31, pp. 3-6, 1953a, and 35, pp. 7-8, 1953b, translated by S. Skans, ARC 16796, 1954.
- Legendre, R., "Écoulement subsonique transversal à un secteur angulaire plan," C. R. Acad. Sci., 243, p. 1716, Nov. 1956.
- Legendre, R., "Nappes de tourbillons en cornets," C. R. Acad. Sci., 258, pp. 429-432, Jan. 1964.
- Legendre, R., "Nappes en cornets aux bords d'attaque d'une aile en delta," Recherche Aeronautique, No. 70, pp. 3-10, May 1959.
- Legendre, R., "Tourbillons en cornet des ailes delta," C. R. Acad. Sci., 257, pp. 3814-3817, Dec. 1963.
- Legendre, R., "Vortex Sheets Rolling-Up along Leading-Edges of Delta Wings," in Progress in Aeronautical Sciences, Vol. 7, D. Küchemann, ed., pp. 7-33, 1966.
- Leibovich, S., "Wave Motion and Vortex Breakdown," AIAA Paper No. 69-645, 1969.
- Levinsky, E. S. and Wei, M. H., "Nonlinear Lift and Pressure Distribution of Slender Conical Bodies with Strakes at Low Speeds," NASA CR-1202, 1968.
- Levinsky, E. S., Wei, M. H. and Maki, R. L., "Theoretical Studies of Vortex Flow on Slender Wing-Body Combinations," NASA Accession No. N70-21358, Also in NASA SP-228, pp. 113-129, 1969.
- Ludwig, H., "Ergänzung zu der Arbeit: Stabilität der Strömung in einem zylindrischen Ringraum," Z. Flugw., 9, No. 11, pp. 359-361, 1961.
- Ludwig, H., "Erklärung des Wirbelaufplatzens mit Hilfe der Stabilitätstheorie für Strömungen mit schraubenlinienförmigen Stromlinien," Z. Flugw., 13, p. 437-442, 1965.

- Ludwig, H., "Stabilität der Strömung in einem zylindrischen Ringraum," Z. Flugw., 8, No. 5, pp. 135-140, 1960.
- Ludwig, H., "Zur Erklärung der Instabilität der über angestellten Deltaflügeln auftretenden freien Wirbelkerne," Z. Flugw., 10, p. 242-249, 1962.
- Mangler, K. W. and Sells, C. C., "The Flow Field near the Centre of a Slender Rolled-Up Conical Vortex Sheet," RAE TR 67029, Jan. 1967.
- Mangler, K. W. and Smith, J. H. B., "A Theory of Flow Past a Slender Delta Wing with Leading Edge Separation," Proc. Roy. Soc. London, Ser. A, 251, p. 200, 1959.
- Mangler, K. W. and Smith, J. H. B., "Behavior of the Vortex Sheet at the Trailing Edge of a Lifting Wing," Aeron. Journ., 72, pp. 906-908, Nov. 1970.
- Mangler, K. W. and Smith, J. H. B., "Calculation of the Flow past Slender Delta Wings with Leading-Edge Separation," RAE Rep. Aero. 2593, May 1957.
- Mangler, K. W. and Smith, J. H. B., "Flow Past Slender Delta Wings with Leading Edge Separation," IX International Congress in Appld. Mech., Brussels, Vol. 2, pp. 137-145, 1955.
- Mangler, K. W. and Weber, J., "Flow Field near Center of a Rolled-Up Vortex Sheet," RAE TR No. 66324, 1966.
- Mangler, K. W. and Weber, J., "Flow Field near Center of a Rolled-Up Conical Vortex Sheet," ZAMM, p. 165-166, 1965.
- Maskell, E. C., "Developments in Study of Edge Vortices," Proc. of Int. Council of Aeron. Sciences - Third Congress, 1962.
- Maskell, E. C., "Flow Separation in Three Dimensions," RAE Rep. No. Aero. 2565, Nov. 1955.
- McCormick, B. W., Tangler, J. L., and Sherief, H. E., "Structure of Trailing Vortices," JA, 5, No. 3, pp. 260-267, 1968.
- McMahon, T. A., "Review of the Vortex Wake Rollup Problem," M.I.T. ASRL TR 145-1, June 1967.
- McMahon, T. A., and Widnall, S. E., "Vortex Wake Rollup and Vorticity Concentration behind an Airfoil," ASRL No. 143-1, June 1967.
- Michael, W. H., "Flow Studies on Flat-Plate Delta Wings at Supersonic Speeds," NACA TN 3472, July 1955.
- Milne-Thomson, L. M., Theoretical Hydrodynamics, Second Edition, MacMillan & Co., Ltd. New York, 1950.

- Mook, D. T. and Maddox, S. A., "Extension of a Vortex-Lattice Method to Include the Effects of Leading-Edge Separation," *JA*, 11, pp. 127-128, Feb. 1974.
- Moore, D. W., "The Discrete Vortex Approximation of a Finite Vortex Sheet," NASA Accession No. N72-24005, 1971.
- Moore, D. W., "A Numerical Study of the Roll-Up of a Finite Vortex Sheet," *JFM*, 63, Part 2, pp. 225-235, 1974.
- Moore, D. W., and Saffman, P. G., "Axial Flow in Laminar Trailing Vortices," *Proc. Roy. Soc., Ser. A*, 333, pp. 491-508, 1973.
- Moore, D. W. and Saffman, P. G., "The Motion of a Vortex Filament with Axial Flow," *Phil. Trans. Proc. Roy. Soc., Ser. A*, 272, pp. 403-429, Oct. 1971.
- Munk, M. M., "The Aerodynamic Forces on Airship Hulls," NACA Rep. 184, 1924.
- Murty, G. S. and Rao, K., "Numerical Study of the Behavior of a System of Parallel Line Vortices," *JFM*, 40, pp. 595-602, 1970.
- Nangia, R. and Hancock, G. J., "A Theoretical Investigation for Delta Wings with Leading-Edge Separation at Low Speeds," ARC CP No. 1086, 1968.
- Newman, B. G., "Flow in a Viscous Trailing Vortex," *Aeron. Quart.*, 10, pp. 149-162, 1959.
- Olsen, J. H., Goldberg, A. and Rogers, M., eds., Aircraft Wake Turbulence and Its Detection, Plenum Press, 1971.
- Örnberg, T., "A Note on the Flow around Delta Wings," KTH Aero TN 38, R.I.T., 1954.
- Peake, D. J., Rainbird, W. J. and Atraghji, E. G., "Three-Dimensional Flow Separation on Aircraft and Missiles," *AIAAJ*, 10, No. 5, pp. 567-580, May 1972.
- Peckham, D. H., "Low Speed Wind Tunnel Tests on a Series of Uncambered Slender Pointed Wings with Sharp Edges," ARC R&M 3186, 1958.
- Peckham, D. H. and Atkinson, S. A., "Preliminary Results of Low Speed Wind Tunnel Tests on a Gothic Wing of Aspect Ratio 1.0," ARC CP No. 508, 1957.
- Perrier, P. and Vitte, W., "Calculation Procedures for Three Dimensional Aerodynamics in Perfect Fluids," NASA TT F-14, 074, 1971.
- Polhamus, E. C., "A Concept of the Vortex Lift of Sharp-Edge Delta Wings Based on a Leading Edge-Suction Analogy," NASA TN D-3767, 1966.
- Polhamus, E. C., "Predictions of Vortex-Lift Characteristics by a Leading-Edge Suction Analogy," *JA*, 8, pp. 193-199, April 1971.

- Portnoy, H. and Russell, S. C., "The Effect of Small Conical Thickness Distributions on the Separated Flow past Slender Delta Wings," ARC CP1189, 1971.
- Pullin, D. I., "A Method for Calculating Inviscid Separated Flow about Conical Slender Bodies," ARL/A14, Australian Defense Scientific Service, Rep. 140, May 1973.
- Randall, J. D. and Leibovich, S., "The Critical State: A Trapped Wave Model of Vortex Breakdown," JFM, 58, pp. 495-515, 1973.
- Rehbach, C., "Calculation of Flows around Zero Thickness Wings with Evolutive Vortex Sheets," NASA TT F-15, 183, 1973a.
- Rehbach, C., "Étude Numérique de nappes tourbillonnaires issues d'une ligne de décollement près du bord d'attaque," Rech. Aerosp., No. 6, pp. 325-330, 1973b.
- Riley, N., "Flows with Concentrated Vorticity: A Report on Euromech 41," JFM, 62, pp. 33-39, 1974.
- Rogers, A., "Application of Two-Dimensional Vortex Theory to the Prediction of Flow Fields behind Wings of Wing-Body Combinations at Subsonic and Supersonic Speeds," NASA TN 3227, 1954.
- Rom, J. and Zorea, C., "The Calculation of the Lift Distribution and the Near Vortex Wake behind High and Low Aspect Ratio Wings in Subsonic Flow," TAE Rep. 168, Israel Inst. of Tech., 1973.
- Rosenhead, L., "The Formation of Vortices from a Surface of Discontinuity," Proc. Roy. Soc., A, 134, pp. 170-192, 1931.
- Rott, N., "On the Viscous Core of a Line Vortex," CR Acad. Sci., pp. 543-553, 1958.
- Roy, M., "Caractères de l'écoulement autour d'une aile en flèche accentuée," C. R. Acad. Sc., Paris, 234, pp. 2501-2504, June 1952.
- Roy, M., "On the Rolling-Up of the Conical Vortex Sheet Above a Delta Wing," in Progress in Aeronautical Sciences, Vol. 7, D. Küchemann, ed., pp. 1-5, 1966.
- Roy, M., "Remarques sur l'écoulement tourbillonnaire autour des ailes en flèche," ZAMP, IX, pp. 554-569, 1958.
- Roy, M., "Sur la Théorie de l'aile en delta: Tourbillons d'apex et nappes en cornet," Recherche Aeronautique, No. 56, pp. 3-12, Feb. 1957.
- Roy, M., "Über die Bildung von Wirbelzonen in Strömungen mit geringer Zähigkeit," Z. Flugw., 7, pp. 217-227, Aug. 1959.

- Sacks, A. H., "Aerodynamic Forces, Moments, & Stability Derivatives for Slender Bodies of General Cross Section," NACA TN 3283, 1954.
- Sacks, A. H., "Vortex Interference on Slender Airplanes," NACA TN 3525, 1955.
- Sacks, A. H., Lundberg, R. and Hanson, C., "A Theoretical Investigation of Aerodynamics of Slender Wing-Body Combinations Exhibiting Leading-Edge Separation," NASA CR-719, 1967.
- Sarpkaya, T., "Effect of the Adverse Pressure Gradient on Vortex Breakdown," AIAAJ, 12, No. 5, p. 602-607, 1974.
- Sarpkaya, T., "On Stationary and Travelling Vortex Breakdowns," JFM, 45, pp. 545-559, 1971.
- Sarpkaya, T., "Experimental Investigation of the Vortex-Breakdown Phenomenon," NASA Accession No. N71-11955, 1970.
- Smith, J. H. B., "Calculations of the Flow over Thick, Conical, Slender Wings with Leading-Edge Separation," ARC R&M 3694, March 1971.
- Smith, J. H. B., "Improved Calculations of Leading-Edge Separation from Slender Delta Wings," RAE TR 66070, March 1966a.
- Smith, J. H. B., "Improved Calculations of Leading-Edge Separation from Slender, Thin, Delta Wings," Proc. Roy. Soc., Ser. A, 306, pp. 67-90, 1968.
- Smith, J. H. B., "Theoretical Work on the Formation of Vortex Sheets," in Progress in Aeronautical Sciences, Vol. 7, D. Küchemann, ed., pp. 35-51, 1966b.
- Smith, J. H. B., "The Theory of a Thin, Slender, Conical Wing with the Wing Boundary Conditions Applied at its Surface," RAE Rep. Aero. 2602, March 1958.
- Smith, J. H. B., "A Theory of the Separated Flow from the Curved Leading Edge of a Slender Wing," ARC R&M No. 3116, Nov. 1957.
- Snyder, M. and Lamar, J., "Application of the Leading-Edge-Suction Analogy to Prediction of Longitudinal Load Distribution and Pitching Moments for Sharp-Edged Delta Wings," NASA TN D-6994, 1972.
- Spreiter, J. R. and Sacks, A. H., "The Rolling Up of the Trailing Vortex Sheet and its Effect on Downwash behind Wings," JAS, 18, p. 21-32, 1951.
- Squire, H. B., "Analysis of the 'Vortex Breakdown' Phenomenon, Part I," Imperial College, Aero. Dept., Rep. 102, 1960.

- Squire, H. B., "Rotating Fluids," in Surveys in Mechanics, Batchelor and Davis, ed., 1956.
- Stern, M., "The Rolling-Up of a Vortex Sheet," ZAMP, 7, pp. 326-342, 1956.
- Stewartson, K. and Hail, M. G., "The Inner Viscous Solution for the Core of a Leading-Edge Vortex," JFM, 15, pp. 306-318, 1963.
- Thiesen, J. G., Scruggs, R. M. and Dixon, C. J., "Theoretical and Experimental Investigations of Vortex Lift Control by Spanwise Blowing: Vol. II, Three-Dimensional Theory for Vortex Lift Augmentation," Lockheed-Georgia, LG73ER-0619, Sept. 1973.
- Thwaites, B., Incompressible Aerodynamics, Clarendon Press, 1960.
- Timm, G. K., "Survey of Experimental Velocity Distribution in Vortex Flows with Bibliography," Boeing SRL, Document DI-82-0683, 1967.
- Treiber, G. E., "An Experimental Investigation of the Effect of Adverse Pressure Gradient on Vortex Breakdown," M.S. Thesis, Naval Post-graduate School, 1973.
- Wang, K. C., "A New Approach to 'Not-So-Slender' Wing Theory," Journal of Math. and Phys., XLVII, No. 4, pp. 391-406, Dec. 1968.
- Ward, G. N., "Supersonic Flow past Slender Pointed Bodies," Quart. Journ. Mech. and Appld. Math., 2, p. 75, 1949.
- Warner, F. J., "On the Solution of 'Jury' Problems with Many Degrees of Freedom," Math. Tables and Other Aids to Computation, 11, pp. 268-271, 1957.
- Werle, H., "Essai de vérification de la conicité de l'écoulement autour d'une aile delta mince avec incidence," Recherch. Aeron., No. 63, pp. 39-40, 1958.
- Westwater, F. L., "The Rolling Up of the Surface of Discontinuity behind an Airfoil of Finite Span," ARC R&M 1692, Aug. 1935.
- Widnall, S. E. and Bliss, D. B., "Slender-Body Analysis of the Motion and Stability of a Vortex Filament Containing an Axial Flow," JFM, 50, pp. 335-353, 1971.
- Wilson, H. and Lovell, J., "Full-Scale Investigation of the Maximum Lift and Flow Characteristics of an Airplane Having Approximate Triangular Planform," NACA RM No. L6K20, 1947.
- Winter, H., "Flow Phenomena on Plates and Airfoils of Short Span," NACA TM No. 798, 1936.

SYMBOLS (commonly used)

A	constant
\mathcal{R}	aspect ratio
a	α/K , constant characterizing delta wings
b	local semispan
C_L	coefficient of lift
C_N	coefficient of normal force
c	constant; phase velocity; chord
D	operator
F	function
f	function
H	total head
i	$\sqrt{-1}$
K	$\tan \epsilon = 1/4 \mathcal{R}$ for delta wings
K_P	potential lift factor
K_V	vortex lift factor
L	lift
M	Mach number
m	constant
m'	apparent mass
O	order
p	pressure
q	dynamic pressure; complex velocity
R	radius
R_e	real part of a complex quantity
r	radius
\bar{r}	r/x
S	complex plane, $2\eta = S - 1/S$; surface function
s	surface coordinate
t	complex plane; time
U	free stream velocity
u	radial velocity in cylindrical coordinates; velocity in x-direction in rectangular coordinates
V	transverse velocity

MBOLS (cont'd)

	circumferential velocity in cylindrical coordinates; velocity in y-direction in rectangular coordinates
W	complex potential
w	axial velocity in cylindrical coordinates; velocity in z-direction in rectangular coordinates
x	axis of symmetry
y	spanwise axis
Z	complex plane, $y + iz$
Z*	complex plane
z	axis perpendicular to wing surface
α	constant; angle of attack
β	constant
Γ	circulation
γ	ratio of specific heats; vortex strength
Δ	change; difference
δ	increment of sheet length in transformed plane
ϵ	semiapex angle of delta wing
ρ	complex plane; $1 + \eta^2$
η	complex plane; $\frac{z + iy}{b}$
θ	azimuthal angle; complex plane $\sqrt{\sigma^2 - b^2}$
κ	vr
λ	wave number; sweep angle
μ	constant characterizing spiral
ν	kinematic viscosity
ξ	function determining shape of sheet
ρ	density; vortex location
σ	frequency; complex plane; arc parameter
τ	velocity
ϕ	velocity potential
ϕ	swirl angle = $\tan^{-1} v/w$; velocity potential; angle
ψ	stream function
ω	complex plane, $e^{i\omega} = \frac{y + iz}{R + x}$

SYMBOLS (cont'd)

Subscripts (commonly used)

$()_c$ value at vortex core

$()_{ax}$ value at axis

$()_x$ differentiation with respect to x; similarly for y and z

Superscripts (commonly used)

$()'$ differentiation with respect to independent variable

$(\bar{})$ complex conjugate

$(\overset{\circ}{})$ differentiation along arc

$()^*$ quantity in transformed Z^* -plane

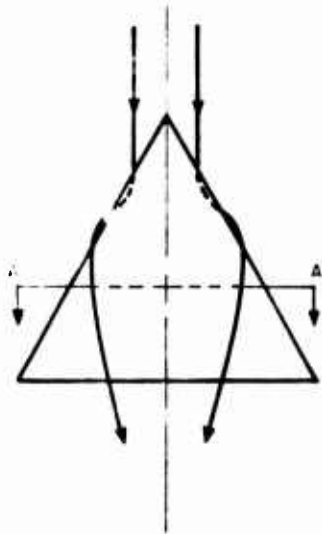

Elements of flow over a triangular wing having a rounded leading edge at high Reynolds numbers

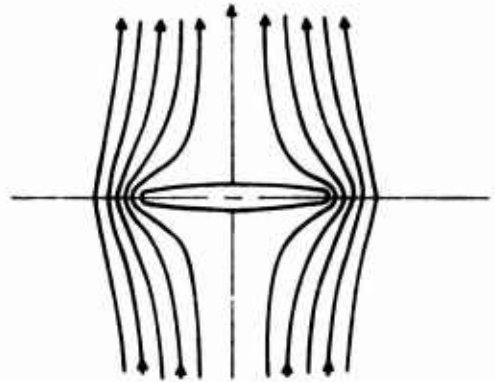

Elements of the vertical component of flow over section AA

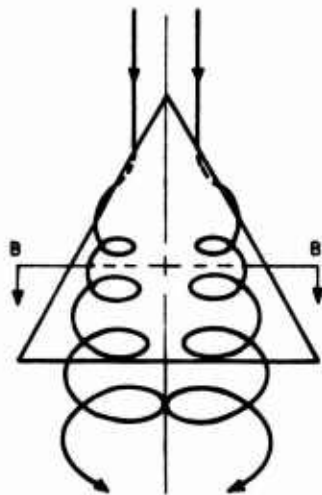

Elements of flow over a triangular wing at low Reynolds numbers or over a triangular wing having a sharp leading edge

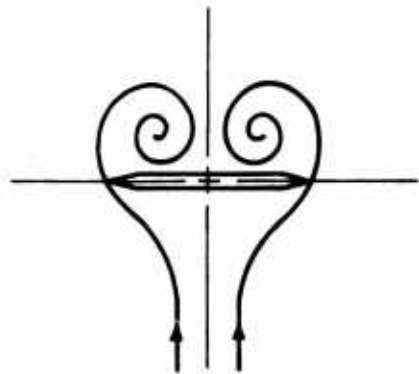

Elements of the vertical component of flow over section BB

Figure 1. Diagrams of the flow over triangular wings [after Wilson and Lovell (1947)].

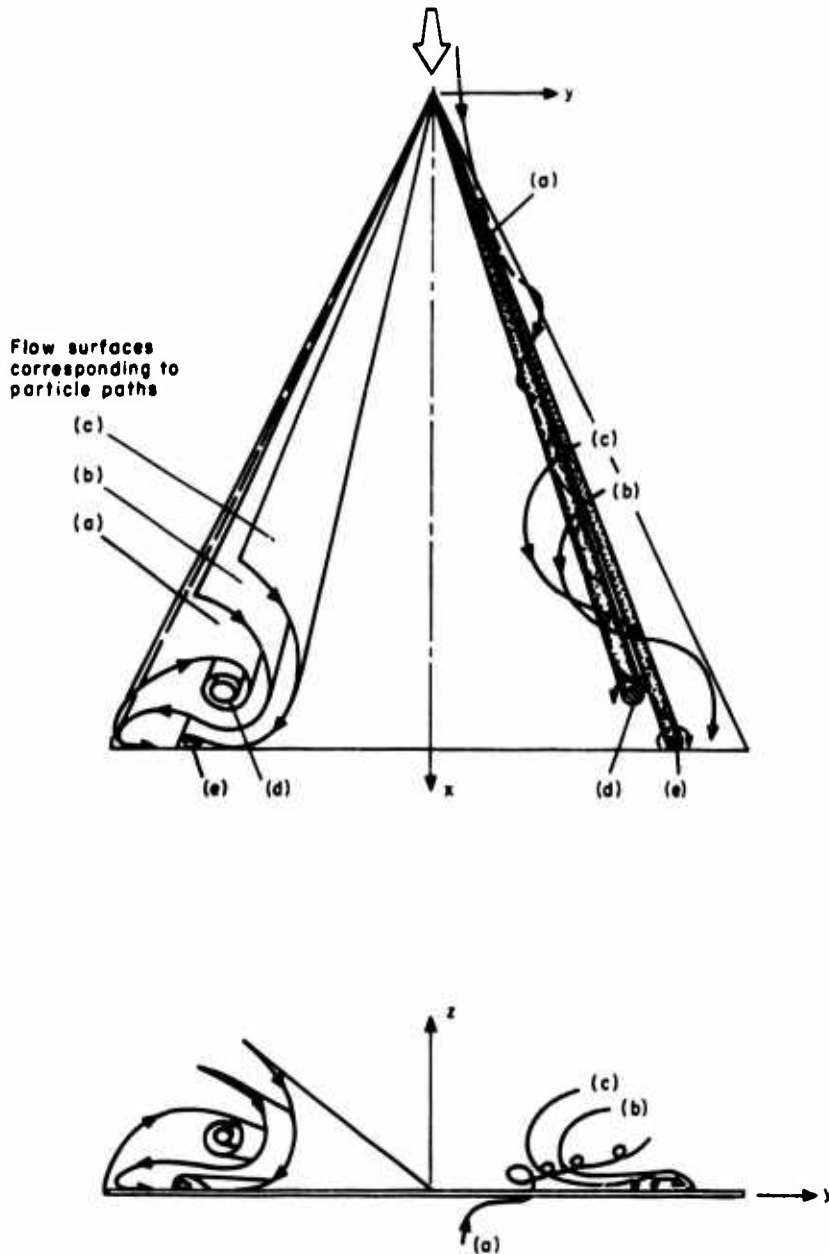

Figure 2. Schematic sketches showing the (suggested) flow on the suction side of the 70° flat plate delta wing at $\alpha \approx 15^\circ$ [after Ornberg (1954)].

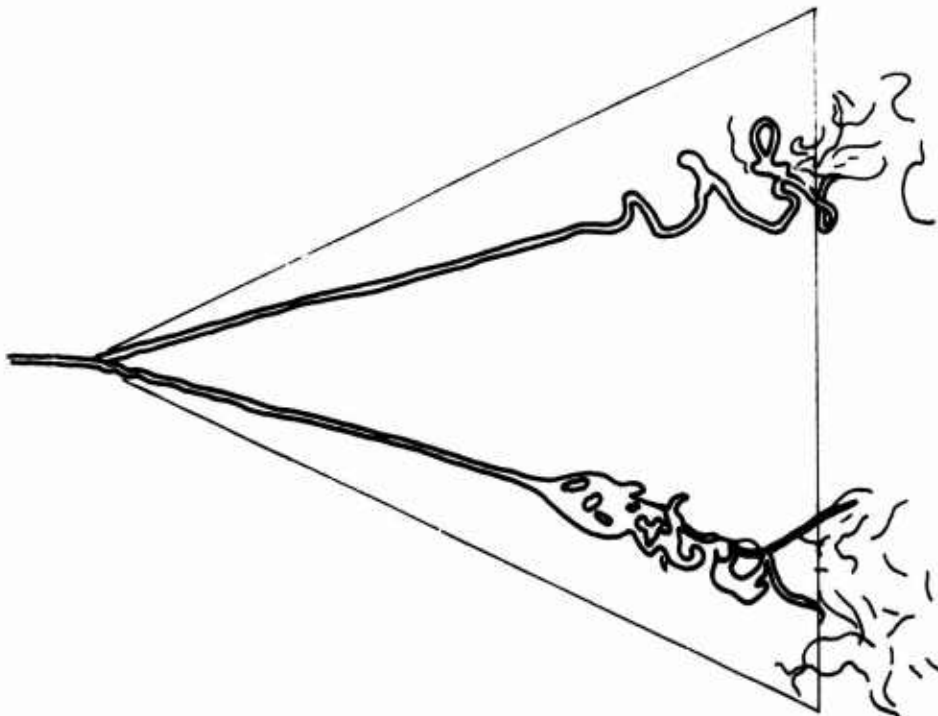

Figure 3. Axial filaments of dye [after Lambourne and Bryer (1961)].

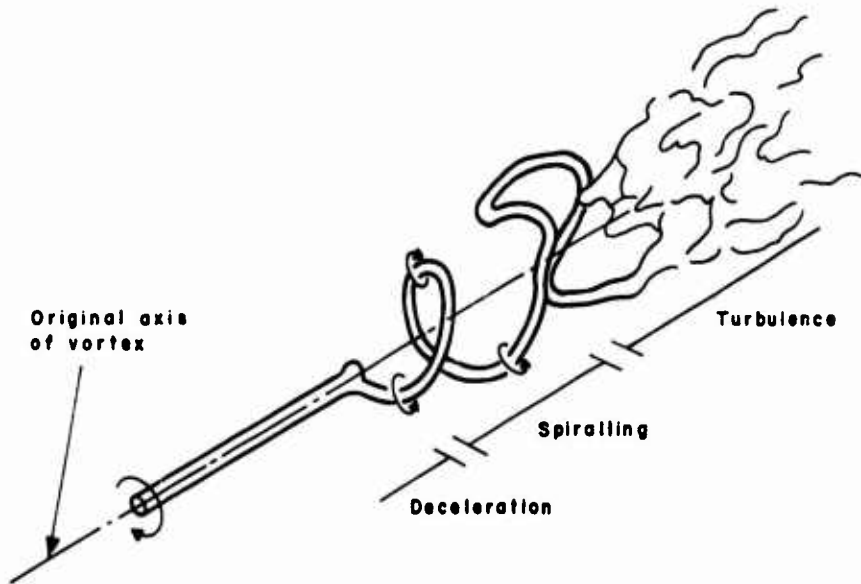

Figure 4. Stages in behaviour of axial filament [after Lambourne and Bryer (1961)].

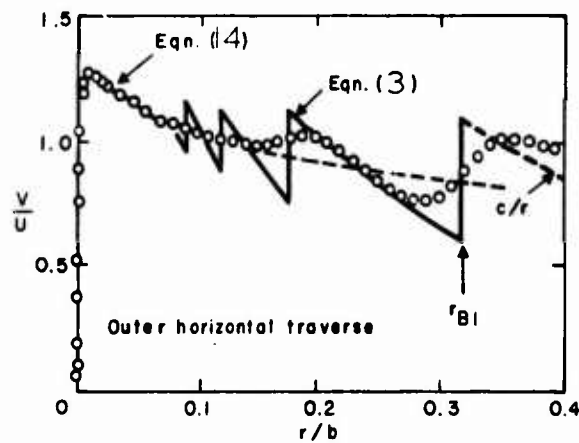
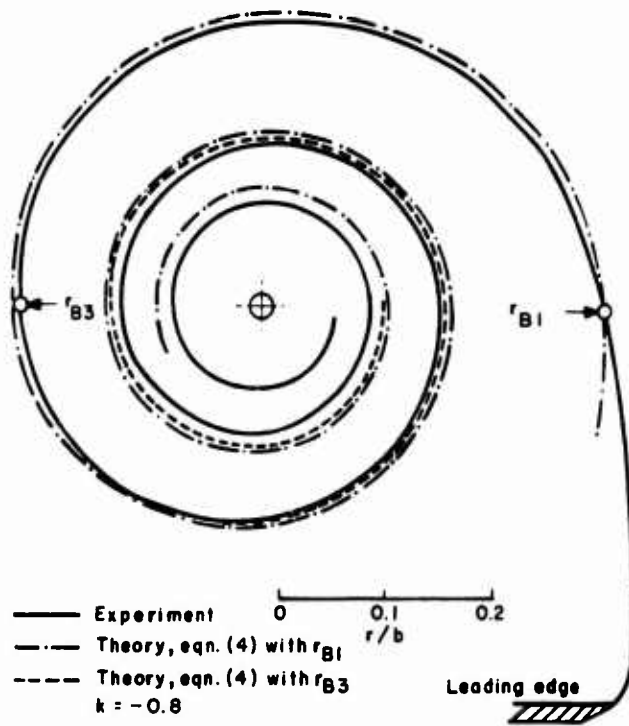

Figure 5. Vortex sheet shape (top) and azimuthal velocity (bottom) [after Küchemann and Weber (1965)].

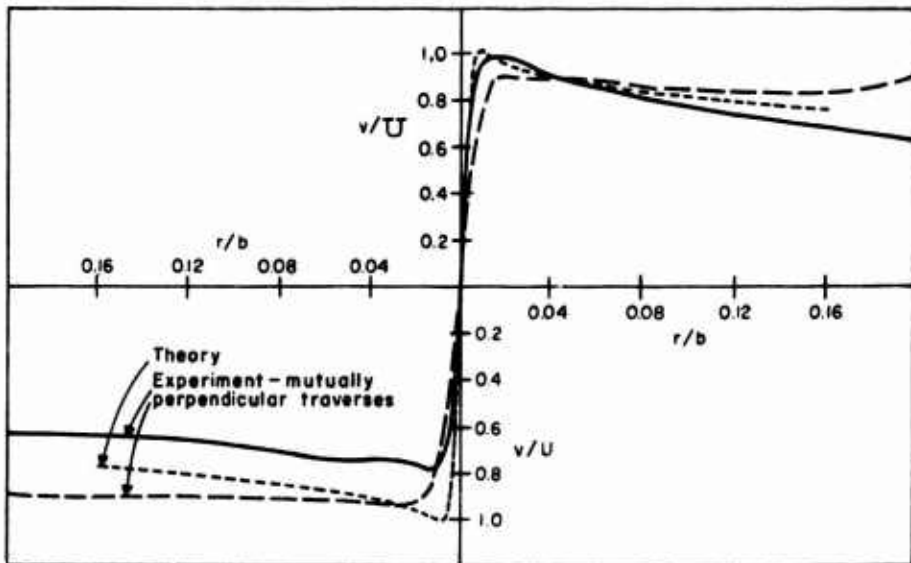
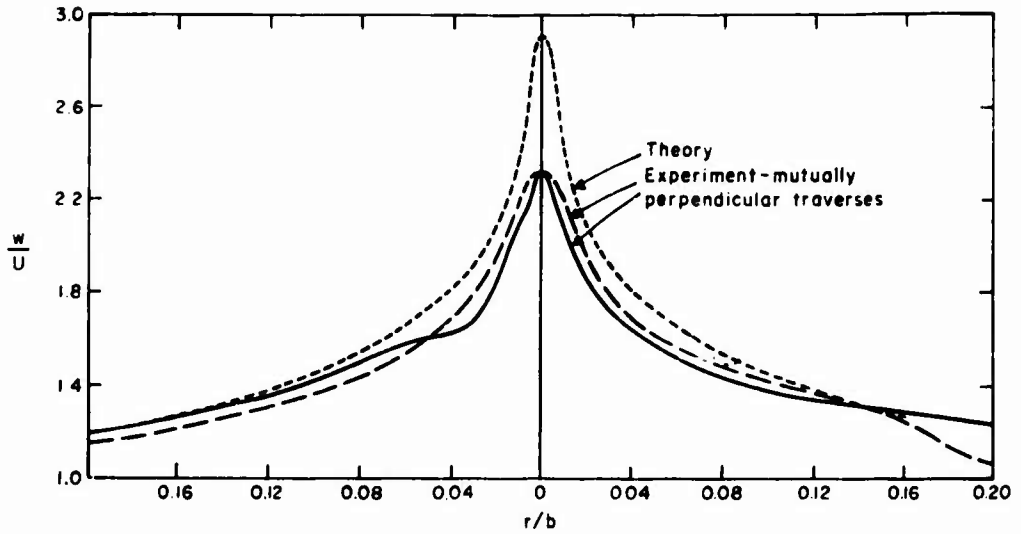

Figure 6. Experimental and theoretical profiles of axial (top) and circumferential velocity (bottom) [after Hall (1961)].

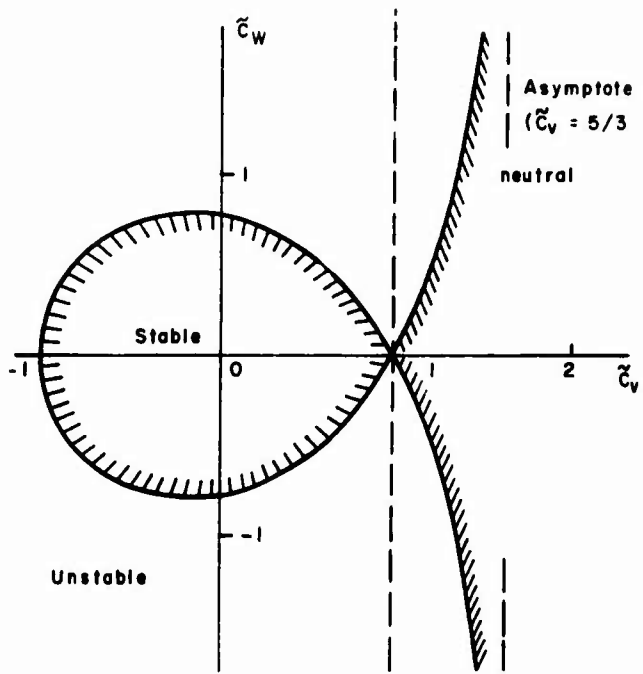

Figure 7. Stable and unstable regions in the $\tilde{\zeta}_w, \tilde{\zeta}_v$ Plane [after Ludwig (1961)].

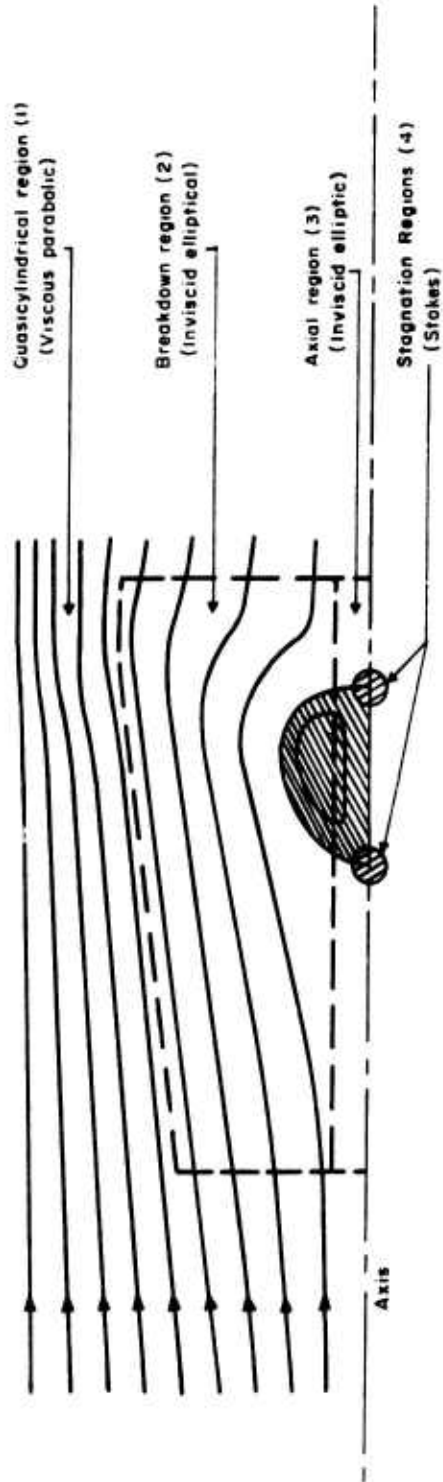

Figure 8. Vortex breakdown flowfield regions [after Bossel (1969)].

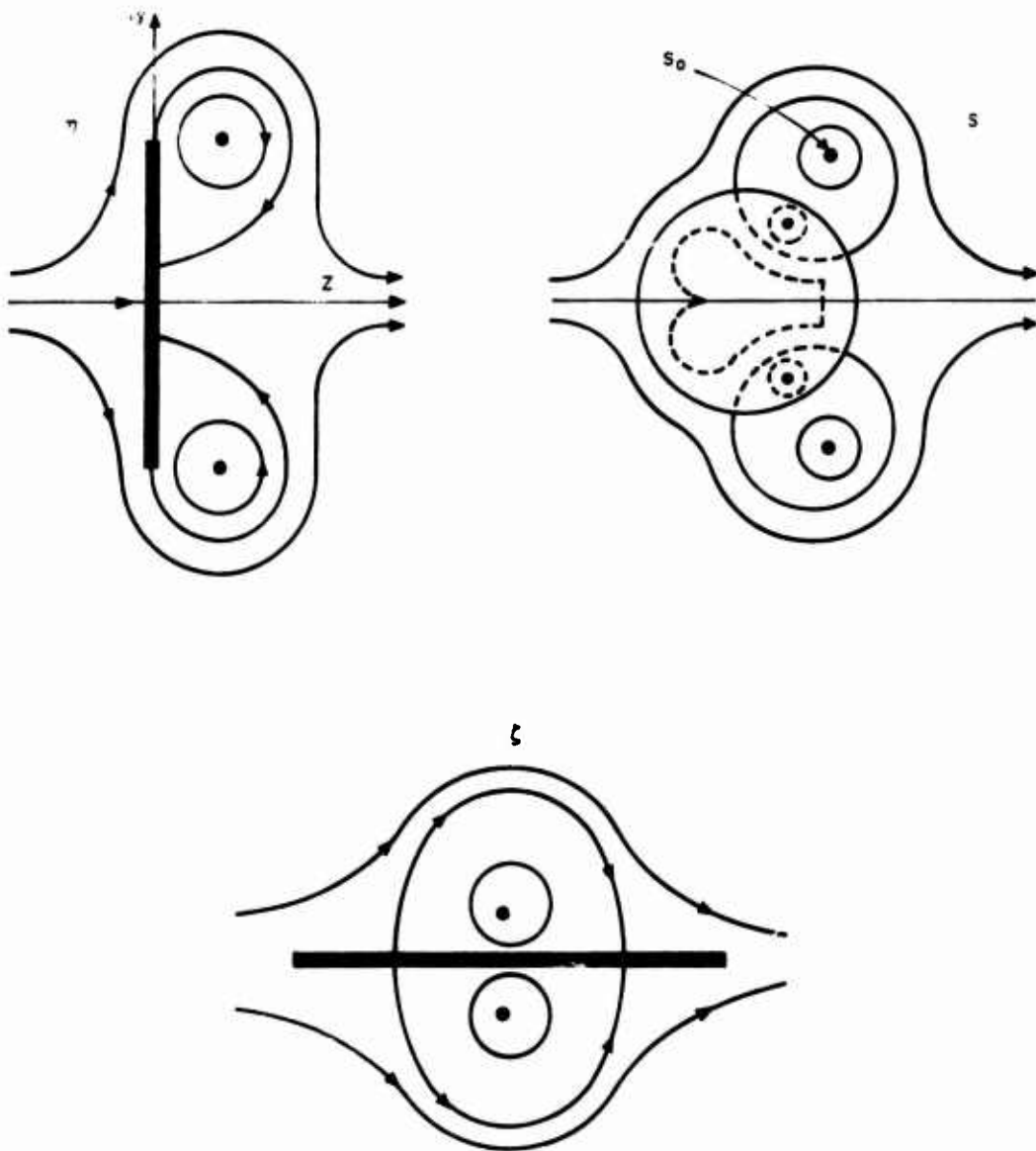

Figure 9. Coordinate systems for potential flow problem [after Legendre (1952)].

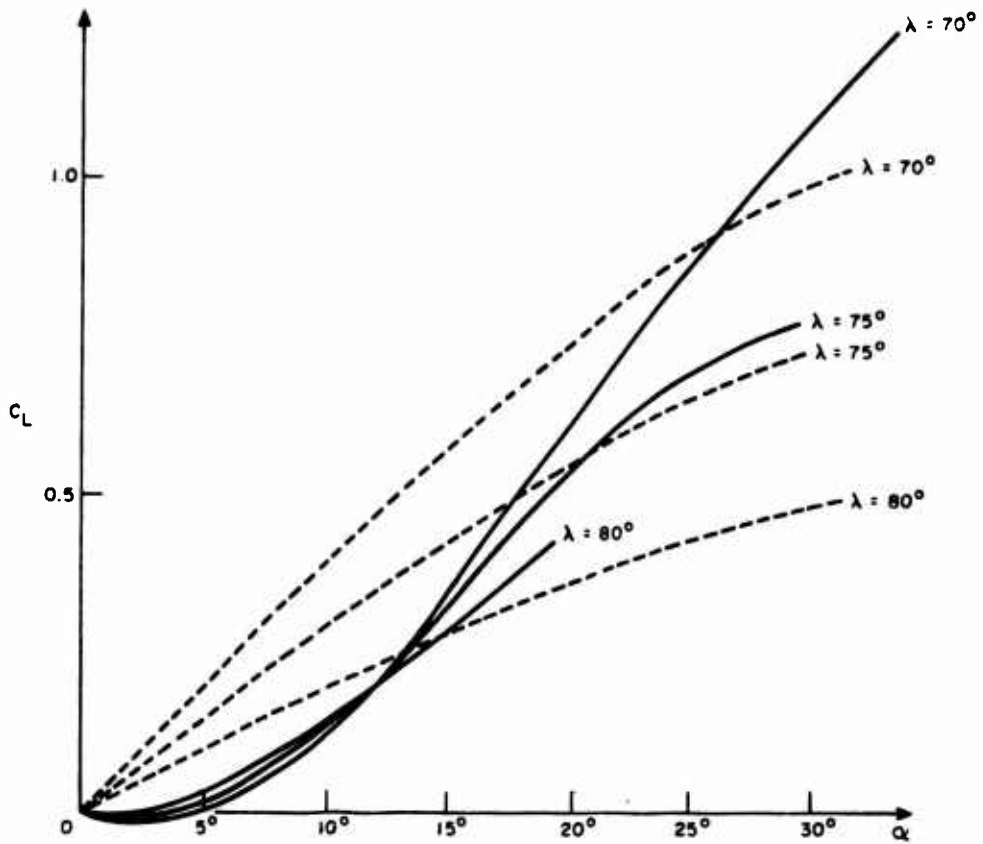

Figure 10. Lift curves for various sweep angles; dashed lines represent Jones result [after Legendre (1952)].

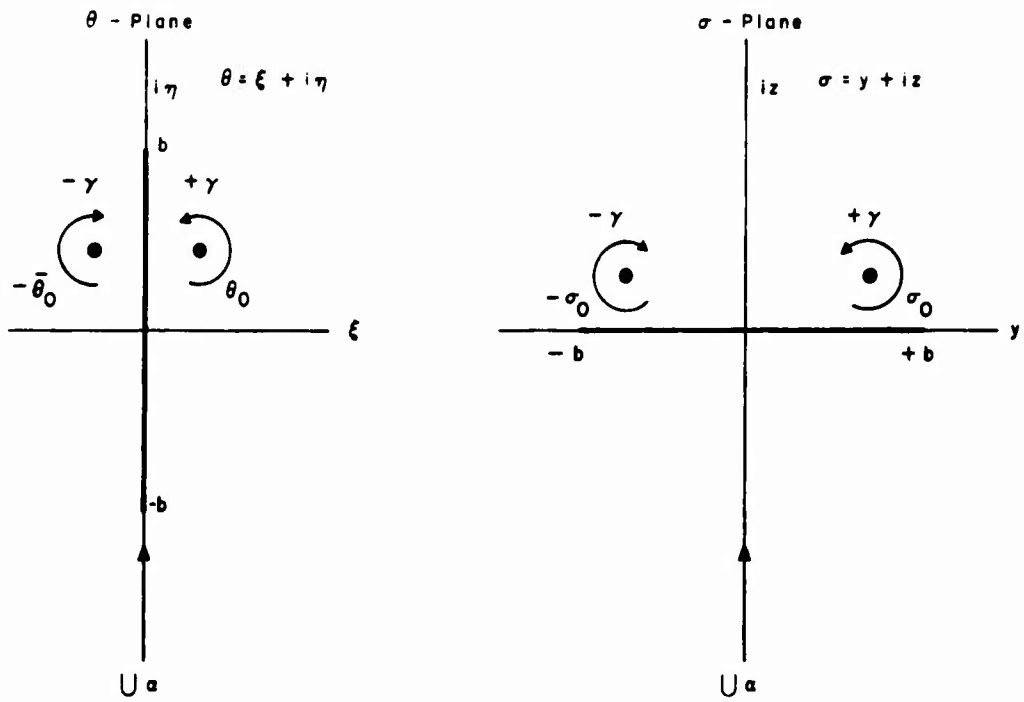

Figure 11. Coordinate system notation [after Brown and Michael (1954)].

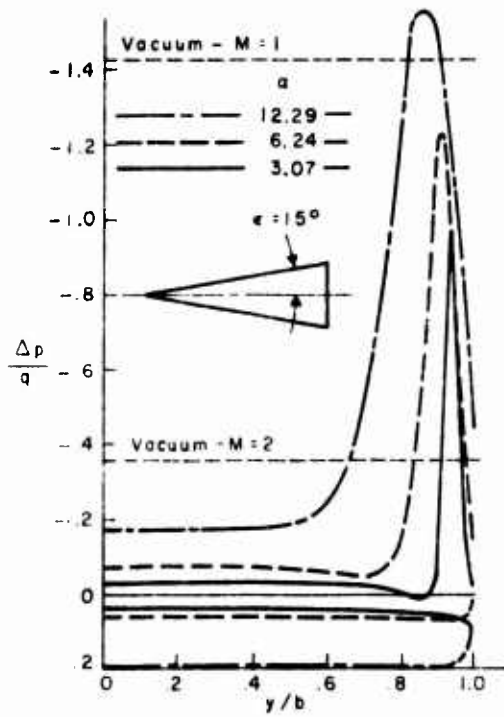

Figure 12. Pressure distributions [after Brown and Michael (1954)].

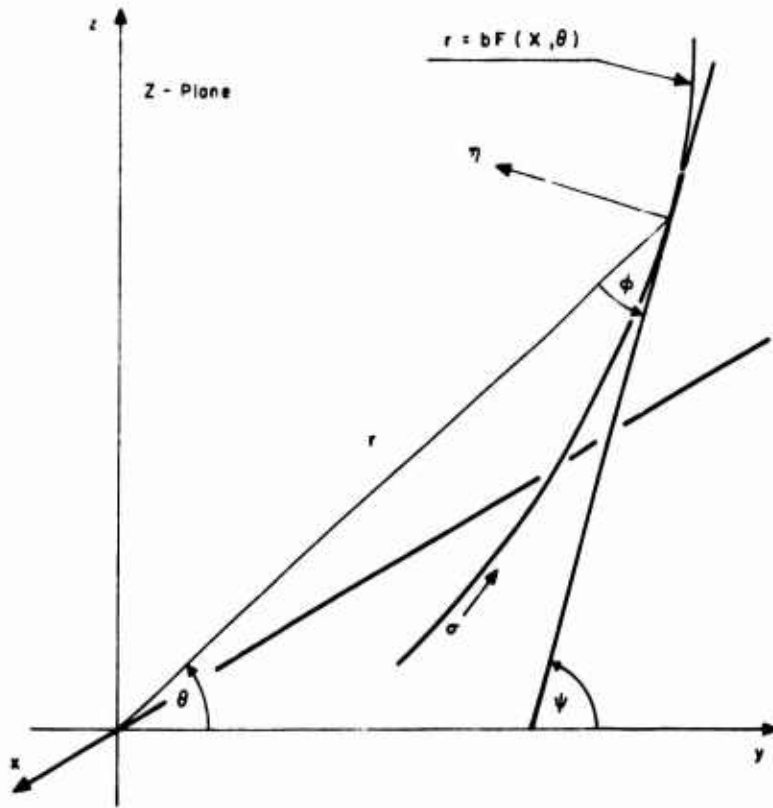

Figure 13. Coordinates for cross-section [after Mangler and Smith (1957)].

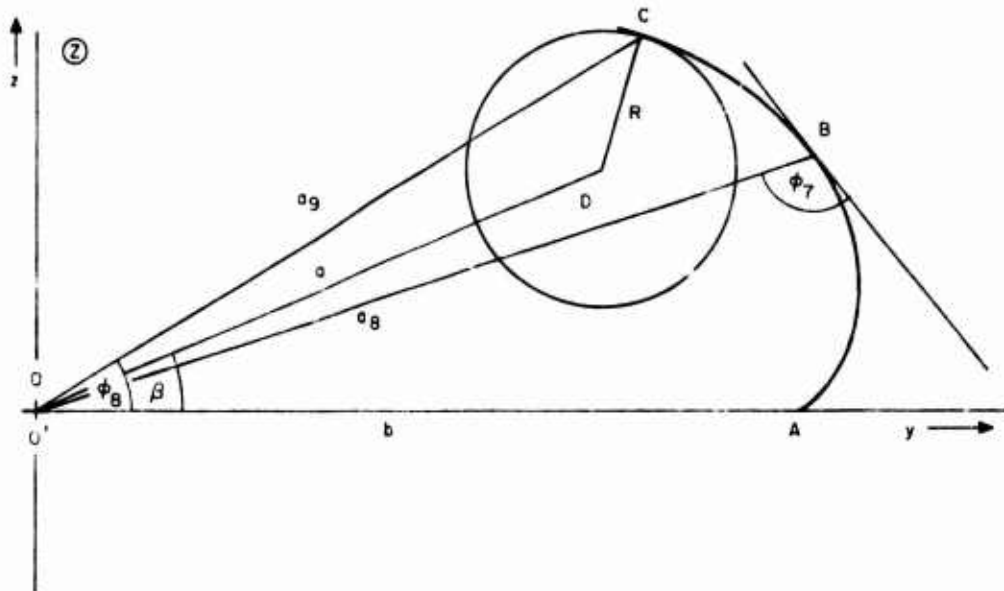

Figure 14. Approximation to vortex sheet [after Mangler and Smith (1957)].

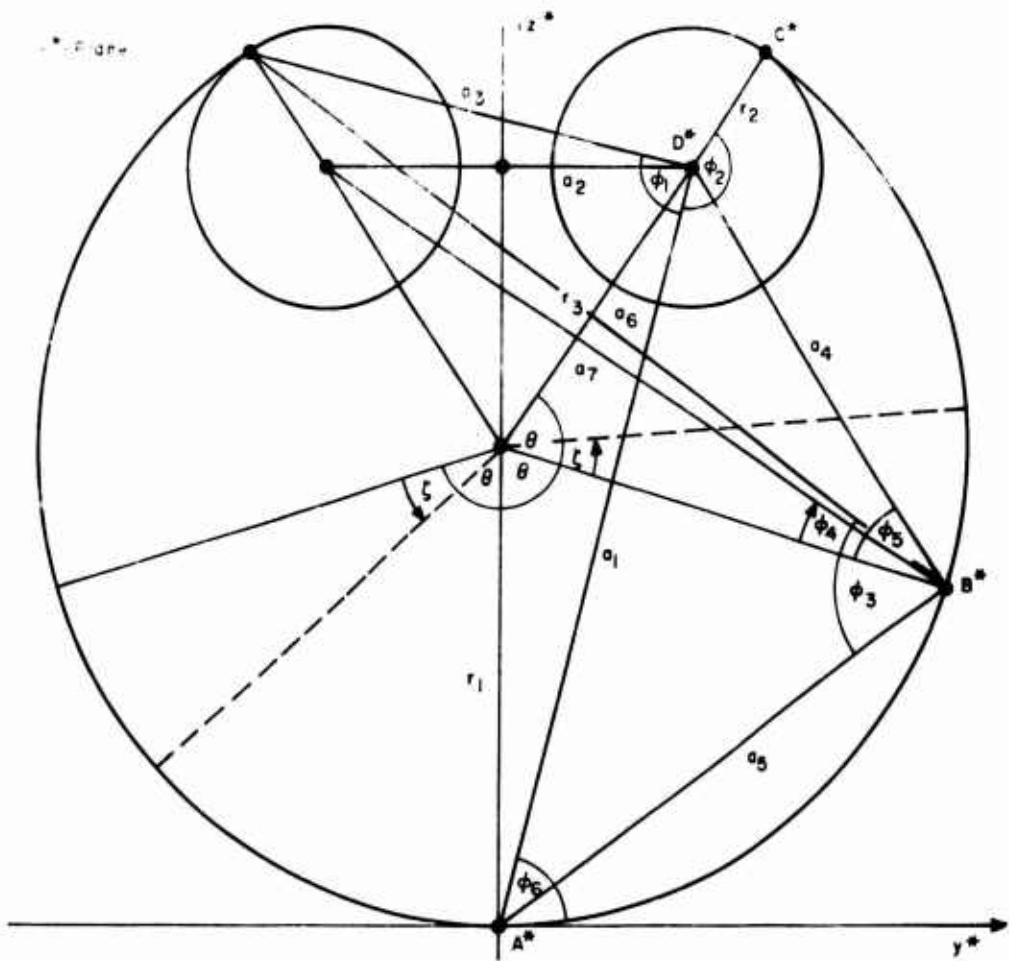

Figure 15. Notation in transformed plane [after Mangler and Smith (1957)].

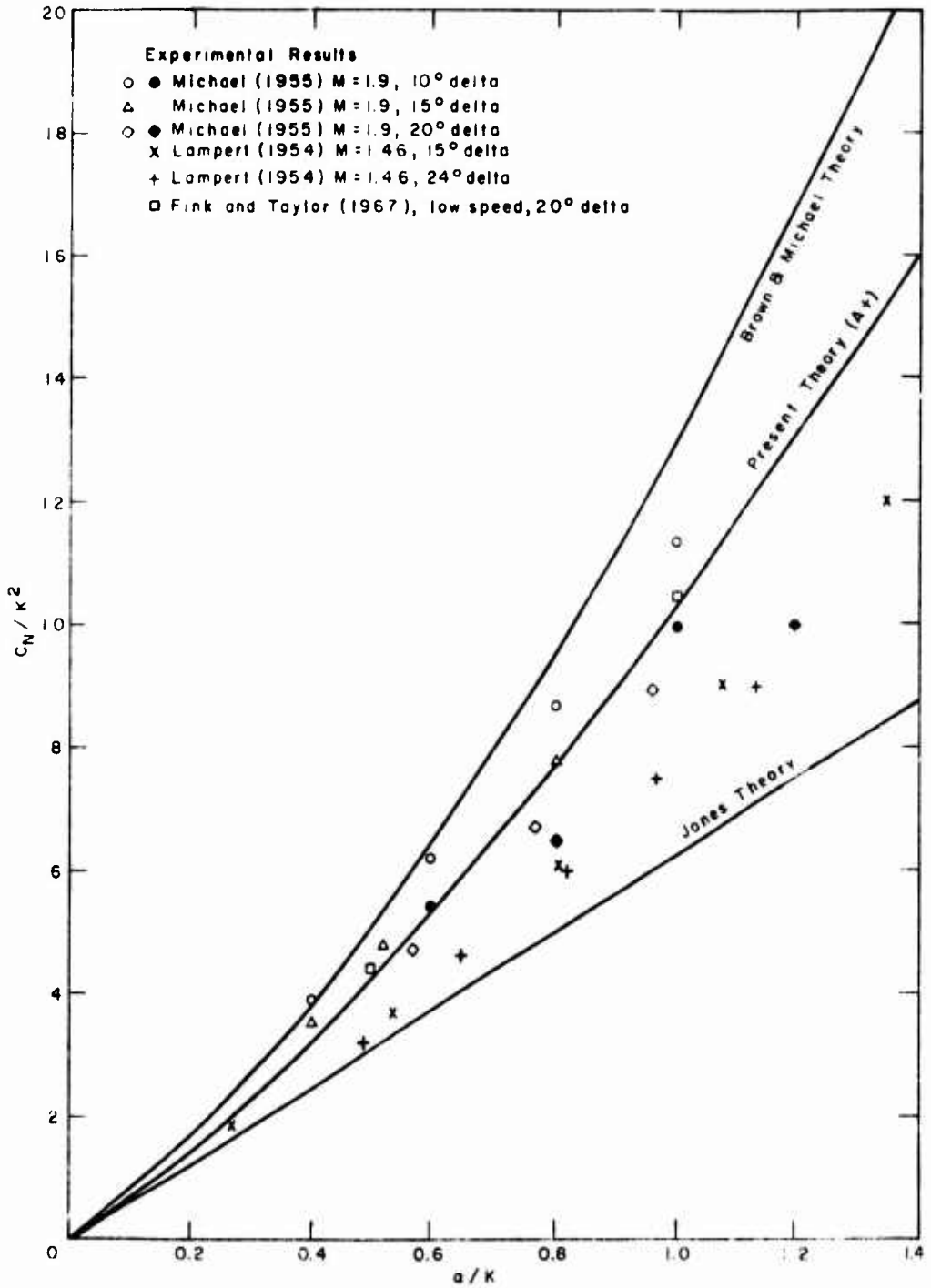

Figure 16. C_N / K^2 Theory and experiment [after Mangler and Smith (1957)].

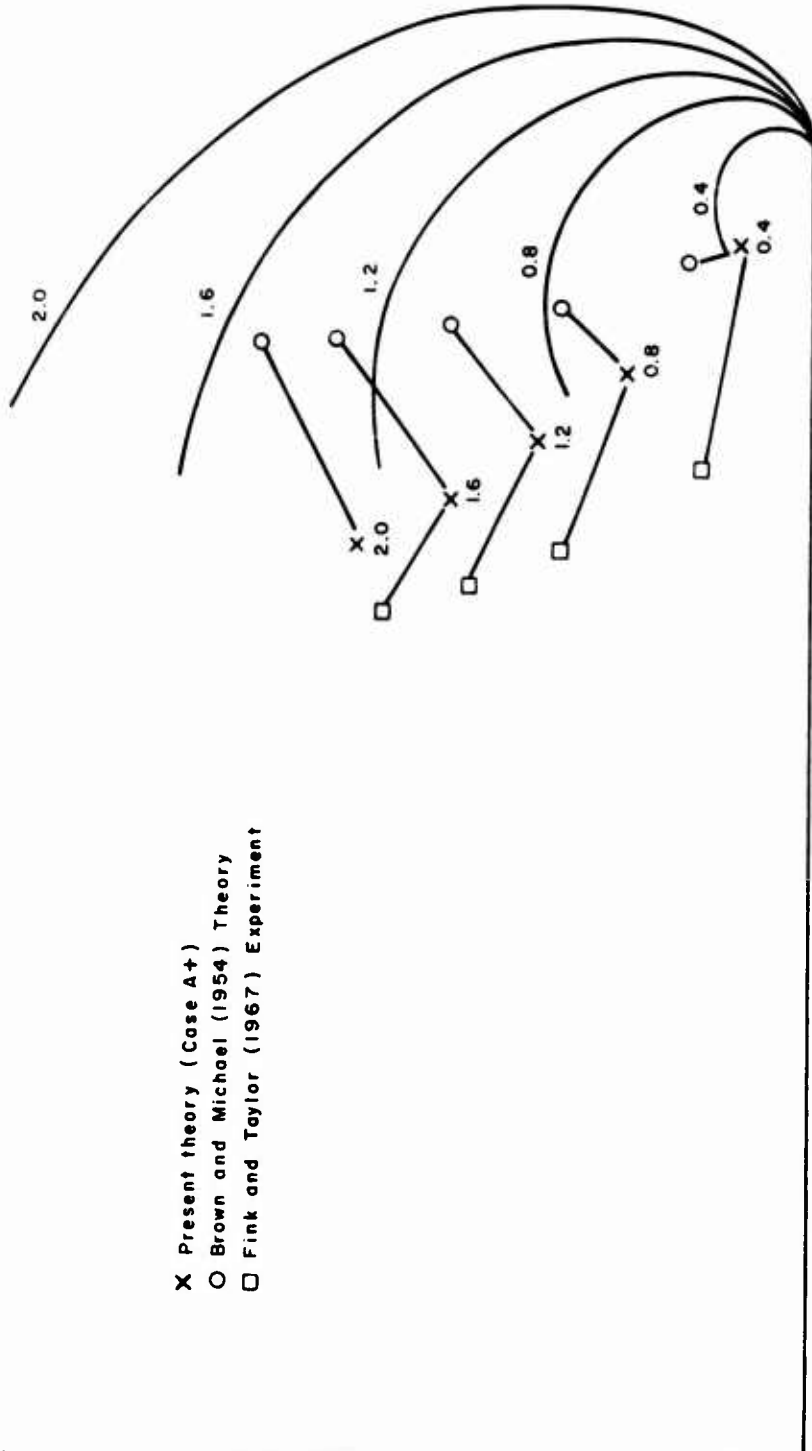

Figure 17. Shape of vortex sheet and position of core center for $a/K=0.4, 0.8, 1.2, 1.6, 2.0$ [after Mangler and Smith (1957)].

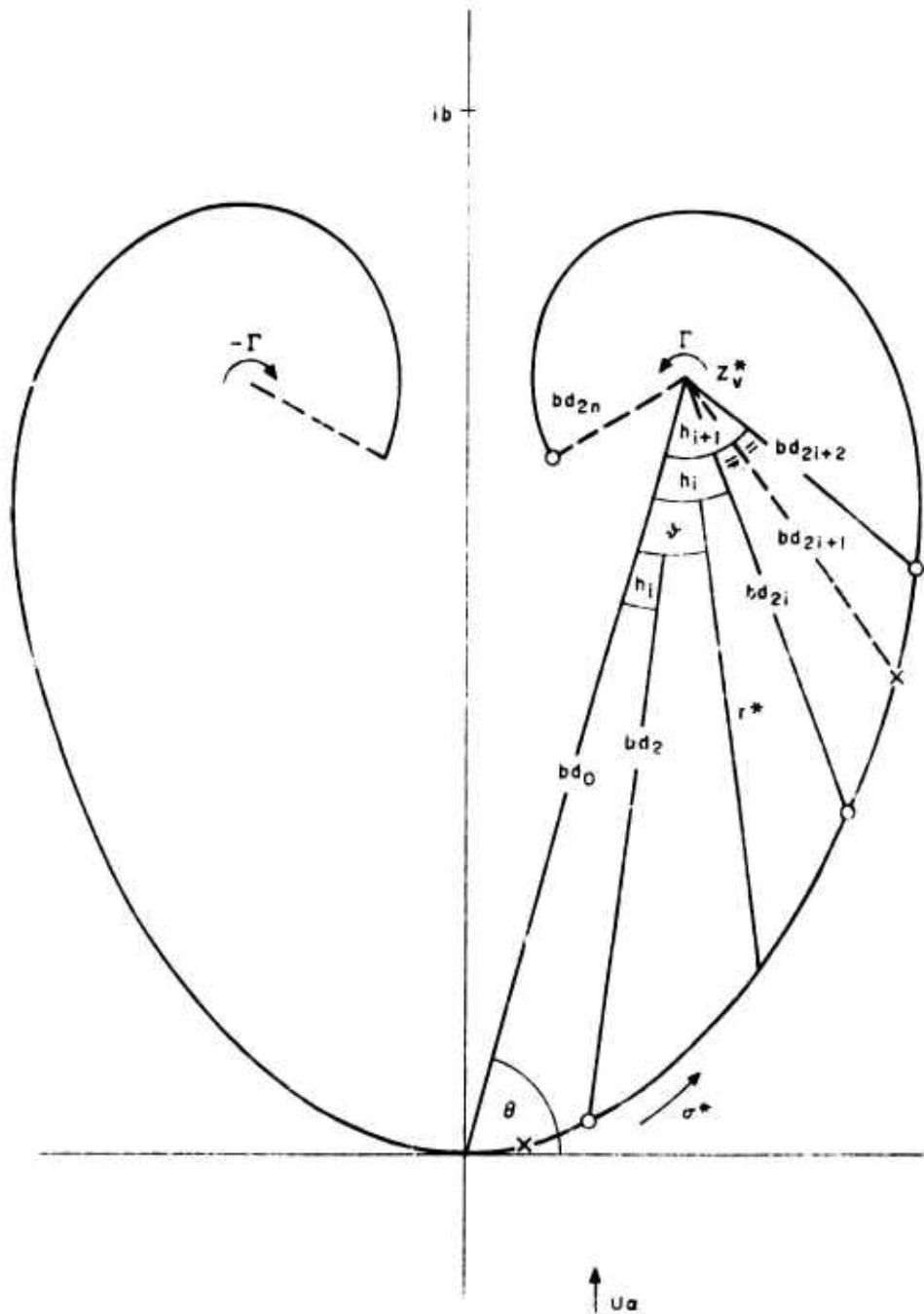

Figure 1B. Configuration in transformed plane, $Z^* = y^* + iz^*$
 \circ , Pivotal points; \times , intermediate points. [after Smith (1960)].

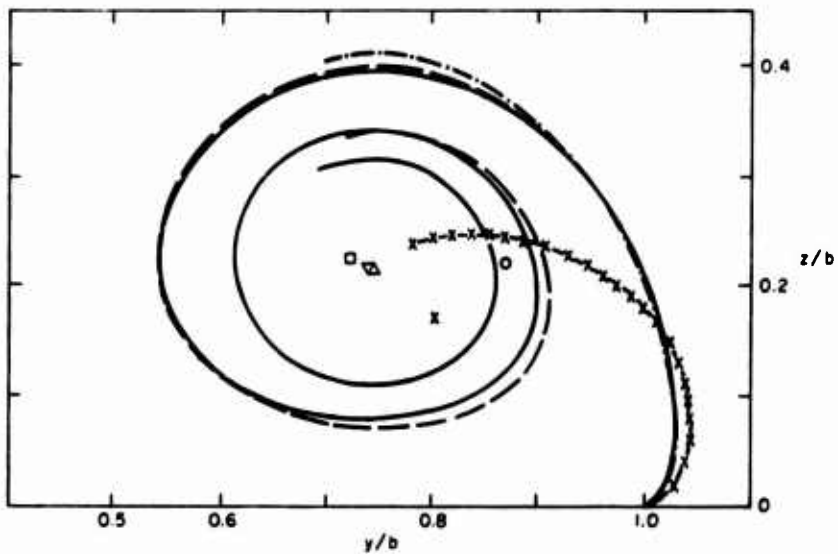

Figure 19. Vortex sheet shapes and isolated vortex positions for $a = 0.91$.
 o, Brown & Michael (1954); x and —x—, Mangler & Smith (1959);
 □ and —□—, present calculation, $n = 14$; Δ and —Δ—, present
 calculation, $n = 21$; ▽ and —▽—, present calculation, $n = 39$ [after
 Smith (1968)].

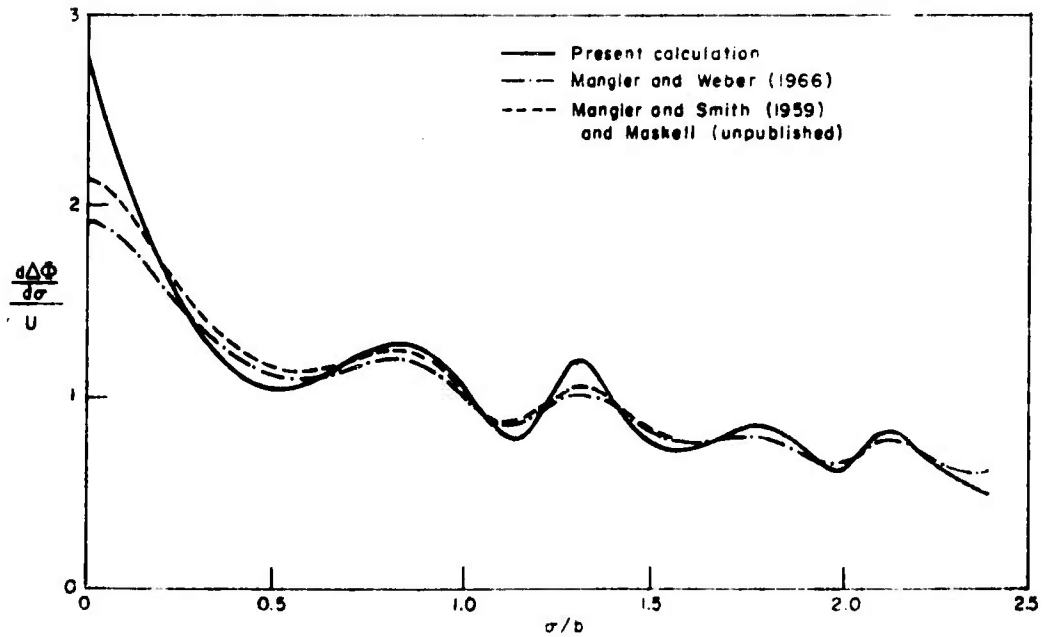
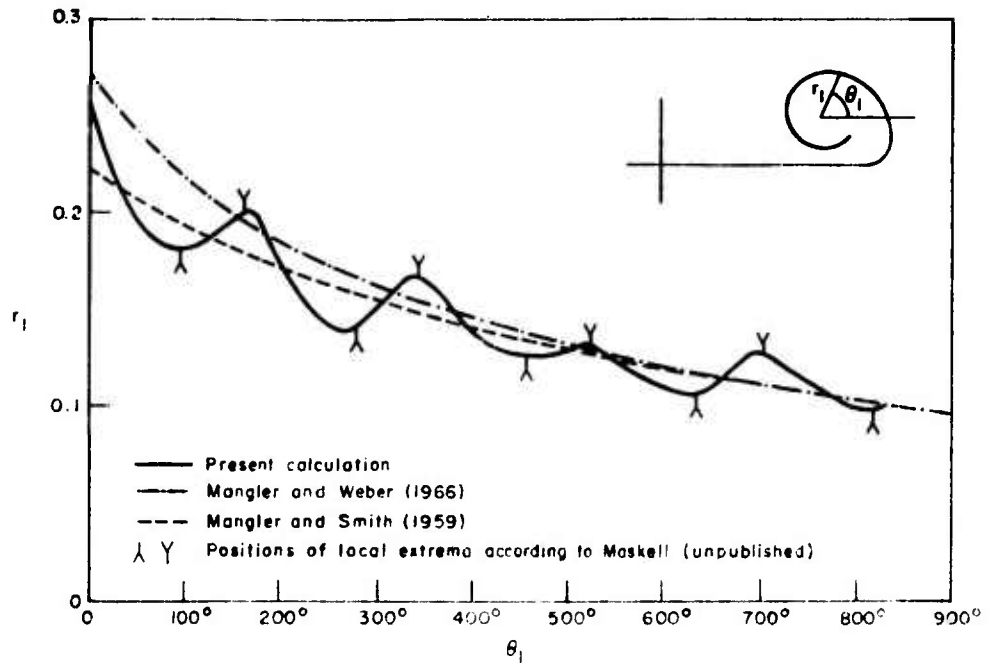

Figure 20. Sheet shape (top) and sheet strength (bottom) compared with asymptotic solutions, $a = .91$, $n = 39$ [after Smith (1965a)].

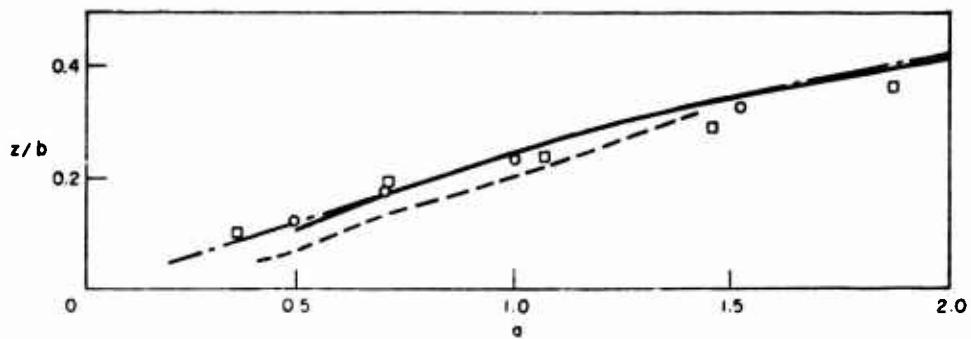
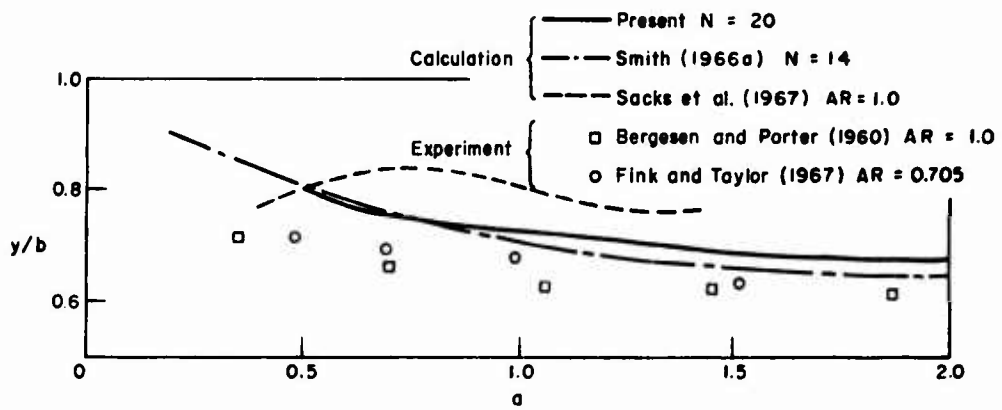
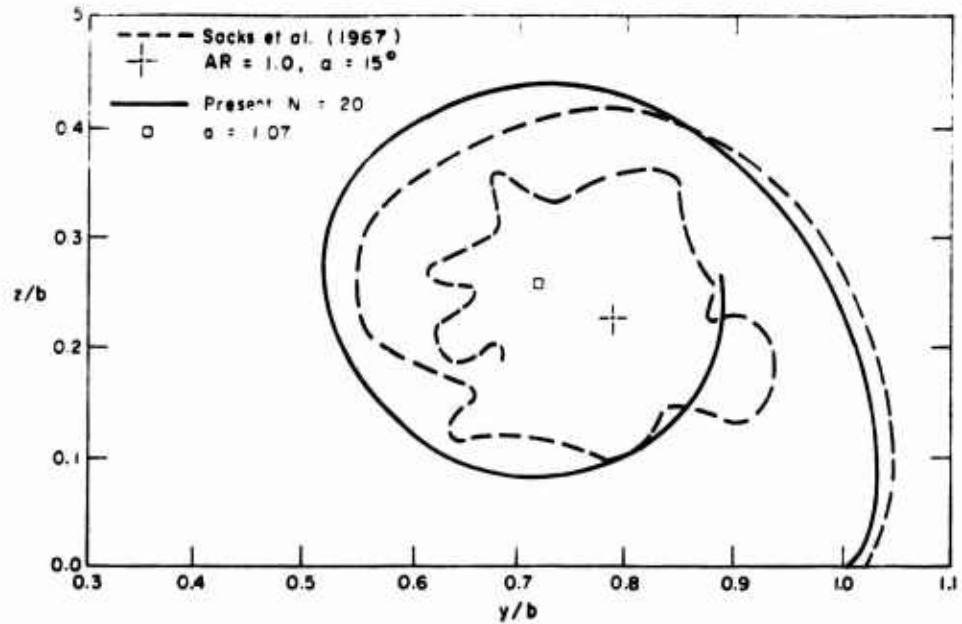

Figure 21. Vortex sheet shape (top), horizontal (middle) and vertical (bottom) position of vortex center [after Pullin (1973)].

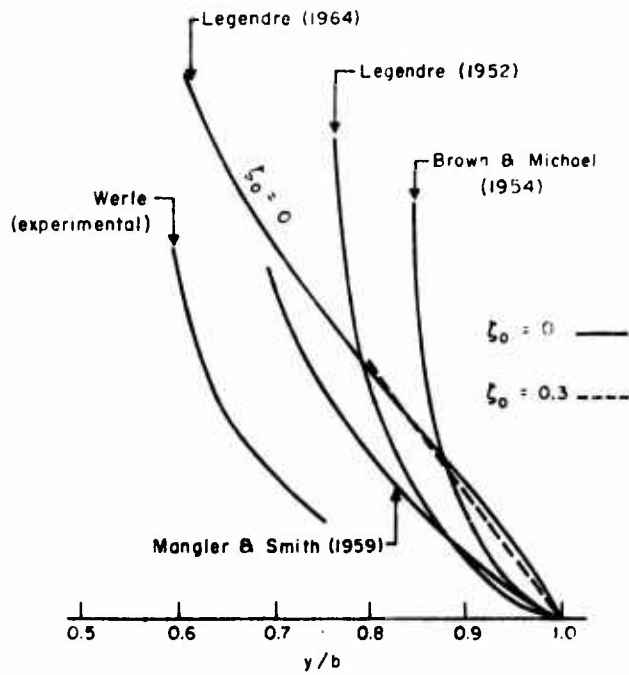

Figure 22. Vortex axis locus comparison of theories with test results [after Legendre (1966)].

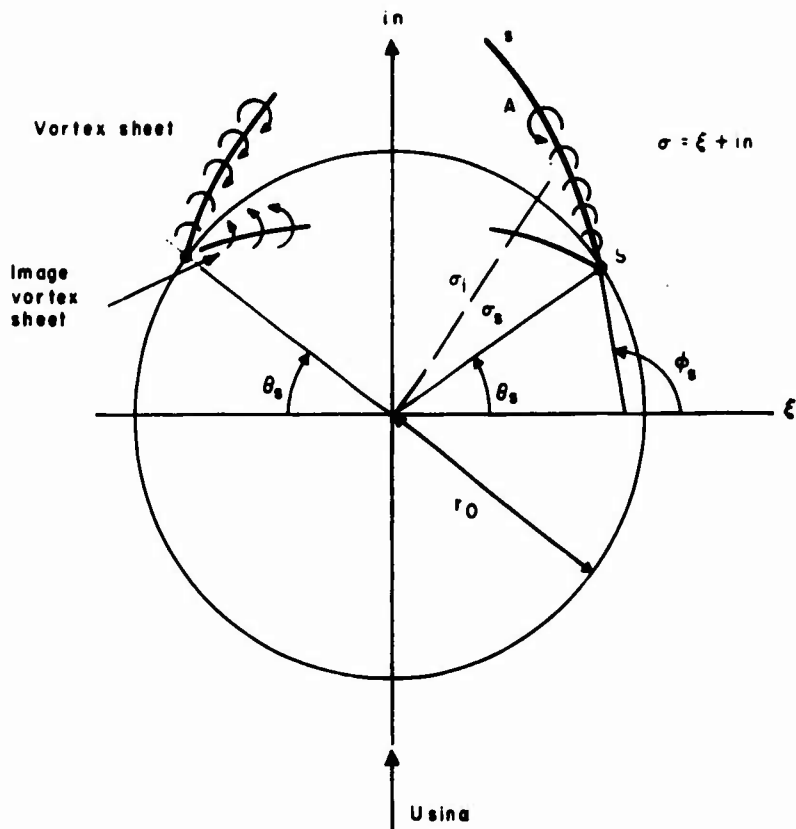

Figure 23. Mathematical model of vortex separation on a 3-D body [after Angelucci (1971)].

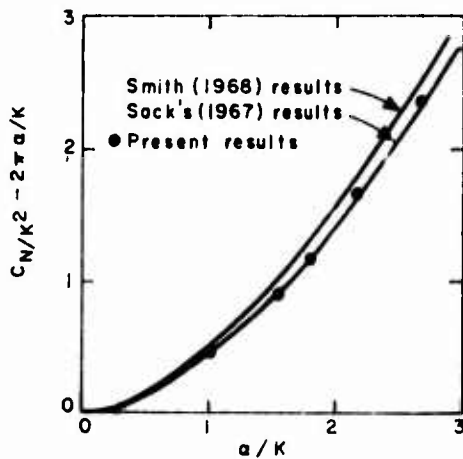
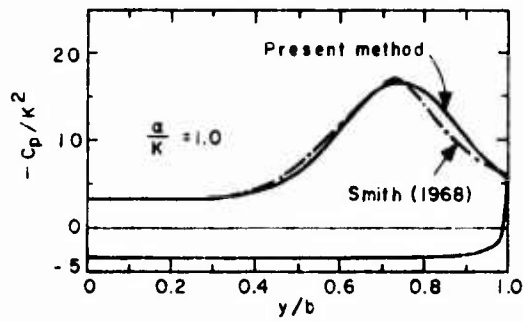
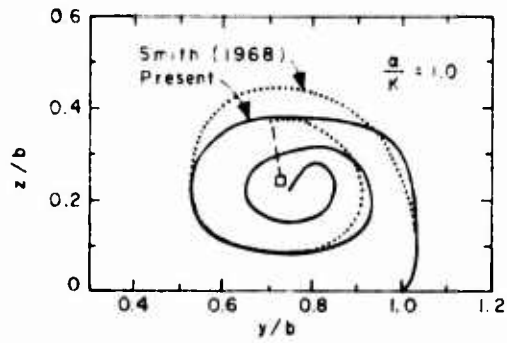

Figure 24. Vortex sheet (top), pressure coefficient (middle) and non-linear normal force increment (bottom) [after Fink and Soh (1974)].

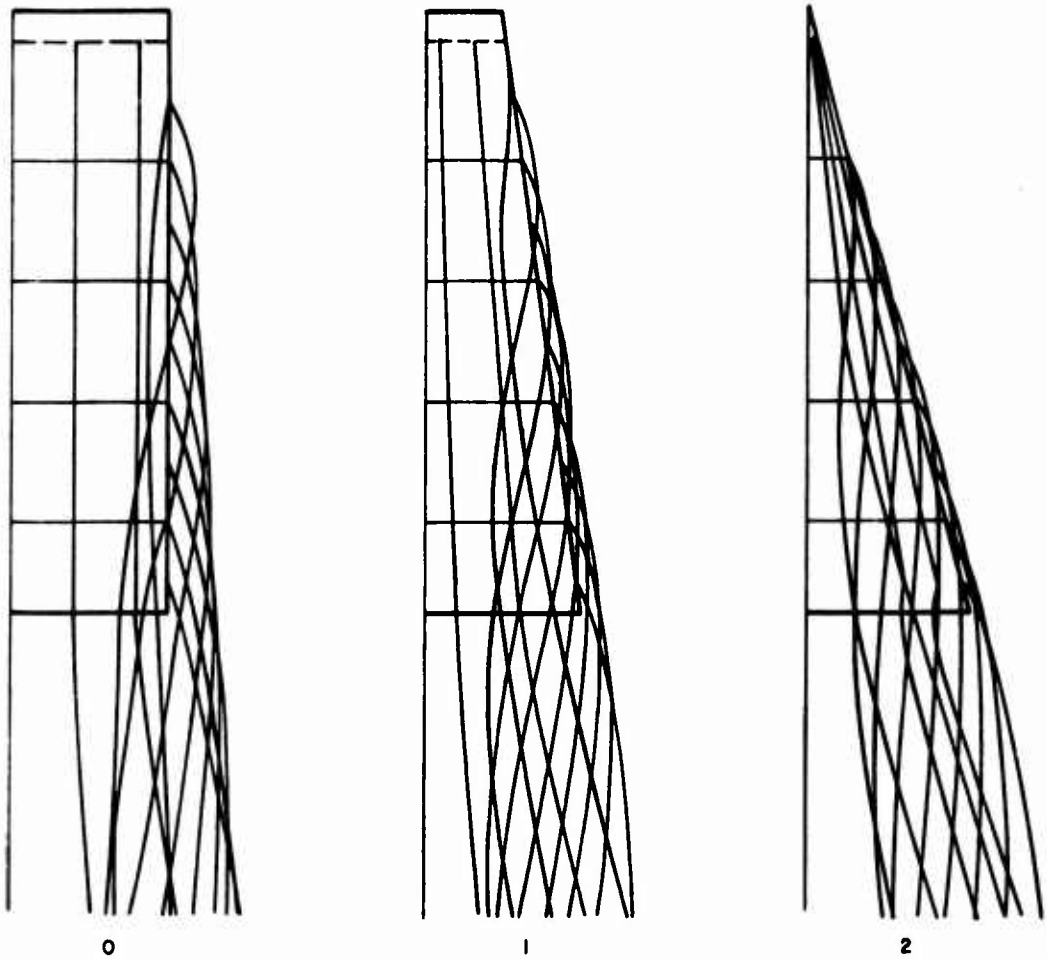

Figure 25. Calculation for a delta wing with leading-edge separation by progressive deformation of a rectangular wing [after Rehbach (1973b)].

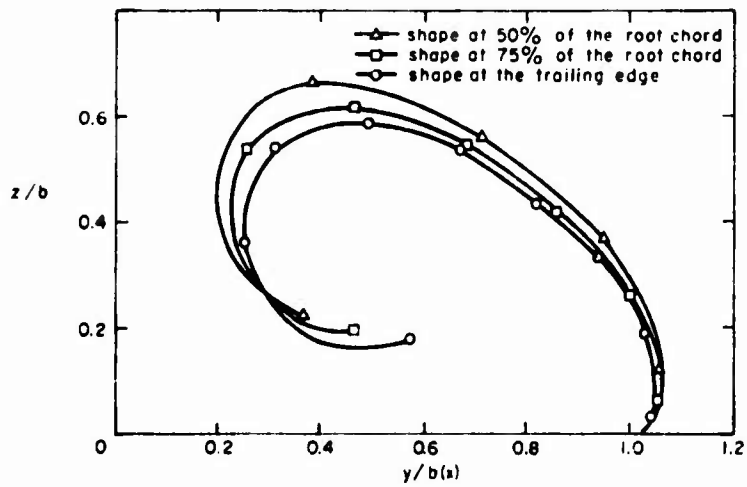

Figure 26. Verification of conicality of the flow [after Rehbach (1973b)].

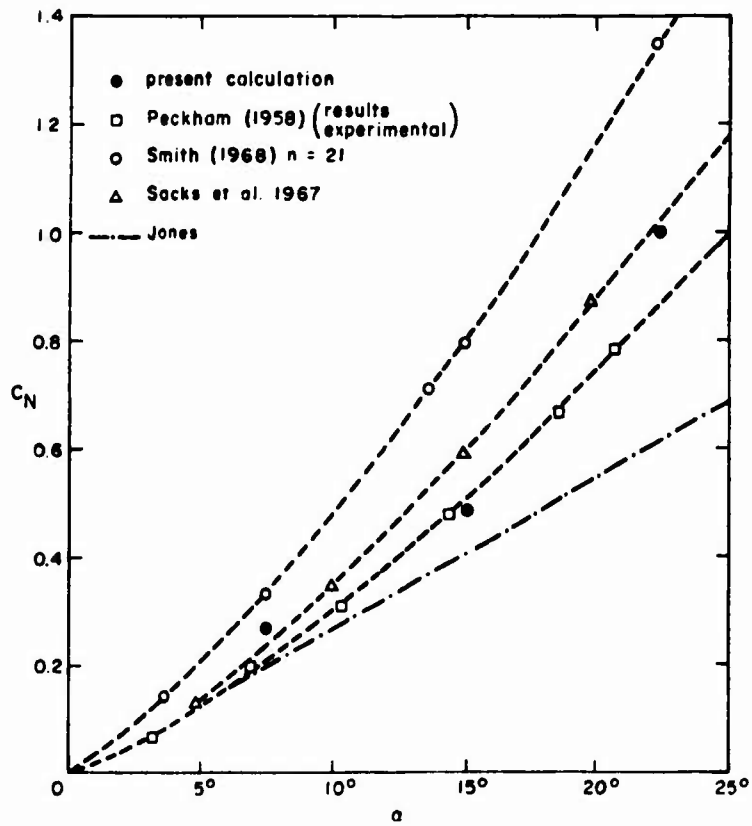
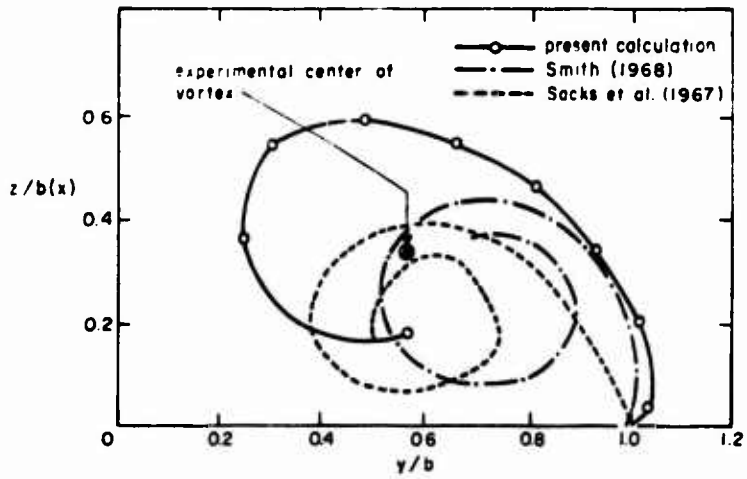

Figure 27. Vortex sheet at the trailing edge (top) and normal force coefficient (bottom) [after Rehbach (1973b)].

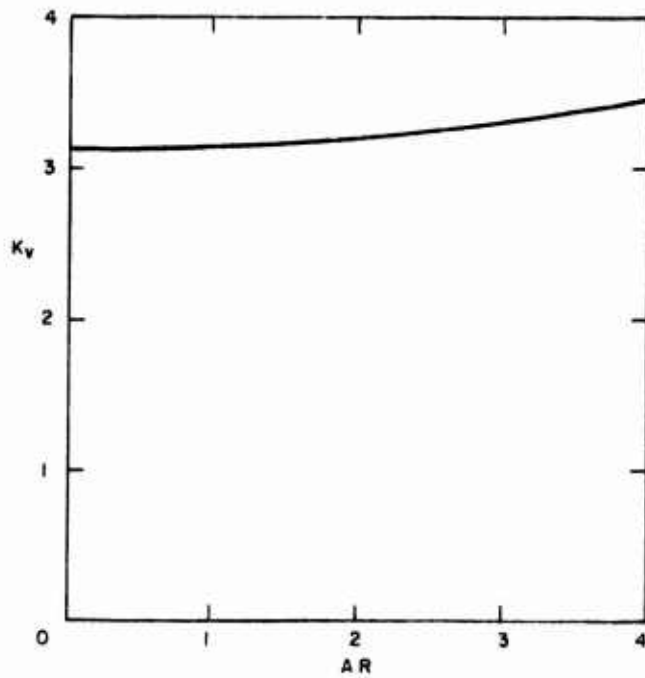
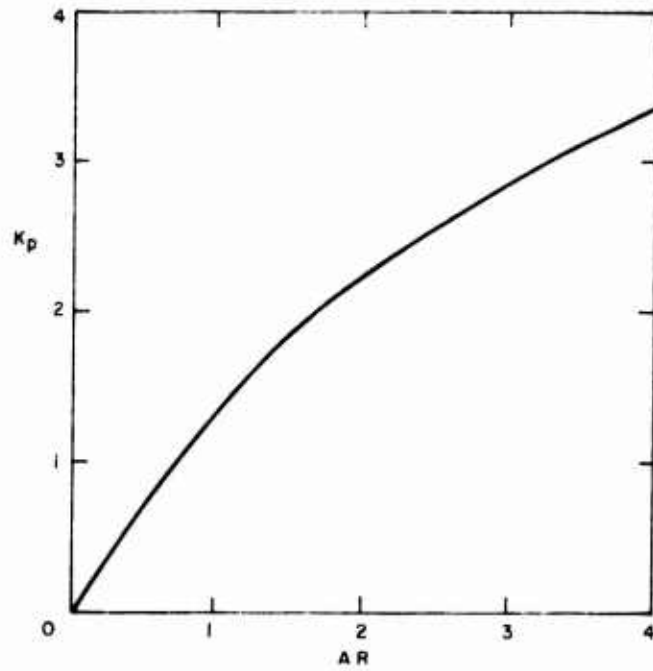

Figure 28. Variation of K_p (top) and K_v (bottom) with aspect ratio [after Polhamus (1966)].

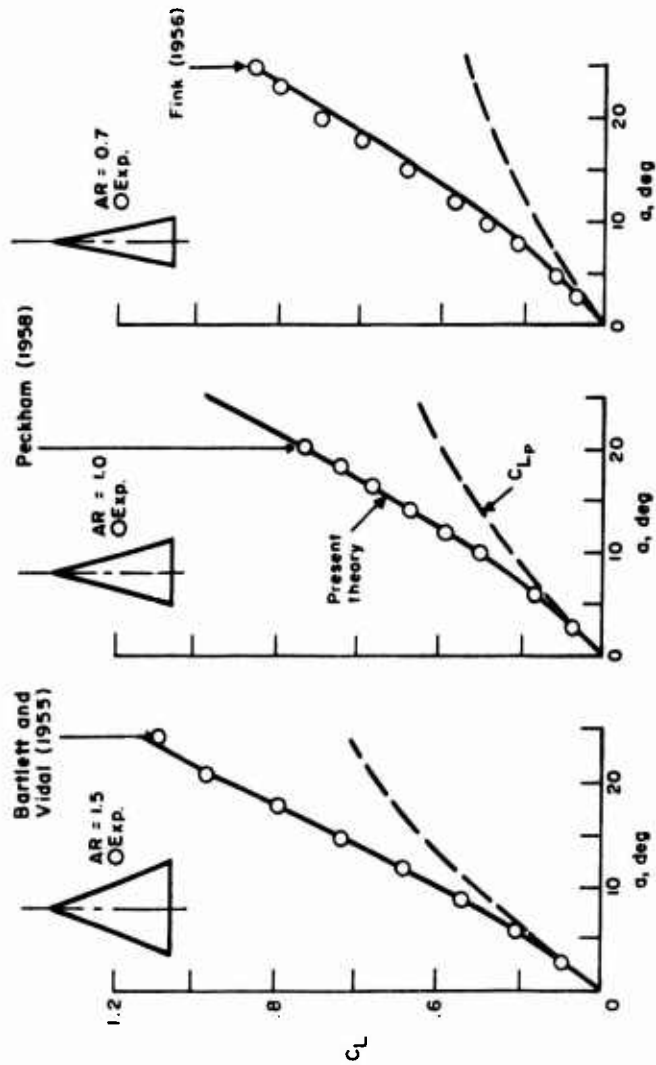

Figure 29. Comparison of present theory with experimental lift of delta wings [after Polhamus (1971)].