

THE EFFECTS OF PERSONAL PROTECTIVE EQUIPMENT UPON THE ARM-REACH CAPABILITY OF USAF PILOTS

MR. MILTON ALEXANDER
USAF AEROSPACE MEDICAL RESEARCH LABORATORY
DR. LLOYD L. LAUBACH
WEBB ASSOCIATES

Abstract: *The lack of published arm-reach data on Air Force flight personnel in actual cockpit situations presents manifest difficulties to the cockpit layout specialist. This paper discusses the results of a study to determine the arm-reach capabilities of aircrewmembers wearing heavy winter flight clothing, survival equipment, and restraint harnesses.*

The study was conducted at Loring AFB, Maine. The sample consisted of 16 male subjects (currently active Air Defense Command pilots). The subjects were selected to approximate closely the various height-weight categories in the ADC flying population. A specially designed apparatus was constructed to measure arm-reach capability. Each subject was measured under four conditions: (1) shirt-sleeved with the inertial reel unlocked, (2) shirt-sleeved with the inertial reel locked, (3) wearing his full assembly of flying gear (hereafter referred to as maximum assembly) including the underarm life preserver and parachute harness with the inertial reel unlocked, and (4) wearing the maximum assembly with the inertial reel locked.

The results of the study indicated that there are significant differences in arm-reach capability of pilots while in the shirt-sleeved and maximum flying assembly conditions throughout most of the spatial envelope.

The lack of published arm-reach data on Air Force flight personnel in simulated cockpit situations presents manifest difficulties to the cockpit layout specialist. This paper will present results of a study that was designed to determine the arm-reach capabilities of USAF pilots wearing heavy winter flight clothing, survival equipment, and restraint harnesses. Obviously, such equipment and conditions do have an effect on the design of cockpits.

The study was conducted at Loring Air Force Base, Maine to assure acquisition of currently active USAF pilots flying operational missions for the Air Defense Command. The test sample was specifically chosen to simulate the various body-size categories of the Air Defense Command flight population. The sample consisted of 16 pilots whose mean age was 33.4 years, ranging from 25 to 46 years; mean height of 69.3 inches, ranging from 66.6 inches to 73.4 inches; and a mean weight of 179.2 pounds, ranging from 145 to 238 pounds.

The test apparatus, illustrated in Figure 1, was designed to measure the arm-reach capability of the subjects and is basically composed of three main components.

The *seat* (see a in Figure 1) is designed in accordance with Military Standard DH2-2, incorporating five inches adjustability, $\pm 2\frac{1}{2}$ inches from the neutral seat reference point along a 13° back

angle. It is equipped with adjustable shoulder restraint harnesses and lap belts which are standard equipment in many USAF cockpits.

The *overhead boom* (see b in Figure 1) is mounted above the seat and is anchored to the frame of the measuring apparatus. It rotates horizontally about an axis through the seat reference point. Its rotation covers an arc of 180° forward of the seat (90° to the right and 90° to the left of a vertical plane perpendicular to the seat pan and passing through the seat reference point to bisect the seat pan) with stops at 30° intervals. Located on the horizontal arm of the overhead boom is a measuring scale with its origin directly vertical to the seat reference point. This scale is graduated in $\frac{1}{4}$ -inch increments from zero inches to 54 inches.

The *vertical rod* (see c in Figure 1) is attached to the horizontal arm of the overhead boom and is capable of fore-aft movement. Standard control knobs are mounted on the vertical rod and are spaced six inches apart beginning six inches above the deck to a height of 60 inches.

An additional knob (see c' in Figure 1) is placed on a separate but corresponding vertical arm at a height of 63 inches above the deck.

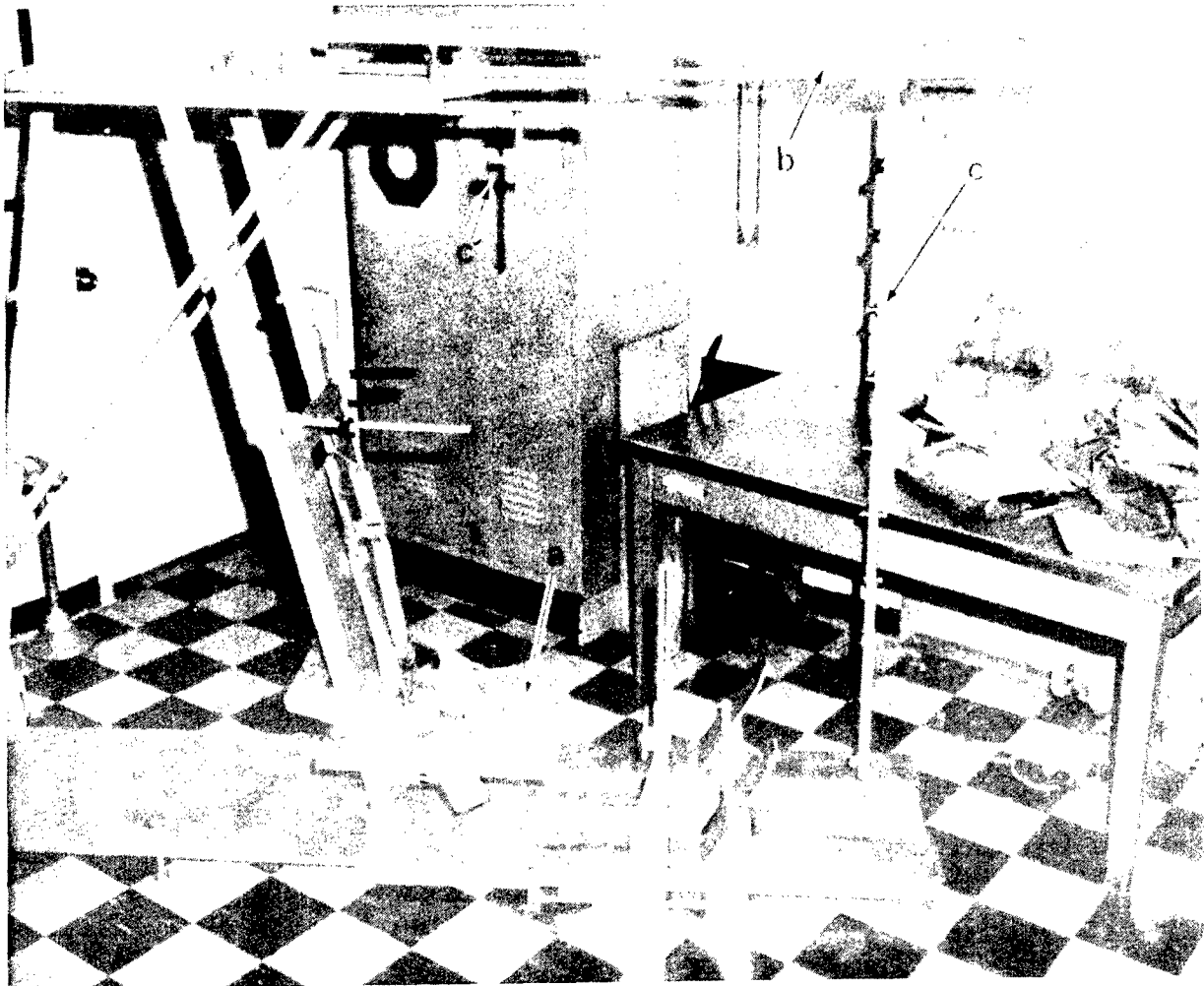

Figure 1. The arm-reach apparatus.

Figure 2 illustrates the personal protective equipment worn by the pilot subjects during the test to determine the arm-reach capability measurements in the encumbered conditions. This assemblage of flight gear is representative of what is worn by Air Defense Command pilots during cold weather missions. It should be noted that the subjects wore the flight gear and garments in accordance with their personal needs.

The reach envelope of each subject was measured under four conditions: (1) shirt-sleeved with the inertial reel unlocked, (2) shirt-sleeved with the inertial reel locked, (3) full assembly with the inertial reel unlocked, and (4) full assembly with the inertial reel locked. The sequence of reach procedure and the knob distances from the deck are illustrated in Figure 3.

Figure 4 illustrates a subject in the arm-reach machine wearing his complete flying assembly. The subject, with the inertial reel

locked, grasps the control knob at the 24-inch level at the position of $L60^\circ$ (left hand at 60° from the seat reference point).

Figure 5 indicates a subject, with the inertial reel locked, reaching and actuating a control knob at the $R90^\circ$, 60-inch level (right arm at 90° from seat reference point reaching a knob located 60 inches above deck height).

Figure 6 illustrates a subject, with the inertial reel unlocked, reaching with his left hand at 30° from seat reference point at 42 inches above deck height.

Figure 7 presents tabular and graphical data for one of the selected arm-reach measurements. This particular illustration presents mean (average) data for the 16 subjects at the 54-inch level with the inertial reel in the unlocked position. It is to be interpreted as follows: e.g., with the inertial reel in the unlocked condition at the position of $R30^\circ$ (right arm actuating control knobs at

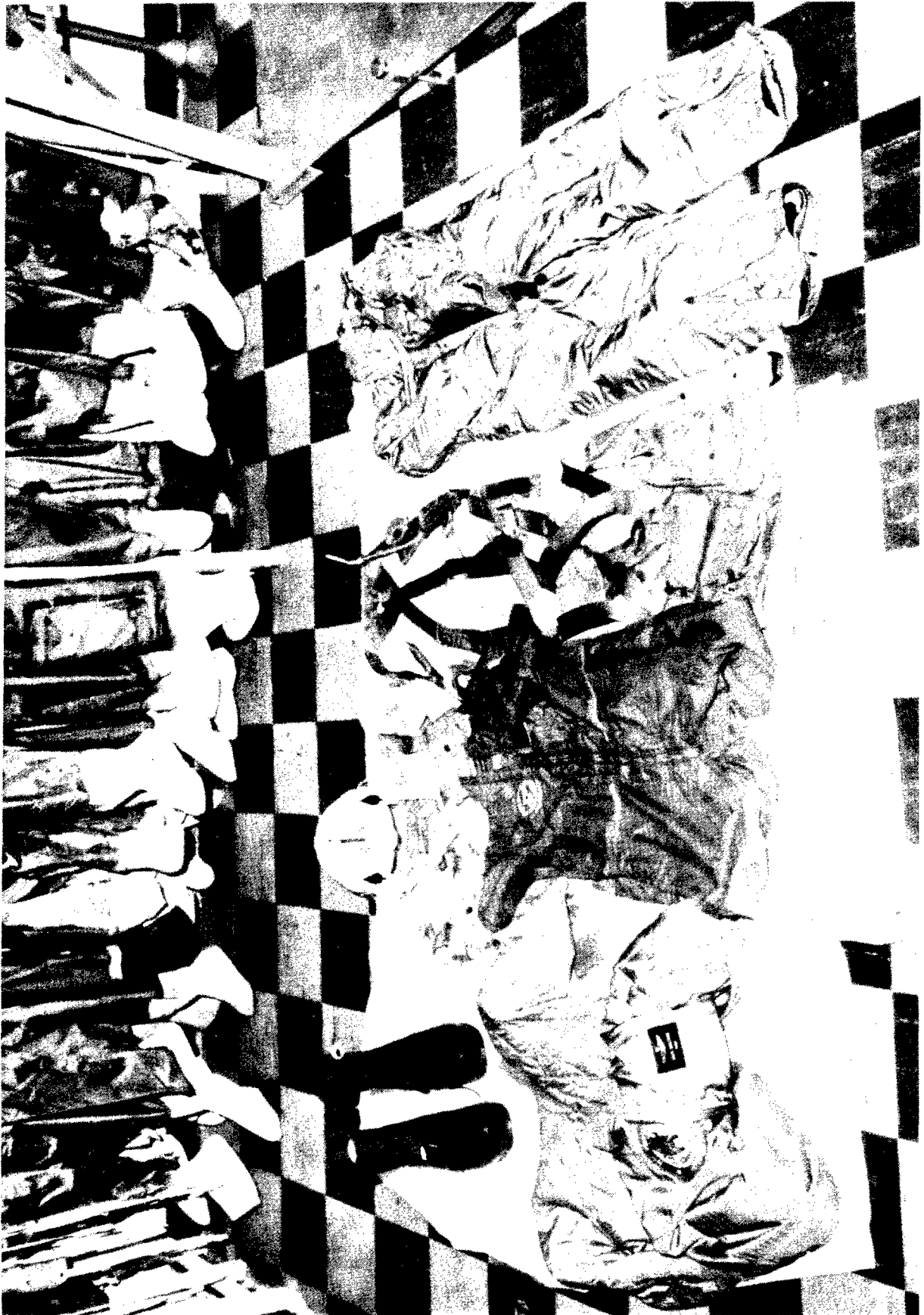
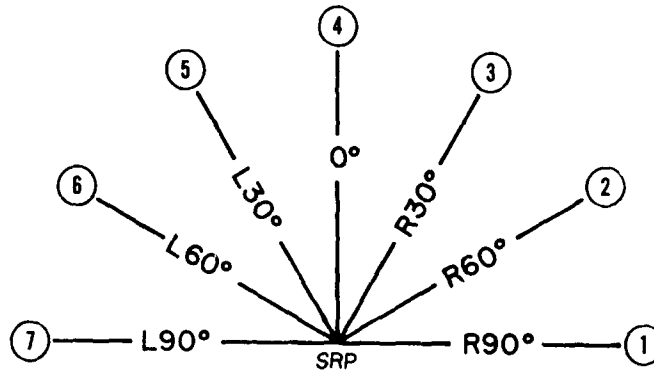

Figure 2. Personal protective equipment.

SEQUENCE OF REACH PROCEDURE



- | | | | |
|---|--|---|----------|
| ① | RIGHT ARM | ⑤ | LEFT ARM |
| ② | RIGHT ARM | ⑥ | LEFT ARM |
| ③ | RIGHT ARM | ⑦ | LEFT ARM |
| ④ | EITHER RIGHT OR LEFT ARM
(SUBJECT'S PREFERENCE) | | |

KNOB DISTANCES FROM DECK

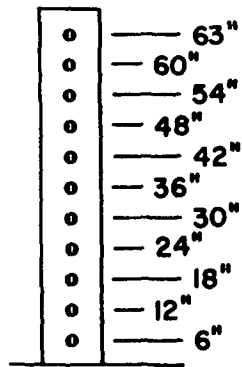

SUBJECT BEGINS AT 6" LEVEL
AND PROCEEDS TO THE 63" LEVEL

Figure 3. Sequence of reach procedure and knob distances from deck.



Figure 4. Subject in test apparatus wearing complete flying assembly

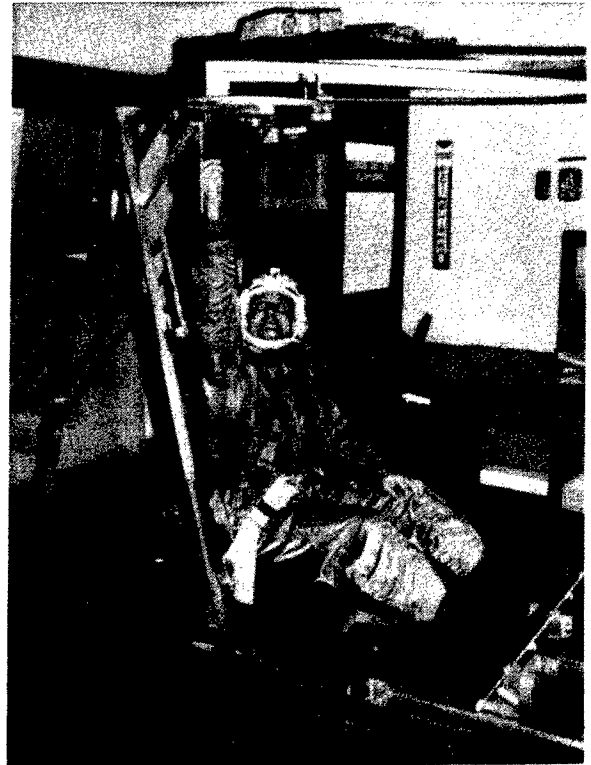

Figure 6. Subject in test apparatus with inertial reel unlocked.

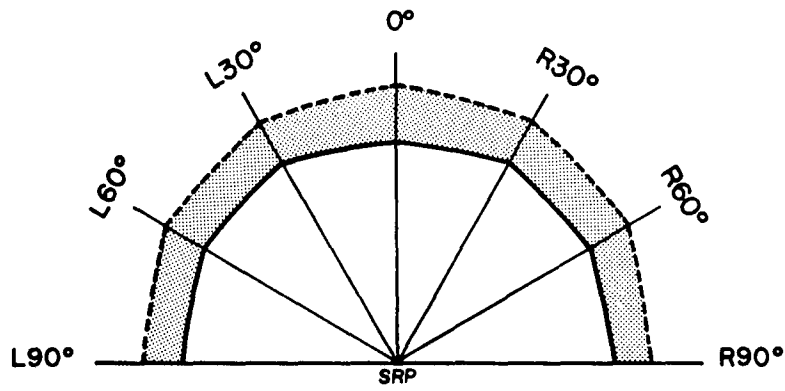

Figure 5. Subject in test apparatus with inertial reel locked.

30° from seat reference point), the mean value for the shirt-sleeved condition was 29.70 inches and the mean value for the maximum assembly condition was 24.80 inches. This condition resulted in a 4.90-inch decrement (Δ) and a percentage difference of 83.5.

The graphical display of the data is an attempt to present an actual arm-reach envelope from the tabular data. The dashed (---) line of the illustration indicates the distances reached from the seat reference point (SRP) while being tested in the shirt-sleeved condition. The solid (—) line indicates the distances reached while the subject wore the maximum assembly of flying gear. The hatched (▨) area indicates the difference between the two conditions. Inspection of Figure 7 indicates differences ranging from 4.22 inches (R90° position) to 6.03 inches (0° position) from the shirt-sleeved to the maximum assembly condition.

Figures 8, 9, 10, 11, and 12 are similar tabular and graphical illustrations that were randomly selected examples of arm-reach data gathered in this study. Inspection of these figures indicates the magnitude of differences between the shirt-sleeved and the maximum assembly conditions. It is interesting to note that the differences in arm-reach capability tend to decrease as the control knob distances



	SHIRT SLEEVED	MAXIMUM ASSEMBLY	Δ	%
R 90°	27.95	23.73	4.22	84.9
R 60°	29.53	24.36	5.17	82.5
R 30°	29.70	24.80	4.90	83.5
0°	29.59	23.56	6.03	79.6
L 30°	29.63	24.72	4.91	83.4
L 60°	29.02	24.28	4.74	83.7
L 90°	27.80	23.38	4.42	84.1

* All measurements in inches

Figure 7. Tabular and graphical arm-reach measurements (unlocked inertial reel--54" level).

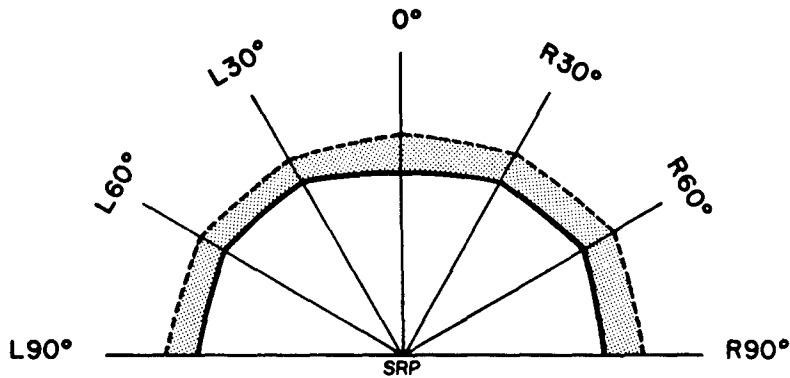

	SHIRT SLEEVED	MAXIMUM ASSEMBLY	Δ	%
R 90°	26.14	21.91	4.23	83.8
R 60°	26.64	22.77	3.87	85.5
R 30°	24.78	21.41	3.37	86.4
0°	23.69	19.44	4.25	82.1
L 30°	24.20	21.47	2.73	88.7
L 60°	25.39	22.39	3.00	88.2
L 90°	25.86	22.08	3.78	85.4

* All measurements in inches

Figure 8. Tabular and graphical arm-reach measurements (locked inertial reel--54" level).

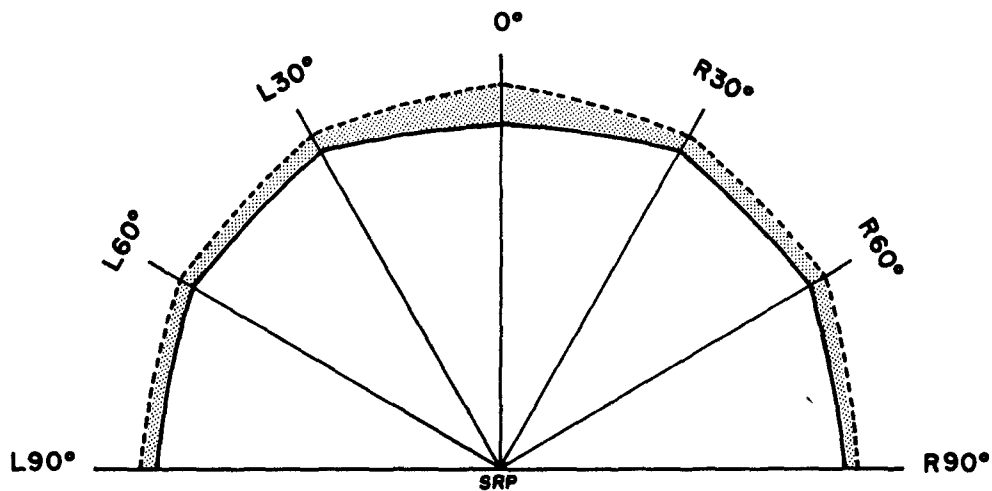

	SHIRT SLEEVED	MAXIMUM ASSEMBLY	Δ	%
R 90°	39.14	37.81	1.33	96.6
R 60°	41.03	39.05	1.98	95.2
R 30°	41.11	39.03	2.08	94.9
0°	41.13	36.73	4.40	89.3
L 30°	41.09	39.11	1.98	95.2
L 60°	40.33	38.78	1.55	96.2
L 90°	39.09	37.19	1.90	95.1

* All measurements in inches

Figure 9. Tabular and graphical arm-reach measurements (unlocked inertial reel--36" level).

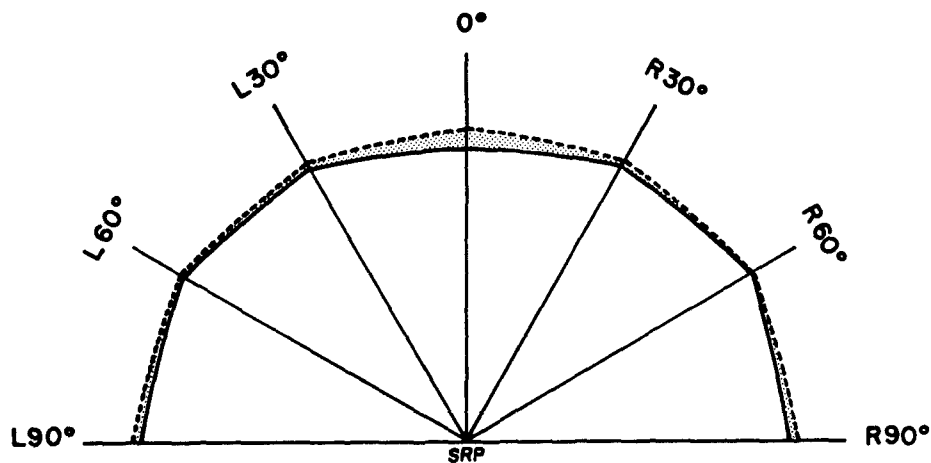

	SHIRT SLEEVED	MAXIMUM ASSEMBLY	Δ	%
R 90°	36.09	35.31	.78	97.8
R 60°	36.06	35.98	.08	99.8
R 30°	34.81	34.03	.78	97.8
0°	33.69	31.44	2.25	93.3
L 30°	34.61	33.84	.77	97.8
L 60°	35.83	35.28	.55	98.5
L 90°	36.05	35.11	.94	97.4

* All measurements in inches

Figure 10. Tabular and graphical arm-reach measurements (locked inertial reel--36" level).

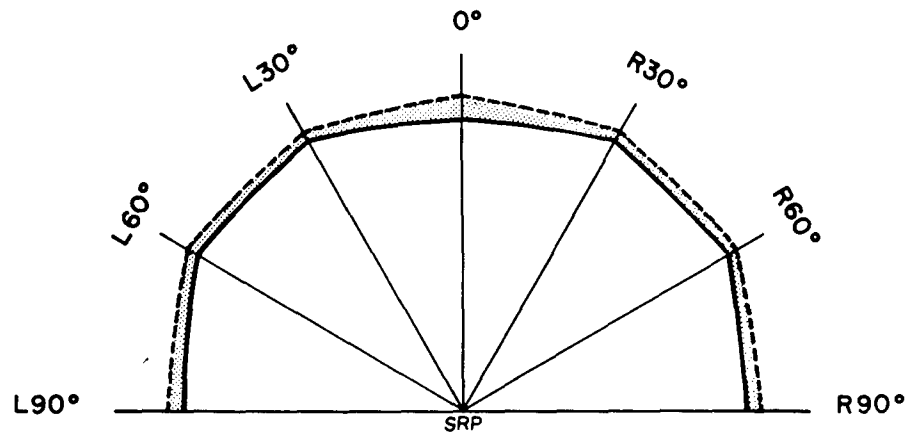

	SHIRT SLEEVED	MAXIMUM ASSEMBLY	Δ	%
R 90°	32.70	31.08	1.62	95.0
R 60°	34.78	33.70	1.08	96.9
R 30°	34.72	33.52	1.20	96.5
0°	33.77	31.11	2.66	92.1
L 30°	34.52	33.41	1.11	96.8
L 60°	34.80	33.59	1.21	96.5
L 90°	32.13	30.66	1.47	95.4

* All measurements in inches

Figure 11. Tabular and graphical arm-reach measurements (unlocked inertial reel--6" level).

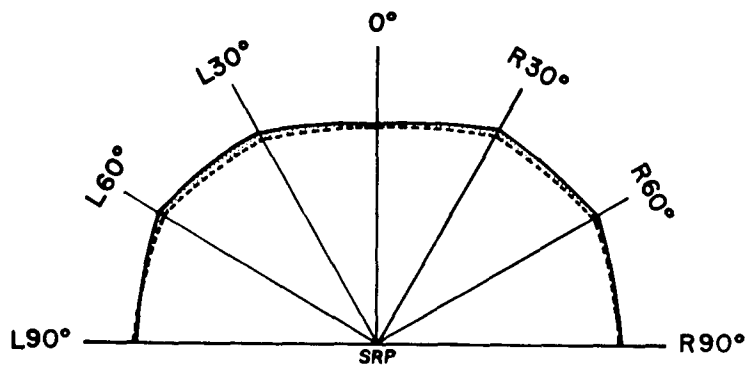

	SHIRT SLEEVED	MAXIMUM ASSEMBLY	Δ	%
R 90°	26.25	26.56	-.31	101.2
R 60°	27.11	27.86	-.75	102.8
R 30°	25.59	26.09	-.50	102.0
0°	23.13	23.11	.02	99.9
L 30°	25.06	25.89	-.83	103.3
L 60°	26.86	27.58	-.72	102.7
L 90°	26.56	26.44	.12	99.5

* All measurements in inches

Figure 12. Tabular and graphical arm-reach measurements (locked inertial reel--6" level).

approach deck level. In fact, the subjects were able (see Figure 12) to reach approximately the same distances in both the shirt-sleeved and the maximum assembly conditions at the six-inch level with the inertial reel locked (actually further at the positions of R90°, R60°, L30°, and L60°).

In summary, the results of the study indicate that there are significant differences in arm-reach capability of pilots while in the shirt-sleeved and maximum flying assembly conditions throughout most of the spatial envelope. These differences seem to be the greatest for the control knobs located highest from the deck and tend to decrease for those knobs approaching deck level.

In general, also, the arm-reach capability of a subject reaching directly in front of his body (designated 0° in this study) yields smaller values than for other positions in this study. The primary reason for this seems to be that the shoulder harness straps severely limit the mobility of the arm/shoulder complex in a position directly in front of the operator.

Cockpit layout specialists should be aware of the differences in arm-reach capabilities of pilots wearing light weight flying clothing (shirt-sleeved) and heavy winter flying assemblies. These differences should be considered in the placement of controls and switches in cockpit design.

A complete presentation of the data for all angles and knob levels will be forthcoming in a USAF technical report.

ACKNOWLEDGMENTS

The authors wish to thank Mr. John W. Garrett for his participation in all phases of the study. LtCol. David Leavitt, Air Defense Command, USAF, deserves the thanks of the authors for handling the administrative details at Loring Air Force Base. Dr. Melvin Warrick and Charles E. Clauser, Human Engineering Division, reviewed the manuscript and offered valuable suggestions. Special appreciation is extended to Dr. John T. McConville, Webb Associates, for his help and encouragement throughout the study.