

AD-A010 235

DATA COMPUTER SUPPORT OF SEISMIC DATA ACTIVITY

Computer Corporation of America

Prepared for:

Defense Advanced Research Projects Agency

30 May 1975

DISTRIBUTED BY:

NTIS

**National Technical Information Service
U. S. DEPARTMENT OF COMMERCE**

157087

ADA010235

DATA COMPUTER SUPPORT OF SEISMIC DATA ACTIVITY
Annual Technical Report

April 22, 1974 to December 31, 1974

Contract No. MDA903-74-C-0227

ARPA Order No. 2613

Submitted to:

Defense Advanced Research Projects Agency
1400 Wilson Boulevard
Arlington, Virginia 22209

Attention: Dr. Carl Romney

Reproduced by
NATIONAL TECHNICAL
INFORMATION SERVICE
U S Department of Commerce
Springfield VA 22151



DOCUMENT CONTROL DATA - R & D

(Security classification of title, body of abstract and indexing annotation must be entered when the overall report is classified)

1. ORIGINATING ACTIVITY (Corporate author)

Computer Corporation of America

2a. REPORT SECURITY CLASSIFICATION

Unclassified

2b. GROUP

3. REPORT TITLE

DATA COMPUTER SUPPORT OF SEISMIC DATA ACTIVITY

4. DESCRIPTIVE NOTES (Type of report and inclusive dates)

Annual Technical Report, April 22, 1974 to December 31, 1974

5. AUTHOR(S) (First name, middle initial, last name)

6. REPORT DATE

May 30, 1975

7a. TOTAL NO. OF PAGES

7b. NO. OF REFS

8a. CONTRACT OR GRANT NO.

MDA903-74-C-0227
b. PROJECT NO.

9a. ORIGINATOR'S REPORT NUMBER(S)

c.

9b. OTHER REPORT NO(S) (Any other numbers that may be assigned this report)

d.

10. DISTRIBUTION STATEMENT

Distribution of this document is unlimited

11. SUPPLEMENTARY NOTES

12. SPONSORING MILITARY ACTIVITY

Defense Advanced Research Projects
1400 Wilson Boulevard
Arlington, Virginia 22209

13. ABSTRACT

14. KEY WORDS	LINK A		LINK B		LINK C	
	ROLE	WT	ROLE	WT	ROLE	WT
datacomputer seismic data base seismic input processor (SIP) Ampex TBM						

Computer Corporation of America
575 Technology Square
Cambridge, Massachusetts 02139

Datacomputer Support of Seismic Data Activity
Annual Technical Report
April 22, 1974 to December 31, 1974

This research is supported by the Advanced Research Projects Agency of the Department of Defense under Contract No. MDA903-74-C-0227. The views and conclusions contained in this document are those of the authors and should not be interpreted as necessarily representing the official policies, either expressed or implied, of the Defense Advanced Research Projects Agency or the U.S. Government.

Table of Contents

	Page
1. Overview.....	1
1.1 Project Goals.....	1
1.2 Status of the Project.....	1
2. TBM.....	4
3. SIP.....	5
4. Coordination with the Seismic Community....	6

Figures

1. CCA Installation.....	2
--------------------------	---

1. Overview

1.1 Project Goals

The purpose of the project is to support the ARPA-NMRO Seismic Data Activity by providing data storage and retrieval services. The Arpanet will be used as the communication channel. As part of the service, seismic data will be (a) collected from the Arpanet; (b) stored; and (c) made available to computers on the Arpanet in a convenient and timely manner. These services represent a special application of the Arpanet Datacomputer supported under Contract No. MDA903-74-C-0225.

The amount of data to be kept on-line necessitates the addition of a mass memory to the Datacomputer System. An Ampex Terabit Memory System (TBM) with a capacity of almost two hundred billion bits has been contracted for and will be installed at CCA in 1975.

Also needed for this project is a small Seismic Input Processor (SIP). The SIP will collect data over the network on a round-the-clock basis. It will reformat the data and buffer it. At regular intervals, the SIP will generate a datalanguage update request and burst the data to the Datacomputer via the TIP (see Figure 1).

1.2 Status of the Project

The activity on the project to date has been primarily in two areas: hardware acquisition and coordination with the seismic community.

CCA has been negotiating with Ampex for the purchase of the TBM Memory System to be incorporated into the Datacomputer. The initial configuration of the TBM will be one transport driver, two dual transport modules, one data channel, and a Communications and Control System (CCS). The CCS contains a

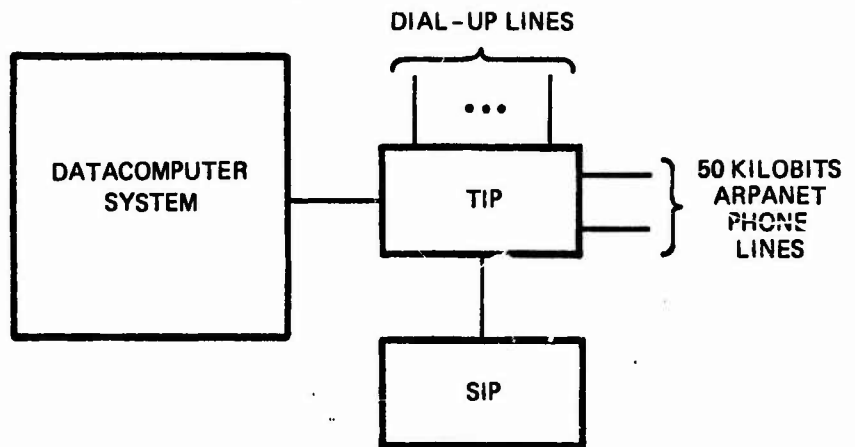

Figure 1 - CCA Installation

Storage Control Processor and a Channel Interface Unit. The delivery of the TBM Memory System is expected to be in August 1975 and acceptance in September 1975.

The SIP hardware will consist of a DEC PDP-11/40 with 28K core, two RPO4 disks with a storage capacity of 176 million bytes, and an Arpanet interface. Installation of the PDP-11 and peripherals is expected to be January 1975. The SIP is expected to be interfaced to the Arpanet in March 1975.

CCA has worked closely with the seismic community to determine requirements for data storage and retrieval services. Efforts are under way to specify suitable file formats for storage of the seismic data. These formats reflect the way in which the data is collected, the way in which it will be used, and the most efficient ways of using the Datacomputer hardware and software.

In order to gain operational experience with seismic data, several sample seismic databases have been loaded onto the Datacomputer. Data from the International Seismic Month has been used for demonstration purposes. A tape of seismic data supplied by SDAC has been loaded for debugging purposes. This data is long period array data from ALPA.

Efforts are also under way to determine the specification of the CCP-SIP protocol. This is a special-purpose protocol that will allow for faster transmission of real-time data than the standard host-host protocol.

2. TBM

In order to satisfy the requirement for a large, on-line seismic file, an Ampex Terabit Memory System (TBM) will be installed at CCA, as a part of the Datacomputer. The basic system is described in Appendix E of our proposal, "Datacomputer Support of Seismic Data Activity," submitted August 13, 1973.

An alternative method of interfacing the TBM to the CCA PDP-10 has been developed. This approach involves the use of a PDP-11/05 in addition to special interface hardware to provide interfacing and control functions for the TBM. The channel interface unit interprets and executes instructions from the PDP-10 via an SA-10 IBM-compatible channel, as well as commands typed at the channel interface unit operating console. The advantage of this new approach is that much of the overhead involved in controlling the TBM is moved from the PDP-10 into the channel interface unit, freeing CPU resources at the PDP -10.

Contract negotiations were conducted during the current reporting period and are nearing completion.

Ampex and CCA are cooperating in facilities specification for the TBM. TBM requirements for power, air conditioning, floor height and other environmental factors must be determined. Once this task is done, site preparations for the TBM can begin.

3. SIP

Seismic data will be collected from the Arpanet and buffered by a small Seismic Input Processor (SIP) before retransmission to the Datacomputer. The SIP will have two 3330-type spindles, which allow for 24-hour buffering of a 15-kilobit per second data stream. This will ease requirements for both the Datacomputer and the Central Communications Processor (CCP) at SDAC.

The SIP will be a host on CCA's IMP. The SIP will communicate with the Datacomputer as any other host would, that is, using datalanguage, network data connections, and the standard Arpanet host-host protocol. Transfer rates will be much higher than normal network communication, however, since no phones lines are involved.

The SIP will communicate with the CCP at SDAC using a data transfer protocol which is being specially developed for this purpose. This protocol will be more efficient for real-time data than the standard Arpanet host-host protocol. CCA continues to coordinate with VSC and BBN in specifying the CCP-SIP protocol.

The SIP hardware specifications, including on-line storage capacity, bandwidth, system software, Arpanet interface, and the like, are described in "Specifications for the Seismic Input Processor (SIP)", dated June 27, 1974. After contacting several vendors, a DEC PDP-11/40 was chosen. The configuration will include 28K core and two RP04 disks.

4. Coordination with the Seismic Community

The amount of seismic data to be collected necessitates that the data be handled as efficiently as possible if the application is to be feasible. Design of the application requires a thorough understanding of how the data is to be collected and how it is to be used. Towards this end, CCA has worked closely with VSC, SDAC, BBN, and others to identify the data storage and retrieval requirements for the seismic application.

Work continues towards specifying the file formats for the seismic data. The bulk of the data is the raw waveforms. It will be segmented into files, each one of which will contain a day's worth of data. This is a size that is convenient both for the Datacomputer and for a seismologist who is analyzing the data. The data is organized first by site and then by time.

CCA has obtained seismic data from SDAC that corresponds to the information to be stored in the Array Long Period File. This data has been loaded into the Datacomputer, and the user program SMART will be modified to access the data. This will give us operational experience with the seismic data and the proposed file formats.