

AD/A-001 672

HYDROSTATIC EXTRUSION OF 60MM MORTAR
TUBES

Richard S. DeFries

Watervliet Arsenal
Watervliet, New York

October 1974

DISTRIBUTED BY:

NTIS

National Technical Information Service
U. S. DEPARTMENT OF COMMERCE
5285 Port Royal Road, Springfield Va. 22151

**Best
Available
Copy**

UNCLASSIFIED

SECURITY CLASSIFICATION OF THIS PAGE (When Data Entered)

REPORT DOCUMENTATION PAGE		READ INSTRUCTIONS BEFORE COMPLETING FORM
1. REPORT NUMBER WVT-TR-74046	2. GOVT ACCESSION NO.	3. RECIPIENT'S CATALOG NUMBER AD/A-001 672
4. TITLE (and Subtitle) HYDROSTATIC EXTRUSION OF 60MM MORTAR TUBES		5. TYPE OF REPORT & PERIOD COVERED
		6. PERFORMING ORG. REPORT NUMBER
7. AUTHOR(s) Richard S. DeFries		8. CONTRACT OR GRANT NUMBER(s)
9. PERFORMING ORGANIZATION NAME AND ADDRESS Benet Weapons Laboratory Watervliet Arsenal, Watervliet, N.Y. 12189 SARWV-RDT		10. PROGRAM ELEMENT, PROJECT, TASK AREA & WORK UNIT NUMBERS AMCMS No. 4497.06.7162 DA Proj. No. 6727162 Proj. No. W1-2-23069
11. CONTROLLING OFFICE NAME AND ADDRESS U.S. Army Armament Command Rock Island, Illinois 61201		12. REPORT DATE October 1974
		13. NUMBER OF PAGES 29
14. MONITORING AGENCY NAME & ADDRESS (if different from Controlling Office)		15. SECURITY CLASS. (of this report) Unclassified
		15a. DECLASSIFICATION/DOWNGRADING SCHEDULE
16. DISTRIBUTION STATEMENT (of this Report) Approved for public release; distribution unlimited.		
17. DISTRIBUTION STATEMENT (of the abstract entered in Block 20, if different from Report)		
18. SUPPLEMENTARY NOTES Reproduced by NATIONAL TECHNICAL INFORMATION SERVICE U.S. Department of Commerce Springfield, VA. 22151		
19. KEY WORDS (Continue on reverse side if necessary and identify by block number) 60MM Mortar Tubes Cold Work Hydrostatic Extrusion Cost Savings Yield Strength Physical Properties		
20. ABSTRACT (Continue on reverse side if necessary and identify by block number) Mortar tubes were successfully hydrostatically extruded from Inconel 718 proving the feasibility of the process. The yield strength of the 718 material was increased from 160 ksi to 240 ksi by the cold work induced by the extrusion process. A cost savings of about \$400 per tube can be realized by hydrostatically extruding the mortar tubes close to finished size and thereby reducing the machining costs, rather than machining the tubes from forgings. Thus, it may be possible to economically utilize Inconel 718 and derive the benefits (SEE REVERSE SIDE)		

UNCLASSIFIED

SECURITY CLASSIFICATION OF THIS PAGE (When Data Entered)

Block No. 20

ABSTRACT (Continued)

of the increased high temperature strength inherent in the material.

As an adjunct to this project, an estimate was made of the potential savings for hydrostatically extruded gun steel mortar tubes compared to forged tubes. It is estimated that a savings of approximately \$63 per tube would be possible.

ia

UNCLASSIFIED

SECURITY CLASSIFICATION OF THIS PAGE (When Data Entered)

ACCESSION for		
NTIS	White Section	<input checked="" type="checkbox"/>
DIC	Ref Section	<input type="checkbox"/>
UNAN. CHANGES		<input type="checkbox"/>
JUSTIFICATION		
BY		
DISTRIBUTION/AVAILABILITY CODES		
Dist.	AVAIL. CODE/ or SPECIAL	
A		

DISPOSITION

Destroy this report when it is no longer needed. Do not return it to the originator.

DISCLAIMER

The findings in this report are not to be construed as an official Department of the Army position unless so designated by other authorized documents.

18

WVT-TR-74046

AD

HYDROSTATIC EXTRUSION OF 60MM MORTAR TUBES

Richard S. DeFries

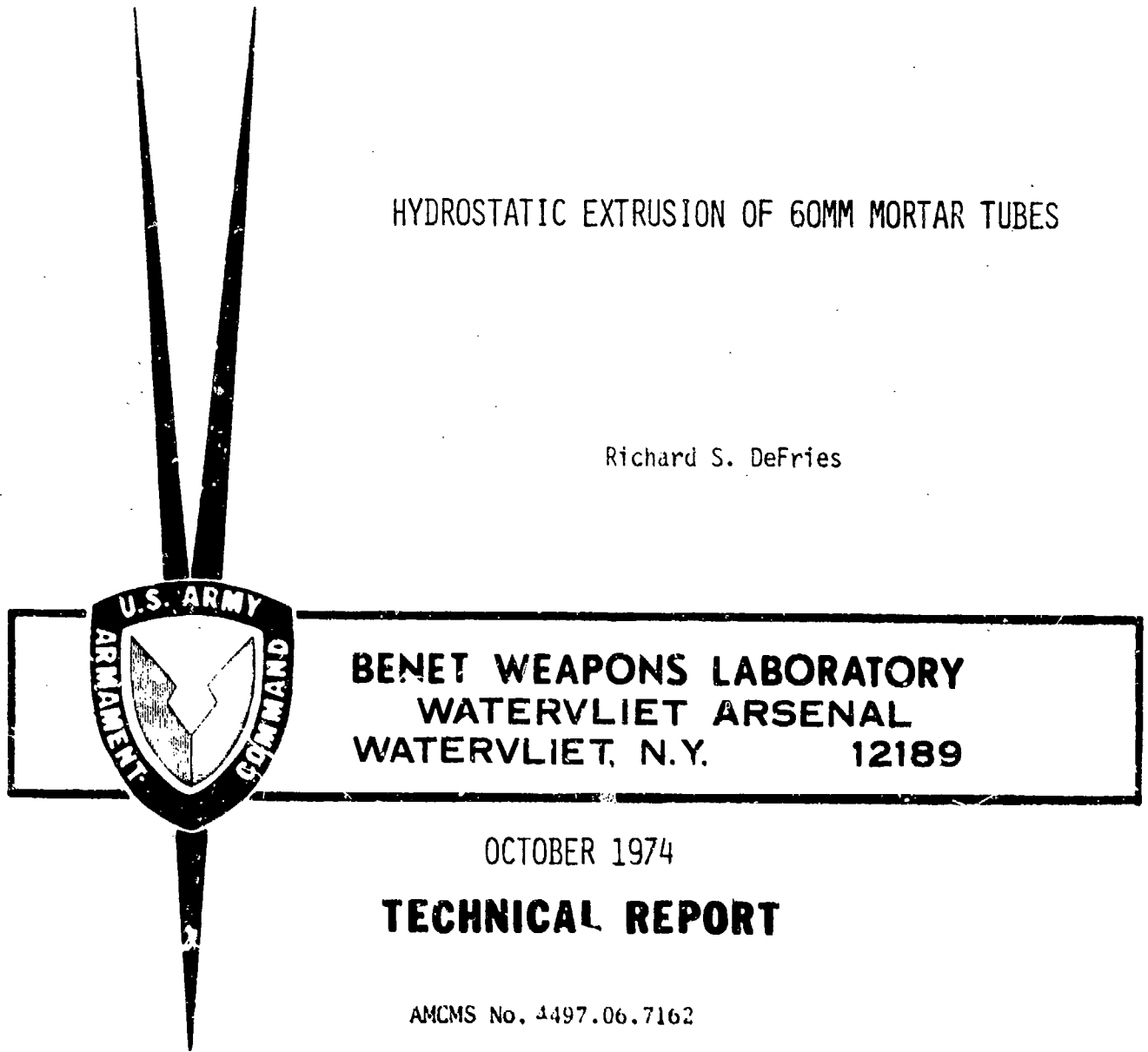

**BENET WEAPONS LABORATORY
WATERVLIET ARSENAL
WATERVLIET, N.Y. 12189**

OCTOBER 1974

TECHNICAL REPORT

AMCMS No. 4497.06.7162

DA Project No. 6727162

Pron No. M1-2-25069

APPROVED FOR PUBLIC RELEASE DISTRIBUTION UNLIMITED

ic

TABLE OF CONTENTS

	Page
DD Form 1473	
Introduction	1
Evaluation Method	1
Results and Discussion	2
A. Processing Parameters	2
B. Visual and Dimensional Check of Tubes	4
C. Mechanical Property Tests	5
D. Machining and Cost Analysis	6
1. Inconel 718	6
2. Low alloy gun steel	7
Conclusions	8

List of Tables

I. Dimensions and Concentricity Data of Extruded Tubes	20
II. Tensile Properties of Extruded and Aged Tube (a)	21
III. Extruded 718 Alloy Pressure Test Data	21
IV. V-Notch Charpy Impact Properties(c) of Extruded and Aged Tubes	22

LIST OF FIGURES

	Page
1. Subscale Inconel Alloy 718 Tube Extruded	9
2. Cu Plated AISI 1018 Alloy Blank (left) and Extruded Tube on the Right	10
3. As-extruded and Aged Inconel 718 Alloy 60mm Tube	11
4. Dimensions of As-extruded 718 Alloy Tube	12
5. I.D. Surface Tensile Tears	13
6. Photographs of I.D. Surface Tensile Tears	14
7. Photographs of O.O. Surface Tensile Tears	15
8. Location of Test Specimens and EB Welded Transverse Tensile Test Specimen	16
9. Subsize Charpy and Tensile Test Specimens	17
10. Extruded 718 Alloy Tube Pressure-strain Pressure Test Data	18
11. As-extruded and machined 718 Alloy 60mm Tube	19

Introduction

This project was concerned with the room temperature hydrostatic extrusion of Inconel 718 alloy 60mm XM225E2 mortar tubes, under Contract #DAAF07-72-C-0360 with Battelle, Columbus, Ohio Laboratories and the evaluation of the tubes produced. The evaluation was made to determine the feasibility of the process, mechanical properties imparted to the tubes by the process and any cost savings the process may incur when compared to the conventional method of manufacturing by machining 60mm tubes from forged or conventionally extruded bar stock.

Evaluation Method

The hydrostatic extrusion process was evaluated in the following manner:

a. Processing parameters:

An in depth study of the processing parameters is presented in the final report¹ submitted to this Arsenal. The optimum extrusion parameters and the costs to hydrostatically extrude 718 alloy 60mm mortar tubes are shown.

b. Visual and Dimensional Check of Tubes:

Dimensional checks were made on the four extruded and aged tubes which were hydrostatically extruded. A metallurgical and/or microscopic investigation of the extruded 718 structure and any surface defects noted on or in the tubes was also conducted.

1. "Production of Inconel 718 Mortar Tubes by Hydrostatic Extrusion"
Final Report by Battelle, Columbus Laboratories, April 1973.
WV 23827

c. Mechanical Property Tests:

One tube was sectioned for longitudinal and transverse tensile and Charpy impact properties. A ten inch long section was cut from the tube for pressure testing.

d. Machining and Cost Analyses:

One tube was finish machined to the 60mm XM225E2 dimensions listed in the prototype, Drawing #WTV-F23990. Cost analyses were obtained for finish machining, in lots of 500 and 1000, Inconel 718 as-extruded and aged tubes (per Drawing #WTV-C22870) and also the cost to finish machine 60mm tubes made by the regular manufacturing methods using forged or conventionally extruded bar stock.

e. Gun Steel Extrusion:

Since, for the immediate future, 60mm mortar tubes will be produced from standard low alloy gun steel, a comparison was made of the cost to produce a hydrostatically extruded tube and a forged tube, considering the subsequent machining costs.

RESULTS AND DISCUSSION

A. Processing Parameters:

The optimum extrusion parameters were developed using sub-size Inconel 718 extrusions (Figure 1) and full size AISI 1018 alloy 60mm tubes. Both the ID and OD were reduced during extrusion to eliminate a shallow surface tensile tearing problem. Figure 2

shows a Cu plated 1018 partially extruded tube which illustrates the original blank size (left side of picture). Using the parameters and tooling below, Battelle successfully extruded four Inconel 718 alloy 60mm tubes. The parameters used to extrude these tubes were:

Fluid - Castor oil

Lubricant - Cu plate and resin-bonded graphite MoS₂ coating

Extrusion Ratio:

Inconel 718 - 2.2:1

Steel 1018 - 2.4:1

Extrusion Pressures:

Inconel 718 Breakthrough - 180 - 195 ksi
Run Out - 150 - 155 ksi

Steel 1018 Breakthrough - 82 - 90 ksi
Run Out - 76 - 82 ksi

Press Ram Speed - Approximately 5 inches/min.

Billet Dimensions - 3.450 in. OD x 2.650 in. ID x 20.0 in long

Tube Dimensions (Nominal) 2.787 in. OD x 2.363 in. ID x
approximately 40 in. long

Die Configuration:

Diameter - 2.765 (Pre-stressed diameter)
Approach Angle - 22-1/2° (half angle)
Land Length - 0.2 in.

Mandrel Configuration: 2.390 in. tapering to 2.356 in. over 22 in.
of length (0.0015 in/in.)

The four Inconel 718 tubes were then straightened, heat treated (aged at 1150°F for 8 hrs.) and subsequently ID honed at Battelle to complete their processing.

B. Visual and Dimensional Check of Tubes

The Inconel 718 alloy as-extruded and aged 60mm tubes (Figure 3) were checked for ID, OD and wall thickness dimensions, and for concentricity and straightness. The results are shown in Table I. The dimensions of the as-extruded tubes (Figure 4) do not conform to the drawing dimensions shown, but do conform to the contract dimensional range aim shown below:

- Length - as specified on the drawing
- O.D. - 2.764" dia. (+ .050 - .005) and 125 RMS finish
- I.D. - 2.390" dia. (+ .025 - .010) and 64-125 RMS finish

The .020" difference in the OD of Tube No. 1, as compared to the other three tubes, is due to the fact that the OD of this tube was centerless ground after extrusion for cost analysis. The difference in the breech to muzzle ID diameters is due to the 0.0015 in/in taper on the mandrel, and would have been larger if the tubes had not been ID honed. The straightness of about .010 inches was obtained after a straightening and aging cycle; the as-extruded tubes had a straightness, based on dimensional deviation of the center line from a truly straight line, of about .049 inches. All of the above measurements were in close agreement with those dimensions measured by Battelle (Table I, Reference 1).

In the visual examination of the tubes, numerous circumferential hairline cracks about .005" deep, thought to be tensile tears, were noted on the ID surfaces (Figure 5). A photomicrograph of a cross section of these cracks, Figure 6, shows the structure of the extruded and aged 718 alloy tubing and it also shows the shear bands leading to the surface

tears. The 45° angle that the shear bands form with the surface of the tubing has been seen in numerous other cold and hot tearing investigations.^{2,3} On the OD, similar but smaller cracks (about .002" deep) were found (Figure 7).

C. Mechanical Property Tests

One tube was sectioned, as indicated in Figure 8A, for longitudinal and transverse tensile and Charpy-impact properties. Sub-size flat tensile and Charpy bars, Figure 9, were machined from these sections. The results are shown in Tables II - IV.

The 0.1% yield strength of the as-extruded and aged 718 material was about 238 ksi, which is about 80 ksi higher than the standard heat-treated and aged alloy. The transverse 0.1% yield strength was recorded as 40 ksi lower than the longitudinal yield because the bars failed prematurely in the electron beam weld used to fabricate the specimens (Figure 8B). The welded tensile specimen is required to obtain the transverse tensile properties in a thin walled tube. The welded specimen was aged after welding and the area in the center of the one inch long test section was reduced by an amount that should have caused the specimen to fail in the center of the transverse test section. Evidently, the area was not reduced enough to prevent a failure in the welds. Rather than fabricate additional specimens, a section of tubing was hydrostatically tested to determine yield strength.

2. Pepe, Dr. J., "Shear Band Tearing During Hydrostatic Extrusion" unpublished report.
3. Defries, R.S., "Hot Tearing Characteristics of Cast Ingots" unpublished, Allegheny Ludlum Steel Co. Report.

The Charpy impact strengths in Table IV, are shown in actual sub-size values and the calculated standard size value using a correlation relation of 4.5 times the sub-size value, determined from previous testing of 81mm mortar tubes.⁴ This transverse value of 13.5 ft-lbs at -40°F is very high for the yield strength experienced.

A 10 inch section was cut from the extruded tube, Figure 8, and pressure tested (Figure 10). The results (Table III) showed that the 0.1% yield strength was about 225 ksi prior to yielding when the seals gave out. Therefore, all types of testing indicate that the extruded and aged 718 material has a 0.1% yield strength in both the longitudinal and transverse directions of about 225 to 242 ksi.

D. Machining and Cost Analysis:

1. Inconel 718

One as-extruded and aged tube was finish machined to the dimensions stated on the current 60mm machined tube drawing (FTV-F23990), with the exception that the OD fin diameter was 2.760 instead of 3.350 inches. The modified fin configuration can be seen on the right side of the tube shown in Figure 11. The fin size was limited because of the size of the extrusion. However, with the use of high temperature alloys, it is expected that the fin may not be required to cool the tube since the 718 alloy retains its high strength (120 ksi) at high (1000-1400°F) temperatures. The modified fins were machined to reduce the weight of the tube. The finish machined tube weighed nine pounds.

An estimated cost analysis on hydrostatically extruded and machined Inconel 718 60mm XM225E2 mortar tubes was made with the assistance of the Arsenal Operations Directorate, and compared to

4. DeFries, R.S., unpublished data.

those tubes machined from forged blanks. This cost analysis was based on the production of 500 and 1000 units. Battelle's extrusion costs¹, in-house current material costs and in-house machining costs were used to determine the cost per 60mm tube for each alloy. The results of this analysis were:

<u>Number</u>	<u>Inconel 718 Extruded</u>	<u>Forging</u>
500 units	\$ 1,783	\$2,165
1000 units	1,720	2,110

2. Low alloy gun steel

For informational purposes, the costs to produce gun steel tubes from extrusions and from forgings were also estimated. It was assumed that the extrusion costs of the gun steel would be the same as those for the Inconel 718 and that two tubes would be produced from each extrusion. The costs are shown below:

<u>Number</u>	<u>Gun Steel Extruded</u>	<u>Forging</u>
500 units	\$ 367	\$ 385
1000 units	292	355

1. "Production of Inconel 718 Mortar Tubes by Hydrostatic Extrusion"
Final Report by Battelle, Columbus Laboratories, April 1973.
WVT 74027.

CONCLUSIONS

Based on the results obtained, the following conclusions are appropriate:

1. Cold hydrostatic extrusion of Inco 718 alloy 60mm mortar tubes is feasible.
2. The yield strength of the 718 can be increased from 160 ksi to 240 ksi by the extrusion process over forged and heat treated components.
3. The toughness or impact strength of the extruded and aged 718, as estimated from sub-size specimens, is high for the yield strength obtained and comparable with the standard treated material.
4. A cost savings of about \$390 can be realized with hydrostatically extruded 60mm 718 alloy mortar tubes. However, the costs are still higher than tubes produced from gun steel.
5. An estimated cost savings of \$63 per mortar tube can be obtained in gun steel.

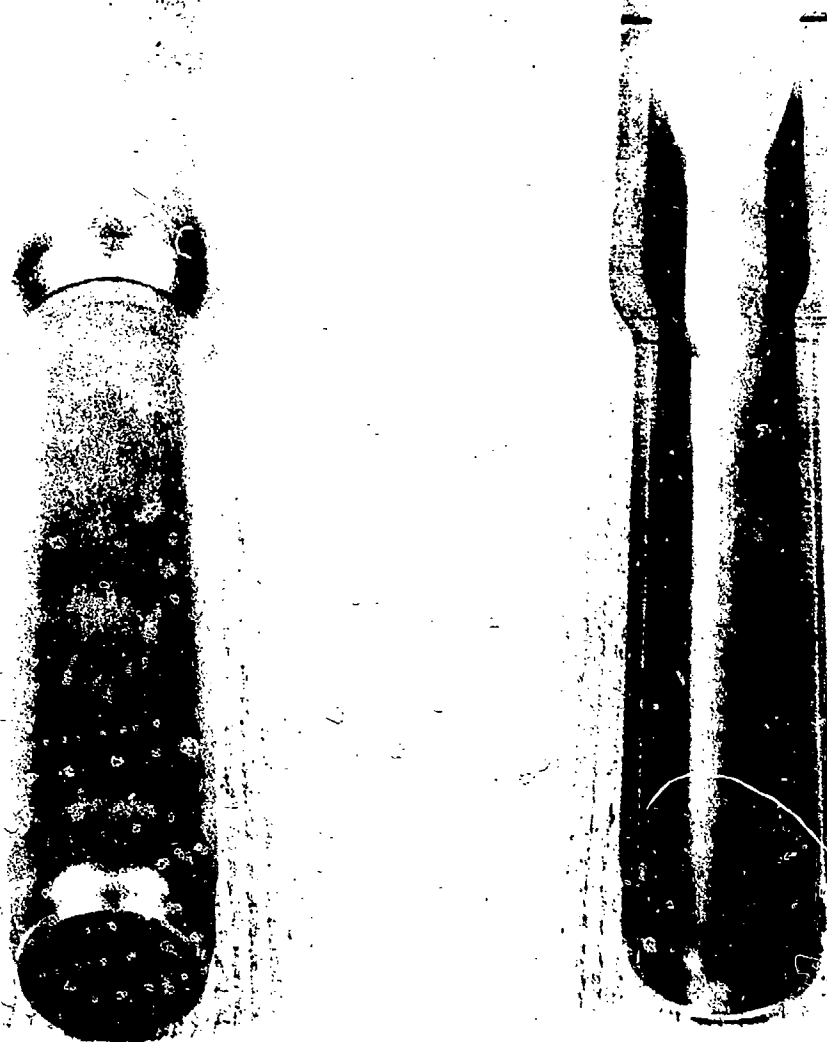

FIGURE 1. SUBSCALE INCONEL ALLOY 718 TUBE EXTRUDED IN THIS PROGRAM SHOWING EXCELLENT ID SURFACE FINISH DUE TO INCORPORATING AN ID REDUCTION DURING EXTRUSION

**COPPER PLATED 1018 ALLOY
BLANK AND EXTRUDED TUBE**

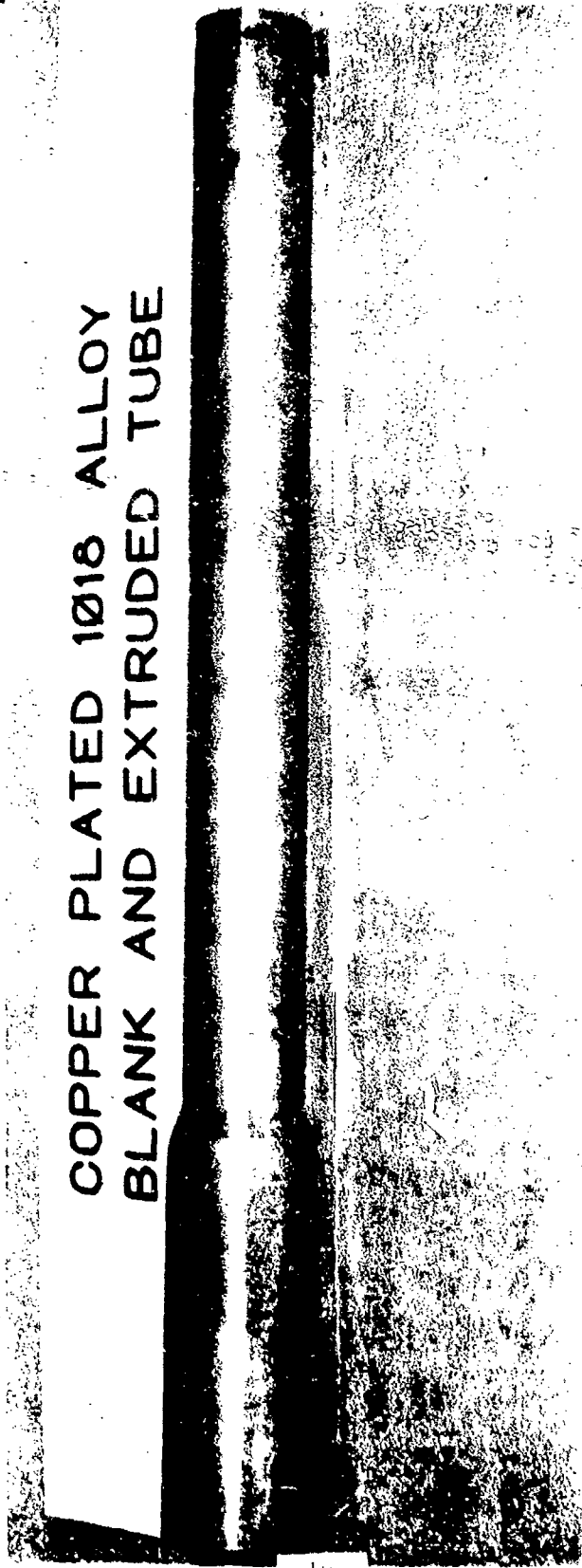

FIGURE 2. Cu Plated AISI 1018 Alloy Blank (left) and Extruded Tube on the Right

EXTRUDED AND AGED 718 ALLOY TUBE

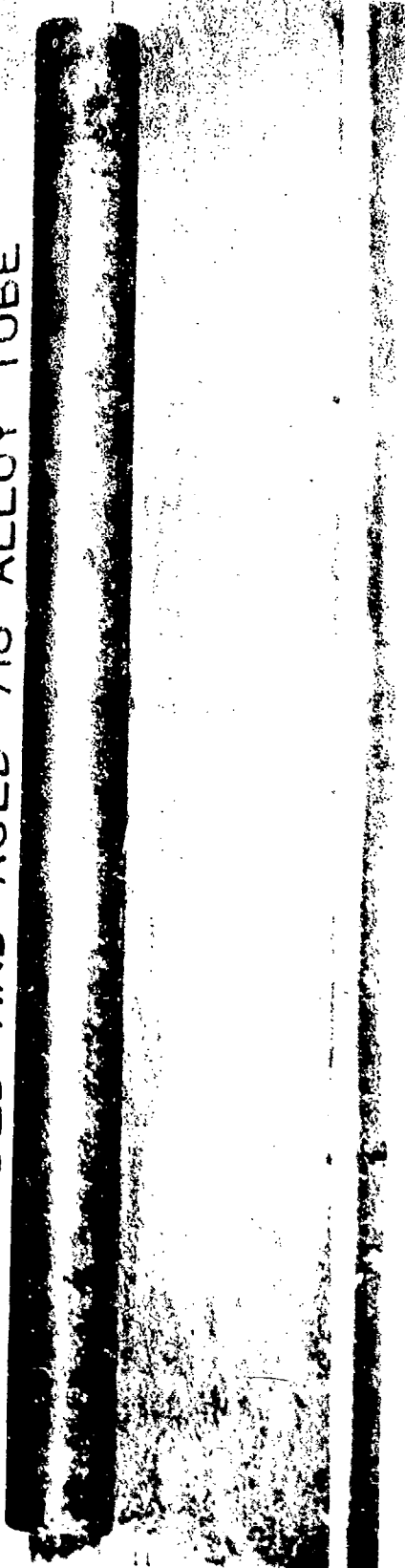

FIGURE 3. As-extruded and Aged Inconel 718 Alloy 60mm Tube

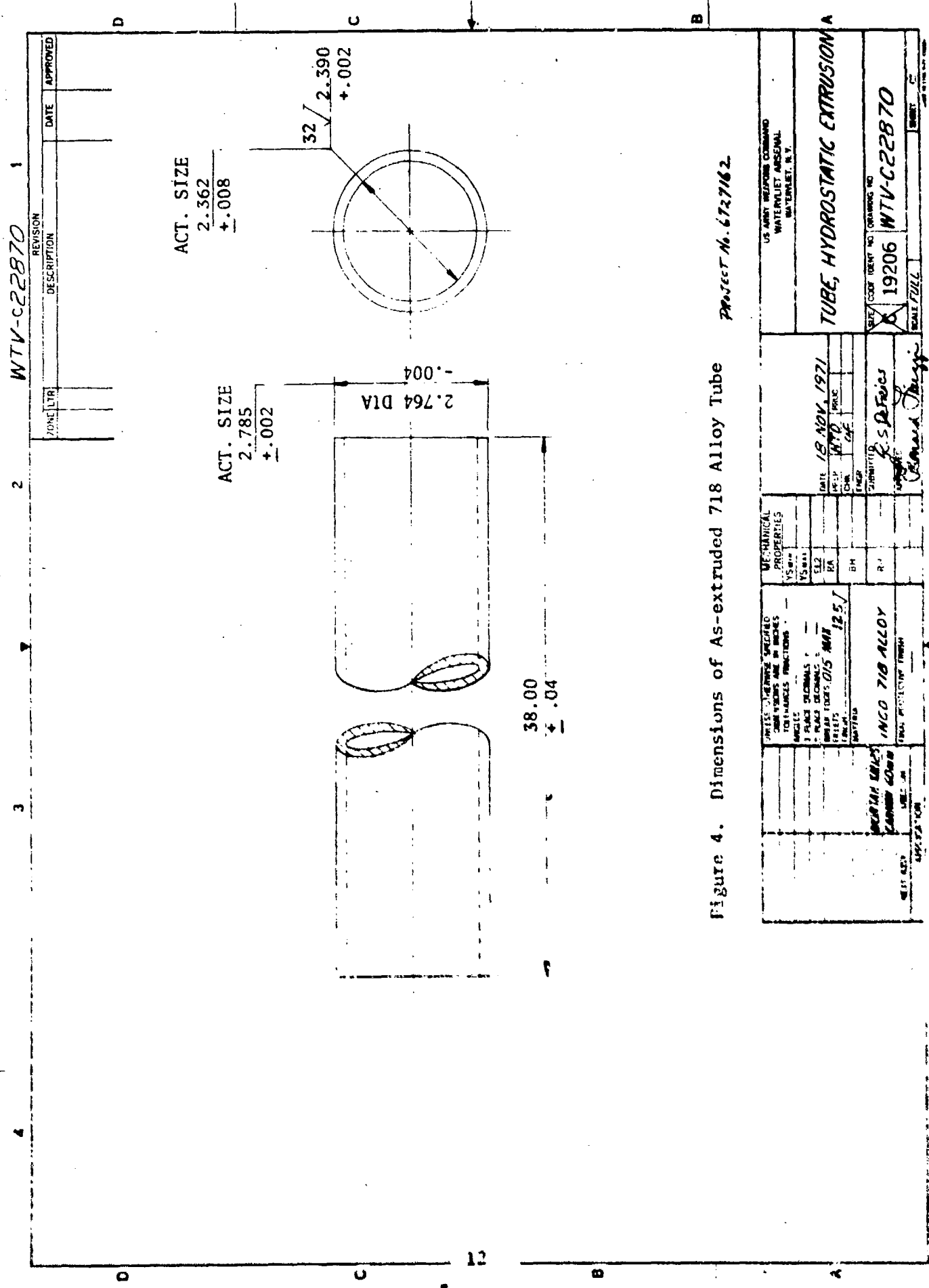

Figure 4. Dimensions of As-extruded 718 Alloy Tube
 PROJECT No. 6727162

WTV-C22870

ZONE	DESCRIPTION	DATE	APPROVED
1			
2			
3			
4			

ACT. SIZE
 2.362
 +.008

ACT. SIZE
 2.785
 +.002

US ARMY RESERVE COMMAND WATERLIET ARSENAL WATERLIET, N.Y.		TUBE, HYDROSTATIC EXTRUSION A	
DATE: 18 NOV. 1971		SIZE / CODE / DEPT NO / DRAWING NO	
BY: [Signature]		19206 WTV-C22870	
CHK: [Signature]		SCALE: FULL	
ENG: [Signature]		APPROVED: [Signature]	
MATERIAL PROPERTIES		MECHANICAL PROPERTIES	
VS 801		VS 801	
SEL 1		SEL 1	
USA 1		USA 1	
BH		BH	
R 1		R 1	
MATERIAL SPECIFICATIONS		MATERIAL SPECIFICATIONS	
1. PLAIN COLUMNS		1. PLAIN COLUMNS	
2. PLAIN COLUMNS		2. PLAIN COLUMNS	
3. PLAIN COLUMNS		3. PLAIN COLUMNS	
4. PLAIN COLUMNS		4. PLAIN COLUMNS	
5. PLAIN COLUMNS		5. PLAIN COLUMNS	
6. PLAIN COLUMNS		6. PLAIN COLUMNS	
7. PLAIN COLUMNS		7. PLAIN COLUMNS	
8. PLAIN COLUMNS		8. PLAIN COLUMNS	
9. PLAIN COLUMNS		9. PLAIN COLUMNS	
10. PLAIN COLUMNS		10. PLAIN COLUMNS	
11. PLAIN COLUMNS		11. PLAIN COLUMNS	
12. PLAIN COLUMNS		12. PLAIN COLUMNS	
13. PLAIN COLUMNS		13. PLAIN COLUMNS	
14. PLAIN COLUMNS		14. PLAIN COLUMNS	
15. PLAIN COLUMNS		15. PLAIN COLUMNS	
16. PLAIN COLUMNS		16. PLAIN COLUMNS	
17. PLAIN COLUMNS		17. PLAIN COLUMNS	
18. PLAIN COLUMNS		18. PLAIN COLUMNS	
19. PLAIN COLUMNS		19. PLAIN COLUMNS	
20. PLAIN COLUMNS		20. PLAIN COLUMNS	
21. PLAIN COLUMNS		21. PLAIN COLUMNS	
22. PLAIN COLUMNS		22. PLAIN COLUMNS	
23. PLAIN COLUMNS		23. PLAIN COLUMNS	
24. PLAIN COLUMNS		24. PLAIN COLUMNS	
25. PLAIN COLUMNS		25. PLAIN COLUMNS	
26. PLAIN COLUMNS		26. PLAIN COLUMNS	
27. PLAIN COLUMNS		27. PLAIN COLUMNS	
28. PLAIN COLUMNS		28. PLAIN COLUMNS	
29. PLAIN COLUMNS		29. PLAIN COLUMNS	
30. PLAIN COLUMNS		30. PLAIN COLUMNS	
31. PLAIN COLUMNS		31. PLAIN COLUMNS	
32. PLAIN COLUMNS		32. PLAIN COLUMNS	
33. PLAIN COLUMNS		33. PLAIN COLUMNS	
34. PLAIN COLUMNS		34. PLAIN COLUMNS	
35. PLAIN COLUMNS		35. PLAIN COLUMNS	
36. PLAIN COLUMNS		36. PLAIN COLUMNS	
37. PLAIN COLUMNS		37. PLAIN COLUMNS	
38. PLAIN COLUMNS		38. PLAIN COLUMNS	
39. PLAIN COLUMNS		39. PLAIN COLUMNS	
40. PLAIN COLUMNS		40. PLAIN COLUMNS	
41. PLAIN COLUMNS		41. PLAIN COLUMNS	
42. PLAIN COLUMNS		42. PLAIN COLUMNS	
43. PLAIN COLUMNS		43. PLAIN COLUMNS	
44. PLAIN COLUMNS		44. PLAIN COLUMNS	
45. PLAIN COLUMNS		45. PLAIN COLUMNS	
46. PLAIN COLUMNS		46. PLAIN COLUMNS	
47. PLAIN COLUMNS		47. PLAIN COLUMNS	
48. PLAIN COLUMNS		48. PLAIN COLUMNS	
49. PLAIN COLUMNS		49. PLAIN COLUMNS	
50. PLAIN COLUMNS		50. PLAIN COLUMNS	

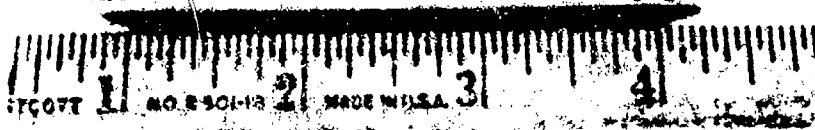

1A

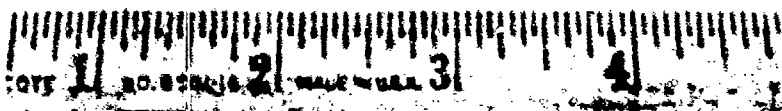

1B

Reproduced from
best available copy.

FIGURE 1. SCOTT NO. 8-301-12



Edge Retainer

Marbles Keament

1909

4416 - 10/10/1909 - 10/10/1909 - 10/10/1909

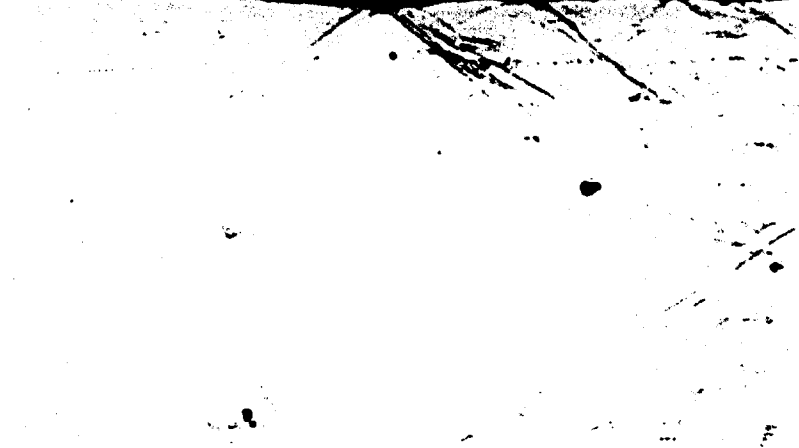

Mobile County

100X

10000

PLAC. 10000 10000

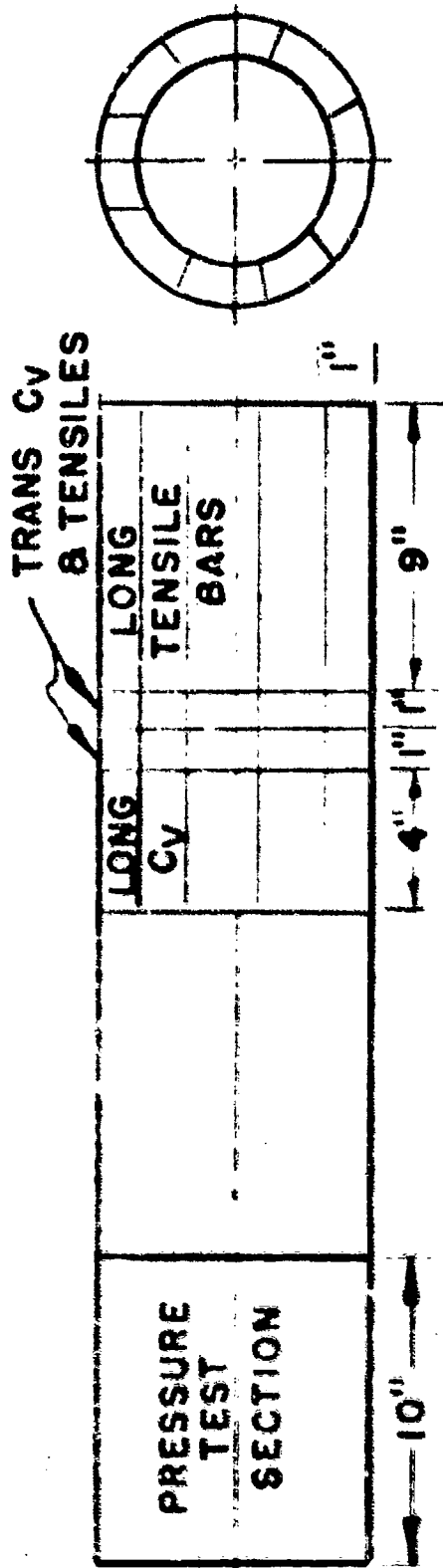

A. LOCATION TEST SPECIMENS FROM EXTRUDED & AGED TUBE

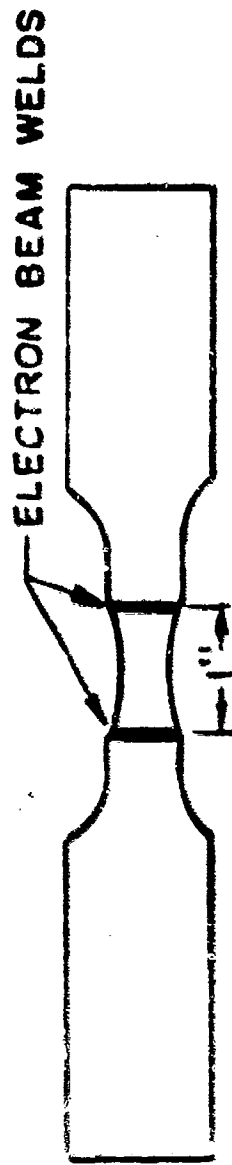

B. ELECTRON BEAM WELDED & AGED TRANSVERSE TENSILE SPECIMEN

FIGURE B. LOCATION OF TEST SPECIMENS AND EB WELDED TRANSVERSE TENSILE TEST SPECIMEN

SUB SIZE CHARPY

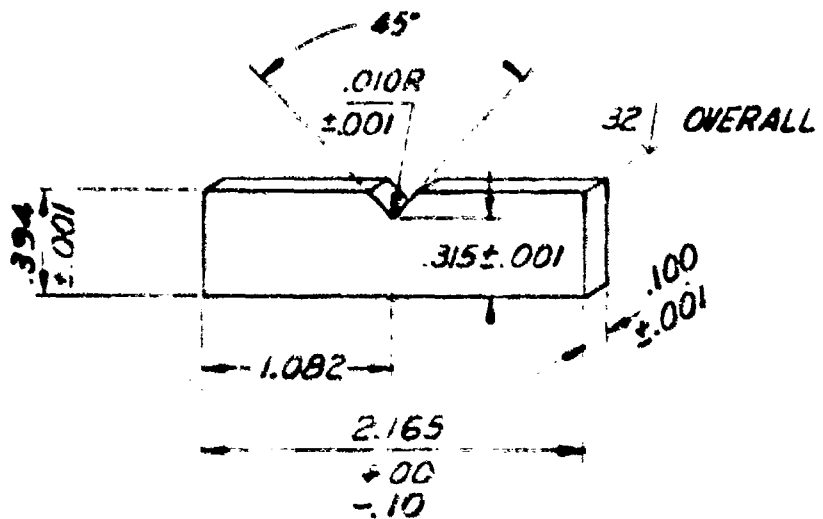

SUB SIZE TENSILE

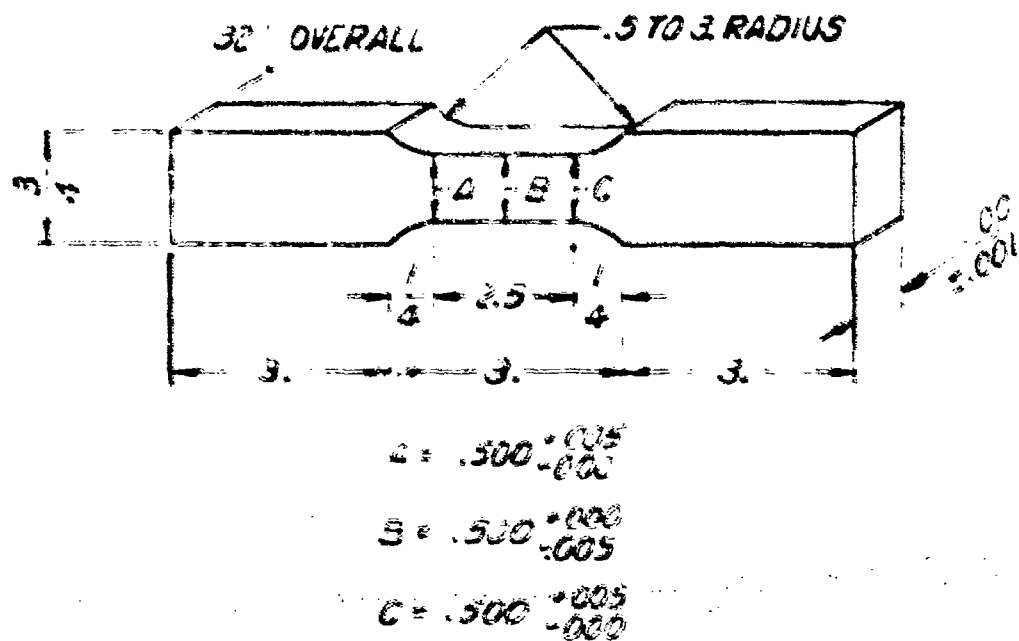

Figure 9. Subsize Charpy and Tensile Test Specimens

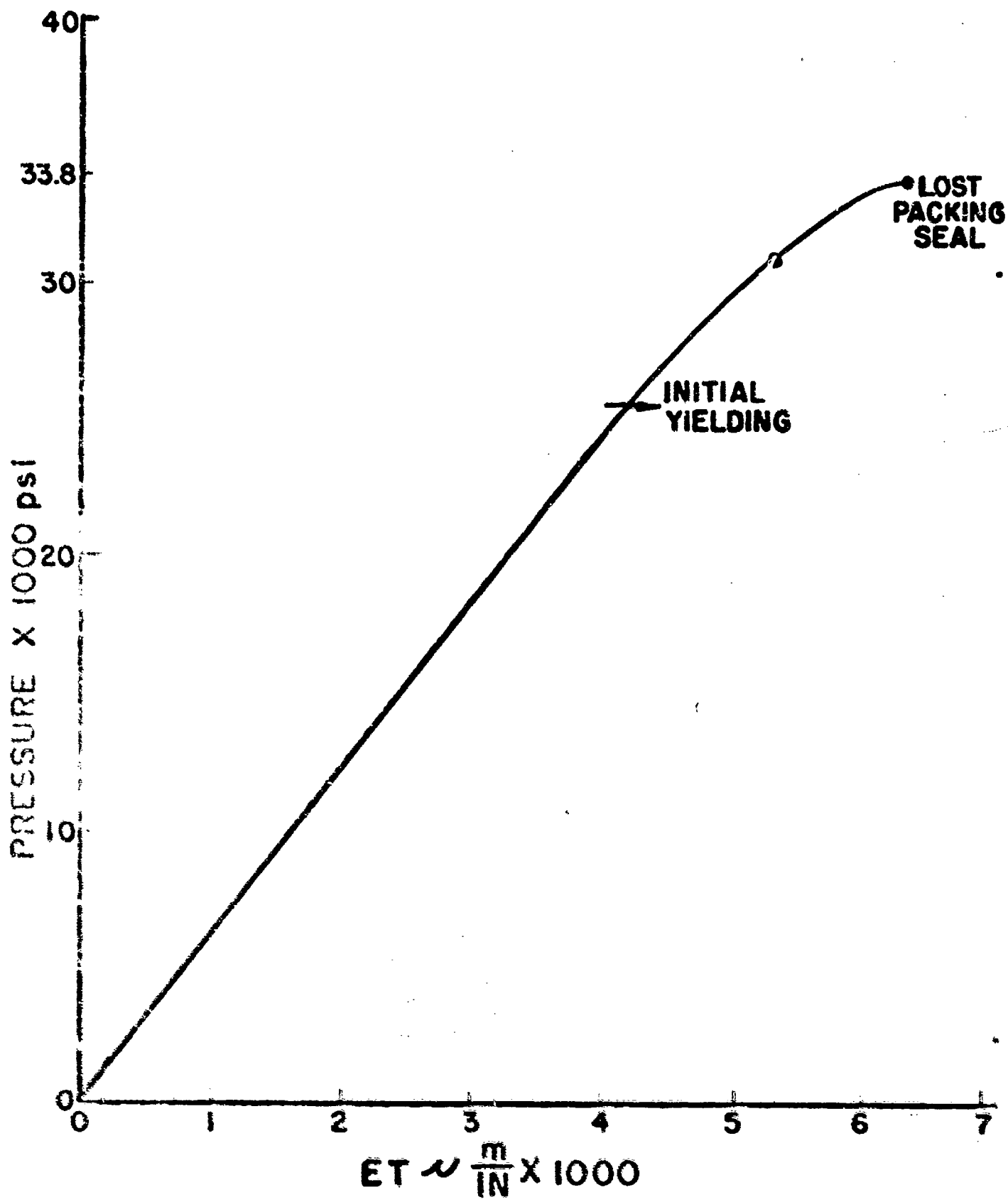
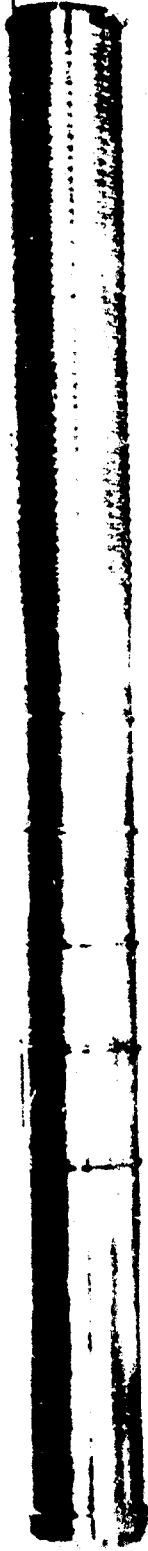

FIGURE 10 EXTRUDED 718 ALLOY TUBE PRESSURE-STRAIN PRESSURE TEST DATA

EXTRUDED AND MACHINED 60MM TUBE



EXTRUDED AND MACHINED 60MM TUBE

TABLE I DIMENSIONS AND CONCENTRICITY CHECK OF EXTRUDED TUBES

NO.	OD		ID (b)		WALL THICKNESS	CONCENTRICITY		STRAIGHTNESS
	BREECH	MUZZLE	BREECH	MUZZLE		BREECH	MUZZLE	
9	(a) 2.761	2.762	2.364	2.368	.198/.197	0.007	0.002	0.005/0.006
10	2.783	2.784	2.361	2.366	.211/.209	0.005	0.001	0.008
11	2.781	2.784	2.363	2.367	.209/.209	0.006	0.001	0.010/0.012
12	2.781	2.783	2.358	2.366	.211/.212	0.005	0.001	0.005/0.012

All values in inches

- (a) OD of this tube was centerless ground before inspection for a cost study.
- (b) ID of tubes were honed before inspection to remove some of the taper caused by the use of a tapered mandrel.

TABLE II TENSILE PROPERTIES OF EXTRUDED AND AGED TUBE (a)

<u>UTS</u> <u>(ksi)</u>	<u>0.1% YS</u> <u>(ksi)</u>	<u>0.2% YS</u> <u>(ksi)</u>	<u>E1</u> <u>%</u>	<u>RA</u> <u>(%)</u>
<u>LONGITUDINAL</u>				
243	231	240	4.8	18.8
250	242	247	3.0	15.0
<u>TRANSVERSE</u>				
231	201	209	2.0	- (b)
232	190	208	6.5	- (b)

TABLE III EXTRUDED 718 ALLOY PRESSURE TEST DATA

Initial Yielding	-----	25.5 ksi
Packing Loss	-----	33.8 ksi
Material 0.1% YS	-----	225.3 ksi

(Computed on the basis of 33.8 ksi internal pressure)

*Failed in the electron beam welded area

TABLE IV V-NOTCH CHARPY IMPACT PROPERTIES(c) OF
EXTRUDED AND AGED TUBES

	Room Temp - (ft-lbs)		-40°F	
Longitudinal	5.2	(23.3) (d)	5.1	(26.0) (d)
	4.8	(21.6)	5.0	(22.6)
	4.6	(20.4)	4.8	(21.6)
Transverse	4.9	(22.0) (d)	3.0	(13.5) (d)

- (a) Flat tensile bars 0.100" thick.
- (b) Tensile bars broke in electron beam weld.
- (c) Impact bars were 0.100" thick subsize specimens.
- (d) Previous studies have shown that the standard size Charpy values are 4.5 times the subsize values.