



AFRL

AIR FORCE RESEARCH LABORATORY//SPACE VEHICLES DIRECTORATE

Small Satellite Thermal Modeling Guide

Initial Release, July 2022

AFRL/RVSV
3550 Aberdeen Dr. SE
Kirtland AFB, NM 87117-5776

DISTRIBUTION STATEMENT A. Approved for public release: distribution unlimited. Public Affairs release approval AFRL20222564



DISCLAIMER

The views expressed are those of the authors and do not reflect the official guidance or position of the United States Government, the Department of Defense, or of the United States Air Force.

Statement from the DoD: The appearance of external hyperlinks does not constitute endorsement by the United States Department of Defense (DoD) of the linked websites, or the information, products, or services contained therein. The DoD does not exercise any editorial, security, or other control over the information you may find at these locations.



Table of Contents

1	Introduction	1
1.1	The Purpose of this Work.....	1
1.2	What is Thermal Design?	1
1.3	Why is Thermal Design Important?	2
1.4	Why is Thermal Modeling and Analysis Important?.....	4
2	Thermal Design Process	5
2.1	Introduction	5
2.2	The Thermal Design Process	5
3	Thermal Modeling.....	11
3.1	Introduction	11
3.2	Fidelity, Accuracy, and Resolution	11
3.3	Thermal Modeling Fundamentals.....	16
3.4	Component Thermal Modeling Process.....	20
3.5	Hand Calculations	22
3.6	Building a Thermal Model.....	29
3.7	Integrated Thermal Model of a 3U CubeSat Bus	41
4	Thermal Analysis	47
4.1	Introduction	47
4.2	Thermal Cases	47
4.3	Operational and Survivable Temperatures.....	49
4.4	Running Simulations	50
4.5	Analyzing Results	51
4.6	Example Thermal Analysis	52
5	Thermal Control.....	61
5.1	Introduction	61
5.2	Thermal Control Methods.....	61
5.3	Mission Lifetime Considerations.....	66
6	Model Verification and Validation	67
6.1	Introduction	67
6.2	Verifying a Model.....	67
6.3	Validating a Thermal Model.....	68



6.4 Model Correlation..... 69

7 Orbital Thermal Environment 73

 7.1 Introduction 73

 7.2 Orbital Mechanics 73

 7.3 Heat Fluxes..... 77

 7.4 Eclipse Duration and Beta Angle [32] 79

Appendix A Nomenclature & Acronyms..... 83

Appendix B Deliverables..... 87

Appendix C Bibliography 89



List of Figures

Fig. 1.1 Iterative Process of Thermal Design..... 2

Fig. 1.2 James Webb Telescope Thermal Insulation [2]..... 3

Fig. 2.1 Typical Thermal Design Process 6

Fig. 3.1 ISISPACE Bracket..... 14

Fig. 3.2 ISISPACE Bracket Thermal Desktop Models 15

Fig. 3.3 Modeling Radiation Absorption 17

Fig. 3.4 Component Thermal Modeling Process 20

Fig. 3.5 In-plane Verses Out-of-plane 26

Fig. 3.6 Steady State Temperature Vs. Internal Heat Generation 29

Fig. 3.7 ISISPACE 3U CubeSat Physical Structure (left) and Thermal Model (right)..... 30

Fig. 3.8 ISISPACE VHF uplink/UHF downlink Full Duplex Transceiver [17]..... 33

Fig. 3.9 Transceiver Parametric Study..... 34

Fig. 3.10 PCB Stack and Structure 35

Fig. 3.11 ISIS 3U Solar Panel..... 36

Fig. 3.12 Modeled Solar Panel and Structure 38

Fig. 3.13 ISISPACE EPS [20]..... 39

Fig. 3.14 EPS Thermal Model 40

Fig. 3.15 Complete Thermal Model 42

Fig. 4.1 Cold Case Orbit (left) and Hot Case Orbit (right)..... 53

Fig. 4.2 Hot Case Operational Thermal Model..... 55

Fig. 4.3 Transceiver Hot Case Operational Temperature Profile 57

Fig. 4.4 Cold Case Survival Thermal Model 58

Fig. 4.5 Transceiver Cold Case Survival Temperature Profile 59

Fig. 4.6 EPS W/Heater Power Cold Case Survival Temperature Profile..... 60

Fig. 5.1 Example of Multilayer Insulation [24] 63

Fig. 5.2 Example Radiator [25] 64

Fig. 5.3 Example Thermal Straps [26] 64

Fig. 5.4 Example Flexible Heaters [27] 65

Fig. 6.1 Thermal margin terminology for JPL/NASA programs [12]..... 68

Fig. 6.2 Types of Errors in Thermal Model Correlation..... 69

Fig. 6.3 Example Initial Model Correlation [31] 70

Fig. 6.4 Example Final Model Correlation [31]..... 70

Fig. 7.1 Anatomy of an Orbit [32] 73

Fig. 7.2 Earth's Orbit Around the Sun [32] 74

Fig. 7.3 Celestial Inertial Coordinate System [32] 74

Fig. 7.4 Solar Vector [32]..... 75

Fig. 7.5 Orbit Normal Vector [32]..... 75

Fig. 7.6 Beta Angle [32] 76

Fig. 7.7 Variation in Beta Angle Due to Seasonal Variation and Orbit Precession [32] 77

Fig. 7.8 Variation in Eclipse Duration as a Function of Beta Angle [32]..... 77

Fig. 7.9 Fraction of Orbit Spent in Sunlight/Eclipse [32] 79

Fig. 7.10 Intermediate Frame [32] 80

Fig. 7.11 Eclipse Entry and Exit [32] 81



List of Tables

Table 3.1 Example Model Iteration for a 3U CubeSat	13
Table 3.2 CubeSat Final Node Number Estimate	13
Table 3.3 Spatially Averaged Properties Example	27
Table 3.4 Hand Calculation Thermal Environment Parameters	27
Table 3.5 Hand Calculation Effective Emissivity and Absorptivity	28
Table 3.6 Hand Calculation Heat Values	28
Table 3.7 CubeSat Structure Final and Node Count Estimates	31
Table 3.8 Example Screw Conductances [5]	32
Table 3.9 Sample TIM Conductance Values	32
Table 3.10 Transceiver Parametric Study	34
Table 3.11 Solar Panel Parameters	37
Table 3.12 Solar Panel Volume and Mass	37
Table 3.13 Solar Panel Effective Specific Heat	37
Table 3.14 Spatially Averaged Solar Panel Parameters	38
Table 3.15 EPS Component Properties 1	39
Table 3.16 EPS Component Properties 2	40
Table 3.17 EPS Calculated Volume and Mass	40
Table 3.18 EPS Effective Specific Heat	40
Table 3.19 Payload Thermal Properties	41
Table 3.20 Complete Thermal Model Node Count	43
Table 3.21 Mass Budget	43
Table 3.22 Connections	44
Table 3.23 Optical Properties	44
Table 3.24 Thermophysical Properties	45
Table 4.1 Typical Orbit-Average Earth IR and Albedo Values for Various Orbits [21]	48
Table 4.2 Example Thermal Cases	49
Table 4.3 ISS Orbital Parameters [22]	52
Table 4.4 Example Thermal Analysis Cases	53
Table 4.5 Heat loads	54
Table 4.6 Component Temperature limits	54
Table 4.7 Hot Case Operational Component Results	56
Table 4.8 Cold Case Survival Component Results	58
Table 5.1 Properties of Common Finishes [23]	62
Table 7.1 Deliverables - Mass Budget	87
Table 7.2 Deliverables - Contactors	87
Table 7.3 Deliverables - Material Properties	87
Table 7.4 Deliverables - Optical Properties	87
Table 7.5 Deliverables - Applied Heat Loads	87
Table 7.6 Deliverables - Thermal Cases	88
Table 7.7 Deliverables - Detailed Orbits Table	88
Table 7.8 Deliverables - Results Table	88



Authors

Isaac Foster. Spacecraft Thermal Engineer, Air Force Research Laboratory Space Vehicles Directorate. MS (Aerospace Engineering), Missouri University of Science and Technology; BS (Aerospace Engineering), Missouri University of Science and Technology.

Reviewers

1st Lt Mary Albrecht. Thermal Thrust Lead, Air Force Research Laboratory Space Vehicles Directorate. BS (Mechanical Engineering), Colorado School of Mines.

Jonathan Allison. Integrated Structural Systems Team Lead, Air Force Research Laboratory Space Vehicles Directorate. MS (Aerospace, Aeronautical and Astronautical Engineering), MIT; BS (Mechanical Engineering), Rice University.

Emi Colman. Junior Systems Engineer support AFRL/SSP, Axient. BS (Mechanical Engineering), Michigan Technological University.

Dr. Derek Hengeveld. Senior Engineer, Redwire Space. PhD (Mechanical Engineering), Purdue University; MS (Engineering), South Dakota State University; BS (Mechanical Engineering), South Dakota State University.

Dr. Henry Pernicka. Professor of Aerospace Engineering, Missouri University of Science and Technology. PhD (Aeronautical and Astronautical Engineering) Purdue University.

Ian Williams. Thermal Subsystem Lead, Missouri S&T Satellite Research Team (M-SAT). Student, Missouri University of Science and Technology.



Revision History

Revision	Primary Author(s)	Notes	Date
1.0	Isaac Foster	Initial Release	July 2022

1 Introduction

“You control the model, don’t let the model control you” – Jon Allison, Air Force Research Laboratory

1.1 The Purpose of this Work

This work is an introduction to the methods and concepts necessary to develop and analyze a small satellite thermal model¹. The reader can apply this knowledge to better develop a successful thermal design. The topics of thermal design, thermal modeling, thermal analysis, and thermal control will be introduced and discussed. Additionally, thermal design from a systems engineering perspective is discussed. Throughout this work, industry standard software is used to demonstrate the methods and concepts being presented.

This work assumes that the reader has a basic understanding of orbital mechanics, heat transfer, and satellite components. While the reader is not required to be an expert in these fields, the reader should understand the basic concepts (i.e., what they are and why they are important). New concepts and topics are introduced and defined as necessary throughout this work.

1.2 What is Thermal Design?

Thermal design is the process of building a thermal model, analyzing the model in different operating conditions, and designing thermal control. The inputs to thermal design include but are not limited to

- Orbital characteristics
- Material properties
- Optical properties
- Mission parameters
- Mission modes
- Mission lifetime
- Payload requirements
- Pointing requirements
- Physical design

These inputs are dynamic and change throughout the design process of the satellite, requiring consistent communication between the thermal team and other subsystems. From these inputs, the process of thermally modeling the satellite, analyzing the thermal model, and applying thermal control is performed. From this process, various outputs are determined which include but are not limited to

- Component minimum and maximum temperatures
- Temperature profiles
- Average heater power required
- Heater duty cycles
- Thermal control requirements (e.g., thermal coating, insulation, etc.)

This process is illustrated in Fig. 1.1.

¹ Small satellites are spacecraft with a mass less than 180 kg. [41].

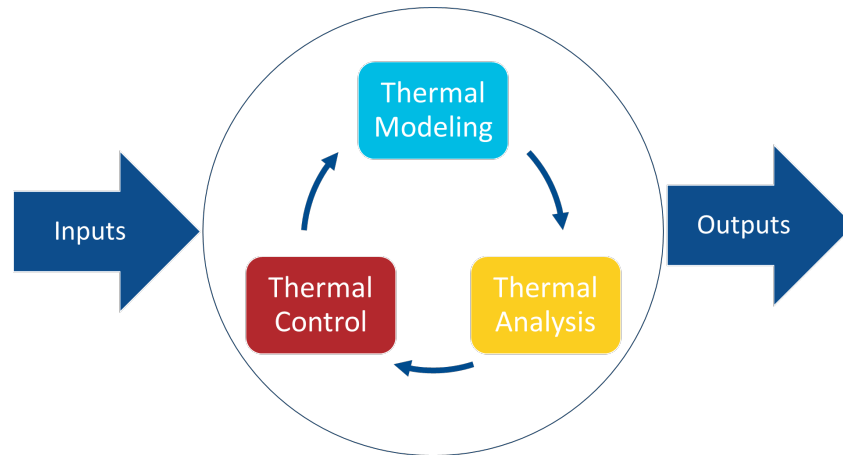

Fig. 1.1 Iterative Process of Thermal Design

The terms “thermal modeling” and “thermal analysis” are often used interchangeably to describe the process of thermal design. However, in this work, thermal modeling, thermal analysis, and thermal control are treated as individual components in the overall process of thermal design. They are defined as follows:

- **Thermal Modeling:** The process of modeling a satellite’s thermal characteristics using representative thermal surfaces. Physical geometry is converted into a thermal model that can be simulated and analyzed.
- **Thermal Analysis:** The process of simulating and analyzing a thermal model. The results of this analysis are used to predict outputs of interest (e.g., on-orbit temperatures) and select thermal control components/methods.
- **Thermal Control:** The process of selecting thermal control hardware and implementing it on the spacecraft.

Thermal modeling, thermal analysis, and thermal control are often performed jointly and iteratively. Changes in the thermal control system of a satellite should be reflected in the thermal model, which will require an updated thermal analysis. Information from an updated analysis will inform changes made to the thermal control. Importantly, thermal control bridges the gap between the thermal model and the physical satellite. Once a model has been built, analyzed, and simulated thermal control applied, it is then necessary to physically apply this thermal control, whether it be the application of surface coatings, heaters, or other thermal control mechanisms (see Section 5 for more details on thermal control hardware). A successful thermal design will cohesively synthesize the results from these three tasks.

1.3 Why is Thermal Design Important?

A good thermal design is critical to mission success. Every satellite component has a temperature and allowable temperature limits. A good thermal design will successfully maintain all component temperatures within allowable limits while meeting all design requirements. A poor thermal design can cause components to fail and result in mission loss. The mission and the payload must drive the thermal design. Some examples of good thermal design and control are provided in the following subsections.

1.3.1 Apollo Spacecraft² Axial Rotation

During the Apollo missions, the Command Module (CM) and Lunar Landing Module (LM) were required to support three astronauts across three different thermal environments: Earth orbit, cislunar space, and lunar orbit. While orbiting the Earth and the Moon, the spacecraft received periodic cooling and heating as it passed in and out of eclipse. This was not the case in cislunar space. To cool the spacecraft and reduce the thermal gradient from the “hot side” to the “cold side,” the spacecraft was spun about its velocity vector, which allowed all sides of the spacecraft to experience periods of heating and cooling, helping to maintain the satellite’s temperature within allowable limits [1]. Today, this maneuver is often referred to as, “barbequing” or “roisserie.”

1.3.2 James Webb Telescope Passive Sunshield

The James Webb Space Telescope’s (JWST) mission is to perform infrared astronomy. To perform measurements in the near-infrared to mid-infrared, instruments must be at cryogenic temperatures³. In order to reach these temperatures, JWST utilizes a five-layer sunshield to passively cool the instrumentation and mirrors. Each layer is made of Kapton and coated with aluminum. This method allows JWST to reach the cryogenic temperatures. However, certain instruments must be cooled to below 50 K. These instruments are actively cooled using cryocoolers. This is an excellent example of a spacecraft design being driven by thermal considerations. Additionally, it is an excellent example of using passive thermal control wherever possible and active thermal control when necessary. Figure 1.2 shows the layers of radiative insulation.

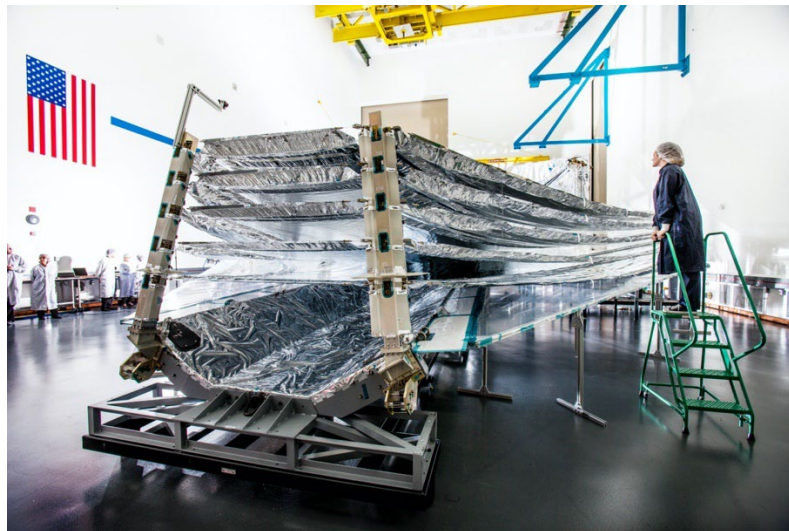

Fig. 1.2 James Webb Telescope Thermal Insulation [2]

1.3.3 Juno Spacecraft Eclipse Avoidance

Due to a failure in the main propulsion system, the Juno spacecraft orbiting Jupiter was forced to alter its pre-defined mission plan. While not immediately dangerous, if the mission plan went unaltered, Juno would pass through Jupiter’s shadow for 11 hours during a future orbit, likely causing the spacecraft to reach unacceptably cold temperatures. Over the course of a 10.5 hour orbital maneuver, the spacecraft’s

² A spacecraft is a vehicle design to operate in space. A satellite is a spacecraft that is orbiting a celestial body.

³ Sources differ on the definition of cryogenic temperatures. One common definition is the boiling point of liquid nitrogen (77.36 K), a temperature below which may be considered cryogenic.

orbit was changed so that it would not pass-through Jupiter's shadow [3]. While not a direct thermal control measure, this example illustrates the effects of orbital mechanics and mission planning on a spacecraft's thermal environment.

1.3.4 TEMPEST-D Thermal Zones

The TEMPEST-D small satellite was built by Colorado State University and JPL to test microwave radiometry. The payload had a required temperature control of +/- 1.5 K for critical components and a maximum temperature gradient of 5 K across the payload mounting platform [4]. To accommodate these restrictions, the payload platform was thermally isolated from the rest of the satellite while heaters were used to thermally control the payload. By thermally isolating the payload, greater temperature control authority was achieved. This is a good example of utilizing the physical design of a satellite for thermal control purposes.

1.4 Why are Thermal Modeling and Analysis Important?

A good thermal model and an accurate thermal analysis are necessary to synthesize a good thermal design. The thermal model must accurately represent the thermal characteristics of the satellite, and the thermal analysis must accurately predict the range of temperatures that satellite components will experience and correctly inform thermal control selection. Additionally, a good thermal model and thermal analysis are necessary for good mission planning. Thermal analysis can reveal mission mode requirements and operational restrictions. These requirements will inform mission planning, which will increase the likelihood of mission success. In contrast, a bad thermal model will lead to an inaccurate thermal analysis, which will lead to poor thermal control selection, resulting in a bad thermal design.

Note that a thermal model can be "right" (i.e., correctly predict on orbit temperatures) and still be a bad model because the model did not answer the right questions, was not completed on time, cost too much money, or was inefficient. Thermal design is not performed independently of the design process for a satellite. Thus, thermal modeling, analysis, and control selection must also adhere to scheduling and budgetary requirements. Additionally, if the thermal engineer does not pose the right questions to the thermal model, then one could argue that it is still a bad thermal model. For instance, if a mission plan calls for an orbital inclination of 0°, it is not useful (i.e., it is asking the wrong question) to determine satellite component temperatures for an orbital inclination of 45°. The model may be "right" but it is still a bad model because it is providing information that is not useful for accomplishing the mission.

2 Thermal Design Process

"Trust the Process"

2.1 Introduction

This section outlines the process of thermal design and describes the steps towards formulating a complete thermal model. Every project will have its own unique requirements, challenges, and deliverables. The thermal design process must serve the mission and the payload. Therefore, the reader should use the steps and processes outlined here as guidelines for their respective project.

2.2 The Thermal Design Process

There are seven primary tasks in a typical thermal design process: characterize, build, simulate, analyze, apply control, verification and validation, and deliver. These seven tasks can be grouped together into four phases:

- Phase 1: Characterize and Build
- Phase 2: Simulate, Analyze, and Apply control
- Phase 3: Verification and Validation
- Phase 4: Deliver

Phase 1 focuses on gathering information about the satellite design and mission plan (characterize) and incorporating this information into a thermal model (build). Initial results from the thermal model can be communicated to other subsystems to inform their design decisions. Phase 2 focuses on simulating the thermal model built in Phase 1 (simulate), analyzing the results of these simulations and drawing useful conclusions (analyze), and applying thermal control based on these conclusions (apply control). Note that the thermal model is continually updated throughout Phase 1 and 2.

Phase 3 establishes confidence in the thermal model by verifying that the thermal model was built correctly (verification) and validating that it was the correct model to build (validation). Phase 4 focuses on communicating the methods, results, and conclusions to the customer. In the context of thermal design, the customer can be other subsystem engineers, program managers, or the entity that is buying the satellite. Note that each of the tasks and phases will have design inputs and outputs. For instance, an input during the Phase 1 would be material properties while an output would be estimated power needs for the thermal control system (TCS). Maturation of the satellite design and progression through the thermal design phases roughly correspond to each other.

Each of the seven primary tasks is described in detail in the following subsections. Figure 2.1 illustrates a typical thermal design process for a satellite. In the figure, example inputs and outputs from various satellite subsystems are given. In reality, there are many more inputs and outputs than illustrated in the figure. Take note of the iteration present within the process of thermal design.

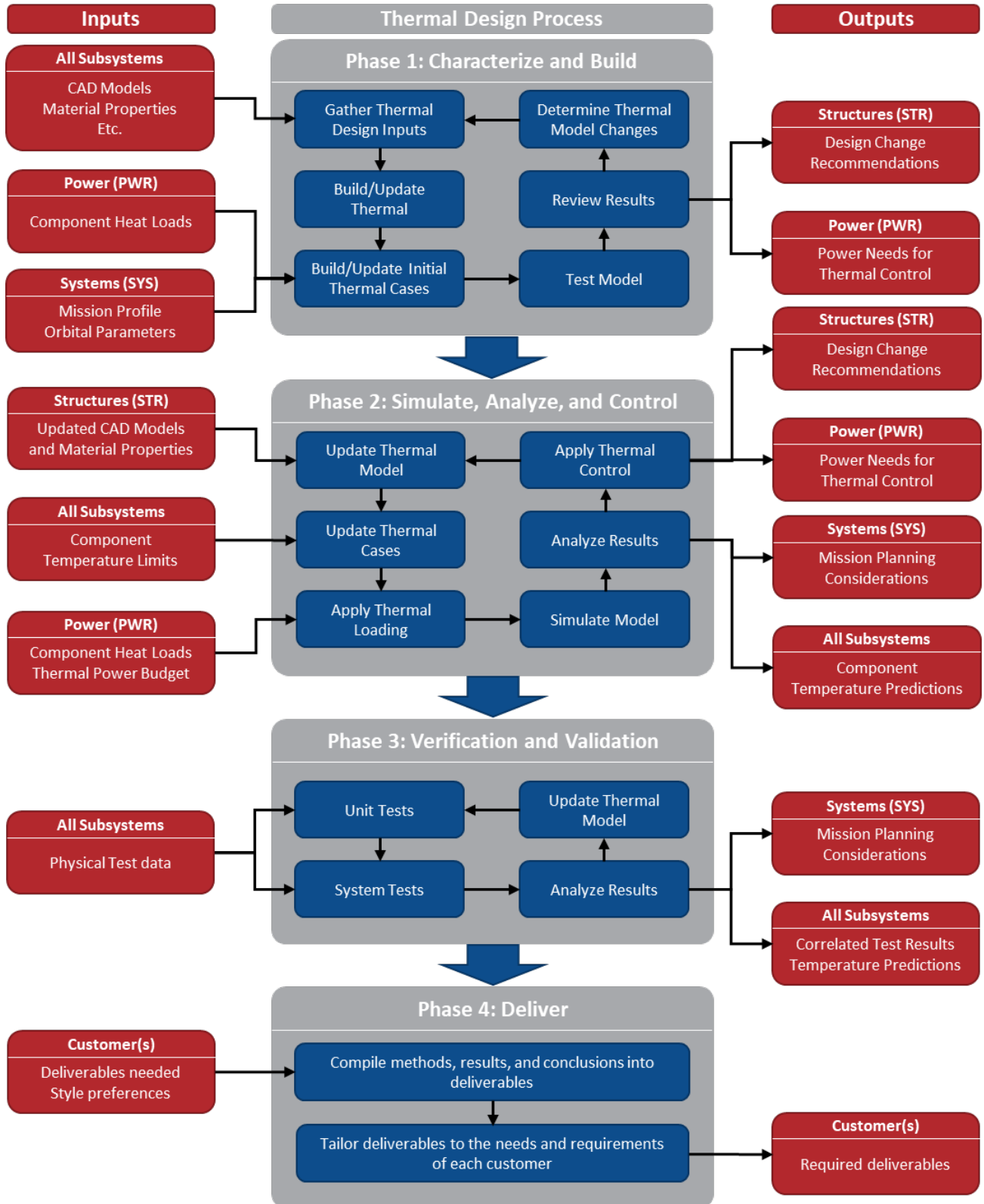

Fig. 2.1 Typical Thermal Design Process

2.2.1 Characterize

The goal of this task is to understand the requirements and parameters of the mission, design, and payload of the satellite. Characterizing and building a model often occur in parallel. This phase requires excellent communication between the thermal team and other subsystem teams, especially the systems engineering team. The thermal team should clearly define what inputs are needed to complete a successful thermal design. At a minimum, the following thermal design inputs should be characterized (this list is not exhaustive):

- **Mission Modes:** The operational modes of a satellite should be characterized from a thermal perspective. The thermal loads a satellite will experience are a function of the component and the mission mode. Components must be able to operate in both “hot” and “cold” mission modes to accomplish the mission. These mission mode extremes should be integrated into hot and cold thermal case definitions.
- **Orbit:** The orbit of a satellite will determine the amount of thermal loading received from the Sun and Earth (or other celestial body). Expected solar flux, Earth albedo, Earth IR, and beta angles should be included in the orbit definition (these environmental characteristics are defined in Section 7). Time of year should also be taken into consideration as this affects the amount of incoming solar radiation. A “hot” and “cold” orbit can be defined that maximize and minimize the amount of thermal loading received from the Earth and Sun, which should be integrated into hot and cold thermal case definitions. These orbits should be defined within the limits of the mission.
- **Material Properties:** Thermophysical and thermo-optical properties of the materials used on the satellite should be determined. Thermophysical properties include density, specific heat capacity, and thermal conductivity. Thermo-optical properties include absorptivity and emissivity. Any components with anisotropic properties should also be determined. Material properties can be obtained from a variety of sources, including the Spacecraft Thermal Control Handbook and matweb.com. Sources used for material properties should always be documented.
- **Resource Allocation:** The thermal control system (TCS) resource allocation should be determined. TCS resources include but are not limited to mass budget, number of temperature sensors, number of heaters, power budget for thermal control, and pointing control of the satellite. Mission modes will affect the power budget and pointing control⁴. Additionally, reliability requirements should be determined as this will affect thermal control component selection. Inputs from other subsystems will determine the resources available for the TSC.
- **Geometry and Heat Flow:** The satellite’s physical geometry should be characterized from a heat flow perspective. A thermal model of the satellite is built using the structural model as a reference. This process is described further in Section 3.6. The geometry and material properties together determine how heat will flow through a satellite via conduction. How components are linked together (screws, epoxy, etc.) should be determined as this will affect component-to-component thermal conductances. Special attention should be given to the location of mission critical components, such as the flight computer and payload. Thermal models should not be built until the heat flow through the satellite has been properly characterized.

⁴ Pointing refers to the direction in which a spacecraft is oriented.



- **Heat Loads:** Heat loads from the space thermal environment and internal components should be characterized in terms of location, timing with respect to mission modes, and magnitude. Heat dissipation from components is usually a function of the mission mode⁵. Thermal loading from the Sun and Earth is a function of the orbit. When heat loads will occur with respect to eclipse/sunlit conditions and other orbit parameters should be carefully determined. Components will often list operational and nominal power usage. This information when combined with component efficiency can be used to determine component heat generation during different mission modes. Mission mode power requirements should be obtained from the power team.

The information gathered during the characterization task and throughout the thermal design process should be organized into deliverables. These deliverables should be reported to the chief engineer, program manager, final customer, and other persons as required. What and how deliverables are reported should be tailored to needs and requirements of the respective person(s) being informed. It is recommended that the following tables be created to track deliverables during the thermal design process. This list is not exhaustive and should be taken as an example only. Appendix B describes these tables in more detail.

- Thermal Model Revisions
- Component and Mass Budget
- Thermal Contactors
- Material Properties
- Optical Properties
- Heat Loads
- Thermal Cases

2.2.2 Build

The goal of this task is to build a thermal model that is accurate, informative, and meets the requirements of the mission. Thermal models represent how heat will be absorbed, stored, and rejected by the satellite and how heat will flow through the satellite. Thermal models do this using thermal objects that represent the physical geometry and thermal characteristics of satellite components. Thermal objects include thermal nodes, thermal surfaces, and thermal solids. A good thermal model will accurately predict the temperatures of the satellite during the mission, accurately inform thermal control selection, and be valid for the conditions being simulated.

Building a thermal model is an iterative and collaborative process often occurring in parallel with the characterization phase. The thermal team should carefully communicate to other subsystem teams what inputs are needed for the thermal model. All required inputs will not be known when a thermal model is begun. Therefore, early thermal models should be simple, which will allow the thermal team to answer basic design questions. As the satellite design matures, the fidelity of the thermal model will increase. As seen in Fig. 2-1, characterizing and building a model also provides information to other subsystems with respect to design decisions and mission planning considerations. Building a thermal model is discussed in Section 3.

2.2.3 Simulate

The goal of this task is to define thermal cases that accurately represent the thermal conditions the satellite will experience and simulate the thermal model in these cases. Thermal cases should accurately represent the various thermal environments the satellite will experience. These cases are often associated

⁵ Dissipation is the conversion of energy from a useful form (electric potential) to a less useful form (heat). Thermal dissipation refers to the heat generated by components. Thermal rejection is the radiation of heat to space.

with specific mission modes. Additionally, thermal cases can represent the maximum and minimum temperatures the satellite could realistically experience during the mission. These maximum and minimum thermal cases are referred to as “hot cases” and “cold cases,” respectively. Simulating maximum and minimum heat loads helps account for errors and uncertainties in the thermal model. Internal heat loads, solar flux, Earth albedo, Earth IR, beta angle, orbit altitude, and TCS power usage should be included in a thermal case definition. By simulating the satellite across a range of thermal conditions, an operational envelope can be defined.

The parameters used for defining thermal cases should remain realistic and within the scope of the mission plan. Theoretical “worst case scenarios” should not be used for hot and cold case definitions [5]. Just like the satellite should be designed for the mission, the thermal model and thermal cases should also be designed for the mission. Hot cases should be representative of the maximum temperatures the satellite may realistically experience during its mission. Cold cases should be representative of the minimum temperatures the satellite may realistically experience during its mission. Nominal cases should be representative of the “normal” temperatures the satellite will experience during its mission, especially when the satellite is not in a power intensive mission mode.

Once thermal cases have been appropriately defined, the thermal model should be simulated in these thermal cases. How a thermal model is simulated depends on the type of thermal model. For a thermal model built in a thermal modeling software like Thermal Desktop, this will involve entering the appropriate parameters and commanding the software to complete the calculations. For a thermal model built “by hand” using Microsoft Excel, MATLAB, or coding language, this will involve writing and solving the necessary mathematical equations. Simulating a thermal model is discussed in Section 4.

2.2.4 Analyze

The goal of this task is to understand the results of simulating the thermal model and draw meaningful, actionable, and informative conclusions. All component minimum and maximum temperatures should be compared against acceptable temperature limits. The location of local hot and cold spots should be identified in relation to heat generating components. As the model matures, thermal margins of components should be determined. If a component is in danger of exceeding temperature limits, thermal control should be applied to increase the thermal margin. The final model should not be overly sensitive to minor adjustments in properties or characteristics (i.e., the model should be robust). Analyzing a thermal model and verifying a thermal model often occur in parallel. Analyzing a thermal model is discussed in Section 4. Verifying a thermal model is discussed in Section 6.2.

2.2.5 Apply Control

The goal of this task is to take the conclusions formed from the thermal analysis and apply thermal control in order to ensure the satellite remains within acceptable temperature limits during the mission. As results are generated from simulating the thermal model and conclusions drawn from the thermal analysis, a thermal control strategy and design should be chosen. Thermal engineers can choose active and/or passive methods to control satellite temperatures. Active thermal control components require electricity and/or moving parts to operate and include heaters, cryocoolers, and pumped fluid loops⁶. Passive thermal control components include surface coatings, insulation, and radiators. In general, passive methods are more reliable than active methods because they do not require moving parts or inputs.

⁶ In industry, heaters are sometimes considered to be passive components, since they require no moving parts. In the context of small satellite design, it is the opinion of the author that heaters be classified as active components.

Additionally, passive methods have lower SWaP-C, have shorter procurement lead times, and do not produce vibrations. SWaP-C stands for size, weight, power, and cost and refers to the amount of available resources a component consumes. Note that size (available volume), weight (mass budget), power (power budget), and cost (financial budget) are all resources in spacecraft design.

The thermal control system of a satellite must meet design requirements, including mass budget, power budget, and structural requirements. Thermal control components can have restrictions on their size, power consumption, time of operation, and physical location. The thermal team must work carefully with other subsystem teams and systems engineers to design a control system that satisfies all design requirements. Thermal control methods are discussed in Section 5.

2.2.6 Verification and Validation (V&V)

The goal of this task is to verify that the thermal model was built correctly and that the right thermal model was built. Thermal models should be verified and validated throughout the thermal design process. Verification is the process of confirming that the thermal model is built correctly. This includes verifying that the correct parameters, materials, and design assumptions have been used. Validation is the process of confirming that the model accurately and appropriately represents the system being modeled. Thermal models can be valid for one set of conditions and invalid for another. Internal checks and physical tests are used for verification and validation. Thermal model verification and validation are discussed in Section 6.

2.2.7 Deliver

The goal of this task is to effectively convey the assumptions, results, and conclusions from the previous thermal design tasks and phases. This involves presenting the model, the assumptions made, the properties and parameters used, and the results obtained. However, results from thermal models are often needed throughout the thermal design process. Initial results from the thermal model will inform early design decisions, which will in turn provide new thermal modeling inputs. Therefore, thermal models should be built iteratively, gradually increasing in complexity, with the results of each iteration reported to the appropriate entities as needed.

All simplifications and assumptions should be well documented and justified. Component thermal margins, average hot and cold case temperatures, nominal case temperatures, and other applicable results should be presented. How conductivity was modeled between components should also be discussed, along with the methods used to represent physical geometry (e.g., finite elements, node networks, 3D solids, 2D surfaces, etc.). The weight of the TCS should be reported against a bill of materials and mass budget. Any power usage required by the TCS to operate should be detailed, especially in relation to mission modes (e.g., heater power required during eclipse when solar cells are inactive). The results presented should build confidence that the model is an accurate representation of on-orbit conditions and correctly predicts the temperatures that the satellite will experience.

In general, the customer will dictate what needs to be delivered and how it is presented. For the thermal team, the customer is not only the final customer (the entity buying the satellite) but also the program manager, chief engineer, and other subsystems. Each of these customers will have their own requirements for what is delivered and how it is presented. Therefore, the thermal team must adapt the deliverables for each customer as needed. Outside of customer guidance, the deliverables should be detailed enough so that another analyst could replicate the work done.

3 Thermal Modeling

"All models are wrong, but some are useful" – George E.P. Box

3.1 Introduction

This section explains the process of thermal modeling. The goal of thermal modeling is to characterize the thermal behavior of a satellite so that it may be accurately simulated in various thermal environments. The concepts of fidelity, accuracy, and resolution are defined and discussed, thermal modeling fundamentals are introduced, and example satellite components are modeled using Thermal Desktop®, an industry standard thermal modeling software. These components are then integrated into a complete thermal model. Additionally, an example process for modeling individual components is presented.

There are many software options for performing thermal modeling. Each piece of software has its own pros, cons, capabilities, and applicability to satellite thermal modeling. Different pieces of software can be used in tandem to complete a successful thermal design. Specific thermal modeling techniques discussed in this guide with respect to Thermal Desktop may or may not be applicable to other software. The reader should select the thermal modeling software based on mission and thermal modeling requirements.

3.2 Fidelity, Accuracy, and Resolution

The fidelity, accuracy, and resolution of a thermal model should be driven by the mission requirements. These terms describe specific aspects of a thermal model and are related but not equivalent. The levels of fidelity, accuracy, and resolution of a thermal model can be determined semi-independently. Fidelity, accuracy, and resolution are defined as follows.

The fundamental principle of fidelity is "correspondence with reality," or to what extent the model simulates/addresses the reality it is simulating [6]. The level of fidelity corresponds to the number of variables, parameters, and design aspects being accounted for. High fidelity models simulate more aspects of reality than low fidelity models⁷. Specifically, geometric fidelity is a description the correspondence between the thermal model's geometry and the physical geometry. Thermal models can be highly accurate with low levels of geometric fidelity and resolution.

Accuracy is a measure of how well a model represents reality [6]. Furthermore, it is a measure of correctness and can be determined when predictions are compared with real-world data. An accurate model will correctly predict the temperatures experienced by satellite components and what thermal control measures are needed. Thermal model accuracy should meet mission requirements and no more. Time and money spent on making the model more accurate than needed is time and money wasted.

Resolution is functionally equivalent to precision [6]. Practically, resolution of a thermal model is determined by the number of nodes, elements, mesh size, etc. Thermal models with high levels of resolution will have more information. Accuracy is limited by resolution not caused by it [6]. A model with a high resolution does not mean it will be accurate. Models that require high levels of accuracy will generally require more nodes (i.e., more resolution), but not always. For instance, a 10,000 node model is not necessarily better or more accurate than an equivalent 100 node model. A thermal model should have as much resolution (i.e., have as many nodes, thermal elements, etc.) as needed as determined by the mission and accuracy requirements. Nodal resolution studies can be performed to determine the

⁷ Aspects of thermal modeling include heat fluxes, physical geometry, heat loads, radiation surfaces, surface coatings, etc.

required level of resolution to obtain accurate results. An example nodal fidelity, accuracy, and resolution study is performed in Section 3.2.3.

3.2.1 Determining Fidelity, Accuracy, and Resolution

The level of accuracy is ultimately determined by the mission. More specifically, accuracy is determined by the requirements of the component in question. For instance, a flight computer will require more accuracy than solar panels because the flight computer will often have stricter temperature requirements than solar panels. In general, components that are more sensitive to temperature (such as electronic components) will require more accuracy than components less sensitive to temperature (such as structural components).

The levels of geometric fidelity and resolution are determined by the design and accuracy requirements. Components that require precise temperature control may require higher levels of resolution (e.g., the flight computer). The level of resolution is determined by the mission requirements and component specifications. Payload and mission critical components will usually require greater levels of resolution than structural or secondary components. Certain components, such as solar panels or bus components, will require more or less resolution depending on the mission requirements.

A thermal model's resolution and geometric fidelity are related but not equivalent. A 3D shape such as a bracket can have a very low geometric fidelity (e.g., modeled as a simple 2D surface) but have a high resolution (i.e., higher node count). This situation can occur when the thermal pathway is simple, but the temperature must be precisely known along that pathway. For instance, a structural bracket with mission critical components attached to it. The bracket can have a low geometric fidelity (e.g., a simple 2D surface), but require a high node count such that the temperature seen by the mission critical components is precisely known. Note that for mesh-based software, increasing resolution is analogous to decreasing mesh size. Iteration or parametric studies are often needed to determine the appropriate levels of geometric fidelity and resolution.

3.2.2 Iteration and Increasing Resolution

The geometric fidelity and resolution of a thermal model should be increased iteratively. One should start with simple models first and slowly increase complexity. Observing changes in results as the geometric fidelity and resolution are increased can help determine when the appropriate levels of geometric fidelity and resolution have been reached. Generally, increasing geometric fidelity and resolution should occur in tandem with the increasing complexity of the physical design. Thermal models should be revision controlled and carefully organized as this will help determine what changes to the thermal model were significant. An example thermal model revision plan is given for a hypothetical 3U CubeSat in Table 3.1.



Table 3.1 Example Model Iteration for a 3U CubeSat

Revision	# Nodes	Model Description	Purpose
A	1	Single node estimated bulk satellite properties	Estimate the thermal environment
B	~6	A node for every "face" of the satellite	Refine estimate of the thermal environment.
C	~10-15	A node for every "face" of the satellite plus nodes for the internal structure and a node for every critical component	Refine heat flux calculations and estimate thermal inertia characteristics. Predict critical component temperatures
D	~15-100	Increased resolution model of the structure. All critical components modeled along with secondary components as needed.	Refine component temperature predictions.
E	~100-300	Increased level of resolution for faces, structure, and components. Components have multiple nodes, as necessary. Thermal pathway resolution is refined. Early thermal control selection simulated.	Refine component temperature predictions. Begin making thermal control selection.
F	~300-600	Increased resolution for all components. Thermal control applied and simulated. Final component selections modeled.	Simulate and evaluate thermal control. Make final temperature predictions. Verify and validate model. Inform final design decisions.

Note that each revision has an incremental increase in fidelity and resolution. Also note that the higher levels of resolution listed in Table 3.1 may not be required depending on the mission, budget, schedule, risk tolerance, etc. In general, the final thermal node count of a thermal model is heavily dependent on the complexity of the spacecraft being modeled. Usually, resolution (i.e., number of nodes) increases with model complexity and fidelity. Thermal models should have enough nodes (i.e., resolution) to meet accuracy requirements and no more. Literature-based and recommended final node counts for different CubeSat sizes are given in Table 3.2.

Table 3.2 CubeSat Final Node Number Estimate⁸

CubeSat Size	Literature-Based Final Node Count	Recommended Final Node Count
1U	100-500	100-200
3U	500-1000	200-600
6U	1000-2000	600-1000
12U	~2000+	~1000

⁸ These estimates are for node-based thermal modeling software. Software that is not node-based will have different markers for measuring resolution. However, the principle of iteration and refinement remains the same.

The MIST 3U CubeSat had a final node count of 6659 [7], while the much larger MR SAT had a final node count between 692 to 2294 nodes, depending on the model revision⁹ [5]. From inspection, EIRSAT-1, a 2U CubeSat appears to have approximately 1000 nodes [8]. The PATCOOL 3U CubeSat used 668 nodes [9]. The 1U STEP Cube Lab satellite had 420 nodes [10].

Despite the literature support for higher node numbers, results from the example thermal model of a 3U CubeSat presented later in this work indicate that these projects likely could have reduced their node count without significantly impacting the results. Simplifying the models (i.e., reducing the final node count, model complexity, etc.) would have the effect of making the model easier to build, simulate, and analyze.

3.2.3 Demonstration of Fidelity Vs. Accuracy

The differences between fidelity and accuracy will be demonstrated using an ISISPACE 3U CubeSat bracket, which is illustrated in Fig. 3.1.

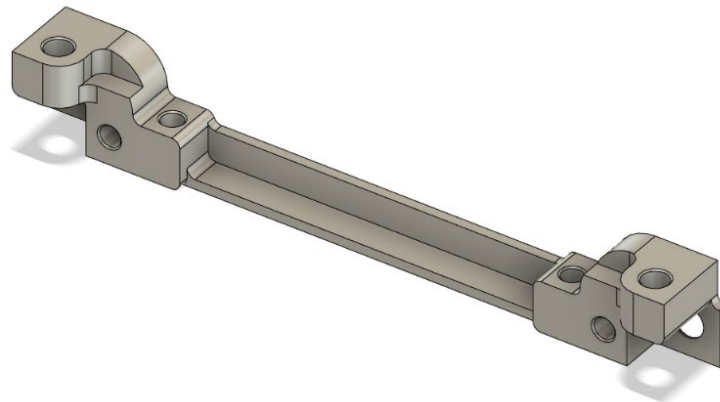

Fig. 3.1 ISISPACE Bracket

The bracket is modeled as aluminum 5754 with corresponding thermophysical and thermo-optical properties. A heat load of 1 W is applied to one end of the bracket, while the other end is coupled to a boundary node set to 273.15 K. Four different thermal models of the bracket were created in Thermal Desktop, each with a different level of fidelity and resolution. These models were simulated to be radiating to a thermal environment with a temperature of 273.15 K until thermal equilibrium (steady state) was reached. The results of the simulation are shown in Fig. 3.2.

⁹ Note that the later model revisions had fewer nodes than earlier model revisions. MR SAT is slightly larger than a 12U CubeSat.

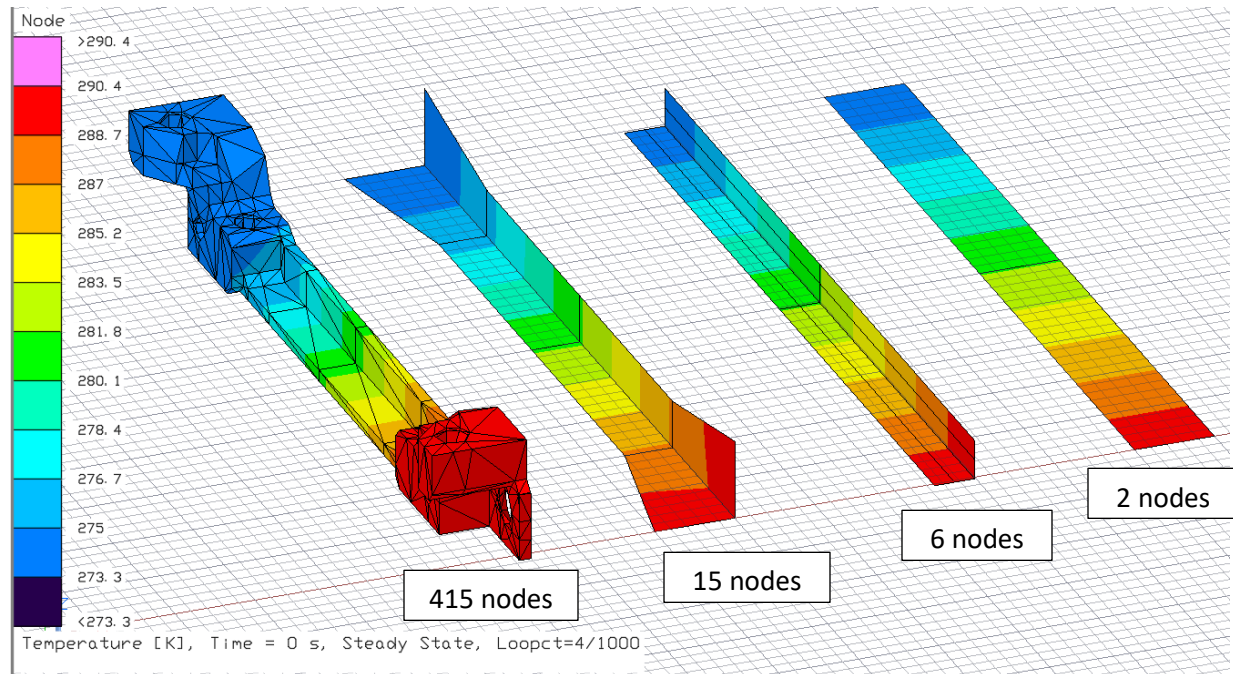

Fig. 3.2 ISISPACE Bracket Thermal Desktop Models

The geometric fidelity of the bracket models decreases from left to right. A mesh of the CAD model was created for the leftmost model with 415 nodes. The second model from the left is a simplified 3D representation of the part, modeling the decrease in cross sectional area, with 15 nodes. The third model from the left is a lower fidelity 3D representation of the bracket with 6 nodes. The rightmost model is a 2D representation of the bracket with 2 nodes.

Different density multipliers were applied to each model so that the mass of each model matched that of the physical component¹⁰. Using aluminum 5754, the mass of each model is 0.01070, 0.01068, 0.01068, and 0.01089 kg, respectively. From left to right, density multipliers of 1, 1.5, 1.6, and 1.6 were used. The thermal conductivities of the second, third, and fourth models were reduced by 10%, 5%, and 5%, respectively¹¹. The thickness of the thin shell elements of the second, third, and fourth models was 0.2, 0.25, and 0.25 cm, respectively¹².

For this demonstration, the leftmost model is considered to be the true/actual results. The minimum temperature of every model was 273.4 K. The maximum temperature of each model was 290.3, 290.2, 290.1, and 290.1 K, respectively. The results show that the geometric fidelity can be lowered significantly, and similar results still be obtained. Note that every reduced geometric fidelity model required changes to conductivity and density to match the “true” results of the leftmost model. The process of adjusting model characteristics is sometimes referred to as “tuning the model.”

¹⁰ In Thermal Desktop, density multipliers are used to adjust the mass of a component without changing the geometry.

¹¹ In Thermal Desktop, conductivities of thermal surfaces and solids can be adjusted to change results

¹² In Thermal Desktop, thin shell elements conduct heat in two dimensions, but have an implicit third dimension for calculating area available for heat rejection.

It should be noted that simplifying thermal geometry will impact radiation exchange since radiation is geometry dependent. Therefore, a component may need to be modeled with a higher geometric fidelity in order to accurately capture the effects of radiation exchange with other components and/or temperature sinks.

3.3 Thermal Modeling Fundamentals

The thermal node is the fundamental building block of a thermal model. Thermal nodes store energy, which is represented by temperature [11]. Example inputs of nodes are thermal capacitance, location, and thermal connections. The output of a node is temperature. Nodes can be linked together to form a thermal network. Conductance values are defined for these connections. Complete thermal models can be created using only nodes, heat loads, and conductance values between nodes.

Thermal surfaces and solids can be used to model the physical geometry of the satellite and how heat will flow. These thermal objects contain nodes, and the resolution of these thermal objects can be adjusted (increasing or decreasing the number of nodes). The shape and orientation of these objects define how they absorb and radiate heat. Connections between these thermal objects can be defined using a variety of thermal connection types.

Thermal networks are a collection of nodes and thermal objects linked together by radiative or conductive thermal coupling. They are like electrical networks in that heat will flow throughout the network and that there is resistance between the nodes. Early thermal models can use simple thermal networks to simulate the thermal characteristics of a satellite without the use of thermal modeling software.

3.3.1 Hand Calculations

Before any thermal model is constructed, hand calculations should be performed to estimate the temperature of the satellite. Hand calculations should model a single node or a small number of nodes. Steady state and transient thermal energy balances can be calculated to estimate the temperature of the satellite. Steady state hand calculations are simpler than transient calculations and are generally preferable for estimation purposes. Beginning a thermal model without performing hand calculations can lead to modeling errors, inaccurate thermal analysis, and a poor thermal design. Hand calculation methods are discussed in Section 3.5.

3.3.2 Modeling Nodes

In Thermal Desktop, nodes can be modeled as diffusion, arithmetic, or boundary¹³. Diffusion nodes have a finite capacitance and will store and release energy. This is the default node when creating surfaces and solids. Arithmetic nodes have zero capacity, which means they will respond instantaneously to any change in energy balance. Boundary nodes have an infinite capacitance and a defined temperature. Every thermal modeling software is different and may not utilize all node types listed here.

Thermal models primarily utilize diffusion nodes. Boundary nodes are useful for when boundary conditions exist, or the temperatures of a component are predefined or otherwise known. Boundary nodes are also useful for examining individual components as they allow for higher fidelity models to be created and tested without having to model the entire satellite. Boundary node conditions can be determined from other thermal models of the satellite or determined arbitrarily. Arithmetic nodes are

¹³ Thermal Desktop utilizes these node types, as well as clone nodes. Clone nodes are not discussed in this work as they are not often used in the context of small satellite thermal modeling.

useful for modeling components with very low time constants where thermal mass is not being used to constrain the temperature of the node.

A fundamental concept of thermal modeling is that a node is isothermal. By extension, everything that the node represents is also isothermal. Therefore, if a satellite component is modeled as a single node, that entire modeled component will have one temperature. Counterintuitively, entire satellite components such as solar panels, Printed Circuit Boards (PCBs), or structural components can often be modeled with a single node (or very few nodes) without losing fidelity or accuracy, as seen in Fig. 3.2. When building a thermal model, a thermal engineer must understand that whatever is being represented by a node is of uniform temperature (isothermal) in the model.

3.3.3 Modeling Radiation

Radiation absorption can be modeled as a heat flux applied to a 2D surface. The model calculates the amount of heat absorbed by the surface (considering the thermal properties assigned to the surface) and deposits this heat into a node or nodes. Absorption can also be modeled as heat load applied to a node where the heat load is hand calculated from the heat flux, surface area, and surface properties. In the case of solids and surfaces, the surface of the material is explicit, while for a node the surface is implicit. Thermal radiation is modeled similarly to absorption. Figure 3.3 illustrates the concepts of modeling radiation absorption.

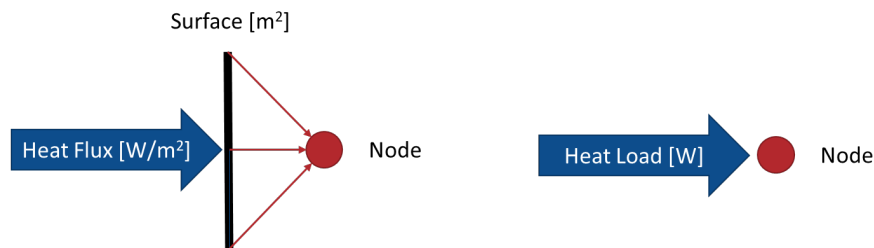

Fig. 3.3 Modeling Radiation Absorption

3.3.4 Modeling Conduction and Thermal Resistance

Fundamentally, conduction is the transfer of energy in the form of heat from one node to another. Thermal conductivity is an intrinsic property of the material and is expressed in units of W/m/K. Conductance is an extrinsic property that is calculated from the material, physical connection, etc. Conductance is expressed in units of W/K. Therefore, when referring to conduction between two thermal nodes, what is actually being discussed is the conductance between two nodes. Conduction between nodes is modeled as a conductance value that is defined for the node-to-node connection. Similarly, other conductance values can be defined for node-to-surface and surface-to-surface connections.

For components bolted or screwed together, there are multiple conduction paths, primarily through the bolt and surface-to-surface contacts¹⁴. Conduction from one physical surface to another is often referred to as the thermal contact conductance. It is a function of the material roughness, surface cleanliness, pressure of the contact, surface area of the contact, and thermal interface material (TIM) properties (if a TIM exists), among other factors. The mechanical joint formed by two surfaces being joined together by a threaded bolt or bolt and nut assembly is called a bolted joint interface. Modeling the thermal

¹⁴ Note that in this sentence, the term surface-to-surface contact does NOT refer to surface-to-surface contactors in Thermal Desktop.

conductance of a bolted joint interface is challenging. Therefore, approximate conductance values are often used. See page 265 of the Spacecraft Thermal Control Handbook for more details on modeling bolted joint interface conductances [12].

Thermal resistance is the inverse of conductance and is measured in units of kelvins per watt (K/W). When describing how heat flows through a satellite, both thermal conductance and thermal resistance are used. Thermal resistances can be added together in parallel and series like electrical resistances, as shown in Section 3.5.3.

3.3.5 Modeling Thermal Geometry

The term “thermal geometry” refers to the simplified geometries used to represent the thermal characteristics of the component being modeled. 2D surfaces and 3D solids are the primary thermal geometries used, with other geometries including thin shell cylinders, solid cylinders, and spheres. The exact thermal geometries available will vary by software. The purpose of thermal geometry is to represent how heat will flow through the satellite without having to model every component on a satellite.

The resolution level and geometric fidelity of the thermal geometry is determined by the design and precision requirements. Thick or highly conductive structures will require fewer nodes than thin and/or low conductivity structures. If conduction is mostly 1D (e.g., brackets, supports, etc.), components should be discretized in one direction and can be modeled in Thermal Desktop as contactors and conductors. If conduction is mostly 2D and planar (e.g., panels or PCBs), components should be discretized in two directions and be modeled in Thermal Desktop as surfaces. If conduction is mostly 2D but not planar (e.g., cylinders, pipes, etc.), uneven environmental loading or radiation should be considered when deciding on circumferential discretization. If conduction is mostly 3D, components should be discretized in three directions and can be modeled in Thermal Desktop as solids [13].

In Thermal Desktop, the thermal properties of individual thermal geometry components can be changed without having to change the geometry itself. This allows for components to be represented by simpler geometry while still having modeled characteristics such as mass match that of the physical component. Additionally, thermal conductivity can be adjusted, along with other properties. This technique is useful for making minor adjustments to individual components to increase the accuracy of the model (i.e., tuning the model).

3.3.6 Understanding Time Constants

A component’s thermal time constant describes the time it takes for a component to respond to a given input. Specifically, it is the time it takes for a component increasing in temperature to reach 63.2% of its final (asymptotic value) or for a component decreasing in temperature to reach (36.8% of its final (asymptotic) value. Components with shorter thermal time constants will experience wider temperature ranges. Therefore, a wider range of thermal environments must be considered for components with shorter time constants [12]. The time constant can be found from Newton’s law of cooling, which is given by Eq. (1).

$$\dot{q} = hA(T - T_s) \quad (1)$$

where \dot{q} is the heat transfer out of the object (W), h is the heat transfer coefficient (W/m²/K), A is the heat transfer surface area (m²), T is the temperature of the object’s heat transfer surface (K), and T_s is the temperature of the sink (K). The addition of heat loads leading to a rise in temperature is given by Eq. (2).

$$\dot{q} = \rho c_p V \frac{dT}{dt} \quad (2)$$

where ρ is the material density (kg/m^3), c_p is the specific heat ($\text{J}/\text{kg}/\text{K}$), V is the volume (m^3), dT is the differential temperature change (K), and dt is the differential change in time (s). Equating Eq. (1) and Eq. (2) gives

$$\rho c_p V \frac{dT}{dt} = -hA(T - T_s). \quad (3)$$

Rearranging gives

$$\frac{dT}{dt} + \frac{1}{\tau} T - \frac{1}{\tau} T_s = 0 \quad (4)$$

where

$$\tau = \frac{\rho c_p V}{hA} \quad (5)$$

where τ is the time constant (s). This means that the time constant of a component is dependent on the material of that component and its thermal connections to other components. Solving this differential equation yields Eq. (6).

$$\Delta T(t) = \Delta T_0 e^{-\frac{t}{\tau}} \quad (6)$$

where ΔT_0 is the initial temperature difference at $t = 0$. Critical components that have short time constants can be insulated to lengthen their time constant without significantly increasing their thermal mass. Insulation has the effect of dampening temperature oscillations. Small satellites are more vulnerable to extreme temperature swings than larger satellites because of their relatively small thermal mass.

The time constant of a component and its location can influence how a component is modeled. Components with short time constants that are placed close to areas of the satellite that will experience rapid changes in temperature may require greater resolution and fidelity than components located deep within the satellite. Within Thermal Desktop, the node with the shortest time constant will determine how tightly the time domain is discretized, while the node with the longest time constant will drive how long the model must be run to observe all relevant transients. Thermal models should be simulated until all transient effects have been observed. In Thermal Desktop, the node with the shortest time constant is referred to as CSGMIN, and the node with the longest time constant is referred to as CSGMAX.

3.4 Component Thermal Modeling Process

The following process shown in Fig. 3.4 can be used to model individual components on a satellite. The process can be summarized into three phases: characterize, define, and execute.

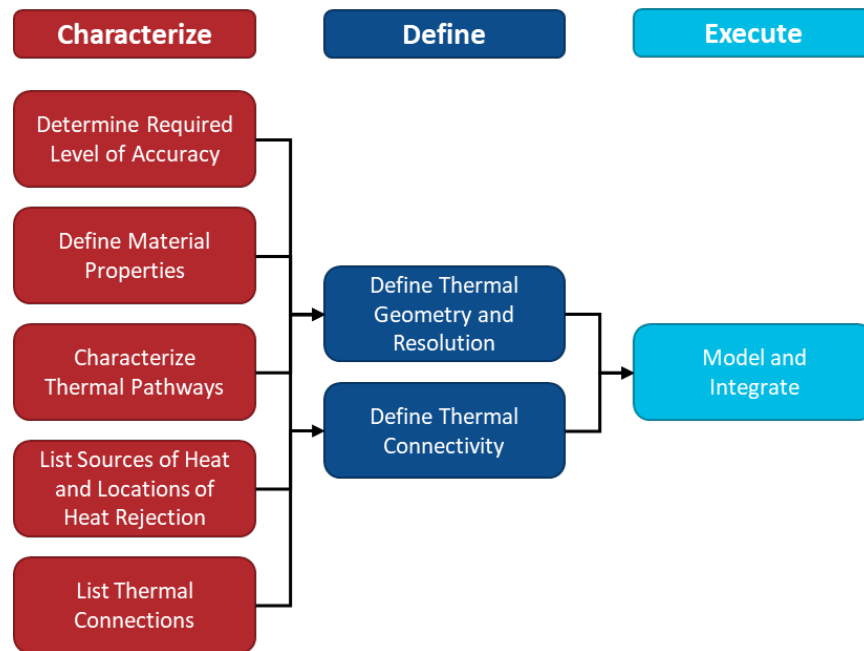

Fig. 3.4 Component Thermal Modeling Process

3.4.1 Characterize

3.4.1.1 Determine Required Level of Resolution and Accuracy

Resolution and accuracy requirements are often derived from operational and survivable temperature limits. Components with stringent operational requirements (e.g., scientific instruments, payload components) will require higher resolutions to accurately predict temperatures to the precision required than more robust components (e.g., solar panels). Generally, the narrower the operational range the greater the accuracy and precision required. Unless otherwise specified, the highest degree of precision required in a thermal model is 1 K.

3.4.1.2 Define Component Properties

The material properties of the component should be defined. Thermophysical properties include density, conductivity, and specific heat. Thermo-optical properties include the absorptivity and emissivity of the component. At a minimum, these properties should be defined along with the mass of the component. Additionally, the radiative area of the component should be defined. Depending on how the component is modeled, the thermophysical and thermo-optical properties may need to be lumped together into an effective conductivity, absorptivity, etc. Appendix A, B, and C of the Spacecraft Thermal Control Handbook Volume 1 are useful references for thermophysical and thermo-optical properties [12].

3.4.1.3 Determine Component Thermal Pathways

The thermal pathways of the component should be characterized in terms of location, direction, magnitude, etc. Material properties and physical geometry define how heat will flow through a component. Characterizing heat flow will inform selection of thermal geometry and resolution level.

Where a component is located will also influence how it is modeled. For instance, a component near a large heat source may need to be modeled differently than a component that experiences little temperature variation because of the temperature gradients the component may experience. Therefore, special attention should be given to component location with respect to overall heat flow through the satellite.

3.4.1.4 Determine Sources of Heat and Locations of Heat Rejection

Sources of heat and locations of heat rejection should be determined. Sources of heat for an individual component include internal heat generation, heaters, and neighboring components. Locations of heat rejection can include thermal couplings to other components and radiating to space. Note that thermal couplings can act as either a heat source or sink, depending on the component temperatures. The magnitudes of heat addition and rejection and during what mission modes they occur should also be determined.

3.4.1.5 Determine Component Thermal Connection Points

The thermal connection points of a component should be listed and characterized. This includes bolt or screw connections and surface-to-surface connections. How a component is physically connected to the satellite or other component will affect the flow of heat. For instance, a bolted joint will transfer heat differently than glue or epoxy. The conductance of each thermal coupling should be determined based off the material properties and type of connection. Multiple connections can be grouped into a single bulk thermal conductance when appropriate. Radiative couplings are normally calculated by the thermal modeling software.

3.4.2 Define

3.4.2.1 Define Component Thermal Geometry and Resolution

After the component's material properties, thermal pathways, sources of heat, locations of heat rejection, and thermal connections have been defined and characterized, the thermal geometry can be chosen. Physical geometry is represented by thermal surfaces and solids. Component models that require higher levels of resolution may require higher levels of geometric fidelity. The geometric fidelity and resolution can be increased over time as the design and thermal model mature. Components should be modeled in such a way as to make changing resolution levels easy. In Thermal Desktop, this means using primitive surfaces and solids whenever possible.

3.4.2.2 Define Component Thermal Connectivity

There are many ways to thermally couple components in thermal modeling. Thermal connectivities should be chosen based on how accurately they reflect "real life" thermal coupling. For every thermal connection point, the thermal conductance of the connection must be known. The thermal conductance of the connection can be absolute (W/K) or be spatially referenced ($W/m^2/K$ or $W/m/K$) using material geometry. Within Thermal Desktop, options for thermal connections include node-to-node, node-to-surface, and surface-to-surface.

3.4.3 Execute

3.4.3.1 Model and Integrate Component

Finally, the component is modeled with the chosen resolution, thermal geometry, and thermal connectivities. How this is done will depend on the software being used. Irrespective of the software, all elements of the model (node numbers, variable names, submodules, connections etc.) should be carefully

tracked and managed¹⁵. A well-organized model with robust naming and organization conventions will make debugging, verifying, and validating a model faster and easier. Therefore, an organizational system should be selected by the thermal engineer that will maximize their respective efficiency, productivity, and organization instead of adhering to a universal organizational standard.

3.5 Hand Calculations

Hand calculations can be used to estimate satellite temperatures and verify results of thermal models. They can also be used to spatially average thermophysical and thermo-optical properties of components, either for initial hand calculated thermal models or for thermal models built using software. In many cases, components with multiple material layers can lump the thermal properties of the material into a new pseudo material.

3.5.1 Heat Fluxes

Four different environmental heat fluxes must be calculated: solar flux, Earth albedo flux, Earth IR flux, and heat rejection from the satellite.

3.5.1.1 Solar Flux

Radiant energy from the Sun, referred to as solar flux, is the most dominant environmental heat source in Low Earth Orbit (LEO). The amount of direct solar radiation absorbed by a surface in units of watts can be calculated using Eq. (7).

$$\dot{q}_{\text{solar}} = \alpha A S \cos \theta \quad (7)$$

where α is the absorptivity of the surface, A is the area of the surface (m^2), S is the solar constant (W/m^2), and θ is the incident angle between the solar normal vector and the solar vector.

3.5.1.2 Earth Albedo

Solar energy that is reflected by the Earth is referred to as “albedo radiation.” The percentage of incident solar radiation that is reflected by the Earth (or by any orbital body) is referred to as the albedo factor. Typical albedo factors for the Earth range between 0.25 and 0.55 [5]. These values are dependent on surface conditions. The Spacecraft Thermal Control Handbook details how to calculate incident albedo radiation [12]. The amount of albedo radiation absorbed by a surface in units of watts can be calculated using Eq. (8).

$$\dot{q}_{\text{albedo}} = \alpha A S A_f F_{\text{Earth} \rightarrow \text{surface}} \quad (8)$$

where α is the absorptivity of the surface, A is the area of the surface (m^2), S is the solar constant (W/m^2), A_f is the albedo factor, and $F_{\text{Earth} \rightarrow \text{surface}}$ is the view factor between the surface and the Earth. A view factor F_{12} measures the fraction of energy that exits an isothermal, opaque, and diffuse surface 1 and is absorbed, reflected, or transmitted by surface 2. View factor definitions can be found in [14].

3.5.1.3 Earth IR

Radiation emitted by the Earth is in the same IR band as radiation typically emitted by satellite. Therefore, the amount of radiation absorbed by the satellite from Earth IR is dependent upon the amount radiated away by the Earth and the emissivity of the surface. Reducing a surface’s emissivity to reduce the amount

¹⁵ In Thermal Desktop, node numbers should be carefully managed. It is useful to group a submodel by a specific name and assign that submodel a band of node numbers (e.g., 1000-1999).

of Earth IR will also have the effect of reducing the surface's ability to reject heat via radiation [5]. The amount of Earth IR energy absorbed by a surface in units of watts can be calculated using Eq. (9).

$$\dot{q}_{\text{IR temperature}} = \sigma \varepsilon A F_{\text{Earth} \rightarrow \text{surface}} T_E^4 \quad (9)$$

where σ is the Stefan-Boltzmann constant ($\text{W}/\text{m}^2/\text{K}^4$), ε is the surface emissivity, A is the surface area (m^2), $F_{\text{Earth} \rightarrow \text{surface}}$ is the view factor between the Earth and the satellite surface, and T_E is the effective ideal radiator, or black body, temperature of the Earth, which is on average 255 K [5]. Some sources, including the Spacecraft Thermal Control Handbook, also provide calculated Earth IR heat flux values [12]. These values are for diffuse radiation; therefore, a view factor must be used. Thus, the amount of Earth IR energy absorbed by a surface in units of watts can also be calculated using Eq. (10).

$$\dot{q}_{\text{IR flux}} = \varepsilon A S_{\text{earth}} F_{\text{Earth} \rightarrow \text{surface}} \quad (10)$$

where ε is the emissivity of surface, A is the surface area (m^2), S_{earth} is Earth IR flux (W/m^2), and $F_{\text{Earth} \rightarrow \text{surface}}$ is the view factor between the satellite surface and the Earth.

3.5.1.4 Satellite Heat Rejection

Heat is rejected by every surface open to space through radiation¹⁶. The amount of heat transferred from a surface to a heat sink (i.e., rejected by the surface) through radiation is given by

$$\dot{q}_{\text{surface} \rightarrow \text{sink}} = A \varepsilon \sigma F_{\text{surface} \rightarrow \text{sink}} (T_{\text{surface}}^4 - T_{\text{sink}}^4) \quad (11)$$

where A is the surface area (m^2), ε is the emissivity of the surface, σ is the Stefan-Boltzmann constant ($\text{Wm}^{-2}\text{K}^{-4}$), $F_{\text{surface} \rightarrow \text{sink}}$ is the view factor from the surface to the sink, T_{surface} is the temperature of the surface, and T_{sink} is the temperature of the heat sink.

In the context of a spacecraft thermal radiation, the heat sink is space itself. Assuming the radiating surface "sees" nothing but space (i.e., does not face another part of the spacecraft), the view factor is 1. Additionally, space has an average temperature of 2.73 K while spacecraft temperatures rang from ~200 to ~400 K. Therefore, $T_{\text{surface}}^4 \gg T_{\text{sink}}^4$, which allows for the assumption that $T_{\text{sink}} = 0$ ¹⁷. The amount of heat radiated away by the entire satellite is thus a function of available surface area, surface emissivity values, and surface temperatures. The total amount of heat rejected by a satellite can be calculated using Eq. (12).

$$\dot{q}_{\text{rejected}} = \sum_{i=1}^n A_i \varepsilon_i \sigma T_i^4, \quad (12)$$

¹⁶ Heat rejection refers to heat transfer through radiation (i.e., the process that cools a spacecraft). Heat dissipation refers to waste generation from components.

¹⁷ This assumption may not be valid if the surface in question has a significant portion of its view obstructed by other portions of the satellite.

where A_i is the surface area of the i^{th} surface (m^2), ε_i is the emissivity of the i^{th} surface, T_i is the temperature of the i^{th} surface (K), σ is the Stefan-Boltzmann constant ($\text{Wm}^{-2}\text{K}^{-4}$), and n is the number of surfaces radiating to space.

3.5.2 Thermal Conductance

Using a known node-to-node conductance value, the heat transfer between nodes can be calculated using Eq. (13).

$$\dot{q}_{1 \rightarrow 2} = -G(T_2 - T_1) \quad (13)$$

where G is the conductance (W/K), T_1 is the temperature of the first node (K), and T_2 is the temperature of the second node (K). The conductance determined by the thermal conductivity, length, and area of the connection. The conductance can also be determined from experimental tests or from literature sources. Heat always flows from the node with the higher temperature to the node with the lower temperature.

3.5.3 Thermal Resistance

Thermal resistance is simply the inverse of conductance, and is measured in units of K/W. Using a known node-to-node thermal resistance value, the heat transfer between nodes can be calculated using Eq. (14).

$$\dot{q}_{1 \rightarrow 2} = -\frac{(T_2 - T_1)}{R} \quad (14)$$

where R is the resistance (K/W), T_1 is the temperature of the first node (K), and T_2 is the temperature of the second node (K). When performing hand calculations, it can be useful to think in terms of resistance. This is because thermal resistances can be added in parallel and series using the same equations as electrical resistance. The total thermal resistance of resistors in series can be calculated using Eq. (15).

$$R_{\text{series}} = \sum_{i=1}^n R_i \quad (15)$$

where R_i is the resistance of the i^{th} component in series (K/W) and n is the total number of components in series. Similarly, the total thermal resistance of resistors in parallel can be calculated using Eq. (16).

$$R_{\text{parallel}} = \frac{1}{\sum_{i=1}^n \frac{1}{R_i}} \quad (16)$$

where R_i is the resistance of the i^{th} component in parallel (K/W) and n is the total number of components in parallel.

3.5.4 Steady State Thermal Energy Balance

Steady state energy balance is given in Eq. (17). The steady state energy balance does not depend on the thermal mass of the satellite. Heat generated by the satellite (in watts) can be simply added into the energy balance equation. Note that Eq. (17) does not include effects from conduction.

$$\dot{q}_{in} + \dot{q}_{generated} = \dot{q}_{out} \quad (17)$$

where $\dot{q}_{generated}$ is the total heat generated internally by the satellite, \dot{q}_{out} is given by Eq. (12), and \dot{q}_{in} is given by Eq. (18).

$$\dot{q}_{in} = \sum_{i=1}^L \dot{q}_{solar,i} + \sum_{j=1}^M \dot{q}_{albedo,j} + \sum_{k=1}^N \dot{q}_{IR,k} \quad (18)$$

where $\dot{q}_{solar,i}$ is the solar radiation absorbed surface i (W), L is the number of surfaces receiving direct solar radiation, $\dot{q}_{albedo,j}$ is the albedo radiation absorbed by surface j (W), M is the number of surfaces receiving albedo radiation, $\dot{q}_{IR,k}$ is the Earth IR radiation absorbed by surface k (W), and N is the number of surfaces receiving Earth IR radiation. Equation (18) can be solved for the average radiative surface temperature or for the radiative surface area required to keep the satellite at a specific temperature. Various parameters can be held constant to estimate mission parameters.

3.5.5 Transient Thermal Energy Balance

The heat flow into the satellite is controlled by how readily the satellite absorbs thermal energy (absorptivity), and the heat flow out of the satellite is controlled by how readily the satellite emits thermal energy (emissivity). The thermal mass of a satellite describes the amount of heat (or energy) the satellite can effectively “store.” Heat capacity and specific heat define an object’s heat storage capacity where heat capacity is “per unit volume” and specific heat is “per unit mass.” Material density ρ and specific heat c_p define the amount of heat stored within a volumetric element in watts, as illustrated in Eq. (19).

$$\dot{q}_{stored} = \left(\rho c_p \frac{\delta T}{\delta t} \right) \Delta x \Delta y \Delta z. \quad (19)$$

Ignoring the effects of conduction between nodes, the transient thermal energy balance of the satellite (or individual component) can be calculated using Eq. (20).

$$\dot{q}_{in} + \dot{q}_{generated} = \dot{q}_{out} + \dot{q}_{stored}. \quad (20)$$

3.5.6 Spatially Averaged Thermal Properties

Thermal properties of components can be spatially averaged into effective values. This is useful when building simplified, low-node-count models of components. Effective values for absorptivity and emissivity can be calculated by taking area-weighted averages. The percentage of total surface area will determine a component’s contribution to the effective optical property. The effective absorptivity and emissivity can be calculated by using Eq. (21) and Eq. (22), respectively, where A_j is the area of the individual component (m^2), A_{total} is the total area of the component (m^2), α_j is the absorptivity of the individual component, and ε_j is the emissivity of the individual component. Note that the sum of A_j values equals A_{total} .

$$\alpha_{effective} = \sum_{j=1}^n \left(\frac{A_j}{A_{total}} \right) \alpha_j \quad (21)$$

$$\varepsilon_{\text{effective}} = \sum_{j=1}^n \left(\frac{A_j}{A_{\text{total}}} \right) \varepsilon_j. \quad (22)$$

The percentage of total mass will determine a component's contribution to the effective specific heat. The effective specific heat can be calculated by using Eq. (23), where M_j is the mass of the component (kg), M_{total} is the total mass of the lumped component (kg), and c_{p_j} is the specific heat of the component (J/Kg/K). Note that the sum of M_j values equals M_{total} .

$$c_{p_{\text{effective}}} = \sum_{j=1}^n \left(\frac{M_j}{M_{\text{total}}} \right) c_{p_j}. \quad (23)$$

Thermal conductivities can also be spatially averaged. When there are two or more layers of different materials, there will be an effective in-plane thermal conductivity and an effective out-of-plane thermal conductivity. In-plane versus out-of-plane is illustrated in Fig. 3.5.

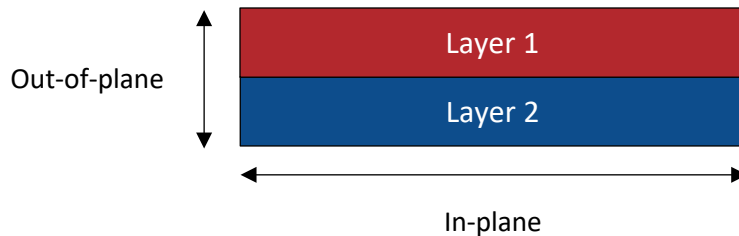

Fig. 3.5 In-plane Verses Out-of-plane

Effective in-plane and out-of-plane thermal conductivity are thickness-weighted averages of in-plane and out-of-plane thermal conductivities, respectively. Assuming that all layers have the same cross-sectional area, in-plane and out-of-plane thermal conductivity can be calculated using Eq. (24) and Eq. (25), respectively.

$$k_{\text{effective}_{\text{in-plane}}} = \frac{1}{t_{\text{total}}} \sum_{j=1}^n (k_j t_j) \quad (24)$$

$$k_{\text{effective}_{\text{out-of-plane}}} = \frac{t_{\text{total}}}{\sum_{j=1}^n \left(\frac{t_j}{k_j} \right)} \quad (25)$$

where t_j is the thickness of the j th layer (m), k_j is the thermal conductivity of the j th layer (W/m/K), and t_{total} is the total thickness of the stack-up (m). Computing effective thermal conductivities for complicated components or components with many layers can be challenging and is generally not advised. Additionally, if layers have very dissimilar thermal conductivities, areas, or thicknesses, the calculated effective thermal conductivity may not be valid.

3.5.6.1 Spatially Averaged Thermal Conductivity Example

The following example will illustrate how to calculate in-plane and out-of-plane thermal conductivities for a simplified geometry. Consider two layers of a material stacked on top of each other, as illustrated in Fig. 3.5. The parameters of the two layers are given in Table 3.3.

Table 3.3 Spatially Averaged Properties Example

Layer	Thickness [m]	Material [--]	Thermal Conductivity [W/m/K]	k _{xy} sum [W/K]	k _z sum [m ² K/W]
1	0.005	Al6061-T6	167.9 [12]	0.8395	0.0119
2	0.005	PCB - 4.6% Cu	18.04 [5]	36.08	0.1109
Total	0.01	--]	--]	371.88	0.1228

Solving Eq. (24) and Eq. (25) yields an in-plane and out-of-plane thermal conductivity of 92.97 and 32.58 (W/m/K), respectively.

3.5.7 Hand Calculation Example

An example 3U CubeSat is used to demonstrate hand calculations using the equations given in the previous subsections. A cold case will be simulated. The orbital thermal parameters are given in Table 3.4. When first modeling a satellite using hand calculations, it is common to model the satellite as a simple sphere or cuboid. Doing this simplifies heat absorption and rejection calculations. These simplified models should be scaled such that the surface area exposed to the Sun, space, and Earth is approximately the same as that of the physical design.

Table 3.4 Hand Calculation Thermal Environment Parameters

Parameter	Value	Unit
Beta angle	0	deg
q_{solar}	1322	W/m ²
Albedo factor	0.3	--]
Stefan-Boltzmann's Constant	5.67E-08	W/m ² /K ⁴
Earth Temperature	255	K

For a 3U satellite with dimensions of 30 by 10 by 10 cm, the total surface area is 1400 cm². Therefore, the 3U satellite will be modeled as a sphere with a radius of 10.56 cm. The cross-sectional area of the sphere is thus 350 cm². For small satellites, most of the available surface area is often covered with solar panels. Therefore, the surface of the sphere is modeled with spatially averaged absorptivity and emissivity values based off ISISPACE's 3U solar panel.

The terms solar panel and solar cell are often used interchangeably. In this work, panel refers to the structural panel to which the solar cells are affixed. Both the panel and solar cell thermo-optical properties must be considered. The total surface area of an ISISPACE's 3U solar panel is 330 cm². The total area of the solar cells is 182 cm². The efficiency of the solar cells is 30%, the emissivity is 0.9, and the absorptivity of the solar cell is listed as 0.91 [5], [15]. Using Eq. (27), the effective absorptivity of the solar cell was



calculated to be 0.637. Using Eq. (21) and Eq. (22), the effective emissivity and absorptivity of the solar panel were calculated to be 0.52 and 0.42, respectively. The calculations are shown in Table 3.5.

Table 3.5 Hand Calculation Effective Emissivity and Absorptivity

Component	Modeled Area [cm ²]	Absorptivity [--]	Emissivity [--]
Panel	147.60	0.150	0.050
Solar Cell	182.40	0.637	0.900
Effective	330.00	0.419	0.520

When calculating absorbed solar radiation, the cross-sectional area of the sphere will be used. When calculating absorbed radiation from Earth Albedo and Earth IR, a view factor from a spherical satellite to a spherical Earth will be used because the radiation is diffuse. The view factor equation for a small sphere (the satellite) to a large sphere (the Earth) is given in Eq. (26).

$$F_{1 \rightarrow 2} = \frac{1}{2} \left[1 - \sqrt{1 - \frac{1}{h^2}} \right], h = \frac{R_{Earth} + alt}{R_{Earth}} \tag{26}$$

where R_{Earth} is the radius of the Earth (valued at 6378 km – the equatorial radius of the Earth), and alt is the altitude of the orbit. The altitude was set to 421 km. A cross-sectional area value of 350 cm² was used for all calculations. A view factor of 0.327 was calculated. An incident angle of 0° was used for Eq. (7). Heat fluxes and absorbed heat values were calculated using Eq. (7), Eq. (8), and Eq. (9). The results are shown in Table 3.6.

Table 3.6 Hand Calculation Heat Values

Source	Heat Flux [W/m ²]	Heat [W]
Solar	555.24	19.43
Earth Albedo	54.42	7.62
Earth IR	40.73	5.70
Internal	[--]	5

An internal satellite heat generation value of 5 W was used for the steady state thermal energy balance equation. This value is meant to represent heat generation from all internal components during operation, including flight computer, payload, transmitter, etc. Using Eq. (17), the steady state temperature of the satellite was calculated to be 309.25 K. The steady state temperature versus internal heat generation is illustrated in Fig. 3.6.

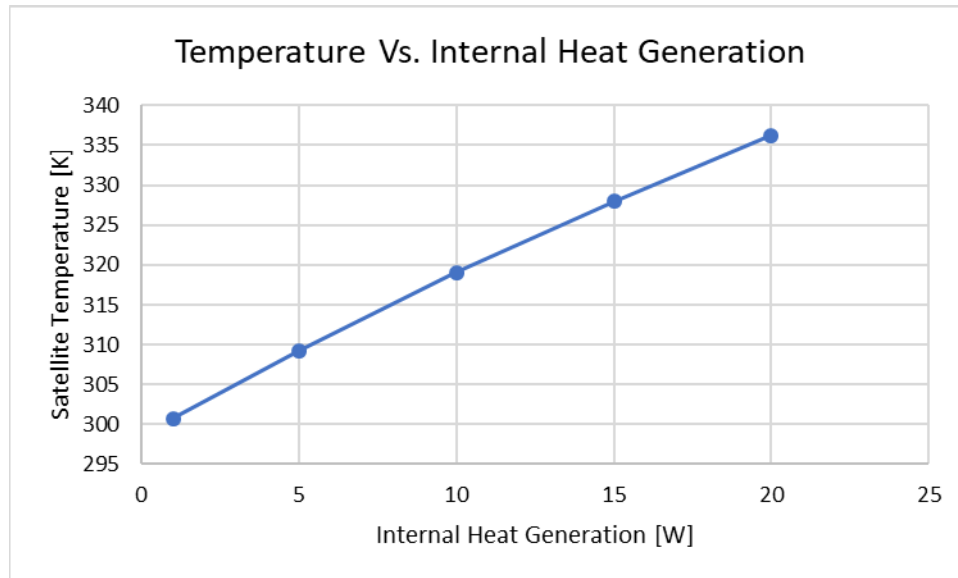

Fig. 3.6 Steady State Temperature Vs. Internal Heat Generation

These example calculations illustrate how to estimate steady state temperature for a simple spherical satellite. Hand calculations for more complex geometries can be performed to estimate steady state temperature.

3.6 Building a Thermal Model

Section 3.6 gives demonstrations of individual component modeling techniques. Section 3.7 demonstrates how to integrate these components into a complete thermal model but does not consider mission specific parameters. Determining how a component is thermally modeled is affected by its location in the satellite, the heat loads it will experience, and the thermal characteristics of the component itself. A component that will experience high heat loads or large temperature swings will be modeled differently than a component that sees little thermal variation. The following thermal modeling examples focus on individual component modeling techniques and do not necessarily consider a component’s location or mission profile in the satellite as such information is mission specific.

Example components were chosen from ISISPACE due to the readily available CAD models, datasheets, and literature examples. In this subsection, the ISISPACE 3U CubeSat structure, VHF/UHF transceiver, 3U solar panel, and Electronic Power System (EPS) will be modeled to illustrate thermal modeling techniques. The industry standard Thermal Desktop software is used for thermal modeling. The principles demonstrated can be applied to other thermal modeling software and other satellite components.

Different missions will require different thermal modeling philosophies and techniques. What may be appropriate for a 3U CubeSat bus may not be appropriate for a 12U or larger CubeSat bus. Therefore, the reader should consider the specifics of their mission as they apply the techniques and principles demonstrated in this work. Additionally, there will always be some disagreement amongst thermal engineers as to what is an acceptable modeling technique and what is not. Therefore, any thermal modeling decision made by the reader should be justified by the mission and its requirements.



3.6.1 Modeling Structures

Thermal models of satellite structures can be simplified with respect to the physical geometry. CubeSat structures are typically made from aluminum, which has a thermal conductivity between 100 and 200 W/m/K depending on the grade of aluminum [12]. This means that heat will readily flow through the structure. Therefore, simple surfaces can be used for modeling the structure. The ISISPACE 3U CubeSat structure is used to demonstrate thermal modeling of a structure and is illustrated in Fig. 3.7, along with a corresponding thermal model of the structure.

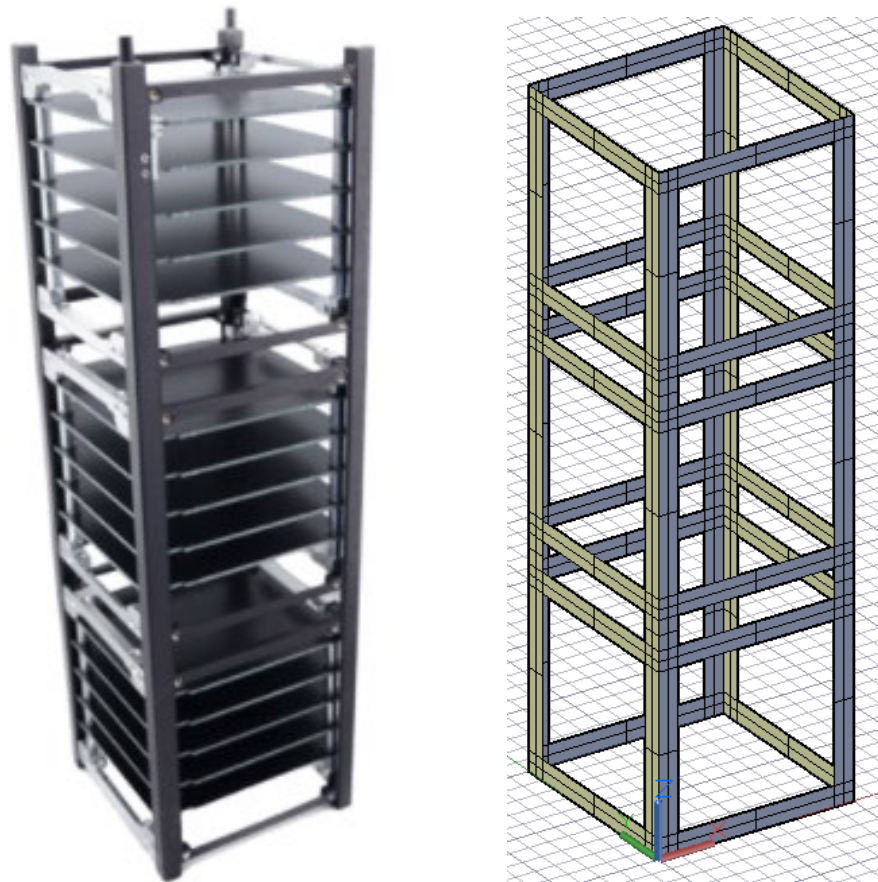

Fig. 3.7 ISISPACE 3U CubeSat Physical Structure (left) and Thermal Model (right)

The structure was modeled as aluminum 5754 [7]. The mass of the physical structure is 0.2428 kg and its operational temperature range is -40 to +80 °C [16]. The structure consists of 6 rectangular frames connected with 12 ribs. Together, the edges of the 6 rectangular frames form a rail. The 15 example PCBs are not modeled. Surface panels are fixed to the brackets and rails with screws (not shown in the figure).

Simple 2D surfaces were used for all rail sections and ribs. For a single 1U section of the model, there are 8 rib surfaces (4 at the top and 4 at the bottom), 8 rail sections (2 at each corner), and 16 square “connection” surfaces. Each surface has one edge node at each corner. Rail sections were modeled with a thickness of 0.15 cm, and rib sections were modeled with a thickness of 0.25 cm. Note that the fillets, bends, screws, screw holes, and other details have not been modeled. These features will have minimal impacts on the heat flow compared to the structure itself. The modeled mass of the structure is 0.245 kg.

Note that in Thermal Desktop, the edge nodes option places “half” nodes on the edges and “quarter” nodes at the corners, thereby allowing the node to span the entire nodal area as with centered nodes. When two surfaces with edge nodes share a common edge and have the same nodal discretization, the nodes can be merged such that the edge node is “shared” between the surfaces. This is equivalent to folding a regular centered node surface along a nodal centerline [37]. This technique can be applied to CubeSats because of their modular construction and small size. This technique may not be appropriate for larger satellites with more complex geometry.

Using the modeling method described, the minimum final node count for different CubeSat sizes is given in Table 3.7¹⁸. Note that this represents the minimum node count using the method previously described. The actual final node count will be higher as the resolution of rail sections and ribs is increased to allow for components to be thermally connected to them. The location of a thermal coupling in a thermal model should roughly correspond to the location of the physical thermal coupling when possible. Therefore, resolution should be increased to allow for more accurate thermal couplings when necessary.

Table 3.7 CubeSat Structure Final and Node Count Estimates

Size	Structure Sub-model Node Count	Literature-Based Final Node Count	Recommended Final Node Count
1U	48	100-500	100-200
3U	144	500-1000	200-600
6U	288	1000-2000	600-1000
12U	576	~2000+	~1000

Comparing the node count of the structural subsystem with that of the recommended final node count for four CubeSat sizes shows that the thermal model of the structural system accounts for a significant portion of the overall final node count. This is to be expected given that the structure is the primary means of heat conduction in a satellite. Note that different CubeSat structures will require different thermal modeling strategies, resulting in different final node counts.

3.6.2 Modeling Structural Connections

Structural connections such as bolts, screws, and PCB standoffs form conduction paths. These connections are referred to as bolted interfaces. The thermal conductance in a bolted interface is influenced by connector size, torque, material selection, surface finishes, and surface roughness [5]. Bolted interface connections usually do not need to be explicitly modeled. Instead, a conductance value can be assigned to the bolted interface that captures the conductance of the bolt or screw and the conductance of the surface-to-surface contacts. Some example bolted interface conductances are given in Table 3.8.

¹⁸ Different thermal modeling techniques can be used to achieve a lower node count than that listed in Table 3-7.

Table 3.8 Example Screw Conductances [5]

Screw Size	Conductance [W/K]	
	Small Stiff Surface	Large Thin Surface
2-56	0.21	0.105
4-40	0.26	0.132
6-32	0.42	0.176
8-32	0.80	0.264
10-32	1.32	0.527
¼-28	3.51	1.054

In Thermal Desktop, structural connections can be modeled as contactors where the conductance of the contactor is the conductance of the bolted interface. Bolted interface connections can also be modeled as an edge-to-edge conductance where the conductance is the conductance of the bolted interface multiplied by the number of bolted interfaces. This is most applicable for components connected at their edges [5].

Thermal interface materials (TIM) can be used to change the conductance of surface-to-surface connections. These can include glues, epoxies, gaskets, and washers. When calculating the conductance of a TIM, the thermal conductivity of the interface material, the adhesive thickness, and the contact area must be known. The conductivity of the adhesive is multiplied by the contact area and divided by the thickness. Table 3.9 gives an example conductance value for a surface-to-surface connection using a TIM.

Table 3.9 Sample TIM Conductance Values

Adhesive	Adhesive Conductivity [W/m/K]	Contact Area [m ²]	Adhesive Thickness [m]	Calculated Conductance [W/K]
Epotek H74	1.3 [5]	0.0001	0.000004 [5]	32.5

3.6.3 Modeling PCBs

PCBs can be modeled as 2D surfaces in most cases. The level of geometric fidelity and resolution is determined by the thermal complexity and sensitivity of the PCB. PCBs with strict operating temperature limits may require more fidelity and resolution. A good rule of thumb is to have one node for every thermal connection point, heat load, or critical component. For instance, a PCB with a single processor would require five nodes: one node for the processor and four nodes for the connection points¹⁹. For large PCBs (greater than 10 by 10 cm) or PCBs with many critical components, higher levels of geometric fidelity and/or resolution may be required²⁰.

Heat loads and the in-plane thermal conductivity of the PCB affect resolution and physical fidelity requirements. PCBs with large heat loads may require higher levels of resolution to accurately predict the

¹⁹ Most PCBs in CubeSats are connected with four standoffs at the corners of the PCB

²⁰ Thermal models of PCBs can become very complicated, depending on the PCB. This section discusses modeling PCBs in the context of satellite thermal modeling. Dedicated thermal models of PCBs may need to be created and the results from these models integrated with the thermal model of the satellite.



temperatures of specific components, especially if the heat load is concentrated²¹. In many cases, PCBs will have variable heat loads depending on the mission mode. What may be an acceptable thermal model for one mission mode may not be valid for another. The in-plane thermal conductivity of a PCB is largely determined by copper content. Increasing copper content in a PCB will increase its thermal conductivity. Usually, PCBs have low in-plane conductivities, which may increase the required resolution. ISISPACE's VHF uplink/UHF downlink Full Duplex transceiver is used to demonstrate modeling a PCB and is illustrated in Fig. 3.8. The transceiver has a mass of 75 g and a power consumption of 0.48 W when receiving and 4 W when transmitting [17]. From inspection, the PCB has two major heat sources and multiple copper fixtures.

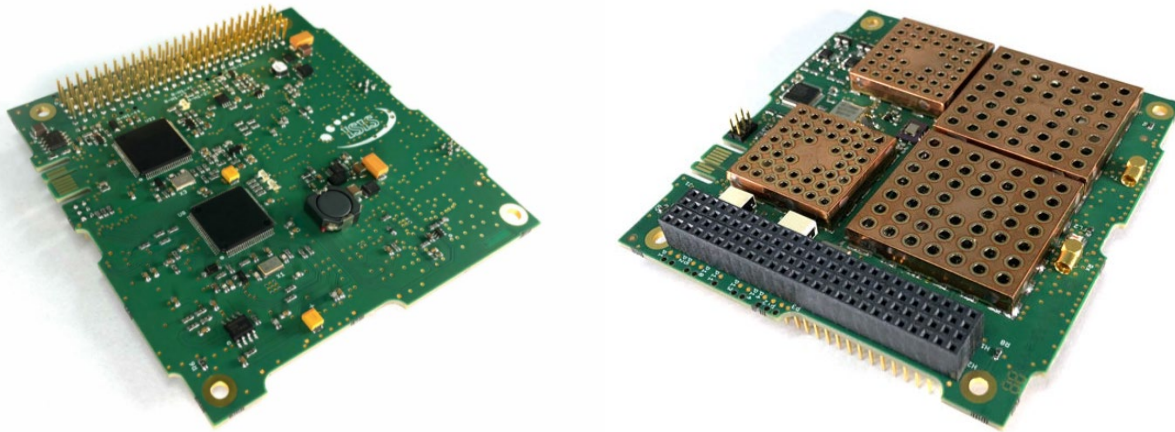

Fig. 3.8 ISISPACE VHF uplink/UHF downlink Full Duplex Transceiver [17]

The PCB was modeled as PCB-4.6% Cu with dimensions of 9 cm by 9 cm by 0.1 cm. The copper fixtures are modeled as a single 3D solid made from C11000 with dimensions of 5.8 cm by 5.8 cm by 0.2 cm. The modeled mass of the transceiver is 0.078 kg. Two heat loads were applied at the location of each processor unit. The heat loads were applied to 1 by 1 cm single node surfaces. These surfaces were thermally connected to the PCB with conductances of 50 W/K. This value was picked arbitrarily to maximize the amount of heat flow from the chip to the PCB without greatly slowing down the model. Calculating chip to PCB conductances is challenging and beyond the scope of this work.

Because the heat generation sources are essentially point sources and because there is a significant amount of copper on the PCB, selecting the proper resolution is important. The increased conductivity and thermal mass of the copper will act as a heat sink for the PCB. However, because the PCB has a low in-plane thermal conductivity, the heat will spread slowly to copper fixtures.

Therefore, a parametric study was performed to determine the resolution level needed. Four thermal models were created. A heat load of 0.48 W (receiving mode) was applied to each PCB model. Each PCB was modeled using edge nodes while the copper fixtures were modeled as a single 3D solid. Each corner of the PCB was connected to a boundary node set to 273.15 K with a conductance of 0.26 W/K. All model parameters were held constant except the resolution level. The results of this study are illustrated in Fig. 3.9.

²¹ What qualifies as a “large” heat load will depend on the PCB and its thermal properties. A “large” heat load is a heat load that saturates the PCB.

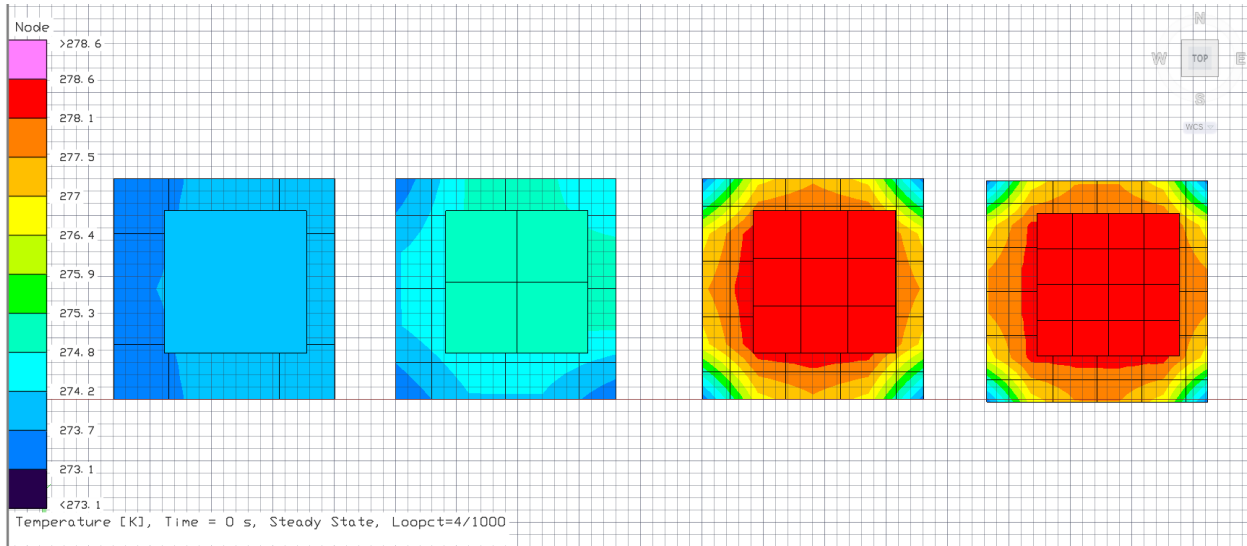

Fig. 3.9 Transceiver Parametric Study

Because of the lower resolution in the first and second thermal models, the heat is transferred more efficiently into the copper heat sink and into the boundary nodes, reducing the overall temperature of the PCB. As the resolution increases, the temperature increases. The maximum temperatures of the PCB versus resolution are given in Table 3.10.

Table 3.10 Transceiver Parametric Study

Resolution [Total Nodes]	Max PCB Temperature [K]
12	273.99
22	274.88
36	278.99
54	278.26
76	278.09

Once higher resolution levels are reached, the maximum temperature of the PCB stabilizes. The total node number of 54 corresponds to 36 PCB nodes, 16 copper fixture nodes, and 2 heat source nodes. The change in temperature compared to resolution illustrates the importance of PCB resolution level and heat load placement. A PCB with a higher in-plane thermal conductivity may require lower levels of resolution before the results stabilize.

3.6.4 Modeling PCB Stacks

PCBs are often stacked together using standoffs. Boards within the stack are somewhat isolated from the structure of the satellite and space thermal environment. Board placement within a PCB stack can be used as a passive thermal control measure. Thermally insulating washers can be inserted into the standoffs to further insulate the boards. Because of the relatively low thermal conductivity of PCBs, it is important to accurately model where the PCBs are connected to other PCBs or the structure (normally at the corners). Heat will flow through these connections, which serve as the primary heat rejection pathway for the PCB.

Node-to-node connections can be placed on the corners of the PCB models to connect them. These connections will have a specified conductance value. In Thermal Desktop, node-to-node connections will “break” if the resolution of the surface or solid is changed (i.e., the number of nodes is changed). However, the renodealized surface or solid can be selected and the merge node tool used to “reconnect” the conductors and thermal geometry, provided the submodules have not been moved.

Placing PCBs with large internal heat generation values in the middle of PCB stacks can cause overheating issues, as the only conduction paths that will exist are the corner PCB standoffs and any header pin connections. Solutions such as thermal straps may be necessary if the heat generation values are large enough to cause overheating.

ISISPACE’s OBC and ISISPACE’s CubeSat Antenna System for 1U/3U are used to illustrate a PCB stack, shown in Fig. 3.10. The structure rail in the foreground has been hidden for ease of viewing. The node-to-node connections from the transceiver to the OBC and the OBC to the structure are depicted as cylinders. The standoffs are modeled as having an individual conductance of 0.26 W/K. Additionally, the PCBs are thermally coupled with a header-pin connection, modeled as having a conductance of 1 W/K [7].

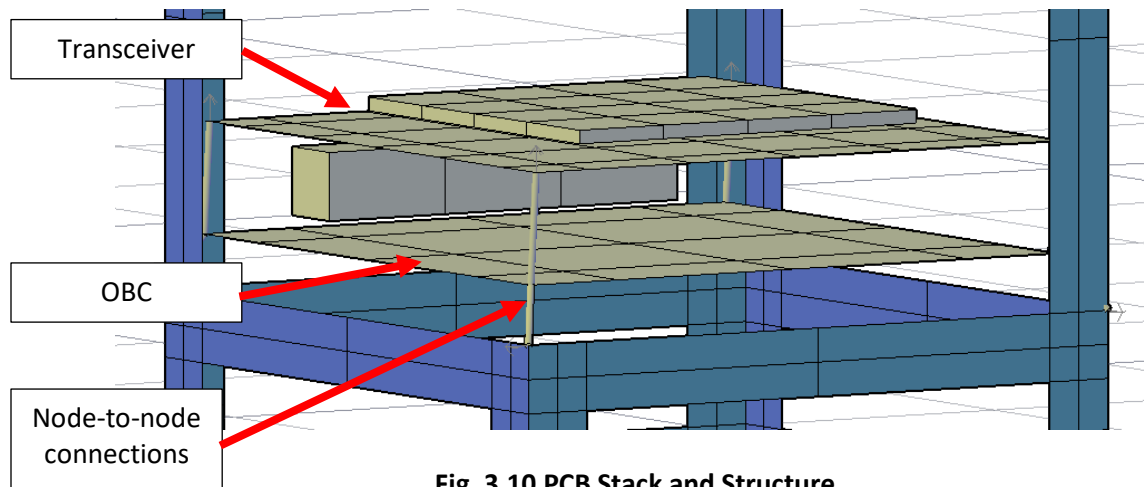

Fig. 3.10 PCB Stack and Structure

Note that the transceiver is located on top of the OBC, meaning that heat from the transceiver must first be transferred through one set of PCB standoffs from the transceiver to the OBC and then through another set of PCB standoffs from the OBC to the structure before the heat can then be transferred from the structure to the radiating surfaces of the satellite and subsequently be dissipated to space. In other words, it will take longer for heat to be rejected from the transceiver than from the OBC.

3.6.5 Modeling Solar Panels

Solar panels are typically constructed in a layered fashion. Solar cells are usually fixed to the backing material with an adhesive, and the solar panel structure is attached to the primary structure with screws. Exact construction of solar panels will vary by manufacturer. Solar panels should be carefully modeled as they usually cover large portions of the satellite.

The thermophysical properties of the structural layers can be spatially averaged. This method is useful for reducing node counts and model complexity. In some cases, the solar cells can be modeled explicitly while the solar panel structure is modeled with spatially averaged properties. This method is useful if the solar cell temperatures must be known explicitly or if there is an additional structure supporting multiple solar

panels (see [5] for this method). If the layers of the solar panel are modeled explicitly, special attention must be paid to the conductance values applied between layers.

The optical properties of a solar panel surface must be carefully modeled. Solar cells will convert absorbed solar radiation into electricity with some efficiency. The effective absorptivity of the solar cell will be determined by the absorptivity of the material properties of the solar cell and the efficiency of the solar cell. The solar cell emissivity is unaffected by solar cell efficiency. The effective absorptivity of the solar cell can be calculated using Eq. (27).

$$\alpha_{eff} = \alpha(1 - \eta) \tag{27}$$

where α_{eff} is the effective absorptivity of the solar cell, α is the absorptivity of the solar cell, and η is the solar cell efficiency. Over time, solar cells will become less efficient because of material degradation. End of life properties may need to be considered if the mission length is long enough. Specifically, the solar cell efficiency will lessen over time, which will increase the amount of heat absorbed by the solar cells.

Solar panels usually have a fixed pointing direction on small satellites. However, solar panels can also be placed on actuators that always point them towards the Sun when mechanically possible (i.e., Sun pointing). If the satellite being modeled utilizes actuating solar panels, this should be reflected in the model. In Thermal Desktop, the actuator tool can be used to fix move geometry during an orbital simulation.

ISIS 3U solar panels were selected to demonstrate how to model solar panels. The 3U solar panels have a length of 33 cm and a width of 10 cm for a total area of 330 cm². Each 3U solar panel has six solar cells, each with a length of 8 cm and a width of 4 cm. The total area of each solar cell is 30.4 cm², including the chamfered edges of the solar cell. With six solar cells the total solar cell area is 181 cm². The BOL efficiency is listed as 30% and the EOL efficiency is listed as 26.5% [15]. The base material is GaInP/GaAs/Ge on Ge substrate [15]. The absorptivity for each solar cell is listed as 0.91 [15]. The total mass of the solar panel is 150 g, and the operational temperature range is -40 to +125 °C [18]. A CAD model of the ISIS 3U solar panel is shown in Fig. 3.11.

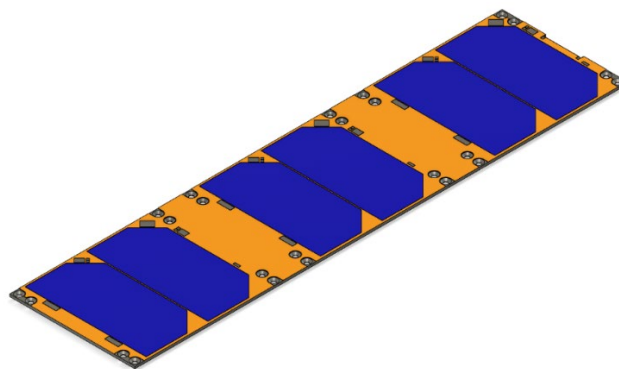

Fig. 3.11 ISIS 3U Solar Panel

The solar panel is modeled using spatially averaged properties. It is assumed that the solar panel backing material is aluminum 6061-T6, and that the solar panel lumped thermophysical and thermo-optical properties are dominated by the backing material and solar cell (i.e., other materials present in the solar

panel will be ignored). The parameters for the solar panel backing material (aluminum 6061-T6) and individual solar cell are given in Table 3.11. The panel and solar cell thermophysical parameters are taken from [5], [12], and [15].

Table 3.11 Solar Panel Parameters

Component	Length [cm]	Width [cm]	Thickness [cm]	Area [cm ²]	Volume [cm ³]	Density [kg/cm ³]	Cp [J/kg/K]
Panel	33	10	0.155	330	51.15	0.00271	961
Solar Cell	8	3.8	0.015	30.4	0.456	0.00532	327

The total volume and mass of all six solar cells and solar panel backing were calculated, and the results are shown in Table 3.12.

Table 3.12 Solar Panel Volume and Mass

Component	Volume [cm ³]	Mass [kg]
Panel	51.15	0.138
6x Solar Cell	2.736	0.014
Total	53.886	0.152

Using the total volume and mass, the calculated effective density is 0.00284 kg/cm³. The effective specific heat was calculated using Eq. (23). The result is shown in Table 3.13.

Table 3.13 Solar Panel Effective Specific Heat

Component	Cp [J/kg/K]
Panel Weighted Specific Heat	869.6787866
Solar Cell Weighted Specific Heat	31.07391964
Effective Specific Heat	900.7527063

Since the panel thickness is dominated by the backing material, the thermal conductivity of aluminum 6061-T6 is used as the thermal conductivity for the lumped solar panel. The effective emissivity, absorptivity, and thermal conductivity (in-plane) were calculated using Eq. (21), Eq. (22), and Eq. (24), respectively. Results are given in Table 3.5. The spatially averaged thermophysical and thermo-optical properties are given in Table 3.14 along with component dimensions and mass.



Table 3.14 Spatially Averaged Solar Panel Parameters

Parameter	Modeled Value
Effective Emissivity	0.52
Effective Absorptivity	0.42
Effective Specific Heat [J/kg/K]	900.75
Thermal Conductivity [W/m/K]	167.9
Mass [kg]	0.153
Length [cm]	33
Width [cm]	10
Thickness [cm]	0.16

The solar panel is modeled as a simple 2D surface. The effective emissivity and absorptivity are used for the top surface optical properties. Optical properties for aluminum 6061-T6 are used for the bottom surface. The solar panel is connected to the structure with 12 4-40 screws, each with a conductance of 0.26 W/K, for a total conductance of 3.12 W/K²². A surface-to-surface contactor is applied from the back of the solar panel to the surface of the structure facing the solar panel with a conductance of 3.12 W/K. The modeled solar panel and the structure to which it is connected is illustrated in Fig. 3.12.

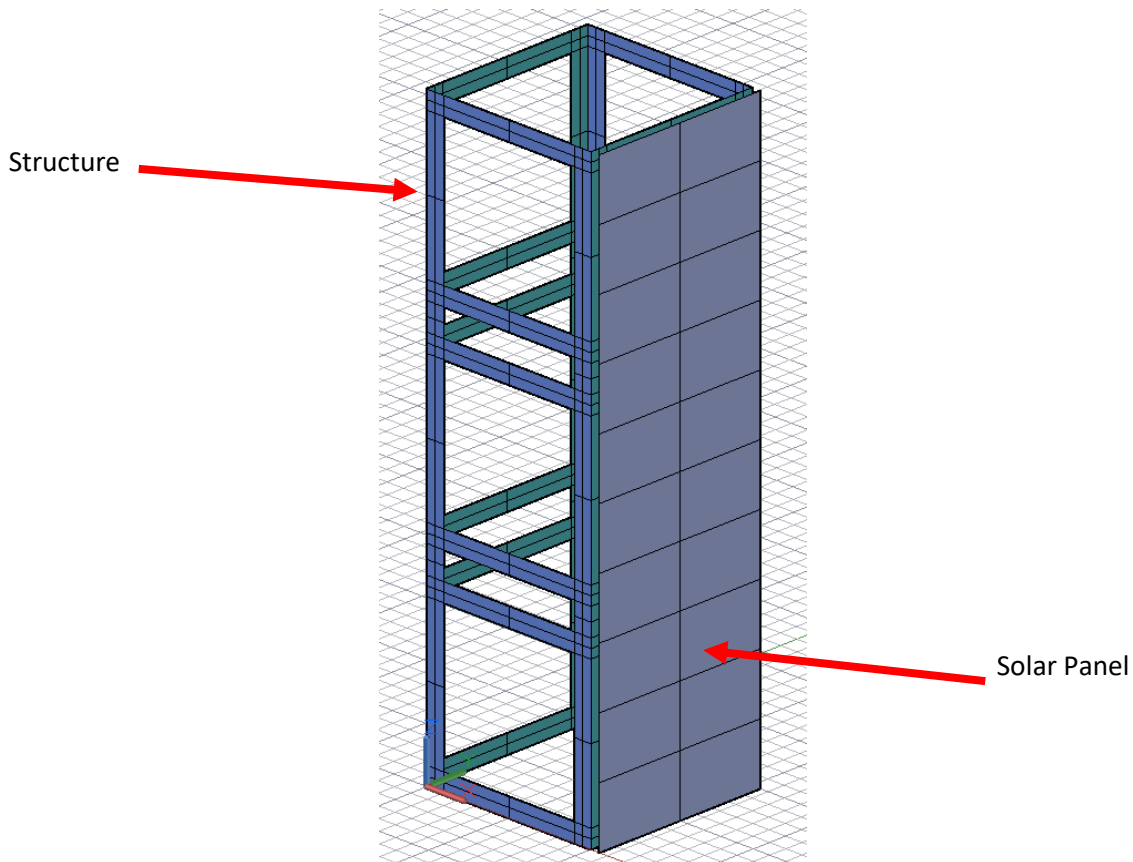

Fig. 3.12 Modeled Solar Panel and Structure

²² The exact screw used is not known. Therefore, a standard screw size was selected.

3.6.6 Modeling Batteries and EPS

Batteries can be modeled as simple 3D solid cylinders. Batteries will generate heat when charging and discharging. The efficiency of a battery is directly related to the temperature of a battery. Therefore, battery thermal management is critical for mission success. Batteries are often insulated to dampen thermal oscillations. Therefore, batteries reject heat primarily through conduction.

The chemistry of the battery will affect its characteristics. Most small satellites use lithium-ion (Li-ion) batteries, which have a higher energy storage capacity, longer life cycle, and lower weight than nickel-cadmium (Ni-Cd) or nickel-hydrogen (Ni-H₂) batteries [19]. The specific heat of the battery should be determined, either from the manufacturer or from a physical test. It is very important that modeled mass of a battery matches that of the physical battery. ISISPACE's Type C Electrical Power System (EPS) unit with daughterboard is used to illustrate the thermal modeling of an EPS and is illustrated in Fig. 3.13. The EPS unit has a reported mass of 0.310 kg [20].

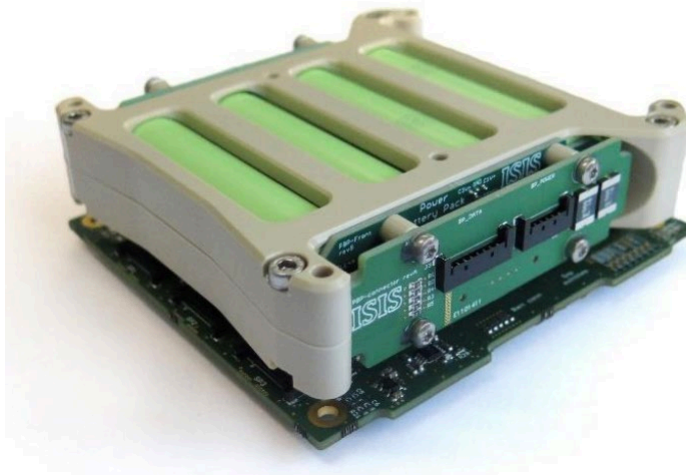

Fig. 3.13 ISISPACE EPS [20]

Because of the complex nature of the EPS unit, spatially averaged properties will be used to thermally model the EPS. The batteries will be modeled using standard lithium polymer (Li-Po) battery thermal properties [5]. The PCB daughterboard will be modeled as PCB-4.6% Cu. The material used for the insulative plastic is not specified by ISIS. Polyether ether ketone (PEEK), a typical space grade thermoplastic, will be used for the insulative plastic material. Finally, to simplify calculations, it will be assumed that the EPS is covered in 850-3M aluminized Mylar tape. Thermophysical and component properties are given in Table 3.15 and Table 3.16.

Table 3.15 EPS Component Properties 1

Component	Length [cm]	Width [cm]	Thickness [cm]	Area [cm ²]	Volume [cm ³]	Density [kg/cm ³]	Cp [J/kg/K]
PCB	9.6	9.2	0.15	88.32	13.248	0.00225977	1154.11
PEEK	[--]	[--]	[--]	[--]	[--]	0.0013	1340



Table 3.16 EPS Component Properties 2

Component	Length [cm]	Radius [cm]	Volume [cm ³]	Density [kg/cm ³]	Cp [J/kg/K]
Battery Cell	6	1	18.84955592	0.003115	601

The calculated volume and mass for each component are given in Table 3.17.

Table 3.17 EPS Calculated Volume and Mass

Component	Volume [cm ³]	Mass [kg]
PCB	13.24	0.0299
4x Battery Cell	75.39	0.2348
PEEK	35.00	0.0455
Total	123.64	0.3103

The volume of PEEK in the model was adjusted until the total mass matched that of the reported EPS mass. The effective density calculated from the total mass and volume is 0.002509 kg/cm³. For a 9 by 9 cm EPS, the effective thickness is 1.53 cm. Equation (23) was used to calculate the effective specific heat. The result is shown in Table 3.18.

Table 3.18 EPS Effective Specific Heat

Component	Specific Heat [J/kg/K]
Weighted PCB	111.34
Weighted Batteries	454.89
Weighted Peek	88.12
Effective	654.36

The thermal model of the EPS (shown in red) and the structure to which it is connected are illustrated in Fig. 3.14.

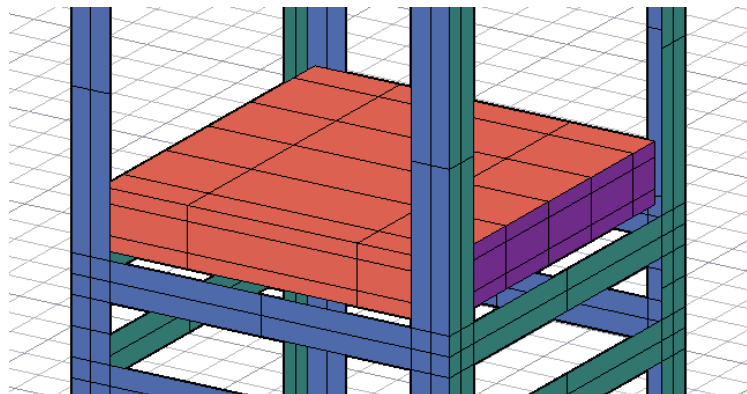

Fig. 3.14 EPS Thermal Model

3.7 Integrated Thermal Model of a 3U CubeSat Bus

To illustrate a complete thermal model of a CubeSat, the components modeled in the previous subsections are integrated into a complete thermal model of a 3U CubeSat bus. Mission critical components such as ISISPACE’s OBC, VHF/UHF antenna, and magnetorquer ADCS unit were also modeled. Additional components that may be selected for a CubeSat mission were not modeled. The integrated model of a 3U CubeSat bus illustrated in this section corresponds approximately to the thermal model revision F as described in Table 3.1.

3.7.1 Example Payload

A dummy payload of 4 PCBs with a mass of 0.4 kg, an instrument with a mass of 0.4 kg, and structure of aluminum 6061-T6 with a mass of 0.2 kg was modeled. Spatially averaged thermophysical properties were calculated using the methods described in Section 3.5 and the results are given in Table 3.19.

Table 3.19 Payload Thermal Properties

Parameter	Modeled Value	Unit
Emissivity	0.15	[--]
Absorptivity	0.05	[--]
Effective Specific Heat	963.844	[J/kg/K]
Thermal Conductivity x-y plane	18.04	[W/m/K]
Thermal Conductivity z-axis	1.04	[W/m/K]
Mass	1	[kg]
Length	8	[cm]
Width	8	[cm]
Thickness	8	[cm]

The location of the payload was selected based on the arbitrary assumption that the payload is an Earth observation payload. Therefore, it must be nadir pointing during operational mission modes.

3.7.2 Heater Application

Two heaters were applied to the model. One heater is located in the EPS unit and has a maximum power of 2.5 W [20]. Another heater is applied to the payload and has a maximum power of 2 W. Both heaters have a turn-on temperature of 273.15 K and turn-off temperature of 278.15 K. When defining heaters, the location of the heater application and the location of the temperature sensor must be determined.

The heat load from the payload heater is applied on the internal node of the payload model. The payload temperature sensor is applied to the same node as the heat load and uses area weighted average temperature. The heat load from the EPS heater is applied onto the bottom nodes of the EPS model. The EPS temperature sensor is applied to the same nodes as the heat load and uses area weighted average temperature.

When applying heaters, careful attention should be paid to heat load and temperature sensor locations. Depending on the results from simulations, heater turn-on and turn-off temperatures may need to be adjusted. These temperatures should be communicated to the CDH subsystem team.



3.7.3 Complete Thermal Model

The complete thermal model of the example 3U CubeSat shown in Fig. 3.15. The solar panel on the minus-y face was hidden to view the internal submodels of the satellite.

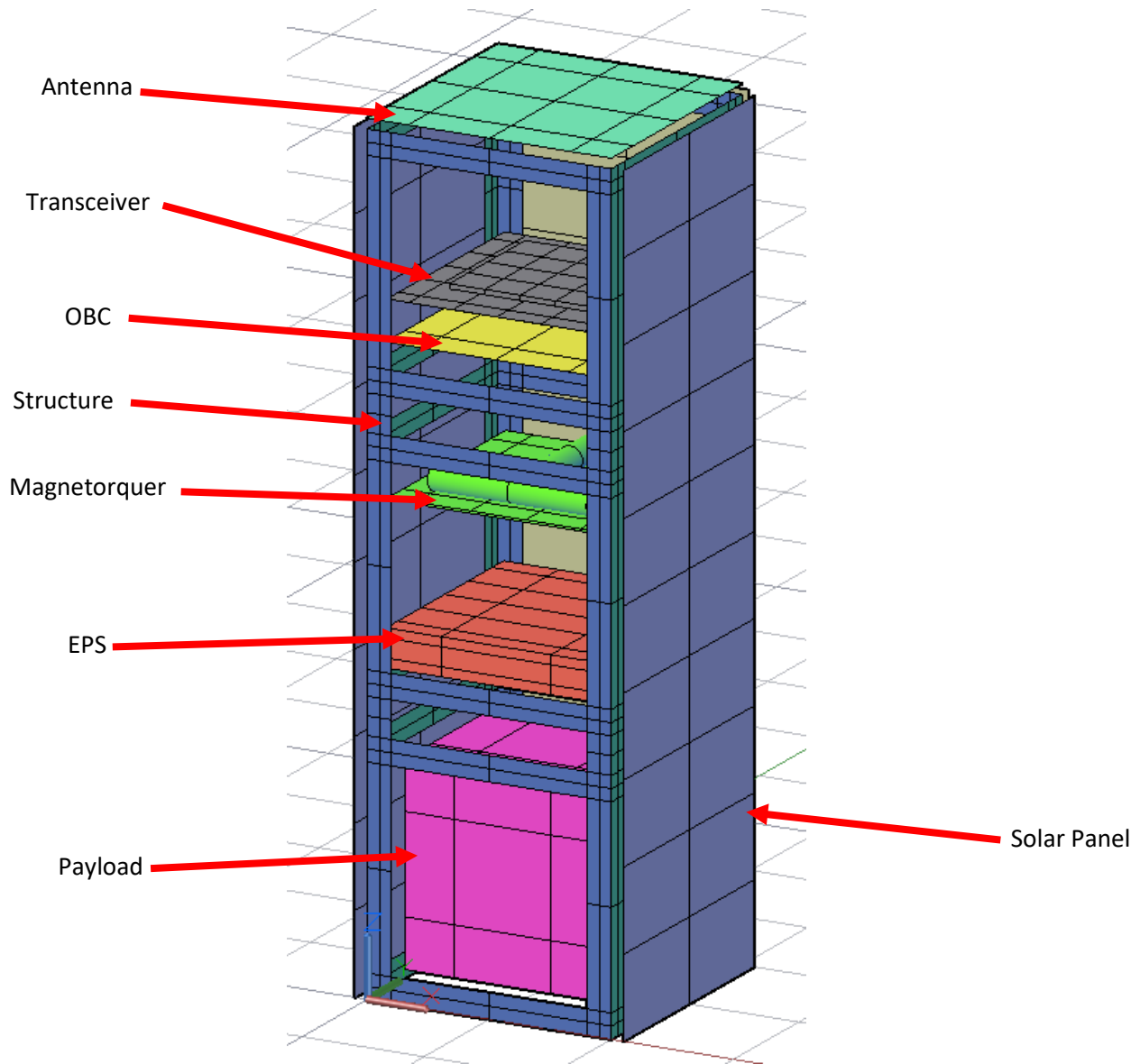

Fig. 3.15 Complete Thermal Model²³

The final node count for each subsystem is given in Table 3.20. The total thermal node count for the model is 425. The submodel with the highest node count is the structure. Each PCB is connected to the structure with 4 PCB standoffs each with a conductance of 0.26 W/K except for the transceiver which is connected to the OBC with 4 PCB standoffs. The payload is connected to the structure with 8 PCB standoffs each with a conductance of 0.26 W/K. The -Z face of the satellite (where the payload is located) is open to space such that the bottom of the payload is open to space. The total node count falls within the final node

²³ Note that the different colors denote different subsystems and do NOT indicate temperature.

count values recommended in Table 3.2 with more nodes available for modeling mission specific components, thermal control components, etc.

Table 3.20 Complete Thermal Model Node Count

Subsystem/Component	Submodel Name	Node Count
3U Structure	STR	144
ISISPACE OBC	OBC	40
ISISPACE VHF uplink/UHF downlink Full Duplex Transceiver	TRANSMITTER	54
ISIS iMTQ Magnetorquer	MAGNETORQUER	57
CubeSat Antenna System for 1U/3U	ANTENNA	9
ISIS 3U Solar Panels	SP	40
ISIS EPS	EPS	54
PAYLOAD	PAYLOAD	27
Total	[--]	425

3.7.4 Mass Budget

The mass budget for the complete thermal model is given in Table 3.21. There is a 0.013 kg discrepancy between the modeled mass and the total mass budget because the thermal geometry is simplified with respect to the physical geometry.

Table 3.21 Mass Budget

Component	Submodel Name	Modeled Material [---]	Total Modeled Mass [kg]	Total Mass Budget [kg]	Details [---]
3U Structure	STR	Aluminum 5754	0.246	0.243	
ISISPACE OBC	OBC	PCB - 4.6% CU	0.096	0.095	
ISISPACE VHF uplink/UHF downlink Full Duplex Transceiver	TRANSMITTER	PCB - 4.6% CU, C11000	0.078	0.075	
ISIS iMTQ Magnetorquer	MAGNETORQUER	PCB - 4.6% CU	0.196	0.196	
CubeSat Antenna System for 1U/3U	ANTENNA	Aluminum 6061-T6, PCB - 4.6%	0.087	0.089	
ISIS 3U Solar Panels	SP	3U_SP_lumped	0.582	0.600	4 3U solar panels
ISIS EPS	EPS	EPS_lumped	0.310	0.310	
PAYLOAD	PAYLOAD	PAYLOAD_lumped	1.000	1.000	
TOTAL	---	---	2.595	2.608	---

3.7.5 Submodel Thermal Connections

The thermal connections from submodel to submodel are listed in Table 3.22. Note that thermal connections within submodels are not listed in this table.

Table 3.22 Connections

From Submodel	To Submodel	Description	Number of Fasteners [---]	Conductance per Fastener [W/K]	Total Conductance [W/K]
OBC	STR	PCB_standoff	4	0.26	1.04
EPS	STR	PCB_standoff	4	0.26	1.04
PAYLOAD	STR	PCB_standoff	8	0.26	2.08
TRANSMITTER	OBC	PCB_standoff	4	0.26	1.04
MAGNETORQUER	STR	PCB_standoff	4	0.26	1.04
3U_SP ²⁴	STR	4-40 Screw	12	0.26	3.12
ANTENNA	STR	4-40 Screw	4	0.26	1.04
OBC	TRANSMITTER	Header-pin	1	1.00	1.00

3.7.6 Thermo-optical Properties

The thermo-optical properties of the materials used in the thermal model are listed in Table 3.24. EOL properties were not considered for this thermal analysis.

Table 3.23 Optical Properties

Component	Location	BOL		EOL		Reference
		α [---]	ϵ [---]	α [---]	ϵ [---]	
Aluminum 6061-T6	Solar Panels	0.160	0.030	[--]	[--]	[12]
Aluminum 5754	STR	0.160	0.030	[--]	[--]	[12]
PCB - 4.6% Cu	PBCs	0.810	0.900	[--]	[--]	[5]
GaAs	3U_SP_lumped	0.920	0.850	[--]	[--]	[5]
C11000	TRANSMITTER, MAGNETORQUER	0.320	0.020	[--]	[--]	TCH
3U_SP_lumped	Solar Panels	0.419	0.520	[--]	[--]	[5], [12]
Tape, 850-3M, aluminized Mylar	EPS	0.150	0.590	[--]	[--]	[5]

²⁴ 3U_SP is the 3U solar panel submodel

3.7.7 Thermophysical Properties

The thermophysical properties of the materials used in the thermal model are listed in Table 3.24.

Table 3.24 Thermophysical Properties

Material	Details	k _{xy} [W/m/K]	k _z [W/m/K]	ρ [kg/m ³]	C _p [J/kg/K]	Reference
Aluminum 6061-T6		167.9	167.9	2710	961	[12]
Aluminum 5754		125	125	2670	961	Matweb
PCB - 4.6% Cu		18.04	18.04	2259.77	1544.11	[5]
li_po		2.49	2.49	3115	601	[5]
PEEK	Unfilled	0.25	0.25	1320	1700	[12]
C11000		391.2	391.2	8860	385.2	[12]
GaAs		0.00329	60.6	5260	334.8	[12]
Payload_lumped	Lumped Property	18.04	167.9	1953	963.8	Calculated
EPS_lumped	Lumped Property	18.04	0.0249	2509	654.36	Calculated
3U_SP_lumped	Lumped Property	167.9	167.9	2842.52	900.75	Calculated



(This page is intentionally left blank)

4 Thermal Analysis

“The model is not the arbiter of reality” – Jon Allison, Air Force Research Laboratory

4.1 Introduction

Thermal analysis is the process of simulating a thermal model, analyzing the results of the simulation, and drawing conclusions. Goals of thermal analysis include the following:

- Determine expected satellite temperatures
- Determine thermal margin between predicted temperatures and temperature limits
- Determine if the design meets TCS requirements

Additionally, thermal analysis should be efficient. The purpose of thermal analysis is to draw conclusions from the data so that decisions can be made and the design can move forward. Many thermal engineers will become bogged down in the analysis phase and interrogate the data to excess. This should be avoided in favor of efficiently analyzing the data and drawing meaningful conclusions.

4.2 Thermal Cases

A thermal case is a specific set of thermal conditions that are usually defined by a mission mode and orbit. Thermal models are simulated using thermal cases. A thermal case should be created to answer a specific set of questions and should represent a mission mode of the satellite and a corresponding orbital thermal environment. Thermal cases should represent the conditions a satellite will realistically experience during its mission. Theoretical “worst case scenarios” should not be used when defining thermal cases (i.e., satellites should not be simulated in conditions they could never experience). Hot and cold case definitions should be based on the extremes the satellite will encounter given the Concept of Operations (CONOPs). Simulating and analyzing theoretical worst case scenarios do not provide meaningful results.

4.2.1 Defining Mission Modes

The most important parameters of a mission mode for thermal analysis are component heat dissipation magnitudes and TCS requirements. Common mission modes include standby, safe, transmit, and operational. Different mission modes will need to be simulated based on the mission requirements and design of the satellite. For every mission mode simulated, the heat generation values for each component should be determined along with the power available for TCS components. Additionally, the orientation of the satellite with respect to the Earth and to the Sun should be determined for every mission mode as this can have significant effects on the thermal behavior of the satellite.

During standby mode, the satellite produces nominal amounts of heat dissipation. During safe mode, the satellite will produce a minimal amount of heat as many components will be turned off or put into reduced power modes. Safe mode is the most likely mode for components to get too cold. Transmit mode will generate significant amounts of heat on the antenna and transceiver. It should be noted if the transmitter and payload (or other components) are operational at the same time as this could generate significant amounts of heat. Operational mission modes vary by satellite but are usually characterized by maximum amounts of heat dissipation. Normally, following deployment from a launch vehicle, a satellite must complete a period of non-operation as defined by the launch vehicle provider. As a result, the thermal design should ensure that the satellite will survive this period of non-operation²⁵.

²⁵ A standard non-operational time requirement is 45 minutes. This time is determined by the launch vehicle provider. The primary concern during this non-operational period is getting too cold.

4.2.2 Defining Thermal Environment Characteristics

For a thermal case, an orbit will have a defined altitude, beta angle, solar flux, albedo factor, and Earth IR value. Additional parameters such as inclination, time of year, Right Ascension of the Ascending Node (RAAN), and eccentricity can also be defined. Keplerian orbits (orbits with a defined RAAN, eccentricity, etc.) are useful for analyzing specific mission conditions at specific times, whereas basic orbits (using only beta angle and altitude) are useful for simulating hot and cold cases (thermal environment extremes).

The beta angle is the angle between the solar vector and its projection onto the orbit plane, and is a function of Orbit Inclination, obliquity of the ecliptic (23.45° for Earth), ecliptic true solar longitude (function of time of year), and RAAN. The maximum and minimum beta angles are limited by the obliquity of the ecliptic and orbit inclination. The beta angle will vary throughout the lifespan of the satellite as the Earth rotates around the Sun and perturbs the RAAN. However, the maximum and minimum beta angles will remain functionally constant. See Section 7.2.3 for more details on calculating beta angles.

The time of year of the mission will affect thermal environment characteristics. At the winter solstice, the Earth is at its closest point to the Sun, and the intensity of the solar flux will be at its maximum of approximately 1414 W/m² [12]. At the summer solstice, the Earth is at its farthest point from the Sun, and the intensity of the solar flux will be at its minimum of approximately 1322 W/m² [12]. At a distance of 1 AU from the Sun, the intensity of the solar flux is known as the solar constant and is equal to 1367 W/m² [12].

The increase and decrease in solar flux will also affect the amount of solar radiation reflected. The surface characteristics of the Earth will also affect the amount of reflected radiation from the Earth. When performing thermal analysis, the effects of time-of-year, surface characteristics, etc., are typically averaged for an orbit. Some typical orbit averaged values are given in Table 4.1. Chapter 2 of the Spacecraft Thermal Control Handbook should be consulted for more detailed information about thermal environment characteristics, thermal case selection, and orbit averaged thermal environment data [12].

Table 4.1 Typical Orbit-Average Earth IR and Albedo Values for Various Orbits [21]

Orbit Inclination [deg]	Beta Angle [deg]	Emitted Radiation [W/m ²]		Albedo Factor [percent]	
		Min	Max	Min	Max
0-30	0	228	275	18	28
	90	228	275	45	55
30-60	0	218	257	23	30
	90	218	257	50	57
60-90	0	218	244	23	30
	90	218	244	50	57

4.2.3 Defining Thermal Cases

Thermal cases are determined by selecting a mission mode (and its associated heat generation values), an orbit, and TCS requirements. At a minimum, internal heat generation values, orbit altitude, beta angle, solar flux, albedo factor, Earth IR, TCS requirements (i.e., available heater power) should be defined. Some example thermal cases are given in Table 4.2.

Table 4.2 Example Thermal Cases

Case Name	Orbit	Mission Mode	Description
Hot Operational	Hot Orbit	Operational	Simulates the orbit with the maximum amount of solar flux, Earth IR, and albedo. Simulates the maximum amount of internal heat generation.
Cold Survival	Cold Orbit	Survival	Simulates the orbit with the minimum amount of solar flux, Earth IR, and albedo. Simulates the minimum amount of internal heat generation.
Cold Operational	Cold Orbit	Standby	Simulates the orbit with the minimum amount of solar flux, Earth IR, and albedo. Simulates the nominal (standby) amount of internal heat generation.
Hot Transmit	Hot Orbit	Transmit	Simulates the transmit mission mode, which generates significant amount of heat on the transceiver and antenna.

For a given time of year, orbits with the maximum and minimum amount of thermal loading (the sum of Earth IR, reflected radiation, and solar flux) can be defined as the “hot orbit” and “cold orbit,” respectively. These orbits can be paired with the mission modes that produce the maximum and minimum amount of internal heat generation to produce hot cases and cold cases, respectively.

Hot and cold cases should represent the extremes of the mission plan. They should not represent the theoretical worst possible conditions. For instance, a beta angle of 90° would be a theoretical worst case condition as this beta angle maximizes sunlit time and thus the temperature of the satellite. This orbit should not be used as a part of a hot case definition unless the mission plan actually calls for a beta angle of 90°.

However, using theoretical worst case conditions and other simplifications can be helpful when performing hand calculations early in the design process. For instance, using a beta angle of 90° can simplify the process of estimating environmental loading. The difference between using theoretical worst case conditions for hand calculations versus thermal case definitions is that hand calculations are used for estimation and scoping out the problem while thermal case definitions are used for thermal design iteration and mission planning. Therefore, it should be clear when theoretical worst case conditions and simplifications are used and for what purpose.

Additionally, “safety factors” should not be added to thermal case definitions. This means that the solar flux should not be artificially increased by 5% to build in a 5% “safety factor” into the model, nor should the material properties of a component be changed to build a factor of safety into the component. The simulated thermal environment should be as accurate to real life conditions as possible.

4.3 Operational and Survivable Temperatures

Components have survivable and operational temperature ranges. The operational temperature range is the range of temperatures in which the component can operate. The survivable temperature range is the range of temperatures in which the component can survive when not in operation. A thermal margin is the difference between the predicted temperature and an operational or survival limit. When thermal margins are applied to the operational and survival limits, the resulting values represent the minimum or

maximum allowable values for simulation results. If a component temperature falls within the allowable range, then no thermal control is required.

External components such as solar arrays and antennas, along with structural components, typically have wider operational and survival temperature ranges than electronic components such as flight computers, IMUs, etc. Temperature data of all components with operational and survivable temperatures should be collected during simulations. For components with a range of temperatures, maximum and minimum temperatures on that component should be collected. Components may have thermal gradient restrictions, which should be noted when analyzing maximum and minimum temperatures.

4.4 Running Simulations

Simulations can be run as steady-state or transient simulations. Steady-state simulations will simulate the model until it reaches thermal equilibrium. Transient simulations will simulate the model over a defined period of time. Transient simulations should be run until an oscillating thermal equilibrium is reached (i.e., bounded cyclical heating and cooling). For some satellites this will be 5 orbits while for others it can be 10. Generally, smaller satellites will reach oscillating thermal equilibrium faster than larger satellites because of thermal capacitive effects.

Steady-state simulations are useful for debugging a thermal model and correlating it with test data. Additionally, running a conduction only model with no environmental heating and looking at temperature gradients can be a useful tool for debugging. However, they should not be used for mission planning and analysis unless the satellite will truly experience a steady-state condition during its mission. This is generally not the case for small satellites as they orbit the Earth and experience constant changes in thermal environment. In Thermal Desktop, steady-state simulations of orbits take the average thermal environment characteristics of the orbital positions being simulated.

Transient simulations are the primary tool in thermal analysis. Thermal models should be run until the oscillating thermal equilibrium is reached. Temperature plots can be used to determine if oscillating thermal equilibrium is reached. The time it takes to reach this state is determined by the node with the longest time constant. Components with long time constants will take longer to respond their surroundings, while components with short time constants will respond faster.

An initial temperature must be specified for all thermal nodes in the thermal model. Typically, nodes are given an initial temperature of 293 K (room temperature) or the expected temperature that they will have when released from the launch vehicle. The farther away the initial temperature is from the average temperature of the node after reaching oscillating thermal equilibrium, the longer it will take for the model to stabilize. Initial conditions in the thermal model should match the expected initial conditions when possible. This is especially important for small satellites with short mission durations.

Simulation runtime restrictions may need to be considered for large projects. Thermal models can be computationally intensive. Large scale or overly complex models can require significant amounts of time to run. Slowly increasing model complexity will allow for efficient testing and verification of lower resolution models. Long simulation runtimes may be an indication of errors within the thermal model and could also indicate that model complexity should be reduced. However, simulations should be run for as long as necessary to capture all transient effects. This time is determined by the component with the maximum time constant.

Specific simulations that correspond to physical tests should be run when possible. All simulation parameters should correspond to the test environment, including heat loads, simulation time, initial temperatures, model geometry, external connection points (boundary conditions), etc. Special care should be taken to ensure that any changing heat loads correspond exactly to the test plan, and that the thermal model matches the test model as closely as possible. Correlating test data with simulation data is an invaluable tool for verifying and validating a model. Correlation, verification, and validation of thermal models are discussed in Section 6.

4.5 Analyzing Results

Results from running simulations are usually in the form of temperature versus time. Every node in the thermal model will have a temperature profile. In most cases, it is infeasible to analyze every node in a thermal model. Therefore, results must be condensed. The primary results that should be extracted include maximum and minimum temperatures, temperature gradients, required TCS power, and thermal margins. Additionally, results should be plotted and compared with hand calculation. These results are described as follows.

- **Maximum and Minimum Temperatures:** For each component, the maximum and minimum temperatures over an orbit should be determined for each thermal case. These should be compared against operational and survivable limits. Some components will need to be more closely examined, with maximum and minimum temperatures for critical sub-components determined.
- **Temperature Gradients:** Some sensitive components including optics and scientific instruments will have temperature gradient requirements. For these components, the maximum and minimum temperature of the component along with the distance between the maximum and minimum temperature should be determined.
- **Analysis of Heater Power:** The power used by the heater (and other TCS components) should be determined. Specifically, the maximum power used should be determined. Every power consuming TCS component must have an allotted power usage in the power budget. Additionally, most TCS requirements will put a limit on power usage (a typical value is 80% of duty cycle). Therefore, the amount of power usage during each thermal case should be determined.
- **Thermal Margins:** Thermal margins for components should be determined for each case. Thermal margin is the difference between the maximum or minimum temperature and the operational or survivable limit. Components that have thermal margins below a specified value (usually between 5 and 10 °C) should be noted. Acceptable thermal margins may change as the thermal model is refined. For instance, before a thermal model is correlated with physical test data, the minimum required thermal margin might be 10 °C whereas after correlation it might be 5 °C. Communication is necessary with other subsystem teams and systems engineers to determine acceptable thermal margins. Refer to MIL-STD-1540 or NASA General Environmental Vehicle Standard (GEVS) for additional guidance on thermal margins.
- **Comparison with Hand Calculations:** Results of thermal models, especially early thermal models, should be compared against hand calculations. It is important to examine the results and determine if they make physical sense. Hand calculations are an invaluable tool for this task.



- **Plot results:** A useful tool is plotting the results of the simulation. Visually examining the data can reveal trends in the data that would otherwise go unnoticed. The temperature of nodes or components can be plotted over time, which is useful for observing trends over time. Temperatures can also be mapped onto the model, which can then be visually inspected. This is useful for observing temperature gradients, heat flow paths, and model debugging.

In addition to these results, it should be determined if the thermal model reached oscillating thermal equilibrium or if the average temperature of the model is still changing. The time it takes for a model to reach oscillating thermal equilibrium will depend on the size and complexity of the model and the maximum time constant present within the model.

4.6 Example Thermal Analysis

The 3U CubeSat bus modeled in Section 3.7 will be used to perform an example thermal analysis. A nominal International Space Station (ISS) orbit was selected for this example thermal analysis with the orbital parameters given in Table 4.3. This orbit was selected because of its easily accessible orbital parameters, orbit stability, and because it is representative of common small satellite orbits. Using Eq. (28), the maximum and minimum beta angles for an inclination of 51.64° were calculated to be ±75.0931°. For simplification purposes, the orbit is assumed to be perfectly circular with a constant altitude of 421 km.

Table 4.3 ISS Orbital Parameters [22]

Name	Date/Time GMT	Inclination [deg]	RAAN [deg]	Eccentricity [--]	Argument of Periapsis [deg]	Period [s]	Maximum Altitude [km]
ISS	2021/07/12 20:37:43	51.6431	217.0648	0.0002083	351.7161	5578	421.232

Using the nominal ISS orbit, four thermal cases were determined. These cases are hot case operational, hot case transmit, cold case operational, and cold case survival. These cases correspond to when the satellite is operational and it the hottest thermal environment, when the satellite is transmitting in the hottest thermal environment, when the satellite is operational in the coldest thermal environment, and when the satellite is in safe mode in the coldest thermal environment, respectively. These thermal cases are listed in Table 4.4.



Table 4.4 Example Thermal Analysis Cases

Case Name	Altitude [km]	Beta Angle [°]	Solar Flux [W/m ²]	Albedo [---]	Earth IR [W/m ²]	Heater Power [W]	Orientation [--]
Hot Case Operational	421	75.1	1,414.0	0.30	265	0	-Z Nadir, Z fast spin
Hot Case Transmit	421	75.1	1,414.0	0.30	265	0	+Z Nadir, Z fast spin
Cold Case Operational	421	0.0	1,317.0	0.15	227	4	-Z Nadir, Z fast spin
Cold Case Survival	421	0.0	1,317.0	0.15	227	4	-Z Nadir, Z fast spin

The beta angle of 75.1° corresponds to the maximum beta angle that could be experienced by the satellite. Note that with a beta angle of this magnitude, the satellite will be in constant sunlight for the hot case (i.e., it is never eclipsed by the Earth). This orbit is paired with maximum values of solar flux, albedo factor, and Earth IR. A beta angle of 0° corresponds to the minimum beta angle magnitude, which corresponds to the orbit with the maximum amount of eclipse time. This orbit is paired with minimum values of solar flux, albedo factor, and Earth IR. For each thermal case, the satellite's -Z face is nadir pointing except for the hot case transmit thermal case where the +Z face is nadir pointing. The satellite is spun about its Z axis so that no solar panel faces the Sun for longer than another. The hot case and cold case orbits are shown in Fig. 4.1.

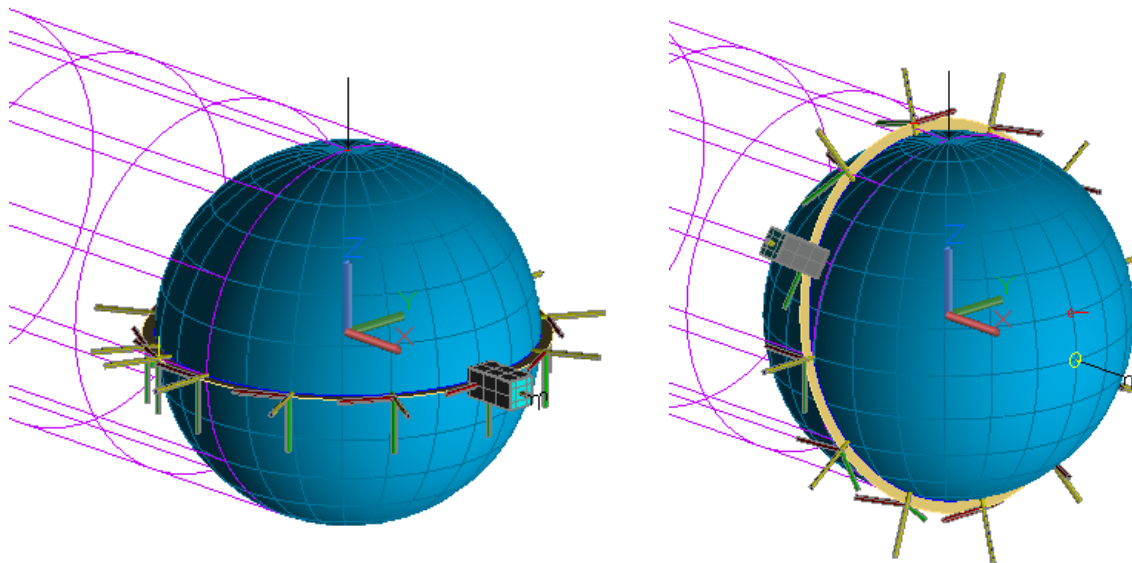

Fig. 4.1 Cold Case Orbit (left) and Hot Case Orbit (right)

Heat loads for each thermal case are given in Table 4.5.

Table 4.5 Heat loads

Component	Submodel Name	Hot Case Operational [W]	Hot Case Transmit [W]	Cold Case Operational [W]	Cold Case Survival [W]
ISISPACE OBC	OBC	0.40	0.40	0.40	0.40
ISISPACE VHF uplink/UHF downlink Full Duplex Transceiver	TRANSMITTER	0.48	4.00	0.48	0.00
ISIS iMTQ Magnetorquer	MAGNETORQUER	1.20	1.20	1.20	0.18
ISIS iEPS Electrical Power System	EPS	0.13	0.13	0.13	0.01
CubeSat Antenna System for 1U/3U	ANTENNA	0.04	0.04	0.04	0.00
Payload	PAYLOAD	2.00	0.00	0.00	0.00
TOTAL	---	4.25	5.77	2.25	0.59

The hot case transmit thermal case has the largest heat load, and the cold case survival thermal case has the smallest heat load. Normally, the communication subsystem will only generate large amounts of heat for small amounts of time (e.g., while it is transmitting). The expected length of transmit time should be factored into a transmit thermal case. Component power efficiency was not considered when determining heat loads. Component operational and survival temperature limits are listed in Table 4.6.

Table 4.6 Component Temperature limits

Component	Submodel Name	Operational		Survival		Heater Control [--]
		Min [°C]	Max [°C]	Min [°C]	Max [°C]	
3U Structure	STR	-40	80	[-]	[-]	No
ISISPACE OBC	OBC	-25	65	[-]	[-]	No
ISISPACE VHF uplink/UHF downlink Full Duplex Transceiver	TRANSMITTER	-20	60	[-]	[-]	No
ISIS iMTQ Magnetorquer	MAGNETORQUER	-40	70	[-]	[-]	No
ISIS iEPS Electrical Power System	EPS	-20	70	-40	85	Yes
CubeSat Antenna System for 1U/3U	ANTENNA	-20	60	[-]	[-]	No
ISIS 3U Solar Panels	SP	-40	125	[-]	[-]	No
Payload	PAYLOAD	-10	50	-10	75	Yes

The EPS is the only component with known survival temperature limits. The payload has an arbitrary operational and survival temperature limit. The EPS and payload are the only components with heater control. Two thermal cases are analyzed: hot case operational and cold case survival.

4.6.1 Example Hot Case Operational Thermal Analysis

The thermal model for the hot case operational thermal case is shown in Fig. 4.2.

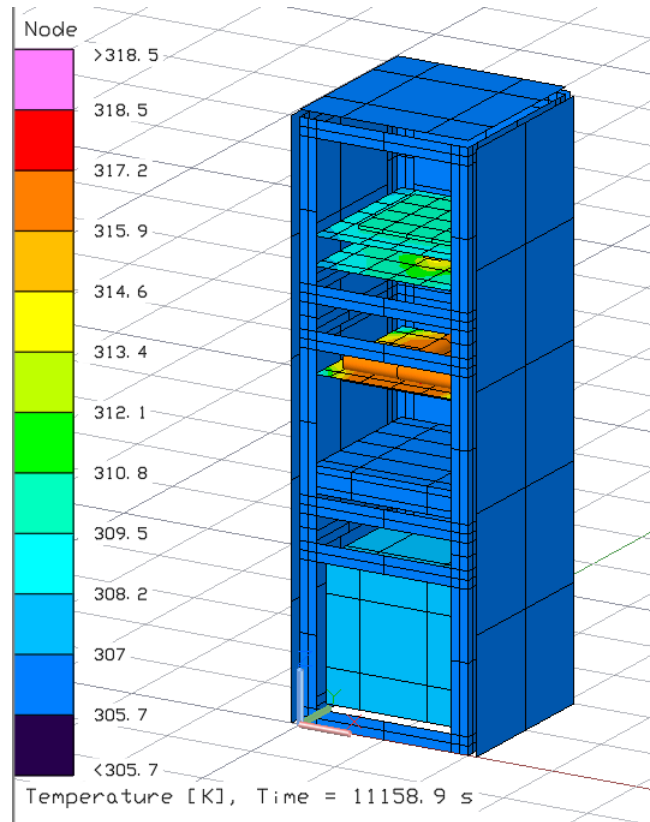

Fig. 4.2 Hot Case Operational Thermal Model

Note that most of the satellite is nearly isothermal, with hot spots on the OBC and magnetorquer. Component maximum and minimum temperatures and total heater power are listed in Table 4.7.



Table 4.7 Hot Case Operational Component Results

Submodel Name	Operational		Survival		Hot Case Operational		Total Heater Power	
	Min [°C]	Max [°C]	Min [°C]	Max [°C]	Min [°C]	Max [°C]	W-hr per orbit [W-hr/orbit]	Max Duty Cycle [W]
STR	-40	80	[--]	[--]	33	35	[--]	[--]
OBC	-25	65	[--]	[--]	34	44	[--]	[--]
TRANSMITTER	-20	60	[--]	[--]	33	39	[--]	[--]
MAGNETORQUER	-40	70	[--]	[--]	34	48	[--]	[--]
EPS	-20	70	-40	85	34	35	0	0.00%
ANTENNA	-20	60	[--]	[--]	33	35	[--]	[--]
SP	-40	125	[--]	[--]	33	35	[--]	[--]
PAYLOAD	-10	50	-10	75	36	37	0	0.00%

All components are within operational, survival, and allowable temperature limits. No heater power was required. Note that the satellite is fairly isothermal and that there is little difference between maximum and minimum values for several components. The component with the largest temperature difference is the magnetorquer.

If the minimum and maximum component temperatures are averaged together, the result is 309 K. Note that this result is very close to the results of the hand calculation performed in Section 3.5.7 (an average satellite temperature of 309 K for a cold operational case). The Thermal Desktop model used an internal heat generation value of 5.77 W while the hand calculation used an internal heat generation value of 5 W. This indicates that either the Thermal Desktop model more efficiently dissipates heat to space or that there is a difference in the space thermal environment parameters (e.g., Earth IR). The correspondence between the two methods illustrates the usefulness of hand calculations in making early predictions. The temperature profile for the transceiver is illustrated in Fig. 4.3.

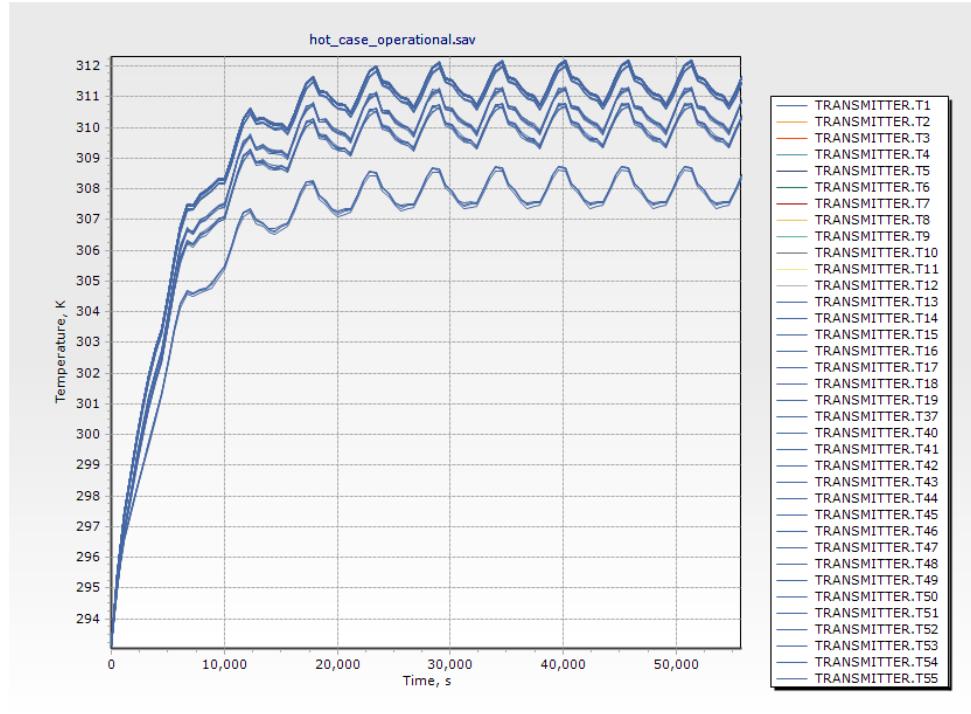

Fig. 4.3 Transceiver Hot Case Operational Temperature Profile

Note that even though the satellite is always in sunlight, it still experiences cyclical heating and cooling. This is due to the nature of the orbit, specifically the difference in the amount reflected radiation and Earth IR received at different latitudes. It takes approximately five orbits for the average temperature of the transceiver to stabilize.

4.6.1.1 Hot Case Operational Results Discussion

Based on the results of the simulation, specifically the maximum and minimum temperatures, little to no action needs to be taken for the hot case. The primary area of concern is the large thermal gradient of the magnetorquer. Since no maximum thermal gradient is reported for the magnetorquer this is an area of possible investigation.

4.6.2 Example Cold Case Survival Thermal Analysis

The thermal model for the cold case survival thermal case is shown in Fig. 4.4.

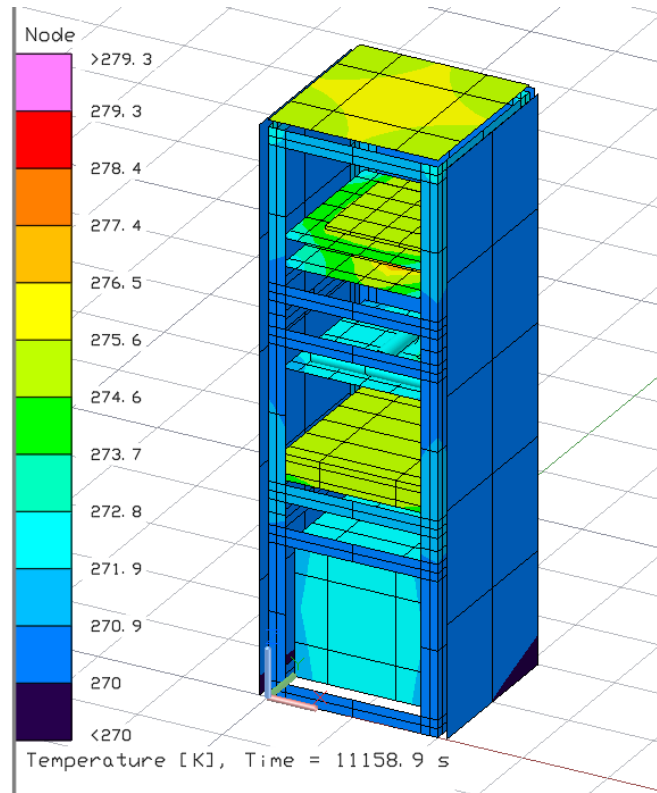

Fig. 4.4 Cold Case Survival Thermal Model

The local hotspots exist on the OBC and EPS. Note that the solar panels and structure are nearly isothermal. Component maximum and minimum temperatures are listed in Table 4.8, along with heater power results.

Table 4.8 Cold Case Survival Component Results

Submodel Name	Operational		Survival		Cold Case Survival		Total Heater Power	
	Min [°C]	Max [°C]	Min [°C]	Max [°C]	Min [°C]	Max [°C]	W-hr per orbit [W-hr/orbit]	Max Duty Cycle [W]
STR	-40	80	[--]	[--]	-13	5	[--]	[--]
OBC	-25	65	[--]	[--]	-11	9	[--]	[--]
TRANSMITTER	-20	60	[--]	[--]	-11	5	[--]	[--]
MAGNETORQUER	-40	70	[--]	[--]	-11	5	[--]	[--]
EPS	-20	70	-40	85	-6	5	2.8025	72.33%
ANTENNA	-20	60	[--]	[--]	-13	4	[--]	[--]
SP	-40	125	[--]	[--]	-13	5	[--]	[--]
PAYLOAD	-10	50	-10	75	-6	4	2.648568	85.33%



All components are within operational and survival limits. Using a thermal margin of 10 °C, the transmitter, antenna, and payload are outside of allowable temperature limits. The heaters use a significant amount of power per orbit, with duty cycles of 72.33% and 85.33% for the EPS and payload heaters, respectively. The duty cycle of 85.33% is outside of the standard industry limit of 80%. The payload, even though it is under heater control, is still outside of allowable temperature limits. The temperature profile for the transceiver is illustrated in Fig. 4.5.

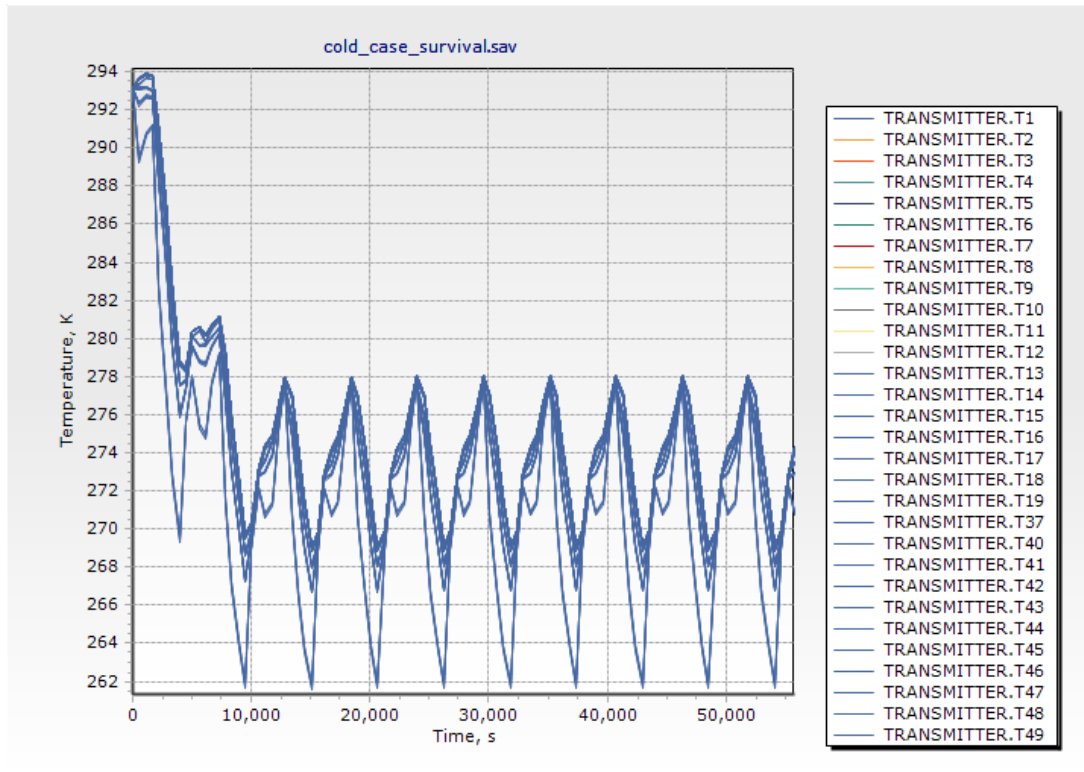

Fig. 4.5 Transceiver Cold Case Survival Temperature Profile

Note the cyclical heating and cooling experienced by the transceiver. This is representative of the heating and cooling experienced by all components on the satellite. It takes approximately three orbits for the transceiver's average temperature to stabilize. To illustrate the effect of a heater on a component, the temperature profile for the EPS is plotted in Fig. 4.6, where the temperature of the EPS is plotted in blue, and the power usage of the heater is plotted in red.

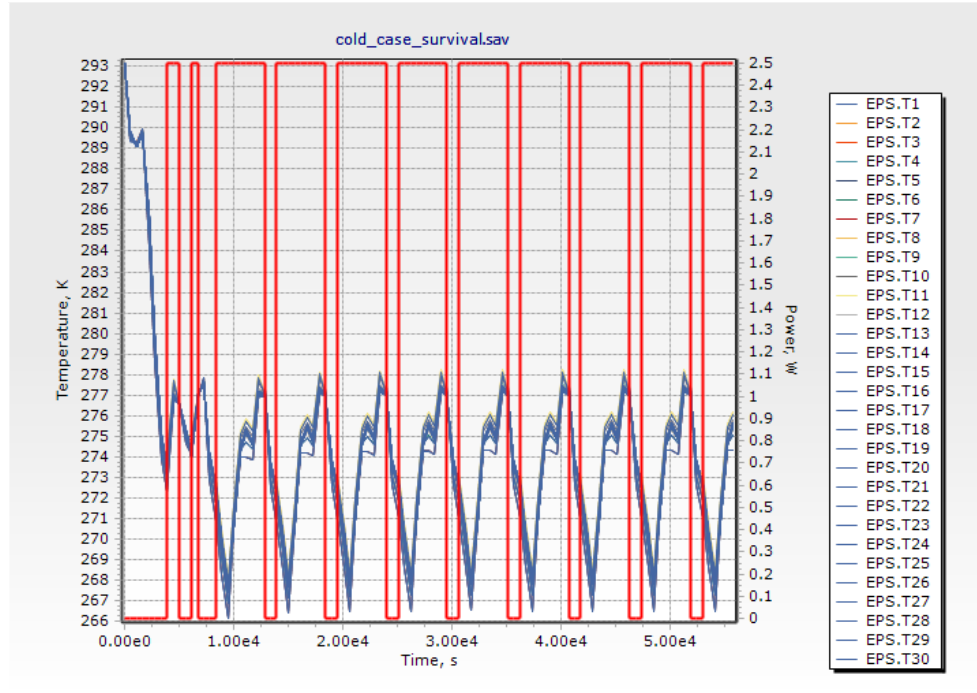

Fig. 4.6 EPS W/Heater Power Cold Case Survival Temperature Profile

The heater turns on at 273.15 K and turns off at 278.15 K. Note that even though the heater is turned on, the temperature of the EPS still drops considerably. This indicates that either the heater placement should be changed, turn-on and turn-off temperatures need to be adjusted, or that there is an error in the EPS thermal model.

4.6.2.1 Cold Case Survival Results Discussion

Both heaters consume a large amount of power and multiple components are outside of allowable temperature limits. Insulation can be applied to the payload to retain more heat. However, there is only a 13 K thermal margin for the hot case operational. This means that applying insulation to the payload may push the payload outside of allowable temperature limits during hot cases. Another solution is applying a larger or more efficient heater to the payload. Insulative washers could be used in the PCB standoff interfaces to limit the amount of heat lost to the structure and subsequently dissipated to space. Similar solutions exist for the transceiver.

It is important to remember that any design changes made to fix problems that occur in one thermal case may negatively affect results in a different thermal case. For instance, if insulative washers are added to the transceiver's PCB standoff interfaces to keep the transceiver warmer during a cold case, this could have the effect of overheating the OBC during a hot case. Therefore, design change effects across all thermal cases must be considered.

5 Thermal Control

"Let the physics of the universe do the work for you" – Isaac Foster, Air Force Research Laboratory

5.1 Introduction

This section introduces the various methods available for thermal control. This list is not exhaustive, nor does it cover every possible application of each component. Thermal control components should be selected such that they meet mission requirements, including mass and power budget requirements.

5.2 Thermal Control Methods

5.2.1 Surface Coatings

Surface finishes and coatings are often used to change the absorptivity and emissivity characteristics of satellite surfaces. By using wavelength-dependent coatings, the amount of solar and Earth IR absorbed can be adjusted along with the amount of radiation emitted from the satellite. Surface coatings can be combined in striped or checkered patterns to create a new effective coating [23].

Solar intensity varies as a function of the wavelength, with a distribution of approximately 7% ultraviolet, 46% visible, and 47% near IR [21]. The wavelengths of solar IR and IR emitted from bodies near room temperature (i.e., satellite surfaces) allows for greater variability in surface coating selection. Coatings can thus be highly emissive to room temperature IR but very reflective to solar IR. In other words, it can have a high emissivity to absorptivity ratio. This will allow the satellite to reject heat more effectively.

Mission duration should be considered when selecting surface coatings. Charged particles, ultraviolet radiation, high vacuum, and contaminant films deposited on the surface of the satellite affect surface coatings and finishes [23]. If the mission will last for months or years, then some surface coatings may be less suitable than others. Some example surface coatings are given in Table 5.1 [23]. Comprehensive lists of surface finishes can be found in the Spacecraft Thermal Control Handbook [12].

Table 5.1 Properties of Common Finishes [23]

Surface Finish	BOL α (Beginning of Life)	ϵ
Optical Solar Reflectors		
• 8 mil Quartz Mirrors	0.05 to 0.06	0.80
• 2 mil Silvered Teflon	0.05 to 0.09	0.66
• 5 mil Silvered Teflon	0.05 to 0.09	0.78
• 2 mil Aluminized Teflon	0.10 to 0.16	0.66
• 5 mil Aluminized Teflon	0.10 to 0.16	0.78
White Paints		
• S13G-LO	0.20 to 0.25	0.85
• Z93	0.17 to 0.20	0.92
• ZOT	0.18 to 0.20	0.91
• Chemglaze A276	0.22 to 0.28	0.88
Black Paints		
• Chemglaze Z306	0.92 to 0.98	0.89
• 3M Black Velvet	~0.97	0.84
Aluminized Kapton		
• ½ mil	0.34	0.55
• 1 mil	0.38	0.67
• 2 mil	0.41	0.75
• 5 mil	0.46	0.86
Metallic		
• Vapor Deposited Aluminum	0.08 to 0.17	0.34
• Bare Aluminum	0.09 to 0.17	0.86
• Vaporized Deposited Gold	0.19 to 0.30	0.80
• Anodized Aluminum	0.25 to 0.86*	0.10
* Anodizing and similar surface treatments must be carefully controlled in order to produce repeatable optical properties		

5.2.2 Insulation

The most common form of insulation on a satellite is multilayer insulation (MLI). MLI is composed of multiple layers of low-emittance films separated by low conductivity spacers between layers. The sheets are often made from Mylar with aluminum vacuum-deposited onto one side of the sheet. The sheets are layered together in such a way as to minimize contact between sheets, thereby reducing conductivity between layers. Gold can also be used for the surface material. Single sheets of Mylar with aluminum or gold vacuum-depositions can also be used when multiple layers are not required.

Increasing the layers has the effect of reducing the effective emittance [23]. This effect is nonlinear, meaning that eventually adding another layer of insulation will not reduce emittance. Given this fact, 25 layers of Mylar insulation are usually enough to obtain a minimal overall conductance²⁶ [23]. However, CubeSats typically do not use MLI as it is inefficient and can cause the satellite to become stuck in the launcher. Additionally, CubeSats typically tumble (i.e., barbeque) which reduces the need for MLI. In Thermal Desktop, insulation can be applied directly to the thermal object being modeled. More

²⁶ For CubeSats, 5-10 layers will be effective due to CubeSat's small size and tendency to tumble.



information about modeling insulation can be found in Peabody’s “Building Thermal Models” [13]. An example of multilayer insulation is depicted in Fig. 5.1.



Fig. 5.1 Example of Multilayer Insulation [24]

Another form of insulation is conduction insulation. Conduction isolators can be placed along conduction paths to reduce the amount of heat flow. For instance, an insulative washer can be applied to PCB standoffs to thermally isolate the PCB from the rest of the structure. Conduction isolators operate in the same way that a resistor operates on a circuit board in that they add thermal resistance to the thermal network. Their performance increases as their length increases, cross-sectional area decreases, and thermal conductivity decreases [23].

5.2.3 Thermal Radiators

The only way to reject heat in space is through radiation. Radiators accomplish this by using highly emissive materials and/or large surface areas. The surface of the radiator effectively couples it to space. The higher the emissivity, the greater the coupling. Surface coating choice is thus an important part in radiator design (see 5.2.1 for more details on surface coatings). The amount of heat rejected by a radiator is a function of its surface area, emissivity, and temperature. The proportionality relationship between is heat rejection and temperature is T^4 . As such, radiator performance is extremely sensitive to temperature. An example of a spacecraft radiator is shown in Fig. 5.2.

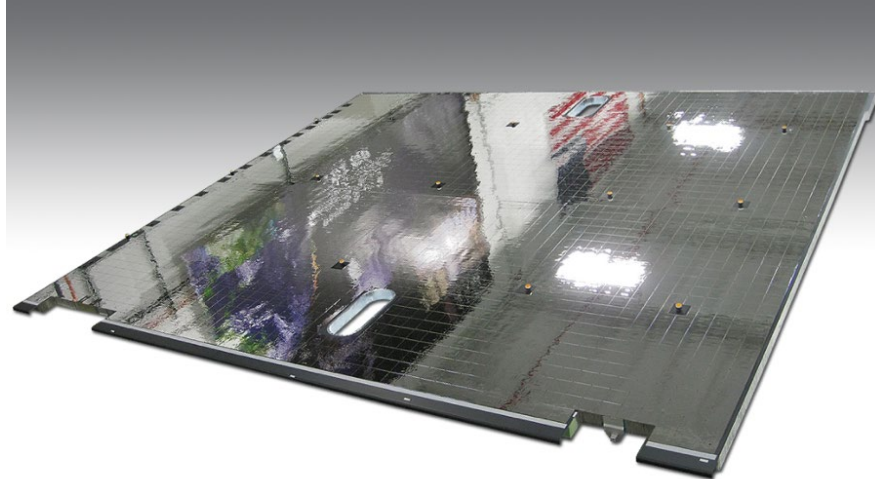

Fig. 5.2 Example Radiator [25]

Small satellites often have limited surface area and rarely make use of dedicated radiators. Instead, surface coatings are primarily used to adjust the radiative properties of exposed surfaces. Insulators can also be used to thermally isolate internal components.

5.2.4 Thermal Straps

Thermal straps are used to thermally couple parts and components of a spacecraft. They are often made of highly conductive materials like copper and graphite. Their most common use is to move heat from one location on a satellite to another when existing thermal conductivity paths are not sufficient or cannot tolerate large thermal gradients [26]. Thermal straps can be made in a variety of shapes and can be made to be rigid or flexible. In Thermal Desktop, they can be modeled as a conductance between two thermal objects. Examples of thermal straps are shown in Fig. 5.3.

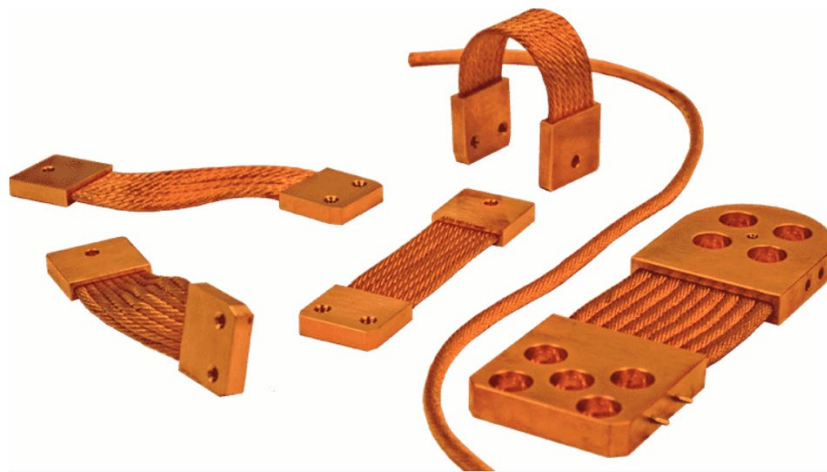

Fig. 5.3 Example Thermal Straps [26]

5.2.5 Heaters

Heaters are sometimes required when passive control is sufficient to maintain components above their minimum survivable and operational temperatures. They can be used with solid-state controllers or

thermostats to provide temperature control to specific components [23]. One of the most common types of heaters is patch heaters. These can be applied directly to components with a simple adhesive. They are available in a variety of shapes, sizes, and wattages. Heater circuits can eventually fail, so redundancy should be considered for long duration missions [23]. In Thermal Desktop, they can be modeled using the heater tool. On and off temperatures can be specified along with the max power to apply [13]. Additional options exist to fully characterize the heater. Examples of flexible heaters are illustrated in Fig. 5.4.

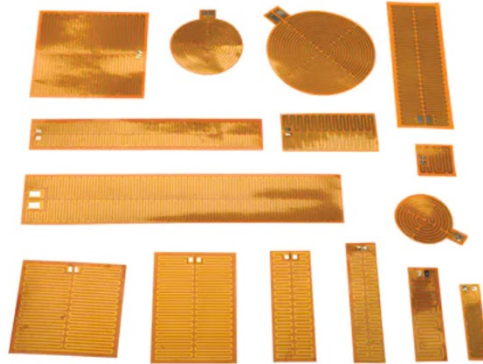

Fig. 5.4 Example Flexible Heaters [27]

5.2.6 Heat Pipes

Heat pipes use a closed-loop two-phase fluid-flow cycle to transport heat from one location to another. They make excellent conductors and heat spreaders. Heat pipes are relatively low mass, require no monitoring while on orbit, and are generally very reliable. Types of heat pipes include constant conductance (CCHP), variable conductance (VCHP), and oscillating (OHPs). Modeling oscillating heat pipes is very challenging due to the nature of their operation. In Thermal Desktop, an OHP can be modeled as a conductor between two nodes with a variable conductance that is a function of both power and average temperature of the two nodes. Another method is to make a vapor node which represents the heat pipe's vapor and then use contactors to connect it to the relevant solid nodes with a contact resistance representing all the paths to and from the vapor²⁷. How to best model an OHP in Thermal Desktop is still being determined. Other tools exist in Thermal Desktop to model constant and variable conductance heat pipes [13].

5.2.7 Phase Change Materials

Phase change materials (PCM) store thermal energy directly by using latent heat (the heat required to conduct a phase change). This allows them to function as thermal batteries because the material will remain at the same temperature until all the material has undergone the phase change. The more PCM is available, the more heat can be stored. PCM is especially useful for dampening thermal oscillations because the PCM will both heat and cool components, depending on whether the component is colder or hotter than the PCM, respectively. The primary cost associated with PCM is the additional mass they introduce into the system. In Thermal Desktop, PCMs can be modeled using the FUSION function when defining thermophysical properties [13].

²⁷ From conversations with Jon Allison.

5.3 Mission Lifetime Considerations

All components are subject to physical degradation over time. Sources of degradation include atomic oxygen, ultraviolet radiation, ionizing radiation, plasma, temperature extremes and thermal cycling, and orbital debris. These sources will cause thermo-optical properties to change over the course of a mission. Long duration missions must understand the impacts that the space environment will have on exposed components. Additionally, components can be damaged while in transit [28].

Surface coatings are particularly susceptible to degradation from the space environment, along with solar panels. Overtime, the efficiency of solar cells will decrease, which will increase the effective absorptivity of solar panels. Typically, solar absorptivity will increase over time while emissivity will experience negligible changes [29]. Thermo-optical properties can experience significant degradation in as little as 0.5 years. Degradation will continue throughout the lifetime of the mission. These changes can be dramatic. For instance, a white paint surface coating can experience an increase in absorptivity from ~ 0.3 to ~ 0.7 of the course of 3 years [29].

As the surface properties of a satellite change, the temperature profile of the satellite will also change. The thermal conductivity of materials changes with temperature. Therefore, changes in satellite temperature profile may adversely affect the thermal conductivities of satellite components if the change in temperature profile is large enough. Normally, this effect does not need to be modeled because the normal range of temperatures likely to be experienced by the satellite is not great enough to cause a significant change in material thermal conductivity. However, the reader should be aware of this effect should the mission requirements require it to be modeled.

Heaters are usually very reliable and have a long flight heritage. However, like all components, they too can fail. Long duration missions or mission with critical components that require precise temperature control may need to consider redundant heaters. Heaters are inexpensive, light weight, and easy to install. The primary limitation for small satellites is available control interfaces for heaters and available surface area to mount the heaters.

6 Model Verification and Validation

“Unverified models are as dangerous as untested planes” – Isaac Foster, Air Force Research Laboratory

6.1 Introduction

Thermal models should be verified and validated. Verifying a thermal model is the process of determining if the model matches agreed-upon specifications, assumptions, and simplifications (i.e., is the model built as intended). For instance, determining if the correct materials, conductance values, and geometry have been used. Validating a thermal model is the process of determining if the model appropriately represents the real system. For instance, determining if the thermal model’s representation of the satellite is appropriate for the set of conditions being simulated. Thermal models can be valid for one set of conditions and invalid for another. In summary, verification answers the question, “have we built the model right?” while validation answers the question, “have we built the right model?”

6.2 Verifying a Model

Verifying a thermal model is primarily done through internal model checks and running test simulations. These include checking that all model parameters are correct. Model convergence is another tool for verification. At a certain point, adding nodes and more complex geometry to the model will not increase the accuracy or precision of results. Convergence can be tested by varying parameters to test sensitivity. Thermal models with more stable results are considered to be more robust and reliable. Additionally, the results of a simulation can be visually inspected to determine if components have not been connected correctly or if other errors may exist within the model.

Verification of a thermal model should be done throughout the thermal design process. Verifying component models as they are built and integrated is more effective than waiting until the entire satellite has been modeled and integrated. Special attention should be given to the variables and parameters used within the model. In many cases, the design will change during the time the model is built. Therefore, it is critical that the model is updated as the design of the satellite is updated. An example list of model parameter checks is given as follows:

- General Model Variable Checks
 - Check that all thermophysical and thermo-optical properties are correctly defined
 - Check all surfaces, solids, and other thermal objects have the correct material and optical properties assigned
 - Check all surfaces and solids have the correct dimensions
 - Check that all components have the correct mass
 - Check that all components have been correctly thermally coupled to the satellite
 - Check for duplicate nodes
- Simulation Variable Checks
 - Check that the correct heat loads are applied
 - Check that the correct orbit is simulated and that the orbit has the correct parameters (if applicable)
 - Check that the correct boundary conditions are used (if applicable)
 - Check temperature maps for steep or discontinuous temperature changes

6.3 Validating a Thermal Model

Validating a thermal model is done primarily through physical tests. Model correlation measures how accurately the model predicts the results of physical tests using the same conditions. Model correlation usually occurs well after the model is completed [13]. Thermal models are normally correlated with completed engineering design units (EDUs). However, submodules could also be correlated with physical tests. This could be useful if the behavior of a specific subsystem under certain conditions must be investigated.

Thermal tests include thermal cycling, thermal balance, and thermal vacuum. The purpose of the thermal cycling test is to reveal defects in the design due to environmental stress. The test cycles the satellite or component through a series of hot and cold temperature plateaus. This test can be performed in ambient pressure or in vacuum. The purpose of the thermal balance test is to determine the effectiveness of the thermal control system and provide data for thermal modeling correlation. The purpose of the thermal vacuum test is to the satellite in the most realistic on-orbit conditions possible to verify the design of the satellite. Usually, the expected temperature extremes with margins added are tested. These tests can be combined into a thermal vacuum cycling test where all three tests are performed in a single test run [30].

There exist three primary uncertainties in thermal modeling: environmental (Earth IR, albedo, etc.), physical (thermo-optical properties thermophysical properties, interface conductances, etc.), and mathematical (calculation, numerical integration, etc.) [30]. To account for these uncertainties, physical tests will add safety margins to thermal tests. Note, this is different than adjusting the parameters of a simulation to build in a thermal margin. Different space programs (NASA, ESA, etc.) and companies will use different thermal margins and definitions. Thermal margin definitions used by JPL/NASA are given in Fig. 6.1.

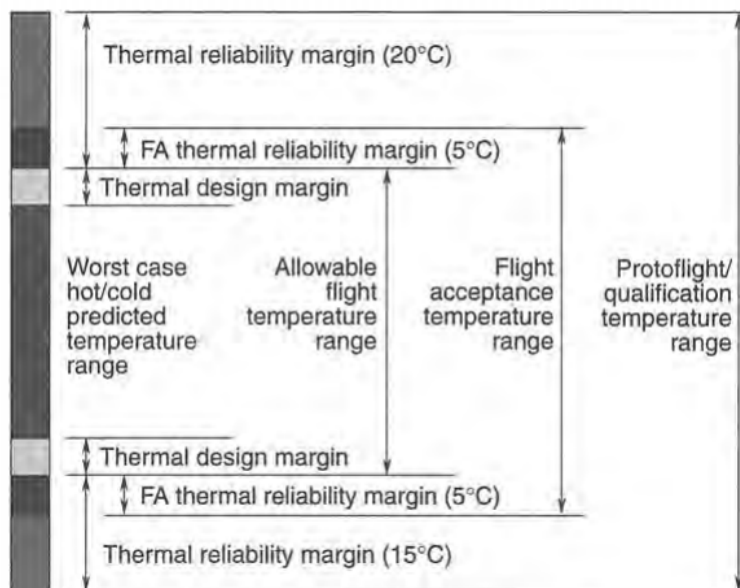

Fig. 6.1 Thermal margin terminology for JPL/NASA programs [12]

6.4 Model Correlation

When correlating a thermal model with test data, it will be necessary to build a thermal case that matches the thermal characteristics of the test. When possible, thermal models should be correlated to test data for unpowered and heater-only cases before more complex tests are performed. Additionally, unpowered cooldowns can be used to check thermal masses [31]. When correlating a model, the error between the model and the test should be calculated. As the model is adjusted, progress and results should be tracked. Data from simulations performed after every major model revision should be stored.

There are three primary error types in thermal model correlation: magnitude, temporal, and slope. Magnitude errors are errors in the minimum and maximum temperatures experienced. Temporal errors are errors where the temperature profile of the model leads or lags the temperature profile of the test. Slope errors are errors in the rate of heating or cooling [31]. These errors are illustrated in Fig. 6.2.

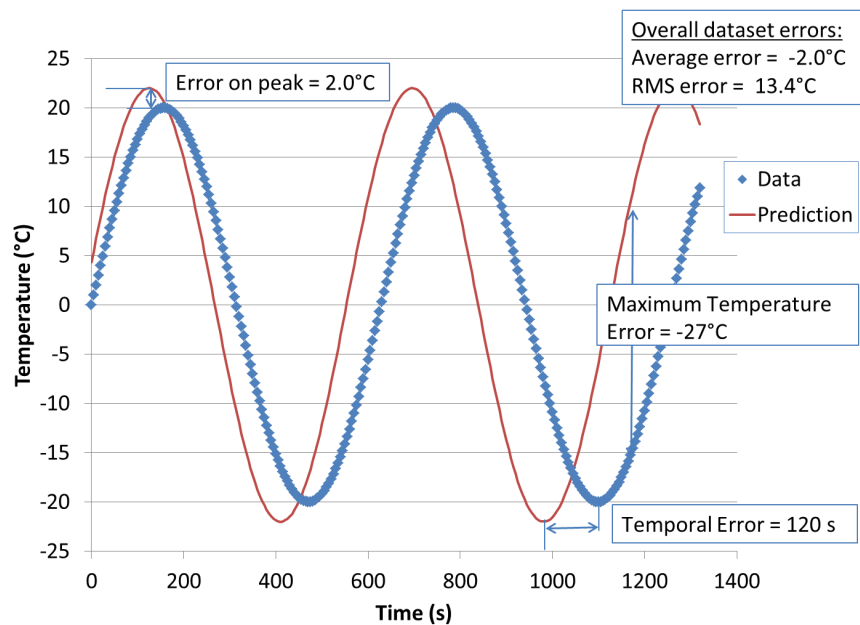

Fig. 6.2 Types of Errors in Thermal Model Correlation

Magnitude errors can indicate errors in the heat applied to the model or in the physical test. Temporal errors can indicate errors in thermal mass or sensor placement, either in the model or in the physical test. Slope errors can indicate errors in thermal mass, physical thermal connections, or modeled conductances [31]. An initial and final model correlation example is given in Fig. 6.3 and Fig. 6.4. Note that the test data shown is not representative of the thermal tests previously described. Also note that the primary error in the two datasets shown is in magnitude.

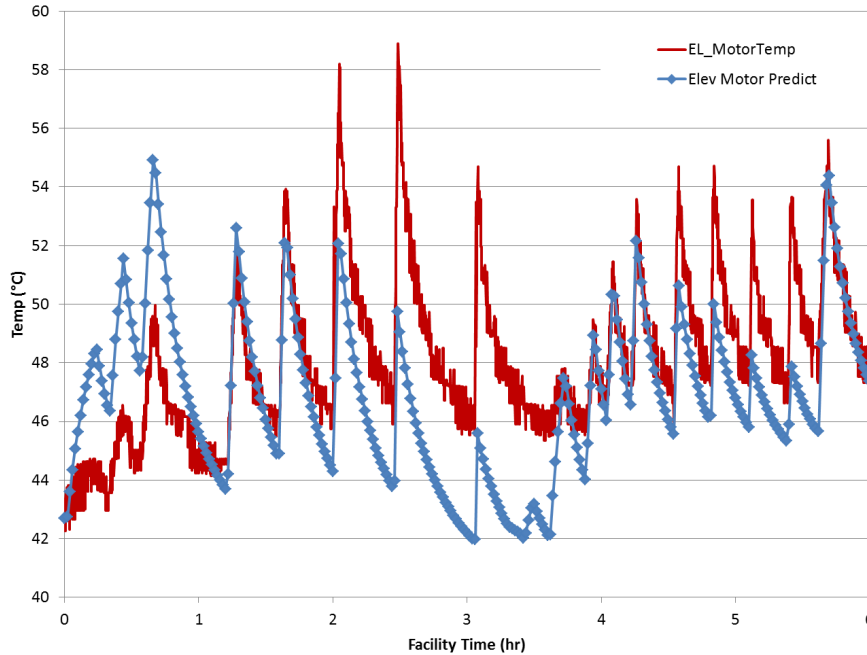

Fig. 6.3 Example Initial Model Correlation [31]

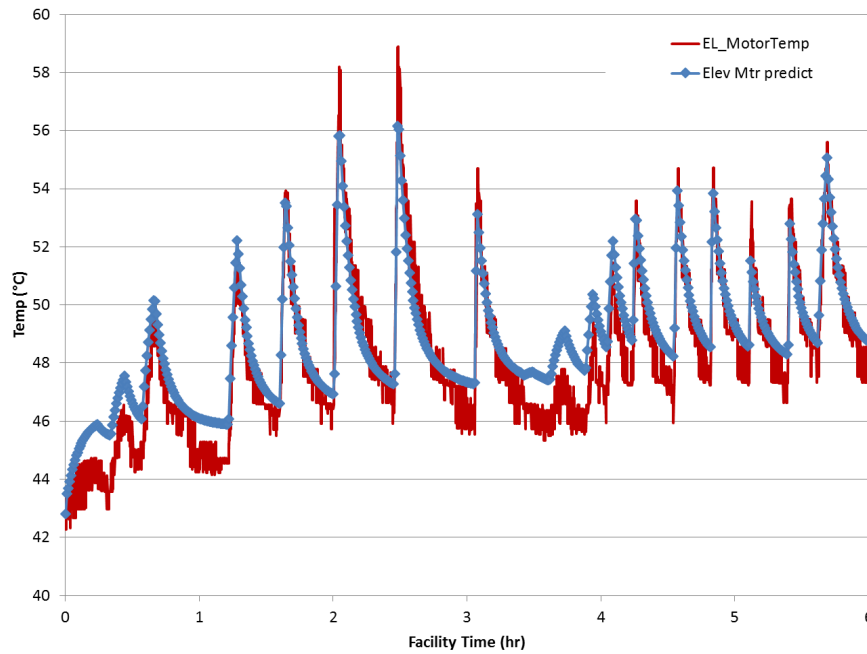

Fig. 6.4 Example Final Model Correlation [31]

6.4.1 Model Correlation with Constraints

It is not always possible to correlate thermal models with test data due to hardware or resource constraints. For instance, universities that build small satellites will often not have access to thermal vacuum chambers necessary for performing thermal vacuum tests. In other cases, a thermal vacuum

chamber is available but the flight hardware to be tested is not available. This subsection gives some suggestions for alternatives for thermal model correlation with physical test data.

First, if flight hardware is not available (or even if it is), test cases can be run to evaluate the model. These cases are not mission specific (i.e., not a thermal case). One such test is a conduction only test where environmental heating terms (solar, albedo, etc.) are not applied. Heat loads are then applied in suitable locations and the model is then run to steady state. Once complete, the temperature map should be carefully evaluated for strange or large thermal gradients, which can indicate a modeling error. Another test that can be run is a radiation only test, where the model is in a fixed orbital position and run to steady-state. Results of external surfaces can be evaluated and compared with hand calculations.

Second, if flight hardware is available but a thermal vacuum chamber is not available, functional benchtop tests can be conducted. For instance, heaters and temperature sensors can be powered on and tested to verify functionality. Thermal tests could also be performed on specific components under controlled conditions. For instance, the flight computer could be simulated to run in different mission modes while temperature data is collected. While not truly representative of a thermal case, this could still provide useful data for verifying the thermal model. On a larger scale, thermal tests can be performed on FlatSat models or EDU models where temperature data is collected as the FlatSat or EDU is tested in different mission modes²⁸. Note that any test in an atmospheric environment must account for convection effects, which will add both complexity and uncertainty to the thermal model.

²⁸ A FlatSat is a high-fidelity representation of the flight model in terms of hardware and software functionality, but where the components have not been integrated onto the bus.



(This page is intentionally left blank)

7 Orbital Thermal Environment

“The Universe is under no obligation to make sense to you” – Neil deGrasse Tyson

7.1 Introduction

This section provides an overview of how the spacecraft orbit about the Earth defines the thermal environment. The fundamentals of orbital mechanics are reviewed along with orbital elements that directly affect the thermal design. This section is not a comprehensive review of orbital mechanics or heat transfer. Its purpose is solely to introduce and review key concepts related to spacecraft thermal design.

7.2 Orbital Mechanics

Orbital mechanics plays an important role in determining a spacecraft’s thermal environment. The orbit of a satellite directly affects the amount of radiation received from the Earth and Sun (or other solar body and Sun). Figure 7.1 shows an example orbit with definitions of several orbital parameters.

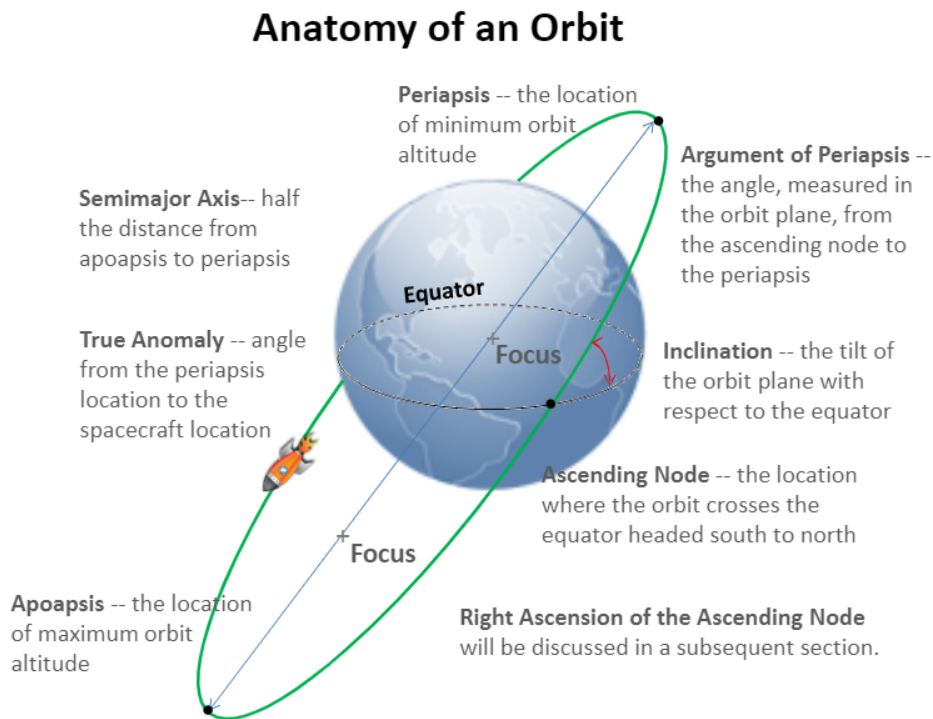

Fig. 7.1 Anatomy of an Orbit [32]

While all elements of an orbit (true anomaly, inclination, etc.) impact the thermal environment, two aspects are of particular importance: eccentricity and beta angle.

7.2.1 Celestial Coordinate System

Understanding the Earth’s orbit around the Sun is important for understanding orbital thermal environments. A simplified representation of the Earth’s orbit around the Sun is shown in Fig. 7.2.

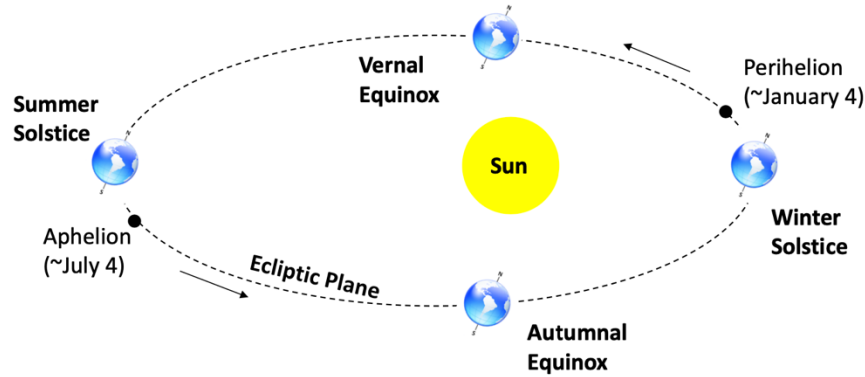

Fig. 7.2 Earth's Orbit Around the Sun [32]

Earth is farthest away from the Sun during July and closest to the Sun during January. This has the effect of changing the amount of solar flux received by approximately 100 W/m^2 . The celestial coordinate system is shown in Fig. 7.3.

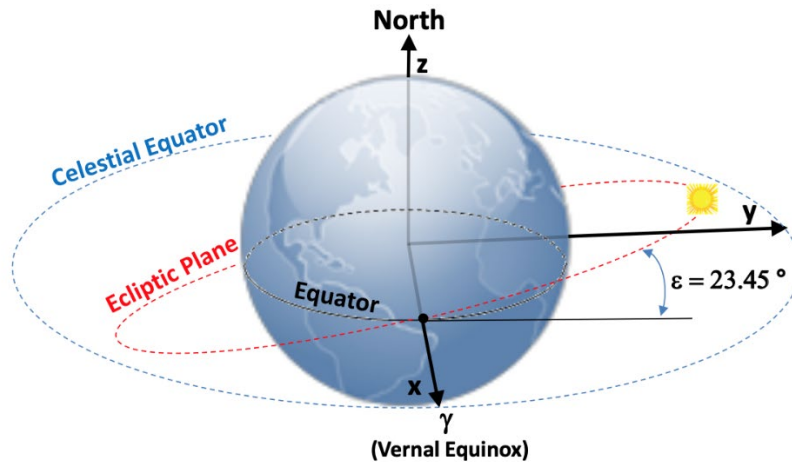

Fig. 7.3 Celestial Inertial Coordinate System [32]

The celestial equator is aligned with Earth's equator. The ecliptic plane is the plane of Earth's orbit around the sun. The solar vector, s , is the unit vector that points from the origin of the celestial coordinate system (the center of the Earth) to the Sun. The solar vector is constrained by the obliquity of the ecliptic (23.45° for Earth, i.e., the Earth's tilt), ϵ , and the ecliptic true solar longitude, Γ , which changes with the time of year and is 0° on the Vernal Equinox. The solar vector is depicted in Fig. 7.4.

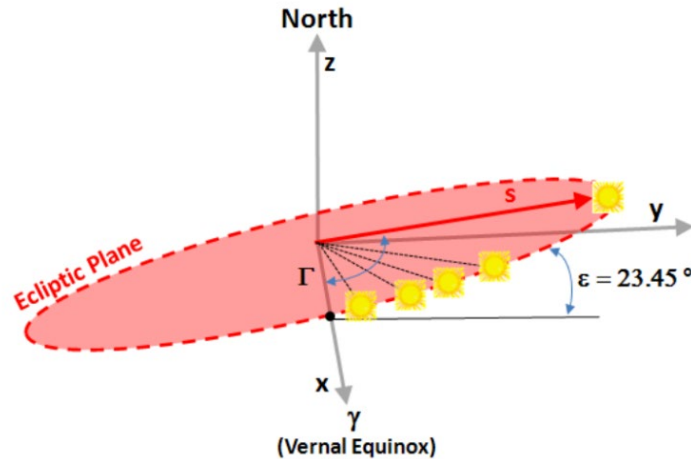

Fig. 7.4 Solar Vector [32]

In addition to the Obliquity of the Ecliptic and Ecliptic True Solar Longitude, the beta angle is a function of Orbit Inclination and Right Ascension of the Ascending Node. Orbit Inclination is a measure of the angular tilt from the equatorial plane, and RAAN is a measure of the angle from where the orbit crosses the equatorial plane moving from south to north and the x-axis. This is depicted in Fig. 7.5.

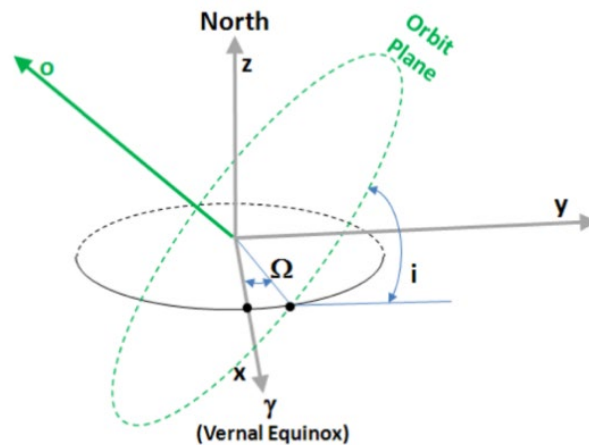

Fig. 7.5 Orbit Normal Vector [32]

7.2.2 Eccentricity

Eccentricity, e , is a measure of an orbit's non-circularity. A circular orbit has an eccentricity of 0. For periodic orbits about a primary body, eccentricity can range from 0 to 0.999 repeating. The lower the eccentricity, the more circular the orbit and vice-versa. Most Earth-orbiting satellites have nearly circular orbits. For instance, the ISS has an orbital eccentricity of approximately 0.0003 (corresponding to a difference of ~ 5 km between apogee and perigee). In most LEO thermal modeling cases, orbits can be modeled as perfectly circular orbits.

The eccentricity of a satellite’s orbit will affect how much radiation is received from the Earth (both reflected and IR). Both the variation in distance and sunlit time causes this effect. The eccentricity of the Earth’s orbit around the Sun will affect the amount of radiation received from the Sun. While most orbits are modeled as circular in thermal design, the eccentricity of an orbit can affect hot and cold case definitions if the eccentricity is high enough.

7.2.3 Beta Angle

Beta angle, β , is the angle between the solar vector, s , and the plane of the orbit, as illustrated in Fig. 7.6. As the beta angle changes, the time spent in eclipse varies and the intensity and direction of heat incident on satellite surfaces change [32]. A beta angle of 0° would correspond to the minimum amount of time spent in eclipse, while a beta angle of 90° would correspond to the minimum amount of time spent in eclipse (i.e., no time spent in eclipse).

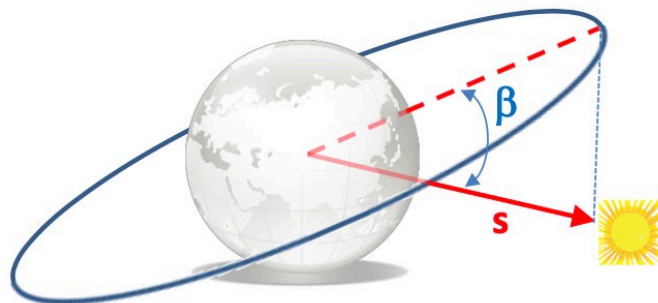

Fig. 7.6 Beta Angle [32]

An orbit with a beta angle of 0° will have a normal vector with respect to the orbit plane perpendicular to solar vector. An orbit with a beta angle of 90° will have a normal vector with respect to the orbit plane parallel to the solar vector. To calculate the beta angle, the inclination, RAAN, obliquity of the ecliptic, and ecliptic true solar longitude must be known. This calculation is beyond the scope of this section. The most important take away is that the beta angle is limited by inclination and obliquity of the ecliptic, as given by Eq. (28).

$$\beta = \pm(\varepsilon + |i|), \tag{28}$$

where ε is the obliquity of the ecliptic and i is the orbital inclination [32]. In the case of the Earth, ε is 23.45° (the Earth’s axial tilt). Because orbital inclination is a defined mission parameter, the minimum and maximum beta angles that are possible for a mission can be determined and used for cold and hot case definitions.

The beta angle is constantly changing, being most affected by the change of seasons causing variation in Ecliptic True Solar longitude and perturbation of the orbit affecting the RAAN angle. These must be considered only if the mission duration is many months or years in length. Eclipse time and heat flux intensities change as a result of variation in beta angle. Example variations in beta angle and sunlit period for a typical ISS orbit are shown in Fig. 7.7 and Fig. 7.8, respectively.

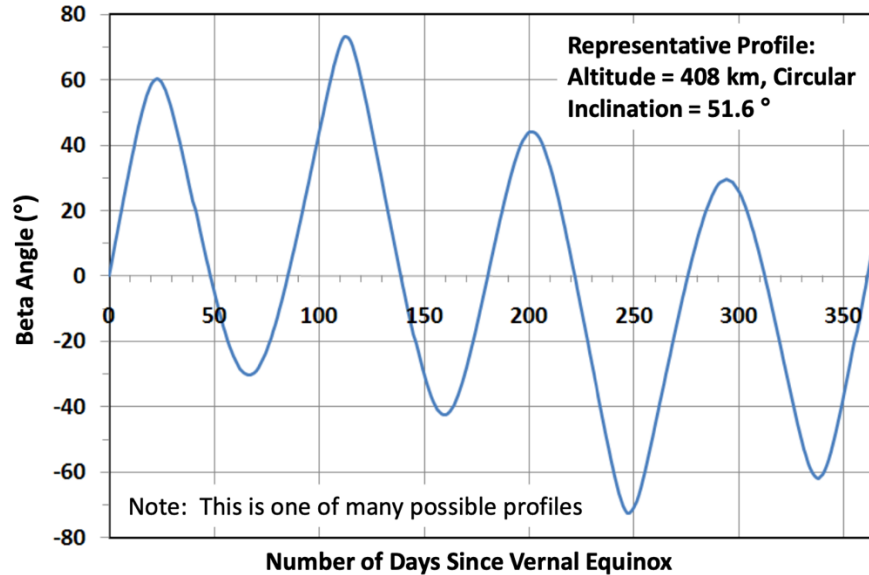

Fig. 7.7 Variation in Beta Angle Due to Seasonal Variation and Orbit Precession [32]

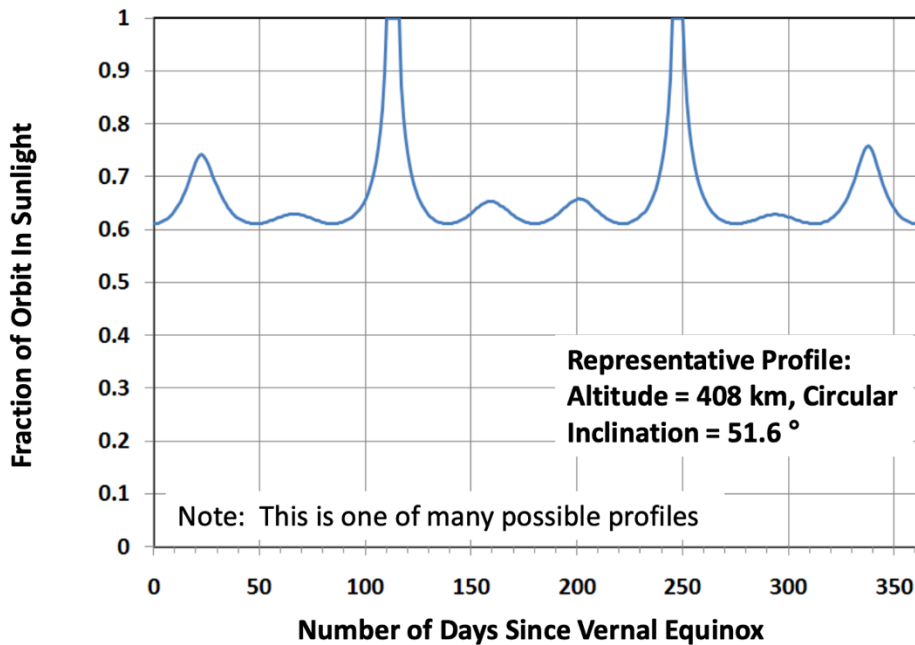

Fig. 7.8 Variation in Eclipse Duration as a Function of Beta Angle [32]

7.3 Heat Fluxes

7.3.1 Solar Flux

Solar flux is the power per unit area received from the sun. Solar flux is the most dominant heat source in LEO. Eccentricity impacts the amount of heat flux received from the primary body the satellite is orbiting. The Earth's orbit about the Sun has an eccentricity of 0.0167086, which means that its aphelion is 1.0167 AU and its perihelion is 0.98329 AU, where 1 AU is approximately 150 million kilometers. This change in

distance from the Sun changes the amount of incoming solar flux. During summer in the northern hemisphere the Earth is at its farthest from the Sun, while during winter in the northern hemisphere the Earth is at its closest to the Sun.

At 1 AU, the amount of solar heat flux received is 1367 W/m^2 [32]. This is considered “nominal” solar heat flux. At aphelion the solar flux received is 1317 W/m^2 and at perihelion the solar flux received is 1414 W/m^2 [12]. These are often used as “cold case” and “hot case” values respectively.

The amount of direct solar radiation absorbed by a surface depends on the absorptivity of the surface α , the solar constant S , and the incident angle θ [5]. The incident angle is the angle between the surface normal vector and the solar vector. Surface coatings can be applied to change the absorptivity and emissivity of a surface.

7.3.2 Earth Albedo

Sunlight reflected by the Earth is called albedo. The amount of reflection is a function of Earth’s surface properties, atmospheric conditions, and incident angle of the incoming sunlight. Albedo radiation has a non-uniform area intensity, meaning that the amount of reflected radiation received by the satellite changes as the satellite orbits the Earth. The amount of heat flux absorbed by the satellite from albedo radiation is dependent on the satellite’s surface absorptivity α , the solar constant S , the albedo factor A_f , and the view factor F between the satellite and the Earth. Local albedo factor values can range between 0.03 and 0.55 [5]. However, albedo radiation can be modeled as a constant because most satellite have a relatively low altitude and orbit the Earth at very high velocities, averaging out the variational effects of changing surface reflectivity.

7.3.3 Earth IR

The Earth absorbs solar radiation and reemits it as long-wave infrared radiation [5]. Earth IR can vary with season, local temperature, latitude, amount of cloud cover, etc. [5]. However, like albedo radiation, one can generally assume Earth IR to be constant. Specific missions may require greater accuracy. The amount of energy absorbed by a satellite is determined by the Stefan-Boltzmann constant σ , Earth’s surface emissivity ϵ , the view factor between the Earth and the satellites surface F , and the effective ideal radiator, or black body, temperature of the Earth T_E , which is on average 255 K [5].

Radiation emitted by the Earth is in the same IR band as radiation typically emitted by satellite. Therefore, the amount of radiation absorbed by the satellite from Earth IR is dependent upon the amount radiated away by the Earth. Reducing a surface’s emissivity to reduce the amount of Earth IR will also have the effect of reducing the surface’s ability to radiate away heat [5].

7.3.4 Satellite Heat Generation

Heat is generated within the satellite by power consuming components and propulsive maneuvers (if the satellite has the capability). All power consuming components produce some amount of waste heat that is proportional to their efficiency. Different mission modes will produce differing amounts of waste heat. Heat generation may also change as the orbit changes (for instance, if the satellite must “sleep” when it is in eclipse). It is very important to understand the mission modes of the satellite when assigning heat generation values to various components. Every component will generate a different amount of heat at different operating loads.

7.3.5 Satellite Heat Rejection

Heat is radiated away (rejected) by the satellite from every surface that is open to space. Space can be considered to have an effective temperature of 0 K. Thus, the amount of heat radiated away by the satellite is a function of available surface area, surface emissivity values, and surface temperature.

7.4 Eclipse Duration and Beta Angle [32]

Because the satellite is orbiting the Earth, it will periodically pass in and out of eclipse, unless the orbit inclination is high enough. Because solar flux is the dominating heat source, the satellite will undergo periodic heating and cooling as it passes in and out of Earth’s umbral and penumbral shadow. The consequence of this is a dynamical heating environment that changes with the orbit. In practice, while sunlit, the satellite will receive direct solar radiation, Earth albedo, and Earth IR. When eclipsed, the satellite will receive Earth IR only.

Because the diameter of the orbit is greater than the diameter of Earth, the amount of sunlit time will always be greater than the amount of time spent in eclipse. The fraction of the orbit spent sunlit and eclipsed is defined by the orbital elements. The methods for calculating the exact time spent in eclipse are beyond the scope of this section. A sample diagram of times spent in sunlight and eclipse is given in Fig. 7.9.

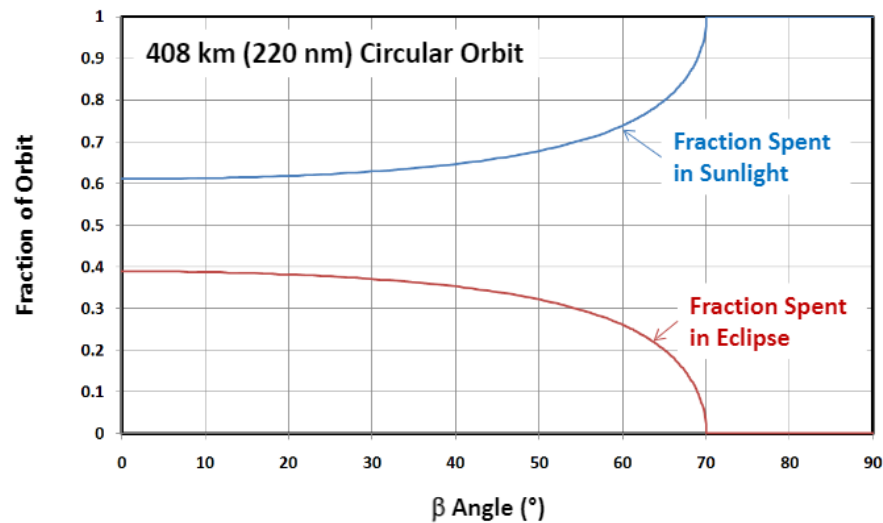

Fig. 7.9 Fraction of Orbit Spent in Sunlight/Eclipse [32]

For highly inclined orbits, the amount of sunlit time can increase dramatically, and in some cases to 100% at specific times of the year as in the case of the ISS. This occurs because of the Earth’s rotation around the Sun. This is an important consideration for determining hot cases. If the satellite has an orbit that will at some point during the year cause it to be sunlit for 100% of its orbit, then the satellite’s TCS will have to be designed in such a way as to mitigate this heat load. Note that while it is possible for a satellite to be sunlit for the entirety of its orbit, it is not possible for a satellite to be eclipsed for the entirety of its orbit²⁹.

²⁹ The only possible exception to this would be a satellite orbiting the Moon while the Moon is completely eclipsed by the Earth. Similar cases exist for moons of other planetary bodies. Note that these cases are highly unlikely.



7.4.1 Calculating Eclipse Duration

An intermediate frame can be defined such that the Sun is always in the x-y plane, as illustrated in Fig. 7.10. The orbit is thus inclined at an angle β .

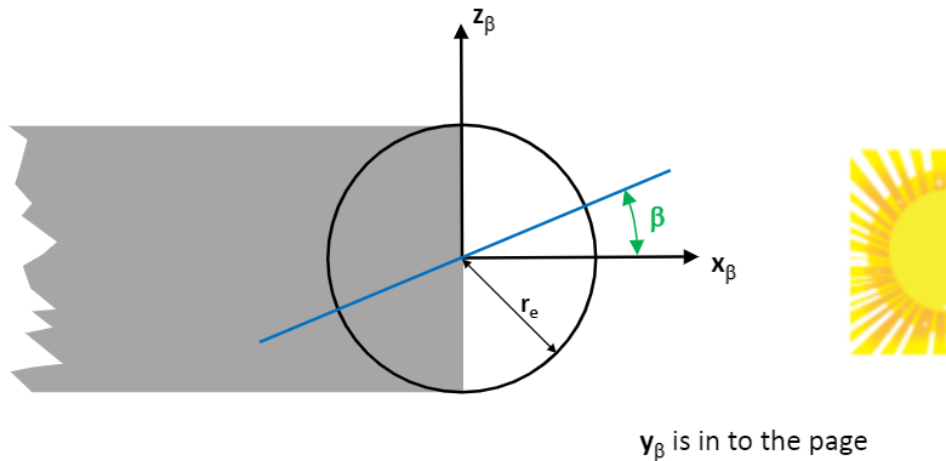

Fig. 7.10 Intermediate Frame [32]

For a low, circular orbit only, the following equations determine the amount of time spent in eclipse.

$$\mathbf{r} = (r_e + h)[\cos\theta\cos\beta\hat{k} + \sin\theta\hat{j} + \cos\theta\sin\beta\hat{k}] \quad (29)$$

where h is the orbit altitude, r_e is planet radius, θ is angle from orbit noon, and β is beta angle. Taking the magnitude of the resulting vector yields the equation

$$|\mathbf{r}| = r_e + h. \quad (30)$$

Next, project this vector onto the intermediate frame giving

$$\vec{r}' = (r_e + h)[\sin\theta\hat{j} + \cos\theta\sin\beta\hat{k}] \quad (31)$$

Taking the magnitude of this vector gives

$$|\vec{r}'| = (r_e + h)\sqrt{\sin^2\theta + \cos^2\theta\sin^2\beta} \quad (32)$$

$$\sin\theta = \sqrt{\frac{1}{\cos^2\beta} \left[\left(\frac{r_e}{r_e + h} \right)^2 - \sin^2\beta \right]} \quad (33)$$

This equation can be solved for θ , which is the angle of eclipse onset. The total angle shadowed is $2(\pi - \theta)$. This value can be used with the period of the orbit to determine the duration of eclipse. Figure 7.11 illustrates eclipse entry and exit as they relate to θ .

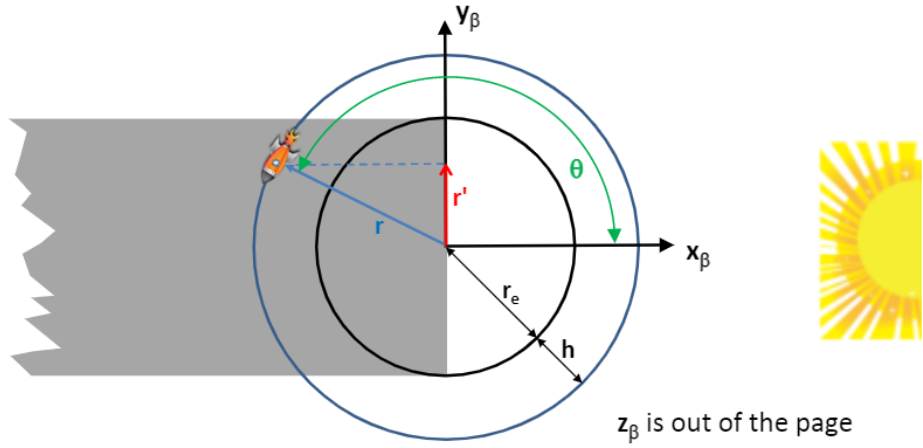

Fig. 7.11 Eclipse Entry and Exit [32]



(This page is intentionally left blank)



Appendix A Nomenclature & Acronyms

Important terms and acronyms used in this work are listed below.

Term	Definition	Acronym / Symbol
Absorptivity	The ability of a material to absorb solar radiation	α
Albedo Heating	Solar energy reflected from an orbiting body	--
Altitude	The distance from a spacecraft to the Earth's surface	Alt
Apogee	The point of highest altitude in an orbit	r_a
Argument of Perigee	The angle within the satellite's orbit plane that is measured from the ascending node line to perigee	--
Ascending Node	Point on an orbit where the spacecraft crosses the equatorial plane, traveling south to north	--
Astronomical Unit	Unit of distance roughly equal to 150 million kilometers	AU
Beginning of Life	A term used to describe characteristics at the beginning of a mission.	BOL
Command and Data Handling	The subsystem responsible for managing all forms of data on the spacecraft and controlling the spacecraft's functions and operations	CDH
Cold Case	A thermal case that simulates the coldest expected conditions	--
Computer Aided Design	Use of computers and software to assist design	CAD
Density	The ratio of an objects mass to its volume	ρ
Eccentricity	A measure of the orbit's ellipticity (non-circularity)	e
Effective Emissivity	The average emissivity of a collection of surfaces	ϵ^*
Emissivity	The ratio of energy radiated from a surface to that of a perfect emitter	ϵ
End of Life (EOL)	Refers to properties and characteristics at the end of a mission	EOL
Heat Capacity	The amount of heat required to change the temperature of an object one unit change in temperature	Cp
Heat Dissipation	The process of heat being generated by satellite components	--
Heat Rejection	The process of rejecting (getting rid of) heat from the spacecraft to space	--
Heat Pipe	A heat-transfer component that uses the thermal conductivity and phase transition properties of a fluid to transfer heat	HP
Heat Transfer Coefficient	The ratio of the heat flux to the temperature difference	h
Hot Case	A thermal case that simulates the hottest expected conditions	--
Inclination	The angle between the orbit plane and the equatorial plane (also the angle from Earth's spin axis to the orbit angular momentum vector)	i
Low Earth Orbit	Earth centered with an altitude less than ~2000 km	LEO



Nadir	The vector pointing from a satellite to the center of the celestial body	--
Operational Temperature	The maximum or minimum temperature a component can experience and still operate.	--
Printed Circuit Board	A laminated structure of conductive and insulative layers to which electronic components are affixed	PCB
Perigee	The point of lowest altitude in an orbit	r_p
Period	The time it takes a spacecraft to make one revolution about the Earth.	--
Phase Change Material	A substance that releases and absorbs energy during phase transition to provide useful heating and cooling	PCM
Power Subsystem	The subsystem responsible for providing, storing, regulating, and distributing power to the payload and other subsystems. [23]	PWR
Right Ascension of the Ascending Node (RAAN)	Angle measured from the vernal equinox to the ascending node line	RAAN
Satellite	1. An object that orbits the Earth, Moon, or other celestial object 2. A spacecraft without any life support systems	--
Solar Flux	Radiant energy from the Sun	S
Spacecraft	A vehicle or device designed for travel or operation outside the Earth's atmosphere	--
Specific Heat Capacity	The heat capacity of a sample divided by the mass of the sample	C_p
Structures Subsystem	The subsystem responsible for designing the structure of the satellite	STR
Survivable Temperature	The maximum or minimum temperature a component can experience and still be functional.	--
Systems Engineering Subsystem	The subsystem responsible for integrating subsystem designs, defining design requirements, and mission planning	SYS
Temperature Limit	A temperature that a component should not exceed	--
Temperature Prediction	A component temperature predicted using hand calculations or thermal modeling software	--
Time Constant	The time in which it takes an object to reach 63.21% of its initial temperature	τ
Thermal Conductivity	The degree to which a material conducts heat	K
Thermal Control System	The system of components used to control the temperature of a spacecraft	TCS
Thermal Coupling	The pairing of two objects such that they can exchange thermal energy	--
Thermal Desktop	An industry standard thermal modeling software	TD
Thermo-electric Cooler	A device that uses electricity to cool an object	TEC
True anomaly	Angular position from periapsis measured along the orbit to the spacecraft's current location	ν



Zenith

The vector pointing in the direction of the spacecraft's
radius vector (center of the planet to spacecraft center of
mass)

--



(This page is intentionally left blank)

Appendix B Deliverables

The following tables are example deliverable tables for use in organizing and delivering thermal modeling and analysis data. An example mass budget table is given in Table 7.1.

Table 7.1 Deliverables - Mass Budget

Component	Submodel Name	Modeled Material [--]	Total Modeled Mass [kg]	Total Mass Budget [kg]	Details [--]

An example thermal contactors table is given in Table 7.2.

Table 7.2 Deliverables - Contactors

From Submodel	To Submodel	Description	Number of Fasteners [--]	Conductance per Fastener [W/K]	Mating Area [cm ²]	Conduction Coefficient [W/m ² /K]	Total Conductance [W/K]

An example material properties table is given in Table 7.3.

Table 7.3 Deliverables - Material Properties

Material	Details	K _{xy} [W/m/K]	K _z [W/m/K]	ρ [kg/m ³]	C _p [J/kg/K]	Reference

An example optical properties table is given in Table 7.4.

Table 7.4 Deliverables - Optical Properties

Material	BOL		EOL		Reference
	α	ε	α	ε	

An example applied heat loads table is given in Table 7.5.

Table 7.5 Deliverables - Applied Heat Loads

Component	Submodel Name	Operational [W]	Standby [W]	Survival [W]	Details	Reference



An example thermal case table is given in Table 7.6.

Table 7.6 Deliverables - Thermal Cases

Case Name	Description	Optical Property	Altitude	Beta Angle	Solar Flux	Albedo	Earth IR	Heater Power
[--]	[--]	[--]	[km]	[°]	[W/m ²]	[--]	[W/m ²]	[W]

Table 7.7 gives an example of a detailed table of orbital parameters. The parameters in this table are used in defining a Keplerian Orbit in Thermal Desktop. The table is organized similarly to a Two-Line Element Set (TLE)³⁰. Current TLEs of various satellites and space stations can be obtained from Celestrak.com (private) or space-track.org (government).

Table 7.7 Deliverables - Detailed Orbits Table

Name	Date/Time	Inclination	RAAN	Eccentricity	Argument of Periapsis	Period	Maximum Altitude
[--]	GMT	[deg]	[deg]	[--]	[deg]	[s]	[km]

An example simulation results table is given in Table 7.8.

Table 7.8 Deliverables - Results Table

Submodel Name	Operational		Survival		Hot Case Operational		TOTAL HEATER POWER	
	Min [°C]	Max [°C]	Min [°C]	Max [°C]	Min [°C]	Max [°C]	W-hr per Orbit [W-hr/orbit]	Max Duty Cycle [W]

³⁰ TLEs are the industry standard method for classifying orbits



Appendix C Bibliography

- [1] M. Collins, *Carrying the Fire: An Astronaut's Journey*, Farrar, Straus and Giroux, 2009.
- [2] National Aeronautics and Space Administration, "James Webb Space Telescope Images," 3 August 2017. [Online]. Available: https://www.nasa.gov/mission_pages/webb/images/index.html. [Accessed 8 July 2021].
- [3] Astronomy Now, "Record rocket firing avoids mission-ending eclipse for Juno," Astronomy Now, 2 October 2019. [Online]. Available: <https://astronomynow.com/2019/10/02/record-rocket-firing-avoids-mission-ending-eclipse-for-juno/>. [Accessed 21 June 2021].
- [4] J. Young, S. Inlow and B. Bender, "Solving Thermal Control Challenges for CubeSats: Optimizing Passive Thermal Design," in *2019 IEEE Aerospace Conference*, Big Sky, 2019.
- [5] K. E. Boushon, *Thermal Analysis and Control of Small Satellites in Low Earth Orbit*, Rolla: College of Engineering and Computing, Missouri University of Science and Technology, 2018.
- [6] D. K. Pace, "Fidelity, Resolution, Accuracy, and Uncertainty," in *Modeling and Simulation in the Systems Engineering Life Cycle*, M. L. Loper, Ed., London, Springer-Verlag London, 2015.
- [7] S. Chandrashekar, *Thermal Analysis and Control of MIST CubeSat*, Stockholm: Kth Royal Institute of Technology School of Electrical Engineering, 2017.
- [8] P. Wallace, A. Kalapura and S. Kim, "Thermal Modelling and Analysis of a Cube Satellite, EIRSAT-1: Steady Analysis," *AIAA SPACE and Astronautics Forum and Exposition*, 2018.
- [9] T. N. Martin, *Thermal Modeling and Analysis Of a Cube Satellite: Passive Thermal Coating Observatory Operating in Low Earth Orbit (PATCOOL)*, Gainesville: University of Florida, 2020.
- [10] S.-J. Kang and H.-U. Oh, "On-Orbit Thermal Design and Validation of 1U Standardized CubeSat of STEP Cube Lab," *International Journal of Aerospace Engineering*, vol. 2016, 2016.
- [11] C&R Technologies, *TD Suite Manual*, 2020.
- [12] D. G. Gilmore, *Spacecraft Thermal Control Handbook Volume 1: Fundamental Technologies*, El Segundo Boulevard: The Aerospace Press, 2002.
- [13] H. L. Peabody, *Building Thermal Models*, Greenbelt, 2017.
- [14] D. J. Howell, "A CATALOG OF RADIATION HEAT TRANSFER," [Online]. Available: <http://www.thermalradiation.net/tablecon.html#C1>.
- [15] AZUR SPACE, "Space Solar Cells," [Online]. Available: <http://www.azurspace.com/index.php/en/products/products-space/space-solar-cells>. [Accessed 30 July 2021].



- [16] ISISPACE, "3-Unit CubeSat Structure," ISISPACE, [Online]. Available: <https://www.isispace.nl/product/3-unit-cubesat-structure/>. [Accessed 8 July 2021].
- [17] ISISPACE, "VHF uplink/UHF downlink Full Duplex Transceiver," ISISPACE, [Online]. Available: <https://www.isispace.nl/product/isis-uhf-downlink-vhf-uplink-full-duplex-transceiver/>. [Accessed 4 August 2021].
- [18] ISISPACE, "Small Satellite Solar Panels," ISISPACE, [Online]. Available: <https://www.isispace.nl/product/isis-cubesat-solar-panels/>. [Accessed 29 July 2021].
- [19] EaglePicher Technologies, "Satellites," EaglePicher Technologies, [Online]. Available: <https://www.eaglepicher.com/markets/space/satellites/>. [Accessed 29 July 2021].
- [20] ISISPACE, "iEPS Electrical Power System," [Online]. Available: <https://www.isispace.nl/product/ieps-electrical-power-system/>. [Accessed 8 August 2021].
- [21] W. J. Larson and J. R. Wertz, *Space Mission Analysis and Design, El Segundo: Microcosm Press, 1999.*
- [22] Heavens Above, "ISS - Orbit," Heavens Above, [Online]. Available: <https://www.heavens-above.com/orbit.aspx?satid=25544>. [Accessed 6 July 2021].
- [23] J. F. Oberright, *Space Mission Engineering: The New SMAD*, J. R. Wertz, D. F. Everett and J. J. Puschell, Eds., Torrance: Microcosm Press, 2018, pp. 685-700.
- [24] Aerospace Fabrication & Materials, "Multilayer Insulation," Aerospace Fabrication & Materials, [Online]. Available: <https://aerospacefab.com/products/multilayer-insulation/>. [Accessed 28 July 2021].
- [25] Applied Aerospace Structures Corp., "Spacecraft Thermal Radiators," Applied Aerospace Structures Corp., [Online]. Available: <https://www.aascworld.com/portfolio/thermal-radiator/>. [Accessed 28 July 2021].
- [26] Thermal Space, "Thermal Straps," Success By design, [Online]. Available: <https://thermal-space.com/thermal-straps/>. [Accessed 25 June 2021].
- [27] Omega, "Polyimide Flexible Heater Sample Kit 15 different Heaters," Omega, [Online]. Available: <https://www.omega.com/en-us/industrial-heaters/surface-heaters/flexible-heaters/p/KHA-KIT-Series>. [Accessed 28 July 2021].
- [28] A. Zinecker, S. Taylor and B. Spivey, "Thermal Materials and Coatings for Near REctilinear Halo Orbit (NRHO)," in *Thermal & Fluids Analysis Workshop*, Virtual, 2020.
- [29] A. Sharma and N. Sridhara, "Degredation of thermal control materials under a simulated radiative space environment," *Advances in Space Research*, vol. 50, no. 10, pp. 1411-1424, 2012.
- [30] L. Jacques, *Thermal Design of the Oufi-1 Nanosatellite*, Liège, 2009.



- [31] R. M. Amundsen, "Common Thermal Modeling Mistakes," in *Thermal And Fluids Analysis Workshop*, 2016.
- [32] S. L. Rickman, "Introduction to On-Orbit Thermal Environments," in *Thermal and Fluids Analysis workshop*, Cleveland, 2014.
- [33] NASA, "James Webb Space Telescope," NASA, [Online]. Available: <https://jwst.nasa.gov/content/observatory/index.html>. [Accessed 21 June 2021].
- [34] I. John S. Carson, "Model Verification and Validation," in *Proceedings of the 2002 Winter Simulation Conference*, San Diego, 2002.
- [35] T. A. Pavlak, J. R. Johannesen and J. J. Bordi, "Juno Trajectory Redesign Following PRM Cancellation," in *AAS/AIAA Astrodynamics Specialist Conference*, Stevenson, 2017.
- [36] ISISPACE, "ISIS On Board Computer," [Online]. Available: <https://www.isispace.nl/product/on-board-computer/>. [Accessed 13 July 2021].
- [37] ISISPACE, "ISIS High Data Rate S-Band Transmitter," [Online]. Available: <https://www.isispace.nl/product/isis-txs-s-band-transmitter/>. [Accessed 13 July 2021].
- [38] T. D. Panczak, S. G. Ring, M. J. Welch, D. Johnson, B. A. Cullimore and D. P. Bell, *Thermal Desktop User's Manual*, Boulder: R&R Technologies, Inc., 2015.
- [39] S. Kayali, "GaAs Material Properties," 1997.
- [40] A. Sole, *Mission Analysis of the OUFTI-Next nanosatellite*, Liege: University of Liege, 2019.
- [41] NASA, "What are SmallSats and CubeSats?," nasa.gov, 26 February 2015. [Online]. Available: <https://www.nasa.gov/content/what-are-smallsats-and-cubesats>.
- [42] NASA, "Is Webb at its Final Temperature?," NASA, 21 April 2022. [Online]. Available: <https://blogs.nasa.gov/webb/2022/04/21/is-webb-at-its-final-temperature/>.