

Technical



TN no. N-1581

Note

title: CONVENTIONAL ANCHOR TEST RESULTS
AT SAN DIEGO AND INDIAN ISLAND

author: R. J. Taylor

date: July 1980

sponsor: Naval Facilities Engineering Command

program nos: YF59.556.091.01.205



CIVIL ENGINEERING LABORATORY

NAVAL CONSTRUCTION BATTALION CENTER
Port Hueneme, California 93043

Approved for public release; distribution unlimited.

Unclassified

SECURITY CLASSIFICATION OF THIS PAGE (When Data Entered)

REPORT DOCUMENTATION PAGE		READ INSTRUCTIONS BEFORE COMPLETING FORM
1. REPORT NUMBER TN-1581	2. GOVY ACCESSION NO. DN987005	3. RECIPIENT'S CATALOG NUMBER
4. TITLE (and Subtitle) CONVENTIONAL ANCHOR TEST RESULTS AT SAN DIEGO AND INDIAN ISLAND		5. TYPE OF REPORT & PERIOD COVERED Not final; Oct 1978 - Dec 1979
		6. PERFORMING ORG. REPORT NUMBER
7. AUTHOR(s) R. J. Taylor		8. CONTRACT OR GRANT NUMBER(s)
9. PERFORMING ORGANIZATION NAME AND ADDRESS CIVIL ENGINEERING LABORATORY Naval Construction Battalion Center Port Hueneme, California 93043		10. PROGRAM ELEMENT, PROJECT, TASK AREA & WORK UNIT NUMBERS 62759N; YF59.556.091.01.205
11. CONTROLLING OFFICE NAME AND ADDRESS Naval Facilities Engineering Command Alexandria, Virginia 22332		12. REPORT DATE July 1980
		13. NUMBER OF PAGES 178
14. MONITORING AGENCY NAME & ADDRESS (if different from Controlling Office)		15. SECURITY CLASS. (of this report) Unclassified
		15a. DECLASSIFICATION/DOWNGRADING SCHEDULE
16. DISTRIBUTION STATEMENT (of this Report) Approved for public release; distribution unlimited.		
17. DISTRIBUTION STATEMENT (of the abstract entered in Block 20, if different from Report)		
18. SUPPLEMENTARY NOTES		
19. KEY WORDS (Continue on reverse side if necessary and identify by block number) Anchors, moorings, holding capacity, seafloor soils.		
20. ABSTRACT (Continue on reverse side if necessary and identify by block number) The Navy has initiated a program to improve fleet mooring capability through tests of existing fleet moorings and a range of conventional anchors in use and projected for use. The results of site surveys and of instrumented anchor and mooring tests at San Diego Harbor, Calif., and at Indian Island, Wash., are presented. Emphasis in the tests was on defining the applicability limits of the Navy's primary fleet mooring anchor, the Stockless anchor, through tests of single and tandem anchors. The Navy can use the data immediately (continued)		

DD FORM 1473

1 JAN 73

EDITION OF 1 NOV 65 IS OBSOLETE

Unclassified

SECURITY CLASSIFICATION OF THIS PAGE (When Data Entered)

20. Continued

for selection and sizing of anchors for sites typical of San Diego sand and Indian Island silty clay seafloors. Other anchors tested included the Navy STATO, BRUCE, Hook, and STEVIN anchors. Test data are presented primarily as plots of anchor penetration, holding capacity, and shank pitch and roll as functions of anchor drag distance. Tandem Stockless anchor arrangements were found that could be easily installed and that resulted in individual anchor efficiencies equal to or exceeding those determined through single-anchor tests. Several anchors were modified to achieve satisfactory performance in the test soils. Guidance for these changes is provided.

Library Card

Civil Engineering Laboratory
 CONVENTIONAL ANCHOR TEST RESULTS AT SAN
 DIEGO AND INDIAN ISLAND, by R. J. Taylor
 TN-1581 178 pp illus July 1980 Unclassified

1. Moorings

2. Anchors

I. YF59,556.091.01.205

The Navy has initiated a program to improve fleet mooring capability through tests of existing fleet moorings and a range of conventional anchors in use and projected for use. The results of site surveys and of instrumented anchor and mooring tests at San Diego Harbor, Calif., and at Indian Island, Wash., are presented. Emphasis in the tests was on defining the applicability limits of the Navy's primary fleet mooring anchor, the Stockless anchor, through tests of single and tandem anchors. The Navy can use the data immediately for selection and sizing of anchors for sites typical of San Diego sand and Indian Island silty clay seafloors. Other anchors tested included the Navy STATO, BRUCE, Hook, and STEVIN anchors. Test data are presented primarily as plots of anchor penetration, holding capacity, and shank pitch and roll as functions of anchor drag distance. Tandem Stockless anchor arrangements were found that could be easily installed and that resulted in individual anchor efficiencies equal to or exceeding those determined through single-anchor tests. Several anchors were modified to achieve satisfactory performance in the test soils. Guidance for these changes is provided.

CONTENTS

	Page
INTRODUCTION	1
PROGRAM OBJECTIVES	1
BACKGROUND	2
Stockless Anchor	2
STATO Anchor	3
High Efficiency Anchors	3
TEST PROGRAM	3
Locations	3
Site Survey	4
Test Anchors	5
TEST PROCEDURES AND EQUIPMENT	7
Measurement System	7
Single Anchor Test	8
Tandem Anchor Tests	10
RESULTS AND DISCUSSION	11
Anchor Test Results - General	11
Stockless Anchor (Single)	12
Stockless Anchor (Tandem)	13
STATO Anchor	14
Stockless Anchor Moorings	16
SUMMARY AND CONCLUSION	16
ACKNOWLEDGMENTS	18
REFERENCES	18
APPENDIXES	
A - Additional San Diego Harbor Seafloor Properties	71
B - Dimensions of All Tested Anchors	83
C - Stockless and STATO Anchor Test Data	93

INTRODUCTION

A program has been initiated for improving the Navy's fleet mooring capability through tests of existing fleet moorings and a range of conventional anchors in use and projected for use. These tests by the Civil Engineering Laboratory (CEL) are being performed in seafloors typical of Navy fleet mooring sites in conjunction with Navy Public Works Centers (PWC) where possible. In addition to the gathering of data on mooring and anchor behavior, anchor installation and proofing procedures are being evaluated to determine those most effective within the capabilities of PWC personnel and equipment.

Ultimately, the test data generated can be used: (1) to simplify and refine anchor selection and sizing, (2) to enable stipulation of anchor/mooring installation and proofing procedures, (3) and to improve the Navy's confidence in its moorings.

This report presents the results of site surveys and of instrumented anchor and mooring tests in the harbor at San Diego, Calif., and at Indian Island, Wash. Test data on Navy Stockless and STATO anchors are presented for immediate use by the Navy for selection and sizing of these anchors for sites typical of San Diego sand and Indian Island silty clay seafloors.

Test data are presented primarily as plots of anchor penetration, holding capacity, shank pitch, and shank roll as functions of anchor drag distance. These data allow complete isolation of anchor behavior from mooring behavior and will ultimately enable the development of an empirical scheme to predict anchor behavior. This task is underway and is scheduled for completion during FY81.

PROGRAM OBJECTIVES

The following are the specific program objectives:

1. To determine the capacity of selected existing moorings by proof testing to establish mooring limit.
2. To determine more accurately the capacity of the Stockless anchor at typical mooring locations.
3. To determine a means for efficiently using Stockless anchors in tandem and thus expand the use of the Navy's current anchor inventory.
4. To evaluate the operational practicality of using the Stockless anchor with welded open flukes, since tests have indicated higher capacities for the anchor with this modification.
5. To determine the capacities of high efficiency anchors in seafloors typical of Navy sites.

6. To gather site and anchor performance data to enable the development of an empirical procedure to predict the behavior of typical Navy drag embedment anchors.

BACKGROUND

Stockless Anchor

Most of the Navy's existing fleet moorings use the stockless anchor. This anchor was never intended for use as a permanent mooring anchor; its primary purpose was as a ship's bower anchor for temporary mooring. The Stockless anchor was not designed for high efficiency (high holding capacity to weight ratio). It was designed to be easily stowed in a ship's hawse pipe and to be easily recovered after use; deep penetration was not desired. Efficiencies of this anchor type are reported (Ref 1, 2, and 3) as approximately 2 in mud and 4-1/2 in sand after setting. Since the largest Stockless anchor available to the fleet weighed 30,000 pounds, the maximum capacities would be 60,000 pounds in mud after proper setting in sediment deep enough to accommodate expected penetration (20 feet to fluke tips) and 135,000 pounds in sand.

Many of the sites at which the Navy has fleet moorings have a soft mud seafloor to the maximum expected anchor burial depth or soft mud seafloors overlying stiff clay, sand, or coral. This latter condition could cause very poor anchor performance because proper anchor embedment might be prevented by the harder substrata. Embedment into the more competent sediment substrata is unlikely if it is significantly stronger than the surface mud or simply if it is granular, thus requiring a reduced fluke angle for embedment at this interface.

Stockless anchors are currently used in up to class AA moorings. In a mud seafloor a single 30,000-pound Stockless anchor is suitable for mooring class F and marginally suitable for mooring class E. This suitability is contingent upon proper setting and sufficient sediment in addition to the acceptability of a minimum safety factor for mooring class E. Because of equipment and procedural limitations, lack of funds, or lack of personnel training in anchor use, mooring anchors are typically not preset, and the existence of sufficient sediment for proper burial is often marginal or unknown.

The Stockless anchor is in great supply in Navy inventory and replacement funds for new, higher efficiency anchors will come slowly; thus, it is important to make use of the inventory. To do this, however, some operational complexities will necessarily be introduced. Tests (Ref 1) of the Stockless anchor in mud with flukes free-swinging and with flukes welded open show significant increases in efficiency for the latter condition, 4 versus 2, indicating that the anchor flukes did not open completely or at all for the free swinging (usual) condition. Towne (Ref 1) briefly experimented with Stockless anchors in parallel (side-by-side, attached to a single pulling point through a length of chain). Results showed that the anchors tended to come together, and that load equalization was of concern. Once the anchors come together, they will not re-embed, thus losing the safety advantage of this basic anchor type. Use of anchors in tandem (series) is an alternative to enable more effective use of the Stockless anchor. However, unless the anchors are properly rigged, the capacity of two anchors can be less

than that for a single anchor. Laboratory experiments (Ref 4) have been performed to determine an appropriate rigging technique for tandem anchors. The laboratory tests suggest rigging methods for tandem fixed and movable fluked anchors that appear feasible in practice. Both possibilities, welded open flukes and tandem anchors, would introduce additional installation complexity but could expand the use of the existing Stockless anchor inventory.

STATO Anchor

Limitations in the use of the Stockless anchor may still exist even if the approaches suggested previously can be successfully utilized. For some mooring classes other higher efficiency anchors may be required. One such anchor, the STATO anchor, was developed by the Navy to efficiently fulfill a variety of Navy anchoring needs. The STATO is recognized as the forerunner of a new breed of high efficiency anchors. During its development, it was tested exclusively in two types of sediment, San Francisco mud and Port Hueneme sand (Ref 3). Its design and rated capacities (20 to 1 in sand and 13 to 1 in mud at 50 feet of drag) were established for these two seafloors. The behavior of the STATO in other seafloors will be different; the differences for the Naval sites of interest could be slight, but without verification higher factors of safety would have to be employed at "unknown" sites.

High Efficiency Anchors

Many new high efficiency anchors have been developed and are available; however, performance data are limited to advertising claims. Advertised data suggest extremely high anchor efficiencies. If these data can be verified then these new anchors have the potential for significant cost savings to the Navy.

TEST PROGRAM

To resolve uncertainties in mooring capacity, anchor selection, sizing, configuration, and installation procedure, prototype testing at Navy sites with typical seafloor conditions is underway. In addition to the prototype tests, development of a predictive technique which depends on those engineering properties of the soil that govern soil reaction to loading by the embedded anchor and chain will be needed. Engineering properties are not a factor in presently used prediction schemes; capacity is always stated in terms of holding capacity to weight ratios and is usually based on a few tests in idealized soils (a sand or a clay). Relating capacity to engineering properties has the potential of enabling more accurate sizing of different or larger anchors or anchors used in seafloors in which they have not been tested.

Locations

After a lengthy pre-selection process which evaluated such things as available site boring logs, geologic charts, and site support, three sites were selected for detailed site surveys: San Diego Harbor, Calif., Indian Island, Wash.; and Subic Bay, Phillipines. Indications were that

these sites would provide a cross section of seafloor types typical of Navy fleet mooring sites as well as very uniform soil deposits to avoid confusion in data analysis. The surveys verified the suitability of San Diego and Indian Island sites; the Subic Bay survey results were inconclusive. Fortunately, a survey of Apra Harbor, Guam was being performed by Chesapeake Division Naval Facilities Engineering Command. These data were provided to CEL, and they indicated that Guam would be a suitable third test site. Anchor tests at Guam have been completed and results will be published in a subsequent report.

The locations of the anchor tests and cores at San Diego and Indian Island are shown in Figures 1, 2, and 3. For reference, the typical orientation of the test barge (shown to scale) during tests of anchors and moorings at San Diego is shown. The lay of the mooring legs is also shown for San Diego moorings.

Site Survey

The site survey at each test location consisted of underway acoustic subbottom profiling using a 5-kHz sound source and a hydrophone array and recorder, and coring using a 10-foot piston corer and an Alpine vibracorer for cores typically to 20 feet. One 40-foot core was attempted at Indian Island; 28 feet of core were recovered. The acoustic survey was performed to rapidly assess vertical and areal uniformity to aid the site selection process. The profile did not prove effective at the shallow water (10 to 15 feet) fine sand site at San Diego or at Indian Island where gassy sediments caused confused records. Fortunately, the vibracorer provided a rapid and easy alternative means to assess soil properties at probable test locations.

Each core was cut into 5-foot sections and transported to CEL for determination of the engineering properties. Usable soil strength data were not obtained from the cores taken at San Diego and Indian Island due to significant sample disturbance. It is planned to return to both sites with an in situ test device with cone penetrometer and vane shear capability. Twelve vibracores were taken at San Diego and six were taken at Indian Island. Not all these cores were completely analyzed; this can be done at a later date if need arises. A few cores were thoroughly analyzed with spot checks made on other cores to determine similarities. For example, the cores at Indian Island were extremely similar; thus, only one was analyzed in detail from that location.

Briefly, the primary test site (location 1) at San Diego (Figure 1), is a very uniform fine sand both areally and vertically. Figures 4 and 5 illustrate this with grain size curves of cores taken several hundred feet apart. Indications are that the seafloor is very dense, based on frequent extraordinarily high chain resistance during testing. As mentioned, this will be determined at a later date to enable eventual development of a predictive scheme. Additional data for San Diego Harbor are provided in Appendix A. Figure 2 shows a second site (location 2) described as a dense clayey sand. It is a very dense fissured seafloor in which only six tests were performed to evaluate the behavior of two particular anchor types in a very hard seafloor.

The Indian Island site shown in Figure 3 consists of a gassy, soft silty clay with shell fragments. Table 1 lists of soil properties for core 3 at Indian Island. The gas in the soil caused soil expansion upon

core recovery, disturbing the samples and making undisturbed shear strength data meaningless.* Typically, the Indian Island mud was almost evenly distributed between silt and clay sized particles. Figures 6 and 7 show the grain size distributions for core 3V. The curves are almost identical with depth to 10 feet; spot checks showed minimal areal variability. Indian Island soil is classified as an organic silty clay of high plasticity. The liquid limit and water content values are relatively high and approximately equal, varying little with depth to 28 feet. Values range from 110 to 160 for water content and 117 to 142 for the liquid limit. The liquidity index (ratio of the difference between natural water content and plastic limit and the plasticity index) for the mud varies between 0.88 and 1.65 which can indicate either a comparatively soft or firm but sensitive soil. For liquidity indices in the above range, soil sensitivities could vary from 5 to 25. Anchor and chain performance suggests that the soil is quite sensitive; in situ strength measurements will be made for verification.

Test Anchors

A variety of test anchors were gathered from the Navy and private industry and are listed below:

<u>Anchor</u>	<u>Nominal Weight, lb (kg)</u>
Stockless	5,000
Stockless	9,000
STATO	1,000
STATO	3,000
STATO	6,000
BRUCE (twin shank)	748 (340)
BRUCE	1,320 (600)
BRUCE	2,200 (1,000)
STEV MUD	1,100 (500)
STEV MUD	2,200 (1,000)
STEV DIG	2,200 (1,000)
STEV FIX (sand)	1,408 (640)
STEV FIX (mud)	2,068 (940)
Hook	1,232 (560)

*Immediately prior to printing this document, shear strength data for Indian Island mud became available. The seafloor is normally consolidated and shear strength measures almost linearly from zero at the surface to 1-1/2 psi at 21 feet. See Figure A-11 in Appendix A for the data.

These anchors are all shown on the deck of the Army National Guard barge (Figure 8) used at Indian Island. Dimensions of all anchors tested are provided in Appendix B.

The Stockless anchor is depicted in Figures 9, 10, and 11. It can be modified by the addition of stabilizers to slightly increase capacity and improve roll stability. The Stockless anchor typically has a 45-to 48-degree fluke angle which is appropriate for mud seafloors. In sand, the angle should be reduced to 32 to 35 degrees for maximum performance. The Stockless anchor was also tested with welded-open flukes to evaluate speculated performance improvement and operational difficulties and advantages. The welded-open Stockless anchor was also used in tests of anchors in tandem (also called piggy-back).

Three sizes of the STATO anchor were tested to evaluate individual anchor behavior as well as to provide data on size effects. The STATO is shown schematically in its sand (34 degree fluke angle) and mud (50 degree fluke angle) configurations (Figure 12). Figure 13 shows the 6K STATO ready for testing.

Two types of BRUCE anchors were made available to the Navy. Figure 14 depicts the standard cast BRUCE anchor, which is designed to be lowered or dropped to the seafloor without concern for its attitude upon contact. Upon dragging (setting), the anchor rotates to its fluke-down orientation. A new welded version of the BRUCE anchor (Figure 15) was provided for tests at Indian Island. It was not fabricated in time for San Diego sand tests. The welded BRUCE anchor looks like the cast anchor but employs a twin plate shank and a hollow fluke section to allow increased fluke area. In fact, the 340-kg welded anchor had about the same fluke area as the 1,000-kg cast anchor. BRUCE cable depressors (either singly or multiple) are designed to attach to the shank (see Figure 16) between the anchor and chain to "depress" the chain, cause increased anchor penetration, and produce higher anchor holding capacity. Nominally, a depressor adds 20% to total system weight.

Four other types of high efficiency anchor were provided for testing, the STEVDIG, STEVMUD, STEVFIX, and Hook. The STEVDIG (Figure 17) is typically used for competent seafloors. Note the "claws" at the tips of the anchor flukes; they were placed to aid in digging into the dense sand and overconsolidated clay-type seafloors of the North Sea. The STEVMUD (Figure 18) is a single-purpose anchor developed for anchoring in mud. The STEVFIX, however, was designed to be used in sand and mud seafloors. Figure 19 shows the STEVFIX without bolt-on plate and stabilizer extensions for mud application. Fluke angle is adjusted for sand (50 degrees) and mud (32 degrees) by the removal (burnout) or addition (welded) of a small insert in the anchor crown.

A movable fluke, pick-type anchor, called the Hook anchor (Figures 20 and 21), was also tested. This anchor is designed primarily for mud, but is usable in sand by restricting the fluke angle to 32 degrees. The Hook is shown with and without auxiliary flukes on the shank and was tested in both configurations.

TEST PROCEDURES AND EQUIPMENT

The basic test setup showing component layout and instrumentation locations is shown schematically in Figure 22. The layout for the tandem Stockless anchor tests is identical except that the instrument package is located on the outboard anchor. The inboard anchor is uninstrumented.

For this test effort, an instrumentation system was devised to isolate anchor behavior from test mooring behavior. It was felt that isolation of anchor behavior was critical to the eventual development of a scheme to predict anchor size effects on capacity and to understand and predict the behavior of conventional anchors as a function of seafloor engineering properties.

Measurement System

Data gathered for all single and tandem anchor tests included load at the test vessel, load at the anchor, anchor depth, anchor longitudinal rotation (shank pitch), transverse rotation (shank roll), mooring line angle at the test platform, and barge displacement. By knowing barge displacement and accounting for test mooring line catenary changes, anchor drag distance is readily calculated.

Spar Marker. Initially, barge position was to be recorded primarily by means of a portable range-range navigation system with a spar buoy reference system used as a backup. The spar marker system proved to be much simpler, more accurate, and more reliable than the navigation system; thus, it was used exclusively during the test effort. The deck of the YC test platform was marked off in 2-foot increments for 100 feet. At the beginning of each test (identified by test anchor movement) a spar buoy (Figure 23) was placed on the bottom at the corner of the barge. Barge motion was recorded in 2-foot increments directly on the oscillograph and digitape-papertape records. At San Diego, a 20- to 35-foot length of gasoline-filled plastic pipe (depended upon test site) was weighted at its base and used as the spar marker. At Indian Island, water depth approached 100 feet; thus, the spar marker was modified to be less sensitive to current. A 30-foot segment of tube was attached to a subsurface taut mooring comprised of a 1-1/2-ft diam float, 85 feet of 1/8-inch wire rope, and an anchor clump.

Instrumentation System. Figure 22 is to be referred to for the overall measurement system layout. The underwater portion of the system is shown in Figure 24 for San Diego and Indian Island. The instrument pack was further streamlined for Indian Island. The load cell is the slender object attached directly between the anchor shank and chain; it measures load at the anchor only. Included in the instrument pack shown strapped to the anchor shank is a pressure transducer to measure water depth from anchor to surface, two inclinometers to measure shank angle and shank/anchor rotation, all signal conditioning equipment, and amplifiers for the load cell. The load cell was connected to the package

by an 8-foot electrical cable. A hose connected to the pressure transducer at the package was connected to a buoy (shown in Figure 24) to ensure that the bitter end remained out of the seafloor. The underwater system was connected to the surface barge by a 1,300-ft-long, six-conductor, underwater electrical cable.

The surface system consists of a deck load cell to measure load between pulling barge and test anchor, a cable inclinometer to measure cable angle at the barge, signal conditioning equipment, biasing and voltage calibrator unit, and recording equipment. Two methods were used to record the data: (1) an analog-to-digital recorder recorded data every 10 seconds and (2) an analog oscillograph was used to record continuously during test.

All transducers (load cells, inclinometers, and pressure transducers) were calibrated before each series of tests and rechecked afterward and found to be within specification of calibrations.

All load cells used for measurements on anchor tests were calibrated at the CEL on a Baldwin load machine with an accuracy of 0.303% of full scale.

Repeatability of the load cells was:

- No. 1 underwater cell - 0.4%
- No. 2 underwater cell - 0.4%
- No. 1 deck load cell - 0.35%
- No. 2 deck load cell - 0.35%

The underwater load cells were checked for temperature drift and found to change 0.019/^o or 38 lb/deg; this is a positive temperature coefficient.

Pressure cells used for depth measurement were calibrated with a deadweight tester and have a built-in signal conditioner and amplifier. Repeatability of pressure transducers was:

- No. 1 pressure transducer - 0.005%
- No. 2 pressure transducer - 0.0045%

The pressure transducers were checked for temperature drift and found to change 0.139 ft/^o; this is a negative temperature coefficient. This change occurred within 60 seconds; therefore, relative changes in depth were correct during testing. Actual recorded depth could be as much as 1-1/2 feet too high, considering the temperature difference between deck and water. Inclinometers were calibrated and found to have an accuracy of 0.2-degree resolution.

Single Anchor Test

The test procedure was the same at San Diego and Indian Island; however, equipment did differ somewhat. A YC barge about 120 feet long served as the anchor pulling and data recovery platform. Photographs of the actual deck layout are given by Figures 25 and 26. A 100-ton-capacity, hydraulic cable puller was provided by the Supervisor of Salvage for the test effort. The cable puller basically consists of a fixed and a movable 2-inch cable gripper controlled through a remote console. The

grippers are alternately actuated and deactuated to haul-in or pay-out the 2-inch hauling line. About 4 feet of movement occurs at each cycle at rates from 0 to 17 ft/min. Each anchor was pulled at about 2 ft/min primarily to agree with previous controlled anchor tests. The cable puller operates as a load-controlled, rather than a strain-controlled, system; it is felt that, even though loading is briefly interrupted during a puller reset cycle, the loading is realistic. The cable puller pulled the anchor and its fixed-length mooring line toward a restraint mooring comprised of one preset 9,000-pound STATO anchor, 2-1/2-inch chain, and a peg-top buoy.

The YC barge was not heavily loaded during mooring or anchor testing; load was transferred from the restraint mooring through the cable puller (which simply rests on the deck) to the test anchor and mooring by a heavy duty padeye fixed to the YC. The padeye-deck attachment had to withstand only the environmental forces on the barge. Barge orientation was maintained during testing because both test and restraint lines passed through open chocks welded at opposite ends of the barge.

A crane barge was used to install and recover all test anchors at each site. The orientation of test barge and crane barge for Indian Island tests is shown in Figure 27. The crane barge was attached to the test barge by a 5/8-inch wire from an 8-ton salvage winch. At San Diego, wind proved to be a formidable problem in controlling crane barge location. Two pusher boats and an LCM-8 were barely able to control crane barge position. During the latter phase of San Diego tests, a stern anchor was placed to help control position in addition to helping restretch the test mooring after completion of a test series. The Figure 27 setup was a further refinement of the test procedure. This setup allowed the crane barge to move back and forth between its stern anchor and the test barge with help from its pusher boats.

For each test location, an attempt was made to minimize the number of times the restraint and test moorings had to be readied and deployed. The barge was layed out as shown in Figure 28. The 400 feet of 2-inch hauling wire was attached to the preinstalled restraint mooring buoy, and the wire was stretched out. The test mooring wire was subsequently stretched out using the crane barge. Two to three shots of chain were then attached to the test line and stretched. This configuration was typical for the beginning of each test day. At this point the LCM-8 would pull the 5/8-inch wire to the test barge and then return to the barge crane with the floated electrical line which would then be connected to the test anchor attached to the test mooring chain.

At San Diego the test anchor was lifted and lowered directly to the seafloor through the crown wire. The tug was released and the anchor pulled. After at least 50 feet of anchor drag the anchor was lifted, hosed off and relowered for another test. Three to four tests could be performed sequentially in a single line before the 2-inch haul line had to be pulled back through the cable puller while the test mooring was restretched. The test mooring was then layed 50 to 75 feet counter-clockwise for the next series.

At Indian Island, crane lift height was not sufficient to lower the anchor directly to the seafloor (about 100-foot depth); therefore, a large sheave was connected to the no. 1 hook. A 160-foot crownwire shackled to the deck at one end and attached to the anchor at the other was then placed in the sheave. With only a 50-foot crane lift, the

anchor was easily lowered to 100 feet through the two-part line. This approach was simple and should be useful to the PWC's where controlled anchor lowering in water depths between 80 and 180 feet is required.

Tandem Anchor Tests

Three tandem anchor arrangements with the Navy Stockless anchor were evaluated. The first method, referred to as the shank-to-shackle technique, and described by Figure 29, proved effective during a brief model study performed in Holland (Ref 4). In the shank-to-shackle method, both Stockless anchors were stabilized and had welded-open flukes because the model tests (Ref 4) showed superior performance with these modifications. A length of chain somewhat in excess of water depth was placed between outboard anchor shank and a padeye welded to the top of the inboard anchor's shank near its shackle connection. It was believed that this aft connection would allow the inboard anchor to function properly. During deployment, the chain would be lightly lashed over the crown of the inboard anchor to prevent fouling.

Figure 29 also shows the second tandem arrangement evaluated (crown-to-shackle technique). It was similar except the joining chain was connected to a padeye attached to the top of the Stockless anchor crown. Again, the flukes were welded open; otherwise they may have closed as soon as any load was applied to the crown by the outboard anchor chain. Figure 30 illustrates the third tandem test arrangement, the ground-ring-to-shackle technique. In this approach the inboard anchor is placed first and then the outboard anchor is lowered and the chain stretched. Welding the flukes open for all three tandem techniques also ensured that both anchors would penetrate immediately, thus insuring a taut mooring.

In addition to evaluating anchor system capacity, installation difficulties were also assessed. The best anchor system could be one that can be installed reliably with PWC assets even though it did not prove to be the highest capacity arrangement. Figure 31 describes the procedure used at Indian Island to install the shank-to-shackle and crown-to-shackle tandem anchor systems. This procedure is similar to that which could be used with fleet moorings, except the mooring would be laid off the bow of a Navy crane barge and chain length between anchors would depend on water depth.

Mooring tests were performed only at San Diego. During these tests, barge displacement, deck load, and line angle were measured. The direction of pull was established to ensure that load was being applied to a single mooring leg. Mooring leg layouts were defined by Reference 5. Load was applied to the test mooring until the rate of barge displacement increased and load dropped off. The test was then abruptly stopped to avoid excessive barge moor displacement and a requirement for leg repositioning.

Two test setups were used (see Figure 32). Pulling one mooring against another was a timesaver because it eliminated the need to install a restraint mooring; however, this could only be done if the mooring leg layouts were suitable. For a dual test setup, the spar marker reference buoy was placed midbarge. By monitoring the direction and displacement rate of the barge relative to the spar, it was possible to determine which of the test moorings yielded.

RESULTS AND DISCUSSION

Anchor Test Results - General

Fifty single and tandem anchor tests and three mooring proof tests were performed at San Diego; twenty-five single and tandem anchor tests were completed at Indian Island. These tests are summarized in Tables 2 through 4. Results of all Navy anchor (Stockless and STATO) tests are described and significant results provided. Each of these anchor tests is further described by a data plot and a data tabulation (see Appendix C). The results of all commercial anchor tests are the subject of a later report.

One data summary is described for guidance. Seven parameters are plotted as functions of true anchor drag distance in Figure 33. In the bottom block, horizontal force at the pulling barge, anchor tension, and chain weight on bottom are plotted versus drag distance. The difference between tension measurements is attributed solely to chain drag both on and in the seafloor. As shown by Figure 33, the contribution of the chain to total mooring load is substantial; this was typical for all the tests. At anchor tension equal to zero, the deck force reflects only chain drag. The 20,000 pounds of chain on bottom caused almost 30,000 pounds of drag resistance in the silt at Indian Island. At 58 feet of drag, roughly 10,000 pounds of chain (about 250 feet) in contact with the seafloor causes about 50,000 pounds of drag resistance. The 3,000-pound (nominal) STATO (actual weight 3,500 pounds) provided about 37,000 pounds of resistance at 58 feet of drag. A safe capacity of this anchor in Indian Island silt is 37,000 pounds. With information on the amount of chain in contact with the seafloor, capacities in excess of the basic anchor capacity could be assumed.

In the center block of Figure 33, anchor shank pitch angle and anchor shank roll angle are plotted versus drag distance. A positive pitch angle indicates shank tip down. As shown, the shank assumes a tip up (negative angle) orientation of about 10 degrees as the anchor approaches peak capacity. During drag, the anchor appeared relatively stable, remaining within 6 to 10 degrees of horizontal.

The top block of Figure 33 presents anchor crown and shank tip penetration as functions of drag distance. In the future, only one depth will be plotted for clarity. Penetration leveled out at about 15 feet to the crown, which translates to 19 feet to the tip of the fluke. It appears that the anchor is still penetrating but at a very shallow angle.

Table 5 is an example of the tabulated data for each anchor test. The table lists the data plotted in Figure 33 in addition to various other pieces of data that may be of use in the eventual analysis of these data. Item number 13 is anchor fluke tip depth; it is assumed that the flukes are completely open. For fixed fluke anchors this is valid but for movable fluke anchors the number must be used with care. In sand it is usually obvious when the fluke is open; there is a sudden increase in shank angle associated with a gradual increase in anchor tension. In mud it is not as obvious but is assumed to occur if anchor penetration is initiated and continues.

Tests of the many anchors in various configurations produced results which are greatly, but not totally, dependent on the testing media, San Diego fine sand and Indian Island mud (silty clay). Six tests were also run in overconsolidated silt at San Diego. Overall results would have been somewhat different (degree of difference unknown at this time) with different mooring line, type, or size. The differences would most likely occur with anchor and deck tension readings and anchor penetrations. Pitch and roll of the anchor would probably not be as sensitive to changes. In selecting chain size, an attempt was made to size it according to previous performance data or to advertised data. Often, the anchors would hold less than expected, thus chain size could have been less. Since the behavior of anchor and chain were isolated in these tests, it is felt that mooring line effects on anchor behavior will eventually be understood and quantified in a usable prediction scheme. Until then, care should be exercised when extrapolating these data to other sites, anchor sizes, and mooring lines.

Stockless Anchor (Single)

This anchor was tested in its normal use condition (unstabilized and with movable flukes free to open to 45 to 48 degrees relative to the centerline of the shank) at both San Diego and at Indian Island. These tests were run for confirmation of previous results (Ref 6) and to illustrate problems with using the Stockless anchor in this configuration for fleet moorings; results were similar. Behavior in sand was erratic for the 5K size (efficiencies of 3 to 5) while behavior in mud was consistent but poor. In comparison, the performance of the stabilized Stockless anchor with flukes welded in the open position at 35 degrees for sand and 48 degrees for mud was quite good.

In sand, anchor behavior was consistent with an average anchor efficiency of 5 to 6 for the 9K anchor and 10 for the 5K anchor. Most significantly, these efficiencies were achieved with minimal drag distance which would result in very taut moorings. Tests were not run with a stabilized anchor with 35-degree movable flukes in sand, but previous data (Ref 7) show that the flukes will eventually dig in sands of low to medium density; the improvement due to the reduced fluke angle could be as much as a factor of two. In dense sand and stiff clay seafloors the probability of the Stockless anchor flukes digging in is very low. Welding open the anchor flukes should greatly increase the probability of suitable anchor behavior in these more competent seafloors. Care should be exercised in comparing the mentioned efficiencies with previously reported data because the above values are for the anchor alone. Previous researchers attempted to determine true anchor capacity by separating the chain effect determined through chain pull tests. As can be seen from the results in Appendix A, the chain effect often increases as the anchor is dragged, and the shank forces chain into the seafloor. This effect will be different for different seafloors. The chain effect is real and is part of the total anchor resistance, but, particularly in sand and until it is better understood, the anchor tension alone provides a conservative estimate of expected performance.

In mud at Indian Island, each of the three configurations (i.e., standard, stabilized with movable flukes, and stabilized with fixed flukes) of the 9K Stockless anchor behaved sufficiently different to

clearly show the advantage of fixing the flukes in the open position in mud. Anchor penetrations at comparable drag distances were greater, anchor tensions were greater, and most importantly, mooring tensions were significantly greater. At 41 feet of drag, deck tensions for the above three configurations were 48,000, 50,000, and 67,000 pounds, respectively. Also, the first anchor appeared to have reached peak depth, the second increased slightly to 53,000 before peaking, and, based upon relative shank angles between two and three, option three would probably penetrate further. To put these differences into proper perspective, the effect of the chain laying on (not in) the seafloor is subtracted to show the "true" difference in capacities for Indian Island mud. The values then become 26,000, 30,000, and 50,000 pounds which translate, according to previous methods of figuring anchor efficiency, to 2.5, 2.6, and 4.4, respectively, for the nominal 9K anchor (true weights were used in determining efficiency). A possible reason for these differences is that the anchor flukes stabilized at a partially open position. Previously reported differences (Ref 1) for San Francisco Bay mud show the same relative differences - 2 versus 3.7 to 4. The lower overall values are explained by the reported lower chain drag in San Francisco Bay mud.

Stockless Anchor (Tandem)

In sand, three methods of rigging tandem anchors were tested (see previous section for descriptions). In terms of performance each was satisfactory; there appears to be a slight performance advantage for the shank-to-shackle rigging arrangement. The outboard anchor carried the instrument pack and outboard anchor performance paralleled that of the single anchor. The performance of the inboard anchor is inferred from the difference between deck tension and anchor tension. Based on the differences, the inboard anchor was functioning at least equally to the outboard anchor. Of the three techniques, the shank-to-shackle and crown-to-shackle techniques were equal in terms of installation ease. The ground-ring-to-shackle approach was also effective but somewhat more difficult to install in shallow water at San Diego. In deeper water at Indian Island, installation would have been significantly more difficult, thus it was not tried there. Model tests (Ref 4) in sand of both shank and crown-to-shackle techniques showed superior performance for the shank-to-shackle technique; attachment to the crown caused rotation of the inboard anchor. Prototype tests in sand and mud with the Stockless anchor with welded-open flukes, showed no indication of inboard anchor instability, inferred by overall mooring capacity. Attachment of chain to the crown rather than the shank does simplify installation in deeper water and does not seem to degrade overall performance.

The techniques found suitable for the Stockless anchor in fine sand and soft silty clay will probably be applicable to the vast range of intermediate soil types.

Use of these rigging techniques with higher efficiency anchors has not been proven at prototype size. Higher efficiency anchors need to penetrate deeply in mud and their light weight in relation to their capacity makes them more sensitive to external forces caused by tandem chain attachments. Tandem anchor chain attachment to the inboard anchor

shackle or chain would seem to limit rotational influences on the inboard anchor and, as long as deployment technique is not compromised, may be the safest alternative for higher efficiency anchors at this time.

STATO Anchor

Three sizes of STATO anchor (1K, 3K, and 6K) were tested in sand at San Diego and mud at Indian Island. The 3K STATO was also test-pulled in a dense clayey sand seafloor at San Diego.

Initially, three sizes were to be tested to get some idea of scale effects and to provide a good basis for comparison with other high efficiency anchors. However, initial results in sand were unexpectedly poor, and sufficient scale data were not obtained. Slight modifications to the STATO were required to bring performance back to its expected level. The chronological test sequence which leads to what appears to be necessary changes to expand STATO utility to a broader range of soil types and strengths is described in the following paragraph.

The 1K STATO was first tested in sand and at 5 to 6 feet of drag the anchor rotated out after a peak load of only about 6,000 pounds, far less than expected. This rapid instability would normally indicate that the anchor was improperly stabilized. Stabilizer width agreed with that listed by the drawings (16 inches); however, it did not agree with that projected from a plot of anchor width versus anchor weight for all other STATO anchors. The 1K STATO had not been fabricated previously, thus this problem had gone undetected. "Normal" stabilizer length should have been about 26 inches. While new 1K anchor stabilizers were being fabricated, the 3K STATO with normal stabilizers was tested. It also proved unstable after achieving an anchor load of about 30,000 pounds. The effect of the mooring chain on anchor stability was insignificant because in the two tests performed, the anchor rotated in opposite directions. The 1K STATO with normal 26-inch stabilizers was tested, and it reached about 10,000 pounds before becoming unstable. Its behavior paralleled that of the 3K STATO with its normal stabilizers. Extended stabilizers were fabricated for the 3K STATO with the intent of shortening them sequentially to determine their minimum allowable length. With 18-inch stabilizer extensions (Figure 34) (143-inch total anchor width), the anchor was pulled again. It built up load initially to about 40,000 pounds and then rotated out. Through 140 feet of drag it did not improve and continued to try to embed as evidenced by the fluctuating shank angle. Anchor fluke angle was checked to verify that it was 35 degrees as intended; it was 37 degrees. A 2-degree reduction in fluke angle was not considered adequate to improve performance. Therefore, it was reduced from about 37 to 31-1/2 degrees (by the addition of a 1/2-inch plate between shank and wedge insert, Figure 35), and the anchor was retested. A 30 to 32-degree fluke angle is currently used by the majority of anchor manufacturers for competent seafloors. The anchor built up load gradually until reaching 65,000 pounds. The load appeared to stabilize. On later examination of the data it was noticed that the anchor was beginning to rotate. To determine whether both the fluke angle reduction and stabilizer extensions were necessary, the normal stabilizers were replaced on the anchor and the anchor re-tested. The anchor rotated at about 12 feet of drag. Apparently, both modifications

were necessary. Since it appeared that the 18-inch extension was a good first guess based upon the slight tendency for rotation, smaller extensions were not tried.

The 6K STATO was then tested using its normal stabilizers. Specified fluke angle was 35 degrees yet measured angle was 32 degrees. This tolerance error was fortunately in the right direction for the San Diego sand. Three tests were performed, and the anchor held 105,000 pounds, 72,000 pounds, and about 60,000 pounds. Anchor rotation was again a problem. When fitted with normal stabilizers, all three sizes of STATO anchor behaved in a similar fashion. It appears that the lengths of stabilizers determined as adequate in Port Hueneme beach sand are not adequate for the denser, more uniform, finer grained sand of San Diego Harbor. As of this writing, accurate soil density measurements in San Diego sand were not available; they will be taken shortly. Based on the behavior of all anchors tested and the large chain resistances recorded, it appears that San Diego sand is of high relative density; the need for STATO fluke angle reduction further substantiates this.

Results of tests in mud at Indian Island were in reasonable agreement with previous results reported for San Francisco Bay mud (Ref 3). Recorded efficiencies, for anchor alone, of the 1K and 3K STATO anchors at 50 feet of drag were 14 and 11, respectively; while total efficiencies, including the effect of buried chain were 20 and 17 respectively. Anchor tension for the 6K STATO was not recorded, however; total efficiency near 50 feet of drag was 14. The 1K and 3K anchors appeared to be nearing their peak load while the 6K anchor load was still increasing; however, the 6K anchor was steadily rotating. At 41 feet of drag the measured maximum rotation of about 45 degrees was recorded and the test stopped to avoid electrical cable failure. Longer stabilizers would probably have limited rotation. The extended stabilizers on the 3K anchor did not seem to noticeably inhibit anchor penetration or degrade performance; stability was apparently helped.

The three tests of the 3K STATO with extended stabilizers in a dense clayey sand were in a designated anchorage area in San Diego Harbor. These data were probably the most interesting. In each test the anchor dug in and increased to peak load rapidly and then pulled out. When recovered, soil was packed between the shank and flukes which would prevent further embedment.

Based on tests performed to date on the STATO it is possible to make some general recommendations for modifications to expand utility of the STATO to a broader range of soil characteristics. For specific applications, perhaps these changes should be made only if performance is less than expected or if data indicate a very competent seafloor. For general utility, the following changes are recommended prior to further usage.

1. For use in sand, measure the fluke angle with the wedge insert in place; if greater than 32 degrees, insert a plate spacer or fabricate a new wedge to achieve the needed fluke angle.

2. For sand and mud, extend the stabilizers according to the recommendations of Figure 36. Existing and projected curves of anchor width versus anchor weight are provided. Obviously, extrapolation on the basis of a single data point can be considered highly questionable

but high efficiency anchors are typically scaled as a direct function of anchor weight. Anchor dimensions are normally scaled according to $(\text{anchor weight})^{1/3}$; however, as can be seen from Figure 36, STATO scaling differs. A line proportional to $\text{wt}^{1/3}$, straight line on a log-log plot, is drawn through the single data point available (3K STATO with 18-inch stabilizer extensions). The reason for this deviation from normal geometric scaling was structural limitations due to required use of mild steel (Ref 8). Using geometric scaling with the single data point, the 200-pound anchor seems suitably stabilized and the 15,000-pound STATO seems reasonably close. However, until additional data are available, the upper curve which parallels the actual data and amounts to about a 35% increase in anchor width should be used to provide a conservative estimate of required anchor width from which stabilizer length can be determined.

3. Use of mud palm extensions in sand does not seem to degrade performance. Reference 3 supports this contention; therefore, unless the STATO will be used exclusively for competent seafloors, the mud palm extensions should be included as a standard part of the anchor.

Stockless Anchor Moorings

All moorings tested at San Diego were class B riser-type moorings with a design load of 125,000 pounds. The principal soil type at each mooring location was fine sand. Standard, unstabilized, 20,000-pound Stockless anchors with 45- to 48-degree fluke angles were typical of all the tested moorings. Each anchor was jetted in until flukes were fully open in the down position. Based upon the data gathered at San Diego, it was determined that the anchors in their standard condition probably would not have embedded during normal dragging. Each mooring was pulled in only one direction, and care was taken not to displace the mooring; thus, load was increased to the onset of slippage and loading was stopped immediately. Moorings 17, 18, and 51 held 118,000, 115,000, and 99,000 pounds maximum, respectively. At these loads - in fact at far less than these loads - all chain was off the seafloor. These loads reflect true anchor capacity for the above described conditions. Continued dragging of the anchors, as could occur during storm activity, would probably have caused them to come out of the seafloor, with low probability of re-embedment. A fleet mooring anchor should continue to sustain near peak load with drag to minimize catastrophic damage. The reduction in fluke angle to 35 degrees and the addition of stabilizers will produce this type of desired behavior. If anchors are to be jetted into sand or stiff clay seafloors then these modifications should be made. Also, by welding the flukes open, the principal advantage of jetting (achievement of a taut mooring) can be realized without the need for diving support.

SUMMARY AND CONCLUSION

This report provides the results of anchor and mooring tests in fine sand and dense clayey sand at San Diego and in mud at Indian Island. Tests at a third site with a clay seafloor are planned for early 1980.

Anchors typical of fleet moorings, Stockless and STATO, as well as a variety of new high efficiency anchors potentially useful with fleet moorings, were tested under controlled conditions to: (1) provide immediate use data for the Navy and (2) provide the basis for the eventual development of a scheme to predict the behavior of anchors as a function of seafloor engineering properties. A great deal of data was gathered, and the implications of these data are not fully understood at this time. Care should be exercised in using these data to specify the performance of larger sizes of the tested anchors in similar or different soils than those of the test sites. The tests clearly provided surprises in anchor behavior and illustrated the great dependence of anchor behavior on soil characteristics. An effort is underway toward a more complete understanding of the data and toward the development of an anchor behavior predictive scheme. Results will be reported at a later date. In the meantime, some tentative conclusions can be drawn and guidance given concerning the use of the various anchors tested.

1. In sand, the stabilized Stockless anchor with welded-open flukes to 35 degrees was often 2 to 4 times more efficient than the standard Stockless anchor. It also held its load more uniformly with drag and developed its peak capacity within a few feet of drag.
2. Tandem anchor arrangements using Stockless anchors with welded-open flukes were found that could be reasonably installed with Navy Public Works assets and that appeared to develop individual anchor efficiencies at least equal to those achieved when pulled singly in sand and mud.
3. In mud, the efficiency of the stabilized Stockless anchor with welded-open flukes (fully opened) was approximately twice that of the stabilized or unstabilized Stockless anchor with freely moving flukes.
4. The standard STATO anchor performed poorly in San Diego sand; however, an increase of about 35% in anchor width (stabilizer extension) and a reduction in fluke angle to about 32 degrees for the 3,000-pound STATO corrected penetration and stability problems and increased anchor efficiency from less than 10 to greater than 20.
5. In mud, STATO performance was in relative agreement with previously reported data; however, some rotational instability was noticed, particularly in the 6K STATO, suggesting the need for an increase in stabilizer length.
6. Previous STATO tests were concentrated in Port Hueneme sand and San Francisco Bay mud. The STATO was designed on the basis of tests in these seafloors. The recent tests were performed in seafloors which expanded performance data to a more dense sand and to a softer mud; these tests suggest anchor modifications. To expand the utility of the STATO to a broader range of soil conditions, stabilizers should be extended. When used in sand only, the standard fluke angle should be 32 degrees rather than 35 degrees.

ACKNOWLEDGMENTS

Messrs. G. Duffy, M. Derr and L. Tucker of CEL were responsible for the design and development of the instrumentation system. Mr. Hank Lingg assisted in the development of the testing procedures and in the onsite testing phase of the effort along with Mr. P. Babineau and Mr. H. Link. Mr. Ron Greene of the Naval Sea System Command also provided valuable onsite assistance during the test phase.

The efforts of Dr. H. Ottsen of Western Instruments in the preparation of the data plots and digital outputs is acknowledged.

The very capable assistance of the Navy Public Works Center, San Diego, and the U.S. Army Washington State National Guard's 144th Transportation Battalion, who provided personnel and floating support during tests at San Diego and Indian Island, respectively, is also acknowledged. The cooperation of Mr. Rob Van Der Haak of Vrijhof Ankers and Mr. Peter Bruce of BRUCE Anchors was greatly appreciated.

REFERENCES

1. Naval Civil Engineering Laboratory. Technical Memorandum M-097: Tests of anchors for moorings and ground tackle design in mud bottom, by R. C. Towne and J. V. Stalcup. Port Hueneme, Calif., Dec 1954.
2. Naval Facilities Engineering Command. Design Manual DM-26: Harbor and coastal facilities. Alexandria, Va., Jul 1968.
3. Naval Civil Engineering Laboratory. Technical Report R-044: New and modified anchors for moorings, by R. C. Towne and J. V. Stalcup. Port Hueneme, Calif., Mar 1960.
4. Holland Shipbuilding, Anker Advies Bureau. Anchors in tandem or use of backup anchors (piggy-backs), by P. J. Klaren.
5. Civil Engineering Laboratory. Technical Memorandum M-42-78-12: San Diego fleet mooring inspection, by J. F. Wadsworth. Port Hueneme, Calif., Aug 1978.
6. Naval Civil Engineering Research and Evaluation Laboratory. Technical Note N-195: Tests of BUSHIPS anchors in mud and sand bottoms, by R. C. Towne and J. V. Stalcup. Port Hueneme, Calif., Aug 1954.
7. _____. Technical Memorandum M-066: Test of anchors for moorings and ground tackle design, by R. C. Towne. Port Hueneme, Calif., Jun 1953.
8. _____. Technical Note N-1463: OTEC single anchor holding capacities in typical deep sea sediments, by P. J. Valent, R. J. Taylor, J. M. Atturio, and R. M. Beard. Port Hueneme, Calif., Dec 1976.

Table 1. Soil Property Data for Vibracore 3 - Indian Island

1. Original vane shear strength data and density data not presented. Soil gases caused significant sample disturbance.
2. Shells and shell fragments were found throughout the cores.
3. Core color was dark olive gray.
4. Soil classification is silty clay.

Increment (in.)	Water Content, %	Remolded Vane Shear Strength, psi	Liquid Limit, %	Plastic Limit, %	Plasticity Index	Specific Gravity	Liquidity Index
0-3	148.30	0.241	142.13	64.40	77.7	2.543	1.09
24-27	146.74	0.198					
36-39	150.49	0.313					
48-51	152.67	0.217	124.64	65.45	59.2	2.521	1.47
60-63							
72-75	143.97	0.313	138.64	71.59	67.1	2.511	1.08
84-87	153.16	0.318					
96-99	161.23	0.194	125.84	70.34	55.5	2.515	1.65
108-111	158.05	0.174					
116-119	155.16	0.184	140.25	70.40	69.9	2.498	1.2
18 ft	134.02						
28 ft	110.46		117.00	65.86	51.1		0.88

Table 2. Summary of Test Data for San Diego Harbor Anchor Tests

Test No.	Series	Anchor	Calendar Date (Julian)	Anchor Description				Water Depth, ft	Remarks	
				Nominal Weight, lb (kg)	Actual Weight, lb (kg)	Fluke Angle, deg	Fixed/Movable Fluke			Anchor Specifics
Location 1 - San Diego Harbor - Uniform Fine Sand										
1	4	Stockless	3/29/79 (88)	5,000	5,350	48	M	Without stabilizers	12	Anchor performance was erratic; efficiency varied from 3 to 5. Chain connector parted; peak load not recorded. Anchor performance was very uniform; Load built up rapidly and remained stable during pull. Anchor flipped over at about 12 ft of drag at an efficiency of 6.
2	4	Stockless	3/29/79 (88)	5,000	5,350	48	M	Without stabilizers	11	
3	4	Stockless	3/29/79 (88)	5,000	5,350	48	M	Without stabilizers	12	
1	5	Stockless	3/30/79 (89)	5,000	5,950	35	F	With stabilizers	16	
2	5	Stockless	3/30/79 (89)	5,000	5,950	35	F	With stabilizers	12	
3	5	Stockless	4/2/79 (92)	5,000	5,950	35	F	With stabilizers	15	
1	6	STATO	4/2/79 (92)	1,000	1,070	35	M	With 16 in. stabilizers	16	
1	7	Hook	4/3/79 (93)	(560)	1,230 (560)	32	M	With auxiliary flukes	12	
2	7	Hook	4/3/79 (93)	(560)	1,230 (560)	32	M	With auxiliary flukes	12	
3	7	Hook	4/3/79 (93)	(560)	1,230 (560)	32	M	With auxiliary flukes	12	

continued

Table 2. Continued

Test No.	Series	Anchor	Calendar Date (Julian)	Anchor Description			Water Depth, ft	Remarks
				Nominal Weight, lb (kg)	Actual Weight, lb (kg)	Fluke Angle, deg		
Location 1 - San Diego Harbor - Uniform Fine Sand (continued)								
1	10	BRUCE	4/3/79 (93)	(600)	1,320 (600)	-	F	----- 15-1/2
2	10	BRUCE	4/3/79 (93)	(600)	1,320 (600)	-	F	----- 15-1/2
3	10	BRUCE	4/4/79 (94)	(600)	1,320 (600)	-	F	----- 13
1	11	BRUCE	4/4/79 (94)	(600)	1,320 (600)	-	F	With 1 cable depressor (120 kg) after load cell 14-1/2
2	11	BRUCE	4/4/79 (94)	(600)	1,320 (600)	-	F	14-1/2
1	12	BRUCE	4/4/79 (94)	(600)	1,320 (600)	-	F	With 2 cable depressors (240 kg) after load cell 14-1/2
1	15	STEVDIG	4/4/79 (94)	(1,000)	2,550 (1,160)	32	M	----- 15-1/2
2	15	STEVDIG	4/4/79 (94)	(1,000)	2,550 (1,160)	32	M	----- 15
3	15	STEVDIG	4/5/79 (95)	(1,000)	2,550 (1,160)	32	M	----- 15

continued

Table 2. Continued

Test No.	Series	Anchor	Calendar Date (Julian)	Anchor Description				Water Depth, ft	Remarks	
				Nominal Weight, lb (kg)	Actual Weight, lb (kg)	Fluke Angle, deg	Fixed/Movable Fluke			Anchor Specifics
Location 1 - San Diego Harbor - Uniform Fine Sand (continued)										
1	9	STEVFIX	4/5/79 (95)	(640)	1,408 (640)	32	M	-----	14-1/2	
2	9	STEVFIX	4/5/79 (95)	(640)	1,408 (640)	32	M	-----	14	
3	9	STEVFIX	4/5/79 (95)	(640)	1,408 (640)	32	M	-----	14	
1	14	STATO	4/5/79 (95)	3,000	3,000	37	M	With original stabilizers	14-1/4	Anchor flipped over after reaching an efficiency of about 10; appeared that stabilizers are too short.
2	14	STATO	4/5/79 (95)	3,000	3,000	37	M	With original stabilizers	14-1/4	
1	13	Stockless	4/5/79 (95)	9,000	11,370	35	F	With stabilizers	14-3/4	Anchor held stably at an efficiency of about 5.
2	13	Stockless	4/5/79 (95)	9,000	11,370	35	F	With stabilizers	15-3/4	
1	16	BRUCE	4/6/79 (96)	(1,000)	2,200 (1,000)	-	F	-----	13	
2	16	BRUCE	4/6/79 (96)	(1,000)	2,200 (1,000)	-	F	-----	13-1/2	

continued

Table 2. Continued

Test No.	Series	Anchor	Calendar Date (Julian)	Anchor Description				Water Depth, ft	Remarks	
				Nominal Weight, lb (kg)	Actual Weight, lb (kg)	Fluke Angle, deg	Fixed/Movable Fluke			Anchor Specifics
Location 1 - San Diego Harbor - Uniform Fine Sand (continued)										
1	17	BRUCE	4/6/79 (96)	(1,000)	2,200 (1,000)	-	F	With 1 cable depressor (200 kg) after load cell	13-1/2	
2	17	BRUCE	4/6/79 (96)	(1,000)	2,200 (1,000)	-	F	With 1 cable depressor at (200 kg) shank	13-1/2	
2	6	STATO	4/9/79 (99)	1,000	1,070	35	M	With 26 in. stabilizers	14-1/2	Anchor flipped over at an efficiency of about 10; stabilizers are too short.
3	14	STATO	4/10/79 (100)	3,000	3,000	37	M	With 18 in. stabilizer extensions	15	Anchor performance was erratic; initiated embedment then rotated and came out.
4	14	STATO	4/10/79 (100)	3,000	3,000	31-1/2	M	With 18 in. stabilizer extensions	14-1/2	Anchor built up load uniformly, was stable, developed an efficiency of 21.
5	14	STATO	4/10/79 (100)	3,000	3,000	31-1/2	M	With original stabilizers	15-1/4	Anchor flipped at about 10 ft of drag.
1	19	STATO	4/11/79 (101)	6,000	6,000	32	M	Original stabilizers	15-1/4	Anchor efficiency varied between 9 and 16; anchor unstable and flipped at above efficiencies; longer stabilizers appear needed.
2	19	STATO	4/11/79 (101)	6,000	6,000	32	M	Original stabilizers	15	
3	19	STATO	4/11/79 (101)	6,000	6,000	32	M	Original stabilizers	14-1/2	

continued

Table 2. Continued

Test No.	Series	Anchor	Calendar Date (Julian)	Anchor Description				Water Depth, ft	Remarks	
				Nominal Weight, lb (kg)	Actual Weight, lb (kg)	Fluke Angle, deg	Fixed/Movable Fluke			Anchor Specifics
Location 1 - San Diego Harbor - Uniform Fine Sand (continued)										
1	20	Stockless	4/11/79 (101)	5,000	5,950 (ea)	35	F	Tandem - shank to shackle rigging; total weight of 11,900 lb	13	Arrangement easy to install; both anchors apparently functioned to peak capacity.
2	20	Stockless	4/11/79 (101)	5,000	5,950 (ea)	35	F		13	
1	21	Stockless	4/12/79 (102)	5,000	5,950 (ea)	35	F	Tandem - crown to shackle rigging; total weight is 11,900 lb	16-3/4	Performance somewhat less than shank-to-shackle technique but somewhat easier to install.
2	21	Stockless	4/12/79 (102)	5,000	5,950 (ea)	35	F		16-1/2	
1	22	Stockless	4/12/79 (102)	5,000	5,950 (ea)	35	F	Tandem - ground ring to shackle rigging; total weight is 11,900 lb	13	Performance comparable to crown to shackle technique but installation more difficult.
4	7	Hook	4/12/79 (102)	(560)	1,230 (560)	32	M	Without auxiliary flukes	12	
5	7	Hook	4/12/79 (102)	(560)	1,230 (560)	32	M	Without auxiliary flukes	11-1/2	
Location 2 - San Diego Harbor - Anchorage Area (1-3 Ft Mud Over Dense Clayey Sand)										
1	24	STATO	4/16/79 (106)	3,000	3,000	31-1/2	M	With 18-in. stabilizer extensions	41	Anchor embedded quickly and reliably to a peak anchor efficiency of 15 to 18, but pulled out with continued drag; ultimately, the dense clayey sand clogged the flukes and prohibited re-embedment.
2	24	STATO	4/16/79 (106)	3,000	3,000	31-1/2	M	With 18-in. stabilizer extensions	41	
3	24	STATO	4/16/79 (106)	3,000	3,000	31-1/2	M	With 18-in. stabilizer extensions	39	

continued

Table 2. Continued

Test No.	Series	Anchor	Calendar Date (Julian)	Anchor Description				Water Depth, ft	Remarks	
				Nominal Weight, lb (kg)	Actual Weight, lb (kg)	Fluke Angle, deg	Fixed/Movable Fluke			Anchor Specifics
Location 2 - San Diego Harbor - Anchorage Area (1-3 Ft Mud Over Dense Clayey Sand)										
1	25	STEVFIX	4/16/79 (106)	(640)	1,408 (640)	32	M	-----	38	
2	25	STEVFIX	4/16/79 (106)	(640)	1,408 (640)	32	M	-----	37	
3	25	STEVFIX	4/16/79 (106)	(640)	1,408 (640)	32	M	-----	36	

Table 3. Summary of Test Data for San Diego Harbor Mooring Tests

Date	Mooring Number	Mooring Class	Anchor	Anchor Weight, lb	Mooring Chain Size/Length Buoy to Anchor	Water Depth	Remarks
3/26/79	17	B	Stockless without stabilizers	20,000	22 ft - 2-3/4 in. riser; 225 ft - 2-1/2 in. leg	36	Anchors jettied-in with flukes down on all San Diego moorings; -SE pull on mooring, max load was 118,000 lb.
3/26/79	18	B	Stockless without stabilizers	20,000	23 ft - 2-3/4 in. riser; 225 ft - 2-1/2 in. leg	37	-SW pull on mooring; max load 115,000 lb.
3/27/79	50 & 51	B	Stockless without stabilizers	20,000	16 ft - 2-3/4 in. riser; 225 ft - 2-1/2 in. leg	28	-E-W pull on moorings, max load 99,000 lb; buoy 51 displaced at above load.

Table 4. Summary Test Data for Indian Island Anchor Tests

Test No.	Date	Anchor	Anchor Description				Water Depth (ft)	Remarks	
			Nominal Weight lb (kg)	Actual Weight lb (kg)	Fluke Angle (deg)	Fixed/Movable Fluke			Anchor Specifics
1	6/19/79	STATO	1,000	1,070	50	M	26 in. long stabilizers	86	Anchor embedded quickly; began to rotate at about 30 ft drag.
2	6/20/79	Hook	(560)	1,230 (560)	50	M	Without auxiliary flukes	82	
3	6/20/79	Hook	(560)	1,230 (560)	50	M	Without auxiliary flukes	87	
4	6/20/79	BRUCE	(1,000)	2,200 (1,000)	-	F		87	
6	6/20/79	BRUCE	(1,000)	2,200 (1,000)	-	F	With 1 cable depressor (200 kg) after load cell	81	
7	6/21/79	Stockless	9,000	11,370	48	F	With stabilizers	79	Anchor load cell erratic for test 7; at comparable drag distance (41 ft) fixed-fluke anchor deck tension was 17,000 lb higher than movable fluke anchor.
8	6/21/79	Stockless	9,000	11,370	48	M	With stabilizers	91	
9	6/21/79	Stockless	5,000	5,950	48	F	With stabilizers	92	Anchor consistently held 4-5 times its own weight; also refers to single anchor performance of tests 11 and 12.
10	6/21/79	Stockless	5,000	5,950	48	F	With stabilizers	92	

continued

Table 4. Continued

Test No.	Date	Anchor	Anchor Description					Water Depth (ft)	Remarks
			Nominal Weight lb (kg)	Actual Weight lb (kg)	Fluke Angle (deg)	Fixed/Movable Fluke	Anchor Specifics		
11	6/22/79	Stockless	5,000	5,950 (ea)	48	F	Tandem - shank to shackle; total weight is 11,900 lb	98	Both tandem arrangements were equally efficient; crown-to-shackle approach slightly easier to install; anchor seems to be initiating rotation near 35 ft of drag (about 15 ft actual anchor drag).
12	6/23/79	Stockless	5,000	5,950 (ea)	48	F	Tandem - crown to shackle; total weight is 11,900 lb	92	
13	6/23/79	Stockless	5,000	5,950	48	M	With stabilizers	87	Anchor penetration about one-half that of fixed fluke anchor; 10,000-15,000 lb reduction in deck tension from fixed fluke anchor.
14	6/23/79	Stockless	5,000	5,950	48	M	With stabilizers	89	
15	6/23/79	BRUCE	(340)	750 (340)	-	F	Twin shank anchor	88	
17	6/23/79	STEVFIX	(640)	1,408 (640)	50	M		92	
18	6/24/79	STEVFIX	(640)	1,408 (640)	50	F	With flukes fixed open	84	
19	6/24/79	STEVFIX	(940)	2,068 (940)	50	F	With fluke extensions and flukes fixed open	83	
20	6/24/79	STEVFIX	(1,000)	2,200 (1,000)	50	M		82	
21	6/25/79	Stockless	9,000	10,500	50	M	Without stabilizers	89	Peak deck tension almost 20,000 lb less than stabilized welded-open fluke version.

continued

Table 4. Continued

Test No.	Date	Anchor	Anchor Description					Water Depth (ft)	Remarks
			Nominal Weight lb (kg)	Actual Weight lb (kg)	Fluke Angle (deg)	Fixed/Movable Fluke	Anchor Specifics		
22	6/25/79	BRUCE	(600)	1,320 (600)	-	F		83	
23	6/25/79	STATO	3,000	3,000	50	M	With 18-in. stabilizer extensions	82	Extended stabilizers did not appear to degrade performance; anchor penetrated and held well.
24	6/25/79	STEVHUD	(500)	1,100 (500)	50	M		83	
25	6/25/79	STATO	6,000	6,600	50	M	With original stabilizers	89	Anchor penetrated and held well but rotated; extended stabilizers might improve performance.

Table 5. Typical Data Output for Anchor Test Pull

TEST DATE 101
 TEST NO. 1
 TEST SERIALS 19
 TEST AREA SAN DIEGO HARBOR 1500 FT. SOUTHWEST OF BNOY 49
 START-END TIMES 1101 - 1122
 SEAFLOOR TYPE FINE SAND BOTTOM. DEPTH 11-12 FT. MLLW
 ANCHOR TYPE STATO *6000LR. NORMAL STABILIZERS 32 NEG. MOV. FLUKES
 ANCHOR WEIGHT 6000.00 LR.
 FLUKF ANGLE-TYPE 32.00 DEG. - 0 0=MOV 1=FIX
 AUX. ANCHOR TYPE 0.00 LR.
 MAIN-AUX ANCHOR SEPARATION 0.00 FEET
 DEPRESSIONS,NO.,WT.EACH-TOTAL WT. 0 - 0.0 - 0.0 LR.
 MOORING LINE DESCRIPTION ANCHOR TO 180FT 2.5IN. STUJLINK CHAIN TO 340FT 2IN WIRE ROPE

NOTE - INITIAL SHANK DEPTH ZEROED TO REFLECT MEASURED WATERDEPTH

Note: Anchor depth at end of drag measured - centerline of shank at anchor crown = (-15) inches.

1. DRAG DISTANCE	2. DECK TENSION	3. ANCHOR TENSION	4. SHANK ANGLE	5. ROTATION ANGLE	6. DECK HORIZ. FORCE	7. DECK DEPTH	8. PACKAGE DEPTH	9. CHAIN LENGTH ON BOTTOM	10. CHAIN WEIGHT ON BOTTOM	11. ANCHOR CROWN DEPTH	12. ANCHOR SHANK TIP DEPTH	13. ANCHOR FLUKE TIP DEPTH	14. WATER DEPTH	15. TOTAL BOTTOM WEIGHT	NOTE - POSITIVE SHANK ANGLE INDICATES SHANK TIP FLOW CROWN	
0.0	0.0	0.0	5.0	7.3	19.8	172.8	8665.1	14.2	15.3	14.2	15.3	14.2	15.3	14.2	15.3	14665.1
2.0	34.5	7.5	4.0	5.8	38.3	145.9	7315.7	14.4	15.2	14.4	15.2	14.4	15.2	14.4	15.2	13315.7
4.0	44.5	11.3	4.0	5.6	44.3	136.0	6864.0	14.5	15.1	14.5	15.1	14.5	15.1	14.5	15.1	12864.0
6.0	49.5	15.0	10.5	5.4	49.3	130.6	6548.0	13.2	15.4	13.2	15.4	13.2	15.4	13.2	15.4	12548.0
7.9	65.0	25.0	8.0	4.9	64.8	112.7	5654.3	13.9	15.6	13.9	15.6	13.9	15.6	13.9	15.6	11654.3
9.7	80.0	37.5	7.0	4.3	79.8	103.9	5208.1	14.4	15.8	14.4	15.8	14.4	15.8	14.4	15.8	11208.1
11.6	102.0	57.5	7.0	3.9	101.8	85.1	4268.8	14.4	15.8	14.4	15.8	14.4	15.8	14.4	15.8	10268.8
13.6	108.0	67.5	7.5	3.7	107.8	84.5	4236.9	14.5	16.1	14.5	16.1	14.5	16.1	14.5	16.1	10236.9
15.5	120.0	80.0	8.0	3.5	119.8	77.8	3880.6	14.4	16.1	14.3	16.2	14.3	16.2	14.3	16.2	9880.6
17.5	128.0	95.0	9.0	3.4	123.8	76.8	3852.4	14.3	16.2	14.3	16.2	14.3	16.2	14.3	16.2	9852.4
19.5	130.0	91.3	10.0	3.4	129.8	69.7	3496.6	14.2	16.3	14.2	16.3	14.2	16.3	14.2	16.3	8496.6
21.5	132.0	93.8	10.3	3.3	131.8	71.9	3607.9	14.2	16.3	14.2	16.3	14.2	16.3	14.2	16.3	8607.9
23.5	131.0	94.4	11.5	3.3	130.8	73.1	3665.5	13.8	16.5	13.8	16.5	13.8	16.5	13.8	16.5	8665.5
25.5	140.0	105.0	12.5	3.3	139.8	62.8	3147.4	13.5	16.1	13.5	16.1	13.5	16.1	13.5	16.1	8147.4
27.5	134.0	100.0	15.0	3.2	133.8	74.3	3726.3	13.5	16.1	13.5	16.1	13.5	16.1	13.5	16.1	8726.3
29.4	117.0	81.3	17.8	3.2	116.8	93.2	4675.3	13.5	16.1	13.5	16.1	13.5	16.1	13.5	16.1	10675.3
31.4	46.0	20.6	33.0	4.0	45.0	159.5	7997.4	15.3	15.3	15.3	15.3	15.3	15.3	15.3	13997.4	

DISTANCE BARGE TRAVELLED 32.0
 DISTANCE ANCHOR TRAVELLED 31.4

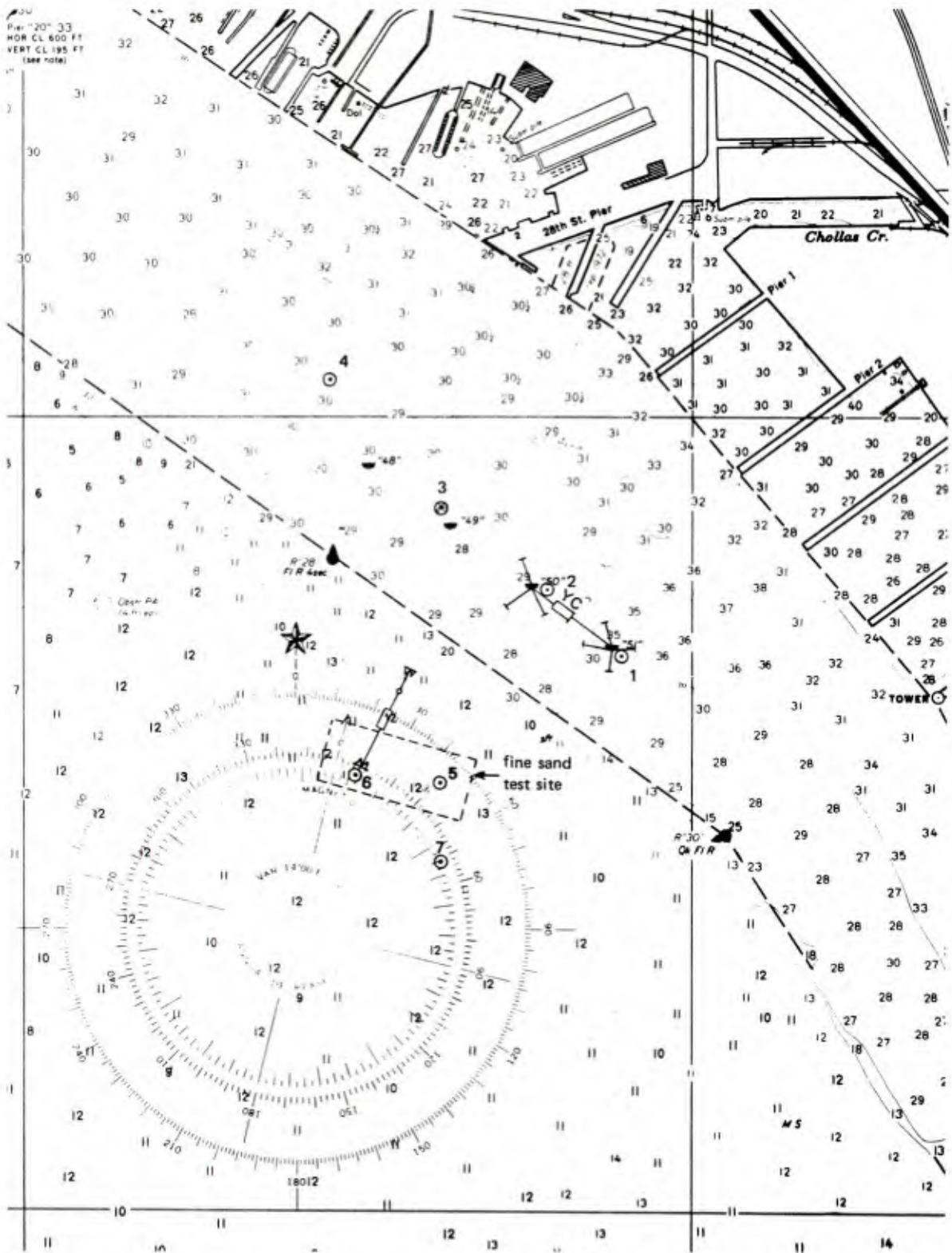

Figure 1. Test and core locations at San Diego Harbor - location 1.

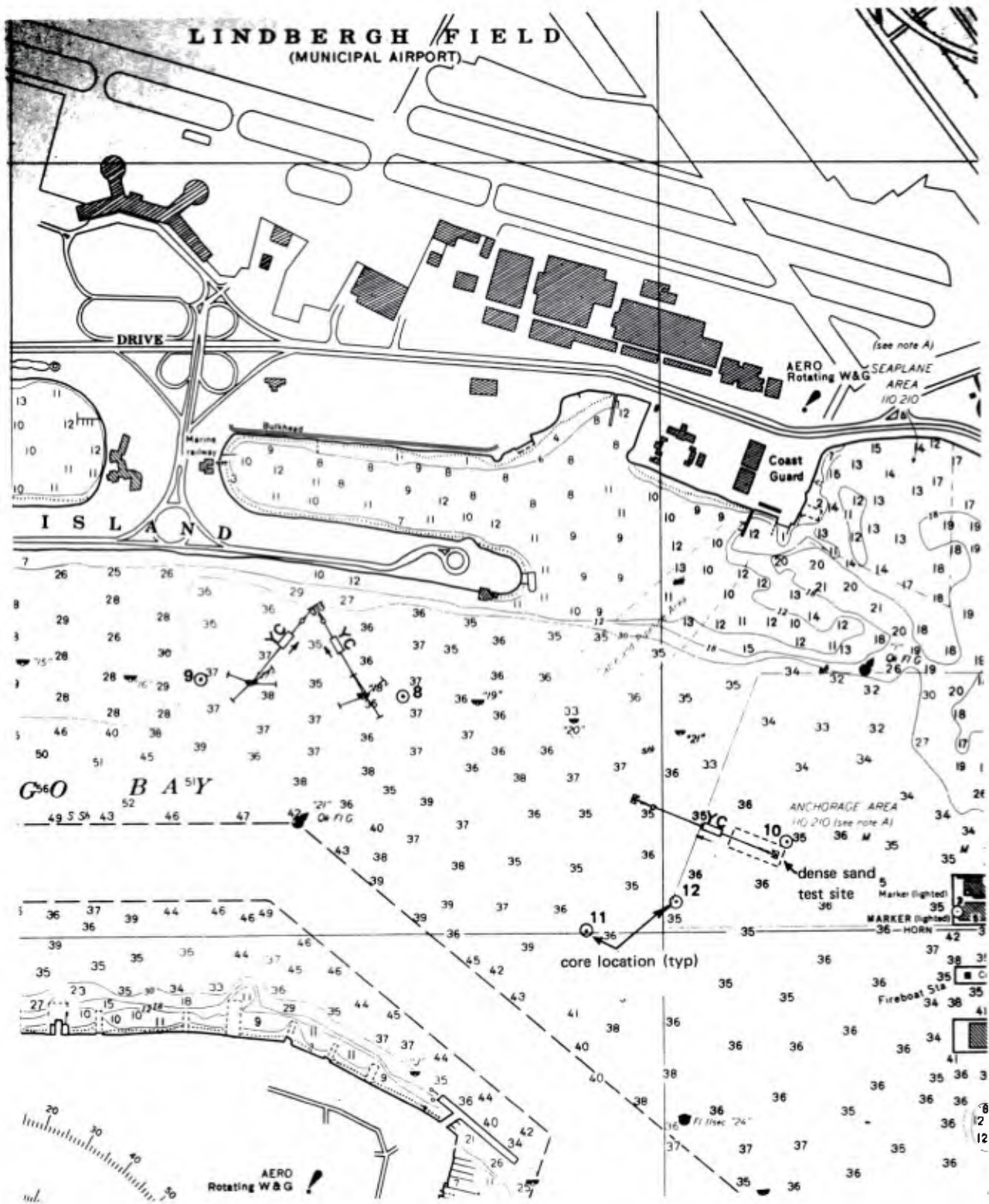

Figure 2. Test and core locations at San Diego Harbor - location 2.

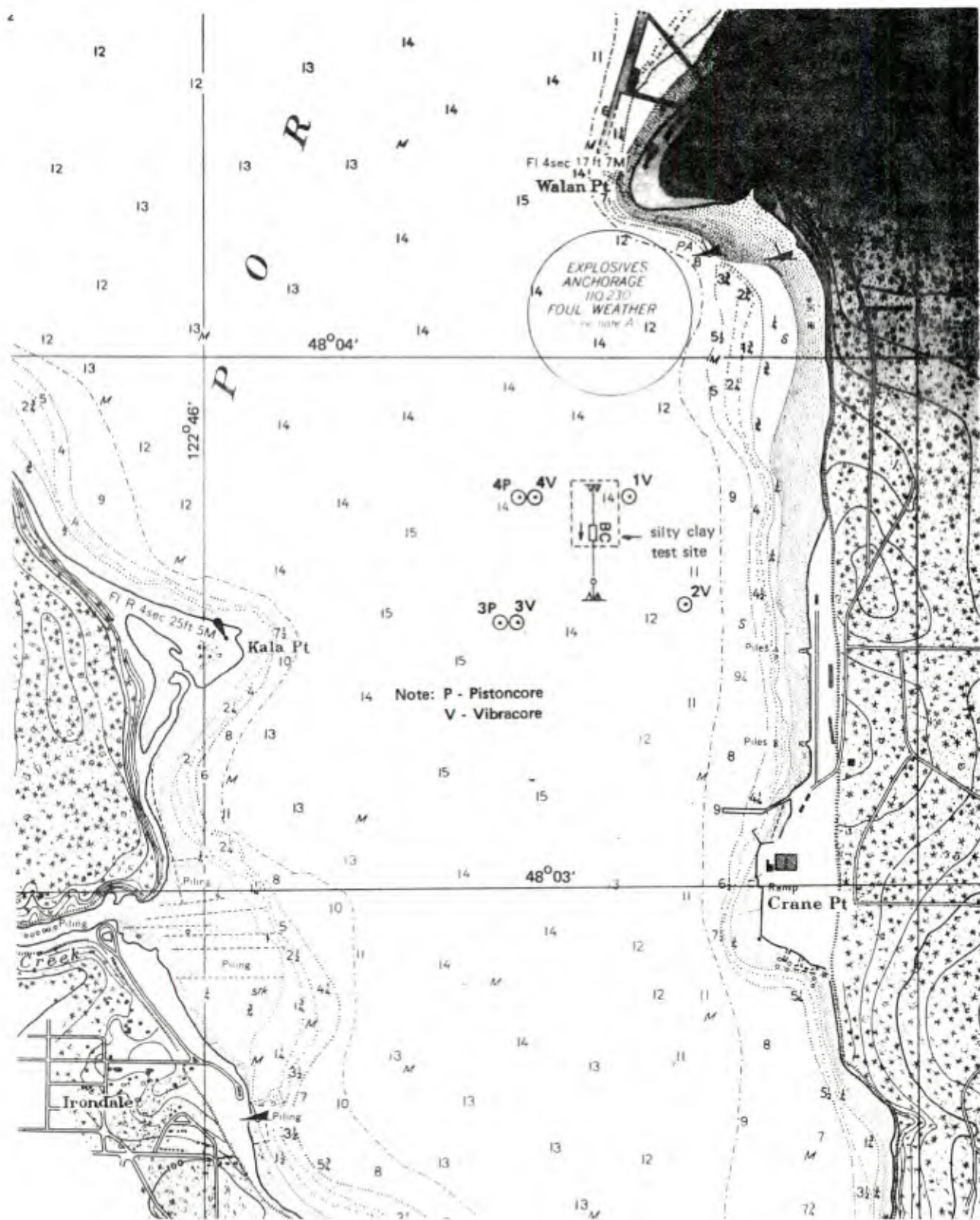

Figure 3. Test and core locations - Indian Island.

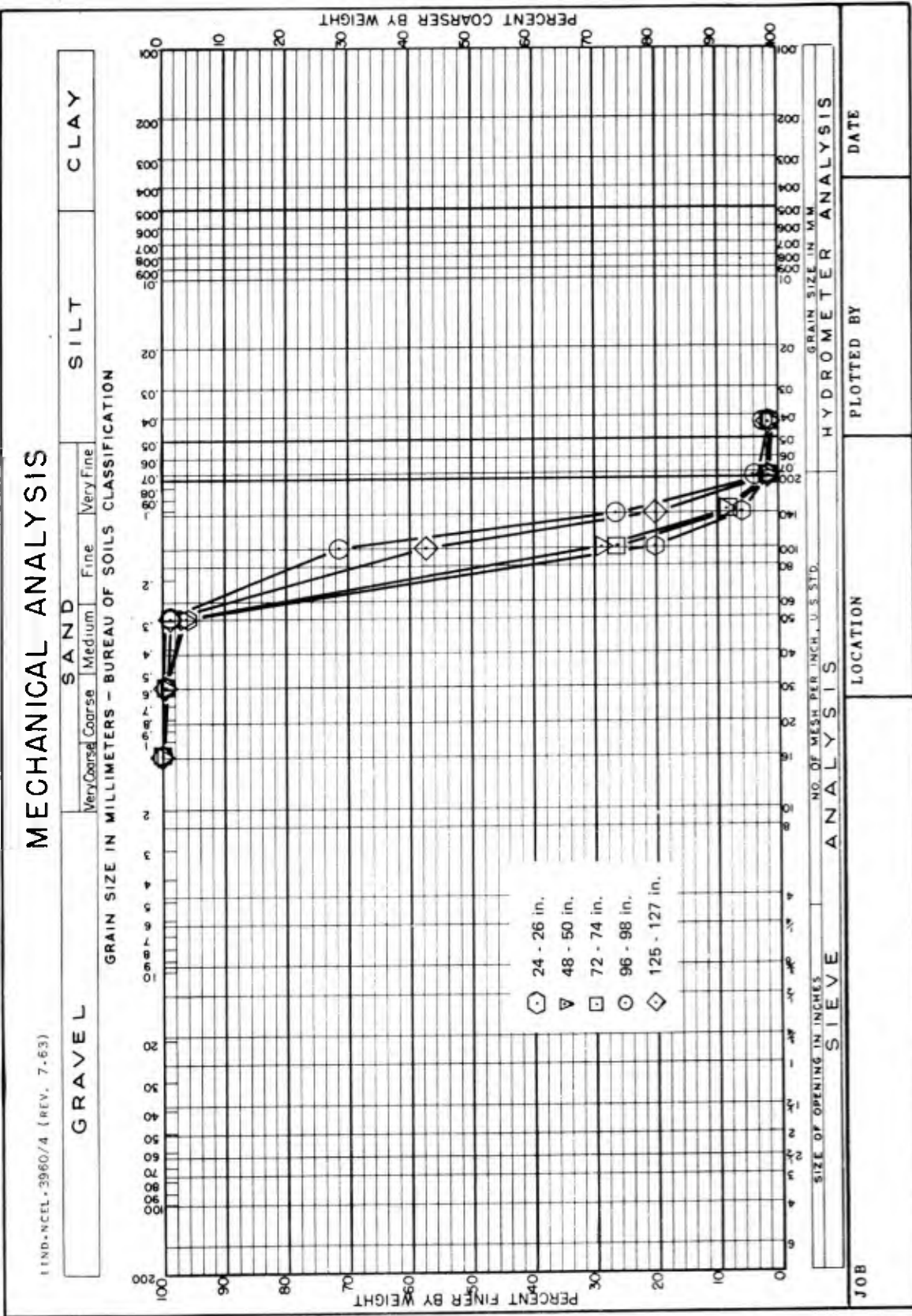

Figure 4. Grain size distribution curves for Vibracore 5 - San Diego Harbor.

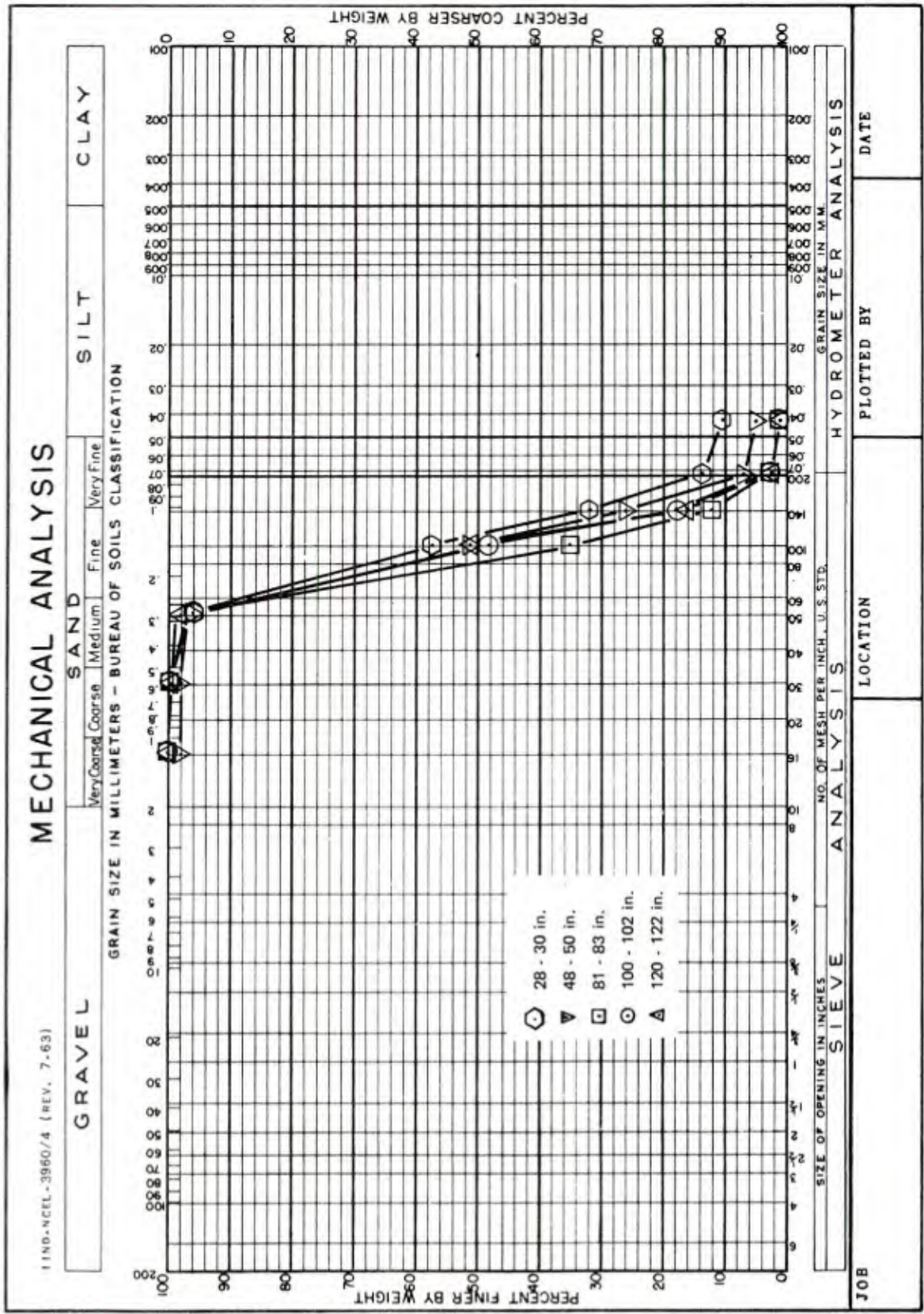

Figure 5. Grain size distribution curves for Vibracore 6 - San Diego Harbor.

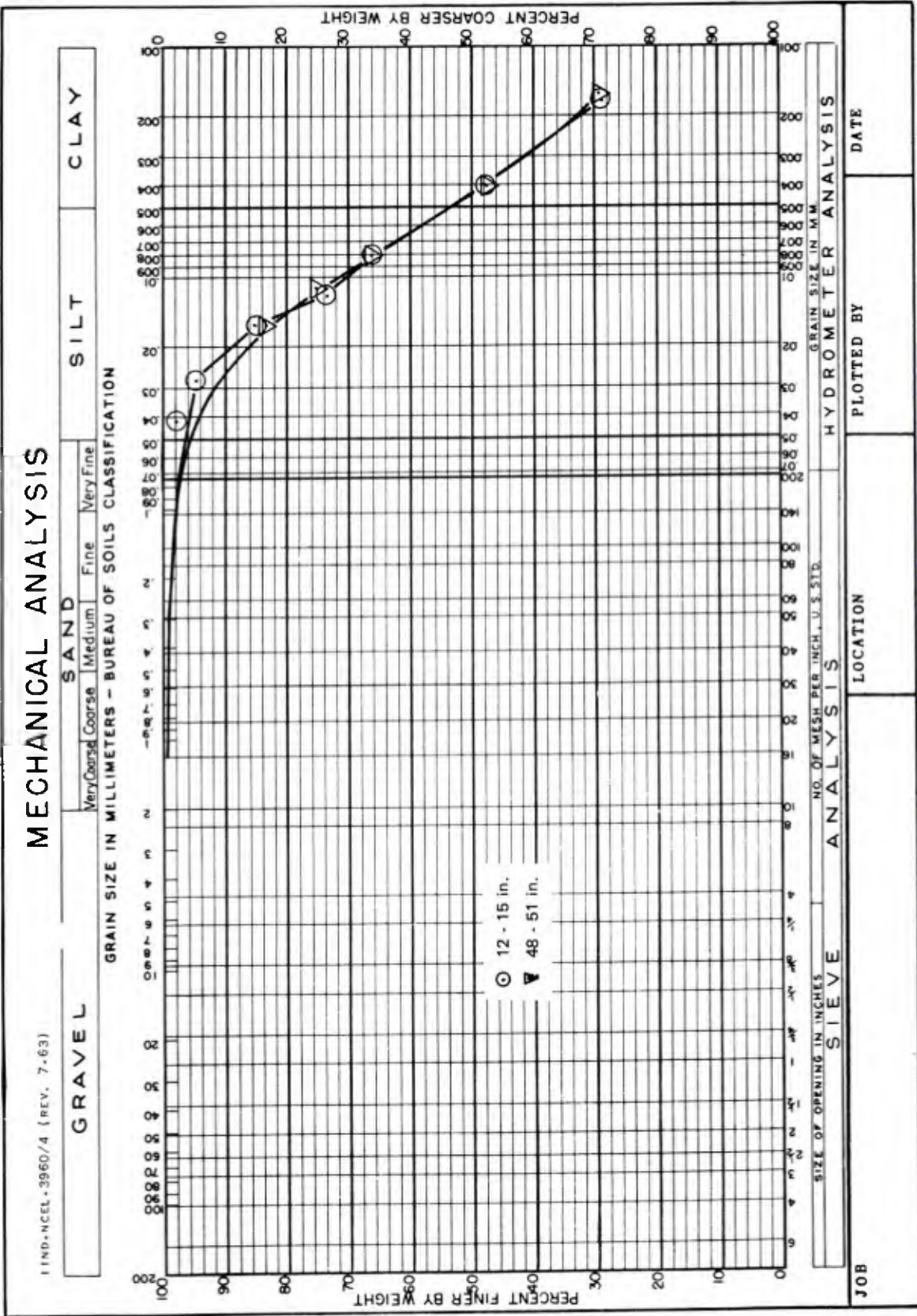

Figure 6. Grain size distribution curves for Vibracore 3 (12 to 51-inch penetration) - Indian Island.

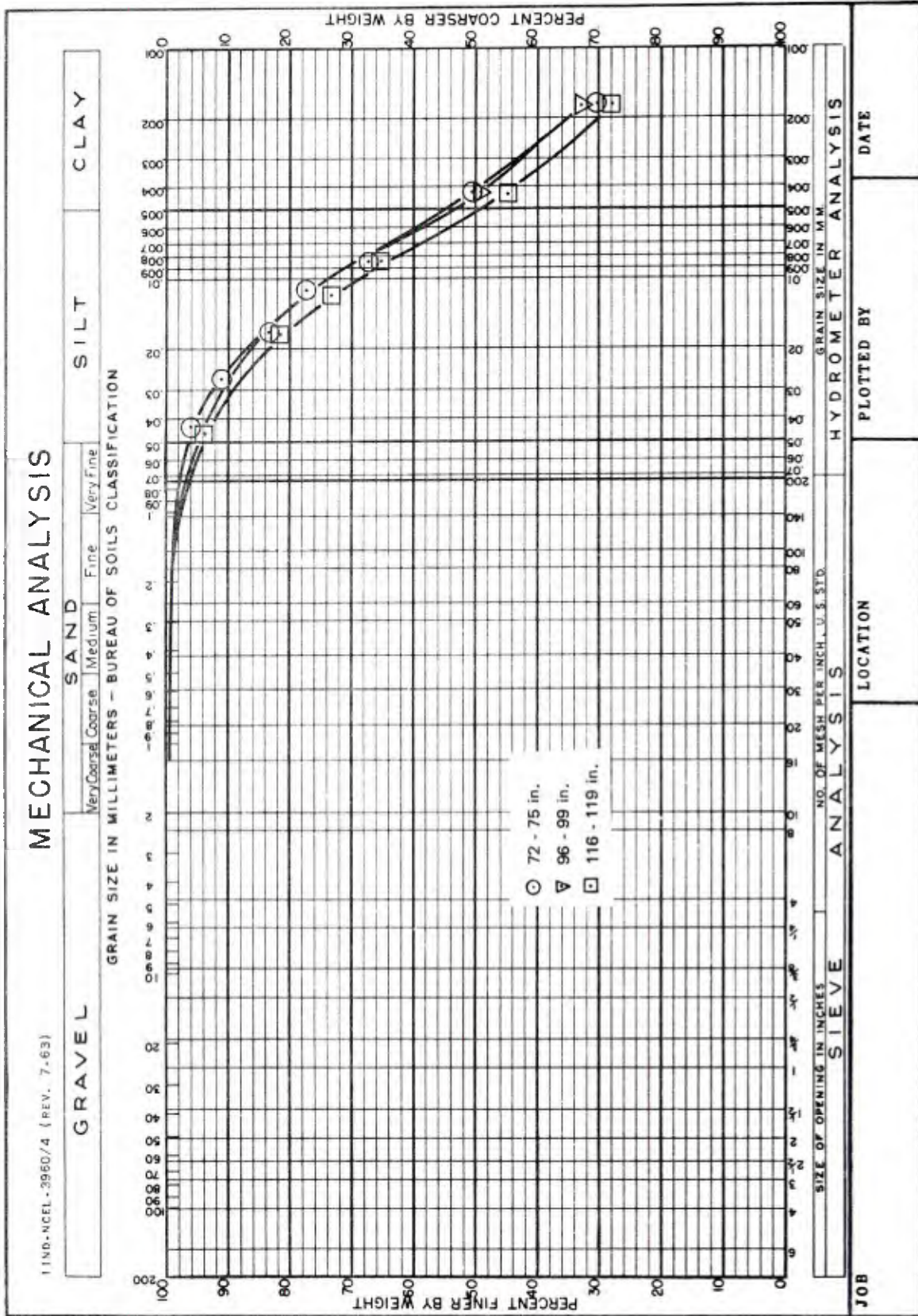
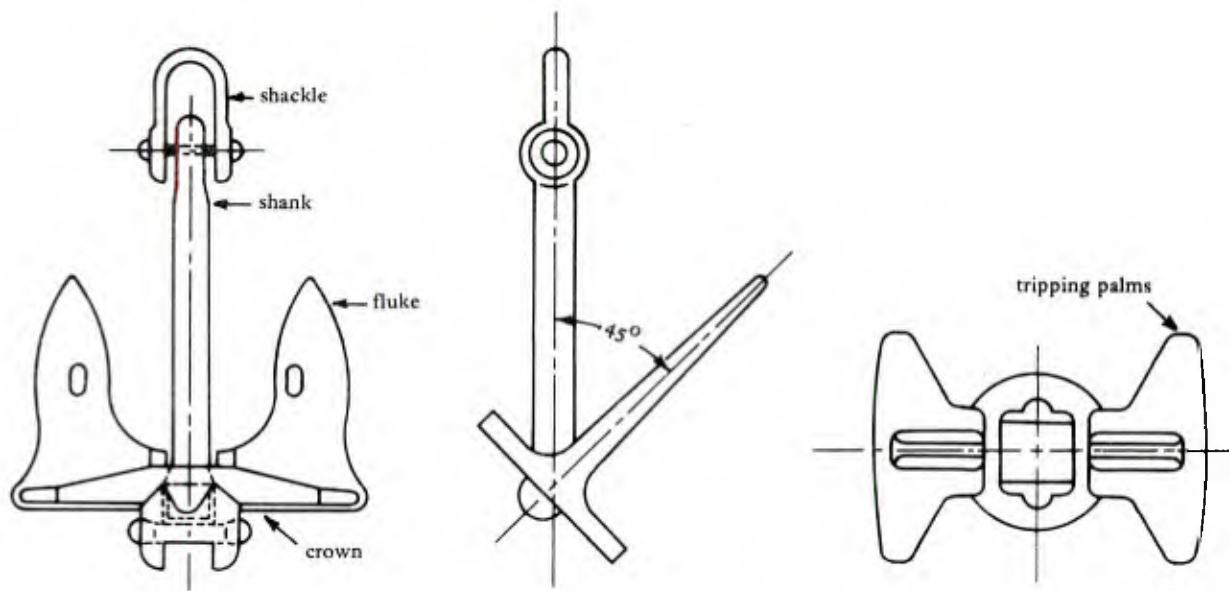
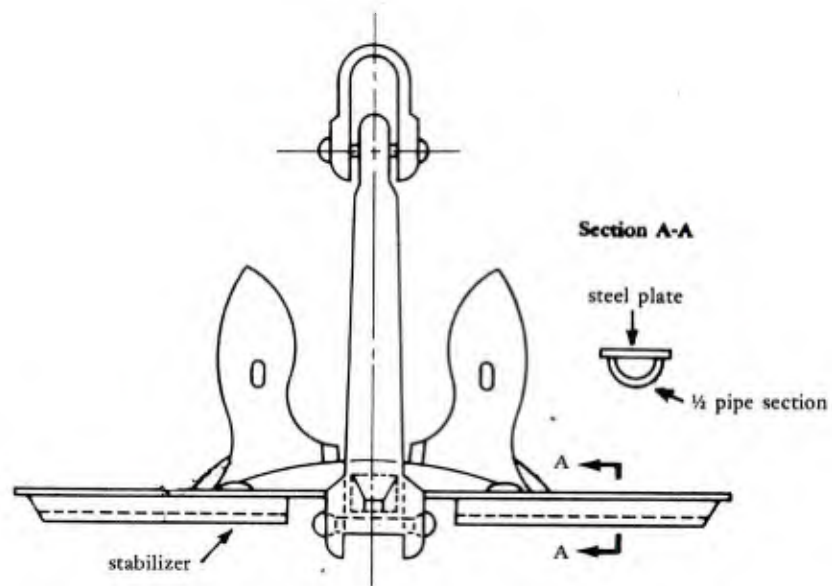



Figure 8. Barge crane with all test anchors.



a. Navy Standard Stockless Anchor



b. Navy Stockless Anchor with Stabilizers

Figure 9. Navy Stockless anchor.



Figure 10. Navy standard Stockless anchor.

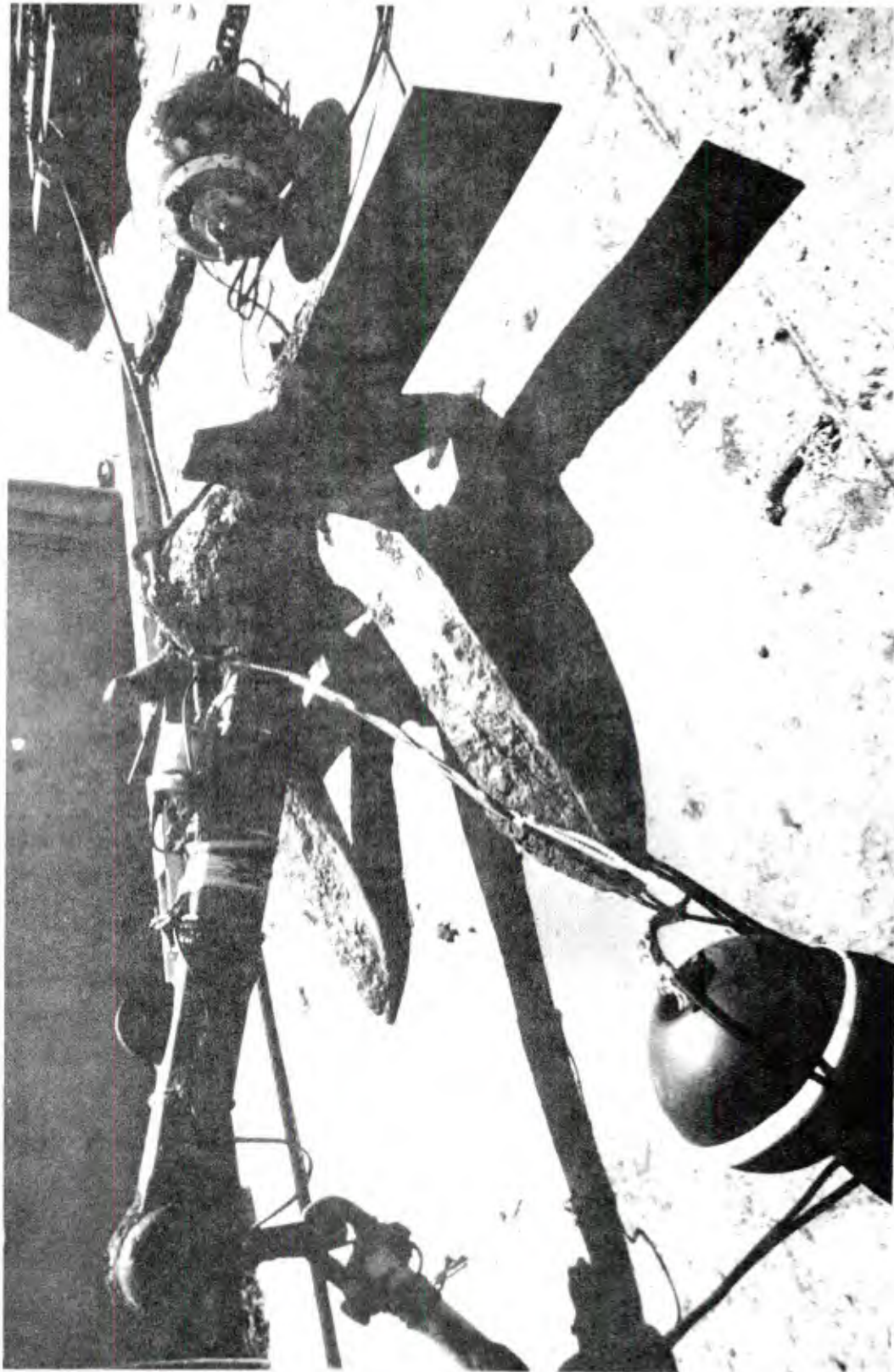

Figure 11. Navy Stockless anchor with stabilizers and welded-open flukes.

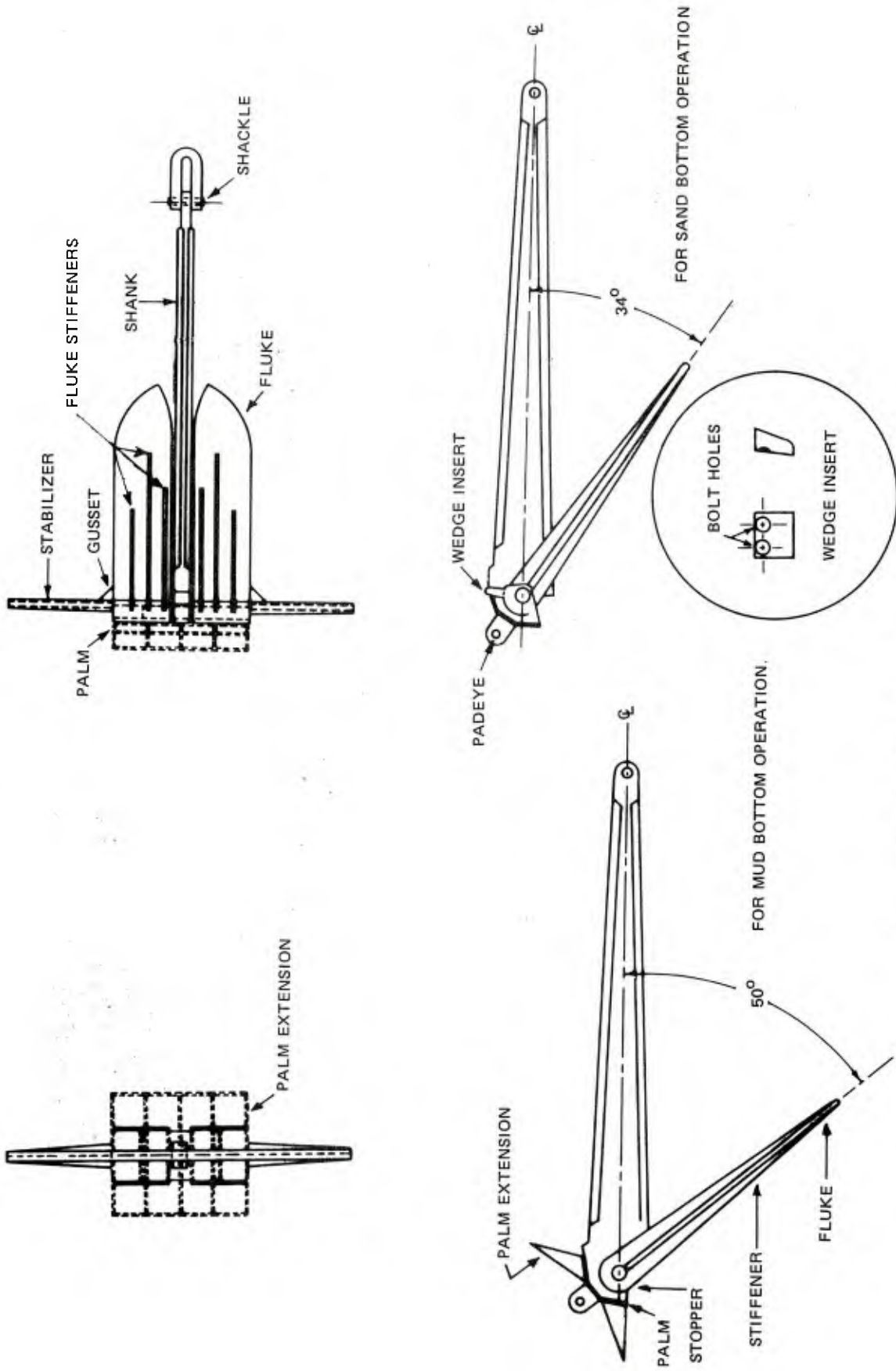

Figure 12. Navy STATO anchor.



Figure 13. Navy 6,000-pound STATO anchor.



Figure 14. Cast BRUCE anchor.

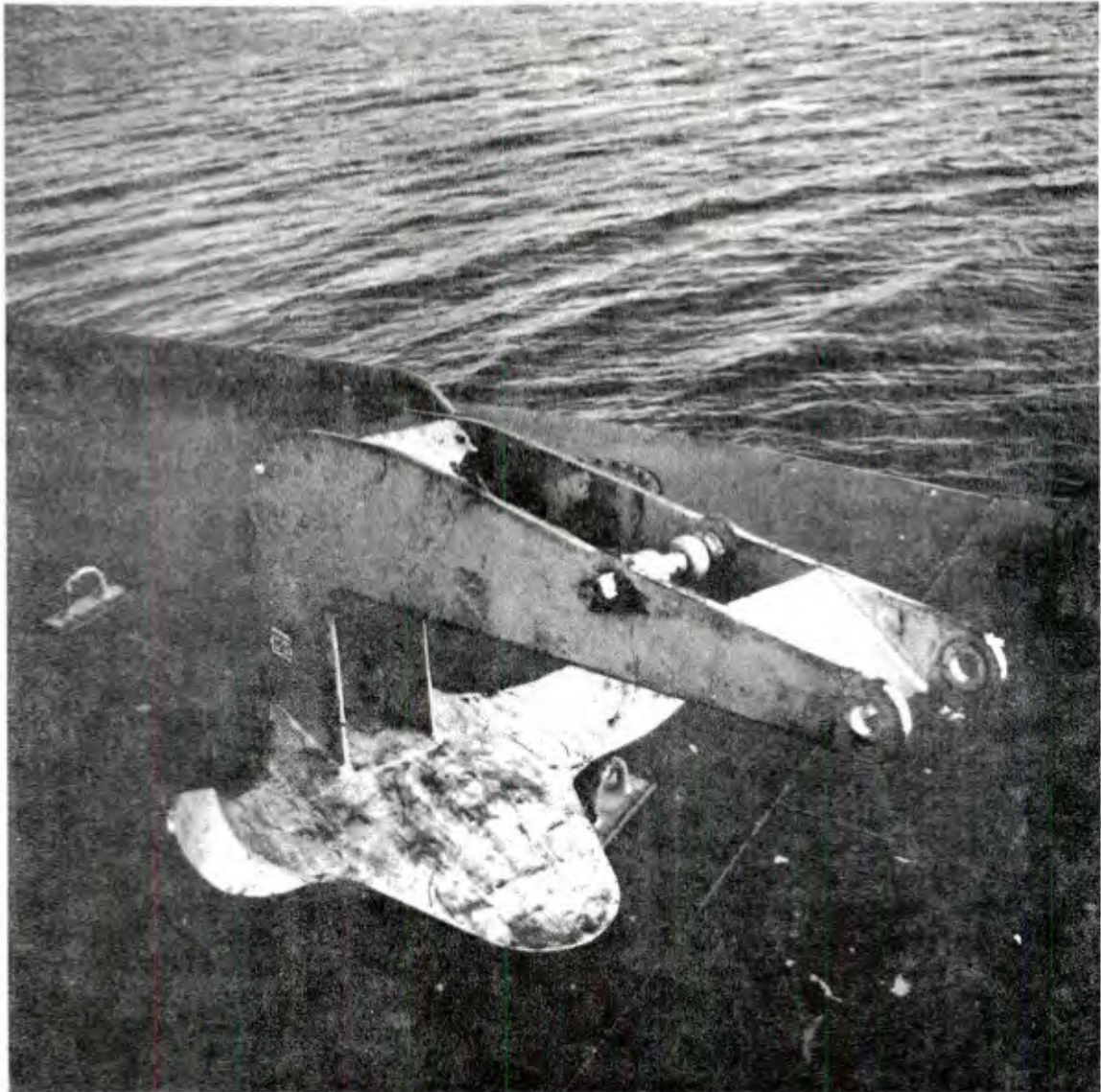

Figure 15. Welded BRUCE anchor.

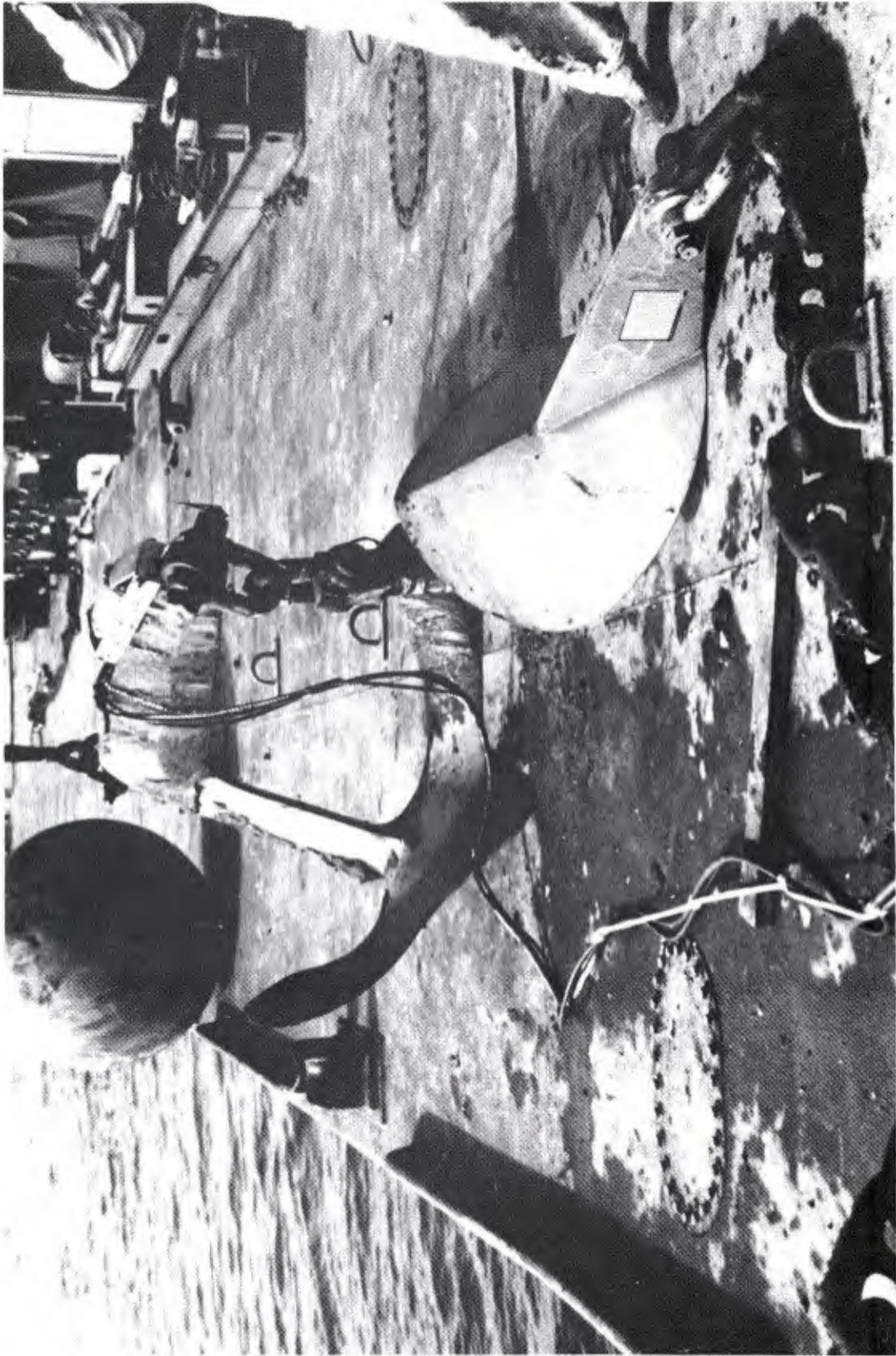

Figure 16. Cast BRUCE anchor with single cable depressor.



Figure 17. STEVDIG anchor.



Figure 18. STEVMUD anchor.



Figure 19. STEVFIX anchor without mud extensions.



Figure 20. Hook anchor.



Figure 21. Hook anchor with auxiliary flukes.

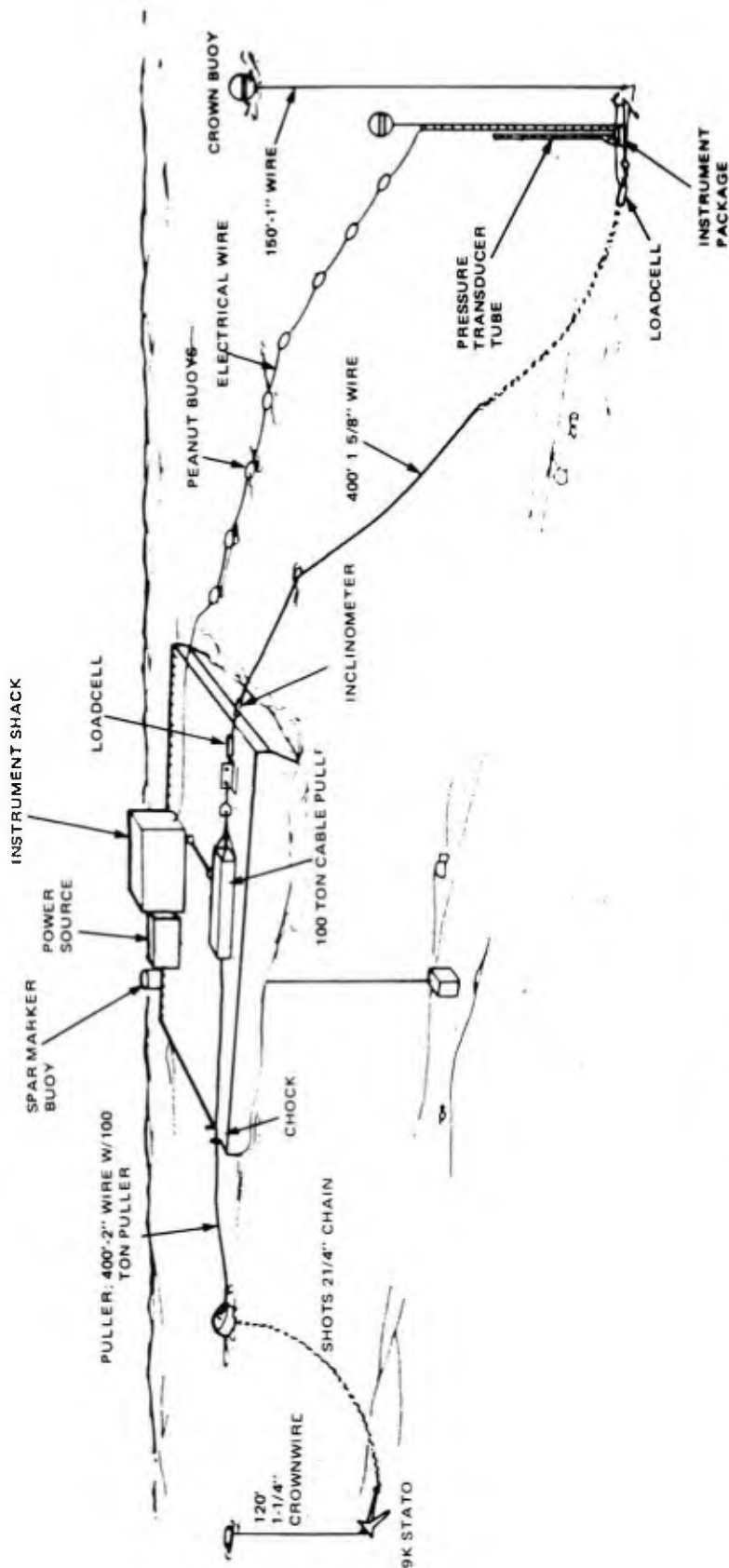

Figure 22. Anchor test setup showing major components.



Figure 23. Spar marker reference buoy.



a. San Diego System



b. Indian Island System

Figure 24. Underwater portion of test measurement system.



Figure 25. Test deck layout showing cable pulling system and prerigged test wire.

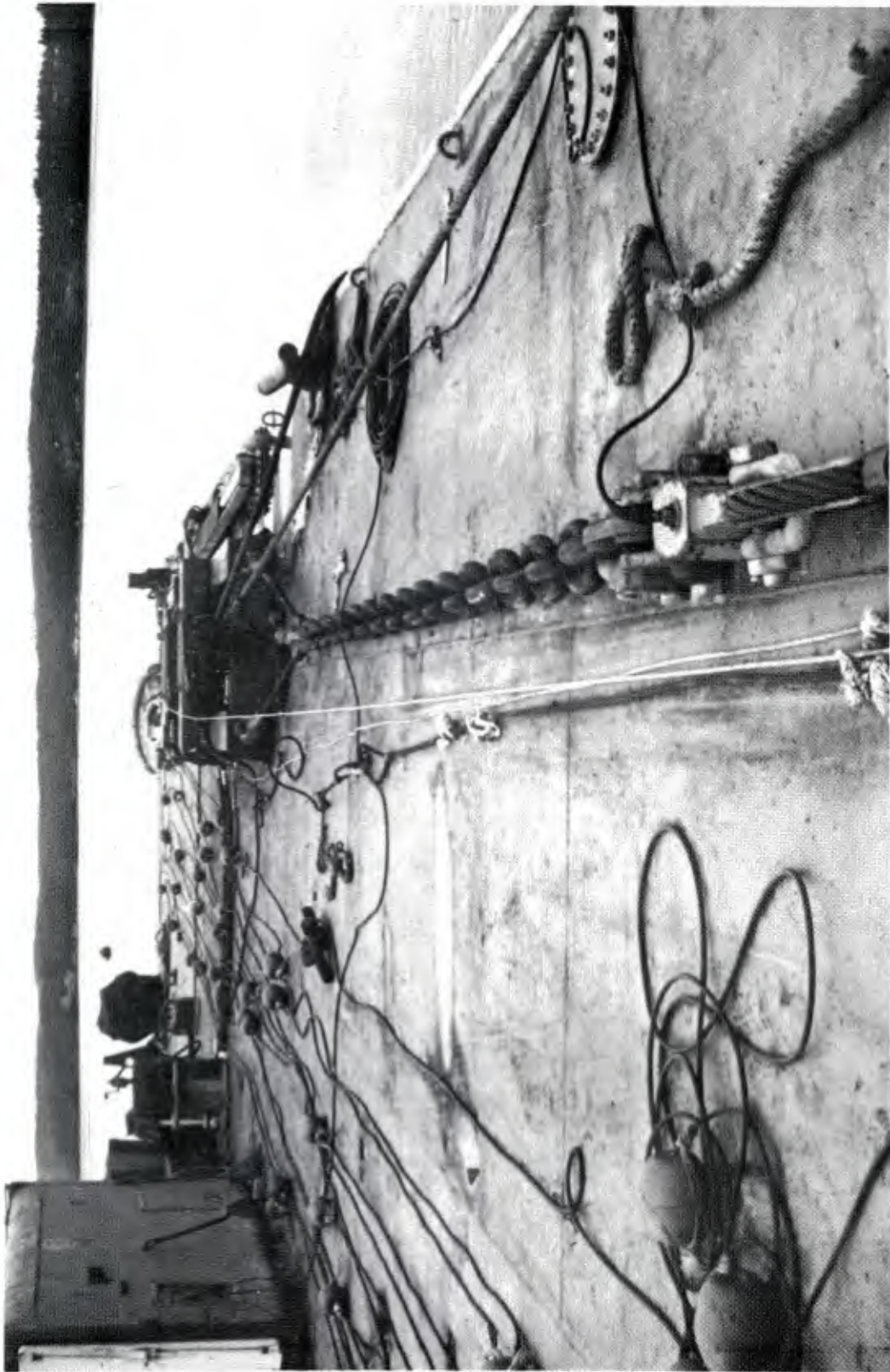

Figure 26. Test deck layout showing deck load cell, cable puller and faked electrical test wire.

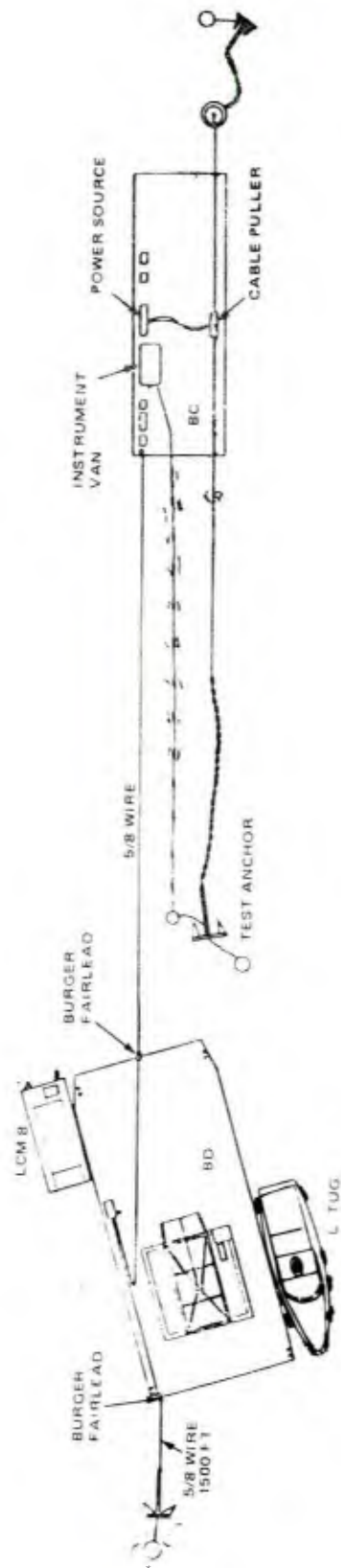

Figure 27. Overall test layout - single and tandem anchor tests.

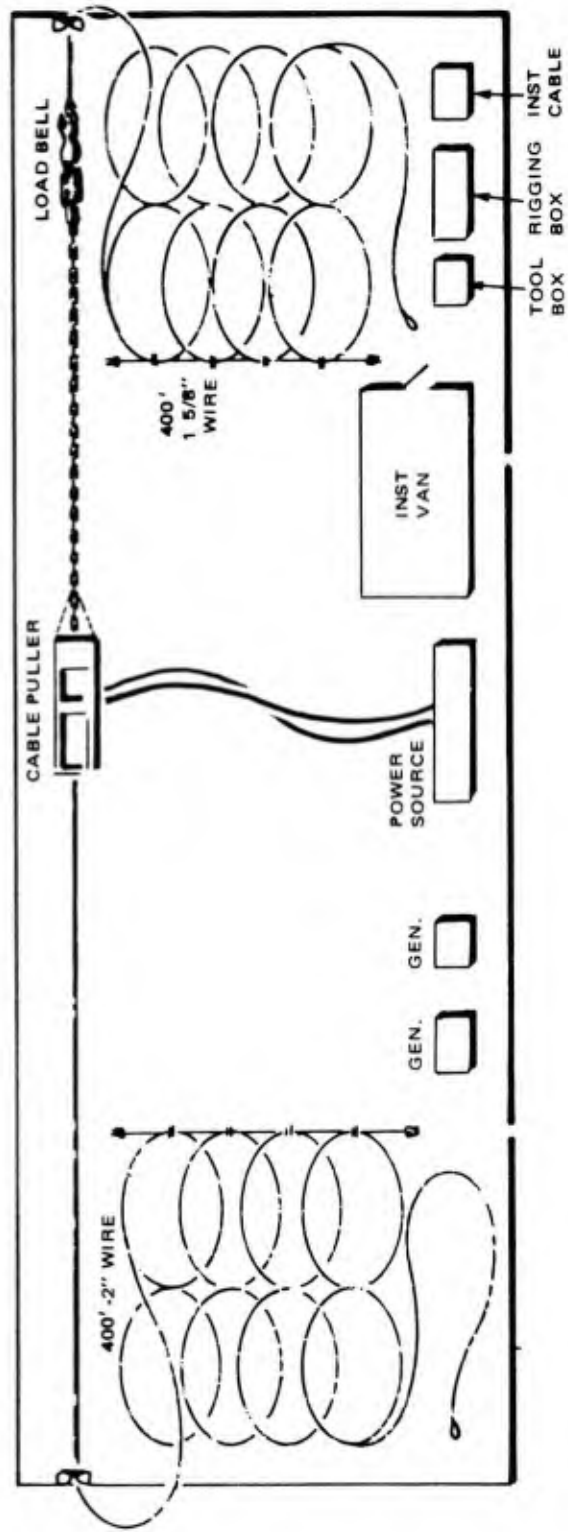

Figure 28. Barge layout for anchor test.

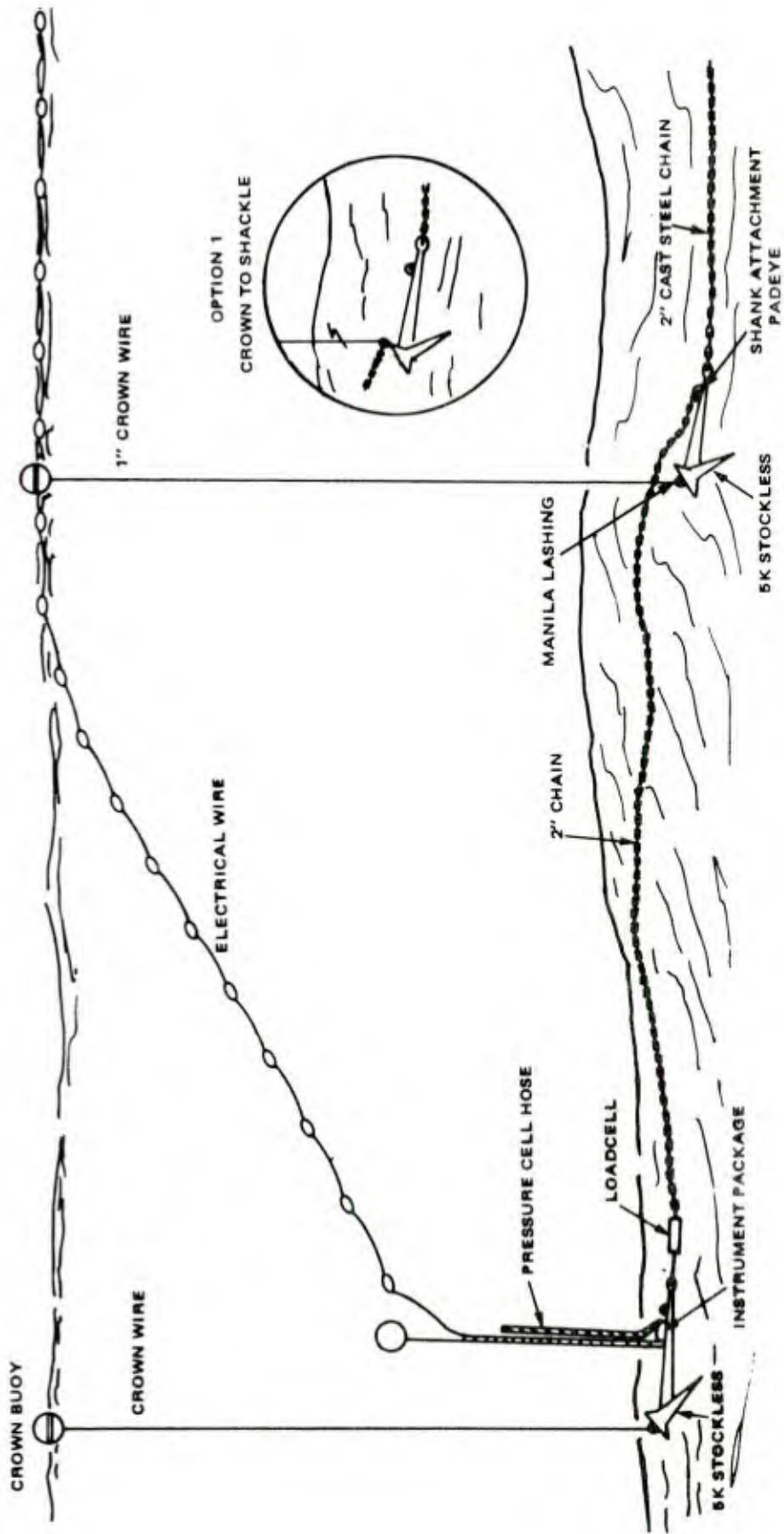

Figure 29. Tandem anchor test setup for shank-to-shackle and crown-to-shackle techniques.

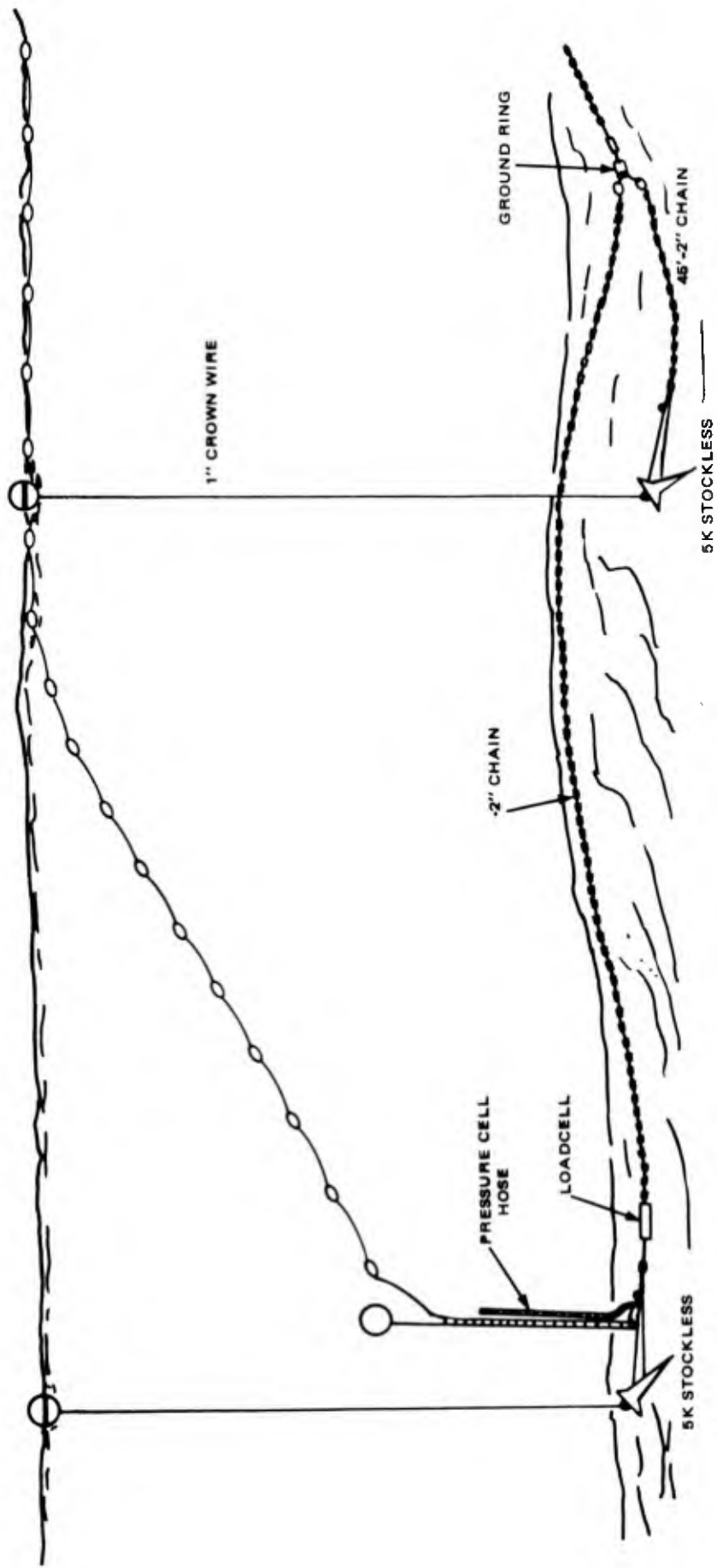
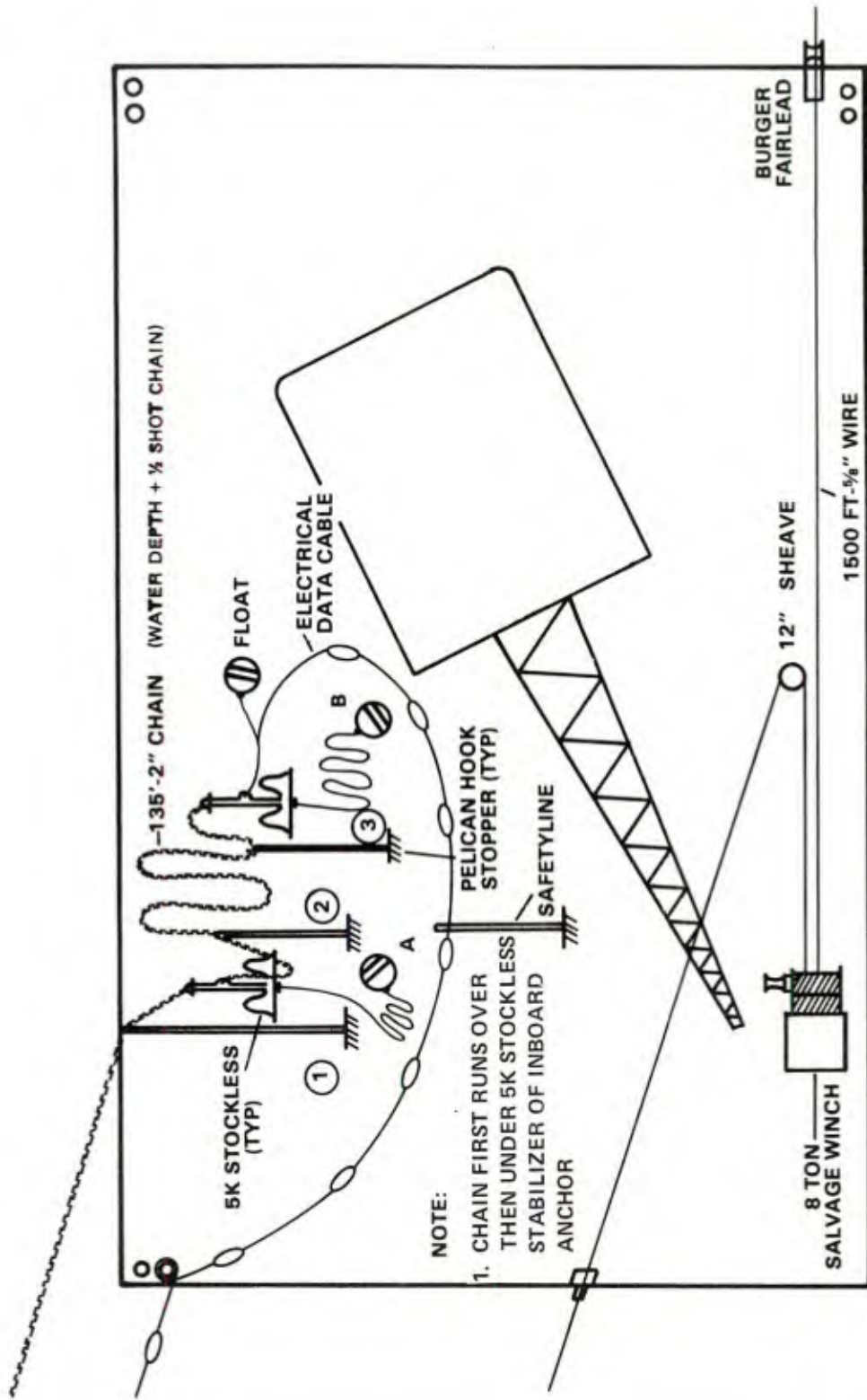

Figure 30. Tandem anchor test setup "ground ring to shackle" technique.



a. Plan view of crane barge.

Figure 31. Tandem anchor deployment method used at Indian Island at 90-foot water depth.

- 2 LIFT TANDEM CHAIN USING 2-PART SYNTHETIC THRU CHAIN AND PLACE CHAIN OVER THE SIDE STILL STRAINED BY PELICAN HOOKS 2 AND 3
- 3 PICK UP INBOARD ANCHOR USING SHEAVE OVER CROWN LINE A; ONCE STRAIN IS TAKEN, TRIP PELICAN HOOK 1 THEN 2

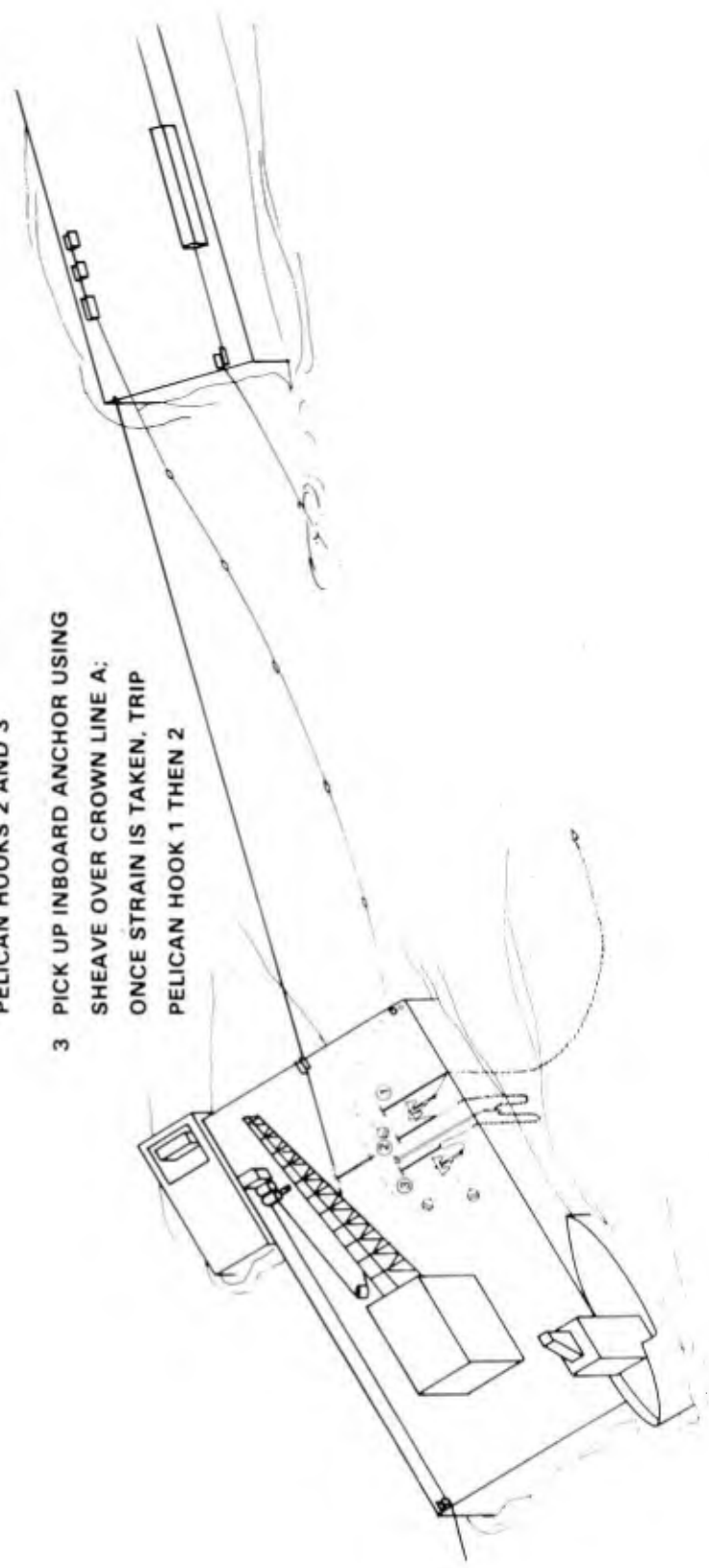

b. Beginning anchor deployment.

Figure 31. Continued.

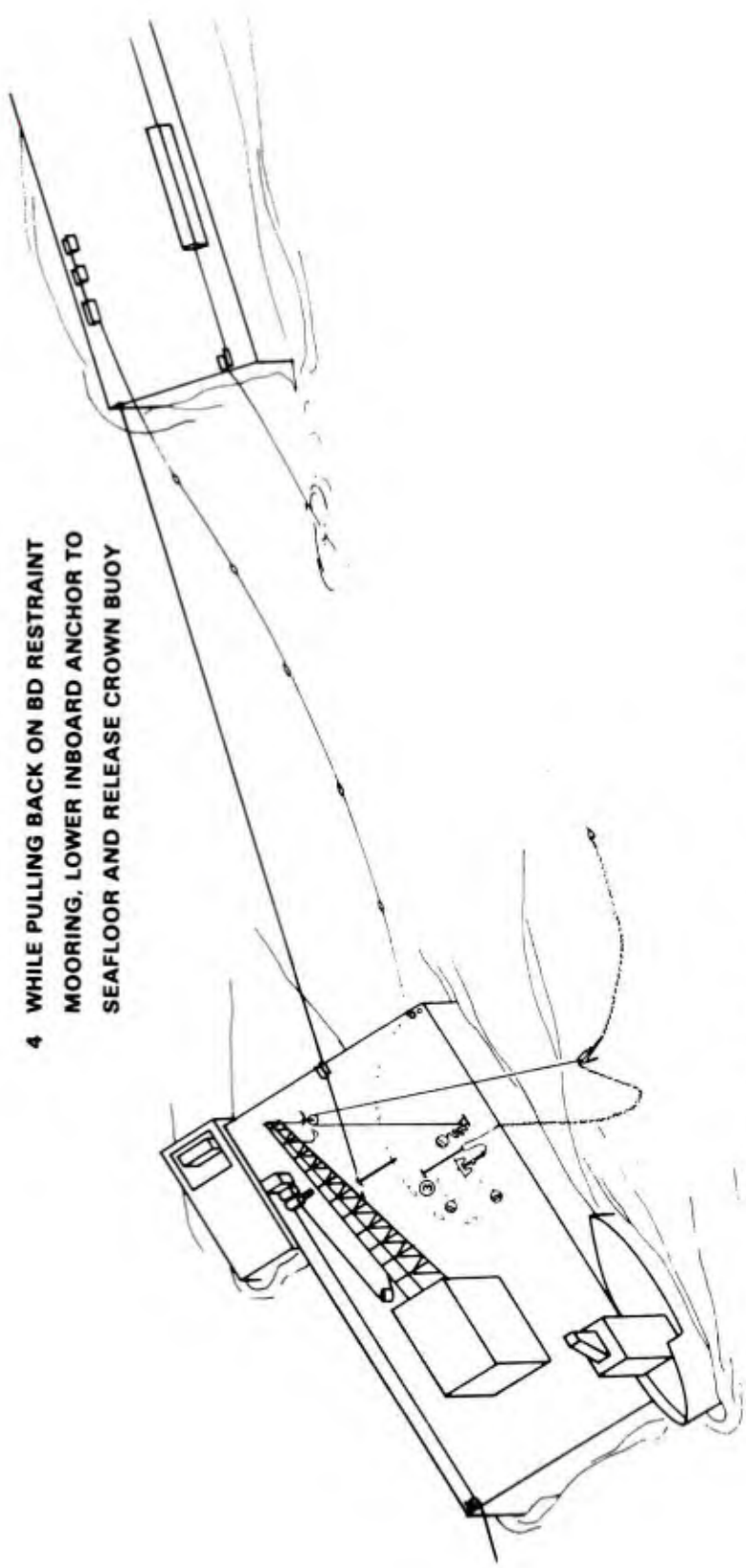

**4 WHILE PULLING BACK ON BD RESTRAINT
MOORING, LOWER INBOARD ANCHOR TO
SEAFLOOR AND RELEASE CROWN BUOY**

c. Lowering inboard anchor to seafloor and releasing crown buoy.

Figure 31. Continued.

5 PICK UP ON OTHER ANCHOR USING SHEAVE OVER CROWN WIRE THEN RELEASE PELICAN HOOK 3

6 BC PULL IN ON DATA CABLE THEN BD RELEASE DATA CABLE FROM CORNER RESTRAINT

7 LOWER ANCHOR TO SEABED WHILE PULLING BACK ON BD RESTRAINT MOORING; THEN RELEASE CROWN BUOY

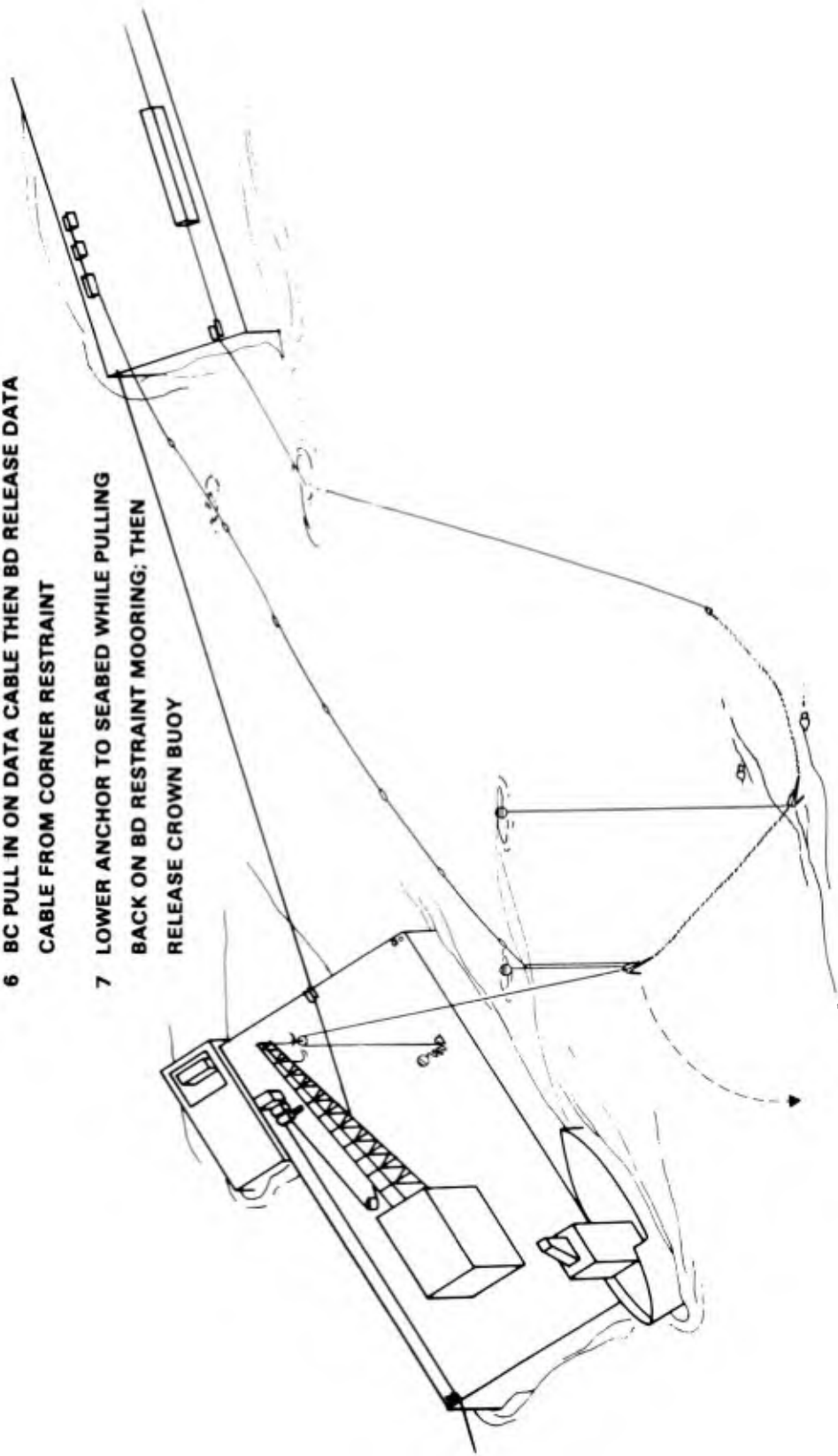

d. Completing anchor deployment.

Figure 31. Continued.

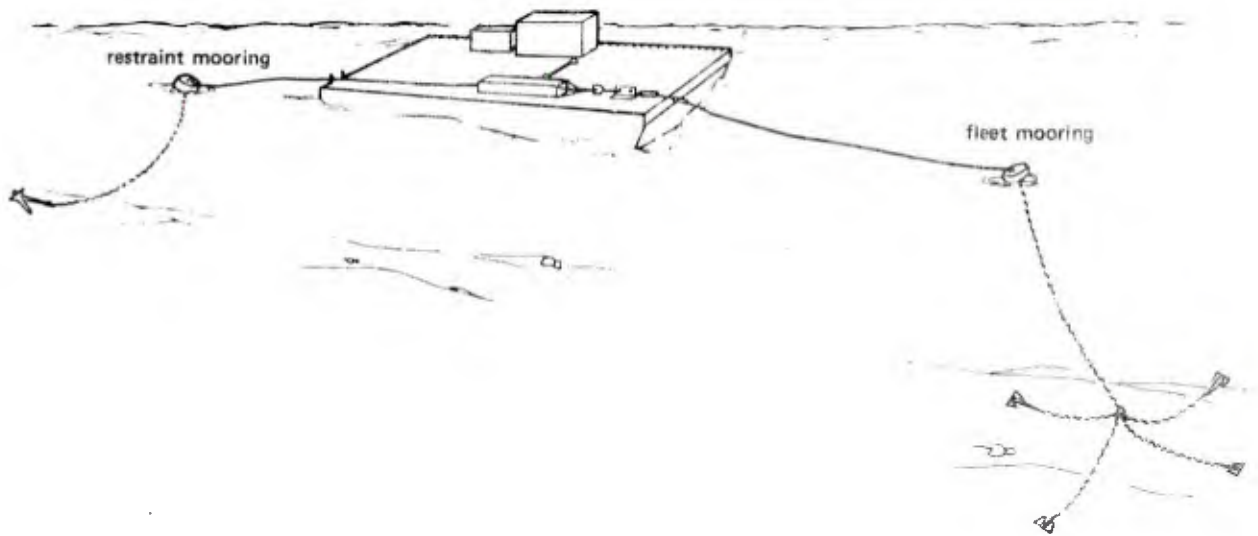

a. Single mooring test pull.

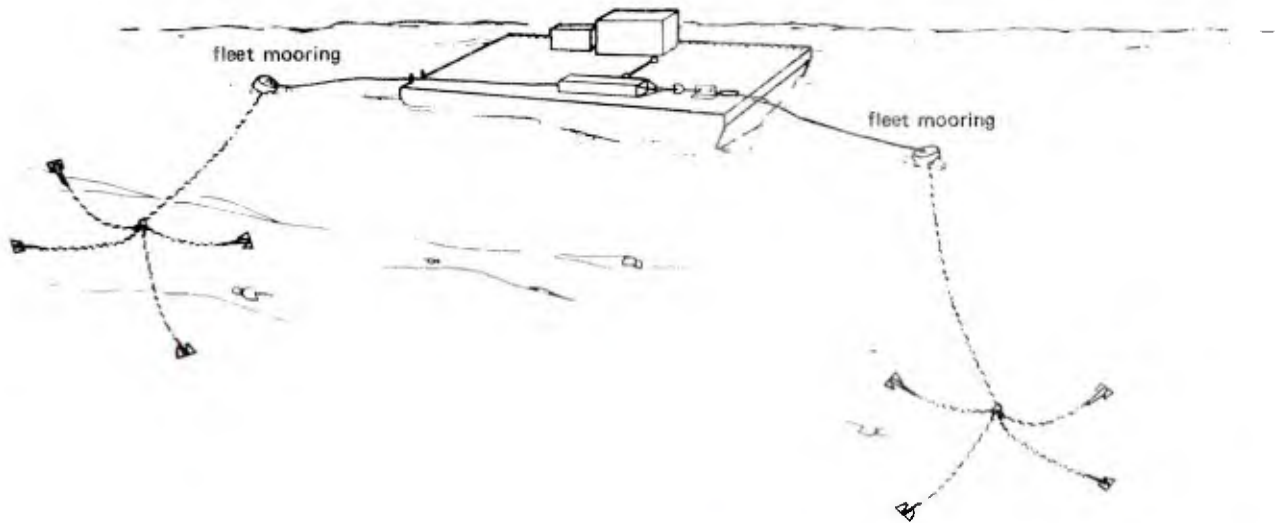

b. Dual mooring test pull.

Figure 32. Mooring test arrangements.

Day # - 176

Test No. - 23

Test Series No. - 0

INDIAN ISLAND WASHINGTON

state silt, 3000lbs. with 18 inch stabilizer extensions

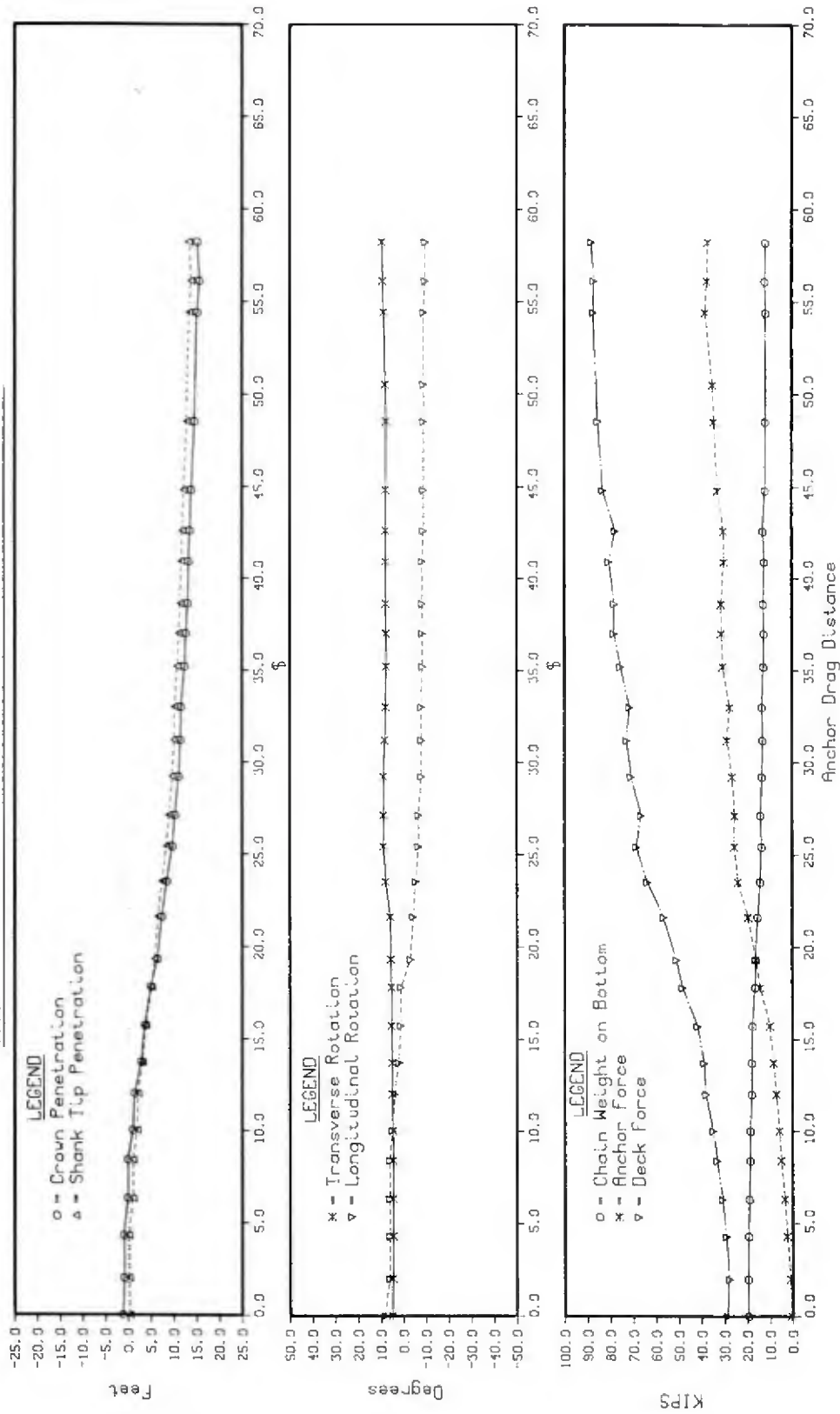

Figure 33. Typical data plot for anchor test pull.



Figure 34. STATO anchor with extended stabilizers attached (standard stabilizer on deck).



Figure 35. STATO anchor with plate addition between shank and wedge insert to reduce fluke angle to about 32 degrees.

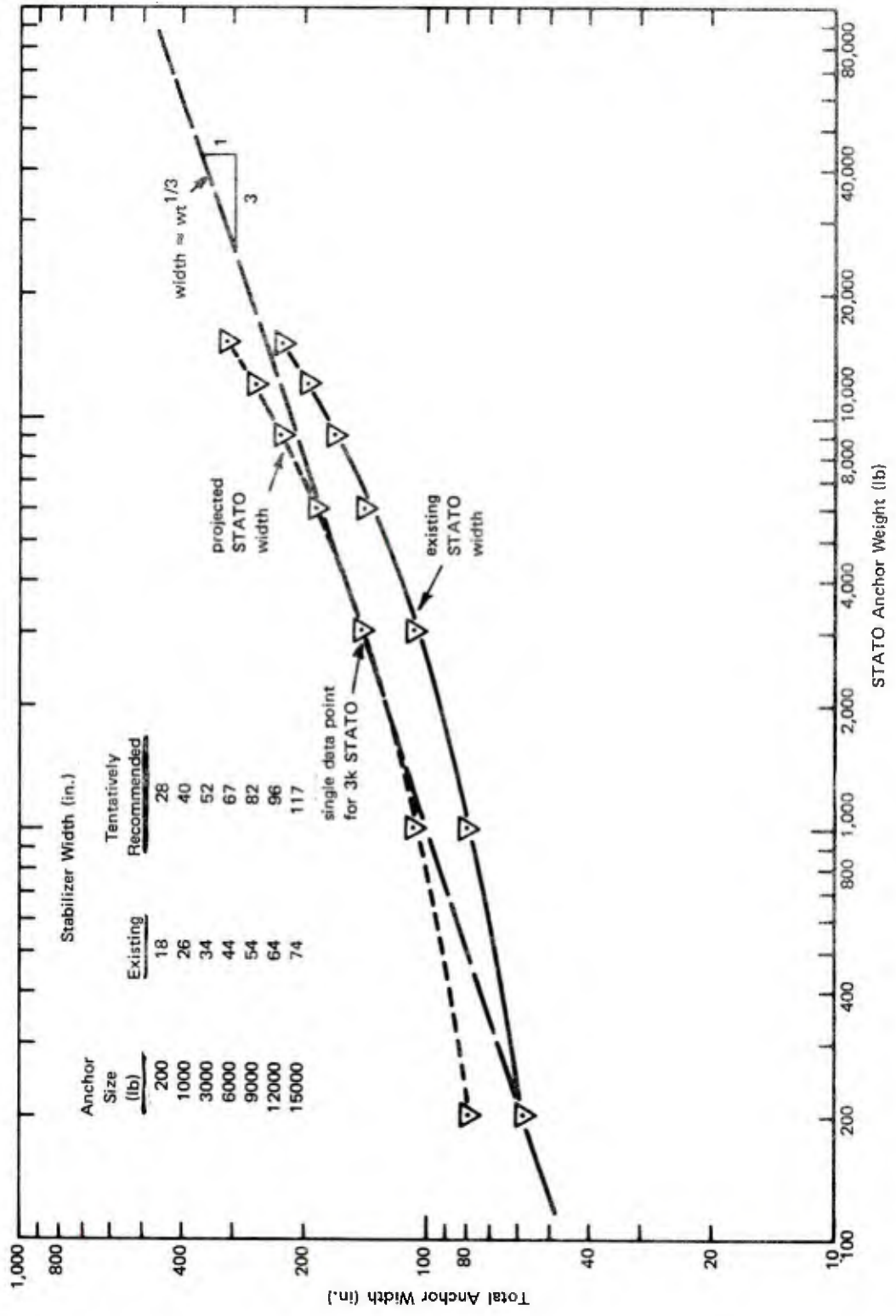

Figure 36. Recommendations for STATO anchor stabilizer lengths.

Appendix A

ADDITIONAL SAN DIEGO HARBOR SEAFLOOR PROPERTIES

Twelve vibracores were taken at San Diego. Of these, only eight cores were analyzed. Principally, San Diego Harbor consists of medium to fine sand with up to 2 to 3 feet of overlying mud in the dredged areas near the moorings (refer to Figures 1 and 2). The shallow area located primarily south of the dredge channel shown in Figure 2 is a uniform fine sand with no detectable surface mud layer. Grain size curves for cores SDV5 and SDV6 (Figures 6 and 7 in the main text) show the extremely uniform nature of the area.

Grain size curves for the remaining six cores are presented as Figures A-1 through A-6. Cores 1, 2, 3, 8, and 9 were taken near prospective moorings and typically show medium to fine sand at expected anchor fluke embedment depths. Cores 10, 11, and 12 were taken to locate an expected soft mud site; however, one was not located. Core 12 was a very uniform, fine-grained sand to 20 feet; it was not analyzed in detail. Cores 10 and 11 showed a very competent strata at 3 to 4 feet below the mud surface. This layer is practically impenetrable to standard ship anchors, yet it is classified as the anchorage area for commercial vessels. The 45- to 47-inch increment of core 10 (Figure A-6) represents the dense clayey sand.

Also provided in this section are plots of accumulative time versus vibracorer penetration depth for several apparently distinct areas (Figures A-7 through A-10). These curves are probably meaningless much below 5 to 7 feet, but they do offer insight into the variability, relative stiffnesses, and sensitivities of certain areas. In particular, Figure A-8 should be noted for cores 5, 6, and 7 at the fine sand test site. The curves are practically superimposed, lending further credence to the uniformity of the fine sand test site.

Figure A-11 provides recent vane shear data for Indian Island mud gathered with a bottom-sitting platform. Shear strength increases almost linearly from zero at the surface to 1-1/2 psi at 21 feet. Remolded shear strength readings were taken at only two depths. These data show a relatively insensitive soil where the ratio of undisturbed to disturbed strength was 1.6 at 7 feet and 2.1 at 10 feet.

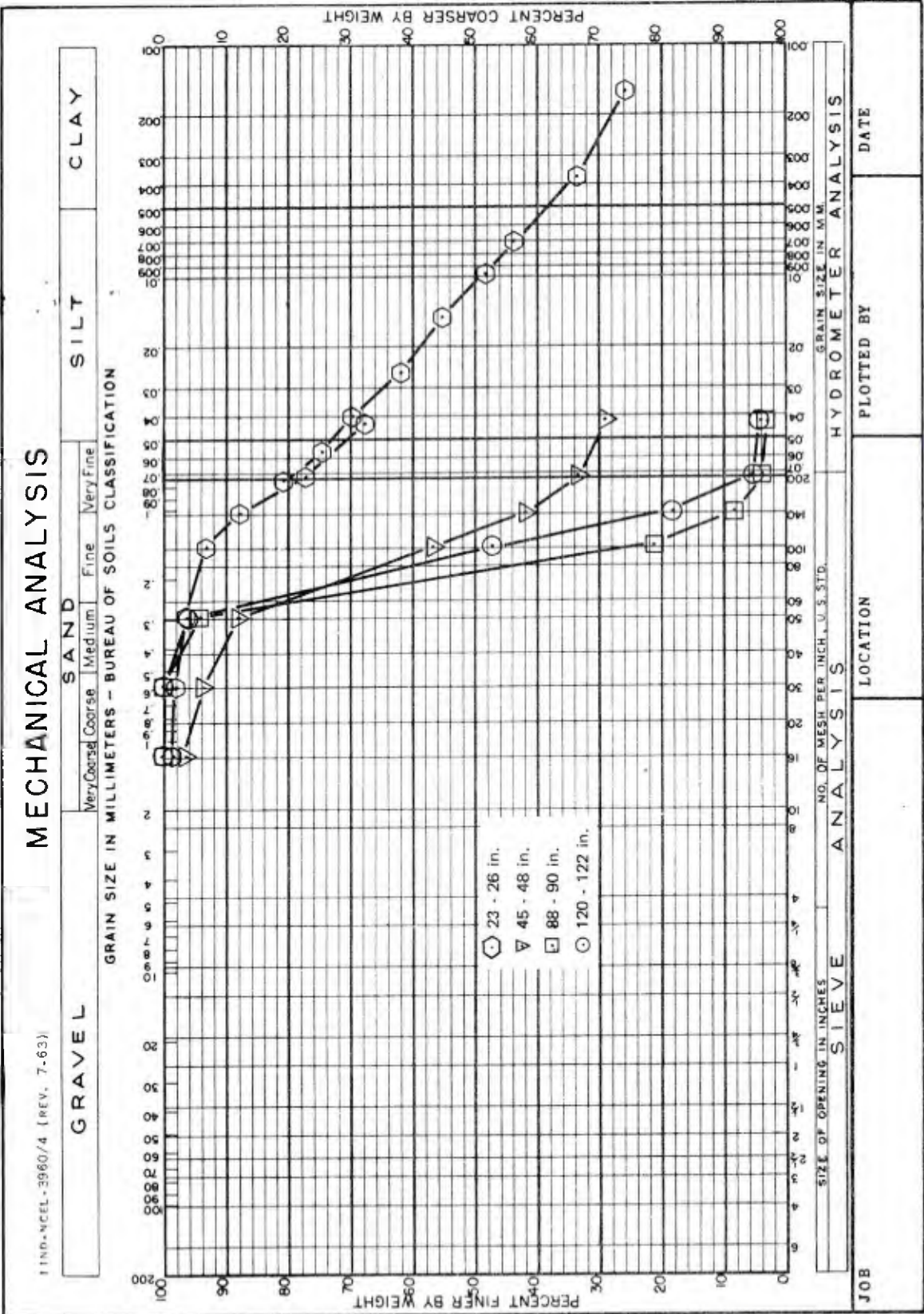

Figure A-1. Grain size distribution curves for Vibracore 1 - San Diego Harbor.

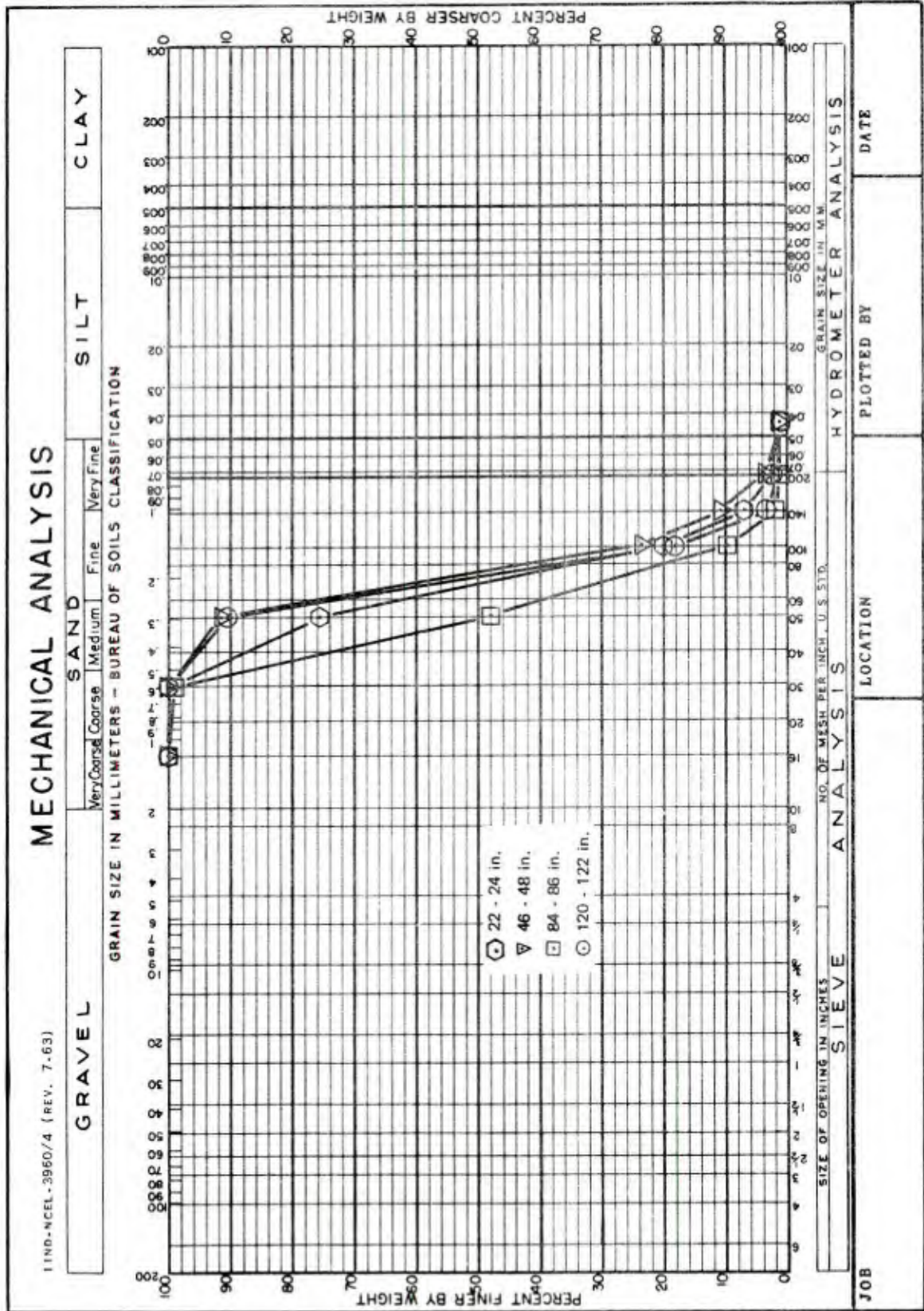

Figure A-2. Grain size distribution curves for Vibracore 2 - San Diego Harbor.

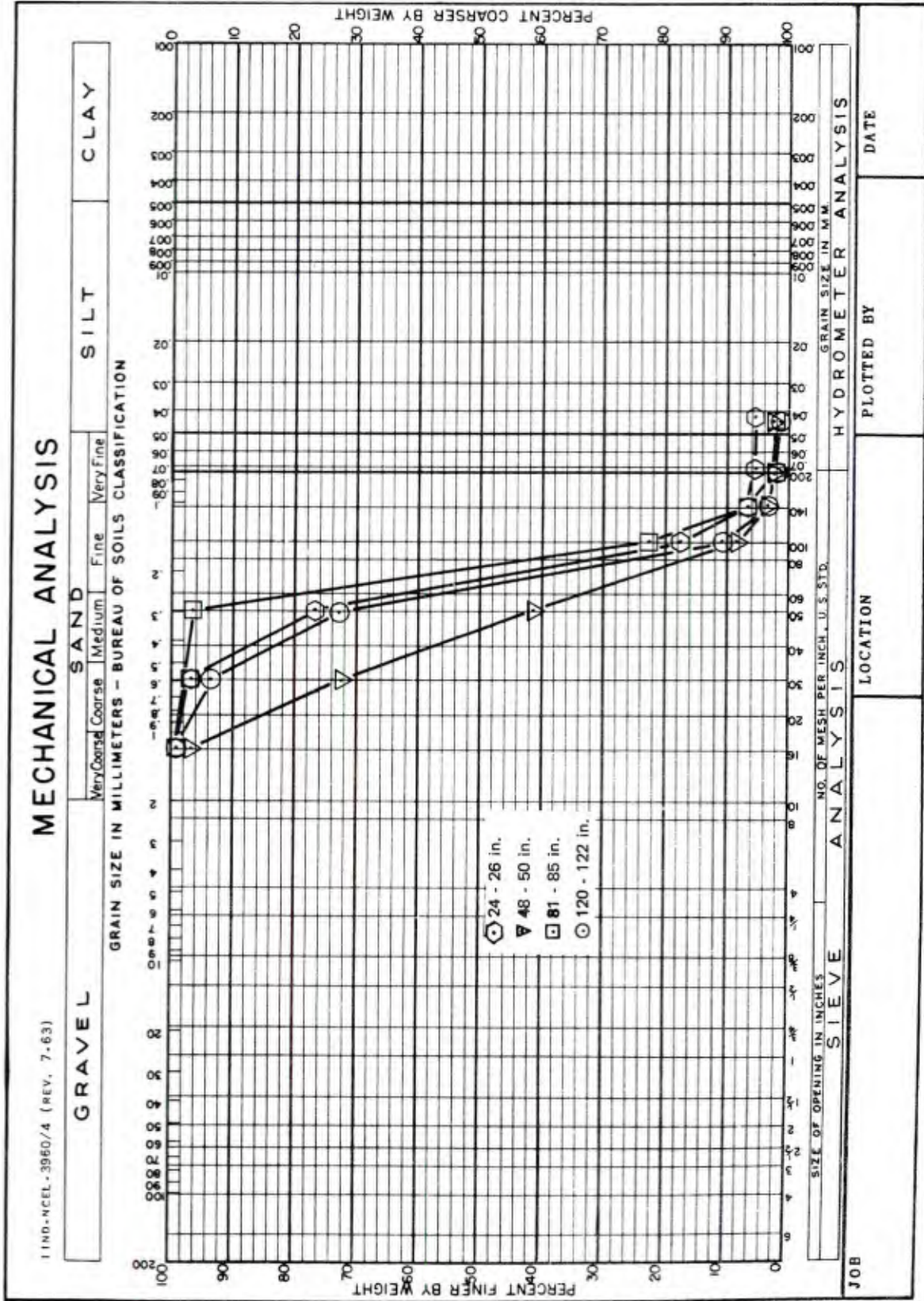

Figure A-4. Grain size distribution curves for Vibracore 8 - San Diego Harbor.

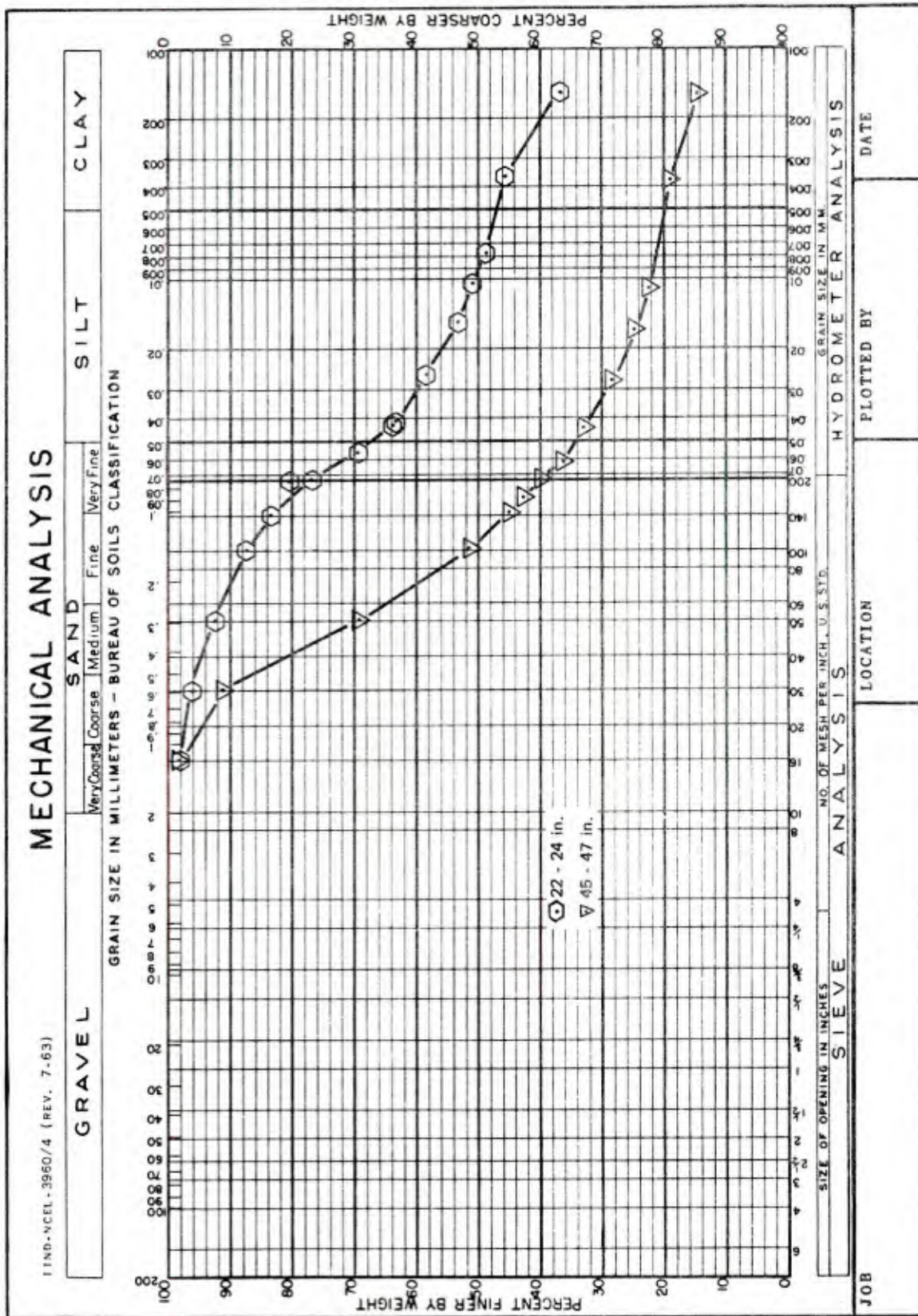

Figure A-6. Grain size distribution curves for Vibracore 10 - San Diego Harbor.

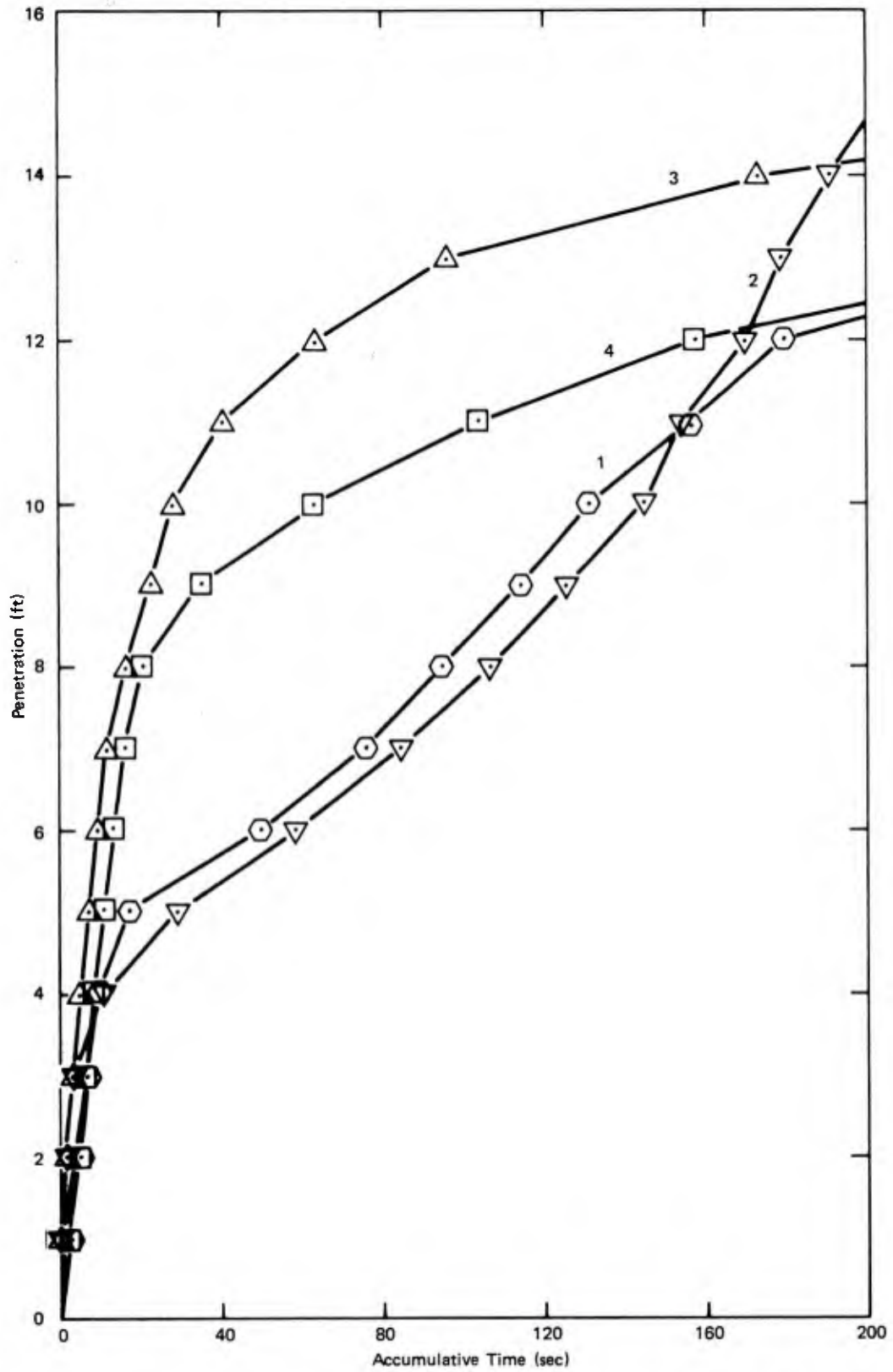

Figure A-7. Vibracorer penetration depth versus time for cores 1-4 - San Diego Harbor.

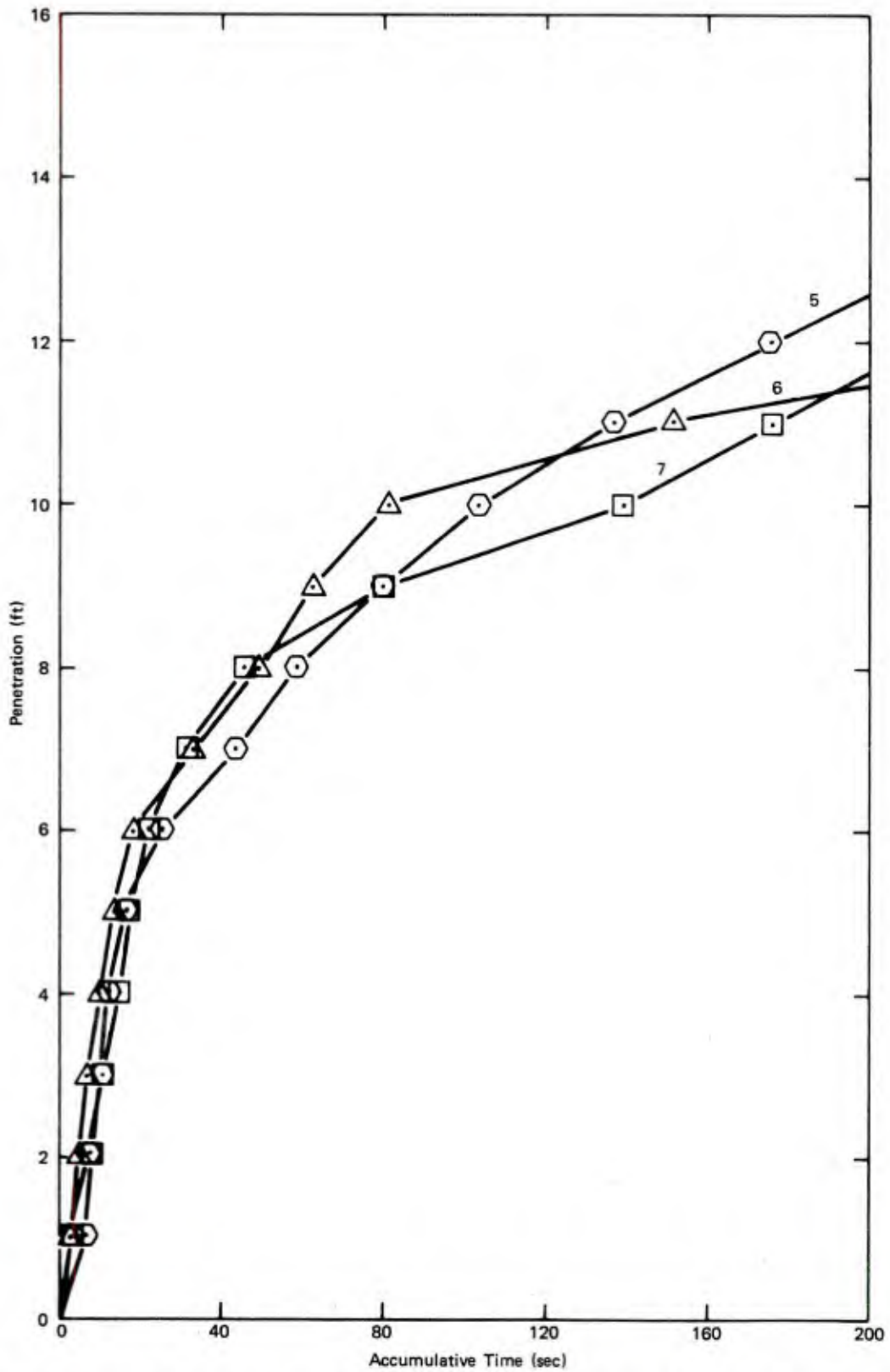

Figure A-8. Vibracorer penetration depth versus time for cores 5-7 - San Diego Harbor.

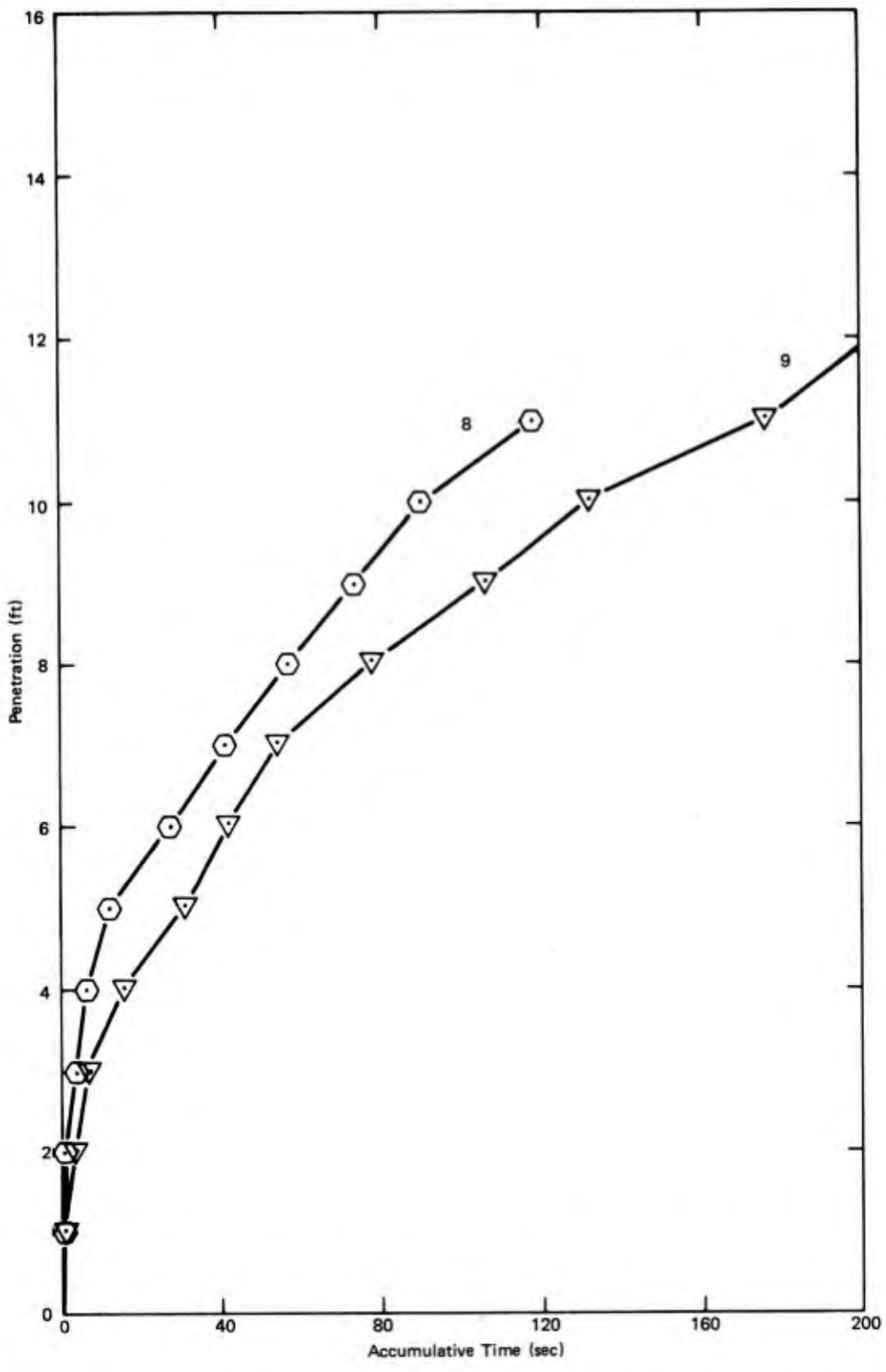

Figure A-9. Vibracorer penetration depth versus time for cores 8-9 - San Diego Harbor.

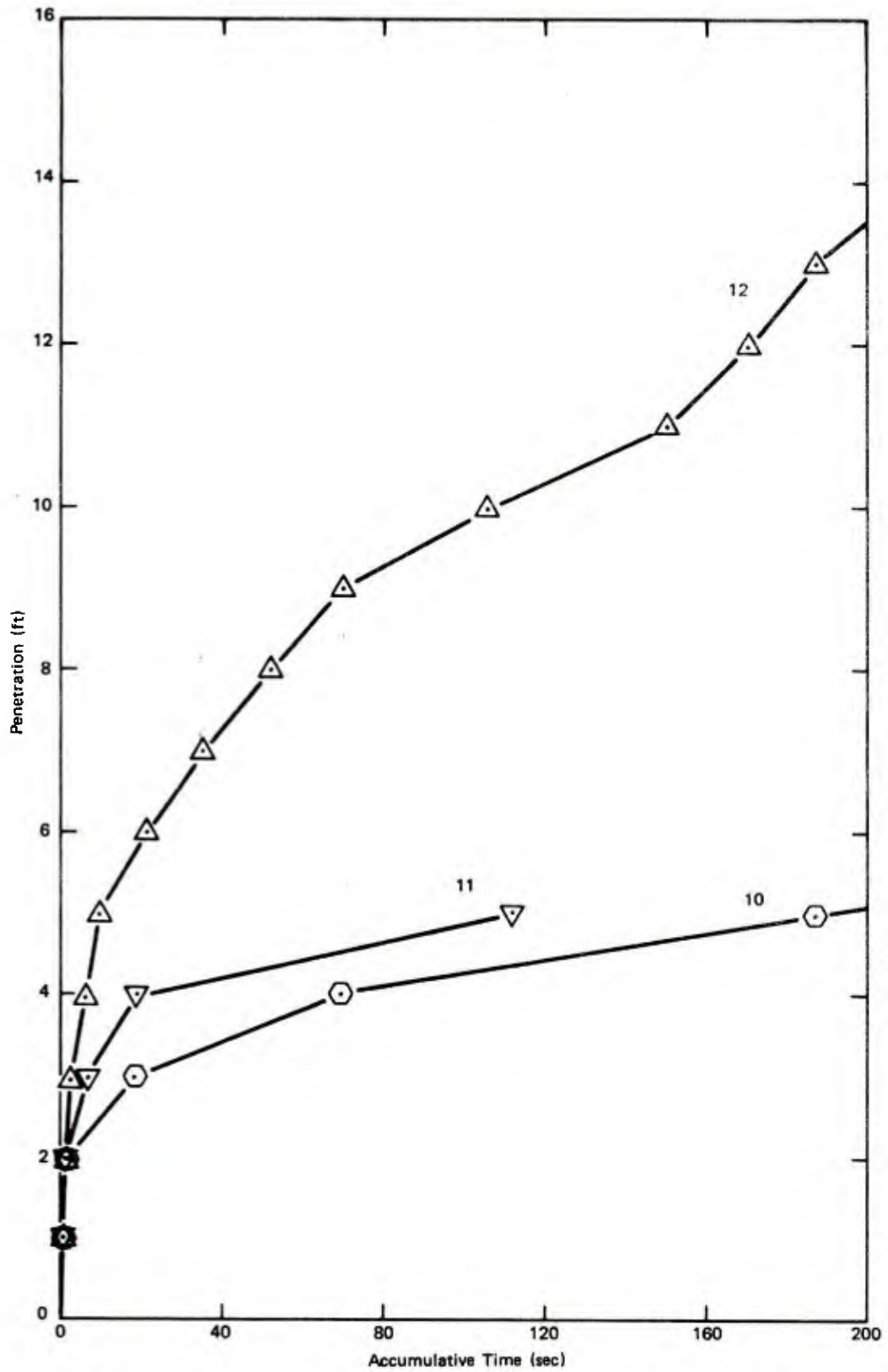

Figure A-10. Vibracorer penetration depth versus time for cores 10-12 - San Diego Harbor.

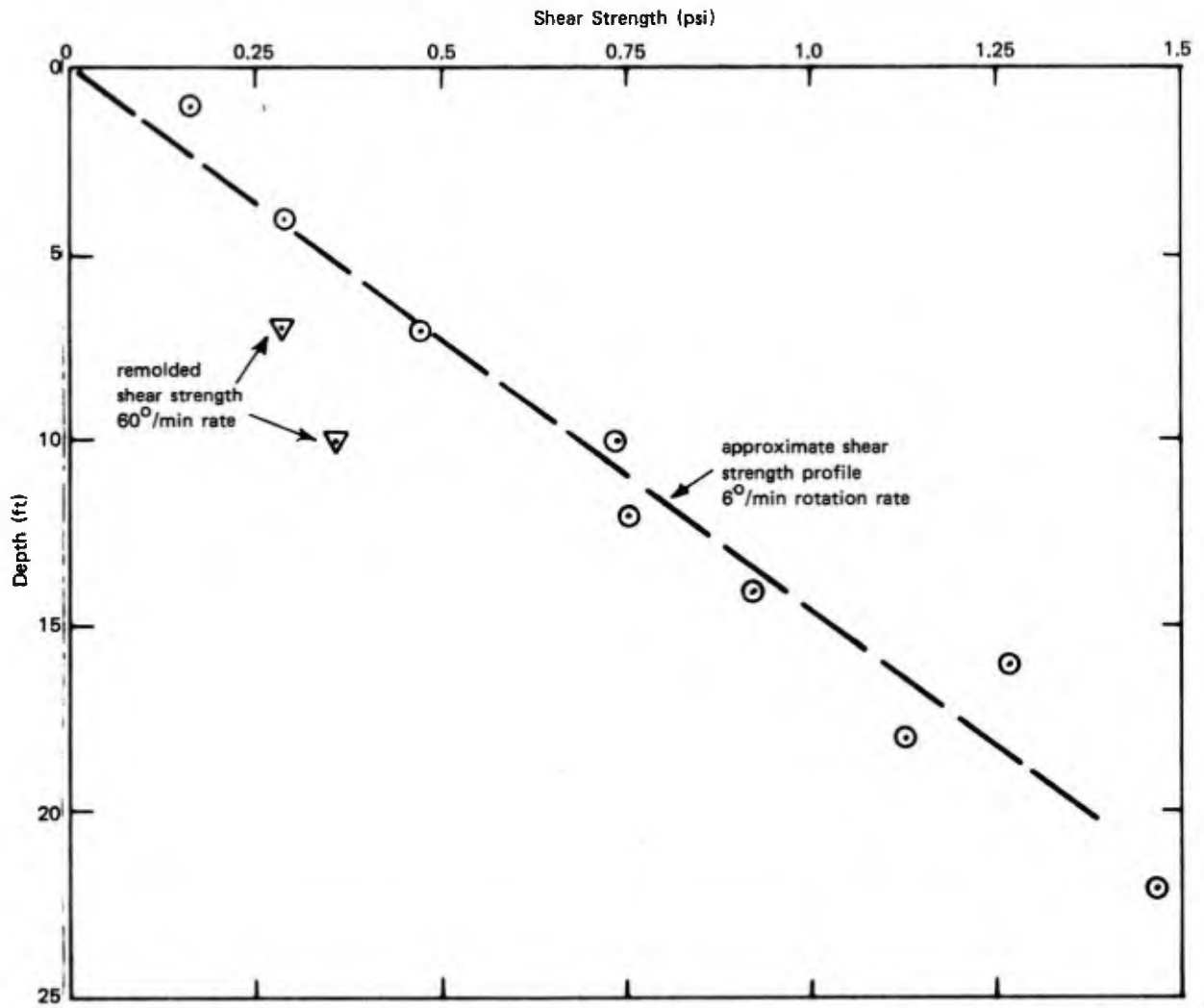

Figure A-11. Vane shear strength profile for Indian Island mud.

Appendix B

DIMENSIONS OF ALL TESTED ANCHORS

General dimensions of all the anchors tested are provided. Also included is a tabularized listing of the location of the instrument package on the shank relative to the shackle end of the shank.

Table B-1. Location of Instrument Package on Anchor Shank

Anchor		Centerline of Package to Shank Tip, in.	
Name	Nominal Size	San Diego	Indian Island
STATO	1,000 lb	18	19-1/4
	3,000 lb	44	34
	6,000 lb	50	34
Stockless	5,000 lb	45	42-1/2
	9,000 lb	29	32
STEVFIX	640 kg	16	58
	940 kg	-	58
STEV MUD	500 kg	-	-
	1,000 kg	-	-
STEV DIG	1,000 kg	21	-
BRUCE	340 kg	-	38
	600 kg	38	33
	1,000 kg	30	18
Hook	560 kg	29	43

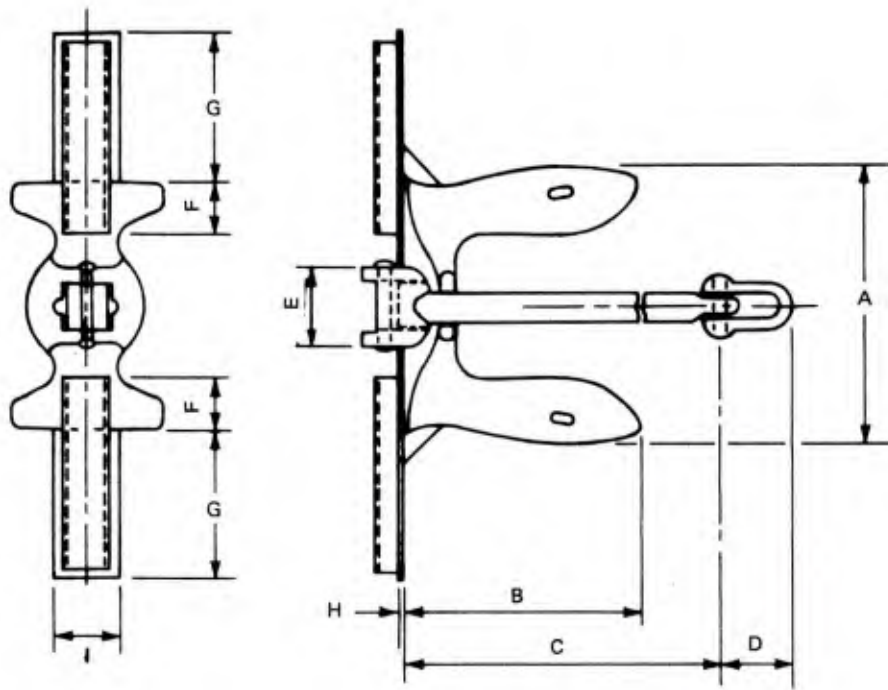

Nominal Weight (lb)	Anchor Dimensions (in.)								
	A	B	C	D	E	F	G	H	I
500	29-3/4	26-7/8	37-1/4	7-5/8	8-1/2	—	—	—	—
1,500	43	38-3/4	53-5/8	11	12-1/8	—	—	—	—
3,000	54-1/8	48-3/4	67-1/2	13-7/8	15-3/8	11	30	1/2	13
5,000	64-1/8	57-3/4	80-1/8	16-1/2	18-1/4	13	36	1/2	16
6,000	67-7/8	62-9/16	85-1/16	17-3/8	19-1/8	14	36	1/2	16
7,000	71-7/16	65-7/8	89-9/16	18-5/16	20-1/8	15	36	1/2	16
9,000	78-1/16	70-3/8	97-1/2	20	22-1/8	16	36	3/4	16
10,000	80-1/2	74-3/16	100-7/8	20-5/8	22-11/16	17	36	3/4	19
13,000	87-7/8	79-1/8	109-3/4	22-1/2	24-7/8	18	40	3/4	19
14,500	90-7/8	83-3/4	114	23-1/4	25-5/8	19	40	3/4	21
18,000	98-3/8	90-3/8	122-3/4	25-1/4	27-3/4	20	45	1	21
20,000	101-7/8	91-3/4	127-1/4	26-1/8	28-7/8	21	45	1	21
25,000	109-3/4	98-7/8	137-1/16	28-1/8	31-1/8	22	48	1	22
30,000	116-5/8	107-1/4	145-5/8	29-13/16	33-3/16	24	50	1	23
40,000	127-3/4	117-13/16	160-1/16	32-11/16	36	27	36	1-1/4	26

Figure B-1. Dimensions of standard Stockless anchor.

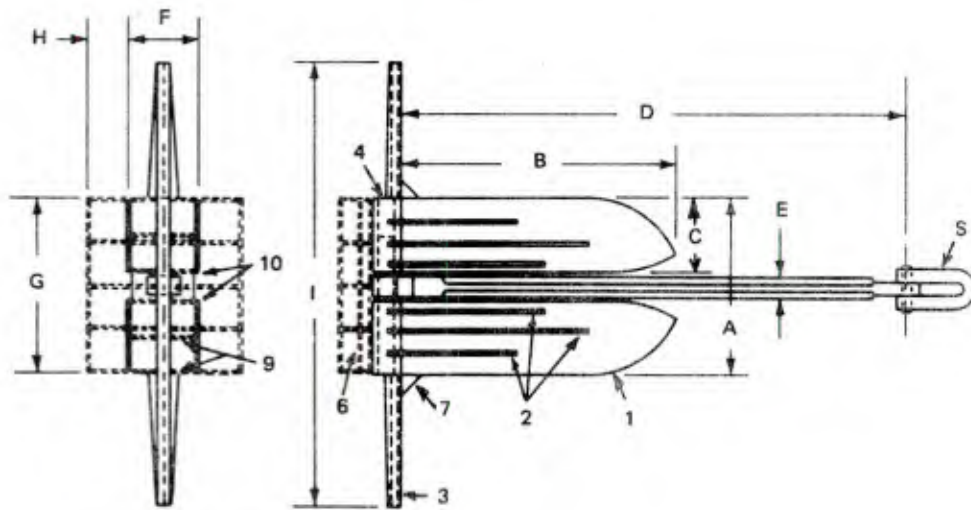

Nominal Weight (lb)	Dimensions of Anchors (in.)								
	A	B	C	D	E	F	G	H	I
200	23	25	10	42	2	9-1/2	23	6	59
1,000	28	43	75	80	—	—	28	—	80
3,000	41-1/2	69	18	129	4	19	41-1/2	13	109-1/2
6,000	55	82	24	144	5	21	55	15	143
9,000	62	96	27	160	6	27	62	16	170
12,000	69	108	30	186	7	30	69	18	197
15,000	76	121	33	205	8	32-3/8	76	20	224

Nominal Weight (lb)	Thickness of Plates (in.)									
	1	2	3	4	5	6	7	8	9	10
200	1/4	1/2	1/4	1/4	1/4	1/4	1/4	1/4 x 4	1/4	1/2
3,000	1-1/4	1	1/2	5/8	5/8	5/8	5/8	1/2 x 6	5/8	5/8
6,000	1-1/2	1	1/2	3/4	3/4	3/4	3/4	5/8 x 7	3/4	3/4
9,000	1-3/4	1-1/8	5/8	7/8	7/8	7/8	7/8	3/4 x 7	7/8	7/8
12,000	2	1-1/4	5/8	1	1	1	1	3/4 x 7	1	1
15,000	2-1/4	1-1/2	5/8	1-1/8	1-1/8	1-1/8	1-1/8	3/4 x 7-1/2	1-1/8	1-1/8

Figure B-2. Dimensions of Navy STATO anchor.

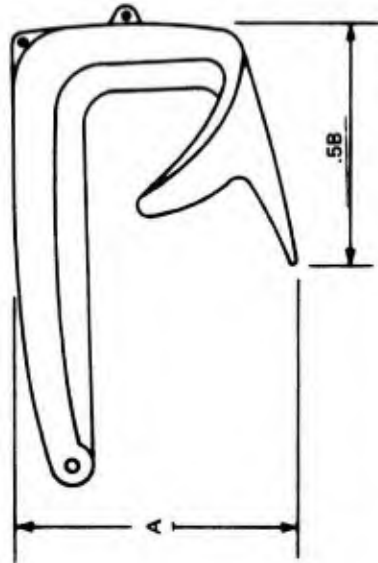
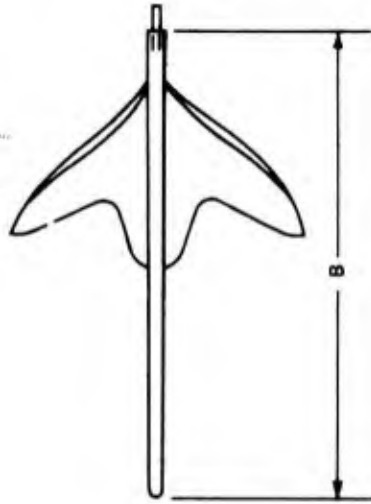
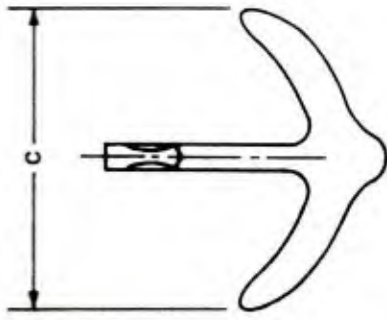

Nominal Weight		Dimensions (mm)		
kg	lb	A	B	C
*340	748	940	1930	1499
600	1320	1160	2050	1311
1000	2200	1375	2430	1554

*Note: 340 kg Bruce is welded, not cast, and has a twin plate shank separated by spacers (see Figure 15.)

Figure B-3. Dimensions of BRUCE anchor.

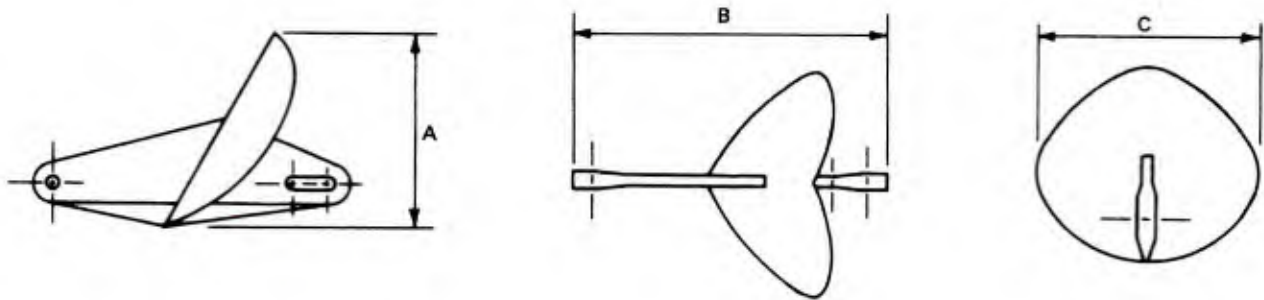

BRUCE ANCHOR
Nominal Weight

<u>kg</u>	<u>lb</u>
600	1320
1000	2200
3000	6600
6500	14300
9000	19800

CABLE DEPRESSOR DIMENSIONS
Nominal Weight

<u>kg</u>	<u>lb</u>	<u>A</u> <u>mm</u>	<u>B</u> <u>mm</u>	<u>C</u> <u>mm</u>
120	264	521	1061	698
200	440	720	1200	830
605	1331	1040	1735	1195
1350	2970	1355	2255	1555
1810	3982	1500	2500	1725

Figure B-4. Dimensions of BRUCE cable depressors.

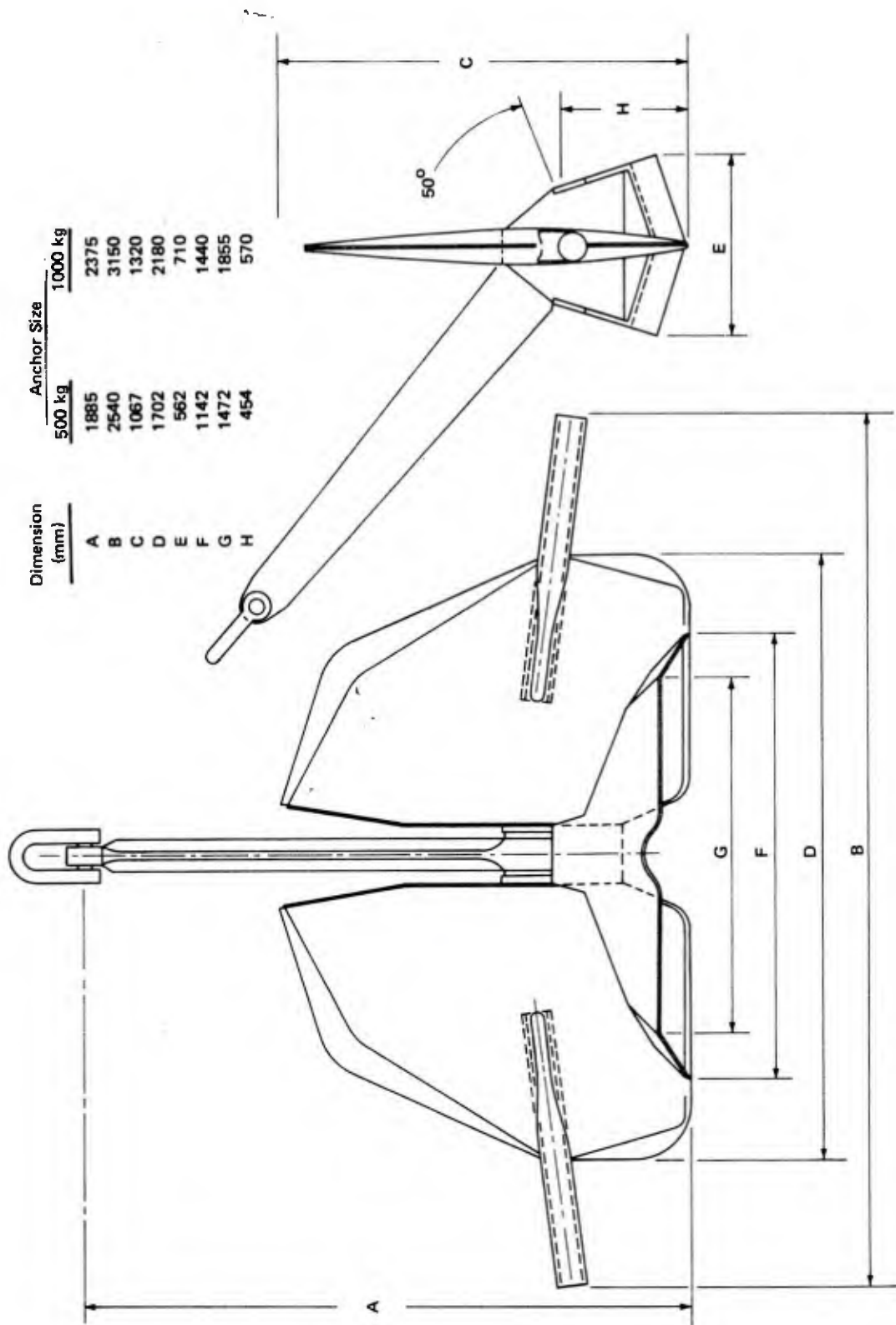

Figure B-5. Dimensions of STEVMUD® anchor.

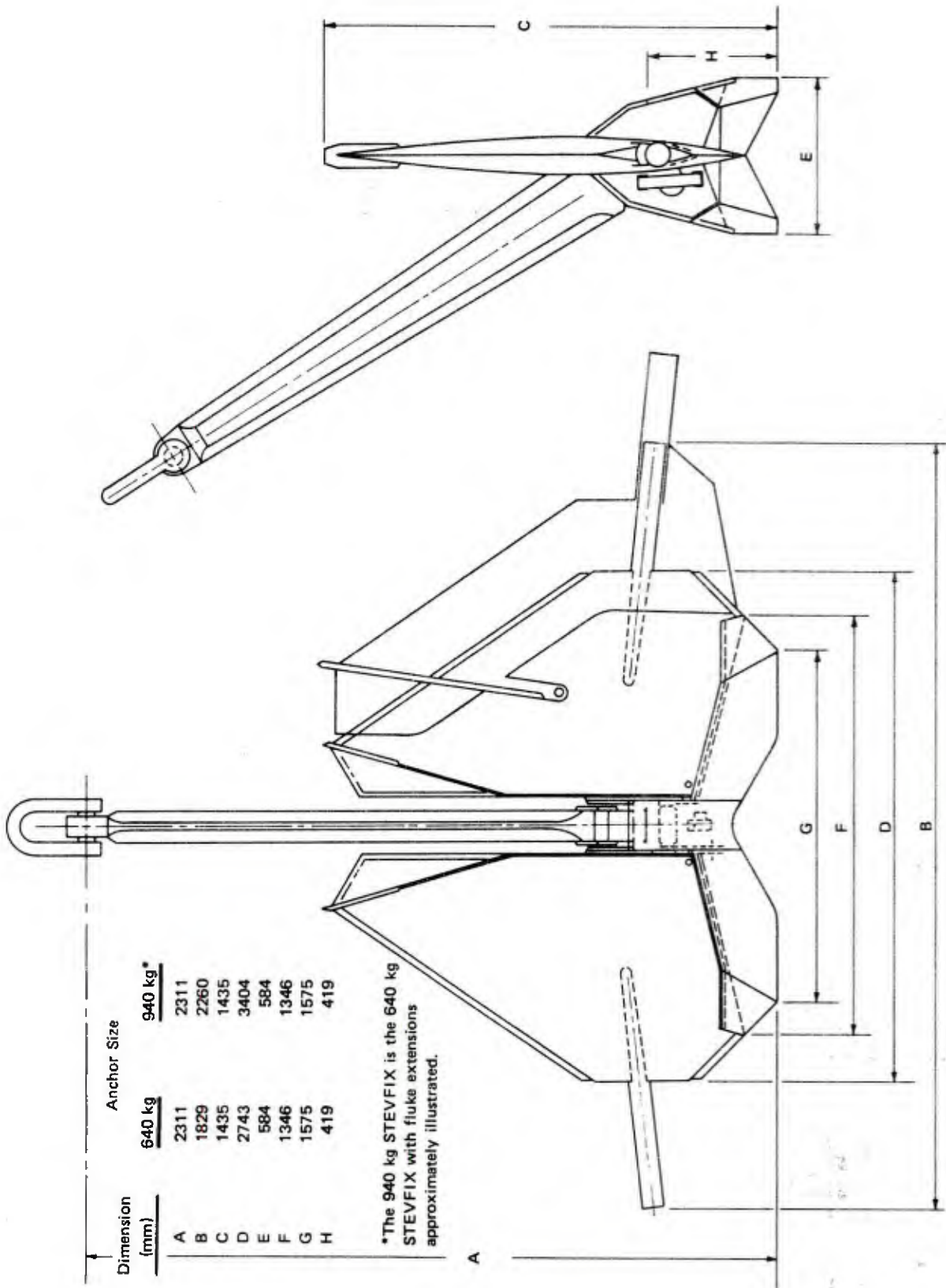

Figure B-6. Dimensions of STEVFIX® anchor.

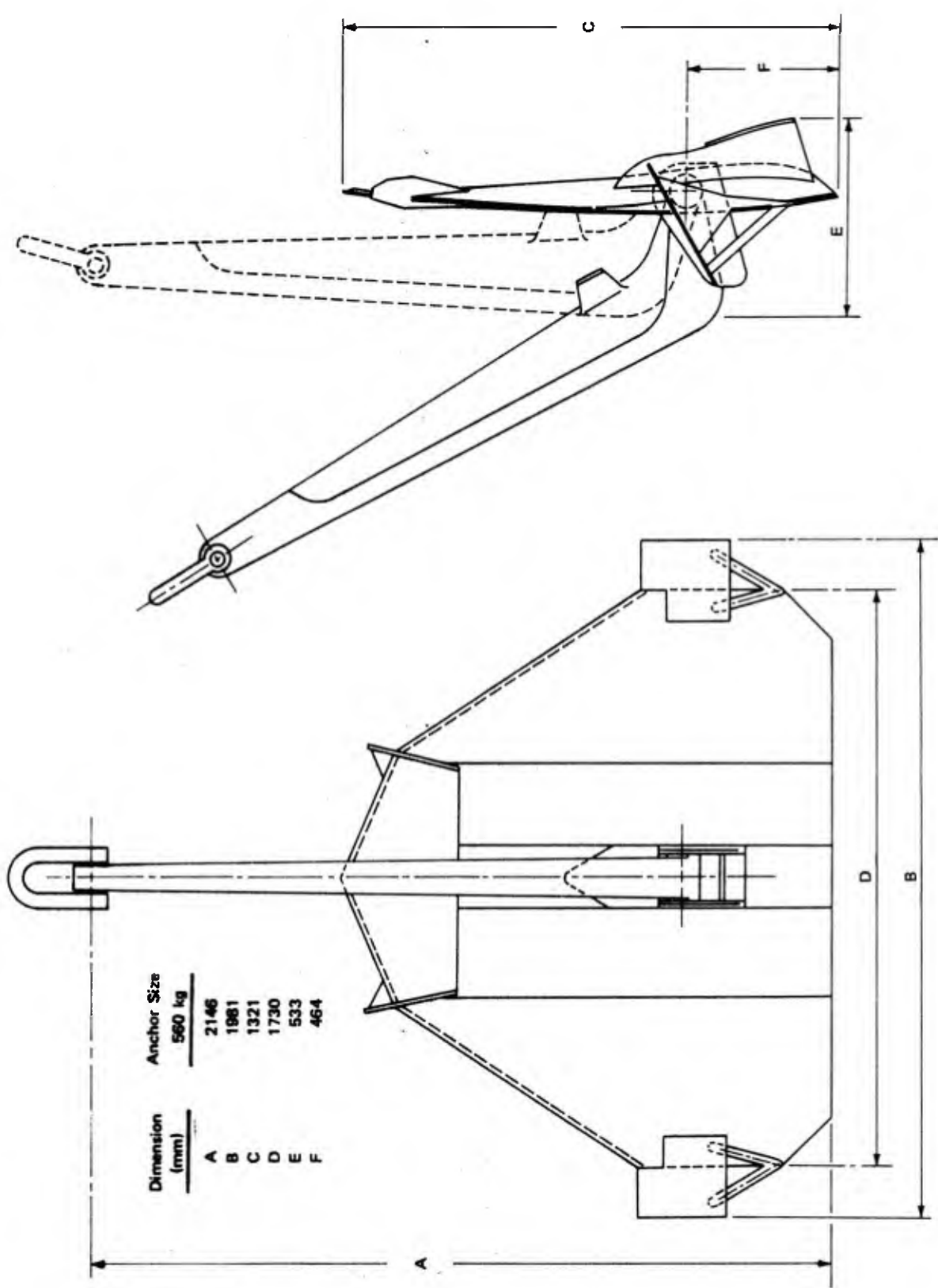

Figure B-7. Dimensions of Hook® anchor.

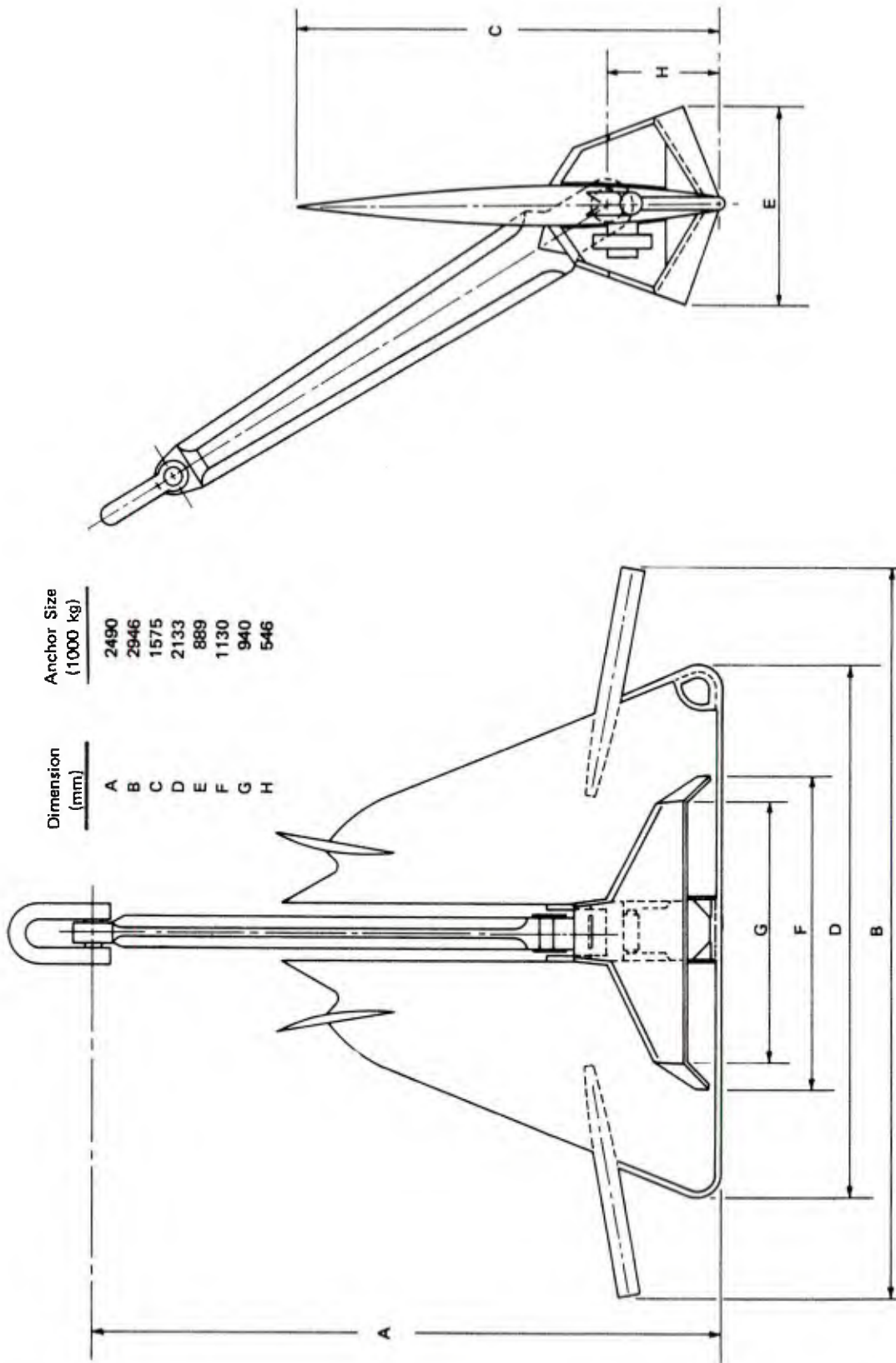

Figure B-8. Dimensions of STEVDIG® anchor.

Appendix C

STOCKLESS AND STATO ANCHOR TEST DATA

All test results for the Stockless and STATO anchors are included in this section. Anchor and deck tension, chain weight on bottom, anchor shank tip and crown penetrations, anchor shank longitudinal rotation (pitch), and anchor transverse rotation (roll) are plotted as functions of true anchor drag distance. Presented opposite each data plot is a digital listing of all plotted data plus additional descriptive data that may be useful during the eventual analysis of the data. When data were unavailable either through instrumentation difficulties or because the instrument pack was not used due to time constraints (this occurred at Indian Island), straight lines with a zero ordinate were plotted. There were several instances at San Diego where partial shorts at the load cell electrical connector occurred during testing. The anchor load cell was particularly sensitive to these shorts since its output, exclusively, was amplified at the anchor and transmitted to the vessel. When this occurred, all data but anchor load cell were recorded. At the fine sand site in San Diego Harbor, problems often occurred with the pressure transducer; these did not occur at the deeper dense clayey sand site at San Diego and at Indian Island. Apparently, partial kinking of the pressure transducer hose was sufficient to restrict water flow into the hose. For those tests where depth readings were obviously in error, columns 4, 11, 12, and 13 on the data summaries are absent. Also, anchor shank penetrations are not listed or plotted for the Stockless anchor even when package depth (column 4) is listed. An error was detected in the specification of package location on the shank. The correct location is listed in Table B-1. Shank penetrations can be calculated directly using the correct location in conjunction with anchor dimensions listed in Appendix B and anchor shank angles listed in Appendix C. Listed on most Appendix C tables is an embedment depth of the centerline of the anchor shank at the crown end of the anchor. This depth was recorded by crown wire measurement at the end of the test. This value reflects only the condition of the anchor at the end of drag and not necessarily peak anchor embedment.

Day # - 88

SAN DIEGO HARBOR 1500FT. SOUTHEAST OF BUOY 49

Test No. - 1

stockless, 5000lb. no stabilizers 48 deg. mov. flukes

Test Series No. - 4

fine sand bottom. depth 11-12 ft. mllv

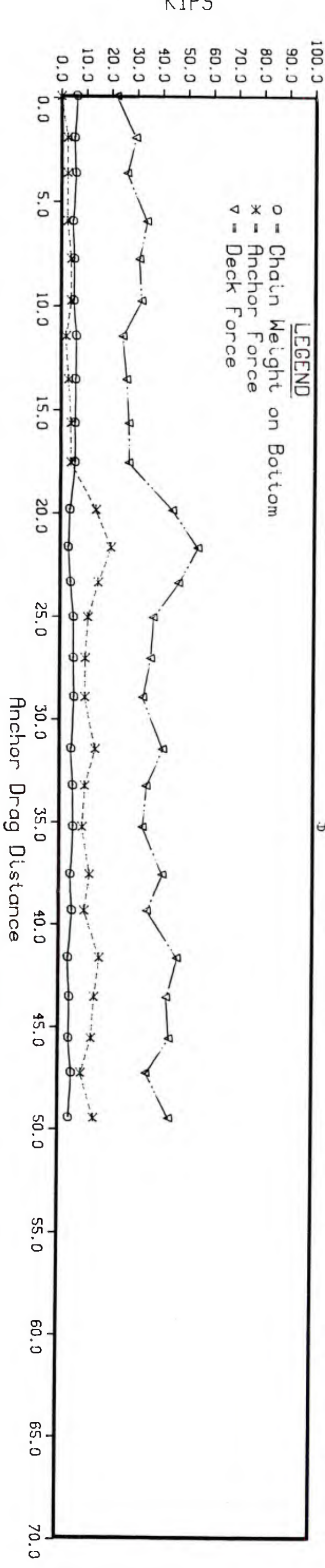
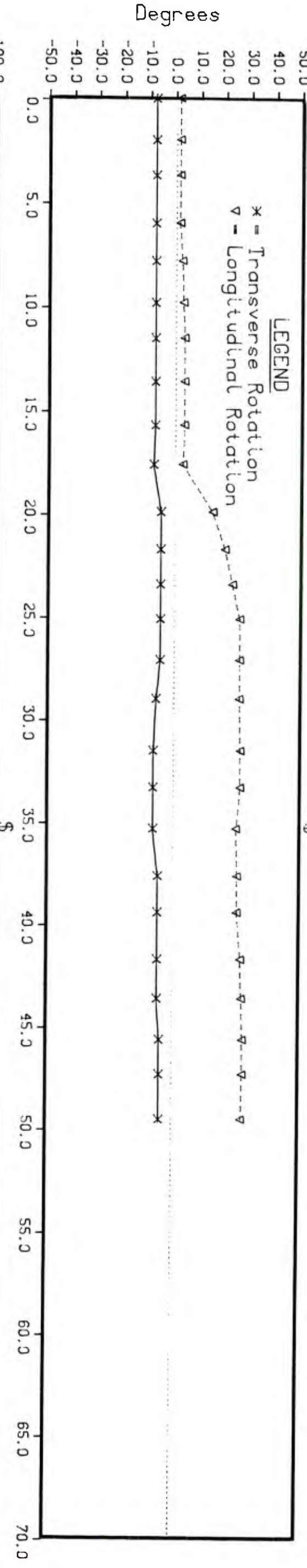
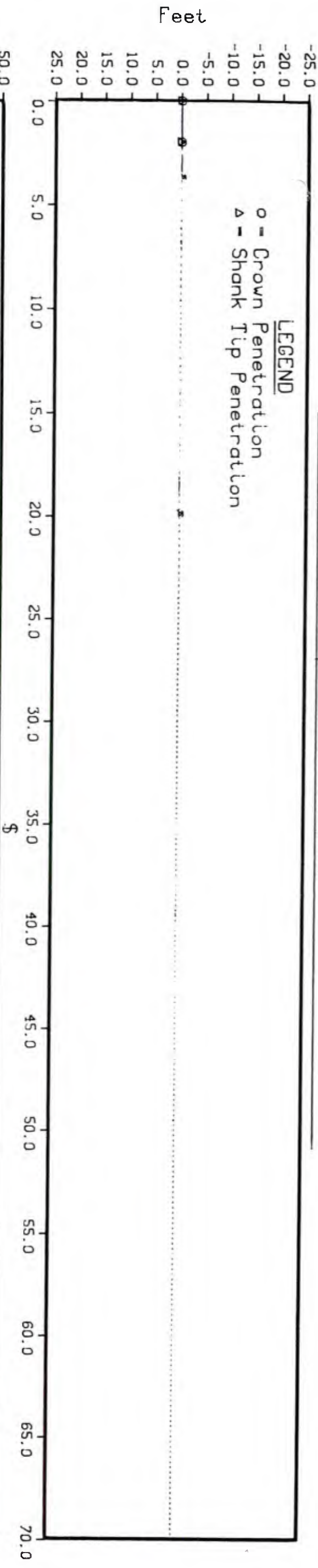

Day # - 88
 Test No. - 2
 Test Series No. - 4

SAN DIE

STOPKISS ANCHOR TEST

TEST DATE
 TEST NO. 2
 TEST SERIES
 START-END TIMES
 START-END TYPE
 ANCHOR TYPE
 ANCHOR WFTHT
 FLUMF ANCHOR TYPE
 FLUMF ANCHOR TYPE
 MAIN-ANCHOR SEPARATION
 DEPRESS-ANCHOR-SEPARATION
 WINDING LINE DESCRIPTION

AR
 4
 SAN DIEGO HARBOUR 1500 FT. SOUTHWEST OF BUOY 49
 142A - 143A
 FINE SAND BOTTOM, DEPTH 11-12 FT. MLLW
 STOPKISS - 5000 LB. NO STABILIZERS 48 DEG. MOV. FLUMFS
 5350.00 LB.
 49.00 DEG. - 0 00MMV 14FT

0.00 FT
 0.00 LB
 ANCHOR TO GIRT 14.2FT, NUTLOCK CHAIN TO 140FT 2-1/2IN STUN-
 LINK CHAIN TO 400FT 2IN. WIP DIMP

1. DRAG DISTANCE	2. TUCK TENSION	3. ANCHOR TENSION	4. PACKAGE DEPTH	5. ROTATION ANGLE	6. SPARK ANGLE	7. WIP DEPTH ANGLE	8. OFF CENTER DEPTH ANGLE	9. CHAIN LENGTH ON BOTTOM	10. CHAIN WFTHT ON BOTTOM	11. ANCHOR PDOWN DEPTH	12. ANCHOR SHANK TIP DEPTH	13. ANCHOR FLUMF TIP DEPTH	14. WATFO DEPTH	15. TOTAL BOTTOM WFTHT
6.0	17.0	6.0	FEET	DEG	DEG	DEG	DEG	FT	FT	FT	FT	FT	FT	FT
2.0	10.0	7.0	FT	DEG	DEG	DEG	DEG	FT	FT	FT	FT	FT	FT	FT
3.0	10.0	3.0	FT	DEG	DEG	DEG	DEG	FT	FT	FT	FT	FT	FT	FT
4.2	12.0	3.0	FT	DEG	DEG	DEG	DEG	FT	FT	FT	FT	FT	FT	FT
6.3	14.0	4.0	FT	DEG	DEG	DEG	DEG	FT	FT	FT	FT	FT	FT	FT
9.5	12.0	6.0	FT	DEG	DEG	DEG	DEG	FT	FT	FT	FT	FT	FT	FT
12.1	14.0	6.0	FT	DEG	DEG	DEG	DEG	FT	FT	FT	FT	FT	FT	FT
12.6	16.0	6.0	FT	DEG	DEG	DEG	DEG	FT	FT	FT	FT	FT	FT	FT
15.8	20.0	11.0	FT	DEG	DEG	DEG	DEG	FT	FT	FT	FT	FT	FT	FT
17.9	24.0	17.0	FT	DEG	DEG	DEG	DEG	FT	FT	FT	FT	FT	FT	FT
19.7	24.0	14.0	FT	DEG	DEG	DEG	DEG	FT	FT	FT	FT	FT	FT	FT
21.6	25.0	17.0	FT	DEG	DEG	DEG	DEG	FT	FT	FT	FT	FT	FT	FT
23.8	27.0	16.0	FT	DEG	DEG	DEG	DEG	FT	FT	FT	FT	FT	FT	FT
25.2	22.0		FT	DEG	DEG	DEG	DEG	FT	FT	FT	FT	FT	FT	FT
27.5	24.0		FT	DEG	DEG	DEG	DEG	FT	FT	FT	FT	FT	FT	FT
29.2	22.0		FT	DEG	DEG	DEG	DEG	FT	FT	FT	FT	FT	FT	FT
31.6	24.0		FT	DEG	DEG	DEG	DEG	FT	FT	FT	FT	FT	FT	FT
33.3	24.0		FT	DEG	DEG	DEG	DEG	FT	FT	FT	FT	FT	FT	FT
35.7	31.0		FT	DEG	DEG	DEG	DEG	FT	FT	FT	FT	FT	FT	FT
37.4	29.0		FT	DEG	DEG	DEG	DEG	FT	FT	FT	FT	FT	FT	FT
39.2	25.0		FT	DEG	DEG	DEG	DEG	FT	FT	FT	FT	FT	FT	FT
41.3	32.0		FT	DEG	DEG	DEG	DEG	FT	FT	FT	FT	FT	FT	FT
43.3	24.0		FT	DEG	DEG	DEG	DEG	FT	FT	FT	FT	FT	FT	FT
45.1	24.0		FT	DEG	DEG	DEG	DEG	FT	FT	FT	FT	FT	FT	FT
47.9	24.0		FT	DEG	DEG	DEG	DEG	FT	FT	FT	FT	FT	FT	FT
49.2	27.0		FT	DEG	DEG	DEG	DEG	FT	FT	FT	FT	FT	FT	FT

DISTANCE GAGE TRAVELLED 50.0
 DISTANCE ANCHOR TRAVELLED 49.2

NOTE - POSITIVE SHANK
 ANGLE INDICATES
 SHANK TIP DOWN
 DOWN

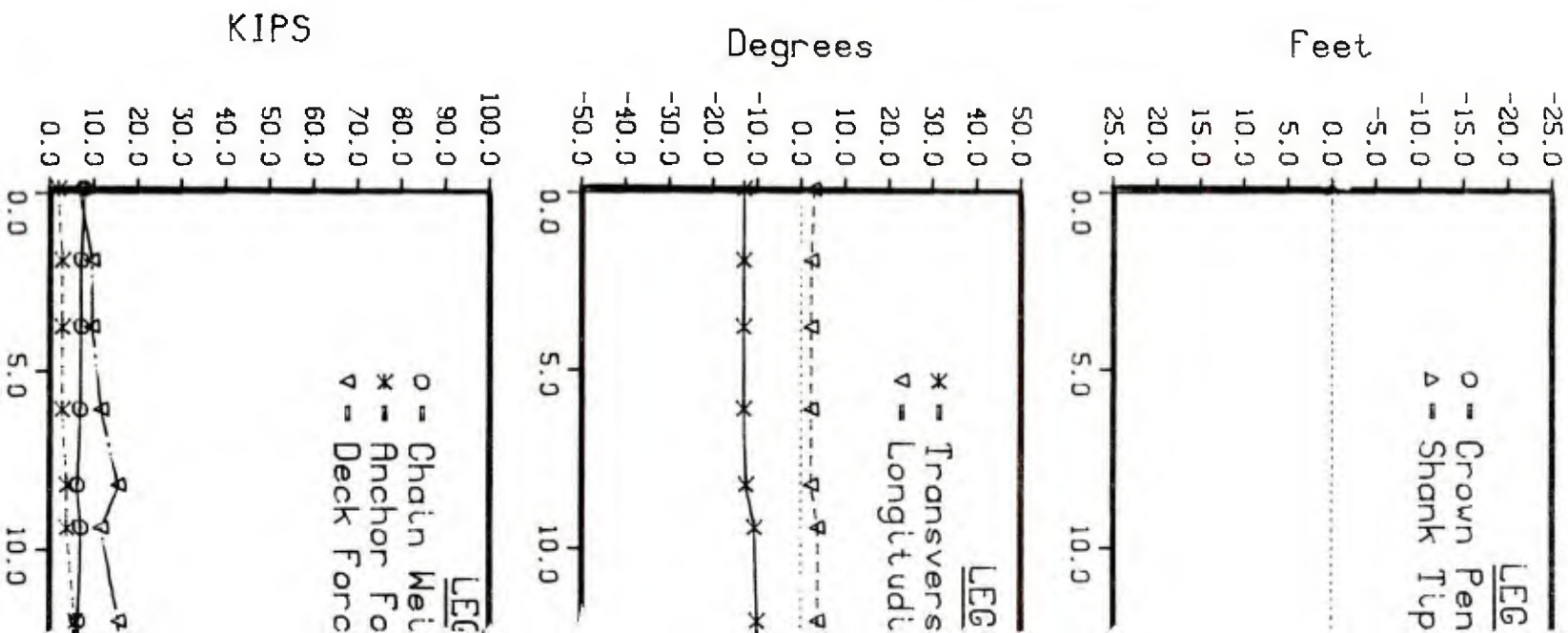

Day # - 88
 Test No. - 2
 Test Series No. - 4

SAN DIEGO HARBOR 1500 FT. SOUTHERST OF BUOY 49

stockless, 5000lb. no stabilizers 48 deg. mov. flukes

fine sand bottom. depth 11-12 ft. mllv

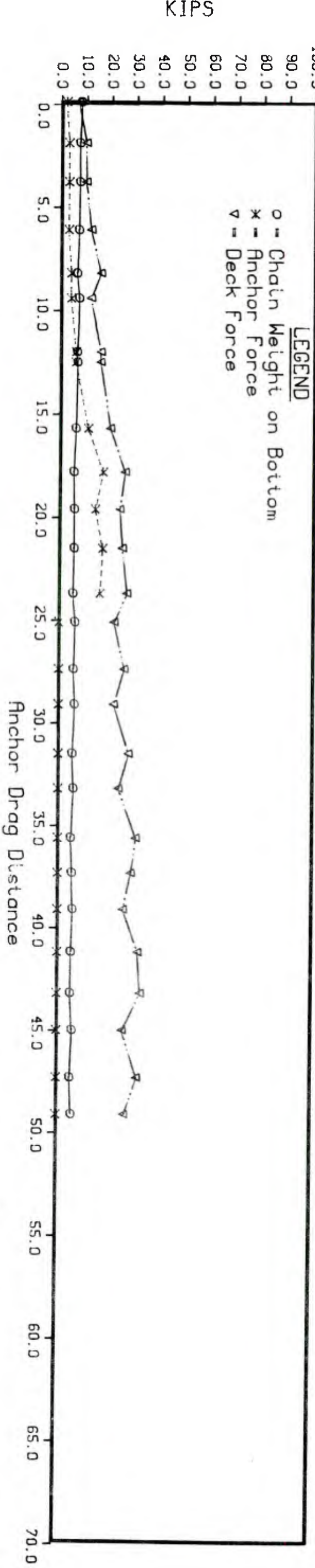
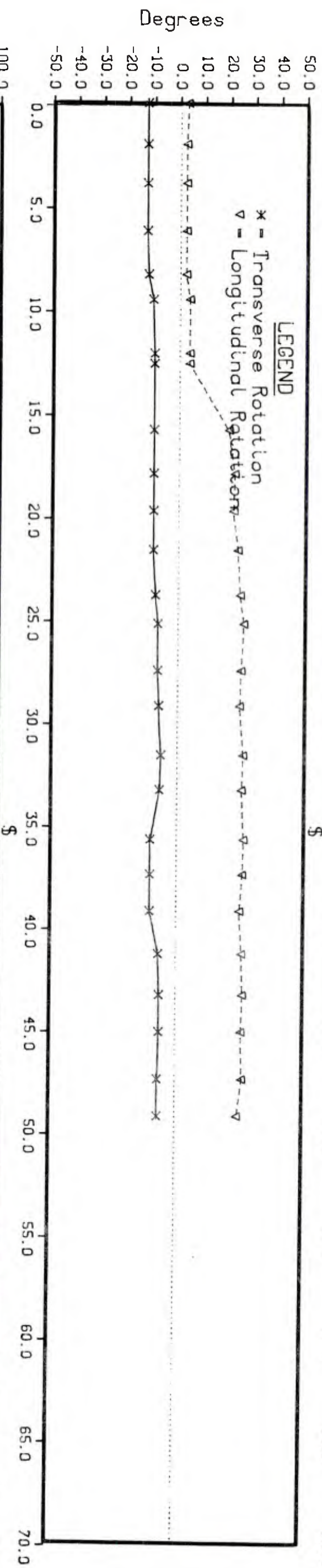
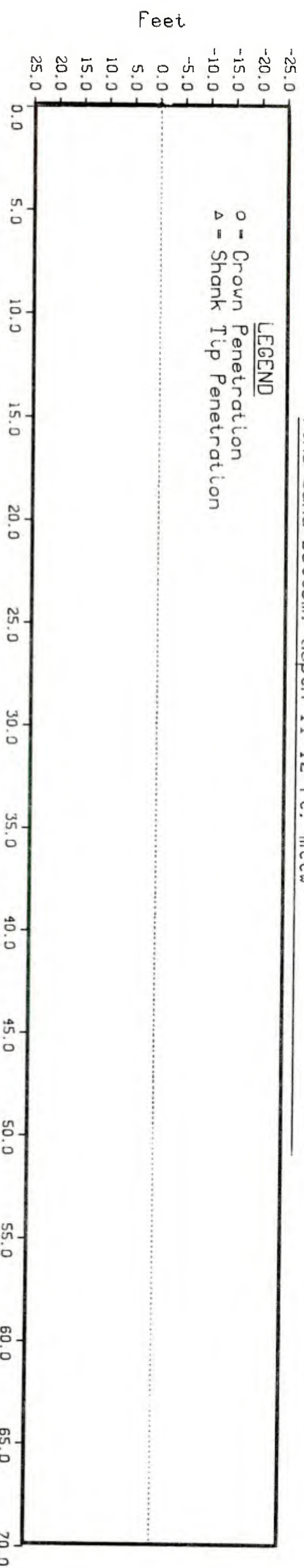

Day # - 88

SAN DIEGO HARBOR 1500 FT. SOUTHEAST OF BUOY 49

Test No. - 3

stockless, 5000lb. no stabilizers 48 deg. mov. flukes

Test Series No. - 4

fine sand bottom. depth 11-12 ft. mlw

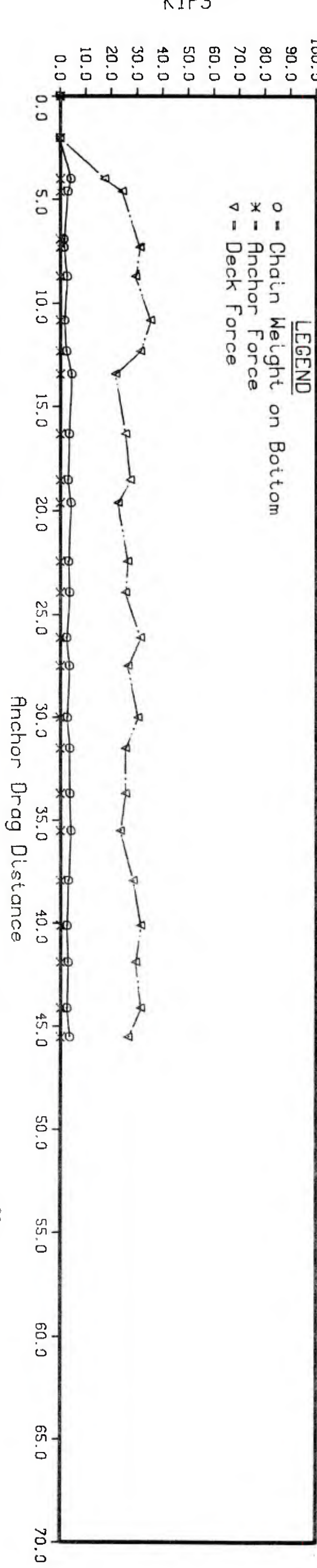
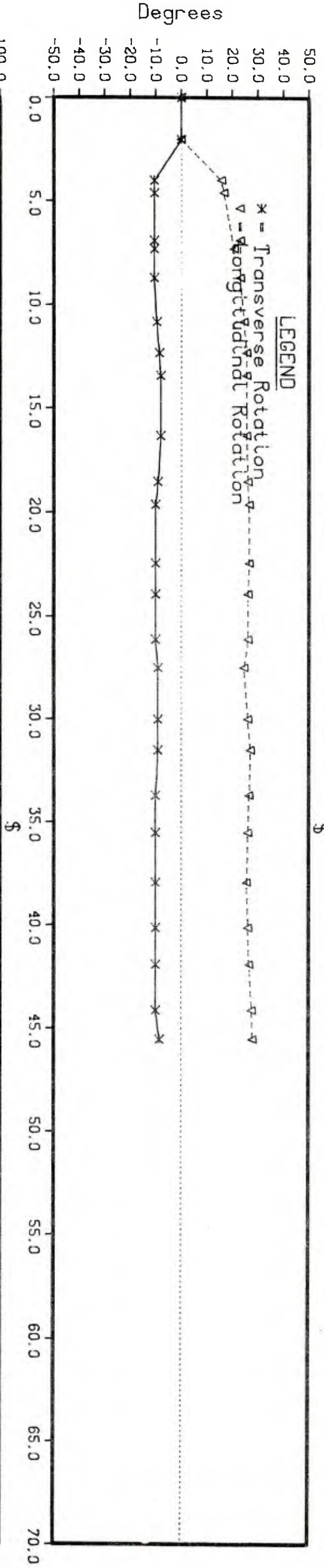
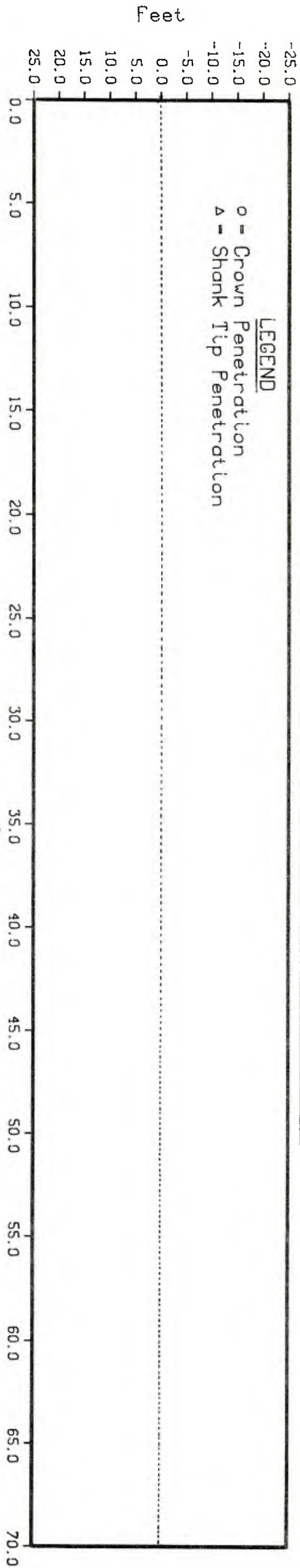

Day # = 89
 Test No. = 1
 Test Series No. = 5

TEST DATE
 TEST NO.
 TEST SPOTS
 TEST APP#
 START-FUN TIME#
 SEAFLOOR TYPE
 ANCHOR TYPE
 ANCHOR WEIGHT
 FLUXE ANCHOR TYPE
 AUX ANCHOR TYPE
 AUX ANCHOR WEIGHT
 MAIN-AUX ANCHOR SEPARATION
 DEPRESSIONS-NO.-WT.-FAC%-TOTAL WT.
 MORTISING LINE DESCRIPTION

STOCKLESS ANCHOR TEST

0.00 19.
 0.0 0.0
 CAN DIEGO HARBOUR 1500 FT. SOUTHWEST OF QUAY 60
 1103 - 1109
 FINE SAND BOTTOM, DEPTH 11-12 FT. MLV
 STOCKLESS 45000LB. STABILIZERS-400LB. PRO. 75 DRG. FX. FLUXE
 9500.00 19. 0.000 1.000 1.000 1.000

0.00 19.
 0.0 0.0
 ANCHOR TO GIFT 1.15PSIN. DIRECTION CHAIN TO 100FT 2-ANCHOR STUN-
 1 INK CHAIN TO 400FT PIN. WIDE PROOF

NOTE - INITIAL CHAIN DEPTH ZEROED TO DEFLECT MEASUREMENT WARPED

1. DECK DISTANCE	2. DECK TO ANCHOR	3. ANCHOR SECTION	4. PACKAGE DEPTH	5. ROTATION ANGLE	6. SLOPE ANGLE	7. WIDE PROOF ANGLE	8. DECK HORIZ. FORCE	9. CHAIN LENGTH ON BOTTOM	10. MAIN WEIGHT ON BOTTOM	11. ANCHOR WEIGHT ON BOTTOM	12. ANCHOR FLUXE TIP DEPTH	13. ANCHOR FLUXE TIP DEPTH	14. WATER DEPTH	15. TOTAL BOTTOM WEIGHT
1	0.0	13.0	1.0	16.1	1.5	-1.1	21.5	12.1	200.2	4486.1			16.0	1647.1
2	0.0	15.0	4.0	16.4	0.0	3.0	20.4	15.7	175.3	3796.5			16.0	1764.5
3	4.0	25.0	14.0	16.9	.5	9.0	16.8	23.9	123.5	2045.9			16.0	2045.9
4	6.0	34.0	22.0	17.0	.5	10.0	16.2	34.6	0.0	2045.9			16.0	2045.9
5	8.0	44.0	27.0	17.3	.5	9.5	13.1	44.8	0.0	2045.9			16.0	2045.9
6	10.0	44.0	28.0	17.5	.5	9.0	11.9	45.0	0.0	2045.9			16.0	2045.9
7	12.0	54.0	35.0	17.7	.5	9.5	12.5	52.7	0.0	2045.9			16.0	2045.9

DISTANCE RANGE TRAVELLED 12.0
 DISTANCE ANCHOR TRAVELLED 4.2

NOTE - POSITIVE GRAVE
 POSITIVE ROTATION
 SHAKE TIP BELN
 FROM

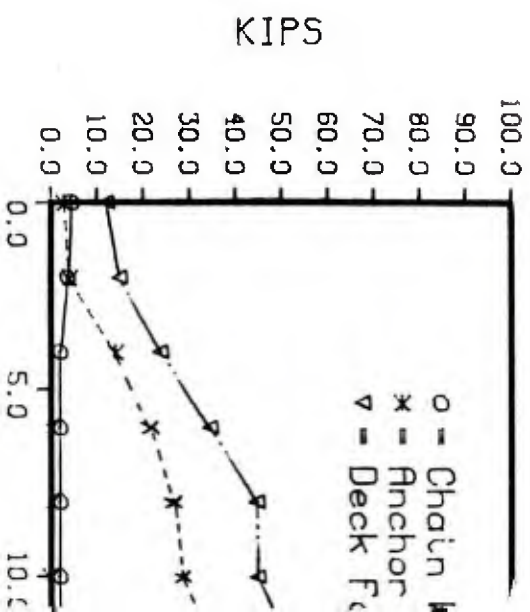
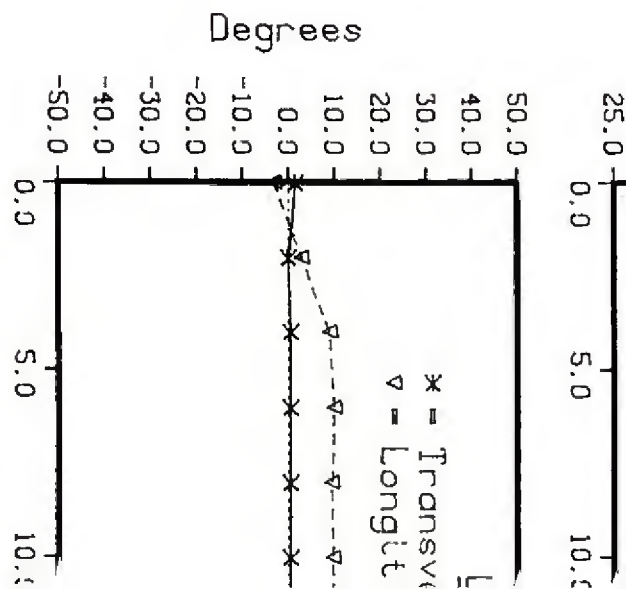
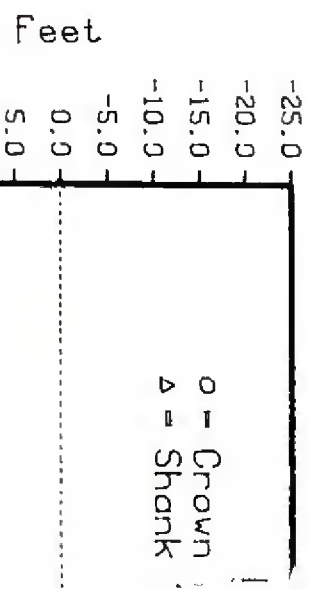

Day # = 89

Test No. = 1

Test Series No. = 5

SAN DIEGO HARBOR 1500 FT. SOUTHEAST OF BUOY 49

stockless, 5000lb. stabilizers-600lb. /pr. 35 deg. fx. fluke

fine sand bottom. depth 11-12 ft. mllw

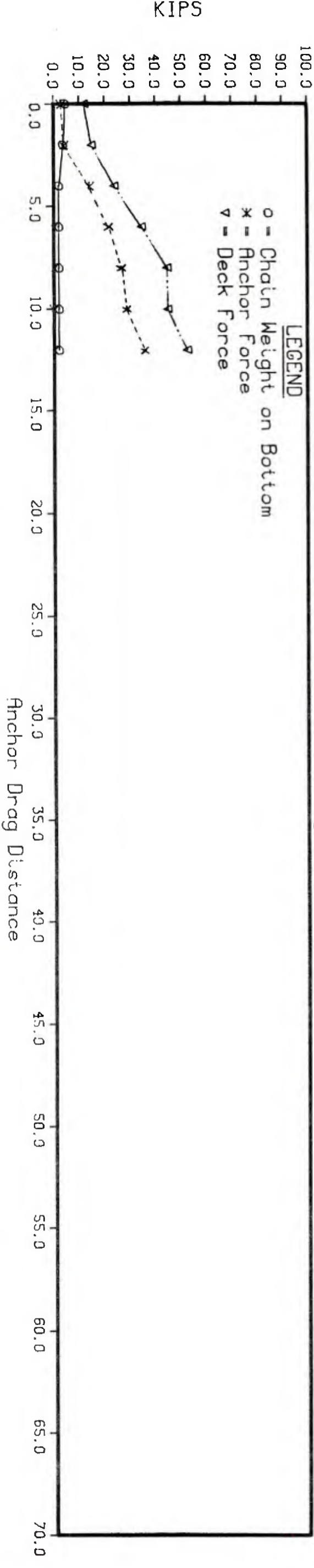
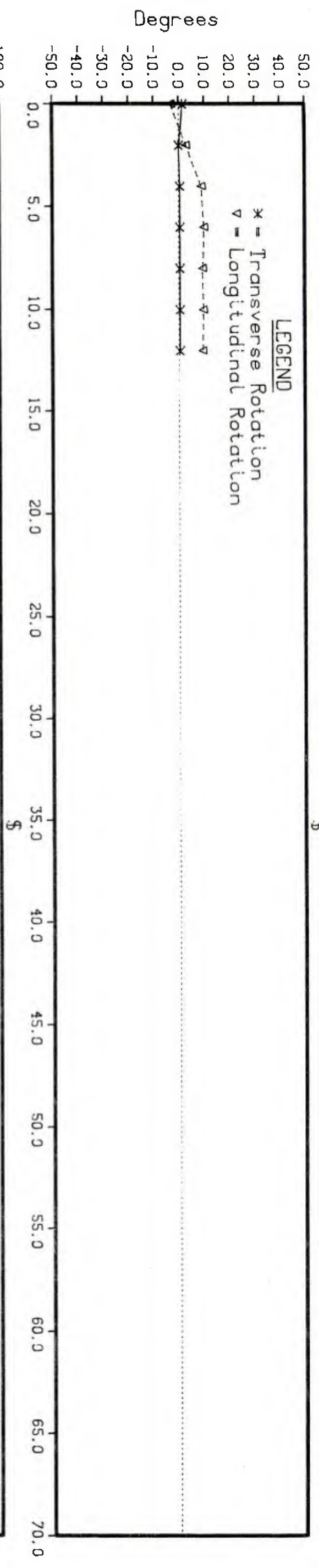
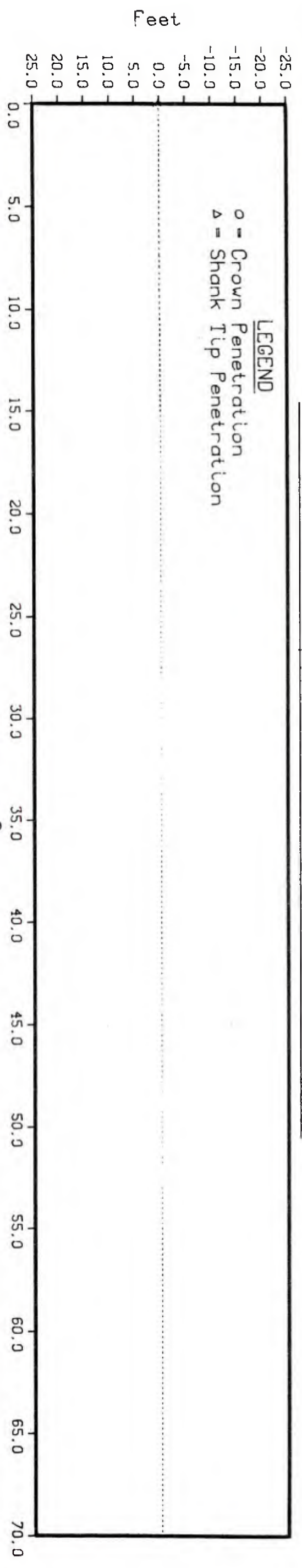

Day # - 89
 Test No. - 2
 Test Series No. - 5

SAN DIEGO

TEST DATE: 08/20/89
 TEST NO.: 2
 TEST SITES: SAN DIEGO HARBOUR 1500 FT. SOUTHWEST OF QUAY 49
 STABIL-END TIME: 1444 - 1453
 ANCHOR TYPE: FINE SAND BOTTOM, DEPTH 11-12 FT. MLLD
 FLUKE WEIGHT: 5950.00 LB.
 FLUKE ANGLE-TYPE: 36.00 DEG. - 1 0200V 1EFFIX
 ANCHOR WEIGHT: 0.00 LB.
 SHANK WEIGHT: 0.00 LB.
 MAIN-BODY ANCHOR SEPARATION: 0.00 FT.
 REOPERATION-UN-SEPARATION: 0.00 FT.
 WINDING LINE DESCRIPTION: ANCHOR TO TOWER PIN, STABIL END CHAIN TO ANCHOR PIN, WIRE ANCHOR

NOTE - INITIAL SHANK DEPTH ZEROED TO DIFFERENT MEASUREMENT WATERFORTH

1	2	3	4	5	6	7	8	9	10	11	12	13	14	15
FEET	WT	KTIC	FEET	WT	WT	WT	WT	FEET	WT	FEET	FEET	FEET	FEET	WT
0.0	414	0.0	0000	0.0	0.0	12.4	1.7	312.2	5036.0	0000	0000	0000	12.0	1184.0
2.0	510	0.0	0000	0.0	0.0	11.7	4.7	178.0	5684.2	0000	0000	0000	12.0	1161.0
4.0	514	0.0	0000	0.0	0.0	12.0	4.6	170.6	5630.0	0000	0000	0000	12.0	1170.0
6.0	524	0.0	0000	0.0	0.0	26.9	5.8	152.5	4553.1	0000	0000	0000	12.0	1060.1
8.0	524	0.0	0000	0.0	0.0	24.1	8.6	140.0	4451.3	0000	0000	0000	12.0	1050.1
10.0	524	0.0	0000	0.0	0.0	24.1	7.1	140.5	5106.4	0000	0000	0000	12.0	1105.4
12.0	524	0.0	0000	0.0	0.0	22.3	10.0	131.0	4103.5	0000	0000	0000	12.0	1105.4
14.0	524	0.0	0000	0.0	0.0	21.2	11.4	121.9	3789.0	0000	0000	0000	12.0	982.9
16.0	524	0.0	0000	0.0	0.0	20.5	10.0	115.3	3448.0	0000	0000	0000	12.0	941.9
18.0	524	0.0	0000	0.0	0.0	20.1	10.0	108.0	3352.3	0000	0000	0000	12.0	1025.1
20.0	524	0.0	0000	0.0	0.0	19.1	11.4	102.0	3417.4	0000	0000	0000	12.0	979.4
22.0	524	0.0	0000	0.0	0.0	22.5	7.4	142.0	5151.6	0000	0000	0000	12.0	1110.4
24.0	524	0.0	0000	0.0	0.0	20.5	11.4	126.3	4010.1	0000	0000	0000	12.0	906.1
26.0	524	0.0	0000	0.0	0.0	17.5	13.7	120.7	3841.8	0000	0000	0000	12.0	870.2
28.0	524	0.0	0000	0.0	0.0	17.6	14.1	118.0	3528.2	0000	0000	0000	12.0	850.2
30.0	524	0.0	0000	0.0	0.0	22.2	14.5	102.5	3528.5	0000	0000	0000	12.0	828.1
32.0	524	0.0	0000	0.0	0.0	22.2	14.4	102.4	3528.5	0000	0000	0000	12.0	828.1
34.0	524	0.0	0000	0.0	0.0	24.2	14.4	102.4	3528.5	0000	0000	0000	12.0	828.1
36.0	524	0.0	0000	0.0	0.0	24.2	14.4	102.4	3528.5	0000	0000	0000	12.0	828.1
38.0	524	0.0	0000	0.0	0.0	24.2	14.4	102.4	3528.5	0000	0000	0000	12.0	828.1
40.0	524	0.0	0000	0.0	0.0	24.2	14.4	102.4	3528.5	0000	0000	0000	12.0	828.1
42.0	524	0.0	0000	0.0	0.0	24.2	14.4	102.4	3528.5	0000	0000	0000	12.0	828.1
44.0	524	0.0	0000	0.0	0.0	24.2	14.4	102.4	3528.5	0000	0000	0000	12.0	828.1
46.0	524	0.0	0000	0.0	0.0	24.2	14.4	102.4	3528.5	0000	0000	0000	12.0	828.1
48.0	524	0.0	0000	0.0	0.0	24.2	14.4	102.4	3528.5	0000	0000	0000	12.0	828.1
50.0	524	0.0	0000	0.0	0.0	24.2	14.4	102.4	3528.5	0000	0000	0000	12.0	828.1
52.0	524	0.0	0000	0.0	0.0	24.2	14.4	102.4	3528.5	0000	0000	0000	12.0	828.1
54.0	524	0.0	0000	0.0	0.0	24.2	14.4	102.4	3528.5	0000	0000	0000	12.0	828.1
56.0	524	0.0	0000	0.0	0.0	24.2	14.4	102.4	3528.5	0000	0000	0000	12.0	828.1
58.0	524	0.0	0000	0.0	0.0	24.2	14.4	102.4	3528.5	0000	0000	0000	12.0	828.1

DISTANCE GAGE TRAVELLED 58.0
 DISTANCE ANCHOR TRAVELLED 33.7

NOTE - POSITIVE SHANK
 ANGLE INDICATES
 SHANK TO BE ON
 PENN.

LEG

o = Crown Pen
 Δ = Shank Tip

Feet

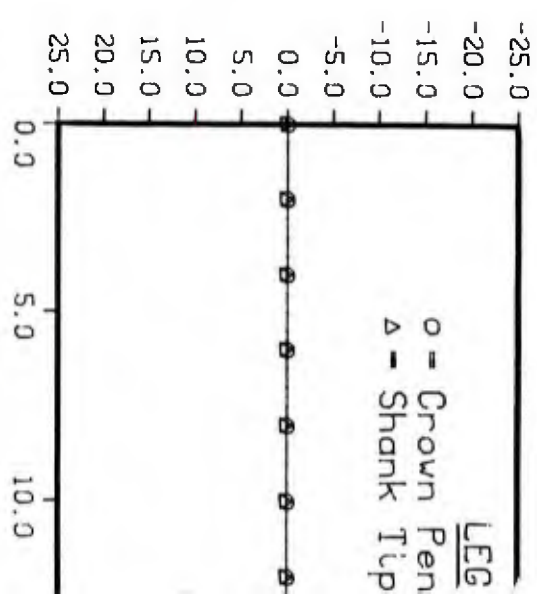

Degrees

* = Transvers
 ∇ = Longitudi

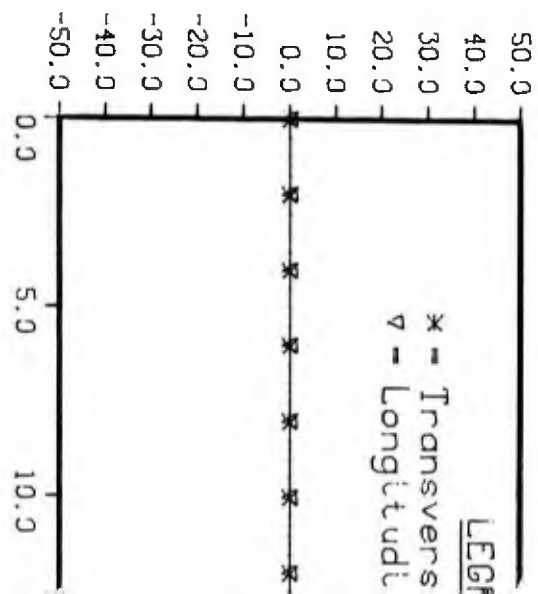

KIPS

o = Chain Weir
 * = Anchor For
 ∇ = Deck Force

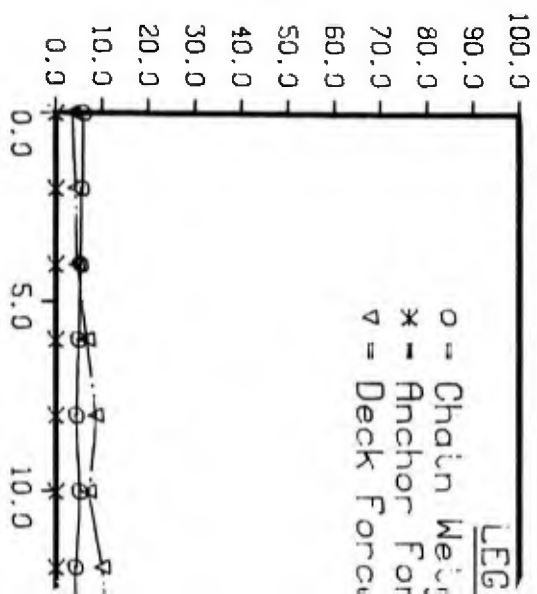

Day # - 89 SAN DIEGO HARBOR 1500 FT. SOUTHEAST OF BUOY 49

Test No. - 2 stockless .5000lb. stabilizers-600lb. /pr. 35 deg. fx. fluke

Test Series No. - 5 fine sand bottom. depth 11-12 ft. mllw

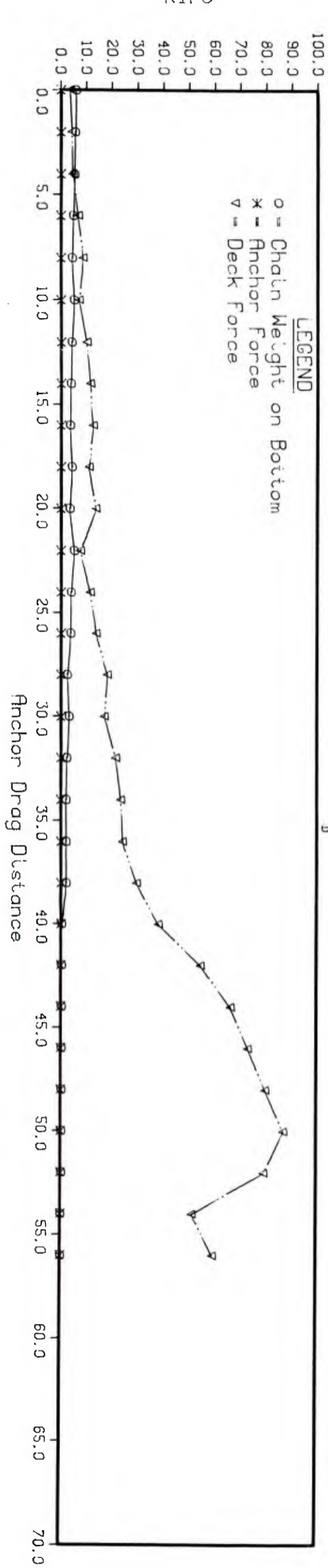
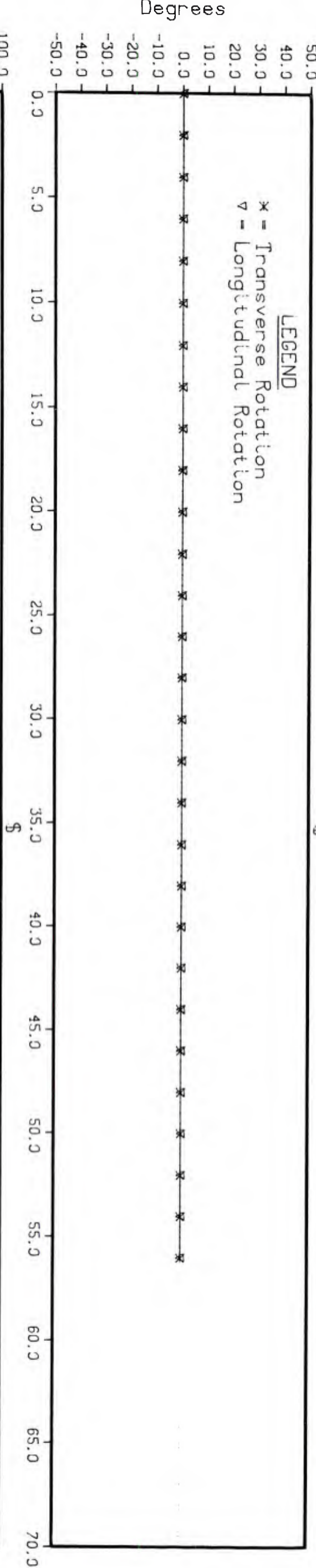
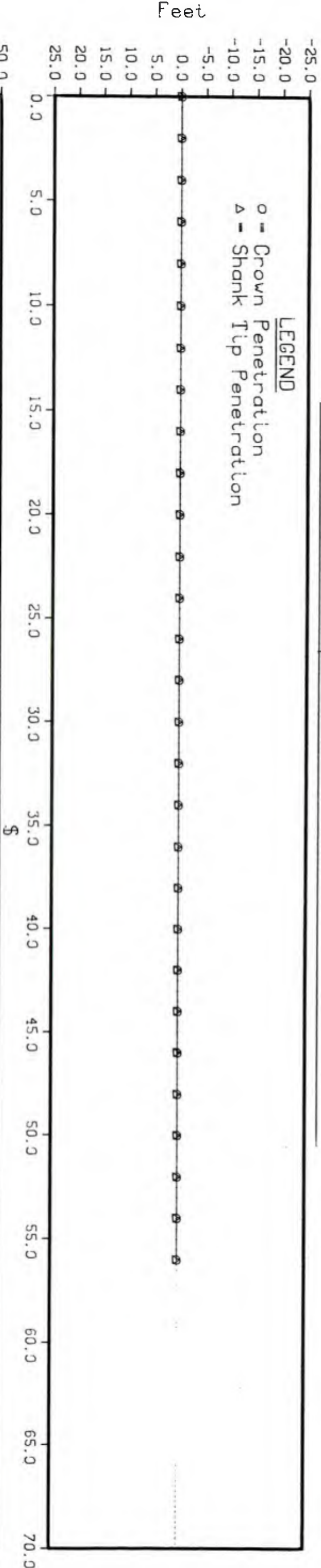

Day # = 92

Test No. = 3

Test Series No. = 5

SAN DIEGO HARBOR 1500 FT. SOUTHEAST OF BUOY 49

stockless, 5000lb. stabilizers-600lb. /pr. 35 deg. fx. fluke

fine sand bottom, depth 11-12 ft. mllw

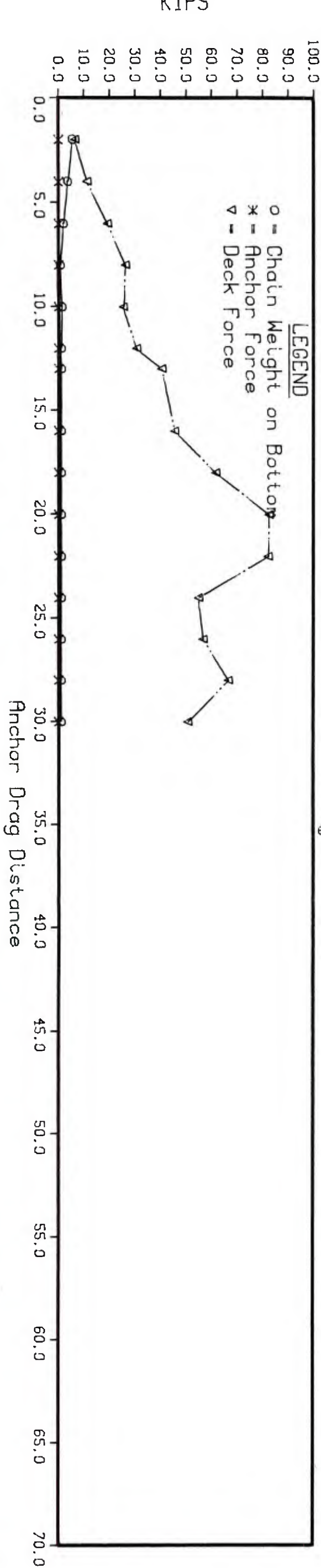
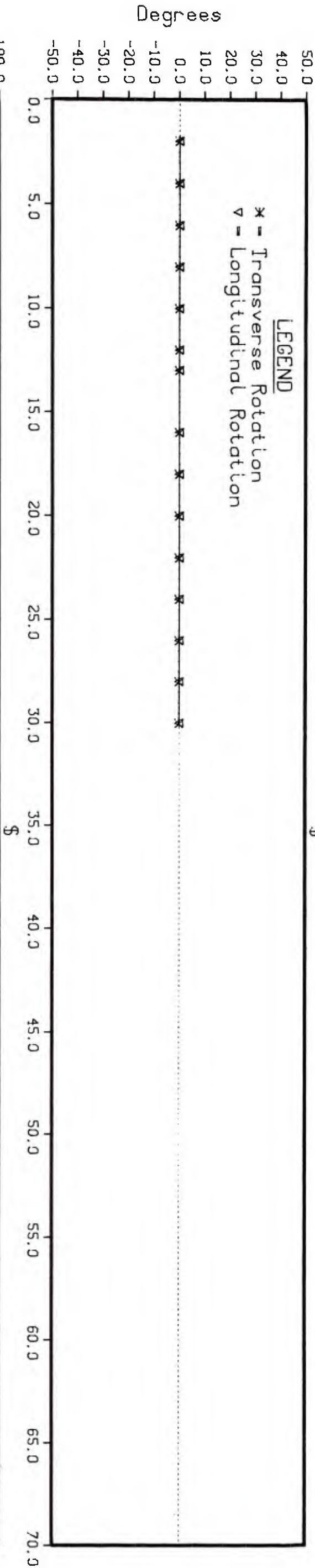
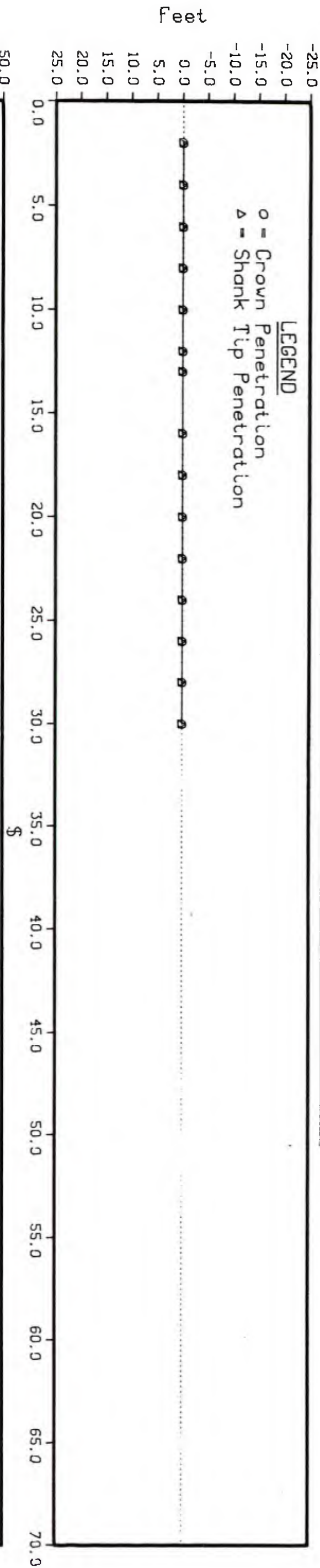

Day # - 92
 Test No. - 1
 Test Series No. - 6

SPAN D

TEST DATE 97
 TEST NO. 1
 TEST SECT'S 6
 TEST AOA 1056 - 1244
 START-ENR TIMES 1056 - 1244
 SEAFLOOR TYPE 1056 - 1244
 ANCHOR TYPE 1056 - 1244
 ANCHOR WEIGHT 1056 - 1244
 FLUXE ANGLE-TYPE 1056 - 1244
 AUX. ANCHOR TYPE 1056 - 1244
 MAIN-ANCHOR WEIGHT 1056 - 1244
 MAIN-AUX ANCHOR SEPARATION 1056 - 1244
 DEPRESSIONS-NO.-WT-EACH-TOTAL WT. 1056 - 1244
 MOORING LINE DESCRIPTION 1056 - 1244

NOTE - INITIAL SHANK DEPTH ZEROED TO REFLECT MEASURED WATERDEPTH

1. DRAG DISTANCE	2. DRAG TENSION	3. ANCHOR TENSION	4. ANCHOR DEPTH	5. ROTATION ANGLE	6. SHANK ANGLE	7. WIDE POPE ANGLE	8. DECK HORIZ. FORCE	9. CHAIN LENGTH ON BOTTOM	10. CHAIN WEIGHT ON BOTTOM	11. ANCHOR FLUXE TIP DEPTH	12. WIDE POPE TIP DEPTH	13. TOTAL BOTTOM WEIGHT	14. ANCHOR FLUXE TIP DEPTH	15. TOTAL BOTTOM WEIGHT
0.0	11.3	0.0	15.9	-13.5	5.0	15.0	15.0	117.5	3172.1	15.1	15.6	17.5	17.5	16.0
2.0	13.3	2.0	15.4	-13.0	5.0	15.0	15.0	117.5	3532.0	14.4	15.4	17.1	17.1	16.0
4.0	16.4	4.0	15.0	-12.0	5.0	15.0	15.0	117.5	3990.4	14.7	15.7	17.1	17.1	16.0
6.0	20.5	7.0	14.1	-12.0	5.0	15.0	15.0	117.5	4448.8	14.1	15.1	17.0	17.0	16.0
8.0	18.5	6.0	15.4	-13.0	5.0	15.0	15.0	117.5	4907.2	15.2	15.2	17.0	17.0	16.0
10.0	13.3	2.0	15.5	-13.0	5.0	15.0	15.0	117.5	5365.6	15.2	15.2	17.0	17.0	16.0
12.0	10.3	1.5	15.4	-13.0	5.0	15.0	15.0	117.5	5824.0	15.2	15.2	17.0	17.0	16.0
13.0	16.3	1.0	15.5	-13.0	5.0	15.0	15.0	117.5	6282.4	15.2	15.2	17.0	17.0	16.0

DISTANCE RANGE TRAVELLED 13.0
 DISTANCE ANCHOR TRAVELLED 11.6

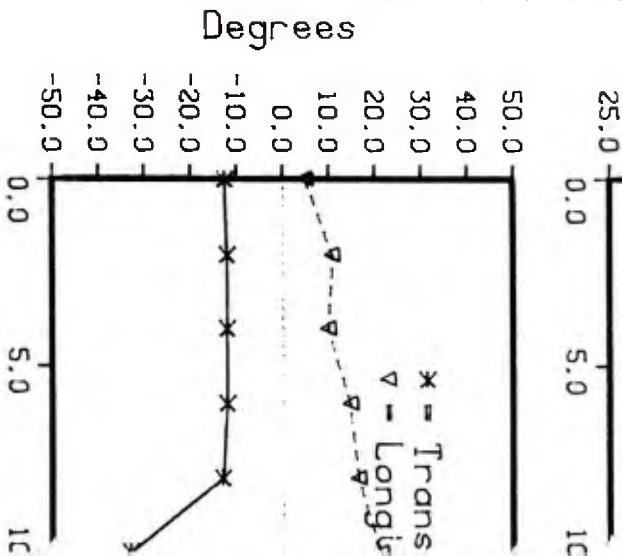
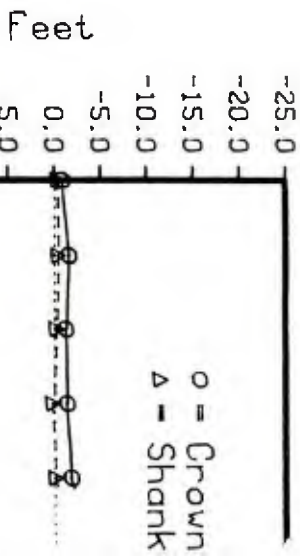

KIPS

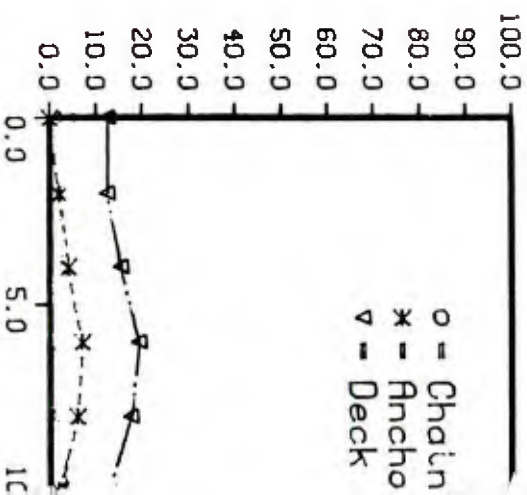

SAN DIEGO HARBOR 1500 FT. SOUTHERST OF BUOY 49

Day # - 92 Test No. - 1 stato 1000lb. 16 in. stabilizers 35 deg. mov. flukes
 Test Series No. - 6 fine sand bottom. depth 11-12 ft. mllw

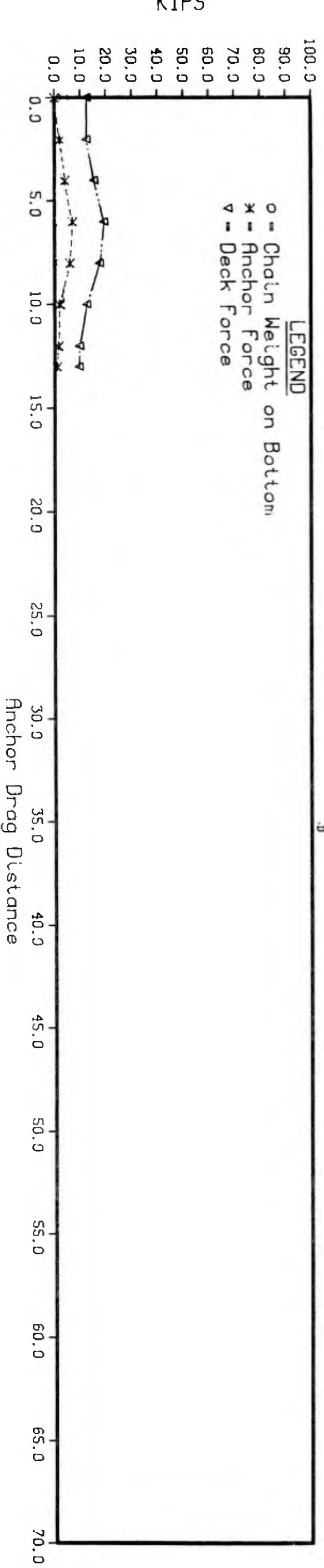
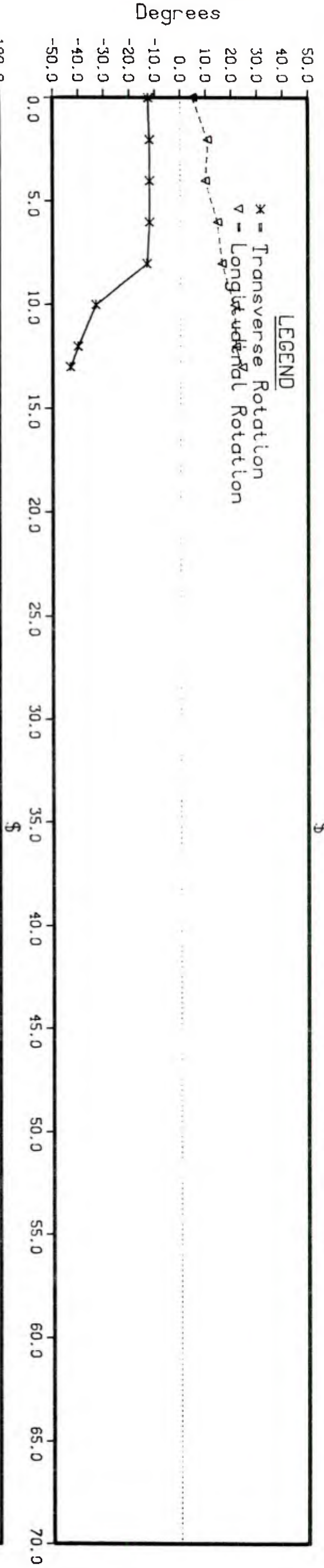
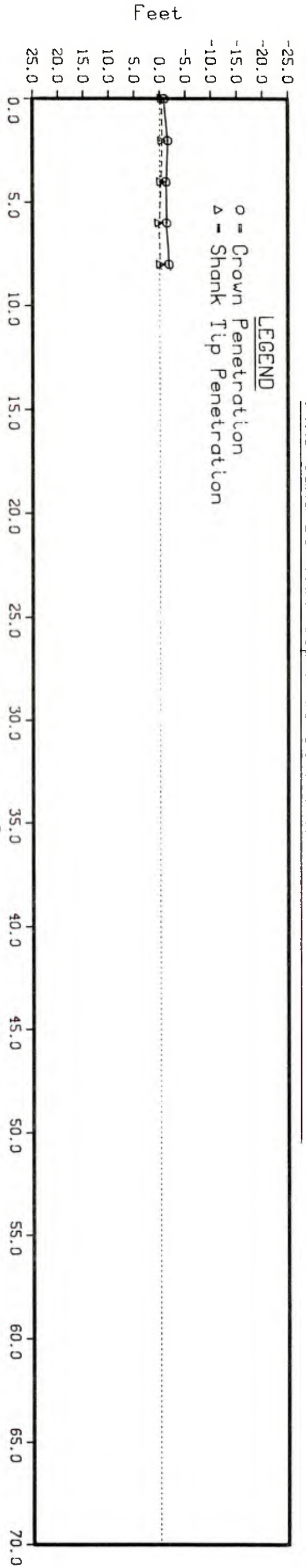

Day # - 95
 Test No. - 1
 Test Series No. - 13

SNR D

STOCKLESS ANCHOR TEST

TEST DATE 95
 TEST NO. 13
 TEST SPEC. CAL DIEGO MARINA 1500 FT. SOUTHWEST OF BAY 49
 TEST AREA 1514 - 1512
 STRUT-FUN TYPE FINE SAND BOTTOM, DEPTH 11-12 FT. MUD
 SEAFLOOR TYPE STOCKLESS 4000LB. STEEL 1750S-4700R/DR. 75 NFG. FT. FLUKE
 ANCHOR TYPE 11370.00 LB.
 ANCHOR WEIGHT 34.00 DR. - 1 02MM IEFIX
 FLUKE ANGLE TYPE 0.00 LR.
 ANCHOR TYPE 0.00 LR.
 ANCHOR WEIGHT 0.00 LR.
 MAIN-LINE ANCHOR SEPARATION 0.00 LR.
 DEEPENING-MAIN-WEIGHT-TOTAL, WT. ANCHOR TO 100FT 2IN. STEELINK CHAIN TO ANCH 2IN. WIRE ROPE
 ANCHORING LINE DESCRIPTION

NOTE - INITIAL CHAIN DEPTH ZEROFT TO REFLECT WEASURED WATERDEPTH

1	2	3	4	5	6	7	8	9	10	11	12	13	14	15
FFFT	KIPG	KIPG	FEFT	NFG	DRG	DRG	KIPG	FEET	LBS	FFFT	FFFT	FFFT	FFFT	LBS
0.0	17.0	4.0	14.2	-4.3	14.0	9.0	16.8	171.0	5432.2	12.7	14.7	16.4	16.4	1702.2
2.0	21.0	4.0	14.8	-4.3	14.0	8.5	16.8	167.7	5375.4	14.7	14.9	17.7	14.8	1770.4
3.2	31.0	1.0	15.4	-1.0	9.3	6.0	10.8	158.7	5051.2	14.5	15.4	17.9	14.8	1570.4
5.5	54.0	15.0	16.2	-1.8	11.5	5.7	40.8	104.5	3325.6	15.1	15.4	18.8	14.8	1421.2
7.7	65.0	45.0	16.2	-1.8	15.5	5.0	44.8	82.5	2626.5	15.1	17.0	18.9	14.8	1385.6
9.1	76.0	51.5	16.5	-1.8	17.5	4.4	75.8	77.3	2641.0	15.0	17.2	19.0	14.9	1381.0
10.8	84.0	50.5	16.3	-1.6	20.0	3.9	67.8	115.2	3456.4	14.5	16.9	18.5	14.9	1503.0
14.8	59.0	15.0	15.9	-1.0	23.0	4.1	62.8	128.0	4073.3	13.8	16.6	18.0	14.8	1540.3
18.8	61.0	15.4	15.6	-0.0	27.0	4.1	59.8	119.0	4787.3	12.9	16.2	17.4	14.9	1517.3
20.8	52.0	35.5	15.4	-0.0	24.0	4.1	59.8	125.8	4001.4	13.0	16.1	17.4	14.8	1531.8
22.8	52.0	34.0	15.7	-0.0	25.0	4.1	51.0	134.7	4287.7	12.8	16.4	17.2	14.8	1565.2
24.9	54.0	40.0	15.7	-0.5	25.5	4.1	48.0	143.7	4283.2	13.2	16.4	17.4	14.8	1544.2
26.9	61.0	46.0	15.7	-5.0	30.0	4.5	44.0	120.2	4092.4	13.3	16.4	17.5	14.8	1538.2
28.8	45.0	24.0	15.5	-5.0	28.8	4.5	48.8	128.1	4095.0	13.0	16.4	17.2	14.8	1638.9
30.9	45.0	32.0	15.3	-3.0	28.2	4.5	41.9	157.6	4595.1	12.9	16.3	17.3	14.8	1638.9
32.8	45.0	27.0	15.2	-3.0	28.2	4.5	47.9	157.6	4595.1	12.9	16.3	17.2	14.8	1638.9
34.9	48.0	31.0	15.4	-2.5	26.5	4.5	47.9	142.2	4595.1	13.0	16.2	17.4	14.8	1580.4
36.9	45.0	31.5	15.4	-2.5	27.0	4.7	45.8	142.2	4595.1	13.1	16.2	17.4	14.8	1580.4
40.9	42.0	27.0	15.4	-3.0	25.8	4.7	41.9	152.4	4825.4	13.1	16.2	17.4	14.8	1620.2
43.0	50.0	31.0	15.7	-2.0	25.0	4.7	49.8	131.8	4190.7	12.4	16.5	17.7	14.8	1554.7
44.9	47.0	30.0	15.8	-2.0	25.8	4.6	46.8	142.1	4522.3	12.5	16.4	17.8	14.8	1582.3
47.0	55.0	38.0	15.8	-2.0	25.8	4.5	54.8	125.0	3976.3	12.5	16.4	17.8	14.8	1534.3
48.9	54.5	37.0	15.8	-2.0	25.8	4.4	54.8	129.2	4110.4	12.5	16.4	17.8	14.8	1540.4
50.9	51.0	33.0	15.5	-2.0	27.0	4.4	50.8	137.6	4378.8	12.3	16.4	17.5	14.8	1574.9

DISTANCE RANGE TRAVELLED 52.0
 DISTANCE ANCHOR TRAVELLED 50.9

NOTE - DIRECTION CHAIN
 ANGLE INDICATES
 CHAIN TO REFLECT
 FROM

Feet

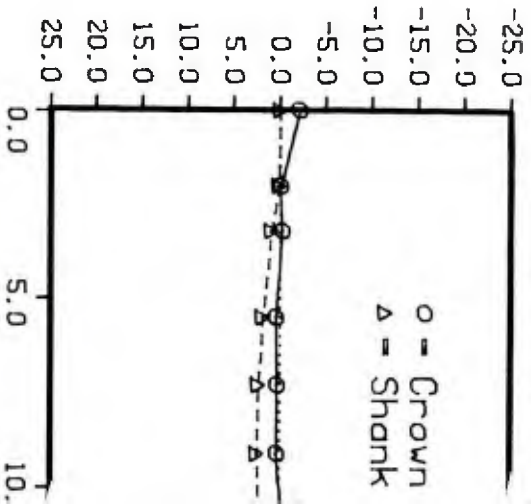

Degrees

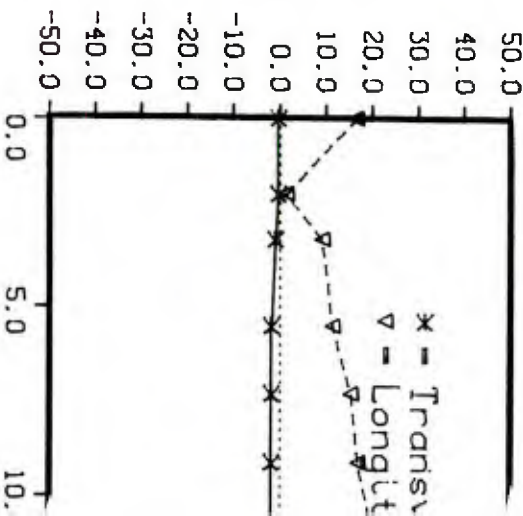

KIPS

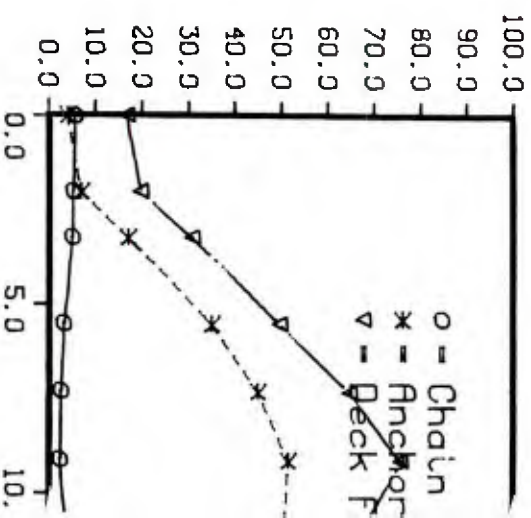

Day # - 95 SAN DIEGO HARBOR 1500 FT. SOUTHEAST OF BUOY 49

Test No. - 1 stockless, 9000lb. stabilizers-670lb/pr. 35 deg. fx. flukes
 Test Series No. - 13 fine sand bottom. depth 11-12 ft. mllw

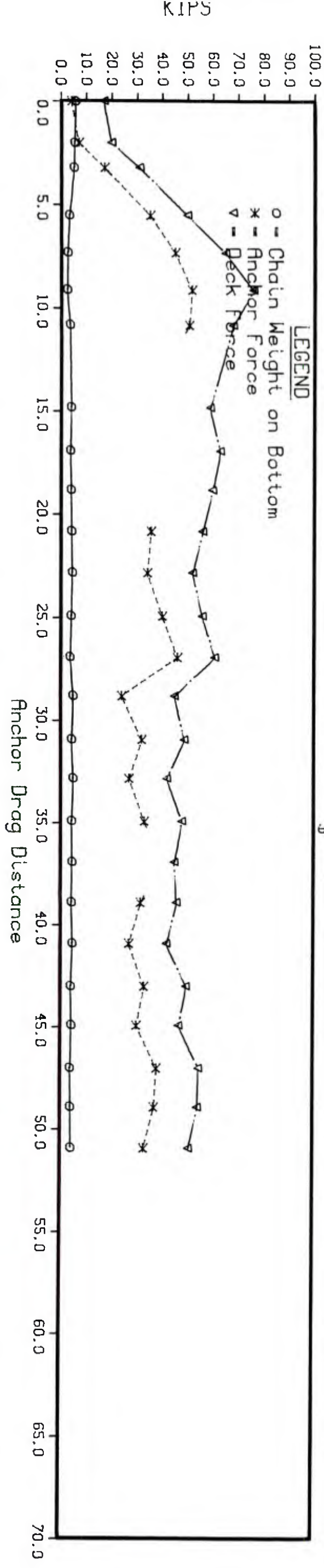
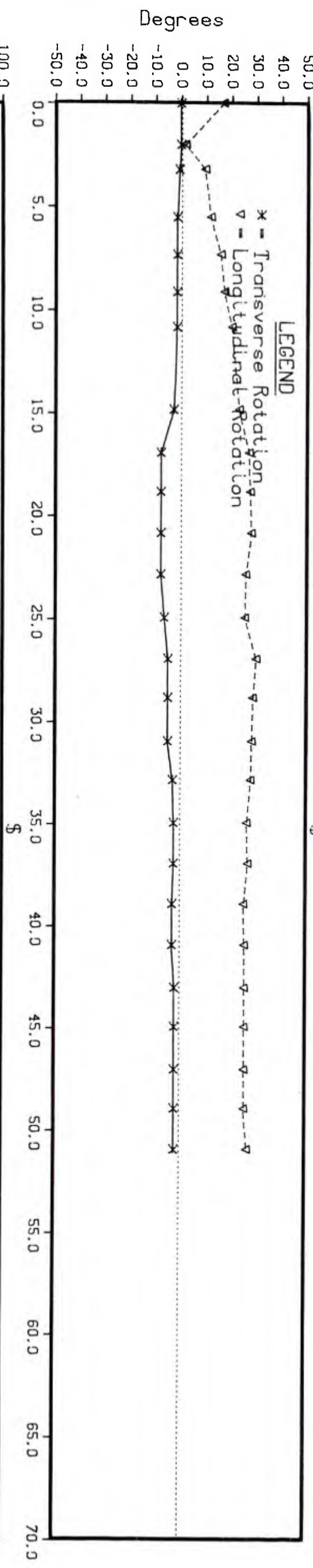
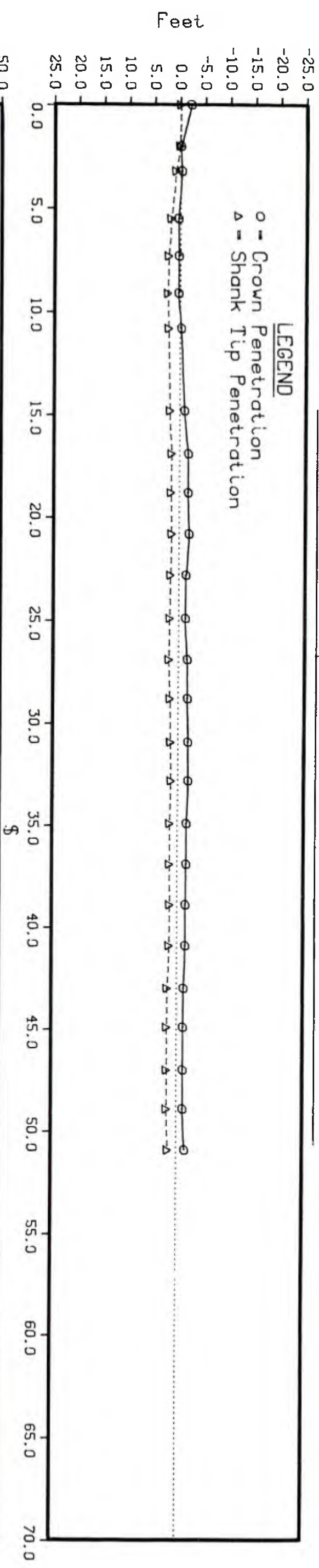

Day # - 95
 Test No. - 2
 Test Series No. - 13

SPAN D

STOCKLESS ANCHOR TEST

TEST DATE 95
 TEST TIME 15
 TEST SPTS 15
 TEST AREA SAN DIEGO MARINA 1500 FT. SOUTHWEST OF BUOY 40
 START-STOP TIME 1546 - 1600
 STATIONING TYPE FINE SAND BOTTOM, DEPTH 11-12 FT. MUD
 ANCHOR TYPE STOCKLESS 10000 LB. STABILIZERS-470LB/PR. 15 DEG. FX. FLUKES
 ANCHOR WEIGHT 11370.00 LB.
 FLUKES AWD/F-TYP* 25.00 DEG. - 1 NEWBY JEFFIX
 AUX. ANCHOR TYPE 0.00 LB.
 AUX. ANCHOR WEIGHT 0.00 PFT
 MAIN-AUX ANCHOR SEPARATION 0.0 LB.
 MDPDSCPS-NO-WT-FACH-TOTAL WT. ANCHOR TO LAOFT 2IN. STABILIZ CHAIN TO ANCHOR 2IN. WIRE ROPE
 WINDING LINE DESCRIPTION

NOTE - INITIAL CHAIN DEPTH ZEROED TO OFFSET WINDROPE

1. DECK DISTANCE	2. DECK TENSION	3. ANCHOR TENSION	4. PACKAGE DEPTH	5. ROTATION ANGLE	6. SHANK ANGLE	7. WIRE ANGLE	8. DECK HOIST ANGLE	9. CHAIN LENGTH ON BOTTOM	10. CHAIN WEIGHT ON BOTTOM	11. ANCHOR CROWN DEPTH	12. ANCHOR SHANK TIP DEPTH	13. ANCHOR FLUKES TIP DEPTH	14. WIRE DEPTH	15. TOTAL BOTTOM WEIGHT
0.0	104.5	5.0	1.1	0.0	-8.2	7.3	19.3	103.5	5813.8	16.4	16.4	13.5	13.5	15.8
2.0	24.0	5.0	14.0	2.5	-2.5	7.3	19.3	183.5	5750.3	16.5	16.5	13.6	13.6	15.8
4.0	24.0	6.0	15.0	2.0	7.5	4.0	22.8	172.5	5688.7	16.7	16.7	14.8	14.8	15.8
7.0	34.0	11.0	15.0	2.5	13.0	5.2	29.8	155.5	4827.5	16.7	16.7	15.2	15.2	15.8
9.4	40.0	15.0	15.0	2.5	13.0	5.2	44.8	132.4	4213.1	16.0	16.0	15.9	15.9	15.8
11.5	75.0	15.0	15.0	2.5	21.0	4.5	59.8	112.6	3584.1	16.0	16.0	16.2	16.2	15.8
13.4	70.0	15.0	15.0	2.5	21.0	3.9	74.8	100.3	3190.5	13.4	16.4	16.4	16.4	15.8
15.4	76.0	15.0	15.0	2.0	23.0	3.7	89.0	118.6	3774.3	13.5	16.4	17.2	17.2	15.8
17.4	71.0	15.0	15.0	2.0	23.0	3.7	75.8	106.4	3387.1	13.5	16.4	17.8	17.8	15.8
19.3	65.0	15.0	15.0	2.0	25.0	3.6	64.0	120.5	3893.5	13.2	16.2	16.4	16.4	15.8
21.3	54.0	14.0	15.0	2.0	25.0	3.6	53.9	132.1	4210.2	13.2	16.2	15.4	15.4	15.8
23.4	66.0	15.0	15.0	2.0	25.0	3.7	65.0	125.7	4672.5	12.7	15.4	16.7	16.7	15.8
25.5	60.0	15.0	15.0	2.0	25.0	4.2	59.8	125.7	4897.3	12.7	15.4	16.2	16.2	15.8
27.4	65.0	15.0	15.0	2.0	25.0	3.9	64.8	121.6	4670.6	13.0	16.1	16.2	16.2	15.8
29.4	85.0	15.0	15.0	2.0	25.0	3.6	84.8	92.8	2854.4	11.0	16.2	16.2	16.2	15.8
31.5	77.5	15.0	15.0	2.5	25.0	3.8	77.3	115.4	4811.8	12.7	16.1	17.2	17.2	15.8
33.3	57.0	18.0	15.0	2.5	28.0	3.5	56.0	151.2	4811.8	12.0	16.1	16.2	16.2	15.8
35.4	61.0	42.0	14.0	2.5	28.0	4.0	49.4	128.0	4836.5	12.1	15.5	15.5	15.5	15.8
37.4	49.5	34.0	14.0	2.5	28.0	4.0	49.4	128.0	4836.5	12.3	15.4	16.6	16.6	15.8
39.5	63.5	46.0	15.0	3.0	25.0	4.1	63.3	117.9	4751.9	12.8	16.0	16.0	16.0	15.8
41.4	55.0	40.0	15.0	3.0	25.0	4.1	63.3	117.9	4359.2	12.9	16.1	16.1	16.1	15.8

DISTANCE RANGE TRAVELLED 42.0
 DISTANCE ANCHOR TRAVELLED 41.4

NOTE - POSITIVE SHANK ANGLE INDICATES SHANK TIP BELOW

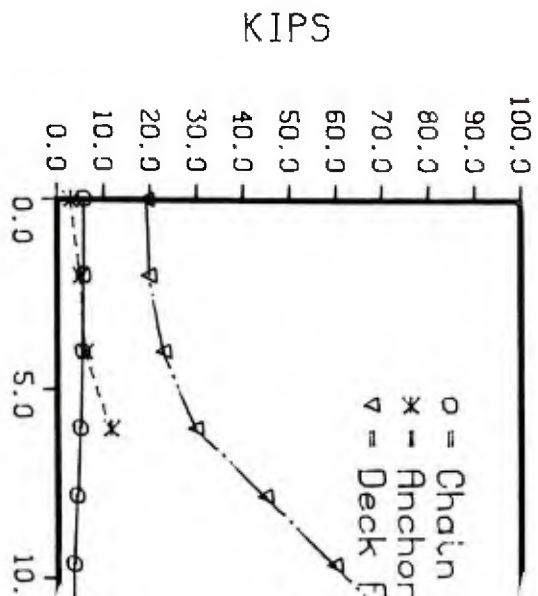
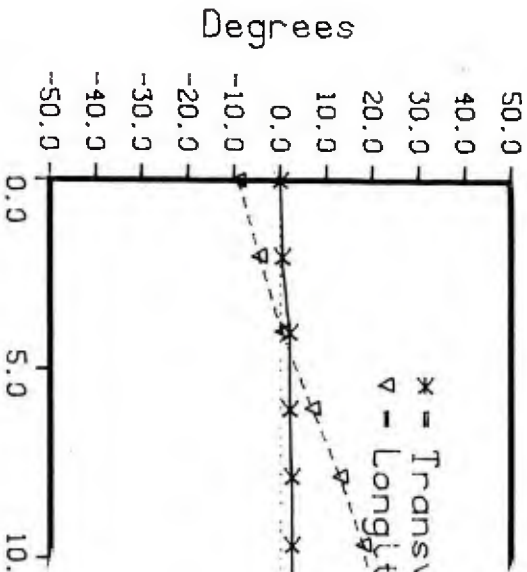
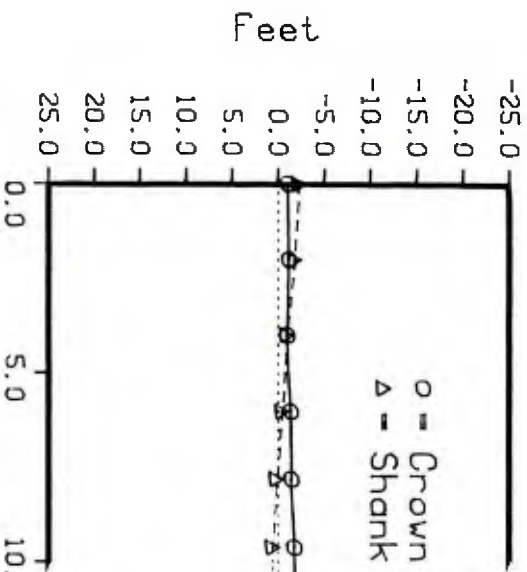

Day # - 95

Test No. - 2

Test Series No. - 13

SAN DIEGO HARBOR 1500 FT. SOUTHEAST OF BUOY 49

stockless, 9000lb. stabilizers-670lb/pr. 35 deg. fx. flukes

fine sand bottom. depth 11-12 ft. mllw

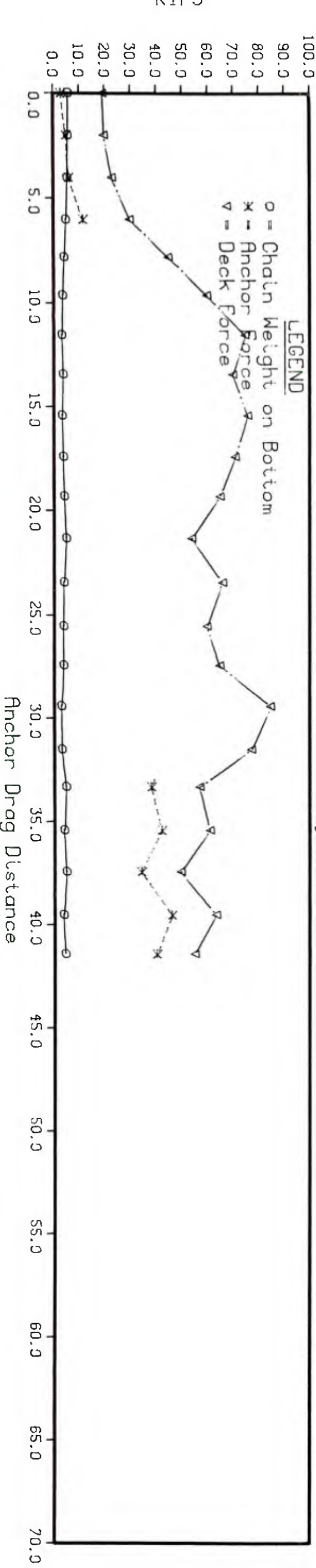
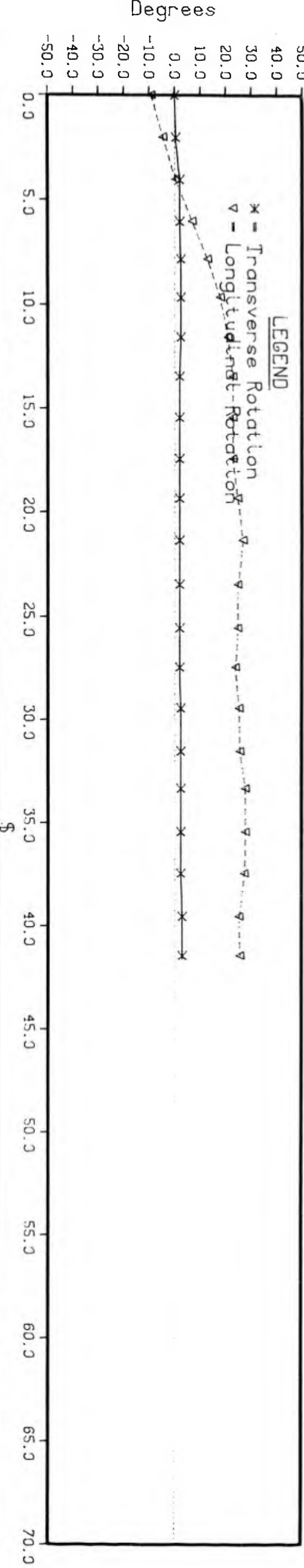
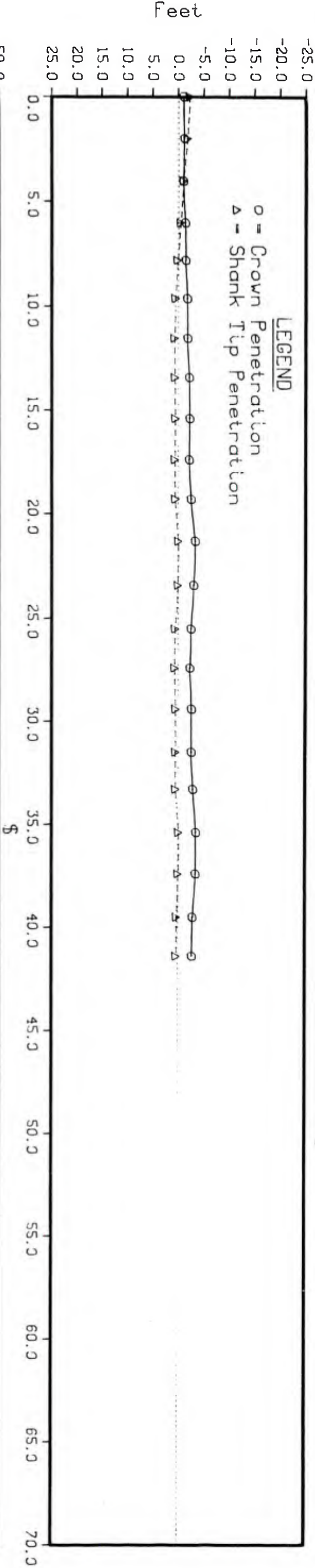

Day # - 95 SRN D
 Test No. - 1
 Test Series No. - 14

STATO ANCHOR TEST

TEST DATE 95
 TEST NO. 1
 TEST SERIES 14
 TEST AREA SAN DIEGO HARBOUR 1500 FT. SOUTHEAST OF QUAY 40
 START-END TIMES 1337 - 1350
 SEAFLOOR TYPE FINE SAND BOTTOM, DEPTH 11-12 FT. MLLW
 ANCHOR TYPE STATO *3000LB., 37 DEG. NOV. FLUMES
 ANCHOR WFLIGHT 3000.00 LB.
 FLUKF ANGLE-TYPE+ 17.00 DEG. - 0 HANOV 1-FIX
 AUX. ANCHOR WFLIGHT 0.00 LB.
 MAIN-ANCHOR SEPARATION 0.00 LB.
 DEPRESSIONS-WFL-EACH-TOTAL WFL. ANCHOR TO LAOFT 21N. STUMLINE CHAIN TO ANOFT 21N. WIRE ROOF
 MONITORING LINE DESCRIPTION

NOTE - INITIAL CHANK DEPTH ZEROED TO EFFECT MEASURED WATERDEPTH

1	2	3	4	5	6	7	8	9	10	11	12	13	14	15	16	17
FFFT	KIPS	KIPS	FEET	DEG	DEG	DEG	KIPS	FEET	LAG	FFFT	FEET	FFFT	FEET	FFFT	FEET	LAG
0.0	17.0	14.5	14.5	-3.5	3.5	9.6	16.8	171.5	5456.5	14.1	16.7	17.9	18.9	14.3	14.3	466.5
4.0	24.0	2.0	15.5	-3.5	3.5	8.1	23.8	154.3	4910.0	15.1	15.7	18.9	14.3	14.3	14.3	7910.5
5.8	25.0	3.0	15.7	-3.5	3.5	7.7	24.8	155.1	4641.9	15.3	15.9	19.1	14.3	14.3	14.3	7941.9
7.8	31.0	2.0	15.8	-3.5	3.5	7.3	29.8	140.8	4479.7	15.4	16.0	19.2	14.3	14.3	14.3	7429.7
9.7	31.0	5.0	16.1	-3.5	3.5	7.1	30.8	140.2	4460.0	15.7	16.3	19.5	14.3	14.3	14.3	7660.0
11.7	32.0	8.0	15.4	-3.5	3.5	7.0	31.8	138.0	4191.8	13.9	16.2	18.6	14.3	14.3	14.3	7391.8
13.6	44.0	16.0	16.2	-3.5	3.5	6.2	43.7	111.2	3539.6	14.6	17.0	19.1	14.3	14.3	14.3	6539.6
15.5	49.0	20.0	16.2	-3.5	3.5	5.9	48.7	102.3	3254.8	14.7	17.0	19.2	14.3	14.3	14.3	6254.8
17.5	57.0	25.5	16.4	-3.5	3.5	5.7	56.7	82.7	2630.4	14.8	17.2	19.4	14.3	14.3	14.3	5630.4
19.3	65.0	31.0	16.4	-3.5	3.5	5.1	64.7	79.0	2513.5	14.7	17.5	19.4	14.3	14.3	14.3	5513.5
21.1	60.0	30.0	16.4	-3.5	3.5	4.9	59.8	99.5	3166.8	14.0	17.6	19.0	14.3	14.3	14.3	6166.8
22.9	38.0	21.0	16.4	-7.0	19.0	4.9	77.9	158.6	5085.8	14.3	17.5	18.0	14.3	14.3	14.3	6085.8
25.1	35.0	17.0	15.9	-10.0	20.0	5.5	74.9	155.2	4937.0	14.3	17.5	18.0	14.3	14.3	14.3	7937.0
26.6	15.0	3.0	15.7	-37.0	16.8	8.9	14.9	151.6	6827.9	14.3	17.5	18.0	14.3	14.3	14.3	9827.9
29.7	15.0	3.0	15.3	-41.0	16.5	8.9	14.8	218.0	5970.9	14.3	17.5	18.0	14.3	14.3	14.3	8970.9
31.8	15.0	3.0	15.4	-44.0	18.3	8.9	15.8	193.8	5816.2	14.3	17.5	18.0	14.3	14.3	14.3	8816.2
34.9	15.0	3.0	16.1	-44.0	20.0	8.7	14.8	226.0	6022.7	14.3	17.5	18.0	14.3	14.3	14.3	9022.7
37.9	12.0	5.0	16.1	-44.0	20.0	8.9	14.8	197.8	5841.7	14.3	17.5	18.0	14.3	14.3	14.3	8841.7
39.8	19.0	6.0	16.7	-44.0	20.0	8.5	17.8	177.0	5631.0	14.3	17.5	18.0	14.3	14.3	14.3	8631.0

DISTANCE RANGE TRAVELLED 40.0
 DISTANCE ANCHOR TRAVELLED 39.8

NOTE - POSITIVE SHANK
 ANGLE INDICATES
 CHANK TIP BELOW
 CRUSH

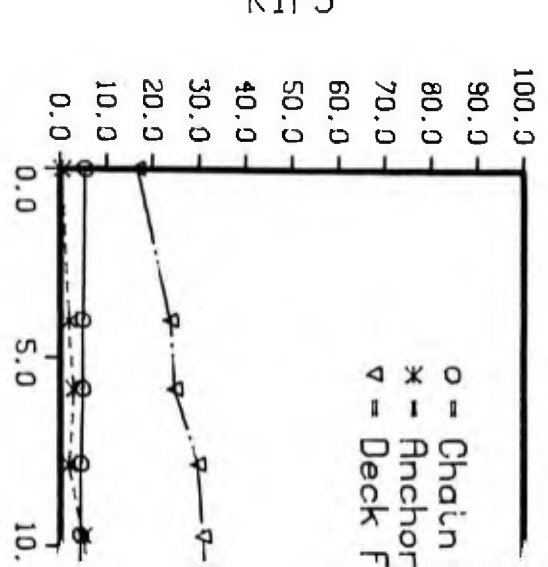
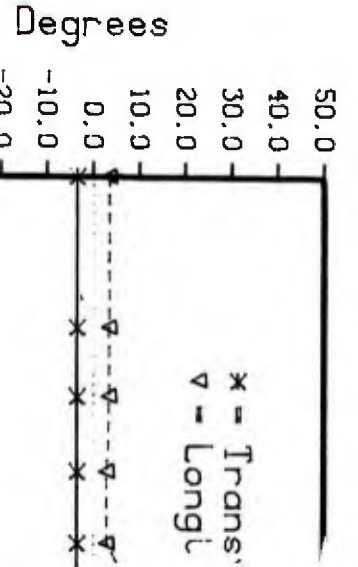
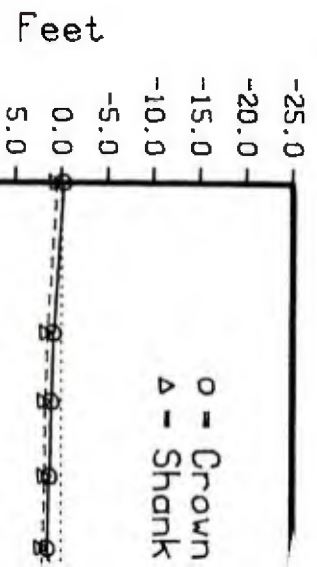

Day # - 95 SAN DIEGO HARBOR 1500 FT. SOUTHEAST OF BUOY 49

Test No. - 1 state , 3000lb. 37 deg. mov. flukes

Test Series No. - 14 fine sand bottom. depth 11-12 ft. mllv

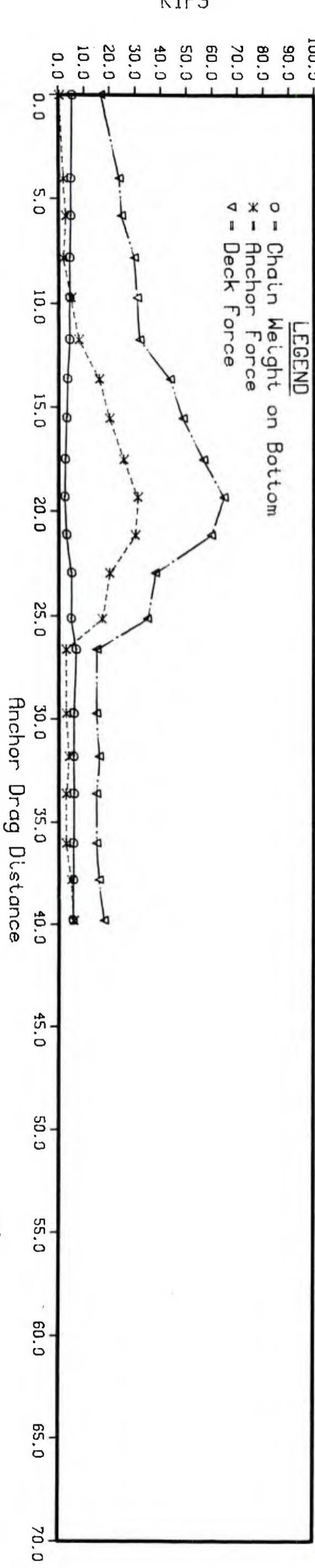
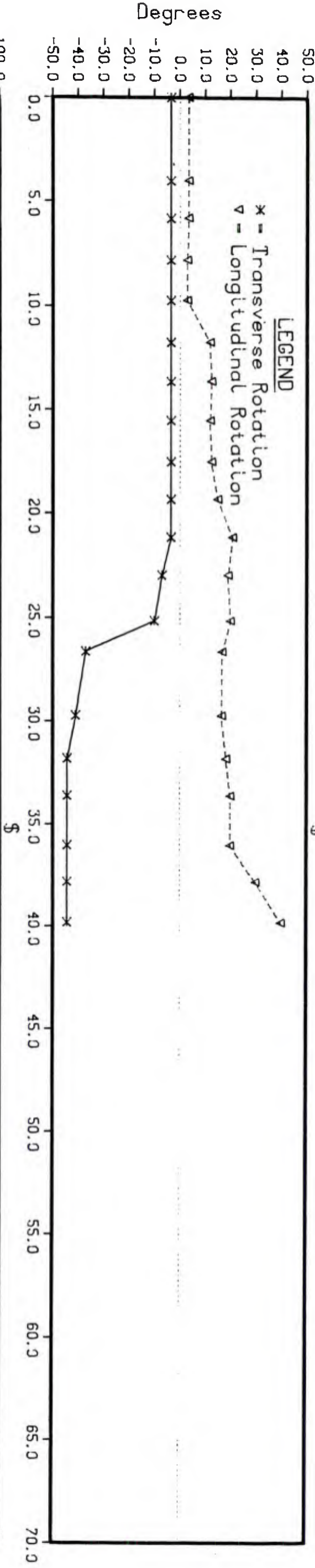
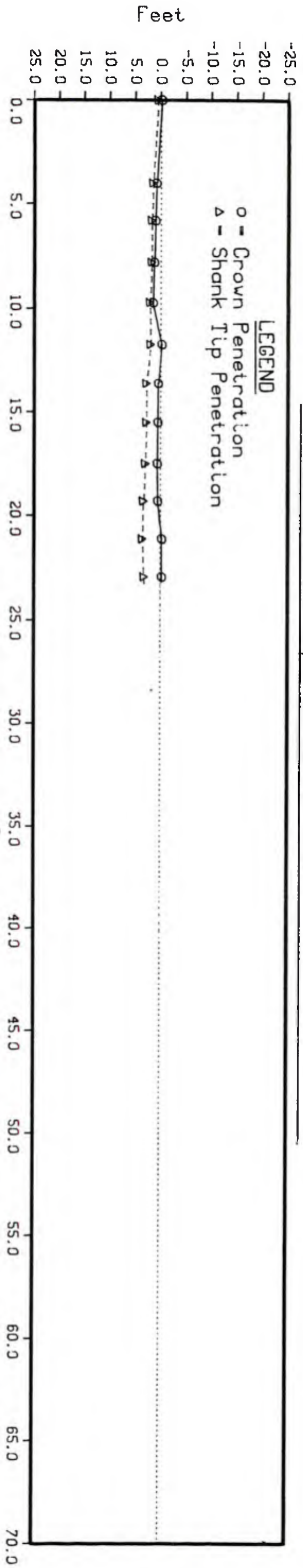

Day # - 95

SRN D

Test No. - 2

Test Series No. - 14

TEST DATE 95
 TEST NO. 2
 TEST AREA SAN DIEGO MARINA 1500 FT. SOUTHWEST OF QUAY 40
 STATION NUMBER 1415
 STATION TYPE TIME SANN BOTTOM, DEPTH 11-12 FT. MLLW
 ANCHOR TYPE STATION *10001P, 37 DEG. MAG. FLUMES
 ANCHOR WEIGHT 3000.00 LB.
 FLUMER ANGLE-TYPE 7.20 DEG. - 0
 FLUMER ANGLE-TYPE 0.00 DEG.
 AUX. ANCHOR TYPE 0.00 DEG.
 AUX. ANCHOR WEIGHT 0.00
 MAIN-AUX ANCHOR SEPARATION 0.00 FT.
 DEPTH-NO.-WT.-FACT-TOTAL WT. ANCHOR TO TANK PIV. STAIN INK CHAIN TO GANTRY PIV. WIRE GANTRY
 MOVING LINE DESCRIPTION

NOTE - INITIAL SHANK DEPTH ZEROED TO PERFECT MEASURED WATERDEPTH

1	2	3	4	5	6	7	8	9	10	11	12	13	14	15
FFFT	WLOC	KLOC	FFFT	DEG	DEG	WLOC	WLOC	EFFT	LOC	FFFT	FFFT	FFFT	FFFT	LOC
1	2	3	4	5	6	7	8	9	10	11	12	13	14	15
0.0	14.0	5.0	14.0	-3.5	3.6	4.5	15.0	311.1	5026.4	17.6	17.4	16.1	16.1	8024.4
2.0	20.0	9.0	13.5	-2.5	13.4	7.8	19.2	175.3	5077.3	11.9	14.2	16.4	16.1	8577.3
4.0	28.0	13.0	14.2	-2.0	12.0	6.8	29.4	148.9	4719.5	12.7	15.0	17.2	16.1	7719.5
5.0	31.0	14.0	14.5	0.0	11.5	5.1	50.4	118.1	3758.0	13.1	15.2	17.5	16.1	4758.0
6.0	32.0	14.0	14.1	0.0	14.0	4.8	49.8	102.8	3270.9	15.0	17.6	17.6	16.1	4270.9
7.0	32.0	14.0	14.0	18.0	14.0	4.5	44.8	125.0	3074.3	15.0	17.6	17.6	16.1	4074.3
8.0	27.0	11.0	13.0	19.0	13.0	4.0	26.0	327.5	4032.9	14.0	17.0	17.0	14.0	3032.9
9.0	20.0	7.0	13.0	44.0	13.0	6.3	19.0	572.6	4084.0	14.0	17.0	17.0	14.0	3084.0
10.0	17.0	7.0	13.0	44.0	13.0	6.3	19.0	572.6	4084.0	14.0	17.0	17.0	14.0	3084.0
11.0	17.0	7.0	13.0	44.0	13.0	6.3	19.0	572.6	4084.0	14.0	17.0	17.0	14.0	3084.0
12.0	17.0	7.0	13.0	44.0	13.0	6.3	19.0	572.6	4084.0	14.0	17.0	17.0	14.0	3084.0
13.0	17.0	7.0	13.0	44.0	13.0	6.3	19.0	572.6	4084.0	14.0	17.0	17.0	14.0	3084.0
14.0	17.0	7.0	13.0	44.0	13.0	6.3	19.0	572.6	4084.0	14.0	17.0	17.0	14.0	3084.0
15.0	17.0	7.0	13.0	44.0	13.0	6.3	19.0	572.6	4084.0	14.0	17.0	17.0	14.0	3084.0

DISTANCE ANCHOR TOAVLLEN 14.0

DISTANCE ANCHOR TOAVLLEN 14.0

NOTE - POSITIVE CURVE
 ANCHOR INDICATES
 CHAIN TIP REGION

Feet

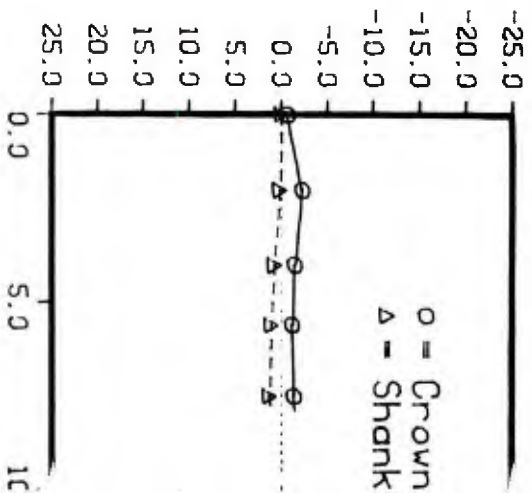

Degrees

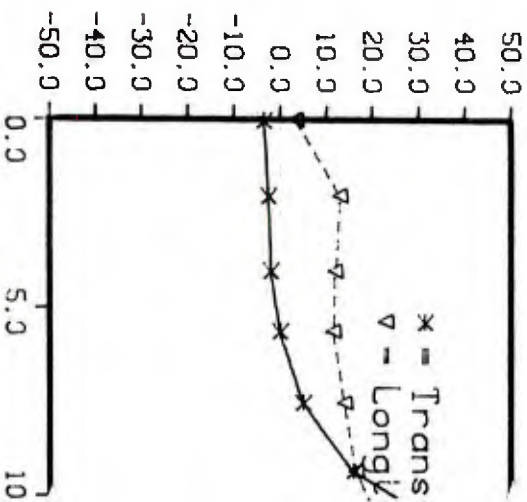

KIPS

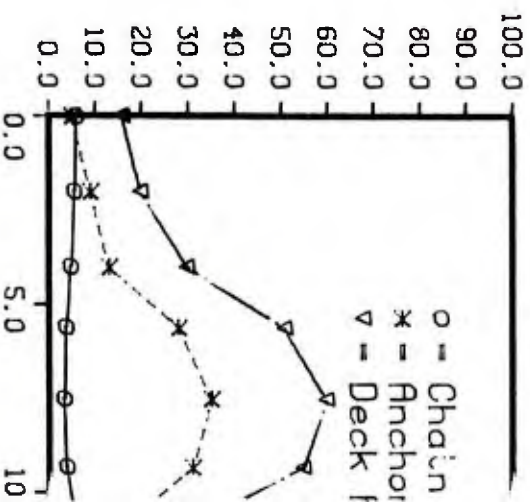

Day # - 95

SAN DIEGO HARBOR 1500 FT. SOUTHEAST OF BUOY 49

Test No. - 2

stato , 3000lb. 37 deg. mov. flukes

Test Series No. - 14

fine sand bottom. depth 11-12 ft. mllv

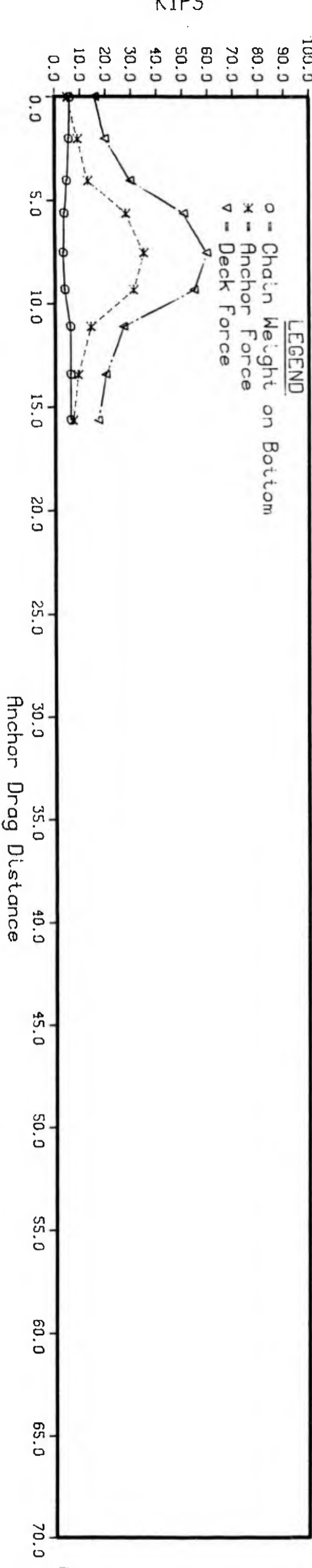
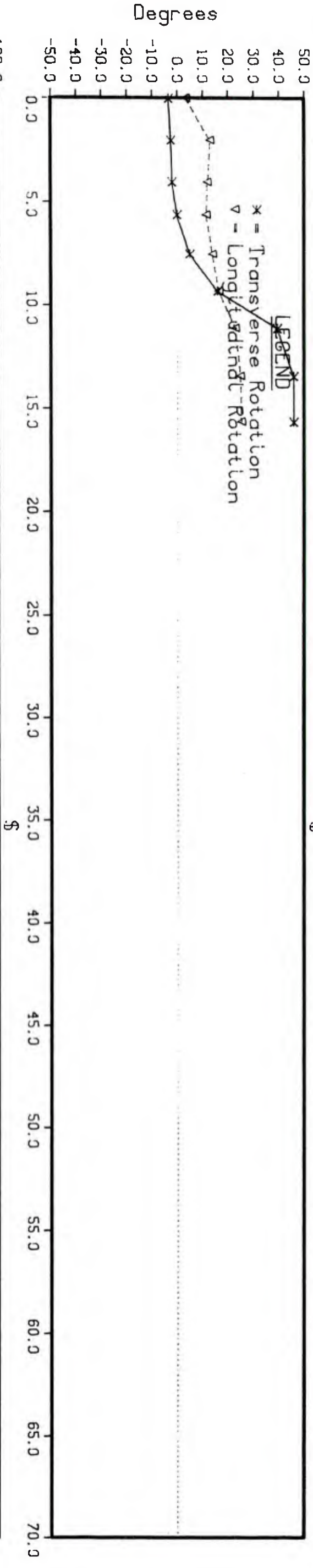
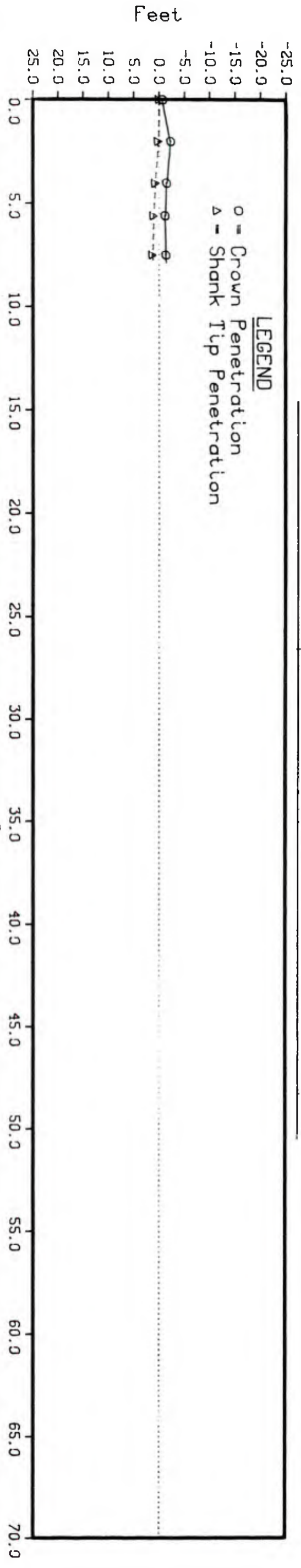

Day # = 99
 Test No. = 2
 Test Series No. = 6

SRN

TEST DATE 99
 TEST NO. 2
 TEST SPECIES
 TEST DEPT 1500
 STABILIZER TYPE
 ANCHOR TYPE
 ANCHOR WEIGHT
 FLUXE ANGL TYPE
 AUX ANCHOR TYPE
 AUX ANCHOR WEIGHT
 MAIN-AUX ANCHOR SEPARATION
 DEPRESSION--WT. FACT--TOTAL WT.
 HOODING LINE DESCRIPTION

STATN ANCHOR TEST

99
 2
 SAN DIEGO HARBOUR 1500 FT. SOUTHWEST OF BUOY 40
 101A - 1013
 FINE SAND BOTTOM. DEPTH 11-12 FT., MLLW
 START 1000.00 LB. *1000 R. 2# IN. STABILIZER 35 DEG. WIND FLUXE
 15.00 DEG. - 0 0=NOV 1#FTX
 0.00 1#R.
 0.00 0.00 - 0.00 1#R.
 ANCHOR TO 100FT 21W. STABILIZER CHAIN TO 400FT 21W. WIND ONDE

NOTE - INITIAL SHANK DEPTH REPORT TO DEFLCT W/ASQUERD WATERDEPTH

1	2	3	4	5	6	7	8	9	10	11	12	13	14	15
FEET	X TIPS	WIPES	FEET	DEG	DEG	DEG	X TIPS	FEET	LB	FFFT	FFFT	FFFT	FFFT	LB
1. DEAG DISTANCE	2. DECK ELEVATION	3. ANCHOR TENSION	4. PACKAGE DEPTH	5. ROTATION ANGLE	6. SHANK ANGLE	7. WIP DEPTH	8. CHAIN LENGTH ON BOTTOM	9. CHAIN WEIGHT ON BOTTOM	10. WIND DEPTH	11. ANCHOR CROWN DEPTH	12. ANCHOR SHANK TIP DEPTH	13. ANCHOR FLUXE TIP DEPTH	14. WIND DEPTH	15. TOTAL BOTTOM WEIGHT
0.0	14.0	6.0	14.3	-5.5	7.0	10.7	178.9	5402.3	14.5	14.5	14.5	14.5	14.5	14.5
2.0	10.5	10.0	14.0	-5.5	7.5	9.1	19.3	163.7	5207.5	14.5	14.5	14.5	14.5	14.5
4.0	21.0	11.0	14.0	-5.5	9.0	8.2	20.8	166.4	5296.4	14.5	14.5	14.5	14.5	14.5
6.0	23.0	11.5	13.0	-5.0	12.0	7.9	22.8	161.2	5130.4	14.5	14.5	14.5	14.5	14.5
8.0	11.0	6.0	13.0	-5.0	12.0	8.2	10.0	135.2	4722.7	14.5	14.5	14.5	14.5	14.5
11.0	11.0	6.0	12.0	10.0	12.0	10.5	10.8	167.3	4287.0	14.5	14.5	14.5	14.5	14.5
15.0	11.0	6.0	13.0	20.0	20.0	10.6	10.8	264.3	4268.1	14.5	14.5	14.5	14.5	14.5
18.0	11.0	6.0	13.0	30.0	30.0	10.5	10.8	259.7	4469.2	14.5	14.5	14.5	14.5	14.5
17.0	11.0	6.0	12.0	30.0	30.0	10.8	10.8	258.4	4230.4	14.5	14.5	14.5	14.5	14.5
19.0	11.0	6.0	13.0	13.0	13.0	10.4	10.8	259.4	4230.4	14.5	14.5	14.5	14.5	14.5
22.0	14.0	10.0	13.0	15.0	15.0	10.4	10.8	267.7	4401.3	14.5	14.5	14.5	14.5	14.5
23.0	25.0	12.0	13.0	13.0	13.0	8.3	26.7	197.8	4682.7	14.5	14.5	14.5	14.5	14.5
25.0	25.0	12.0	13.0	13.0	13.0	7.3	26.8	160.7	5115.0	14.5	14.5	14.5	14.5	14.5
26.0	15.0	0.0	13.0	13.0	13.0	7.5	15.0	264.2	4203.2	14.5	14.5	14.5	14.5	14.5
29.0	14.0	0.0	13.0	23.0	23.0	9.5	13.8	219.5	4980.9	14.5	14.5	14.5	14.5	14.5

UNIT - POSITIVE SHANK
 ANGLE INDICATES
 SHANK TIP RPLN
 POSITIVE

DISTANCE RANGE TRAVELLED 30.0
 DISTANCE ANCHOR TRAVELLED 29.6

Feet

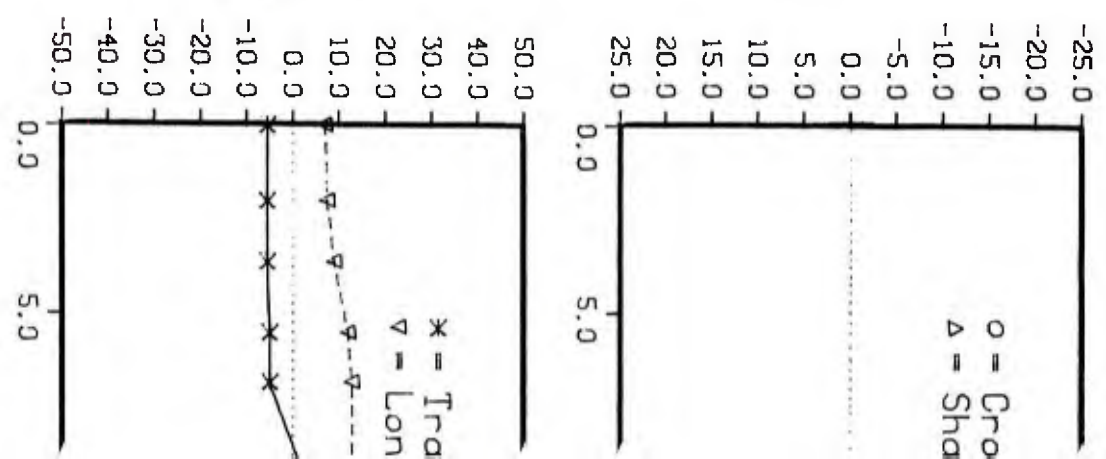

Degrees

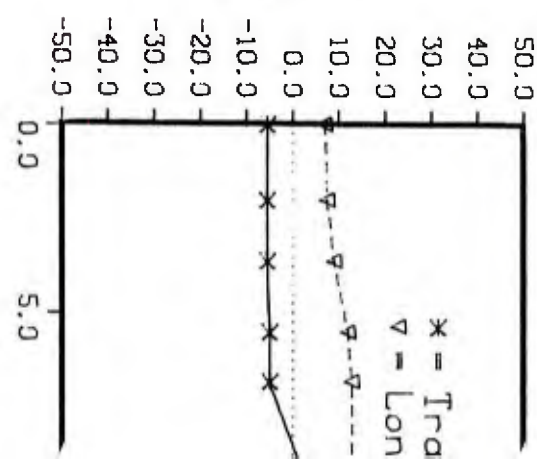

KIPS

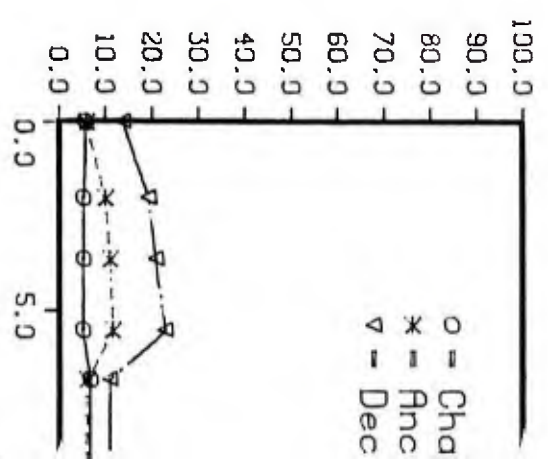

Day # = 99 SAN DIEGO HARBOR 1500 FT. SOUTHEAST OF BUOY 49
 Test No. = 2 state ,1000lb. 26 in. stabilizers 35 deg. mov. flukes
 Test Series No. = 6 fine sand bottom. depth 11-12 ft. mllw

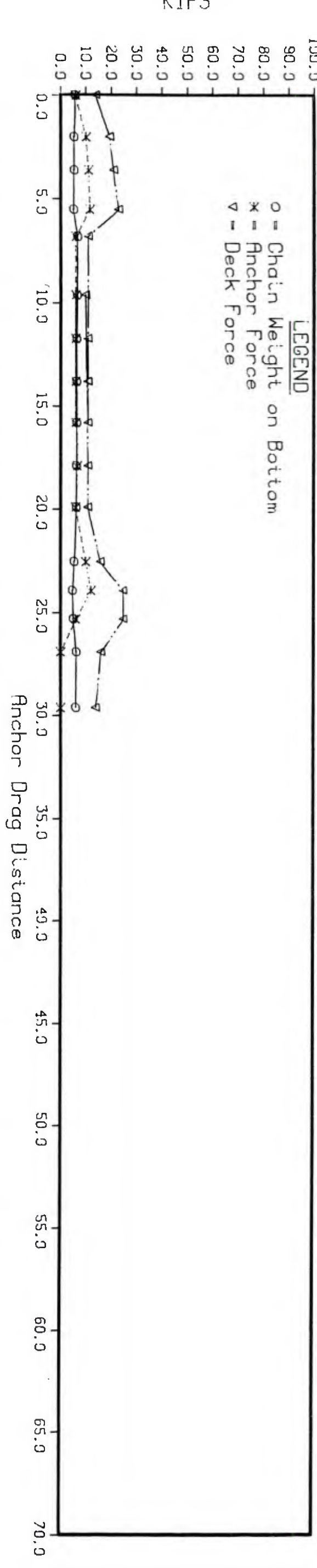
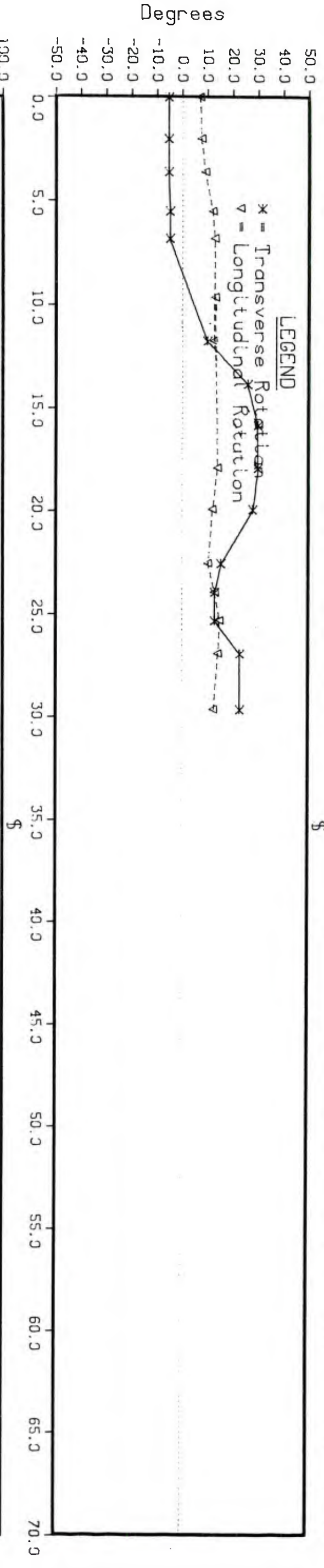
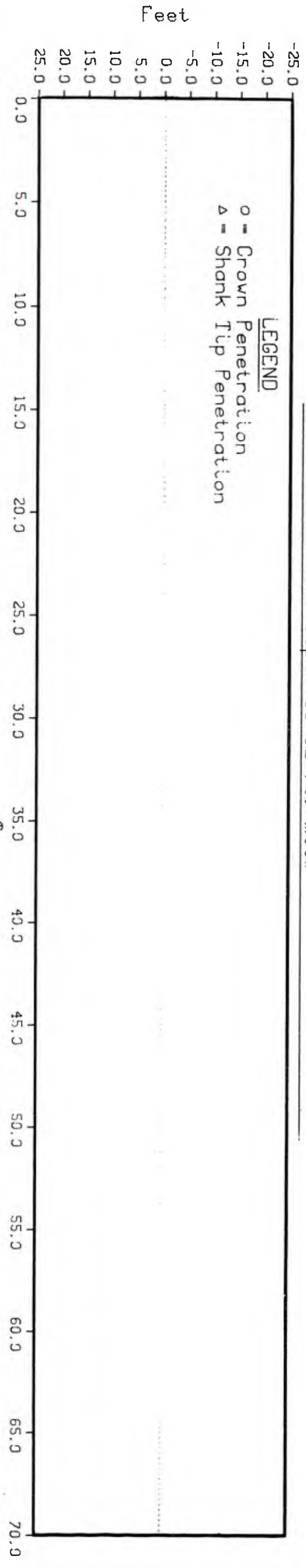

Day # - 100

SPN 1

Test No. = 3

Test Series No. = 14

TEST DATE
TEST NO.
TEST DEPTH
TEST AREA
START-STOP TIMES
SFACTOR TYPE
ANCHOR TYPE
ANCHOR WEIGHT
FLUX ANGLE-TYPE
AUX. ANCHOR TYPE
AUX. ANCHOR WEIGHT
MAIN-AUX ANCHOR SEPARATION
NEAREST-ANCHOR-WEIGHT-TOTAL WT.
ANCHOR IN DESCRIPTION

STATO ANCHOR TEST

100
3(PART 1)
SUN DIEGO MARINA 1500 FT. SOUTHWEST OF BUNY 40
Q30 - LINS
FINE SAND BOTTOM, DEPTH 11-12 FT., MLW
STATO *TONN B, 18 IN, STABILIZERXXI, 17 NFA, NOV, FLURES
3000.00 LB, 0
17.00 NFA - 0
0.00 LB,
0.0 FEET
0.0 - 0.0 LB,
ANCHOR TO HOFT 2IN, STAINLESS CHAIN TO ANCH 2IN, WIPF BOFF

NOTE - INITIAL SHANK DEPTH ZERO TO DEFLECT WEASURED WATERDEPTH

1. BALL DISTANCE	2. DRK TENSION	3. ROTATION ANGLE	4. CHAIN ANGLE	5. CHAIN LENGTH ON BOTTOM	6. CHAIN WEIGHT ON BOTTOM	7. ANCHOR FLUX TIP DEPTH	8. ANCHOR DEPTH	9. ANCHOR WEIGHT	10. ANCHOR WEIGHT TIP DEPTH	11. ANCHOR WEIGHT	12. ANCHOR WEIGHT	13. ANCHOR WEIGHT	14. ANCHOR WEIGHT	15. ANCHOR WEIGHT	16. ANCHOR WEIGHT	17. ANCHOR WEIGHT	18. ANCHOR WEIGHT	19. ANCHOR WEIGHT	20. ANCHOR WEIGHT	
0.0	27.0	5.0	18.7	62.0	30.0	6.2	20.0	168.0	5175.4											
4.0	74.0	10.0	18.1	62.0	21.0	3.3	44.0	161.0	5151.0											
7.0	64.0	17.0	15.1	79.0	21.0	3.9	60.0	114.2	3872.6											
9.0	70.0	40.0	15.4	79.0	20.0	51.0	60.0	107.0	4800.5											
11.7	69.0	25.0	15.0	75.0	25.0	4.0	51.0	107.0	4801.4											
13.7	34.0	0.0	15.1	62.0	31.0	4.0	31.0	253.2	4198.7											
15.7	25.0	0.0	15.0	42.0	30.0	5.6	28.0	173.6	5661.7											
18.0	29.0	0.0	14.8	42.0	30.0	5.6	27.0	176.2	5607.0											
19.0	28.0	0.0	14.7	42.0	30.0	5.6	27.0	176.2	5607.0											
22.1	33.5	9.0	14.8	42.0	28.0	5.5	24.0	155.2	4937.0											
24.1	35.0	6.0	14.8	42.0	28.0	5.5	24.0	155.2	4937.0											
26.1	35.0	7.0	14.8	42.0	28.0	5.5	24.0	155.2	4937.0											
28.0	28.0	1.0	14.4	42.0	28.0	5.3	24.0	159.0	5058.4											
29.9	28.0	1.0	14.4	42.0	28.0	5.3	24.0	159.0	5058.4											
32.0	32.0	3.0	15.0	42.0	32.0	5.4	21.0	164.2	5224.5											
34.1	34.0	6.0	14.8	42.0	31.0	5.4	20.0	154.1	4803.7											
36.1	34.0	7.0	14.8	42.0	29.0	5.4	20.0	154.1	4803.7											
38.1	44.0	10.0	15.0	42.0	25.0	4.7	43.0	197.3	6486.9											
39.0	44.0	11.0	15.0	42.0	21.0	4.4	43.0	197.3	6486.9											
42.0	54.0	24.0	15.2	42.0	21.0	4.4	43.0	197.3	6486.9											
43.0	39.5	16.5	15.4	41.3	26.0	4.4	43.0	197.3	6486.9											
47.8	39.5	16.5	15.2	41.0	24.0	4.4	43.0	197.3	6486.9											
49.8	35.0	15.0	15.5	42.0	30.0	4.6	39.0	172.4	5241.2											
51.0	34.0	10.0	15.4	42.0	31.0	4.9	37.0	158.6	5045.4											
53.0	34.5	15.0	15.4	42.0	31.0	5.1	34.0	164.2	5224.5											
56.0	35.0	14.0	15.1	42.0	28.0	5.3	34.0	164.2	5224.5											
58.0	29.0	18.0	15.0	42.0	25.0	5.2	28.0	149.5	4754.0											
60.1	44.0	14.0	14.4	42.0	23.0	5.1	43.0	171.7	4280.0											
62.0	44.0	20.0	14.0	42.0	23.0	4.0	42.0	142.4	4248.9											
64.0	44.0	15.0	13.7	42.0	23.0	4.7	42.0	142.4	4248.9											
66.0	39.5	15.0	13.7	42.0	23.0	4.7	42.0	142.4	4248.9											
68.0	39.5	15.0	13.7	42.0	23.0	4.7	42.0	142.4	4248.9											
69.0	44.0	22.0	13.4	42.0	23.0	4.7	43.0	153.1	5025.0											
70.0	44.0	22.0	13.4	42.0	23.0	4.7	43.0	153.1	5025.0											
72.0	44.0	22.0	13.4	42.0	23.0	4.7	43.0	153.1	5025.0											
74.0	44.0	22.0	13.4	42.0	23.0	4.7	43.0	153.1	5025.0											

NOTE - POSITIVE SHANK ANGLE INDICATE SHANK TIP BELOW CHAIN

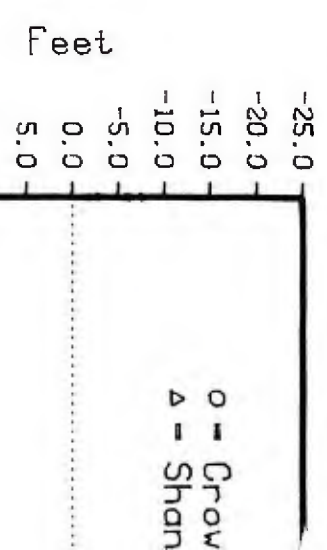
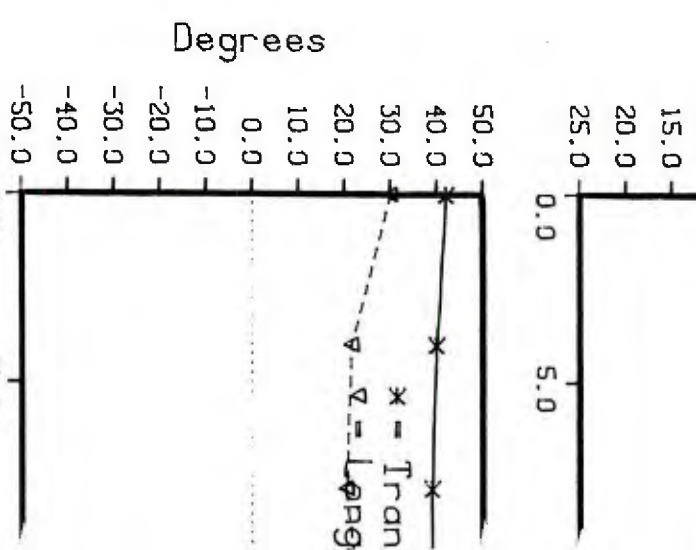

KIPS

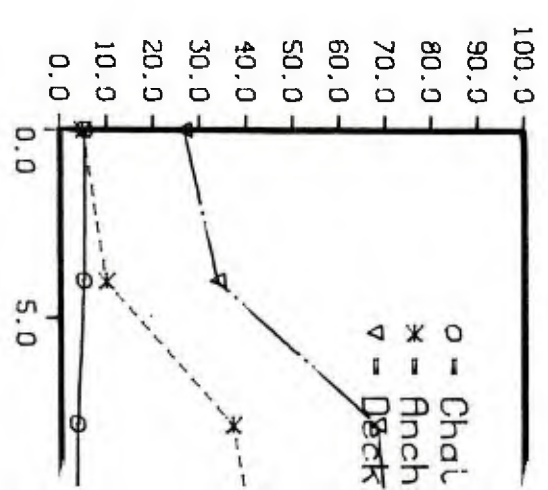

Day # - 100 SAN DIEGO HARBOR 1500 FT. SOUTHEAST OF BUOY 49

Test No. - 3 state, 3000lb. 18 in. stabilizerext. 37 deg. mov. flukes
 Test Series No. - 14 fine sand bottom. depth 11-12 ft. mllw

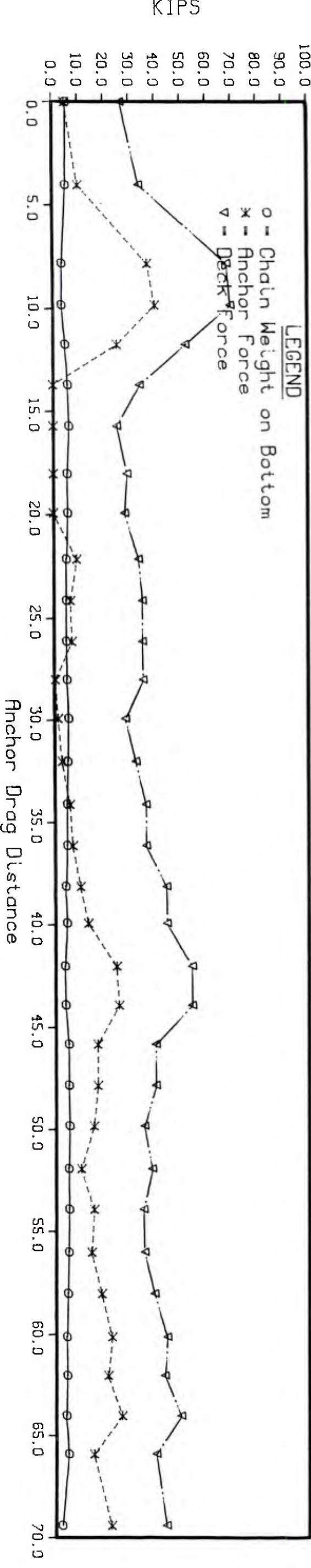
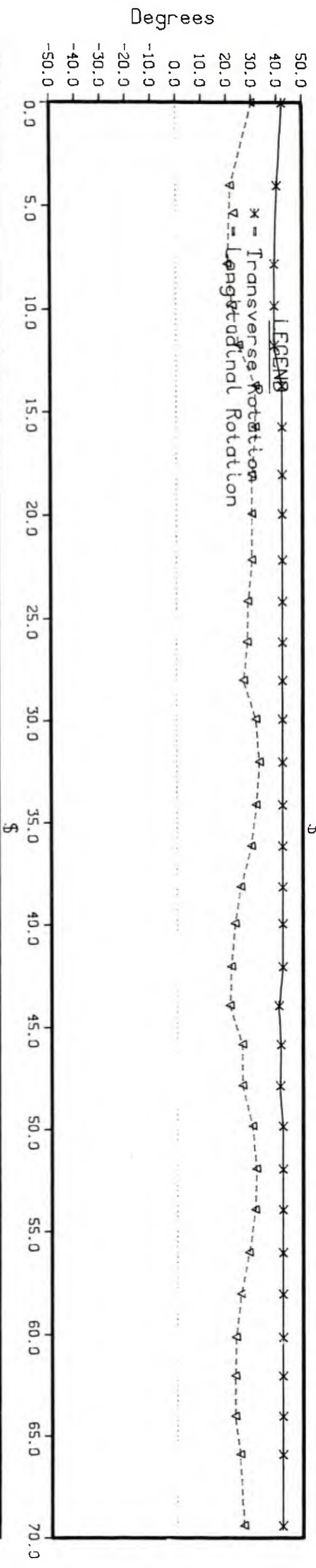
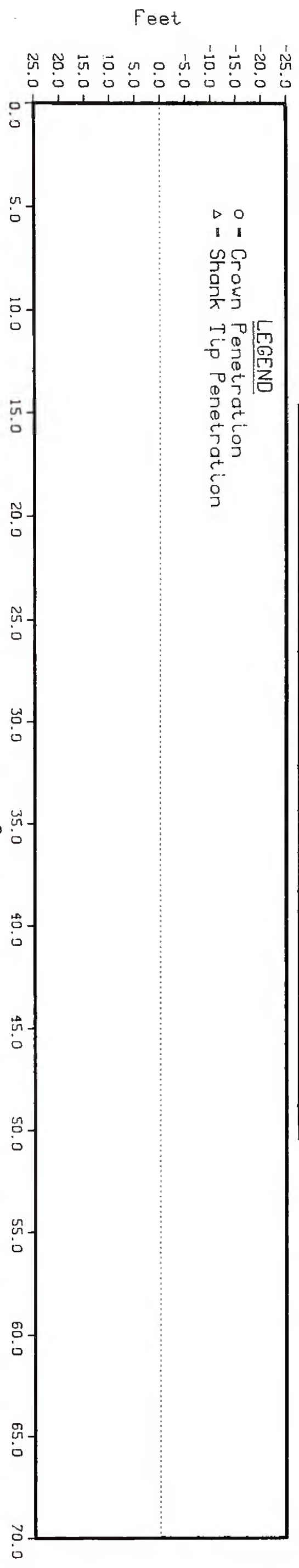

Day # = 100

SAN DIEGO HARBOR 1500 FT. SOUTHEAST OF BUOY 49

Test No. = 3

Test Series No. = 14

stato , 3000lb. 18 in. stabilizext, 37 deg. mov. flukes
fine sand bottom. depth 11-12 ft. mllw

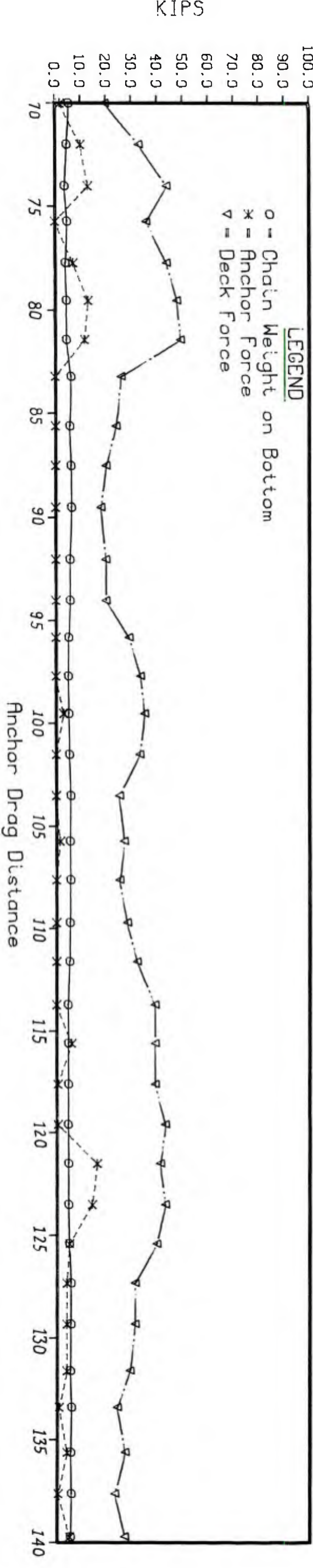
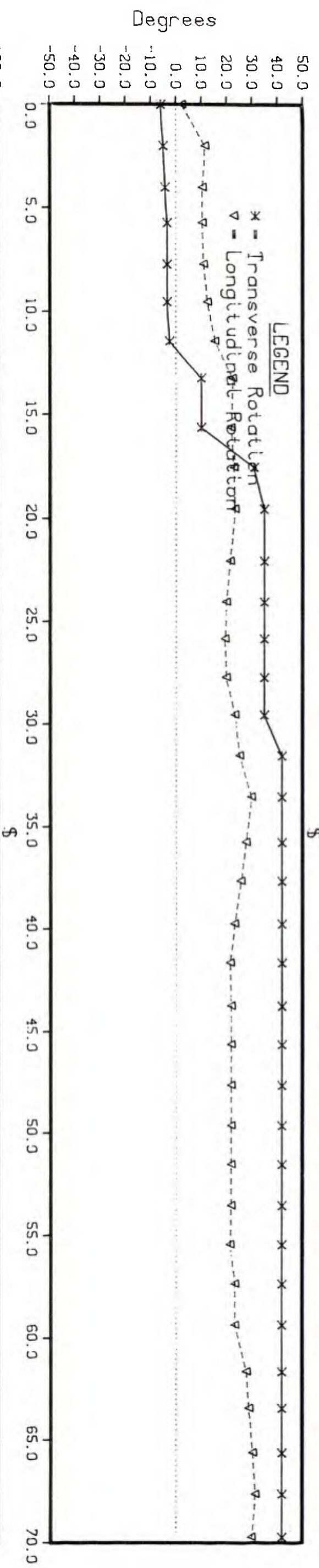
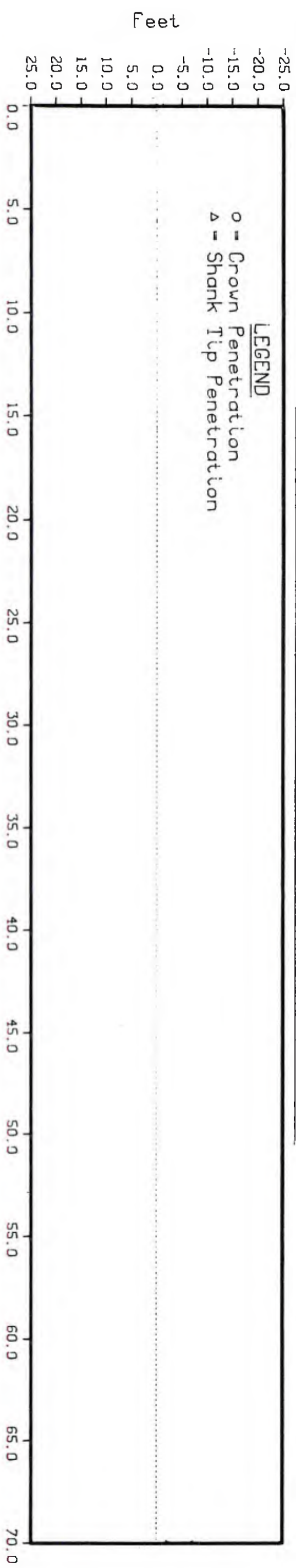

Day # = 100

SAN DIEGO HARBOR 1500 FT. SOUTHERST OF BUOY 49

Test No. = 4

stato , 3000lb. 18 in. stabilizerext. 31.5deg.mov. flukes

Test Series No. = 14

fine sand bottom. depth 11-12 ft. mllw

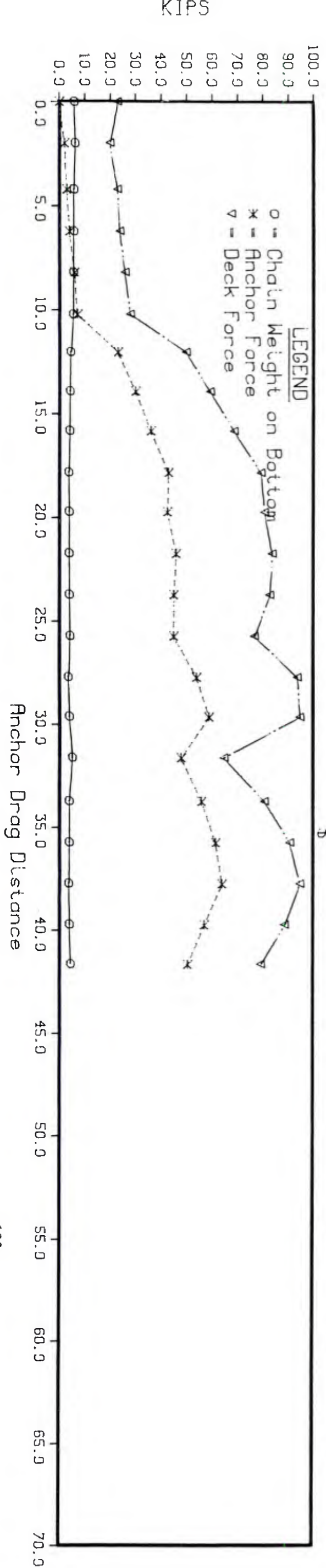
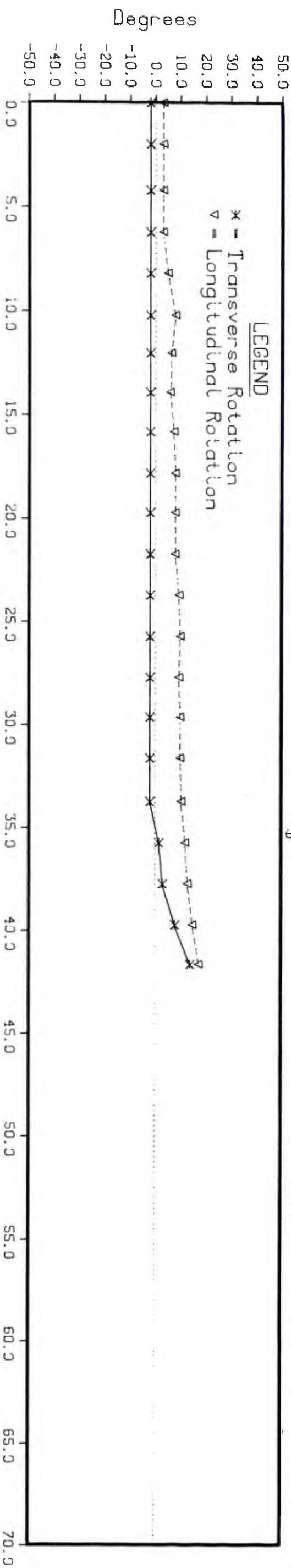
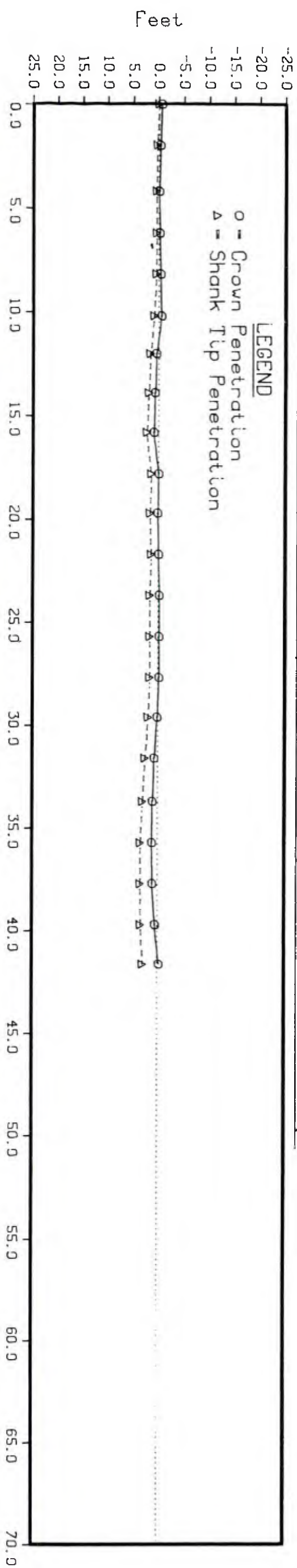

Day # - 100
 Test No. - 5
 Test Series No. - 14

SRN L

TEST DATE 100
 TEST NO. 5
 TEST SITE 14 DIEGO HARBOUR 1500 FT. SOUTHWEST OF QUAY 49
 TEST SEAS 1400-1450
 SEAFLOOR TYPE FINE SAND BOTTOM, DEPTH 11-12 FT. MLW
 ANCHOR TYPE 3000.00 LB. NORMAL STABILIZERS 31.50CG.MOV. FLUKES
 ANCHOR WEIGHT 71.50 DEG. LB. 0.5MOV 3.5FTX
 FLUKE ANGLE-TYPE 0.00 1A.
 AUX. ANCHOR TYPE 0.00 FEET 0.0 LB.
 MAIN-AUX ANCHOR SEPARATION 0.00 FEET 0.0 LB.
 DEPRESSION-AUX-TYPE-EACH-TOTAL WT. ANCHOR TO 1A0FT 21W. STUJLW CHAIN TO 40FT 21W. WJOF ROPF
 MORNING LINE DESCRIPTION

NOTE - INITIAL CHANK DEPTH ZEROED TO REFLECT MEASUREMENT

1	2	3	4	5	6	7	8	9	10	11	12	13	14	15
FEET	KIPG	KIPG	FEET	DEG	DEG	DEG	VJOF	FEET	LB	FEET	FEET	FEET	FEET	LB
1.	2.	3.	4.	5.	6.	7.	8.	9.	10.	11.	12.	13.	14.	15.
Node DISTANCE	NECK TENSION	ANCHOR TENSION	ROTATION ANGLE	SHANK ANGLE	WJOF ANGLE	CHAIN LENGTH ON BOTTOM	CHAIN WEIGHT ON BOTTOM	ANCHOR WEIGHT ON BOTTOM	ANCHOR PROW DEPTH	ANCHOR SHANK TIP DEPTH	ANCHOR FLUKE TIP DEPTH	WJOF DEPTH	TOTAL BOTTOM WEIGHT	
0.0	15.0	0.0	12.5	-4.5	10.5	7.8	17.8	198.9	5288.7	13.2	15.2	17.1	15.2	8848.7
5.0	32.0	0.0	12.5	-4.5	10.5	6.5	11.8	146.7	4669.1	13.7	15.6	17.6	15.2	7688.1
10.0	32.0	0.0	12.5	-4.5	10.5	5.3	10.8	147.2	4659.1	14.1	16.1	18.1	15.2	7688.1
15.0	32.0	0.0	12.5	-4.5	10.5	5.0	10.8	147.2	4659.1	14.4	16.3	18.4	15.2	7688.1
20.0	32.0	0.0	12.5	-4.5	10.5	4.8	10.8	147.2	4659.1	14.7	16.4	18.5	15.2	7688.1
25.0	32.0	0.0	12.5	-4.5	10.5	4.7	10.8	147.2	4659.1	14.7	16.4	18.5	15.2	7688.1
30.0	32.0	0.0	12.5	-4.5	10.5	4.6	10.8	147.2	4659.1	14.7	16.4	18.5	15.2	7688.1
35.0	32.0	0.0	12.5	-4.5	10.5	4.5	10.8	147.2	4659.1	14.7	16.4	18.5	15.2	7688.1
40.0	32.0	0.0	12.5	-4.5	10.5	4.4	10.8	147.2	4659.1	14.7	16.4	18.5	15.2	7688.1
45.0	32.0	0.0	12.5	-4.5	10.5	4.3	10.8	147.2	4659.1	14.7	16.4	18.5	15.2	7688.1
50.0	32.0	0.0	12.5	-4.5	10.5	4.2	10.8	147.2	4659.1	14.7	16.4	18.5	15.2	7688.1
55.0	32.0	0.0	12.5	-4.5	10.5	4.1	10.8	147.2	4659.1	14.7	16.4	18.5	15.2	7688.1
60.0	32.0	0.0	12.5	-4.5	10.5	4.0	10.8	147.2	4659.1	14.7	16.4	18.5	15.2	7688.1
65.0	32.0	0.0	12.5	-4.5	10.5	3.9	10.8	147.2	4659.1	14.7	16.4	18.5	15.2	7688.1
70.0	32.0	0.0	12.5	-4.5	10.5	3.8	10.8	147.2	4659.1	14.7	16.4	18.5	15.2	7688.1
75.0	32.0	0.0	12.5	-4.5	10.5	3.7	10.8	147.2	4659.1	14.7	16.4	18.5	15.2	7688.1
80.0	32.0	0.0	12.5	-4.5	10.5	3.6	10.8	147.2	4659.1	14.7	16.4	18.5	15.2	7688.1
85.0	32.0	0.0	12.5	-4.5	10.5	3.5	10.8	147.2	4659.1	14.7	16.4	18.5	15.2	7688.1
90.0	32.0	0.0	12.5	-4.5	10.5	3.4	10.8	147.2	4659.1	14.7	16.4	18.5	15.2	7688.1
95.0	32.0	0.0	12.5	-4.5	10.5	3.3	10.8	147.2	4659.1	14.7	16.4	18.5	15.2	7688.1
100.0	32.0	0.0	12.5	-4.5	10.5	3.2	10.8	147.2	4659.1	14.7	16.4	18.5	15.2	7688.1

WJOF - POSITIVE SHANK ANGLE INDICATES SHANK TIP RISE FROM

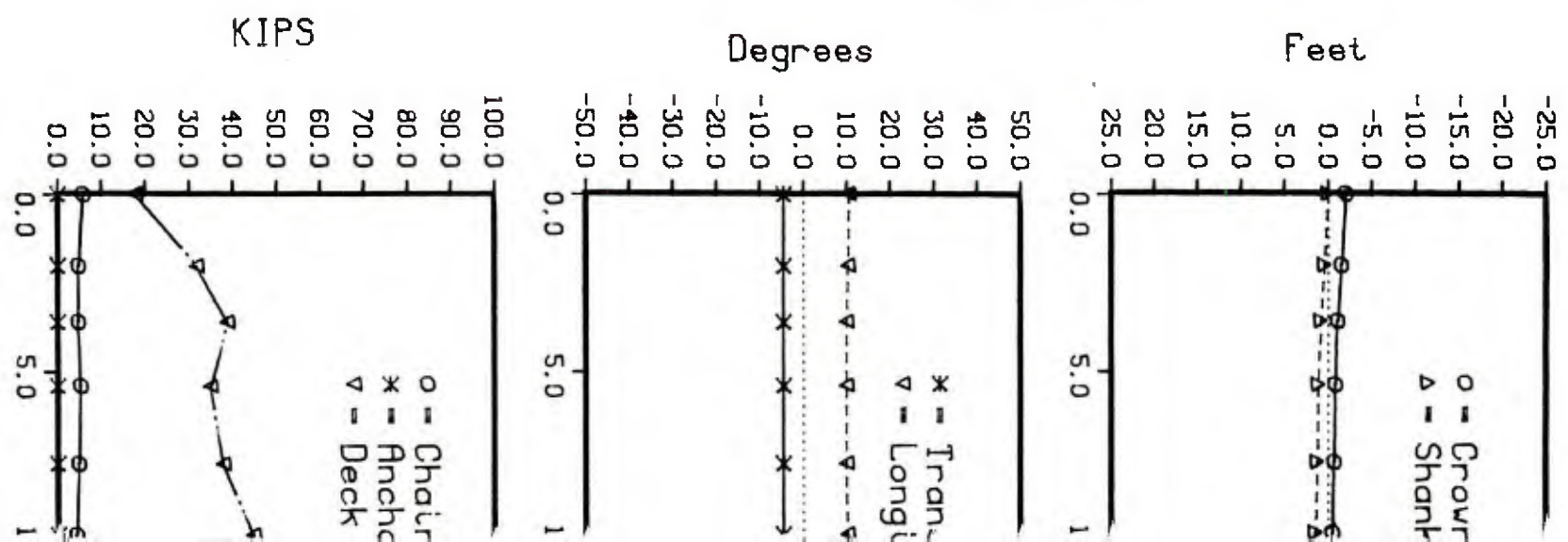

Day # - 100

SAN DIEGO HARBOR 1500 FT. SOUTHEAST OF BUOY 49

Test No. - 5

stato 3000lb. normal stabilizers 31.5deg.mov. flukes

Test Series No. - 14

fine sand bottom. depth 11-12 ft. mllw

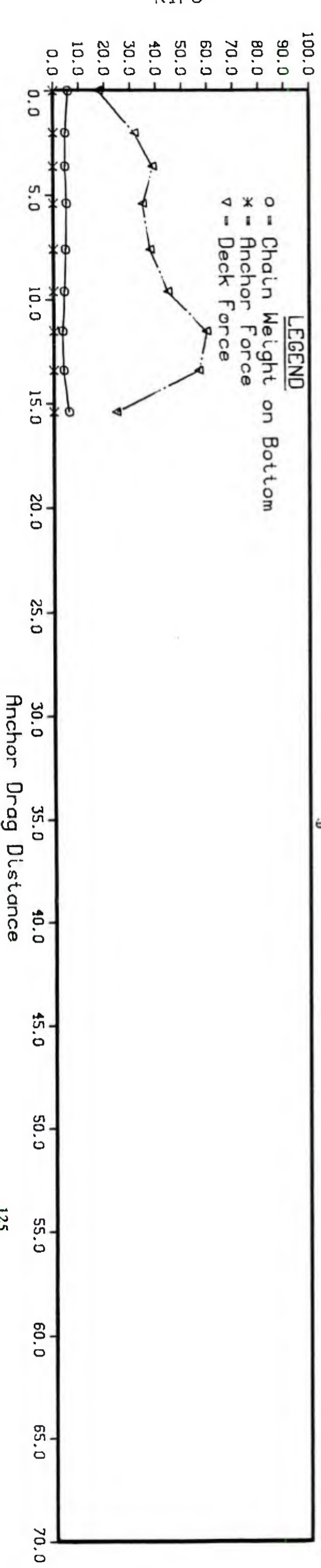
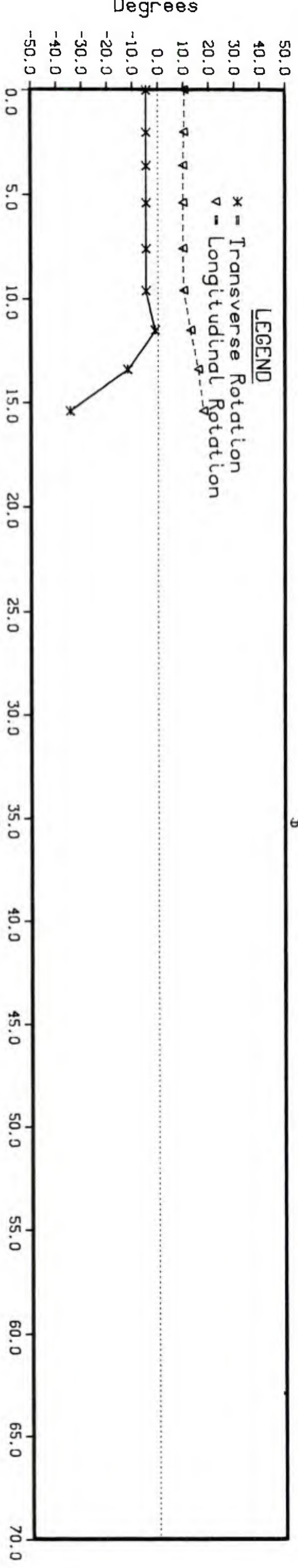
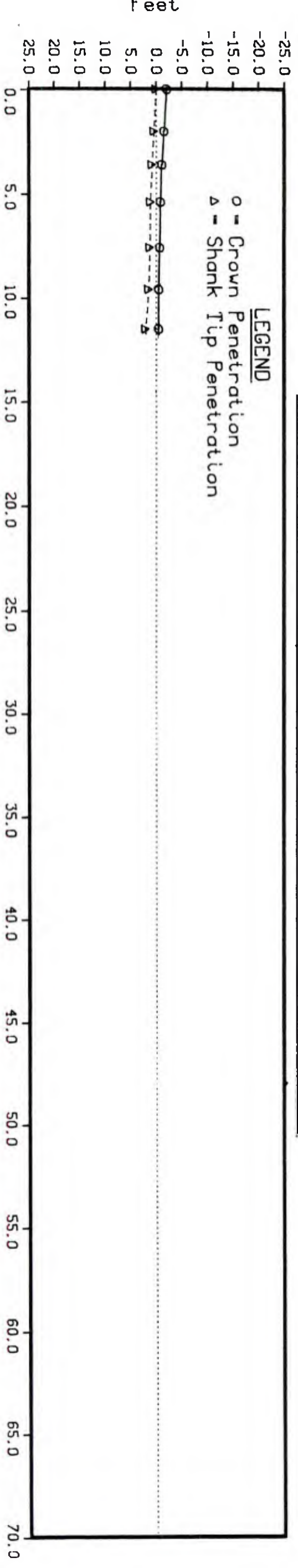

Day # = 101
 Test No. = 1
 Test Series No. = 19

SPAN DIE

TEST DATE	TEST NO.	TEST NO.	TEST NO.
101	101	101	101
TEST SERIES	19	19	19
TEST AREA	SPAN DIE	SPAN DIE	SPAN DIE
START-END TIMES	1101 - 1122	1101 - 1122	1101 - 1122
SEAT/FLOOR TYPE	FINE SAND BOTTOM, DEPTH 11-12 FT. MUD	FINE SAND BOTTOM, DEPTH 11-12 FT. MUD	FINE SAND BOTTOM, DEPTH 11-12 FT. MUD
ANCHOR TYPE	6000LB. NORMAL STABILIZERS	6000LB. NORMAL STABILIZERS	6000LB. NORMAL STABILIZERS
ANCHOR WEIGHT	32 DEG. MOV. FLUKES	32 DEG. MOV. FLUKES	32 DEG. MOV. FLUKES
FLUKE ANGLE/TYPE	32.00 DEG.	32.00 DEG.	32.00 DEG.
AUX. ANCHOR TYPE	0.00 LB.	0.00 LB.	0.00 LB.
AUX. ANCHOR WEIGHT	0.0 FEET	0.0 FEET	0.0 FEET
AUX. ANCHOR SEPARATION	0.0 LB.	0.0 LB.	0.0 LB.
DEPRESSIONS/NO. OF EACH-TOTAL WT.	ANCHOR TO LAIFT 2.5 IN. STUD LINK CHAIN TO 340FT PIN WIRE ROPE	ANCHOR TO LAIFT 2.5 IN. STUD LINK CHAIN TO 340FT PIN WIRE ROPE	ANCHOR TO LAIFT 2.5 IN. STUD LINK CHAIN TO 340FT PIN WIRE ROPE
MOORING LINE DESCRIPTION			

NOTE - INITIAL SHANK DEPTH ZEROED TO REFLECT UNASSIGNED WATERDEPTH

1. DRAG DISTANCE	2. DECK TENSION	3. ANCHOR TENSION	4. PACKAGE DEPTH	5. ROTATION ANGLE	6. SHANK ANGLE	7. WIRE ROPE ANGLE	8. DECK HORIZ. FORCE	9. CHAIN LENGTH ON BOTTOM	10. CHAIN LENGTH ON BOTTOM	11. ANCHOR CROWN DEPTH	12. ANCHOR SHANK TIP DEPTH	13. ANCHOR FLUKE TIP DEPTH	14. WATF DEPTH	15. TOTAL BOTTOM WEIGHT
0.0	20.0	0.0	14.9	-4.5	5.4	7.3	19.8	172.8	18.2	15.1	18.5	15.1	15.1	1465.1
2.0	38.5	7.5	14.9	-4.3	4.0	5.0	18.3	145.9	14.4	15.2	18.6	15.1	15.1	1331.7
4.0	44.5	11.3	14.9	-4.3	3.2	5.6	44.3	136.9	14.5	15.1	18.6	15.1	15.1	1284.0
6.0	49.5	15.0	14.6	-2.5	10.5	5.4	49.3	130.6	13.2	15.4	18.0	15.1	15.1	1254.0
7.2	65.0	25.0	15.0	-2.5	8.0	4.9	64.8	112.7	10.9	15.6	18.5	15.1	15.1	1165.1
9.7	80.0	37.5	15.1	-2.5	7.0	4.3	79.8	103.9	10.1	15.8	18.9	15.1	15.1	1124.8
11.6	107.0	57.5	15.1	-2.5	7.4	3.9	101.8	85.1	10.7	15.8	18.9	15.1	15.1	1024.8
13.4	138.0	67.5	15.1	-2.5	8.0	3.7	107.8	84.5	10.7	16.1	19.0	15.1	15.1	980.6
15.5	120.0	80.0	15.5	-2.5	8.0	3.5	119.8	77.4	10.4	16.1	19.0	15.1	15.1	940.6
17.5	124.0	85.0	15.5	-3.5	9.0	3.4	129.8	76.8	10.4	16.2	19.0	15.1	15.1	940.6
19.5	130.0	91.3	15.6	-4.5	10.0	3.4	129.8	76.8	10.4	16.2	19.0	15.1	15.1	940.6
21.5	132.0	93.0	15.6	-4.5	10.0	3.3	131.8	71.9	10.4	16.2	19.0	15.1	15.1	940.6
23.5	131.0	94.4	15.5	-8.5	11.5	3.3	130.8	66.7	10.4	16.2	19.0	15.1	15.1	940.6
25.5	140.0	100.0	15.4	-10.8	12.5	3.2	139.8	62.8	10.4	16.2	19.0	15.1	15.1	940.6
27.5	174.0	100.0	15.2	-10.8	12.5	3.2	139.8	62.8	10.4	16.2	19.0	15.1	15.1	940.6
29.5	174.0	100.0	15.2	-10.8	12.5	3.2	139.8	62.8	10.4	16.2	19.0	15.1	15.1	940.6
31.9	140.0	28.0	15.1	-24.2	12.1	3.2	110.8	48.2	10.4	16.1	18.2	15.1	15.1	875.3
			15.0	33.0		4.0	45.0	159.5						1397.6

DISTANCE FROM TRANSDUCER TO ANCHOR TIP 32.0
 DISTANCE FROM TRANSDUCER TO ANCHOR TIP 31.4

Note: Anchor depth at end of drag measured - centerline of shank at anchor crown - (1-15) inches

NOTE - POSITIVE SHANK ANGLE INDICATES SHANK TIP BTLIN FROM

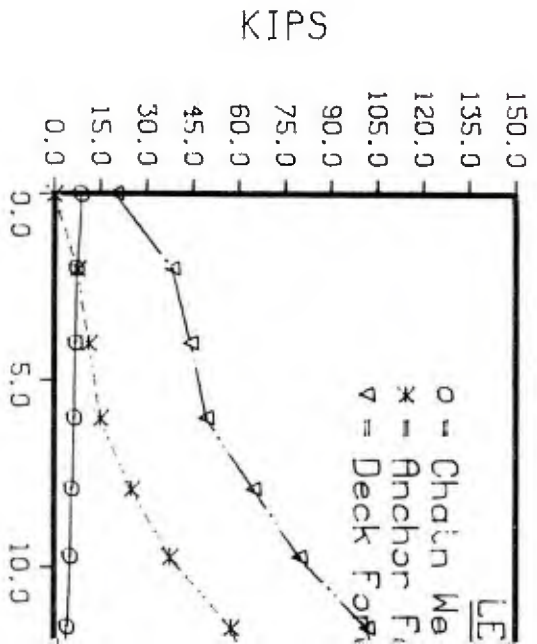
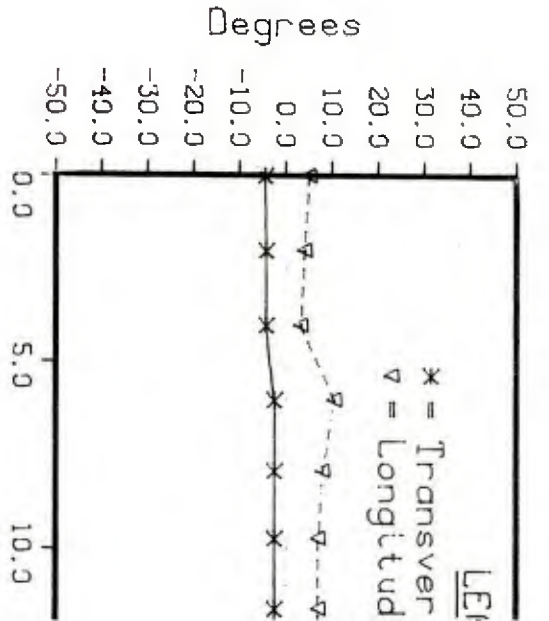
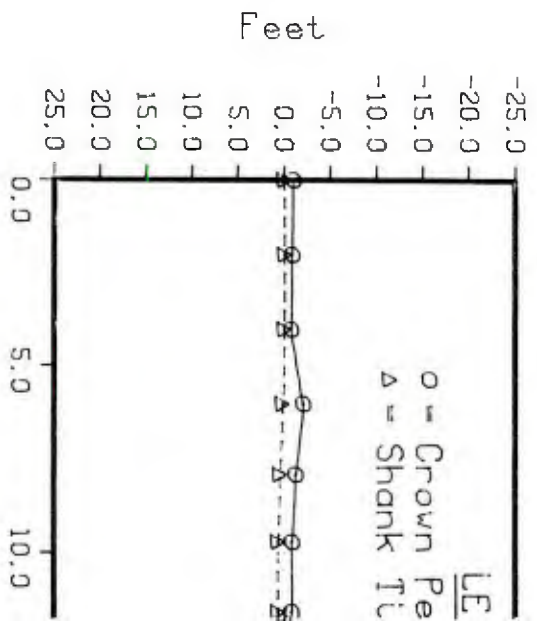

KIPS

Degrees

Feet

Day # = 101

SAN DIEGO HARBOR 1500 FT. SOUTHEAST OF BUOY 49

Test No. = 1

state , 6000lb. normal stabilizers 32 deg. mov. flukes

Test Series No. = 19

fine sand bottom, depth 11-12 ft. mllw

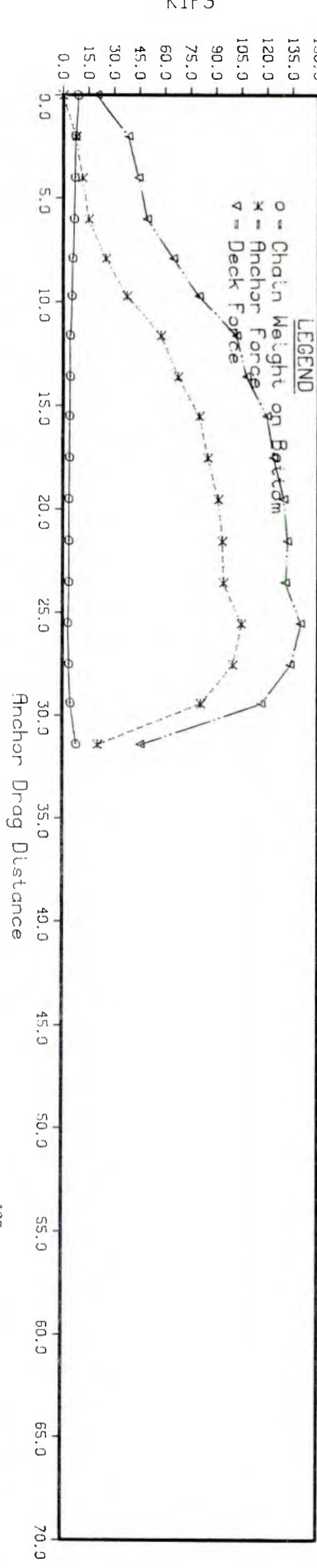
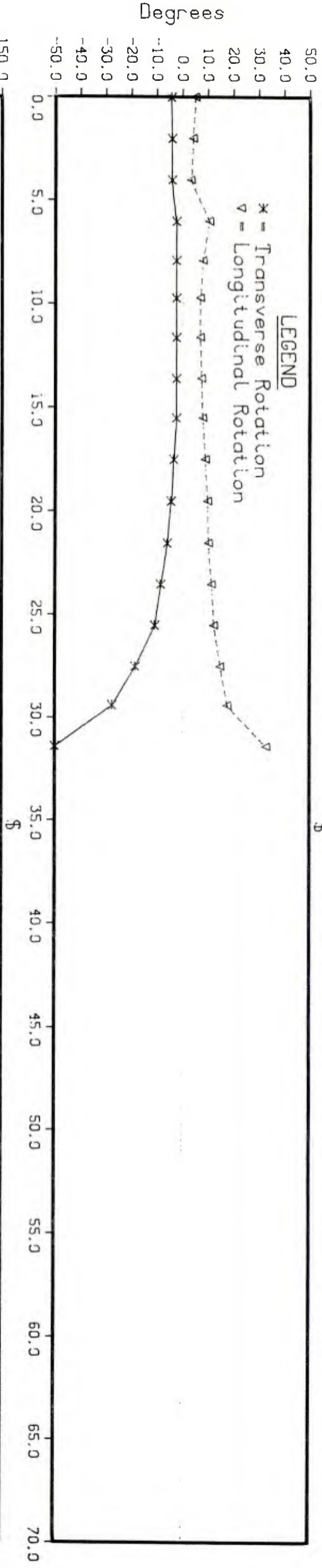
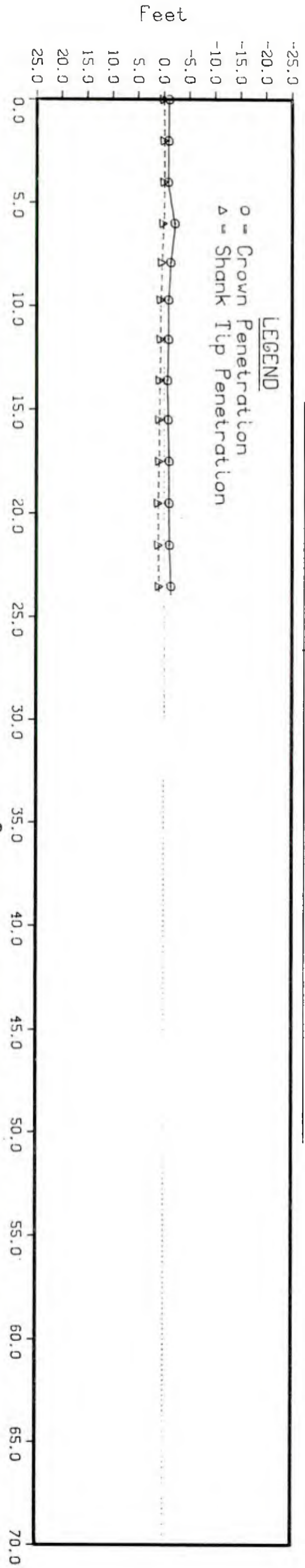

Day # = 101

SRN DIE

Test No. = 2

Test Series No. = 19

TEST DATE 101
 TEST NO. 2
 TEST SLOPE 15
 TEST AREA SAN DIEGO HARBOUR 1500 FT. SOUTHWEST OF RUNY 49
 START-END TIMES 11:00 - 11:30
 ANCHOR TYPE STAD -6000LB. NOMINAL STABILIZERS 32 DEG. MOV. FLUKES
 ANCHOR WEIGHT 6000.00 LB.
 FLUKE ANGLE-TYPE 32.00 DEG. - 0 0MOV LAFIX
 ANCHOR TYPE 0.00 LB.
 AUX. ANCHOR WEIGHT 0.00 LB.
 MAIN-AUX ANCHOR SEPARATION 0.00 LB.
 DEPRESSION-NO.-WT-EACH-TOTAL WT. ANCHOR TO 10FT 2.5IN. STUDLINK CHAIN TO 140FT 2IN WIRE ROPE
 HOORING LINE DESCRIPTION

NOTE - INITIAL SHANK DEPTH ZEROED TO REFLECT MEASURED WATERDEPTH

1. DRAG DISTANCE	2. DECK TENSION	3. ANCHOR TENSION	4. PACKAGE DEPTH	5. ROTATION ANGLE	6. SHANK ANGLE	7. WIRE ROPE ANGLE	8. DECK HORIZ. FORCE	9. CHAIN LENGTH ON ROTUM	10. ANCHOR CROWN DEPTH	11. ANCHOR SHANK TIP DEPTH	12. ANCHOR FLUKE TIP DEPTH	13. WATER DEPTH	14. TOTAL BOTTOM WEIGHT
0.0	29.5	14.6	14.6	0.0	5.6	6.1	29.3	160.9	3671.6	14.0	15.0	18.3	13.0
2.0	39.5	12.5	14.5	0.0	3.6	5.6	19.3	166.9	7351.9	14.1	14.8	19.2	13.0
3.0	39.0	10.6	14.5	0.0	3.5	5.5	16.8	166.9	7469.4	13.6	13.4	19.2	13.0
3.8	95.0	23.6	14.5	1.0	12.5	4.6	79.8	188.5	5293.5	12.4	12.4	18.9	13.0
7.2	85.0	55.0	14.8	2.5	11.0	4.5	82.8	188.1	4981.5	13.2	12.7	18.7	13.0
9.8	85.0	50.6	14.8	3.0	11.0	3.7	162.8	93.4	4559.2	13.4	12.7	18.3	13.0
11.6	103.0	68.4	14.7	3.0	11.0	3.7	162.8	93.4	4482.7	13.4	12.7	18.3	13.0
12.6	113.0	75.8	14.7	3.0	11.0	3.7	162.8	93.4	4482.7	13.4	12.7	18.3	13.0
12.6	60.0	32.8	14.3	3.0	21.9	3.4	89.4	152.5	7468.0	11.5	15.5	16.5	15.0
17.5	59.5	31.3	14.0	3.0	21.9	3.4	89.4	152.5	7366.7	11.4	15.5	16.5	15.0
19.7	64.0	35.0	14.4	3.0	19.3	4.2	61.8	130.0	4519.2	11.4	15.4	16.6	15.0
21.7	57.0	28.8	13.6	3.0	20.0	4.5	56.8	134.3	4734.2	10.9	15.4	16.6	15.0
23.7	55.0	28.8	13.7	3.0	19.5	4.5	56.8	137.4	4691.1	11.1	15.1	16.7	15.0
25.8	51.0	25.0	13.6	-2.0	19.5	4.7	50.8	140.1	7027.5	11.0	15.0	16.6	15.0
27.6	50.0	23.8	13.5	-12.5	20.5	4.7	49.8	141.8	7169.5	11.0	15.0	16.6	15.0
29.8	45.0	18.8	13.6	-20.0	19.0	4.9	44.8	146.8	7362.6	11.0	15.0	16.6	15.0

DISTANCE RANGE TRAVELLED 30.0
 DISTANCE ANCHOR TRAVELLED 29.8

Note: Anchor depth at end
 of drag measured -
 centerline of shank at
 anchor crown = (24) inches.

NOTE - POSITIVE SHANK
 ANGLE INDICATES
 SHANK TIP BELOW
 CROWN.

Feet

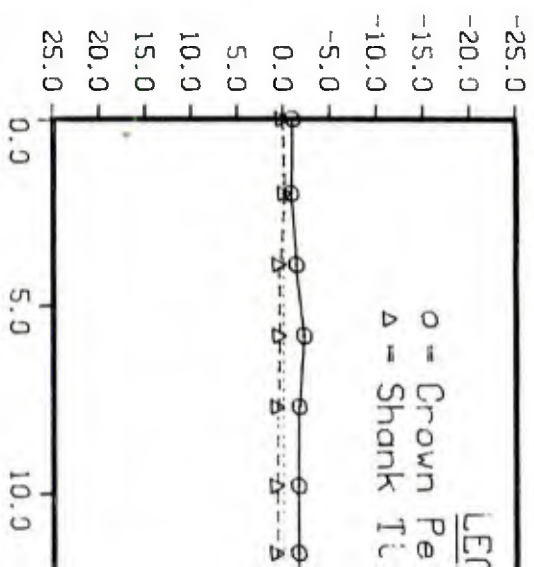

Degrees

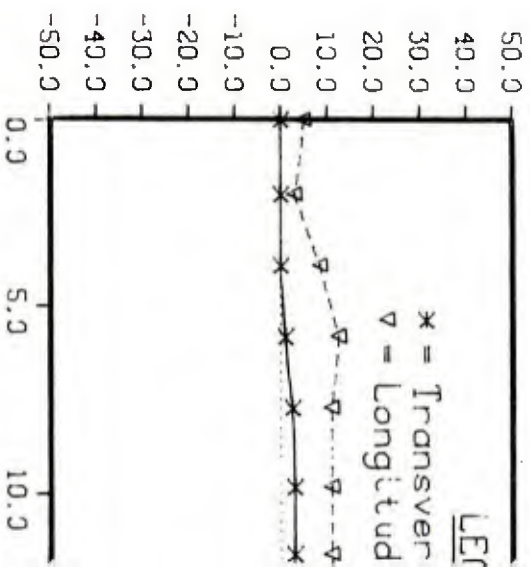

KIPS

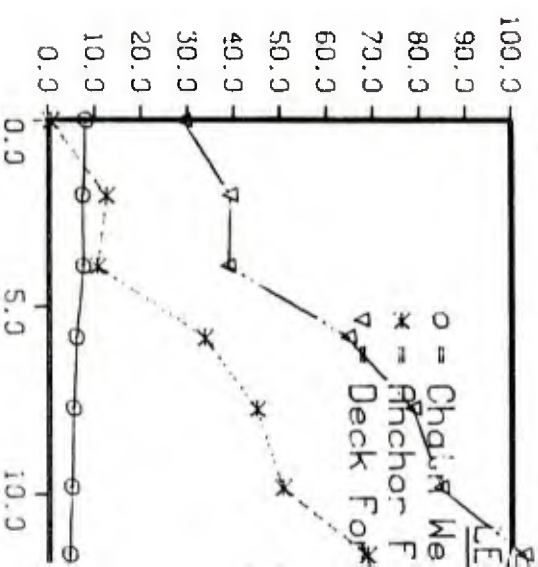

Day # = 101 SAN DIEGO HARBOR 1500 FT. SOUTHEAST OF BUOY 49

Test No. = 2 state ,6000lb. normal stabilizers 32 deg. mov. flukes

Test Series No. = 19 fine sand bottom. depth 11-12 ft. mllw

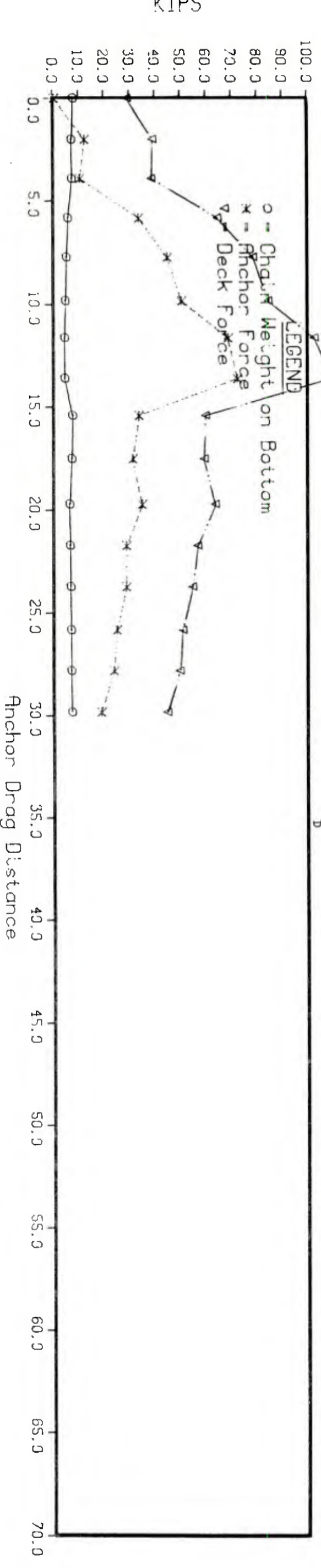
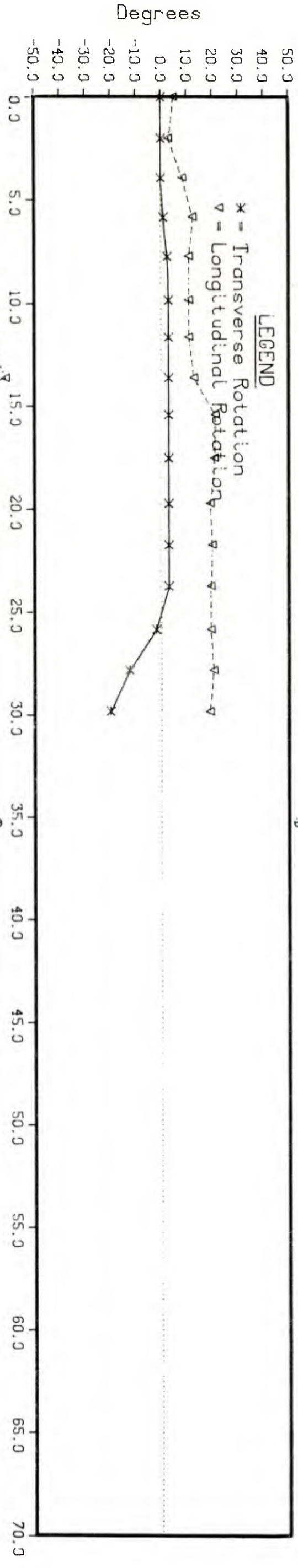
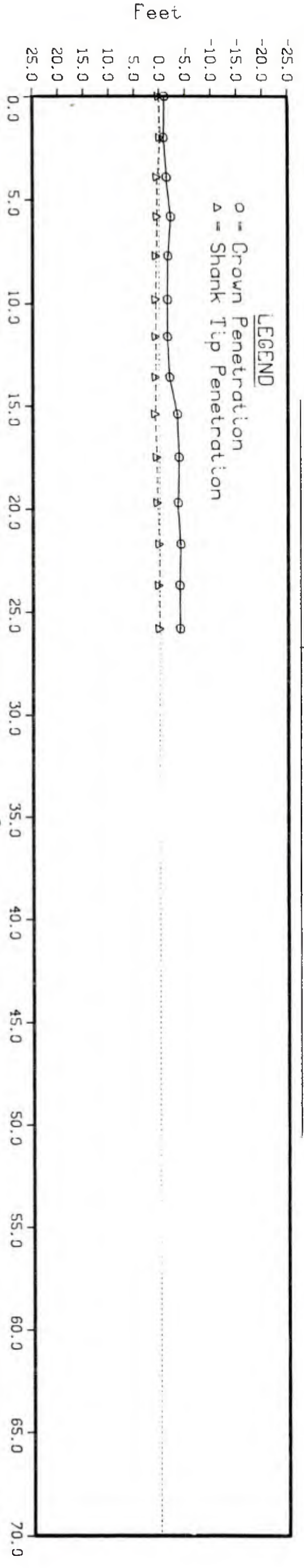

Day # - 101
 Test No. - 3
 Test Series No. - 19

SRN DI

TEST DATE 101
 TEST NO. 3
 TEST SERIES 101
 START-END TIMES 1310-1720
 SEAFLOOR TYPE SAND DIEGO HARBOR 1500 FT. SOUTHEAST OF RUBY 49
 ANCHOR TYPE FINE SAND BOTTOM, DEPTH 11-12 FT., MLLW
 ANCHOR WEIGHT 6000.00 LB., NORMAL STABILIZERS 32 DEGR. MOV. FLUKES
 FLUKE ANGLE TYPE 12.00 DEGR. - 0 0MOV 1=FIX
 AUX. ANCHOR TYPE 0.00 1R.
 MAIN-AUX ANCHOR SEPARATION 0.0 FEET
 DEPRESSORS-NO.-WT-EACH-TOTAL WT. 0.0 - 0.0 LB.
 MOORING LINE DESCRIPTION ANCHOR TO LAOFT 2-STN. STUDDING CHAIN TO 34OFT PIN WIRE ROPE

NOTE - INITIAL CHAIN DEPTH ZEROED TO REFLECT WFAKUPED WATERDEPTH

1. OBAG DISTANCE	2. DRCK FENSTION	3. ANCHOR TENSION	4. PACKAGE DEPTH	5. ROTATION DEG	6. SHANK ANGLE DEG	7. WIRE ROPE ANGLE DEGR HORIZ.	8. CHAIN LENGTH ON BOTTOM	9. CHAIN WEIGHT ON BOTTOM	10. ANCHOR CROWN DEPTH	11. ANCHOR SHANK TIP DEPTH	12. ANCHOR FLUKE TIP DEPTH	13. WATF DEPTH	14. TOTAL BOTTOM WEIGHT	15. ANCHOR FLUKE TIP DEPTH	16. WATF DEPTH	17. TOTAL BOTTOM WEIGHT
6.0	28.0	5.0	14.1	-2.5	4.5	8.1	29.7	142.0	1120.1	13.3	14.4	17.4	14.5	1319.3	14.5	1319.3
8.0	35.0	5.0	14.0	-2.5	4.5	8.2	29.8	142.0	1120.3	13.3	14.3	17.6	14.5	1403.4	14.5	1403.4
4.1	44.0	12.5	13.1	-2.5	3.5	8.2	43.8	143.2	1218.6	13.6	14.3	17.7	14.5	13218.6	14.5	13218.6
6.1	45.0	13.5	13.5	-2.5	3.5	8.0	44.8	143.3	1218.4	11.9	14.5	16.8	14.5	13284.4	14.5	13284.4
8.2	55.0	32.5	13.5	-2.0	3.5	4.0	47.8	147.9	4237.9	12.3	14.5	17.5	14.5	12274.2	14.5	12274.2
9.9	68.0	32.5	14.0	0.0	3.5	3.2	60.4	158.7	4227.3	12.3	14.5	17.5	14.5	10927.3	14.5	10927.3
11.8	100.0	55.0	14.2	0.0	3.5	3.6	169.8	85.7	4227.3	12.3	14.5	17.5	14.5	10899.4	14.5	10899.4
13.7	110.0	41.3	13.4	0.5	3.5	3.5	79.9	126.1	4322.5	11.9	14.5	17.5	14.5	12322.5	14.5	12322.5
17.7	94.0	25.0	13.4	11.0	21.5	3.4	57.9	154.8	7325.5	10.8	14.5	16.9	14.5	13267.5	14.5	13267.5
19.8	60.0	28.8	13.6	30.0	24.5	4.1	50.4	137.9	6916.2	10.8	14.5	16.9	14.5	12814.0	14.5	12814.0
21.8	45.0	18.8	13.7	40.0	26.5	4.1	44.9	159.3	7949.0	10.8	14.5	16.9	14.5	13742.0	14.5	13742.0
23.8	45.0	17.5	13.7	40.0	26.5	4.4	44.9	154.6	7754.0	10.8	14.5	16.9	14.5	13742.0	14.5	13742.0

DISTANCE BARGE TRAVELLED 24.0
 DISTANCE ANCHOR TRAVELLED 23.8

Note: Anchor depth at end
 of drag measured -
 centerline of shank at
 anchor crown = (S) inches.

NOTE - POSITIVE SHANK
 ANGLE INDICATES
 SHANK TIP BELOW
 CROWN

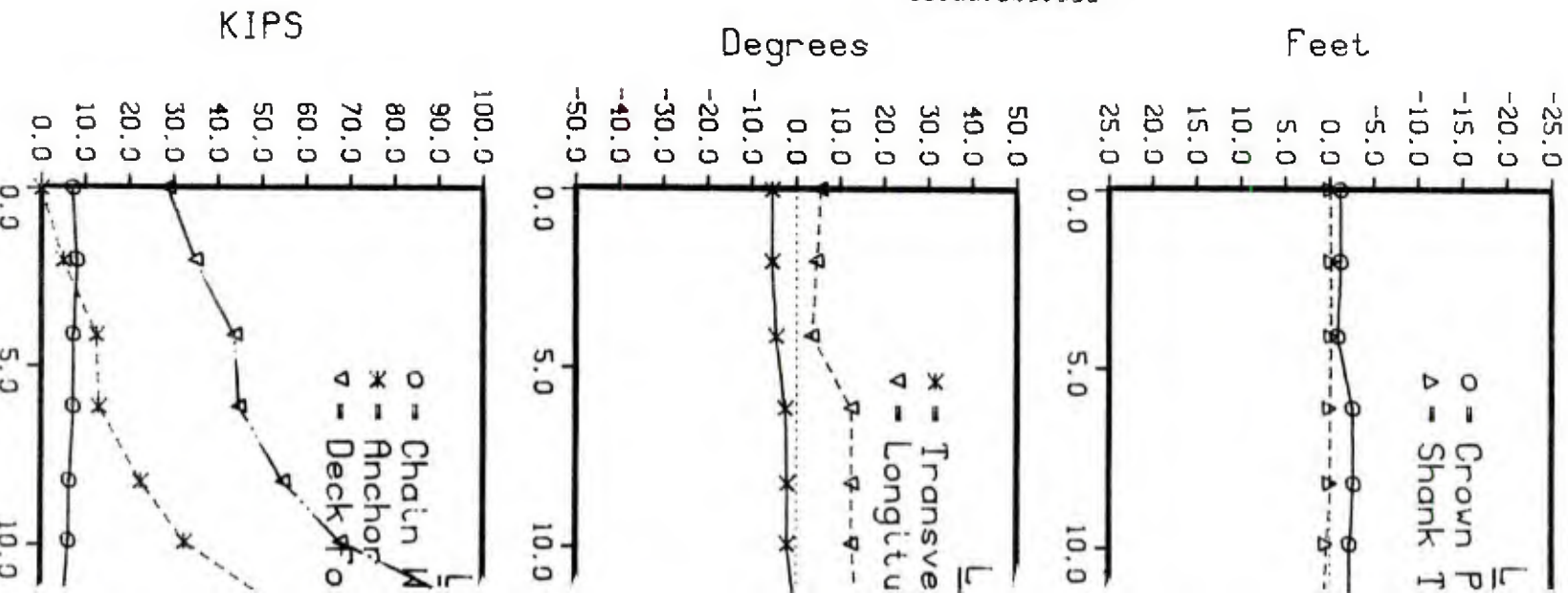

Day # = 101 SPAN DIEGO HARBOR 1500 FT. SOUTHEAST OF BUOY 49
 Test No. = 3 stato , 6000lb. normal stabilizers 32 deg. mov. flukes
 Test Series No. = 19 fine sand bottom. depth 11-12 ft. mllw

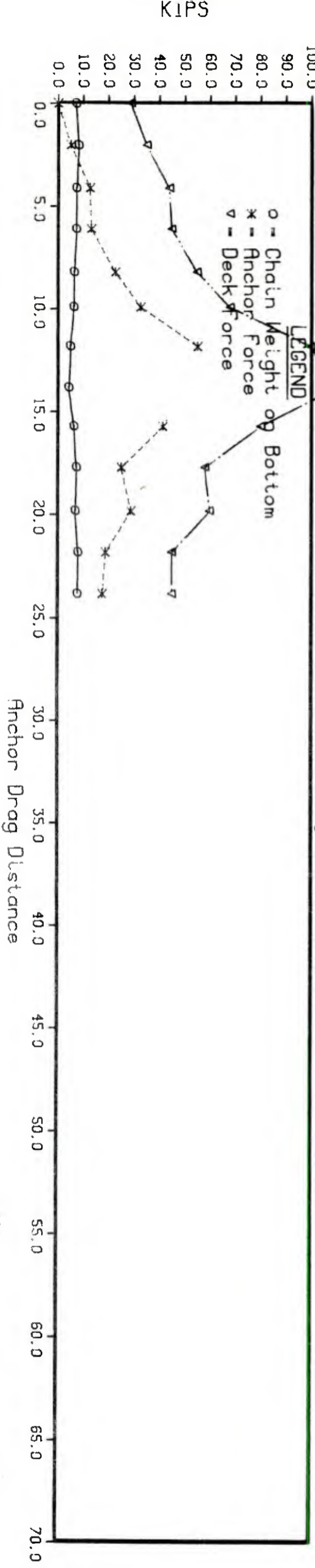
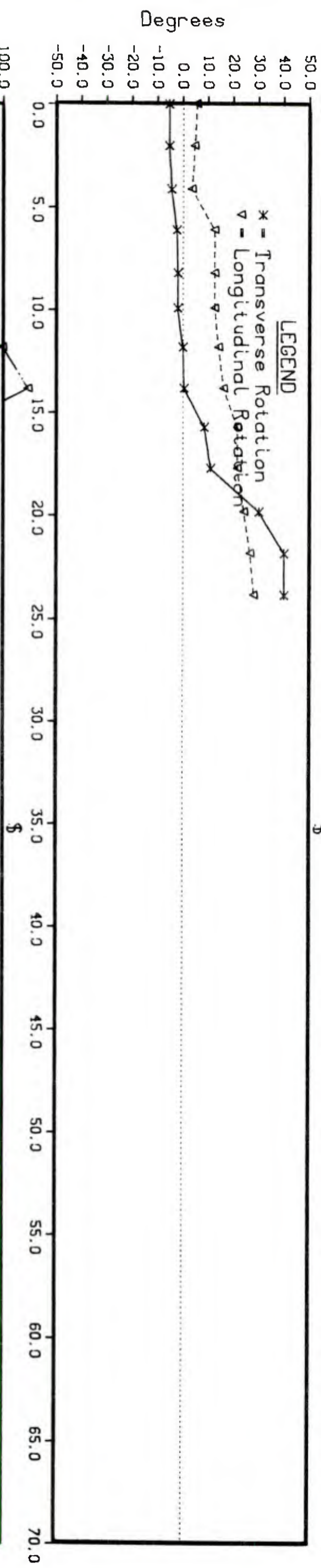
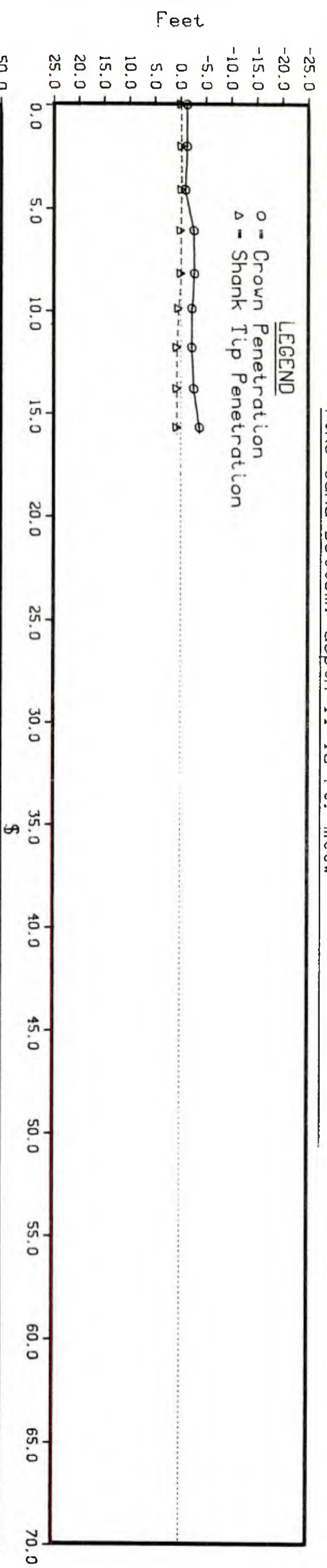

Day # = 101 SPAN
 Test No. = 1
 Test Series No. = 20

STOCKLESS ANCHOR TEST

TEST DATE 101
 TEST NO. 1
 TEST AREA 20
 START-END TIMES CAN OIEG HANNO 1500 FT. SOUTHWEST OF RUDY 49
 SEAFLOOR TYPE 1400 - 1421
 ANCHOR TYPE FINE SAND BOTTOM, DEPTH 11-12 FT. WLL
 ANCHOR WFTGHT STOCKLESS 5000LB. TANDEM SHANKTOSHACKLE 35 NEG. FX. FLUKES
 FLUKE ANGLE-TYPE 5950.00 LB.
 AUX. ANCHOR TYPE 1500 OFG. - 1 HANNO LEFTY
 MAIN-AUX ANCHOR SEPARATION 5000LB STOCKLESS ANCHOR
 DEPRESSORS-MIN-WT-EACH-TOTAL WT. 5950.00 - LB.
 HOORING LINE DESCRIPTION 45.0 FEET
 0 - 0.0 LB.
 ANCHOR TO 45FT 2IN. STUOLNK CHAIN TO AIR ANCHOR TO 180FT
 2.5IN STUOLNK CHAIN TO 240FT 2IN. WTOP ROPE

NOTE - INITIAL CHANK DEPTH REPORT TO REFLECT MEASURED WATERDEPTH

1	2	3	4	5	6	7	8	9	10	11	12	13	14	15
FEET	KIPS	KIPS	FEET	OFC	DEG	DEG	KIPS	FEET	LB	FEET	FEET	FEET	FEET	FEET
1	2	3	4	5	6	7	8	9	10	11	12	13	14	15
DEG	TENSION	TENSION	DEPTH	DECK HORIZ	DECK HORIZ	DECK HORIZ	DECK HORIZ	DECK HORIZ	DECK HORIZ	DECK HORIZ	DECK HORIZ	DECK HORIZ	DECK HORIZ	DECK HORIZ
0.0	19.0	0.0	0.0	0.0	-7.5	6.2	18.9	244.9	0.0	0.0	0.0	0.0	13.0	22486.3
2.0	24.0	0.0	0.0	0.0	-7.5	8.2	23.8	200.2	9215.2	0.0	0.0	0.0	13.0	21115.2
3.8	30.0	2.5	0.0	0.0	-5.0	7.4	29.8	191.4	8774.4	0.0	0.0	0.0	13.0	20074.4
5.7	36.0	2.5	0.0	0.0	-4.5	7.3	29.8	192.4	8826.4	0.0	0.0	0.0	13.0	20726.4
7.8	37.0	3.8	0.0	0.0	0.0	7.1	16.7	177.3	8865.0	0.0	0.0	0.0	13.0	19985.0
9.6	42.0	7.5	0.0	0.0	2.7	6.4	41.7	175.1	7965.6	0.0	0.0	0.0	13.0	19874.0
11.6	41.0	7.5	0.0	0.0	3.0	6.5	40.7	175.9	7997.0	0.0	0.0	0.0	13.0	19874.0
13.3	59.5	15.3	0.0	0.0	8.0	5.4	59.2	156.8	7098.0	0.0	0.0	0.0	13.0	19874.0
15.3	79.5	23.1	0.0	0.0	7.7	5.1	79.2	127.5	5571.2	0.0	0.0	0.0	13.0	17471.2
17.2	101.0	31.3	0.0	0.0	7.5	4.7	100.7	103.4	4362.5	0.0	0.0	0.0	13.0	16244.5
19.0	104.0	33.8	0.0	0.0	7.5	4.4	99.7	115.5	4966.4	0.0	0.0	0.0	13.0	16664.4
21.1	126.0	40.0	0.0	0.0	7.0	4.4	129.2	82.6	2818.1	0.0	0.0	0.0	13.0	14718.1
23.0	129.5	40.0	0.0	0.0	7.0	4.1	129.2	83.8	1319.4	0.0	0.0	0.0	13.0	15270.4
24.9	137.0	43.8	0.0	0.0	6.5	3.9	126.7	81.8	1320.2	0.0	0.0	0.0	13.0	15270.2
27.0	155.0	51.3	0.0	0.0	6.5	3.9	154.6	58.2	2095.9	0.0	0.0	0.0	13.0	13905.9

DISTANCE RANGE TRAVELLED 26.0
 DISTANCE ANCHOR TRAVELLED 27.0

Note: Anchor depth at end of drag measured at centerline of shank at anchor crown = 10 inches.

NOTE - POSITIVE SHANK ANGLE INDICATES SHANK TIP BELOW CROWN

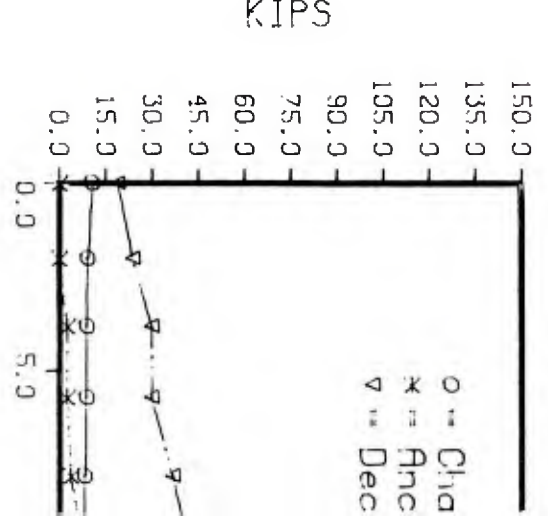
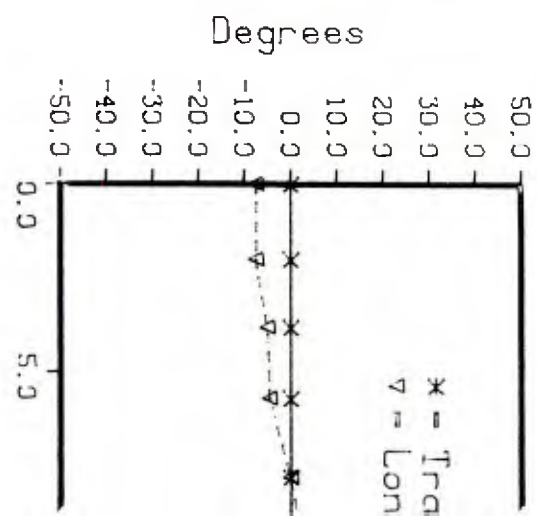
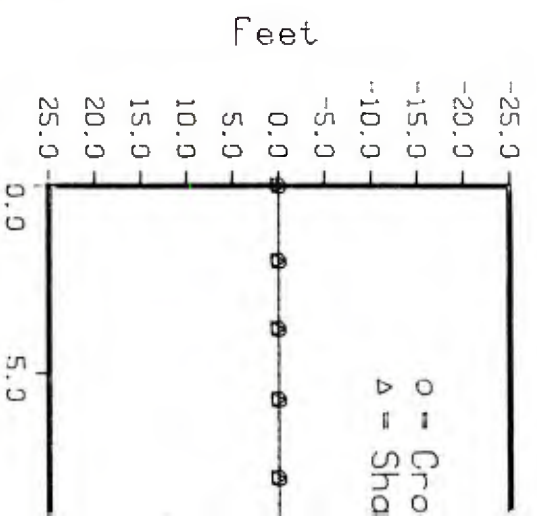

Day # = 101

Test No. = 1

Test Series No. = 20

SAN DIEGO HARBOR 1500 FT. SOUTHERST OF BUOY 49

stockless, 5000lb. lander, shanktooshackle 35 deg. fx, flukes.
fine sand bottom, depth 11-12 ft. mllw

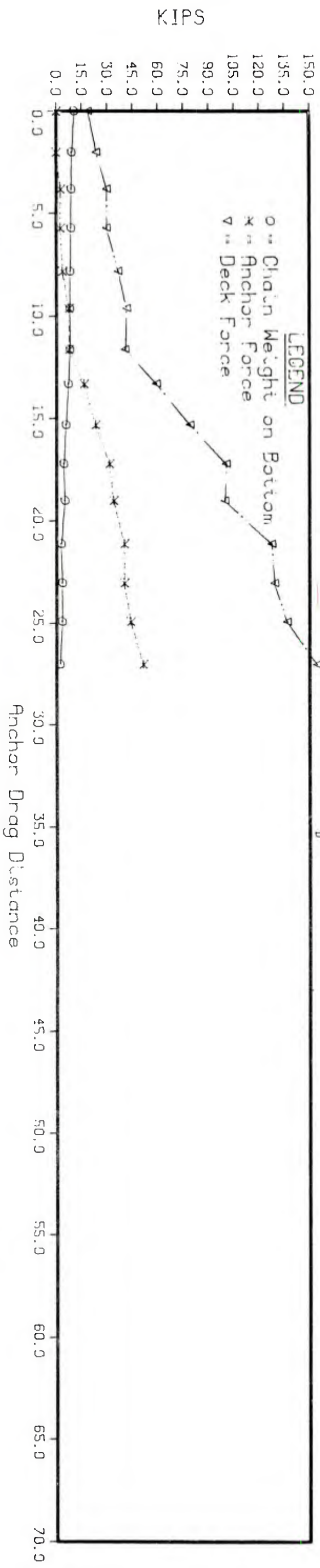
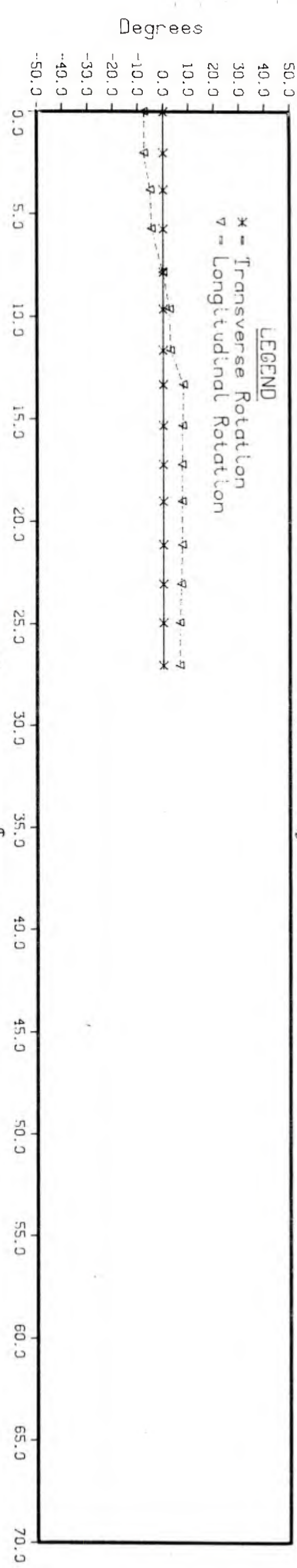
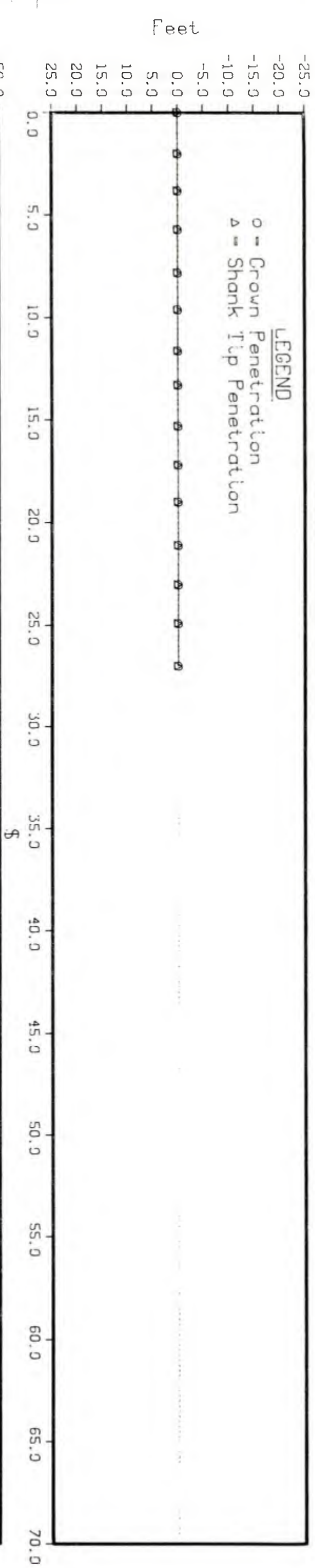

Day # = 101
 Test No. = 2
 Test Series No. = 20

SAN

STORLESS ANCHOR TEST

TEST DATE 101
 TEST SERIES 20
 TEST AREA SAN DIEGO HARBOR 1500 FT. SOUTHWEST OF RUNG 49
 START-END TIMES 5:40 AM TO 5:11 PM
 SECT/FLOOR TYPE 51 BOTTOM, DEPTH 11-12 FT. MLW
 ANCHOR TYPE FINE SAND, SANDY SILT
 ANCHOR WEIGHT STOCKLESS 5000 LB. TANDEN SHANKTYPHICAL F 35 NEG. FX. FLUKES
 TURE ANGLE-TIME 15-00 DEG. - 1 05 MINV 14 FT 11
 AUX. ANCHOR TYPE 5000 LB STOCKLESS ANCHOR
 5950.00 LB.
 MAIN-AUX ANCHOR SEPARATION 45.0 FEET
 DEPRESSORS-NO.-WT-EACH-TOTAL WT. 0 - 0.0 - 0.0 LB.
 MOORING LINE DESCRIPTION ANCHOR TO 45FT PIN, STUJLINK CHAIN TO AUX ANCHOR TO 100FT
 2.5IN STUJLINK CHAIN TO 300FT 2IN. WIRE PUFF

1. DECK DISTANCE	2. DECK TENSION	3. ANCHOR TENSION	4. PACKAGE DEPTH	5. ROTATION ANGLE	6. SHANK ANGLE	7. WIRE ROPE ANGLE	8. DECK HORIZ. FORCE	9. CHAIN LENGTH ON BOTTOM	10. ANCHOR CROWN DEPTH	11. ANCHOR SHANK TIP DEPTH	12. ANCHOR FLUK TIP DEPTH	13. WATER DEPTH	14. TOTAL BOTTOM WIGHT	15. ANCHOR TO 100FT
FEET	KIPS	KIPS	FEET	DEG	DEG	DEG	KIPS	FEET	FEET	FEET	FEET	FEET	FEET	FEET
0.0	24.0	0.0	11.8	-1.5	-9.4	8.1	23.4	201.0	9256.7	13.0	2115A17	13.0	2021A.1	13.0
2.0	34.0	3.8	12.3	-1.5	0.0	7.3	33.7	182.3	6318.1	13.0	1992A.4	13.0	1992A.4	13.0
3.8	39.5	6.3	12.0	-1.3	2.5	6.7	49.2	176.6	4703.4	13.0	16491.4	13.0	16491.4	13.0
5.7	55.0	12.5	13.1	-1.0	6.5	5.3	54.7	151.9	4710.5	13.0	1610.5	13.0	16421.7	13.0
7.5	75.0	18.8	12.9	-1.0	8.0	4.9	74.7	130.3	4523.7	13.0	15421.7	13.0	15421.7	13.0
9.4	95.0	26.3	13.3	-1.0	8.0	4.4	93.7	124.7	4426.7	13.0	15691.4	13.0	15691.4	13.0
11.1	94.0	41.3	13.9	-1.0	8.1	4.3	117.7	92.0	3790.4	13.0	15691.4	13.0	15691.4	13.0
12.9	118.0	43.8	13.4	-1.0	8.1	4.2	123.7	87.4	3556.4	13.0	15581.4	13.0	15581.4	13.0
14.1	128.5	20.0	13.4	-1.0	8.4	4.0	129.2	88.3	3604.4	13.0	15581.4	13.0	15581.4	13.0
17.1	137.0	23.8	13.4	-1.0	8.4	4.0	144.7	90.7	2871.2	13.0	15581.4	13.0	15581.4	13.0
18.1	137.0	23.8	13.4	-1.0	8.4	4.0	144.7	90.7	2871.2	13.0	15581.4	13.0	15581.4	13.0
20.1	144.0	53.0	13.4	-1.0	8.4	3.9	153.7	73.2	2844.1	13.0	15744.1	13.0	15744.1	13.0

DISTANCE RANGE TRAVELLED 24.0
 DISTANCE ANCHOR TRAVELLED 23.1

Note: Anchor depth at end
 of drag measured at
 centerline of shank at
 anchor crown = 22 inches.
 NOTE - POSITIVE SHANK
 ANGLE INDICATES
 SHANK TIP BELOW
 BOW

Feet

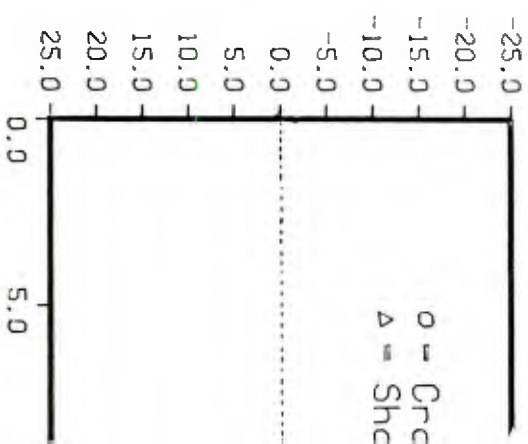

Degrees

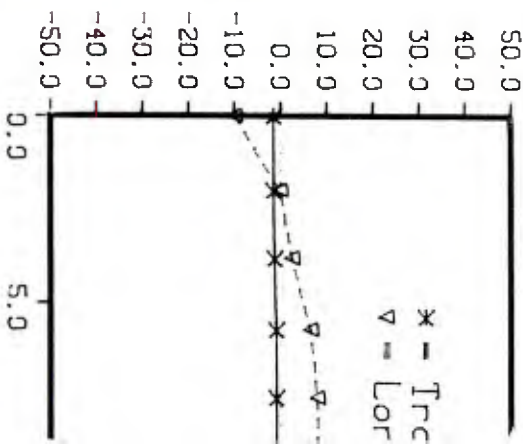

KIPS

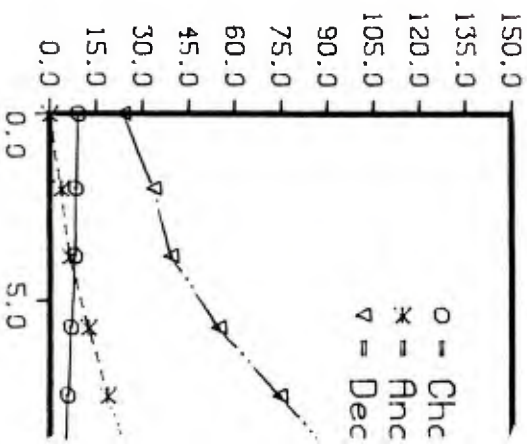

Day # = 101 SAN DIEGO HARBOR 1500 FT. SOUTHEAST OF BUOY 49
 Test No. = 2 stockless, 5000lb. tandem shankto shackle 35 deg. fx. flukes
 Test Series No. = 20 fine sand bottom, depth 11-12 ft. mllw

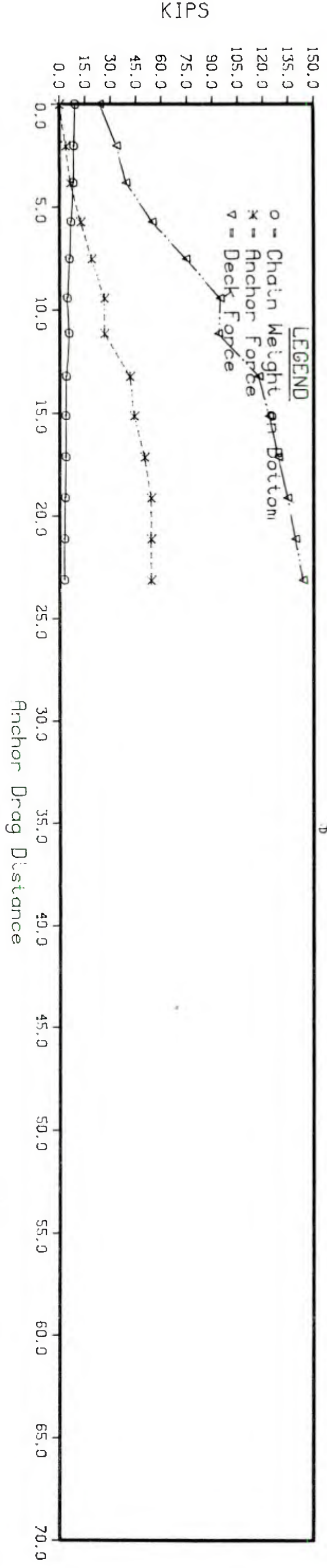
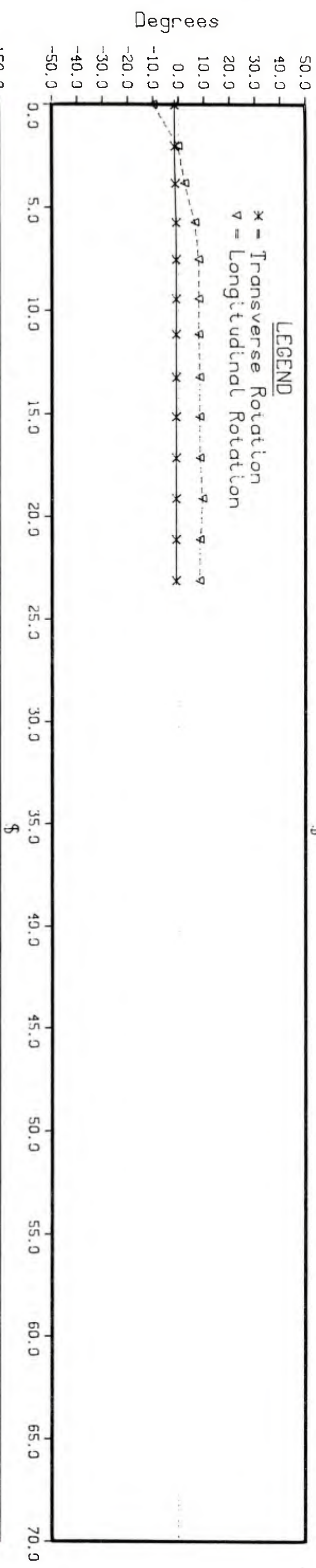
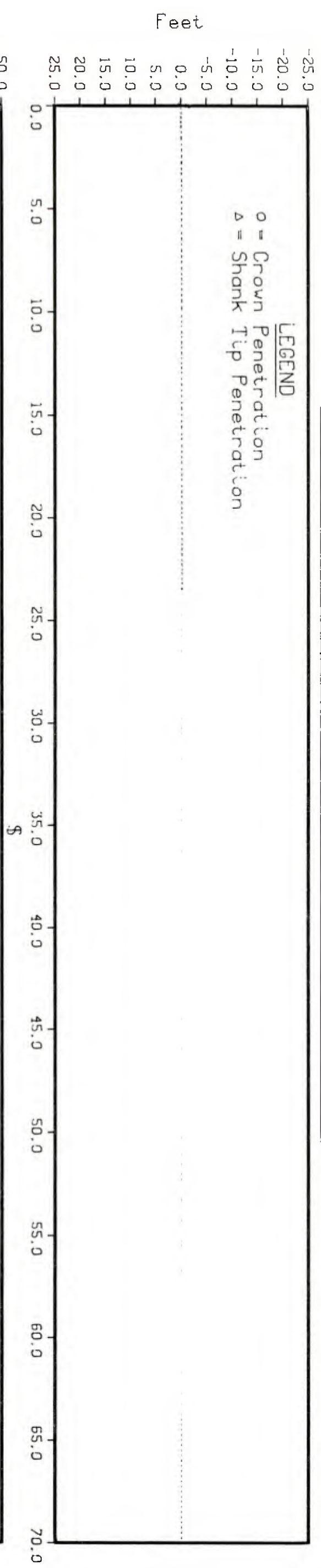

Day # = 102 SRN
 Test No. = 1
 Test Series No. = 21

STOCKLESS ANCHOR TEST

TEST DATE 102
 TEST NO. 1
 TEST SITES 21
 TEST AREA 4AN DIEGO HARBOUR 1500 FT. SOUTHWEST OF QUAY 49
 START-END TIMES 9:29 04N
 SEAFLOOR TYPE FINE SAND BOTTOM, DEPTH 11-12 FT., MLLW
 ANCHOR TYPE STOCKLESS 5000LB. TANKER CUMMINS/STOCKLESS 35 DEG. FX. FLUMES
 ANCHOR WEIGHT 15,000 LBS. 10' 85000 LBS FT
 FLUX ANGLE-TYPE 4500LB STOCKLESS ANCHOR
 AUX. ANCHOR TYPE 4500 LB. 10'
 AUX. ANCHOR WEIGHT 4500 LBS.
 MAIN-AUX ANCHOR SEPARATION 0.0-0.0
 DEPRESSIONS-IND.-WT.-EACH-TOTAL WT. 0.0-0.0
 HOORING LINE DESCRIPTION ANCHOR TO 45FT PIN, STUDLINK CHAIN TO AUX ANCHOR TO 100FT
 2.5IN STUDLINK CHAIN TO 40FT PIN, WIRE ROPE

1. DRAG DISTANCE	2. DECK TENSION	3. ANCHOR TENSION	4. PACKAGE DEPTH	5. ROTATION ANGLE	6. SHANK ANGLE	7. WIRE ROPE ANGLE	8. DECK HORIZ. FORCE	9. CHAIN LENGTH ON BOTTOM	10. CHAIN WEIGHT ON BOTTOM	11. ANCHOR DOWN DEPTH	12. ANCHOR SHANK TIP DEPTH	13. ANCHOR FLUX TIP DEPTH	14. WIRE DEPTH	15. TOTAL BOTTOM WEIGHT
0.0	21.0	1.3	0.0	-2.0	-7.0	7.0	7.0	20.0	211.6	0.0	0.0	0.0	0.0	0.0
2.0	21.5	3.0	0.0	-2.0	-7.0	6.0	6.0	19.0	194.0	0.0	0.0	0.0	0.0	0.0
3.0	21.5	15.0	0.0	-2.0	-7.0	4.0	4.0	17.0	174.0	0.0	0.0	0.0	0.0	0.0
4.0	21.5	11.0	0.0	-2.0	-7.0	3.0	3.0	15.0	157.5	0.0	0.0	0.0	0.0	0.0
5.0	21.5	11.0	0.0	-2.0	-7.0	2.0	2.0	13.0	139.5	0.0	0.0	0.0	0.0	0.0
6.0	21.5	11.0	0.0	-2.0	-7.0	1.0	1.0	11.0	121.5	0.0	0.0	0.0	0.0	0.0
7.0	21.5	11.0	0.0	-2.0	-7.0	0.0	0.0	9.0	103.5	0.0	0.0	0.0	0.0	0.0
8.0	21.5	11.0	0.0	-2.0	-7.0	0.0	0.0	7.0	85.5	0.0	0.0	0.0	0.0	0.0
9.0	21.5	11.0	0.0	-2.0	-7.0	0.0	0.0	5.0	67.5	0.0	0.0	0.0	0.0	0.0
10.0	21.5	11.0	0.0	-2.0	-7.0	0.0	0.0	3.0	49.5	0.0	0.0	0.0	0.0	0.0
11.0	21.5	11.0	0.0	-2.0	-7.0	0.0	0.0	1.0	31.5	0.0	0.0	0.0	0.0	0.0
12.0	21.5	11.0	0.0	-2.0	-7.0	0.0	0.0	0.0	13.5	0.0	0.0	0.0	0.0	0.0
13.0	21.5	11.0	0.0	-2.0	-7.0	0.0	0.0	0.0	11.0	0.0	0.0	0.0	0.0	0.0
14.0	21.5	11.0	0.0	-2.0	-7.0	0.0	0.0	0.0	9.0	0.0	0.0	0.0	0.0	0.0
15.0	21.5	11.0	0.0	-2.0	-7.0	0.0	0.0	0.0	7.0	0.0	0.0	0.0	0.0	0.0
16.0	21.5	11.0	0.0	-2.0	-7.0	0.0	0.0	0.0	5.0	0.0	0.0	0.0	0.0	0.0
17.0	21.5	11.0	0.0	-2.0	-7.0	0.0	0.0	0.0	3.0	0.0	0.0	0.0	0.0	0.0
18.0	21.5	11.0	0.0	-2.0	-7.0	0.0	0.0	0.0	1.0	0.0	0.0	0.0	0.0	0.0
19.0	21.5	11.0	0.0	-2.0	-7.0	0.0	0.0	0.0	0.0	0.0	0.0	0.0	0.0	0.0
20.0	21.5	11.0	0.0	-2.0	-7.0	0.0	0.0	0.0	0.0	0.0	0.0	0.0	0.0	0.0
21.0	21.5	11.0	0.0	-2.0	-7.0	0.0	0.0	0.0	0.0	0.0	0.0	0.0	0.0	0.0
22.0	21.5	11.0	0.0	-2.0	-7.0	0.0	0.0	0.0	0.0	0.0	0.0	0.0	0.0	0.0
23.0	21.5	11.0	0.0	-2.0	-7.0	0.0	0.0	0.0	0.0	0.0	0.0	0.0	0.0	0.0
24.0	21.5	11.0	0.0	-2.0	-7.0	0.0	0.0	0.0	0.0	0.0	0.0	0.0	0.0	0.0
25.0	21.5	11.0	0.0	-2.0	-7.0	0.0	0.0	0.0	0.0	0.0	0.0	0.0	0.0	0.0
26.0	21.5	11.0	0.0	-2.0	-7.0	0.0	0.0	0.0	0.0	0.0	0.0	0.0	0.0	0.0
27.0	21.5	11.0	0.0	-2.0	-7.0	0.0	0.0	0.0	0.0	0.0	0.0	0.0	0.0	0.0
28.0	21.5	11.0	0.0	-2.0	-7.0	0.0	0.0	0.0	0.0	0.0	0.0	0.0	0.0	0.0
29.0	21.5	11.0	0.0	-2.0	-7.0	0.0	0.0	0.0	0.0	0.0	0.0	0.0	0.0	0.0
30.0	21.5	11.0	0.0	-2.0	-7.0	0.0	0.0	0.0	0.0	0.0	0.0	0.0	0.0	0.0

Note: Anchor depth at end of drag measured - centerline of shank at anchor crown = 25 inches.

NOTE - POSITIVE SWANK ANGLE INDICATES SHANK TIP BEING DOWN

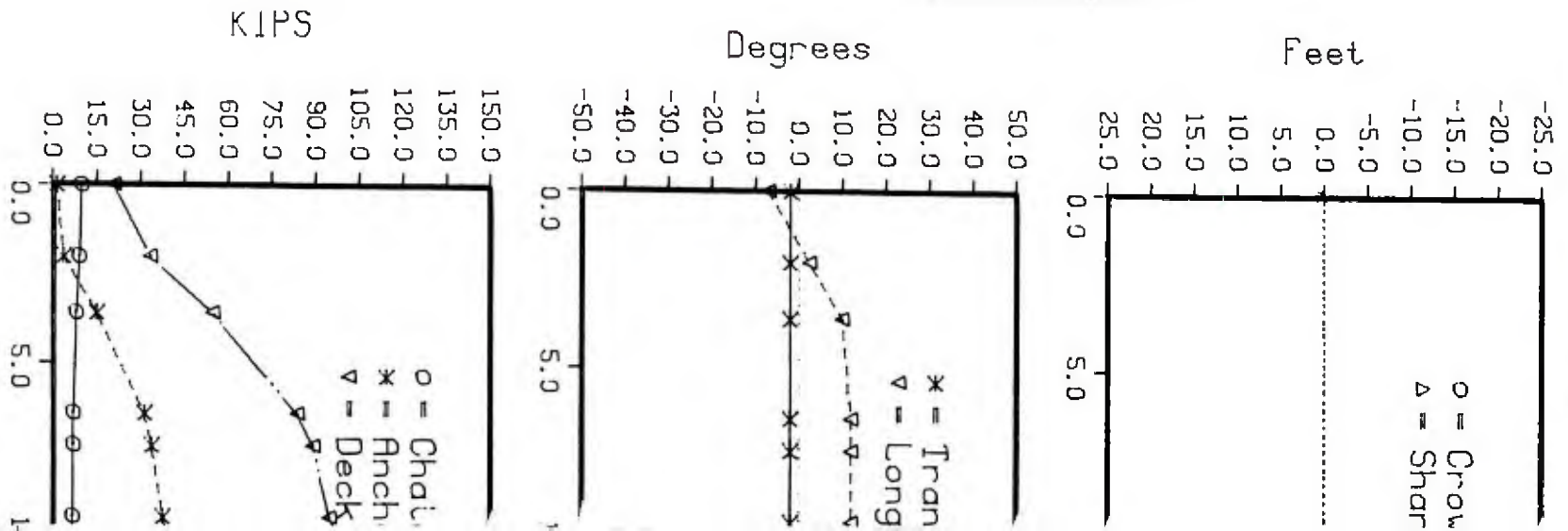

Day # = 102 SAN DIEGO HARBOR 1500 FT. SOUTHEAST OF BUOY 49

Test No. = 1

Test Series No. = 21 stockless, 5000lb. tandem crowntoshackle 35 deg. fx. flukes
fine sand bottom. depth 11-12 ft. mllw

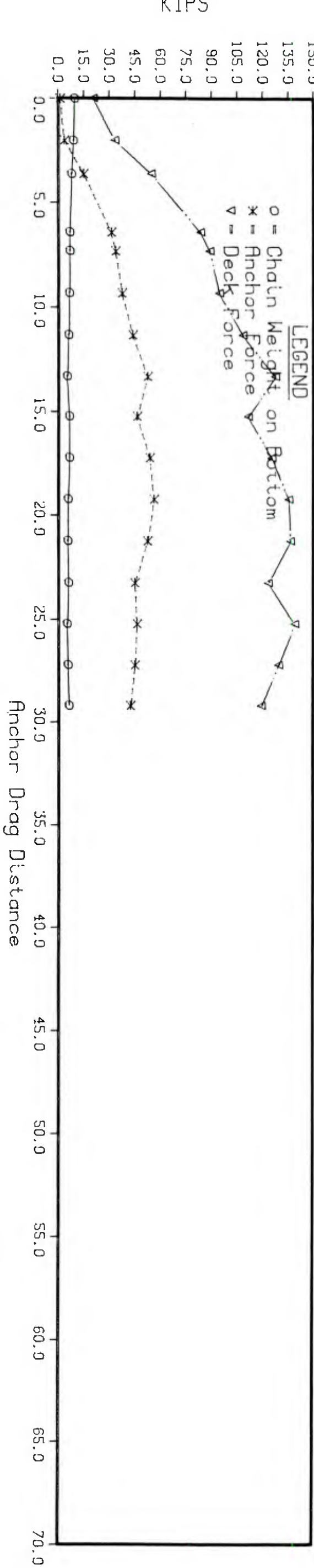
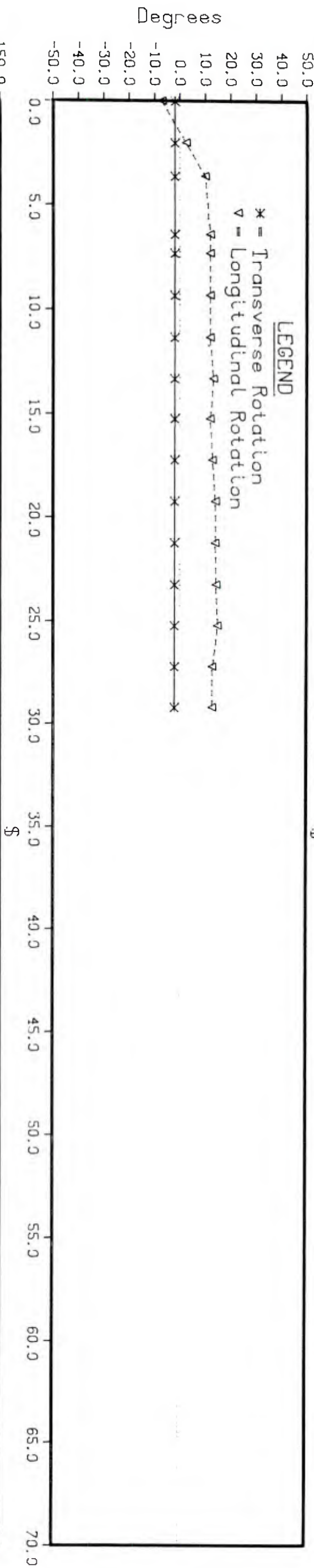
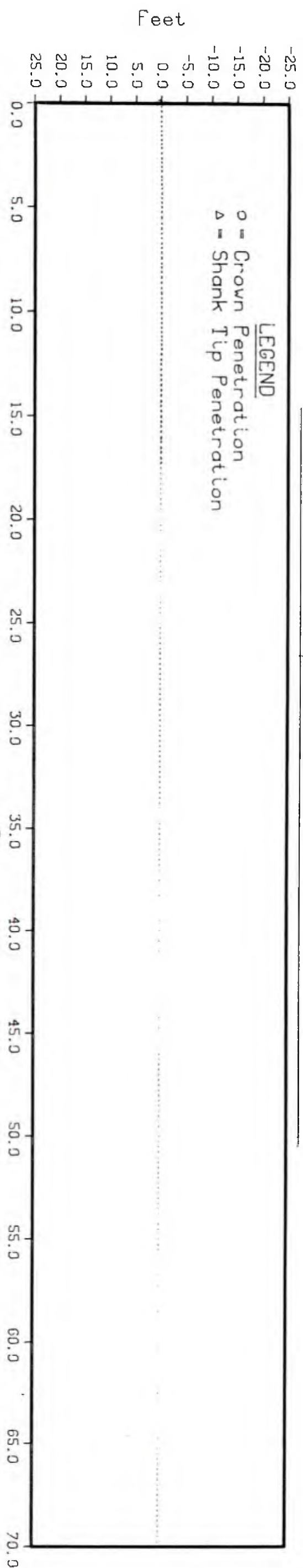

Day # = 102 SRN
 Test No. = 2
 Test Series No. = 21

STOCKLESS ANCHOR TEST

TEST DATE 102
 TEST NO. 2
 TEST AREA SAN DIEGO HARBOR 1500 FT. SOUTHWEST OF BUOY 49
 START-END TIMES 1007 - 1020
 SEAT/DR TYPE FINE SAND BOTTOM, DEPTH 11-12 FT. MLW
 ANCHOR TYPE STOCKLESS 5000L.R. TANDEN CRUMPHOSHAFFLE 75 DEG. FX. FLUMERS
 ANCHOR WEIGHT 5950.00 LB.
 FLUME WEIGHT 75.00 DEFT. - 1 02KRV 13FT13
 FLUME ANGLE-TYPE 5000LB STOCKLESS ANCHOR
 AUX. ANCHOR TYPE 5950.00 LB.
 MAIN ANCHOR WEIGHT 45.0 FEET
 DEPRESSORS-NO.-WT.-EACH-TOTAL WT. 0 - 0.0 - 0.0 LB.
 MOORING LINE DESCRIPTION ANCHOR TO 45FT 2IN. STUPLINK CHAIN TO AUX ANCHOR TO 100FT
 2.5IN STUPLINK CHAIN TO 340FT 2IN. WJOF RMPF

1. DRAG DISTANCE	2. DEPTH TENSION	3. ANCHOR TENSION	4. PACKAGED DEPTH	5. ROTATION ANGLE	6. CHAIN LENGTH ON BOTTOM	7. CHAIN WEIGHT FROM BOTTOM	8. ANCHOR FROM DEPTH	9. ANCHOR SHANK TIP DEPTH	10. ANCHOR FLUME TIP DEPTH	11. WJOF DEPTH	12. TOTAL ROTATION WEIGHT	13. ANCHOR FLUME TIP DEPTH	14. WJOF DEPTH	15. TOTAL ROTATION WEIGHT
0.0	21.0	1.9	14.6	0.7	-7.5	6.5	22.9	216.5	9175.5	16.5	21970.6	16.5	21275.5	16.5
2.0	36.0	5.0	15.1	0.0	5.2	7.9	35.9	203.4	8177.5	16.4	20277.5	16.5	19757.0	16.5
4.0	52.0	8.7	15.4	0.0	7.5	6.7	51.8	183.5	6877.0	16.5	18257.0	16.5	17657.0	16.5
5.9	65.0	27.5	16.0	0.0	11.0	7.9	44.8	153.2	4597.0	16.5	15497.0	16.5	14897.0	16.5
7.8	102.0	28.8	16.1	0.2	11.5	7.4	101.8	147.8	4599.0	16.5	15499.0	16.5	14899.0	16.5
9.8	119.0	37.5	16.4	0.2	10.4	3.3	118.8	131.9	5788.2	16.5	17488.2	16.5	16888.2	16.5
11.7	105.0	35.6	16.4	0.2	8.5	3.1	128.7	129.9	5689.2	16.5	16889.2	16.5	16289.2	16.5
13.7	128.5	45.4	16.4	0.2	8.5	3.0	133.8	128.6	5425.1	16.5	17525.1	16.5	17525.1	16.5
17.7	119.5	51.8	16.8	0.5	8.4	2.9	139.1	127.7	5428.4	16.5	17488.4	16.5	17528.4	16.5
19.6	141.5	57.5	16.6	0.5	7.7	2.8	143.1	128.7	5428.4	16.5	17528.4	16.5	17528.4	16.5
21.6	141.0	56.3	16.7	0.5	7.0	2.6	140.8	131.1	5750.5	16.5	17650.5	16.5	17650.5	16.5
23.6	138.0	50.0	16.6	0.5	7.0	2.5	137.9	140.4	6418.4	16.5	18518.4	16.5	18518.4	16.5
25.6	144.0	56.3	16.6	0.5	7.0	2.7	143.8	133.2	5855.0	16.5	17755.0	16.5	17755.0	16.5
27.6	139.0	48.8	16.8	0.5	7.5	2.7	138.8	137.9	6890.5	16.5	17990.5	16.5	17990.5	16.5

NOTE - POSITIVE SHANK ANGLE INDICATES SHANK TIP BFLON FROM

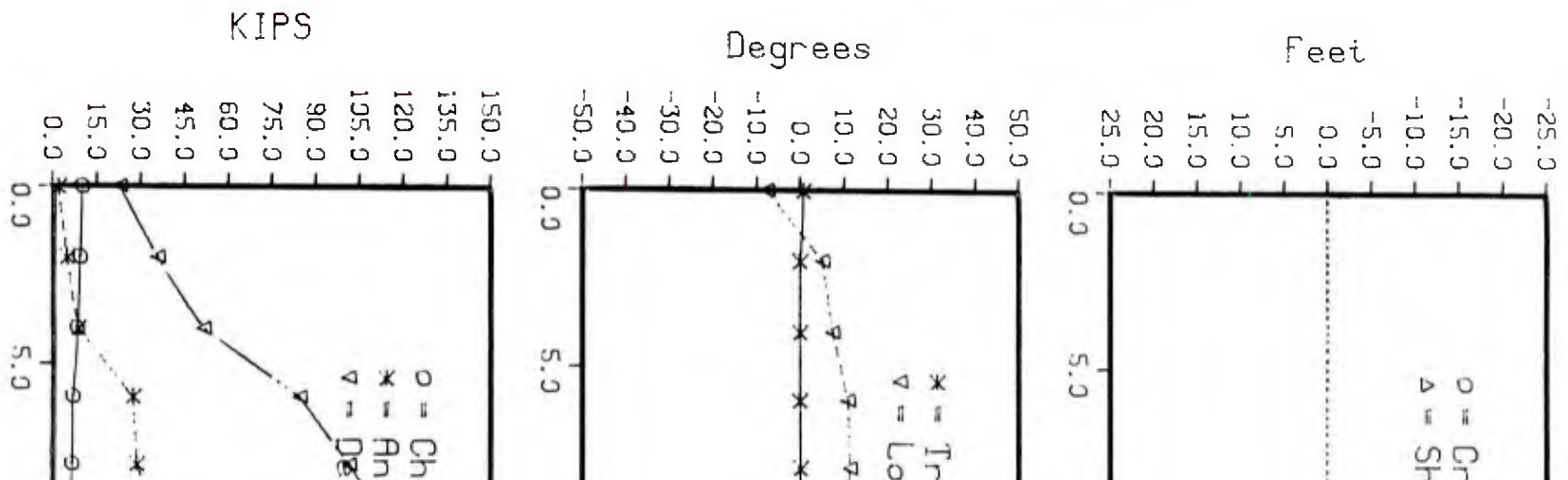

Day # = 102 SAN DIEGO HARBOR 1500 FT. SOUTHEAST OF BUOY 49
 Test No. = 2 stockless, 5000lb. landem crowsnackles 35 deg. f.x. flukes
 Test Series No. = 21 fine sand bottom, depth 11-12 ft. mllw

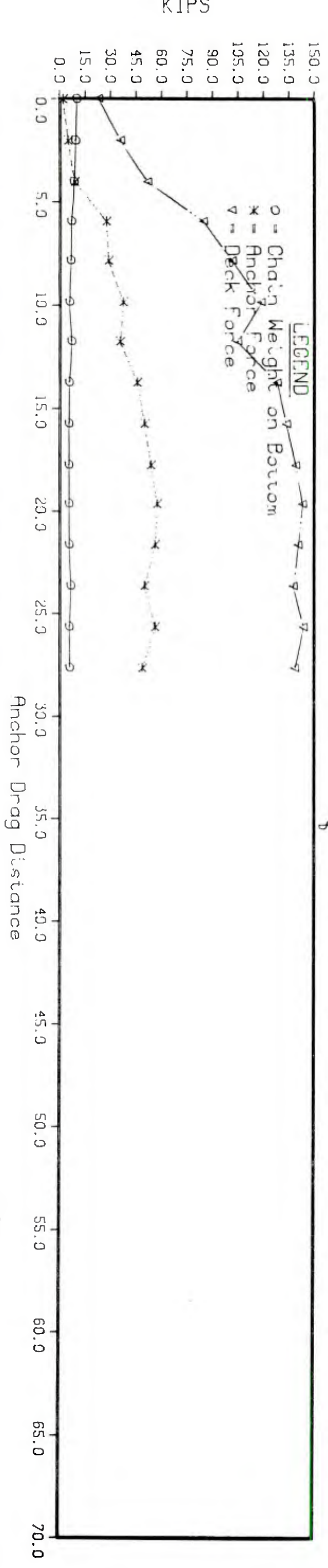
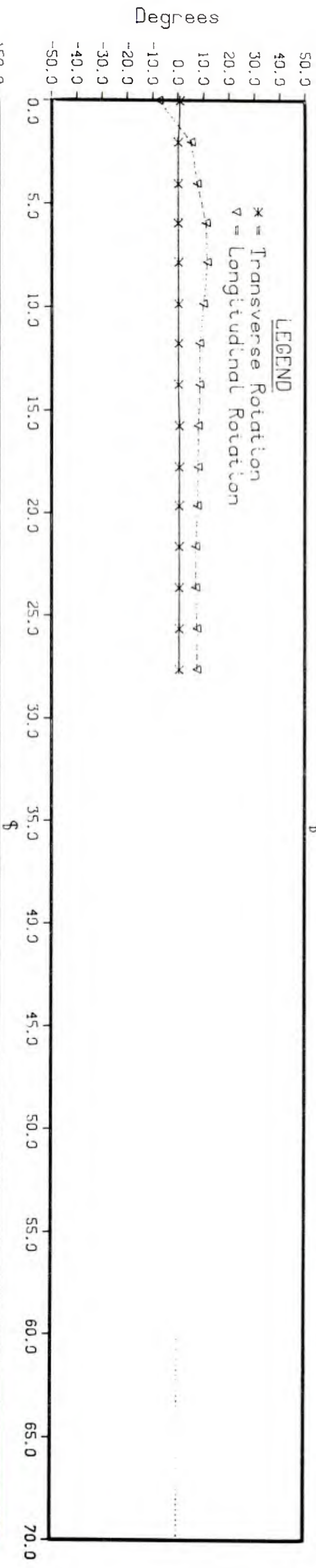
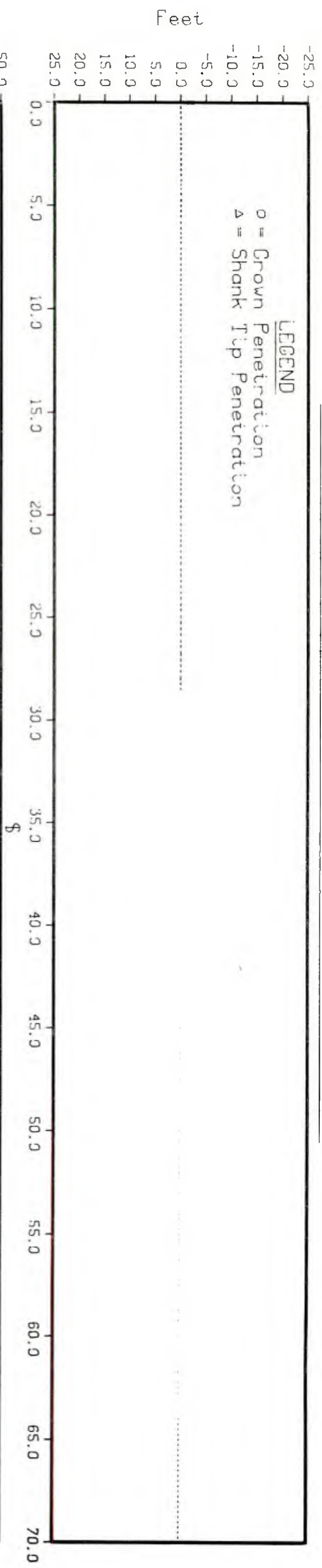

Day # = 102 SRN 1
 Test No. = 1
 Test Series No. = 22

STOCKLESS ANCHOR TEST

TEST DATE 102
 TEST SPELFS 1
 TEST AREA 32 SAN Diego Harbor 1500 FT. SOUTHWEST OF BUOY 40
 START-END TIMES 1302 - 1322
 SEAFOOR TYPE FINE SAND BOTTOM, DEPTH 11-12 FT., MLTY
 ANCHOR TYPE STOCKLESS 45000 LB. TANDEN GR. PLINGTOSHACKLE 75 DEG. FIX. FLUXE
 ANCHOR WEIGHT 5850.00 LB.
 FLIME ANGLE-TYPE 15.00 DEG. - 1 02MMV 15FTX
 AUX. ANCHOR TYPE ENOBLR STOCKLESS ANCHOR
 MAIN-ANCHOR WEIGHT 5950.00 LB.
 DEPRESSORS+NO.-WT.-EACH-TOTAL 90.0 FEET
 MOORING LINE DESCRIPTION 0.0 LB. ANCHOR TO 90FT PIN, STUPLINK CHAIN TO AUX ANCHOR-ORROUND PIN TO 45FT PIN CHAIN TO 190FT 2.5IN CHAIN TO 340FT PIN WIPF DOP

1. ORAO DISTANCE	2. DECK TENSION	3. ANCHOR DEPTH	4. PACKAGE DEPTH	5. ROTATION ANGLE	6. SHANK ANGLE	7. WIRE DIAP ANGLE	8. DECV HORIZ. PROF	9. CHAIN LENGTH ON BOTTOM	10. CHAIN WEIGHT ON BOTTOM	11. ANCHOR FROM DEPTH	12. ANCHOR SHANK TIP DEPTH	13. ANCHOR FLIME TIP DEPTH	14. WAFD DEPTH	15. TOTAL BOTTOM WEIGHT
94.0	24.0	1.9	10.4	45	-8.6	4.0	23.9	708.4	*****	*****	*****	*****	*****	*****
2.0	49.0	7.5	11.4	47	1.2	4.3	49.9	205.2	*****	*****	*****	*****	*****	*****
3.9	44.0	4.1	11.7	47	6.5	4.0	47.9	201.7	*****	*****	*****	*****	*****	*****
7.8	44.0	17.5	11.8	47	8.5	3.9	44.9	207.4	*****	*****	*****	*****	*****	*****
6.9	74.0	21.5	12.1	47	10.0	3.5	73.9	207.8	*****	*****	*****	*****	*****	*****
11.0	87.0	21.3	12.3	47	8.5	3.0	84.9	207.7	*****	*****	*****	*****	*****	*****
13.0	102.0	32.1	12.4	47	8.5	3.0	101.9	207.7	*****	*****	*****	*****	*****	*****
15.7	121.0	40.0	12.4	47	9.0	2.4	120.9	207.7	*****	*****	*****	*****	*****	*****
17.7	125.0	42.5	12.2	47	9.0	2.4	129.9	250.7	*****	*****	*****	*****	*****	*****
21.7	129.0	37.5	12.5	47	8.0	2.4	125.9	253.2	*****	*****	*****	*****	*****	*****
23.7	133.0	45.3	12.7	47	8.0	2.4	132.9	247.4	9937.4	*****	*****	*****	*****	*****
25.7	146.0	50.0	12.7	47	8.0	2.4	145.9	236.5	9388.3	*****	*****	*****	*****	*****
27.6	145.0	50.0	12.5	47	7.5	2.1	144.9	252.5	*****	*****	*****	*****	*****	*****
29.5	65.0	31.3	12.4	47	7.5	1.3	65.0	420.9	*****	*****	*****	*****	*****	*****
DISTANCE RANGE TRAVELLED 30.0														
DISTANCE ANCHOR TRAVELLED 29.5														

Note: Anchor depth at end of drag measured - centerline of shank at anchor crown = 16 inches.

NOTE - POSITIVE SHANK ANGLE INDICATES SHANK TIP BELOW TOWNL

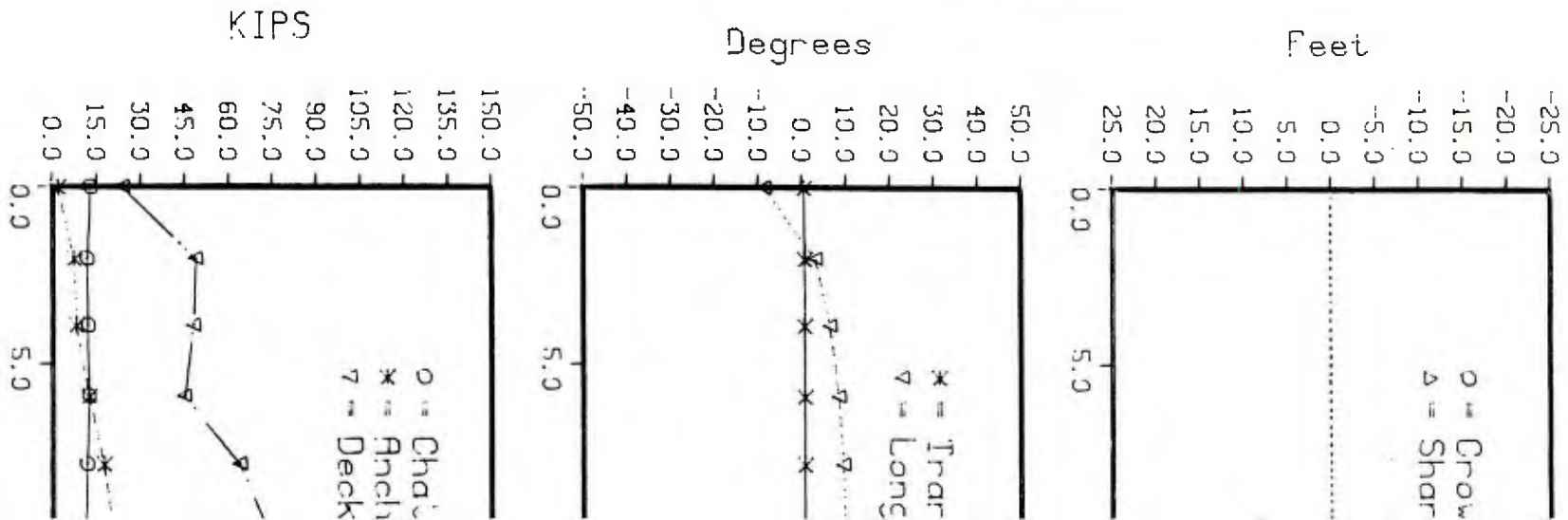

Day # = 102 SPN DIEGO HARBOR 1500 FT. SOUTHEAST OF BUOY 49
 Test No. = 1 stockless, 5000lb. tandem gr. ring/shackle 35 deg. fix. fluke
 Test Series No. = 22 fine sand bottom, depth 11-12 ft. mlv

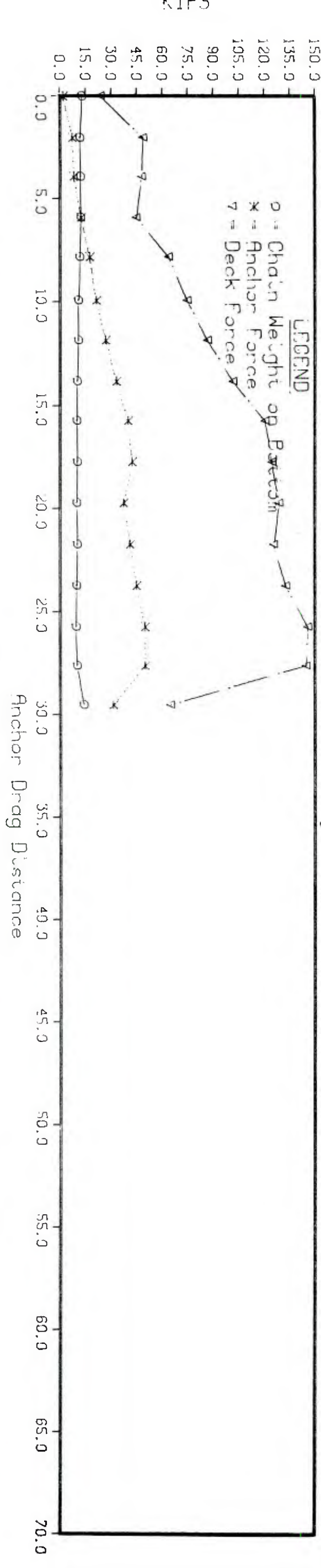
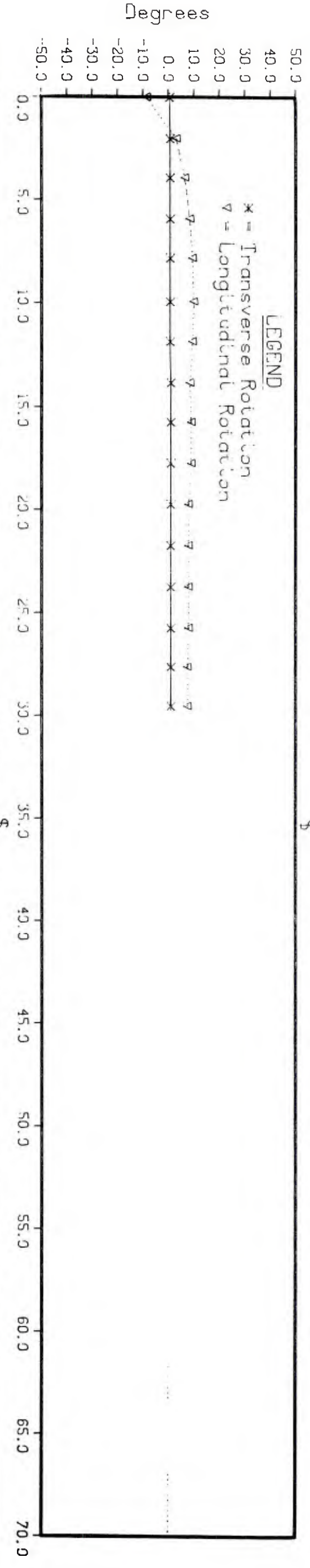
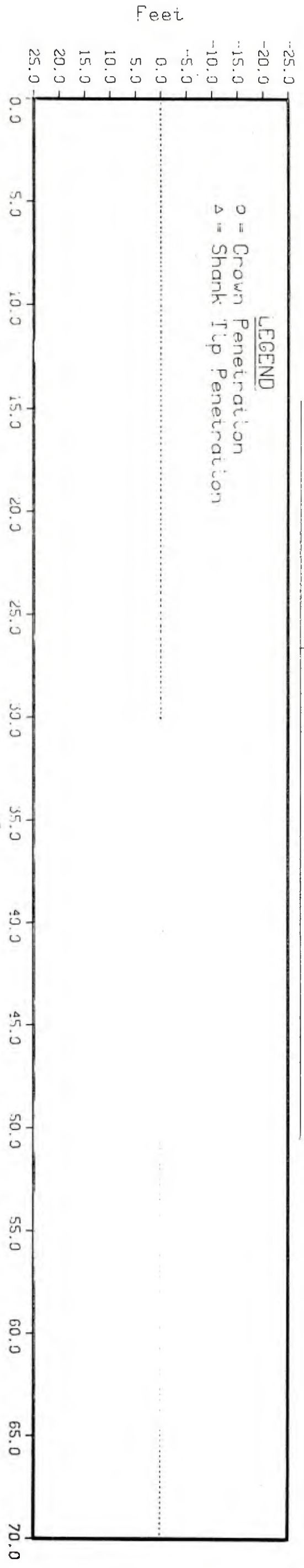

Day # = 106
 Test No. = 1
 Test Series No. = 24

SRN C

STATO ANCHOR TEST

TEST DATE 106
 TEST NO. 1
 TEST SPTS 24
 TEST AREA SAN DIEGO HARBOR AT BUOY 21
 STATION TYP 1127 - 1140
 SEAFLOOR TYPE 1-3 FT. WUD OVER DENSE SAND. DEPTH 35-38 FT. MLW
 ANCHOR TYPE STATO *3000 LB. WT., STABILIZER EXT. 31.5 DEG. ANV. FLUMES
 ANCHOR WEIGHT 3000.00 LB.
 FLUME ANGLE TYPE 91.59 DEG. - 0 0 ANV 18 FTX
 AUX. ANCHOR TYPE
 AUX. ANCHOR WEIGHT
 MAIN-AUX ANCHOR SEPARATION 0+00 LR.
 DEPTHSS+MN.-WT.FACT-TOTAL WT. 0+00 FEET
 ANCHOR TO SHFT 31W STUDY CHAIN TO 180FT 2-STW STUDY CHAIN TO 340FT 31W WTOP DWP 0+00 LR.
 ANCHOR TO SHFT 31W WTOP DWP 0+00 LR.
 CHAIN TO SHFT 31W WTOP DWP 0+00 LR.

1	2	3	4	5	6	7	8	9	10	11	12	13	14	15
FEET	KIPS	KIPS	FEET	DEG	DEG	FEET	KIPS	FEET	LB	FEET	FEET	FEET	FEET	LB
1. NEAR DISTANCE	2. DECK TENSION	3. ANCHOR TENSION	4. PACKAGE WEIGHT	5. ROTATION ANGLE	6. SHANK ANGLE	7. KIP ANGLE	8. CHAIN LENGTH ON BOTTOM	9. CHAIN WEIGHT ON BOTTOM	10. ANCHOR WEIGHT	11. ANCHOR WEIGHT	12. WATER DEPTH	13. ANCHOR FLUME TIP DEPTH	14. TOTAL BOTTOM WEIGHT	15. TOTAL BOTTOM WEIGHT
0.0	13.0	1.3	40.4	-2.3	5.1	13.9	17.6	251.2	0000.0	39.9	40.0	40.0	41.0	1947.2
2.0	17.5	3.8	40.4	-2.3	4.5	13.6	17.0	231.4	0005.2	40.0	40.0	40.0	41.0	1947.2
3.0	21.0	6.1	40.4	-2.3	3.1	12.7	22.4	212.6	0017.7	40.1	40.0	40.0	41.0	1947.2
5.5	26.0	8.1	40.4	-2.3	2.0	12.2	23.5	212.3	0088.4	40.2	40.0	40.0	41.0	1947.2
0.0	30.0	13.8	40.4	-2.0	1.2	10.0	29.4	197.3	0273.2	40.8	40.0	40.0	41.0	1947.2
10.0	36.0	18.4	40.4	-2.5	13.4	10.6	35.4	181.4	0441.0	39.9	41.0	41.0	41.0	1947.2
19.1	43.0	26.0	41.4	-2.5	12.0	10.3	47.2	142.3	0487.7	39.9	42.1	43.0	41.0	1947.2
14.4	51.0	39.0	41.5	-2.5	9.3	9.5	52.8	117.4	0540.2	40.4	42.0	44.2	41.0	1947.2
14.6	62.0	43.2	41.5	-2.5	8.0	9.4	63.1	105.0	0617.3	40.4	41.0	44.4	41.0	1947.2
17.7	65.0	46.4	41.3	4.5	13.9	9.0	64.4	173.1	0710.4	41.0	41.0	44.4	41.0	1947.2
19.6	35.0	21.9	40.4	4.5	13.9	9.0	74.5	200.7	0814.1	41.0	41.0	44.4	41.0	1947.2
24.0	33.0	20.3	40.4	19.0	15.5	9.0	92.5	200.3	0906.5	41.0	41.0	44.4	41.0	1947.2
26.3	40.0	28.9	40.4	19.0	15.5	9.0	92.5	200.3	0906.5	41.0	41.0	44.4	41.0	1947.2
28.7	51.0	38.1	41.1	19.0	15.5	9.0	92.5	200.3	0906.5	41.0	41.0	44.4	41.0	1947.2
30.2	59.5	42.5	40.9	11.5	8.3	9.1	91.3	140.4	0989.4	41.0	41.0	44.4	41.0	1947.2
38.1	17.0	8.1	40.1	33.8	22.5	11.7	16.6	244.7	0000.0	41.0	41.0	44.4	41.0	1947.2

DISTANCE RADOF TRAVELLED 40.0
 DISTANCE ANCHOR TRAVELLED 38.1
 UNIT - POSITIVE SHANK
 ANG F INDICATES
 SHANK TIP BELOW
 CHAIN

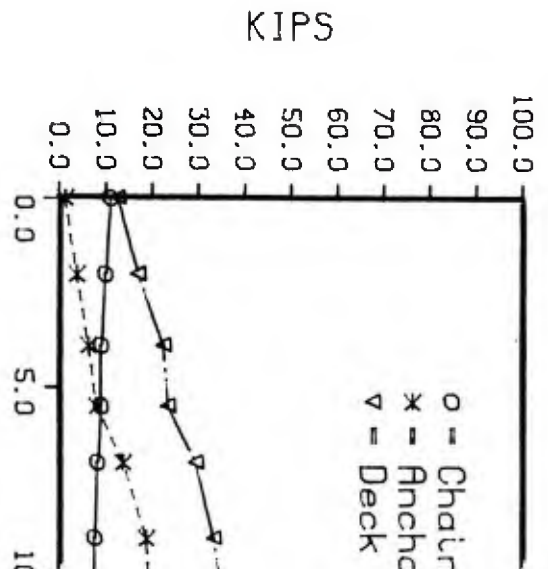
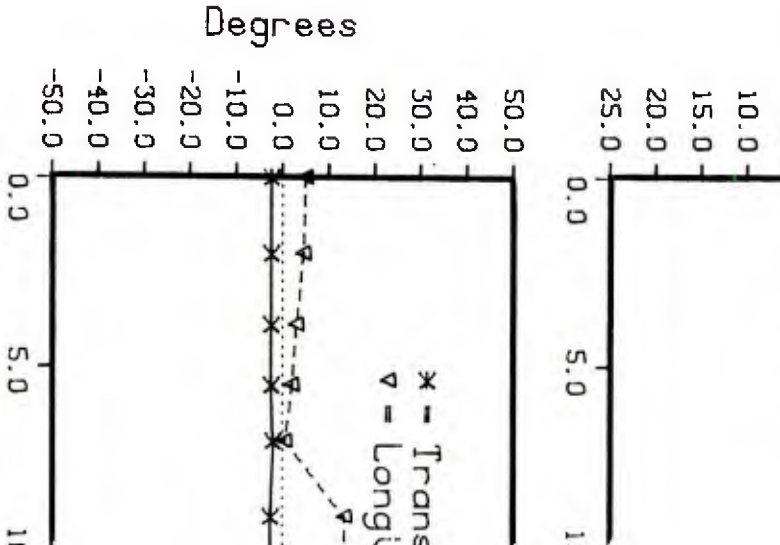
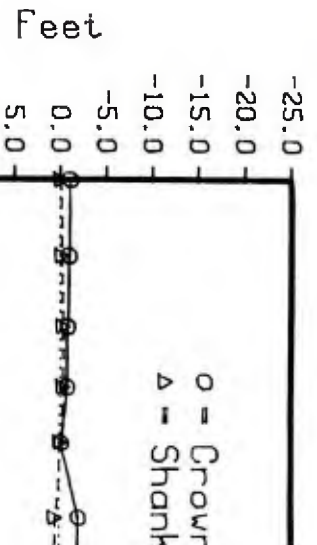

Day # - 106 SAN DIEGO HARBOR AT BUOY 21

Test No. = 1

Test Series No. = 24

stato 3000lb. 18 in. stabilizerext. 31.5 deg.mov.flukes
 1-3 ft. mud over dense sand depth 35-38 ft. mllw

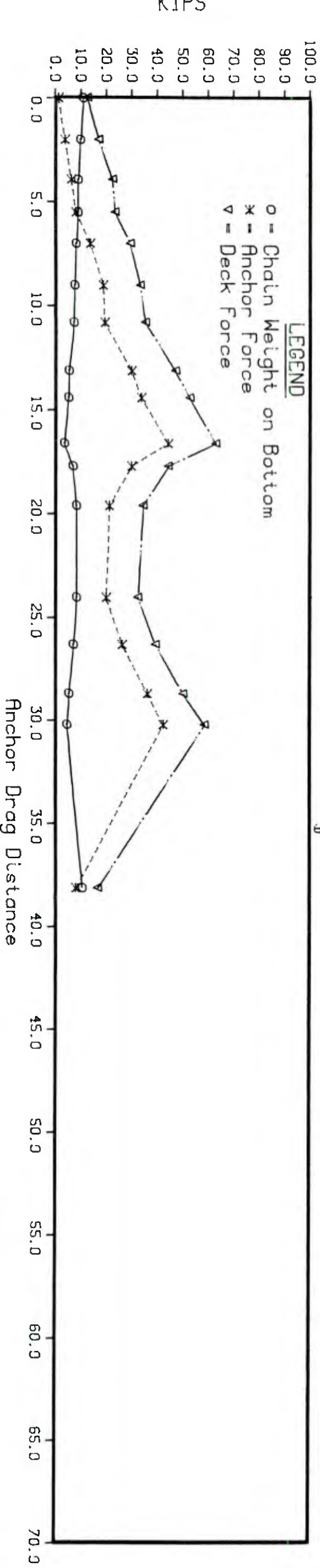
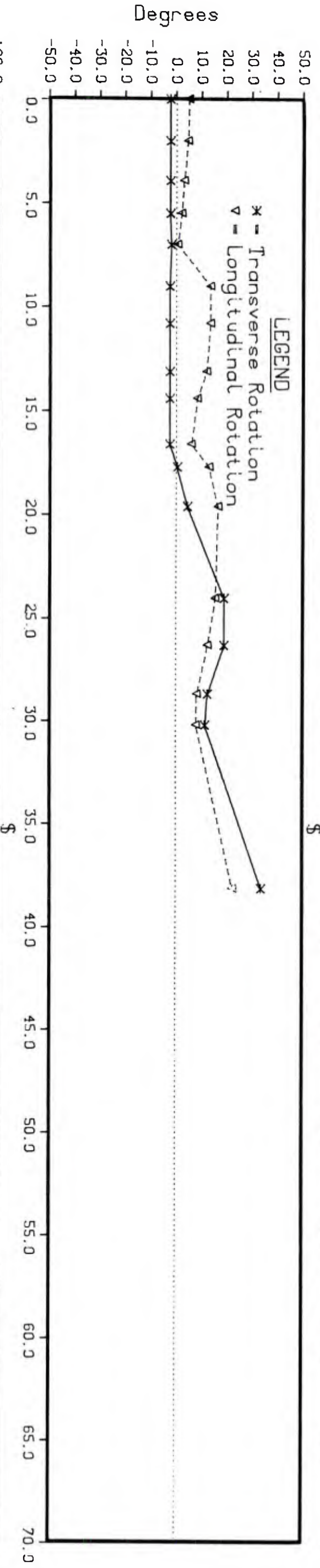
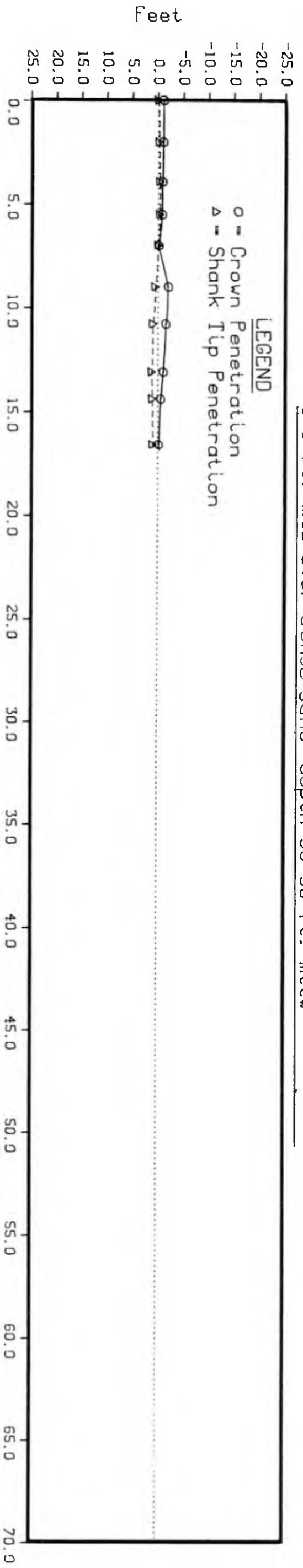

Day # - 106
 Test No. - 2
 Test Series No. - 24

SAN

TEST DATE 106
 TEST MOD 2
 TEST AREA 24
 START/END TIMES 1227 - 1234
 STATION ID 1-3 FT. MUD OVER DENSE SAND. DEPTH 35-38 FT. MUD
 ANCHOR TYPE STARO *3000LB. 1/2" TN. STABILIZEREXT. 31.5 DEG-MOV-FLOWES
 ANCHOR HEIGHT 3000.00 LB.
 FLUXE ANGLE TYPE 11.50 DEG. - 0 DEGREE LEFTX
 AUX ANCHOR TYPE 0.00 FT. R.
 AUX ANCHOR HEIGHT 0.00 FT. R.
 MAIN-AUX ANCHOR SEPARATION 0.00 FT. R.
 DEPRESSIONS-NO.-WT. EACH-TOTAL WT. 0.00 LB.
 MORNING LINE DESCRIPTION ANCHOR TO TAFFT 21M STUOLINK CHAIN TO TAFFT 2.5M STUOLINK

1	2	3	4	5	6	7	8	9	10	11	12	13	14	15
FEET	KIPS	FEET	DEG	DEG	DEG	KIPS	FEET	LB	FEET	FEET	FEET	FEET	FEET	LB
0.0	15.0	0.0	40.1	-1.0	4.4	13.2	14.4	245.2	*****	19.4	40.4	43.1	40.4	1364.9
2.0	23.0	0.0	40.2	-1.0	2.5	11.7	22.5	220.5	9486.1	19.4	40.4	43.2	40.4	12806.1
4.1	27.0	0.0	40.4	-1.0	2.1	11.4	26.5	207.0	8733.5	19.4	40.4	43.2	40.4	11771.5
6.0	52.0	0.0	40.4	-1.0	2.5	10.0	51.2	133.4	5040.5	40.5	41.0	43.6	40.4	6040.5
7.6	63.5	0.0	40.7	-1.0	3.4	9.3	108.4	1808.4	40.4	40.4	43.7	40.4	40.4	6000.4
9.4	65.0	0.0	41.0	-1.0	5.4	9.0	44.2	1902.0	40.4	41.4	43.9	40.4	40.4	6002.0
10.1	37.0	0.0	40.3	3.5	14.5	8.5	74.4	204.4	4601.3	39.1	41.4	43.3	40.4	11601.3
12.1	37.0	0.0	40.3	3.5	15.3	8.6	74.6	209.1	4876.5	38.4	41.2	42.7	40.4	11876.5
18.1	21.0	0.0	39.8	5.2	17.5	0.9	22.7	234.4	*****	17.5	40.4	42.0	40.4	11714.4

DISTANCE RANGE TRAVELLED 20.0
 DISTANCE ANCHOR TRAVELLED 19.4

NOTE - POSITIVE SHANK
 ANGLE INDICATES
 SHANK TIP BELOW
 CHAIN

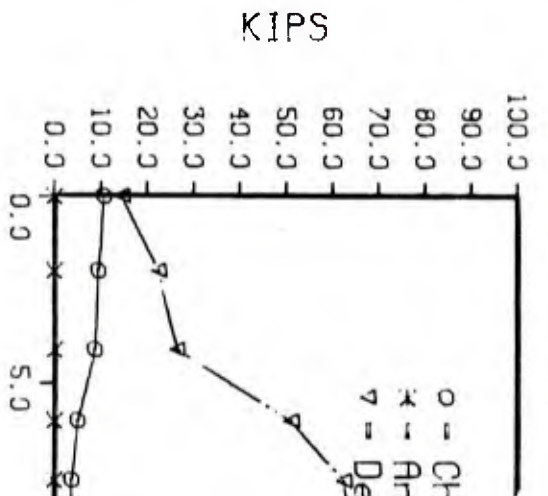
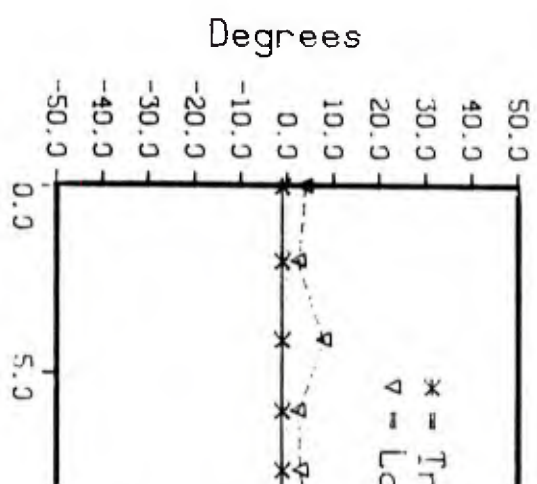
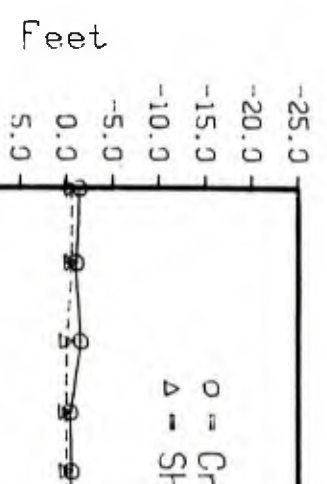

Day # - 106 SAN DIEGO HARBOR AT BUOY 21

Test No. = 2

Test Series No. - 24

stato 3000lb. 18 in. stabilizext. 31.5 deg.mov.flukes
 1-3 ft. mud over dense sand depth 35-38 ft. mllw

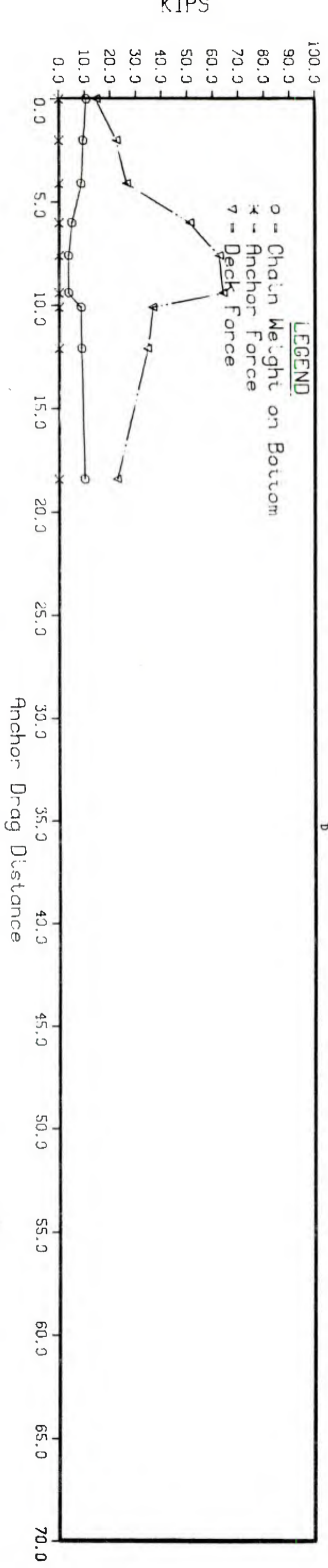
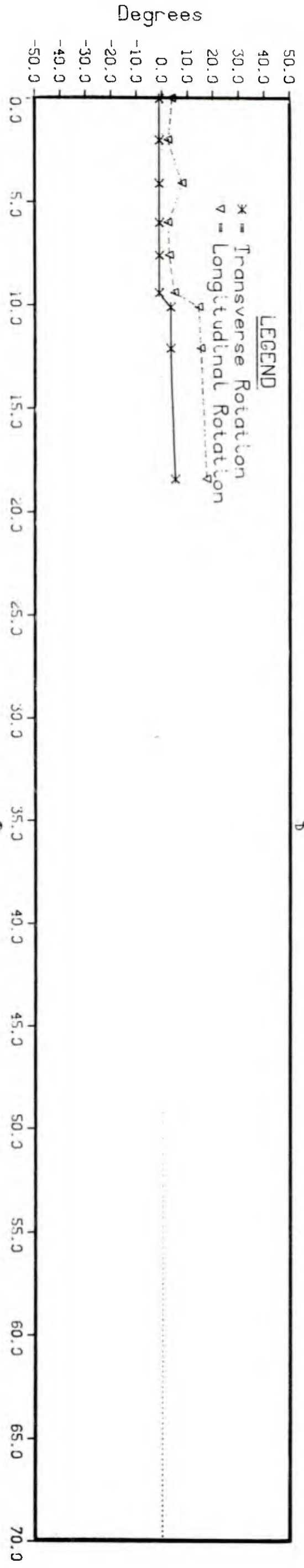
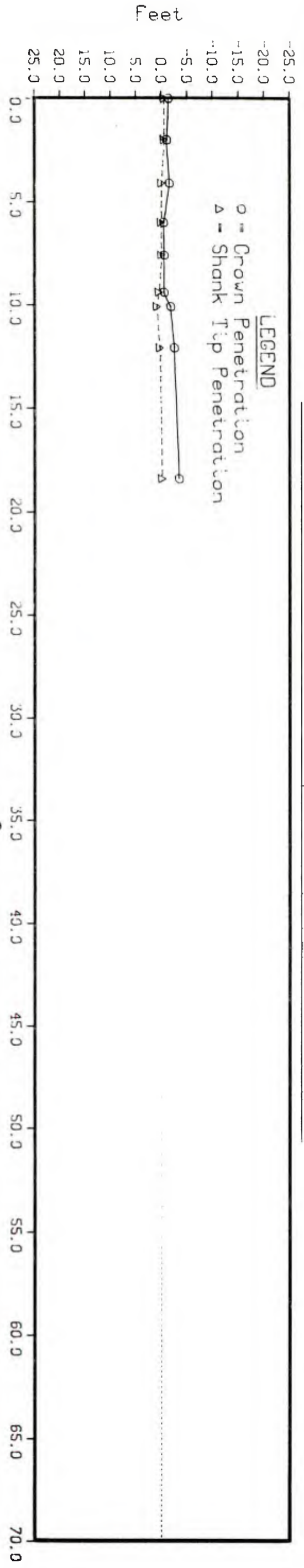

Day # = 106
 Test No. = 3
 Test Series No. = 24

SRN

STATO ANCHOR TEST

TEST DATE 106
 TEST NO. 3
 TEST SPECIFIC
 TEST ABFA
 STAD-FUN TIMES
 STAFFING TYPE
 ANCHOR TYPE
 ANCHOR WEIGHT
 FLUXE ANCHOR TYPE
 AUX. ANCHOR TYPE
 MAIN-AUX ANCHOR SEPARATION
 DEPRESSIONS, WT. FACTOR, TOTAL WT.
 PROBING TIME DESCRIPTION

106
 3
 SAW DIEGO HARBOR AT BAY 21
 130 - 1330
 1-3 FT. WIND OVER DENSE SAND. DEPTH 35-38 FT. WIND
 STATO 3000.00 19.
 3000.00 19.
 21.50 DEG. - 0 0.5000 15FTX
 0.00 1R.
 0.00 0.00 0.00 LB.
 ANCHOR TO 30FT 3IN STUDY TW CHAIN TO 100FT 2.5IN STUDY TW
 CHAIN TO 300FT 3IN WIRE CABLE

1. DRAE DISTANCE	2. OPER FUNCTION	3. ANCHOR FUNCTION	4. BARXKAF PRETS	5. ROTATION ANGLE	6. WIRE DEPTH	7. WIRE ANGLE	8. WIRE ANGLE	9. CHAIN LENGTH ON BOTTOM	10. CHAIN WEIGHT ON BOTTOM	11. ANCHOR FROM DEPTH	12. ANCHOR FROM DEPTH	13. ANCHOR FLUXE TIP DEPTH	14. WIRE DEPTH	15. TOTAL BOTTOM WEIGHT
0.0	16.0	6.6	17.9	5	3.6	17.5	19.5	17.4	225.4	418.5	115	111	112	114
2.0	20.0	6.3	17.4	5	3.6	17.5	19.5	17.4	225.4	418.5	115	111	112	114
4.0	24.0	6.7	17.4	0.0	16.0	11.2	22.6	220.4	460.8	381	127	127	127	127
6.0	28.0	7.5	17.7	0.0	15.7	11.2	22.6	220.4	460.8	381	127	127	127	127
8.0	32.0	8.3	18.5	-4.5	14.7	9.3	22.6	190.2	488.6	381	127	127	127	127
10.0	36.0	9.1	18.4	-4.5	14.0	8.8	22.6	129.8	488.6	381	127	127	127	127
12.0	40.0	9.5	18.4	-4.5	13.0	8.3	22.6	109.1	488.6	381	127	127	127	127
14.0	44.0	9.9	18.4	-4.5	12.0	7.8	22.6	88.4	488.6	381	127	127	127	127
16.0	48.0	10.3	18.4	-4.5	11.0	7.3	22.6	67.7	488.6	381	127	127	127	127
18.0	52.0	10.7	18.4	-4.5	10.0	6.8	22.6	47.0	488.6	381	127	127	127	127
20.0	56.0	11.1	18.4	-4.5	9.0	6.3	22.6	26.3	488.6	381	127	127	127	127
22.0	60.0	11.5	18.4	-4.5	8.0	5.8	22.6	5.6	488.6	381	127	127	127	127
24.0	64.0	11.9	18.4	-4.5	7.0	5.3	22.6	0.0	488.6	381	127	127	127	127

NOTE - POSITIVE SHAWK
 ANGLE INDICATES
 SHAWK TIP POSITION
 DOWN

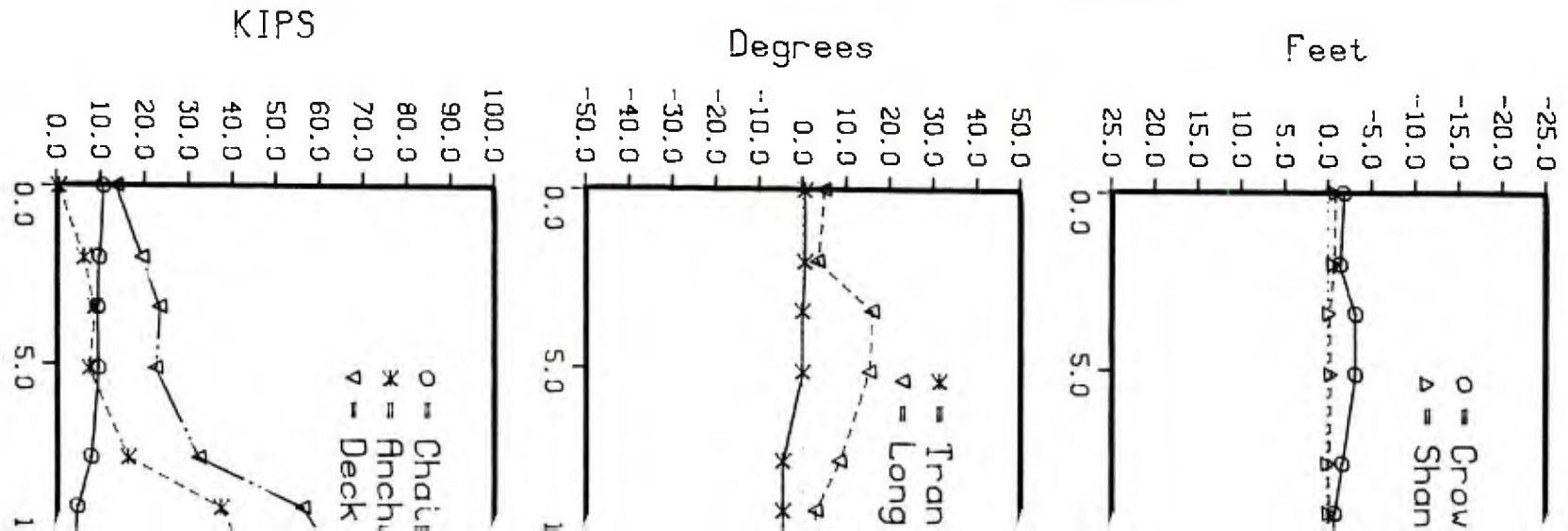

Day # - 106

SAN DIEGO HARBOR AT BUOY 21

Test No. - 3

Test Series No. - 24

stato 3000lb. 18 in. stabilizerext. 31.5 deg.mov.flukes
1-3 ft. mud over dense sand depth 35-38 ft. mllw

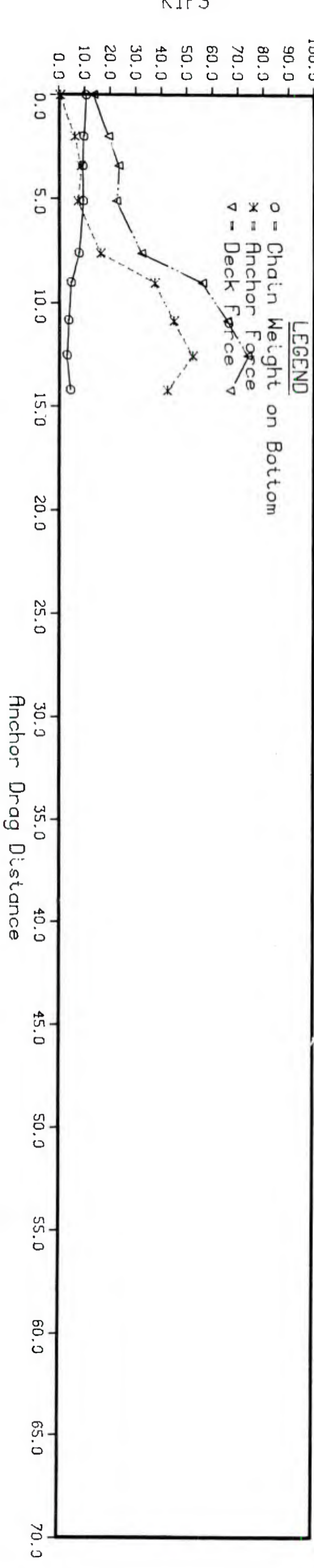
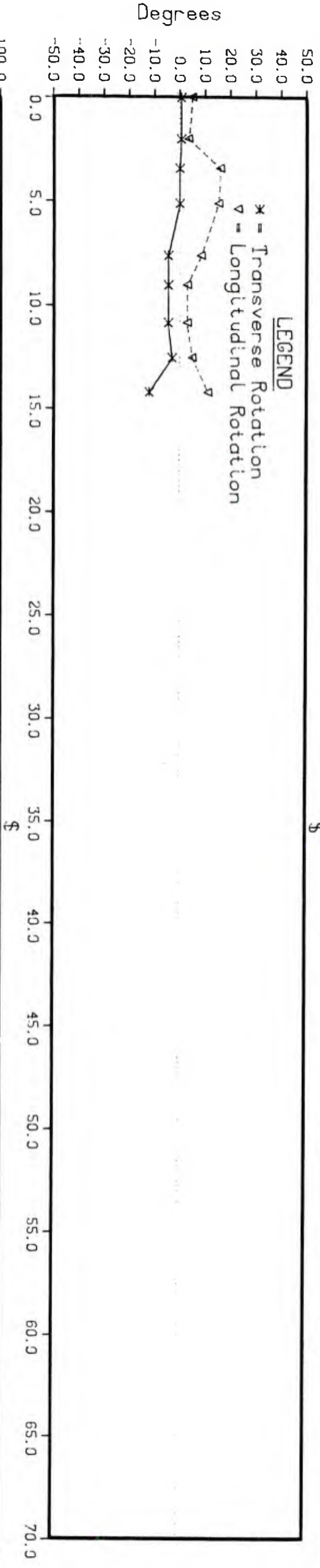
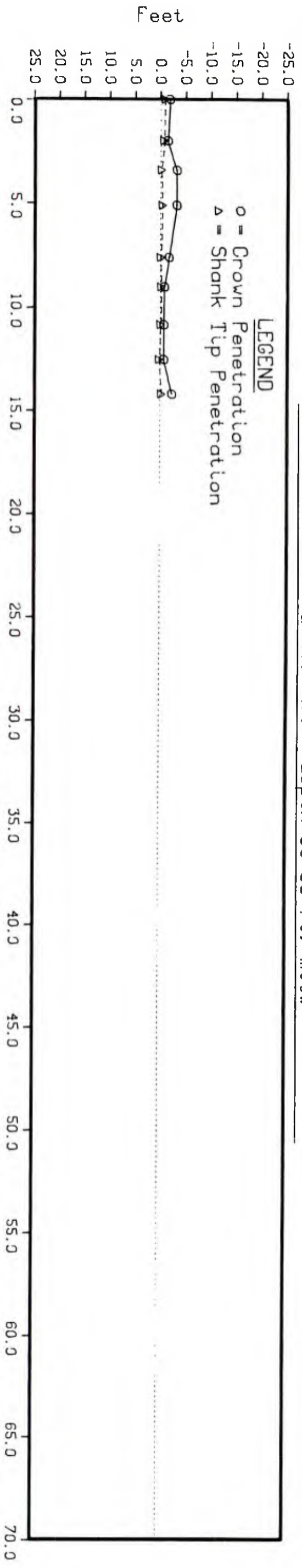

Day # = 170
 Test No. = 1
 Test Series No. = 0

INDIAN

TEST DATE 170
 TEST NO. 1
 TEST AREA INDIAN ISLAND WASHINGTON
 START-END TIMES 1700 - 1720
 SCALE/DOR TYPE SLEET
 ANCHOR TYPE 10000LB. 16 IN. STABILIZERS 50 DEG. MOV. FLUKES
 ANCHOR HEIGHT 1070.00 LB.
 FLUME ANGLE-TYPE 50-00 DEG. - 0 0-MOV 1-PIK
 ALK, ANCHOR TYPE 0.00 LB.
 AUX. ANCHOR WEIGHT 0.00 LB.
 PAIN-AUX ANCHOR SEPARATION 0.00 LB.
 DEPRESSORS-NO.-MT-EACH-TOTAL MT. 90 FT., 2 IN. CHAIN, 300 FT., 2.5 IN. CHAIN, 400 FT., 1 5/8 IN. IMRC ROPE, 346 FT., 2 IN. IMRC ROPE

1	2	3	4	5	6	7	8	9	10	11	12	13	14	15
FEET	KIPS	KIPS	FEET	DEG	DEG	DEG	KIPS	FEET	LB'S	FEET	FEET	FEET	FEET	LB'S
0.0	14.0	2.6	89.4	1.7	-9.4	15.4	447.1	20773.9	89.7	88.7	92.2	88.4	21843.9	
2.0	13.1	2.2	89.2	1.7	-9.3	15.1	449.2	20801.3	89.6	88.8	92.3	88.4	21971.3	
4.0	14.6	2.4	89.2	1.7	-9.6	15.0	443.8	20671.4	89.6	88.8	92.3	88.4	21875.4	
6.0	16.3	2.6	89.6	1.7	-11.7	15.7	432.1	20218.2	89.3	89.1	92.4	88.4	21441.2	
8.0	19.2	3.4	90.9	2.1	-13.7	16.1	418.7	20018.9	90.0	89.4	93.0	88.4	21080.7	
10.0	19.3	4.4	91.0	2.1	-15.0	16.2	431.0	19843.4	91.5	89.9	93.2	88.4	20953.8	
12.0	22.0	5.6	91.0	3.1	-17.4	17.5	423.3	19575.6	92.1	90.4	94.2	88.4	20649.6	
14.0	24.7	6.8	92.4	3.4	-18.0	17.0	413.5	19109.2	92.5	90.8	94.6	88.4	20262.9	
16.0	25.2	7.4	92.4	3.4	-16.4	17.0	425.6	19109.2	92.9	91.2	95.0	88.4	20159.2	
18.0	26.3	8.6	92.5	3.6	-17.5	12.5	412.7	19049.1	93.0	91.2	95.1	88.4	19973.3	
20.0	28.5	10.0	93.1	3.6	-19.3	12.3	427.9	18661.3	93.7	91.7	95.6	88.4	19733.3	
22.0	29.6	10.4	93.8	3.3	-21.3	12.1	428.9	18528.2	94.4	92.2	96.6	88.4	19598.2	
24.0	30.6	10.8	94.5	3.3	-24.8	11.9	400.2	18418.0	95.5	92.0	98.5	88.4	19488.0	
26.0	31.6	11.2	94.5	3.3	-30.4	11.7	397.9	18308.2	96.3	92.7	97.2	88.4	19376.2	
27.9	32.2	11.4	95.3	3.6	-38.6	11.5	397.6	18291.6	96.3	92.7	97.2	88.4	19361.6	
29.9	33.4	11.8	95.4	4.2	-33.9	11.4	393.8	18097.4	96.3	92.9	97.4	88.4	19167.4	
31.6	32.0	11.6	95.3	4.3	-24.6	11.4	399.5	18383.8	96.0	93.5	97.7	88.4	19493.8	
33.9	33.6	12.4	95.3	5.7	-30.6	11.4	393.0	18074.6	96.2	93.1	97.4	88.4	19144.6	
35.8	33.6	12.4	95.3	7.3	-30.6	11.3	394.0	18107.3	96.3	93.3	97.6	88.4	19172.3	
37.8	33.9	12.4	95.9	8.3	-27.5	11.3	393.3	18063.6	96.7	93.5	98.1	88.4	19133.6	
39.9	34.6	13.0	95.8	8.4	-31.2	11.3	390.8	17948.1	96.7	93.5	97.9	88.4	19018.1	
41.7	34.6	13.0	95.8	9.1	-34.0	11.2	393.9	18019.0	96.8	93.5	97.9	88.4	19089.0	
43.5	34.6	13.0	95.8	9.8	-35.1	11.1	393.6	18009.5	96.9	93.4	97.8	88.4	19059.5	
45.3	35.5	14.0	95.8	9.9	-35.9	10.9	392.2	18011.1	97.0	93.2	97.7	88.4	19037.1	
47.4	35.8	14.6	96.4	9.9	-36.0	10.9	390.8	17946.7	97.4	93.8	98.3	88.4	19016.7	

1. DRAG DISTANCE
 2. DECK TENSION
 3. ANCHOR TENSION
 4. PACKAGE DEPTH
 5. ROTATION ANGLE
 6. SHANK ANGLE
 7. KIRE ROPE ANGLE
 8. DECK HORIZ. FORCE
 9. CHAIN LENGTH ON BOTTOM
 10. CHAIN WEIGHT ON BOTTOM
 11. ANCHOR CROWN DEPTH
 12. ANCHOR SHANK TIP DEPTH
 13. ANCHOR FLUME TIP DEPTH
 14. WATER DEPTH
 15. TOTAL BOTTOM WEIGHT

NOTE - POSITIVE SHANK ANGLE INDICATES SHANK TIP BELOW CROWN

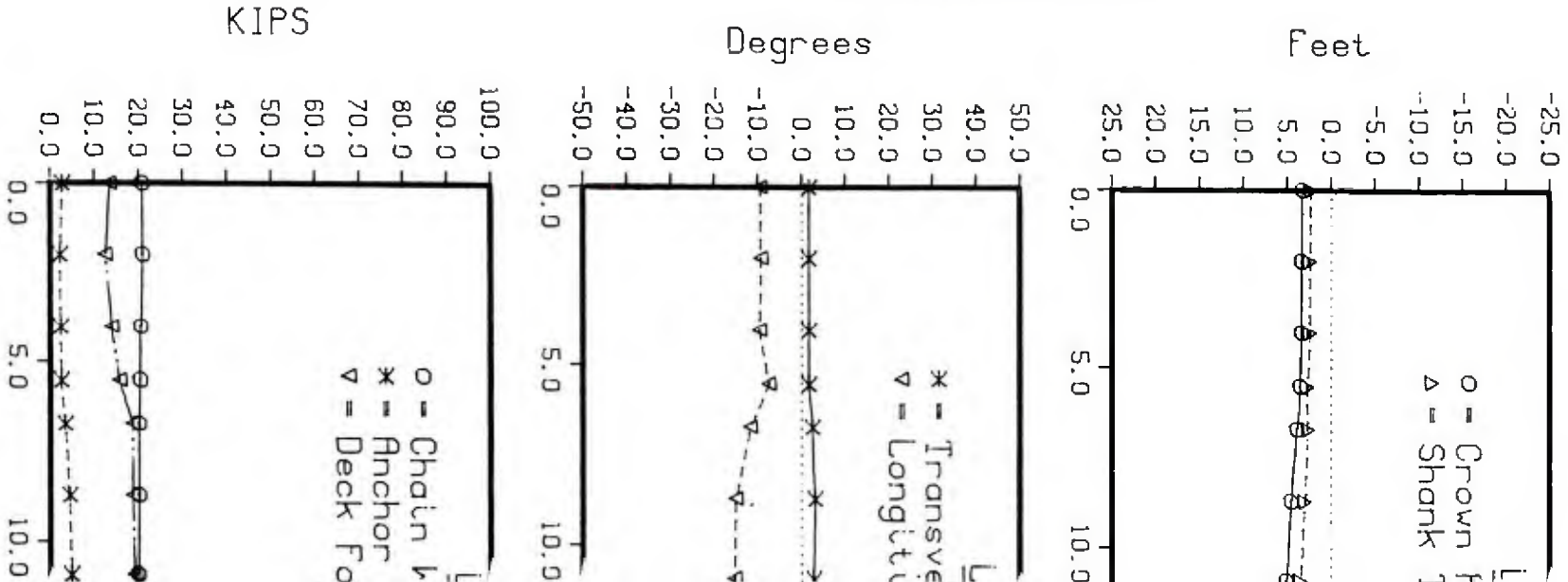

INDIAN ISLAND WASHINGTON

Day # = 170
 Test No. = 1
 Test Series No. = 0
 stato 1000lb, 16 in. stabilizers 50 deg. mov. flukes
 silt

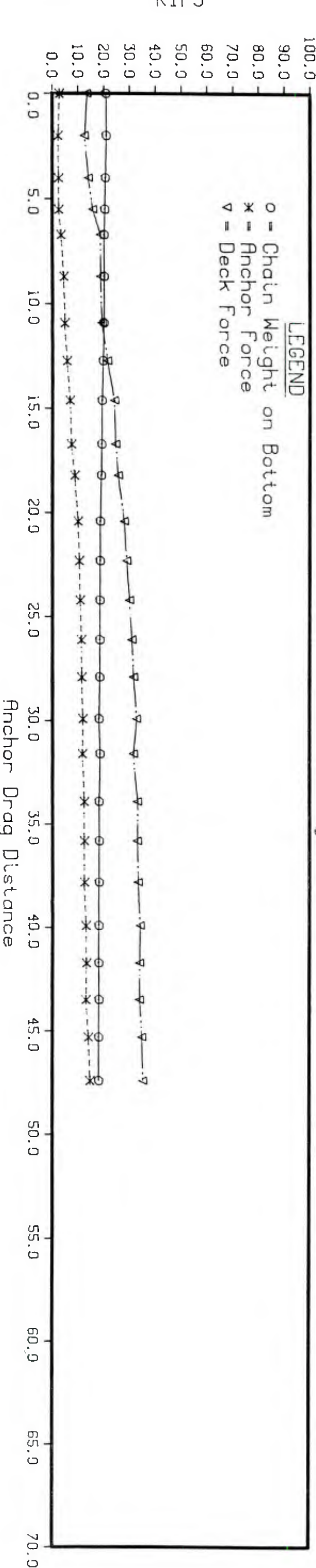
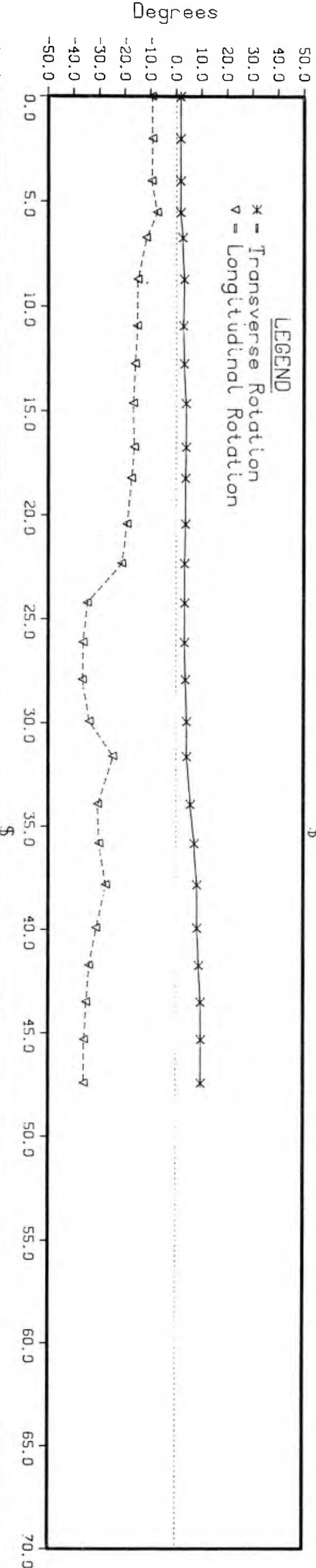
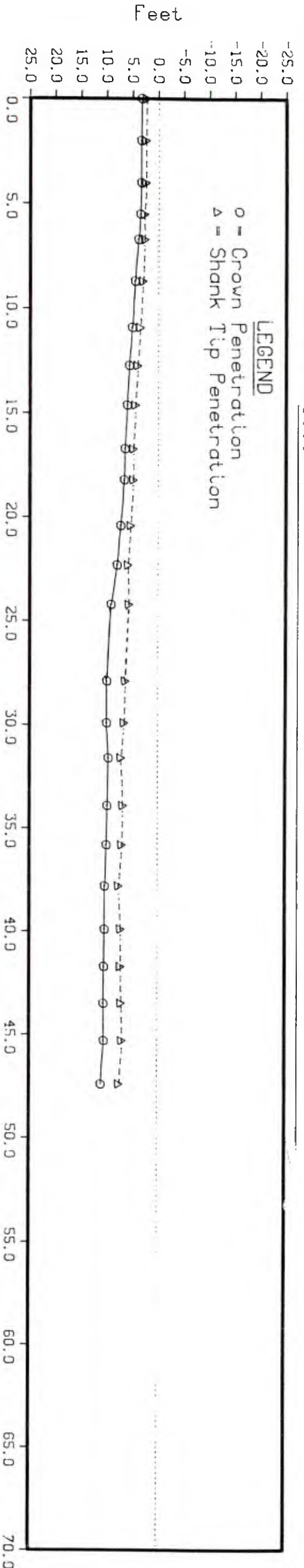

Day # = 172 INDIA
 Test No. = 7
 Test Series No. = 0

STOCKLESS ANCHOR TEST

TEST DATE 172
 TEST NO. 7
 TEST AREA INDIAN ISLAND WASHINGTON
 START-END TIMES 1255 - 1320
 SEAFLOOR TYPE SILT
 ANCHOR TYPE STOCKLESS 9000LBS.+W+STA05+ 48 DEG FX FLUKES
 ANCHOR HEIGHT 11370 LB.
 FLUKES ANGLE-TYPE 48-00 DEG. - 0 0-MOV 1-FIX
 ANCHOR HEIGHT 0-00 LB.
 ANCHOR SEPARATION 0-00 LB.
 DEPRESSIONS+NO.-WT.+EACH-TOTAL MT. 90 FT. 2 IN. CHAIN, 360 FT. 2.5 IN. CHAIN, 400 FT. 1 5/8 IN. LMC ROPE, 340 FT. + 2 IN. LMC ROPE

1. DRAG DISTANCE	2. DECK TENSION	3. ANCHOR DEPTH	4. PACKAGE DEPTH	5. ROTATION ANGLE	6. SHANK ANGLE	7. WIRE ROPE ANGLE	8. DECK HORIZ. FORCE	9. CHAIN LENGTH ON BOTTOM	10. CHAIN HEIGHT ON BOTTOM	11. ANCHOR CROWN DEPTH	12. ANCHOR SHANK TIP DEPTH	13. ANCHOR FLUKE TIP DEPTH	14. WATER DEPTH	15. TOTAL BOTTOM WEIGHT
0.0	18.0	2.5	79.0	5.4	-17.4	15.8	17.3	427.7	1980.0	80.6	78.2	83.6	78.4	20937.0
2.0	23.4	9.1	80.1	5.3	-12.6	14.7	22.6	407.9	18806.7	81.3	79.5	84.7	78.8	19943.7
3.2	24.3	9.1	80.8	5.3	-11.2	14.1	23.5	407.6	18791.5	81.8	80.3	85.3	78.8	19928.5
5.3	25.2	10.1	81.3	4.2	-11.0	14.0	24.4	404.4	18631.5	81.9	80.4	85.4	78.8	19768.5
6.9	25.7		81.3	3.6	-10.8	13.8	24.9	404.1	18615.1	82.3	80.8	85.8	78.8	19752.1
8.5	26.7		82.3	3.1	-8.0	13.1	28.0	395.9	18205.1	83.1	81.9	86.8	78.8	19342.1
10.7	32.2		82.5	2.8	-6.0	12.8	31.4	389.9	17603.9	83.1	82.2	87.0	78.8	18740.9
12.4	36.3		83.7	2.1	-4.9	12.2	35.5	372.5	17031.7	84.2	83.5	88.2	78.8	18168.7
14.1	39.2	22.0	84.4	1.6	-4.7	11.8	38.3	365.6	16684.8	85.4	84.2	88.9	78.8	17821.8
16.4	44.0	26.4	84.9	1.2	-4.9	11.7	43.1	348.7	15835.2	85.4	84.7	89.4	78.8	16972.2
18.6	45.6		85.9	.8	-5.4	11.4	46.9	341.6	15480.4	87.2	85.6	90.4	78.8	16617.9
19.4	47.0		86.6	.6	-6.3	11.1	52.2	327.7	14935.1	87.9	87.0	91.1	78.8	1617.9
22.1	53.1	31.6	87.3	.5	-6.3	10.8	57.3	312.9	14792.4	88.9	87.8	92.6	78.8	15929.4
23.8	53.1		88.1	.1	-7.6	10.6	57.3	312.3	14613.6	91.6	90.6	95.4	78.8	15150.6
25.8	58.3	32.6	90.9	-4	-8.1	10.3	58.5	312.9	14005.7	91.6	90.6	95.4	78.8	15222.7
28.1	59.5		91.8	-9.8	-7.8	10.3	60.2	308.2	13808.4	92.1	91.5	96.8	78.8	14943.4
32.1	60.7	33.1	93.2	-1.2	-8.3	10.1	59.8	312.7	13431.6	92.9	91.9	96.8	78.8	14568.6
33.9	60.7		93.2	-1.3	-8.3	10.1	63.4	312.7	13431.6	94.0	92.7	97.6	78.8	15112.6
35.0	65.4	33.8	93.2	-1.5	-8.4	10.1	63.4	288.2	13310.5	94.4	92.6	97.7	78.8	14441.8
37.1	64.4		92.2	-1.2	-8.4	10.1	60.3	288.2	12810.5	94.4	93.2	98.1	78.8	14447.5
39.1	67.3	35.9	94.1	-1.2	-8.4	10.1	60.3	288.2	12810.5	94.4	93.4	98.1	78.8	14447.5
41.3	67.3		94.1	-1.5	-8.8	10.1	60.3	288.2	12884.3	95.0	93.7	98.7	78.8	14012.0

DISTANCE BARGE TRAVELLED 44.0
 DISTANCE ANCHOR TRAVELLED 41.3

NOTE - POSITIVE SHANK ANGLE INDICATES SHANK TIP BELOW CROWN

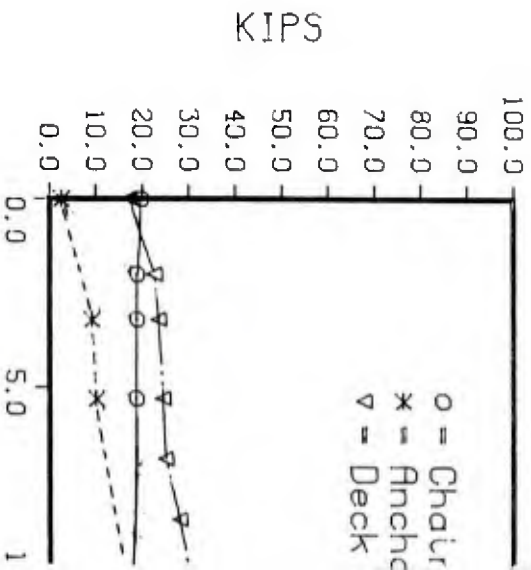
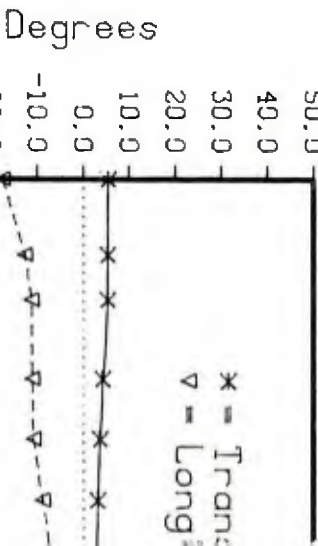
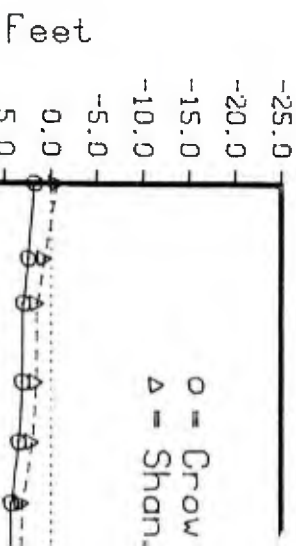

Day # = 172 INDIAN ISLAND WASHINGTON
 Test No. = 7 stockless 9000lbs.w.stabs, 48 deg fx flukes
 Test Series No. = 0 silt

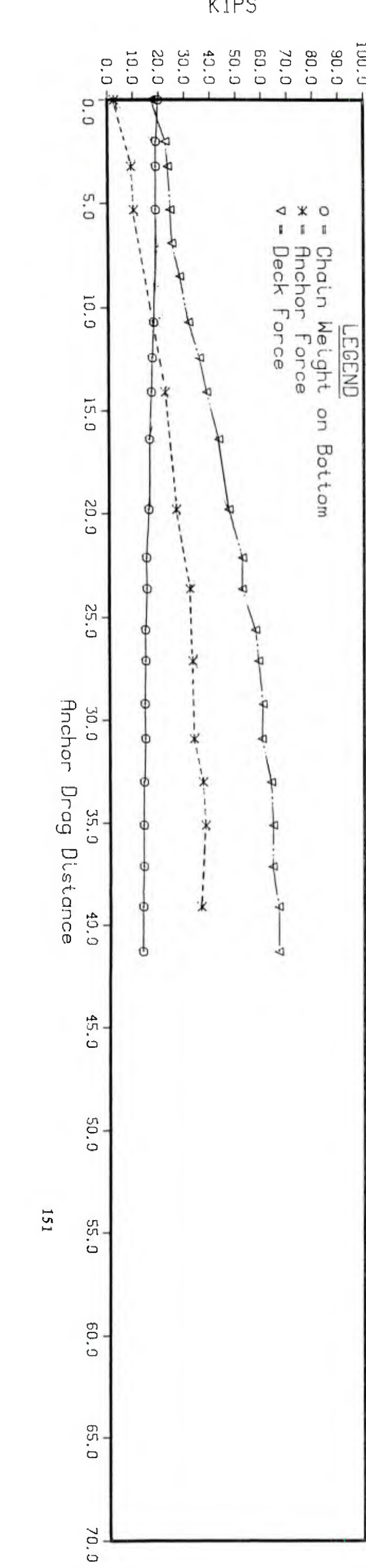
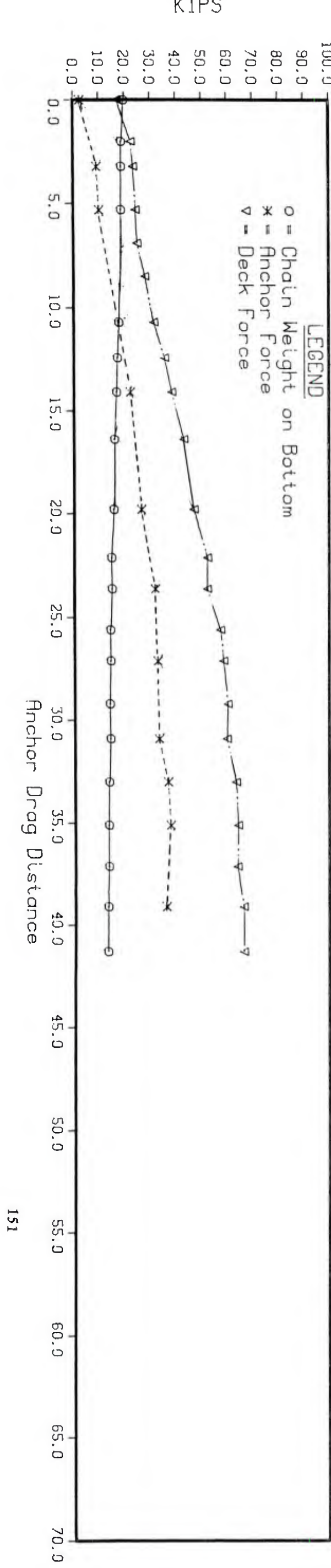
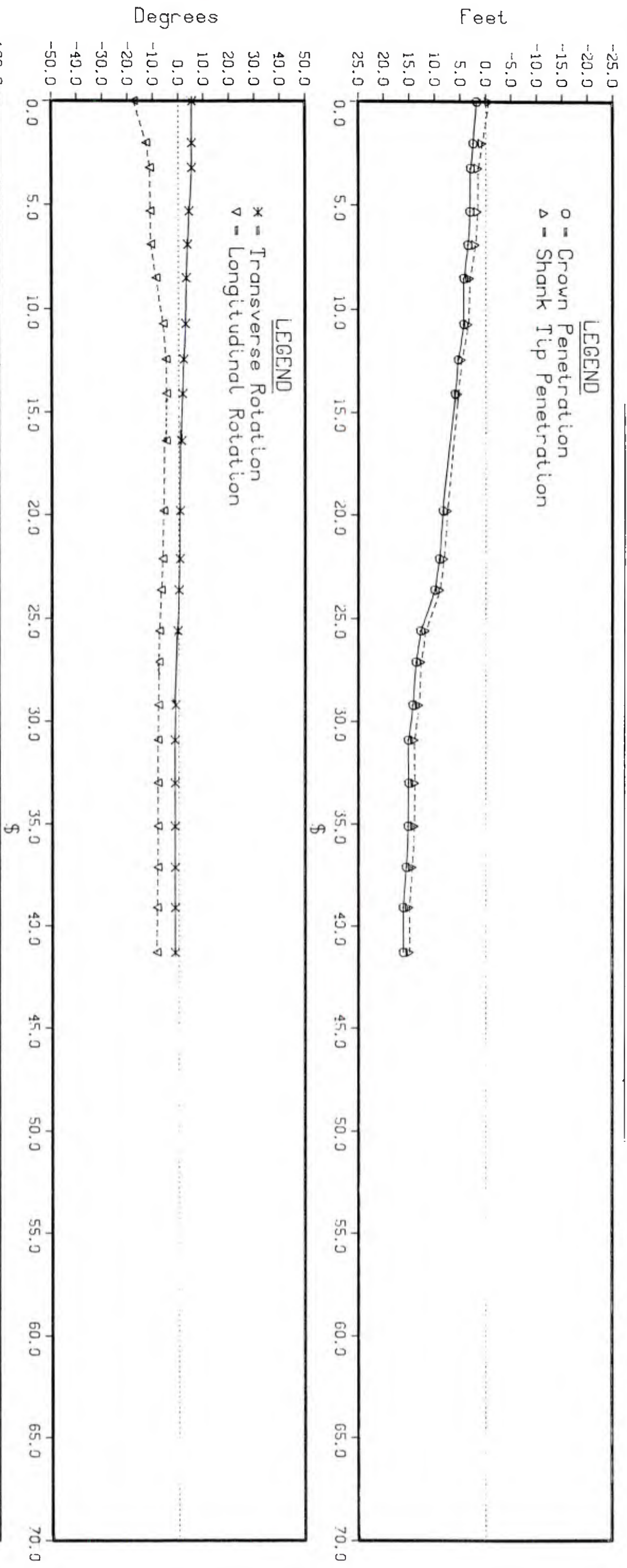

Day # - 172
 Test No. - 8
 Test Series No. - 0

IND.

STOCKLESS ANCHOR TEST

TEST DATE 172
 TEST NO. 8
 TEST RUK E
 TEST AREA INDIAN ISLAND WASHINGTON
 START-END TURNS 1430 - 1447
 START FLOOR TYPE SILET
 STOCKLESS *900LB. STABILIZERS, 48 DEG. MON. FLUKES
 ANCHOR TYPE 11370 LB. C-MOV 1-FIX
 ANCHOR HEIGHT 48.00 DEG. - 0
 FLUKE HEIGHT 0.00 LB.
 ANCHOR TYPE 0.0
 ANCHOR HEIGHT 0.0
 MAIN-AUX ANCHOR SEPARATION 0.0 FT., 2 IN. CHAIN, 300 FT., 2-3 IN. CHAIN, 400 FT., 1 5/8 IN.
 DEPRESSIONS-IND.-W/EACH-TOTAL WT. IMRC ROPE, 346 FT., 2 IN. IMRC ROPE

1	2	3	4	5	6	7	8	9	10	11	12	13	14	15
FEET	KIPS	FEET	FEET	DEG	DEG	DEG	KIPS	FEET	LBS	FEET	FEET	FEET	FEET	LBS
0.0	20.9	3.3	91.0	0.0	-1.9	14.4	20.1	421.9	19909.2	91.2	90.9	99.4	90.8	20846.2
2.0	28.5	9.6	97.7	-1.7	-13.0	12.8	27.7	389.7	18394.5	99.0	97.1	102.3	90.8	19931.5
4.8	31.8	11.4	98.4	-1.4	-13.0	12.8	31.0	389.0	17657.7	99.7	97.8	103.0	90.8	18794.5
6.7	33.7	12.6	97.9	-2.7	-13.0	12.6	32.9	379.2	17369.2	99.2	97.3	102.5	90.8	18906.2
8.4	35.6	14.7	98.7	-1.1	-13.8	12.2	34.8	375.1	17163.5	100.0	98.1	103.3	90.8	18900.5
10.4	37.8	15.9	99.1	0.0	-14.2	12.0	36.9	368.7	16838.8	100.5	98.5	103.7	90.8	17975.8
12.4	39.9	17.7	98.9	0.0	-14.8	11.9	39.0	361.8	16498.1	100.3	98.2	103.5	90.8	17633.1
14.0	41.3	18.7	100.0	0.0	-15.1	11.6	40.4	360.0	16405.1	101.5	99.3	104.6	90.8	17542.1
16.1	43.1	20.5	99.6	-2.3	-15.5	11.5	42.2	359.5	16127.6	101.1	98.9	104.2	90.8	17264.6
17.8	43.2	21.0	100.3	-2.4	-15.8	11.4	43.3	359.5	16127.6	101.8	99.6	104.9	90.8	17218.1
20.0	44.8	22.5	100.5	-2.1	-16.0	11.4	43.9	359.5	15980.2	102.0	99.8	104.9	90.8	16982.6
21.9	45.9	23.5	100.3	-2.2	-16.3	11.3	44.0	346.9	15980.2	102.9	99.6	104.9	90.8	16982.6
24.1	46.1	24.0	100.0	-2.1	-16.4	11.3	44.2	346.9	15980.2	102.6	100.3	104.9	90.8	16982.6
28.9	46.3	24.9	100.0	-2.2	-16.5	11.2	44.0	346.9	15980.2	102.4	100.6	104.9	90.8	16829.1
32.9	46.5	25.8	100.8	-2.4	-16.9	11.2	44.0	348.1	15980.2	102.4	100.6	104.9	90.8	16829.1
37.1	48.0	26.8	101.4	-2.4	-16.9	11.1	47.7	339.4	15971.7	102.4	100.7	104.9	90.8	16829.1
31.6	46.6	24.8	101.4	-2.4	-16.5	11.1	46.0	345.4	15676.2	103.5	101.2	106.5	90.8	16829.1
33.9	48.6	26.8	101.9	-2.4	-16.4	11.1	47.7	339.0	15950.7	103.5	101.2	106.5	90.8	16829.1
35.6	48.6	26.5	101.7	-2.4	-16.4	11.0	47.7	341.6	15848.0	103.3	101.0	106.3	90.8	16829.1
32.7	49.8	27.5	101.8	-2.4	-16.4	11.0	48.9	336.9	15844.4	103.4	101.1	106.4	90.8	16381.4
39.7	51.1	28.0	102.2	-2.4	-16.4	10.9	50.2	333.1	15875.5	103.8	101.4	106.8	90.8	16381.4
41.4	50.4	27.3	102.1	-2.4	-16.4	10.8	49.5	337.4	15868.8	103.7	101.4	106.7	90.8	16381.4
43.6	52.4	29.1	102.4	-2.4	-16.5	10.8	51.4	330.2	14909.1	104.0	101.7	107.0	90.8	16046.1
45.4	52.6	29.6	102.2	-2.4	-16.5	10.7	51.8	330.7	14933.7	103.8	101.5	106.8	90.8	16076.7
47.4	53.3	30.3	102.6	0.0	-16.6	10.7	52.4	339.1	14855.6	104.2	101.9	107.2	90.8	15992.6
49.4	53.0	30.3	102.5	-2.3	-16.6	10.6	52.0	330.8	14942.1	104.1	101.8	107.1	90.8	16079.1

DISTANCE RANGE TRAVELLED 50.0
 DISTANCE ANCHOR TRAVELLED 49.4

NOTE - POSITIVE SHANK
 ANGLE INDICATES
 SHANK TIP BELOW
 CROWN

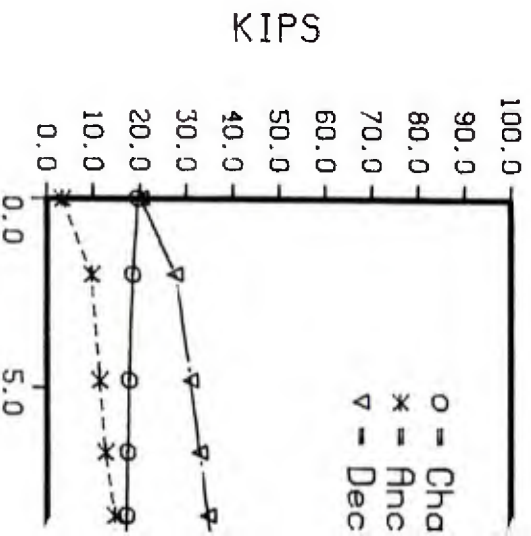
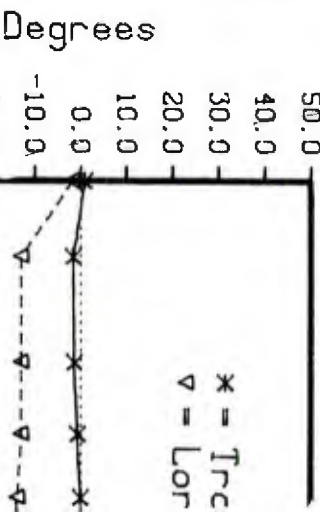
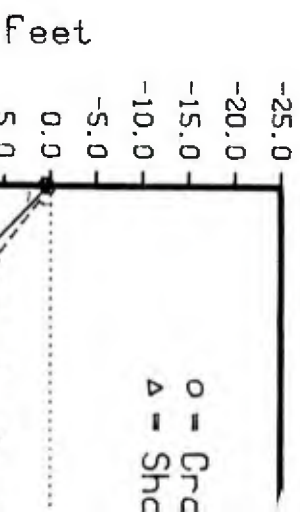

Day # - 172

INDIAN ISLAND WASHINGTON

Test No. - 8

Test Series No. - 0

stockless, 9000lb. stabilizers, 48 deg. mov. flukes
silt

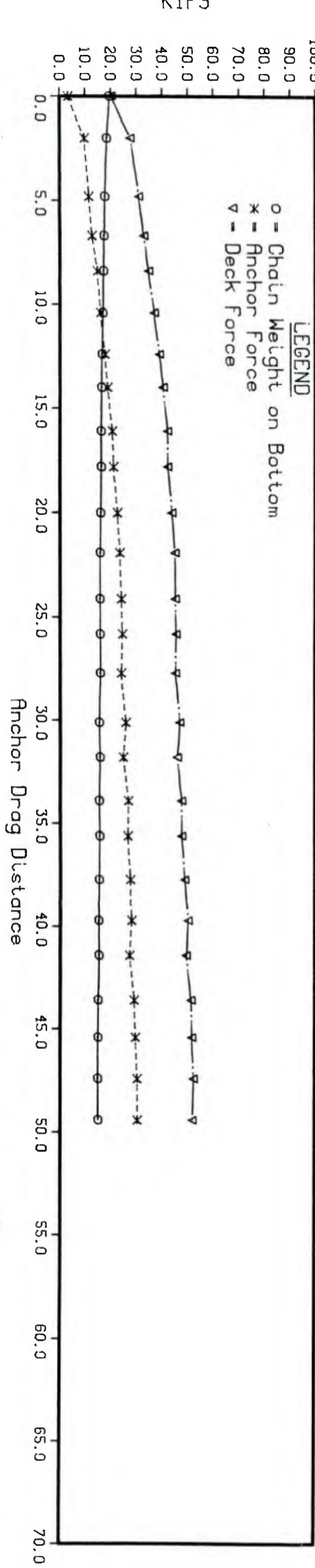
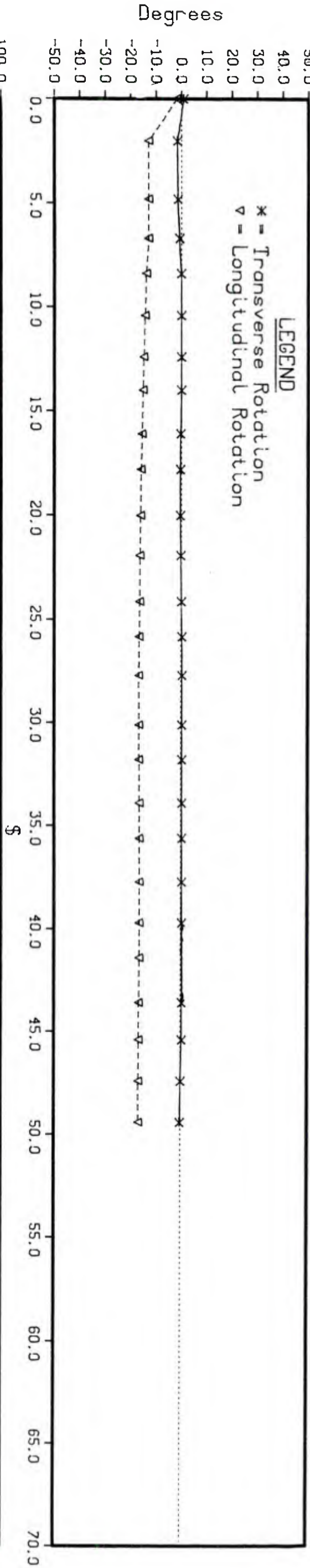
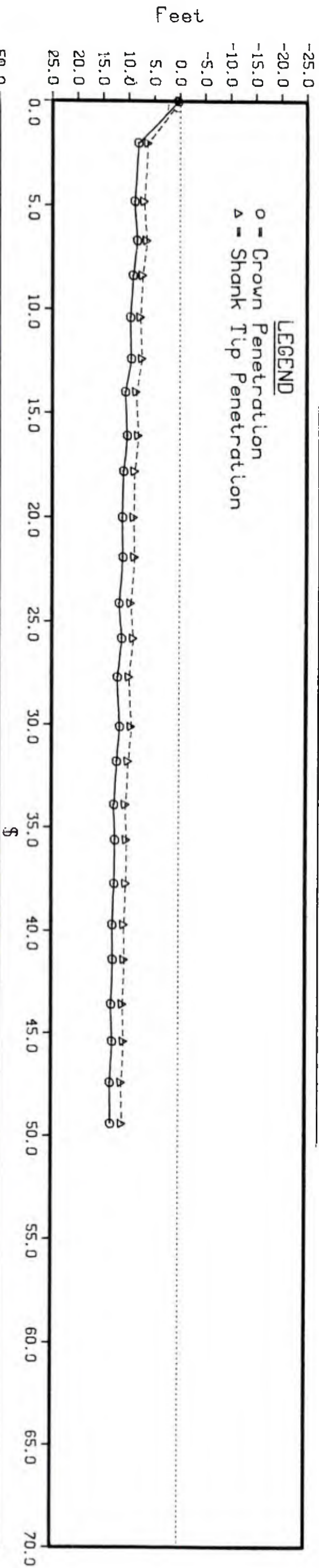

Day # - 172
 Test No. - 9
 Test Series No. - 0

INDI

STOCKLESS ANCHOR TEST

TEST DATE 172
 TEST NO. 9
 TEST RUN INDIAN ISLAND WASHINGTON
 START-END TIMES 1638 - 1657
 SEAFLOOR TYPE SILT
 ANCHOR TYPE STOCKLESS *9000LB., STABILIZERS, 48 DEG. FK, FLUKES
 ANCHOR HEIGHT 5950.00 LB.
 FLUKE ANGLE-TYPE 48.00 DEG. - 1 C-MOV 1-FIX
 ANCHOR TYPE 0.00 LB.
 ANCHOR HEIGHT 0.0 FEET
 ANCHOR SEPARATION 0.0 LB.
 ANCHOR SEPARATION 90 FT., 2 IN. CHAIN, 360 FT., 2.5 IN. CHAIN, 400 FT., 1 5/8 IN.
 DEPRESSORS, NO. - EACH-TOTAL WT. 1MRC ROPE, 346 FT., * 2 IN., 1MRC ROPE
 FOOTING LINE DESCRIPTION

1. DRAG DISTANCE	2. DECK TENSION	3. ANCHOR TENSION	4. PACKAGE DEPTH	5. ROTATION ANGLE	6. SHANK ANGLE	7. SHANK ANGLE	8. SHANK ANGLE	9. CHAIN LENGTH ON BOTTOM	10. ANCHOR WEIGHT ON BOTTOM	11. ANCHOR CROWN DEPTH	12. ANCHOR SHANK TIP DEPTH	13. ANCHOR FLUKE TIP DEPTH	14. WATER DEPTH	15. TOTAL BOTTOM WEIGHT
0.0	18.1	1.2	92.2	24.6	-19.6	15.6	12.5	422.7	1988.9	93.2	91.2	92.2	22761.9	
2.0	18.0	1.2	92.3	24.6	-19.5	15.7	12.4	428.6	1988.1	93.1	91.3	92.2	22766.1	
3.7	18.8	1.6	92.4	24.6	-19.5	15.3	18.2	426.8	19752.6	93.5	91.5	92.2	22762.6	
5.5	19.0	1.6	92.5	24.5	-19.5	15.1	18.4	426.6	19745.9	93.5	91.5	92.2	22763.9	
7.1	20.2	1.8	92.5	24.5	-19.5	14.7	19.5	423.9	19605.9	93.7	91.7	92.2	22769.9	
9.2	21.1	1.0	92.7	24.0	-19.5	14.5	20.5	422.3	19440.8	93.7	91.7	92.2	22769.9	
10.7	21.2	1.2	92.7	23.0	-18.6	14.2	20.5	422.3	19273.3	94.0	92.2	92.2	22769.9	
13.0	22.4	1.4	93.1	22.1	-17.7	14.1	21.7	417.2	19273.3	94.0	92.2	92.2	22769.9	
14.5	22.8	1.6	93.2	20.3	-16.9	14.0	22.1	416.2	18986.8	94.1	92.3	92.2	22769.9	
16.8	24.4	2.2	93.6	17.5	-14.8	13.6	23.7	411.5	18601.7	94.7	92.9	92.2	22769.9	
19.1	26.3	3.0	94.1	13.9	-14.8	13.5	25.6	403.8	18601.7	94.9	93.3	92.2	22769.9	
20.7	26.7	3.0	94.6	9.3	-14.3	13.2	26.0	398.6	18339.2	95.4	93.6	92.2	22769.9	
22.8	28.3	4.0	94.9	6.8	-13.9	13.0	27.6	392.9	18039.2	95.7	94.1	92.2	22769.9	
24.9	30.0	5.2	95.3	3.4	-13.8	12.9	29.2	382.6	17811.9	96.0	94.5	92.2	22769.9	
26.6	32.0	7.0	95.3	2.0	-12.0	12.5	31.3	388.1	17537.2	97.0	94.6	92.2	22769.9	
28.2	34.5	8.4	96.1	1.4	-15.4	12.0	33.7	376.6	16793.1	97.1	95.8	92.2	22769.9	
30.7	38.4	11.2	96.4	1.1	-11.3	11.9	37.6	367.8	16212.0	97.4	96.1	92.2	22769.9	
32.5	38.3	11.4	96.7	1.1	-11.2	11.8	37.5	369.6	16212.0	97.4	96.1	92.2	22769.9	
34.8	42.1	13.4	97.2	1.3	-11.1	11.7	41.2	351.9	15908.5	98.2	97.0	92.2	22769.9	
36.4	44.2	14.6	97.6	1.3	-11.0	11.4	43.3	356.2	15908.5	98.2	97.5	92.2	22769.9	
38.4	47.0	14.8	98.1	1.2	-11.0	11.3	44.1	350.2	15914.0	98.0	97.8	92.2	22769.9	
40.6	48.4	16.4	98.4	1.2	-11.0	11.3	46.5	349.9	15930.3	98.0	98.2	92.2	22769.9	
42.5	48.1	17.6	98.6	1.3	-11.0	11.2	47.2	339.9	15945.3	98.2	98.2	92.2	22769.9	
44.2	50.3	17.8	98.9	1.3	-11.0	11.1	47.2	332.5	15945.3	98.6	98.2	92.2	22769.9	
46.2	50.7	18.0	99.2	1.4	-11.0	11.0	49.8	332.5	15945.3	98.9	98.5	92.2	22769.9	
48.2	50.6	18.0	99.5	1.7	-11.3	10.9	49.7	332.5	15945.3	100.2	98.8	92.2	22769.9	
50.3	52.0	18.8	99.5	1.7	-11.3	10.9	49.7	332.5	15945.3	100.2	98.8	92.2	22769.9	
52.4	52.9	19.8	100.8	1.7	-11.3	10.9	51.0	326.3	14913.4	103.6	102.1	92.2	22769.9	
54.4	53.5	20.4	101.3	1.7	-11.3	10.9	52.0	326.3	14913.4	103.6	102.1	92.2	22769.9	
56.2	53.9	20.4	101.3	1.7	-11.3	10.8	52.9	326.3	14913.4	103.6	102.1	92.2	22769.9	
57.3	54.4	20.6	101.7	1.7	-11.3	10.3	53.5	331.8	14921.8	102.8	100.3	92.2	22769.9	

CISTANCE BARGE TRAVELLED 60.0
 DISTANCE ANCHOR TRAVELLED 57.3

NOTE - POSITIVE SHANK ANGLE INDICATES SHANK TIP BELOW CROWN

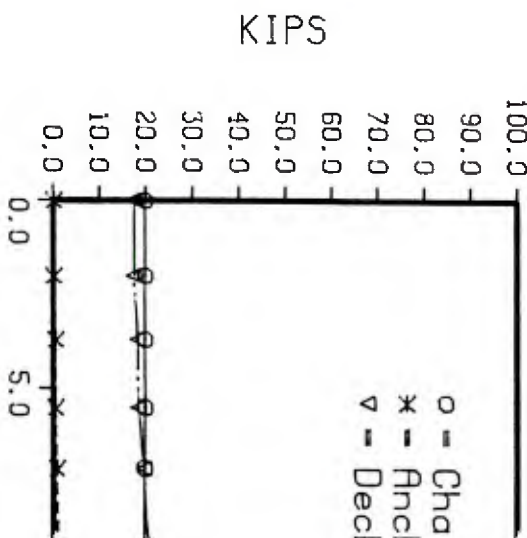
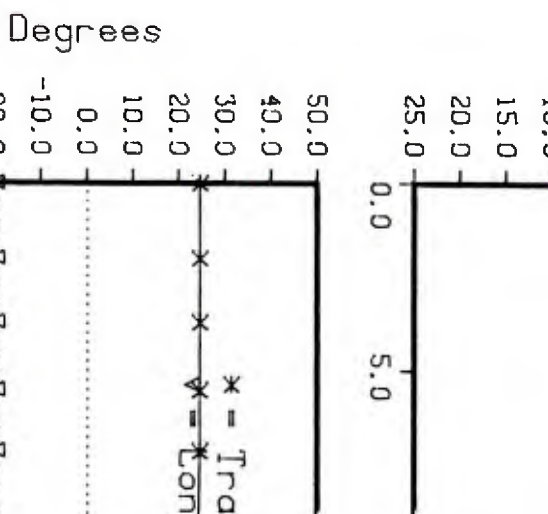
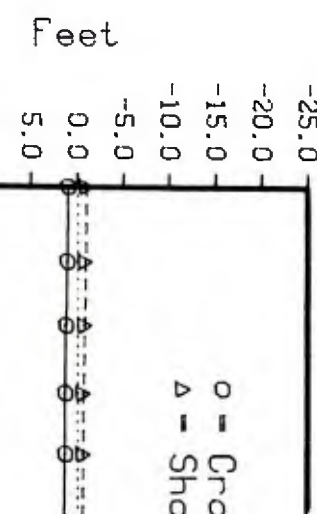

Day # - 172

INDIAN ISLAND WASHINGTON

Test No. - 9

Test Series No. - 0

stockless, 5000lb. stabilizers, 48 deg. fx. flukes
silt

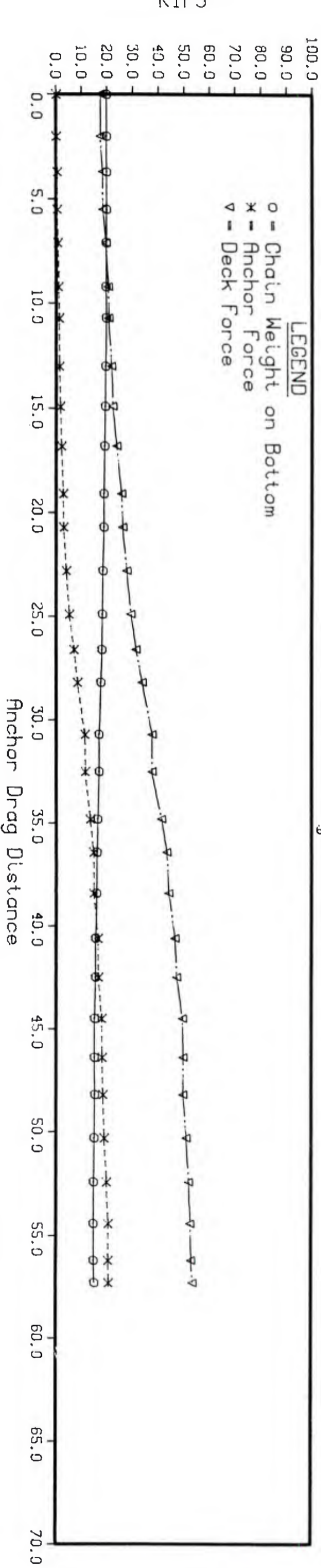
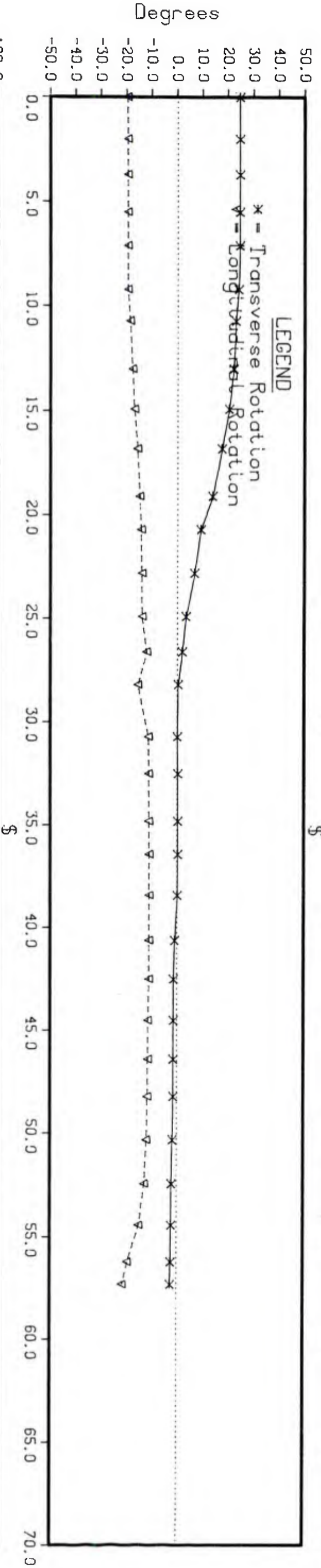
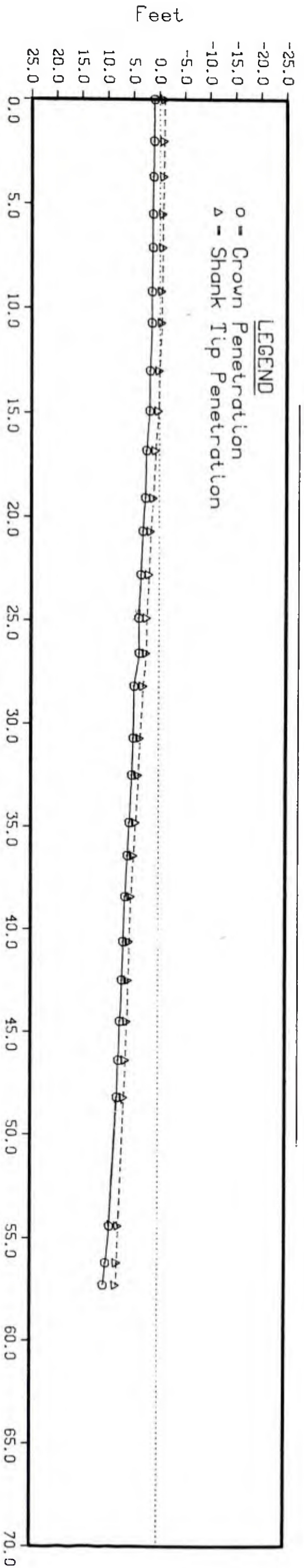

Day # = 172
 Test No. = 10
 Test Series No. = 0

INDI

STINGLESS ANCHOR TEST

Test Date: 172
 Test No: 10
 Test Area: INDIAN ISLAND WASHINGTON
 Station Type: 1700 - 1720
 Silt: SILT
 Anchor Type: STINGLESS *5000L.R. START 17205.44 OFG. FX. PLUMPS
 Anchor Weight: 5950.00 LB.
 Anchor Height: 49.00 OFG. - 1
 Date: 0.00 172
 Time: 0.00 172
 Location: 00 FT. 2 IN. CHAIN 140 FT. 2.5 IN. CHAIN 400 FT. 1 5/8 IN. CHAIN UNDER THE ST. 2 IN. TAIL ANCHOR

1. DISTANCE	2. DEPTH	3. ANCHOR TENSION	4. ANCHOR TENSION	5. ROTATION ANGLE	6. SWAY ANGLE	7. ANCHOR DEPTH	8. ANCHOR DEPTH	9. CHAIN LENGTH ON BOTTOM	10. CHAIN WEIGHT ON BOTTOM	11. ANCHOR DEPTH DEPTH	12. TOTAL BOTTOM WEIGHT	13. ANCHOR FLANGE TIP DEPTH	14. ANCHOR FLANGE TIP DEPTH	15. TOTAL BOTTOM WEIGHT
0.0	27.4	1.2	92.6	-10.5	0.0	13.4	31.1	412.4	1064.7	92.6	92.6	92.6	92.6	2604.7
2.0	24.1	1.2	92.6	-10.5	0.0	13.4	31.1	412.4	1064.7	92.6	92.6	92.6	92.6	2604.7
4.0	20.7	1.2	92.6	-10.5	0.0	13.4	31.1	412.4	1064.7	92.6	92.6	92.6	92.6	2604.7
6.0	17.3	1.2	92.6	-10.5	0.0	13.4	31.1	412.4	1064.7	92.6	92.6	92.6	92.6	2604.7
8.0	13.9	1.2	92.6	-10.5	0.0	13.4	31.1	412.4	1064.7	92.6	92.6	92.6	92.6	2604.7
10.0	10.5	1.2	92.6	-10.5	0.0	13.4	31.1	412.4	1064.7	92.6	92.6	92.6	92.6	2604.7
12.0	7.1	1.2	92.6	-10.5	0.0	13.4	31.1	412.4	1064.7	92.6	92.6	92.6	92.6	2604.7
14.0	3.7	1.2	92.6	-10.5	0.0	13.4	31.1	412.4	1064.7	92.6	92.6	92.6	92.6	2604.7
16.0	0.3	1.2	92.6	-10.5	0.0	13.4	31.1	412.4	1064.7	92.6	92.6	92.6	92.6	2604.7
18.0	-3.1	1.2	92.6	-10.5	0.0	13.4	31.1	412.4	1064.7	92.6	92.6	92.6	92.6	2604.7
20.0	-6.5	1.2	92.6	-10.5	0.0	13.4	31.1	412.4	1064.7	92.6	92.6	92.6	92.6	2604.7
22.0	-9.9	1.2	92.6	-10.5	0.0	13.4	31.1	412.4	1064.7	92.6	92.6	92.6	92.6	2604.7
24.0	-13.3	1.2	92.6	-10.5	0.0	13.4	31.1	412.4	1064.7	92.6	92.6	92.6	92.6	2604.7
26.0	-16.7	1.2	92.6	-10.5	0.0	13.4	31.1	412.4	1064.7	92.6	92.6	92.6	92.6	2604.7
28.0	-20.1	1.2	92.6	-10.5	0.0	13.4	31.1	412.4	1064.7	92.6	92.6	92.6	92.6	2604.7
30.0	-23.5	1.2	92.6	-10.5	0.0	13.4	31.1	412.4	1064.7	92.6	92.6	92.6	92.6	2604.7
32.0	-26.9	1.2	92.6	-10.5	0.0	13.4	31.1	412.4	1064.7	92.6	92.6	92.6	92.6	2604.7
34.0	-30.3	1.2	92.6	-10.5	0.0	13.4	31.1	412.4	1064.7	92.6	92.6	92.6	92.6	2604.7
36.0	-33.7	1.2	92.6	-10.5	0.0	13.4	31.1	412.4	1064.7	92.6	92.6	92.6	92.6	2604.7
38.0	-37.1	1.2	92.6	-10.5	0.0	13.4	31.1	412.4	1064.7	92.6	92.6	92.6	92.6	2604.7
40.0	-40.5	1.2	92.6	-10.5	0.0	13.4	31.1	412.4	1064.7	92.6	92.6	92.6	92.6	2604.7
42.0	-43.9	1.2	92.6	-10.5	0.0	13.4	31.1	412.4	1064.7	92.6	92.6	92.6	92.6	2604.7
44.0	-47.3	1.2	92.6	-10.5	0.0	13.4	31.1	412.4	1064.7	92.6	92.6	92.6	92.6	2604.7
46.0	-50.7	1.2	92.6	-10.5	0.0	13.4	31.1	412.4	1064.7	92.6	92.6	92.6	92.6	2604.7
48.0	-54.1	1.2	92.6	-10.5	0.0	13.4	31.1	412.4	1064.7	92.6	92.6	92.6	92.6	2604.7
50.0	-57.5	1.2	92.6	-10.5	0.0	13.4	31.1	412.4	1064.7	92.6	92.6	92.6	92.6	2604.7

NOTE - POSITIVE SWAY AND ANCHOR TENSION INDICATES SWAY TO RIGHT ONLY.

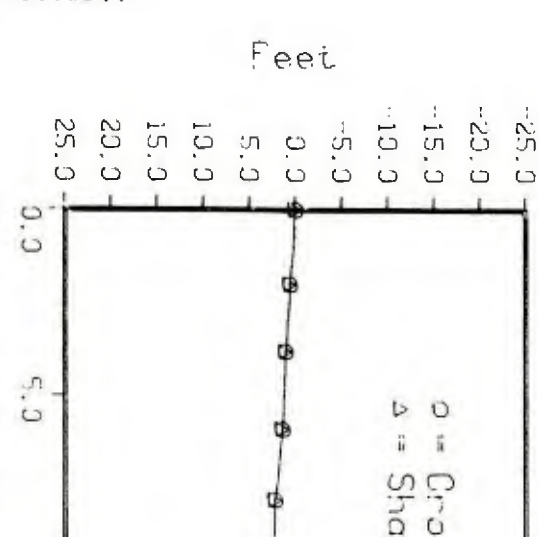
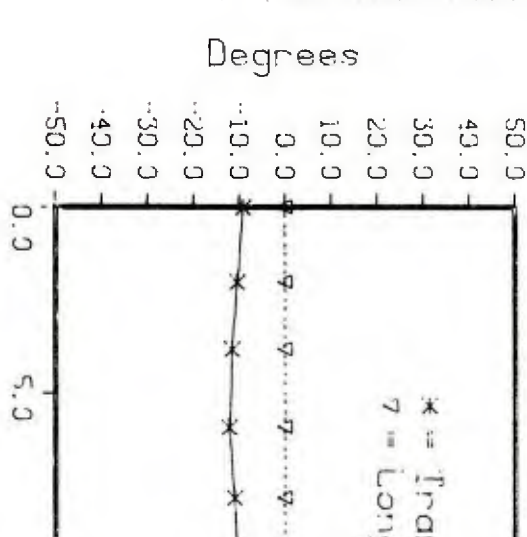
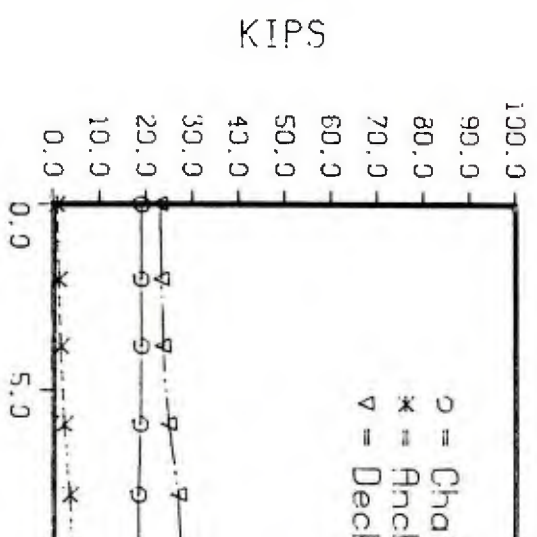

Day # = 172

INDIAN ISLAND WASHINGTON

Test No. = 10
Test Series No. = 0

stockless, 5000lb. stabilizers, 48 deg. rx, flukes
silt

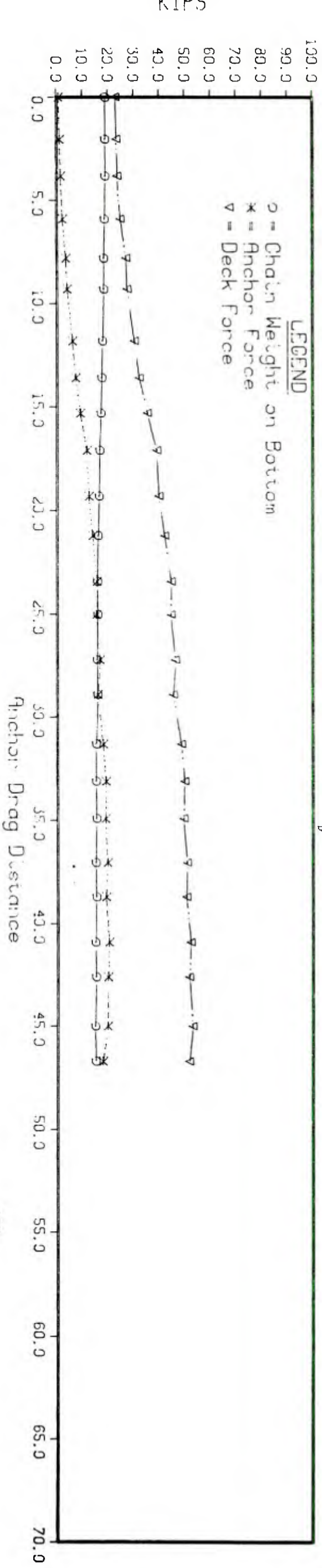
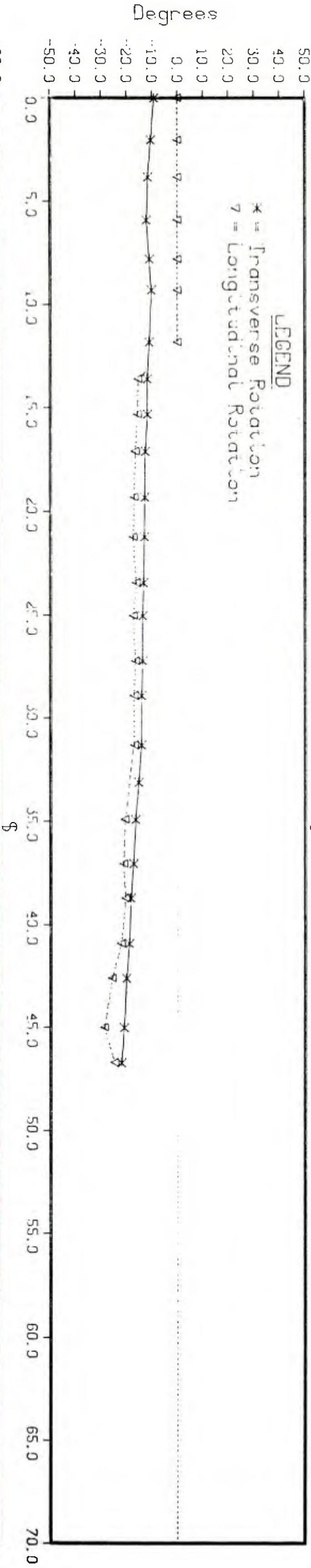
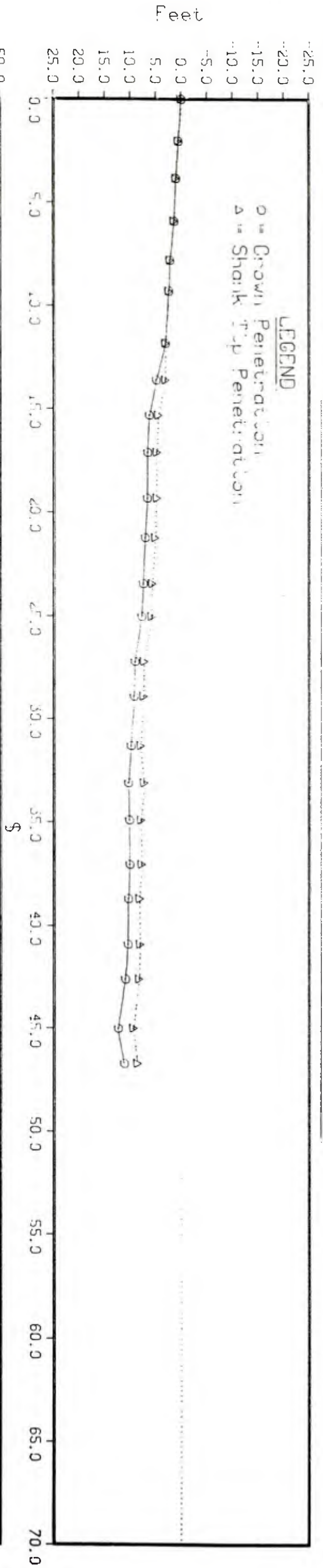

Day # = 173
 Test No. = 11
 Test Series No. = 0

INDIF

STOCKLESS ANCHOR TEST

TEST DATE 173
 TEST NO. 11
 TEST AREA INDIAN ISLAND WASHINGTON
 START-END TIMES 1830 - 1800
 \$117
 \$117
 STOCKLESS *5000LB. TAND SHANK-SHACKLE*STABS*40 DEG FX FLUKES
 9950-00 LB
 44.00 DEG. * 1 0-MOV 1-FIX
 9950-00 LB.
 135-0 FEET
 0 - 0.0 LB.
 135FT. ZIN. CHAIN ATTD TO (ENBD ANCHOR SHANK*30DFT-2-SIN
 CHAIN, 400 FT. 1 5/8 IN. 13RC ROPE, 346 FT. 2 IN. 13RC ROPE

1. DRAG DISTANCE	2. DECK TENSION	3. ANCHOR TENSION	4. PACKAGE DEPTH	5. ROTATION ANGLE	6. SHANK ANGLE	7. WIRE ROPE ANGLE	8. DECK HORIZ. FORCE	9. CHAIN LENGTH ON BOTTOM	10. ANCHOR WEIGHT ON BOTTOM	11. ANCHOR CROWN DEPTH	12. ANCHOR SHANK TIP DEPTH	13. ANCHOR FLUKE TIP DEPTH	14. WATER DEPTH	15. TOTAL BOTTOM WEIGHT
0.0	20.0	44.0	97.7	-3.1	-11.1	14.2	19.4	473.4	2126.5	98.4	97.1	101.2	97.7	3316.5
2.0	20.0	44.0	98.3	-3.1	-12.0	14.6	19.9	467.5	2096.5	99.0	97.6	101.8	97.7	3286.5
3.7	23.9	44.0	98.1	-3.2	-12.0	13.5	24.7	457.6	2022.7	99.0	97.6	101.6	97.7	3212.7
5.0	23.9	44.0	98.3	-3.2	-12.0	12.5	29.0	442.6	1972.2	99.0	97.6	101.8	97.7	3162.2
6.2	23.2	44.0	98.4	-3.2	-12.0	12.1	28.6	436.3	2006.4	99.1	97.7	101.9	97.7	3190.6
8.0	32.9	44.0	98.4	-3.2	-12.0	11.3	35.2	430.1	1939.7	99.3	97.7	101.9	97.7	3129.7
10.0	33.9	44.0	98.3	-3.2	-10.1	10.4	42.7	419.1	1834.1	99.3	98.8	102.2	97.7	3094.9
11.0	43.4	44.0	98.4	-3.2	-8.0	10.1	42.1	410.4	1830.1	100.1	98.1	102.9	97.7	3024.1
13.0	43.4	44.0	98.4	-3.2	-8.0	10.1	42.1	410.4	1830.1	100.1	98.1	102.9	97.7	3000.5
15.1	46.9	44.0	98.4	-3.2	-8.0	10.1	42.1	410.4	1830.1	100.1	98.1	102.9	97.7	2987.5
16.1	46.9	44.0	98.4	-3.2	-8.0	10.1	42.1	410.4	1830.1	100.1	98.1	102.9	97.7	2987.5
18.9	50.8	44.0	101.2	-3.7	-8.0	9.8	50.2	398.1	1748.0	101.4	100.4	104.4	97.7	3030.8
20.7	51.0	44.0	101.2	-3.9	-8.0	9.6	50.3	400.1	1740.9	101.4	100.4	104.4	97.7	3030.8
22.4	57.6	44.0	102.1	-3.8	-8.4	9.4	56.8	382.6	1631.2	102.4	101.7	105.9	97.7	2882.0
24.7	60.6	44.0	102.7	-3.8	-8.4	9.3	59.8	376.1	1630.4	103.0	102.3	106.9	97.7	2882.0
26.6	64.9	44.0	103.4	-3.1	-8.5	9.1	64.1	366.6	1591.2	103.7	103.0	106.5	97.7	2784.4
30.0	70.3	44.0	104.7	-2.5	-8.5	8.6	69.5	361.4	1564.4	105.0	104.3	108.2	97.7	2754.6
32.2	72.1	44.0	104.7	-2.5	-8.5	8.6	70.1	359.2	1531.1	105.1	104.4	108.3	97.7	2743.7
34.1	70.9	44.0	104.7	-2.5	-8.5	8.6	70.1	359.2	1531.1	105.1	104.4	108.3	97.7	2743.7
36.3	73.2	44.0	105.2	-2.5	-8.5	8.6	74.4	345.4	1486.0	105.8	105.1	109.0	97.7	2676.0
38.0	75.4	44.0	105.7	-2.5	-8.5	8.4	74.5	344.9	1530.2	106.0	105.2	109.0	97.7	2726.4
40.0	75.4	44.0	106.2	-2.5	-8.6	8.4	74.5	344.9	1530.2	106.0	105.2	109.0	97.7	2694.3
41.9	76.3	44.0	106.2	-1.8	-8.6	8.4	75.5	349.1	1504.3	106.3	105.5	109.7	97.7	2694.3
44.0	77.8	44.0	106.7	-1.8	-8.6	8.4	77.0	337.7	1457.4	106.6	105.6	109.8	97.7	2665.7
44.1	80.0	44.0	106.7	-1.8	-8.6	8.4	77.0	337.7	1457.4	106.6	105.6	109.8	97.7	2665.7
49.9	81.9	44.0	107.0	-1.6	-8.6	8.3	81.0	335.8	1436.0	107.3	106.5	110.5	97.7	2626.7
52.0	83.0	44.0	107.0	-1.6	-8.6	8.3	82.1	332.3	1419.1	107.3	106.5	110.5	97.7	2626.7
53.8	81.8	44.0	107.2	-1.5	-8.6	8.2	80.9	338.9	1432.7	107.5	106.7	110.7	97.7	2642.7
55.8	83.9	44.0	107.4	-1.9	-8.6	8.1	83.0	334.4	1429.5	107.7	106.9	110.9	97.7	2619.5
58.0	86.8	44.0	107.7	-0.8	-8.6	8.2	85.9	323.3	1374.0	108.0	107.3	111.2	97.7	2564.0

DISTANCE RANGE TRAVELLED 62.0
 DISTANCE ANCHOR TRAVELLED 58.0

NOTE - POSITIVE SHANK ANGLE INDICATES SHANK TIP BELOW CROWN

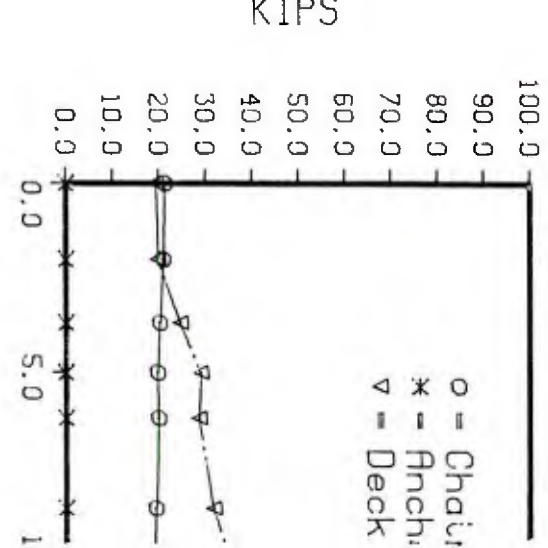
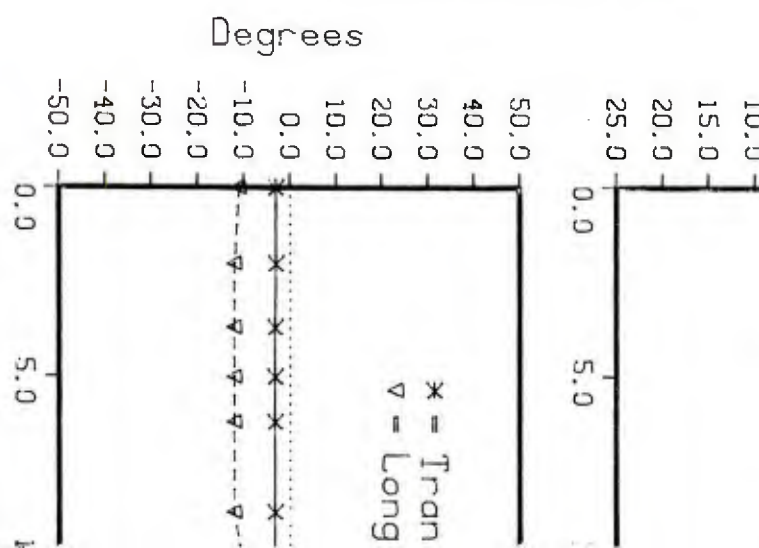
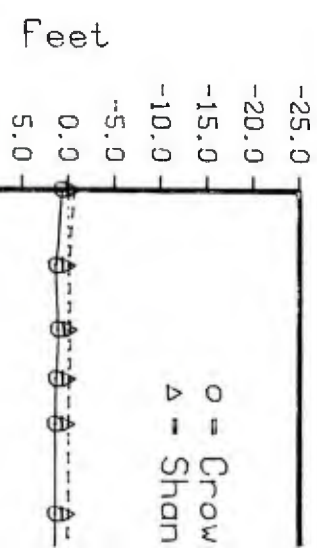

Day # = 173 INDIAN ISLAND WASHINGTON

Test No. = 11 stockless, 5000lb. land shank-shackle, stabs, 48 deg fx flukes,
 Test Series No. = 0 silt

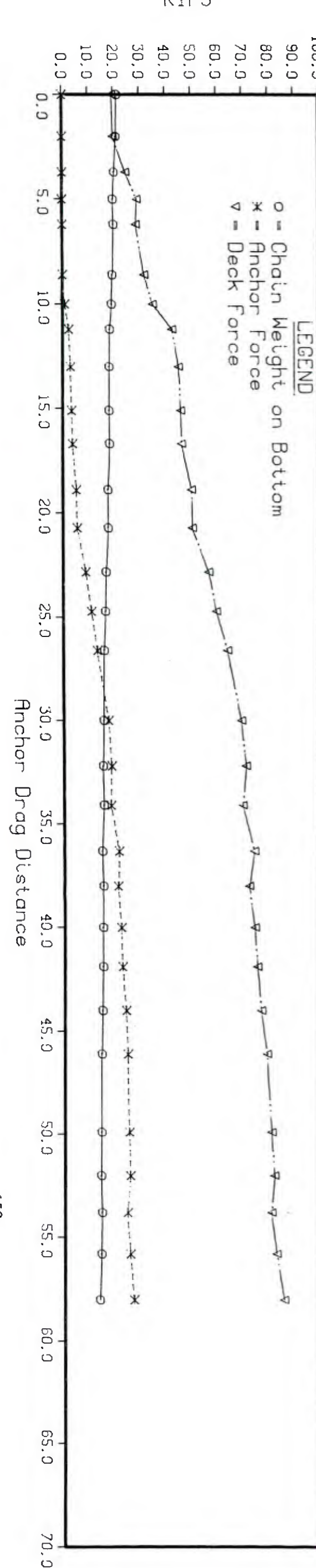
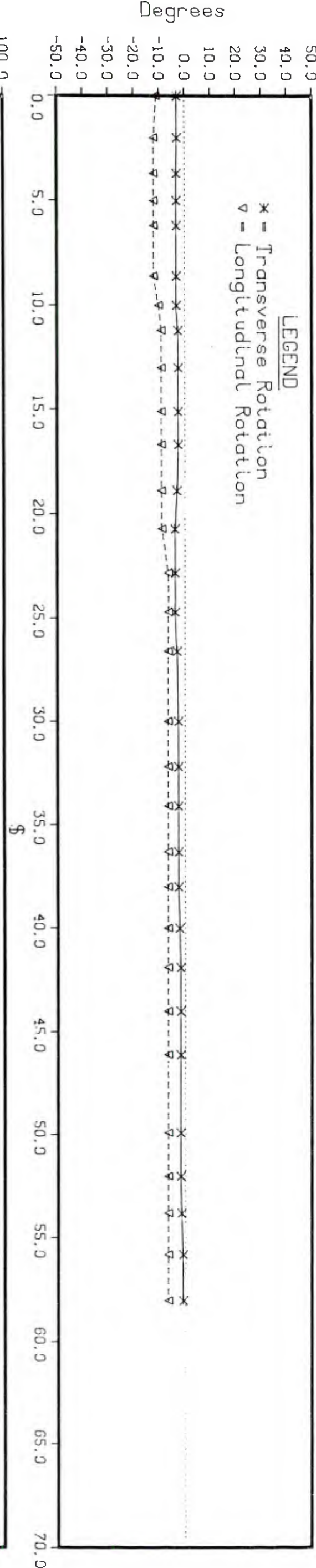
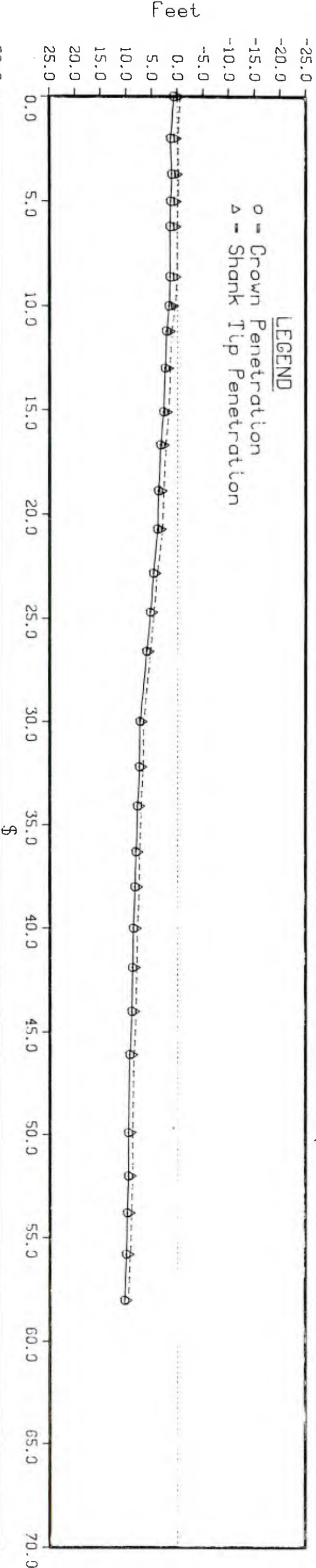

Day # = 174
 Test No. = 12
 Test Series No. = 0

INDIAN

STOCKLESS ANCHOR TEST

TEST GATE 174
 TEST NO. 12
 TEST RUN 0
 TEST AREA INDIAN ISLAND WASHINGTON
 START-END TIMES 1005 - 1040
 SMOOD TYPE SILET
 ANCHOR WEIGHT STOCKLESS 5000LB, TAND CRDM-CROWN-SHACKLE, STABS, 48 DEG FX FLURES
 FLURE ANGLE ESTYPE 5950.00 LB.
 AUX. ANCHOR TYPE 48.00 DEG. - 1 0-MOV 1-FIX
 AUX. ANCHOR WEIGHT 5660.00 LB.
 MAIN-AUX ANCHOR SEPARATION 135.0 FEET
 DEPRESSORS-ND-HIT-EACH-TOTAL WT. 0.0 LB.
 MOORING LINE DESCRIPTION 135FT. 2IN. CHAIN ATT'D TO INBRD ANCHOR SHANK, 200FT. 2.5IN CHAIN, 400 FT. 1 5/8 IN. LIRC ROPE, 346 FT. 2 IN. INRC ROPE

1	2	3	4	5	6	7	8	9	10	11	12	13	14	15
FEET	KIPS	KIPS	FEET	DEG	DEG	DEG	KIPS	FEET	LB	FEET	FEET	FEET	FEET	LB
1	2	3	4	5	6	7	8	9	10	11	12	13	14	15
6.0	23.0	4.4	0.0000	2.3	-13.0	13.5	23.1	459.8	20583.9	0.0000	0.0000	0.0000	91.7	32463.5
2.0	21.0	4.4	0.0000	2.3	-14.1	13.6	21.1	468.8	21034.3	0.0000	0.0000	0.0000	91.7	32934.3
4.2	20.1	4.4	0.0000	2.3	-14.1	14.1	19.5	473.1	21251.3	0.0000	0.0000	0.0000	91.7	33151.3
6.4	19.9	4.4	0.0000	2.3	-14.1	14.2	19.3	473.1	21250.8	0.0000	0.0000	0.0000	91.7	33150.8
8.5	22.1	4.4	0.0000	2.3	-14.0	13.8	21.5	465.7	20682.0	0.0000	0.0000	0.0000	91.7	32782.0
10.4	22.3	4.4	0.0000	2.3	-14.1	13.7	21.6	465.6	20674.2	0.0000	0.0000	0.0000	91.7	32774.2
11.9	24.4	4.4	0.0000	2.4	-14.0	13.1	23.8	460.8	20631.0	0.0000	0.0000	0.0000	91.7	32337.0
14.2	25.3	4.4	0.0000	2.4	-14.1	13.0	24.7	456.8	20431.6	0.0000	0.0000	0.0000	91.7	32233.6
15.6	27.5	4.4	0.0000	2.4	-14.2	12.4	26.8	453.3	20259.7	0.0000	0.0000	0.0000	91.7	32159.7
17.2	29.0	4.4	0.0000	2.0	-14.2	12.2	28.9	446.2	19904.6	0.0000	0.0000	0.0000	91.7	31804.6
18.7	29.6	4.4	0.0000	2.0	-13.9	12.1	28.8	447.4	19962.0	0.0000	0.0000	0.0000	91.7	31821.0
21.0	29.4	4.4	0.0000	2.0	-13.9	11.5	33.5	435.2	19351.1	0.0000	0.0000	0.0000	91.7	31621.1
23.6	37.4	4.4	0.0000	2.2	-14.4	11.3	39.9	423.4	18761.0	0.0000	0.0000	0.0000	91.7	30661.0
25.2	37.8	4.4	0.0000	2.2	-14.4	11.0	39.9	423.5	18694.2	0.0000	0.0000	0.0000	91.7	30661.0
27.3	40.1	4.4	0.0000	2.3	-14.4	11.0	39.9	423.5	18694.2	0.0000	0.0000	0.0000	91.7	30661.0
29.3	40.8	4.4	0.0000	2.3	-14.4	10.9	40.3	418.8	18521.9	0.0000	0.0000	0.0000	91.7	30421.9
31.0	40.3	4.4	0.0000	2.3	-14.4	10.8	39.6	420.2	18450.1	0.0000	0.0000	0.0000	91.7	30421.9
32.8	42.6	4.4	0.0000	2.3	-14.4	10.5	41.9	415.9	18381.8	0.0000	0.0000	0.0000	91.7	30281.8
34.9	44.4	4.4	0.0000	2.3	-14.4	10.4	43.6	410.4	18316.5	0.0000	0.0000	0.0000	91.7	30281.8
37.2	50.2	4.4	0.0000	3.1	-14.5	9.9	49.4	410.4	18316.5	0.0000	0.0000	0.0000	91.7	30281.8
38.6	52.7	4.4	0.0000	3.8	-14.5	9.7	52.0	390.6	17135.0	0.0000	0.0000	0.0000	91.7	29035.0
40.3	52.8	4.4	0.0000	3.8	-14.5	9.7	52.0	390.6	17135.0	0.0000	0.0000	0.0000	91.7	29035.0
42.4	53.7	4.4	0.0000	4.8	-14.5	9.7	52.9	390.2	17245.5	0.0000	0.0000	0.0000	91.7	2917.7
44.4	57.1	4.4	0.0000	4.8	-14.5	9.6	56.3	380.7	16617.7	0.0000	0.0000	0.0000	91.7	28879.6
46.5	61.9	4.4	0.0000	4.4	-14.1	9.1	61.9	375.7	16367.3	0.0000	0.0000	0.0000	91.7	28267.3
47.7	62.7	4.4	0.0000	4.4	-14.1	9.1	61.9	375.7	16367.3	0.0000	0.0000	0.0000	91.7	28267.3
50.1	67.4	4.4	0.0000	4.4	-14.1	8.9	68.3	357.7	15537.7	0.0000	0.0000	0.0000	91.7	27366.6
51.8	69.2	4.4	0.0000	4.4	-14.1	8.9	70.0	353.4	15249.9	0.0000	0.0000	0.0000	91.7	27366.6
53.9	70.8	4.4	0.0000	4.4	-14.1	8.7	74.5	342.7	14710.8	0.0000	0.0000	0.0000	91.7	26610.8
55.8	75.4	4.4	0.0000	4.8	-14.1	8.6	73.6	345.4	14997.9	0.0000	0.0000	0.0000	91.7	26610.8
57.6	74.4	4.4	0.0000	4.8	-14.1	8.3	78.5	341.6	14655.4	0.0000	0.0000	0.0000	91.7	26555.4
59.3	79.4	4.4	0.0000	4.8	-14.1	8.3	78.5	339.4	14548.6	0.0000	0.0000	0.0000	91.7	26448.6
61.4	79.4	4.4	0.0000	4.8	-14.1	8.3	78.5	339.4	14548.6	0.0000	0.0000	0.0000	91.7	26448.6

DISTANCE GARGE TRAVELLED 92.0
 DISTANCE ANCHOR TRAVELLED 89.2

NOTE - POSITIVE SHANK ANGLE INDICATES SHANK TIP BEHIND CROWN

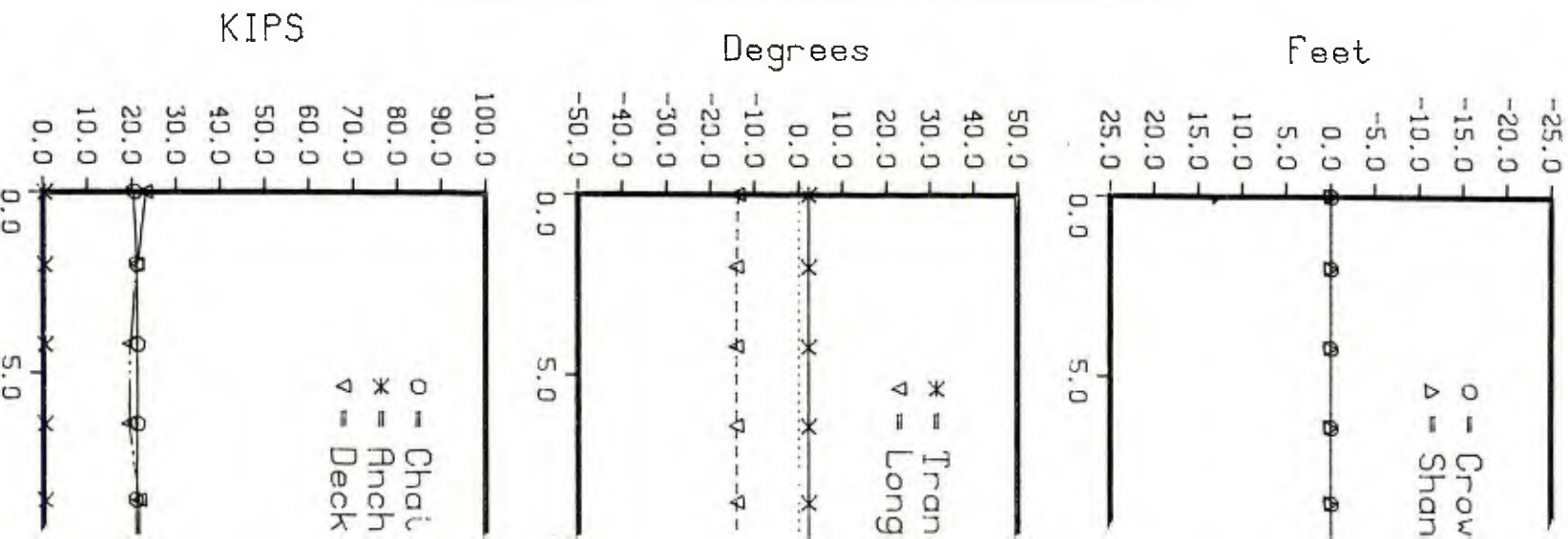

Day # = 174

INDIAN ISLAND WASHINGTON

Test No. = 12

Test Series No. = 0

stockless, 5000lb. land crown-shackle, studs, 48 deg fx flukes
silt

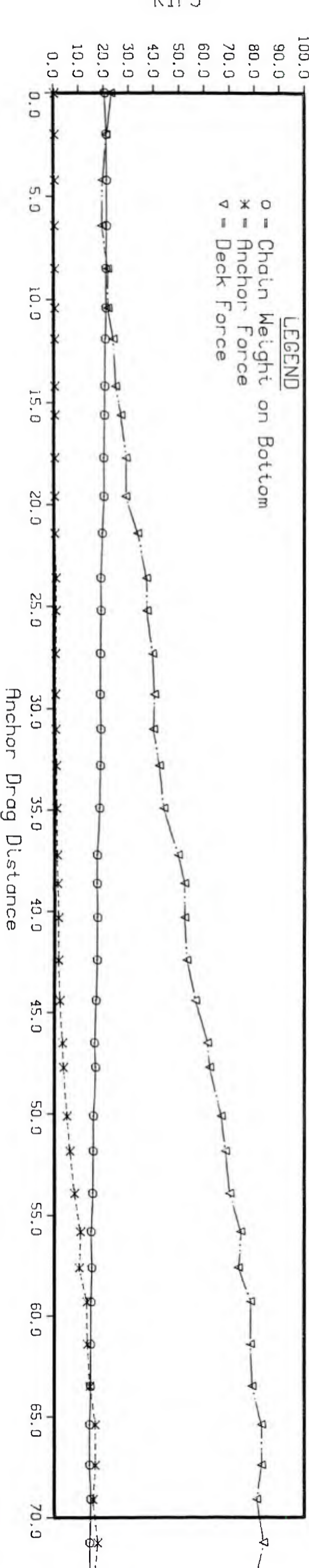
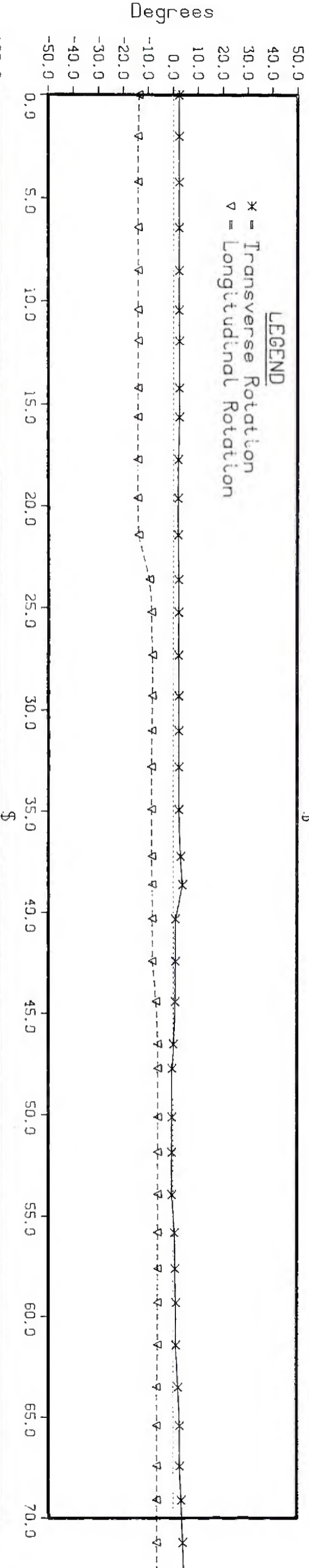
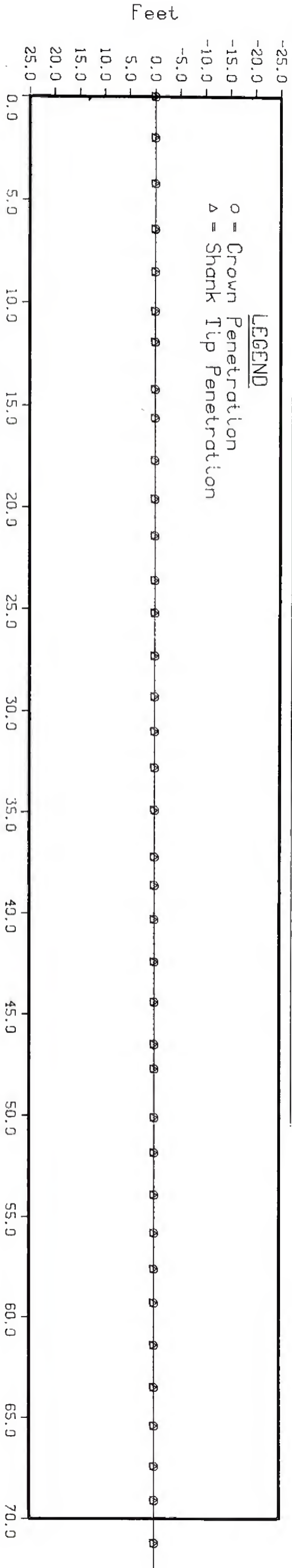

Day # - 74 **INC**
 Test No. = 13
 Test Series No. - 0

STOCKLESS ANCHOR TEST

TEST DATE 24
 TEST NO. 13
 TEST AREA INDIAN ISLAND WASHINGTON
 START-END TIMES 1225 - 1326
 SEALOOR TYPE SILT
 ANCHOR TYPE STOCKLESS 5000LBS. WITH STABLS. MOVABLE FLUKES 48 DEG.
 ANCHOR HEIGHT 5950.00 LB.
 FLUME ANGLE-TYPE 48.00 DEG. - 0
 AUX. ANCHOR TYPE 0-MOV 1-FIX
 MAIN-ANCHOR HEIGHT 0.00 LB.
 DEPRESSORS-NO.-WT-EACH-TOTAL WT. 0 - 0.0 LB.
 MORING LINE DESCRIPTION 135 FT. 2 IN. CHAIN-360 FT. 2.5 IN. CHAIN-400 FT. 1 5/8 IN. IMC ROPE, 346 FT. * 2 IN. IMC ROPE

1. DEAC DISTANCE FEET	2. DECK EXTENSION FEET	3. ANCHOR DEPTH FEET	4. ANCHOR DEPTH FEET	5. ROTATION ANGLE DEG	6. SHANK ANGLE DEG	7. WIRE ROPE ANGLE DEG	8. DECK HORIZ. FORCE	9. CHAIN LENGTH ON BOTTOM FEET	10. CHAIN HEIGHT ON BOTTOM LBS	11. ANCHOR FLUME TIP DEPTH FEET	12. WATER DEPTH FEET	13. TOTAL BOTTOM HEIGHT FEET	14. ANCHOR FLUME TIP DEPTH FEET	15. TOTAL BOTTOM HEIGHT FEET
0.0	20.2	86.9	87.5	-5.7	-7.9	-7.8	13.1	43.0	21248.4	87.2	86.6	90.5	86.9	27198.4
2.6	28.0	87.5	88.4	-7.9	-9.0	-8.0	11.0	43.7	20978.7	86.0	87.1	91.0	86.9	26429.7
3.4	28.4	88.4	88.6	-10.0	-9.1	-11.7	7.9	44.2	20300.1	88.9	87.9	91.9	86.9	26250.1
5.5	30.6	88.6	89.1	-10.4	-9.1	11.6	27.6	45.4	19198.8	89.1	88.1	92.1	86.9	25914.8
7.3	28.4	89.1	89.2	-10.4	-11.0	11.6	26.5	45.4	20153.1	89.7	88.5	92.5	86.9	26174.4
9.3	29.2	89.2	89.5	-10.4	-11.4	11.6	28.5	45.4	20111.1	90.9	88.6	92.7	86.9	26142.1
11.0	29.1	89.5	89.8	-10.4	-11.4	11.5	30.1	44.8	20027.1	90.5	88.9	93.0	86.9	25973.1
13.2	30.7	89.8	89.9	-11.0	-12.6	11.4	29.5	45.2	20207.4	90.6	89.1	93.3	86.9	25912.4
14.9	30.1	90.3	90.3	-12.1	-13.7	11.0	31.6	44.7	19964.1	91.1	89.5	93.7	86.9	25814.1
16.6	32.4	90.4	90.7	-12.9	-14.2	10.8	33.4	44.4	19794.1	91.2	89.6	94.0	86.9	25744.1
19.0	33.3	90.7	90.7	-13.7	-14.7	10.7	34.6	44.0	19594.6	91.5	89.9	94.1	86.9	25644.6
20.5	34.0	90.7	90.7	-14.1	-14.7	10.7	34.6	44.0	19594.6	91.5	89.9	94.1	86.9	25644.6
22.6	35.2	91.0	91.0	-14.3	-14.7	10.4	38.4	43.0	19104.6	92.1	90.4	94.7	86.9	25094.8
24.5	34.6	91.0	91.5	-15.2	-15.2	10.3	38.1	43.4	19258.3	92.3	90.7	94.9	86.9	25094.8
28.6	39.0	91.5	91.5	-15.4	-15.2	10.3	39.2	42.9	19042.3	92.3	90.7	94.9	86.9	24992.3
30.3	38.7	91.5	91.7	-15.4	-15.2	10.2	38.3	43.9	19287.4	92.5	90.9	95.1	86.9	24992.3
32.5	39.9	91.5	91.6	-15.8	-15.2	10.2	40.1	426.9	18934.5	92.4	90.8	95.0	86.9	24884.5
34.2	38.9	91.6												
36.5	40.8													

DISTANCE BARGE TRAVELLED 38.0
 DISTANCE ANCHOR TRAVELLED 36.5

NOTE - POSITIVE SHANK ANGLE INDICATES SHANK TIP BELOW CROWN

Feet

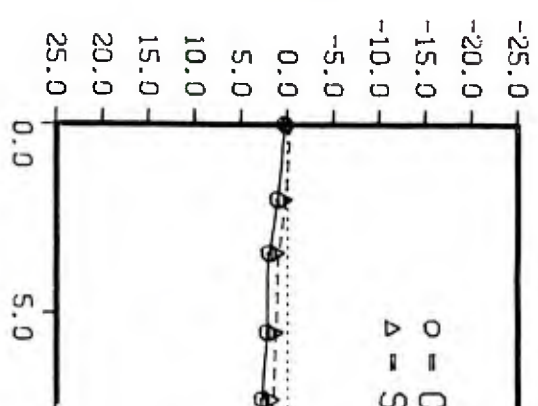

Degrees

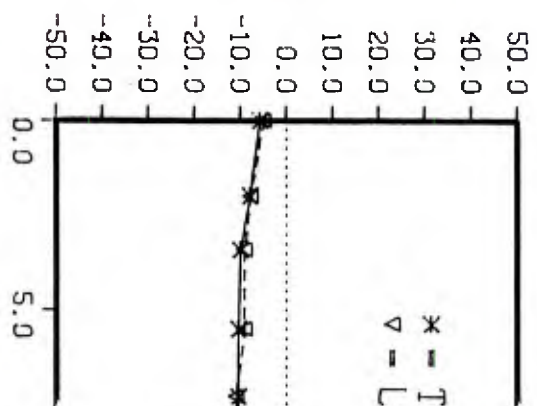

KIPS

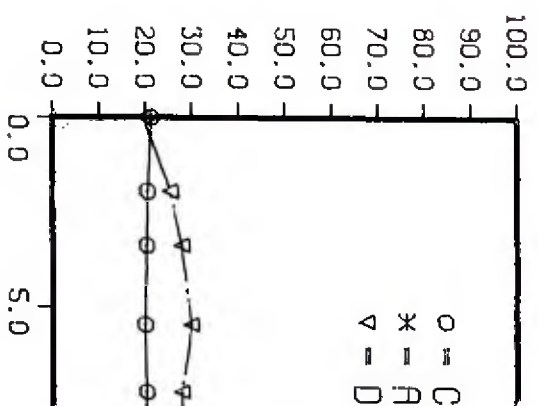

INDIAN ISLAND WASHINGTON

Day # - 74
 Test No. = 13
 Test Series No. = 0
 stockless 5000lbs. with stabs, movable flukes 48 deg.
 silt

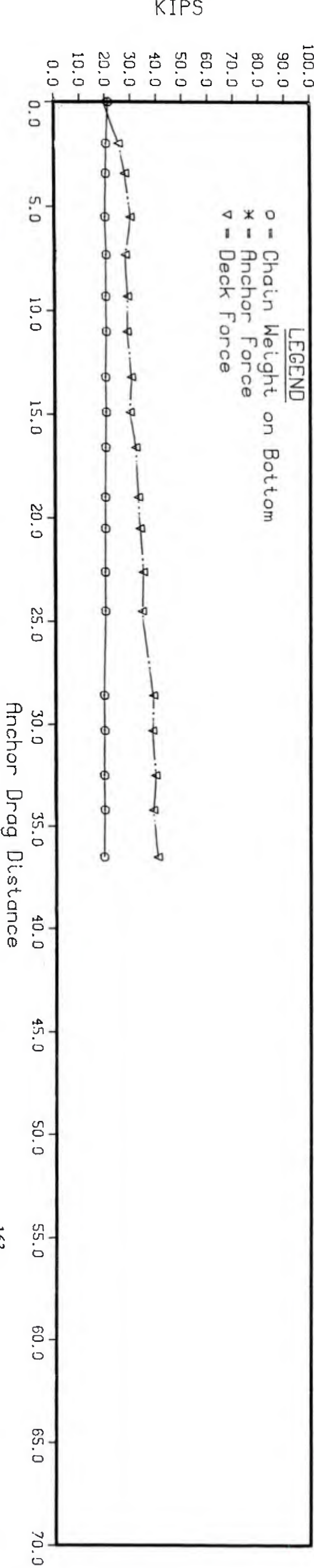
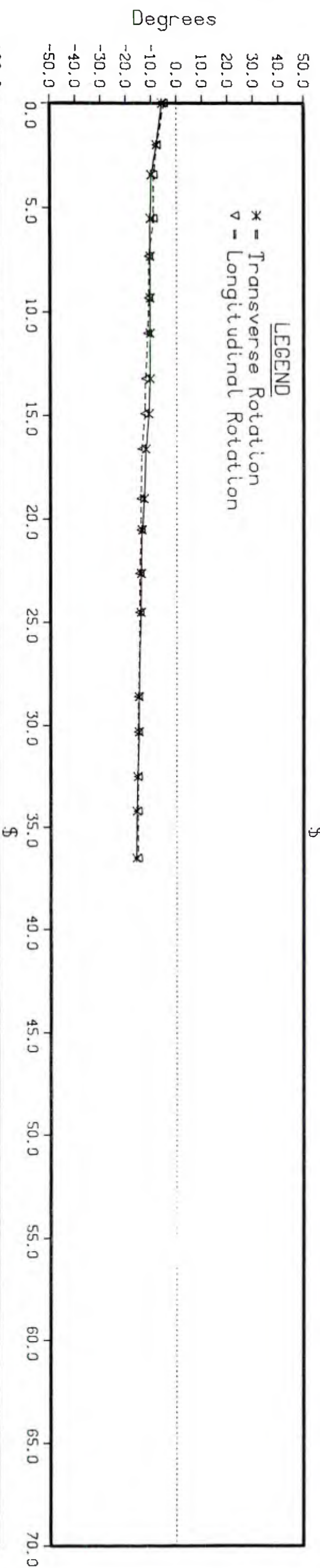
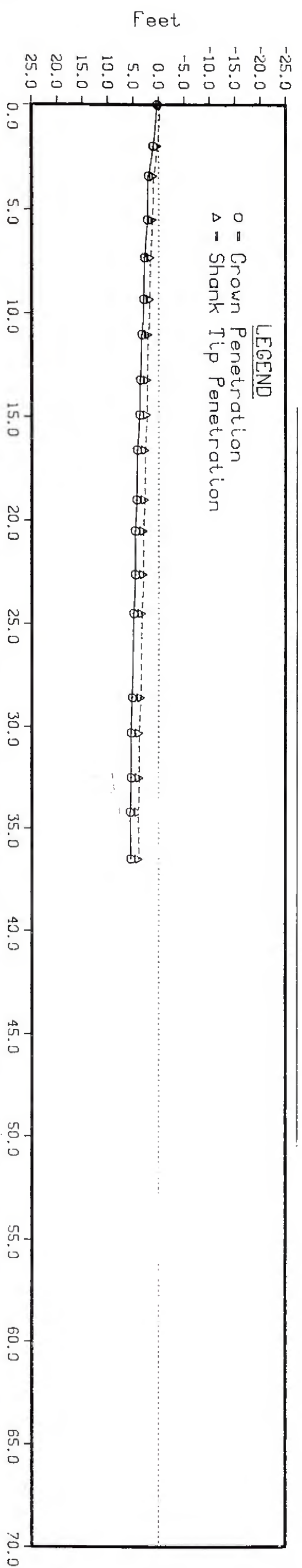

Day # = 174
 Test No. = 14
 Test Series No. = 0

INDI

TEST DATE 174
 TEST NO. 14
 TEST RUN 0
 TEST AREA INDIAN ISLAND WASHINGTON
 START-END TIMES 1335 - 1350
 SEAFLOOR TYPE SILT
 ANCHOR TYPE STOCKLESS 5000LBS. WITH STABS. MOVABLE FLUKES 40 DEG.
 ANCHOR HEIGHT 5950.00 LB.
 FLUME ANGLE-TYPE 48.00 DEG. - 0 C-MOV 1-FIX
 AUX. ANCHOR TYPE 0.00 LB.
 ANCHOR ANCHOR SEPARATION 0.0 LB.
 DEPRESSORS+NO.-M1-EACH-TOTAL MT. 0.0 LB.
 PEERING LINE DESCRIPTION 135 FT. 2 IN. CHAIN+360 FT. 2.5 IN. CHAIN+400 FT. 1 5/8 IN. IMRC ROPE + 346 FT. + 2 IN. IMRC ROPE

1	2	3	4	5	6	7	8	9	10	11	12	13	14	15
FEET	KIPS	KIPS	FEET	DEG	DEG	DEG	KIPS	FEET	LBS	FEET	FEET	FEET	FEET	LBS
1	2	3	4	5	6	7	8	9	10	11	12	13	14	15
FEET	KIPS	KIPS	FEET	DEG	DEG	DEG	KIPS	FEET	LBS	FEET	FEET	FEET	FEET	LBS
0.0	22.08	00000	88.9	-2.4	-3.9	13.2	22.2	463.0	20944.7	69.2	88.7	92.5	88.9	26804.7
2.0	22.6	00000	89.1	-3.1	-3.9	13.2	22.0	460.0	20966.6	88.4	88.0	92.7	88.9	26980.6
4.0	25.1	00000	89.3	-3.3	-3.9	12.7	24.5	460.7	20628.7	89.6	89.1	92.9	88.9	26578.7
5.6	29.1	00000	90.2	-2.4	-6.6	11.9	28.5	451.0	20141.0	90.6	89.8	93.0	88.9	26081.0
7.2	30.6	00000	90.8	-3.0	-9.3	11.5	30.0	448.0	20032.5	91.4	90.3	93.0	88.9	25982.5
8.0	31.3	00000	91.5	-3.5	-10.9	11.3	30.7	448.1	19988.6	92.1	90.9	95.0	88.9	25988.6
9.4	34.2	00000	91.6	-3.8	-11.4	11.2	33.5	437.8	19483.6	92.3	90.9	95.1	88.9	25433.6
11.0	36.2	00000	92.0	-4.0	-12.8	10.9	35.6	434.7	19325.4	92.7	91.3	95.5	88.9	25275.4
12.7	37.2	00000	92.2	-4.7	-13.8	10.6	37.6	426.7	18924.2	93.0	91.4	95.7	88.9	24874.2
15.0	39.2	00000	92.3	-5.2	-14.4	10.6	38.5	424.8	18768.4	93.1	91.5	95.8	88.9	25030.3
18.9	39.4	00000	92.7	-5.4	-14.4	10.6	37.6	423.2	18768.4	93.5	91.9	96.2	88.9	24718.4
19.1	40.1	00000	92.9	-6.0	-14.5	10.3	38.8	429.7	18076.9	93.7	92.1	96.4	88.9	25026.9
20.6	41.1	00000	93.0	-6.5	-14.5	10.2	40.4	425.2	18649.6	94.0	92.4	96.5	88.9	24799.6
22.6	41.9	00000	93.2	-7.0	-14.4	10.3	41.2	421.2	18649.6	94.6	92.4	96.7	88.9	24599.3
24.1	41.3	00000	93.2	-7.5	-14.4	10.1	40.7	426.2	18649.3	94.0	92.4	96.7	88.9	24522.3
26.4	42.6	00000	93.2	-7.9	-14.5	10.2	42.0	419.7	18572.3	94.4	92.6	96.7	88.9	24522.3
28.1	42.5	00000	93.5	-9.0	-13.2	10.2	42.0	420.1	18594.5	94.4	92.6	96.9	88.9	24544.5
29.7	42.7	00000	93.5	-10.7	-13.2	10.2	42.1	420.3	18594.2	94.7	92.6	97.2	88.9	24604.2
31.2	43.0	00000	93.9	-11.3	-12.2	10.1	42.5	418.0	18588.1	94.7	92.8	97.2	88.9	24370.1
36.5	43.2	00000	93.9	-11.9	-12.2	10.1	42.5	418.0	18588.1	94.7	92.9	97.2	88.9	24370.1
38.5	43.2	00000	93.9	-12.0	-12.2	10.1	42.5	418.0	18588.1	94.7	92.9	97.2	88.9	24370.1
40.7	44.9	00000	93.9	-12.4	-13.2	10.1	44.2	413.9	18282.9	94.8	93.0	97.3	88.9	24232.9

NOTE - POSITIVE SHANK ANGLE INDICATES SHANK TIP BELOW CROWN

DISTANCE BARGE TRAVELLED 42.0
 DISTANCE ANCHOR TRAVELLED 40.7

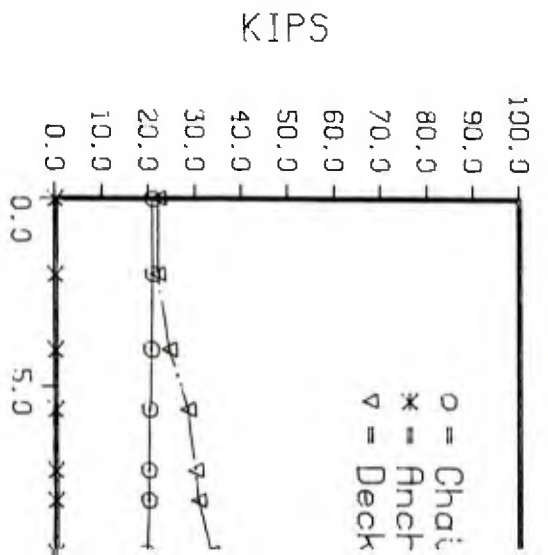
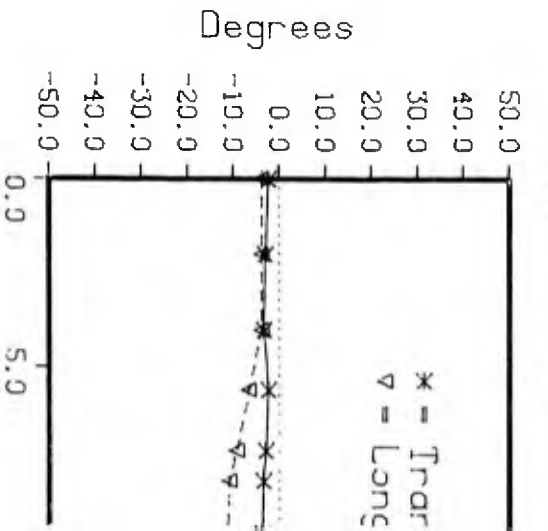
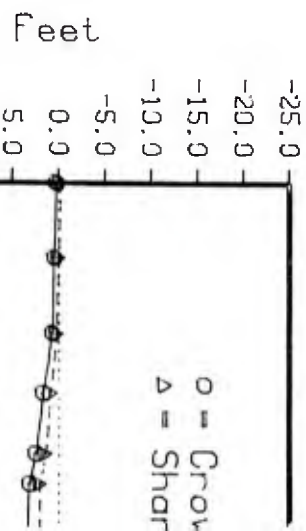

Day # = 174

INDIAN ISLAND WASHINGTON

Test No. = 14

Test Series No. = 0

stockless 5000lbs. with sidbs, movable flukes 48 deg.
silt

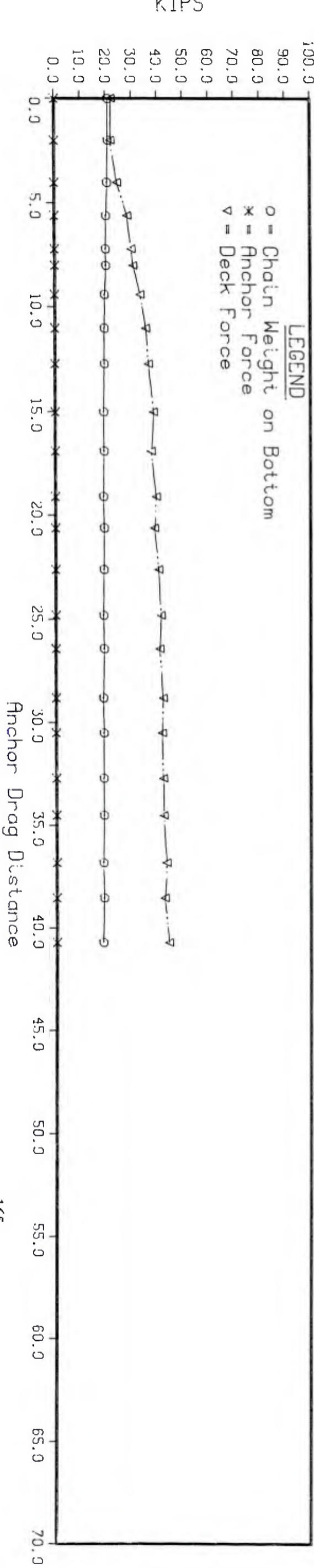
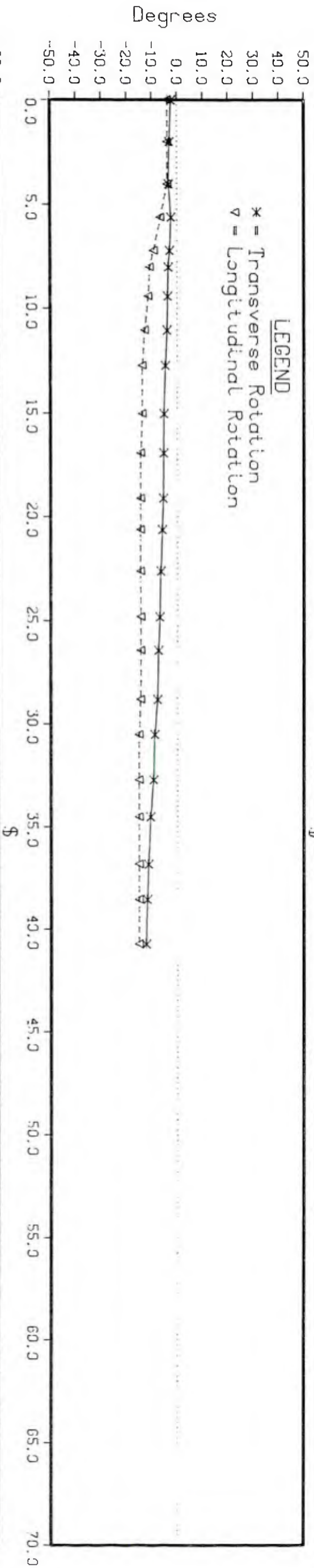
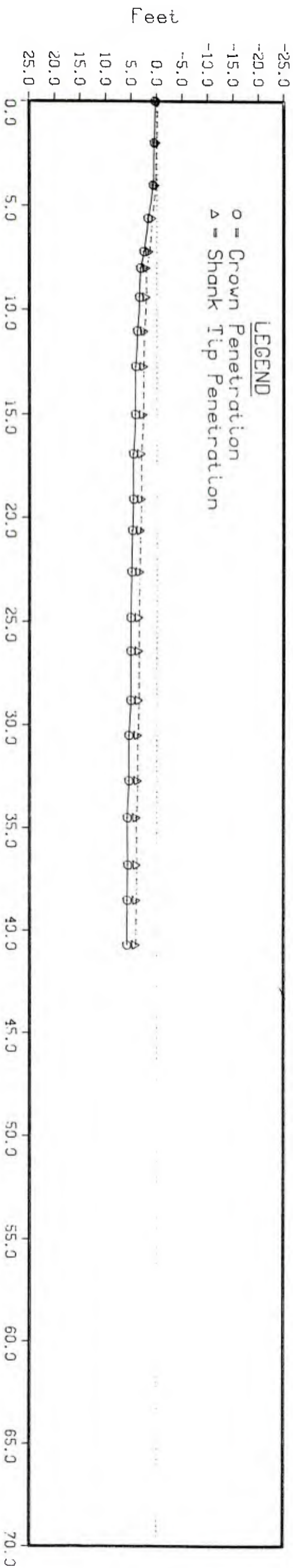

Day # = 176 INDI
 Test No. = 21
 Test Series No. = 0

STOCKLESS ANCHOR TEST

TEST DATE 176
 TEST NO. 21
 TEST RUN 0
 START-END TIMES INDIAN ISLAND WASHINGTON
 SEAFLOOR TYPE 830 - 900
 ANCHOR TYPE SILT
 ANCHOR HEIGHT STOCKLESS + 9000LBS... NO STABS... 48 DEG. MOVABLE FLUKES
 FLUKE ANGLE-TYPE 10900 LB.
 AUX. ANCHOR TYPE 48.00 DEG. - 0 O-MGV 1-FIX
 RAIN-AUX ANCHOR SEPARATION 0.00 LB.
 DEPRESSORS-AND-TIP-EACH-TOTAL WT. 0.0 - 0.0 LB.
 MOORING LINE DESCRIPTION 135 FT. 2 IN. CHAIN+360 FT. 2.5 IN. CHAIN+400 FT. 1 5/8 IN. IMRC ROPE, 346 FT. + 2 IN. IMRC ROPE

1. DRAG DISTANCE	2. DECK TENSION	3. ANCHOR TENSION	4. PACKAGE DEPTH	5. ROTATION ANGLE	6. SHANK ANGLE	7. MIRE ANCHOR ANGLE	8. DECK HORIZ. FORCE	9. CHAIN LENGTH DR. BOTTOM	10. ANCHOR WEIGHT DR. BOTTOM	11. ANCHOR GRWTH DEPTH	12. ANCHOR SHANK TIP DEPTH	13. ANCHOR FLUKE TIP DEPTH	14. WATER DEPTH	15. TOTAL BOTTOM WEIGHT
0.0	24.9	0000	0000	0000	0000	0000	14.8	24.0	483.9	19787.5	0000	0000	09.5	20877.5
2.0	27.0	0000	0000	0000	0000	0000	14.8	26.1	433.6	19271.6	0000	0000	09.5	20341.6
3.3	28.9	0000	0000	0000	0000	0000	14.2	28.0	429.5	19066.0	0000	0000	09.5	20136.0
5.0	30.1	0000	0000	0000	0000	0000	13.9	29.2	426.2	18904.4	0000	0000	09.5	19974.4
6.9	32.7	0000	0000	0000	0000	0000	13.6	31.8	417.9	18482.9	0000	0000	09.5	19532.9
8.9	32.8	0000	0000	0000	0000	0000	13.6	31.8	417.9	18482.9	0000	0000	09.5	19532.9
11.0	34.7	0000	0000	0000	0000	0000	13.4	33.8	413.3	18104.4	0000	0000	09.5	19174.4
12.0	34.4	0000	0000	0000	0000	0000	13.2	33.5	409.0	17865.7	0000	0000	09.5	19377.6
14.9	38.7	0000	0000	0000	0000	0000	13.0	35.8	409.0	17865.7	0000	0000	09.5	18935.7
14.9	38.7	0000	0000	0000	0000	0000	13.0	35.8	409.0	17865.7	0000	0000	09.5	18935.7
18.6	38.7	0000	0000	0000	0000	0000	12.9	37.7	398.6	17426.7	0000	0000	09.5	18587.7
20.5	39.5	0000	0000	0000	0000	0000	12.8	38.5	398.6	17426.7	0000	0000	09.5	18587.7
22.4	40.3	0000	0000	0000	0000	0000	12.7	39.3	394.4	17304.9	0000	0000	09.5	18274.9
24.2	41.6	0000	0000	0000	0000	0000	12.5	40.7	391.9	17176.8	0000	0000	09.5	18228.8
26.1	41.7	0000	0000	0000	0000	0000	12.4	40.7	391.9	17176.8	0000	0000	09.5	18228.8
28.0	43.0	0000	0000	0000	0000	0000	12.2	42.6	385.6	16865.3	0000	0000	09.5	17935.3
30.0	43.7	0000	0000	0000	0000	0000	12.1	44.6	379.6	16527.3	0000	0000	09.5	17634.5
31.9	46.1	0000	0000	0000	0000	0000	12.1	45.1	378.9	16527.3	0000	0000	09.5	17497.3
33.9	46.7	0000	0000	0000	0000	0000	12.0	45.7	376.5	16404.8	0000	0000	09.5	17415.8
36.1	48.0	0000	0000	0000	0000	0000	12.0	47.0	373.1	16142.8	0000	0000	09.5	17207.4
37.8	47.9	0000	0000	0000	0000	0000	11.9	46.9	373.1	16142.8	0000	0000	09.5	17207.4
39.9	49.0	0000	0000	0000	0000	0000	11.9	47.9	369.2	16038.0	0000	0000	09.5	17109.0
41.3	49.1	0000	0000	0000	0000	0000	11.8	47.0	375.2	16138.9	0000	0000	09.5	17409.9
43.8	49.8	0000	0000	0000	0000	0000	11.8	48.8	367.8	15978.9	0000	0000	09.5	17049.5
45.9	48.8	0000	0000	0000	0000	0000	11.7	47.8	373.3	16247.2	0000	0000	09.5	17317.2

NOTE - POSITIVE SHANK ANGLE INDICATES SHANK TIP BELOW CROWN

DISTANCE BARGE TRAVELLED 48.0
 DISTANCE ANCHOR TRAVELLED 45.0

Feet

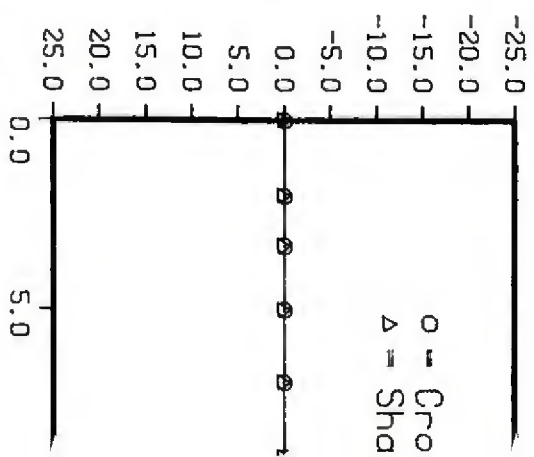

Degrees

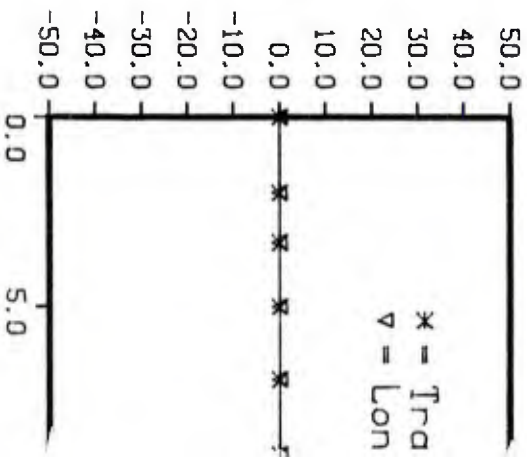

KIPS

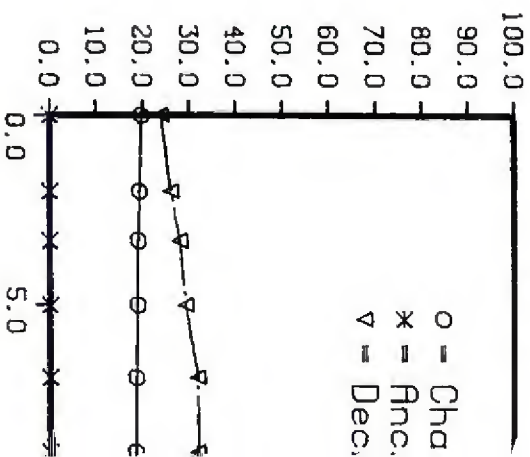

Day # = 176 INDIAN ISLAND WASHINGTON

Test No. = 21

stockless, 9000lbs., no stabs. 48 deg. movable flukes

Test Series No. = 0

silt

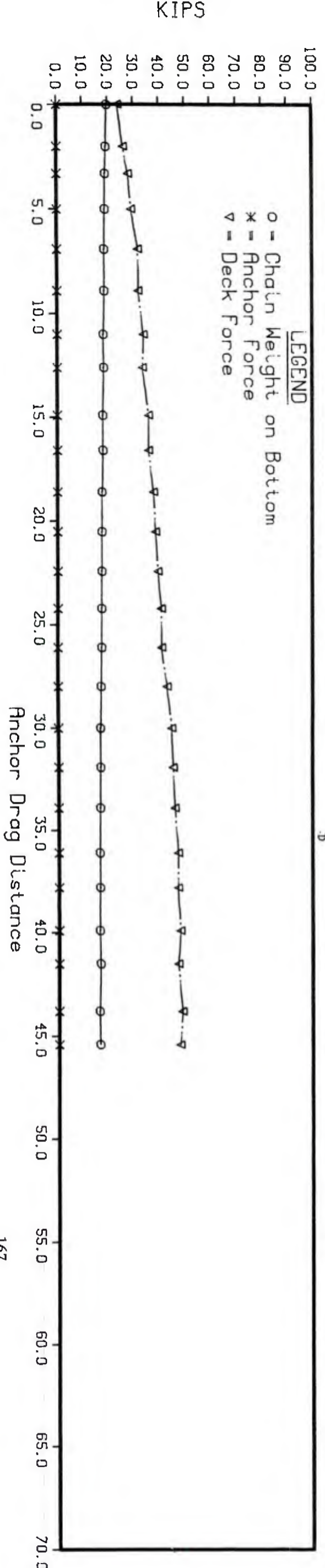
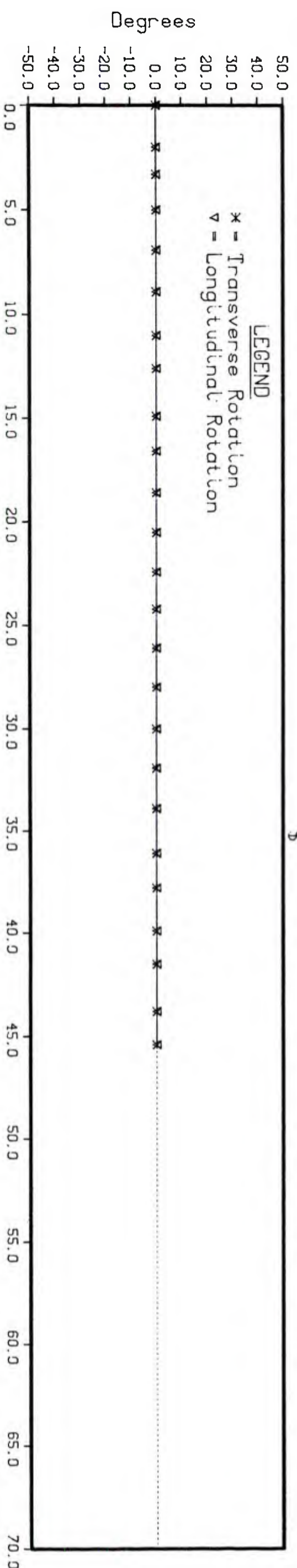
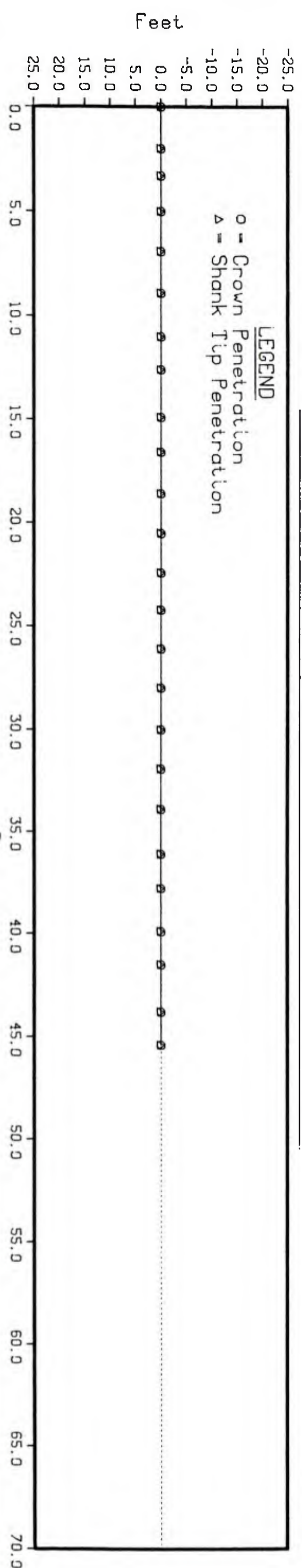

Day # = 176 IN
 Test No. = 23
 Test Series No. = 0

TEST DATE
 TEST NO. 176
 TEST RUN 23
 TEST AREA INDIAN ISLAND WASHINGTON
 START-END TYPES 1030 - 1100
 SEAFLOOR TYPE SILT
 ANCHOR TYPE STRAIT
 ANCHOR HEIGHT 3500.00 LB.
 FLUKE ANGLE-TYPE 48-00 DEG - 0
 AUX ANCHOR TYPE 0-MOV 1-FIX
 MAIN-AUX ANCHOR SEPARATION 0-00 LB.
 DEPRESSORS-MOV-EACH-TOTAL MT. 0 - 0-0 LB.
 FLOORING LINE DESCRIPTION 135 FT. 2 IN. CHAIN, 360 FT. 2.5 IN. CHAIN, 400 FT. 1 5/8 IN. LARC ROPE + 346 FT. + 2 IN. LARC ROPE

1	2	3	4	5	6	7	8	9	10	11	12	13	14	15
FEET	KIPS	KIPS	FEET	DEG	DEG	DEG	KIPS	FEET	FEET	FEET	FEET	FEET	FEET	LB'S
5-0	49-9	1-6	81-9	5-0	8-2	13-1	28-7	437-8	19479-8	80-0	82-3	85-7	81-9	22919-8
4-0	10-0	1-0	81-9	4-2	0-1	13-1	28-0	441-0	19647-3	81-1	82-2	85-9	81-9	23182-3
4-3	12-1	2-4	81-9	4-6	0-1	13-1	29-3	435-4	19358-3	81-0	82-1	85-8	81-9	22898-3
8-4	34-1	2-0	82-7	4-6	0-1	12-9	30-9	429-8	19080-3	81-9	83-0	86-7	81-9	22980-3
10-0	35-8	5-8	83-6	4-6	0-0	12-9	32-2	421-8	18870-3	81-9	83-0	86-7	81-9	22170-3
12-0	38-9	7-2	83-9	4-9	3-8	12-9	32-0	408-5	18518-9	83-0	83-9	87-7	81-9	22014-4
13-7	39-7	8-4	85-0	5-0	2-1	11-9	38-4	408-6	19026-2	83-4	84-1	88-0	81-9	21526-2
15-7	42-6	10-0	85-7	5-3	1-2	11-6	41-7	398-1	18583-9	84-8	85-1	89-3	81-9	21490-9
17-4	49-2	14-2	87-0	5-3	-3-1	11-6	48-3	378-5	17587-9	86-6	87-8	90-9	81-9	21033-3
18-3	52-1	16-2	87-9	5-6	-4-3	10-9	51-1	371-6	16259-4	86-4	87-1	92-5	81-9	20574-4
21-6	57-8	19-6	88-7	5-8	-5-4	10-5	56-7	354-1	15285-8	86-7	88-9	93-2	81-9	19739-4
23-5	64-9	24-0	89-6	8-0	-6-6	10-5	63-6	331-8	14266-7	89-3	88-9	94-4	81-9	19789-6
25-4	69-8	25-6	90-6	8-0	-7-8	10-3	68-6	321-4	13643-8	91-6	90-3	95-4	81-9	17164-4
27-1	67-6	25-4	91-2	8-9	-6-6	10-3	66-5	330-4	14096-3	92-2	90-9	96-8	81-9	17502-3
29-2	72-0	26-6	91-9	8-9	-7-8	10-2	70-9	317-6	13442-6	93-0	91-6	96-8	81-9	16952-6
31-0	74-0	28-8	92-3	8-3	-7-8	10-1	72-9	310-7	13109-0	93-4	92-0	97-2	81-9	16609-0
31-2	74-0	28-8	92-3	7-9	-8-3	10-1	71-5	317-5	13446-6	93-5	92-1	97-3	81-9	16946-6
33-2	76-6	30-6	93-1	7-7	-8-3	9-9	78-4	298-6	12718-6	94-3	92-7	98-1	81-9	16218-6
36-6	79-3	31-2	93-8	7-8	-8-3	9-8	78-4	298-6	12718-6	94-6	93-0	98-4	81-9	15998-9
40-9	81-8	30-0	94-0	7-8	-8-3	9-8	80-6	293-6	12251-7	95-0	93-4	98-8	81-9	16251-7
42-6	81-8	30-0	94-2	7-8	-8-9	9-8	80-6	293-6	12251-6	95-2	93-6	99-0	81-9	15751-6
44-2	84-4	32-8	94-5	7-8	-8-9	9-7	77-8	285-4	12843-1	95-5	93-8	99-2	81-9	16343-1
48-5	85-6	34-4	95-2	7-7	-8-9	9-5	85-4	285-2	11828-1	96-3	94-8	100-2	81-9	15469-3
50-5	88-6	35-0	95-0	8-1	-8-9	9-4	87-4	281-7	11653-4	96-5	94-8	98-0	81-9	15328-1
53-4	88-4	38-2	95-8	8-7	-8-9	9-4	87-4	281-7	11653-4	97-1	95-4	100-8	81-9	15153-4
58-1	88-4	37-4	96-2	9-1	-9-6	9-3	88-2	286-7	11902-6	97-6	95-8	101-2	81-9	15402-6
58-2	89-4	37-0	95-7	9-5	-9-6	9-3	88-2	282-4	11688-7	97-1	95-3	100-7	81-9	15188-7

1. DRAG DISTANCE
 2. DECK TENSION
 3. ANCHOR TENSION
 4. PACKAGE DEPTH
 5. ROTATION ANGLE
 6. SHANK ANGLE
 7. WIRE ROPE ANGLE
 8. DECK HORIZ. FORCE
 9. CHAIN LENGTH ON BOTTOM
 10. ANCHOR WEIGHT ON BOTTOM
 11. ANCHOR CROWN DEPTH
 12. ANCHOR SHANK TIP DEPTH
 13. ANCHOR FLUKE TIP DEPTH
 14. WATER DEPTH
 15. TOTAL BOTTOM HEIGHT

60-0
 58-2

NOTE - POSITIVE SHANK ANGLE INDICATES SHANK TIP BEHIND CROWN

Feet

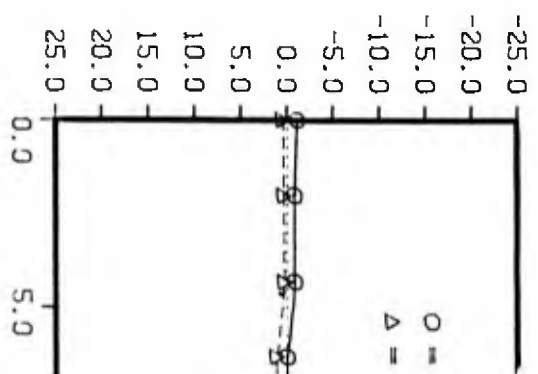

Degrees

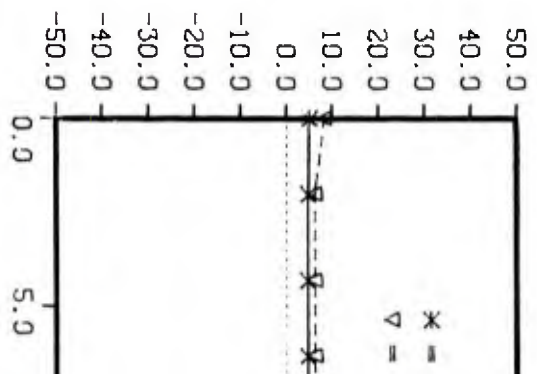

KIPS

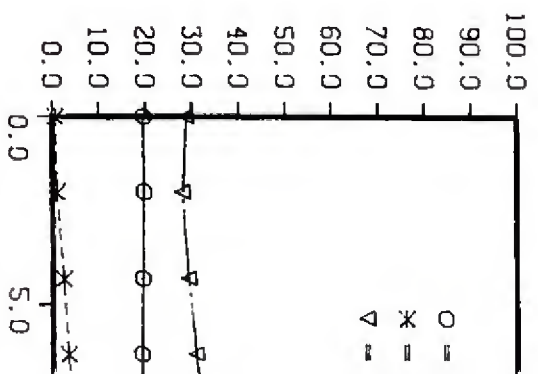

Day # = 176

INDIAN ISLAND WASHINGTON

Test No. = 23

Test Series No. = 0

state _____, 3000lbs. with 18 inch stabilizer extensions
silt _____

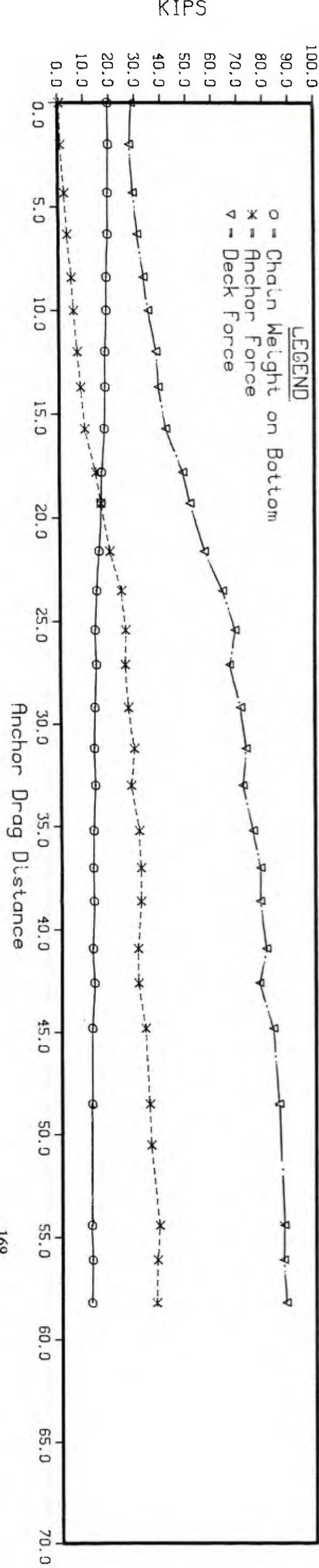
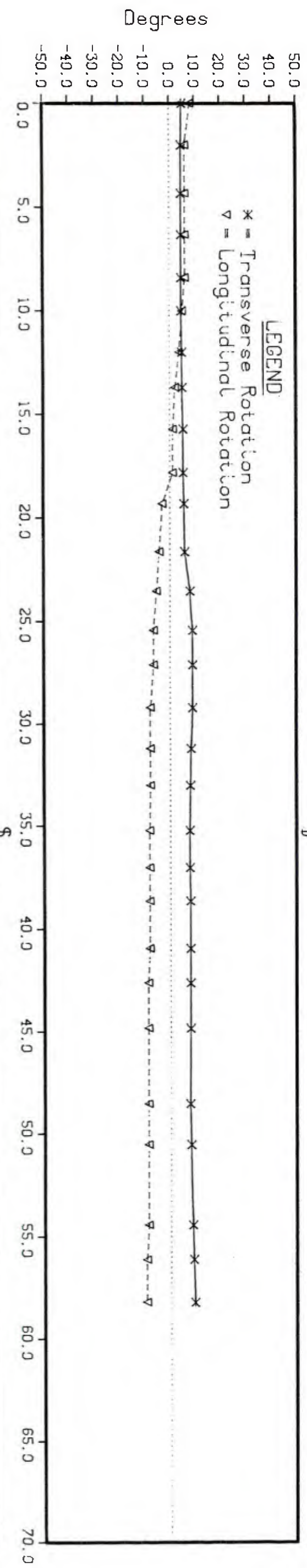
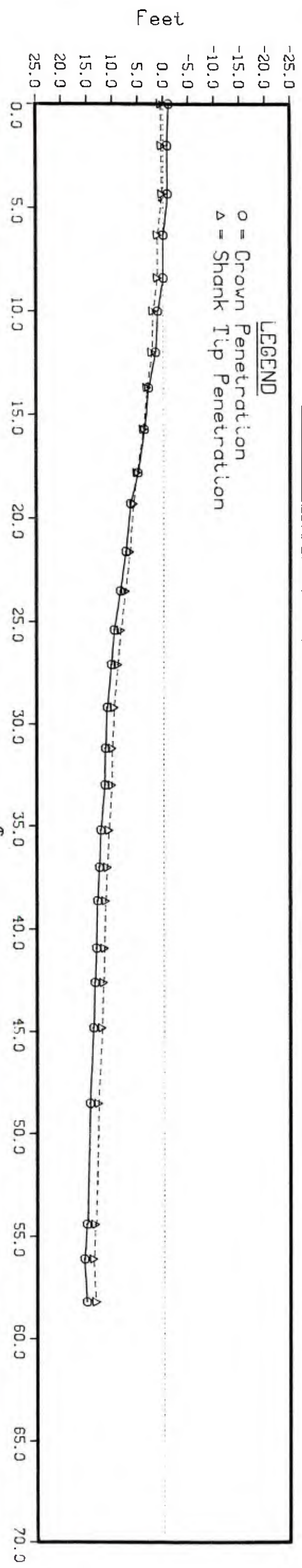

INDIAN ISLAND WASHINGTON

Day # = 176
 Test No. = 25
 Test Series No. = 0
 state 6600lbs. normal stabilizers 50 deg. mov. flukes
silt

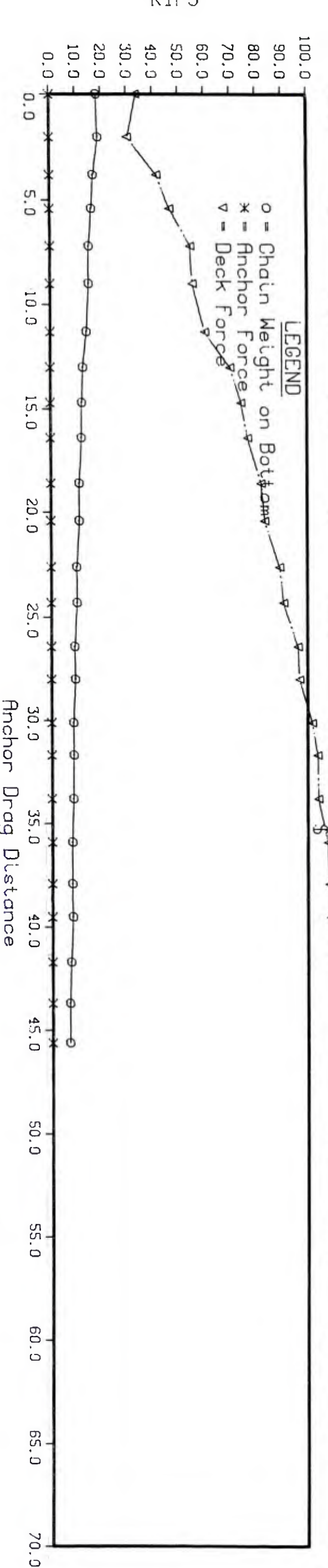
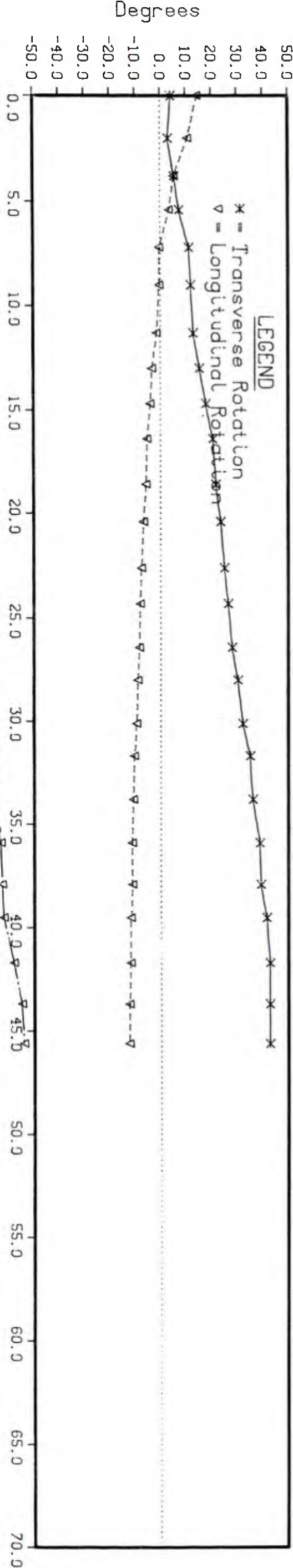
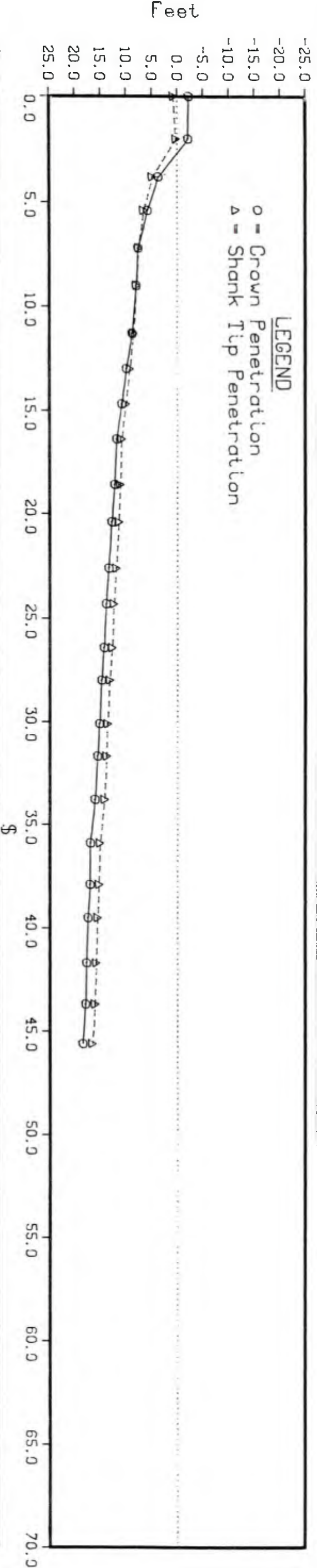

DISTRIBUTION LIST

AFB AF Tech Office (Mgt & Ops), Tyndall, FL; AUL/LSE 63-465, Maxwell AL; CESCH, Wright-Patterson;
Stinfo Library, Offutt NE
ARCTICSUBLAB Code 54, San Diego, CA
ARMY ARRADCOM, Dover, NJ; BMDSC-RE (H. McClellan) Huntsville AL; DAEN-MPE-D Washington DC
ARMY COASTAL ENGR RSCH CEN Fort Belvoir VA; R. Jachowski, Fort Belvoir VA
ARMY COE Philadelphia Dist. (LIBRARY) Philadelphia, PA
ARMY CORPS OF ENGINEERS MRD-Eng. Div., Omaha NE; Seattle Dist. Library, Seattle WA
ARMY CRREL A. Kovacs, Hanover NH
ARMY DARCOM AMCPM-CS (J. Carr), Alexandria VA
ARMY ENG WATERWAYS EXP STA Library, Vicksburg MS
ARMY ENGR DIST. Library, Portland OR
ARMY ENVIRON. HYGIENE AGCY Water Qual Div (Doner), Aberdeen Prov Ground, MD
ARMY MAT SYS ANALYSIS ACT Code DRXSY-CM (M Ogorzalek) Aberdeen Proving Grnd MD
ARMY MATERIALS & MECHANICS RESEARCH CENTER Dr. Lenoe, Watertown MA
ARMY MOBIL EQUIP R&D COM Code DRXFB-MR Fort Belvoir VA; F Stora Fort Belvoir VA; Fuel
Hndlng Equip Br., Ft Belvoir, VA; Mr. Cevasco, Fort Belvoir MD
ARMY MTMC Trans Engr Agency (D F Eichhorn) Newport News VA
ARMY TRANSPORTATION SCHOOL MAJ T Sweeney, Code ATSP CD-TE Fort Eustis VA; V Quinby Code
ATSP-CPO-MS Fort Eustis VA
ARMY TRNG & DOCTRINE CMD Code ATCD-SP-L Fort Monroe VA
ASST SECRETARY OF THE NAVY Spec. Assist Energy (Leonard), Washington, DC; Spec. Assist
Submarines, Washington DC
BUREAU OF RECLAMATION Code 1512 (C. Selander) Denver CO
CENTER FOR NAVAL ANALYSES Document Center (Darke), Arlington, VA
CINCLANT Civil Engr. Supp. Plans. Ofc Norfolk, VA
CINCPAC Fac Engrng Div (J44) Makalapa, HI
CNM Code 03462, Washington DC; Code 043 Washington DC
CNO Code NOP-964, Washington DC; Code OP 323, Washington DC; Code OP 405, Washington DC; Code OP
414, Washington DC; Code OP 97 Washington DC; Code OP 987 Washington DC; Code OPNAV 09B24
(H); Code OPNAV 22, Wash DC; Code OPNAV 23, Wash DC; OP987J (J. Boosman), Pentagon
COMCBPAC Operations Off, Makalapa HI
COMDEVGRUONE San Diego, CA
COMFLEACT, OKINAWA PWO, Kadena, Okinawa
COMNAVBEACHPHIBREFTRAGRU ONE San Diego CA
COMNAVMARIANAS Code N4, Guam
COMOCEANSYSPAC SCE, Pearl Harbor HI
COMSUBDEVGRUONE Operations Offr, San Diego, CA
NAVSURFLANT Norfolk, VA
NAVSURFPAC San Diego, CA
COMOPTEVFOR CMDR, Norfolk, VA; Code 701A, San Diego, CA
DEFENSE INTELLIGENCE AGENCY Dir., Washington DC
DMAHC Code LAL Washington DC
DLSIE Army Logistics Mgt Center, Fort Lee, VA
DNA STIL, Washington DC
DOE Dr. Cohen
DTNSRDC Anna Lab (Code 1175) Annapolis MD; Anna Lab (Code 1568) Annapolis MD
DTNSRDC Code 1706, Bethesda MD; Code 172 (M. Krenzke), Bethesda MD
DTNSRDC Code 2785 (Bloomquist), Annapolis, MD; Code 284 (A. Rufolo), Annapolis MD
FMFLANT CEC Offr, Norfolk VA
FMFPAC CG Pearl Harbor
GSA Fed. Sup. Serv. (FMBP), Washington DC
HCU ONE CO, Bishops Point, HI
MARINE CORPS BASE First Service Support Group Camp Pendleton CA; PWO Camp Lejeune NC; PWO,
Camp S. D. Butler, Kawasaki Japan

MCAS Facil. Engr. Div. Cherry Point NC; CO, Kaneohe Bay HI; Code PWE, Kaneohe Bay HI; PWO Kaneohe Bay HI
 MCDEC NSAP REP, Quantico VA; P&S Div Quantico VA
 MCRD PWO, San Diego Ca
 MILITARY SEALIFT COMMAND Washington DC
 NAF PWO, Atsugi Japan
 NALF OINC, San Diego, CA
 NARF Code 100, Cherry Point, NC
 NAS Code 18700, Brunswick ME; Dir. Util. Div., Bermuda; ENS Buchholz, Pensacola, FL; PWD Maint. Div., New Orleans, Belle Chasse LA; PWO Belle Chasse, LA; PWO Key West FL; PWO, Glenview IL; SCE Norfolk, VA
 NATL RESEARCH COUNCIL Naval Studies Board, Washington DC
 NAVACT PWO, London UK
 NAVAEROSPREGMEDCEN SCE, Pensacola FL
 NAVCHAPGRU CO Williamsburg VA
 NAVCOASTSYSCEN Code 719, Panama City, FL; Code 772 (C B Koesy) Panama City FL
 NAVCOASTSYSTCTR CO, Panama City FL; Code 713 (J. Quirk) Panama City, FL; Code 715 (J. Mittleman) Panama City, FL; Library Panama City, FL
 NAVCOMMAREAMSTRSTA PWO, Norfolk VA; PWO, Wahiawa HI; SCE Unit 1 Naples Italy
 NAVCOMMSTA Code 401 Nea Makri, Greece; PWO, Exmouth, Australia
 NAVEDTRAPRODEVCCEN Tech. Library
 NAVELEXSYSCOM Code PME-124-61, Washington DC
 NAVENVIRHLTHCEN CO, Alexandria, VA
 NAVEODFAC Code 605, Indian Head MD
 NAVFAC PWO, Centerville Bch, Ferndale CA
 NAVFACENGCOM Code 043 Alexandria, VA; Code 044 Alexandria, VA; Code 0451 Alexandria, VA; Code 0453 (D. Potter) Alexandria, VA; Code 0453C, Alexandria, VA; Code 0454B Alexandria, Va; Code 04B3 Alexandria, VA; Code 04B5 Alexandria, VA; Code 06, Alexandria VA; Code 100 Alexandria, VA; Code 1002B (J. Leimanis) Alexandria, VA; Code 1113 (T. Stevens) Alexandria, VA; Code 1113 Alexandria, VA; Code PC-21, Alexandria, VA; Morrison Yap, Caroline Is.; PC-2 Alexandria, VA; PC-2 Alexandria, VA
 NAVFACENGCOM - CHES DIV. Code 402 (D Scheesele) Washington, DC; Code 405 Wash, DC; Code FPO-1 Wash, DC; Code FPO-11P, Wash. DC; Code FPO-1E, Wash. DC; FPO-1 (Spencer) Wash, DC; FPO-1 Wash, DC
 NAVFACENGCOM - LANT DIV. Eur. BR Deputy Dir, Naples Italy; European Branch, New York; RDT&ELO 102, Norfolk VA
 NAVFACENGCOM - NORTH DIV. (Boretsky) Philadelphia, PA; CO; Code 09P (LCDR A.J. Stewart); Code 1028, RDT&ELO, Philadelphia PA; Design Div. (R. Masino), Philadelphia PA; ROICC, Contracts, Crane IN
 NAVFACENGCOM - PAC DIV. Code 2011 Pearl Harbor, HI; Code 402, RDT&E, Pearl Harbor HI; Commander, Pearl Harbor, HI
 NAVFACENGCOM - SOUTH DIV. Code 90, RDT&ELO, Charleston SC
 NAVFACENGCOM - WEST DIV. Code 04B San Bruno, CA; O9P/20 San Bruno, CA; RDT&ELO Code 2011 San Bruno, CA
 NAVFACENGCOM CONTRACT Eng Div dir, Southwest Pac, Manila, PI; OICC, Southwest Pac, Manila, PI; ROICC, Keflavik, Iceland
 NAVFORCARIB Commander (N42), Puerto Rico
 NAVOCEANO Code 1600 Bay St. Louis, MS; Code 3432 (J. DePalma), Bay St. Louis MS
 NAVOCEANSYSCEN Code 41, San Diego, CA; Code 4473 Bayside Library, San Diego, CA; Code 52 (H. Talkington) San Diego CA; Code 5204 (J. Stachiw), San Diego, CA; Code 5214 (H. Wheeler), San Diego CA; Code 5221 (R. Jones) San Diego Ca; Code 5311 San Diego, CA; Tech. Library, Code 447
 NAVPGSCOL Code 61WL (O. Wilson) Monterey CA; D. Leipper, Monterey CA; E. Thornton, Monterey CA
 NAVPHIBASE C O ACB ONE San Diego CA; CO, ACB 2 Norfolk, VA; COMNAVBEACHGRU TWO Norfolk VA; Code S3T, Norfolk VA; Dir. Amphib. Warfare Brd Staff, Norfolk, VA; Harbor Clearance Unit Two, Little Creek, VA
 NAVREGMEDCEN SCE (D. Kaye); SCE, Guam
 NAVSCOLCECOFF C35 Port Hueneme, CA

NAVSEASYSKOM Code 00C-DG DiGeorge, Washington, DC; Code 0325, Program Mgr, Washington, DC;
 Code OOC (LT R. MacDougal), Washington DC; Code OOC-D, Washington, DC; Code PMS 395 A 3,
 Washington, DC; Code PMS 395 A2, Washington, DC; Code SEA OOC Washington, DC
 NAVSEC Code 6034 (Library), Washington DC
 NAVSECGRUACT PWO, Adak AK
 NAVSHIPREPFAC Library, Guam; SCE Subic Bay
 NAVSHIPYD; Code 202.4, Long Beach CA; Code 202.5 (Library) Puget Sound, Bremerton WA; Code 400,
 Puget Sound; Code 440 Portsmouth NH; Code 440, Puget Sound, Bremerton WA; L.D. Vivian; Salvage
 Supt, Phila., PA; Tech Library, Vallejo, CA
 NAVSTA CO Naval Station, Mayport FL; CO Roosevelt Roads P.R. Puerto Rico; PWD (LTJG.P.M.
 Motolenich), Puerto Rico; PWO Midway Island; PWO, Keflavik Iceland; PWO, Mayport FL; SCE, Guam;
 SCE, Subic Bay, R.P.; Utilities Engr Off. (A.S. Ritchie), Rota Spain
 NAVSUPACT Code 413, Seattle WA; LTJG McGarran, SEC, Vallejo, CA; Security Offr, San Francisco, CA
 NAVSURFWPCEN PWO, White Oak, Silver Spring, MD
 NAVTECHTRACEN SCE, Pensacola FL
 NAVWPNCEN Code 2636 (W. Bonner), China Lake CA
 NAVWPNSTA Code 092, Colts Neck NJ
 NAVWPNSTA PW Office (Code 09C1) Yorktown, VA
 NAVWPNSTA PWO, Seal Beach CA
 NAVWPNSUPPCEN Code 09 Crane IN
 NCBU 405 OIC, San Diego, CA
 NCBC Code 10 Davisville, RI; Code 155, Port Hueneme CA; Code 156, Port Hueneme, CA
 NCR 20, Commander; FWD 30th CDR Diego Garcia Island
 NMCB 5, Operations Dept.; 74, CO
 NOAA Library Rockville, MD
 NORDA Code 410 Bay St. Louis, MS; Code 440 (Ocean Rsch Off) Bay St. Louis MS; Code 500, Bay St. Louis,
 MS
 NRL Code 8400 Washington, DC; Code 8441 (R.A. Skop), Washington DC; Rosenthal, Code 8440, Wash. DC
 NSD SCE, Subic Bay, R.P.
 NTC OICC, CBU-401, Great Lakes IL
 NUCLEAR REGULATORY COMMISSION T.C. Johnson, Washington, DC
 NUSC Code 131 New London, CT; Code EA123 (R.S. Munn), New London CT; Code S332, B-80 (J. Wilcox);
 Code TA131 (G. De la Cruz), New London CT
 OCEANAV Mangmt Info Div., Arlington VA
 OCEANSYSLANT LT A.R. Giancola, Norfolk VA
 OFFICE SECRETARY OF DEFENSE ASD (MRA&L) Code CSS/CC Washington, DC
 ONR (Dr. E.A. Silva) Arlington, VA; BROFF, CO Boston MA; Code 481, Arlington VA; Code 481, Bay St.
 Louis, MS; Code 700F Arlington VA; Dr. A. Laufer, Pasadena CA
 PHIBCB 1 P&E, Coronado, CA
 PMTC Code 3144, Point Mugu, CA; Code 3331 (S. Opatowsky) Point Mugu, CA; EOD Mobile Unit, Point
 Mugu, CA; Pat. Counsel, Point Mugu CA
 PWC CO Norfolk, VA; CO, (Code 10), Oakland, CA; CO, Great Lakes IL; Code 10, Great Lakes, IL; Code
 120, Oakland CA; Code 120C, (Library) San Diego, CA; Code 128, Guam; Code 154, Great Lakes, IL;
 Code 200, Great Lakes IL; Code 220.1, Norfolk VA; Code 30C, San Diego, CA; Code 400, Great Lakes,
 IL; Code 400, Pearl Harbor, HI; Code 400, San Diego, CA; Code 420, Great Lakes, IL; Code 420,
 Oakland, CA; Code 700, San Diego, CA
 UCT TWO OIC, Norfolk, VA; OIC, Port Hueneme CA
 U.S. MERCHANT MARINE ACADEMY Kings Point, NY (Reprint Custodian)
 US DEPT OF INTERIOR Bureau of Land MNGMNT - Code 733 (T.E. Sullivan) Wash, DC
 US GEOLOGICAL SURVEY Off. Marine Geology, Piteleki, Reston VA
 US NATIONAL MARINE FISHERIES SERVICE Highlands NY (Sandy Hook Lab-Library)
 US NAVAL FORCES Korea (ENJ-P&O)
 USCG (G-ECV) Washington Dc; (G-MP-3/USP/82) Washington Dc; (Smith), Washington, DC; G-EOE-4/61 (T.
 Dowd), Washington DC
 USCG R&D CENTER CO Groton, CT; D. Motherway, Groton CT; Tech. Dir. Groton, CT
 USDA Forest Service, San Dimas, CA
 USNA Ch. Mech. Engr. Dept Annapolis MD; Ocean Sys. Eng Dept (Dr. Monney) Annapolis, MD; Civil Engr
 Dept (R. Erchyl) Annapolis MD; PWD Engr. Div. (C. Bradford) Annapolis MD

AMERICAN CONCRETE INSTITUTE Detroit MI (Library)
 AMERICAN UNIVERSITY Washington DC (M. Norton)
 CALIF. DEPT OF FISH & GAME Long Beach CA (Marine Tech Info Ctr)
 CALIF. DEPT OF NAVIGATION & OCEAN DEV. Sacramento, CA (G. Armstrong)
 CALIF. MARITIME ACADEMY Vallejo, CA (Library)
 CALIFORNIA INSTITUTE OF TECHNOLOGY Pasadena CA (Keck Ref. Rm)
 CALIFORNIA STATE UNIVERSITY LONG BEACH, CA (CHELAPATI); LONG BEACH, CA (YEN); LOS ANGELES, CA (KIM)
 CATHOLIC UNIV. Mech Engr Dept, Prof. Niedzwecki, Wash., DC
 COLORADO STATE UNIV., FOOTHILL CAMPUS Fort Collins (Nelson)
 CORNELL UNIVERSITY Ithaca NY (Serials Dept, Engr Lib.)
 DAMES & MOORE LIBRARY LOS ANGELES, CA
 DUKE UNIV MEDICAL CENTER B. Muga, Durham NC; DURHAM, NC (VESIC)
 FLORIDA ATLANTIC UNIVERSITY Boca Raton FL (W. Hartt); Boca Raton FL (W. Tessin); Boca Raton, FL (McAllister)
 FLORIDA TECHNOLOGICAL UNIVERSITY ORLANDO, FL (HARTMAN)
 GEORGIA INSTITUTE OF TECHNOLOGY Atlanta GA (School of Civil Engr., Kahn); Atlanta GA (B. Mazanti)
 INSTITUTE OF MARINE SCIENCES Morehead City NC (Director)
 IOWA STATE UNIVERSITY Ames IA (CE Dept, Handy)
 WOODS HOLE OCEANOGRAPHIC INST. Woods Hole MA (Winget)
 KEENE STATE COLLEGE Keene NH (Cunningham)
 LEHIGH UNIVERSITY BETHLEHEM, PA (MARINE GEOTECHNICAL LAB., RICHARDS); Bethlehem PA (Fritz Engr. Lab No. 13, Beedle); Bethlehem PA (Linderman Lib. No.30, Flecksteiner)
 LIBRARY OF CONGRESS WASHINGTON, DC (SCIENCES & TECH DIV)
 MAINE MARITIME ACADEMY CASTINE, ME (LIBRARY)
 MICHIGAN TECHNOLOGICAL UNIVERSITY Houghton, MI (Haas)
 MIT Cambridge MA; Cambridge MA (Rm 10-500, Tech. Reports, Engr. Lib.); Cambridge MA (Whitman)
 NATL ACADEMY OF ENG. ALEXANDRIA, VA (SEARLE, JR.)
 NEW MEXICO SOLAR ENERGY INST. Dr. Zwibel Las Cruces NM
 NORTHWESTERN UNIV Z.P. Bazant Evanston IL
 OREGON STATE UNIVERSITY (CE Dept Grace) Corvallis, OR; CORVALLIS, OR (CE DEPT, BELL); Corvallis OR (School of Oceanography)
 PENNSYLVANIA STATE UNIVERSITY STATE COLLEGE, PA (SNYDER); State College PA (Applied Rsch Lab); UNIVERSITY PARK, PA (GOTOLSKI)
 PURDUE UNIVERSITY Lafayette IN (Leonards); Lafayette, IN (Altschaeffl); Lafayette, IN (CE Engr. Lib)
 SAN DIEGO STATE UNIV. 1. Noorany San Diego, CA; Dr. Krishnamoorthy, San Diego CA
 SCRIPPS INSTITUTE OF OCEANOGRAPHY LA JOLLA, CA (ADAMS)
 SEATTLE U Prof Schwaegler Seattle WA
 SOUTHWEST RSCH INST King, San Antonio, TX; R. DeHart, San Antonio TX
 STANFORD UNIVERSITY Engr Lib, Stanford CA; STANFORD, CA (DOUGLAS)
 STATE UNIV. OF NEW YORK Buffalo, NY; Fort Schuyler, NY (Longobardi)
 TEXAS A&M UNIVERSITY College Station TX (CE Dept. Herbich); W.B. Ledbetter College Station, TX
 UNIVERSITY OF CALIFORNIA BERKELEY, CA (CE DEPT, GERWICK); BERKELEY, CA (CE DEPT, MITCHELL); Berkeley CA (B. Bresler); Berkeley CA (Dept of Naval Arch.); Berkeley CA (E. Pearson); DAVIS, CA (CE DEPT, TAYLOR); La Jolla CA (Acq. Dept, Lib. C-075A); M. Duncan, Berkeley CA; SAN DIEGO, CA, LA JOLLA, CA (SEROCKI)
 UNIVERSITY OF CONNECTICUT Groton CT (Inst. Marine Sci, Library)
 UNIVERSITY OF DELAWARE Newark, DE (Dept of Civil Engineering, Chesson)
 UNIVERSITY OF HAWAII HONOLULU, HI (SCIENCE AND TECH. DIV.); Honolulu HI (Dr. Szilard); Ocean Engrng Dept
 UNIVERSITY OF ILLINOIS Metz Ref Rm, Urbana IL; URBANA, IL (DAVISSON); URBANA, IL (LIBRARY); URBANA, IL (NEWMARK)
 UNIVERSITY OF MASSACHUSETTS (Heronemus), Amherst MA CE Dept
 UNIVERSITY OF MICHIGAN Ann Arbor MI (Richart)
 UNIVERSITY OF NEBRASKA-LINCOLN Lincoln, NE (Ross Ice Shelf Proj.)
 UNIVERSITY OF NEW HAMPSHIRE DURHAM, NH (LAVOIE)
 UNIVERSITY OF NOTRE DAME Katona, Notre Dame, IN

UNIVERSITY OF PENNSYLVANIA PHILADELPHIA, PA (SCHOOL OF ENGR & APPLIED SCIENCE, ROLL)
 UNIVERSITY OF RHODE ISLAND KINGSTON, RI (PAZIS); Narragansett RI (Pell Marine Sci. Lib.)
 UNIVERSITY OF SO. CALIFORNIA Univ So. Calif
 UNIVERSITY OF TEXAS Inst. Marine Sci (Library), Port Arkansas TX
 UNIVERSITY OF TEXAS AT AUSTIN Austin TX (R. Olson)
 UNIVERSITY OF WASHINGTON Seattle WA (M. Sherif); Dept of Civil Engr (Dr. Mattock), Seattle WA;
 SEATTLE, WA (APPLIED PHYSICS LAB); SEATTLE, WA (MERCHANT); SEATTLE, WA (OCEAN
 ENG RSCH LAB, GRAY); SEATTLE, WA (PACIFIC MARINE ENVIRON. LAB., HALPERN); Seattle
 WA (E. Linger); Seattle, WA Transportation, Construction & Geom. Div
 VIRGINIA INST. OF MARINE SCI. Gloucester Point VA (Library)
 ALFRED A. YEE & ASSOC. Honolulu HI
 AMETEK Offshore Res. & Engr Div
 AMSCO Dr. R. McCoy, Erie, PA
 ARCAIR CO. D. Young, Lancaster OH
 ARVID GRANT OLYMPIA, WA
 ATLANTIC RICHFIELD CO. DALLAS, TX (SMITH)
 BATTELLE-COLUMBUS LABS (D. Hackman) Columbus, OH
 BECHTEL CORP. SAN FRANCISCO, CA (PHELPS)
 BELGIUM HAECON, N.V., Gent
 BETHLEHEM STEEL CO. Dismuke, Bethlehem, PA
 BOUW KAMP INC Berkeley
 BRAND INDUS SERV INC. J. Buehler, Hacienda Heights CA
 BRITISH EMBASSY Sci. & Tech. Dept. (J. McAuley), Washington DC
 BROWN & CALDWELL E M Saunders Walnut Creek, CA
 BROWN & ROOT Houston TX (D. Ward)
 CANADA Can-Dive Services (English) North Vancouver; Library, Calgary, Alberta; Lockheed Petro. Serv.
 Ltd, New Westminster B.C.; Lockheed Petrol. Srv. Ltd., New Westminster BC; Mem Univ Newfoundland
 (Chari), St Johns; Nova Scotia Rsch Found, Corp. Dartmouth, Nova Scotia; Surveyor, Nenninger &
 Chenevert Inc., Montreal; Trans-Mnt Oil Pipe Lone Corp. Vancouver, BC Canada; Warnock Hersey Prof.
 Srv Ltd, La Sale, Quebec
 CHEVRON OIL FIELD RESEARCH CO. LA HABRA, CA (BROOKS)
 COLUMBIA GULF TRANSMISSION CO. HOUSTON, TX (ENG. LIB.)
 CONCRETE TECHNOLOGY CORP. TACOMA, WA (ANDERSON)
 CONTINENTAL OIL CO O. Maxson, Ponca City, OK
 DILLINGHAM PRECAST F. McHale, Honolulu HI
 EVALUATION ASSOC. INC KING OF PRUSSIA, PA (FEDELE)
 EXXON PRODUCTION RESEARCH CO Houston, TX (Chao)
 FRANCE Dr. Dutertre, Boulogne; L. Pliskin, Paris; P. Jensen, Boulogne; Roger LaCroix, Paris
 GEOTECHNICAL ENGINEERS INC. Winchester, MA (Paulding)
 GOULD INC. Shady Side MD (Ches. Inst. Div., W. Paul)
 GRUMMAN AEROSPACE CORP. Bethpage NY (Tech. Info. Ctr)
 HALEY & ALDRICH, INC. Cambridge MA (Aldrich, Jr.)
 ITALY M. Caironi, Milan; Sergio Tattoni Milano
 LAMONT-DOHERTY GEOLOGICAL OBSERV. Palisades NY (McCoy); Palisades NY (Selwyn)
 LIN OFFSHORE ENGRG P. Chow, San Francisco CA
 LOCKHEED MISSILES & SPACE CO. INC. L. Trimble, Sunnyvale CA; Sunnyvale CA (Ryniewicz);
 Sunnyvale, CA (K.L. Krug)
 LOCKHEED OCEAN LABORATORY San Diego CA (F. Simpson)
 MARATHON OIL CO Houston TX
 MARINE CONCRETE STRUCTURES INC. MEFAIRIE, LA (INGRAHAM)
 MC CLELLAND ENGINEERS INC Houston TX (B. McClelland)
 MEXICO R. Cardenas
 MOBIL PIPE LINE CO. DALLAS, TX MGR OF ENGR (NOACK)
 MOFFATT & NICHOL ENGINEERS (R. Palmer) Long Beach, CA
 NEWPORT NEWS SHIPBLDG & DRYDOCK CO. Newport News VA (Tech. Lib.)
 NORWAY A. Torum, Trondheim; DET NORSKE VERITAS (Library), Oslo; DET NORSKE VERITAS
 (Roren) Oslo; I. Foss, Oslo; J. Creed, Ski; Norwegian Tech Univ (Brandtzaeg), Trondheim

OCEAN ENGINEERS SAUSALITO, CA (RYNECKI)
 OCEAN RESOURCE ENG. INC. HOUSTON, TX (ANDERSON)
 PACIFIC MARINE TECHNOLOGY Long Beach, CA (Wagner)
 PRESCON CORP TOWSON, MD (KELLER)
 R J BROWN ASSOC (McKeehan), Houston, TX
 RAND CORP. Santa Monica CA (A. Laupa)
 RAYMOND INTERNATIONAL INC. E Colle Soil Tech Dept, Pennsauken, NJ
 RIVERSIDE CEMENT CO Riverside CA (W. Smith)
 SANDIA LABORATORIES Library Div., Livermore CA; Seabed Progress Div 4536 (D. Talbert) Albuquerque
 NM
 SEATECH CORP. MIAMI, FL (PERONI)
 SHELL DEVELOPMENT CO. Houston TX (C. Sellars Jr.); Houston TX (E. Doyle)
 SHELL OIL CO. HOUSTON, TX (MARSHALL); Houston TX (R. de Castongrene); I. Boaz, Houston TX
 SWEDEN GeoTech Inst; VBB (Library), Stockholm
 TECHNICAL COATINGS CO Oakmont PA (Library)
 TIDEWATER CONSTR. CO Norfolk VA (Fowler)
 TRW SYSTEMS CLEVELAND, OH (ENG. LIB.); REDONDO BEACH, CA (DAI)
 UNITED KINGDOM A. Denton, London; Library, Bristol; R. Browne, Southall, Middlesex; Taylor,
 Woodrow Constr (014P), Southall, Middlesex; Univ. of Bristol (R. Morgan), Bristol
 WESTINGHOUSE ELECTRIC CORP. Annapolis MD (Oceanic Div Lib, Bryan)
 WESTINTRUCORP Egerton, Oxnard, CA
 WM CLAPP LABS - BATTELLE DUXBURY, MA (LIBRARY); Duxbury, MA (Richards)
 WOODWARD-CLYDE CONSULTANTS (A. Harrigan) San Francisco; PLYMOUTH MEETING PA (CROSS,
 III)
 AL SMOOTS Los Angeles, CA
 ANTON TEDESKO Bronxville NY
 BARA, JOHN P. Lakewood, CO
 BRAHTZ La Jolla, CA
 BULLOCK La Canada
 F. HEUZE Alamo, CA
 LAYTON Redmond, WA
 WM TALBOT Orange CA