

AWARD NUMBER: **W81XWH-14-C-0101**

TITLE: **Advanced Modular Manikin**

PRINCIPAL INVESTIGATOR: **Robert M. Sweet, MD, FACS**

CONTRACTING ORGANIZATION: **REGENTS OF THE UNIVERSITY OF MINNESOTA**  
**MINNEAPOLIS MN 55455-2009**

REPORT DATE: **June 2020**

TYPE OF REPORT: **Final**

PREPARED FOR: **U.S. Army Medical Research and Materiel Command**  
**Fort Detrick, Maryland 21702-5012**

DISTRIBUTION STATEMENT: **Approved for Public Release;**  
**Distribution Unlimited**

The views, opinions and/or findings contained in this report are those of the author(s) and should not be construed as an official Department of the Army position, policy or decision unless so designated by other documentation.

REPORT DOCUMENTATION PAGE			Form Approved OMB No. 0704-0188		
Public reporting burden for this collection of information is estimated to average 1 hour per response, including the time for reviewing instructions, searching existing data sources, gathering and maintaining the data needed, and completing and reviewing this collection of information. Send comments regarding this burden estimate or any other aspect of this collection of information, including suggestions for reducing this burden to Department of Defense, Washington Headquarters Services, Directorate for Information Operations and Reports (0704-0188), 1215 Jefferson Davis Highway, Suite 1204, Arlington, VA 22202-4302. Respondents should be aware that notwithstanding any other provision of law, no person shall be subject to any penalty for failing to comply with a collection of information if it does not display a currently valid OMB control number. <b>PLEASE DO NOT RETURN YOUR FORM TO THE ABOVE ADDRESS.</b>					
<b>1. REPORT DATE</b> June 2020		<b>2. REPORT TYPE</b> Final		<b>3. DATES COVERED</b> 09/05/2014 - 02/25/2020	
<b>4. TITLE AND SUBTITLE</b> Advanced Modular Manikin			<b>5a. CONTRACT NUMBER</b> W81XWH-14-C-0101		
			<b>5b. GRANT NUMBER</b>		
			<b>5c. PROGRAM ELEMENT NUMBER</b>		
<b>6. AUTHOR(S)</b>  Robert M. Sweet, MD, FACS  E-Mail: rsweet@uw.edu			<b>5d. PROJECT NUMBER</b>		
			<b>5e. TASK NUMBER</b>		
			<b>5f. WORK UNIT NUMBER</b>		
<b>7. PERFORMING ORGANIZATION NAME(S) AND ADDRESS(ES)</b> REGENTS OF THE UNIVERSITY OF MINNESOTA OFFICE OF SPONSORED PROJECTS 200 OAK ST SE MINNEAPOLIS MN 55455-2009			<b>8. PERFORMING ORGANIZATION REPORT NUMBER</b>		
<b>9. SPONSORING / MONITORING AGENCY NAME(S) AND ADDRESS(ES)</b>  U.S. Army Medical Research and Development Command Fort Detrick, Maryland 21702-5012			<b>10. SPONSOR/MONITOR'S ACRONYM(S)</b>		
			<b>11. SPONSOR/MONITOR'S REPORT NUMBER(S)</b>		
<b>12. DISTRIBUTION / AVAILABILITY STATEMENT</b>  Approved for Public Release; Distribution Unlimited					
<b>13. SUPPLEMENTARY NOTES</b>					
<b>14. ABSTRACT</b> The goal of this project is to design and test an open-standard interoperable, modular healthcare simulation platform. The AMM team has built a core simulation platform designed for the easy integration of peripheral physical and digital simulation systems that communicate seamlessly despite being created by independent entities. These modules publish and subscribe through the platform and share a common patient state. The shared physiology engine also has the capability of being modular. In order to demonstrate AMM 's capabilities, we provide a full body demonstration system with physical and digital modules and an open source physiology engine (BioGears). The demo AMM represents a spectrum of human conditions relevant for all Roles and a variety of training backgrounds of military medical and trauma care. AMM deliverables include central computing capabilities, a digital male and female anthropomorphic dataset, data libraries that allow AMM compatible vendors to publish and subscribe data elements, and technological standards. We provide the specifications for a tool-less, unified connector providing data, power, air and fluid. AMM has been designed, prototyped, lab-tested and field-tested in the Demo unit for connection of modules to other modules. In an American College of Surgeons study of military providers in a military training center, the system was easy to use and demonstrated superiority over individual modules in a multi-ROLE, multi provider trauma scenario and especially showed enhanced training and assessment capabilities for interprofessional trauma teams.					
<b>15. SUBJECT TERMS</b> Modular, Manikin, Open Source					
<b>16. SECURITY CLASSIFICATION OF:</b>			<b>17. LIMITATION OF ABSTRACT</b>  Unclassified	<b>18. NUMBER OF PAGES</b>  125	<b>19a. NAME OF RESPONSIBLE PERSON</b> USAMRMC
<b>a. REPORT</b>  Unclassified	<b>b. ABSTRACT</b>  Unclassified	<b>c. THIS PAGE</b>  Unclassified			<b>19b. TELEPHONE NUMBER (include area code)</b>

# Table of Contents

<b>1</b>	<b>EXECUTIVE SUMMARY .....</b>	<b>4</b>
<b>2</b>	<b>KEYWORDS .....</b>	<b>6</b>
<b>3</b>	<b>ADVANCED MODULAR MANIKIN DELIVERABLES.....</b>	<b>8</b>
3.1	TECHNOLOGICAL AND ANATOMIC STANDARDS.....	8
3.1.1	<i>Contract Data Requirements List (CDRLs)</i> .....	9
3.1.2	<i>System Architecture</i> .....	10
3.1.3	<i>Data Libraries and Structure</i> .....	11
3.1.4	<i>Anthropomorphic Male and Female Anatomic Data Sets (Alpha)</i> .....	14
3.1.5	<i>CREST Universal Segment Connector (USC)</i> .....	15
3.2	CENTRAL COMPUTING CAPABILITIES.....	22
3.2.1	<i>AMM Central Operating Resources (CORE)</i> .....	22
3.2.2	<i>Advance Modular Manikin Developer’s Kit (AMMDK)</i> .....	27
3.2.3	<i>Network Manager</i> .....	32
3.2.4	<i>CREST Reference Design Box</i> .....	34
3.3	ALPHA FULL-BODY PATIENT PROTOTYPE.....	36
3.3.1	<i>Development Phases</i> .....	37
3.3.2	<i>Development and Integration of Modules</i> .....	42
3.4	ACS FIELD-TESTING (FULL REPORT PROVIDED IN APPENDIX).....	59
3.4.1	<i>ACS Study Administrative Summary of Events</i> .....	60
3.4.2	<i>Scenario Development</i> .....	63
3.5	DELIVERY AND DEMONSTRATION OF MALE “BETA” FULL BODY PATIENT PROTOTYPE .....	65
3.5.1	<i>Alpha Prototype vs Beta Prototype</i> .....	65
3.5.2	<i>AMM 1.0 Standard and Modular Capabilities in Beta</i> .....	70
3.5.3	<i>Beta Build</i> .....	72
3.6	NEXT STEPS .....	73
<b>4</b>	<b>IMPACT.....</b>	<b>74</b>
4.1	ADOPTION OF AMM STANDARDS BY OTHER PROJECTS.....	74
<b>5</b>	<b>RISKS.....</b>	<b>77</b>
<b>6</b>	<b>PRODUCTS.....</b>	<b>77</b>
6.1	PUBLICATIONS.....	77
6.2	PRESENTATIONS .....	78
<b>7</b>	<b>PARTICIPANTS &amp; OTHER COLLABORATING ORGANIZATIONS .....</b>	<b>78</b>
<b>8</b>	<b>SPECIAL REPORTING REQUIREMENTS.....</b>	<b>80</b>
<b>9</b>	<b>APPENDIX .....</b>	<b>81</b>
	APPENDIX I: CDRL SUMMARY .....	81
	APPENDIX II: ANTHROPOMORPHIC ANATOMIC MALE AND FEMALE DATA SETS.....	85
	APPENDIX III: ACS FULL STUDY REPORT .....	91

## 1 Executive Summary

**The Charge:** As stated in the announcement for the Advanced Modular Manikin™ (AMM™) and detailed in the solicitation W81XWH-13-R-0032 from JPC-1, the program seeks to:

*“Advance the state of the art in medical simulation-based training. It is anticipated that the core AMM system will be state of the art, modular, and relatively autonomous. It will serve as a core platform that allows scaling from a simple, to a vastly more capable unit, using future commercial upgrades, “peripherals” that can be obtained from a variety of potential sources.*

*The intent is that the AMM be a platform upon which future technologies can reside through development of advanced peripherals through other efforts. It is envisioned that the advanced modular manikin be compatible with a wide array of peripherals and/or extensions leveraged with open-source / open-standard physical attachments, supply (electrical/fluid) connections and communications links. This broad AMM platform to be developed should have the ability to host capabilities that do not yet exist but that are anticipated to be developed within the next five to ten years. Creation of the AMM platform will allow for a usable manikin system that can incorporate future advances, from a variety of sources, easily into military medical training.”*

Phase II of the program was funded to move the proof of concept demonstrated at the end of Phase I forward, so that any interested parties can use the published standards and the core platform to build new modules with, or to upgrade existing trainers to benefit from the technology developed under AMM. All of the work being done for AMM is being published under Creative Commons 4.0 as open source with open standards and will bear no licensing fees.

Phase II also finalized the move from a manikin-based concept to a truly interoperable, integrated system allowing virtual, physical and hybrid implementations, with a connection point to compare outcomes to actual patient care.

**The AMM Team:** The program assembled a multi-disciplinary development team that represented several critical technology areas needed to design, build, and test a next generation open source healthcare simulation platform. The institutions/entities that contributed to our effort included the University of Minnesota, the University of Washington, Vcom3D, Entropic Engineering, Applied Research Associates (ARA), STTC Army Futures Command, San Diego Naval Hospital and the American College of Surgeons Division of Education. External simulation companies peripherally worked on this project, in that they successfully built modules that were compatible with our platform. They included CAE Healthcare and ACDET.

### **AMM Team leadership**

Principal Investigator: Robert M. Sweet, MD, FACS, University of Minnesota (now University of Washington)

Co-PI: Mojca R. Konia, MD, PhD, MACM, University of Minnesota

Subcontract: University of Washington CREST – PI: David Hananel

Subcontract: Vcom3D – PI: Ed Sims, PhD

Subcontract: American College of Surgeons – PI: Ajit Sachdeva, MD, FRCSC, FACS



**Key Deliverables:** In this report, we describe several key deliverables for the project. The first section of deliverables includes **technological and anatomic standards** such as the system architecture, CDRLs, data models and libraries, and complete digital 3-D alpha male and female anthropomorphic datasets. In addition, we designed, tested and provided the design for a tool-less CREST Universal Segment Connector (USC) that provides data, power, air and fluid for module developers.

The second section of deliverables includes **central computing capabilities** such as the AMM software CORE, AMM Developer's toolkit, network manager and the specifications for a CREST reference design box.

The third section of deliverables includes the **development of an alpha hybrid physical/virtual patient** and the **integration of modules** such as the BioGears® physiology engine and several internal and third party peripherals that follow the AMM standards. This is the patient that was used to support the fourth section of the reported deliverables, which describes the American College of Surgeons Division of Education/San Diego Naval Hospital successful evaluation and field test of the platform. Key findings from the study as it relates to the actual platform were as follows:

1. The use of an integrated AMM at a DoD CONUS medical site for the training of first responders, surgeons and anesthesiologists, and similar roles to those in civilian emergency departments, along with forward deployed Role II and III surgical sites is feasible.
2. The integrated form of the AMM was perceived to be superior to the peripheral task trainers alone in supporting the whole of a defined trauma scenario, one that could occur both in deployed or CONUS settings.
3. One of the strongest points of the AMM was its perceived ability to enhance inter-professional team training that involves multiple specialties/disciplines of the care team.
4. Another very highly rated characteristic of the AMM was its ability to show physiologic data to the learners/trainees through realistic monitoring equipment, including a feedback mechanism, and a physiologic engine, which had its own learning system that did not require input from an observer/controller, and as a result, vastly improved the realism of the trauma scenario.

The fourth and final deliverable was two fully functional beta full body patient prototypes to the Department of Defense which successfully demonstrates interoperability with either BioGears or an existing, market-tested physiology engine with broad capabilities (CAE Healthcare).

**Timeline:** The Phase II timeline of accomplishments can be broken down as follows:

- **Year 1:** Finalized high level design and anatomic/technological standards, refinement of the architecture and major sub-systems, connector and software builds,

physiology engine testing and refinements, breadboarding various components, preliminary preparation for the ACS study and development of communication protocols.

- **Year 2:** Refining and testing the computing capabilities, refining and testing the technological standards including the data models and CREST Universal Segment Connector (USC), internal and external peripheral development and testing, iteration and testing towards a full integrated alpha prototype, further preparations/planning for the ACS study .
- **Year 3:** Full integration of two physiology engines and several peripherals into alpha and beta AMM systems/patients, consolidation, miniaturization and simplification of computing capabilities, documentation of CDRLs and creation of a developer's kit, completion of a field test of the AMM platform by the American College of Surgeons (ACS).

## 2 Keywords

Modular, Manikin, Open Source

Glossary of important terms:

1. AMM - Advanced Modular Manikin. Name of the project as well as the Trademark name of operating system/standards and platform that will be provided under the efforts of this contract as a deliverable to the U.S. Department of Defense.
2. Phase 1 AMM - 4 Advanced Modular Manikin Prototype concepts designed under four competitive contracts that ended February 2016.
3. Phase 2 AMM - After selection, University of Minnesota-led contract to develop the Advanced Modular Manikin standards and platform that ends in September 2019.
4. "CORE" - Central operating resources (computer, power, fluid, air)
5. "Module" or "Peripheral" – Interchangeably refers to a physical or digital capability or system that can be connected to the AMM platform.
6. "Smart Compatible Module"- A module that transmits data bidirectionally to and from the CORE system and therefore contributes and/or responds to changes in conditions communicated across the system.
7. "Dumb Compatible Module" – A module that may be physically compatible, but doesn't transmit data to and from the CORE.
8. "Segment"- One of 6 parts of the human form that can connect. (Left arm, right arm, left leg, right leg, head and neck, torso).
9. "Data-bus"- Data backbone that allows all components to communicate.
10. DDS – Data Distribution Services, the open source communication protocol that was selected for the AMM backbone.
11. "Physiology Engine"-Software module that receives and generates physiologic states.
12. "Fidelity" – "Likeness to the model we are intending to simulate". There are 4 main sub-classifications of fidelity for medical simulation: Anatomic fidelity, Physiologic fidelity, Tissue fidelity and Affective fidelity (Hananel, Sweet).

13. "Generalizability for Learning groups"- Ability of the system to accommodate the development and interoperability of modules that are educationally relevant for multiple learning groups.
14. "Generalizability for environments"- Ability of the system to accommodate the development and interoperability of modules across multiple healthcare environments/Roles.
15. "Roles"- Military medical facilities focused on escalating levels of specialized care/expertise. (0-4)
16. "Ruggedness"- Refers to the ability to withstand the wear and tear of the intended uses of the training system.
17. "Laboratory Bench testing"- Refers to testing of the mechanics/operability of the system that occurs under standard conditions created in the laboratory
18. "Educational Field testing"- Refers to testing of the system that occurs under the conditions encountered during the intended educational training.
19. "Clinical bench testing"- Refers to testing of the clinical interventions of the system that occurs under standard conditions created in the laboratory.
20. "Interconnectivity"- Ability of modules/peripherals to be able to physically connect through the CORE.
21. "Inter compatibility"- Ability of modules/peripherals to transmit and receive standard, interpretable data across the CORE.
22. "Interoperability"- Products from multiple companies can work within the same system.
23. "Automated metrics"-Learning data that is automatically derived from the module.
24. "Mules"- Early Prototypes meant to troubleshoot and test interoperability.
25. "Alpha" – The patient and platform being used for the ACS-AEI run study.
26. "Beta" – The patient and platform being used for our final delivery and demonstration to JPC-1 at the end of the contract.
27. "Data Model" - An abstract model that organizes elements of data and standardizes how they relate to one another and to the properties of real-world entities.
28. "Data Objects" – Data Models include multiple data objects that relate to a recognizable physical or conceptual object (i.e. patient, learner, course) that is made up of multiple Data Elements.
29. "Data Elements" – Any unit of data defined for processing is a data element; for example, Student ID, Student Name, Student Address and Student City. A data element is defined by size (in characters) and type (alphanumeric, numeric only, true/false, date, etc.). A specific set of values or range of values may also be part of the definition.
30. "AMM Data Tables" – a set of tables that capture all patient specific data elements that are used to create the initial patient state, and is appended to during the scenario run similar to an Electronic Medical Record as the state of the patient changes.
31. "AMM Developers Kit (AMMDK)" – a set of custom hardware and software to help developers start work on an AMM compatible module. It comes preinstalled with all software (AMM, BioGears, DDS), so that you have a running AMM compute module out of the box.
32. "Reference Design Box (also referenced as the Black Box)" – a complete AMM CORE in a box with a USC to connect an AMM segment for development box. In

addition to the AMMDK hardware and software it includes a power supply, fluid and air supply compatible with AMM 1.0 standards as published.

33. “CREST Universal Segment Connector” – standardized connector kit designed for AMM, that provides the physical connection between segments, as well as, data, power, 2 types of fluid, a return line and air. The design files are published and the connectors are available for development via the AMM web site.

**It should be noted that our concept of AMM is not limited to a physical manikin. It is a platform/operating system and set of standards that facilitates interoperability between hardware and software systems for the purpose of healthcare simulation training and assessment. It is open source and has the capability of including a mix of physical systems, virtual systems, medical device and software engines, etc. Our platform will demonstrate interoperability between and among examples of each of these entities.**

### 3 Advanced Modular Manikin Deliverables

#### 3.1 Technological and Anatomic Standards

##### **Executive Summary:**

The AMM 1.0 standards cover the Contract Data Requirements Lists (CDRLs), system architecture, anthropomorphic male and female data sets, and the Universal Segment Connector (USC).

The concept of a modular, distributed, interoperable patient simulator, where modules could potentially come from different vendors presented a unique set of challenges that were best mitigated through open standards. We envisioned these challenges moving from the outside inwards.

The outermost layer was one of standard human anatomy. If different parts of the body are made by different companies, we need standards that define the outer shell so at connection points they match in terms of size, color and texture. Continuing from there, we needed all anatomic structures that are critical to a training scenario to nestle into the patient as required and fill the available space with addition of fat and connective tissues. To that end we have created data sets for an initial (alpha) male and female patient with all the pertinent information and made it available through the AMM website. We anticipate other patient datasets with different phenotypes could be created subsequently in the future (beta, gamma, etc.). Furthermore, we documented the content and structure of those data sets, so that when one would like to create a new patient data set there is a standardized way to easily publish those to the simulation community.

The next layer was at the connection points of the segments, defined as head, torso and four limbs. Vendors need a standard way to transmit power, data, fluid and air to and from their segment or organ to other vendor’s segments or organs. A given vendor could decide to combine two segments without a connector if the educational intent or technological footprint of their module required two or more adjacent segments or straddle the cut line. The cut lines were defined anatomically and geometrically, including attachment locations for the segment connectors with proper orientation to maintain integrity of the skin layer.

The CREST universal segment connectors were created as a standard component that provides for a physical connection, exchangeability, as well as transfer of data, power, fluids and air as defined in the AMM specifications. It is a single, unisex part number. The design is published as open source and there is a vendor that has signed on as the initial supplier accessible through the web site.

The innermost layer of the standards addressed central supplies made available to all segments: power, fluids and data. The specifications for power, fluid and air were derived from the requirements phase and are published. Different implementations could place the source for central supplies in any segment, or external to the manikin.

Data transport was addressed by using the open source [Data Distribution Services](#) (DDS) standards. The most critical part, to ensure interoperability without exposing potentially competing vendors IP, was addressed by the Data Models at the heart of the AMM architecture. The architecture supports a model of decoupled complexity: any decisions that can be made locally are required to stay local, i.e. communication with sensors and actuators, interpretation of physiologic data to be rendered locally, events that would only have local consequences. Only data that will have systemic consequences need to be communicated back to the CORE. As such the modules don't have an awareness of what other modules are connected; but can collectively be influenced by a sum of the effects of all of the other modules connected to the system. We chose actual physiologic and event data elements to be the common standard that is actually transmitted between modules within the system. These collectively have the potential to drive systemic changes, such as vital signs, patient signs and symptoms, laboratory values, radiologic findings, physiologic states and conditions and even a patient's mood or behavior. In addition, learner performance data based on a set of standards and module performance data for technicians is defined and communicated to the CORE.

All work products created under this contract published under Creative Commons 4.0 Attribution on the AMM website: [www.advancedmodularmanikin.com](http://www.advancedmodularmanikin.com). These include the data models, anatomic data sets, instructional manuals, source code and drawing files. The available data represents the first formal release, AMM 1.0. The site includes an Intake Form for potential industry partners to use and identify their area of interest and start a dialogue with the AMM team.

### **3.1.1 Contract Data Requirements List (CDRLs)**

CDRLs were required and delivered on schedule. They are published on the AMM Website. <https://www.advancedmodularmanikin.com/cdrls.html>.

Information regarding the final deliverables from the Advanced Modular Manikin Phase II Program (Contract # W81XWH-14-C-0101) may be referenced in the CDRLs below:

**A001:** Software Design Description (SDD)

**A002:** Software Product Specifications (SPS)

**A003:** Commercial Drawings and Associated Lists

**A004:** Product Drawings/Models and Associated Lists

- A005:** Software User's Manual (SUM)
- A006:** Page-Based Technical Manual (TM)
- A007:** Interface Design Description (IDD)
- A008:** System/Subsystem Specification (SSS)
- A009:** Test Procedure
- A010:** Test/Inspection Report
- A011:** Interface Control Document (IDC)

A summary of each CDRL may also be found in Appendix I.

### **3.1.2 System Architecture**

#### **Executive Summary:**

The design was based on a system of systems approach. Some of the modules were intact full systems that are able to be used as standalone part task trainers. The architecture incorporates decoupled complexity principles, such that local computations and decisions that do not require a systemic response are handled locally and not transmitted to the CORE compute module. Communication between modules is handled through Data Distribution Services (DDS), an open standards-based service, for real time communications. Where interdependence is essential, the information is disseminated through the CORE compute module via DDS. A module manager supports dynamic configuration based on individual scenario requirements.

#### *3.1.2.1 Requirements Review*

Review of the AMM System/Subsystem Specification (SSS) completed on January 19, 2017. Draft version delivered as part of IPR 1 package. See CDRL A008 System/Subsystem Specifications for additional information.

#### *3.1.2.2 System Architecture*

The system architecture for software and firmware is shown in Figure 1. This includes the Management of AMM functions and services.

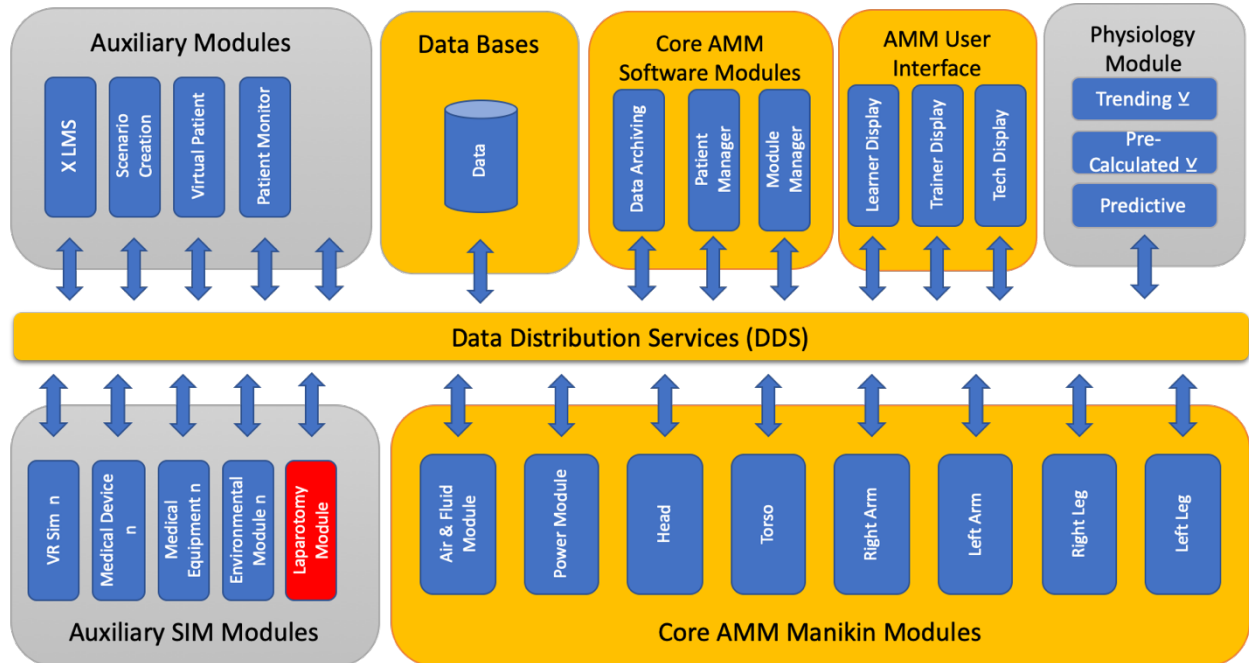

*Figure 1: AMM Architecture*

### 3.1.3 Data Libraries and Structure

**Executive Summary:** In order to assure proper communication of the state of the patient between modules, a standard data dictionary was created. A top-level diagram for this structure is shown in Figure 2. Only the top level is shown, since the lowest level contains 100's of entries defining the detail information being exchanged during operation. All data model specifications are also published at <https://github.com/AdvancedModularManikin/specification>, with a detailed Developer's Guide available at <https://advancedmodularmanikin.github.io/>. These shall reflect the evolving nature of the AMM specifications and should always be viewed as the current standard specification.

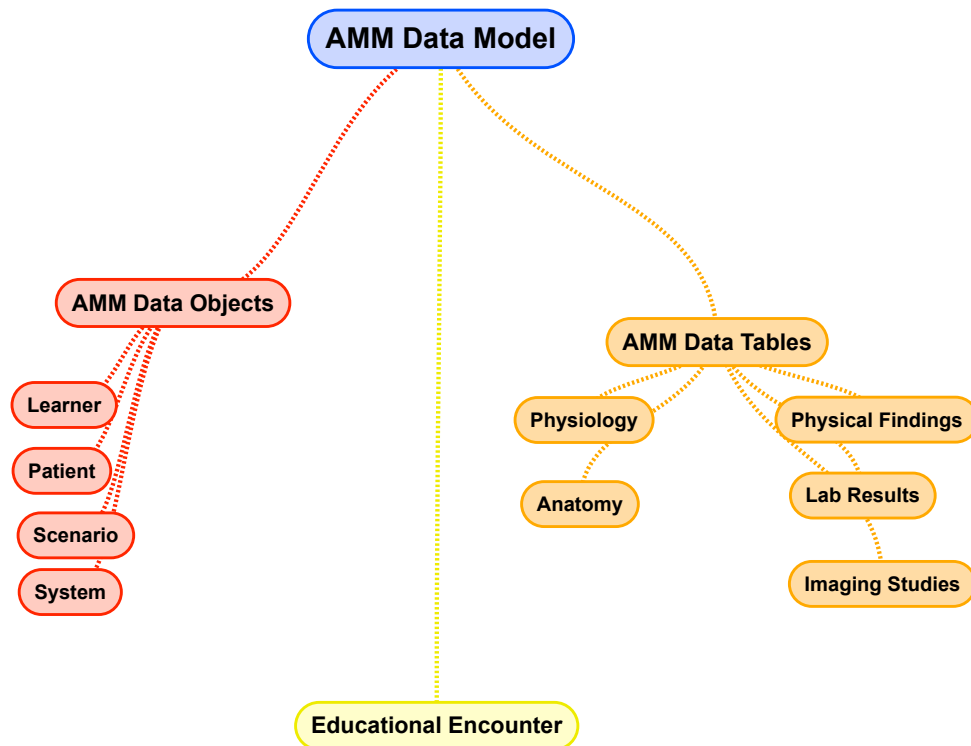

*Figure 2: Top Level Data Structure*

At a high level, the AMM Data Models consist of a set of Configuration Data, which describes module functionality and settings needed to configure an AMM system for a specific simulation, and a set of Operational Data, which describes how modules function together as a cohesive unit during the course of a simulation. Along with these two data models, behavior expectations and connectivity-related rules have been documented to ensure complete module interoperability.

The Configuration Data Model is centered around the idea of the capabilities of a module, which are logically encapsulated units of functionality. Using standard naming conventions for capabilities helps ensure that module functionality can be readily compared and enables scenario definitions to be evaluated and compared with the capabilities of the available modules. In order to maintain extensibility of the AMM standard, while also minimizing complications due to version compatibility between modules, the definitions for capabilities are maintained in a glossary that can be readily updated as new features are developed. Our approach maintains compatibility with older modules even as new modules are created.

The Operational Data Model is broadly centered around three concepts: The first is the state of the scenario being simulated, which broadly consists of the state of both the patient and their environment. The second category represents data that are generated as a result of some event. Events are frequently caused by a user intervention but are



sometimes triggered by the scenario. The third category of data is information about the state of the simulator, including configuration of Modules and control of the simulation data & progression. To practitioners, Events, as a record of ‘what happened’, are of most interest. As with module Capabilities, Event definitions are maintained in a glossary separate from the rigid data types definition. This, again, enables extensibility and development of new features while maintaining backward compatibility.

All of the specific data types used by the **AMM Data Models** are captured in an Interface Definition Language (IDL) file, a format which is commonly used by DDS software to define data types. Additionally, many fields in the AMM Data Models are structured XML, with contents defined by XML Schema definition files also included in the repository.

The **AMM Data Objects** define the major components that make up a simulation as follows:

1. Patient – Described by the anatomic and physiologic components, that initial set is layered with disease states and injuries as a basis of scenarios. The data set is appended to during the scenario run.
2. Learner – From an AMM perspective this data object is limited to performance assessment data and to be able to maintain a uniformed format is currently limited to, performed correctly or an error occurred with a description of the error.
3. System – This data object tracks the state of each plug-in component of the integrated system to support a distributed, modular, interoperable design and signal each plugged in components capabilities to the system and its state before and during an educational encounter.
4. Scenario – This data object defines the scenario file that is created by the educator to accomplish the learning objectives they have. It relates to Data Objects 1-3 and provides the narrative to elicit the behaviors the educator would like to observe and assess.

The **Educational Encounter** is a collection of identifying data elements and run time data collected that defines a specific educational encounter, including the scenario, who the participants were, environmental conditions under which the scenario was run, hardware and software revision numbers in case required for a study, a log of the scenario and learner performance data synchronized to the scenario log. The entirety of this data set is a permanent record of an individual Educational Encounter.

**AMM Data Tables** capture all patient specific data elements that are used to create the initial patient state and are appended to during the scenario run similar to an Electronic Medical Record as the state of the patient changes.

1. Physiology – The physiologic data includes all of the variables that are used within the physiology engine. An initial set that is part of the scenario file establishes the beginning state of the patient as the scenario begins. This data set

is updated around 60Hz throughout the simulation run based on treatment choices, environmental conditions and the patient's history, like pre-existing conditions.

2. Anatomy – The anatomic files are based on the patient that was selected for the reference The patient data set and is identical for physical and virtual patients that are used for the educational encounter.
3. Physical Findings – The Physical Findings table was researched and created as part of the AMM project and lists Physical Findings commonly looked for by 32 separate medical specialties. They are either selected as part of defining the initial patient state or can be generated by changes to the patient state over time. They represent a set of cues that need to be recognized by the providers to make decisions about the patient. The table includes the name, locations, clinical significance and aa translation for the developers so they know what to render on the physical or virtual instantiations of the patient.
4. Lab Results – Lab results can be part of the patient history at the beginning of the scenario or can be generated by the physiology engine as requested by the providers during the scenario with an adequate delay based on how long it would take to process the samples in the real world.
5. Imaging Studies – Imaging studies, including the digital files and radiology reports can be part of the patient history at the beginning of the scenario, or can be presented during a scenario based on the patient case if they were included by the scenario creator ahead of time.

#### **3.1.4 Anthropomorphic Male and Female Anatomic Data Sets (Alpha)**

**Executive Summary:** We thought that it was important to provide a single anthropomorphic male and female data set for the purpose of interoperability to the simulation community. By no means was it meant to be exclusive, as we anticipate additional anthropomorphic data sets serially designed to provide future compatibility for other patient phenotypes (i.e. “Beta”, “Gamma”, etc.). The “Alpha” male and female anatomical 3D data sets were completed and provided as open source reference standards to the healthcare simulation community. They were made available for distribution in OBJ, STL, and IGES formats. Basic anatomy has been separated into groups. Within each of these groups, files for individual organs, structures, bones, and muscles were made available as an Open Source for developers. For instance, if a developer were interested in creating a module related to the pancreas, they have the ability to select the relevant anatomic data (*Figure. 3*). *See Appendix II* for screen captures of the full-body anatomic datasets.



*Figure. 3: Male pancreas, derived from the alpha anatomic data set.*

For the purpose of anatomic modularity, the anatomic datasets standardized the location and orientation of cut lines to separate the head/neck, torso, arms, and legs. We refer to each of these anatomic parts as a “segment” (*Figure. 4*). The placement of segmentations for the AMM standard male and female bodies are described in CDRL A004.

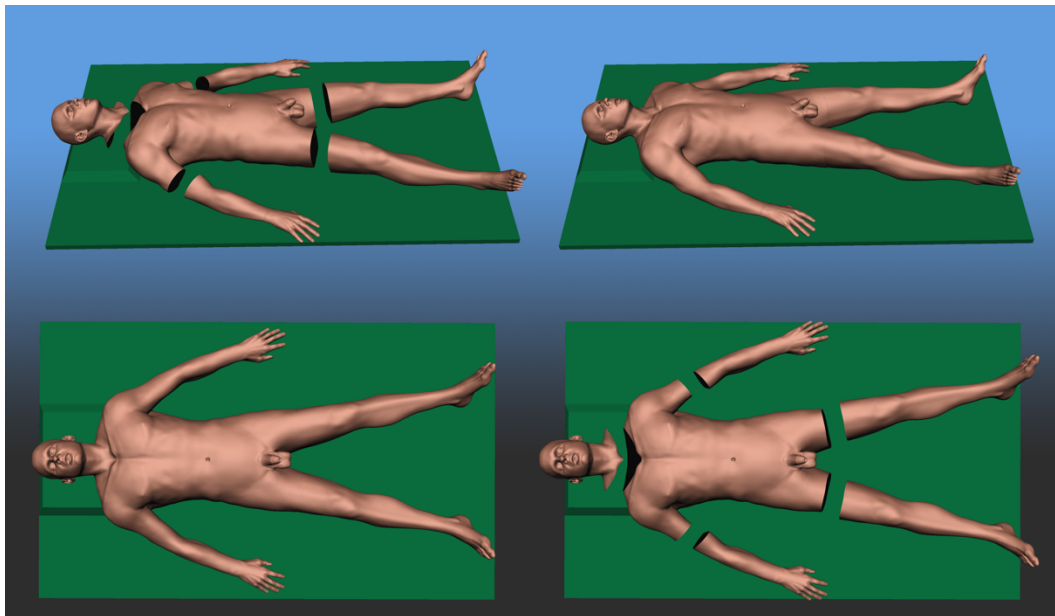

*Figure. 4: Standardized cut lines that separate the anatomic segments of the dataset.*

### 3.1.5 CREST Universal Segment Connector (USC)

**Executive Summary:** The USCs are critical to ensure interoperability, and provide tool-less mechanical coupling, power, data, fluid, and air delivery between the anatomic segments. The Universal Segment Connectors that bring together the six segments, head, torso and limbs were tested and fabricated for integration into the segments (*Figure. 5*).

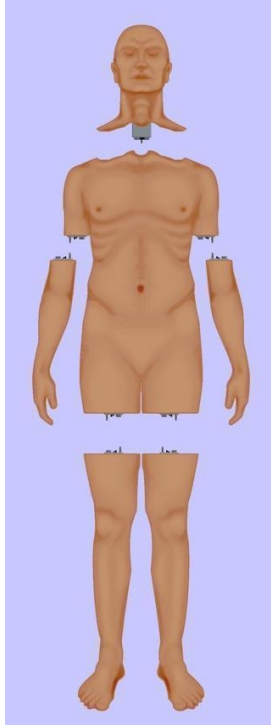

*Figure 5: AMM Manikin Segments with the integrated USC.*

We completed several designs and iterations and functional testing before coming to the final design. Testing included:

1. Mate/De-mate
2. Axial Load
3. 3-point Bending
4. Vibration

The CREST USC is published on the AMM website and is available from a vendor through the website. **The AMM connector successfully passed all bench tests.** For details on the connector test protocols used, refer to CDRL A009 Test Procedures. For details on the test results obtained refer to CDRL A010 Test Results.

The design files were included in the open source package, and therefore interested parties can also choose to produce their own copies as long as they use the published information to ensure compatibility with the AMM 1.0 Standard.

The end result was a compact, functional connector which provided four fluid pathways along with an electrical connector that provided Ethernet connectivity (including Power over Ethernet [PoE]). The tool-less connection feature made it easy for simulation technicians to swap segments.

#### *3.1.5.1 CREST USC Specifications*

The University of Washington and Entropic Engineering teams designed and fabricated a universal connector for AMM physical modules, as shown in the schematics in Figure 6 and 7 and photo in Figure 8. Additional information regarding the use and specifications of the USC may be found in CDRL A011. The connector is locked and released by a

simple pin and latch mechanism, with the latch being inside a spring-loaded button. Both the electrical connector (from TE) and the Schrader valves are inexpensive commodity components (*Figure 6*).

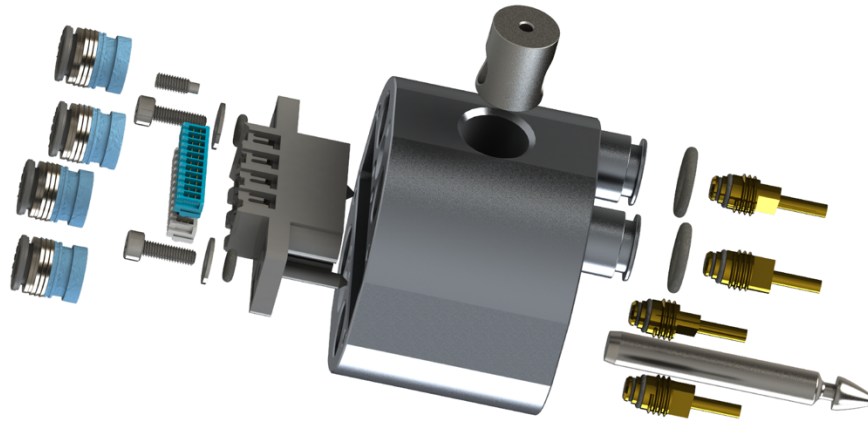

*Figure 6: CREST Universal Segment connector exploded view.*

## Advanced Modular Manikin Connector Dimensional Overview

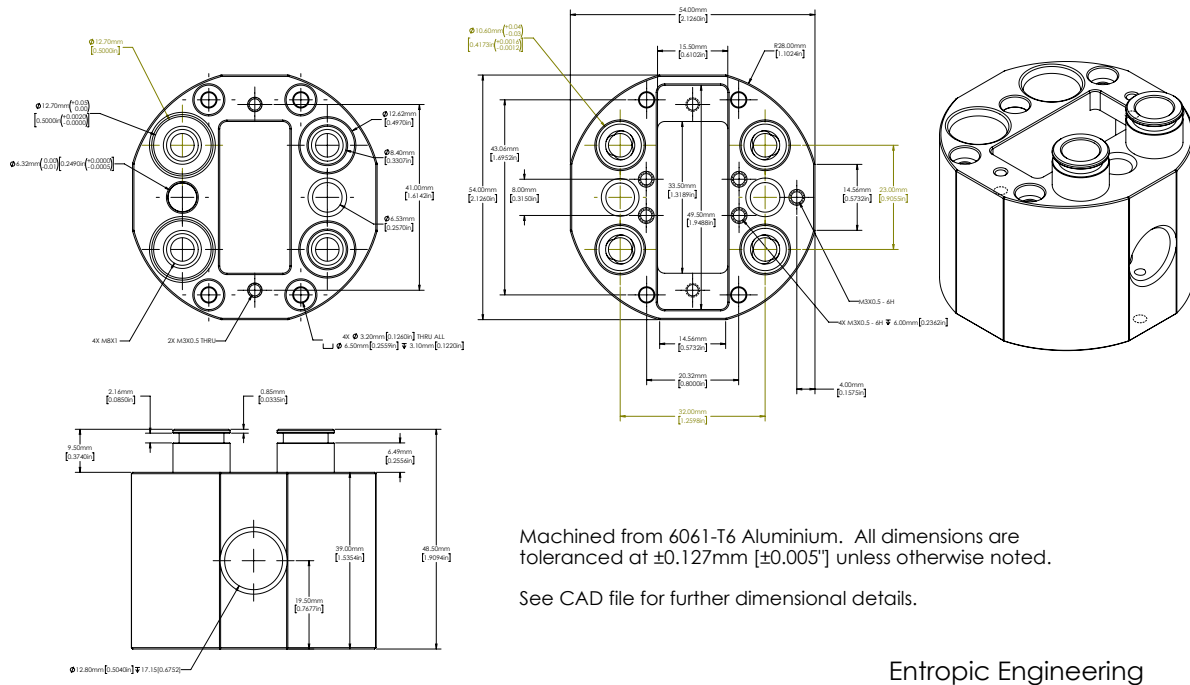

**Figure 7: Universal Segment Connector designed by UW CREST and Entropic Engineering.**



**Figure 8: CREST Universal Segment Connector with release button.**

When mated, the protrusions insert into the sockets, causing opposing valves to open each other completely. The O-rings on the protrusions engage before the Schrader valves initially make contact, helping to ensure minimal leakage. This design also provides for a small gap between the connectors, providing resilience against minor damage and debris on the surface of the connector face. Because the holding force is carried by the interface

between the pin & button, both are made of hardened steel and manufactured separately from the body of the connector, as highlighted by the color difference of the button in Figure 8. This separation of functions also allows for tuning of the maximum holding force by modifying only the geometry of button or pin, and also provides for enhanced serviceability of the connector. Additionally, the Schrader valves simply screw into the main connector body and can also be easily replaced if damaged.

The desired design constraints that were met allows the same connector to be used for male and female manikins, as well as, neck and all limbs. Finally, both halves of the connector are identical, reducing part count and overall manufacturing cost.

#### 3.1.5.2 *USC Integration*

The connector mates to the rest of the manikin by means of four bolt holes, with the intent that every module manufacturer will determine and fabricate whatever fixture best fits their needs. An example CREST ‘sleeve’, which could be used to integrate the connector into an arm module is depicted in Figure 9.

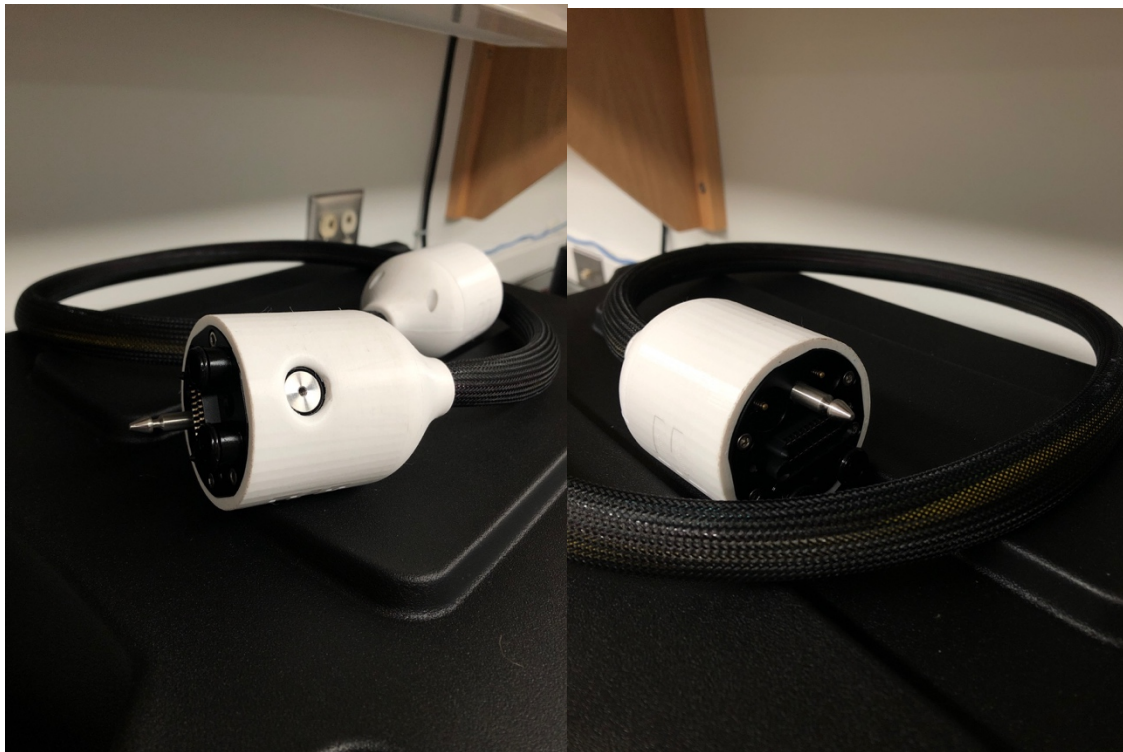

*Figure 9: Example ‘sleeve’ for integrating Universal Connector into a module.*

#### 3.1.5.3 *CREST USC Testing:*

The UMN engineering team lead the USC bench testing effort. They consisted of Dr. Mojca Konia, Dr. Kenneth Kiberenge, Dr. Jon Keller (UW), John Hoschette, Dr. Tim Kowalewski, and students Rebecca Smith and Mark Gilbertson. The students started setting up the AMM verification lab, writing detailed protocols and obtaining test equipment. The students received supervision and mentoring from Professor Timothy Kowalewski, PhD and Entropic Engineering.

All tests were performed on three different sets of connectors: (1) a connector manufactured by Entropic Engineering, (2) a connector manufactured by a second party vendor, and (3) a hybrid connector with one half manufactured by Entropic, and one half manufactured by the second party vendor. Testing included a mate/de-mate test, axial load test, three-point bending test, and a vibration test. The connectors were analyzed for their mechanical, electrical, and fluidic capabilities during these tests.

**Results:**

For each test, the criteria for success are as follows:

1. Mate/De-mate Test  
 Mate/De-mate 2000 times without degradation in performance to latch or electrical pins or fluid connectors.
2. Axial Load Test  
 MECHANICAL: The connector is able to withstand an axial load of at least 300 lbs.  
 ELECTRICAL: The electrical contacts inside the connector remain in contact under an axial load of 200 lbs.  
 FLUID: Fluid can be run through the connector’s fluid lines without leakage while the connector sustains an axial load of 200 lbs.
3. Three Point Bending Test  
 MECHANICAL: The connector is able to withstand a bending moment of 100 ft-lbs. without sustaining any mechanical failure or deformation  
 ELECTRICAL: The electrical contacts inside the connector remain in contact under an applied moment of 100 ft-lbs.  
 FLUID: Fluid can be run through the connector’s fluid lines without leakage while the connector sustains an applied moment of 100 ft-lbs.
4. Vibration Test  
 MECHANICAL: The connector is able to experience vibrations of frequencies ranging from 10 Hz - 1.5 kHz without sustaining any mechanical failure or deformation  
 ELECTRICAL: The electrical contacts insides the connector remains in contact and operational while connector is subjected to vibration with frequencies ranging from 10 Hz - 1.5 kHz  
 FLUID: Fluid can be run through the connector’s fluid lines without leakage while the connector is subjected to vibration with frequencies ranging from 10 Hz - 1.5 kHz

Test Performed	Sub-Test	Connector	Test Spec.	Pass/Fail
Mate/Demate		Entropic	300 lbs.	Pass
	Mechanical	2nd Party	300 lbs.	Pass
		Hybrid	300 lbs.	Pass
		Entropic	200 lbs.	Pass
Axial Load	Electrical	2nd Party	200 lbs.	Pass
		Hybrid	200 lbs.	Pass
		Entropic	200 lbs.	Pass



	Fluid	2nd Party	200 lbs.	Pass
		Hybrid	200 lbs.	Pass
		Entropic	100 ft-lbs.	Pass
	Mechanical	2nd Party	100 ft-lbs.	Pass
		Hybrid	100 ft-lbs.	Pass
		Entropic	100 ft-lbs.	Pass
3 Point Bending, Torque	Electrical	2nd Party	100 ft-lbs.	Pass
		Hybrid	100 ft-lbs.	Pass
		Entropic	100 ft-lbs.	Pass
	Fluid	2nd Party	100 ft-lbs.	Pass
		Hybrid	100 ft-lbs.	Pass
		Entropic	10 Hz - 1.5 kHz	Pass
	Mechanical	2nd Party	10 Hz - 1.5 kHz	<b>Fail*</b>
		Hybrid	10 Hz - 1.5 kHz	Pass
		Entropic	10 Hz - 1.5 kHz	Pass
Vibration	Electrical	2nd Party	10 Hz - 1.5 kHz	Pass
		Hybrid	10 Hz - 1.5 kHz	Pass
		Entropic	10 Hz - 1.5 kHz	Pass
	Fluid	2nd Party	10 Hz - 1.5 kHz	Pass
		Hybrid	10 Hz - 1.5 kHz	Pass

*Table 1: Summary of test results.*

\*This was considered a failed test because, during the vertical orientation test, one of the internal screws became unscrewed and fell out of the back of the connector. The proposed steps necessary to prevent this mode of failure in future connectors is to ensure that Loctite is used when mounting all screws in the connector. See Figure 10.

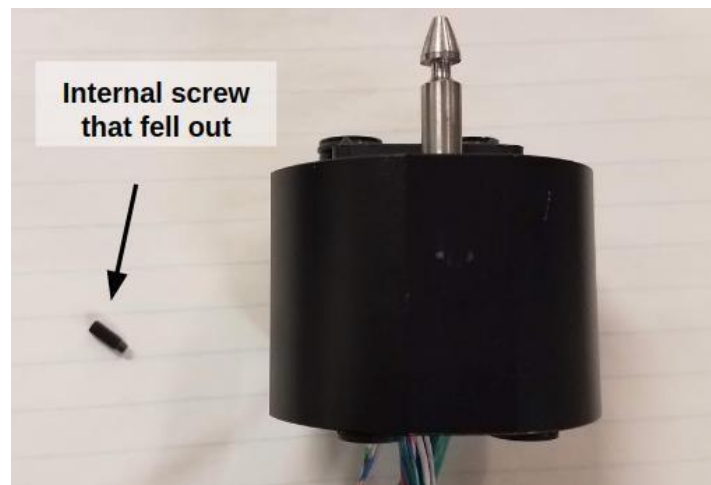

*Figure 10: Connector with screw that backed out during vibration.*

### 3.2 Central Computing Capabilities

#### 3.2.1 AMM Central Operating Resources (CORE)

**Executive Summary:** In order to present AMM as a platform and provide developers with an essential tool for AMM-compatible module development, a reference design is provided that integrates the platform systems into a single non-manikin unit. These represent the AMM Central Operating Resources or CORE. The final designs and Bill of Material of the AMM CORE were published on the AMM website (CDRL A004). The design files are part of the open source package, thus interested parties can also choose to produce their own copies as long as they use the published information to ensure compatibility.

High level diagrams of CORE functions are depicted in figures 11-12.

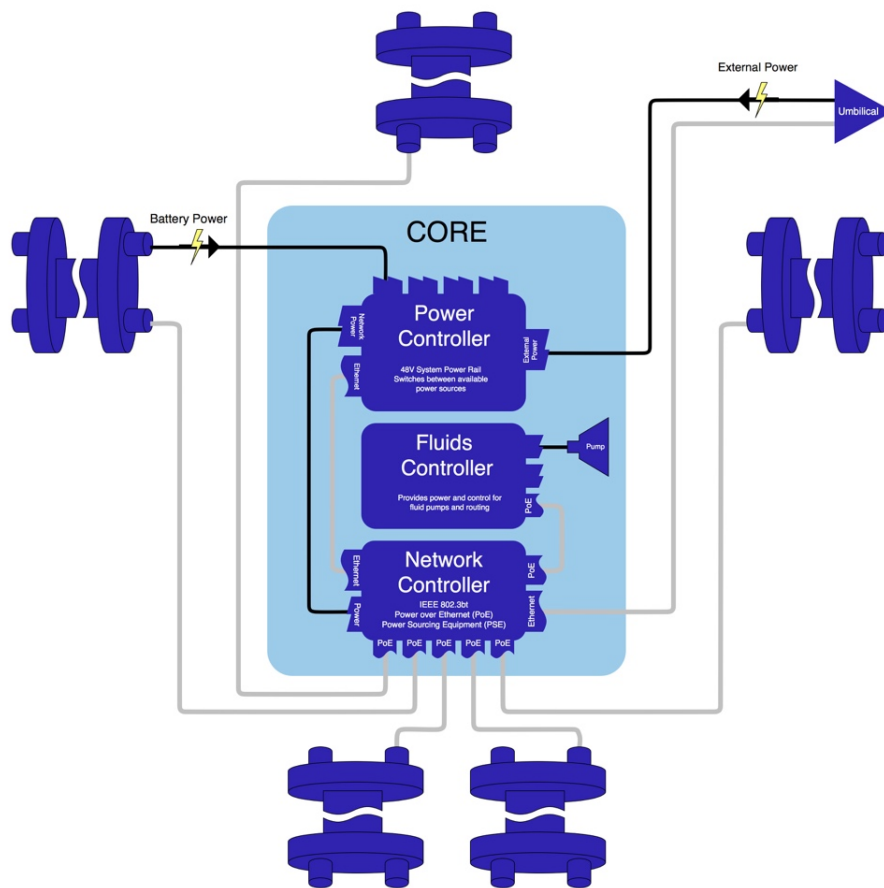

*Figure 11: AMM CORE system, where segment connectors are depicted by dark blue circles.*

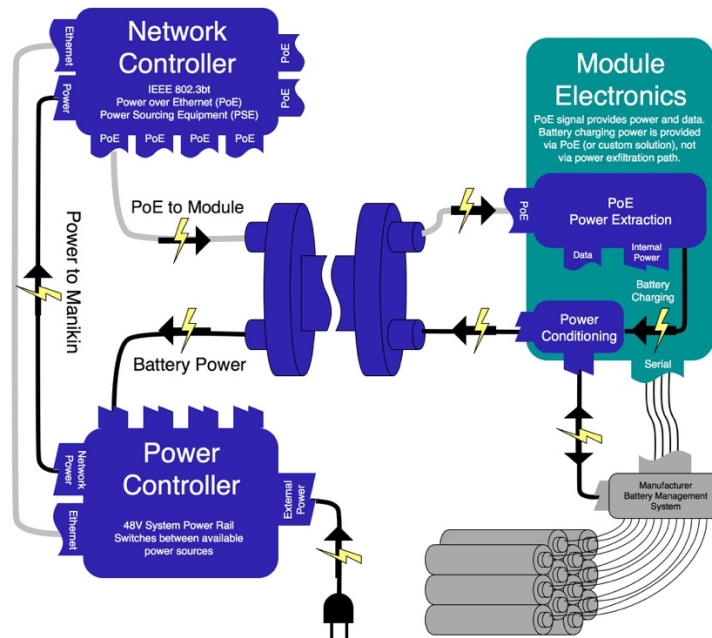
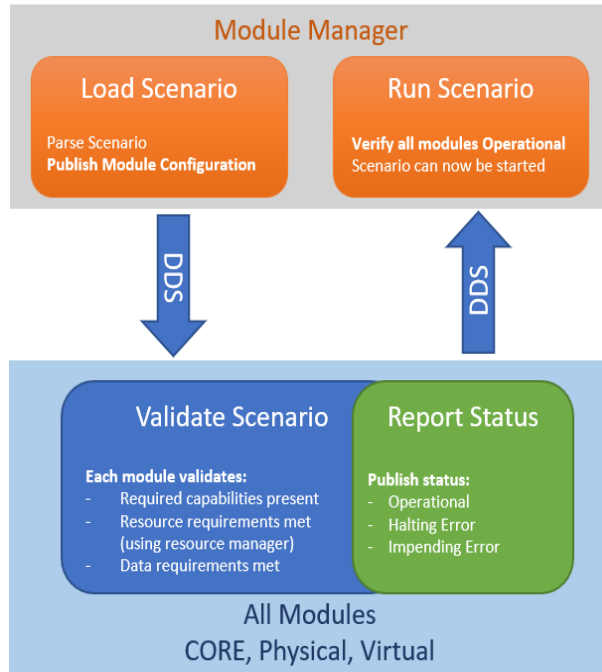

**Fig. 12: Power system architecture, including CORE components and developed modules.**

The following CORE components were integrated:

1. AMM Module Manager:

The *Module Manager* is a CORE software component that coordinates the participation, initialization, configuration, and termination of AMM modules during the educational encounter. All AMM-compliant modules must perform an appropriate handshake procedure which includes information about the module, the capabilities it provides, and the configuration data needed to provide those capabilities. The Module Manager is also responsible for loading scenarios and publishing the configuration data specific to each module to enable the capabilities required by the scenario. The Modules must validate their configuration and report the operational status of each of their enabled capabilities. The Module Manager aggregates the operational status of all the modules to determine if all of the required capabilities of a scenario are available and operational. Figure 13 below illustrates the primary functions of the Module Manager and its interaction with each Module as a scenario is loaded and then run.



**Figure 13: Module Manager Operational Overview**

2. AMM Simulation Manager

The *Simulation Manager* is a CORE software module that drives the simulation by publishing simulation ticks at a frequency of 50 Hz.

3. AMM Logger

The *Logger* is a CORE software module that monitors DDS message traffic for the purposes of analysis, debugging, and general health of the system.

4. AMM REST Adapter

The *REST Adapter* is a web service that converts REST requests to DDS messages in support of web browser-based modules like the Dashboard.

5. AMM TCP Bridge

The *TCP Bridge* is a socket server that handles tcp communications with socket clients and converts them to DDS messages in support of modules which cannot natively implement DDS but can open network sockets such as the virtual patient and virtual equipment.

6. AMM Serial Bridge:

The *Serial Bridge* is a service that handles communications with hardware over a serial interface and converts them to DDS messages in support of physical components with microcontrollers.

*DDS Selection*

We selected the Data Distribution Service (DDS) API / Real Time Publish Subscribe (RTPS) protocol as the communications infrastructure middleware after reviewing several alternatives. Because of the variety and volume of data expected to be transmitted in such a sophisticated system as AMM, the need for a publish-subscribe data-exchange pattern was recognized even in Phase 1. Additionally, because module connectivity may

be unreliable, the need for Quality of Service (QoS) controls for data delivery was identified. Finally, to facilitate ease of connecting modules external to the physical manikin, IP networking technology was deemed critical.

Based on the communications requirements of the project, Entropic Engineering evaluated ZeroMQ, MQTT, and DDS. ZeroMQ was the simplest, light-weight data transport option, with very low overhead, but had no QoS controls. MQTT was the most widely adopted of the options we evaluated, had only slightly more overhead than ZeroMQ, and provided very simple QoS controls. DDS was far more sophisticated and complicated than either ZeroMQ or MQTT. In addition, it had the ability to handle many of the complexities of networked data distribution that would otherwise need to be handled by the modules or by a centralized broker. DDS had very robust QoS controls, handled node discovery via RTPS, was completely distributed and required no central broker, and provided a standardized means of data encapsulation. Furthermore, DDS completely abstracts the actual data exchange, meaning module software doesn't need to send or receive individual messages, but rather simply publish and subscribe to changes in data.

A data model was defined and documented in the Interface Design Document (IDD) and software modules were developed and tested including the Simulation Manager, Physiology Engine Bridge, Virtual Patient, Virtual Patient Monitor, and Web Interface Adapter. Hardware interfaces were prototyped using an Arduino microcontroller. Figure 14 below shows the hardware and software configuration design.

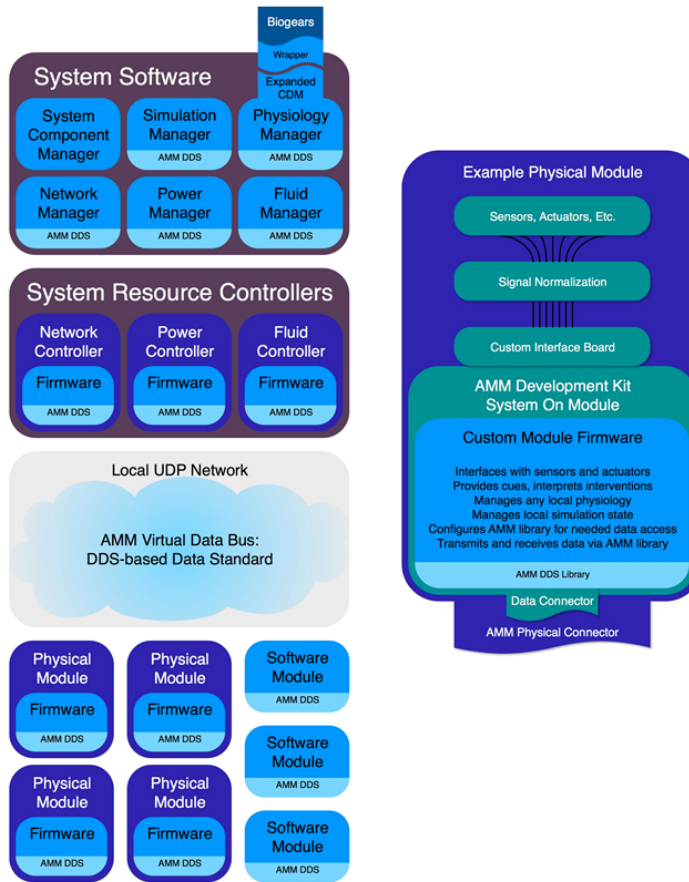

**Figure 14: Hardware and Software Configuration**

*FastRTPS Selection*

Once DDS was selected as a middleware, Sub-contractor, Entropic Engineering, surveyed the small market of vendors supplying DDS-compliant software. Because of the requirement to create an open source software library, free of licensing requirements to enable module development, only vendors who provided an open-source version of their software were considered. These included RTI’s Connxt DDS under the RTI Open Community Source License, PrismTech’s OpenSplice DDS Community version, OCI’s OpenDDS, and eProsimia’s FastRTPS. RTI’s open source license was incompatible with the needs of the AMM project, so it was removed from further consideration.

OpenSplice & OpenDDS both had compatibility problems with other DDS implementations when connecting using RTPS, the protocol used for DDS interoperability. Additionally, neither OpenSplice DDS or OpenDDS provided all of the features of the DDS specification that were required for AMM data exchange. Bids were sought from PrismTech and OCI to update their respective software to provide the required functionality. The bids were in the \$60k & \$30k range, respectively.

While FastRTPS didn't provide the full functionality as defined in the DDS specification, it complied with the RTPS DDS Interoperability specification. Furthermore, it has a software API with the potential to address any missing functionality relatively easily, whereas enhancements to the other two software products would only be possible by hiring the respective vendors.

Finally, in the professional opinion of Entropic Engineering, FastRTPS was simpler and more elegant, easier to compile and build on embedded hardware, and easier to use to build applications.

### 3.2.2 Advance Modular Manikin Developer's Kit (AMMDK)

**Executive Summary:** AMMDK is a powerful board set intended for development work that includes pre-installed software to run the full AMM platform and the necessary development environment (Fig. 15). The final design of AMMDK was published on the AMM website. It has been fully documented in CDRL A004. The design files are part of the open source package, thus interested parties can also choose to produce their own copies as long as they use the published information to ensure compatibility. Alternately, they can create their own board set as long as they follow the published standards on DDS implementation and the Data Models.

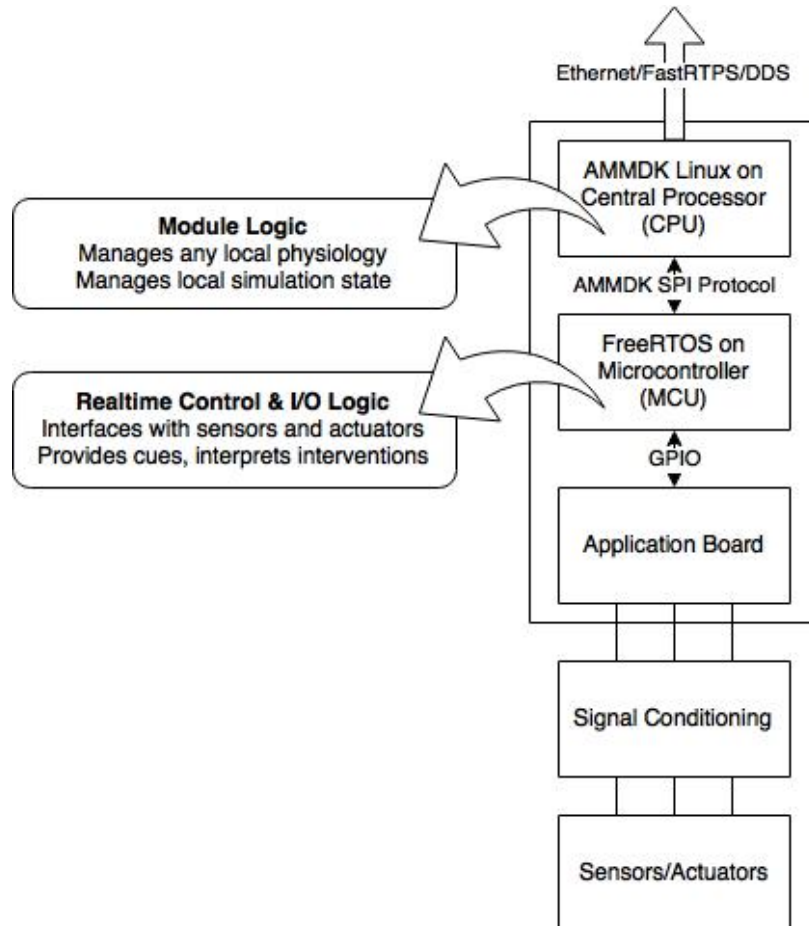

*Fig. 15: Role of the AMMDK.*

The AMM team has released two levels of developer’s kits to support adoption of the standard by industry and fellow researchers. One level includes only the electronics that is delivered with all software pre-installed and ready to go. The second level, our Reference Design Box, includes the AMM Central Operating Resources, the compute platform, as well as the central resources: fluid, power and air delivered across a CREST Universal Segment Connector.

All of this code has been released, including tutorials for how to utilize them, on the AdvancedModularManikin github account.

### 3.2.2.1 AMMDK Electronic Components

Entropic Engineering has designed and manufactured the AMM Developer Kit (AMMDK) electronics and firmware libraries to enable rapid prototyping and development of new AMM-compatible modules. As shown in Figure 16, the AMMDK is built around the “Qualcomm® Snapdragon™ 820E high performance embedded platform”, which is designed to provide powerful, energy-efficient, multi-core processing for the next generation of embedded computing applications, with manufacturer support until at least 2025.

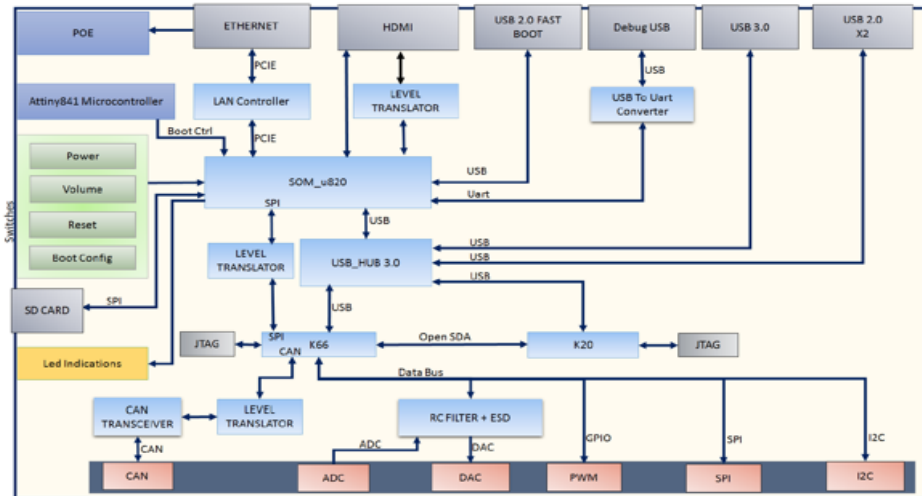

**Figure 16: AMMDK Logical Block Diagram**

The completed AMMDK hardware, shown in Figure 16, enables module makers to develop new peripherals with a variety of modalities such as VR, computer vision, and neural networks. It also allows connectivity to sensors and actuators, while providing precise, real-time control as needed. The AMMDK also provides many wireless capabilities, including Bluetooth, Bluetooth Low Energy, Wi-Fi, and GPS, along with six-axis motion sensing, and the AMMDK can be powered either from a standard 12V barrel jack, or can be supplied with power and data connectivity via a single cable with Power over Ethernet (PoE).

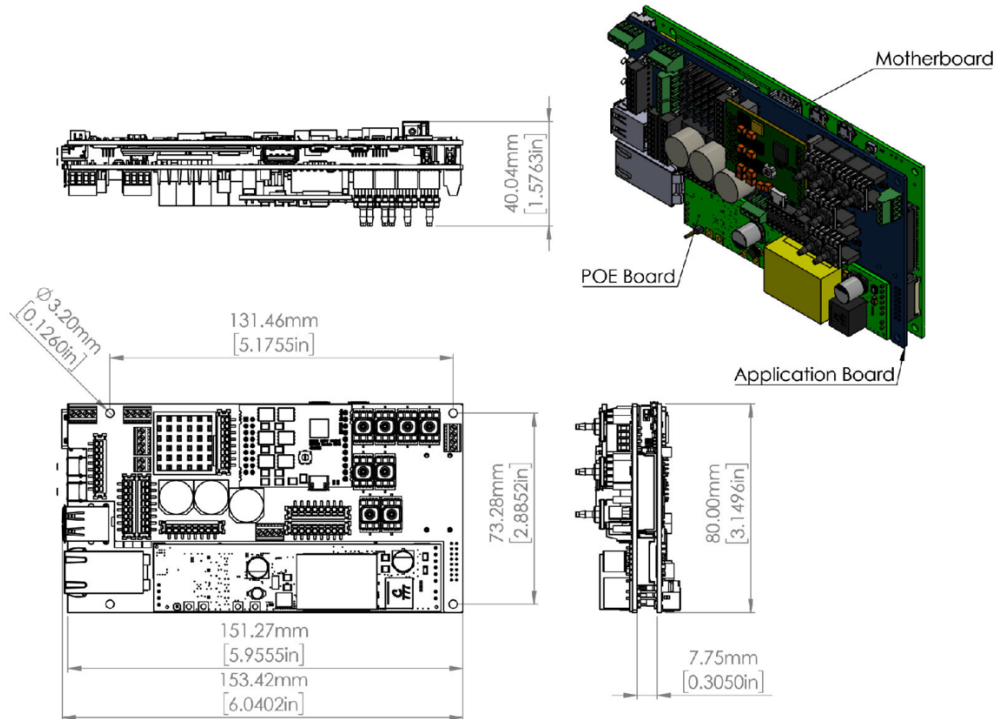



*Figure 17: AMMDK Electronics Hardware*

In order for the AMMDK hardware ‘motherboard’ to connect to specific peripheral devices such as sensors and actuators, an application-specific ‘daughterboard’ needs to be connected to provide the required signal conditioning, level shifting, and physical connections to the peripherals. This ‘Application Board’ connects to the AMMDK by way of the three pin-header connectors located on the right edge of the board in Figure 18 and is able to stack on top of the AMMDK, much like a ‘shield’ for hobbyist electronics systems.

For example, the modules CREST produced for the reference manikin, Entropic Engineering designed and manufactured a ‘CREST Application Board’ to meet the needs of the CREST modules. Figure 18 also shows how the CREST Application Board fits on top of the AMMDK board to save valuable space by reducing the needed electronics footprint. As shown in Figure 19, the AMMDK ‘stack’ of boards consolidates much disparate functionality into a single, compact unit, requiring only a single ethernet cable for connectivity and power.



**Figure 18: Assembly of CREST Application Board stacked on top of AMMDK Board**

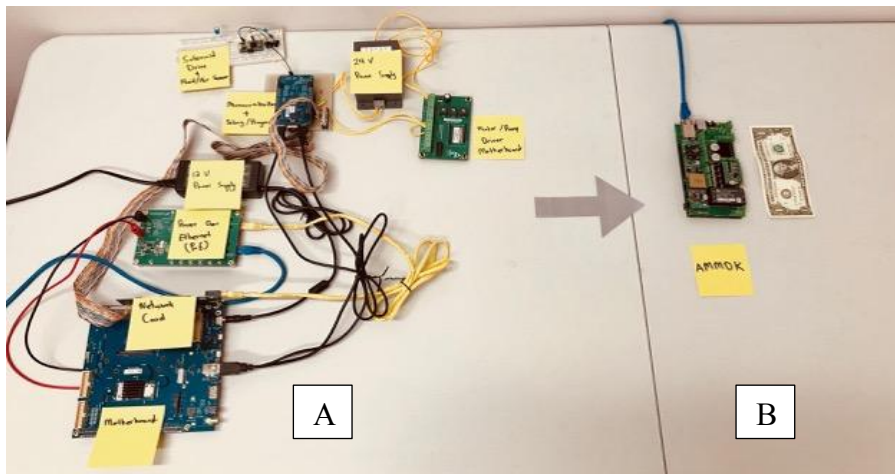

**Figure 19: Consolidation of A) Prototype Hardware into B) AMMDK + CREST Application Board**

### 3.2.2.2 AMM Development Kit (AMMDK) Processor Architecture

It was quickly determined that the ARM chip architecture was the only solution to fit the two primary requirements, while potentially meeting the third. (Intel mobile processors were also briefly considered, but the product line was discontinued, and all products were cancelled by Intel in mid 2017.) Entropic Engineering then evaluated the ARM product family to determine which processor would best meet the project needs.

The AMM system architecture required every physical module to have embedded computer hardware. Entropic Engineering identified the following requirements for the embedded hardware: 1) It needs to have sufficient compute power to run a DDS software library with sufficient data throughput to handle the complex data needs of a sophisticated module. 2) It needs to be able to be reasonably miniaturized to fit inside the mechanical, thermal, and power envelope footprints available within a module segments of a manikin. 3) It would be desirable to be able to run the physiology engine along with the other CORE software functions required by AMM.

The ARM Cortex-A series of processors were found to offer sufficient performance while being available on products that would fit the physical requirements. The Cortex-A53 was found to provide sufficient computational power to run the physiology engine, DDS, and a prototype version of the CORE software, but was at near capacity while only transmitting a small fraction of the data that would be required in a fully operational manikin. Under full load, the A53 series chips would likely fail to perform adequately. The Cortex-A72 provides significantly more computational resources than the A53, with roughly the same physical requirements, albeit at a slightly higher cost. Because this hardware is intended to be used for development and prototyping, rather than production, the enhanced capabilities were determined to far outweigh the moderate cost difference.

While the Cortex-A series of processors provide the required computational power, they lack the features required to control and interface with sensors and actuators. Additionally, the A-series chips will be running a version of Linux, which means they will not be able to guarantee deterministic real-time control loop performance. To meet these needs, Entropic Engineering selected the Cortex-M4 processor for use as ‘daughter’ chip of the A72. Cortex M4 chips are widely available, inexpensive, and performant for their role as an interface to hardware systems. Because many ARM chips use a hardware architecture called ‘big.LITTLE’, Entropic Engineering has taken to calling the M4 chip ‘TINY’ for convenience and amusement.

### 3.2.2.3 *AMMDK Processor Vendor Selection*

With the architecture of the embedded hardware selected, Entropic Engineering identified and evaluated chip manufacturers that provided packages containing the selected compute cores. NXP Semiconductor’s iMX8 processor was identified as the ideal processor for the project needs as it included multiple of both the A72 and M4 cores in a single package. Unfortunately, the part wasn’t available until at least late 2018, and there was uncertainty about the product lifecycle and support given the company’s status at the time. Entropic reached out to two system integration companies who would likely be some of the first vendors to have access to these processors in an effort to receive samples to evaluate.

In lieu of access to a chip that combines the A72 and M4 compute cores, Entropic Engineering evaluated vendors for providing the processors, separately. The Qualcomm Snapdragon 820 processors provides four A72 compute cores, are widely available at relatively low-cost, and best meet the high-power computational needs of the AMM. Through market research, Entropic determined that Snapdragon 820 would be available

through multiple vendors through at least 2025, with physical requirements being met by the following: Intrinsic Open Q 820 and OpenQ Micro 820 SoM (System on Module), Inforce 6601 Micro SoM, and eInfochips Eragon 820 SoM.

Entropic Engineering evaluated the vendor offerings and selected the Intrinsic product. The eInfochips hardware had poor thermal design, and the software was built using outdated libraries and poorly supported. Similarly, the Inforce software package lacked basic features, also contained many outdated libraries. Furthermore, Inforce responded slowly or not at all to support requests and wouldn't release technical documentation to facilitate incorporating their product in custom applications. This was contracted by Intrinsic providing a consistent point of contact for support, providing software patches in response to bug reports and feature requests, releasing detailed schematics and CAD files to aid in integrating their SoM (System on Module), and promptly repairing hardware that was damaged in shipping.

Because most of the available Cortex M4 manufacturers all support the same feature set, Entropic Engineering selected the NXP K66 processor because it had the largest collection of community-created open source software libraries at the time, thus minimizing future effort needed by modules developers to connect to external hardware. The K66 supported a wide array of peripheral capabilities including Ethernet, UART, I2C, SPI, USB, CAN, GPIO, ADC, DAC, DSP, FPU, MMU. It was also widely available with a robust supply chain and product lifespan.

### 3.2.3 Network Manager

#### **Executive Summary:**

Entropic Engineering developed a set of electronics capable of running the CORE software and provided power and network connectivity for physically attached segment modules. We have chosen to call this component the “Network Manager” in order to distinguish its functionality from that of the CORE software stack, which is not required to be run on the same hardware (Figures 20 and 21). In practice, we expect users to run the CORE software stack on the network manager, effectively turning it into the ‘CORE’ of the manikin.

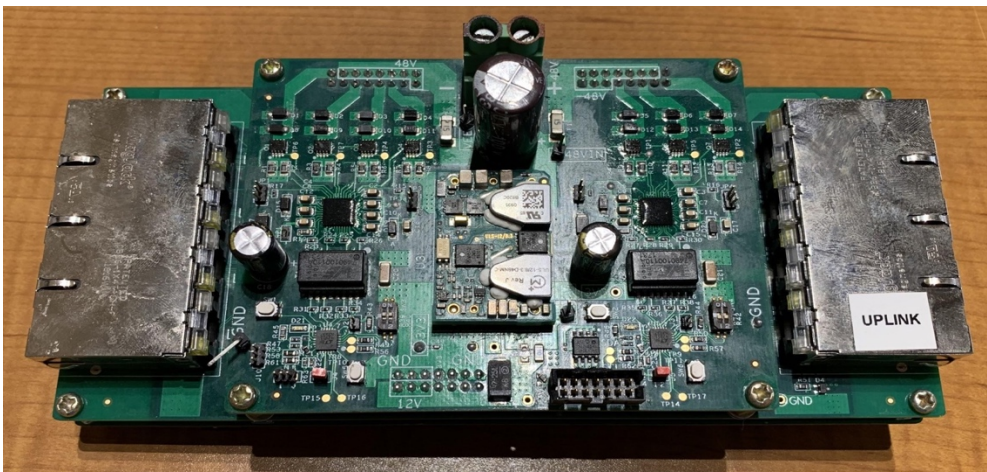

*Figure 20: Top of Network Manager*



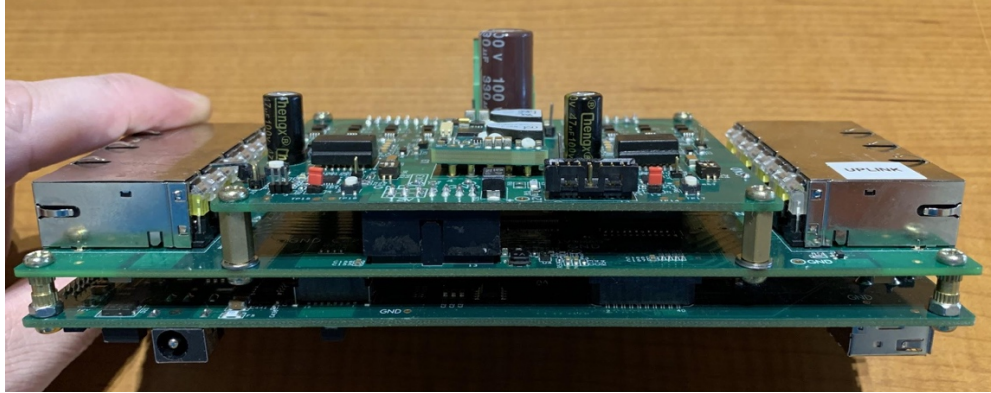
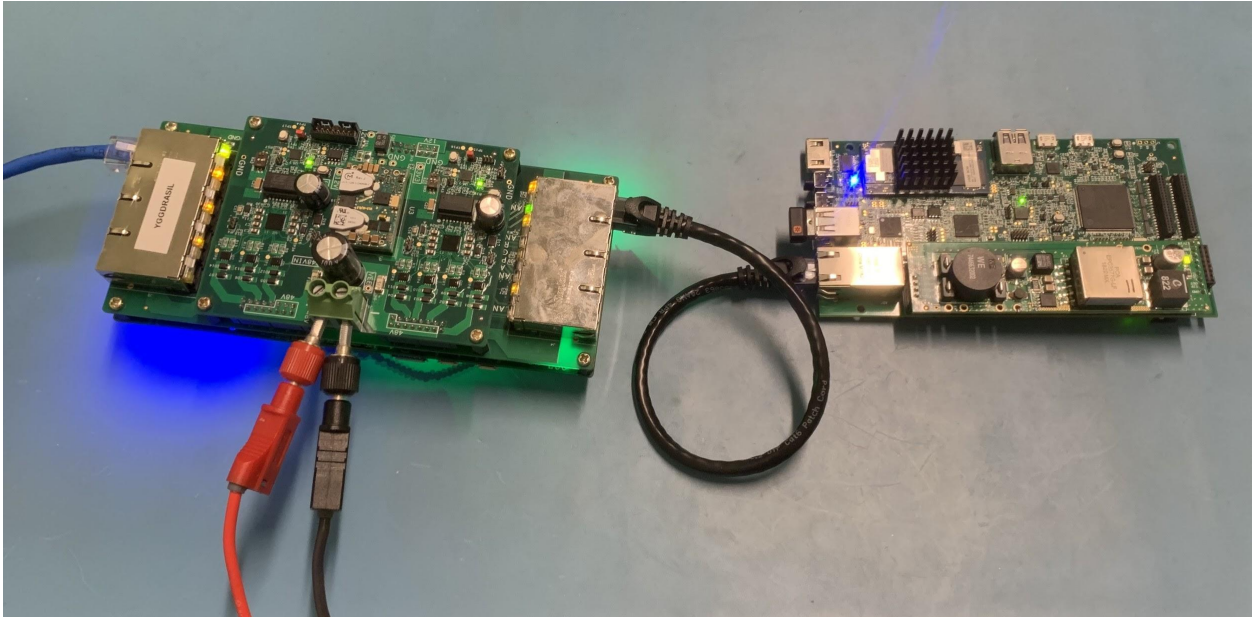

*Figure 21: Side view of Network Manager*

### *3.2.3.1 Network Manager Capabilities*

As shown in Figure 22, the Network Manager provides one ethernet uplink port and seven Power-over-Ethernet (PoE) enabled ethernet ports for Local Area Network (LAN) connectivity within the AMM. These seven ports provide power and data connectivity to all of the attached segment modules. Additionally, the Network Manager provides Wi-Fi connectivity and full Internet Protocol (IP) router functionality.

The Network Manager was designed as an extension to the AMM Developers Kit Common Compute Board (AMMDK-CCB). It maintains all of the functionality of the AMMDK-CCB and provides additional power & networking capabilities. This enables the Network Manager to serve as the sole computer inside (in this case), the torso segment, and provides both CORE AMM functionality, along with connecting to any hardware needed for torso module capabilities. The Network Manager runs the same “AMMDK OS” (based on Debian Linux) as the AMMDK. This simplifies the overall software development and maintenance requirements for the project.



*Figure 22: Network Manager providing power & data for an AMMDK*

The Network Manager is fully compliant with the very latest and most powerful PoE standard, IEEE 802.11bt. This enables compatibility with nearly all PoE Powered Devices (PDs) available on the market today and will provide compatibility with the next generation of PoE devices. Each of the seven LAN ports can provide up to 75W of power and one gigabit of data throughput, ensuring ample resources for the development of a wide array of module capabilities, including robotic actuators.

#### **3.2.4 CREST Reference Design Box**

In order to present AMM as a platform and provide developers with an essential tool for AMM-compatible module development, a reference design box was developed to integrate the platform systems into a single non-manikin unit. The reference design contains all central computing capabilities (CORE, AMMDK, Network Manager).

The CREST Reference Design Box enables the complete set of AMM software, provide system resources, and allow connection of one external AMM-compatible module or task trainer. The self-contained unit is externally powered from 120V mains. It provides pressurized air, two individual fluids to an external AMM module according to the standard fluidic specifications. A pass-through is provided for waste fluid such as IV fluid. The compute platform consists of an AMMDK embedded system to control the fluidics system and a Network Manager embedded system to run the AMM system software, provide networking services and PoE power injection for the AMM connector. A network uplink to the internet is provided for connectivity. The Network Manager also provides wireless (Wi-Fi) connectivity for peripherals such as tablets and instructor interface. Service access to fluids is separated from power equipment and electronics such that fluids can be refilled safely while the system is powered on.

The design has been documented for public distribution. This documentation has been submitted to the DoD with the project CDRL (A004). It contains BOM, electrical and fluidics schematics, solid models of custom parts and assembly documentation. The *physical* CREST Reference Design Box was not a deliverable of this project but demonstrates the capabilities of the AMM platform.

The design is shown in Figures 23-25.



*Figure 23: Rendering of the AMM Reference Design Box*

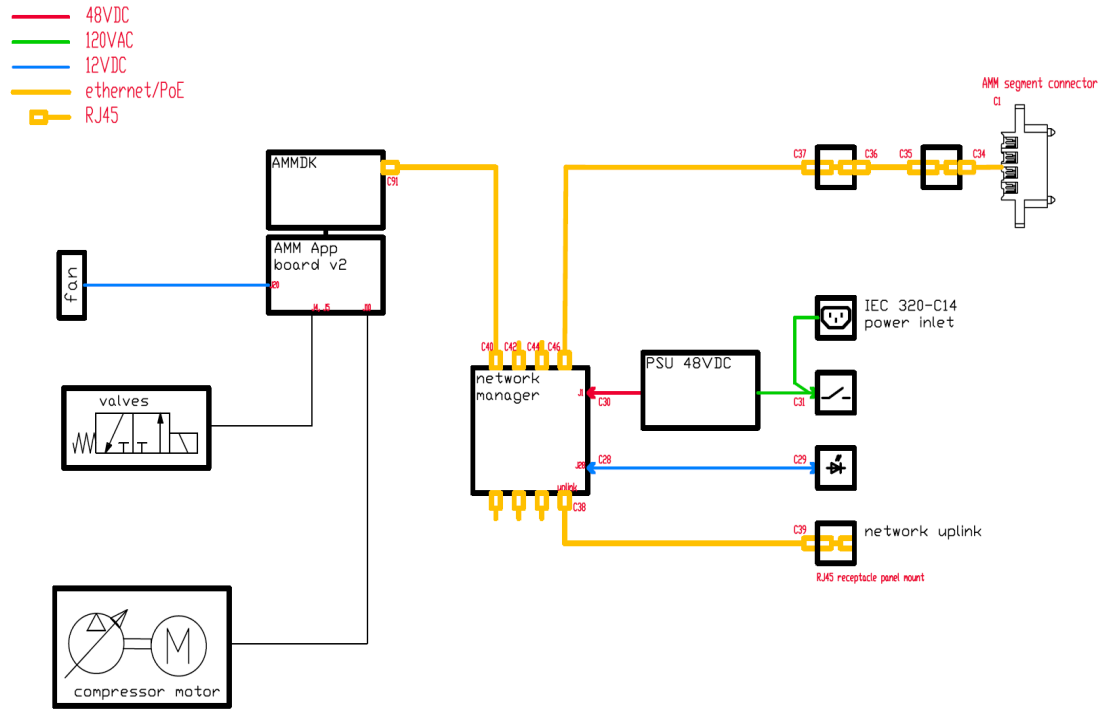

Figure 24: AMM Reference Design Box block diagram

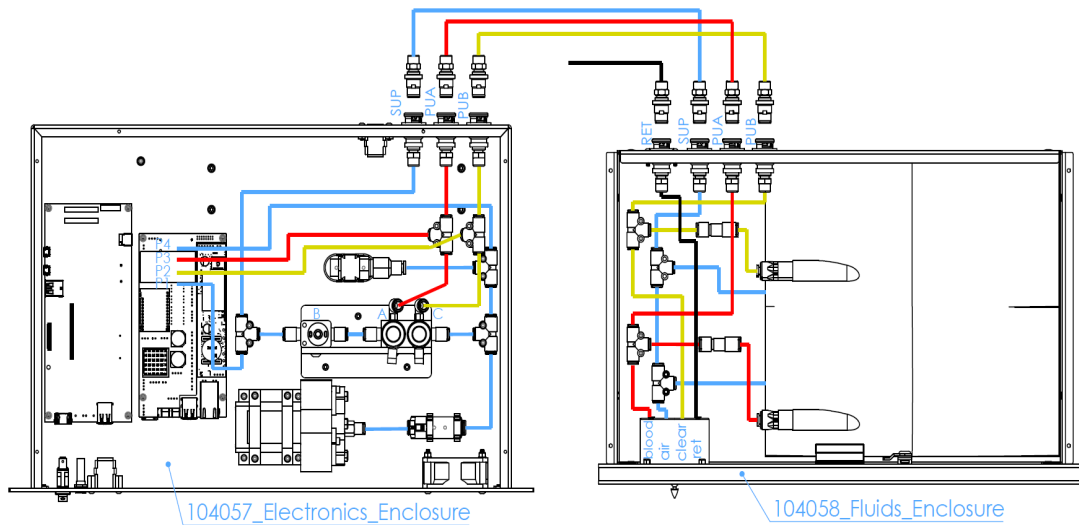

Figure 25: AMM CORE components and hose routing schematic

### 3.3 Alpha Full-Body Patient Prototype

**Executive Summary:** In order to demonstrate the AMM Platform, an Alpha full-body male patient was built. The alpha prototype was built to house modules relevant to a cross-disciplinary and multi-role scenario. The multimodal alpha prototype includes both



physical and digital modules, which are synchronized. We successfully tested and integrated modules developed by UW CREST and 3<sup>rd</sup> party vendors. These modules are either physical, virtual or digital, which highlights the multimodal capabilities of the AMM platform.

<b>Module</b>	<b>Modality</b>	<b>Vendor</b>
<b>Airway Head</b>	Physical	UW CREST
<b>IV Arm</b>	Physical	UW CREST
<b>Laparotomy</b>	Physical	UW CREST
<b>Abdominal Ultrasound</b>	Virtual	CAE
<b>Abdominal Palpation</b>	Physical	ACDET
<b>Guided User Interface (Technician)</b>	Virtual	VCOM3D
<b>Virtual Patient</b>	Virtual	VCOM3D
<b>Patient Monitor</b>	Digital	VCOM3D
<b>IV Pump</b>	Digital	VCOM3D
<b>Ventilator</b>	Digital	VCOM3D
<b>Labs</b>	Digital	VCOM3D
<b>Urine Meter</b>	Digital	VCOM3D
<b>Fluidics (Blood, Air, Waste)</b>	Physical	UW CREST
<b>Open Source Physiology Engine</b>	Digital	ARA
<b>Commercial Physiology Engine</b>	Digital	CAE

*Table 2: AMM Alpha modules, modalities, and vendors.*

Numerous improvements and refinements have been implemented to Alpha in order to prepare this prototype for the ACS study. One of the most valuable capabilities that AMM provides are for modules to connect to a physiology engine of choice. Therefore, extensive and iterative testing and verification of the ARA BioGears open source physiology engine was performed and integrated. Results from the ACS study and testing the alpha prototype informed the UW CREST team on changes made to the next patient prototype; Beta.

### 3.3.1 Development Phases

**Executive Summary:** In order to achieve the Alpha prototype, two system integration events were held. The two events are referred to as Mule I (May 2018) and Mule II (October 2018). The components and software developed by sub-contractors and vendors were brought together and integrated to assess state of progress, system performance and solve interoperability issues. Initial integration was completed for the pre-pilot demonstration in January 2019. Based on results and feedback from this demonstration a number of issues were addressed, and improvements integrated on an ongoing basis into the prototype. The prototype was tested in a clinical setting again during the study pilot in March of 2019.

### 3.3.1.1 Mule I

Our purpose for Mule I was to integrate electronics, fluidics, and several software modules. This was to demonstrate the fluidics system capabilities through proof of concept with a bleeding inferior vena cava prototype. The external configuration was chosen to facilitate development and troubleshooting fluidics and software system outside of a full-body manikin.

**Outcomes:** The fluidics supply system was successfully integrated and assembled in a set of external enclosures for the internal integration and demonstration of Mule I. The demonstrated scenario was a clinical procedure and the prototype was draped for realism (*Figure 26*).



*Figure 26: Mule I Integration: Bleeding Vena Cava prototype module connected to Fluidics system, both running on identical sets of AMMDK CCB & Application Boards.*

#### System Design Features:

- Double sided spill proof connectors at module interfaces (no leakage)
- Reservoir refill via spill proof quick connect
- Quiet operation pumps/valves/hoses/exhaust  $\leq 45$  dB
- Low system pressure for air and fluids 15 psi max
  - The Mule I benchtop system was limited to 7 psi system pressure for air and fluids based on available flexible reservoirs.
- Constant pressure fluid supply via flexible accumulator/reservoir
- Single intermediate power source: compressed air

The fluidics supply system can be configured to house the major system components within the torso. Alternatively, the compressor may be placed in any other segment or externally. The main manifold, check valve manifold and reservoirs can be placed in any segment or externally. However, these components have to be collocated as a group. Figures 27 and 28 below show the component overview and schematic.

mule #1

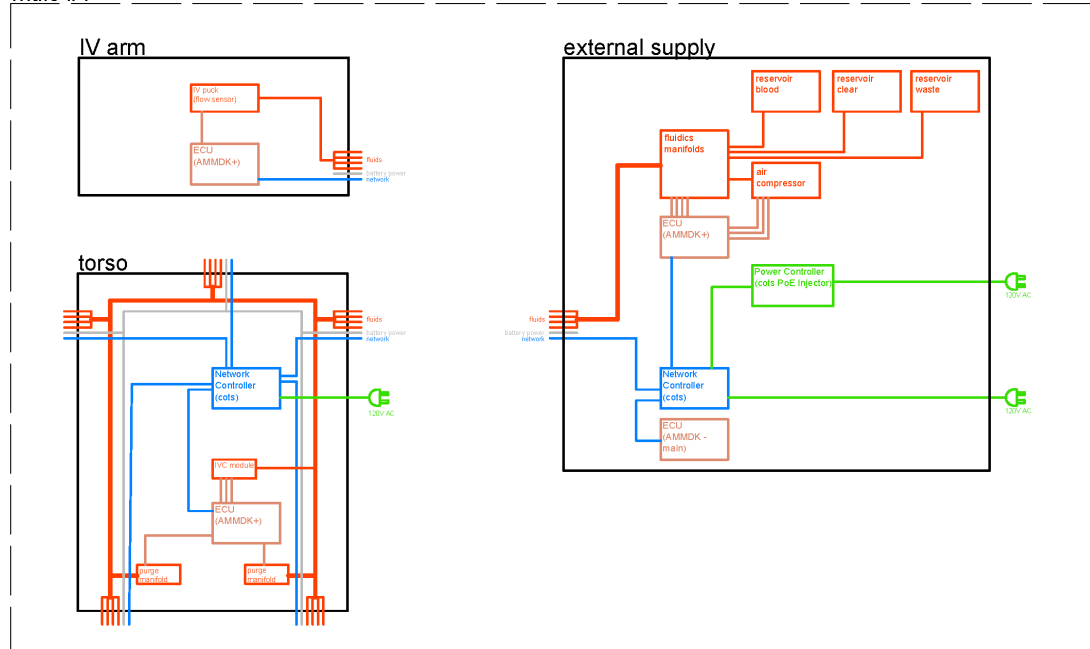
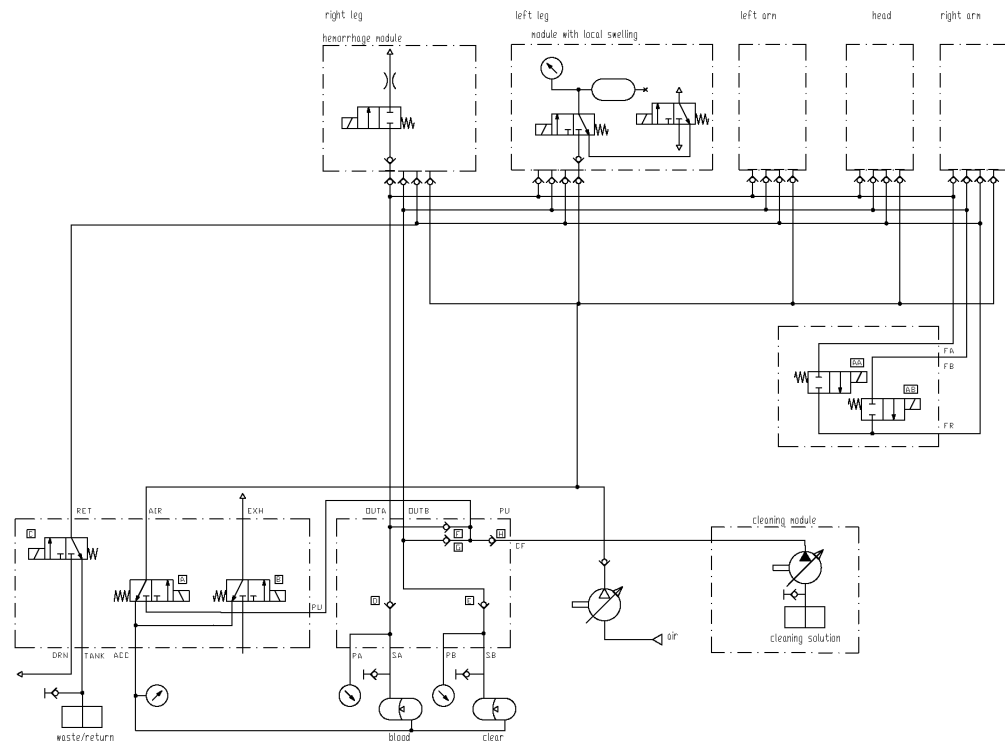

Figure 27: AMM system component overview at integration



**Figure 28: Fluidics supply system schematic showing external supply layout**

### 3.3.1.2 Mule II

Integration work for Mule II represented the first full integration of smart modules and platform components into a physical form. The basic structural components for the manikin torso: spine, neck, shoulders and lower torso are shown below in Figure 29. Note that the chest, head and torso components/interconnections were added. The skeleton infrastructure provided the rigidity for mounting components and allowed for open areas for fluid and electrical cable routing. The manikin's infrastructure allowed for easy assembly and maintenance. The shoulder joint structure was designed and built with CAD and 3D printed parts where possible. The shoulder joint design provided strength as well as freedom of movement of the arms in motions that similar to a human.

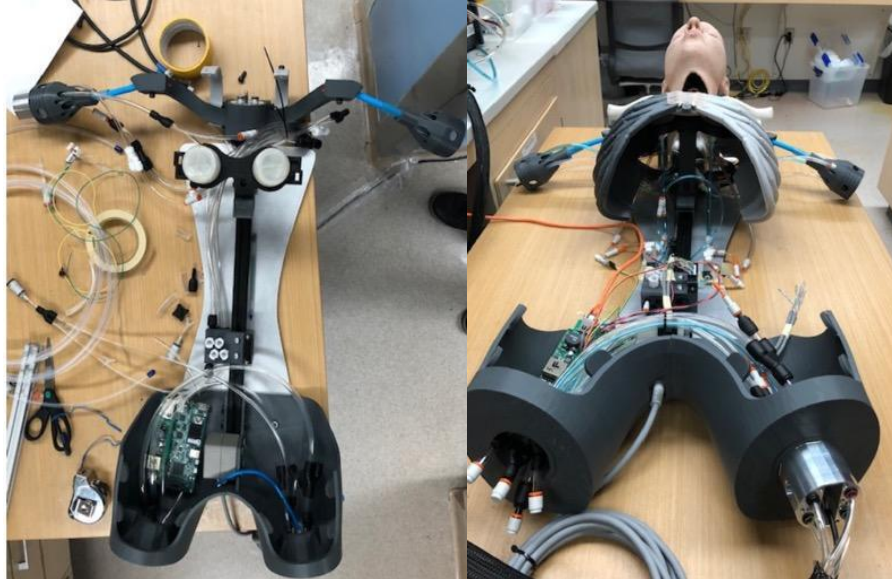

**Figure 29: Left side: skeleton infrastructure, right side: chest, head and torso/leg components added.**

A close-up of the head, neck, and shoulders are shown on the left side of Figure 29. On the right side of Figure 29 is a close-up of the lower torso showing the routing of fluid lines, placement of electronics and the universal connector interface. The torso controller executed CORE software services and also controlled the chest rise of the manikin in accordance to information obtained from the physiology engine.

### *3.3.1.3 Physical Alpha Male Manikin Structure*

The manikin structure was laid out to provide a structural chassis, support segment connectors, a rib cage, and control system to simulate chest rise. Furthermore, to accommodate the goals of the ACS study scenario, development of a modular abdominal module was undertaken under a separate funding mechanism. This module made it possible to swap out key functional components in the abdominal space.

The vision the team had for the manikin has been that of a LEGO™ set, that allows for the rapid design of new modules based on the AMM Standards. The basic internal structure for the initial manikin torso was developed, as shown in Figure 30 and 31. The torso is structurally supported by T-slotted aluminum extrusion mounted to a base plate.

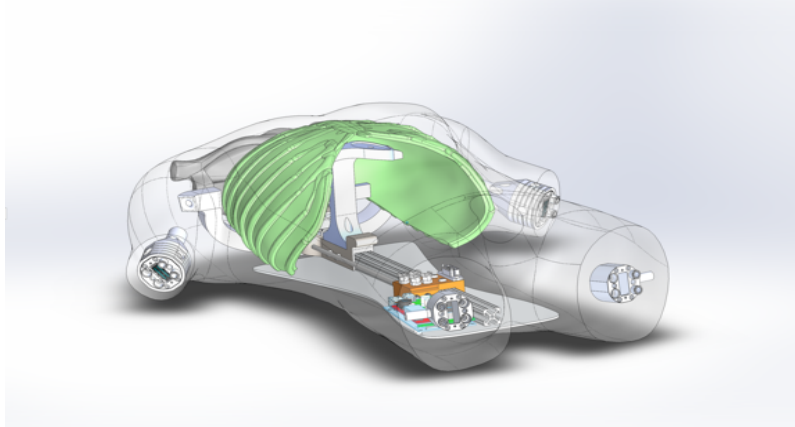

*Figure 30: CAD rendering of structural manikin chassis for the torso.*

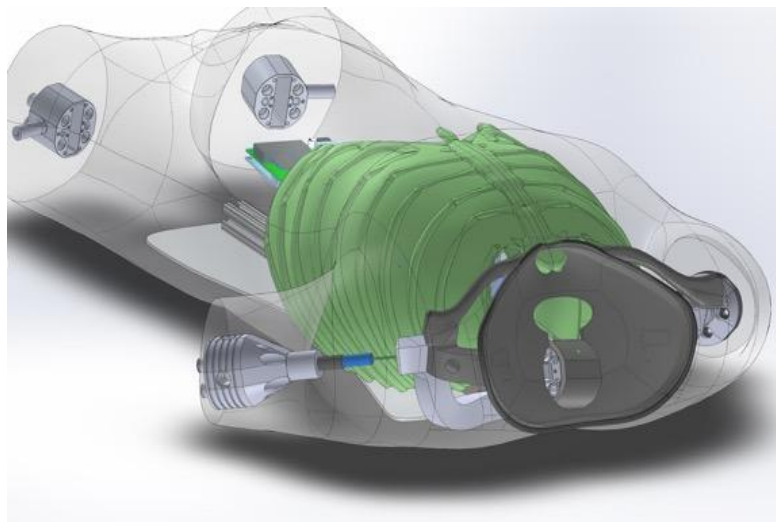

*Figure 31: Structural manikin chassis with head interface plate, head connector, shoulder joints and rib cage plates.*

Continuing with this example, in order to make swapping out the abdominal module a user-friendly process, a spine connector (a connector arrangement in the area of the spine) that provides fluids and electrical connections to the abdominal module was developed under a separately funded CREST laparotomy module effort. The laparotomy module was used during the ACS study as an exchangeable module with the ACDET abdominal exam module (see below).

### **3.3.2 Development and Integration of Modules**

Modules are defined as independent building blocks that provide incremental capabilities to the CORE or provide training opportunities for different medical and trauma related conditions. The focus of this specification is on the platform, a much broader definition than a physical manikin, as illustrated in Figure 32, and on how it can be extended by medical simulation developers by adding:

- Modules that provide incremental capabilities to the CORE, including authoring tools, after action review tools, different physiology engines.

- Modules that add training opportunities, including IV/IO arms, intubation heads, laparotomy abdomens, virtual stethoscopes. These can be physical, virtual, digital or hybrid part task trainers.

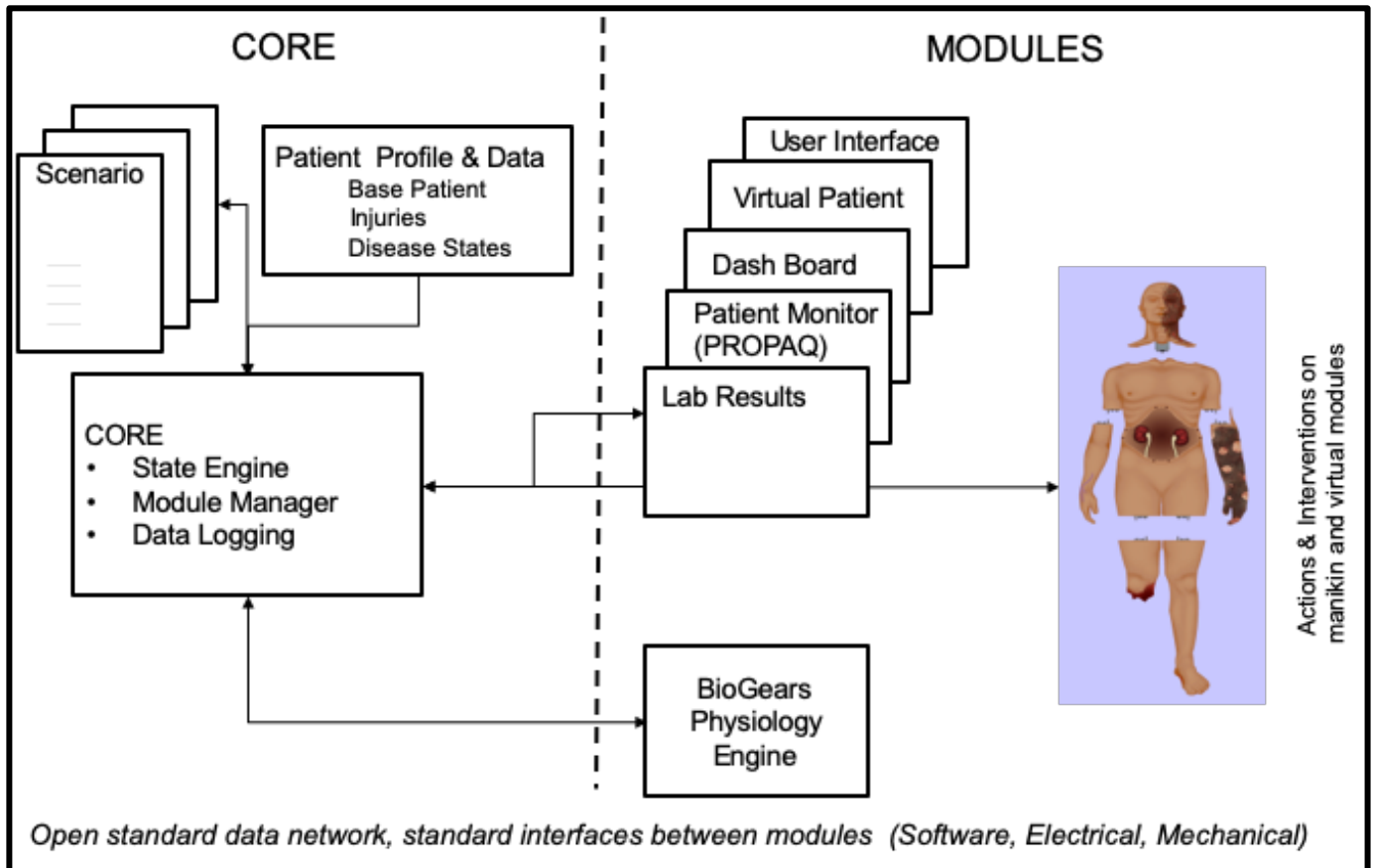

Figure 32: Functional Overview of AMM Platform and Modular Capabilities.

The Alpha patient prototype integrated both physical and digital modules to showcase the interoperability and modularity of a manikin in an interdisciplinary training scenario. The decisions for designing and implementing the modules below were to fulfill the needs of the ACS Study and the designed scenario.

The modules below are described by design, integration into the AMM system, and function.

### 3.3.2.1 UW CREST Physical Modules

Modules designed by UW CREST follow the AMM Standards. With the exception of the fluidics module, the modules developed by CREST were funded under separate mechanisms and not a direct deliverable to the AMM Phase II Project. All were utilized here to demonstrate the capabilities of the AMM platform.

### 3.3.2.2 CREST Fluidics Module

Figure 33 represents a human fluid and air roadmap for the AMM project.



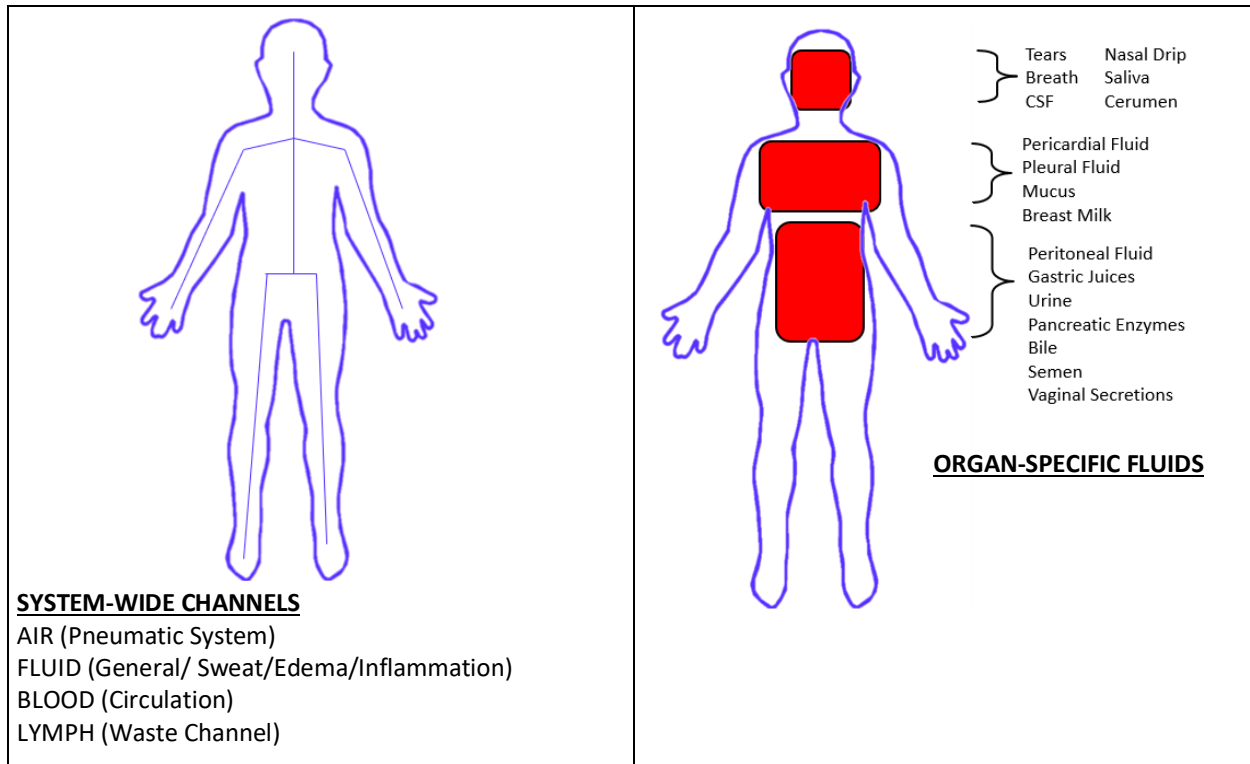

*Figure 33: System-wide channels and organ-specific fluids.*

The AMM fluidics system functional requirements were completed. Initial integration tests were completed at the Microsoft IoT Lab in 2017.

#### **Fluidics system features**

- Supply of pressurized fluids to modules: blood, clear, air
- Fluid return line from modules to waste tank or drain
- Flushing/purging for all main fluid lines for cleaning and transportation
- Air compressor and reservoir/main manifold assembly can be placed independently in any module: extremities, head or torso
- Double sided dry break connectors at module interfaces
- Reservoir refill via spill proof quick connect
- Cleaning module can be connected externally at main manifold
- Intervention specific functionality is implemented in modules
- Quiet operation pumps/valves/hoses/exhaust  $\leq 45$  dB (noise inside a library or a babbling brook)

#### **The requirements supported the following media to extremity and head modules**

- Blood
- Clear fluids (i.e. sweat, peritoneal fluid, urine, tears, etc.)
- Air

**The requirements also provided for recirculation for all extremity lines for:**



- Cleaning, purging/drying
- Support for line cleaning and purging/drying
- Fluid return (waste)
- Minimize required complexity of modules
- Reservoir refill via spill proof quick connect
- Quiet operation pumps/valves/hoses/exhaust  $\leq 45$  dB
- Low pressure  $< 75$  psi air and fluids flow control via pump speed (flow starved circuit)

	Port type/fluid	Flow rate	Pressure	Reservoir capacity/other
1	Blood simulant	1.5 l/min	1.03 bar	$\leq 6$ l
2	Clear fluid (water)	250 ml/min	1.03 bar	$\leq 1$ l
3	Waste/discharge (liquid)		1.03 bar	$\leq 2$ l
4	Compressed air		1.03 bar	
	Port type	Pin	Voltage	Type
5	Electric - data	8 pin x 2 A		Ethernet
6	Electric - power	5 pin x 4 A	48 V	

*Table 3 Module connection port specifications.*

### 3.3.2.3 Airway Head (Funded under W911NF-17-C-0043)

**Function:** The airway head supports bag valve mask ventilation and endotracheal tube intubation. Manual ventilation into the manikin provides observable chest rise and changes in patient physiology.

**Design:**



*Figure 34: CREST Endotracheal Intubation head*

**System Integration:**

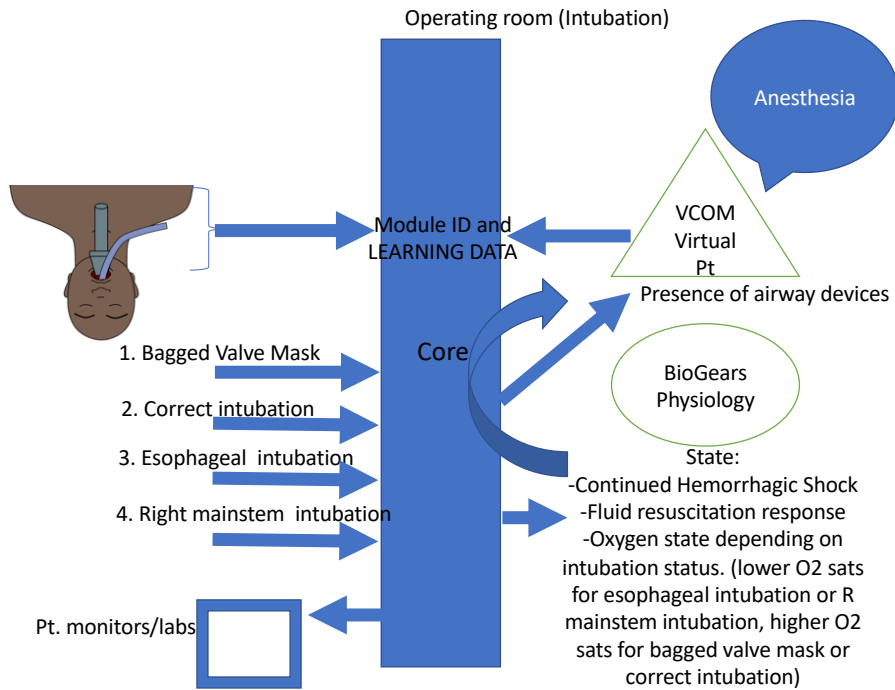

*Figure 35: Communication Diagram for Endotracheal Intubation: When the module connects, a handshake with core identifies the module. BVM and Correct intubation is recognized by sensors in the module that communicate this status to core. Incorrect (esophageal or right mainstem intubation) also*

provide this information to core and influences the state of the patient. Status is also mirrored in a separate virtual patient module.

### 3.3.2.4 IV Arm (Funded under W911NF-17-C-0043 )

**Function:** This module provides an output of heartrate in the form of a radial pulse. There is also a location to place an IV and administer fluids/medication, which can be registered by the system.

#### Design:



Figure 36: CREST IV arm with USC and replaceable IV puck

#### System Integration:

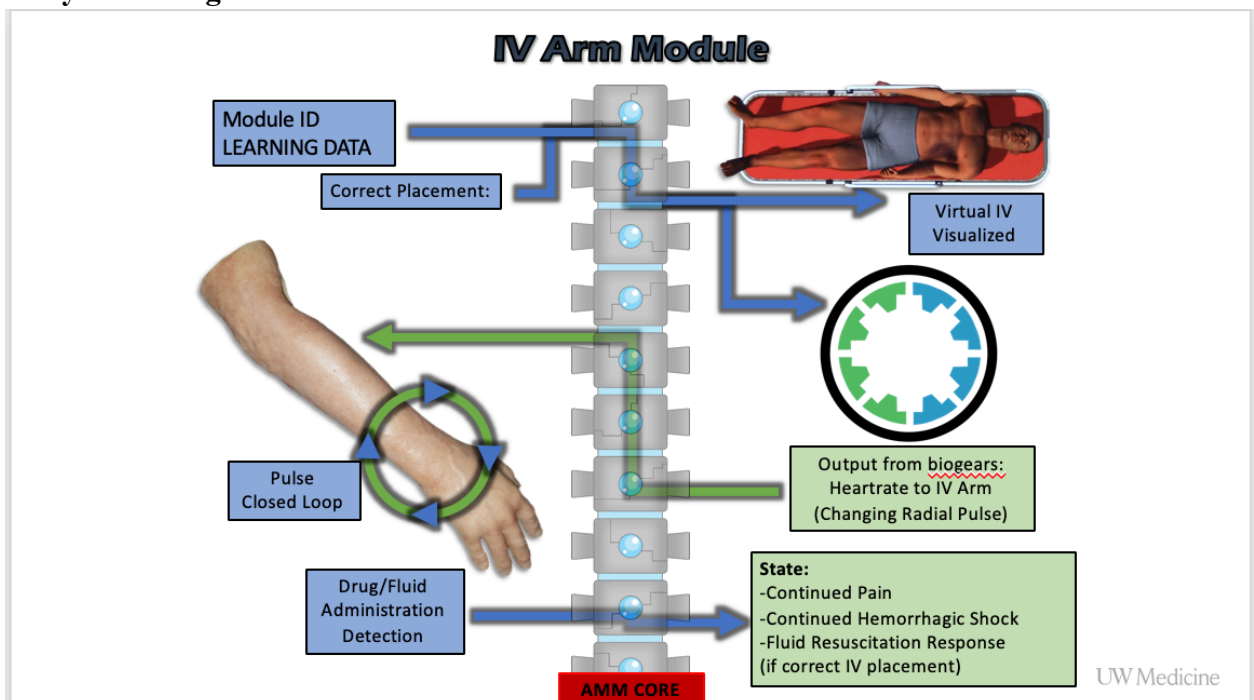

*Figure 37: Communication Diagram for IV arm: When the module connects, a handshake with core identifies the module. Correct placement is recognized by the module and a notification is provided to core. A separate module: the virtual patient is subscribing to “successful IV placement” and a virtual IV appears when the CORE recognizes this. If fluid is provided to the module, this is recognized and this information is provided to CORE who provides it to all modules (both virtual patient and BioGears). BioGears responds appropriately. A radial pulse on the module is driven solely through subscribing to “pulse” from the CORE. This is provided back to the arm through the CORE by information provided by BioGears.*

### 3.3.2.5 Laparotomy Module

**Function:** The laparotomy module was designed for an exploratory laparotomy, which led to a splenectomy, IVC repair, and cystography. Bleeding affected the patient physiology in real time, while blood simulant was observed as physical blood loss. Successful repairs to the fabricated abdomen allowed for patient recovery.

#### Design:



*Figure 38: CREST Trauma Laparotomy Module: Splenectomy, vessel laceration repair, cystorrhaphy*

#### System Integration:

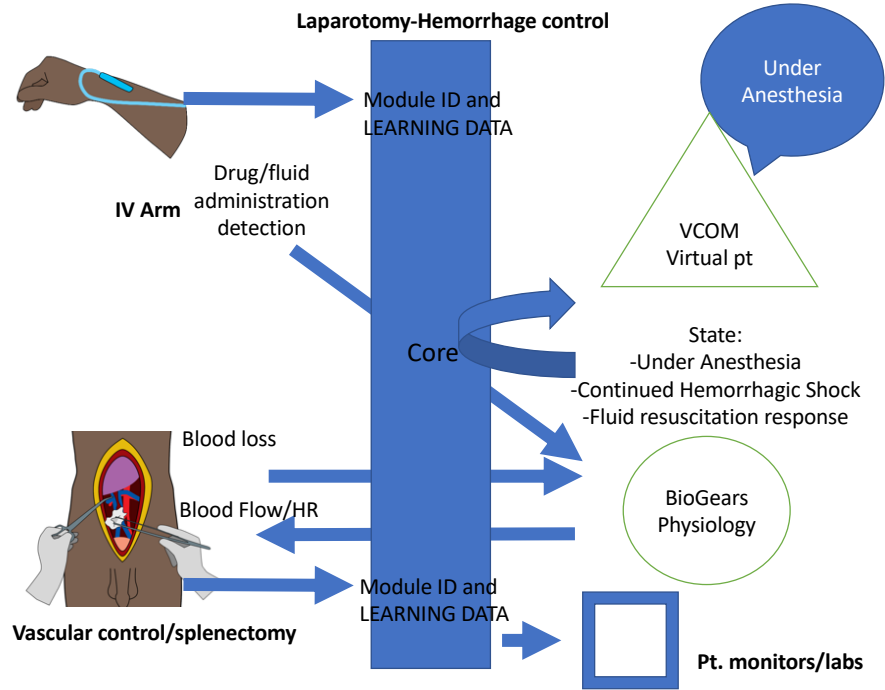

29

**Figure 39: Communication Diagram for CREST Laparotomy: When the module connects, a handshake with core identifies the module. Blood loss from a fractured spleen and common iliac vein are recognized by the module and communicated through CORE to the physiology engine. Fluids provided through IV Arm module also contribute to vitals. Venous bleeding rates in laparotomy module impacted by CVP.**

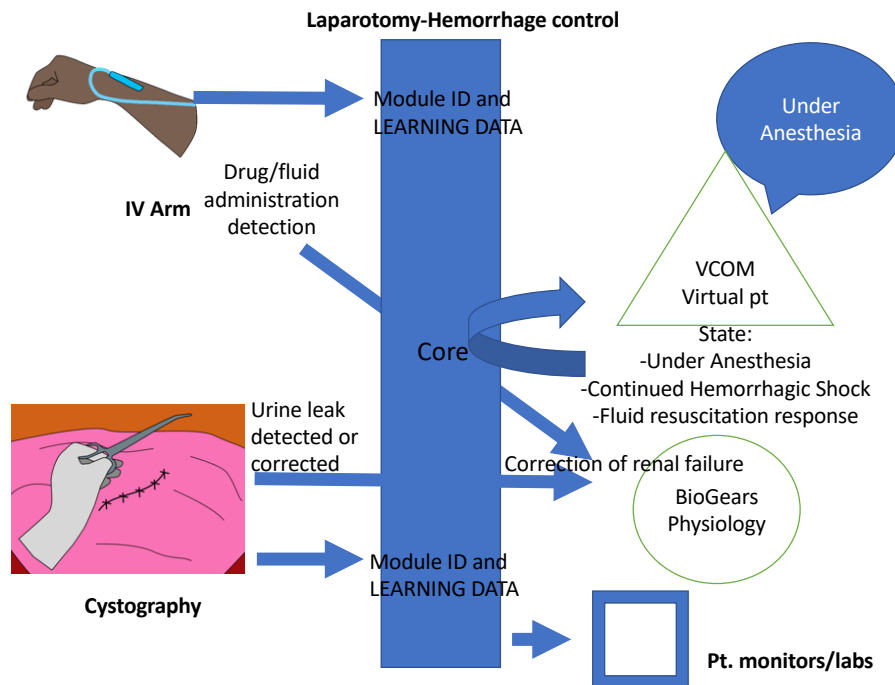

30

**Figure 40: A leak after Bladder closure also is detected and communicated through CORE**

### 3.3.2.6 3<sup>rd</sup> Party Modules

In addition to the AMM-compatible modules, developed by the CREST team, the true capabilities of AMM are displayed by has been working with a number of researchers and industry partners to begin integration of select modules/part-task trainers. The purpose of this effort is to test the completeness of data models, standards, and ease of working with the Advanced Modular Manikin Developers Kit (AMMDK). Modules chosen for integration into the alpha prototype were the ARA BioGears Physiology Engine, CAE Physiology Engine, Vcom3D GUI and tablet applications, CAE Ultrasound software, and the ACDET abdominal palpation trainer.

#### 3.3.2.6.1 Commercial Modules

The existing commercial products were successfully integrated into the alpha system and was compatible with the AMM Platform.

##### 3.3.2.6.1.1 ACDET Palpation Module

**Function:** This module provides tactile feedback consistent with a gradually worsening acute abdomen with a pain response to rebound tenderness and left upper quadrant tenderness (spleen injury).

**Design:**



*Figure 41: ACDET abdominal exam simulator integrated into AMM alpha patient/AMM platform.*



## System Integration:

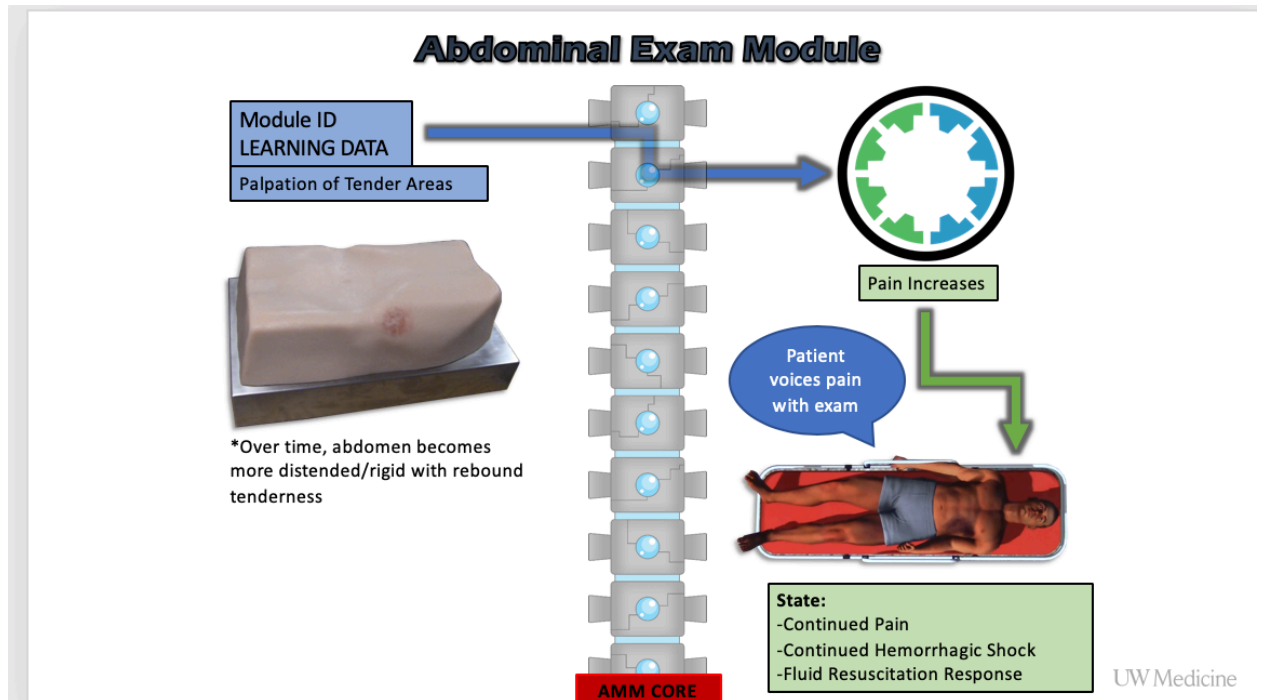
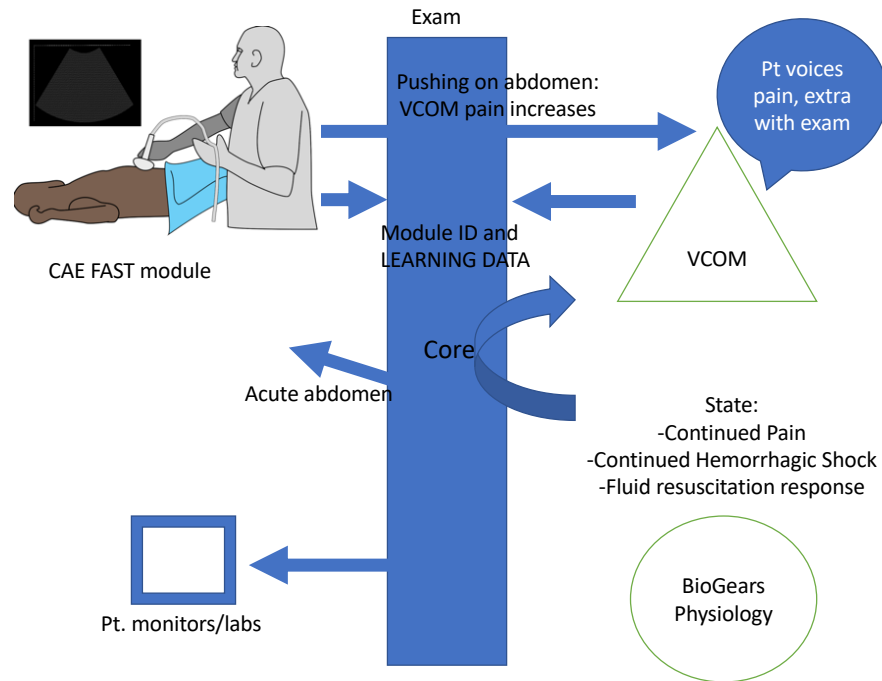

*Figure 42: Communication Diagram for ACDET Abdominal Exam Simulator: When the module connects, a handshake with core identifies the module. Palpation/release on the abdomen stimulates a pain response communicated through CORE which sends signal to virtual patient subscribing for pain and the virtual patient writhes in pain and moans. BioGears receives a "short" pain response which is seen physiologically.*

### 3.3.2.6.1.2 CAE Ultrasound Module

**Function:** This commercial product provided capabilities of displaying an ultrasound dataset that matched the injuries described in the patient scenario. This allowed for a clinician to perform a FAST exam and identify the need for an exploratory laparotomy.

## System Integration:



**Figure 43: Communication Diagram of CAE FAST exam module. This VR module is registered with the abdominal exam simulator and alpha AMM. Examination on the physical manikin yields appropriate virtual images and pain is still registered through the ACDET abdominal exam module as described in Figure 42.**

### 3.3.2.6.1.3 Vcom3D Software Modules

We have defined a preliminary ‘web application flow,’ allowing for easier AMM web-connected application development. This allows us to more rapidly prototype and build AMM user interfaces for demonstration and testing.

Figure 44 illustrates the overall AMM CORE stack, highlighting the REST Adapter. The REST Adapter allows for curated access to the DDS bus using standard HTTP requests, allowing developers to build web applications and interfaces that can interact with AMM. Also shown as part of the CORE stack are the TCP bridge (used for network-connected modules, such as virtual equipment) and a generic serial bridge (used to connect to Arduino-type hardware), both of which are available in our AMM GitHub repository.



AMM – Web Application Flow (for web dashboards, instructor interface, etc.)

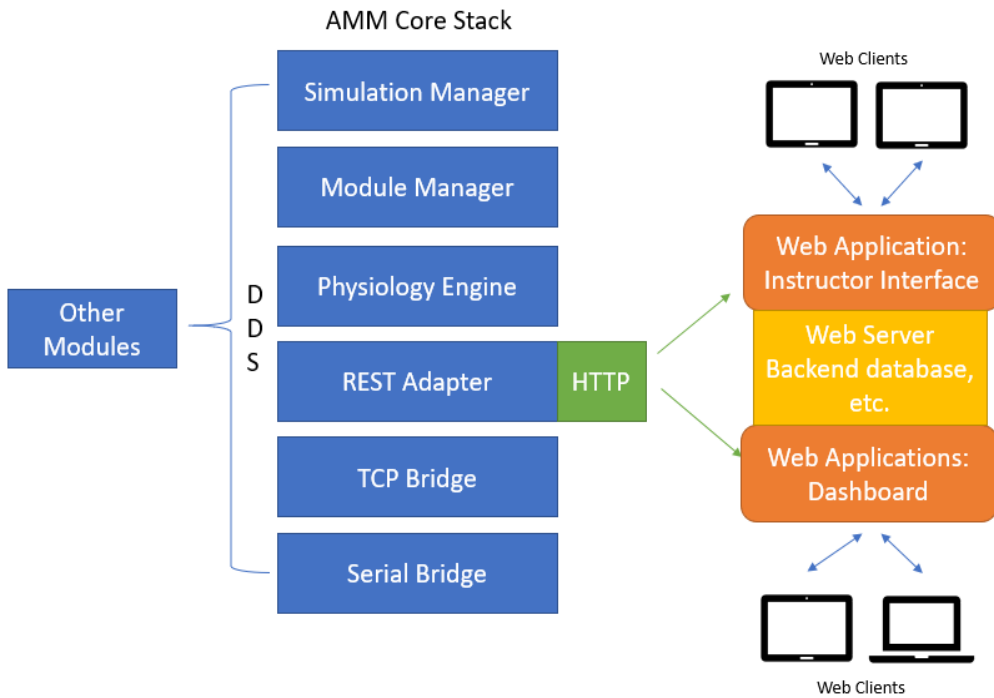

Figure 44: Web Application Flow for UI Development

VCom3d released a series of applications which represented an integrated virtual patient benchtop testbed. Verification efforts included testing this application and providing feedback to further improve the applications.

Final tablet applications implemented into the alpha patient prototype and the ACS study include:

1. Guided User Interface
2. Patient Monitor
3. Ventilator
4. Labs
5. Urine Meter
6. IV Pump
7. Virtual Patient (as described above)

These applications were digitally implemented and followed the AMM Standards.

### 3.3.2.7 Physiology Engines

**Executive Summary:** One of the most important features that makes the AMM platform attractive for developers is the ability for modules to contribute (publish), and subscribe to data driven by, the state of the patient, as represented by a physiology engine. We chose an open source platform, BioGears, to perform verifications and

iterations of models for hemorrhage, pain response, ventilation, and sepsis. We were able to verify the first three models, which were included in the ACS scenario. The sepsis model could not be verified and was not included.

In order to demonstrate the modularity of our platform, we successfully integrated a commercial physiology engine made by CAE, with a broad spectrum of physiologic states. It was integrated in the beta patient prototype.

#### 3.3.2.7.1 BioGears Physiology

**Purpose:** Our team became familiar with and evaluated several physiology engines with the goal of evaluating the feasibility of the physiology engine within the AMM and well as recognizing each physiology engine's limitations. Even though the AMM platform was designed to allow to accommodate different physiology engines, because of its open source status, ARA BioGears was selected as the physiology engine for the alpha prototype. The physiology engine simulates the patient's response to therapy, intervention, and drug administration. The ACS team and UW CREST developed a scenario whereby the patient has suffered trauma and needed medical treatment in the field, in the Emergency Department, and in the Operating Room.

The BioGears physiology engine simulated the patient vitals and provided detailed information to the instructor/trainee during the exercise. The BioGears physiology engine was programmed for initial conditions and then updates were sent as to the patient's condition as the scenario unfolds.

**Outcomes:**

Figure 45 shows the graphic user interface of BioGears which was used to create executable actions that resembled the proposed scenarios for the AMM.

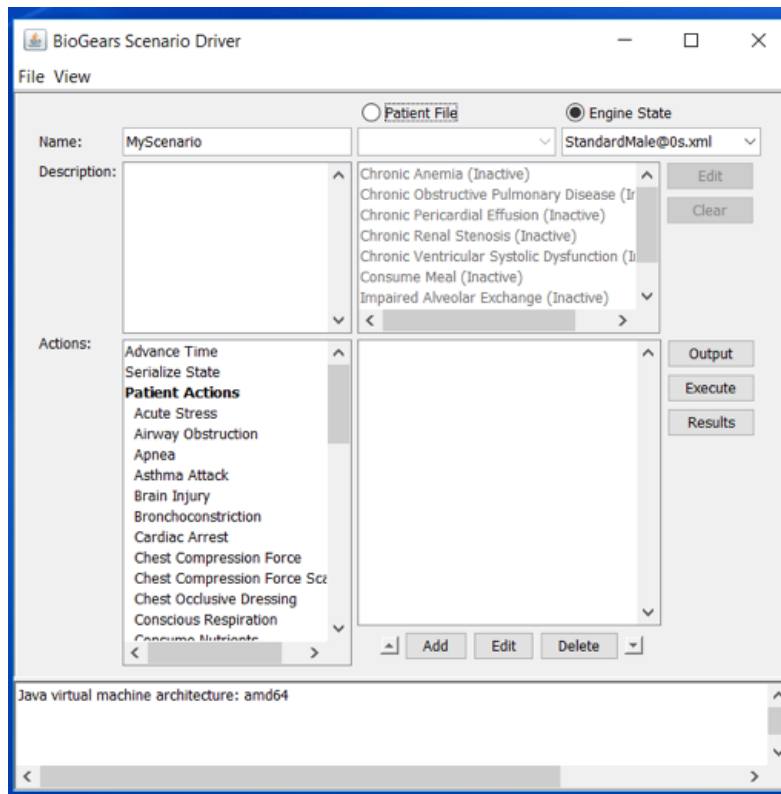

*Figure 45: BioGears scenario driver.*

BioGears validation of models used in scenarios was reviewed. Below is graphic representation of the methodology and testing done by BioGears for the four physiologic states/conditions needed for our scenarios (hemorrhage (*Figure 46*), pain response (*Figure 47*), and pneumothorax [labeled as ventilation (*Figure 48*).

## BioGears Methodology: Hemorrhage

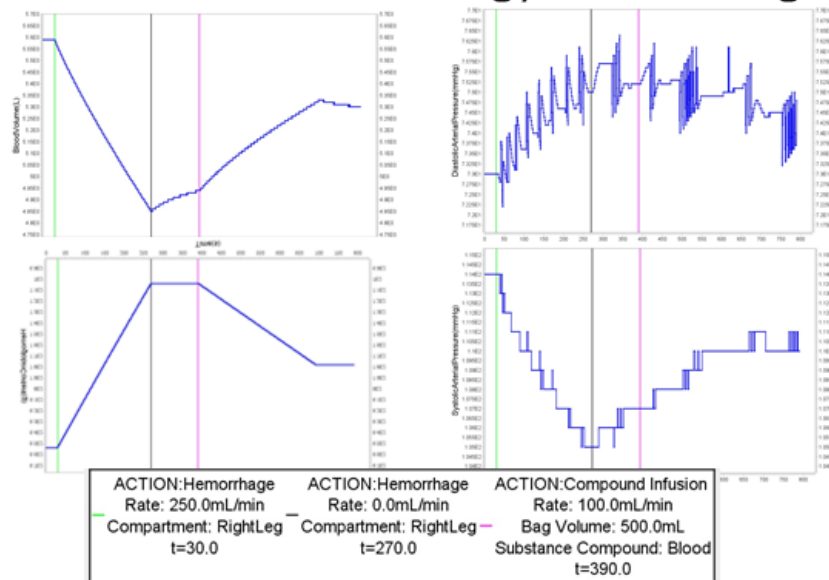

Figure 46: BioGears methodology for hemorrhage

## BioGears Methodology: Pain Response

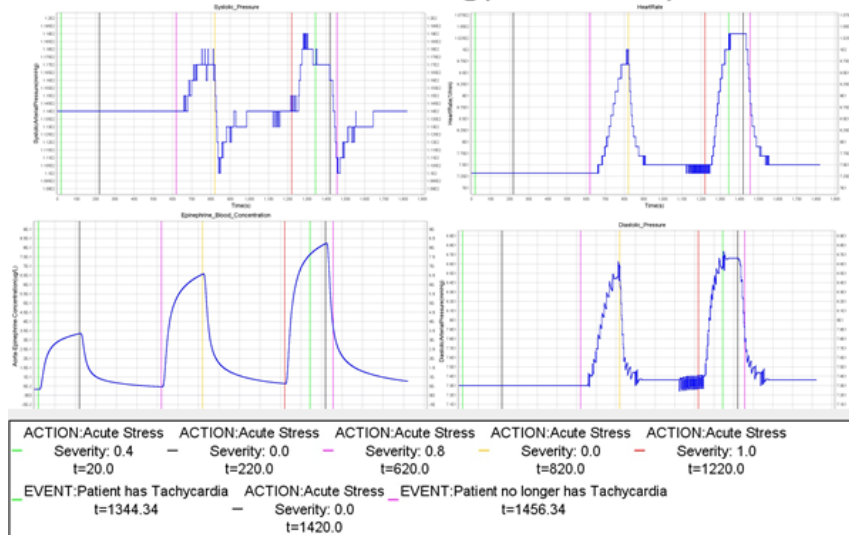
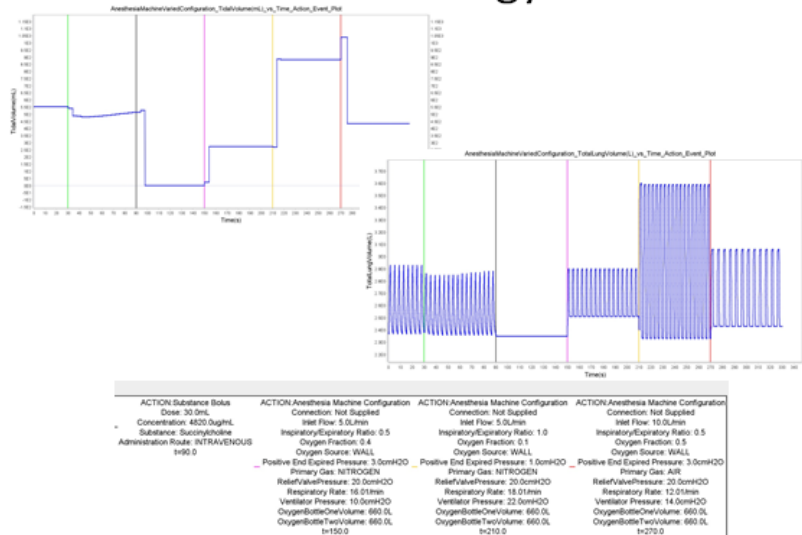

Figure 47: BioGears methodology for pain response

## BioGears Methodology: Ventilation



**Figure 48: BioGears methodology for ventilation**

Sepsis wasn't available with initial testing, but we worked with BioGears to help efforts of creating and validating a system. We supported work on the development of this state, but ultimately did not use it in our alpha or beta demos due to concerns of the model's validity.

### 3.3.2.7.2 BioGears Modifications by ARA

Response to the finalized ACS scenario required ARA to implement new modifications to the BioGears physiology engine. The following actions were taken.

#### **For Sepsis:**

ARA incorporated a mathematical model from literature describing the interaction of a pathogen population and the immune system. A "Sepsis Action" was created that establishes an infection (i.e. an initial amount of pathogen) in the body. The Sepsis Action allows the user to specify a location and severity. The location describes the BioGears compartment which will first begin to experience altered blood flow. The severity establishes how quickly the infection evolves and the time it takes for the virtual patient to enter septic shock.

ARA linked the evolution of the pathogen and immune cell populations to symptoms consistent with systemic inflammatory response syndrome (SIRS), such as fever and elevated heart rate, respiration rate, and white blood cell count. Increased endothelial permeability and tissue hypoxia as a function of pathogen population were included in the model. These events produce systemic symptoms of severe sepsis (hypotension, increased blood lactate levels, decreased urine production rate) via the physiologically based feedback models already existing in BioGears. A system variable to track Total Bilirubin, which is used to diagnose liver failure during Sepsis, was created.

Norepinephrine was added to the BioGears substance library. Norepinephrine is a pressor used during Sepsis treatment to support blood pressure. An action was established supporting Antibiotic administration. The antibiotic gradually eliminates the pathogen, eventually returning the virtual patient to a normal state.

Several example scenarios were created with different severities to illustrate the range of responses that can be produced by the Sepsis action.

ARA highlighted treatment actions (saline infusion, norepinephrine infusion, antibiotic administration) in the examples. A dynamic sepsis and treatment protocol were created in the BioGears Software Development Kit (SDK) and the BioGears Graphical User Interface was patched to include support for sepsis.

**For Pain:**

ARA created a “Pain Stimulus” action in BioGears defined by a location and a severity. The location identifies which part of the body is in pain. The severity correlates with the Visual Analogue Score (VAS). ARA included a “Pain Susceptibility” parameter that describes how the virtual patient perceives pain. The Pain Susceptibility parameter modifies the VAS. When a pain stimulus is initiated, virtual patients with high susceptibility report a higher VAS than patients with low susceptibility.

ARA modeled physiological responses to pain severity. Heart rate, respiration rate, and blood pressure increase as pain severity increases. Epinephrine production is stimulated in response to pain. ARA modeled the mitigating effect of BioGears analgesic drugs (Morphine and Fentanyl) on pain severity. As the concentration of an analgesic increases in the body, the VAS reported by the virtual patient decreases. Finally, ARA created an example Pain scenario in the SDK.

**For Action Recognition:**

The BioGears team has provided functional patches to the upstream repository <https://github.com/AdvancedModularManikin/DDS>.

3.3.2.7.3 BioGears Physiology Model Testing

BioGears has released 3 versions of the physiology engine (v6.1, v6.3, v7.0). Validation of the accuracy of each version as well as recommendations to improve the physiology engines was performed.

The initial testing of the of the BioGears physiology engine dealt with how well it could simulate the patient’s condition during the scenario. Initial testing showed the model lacked significant capabilities which were then added. CDRL A010 summarizes the testing completed on versions v6.1, v6.3, v7.0 including Sepsis and Pain.

Overall the BioGears v7.0 was significantly improved and the recommendation was made to include this in the ACS study.

#### 3.3.2.7.4 CAE Physiology

**Purpose:** To demonstrate the extended usability and functionality of the AMM architecture, we developed a drop-in replacement module for the BioGears wrapper which allows you to run a simulation using the CAE physiology engine with most patient actions available and all patient physiology data being published.

**Outcomes:** The engine is deterministic and provides a mechanism to step the simulation by a configurable period. We have hard-coded a time-step of 20ms, which allows us to operate at the standard 50hz that we operate BioGears at. As with the BioGears wrapper this can be adjusted.

As with BioGears, drug and anesthetic gases definitions are loaded once from a JSON file at initialization of a patient. Patient initial state is also loaded once from a JSON file at initialization of a patient. The AMM Simulation Control “SAVE” can be issued to save the current patient state. You can then rename that patient state and reuse it.

We utilize the CAE Physiology SDK C++ API to retrieve data and perform interventions.

Memory and CPU usage are minimal per patient compared to BioGears.

The CAE wrapper utilizes all of the standard interfaces we developed for use with BioGears so it is a drop-in replacement. This means that Physiology Modifications are transmitted on the AMM bus (per the 1.0 specification updates) and are compatible with both BioGears and CAE without extra work on the user’s part.

A full gap analysis of differences between the BioGears Physiology Engine and the CAE Physiology Engine has been published to the open source GitHub repository.

The CAE physiology engine must be licensed separately, but the wrapper is provided as open source software.

### 3.4 American College of Surgeons Field-Testing (Full Report provided in Appendix)

**Unedited executive summary as provided by the ACS:** Meeting the next generation of educational needs in healthcare requires re-thinking of current platforms and delivery methods. Simulation is a widely used educational tool that has greatly enhanced the engagement of learners to augment the use of traditional textbooks and classroom lectures. However, no integrated model exists that combines individual task accomplishment with the overall management of a patient. Furthermore, there is no one manikin flexible enough to allow for additions to its learning platform. The Advanced Modular Manikin (AMM) was designed to meet these gaps. This study, funded by JPC1, is a collaboration between the University of Minnesota, the University of Washington, the American College of Surgeons (ACS) and the Department of Defense (DoD). Our study incorporated military personnel from the Naval Medical Center at San Diego and included 14 three-person teams. The design was a randomized crossover study, where each team was exposed to treating a patient who

sustained injuries from a motor vehicle accident. Each member of the team was subjected to the scenario twice, once by using the fully integrated AMM with peripheral parts, and other by using partial task trainers alone. The study measured demographics, a Global Rating Scale, and the Simulator Experience Assessment Questionnaires, along with the data collected from focus groups. Our main findings were:

1. An open-sourced, integrated training platform, known as the Advanced Modular Manikin (AMM), was developed and used for training purposes. It can have multiple independent developers contributing modules to the platform. The project was implemented by a third party, the Division of Education of the American College of Surgeons (not the original developers) and was conducted at a DoD training site.
2. The use of an integrated AMM at a DoD CONUS medical site for the training of first responders, surgeons and anesthesiologists, and similar roles to those in civilian emergency departments, along with forward deployed Role II and III surgical sites is feasible.
3. The integrated form of the AMM was perceived to be superior to the peripheral task trainers alone in supporting the whole of a defined trauma scenario, one that could occur both in deployed or CONUS settings.
4. One of the strongest points of the AMM was its perceived ability to enhance inter-professional team training that involves multiple specialties/disciplines of the care team.
5. Another very highly rated characteristic of the AMM was its ability to show physiologic data to the learners/trainees through realistic monitoring equipment, including a feedback mechanism, and a physiologic engine, which had its own learning system that did not require input from an observer/controller, and as a result, vastly improved the realism of the trauma scenario.
6. Although the aim of this study was not to evaluate the specific modules, we did note the increased workload of the anesthesiologists was greater due to the unfamiliar interface of the ventilator and the medication administration pump modules. This lack of realism as to what they used in the scenario as compared to what they would normally use did correspond to less satisfaction as well.

### **3.4.1 ACS Study Administrative Summary of Events**

#### *3.4.1.1 AMM Phase II Kickoff Meeting at the University of Washington*

Key staff, including Ajit K. Sachdeva, MD, FRCS, FACS; Patrice Gabler Blair, MPH; Kathy Johnson, EdM; and Cathy Sormalis, from the American College of Surgeons (ACS) Division of Education, participated in an all-day meeting on October 29, 2016, which was part of the AMM Phase II Kickoff meeting held at the University of Washington, Seattle Washington, from October 28 to November 1, 2016. The objectives of the kickoff meeting centered on team formation, roles and responsibilities; the time-phased program plan; technical objectives and manikin architecture; data items; financials and budgets.

Following this meeting, Dimitrios Stefanidis, MD, PhD, FACS; Raj Aggarwal, MD, PhD, FRCS, FRCS; and Robert Rush, MD, FACS, were identified as consultants for the project, and two ACS staff were formally added as consultants: Patrice Gabler Blair, MPH; and Gysung Lee, PhD. Several conference calls were convened to discuss



various research strategies, timelines, and next steps, starting with plans for an in-person meeting of the ACS workgroup and the AMM Phase II leaders.

#### 3.4.1.2 *ACS AMM Project Kickoff Meeting*

The ACS AMM Project Kickoff Meeting was held on June 4 and 5, 2017, in Chicago. Most of the time across the 1.5 days was devoted to developing common terminology; clarifying the specific focus of research to be done; e.g., evaluating the modular platform versus peripherals; and developing consensus regarding viable options for the research study design. Specific research activities, such as bench testing that might be best completed at the University of Minnesota, were identified. Other opportunities to solicit early informal feedback from users, such as pilot testing at the University of Washington, might be used to allow incorporation of that feedback into the AMM development process. Other topics discussed included sample scenarios that might be used to assess the module, submissions to institutional review boards, possible selection criteria for participating ACS-Accredited Education Institutes, timelines, and next steps.

#### 3.4.1.3 *Development of Study Design, Research Instruments, and Simulation Scenarios*

During the following months, numerous small-group and large-group telephone calls were conducted to discuss further and develop consensus regarding the study design. It was determined that the ACS AMM study would be conducted using a randomized cross-over design with two conditions: Condition 1 will evaluate the peripherals while connected to the AMM platform, and Condition 2 will solely evaluate the peripherals. Through a power analysis, the ACS study team estimated 51 study participants for each of the three participant groups (First Responders, Anesthesiologists, and Surgeons) at each study site.

The ACS study team also developed three custom-developed assessment instruments for quantitative and qualitative data collection and analysis for the study. These assessment instruments are as follows: Demographic Questionnaire, Simulator Experience Assessment Questionnaire, and AMM Global Rating Scale Scenario quality global rating scale.

The AMM simulation scenario was additionally developed with the consideration of several factors. These factors include the capabilities of the AMM to be evaluated and peripherals being developed, the range of clinical expertise of civilian and military participants, the procedures to be performed, and the estimated length of the simulation. The AMM scenario had three scenes and followed a patient from on-site at a motor vehicle accident to the emergency department trauma bay and later to the operating room. The AMM scenario required a team of three healthcare providers (a first responder, an anesthesiologist, and a surgeon) and two confederates (in assistant roles) to simulate the three proposed patient care scenes.

#### 3.4.1.4 *AMM Pilot Study at the University of Washington*

A two-day pilot test was conducted in March 2019, at the University of Washington. On the first day, the ACS study team worked with the mannikin platform and peripherals and performed a test run of both conditions of the study. On the second day, two teams of

recruited participants (one first responder, anesthesiologist, and surgeon on each team) concurrently completed all components of the study. As a result of the two-day pilot, adjustments were made to the manikin platform and peripherals; the planned simulation scenario; the site personnel roles, scripts and training needs; the room sets, timing and flow of the simulation scenario; the assessment instruments for data collection; and the data flow and reconciliation processes.

#### *3.4.1.5 Request for Application (RFA) Announcement and Site Selection*

Once all the AMM study materials, including the study protocol, research instruments, and the simulation scenario, the RFA was distributed electronically on March 6, 2019, to over 200 institute directors, surgery directors, and administrators of the 92 ACS Accredited Education Institutes (AEIs). In addition, a special, two-hour informational session was offered on March 15 during the 2019 ACS Simulation Summit for those interested in the project, and approximately 15 individuals attended representing seven programs.

Eight applications were received by the April 1, 2019, deadline and underwent a very thorough review and rating process. By the end of April 2019, the following three sites had been selected and invited to participate in the study:

- Naval Medical Center San Diego (NMCSA), San Diego, California
- Penn State Health Milton S. Hershey Medical Center, Hershey, Pennsylvania
- Canadian Surgical Technologies and Advanced Robotics (CSTAR), London, Ontario, Canada

Each of the three sites agreed to participate and have been engaging in ongoing discussions with ACS staff since that time.

#### *3.4.1.6 Institutional Review Board (IRB) Process*

In parallel with the RFA process, following the finalization of the study protocol and supporting documents, an Internal Review Board (IRB) application was submitted to the American Institutes for Research (AIR), and the approval decision was received on July 5, 2019. A Human Research Protocol Submission Form with the AIR IRB application package was submitted to the Human Research Protection Office (HRPO) for a pre-review, and initial feedback was received on July 11, 2019. The accepted study protocol and supporting documentation from the IRB reviews were shared with the three study sites in mid-July so that they could begin preparing their local IRB applications.

#### *3.4.1.7 Selection of the AMM Study Site*

The IRB application process at three sites took much longer than our original anticipation, and only two sites, NMCSA and CSTAR, submitted their IRB approval letters to the ACS. The ACS study team had a teleconference with the AMM team members at the University of Washington and the University of Minnesota on December 6, 2019, to discuss the current on-site research study execution plans and the upcoming research study deadline of January 25, 2020. In consideration of multiple factors, including the tight research study schedule, manikin shipment logistics, UW's DoD contractual requirement of involving one military site, and logistics for collecting the best

research dataset, the ACS team has decided to conduct the AMM study at the NMCS D in early January.

#### 3.4.1.8 *AMM Study and Data Collection at the NMCS D*

The ACS study was executed at the NMCS D for 11 days from January 7 to January 17, and 14 participants team (14 Corpsmen, 14 Anesthesiologists, and 14 Surgeons) volunteered for the study. Two simulation technicians from the University of Washington stayed at the NMCS D throughout the study period, and several ACS study team members visited the NMCS D for staff training and study monitoring. All the study data were collected and transmitted to the ACS for further data analysis.

#### 3.4.1.9 *AMM Study Data Analysis*

The AMM study team created a REDCap database and stored all the AMM study data collected at the NMCS D. The data set was then statistically analyzed by a statistician, and the results were discussed with the rest of the AMM study team during the data analysis period.

### 3.4.2 **Scenario Development**

#### 3.4.2.1 *Final Scenario for ACS Usability Study*

The scenario that will be used for the validation study by the American College of Surgeons has been finalized. This scenario is also important for the performance specifications testing and clinical value/verification study at the University of Minnesota. The storyboard in Figure 28 below shows the scenario and demonstrates the communication inputs and outputs through the case. Particular attention was paid to making the scenario appropriate across several roles of care, levels of training and features the interoperability and usability of the system.

The following is a synopsis of the scenario to be demonstrated contiguously across physical and virtual platforms.

- A male individual is riding in a Humvee Vehicle travelling at high speeds when an explosive is detonated underneath it. The individual inside is seat-belted as the vehicle rolls over several times. Rescue team arrives and extracts the individual from the rolled over vehicle. The individual is breathing and awake but appears to be in pain.
- An initial inspection is done, and no noticeable injuries found.
- IV catheter is placed, fluids connected, and vitals are checked.
- Physical Exam – abdomen becomes tender and mildly distended; patient continues to be in pain.
- Vital Signs/Physiology Engine Output– shock state – still has tachycardia. BP starts trending down to 90’s systolic.
- FAST Exam – free fluid found in abdomen.
- Vital Signs/Physiology Engine Output – shock state – mild hypotension and continued tachycardia.
- Vital Signs/Physiology Engine Output – shock state – ongoing resuscitation by IV fluids. Mild tachycardia and systolic in the 90’s or high 80’s.
- Laparotomy

- IVC bleeding.
- Spleen ruptured.
- Bladder ruptured.
- Spleen removed.
- IVC repaired.
- Bladder rupture repaired

For a full description of the scenario executed on the AMM platform in the ACS study is described in CDRL A009, under medical scenario verification.

### 3.5 Delivery and Demonstration of Male “Beta” Full Body Patient Prototype

**Executive Summary:** The Beta system is a full body manikin prototype that implements the AMM platform, including final software and connector standards, expansion for including the CAE physiology engine and its capabilities. It was aimed at demonstrating the functional performance of the platform, taking into consideration performance outcomes of the alpha prototype. Changes include improving the physical structure and appearance of the manikin, bug fixes to software modules, and upgrades to the AMM standard. While the

Two units were required for the final delivery.

Beta physical deliverables (two identical units):

1. Prototype airway torso
2. Head with airway sock
3. IV arm (Right)
4. Left Arm
5. Bilateral legs
6. Central supply stack
7. Tablet with Module Manager
8. CAE fast exam unit

Beta digital deliverables:

9. BioGears physiology engine
10. CAE physiology engine
11. Control module (AMM CORE)

#### 3.5.1 Alpha Prototype vs Beta Prototype

From the end-user’s perspective, the Alpha and Beta systems are identical in operation, but differ in the modules that are included. Software changes made between Alpha and Beta did not affect the end-user’s interactions with either systems. For verification, a use case test was designed and performed on both systems.

The test was designed with a fixed set of inputs executed via macros such that the timelines associated with the identical tests. The output of the Alpha and Beta systems was identical, indicating that a user of either systems would not be able to differentiate the two.

The test scenario is a list of inputs, derived from the ACS scenario, simplified, and focused on final deliverables at the end-of-project. The test scenario was executed with Selenium IDE, which scripted all the necessary clicks on the User Interface. The same script was applied to the Alpha and Beta Systems, and the log files were saved and compared as system outputs.

Below is the developed test scenario that the Selenium IDE script executed:

Alpha vs Beta Test Scenario	
Input:	Purpose:
Power on the system	Provide power to the supply stack/manikin
Click services page, stop all core services.	Demonstrating how to initialize the system
Restart the Module Manager	Turn on the Module Manager
Restart the Physiology Manager	Turn on Physiology Manager functions
Restart the Rest Adapter	Turn on Rest Adapter functions
Restart the Sim Manager	Turn on Sim Manager functions
Restart the TCP Bridge	Turn on TCP Bridge functions
Restart Fluidics Services	Turn on fluidics services functions
Restart Torso Services	Turn on torso services functions
Restart IV Arm	Turn on IV arm functions
Click Actions -> Technical -> Start Fluidics -> Main Dashboard	Pressurize the fluidics system so that it reaches a ready status
Click ACS Scene 2 page -> Load Scenario 2	Scene configurations are published to connected modules
Click Load Patient State Scene 2	Patient conditions are published to connected modules
Start Scenario	Begin simulation
Click Insert IV Cath	Verify that a catheter is inserted into the IV Arm module and it is registered by the system
Click Give Succs	Administer drugs to the patient to observe patient state changes
Click BVM On	Resuscitate the patient and observe patient state changes
Click BVM Off	Remove BVM and observe patient state changes
Click Intubate -> Tape and Ventilate	Intubate the patient correctly to resuscitate the patient and observe patient state changes
Give Saline 2L	Administer fluids to observe patient state changes
Give Blood 2U	Administer fluids to observe patient state changes

*Table 4: Testing approach to compare Alpha vs. Beta AMM platforms.*

### Design Changes

**Objective:** The final two Beta patients, delivered at the end of the project had physical design improvements to sustain repeated demonstrations. This included modifications in appearance, functionality, and fidelity of the full body manikin. These design changes were completed during the no cost extension period, as it afforded additional prototyping, testing, and iterations.

Changes to the manikin structure include:

1. The back shell upgraded to a more robust design and supports a different chest rise hinge mechanism.
2. A smoother chest rise mechanism was integrated.

3. Improved ribcage production process to increase 3D print quality and future maintenance.
4. Backplate allowed the torso skin to be secured and prevented the manikin from sliding on a tabletop surface.
5. The spine connector was removed to afford space for the AMM control module.
6. The boardshorts were removed. See Figure 49.

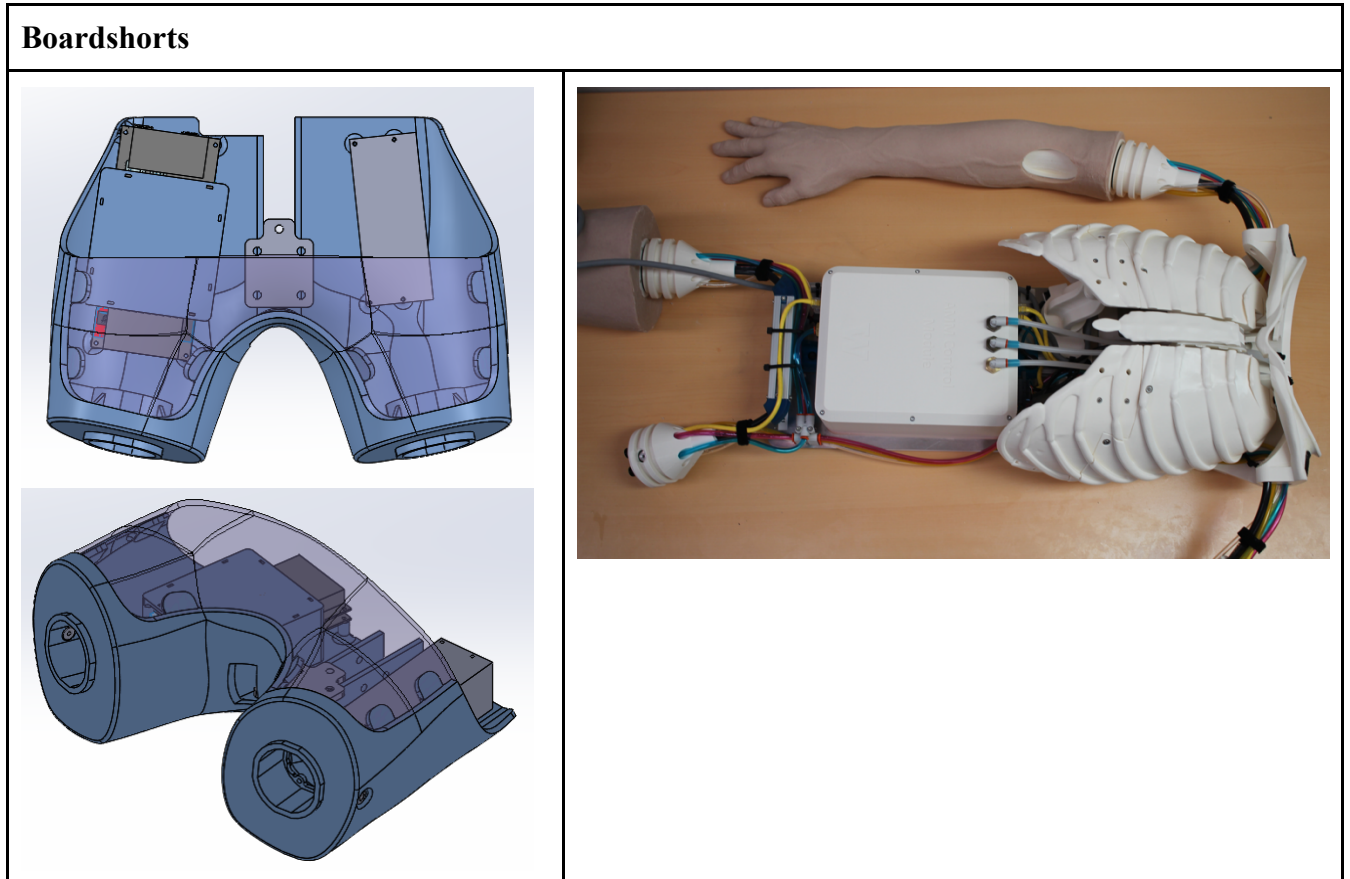

*Figure 49: No board shorts were used. Leg routing was done with steel cable through the 80/20 seen in the above image. Foam was used to provide the shape of the thighs. All electronic components were put inside the torso controller and external fluid stack.*

### System Changes

**Control System Changes:** System changes made to the alpha prototype brought the beta prototype to the AMM 1.0 Standard and consolidated relevant electronic components and hose routing to improve the spatial arrangement and efficiency.

## Control System Changes

Alpha Prototype	Beta Prototype
<ul style="list-style-type: none"> <li>• The torso controller ECU is a Dragonboard 410c embedded board. The CORE software services are running on a separate ECU (AMMDK). Both embedded systems are mounted in the torso.</li> <li>• The Wi-Fi router that enables connection to simulated Operating Room devices, service laptop etc. is external to the manikin with a wired ethernet connection.</li> <li>• System power to all modules is provided from three 12V circuits. The power bricks are housed in the supply stack and power is routed through the designated DC power pins on the AMM connector.</li> <li>• Power, networking, and fluids are supplied only to the right arm to support an AMM compatible IV arm module.</li> </ul>	<ul style="list-style-type: none"> <li>• The majority of control system components are assembled into a removable control module box that is mounted in the abdominal space of the beta manikin. The torso controller is a Dragonboard 410c embedded board. Torso control and CORE software with the exception of the physiology engine are running on this ECU.</li> <li>• The Wi-Fi router is integrated into the control module box.</li> <li>• The system components are powered and networked via PoE network switches/injectors that supply up the 25W per channel (IEEE 802.3at). The DC supplies for the switches are routed through the designated DC power pins on the AMM connector with external power bricks connected to 120V mains.</li> <li>• Power and networking connections are supplied via PoE connections to all AMM segment connectors. The PoE connection to the right leg supports a 60W module (IEEE 802.3bt) that is necessary to drive the fluidics supply.</li> </ul>

*Table 5: Summary of Control System Changes going from Alpha to Beta AMM Platform.*



## Fluid Supply Stack

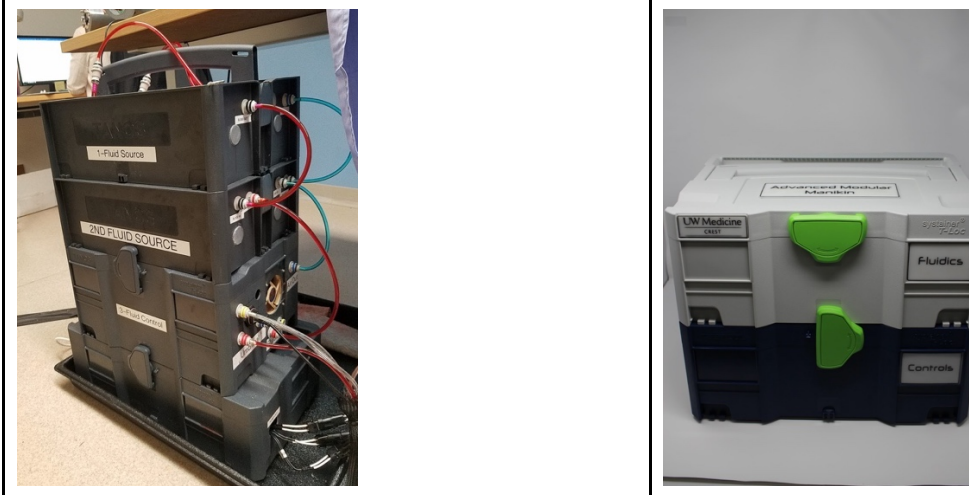

*Figure 50: Fluid Supply stack consolidation*

As demonstrated in Figure 50, in the Alpha prototype to the left, the power supplies, Wi-Fi router, and fluidics supply are configured into four total boxes. This stack at left is designed to hold 4L of water. The fluidics supply module has a separate power supply that is connected to 120V of main power that is connected within the supply stack. As shown at right, the Beta prototype has a smaller fluidics stack, since it is isolated to containing the fluidics supply only. The AMMDK that controls the fluidics module also runs the relevant physiology engine, as the internal torso ECU is not powerful enough to run the physiology simulation in real time. The modular nature of the data architecture allows the individual CORE modules to run on any hardware connected to the system. In the beta iteration, the fluidics supply is supplied with power and the network connection from the torso via the Universal Segment Connector.

## Internal Routing and Electronics



*Figure 51: As shown by the internal components of the fluidics supply stacks, the beta prototype has decreased the amount of space needed by moving the Wi-Fi router and power supplies from the stack. Furthermore, the hoses do not route the full 4 L of fluids, but also provides a loop back through the fluidics box for waste (yellow tubing).*

### 3.5.2 AMM 1.0 Standard and Modular Capabilities in Beta

As described in year 3 accomplishments, the beta prototype differs from the alpha prototype in that the beta prototype is adherent to the published official AMM 1.0 Standards.

Specifically, the CORE software is fully compliant and improved in robustness, while the hardware (PoE) support the 1.0 Standards (see control system changes in part B).

The beta prototype also integrates various modules and capabilities to demonstrate the functionality of the AMM platform. While the alpha prototype integrated only the BioGears Physiology Engine, the beta prototype allows for the CAE Physiology Engine to be independently be used as well. Importantly, the changes to the fluidics module explain how the fluidics service is also responsible for running the chosen physiology engine. The integration of a second physiology engine is an example of a potential application of the AMM platform on existing simulation technology.

In consolidating various electronic components and their respective functionalities, the beta prototype also contains an AMM control module in the abdominal region. While the torso control system components of the alpha prototype were individually mounted into spaces under the rib cage and housed in the boardshorts, the control system components were assembled into a control module box in the beta prototype (Fig. 52). The control module box is mounted into where the palpation module and laparotomy module previously connected to the system. Since the control box itself is modular, it can be easily removed from the manikin. However, this meant that the spine connector in the alpha prototype was removed from the beta prototype in order to create the space necessary for the control module box. Furthermore, the palpation module and laparotomy module were intended for proof of concept in terms of functionality and compatibility with the AMM platform. If either module were connected to the reference design box, it would behave as a module would on the AMM system. Removal of the spine connector afforded both physical and electronic design changes to improve the realism and efficiency of the full-body manikin.

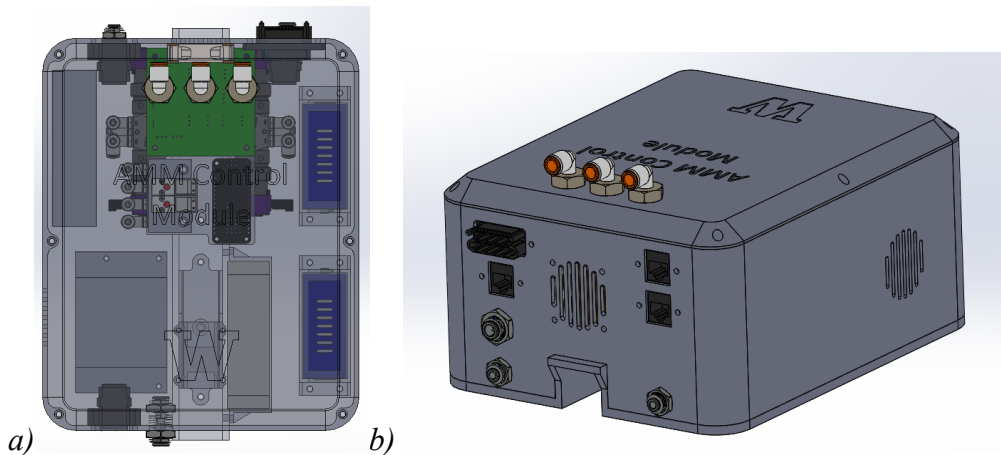

**Figure 52:** a) The AMM control module and the internal components. b) The exterior of the AMM control module.

The beta prototype includes the capabilities of toggling between the two integrated physiology engines through the updated guided user interface; BioGears and CAE physiology. This demonstrates the modularity of physiology engines in that the physiological outputs between the two will vary, even when the physiological inputs are identical. This

capability expands beyond BioGears and CAE physiology, such that other groups may develop their own relevant physiology engines and implement it into the AMM system.

To reflect the updated software capabilities, the user interface also received improvements from the user interface intended for the ACS Usability Study. Firstly, the ACS Study scenario specific pages were removed. New pages including relevant functions were added. Ease of use was improved with user feedback.

### 3.5.3 The Beta “twins” Build

**Objective:** The full-body Beta units implemented the aforementioned physical design and system changes to the alpha prototype during the allotted month after the ACS Usability Study. Efforts were attributed to improving existing functionality and reliability, while increasing the overall capabilities.

**Outcomes:** As a result of these efforts, the two identical delivered beta units are the most up-to-date full body manikins developed by CREST Lab in terms of software, systems, and physical design (*Figure 53*). Key changes were supported feedback received from healthcare professionals, simulation technicians, and collaborative efforts with the American College of Surgeons.

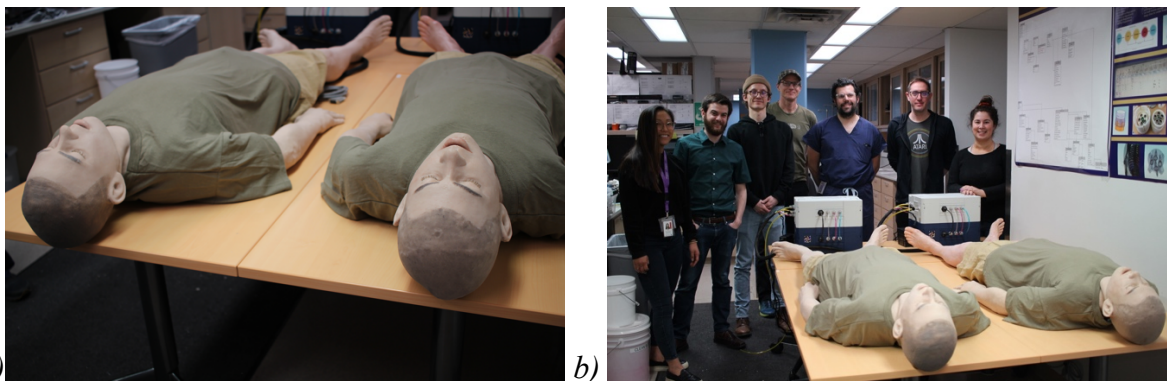

*Figure 53: a) Two identical beta units from a superior view. b) Several UW CREST team members alongside the two beta units.*

Each Beta twin was packaged into five pelican cases per unit; this separated the deliverables to Beta A and Beta B. The cases consist of 1) fluidics boxes, tablets, 2) manikin torso, 3) head, arms, 4) legs, and 5) the CAE ultrasound module (Fig. 5). The Beta units were delivered to the United States Army Research Laboratory in Orlando, Florida. At a later date, the UW CREST Team will use a beta unit to perform a final demonstration of the capabilities of the Advanced Modular Manikin.





*Figure 54: The packed beta units, separated by parts, organized by units A and B.*

### 3.6 Next Steps

The DoD has funded a series of Open Source projects to further state-of-the-art in healthcare simulation and lower the barrier to entry for companies into the world of high-fidelity simulation. Both academia and industry are seeing the significance of these projects and recognize the advantages of a fresh start with a modern architecture providing ease of use and connectivity.

As required by the funders the AMM platform is indeed modular, distributed and interoperable. Although we have created considerable documentation, a developer's kit and sample code, we have not gone far enough to support a broad-based adoption. The developer's tool kit provides a fully functional AMM CORE with all necessary software preloaded to help interested parties start development projects. The development team needs to continue to support the project, perform outreach and expand the code base until a healthy open source community is established to fully realize the value of this investment.

It is envisioned that an initial 3-year sustainment effort would lead to broader adoption of the standards. The principal focus of the sustainment effort will be around outreach and support for teams that want to start working with the AMM platform. To that end we would propose the following:

- A yearly developers conference to introduce interested parties to the standards and developer's toolkit
- Outreach to simulation societies and professional healthcare societies
- Cost reduction and simplification of the toolkit to bring it in-line with academic projects like capstone projects
- Identify a vendor(s) that is interested in producing the developer's tool kit
- Continue improving the AMM web site and expand documentation with examples
- Based on requirements from ongoing projects expand the data models to cover new interventions and disease states as required
- Provide early support to other engineering teams, with the expectation that if effort levels expand, they would have to provide funding out of their project budgets

## 4 Impact

### 4.1 Adoption of AMM Standards by other Projects.

AMM interoperability standards have been adopted by two DHA-funded Small Business Innovation Research (SBIR) projects and, more recently, an Army Broad Agency Announcement (BAA) project. These early-adopter projects are providing further feedback on the usability of the standards and demonstrate its adaptability to a range of medical treatment facility roles, patient conditions, and provider capabilities. They also show the ability to tailor the implementation for use with part task trainers and virtual simulations using inexpensive hardware. Results of the two SBIR projects were demonstrated at the International Meeting on Simulation in Healthcare (IMSH) in January 2018.

Blended Reality Medical Training System, (BRMTS), Contract No. W81XWH-17-C-0161. For this project, Strategic Operations (STOPS), with Vcom3D as subcontractor, is developing a Humeral Head Intraosseous (HHIO) infusion training system. Vcom3D integrated the AMM Core on a credit card-size SoM embedded in a Humeral Head Intraosseous (HHIO) trainer as seen below in Figure 56. Also embedded is a microcontroller (shown in correct size proportion to the SoM). The system also includes a virtual patient, virtual patient monitor, and instructional software, all of which interface with the CORE. Thus, the virtual patient responds appropriately to simulated blood loss and infusion of fluids.



*Figure 55: The BRMTS implements the AMM Core on a credit card-size computer embedded in the HHIO trainer.*

Advanced Female Trauma Training System (AFTTS), Contract No. W81XWH-17-C-0181. For this project, Vcom3D, with University of Washington CREST as subcontractor, is developing a manikin and virtual patient for training Combat Medics and other providers in treating female victims of battlefield injuries. As with the BRMTS, the AFTTS implements the AMM Core on a credit card-size SoM and integrates a virtual patient, virtual patient monitor, and a manikin with sensors. However, the AFTTS includes lab reports and the manikin includes actuators as well as sensors. For the Phase I prototype, we simulated a tension pneumothorax and the response to needle decompression, infusion of fluids, and pain medication. Response to the pneumothorax and decompression includes uneven chest rise (both in the manikin and in the virtual patient) and

poor oxygenation. For the current Phase II, we are developing a simulation of chest rise and its response to pneumothorax and its treatment by needle decompression, as shown in the Figure 57 below.



*Figure56: AFTTS Manikin and Chest Rise Mechanism*

Immersive Modular Patient Care Team Trainer (IMPACTT), Contract No W911NF-18-C-0040. Vcom3D has completed the first year of a two-year project to develop an Advanced Virtual Patient with team training capabilities. This system uses the same messaging, scenario control, and physiology modeling infrastructure as AMM and AFTTS. The initial training scenarios includes burn and polytrauma patients who receive resuscitation, wound management, and rehabilitation care.

IMPACTT, shown in Figures 57 and 58, enables four or more providers, including a physician, nurse, respiratory specialist, and technician, to practice teamwork skills while treating a virtual trauma victim in an austere emergency room environment. A built-in assessment tool provides a summary of both individual and team performance. IMPACTT was demonstrated to JPC-1 at an IPR in late October 2019, at the Interservice/Industry Training, Simulation, and Education Conference (IITSEC) in December 2019, and at the International Meeting on Simulation in Healthcare (IMSH) in January 2020.

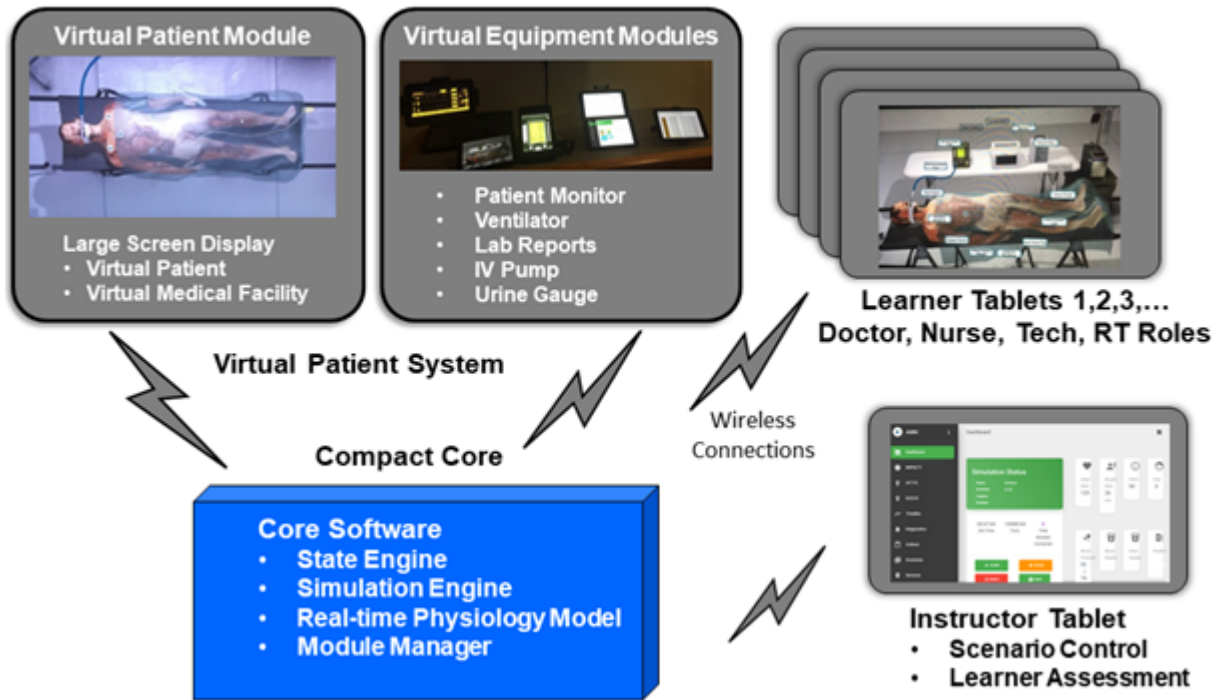

Figure 57: Vcom3D, Inc. Virtual Patient System.

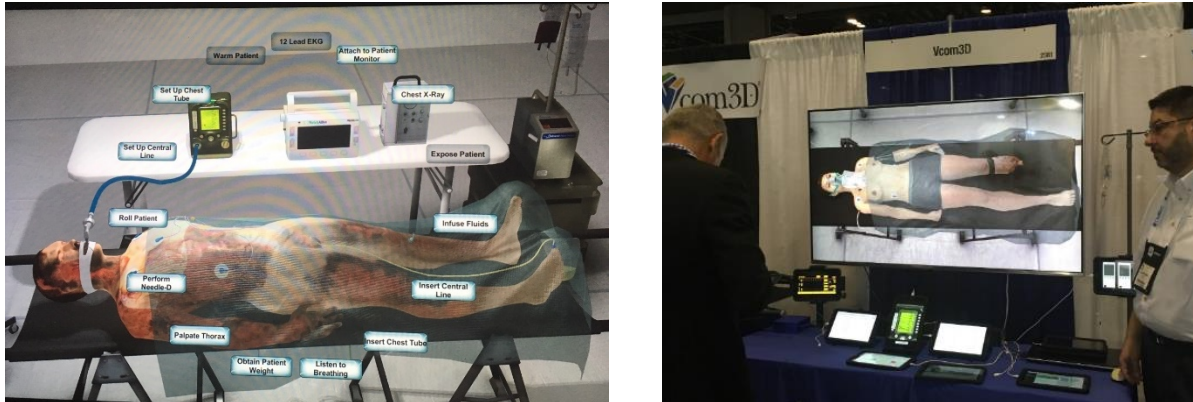

Figure 58: IMPACTT Virtual Male Burn Patient and Female Polytrauma Patient

AMM interoperability standards have been adopted by other projects, including both commercially funded development and projects funded by DHA. These early-adopter projects are providing further feedback on the usability of the standards and they demonstrate an adaptability to a range of medical treatment facility roles, patient conditions, and provider capabilities. They also show the ability to tailor the implementation for use with part task trainers using inexpensive hardware. Other third-party modules being developed to the AMM standards include an Abdominal Simulator (AbSim) by ACDET, Fort Worth, Tx, and a lower-leg fasciotomy training system funded by Army Futures Command and led by Simetri, Orlando, FL



In addition to the modules that are demonstrated in *Alpha AMM*™, projects developing or incorporating trainers using the standards that our team is aware of as of the time of this report include a Point of Injury Training System (POINTS) prototype led by IVIR, Sarasota, FL and SimQuest, Annapolis, Md, a Humeral Head Intraosseous (HHIO) Infusion trainer being developed by Strategic Operations, San Diego, CA, an Abdominal Simulator (AbSim) by ACDET, Fort Worth, Tx, a lower-leg fasciotomy training system funded by Army Futures Command and led by Simetri, Orlando, FL, the Advanced Female Trauma Training System (AFTTS) led by Vcom3D, Inc. and Immersive Modular Patient Care Team Trainer (IMPACTT), a second project led by Vcom3D. UW CREST and VCOM3D are exploring the development of middle-ware to facilitate the integration of CAE's commercial physiology engine as well.

The AFTTS, Contract No. W81XWH-17-C-0181, led by Vcom3D, with University of Washington CREST as subcontractor, was demonstrated to JPC-1 integrated into a prototype Point of Injury Training System (POINTS) on June 19, 2019. While the AFTTS modules communicated via the AMM™ Distributed Data Services (DDS) bus, the system was integrated with other POINTS systems via a High-Level Architecture (HLA) gateway. One of these POINTS systems was the HumMod Physiology Engine, which modeled patient physiology response to injuries and interventions. As part of the demonstration, a decompression needle was used to deflate a tension pneumothorax in the AFTTS manikin. After decompression, bilateral chest motion resumed in the AFTTS manikin, and vital signs returned to normal.

## **5 Risks**

The following have been communicated with the COR previously and still remain open issues.

1. Patent application (US20160055767A1-Harvard AMM) by the CIMIT team. This application is a concern given the similarities in direction and the potential impact on the plan to provide AMM II as open and royalty free. We have discussed this at the IPR with JPC-1 as a risk and discussed coordinated strategies to mitigate this risk with JPC-1.
2. SynDaver use of Advanced Modular Manikin name for their manikin.

All other previously described technical risks were successfully mitigated.

## **6 Products**

### **6.1 Publications**

Barnes JJ 3rd, Konia MR. Exploring Validation and Verification: How They Are Different and What They Mean to Healthcare Simulation. *Simul Healthc.* 2018 Oct;13(5):356-362. PubMed PMID: 29771813.

Sims, E., Silverglate, D., Hananel, D., Sweet, R., Reihisen, T., and Norfleet, J. "A Modular Architecture for Blending Virtual and Manikin-Based Medical Simulations", Proceedings of the Interservice/Industry Training Simulation and Education Conference (I/ITSEC), December 2016, Orlando, FL.

Sims, E., Silverglate, D., and Sotomayor, T. "Using the Advanced Modular Manikin Architecture to Extend the Scope of Medical Task Trainers", Proceedings of the Interservice/Industry Training Simulation and Education Conference (I/ITSEC), December 2018, Orlando, FL.

## 6.2 Presentations

Sweet, RM., International Meeting on Simulation in Healthcare, “JPCI Advanced Modular Manikin Phase II Update”, Jan. 30, 2019, San Antonio TX.

Sweet, RM., Society Academic Urologists, “Novel Education Tools that Work”, Feb 1, 2019, Houston TX.

Sweet, RM., UCF 1<sup>st</sup> Partnership II, “AMM JETS Core Presentation”, Feb. 12, 2019, Orlando FL.

Sweet, RM., ACS Surgical Simulation Summit, “Surgeons and Engineers: A Dialogue on Surgical Simulation”, Mar. 16, 2019, Chicago IL.

Sweet, RM., Engineering and Urology. Translational Success State-of-the-Art and Future: “Simulation in Urology: Where we are and where we are going”. May 5, 2019, Chicago IL.

Sweet, RM., American College of Surgeon Committee Presentation, “Surgical Skills Training for Practicing Surgeons”, June 28, 2019, Chicago IL.

Sweet, RM., Chehalis STEM Academy, “Simulation Design Process and Engineering Considerations: Surgery on the Manikin”, July 18, 2019, Chehalis WA.

Sweet, RM., Surgery Grand Rounds at Walter Reed National Military Hospital, “Advancement in Simulation Science and Technologies for Military Medical Training”, Aug. 14, 2019, Bethesda MD.

Sweet, RM., Military Health Systems Research Symposium (MSHRS), “Training Effectiveness for Point of Injury Medical Care - Advanced Modular Manikin Phase 2 Update”, Aug. 20, 2019, Kissimmee FL.

Sweet, RM., The Society of Laparoscopic Surgeons MIS Week, “It’s Alive”: The Advanced Modular Manikin Platform”, Sept. 5, 2019, New Orleans, LA.

Sweet, RM., International Society for Medical Innovation and Technology. *Gerhard Buess Keynote Lecture*. “The Advanced Modular Manikin Platform: A disruptive technology for Surgical Simulation”. October 11, 2019, Heilbronn, Germany.

Silverglate, D. “The Advanced Modular Manikin Architecture and Reference Implementation”. ACS Surgical Simulation Summit - Surgeons and Engineers: A Dialogue on Surgical Simulation”, Mar. 15, 2019, Chicago IL

## 7 Participants & Other Collaborating Organizations

Name:	Robert M. Sweet, MD, FACS
-------	---------------------------

Project Role:	Principal Investigator
Nearest person month worked:	4
Contribution to Project:	Dr. Sweet was the principal investigator on this project, overseeing development through subcontractors, verification testing, validation plans and project management.

Name:	Mojca Konia, MD,
Project Role:	Co-Principal Investigator
Nearest person month worked:	4
Contribution to Project:	Dr. Konia was co-principal investigator overseeing verification testing and project management at the University of Minnesota.

Name:	John Hoschette, MSEE, MBA
Project Role:	Project Manager
Nearest person month worked:	28
Contribution to Project:	Mr. Hoschette was responsible for project management along with verification of hardware and software.

Name:	John Raymond, MS
Project Role:	Contracts Manager
Nearest person month worked:	18
Contribution to Project:	Mr. Raymond was responsible for contract management, monitoring subawards, monitoring deliverables and submitting reports.

Name:	John (Jake) Barnes II, MD
Project Role:	Researcher – physiology verification
Nearest person month worked:	12
Contribution to Project:	Dr. Barnes was responsible for verification of physiology for the manikin and modules.

Name:	Kenneth Kiberenge, MD
Project Role:	Post Doc Researcher – physiology verification
Nearest person month worked:	6
Contribution to Project:	Dr. Kiberenge was responsible for verification of physiology for the manikin and modules.

Name:	Mark Gilberton
Project Role:	Graduate Research Assistant – hardware/software verification

Nearest person month worked:	2
Contribution to Project:	Mr. Gilberton was responsible for testing and verification of the hardware/software design including the fluid system and connectors

Name:	Rebecca Smith
Project Role:	Graduate Research Assistant – hardware/software verification
Nearest person month worked:	7
Contribution to Project:	Ms. Smith was responsible for testing and verification of the hardware/software design including the fluid system and connectors

Name:	Kai-Bin Ooi
Project Role:	Research Professional/Technician
Nearest person month worked:	8
Contribution to Project:	Ms. Ooi was responsible for stress testing the AMM platform, developing protocols for operation, maintenance of the AMM platform during the ACS study as well as troubleshooting issues.

Partner Organizations

Subcontract: University of Washington CREST – PI: David Hananel

Subcontract: Vcom3D – PI: Ed Sims, PhD

Subcontract: American College of Surgeons – PI: Ajit Sachdeva, MD, FRCSC, FACS

Subcontract: Army Research Laboratory – PI: Jack Norfleet, PhD

**8 Special Reporting Requirements**

Does not apply.

## 9 Appendix

### Appendix I: CDRL Summary

#### Contract Data Requirements List

[https://en.wikipedia.org/wiki/Contract\\_data\\_requirements\\_list](https://en.wikipedia.org/wiki/Contract_data_requirements_list)

The developers of the platform have agreed to publish the AMM platform under the following open source licensing option:

*Creative Commons Attribution 4.0 International (CC BY 4.0)* <https://creativecommons.org/licenses/by/4.0/deed.ast>.

*Share — copy and redistribute the material in any medium or format*

*Adapt — remix, transform, and build upon the material for any purpose, even commercially.*

*The licensor cannot revoke these freedoms as long as you follow the license terms.*

#### CDRL A0001 - SDD

This document is the AMM Software Design Description CDRL A001 SDD of Contract # W81XWH-14-C-0101, Phase II. The outline and subject matter content are based on DID DI-IPSC-81435A as required by the contract. The DID has been tailored to describe an open platform and open-source reference software that can be run on either the AMM reference computer hardware, or other user-selected computer systems. This document is unclassified and contains no proprietary information, trade secrets, copyrighted material or classified information. Unlimited distribution.

The purpose of the SDD is to describe the AMM reference software that, in conjunction with the Interface Design Description (IDD) CDRL A007, and Software Product Specification (SPS) CDRL A002, can be used by developers to create new AMM modules.

*A software design description (a.k.a. software design document or SDD; just design document; also Software Design Specification) is a written description of a software product, that a software designer writes in order to give a software development team overall guidance to the architecture of the software project. An SDD usually accompanies an architecture diagram with pointers to detailed feature specifications of smaller pieces of the design. Practically, the description is required to coordinate a large team under a single vision, needs to be a stable reference, and outline all parts of the software and how they will work.*

#### CDRL A002 – SPS (Software Product Specification)

This is the Advanced Modular Manikin (AMM ) Software Product Specification (SPS) CDRL Item A002 of Contract # W81XWH-14-C-0101, Phase II. This SPS describes the “as built” design of the AMM Reference Software Computer Software Configuration Items (CSCIs) and describes the compilation, build, and modification procedures.

This CDRL is formatted to the requirements of Data Item Description Number DI-IPSC-81441A as required. It has been tailored to reflect the fact that the AMM Reference Implementation has been designed to run on a wide range of Linux and Windows systems.

*The Software Product Specification (SPS) contains or references the executable software, source files, and software support information, including "as built" design information and compilation, build, and modification procedure*

### **CDRL A003 - Commercial Drawings and Associated Lists**

CDRL A003 is intended for acquiring drawings and associated lists for commercial products at the end of the System Development and Demonstration Phase and during subsequent phases of the DoD materiel life cycle. The outline and subject matter content are based on DI-SESS-81000E as required by the contract. The DID has been tailored as appropriate. The commercial drawings and associated lists are contractor format.

All drawings and lists included in this document are either required components of the CORE AMM system that for compliance purposes must be included in the system or components included as part of a reference implementation to demonstrate the functionality of AMM platform. For instance, components of the fluidics system may not be required for modules being developed for the platform as long as the connectors are AMM compatible. Contact the Technical Director <dhananel@uw.edu> for further information.

The drawing reference document (Dwg. No. 100100) includes the system schematic design documents and an indented bill of materials for the mechanical assembly. Drawing reference items with 6-digit numerical part numbers are contractor assemblies and manufactured parts. All commercial items are referenced with drawing number indicating OEM in short form and OEM part number. Commercial items are further documented in this document. Contractor assemblies are documented in CDRL A004.

### **CDRL A004 – Product Drawings/Models and Associated Lists**

This CDRL Item A004 of Contract # W81XWH-14-C-0101, Phase II provides AMM product drawings/models and associated lists.

The outline and subject matter content of CDRL A004 are based on DI-SESS-81000E as required by the contract. The DID has been tailored as appropriate.

The reference system design CAD is in SolidWorks. The drawing reference document (Dwg. No. 100100) includes the system schematic design documents and an indented bill of materials for the mechanical assembly. The drawings/models and associated lists are contractor format.

Drawing reference items with 6-digit numerical part numbers are contractor assemblies and manufactured parts. All commercial items are referenced with drawing number indicating OEM in short form and OEM part number. Commercial items are further documented in CDRL A003.

### **CDRL A005 – SUM (Software Product Specification)**

This is the final version of the Software User's Manual as required by CDRL A005. The outline and subject matter content are based on DID DI-IPSC-81443A as required by the contract. The DID has been tailored as appropriate. This document is unclassified and contains no proprietary information, trade secrets, copy righted material or classified information. Unlimited distribution.

This CDRL is formatted to the requirements of Data Item Description Number DI-IPSC-81443A as required. This document is a Software User Manual which identifies the necessary information for a module supplier to successfully interface to software in the manikin.

*A user guide, also commonly called a technical communication document or manual, is intended to give assistance to people using a particular system.[1] It is usually written by a technical writer, although user guides are written by programmers, product or project managers, or other technical staff, particularly in smaller companies.[2]*

*User guides are most commonly associated with electronic goods, computer hardware and software, although they can be written for any product.[3]*

*Most user guides contain both a written guide and associated images. In the case of computer applications, it is usual to include screenshots of the human-machine interface(s), and hardware manuals often include clear, simplified diagrams. The language used is matched to the intended audience, with jargon kept to a minimum or explained thoroughly.*

### **CDRL A006 - Page-based Technical Manual (TM)**

This is the final document version as required by CDRL A006. The outline and subject matter content are based on MIL-STD-40051-2C as required by the contract. The DID has been tailored as appropriate. This document is unclassified and contains no proprietary information, trade secrets, copyrighted material or classified information. Unlimited distribution.

This document is a Page-based Technical Manual which identifies the necessary information for manikin operation.

### **CDRL A007 - Interface Design Description (IDD)**

This document is the AMM Interface Design Document (IDD) CDRL A007 of Contract # W81XWH-14-C-0101, Phase II. The outline and subject matter content are based on DID DI-IPSC-81436A, as required by the contract. The DID has been tailored to describe an open platform and open-source reference software that can be run on either the AMM reference computer hardware, or other user-selected computer systems. This document is unclassified and contains no proprietary information, trade secrets, copyrighted material or classified information and is available for unlimited distribution.

*The Interface Design Description (IDD) describes the interface characteristics of one or more systems, subsystems, Hardware Configuration Items (HWICIs), Computer Software Configuration Items (CSCIs), manual operations, or other system components. An IDD may describe any number of interfaces.*

### **CDRL A008 - System/Subsystem Specification (SSS)**

This document is the System/Subsystem Specification (SSS) CDRL Item A008 of Contract # W81XWH-14-C-0101, Phase II. The outline and subject matter content are based on DID DI-IPSC-81431A as required by the contract. The DID has been tailored as appropriate. This document is unclassified and contains no proprietary information, trade secrets, copyrighted material or classified information and is available for unlimited distribution.

*The System/Subsystem Specification (SSS) specifies the requirements for a system or subsystem and the methods to be used to ensure that each requirement has been met.*

### **CDRL A009 - Test Procedure**

This is the Advanced Modular Manikin (AMM ) Test Procedures CDRL Item A009 of Contract # W81XWH-14-C-0101, Phase II. This document defines the procedures used for testing all aspects of the platform performance during the development process.

This CDRL is formatted to the requirements of Data Item Description Number Data Item Description Number DI-NDTI-80603A. This document is unclassified and contains no proprietary information, trade secrets, copyrighted material or classified information and is available for unlimited distribution.

The test procedure has been divided into parts. In section 3.1 the AMM Medical Scenario Verification Tests (MSVTs) are defined. These are tests related to patient events and how well the manikin performs in relation to actual human data. In section 3.2 the Engineering Verification Tests (EVTs) are defined. These tests verify the engineering of the manikin as related to size, weight, construction workmanship, motion and electrical/software functionality. They also verify the reliability and usability in relevant environments.

The tests procedures provide the following information per Data Item Description Number DI-NDTI-80603A.

- Purpose of the test
- Description of the Test Article
- Test Requirements
- Test Equipment
- Step by Step Test Procedure
- Data Sheet

All tests described in this document relate to the AMM platform and not the individual modules that were used to demonstrate the operation of the platform. Module developers can use the Reference Design of AMM CORE as documented in CDRL A004, Section 3.1 both for development work but also to test for compatibility.

### **CDRL A010 - Test/Inspection Report**

This is the Advanced Modular Manikin (AMM ) Test Inspection Report CDRL Item A010 of Contract # W81XWH-14-C-0101. This document is unclassified and contains no proprietary information, trade secrets, copyrighted material or classified information and is available for unlimited distribution.

This CDRL is formatted to the requirements of Data Item Description DI-NDTI-80809B as required and has been tailored as appropriate. This document is the Test/Inspection Report for developmental tests performed on the BioGears Physiology Engine, Universal Hybrid Connector, Virtual Patient module, fluid system, and Core Software. All test results included in this document are either for required components of the CORE AMM system (that for compliance purposes must be included in the system) or components included as part of a reference implementation to demonstrate the functionality of AMM platform. For instance, components of the fluidics system may not be required for modules being developed for the platform as long as the connectors are AMM compatible.



### **CDRL A011 - Interface Control Document (ICD)**

This is the Advanced Modular Manikin (AMM ) Interface Control Document (ICD) CDRL Item A011 of Contract # W81XWH-14-C-0101. This CDRL addresses the requirements of Data Item Description Number DI-SESS-81248B as required. It is tailored to address the interfaces of AMM , which is not a specific training manikin, but a medical simulation platform, including specifications and a Reference Implementation (RI). This document is unclassified and contains no proprietary information, trade secrets, copyrighted material or classified information and is available for unlimited distribution.

This Interface Control Document (ICD) is an “Umbrella Document”. It describes how AMM interface requirements are controlled, by referencing other CDRLs, especially the Interface Description Document (IDD), and industry standards that provide detailed interface descriptions.

As an AMM design principle, interfaces between AMM modules, including mechanical, fluid, data, and electrical, are required by the AMM standards, whereas interfaces within a module may be determined by individual developers, as long as interface requirements between modules are met.

*An interface control document in systems engineering and software engineering, provides a record of all interface information generated for a project. The underlying interface documents provide the details and describe the interface or interfaces between subsystems or to a system or subsystem.*

### **Appendix II: Anthropomorphic Anatomic Male and Female Data Sets**

The following male and female images display the full-body layers of granularity in our anatomic dataset; skin, muscle, skeletal, vascular, and organ layers.

Within each layer, there is the ability to select specific anatomic structures of interest. For instance, if one were to examine the organ layer, they could choose to utilize the dataset for a single organ, such as the pancreas.

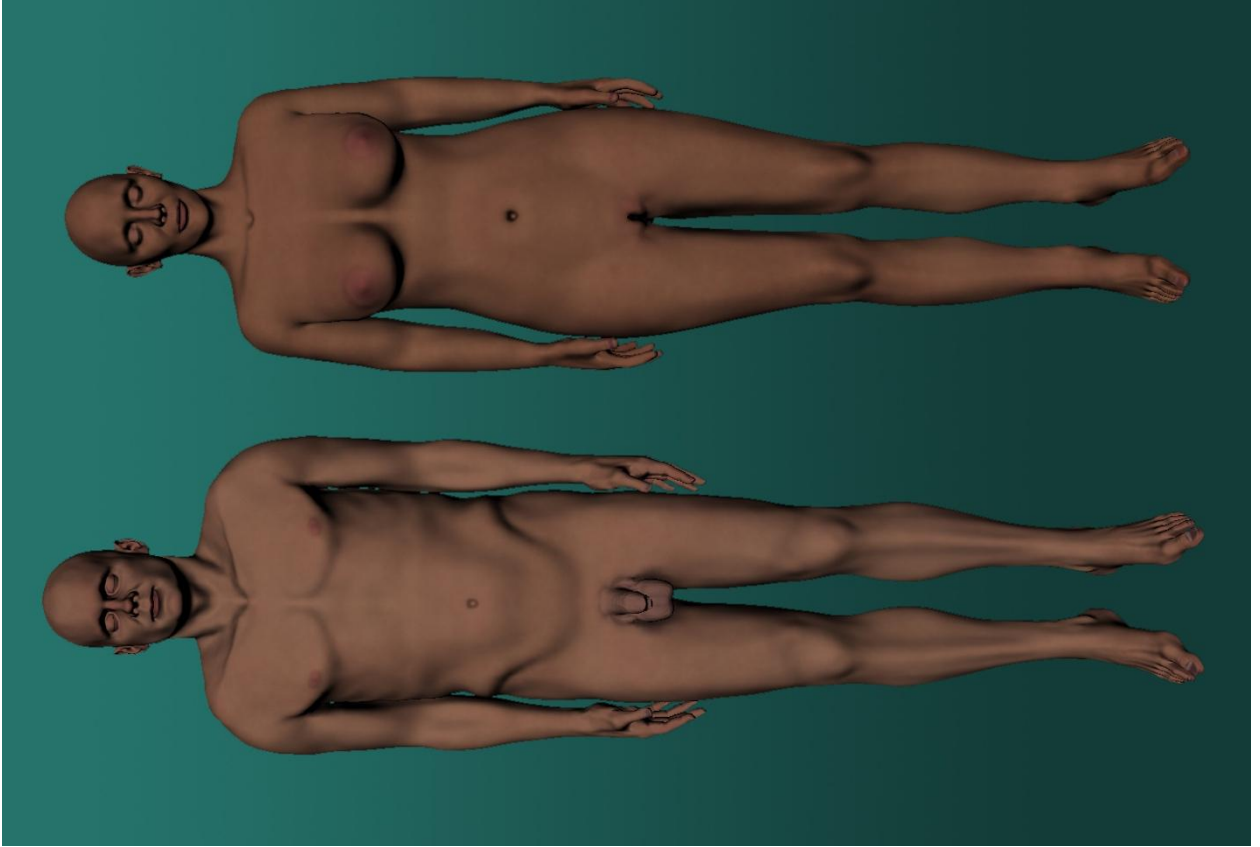

*Figure 1: Epidermis layer*

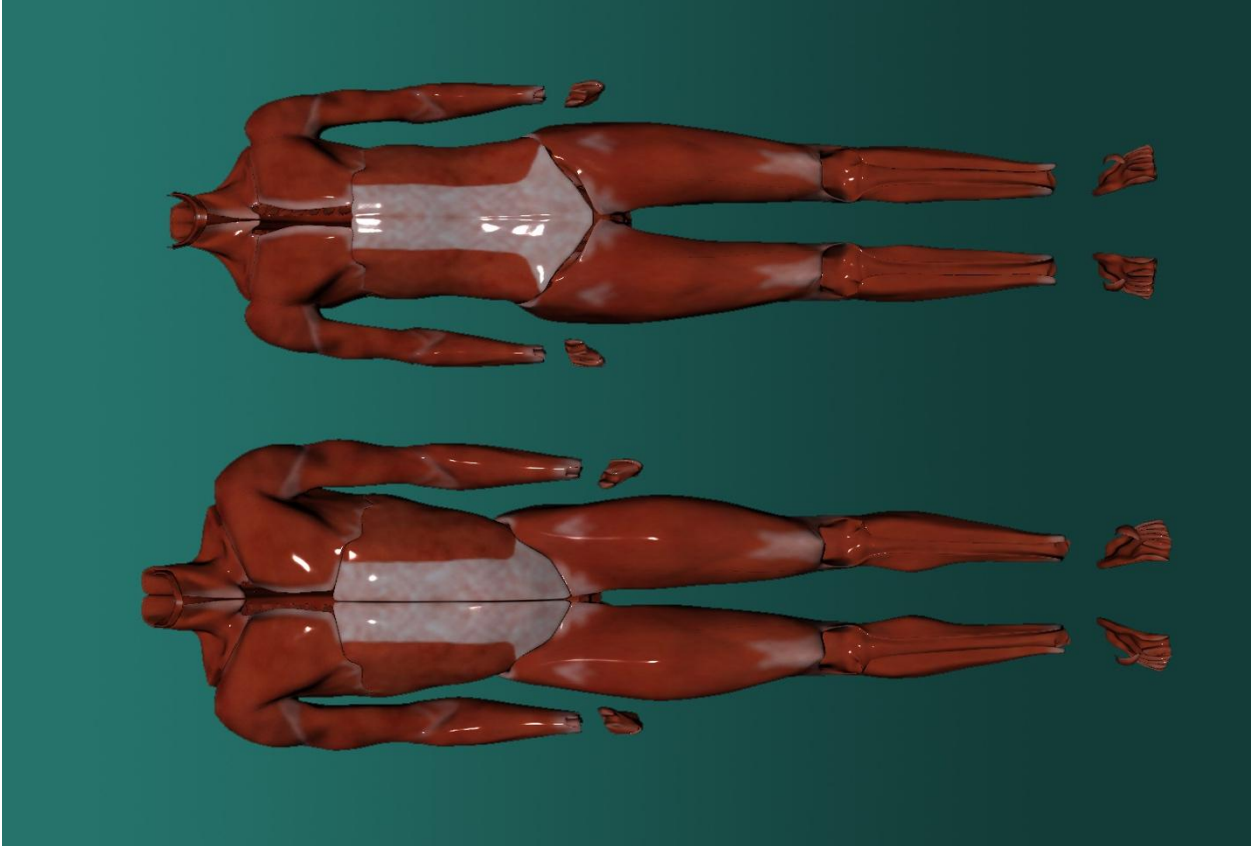

*Figure 2: Muscle Groups*

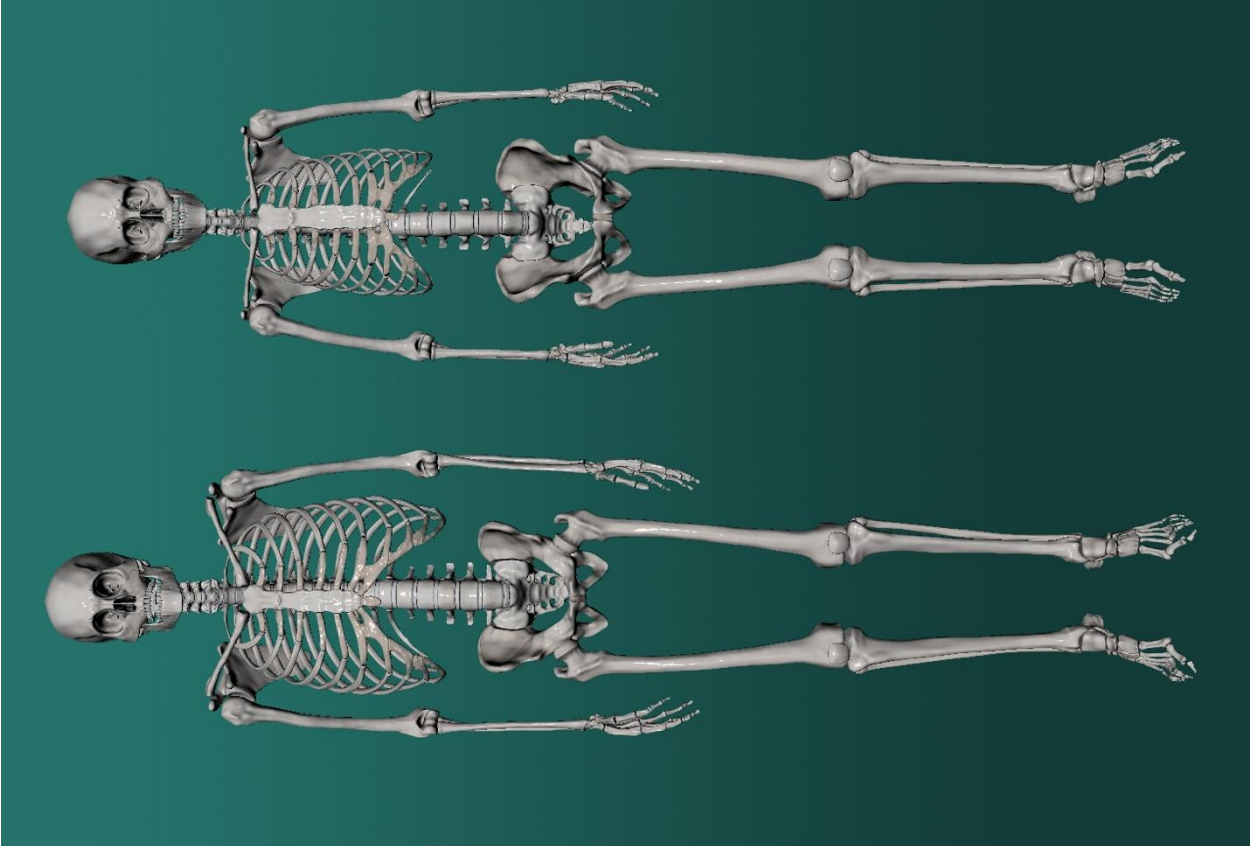

*Figure 3: Full Skeleton*

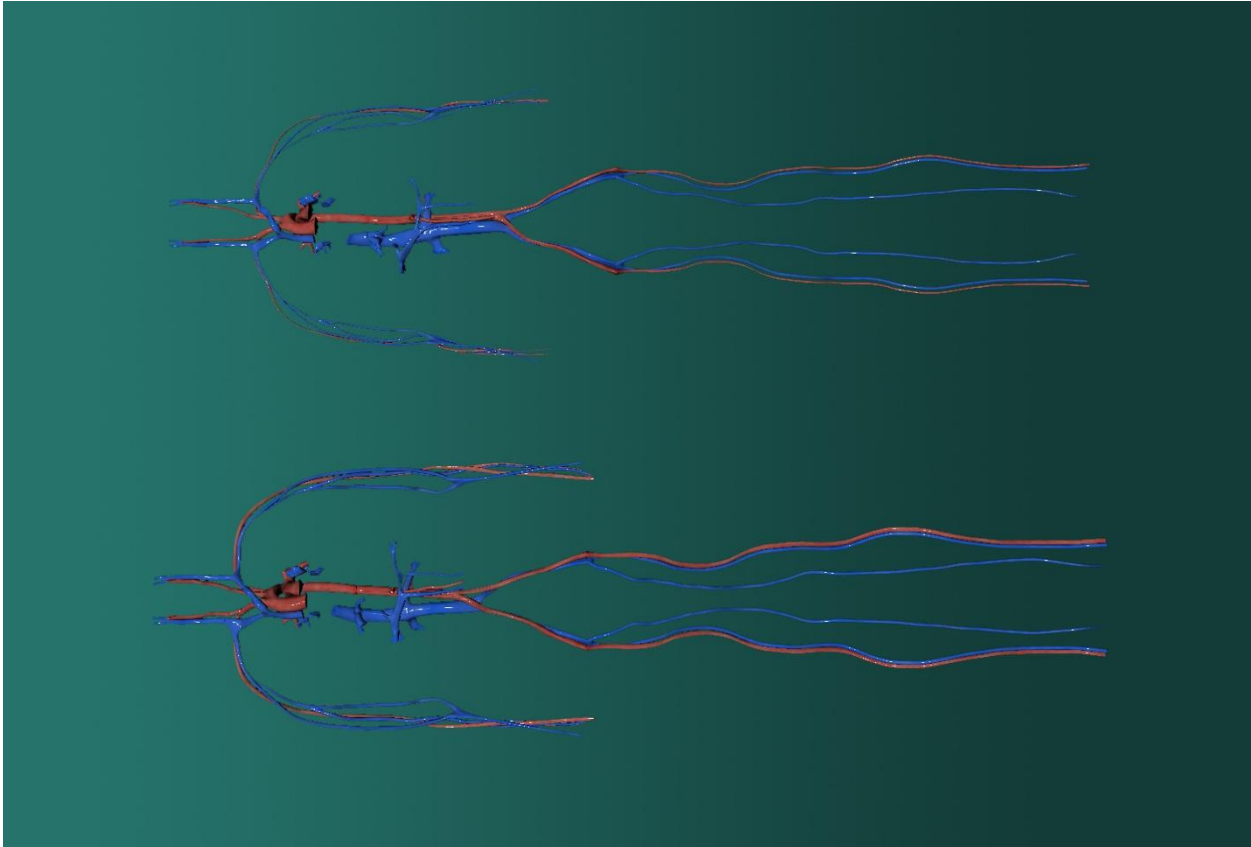

*Figure 4: Large Vasculature*

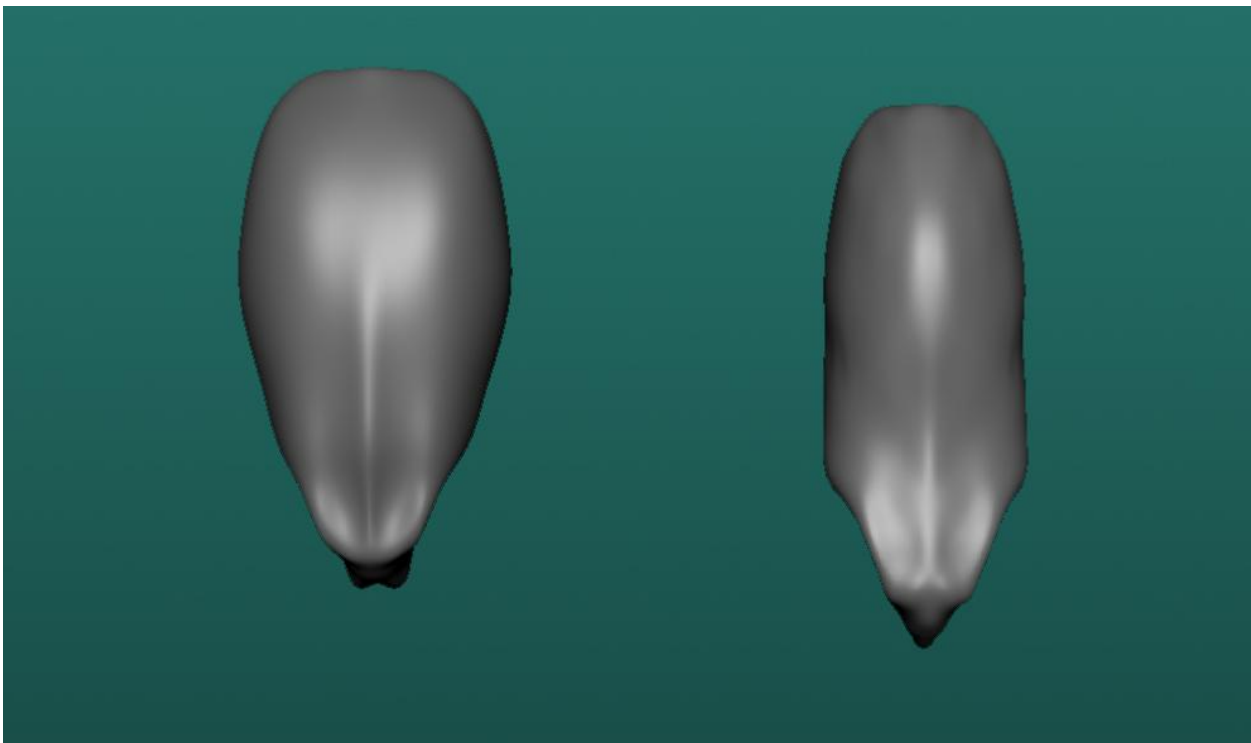

*Figure 5: Body Cavity (negative organ space)*



*Figure 6: Brain/ocular//airway and esophagus*

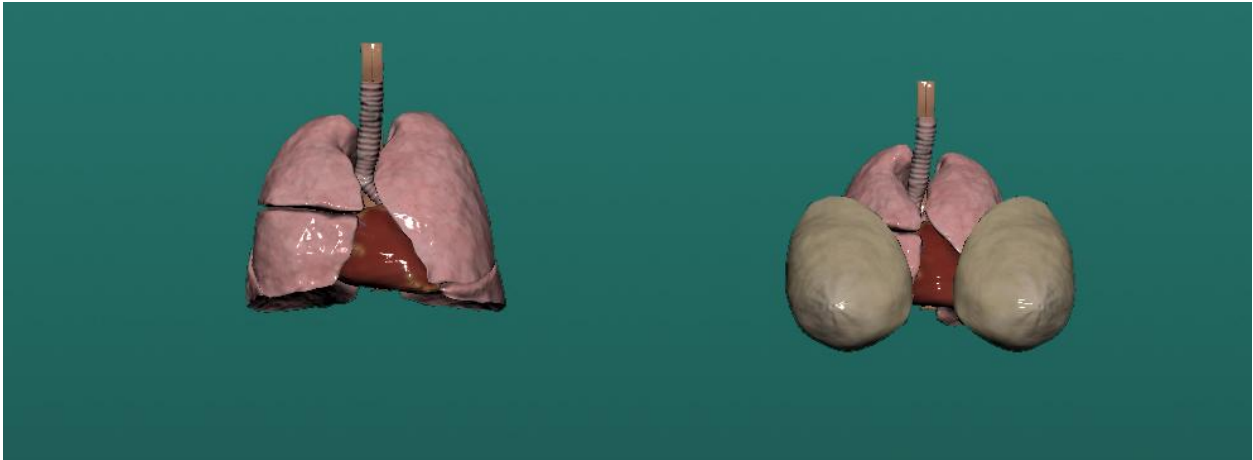

*Figure 7: Thoracic Organs*



*Figure 8: Abdomen Organs; Male External Genitalia*



**Figure 9: Individual organ (Pancreas)**

**Appendix III: ACS Full Study Report (provided exactly as submitted to PI)**



**AMERICAN COLLEGE OF SURGEONS**

*Inspiring Quality:*

*Highest Standards, Better Outcomes*

**100+years**

**AMERICAN COLLEGE OF SURGEONS | DIVISION OF EDUCATION**

*Blended Surgical Education and Training for Life®*

**American College of Surgeons (ACS) - Division of Education**

**Subcontract Number: N006060603K**

**Prime Contract Number: W81XWH-14-C-0101**

**Final Report for Period: 9/26/16 – 1/25/20**

**Ajit K. Sachdeva, MD, FACS, FRCSC, FSACME, Principal Investigator**

**ADVANCED MODULAR MANIKIN™**

**ACS STUDY REPORT**

Dimitrios Stefanidis, MD, PhD, FACS

Robert Rush, MD, FACS

Rajesh Aggarwal, MD, PhD, FRCS, FACS

Yoon Soo Park, PhD

Patrice Gabler Blair, MPH

Gyusung Isaiah Lee, PhD

Kathleen A. Johnson, EdM

Cathy Sormalis, BS

Ajit K. Sachdeva, MD, FACS, FRCSC, FSACME



# TABLE OF CONTENTS

<b>I. EXECUTIVE SUMMARY</b> .....	ERROR! BOOKMARK NOT DEFINED.
<b>II. INTRODUCTION</b> .....	97
2.1 BACKGROUND	97
2.2 STUDY PURPOSE AND HYPOTHESIS	98
<b>III. STUDY DESIGN AND METHODS</b> .....	99
3.1. STUDY DESIGN	99
FIGURE 3.1. STUDY DESIGN: RANDOMIZED CROSS-OVER	99
3.2. SIMULATION SCENARIO AND PARTICIPANTS	100
FIGURE 3.2. SCENARIO SCENES AND STUDY PARTICIPANTS	100
3.3. STUDY PROTOCOL AND SCENARIO DETAILS (WITH TIMELINE)	<b>ERROR! BOOKMARK NOT DEFINED.</b>
3.4 STUDY OUTCOMES	103
3.5. DATA COMPILATION AND ANALYSIS	103
<b>IV. RESULTS</b> .....	<b>105</b>
4.1. PARTICIPANT CHARACTERISTICS	105
<b>Table 4.1. Participant Demographic Characteristics</b> .....	105
4.2. PERCEIVED WORKLOAD: NASA-TLX105	
<b>Figure 4.2.1. Change in Participant Workload by Scene based on NASA TLX ratings</b> .....	106
<b>Table 4.2.1. Comparison of Workload Ratings by Participant Background</b> .....	107
<b>Table 4.2.2. Mixed-Effects Regression of Temporal Effect of Workload Ratings by Scenario</b> .....	107
4.3. SIMULATOR EXPERIENCE: ASSESSMENT QUESTIONNAIRE	109
<b>Table 4.3. Participant Simulator Experience Comparison between Study Conditions</b> .....	109
4.4. GLOBAL RATINGS OF PARTICIPANT EXPERIENCE WITH AMM	109
<b>Figure 4.4.1. Experience Comparisons by Participant Group based on Global Ratings</b> .....	109
<b>Table 4.4. Experience Comparisons by Participant Group based on Global Ratings</b> .....	110
4.5. PREPARATION TIME AND DURATION (MINUTES)	110
<b>Figure 4.5.1. Preparation Time and Duration by Condition and Scene</b> .....	111
<b>Table 4.5. Preparation Time and Duration by Condition and Scene</b> .....	111
4.6. COMPARISON OF STUDY OUTCOMES BY CONDITION	111
<b>Table 4.6. Comparison of Study Outcomes by Condition and Demographic Characteristics</b> .....	112
4.7. FOCUS GROUP RESULTS	113
<b>V. DISCUSSION</b> .....	<b>114</b>
<b>VI. REFERENCES</b> .....	<b>117</b>
<b>VII. APPENDIX</b> .....	<b>119</b>
<b>TABLE A1. ITEM-LEVEL STATISTICS OF PARTICIPANT WORKLOAD BY ROLE (INTEGRATED AMM)</b> .....	<b>119</b>
<b>TABLE A2. ITEM-LEVEL STATISTICS OF PARTICIPANT WORKLOAD BY ROLE (PERIPHERALS)</b>	<b>120</b>
<b>TABLE A3. ITEM-LEVEL STATISTICS OF PARTICIPANT SIMULATION EXPERIENCE BY ROLE (INTEGRATED AMM)</b> .....	<b>121</b>
<b>TABLE A4. ITEM-LEVEL STATISTICS OF PARTICIPANT SIMULATION EXPERIENCE BY ROLE (PERIPHERALS)</b> .....	<b>122</b>
<b>TABLE A5. SIMULATION EXPERIENCE COMPARISON BETWEEN AMM AND PERIPHERAL BY ROLE</b> .....	<b>123</b>
<b>TABLE A6. ITEM-LEVEL STATISTICS INTEGRATED AMM EXPERIENCE BY ROLE (BASED ON GLOBAL RATINGS)</b> .....	<b>124</b>



## I. EXECUTIVE SUMMARY

Meeting the next generation of educational needs in healthcare requires re-thinking of current platforms and delivery methods. Simulation is a widely used educational tool that has greatly enhanced the engagement of learners to augment the use of traditional textbooks and classroom lectures. However, no integrated model exists that combines individual task accomplishment with the overall management of a patient. Furthermore, there is no one manikin flexible enough to allow for additions to its learning platform. The Advanced Modular Manikin (AMM) was designed to meet these gaps. This study, funded by JPC1, is a collaboration between the University of Minnesota, the University of Washington, the American College of Surgeons (ACS) and the Department of Defense (DoD). Our study incorporated military personnel from the Naval Medical Center at San Diego and included 14 three-person teams. The design was a randomized crossover study, where each team was exposed to treating a patient who sustained injuries from a motor vehicle accident. Each member of the team was subjected to the scenario twice, once by using the fully integrated AMM with peripheral parts, and other by using partial task trainers alone. The study measured demographics, a Global Rating Scale, and the Simulator Experience Assessment Questionnaires, along with the data collected from focus groups. Our main findings were:

1. An open-sourced, integrated training platform, known as the Advanced Modular Manikin (AMM), was developed and used for training purposes. It can have multiple independent developers contributing modules to the platform. The project was implemented by a third party, the Division of Education of the American College of Surgeons (not the original developers) and was conducted at a DoD training site.
2. The use of an integrated AMM at a DoD CONUS medical site for the training of first responders, surgeons and anesthesiologists, and similar roles to those in civilian emergency departments, along with forward deployed Role II and III surgical sites is feasible.
3. The integrated form of the AMM was perceived to be superior to the peripheral task trainers alone in supporting the whole of a defined trauma scenario, one that could occur both in deployed or CONUS settings.
4. One of the strongest points of the AMM was its perceived ability to enhance inter-professional team training that involves multiple specialties/disciplines of the care team.
5. Another very highly rated characteristic of the AMM was its ability to show physiologic data to the learners/trainees through realistic monitoring equipment, including a feedback mechanism, and a physiologic engine, which had its own learning system that did not require input from an observer/controller, and as a result, vastly improved the realism of the trauma scenario.
6. Although the aim of this study was not to evaluate the specific modules, we did note the increased workload of the anesthesiologists was greater due to the unfamiliar interface of the ventilator and the medication administration pump modules. This lack of realism as to what they used in the scenario as compared to what they would normally use did correspond to less satisfaction as well.

7. The next steps include evaluating the broad training effects of multiple learner groups, the applicability to and development of scenarios/locations, the testing of new training modules as they are developed, and finally to use the AMM in a field setting.

## II. INTRODUCTION

### 2.1 Background

The demonstrated effectiveness of simulation for the training of healthcare workers has led to its quick adoption and incorporation in the training of health professionals. Today, the majority of physician, nursing, and other healthcare professionals' training programs rely on simulation to more effectively train their personnel. As a result of the increased use of simulation for training in medicine, various simulators have been developed to address multiple training needs. Besides task trainers that focus on specific technical skills and procedures, manikin-based simulators have been developed to enable training in clinical decision making and patient management. Despite the development and availability of numerous simulators of variable fidelity and cost, a number of training needs are, however, still not met. For example, no integrated simulators exist that enable the practice of surgical procedures where the surgical, anesthesia, and nursing teams can engage simultaneously on the same manikin similar to real clinical team practice. As a result, educators have created simulation models to allow for team training, but their disjointed nature (i.e. the simulation models used by anesthesia and the surgical team do not communicate with each other) may compromise their clinical relevance and effectiveness. Further, the common practice of manipulating vital signs by instructors based on learner actions often does not adhere to accurate physiologic processes and may compromise the quality of learning and teach the wrong lessons.

The military has been an early adopter of simulation and uses it widely to train and improve the readiness of its personnel for combat conditions. Nevertheless, military medical training has also traditionally relied on live animal use given the suboptimal fidelity of existing simulators raising concerns by animal protection agencies who have called for the replacement of animal use with inanimate simulators. To that end, bipartisan legislation was introduced in the US Congress (*Battlefield Excellence through Superior Training Practices Act 2017*) to replace the use of animals in live tissue training with superior human simulation technology. Further, in 2013 the US Army required all non-medical personnel, and certain medical personnel, to use human simulation training methods exclusively, instead of live tissue training using animals (Brooks, 2013).

To overcome the limitations of available simulators and address the stated ethical concerns with the use of animal models for training of healthcare personnel, the Department of Defense (DoD) has created the Joint Program Committee-1/Medical Simulation and Information Sciences (JPC-1/MSIS) Research Program and announced a solicitation of applications for developing the Advanced Modular Manikin (AMM). As stated in the announcement for the AMM and detailed in the solicitation W81XWH-13-R-0032 from JPC-1: "...the core AMM system will be state-of-the-art, modular, and relatively autonomous ... will serve as a core platform that allows scaling from a simple, to a vastly more capable unit, using future commercial upgrades, ("peripherals") that can be obtained from a variety of potential sources ... be a platform upon which future technologies can reside through development of advanced peripherals through other efforts ... be compatible with a wide array of peripherals and/or extensions leveraged with open-source / open-standard physical attachments, supply (electrical/fluid) connections and communications

links ... should have the ability to host capabilities that do not yet exist, but that are anticipated to be developed within the next five to ten years.”

Thus, the JPC meant to create a simulation platform to improve military medical training by promoting the interconnectedness and interoperability of a variety of advanced simulators (“peripherals”) connected into one manikin unit. As a result of this announcement and successful completion of a competitive application process, the first AMM has been developed by the Center for Research in Education and Simulation Technologies (CREST) at the University of Minnesota and University of Washington. To assess the value of this new AMM and obtain feedback from learners, a pilot study was designed through a partnership with the Research and Development Committee of the Accredited Education Institutes of the American College of Surgeons.

## 2.2 Study Purpose and Hypothesis

The purpose of this study was to specifically assess user experience and workload with the AMM as compared to the experience when using stand-alone peripheral simulators to achieve the learning objectives of the same standardized simulation scenario. We hypothesized that the integrated AMM platform would provide improved participant experience compared to the use of peripheral simulators during this standardized simulation scenario. The study also aimed to provide user feedback to the developers of the AMM to be considered for future improvements of the manikin.

### III. STUDY DESIGN AND METHODS

The study was designed and administered by a steering committee including leadership of the ACS Division of Education and the Research and Development Committee of the ACS Accredited Education Institutes Consortium, ACS staff, and AMM investigators at University of Minnesota and University of Washington. The steering committee participated in monthly calls to develop the protocol first and oversee the study conduct and progress later. Institutional Review Board approval was obtained from the American Institutes for Research, the Human Research Protections Office (HRPO) and the local site. A detailed administrative report of all the activities leading up to the conduct of this study is attached as the **ACS AMM Administrative Report** in the appendix.

#### 3.1. Study Design

A randomized single-blinded cross-over design with two conditions was used to test the hypothesis of this study. All participants completed a simulation session using a pre-determined, standardized scenario. Each participant completed the scenario twice, under one of the two different conditions with random allocation to condition sequence (Figure 3.1). Importantly, participants were blinded to the condition.

Figure 3.1. Study Design: Randomized Cross-Over

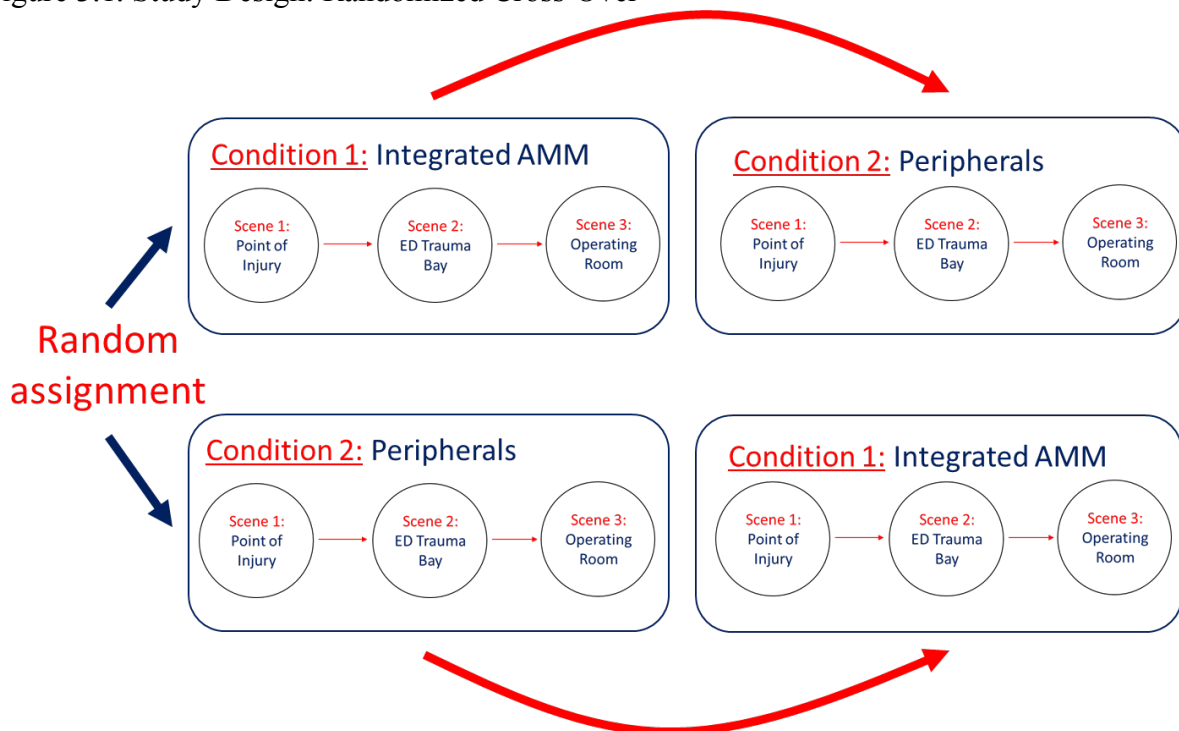

During Condition 1, the scenario was conducted on the AMM and its peripherals while they were connected to the AMM platform ('integrated AMM' condition). During Condition 2 ('peripherals only' condition), the same scenario was conducted on peripherals only, acting as

standalone simulators without being connected to the AMM platform. Commercially available simulators were also used during this condition as needed to accomplish the objectives of the scenario.

All participants completed a baseline questionnaire at the beginning of the study including the participant's demographics (age, ethnicity, gender), military classification, level of education, years of professional experience, clinical practice setting, and prior experience with simulation training. After completion of both conditions, participants completed a questionnaire detailing questions on their experience with each condition and rated their experience with the AMM on a global rating scale developed for the purposes of this study. In addition, after each condition, participants rated the workload they experienced on the validated NASA-TLX questionnaire.

Upon completion of all study conditions and questionnaires, all study subjects participated in a focus group where their opinions on their experience were elicited by a facilitator using a standardized script. Technician and confederate feedback on their experience with the AMM platform was also obtained after the first day of the study and at the conclusion of the study. We also measured and compared preparation time and duration of each scenario scene.

### 3.2. Simulation Scenario and Participants

The steering committee chose to develop a trauma scenario in order to be applicable to both the military and civilian environments. A trauma scenario comprised of the following three scenes was used for the simulation. The scenario (1) begins on a roadside after a motor vehicle crash, (2) moves to an emergency department/trauma bay for evaluation and stabilization of the patient, and (3) concludes in an operating room. All scenes take place in the same physical space with breaks in between to allow for room turnover. (Figure 3.2)

Figure 3.2. Scenario Scenes and Study Participants

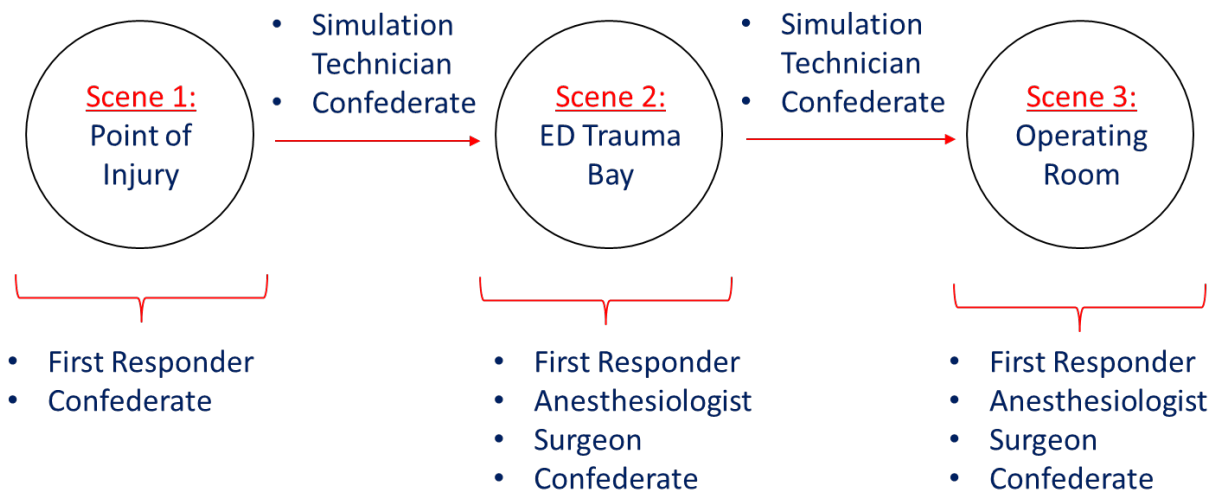

- a. Scene 1: Point of Injury (POI). A 30-year-old male involved in a motor vehicle crash has self-extricated from the vehicle and is encountered lying on the ground by the first responder. The first responder performs an initial assessment, starts an IV and fluid



administration, places the patient on a cardiac monitor and pulse oximeter, and immobilizes the patient for transport.

- b. Scene 2: Emergency Department (ED) trauma bay. Upon arrival at the trauma bay, the first responder gives a report to the trauma team: anesthesiologist, surgeon, and ED nurse (confederate). The patient is placed on the ED monitor by the nurse, who also conveys lab and x-ray results. The anesthesiologist performs an initial assessment. GCS is reassessed as 9-10. The patient localizes pain; airway and breathing remain clear, and the patient remains hypotensive, prompting the providers to start an additional IV and administer an additional fluid bolus. Refractory hypotension and increasing abdominal distention prompted the providers to continue the administration of fluids and blood products and conduct a FAST exam. As the FAST exam is performed, the patient decompensates, prompting the anesthesiologist to intubate in the ED and the decision to go to the OR.
- c. Scene 3: Operating room (OR). *[In the OR, the patient has been fully anesthetized and transferred to the anesthesia ventilator and OR monitors. The patient's abdomen has been prepped and draped. When participants enter the scene, the laparotomy incision has been made, and retractors are in place.]* The patient remains hypotensive, and fluid resuscitation is continued. The surgeon packs all quadrants of the abdomen, systematically searches for bleeding, removes the spleen and repairs the bladder injury, recognizes and repairs an iatrogenic iliac vein injury, performs re-exploration for missed injuries or continued bleeding, and decides to leave the abdomen open. The team completes pre-ICU transfer time-out. The patient's outcome is positive.

### 3.3 Study Protocol and Scenario Details (with Timeline)

Each participating team completed the same set of steps (6 hours, 35 minutes).

- a. Registration and instruction (30 minutes): The participants (two teams at a time) arrived at the simulation center and moved to the registration room to sign in. The project administrator gave an orientation to the study, and participants completed an informed consent form and Demographic Questionnaire. The two teams were randomized by the project administrator to Condition 1 or Condition 2 and escorted to the associated room where the simulation technician and confederate did the prebriefing for the participants. The simulation technicians, confederates, and data collectors remained with the team to which they were assigned for the duration of both conditions.
- b. Prebrief (30 minutes): In each simulation room, the simulation technician and confederate oriented the participants for 15 minutes. During this time, the simulators were set to normal states to allow participants to observe non-pathologic vital signs and the layout of this information on the monitors. Participants had the opportunity to explore the simulation room, with assistance from the simulation technician and confederate, to identify the location of essential equipment and supplies. The anesthesiologist was oriented to the operation of the virtual intravenous pump; the surgeon was asked to rearrange the available surgical instruments to their preference. Following the prebrief

period, the simulation technician and confederate had 15 minutes to finalize setup for the beginning of the scenario.

- c. First run of the scenario (85 minutes):
  - Scene 1 (POI, 15 minutes): The scenario started at the point of injury. The first responder performed a primary survey of the patient and other required initial interventions.
  - Scene change (10 minutes): The scene was changed from POI to the trauma bay or ED setting by the simulation technician and confederate. During this transition, one participant team waited in a room, while the other team remained in a different room until the next scene was prepared. The first responder completed the NASA-TLX for Scene 1.
  - Scene 2 (trauma bay or ED, 10 minutes): The second scene was in a trauma bay or emergency department setting, during which the participants stabilized the patient for surgery.
  - Scene change (20 minutes): The scene was changed from the trauma bay or ED to OR setting by the simulation technician and confederate. The first responder, anesthesiologist, and surgeon completed the NASA-TLX for Scene 2.
  - Scene 3 (OR, 30 minutes): The third scene took place in the operating room for surgical management of the patient's injuries.
- d. Questionnaire completion and switch (45 minutes): Each participant team returned to the room that they waited in during scene changes. They completed study questionnaires while the simulation technicians and confederates set up the simulation rooms for the second run. The first responder, anesthesiologist, and surgeon completed the NASA-TLX for Scene 3 and the Simulator Experience Assessment Questionnaire for the appropriate condition.
- e. Prebrief for the second run of the scenario (30 minutes): In each simulation room, the simulation technician and confederate oriented the participants to their second condition.
- f. Second run of the scenario (85 minutes): Each team went through the same scenario under the other condition, completing questionnaires during scene changes.
- g. Questionnaire completion (30 minutes). Each participant team returned to the room that they waited in during scene changes and completed study questionnaires, as in step d. Participants also completed the AMM Global Rating Scale at this time.
- h. Focus group discussion (60 minutes): Once all questionnaires were completed and submitted to the research team, both team members met in the same room for a focus group discussion. The focus group was facilitated using predetermined questions. The objective of these discussions was to collect more in-depth feedback about participants' experiences with the simulators, how they might be improved, and how this simulation experience compared to the participants' prior experiences with simulation-based

exercises. Each focus group discussion was audio-recorded and summarized at each study site.

### 3.4 Study Outcomes and Assessment Tools

To accomplish our study objectives and test our hypothesis we used a number of tools to assess participant experience and workload during the scenarios.

- a. The **Demographic Questionnaire** was administered before the first simulation session to collect participants' demographic and experience information including the participant's age, ethnicity, gender, military classification, level of education, years of professional experience, current clinical practice setting, and the role that they typically fulfill during simulation-based exercises.
- b. **Simulator Experience Assessment Questionnaires**, specific to each study condition, were used to capture data related to the participant's interaction with the AMM or peripherals, including setup, response to clinical interventions, the realism of performing specific procedures, and the physical and cognitive workload experienced by participants. Questions were tailored to be applicable to each study condition. Questions that were identical for both conditions were analyzed separately and are referenced in this report as common items (see tables A3 and A4 in Appendix)
- c. The **AMM Global Rating Scale** asked participants to rate their perception of the AMM across three domains: simulation (scope, modality, and environment), fidelity (physical, conceptual, and emotional), and engagement (behavioral, emotional, and cognitive).
- d. **NASA-Task Load Index (NASA-TLX)**: To assess participant workload, we used the NASA-TLX questionnaire, a workload assessment instrument,<sup>11</sup> which has been used extensively for this purpose and shown to be sensitive and diagnostic in a variety of tasks including simulation.<sup>12,13</sup> Subjects rate the mental, physical, and temporal demands of the task, and their performance, effort, and frustration level during task execution.

We also recorded scene duration and preparation time to obtain insight on the effort involved to administer the scenarios using the AMM.

### 3.5. Data Compilation and Analysis

To compare participant experience between conditions, the average ratings on the 5-point Likert scales of the common simulation experience-related questions to both conditions (table A5) were

calculated and compared. For the global rating scale reflecting overall AMM participant experience, the mean was calculated across all items. Summary scores for the NASA-TLX were generated by taking the sum of the six item-level responses, as conducted in standard practice.<sup>12</sup> For preparation time and scene duration, an average was taken across teams. Descriptive statistics were used to evaluate trends in data, both at the individual level and at the team level. T-tests and analysis of variance (ANOVA) were used to compare performance by scene and by condition. Mixed-effects regression models were used to account for nested effects within teams and individuals and to evaluate differences between study conditions (AMM versus Peripherals) controlling for scene, participant role within team, and other relevant demographic characteristics (age, gender, professional experience). Data compilation and analysis were conducted using Stata 16 (College Station, TX).

## IV. RESULTS

### 4.1. Participant Characteristics

Data were collected from January 7, 2020 to January 17, 2020 at a single institution. A total of 14 teams consisting of a first responder, anesthesiologist, and surgeon (n=42 total) participated in the study and completed all assessment tools. Assessment tools were also completed by 4 study confederates and 4 technicians.

**Demographic characteristics:** The demographic distribution of participants was as follows (see also Table 4.1):

- Age: 18-34 (56%), 35-44 (36%), 45+ (8%)
- Race/Ethnicity: Caucasian (52%), Other (48%)
- Gender: Female (27%), Male (73%)
- Military status: Active duty military (85%)
- Experience: Less than 5 years (67%)

Table 4.1. Participant Demographic Characteristics

Role	Age			Race/Ethnicity		Gender	
	18-34	35-44	45+	Caucasian	Non-Caucasian	Female	Male
First Responder	13	1		7	7	6	7
Anesthesiologist	5	5	4	6	8	5	9
Surgeon	4	10		11	3	2	12
Confederate	2	2			4		4
Technician	4			2	2		4
Total	28	18	4	26	24	13	36

Note: 85.4% of participants are active-duty military; 67% of participants have < 5 years of experience; non-response from 1 participant for gender.

### 4.2. Perceived Workload: NASA-TLX

- Overall, AMM had significantly greater aggregate perceived workload than the Peripherals condition, Cohen's  $d = .35$ ,  $p = .010$ .
- The difference in perceived workload was significantly greater for the anesthesiologist in the ER and in the OR. See Table 4.2.1
- There were no significant differences in AMM versus Peripherals in perceived workload, for temporal comparison across scenes (point of injury, emergency room, operating room). See Figure 4.2.1 and Table 4.2.2.

Figure 4.2.1. Change in Participant Workload by Scene based on NASA TLX ratings

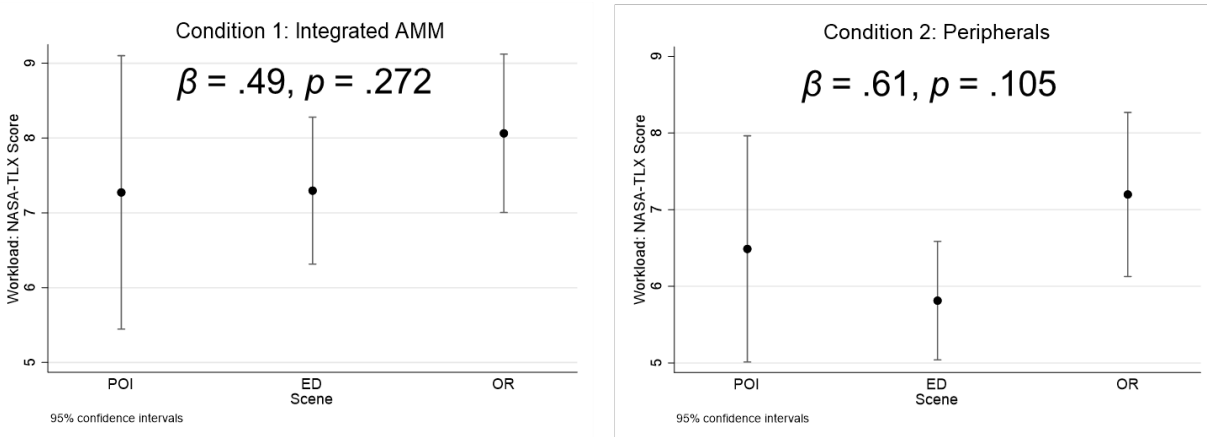

- Overall, no significant change in workload by scene,  $\beta = .62, p = .067$  (Mixed-Effects Regression). There was significant difference by condition,  $\beta = 1.12, p = .005$  (Mixed-Effects Regression).

Table 4.2.1. Comparison of Workload Ratings by Participant Background

Scenario	Role	Integrated AMM			Peripherals			Effect size (Cohen's <i>d</i> )	paired <i>t</i> -test <i>p</i> -value
		<i>N</i>	Mean	SD	<i>n</i>	Mean	SD		
Point of Injury	First Responder	14	43.62	18.96	14	38.94	15.36	.27	.479
	Overall	14	43.62	18.96	14	38.94	15.36	.27	.479
Emergency Room	First Responder	14	38.16	21.48	14	29.52	13.44	.48	.213
	Anesthesiologist*	14	52.98	16.20	14	41.16	11.82	.78	.037
	Surgeon	14	40.20	16.20	14	34.02	17.46	.37	.341
	Overall*	42	43.80	18.90	42	34.86	14.88	.51	.018
Operating Room	First Responder	14	35.28	14.04	14	38.10	17.04	-.18	.637
	Anesthesiologist**	14	59.34	19.32	14	36.48	16.92	1.07	.003
	Surgeon	14	50.52	20.46	14	55.02	23.16	-.21	.591
	Overall	42	48.36	20.40	42	43.20	20.64	.25	.253
Overall	First Responder	42	39.00	18.30	42	35.52	15.60	.20	.351
	Anesthesiologist***	28	56.16	17.82	28	38.82	14.52	.95	< .001
	Surgeon	28	45.36	18.84	28	44.52	22.80	.04	.881
	Sub-Mean <sup>‡</sup>	98	44.88	18.32	98	38.60	17.13	.35	.014
	Confederate	4	35.28	14.22	4	32.76	18.30	.17	.835
	Technician	4	31.26	12.06	4	22.74	10.98	.73	.336
	Overall**	106	44.82	19.32	106	38.16	17.88	.35	.010

Note:

1. Cohen's *d* is used to measure standardized effect size in differences between the two study conditions: Integrated AMM and Peripherals.
2. Note: \*  $p < .05$ ; \*\*  $p < .01$ . \*\*\*  $p < .001$ ; high rating indicates greater complexity or workload.
3. <sup>‡</sup> is mean taken across first responder, anesthesiologist, and surgeon (excluding confederate and technicians).

Table 4.2.2. Mixed-Effects Regression of Temporal Effect of Workload Ratings by Scenario

Condition	Factor	Coefficient	SE	<i>p</i> -value
Peripherals	Fixed Effect			

	Temporal Effect of Scenario	.61	.38	.105
	Intercept	5.72	.65	< .001
	Random Effect			
	SD (Temporal Effect of Scenario)	.17	1.53	
	SD (Intercept)	1.33	.57	
	SD (Residual)	2.60	.20	
	Fixed Effect			
	Temporal Effect of Scenario	.49	.44	.272
	Intercept	7.00	.69	< .001
Integrated AMM	Random Effect			
	SD (Temporal Effect of Scenario)	.33	.76	
	SD (Intercept)	1.02	.59	
	SD (Residual)	3.01	.24	
	Fixed Effect			
	Temporal Effect of Scenario	.62	.30	.067
	AMM versus Peripheral	1.12	.40	.005
	Intercept	5.80	.56	< .001
Overall	Random Effect			
	SD (Temporal Effect of Scenario)	.33	.43	
	SD (Intercept)	1.15	.37	
	SD (Residual)	2.81	.15	

Note: Results indicate no temporal effect of scenario for each condition and across conditions. This indicates no changes in perceived workload between scenarios.



### 4.3. Simulator Experience: Assessment Questionnaire

- Overall, there were significant differences in the simulator experience between the AMM and Peripherals for both common and all items, (Cohen's  $d = .25$ ,  $p = .016$  and  $.28$  and  $.001$ , respectively)
- Surgeons had significantly a better simulation experience in the AMM, Common items: Cohen's  $d = .60$ ,  $p = <.001$ ; All Items: Cohen's  $d = .78$ ,  $p = <.001$ .
- There were no significant differences in simulator experience for other roles (first responder, anesthesiologist, confederate, and technician). See Table 4.3.
- 

Table 4.3. Participant Simulator Experience Comparison between Study Conditions

Items	Role <sup>3</sup>	Integrated AMM		Peripherals		Effect size (Cohen's $d$ )	$t$ -test $p$ -value
		Mean	SD	Mean	SD		
Common Items <sup>2</sup>	First Responder	3.42	.82	3.19	1.29	.21	.263
	Anesthesiologist	2.74	.79	2.73	.70	.01	.944
	Surgeon***	3.20	.71	2.78	.64	.60	< .001
	Overall <sup>‡</sup> *	3.12	.81	2.90	.92	.25	.016
All Items	First Responder	3.26	.61	3.19	1.29	.09	.577
	Anesthesiologist	2.74	.68	2.73	.70	.01	.921
	Surgeon***	3.26	.55	2.78	.64	.78	< .001
	Overall <sup>‡</sup> **	3.09	.61	2.90	.92	.28	.001

Note:

1. Higher rating indicates better experience; analysis conducted at the item level.
2. Common items are highlighted in Tables A3 and A4 in the Appendix.
3. \*  $p < .05$ ; \*\*  $p < .01$ . \*\*\*  $p < .001$
4. <sup>‡</sup> is mean taken across first responder, anesthesiologist, and surgeon (excluding confederate and technicians).

### 4.4. Global Ratings of Participant Experience with AMM

- Anesthesiologists had significantly lower global rating for the AMM, compared to first responders and surgeons,  $p < .001$ .
- There were no significant differences in global perception of the AMM between the first responder and the surgeon,  $p = .966$ . See Table 4.4.

Figure 4.4.1. Experience Comparisons by Participant Group based on Global Ratings

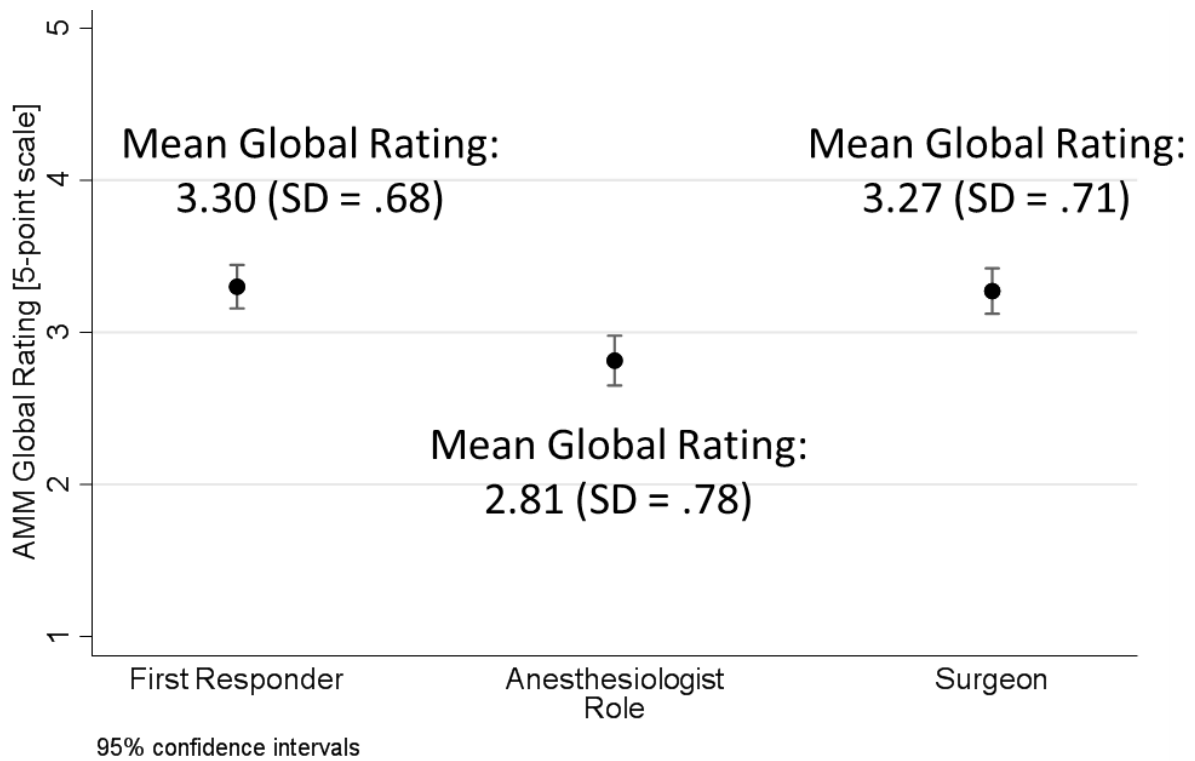

Higher rating indicates better experience; Multiple group comparison using Scheffe: first responder vs. anesthesiologist,  $p < .001$ ; first responder vs. surgeon,  $p = .966$ ; anesthesiologist vs. surgeon,  $p < .001$ .

Table 4.4. Experience Comparisons by Participant Group based on Global Ratings

Role	<i>n</i>	Mean	SD	ANOVA <i>p</i> -value
First Responder	42	3.30	.68	< .001
Anesthesiologist	42	2.81	.78	
Surgeon	42	3.27	.71	
Overall	126	3.13	.73	

Note:

1. Higher rating indicates better rating;
2. Multiple group comparison using Scheffe: first responder versus anesthesiologist,  $p < .001$ ; first responder versus surgeon,  $p = .966$ ; anesthesiologist versus surgeon,  $p < .001$ .

#### 4.5. Preparation Time and Duration (Minutes)

- Overall, there were no significant differences in preparation time or simulation time for AMM and Peripherals,  $p = .214$ .
- For point of injury, the AMM had significantly longer simulation duration (Mean = 7.79, SD = 3.83) versus the Peripheral (Mean = 3.43, SD = 2.21),  $p = .001$ . See Table 4.5.

Figure 4.5.1. Preparation Time and Duration by Condition and Scene

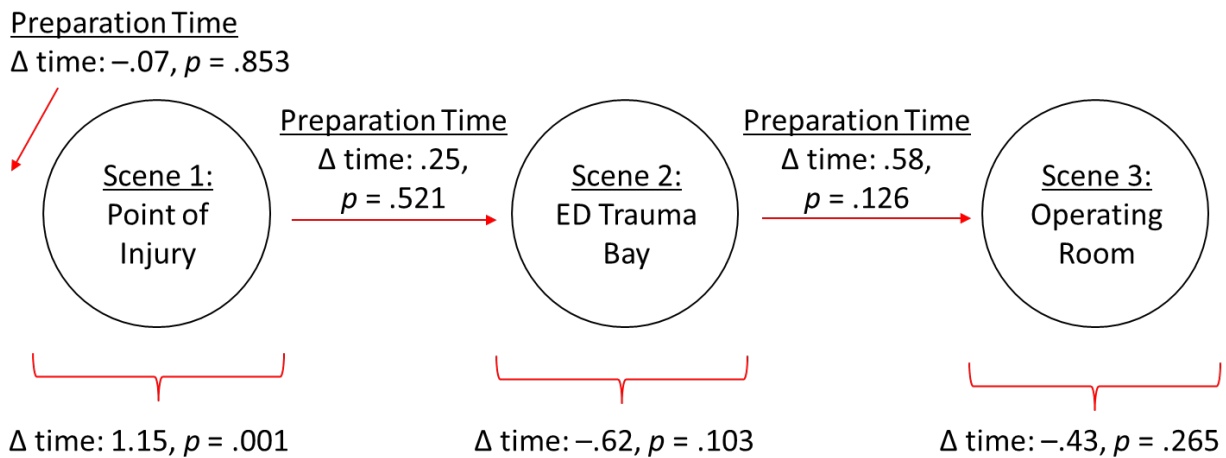

Note: “ $\Delta$  time” indicates differences in effect sizes (Cohen’s  $d$ ) between conditions.

Table 4.5. Preparation Time and Duration by Condition and Scene

Scenario	Integrated AMM			Peripherals			Effect size (Cohen's $d$ )	$p$ -value
	$n$	Mean	SD	$n$	Mean	SD		
Pre-brief Room	14	18.29	6.94	13	18.92	10.54	$-.07$	$.853$
Point of Injury**	14	7.79	3.83	14	3.43	2.21	$1.15$	$.001$
Scene Change to ED	14	7.21	2.61	14	6.43	3.69	$.25$	$.521$
ED Trauma Bay	14	3.64	2.02	14	5.00	2.22	$-.62$	$.103$
Scene Change to OR	14	12.50	15.52	14	5.93	1.21	$.58$	$.126$
OR	14	9.93	2.70	14	11.36	3.84	$-.43$	$.265$
Overall	84	9.89	8.49	83	8.39	7.03	$.19$	$.214$

Note: \*  $p < .05$ ; \*\*  $p < .01$ . \*\*\*  $p < .001$

#### 4.6. Comparison of Study Outcomes by Condition

Mixed-effects regression models were used to examine results controlling for age, gender, race/ethnicity, professional experience.

**Perceived Workload: NASA-TLX:**

- For the AMM condition, older participants (35+ years;  $\beta = 1.25, p = .049$ ), females ( $\beta = 2.08, p = .005$ ), and Caucasians ( $\beta = 3.02, p < .001$ ) reported greater perceived workload.
- For the Peripherals condition, older participants (35+ years;  $\beta = 1.17, p = .047$ ) and Caucasians ( $\beta = 1.80, p = .003$ ) reported greater perceived workload.

**Simulator Experience:**

- For the AMM: younger participants (< 35 years:  $\beta = .43, p = .007$ ) reported better simulator experience.
- For the Peripherals condition, younger participants (< 35 years:  $\beta = .43, p = .007$ ) and Non-Caucasians ( $\beta = .53, p = .010$ ) reported greater simulator experience.

Table 4.6. Comparison of Study Outcomes by Condition and Demographic Characteristics

Type	Factor	Peripheral			AMM		
		Coefficient	SE	p-value	Coefficient	SE	p-value
	Fixed Effect						

NASA-TLX	Age 35+	1.18	.59	.047	1.25	.64	.049
	Female	1.22	.74	.101	2.08	.75	.005
	Caucasian	1.80	.61	.003	3.02	.67	< .001
	Experience 5+ years	-.04	.78	.959	.46	.80	.564
	Intercept	4.65	.78	< .001	4.64	.75	< .001
	Random Effect						
	SD (Intercept)	1.33	.45		.45	.67	
	SD (Residual)	2.51	.20		2.82	.22	
Simulated Assessment	Fixed Effect						
	Age 35+	-.53	.20	.007	-.43	.16	.007
	Female	-.27	.28	.326	-.02	.22	.932
	Caucasian	-.53	.20	.010	-.15	.16	.378
	Experience 5+ years	-.06	.26	.826	.22	.19	.250
	Intercept	3.65	.27	< .001	3.38	.20	< .001
	Random Effect						
	SD (Intercept)	.43	.15		.19	.16	
	SD (Residual)	.69	.07		.57	.06	
Global Rating	Fixed Effect						
	Age 35+	-.31	.15	.033	-.31	.15	.033
	Female	-.02	.17	.915	-.02	.17	.915
	Caucasian	.06	.14	.682	.06	.14	.682
	Experience 5+ years	.09	.20	.636	.09	.20	.636
	Intercept	3.23	.19	< .001	3.23	.19	< .001
	Random Effect						
	SD (Intercept)	.38	.10		.38	.10	
	SD (Residual)	.63	.04		.63	.04	

Note:

1. Demographic characteristics used: Age (35+ versus less than 35), gender (female versus male), Race/Ethnicity (Caucasian versus Others), Experience (5+ years versus other)

#### 4.7. Focus Group Results

All subjects participated in the focus groups at the end of their simulation experience. Analysis of the provided feedback revealed several common themes. The majority of participants with few exceptions felt that the scenario was well designed, realistic, and engaging. Some participants (first responders and anesthesia) indicated that they would have liked to be assigned more tasks to do in some of the scenes (point of injury and operating room, respectively). Participants

unanimously preferred condition 1 (AMM) over condition 2 (peripherals) due to its increased realism, physiologic responsiveness, and feedback provided on their interventions. They enjoyed having access to more monitors providing them feedback on the patient's condition in a real time fashion and being able to interact with the manikin through the tablets when using the AMM. On the other hand, several anesthesiologists did not like the interaction with said tablets as they perceived them to be cumbersome to use for ventilator and medication set ups. In regards to the AMM platform, participants liked its bleeding and urination capability, the real life feel of tissues, the ability to perform full procedures especially the repair of the vascular injury, but disliked the more difficult airway for intubation, not having some intraabdominal organs and inaccurate anatomy, and its inability to be rolled. Participants felt overwhelmingly that the AMM was a great product filling a significant need (i.e. enabling the performance of procedures on a manikin) but that it also had significant room for improvements. They specifically suggested adding more sites to palpate pulses, adding more audible signals to inform learners of the patient's condition, improving the anatomical relation of the abdominal organs, and improving the user interface (tablets).

## V. DISCUSSION

Scenario-based training has become an invaluable adjunct to the training of healthcare professionals. While numerous high and low fidelity simulators have been developed to enable this type of training, no simulator currently exists that allows every member of the trauma or operating room teams to be meaningfully engaged in training concurrently. The aim of this project was to evaluate such a novel simulation platform, the Advanced Modular Manikin (AMM), that allows the concurrent engagement of anesthesiologists via airway and ventilation management, surgeons via the ability to assess and operate on the manikin, and nurses and other healthcare professionals via patient assessment and performance of various procedures. We set out to assess the value of the AMM for learner experience during a trauma scenario, applicable to both the military and civilian world. Using a robust study design, we sought to compare user experience when working on the simulation scenario with a fully integrated AMM versus with various stand-alone simulators (peripherals) addressing the same tasks. We further aimed to obtain useful feedback on the AMM platform to help the developers further improve this promising simulation platform. Given the early stage of development of this simulator, we did not intend to perform a complete validation study and did not focus on assessing participant performance or learning.

Based on participant experience and focus group data, our study revealed that group participants enjoyed their experience with the AMM and overwhelmingly preferred using it during the scenario versus working with separate disconnected simulators. Nevertheless, the experience with the AMM was dependent on participant group: surgeons rated their AMM experience significantly higher compared with the peripheral condition while the other two groups either showed a nonsignificant statistically increase in rating favoring the AMM (first responders), or their ratings remained flat between the two conditions (anesthesiologists). Further, overall ratings of participants on the global rating scale were statistically significantly worse for anesthesiologists compared to both the other two groups. The latter finding appears to be a consequence of the increased workload our anesthesiology participants experienced when using

the AMM. Indeed, compared to the other two participant groups who did not see any significant differences in workload between conditions, anesthesiologists, experienced higher workload with the AMM in all three scenes of the scenario and overall. The increased workload scores were driven by the subscales of high mental demand and frustration. Our focus group results suggested that the driver of this increased workload was mainly related to the simulated pumps and ventilator management interface anesthesiologists had to use. Both of these interfaces were delivered via iPads and were found to be very cumbersome, frustrating, and unrealistic to use by participants. The focus group results also suggested that this was the main factor that the experience of anesthesiologists was statistically worse than that of the other two groups. In addition, anesthesiologists felt that the scenario did not include enough tasks for them to do in some of the scenes, especially in the OR scene where several preparatory steps had been omitted and for the peripherals condition specifically where they did not have a ventilator to manage. The lower workload ratings under this condition confirmed this.

On the other hand, our focus groups also suggested that all participants were excited with the concept of the AMM as it clearly is addressing an unmet need in scenario-based training. The most excitement was expressed by participating surgeons and first responders. It was mostly driven by the OR scene as participants truly enjoyed the injuries they had to identify and repair. Interestingly, the experience with the AMM in the OR scene was rated higher than the peripherals condition even though the injuries to be repaired were identical in both conditions as the same abdominal module was used. However, the AMM condition included active bleeding and urine leak from injury sites that contributed to physiologic changes of the manikin (i.e. the more blood loss occurred during repair of an injury the more tachycardic and unstable the patient became) making the scenario more realistic and engaging at the same time. Interestingly, surgeon workload scores were found to be increased under the AMM condition (average NASA-TLX score of 50 versus 35 in the peripheral condition), but they rated their experience higher. This is in contrast to the findings with the anesthesiologists whose higher workload was associated with lower experience ratings, suggesting that increased workload per se does not necessarily mean that simulator experience will be worse, but rather it depends on the type of experience and the source of the increased workload; if the experience is enjoyable, participants do not mind increased workload, if not, then they do. These findings further attest to the importance participants place on the realism of their simulated experience. Surgeons rated their experience higher as the procedures they performed on the AMM seemed more realistic to them, while anesthesiologists rated it lower as they perceived the IV pumps and ventilation management were unrealistic. Our findings contrast studies that suggest that simulation fidelity is not an important determinant for participant performance and engagement.<sup>7,14-16</sup> Nevertheless, this difference in our findings is likely related to the type and fidelity of the simulation used; while less complex tasks may not require a high fidelity simulator,<sup>14,16</sup> studies have shown that for some tasks higher fidelity simulation is associated with improved learning outcomes.<sup>17-19</sup> Indeed, the need for a simulator that enables the conduct of procedures in the operating room on an anesthetized and ventilated patient is pervasive in the surgical community. While a number of high fidelity manikins exist that effectively simulate the management of an anesthetized and ventilated patient, surgical training programs have to revert to makeshift abdominal models<sup>6</sup> to enable the performance of procedures in the OR setting. Importantly, such makeshift models are typically not connected meaningfully to physiology engines that allow participants to see the effect of their actions on the patient overall condition and depend on arbitrary changes of the

patient physiology determined by their instructors that may or not accurately approximate reality. These issues decrease the realism of participant experience, make the “suspension of disbelief” harder, and could negatively impact participant experience and knowledge acquisition.

Our study is unique in that we focused on the assessment of participant simulation experience using a robust design and a novel assessment tool. It deviates from the traditional assessment of simulator validity employed widely in the literature, often using outdated validity concepts. We chose this approach as our goal was to assess the value of the AMM platform that enables interoperability and interconnectivity of a variety of simulators (peripherals) rather than focusing on the assessment of a specific simulator. We were less interested in examining the validity of each component and more interested in assessing the value of the AMM platform that enables the connection of a variety of simulators to a physiology engine, making it possible to conduct a variety of scenarios for a variety of learner groups. Hence, our investigator team felt that examining the learner experience between the fully integrated AMM versus its disconnected components in the same standardized scenario was the best approach to address our aim.

Further, the data gathered and the focus groups conducted at the end of participant experience provided our team with valuable feedback on what works well with the AMM and what needs to be worked on further to improve it. The AMM development team has taken this information and will be implementing changes to address any identified shortcomings.

Importantly, interprofessional engagement and education is a critical part of modern clinical practice, none more so for complex and emergent medical conditions. The development of simulation technologies and platforms for interprofessional practice, with a focus beyond technical skills, encompassing attitudes and behaviors for communication, decision making, situational awareness, and team working, are an important aspect for the development and implementation of the Advanced Modular Manikin (AMM). This project brings together first responders, surgeons and anesthesiologists with respect to a complex pathway-based trauma scenario, at point of injury, in the trauma bay of an emergency department, and in the operating room. While the intent of the research study was not to measure the skills pertaining to interprofessional training and practice, the further development of the AMM shall look to explore interactions between clinical team members, to further develop and refine their skills to the timely and coordinated management of a complex and seriously unwell patient.

Our study has a number of limitations. While our original intention was to perform a multi-institutional study, in the end, our results were collected from a single institution due to logistical reasons and may not be generalizable to other institutions. In addition, our results were obtained in the military setting and may not translate to the civilian setting. However, the scenario that we used was applicable to both civilian and military settings, and many participants have had clinical experiences in the civilian sector. Further, our sample size may not have been adequate to detect statistically significant differences for some of the collected parameters. The inclusion of the first responders on scene 1 as first assistants in the operating room (scene 3) may not present a realistic scenario in civilian settings; however, it is a scenario applicable to the military where under combat conditions and limited resources, the same members of the team may have to cover different team roles. Finally, the tools we used to assess participant experience have not been validated for this use previously and may thus introduce bias in our results. Nevertheless,



all the tools we used were developed by subject matter experts using a rigorous process, including several rounds of feedback by multiple team members and revisions. We believe our study offers a novel robust global rating scale for simulator experience whose use in the literature will provide data to support its validity and reliability.

In conclusion, the first comprehensive evaluation of the AMM suggests that it is a valuable resource for scenario-based training and has the potential in its current form to enhance the learner experience, especially for surgeons. The feedback obtained on the AMM platform from this study will help further improve, augment, and enhance its value for other learner groups as well.

## VI. REFERENCES

1. Motola I, Devine LA, Chung HS, Sullivan JE, Issenberg SB. Simulation in healthcare education: a best evidence practical guide. AMEE Guide No. 82. *Med Teach*. 2013;35(10):e1511-1530.
2. Reznick RK, MacRae H. Teaching surgical skills--changes in the wind. *N Engl J Med*. 2006;355(25):2664-2669.
3. Fung L, Boet S, Bould MD, et al. Impact of crisis resource management simulation-based training for interprofessional and interdisciplinary teams: A systematic review. *J Interprof Care*. 2015;29(5):433-444.
4. Robertson JM, Dias RD, Yule S, Smink DS. Operating Room Team Training with Simulation: A Systematic Review. *J Laparoendosc Adv Surg Tech A*. 2017;27(5):475-480.
5. Hegland PA, Aarlie H, Stromme H, Jamtvedt G. Simulation-based training for nurses: Systematic review and meta-analysis. *Nurse Educ Today*. 2017;54:6-20.
6. Powers KA, Rehrig ST, Irias N, et al. Simulated laparoscopic operating room crisis: An approach to enhance the surgical team performance. *Surg Endosc*. 2008;22(4):885-900.
7. Sparks JL, Crouch DL, Sobba K, et al. Association of a Surgical Task During Training With Team Skill Acquisition Among Surgical Residents: The Missing Piece in Multidisciplinary Team Training. *JAMA Surg*. 2017;152(9):818-825.
8. Battlefield Excellence Through Superior Training Practices Act. In: Bill 115<sup>th</sup> Congress, ed. Washington 2017.
9. Brooks D. Activists: Army to Limit Live Animal Training. 2013. <https://www.military.com/daily-news/2013/04/02/activists-army-to-limit-live-animal-training.html>. Accessed 28 March 2020.
10. Advanced Modular Manikin. govtribe.com. <https://govtribe.com/opportunity/federal-contract-opportunity/advanced-modular-manikin-w81xwh13r0032>. Published 2013. Accessed.
11. Hart SGS, L.E. Development of NASA-TLX (Task Load Index): Results of Empirical and Theoretical Research. *Advances in Psychology*. 1988;52: 139-183.
12. Hart SG. NASA-Task Load Index (NASA-TLX); 20 Years Later. *Proceedings of the Human Factors and Ergonomics Society Annual Meeting*. 2006;50(9):904-908.

13. Yurko YY, Scerbo MW, Prabhu AS, Acker CE, Stefanidis D. Higher mental workload is associated with poorer laparoscopic performance as measured by the NASA-TLX tool. *Simul Healthc*. 2010;5(5):267-271.
14. Tan SC, Marlow N, Field J, et al. A randomized crossover trial examining low- versus high-fidelity simulation in basic laparoscopic skills training. *Surg Endosc*. 2012;26(11):3207-3214.
15. Finan E, Bismilla Z, Whyte HE, Leblanc V, McNamara PJ. High-fidelity simulator technology may not be superior to traditional low-fidelity equipment for neonatal resuscitation training. *J Perinatol*. 2012;32(4):287-292.
16. Friedman Z, Siddiqui N, Katznelson R, Devito I, Bould MD, Naik V. Clinical impact of epidural anesthesia simulation on short- and long-term learning curve: High- versus low-fidelity model training. *Reg Anesth Pain Med*. 2009;34(3):229-232.
17. Kim J, Park JH, Shin S. Effectiveness of simulation-based nursing education depending on fidelity: a meta-analysis. *BMC Med Educ*. 2016;16:152.
18. Johnson GG, Brindley PG, Gillman LM. Fidelity in surgical simulation: further lessons from the S.T.A.R.T.T. course. *Can J Surg*. 2020;63(2):E161-E163.
19. Cheng A, Lockey A, Bhanji F, Lin Y, Hunt EA, Lang E. The use of high-fidelity manikins for advanced life support training--A systematic review and meta-analysis. *Resuscitation*. 2015;93:142-149.
20. Choi W, Dyens O, Chan T, Schijven M, Lajoie S, Mancini ME, Dev P, Fellander-Tsai L, Ferland M, Kato P, Lau J, Montonaro M, Pineau J, Aggarwal R. Engagement and learning in simulation: recommendations of the Simnovate Engaged Learning Domain Group. *BMJ Stel* 2017; 3(Suppl 1): S23–S32.

## VII. APPENDIX

Table A1. Item-Level Statistics of Participant Workload by Role (Integrated AMM)

Scenario	NASA-TLX Items – AMM	First Responder (n = 14)		Anesthesiologist (n = 14)		Surgeon (n = 14)		Confederate (n = 4)		Technician (n = 4)	
		Mean	SD	Mean	SD	Mean	SD	Mean	SD	Mean	SD
Point of Injury	Mental demand: How mentally demanding was the task?	8.50	5.12								
	Physical demand: How physically demanding was the task?	4.93	3.85								
	Temporal demand: How hurried or rushed was the pace?	6.86	3.28								
	Performance: How successful were you?	7.64	5.01								
	Effort: How hard did you have to work to accomplish your level?	7.79	4.33								
	Frustration: How insecure, discouraged, irritated, stressed, and annoyed were you?	7.93	5.97								
ED Trauma Bay	Mental demand: How mentally demanding was the task?	6.86	4.77	9.64	5.02	8.57	4.00				
	Physical demand: How physically demanding was the task?	4.86	3.80	6.57	4.28	6.00	3.56				
	Temporal demand: How hurried or rushed was the pace?	7.71	4.50	8.14	5.13	7.93	4.19				
	Performance: How successful were you?	6.43	4.59	8.29	4.63	6.14	4.72				
	Effort: How hard did you have to work to accomplish your level?	6.86	3.73	9.93	4.69	7.21	3.22				
	Frustration: How insecure, discouraged, irritated, stressed, and annoyed were you?	5.29	4.70	9.93	5.55	5.14	3.65				
Operating Room	Mental demand: How mentally demanding was the task?	8.00	4.34	10.86	5.16	10.21	3.89				
	Physical demand: How physically demanding was the task?	6.36	4.04	8.57	4.38	8.71	4.05				
	Temporal demand: How hurried or rushed was the pace?	7.14	3.93	9.21	3.88	8.71	3.06				
	Performance: How successful were you?	5.00	2.81	8.21	4.78	5.50	3.38				
	Effort: How hard did you have to work to accomplish your level?	5.71	2.61	9.86	5.04	9.86	4.53				
	Frustration: How insecure, discouraged, irritated, stressed, and annoyed were you?	5.00	5.35	12.29	5.46	8.93	3.63				
Overall	Mental demand: How mentally demanding was the task?	7.79	4.74	10.25	5.09	9.39	3.95	5.75	0.35	8.75	1.77
	Physical demand: How physically demanding was the task?	5.38	3.90	7.57	4.33	7.36	3.81	6.00	1.41	2.25	1.77
	Temporal demand: How hurried or rushed was the pace?	7.24	3.90	8.68	4.51	8.32	3.63	8.50	4.95	6.25	2.47
	Performance: How successful were you?	6.36	4.14	8.25	4.71	5.82	4.05	4.25	1.77	2.50	0.71
	Effort: How hard did you have to work to accomplish your level?	6.79	3.56	9.90	4.87	8.54	3.88	5.25	3.18	8.25	2.47
	Frustration: How insecure, discouraged, irritated, stressed, and annoyed were you?	6.07	5.34	11.11	5.51	7.04	3.64	5.50	3.54	3.25	0.35

Note: Overall based on mean rating across scenarios for available participant data.

Table A2. Item-Level Statistics of Participant Workload by Role (Peripherals)

Scenario	NASA-TLX Items – Peripherals	First Responder (n = 14)		Anesthesiologist (n = 14)		Surgeon (n = 14)		Confederate (n = 4)		Technician (n = 4)	
		Mean	SD	Mean	SD	Mean	SD	Mean	SD	Mean	SD
Point of Injury	Mental demand: How mentally demanding was the task?	6.64	4.31								
	Physical demand: How physically demanding was the task?	4.00	3.30								
	Temporal demand: How hurried or rushed was the pace?	6.43	4.30								
	Performance: How successful were you?	6.64	3.75								
	Effort: How hard did you have to work to accomplish your level?	8.43	5.09								
	Frustration: How insecure, discouraged, irritated, stressed, and annoyed were you?	6.79	5.16								
ED Trauma Bay	Mental demand: How mentally demanding was the task?	4.93	3.56	8.07	4.44	6.57	3.52				
	Physical demand: How physically demanding was the task?	3.64	2.85	6.93	5.23	4.21	2.49				
	Temporal demand: How hurried or rushed was the pace?	5.43	3.39	7.07	4.25	5.93	3.71				
	Performance: How successful were you?	5.14	3.87	4.79	2.45	4.57	2.90				
	Effort: How hard did you have to work to accomplish your level?	5.29	2.53	7.14	3.26	6.57	3.27				
	Frustration: How insecure, discouraged, irritated, stressed, and annoyed were you?	5.07	4.19	7.14	4.51	6.14	4.94				
Operating Room	Mental demand: How mentally demanding was the task?	7.64	5.05	7.21	5.62	9.71	3.98				
	Physical demand: How physically demanding was the task?	6.14	4.65	4.79	4.54	10.14	5.12				
	Temporal demand: How hurried or rushed was the pace?	7.36	2.62	5.79	4.71	9.07	3.72				
	Performance: How successful were you?	5.43	2.28	5.52	2.65	6.50	4.11				
	Effort: How hard did you have to work to accomplish your level?	6.93	2.99	4.80	3.34	10.29	4.69				
	Frustration: How insecure, discouraged, irritated, stressed, and annoyed were you?	4.57	3.42	6.80	5.82	9.29	4.99				
Overall	Mental demand: How mentally demanding was the task?	6.40	4.31	7.64	5.03	8.14	3.75	5.50	3.54	4.75	1.77
	Physical demand: How physically demanding was the task?	4.59	3.60	5.86	4.89	7.18	3.81	4.00	2.12	2.25	1.06
	Temporal demand: How hurried or rushed was the pace?	6.41	3.44	6.43	4.48	7.50	3.72	5.50	3.54	4.50	1.41
	Performance: How successful were you?	5.74	3.30	5.16	2.55	5.54	3.51	6.50	3.54	1.50	0.71
	Effort: How hard did you have to work to accomplish your level?	6.88	3.54	5.97	3.30	8.43	3.98	5.25	1.06	6.75	0.35
	Frustration: How insecure, discouraged, irritated, stressed, and annoyed were you?	5.48	4.26	6.97	5.17	7.72	4.97	6.00	3.54	1.00	0.00

Note: Overall based on mean rating across scenarios for available participant data.

Table A3. Item-Level Statistics of Participant Simulation Experience by Role (Integrated AMM)

Item: Simulation Experience – AMM	First Responder (n = 14)		Anesthesiologist (n = 14)		Surgeon (n = 14)		Confederate (n = 4)		Technician (n = 4)	
	Mean	SD	Mean	SD	Mean	SD	Mean	SD	Mean	SD
Rate your overall perception of the ease or difficulty of simulator use throughout all scenes of the scenario.	3.64	0.85	2.71	0.80	3.36	0.65	3.75	0.71	3.25	1.77
Physical assessment of the simulated patient with the AMM was:	3.36	1.22	2.57	1.05	3.00	0.88				
The AMM's physiologic response to injury was:	3.57	1.11	2.93	1.01	3.93	1.01				
The AMM's physiologic response to IV fluid administration was:	3.36	1.15	2.79	1.26	3.21	1.49				
The AMM's physiologic response to medication administration was:	1.14	1.11	2.64	1.37	2.71	1.98				
Inserting an IV on the AMM was:	3.29	1.55	1.93	1.77						
Intubating the AMM was:	0.79	0.86	2.29	1.38						
How intuitive was interacting with the patient monitor?	2.29	1.62	2.57	1.18						
To what degree did the patient monitor accurately reflect monitors that you have used clinically?	1.57	1.56	2.86	0.76						
Did the patient monitor display the information that you needed to appropriately manage the AMM as a patient?	2.79	1.87	3.00	1.29						
Did the virtual patient increase the fidelity of the AMM?	2.63	1.87								
How often did you refer to the virtual patient for additional information about the AMM's status?	1.86	1.33								
Did the virtual patient confuse or complicate your management of the AMM?	1.93	1.74								
How intuitive was operating the IV pumps?			2.21	1.48						
To what degree did the IV pumps accurately reflect IV pumps that you have used clinically?			1.93	1.25						
Did the IV pumps contain the functions that you needed to appropriately manage the AMM as a patient?			2.29	1.09						
How intuitive was operating the mechanical ventilator?			3.14	1.12						
To what degree did the mechanical ventilator accurately reflect ventilators that you have used clinically?			2.93	1.15						
Did the mechanical ventilator contain the functions that you needed to appropriately manage the AMM as a patient?			3.29	0.91						
Did the virtual patient increase the fidelity of the AMM?			3.00	1.46						
How often did you refer to the virtual patient for additional information about the AMM's status?			2.57	1.59						
Did the virtual patient confuse or complicate your management of the AMM?			1.71	0.91						
Performing a FAST exam on the AMM was:					3.21	1.33				
The anatomy of the surgical abdomen was:					2.93	0.95				
Performing the necessary surgical procedures on the AMM was:					3.50	0.88				
How intuitive was interacting with the patient monitor?					1.79	1.91				
To what degree did the patient monitor accurately reflect monitors that you have used clinically?					2.29	1.57				
Did the patient monitor display the information that you needed to appropriately manage the AMM as a patient?					2.86	1.78				
Did the virtual patient increase the fidelity of the AMM?					2.29	1.59				
How often did you refer to the virtual patient for additional information about the AMM's status?					2.14	1.24				
Did the virtual patient confuse or complicate your management of the AMM?					2.07	1.29				
The weight of the airway trainer was:							3.50	1.41	4.75	0.35
The weight of the IV arm was:							3.50	1.41	5.00	0.00
The weight of the surgical abdomen was:							2.75	3.54	4.75	0.35
Installing the surgical abdomen was:							1.25	3.54	4.50	0.71
The connection ports of the arm or head were:							0.75	2.12	4.50	0.00
The connection ports of the palpation abdomen were:									5.00	0.00
The connection ports of the surgical abdomen were:									5.00	0.00
The organs within the surgical abdomen were:									4.25	0.35
Rate your overall perception of the ease or difficulty of simulator use throughout all scenes of the scenario.							4.00	0.00		
Based on your observation, the AMM's physiologic response to injury:							2.50	0.00		
Based on your observation, the AMM's physiologic response to IV fluid administration:							2.75	0.71		
Based on your observation, the AMM's physiologic response to medication administration:							2.25	2.12		
The AMM and its computer and/or tablets:									2.50	0.71
The training or instruction that I received:									2.00	0.71

Table A4. Item-Level Statistics of Participant Simulation Experience by Role (Peripherals)

Item: Simulation Experience – Peripherals	First Responder (n = 14)		Anesthesiologist (n = 14)		Surgeon (n = 14)		Confederate (n = 4)		Technician (n = 4)	
	Mean	SD	Mean	SD	Mean	SD	Mean	SD	Mean	SD
Rate your overall perception of the ease or difficulty of simulator use throughout all scenes of the scenario.	3.36	1.26	3.29	1.39	3.14	0.51	4.00	0.00	4.75	0.35
Physical assessment of the simulated patient using peripherals-only was:	2.93	1.55	1.93	0.88	2.14	0.90				
Inserting an IV on the IV arm/trainer was:	3.57	1.23	1.29	1.64						
Performing a FAST exam on the ultrasound abdomen was:					1.71	1.11				
Intubating the airway trainer was:	0.71	1.30	1.79	1.26						
The anatomy of the surgical abdomen was:					2.79	1.16				
Performing the necessary surgical procedures on the surgical abdomen was:					3.14	0.88				
The weight of the airway trainer was:							4.00	1.41	4.50	0.71
The weight of the IV arm was:							4.00	1.41	5.00	0.00
The weight of the palpation abdomen was:							4.00	1.41	4.50	0.71
The weight of the ultrasound abdomen was:							4.00	1.41	4.50	0.71
The weight of the surgical abdomen was:							2.50	3.54	4.50	0.71
The organs within the surgical abdomen were:									4.50	0.71
Rate your overall perception of the ease or difficulty of peripherals-only use throughout all scenes of the scenario.							3.50	0.71	1.50	0.71
The palpation abdomen and its computer:									3.75	1.06
The ultrasound abdomen and its computer:									3.25	0.35
The training or instruction that I received:									2.00	1.41

**Note: In Tables A3 and A4, the highlighting indicates common items.**

Table A5. Simulation Experience Comparison between AMM and Peripheral by Role

Simulation Experience (Common Items)	Role	Integrated AMM		Peripheral		<i>p</i> -value
		Mean	SD	Mean	SD	
Rate your overall perception of the ease or difficulty of simulator use throughout all scenes of the scenario.	First Responder	3.64	.85	3.36	1.26	.497
	Anesthesiologist	2.71	.80	3.52	1.16	.041
	Surgeon	3.36	.65	3.14	.51	.328
	Overall	3.24	.76	3.34	.98	.603
Physical assessment of the simulated patient with the AMM / peripherals-only was:	First Responder	3.36	1.22	2.93	1.55	.422
	Anesthesiologist	2.57	1.05	2.06	.83	.166
	Surgeon	3.00	.88	2.07	1.08	.019
	Overall	2.98	1.05	2.35	1.15	.010
Inserting an IV on the AMM / IV arm trainer was:	First Responder	3.29	1.55	3.57	1.23	.601
	Anesthesiologist	2.95	1.14	3.00	1.12	.908
	Surgeon					
	Overall	3.12	1.34	3.29	1.17	.615
Performing a FAST exam on the AMM / ultrasound abdomen was:	First Responder					
	Anesthesiologist					
	Surgeon	3.21	1.33	3.07	.90	.747
	Overall	3.21	1.33	3.07	.90	.747
Intubating the AMM / airway trainer was:	First Responder	2.75	1.26	2.00	1.57	.175
	Anesthesiologist	2.74	1.02	2.86	1.18	.776
	Surgeon					
	Overall	2.75	1.14	2.43	1.38	.348
The anatomy of the surgical abdomen was:	First Responder					
	Anesthesiologist					
	Surgeon	2.93	.95	2.79	1.16	.730
	Overall	2.93	.95	2.79	1.16	.730
Performing the necessary surgical procedures on the AMM / surgical abdomen was:	First Responder					
	Anesthesiologist					
	Surgeon	3.50	.88	3.14	.88	.289
	Overall	3.50	.88	3.14	.88	.289

Note: Analysis based on item-level comparison.

Table A6. Item-Level Statistics of Integrated AMM Experience by Role (based on Global Ratings)

Global Items – Integrated AMM	Overall (n = 42)		First Res (n = 1)
	Mean	SD	Mean
Simulator scope: the extent to which the AMM supports the clinical scenario.	3.33	0.91	3.57
Scenario scope: the extent to which the scenario allowed for the evaluation of the AMM.	3.40	1.13	3.57
Visual fidelity	2.76	1.04	3.14
Tactile fidelity	2.55	1.19	2.71
Conceptual fidelity the degree to which the AMM supports the clinical progression of the scenario in a believable manner	3.26	1.13	3.36
Emotional fidelity: the degree to which the AMM generates the feelings that participants would expect in a real situation.	2.40	1.41	2.50
Behavioral engagement: the degree to which the AMM encourages participants to willfully accept the scenario as real.	3.10	1.07	3.07
Emotional engagement: participants' attitudes toward, and interest in treating the AMM.	2.88	1.03	3.07
Cognitive engagement: the degree to which participants devote full attention (focus) to treating the AMM.	3.62	1.02	3.71
Interprofessional engagement: the degree to which the AMM encourages participants to work as a team toward a common goal.	3.98	0.96	4.29

### Acknowledgement

The investigators would like to acknowledge Ms. Sally Schiller and Dr. Imade Ihianle for their tireless support of this project.