

FINAL REPORT

Demonstration of a Full-Scale Fluidized Bed Bioreactor for the Treatment of Perchlorate at Low Concentrations in Groundwater

ESTCP Project ER-200543

OCTOBER 2017

Todd S. Webster, Ph.D., P.E.
Envirogen Technologies, Inc.

Distribution Statement A
This document has been cleared for public release



Page Intentionally Left Blank

This report was prepared under contract to the Department of Defense Environmental Security Technology Certification Program (ESTCP). The publication of this report does not indicate endorsement by the Department of Defense, nor should the contents be construed as reflecting the official policy or position of the Department of Defense. Reference herein to any specific commercial product, process, or service by trade name, trademark, manufacturer, or otherwise, does not necessarily constitute or imply its endorsement, recommendation, or favoring by the Department of Defense.

Page Intentionally Left Blank

REPORT DOCUMENTATION PAGE

Form Approved
OMB No. 0704-0188

The public reporting burden for this collection of information is estimated to average 1 hour per response, including the time for reviewing instructions, searching existing data sources, gathering and maintaining the data needed, and completing and reviewing the collection of information. Send comments regarding this burden estimate or any other aspect of this collection of information, including suggestions for reducing the burden, to Department of Defense, Washington Headquarters Services, Directorate for Information Operations and Reports (0704-0188), 1215 Jefferson Davis Highway, Suite 1204, Arlington, VA 22202-4302. Respondents should be aware that notwithstanding any other provision of law, no person shall be subject to any penalty for failing to comply with a collection of information if it does not display a currently valid OMB control number.
PLEASE DO NOT RETURN YOUR FORM TO THE ABOVE ADDRESS.

| | | | | | |
|--|-------------|--------------------------------------|----------------------------|---|---|
| 1. REPORT DATE (DD-MM-YYYY) 10/15/2017 | | 2. REPORT TYPE ESTCP Final Report | | 3. DATES COVERED (From - To) 3/9/2006 - 9/30/2011 | |
| 4. TITLE AND SUBTITLE Demonstration of a Full-Scale Fluidized Bed Bioreactor for the Treatment of Perchlorate at Low Concentrations in Groundwater | | | | 5a. CONTRACT NUMBER Contract: 06-C-0009 | |
| | | | | 5b. GRANT NUMBER | |
| | | | | 5c. PROGRAM ELEMENT NUMBER | |
| 6. AUTHOR(S) Todd Webster | | | | 5d. PROJECT NUMBER ER-200543 | |
| | | | | 5e. TASK NUMBER | |
| | | | | 5f. WORK UNIT NUMBER | |
| 7. PERFORMING ORGANIZATION NAME(S) AND ADDRESS(ES) Envirogen Technologies Inc. 4777 Winona Avenue San Diego, CA 92115 | | | | 8. PERFORMING ORGANIZATION REPORT NUMBER ER-200543 | |
| 9. SPONSORING/MONITORING AGENCY NAME(S) AND ADDRESS(ES) Environmental Security Technology Certification Program 4800 Mark Center Drive, Suite 17D03 Alexandria, VA 22350-3605 | | | | 10. SPONSOR/MONITOR'S ACRONYM(S) ESTCP | |
| | | | | 11. SPONSOR/MONITOR'S REPORT NUMBER(S) ER-200543 | |
| 12. DISTRIBUTION/AVAILABILITY STATEMENT Distribution A; unlimited public release | | | | | |
| 13. SUPPLEMENTARY NOTES | | | | | |
| 14. ABSTRACT Perchlorate is a highly soluble salt-anion that can negatively affect the ability of the human thyroid to adequately uptake iodine. The majority of the perchlorate contamination in groundwater is believed to be attributable to historical disposal practices by the aerospace and ordnance industries, the military and chemical manufacturers. The overall objective of this project was to provide an effective and reliable water treatment solution for a perchlorate-laden well in the City of Rialto, CA. In doing so, this would allow the local water authority the ability to utilize a valuable but impaired-quality water source, increasing the water security of the community and reducing its dependence on imported water. | | | | | |
| 15. SUBJECT TERMS perchlorate treatment, biological fluidized bed reactor, drinking water treatment, full-scale, Perchlorate, potable water, Fluidized Bed Bioreactor, Hydraulic Residence Time, Oxidation-Reduction Potential, Rialto Ammunition Storage Point, Total Organic Carbon | | | | | |
| 16. SECURITY CLASSIFICATION OF: | | | 17. LIMITATION OF ABSTRACT | 18. NUMBER OF PAGES 91 | 19a. NAME OF RESPONSIBLE PERSON |
| a. REPORT | b. ABSTRACT | c. THIS PAGE | | | Todd Webster |
| UNCLASS | UNCLASS | UNCLASS | UNCLASS | | 19b. TELEPHONE NUMBER (Include area code) 619-887-2587 |

Page Intentionally Left Blank

FINAL REPORT

Project: ER-200543

TABLE OF CONTENTS

| | Page |
|--|-------------|
| EXECUTIVE SUMMARY | ES-1 |
| 1.0 INTRODUCTION | 3 |
| 1.1 BACKGROUND | 3 |
| 1.2 OBJECTIVE OF THE PROJECT | 3 |
| 1.3 REGULATORY DRIVERS | 4 |
| 2.0 TECHNOLOGY DESCRIPTION | 5 |
| 2.1 TECHNOLOGY OVERVIEW | 5 |
| 2.2 TECHNOLOGY DEVELOPMENT | 6 |
| 2.3 ADVANTAGES AND LIMITATIONS OF THE TECHNOLOGY | 10 |
| 3.0 PERFORMANCE OBJECTIVES OF FULL-SCALE PLANT | 13 |
| 3.1 FULL-SCALE PLANT PURPOSE | 13 |
| 3.2 QUANTITATIVE PERFORMANCE OBJECTIVE | 14 |
| 4.0 FACILITY/SITE DESCRIPTION | 15 |
| 4.1 LOCATION AND OPERATIONS | 15 |
| 4.2 SITE CONDITIONS | 16 |
| 4.3 GENERAL WATER CHEMISTRY OF WELLS | 17 |
| 5.0 FULL-SCALE GROUNDWATER TREATMENT PLANT | 19 |
| 5.1 TECHNOLOGY COMPONENTS AND PLANT DESCRIPTION | 19 |
| 5.2 DESIGN AND OPERATIONAL DETAILS OF PLANT | 35 |
| 5.2.1 Modes of Operation | 35 |
| 5.2.2 Influent De-aeration Tank | 36 |
| 5.2.3 Fluidized Bed Bioreactor | 37 |
| 5.2.4 Aeration | 40 |
| 5.2.5 Solids Removal | 42 |
| 5.2.6 Dissolved Air Floatation | 44 |
| 5.2.7 Disinfection | 46 |
| 5.3 OPERATIONAL START-UP | 49 |
| 5.3.1 Dry Test | 49 |
| 5.3.2 Wet Test | 49 |
| 5.3.3 Batch Operation | 49 |
| 5.3.4 Acclimation | 50 |
| 5.3.5 Steady-State Operation | 50 |
| 5.4 SAMPLING PROTOCOL | 51 |
| 5.5 SAMPLING RESULTS | 51 |

TABLE OF CONTENTS (Continued)

| | Page |
|--|-------------|
| 6.0 PERFORMANCE ASSESSMENT | 59 |
| 7.0 COST ASSESSMENT..... | 61 |
| 7.1 BACKGROUND | 61 |
| 7.1.1 New Technology..... | 61 |
| 7.1.2 Unique Location..... | 62 |
| 7.1.3 Designed for Expansion..... | 62 |
| 7.1.4 Permitting Considerations..... | 62 |
| 7.2 GROUNDWATER TREATMENT PLANT CAPITAL COSTS..... | 63 |
| 7.3 GROUNDWATER TREATMENT PLANT OPERATIONAL COSTS..... | 64 |
| 7.3.1 Electricity Usage..... | 65 |
| 7.3.2 Chemical Usage | 65 |
| 7.3.3 Labor Usage | 66 |
| 7.4 COST COMPARISON WITH ION EXCHANGE..... | 66 |
| 7.5 COSTING COMMENTS AND CONCLUSIONS..... | 68 |
| 8.0 IMPLEMENTATION ISSUES | 69 |
| 8.1 REGULATIONS..... | 69 |
| 8.2 END USER CONCERNS..... | 70 |
| 8.3 LESSONS LEARNED..... | 71 |
| 9.0 REFERENCES | 75 |
| APPENDIX A POINTS OF CONTACT | A-1 |

LIST OF FIGURES

| | Page |
|-------------|--|
| Figure 2.1 | Biological Treatment of Perchlorate (from Webster and Togna 2009)..... 5 |
| Figure 2.2 | Typical Fluidized Bed Reactor Schematic. 6 |
| Figure 2.3 | Schematic of Pilot-scale FBR Treatment Plant (Webster and Togna, 2009). 7 |
| Figure 4.1 | Location of Groundwater Treatment Plant..... 16 |
| Figure 5.1 | Overall Area Process Flow Diagram..... 20 |
| Figure 5.2 | Process Flow Layout of Plant (Webster and Litchfield, 2017). 21 |
| Figure 5.3 | Plant Process Flow Diagram. 22 |
| Figure 5.4 | SCADA Screenshot of Treatment Plant. 23 |
| Figure 5.5 | SCADA Screenshot of Feed System. 24 |
| Figure 5.6 | SCADA Screenshot of FBR System. 25 |
| Figure 5.7 | SCADA Screenshot of Filtration System. 26 |
| Figure 5.8 | SCADA Screenshot of Water Holding System/chlorination System..... 27 |
| Figure 5.9 | FBR System..... 28 |
| Figure 5.10 | Aeration System. 29 |
| Figure 5.11 | Solids Removal - TridentSystem. 30 |
| Figure 5.12 | Solids Removal- DAF System. 31 |
| Figure 5.13 | Backwash Tanks and Disinfection System. 32 |
| Figure 5.14 | Chemical Addition System 1..... 33 |
| Figure 5.15 | Chemical Addition System 2..... 34 |
| Figure 5.16 | Photo of Full-scale Groundwater Treatment Plant. 35 |
| Figure 5.17 | Sampling locations in Groundwater Treatment Plant. 53 |
| Figure 5.18 | Perchlorate Treatment across the FBRs. 55 |
| Figure 5.19 | Nitrate Treatment across the FBRs. 55 |
| Figure 5.20 | Residual Dissolved Organic Carbon for the FBRs..... 56 |
| Figure 5.21 | Expanded Media Bed Heights for the FBRs. 56 |

LIST OF TABLES

| | Page |
|-----------|---|
| Table 3.1 | Performance Objective..... 13 |
| Table 5.1 | Design Feed/Effluent Parameters. 19 |
| Table 5.2 | Timeline for Activities..... 49 |
| Table 5.3 | Monitoring Schedule for Wells and Analysis Points for Continuing Operations.... 52 |
| Table 5.4 | California Regulatory Limits for Drinking Water. 54 |
| Table 5.5 | Average, Minimum and Maximum Values for Potable Water Analyses from the Clear Well. 57 |
| Table 5.6 | Average, Minimum and Maximum Values for Disinfection by-Products for Potable Water Analyses from the FBRs. 58 |
| Table 7.1 | Total Costs for Groundwater Treatment Plant Design, Fabrication, Construction and Installation..... 63 |
| Table 7.2 | Total Costs for Treatment Plant and Associated Site Work. 64 |
| Table 7.3 | Total Operating Cost from October 2016 through February 2017. 65 |
| Table 7.4 | Capital Cost Comparison. 67 |
| Table 7.5 | Ion Exchange Operating Costs..... 67 |

ACRONYMS AND ABBREVIATIONS

| | |
|-----------|---|
| ACH | Aluminum Chlorohydrate |
| ASTM | American Society for Testing and Materials |
| AMSL | Above Mean Sea Level |
| | |
| COC | Chain of Custody |
| COTS | Commercially-off-the-shelf |
| | |
| DDW | Division of Drinking Water |
| DPH | Department of Public Health |
| DO | Dissolved Oxygen |
| DOC | Dissolve Organic Carbon |
| DoD | Department of Defense |
| | |
| ECAM | Economic Cost Analysis Methods |
| EPA/USEPA | United States Environmental Protection Agency |
| ESTCP | Environmental Security Technology Certification Program |
| EW | Extraction Well |
| | |
| FBR | Fluidized Bed Bioreactor |
| Fe | Iron |
| | |
| GAC | Granulated Activated Carbon |
| gpm | Gallons per minute |
| | |
| HASP | Health & Safety Plan |
| HRT | Hydraulic Residence Time |
| | |
| LGAC | Liquid Granular Activated Carbon |
| LOC | Level(s) of Concern |
| | |
| MCL | Maximum Contaminant Level |
| MDL | Method Detection Limits |
| Mn | Manganese |
| MSL | Mean Sea Level |
| MW | Monitoring Well |
| | |
| NL | Notification Limit |
| NSF | National Sanitary Foundation |
| | |
| O&M | Operation & Maintenance |
| ORP | Oxidation-Reduction Potential |
| | |
| PHG | Public Health Goal |
| P&ID | Piping and Instrumentation Diagram |

| | |
|-----------|--|
| P&T | Pump & Treat |
| PI | Principal Investigator |
| PQL | Practical Quantitation Limit |
| QA | Quality Assurance |
| QC | Quality Control |
| QAPP | Quality Assurance Project Plan |
| RASP | Rialto Ammunition Storage Point |
| RCRA | Resource Conservation and Recovery Act |
| RfD | Reference Dose |
| RI | Remedial Investigation |
| RI/FS | Remedial Investigation/Feasibility Study |
| RW#6 | Rialto Well #6 |
| SARWQCB | Santa Ana Regional Water Quality Control Board |
| SCADA | Supervisory control and data acquisition |
| TOC | Total Organic Carbon |
| USACE | United States Army Corp of Engineers |
| UV | Ultraviolet Irridation |
| VOA | Volatile Organic Analysis |
| VOC | Volatile Organic Compounds |
| WVWD | West Valley Water District |
| WVWD #11 | West Valley Water District Well #11 |
| WVWD #33 | West Valley Water District Well #33 |
| WWI, WWII | World War I, World War II |

ACKNOWLEDGEMENTS

This Environmental Security Technology Certification Program project was a collaborative effort amongst the personnel from many agencies, including West Valley Water District, City of Rialto, Santa Ana Regional Water Quality Control Board, the State Water Resources Control Board- Division of Drinking Water, the Santa Ana Water Shed Project Authority, and Envirogen Technologies, Inc. The various agency associated staff and their consultants provided continual support of the project objectives. In particular, special thanks to Mr. Thomas Crowley, Mr. Butch Araiza, and Mr. Matt Litchfield of West Valley Water District for their vision to see this project through to completion. Additional thanks to the operators at the West Valley Water District, Mr. Sergio Granda and Mr. Brian Grubert, for their dedication to the start-up and operation of the facility. Finally, special thanks to Mr. Corey Wall, Mr. Sam Wong, and Mr. Matt Zwartjes of Envirogen Technologies, Inc. for their continued support to make the plant fully operational and eventually permitted to produce potable drinking water.

Page Intentionally Left Blank

EXECUTIVE SUMMARY

Perchlorate is a highly soluble salt-anion that can negatively affect the ability of the human thyroid to adequately uptake iodine. Since early 1997, with the improvement of analytical techniques, the oxyanion has been detected in several regions of California. The majority of the perchlorate contamination in groundwater is believed to be attributable to historical disposal practices by the aerospace and ordinance industries, the military and chemical manufacturers.

Objectives of the Demonstration

The overall objective of this project was to provide an effective and reliable water treatment solution for a perchlorate-laden well in the City of Rialto, CA. In doing so, this would allow the local water authority the ability to utilize a valuable but impaired-quality water source, increasing the water security of the community and reducing its dependence on imported water.

In meeting this objective, West Valley Water District (WVWD), located in Rialto, CA, has commissioned the “first-of-its-kind” full-scale Groundwater Treatment Plant using a fluidized bed biological reactor (FBR) technology to biologically treat water laden with the oxyanions of perchlorate and nitrate. Highly contaminated perchlorate-laden water is being treated by the new facility to produce up to 3 million gallons per day (MGD) of quality drinking water for area residents.

The new treatment plant was designed and developed based on a year-long successful pilot demonstration study conducted by Envirogen Technologies, Inc. and funded through the Environmental Security and Technology Certification Program. From the pilot study, the FBR was demonstrated to be an effective means to biologically treat perchlorate to a concentration less than the California MCL. Based on the success of the demonstration project, the team headed by Envirogen Technologies, Inc. and WVWD collaborated to design, install, start-up, and operate a full-scale FBR system capable of treating 2000 gpm for the treatment of nitrate and perchlorate laden groundwater. Downstream equipment includes dual media filtration, re-aeration, and chlorine disinfection for delivery to the potable supply. The system was built and installed by 2013 and commissioned in 2016, representing the first full-scale permitted drinking water system in the world using this specific FBR technology for these contaminants.

Technology Description

The FBR is a fixed-film reactor in which the biological media, specified granular activated carbon (GAC), is suspended or fluidized within the reactor vessel by the upward flow of water through the system. Because the GAC particles are small and suspended, they present a large surface area for microbial growth and attachment. A precise amount of electron donor is provided to the FBR where, under anoxic conditions, the attached microorganisms perform an oxidation/reduction reaction in consuming all of the dissolved oxygen, nitrate, and perchlorate. The by-products of the process are nitrogen gas, chloride ion, carbon dioxide, heat generation and additional biomass. This “living” media bed expands and fluidizes further such that longer media bed hydraulic retention times can be achieved for effective and complete contaminant removal. The FBR technology completely destroys the perchlorate, ensuring that it will no longer be an environmental hazard for future generations.

Demonstration Results

The plant effluent water is required at all times to meet the requirements per the California Code Regulations Title 22, Div.14, Ch.15 and Ch.17 for drinking water, including meeting the current MCLs in the State of California of 6.0 µg/L for perchlorate and 10 mg/L for nitrate-N. These treatment goals applied to all phases of operation after initial start-up and were the completion criteria for the project.

Throughout acclimation and steady-state operations, the full-scale FBRs have proven to be reliable, resilient, and effective in eliminating nitrate and perchlorate from the feed groundwater. The downstream equipment, utilized to remove solids and disinfect the FBR effluent so that it was suitable as potable water, also shown to be successful in meeting all drinking water regulatory requirements.

The FBR was naturally inoculated with only the incoming contaminated groundwater. No outside inoculum was provided to the FBR system. Originally, after operating the system in FBR recycle and then plant recycle, the effluent of the system was discharged through a temporary ion exchange system to a natural basin until the biomass growth occurred and full treatment was demonstrated. Microbial attachment and perchlorate treatment occurred by Day 33, but due to a number of mechanical and process adjustments to both FBRs and downstream equipment, it took until Day 99 for the FBRs to completely acclimate so that discharge could be sent directly to the basin without ion exchange treatment. The FBRs were fully capable of complete elimination of perchlorate from this time forward.

Over the first 250 days of operation, perchlorate and nitrate-nitrogen concentrations ranged from approximately 450 µg/L to 150 µg/L and 5 mg/L to 3.5 mg/L, respectively. Once basin discharge began, there was not a single occurrence of discharge of effluent exceeding any of the California MCLs. The plant was permitted in May, 2016 and began full operation providing water to consumers in October, 2016.

Both capital and operating data are provided in the report, demonstrating that the FBR technology is predominantly more cost-effective when increasing oxyanion concentrations occur.

A comparison to ion exchange technology is provided which demonstrates a potential 5-yr payback is possible as the perchlorate concentrations increase.

Implementation Issues

Implementation issues of the FBR technology are provided in the report, with detailed assessment of numerous lessons learned during the design, fabrication, construction, installation, and operation of the facility. Ultimately, the development of this Groundwater Treatment Plant was a shared responsibility of numerous governmental agencies and private companies, making it possible to treat a significantly impaired resource to produce potable water for the better of the community.

1.0 INTRODUCTION

West Valley Water District (WVWD), located in Rialto, CA, has commissioned a full-scale Groundwater Treatment Plant using a fluidized bed biological reactor (FBR) technology to biologically treat water laden with the oxyanions of perchlorate and nitrate. Contaminated perchlorate-laden water from the City of Rialto Well #6 and nitrate-laden water from West Valley Water District Well #11 is being treated by the new facility to produce up to 3 million gallons per day (MGD) of quality drinking water for area residents that meets all of the Safe Drinking Water Act requirements. The treatment plant represents a significant progression toward addressing the clean-up of a major perchlorate plume that has threatened the Rialto-Colton Basin's water supply since its detection in 1997.

1.1 BACKGROUND

Perchlorate is a highly soluble salt-anion that can negatively affect the ability of the human thyroid to adequately uptake iodine. Since early 1997, with the improvement of analytical techniques, drinking water testing performed throughout California has revealed contamination in several regions of the state at levels as low as 1 µg/L (ASTSWMO, 2011).

The majority of the perchlorate contamination in groundwater is believed to be attributable to historical disposal practices by the aerospace and ordinance industries, the military and chemical manufacturers. Perchlorate salts have been used in the U.S. defense and space programs for several decades as primary oxidants in the solid propellants that power rocket motors, rocket boosters, and missiles. In past disposal practices, solid perchlorate-containing fuels were often burned in open-burn and open-detonation areas, and aqueous processing waters or wastewaters were released to surface soils or discharged into lagoons or evaporation ponds. With such past disposal practices and the mobility of the anion, a number of drinking water aquifers throughout the state have been contaminated with perchlorate.

Traditional treatment practices of perchlorate laden groundwater rely nearly exclusively on one-pass ion exchange systems, which use resin that requires disposal once its capacity is exhausted. This phase transfer technology may be cost-effective for relatively low nitrate and perchlorate loading rates. However, at higher concentrations, the increased resin usage and waste handling costs have a significant impact on the economic viability of ion exchange treatment, leading to the search for a cost-effective alternative for the dual treatment of moderate to high concentrations of perchlorate to produce potable water. Based on the prevalence of perchlorate in drinking water aquifers and the importance of available quality drinking water to the health and security of local communities, the further development of reliable, cost-effective treatment technologies is warranted.

1.2 OBJECTIVE OF THE PROJECT

The overall project objective was to provide an effective and reliable water treatment solution for a perchlorate-laden well in the City of Rialto, CA. In doing so, this would allow the local water authority the ability to utilize a valuable but impaired-quality water source, increasing the water security of the community and reducing its dependence on imported water. In meeting this objective, the project has created the first full-scale permitted drinking water system in the world using this specific technology for these contaminants - a "first-of-its-kind" biological treatment plant.

From this objective, performance data and cost information of the full-scale application have been generated.

1.3 REGULATORY DRIVERS

For perchlorate, no US Federal drinking water standard MCL has been established, requiring individual states to proactively establish their own advisory levels or MCLs. Currently, only Massachusetts (2 µg/L, 2006) and California (6 µg/L, 2007) have established MCLs for perchlorate (AWWA, 2016), while other states have set advisory levels ranging from 1 to 18 µg/L, including New Mexico, New York, Arizona, Nevada, and Maryland (ASTSWMO, 2011).

The current MCL for drinking water standards in the State of California is 6.0 µg/L for perchlorate and 10 mg/L for nitrate-N. Even though the State MCL for perchlorate is 6.0 µg/L, the treatment objective is to eliminate any detectable levels (≤ 1 µg/L) of perchlorate concentrations in the plant effluent water. The plant effluent water is required to meet all requirements per the California Code Regulations Title 22, Div.14, Ch.15 and Ch.17 for drinking water (per the Federal Safe Drinking Water Act). These treatment goals applied to all phases of operation after initial start-up and were the completion criteria for the project.

2.0 TECHNOLOGY DESCRIPTION

2.1 TECHNOLOGY OVERVIEW

Through anoxic respiration, perchlorate-reducing organisms commonly found in soil and the environment couple the oxidization of an organic substrate to the reduction of perchlorate (Kengen et al., 1999; Song and Logan, 2004; Zhang et al., 2002). This respiratory process, which produces chloride and oxygen as degradation products, closely resembles dissimilatory nitrate reduction, where nitrate is reduced to nitrogen gas (Figure 2.1).

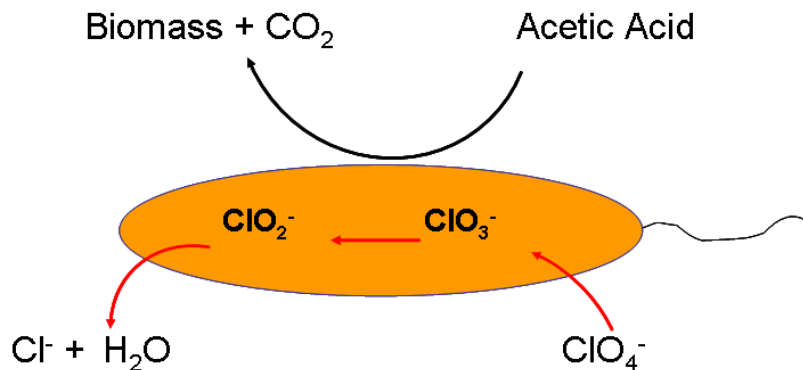

Figure 2.1 Biological Treatment of Perchlorate (from Webster and Togna 2009).

In order to ensure that the naturally occurring perchlorate degrading microorganisms can effectively treat large volumes of perchlorate laden groundwater to desired levels, the microorganisms must be maintained at a high density with sufficient contact time. Several fixed film bioreactors exist that allow for high density growth and sufficient contact time to treat perchlorate, with the fluidized bed bioreactor (FBR) most prevalent in use for non-potable water oxyanion treatment. The FBR is one of two biological treatment technologies approved by the State Water Resources Control Board-Division of Drinking Water (DDW) as permissible for treating perchlorate laden water to drinking water.

A fluidized bed bioreactor is a fixed-film reactor in which the biological media, specified granular activated carbon (GAC), is suspended or fluidized within the reactor vessel by the upward flow of water through the system (Figure 2.2). Because the GAC particles are small and suspended, they present a large surface area for microbial growth and promote a biomass density that is often several times that of other bioreactor designs under similar loading conditions (USEPA 1993; Sutton and Mishra 1994). A precise amount of electron donor (i.e., NSF approved acetic acid) is provided to the FBR where, under anoxic conditions, the attached microorganisms perform an oxidation/reduction reaction in consuming all of the dissolved oxygen, nitrate, and perchlorate. The precise amount of electron donor addition allows for complete perchlorate reduction while minimizing the subsequent processes of sulfate reduction or methanogenesis within the FBR.

The by-products of the process are nitrogen gas, chloride ion, carbon dioxide, heat generation and additional biomass. As the microorganisms acclimate and grow to increasing higher biomass quantities, the amount of attached microbes per media particle increases.

Since the microbes primarily consist of water, the volume of the microbe/media particle increases, but the specific density decreases. This allows the “living” media bed to expand and fluidize further such that longer media bed hydraulic retention times can be achieved for effective and complete contaminant removal. Ultimately, the FBR is a unique bioreactor configuration as it promotes higher biomass development on the media, but the bed expansion/mean cell age can be controlled by in-situ patented biomass control systems.

Unlike phase transfer technologies such as ion exchange, the FBR technology completely destroys the perchlorate. The complete destruction of the perchlorate ion ensures that it will no longer be an environmental hazard for future generations.

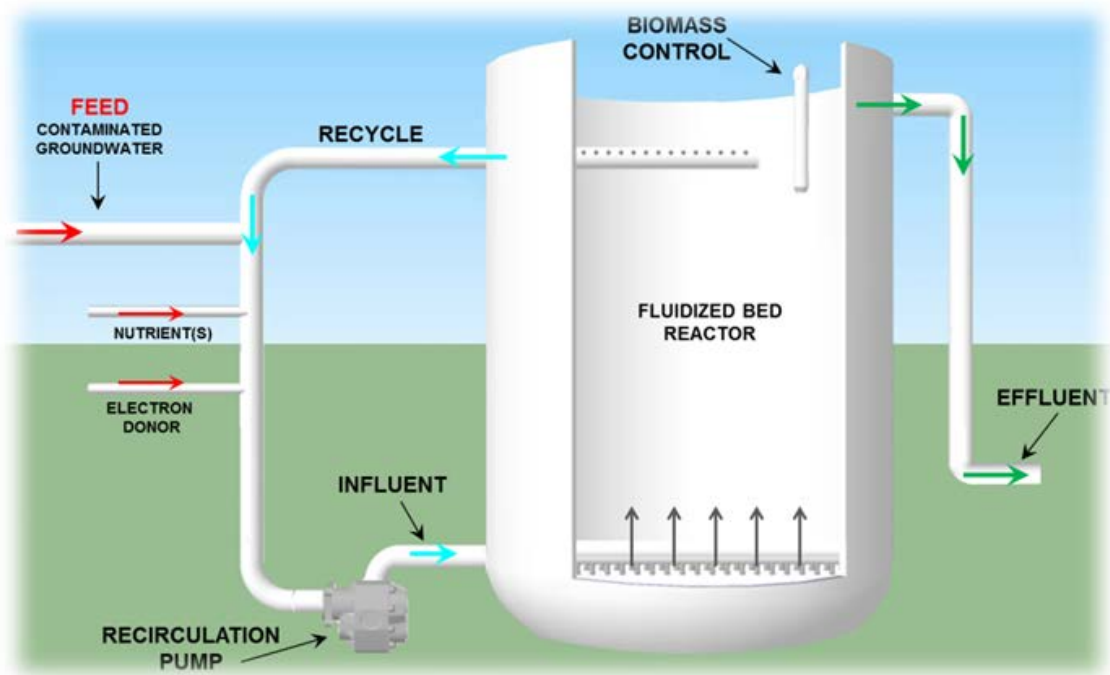

Figure 2.2 Typical Fluidized Bed Reactor Schematic.

For any biological treatment system producing potable water, the effluent requires further treatment to meet the Surface Water Treatment Rule requirements of the Safe Drinking Water Act and California Title 22 Regulations. This downstream equipment can include reaeration, dual media filtration to remove biological solids, and disinfection for delivery to the potable supply.

2.2 TECHNOLOGY DEVELOPMENT

From a pilot demonstration study previously conducted, the FBR was demonstrated to be a cost-effective means to biologically treat perchlorate to less than the California MCL of 6 $\mu\text{g/L}$ for increasing oxyanion concentrations. Following the FBR system, water passed through a pilot surface water treatment plant consisting of a post-aeration unit and multimedia filter to meet all of the primary and secondary MCL requirements. A full description of the pilot study and results can be found in the 2009 Final Report entitled *Demonstration of a Full-Scale Fluidized Bed Bioreactor for the Treatment of Perchlorate at Low Concentrations in Groundwater* (Webster and Togna, 2009).

The pilot demonstration study was conducted at the City of Rialto Wellhead #2 (Rialto, CA) to treat perchlorate laden groundwater to potable water standards using the FBR treatment train. The main objective of this demonstration project was to demonstrate the efficacy of a potential full-scale FBR for the treatment of both lower ($<100 \mu\text{g/L}$) and higher ($>1000 \mu\text{g/L}$) concentrations of perchlorate in groundwater to the current Maximum Contaminant Level (MCL) for perchlorate established in the State of California of $6 \mu\text{g/L}$. In addition, plant effluent water was also required to meet all Federal Safe Drinking Water Act and California Code of Regulations, Title 22 drinking water requirements. This project was set up to test and validate the following: (1) *ex situ* bioremediation of nitrate and perchlorate contaminated groundwater through a fluidized bed bioreactor via an anoxic biological coupling reaction using an added electron donor; (2) the short- and long-term performance effects in allowing the system to be self-inoculated with the incoming groundwater versus manually inoculating with a non-pathogenic microbial consortium that has been developed in other FBR perchlorate treatment units; (3) the resulting short-term performance effects in the simulation of both a feed pump failure (i.e., system remains in recycle) and an electrical shutdown; (4) the use of a post aeration vessel, multimedia filter, and LGAC to produce a potable-like effluent water stream; (5) the operational effectiveness of on-line nitrate and perchlorate analyzer systems; (6) a comparison of system effluent disinfection through both chlorination and UV; and (7) long-term monitoring of system robustness and performance under steady-state and spiking perchlorate concentrations. A schematic of the pilot system is provided in Figure 2.3.

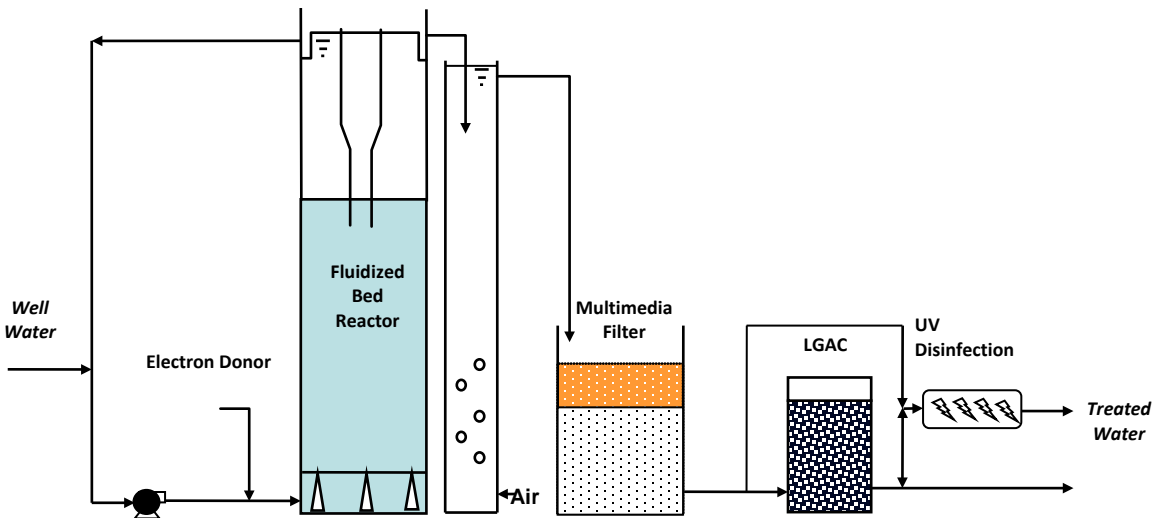

Figure 2.3 Schematic of Pilot-scale FBR Treatment Plant (Webster and Togna, 2009).

The operation of the plant was conducted from March, 2007 to March, 2008, with an overall uptime for water production from the plant during the first year of operation at 94%. Using only the feed groundwater at 50 gpm, the FBR system was biologically seeded and demonstrated effective removal of the nitrate and perchlorate to non-detect levels within 28 days from the beginning of system operation. The typical system feed chemical concentrations were recorded as nitrate-nitrogen at 6.1-6.3 mg/L, oxygen at 8.1 mg/L, and perchlorate at approximately 50-53 $\mu\text{g/L}$. The FBR media hydraulic residence time (HRT) was 12.2 minutes. The electron donor (50% acetic acid) and the nutrient formulation (1.7% phosphoric acid) addition rates were set by fully-automated plant utilizing Programmable Logic Controller (PLC) technology.

The PLC operated a proprietary model that accounted for the stoichiometric requirements of 50% acetic acid to theoretically treat the known feed flow and oxygen, nitrate, and perchlorate concentrations. This iterative model used feed forward control logic based on effluent contaminant concentrations to meet the FBR system electron donor requirements for complete nitrate and perchlorate treatment. Based on the non-spiking condition average feed concentrations of oxygen, nitrate-nitrogen, perchlorate, and a feed flow of 50 gpm, the required amount of 50% acetic acid and 1.7% phosphoric acid was 15 mL/min (16.2 mg/L as carbon, including an excess percentage of electron donor of 20-25%) and 10.5 mL/min (0.3 mg/L as P), respectively. This level of 50% acetic acid addition minimized carryover of the electron donor to the effluent and prevented sulfate reducing conditions from developing. Maintaining approximately 2-3 mg/L residual dissolved organic carbon (DOC) at the FBR effluent ensured that the system operated optimally. Based on the feed contaminant concentrations and the electron donor and nutrient additions rates, the FBR treatment system was capable of removing all three chemical constituents at or below the instrument detection levels. When the system was spiked with perchlorate up to 1,000 µg/L at a feed flowrate of 25 gpm, the PLC model added an incremental amount of 50% acetic acid of 8.5 mL/min (18.0-19.3 mg/L as carbon) and the perchlorate was treated to below the California State MCL of 6 µg/L. The maximum concentration of perchlorate that was demonstrated to be consistently treated through the FBR at a feed flowrate of 25 gpm was approximately 4,000 µg/L of ClO₄. At this concentration, the required amount of 50% acetic acid was 11 mL/min (23.8 mg/L as carbon) and 99.65% removal was attained (9.6 g of perchlorate/m³ expanded media bed/hr).

During the course of the study, the FBR treatment system was demonstrated to effectively and quickly recover from a variety of shutdown scenarios. A simulated feed pump failure was tested twice and the resulting recovery times for complete perchlorate treatment for each experiment were less than 24 hours and 8 hours. A complete plant electrical failure scenario was demonstrated twice and short recovery times of less than 2 hours for nitrate treatment (perchlorate was never observed in the effluent) were observed after both experiments. Some degree of adsorption and biodegradation contributed to the treatment of both the nitrate and perchlorate. The general trend observed for all of the shutdown scenarios was that the longer the plant operated and a mature biomass developed, a more rapid recovery time resulted. During a nutrient shutdown experiment, initial breakthrough of perchlorate was observed within 12 hours. Once the nutrient was restarted, complete nitrate and perchlorate removal occurred within four hours. This result indicated the critical need for the addition of a consistent nutrient source during the operation of the FBR treatment plant to ensure complete perchlorate treatment.

The downstream equipment operated effectively to produce effluent water that met all drinking water standards established under the Federal Safe Drinking Water Act and the California Code of Regulations, Title 22 requirements. The post-aeration vessel raised the dissolved oxygen concentrations from less than 1 mg/L to above 7.5 mg/L consistently at an HRT of 8 minutes. The addition of 1 mL/min (0.4 gpd, 2.5 mg/L dose) of the 48% aluminum sulfate and 4 mL/min (1.5 gpd, 0.17 mg/L dose) of the 0.8% cationic polymer were found optimal for effective filtration to less than 0.1 NTU, resulting in six adsorption clarifier flushes per day and one multimedia filter backwash per day. The LGAC was utilized as a polishing system for the effluent. It demonstrated minimal pressure drop (<1 psi), no observation of biomass clogging for the duration of the LGAC use, and color and/or odor issues (microbiological in origin) in the LGAC effluent were never detected. Even though effective, this final process step was not considered a requirement and eventually eliminated for the next scale.

Using on-site instrumentation and off-site laboratory analyses, the data collected to demonstrate treatment effectiveness of the downstream surface water treatment equipment included both primary and secondary MCL requirements: organics, inorganics, metals, disinfection byproducts, total coliform, *E. coli*, heterotrophic plate counts, dissolved and suspended solids, alkalinity, pH, and color. All data met the established Quality Assurance/Control guidelines established prior to the commencement of the demonstration. The system was tested and operated under various conditions, including steady-state operation, feed water restart, plant restart, and during the perchlorate spiking study up to 4,000 µg/L. Regardless of the operating condition (i.e., steady-state, feed restart, plant restart, etc.), at feed concentrations up to 1,000 µg/L of ClO₄, all of the State of California regulatory limits for potable water were met.

Concerns about the potential pathogenic microbiological carryover from the FBR through the entire FBR treatment plant and the possible subsequent disinfection by-product formation potential prompted their measurement. Across the plant, the levels of *E. Coli* were always below the Minimum Detection Limit (<1.0 Most Probable Number/100 mL). The heterotrophic plate count and total coliform data varied, but clearly the heterotrophic plate counts and total coliform were higher from the FBR effluent than the Trimite multimedia filter effluent. In treating the Trimite multimedia filter effluent microbiology, the chlorination and UV studies demonstrated a 3-4 log removal of heterotrophic plate count and complete removal of total coliform at a CT of 4 mg-min/L and a UV residence time of 6 seconds (at a minimum dose of 40 mJ/cm²). For all measurements of disinfection by-product formation potential under various operating conditions, plant effluent never exceeded 30 µg/L of either total trihalomethanes or haloacetic acid 5 (below the State limits of TTHMs and HAA5 at 80 and 60 µg/L, respectively).

The use of on-line instrumentation to measure nitrate-nitrogen and perchlorate simultaneously at the feed and effluent of the FBR system was effectively performed. Both on-line analyzers met their objective of providing reliable, consistent data. A number of issues were seen throughout the course of the demonstration with both types of on-line analyzers. For the perchlorate analyzer, which involved ion chromatography, matrix interference at higher feed concentrations occurred, differing instrument operating characteristics resulted in differences between on-line and off-site laboratory perchlorate measurements, and the instrument guard and analytical columns required routine replacement. For the nitrate analyzers, which involved UV absorption, issues included solids interference with parameter measurement, mechanical and process issues, and recalibration issues.

Four electron donor reduction experiments were conducted to demonstrate the correlation between nitrate-N removal and perchlorate removal. During the different experiments, the electron donor was reduced to the FBR to observe the nitrate effluent concentration for which the perchlorate concentration would exceed the State of California MCL. Using the on-line nitrate and perchlorate analyzers, the results of the four experiments concluded that as nitrate-N levels approached near 0.3 mg/L, perchlorate concentrations were observed to exceed the State of California MCL. The on-line analyzers demonstrated their effectiveness to accurately measure both nitrate and perchlorate during short intervals of sampling. However, though it is possible to control the FBR effluent nitrate-N concentrations at or below 0.3 mg/L, both instruments are recommended for the first full-scale application.

Considerable process development was implemented in the design of the demonstration FBR treatment plant to ensure a consistent supply of potable-like water (i.e., meets all regulatory standards but is not delivered for consumption). Using only NSF-60 compliant additives, constant on-line instrumentation to ensure contaminant removal, and a sophisticated electron donor addition model to adequately monitor and respond to process changes/requirements, the demonstration project proved out that the FBR treatment system is a robust, dependable treatment technology for perchlorate treatment. The implementation of such a technology to treat contaminated groundwater, rather than simply rely on phase transfer, to drinking water standards serves as a new paradigm of water treatment for significantly impaired resources.

2.3 ADVANTAGES AND LIMITATIONS OF THE TECHNOLOGY

A large number of water agencies presently have drinking water aquifers contaminated with low levels of perchlorate throughout California, as well as in other parts of the United States. Primarily, ion exchange technologies have been used to treat the perchlorate in these cases. These ion exchange systems require a moderate initial capital expenditure, but have extensive operational costs. After a period of time, either the resin requires regeneration, producing a brine stream with perchlorate that requires treatment, or replacement. The replaced resin is generally transferred to an out-of-state treatment center where the resin is further treated to destruct the perchlorate. The additional treatment of the brine or the resin incurs further operational costs not associated with the biological treatment of the perchlorate in the FBR. The operational costs associated with the FBR include the electron donor, nutrients (if required), biomass solids disposal, electricity to operate the pumps, and manpower for maintenance of the system. The latter two costs are required for both the FBR and the ion exchange technologies.

The main advantages of utilizing an FBR for perchlorate treatment are:

- Reduced operating cost compared to traditional phase transfer technologies such as ion exchange or carbon adsorption for increasing oxyanion concentrations.
- Complete destruction of the perchlorate rather than transfer to a secondary medium, such as a resin or granular activated carbon.
- Capable of treating both nitrate and perchlorate in one system to drinking water action levels.
- Unlike other treatment technologies, no need to adjust the pH significantly for treatment and then readjust the pH for corrosion control.

During the demonstration phase of the WVWD perchlorate treatment facility operations, the FBR successfully performed as an effective treatment alternative to the traditional technology for perchlorate removal, ion exchange. Depending on the oxyanion concentrations of nitrate, perchlorate, and sulfate, the FBR is capable of providing treatment of up higher concentrations of perchlorate (potentially up to and above 1000 µg/L) at a flow rate of 2000 gpm. Utilizing ion exchange for this loading would require use and disposal of ion exchange resins in volumes that could prove cost prohibitive for many water providers (See Section 7.4 for further discussion). The nature of ion exchange dynamics also presents the risk of large breakthroughs of perchlorate from the system when one or more vessels of resin become saturated with perchlorate.

The performance of the FBR has proven to be reliable and resistant to negative effects from changing conditions such as chemical dosing, flow rates, and contaminant concentrations.

The construction and operation of a drinking water plant using the FBR for perchlorate treatment does present some limitations and challenges. First, per the DDW requirements, an on-line perchlorate analyzer is necessary for ensuring complete treatment and for providing real-time effluent perchlorate concentrations. These analyzers require enhanced knowledge beyond what plant operators normally have, as well as time and attention from operators. The FBR itself, combined with the drinking water control logic, requires attention and specialized knowledge from operators. Second, the capital costs of the entire plant can be high for many water districts/providers compared to ion exchange. However, these costs can eventually be recouped by a water utility from savings in operational costs if oxyanion concentrations are anticipated to increase.

Page Intentionally Left Blank

3.0 PERFORMANCE OBJECTIVES OF FULL-SCALE PLANT

Based on the success of the demonstration project, the team headed by Envirogen and West Valley Water District collaborated to design, install, start-up, and operate a full-scale FBR system capable of treating 2000 gpm for the treatment of nitrate and perchlorate laden groundwater. Downstream equipment includes re-aeration, dual media filtration and chlorine disinfection for delivery to the potable supply. The system was built and installed by 2013. This project represents the first full-scale permitted drinking water system in the world using this specific technology for these contaminants.

3.1 FULL-SCALE PLANT PURPOSE

The Groundwater Treatment Plant is designed primarily to meet the objectives:

- treat nitrate and perchlorate from Rialto Well #6 and WVWD Well #11 water using biological FBRs
- increase the dissolved oxygen (D.O.) concentration of the FBR-treated water
- decrease turbidity/total suspended solids (TSS) concentration of the FBR-treated water to meet drinking water criteria
- disinfect the treated water prior to discharging to the WVWD reservoir

Through the plant start-up and operation, the plant incorporates:

- self-inoculation of the FBRs with the naturally-occurring bacteria in the groundwater
- complete treatment of nitrate and perchlorate under steady-state conditions
- capability to handle variances in the feed water
- the implementation of a drinking water system control logic

Through the incorporation of the above, the sole performance objective of the full-scale Groundwater Treatment Plant is provided in Table 3.1.

Table 3.1 Performance Objective.

| Performance Objective | Metric | Data Requirements | Success Criteria | Performance Objective Met? |
|---|---|-------------------------|---|---|
| Quantitative Performance Objectives | | | | |
| Meet drinking water standards of California Code Regulations Title 22, Div.14, Ch.15 and Ch.17. | -<1 mg/L NO ₃ -N and <6 µg/L ClO ₄ (CA MCL) - oxygen > 7.0 mg/L - turbidity < 0.3 NTU - odor and color removal - 4 log inactivation of viruses - 4-5 log inactivation of bacteria - Less than 80 and 60 µg/L for TTHMs and HAA5, respectively | Outside laboratory data | Complete nitrate and perchlorate treatment, as well as meeting MCLs and quality standards for all other permitted parameters. | Yes. For concentrations up to 5.94 mg/L NO ₃ -N and 400 µg/L ClO ₄ , regulatory standards met. Met all primary and secondary MCL data quality objectives for potable water. |

3.2 QUANTITATIVE PERFORMANCE OBJECTIVE

Meet Drinking Water Regulatory Standards

The FBR treatment system effluent water must meet the drinking water standards established under the Federal Safe Drinking Water Act and the California Code of Regulations, Title 22 requirements. Using on-site instrumentation and off-site laboratory analyses, the data collected included both primary and secondary MCL requirements: organics, inorganics, metals, disinfection byproducts, total coliform, *E. coli*, heterotrophic plate counts, dissolved and suspended solids, alkalinity, pH, and color. The data was scrutinized to meet all data quality objectives. For concentrations up to 5.94 mg/L NO₃-N and 400 µg/L ClO₄, all primary and secondary regulatory standards were met under all operating conditions.

In order for the plant effluent water to meet potable water standards, effective treatment of the FBR effluent water was required from the downstream equipment of the post-aeration vessel, multimedia filter, and chlorination system. Using on-site analytical equipment and off-site laboratory analysis, a number of parameters were analyzed and measured to ensure the water met potable water regulatory standards. These parameters included:

- Post-aeration oxygen concentration
- Multimedia filter effluent turbidity, metals, inorganics, and organics
- LGAC effluent water color and odor (microbiological in origin)
- Disinfection byproduct formation potential
- Chlorination log inactivation of bacteria

Based on the results demonstrated at the full-scale, the downstream equipment did prove effective and capable of collectively meeting the potable water regulatory requirements. It was shown that the post aeration system could consistently meet greater than 7 mg/L of dissolved oxygen. The multimedia filter effluent turbidity was less than 0.1 NTU and metals, inorganics, and organics met all primary and secondary drinking water MCLs. Through chlorination, a 4-5 log removal of heterotrophic plate count was obtainable. No disinfection byproduct formation potential exceeded the potable water limits.

4.0 FACILITY/SITE DESCRIPTION

4.1 LOCATION AND OPERATIONS

The full-scale Ground Water Treatment Plant is located at the West Valley Water District Headquarters in the City of Rialto, California (the City), approximately 60 miles east of Los Angeles (Figure 4-1). The City is situated in the San Bernardino Valley, within the Santa Ana River Basin Watershed. The land surface slopes gently to the southeast from a high of approximately 2,000 feet above mean sea level (amsl) at the base of the San Gabriel Mountains, to a low of approximately 950 feet amsl near the Santa Ana River. The elevation at the Project site is approximately 1,300 feet amsl.

The City overlies the Rialto-Colton Basin (RCB), which is a groundwater basin located within the Santa Ana River Basin Watershed. Large portions of groundwater in the RCB are currently contaminated with perchlorate, nitrate, and VOCs, including TCE. The majority of groundwater recharge to the RCB occurs as underflow from adjacent groundwater basins. The perchlorate and VOC contamination in the RCB is believed to be attributable to both historical disposal practices associated with the former Rialto Backup Ammunition Storage Point (RASP) and more recent activities at and near the County of San Bernardino's Mid-Valley Sanitary Landfill, a property referred to as the 160-acre area. Specifically, sources of contamination from the RASP now include:

- 160 Acre Parcel - In the early 1950's West Coast Loading corporation operated at the parcel, providing loading, assembly, and testing of munitions containing perchlorate. In 1957, Goodrich purchased the 160-acre parcel site and conducted research, development, and production of missiles on site. In 1966, Goodrich sold the property and subsequently, a number of defense contractors, fireworks manufacturers, and pyrotechnic companies have operated at the site using perchlorate based materials.
- Mid-Valley Sanitary Landfill - The County of San Bernardino has operated the Mid-Valley Sanitary Landfill since 1958. The landfill is a Class III solids waste facility. The landfill was expanded in the late 1990's over the majority of the RASP explosive bunkers. Over the prior 40 years, the bunkers were used by various fireworks and pyrotechnic companies in the storage and manufacture of perchlorate-based products.
- Denova Environmental Site - To the west of the 160-acre parcel is an area that was occupied by an explosive waste treatment, storage, and disposal facility operated by Denova Environmental, Inc. This area was shut down in 2002.



Figure 4.1 Location of Groundwater Treatment Plant.

4.2 SITE CONDITIONS

The aquifer system beneath the 160-acre parcel consists primarily of coarse to medium sand, silt and clay with a thickness of 160 to 600 feet (Wolfenden and Kadhim, 1997). Three continuous aquifers exist beneath the RASP and 160-acre parcel. They consist of an upper aquifer (Zone A), an intermediate aquifer (Zone B), and a deep aquifer (Zone C). The majority of water utilized for potable water is pumped from the Zone C aquifer that has a depth from 478 to 700 feet (GLA, 1997, 2003, 2005). The aquifers are separated by aquitards ranging from one to thirty feet in depth.

Groundwater flows northwest to southeast toward the Santa Ana River. At approximately halfway in the basin, groundwater flow turns toward the west and passes over the southeastern extent of the Rialto-Colton fault into North Riverside and Chino Basin with the remainder of flow going to the Santa Ana River.

The Rialto-Colton Basin generally consists of alluvial sediments, with groundwater typically at depths of 450 feet or more. The basin is bounded by the San Jacinto Fault on the northeast, the Rialto-Colton Fault on the southwest, the San Gabriel Mountains on the northwest and the Santa Ana River on the southeast. Groundwater flows northwest to southeast toward the Santa Ana River. At approximately halfway in the basin, groundwater flow turns toward the west and passes over the southeastern extent of the Rialto-Colton fault into North Riverside and Chino Basin with the remainder of flow going to the Santa Ana River.

The hydrogeological analysis shows that the source-water areas extend upgradient, covering approximately the central two-thirds of the width of the mid to northern RCB. The total size of the overall source-water area for the Project wells is slightly less than two square miles.

4.3 GENERAL WATER CHEMISTRY OF WELLS

Various feed water sources were utilized through the startup of the facility. Each varies in initial quality as well as pre-permit discharge requirements. WVWD Well #33 water is a proven clean water source and is utilized for the initial loading and wet test of the facility.

Following the loading and wet test, process feed water is provided by two Public Water System drinking water production wells, Rialto Well No. 6 and West Valley Water District Well #11. The Rialto Well # 6 site represents a location in the Rialto-Colton Groundwater Basin where elevated maximum concentrations of perchlorate (up to 320 micrograms per liter [$\mu\text{g/L}$]) have been detected. Nitrate levels have been detected at 13 mg/L. Increased perchlorate detection caused the City of Rialto to inactivate Rialto Well #6 for drinking water supply in December 2001.

For WVWD Well #11, concentrations of nitrate have been detected above the MCL in water samples collected in June 1999 (52.2 mg/l) and August 1999 (48.7 mg/l), prompting its removal from service. Most recent samples taken 15 December 2009 show the greatest concentrations to date at 54 mg/L. WVWD Well #11 has also shown perchlorate concentrations detected near the MCL.

For Wells # 6 and 11, with the exception of nitrate and perchlorate, the water meets all regulatory drinking water requirements.

Page Intentionally Left Blank

5.0 FULL-SCALE GROUNDWATER TREATMENT PLANT

The purpose of this section is to provide the overall design and configuration of the groundwater treatment plant. The plant was designed based on the parameters shown in Table 5.1.

Table 5.1 Design Feed/Effluent Parameters.

| Parameter | Units | Feed Value | Effluent Goal |
|------------------|--------------------------|-------------------------|-------------------------|
| Feed Flowrate | m ³ /hr (gpm) | 454 (2000) ¹ | 454 (2000) ¹ |
| Dissolved Oxygen | mg/L | 7.0 | >5.0 |
| Nitrate-nitrogen | mg/L | 4.5 | 0.1 |
| Perchlorate | mg/L | 0.3 | <0.006 |
| pH | S.U. | 6.0-8.0 | 6.0-8.0 |
| TSS | mg/L | <0.2 | <0.2 |
| Temperature | °C | 13-24 | 13-24 |

¹ Plant infrastructure was designed and constructed to eventually treat up to 908 m³/hr (4000 gpm).

5.1 TECHNOLOGY COMPONENTS AND PLANT DESCRIPTION

The Groundwater Treatment Plant construction and installation was completed by the end of 2014. Over the next two years, the plant was operated with the effluent proceeding to a local watershed while the California DDW established the permit operating conditions and issued the official operating permit. See Figures 5.1-5.3 for the overall area process flow diagram, the process flow schematic of the plant, and the treatment plant process flow diagram, respectively.

The full-scale groundwater treatment plant consists of the following individual components:

- Three wells – District Wells No. 11 and 33, Rialto Well No. 6
- One de-aeration tank which releases dissolved gases and allows for blending of water from the three well sources.
- Two FBR Systems that consist of the following:
 - Two FBR tanks in parallel, each 4.3 m (14 feet) in dia. by 7.3 m (24 feet) tall
 - Two re-aeration units, each 3.7 m (12 feet) in dia. by 7.3 m (24 feet) tall
- Two clarification/filtration units in parallel
- One chlorine contact basin to produce a CT of 4 mg/L min at 908 m³/hr (4000 gpm)
- One solid handling system that consists of:
 - Backwash water storage basin
 - One dissolved air flotation unit
 - One dewatering press
- Two reservoirs that are in parallel and typically float on the system together
- One discharge system for start-up activities that consists of:
 - Two ion exchange vessels (one upflow and one downflow) in series

- Cactus Basin
- One complete Supervisory control and data acquisition (SCADA) system

The three water wells feed the de-aeration tank where entrained gas is removed. The water proceeds to either/both FBRs where denitrification and perchlorate reduction occur under the anoxic conditions. The effluent of the FBRs proceeds to the post-aeration vessels where oxygen is added back into the water. The aerated water has some level of solids present (generated from the FBRs), so it is pumped to two Trident Systems where solids are removed via clarification and filtration. The effluent of the Trident Systems proceeds to the chlorine contact tank where disinfection occurs. From this tank, the effluent proceeds to the reservoir or basin per the operational requirements.

See Figures 5.4-5.8 provide the SCADA screenshots of the plant, Figures 5.10-5.17 provide further detailed drawings of the plant, and Figure 5.18 is a photo of the full-scale plant.

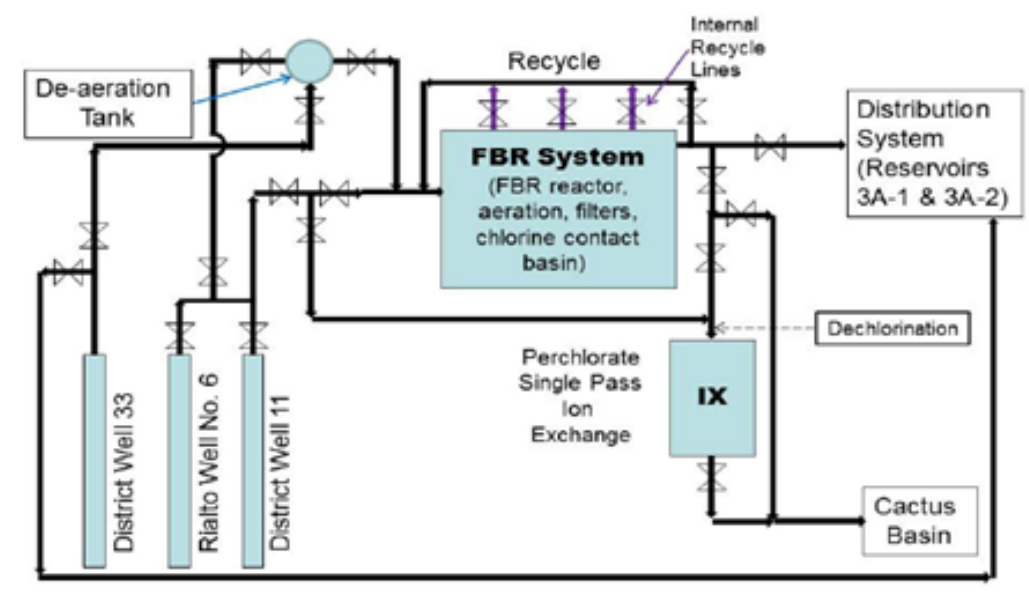

Figure 5.1 Overall Area Process Flow Diagram.

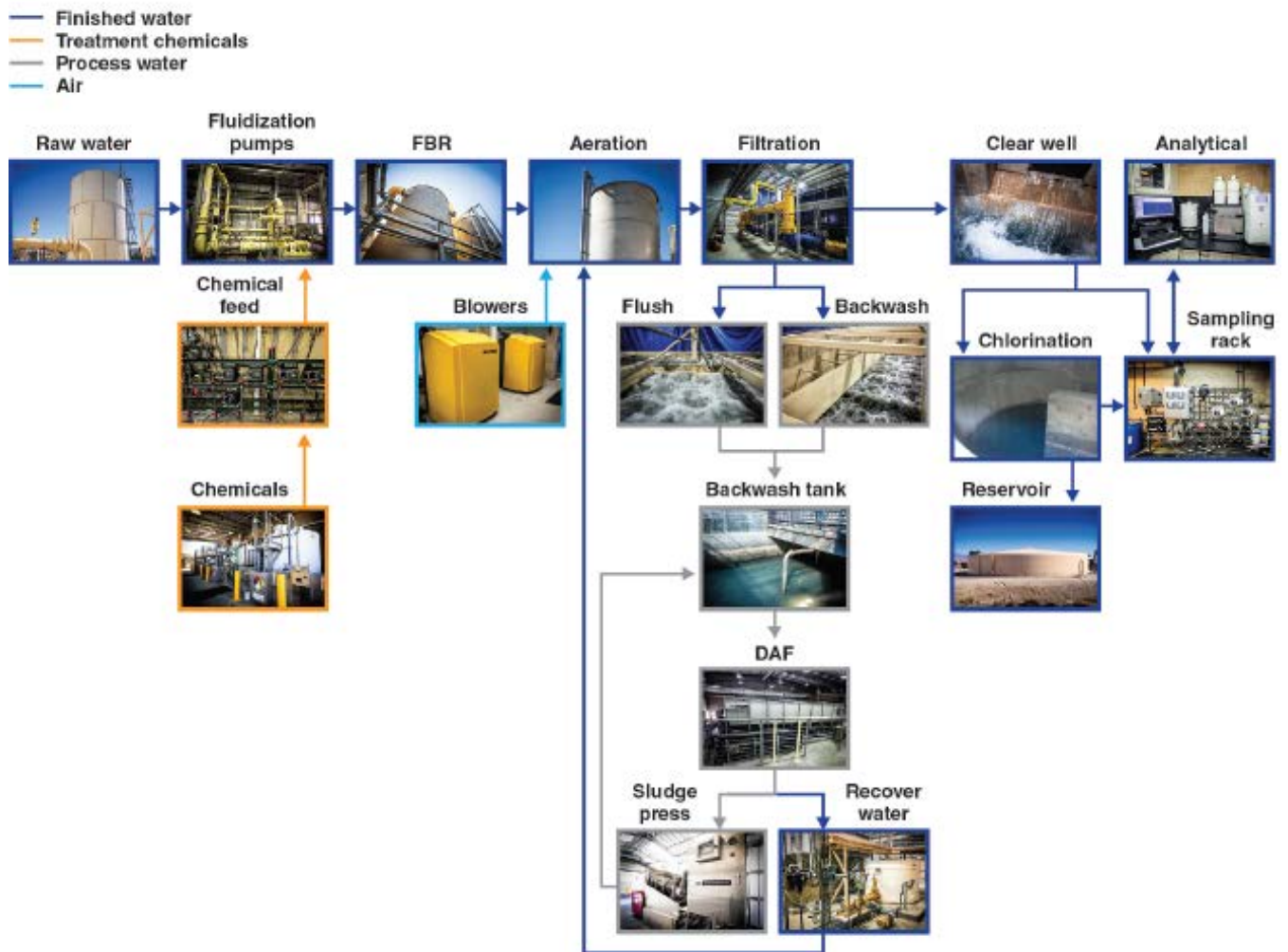
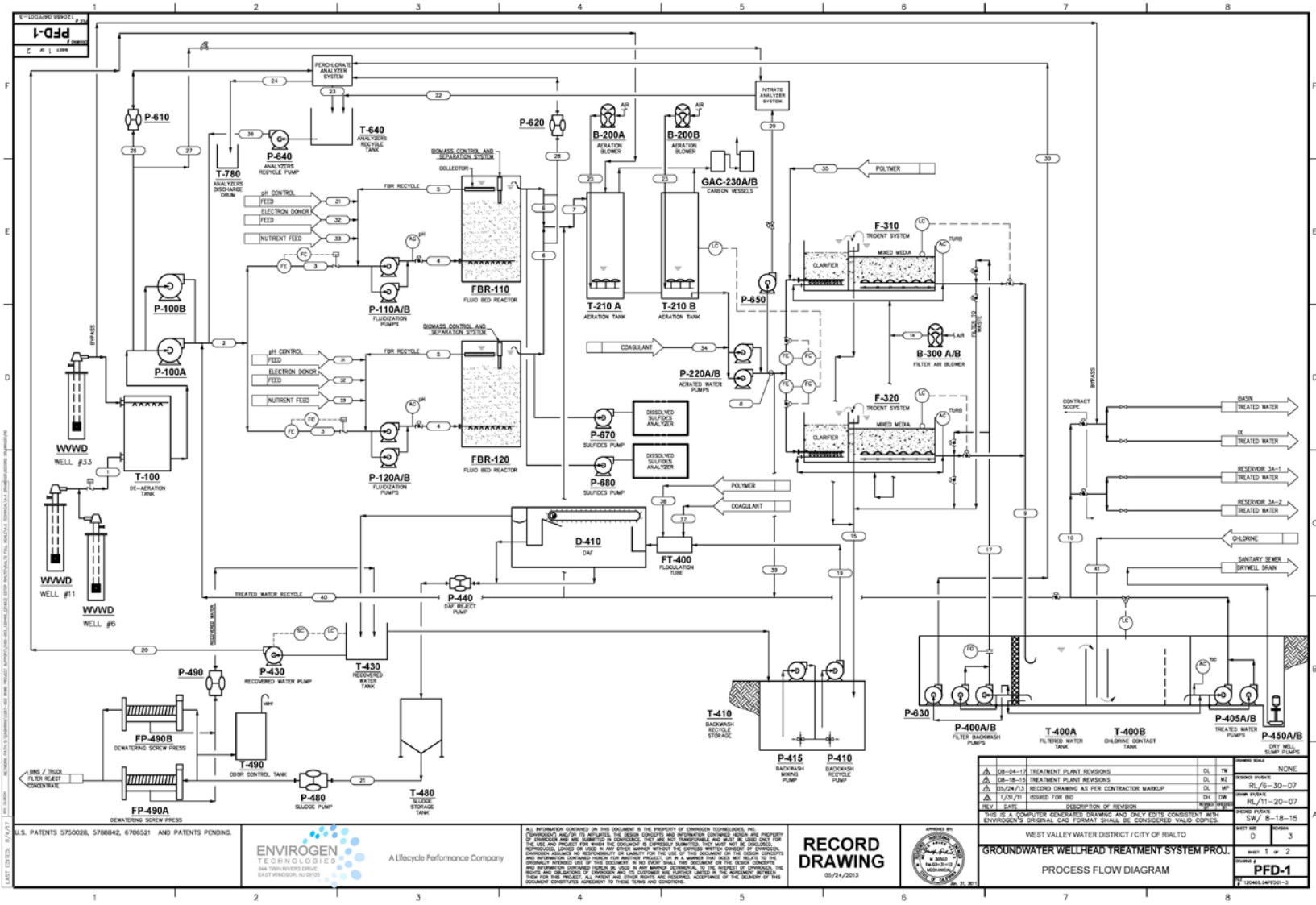

Figure 5.2 Process Flow Layout of Plant (Webster and Litchfield, 2017).



| NO. | DATE | DESCRIPTION OF REVISION | BY | CHKD |
|----------|------|---|----|------|
| 08-04-17 | | TREATMENT PLANT REVISIONS | DL | TW |
| 08-18-15 | | TREATMENT PLANT REVISIONS | DL | MZ |
| 05/24/13 | | RECORD DRAWING AS PER CONTRACTOR MARKUP | DL | MP |
| 1/29/11 | | ISSUED FOR BID | DH | DW |
| | | | | |

WEST VALLEY WATER DISTRICT / CITY OF RIALTO
GROUNDWATER WELLHEAD TREATMENT SYSTEM PROJ.
 PROCESS FLOW DIAGRAM
PFD-1

Figure 5.3 Plant Process Flow Diagram.

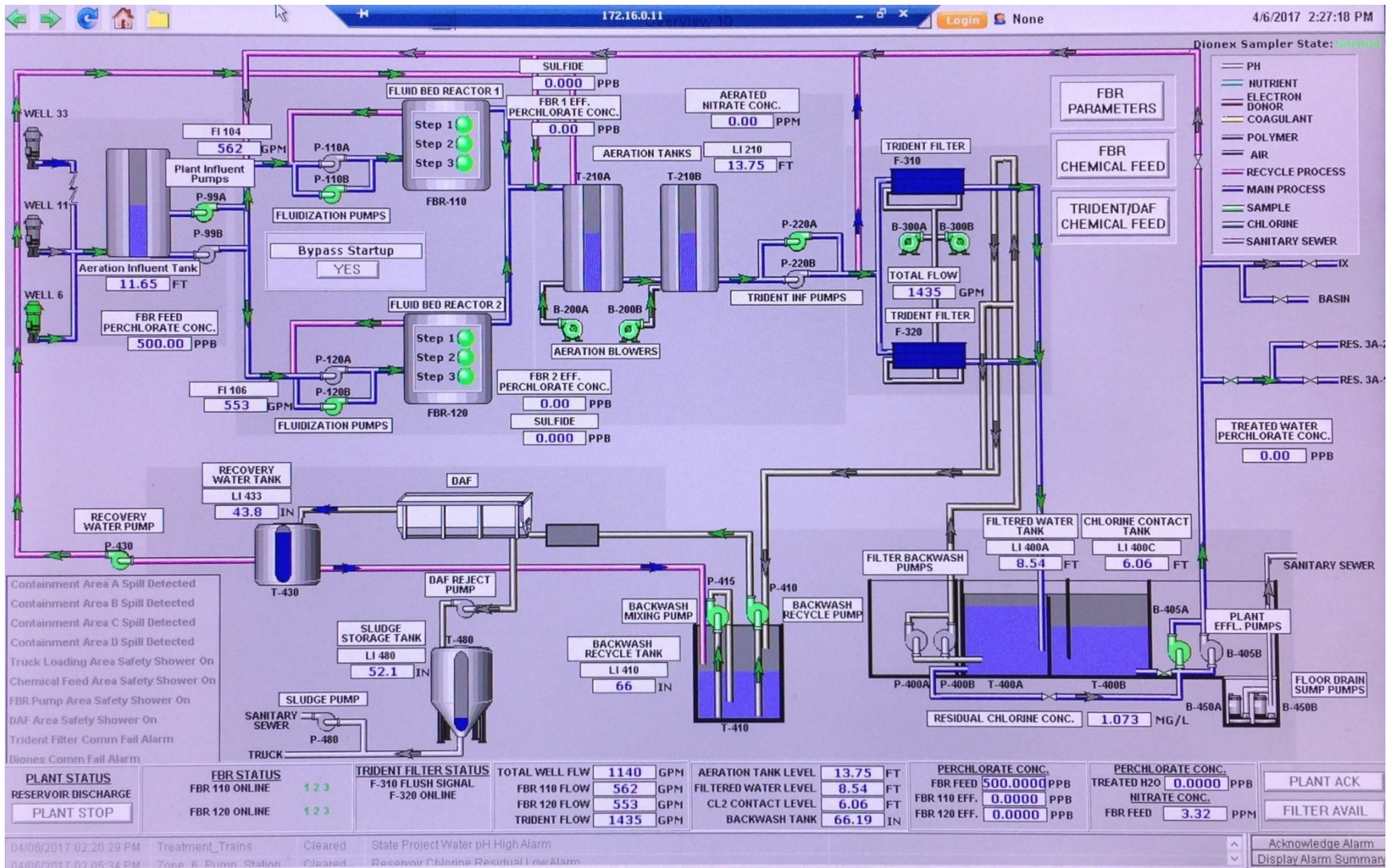

Figure 5.4 SCADA Screenshot of Treatment Plant.

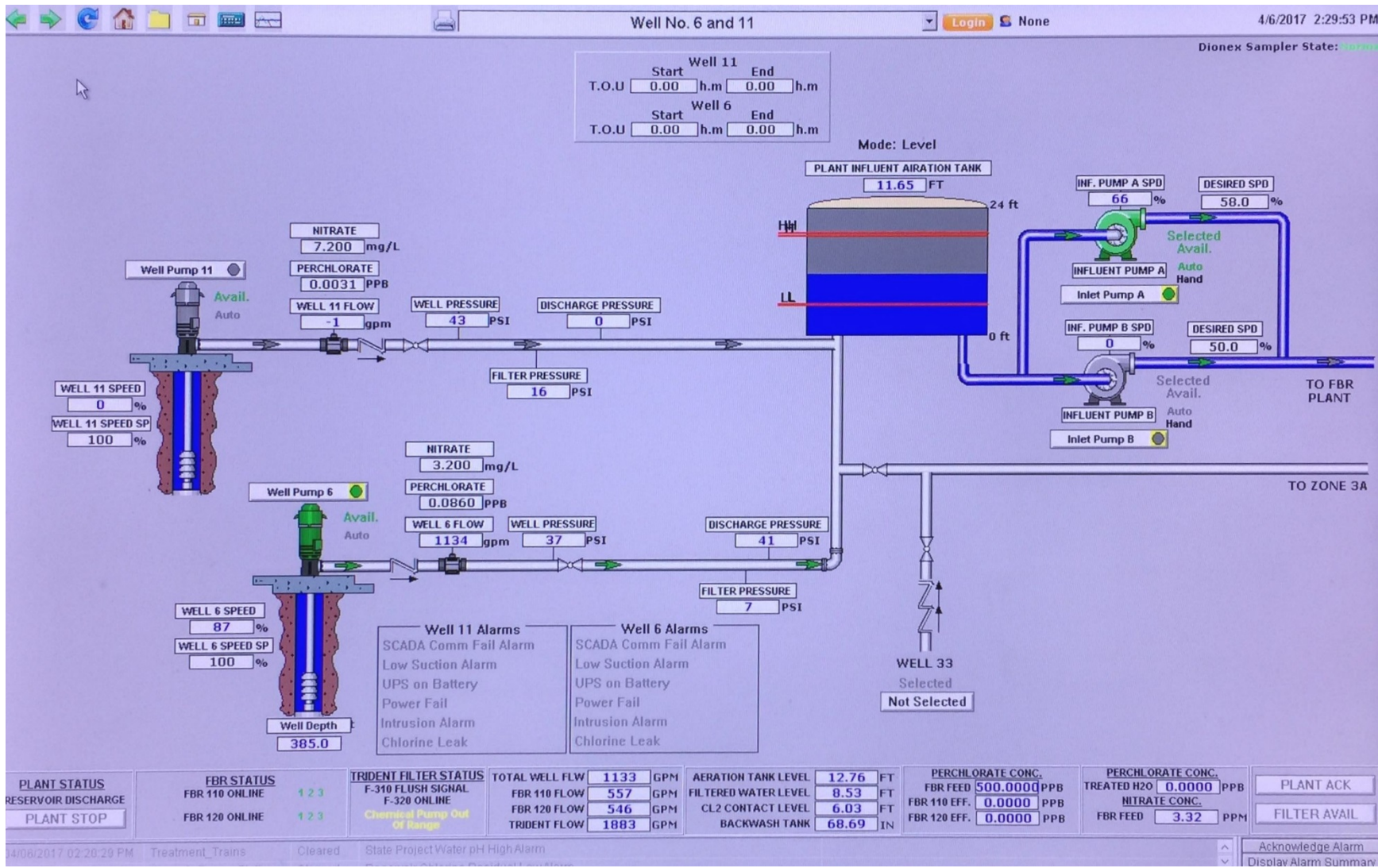

Figure 5.5 SCADA Screenshot of Feed System.

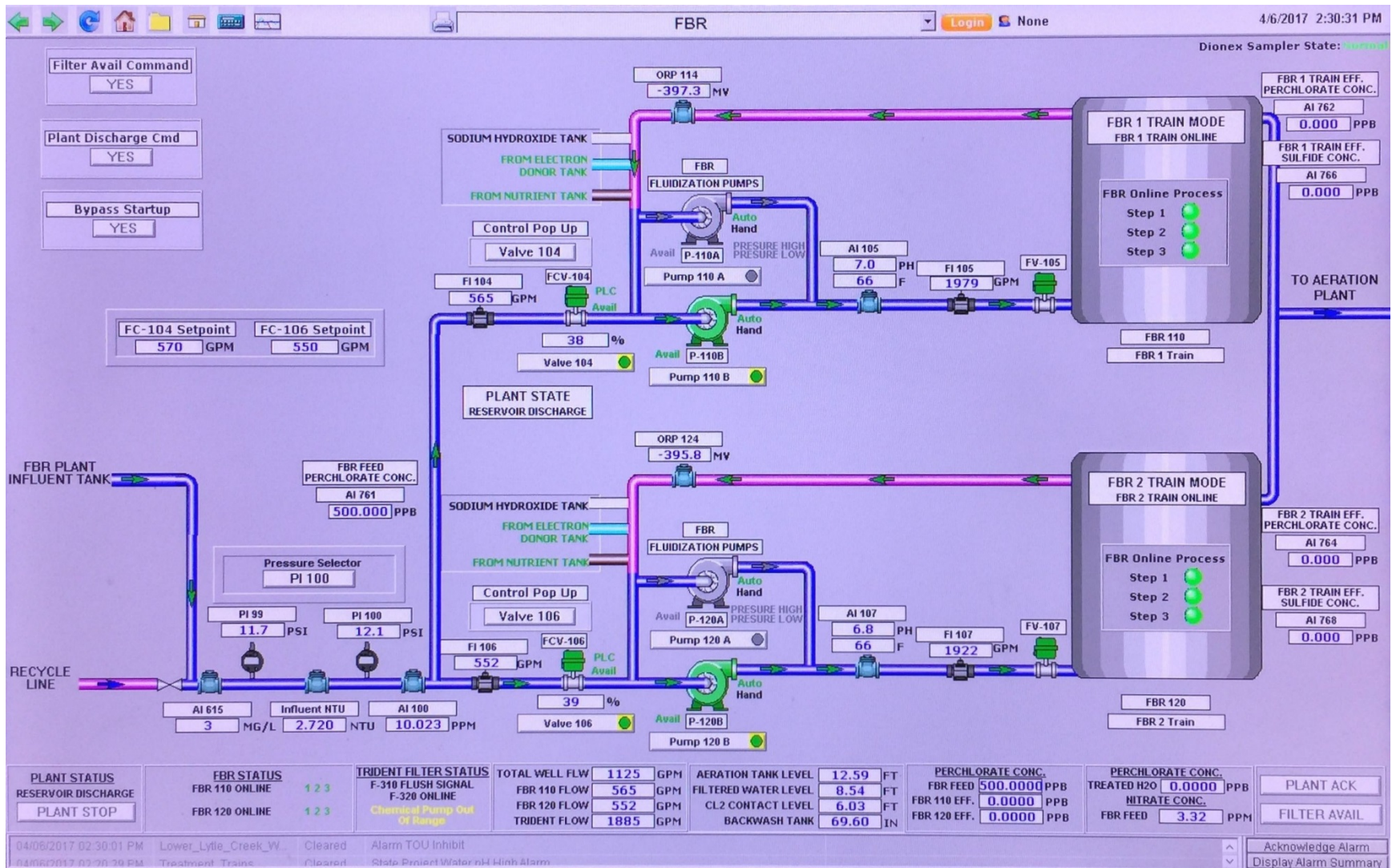

Figure 5.6 SCADA Screenshot of FBR System.

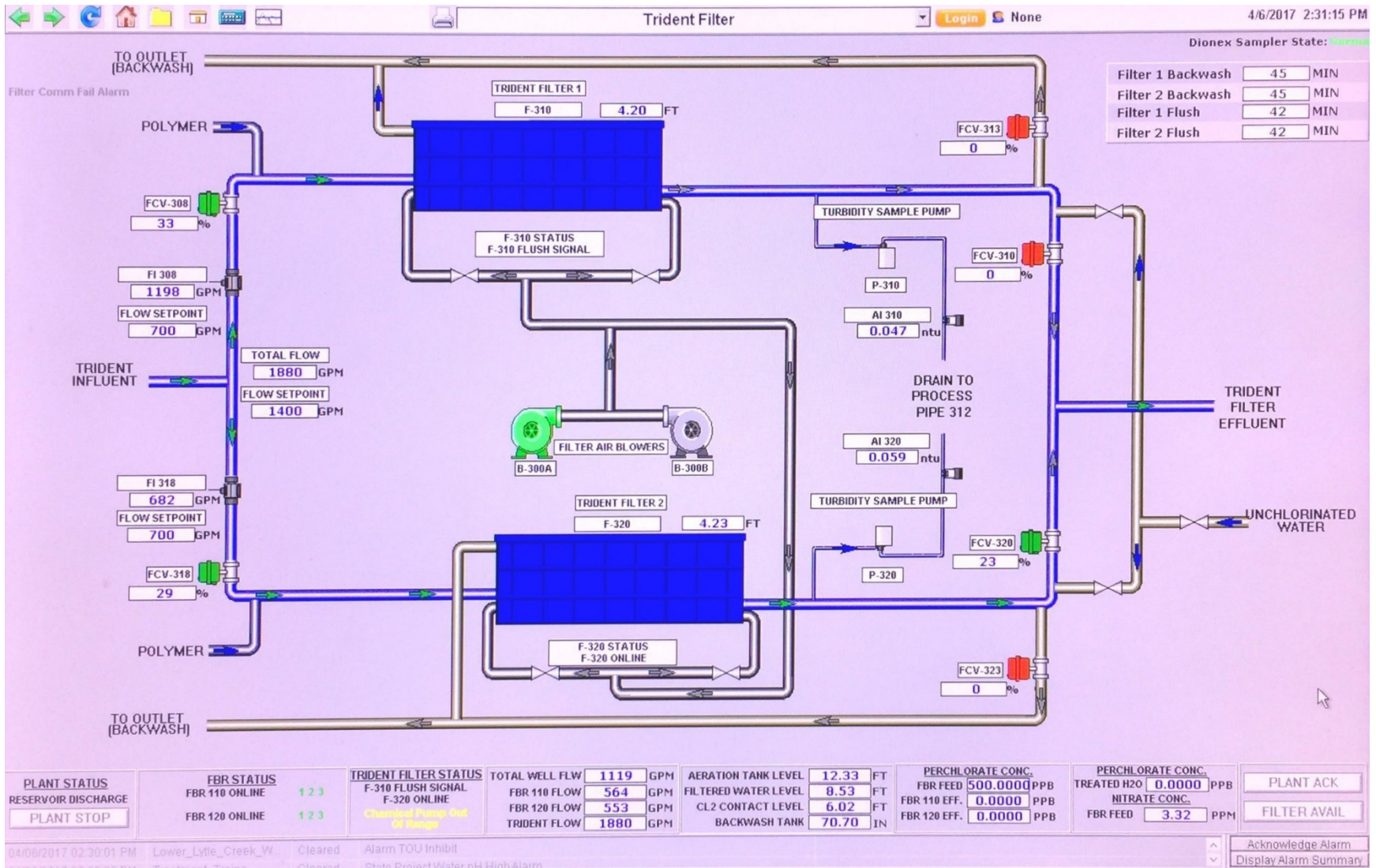

Figure 5.7 SCADA Screenshot of Filtration System.

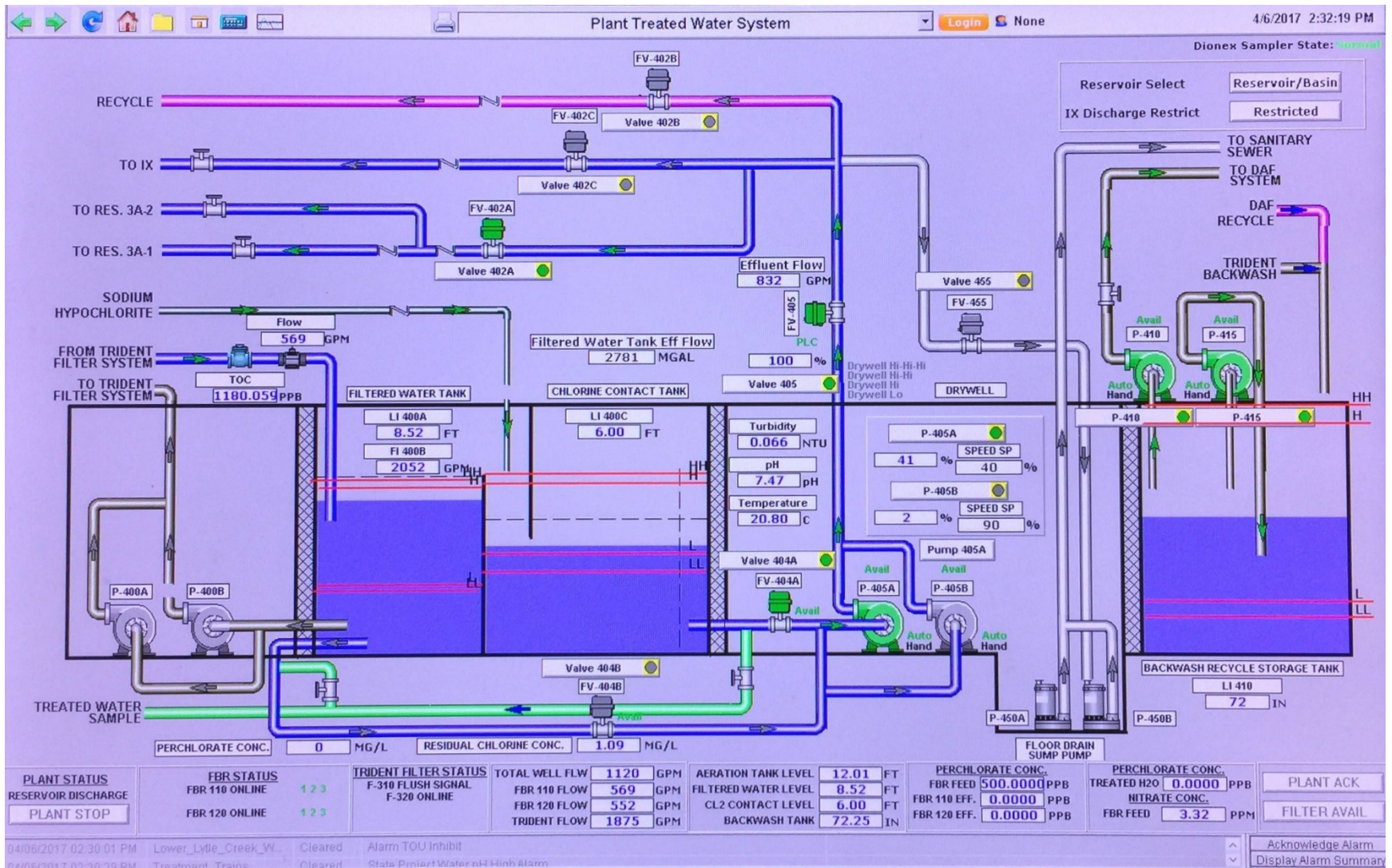

Figure 5.8 SCADA Screenshot of Water Holding System/chlorination System.

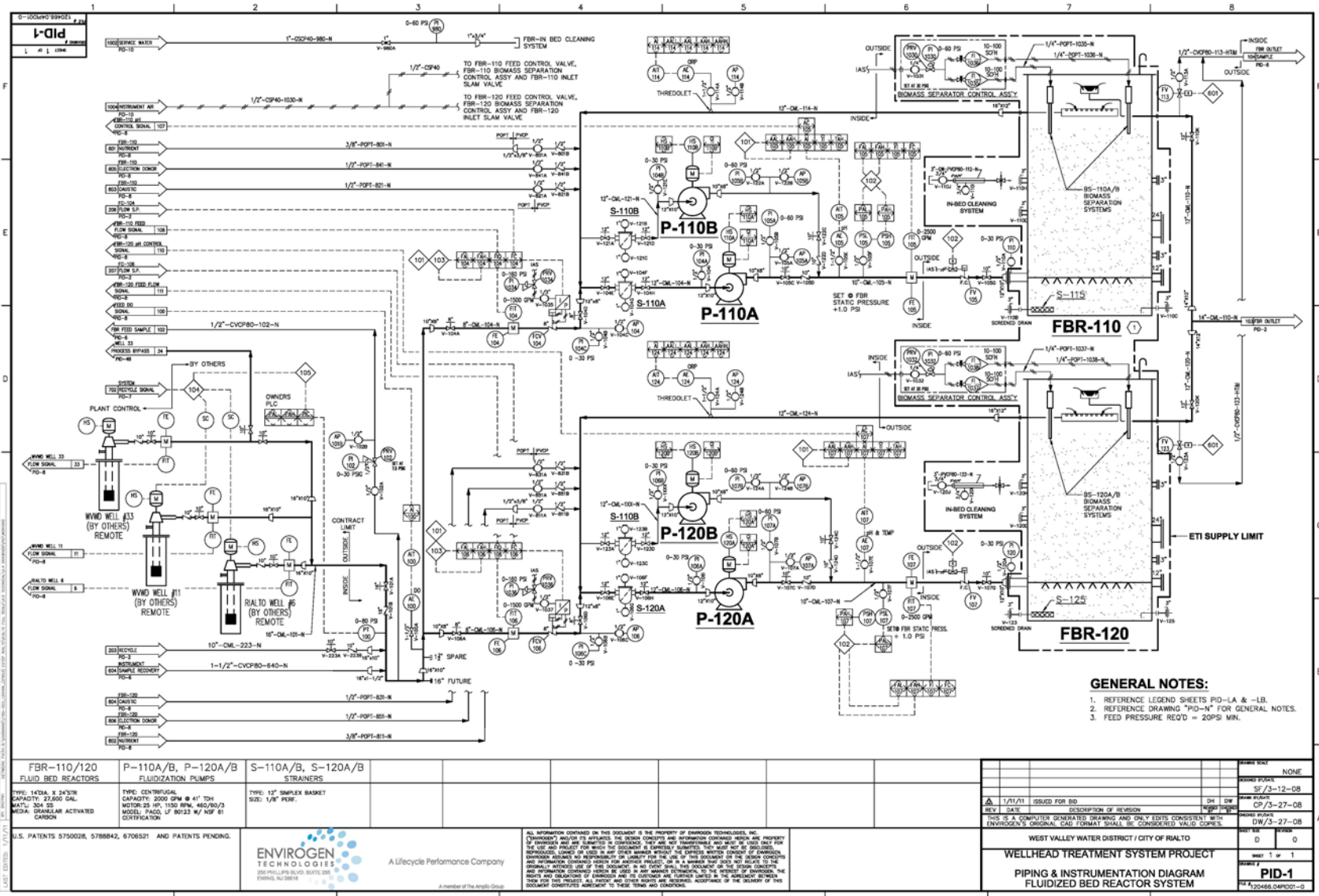

Figure 5.9 FBR System.

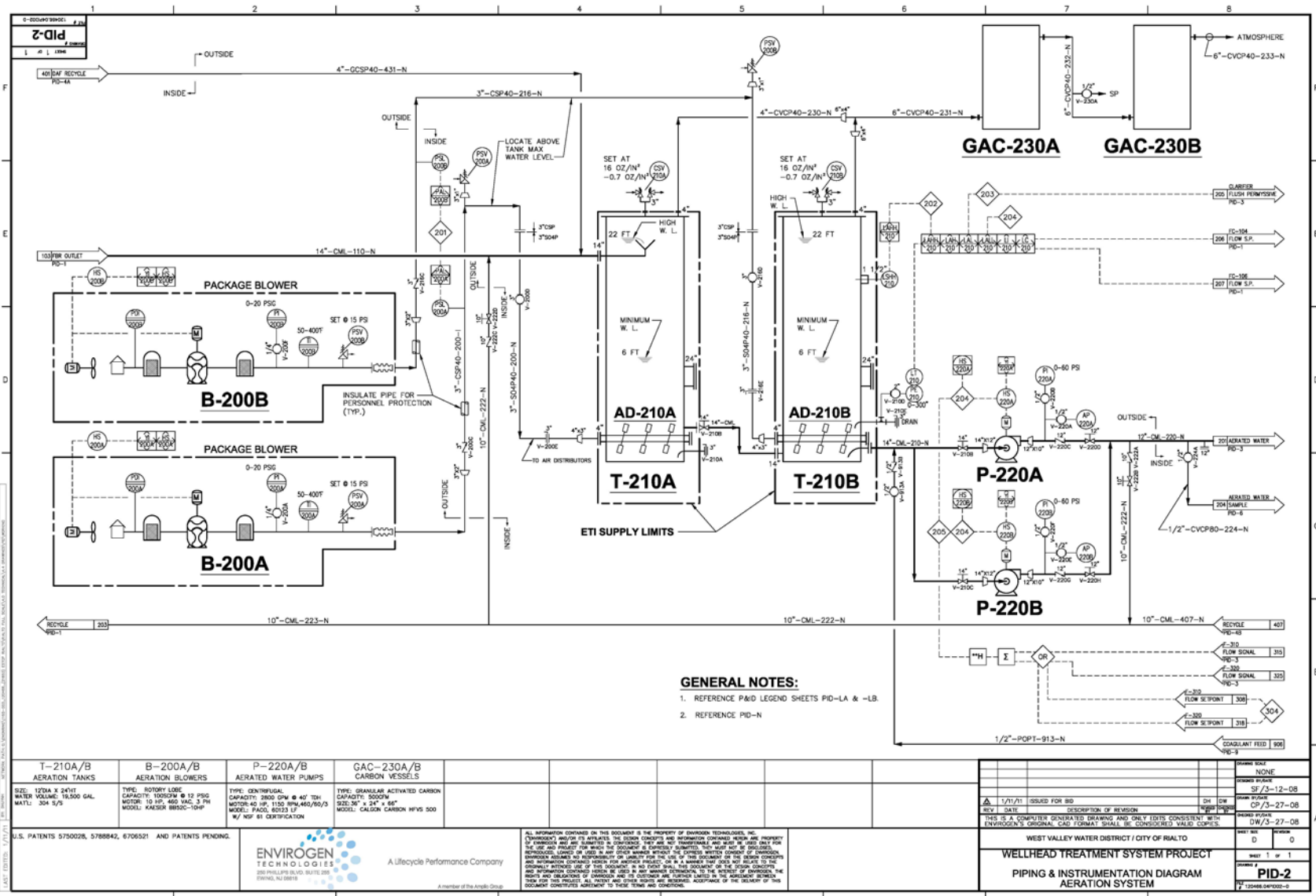

Figure 5.10 Aeration System.

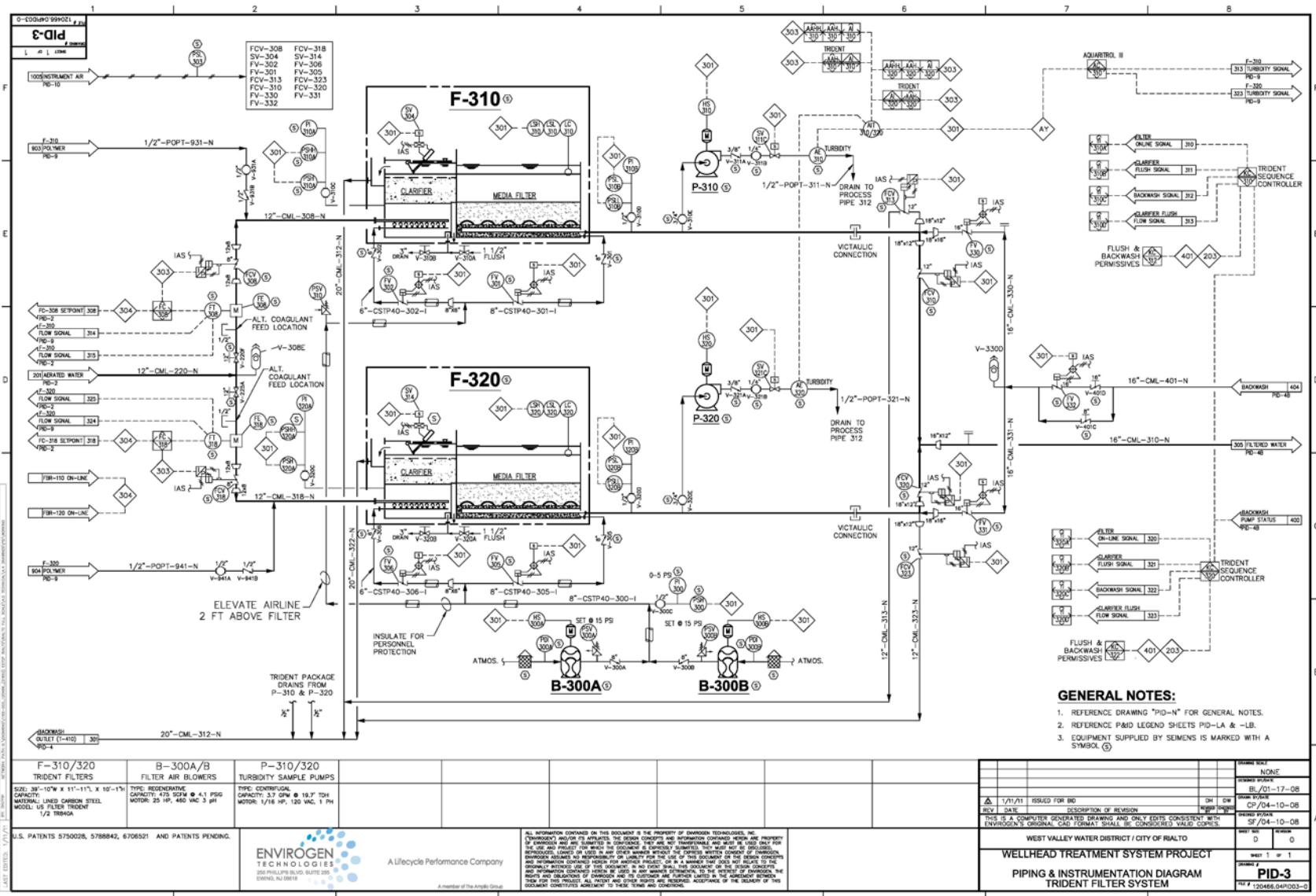

Figure 5.11 Solids Removal - TridentSystem.

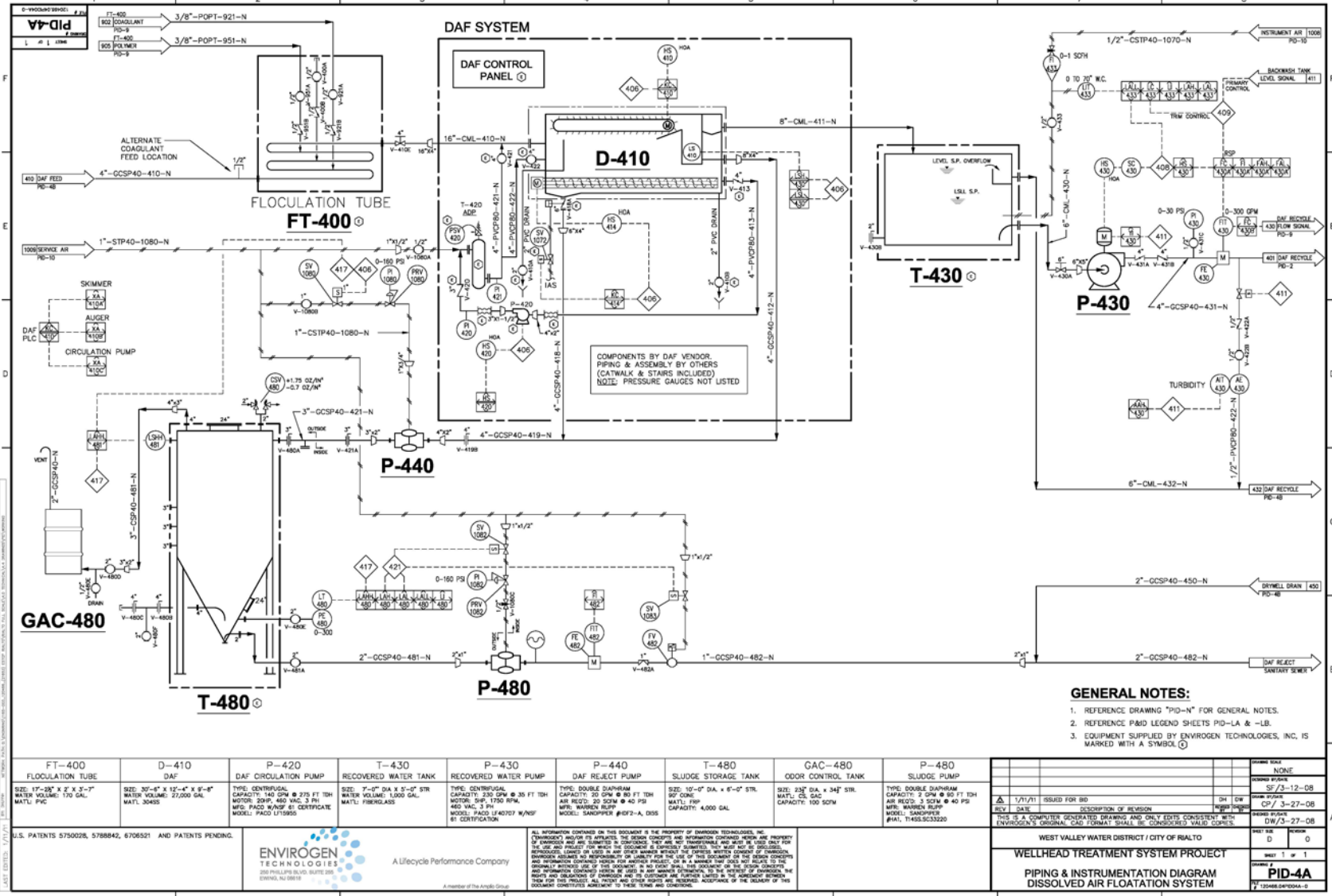
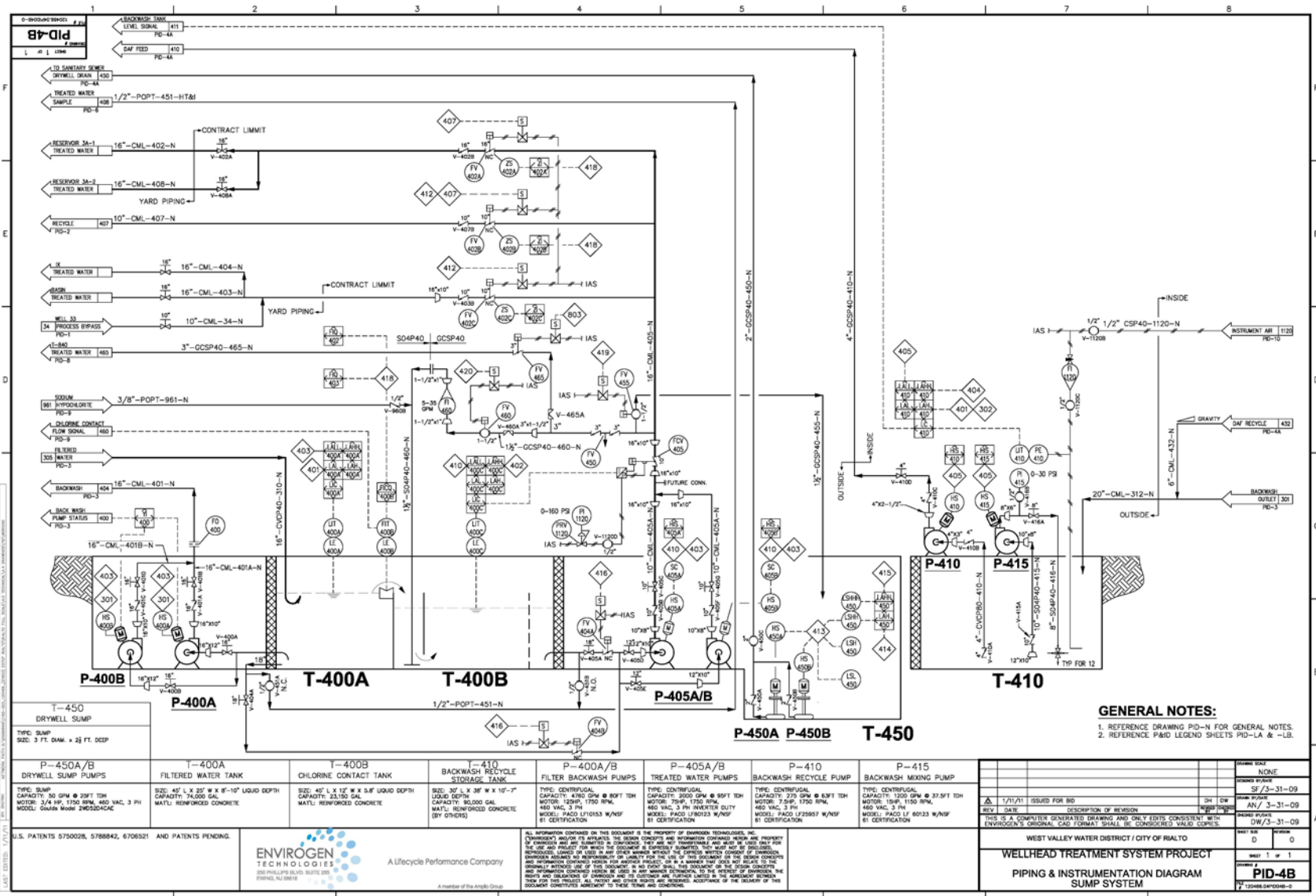

Figure 5.12 Solids Removal- DAF System.



GENERAL NOTES:
 1. REFERENCE DRAWING PID-N FOR GENERAL NOTES.
 2. REFERENCE P&ID LEGEND SHEETS PID-LA & -LB.

| | | | | | | | | |
|--|--|---|---|--|--|--|--|---|
| T-450 DRYWELL SUMP TYPE: SUMP SIZE: 3 FT. DIA. x 28 FT. DEEP | P-400A/B DRYWELL SUMP PUMPS TYPE: SUMP CAPACITY: 90 GPM @ 80FT TDH MOTOR: 3/4 HP, 1750 RPM, 450 VAC, 3 PH MODEL: Goulds Model 2R652C4C | T-400A FILTERED WATER TANK SIZE: 45' L X 25' W X 8'-10" LIQUID DEPTH CAPACITY: 21,150 GAL. MATL: REINFORCED CONCRETE | T-400B CHLORINE CONTACT TANK SIZE: 45' L X 12' W X 8' LIQUID DEPTH CAPACITY: 21,150 GAL. MATL: REINFORCED CONCRETE | T-410 BACKWASH RECYCLE STORAGE TANK SIZE: 30' L X 36' W X 10'-7" LIQUID DEPTH CAPACITY: 80,000 GAL. MATL: REINFORCED CONCRETE (BY OTHERS) | P-400A/B FILTER BACKWASH PUMPS TYPE: CENTRIFUGAL CAPACITY: 1800 GPM @ 80FT TDH MOTOR: 125HP, 1750 RPM 450 VAC, 3 PH MODEL: PACO LP1503 W/NSP 81 CERTIFICATION | P-405A/B TREATED WATER PUMPS TYPE: CENTRIFUGAL CAPACITY: 2000 GPM @ 80FT TDH MOTOR: 125HP, 1750 RPM 450 VAC, 3 PH MODEL: PACO LP1503 W/NSP 81 CERTIFICATION | P-410 BACKWASH RECYCLE PUMP TYPE: CENTRIFUGAL CAPACITY: 220 GPM @ 80FT TDH MOTOR: 7.5HP, 1750 RPM 450 VAC, 3 PH MODEL: PACO LP2585 W/NSP 81 CERTIFICATION | P-415 BACKWASH MIXING PUMP TYPE: CENTRIFUGAL CAPACITY: 1500 GPM @ 37.5FT TDH MOTOR: 15HP, 1150 RPM 450 VAC, 3 PH MODEL: PACO LP 60123 W/NSP 81 CERTIFICATION |
|--|--|---|---|--|--|--|--|---|

U.S. PATENTS 5750206, 5788842, 6706521 AND PATENTS PENDING.



ALL INFORMATION CONTAINED ON THIS DOCUMENT IS THE PROPERTY OF ENVIROGEN TECHNOLOGIES, INC. ENVIROGEN'S AND/OR ITS AFFILIATES, THE DESIGN CONCEPTS AND INFORMATION CONTAINED HEREIN ARE PROPERTY OF ENVIROGEN AND ARE CONFIDENTIAL AND UNPUBLISHED. ANY REPRODUCTION OR DISSEMINATION OF THIS DOCUMENT OR ANY PART THEREOF WITHOUT THE WRITTEN PERMISSION OF ENVIROGEN IS STRICTLY PROHIBITED. ENVIROGEN AND/OR ITS AFFILIATES, THE DESIGN CONCEPTS AND INFORMATION CONTAINED HEREIN ARE CONFIDENTIAL AND UNPUBLISHED. ANY REPRODUCTION OR DISSEMINATION OF THIS DOCUMENT OR ANY PART THEREOF WITHOUT THE WRITTEN PERMISSION OF ENVIROGEN IS STRICTLY PROHIBITED. ENVIROGEN AND/OR ITS AFFILIATES, THE DESIGN CONCEPTS AND INFORMATION CONTAINED HEREIN ARE CONFIDENTIAL AND UNPUBLISHED. ANY REPRODUCTION OR DISSEMINATION OF THIS DOCUMENT OR ANY PART THEREOF WITHOUT THE WRITTEN PERMISSION OF ENVIROGEN IS STRICTLY PROHIBITED.

| | |
|--------------------------------|-----------------------------|
| DESIGN SCALE NONE | DESIGN NUMBER SF/3-31-09 |
| DESIGNER DH DW | CHECKED DW/3-31-09 |
| PROJECT NUMBER D 0 | SHEET NUMBER 1 OF 1 |
| PROJECT TITLE PID-4B | DATE 12/04/08 04:00:00 |

Figure 5.13 Backwash Tanks and Disinfection System.

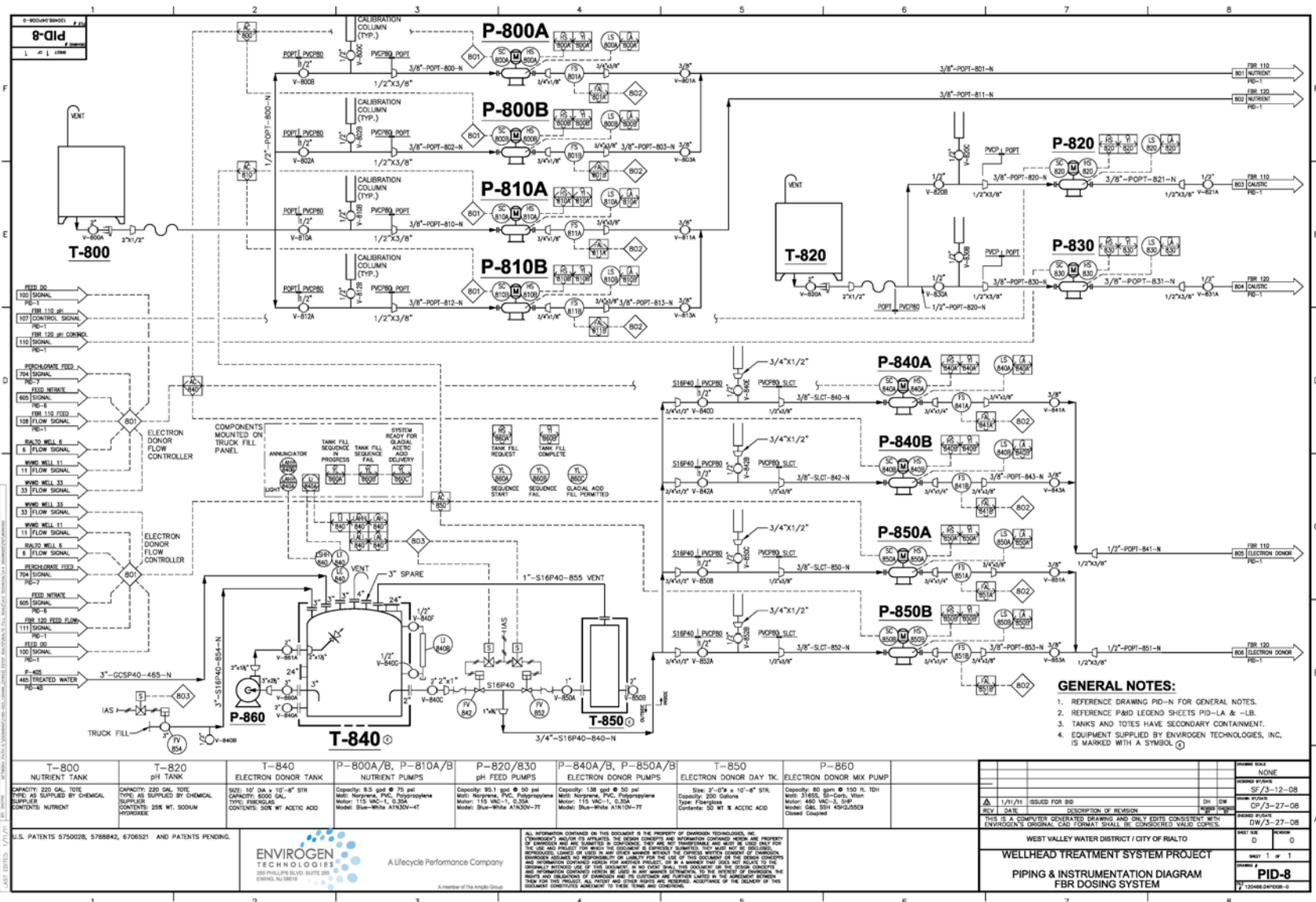

Figure 5.14 Chemical Addition System 1.

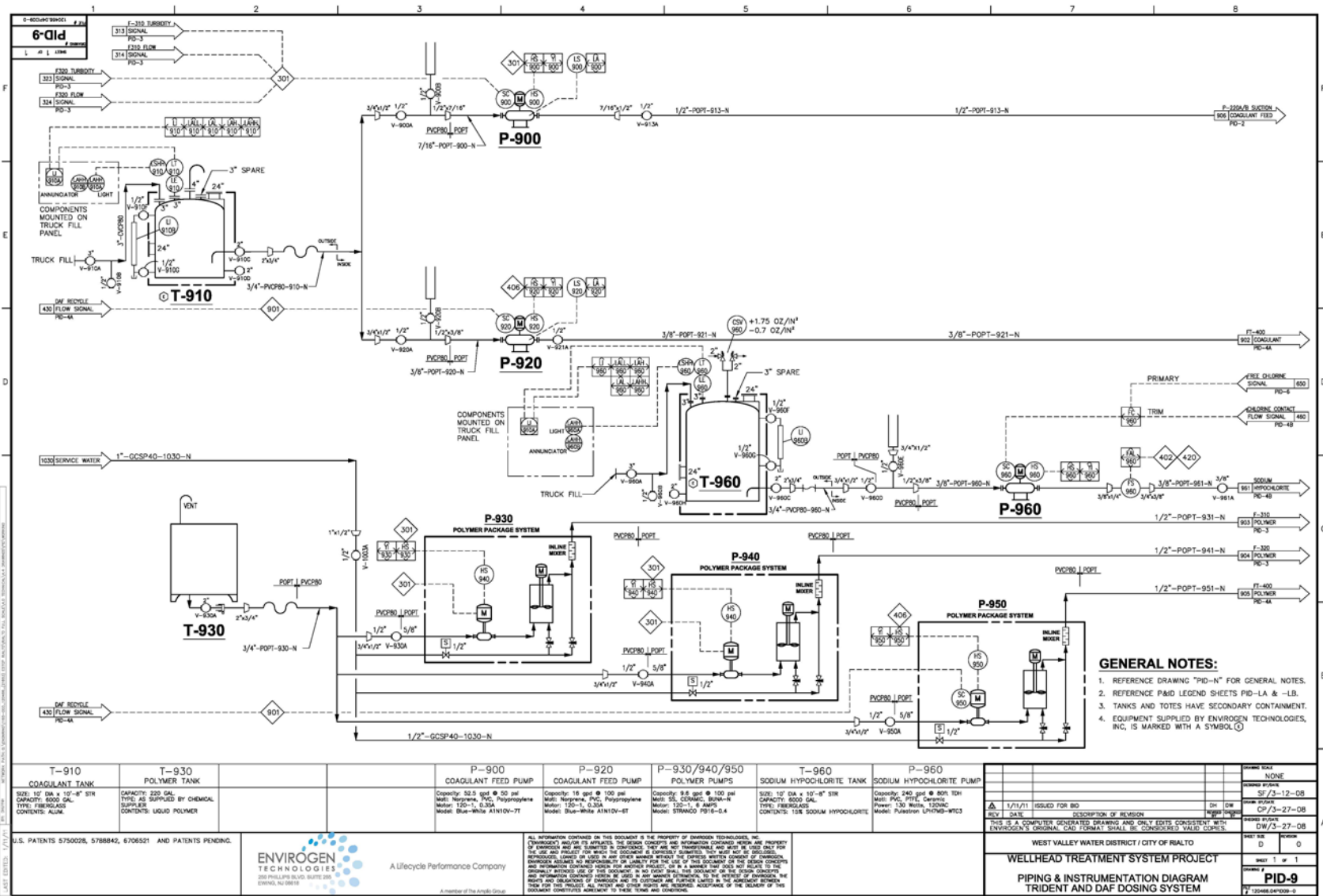

Figure 5.15 Chemical Addition System 2.



Figure 5.16 Photo of Full-scale Groundwater Treatment Plant.

5.2 DESIGN AND OPERATIONAL DETAILS OF PLANT

The overall plant-wide process is detailed in the sections that follow. See Figures 5.10-5.17 for detailed drawings of the plant

5.2.1 Modes of Operation

The Groundwater Treatment Plant is capable of being operated in different process modes:

- System Shutdown mode - All groundwater well pumps are de-energized. All process equipment in the treatment system is de-energized. All automated valves are in their fail-safe position. No well water is fed into the treatment system and no process water exits the treatment system effluent. All run permissive are withdrawn. System Shutdown mode triggers both FBR-110 Shutdown mode and FBR-120 Shutdown mode. If FBR-110 Shutdown mode and FBR-120 Shutdown mode occurs simultaneously, the treatment system PLC initiates System Shutdown mode.
- FBR-110 Shutdown mode - In FBR-110 Shutdown mode, P-110A and P-110B are de-energized with FCV-104 and FV-105 in the closed position. The electron donor addition, nutrient addition, and caustic adjustment to FBR-110 are disabled. Nitrate and perchlorate sampling at FBR-110 outlet and turbidity sampling at the specific downstream Trident System are disabled. The treatment system PLC can operate FBR-120 in another process mode independent of FBR-110, and it will adjust downstream unit operations to accommodate FBR-110 being in FBR-110 Shutdown mode.
- FBR-120 Shutdown mode - In FBR-120 Shutdown mode, P-120A and P-120B are de-energized with FCV-106 and FV-107 in the closed position. The electron donor addition, nutrient addition, and caustic adjustment to FBR-120 are disabled. Nitrate and perchlorate sampling at FBR-120 outlet and turbidity sampling at the specific downstream Trident System are disabled. The treatment system PLC can operate FBR-110 and the operating Trident System in another process mode independent of FBR-120, and it will adjust downstream unit operations to accommodate FBR-120 being in FBR-120 Shutdown mode.

- FBR-110 Feed Shutdown mode - In FBR-110 Feed Shutdown mode, P-110A or P-110B is energized with FV-105 in an opened position, enabling the fluidization of FBR media with recycle flow from FBR-110. The feed to FBR-110 is disabled with FCV-104 in closed position. The treatment system PLC can operate FBR-120 and the downstream operating Trident System in another process mode independent of FBR-110, and it will adjust downstream equipment to accommodate FBR-110 being in FBR-110 Feed Shutdown mode. Nitrate and perchlorate sampling at the FBR-110 outlet are disabled.
- FBR-120 Feed Shutdown mode - In FBR-120 Feed Shutdown mode, P-120A or P-120B is energized with FV-107 in an opened position enabling the fluidization of FBR media with recycle flow from FBR-120. The feed to FBR-120 is disabled with FCV-106 in closed position. The treatment system PLC can operate FBR-120 and the downstream operating Trident System in another process mode independent of FBR-110, and it will adjust downstream equipment to accommodate FBR-120 being in FBR-120 Feed Shutdown mode. Nitrate and perchlorate sampling at the FBR-120 outlet are disabled.
- FBR-110 Online mode - In FBR-110 Online mode, P-110A or P-110B is energized with FCV-104 and FV-105 in an opened position, enabling the feed flow to FBR-110 and the fluidization of FBR media with the combined flow of feed and FBR recycle water. Electron donor addition, nutrient addition and caustic adjustment to FBR-110 are enabled. Feed and FBR-110 outlet nitrate and perchlorate sampling are enabled.
- FBR-120 Online mode - In FBR-120 Online mode, P-120A or P-120B is energized with FCV-106 and FV-107 in an opened position enabling the feed flow to FBR-120 and the fluidization of FBR media with the combined flow of feed and FBR recycle water. Electron donor addition, nutrient addition and caustic adjustment to FBR-120 are enabled. Feed and FBR-120 outlet nitrate and perchlorate are enabled.
- System Recycle Mode – In System Recycle mode, FBR-110 Online mode or FBR-120 Online mode or both need to be active. The system PLC operates and adjusts the downstream equipment as needed. FV-402A and FV-402C are closed. FV-402B is opened for recycling water from T-400B back to the feed. Sodium hypochlorite feed is disabled.
- Basin/IX discharge – In Basin/IX Discharge, FV-402A is closed and FV-402C is opened if FBR-110 Online mode or FBR-120 Online mode is active. Sodium hypochlorite feed is disabled.
- Reservoir discharge – In Reservoir Discharge, FV-402A is opened and FV-402C is closed if FBR-110 Online mode or FBR-120 Online mode is active.

5.2.2 Influent De-aeration Tank

Due to high and variable presence of air bubbles in the combined raw well water, a de-aeration tank and two influent pumps are needed at the headworks of the facility. Wells Rialto #6, WVWD #11, and WVWD #33, are connected to the de-aeration tank. All three wells show significant amounts of entrained air and the de-aeration tank removes the air bubbles from the well water.

There exists two components to the de-aeration facilities:

1. There is a 31,000-gallon steel bolted tank (T-100) which receives well water from the 16-inch raw water pipeline. The inlet water is pumped through a number of spray nozzles thereby stripping excess oxygen/air from the inlet water. A level transmitter provides the liquid level to the PLC, which then adjusts the speed of the well pumps in order to maintain a near-constant level in the de-aeration tank according to an operator-selected setpoint.
2. Two influent pumps, one duty and the other on standby controlled by a new VFD. The VFD regulates the duty influent pump to maintain the inlet pressure to the facility at twelve (12) psig. A manual shut-off gate valve V-101A, along with a check valve V-101B, is located at the front end of the treatment system as a definitive means for isolating the treatment plant feed stream during plant maintenance activities

An influent pump (P-100A/B) connected to T-100 feeds the well water to the fluidized bed reactors FBR-110 and FBR-120. Water from each well has different characteristics, so the flow rate from each well is shared with the Treatment System PLC.

5.2.3 Fluidized Bed Bioreactor

5.2.3.1 Process Flow

The well water from Rialto #6, WVWD #11, and temporarily from WVWD #33, is combined from T-100 with the recycle flow and fed to the fluidized bed reactors FBR-110/FBR-120 (Refer to Figures 5.9 and 5.14). A manual shut-off gate valve V-101A, along with a check valve V-101B, is located at the front end of the treatment system. The recycle stream from chlorine contact tank T-400B is tied into the process line after V-101A and V-101B. The sample recovery stream is also tied into the process line before the feed combines with the fluidization flow.

The feed water is analyzed prior to combining with the recycle fluidization flow of each FBR. An in-line dissolved oxygen (D.O.) analyzer AE/AIT-100 measures oxygen concentration, while a feed sample is diverted from the process line for on-line nitrate (AE-615) and perchlorate (AE-770) analysis. The feed process line is then divided into two separate streams entering FBR-110/FBR-120, with each line having a manual shut-off gate valve V-104A/V-106A. Flow meters FE-104/FIT-104 and FE-106/FIT-106 downstream of the shut-off gate valves measure the feed flow to each of the respective FBRs. Pneumatic actuated flow control valves FCV-104/FCV-106, followed by additional manual isolation gate valves V-104D/V-106D, are located downstream of the flow meter. The position of FCV-104/FCV-106 is controlled by the system PLC based on the feed flow set points. The feed flow then ties into the FBR fluidization flow.

The combined feed and fluidization flow enters the FBR internal distribution system through fluidization pump P-110A/P-110B for FBR-110 and P-120A/P120B for FBR-120. When operational, one fluidization pump operates while the other one is used as spare for each FBR. The combined feed flow/fluidization flow proceeds on the suction sides of pumps P-110A, P-110B, P-120A, and P-120B through strainer baskets S-110A, S-110B, S-120A and S-120B. Electron donor, nutrient, and caustic are added at the FBR recycle line upstream of the strainer baskets and the fluidization pumps. Based on FBR feed rate and mass loading of oxygen, nitrate, and perchlorate of the well water, the system PLC adjusts the pump speed of chemical pumps P-800A/P-800B, P-810A/P-810B, P-840A/P-840B, and P-850A/P-850B to control the electron donor (diluted glacial acetic acid) and nutrient dosage rate to the FBRs.

After each fluidization pump, the water proceeds through isolation valves V-105C and V-107C, and check valves V-105D and V-107D downstream of the pump discharge. The in-line pH analyzers measure the pH level of the FBRs. pH analyzer AE-105/AIT-105 monitors FBR-110 and AE-107/AE-107 monitors FBR-120. Based on continuous pH monitoring, the system PLC controls the speed of chemical pumps P-820/P-830 to control the dosage rate of caustic to the FBRs if necessary.

The fluidization pump discharge is next monitored by pressure switch PSL-105/PSH-105 and PSL-107/PSH-107. The fluidization flow is used to hydraulically fluidize the media in FBR-110/FBR-120 approximately 30% of the settled bed height (3.15 meters), and is monitored by flow meters FE-105/FIT-105 and FE-107/FIT-107. Pneumatic actuated flow control valves FV-105 and FV-107 enable the fluidization flow and close in FBR Shutdown mode. Based on the initial settled and expanded bed level, the fluidization flow rate per FBR is manually set using valves V-105G and V-107G. FBR-treated water exits at the overflow weir located near the top of the FBR vessel. A portion of the FBR-treated water returns to the process recycle line through a perforated pipe beneath the overflow weir. The oxidation-reduction potential (ORP) of FBR-treated water is monitored by ORP analyzer AE-114/AIT-114 for FBR-110 and AE-124/AIT-124 for FBR-120. The FBR outlet stream proceeds to the aeration process.

FBR outlet sample line is diverted from the FBR outlet for the in-line nitrate and on-line perchlorate analysis. The duration of each perchlorate analysis is approximately 30 minutes. Detection of nitrate or perchlorate concentrations above system set points trigger a System Recycle mode which will recycle the water at the chlorine contact tank T-400B after chlorination back to the system feed for further perchlorate treatment. The hydraulic residence time at the FBR outlet to the outlet of the chlorine contact tank T-400B will exceed the perchlorate analysis duration. During System Recycle mode, the system PLC will sample the FBR outlet to confirm complete treatment of nitrate and perchlorate. The PLC will also adjust electron donor and nutrient dosage rates during the System Recycle mode and after the FBR enters the FBR Feed mode to account for changing inlet conditions.

As with virtually all biological processes, excess biomass byproduct is produced. The biomass will accumulate on the FBR media causing the fluidized bed height to increase. The biomass separators BS-110A/B and BS-120A/B located at the top of the FBR-110 and FBR-120, respectively, remove the excess biomass accumulation on the media. The process is further defined in Patents #US 6706521 and US5788842A. The separator lifts media from the top of the fluidized media bed using an air lift tube. Media with attached biomass and water is directed through the lift tubes into the mixing chamber located at the water surface. Both lifting and mixing can be controlled by adjusting the airflow at FI-1035/FI-1036 to the biomass separator. The media and biomass are separated in the mixing chamber. With the detached media and biomass dropping back into the water, the lighter biomass exits with the FBR outlet and the media falls back downward in the vessel. The biomass separator is operated continuously. Under certain conditions, the biomass growth does not occur at the top of the media bed, but closer to the bottom. In this event, an in-bed educator cleaning system is implemented to control the fluidized bed height. The in-bed educator provides highly pressurized water that agitates the lower sections of the bed and separates the media from the biomass, reducing media bed height. The in-bed cleaning is manually operated and is conducted as needed.

FBR-110 and FBR-120 are capable of being operated independently. One FBR can operate in FBR Feed mode while another FBR can operate in FBR Feed Shutdown mode or FBR Shutdown mode. The system PLC has the capability to decrease the system feed flow rate to accommodate the change and will make adjustments to maintain the mass balances of the unit operation downstream of the FBRs. In FBR-110 Feed mode and FBR-120 Feed mode, the feed flow of the system will remain constant with the exception of when the Trident Systems downstream perform a Clarifier Forward Flush or Filter Backwash (see Section 5.2.5). In such cases, the PLC will adjust the feed flow based on the water level measured in aeration tank T-210B. If FBR Feed Shutdown mode is triggered by an alarm condition, the feed flow of the corresponding FBR will be stopped, but the fluidization flow continues. If FBR Shutdown mode is triggered by alarm condition, the corresponding FBR will shut down without feed and fluidization flow. A System Shutdown mode will also trigger the FBR Shutdown mode.

5.2.3.2 Performance Goals, Optimization, and Monitoring

The performance goals of the FBR unit operation are to biologically treat the nitrate (as nitrogen) to below the MCL of 10.0 mg/L and perchlorate to below the MCL of 6 µg/L in the feed water.

When one or both FBRs are changed to On-line mode, the plant also initiates System Recycle. The system PLC requires the collection and analysis of perchlorate samples from both FBR outlets and from the plant effluent. After confirming the perchlorate is treated to a non-detect level, the system initiates feed water to the plant and begins an internal timer to account for the hydraulic retention time of the feed. The system PLC requires collection and analysis of samples from the FBR outlets and plant effluent again to confirm complete nitrate and perchlorate treatment. If the nitrate and perchlorate concentrations are below detectable levels, the system collects and analyzes feed load samples for feed load calculations. A normal startup sequence is then completed. If the FBR outlet samples indicate detectable perchlorate concentrations, the plant reverts back to plant recycle mode. The feed is restarted only if the water is retreated and below detectable levels of nitrate and perchlorate.

When feed to the system is initiated, the system PLC monitors the actual dissolved oxygen, nitrate, and perchlorate loading (feed flow rate measured by FIT-104 and FIT-106, the feed dissolved oxygen measured by AIT-100, nitrate concentration measured by AIT-615, and perchlorate concentration measured by AIT-716) and calculates a theoretical electron donor requirement to treat the load conditions. This calculation is based on a stoichiometric model that Envirogen developed and corroborated during the previous field FBR demonstration at Rialto Wellhead #2. This calculation is then compared to an initial assessment of the load and electron donor dosing rate inputted by an operator. The PLC selects the larger of the loading conditions and applies the corresponding electron donor and nutrient dosage to the FBR system(s). Through an iterative process, the system PLC continuously monitors the feed load when FBR-110 Online mode or FBR-120 Online mode is active, and updates the electron donor and nutrient dosage rates accordingly. The system also monitors and adjusts the pH of the water by adjusting the caustic dosage rate.

The system PLC optimizes the operations of FBR-110 and FBR-120 and refines the electron donor and nutrient dosage rates. The feed load conditions are used in the primary control logic and the FBR outlet conditions are used in the trim control logic. At the FBR-110 outlet and FBR-120 outlet, the system PLC continues to evaluate the nitrate concentrations measured by AIT-224 and the perchlorate concentrations measured by AIT-716. After each evaluation, if the feed load condition stabilizes and no fluctuation is recorded at the outlet, the system PLC adjusts the electron donor and nutrient dosage rates in small incremental percentages as trim control. There are minimum electron donor and nutrient dosage rates to clip the trim control logic adjustments. The trim control logic resets if the primary control logic recalculates the electron donor and nutrient dosage rates caused by changes in feed load condition or if the outlet nitrate and/or perchlorate concentrations are detected.

The chemical feed system delivers electron donor and nutrients to the FBR unit operation. FBR-110 and FBR-120 utilize 50% acetic acid (diluted from glacial acetic acid) as the electron donor and 85% phosphoric acid as nutrient. The dosage rates are calculated based on the PLC stored stoichiometric model and are refined when FBR-110 and FBR-120 are operating. The system PLC also monitors and adjusts the pH of FBR-110 and FBR-120.

For routine operations, one of the electron donor feed pumps is on duty and the other is on standby. If a no-flow situation occurs, the standby pump is activated and takes over as the duty pump. If the standby pump that becomes the duty pump has either one of these problems, the plant is put into recycle mode. When the plant is placed into recycle mode, all treated water stops flowing to the treated water reservoirs. This effectively isolates the WTS and stops all deliveries of treated water from the WTS.

5.2.4 Aeration

5.2.4.1 Process Flow

The FBR outlet water is fed to the aeration tanks T-210A and T-210B through the top header at T-210A 120 (Refer to Figures 5.10 and 5.15)). T-210A and T-210B are connected to each other in series to maintain equalized volumes between the two tanks. The level of T-210A/T-210B is monitored by the system PLC through the pressure-based level analyzer PE-210/LT-210 at T-210B. The aerated water exits T-210B through aerated water pump P-220A/P-220B.

When operational, a stream of DAF recycle is combined with FBR outlet and re-enters the aeration tank T-210A. The DAF recycle water is the Trident System flush and backwash water recovered by the DAF solid removal process, and has already been treated by FBR-110 or FBR-120 at this stage.

Aeration tanks T-210A/T-210B are connected to aeration blowers B-200A/B-200B, respectively. T-210A and T-210B are equipped with membrane air distributors AD-210A and AD-210B at the bottom and fine bubbles are created by the air distributors when they are supplied with adequate air pressure. The dissolved oxygen (D.O.) concentration of the water increases with the air bubbles diffusing through the water columns in T-210A/T-210B. Two granular activated carbon vessels GAC-230A and GAC-230B are connected to T-210A/T-210B to treat any off-gases being stripped by the aeration process.

Downstream of aeration tank T-210B and upstream of the aerated water pumps P-220A/P-220B, coagulant of aluminum chlorohydrate (ACH) at 50% strength is added to the aerated water, typically at approximately 45 ml/min. The injection point is located upstream of aeration water pumps P-220A/P-220B. Only one pump operates during normal operation and the other pump is used as spare. Pumps P-220A and P-220B provide mixing before the aerated water enters the downstream Trident Systems F-310 and F-320. Both water pumps P-220A and P-220B have upstream isolation manual gate valves V-210B/V-210C, downstream check valves V-220C/V-220G, and isolation manual gate valves V-220D/V-220H. A recycle line is diverted from the process line with check valve V-222A and manual isolation gate valve V-222B, and is connected to the recycle line from treated water pumps P-405A/P-405B. If in use, the combined recycle line is connected back into the process upstream of the FBR. An aerated water sample line is diverted from the process downstream of P-220 for on-line nitrate analysis.

If the FBR outlet flow is decreased due to changes in the process upstream (e.g., reduction in feed flow), with the aerated water flow rate remaining constant, the water level in T-210A/T-210B will decrease. If the water level falls below the level-alarm-low set point, the clarifier flush will be withdrawn. If the water level falls below the level alarm-low-low set point LALL-210, P-220A/P-220B will be shut down and aerated water stream will stop. P-220A and P-220B will restart when water level in T-210A/T-210B returns to the preset level. If the water level in T-210A/T-210B reaches to the aeration tank high-high level LAHH-210 set point, the system will enter into System Shutdown mode.

5.2.4.2 Performance Goals, Optimization, and Monitoring

The performance goal of the aeration unit operation is to increase the dissolved oxygen concentration of the water at the FBR outlet to aerobic conditions.

When FBR-110 Online mode, FBR-120 Online mode or both modes are initiated, the system PLC monitors the water level of T-210A and T-210B as measured by level analyzer PE-210/LT-210. When operational, the water level in T-210A/T-210B remains constant with the exception of when the downstream Trident System F-310/F-320 enters a clarifier flush or filter backwash or being removed from service. If one of these situations occurs, the feed to the Trident System is disabled temporarily and will cause the water level in T-210A/T-210B to increase. The PLC adjusts the feed flow rate to FBR-110 and FBR-120 to accommodate the increase of water level in T-210A/T-210B until it gradually returns to the normal operating level upon completion of the clarifier flush or the filter backwash or when the Trident System is back on-line.

The dissolved oxygen in the effluent of T-210A/T-210B is optimized via monitoring of effluent oxygen concentrations versus the normal operating level within the tanks. Increases and decreases in dissolved oxygen concentrations can be regulated by adjusting the set point for the aeration tank level height.

The chemical feed system delivers the ACH coagulant solution downstream of aeration tank T-210B and upstream of aerated water pump P-220A/P-220B. The coagulant dosage rates are proportional to the aerated water flow rate to the Trident Systems F-310 and F-320 measured by flow analyzer FT-308 and FT-318. The dosing rates are optimized by determining the effectiveness of solids removal in the downstream Trident System and resultant turbidity of the filter effluent.

5.2.5 Solids Removal

5.2.5.1 Process Flow

The aerated water is divided into two process streams before being fed to Trident Systems F-310 and F-320 120 (Refer to Figures 5.11 and 5.15). Prior to entering the Trident Systems, each process stream has an individual manual isolation gate valve V-225A/V-220F, flow meter FT-308/FT-318, and pneumatic flow control valve FCV-308/FCV-318. The flow rate entering each Trident System is monitored by the respective flow meters FE-308 and FE-318, and the flow rate is controlled by flow control valves FCV-308/FCV-318 based on the Trident feed flow set point and the measured flow rate. Downstream of FCV-308/FCV-318, if required, polymer is injected into the process line, and the water is then fed to the two-stage Trident Systems F-310 and F-320.

Each Trident System F-310 or F-320 consists of a first stage Clarifier and a second stage Media Filter, which are separate and independent processes. The Clarifier removes the majority of the suspended solids and the Media Filter removes the finer particles. The Clarifier is bottom fed with the aerated water. The Clarifier is loaded with beads made with special material and is designed for removal of coagulated solids. The clarified water overflows into a weir and then proceeds to the top of the Media Filter stage. The Media Filter is loaded with mixture of fine sand and anthracite and is used to further polish the clarified water. A filter effluent pump is connected to the bottom of each Media Filter, with water exiting the Trident systems via these pumps. The suction sides of the filtered water pumps are monitored by pressure switches PSL-310B/PSL-320B and PSL-310B and PSL-320B. By maintaining the water level in the Filter Media measured by level controller LC310/LC320, each Trident System maintains the flow rate of the filtered water through the pneumatic actuated valves FV-330 and FV-331.

A sample line at each Trident System is diverted from the filtered water for turbidity measurement. The sample flows through manual isolation ball valve V-310E/V-320E, is extracted by turbidity sample pump P-310/P-320, flows through check valve V-311A/V-321A and manual isolation ball valve V-311B/V-321B, before entering the in-line turbidity analyzer AIT-310/AIT-320. The sample water drains into the backwash outlet stream. If the individual turbidity-alarm-high-high AAHH-310 or AAHH-320 is triggered, the corresponding Trident System will be removed from service. Removing one Trident System from service will cause the water level in aeration tank T-210B to increase, and the system PLC will adjust the feed to FBR-110 and FBR-120 to accommodate the changes. If both AAHH-310 and AAHH-320 are triggered, System Recycle mode will be initiated.

Two air blowers B-300A and B-300B are connected to Trident Systems. The air blowers are configured to be interchangeable. The blowers are used to air-scour the Trident Systems during Clarifier flush and Media Filter backwash. When operational, the blower discharge pressure is monitored by pressure switch PSH-300. The air-scour flow rate to each Trident System is controlled by pneumatic actuated valve FV-302/FV-306. Check valves V-301, V-302, V-305, V-306, V-300A, and V-300B are installed in the air line to prevent backflow of water into the air blowers. If both aeration blowers fail to start or do not provide sufficient air pressure exceeding the set point PSH-300, the Trident Systems will be removed from service and FBR Feed Shutdown mode will be initiated.

The Pressure switches PSH-310A/PSHH-310A and PSH-320A/PSHH-320A located at the inlet of the Trident Systems F-310 and F-320 monitor the pressure of each Clarifier. Periodically, the Trident Systems initiate a pressure set point Clarifier flush. As the suspended solids that are removed begin to accumulate at the Clarifier, they create back pressure against the Clarifier inlet and cause the Clarifier inlet pressure to increase. If the pressure at the Clarifier inlet exceeds the set point of PSH-310A or PSH-310B, the respective Trident System will initiate a clarifier flush to remove the accumulated solids in the Clarifier. The Clarifier flush utilizes aerated water to flush the accumulated solids, and the flush water produced during this process exits the Trident System through the backwash outlet stream for further solids removal treatment.

If the pressure at the Clarifier exceeds the set point of PSHH-310A or PSHH-320A, the respective Trident System will be removed from service by closing the inlet flow control valve. A Clarifier flush can also be initiated over a set time period though the PLC if desired. One only Trident System can perform a Clarifier flush at a time.

Pressure switches PSL-310B/PSL-320B and PSL-310B/PSLL-32B, located at the outlet of F-310/F-320, monitor the pressure of the corresponding Media Filter. Similar to the Clarifier flush, the Trident Systems initiate a pressure set point Media Filter backwash periodically. As the suspended solids being removed begin to accumulate at the Media Filter, they create plugging and cause a decrease of suction pressure at the filtered water pumps. If the pressure at the filtered water pump suction decreases below the set point of PSL-310A or PSL-310B, the respective Trident System will initiate a Media Filter backwash to remove the accumulated solids in the Media Filter. Media Filter backwash will also be initiated if the turbidity of the filtered water, measured by AIT-310/AIT-320, stays above AAH-320/AAH-20 set point for a preset time period.

Different than the Clarifier flush, the Media Filter backwash utilizes backwash water to remove the accumulated solids. The backwash water is previously filtered water that is stored in filtered water tank T-400A. When backwash water is required during the Media Filter backwash process, backwash water is enabled by the system PLC by a pneumatic actuated valve FV-332. The upstream manual isolation gate valve V-401D is used to completely close the backwash flow through FV-332. The backwash can also be manually enabled by opening manual isolation gate valve V-401C. Pneumatic actuated valves FV-330 and FV-331 control the individual backwash flow rates to the respective Trident System. The backwash water produced during this process exits the Trident System through the backwash outlet stream for further solids removal treatment.

If the pressure at the Media Filter decreases below the set point of PSL-310A or PSL-320A, the respective Trident System will be removed from service by closing the inlet flow control valve FCV-308 or FCV-318. A Media Filter backwash can also be initiated over a set time period though the PLC if desired. Only one Trident System can perform Media Filter backwash at a time.

During the Clarifier flush and Filter backwash, the generated flush and backwash water is diverted to a backwash recycle storage tank T-410. Since the flush and backwash water is not a continuous feed, storing the flush and backwash water in tank T-410 provides an equalized feed to the dissolved air flotation (DAF) unit D-410 via backwash recycle pump P-410. Backwash mixing pump P-415 provides continuous mixing in T-410 to prevent the solids from settling.

Level indicator transmitter LIT-410 monitors the mixture level in T-410. Mixture level above the level-alarm-high-high set point will initiate System Recycle Mode. Mixture level above the level-alarm-high set point will withdraw the Trident Clarifier Flush and Filter Backwash permissive. Mixture level below level-alarm-low set point will initiate an informational alarm. Mixture level below level-alarm-low-low setpoint will cause pumps P-410 and P-415 to shut down.

If one FBR is in Shutdown mode or Feed Shutdown mode while another FBR is in Online mode, the Trident Systems will continue to operate at normal operating flow rates and eventually decrease the aeration tank T-210B water level to below the LALL-210 set point. This will de-energize aerated water pump P-220A/P-220B and disable flow to F-310 and F-320. With the one upstream FBR still in operation, it continues to feed the aeration unit operation. Once the water level in T-210 increases to a preset level, the aerated water pump P-220A/P-220B will be re-started.

5.2.5.2 Performance Goals, Optimization, and Monitoring

The performance goals of the Trident System unit operation are to remove the suspended solids and to decrease the turbidity level in the process water to meet or be below the California Drinking Water Quality Standard.

The Trident Systems continuously monitor the turbidity of the filtered water measured by turbidity meters AIT-310 and AIT-320, with the plant PLC adjusting the coagulant dosage rates to maintain the turbidity level of the filtered water.

The chemical feed system delivers coagulant and polymer to the Trident System unit operation. The coagulant dosage rates can be manually adjusted or can be adjusted by the Trident System. The polymer dosage rates are preset by the operator.

5.2.6 Dissolved Air Floatation

5.2.6.1 Process Flow

Flush and backwash water that Trident Systems produced during the Clarifier flush and Media Filter backwash are stored in the backwater recycle storage tank T-410 120 (Refer to Figures 5.12 and 5.15). Backwash recycle pump P-410 transfers the water to the DAF unit D-410 for further solids removal/concentration. Check valve V-410A, followed by manual isolation valve V-410B, is located at the suction of P-410. Check valve V-410C, followed by manual isolation valve V-410D, is located downstream of P-410 discharge. Backwash mixing pump P-415 is installed at T-410, continuously mixing the water to prevent solids settling in T-410. Check valve V-415A is located at the suction of P-415 and is connected to tank mixers with a manual valve V-416A installed at the discharge.

The backwash recycle storage tank water level is monitored by pressure-based level analyzer PE-410/LIT-410. If the water level of T-410 exceeds the LAH-410 set point, the Clarifier flush or Media Filter backwash permissive to the Trident Systems will be withdrawn. If the water level of T-410 exceeds LAHH-410 set point, the system PLC will operate in System Recycle mode. If the water level of T-410 decreases below LALL-410 set point, P-410 will be disabled.

The DAF feed transfers from T-410 and is fed to the flocculation tube FT-400 upstream of the inlet of the dissolved air flotation unit D-410. Using the same chemicals as used in the Trident Systems, the coagulant and polymer are injected at FT-400. The dosage rates of the coagulant and polymer are controlled by the system PLC based on the DAF recycle flow rate measured by FIT-430 at the back end of the process. A manual isolation gate valve V-410E is downstream of FT-400. The DAF feed is then combined with a pressurized water stream. Service air stream is added to T-420 to aerate the pressurized water. The pressurized water stream is circulated from the outlet of D-410 and further pressurized and aerated prior to combining with the DAF feed. The combined stream then enters D-410. The pressurized stream can also enter D-410 separately without combining with the DAF feed. The flow of pressurized water stream can be regulated/enabled by manual valves V-421 or V-422.

After the streams enter D-410, the DAF removes the suspended solids from the water stream through the upper skimmer and the lower sludge auger. The atmospheric pressure at D-410 causes the pressurized and aerated water stream that enters D-410 to release fine air bubbles. The air bubbles lift the coagulated/flocculated solids in the water to the top of D-410. The DAF-treated water exits D-410 and enters recovered water tank T-430. A stream of DAF-treated water is circulated from D-410 through the DAF circulation pump P-420, followed by check valve V-420, to the pressurization vessel T-420.

After the solid removal process at the DAF, the recovered water stored at T-430 is then returned back as DAF recycle to the aeration tank T-210A via pump P-430. Manual isolation valve V-430A is located at the suction of the recovered water pump P-430. Manual isolation valve V-431A followed by check valve V-431B are located at the discharge of P-430. The recovered water flow rate is monitored by flow meter FE-430/FIT-430. The pump speed of P-430 is controlled by the system PLC based on the levels of T-410 and T-430. The P-430 run permissive will be withdrawn if the water level in T-430 decreases below the LSSL-433 set point.

A sample line is diverted from the DAF recycle for turbidity measurement. The sample line is enabled by an in-line solenoid valve, followed by check valve V-422A and manual isolation valve V-422B. The sample is measured by the in-line turbidity analyzer AE-430/AIT-430. The sampling line combines with the overflow from T-430 and is returned to the backwash recycle storage tank T-410 as DAF recycle.

With the air bubbles carrying the suspended solids to the surface of D-410, the top skimmer pushes the solids to the collection trough of D-410. The trough is connected to pneumatic diaphragm DAF reject pump P-440. Level switch-410 monitors the solid level in the trough and activates P-440 to remove accumulated solids. P-440 operates between the set points of LSL-430 and LSJH-430. While majority of the suspended solids are removed by the top skimmer, settling of solids may occur and can be removed by the bottom sludge auger through the bottom outlet nozzle of DAF, with the pneumatic actuated valve V-418A enabling the sludge flow. The bottom outlet nozzle stream is combined with the sludge stream from the collection trough, and is connected to the suction of the DAF reject pump P-440.

The DAF reject removed by P-440 enters sludge storage tank T-480. The cone-shaped bottom of T-480 is connected to a manual isolation valve V-481A, followed by a pneumatic diaphragm sludge pump P-480. Pressure-based level analyzer PE-480/LT-480 measures the sludge level in T-480.

A built-in pulsation damper P-480 stabilizes the DAF reject flow. The DAF reject flow rate is measured by flow meter FE-482/FIT-482. Manual valve V-482A enables the adjustments of DAF reject flow and pneumatic actuated valve FV-482 enables the flow of DAF reject flow. Both P-480 and FV-482 operate between LAL-480 and LAH-480. The DAF reject flow combines with the drywell drain and exits to solids press system to increase the solids content from 2-3% to 15-20%. Ultimately, these solids are landfilled off-site. T-480 is also connected to granular activated carbon GAC-480 to treat the off-gas exiting T-480. If the sludge level in T-480 exceeds the LAHH-480 set point, the system will enter System Recycle mode and the DAF reject pump P-440 pump run permissive will be withdrawn. An additional level switch LSHH-481 is installed at T-480. If the sludge level in T-480 exceeds the LAHH-481 set point, the plant will enter System Recycle mode and the DAF reject pump P-440 pump run permissive will be withdrawn (if LAHH-480 has not already been triggered).

The DAF and its downstream equipment, including P-430, P-440, and P-480 will be shut down if P-410 is shut down. In FBR-110 and FBR-120 Feed Shutdown mode, FBR-110 and FBR-120 Shutdown mode, and System Recycle mode, the Clarifier flush or Media Filter backwash permissive is withdrawn. Subsequently, the level in the Backwash Recycle Storage Tank T-410 will decrease below the set point of LALL-4410, causing P-410 to shut down. This will eventually lead to the shutdown of the DAF and its downstream equipment.

5.2.6.2 Performance Goals, Optimization, and Monitoring

The performance goals of the DAF unit operation are to clarify the Trident Clarifier flush and Media Filter backwash water and consolidate the removed solids.

When operational, the system PLC monitors the turbidity of the DAF recycle stream measured by turbidity meter AE-430/AIT-430. If the turbidity of the DAF recycle stream exceeds the operator adjustable set point, the system PLC will alert the operator with a high turbidity alarm.

The DAF recycle flow rate is controlled by the system PLC. The system PLC monitors the water levels in the backwash recycle storage tank T-410 and recovered water tank T-430, and adjusts the speed of recovered water pump P-430. DAF recycle flow control FC-430A/FC-430B use the water level in T-410 as primary control and water level in T-430 as trim control to determine the DAF recycle flow rate.

The chemical feed system delivers coagulant and polymer solution to the DAF unit operation to enhance solids removal. The dosage rates are controlled by the system PLC and is proportional to the DAF recycle flow rate measured by FE-430/FIT-430. The proportionality constants of the coagulant and polymer dosage rates are operator adjustable and are determined by initial jar test. The operator can refine the proportionality constants to achieve optimum dosage rates.

5.2.7 Disinfection

5.2.7.1 Process Flow

After treatment of the Trident Systems, the filtered water is fed to filtered water tank T-400A. T-400A stores approximately 74,000 gallons of filtered water 120 (Refer to Figures 5.13 and 5.15). Water above the overflow level of T-400A enters the Chlorine Contact Tank T-400B through the overflow weir. The water level in T-400A is monitored by level sensor LE-400A/LIT-400A.

Tank T-400A provides backwash water to the Trident Systems via Filter Backwash Pumps P-400A/P-400B during the Media Filter backwash process. Only one pump operates at a time with another one used as spare. Isolation valve V-400A is located in between T-400A and the suction of pumps P-400A/P-400B. P-400A and P-400B each have one check valve V-401A/V-401C and one isolation manual gate valve V-401B/V-401D at the discharge. An in-line orifice plate FO-400 in the shared discharge line of P-400A/P-400B prevents any upset to the Media Filter backwash due to unexpected change of conditions at the upstream pumps P-400A/P-400B or the downstream valves FV-300, FV-331, FV-332.

If the water level in T-400A decreases below LAL-400A, the Trident Media Filter backwash permissive will be withdrawn. If water level in T-400A decreases below LALL-400A, P-400A and P-400B will be disabled. LALL-400A will also disable P-405 if system is operating in System Recycle mode.

The treated water exits Tank T-400A and enters the Chlorine Contact Tank T-400B through the overflow weir. Level sensor LE-400B monitors the level at the overflow weir, and the system PLC converts the level measurement and monitors the flow rate entering the T-400B. As the treated water enters the chlorine contact tank T-400B, sodium hypochlorite is added to T-400B through a recycled push water stream from the discharge of treated water pump P-405A/P-405B. The chlorinated water exits T-400B through treated water pump P-405A/P-405B. Only one pump operates under normal operating conditions with the other used as spare. A manual gate valve V-405A followed by another pneumatic-actuated butterfly valve FV-404A are located upstream of pumps P-405A/P-405B. P-405A and P-405B also have isolation valves V-405D/V-405E at the suction and V-405C/V-405G at the discharge. Check valves V-405B/V-405F are located at the discharge of P-405A/P-405B. The treated water flow rate is controlled by the pneumatic actuated valve FCV-405. The position of FCV-405 is controlled by the system PLC based on the measurements obtained by level sensor LE-400C/LIT-400C.

Sample streams are branched off from the process and are connected to T-400A and T-400B with manual isolation ball valves V-451A and V-451B. This continuous sampling stream flows to the in-line free chlorine analyzer AE-650/AIT-605 and on-line perchlorate analyzer AIT-760.

The treated water can enter different discharge lines. Each line has one pneumatic actuated valve, FV-402A, FV-402B, FV-402C, and they are controlled by the system PLC. Each of these actuated valves is followed by another check valve, V-402B, V-407B or V-403B. The system PLC also adjusts the pump speed of P-405A/P-405B based on operator's selection of discharge line.

During the start-up period, the treated water flows to the IX/Basin discharge line. As do all biological processes, FBR-110 and FBR-120 require an acclimation period. The untreated perchlorate is removed by the downstream IX system. The well bypass stream from well WVWD #33 is also connected to this discharge line if processing well water directly through the downstream IX system or discharging well water to the basin is desired. A pressure safety valve PSV-403 is installed at the discharge line.

With a drinking water permit approval for the treatment system, the treated water flows to the reservoir discharge line. The recycle discharge line leads the treated water back to the feed of the FBR.

A stream of treated water is diverted from the main process line at the discharge of P-405A/P-405B. This stream of treated water is used as push water for sodium hypochlorite injection at T-400B, as dilution water for concentrated electron donor, and as flush water for the drywell sump T-450. Pneumatic actuated flow valve FV-455 enables flow to be used as flush water for the drywell sump.

Backflow preventing valve FV-450 is installed at the shared line for the treated water stream and for the push water stream going back to T-400B. Manual valve V-465A and pneumatic actuated valve FV-465 enable treated water flow to be used as dilution water for the electron donor (glacial acetic acid). Manual valve V-460A and pneumatic actuated valve FV-460 enable push water flow to be delivered to T-400B. The push water flow rate is measured by flow indicator FI-460. Valves FV-455, FV-460, and FV-465 are controlled by the system PLC.

A drywell sump T-450 is installed next to drywell where treated water pumps P-405A and P-405B are located. The sump catches accumulated rain water and prevents water level from submerging P-405A and P-405B.

5.2.7.2 Performance Goals, Optimization, and Monitoring

The Surface Water Treatment Rule requires the plant to establish a disinfection chlorination contact time (CT) that will achieve 4 log virus removal with disinfection by-products below the MCLs. Free chlorine residual will also be reported with the established CT as required by the disinfection protocol. The performance goal of the disinfection system is to provide adequate chlorine contact time for disinfecting the filtered water, a minimum CT of 4 mg/L min. In addition, this system also provides backwash water for the Trident Systems via pump P-400A or P-400B, and dilution waterline for the glacial acetic acid used as electron donor.

When feed to the system is initiated and the filtered water is entering the sump system, the system monitors the water level at chlorine contact tank T-400B and maintains the water level by controlling FCV-405.

When discharge of system effluent to the reservoir is selected, the system PLC enables sodium hypochlorite addition to the chlorine contact tank T-400B. The system monitors the free chlorine of the treated water measured by AE-650/AIT-650 and the flow rate entering T-400B measured by the overflow weir flow meter LE-400B/FIT-400B. From these measurements, the PLC determines the dosage rate of sodium hypochlorite to reach a fixed residual concentration. The free chlorine measurement collected via AE-650 and the flow rate measurement collected via FIT-400B are used to determine the sodium hypochlorite dosage rate. The dosage rate can also be refined through the operator-adjustable gain factors for both the free chlorine and the flow rate.

The system PLC also flushes the drywell sump periodically with operator-adjustable duration and frequency. Level switches LSL-450, LSH-450, LSHH-450 are installed at the drywell sump to operate primary drywell sump pump P-450A and secondary drywell sump pump P-450B. The drywell drain discharged from P-450A and P-450B is connected to sanitary sewer. P-450A operates between LSL-450 and LSH-450 and P-450B operates between LSL-450 and LSHH-450. At LSHHH-450, the system initiates System Recycle mode.

The chemical feed system delivers sodium hypochlorite to the chlorine contact tank T-400B for disinfecting the treated water. The dosage rates are calculated and controlled by the system PLC.

5.3 OPERATIONAL START-UP

The schedule for the operational start-up is provided in Table 5.2.

Table 5.2 Timeline for Activities.

| Mode of Operation | Well 33 (gpm) ¹ | Well 6 (gpm) ² | Well 11 (gpm) ³ | Plant flow Rate (gpm) | Estimated Duration (days) | Discharge (gpm) |
|--------------------------------|----------------------------|---------------------------|----------------------------|-----------------------|---------------------------|--|
| Wet Test | Up to 2000 | 0 | 0 | 2000 | 30 | 2000 to basin |
| Batch Mode | 0 | 0 | 0 | 0 | 10 | 0 |
| Continuous Acclimation-Phase 1 | 500 | Up to 500 | Up to 500 | 1,000 | 15 | 1,000 (to IX) 1500 to basin; no disinfection |
| Continuous Acclimation-Phase 2 | | Up to 750 | Up to 750 | 1,000 | 15 | Up to 1,000 (to IX) |
| Steady-State | 0 | 2,000 1,000 0 | 2,000 1,000 0 | 2000 | 60 | 2000 (no IX); disinfection and dechlorination |

1 Clean water

2 High ClO₄, low NO₃

3 Low ClO₄, high NO₃

5.3.1 Dry Test

Prior to process startup, Envirogen conducted a mechanical shakedown of the facility and a dry function test simulating the plant functionality and control. All signals to and from pumps, switches, instruments, and valves were tested. All alarms were tested to be simulated and checked prior to the wet test

5.3.2 Wet Test

The second phase of the shakedown was the wet test using clean water from WVWD Well #33. This included the initial clean water tests of the FBR system, the Aeration system, the Trident System (multimedia filter) system, the Disinfection system, the DAF system, and the Solid Handling system of the plant. These systems were checked for leaks and full operation capabilities.

5.3.3 Batch Operation

Following completion of the functional wet test, the pre-operation tasks for each unit operation proceeded, including the GAC media loading/flushing of the FBRs and the Trident Systems.

The system was then placed in a batch mode to begin to build biological acclimation and concentration on the media. WVWD Well #11 water in combination with Rialto Well #6 water was introduced into the system. WVWD Well #11 is currently not in operation, but historical data indicates Well 11 has the highest nitrate concentration while Rialto Well #6 has the highest perchlorate concentration between the three groundwater wells. In batch mode, one tank volume of the blended well water was added to the FBR as well as the electron donor and nutrient. Grab samples were collected and analyzed for nitrate, perchlorate, ortho-phosphate, and Total Organic Carbon (TOC) concentrations. A gradual decline of these concentrations indicated biological activity was occurring within the FBRs. This process was repeated while the plant was in recycle mode if necessary.

5.3.4 Acclimation

Over the first 40 days of the start-up process, the system operated in both batch mode and in feed mode at flow rates up to 1,000 gpm. During this time, nutrients and electron donor were gradually increased allowing the naturally-occurring microbes in the groundwater to fully inoculate the FBRs. Dissolved oxygen, nitrate, and perchlorate were monitored regularly to determine treatment effectiveness. After all the nitrate and perchlorate were treated in batch mode, the FBRs were placed into the online modes. The feed flow was ramped up per FBR, but the total flow remained below 1,000 gpm so that it would not exceed the flow capacity of the downstream Ion Exchange unit for polishing prior to discharge to the Cactus Basin. The acclimation period was considered complete when the plant effluent water met the required perchlorate concentration, oxygen concentration, and turbidity levels. Before ramping up flow further, the system was evaluated to ensure that all instrumentation and programming were operational per design, and all equipment fully functional.

5.3.5 Steady-State Operation

Following the acclimation period, during which the FBRs achieved full treatment at 1,000 gpm, the steady state operation began. The feed flow was gradually increased from 1,000 gpm to 2,000 gpm to the entire plant. The feed flow was increased in increments and the treated water quality closely monitored to minimize interruptions of the treatment process. The plant was operated in its designed condition, with the exception that the plant effluent was discharged to the basin instead of the WVWD reservoir. The disinfection system was also operated to chlorinate the water at the back end of the process. During this period, the on-site field/process engineer evaluated and optimized the process parameters for each unit operations. The system demonstrated its ability to meet the treatment goals. During this phase of the test, any non-simulated alarms or issues, as well as the plant's response were documented. The steady state operation phase was completed with concurrence from DDW and WVWD that the plant had demonstrated full treatment of the feed water.

During the steady state operation, the system demonstrated the Drinking Water Control Logic. The control logic was designed to ensure complete treatment as well as optimizing chemical additions by evaluating the feed load, which includes the feed flow rates and chemical concentrations, and subsequently monitoring the outlet concentrations of perchlorate and nitrate. By evaluating the historical and current data, the control logic refined the chemical addition rates to the FBR system. The control logic also prevented non-compliant water from exiting the plant when it detected incomplete treatment at the outlet.

5.4 SAMPLING PROTOCOL

During the batch, acclimation, and steady-state phases of operation of the Groundwater Treatment Plant, various levels of sampling and analysis occurred. This included the use of on-line instrumentation, as well as through grab samples with on-/off-site analyses. The specific sampling required of the wells and of the plant is provided in Table 5.3, with the sampling locations provided in Figure 5.17.

5.5 SAMPLING RESULTS

The success of the demonstration and the effectiveness of the FBR treatment system was primarily based on:

- the ability of the incoming groundwater to effectively colonize the fluidized bed media
- the treatment of nitrate-N and perchlorate in the FBR effluent consistently measured at levels less than 1 mg/L and 6 µg/L, respectively
- the functionality of the on-line instruments to measure the flowrate and the contaminants of interest and appropriately adjust the electron donor dosing rates
- the ability of the downstream equipment to meet the requirements of the surface water treatment rules for drinking water (CCR Title 22, Div. 14, Ch. 17, Table 5.4)

Over the course of start-up and through steady-state operation, on-site and off-site laboratory and field parameters were collected to assess the FBR treatment system effectiveness. This collected data are provided in Figures 5.18-5.21 and in Tables 5.5-5.6, referenced throughout this document.

Table 5.3 Monitoring Schedule for Wells and Analysis Points for Continuing Operations.

| MONITORING SCHEDULE | | | | | | | | | | | | |
|-----------------------------------|------------------------|---------------------------|-------------------------|---------------------|------------------|---------------------|-------------------------|----------------------|---|-------------------|------------------------------|------------------------|
| Site/Location | Monthly Analyses | | Quarterly Analyses | | | Annual June | | | Triennial June | | | |
| | Coliform P/A | General Physical | PCE | DBCP | Cr6 | 504 | MTBE | Radiological | Check monitoring schedule for full title 22 delinquencies | | | |
| Groundwater Wells | X | X | X | X | X | X | | | | | | |
| Well 6 3610038-008 | X | X | X | X | X | X | | | | | | |
| Well 11 3610004-050 | X | X | X | X | X | X | | | | | | |
| Well 33 3610004-030 | X | X | X | X | X | X | X | X | | | | |
| Site/Location | Annual - June | | | | | | | | | | | |
| Monitoring Wells | General Mineral | Inorganic Chemical | General Physical | Radiological | VOC | SOC | | | | | | |
| Sentential Well | X | X | X | X | X | X | | | | | | |
| Rialto Well 3 | X | X | X | X | X | X | | | | | | |
| Rialto Well 4 | X | X | X | X | X | X | | | | | | |
| Rialto Well 5 | X | X | X | X | X | X | | | | | | |
| District Well 10 | X | X | X | X | X | X | | | | | | |
| *See attached panel refrence. | | | | | | | | | | | | |
| Site/Location | Weekly | | | | | | | | | Monthly | | |
| Fluidized Bed Reactor | Nitrate | TOC | Alkalinity | Perchlorate | Turbidity | Coliform P/A | General Physical | TDS & TSS | TCE | Alkalinity | Sulfide & Sulfate | THM & HAA's |
| Plant Influent | X | | | X | | | | | X | X | | |
| FBR Effluent/Train 1 | | | | | | | | | X | | | |
| FBR Effluent/Train 2 | | | | | | | | | X | | | |
| Post Aeration Tank | | | | | | | | | X | | | |
| DAF Holding Tank | | | | | | | | | | | | |
| Clear well | | | | | | | | | | | | |
| Combined Filter Effluent | | | | | | | | | | | | |
| Plant Effluent (Chlorine Contact) | X | X | X | X | X | X | X | X | X | | X | X |
| Zone 3A Reservoir | | | | | | | | | | | | X |

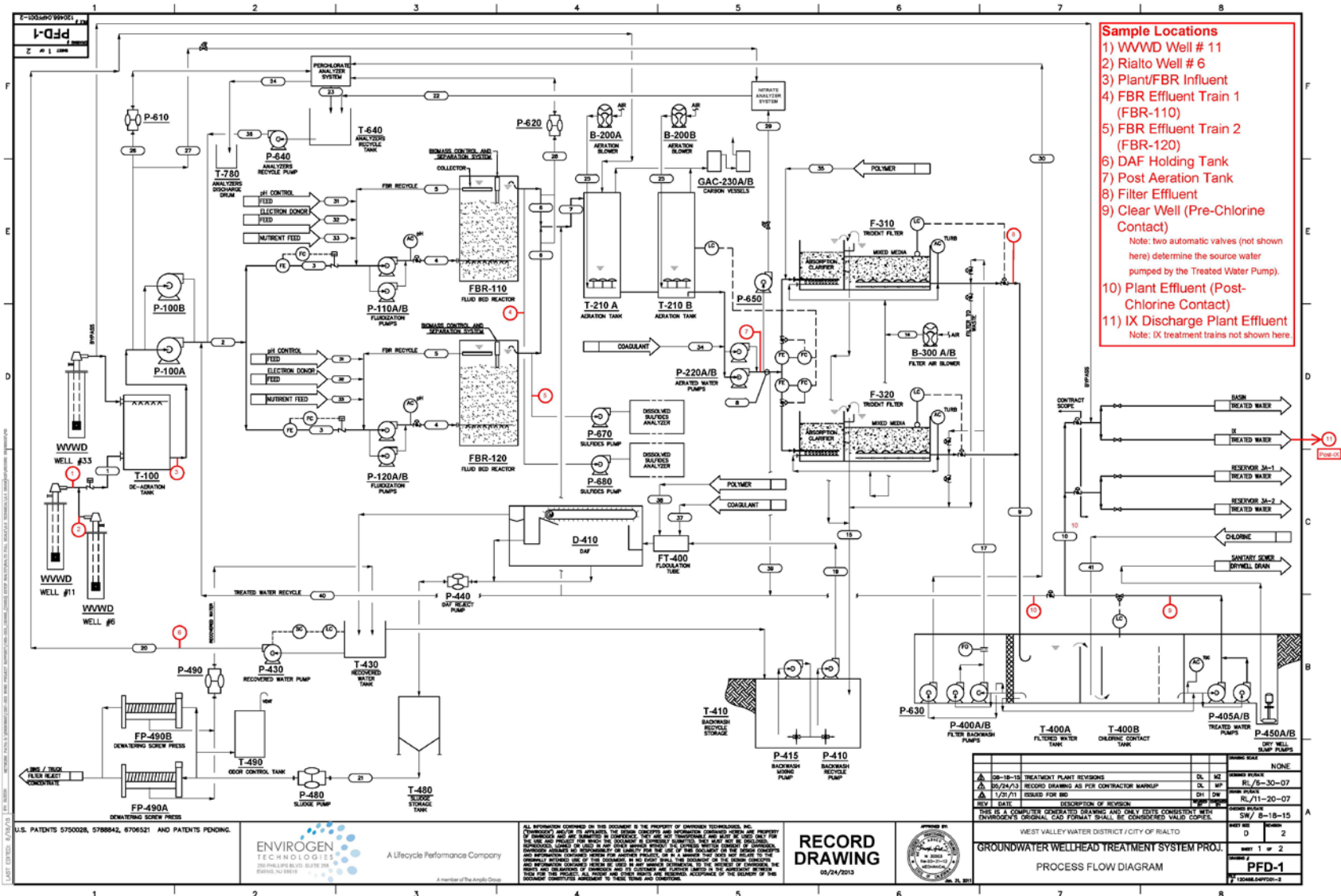

Figure 5.17 Sampling locations in Groundwater Treatment Plant.

Table 5.4 California Regulatory Limits for Drinking Water.

| Analytes | California State Regulatory Limits |
|-------------------------------------|---|
| Inorganics MCL | |
| Antimony | 0.006 mg/L |
| Arsenic | 0.01 mg/L |
| Barium | 1.0 mg/L |
| Beryllium | 0.004 mg/L |
| Cadmium | 0.005 mg/L |
| Chromium | 0.05 mg/L |
| Cyanide | 0.15 mg/L |
| Lead | 0.015 mg/L |
| Mercury | 0.002 mg/L |
| Perchlorate | 6 µg/L |
| Nickel | 0.1 mg/L |
| Nitrate (as NO ₃) | 45 mg/L |
| Nitrite (as N) | 1 mg/L |
| Nitrate-N/Nitrite-N | <10 mg/L (combined) |
| Selenium | 0.05 mg/L |
| Thallium | 0.002 mg/L |
| Disinfection By-products MCL | |
| Haloacetic Acids (five) | 60 µg/L |
| Total Trihalomethanes | 80 µg/L |
| Secondary MCLs | |
| Aluminum | 0.2 mg/L |
| Chloride | <250 mg/L (recommended) |
| Color | 15 units |
| Copper | 1.0 mg/L |
| Foaming Agents (MBAS) | 0.5 mg/L |
| Iron | 0.3 mg/L |
| Manganese | 0.05 mg/L |
| Odor-Threshold | 3 units |
| Silver | 0.1 mg/L |
| Specific Conductance | <900 µS/cm (recommended) |
| Sulfate | <250 mg/L (recommended) |
| Total Dissolved Solids | <500 mg/L (recommended) |
| Turbidity | <0.3 NTUs |
| Zinc | 5.0 mg/L |
| Microbiological Requirements | |
| Heterotrophic Plate Counts | <500 CFUs/ml |
| Total Coliform/ <i>E. Coli</i> | <1 MPN/100 ml |

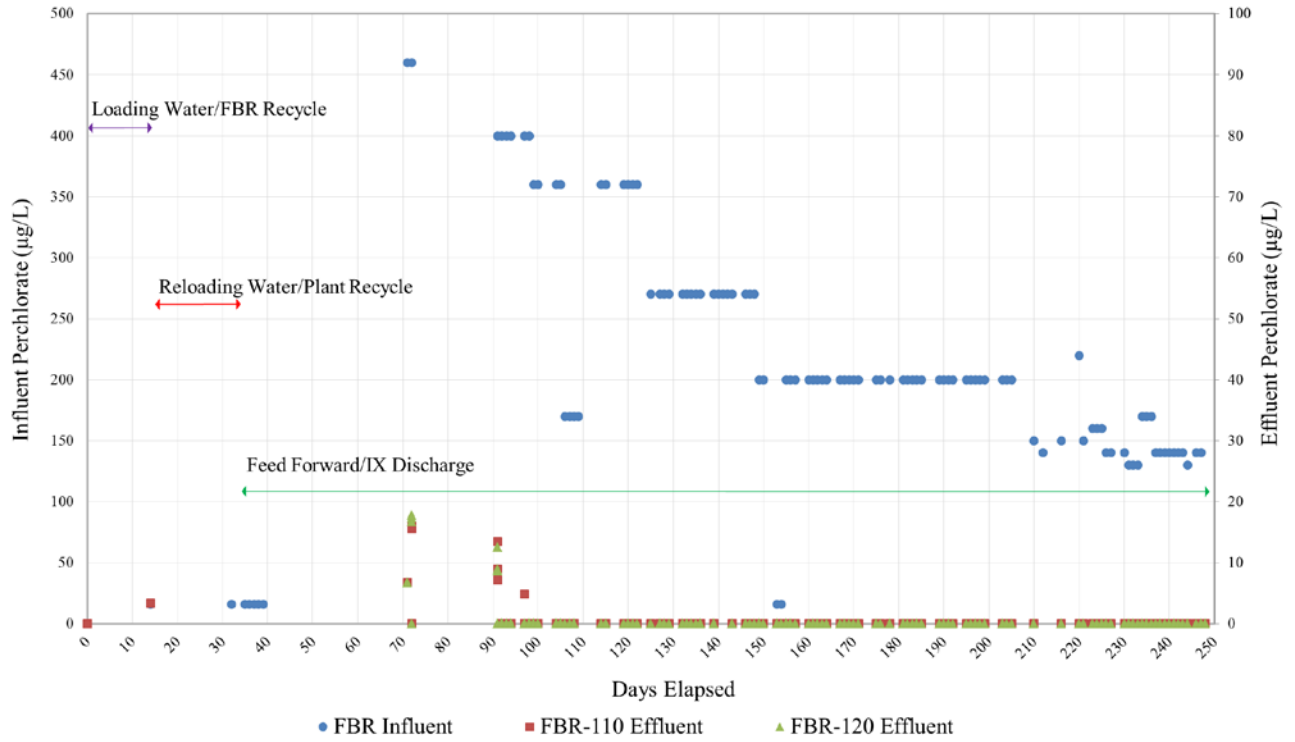

Figure 5.18 Perchlorate Treatment across the FBRs.

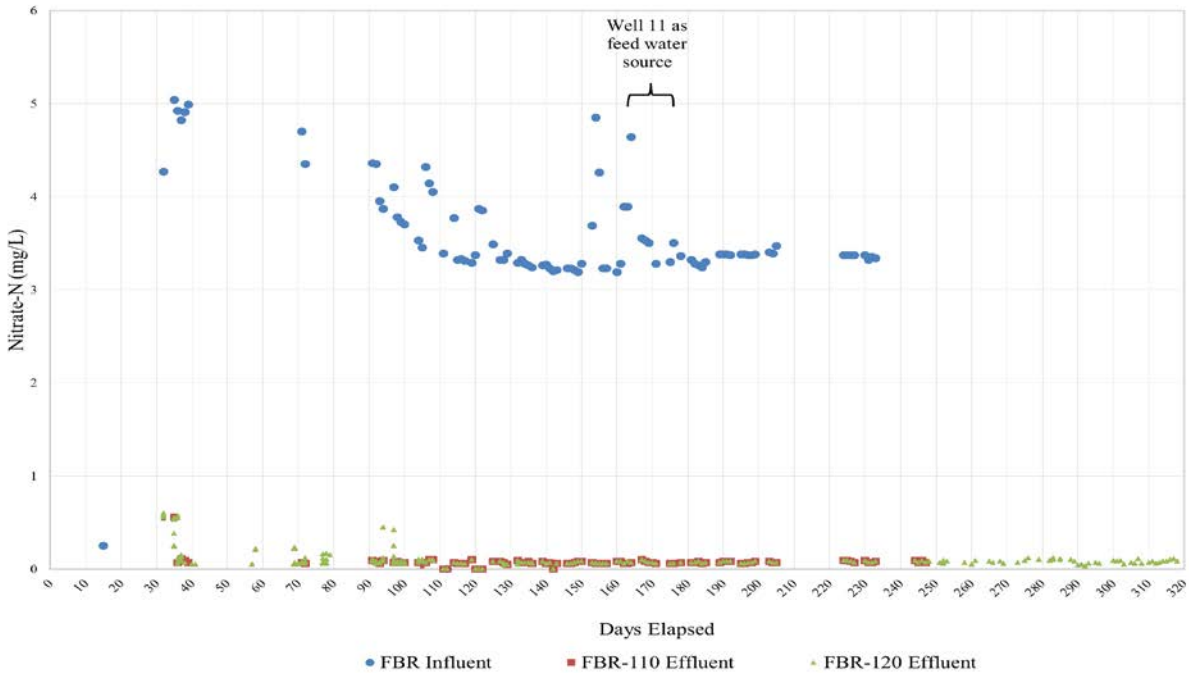

Figure 5.19 Nitrate Treatment across the FBRs.

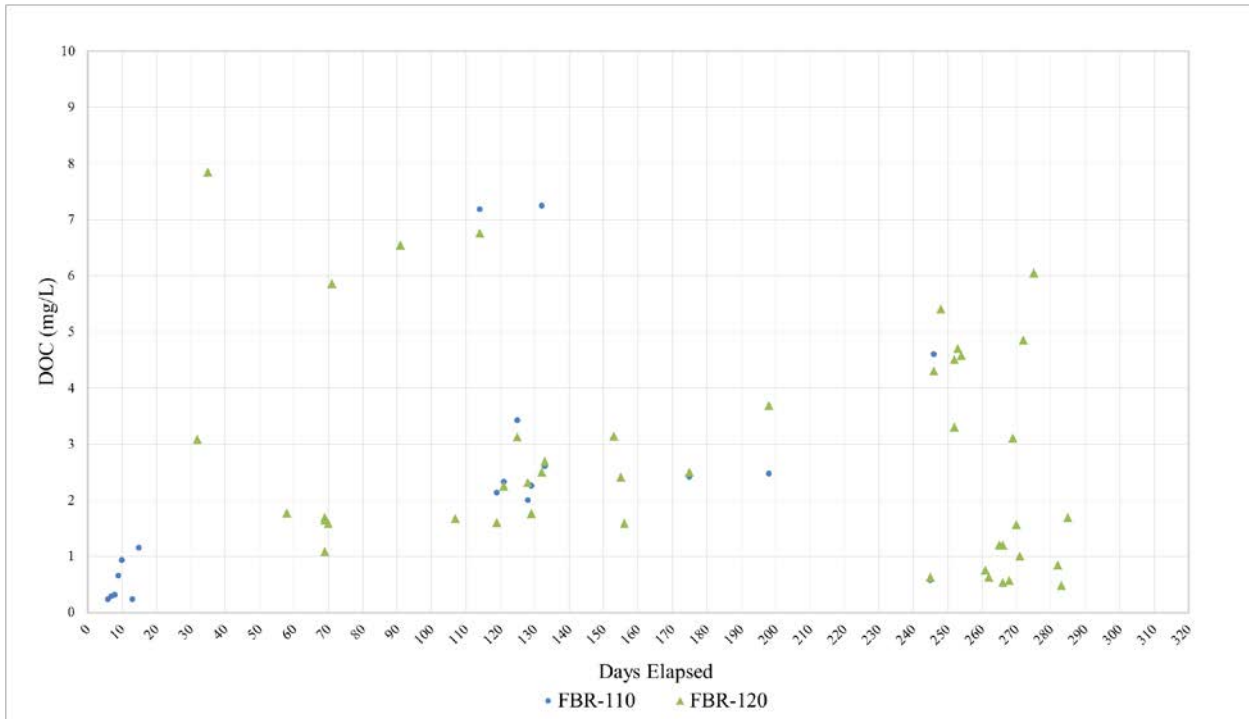

Figure 5.20 Residual Dissolved Organic Carbon for the FBRs.

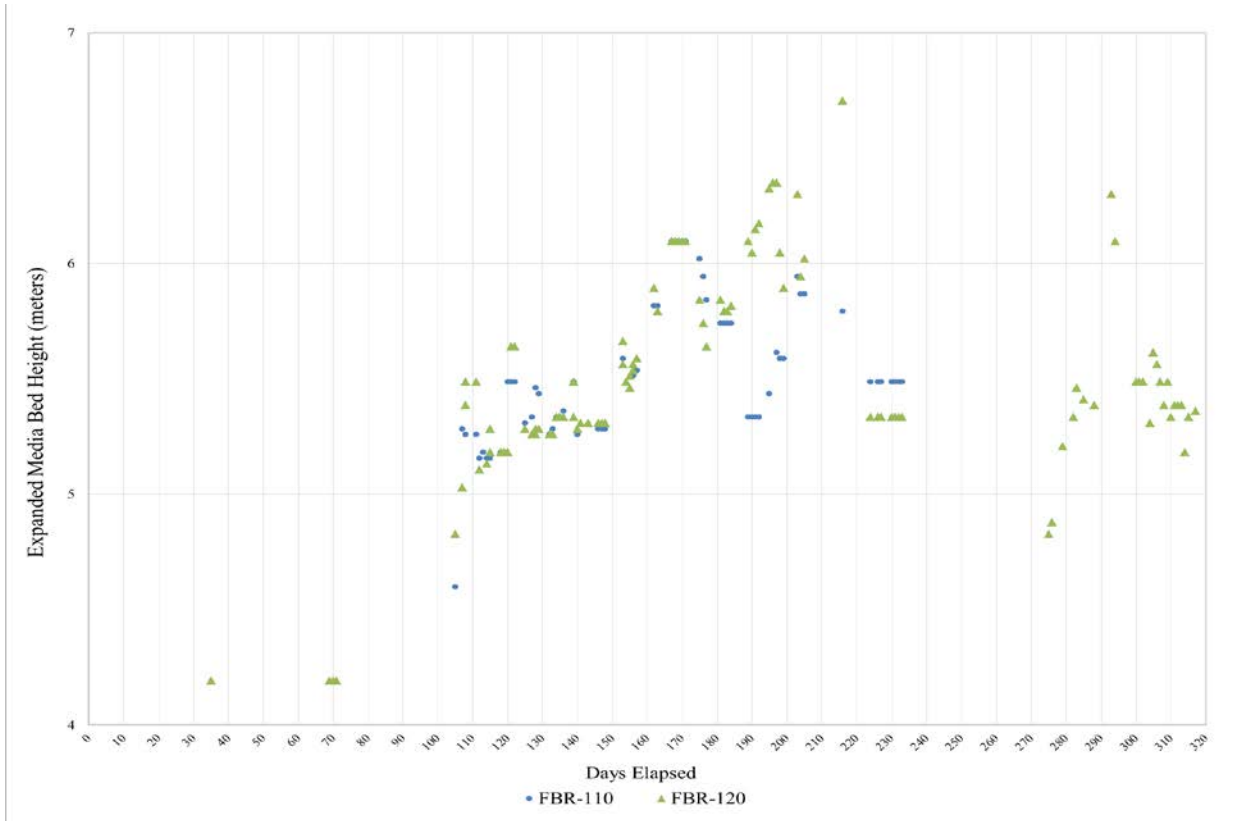

Figure 5.21 Expanded Media Bed Heights for the FBRs.

Table 5.5 Average, Minimum and Maximum Values for Potable Water Analyses from the Clear Well.

| Analyte | Average | Minimum | Maximum | MCL (≤) | Units |
|---|---------|-----------|-----------|----------|--------------|
| 1,1,1-Trichloroethane | n/a | < 0.00039 | < 0.00100 | 0.2 | mg/L |
| 1,1,2,2-Tetrachloroethane | n/a | < 0.00034 | < 0.00100 | 0.201 | mg/L |
| 1,1,2-Trichloroethane | n/a | < 0.00029 | < 0.00100 | 0.005 | mg/L |
| 1,1-Dichloroethane | n/a | < 0.00032 | < 0.00100 | 0.005 | mg/L |
| 1,1-Dichloroethylene | n/a | < 0.00034 | < 0.00100 | 0.006 | mg/L |
| 1,2,4-Trichlorobenzene | n/a | < 0.00031 | < 0.00100 | 0.005 | mg/L |
| 1,2-Dibromo-3-chloropropane / DBCP | n/a | < 0.00035 | < 0.00035 | 0.0002 | mg/L |
| 1,2-Dichlorobenzene | n/a | < 0.00033 | < 0.00100 | 0.6 | mg/L |
| 1,2-Dichloroethane | n/a | < 0.00028 | < 0.00100 | 0.0005 | mg/L |
| 1,2-Dichloropropane | n/a | < 0.00028 | < 0.00100 | 0.005 | mg/L |
| 1,3-Dichloropropene | n/a | < 0.00051 | < 0.00051 | 0.0005 | mg/L |
| 1,4-Dichlorobenzene | n/a | < 0.00037 | < 0.00100 | 0.005 | mg/L |
| Alkalinity (total, as CaCO ₃) | 160.48 | 120 | 180 | n/a | mg/L |
| Barium (total) | 0.02 | 0.019 | < 0.1 | 1 | mg/L |
| Benzene | n/a | < 0.00030 | < 0.00100 | 0.001 | mg/L |
| Cadmium (total) | n/a | < 0.0010 | < 0.0010 | 0.005 | mg/L |
| Carbon tetrachloride | n/a | < 0.00032 | < 0.00100 | 0.0005 | mg/L |
| Chloride, Secondary MCL | 7.67 | 5.8 | 11 | 250 | mg/L |
| Chromium (total) | n/a | < 0.01 | < 0.01 | 0.05 | mg/L |
| cis-1,2-Dichloroethylene | n/a | < 0.00036 | < 0.00100 | 0.006 | mg/L |
| Conductivity, Secondary MCL | 347.14 | 290 | 390 | 900 | micromhos/cm |
| Dichloromethane | 0.01 | < 0.00034 | 0.015 | 0.005 | mg/L |
| Ethylbenzene | n/a | < 0.00043 | < 0.00100 | 0.3 | mg/L |
| Ethylene dibromide / EDB | n/a | < 0.00030 | < 0.00030 | 0.00005 | mg/L |
| Haloacetic acids 5 / HAA5 | 0.02 | < 0.0010 | 0.0195 | 0.06 | mg/L |
| Iron (total), Secondary MCL | 0.03 | 0.029 | < 0.1 | 0.3 | mg/L |
| Manganese (total), Secondary MCL | 0.01 | 0.0064 | < 0.02 | 0.05 | mg/L |
| Mercury (total) | n/a | < 0.0010 | < 0.0010 | 0.002 | mg/L |
| Methyl tert-butyl ether / MTBE, Secondary MCL | n/a | < 0.00025 | < 0.00300 | 0.005 | mg/L |
| Monochlorobenzene | n/a | < 0.00046 | < 0.00100 | 0.07 | mg/L |
| Nickel (total) | n/a | < 0.01 | < 0.01 | 0.1 | mg/L |
| Nitrate (as N) | 0.59 | 0.24 | 0.96 | 10 | mg/L |
| Nitrite (as N) | n/a | < 0.4 | < 0.4 | 1 | mg/L |
| Perchlorate | 0.03 | 0.00083 | 0.14 | 0.04 | mg/L |
| Styrene | n/a | < 0.00035 | < 0.00100 | 0.1 | mg/L |
| Sulfate, Secondary MCL | 14.77 | 9.3 | 23 | 250 | mg/L |
| Tetrachloroethylene / PCE | n/a | < 0.00050 | < 0.00100 | 0.005 | mg/L |
| Toluene | n/a | < 0.00045 | < 0.00100 | 0.15 | mg/L |
| Total Coliforms (MPN / PA) | 18.44 | A | 200 | 1,000, P | MPN/100mL |
| Total Dissolved Solids / TDS, Secondary MCL | 212.62 | 170 | 280 | 500 | mg/L |
| Total Trihalomethanes / TTHM | n/a | < 0.0010 | < 0.0010 | 0.08 | mg/L |
| trans-1,2-Dichloroethylene | n/a | < 0.00032 | < 0.00100 | 0.01 | mg/L |
| Trichloroethylene / TCE | n/a | < 0.00035 | < 0.00100 | 0.005 | mg/L |
| Trichlorofluoromethane | n/a | < 0.00043 | < 0.00100 | 0.15 | mg/L |
| Vinyl chloride | n/a | < 0.00033 | < 0.00100 | 0.0005 | mg/L |
| Xylenes (total) | n/a | < 0.00032 | < 0.00032 | 1.75 | mg/L |
| Zinc (total), Secondary MCL | n/a | < 0.05 | < 0.05 | 5 | mg/L |

n/a indicates that the values were always below detection, so no average could be calculated.

Table 5.6 Average, Minimum and Maximum Values for Disinfection by-Products for Potable Water Analyses from the FBRs.

| FBR -110 Effluent | Average | Minimum | Maximum | MCL (≤) | Units |
|---|----------------|----------------|----------------|----------------|--------------|
| Bromodichloromethane (max potential) | 11.2 | 11.2 | 11.2 | | µg/L |
| Bromoform (max potential) | n/a | < 4.0 | < 4.0 | | µg/L |
| Chloroform (max potential) | 17.6 | 17.6 | 17.6 | | µg/L |
| Dibromoacetic acid (Formation Potential) | n/a | < 1.0 | < 1.0 | | µg/L |
| Dibromochloromethane (max potential) | 5.6 | 5.6 | 5.6 | | µg/L |
| Haloacetic acids 5 / HAA5 (Formation Potential) | 6.5 | 6.5 | 6.5 | 60 | µg/L |
| Monobromoacetic acid (Formation Potential) | n/a | < 1.0 | < 1.0 | | µg/L |
| Monochloroacetic acid (Formation Potential) | n/a | < 2.0 | < 2.0 | | µg/L |
| Total Trihalomethanes / TTHM (max potential) | 34.4 | 34.4 | 34.4 | 80 | µg/L |
| Trichloroacetic acid (Formation Potential) | 1.3 | 1.3 | 1.3 | | µg/L |
| | | | | | |
| FBR-120 Effluent | Average | Minimum | Maximum | MCL (≤) | Units |
| Bromodichloromethane (max potential) | 13.2 | 13.2 | 13.2 | | µg/L |
| Bromoform (max potential) | n/a | < 4.0 | < 4.0 | | µg/L |
| Chloroform (max potential) | 20.4 | 20.4 | 20.4 | | µg/L |
| Dibromoacetic acid (Formation Potential) | n/a | < 1.0 | < 1.0 | | µg/L |
| Dibromochloromethane (max potential) | 7.2 | 7.2 | 7.2 | | µg/L |
| Dichloroacetic acid (Formation Potential) | 5.9 | 5.9 | 5.9 | | µg/L |
| Haloacetic acids 5 / HAA5 (Formation Potential) | 7.5 | 7.5 | 7.5 | 60 | µg/L |
| Monobromoacetic acid (Formation Potential) | n/a | < 1.0 | < 1.0 | | µg/L |
| Monochloroacetic acid (Formation Potential) | n/a | < 2.0 | < 2.0 | | µg/L |
| Total Trihalomethanes / TTHM (max potential) | 40.8 | 40.8 | 40.8 | 80 | µg/L |
| Trichloroacetic acid (Formation Potential) | 1.6 | 1.6 | 1.6 | | µg/L |

n/a indicates that the values were always below detection, so no average could be calculated.

6.0 PERFORMANCE ASSESSMENT

The Groundwater Treatment Plant is a full-scale system that was designed, fabricated, constructed and installed to be fully functional and operational to produce potable water from a compromised water supply source. The sole objective was to build this initial plant and make it operational so that the Division of Drinking Water would permit the system as a full potable water production facility. Hence, the primary quantitative objective as described in Section 3.0 and Table 3.1 was to meet the regulatory requirements of potable water production.

Throughout acclimation and steady-state operation, the FBRs have proven to be reliable, resilient, and effective in eliminating nitrate and perchlorate from the feed groundwater. The downstream equipment, utilized to remove solids and disinfect the FBR effluent so that it was suitable as potable water, also shown to be successful in meeting all drinking water regulatory requirements. Figures 5.11-5.12 and Tables 5.4-5.5 show these results over time while the plant proceeded from start-up through steady-state operation.

The FBR was naturally inoculated with only the incoming contaminated groundwater. No outside inoculum was provided to the FBR system. Originally, after operating the system in FBR recycle and then plant recycle, the effluent of the system was discharged through a temporary ion exchange system to a natural basin until the biomass growth occurred and full treatment was demonstrated. Counting the day that well water was loaded into the FBRs as Day 1, it took just 33 days for the FBRs to acclimate (that is, grow a substantial microbial community capable of fully treating the well water). This achievement of acclimation allowed for the start of continuous feed to both FBRs with near-complete treatment of perchlorate. Due to a number of mechanical and process adjustments to both FBRs, as well as the downstream equipment, feed water was often intermittently added to the system (interruptions were frequent during the first 90 days of operation). Therefore, it took until Day 99 for the FBRs to completely acclimate so that discharge could be sent directly to the basin without ion exchange treatment. The FBRs were fully capable of complete elimination of perchlorate from this time forward.

Success of the natural inoculation process within the FBRs was indicated by:

- non-detect nitrate and perchlorate values in the FBR effluent water (Figures 5.11-12)
- reduction of dissolved organic carbon post the FBRs (Figure 5.13)
- visual observation of microbial growth within the FBR and microbial expansion of the FBR bed (Figure 5.14) from the settled bed height of 3.15 meters (10.33 feet), hydraulically expanded bed height of 4.0 meters (13.25 feet), and a desired hydraulic/biological expanded bed height of 5.26 meters (17.25 feet).

Once basin discharge began (i.e. once the ion exchange polishing units were no longer required but before permitting of the plant for drinking water production), there was not a single occurrence of discharge of effluent exceeding the California MCL for perchlorate (Figure 5.11).

It should be noted that the perchlorate and nitrate-nitrogen concentrations over the first 250 days steadily decreased from approximately 450 µg/L to 150 µg/L and 5 mg/L to 3.5 mg/L, respectively. This decline is indicative of the lack of operation of these groundwater wells for an extended period of time combined with the drought conditions that the State of California was experiencing over a four-year period. As rain events increase in the area, the levels of these oxyanions is expected to increase as salts in the vadose zone are dissolved during aquifer recharge. Per the pilot study findings (Webster and Togna, 2009), the FBRs will be capable of treating higher concentrations of perchlorate and nitrate when these increases occur.

7.0 COST ASSESSMENT

The Groundwater Treatment Plant was designed, fabricated, constructed, installed, permitted, and made operational over a seven-year period (2009-2016). The overall capital and operating costs are presented, with assumptions provided as necessary. A comparison of costs to IX technology is also provided.

7.1 BACKGROUND

There were a number of areas that impacted cost of the overall Groundwater Treatment Plant that were unique to this project. These areas included:

- First-ever implemented treatment process for potable water production
- Unique site location that required extensive design and construction detail
- Designed with infrastructure to handle larger flows and loads for future expansion
- Extensive design and permitting considerations as the source water was deemed a Significantly Impaired Water Resource by the DDW

7.1.1 New Technology

Being a new type of treatment plant, extensive requirements were placed on the design and infrastructure. This included extensive primary and secondary instrumentation, equipment, and controls to ensure that all operational possibilities were considered and safeguards implemented. With all of these additional requirements, costs were proportionately higher than would be required for the next similar plant designed, installed, and operated. Some examples of these features/requirements included:

- Dual fluidization pumps
- Dual aeration tanks
- Dual blowers
- Single pass clarifier/multimedia filters (versus continuous backwashing media filters)
- DAF with sludge holding tanks
- Chlorine contact chamber size requirement (versus UV and chlorination combined)
- Contingent systems for pH control
- Back up all pumps utilized for chemical addition systems
- Sulfide analyzers for the effluent of the FBRs
- TOC analyzers for the effluent of FBRs and plant
- Controls associated with all of the above

7.1.2 Unique Location

After detailed consideration, understanding the uniqueness of this treatment plant, it was decided by all involved parties to locate the facility on the grounds of the West Valley Water District property. This detailed consideration included accessibility, proximity to neighborhoods, potential traffic issues, and current available infrastructure. The WVWD property had challenges, as the available site location for construction was positioned on an area which had been used prior in a landfill capacity. Hence, considerable design and costing was required to develop the site so as to be suitable for locating the plant that would not typically be associated with siting this or any treatment system. Still, it is difficult to separate out all of these costs associated with this unique site location, as there is overlap in the design regardless of the site location. Hence, all costs for the Groundwater Treatment Plant are provided in the costing evaluation with the caveat that significant portions of this costing element could have been reduced had a different site location been implemented. The ensuing sections discuss some of these considerations and potential cost reductions.

7.1.3 Designed for Expansion

The Groundwater Treatment Plant was designed with the necessary infrastructure capable of treating up to 4000 gpm. All piping, tanks, valves, and related infrastructure were sized accordingly, but the actual treatment equipment installed was designed to only treat 2000 gpm. This potential additional 2000 gpm capacity was designed into the plant infrastructure as WVWD and the City of Rialto desired the ability to expand the plant in the future if necessary. Hence, costs provided in this analysis take into consideration this potential expansion.

7.1.4 Permitting Considerations

In the State of California, an additional safeguard for utilizing the best source of available water for any drinking water plant has been established under the DPH Memorandum 97-005 Policy Guidance for Direct Domestic Use of Extremely Impaired Sources (DPH is now considered the DDW under the State Water Resources Control Board). For the Rialto-Colton Basin, where multiple contaminants potentially exist (i.e., nitrate, perchlorate, TCE, etc.), this permitting policy was required as the groundwater met one or more of the following criteria:

- Exceeds 10 times an MCL or notification level (NL) based on chronic health effects
- Exceeds 3 times an MCL or NL based on acute health effects
- Is extremely threatened with contamination due to proximity to known contaminating activities
- Contains a mixture of contaminants of health concern
- Is designed to intercept known contaminants of health concern

Other states may have comparable policies. The DPH 97-005 policy defines a 12 step procedure that was required before a domestic water supply permit for the plant was issued:

- Source water assessment performed
- Raw water quality characterization performed

- Source protection program developed
- Effective monitoring and treatment developed
- Develop health risks with proposed treatment failure
- Alternative source identification and comparison of potential health risks
- Completion of California Environmental Quality Act review
- Permit application completion
- Public hearing
- DPH evaluation
- DPH approval requirement
- Issuance or denial of permit

The permit requirements as defined above for such a plant were extensive due to the nature of the feed water as a substantially impaired resource. Hence, ample consideration in the design requirements was necessary to ensure that the special required permitting would eventually be granted by the DDW. This level of permitting would be required regardless if this was a new or a traditional treatment approach. Still, costs were higher in terms of resources required due to this special permitting requirement. However, due to the fact that every site has some level of unique permitting requirements, these costs were included in the overall analysis.

7.2 GROUNDWATER TREATMENT PLANT CAPITAL COSTS

The Groundwater Treatment Plant total costs for design, fabrication, construction, and installation are provided in Table 7.1 (rounded to nearest thousand dollars).

Table 7.1 Total Costs for Groundwater Treatment Plant Design, Fabrication, Construction and Installation.

| Activity/Phase | Project Cost |
|--------------------------------------|--------------|
| Preliminary Design/Grant Application | \$2,119,000 |
| Project Management | \$553,000 |
| NCP Compliance | \$381,000 |
| DDW 97-005 Permit | \$406,000 |
| Gas Tank(s) Relocation | \$65,000 |
| Treatment Plant/Site Work | \$16,433,000 |
| Pipeline/Site Work | \$1,056,000 |
| Well-Modification/SCADA | \$1,283,000 |
| Monitoring Wells | \$750,000 |
| Total | \$23,046,000 |

The majority of the costs were allocated to (a) the design and funding application development that occurred through design engineers and consultants and (b) the treatment plant equipment and site work. With exception to these two areas, the other costs associated with the project were required irrespective of the technology chosen. Significant consulting work was needed to bring in the necessary funding resources for the project from a variety of state and regional resources. Although, it should be recognized that some of these costs would be necessary for any treatment approach chosen.

Approximately 71% of the costs were allocated through the Treatment Plant/Site Work. Table 7.2 provides a breakout of these costs, with the plant construction being the largest percentage contributor. The Owner Furnished Equipment constituted the costs for the system components, while engineering for many of these component pieces was built into the Preliminary Design cost. A request for proposals was developed for the plant construction and released for competitive bid by a number of general contractors. Ultimately, the concepts mentioned previously of the unique site location and overdesign of the system to eventually handle larger loads drove the costs of the plant construction to a higher level.

Table 7.2 Total Costs for Treatment Plant and Associated Site Work.

| Treatment Plant/Site Work | Cost |
|----------------------------------|--------------|
| Plant Construction | \$11,250,000 |
| Below Grade Piping | \$235,000 |
| Grading-Site Work | \$85,000 |
| Subcontractors | \$130,000 |
| Owner Furnished Equipment | \$2,052,000 |
| Construction Management | \$870,000 |
| Consultants | \$1,048,000 |
| Miscellaneous | \$763,000 |
| Total | \$16,433,000 |

7.3 GROUNDWATER TREATMENT PLANT OPERATIONAL COSTS

Operation of the Groundwater Treatment Plant officially began in October, 2016, after receiving an operational permit by the DDW in May, 2016. Based on the operation of the facility since October, the operating costs are provided in Table 7.3.

Table 7.3 Total Operating Cost from October 2016 through February 2017.

| Operating Services/Supplies | Oct, 16 | Nov, 16 | Dec, 16 | Total Qtr 1 | Jan, 17 | Feb, 17 | Total Qtr 2 | Total to Date |
|---|------------------|------------------|-------------------|--------------------|------------------|-------------------|--------------------|----------------------|
| Professional Services/Consultants | \$ 3,491 | \$ 446 | \$ 4,840 | \$ 8,777 | \$ 10,119 | \$ 325 | \$ 10,444 | \$ 19,221 |
| Professional Services/Alarm | \$ 384 | \$ 128 | \$ 128 | \$ 640 | \$ 128 | \$ 136 | \$ 264 | \$ 904 |
| Utility Services/Electrical | \$ 32,975 | \$ 27,334 | \$ 16,280 | \$ 76,589 | \$ 34,845 | \$ 23,944 | \$ 58,789 | \$ 135,379 |
| Professional Services/Janitorial | | \$ 75 | | \$ 75 | \$ 1,054 | | \$ 1,054 | \$ 1,130 |
| Other Misc./District Costs | \$ 3,094 | \$ 62 | \$ 1,527 | \$ 4,683 | \$ 7,273 | \$ 6,506 | \$ 13,779 | \$ 18,461 |
| Professional Services/Lab Tests | \$ 2,570 | \$ 4,268 | \$ 3,273 | \$ 10,110 | \$ 3,329 | \$ 4,840 | \$ 8,169 | \$ 18,279 |
| Professional Services/Sludge Disposal | | | \$ 1,476 | \$ 1,476 | \$ 2,214 | \$ 1,476 | \$ 3,690 | \$ 5,166 |
| Operating Supplies/Chemicals | \$ 27,283 | \$ 22,058 | \$ 37,880 | \$ 87,220 | \$ 3,535 | \$ 25,804 | \$ 29,340 | \$ 116,560 |
| Repair & Maintenance/Structures/Facility | \$ 4,389 | \$ 3,464 | \$ 1,880 | \$ 9,734 | \$ 3,009 | \$ 9,887 | \$ 12,897 | \$ 22,631 |
| Misc./Permits & Fees | | | \$ 11,877 | \$ 11,877 | | \$ 11,622 | \$ 11,622 | \$ 23,499 |
| Operating Services/Supplies Subtotal | \$ 74,186 | \$ 57,835 | \$ 79,160 | \$ 211,181 | \$ 65,507 | \$ 84,541 | \$ 150,048 | \$ 361,229 |
| Labor | \$ 25,012 | \$ 21,371 | \$ 23,841 | \$ 70,225 | \$ 24,517 | \$ 21,622 | \$ 46,139 | \$ 116,364 |
| Grand Total | \$ 99,198 | \$ 79,206 | \$ 103,002 | \$ 281,406 | \$ 90,024 | \$ 106,163 | \$ 196,187 | \$ 477,593 |

Typically, the first year of operation of any plant results in higher operating costs as initial plant issues are addressed, and familiarity with the operation occurs by staff. Since the plant has been only operating for approximately six months, the costs are expected to be higher than might be seen for ensuing years. Still, based on the review of the operating costs, three areas in particular dominate the overall cost of operation. These cost areas are in the electricity, the chemical, and the labor usage. These overall costs are detailed further.

7.3.1 Electricity Usage

The electrical usage is based on the usage for the entire plant, including the extraction wells and associated pumping. Also, the cost for electricity is significantly higher in California, and depends on location within the State. For West Valley Water District, an average electrical rate of \$0.12/kwh was utilized to calculate the costs. This is a California rate, local to the area. Other areas of the state or country will differ significantly on for both peak and average rates.

7.3.2 Chemical Usage

The major driver of the chemical usage is the concentration levels of oxygen, nitrate, and perchlorate in the feed stream. The use of electron donor (e.g., acetic acid) is a direct function of these three chemical components. Specifically for drinking water applications like this one at WVWD, the concentrations of oxygen and nitrate drive the electron donor usage more than the concentration of perchlorate. Assuming stoichiometric treatment of the nitrate, oxygen, and perchlorate, three times as much acetic acid is required to treat a known concentration of nitrate compared to a known concentration of oxygen. In comparison with perchlorate treatment, five times as much acetic acid is required to treat a known concentration of nitrate. These differences in electron donor requirements result in larger increases in operating costs as the nitrate concentrations increase compared with the oxygen and perchlorate concentrations. Accordingly, changes in oxygen concentration affect operating cost more than perchlorate concentration as the oxygen increases up to the water solubility limit (approximately 9 mg/L). Since the amount of electron donor required for a typical drinking water application constitutes a significant portion of the overall operating costs, changes in electron donor demand based on chemical water composition will affect the overall operating cost budget.

Chemical usage provided includes all chemicals to effectively operate the Groundwater Treatment Plant. These chemicals included NSF 60 approved acetic acid, phosphoric acid, sodium hypochlorite, coagulant (aluminum chlorohydrate), and polymer. The acetic acid is the largest contributor to chemical usage, with 144 gallons/day of 50% acetic acid being used. With no other potable water production bioreactors using electron donors, the NSF 60 approved acetic acid was the only suitable option for this particular system. As the technology continues to mature and subsequent units are built, other electron donors will become NSF 60 compliant and possibly available at a lower cost.

7.3.3 Labor Usage

The labor for the facility included three operators working swing shifts over a 9-hour day, seven days a week. These three operators allocated their time between the new Groundwater Treatment Plant and an existing second, off-site surface water treatment plant. Presumably, as familiarity with the new plant improves and operational issues are minimized, less operator attention will be required. It is surmised that for future years, less attention might be required for a 9-hour shift to operate and maintain the facility.

7.4 COST COMPARISON WITH ION EXCHANGE

The Groundwater Treatment Plant was designed to biologically treat the conditions observed today that are provided in Table 5.1. However, prior investigations of the Rialto-Colton Basin have shown that as the contaminated plumes migrate, the potential exists for increasing oxyanion concentrations over the next few decades (Geosyntec Consultants, 2007). Hence, for this situation where increases in oxyanion concentrations could occur, additional treatment capacity is available in the two FBRs to treat higher concentrations up to 1 mg/L perchlorate. As the comparison is made between the Groundwater Treatment Plant using biological treatment versus single pass ion exchange, this long-term treatment vision must be considered.

For the technology comparison, the assumptions are:

- A 2000 gpm plant that is designed and constructed with 4000 gpm infrastructure
- Well 6 ClO₄ concentration = 230 ug/L today, 1 mg/L future
- Well 6 NO₃-N concentration = 4.5 mg/L today/future
- Well 6 Chloride, SO₄ and HCO₃ concentrations at 6.4 mg/L, 13 mg/L, and 183 mg/L, respectively.
- ClO₄ detectable level at 0.75 ug/L
- FBR operational costs assumed at \$85,000 per month (assumes monthly costs to reduce slightly over time as familiarity develops with plant operation)
- Perchlorate selective resin priced at \$370/ft³ for resin removal and replacement
- Transportation and disposal of spent resin at \$30/ft³
- IX operational costs with labor, electricity, repair, and supplies estimated at \$40,000/month

An attempt has been made to normalize the data in Tables 7.1-7.3 such that capital items required for both the biological and ion exchange processes could be compared. From a capital cost perspective, Table 7.4 demonstrates that the capital costs are higher by approximately 1.9X for a biological treatment plant than an ion exchange treatment plant. This difference in pricing is largely due to the necessary additional equipment on the backend of the biological system that is not required for the IX.

The operating costs for the IX are presented in Table 7.5 and are provided for two conditions of both lower and higher concentrations of perchlorate. Computer models were utilized to estimate when breakthrough of the lead bed of a lead-lag bed system would occur. Breakthrough occurs when the lead bed demonstrates 0.75 µg/L of perchlorate. WVWD operates their other ion exchange units in this manner, so this operating requirement was utilized for this comparison. For the biological process, the increase in oxyanions has minimal effect in terms of electricity, electron donor, or labor usage. Hence, the \$85,000/month assumed operating costs are applicable for either condition and used in the comparison.

Table 7.4 Capital Cost Comparison.

| Treatment Plant/Site Work | Biological System | IX System |
|---------------------------------|-------------------|-------------|
| Plant Construction ¹ | \$5,000,000 | \$2,300,000 |
| Below Grade Piping | \$235,000 | \$50,000 |
| Grading-Site Work | \$85,000 | \$50,000 |
| Subcontractors | \$130,000 | \$100,000 |
| Owner Furnished Equipment | \$2,052,000 | \$1,500,000 |
| Construction Management | \$870,000 | \$500,000 |
| Consultants | \$1,048,000 | \$500,000 |
| Miscellaneous | \$763,000 | \$300,000 |
| Total | \$10,183,000 | \$5,300,000 |

¹Cost normalized to remove aspects associated with specific site (i.e., built on a landfill)

Table 7.5 Ion Exchange Operating Costs.

| Operating Costs | Condition 1 ¹ | Condition 2 ² |
|-------------------------------------|--------------------------|--------------------------|
| Monthly Operating Cost ³ | \$40,000 | \$40,000 |
| Monthly Resin Replacement | \$40,000 ⁴ | \$111,000 ⁵ |
| Monthly Resin Disposal | \$3,000 | \$9,000 |
| Monthly Miscellaneous | \$5,000 | \$5,000 |
| Monthly Total Cost | \$88,000 | \$165,000 |

1 Condition 1 is Nitrate-N at 4.5 mg/L, Perchlorate 230 µg/L

2 Condition 2 is Nitrate-N at 4.5 mg/L, Perchlorate 1 mg/L

3 Includes labor, electricity, repairs, and supplies

4 Model prediction indicates bed volume change out at 110,000 BVs

5 Model prediction indicates bed volume change out at 40,000 BVs

Based on the data in Table 7.5, the monthly operating costs for Condition 1 are similar between the biological and ion exchange systems. Hence, no payback of the additional capital costs for the biological plant can be expected if the oxyanion concentrations remain at today's levels. However, it should be noted that the risks associated with the cradle-to-grave aspect of the resin disposal have not been quantified and incorporated into the IX operating costs.

As the oxyanion concentrations increase in Condition 2, without considering the cost of money, the data indicates that a 5-year payback for the FBR capital cost is achievable. If the perchlorate concentrations only increase to half these levels or nitrate concentrations increase by 1-2 mg/L, then a 10-yr payback is achievable. Since this treatment plant is anticipated to operate for at least a few decades as it cleans up the basin aquifer, the long-term cost-effectiveness of the Groundwater Treatment Plant can be realized.

7.5 COSTING COMMENTS AND CONCLUSIONS

The Groundwater Treatment Plant was developed to produce potable water such that over the long course of remediating the local groundwater basin, a valuable resource could be cleaned and utilized by the public. Capital costs were higher for a number of reasons previously described. Operating cost data is very limited and reflects an initial six-month period of operation while certain operating and maintenance requirements are evaluated, with associated costs mitigated.

A biological perchlorate treatment plant can be more cost-effective than competing traditional technologies such as ion exchange as oxyanion concentrations increase. For the Rialto-Colton basin, pockets of increased levels of perchlorate and nitrate have been observed that ultimately might one day feed the Groundwater Treatment Plant. For such increases in load, minimal increase in addition of electron donor is required. Hence, whether treating 230 µg/L or 1 mg/L of perchlorate, the effective operating costs will essentially not increase. Under similar increasing concentrations, traditional technologies such as single-pass ion exchange will see more rapid utilization of media and ultimately require more frequent, extensive bed changeouts.

In implementing such a biological plant in other areas of the country, factors such as permitting requirements and costs for land to site the project, as well as costs for utilities and labor, will all be highly dependent on geographic location. Hence, comparative review of the costing with other locales of this new technology application in an area with a significantly impaired resource must be considered and acknowledged. With the lessons learned presented in Section 8.0 of this report, along with an increasing familiarity of biological treatment approaches by the regulatory community for potable water production, both capital and operating costs for future systems can only be expected to be reduced.

8.0 IMPLEMENTATION ISSUES

For this full-scale plant, the implementation of the FBR treatment system to treat contaminated groundwater to drinking water has been shown to be technically possible and effective. Numerous implementation issues were required to be addressed as they pertained to regulations and end user concerns, ultimately leading to a number of lessons learned in designing and building this first biological plant for nitrate and perchlorate treatment.

8.1 REGULATIONS

For all drinking water systems installed in the United States, the Environmental Protection Agency has established regulations under the United States Safe Drinking Water Act that must be complied. Under the National Primary Drinking Water Regulations (40 CFR part 141), these regulations include, but are not limited to:

- Surface Water Treatment Rule
- Interim, Long Term 1, and 2 Enhanced Surface Water Treatment Rules
- Stage 1 and 2 Disinfection By-Product Rule
- Total Coliform Rule
- Groundwater Rule
- Lead and Copper Rule

All new, modified, and/or existing drinking water production plants are required to comply with these regulations. Under certain circumstances, statewide regulatory agencies are provided primacy to implement these regulations. In the event that regulations do not exist for a particular contaminant or a state determines that a more restrictive regulation is required, such authority to develop new or more stringent regulations is provided to each individual state by the federal government. The DDW serves as the primacy agent within the State of California. In some cases, compared to the federal limits, the State of California has more stringent primary and secondary MCLs established under the Title 22 California Code of Regulations. Hence, any implementation of a drinking water production plant in the State of California requires that all Title 22 regulations are met.

In implementing this full-scale Groundwater Treatment Plant in the Rialto-Colton basin, after a lengthy detailed permit application process due to the significantly impaired resource issue, the DDW issued an amendment to the domestic water supply permit (Permit Amendment NO. 05-13-16PA-10) for the West Valley Water District System No. 3610004. In addition to meeting all of the regulatory requirements of Title 22, as well as other California Health and Safety Code regulations, the DDW also imposed a number of additional permit conditions on the FBR treatment technology as a means to produce potable drinking water. In brief, these included:

- The use of NSF 60 and 61 approved additives.
- The implementation of perchlorate, nitrate, TOC, and hydrogen sulfide analyzers for monitoring and feedback control of the plant.

- Use of non-pathogenic seed inoculum, unless using an indigenous inoculum from the groundwater (this was the case for this plant).
- The need for certified operators that meet Grade T4 as the Chief Operator and Grade T3 as the Shift Operator.
- Phosphate-phosphorus limits in the effluent to be maintained between 0.5-1.0 mg/L.
- The maximum flowrate for this specific plant operation shall not exceed 2000 gpm.

It is possible that some of these requirements might be removed or modified after an extended period of operation of the plant and demonstration of the system robustness. If this occurs, future plants in the State of California, as well as in other States, might be less restricted in their initial permit requirements.

8.2 END USER CONCERNS

The primary end-users of this technology are municipalities that provide drinking water to its constituents. Additional stakeholders with interest in this plant operation include the California Division of Drinking Water, the Environmental Protection Agency, and the Department of Defense. The general concerns for all of the end users include: (1) technology performance; (2) technology cost; (3) ease of operation; (4) technology robustness; and the (5) effluent water quality. These issues were effectively addressed and demonstrated in prior studies (Webster et. al, 2009; Webster and Togna, 2009).

Considerable process development has been implemented to ensure that the FBR treatment plant supplies a consistent supply of potable water. Using only NSF-60 compliant additives, self-inoculation with a non-pathogenic microbial source, constant on-line instrumentation to ensure contaminant removal, and a sophisticated model to adequately monitor and respond to process changes/requirements, the FBR treatment system is proven to be a robust, dependable treatment technology for perchlorate treatment. The use of biological reactors in the United States is a novel concept in potable-water production, but not completely without precedent (Evans, 2010). With recent developments of indirect potable water reuse occurring throughout the United States, the concept of biological treatment at wastewater treatment plants to eventually produce potable water is gaining continual acceptance (Athavaley, 2008).

The FBR treatment system technology is a custom built system and is not considered a commercially-off-the-shelf technology. However, numerous systems of varying comparable size have been previously built and installed elsewhere treating more than 11 million gallons of perchlorate contaminated water to non-detect every day. Specific components of the FBR described in this report are considered proprietary or are patented by Envirogen Technologies, Inc. These components include the FBR vessel distribution headers, the biomass removal system, the on-line water sampling system used in conjunction with the perchlorate analyzer, and the control logic for the electron donor addition by the PLC. Other system components of the overall FBR treatment system (e.g., SIEMENS Trimite multimedia System) are considered proprietary or patented by others.

The implementation of such a technology to treat contaminated groundwater, rather than simply rely on phase transfer, to drinking water standards serves as a new paradigm of water treatment for significantly impaired resources. The DDW has taken great strides over the past 15 years to fully understand the efficacy of the technology, and has implemented numerous safeguards in the permitting process to ensure that the usage of such a treatment approach occurs while protecting and safeguarding the public. With quality supplies of water rapidly declining throughout the United States and existing supplies often hindered by multiple contaminants, the implementation of such a biological treatment plant has been effectively used for multiple contaminant removal to drinking water standards.

8.3 LESSONS LEARNED

Over the duration of the full-scale Groundwater Treatment Plant design, fabrication, construction, installation, and operation, the seven-year process resulted in a number of lessons learned. Many of these lessons learned have been addressed in detail throughout prior sections of the report.

In summary, the design/equipment/operation lessons include:

- Groundwater hydrology is essential to characterize and understand the potential for changing conditions for the particular well that water is being extracted. The City of Rialto Well #6 was characterized numerous times prior. However, the pump had not been fully operated for extended periods for years. High dissolved gas concentrations were observed from the source wells after prolonged operation, resulting in increasing load of electron acceptor (e.g., oxygen) to the FBR systems, as well as causing entrapment of bed media creating carryover conditions. A feed equalization tank was installed to allow the pressurized gas in the feed water to be released to atmosphere. This resulted in the decrease of dissolved oxygen load on the FBRs and minimized the entrained gas bubbles.
- Dissolved sulfide meters were installed at the FBR effluent lines. However, the operation and efficacy of such meters was limited. The meters were somewhat ineffective on occasion with the set-up due to accumulation of biomass within the metering system, resulting in inaccurate dissolved sulfide measurements. Hydrogen sulfide monitoring is effective as a complimentary analytical tool for the other plant instrumentation, but is not sufficient as a stand-alone indicator of perchlorate treatment effectiveness. In numerous cases, concentrations of hydrogen sulfide often decreased below the detection limit of the instrument while complete perchlorate treatment still occurred.
- Biomass separation systems were implemented and operated to control the biomass growth in the FBRs. Operating the biomass separation systems intermittently (such as periodic usage of the biomass separator pumps at full strength) caused surges of total suspended solids (TSS) loading at the effluent of the FBR, resulting in the significant decrease of the flush and backwash frequencies of the downstream filtration system. More continuous operation is the recommended standard operating procedure.
- Bed height control should be carefully monitored. Potentially, up to four biomass separators per FBR could be required. If only two biomass separators are utilized, a single diaphragm pump mounted on the top of each FBR can be employed for refined bed height control.

- In-bed biomass control assemblies require higher flows and pressures in order to significantly reduce fluidized media bed height. Current operating pressures at the plant only approached 30 psi. In general, FBR fluidized bed heights respond only to higher pressures provided for in-bed biomass separation. Hence, in such cases, a booster pump is warranted to provide the pressure and flow.
- The vents of the aeration vessels were connected to a vapor phase granular activated carbon (GAC) system to treat any volatile organic compounds that could be stripped from the water by the aeration. The accumulated moisture in the GAC system created a gradually increasing back pressure inside the aeration vessels. The back pressure modified the liquid levels in the FBRs. A de-misting system (a drum with plastic media) was added prior to the GAC system to remove the moisture from the air exiting the aeration vessels.
- The addition of turbidity meter prior to the influent to the filtration system (downstream of the aeration vessels) was found to be warranted. The turbidity meter acted as a safeguard by monitoring the TSS loading rate to the filters, thus preventing an overloading condition to the filtration system.
- As another safeguard, the “percentage open” capabilities of the flow control valves (FCV-308 and FCV-318) were capped/ limited to prevent flow surges to the filters during start-up. This implemented control protected potential issues with excessive solids and hydraulic loading to the filters.
- Aluminum sulfate was added to the filtration system and tested for its capabilities as an effective coagulant. However, after testing under numerous conditions, it was determined to be ineffective to remove the TSS at the full-scale plant. Ironically, for the solids treated at the pilot-scale, it was effective (Webster and Togna, 2009). Instead, aluminum chlorohydrate (ACH) was determined to be most cost-effective.
- Since this was a potable water drinking plant, the originally designed open top backwash recycle storage tank was covered to prevent animals (e.g., rodents and birds) from entering the tank.
- It was discovered that a secondary flocculation tube system was required upstream of the DAF system to provide additional flocculation time. Thus, improving the sludge percentage concentration produced from the DAF.
- A larger air compressor system was adopted (the original design was replaced) to provide additional air required for concurrent operations of all of the pneumatic diaphragm pumps.
- All pneumatic diaphragm sampling pumps were replaced with electric centrifugal pumps to prevent draining of the air compressor system.
- A volute dewatering system was eventually added to the plant to recover water from the solids handling process and increase the percentage of biosolids concentration. This additional treatment step was also required as the solids in the effluent were higher than expected and potentially exceeding the discharge requirement.

- The nitrate analyzer required pressure regulators to prevent the sample water pressure from exceeding 5 psi.
- The analytical recycle pump required a higher discharge head to overcome feed line pressure during system recycle.
- Additional purging time for perchlorate samples was required to accommodate the distance between the analytical rack and ion chromatography analyzer. Seventeen minutes of sample preparation time was added to the 13 minutes of sample run time. For future systems, the location of the sampling rack and analyzer should be designed closer to the sampling locations to minimize the amount of purging time required.
- Although the electron donor injection system had flow alarm switches, upon operation, additional flow switches were required to be added in closer proximity to the injection locations to ensure no rupture occurred in the electron donor conveyance tubing. Otherwise, the pumps may continue to operate without actually feeding chemicals to the FBRs.
- Maintenance of the TOC concentrations at or near approximately 1 mg/L is important to reliably meet reduction of perchlorate to concentrations below the California MCL. When the electron donor (e.g., acetic acid) delivery fails, incomplete treatment is possible within one hour of chemical feed cessation. Therefore, multiple leak detectors and low-flow switches are required to alert operators of insufficient electron donor delivery to the FBR. The addition of an on-line TOC analyzer for the effluent of the plant has contributed to the reliability and confidence in the TOC delivery to the microbes for complete reduction of perchlorate.
- Based on improved costs, it was originally anticipated to use glacial acetic acid and dilute to 50% (volume/volume) with a dilution day tank. However, due to the flammability and safety concerns with glacial acetic acid, 80% (volume/volume) acetic acid was instead delivered and eventually diluted in the day tank. This reduction of 20% in the concentration of acetic acid significantly improved the safety of the chemical delivery and minimized the flammability hazard. The cost increase was marginal for the 80% acetic acid compared with glacial acetic acid.
- Proper maintenance and monitoring of the perchlorate analysis system (e.g., ion chromatography analyzer) is necessary to ensure accurate and real-time data regarding effluent perchlorate concentrations. Issues with sample delivery/integrity, instrument calibration, and viability of consumables can contribute to inaccurate effluent perchlorate results. Therefore, it is imperative that operations staff monitor often the perchlorate sampling and analysis system in order to prevent and rectify any anomalies in the automated analyses.
- The interruption of forward feed flow to the plant is more detrimental to the system performance in the early stages of bed biofilm maturation. In general, plant interruptions should be kept at a minimum in the first sixty days of operation in order to maximize perchlorate removal performance.

Ultimately, the lessons detailed above provided design enhancements and improvements that will make the next future plant more automated and less costly to build and operate. In addition, such lessons also provided thorough guidance to the DDW that will transfer to other clients and regulatory agencies. Thus, facilitating the implementation and permitting of the “second-of-its-kind” biological potable water production plant for nitrate and perchlorate treatment.

9.0 REFERENCES

- ASTSWMO (Association of State and Territorial Solid Waste Management Officials), 2011. Perchlorate Policy Update. Washington, D.C.
- Athavaley, A. 2008. *The Wall Street Journal*, May 23, 2008.
- Evans, P., 2010. *Opflow*, 36:7:12
- Geosyntec Consultants. 2007. *Goodrich Corporation Progress Report for the Month of September, 2007, 160-Acre Parcel, Rialto, California*.
- Kengen, S.W.M., G.B. Rikken, W.R. Hagen, C.G. van Ginkel, and A.J.M. Stams. 1999. *J. Bacteriol.* 181: 6706-6711.
- Schwartz, W., T. Webster. 2013. International Water Conference, Orlando, FL.
- Song, Y, and B.E. Logan. 2004. *Water Resources*. 38: 1626-1632.
- Sutton, P. M. and P.N. Mishra. 1994. *Water Science & Technology*. 29: 309-317.
- Webster, T., Guarini, W.J., and H.S. Wong, 2009. *J. AWWA*. 101(5): 137-151.
- Webster, T. and A.P. Togna, 2009. Environmental Security Technology Certification Program Final Report. Project # 200543.
- Webster, T. and M.H. Litchfield, 2017. *J. AWWA*. 109(5): 30-40.
- Zhang, H., M.A. Bruns, and B.E. Logan. 2002. *Environmental Microbiology*. 4: 570-576.

Page Intentionally Left Blank

APPENDIX A POINTS OF CONTACT

| Point of Contact Name | Organization Name Address | Phone Fax Email | Role in Project |
|-----------------------|--|---|--|
| Todd S. Webster | Envirogen Technologies 10400 Trademark Street Rancho Cucamonga, CA | P: 619-286-2587 twebster@envirogen.com | Principal Investigator/Field Project Manager |
| Matthew H. Litchfield | West Valley Water District, 855 W Base Line Rd, Rialto, CA | P: 909-820-3701 mlitchfield@wvwd.org | General Manager |

Todd S. Webster

10-23-17

Signature

Date