



TECHNICAL REPORT 3077  
December 2017

## **Implementation and Testing of the JANUS Standard with SSC Pacific's Software-Defined Acoustic Modem**

Daniel Sura  
Michael Pfetsch  
Nghia Tran  
Dusan Radosevic  
Dr. Patrick Longhini  
Dr. Burton Neuner III

Approved for public release.

SSC Pacific  
San Diego, CA 92152-5001

**SSC Pacific**  
**San Diego, California 92152-5001**

---

---

**M. K. Yokoyama, CAPT, USN**  
**Commanding Officer**

**W. R. Bonwit**  
**Executive Director**

**ADMINISTRATIVE INFORMATION**

The work described in this report was performed for the Office of Naval Research (ONR) Forward Deployed Energy and Communications Outpost (FDECO) Innovative Naval Prototype (INP) Program by the Advanced Photonic Technologies Branch (Code 55360), Space and Naval Warfare Systems Center Pacific (SSC Pacific), San Diego, CA. Further support was provided by the 55340 Enterprise Communications and Networks Branch (Code 55340), the Mission Systems Engineering Branch (Code 56170), the Littoral Engineering Branch (Code 56430), the Unmanned Systems Science and Technology Branch (Code 71710), and the Advanced Concepts and Applied Research Branch (Code 71730), SSC Pacific, San Diego, CA.

Released by  
Sarah Lauff, Head  
Advanced Photonic Technologies Branch

Under authority of  
Clark R. Hendrickson, Head  
Enterprise Communications  
and Networks Division

The citation of trade names and names of manufacturers is not to be construed as official government endorsement or approval of commercial products or services referenced in this report.

Debian™ is a trademark of Software in the Public Interest, Inc.  
Linux® is the registered trademark of Linus Torvalds in the U.S. and other countries.

## **EXECUTIVE SUMMARY**

This report presents Space and Naval Warfare (SPAWAR) Systems Center Pacific's (SSC Pacific) preliminary efforts to implement and test the JANUS acoustic communication protocol onto a software-defined acoustic modem previously developed by engineers working at the center. The SSC Pacific developed acoustic modem serves as an ideal open platform suitable for testing and evaluating physical layer protocols such as JANUS, which has recently become a North Atlantic Treaty Organization (NATO) adopted standard. The system configuration, implementation approach, laboratory, tank, and field tests at SSC Pacific's Transducer Evaluation Center (TRANSDEC) facility are discussed. The outcome of the preliminary testing and several lessons learned have paved the path for a promising future effort to create an integrated software-defined interoperable solution for the U.S. Navy's underwater acoustic communication operations with NATO and non-NATO military and civilian maritime assets.

## ACRONYMS

SPAWAR	Space and Naval Warfare
SSC Pacific	SPAWAR Systems Center Pacific
NATO	North Atlantic Treaty Organization
TRANSDEC	Transducer Evaluation Center
CMRE	Centre for Maritime Research and Experimentation
FH-BFSK	Frequency-Hopped Binary Frequency Shift Keying
ONR	Office of Naval Research
INP	Innovative Naval Prototype
FDECO	Forward Deployed Energy and Communications Outpost
CONOPS	concept of operations
DSP	digital signal processor
FPGA	field programmable gate array
ADC	analog to digital converter
DAC	digital to analog converter
SPI	serial peripheral interface

# CONTENTS

<b>EXECUTIVE SUMMARY .....</b>	<b>iii</b>
<b>ACRONYMS.....</b>	<b>iv</b>
<b>1. INTRODUCTION.....</b>	<b>1</b>
<b>2. SSC PACIFIC MODEM HARDWARE LAYOUT.....</b>	<b>2</b>
<b>3. JANUS SOFTWARE IMPLEMENTATION APPROACH.....</b>	<b>3</b>
<b>4. SYSTEM BENCH TESTING.....</b>	<b>4</b>
<b>5. ISSUES AND CHALLENGES .....</b>	<b>6</b>
<b>6. TANK AND FIELD EXPERIMENTS .....</b>	<b>8</b>
<b>6.1 TRANSDEC RESULTS ANALYSIS.....</b>	<b>11</b>
<b>7. SUMMARY.....</b>	<b>14</b>
<b>8. FUTURE WORK .....</b>	<b>14</b>
<b>9. LONG-TERM IMPACT TO R&amp;D, INTEROPERABILITY, AND THE FLEET .....</b>	<b>15</b>
<b>REFERENCES .....</b>	<b>17</b>

## Figures

1. Diagram showing SSC Pacific modem system layout .....	2
2. Diagram showing JANUS and auxiliary software code implementation. ....	3
3. Photo showing two SSC Pacific software-defined modems tested in the laboratory with JANUS code .....	4
4. Time-trace containing JANUS signal generated by the transmitting modem.....	5
5. Plot of the frequency response containing JANUS signal generated by the transmitting modem.....	5
6. Time-trace showing a recorded JANUS signal with unwanted gaps .....	6
7. Frequency response showing a JANUS signal with unwanted gaps.....	7
8. Time-trace showing unwanted distortions in the received JANUS signal.....	7
9. Time-trace showing correctly received and demodulated JANUS Signal.....	8
10. Frequency response showing correctly received and demodulated JANUS signal.....	8
11. Photo showing test tank with SSC Pacific modem transducers .....	9
12. Time-trace showing a typical JANUS signal after passing through tank of water; distortion is present .....	9
13. Frequency response showing a typical JANUS signal after passing through tank of water.....	9
14. Photo showing modem hardware resting on deck at TRANSDEC .....	10
15. Photo showing transducer suspended in water at TRANSDEC .....	10
16. Time-trace showing 4 kHz bandwidth JANUS signal after passing through the acoustic channel at TRANSDEC.....	11
17. Frequency response showing 4 kHz JANUS signal after passing through the acoustic channel at TRANSDEC.....	11

18. Plot showing an example of transmitted data (upper), and raw received data (lower) with deviation from center frequency .....	12
19. Plot showing an example of demodulated data with frequency hopping in the transmitted (upper) and received (lower) signals as a function of time.....	13
20. Plot showing example demodulated data after decoding is performed .....	13
21. Plot showing BER vs bandwidth for testing performed at TRANSDEC .....	14

# 1. INTRODUCTION

Underwater acoustic communication technologies deployed by U.S. and international military and civilian organizations have for decades operated without any type of widely adopted standards or protocols. Scientists and engineers at the North Atlantic Treaty Organization (NATO) Centre for Maritime Research and Experimentation (CMRE) based out of La Spezia, Italy have spent years developing a physical coding scheme called JANUS, which is based on frequency-hopped binary frequency shift keying (FH-BFSK) modulation and uses 13 pairs of orthogonal tones mapped in the acoustic band of an operator specified bandwidth, which is nominally  $1/3$  of the center frequency [1]. The ease of implementation and proven robustness in harsh underwater acoustic communication channels paved the way for the CMRE to propose JANUS as an international standard to the NATO community, with the goal of providing acoustic modem designers the tools necessary to implement the coding scheme into several different types of compatible hardware platforms of choice for a truly interoperable communications capability.

JANUS was successfully recognized as a NATO standard in April 2017 under Standardization Agreement (STANAG) 4748 to define a set of undersea acoustic processes, terms, and conditions for common military or technical procedures or equipment between the member countries of the alliance [2]. In its current state, the JANUS tool set is aimed at performing robust data transmissions at up to about 150 bps with some of the standard settings, and utilizes a 64-bit header containing a bit allocation table with an application data block defined by any of the 64 standardized schemes, specified for any of the 256 user classes reserved for different countries and/or organizations. Additionally, payload data can be inserted up to a maximum size of 480 bytes for each signal transmission.

JANUS has several applications within the international maritime community, for instance, the current JANUS toolset capabilities could be utilized for sending and receiving identification or distress signals among communication nodes such as surface and moored subsea buoys, submarines, unmanned undersea vehicles, and surface vessels operating acoustic modems that run the JANUS protocols.

SSC Pacific's interest in testing and implementing the JANUS protocols is motivated by the quest to develop a truly interoperable solution for the U.S. Navy with a universal communication capability to send and receive data transmissions to and from military and civilian assets globally across the subsea domain. This effort would also present a new alternative solution to the U.S. Navy's current reliance on commercially available acoustic modem technology that is proprietary in nature and has very limited options for customization and interoperability [3].

Furthermore, software-defined acoustic modems provide an appropriate architecture for the hardware portion of an interoperable solution as they can be easily reconfigured and have been utilized by research institutions for various applications. Based on a U.S. Patent Pending [4], SSC Pacific has already developed a software-defined acoustic modem that is capable of hosting a wide variety of modulation and demodulation algorithms, making it a suitable choice for implementing JANUS, performing test and evaluation, and giving demonstrations to the U.S. Navy and NATO community. Although Space and Naval Warfare Systems Center Pacific (SSC Pacific) has collaborated with the CMRE in the past to perform JANUS testing with a software-defined acoustic modem in San Diego waters [5], the modem equipment and design did not belong to SSC Pacific. This report presents the successful efforts to implement and test the JANUS protocol on SSC Pacific-developed and owned acoustic modems in laboratory and outdoor settings. Building on the success of this study, the in-house modems will be again be employed to demonstrate JANUS capabilities between unmanned undersea platforms within the Office of Naval Research (ONR) Innovative Naval

Prototype (INP) “Forward Deployed Energy and Communications Outpost (FDECO) Program. Lastly, lessons learned from this integration effort may be applied to future U.S. and NATO modem programs.

## 2. SSC PACIFIC MODEM HARDWARE LAYOUT

SSC Pacific’s approach to developing an open acoustic modem platform revolves around implementation of a software-defined architecture that can be easily programmed, host various types of communication algorithms, and tuned for a variety of concept of operations (CONOPS). To conform to the novel algorithms and CONOPS, modular modems were designed to be modular and support broad frequencies and high data rates at the expense of range distance.

To accomplish this, the SSC Pacific modem utilizes several key components including an embedded processor board, a digital signal processor (DSP) development board with an onboard field programmable gate array (FPGA) processor, analog transmit and receive electronics, and a transducer. The system layout for SSC Pacific’s modem architecture is shown in Figure 1.

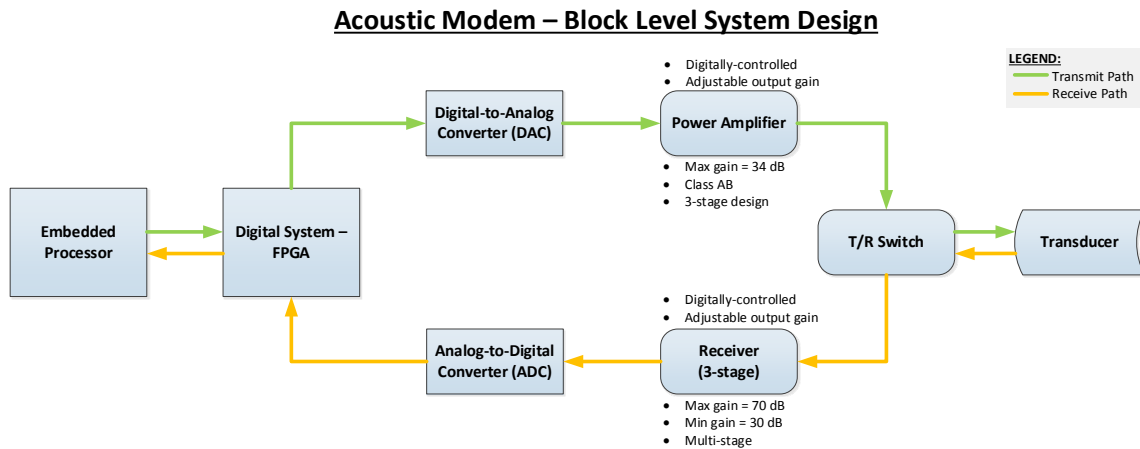

Figure 1. Diagram showing SSC Pacific modem system layout.

In the current system configuration, the embedded processor is used for configuring and running mission scripts, storing relevant data, and manipulation of data for several types of CONOPS. The DSP development board has an integrated FPGA processor that has run some of the non-JANUS communication algorithms developed in the past. This board also contains integrated analog-to-digital (ADC) and digital-to-analog (DAC) circuitry for passing the signals to/from the acoustics related analog components. The analog components are comprised of a transmit power amplifier with programmable gain, impedance matching circuitry, a receive preamplifier with programmable gain, a receive bandpass filter, a receiver amplifier, and circuitry to switch the transducer electrical contacts between the transmission and reception analog paths.

In SSC Pacific’s preliminary JANUS implementation, the modulation and demodulation is performed by the embedded processor and the digital data is passed to/from the FPGA, which was configured to operate in a pass-through mode only. There are several possible advantages to utilizing the FPGA for performing the modulation and demodulation in the JANUS protocol; however, preliminary efforts were focused on performing test and evaluation of the “ready-to-go” software downloaded from the JANUS wiki website [6]. Future work may include a more involved effort to program JANUS into an FPGA processor to eliminate the need for an embedded processor platform.



The transmit path consists of a pre-determined ASCII payload, which custom code on the embedded processor sends to the JANUS modulator running locally. From there the data passes to the FPGA via a Serial Peripheral Interface (SPI) bus and then to the DAC. The electrical signal is then amplified, tuned, and passed to the transducer where the signal is converted into an acoustic pressure wave. The receive path is the mere opposite, where acoustic pressure waves are converted by the transducer into an electrical signal, which is amplified, then filtered, amplified again, filtered again, and converted to digital by the ADC onboard the DSP board. The signal is then sent to the FPGA, which acts as a pass-through component and sends it to the embedded processor via the SPI channel. Finally, the embedded processor performs demodulation of the signal with JANUS, and the ASCII payload is made available for manipulation/displaying depending upon received signal performance and operational bit error rate (BER) levels.

### 3. JANUS SOFTWARE IMPLEMENTATION APPROACH

A straightforward approach was followed for implementing the JANUS algorithms into the SSC Pacific modem. The initial goal was to download the JANUS software from the wiki website and run the modulation and demodulation code with little to no modifications so field testing could be performed sooner. Upon reviewing the JANUS installation and user manual and evaluating the code locally using a laptop, it was confirmed that SSC Pacific’s initial efforts could be focused on developing interface code that reads and writes to/from data files the JANUS code can manipulate utilizing its cargo payload attribute. The aim in this approach was to first gain confidence with using JANUS by performing preliminary test and evaluation and then later develop a cohesive code set that has the JANUS modulation and demodulation functions built-in and integrated with the rest of the existing modem code.

Integration of the unmodified JANUS software with the existing modem architecture required development of C++ code and bash scripts for both transmit-side and receive-side chains. A Debian™ Linux® based operating system was installed on the SSC Pacific modem’s embedded processor and serves as the host environment for compiling and executing all of the code and scripts. The layout for the transmit/receive data flow is shown in Figure 2 and was designed to operate in a half-duplex mode.

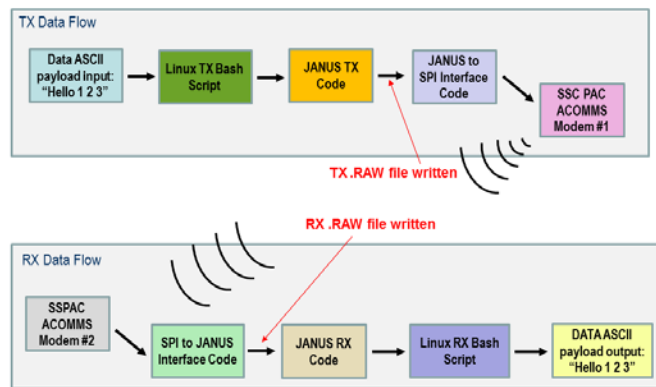

Figure 2. Diagram showing JANUS and auxiliary software code implementation.

The SPI code developed for the transmit side serves to read binary data from a .RAW file written to the storage drive by the JANUS modulator and then send it to the FPGA, which was configured to

operate in a pass-through mode only (no additional signal modulation or conditioning is performed). Conversely, the receive side SPI code reads the digitized acoustic signal from the FPGA (also configured for pass-through mode in reception), and writes it to a binary .RAW data file that is read by the JANUS demodulator. The transmit and receive side bash scripts serve to automate the code execution and to retrieve ASCII payload input from the user for transmission, and output of the demodulated payload to the screen or a local file after reception.

In the current configuration, transmission of data is performed sequentially when the bash script retrieves an ASCII payload input from the user or a predefined string constant. The bash script then calls the JANUS modulator and passes it the input ASCII payload data. Next, the bash script calls the SPI C++ code which reads the binary data file written by JANUS and sends it to the FPGA where it is then converted to analog and is transmitted through the acoustic channel via the transducer.

The reception of data occurs in merely the opposite fashion. Acoustic signals travelling through the underwater acoustic channel are captured by the transducer. Meanwhile, the bash script first calls the SPI code, which runs in a loop and reads the digitized acoustic data from the FPGA for a given number of seconds (specified by the user) and outputs it to a binary .RAW file. Next, the bash script calls the JANUS demodulator which reads the signal from the locally stored .RAW binary file, demodulates it, and outputs the received payload message content. Lastly, the bash script parses the JANUS output so the payload message is easily viewable on the user's screen.

#### 4. SYSTEM BENCH TESTING

Prior to performing any field tests, system bench testing was performed utilizing two SSC Pacific acoustic modems. Figure 3 shows a photograph of some of the equipment utilized, including laptops to configure transmit and receive test scripts and retrieve data, power supplies to power the acoustic modem hardware, and an oscilloscope to monitor signal output and reception. In this setup, tests were performed in one direction where one modem acted as the transmitter, and the other modem acted as the receiver. A coaxial cable was connected between one of the transmitter's DSP analog output ports and one of the receiver's DSP analog input ports.



Figure 3. Photo showing two SSC Pacific software-defined modems tested in the laboratory with JANUS code.

For the majority of testing, the JANUS modulator/demodulator was configured to operate with a 49-kHz center frequency, a 4-kHz bandwidth, and a 160-kHz sampling frequency to match the frequency resonance and sampling rate of the particular SSC Pacific modem configuration utilized at the time of testing. As part of a system checkout, the JANUS transmitter and receiver settings were

verified by observing the time-trace and frequency response of the JANUS modulator's output for various center frequencies and bandwidths. A simple ASCII payload message was used as an input for this verification effort. Payloads are built in 8-byte increments, up to 480 bytes (a 5-byte message would be sent as an 8-byte payload where the 3 remaining unused bytes are padded with zeros).

Figure 4 shows the time-trace that was generated by the embedded processor using JANUS protocol. The .RAW binary data file was uploaded to a laptop for performing analysis. The time trace appears correct according to typical FH-BFSK signal characteristics. The frequency response for this same signal is shown in Figure 5 and has a 40-kHz bandwidth centered at 115 kHz. It also appears correct according to the settings configured at the time of testing.



Figure 4. Time-trace containing JANUS signal generated by the transmitting modem.

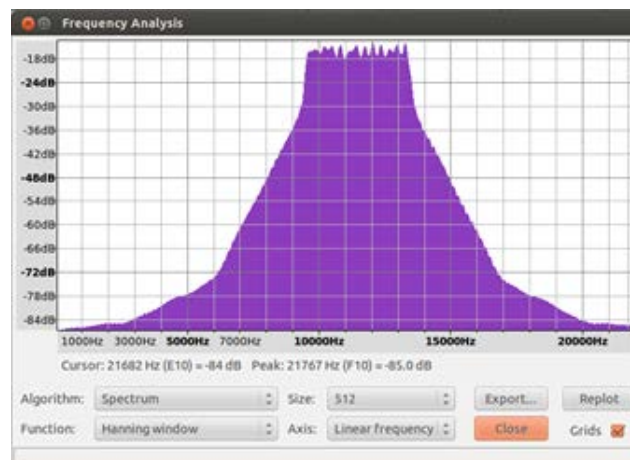

Figure 5. Plot of the frequency response containing JANUS signal generated by the transmitting modem.

Furthermore, the JANUS .RAW binary output file from the transmitter was manually uploaded onto a laptop and then downloaded to the receiver for further verification. The JANUS demodulator was then manually run with this file and the output was observed. For each of the tests, the receiver successfully demodulated the data and returned the correct ASCII payload message confirming JANUS was properly configured with compatible settings on both ends.

Next, the system was tested in its entirety utilizing the coaxial cable between the transmitter and receiver. For this testing, the receive side bash script was initialized first and started recording with a pre-determined duration that exceeded the signal duration sent by the transmitter. A suitable recording duration was pre-determined by observing the JANUS transmit signal when a known ASCII payload was used, or setting it to a larger than necessary duration when a random ASCII payload (up to the 480-byte JANUS limit) was typed from the keyboard by the user. Next, the transmitter bash script was run and the user typed the ASCII text of choice, or the user input was bypassed and a default text message was sent. If the record duration was correctly configured, the receiver completed recording to file after the transmission was complete so the entire signal was captured. The receiver bash script then called the JANUS demodulator, the recorded binary file was processed, and the ASCII payload was parsed and printed to the screen.

The initial system bench testing efforts yielded unsuccessful demodulation, resulting from some system issues (as discussed in Section 5). Once these important issues were resolved, the system performed as expected when connecting the modems with a coaxial cable, and the team was able to demodulate the JANUS signal and output the correct ASCII payload. With the completion of the cabled bench testing, the effort focused on water testing in the laboratory (small tank) and in the field (large outdoor test pool). These results are presented and discussed in Section 6.

## 5. ISSUES AND CHALLENGES

The majority of issues encountered during the implementation of JANUS revolved around how the FPGA buffer onboard the SSC Pacific modem was utilized. Preliminary bench testing yielded unsuccessful signal demodulation due to unwanted and random gaps in the signal both from the transmit operation and the recording process coded in the receiver. Figure 6 shows a time-trace of a typical JANUS signal containing these unwanted gaps. The corresponding frequency response for this signal is shown in Figure 7. It was also discovered that portions of the JANUS signal contained severe distortion effects as shown in Figure 8. This effect was also linked to some of the buffer settings and how the FPGA buffer was queried, enabled/disabled, and read/written.



Figure 6. Time-trace showing a recorded JANUS signal with unwanted gaps.

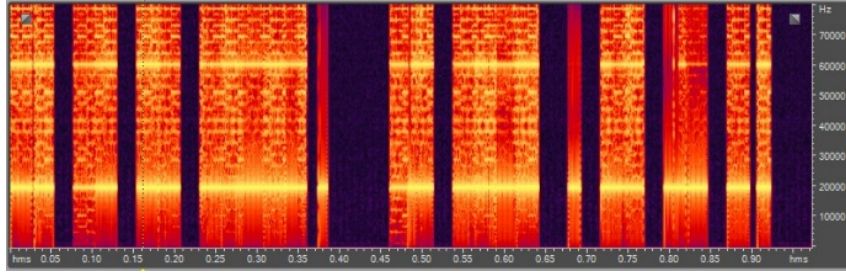

Figure 7. Frequency response showing a JANUS signal with unwanted gaps.

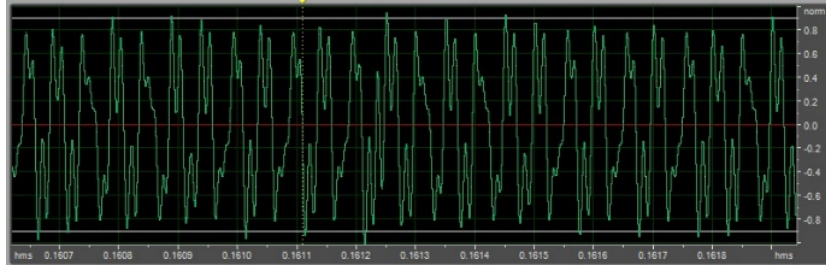

Figure 8. Time-trace showing unwanted distortions in the received JANUS signal.

The transmit-side and receive-side chain required several iterations of trial and error with changing settings and modifying code before a suitable configuration was achieved. This required both reprogramming of the transmit and receive mode FPGA images and modifications to the C++ transmit and receive SPI code segments which read and write the JANUS signal to/from file. A working solution was achieved for the transmitter by reading one full 4096 byte buffer at a time from the JANUS .RAW binary file and sending it to the FPGA iteratively until the end of file was reached. It was also critical to have the correct amount of delay in the loop (100 microseconds typically) and querying the FPGA ready state no sooner than every eighth buffer.

A similar approach was followed for the receive side, however the SPI code was modified to calculate a total number of 4096 data blocks based on how long the user requests to record data. A loop iteratively reads half of the 4096 buffer size from the FPGA and writes it to memory until the entire set of blocks corresponding to the record duration specified by the user is read. In contrast to the transmitter's querying frequency, the receiver FPGA ready state is queried every iteration, however, the correct amount of delay is required in the loop (about 100 microseconds typically). To prevent any additional unwanted gaps in the signal (possibly from hiccups caused by slower write to file operations), all of the acoustic signal data recorded in the embedded processor's RAM is finally written to a stored file in a loop, 4096 bytes at a time after it is converted from unsigned int16 to signed int16. This data is written and stored onto a flash disk installed on the embedded processor.

Once this configuration was established, bench testing with a coaxial cable between the transmitter and receiver yielded successful results; a representative time-trace is shown in Figure 9, which appears to have no signal gaps whatsoever. The corresponding frequency response for this signal is shown in Figure 10. It is relatively easy to see the frequency hopping characteristics typical in BH-FSK for this 4-kHz bandwidth signal centered at 49 kHz. Several transmissions with varying center frequencies and bandwidths were performed, and the JANUS demodulator was able to output the correct ASCII payload inputted by the user on the transmit side. The focus then shifted to performing tests with the transducers in a tank of water and then in the field.

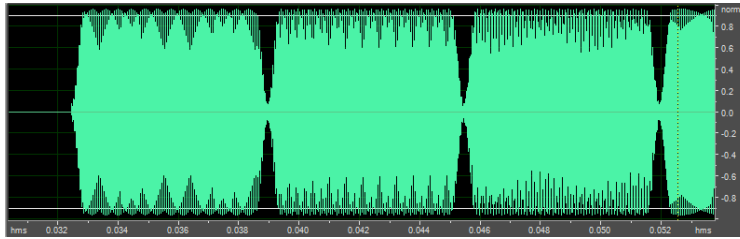

Figure 9. Time-trace showing correctly received and demodulated JANUS Signal.

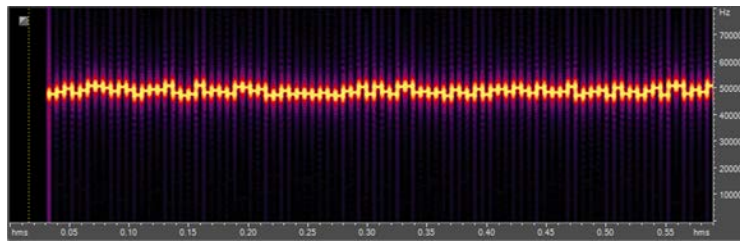

Figure 10. Frequency response showing correctly received and demodulated JANUS signal.

Another issue resulted from how the JANUS implementation was performed. The initial focus was to test and evaluate the physical layer capabilities of JANUS and focus on the network layer portion at a later time. In its current state, the system can only perform one way transmissions where the receiver needs to be run first and the signal duration needs to be known or guessed ahead of time. This limitation did not prevent test and evaluation in the laboratory and field, however the SSC Pacific team is cognizant of the need to develop a more robust solution for automated bi-directional transmissions once a network layer will be integrated into the system.

Lastly, one of the bigger issues and challenges resulted from the environment itself when performing in-water tests. Testing in a tank of water and at SSC Pacific's Transducer Evaluation Center (TRANSDEC) facility resulted in multipath reverberation, which caused unwanted degradation of signal fidelity. The attempt by JANUS to demodulate and output the correct ASCII payload was unsuccessful for several cases. Our initial testing was able to circumvent this issue with careful positioning of the transmit-side and receive-side transducers by trial and error. The test results and impact from multipath effects will be discussed in greater detail in the next section.

## 6. TANK AND FIELD EXPERIMENTS

Building on successful cabled tests in the laboratory, but before testing out in the field, a set of experiments were performed with transducers in a tank of water. The tank is 1.5 m long by 0.91 m wide by 0.91 m high, is made of plastic, and is filled with tap water about halfway from the top. Figure 11 shows an image of the tank setup with the transducers placed at the bottom approximately 0.6 m apart.



Figure 11. Photo showing test tank with SSC Pacific modem transducers.

Several transmissions were performed in a similar manner to the bench tests with the receiver side running a few seconds before the transmitter sent the acoustic signal. The JANUS modulated signals contained a 480 byte ASCII payload and were configured for operation at a center frequency of 49 kHz and various different bandwidths. A time-trace showing the received JANUS signal with a center frequency of 49 kHz and bandwidth of 4 kHz is shown in Figure 12. The corresponding frequency response is shown in Figure 13. The signal appears to have more distortion present when analyzing the plots visually and comparing to the bench tests that utilized a coaxial cable. This is likely attributed to severe multipath effects from the tank walls and water surface.

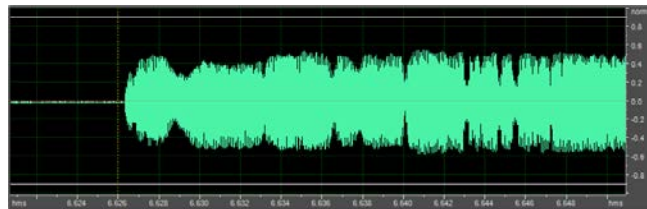

Figure 12. Time-trace showing a typical JANUS signal after passing through tank of water; distortion is present.

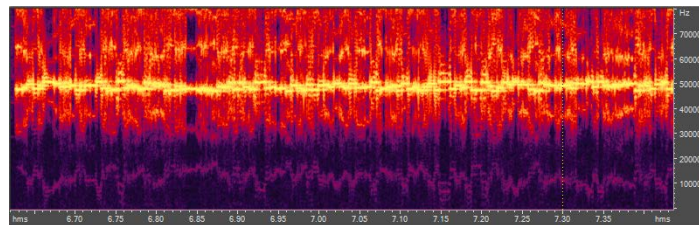

Figure 13. Frequency response showing a typical JANUS signal after passing through tank of water.

We noted that transducer placement played a critical role in whether the ASCII payload was demodulated successfully by JANUS on the receiver side. The majority of 4-kHz bandwidth signals were demodulated successfully; however, higher bandwidth configurations such as 8, 12, 16, and 20 kHz were very unreliable, or did not appear to work at all, attributed to sensitivity of transducer placement or multipath effects.

Rather than analyze BER and SNR in the position-sensitive tank environment, these laboratory tests were aimed at verifying the overall system functionality and confirming that the transducers were correctly transmitting and receiving acoustic signals. It became apparent that transducer placement and transmitter attenuation (reducing the output level so the receiver signal would not be saturated) were critical for proper signal demodulation due to limitations in the environment and that any unsuccessful transmissions were not caused by a hardware or software system issue. Once the system functionality was confirmed, focus shifted to performing tests in a much larger, yet still controlled environment.

The final test efforts were performed at SSC Pacific's TRANSDEC facility, which contains a very large 91 m by 61 m by 12 m deep pool containing 6 million gallons of chemically treated fresh water. The pool was specifically designed to have low ambient noise and anechoic properties, suitable for transducer calibration and underwater acoustic testing for various SONAR and acoustic communication applications. Figure 14 shows a photograph of the transmitter side modem electronics resting on the end of the main deck at TRANSDEC. Figure 15 shows an image of the transmitter transducer suspended into the water.



Figure 14. Photo showing modem hardware resting on deck at TRANSDEC.



Figure 15. Photo showing transducer suspended in water at TRANSDEC.

Tests at TRANSDEC were performed in a similar manner as the tank tests, where the receiver was run for a few seconds before and after the transmitter sent the acoustic signal. Both the receiver and transmitter transducers were suspended in the water by about 0.6 m, and placed apart a distance of 4.15 m and 13 m, and aligned nearly in the center of the pool where the main deck is located. An attenuator of 19 dB was placed before the transmitter transducer to avoid saturating the receiver. The JANUS-modulated signals contained a 480 byte ASCII payload and were configured for a 49 kHz center frequency with a variety of bandwidths (including 4, 8, 12, 16, and 20 kHz), and transmitted at



4.15 m and 13 m distances. A time-trace showing a typical received JANUS signal with a center frequency of 49 kHz and bandwidth of 4 kHz is shown in Figure 16. The corresponding frequency response for this signal is shown in Figure 17. The signals appeared to have similar amounts of distortion as with the tank tests when inspecting the plots visually and this is likely traceable to multipath effects from the water surface since the transducers were not suspended very deep. The visual distortion in the frequency plot also appears to build up the first couple hundred milliseconds and then stabilize.

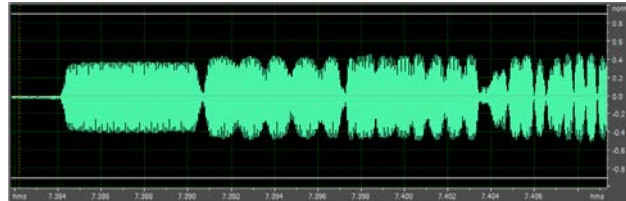

Figure 16. Time-trace showing 4 kHz bandwidth JANUS signal after passing through the acoustic channel at TRANSDEC.

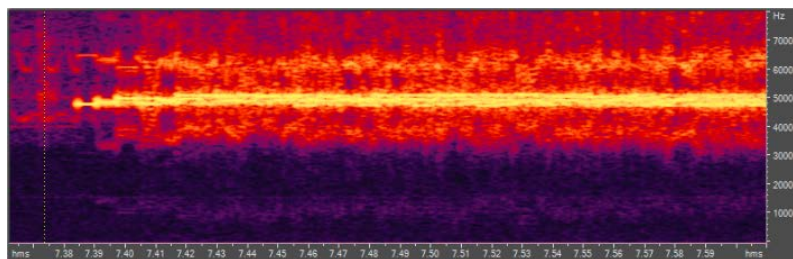

Figure 17. Frequency response showing 4-kHz JANUS signal after passing through the acoustic channel at TRANSDEC.

As observed in tank testing, it was noted that transducer placement also played a critical role in the JANUS code's ability to demodulate the received signal and output the correct ASCII payload. Successful transmissions were achieved almost exclusively with the 4-kHz bandwidth cases and some of 8 kHz bandwidth cases; adjusting the transmitting transducer's location very slightly right or left (on the order of 25 to 30 cm) on the dock's end at a 13-m distance was required. Performance at the shorter distance of 4.15 m had similar behavior where a 4-kHz bandwidth (and for some cases, 8-kHz bandwidth) and transducer position adjustments were required for successful signal demodulation.

The varying detection performance indicates the issues are environment related as all of the hardware and software settings were kept the same when the transmitter transducer was moved small amounts for several different transmissions. Although the results have shown some instances of unsuccessful signal demodulation, it can be concluded they are not a result of the JANUS implementation approach or any issues with the SSC Pacific software-defined modem design or equipment. The numerous instances of successful signal demodulation indicate the system electronics and code are properly utilizing the transducers to send and receive acoustic signals.

## 6.1 TRANSDEC RESULTS ANALYSIS

The data collected at TRANSDEC was analyzed further to characterize BER and potentially identify the cause of some signal detection issues with the higher bandwidth configurations. To better understand how JANUS is implemented, Figure 18 shows a plot of raw transmitted data (upper) and

raw received data (lower). The actual transmitted signal amplitude is constant, but appears slightly irregular, an artifact of the finite sample rate. The transmit and receive signals are too dense to view in the allotted plotting space; however, green lines were overlaid to represent how far the raw data frequency is from the configured center frequency of 49 kHz. The plots indicate deviation values from the center frequency of approximately  $-1.2$  kHz (47.8 kHz), to  $-0.4$  kHz (48.6 kHz), to  $+0.8$  kHz (49.8 kHz). Notice the transmit signal appears smooth while the received signal does not. This is due to effects caused by signal propagation in the underwater acoustic channel.

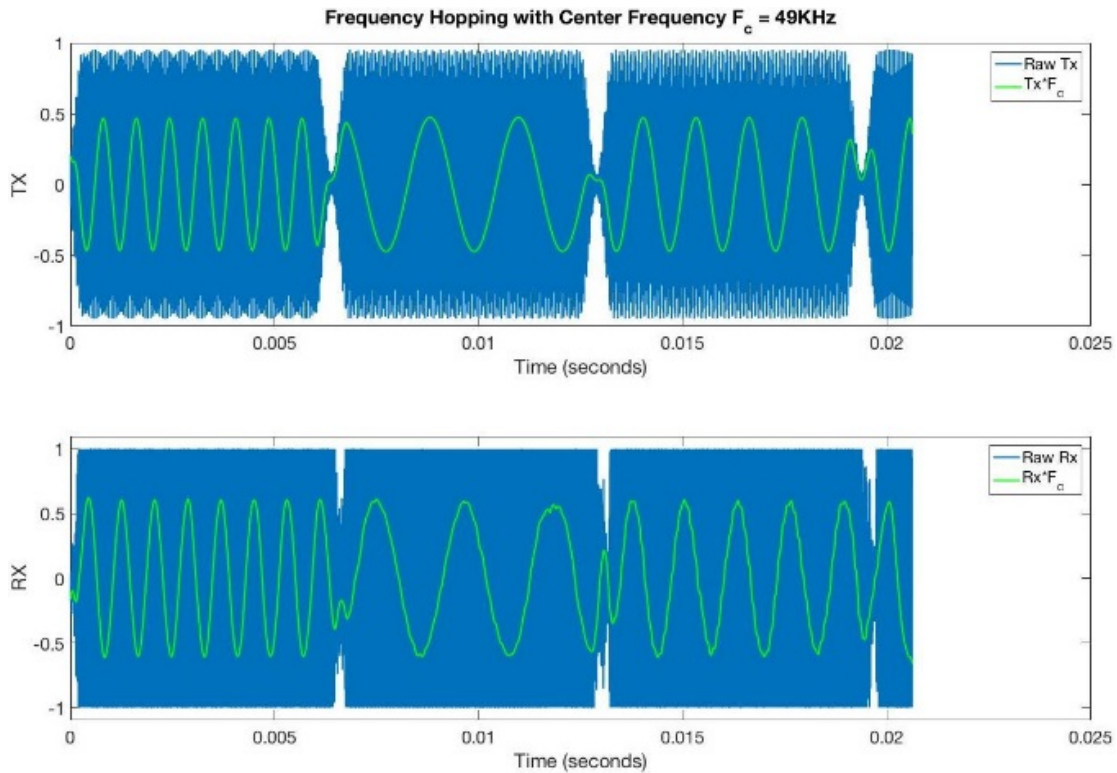

Figure 18. Plot showing an example of transmitted data (upper), and raw received data (lower) with deviation from center frequency.

The instantaneous transmit and receive frequencies after demodulation of the data are shown in Figure 19, with the center frequency of 49 kHz marked by a red line. The plots show the frequency hopping more clearly for both cases. Notice the receive plot captures some of the expected noise and acoustic channel effects present in the test environment.

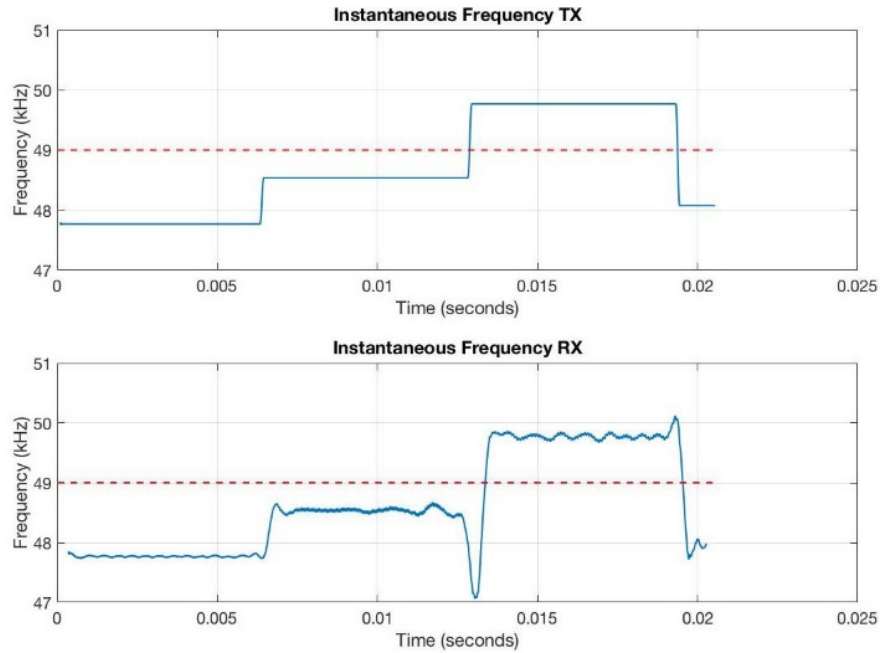

Figure 19. Plot showing an example of demodulated data with frequency hopping in the transmitted (upper) and received (lower) signals as a function of time.

For proper BER analysis, the demodulation process involved finding the beginning and end of the received data, finding transitions between frequency hops (quiet spaces), and decoding bits by analyzing the frequency of each packet. Figure 20 shows a plot of example demodulated data, illustrating the difference between the assigned values of “0” or “1”. In this analysis, decoded means that a bit is assigned a 0 or 1 value depending upon if there is a small shift in frequency away from the main frequency of that packet. For example, in the plot, RX<sub>1</sub> and RX<sub>2</sub> have identical frequencies (bits) for 7 out of 9 packets, but different frequencies (bits) for 2 out of 9 packets. In the packets where RX<sub>1</sub> steps away from RX<sub>2</sub>, the bit is assigned a value of 1.

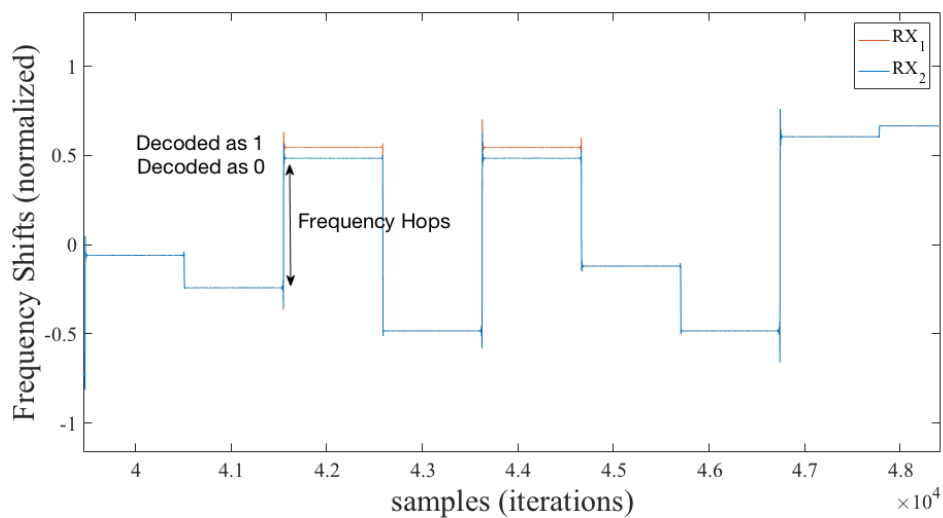

Figure 20. Plot showing example demodulated data after decoding is performed.

Figure 21 shows a summary plot of all TRANSDEC test data with regards to BER vs. bandwidth. This data corresponds to a configuration and setup with a center frequency of 49 kHz, transmitter transducer attenuation of 19 dB, transducer depth of 2 m, receiver depth of 2 m, range distance of 4.15 m in one test, and range distance of 13 m in all other tests. All test files were analyzed, and errors were tracked by comparing the received data to the transmitted data. An error value of 0 means that all the data was received (i.e., 0% or 0.0 error rate), and a value of 1 corresponds to unsuccessful signal demodulation (i.e., 100% or 1.0 error rate). A set of varying bandwidths were tested: 4, 8, 12, 16, and 20 kHz.

While multiple tests were conducted for each bandwidth, the minimum achievable BER was noted for each case, and then plotted. The plot shows that BER increases with bandwidth until a 100% error rate is observed at 20 kHz. The exact reason for this error rate is under study, but it is presently believed that multipath effects from the environmental conditions at TRANSDEC are a major contributor, since bench testing showed no issues with the higher bandwidth cases. Overall, the implementation was successful and test results are promising; there are many follow-on work opportunities, as described in Section 8.

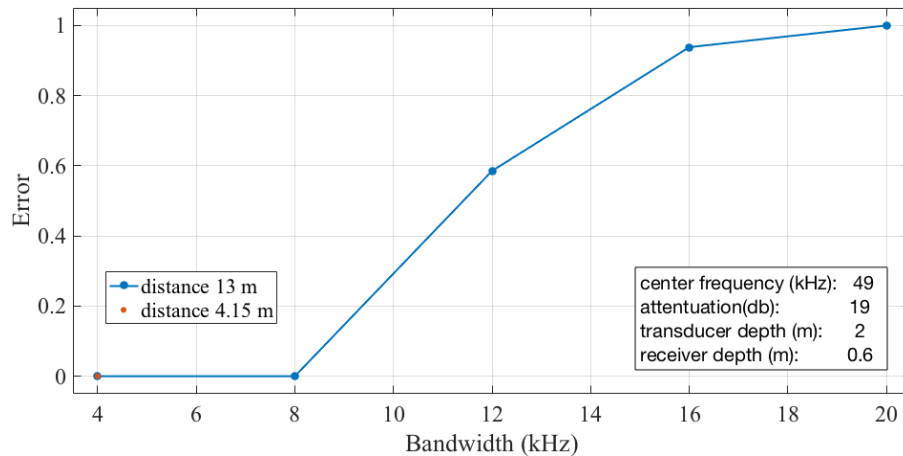

Figure 21. Plot showing BER vs. bandwidth for testing performed at TRANSDEC.

## 7. SUMMARY

In summary, the NATO STANAG 4748 framework, known as JANUS acoustics protocol, was successfully installed and implemented on software-defined acoustic modems at SSC Pacific. Initial laboratory and field tests were successful but suggest that tests should be repeated with longer duration in an environment where multipath effects will be less prevalent, and over longer distances that do not require the use of transducer attenuators. Open ocean testing with full submergence of the pressure-housed electronics and transducers for both the transmitter and receiver will likely result in significantly improved performance. This is described in our plan for future work in the following section.

## 8. FUTURE WORK

The initial code implementation approach proved to be acceptable for allowing the physical layer properties of the JANUS toolset to be tested and evaluated when running on the SSC Pacific software-defined acoustic modem. Based on the encouraging results shown in the previous section,

the end goal is to use lessons learned in previous work as a foundation for developing a fully capable acoustic modem that retains the software-defined flexibility, utilizes the JANUS protocols for bi-directional half duplex and perhaps full duplex communications, and has an integrated network and application layer.

The future focus will be centered upon developing a more robust C++ code that utilizes the JANUS modulation and demodulation functions directly and sends and receives data to and from the FPGA and the embedded processor. This code will eliminate the need for reading and writing the acoustic data stream to files, will enable programming of data packetization and re-transmission techniques, and will allow bi-directional communication (i.e., “listen and transmit”) modes to be developed.

Some other future work currently planned includes testing the existing system in more open ocean environments with transducers in deeper water where multipath effects will be less prevalent and evaluating signal performance. Past studies on Doppler compensation of JANUS signals have been performed [7], and the default JANUS code has compensation capabilities, but our future test and evaluation plans include applying motion between the transmitter and receiver and analyzing signal performance for the specific JANUS configurations utilized by the SSC Pacific modem. Additionally, these tests will involve analyzing larger amounts of data at a parameter set. Based on test results, 480 bytes appears insufficient to accurately characterize BER performance. Future testing will likely require code modifications such that longer data streams and lengthier transmissions can be conducted. There are also plans for integration of network layer solutions such as SUNSET [8] and DESERT [9], which are currently being evaluated by SSC Pacific engineers for use on different efforts.

Lastly, one of the larger visions for this effort is to integrate an SSC Pacific modem running JANUS into one of the ONR FDECO outposts and on an unmanned undersea vehicle (UUV), which would create an opportunity for SSC Pacific to demonstrate to stakeholders bi-directional acoustic communications with JANUS for homing and docking operations and data transfer. Similar feasibility efforts with JANUS have been demonstrated [10]. It’s possible that other NATO nations and modem manufacturers will offer a commercial off-the-shelf (COTS) solution that natively employs JANUS protocols. This would allow demonstrating interoperability by equipping an unmanned platform with a non-SSC Pacific modem, and performing communications testing with the SSC Pacific modem integrated into another unmanned platform. Excellent possibilities exist to demonstrate interoperability via JANUS: communication between different platforms (UUVs, docks, buoys, etc.) and different nations can revolutionize the undersea environment.

## **9. LONG-TERM IMPACT TO R&D, INTEROPERABILITY, AND THE FLEET**

The positive impact from successful implementation and widespread use of JANUS for underwater acoustic communications by the U.S. Navy cannot be overstated. Preliminary test and evaluation has proved that JANUS is a suitable option for performing several research and development efforts and exploring applications where robust lower data rate operation is required. One such example is development and testing of customized networking and application layers, and cybersecurity techniques for several different types of Navy CONOPS. Due to its ease of use and robust nature, JANUS is an excellent candidate for the physical layer on which these additional layers would be developed and tested. Some other types of research and development applications where JANUS could be utilized include: development of new UUV homing techniques that require acoustic

communications, development of future acoustic modem hardware versions that need a physical layer, and development of assured underwater acoustic communication solutions where JANUS is used as the underlying signal.

As stated earlier in this report, the U.S. Navy has an emerging need for an alternative solution to limitations from utilizing commercial off-the-shelf underwater acoustic modems that operate on proprietary hardware and software. Interoperability becomes possible with a software-defined acoustic modem such as SSC Pacific's when it is running JANUS. For instance, any variety of hardware that can host JANUS algorithms can be utilized to communicate with a completely different modem developed by a different manufacturer or nation. One future possibility to take full advantage of interoperability would be to equip a platform with a suite of SSC Pacific modems, each with different transducers, and tune the settings to perform communications at different frequencies and bandwidths for different operations such as homing, general simultaneous communications with multiple UUV platforms, or utilization of the standardized JANUS frequencies for communicating with other NATO assets.

There are several advantages for the U.S. Navy fleet to utilize underwater acoustic modems running the JANUS protocol. For example, Navy maritime assets deployed subsea or on the surface of the ocean could utilize JANUS to identify other assets that may be from friendly NATO nations. The reverse could be performed to allow the U.S. Navy to identify itself when in international waters where other NATO assets are known to operate beneath or on the surface. Lastly, the use of JANUS by the U.S. Navy fleet would likely encourage several other NATO nations to expedite the adoption of JANUS, increase the number of active members participating in the JANUS community, and perhaps inspire more collaboration and future state of the art software-defined acoustic modem development between nations.

## REFERENCES

1. J. R. Potter, J. Alves, D. Green, G. Zappa, I. Nissen, and K. McCoy. 2014. “The JANUS Underwater Communications Standard.” *Proceedings of the IEEE Conference on Underwater Communications and Networking*. September 3–5, Sestri Levante, Italy. IEEE.
2. NATO STANAG-4748: <http://nso.nato.int/nso/nsdd/listpromulg.html>
3. J. Alves, T. Furfaro, K. LePage, A. Munafò, K. Pelekanakis, R. Petroccia, and G. Zappa. 2016. “Moving JANUS Forward: A Look into the Future of Underwater Communications Interoperability.” IEEE OCEANS Conference. September 19–23, Monterey, CA.
4. D. Radosevic, and M. W. Pfetsch. “Software-Defined Acoustic Communications System,” U.S. Patent Pending, Navy Case #103087.
5. R. Petroccia, G. Cario, M. Lupia, V. Djapic, and C. Petrioli. 2015. “First In-field Experiments with a “Bilingual” Underwater Acoustic Modem Supporting the JANUS Standard.” *Proceedings of the IEEE OCEANS Conference*. May 18–21, Genova, Italy. IEEE.
6. JANUS wiki. Accessed: February 2017. [Online]. Link: <http://www.januswiki.org/tiki-index.php>.
7. G. Zappa, I. Nissen, and J. Potter. 2011. “Doppler Compensation for JANUS Applied to Data Collected in the Baltic Sea.” *Proceedings of the 4th International Conference and Exhibition on Underwater Acoustic Measurements: Technology & Results* (pp. 1537–1544). June 20–24, Kos, Greece.
8. C. Petrioli, R. Petroccia, J. R. Potter, and D. Spaccini. 2015. “The SUNSET Framework for Simulation, Emulation and At-sea Testing of Underwater Wireless Sensor Networks,” *Ad Hoc Networks and Physical Communication* 34 (November) 224–238.
9. R. Masiero, S. Azad, F. Favaro, M. Petrani, G. Toso, F. Guerra, P. Casari, and M. Zorzi. 2012. “DESERT Underwater: An NS–Miracle-based Framework to Design, Simulate, Emulate and Realize Test-beds for Underwater Network Protocols.” *Proceedings of OCEANS 2012 – Yeosu*. May 21–24, Yeosu, South Korea.
10. R. Petroccia, J. Alves, and G. Zappa. 2016. “Fostering the Use of JANUS in Operationally-Relevant Underwater Applications.” *Proceedings of the 3rd IEEE Conference on Underwater Communications and Networking (UComms)*. August 30–September 1, Lerici, Italy. IEEE.

**REPORT DOCUMENTATION PAGE**

*Form Approved  
OMB No. 0704-01-0188*

The public reporting burden for this collection of information is estimated to average 1 hour per response, including the time for reviewing instructions, searching existing data sources, gathering and maintaining the data needed, and completing and reviewing the collection of information. Send comments regarding this burden estimate or any other aspect of this collection of information, including suggestions for reducing the burden to Department of Defense, Washington Headquarters Services Directorate for Information Operations and Reports (0704-0188), 1215 Jefferson Davis Highway, Suite 1204, Arlington VA 22202-4302. Respondents should be aware that notwithstanding any other provision of law, no person shall be subject to any penalty for failing to comply with a collection of information if it does not display a currently valid OMB control number.

**PLEASE DO NOT RETURN YOUR FORM TO THE ABOVE ADDRESS.**

<b>1. REPORT DATE (DD-MM-YYYY)</b> December 2017		<b>2. REPORT TYPE</b> Final	<b>3. DATES COVERED (From - To)</b>		
<b>4. TITLE AND SUBTITLE</b>  Implementation and Testing of the JANUS Standard with SSC Pacific's Software-Defined Acoustic Modem			<b>5a. CONTRACT NUMBER</b>		
			<b>5b. GRANT NUMBER</b>		
			<b>5c. PROGRAM ELEMENT NUMBER</b>		
<b>6. AUTHORS</b>  Daniel Sura                    Dr. Patrick Longhini Michael Pfetsch             Dr. Burton Neuner III Nghia Tran Dusan Radosevic			<b>5d. PROJECT NUMBER</b>		
			<b>5e. TASK NUMBER</b>		
			<b>5f. WORK UNIT NUMBER</b>		
<b>7. PERFORMING ORGANIZATION NAME(S) AND ADDRESS(ES)</b>  SSC Pacific 53560 Hull Street San Diego, CA 92152-5001			<b>8. PERFORMING ORGANIZATION REPORT NUMBER</b>  TR 3077		
<b>9. SPONSORING/MONITORING AGENCY NAME(S) AND ADDRESS(ES)</b>  Office of Naval Research Forward Deployed Energy and Communications Outpost Innovative Naval Prototype Program 875 N. Randolph Street Arlington, VA 22203-1995			<b>10. SPONSOR/MONITOR'S ACRONYM(S)</b> ONR FDECO INP		
			<b>11. SPONSOR/MONITOR'S REPORT NUMBER(S)</b>		
<b>12. DISTRIBUTION/AVAILABILITY STATEMENT</b>  Approved for public release.					
<b>13. SUPPLEMENTARY NOTES</b>  This is work of the United States Government and therefore is not copyrighted. This work may be copied and disseminated without restriction.					
<b>14. ABSTRACT</b>  This report presents Space and Naval Warfare Systems Center Pacific's (SSC Pacific) preliminary efforts to implement and test the JANUS acoustic communication protocol onto a software-defined acoustic modem previously developed by engineers working at the Center. The SSC Pacific developed acoustic modem serves as an ideal open platform suitable for testing and evaluating physical layer protocols such as JANUS, which has recently become a North Atlantic Treaty Organization (NATO) adopted standard. The system configuration, implementation approach, laboratory, tank, and field tests at SSC Pacific's Transducer Evaluation Center (TRANSDEC) facility are discussed. The outcome of the preliminary testing and several lessons learned have paved the path for a promising future effort to create an integrated software-defined interoperable solution for the U.S. Navy's underwater acoustic communication operations with NATO and non-NATO military and civilian maritime assets.					
<b>15. SUBJECT TERMS</b>  JANUS; NATO; frequency-hopped binary frequency shift keying (FH-BFSK) modulation; universal communication capability; software-defined acoustic modems; digital signal processor (DSP); Field Programmable Gate Array (FPGA); underwater acoustic communications					
<b>16. SECURITY CLASSIFICATION OF:</b>			<b>17. LIMITATION OF ABSTRACT</b>	<b>18. NUMBER OF PAGES</b>	<b>19a. NAME OF RESPONSIBLE PERSON</b>
<b>a. REPORT</b>	<b>b. ABSTRACT</b>	<b>c. THIS PAGE</b>			Burton Neuner III
U	U	U	U	26	<b>19b. TELEPHONE NUMBER (Include area code)</b> (619)553-2885



## INITIAL DISTRIBUTION

84300	Library	(1)
85300	Archive/Stock	(1)
55340	D. Sura	(1)
55360	B. Neuner III	(1)
56170	D. Radosevic	(1)
56430	M. Pfetsch	(1)
71710	N. Tran	(1)
71730	P. Longhini	(1)

Defense Technical Information Center  
Fort Belvoir, VA 22060-6218 (1)

Approved for public release.



SSC Pacific  
San Diego, CA 92152-5001