

High Power Combiner/Divider with Coupled Lines for Broadband Applications

Ali Darwish¹, Kenneth McKnight¹, Mona Zaghloul², Edward Viveiros¹,
and H. Alfred Hung¹

¹Army Research Laboratory, Adelphi, MD

²George Washington University, Washington DC

Abstract — *A broadband Gysel divider has been demonstrated. The new concept uses a coupled line segment in the design to improve isolation and matching. Significant improvement in operation bandwidth are realized compared to the conventional approach, while maintaining low-loss, ease of design, and flexibility. The coupled-Gysel divider is demonstrated with a 2.5 – 8 GHz, 105% fractional bandwidth, and 0.1 dB loss. Another divider operates from 3.4 – 10.2 GHz, with 100% fractional bandwidth and 0.2 dB of insertion loss. The structure works well reciprocally as a combiner. A novel isolation structure will also be presented.*

I. INTRODUCTION

Power divider/combiners are traditionally used in the development of high power solid state amplifiers to feed/combine multiple lower power devices or monolithic microwave integrated circuits (MMICs). Broadband power combiners are required for emerging applications in Electronic Warfare (EW), multi-band radar, and multi-function RF.

The Wilkinson divider is one of the most commonly used power dividers [1] because of its simplicity, and size. It has also been researched extensively. One of the main limitations of the Wilkinson divider stems from the isolation resistor. It poses two problems. First, it is assumed to have zero or very small electrical delay. Second, it is a floating resistor (no ground connection). The requirement of having a very small electrical length is difficult to satisfy, especially, for discrete resistors (such as surface mount resistors). Reducing the resistor's physical dimension reduces its power handling capability. Additionally, the fact that it is not grounded makes it difficult to dissipate the heat. The Gysel divider/combiner [2] solves both problems and can be used for combining high power signals. Many improvements on the original concepts were introduced. For example, operating the Gysel with equal/unequal power division and arbitrary terminal impedances has been shown [3]-[4]. Additionally, dual-frequency operation has been demonstrated [5].

Coupled lines have been used with Wilkinson dividers [6] to extend the bandwidth. They have also been used with Gysel dividers [7] to introduce signal filtering or dual band operation [8]. The use of coupled lines gives flexibility. However, the added complexity may lead to greater losses in the divider and complicate the design process as the circuit acquires more poles and zeros. Thus, it is desirable to maintain the simplicity of the original Gysel structure (with its low loss, due to low impedance, lines) while introducing the minimum number of coupled lines.

This paper presents a broadband Gysel divider which utilizes a coupled line segment to significantly extend the bandwidth without increasing the insertion loss. Simulations and measurements are presented for two cases: a 2.5 – 8 GHz (105% fractional bandwidth) divider with 0.1 dB loss, and a 3.4 – 10.2 GHz (100% fractional bandwidth) divider with 0.2 dB loss.

This is one of the largest bandwidth demonstrated for a Gysel power divider. This bandwidth is accomplished while maintaining low RF loss and design simplicity.

II. COUPLED-GYSEL DIVIDER/COMBINER

The schematic of a classical Gysel divider is shown in Fig. 1a, the even mode equivalent circuit is shown in Fig. 1b, and the odd mode is shown in Fig. 1c. The basic idea is that we would like the even mode (entering port 1) to see a high impedance to the right of A1 and A2, and the odd mode to see a low impedance to the right of A1 and A2. This is achieved, in the Gysel divider, through the virtual opens/shorts and the associated $\lambda/4$ transformations. Clearly, the bandwidth can be improved if we can control the impedances of the odd/even modes independently. At the same time, we would like to preserve the simplicity of the design and its low loss features. The proposed coupled-Gysel, Fig. 2a, replaces the Z2-line with a single coupled line. It turns out that replacing the other lines

(Z1, and Z3) with coupled lines increases complexity/loss while adding negligible benefits. The even/odd mode equivalent circuits are shown on Figs. 2b, and 2c, respectively.

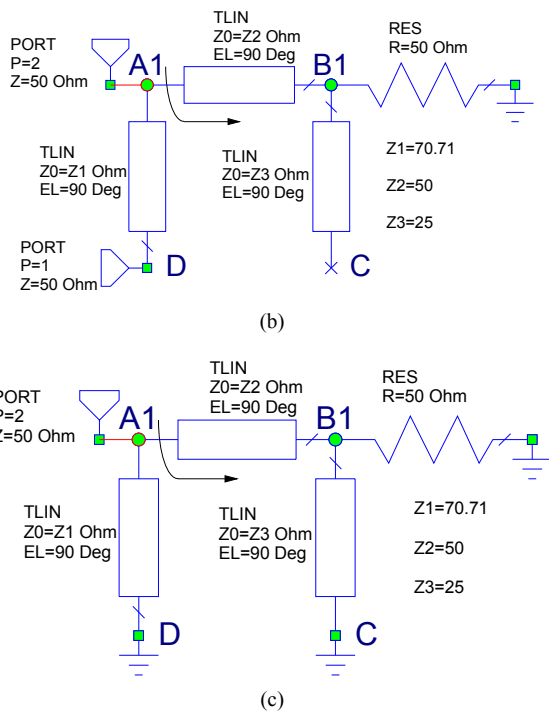
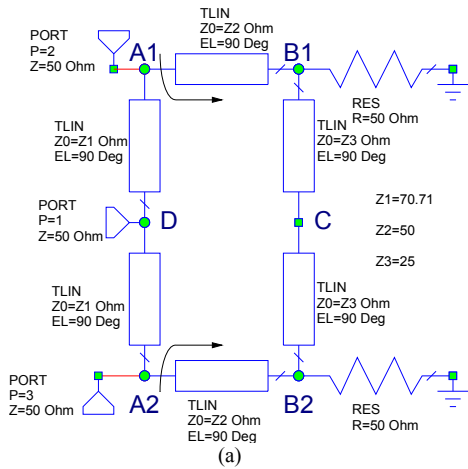

Fig. 1. (a) Schematic of Gysel divider, (b) even mode, and (c) odd mode equivalent circuit of Gysel divider

The only new design parameters are Z_{even} and Z_{odd} . Choosing Z_{even} is fairly simple. Since the even mode should see an open circuit, to the right of A1 and A2, we should choose Z_{even} as large as possible. Choosing Z_{odd} is more interesting. The odd mode sees a shorted (at D) $\lambda/4$ Z1-line in parallel with the Zodd-line. Choosing a Zodd equal to 50Ω gives a perfect match to the odd mode at f_0 , as expected. Choosing $Z_{odd} > 50 \Omega$ is disadvantageous as it directs more energy towards the Z1-line. Choosing $Z_{odd} < 50 \Omega$ reduces the match at f_0 at the expense of a larger bandwidth. Choosing Z_{odd} between $25 - 50 \Omega$ increases the bandwidth while maintaining reasonable isolation ($> 10 - 30$ dB) across the band.

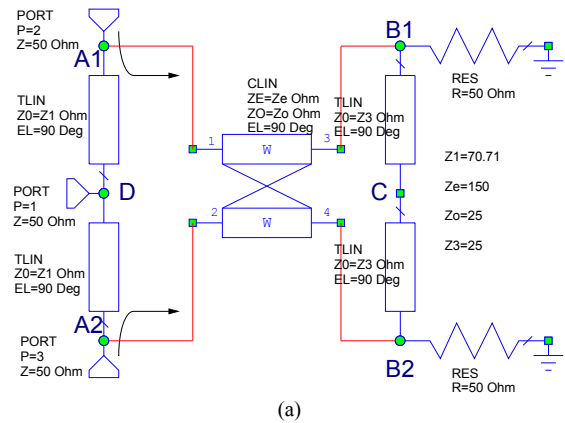

Fig. 2. (a) Schematic of proposed coupled-Gysel divider

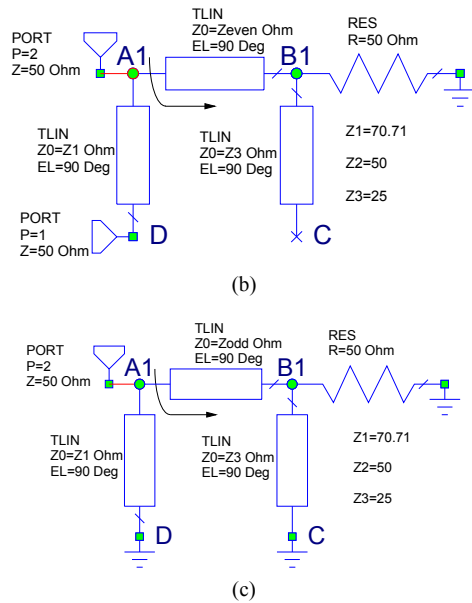

Fig. 2. (b) even mode, and (c) odd mode equivalent circuit of coupled-Gysel divider.

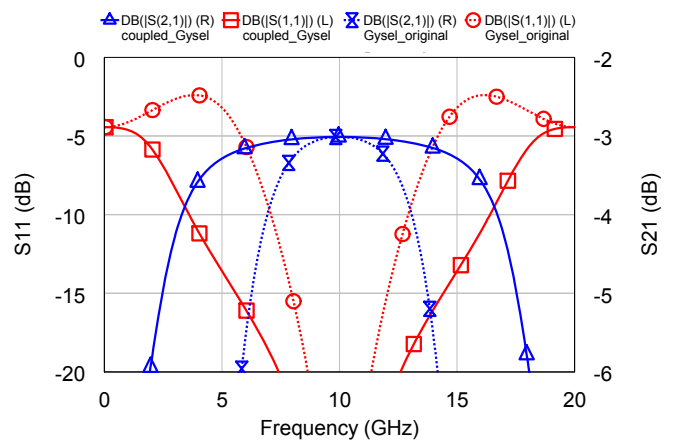

Fig. 3a. Simulation of S11 (left axis), and S21 (right axis) for classical (dotted lines), and coupled-Gysel (solid lines).

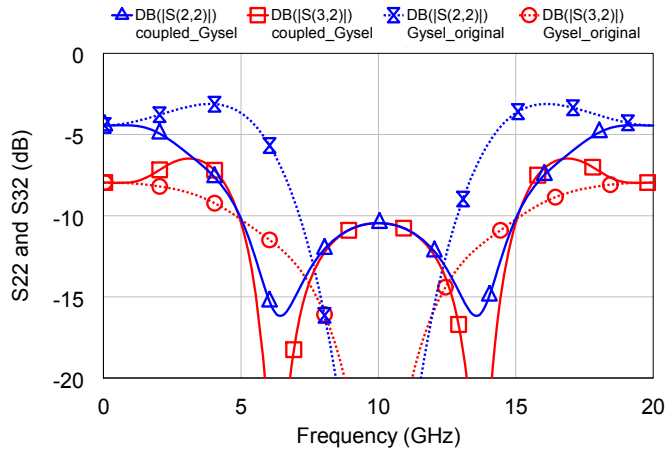

Fig. 3b. Simulation of S22, and S32 (isolation) for classical (dotted lines), and coupled-Gysel (solid lines).

Assuming a center frequency of 10 GHz, Figs. 3a, and 3b show a comparison between a classical and a coupled-Gysel, where $Z_{even} = 250 \Omega$, and $Z_{odd} = 25 \Omega$ were used, as an example. If we define bandwidth as a 1 dB drop in insertion loss, then the classical Gysel covers 7 – 13 GHz (60% fractional bandwidth), and the coupled-Gysel covers 3.3 – 16.7 GHz (133% fractional bandwidth). If we define bandwidth by a minimum of 10 dB isolation, and input/output insertion loss, then the classical Gysel covers 7.12 – 12.88 GHz (57% fractional bandwidth), and the coupled-Gysel covers 4.95 – 15.05 GHz (101% fractional bandwidth).

III. IMPROVED COUPLED-GYSEL IMPLEMENTATION

This section presents implementations (using Rogers® Duroid 6010 25-mil material) of the new divider as a verification of the theory. Two implementations are presented; a 2.5 – 8 GHz divider, and a 3.4 – 10.2 GHz divider. A picture of the fabricated 2.5 – 8 GHz divider is shown in Fig. 4. It measures $0.2'' \times 0.6''$ only. The coupled line was implemented using two narrow microstrip lines with 3 mil width and a 2.1 mil gap (should support about 300 W CW before air breakdown) and equivalent Z_{even} and Z_{odd} impedances are 150Ω , and $Z_{odd} = 40 \Omega$, respectively. The measured performance is shown in Fig. 5, along with the simulation. The bandwidth based on 1-dB insertion loss is 2.5 – 8 GHz (105% fractional bandwidth), and the insertion loss in the center of the band is 3.1 dB; hence the divider has 0.1 dB of loss. A higher frequency divider was also implemented. Fig. 5 shows the simulation and measurement. The bandwidth based on the 1-dB insertion loss is 3.4 – 10.2 GHz (100% fractional bandwidth), and the RF loss in the center of the band is 3.2 dB; the divider's loss is 0.2 dB.

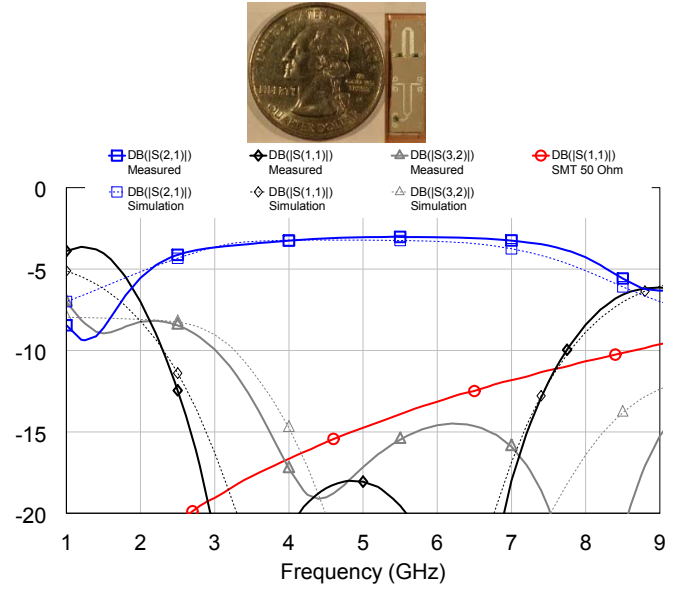

Fig. 4. Picture of coupled-Gysel divider covering 2.5 – 8 GHz. Insertion loss, return loss, and isolation. Also shown is the measured SMT 50 Ω termination.

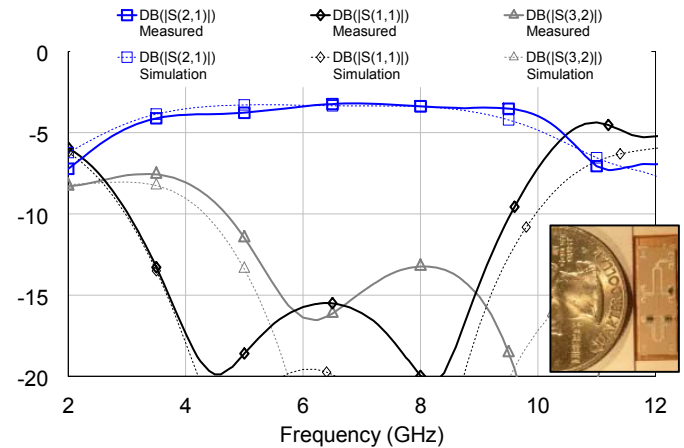

Fig. 5. Insertion loss, return loss, and isolation of 3.4 – 10.2 GHz coupled-Gysel divider. A picture of the fabricated divider is shown in the inset.

IV. CONCLUSIONS

The concept, and implementations of a novel Gysel divider/combiner structure have been demonstrated. The divider/combiner are applicable to various high-power, broadband radar, EW and phased-array applications.

REFERENCES

- [1] E. Wilkinson, "An N-way hybrid power divider," IRE Transactions on Microwave Theory Tech., vol. MTT-8, no. 1, pp. 116–118, Jan. 1960.
- [2] U. H. Gysel, "A new N-way power divider/combiner suitable for high-power applications," IEEE International Microwave Symposium Digest, pp. 116–118, 1975.
- [3] Y. Wu, Y. Liu, and S. Li, "A Modified Gysel Power Divider of Arbitrary Power Ratio and Real Terminated Impedances," IEEE Microwave and Wireless components letters, vol. 21, no. 11, pp. 601 – 603, 2011.
- [4] Z. Sun, L. Zhang, and Y. Yan, "A Novel Unequal Dual-band Gysel Power Divider," IEEE International Microwave Symposium, Baltimore, MD, 2011.
- [5] Z. Sun, L. Zhang, Y. Yan, and X. Tong "Modified Gysel Power Divider for Dual-Band Applications," IEEE Microwave and Wireless components letters, vol. 21, no. 1, pp. 16 – 18, 2011.
- [6] J. Li, Y. L. Wu, Y. Liu, J. Shen, S. Li, and C. Yu, "A Generalized Coupled-Line Dual-Band Wilkinson Power Divider with Extended Ports," Progress in Electromagnetic Research, vol. 129, pp. 197 – 214, 2012.
- [7] K. X. Wang, X. Y. Zhang, and B. Hu, "Gysel Power Divider With Arbitrary Power Ratios and Filtering Responses Using Coupling Structure," IEEE Transactions on Microwave Theory and Tech., vol. 62, no. 3, pp. 431 – 440, 2014.
- [8] W. Wang, Y. Wu, and Y. Liu, "A Novel High-Power Dual-Band Coupled-Line Gysel Power Divider with Impedance-Transforming Functions," The Scientific World Journal, vol. 2014, article ID 831073, 2014.