



DEPARTMENT OF THE NAVY

OFFICE OF COUNSEL
NAVAL UNDERSEA WARFARE CENTER DIVISION
1176 HOWELL STREET NEWPORT RI 02841-1708

IN REPLY REFER TO

Attorney Docket No. 300085
25 May 2017

The below identified patent application is available for licensing. Requests for information should be addressed to:

TECHNOLOGY PARTNERSHIP ENTERPRISE OFFICE
NAVAL UNDERSEA WARFARE CENTER
1176 HOWELL ST.
CODE 00T2, BLDG. 102T
NEWPORT, RI 02841

Serial Number 15/272,536
Filing Date 22 September 2016
Inventor Kurt M. Czepizak et al

Address any questions concerning this matter to the Office of Technology Transfer at (401) 832-1511.

DISTRIBUTION STATEMENT
Approved for Public Release
Distribution is unlimited

VARIABLE LENGTH INFLATABLE RAMP LAUNCH AND RECOVERY SYSTEM

STATEMENT OF GOVERNMENT INTEREST

[0001] The invention described herein may be manufactured and used by or for the Government of the United States of America for governmental purposes without the payment of any royalties thereon or therefor.

CROSS REFERENCE TO OTHER PATENT APPLICATIONS

[0002] None.

BACKGROUND OF THE INVENTION

(1) Field of the Invention

[0003] The present invention relates to launch and recovery systems, and more particularly a lightweight, containerized, inflatable launch and recovery system for towed bodies.

(2) Description of the Prior Art

[0004] Various at-sea training exercises require the launch, tracking and recovery of undersea vehicles. Due to the high costs of such vehicles; it is imperative that precautions be taken to ensure that the vehicles are not lost during exercises. Through the use of a towed body, these exercises can simulate the launch and tracking of an undersea vehicle while enabling recovery of the vehicle at the conclusion of the exercise.

[0005] Launch and recovery systems for towed bodies used in undersea warfare exercises often require installations and

infrastructures that are unique to the host vessel; especially when installed aboard research vessels. The specialized handling equipment used aboard research vessels lacks the adaptability required for general use aboard multiple fleet platforms. The inability of the specialized handling equipment to readily support multiple platforms can limit fleet exercises.

Furthermore, research vessels are typically unable to operate at fleet tactical speeds.

[0006] Current systems are generally vessel specific and rigid. The systems are often constructed of metal frames. These frames can take up considerable deck space that could otherwise be used for tactical operations. During at-sea exercises, the frames sometimes are subjected to overload events. As a result, the frames may permanently deform or fracture; thereby, rendering the system inoperable.

[0007] What is therefore needed is a more flexible towed body launch and recovery system design that will enable deployment from a variety of fleet platforms. The system should be capable of operation at tactical speeds. Furthermore, a system is needed that provides a structurally fail-safe mode of operation during an overload event. For example: an overload on the system should not cause major structural damage that shuts down the system.

[0008] There is also a need to minimize the deck space requirements of the launch and recovery system. In meeting these needs, the system should also reduce installation costs and infrastructure requirements.

SUMMARY OF THE INVENTION

[0009] Accordingly, it is an objective of the present invention to provide a structurally safe mode of operation for a towed body launch and recovery system.

[0010] It is a further objective of the present invention to minimize the deck space requirements of the towed body launch and recovery system.

[0011] It is a still further objective of the present invention to provide a towed body launch and recovery system that reduces installation costs and infrastructure requirements by providing a self-contained system that requires few modifications for different platforms.

[0012] In accordance with these and other objective made apparent hereinafter, an inflatable launch and recovery system with a capture and swing support for a towed body is provided to accommodate variable freeboard heights. A variable length of the ramp is achieved by changing the length of deployed air beams of the system.

[0013] In operation and during deployment, the air beams unwind off an air beam winch at varying lengths with aft ends of the air beams located in the ABDF. During the deployment, the air beams are extruded from the aft end of the ABDF where the beams are no longer restricted from expanding diametrically. Diametrically, as defined here, is the direction outward and at every point perpendicular to the circumference of the circular air beam.

[0014] The air beams are inflated from an aft end with hoses that extend a length of the beams; thereby, causing a flattened shape of the beams to inflate into a circular or rounded shape. The air hoses maintain a predetermined orientation by pressurizing the air beams within the ABDF. Rollers near the air beam winches seal the air beams; thereby, allowing the beams to inflate to a design pressure and then become rigid. As the air beams inflate and contact the ABDF; this inflation outwardly extrudes the beams. Once the desired length of the air beams is inflated; the length is fixed by locking the rollers to prevent a further extension of the air beams.

[0015] To deploy a tow body into the liquid medium, a positioning cart transitions from the ABDF to the aft end of the deployed and inflated air beams. By using inflated air beams with constant diameters; the positioning cart with vertical wheel spacing securely engages the extended air beams and can then deploy a tow body.

[0016] The invention simplifies the transition between the ABDF and the air beams because a large step down to a different diameter is not needed. Also, the positioning cart can travel the length of the ABDF and the inflatable air beams for deployment and when not in use, for retraction.

[0017] The positioning cart is the primary interface with the tow body by hosting a capture and swing support for tow body capture and release. A translating arch that rides rails of the positioning cart moves from the forward to the aft end of the

positioning cart where the tow body can be released from the capture boom and swing support.

[0018] To further the modularity of the inventive system, the interchangeable tow body hardware allows for various top tow and nose tow bodies to be used. The cart and deployment operations remain the same, with only the interface hardware being interchangeable for different mission packages.

[0019] Other objects, features and advantages of the present invention including various novel details of construction and combinations of parts, will now be more particularly described with reference to the accompanying drawings and pointed out in the claims. It will be understood that the particular assembly embodying the invention is shown by way of illustration only and not as a limitation of the invention. The principles and features of this invention may be employed in various and numerous embodiments without departing from the scope of the invention.

BRIEF DESCRIPTION OF THE DRAWINGS

[0020] Reference is made to the accompanying drawings in which are shown illustrative embodiments of the invention, from which its novel features and advantages will be apparent, wherein corresponding reference characters indicate corresponding parts throughout the several views of the drawings and wherein:

[0021] **FIG. 1** depicts a launch and recovery system of the present invention in which a variable length inflatable ramp launch and recovery system is in an extended position;

[0022] **FIG. 2** depicts the inflatable ramp launch and recovery system in a stowed position;

[0023] **FIG. 3** depicts the inflatable ramp launch and recovery system at a tilt;

[0024] **FIG. 4** depicts the inflatable ramp launch and recovery system at a tilt with the scope of extension exceeding that of **FIG. 3**;

[0025] **FIG. 5** depicts the launch and recovery system in which there is an air beam transition from a flattened shape inside a drum to a cylindrical shape inside an air beam deployment frame (ABDF) with parts of the figure shown as transparent to ease identification of the location of certain components;

[0026] **FIG. 6** depicts the launch and recovery system in which air hoses are used to fill and orient the air beam;

[0027] **FIG. 7** depicts the launch and recovery system with sealing and drive rollers for the air beam;

[0028] **FIG. 8** depicts the launch and recovery system with a side view of the positioning cart transition from the ABDF to the inflatable air beams with parts of the figure shown as transparent to ease identification of the location of certain components;

[0029] **FIG. 9** depicts the launch and recovery system with an isometric view of transition from the ABDF to the inflatable air beams with parts of the figure shown as transparent to ease identification of the location of certain components; and

[0030] **FIG. 10** depicts the launch and recovery system in the deployed position.

DETAILED DESCRIPTION OF THE INVENTION

[0031] Referring now to **FIG. 1**, there is shown an inflatable launch and recovery system **10** mounted on a vessel **A** (only partially shown in the figure) with the system shown in an extended position. Typically, the inflatable launch and recovery system **10** is mounted at an aft end of the vessel **A**, such that the system can trail behind the vessel when deployed. In the stowed position, the inflatable launch and recovery system **10** is mostly deflated.

[0032] In the figure, the launch and recovery system **10** is mechanically connected to a mounting frame **12** and is movable to a tilted position by use of a tow cable winch **14** and pistons (not shown). The tow cable winch **14** allows the system **10** to hinge off the mounting frame **12**.

[0033] A tow cable **15** passes from the tow cable winch **14** around a pulley **16** and attaches to a capture boom and swing support **17**. The launch and recovery system **10** extends from the mounting frame **12** such that an air beam deployment frame (ABDF) **18**, dual air beams **20**, a translating arch **22** and a positioning cart **24** move to a direction for deployment or release of a tow body **100** (not shown). Indirectly, the tow cable **15** also affects the translating arch **22** and the positioning cart **24**. See **FIG. 10** for placement of the tow body **100**.

[0034] The air beams **20** are braided, fabric structures that can be pressurized to provide axial, bending, shear and torsional stiffness. In operation, each air beam **20** unwinds from an air beam winch **25** and when inflated extrudes out of the ABDF **18**. The

ABDF **18** is a rigid and hollow support structure that houses the deflated air beams **20**; serves as an attachment structure for the air beams and tilts as a guide for deployment or retrieval of the air beams. The air beam winch **25** winds the tow cable **15** and secures the deflated air beams **20**.

[0035] The positioning cart **24** is a rigid structure that sits atop the ABDF **18** and travels to the end of the extended air beams **20** for deployment. The positioning cart **24** supports the translating arch **22** and has rails **26** for the arch to slide across when the system **10** is in the tilted position. The translating arch **22** slides across the positioning cart **24** to the deploying position.

[0036] The mounting frame **12** is a structure that attaches to the ABDF **18** and to sockets on the deck of the vessel **A**. The mounting frame **12** includes an aft hinge for tilting the ABDF **18** and a piston (not shown) to hold the ABDF at different tilt angles. The tow cable winch **14** transitions the positioning cart **24** along the ABDF **18** and the air beams **20**. The tow cable winch **14** also extends the tow cable **15** into the water to tow a tow body **100** during deployment and retraction during retrieval of the tow body.

[0037] In **FIG. 2**, the variable length inflatable ramp launch and recovery system **10** is shown in a stowed position. In the figure, the system **10** is secured on the mounting frame **12** by the tow cable winch **14** and is also secured by being in a position at rest on the frame. In **FIG. 3**, the launch and recovery system **10** is shown at a tilt with the translating arch **22** and the cart **24**

positioned proximate to the air beam winch **25** with the air beams **20** partially deployed.

[0038] In **FIG. 4**, the launch and recovery system **10** in a tilted position is shown with the translating arch **22** and the positioning cart **24** positioned proximate to the air beam winch **25** with the air beams **20** fully deployed. The system **10** is held in position by the tow cable winch **14** and the tow cable **15**.

[0039] In **FIG. 5**, the air beam winch **25** is shown extending the air beam **20** thru a transition area **28** where an uninflated air beam is inflated. In **FIG. 6**, the air beam **20** extends thru the ABDF **18** and is positioned on the cart **24** where air hoses **30** inflate the air beam as cart wheels **32** contain the inflation. The cart wheels **32** attach to the cart **24** at the inflatable air beams **20** and the ABDF **18**. Due to the minimal diametric difference between the ABDF **18** and the air beams **20**, no step down is necessary.

[0040] In **FIG. 7**, the inflation of an air beam **20** is shown. In the figure, the air beam **20** is unrolled from the air beam winch **25**. Prior to inflation, the transition area **28** restricts the inflation until the air beam **20** can be inflated by the air hoses **30**. The air hoses **30** are embedded on the side of the air beams **20** such that both the hoses and the air beam coil and deploy together while the air hoses inflate the air beam (See **FIG. 10** for the air hoses positioned on a deployed air beam).

[0041] The transition area **28** includes sealing rollers **40** and drive rollers **42**. The sealing rollers **40** and drive rollers **42** are activated through the use of motors and controllers (not

shown) with the sealing and drive rollers operating independently. The sealing rollers **40** only translate in and out to seal the air beams **20** and can spin freely. The drive rollers **42** translate in and out to engage the air beams **20** and additionally have a driven rotation to force extrusion.

[0042] The drive rollers **42** extrude the air beams **20** from the air beam winch **25** and the sealing rollers **40** seal the air beams during inflation. The air beams **20** enter a forward end of the ABDF **18** and extend out an aft end of the ABDF during deployment. The air hoses **30** run the length of the air beams **20** and can inflate from the aft end of the air beams. The air hoses **30** also orient the air beams **20** inside the ABDF **18**. The air for the air hoses **30** is supplied from an onboard tank which is replenished by an air compressor.

[0043] In **FIG. 8**, a side view of the positioning cart **24** is shown with the inflatable air beam **20** encased. The positioning cart **24** includes the cart wheels **32** sized to roll on the extended and inflated air beams **20**. As shown in **FIG. 9** and **FIG. 10**, the positioning cart **24** includes the translating arch **22** and a capture boom and swing support **17** which can hold the tow body **100**.

[0044] The capture boom and swing support **17** is a tow body interface underneath the translating arch **22** that is used to capture and release the tow body **100**. The capture boom and swing support **17** can also provide support to the tow body **100**. The tow body **100** is deployed and towed in the water behind the vessel **A**.

The tow body **100** can have either a nose or top towing fixture.

[0045] In operation, the air beams **20** unwind off the air beam winch **25** at varying lengths. The uninflated air beams **20** deploy from the air beam winch **25** where the beams enter the air beam deployment frame (ABDF) **18** and are no longer restricted from expanding diametrically.

[0046] The air beams **20** are inflated from an aft end with the air hoses **30** that extend a length of the beams to a ring-secured and hardened end cap **44**; thereby, causing a flattened shape of the beams to inflate into a rounded shape. The air hoses **30** maintain a predetermined orientation of the air beams **20** inside the ABDF **18**. The sealing rollers **40** near the air beam winches **25** seal the air beams **20**; thereby, allowing the beams to inflate to a design pressure and become rigid. As the air beams **20** inflate and contact the ABDF **18**; this inflation outwardly extrudes the beams.

[0047] Once the desired length of the air beams **20** is inflated; the length is fixed by locking the sealing rollers **40** to prevent further extrusion. Through this inflation; variable freeboard heights are accommodated to allow for installation of the system onto different host ships.

[0048] To deploy the tow body **100** into a liquid medium, the positioning cart **24** transitions from the ABDF **18** to the aft end of the variable length inflatable ramp launch and recovery system **10**. By using inflatable air beams with constant diameters; the positioning cart **24** with fixed vertical wheel spacing is able to deploy the tow body **100**. The invention simplifies the transition

between the ABDF **18** and the air beams **20** because a large step down does not need to be overcome. The positioning cart **24** can scale the length of both the ABDF **18** and the inflatable air beams **20** for deployment and retract back into the ABDF when not in use. The positioning cart **24** is the primary interface with the tow body by hosting the capture boom and swing support **17** for capture and release. The translating arch **22** moves from the forward to the aft end of the positioning cart **24** on the rails **26** to where the tow body **100** is released from the capture boom and swing support **17**.

[0049] The air beams **20** can be fabricated of continuously circular braided material, reinforced with tensile webbing straps for shaping. As is known to those of skill in the art, tubes fabricated in this manner maintain their shapes when inflated.

[0050] For enhanced damage tolerance and puncture resistance; the skins of the drop stitch and tube fabrics would use dense woven architectures. For even greater damage tolerance and improved drop yarn strength; the use of crimp-imbalanced woven architectures are recommended in accordance with United States Patent No. 8,555,472 and the progeny of this referenced patent. The air beams **20** can be protected from environmental exposure through the use of a laminated elastomeric coating.

[0051] As a further example, the inflatable air beams **20** can be constructed solely of spacer fabrics, cylindrical arches, cylindrical beams, or any mixture thereof using any flexible material that can maintain a shape when inflated and subjected to anticipated loads.

[0052] To further the modularity of the inventive system, the interchangeable tow body hardware allows for various top tow and nose tow bodies to be used. The cart and deployment operations remain the same, with only the interface hardware needing replacement for different mission packages.

[0053] The foregoing description of the preferred embodiments of the invention has been presented for purposes of illustration and description only. It is not intended to be exhaustive or to limit the invention to the precise form disclosed; and obviously many modifications and variations are possible in light of the above teaching.

[0054] It will be understood that many additional changes in the details, materials, steps and arrangement of parts, which have been herein described and illustrated in order to explain the nature of the invention, may be made by those skilled in the art within the principle and scope of the invention as expressed in the appended claims.

VARIABLE LENGTH INFLATABLE RAMP LAUNCH AND RECOVERY SYSTEM

ABSTRACT OF THE DISCLOSURE

A launch and recovery system for a towed body is provided in which uninflated air beams extrude from winches where the beams enter a deployment frame and are inflated. Sealing rollers near the winches seal the air beams when the desired length of the air beams is inflated. To deploy the towed body, a positioning cart moves along the inflated air beams from an end of a deployment frame. A translating arch moves from the forward to the aft end of the positioning cart on the rails to where the tow body is released from the capture boom and swing support. The positioning cart can retract back into the deployment frame when not in use.

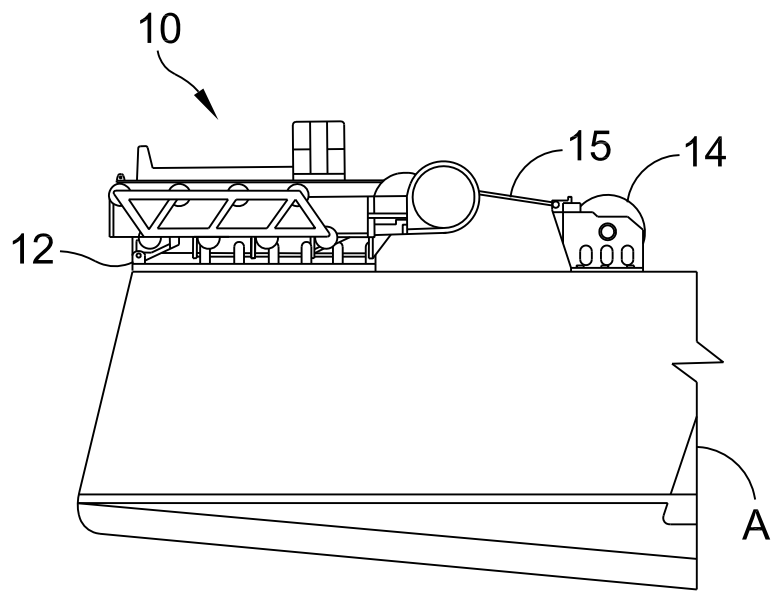
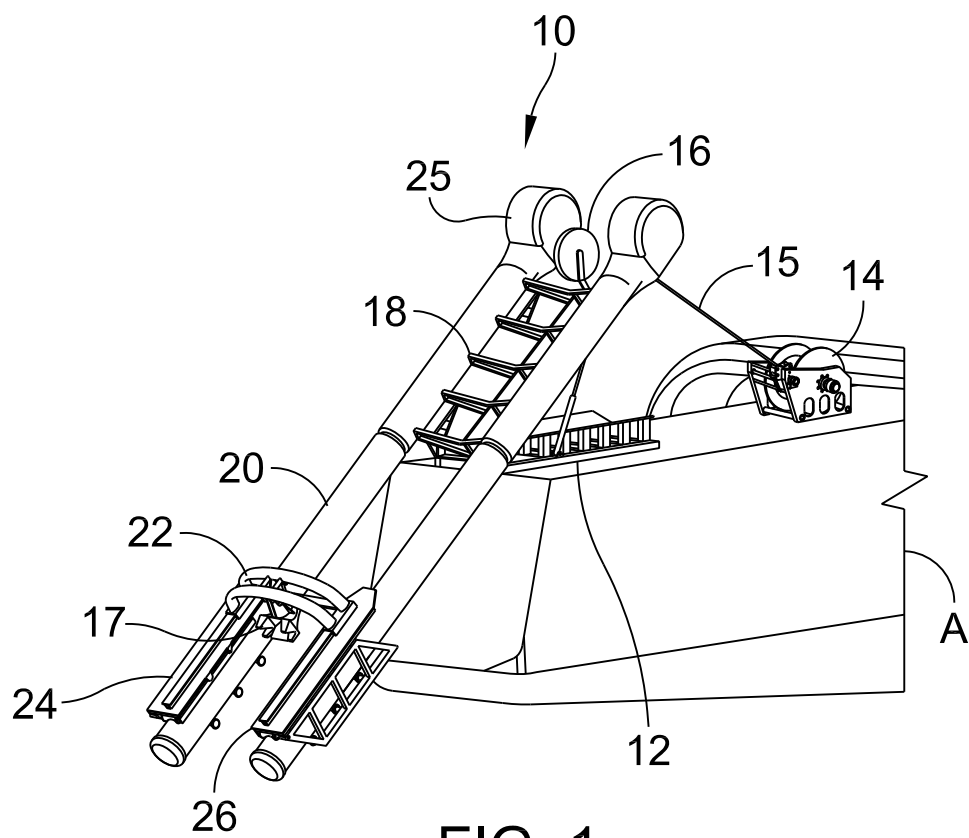

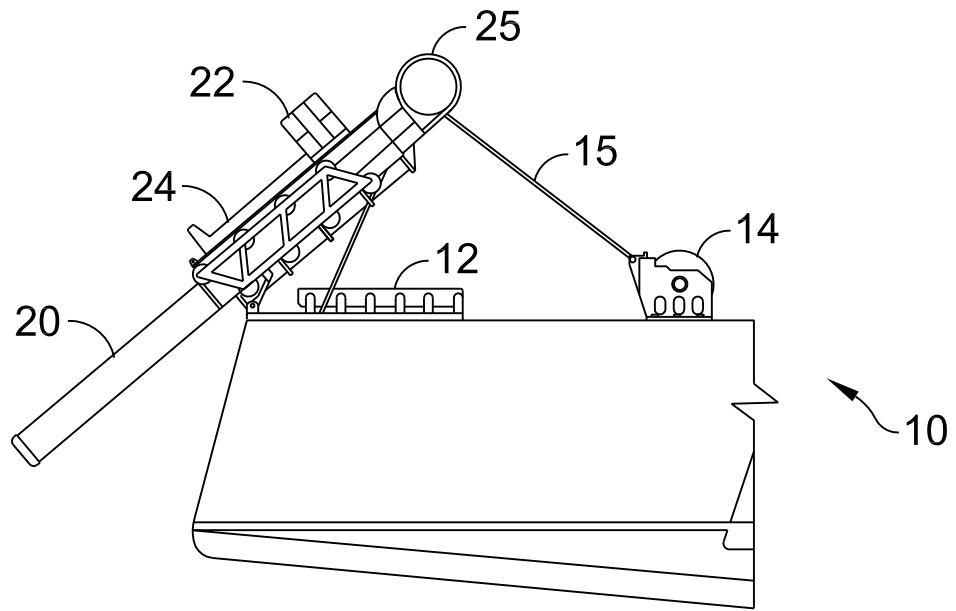

FIG. 3

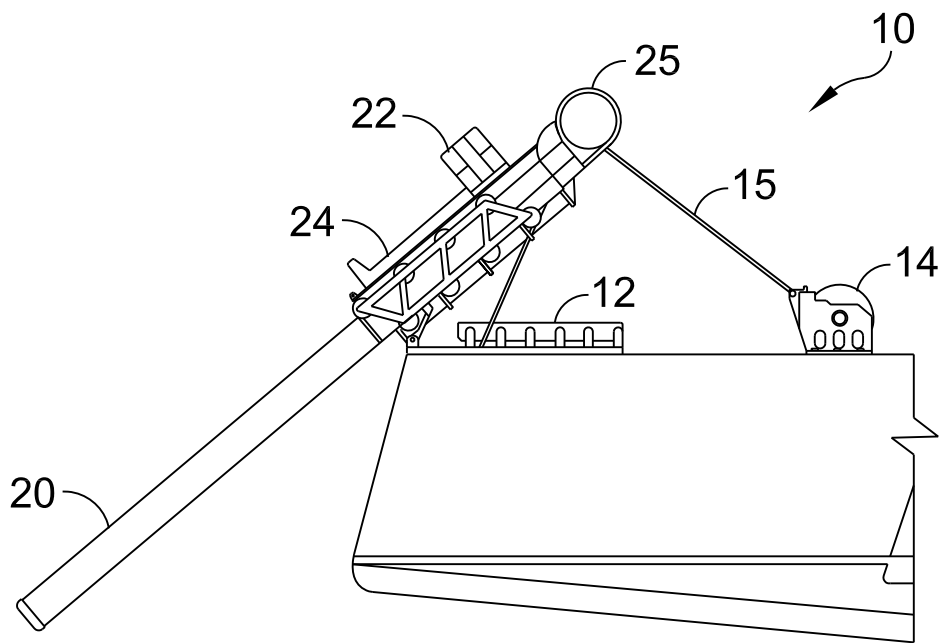

FIG. 4

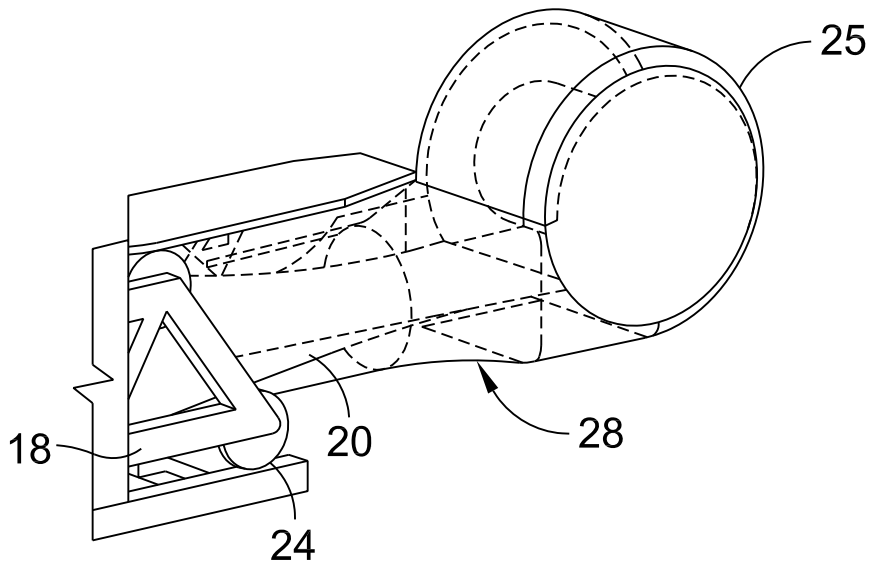

FIG. 5

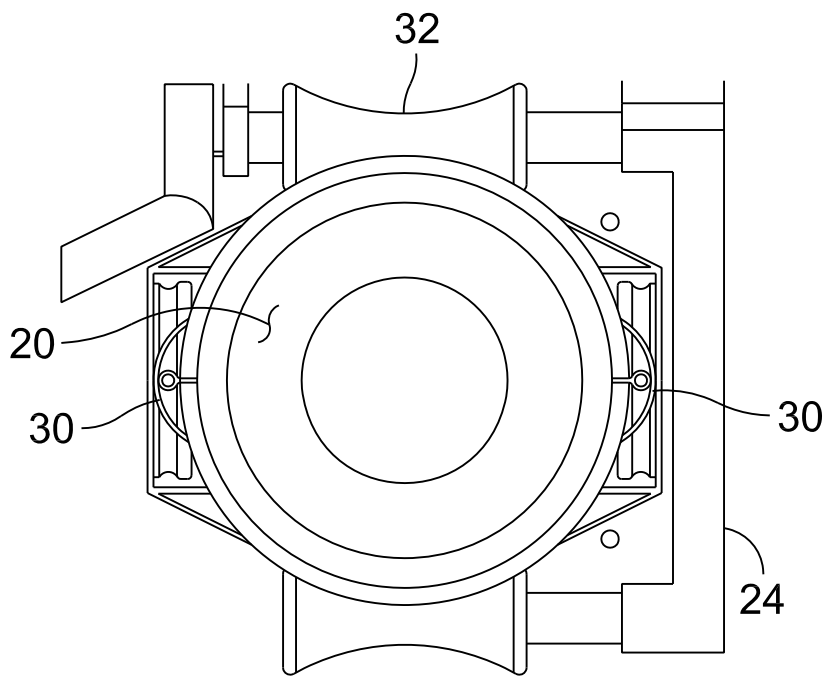

FIG. 6

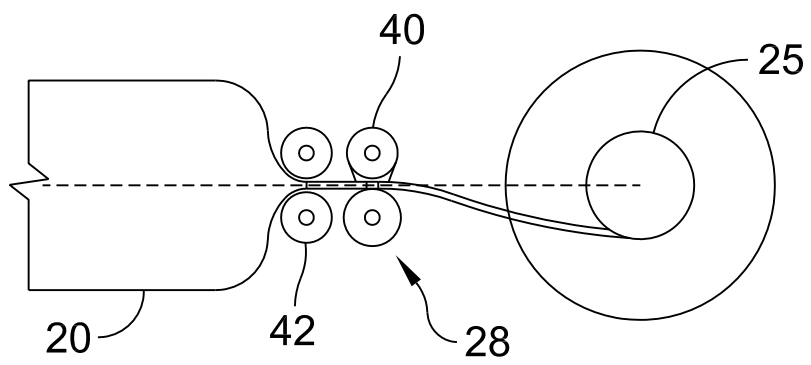

FIG. 7

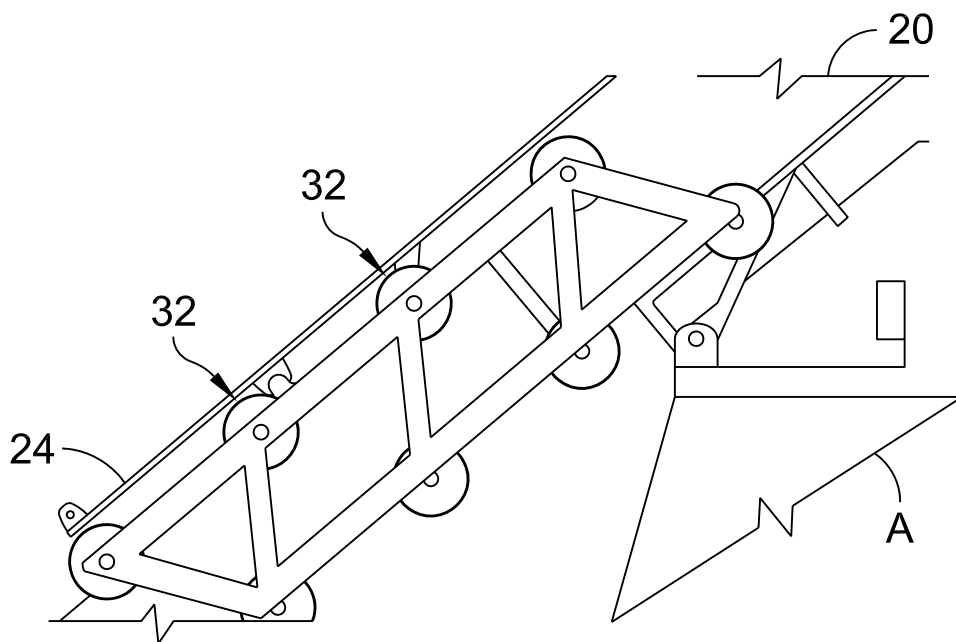

FIG. 8

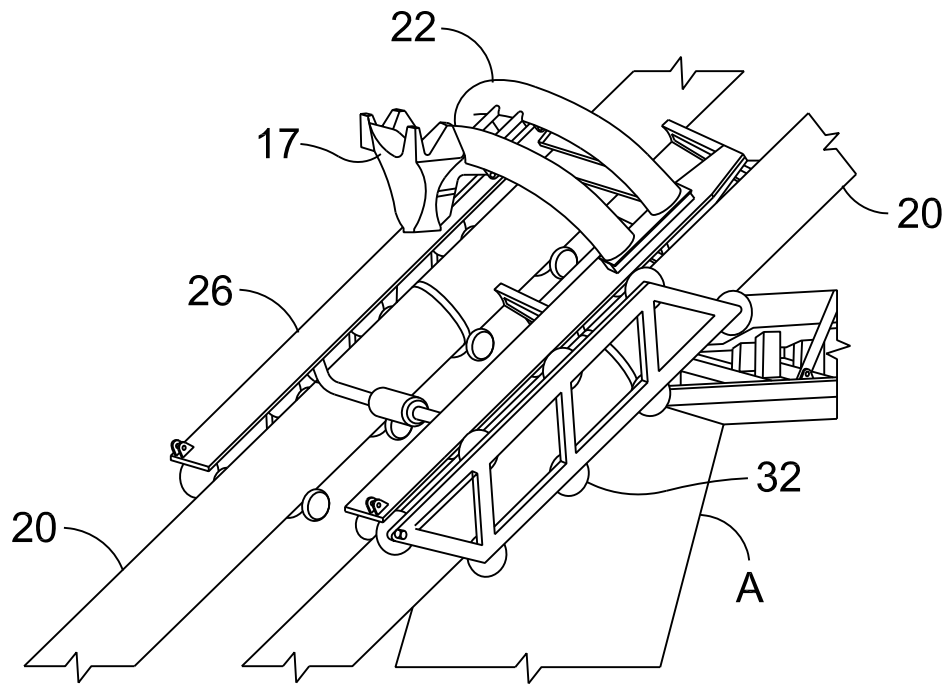

FIG. 9

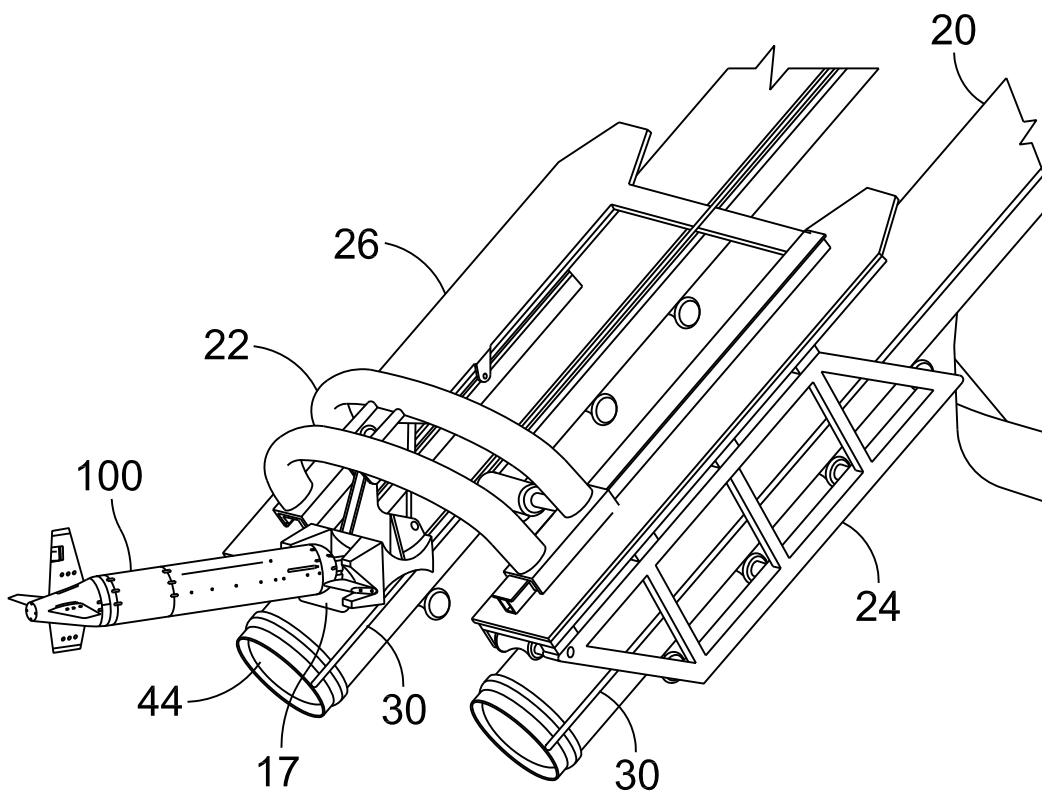

FIG. 10