



**US Army Corps
of Engineers®**
Engineer Research and
Development Center



Engineering for Polar Operations, Logistics, and Research (EPOLAR)

Tidal Energy Resource Assessment for McMurdo Station, Antarctica

Brendan A. West, Ian F. Gagnon, and Martin Wosnik

December 2016



The U.S. Army Engineer Research and Development Center (ERDC) solves the nation's toughest engineering and environmental challenges. ERDC develops innovative solutions in civil and military engineering, geospatial sciences, water resources, and environmental sciences for the Army, the Department of Defense, civilian agencies, and our nation's public good. Find out more at www.erdclibrary.usace.army.mil.

To search for other technical reports published by ERDC, visit the ERDC online library at <http://acwc.sdp.sirsi.net/client/default>.

Tidal Energy Resource Assessment for McMurdo Station, Antarctica

Brendan A. West

*U.S. Army Engineer Research and Development Center (ERDC)
Cold Regions Research and Engineering Laboratory (CRREL)
72 Lyme Road
Hanover, NH 03755-1290*

Ian F. Gagnon and Martin Wosnik

*University of New Hampshire
School of Marine Science and Ocean Engineering
Chase Ocean Engineering Laboratory
24 Colovos Rd
Durham, NH 03824*

Final Report

Approved for public release; distribution is unlimited.

Prepared for National Science Foundation, Division of Polar Programs
Antarctic Infrastructure and Logistics
4201 Wilson Boulevard
Arlington, VA 22230

Under Engineering for Polar Operations, Logistics, and Research (EPOLAR)
EP-ANT-16-14, "Ocean Energy Feasibility Study for McMurdo Station,
Antarctica"

Abstract

The U.S. Antarctic Program (USAP) is interested in expanding renewable energy capabilities at McMurdo Station, Antarctica, to reduce costs and emissions. Previous assessments considered wind, solar, and geothermal energy resources but not ocean energy resources such as tidal energy. The National Science Foundation, Division of Polar Programs, Antarctic Infrastructure and Logistics, commissioned the Cold Regions Research and Engineering Laboratory to assess the feasibility of a tidal energy system in the waters near McMurdo Station. This study used industry standards to assess relevant datasets, including bathymetry, tidal characteristics, meteorological, and icing data. Unfortunately, the available data was insufficient for full annual energy production estimates; however, the data unanimously indicated that current speeds within Winter Quarters Bay and the adjacent McMurdo Sound are much too low for tidal energy generation. The maximum measured current speed was less than the typical cut-in speed for most tidal energy turbines. Additional challenges, including the recent declaration of the Ross Sea as a marine protected area and the need for high-strength infrastructures to withstand icing, make the McMurdo Station region a poor location for a tidal energy installation. USAP would likely fail to recoup the costs associated with such a system. Although tidal energy is not suitable for this case, this report presents a collated set of various tidal-related data for the McMurdo Station region, which may be of use to other studies.

DISCLAIMER: The contents of this report are not to be used for advertising, publication, or promotional purposes. Citation of trade names does not constitute an official endorsement or approval of the use of such commercial products. All product names and trademarks cited are the property of their respective owners. The findings of this report are not to be construed as an official Department of the Army position unless so designated by other authorized documents.

DESTROY THIS REPORT WHEN NO LONGER NEEDED. DO NOT RETURN IT TO THE ORIGINATOR.

Contents

Abstract	ii
Figures and Tables.....	v
Preface.....	vi
Acronyms and Abbreviations.....	vii
1 Introduction.....	1
1.1 Background.....	1
1.2 Objectives.....	1
1.3 Approach.....	2
2 Review of Tidal Energy.....	3
2.1 The earth's tides.....	4
2.2 Tidal energy.....	8
2.3 Tidal energy converters.....	12
2.4 Tidal energy regulations.....	14
3 Data Collection.....	15
3.1 Bathymetry and seafloor composition.....	15
3.2 Tidal characteristics.....	17
3.2.1 <i>Current speeds</i>	18
3.2.2 <i>Current directions</i>	20
3.2.3 <i>Nathaniel B. Palmer ADCP mobile surveys</i>	20
3.2.4 <i>Tidal height</i>	21
3.2.5 <i>Tidal constituents</i>	23
3.3 Meteorological and climate data.....	24
3.3.1 <i>Wind and atmospheric pressure</i>	24
3.3.2 <i>Wave climate</i>	25
3.3.3 <i>Turbulence</i>	25
3.3.4 <i>Stratification and seawater density</i>	28
3.3.5 <i>Ocean water temperature</i>	28
3.3.6 <i>Ice-related data</i>	29
3.4 Meeting IEC data requirements.....	31
4 Resource Assessment.....	32
4.1 Observations from data.....	32
4.2 Modeling.....	33
5 Additional Considerations.....	35
5.1 McMurdo Sound ecology.....	35
5.2 Environmental effects.....	36
5.3 Electrical grid considerations.....	40

6	Conclusions and Recommendations	42
	References	44
	Appendix A: Locations of Reported Current Speeds and Directions.....	48
	Appendix B: Locations of Reported Tidal Constituents	50
	Appendix C: Acoustic Doppler Current Profiler Information	51
	Report Documentation Page	

Figures and Tables

Figures

1	Tidal bulges explained by the variation in gravitational tractive force throughout the diameter of the earth (not to scale). F_c represents the centrifugal forces, and F_g represents the gravitational forces.....	5
2	Diurnal and tropic tides explained by the out-of-plane orbit of the moon with respect to the earth's equator	6
3	Spring tide, showing amplified tidal elevations (not to scale)	7
4	Neap tide, showing smaller tidal elevations (not to scale)	7
5	Representative C_p vs. λ curve for a cross-flow tidal turbine, from Bachant and Wosnik (2015). The particular turbine rotor in Fig. 5 (UNH RVAT) was not designed to have the highest power coefficient possible, only to provide a high-fidelity data set for a simple geometry turbine model at reasonably high blade chord Reynolds numbers.....	9
6	Tidal energy turbine diagrams	13
7	Relevant locations near McMurdo Station	16
8	Bathymetry outside Winter Quarters Bay. Numbers indicate depth in meters, as referenced to the WGS 1984 datum	17
9	Annual exceedance probabilities for different elevations of low and high tides, as referenced to the Scott Base tidal gauge datum and RSRGD2000. The historical data used for this analysis are from the Scott Base tidal gauge	23
10	Elevated submarine features near Winter Quarters Bay	27
11	Icebreaker approach path. (Photo courtesy of NSF.).....	30
A-1	Map illustrating the magnitude and direction of tide measurements at different locations around McMurdo Station. Table A-1 provides additional information for each measurement site.....	48
C-1	A LinkQuest FlowQuest 1000 ADCP. The piezoelectric oscillators can be seen on the sloped surfaces at the bottom of the image.....	51
C-2	A bottom mounted ADCP configuration with an external battery pack on a triangular mounting system (<i>left</i>) and a surface mounted ADCP configuration pole mounted over the bow of a floating platform (<i>right</i>)	52
C-3	Illustration of Doppler shift.....	53

Tables

1	Ocean energy sources (Lewis et al. 2011).....	3
2	Causes of environmental effects due to tidal energy installations (Polagye et al. 2010).....	36
A-1	Additional information supporting measurements in Fig. A-1.....	49
B-1	Reported tidal constituents for sites close to McMurdo Station.....	50

Preface

This study was conducted for the National Science Foundation, Division of Polar Programs (NSF-PLR), under Engineering for Polar Operations, Logistics, and Research (EPOLAR) EP-ANT-16-14, “Ocean Energy Feasibility Study for McMurdo Station, Antarctica.” The technical monitor was Margaret Knuth, Operations Manager, NSF-PLR, Antarctic Infrastructure and Logistics.

The work was performed by Brendan A. West (Terrestrial and Cryospheric Sciences Branch, J.D. Horne, Chief), U.S. Army Engineer Research and Development Center, Cold Regions Research and Engineering Laboratory (ERDC-CRREL), and Ian F. Gagnon (Dr. Martin Wosnik, Advisor) and Dr. Martin Wosnik, University of New Hampshire (UNH), School of Marine Science and Ocean Engineering. At the time of publication, Janet Hardy was the program manager for EPOLAR. The Deputy Director of ERDC-CRREL was Dr. Lance Hansen, and the Director was Dr. Robert Davis.

The authors wish to thank Cathleen Torres Parisian, Geospatial Support Specialist, Polar Geospatial Center (PGC), University of Minnesota, for her assistance producing bathymetric data and collated current speed and direction maps and Glen Rowe, Senior Tidal Officer, New Zealand Hydrographic Authority, for his assistance acquiring Scott Base tide gauge records.

COL Bryan S. Green was the Commander of ERDC, and Dr. Jeffery P. Holland was the Director.

Acronyms and Abbreviations

AC	Alternating Current
ADCP	Acoustic Doppler Current Profiler
AEP	Annual Energy Production
AIL	Antarctic Infrastructure and Logistics
BOEM	Bureau of Ocean Energy Management
CTD	Conductivity, Temperature, and Depth
CRREL	U.S. Army Cold Regions Research and Engineering Laboratory
DC	Direct Current
EMF	Electromagnetic Effects
ENSO	El Niño Southern Oscillation
EPOLAR	Engineering for Polar Operations, Logistics and Research
ERDC	Engineer Research and Development Center
FERC	Federal Energy Regulatory Commission
GPS	Global Positioning System
IEC	International Electrotechnical Commission
MPA	Marine Protected Area
NOAA	National Oceanic and Atmospheric Administration
NSF	National Science Foundation
OCS	U.S. Outer Continental Shelf
OTEC	Ocean Thermal Energy Conversion
PCBs	Polychlorinated Biphenyls
PGC	Polar Geospatial Center

PLR	Division of Polar Programs
RSRGD200	Ross Sea Region Geodetic Datum 2000
UNH	University of New Hampshire
USAP	United States Antarctic Program
WGS	World Geodetic System

1 Introduction

1.1 Background

McMurdo Station is the National Science Foundation's (NSF) primary research facility in Antarctica and supports thousands of researchers and their projects each year. To date, a significant portion of the station's energy demand is generated with fuel shipped from the United States. Shipping approximately 6 million gallons of fuel to McMurdo each year is expensive and requires icebreaking and other logistical expenses. The U.S. Antarctic Program (USAP) has identified an opportunity to reduce its operational costs and carbon footprint in Antarctica by exploring renewable energy options. In recent years, USAP has "undertaken a number of energy-related studies"; but "the status of these studies and associated recommendations are unclear" (U.S. Antarctic Program Blue Ribbon Panel 2012). These studies have predominantly considered solar, wind, geothermal, and waste wood and paper products as energy sources. One renewable energy resource that has not been fully assessed for McMurdo Station is the ocean water of Winter Quarters Bay and McMurdo Sound.

The ocean provides a variety of unique energy resources that can be harnessed for energy generation. In recent years, tidal energy systems have proven capable of producing significant amounts of energy by harnessing the kinetic energy of ocean currents (e.g., the installation of SeaGen in Strangford Narrows in Northern Ireland). McMurdo Station's renewable energy initiative and location on the edge of McMurdo Sound warrants a feasibility assessment of tidal energy in support of the station. Although tidal energy has been explored in Arctic locations, to our knowledge, a tidal energy system at McMurdo would be the first of its kind in the Antarctic region. The system would experience unique conditions due to Antarctica's distinctive climate and location.

1.2 Objectives

The primary objective of this study is to collate data recorded near McMurdo Station that are relevant to tidal energy assessments and to evaluate the feasibility of installing a turbine there. Based on the relevant data, this study will consider a number of criteria related to tidal energy

installations, including the speed of local ocean currents, the bathymetry and composition of the local seafloor, the potential icing conditions, and the possible impact of a turbine on the local ecosystem. This study will provide a recommendation as to whether USAP would benefit from installing a tidal energy system at McMurdo Station.

1.3 Approach

This study will follow the recommendations of the International Electrotechnical Commission (IEC) Technical Specification for tidal energy resource assessment and characterization (IEC TS 62600-201:2015). The IEC is an organization that develops international standards for all electrical, electronic, and related technologies with input from subject matter experts from different countries. The IEC has developed best-practice documents for assessing a variety of renewable energy resources, including wind, solar, and marine energies (wave and tidal). The IEC 62600-201 Technical Specification addresses tidal energy resource assessments and presents “techniques that are expected to provide fair and suitably accurate results” (IEC 2015). We have decided to follow the recommendations of this document because the IEC standards offer, as close as possible, an international consensus on tidal energy resource assessments. The only recommendation not followed is modeling of the tidal resource, as explained in Section 4.2.

The IEC 62600-201 document provides recommendations on what types of data to collect and the types of analyses needed to accurately assess a tidal resource. The document provides guidance for two different types of studies: a Stage 1 feasibility study and a Stage 2 layout design study. This current study fits the Stage 1 definition, and these guidelines were followed as closely as possible where applicable. Any deviations from the standards are explicitly stated. This study provides an example of applying the IEC 62600-201 Technical Standard to an actual resource assessment.

2 Review of Tidal Energy

Energy can be extracted from the ocean via six known sources as described in Table 1.

Table 1. Ocean energy sources (Lewis et al. 2011).

Source	Origin	Extraction Mechanism Examples
Wave	Kinetic energy from wind	Oscillating water column, oscillating body, overtopping
Tidal Range	Tidal rise and fall from celestial-body gravitational effects	Tidal barrage with turbines to separate basins, tidal lagoons
Tidal Currents	Flow resulting from tidal rise and fall in coastal regions	Axial-flow turbines, cross-flow turbines, reciprocating devices
Ocean Currents	Flow resulting from wind driven and thermohaline circulation	
Thermal Gradients	Temperature difference between surface and deep ocean layers	Ocean thermal energy conversion (OTEC) plants
Salinity Gradients	Salinity difference between fresh and ocean water in estuaries	Reversed electrodialysis, pressure-retarded osmosis

Ice cover in McMurdo Sound and Winter Quarters Bay inherently eliminates wave energy extraction from consideration at McMurdo. It may be possible to deploy a seasonal system when the ice is gone each year, but the variability of that timeframe makes it difficult to generate reliable energy. In addition, the energy yield would need to be large to warrant the annual installation and removal costs. Tidal lagoons require permanent dams to block off large areas of water, which is impractical for a region with moving ice sheets and the need for large-ship port accessibility. OTEC plants require warm surface water (>25°C) and access to cold (deep) ocean water to achieve sufficiently large temperature differences to operate a low-temperature Rankine cycle (typically an organic NH₃ cycle). The waters near McMurdo stay close to freezing nearly all year across various depths (Hunt et al. 2003) and do not provide sufficient temperature differences within the ocean for OTEC. Salinity-based converters require a consistent source of fresh water, which is produced at McMurdo via runoff or melting ice sheets, but is insufficient for energy extraction purposes. The only potentially feasible ocean energy source for the McMurdo region is from currents—specifically tidal currents.

2.1 The earth's tides

The moon and sun's gravitational forces are the main drivers of the earth's tides. As the earth rotates around the sun and the moon around the earth, they exert varying amounts of gravitational pull on the earth and its oceans, as given by Newton's law of universal gravitation:

$$F_g = G \frac{m_1 m_2}{r^2}$$

where

G = the gravitational constant ($6.674 \times 10^{-11} \frac{Nm^2}{kg^2}$),

m_1 and m_2 = the masses of two objects, and

r = the distance between the centers of mass of the two objects.

The gravitational force between two forces varies directly with the product of the two masses and inversely with the square of the distance between them.

The earth and moon rotate around their shared combined center of mass, called a barycenter. This barycenter is located slightly within the earth's crust. As the earth and moon rotate around this point, they experience two equal and opposing forces at their own centers of mass. The first force acting on each body is the gravitational pull between the two masses that acts in the direction towards the other object. The second force acting on each body is the centrifugal force acting on the mass of each body pulling it away from the barycenter.

These two forces are balanced at the center of the earth but vary throughout the earth's diameter. As one moves closer to the side of the earth closest to the moon, the gravitational force from the moon increases as the r in Newton's law of universal gravitation decreases. As one moves to the side of the earth farthest from the moon, the centrifugal force remains constant; but the gravitational force from the moon decreases as the distance from the moon increases. These net forces are called tractive forces. This increase in gravitational force on the near-moon side of the earth and decrease in force on the far-moon side of the earth results in the moon's gravitational pull elevating the oceans on the near and far moon sides of the

earth, as visualized in Figure 1. The sides of the earth perpendicular to a line drawn from the center of the earth to the center of the moon will experience lowered sea levels as they experience a balance between the centrifugal forces and gravitational forces and thus no net force to lift the water away from the center of the earth.

Figure 1. Tidal bulges explained by the variation in gravitational tractive force throughout the diameter of the earth (not to scale). F_c represents the centrifugal forces, and F_g represents the gravitational forces.

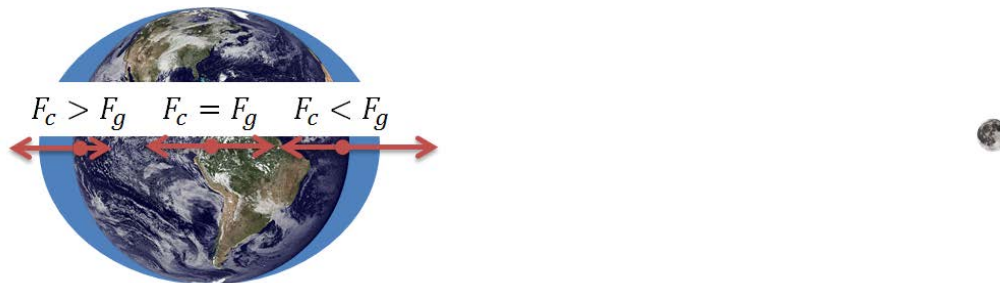

These two bulges of elevated sea levels and areas in between of lowered sea levels explain why in most places on the earth there are two tides per lunar day. A lunar day is the amount of time between successive moonrises, which is about 24 hr and 50 min. When a location experiences two high tides (caused by the elevated sea levels) and two low tides (caused by the lowered sea levels) every lunar day, the area is said to experience semidiurnal tides.

The moon does not revolve around the earth in a perfectly equatorial plane. Sometimes it is above the equatorial plane, and other times it is below the equatorial plane. This causes the two tidal bulges to align themselves with the moon's angle with respect to the equatorial plane, as visualized in Figure 2. This tilt in tidal bulge alignment causes only one bulge at some very extreme northern and southern latitudes, such as in Antarctica. This singular bulge explains why McMurdo Sound experiences only one high and one low tide per lunar day, which is known as diurnal tides (Barry and Dayton 1988). At less extreme latitudes, this tilt in alignment typically causes one of the tidal cycles each lunar day to be slightly stronger than the other. These are called tropic tides, and the difference between the two tides in one day is called the diurnal inequality.

Figure 2. Diurnal and tropic tides explained by the out-of-plane orbit of the moon with respect to the earth's equator.

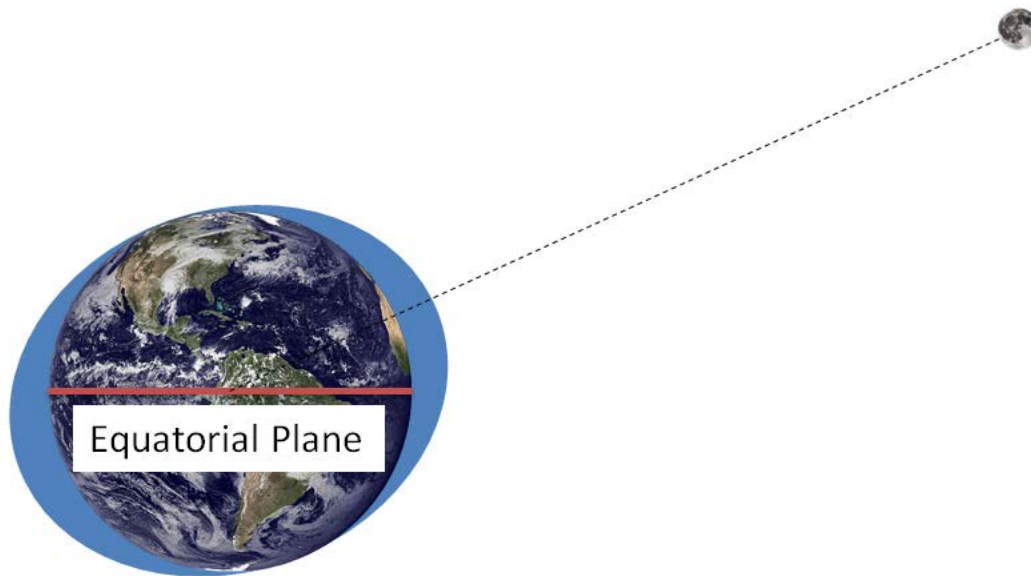

Even though the sun is far from the earth, its large mass still affects earth's tides. However, the tractive forces created by the sun's gravitational pull are less than half as strong as the lunar tractive forces (Boon 2004).

The combined lunar and solar tractive forces create the spring–neap cycle of the tides. When the earth, moon, and sun are all in line with one another, their tractive forces act parallel to each other and create larger tidal effects. When this happens, these higher high tides and lower low tides are called spring tides (Figure 3). When the moon is at a right angle, perpendicular to the earth–sun connecting line, the lunar and solar tractive forces act perpendicularly to each other and offset each other's tidal effects. This creates lower high tides and higher low tides, known as neap tides (Figure 4). The moon orbits the earth every 29.53 days with respect to the sun. The spring–neap tidal cycle occurs over this interval.

Figure 3. Spring tide, showing amplified tidal elevations (not to scale).



Figure 4. Neap tide, showing smaller tidal elevations (not to scale).



All these periodic tidal cycles, including the lunar and spring–neap cycle, can be described mathematically with harmonic constituents. Both tidal elevations and tidal currents can be described with this harmonic constituent method. Each constituent consists of a frequency, ω , amplitude (height or speed), R , and phase, φ . With this information, the tidal current or sea levels at a given location can be calculated by summing each constituent's effect with the mean water velocity or sea level, h_0 , and non-astronomical water-level effects, $\sigma(t)$ (Rowell 2013).

$$h(t) = h_0 + \sum_{j=1}^m R_j \cos(\omega_j t - \varphi_j) + \sigma(t)$$

The frequency of each constituent is the same at every point on the earth because they are driven by the periodic gravitational loading of astronomical bodies. The amplitude of each constituent varies around the earth because of Newton's universal law of gravitation. The phase of each constituent also varies around the earth due to frictional effects. If not readily available, the constituent amplitudes and phases for a given location can be calculated from sea-level or tidal-current data recorded at that site.

2.2 Tidal energy

The energy that can be converted from a tidal energy resource is estimated similarly to that from a wind resource. The obvious difference between the two energy resources is the densities of the working fluids. Tidal current speeds are typically much slower than viable wind speeds; however, seawater is over 800 times denser than air, which plays a significant role in the kinetic energy of the tides. The following section provides an overview of typical calculations used in tidal energy assessments to characterize the energy resource at a site.

Assuming a turbine is used at a particular location, we can estimate the instantaneous power it could produce if both the tidal current speeds and the characteristics of that turbine are known:

$$P(t) = C_p(\lambda) \frac{1}{2} \rho A U^3(t) = C_p P_{available}$$

where

- P = the amount of power produced;
- ρ = the density of the fluid driving the turbine;
- A = the area of the flow intercepted by the turbine's rotor;
- $U(t)$ = the current speed at a particular time, t , as described by a current speed distribution constructed from a large time series of recorded speed data; and
- C_p = the coefficient of power, specified by the turbine manufacturer, which has values that vary with the turbine's tip speed ratio, λ , as illustrated in Figure 5.

Figure 5. Representative C_p vs. λ curve for a cross-flow tidal turbine, from Bachant and Wosnik (2015). The particular turbine rotor in Fig. 5 (UNH RVAT) was not designed to have the highest power coefficient possible, only to provide a high-fidelity data set for a simple geometry turbine model at reasonably high blade chord Reynolds numbers.

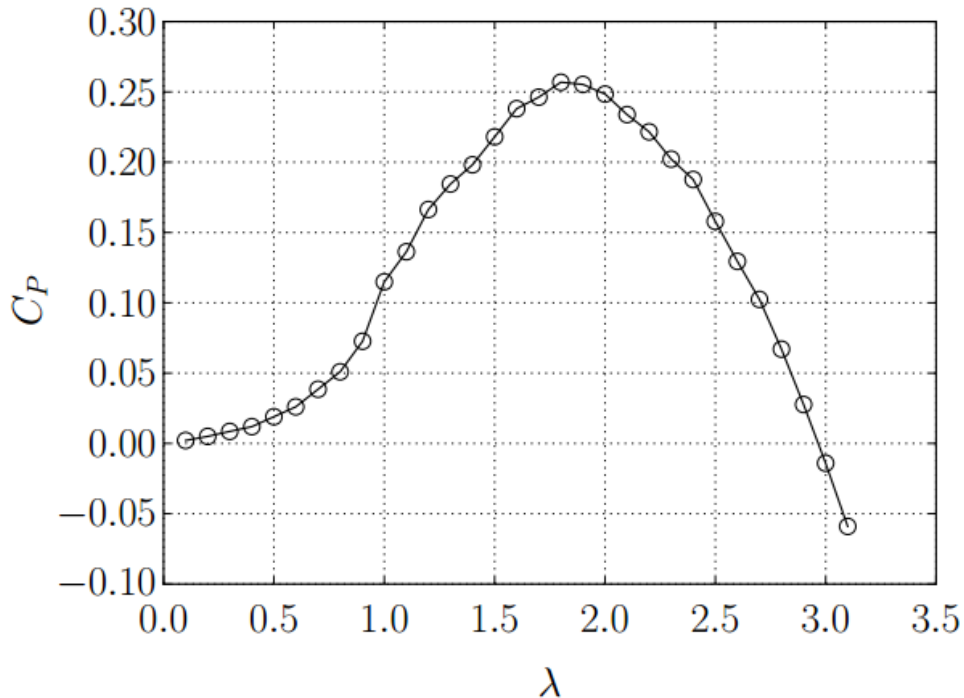

Tip speed ratio, λ , is defined as

$$\lambda = \frac{\omega R}{U}$$

where ω is the angular velocity of the blade and R is the rotor's radius. As a first approximation, the C_p at optimum λ can be selected and assumed to be constant for the calculations in a tidal energy resource assessment.

In reality, the power coefficient of a tidal turbine is not constant over its operational range: the tidal turbine will not produce any power until its "cut-in speed" is reached. The power coefficient then typically quickly increases to its maximum value. Once the rated power of the turbine power train (gearbox and generator) is reached, the power does not increase any further with increasing tidal current speed, and hence the conversion efficiency will start to decrease. In practice, this power-limiting operation is achieved by operating the turbine rotor under off-peak conditions (e.g., by

changing the tip-speed ratio or blade pitch) similar to how large wind turbines are operated and controlled.

By integrating the power equation over a given time period, one can determine the amount of energy that can be produced at that location during that timeframe:

$$E = \int_{t_0}^{t_f} P(t) dt$$

Long-term time series of tidal current velocity data (e.g., obtained from bottom-mounted acoustic Doppler current profilers [ADCPs] at a candidate location) can be sorted into “bins” to produce a velocity histogram. If the sample interval is of sufficient length, this velocity histogram will approach a representative probability distribution for the tidal current velocity. IEC (2015) recommends that “Current profiler deployments shall span a minimum of 35 days if being used for calibration/validation of the model simulations and 90 days if being used to directly compute the AEP.” The mean annual energy production (AEP, in kWh) for an individual tidal energy converter to be deployed at the measurement location can then be estimated as

$$AEP = N \cdot TEC_{Availability} \cdot \sum_{i=1}^{N_B} P_i(U_i) \cdot f_i(U_i)$$

where

N = the number of hours in a year,

$TEC_{Availability}$ = the expected availability of the tidal energy converter,

N_B = the number of velocity bins in the tidal energy converter power curve,

U_i = the average velocity (in m/s) in the i th bin of the velocity histogram or tidal energy converter power curve,

$P_i(U_i)$ = the power in kW generated by the tidal energy converter in the i th velocity bin, and

$f_i(U_i)$ = the proportion of time for which the mean tidal current velocity occupies a value within the i th velocity bin.

The AEP equation given in IEC (2015) is essentially a discretization of the energy integral given in the previous equation. Note that the application of this method requires information about the turbine power curve, $P_i(U_i)$, which at this point are often not readily available for many tidal energy conversion devices that are still under development.

Turbulence can affect how much energy a turbine extracts from the ocean. However, the magnitude of its effect on a turbine's energy production is difficult to quantify; so IEC states that "no correction for the effect of turbulence should be performed" when estimating the energy produced at a given site (IEC 2015). Section 3.3.3 provides additional information on turbulence at a tidal energy site.

Time-averaged metrics are typically calculated to characterize a tidal energy site and to aid in the selection of a turbine for the site. A metric that is commonly computed to determine the power available at a proposed site is the mean kinetic power density (Polagye and Thompson 2012). Mean kinetic power density can be calculated as

$$\bar{K} = \frac{1}{2} \overline{\rho |U^3|}.$$

This value multiplied by the proposed turbine rotor area, A , and coefficient of power, C_p , provides the average power rating of the turbine at this site. By multiplying this average power rating by some period of time, one can determine the average amount of energy that could be produced at this site. The mean kinetic power density can also be used to compare the expected yield at different sites without considering a specific turbine.

The maximum speed recorded over a survey of sufficient length can be used to determine the turbine's maximum possible power output. (Should a turbine be selected for maximum energy yield, then this value would also be the turbine's "rated power." Should a turbine be selected for high capacity factor, then the rated power of the turbine would likely be substantially lower than this value). The maximum speed is also typically used in estimating drag loads on the turbine deployment structure, which scale with the square of the tidal currents.

The mean kinetic power asymmetry is computed as the ratio of the mean kinetic energy in the ebb tides, $\overline{K_{ebb}}$, and the mean kinetic energy in the flood tides, $\overline{K_{flood}}$,

$$\phi = \frac{\overline{K_{ebb}}}{\overline{K_{flood}}}.$$

Large power asymmetries at a potential site indicates that one tide produces much more energy than the other tide. This could lead to longer periods without sufficient power production and necessitate a larger energy storage system if continuous power is required from the conversion device.

Depending on the type of turbine, the ebb/flood directional asymmetry may be important. The ebb/flood directional asymmetry is a measure of the difference between the mean flood tide direction, $\overline{\theta_{flood}}$, and mean ebb tide direction, $\overline{\theta_{ebb}}$, and is calculated as

$$\bar{\theta} = \overline{\theta_{flood}} - \overline{\theta_{ebb}} - 180^\circ.$$

For fixed-yaw axial-flow turbines or cross-flow turbines with their axes oriented horizontally, this metric is critical to determine the directional orientation of the turbine.

2.3 Tidal energy converters

There are various ways to harness the kinetic energy of currents. The most common ways are with cross-flow or axial-flow turbines. These turbine styles differ in the relationships between the direction of their rotational axis and the flow direction, as illustrated in Figure 6.

The rotational axis of a cross-flow turbine is perpendicular to the direction of flow. This allows the turbine to extract energy regardless of the flow's horizontal direction, if the turbine is installed with vertical orientation. An axial-flow turbine must be oriented with the direction of flow; otherwise, it will not be able to convert all of the available energy (Lewis et al. 2011). This means that axial turbines must be equipped with either yaw capability or bidirectional blades (fixed bidirectional blade profiles or a 180° pitch systems). Axial-flow turbines typically have somewhat higher power coefficients than cross-flow turbines.

Figure 6. Tidal energy turbine diagrams.

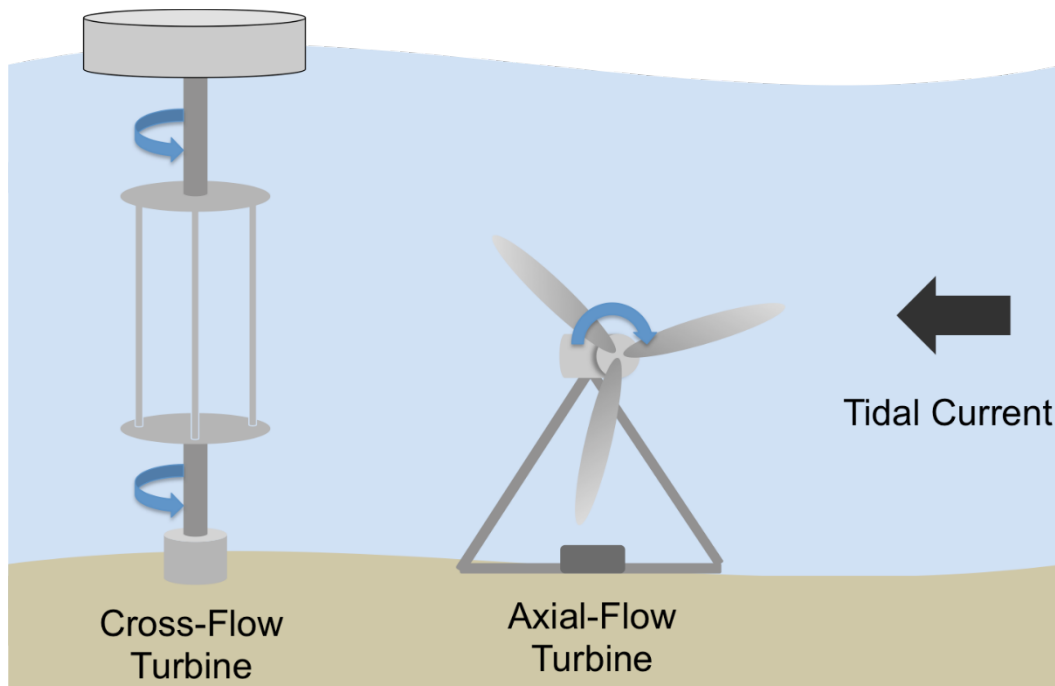

Turbines have been used for different applications for a very long time, and their mechanics are fairly well understood. Turbines function under the basic principal of converting kinetic or potential energy in the flow to rotational mechanical energy and then into electricity via a generator. Similar to airplane wings, turbine blades generate lift as flow passes around them. The blades are connected to the same central hub, so the lift generated on each blade produces torque and rotation of the connected shaft. A series of gears increases the rotational speed, which is converted into electric current via an electric generator (Pierce and Wood 2014). The electricity is taken away from the system via cables.

In addition to turbine technologies, there has been progress with systems that harness different flow phenomena to produce energy. Most of these methods are still in developmental phases but try to harness the motion of oscillating bodies due to vortex shedding or fluid-induced fluttering (Lewis et al. 2011). For example, bluff bodies in cross flow produce alternating forces due to shedding vortices, which can be harnessed for power (Bernitsas et al. 2008). Although these methods show promise, the vast industry experience with turbines has made them the predominant method for tidal energy conversion at this point.

2.4 Tidal energy regulations

Ocean energy projects planned for installation on the U.S. Outer Continental Shelf (OCS) must follow regulations from the U.S. Department of the Interior's Bureau of Ocean Energy Management (BOEM) and the Federal Energy Regulatory Commission (FERC). Considering that McMurdo Station does not fall under the OCS jurisdiction, it is unclear what kinds of legal framework must be followed for an ocean energy system to be installed at that location. The authors recommend that USAP review the BOEM and FERC regulations and other legal guidelines for such a system, if one is to be installed.

During the writing of this report, it was announced that several countries agreed to make the Ross Sea a Marine Protected Area (MPA). This "no-take" policy will protect the area from commercial fishing for 35 years and will prevent the removal of any marine life or minerals (McGrath 2016). Although this policy is a great step towards protecting the Ross Sea, it could make the regulation process more difficult for a tidal energy system in that area due to the system's potential environmental effects. There are multiple types of MPAs, and specific details about the Ross Sea MPA are necessary to know what types of activities and actions are now restricted there. Some MPAs do not allow laying any underwater cables, which would critically impede the prospects of a tidal energy system at McMurdo.

3 Data Collection

This study did not install instruments and collect new data at McMurdo but relied on data recorded during other studies. McMurdo Station is unique in its abundance of data as it has been a scientific hub for decades and has a large catalogue of data collected onsite or nearby. However, this means that relevant datasets must be collated before assessing the overall tidal resource. In addition, it means that the available data may not adhere to IEC 62600-201 standards. The following sections present the available data and compare it against the corresponding IEC criteria.

3.1 Bathymetry and seafloor composition

IEC 62600-201 requires bathymetric data to be reviewed by an oceanographic center to ensure its quality (IEC 2015). The Polar Geospatial Center (PGC) at the University of Minnesota produced bathymetric maps for both Winter Quarters Bay and a portion of McMurdo Sound surrounding the station. These maps reference data collected by Davey (2004). It was collected via multibeam sonar, as described in Davey and Jacobs (2007). This data references the World Geodetic System (WGS) 1984 datum UTM Zone 58S coordinate system and is presented in a transverse Mercator projection (Davey 2004). Figure 7 contains labels for the different locations referenced in this and subsequent sections.

Winter Quarters Bay is fairly shallow compared to the rest of McMurdo Sound. Depth samplings measured by Crockett and White (1997) indicate the bay's center is 20 m deep on average (with a max depth of 33 m) but gets fairly shallow at its mouth due to a submarine ridge. This ridge is as shallow as 13 m near its center and protects the bay from icebergs entering it (Crockett and White 1997). However, it also interrupts current flow coming from McMurdo Sound, which results in low current speeds within the bay. These low speeds cause material to accumulate in larger amounts than other similar-depth locations near McMurdo. This material is "gravel in some places yet fine and fluid at other sites with coarse particles intermixed" and has a combined silt and clay composition that varies between 21% and 68% (Crockett and White 1997). The concentration of fine material decreases towards the bay's mouth (Crockett and White 1997). The seafloor's composition is important to determine what kind of foundation or mooring would be necessary for a tidal energy system.

Figure 7. Relevant locations near McMurdo Station.

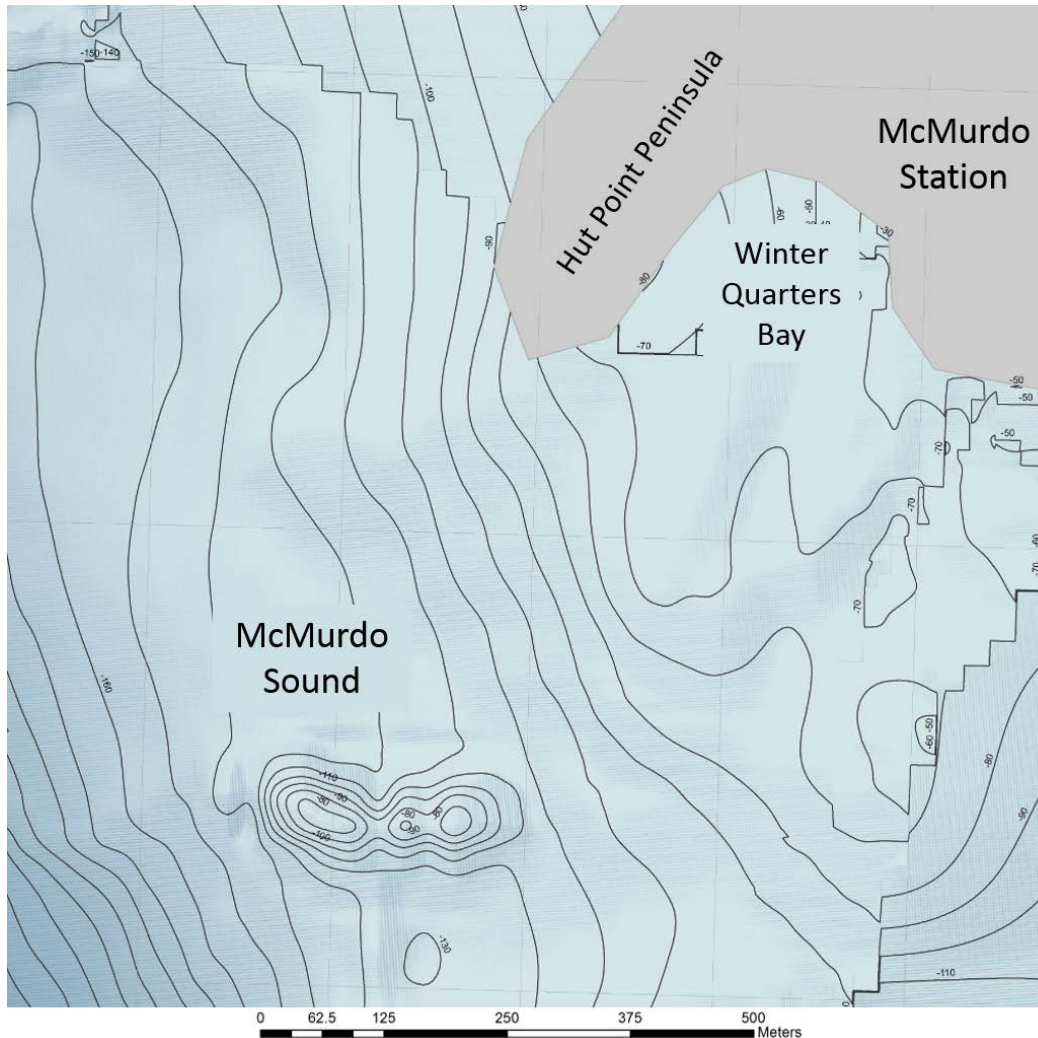

A large amount of debris has accumulated in Winter Quarters Bay because of poor trash regulations at McMurdo Station in the past. “The bottom is littered with debris such as drums, equipment, tanks, tires, all types of metal objects, and cables, especially on the southeastern side where dumping took place” (Crockett and White 1997). Unfortunately, these practices have contaminated the seafloor sediments with “polychlorinated biphenyls (PCBs), metals, and hydrocarbon fuels” (Crockett and White 1997).

The bathymetric data from PGC indicate that the ocean floor drops quickly beyond the submarine ridge of Winter Quarters Bay. Depths reach 200 m within approximately 1 km from the mouth of Winter Quarters Bay and reach greater than 500 m farther into McMurdo Sound. These depths are

unlikely to have fast tidal currents and are too extreme for tidal energy installations because they would make maintenance procedures very difficult. In addition, the quick ocean floor drop off connects with a crescent-shape depression (Figure 8) that likely affects current flow coming from McMurdo Sound.

Figure 8. Bathymetry outside Winter Quarters Bay. Numbers indicate depth in meters, as referenced to the WGS 1984 datum.

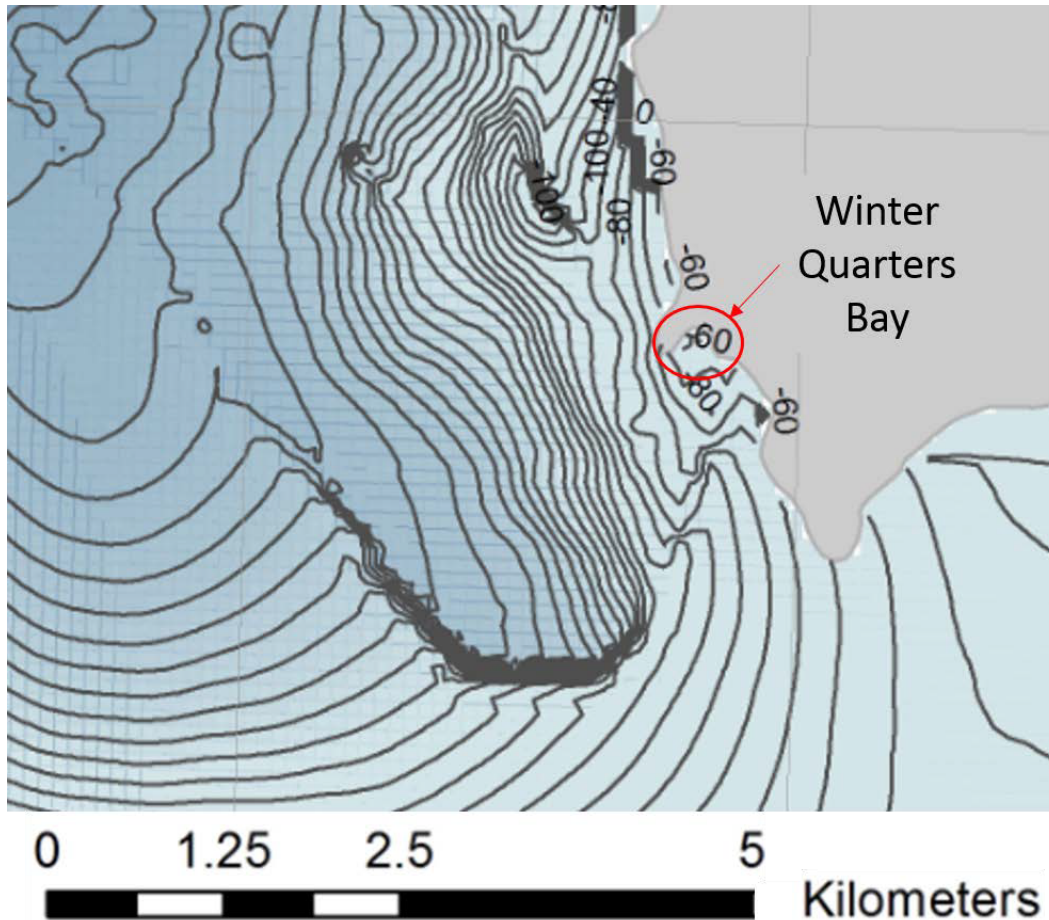

The available bathymetric data and sediment records for the area around McMurdo Station meet IEC 62600-201 standards. However, the data indicate that it is a challenging location to install a tidal energy device.

3.2 Tidal characteristics

Datasets including current speeds and directions, tidal height, and tidal harmonic constituents are all important for energy assessments because

they reflect the amount of energy available in that particular tidal resource, as well as its periodicity. The following sections present findings related to each data type.

3.2.1 Current speeds

Current speed data and observations were collated from a number of studies dating back to 1959. Appendix A presents several of these data points overlaid on a map to illustrate the geographic distribution of measured speeds around Winter Quarters Bay. These studies used a variety of measurement techniques and recorded data over different timeframes. Many of these studies recorded currents for a few hours or days while one source recorded speeds and direction every 15 min for 11 straight months between 1993 and 1994 (Barry 1995). One other resource provided data measured from a shipboard ADCP on the *Nathaniel B. Palmer* research vessel for a number of transects between McMurdo Station and locations in Chile and New Zealand. Although there are a number of datasets available, they fail to meet IEC standards for such data.

For energy estimate calculations made directly from measured data, IEC requires speed and direction data recorded in 2–10 min averages for a minimum of 90 continuous days, with a minimum sampling rate of at least one measurement every 20 seconds (IEC 2015). Long-term measurements have a higher chance of recording all of the many temporal variations of tidal resources discussed in Section 2.1. Averaging data over 2–10 min reduces the effect of turbulence on measurements but is not so coarse that it misses meaningful variations in current speed and direction. In addition, IEC requires studies to record all three directional velocity components and standard deviations and to organize the data into vertical bins reflecting depth (IEC 2015). With the proper speed datasets, it is possible to create a probability distribution that accurately reflects how often different current speeds occur for that site. These distributions can be used to make energy estimates, as explained in Section 2.2. Assuming a site's speed distribution based on a few hours of data or a variety of spot-checks is highly inaccurate because it does not account for the full distribution of speeds at that site.

Unfortunately, the available current speed and direction datasets for Winter Quarters Bay and McMurdo Sound do not meet the IEC standards for

those data types. The long-term study (Barry 1995) meets the temporal criteria set by IEC but fails to meet IEC standards due to its temporal resolution and lack of three-dimensional velocity measurements. Regardless, we reached out to the authors for this data but were unable to acquire any of it. Although the available datasets do not meet the requirements for a full energy assessment, they all indicate the same thing, which is that the current speeds are very low, at least from a tidal energy perspective.

Within Winter Quarters Bay, measurements “showed such minimal current speeds that the bay can be considered practically stagnant (Raytheon 1983)” (Crockett and White 1997). The same source references “an incident of a strong current flowing from Hut Point toward and under the Ice Pier” but does not provide a magnitude for this current (Crockett and White 1997). Barry (1995) reports that flow past Hut Point can accelerate to speeds as high as 50 cm/s but does not provide additional information on where or how that value was measured. In summary, all of the reported speeds for Winter Quarters Bay were on the order of cm/s, with many of the stated values below 10 cm/s (Appendix A).

Additional references studied currents in the region of McMurdo Sound adjacent to Winter Quarters Bay. Many of these are illustrated in Appendix A (Gilmour et al 1962; Tressler and Ommundsen 1962; Heath 1971a). Unfortunately, they all reported very low current speeds, also. One source stated that the strongest mean current they observed was at a depth of 400 m and had a velocity of 28 cm/s (Heath 1971a). Other reported speeds ranged between approximately 4 and 30 cm/s (Appendix A). The current speeds in McMurdo Sound are “strongly influenced by the tides,” and “the currents are strongest when the tidal range is greatest” (Heath 1971a). These sources indicate that the Ross Ice Shelf affects currents by introducing melt water and frictional effects (Heath 1971a).

Many of the McMurdo Sounds studies recorded data for a number of days but many fewer than the 90 days required by IEC. It is possible that the reported tidal current values do not fully describe the tidal energy resource of McMurdo Sound; however, the sheer number of reported low speed measurements implies it is not an erroneous trend.

3.2.2 Current directions

Current direction patterns in the greater McMurdo Sound can be intricate; however, those in the general vicinity of McMurdo Station are more straightforward. Measurements during austral winter months indicate that flow originates from beneath the Ross Ice Shelf, then continues north-northeast past Hut Point Peninsula, and then joins flow in the rest of the Sound (Lewis and Perkin 1985; Heath 1971a).

The flow patterns in Winter Quarters Bay and the Sound directly next to the bay are more complex than those elsewhere in the Sound. The Barry (1995) long-term study indicates that the current direction near Winter Quarters Bay reverses between winter and summer months. During the winter months it follows a north-northwest trend, similar to those reported in the Sound; however, the trend reverses and flows south-southeast during the summer months (Barry 1995). When the general flow has a southern trend, it produces a counterclockwise recirculation zone downstream of Hut Point, within the region adjacent to Winter Quarters Bay (Barry 1995). This recirculating feature has been referred to as the “McMurdo gyre,” and multiple sources indicate its directionality and severity may vary with tide, season, and ice cover (Crockett and White 1997; Barry 1995). It is apparent that additional measurements are needed to fully understand the dynamics of this gyre.

Because of the short data-collection timeframes, it is not apparent from the available data whether the direction of flow in the greater McMurdo Sound changes during the year.

3.2.3 *Nathaniel B. Palmer* ADCP mobile surveys

Data recorded during mobile surveys are useful in conjunction with stationary measurements because they provide information on the spatial distribution of tides within an area. IEC requires that the mobile vessel follow a “single line, or undertake a ladder survey or box-circuit, for a full diurnal or semidiurnal tidal cycle” (IEC 2015). Unfortunately, the *Nathaniel B. Palmer* ADCP data was collected while the vessel was conducting studies with different purposes, so it did not follow any of the suggested paths or collect data for sufficient durations. The best this ADCP data can provide are additional spot-checks for different areas around McMurdo Station, if warranted.

3.2.4 Tidal height

Tidal height data provides information on the range of low and high tides at the site, which is useful when positioning a turbine. Bottom-mounted turbines must remain fully submerged underwater and provide adequate draft for ships traveling over them. Surface-mounted turbines must always have enough water to operate in to ensure their blades will not strike the ground during a low water event. One source states that the typical tidal range for the greater McMurdo Sound is approximately 0.25 m (Bartek and Anderson 1991). Unfortunately, we do not have sufficient tidal gauge data for the McMurdo Station area to determine what typical high- and low-tide heights are for that region; however, the tidal constituents described in Section 3.2.5 provide some insight as to typical tidal amplitudes near the Station. These constituent amplitudes (Appendix A) are in good agreement with the 0.25 m amplitude stated by Bartek and Anderson (1991).

In addition to the constituent data, Scott Base has a tidal gauge that has recorded hourly tidal heights since 15 January 2001 and every 5 min since 20 May 2007. Scott Base and McMurdo Station are about 3 km apart; however, they are located on opposite sides of Hut Point Peninsula. As mentioned in Section 3.2.1, flow follows a north–south path along the end of Hut Point Peninsula, which can cause slight differences between the tides at each station. Heath (1971b) compared 30-day tidal-height records from both sites and concluded that the tidal amplitudes at McMurdo are generally smaller than those at Scott Base, and high tide at McMurdo occurs approximately 1 hr later than at Scott. Ideally, there would be longer periods of overlapping data for both sites to provide a concrete relationship between their tides. However, we were unable to get historical tidal height data for McMurdo from any of the reference authors.

We decided to calculate an annual exceedance probability based on the Scott Base tidal gauge since 2001. The exceedance probability indicates the likelihood of extreme tides within a given year, based on a historical dataset of tidal heights. Using the Scott Base historical tidal data may provide an upper limit to the tidal range at McMurdo, considering Scott's tides are reportedly larger than McMurdo's. To calculate the exceedance probabilities, one must separate the tidal elevation data into 1-year intervals. Then the maximum (or minimum when plotting low tide exceedance elevation)

tidal elevation must be found for each year interval. The annual maximum tidal elevations are then ranked from highest to lowest (or lowest to highest for low tide). To calculate the probability, P , of each interval's maximum tidal elevation occurring, one must use

$$P = \frac{R}{n + 1} * 100\%$$

where

R = the rank of the maximum tidal elevation and
 n = the number of yearlong intervals used.

The result represents the probability of that tidal elevation occurring in a yearlong period.

The following charts show exceedance probabilities for annual high and low tides based on the Scott Base tidal data recorded between 15 January 2001 and 14 January 2013. During this time, the tide gauge reported tidal elevations at a frequency of once per hour. The amount of missing data in a year ranged from 0–252 days and was omitted from the analysis. Corrections have been made in this data for changes in the tidal gauge's "zero" reference point such that all measurements are with respect to the gauge's original "zero" reference point, which was 11.30 m below BM A at Scott Base. BM A is a geodetic mark that is part of the Ross Sea Region Geodetic Datum 2000 (RSRGD2000) coordinate system. It is located at 77°50'59.62836" S 166°46'00.26966" E and has an ellipsoid height of –44.748 m (Land Information New Zealand 2016). The high and low tides are presented with respect to the Scott Base tidal gauge's "zero" point and the RSRGD2000 coordinate system.

The results in Figure 9 indicate that there is approximately an 8% probability each year that the high tides will reach a maximum approximate height of 3 m above the gauge's original zero and that the low tides will reach a minimum approximate height of 1 m above the gauge's original zero. So, the maximum tidal range this region could expect, however unlikely it may be, could be on the order of 2 m. It is important to note that this does not account for variations in wave height, as described in Section 3.3.2.

Figure 9. Annual exceedance probabilities for different elevations of low and high tides, as referenced to the Scott Base tidal gauge datum and RSRGD2000. The historical data used for this analysis are from the Scott Base tidal gauge.

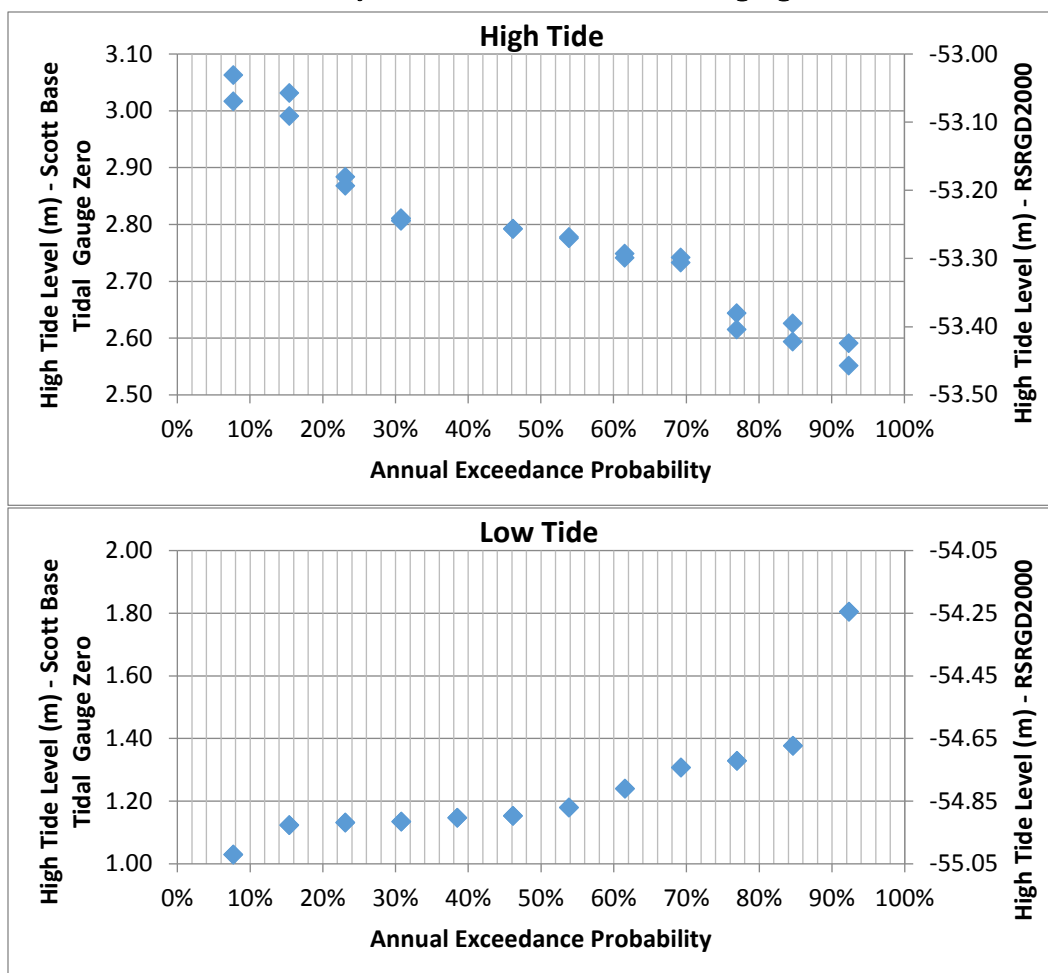

3.2.5 Tidal constituents

IEC requires four to eight tidal constituents for estimating tidal amplitudes as part of a Stage 1 feasibility study. Fortunately, a number of references provide more than enough tidal constituent values to meet this requirement. Appendix B tabulates them for different locations in the McMurdo region.

Multiple sources found that the tides follow approximately 13-day cycles (Heath 1971b; Barry and Dayton 1988; Crockett and White 1997). Heath (1971b), Williams and Robinson (1980), and Barry (1995) each recorded data for nearly a month near McMurdo Station; and they all found that the O1, P1, and K1 tidal constituents had the largest amplitudes. However,

these amplitudes are small when compared to typical tidal energy resources, which may suggest that nonastronomical effects dominate the harmonics of the tides in McMurdo Sound. These effects could include weather and strong winds, among others. The reported amplitudes and phases (Appendix B) are in good agreement with each other, considering that the data were measured with different methods in different locations, between which the non-astronomical effects may vary.

3.3 Meteorological and climate data

IEC requires wind and atmospheric pressure measurements if the study necessitates hydrodynamic modeling of the tidal resource. These meteorological phenomena can affect tidal currents, so they must be accounted for in any simulations. However, IEC does not require such modeling for sites with small proposed systems (<10 MW). Although it is not required, a number of references described the effects of wind and atmospheric pressure on the oceanography of McMurdo Sound. Their effects are briefly discussed here for completeness.

3.3.1 Wind and atmospheric pressure

Barry and Dayton (1988) state that wind patterns of different scales can affect the currents in McMurdo Sound. “Local winds and topographic effects contribute to small scale current patterns,” while “larger scale wind-driven currents such as the coastal current along the Ross Ice Shelf barrier (Lewis and Perkin 1985) . . . control regional circulation patterns and water quality within the Sound” (Barry and Dayton 1988).

Variations in currents from one year to the next may originate from large weather patterns such as the El Niño Southern Oscillation (ENSO), which has been shown to strongly correlate with “various high latitude oceanographic parameters including polar and sub-polar air temperature and winds, ice cover, sea surface temperatures (Rogers and van Loon 1979; Royer 1985; Niebauer 1984), and oceanic circulation (Kawabe 1985; Mysak 1985)” (Barry and Dayton 1988). This reference states that ENSO events likely affect the McMurdo area and can cause significant changes in winds, which subsequently affect ocean currents (Barry and Dayton 1988). The interaction between wind and atmospheric pressure in the

McMurdo Sound area is complex. If future studies need wind data, approximately 40 years of data at 3 hr resolution is available from the meteorological station at McMurdo Station.

3.3.2 Wave climate

There is little information available related to the wave climate near McMurdo Station. Wave climate data is composed of average wave height, period, and direction for a given location (Herbich and Walters 1982). This information is important because waves can directly affect tidal energy systems if they are strong enough. IEC (2015) states that resource assessments should consider the impact of wave–current interactions for the site of interest because waves can “potentially impact the long-term tidal energy resource” at a given location. Wave heights measured in other regions of McMurdo Sound include 0.2–0.4 m near Spike Cape, 0.08–0.7 m near Cape Royds (with period of 0.8–6 s), and 1.2–1.5 m during a storm near Cape Bird (Butler 1999). Unfortunately, these are only spot-checks and are also very far away from McMurdo Station.

Although there is little reported data, McMurdo Station likely has a variable wave climate due to its unique environment. For a large portion of the year, Winter Quarters Bay and parts of McMurdo Sound are covered with ice, which obviously hinders wave action. However, Antarctica has a very strong wind resource, which helps wave generation when the waters are clear. In addition, Winter Quarter Bay has a shallow submarine ridge at its mouth that may protect the bay from incident swells. Considering the potential impact of waves on an installed system and McMurdo’s unique climate, additional wave climate measurements are recommended for the McMurdo area to assess the relationship between ice coverage, wind speeds, and subsequent waves.

3.3.3 Turbulence

It is important to characterize the amount of turbulence in a tidal resource because it directly affects how much energy a turbine may extract from that site. Turbulent flow contains eddies, mixing, and other complex flow structures that are difficult to model and predict. Because turbines are designed to capture flow in specific directions, they are unable to capture all

the energy in turbulent flow. In addition, high-turbulence flow may entrain sediment, which can change the flow's density and impart additional loads onto the turbine.

One of tidal energy's greatest advantages is that it is predictable and consistent due to its driving forces (Section 2.1). However, the unpredictable nature of turbulence adds an irregular element to account for. Unfortunately, it is difficult to characterize and quantify turbulence. IEC states that at present there are significant unknowns in terms of what "scale, frequency and magnitude of current variability (resulting from eddies/turbulence) are important [for tidal energy assessments]" and that turbulence effects are a "subject of ongoing research" in this field (IEC 2015).

Although turbulence is difficult to quantify exactly, IEC recommends calculating turbulence intensity, I , which is the ratio of velocity standard deviation, u' , to velocity mean, \bar{U} (IEC 2015).

$$I = \frac{u'}{\bar{U}}$$

Velocity standard deviation gives an indication of the flow's variability, and normalizing it by the mean indicates how significant that variability is to the overall flow. I must be calculated from a large number of statistically independent samples measured while the tidal current mean velocity remains essentially unchanged, requiring high-frequency data. Using data averaged over several minutes (or greater timeframes) fails to capture the speed variations due to turbulence. Unfortunately, all of the reported speed data for the McMurdo area are averaged over large timeframes (hours, days, or months).

Additional quantities such as turbulent kinetic energy (K) and kinetic energy dissipation (ε) provide further characterizations of a site's turbulence. Turbulent kinetic energy is defined as

$$K = \frac{3}{2}(\bar{U}I)^2$$

where I is the turbulent intensity defined above. Turbulent kinetic energy dissipation is defined as

$$\varepsilon = \frac{15}{2} \nu \overline{\left(\frac{\partial U}{\partial z}\right)^2}$$

where ν is kinematic viscosity of seawater and $\overline{\left(\frac{\partial U}{\partial z}\right)^2}$ is the “time average of the square of the vertical gradient of the horizontal velocity” (IEC 2015). However, these quantities require accurate U values and vertical speed data measurements, which are unavailable for McMurdo Station.

Geologic features can create eddies or complex flow structures that could affect a tidal energy systems located downstream. As previously mentioned, the south-southeast flow past Hut Point creates a recirculation zone inside Winter Quarters Bay. In addition, the PGC bathymetry data indicates elevated features approximately 500 m from the end of Hut Point (Figure 10).

Figure 10. Elevated submarine features near Winter Quarters Bay.

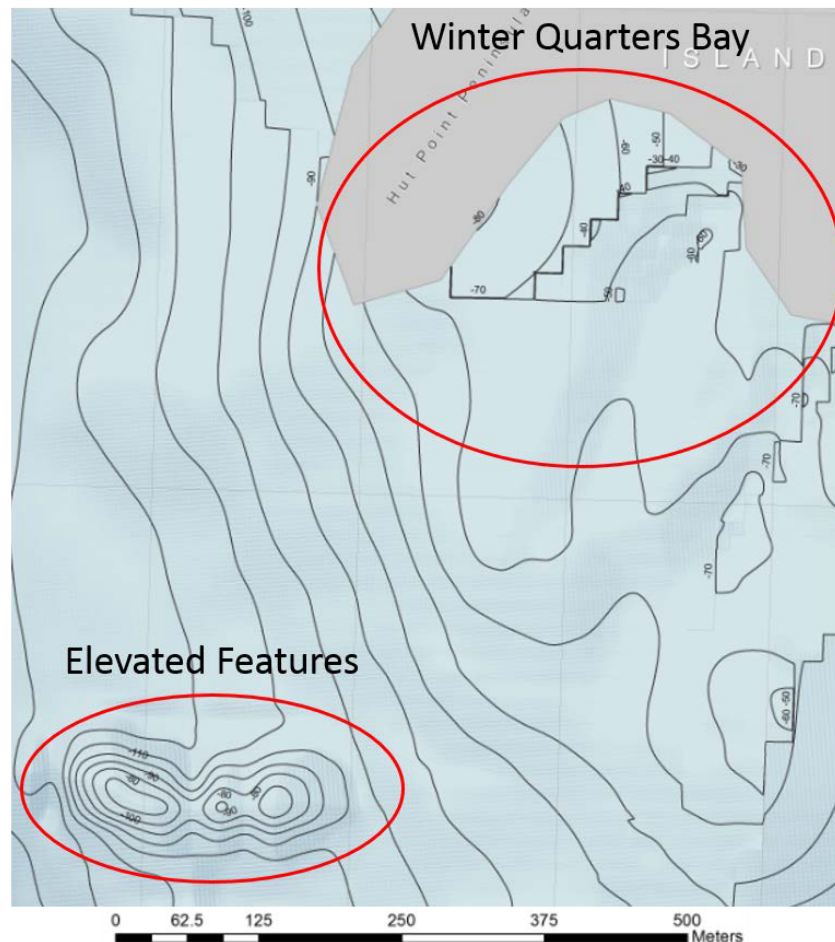

These features are elevated approximately 40 m above their surroundings and could produce complex flow structures in the flow around them. Unfortunately, there are no references looking at the turbulent effects produced by these features. It is apparent from the available data that additional measurements are necessary to assess the site's turbulence.

3.3.4 Stratification and seawater density

Stratification of different seawater parameters, including salinity, temperature, and density, can influence tidal speeds. Crockett and White (1997) report that within McMurdo Sound, "vertical variation in temperature and salinity in winter and spring is only slight, but some stratification occurs in summer (Barry 1988)." Other sources have produced depth profiles of salinity, temperature, and density; and they each indicate little variation near McMurdo (Lewis and Perkin 1985; (Barry and Dayton 1988). Salinity, temperature, and density are typically measured with conductivity, temperature, and depth (CTD) instruments. CTD measurements in the early 1990s indicated that a brine pool subsists at the bottom of Winter Quarters Bay below depths of 23 m. This pool contains "elevated salinity, decreased temperature, decreased oxygen, and decreased pH" (Crockett and White 1997). The existence of this pool is indicative of stagnant water.

3.3.5 Ocean water temperature

Water-temperature data is an important quantity for this site as the cold climate conditions in Antarctica are unlike those for most tidal energy installations. Ocean temperatures in McMurdo Sound are essentially at or very close to the freezing point for most of the year. Hunt et al. (2003) measured ocean temperatures for 2 years at different locations around McMurdo and measured temperatures above freezing approximately 15–20 days per year. They concluded that the waters in McMurdo Sound are "extremely thermally stable and cold . . . CTD casts early in the season (August through early December) showed highly stable water temperature at these sites . . . , varying by less than 0.01°C from the surface to at least 400 m" (Hunt et al. 2003). This means a system within McMurdo Sound will have to operate in a consistently cold environment with temperatures near the freezing point. It is important to note that this data is from the early 2000s, so it is possible that water temperatures have slightly increased in recent years due to global warming.

3.3.6 Ice-related data

IEC does not require an assessment of ice-related data for feasibility studies; however, most studies are for regions where ice formation is not as common as it is in Antarctica. A turbine located in McMurdo Sound would be subject to two sources of ice damage—ice scour and anchor ice. “In the McMurdo Sound region, ice floes from the nearby Ross Ice Shelf occasionally scrape the bottom as they move with the tides and currents during the breakup period. This scouring can occur to depths of at least 15 m, depending on the size of the floe (Dayton et al. 1970)” (Crockett and White 1997). This means that any turbine located in waters shallower than 15 m faces the risk of impacts with ice floes, which could cause considerable damage. However, the submarine ridge at the mouth of Winter Quarters Bay likely protects the bay from very large floes.

Anchor ice is the formation of platelet ice crystals on solid surfaces in shallow water. This primarily occurs in McMurdo Sound during spring months. These platelets can grow and become buoyant enough to lift weights as heavy as 25 kg. “The anchor ice phenomenon is common to depths of about 15 m, encompassing virtually any surface found to this depth. Below the 15 m depth, these anchor ice aggregates become discontinuous, decreasing in abundance down to a depth of 33 m at which they cease to form” (Crockett and White 1997). Ice scouring and anchor ice may be issues within Winter Quarters Bay; however, most depths outside of the bay are deeper than 33 m, so they are less of a concern. Barry and Dayton (1988) state that ice-platelet growth is worst in the southwestern region of McMurdo Sound, away from McMurdo Station.

Each winter, McMurdo Sound and Winter Quarters Bay are covered with sea ice; and in some areas, the ice can reach thicknesses greater than 2 m (Leventer 1987; Lever 2016). Every year, an icebreaker vessel breaks a path to the McMurdo Station ice pier to drop off supplies for the new year and to collect waste from the previous year. Obviously, this vessel could cause serious damage to any tidal energy system sitting in its path, and could receive damage as well.

Figure 11 is from NSF, which claims that the ship’s approach path does not deviate much year to year from the one pictured. Referencing the PGC bathymetry data, the icebreaker approaches from the heart of McMurdo

Sound, creates a turning basin above the crescent-shape depression outside of Winter Quarters Bay (Figure 8), and then approaches the McMurdo Ice Pier along a path parallel to Hut Point. As mentioned previously, the waters outside the bay are deep, which means any system located in that area would likely be safe from impacts with the vessel. However, Winter Quarters Bay is rather shallow in areas; and the under-keel clearance of some larger vessels in the bay, such as the U.S. Coast Guard *Polar Star*, are small enough that impacts with a turbine system could occur (United States Coast Guard 2014). This is especially true for any energy system located near the mouth of the bay, where depths can get as shallow as 13 m (Crockett and White 1997). Underwater cables running through Winter Quarters Bay to connect the energy system with the electrical grid at McMurdo would likely be safe from collisions with icebreaker vessels and their propellers but would need to be marked to prevent the ships from anchoring over or across them.

Figure 11. Icebreaker approach path. (Photo courtesy of NSF.)



The thick and consistent ice cover during winter months would make maintenance or other system operations very difficult and expensive to conduct. Although tidal turbine systems have been deployed in high-latitude locations where temperatures can approach freezing, these sites do

not experience extensive ice cover and its associated issues like McMurdo Station does.

3.4 Meeting IEC data requirements

This study used relevant data recorded by other studies in the McMurdo area. Unfortunately, the data was not recorded to the specifications of IEC for a full resource assessment including energy estimates. The primary shortcoming is with respect to current speeds and direction, which are either too short or do not provide values at the necessary temporal resolution. Multiple authors were contacted regarding their measurements; however, very few responded with available data. Although additional measurements with new instrumentation would provide the data needed for a full energy assessment, all of the reported values agree that tidal current speeds are generally very low in the vicinity of McMurdo Station, too low for tidal energy conversion.

4 Resource Assessment

IEC recommends that a site's energy potential be estimated from a combination of measured data and modeling results. This section presents conclusions from the data reported in Section 3 and a brief introduction into harmonic constituent modeling and an explanation as to why it was not conducted for this study.

4.1 Observations from data

After considering the available data relevant to tidal energy in the waters near McMurdo Station, it is easy to conclude that the data is insufficient for a full tidal energy assessment. However, what data is available points overwhelmingly against the feasibility of tidal energy systems in the area. The current speeds are so low in Winter Quarters Bay that Crockett and White (1997) referred to it as "practically stagnant." Unfortunately, the speeds outside of the bay are not much faster and range from a few centimeters per second to just over 30 cm/s. Tidal turbines start to generate power for currents above their cut-in speeds, which are usually 50 cm/s or greater, and do not operate optimally until currents reach even higher speeds.

Aside from the low current speeds, Winter Quarters Bay does not provide a great physical location to install a tidal turbine. Low current speeds have caused large sediment accumulation, which can be problematic for a hydrokinetic turbine. It is possible to build foundations in fine sediment, especially if bedrock is not too deep; however, fine sediments can foul turbine components if there is a large amount in the water. If enough sediment collects on the turbine, it may interfere with its operation altogether. The sediment is coarser towards the mouth of the bay; however, this is where depths get shallower due to the submarine ridge. In addition, years of poor trash regulation at McMurdo mean that building a turbine foundation may require removal of debris and contaminants.

The bay is not significantly deep, so there are icing risks for any turbines located there. A turbine at depths shallower than 33 m is subject to anchor ice, which could significantly damage or destroy the system. At even shallower depths, a turbine could be impacted by ice floes and icebreakers, which would obviously damage the system. Turbines are typically elevated

some distance off the seafloor to avoid fouling from sediments or plants and to avoid low speeds near the bottom surface. Considering the annual exceedance results in Section 3.2.4, a system located outside of Winter Quarters Bay but in the vicinity of the Station is likely safe at extreme low tides from exposure or impacts with passing ships. However, the seafloor in McMurdo Sound reaches depths that are significant enough that the system would be difficult to maintain and monitor. A workshop hosted by the U.S. Department of Commerce, the National Oceanic and Atmospheric Administration (NOAA), and the National Marine Fisheries Service stated, “[tidal energy] device developers have not recommended deployments deeper than 80 m for operational reasons” (Polagye et al. 2010). Within a kilometer from the Station, McMurdo Sound reaches depths well below 80 m.

Multiple sources report that the general current direction past Winter Quarters Bay changes between winter and summer months. These direction changes are problematic if they are not close to 180° differences. Most tidal systems are designed to capture tides going in and out, so they should handle 180° direction changes easily. However if the changes are different, say 150°, then the system would fail to capture as much energy as it potentially could. Reorienting the system every 6 months to account for the seasonal direction changes is impractical and inefficient.

4.2 Modeling

IEC does not require hydrodynamic modeling if the power output of the proposed system is less than 10 MW, which would be the case for a system at McMurdo Station; but it does recommend harmonic decomposition analysis for Stage 1 studies. As explained in Section 2.1, tides can be described in terms of their harmonic constituents, which can be used to reconstruct tidal height or speed estimates at different points in time. With a simulated time series of tidal heights or speeds, it is possible to estimate the site’s tidal range or speed distributions. However, these results are only useful if they can be sufficiently validated.

As with other simulation efforts, there must be physical measurements to validate the simulated results against. Otherwise, there is no way to know if the models are producing realistic results. One way to validate a simulation is with hindcasting, which is the process of simulating a past

timeframe that overlaps with physical measurements and then comparing the two datasets. IEC states that for Stage 1 harmonic analysis efforts, “time series of current speed and directions at 30 min intervals over the period should be predicted” (IEC 2015). This resolution of measured data is not available for the McMurdo area, which means hindcasting validation is not feasible. Thus, we are unable to simulate tidal height and tidal current data for McMurdo Station’s tidal energy resource. In addition, there is likely little to gain from modeling because the measured data overwhelmingly agree. Simulation results indicating high current speeds would be highly suspect as there are no reported speeds to corroborate it.

For studies where model validation is possible, one program to predict tidal currents and tidal elevations is U-Tides. The details of how this method works can be found in (Codiga 2011). Modeling currents and tides with large-scale oceanographic models, such as the Regional Oceanic Modeling System, may be useful in future initiatives. However, these modeling types are beyond the scope of this project.

5 Additional Considerations

The following sections present information regarding important topics to consider when systems are actually installed. Because the McMurdo area is unsuitable for tidal energy, these topics are not fully investigated for that particular area. Instead, these sections provide general overviews as these are still important topics to acknowledge.

5.1 McMurdo Sound ecology

The seclusion of Antarctica's environment has led to one of the world's oldest and most unique wildlife communities. This ecological system exhibits a high degree of endemism and is much different from that found in the Arctic. A number of references characterize the Antarctic ecology, but we will focus on the regions around McMurdo Station where a tidal energy system could be installed.

The natural occurrence of ice scour and anchor ice in shallow regions of McMurdo Sound have shaped the benthic communities in those regions. Crockett and White (1997) characterize these regions "as having 'a general organic barrenness,' in which the combination of abrasion from moving masses of ice and heavy anchor-ice formation effectively remove any life forms that become established annually." This has resulted in low numbers of sessile species in these regions. However, these waters still host sea urchins; starfish; scavenger species; and occasionally isopods, sea spiders, and some fish species (Crockett and White 1997). The prevalence of sessile species increases as depths approach 33 m, below which ice scour and anchor ice are rare or nonexistent. Although the low inhabitation of these regions is good for a tidal energy installation, the icing concerns are not good; and we do not recommend that a system be installed at these shallow depths.

Below 33 m, the fauna community is dominated by a "complex sponge spicule mat community" that is typically 1 m thick or more and is composed of several sponge, mollusk, bryozoan, and polychaete species (Crockett and White 1997). Crockett and White (1997) consider this sponge mat to be very stable and state that it supports a host of starfish, nudibranchs, and species that feed off detritus. A tidal energy system installed in these regions would require removal of the sponge mat, which

would negatively impact the local benthic community. Maintenance and removal would likely damage adjacent regions of the mat. The new international agreement making the Ross Sea an MPA may prevent installation of such a system.

5.2 Environmental effects

Most prospective alternative energy systems require consideration of how that system might affect its local environment. Although these systems may mitigate the harmful emissions of fossil fuels, they can impact the environment in different ways. As the field of tidal energy has grown in recent years, there have been several efforts to understand how these installations affect the local plant and animal life. This is an area of ongoing research, and many of the effects are not fully understood. Table 2 contains a list of potential ways a tidal energy installation could impact its local environment.

Table 2. Causes of environmental effects due to tidal energy installations (Polagye et al. 2010).

Cause	Description
Static	The sheer presence of an installation can interrupt habitats, flow patterns, and sediment transport. Installation and removal procedures may cause disturbances.
Dynamic	Moving blades can collide with wildlife; wakes disrupt flow downstream.
Chemical	Lubricants, paints, and chemical coatings are potential contaminants.
Acoustic	Devices' noise signatures may disrupt wildlife activities and communication.
Electromagnetic	Systems contain electronic components and generate electricity, which produce local electromagnetic fields that may harm wildlife.
Energy Removal	The environment and ecology is accustomed to a certain level of energy. A device inherently removes energy from that system.
Cumulative	These individual effects, or the effects from multiple installed systems, can combine to permanently impact the local environment.

The most significant static effect caused by small installations is how the system's physical body alters flow hydrodynamics in the near field and the resultant sediment transport. Changing the amount of sediment transport or where it transports to will ultimately affect the local benthic community by physically reshaping its environment. Studies have shown that fish species common to reef environments are attracted to new structures; however, it is unknown how marine mammals and seabirds respond to the

structure (Polagye et al. 2010). It is possible that fish species common to the McMurdo area are not attracted to new installations and would in fact leave that area. Additional information about fish species in that area is necessary. If the wildlife communities are attracted to the structure and incorporate it into its ecosystem, then system maintenance and removal could disrupt that community further.

The most obvious concern with respect to a tidal system's dynamics is when blades strike wildlife. Turbine blades are rigid and can spin at high rates, depending on current speed. An impact between one of these rotating blades and any marine life could cause severe damage or death. This is a great concern for tidal energy systems and has been a prominent question in the field. Some studies suggest that "marine mammals and fish may see or hear the device and either avoid the area or take evasive action at close range" (Polagye et al. 2010). In addition, the first experiments with marine hydrokinetic turbines and live fish at two laboratories demonstrated survival rates close to indistinguishable from control populations that were not exposed to turbines (Amaral et al. 2011; Castro-Santos and Haro 2012). The behavior of animals around such systems requires additional research; and the question still remains for smaller, less advanced forms of life that may not have the ability to detect and avoid spinning turbine blades. Many system manufacturers have taken steps to mitigate the severity of impacts with their moving components and claim that impacts with fish or marine mammals would not be harmful. The currents are so slow in the McMurdo area that a turbine would spin at very low speeds, if at all. Impacts with marine wild life would likely be minor.

Spinning turbine blades also produce wakes that contain velocity and pressure variations. However, Polagye et al. (2010) concluded that these variations are "highly localized to the blades" and that the dynamic nature of ocean currents would likely "mask any measureable effect" of a turbine wake. If an animal is close enough to the spinning blades that they experience velocity and pressure variations, then they are likely in danger of getting struck, which is of higher concern.

The primary fear with chemical effects is that the wildlife will ingest or absorb the chemicals and become sick or die. In areas where people catch fish for consumption, these contaminants could then affect the human

population, though that is not the case in Antarctica. Chemicals may be released during installation, operation, maintenance, or removal procedures of a tidal energy system. These chemicals may include lubricants used within the system's moving components, hydraulic fluids used to transmit power, fuel from support ships used during installation or removal, cleaning solvents used during maintenance, or any paints used to coat system components. Acute spills, where large amounts are released, have a higher likelihood of causing severe damage than a slow release. Acute spills are obviously at the highest level of concern when it comes to chemical impacts on the local environment, and steps should be taken to avoid such spills.

Oceans naturally have ambient noise due to the motion of water, animal interactions, boat activity, and many more processes. If the noise becomes too loud in a given area, then it can physically harm an animal or affect its ability to communicate if it uses echolocation or other audial means. Tidal energy turbines produce "particularly high ambient noise levels" because of cavitation, vibrating components, or rotating components in the generator and gearbox (Polagye et al. 2010). If sound levels reach 120 dB, then there can be "disruptions of [animal] behavior, including temporary shifts in hearing threshold (e.g., often resulting in change of swimming path as part of avoidance)"; and if levels go higher than 180 dB, then there is an "immediate risk of mortality or physical injury (e.g., permanent hearing threshold shifts)" (Polagye et al. 2010). Examples of when sound levels could reach above 180 dB are pile driving during system installation or emergency braking when the system must stop immediately due to an issue. Sounds can reach above the 120 dB threshold because of maintenance, drilling to install power cables, rotor spinning, and the system's power train (Polagye et al. 2010). However, ocean ambient noise alone can reportedly reach levels above 120 dB. In some regions, fast tidal currents can create noise levels higher than 135 dB (Bassett et al. 2014). This is why it is necessary for sound measurements in the region near McMurdo Station to determine the acoustic baseline. It is difficult to determine whether a tidal energy system would introduce harmful levels of noise to that environment without baseline acoustic data.

The main intention of a tidal energy system is to produce electricity, which is transported to land for use via power cables. Additional details on the electricity transfer are covered in Section 5.3. Electromagnetic effects

(EMF) are produced by a number of components in a tidal energy system, including the electric generator, converters, electronic controls, and the power cables. Wires carrying alternating current (AC) produce both electric and magnetic fields, whereas those carrying direct current (DC) produce only a static magnetic field. The metal shields around cables do reduce the electric fields to some extent, and additional protective housings for ice effects may reduce the fields further. The effect of electric and magnetic fields on different marine species is not well understood. Polagye et al. (2010) report that different marine animals “are sensitive to EMF [but], their specific behavioral and physiological responses could not be established.” Certain marine species, such as eels, sharks, and sea turtles use senses that are tuned to electric and magnetic fields for navigation or migration. The fields produced by tidal energy systems could be very harmful to those species; however, it is not obvious how detrimental they would be. Additionally, we did not find records of sharks or sea turtles in the regions adjacent to McMurdo Station. To minimize the potential impact of EMF effects, the distance between the system and shore should be as short as possible to reduce the total length of power cables.

For pilot-scale projects, the effect of energy removal on an environment is considered “immeasurably small” and well within the magnitude of natural variability. The effect of energy removal is more significant for installations with multiple turbines, which remove a larger amount of energy from the ecosystem.

It is difficult to conclusively state the environmental impact of a tidal energy system installed in the McMurdo area based on the available information. However, what is available suggests that the biggest concern for such a system would be its static effects. Installing the system would require removal of the native sponge mat, and additional maintenance could further damage that ecosystem. Altering the local flow characteristics may affect how the wildlife in the mat receives nutrients or cause sediment to build up over the mat. The low current speeds suggest that impacts between the blades and wildlife would likely be minor due to low blade speed.

5.3 Electrical grid considerations

McMurdo Station and Scott Base share the output of three large wind turbines that were commissioned by the National Renewable Energy Laboratory in 2010. As part of that installation, a joint power grid was constructed between the two facilities so that they can share the generated electricity. This grid includes underground cables, a flywheel system that can provide short-term power if wind speeds drop, and converters to account for the different AC frequencies each station operates at (Verrengia 2010). Many of the electrical challenges associated with renewable energy systems, such as converters and power conditioning, have been addressed with the unified McMurdo–Scott Base power grid, which serves as a great foundation for future renewable energy projects in that area. Additional energy systems may be able to capitalize on the infrastructure in this shared grid.

At the system level, a typical tidal energy system contains a generator that converts the turbine's rotational energy into AC. As most tidal energy installations are located close to shore, the generated electricity is commonly transmitted via a high-voltage AC power transmission system. In addition, the electricity likely passes through a step-up transformer before entering the on-shore electrical grid (Polagye et al. 2010). Because the unified McMurdo–Scott Base grid was designed with renewable energy in mind, the biggest electrical concern for a tidal energy system in McMurdo Sound is when the power is being transmitted via cables from the turbine to the grid.

As highlighted in previous sections, power cables running through Winter Quarters Bay would be exposed to harsh conditions. These cables would require heavy-duty housings to protect against ice scour and anchor ice, which could significantly damage the cables. Severing the cables could potentially harm any wildlife in the area and would lead to critical system damage that would require maintenance or replacement. Elevated platforms may mitigate concerns regarding anchor ice by lifting the cables above the seafloor, but this would require additional disturbances to the sponge mat ecosystem. In addition, the interface where cables exit the water would require high-strength conduits to withstand ice-induced loadings from seasonal ice and icebreaker operations. Although the rest of the evidence points against it, if a system were installed, the power cables

should run along the eastern side of the bay because icebreaking vessels approach the west side of the bay where the Ice Pier is located. Depending on where the system were installed, it may be better to run cables to the end of Hut Point and then finish the remaining wiring above ground. However, all of these additional features add costs to a system that would likely produce little or no energy.

Licensed professionals familiar with the exact electrical needs of renewable energy systems and the harsh climate of Antarctica should define the specific electrical component required for such a system. This includes inverters, connectors, and safety and metering equipment in addition to more basic things such as appropriate wiring and housing fixtures.

6 Conclusions and Recommendations

The data corresponding to McMurdo Station's tidal resource is insufficient for a full energy assessment. However, it provides enough evidence that we may conclude that tidal energy is not feasible for that region of McMurdo Sound. Current speeds are so low that a tidal turbine would struggle to even begin generating power, let alone produce a meaningful amount. We did not find reported tidal current speed values greater than 30 cm/s within McMurdo's vicinity. Current speeds are slightly larger in McMurdo Sound than in Winter Quarters Bay, but the seafloor becomes deep fairly quickly outside of the bay. Within a relatively small distance, the seafloor reaches depths that are too deep for tidal energy installations. Dealing with the ice-related challenges of McMurdo Station and its surrounding ocean may be possible with enough time and resources. However, the weak tidal energy resource does not warrant the investment and logistical steps needed for such a system. Considering the low tidal current speeds, issues with depth, and icing concerns, it is not advisable to install a tidal energy conversion system at McMurdo Station.

Long-term and high-temporal-resolution data (>90 continuous days, <10 min resolution) is necessary for a meaningful AEP estimation. Future scientific studies in the area may look at relevant data for different research purposes, but data collection specifically for tidal energy purposes is unnecessary. For future reference, Appendix C provides information on current speed and direction measurements and instrumentation.

This conclusion does not mean that tidal energy is not worthwhile in other regions of Antarctica; it just does not make sense for McMurdo Station. Palmer Station is NSF's smallest station in Antarctica, but it is located on the coast of Anvers Island and may have a more promising tidal resource than McMurdo. A quick overview of Palmer and its surroundings highlights a series of small nearby islands. Currents may funnel between these islands, increasing their speed. In addition, these islands provide potential equipment installation sites, which effectively increase the distance a tidal energy system could be installed from the station. Perhaps the most beneficial aspect of Palmer Station's tidal resource is that it has a direct line with the open ocean, which is something McMurdo Station lacks. Except for a few small islands directly east of Palmer Station, currents are not

blocked as they approach the station from the open ocean. Barring any underwater features, Palmer Station may prove to have a better tidal energy potential than McMurdo. However, the same icing concerns remain for Palmer Station. If the achievable tidal energy yield is significant, then it may be worthwhile for the extra icing precautions. In addition, there have been a few scientific studies in recent years that have deployed bottom-mounted ADCP units near Palmer Station to measure current speeds and directions. This type of data is what is needed for full energy assessments for a particular location.

USAP should continue to consider renewable energy at McMurdo Station, especially wind and solar energy sources. Antarctica's katabatic winds often produce very high wind speeds, which can produce large amounts of power. The shared wind turbine array with Scott Base proves that wind energy in the McMurdo region is a viable option. McMurdo already draws a sizable amount of energy from these turbines, and expanding the array could offset a significant portion of the Station's energy needs without needing to install an entirely new electricity transfer system. Another renewable resource of interest for McMurdo is solar energy. One of the main drawbacks of normal solar arrays is the intermittence of sunlight. However, constant sunlight during the austral summer mitigates the primary reason for low sunlight—nighttime. The austral summer timeframe coincides nicely with when most researchers visit McMurdo Station and increase its energy demands. A high wind-energy potential combined with constant sunlight provides McMurdo with a promising renewable energy resource that could very well offset most of its energy needs. As with any installation in the McMurdo region, these energy systems must be able to withstand some of the most extreme conditions on earth. Experiences from installing and operating the shared wind turbine array should provide useful guidance for any new systems.

References

- Amaral, S., N. Perkins, D. Giza, and B. McMahon. 2011. *Evaluation of Fish Injury and Mortality Associated with Hydrokinetic Turbines*. EPRI Report ID 1024569. Palo Alto, CA: Electric Power Research Institute.
- Bachant, P., and M. Wosnik. 2015. Characterizing the Near-Wake of a Cross-Flow Turbine. *Journal of Turbulence* 16 (4): 392–410. doi:<http://dx.doi.org/10.1080/14685248.2014.1001852>.
- Barry, J. P., 1988, Hyrdographic Patterns in McMurdo Sound, Antarctica, and Their Relationship to Local Benthic Communities. *Polar Biology* 8: 377–391.
- . 1995. *Ocean Current Observations near McMurdo Station, Antarctica, 1993 to 1994: Relation to Wastewater Discharge Dispersal*. Idaho National Engineering Laboratory.
- Barry, J. P., and P. K. Dayton. 1988. Current Patterns in McMurdo Sound, Antarctica and Their Relationship to Local Biotic Communities. *Polar Biology* 8:367–376.
- Bartek, L. R., and J. B. Anderson. 1991. Fades Distribution Resulting From Sedimentation Under Polar Interglacial Climatic Conditions Within a High-Latitude Marginal Basin, McMurdo Sound, Antarctica. *Special Paper of the Geological Society of America* 261: 27–49.
- Bernitsas, M. M., K. Raghavan, Y. Ben-Simon, and E. M. Garcia. 2008. VIVACE (Vortex Induced Vibration Aquatic Clean Energy): A New Concept in Generation of Clean and Renewable Energy From Fluid Flow. *Journal of Offshore Mechanics and Arctic Engineering* 130 (4): 15.
- Boon, J. 2004. *Secrets of the Tide: Tide and Tidal Current analysis and Predictions, Storm surges and Sea Level Trends*. Chichester, UK: Horwood Publishing.
- Butler, E. R. 1999. Process Environments on Modern and Raised Beaches in McMurdo Sound, Antarctica. *Marine Geology* 162 (1): 105–120.
- Castro-Santo, T., and A. Haro. 2012. *Survival and Behavior of Juvenile Atlantic Salmon and Adult American Shad on Exposure to a Hydrokinetic Turbine*. EPRI Report ID 1026904. Palo Alto, CA: Electric Power Research Institute.
- Codiga, D. L. 2011. *Unified Tidal Analysis and Prediction Using the UTide Matlab Functions*. Technical Report 2011-01. Narragansett, RI: University of Rhode Island, Graduate School of Oceanography.
- Crockett, A. B., and G. J. White. 1997. Comprehensive Characterization Report on Winter Quarters Bay, McMurdo Station, Antarctica. Idaho Falls, Idaho: Idaho National Engineering Laboratory, Environmental Assessment Technologies.
- Davey, F. J. 2004. *Ross Sea Bathymetry, 1:2,000,000. version 1.0*. Institute of Geological and Nuclear Sciences Geophysical Map 16 (P. G. Center, Compiler). Lower Hutt, New Zealand: Institute of Geological and Nuclear Sciences Limited.

- Davey, F. J., and S. S. Jacobs. 2007. Influence of Submarine Morphology on Bottom Water Flow Across the Western Ross Sea Continental Margin, in Antarctica. In *A Keystone in a Changing World—Online Proceedings of the 10th ISAES*, ed. A. K. Cooper and C. R. Raymond. Reston, VA: U.S. Geological Survey.
- Dayton, P. K., G. A. Robilliard, and R. T. Paine. 1970. Benthic Faunal Zonation as a Result of Anchor Ice at McMurdo Sound, Antarctica. IN *Antarctic Ecology*, ed. M. W. Holdgate, 1:244–258. New York: Academic Press.
- Gilmour, A. E., W. J. MacDonald, and F. G. Hoeven. 1962. Winter Measurements of Sea Currents in McMurdo Sound. *New Zealand Journal of Geology and Geophysics* 5 (5): 778–789.
- Heath, R. A. 1971a. Circulation and Hydrology Under the Seasonal Ice in McMurdo Sound, Antarctica. *New Zealand Journal of Marine and Freshwater Research* 3 (3–4): 497–515.
- . 1971b. Tidal Constants for McMurdo Sound, Antarctica. *New Zealand Journal of Marine and Freshwater Research* 5 (2): 376–380.
- Herbich, J. B., and T. Walters. 1982. Wave Climate. In *Beaches and Coastal Geology*, 855–856. New York: Springer US.
- Hunt, B. M., K. Hoeffling, and C. H. Cheng. 2003. Annual Warming Episodes in Seawater Temperatures in McMurdo Sound in Relationship to Endogenous Ice in Notothenioid Fish. *Antarctic Science* 15 (3): 333–338.
- IEC (International Electrotechnical Commission). 2015. *Marine Energy—Wave, Tidal and Other Water Current Converters—Part 201: Tidal Energy Resource Assessment and Characterization*. TS 62600-201:2015. Geneva, Switzerland: International Electrotechnical Commission.
- Kawabe, M. 1985. El Niño Effects in the Kuroshio and Western North Pacific. In *El Niño North: Nino Effects in the Eastern Subarctic Pacific Ocean*, ed. W. S. Wooster and D. L. Fluharty, 116–118. Seattle, WA: University of Washington, Washington Sea Grant Program.
- Land Information New Zealand. 2016. DJRB: Mark Details. <http://apps.linz.govt.nz/gdb/index.aspx?mode=&sessionid=46134177123119561479395696&code=DJRB&action=+setfoundmarks+updatelist&foundmarklist=&listaction=clear+add&mark=> (accessed 17 November 2016).
- Leventer, A., R. B. Dunbar, M. R. Allen, and R. Y. Wayper. 1987. Ice Thickness in McMurdo Sound. *Antarctic Journal of the United States* 22 (5): 94–96.
- Lever, J. H. 2016. *Autonomous Sea-Ice Thickness Survey*. ERDC/CRREL SR-16-4. Hanover, NH: U.S. Army Engineer Research and Development Center.
- Lewis, E. L., and R. G. Perkin. 1985. The Winter Oceanography of McMurdo Sound, Antarctica. In *Oceanology of the Antarctic Continental Shelf*, ed. S. S. Jacobs. Washington, DC: American Geophysical Union.

- Lewis, A., S. Estefen, J. Huckerby, K. S. Lee, W. Musial, T. Pontes, and J. Torres-Martinez. 2011. Ocean Energy. In *Report on Renewable Energy Sources and Climate Change Mitigation*, ed. R. P.-M. O. Edenhofer. Cambridge, UK: Cambridge University Press.
- McGrath, M. 2016. World's Largest Marine Protected Area Declared in Antarctica. *BBC News*, 28 October. <http://www.bbc.com/news/science-environment-37789594>.
- Mysak, L. A. 1985. On the Interannual Variability of Eddies in the Northeast Pacific Ocean. In *El Niño North: Niño Effects in the Eastern Subarctic Pacific Ocean*, ed. W. S. Wooster and D. L. Fluharty, 97–106. Seattle, WA: University of Washington, Washington Sea Grant Program.
- Niebauer, H. J. 1984. On the Effect of El Niño Events in Alaskan Waters. *Bulletin of the American Meteorological Society* 65:472–473.
- Pierce, E. R., and D. Wood. 2014. How Does a Wind Turbine Work? *Energy.gov*. Washington, DC: U.S. Department of Energy. <http://energy.gov/articles/how-wind-turbine-works> (accessed 27 September 2016).
- Polagye, B., and J. Thompson. 2012. Tidal Energy Resource Characterization: Methodology and Field Study in Admiralty Inlet, Puget Sound, WA (USA). In *Proceedings of the Institution of Mechanical Engineers Part A: Journal of Power and Energy* 227 (3): 352–367.
- Polagye, B., B. V. Cleve, A. Copping, and K. Kirkendall. 2011. *Environmental Effects of Tidal Energy Development*. NOAA Technical Memorandum NMFS F/SPO-116. Seattle, Washington: U.S. Department of Commerce, National Oceanic and Atmospheric Administration, National Marine Fisheries Service.
- Raytheon. 1983. *Report on the McMurdo Station Water Quality Study*. Performed for ITT Antarctic Services, Paramus, New Jersey. Middletown, RI: Raytheon Services Company.
- Rogers J. C., and H. van Loon. 1979. The Seesaw in Winter Temperatures Between Greenland and Northern Europe. Part II: Some Oceanic and Atmospheric Effects in Middle and High Latitudes. *Monthly Weather Review* 107:509–519.
- Rowell, M. 2013. Experimental Evaluation of a Mixer-Ejector Hydrokinetic Turbine at Two Open-Water Tidal Energy Test Sites in NH and MA. *Marine Technology Society Journal* 47 (4): 67–79.
- Royer, T. C. 1985. Coastal Temperature and Salinity Anomalies in the Northern Gulf of Alaska, 1970–84. In *El Niño North: Niño Effects in the Eastern Subarctic Pacific Ocean*, ed. W. S. Wooster and D. L. Fluharty, 107–114. Seattle, WA: University of Washington, Washington Sea Grant Program.
- Tressler, W. L., and A. M. Ommundsen. 1962. *Seasonal Oceanographic Studies in McMurdo Sound, Antarctica*. Washington, DC: U.S. Navy Hydrographic Office.

- U.S. Antarctic Program Blue Ribbon Panel. 2012. *More and Better Science in Antarctica Through Increased Logistical Effectiveness*. Washington, DC: National Science Foundation.
- United States Coast Guard. 2014. Aircraft, Boats, and Cutters: Cutters. Washington, DC: Department of Homeland Security, United States Coast Guard. <https://www.uscg.mil/datasheet/icepolr.asp> (accessed 11 October 2016).
- Verrengia, J. 2010. Wind and Solar Energy Power Polar Research. Washington, DC: National Renewable Energy Laboratory. <http://www.nrel.gov/news/features/2010/1528>.
- Williams, R. T., and E. S. Robinson. 1980. The Ocean Tide in the Southern Ross Sea. *Journal of Geophysical Research* 85 (C11): 6689–6696.

Appendix A: Locations of Reported Current Speeds and Directions

Figure A-1. Map illustrating the magnitude and direction of tide measurements at different locations around McMurdo Station. Table A-1 provides additional information for each measurement site.

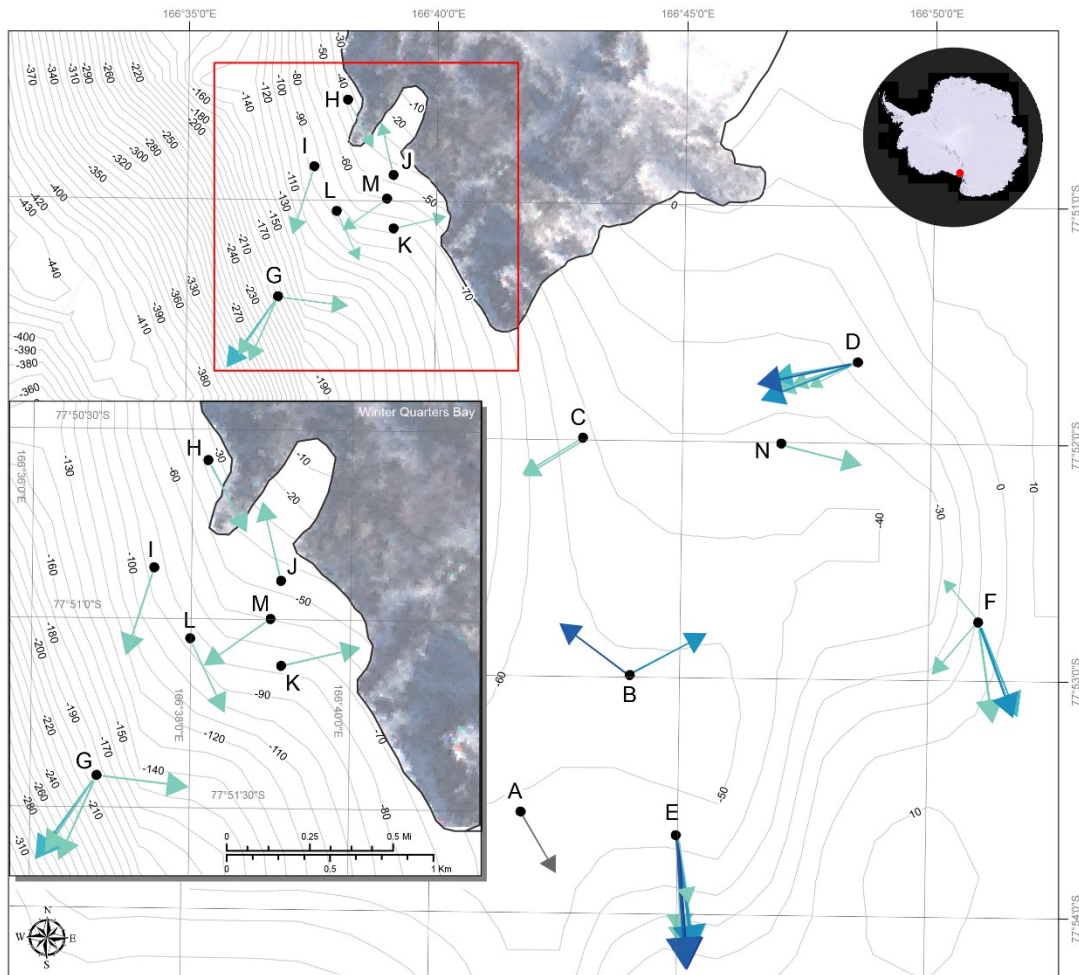

Observed Current Data

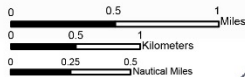
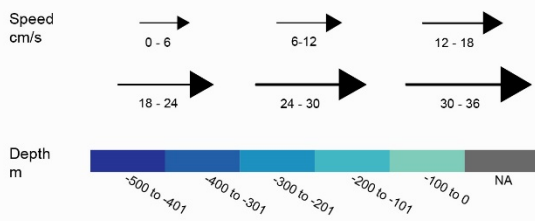

WGS84 Antarctic Polar Stereographic Projection
 Observed data provided by Brendan West, CRREL
 Bathymetry data: Marine Geoscience Data System (MGDS)
 Basemap imagery: Landsat Image Mosaic of Antarctica (LIMA)
 Cartography by Cathleen Torres Parisian, PGC
 November 2016



All Contour Intervals 10 m

Site ID	Depth m	Speed cm/s	Cardinal Direction	Site ID	Depth m	Speed cm/s	Cardinal Direction
A	NA	7.5	SE	F	25	6	NW
B	< 300	15.4	NE*	50	12	SSW	
	300	15.4	WNW*	100	19	SSE	
C	< 25	11.9	SW*	200	21	SE	
	25	11.9	SW*	300	22	SE	
D	25	6	SW	G	25	9	E
	50	12	WSW	50	12	S	
	100	15	WSW	100	13	SSW	
	200	17	WSW	150	11	SSW	
	300	22	SW	H	16	3.6	SE
E	400	24	WSW	I	39	11.7	S
	25	8	SSE	J	15	3.5	NNW
	50	20	SSE	K	32	4.1	ENE
	100	29	SSE	L	37	3.8	SE
	200	28	SSE	M	25	4.3	SW
	300	30	SSE	N	30	15	E
	400	31	SSE	All Cardinal Directions derived from observed directional degrees unless otherwise noted			
500	32	SSE	* denotes average				

Table A-1. Additional information supporting measurements in Fig. A-1.

Point	Latitude	Longitude	Measurement Timeframe	Notes	Reference
A	-77° 53'35"	166° 41'50"	Intermittent periods: Apr.-Aug. 1959 (speed) and May-Aug. (direction)	Through hole in ice	Gilmour et al. (1962)
B	-77° 53'	166° 44'	Intermittent periods: May-Dec. 1960	Through hole in ice	Tressler and Ommundsen (1962)
C	-77° 52'	166° 43'	Two separate holes: Dec. 1960-Feb. 1961 and Apr.-Dec. 1961	Through hole in ice	Heath (1971a)
D	-77° 51'40"	166° 48'30"	Individual depth measurements 31 Dec. 1970-11 Jan. 1971	Through hole in ice (speed values are "max" measurement values)	Heath (1971a)
E	-77° 53'40"	166° 45'00"	Individual depth measurements 16-17 Jan. 1971	Through hole in ice (speed values are "max" measurement values)	Heath (1971a)
F	-77° 52'45"	166° 51'00"	Individual depth measurements 17-19 Jan. 1971	Through hole in ice (speed values are "max" measurement values)	Heath (1971a)
G	-77° 51'25"	166° 36'50"	Individual depth measurements 1-2 Feb.1971	Through hole in ice (speed values are "max" measurement values)	Heath (1971a)
H	-77° 50'34.97"	166° 38'11.77"	1752 17 Dec. 1993-1052 18 Nov. 1994		Barry (1995)
I	-77° 50'52.02"	166° 37'31.88"	1719 17 Dec. 1993-1119 18 Nov. 1994		Barry (1995)
J	-77° 50'53.95"	166° 39'7.57"	1517 17 Dec. 1993-0717 18 Nov. 1994		Barry (1995)
K	-77° 51'7.46"	166° 39'8.26"	1443 17 Dec. 1993-0943 18 Nov. 1994		Barry (1995)
L	-77° 51'3.24"	166° 37'59.51"	1047 17 Dec. 1993-0347 18 Nov. 1994		Barry (1995)
M	-77° 51'	166° 39'	18 Nov.-23 Nov. 1984		Barry and Dayton (1988)
N	-77° 52'	166° 47'	14 Jan.-15 Jan. 1984		Barry and Dayton (1988)

Appendix B: Locations of Reported Tidal Constituents

Table B-1. Reported tidal constituents for sites close to McMurdo Station.

Latitude	Longitude	Amplitude (cm)	Phase (°)	Timeframe	Reference
-77° 51' 10"	166° 39' 20"	K1 = 23	212	4 Jan. 1971-3 Feb. 1971	Heath (1971b)
		P1 = 8	213		
		O1 = 21	195		
		M2 = 4	242		
		S2 = 2	327		
		N2 = 2	263		
		K2 ≈ 0	82		
		M4 ≈ 0	270		
		MS4 ≈ 0	335		
-77° 51' 0"	166° 39' 36"	K1 = 26	196	29 day dataset	Williams and Robinson (1980)
		P1 = 9	196		
		O1 = 26	186		
		M2 = 4	6		
		S2 = 2	268		
		N2 = 3	234		

Appendix C: Acoustic Doppler Current Profiler Information

An acoustic Doppler current profiler (ADCP) is an instrument typically used to measure current profiles in a body of water. Developed in the late 1970s and early 1980s, these instruments have become the standard for field measurements of water currents.

Figure C-1. A LinkQuest FlowQuest 1000 ADCP. The piezoelectric oscillators can be seen on the sloped surfaces at the bottom of the image.



ADCP instruments are typically deployed in two configurations. Bottom-mounted ADCPs are mounted on the seafloor looking upwards towards the surface of the water. This configuration generates velocity profiles that are in reference to the seabed. Typically, one must provide batteries and a retrieval system for bottom-mounted deployments. ADCPs can also be deployed in a surface-mounted configuration where they are mounted through the hull of a ship or over the side of a vessel. In the surface-mounted configuration, the ADCP is facing downwards towards the seabed. This configuration creates velocity profiles that are in reference to their near-surface mounting location. The water surface constantly moves

due to wave and tidal action, and it is difficult to predict how the mounting structure will move with respect to the water surface. When using surface-mounted ADCPs, the data is typically corrected for the position (both horizontal and vertical) and the attitude of the ADCP. Other auxiliary instruments are typically used to provide correction factors for surface-mounted ADCPs.

Figure C-2. A bottom mounted ADCP configuration with an external battery pack on a triangular mounting system (*left*) and a surface mounted ADCP configuration pole mounted over the bow of a floating platform (*right*).

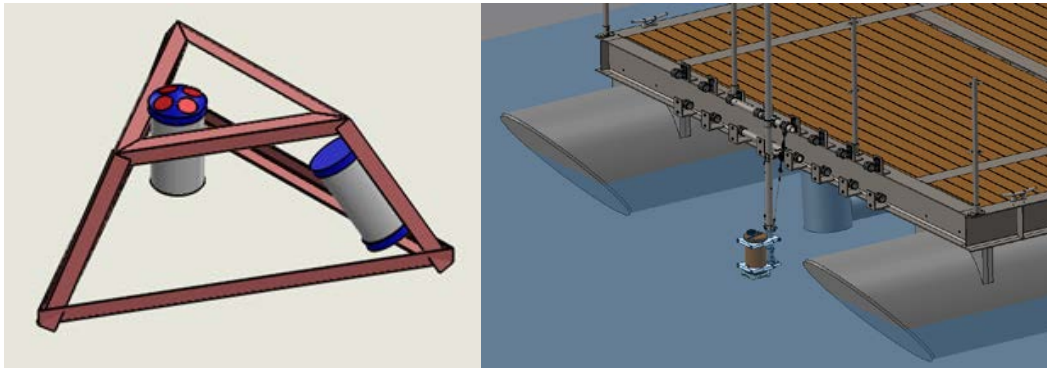

ADCPs use piezoelectric oscillators to transmit sound of a known frequency. This sound is scattered by suspended particles in the water, and some is reflected back to the piezoelectric oscillators. The oscillators sense the frequency of that backscattered sound, and the difference between the frequency of the transmitted sound and the backscattered sound is the Doppler shift.

By measuring the Doppler shift of backscattered sound, one can determine the speed of the object that scattered that signal. When an object is moving towards the sound-emission source, it will reflect the signal at an increased frequency directly proportional to the speed of the object. When an object is moving away from the sound-emission source, it will reflect the signal at a decreased frequency directly proportional to the speed of the object. By assuming suspended particles have the same speed as the water, one can determine the speed of the flow.

Figure C-3. Illustration of Doppler shift.

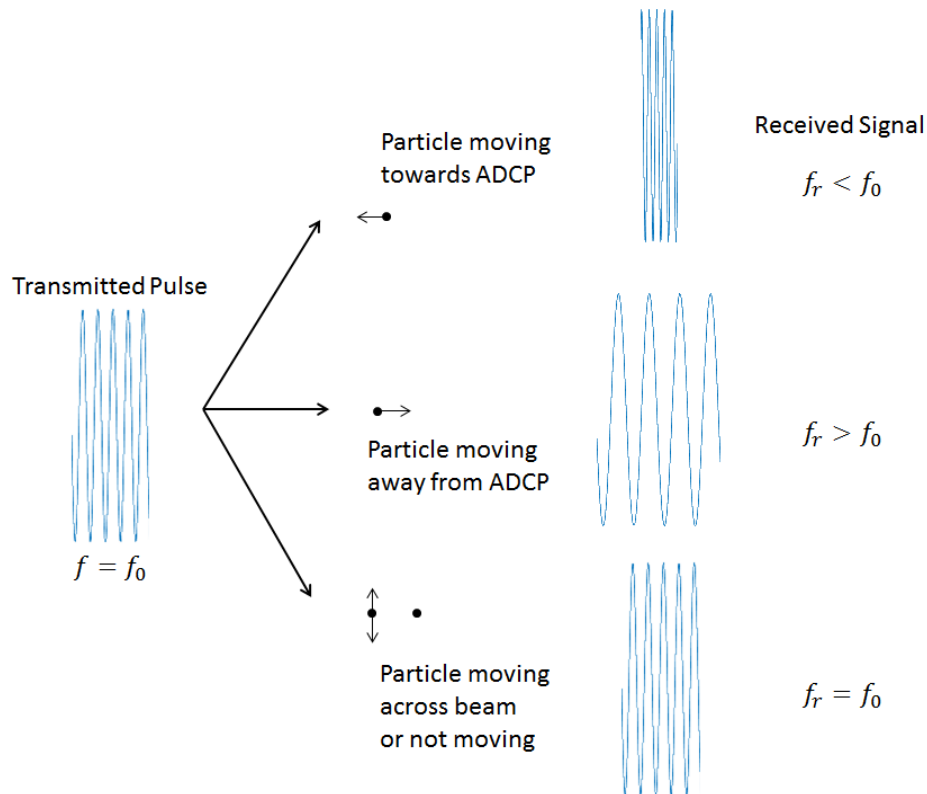

To determine the velocity of the water, which includes both speed and direction, one must use multiple piezoelectric oscillators to generate multiple beams of sound. By pointing at least three, but typically four, beams in different known directions and analyzing the trigonometric relationships between the speeds measured in each of those beams, the instrument can determine three-dimensional velocity components. Because the beams are all angled away from one another, they are all measuring the current in different places. The trigonometric relationships assume homogeneity across all beams to correctly compute velocity. This typically is a reasonable assumption in most river and ocean flows.

ADCPs have the ability to generate current–depth profiles, which reflect variations in speed with respect to depth. To do this, the ADCP uses temporal gating. By measuring the amount of time it takes for sound to reflect back to the piezoelectric oscillators, the ADCP can determine how far away that sound is coming from. The ADCP determines a velocity measurement from the sound it senses over a very small time interval. Each of these velocity measurements taken over very small time intervals creates a velocity measurement at a given depth determined by the amount of time it took

for that sound to return to the piezoelectric oscillators. Because the measurements have to be performed over very small intervals, the measurements of velocity are an average measurement of velocity over a given depth bin instead of being a point measurement of velocity.

ADCPs can be set up to perform in many custom configurations; however, they ping sound bursts and then listen for backscatter approximately every two seconds. The uncertainty associated with these measurements is too high for most measurement requirements, so a series of velocity measurements from individual pings are ensemble averaged to calculate a velocity estimate with higher certainty.

ADCPs are often accompanied by a range of other sensors to supplement their velocity measurements. Pressure sensors help determine the ADCP's distance from the water surface. Gyrocompasses, synchros, and GPS (global positioning system) determine the ADCP's attitude and position. Additional ADCP beams can be used to track the bottom, helping determine the distance from the ADCP to the seafloor and the velocity of the ADCP with respect to the seafloor. ADCP's often measure water temperature to help correct for variations in sound speed.

REPORT DOCUMENTATION PAGE

Form Approved
OMB No. 0704-0188

Public reporting burden for this collection of information is estimated to average 1 hour per response, including the time for reviewing instructions, searching existing data sources, gathering and maintaining the data needed, and completing and reviewing this collection of information. Send comments regarding this burden estimate or any other aspect of this collection of information, including suggestions for reducing this burden to Department of Defense, Washington Headquarters Services, Directorate for Information Operations and Reports (0704-0188), 1215 Jefferson Davis Highway, Suite 1204, Arlington, VA 22202-4302. Respondents should be aware that notwithstanding any other provision of law, no person shall be subject to any penalty for failing to comply with a collection of information if it does not display a currently valid OMB control number. **PLEASE DO NOT RETURN YOUR FORM TO THE ABOVE ADDRESS.**

1. REPORT DATE (DD-MM-YYYY) December 2016			2. REPORT TYPE Technical Report/Final			3. DATES COVERED (From - To)		
4. TITLE AND SUBTITLE Tidal Energy Resource Assessment for McMurdo Station, Antarctica						5a. CONTRACT NUMBER		
						5b. GRANT NUMBER		
						5c. PROGRAM ELEMENT NUMBER		
6. AUTHOR(S) Brendan A. West, Ian F. Gagnon, and Martin Wosnik						5d. PROJECT NUMBER		
						5e. TASK NUMBER EP-ANT-16-14		
						5f. WORK UNIT NUMBER		
7. PERFORMING ORGANIZATION NAME(S) AND ADDRESS(ES) U.S. Army Engineer Research and Development Center (ERDC) Cold Regions Research and Engineering Laboratory (CRREL) 72 Lyme Road Hanover, NH 03755-1290						8. PERFORMING ORGANIZATION REPORT NUMBER ERDC/CRREL TR-16-17		
9. SPONSORING / MONITORING AGENCY NAME(S) AND ADDRESS(ES) National Science Foundation, Division of Polar Programs Antarctic Infrastructure and Logistics 4201 Wilson Boulevard Arlington, VA 22230						10. SPONSOR/MONITOR'S ACRONYM(S) NSF		
						11. SPONSOR/MONITOR'S REPORT NUMBER(S)		
12. DISTRIBUTION / AVAILABILITY STATEMENT Approved for public release; distribution is unlimited.								
13. SUPPLEMENTARY NOTES Engineering for Polar Operations, Logistics, and Research (EPOLAR)								
14. ABSTRACT The U.S. Antarctic Program (USAP) is interested in expanding renewable energy capabilities at McMurdo Station, Antarctica, to reduce costs and emissions. Previous assessments considered wind, solar, and geothermal energy resources but not ocean energy resources such as tidal energy. The National Science Foundation, Division of Polar Programs, Antarctic Infrastructure and Logistics, commissioned the Cold Regions Research and Engineering Laboratory to assess the feasibility of a tidal energy system in the waters near McMurdo Station. This study used industry standards to assess relevant datasets, including bathymetry, tidal characteristics, meteorological, and icing data. Unfortunately, the available data was insufficient for full annual energy production estimates; however, the data unanimously indicated that current speeds within Winter Quarters Bay and the adjacent McMurdo Sound are much too low for tidal energy generation. The maximum measured current speed was less than the typical cut-in speed for most tidal energy turbines. Additional challenges, including the recent declaration of the Ross Sea as a marine protected area and the need for high-strength infrastructures to withstand icing, make the McMurdo Station region a poor location for a tidal energy installation. USAP would likely fail to recoup the costs associated with such a system. Although tidal energy is not suitable for this case, this report presents a collated set of various tidal-related data for the McMurdo Station region, which may be of use to other studies.								
15. SUBJECT TERMS Energy conservation--Analysis, EPOLAR, McMurdo Station (Antarctica), NSF, Ocean energy resources, Renewable energy sources--Antarctica -- Analysis, Tidal energy resource assessment, Tidal power--Antarctica, Tides-- Antarctica --McMurdo Sound								
16. SECURITY CLASSIFICATION OF:				17. LIMITATION OF ABSTRACT	18. NUMBER OF PAGES	19a. NAME OF RESPONSIBLE PERSON		
a. REPORT Unclassified	b. ABSTRACT Unclassified	c. THIS PAGE Unclassified	SAR			65	19b. TELEPHONE NUMBER (include area code)	