



**US Army Corps  
of Engineers®**  
Engineer Research and  
Development Center



*DoD Corrosion Prevention and Control Program*

# **Demonstration of a Model-Based Technology for Monitoring Water Quality and Corrosion in Water-Distribution Systems**

Final Report on Project F07-AR05

Vicki L. Van Blaricum, Kevin Russell,  
and Robert Broadwater

December 2016

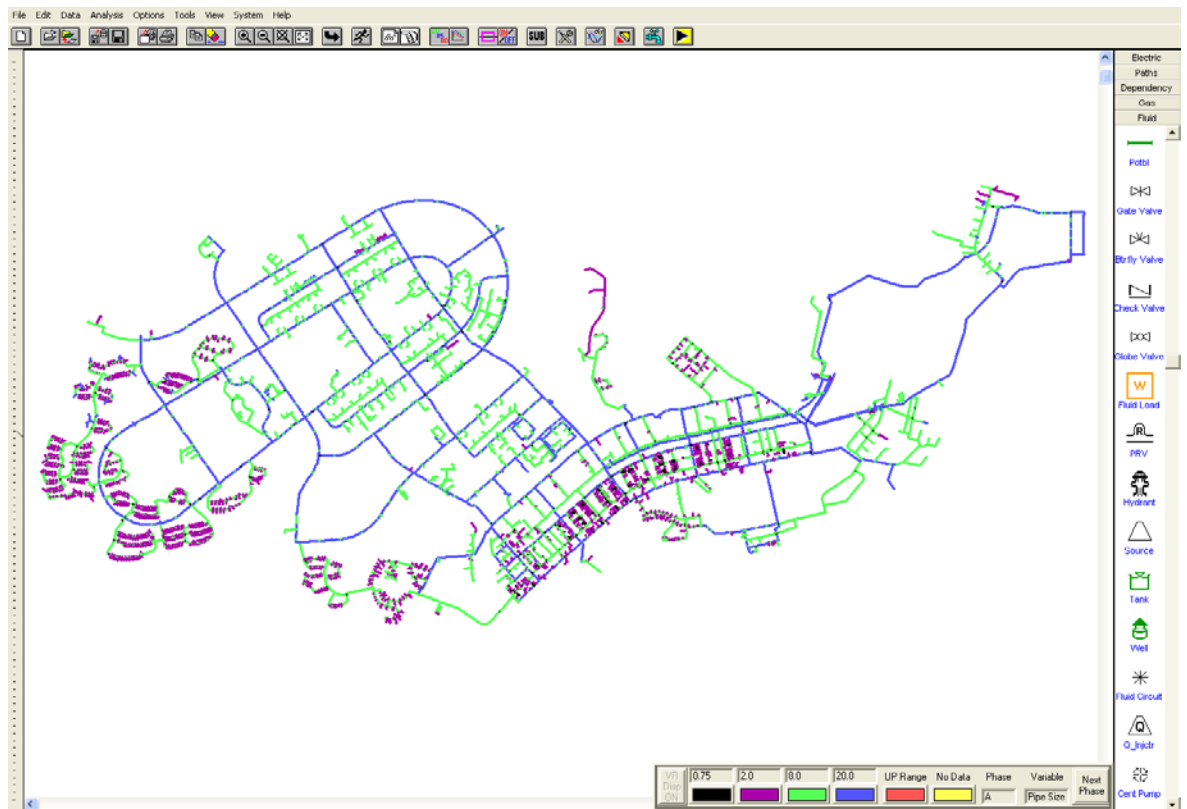

**The U.S. Army Engineer Research and Development Center (ERDC)** solves the nation's toughest engineering and environmental challenges. ERDC develops innovative solutions in civil and military engineering, geospatial sciences, water resources, and environmental sciences for the Army, the Department of Defense, civilian agencies, and our nation's public good. Find out more at [www.erdcenter.usace.army.mil](http://www.erdcenter.usace.army.mil).

To search for other technical reports published by ERDC, visit the ERDC online library at <http://acwc.sdp.sirsi.net/client/default>.

# **Demonstration of a Model-Based Technology for Monitoring Water Quality and Corrosion in Water-Distribution Systems**

Final Report on Project F07-AR05

Vicki L. Van Blaricum

*Construction Engineering Research Laboratory  
U.S. Army Engineer Research and Development Center  
2902 Newmark Drive  
Champaign, IL 61822*

Kevin Russell and Robert Broadwater

*Electrical Distribution Design  
311 Cherokee Drive  
Blacksburg, VA 24060-0382*

Interim report

Approved for public release; distribution is unlimited.

Prepared for Office of the Secretary of Defense (OUSD(AT&L))  
3090 Defense Pentagon  
Washington, DC 20301-3090

Under Project F07-AR05, "Corrosion Detection and Management System for Potable  
Water at Fort Drum"

## Abstract

The objective of this project was to demonstrate an always-on, model-based monitoring technology for potable water-distribution systems. The technology uses near-real-time sensor data to estimate key water-quality parameters and corrosivity indices throughout the network so localized corrosion problems can be detected. Researchers successfully created a computerized model of the Fort Drum, NY, water-distribution system, but an unforeseen project-scheduling conflict with a major upgrade of the installation's Supervisory Control and Data Acquisition (SCADA) system prevented completion of the user interface between the model and sensors. The model was successfully tested offline, however, using archived sensor data. It estimated key water-quality parameters and corrosivity indices throughout the distribution system, but its accuracy was validated at only one location. The results were promising but did not return enough data to validate simulation accuracy or to conclude that real-time operation would be successful. Therefore, the demonstrated system cannot be recommended for implementation.

This report documents the modeling technology, creation of the Fort Drum model, the general sensor interface design, offline demonstration of the model, and results of evaluation against the project metrics. Lessons learned are documented and recent advances in similar technology are discussed.

**DISCLAIMER:** The contents of this report are not to be used for advertising, publication, or promotional purposes. Citation of trade names does not constitute an official endorsement or approval of the use of such commercial products. All product names and trademarks cited are the property of their respective owners. The findings of this report are not to be construed as an official Department of the Army position unless so designated by other authorized documents.

**DESTROY THIS REPORT WHEN NO LONGER NEEDED. DO NOT RETURN IT TO THE ORIGINATOR.**

# Contents

<b>Abstract</b> .....	<b>ii</b>
<b>Figures and Tables</b> .....	<b>v</b>
<b>Preface</b> .....	<b>vi</b>
<b>Unit Conversion Factors</b> .....	<b>vii</b>
<b>1 Introduction</b> .....	<b>1</b>
1.1 Problem statement.....	1
1.2 Objective.....	2
1.3 Approach.....	2
1.4 Metrics.....	2
<b>2 Technical Investigation</b> .....	<b>4</b>
2.1 Technology overview.....	4
2.2 Fort Drum implementation.....	5
2.2.1 <i>Model building</i> .....	5
2.2.2 <i>Live interface with SCADA system</i> .....	6
2.2.3 <i>Termination of demonstration and change of project focus</i> .....	7
2.2.4 <i>Offline hydraulic and water quality simulation</i> .....	8
<b>3 Discussion</b> .....	<b>9</b>
3.1 Model output results.....	9
3.2 Lessons learned.....	13
3.2.1 <i>Availability and accuracy of data</i> .....	13
3.2.2 <i>Live interface with SCADA system</i> .....	13
3.3 Current state of the art (December 2016).....	14
3.3.1 <i>Advances in water distribution system modeling technology</i> .....	14
3.3.2 <i>Advances in the DEW-Water system</i> .....	14
<b>4 Economic Summary</b> .....	<b>16</b>
4.1 Costs and assumptions.....	16
4.2 Projected return on investment (ROI).....	17
<b>5 Conclusions and Recommendations</b> .....	<b>19</b>
5.1 Conclusions.....	19
5.2 Recommendations.....	20
5.2.1 <i>Applicability</i> .....	20
5.2.2 <i>Implementation</i> .....	20
5.2.3 <i>Future work</i> .....	21
<b>References</b> .....	<b>22</b>

**Appendix: Development and Implementation of Graph Trace Analysis for  
Water Quality and Corrosion Monitoring.....23**

**Report Documentation Page**

# Figures and Tables

## Figures

Figure 1. Water quality and corrosion monitoring system overall arrangement. ....	5
Figure 2. Screen capture from DEW-Water showing color-coded pressure results generated by the model. ....	9
Figure 3. Screen capture showing results of Ryznar Index simulation. ....	10
Figure 4. Corrosion index violation and variables shown in zoomed-in view. ....	10
Figure 5. Langelier Index and specific conductance display for area supplying building 1999. ....	11
Figure 6. Reproduction of originally projected ROI calculation from F07-AR05 project management plan (September 2006). ....	18

## Tables

Table 1. Manually collected water chemistry data from 20 July 2009. (LI – Langelier Index, RI – Ryznar Index) ....	11
Table 2. Summary of results according to project metrics. ....	12
Table 3. Summary of costs for Project F07-AR05. ....	16
Table 4. Cost assumptions for Alternative 1. ....	17
Table 5. Cost assumptions for projected Alternative 2. ....	17

## Preface

This study was conducted for the Office of the Secretary of Defense (OSD) under Corrosion Prevention and Control Program Project F07-AR05, “Corrosion Detection and Management System for Potable Water at Fort Drum.” The proponent was the U.S. Army Office of the Assistant Chief of Staff for Installation Management (ACSIM), and the stakeholder was the U.S. Army Installation Management Command (IMCOM). The technical monitors were Daniel J. Dunmire (OUSD(AT&L)), Bernie Rodriguez (IMPW-FM), and Valerie D. Hines (DAIM-ODF).

The work was performed by the Materials Branch of the Facilities Division (CEERD-CFM), U.S. Army Engineer Research and Development Center, Construction Engineering Research Laboratory (ERDC-CERL). At the time of publication, Vicki L. Van Blaricum was Chief, CEERD-CFM; Donald K. Hicks was Chief, CEERD-CF and Kurt Kinnevan, CEERD-CZT was the Technical Director for Adaptive and Resilient Installations. The Deputy Director of ERDC-CERL was Dr. Kirankumar Topudurti and the Director was Dr. Ilker Adiguzel.

The following Fort Drum Department of Public Works (DPW) personnel are gratefully acknowledged for their support and assistance in this project:

- Tom Ferguson – Chief, Operations and Maintenance Division, Directorate of Public Works
- Ed Rohr – Chief, Utilities Branch
- John Field, Telemetry Systems Engineer

The Commander of ERDC was COL Bryan S. Green and the Director was Dr. Jeffery P. Holland.



## Unit Conversion Factors

Multiply	By	To Obtain
degrees Fahrenheit	$(F-32)/1.8$	degrees Celsius
feet	0.3048	meters
gallons (U.S. liquid)	3.785412 E-03	cubic meters
inches	0.0254	Meters
mils	0.0254	millimeters
square feet	0.09290304	square meters

(This page intentionally blank)

# **1 Introduction**

## **1.1 Problem statement**

Water-distribution systems are a critical part of the infrastructure needed to support daily activities and fire suppression capability at military installations. Internal corrosion of the distribution piping can lead to costly leaks and failures, poor water quality for occupants, and loss of ability to meet fire-suppression flow requirements. The annual cost of corrosion-related failures in water distribution piping in the Department of Defense (DoD) is estimated to be \$167 million (Herzberg, O'Meara, and Stroh 2014).

Fort Drum, NY, like many other large military installations, has battled ongoing localized corrosion and water quality problems in their potable water-distribution system for many years. Fort Drum's water system is particularly challenging to manage because it has experienced significant water demand growth and system expansion and has a highly variable user demand that fluctuates with soldier deployment and mission changes. An additional complication is that Fort Drum uses water from two sources: (1) treated groundwater from its on-post wells and (2) treated surface water supplied by the Development Association of the North Country (DANC). Significant water quality problems including discoloration, sediment, and odor occurred for many years in the areas where water from the two sources mixes together. At the time of this project, the Fort Drum DPW was controlling the water quality problems by performing extensive flushing of the water mains in the affected areas.

A previous DoD Corrosion Prevention and Control Program project demonstrated that remotely-monitored online sensors can effectively and continuously measure and report water quality parameters and corrosion rates within potable water-distribution systems (Van Blaricum et al. 2007). However, a sensor simply provides a stream of data that is measured at one single location in the distribution system. System status and activity between the sensor locations, which may be several miles apart, remain unknown. This essentially leaves large parts of the system unmonitored, and localized water quality or corrosion problems may remain undetected until a major failure occurs

To address this problem, the DoD Corrosion Prevention and Control Program funded ERDC-CERL to investigate the application of an always-on model-based monitoring system to provide near real-time information about the corrosivity of water throughout the distribution network so that localized corrosion problems can be detected.

## **1.2 Objective**

The objective of this work was to customize and demonstrate an always-on model-based monitoring system that uses near-real time sensor data to estimate key water quality parameters and corrosivity indices at all points in a potable water-distribution system so that localized problems can be quickly detected.

## **1.3 Approach**

This project involved the following major steps:

- Construct a detailed computerized model of Fort Drum's water-distribution system.
- Interface the model with Fort Drum's existing Supervisory Control and Data Acquisition (SCADA) system so that the model can receive and perform calculations with "live" sensor data.
- Compare the model-predicted "virtual" water quality/corrosivity values with hand-collected field measurements to validate model accuracy.

## **1.4 Metrics**

The design and performance metrics for the demonstrated system were as follows:

1. Allows near real-time data from online pressure, flow, and water quality sensors to be automatically incorporated into a computerized water-distribution system model via a standard SCADA system.
2. Uses the model and online sensor data to calculate estimated values of key water quality parameters including pH, alkalinity, hardness, and chlorine residual at all points throughout the distribution system.
3. Uses the model and online sensor data to calculate estimated values of commonly-used water corrosivity indices including the Langelier Index (APHA, AWWA, and WEF 2012) and Ryznar Index (APHA, AWWA, and WEF 2012) at all points throughout the distribution system.

4. Estimates corrosion index values within  $\pm 20\%$  of field measured values.
5. Assists in compliance with Army water treatment and corrosion control guidance (Technical Manual [TM] 5-813-3).
6. Functions unobtrusively with everyday water system operations activities and procedures.

## 2 Technical Investigation

### 2.1 Technology overview

The model demonstrated in this project is a special version of EDD Corporation's Distribution Engineering Workstation (DEW) that is customized to perform analyses of water-distribution systems and water quality. (The model hereinafter is referred to as "DEW-Water".) It uses sensor data obtained at key locations such as tanks, pressure-control stations, and water-treatment plants, and uses it to estimate and display system-wide "virtual" water quality and corrosion measurements and indexes in near-real-time, at every component in the distribution system. These model-based values are then displayed on user-customizable maps that alert the water system operator to water quality and/or corrosivity problems. DEW-Water is designed to work well with typical water system operation practices and is compatible for use with industry-standard SCADA systems.

DEW-Water was selected because at the time this project was executed it was the only U.S.-developed software package that could accept live sensor data and also was fully integrated with an established software solution for the modeling and monitoring of electric distribution systems. It was envisioned that this approach would be extended to other utility-distribution systems including natural gas, chilled water, steam, hot water, and wastewater so that military installations would have an integrated software tool to monitor and manage utility system operations and determine the best way to continue mission-critical functions in the event of an electrical grid outage.

DEW-Water utilizes graph trace analysis (GTA), which is based on a combination of concepts from physical network modeling that was developed in the 1960s to provide a standardized approach for formulating steady-state and transient analysis equations for multidiscipline systems. See the Appendix for a more detailed explanation of GTA technology.

The DEW-Water implementation at Fort Drum consists of three applications:

- Time-sequence analysis
- Water-quality analysis
- Corrosion analysis

A technical description of these applications is presented in the Appendix.

The real-time DEW-Water model uses a standard TCP/IP network connection for read-only access to the SCADA database. The DEW Field Workstation Interface can be used remotely by personnel in the field to record manually collected measurements and component status information, and to remotely run model-based analysis. When the Field Workstation is connected to the TCP/IP network, manually recorded measurements and status information are automatically transferred to the real-time model where they are stored and used with SCADA data to perform analysis (see Figure 1).

Figure 1. Water quality and corrosion monitoring system overall arrangement.

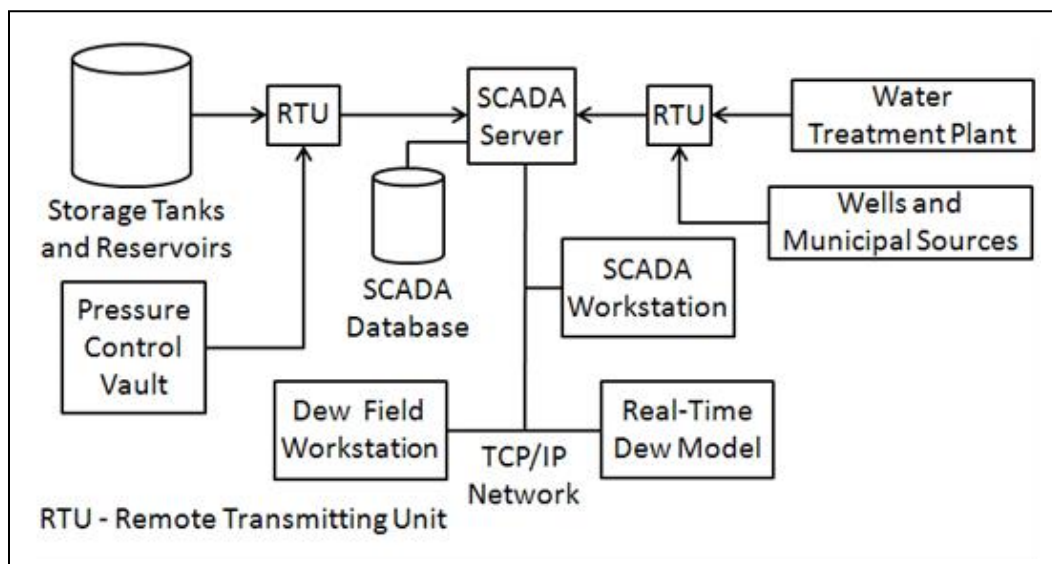

## 2.2 Fort Drum implementation

### 2.2.1 Model building

DEW-Water models are built with a one-to-one correspondence between the model and the real system and include service connections down to the level of individual buildings. This approach simplifies model use and validation because working with the model becomes much like working with the real system.

The Fort Drum DEW-Water model was built by extracting system attribute and arrangement data from GIS drawings, running the GIS data through EDD's automated model builder application, and making manual corrections where needed. Some parts of the model had to be built entirely by

hand because the quality of GIS data did not allow the automated model builder application to be used.

Water demand data were collected for large buildings from Fort Drum Engineer Plans and Services (EP&S). These were used to define static loads at service connections for these buildings. Demand estimates for smaller buildings were generated using area data (measured in square feet) from Fort Drum's facility inventory data.

Once the initial model was built, it was checked and refined using engineering drawings, interviews with water system operators, and comparison against measured flow and pressure data.

### **2.2.2 Live interface with SCADA system**

Fort Drum has an existing commercial SCADA system that is used to monitor and control pressure, flow rates, valves, pumps, and water treatment operations. Remote sensors and controls are located throughout the water-distribution system and are connected to remote terminal units (RTUs) that are in turn connected to a central server. The SCADA system aggregates measurements and component state information, (such as open, closed, on and off) and stores them in a centralized database. This information is displayed on customized control screens in the water system operator's office. The SCADA system also provides programmable alarms, automated operator notification and standardized analysis features such as data plotting and trending.

The next step in the DEW-Water setup process was to interface this existing SCADA system with the DEW-Water model of the Fort Drum water-distribution system that was built as described above. This involved the following general steps:

1. Survey SCADA system operation. Document measurement tag names and locations, database type used to aggregate and archive data, and collect a sample set of archived data.
2. Obtain an ODBC driver for the specific database architecture used by the SCADA system. Each database supplier uses a unique ODBC driver, but once installed the driver provides standard interface capability. Database software publishers typically provide their drivers free of charge.



3. Define and install a SCADA database system connection configuration text file. Both the real-time interface and the SCADA simulator automatically search a user-designated directory for connection configuration files from which the user may select. This design feature allows the user to maintain model and configuration files together.

### **2.2.3 Termination of demonstration and change of project focus**

Once the connection between the DEW-Water model and the SCADA system database has been made, normally the model would be run with live data over a period of several months so that it could be refined and corrected as needed in order to accurately reflect actual system operation.

However, an unforeseen and terminal problem arose for this project as the Fort Drum DPW began a major upgrade of their SCADA system at roughly the same time as our project team was attempting to interface the computer model with the online sensors. This interface would have allowed the model to generate results in near real-time with live sensor data and display them to the water system operator. The SCADA system upgrade was required in order to comply with stringent new Army computer network security requirements arising from elevated wartime threat levels and it could not be delayed.

The project team tried to complete the interface, however the contractors who were installing the SCADA system upgrade were working independently of our team and were changing the SCADA system architecture periodically in order to carry out the requirements of their contract. The interface would work for a short period of time, then the SCADA system contractor would make a change and the interface would no longer work. Stated in plain language, the CPC project team was trying to hit a moving target. After 18 months, the SCADA system architecture still was not stable and CPC project funds were nearly exhausted.

The project team and DPW management reached the consensus that completing the live sensor interface would not be possible under the circumstances summarized above. The team decided that best course of action at this point was to use remaining project resources to conduct offline analyses using historical sensor data from SCADA system archives.

#### **2.2.4 Offline hydraulic and water quality simulation**

Archived water system operation data from January – July 2009 were downloaded from Fort Drum's SCADA system to a Microsoft Excel file. The Excel file was then transferred to a stand-alone computer running DEW-Water and was used to simulate water system operation. This step allowed the model to be corrected and refined without being connected to the live sensors.

The next step was to perform a water quality and corrosivity simulation for the week of 20 July 2009 using the archived data. In order to validate the simulation's accuracy, results were compared with data that were manually collected in the field. Building 1999 was selected for this comparison because it is located in an area where (1) mixing of the two Fort Drum water sources and fluctuations in water chemistry are known to occur; (2) water quality problems (discoloration and sediment) are frequently observed; and (3) there are no sensors nearby.

## 3 Discussion

### 3.1 Model output results

Figure 2 reproduces a sample screen capture showing the system pressure results generated by the model. Figure 3 shows a sample of the water quality and corrosivity simulation results. Areas where the Ryznar Index exceeded user-specified high and low limits are highlighted. Figure 4 shows the same section zoomed in.

At the closer zoom level, index values for individual components are displayed. Components with out-of-limit values are also marked with an error symbol. A user can access additional error information for each component by clicking on the component, and then viewing the component's message information from a dialog box. Components with errors can also be viewed as a list.

Figure 2. Screen capture from DEW-Water showing color-coded pressure results generated by the model.

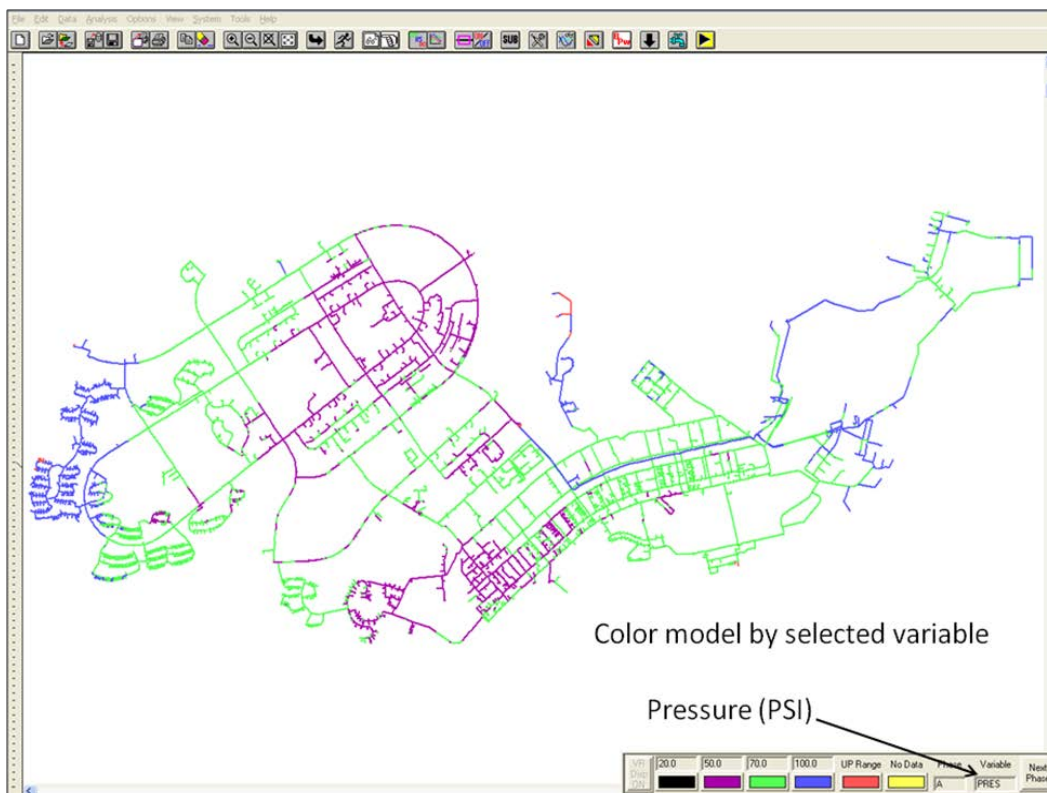

Figure 3. Screen capture showing results of Ryznar Index simulation.

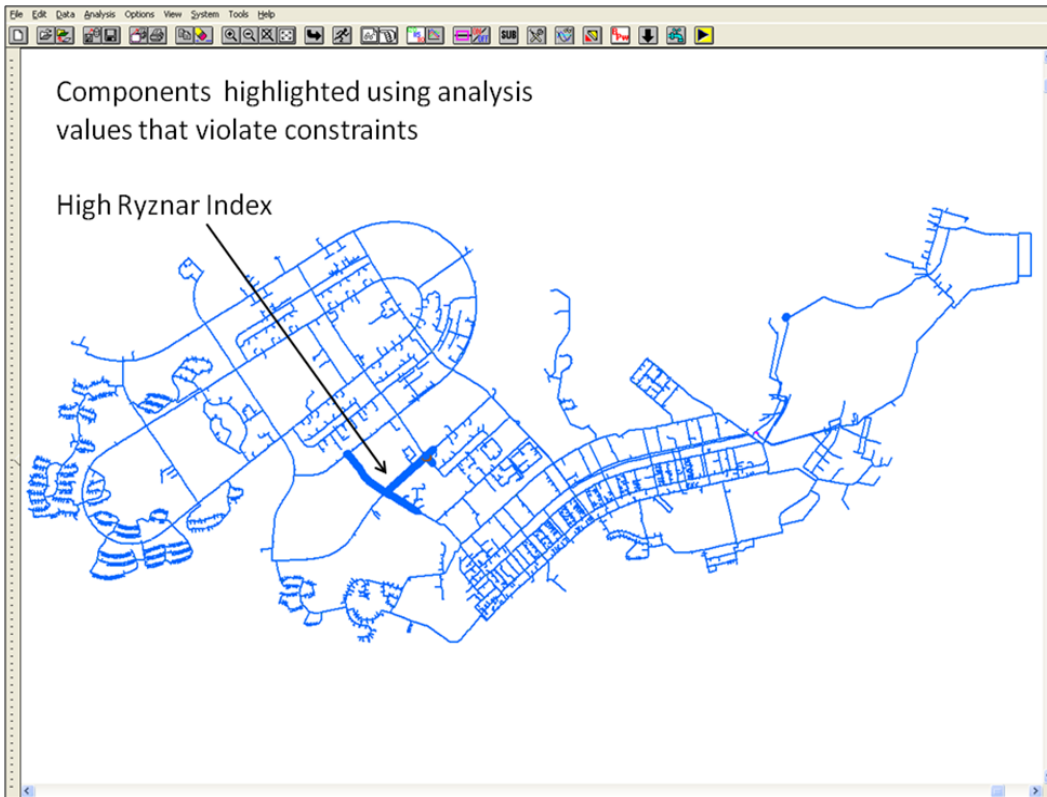
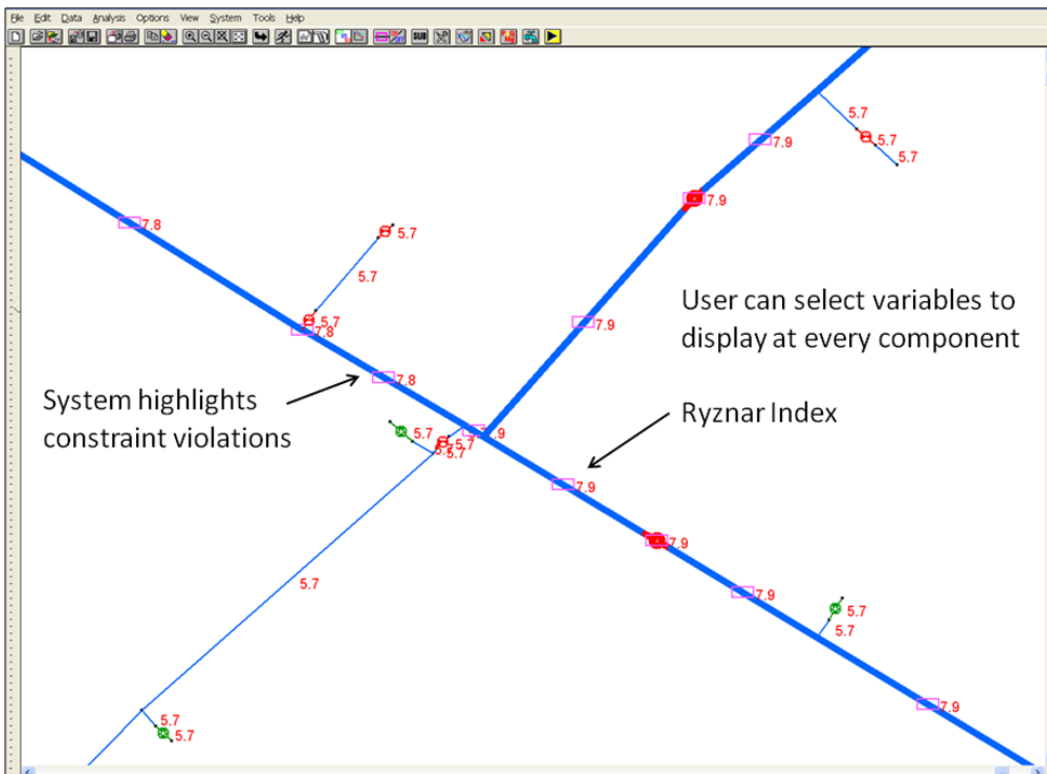

Figure 4. Corrosion index violation and variables shown in zoomed-in view.



The next step was to compare model-generated water quality and corrosivity results with the field measurements that were collected manually (Table 1).

Table 1. Manually collected water chemistry data from 20 July 2009. (LI – Langelier Index, RI – Ryznar Index)

Location	ph	Spec Cond (microS)	Alk (mg/L)	Calcium Hardness (mg/L)	LI	RI
Tank 1	7.72	349	70	86	-0.22	8.16
Tank 3	7.88	300	61	78	-0.15	8.19
Danc (Municipal Source)	7.83	210	36	56	-0.55	8.93
Water Treat Plant (Wells)	8.02	369	62	84	0.01	8.00
Building 1999	7.89	211.4	40	57	-0.44	8.77

Measurements taken 7/23/09

The screen shot shown in Figure 5 shows simulation results for the area that supplies Building 1999. The display is set to show Langelier Index by color, and we can see that there is a reasonably good match between the manually measured value of -0.44 and the simulated value of -0.5 indicated by the black color of the piping in Figure 5. We can also see that the specific conductance of the water matches closely. The display is set to show specific conductance numerically. The manually measured value is 211.4 microsiemens and the simulation calculated a value of 210.1.

Figure 5. Langelier Index and specific conductance display for area supplying building 1999.

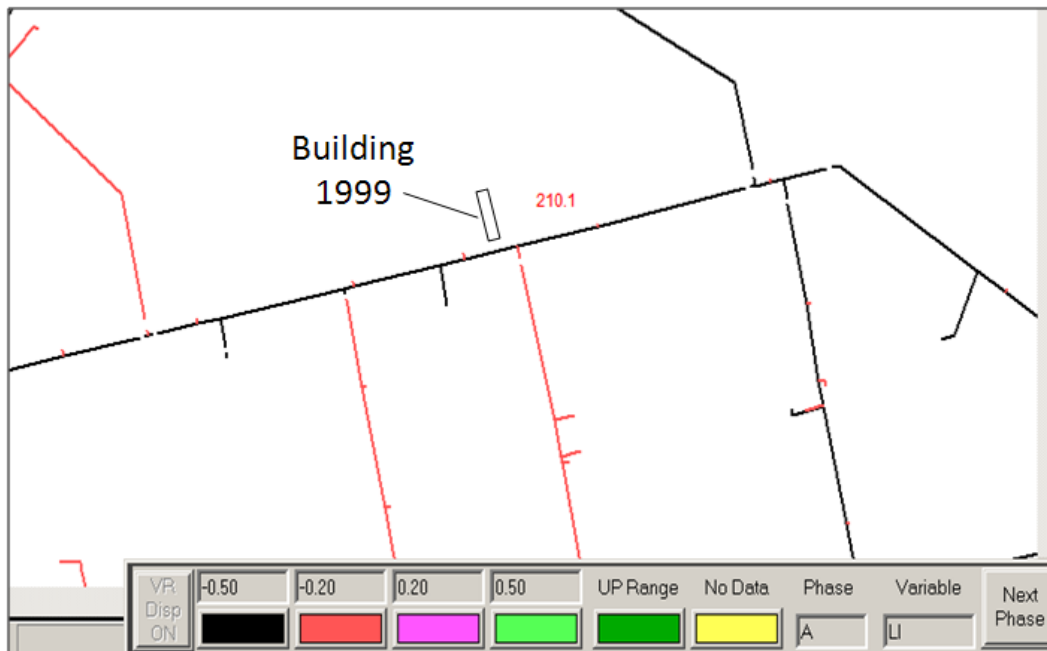

The team observed that the specific conductance and the Langelier Index cycled back and forth between the values for the two water sources (DANC and the on-post wells) as their pumps cycled on and off according to their pre-programmed settings.

The Fort Drum DPW was interested in investigating whether the model could help them determine the percentage of well water and DANC water that was contained in each pipe. They wanted to be able to adjust water system operation so that the more corrosive DANC water would not enter into certain areas of the distribution system. It was suggested that because of the apparent correlation between the water source and specific conductance, the latter should be investigated as a possible measure of the source water percentages throughout the system.

While the simulation results for one location at one point in time correlated well with measurements collected manually in the field, we do not have enough data to definitively prove the model's accuracy due to termination of the planned demonstration as discussed previously in section 2.2.3.

Table 2 summarizes the results of this demonstration against the metrics that were specified in Chapter 1, section 1.4.

**Table 2. Summary of results according to project metrics.**

<b>Metric</b>	<b>Result</b>
1. Allows near real-time data from online pressure, flow and water quality sensors to be automatically incorporated into a computerized water-distribution system model via a standard SCADA system.	We were able to manually feed archived sensor data into the model, but were unable to set up the automated near real-time interface.
2. Uses the model and online sensor data to calculate estimated values of key water quality parameters including pH, alkalinity, hardness, and chlorine residual at all points throughout the distribution system.	We were able to use the model to calculate the estimated values using manually-fed sensor data but were unable to validate the accuracy of the results.
3. Uses the model and online sensor data to calculate estimated values of commonly-used water corrosivity indices including the Langelier Index and Ryznar Index at all points throughout the distribution system.	We were able to use the model to calculate the estimated values using manually-fed sensor data. .
4. Estimates corrosion index values within $\pm 20\%$ of field measured values.	Accuracy of the results within was validated at one location at one point in time.
5. Assists in compliance with Army water treatment and corrosion control guidance (Technical Manual [TM] 5-813-3)	If proven accurate, simulation results could assist in maintaining proper corrosion control throughout the distribution system. Even manually-fed sensor measurements can produce valuable insights.
6. Functions unobtrusively with everyday water system operations activities and procedures	This could not be evaluated because we were unable to set up the automated near real-time interface.

## **3.2 Lessons learned**

### **3.2.1 Availability and accuracy of data**

Water-distribution system models are typically built using a combination of GIS data, engineering design specifications, inventory/capital investment data, water-usage records, manually entered information from engineering drawings and interviews with system operators. It is common for data from multiple sources such as these to have a large number of errors and inconsistencies.

Manually building a model and collecting missing information can be very time-consuming and expensive, so it is highly advantageous to begin with an accurate and complete GIS data set. This minimizes the amount of manual data entry required, since DEW-Water automatically converts GIS data into a water system model. At Fort Drum, much of the detailed data required for the DEW-water model was missing from the GIS files and had to be manually entered. We found that utilizing engineering graduate students and research interns under the direction of an experienced modeler helped to reduce the cost of building the initial system model.

### **3.2.2 Live interface with SCADA system**

The first and foremost lesson was that the live interface should be installed at a time when the architecture of the SCADA system is stable and is not expected to change. Otherwise, time and money will be wasted because the interface will stop working as soon as the SCADA system changes.

Second, the installation Directorate of Information Management (DOIM) (or equivalent organization) should be involved throughout the entire process of planning, designing, and installing the live interface. Any required approvals, certificates of networkiness, security permissions, or other required documentation for the monitoring system interface should be obtained before the work is started.

Finally, it is critical to have people on the monitoring system project team with a deep understanding of the SCADA system architecture, the location and operation of the remote sensors, and strong interest in getting the technology implemented. We were fortunate to have such a person from the DPW available to us, and his interest and involvement in this project

enabled us to make significant progress in spite of the obstacles that eventually stopped the demonstration.

### **3.3 Current state of the art (December 2016)**

#### **3.3.1 Advances in water-distribution system modeling technology**

The state of the art in the area of sensor-enabled water-distribution system models has advanced significantly since this work was performed in 2009.

At the time this report was prepared, several real-time network modeling systems were readily available on the market. According to water industry technical literature, such systems automatically read real-time sensor data, instantly update the hydraulic and water quality models, and analyze water system operations. They provide the water system operator with an easy-to-understand “dashboard” that allows them to proactively identify trouble spots, quickly assess system integrity, optimize system operation, identify water losses, respond to emergencies, and continuously monitor the entire water network. (Boulos and Niraula 2016).

Today’s systems are capable of monitoring and modeling a wide variety of water quality parameters, including those that impact water corrosivity. They can aid users with water quality regulatory compliance and can help reduce the energy required for pumping. (Boulos et al. 2014).

#### **3.3.2 Advances in the DEW-Water system**

As stated in section 2.1, one reason for selecting the DEW-Water system for this project was its potential for integrating the water-distribution system model with other utility system models. The manufacturer extended the DEW system over time to incorporate water, electric, and gas-distribution systems into a single, integrated model under a separate project funded by the Small Business Technology Transfer (STTR) project (Feinauer, Ison and, Broadwater 2010). The integrated system allows interdependencies between the utilities to be modeled. For example, an outage in the electricity-distribution system might cause a water-distribution system interruption due to lack of power to pumps and chemical-treatment equipment. In such a situation, the integrated model could be used to help determine the best course of action for restoring electrical service such that disruptions in water service are minimized at critical locations



such as hospitals or industrial plants (Kleppinger, Broadwater, and Scirbona 2010). All of the interdependent DEW models are based on the Graph Trace Analysis methods discussed in the Appendix and elsewhere in this report (Russell and Broadwater 2012.)

## 4 Economic Summary

### 4.1 Costs and assumptions

Total actual costs for the execution of this demonstration project are shown in Table 3.

Table 3. Summary of costs for Project F07-AR05.

Category	Cost
Contract	\$618,257
Labor	\$94,856
Travel (estimated)	\$10,337
Total	\$723,450

In Chapters 2 and 3 (sections 2.2.3 and 3.2, respectively) it was explained why the technology could not be installed and operated as planned at Fort Drum. therefore we were unable to obtain actual economic benefit data for this project and an actual ROI could not be calculated.

Following is a brief summary of the cost assumptions that were used when the project was proposed. The description of Alternative 2 does not represent an actual economic return on the Fort Drum demonstration, but is offered to explain the potential return on a successfully implemented system at the time the project proposal was accepted.

**Alternative 1: No Monitoring Technology.** This alternative assumes that the corrosion and water quality problems would continue to worsen over time and that the distribution system piping would require replacement every 20 years. It was also assumed that some occupants would periodically require bottled water when localized corrosion-induced water quality problems (discoloration, unpleasant taste, and odor) made the water unsuitable for drinking. Cost assumptions for this option are presented in Table 4.

Table 4. Cost assumptions for Alternative 1.

Item	Cost	Frequency
Complete replacement of distribution system piping	\$21 million	Year 10 and Year 30
Leak repair	\$40,000	Annual
Bottled water for drinking	\$20,000 per day**	0 days in the year of piping replacement increasing linearly to 30 days during the last year of pipe life.

\*\* Based on an estimate of 2 gallons per day for 10,000 affected people at a cost of \$1 per gallon.

**Alternative 2 (Hypothetical): Successful Implementation.** If the demonstrated technology had been fully implemented as planned, it was assumed that localized corrosion problems would be eliminated through early detection and prompt follow-on maintenance; and that the life of the distribution system would consequently be extended so that replacement would not have been required during the 30-year ROI analysis period. (The limited results of this project discussed in Chapter 2 indicate that this assumption would have been feasible under favorable implementation conditions.) Assumed costs for this option are summarized in Table 5.

Table 5. Cost assumptions for projected Alternative 2.

Item	Cost	Frequency
Monitoring system routine maintenance	\$40,000	Annual
Replacement of sensors and selected system hardware	\$350,000	Every 10 years
Bottled water	\$20,000 per day**	3 days per year

\*\* Based on an estimate of 2 gallons per day for 10,000 affected people at a cost of \$1 per gallon.

## 4.2 Projected return on investment (ROI)

Because we were unable to implement the technology as planned, the actual ROI for this demonstration is zero (0).

When this project was proposed in 2006, a favorable projected ROI of 21.6 was calculated based on the assumptions presented above and the guidelines prescribed by OMB Circular A-94 (OMB 1992).<sup>\*</sup> Figure 6, below, reproduces the original calculations to illustrate the project team’s conception of how costs and benefits would accrue over the 30-year analysis period. We include this figure to help explain the potential size of return on investment if a current, mature version of water-distribution system monitoring technology (see section 3.3) were found to be suitable for DoD implementation based on assumptions used for this project.

Figure 6. Reproduction of originally projected ROI calculation from F07-AR05 project management plan (September 2006).

								Investment Required	770,000		
								Return on Investment Ratio	21.63	Percent	2163%
								Net Present Value of Costs and Benefits/Savings	1,555,205	18,208,809	16,653,604
A	B	C	D	E	F	G	H				
Future	Baseline	Baseline	New System	New System	Present Value	Present Value	Total Present				
Year	Costs	Benefits/Savin qs	Costs	Benefits/Savin qs	of Costs	of Savings	Value				
1	400,000		100,000		93,460	373,840	280,380				
2	430,000		100,000		87,340	375,562	288,222				
3	460,000		100,000		81,630	375,498	293,868				
4	490,000		100,000		76,290	373,821	297,531				
5	520,000		100,000		71,300	370,780	298,460				
6	550,000		100,000		66,630	366,465	299,835				
7	580,000		100,000		62,270	361,166	298,896				
8	610,000		100,000		58,200	355,020	296,820				
9	640,000		100,000		54,390	348,096	293,706				
10	21,000,000		450,000		228,735	10,674,300	10,445,565				
11	70,000		100,000		47,510	33,257	-14,253				
12	100,000		100,000		44,400	44,400					
13	130,000		100,000		41,500	53,950	12,450				
14	160,000		100,000		38,780	62,048	23,268				
15	190,000		100,000		36,240	68,856	32,616				
16	220,000		100,000		33,870	74,514	40,644				
17	250,000		100,000		31,660	79,150	47,490				
18	280,000		100,000		29,590	82,852	53,262				
19	310,000		100,000		27,650	85,715	58,065				
20	340,000		450,000		116,280	87,856	-28,424				
21	370,000		100,000		24,150	89,355	65,205				
22	400,000		100,000		22,570	90,280	67,710				
23	430,000		100,000		21,090	90,687	69,597				
24	460,000		100,000		19,710	90,666	70,956				
25	490,000		100,000		18,420	90,258	71,838				
26	520,000		100,000		17,220	89,544	72,324				
27	550,000		100,000		16,090	88,495	72,405				
28	580,000		100,000		15,040	87,232	72,192				
29	610,000		100,000		14,060	85,766	71,706				
30	21,000,000		450,000		59,130	2,759,400	2,700,270				

<sup>\*</sup> FY07 Tri-Service/Army Facilities CPC Project Management Plan: Corrosion Detection and Management System for Potable Water at Fort Drum (OMA), submitted by Vincent Hock 27 September 2006.

## 5 Conclusions and Recommendations

### 5.1 Conclusions

This report described the configuration and offline demonstration of DEW-Water, a water-distribution and corrosion-monitoring system that uses Graph Trace Analysis (GTA) with SCADA data to model data-based, real-time measurements for all components in the water system. The system then uses the modeled measurements to generate corrosion indexes and values that provide early indication of potential corrosion problems.

Due to the technical problems described in Chapter 2, the technology could not be implemented at Fort Drum as intended in the 2006 project management plan. It must be concluded that it is not feasible to install this type of monitoring technology when an installation's SCADA system architecture is being continually changed, such as what occurred during the security upgrades that were taking place during execution of this CPC project.

A critical lesson learned was that future implementations of this type of technology, whether in a demonstration project or real-world adoption by a DPW, should proceed only when the SCADA system architecture is fully established. Any implementation must be coordinated at early planning stages with the Directorate of Information Management (DOIM) or equivalent onsite authority. The highest ROI for this type of technology would be obtained at locations where severe corrosion and water quality problems are known to exist and resistant to other solutions.

A DEW-Water model of the Fort Drum water-distribution system was successfully built and run offline using archived sensor data, but its accuracy could be validated only at one location in the distribution network. Although this limited result suggests that real-time operation could have been successful had Fort Drum's SCADA system updates been completed in time to fully develop and test a stable DEW-Water/SCADA system interface, the project did not produce a successful implementation of the technology. Therefore, there is no basis for concluding that the system functioned as intended.

As evaluated against the metrics presented in section 1.4, some limited conclusions can be offered. Based on the summary presented in Table 2,

success for metrics 1, 2, 3, and 6 could not be fully verified because validation required a functional real-time sensor interface. Nevertheless, the research team was able to produce reasonable results against these metrics using manually fed archived sensor data. Metric 4 required estimated corrosion index values to be within  $\pm 20\%$  of field-measured values, and that goal was successfully met at one location in the distribution network. As noted, though, that was not enough data to conclude that the metric would be achieved throughout the entire distribution system. Metric 5 required the technology to assist in compliance with Army water treatment and corrosion control guidelines. This metric was verified in that the offline model provided the Fort Drum DPW valuable insights about effects of the installation's dual water supplies on operation of the water-distribution system.

## **5.2 Recommendations**

### **5.2.1 Applicability**

Model-based water distribution monitoring technology is applicable to any installation that has not outsourced the operation of its water-distribution system. It is best suited to installations with an already-existing SCADA system and experienced SCADA operators. Implementation is likely to be prohibitively expensive if a SCADA system needs to be installed, and the model will only remain useful if it is properly updated when changes are made to the water network and the SCADA system. It will produce the most value for installations with known water quality and corrosion issues.

### **5.2.2 Implementation**

Considering the logistical problems with this project and the lack of data to validate model accuracy, the results of this project cannot provide the basis for recommending DoD-wide implementation of this technology. However, the results should not be interpreted to mean that remote-monitoring technology of this type should be ruled out as an option for use on DoD installations. As noted in section 3.3, more mature versions of this technology were available at the time this report was published. A market survey and evaluation of currently available utility-monitoring technologies may be beneficial for identifying new automated tools for corrosion prevention and control for water-distribution networks and could provide the basis for a future investigation or demonstration.

### 5.2.3 Future work

Monitoring water quality and corrosion in water-distribution systems continues to be a topic of interest to the Army. A future study, informed by the lessons learned in this project, could address some or all of the following areas:

- Demonstration and validation of the current generation of water-system models that incorporate real-time sensor data
- Demonstration and validation of integrated utility-system models that include water, electrical, gas, and sewer systems
- Demonstration and validation of methods that can be used to model and forecast water corrosivity for locations that are not linked to SCADA systems

## References

- American Public Health Association (APHA), American Water Works Association (AWWA), and Water Environment Federation (WEF), 2012, *Standard Methods for the Examination of Water and Wastewater, 22<sup>nd</sup> Edition*.
- Boulos, Paul F. and Akshaya Niraula, 2016, "Optimize Operations Using Real-Time Data and Predictive Tools," *AWWA Opflow*, Vol. 42, No. 4 (April 2016).
- Boulos, Paul F., Laura B. Jacobsen, J. Erick Heath, and Sri Kamojjala, 2014, "Real-Time Modeling of Water Distribution Systems: A Case Study," *Journal AWWA*, Vol. 106, No. 9 (September 2014.)
- Feinauer, Lynn R., Molly E. Ison, and Robert P. Broadwater. 2010. "Generic Algorithms for Analysis of Interdependent Multidomain Network Systems." *International Journal on Critical Infrastructures*, Vol. 6, No. 1, p. 81-95.
- Herzberg, Eric F., Norman T. O'Meara, and Rebecca F. Stroh. February 2014. *The Annual Cost of Corrosion for the Facilities and Infrastructure of the Department Of Defense*. Report DAC21T4. Tysons, VA: LMI Government Consulting.
- Kleppinger, D., Robert Broadwater, and Charlie Scirbona. March 2010. "Generic Reconfiguration for Restoration." *Electric Power Systems Research Journal* 80(3) 287–295.
- Office of Management and Budget (OMB). 1992. *Guidelines and Discount Rates for Benefit-Cost Analysis of Federal Programs*. OMB Circular No. A-94. Washington, DC: Office of Management and Budget.
- Russell, Kevin, and Robert Broadwater. September 2012. "Graph Trace Analysis Based Interdependent System Recoverability Analysis Criteria: Constraints and Measures." *Naval Engineers Journal*, 124(3), 47–56.
- Technical Manual (TM) 5-813-3, *Water Supply, Water Treatment* (Headquarters, Department of the Army, [HQDA], Washington, DC, 16 September 1985).
- Van Blaricum, V. L., Vincent F. Hock, James Bushman, Bopinder Phull. 2007. *Demonstration of Pipe Corrosion Sensors at Fort Bragg, NC: Final Report on Project AR-F-317 for FY05*. ERDC-CERL TR-07-21. Champaign, IL: Engineer Research and Development Center, Construction Engineering Research Laboratory.



## **Appendix: Development and Implementation of Graph Trace Analysis for Water Quality and Corrosion Monitoring**

This appendix contains a report prepared under Contract No. W9132T-06-D-001 by Electrical Distribution Design (EDD), Blacksburg, VA. EDD is the developer of the DEW-Water software that was used for this demonstration. EDD's report provides documentation of DEW-Water, including an explanation of the theory behind the Graph Trace Analysis technique implemented in DEW-Water. It also documents the water quality modeling and corrosivity index calculations, and describes how they are implemented in the software. Details of software operation, reports, and the user interface are also presented.

**Graph Trace Analysis Based  
Water Quality and Corrosion Monitoring  
and Analysis Development and  
Implementation**

**Interim Report**

Period of Report: 28 Sep 2007 to 31 Jul 2009

Principle Investigator: Dr. Robert Broadwater

Contract No.:	W9132T-06-D-001
Contractor Name:	Electrical Distribution Design
Contractor Address:	311 Cherokee Dr Blacksburg, VA 24060-0382

**U.S. Army Engineer Research and  
Development Center**

Preparer of Report: Kevin Russell: (540) 951-2753, kevin-russell@edd-us.com

# **Graph Trace Analysis Based Water Quality and Corrosion Monitoring and Analysis Development and Implementation**

## **Abstract**

This report discusses Graph Trace Analysis (GTA) based monitoring system development completed to date by Electrical Distribution Design, Inc. (EDD) under Army contract W9132T-06-D-001. Work included system design, installation and the start of extended testing. The goal for this work is to develop a water distribution analysis system that combines Supervisory Control and Data Acquisition (SCADA) measurements with a detailed system model to generate and display system wide “virtual” water quality and corrosion measurements and indexes in real-time, at every component in the water system. This capability is needed to integrate the extensive fluid analysis, water quality, and operation history related data needed for real-time monitoring and control of water distribution system corrosion. Completed testing showed that the system produced sufficient information using limited measurements and water system design data to support standard corrosion monitoring and evaluation of sensor placement and system operation options. Extended testing will include adding new SCADA measurements and further model refinement. Work also showed that the new system can be readily adapted for SCADA and water system change from major upgrades and construction, and that it can also be used as a general tool to support continual improvement in other water system related engineering areas.

## **Forward**

**Contract Information:** Contract No. W9132T-06-D-001  
Contract Performance Period: 28 Sep 07 – 31 Dec 09  
Government Technical Monitor: Vicki L. VanBlaricum ERDC

**Principle Investigator:** Dr. Robert Broadwater,  
Electrical Distribution Design, Inc.  
311 Cherokee Dr  
Blacksburg, VA 24060  
Phone: (540) 951-7027  
Email: [dew@vt.edu](mailto:dew@vt.edu)

# Table of Contents

Introduction.....	1
Objective.....	2
Background.....	3
Scope.....	7
System Overview .....	7
System Development and Testing .....	11
Time Sequence Analysis.....	11
Water Quality Analysis.....	16
Corrosion Analysis.....	23
Results Interface.....	32
Reports and Plots .....	32
Variable Display and Range Display Setup.....	34
Dynamic Display Functionality .....	35
Automatic Calibration.....	37
System Installation Steps and Observations .....	38
Model Building .....	38
Mode of Technology Transfer .....	40
Summary.....	41
Conclusions.....	42
Recommendations.....	42
References.....	42

## Introduction

This report discusses the development of a new model-based water distribution analysis system. The system uses standard measurements taken at key points such as tanks, pressure control stations and water treatment plants and uses them to generate and display system wide “virtual” water quality and corrosion measurements and indexes in real-time, at every component in the distribution system. The system is designed to work well with typical water system operation practices, and is compatible for use with industry standard Supervisory Control and Data Acquisition (SCADA). Water distribution system operators typically use SCADA to monitor pressure and flow, and water quality and corrosion related measurements at a limited number of locations. The number of measurement locations and sensors, and types of sensors used to monitor water distribution systems are often limited by cost and maintenance requirements. In addition, corrosion monitoring is particularly difficult to apply to water distribution systems because it requires coordination of a large amount of data that includes SCADA and lab analysis generated measurement values, individual distribution system component characteristics, and historical operation data. This leaves large parts of the system unmonitored and as water system quality and security requirements have increased, it has become increasingly difficult to track and manage the many complex factors involved.

Fort Drum, which was chosen as the initial test site for the new system, is particularly challenging to manage because it is experiencing significant water demand growth and system expansion, has a widely varying customer demand that fluctuates with soldier deployment and mission change, and uses multiple on-post and municipal water sources which complicates water quality and corrosion monitoring and control.

The new system takes in live measurements from Fort Drum’s SCADA system, attaches them to their respective components in a detailed model, and then combines them with system topology, physics-based characteristics and historical operation data contained in the model to estimate real-time “virtual” water quality measurements and corrosion indexes for every point in the system. These “virtual” measurements are then used to drive customized displays, generate problem flags and alarm indications.

Initial system development and on-site testing was first completed in December 2008, and then was redone in July 2009 after completion of Fort Drum major software changes to their SCADA system. The new model-based monitoring system went through extensive off-line testing at EDD during that period, and is now ready for extended on-site testing and refinement which is scheduled to begin in August 2009 and continue through December 2009. Remaining work will include pressure, flow and water quality calibration and testing, model refinement, and the addition of new SCADA measurement points for both corrosion and water quality.

To provide for testing while Fort Drum’s SCADA system was unavailable EDD built identical example models using the new system and EPANET, which is a widely used water flow and quality simulation software package sponsored by the Environmental Protection Agency. Results for pressure, flow and chlorine decay for both test systems were very close. Details are provided in the report.

Successful corrosion monitoring testing was conducted during monitoring analysis system reinstallation at Fort Drum during July 2009 using recent historical source flow and tank pressure data collected by SCADA and manually taken corrosion index related data collected by Fort Drum personnel. Results showed that the system could be used to generate source water mixing and corrosion index information that is sufficient for Fort Drum use to begin evaluating system operation and measurement options, sensor placement and possible water treatment options. Results also showed that hand collected Specific Conductance measurements, which are used to estimate corrosion index values, are useful for helping evaluate model mixing and flow results.

The GTA analysis approach used in the new system was originally developed by EDD for the power utility industry. Because of the multidiscipline concepts it is based on, GTA is now being used for a number of different applied research projects that include power utility transmission and distribution system design and next generation control, renewable energy, smart grid and micro grid related initiatives. During the December 2008 to July 2009 period that Fort Drum's SCADA system was not available for use, EDD upgraded the monitoring analysis system to include new real-time monitoring functionality that was developed under sponsorship by the commercial power utility industry. System development was also coordinated with Army sponsored development of reconfiguration for damage isolation and recovery analysis and remote interface capability which can be run from the same model and same interface as the one being used for water quality and corrosion monitoring system.

## **Objective**

The main objectives for this project are to develop new model-based water distribution water quality and corrosion monitoring and analysis capability that:

- Can be used with standard SCADA
- Can be used to simplify analysis and data management for the many hard to measure, highly interactive and application specific factors that drive water quality and corrosion monitoring and analysis
- Provides visual, model based analysis and display capability that corresponds closely with the water distribution system arrangement and operation characteristics
- Is designed to work as a natural part of operations activities and procedures
- Can serve as a platform for future monitoring, control and security related water distribution system research and development
- Can be readily upgraded and refined as sensor and analysis technology improves and critical infrastructure design and operation priorities change

The secondary objective for this work is to evaluate GTA's potential for use in development of a unified critical infrastructure analysis and information management approach. The work performed under this project marks the first time GTA has been used for monitoring and analysis of a water distribution system. If through the performance of the new system, GTA's core multidiscipline analysis characteristics can be shown to be usable with both power and water systems, then it has strong potential for application to other systems such as gas, sewer and steam.

## Background

The water quality and corrosion analysis and data management problems Fort Drum is working to address are typical of the general issues that complicate critical infrastructure system design and control. Military and commercial work in this area has traditionally been very different. As pressures from load growth, security and survivability, efficiency, and environmental issues increase, the analysis and information management problems associated with military and civilian critical infrastructure system design and control have become more and more alike. This presents significant potential for collaboration between the military and civilian sectors and also calls for the development of a unified critical infrastructure analysis approach.

Research and operations management areas that fall into this category include:

- Military base utility system management, expansion and renewal
- Army micro-grid development
- Department of Energy and utility industry smart grid and renewable energy development
- Navy all electric ship, reduced manning and automated damage control development
- Homeland Security disaster management and preparedness

EDD has been working with major utilities and research organizations for over 20 years to develop model-based solutions for critical infrastructure system analysis. These include the Army Corps of Engineers Construction Engineering Research Laboratory (CERL), Office of Naval Research (ONR), Department of Energy (DOE), National Renewable Energy Lab (NREL), Consolidated Edison, DTE Energy, Southern California Edison, Ameren, Virginia Tech, Georgia Tech, Columbia University and the University of West Virginia. Through work with these groups EDD is finding that integrating analysis and data management for operation and support of reconfigurable systems that involve a large number of complex analysis and data management factors typically exceeds the capability of standard approaches. This is especially true when independently developed systems are brought together to perform integrated functions. EDD's development and use of GTA to address this problem constitutes a new paradigm in integrated system analysis.

GTA is based on a combination of concepts from Physical Network Modeling which was developed in the 1960's to provide a standardized approach for formulating steady-state and transient analysis equations for multidiscipline systems [1], and Generic Programming. Physical network analysis treats components as generic devices with system specific across and through terminal characteristics. The across variable for an electrical component is voltage. The through variable is current. Across and through variables for fluid components are pressure and flow. Similar characteristics can be defined for heat transfer and mechanical systems. Generic programming is a collection of advanced information management concepts that have been implemented in the C++ Standard Template Library [2]. For example, a generic sort algorithm uses iterators provided by a container to sort objects stored in the container. The sort algorithm is written so that it can be used regardless of what types of objects are stored in the container. In GTA the model acts as a system container. Each component object stored

in the model is assigned a standardized set of iterators that define its relationships with the other components and data stored in the model “container.” See Figure 1.

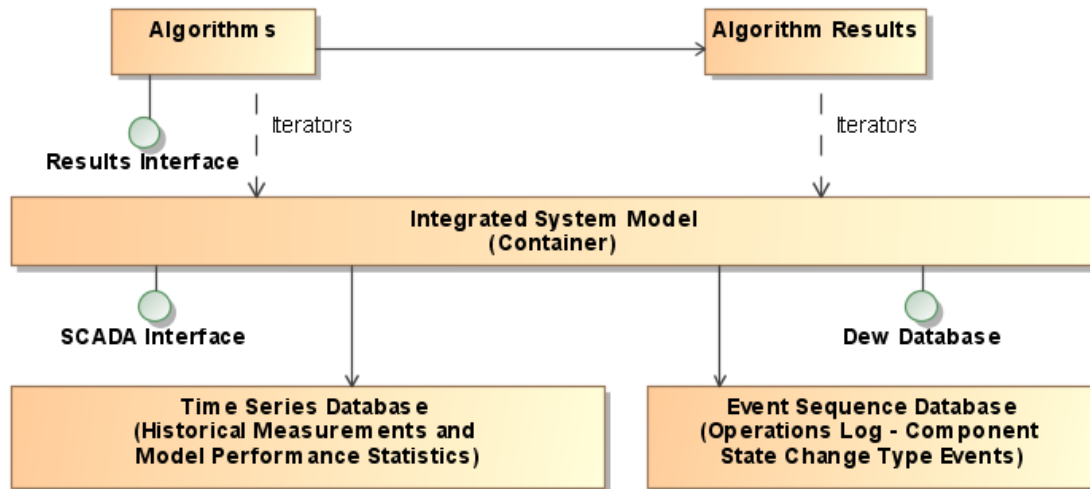

**Figure 1. Graph Trace Analysis (GTA) High-Level Architecture**

As components are added, modified, deleted or change state, their iterators are automatically updated. In GTA, iterators are implemented with pointers, which “point to” specific locations in memory. This makes iterator based operations very fast. When a change occurs in the model, only the iterators that are directly affected by the change need to be updated. The majority of these iterators are defined as the model is built. Managing topology and physics based relationships in this way speeds up analysis and makes it possible to analyze large models rapidly when a significant number of configuration changes occur; to integrate discrete, steady state and transient component and system level analysis at multiple levels of fidelity, and to also distribute collaborative analysis for multiple system types and levels across multiple processors [3].

EDD refers to the use of iterators, component objects, system containers and generic algorithms to solve engineering physical network problems as “Generic Analysis.” Generic Analysis goes beyond traditional Object Oriented Programming which focuses on encapsulating objects and data according to functional decomposition based associations and boundaries [4]. This provides a well structured approach, but its use implies the assumption that functional decomposition based encapsulation will divide systems and analysis problems into naturally occurring stable sets of functions and data. This assumption is not valid for reconfigurable, critical infrastructure systems where different activities share components and information in different ways. As operation priorities, equipment status, and the specific type of analysis being performed change, so do the functional decomposition based associations and boundaries between systems, components and data.



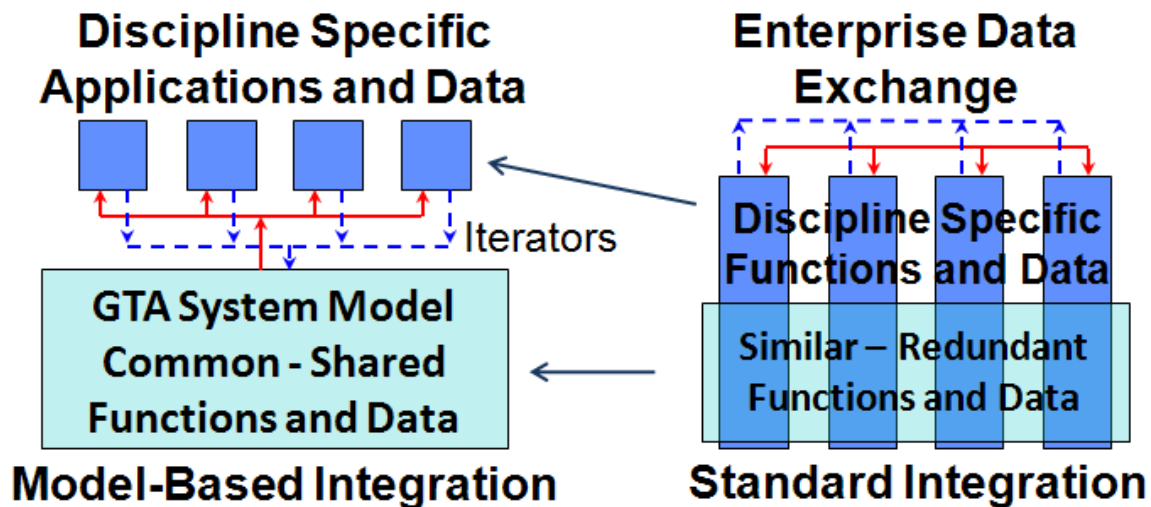
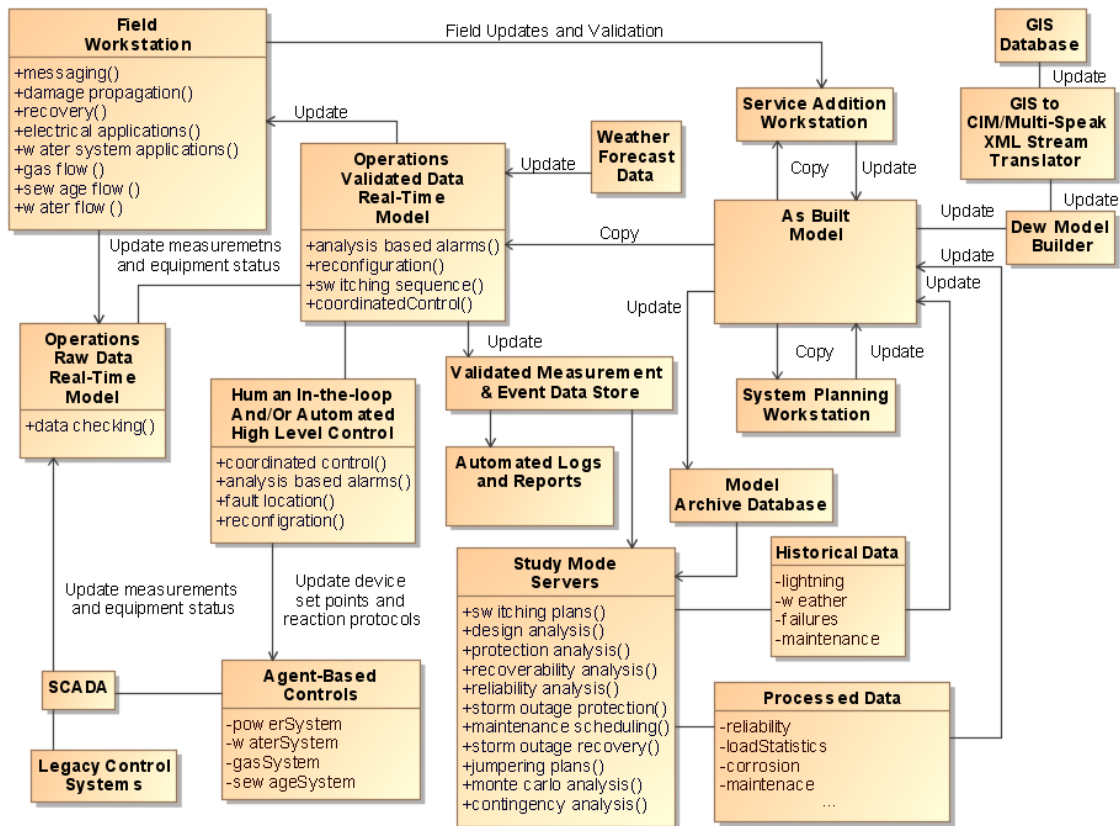

Figure 2. GTA Model-Based vs. Standard Integration

A large number of the functions and data elements used for integrated, multidiscipline, and multi-fidelity analysis are often similar when examined from a high-level point of view, but at the implementation level are typically significantly different. This leads to complex integration problems that have to be dealt with repeatedly as software and data is changed and maintained. The Object Oriented Analysis and Design (OOA&D) concepts used in Dew make it possible to decompose complex system problems both hierarchically (vertically) and horizontally along commonality based lines [4, 5] into relatively simple, re-composable pieces. The common analysis and data management pieces are abstracted and made part of the common model. The remaining distinct application pieces then work from and collaborate with each other through the model. See Figure 2.

EDD is now working with several leading utilities and research organizations to formalize GTA model-based analysis and data management into an enterprise wide Integrated System Model (ISM) based design, management and control approach. See Figure 3. To facilitate collaborative development of this concept, EDD provides its GTA-based Distributed Engineering Workstation (Dew) software to major utilities, government research organizations and universities under free license. Each group maintains and controls their own models but gets free license access to Dew and any new algorithms developed by EDD through user support.



**Figure 3. Integrated System Model (ISM) Architecture**

The benefits of using a GTA-based Integrated System Model (ISM) include:

**Use of an ISM eliminates:**

1. Throw away studies
2. Fragmented simulation of a physical plant
3. Redundant data and interfaces
4. “Stove piped” thinking and partial solutions
5. “Empires” of data and algorithms

**Use of an ISM provides:**

1. Common model for design, planning, operations, and control
2. Reuse of software
3. Reuse of efforts
4. Collaborative solutions to emergent problems
5. Placement of data in the proper context through reference to a physical model
6. Placement of asset decisions on level playing field
7. Defensible decisions based upon quantitative analysis
8. Improved communication throughout large organizations
9. Reduction in cost, effort, and time required for studies (model building and data gathering typically require 80 to 90 percent of total simulation effort)
10. More time analyzing alternative solutions to problems rather than gathering data and creating “from scratch” solutions

## Scope

The report describes system architecture development, system operation and initial testing. The system development plan included a 6 month testing period that was scheduled to start immediately after completion of initial development and testing. The final testing period is currently on hold as Fort Drum completes upgrade and replacement of their water distribution SCADA system, which is being completed under separate contract. SCADA system upgrade work was originally scheduled to be completed at the beginning of the development project, but experienced procurement and Information Technology (IT) certification delays.

## System Overview

The primary purpose for the new system is to provide detailed water quality and corrosion analysis based monitoring and display capability that covers all components in the water distribution system, and is specifically designed to work well with standard water distribution system operation procedures. Most water distribution monitoring and control systems include water quality and corrosion sensing, but focus on system operation at major components such as tanks and water treatment plants. The major factors that drive corrosion and water quality analysis also involve a large number of remotely located components that are typically not monitored. The main factors for corrosion and water quality analysis are also closely related, are difficult to monitor and quantify, and require management of a large amount system component characteristic and historical data. The integrated analysis and information management capabilities provided by EDD's GTA based Dew software directly addresses these problems.

Fort Drum has a commercial SCADA system that is used to monitor and control major water distribution system components such as water treatment, storage, pumping and pressure control. The system aggregates measurements and component state information, (such as open, closed, on and off) and stores them in a centralized database. Standard water quality and corrosion indicators are monitored at major control points. This information is displayed on customized control screens which are programmed to act as remote control stations. The system also provides programmable alarms, automated operator notification and standardized analysis features such as data plotting and trending. Remote sensors and controls are connected to a dedicated SCADA network that is connected to a central server. This network is setup to be physically isolated from Fort Drums IT data network. SCADA Data is aggregated and stored at the server. Remote SCADA workstations access data from the server for display and analysis, and also serve as remote control stations.

The Dew Real-Time model uses a standard TCP/IP Network connection for read only access to SCADA database. The Dew Field Workstation Interface can be used remotely by personnel in the field to record manually collected measurements and component status information, and to remotely run model-based analysis. When the Field Workstation is connected to the TCP/IP network, manually recorded measurements and status information are automatically transferred to the real-time model where they are stored and used with SCADA data to perform analysis. For commercial utility use, the Filed Interface can be used with a wireless network connection. See Figure 4.

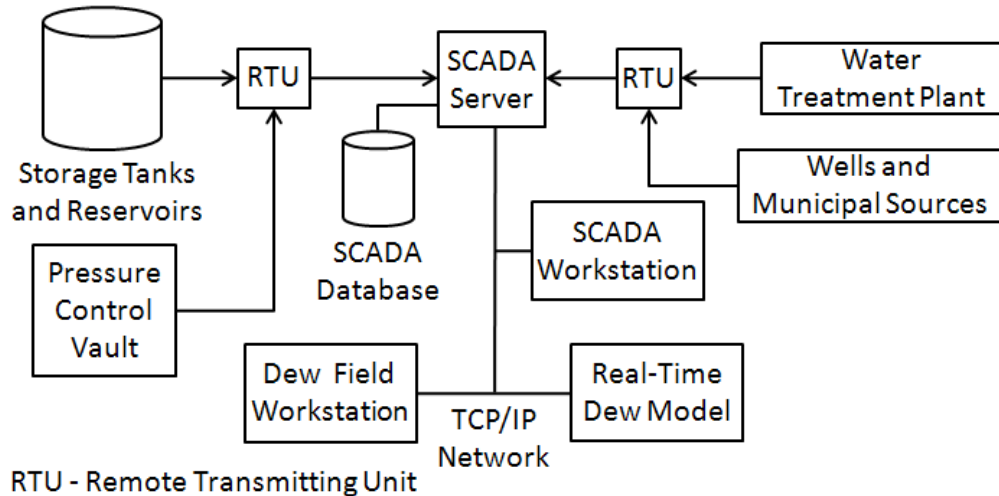

**Figure 4. Water Quality and Corrosion Monitoring System Overall Arrangement**

Figure 5 shows the basic data and analysis flow for the new system. The system automatically reads measurements from SCADA at regular user set time intervals. These measurements are then attached to the model. The fluid flow, water quality and corrosion analysis modules provided by the system are also attached to the model, and are used to generate detailed hydraulic, water quality and corrosion “virtual” measurements and indexes for every component in the system. These values are also used to generate high and low limit error flags which are used together with “virtual” measurements to drive displays and generate reports.

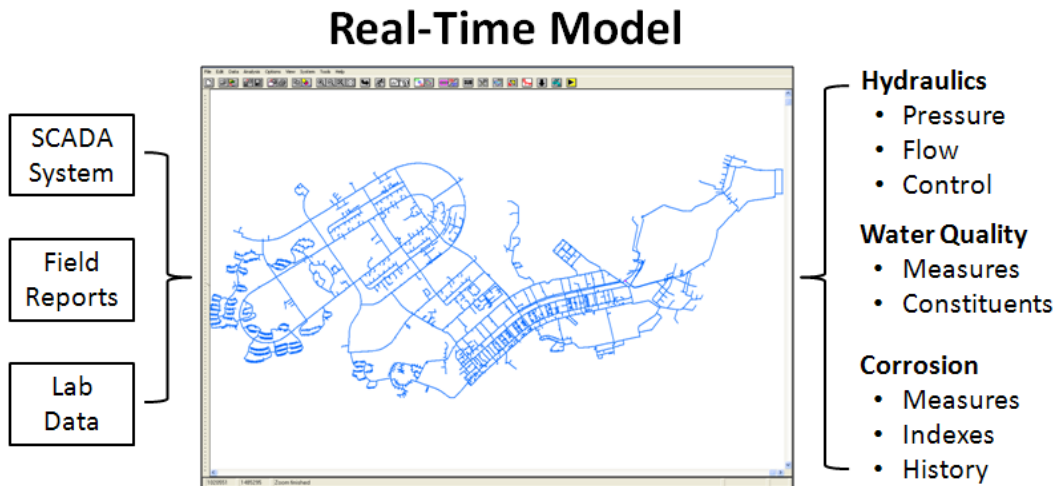

**Figure 5. System analysis and monitoring data flow**

Figure 6 shows example display results that were done using a small set of corrosion test data. Components that exceed user specified measurement and corrosion index high and low limits are highlighted and flagged. Out of limit flags are also used to drive report generation and general display functionality.

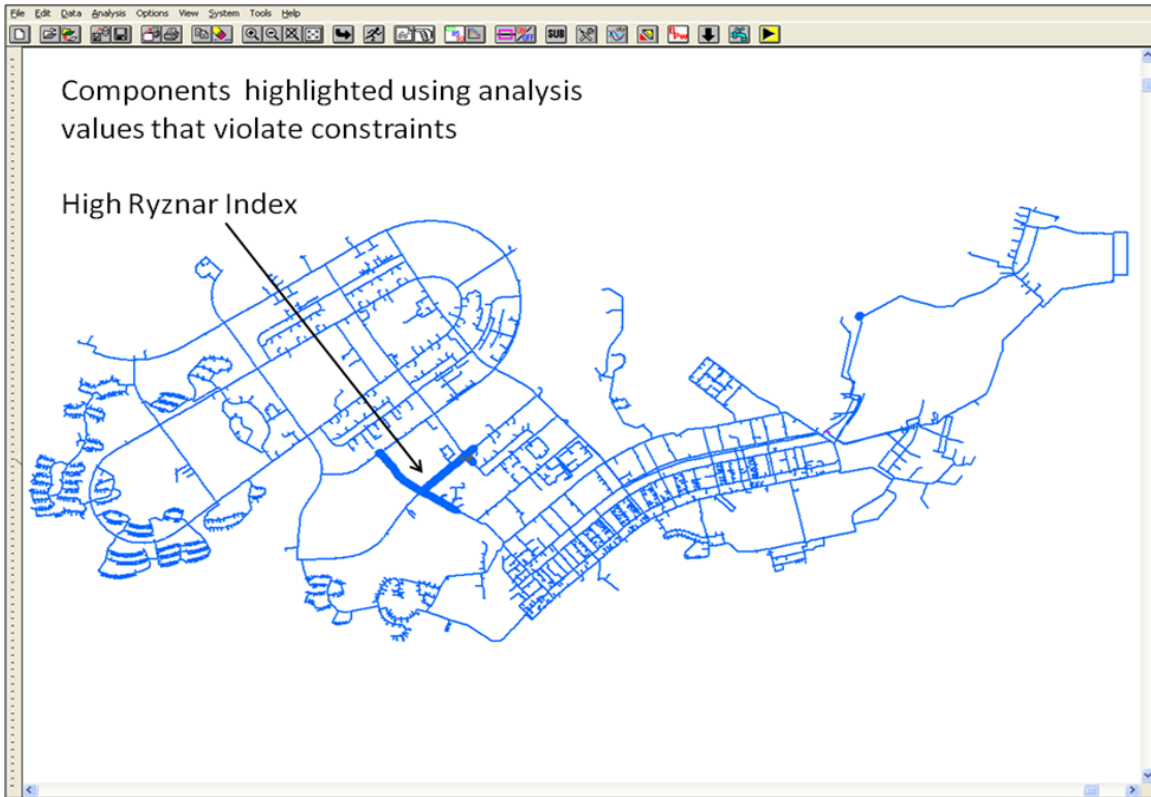

**Figure 6. Corrosion index violation highlights – Zoomed out display**

Figure 7 shows the same section zoomed in. At the closer zoom level, index values for individual components are displayed. Components with out of limit values are also marked with an error symbol. A user can access additional error information for each component by clicking on the component, and then viewing the component's message information from a dialog box. Components with errors can also be viewed as a list. This function includes a synchronized pan feature. When the user double clicks a component in the list, the display automatically pans to that component. See Figure 8.

Figures 9 shows component level results being used to color the display by pressure levels set by the user. This same feature can be used to color the display by any result value type that has been defined for a Dew application. The user first selects the type of analysis being used, and then gets a detailed list of all variables that the selected application can display.

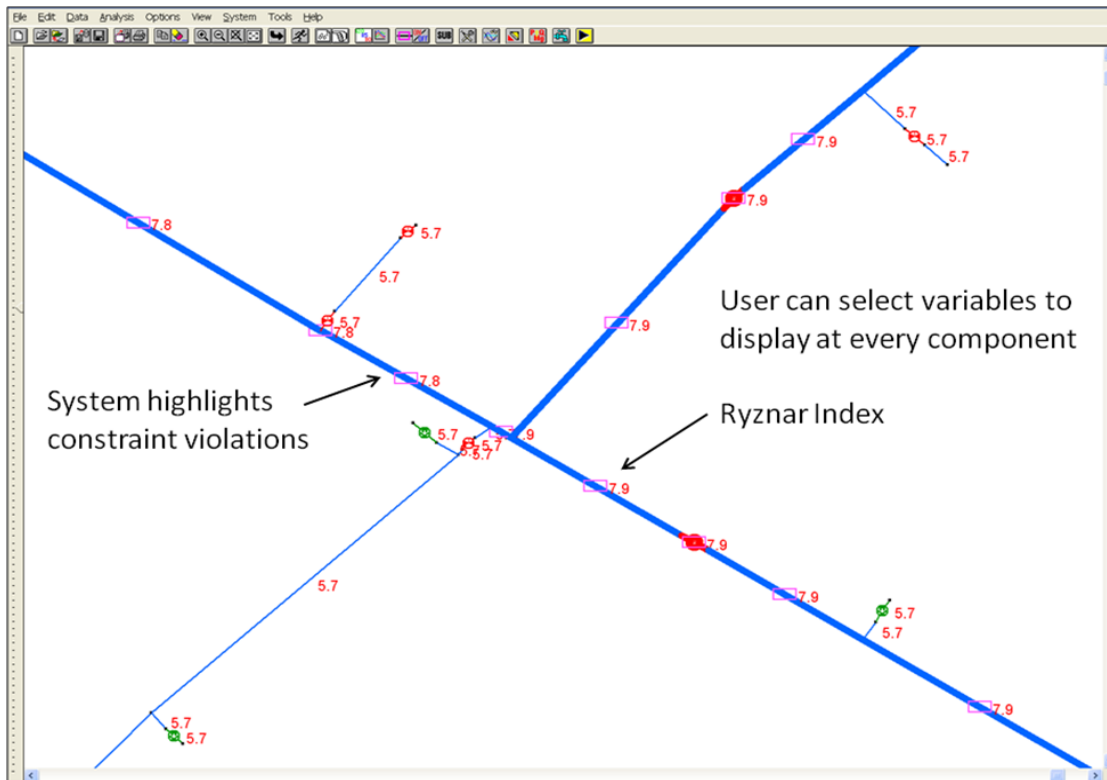

Figure 7. Corrosion index violation and variables – Zoomed in display

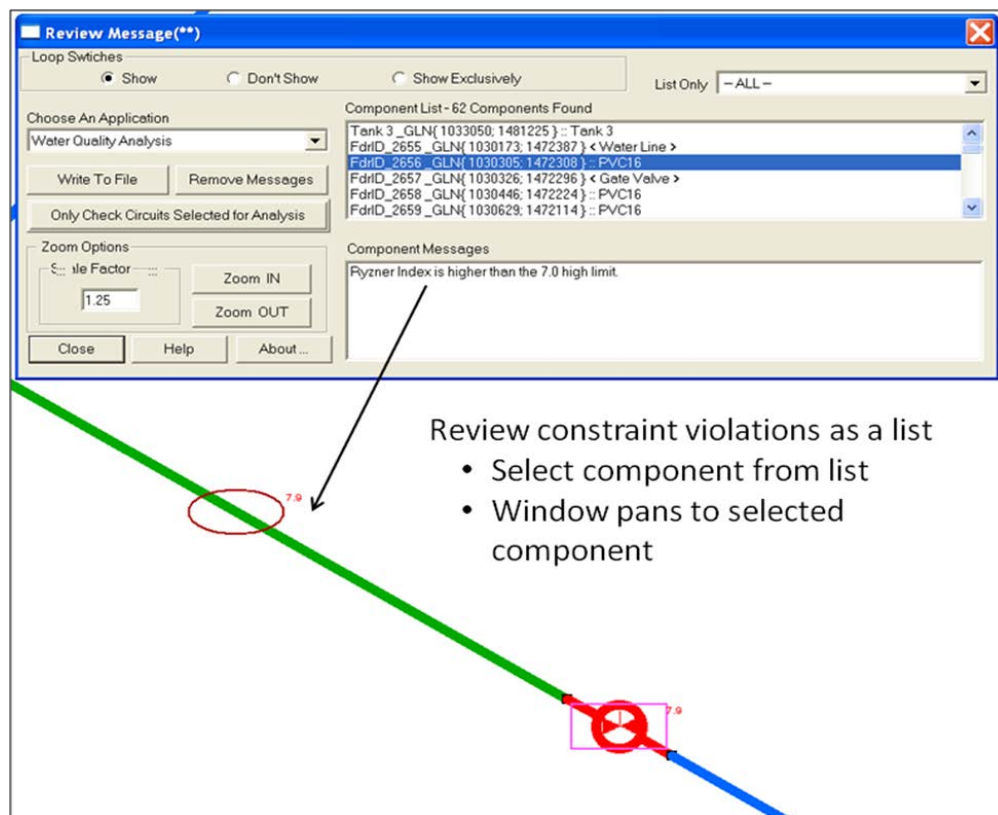
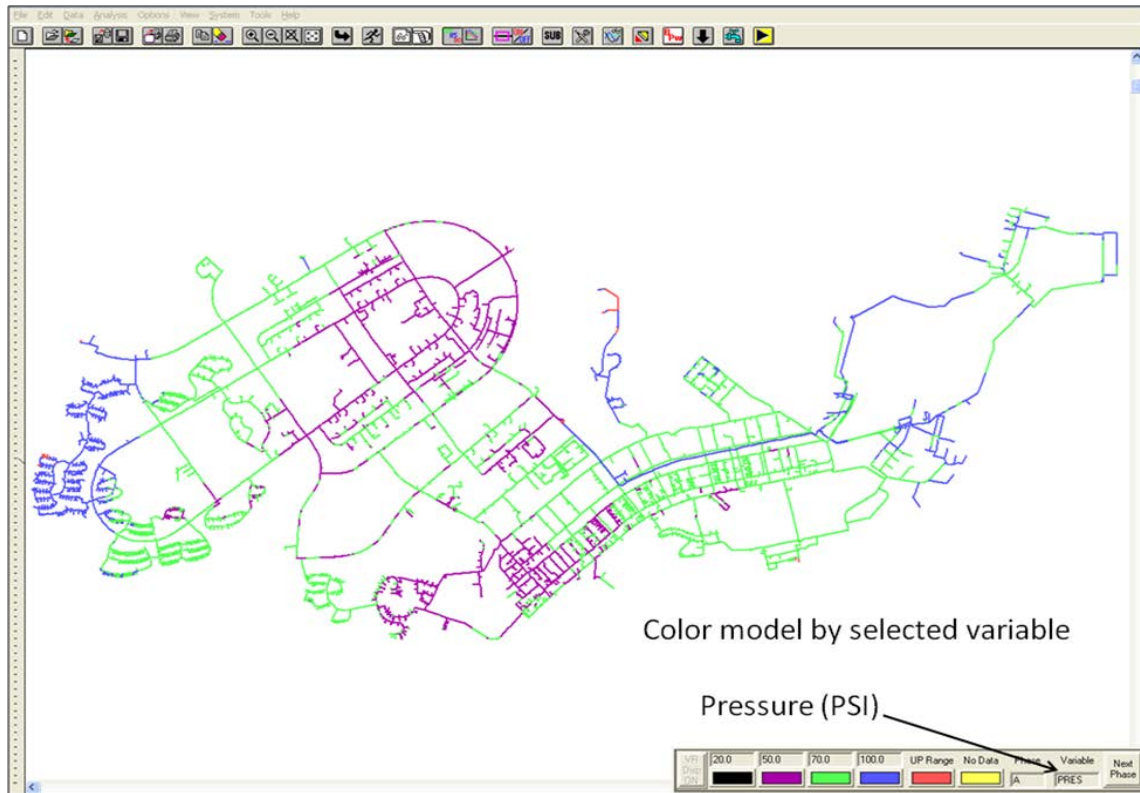

Figure 8. Variable limit violation list and pan to component dialog



**Figure 9. Variable range display set to display component pressure by color**

## System Development and Testing

Software development work performed for this project was based on modification and extension of EDD's existing Dew software, using Dew's standardized architecture for model-based collaborative applications. As a result, the new analysis applications are fully compatible with EDD software that has already been developed or is now under development as part of other government and industry sponsored projects. The Field Interface and Hydraulic analysis applications were initially developed under Army funded STTR research [6], and were further tested and refined as part of work for this project. The Dew-SCADA interface, measurement management, and display feature work performed for this project was based on modification of previous work that was originally developed for use with large commercial power systems [7]. Major component functionality and development for the water quality and corrosion analysis, data management and display are discussed in the following sections.

### Time Sequence Analysis

The Time-Sequence Analysis application serves as the controlling module for running the hydraulic analysis application, and water quality and corrosion analysis application. Each of these applications can also be run separately and can be used for both design and operations analysis. The Time-Sequence application also coordinates data flow from SCADA and the Field Interface to the model. Analysis can be run in real-time, or can be run in playback mode using time stamped SCADA and Event data that has been stored in the Time-Series and Event stores. The system architecture for the Time-Sequence

analysis application is shown in Figure 10. The setup dialog for Time-Sequence analysis is shown in Figure 8. Development work for the Time-Sequence analysis application was based on modification and extension of real-time analysis for power utility, integrated transmission and distribution system monitoring and supervisory control [7].

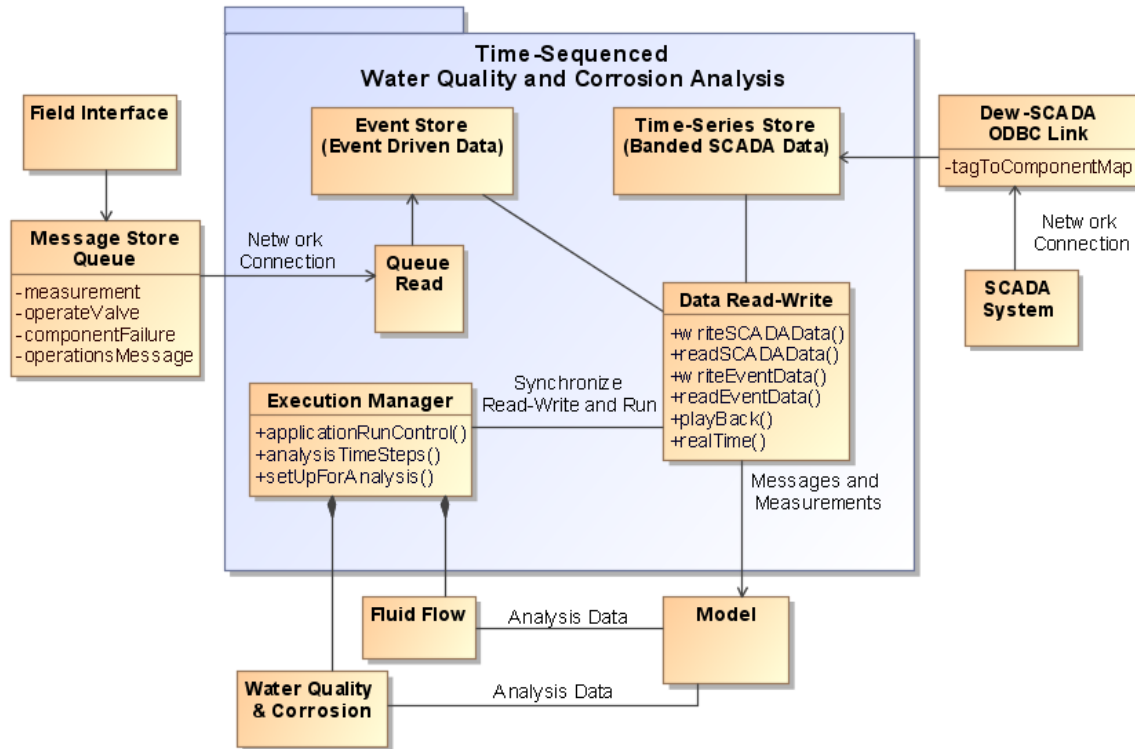

Figure 10. Model-based water quality and corrosion monitoring system architecture

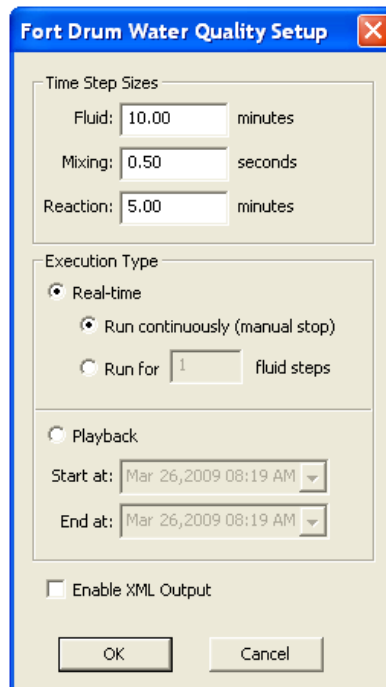

Figure 11. Water quality and corrosion Time-Sequence analysis setup



The fluid step size box shown in Figure 11 sets the time interval between fluid flow analysis runs. The mixing step size specifies the time increment step size that each water quality mixing analysis run will be broken up into. For example, if the fluid analysis step size is set to 10 minutes, mixing will run in 0.5 second increments 1200 times for a total of ten minutes of mixing analysis. Setting reaction time to 5.0 minutes will cause reaction to run twice within the 10 minute interval between fluid steps.

The Dew-SCADA link shown in Figure 10 is used to query the SCADA database at regular intervals which are set by the user. Measurements are read from the SCADA database and stored as time banded data in the Time Series Store. Mapping between SCADA measurement names or tags and model components, time intervals between queries, measurement type definitions, SCADA database names and SCADA database table names are defined through the use of an XML formatted configuration file that is loaded automatically when the interface is run.

Time banded data is structured to conform to the data storage format used in SCADA. This also simplifies using stored data to play back past events. The Time Series Store can also be used to store a scripted series of data points that can then be used for testing, training and design evaluation. Time band resolution can be varied according to the types of analysis to be performed. For design analysis, time bands are typically set to one hour which works well for analyzing system operation over a year's worth of time series data. For real-time monitoring time bands can be set to 5 or 10 minute intervals which correspond well with SCADA refresh rates. Within each time band, only the data points with the most recent time stamp are saved. This eliminates processing of redundant data points and also helps simplify analysis across extended periods of time. The tradeoff with using time banded data is that some critical event data may be lost, such as an automatic valve or switch that operates several times within a short period of time. For this reason, an Event Store is provided to record significant event driven sequential data that can be attached to the model together with time banded data.

For the current implementation at Fort Drum all SCADA data is stored as time banded data in the Time Series Store. All manually entered measurement and component status data collected using the Field Interface is stored in the Event Store. During play back, time stamped Event Store data is read in and attached to the model first. Time stamped Time Series Store data is then attached. At the component level, data time stamps and measurement type designations are used to differentiate between measurements and determine which ones will be used for analysis.

The real-time system interface uses an Open Database Connectivity (ODBC) driver and TCP/IP network connection to communicate with the SCADA system. Access to the SCADA system is read only and has no affect on the operation of the SCADA system. See Figure 10. The use of these standards will simplify future use of the real-time analysis system with other SCADA systems. During the first half of the project, the real-time system was interfaced to Microsoft Access SCADA data files, which were being used by Fort Drum's old Bristol Babcock SCADA system. During the second half of the project, Fort Drum updated to a new Bristol Babcock SCADA system that uses a database called Polyhedra, which is also ODBC compliant. This required the installation of a new Polyhedra ODBC driver, which was provided by Bristol Babcock. Some minor modification to the Dew real-time interface data table format was also required. The

capability to select different database connection options can be added to the system in the future if the Army chooses to use the new system with other SCADA systems.

## Measurements

Dew manages data and analysis by referencing everything to components that are stored together in the model, in memory. Each component has a one to one correlation with a real component in the system, and is structured as much as possible to function the way the component in the real system does. This simplifies integration and the development of new types of analysis. Measurements collected through SCADA and the Field Interface are referenced to individual components in the model using component unique ID's. These ID's can be specified by the system operator, or be set to match database ID's used to map components in a Geographic Information System (GIS), which is the typical source for model build information. Events such as valve operation and equipment failure can also be treated and stored as measurements that get hung at components, just like SCADA measurements. When a measurement is hung at a component, the component reacts to it according to its predefined behavior. For example, if a close measurement is hung at a valve, it closes. Automatic pressure control valves can be set to run automatically by hanging a control valve auto message, or be run remotely using SCADA valve percent open control commands. Level measurements at tanks and pressure measurements at pumps are used to set pressure boundary conditions at those components.

Measurements are defined in Dew using a standard table in the Dew database that sets measurement name, units and analysis type. When Dew is started up, it loads measurements defined by the table into memory, and then uses them to populate measurement structures and drop down lists for data entry and display. Defined measurements also show up in component dialog box, which can be used to manually hang new measurement values or to view measurements that were downloaded from SCADA. Figure 12 shows how a component dialog can be used to manually attach a pressure measurement.

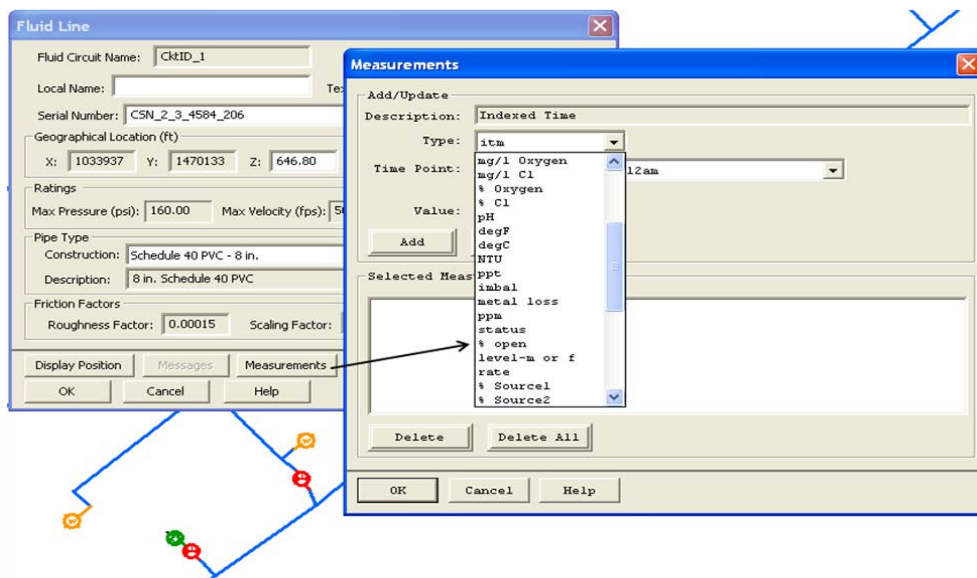

Figure 12. Measurement added manually using component dialog

## Measurement Table

Table 1 shows the hydraulic, water quality and corrosion analysis measurements that are currently defined for the system. These values are coordinated with output variables that have been defined for each application, and like measurements are used to define drop down list variables for output and displays.

**Table 1. Currently Defined Water Quality and Corrosion Analysis Measurements**

Display Name	Standard Description	Mix	React	Regulated
itm	Indexed Time			
sec	Time in Seconds			
psi	Pressure			
lb/s	Mass Flow Rate			
gal/min	Volumetric Flow Rate			
in	Length small			
ft	Length medium			
mi	Length large			
microS/cm	Specific Conductance micro	Y		
mS/cm	Specific Conductance milli	Y		
mV	Oxidation Reduction Potential	Y		
Volts	Voltage			
Amps	Current			
mg/l Oxygen	Oxygen Concentration	Y		
mg/l Cl	Chlorine Concentration	Y	Y	Y
% Oxygen	% Oxygen Saturation	Y		
pH	pH	Y		Y
degF	Temperature Deg F	Y		Y
degC	Temperature Deg C	Y		Y
NTU	Turbidity	Y		Y
ppt	Salinity	Y		
imbal	Imbalance (%)			
metal loss	Metal Loss (%)			
ppm	Contamination	Y	Y	
status	Control Status			
% open	Valve Percent Open			
level-m or f	Fluid Level			
rate	Corrosion Rate			
% Source	Source tracing			
mg/l Chlorid	Chloride Concentration	Y		Secondary
mg/l SO4	Sulfate Concentration	Y		Y
mg/l Na+	Sodium Ion Concentration	Y		
mg/l Alk	Alkalinity	Y		
sec Age	Global Age	Y		
mg/L Pb	Lead Concentration	Y		
mg/L Cu	Copper Concentration	Y		
mg/L TTHM	TTHM Concentration	Y		

**Table 1. (Continued)**

Display Name	Standard Description	Mix	React	Regulated
mg/L HAA5	HAA <sub>5</sub> Concentration	Y		
mg/L Ca	Calcium Concentration	Y		
mol/L HCO	Bicarbonate Concentration	Y		

## **Water Quality Analysis**

Water quality and corrosion analysis is performed through the combination of four sets of analysis which are hydraulics (fluid flow), mixing, reaction and corrosion. Fluid flow was implemented as a distinct application that can be run separately for individual time points, or be run automatically from within the Time-Sequence application. The fluid flow application was designed so that it could be used with minor modification to perform flow analysis for gas and other fluids. Mixing, reaction and corrosion analysis are structured together in another application which can also be run manually, or automatically together with fluid flow. Fluid flow must be run prior to water quality to set flow values for each component. Water quality uses these values to calculate mixing and reaction. Application functionality and testing are discussed in the following sections.

### **Fluid Flow (Hydraulics)**

The fluid flow application was originally developed as part of Army sponsored Small Business Technology Transfer (STTR) research [6]. It is based on the use of new GTA based engineering generic analysis concepts that described in detail in reference [8]. The engineering generic analysis concepts discussed in reference [6] show significant potential for development of a unified integrated analysis approach for interdependent systems. This includes performing discrete event, steady state and transient analysis together in a collaborative way. The work discussed in this report constitutes the first time that Generic Analysis approach has been used to apply integrated GTA based discrete event and time sequenced steady state analysis together for analysis of a water distribution system. All previous work in this area has been applied to design and control analysis for power systems.

The fluid flow application calculates steady state pressure and flow for every component in the system for a specified point in time. For real-time analysis, fluid flow and water quality and corrosion are run together across sequential time points that are managed by the time sequence application. Pressure and/or flow boundary conditions at tanks, sources and pumps are set using SCADA measurements and/or manually entered measurements, and water demand estimates defined at buildings. Valve operation and discrete “event” monitoring for automatic and remotely operated valves are controlled through attachment of control valve position measurements and open/close control signals recorded by SCADA. Operation of manual valves can be recorded and then automatically passed to the model through the Field Interface. Valves can also be manually opened and closed in the real-time model by the user through the valve component dialog or by double right clicking the valve.

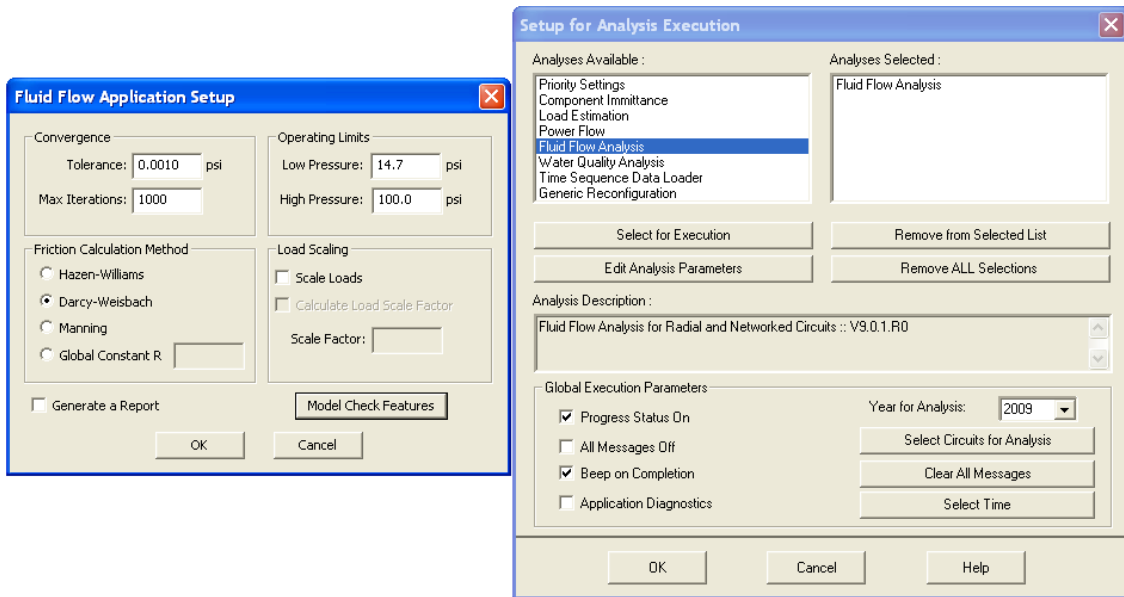
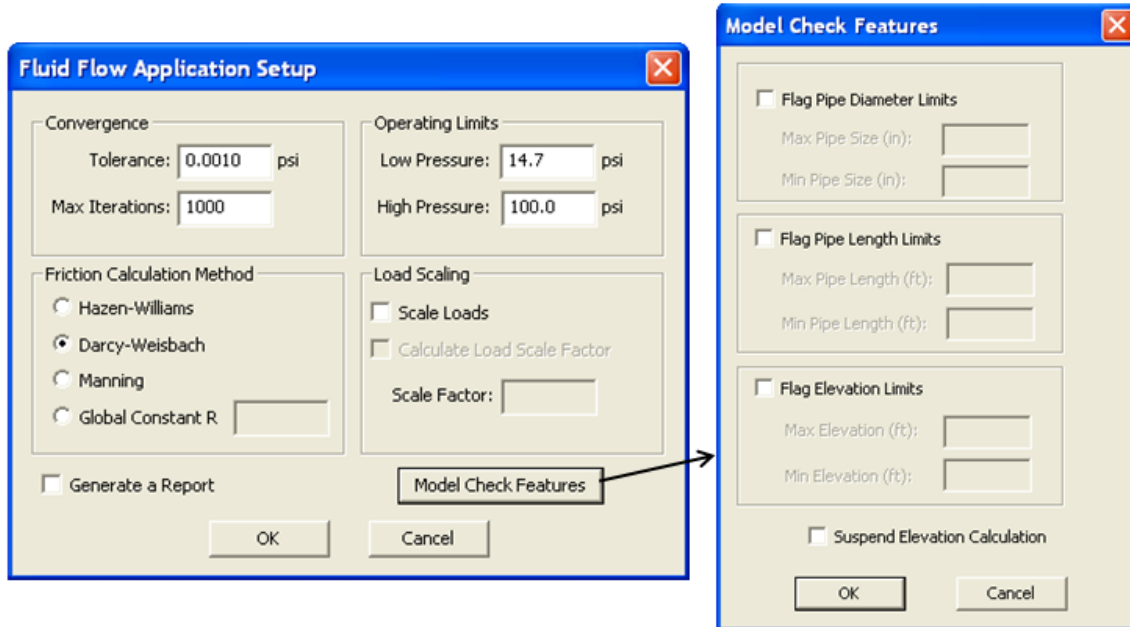

**Figure 13. Fluid Flow application setup dialog**

Users can choose from three standard water system analysis methods using the fluid flow application setup dialog. See Figure 13. These analysis method options are: Darcy-Weisbach, Hazen-Williams and Manning. Pipe and valve resistance related coefficients for each method are specified as component engineering specifications stored in the database according to pipe material type, construction and size. When a model is loaded into the system engineering specifications from the database are loaded into memory. Each component is assigned an index to its corresponding engineering specification data, which it shares with other components of the same type. Having components share common data in memory through the use of indexes, or pointers makes it possible to model large systems down to a significant amount of detail without using large amounts of data storage. This also significantly reduces or eliminates the need to perform database access during analysis.

The fluid flow application setup dialog also allows users to set high and low pressure limits for components. These values are used to generate display highlighting and error flags. The model check sub-dialog provides the capability to suspend elevation effects on pressure calculations, and to mark pipes by length, diameter and elevation limits. These options are provided to help simplify model building and validation. See Figure 14.

As mentioned earlier, initial development and testing for the fluid flow application was performed as part of Army funded STTR research. Additional details for development and testing of this application can be found in reference [6]. Additional fluid testing results generated as part of water quality analysis testing are shown in Table 2.



**Figure 14. Model check sub-dialog**

## Mixing

Water system mixing analysis is typically performed at nodes instead of the transport segments defined by pipes. GTA uses an edge – edge model (real component to real component – no nodes) and manages fluid flow related data by direct reference to modeled pipe components. Mixing is calculated as a function of flow rate into a segment, time step and segment size using a Continuous Stirred Tank Reactor (CSTR) type of approach for both pipe segments and tanks [9]. The total amount of time used for each mixing analysis run is set according to the time step used for fluid flow analysis. Mixing analysis is run sequentially using the mixing analysis step size set by the user in the water quality application setup dialog. As mentioned above in the fluid flow section, if the fluid step size is set to 10 minutes, mixing will run 1200 times in 0.5 second increments if the mixing step size is set to 0.5 seconds. Constituent concentrations, source tracking and age tracking are performed using a simple weighted average determined by percentage of mass flow into a segment from the adjacent segments that supply flow to it. In standard water system analysis terms, this constitutes a Eulerian discrete volume method. Reference [10] provides a good discussion of standard water system analysis methods.

Constituent values at boundary points are set by attaching a measurement for that constituent to a component either manually or automatically using measurements downloaded from SCADA. Constituent measurements can be attached to any component in the system, where they are available for use for display, additional analysis and calibration that uses scaling factors to adjust model results to match SCADA reference measurements. Constituent measurements hung at “set point” components are treated as analysis boundary conditions. See Figure 15. Constituent measurements currently defined in the system are listed above in Table 1. A “Y” in the mix column indicates that its corresponding constituent is used as a boundary condition for mixing analysis.

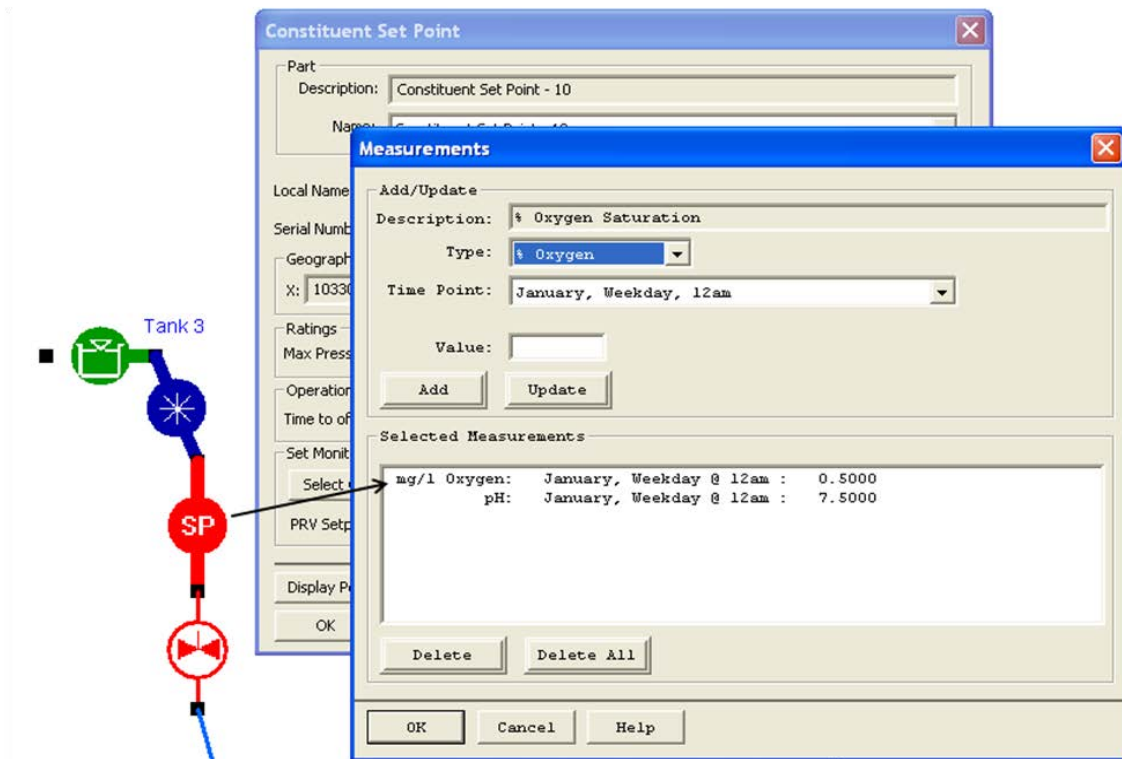

Figure 15. Constituent values hung as measurements at a set point component

## Reaction

The change in constituent concentration due to bulk reaction is done using the general form of the first order bulk reaction equation [9]. Currently the only constituents that are included in the reaction calculation are chlorine and a general “contaminant” constituent.

The general form of the bulk reaction rate formula was assumed to be:

$$R = K_b C^n$$

Where:

$K_b$  = bulk reaction rate coefficient

$C$  = reactant concentration

$n$  = reaction order

$R$  = reaction rate, change in concentration (Mass/vol) per time

Reaction can be set to run after each mixing step, multiple times for each mixing step, or after a multiple number of mixing steps by setting the reaction time step in the water quality setup dialog. Initial constituent values and limits can be set using the constituent settings sub-dialog. See Figures 16 and 17.

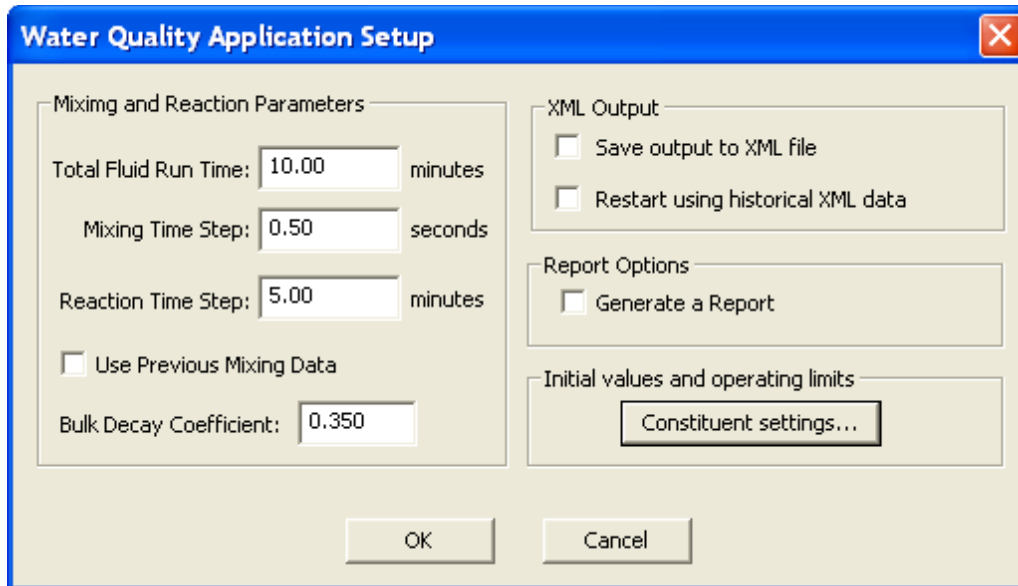

Figure 16. Water quality application setup dialog box

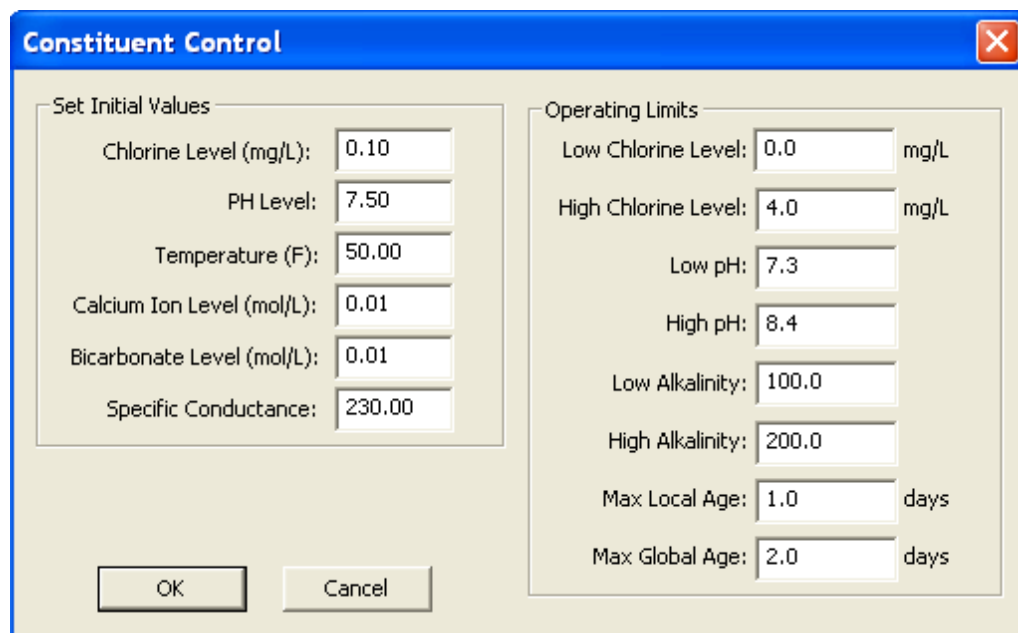

Figure 17. Water quality constituent initial value and limit setting sub-dialog box

### Water Quality Analysis Testing

Mixing and reaction analysis results for chlorine were compared with analysis results generated using EPANET [11], which is an widely used open software program provided by the Environmental Protection Agency, for the example system shown in Figures 18 and 19. Chlorine injection was set to 2.0 mg/L. The system has 40 demand loads, 56 cast iron pipe sections that are each 500 feet long and vary in diameter between 4 inches and 12 inches. The system was supplied by a single pump driven source. Analysis was run for 404 hours which insured that mixing and reaction values had reached steady state, a fluid flow time step of 1 hour. The Dew mixing and reaction step size was set to 0.5



seconds. The analysis method used was Hazen Williams. The green X's shown in Figure 18 mark the location of cotrees, which Dew uses as part of flow analysis. Dew fluid flow convergence settings were set to solve flow to a pressure difference across all cotrees to a point at or below 0.00001 psi. Dew solves network flows by first generating a radial solution using backwards and forwards iteration, and then adjusts flows across loop junction points or cotrees so that the summation of pressure drops around all loops sum to zero. Convergence criteria for the EPANET solution was set to 0.001, which is based on the sum of all flow changes divided by the sum of all flows [11].

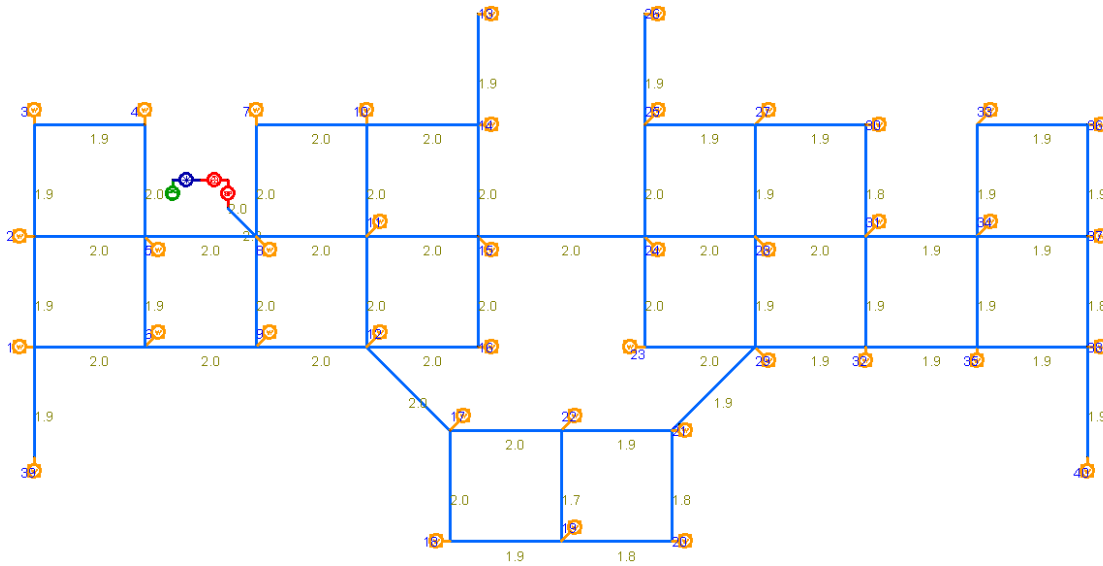

Figure 18. Dew fluid flow and water quality analysis test system chlorine decay results

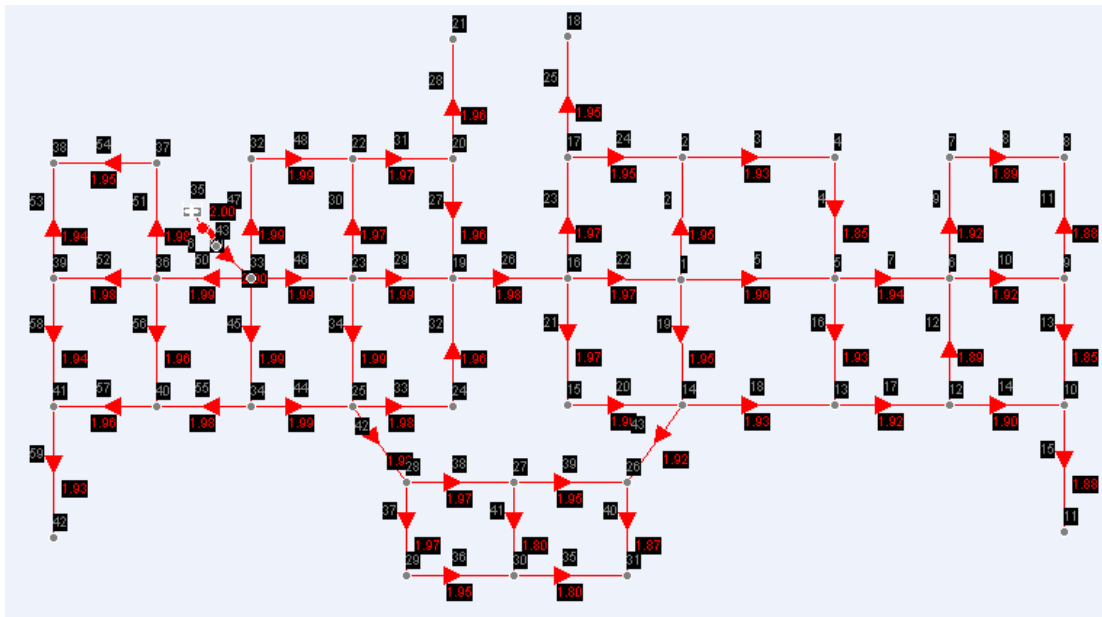

Figure 19. EPANET fluid flow and water quality analysis test system chlorine decay results

The difference in chlorine display values shown in Figures 18 and 19 are mainly due to rounding done by Dew's display function. Table 2 shows a detailed comparison of analysis results between Dew and EPANET.

**Table 2. Dew – EPANET Chlorine Mixing and Reaction Results Comparison**

Pipe Name	Diam (in)	Length (ft)	Dew	EPANET	Flow	Dew	EPANET	Cl
			Flow (gpm)	Flow (gpm)	Diff	Cl mg/L	Cl mg/L	Diff
2	6	500	12.36	12.36	0.00	1.94	1.95	0.01
3	6	500	14.38	14.27	0.11	1.92	1.93	0.01
4	6	500	2.81	2.70	0.11	1.80	1.85	0.05
5	8	500	41.79	41.92	0.13	1.96	1.96	0.00
6	12	500	347.20	347.20	0.00	2.00	2.00	0.00
7	4	500	20.79	20.79	0.00	1.94	1.94	0.00
8	4	500	3.32	3.34	0.02	1.87	1.89	0.02
9	4	500	9.11	9.13	0.02	1.91	1.92	0.01
10	4	500	9.44	9.45	0.01	1.91	1.92	0.01
11	4	500	2.47	2.45	0.02	1.85	1.88	0.03
12	4	500	3.56	3.58	0.02	1.88	1.89	0.01
13	4	500	1.18	1.21	0.03	1.80	1.85	0.05
14	4	500	10.40	10.37	0.03	1.90	1.91	0.01
15	4	500	5.79	5.79	0.00	1.88	1.87	0.01
16	6	500	12.24	12.26	0.02	1.92	1.93	0.01
17	4	500	19.74	19.74	0.00	1.92	1.92	0.00
18	6	500	19.07	19.05	0.02	1.93	1.94	0.01
19	6	500	13.14	13.15	0.01	1.94	1.95	0.01
20	6	500	21.17	21.14	0.03	1.95	1.95	0.00
21	6	500	32.74	32.71	0.03	1.97	1.97	0.00
22	8	500	78.86	79.00	<b>0.14</b>	1.97	1.97	0.00
23	6	500	36.73	36.62	0.11	1.97	1.97	0.00
24	6	500	13.59	13.48	0.11	1.94	1.95	0.01
25	6	500	11.57	11.57	0.00	1.94	1.95	0.01
26	8	500	159.90	159.90	0.00	1.98	1.98	0.00
27	6	500	25.23	25.22	0.01	1.96	1.96	0.00
28	6	500	11.57	11.57	0.00	1.94	1.96	0.02
29	8	500	121.08	121.10	0.02	1.99	1.99	0.00
30	6	500	9.40	9.42	0.02	1.96	1.97	0.01
31	6	500	48.37	48.36	0.01	1.97	1.97	0.00
32	6	500	25.16	25.15	0.01	1.96	1.96	0.00
33	6	500	36.73	36.72	0.01	1.97	1.98	0.01
34	6	500	31.41	31.40	0.01	1.98	1.98	0.00
35	4	500	4.23	4.16	0.07	1.79	1.80	0.01
36	4	500	5.97	5.99	0.02	1.94	1.95	0.01
37	4	500	11.76	11.78	0.02	1.96	1.97	0.01
38	4	500	13.52	13.49	0.03	1.97	1.97	0.00
39	4	500	3.68	3.75	0.07	1.93	1.95	0.02

**Table 2. (Continued)**

			Dew	EPANET	Flow	Dew	EPANET	CI
Pipe Name	Diam (in)	Length (ft)	Flow (gpm)	Flow (gpm)	Diff	Cl mg/L	Cl mg/L	Diff
40	4	500	1.56	1.63	0.07	1.83	1.87	0.04
41	12	500	4.04	3.95	0.09	1.66	1.80	<b>0.14</b>
42	4	500	31.07	31.07	0.00	1.98	1.98	0.00
43	4	500	3.67	3.67	0.00	1.91	1.92	0.01
44	6	500	47.96	47.95	0.01	1.98	1.99	0.01
45	6	500	72.00	71.98	0.02	1.99	1.99	0.00
46	8	500	173.45	173.50	0.05	1.99	1.99	0.00
47	6	500	62.11	62.08	0.03	1.99	1.99	0.00
48	6	500	50.54	50.51	0.03	1.98	1.99	0.01
50	4	500	28.06	28.07	0.01	1.99	1.99	0.00
51	4	500	9.41	9.41	0.00	1.97	1.98	0.01
52	4	500	9.95	9.92	0.03	1.97	1.98	0.01
53	4	500	2.17	2.17	0.00	1.90	1.94	0.04
54	4	500	3.62	3.62	0.00	1.93	1.95	0.02
55	4	500	12.47	12.46	0.01	1.98	1.98	0.00
56	4	500	2.92	2.95	0.03	1.94	1.96	0.02
57	4	500	9.60	9.62	0.02	1.95	1.96	0.01
58	4	500	1.98	1.96	0.02	1.90	1.94	0.04
59	4	500	5.79	5.79	0.00	1.92	1.93	0.01
				<b>Average</b>	<b>0.03</b>			<b>0.01</b>
				<b>Max</b>	<b>0.14</b>			<b>0.14</b>

## Corrosion Analysis

A large amount of water distribution system corrosion analysis research has been completed by industry and academia that is documented in open literature. Taking corrosion analysis work from the lab and applying in the field on real systems is difficult because it requires coordination of a large amount of data that includes SCADA measurements, lab analysis generated measurements, individual distribution system component characteristics, and historical operation data. One of the main goals for this project is to develop a comprehensive system for managing and applying corrosion analysis related data and calculations together, in a way that fits well with standard water distribution system operation and maintenance practices.

To perform corrosion analysis, the time sequence analysis application first runs fluid flow to determine flow values for each component. The water quality application is then used to perform mixing and reaction calculations. All of these measured and generated values are then available for calculating new indexes and measures that can be used for corrosion analysis. Detailed physical characteristic and historical operation information can also be used through the pointers managed by the system.

For the purpose of demonstration and initial evaluation, two corrosion indexes and an iron release model equation were selected for programming. The first two, the Langelier and Ryznar indexes, were selected because they are the most commonly used. The third, the Iron Release Flux Model, was found through review of current academic literature and was selected because it required the coordination of several constituent and piping physical property related variables included a term related to flow velocity. The Corrosion index calculations were successfully tested against simple example problem results, but have not yet been tested at Fort Drum with real system operation data. The iron release model equation was also tested using a small set of example data. Additional corrosion index and measure field testing is subject to Fort Drum completion of ongoing SCADA system upgrade work. The indexes and iron release model equation are defined as water quality application variables that can be used to generate error lists, displays and plots that are designed to work with more standard variables such as pressure and flow, defined for other applications. See Figure 20.

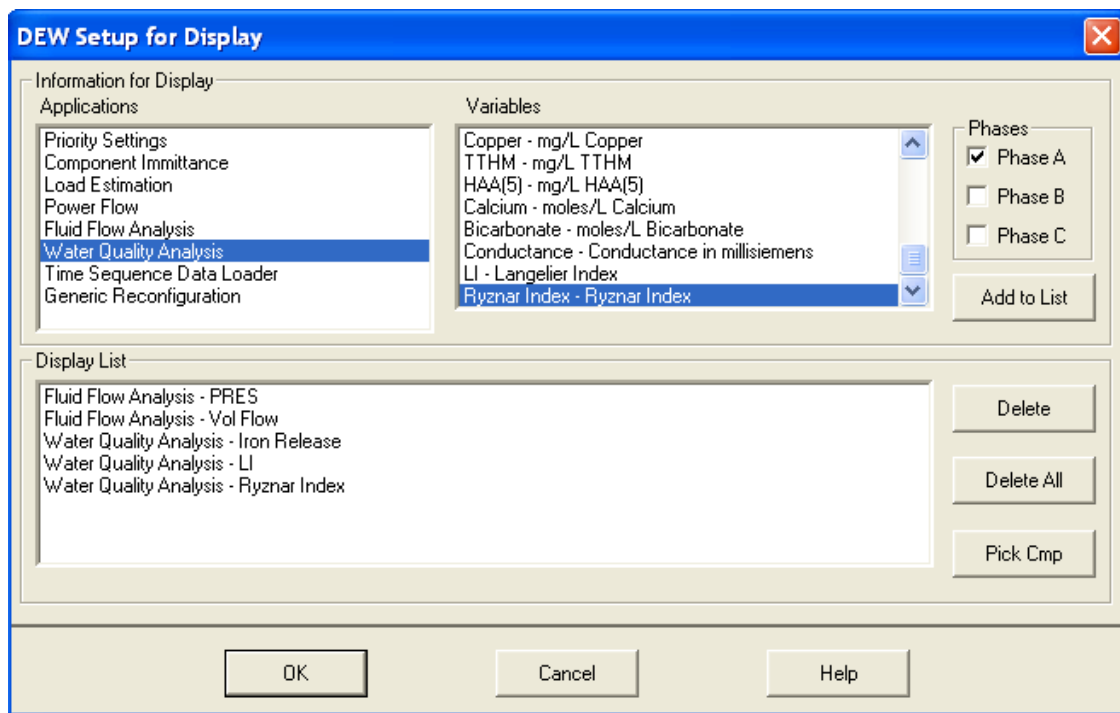

**Figure 20. Water quality application – Corrosion Index setup for display dialog**

### Corrosion Indexes

A variety of efforts have been undertaken to develop simple to use indicators for quantifying and monitoring the corrosivity of treated water. Many of these indices provide an indication of water's capability to precipitate calcium carbonate ( $\text{CaCO}_{3(s)}$ ). Precipitated calcium carbonate (or calcite) is thought to provide a protective layer along the surface of pipes that prevents the corrosion reaction from proceeding. Such indices include: the Langelier Saturation Index, the Ryznar Index, the Aggressiveness Index, the Driving Force Index, Dye's Momentary Excess, and the Calcium Carbonate Precipitation Potential [12]. Other indices are built around the use of other water quality variables.

These include the Larson Ratio, the Modified Larson Ratio, and the Riddick Corrosion Index [13].

Regardless of their widespread use, no single index has been found to be uniformly applicable as a reliable indicator for water corrosivity. This is likely due to the complexity of corrosion interactions and the typical data management and integration problems involved with the monitoring and operation of large distribution systems. There are over 15 water quality parameters that are thought to have some effect on corrosion. Differentiation must also be made between the corrosion reaction, scale formation processes, and scale release/red water problems. Each water quality parameter may have varying effects on each of these processes. Thus, the use of any corrosion index should be approached with caution. The analysis and integrated data management structures provided by the new system are intended to help evaluate and refine the use of corrosion indexes over time. A summary discussion of the Langelier Index, the Ryznar Index, and the Iron Release Flux Model are provided in the following sections.

### *Langelier Index*

The Langelier Index (LI) is a measure of water's pH relative to its pH of saturation with  $\text{CaCO}_{3(s)}$ . LI provides an indication as to whether water will precipitate  $\text{CaCO}_{3(s)}$  or if it is under saturated with respect to Calcium ( $\text{Ca}^{2+}_{(aq)}$ ) and Bicarbonate ( $\text{HCO}_3^-_{(aq)}$ ). The LI index is derived from thermodynamic data for the following reaction:

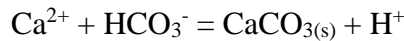

LI is determined from the following equation:

$$\text{LI} = \text{pH}_a - \text{pH}_s$$

Where:

$$\text{pH}_s = \text{pK} - \log[\text{Ca}^{2+}] - \log[\text{HCO}_3^-] - \log \gamma_{\text{Ca}^{2+}} - \log \gamma_{\text{HCO}_3^-} \quad [14]$$

In which:

LI = Langelier Index

$\text{pH}_a$  = measured pH

$\text{pH}_s$  = pH at which solution is saturated with  $\text{CaCO}_{3(s)}$

$\text{pK} = 1.85 = -\log K$  (K is the equilibrium constant for the above reaction) [15]

$[\text{Ca}^{2+}]$  = Calcium ion concentration in Moles/Liter

$[\text{HCO}_3^-]$  = Bicarbonate concentration in Moles/Liter

$\gamma$  = activity coefficient

A positive LI value indicates that water is saturated with respect to  $\text{CaCO}_3$  and is thus deemed "noncorrosive." A protective layer of  $\text{CaCO}_3$  is expected to form on the pipe wall. A negative LI value indicates that the water is undersaturated with respect to  $\text{CaCO}_3$ . Concentration of  $\text{Ca}^{2+}$  can be measured using an electrode or can be determined in the lab via atomic absorption spectroscopy. Bicarbonate ( $\text{HCO}_3^-$ ) concentration is related to alkalinity and for pH ranges of treated water (~6.5 – 9) can be assumed to equal alkalinity. Bicarbonate is the dominant alkalinity species for a pH range of ~ 6.5-9.

Alkalinity is typically reported as mg/L as CaCO<sub>3</sub>. To convert to Moles/L of bicarbonate, divide alkalinity by 5 x 10<sup>4</sup>.

#### *Ryznar Index*

The Ryznar Index is similar to the Langelier Index in that it uses water's tendency to precipitate CaCO<sub>3</sub> as an indicator for corrosivity. The pH<sub>s</sub> term used in the Ryznar index calculation is identical to the pH<sub>s</sub> term used in the Langelier Index. The Ryznar Index is calculated as follows:

$$RI = 2 * pH_s - pH_a$$

Where:

RI = Ryznar Index

pH<sub>s</sub> = pH at which solution is saturated with CaCO<sub>3(s)</sub>

pH<sub>a</sub> = measured pH

Typically, an RI value between 5.0 and 7.0 is desirable. Heavy scale is expected to form when the RI is below 5.0 to 5.5. Significant corrosion is expected when the value is above 7.0. An increasing value for RI indicates increasing corrosivity of water.

#### *Langelier and Ryznar Corrosion Index Testing*

Langelier and Ryznar corrosion index calibration and testing to date has been limited because of Army SCADA system procurement and IT security related installation delays. During June and July of 2009, EDD worked to develop and test the capability to run corrosion monitoring using archived system operation data downloaded from Fort Drum's SCADA system to a Microsoft Excel file. The Excel file was then transferred to a standalone computer and used to perform corrosion monitoring simulation for data collected the week of 20 July 2009. This data was combined with hand collected corrosion index data (See Table 1), that was then used with archived SCADA data to simulate water system operation. Results showed that the model generated a reasonable estimate for a non-monitored site (Building 1999), that was selected because it was located in an expected groundwater/surface water mixing zone. Simulation results showed areas where ground water from Fort Drum's wells mix with surface water, which is supplied to the system the systems single connection to a municipal source (Danc). The mixing boundary areas identified by the simulation matched areas where Fort Drum has historically seen significant levels of precipitate, which Fort Drum currently addresses using flushing. This condition is common for systems where ground and surface water mix.

Fort Drum recently completed approval for online use of corrosion monitoring on their SCADA network. This will provide the capability to use the corrosion monitoring system with live measurements that are automatically downloaded from SCSDA. This capability will also provide for detailed calibration and testing, which will start in August 2009 and continue through December 2009.

**Table 1. 20 July 2009 Corrosion Index Data (LI – Langelier, RI – Ryznar).**

Location	ph	Spec Cond (microS)	Alk (mg/L)	Calcium Hardness (mg/L)	LI	RI
Tank 1	7.72	349	70	86	-0.22	8.16
Tank 3	7.88	300	61	78	-0.15	8.19
Danc (Municipal Source)	7.83	210	36	56	-0.55	8.93
Water Treat Plant (Wells)	8.02	369	62	84	0.01	8.00
Building 1999	7.89	211.4	40	57	-0.44	8.77
Measurements taken 7/23/09						

The screen shot shown in Figure 21 is for the area that supplies Building 1999. Building 1999 was selected for hand measurement because it lies in between the groundwater and surface water system sources, and it is not monitored by SCADA. The display is set to show Langelier Index by color, Black is less than or equal to -0.5, and Specific Conductance is set to display numerically in microSiemens. Figure 21 shows that the system estimate for Langelier Index and Specific Conductance at Building 1999 reasonably matches the measurements taken at Building 1999. Through the course of the simulation, the Specific Conductance and the Langelier Index cycled back and forth between -0.5 and -0.2 as source water shifted from ground to surface as the pumps for these sources cycled according to their system operation settings. Additional testing needs to be performed using regularly scheduled hand measurements at several locations and live SCADA measurements to refine the model further. It appears that the apparent correlation between Specific Conductance and water source can be used to help calibrate model pressure and flow results, which is what drives mixing of water from the two main sources.

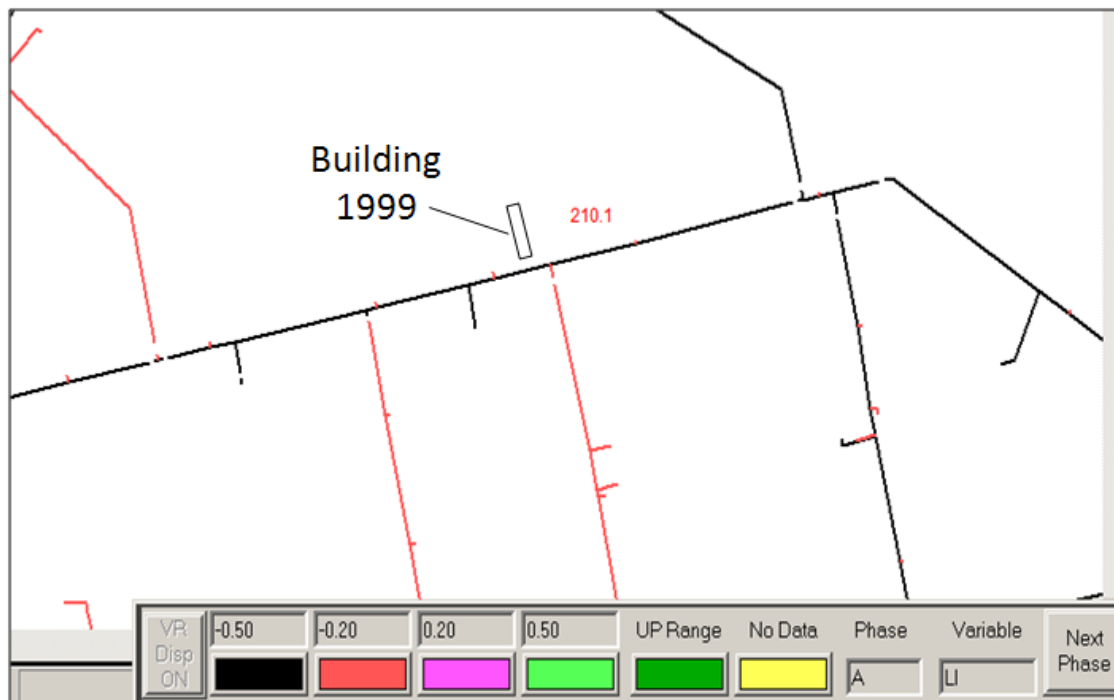

**Figure 21. Corrosion monitoring display for area supplying Building 1999**

### *Iron Release Flux Model*

Red water is one of the most prominent causes of consumer complaints and aesthetic water quality problems affecting water utilities. Red water is typically associated with concentrations of iron ( $\text{Fe}^{+++}$ ) in bulk water. Iron may be derived from source water, treatment processes, or most likely from iron pipe corrosion.

Iron corrosion in water distribution systems is an extremely complex electrochemical/physicochemical process that results from chemistry of the interface between the water and the pipe wall as well as the physical/mechanical characteristics of flow through the pipe. Corrosion results in the deterioration of metal (typically iron) pipe by an oxidation reaction at the pipe surface. As a result of this reaction, scaling forms on the pipe wall. While corrosion scaling aids in corrosion resistance by creating a barrier between the conductive water and the metallic surface of the pipe, it also serves as a reservoir for corrosion products that can be released into the water supply. Thus, it is important to point out the distinction between the rate of corrosion and the release of corrosion products. While the rate of corrosion influences how much material is available for release into the water supply, the mechanism of release is often unrelated. Corrosion processes and mechanisms are generally well understood and have been the subject of a vast number of research efforts over the last 100 years or more. Yet, the processes and mechanisms of corrosion release are not thoroughly understood and disagreement still exists among experts.

The iron release flux model was developed by researchers at the University of Central Florida [16, 17]. Their model simulates iron concentration based on a novel surface release flux term, pipe material, pipe geometry, and hydraulic retention time. The flux term is dependent upon pipe material and Reynolds number. A summary of the iron release flux model and its derivation is provided below.

The iron release flux model builds on the presumption that iron scale release is dominated by film release mechanisms and not by concentration gradients and equilibrium solubility. The justification for this conclusion lies in the fact that particulate iron is the predominant form of iron in water aged iron pipes. Past experiments have shown that as total iron concentration increases (due to scale release), dissolved iron concentrations remain low and steady (well below the siderite solubility threshold) and particulate concentrations increase proportional to total iron increase. Models based on solubility have been shown to underestimate total iron concentrations.

Flux model derivation was based on both the one dimensional partial differential approach to the advection/ dispersion equation as well as steady state mass balance. Both derivations resulted in the same flux equation:

$$\Delta[\text{Fe}] = (4 * K_m * \text{HRT}) / D$$

Where:

$\Delta[\text{Fe}]$  = the change in iron concentration along pipe reach ( $\text{M/L}^3$ )

$K_m$  = flux term ( $\text{M/L}^2/\text{t}$ )

HRT = hydraulic retention time (T)



D = diameter of pipe (L)

L = length of pipe (L)

The flux term ( $K_m$ ) provides for the film release mechanism inherent within the iron release model. The flux term is defined as the iron mass rate of release (ie. film release) per unit area and has units of  $\text{mg}/\text{m}^2\cdot\text{day}$ . Iron concentration in water exiting the distribution pipe is directly proportional to the flux term and the hydraulic retention time (days) and inversely proportional to the pipe diameter (m).

Flux term values were determined experimentally and found to be dependent upon Reynolds number and pipe material. Under laminar flow conditions ( $\text{Re} < 2,000$ ), the flux term remained relatively constant. For turbulent flow ( $\text{Re} > 2,000$ ), flux term values increased proportionally with Reynolds number increases.

Experiments conducted for flux term determination only involved single source water. While these experiments were not intended to reveal the effect of water chemistry on iron release, additional experiments conducted at the University of Central Florida may be incorporated to allow for adjustments to the flux term (in the absence of experimental values). This work involved an empirical statistical model that estimates changes in water color (surrogate for iron concentration) depending upon water chemistry. Source waters of varying composition were fed through a pilot distribution system of 18 lines of pipe made up of unlined cast iron, lined cast iron, galvanized pipe, and PVC pipe. Color was measured at the inlet and outlet of each line. Water parameters included in the statistical model development included: DO, conductivity, sulfate concentration, chloride ion concentration, sodium, temperature, hydraulic retention time (HRT), alkalinity, calcium, silica ( $\text{SiO}_2$ ),  $\text{UV}_{254}$ , and pH. Based on data results and statistical analysis of variance (ANOVA), the resulting best fit model was developed (brackets indicate concentration in  $\text{mg}/\text{L}$ ):

$$\Delta\text{Color} = \frac{[\text{Cl}^-]^{0.485} * [\text{SO}_4^{2-}]^{0.118} * [\text{Na}^+]^{0.561} * [\text{DO}]^{0.967} * T^{0.813} * \text{HRT}^{0.836}}{20.9411 * [\text{Alk}]^{0.912}}$$

The flux model and the statistical model may be unified by the following relationship (assuming color change as a surrogate for iron concentration):

$$\frac{K_{m_1}}{K_{m_2}} = \frac{\Delta C_1}{\Delta C_2}, \text{ and therefore } K_{m_2} = K_{m_1} \frac{\Delta C_2}{\Delta C_1}$$

Since  $K_{m_1}$  and  $\Delta C_1$  are known values determined during the flux experiments and  $\Delta C_2$  can be calculated based on water quality parameters using the statistical model, the flux term ( $K_{m_2}$ ) may be adjusted for any source water. Figures 22 and 23 shows the change in iron concentration verses Reynolds number for varying water chemistries and varying pipe materials.

#### *Flux Model Derivation*

One dimensional partial differential derivation of advection dispersion equation with source generation/ decay term (neglecting diffusion):

$$\frac{\partial C_{(t,x)ij}}{\partial t} = -u_{ij} \frac{\partial C_{(t,x)ij}}{\partial x} + k_{ij} C_{(t,x)ij}$$

Where:

C = concentration (M/L<sup>3</sup>)

x = location along pipe length

t = time

u = flow velocity (L/t)

k = first order rate constant (t<sup>-1</sup>)

Manipulation allow for the introduction of the flux term (K<sub>m</sub>):

$$\partial C_{(t,x)}/\partial t = - \left( \frac{Q}{A} \right) \frac{\partial C_{(t,x)}}{\partial x} + K_m \left( \frac{SA}{V} \right)$$

Where:

A = cross sectional area (L<sup>2</sup>)

SA = surface area (L<sup>2</sup>)

Q = flow rate (L<sup>3</sup>/t)

V = Volume (L<sup>3</sup>)

K<sub>m</sub> = flux (M/L<sup>2</sup>/t)

Further manipulation results in the flux equation:

$$\Delta [\text{Fe}] = \frac{4K_m \text{HRT}}{D} = \frac{4K_m L}{uD}$$

Where:

Δ[Fe] = the change in iron concentration along pipe reach (M/L<sup>3</sup>)

HRT = hydraulic retention time (T)

D = diameter of pipe (L)

L = length of pipe (L)

Steady state mass balance derivation:

Input – Output + Generation = Accumulation

$$QC_{in} - QC_{out} + K_m SA = 0$$

$$(C_{out} - C_{in}) = \Delta C = \frac{K_m SA}{Q}$$

$$\Delta C = \Delta [Fe] = \frac{K_m \pi DL}{u (\pi D^2/4)}$$

$$\Delta [Fe] = \frac{4 K_m L}{uD} = \frac{4 K_m HRT}{D}$$

### Flux Model Example Results

Note that Figures 22 and 23 were generated using the example data shown in Table 3. Results for Tampa are based on data presented in reference [18]. Data for Blacksburg and Fort Drum are ‘best guess’ estimates based on review of a limited set of available sample data and are provided for demonstration purposes.

**Table 3. Example Iron Release Data**

	[Cl-]	[S042-]	[Na+]	[DO]	T	[Alk]	Pipe Len	Pipe Diam
Tampa	38	66	31.3	7.5	20	148	100	0.61
Blacksburg	13.83	7.02	9.35	9	20	100	100	0.61
Fort Drum (winter)	15	28	10.5	10	12.5	75	100	0.61
Fort Drum (summer)	15	28	10.5	9	20	75	100	0.61

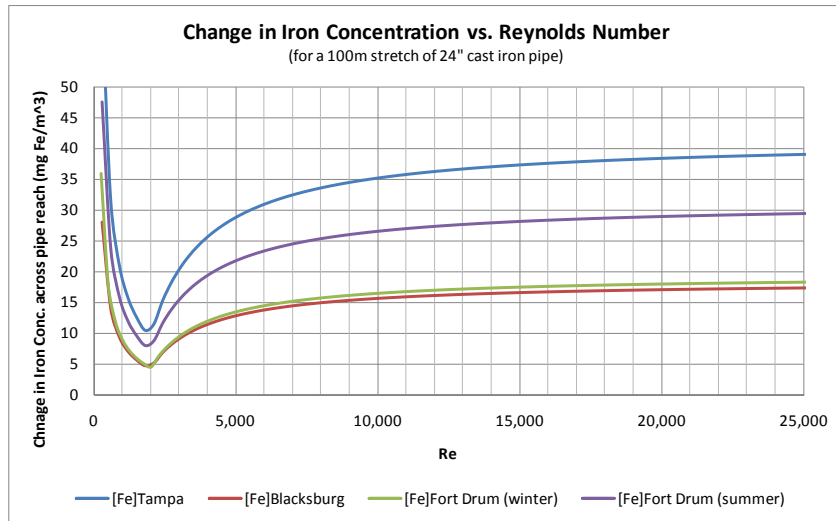

**Figure 22. Example data iron release concentration results for iron pipe.**

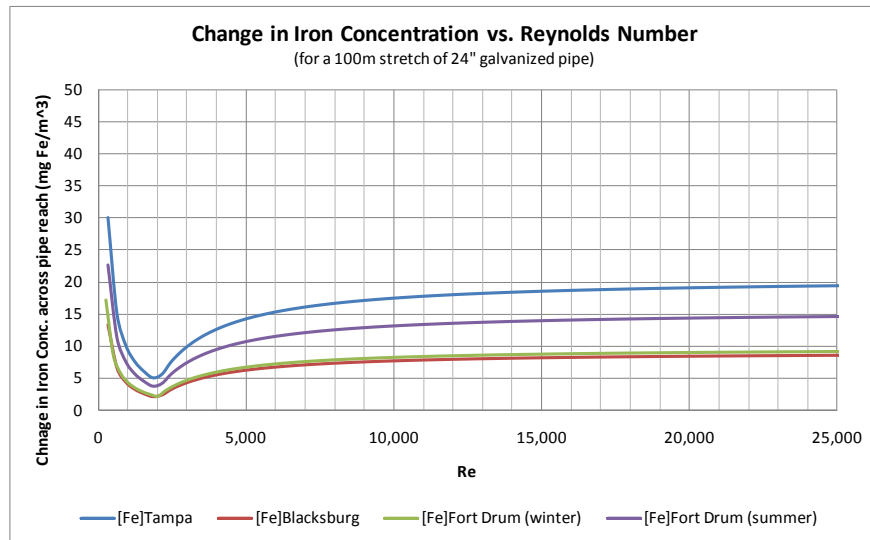

**Figure 23. Example data iron release concentration results for galvanized pipe.**

## Results Interface

The report, plot and display features used in Dew are specifically designed for use in model-based analysis for integrated system design, monitoring, control and operations management of critical infrastructure systems. As a result, many of the display features used in Dew are fundamentally different from the ones typically used in CAD and GIS based systems. The goal for the architecture used in Dew is to structure analysis and display as a natural extension of the topology and operation of the systems being modeled. Many of the fundamental display and data structure concepts used in GIS and CAD are patterned after the conventions used in drafting. This typically works well for modeling individual systems but leads to integration problems when used for analysis and control of multiple systems. The following sections describe how Dew's display features are used to structure reports and displays for water system analysis and real-time monitoring. The goal for this work was to produce standard water system analysis and display functionality that operates within the Dew framework, and is also fully interoperable with Dew modeling and analysis of other system types such as power, sewage and natural gas.

## Reports and Plots

Plot and variable display features for water system analysis are selected and controlled through the use of the Analysis Menu options, the user tool bar display control buttons, and mouse driven quick menus. Water system plot and display capabilities were developed using the Graphic User Interface (GUI) architecture currently used in Dew. This simplifies user specific tailoring and future development. Reports are generated as part of setting up and running analysis using application's setup dialogs. The setup dialogs for fluid flow and water quality are shown in Figures 13, 14, 16 and 17.

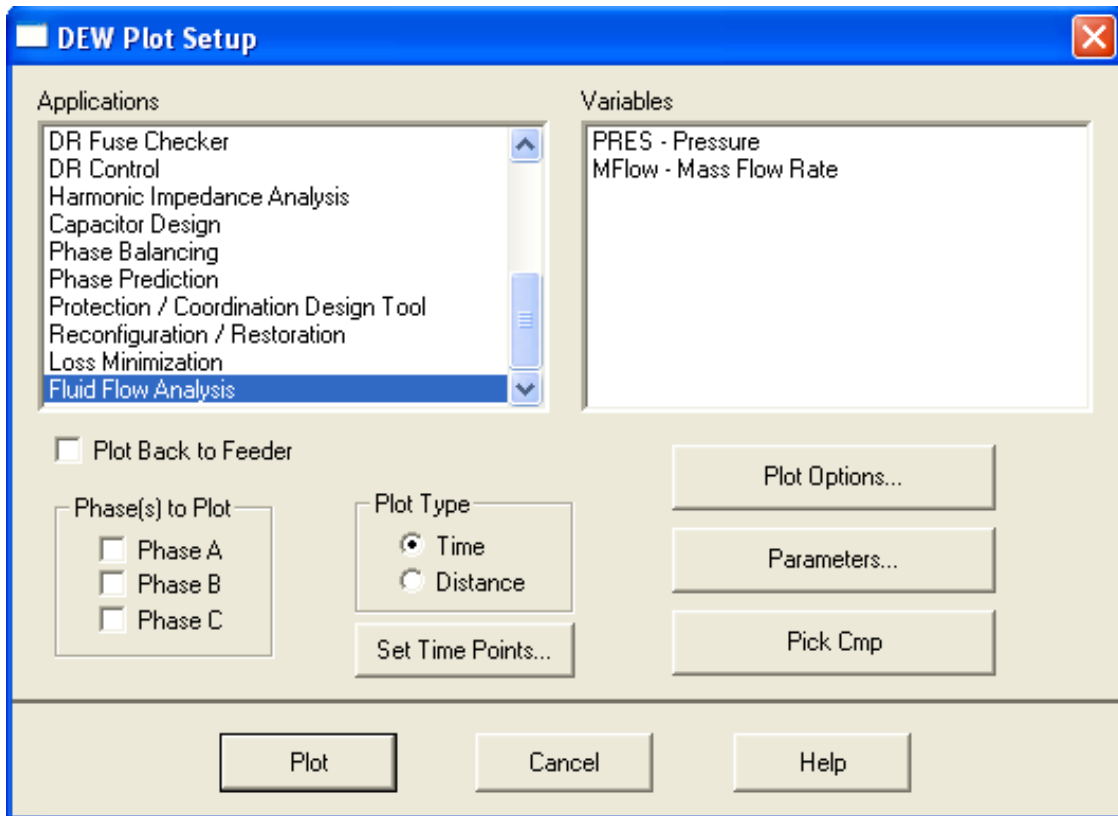

Figure 23. Plot setup dialog

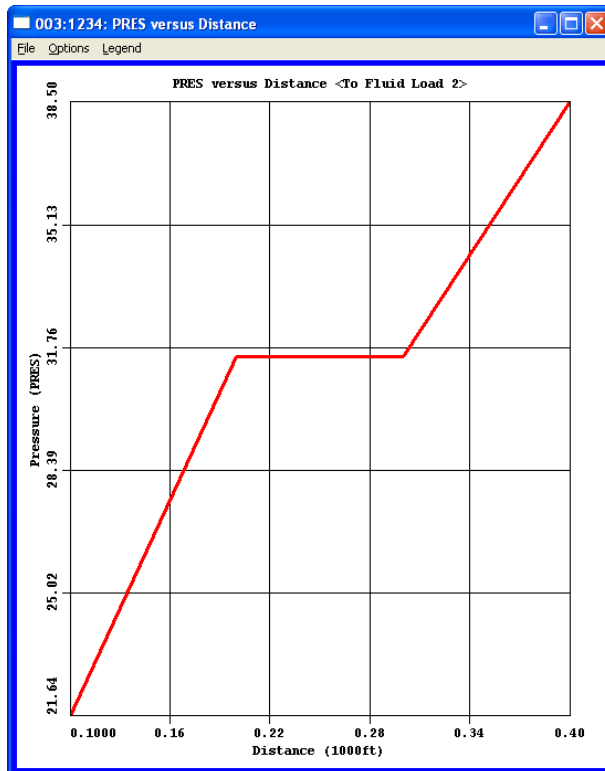

Figure 24. Example plot – pressure vs. distance back to source

## Variable Display and Range Display Setup

The standard dialogs for plot setup, variable display and variable range display are shown in figures 23 through 27. The main feature for these dialogs is the selection boxes for applications and variables. When a user selects an analysis application, the available member variables that can be included in a plot or display are shown in the variables box. See Figures 23, 25 and 26. The applications and variables shown in these lists are set when Dew initializes. When first started, Dew searches through its dynamic-link library (dll) application folder to identify and register available applications. As part of this process applications declare the variables they offer for use by other applications. These variables are also available for plotting and visual display. This architecture simplifies tailoring for individual user preferences and also provides for future development. Removing a dll from the Dew application directory removes it and its member variables from the setup dialog options list. Figure 9 shows fluid flow pressure results colored for variable range display. Figure 27 shows variable range display being used to highlight pipe size.

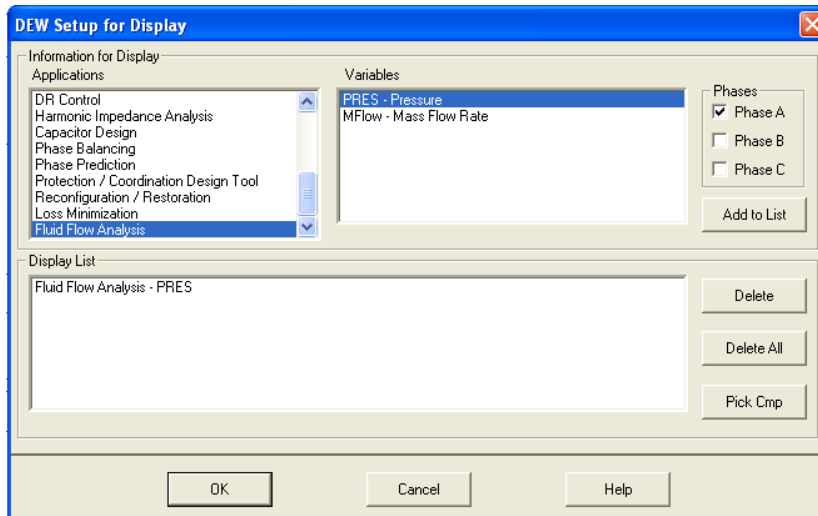

Figure 25. Variable display setup

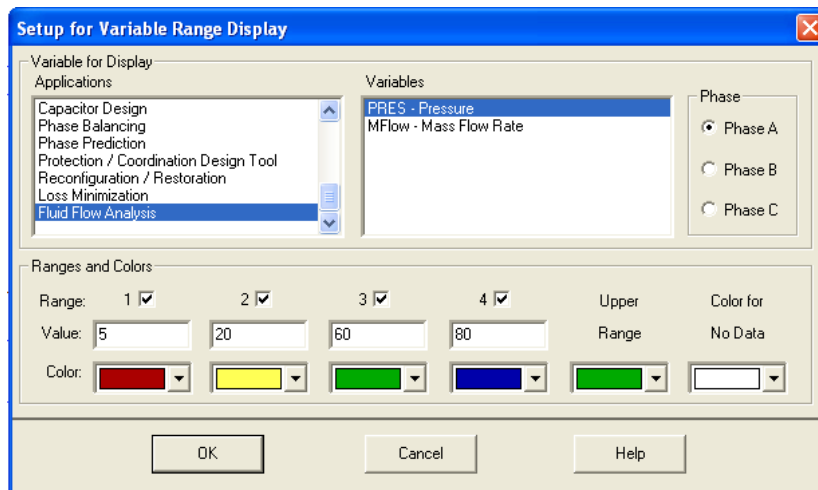

Figure 26. Variable display setup

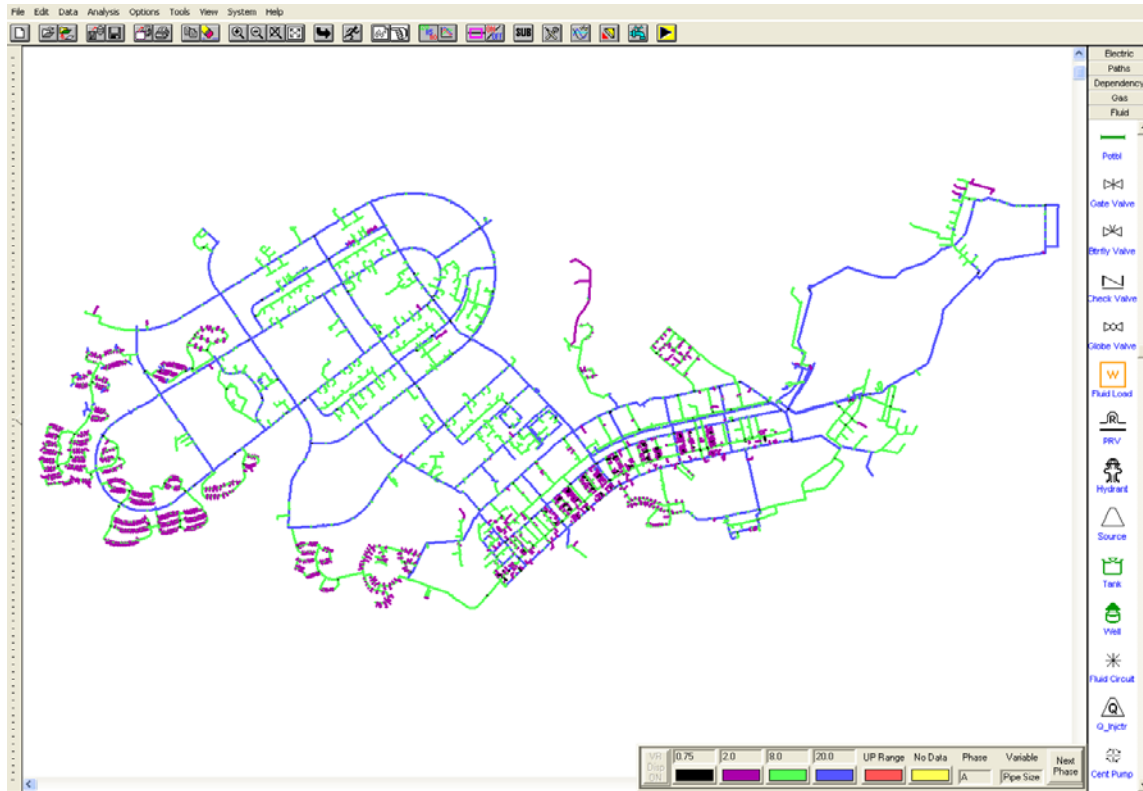

Figure 27. Variable range display used to show pipe size

## Dynamic Display Functionality

Dew provides dynamic display features that vary colors and symbols as a function of component status, display screen zoom level, system operating range level, and connectivity. These features are defined through a combination of symbol and color definitions specified in the database, display options set by users through mouse driven quick menus, and topology and physics based relationships that are automatically derived directly from the model using GTA-based functions. Component colors and symbols can be set to represent different attributes and conditions at different zoom levels. Zoom level set points for different views can be modified by the user. In the close in zoom range, the default view uses colors and symbols to depict component type and state.

## Component Type and State Display

Figure 28 shows a fluid line segment with four gate valves, each in a different state. Symbols and colors used for each component state can be custom defined in the database. A color for “loss of service” can also be assigned that will override other state coloration.

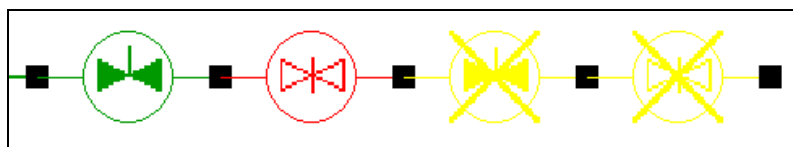
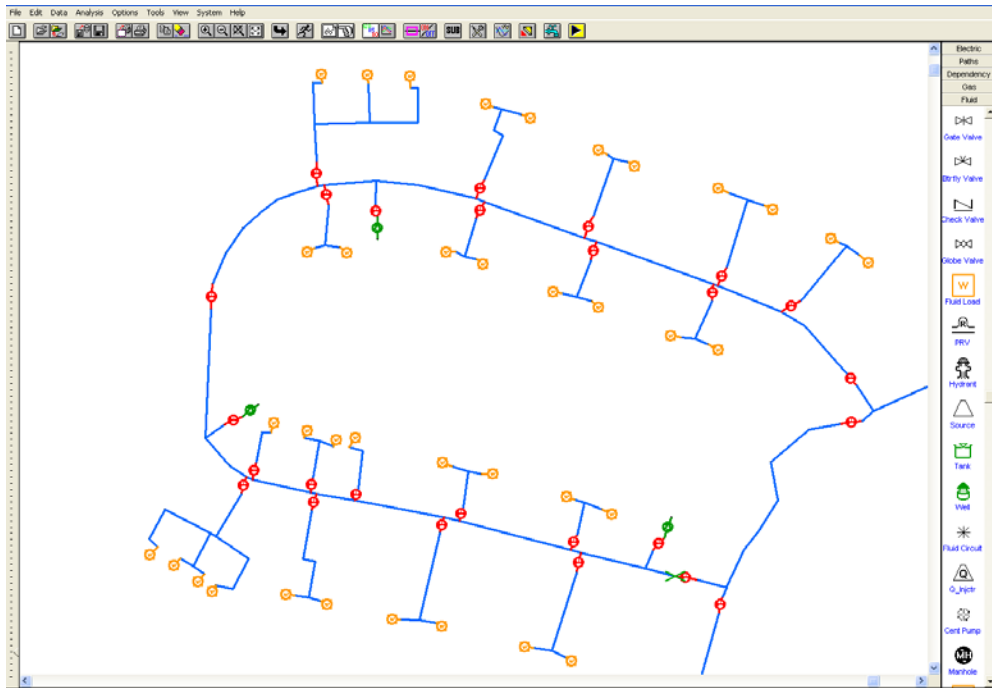

Figure 28. Valve state displays: Open, Closed, Open Failed and Closed Failed

## Variable Zoom Level Display

As the zoom level is increased, non-length components such as valves drop out of the view and only components with length, such as pipes are shown. As zoom level is increased further, coloring is changed to show connectivity by circuits or zones. Settings for each of these functions can be adjusted by the user. See Figures 29 and 30.



**Figure 29. Zoomed in – components colored by component type**

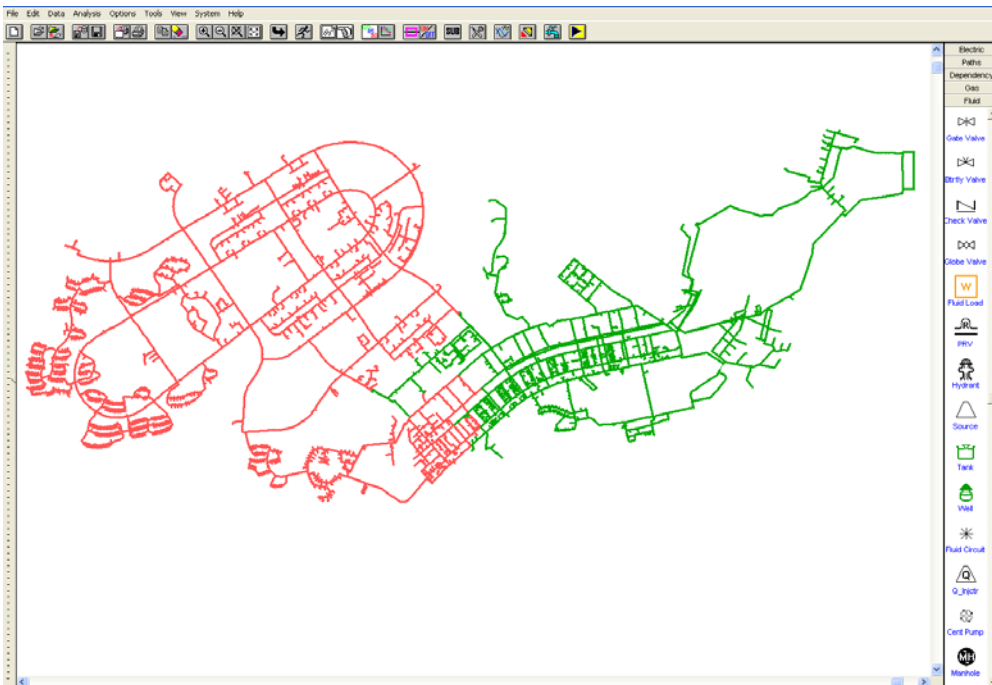

**Figure 30. Color by circuit or zone**



## Overview Zoom Window and Loss of Service Propagation

The overview zoom window can be used to show views on multiple screens at multiple zoom levels. See figure 31. By bringing up the overview zoom window a user can set a bounding box (shown in red) that then pans and zooms the main display window to the area marked within the bounding box. Sections that have lost service are highlighted in the overview window.

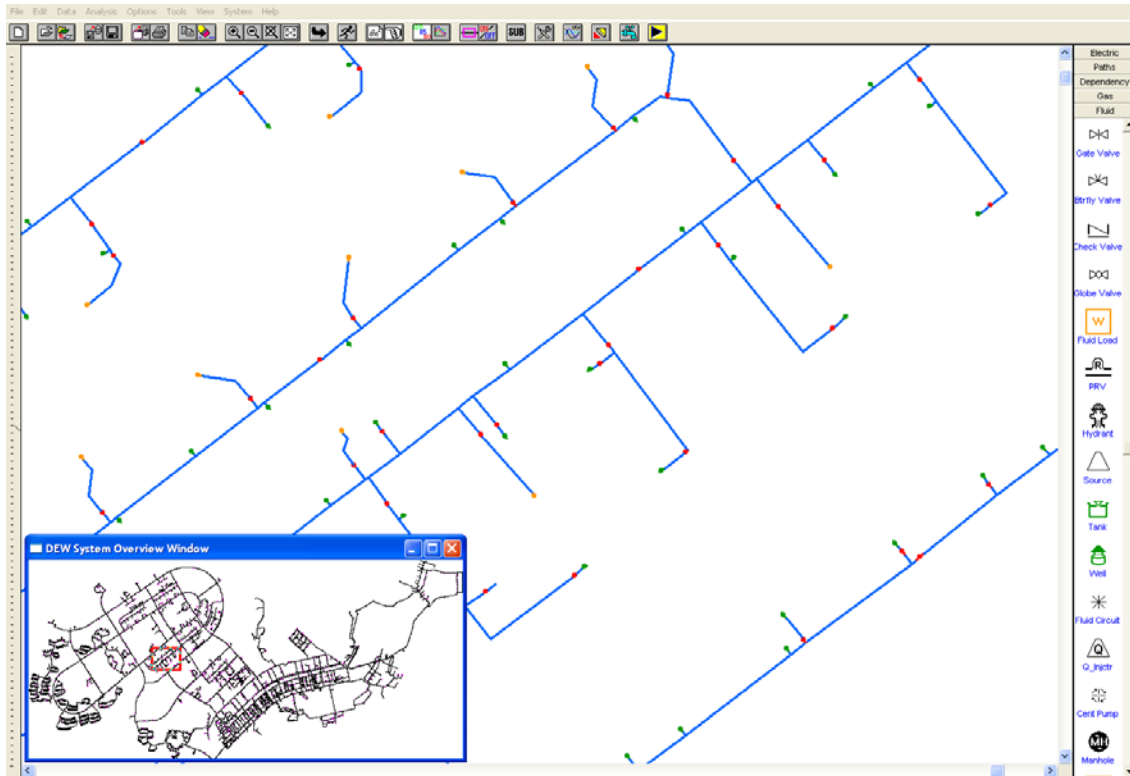

Figure 31. Coordinated multiple level views

## Automatic Calibration

Water distribution system models are usually calibrated manually against SCADA and manually collected measurements. Water system model flow and chlorine reaction calibration has also been done automatically using least squares optimization [19]. A problem with this approach is that it is difficult to map coefficient weights and uncertainties to actual system conditions and operation history. EDD has successfully used time sequenced based statistical load modeling and load scaling against real-time SCADA measurements for design and operations monitoring of power systems. EDD has also performed beginning research using a least squares approach with power system load statistics and found that additional research is required before this approach can be used to produce consistent results that closely match actual system conditions. Under this project, EDD began work to apply proven GTA based load scaling and calibration to Fort Drum's water system. The primary difference between doing this with water and power systems is that with water systems you have to deal with significant uncertainties in demand and pipe characteristics, both of which have a large affect on pressure, flow, chlorine decay and corrosion reactions. With power system, line characteristic can be

modeled to a much higher level of certainty using standard manufacturer information and construction details. Water system demands are also not typically modeled in as much detail as power system loads, but could be. Doing so would make it easier to use SCADA measurements to help estimate pipe characteristics and also monitor changes in pipe characteristics over time.

Scaling and calibration work that has been completed to date for this project includes development of a global demand scaling function that uses SCADA flow measurements at sources and tanks to automatically scale demand loads at building connections, and a resistance scaling factor that can be used manually to adjust pressure loss related factors that are automatically derived for each pipe using the material and size data stored in the database. Remaining development work includes making the resistance scaling factor automatic, adding a scaling factor for chlorine decay and testing other new calibration concepts such as the use of an automated trace function that divides the system into measurement segments bounded by specified measurement types, and a Measurement Matching Agent (MMA) that uses SCADA measurements, measurement segment boundaries and scaling factors to automatically track and refine scaling.

## **System Installation Steps and Observations**

The following section provides recommended steps for implementing the new system along with observations from implementation work performed at Fort Drum. Installation work can be divided up into three major parts: model building, defining SCADA to corrosion monitoring analysis system connectivity, and network security.

### **Model Building**

The amount of time and data correction required to build a new GTA model can vary greatly depending on system size, and the quality and quantity of system design and demand data available. GTA models are built with a one-to-one correspondence between the model and the real system and include service connections down to the level of individual buildings. This simplifies model use and validation because working with the model becomes much like working with the real system. GTA models are typically built using a combination of GIS data, engineering design specifications, inventory/capital investment data, manually entered information from engineering drawings and interviews with system operators. It is also common for data from multiple sources such as these to have a large number of errors and inconsistencies. Once a model is completed, it is typically the most complete and accurate single source documentation available for the system.

The preferred method for building a model is to extract attribute and arrangement data from GIS, run the GIS data through EDD's model builder application, and then check and refine the model using engineering drawings and by running analysis on the model. This was the method used for building the Fort Drum water system model.

### **Model Build Steps and Observations**

1. EDD obtained GIS drawings and data from GIS personnel. Water system GIS maps and data will typically require a significant amount of manual correction work to build the initial model. This is true for both government and civilian systems.

2. EDD used GIS data, drawings and EDD's model-builder application to build the model. If the data quality is not sufficient to support an automated build, the model can also be built by hand. Over the course of installation period work, Fort Drum's GIS personnel used feedback from EDD and work with a GIS contractor as part of work under a space contract, not related to model building work, to translate their GIS database over to Army mandated geospatial data standards. This resulted in a significant improvement in Fort Drum's GIS data for use in both mapping and for building models. Significant potential exists for coordinating Army GIS data standardization with GTA model build work. Additional information on Army GIS database standards and GTA model building can be found in reference [6].
3. EDD collected water demand data for large buildings from Fort Drum Engineering Planning. These were used to define static loads at service connections for these buildings. Demand estimates for smaller buildings were generated using area (ft<sup>2</sup>) data from Fort Drum's facility inventory data. Fort Drum is also working to develop water demand profiles by building type using metering. This data could be used in future work to develop time-series demand curves at major buildings. The static loads currently used in the model are being scaled manually to match daily average demand. Automatic time-series type model wide scaling based on flow measurements at sources will be implemented as part of remaining automated calibration development. Initial model testing performed in July 2009 showed that manual scaling combined with the use of static loads modeled down to individual building service connections is sufficient to produce usable corrosion monitoring data. The implementation of automated scaling and possible future building level demand curves should further improve results.
4. EDD ran the new model with historical SCADA data from January 2009 to July 2009 and used analysis results to refine and correct the model. Based on results, a significant amount of model correction and refinement can be performed remotely by a developer using historical SCADA data.
5. Fort Drum began running the model with live data again after a 6 month break in July. Based on experience with commercial utilities, this should result in further model refinement, and should also help facilitate cooperation and feedback between GIS and Operations personnel. Power utility operations personnel also use real-time GTA models to identify misalignment and installation problems, and to help monitor SCADA system operation by noting disagreements between the model, SCADA and personnel observation of the system. Similar results are expected for use of the real-time system with the water system.

### **SCADA System Live Interface Implementation Steps and Observations**

The SCADA interface is designed to be easy to use with multiple types of SCADA systems. During the course of implementation work, Fort Drum SCADA system interface requirements changed three times as the system was upgraded. The SCADA system is now scheduled to change again when Fort Drum expands its system further and changes system providers. As a result, the SCADA link for the corrosion monitoring system has become readily adaptable for use with different SCADA systems.

1. EDD surveyed SCADA system operation and documented measurement tag names and locations, database type used to aggregate and archive data, and collected a sample set of archived data.
2. EDD obtained an ODBC driver for the specific type of database used by the SCADA system. ODBC drivers are unique to each database supplier, but once installed provides standard interface capability. Database suppliers typically provide ODBC drivers free of charge.
3. EDD defined and installed a SCADA database system connection configuration text file. Both the real-time interface and EDD SCADA simulator automatically look in a user designated directory for available connection configuration files, which the user can then select from. This allows the user to maintain model and configuration files together.

### **Engineering Network Security Issues and Observations**

The corrosion monitoring analysis system is designed to be able to operate with ODBC compliant SCADA systems by connecting to the same engineering data network that the SCADA system uses to aggregate measurements and control signals. From preliminary review of best practice and DoD network security requirements, engineering data networks should be kept physically separate from IT networks, which is how Fort Drum's engineering data network is setup. If an engineering data network is interconnected with an IT network, then all of the security requirements that are applied to the IT network must also be applied to the engineering data network. This could result in significant problems with engineering analysis and control system software operation on the engineering data network because these systems are typically designed to operate like control systems, which can be very different from standard IT systems.

The general problems that result from the lack of engineering data network specific standard security requirements contributed to Fort Drum SCADA system installation delays. Because engineering network security requirements are not well defined for distribution level systems (in the power utility industry transmission level control is generally well defined and distribution level data communication security is not). The root cause for these problems appears to be closely related to the complexity of these systems, differences between engineering and IT systems, and the number of traditionally separate organization boundaries that these systems cross. These same general problems will most likely have significant negative impact on growing DoD efforts to improve utility system security, survivability and efficiency through the use of automation, and efforts to implement next generation systems such as micro grids and renewable energy sources.

### **Mode of Technology Transfer**

EDD provides its Dew software under free license to the government, academia and the utility industry. EDD charges for new development, consulting and support. When new applications become available through development support provided by one customer or group of customers, EDD then makes it available to other Dew license holders. This strategy has produced a growing network of leading research organizations and utilities that are both formally and informally collaborating through their use of Dew software.

The work being performed under this project fits well within this development and transition strategy, and should also naturally extend work performed under this project to commercial application where it can be further used, developed and refined through commercial investment. The reverse is also true for military application of current DOE and utility sponsored GTA development.

The specific plan for transitioning development work at Fort Drum is to work during the remaining testing portion of the project to get models and applications to the point where Fort Drum personnel use them as a regular part of day-to-day activities for both normal and emergency operations. As additional research and development opportunities present themselves EDD will be available for providing additional development, implementation and operation support. EDD will also be available for implementing and supporting use of Fort Drum development work at other DOD bases and facilities.

## Summary

This report discusses the development and initial testing of a new water distribution and corrosion monitoring system that uses EDD's multidiscipline Graph Trace Analysis (GTA) approach together with SCADA data to generate real-time "virtual" measurements for all components in the water system. The system then uses those measurements to generate corrosion indexes and measures that provide early indication of potential corrosion problems. Initial testing has been completed with satisfactory results and the system is now ready for extended period operational testing.

The use of EDD's approach provided the capability to coordinate this work with several other GTA model-based critical infrastructure system integrated design and control development projects. This included Army sponsored integrated power, water, gas and sewage system collaborative hazard management algorithm development, and real-time monitoring for supervisory control of integrated commercial power utility transmission and distribution systems. Many of the integrated analysis and data management issues critical to development of next generation water distribution system design, water quality and corrosion monitoring and security are very similar to the breakthrough technology issues that still need to be addressed to fully implement Navy all electric ship power system and reduced manning automation, Army micro-grid development, DOE smart grid and renewable energy development, and Homeland Security critical infrastructure analysis for disaster management.

The size and complexity of the critical infrastructure design and control problems makes developing standalone solutions problematic. The use of a unified approach such as GTA directly addresses this problem. Characteristics that make GTA well suited for collaborative use and development include:

- Uses a shared model for all analysis and operational functions
- Derives functional, spatial and temporal relationships directly from a shared model
- Performs design and control analysis in ways that naturally fits the problem domain
- Collaboratively structures steady-state, discrete event, and transient analysis across multiple system types
- Eliminates the need for manipulating large matrices
- Simplifies integration for multi-domain problems

- Reduces data collection and storage requirements
- Performs analysis fast enough to support real-time supervisory control of systems with millions of nodes and thousands of switching devices
- Naturally structures distributed processing

## Conclusions

Results show that GTA can be used to successfully build and operate a detailed water distribution system in real-time that provides relevant hydraulic, water quality and corrosion information in a way that works well as part of day-to-day system operations. Successful coordination of this work with other GTA-based development for design, monitoring and supervisory control of other systems offers significant potential for continued development and implementation of integrated critical infrastructure system analysis for design, operations management and control.

## Recommendations

In addition to completing final testing, pending Fort Drum completion of SCADA upgrades, EDD recommends that the Army consider:

1. Using the real-time monitoring work EDD has completed under this contract to implement real-time monitoring for Fort Drum's power, gas and sewage systems.
2. Development of a commercial grade Dew - GIS translation application that can be used keep the water system model current with GIS system updates. This same system could also be used to maintain Fort Drum's GTA-based power, gas and sewage system models that were developed under Army funded STTR research [6].
3. Use EDD's Dew software based commercial utility load estimation applications to develop detailed time-series water demand models at the building level [20]. Use of this software is included under the Dew free license agreement EDD is providing to the Army as part of this project. Working to define and validate time series demand loads for the water system will significantly improve real-time analysis scaling results by reducing uncertainty for flow estimates. Detailed demand modeling will also provide for new design analysis capability that the Army can use to evaluate infrastructure system expansion and emergency operation requirements.
4. Work to help define and generate multi-area interest between engineering and IT, at both local and support command levels to define engineering network related security problems and standardized solutions.

## References

1. Blackwell, W., "Mathematical Modeling of Physical Networks," The MacMillan Company, New York, 1968.
2. D. Musser, and A. Saini, "STL Tutorial and Reference Guide: C++ Programming with the Standard Template Library," Addison-Wesley, 1996.
3. Li, F. and R. Broadwater, "Distributed Algorithms with Theoretic Scalability Analysis of Radial and Looped Load Flows for Power Distribution Systems," Electric Power Systems Research 65 (2003), 169-177.

4. G. Booch, R. Maksimchuck, M. Engel, B. Young, J. Conallen, and K. Houston, "Object-Oriented Analysis and Design with Applications," Third Edition, Addison-Wesley, 2007.
5. B. McLaughlin, G. Pollice, and D. West, "Head First, Object-Oriented Analysis and Design," O'Reilly Media, Inc., 2007.
6. K. Russell, R. Broadwater. "Collaborative Tools for Integrated Hazard Management STTR A05-T026 Phase II Interim Report," completed for the U.S. Army Corps of Engineers – Engineer Research Development Center, Contract W9132T-06-C-0038, U.S. Army Construction Engineering Research Laboratory, 2008.
7. A. Sugg, R. Seguin, and C. Scirbona, "Three Utilities Implement Packaged Distribution System," *Transmission & Distribution World*, Sep 2002, pp. 52-58.
8. L. Feinauer, K. Russell and R. Broadwater, "Graph Trace Analysis and Generic Algorithms for Interdependent Reconfigurable System Design and Control," *Naval Engineers Journal*, Volume 120, Issue 1, 2008.
9. T. Walski, D. Chase, et al., "Haestad Methods, Advanced Water Distribution Modeling and Management," Haestad Press, Waterbury, Connecticut, 2004.
10. L. Rossman and B. Boulos, "Numerical methods for modeling water quality in distribution systems: A comparison." *Journal of Water Resources Planning and Management-Asce*, March-April 1996, Vol. 122, No. 2, 137-146.
11. National Risk Management Research Laboratory, Office of Research and Development, "EPANET 2 Users Manual," U.S. Environmental Protection Agency, Cincinnati, OH, Available from <http://www.epanet.com>.
12. McNeill, L. S. and M. Edwards, "Iron pipe corrosion in distribution systems." *Journal American Water Works Association*, 2001, Vol. 93, pp. 88-100.
13. S. A., Imran, J. D. Dietz, et al. "Modified Larson's Ratio Incorporating Temperature, Water Age, and Electroneutrality Effects on Red Water Release," *Journal of Environmental Engineering*, 2005, Vol. 131, No. 11, pp. 1514-1520.
14. AwwaRF and D. V.-T. Wasser, "Internal corrosion of water distribution systems," 1996, Denver, CO, The Foundation.
15. D. Langmuir, "Aqueous Environmental Geochemistry," Prentice-Hall, Inc., 1997.
16. G. Mutoti, "A Novel Model for the Prediction of Iron Release in Drinking Water Distribution Pipe Networks," Ph.D. Dissertation, Department of Civil and Environmental Engineering, University of Central Florida, 2003.
17. Ginasiyo Mutoti et al., "Development of a novel iron release flux model for distribution systems," *Journal of the American Water Works Association*, January 2007, Vol. 99, No. 1, p. 104.
18. S. Imran, J. Dietz, et al., "Red Water Release in Drinking Water Distribution Systems," *Journal American Water Works Association*, 2005, Vol. 97, No. 9, pp. 1514-1520.
19. Z. Kapelan, D. Savoc, and G. Walters, "Calibration of Water Distribution Hydraulic Models Using a Bayesian-Type Procedure," *Journal of Hydraulic Engineering, ASCE*, August 2007, p. 927.
20. R. Broadwater, A. Sargent, A. Yarali, H. Shaalan, and J. Nazarko, "Estimating Substation Peaks From Load Research Data," *IEEE Transactions on Power Delivery*, January 1997, Vol. 12, No. 1, pp. 451-456.

# REPORT DOCUMENTATION PAGE

*Form Approved*  
*OMB No. 0704-0188*

Public reporting burden for this collection of information is estimated to average 1 hour per response, including the time for reviewing instructions, searching existing data sources, gathering and maintaining the data needed, and completing and reviewing this collection of information. Send comments regarding this burden estimate or any other aspect of this collection of information, including suggestions for reducing this burden to Department of Defense, Washington Headquarters Services, Directorate for Information Operations and Reports (0704-0188), 1215 Jefferson Davis Highway, Suite 1204, Arlington, VA 22202-4302. Respondents should be aware that notwithstanding any other provision of law, no person shall be subject to any penalty for failing to comply with a collection of information if it does not display a currently valid OMB control number. **PLEASE DO NOT RETURN YOUR FORM TO THE ABOVE ADDRESS.**

<b>1. REPORT DATE (DD-MM-YYYY)</b> December 2016			<b>2. REPORT TYPE</b> Final Technical Report		<b>3. DATES COVERED (From - To)</b>	
<b>4. TITLE AND SUBTITLE</b> Demonstration of a Model-Based Technology for Monitoring Water Quality and Corrosion in Water-distribution systems: Final Report on Project F07-AR05					<b>5a. CONTRACT NUMBER</b> W9132T-06-D-001	
					<b>5b. GRANT NUMBER</b>	
					<b>5c. PROGRAM ELEMENT NUMBER</b> Corrosion Prevention and Control	
<b>6. AUTHOR(S)</b> Vicki L. Van Blaricum, Kevin Russell, and Robert Broadwater					<b>5d. PROJECT NUMBER</b> CPC F07-AR05	
					<b>5e. TASK NUMBER</b>	
					<b>5f. WORK UNIT NUMBER</b>	
<b>7. PERFORMING ORGANIZATION NAME(S) AND ADDRESS(ES)</b>  U.S. Army Engineer Research and Development Center Construction Engineering Research Laboratory P.O. Box 9005 Champaign, IL 61826-9005					<b>8. PERFORMING ORGANIZATION REPORT NUMBER</b>  ERDC/CERL TR-16-25	
<b>9. SPONSORING / MONITORING AGENCY NAME(S) AND ADDRESS(ES)</b>  Office of the Secretary of Defense (OUSD(AT&L)) 3090 Defense Pentagon Washington, DC 20301-3090					<b>10. SPONSOR/MONITOR'S ACRONYM(S)</b>  OSD	
					<b>11. SPONSOR/MONITOR'S REPORT NUMBER(S)</b>	
<b>12. DISTRIBUTION / AVAILABILITY STATEMENT</b>  Approved for public release; distribution is unlimited.						
<b>13. SUPPLEMENTARY NOTES</b>						
<b>14. ABSTRACT</b>  The objective of this project was to demonstrate an always-on, model-based monitoring technology for potable water-distribution systems. The technology uses near-real-time sensor data to estimate key water-quality parameters and corrosivity indices throughout the network so localized corrosion problems can be detected. Researchers successfully created a computerized model of the Fort Drum, NY, water-distribution system, but an unforeseen project-scheduling conflict with a major upgrade of the installation's Supervisory Control and Data Acquisition (SCADA) system prevented completion of the user interface between the model and sensors. The model was successfully tested offline, however, using archived sensor data. It estimated key water-quality parameters and corrosivity indices throughout the distribution system, but its accuracy was validated at only one location. The results were promising but did not return enough data to validate simulation accuracy or to conclude that real-time operation would be successful. Therefore, the demonstrated system cannot be recommended for implementation.  This report documents the modeling technology, creation of the Fort Drum model, the general sensor interface design, offline demonstration of the model, and results of evaluation against the project metrics. Lessons learned are documented and recent advances in similar technology are discussed.						
<b>15. SUBJECT TERMS</b>  Water quality; Water-Distribution; Water-Corrosion; Water chemistry; Water-pipes; Groundwater; Corrosion and anti-corrosives; Graph trace analysis; Remote monitoring						
<b>16. SECURITY CLASSIFICATION OF:</b>			<b>17. LIMITATION OF ABSTRACT</b>	<b>18. NUMBER OF PAGES</b>	<b>19a. NAME OF RESPONSIBLE PERSON</b>	
<b>a. REPORT</b> Unclassified	<b>b. ABSTRACT</b> Unclassified	<b>c. THIS PAGE</b> Unclassified			<b>19b. TELEPHONE NUMBER (include area code)</b>	