

FINAL REPORT

Limited Scope Design Study for Multi-Sensor Towbody

SERDP Project MR-2501

JUNE 2016

Dr. Kevin Williams
Tim McGinnis
Vern Miller
Ben Brand
Russ Light
University of Washington

Distribution Statement A

This document has been cleared for public release



Page Intentionally Left Blank

This report was prepared under contract to the Department of Defense Strategic Environmental Research and Development Program (SERDP). The publication of this report does not indicate endorsement by the Department of Defense, nor should the contents be construed as reflecting the official policy or position of the Department of Defense. Reference herein to any specific commercial product, process, or service by trade name, trademark, manufacturer, or otherwise, does not necessarily constitute or imply its endorsement, recommendation, or favoring by the Department of Defense.

Page Intentionally Left Blank

REPORT DOCUMENTATION PAGE

*Form Approved
OMB No. 0704-0188*

The public reporting burden for this collection of information is estimated to average 1 hour per response, including the time for reviewing instructions, searching existing data sources, gathering and maintaining the data needed, and completing and reviewing the collection of information. Send comments regarding this burden estimate or any other aspect of this collection of information, including suggestions for reducing the burden, to Department of Defense, Washington Headquarters Services, Directorate for Information Operations and Reports (0704-0188), 1215 Jefferson Davis Highway, Suite 1204, Arlington, VA 22202-4302. Respondents should be aware that notwithstanding any other provision of law, no person shall be subject to any penalty for failing to comply with a collection of information if it does not display a currently valid OMB control number.
PLEASE DO NOT RETURN YOUR FORM TO THE ABOVE ADDRESS.

1. REPORT DATE (DD-MM-YYYY) 21/07/2016		2. REPORT TYPE Final Report		3. DATES COVERED (From - To) July 2015 - July 2016	
4. TITLE AND SUBTITLE Limited Scope Design Study for Multi-Sensor Tow Body				5a. CONTRACT NUMBER W912HQ-15-P-0032	
				5b. GRANT NUMBER	
				5c. PROGRAM ELEMENT NUMBER	
6. AUTHOR(S) Dr. Kevin Williams University of Washington, Applied Physics Laboratory				5d. PROJECT NUMBER MR-2501	
				5e. TASK NUMBER	
				5f. WORK UNIT NUMBER	
7. PERFORMING ORGANIZATION NAME(S) AND ADDRESS(ES) UW-APL, 1013 NE 40th Street, Seattle, Washington 98105-6698				8. PERFORMING ORGANIZATION REPORT NUMBER	
9. SPONSORING/MONITORING AGENCY NAME(S) AND ADDRESS(ES) Strategic Environmental Research and Development Program 4800 Mark Center Drive Suite 17D03 Alexandria, VA 22350-3605				10. SPONSOR/MONITOR'S ACRONYM(S) SERDP	
				11. SPONSOR/MONITOR'S REPORT NUMBER(S)	
12. DISTRIBUTION/AVAILABILITY STATEMENT Approved for public release; distribution is unlimited.					
13. SUPPLEMENTARY NOTES N/A					
14. ABSTRACT Munitions, left behind from past military training and weapons testing activities, are present in shallow water (<50 m) at thousands of current and former Department of Defense (DoD) sites encompassing millions of acres. This design study addresses the munitions remediation in shallow water problem with a system that uses a Multi-Sensor Towbody (MuST) and surface vessel with support infrastructure. The hardware and software systems on the surface vessel leverage relatively low-cost, commercial off-the-shelf (COTS) components and reduce the number and complexity of expensive in-water components.					
15. SUBJECT TERMS N/A					
16. SECURITY CLASSIFICATION OF:			17. LIMITATION OF ABSTRACT	18. NUMBER OF PAGES	19a. NAME OF RESPONSIBLE PERSON
a. REPORT	b. ABSTRACT	c. THIS PAGE			Dr. Kevin Williams
U	U	U	UU	55	19b. TELEPHONE NUMBER (Include area code) 206-295-4108

Page Intentionally Left Blank

TABLE of CONTENTS

1.	MULTI-SENSOR TOWBODY OVERVIEW	4
1.1.	In-water components	5
1.1.1.	<i>FOCUS-3 towbody</i>	5
1.1.2.	<i>EdgeTech 2205</i>	9
1.1.3.	<i>EdgeTech eBOSS</i>	9
1.1.4.	<i>Sound speed sensor</i>	9
1.1.5.	<i>Doppler velocity log</i>	10
1.2.	Shipboard components	10
1.2.1.	<i>Navigation and positioning hardware</i>	10
1.2.2.	<i>Towbody handling hardware</i>	12
1.2.3.	<i>Sonar system displays and analysis stations</i>	15
1.3.	Operations	17
1.3.1.	<i>Ship capabilities</i>	17
1.3.2.	<i>Deck equipment</i>	17
1.3.3.	<i>Deployment and recovery</i>	18
1.3.4.	<i>Surveying</i>	19
1.4.	Addition of guest sensors	22
2.	POSSIBLE COMPONENTS FOR AN ENHANCED SYSTEM	24
2.1.	USBL	24
2.2.	Inertial measurement unit	24
3.	PLATFORM APPROACHES: TOWBODY vs. AUV	26
4.	APPENDIX A. MuST Requirements	27
4.1.	Vessel	27
4.1.1.	<i>Maximum sea state</i>	27
4.1.2.	<i>Speed/maneuverability</i>	27
4.1.3.	<i>Space requirements</i>	27
4.1.4.	<i>Deck equipment</i>	27
4.1.5.	<i>Vessel power supply</i>	27
4.1.6.	<i>Vessel positioning</i>	27
4.1.7.	<i>Vessel heading/attitude</i>	27
4.2.	Towbody	27
4.2.1.	<i>Environmental</i>	27
4.2.2.	<i>Towbody positioning/navigation</i>	28

4.2.3.	<i>Towbody heading/attitude</i>	28
4.2.4.	<i>Towbody motion sensing</i>	28
4.2.5.	<i>Towbody stability</i>	28
4.2.6.	<i>Towbody control</i>	28
4.3.	Sonar.....	28
4.3.1.	<i>Low frequency/high grazing angle/high bandwidth acoustic sonar</i>	28
4.3.2.	<i>High frequency/mid-to-low grazing angle sonar</i>	28
4.4.	Geolocation of munitions	29
4.5.	Guest sensors.....	29
5.	APPENDIX B. MuST Specifications	30
5.1.	Vessel	30
5.1.1.	<i>Vessel power supply</i>	30
5.1.2.	<i>Vessel positioning</i>	30
5.1.3.	<i>Vessel heading/attitude</i>	30
5.2.	Towbody.....	30
5.2.1.	<i>Environmental</i>	30
5.2.2.	<i>Towbody positioning/navigation</i>	30
5.2.3.	<i>Towbody heading/attitude</i>	30
5.2.4.	<i>Towbody motion sensing</i>	30
5.2.5.	<i>Towbody control</i>	31
5.3.	Towbody shipboard handling equipment.....	31
5.4.	Sonar.....	31
5.4.1.	<i>Low frequency/high grazing angle/high bandwidth acoustic sonar</i>	31
5.4.2.	<i>High frequency/mid-to-low grazing angle sonar</i>	31
5.5.	Geolocation of munition.....	31
5.6.	Guest sensors.....	31
6.	APPENDIX C. Supplemental Information	32
6.1.	Position error calculations.....	32
6.2.	Vendor quotes	34
6.3.	Vendor data sheets	40
7.	APPENDIX D. Example Munitions Remediation Survey Vessel.....	45
8.	APPENDIX E. Non-Recurring Engineering for Baseline Build and Test.....	46
8.1.	Sensor integration, control and monitoring software development	46
8.2.	Low-frequency processing and classification development.....	46
8.3.	Engineering tests	46

8.3.1.	<i>Acoustic test facility</i>	47
8.3.2.	<i>Salt water test tank</i>	47
8.3.3.	<i>Lake Washington and Puget Sound</i>	47
8.4.	<i>In-field demonstration</i>	48
8.4.1.	<i>Munitions placement</i>	48
8.4.2.	<i>Munitions operational tests</i>	48

LIST OF FIGURES

Figure 1.	Integrated 5-year plan.....	3
Figure 2.	MuST mechanical components	5
Figure 3.	MuST functional block diagram.....	6
Figure 4.	Hemisphere Vector VS330 GNSS and compass.....	11
Figure 5.	Rochester tow cable cross section	12
Figure 6.	Nexus multiplexer and shipboard control computer and console	13
Figure 7.	FOCUS-3 vehicle control and data display.....	14
Figure 8.	Main graphical display	14
Figure 9.	CORMAC Q4 stainless steel deck winch.....	15
Figure 10.	EdgeTech DISCOVER software main display screen	16
Figure 11.	Example of a block insert that has been machined for a 0.393-in cable	18
Figure 12.	FOCUS-3 vehicle positioned for deployment using an A-frame	18
Figure 13.	Tow cable routing to the tow arm on the vessel fantail.....	19
Figure 14.	EdgeTech eBOSS and EdgeTech 2205 1600-kHz sidescan sonar beam geometry and swath coverage	20
Figure 15.	Typical munitions remediation survey area	21
Figure 16.	NEXUS power supply block diagram	22
Figure 17.	NEXUS data telemetry system block diagram.....	23
Figure 18.	Submersible inertial measurement unit and Doppler velocity log	25
Figure 19.	Underwater vehicle position plot.....	25
Figure 20.	Tow vehicle position error estimate using heading and cable length.....	33
Figure 21.	Aerial photo of the PNNL Marine Sciences Laboratory	48
Figure 22.	Chart of Sequim Bay	49

LIST OF TABLES

Table 1. Hardware costs for towbody and AUV solutions	2
Table 2. Non-recurring engineering, testing, and demonstration activities and costs	2
Table 3. FOCUS-3 attitude and heading reference system (AHRS) specifications	7
Table 4. Inertial Labs motion reference unit (MRU) specifications	8
Table 5. FOCUS-3 pressure (depth) sensor specifications	8
Table 6. FOCUS-3 acoustic altimeter specifications	9
Table 7. Rochester tow cable specifications	13
Table 8. NEXUS multiplexer specifications	23
Table 9. Specifications for EvoLogics S2CR 48/78 USBL	24
Table 10. Sources of error in estimates of tow vehicle position	32

ACRONYMS

ATF	Acoustic test facility
AHRS	Attitude and heading reference system
AUV	Autonomous underwater vehicle
COTS	Commercial off-the-shelf
DCL	Detection-classification-localization
DoD	Department of Defense
DVL	Doppler velocity log
eBOSS	EdgeTech Buried Object Scanning System
ESTCP	Environmental Security Technology Certification Program
GIS	Geographical information system
GNSS	Global navigation satellite system
GPS	Global positioning system
IMU	Inertial motion unit
INS	Integrated navigation system
MMI	Man-machine interface
MRU	Motion reference unit
MSL	Marine Science Laboratory
MuST	Multi-Sensor Towbody
NRE	Non-recurring engineering
PNNL	Pacific Northwest National Laboratory
RTK	Real-time kinematic
SBAS	Satellite-based augmentation system
SERDP	Strategic Environmental Research and Development Program
USBL	Ultra-short baseline
WAAS	Wide area augmentation system

ABSTRACT

Munitions, left behind from past military training and weapons testing activities, are present in shallow water (<50 m) at thousands of current and former Department of Defense (DoD) sites encompassing millions of acres. The Strategic Environmental Research and Development Program (SERDP) and Environmental Security Technology Certification Program (ESTCP) are focused on the development of sensors, systems, and platforms to remediate this munitions problem. These programs must determine how to invest their limited resources to improve the DoD's ability to address cleanup requirements and leverage past, present, and planned remediation initiatives by other organizations and research programs.

The U.S. Navy is engaged in similar research under its mine countermeasure programs. Though the sensors used are similar in Navy and non-Navy systems, the operational requirements differ. Time constraints and the requirement of covert operations drive Navy solutions toward autonomous underwater vehicles (AUVs) with automated target recognition to address the detection-classification-localization (DCL) problem. Though capable, the costs — acquisition, modification, operation, maintenance, and updates — for AUVs are not optimal for the remediation task. In addition, the personnel carrying out the remediation may not have the appropriate clearance or background to operate AUVs carrying U.S. Navy instrument packages.

This design study addresses the munitions remediation in shallow water problem with a system that uses a Multi-Sensor Towbody (MuST) and surface vessel with support infrastructure. The hardware and software systems on the surface vessel leverage relatively low-cost, commercial off-the-shelf (COTS) components and reduce the number and complexity of expensive in-water components. The design study started by developing a set of requirements including the mechanical envelope and candidate sensors for the towbody, support vessel systems (winch, tow cable, electronics, sensors), electrical power and data interfaces, and guest ports for instrument packages that can be hosted on the towbody. The initial focus for sensors in this study is on acoustic sources and receivers, but the longer-term goal is for “multi-modal” sensor packages (e.g., acoustics plus magnetics).

The baseline system that meets these requirements:

- FOCUS-3 towbody manufactured by MacArtney Underwater Technology
- Two sonar systems mounted on the FOCUS-3
 - Low-frequency, high-grazing angle, high-bandwidth acoustics system (EdgeTech Buried Object Scanning System — eBOSS)
 - High-frequency, mid-to-low-grazing angle side scan sonar (EdgeTech 2205)
- Shipboard handling system for the FOCUS-3
- Shipboard data acquisition and analysis hardware and software

Together, the EdgeTech sonars can image the top 1–2 m of the sediment with resolution voxels of 10 cm x 10 cm x 10 cm (eBOSS operating at 5–35 kHz) and image the sediment/water interface with sub-cm pixel resolution (2205 operating at 1600 kHz). The system also has power and data communications and auxiliary ports to add other sensor modalities.

Munitions remediation surveys can be completed at a rate of about 0.1 km²/h. Regions of interest are identified, logged during the survey, processed by classification algorithms, and made available to the operator in graphical displays, who makes initial classification and detection decisions. The MuST system uses a combination of in-water sensors and shipboard equipment and software to calculate the geo-referenced position of detected munitions on the seafloor. Future phases of the project may require greater munitions position accuracy; we present several optional underwater positioning techniques and equipment. The proposed MuST system provides near-term capabilities and has flexibility to accommodate integration of enhanced munitions position accuracy and classification techniques, equipment, and software.

The in-water and overall costs are less for the towbody solution presented here than for an AUV such as the industry standard REMUS 600 manufactured by Kongsberg (Table 1). Assessing in-water costs is important because of the significant risk (and replacement cost) for these assets during operation. Our conclusion is that the towbody solution is the best choice for munitions remediation in shallow water.

Table 1. Hardware costs for towbody and AUV solutions

Subsystem	In-Water Cost (\$)	Shipboard Cost (\$)	TOTAL (\$)
Towbody	321,185	202,775	523,960
AUV	950,000	250,000	1,200,000
Sonars (same for Towbody and AUV)	426,220	29,500	455,720

Hardware is not the only cost in building and testing a first-generation DCL system. The non-recurring engineering (NRE) costs needed to build, test, and demonstrate the towbody system presented here would be separated across three fiscal years to distribute costs over an achievable engineering timeline (Table 2).

Table 2. Non-recurring engineering, testing, and demonstration activities and costs

Year	NRE/Testing/Demo Costs (\$)	Primary Tasks and Activities
FY1	731,456	Procurement, define interfaces, begin construction
FY2	510,461	Finish system build, perform two 7-day engineering tests in Lake Washington and Puget Sound
FY3	691,877	Perform two 7-day operational demonstrations over a munitions field placed by Pacific Northwest National Laboratory in Sequim Bay

To incorporate magnetics into the towbody's operation, a secondary array displaced below and aft of the FOCUS-3 towbody would be added. MacArtney Underwater Technology has done this before and is currently doing so. We have discussed in some detail a concept put

forth by the Naval Surface Warfare Center to add a secondary array 3 m below the main towbody. MacArtney felt this was possible from a control standpoint and that heights of 1 m off the bottom for this secondary array are feasible. From an obstacle avoidance standpoint, a pre-mission sidescan survey will be needed whether or not magnetics is included to assure identification of structures that protrude into the water column. However, no-fly zones will become larger due to the reduced height when both magnetics and acoustics are in operation simultaneously. Furthermore, area coverage for a magnetics survey is less than an acoustics one; a combined acoustics/magnetics operation would require closer track line spacing and increase the time needed to cover an area of interest.

It is important to note that the present design study is part of an integrated 5-year plan (Figure 1). The plan, as envisioned, involves contemporaneous classifier development/testing and towbody design/construction/testing. The last 2 years of the 5-year plan will involve demonstration of the performance capability of the combined classifier/towbody system. Implementation of this plan is being funded by SERDP projects (Figure 1) and by a separate Office of Naval Research (ONR) effort, which is focused on the target response to sound and the subsequent classification, but not on methods to deploy sensors (e.g., implementation on a towbody). The ONR funding is similar to that of MR-2505 and includes funds for UNOLS ship time during the FY17 experiment (approximately \$450,000.00).

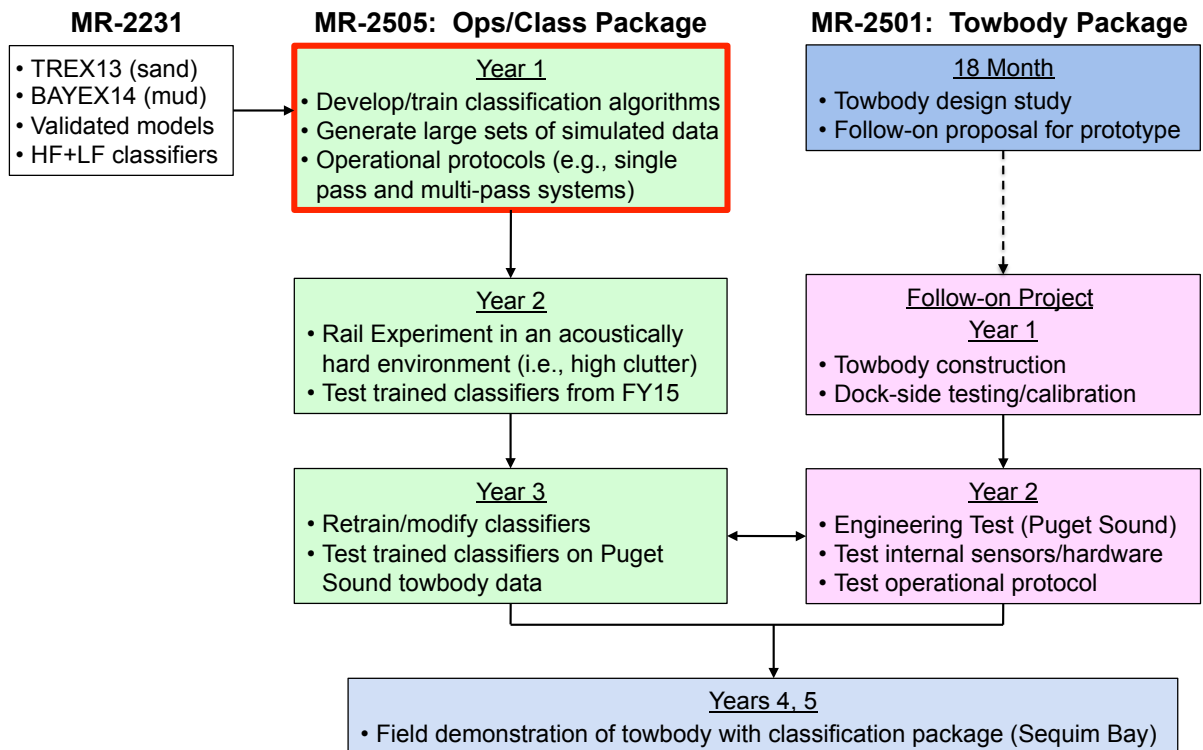

Figure 1. Integrated 5-year plan using results from previous field efforts (TREX13, BAYEX14) to develop classifiers, an experiment in a high-clutter environment to test and improve those classifiers, and a parallel towbody development effort followed by demonstrations of the combined classifier/towbody system.

1. MULTI-SENSOR TOWBODY OVERVIEW

The design philosophy for the Multi-Sensor Towbody (MuST) is based on the following concepts:

- Design using COTS components whenever possible to reduce design costs, and provide industry based replacement parts and support to enhance system longevity.
- Design using modular components so that the system can be supported by non-engineering staff in the field.
- Minimize weight, size, power needs, and complexity so the system can be hosted on a variety of vessels of opportunity.
- Use a tow cable that has copper conductors for power and fiber-optics for data. A fiber-optic data connection ensures current and future bandwidth requirements will be met to support a variety of high-bandwidth sensors (e.g., acoustics and video).
- Design a system that considers cost and capability with the goal of meeting initial construction and demonstration baseline needs that can also inform and integrate additional capability choices.

This design study developed a set of mechanical and functional requirements and specifications (Appendices A and B, Figures 2 and 3) including the mechanical envelope and candidate sensors for the towbody, support vessel systems (winch, tow cable, electronics, and sensors), electrical power and data interfaces, and guest ports for instrument packages that can be hosted on the towbody.

The baseline system specifications that meets these requirements:

- FOCUS-3 towbody manufactured by MacArtney Underwater Technology (Figure 2a)
- Two sonar systems mounted on the FOCUS-3 (Figure 2b)
 - Low-frequency, high-grazing angle, high-bandwidth acoustics system (EdgeTech Buried Object Scanning System — eBOSS)
 - High-frequency, mid-to-low-grazing angle side scan sonar (EdgeTech 2205)
- Shipboard handling system for the FOCUS-3 (Figure 2c and d)
- Shipboard data acquisition and analysis hardware and software

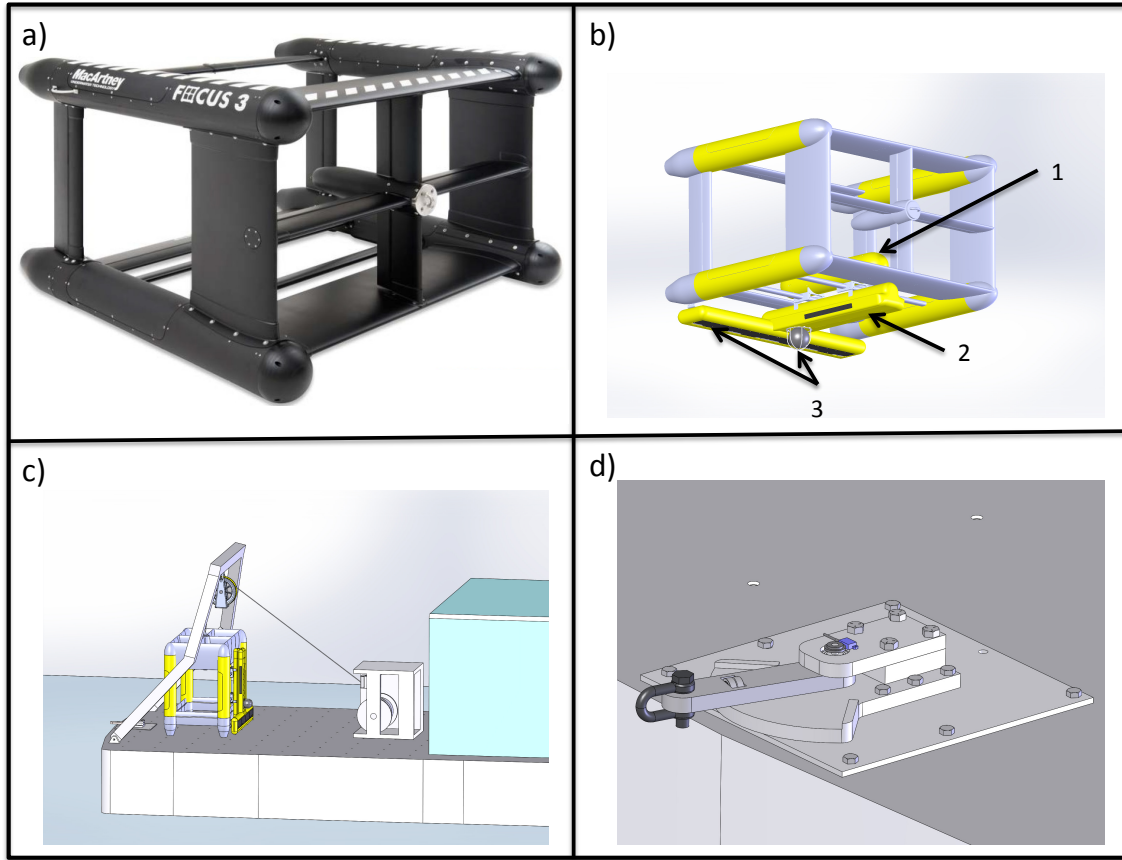

Figure 2. MuST mechanical components. a) FOCUS-3 towbody, b) towbody with EdgeTech eBOSS (3) and 2205 sonar (2) integration, c) towbody, vessel fantail, and winch layout for deployment and recovery operations, and d) tow point cable angle encoder.

1.1. In-water components

1.1.1. FOCUS-3 towbody (blue boxes 1, 4, 5, 6, and 9 in Figure 3)

The FOCUS-3 is the latest generation remotely operated towed vehicle in the FOCUS and TRIAXUS product line manufactured by MacArtney Underwater Technology. The FOCUS-3 has sufficient width (2 m) to mount the EdgeTech eBOSS receiving array without overhang (Figure 2b, labeled ‘3’)

The FOCUS-3 uses proven computer technology and fiber-optic telemetry for vehicle and sensor communication providing high-speed data acquisition and transfer capacity. A shipboard PC controls the vehicle based on inputs from the onboard vehicle sensors, according to a pre-programmed flight path. The tow cable is a small-diameter, low-drag electro-optical-mechanical cable that supplies power and transmits control data to the vehicle. Data generated by the onboard instrumentation and sensors are transmitted to the surface via the NEXUS fiber-optic multiplexer system (Figure 2b, labeled ‘1’). The tow cable and winch, with a combination electrical and fiber-optic slip ring, are used for towing operations. The towbody has integrated depth (pressure) and acoustic altimeter sensors as feedback to the control system. To obtain more accurate altitude, a separate sound speed sensor is needed.

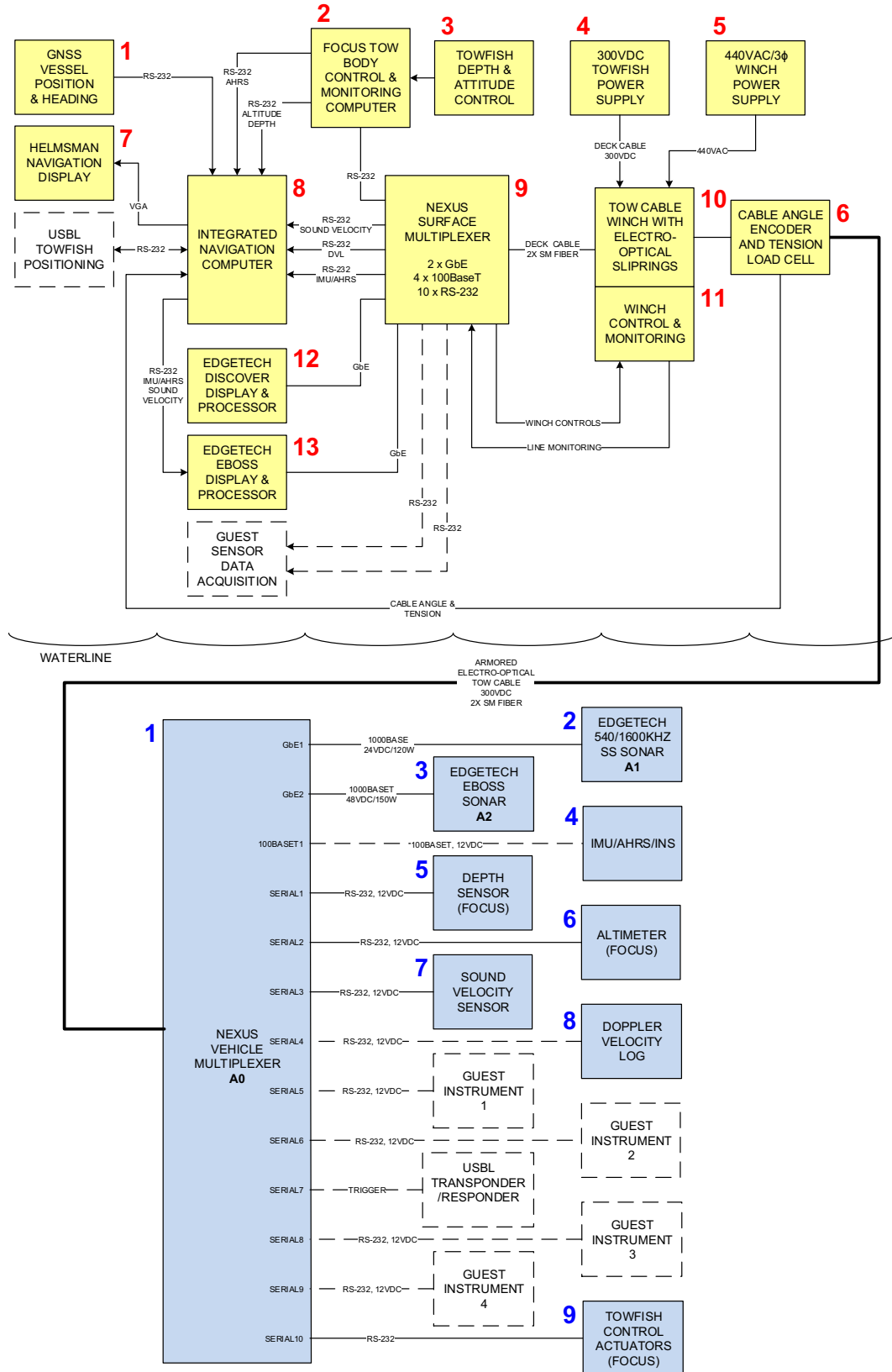

Figure 3. MuST functional block diagram of shipboard (yellow) and in-water (blue) components with optional components (dashed boxes and lines).

The system operates at up to 400 m depth at 5 kn with a controllable horizontal movement of +/- 80 m. The cable layback ratio is a function of tow speed and is approximately 1:4–1:5 for tow speeds of 3–4 kn. The man–machine interface (MMI) for the FOCUS-3 control console has a Windows operating system. MuST can carry a broad range of sensor packages, offering flexibility and future expansion.

FOCUS-3 towbody features:

- Steerable towed data collection
- Stable in all planes
- Operating depth of 400 m @ 5–6 kn
- High data transmission rates
- Software controlled vertical and horizontal steering functions
- Built-in standard control sensors
- User friendly controls and displays
- Modular rugged and streamlined design
- Low-noise magnetic and acoustic signatures
- High payload for peripheral equipment
- Quick-change custom buoyancy packs

The FOCUS-3 towbody includes an attitude and heading reference system (AHRS; Table 3) with a three-axis angular rate gyro, three-axis orthogonal accelerometers, and three-axis magnetometer. AHRS data can be output in a user specified format to an external computer from one of the serial ports on the surface console computer at a rate of 2 Hz.

Table 3. FOCUS-3 attitude and heading reference system (AHRS) specifications

Orientation range	360° full scale (FS)
Sensor ranges	
- Gyros	± 300°/s FS
- Accelerometers	± 5 G FS
- Magnetometers	± 1.2 Gauss FS
A/D resolution	16 bit
Accelerometer nonlinearity	0.2%
Accelerometer bias stability	0.010 G
Gyro nonlinearity	0.2%
Gyro bias stability	0.7°/s
Orientation resolution	< 0.1° minimum
Orientation accuracy	± 0.5° (static); ± 2.0° (dynamic)
Surface console output rate	2 Hz

An upgraded motion reference unit (MRU; Table 4) will supplement the standard FOCUS-3 AHRS to improve towbody motion control and geolocation.

Table 4. Inertial Labs motion reference unit (MRU) specifications

Heave units measurement range	$\pm 300^\circ$
Heave resolution	0.01 m
Heave accuracy, RMS	5% (0.05 m)
Pitch, roll range	$\pm 90^\circ, \pm 180^\circ$
Pitch and roll angular resolution	0.01°
Pitch and roll static accuracy	0.05°
Pitch and roll dynamic accuracy	0.08° RMS
Pitch and roll post-processing accuracy	0.03° RMS
Heading range	$0-360^\circ$
Heading angular resolution	0.01°
Heading static accuracy	0.3°
Heading dynamic accuracy	0.6° RMS
Heading post-processing accuracy	0.1° RMS
Timestamps accuracy	< 5 ms
Gyroscopes measurement range	$\pm 450^\circ/\text{s}$
Gyroscopes bias in-run stability	$1^\circ/\text{hr}$ RMS
Gyroscopes noise density	$0.004^\circ/\text{s} \sqrt{\text{Hz}}$
Accelerometers measurement range	± 8 G RMS
Accelerometers bias in-run stability	0.005 mG
Accelerometers noise density	0.015 mG $\sqrt{\text{Hz}}$
Magnetometers measurement range	± 1.6 Gauss
Magnetometers bias in-run stability	0.2 nT RMS
Magnetometers noise density, PSD	0.3 nT $\sqrt{\text{Hz}}$

The FOCUS-3 towbody integral pressure sensor (Table 5) calculates the vehicle's depth beneath the sea surface. Data can be output in a user specified format to an external computer from one of the serial ports on the surface console computer.

Table 5. FOCUS-3 pressure (depth) sensor specifications

Principle	Precision quartz crystal resonator
Range	0 – 700 m
Accuracy	0.005% FS, 3.5 cm
Resolution	0.005% FS, 3.5 cm
Temperature range	0°C to $+50^\circ\text{C}$

The FOCUS-3 towbody integral acoustic altimeter (Table 6) measures the vehicle's height above the seafloor using the two-way travel time of an acoustic pulse. The altitude calculation is a function of the local sound speed and the altitude calculation can be improved by using

measured sound data (we have chosen an AML Oceanographic sound speed measurement unit – Appendix C). Data can be output in a user specified format to an external computer from one of the serial ports on the surface console computer.

Table 6. FOCUS-3 acoustic altimeter specifications

Principle	Acoustic altimeter
Frequency	200 kHz
Range	0.6 – 50 m
Accuracy	< 0.5% FSD
Resolution	2 cm

1.1.2. EdgeTech 2205 (blue box 2 in Figure 3)

The EdgeTech 2205 is an unpackaged version of the 4125 side scan sonar system that allows the user to custom configure the electronics and acoustic arrays. This flexibility allows placement that maintains the best towbody control while minimizing the acoustic interference from the body itself. The 2205 provides high-resolution imagery (sub-cm pixels at 1600 kHz out to 35 m range). The 2205 operates at two frequencies: 600 kHz provides wide coverage during survey missions preceding the DCL effort; 1600 kHz is the default frequency and is ideally suited to examine the water/sediment interface for very small targets.

1.1.3. EdgeTech eBOSS (blue box 3 in Figure 3)

The EdgeTech eBOSS is a wideband sonar that generates multi-aspect imagery of buried, partially buried, and proud targets using an omnidirectional projector that transmits pulses in the 5–35-kHz band and hydrophone arrays mounted on the towbody that measure the backscattering from the seabed. Matched-filtered hydrophone data are coherently summed using time-delay focusing to form an image of the seabed. To improve target imagery resolution, time-delay focusing is extended to hydrophone data collected over several transmissions. With synthetic aperture processing, the along track resolution of target imagery improves with distance traveled while forming the synthetic aperture. The use of synthetic aperture processing also allows the along vehicle dimension of the array to be reduced, thereby reducing the hydrophone array drag and surface area and enabling the deployment of eBOSS on AUVs and towbodies.

The depths of seabed imaging depend on the sediment type. In sand, 1–2-m depths are possible, while in mud greater depths can be imaged because of reduced acoustic attenuation and the nearly matched sound speeds of mud and water. To date eBOSS processing has not included use of spectral information to classify targets, but our previous work gives us confidence that there is much to be gained by adding this to the processing chain.

1.1.4. Sound speed sensor (blue box 7 in Figure 3)

AML Oceanographic Micro-X is a real-time sound speed sensor with a field-swappable sensor head that contains embedded electronics where calibration coefficients are

stored. Sensor heads can be moved between instruments without impacting field accuracy. The Micro-X offers 25-Hz sampling, ensuring excellent data resolution.

In addition to the sound velocity sensor mounted on the towbody, a small profiling system will be included to allow an independent sound velocity profile to be made at the beginning and end of each survey day of operation. The HYPACK integrated navigation system software has an integrated CTD interface that reads the CTD data from multiple casts, grids the data, and interpolates water sound speed over space and time.

1.1.5. Doppler velocity log (blue box 8 in Figure 3)

An acoustic Doppler velocity log (DVL) is a hydro-acoustic device that measures the 3D velocity of a vehicle by using the Doppler effect of sound waves scattered back from the seafloor. The DVL contains 3–4 piezoelectric transducers that transmit and receive acoustic signals. The frequency shift of the received echo is proportional to the vehicle velocity. To measure 3D velocities, at least three transducers and acoustic beams are required. DVLs are available in a range of 300–3000 kHz.

DVLs can be used independently in dead reckoning scenarios or combined with inertial measurement units (section 2.2). Several manufacturers now build small DVLs that are easily mounted on a towbody. The Teledyne Explorer DVL is one example. It operates at 614 kHz and allows bottom tracking to at least 80 m, more than enough for the munitions remediation effort.

1.2. Shipboard components

1.2.1. Navigation and positioning hardware (yellow boxes 1, 6, 7, and 8 in Figure 3)

Navigation. There are a variety of navigation packages available in the industry today. We have previous experience with the HYPACK system and have chosen it for the MuST system. HYPACK has all of the tools necessary to perform munitions remediation surveys including designing a survey, exporting data to CAD, creating side scan mosaics, and creating/modifying electronic charts. The HYPACK SURVEY program accepts input from GPS, USBL, and other range-bearing systems, echo sounders, magnetometers, telemetry tide systems, and over 200 other sensors.

The HYPACK computer connects to all the navigation sensors and has the following functions:

- Acquire data from all navigation sensors
 - Vessel differential GPS
 - Cable angle encoder
 - Cable length monitor
 - USBL (if available)
 - Vehicle Doppler velocity log
 - Vehicle three-axis gyros
 - Vehicle three-axis accelerometers
- Use a Kalman filter algorithm to calculate an optimal vehicle position estimate
- Display the vessel and vehicle position

- Allow survey track lines to be generated and displayed
- Provide a helmsman monitor for the vessel operator
- Store all raw navigation data and calculate position estimates

HYPACK combines the *absolute* position estimates (GPS position of the vessel and ranges and bearing to the vehicle) with the *relative* velocity, motion, and attitude measurements from the sensors onboard the vehicle to calculate and estimate of the vehicle’s position using a Kalman filter or similar.

Vessel positioning. A global navigation satellite system (GNSS) will be used for the vessel positioning. GNSS is the standard generic term for satellite navigation systems that provide autonomous geo-spatial positioning with global coverage. This term includes the GPS, GLONASS, Galileo, Beidou, and other regional systems.

Real-time kinematic (RTK) satellite navigation is a technique used to enhance the precision of position data derived from satellite-based positioning systems. It uses measurements of the phase of the signal’s carrier wave, rather than the information content of the signal, and relies on a single reference station or interpolated virtual station to provide real-time corrections, resulting in centimeter-scale accuracy. RTK needs a base and receiver or a cell-link to a local virtual reference network. The Atlas service broadcasts corrections via L-band (satellite). The Wide Area Augmentation System (WAAS) [a satellite-based augmentation system (SBAS)] was developed to augment GPS, with the goal of improving its accuracy, integrity, and availability. It uses a network of ground-based reference stations in North America and Hawaii to measure small variations in GPS satellites’ signals in the Western Hemisphere.

To take advantage of RTK and WAAS, we have chosen the Hemisphere GNSS Vector VS330 dual antenna unit for position and heading (Figure 4). The Vector VS330 is RTK, Atlas L-band, and SBAS capable. Integrated gyro and tilt sensors deliver fast start-up times and provide heading updates during temporary loss of satellite communications. The Vector VS330 uses two antennas to determine the vessel heading; accuracy can be improved by increasing the separation distance between the two antennas.



Figure 4. Hemisphere Vector VS330 GNSS and compass

Towbody positioning. Underwater munition geolocation requires determining the position of the towbody relative to the vessel. One possible method is to use an ultra-short base line (USBL) system to determine towbody position relative to the vessel and then use the acoustic data acquired by the eBOSS and/or 2205 to determine the position of the munition to within 1 m (Appendix C). This method, however, would increase the capital cost and mobilization complexity of the system.

Another method uses the length of the tow cable, measured precisely with a line monitoring system, and a cable angle encoder on the deck-mounted cable tow point (Figure 2d) to geolocate the munition to within 3 m (Appendix C). The cable angle encoder system includes a processor that reads the cable angle, adds any correction for vessel heading, applies an additional correction for tow cable catenary shape (as needed), and uses that information with the cable length to calculate a range and bearing to the towbody. This information is converted to the same format as a USBL output data string, which also contains range and bearing information; these data can be read by a COTS navigation software system such as HYPACK. (Thus the baseline system does not include a USBL, but could as a future enhancement. See section 2.)

1.2.2. Towbody handling hardware (yellow boxes 2, 3, 4, 5, 9, 10, and 11 in Figure 3)

Tow cable. An electro-optical-mechanical armored cable is required to tow, power, and communicate with the FOCUS-3. The armored cable recommended by the towbody manufacturer is the Rochester tow cable (Figure 5 and Table 7).

The cable has two single-mode optical fibers that transmit towbody control and monitoring data, the engineering sensor data, and the controls and acoustic data to/from the sonars. The cable also has the conductors to transfer power. The cable optical and electrical core is embedded in two layers of high-strength galvanized steel armor wires that provide mechanical protection and the tensile strength to handle loads experienced during FOCUS-3 tow operations.

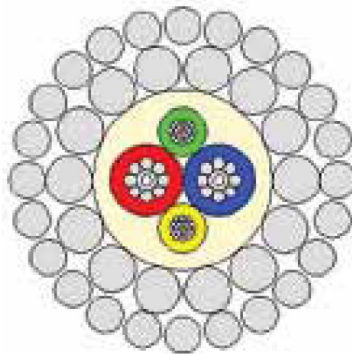

Figure 5. Rochester tow cable cross section. Red and blue, optical fibers; green and yellow, electrical conductors.

Table 7. Rochester tow cable specifications

Electrical conductors	2 x #18 AWG	
Optical fibers	2 x 8.3/125 μm single mode fibers	
Armor	Two layers high tensile strength steel	
Overall diameter	9.98 mm	0.393 in
Weight in air	382 kg/km	257 lb/kft
Weight in seawater	315 kg/km	212 lb/kft
Specific gravity (seawater)	5.7	
Breaking strength	71 kN	16,000 lbf
Working load	15 kN	3,400 lbf
Voltage rating	1200 V	
DC resistance	21.3 Ω/km	6.5 Ω/kft
Attenuation @ 1310 and 1550 nm	0.45 dB/km and 0.35 dB/km	

Surface multiplexer, towbody control and monitoring computer, depth and attitude control, and power supply. The FOCUS-3 control station (Figure 6) and system software include all functions necessary for vehicle control and data display (Figure 7). Data from the vehicle sensors, vessel navigation information system, and the winch are presented as text and graphics (Figure 8).



Figure 6. Nexus multiplexer and shipboard control computer and console

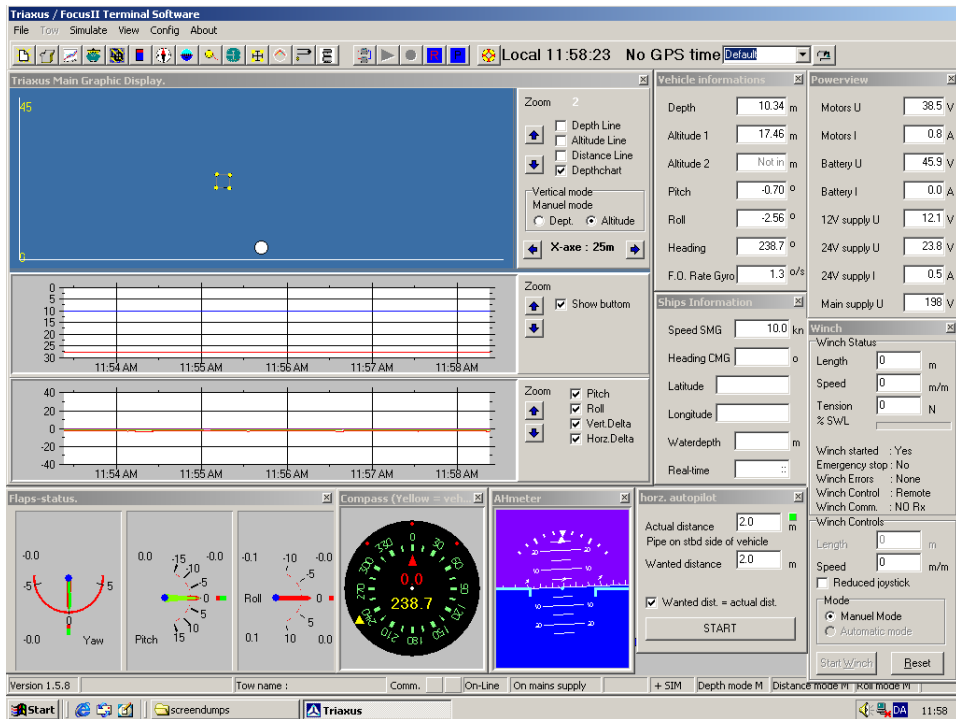

Figure 7. FOCUS-3 vehicle control and data display

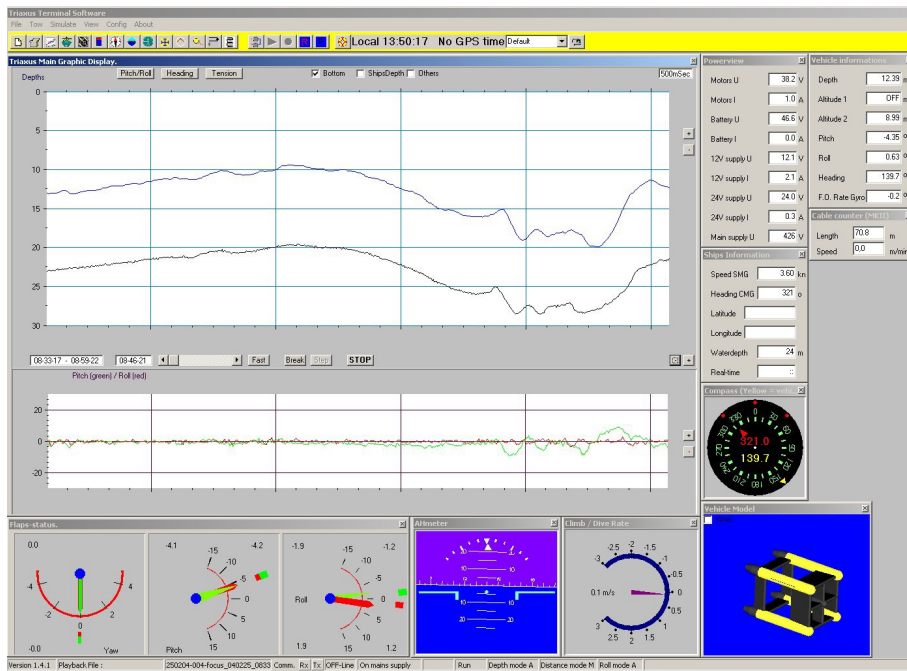

Figure 8. Main graphical display showing an example of the Auto Altitude mode. The blue line is the path of the FOCUS-3 vehicle and the black line is the seabed as determined by the vehicle altimeter and depth sensors.

Winch: Control, monitoring, and power supply. The MacArtney CORMAC Q4 stainless steel winch (Figure 9) is self-contained in a protective frame (1 m x 1.3 m x 1 m) and designed and engineered to require minimal maintenance. The CORMAC Q4 modular design accommodates a variety of tasks. Intelligent features include a soft-start function that makes the winch easy to handle, improves equipment maneuverability, and protects the motor and gear. The CORMAC Q4 winch is fitted with an electric-drive level wind to improve spooling performance, while easing changes in cable diameter. It can be configured to operate with a Focal model 180/206 electro-optical slip ring.



Figure 9. CORMAC Q4 stainless steel deck winch with protective frame (1 m x 1.3 m x 1 m)

1.2.3. Sonar system displays and analysis stations (yellow boxes 12 and 13 in Figure 3)

EdgeTech 2205. The EdgeTech 2200/2205 includes the DISCOVER side scan sonar acquisition and processing software as part of the system. DISCOVER is a modular software package compatible with many of EdgeTech's sonar systems. It serves as the sonar image processing, display, storage, and surface control station (Figure 10).

Raw data are received and recorded in EdgeTech native sonar file format (.jsf). The data can also be stored in eXtended triton format (.xtf) and on any device that is identified as a hard drive by the operating system. Data from any connected sensors are also logged. DISCOVER can be installed on any host PC for data replay. We anticipate installation in a Windows-based laptop with external hard drives.

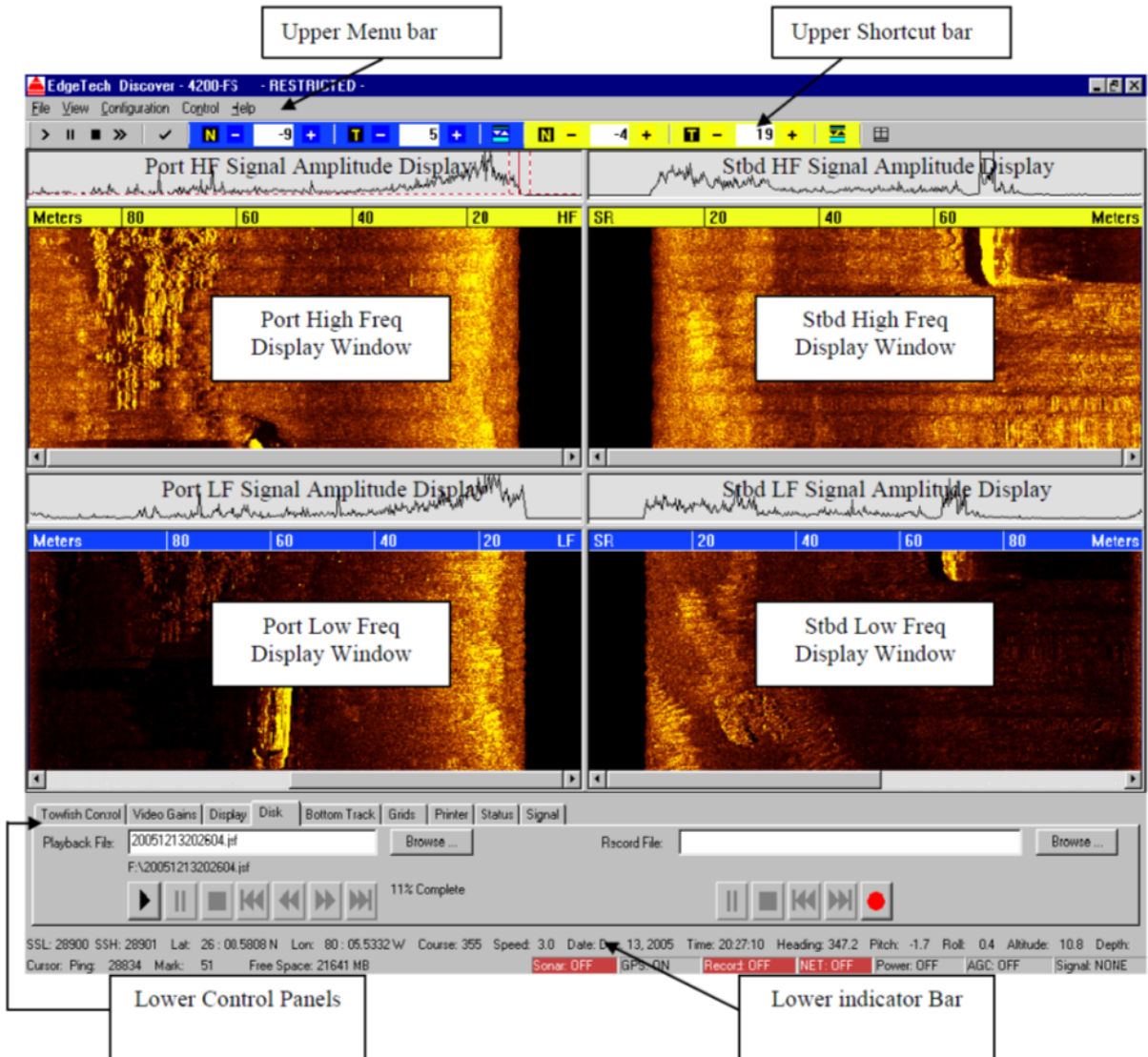

Figure 10. EdgeTech DISCOVER software main display screen

EdgeTech eBOSS. Real-time processing and display software for eBOSS is less developed than for the 2205 because it is a new product. An eBOSS external message set is sent to an eBOSS controller application. Controller behavior is defined by settings maintained in configuration files. The eBOSS controller application creates these configuration files from its local user interface upon operator command. These files specify how all data acquisition, processing, local display, and remote transmission occur. The application behaves in acquisition only mode or as a real-time processing and display package. The type of software required, beyond command and control, depends on how eBOSS interacts with other systems and its real-time mission.

There are multiple Matlab scripts available from EdgeTech to read and analyze eBOSS data files. However, we have planned for a significant NRE effort to augment the standard processing with that to perform frequency/angle analyses and to develop shipboard displays of them. Appendix E includes costs to initialize this effort but we anticipate separate SERDP

efforts as a necessity because integrating and expanding ongoing developments in shallow water munitions classification into eBOSS operations represents a significant effort.

1.3. Operations

The towbody system concept of operation is based on detection and classification of munitions in an area of one to several square kilometers in water depths of 6–40 m. Surveys in shallower depths could use the same sensors but on a surface tow system or alternative. The hardware could support operations in deeper water, but munition geolocation errors may increase.

The assumption is that the survey area has been examined to assure there are no in-water hazards to endanger towbody operations. An approximate area coverage rate of 0.1 km²/h is possible given a region with high sound speed sediments (where there is a critical grazing angle), a 4-kn vessel survey speed, a 5-m height above the bottom for the towbody, and a 15-m separation between survey track lines. The line separation is set by the need to operate above the critical grazing angle to obtain good acoustic penetration. For regions with low sound speed sediments (mud) the track line separations could be larger with a corresponding increase in the area coverage rate.

The classification of detected objects is not performed in real time. Regions of interest are identified, made available to the operator, and logged during the survey. All raw sonar data are recorded for later computer aided detection and classification using the logged information as a guide.

1.3.1. Ship capabilities

The FOCUS-3 tow vehicle may be deployed from a medium-sized vessel (50 ft) that has a minimum deck space of approximately 20 ft long x 12 ft wide to accommodate the tow vehicle and the CORMAC Q4 winch. The vessel must be equipped with an A-frame or a crane that is capable of launching the tow vehicle off the stern. The Applied Physics Laboratory's R/V *Jack Robertson* is an example of a vessel that is capable of deploying the FOCUS-3 tow vehicle (Appendix D).

1.3.2. Deck equipment

The vessel A-frame or crane must be capable of swinging 6000 lb from the deck to a position off the stern. The anticipated loads for launching the FOCUS-3 vehicle are less than 1000 lb but a 6:1 safety factor should be used with the A-frame or crane to allow for higher than anticipated loads during the survey operation. The lifting equipment must provide a minimum deck clearance of 10 ft between a block suspension point on the A-frame or crane and the deck at all positions of the rotation. The A-frame or crane must provide a minimum reach of 6 ft aft of the stern for clearance between the deck and the tow vehicle. The lifting equipment must also provide approximately 6 ft of forward rotation from the point where two of the FOCUS-3 vehicle's feet are resting on the deck to permit the vehicle to be positioned on its side for servicing.

A minimum 16-in diameter sheave is hung from the crane or A-frame. The sheave should utilize a polyurethane liner with a throat diameter of 0.412 in (to accommodate the 0.393-in

cable) and sufficient chamfer for cable retention during turning maneuvers when the towbody is not in line with the ship's heading. Figure 11 shows an example of a block insert that has been machined to meet the requirements for the 0.393-in cable used for this operation.

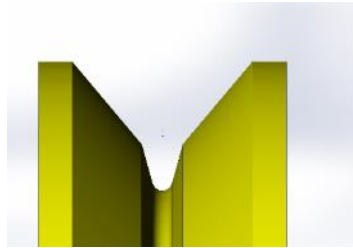

Figure 11. Example of a block insert that has been machined for a 0.393-in cable

1.3.3. Deployment and recovery

Prior to a deployment, the FOCUS-3 vehicle is positioned on its end tubes with the transducer side facing forward. A block is hung from the crane or the A-frame and the 0.393-in cable from the CORMAC Q4 winch is routed over the block and attached to the tow point on the vehicle (Figure 12).

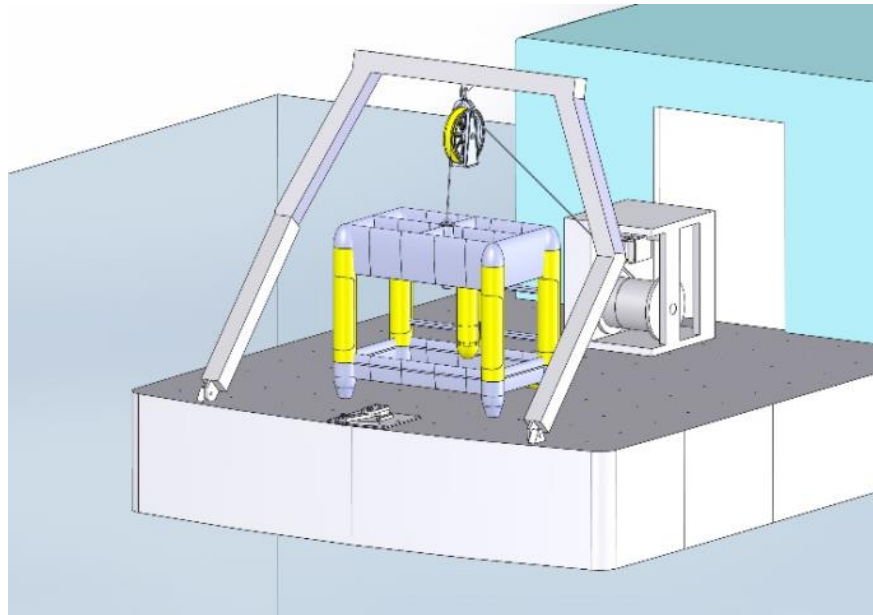

Figure 12. FOCUS-3 vehicle positioned for deployment using an A-frame

The vehicle is set in the water by simultaneously rotating the A-frame aft while controlling the height of the vehicle through pay-in or pay-out of the cable on the winch. A similar procedure is used when the vehicle is launched by crane, but because the crane is not positioned on the centerline of vessel, crane rotation will require that the block be repositioned continuously to keep the vehicle on the vessel's centerline.

The FOCUS-3 is slightly positively buoyant, so the vehicle will float once it is placed in the water. Because of the buoyancy and the flying characteristics of the vehicle, the vessel must

be under way during launch and recovery operations to create a drag on the vehicle and minimize the possibility that the vehicle may fly forward and impact the stern.

The cable on the winch is payed out until the vehicle reaches its desired position for a survey run, which is approximately 200 m aft of the vessel. At this point, a preformed wire cable grip is attached to the tow cable to secure it to the tow bar arm at the stern deck edge (Figure 13).

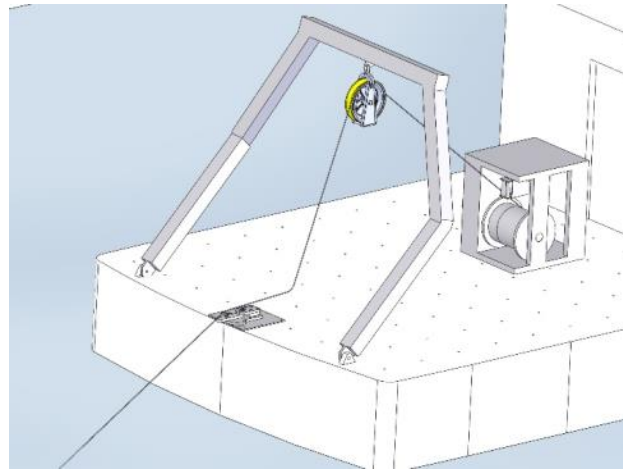

Figure 13. Tow cable routing to the tow arm on the vessel fantail

The recovery of the FOCUS-3 vehicle is a reverse of the procedures used during launch. The vessel must be under way during the recovery, because the vehicle may fly into the stern if there is insufficient drag to keep the vehicle aft.

1.3.4. Surveying

The shape of the survey area will define the path that the survey ship must follow and the efficiency of the operation. When the tow vehicle is operating at 35 m depth, it will be positioned approximately 220 m aft of the tow vessel for optimum vehicle stability. Assuming that the survey area is 1 nm square and the tow vessel follows a straight line (until the tow vessel leaves the area of interest) then the survey area will require approximately 0.5 nm of free space on both ends of the area to allow the vessel to turn with a 220-m streaming cable. Thus the total operational area will be 2 nm long by 1 nm (1850 m) wide.

During a survey run, it may be necessary for the vessel's speed to increase, decreasing the towbody depth and preventing contact with the seafloor. The survey vessel will depart from its straight heading and begin to turn approximately 0.14 miles after it leaves the square survey box. The turn will continue in a direction that allows the ship to pick up a track parallel to the previous one after the turn is complete. The vessel must be on its new straight line heading for a minimum distance of 0.28 miles after completing its turn and prior to entry into the survey box to provide sufficient towing distance for the towed body to once again follow the vessel's heading.

The survey commences once the tow vessel enters the area of interest. During a run, the position and heading of the vessel, the cable angle with respect to the ship, depth of the tow

vehicle, and cable length from the tow arm to the tow vehicle are recorded continuously. An absolute position and error estimate for the tow vehicle are calculated (Appendix C).

Track line spacing is determined by the coverage and desired overlap of the eBOSS sonar imagery. The critical acoustic grazing angle of the eBOSS sonar for sand is approximately 28°. For a nominal vehicle altitude of 5 m above the bottom, the coverage swath width is:

$$2 \times (5 \text{ m} / \tan 28^\circ) = 18.8 \text{ m}$$

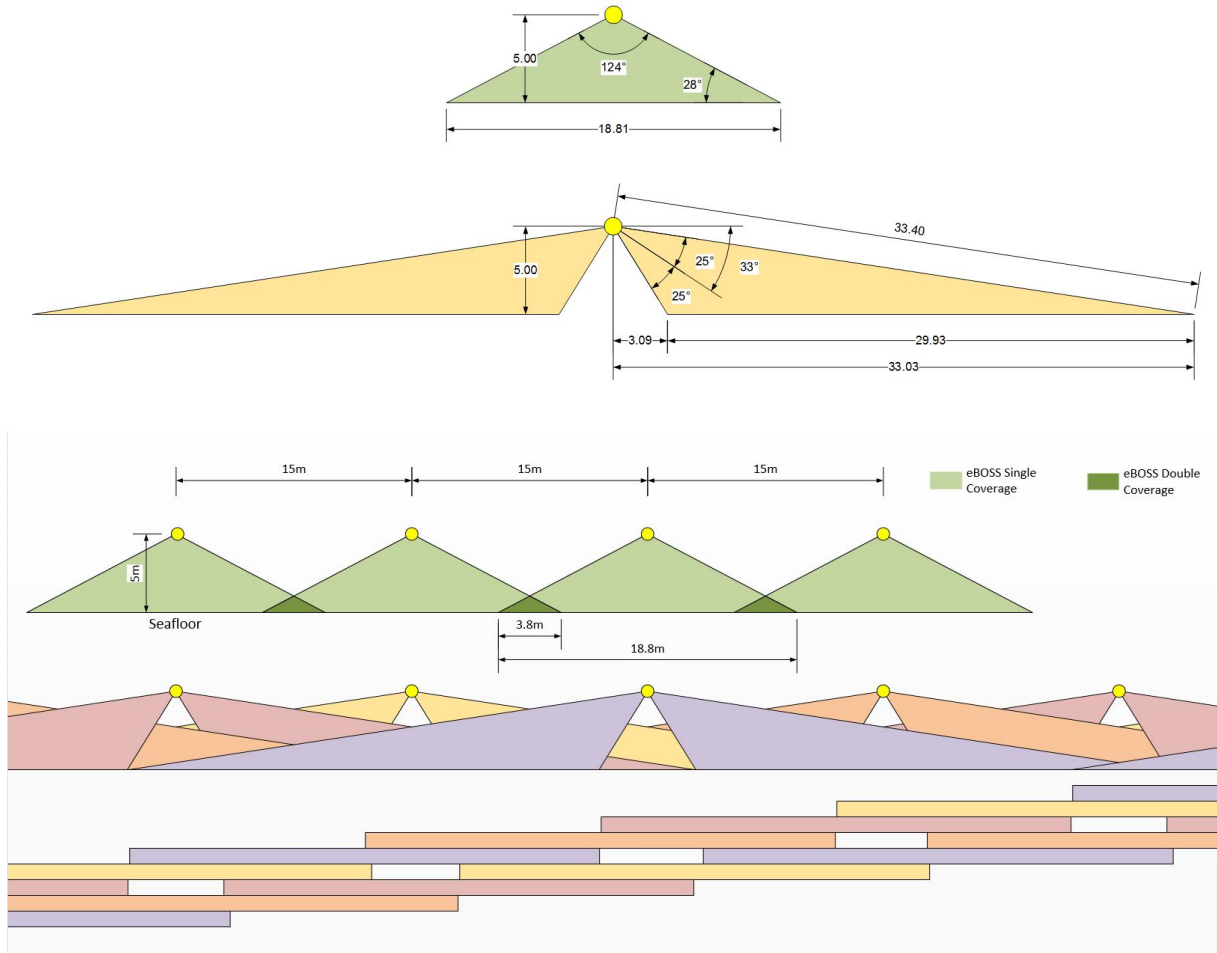

Figure 14. Top: EdgeTech eBOSS (green) and EdgeTech 2205 1600-kHz sidescan sonar (yellow) beam geometry. Bottom: Swath coverage of the EdgeTech eBOSS (125%) and EdgeTech 2205 1600-kHz sidescan sonar (400%) with 5-m altitude and 15-m track line spacing.

This assumes that eBOSS can cover 124° of cross-range angle. Manufacturer specification is >80°, but eBOSS currently uses omnidirectional sources and receivers and regularly makes images out to the critical angle. It is possible that a reduced angular width might be realized if the beamwidth of the source were to be reduced to improve overall calibration needed for more advanced processing (e.g., target strength as a function of angle and frequency). Assuming omnidirectional sources and receivers are used, a 124° grazing angle can be accessed.

With 15 m track line spacing, there is approximately 125% coverage for the eBOSS imagery, i.e., 3.8 m of overlap (Figure 14). Because the high-frequency side scan sonar does not provide good imagery directly below the towbody at nadir, it is important to have overlap of that seafloor area from adjacent track lines. With 15-m track line spacing and 35-m swath coverage (the sonar manufacturer estimates a 35-m range/70-m swath), the high-frequency side scan sonar has approximately 400% coverage (Figure 14).

A 1 nm² area for DCL operations requires 60–70 h of vessel time given the turning distance requirements and area coverage rates (Figure 15).

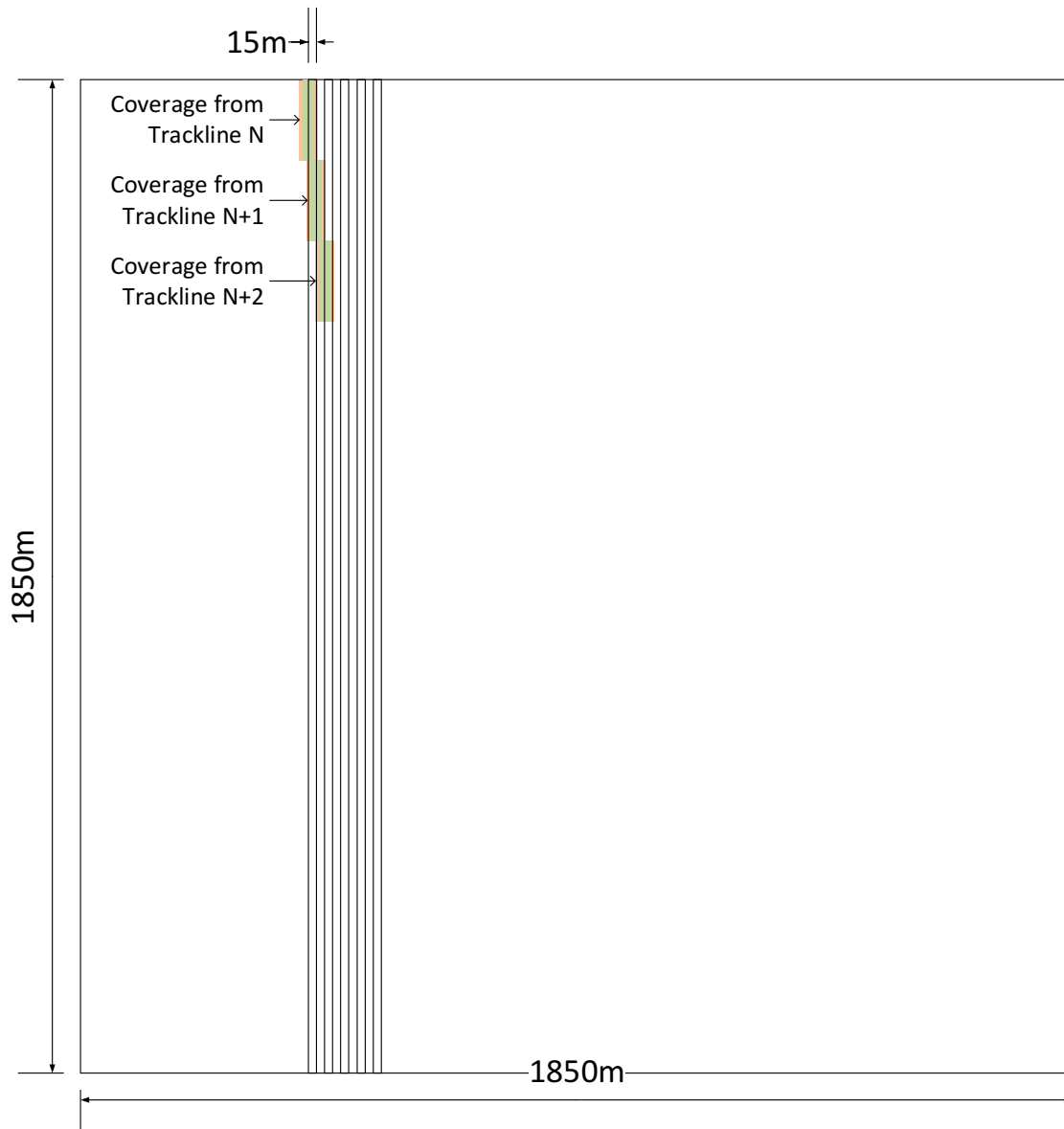

Figure 15. Typical munitions remediation survey area of 1 nm² (3.4 km²) with track lines spaced at 15 m.

1.4. Addition of guest sensors

The MacArtney NEXUS Data Telemetry System will be configured to provide sufficient power and data communications channels to power at least four additional guest sensors or instruments (Figure 16 and Table 8). The data communications channels (Figure 17) include 100BaseT Ethernet, RS-232, RS-485, and TTL trigger signals.

The shipboard 300-Vdc power supply provides power to the towbody via the electro-optical tow cable (Figure 16). The NEXUS power system in the towbody converts the 300 Vdc to lower voltages of 48 Vdc, 24 Vdc, and 12 Vdc for the towbody subsystems and the user payloads.

There are two 48-Vdc busses, one with a battery backup. In the event power loss, the data communications and the towbody control functions will continue to operate on battery power, mitigating the loss of towbody controls and the possibility of towbody impact with the seafloor. With the battery backup, all critical towbody instruments, controls, and data communications will continue to function and the operator can control the towbody to the surface for recovery and repair.

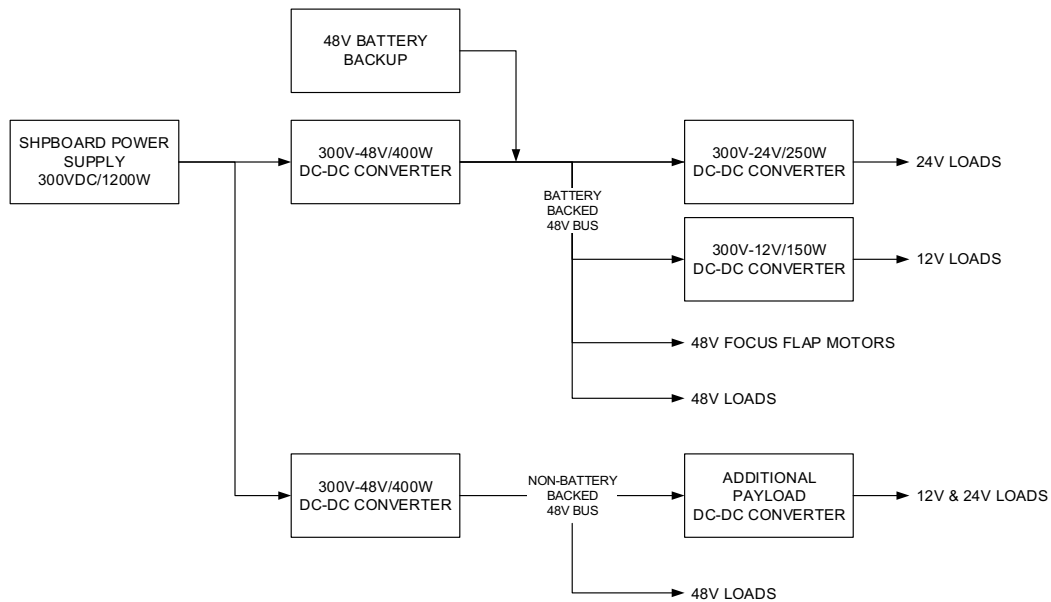

Figure 16. NEXUS power supply block diagram

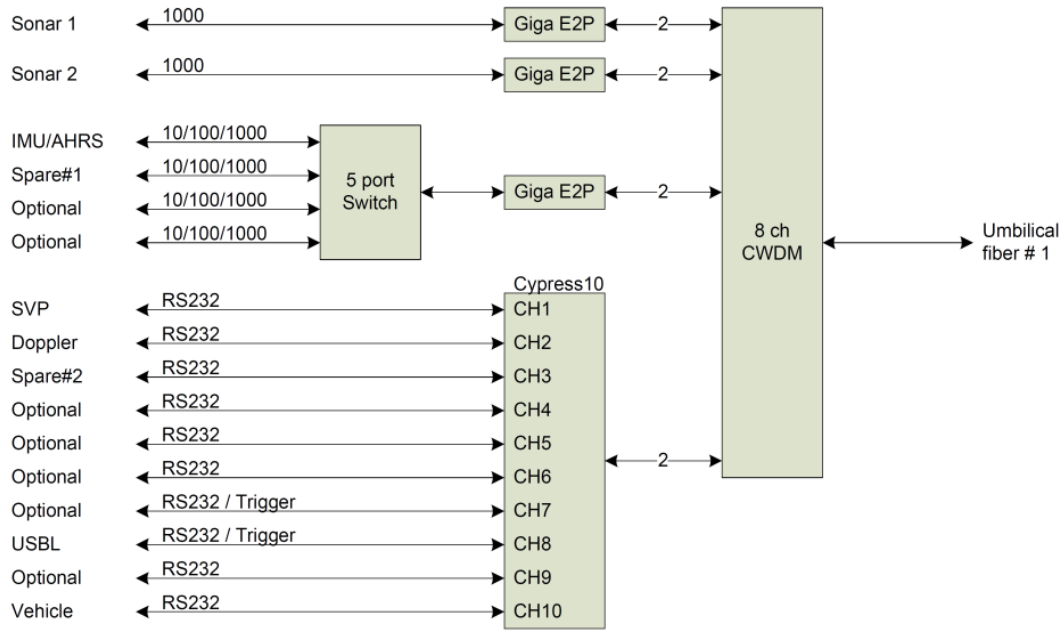

Figure 17. NEXUS data telemetry system block diagram

Table 8. NEXUS multiplexer specifications

Fiber-optic Telemetry	
Fiber type	Singlemode fiber – 9/125
Number of fibers	1
Number of optical wavelengths	8
Optical multiplexing	Coarse wave division multiplexing (CWDM)
Optical flux budget	>26 dB
Data Channels	
Gigabit Ethernet (1000BaseT)	3 channels
10/100/1000 BaseT	5 channels (uses 1 Gigabit Ethernet channel)
RS-232 ports	6
RS-232/485 ports	2
RS-232/485//TTL trigger ports	2
Leak sensors	1
Electrical	
Surface supply voltage	300 V nominal (250–425 Vdc)
Towbody output voltages	48/24/12 Vdc
Load power switching	2 x 48 Vdc, 10 x 24 Vdc, and 8 x 12 Vdc

2. POSSIBLE COMPONENTS FOR AN ENHANCED SYSTEM

It is our opinion that we will obtain adequate position accuracy to achieve the objectives of this phase of the munitions remediation project by using the vessel GPS, the tow cable angle indicator, and the FOCUS-3 AHRS, depth sensor, and altimeter.

Future phases of the project may require greater munitions position accuracy; there are several optional underwater positioning techniques and equipment that can be used to improve position accuracy.

2.1. USBL

Ultra-short baseline (USBL) is an underwater positioning technique that involves a transceiver mounted to the ship to measure the range and bearing to a transponder mounted on an underwater vehicle or platform. The range is determined by measuring the two-way travel time of an acoustic signal between the vessel and the vehicle and using the in-water sound speed to calculate the distance. The bearing can be determined by measuring the difference in phase between the received signal at multiple transducers in the transceiver. This allows the USBL system to determine a time-phase difference for each transducer and calculate the bearing of the arriving signal. USBL systems are used in water depths from less than 10 m to several thousand meters. Position uncertainties of less than 1 m at 500 m are available from several COTS systems (Appendix C). The EvoLogics S2CR 48/78 USBL (Table 9) would be appropriate for the MuST system because its operating frequencies are outside the band of the primary sonars.

Table 9. Specifications for EvoLogics S2CR 48/78 USBL

Operating depth	200 m
Range	1000 m
Frequency band	48–78 kHz
Range accuracy	0.01 m
Bearing accuracy	0.1°

2.2. Inertial measurement unit

An inertial measurement unit (IMU) typically contains three accelerometers, three magnetometers, and three gyros that measure the vessel's attitude, heading, and three-axis acceleration and rotation. There are several IMU manufacturers (Figure 18 shows an IMU and DVL). These systems are self-contained and have good short-term accuracy. Output can be combined with USBL and DVL information to enhance positioning (Figure 19). Sub-meter position accuracy can be achieved with a combined USBL and IMU system (Appendix C).



Figure 18. Submersible inertial measurement unit (left) and Doppler velocity log (right)

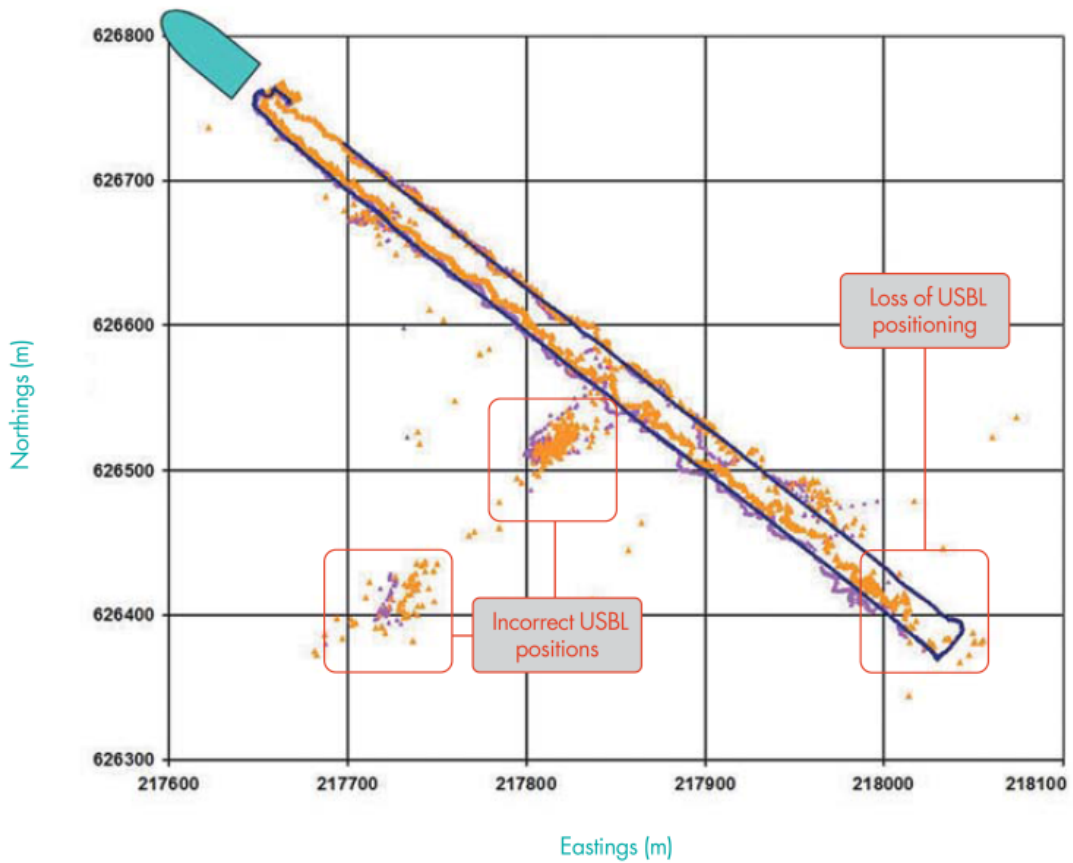

Figure 19. Underwater vehicle position plot. Yellow dots are USBL position fixes. Blue dots are Kalman filtered position estimates using USBL, DVL, and inertial navigation system data.

3. PLATFORM APPROACHES: TOWBODY vs. AUV

This design study is motivated by the hypothesis that towed systems are a viable and cost effective solution for wide area, shallow water munitions remediation surveys. A towbody system offers operational simplicity, 24/7 operational capability, strap on sensors with low integration cycles, surface based power and data handling, and lower in-water costs and risks.

An AUV vehicle with a payload capacity to handle the eBOSS and 2205 sonars would be similar to the REMUS 600 (Kongsberg) or the SeaCat (Atlas). These systems have an initial hardware investment of more than one million dollars, plus the cost of the sonar sensors (which is the same for towbody and AUV platforms), most of which represent in-water assets. Integrating the eBOSS sonar heightens risk, because obtaining high cross-range resolution requires incorporating wings on the AUV that can be damaged during deployment, operations, and recovery. Integrating both baseline sonar systems presented here and any future guest sensors into the AUV would require consideration of the buoyancy, space, power, and propulsion impacts (with the implied additional NRE for each sensor) to a greater degree than with a towbody.

Given our choice of a relatively large towbody and the housing of control, power, and data storage shipboard, the cost of incorporating new sensors for initial proof of concept tests are anticipated to be low. The chosen towbody requires no modifications to achieve cross-range extent. A towbody solution also allows immediate data access, as well as assessment and alteration of operational strategy as needed. Furthermore, much of the navigation efforts are handled shipboard with continuous access to GPS assets. Finally, the involvement of a man-in-loop for detection and classification tasks, though a concern in naval operations, is a real-time asset for munitions remediation efforts and again points to the utility of the towbody solution.

4. APPENDIX A. MuST Requirements

4.1. Vessel

4.1.1. *Maximum sea state*

Launch and recovery	Sea state 1–2
Survey operations	Sea state 2–3

4.1.2. *Speed/maneuverability*

Maximum speed	4 kn
Minimum speed	2 kn

4.1.3. *Space requirements*

Deck size	6 m x 4 m
Lab size	5 m x 5 m

4.1.4. *Deck equipment*

Crane reach	6 ft aft of stern, 8 ft forward of stern
Crane working load	6000 lb at defined crane reach
A-frame height	10 ft minimum over entire range of swing
A-frame width	12 ft
A-frame working load	6000 lb
Tow cable winch safe working load	7500 N

4.1.5. *Vessel power supply*

Winch voltage	208/240/480 VAC, 1/3 ph
Winch power	7.5 kW
Lab voltage	120 VAC
Lab current	20 A

4.1.6. *Vessel positioning*

Position accuracy	1 m
Position update rate	10 Hz

4.1.7. *Vessel heading/attitude*

Heading accuracy	0.2° RMS
Attitude accuracy	1° RMS

4.2. Towbody

4.2.1. *Environmental*

Minimum water depth	6 m
Maximum water depth	40 m
Altitude range	4–6 m

Altitude control error <0.5 m

4.2.2. Towbody positioning/navigation

Position accuracy 1 m
Depth accuracy 2 cm
Altitude accuracy 10 cm

4.2.3. Towbody heading/attitude

Heading accuracy 0.5°
Attitude accuracy 0.01°

4.2.4. Towbody motion sensing

Three-axis accelerometer accuracy 0.15 G
Three-axis gyro accuracy 2°/s

4.2.5. Towbody stability

Surge velocity ±0.2 m/s
Max ping-to-ping displacement 0.25 m
Sway velocity ±0.2 m/s
Heave velocity ±0.1 m/s
Crab angle ±20°
Yaw rate 1°/s
Static pitch offset ±5°
Nominal pitch offset 0°
Pitch rate 1°/s
Static roll offset ±2°
Nominal roll offset 0°
Roll rate 2°/s
Maximum altitude 30 m
Minimum altitude 4 m

4.2.6. Towbody control

Depth control active, by towbody depth sensor
Altitude control active, by towbody altimeter

4.3. Sonar

4.3.1. Low frequency/high grazing angle/high bandwidth acoustic sonar

Imaging voxel size 10 cm x 10 cm x 10 cm (or better)
Sediment penetration depth > 1 m

4.3.2. High frequency/mid-to-low grazing angle sonar

Imaging pixel size 1 cm x 1 cm

4.4. Geolocation of munitions

Absolute position error < 2 m

4.5. Guest sensors

Quantity	4
Power Interface	12 VDC, 24 VDC, 48 VDC
Data interface	100/1000BaseT or RS-232

5. APPENDIX B. MuST Specifications

5.1. Vessel

5.1.1. Vessel power supply

Winch voltage	208/240/480 VAC, 1/3 ph
Winch power	7.5 kW
Lab voltage	120 VAC
Lab current	20 A

5.1.2. Vessel positioning

Position accuracy	1 m
Position update rate	10 Hz

5.1.3. Vessel heading/attitude

Heading accuracy	0.2° RMS
Attitude accuracy	1° RMS

5.2. Towbody

Manufacturer	MacArtney
Model	FOCUS-3
Size	1.25 m (H) x 1.25 m (W) x 1.85 m (L)
Weight (air)	180 kg (with instrumentation)

5.2.1. Environmental

Minimum water depth	6 m
Maximum water depth	40 m
Altitude range	4–6 m
Altitude control error	<0.5 m

5.2.2. Towbody positioning/navigation

Position accuracy	1 m
Depth accuracy	2 cm
Altitude accuracy	10 cm

5.2.3. Towbody heading/attitude

Heading accuracy	0.5°
Attitude accuracy	0.01°

5.2.4. Towbody motion sensing

Three-axis accelerometer accuracy	0.15 G
Three-axis gyro accuracy	2°/s

5.2.5. *Towbody control*

Depth control	active, by towbody depth sensor
Altitude control	active, by towbody altimeter

5.3. **Towbody shipboard handling equipment**

Crane reach	6 ft aft of stern, 8 ft forward of stern
Crane working load	6000 lb at defined crane reach
A-frame height	10 ft minimum over entire range of swing
A-frame width	12 ft
A-frame working load	6000 lb
Tow cable winch safe working load	7500 N

5.4. **Sonar**

5.4.1. *Low frequency/high grazing angle/high bandwidth acoustic sonar*

Manufacturer	EdgeTech
Model	eBOSS
Frequency fange	5–35 kHz
Source/receiver beamwidths	> 80° at all frequencies
Source level	> 180 dB re 1 μ Pa
Receive sensitivity	> -170 dB re 1V/ μ Pa (with built-in preamp)
Imaging pixel size	10 cm x 10 cm x 10 cm (or better)
Sediment penetration depth	> 1 m

5.4.2. *High frequency/mid-to-low grazing angle sonar*

Manufacturer	EdgeTech
Model	2205
Frequency	1600 kHz
Source/receiver horiz beamwidth	< 0.25°
Source/receiver vert beamwidth	> 45°
Source level	> 220 dB re 1 μ Pa
Receive sensitivity	> -170 dB re 1V/ μ Pa (with built-in preamp)
Imaging pixel size	1 cm x 1 cm

5.5. **Geolocation of munition**

Absolute position error	< 3 m (tow cable angle indicator with 125 m of cable) < 1 m (if optional USBL, IMU, DVL added)
-------------------------	---

5.6. **Guest sensors**

Quantity	4
Power interface	12 VDC, 24 VDC, 48 VDC
Data interface	100/1000BaseT or RS-232

6. APPENDIX C. Supplemental Information

6.1. Position error calculations

The cable length and angle method to determine tow vehicle position uses an angular encoder to measure the angle of the tow cable and a line counter to measure its length. The accuracy of estimating the tow vehicle position by this method is determined by the accuracy of the angle and length measurements, the tow speed, tow vehicle depth, local currents, and the degree to which the tow cable shape deviates from a straight line.

Cable angle is measured by a Pepperl+Fuchs MNI40N magnetic incremental encoder that is part of the tow arm. A cable counter on the CORMAC Q4 winch measures the length of the tow cable. The tow vehicle depth is measured by a quartz pressure gauge in the FOCUS-3 vehicle. The error estimates shown in this study do not include the tow vehicle depth, as this component has minimal impact (6 mm error at 200 m range) on range calculation.

A large component of the error in the cable length and angle method as well as the USBL method relates to the position and heading of the ship. In this study, the Vector VS330 GNSS receiver was selected. The VS330 has 0.3-m position accuracy (GNSS) and 0.04° RMS heading accuracy with 2.0-m antenna separation. The sources of error and their effect upon the magnitude of the position error estimate are shown in Table 10 for tow cable lengths of 125 m and 220 m. Though there will likely be some degree of correlation between errors, Table 10 assumes complete correlation (worst case). If errors are assumed to be completely uncorrelated and random (and thus add in quadrature), the errors give at the bottom of Table 10 reduce from 3.99, 2.15, and 0.84 m to 2.4, 1.26, and 0.51 m, respectively.

Table 10. Sources of error in estimates of tow vehicle position at 2.0 m/s tow speed and 0.25 m/s cross currents

Source of Error	Error	Error for Cable Length/Angle Method (220 m)	Error for Cable Length/Angle Method (125 m)	Error USBL Tracking Method (220 m)
Angular Encoder Error	< 0.5 degrees	1.94	1.14	
Cable Position Uncertainty	By OrcaFlex	1.35	0.37	
Cable Length Uncertainty	<0.25 m	0.25	0.25	
Ship's GPS Position (GNSS) (RMS)	0.3 m	0.3	0.3	0.3
Ship's Heading (2 m Antenna) (RMS)	.04 degrees	0.15	0.09	0.15
USBL Slant Range Accuracy (RMS)	0.01 m			0.01
USBL Asimuth Resolution	0.1 degrees			0.38
POSITION ERROR ESTIMATE (meters)		3.99	2.15	0.84

The underlying assumption for the cable length and angle method is that the cable forms a straight line between the ship and the tow vehicle. In actuality, the cable arcs and the magnitude of the arc is determined by the weight of the tow cable, the tow speed, current conditions, and the drag of the tow vehicle. An increase in tow cable weight and currents increases the cable arc, while an increase in towing speed or tow vehicle drag decreases the

cable arc. As the arc of the tow cable increases, the error in the position estimate for the tow vehicle will increase. Ideally, to minimize the tow cable arc, tow speed is increased and tow cable length is decreased, but there are limits to these options. Increasing the velocity of the tow vehicle to greater than 2 m/s (4 kn) impacts the accuracy of the acoustic imaging and decreasing the cable length to less than 200 m increases the transmission of vessel motion to the tow vehicle and negatively impacts the stability of the tow vehicle.

The software OrcaFlex from Orcina was used to estimate the effect of cable arc. A towbody model was created in OrcaFlex and the variables of tow cable and vehicle body drag were adjusted until the tow cable lengths and tensions matched the estimates for the FOCUS-3 vehicle operation as provided by McCartney. The results of this analysis provided estimates for tow vehicle position as a function of tow speed and cross currents. These results were then compared to the results from a straight line assumption and estimates of position error were made for the cable position uncertainty. If the tow vehicle position is calibrated in a tracking range, it will be possible to minimize the effect of the cable uncertainty by refining the cable model. Figure 20 shows how tow speed, cable length, and ocean currents affect the estimate of tow vehicle position.

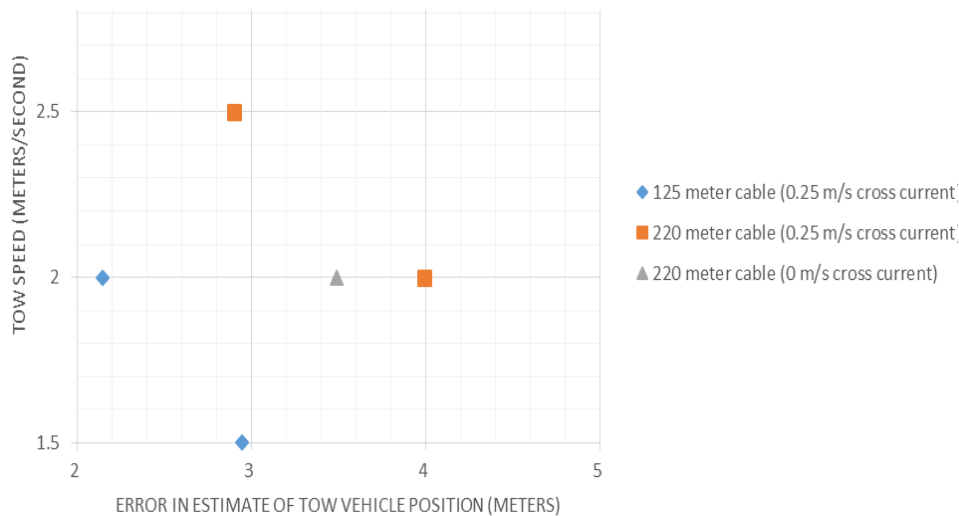

Figure 20. Tow vehicle position error estimate using heading and cable length

As a comparison to the cable length and angle method, a EvoLogics S2CR 48/78 USBL system was used to calculate tow vehicle position with respect to the vessel over the same experimental parameters. The USBL system provides heading and direction between the ship and the tow vehicle without having to consider the impact of tow cable, tow vehicle, and oceanographic conditions. The USBL tracking system eliminates these variables but with higher costs. Error estimates for a USBL tracking system are less than those for the cable length and angle method (Table 10).

These calculations show the degree to which each variable impacts error in the position estimation of a tow vehicle. The USBL tracking system eliminates the need to factor oceanographic conditions and tow speeds in the calculations, but the cable measurement method has lesser cost and operational complexity.

6.2. Vendor quotes



University of Washington
 Applied Physics Laboratory
 1013 NE 40th Street
 Seattle, WA 98105-6698
 USA
 Tim McGinnis

MacArtney Inc.
 2901 W Sam Houston Pkwy N
 Suite D-260
 Houston, TX 77043

Phone No. 0017132867575
 Fax No. 0017132867519
 Home Page www.macartney.com
 E-mail mac-us@macartney.com

Revision 2

Quotation US132919

Delivery Time	16-20 weeks ARO	Date	18 March 2016
Payment Terms	30 days net	Our Ref.	Don Bryan
Delivery Terms	Ex works Origin	Your Ref.	Tim McGinnis
Validity	30 days	Customer No.	1223
End User			

Product No.	Description	Quantity	Unit Price	USD
<u>With reference to your inquiry, we are pleased to quote:</u>				
FOCUS System complete:				
95005500	FOCUS ROTV to include: FOCUS towfish - Extended version for BOSS Subsea controller incl. sub end NEXUS multiplexer and Fibre optic based telemetry system Multifunction pod w. Battery Back-up system power supplies and fibre optic converters	1	299,025.00	299,025.00
95005500	FOCUS Topside control system: 19" rack system built into portable flightcase with: Main power supply, topside NEXUS de-mux I/O ports for winch, vehicle and navigation Ruggedized computer, PC display & keyboard Ground fault protection system and control console w. joystick for winch control and joystick for manual flight control and track ball. FOCUS flight control software	1	45,425.00	45,425.00
92003490	CORMAQ Q4 winch	1	79,950.00	79,950.00
			Continued to Site . . . 2	424,400.00

FOCUS-3 towbody, winch, and tow cable (double click to open PDF file)



4 Little Brook Road, West Wareham, MA 02576
 Tel: (508)291-0057 Fax: (508) 291-2491
 Email: info@edgetech.com Web: www.edgetech.com

Date: 22-Feb-2016

Quotation #: M16-166

QUOTATION
 eBOSS

PREPARED FOR:
 Company: Applied Physics Laboratory
 Address: University of Washington
 1013 NE 40th Street
 Seattle, WA 98105
 Attn: Kevin Williams
 Tel: (206) 295-4108
 E-mail: williams@apl.washington.edu

QTY.	PART #	DESCRIPTION	PRICE	UNIT	TOTAL
		<u>BOSS Deliverables</u>			
1		eBOSS (Buried Object Scanning Sonar) System Standard System Including: Underwater eBOSS Processor with 16 to 36 VDC Input Power, Trigger lines, Ethernet and Serial Interfaces. Additional electronics to power up to 2 projectors. Receive Hydrophone Arrays 4 PVDF array panels, rated to 1000m water depth. eBOSS data acquisition software license Includes AUV data transfer interface. Custom eBOSS Pressure Electronics Housing Rated to 100m water depth. eBOSS Transmit Source(s) Rated to 100m water depth. Frequencies TBD; estimated 5 to 35 KHz.	350,000	ea.	350,000
1		Integration Support 2 weeks on-site support Travel, accommodation and subsistence expenses included			
QUOTATION TOTAL					\$ 350,000

Terms & Conditions: EdgeTech's Standard Terms & Conditions apply to all sales
 Estimated Delivery: 5 Months ARO
 Payment Terms: Net 30
 Validity: 120 days
 Delivery: EXW (Ex-works) West Wareham, MA, USA

For EdgeTech:
 Rick Babicz
 Tel: +1 561 228 9201
 Fax: +1 508 291 2491
 Email: Rick.Babicz@EdgeTech.com
 Web: www.edgetech.com

EdgeTech Marine - West Wareham, MA / Boca Raton, FL USA

EdgeTech eBOSS (double click to open PDF file)



4 Little Brook Road, West Wareham, MA 02576
 Tel: (508)291-0057 Fax: (508) 291-2491
 Email: info@edgetech.com Web: www.edgetech.com

Date: 29-Feb-2016

Quotation #: M16-164a

QUOTATION

2205 Hosted Platform System (540/1600 kHz)

PREPARED FOR:

Company: Applied Physics Laboratory
 Address: University of Washington
 1013 NE 40th Street
 Seattle, WA 98105
 Attn: Kevin Williams
 Tel: (206) 295-4108
 E-mail: williams@apl.washington.edu

QTY.	PART #	DESCRIPTION	PRICE	UNIT	TOTAL
1		<u>Electronics</u> Base 2205 Electronics Package, 48V Power Supply, Ethernet, Test	42,200	ea.	42,200
1		<u>Pressure Housing, Endcap & Connectors</u> 1000m Rated Aluminum Pressure Housing - Side Scan Only 1000m Rated Aluminum Pressure Housing - Sized for expansion	10,000 13,500	ea. ea.	10,000 13,500
1		<u>Side Scan Arrays</u> Dual Simultaneous Frequency 540/1600 kHz. 2km-rated arrays.	25,000	set	25,000
1	0010496	<u>ROV Topside Processor</u> 19" Rack Mountable Topside Display Computer with 23" High Resolution Monitor, Mass Storage Hard Drive, DVD-RW, Keyboard & Trackball. Includes DISCOVER Software Suite.	29,500	ea.	29,500
		<u>System Options</u> Internal Data Storage within EdgeTech Electronics Two additional RS-232 serial port interfaces for pressure housing (note: two are included as standard) Pressure Test with Certificate	2,500 2,500 2,500	ea. ea. ea.	
QUOTATION TOTAL USD					\$ 106,700

Terms & Conditions: EdgeTech's Standard Terms & Conditions apply to all sales
 Estimated Delivery: 3 Months ARO
 Payment Terms: Net 30
 Validity: 120 days
 Delivery: EXW (Ex-works) West Wareham, MA, USA

For EdgeTech:

Rick Babicz
 Tel: +1 561 228 9201
 Fax: +1 508 291 2491
 Email: Rick.Babicz@EdgeTech.com
 Web: www.edgetech.com

EdgeTech Marine - West Wareham, MA / Boca Raton, FL USA

EdgeTech 2205 (double click to open PDF file)



Product Quote

AML Oceanographic

Unit A - 2071 Malview Ave
Sidney BC V8L 5X8
CANADA
1-250-656-0771
www.AMLoceanographic.com

Quote Number 25797

Bill To

University of Washington
Box 357940
Seattle Washington 98195
United States

Ship To

University of Washington
Marine Sciences Building, Rm G
1501 NE Boat St.
Seattle WA 98195
United States

Created Date
Sales Contact
Sales Rep
Billing Currency
Terms
Quoted Lead Time
Quote Expiry Date
Other Notes

26/2/2016
University of Washington : Kevin Williams
Kevin Wilson
USD
Net 30
Less than 1 week ARO
24/8/2016

Product Code	Description	Options	Quant...	Unit Price	Amount
PDC-MIX-P1S0-60	The Micro-X is the ideal single parameter instrument. Its small size and flexibility utilizing Xchange sensors make it ideal for hull or pole mounted installations or AUV/ROV integration. Housing is titanium, rated to 6000m. Xchange sensors must be ordered separately from the X-Series instrument.		1	2,995.00	2,995.00
XCH-SV-STD	SV-Xchange™ Calibrated Field-Swappable Sensor, 1375-1625 m/s		1	995.00	995.00
CBA-MC6M-002	2m Data / Power Cable with Male Micro 6 (MCIL-6-MP) Termination		1	450.00	450.00

Total \$4,440.00

Shipping: Not included, FOB (Freight on Board) Sidney, B.C. Canada (Freight & Insurance Collect)
Duties / Taxes: All duties, taxes, insurance, etc. are the responsibility of the purchaser
Inclusions: All AML Oceanographic instruments come with User Documentation and a Certificate of Conformity

Xchange your old ideas! AML Oceanographic is the only manufacturer of oceanographic instrumentation to offer Xchange field-swappable sensor-heads and X Series Sensor Xchangeable Instruments. Visit www.AMLoceanographic.com for more details.

AML Oceanographic sound speed sensor (double click to open PDF file)



3/16/2016

Quote Transmittal:

Contact Name	Tim McGinnis	Prepared By	Paul Devine
Phone	(206) 643-1346	Phone	(866) 842-2671
Contact Email	tmcginnis@apl.washington.edu	Email	paul.devine@teledyne.com

Quote To:

Account Name	University of Washington Applied Physics Lab	Quote Number	00014288
Mailing Address	622 Henderson Hall University of Washington Seattle, Washington 98196 United States	Expiration Date	3/16/2016

System Quote:

Product Code	Product Description	Sales Price	Quantity	Total Price
WHMZ1200	WH Monitor 1200 kHz DR ADCP	\$19,320.00	1.00	\$19,320.00
WHBTKZ	WH Shallow Water Bottom Track for 1200kHz "ZedHed" (Monitor/Sentinel units require WHBTK-HA to be installed prior)	\$1,260.00	1.00	\$1,260.00
WHBTKFI	WH High Accuracy Bottom Tracking Mode 4/6, Accuracy +/- 0.4%	\$1,576.00	1.00	\$1,576.00
Grand Total				\$22,156.00

Export Note:

These commodities, technology, or software were exported from the United States in accordance with the Export Administration Regulations. Diversion contrary to U.S. law is prohibited.

Anti-boycott Clause:

Under U.S. law, Teledyne RD Instruments may not comply with any General Terms and Conditions, which may violate or be inconsistent with U.S. Anti-boycott laws.

Any purchase orders received from your company must have the anti-boycott clauses deleted from your General Terms & Conditions and deleted from any other documents that are part of your purchase orders. Confirmation of deletions of anti-boycott clauses by your company should be in writing.

Payment Note:

If payment in advance, Seller shall add, and Buyer shall pay to Seller, a processing fee of \$500 to all Orders paid by letter of credit.

Terms & Conditions:

Teledyne RD Instruments, a business unit of Teledyne Instruments, Inc.
14020 Stowe Drive, Poway, California 92064 USA
TEL: +1-858-842-2600 FAX: +1-858-842-2822

Teledyne RDI Doppler velocity log (double click to open PDF file)

Ocean Innovations
 7416 Cabrillo Ave.
 La Jolla, CA 92037
 (858)454-4044
 brock@o-vations.com
 www.o-vations.com



Quote

ADDRESS
University of Washington 4300 Roosevelt Way NE SEATTLE, WA 98105 206-685-7765

SHIP TO
University of Washington Henderson Hall (APL) 1013 NE 40th St. Seattle, WA 98105 206-685-4154

QUOTE #	DATE	
1603-220	03/22/2016	

DESCRIPTION	QTY	RATE	AMOUNT
IXBlue Inc. Standard ROVINS	1	110,000.00	110,000.00T
IXBlue Inc. ROVINS NANO	1	66,000.00	66,000.00T
TSS Saturn 10 surface INS	1	86,700.00	86,700.00
TSS Saturn 10 subsurface INS in 4000m rated housing	1	103,700.00	103,700.00
TRITECH Micron INS in 500m rated housing	1	13,430.00	13,430.00T
TRITECH MicronNav USBL system including surface interface unit, dunking transducer on 10m cable, and subsea transponder	1	15,744.00	15,744.00T
MISC Inertial Labs MRU-P surface unit	1	9,315.00	9,315.00T
hemisphere VS330 receiver standard config - L1 GPS, L1 GLONASS, 10Hz, Raw data	1	5,100.00	5,100.00T
hemisphere A45 Antenna	2	950.00	1,900.00T

Quotes are valid for 30 days. Prices do not include shipping or any applicable sales tax, unless otherwise noted. Locking sleeves, nuts and washers are not included in connector pricing unless specifically stated. Please let us know if you need them. Visit our website at www.o-vations.com for Terms and Conditions. Thank you for the opportunity to provide this quote.

SUBTOTAL	411,889.00
TAX (0%)	0.00
TOTAL	\$411,889.00

Accepted By

Accepted Date

Inertial motion units/inertial navigation systems (part of enhanced system; double click to open PDF file)

6.3. Vendor data sheets



FOCUS 3



FOCUS 3 represents the 3rd generation FOCUS vehicles in the family of ROTV systems designed, developed and manufactured by MacArtney.

FOCUS 3 is the result of more than 25 years of constant product development and customer feedback. The design philosophy of the FOCUS 3 system remains the same as for the rest of the MacArtney ROTV systems: to provide a robust, easy-to-use, accurate, steerable, open and flexible instrumentation platform which can be deployed for a wide variety of underwater data acquisition and inspection applications.

The FOCUS 3 vehicle is constructed using carbon fibre technology for the wing sections like the successful FOCUS 2 and TRIAXUS vehicle designs, whereas the instrumentation pods are made from anodised aluminium, making them more durable for potential impact with the seabed. The instrumentation pods are bolted onto the wing sections through a modular design allowing for onsite repairs of the vehicle in case of an accident.

The modular design of FOCUS 3 includes the option of increasing the wing sections allowing for operations at depths of up to 1000 m. Increasing the size of the wing sections also makes more space available for installation of more sensors on to FOCUS 3.

FOCUS 3 can operate a number of acoustic survey sensors and instruments simultaneously ensuring maximum usage of ship time.

The GUI is an easy-to-use Windows based software package. The system is designed to carry a broad range of sensor packages from leading manufacturers of underwater equipment.

Survey equipment

- Side scan sonar
- Multi-beam sonar
- Synthetic aperture sonar
- Mechanical forward-looking sonar
- Mechanical scanning profiling sonar
- Subbottom profiler
- Magnetometer
- Video camera
- Laser line scan camera
- Fibre optic gyro
- Inertial navigation system
- Bottom tracking doppler log
- Responder for USBL

The 1000 m rated FOCUS 3 features

- Carbon fibre wing sections
- Instrumentation pods made from anodised aluminium
- Neutral to heavy trimming in water
- Extended wing sections
- Increased payload capacity
- Pressure vessels with higher pressure rating
- Internal and external cargo rails

Other features and benefits

- Very stable, steerable instrumentation platform
- Operating depth of 1000 m at 5 knots
- High and flexible payload capacity
- Online data acquisition
- High data transmission capacity; tens of GB
- Software controlled steering functions
- Built-in standard control sensors
- User-friendly controls and displays
- Modular, rugged and streamlined design
- Low noise magnetic and acoustic signatures
- Quick-change of sensors
- Proven cost-effective survey tool

Applications

- Pipeline inspection
- Large area searches and MCM
- Site surveys and sea floor mapping
- Cable route surveys
- UXO detection

Standard vehicle control sensors

- Attitude sensor
- Depth sensor
- Altimeter



03-2016

www.macartney.com

MacArtney FOCUS-3 towbody (double click to open PDF file)

CORMAC Q

Stainless steel winch series



MacArtney CORMAC Q stainless steel winches are dependable and versatile systems self-contained in protective frames. The CORMAC Q series includes five different standard models (CORMAC Q2, Q3, Q4, Q5 and Q6) which are all available in HS (high speed) versions.

CORMAC Q winches are designed and engineered for optimal durability and require minimal maintenance. Operators are allowed to choose between a broad range of specifications including speed, pull, motor size and cable capacity. The modular outline of the CORMAC Q design ensures that the winches can be easily modified to accommodate a variety of tasks.

CORMAC Q winches come with several intelligent features which allow for accurate and effective equipment handling. A soft-start function makes the winch easy to handle, improves equipment manoeuvrability and protects the motor and gear.

All CORMAC Q winches are fitted with an electric driven level wind, allowing for significantly improved spooling performance, while making it possible to easily change cable diameter. All CORMAC Q winches are prepared for a Focal model 180 electric/electro-optical slip ring.

Features and benefits

- All structural components made from glass blasted stainless steel
- Minimal maintenance required
- Integrated protection frame and grating
- Frame mounted control panel
- Electric driven level wind
- Designed, tested and certified according to The Machinery Directive; Type IIB Declaration
- Long and proven track record

Applications

- Side scan sonar systems
- ROV systems
- Oceanographic profiling CTD systems
- Light towed equipment and platforms
- Underwater TV systems
- Diver communication lines
- General marine instrumentation

System options

- Service and maintenance programme
- Spare parts package
- Remote control with joystick and emergency stop (10 m cable)
- Remote control with joystick, emergency stop and display for indication of deployed cable length and speed (10 m cable)
- Wireless remote control with joystick and emergency stop
- Cable status indicator (speed and length)
- A-frame or davit
- Cable sheave
- Vibration absorbing installation brackets
- Focal electric/electro-optical slip ring model 180
- CE marking (if cable and termination is supplied)
- Fork lift pockets (standard on CORMAC Q5 and Q6)
- Tarpaulin cover



DATALINE®

Description	Inch	mm
ELEMENT A: Electro-Light® (2)		
Fbr: 8.3/125/245 µm SM	0.010	0.25
Bfrr: Hytrel®	0.024	0.61
Cdr: #18 AWG (0.91 mm ²) HD Cu	0.054	1.37
Ins: PP	0.084	2.13
ELEMENT B: Single (2)		
Cdr: #24 AWG (0.24 mm ²) HD Cu	0.024	0.61
Ins: PP	0.056	1.42
ASSEMBLY		
Core: N/A		
Layer 1: 2 Element A's with 2 Element B's in interstices.	0.168	4.27
BELT		
HDPE	0.205	5.21
STRENGTH MEMBER		
Layer #1: 14/0.052" GEEIPS	0.309	7.85
Layer #2: 24/0.042" GEEIPS	0.393	9.98

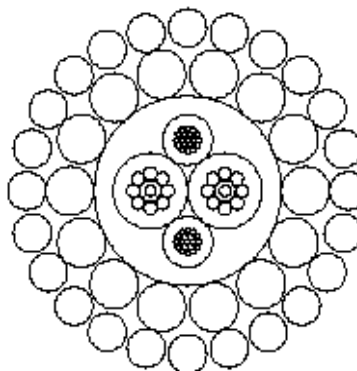

Hytrel® is a registered trademark of DuPont.

PROPRIETARY: Use Pursuant to Company Instructions



Instrumentation and Control Cable			
Code: IM0080172P005			
Date	Page	Revision	Part No.
02/08/2013	1	H	A305382

Rochester tow cable (double click to open PDF file)

S2CR 48/78 USBL

PRODUCT INFORMATION



Simultaneous positioning and communication

S2C Technology: accurate 3D positioning and reliable data transmissions with up to 31.2 kbit/s

Horizontally omnidirectional beam pattern, optimized for short and medium range operations in reverberant shallow waters

TECHNICAL SPECIFICATIONS

GENERAL	OPERATING DEPTH	Delrin	200 m
		Aluminium Alloy	1000 m
		Stainless Steel	2000 m
		Titanium	2000 m
	OPERATING RANGE		1000 m
	FREQUENCY BAND		48 - 78 kHz
	TRANSDUCER BEAM PATTERN		horizontally omnidirectional
USBL	SLANT RANGE ACCURACY ¹⁾		0.01 m
	BEARING RESOLUTION		0.1 degrees
	NOMINAL SNR		10 dB
CONNECTION	ACOUSTIC CONNECTION		up to 31.2 kbit/s
	BIT ERROR RATE		less than 10 ⁻¹⁰
	INTERNAL DATA BUFFER		1 MB, configurable
	HOST INTERFACE ²⁾		Ethernet, RS-232 (RS-485/422*)
	INTERFACE CONNECTOR		up to 2 SubConn® Metal Shell 1500 Series
POWER	CONSUMPTION	Stand-by Mode	2.5 mW
		Listen Mode ³⁾	5 - 285 mW
		Receive Mode ⁴⁾	less than 1.3W
		Transmit Mode	5.5 W, 250 m range 8 W, 500 m range 18 W, 1000 m range 60 W, max. available
	POWER SUPPLY ⁵⁾		External 24 VDC (12 VDC*) or internal rechargeable battery*
PHYSICAL	DIMENSIONS ⁶⁾	Housing/USBL sensor	Ø 110 mm x 170 mm, /Ø 130 mm x 145 mm
		Total length	315 mm
	WEIGHT dry/wet	Delrin	4790/1090 g
	Aluminium Alloy	5500/1800 g	
	Stainless Steel	11400/6200 g	
	Titanium	9900/4900 g	

¹⁾ optional

²⁾ Slant range estimation is based on the measured time delay; slant range accuracy depends on sound velocity profile, refraction and signal-to-noise ratio.

³⁾ See the Configuration Options for available standard interface combinations.

⁴⁾ Low configurable Listen Mode is only available with a WakeUp module installed. Power consumption in Listen Mode depends on Listen Mode settings.

⁵⁾ Power consumption for the RS232 interface option: Add 600 mW for the Ethernet interface option.

⁶⁾ Contact EvoLogics for more information on power supply options.

⁷⁾ Dimensions of a Delrin housing, other builds are slightly larger.

* Specifications subject to change without notice. © EvoLogics GmbH - June 2012

EvoLogics USBL positioning and communications system (part of enhanced system; double click to open PDF file)

Motion Reference Units



- IP-67 sealed
- 5% / 5 cm Heave accuracy
- 0.03 m/sec Velocity accuracy
- 0.08 deg Pitch and Roll accuracy
- 0.005 m/sec² Acceleration accuracy
- 0.0002 deg/sec Angular rate accuracy
- NMEA 0183 and TSS1 output data format
- 60 cm real-time horizontal position accuracy
- 5 cm post processing horizontal position accuracy



MRU-B (Basic)
MRU-E (Enhanced)
MRU-P (Professional)

Datasheet
Revision 1.0

Inertial Labs MRU (double click to open PDF file)

7. APPENDIX D. Example Munitions Remediation Survey Vessel

R/V Robertson at APL-UW

The Research Vessel *Robertson* joined the APL-UW fleet in September 2008. The vessel has a single engine and semidisplacement hull of hand-laid fiberglass with a deep keel and full skeg for propeller protection. The aft work deck is less than 4 ft off the water line, is of a very strong aluminum construction with threaded holes on 24" centers, and clear of obstructions (a 20-ft van will fit on deck). The lab and wheelhouse are foam cored fiberglass for stiffness, insulation, and low weight, and there are large windows for 360-degree visibility from the raised wheelhouse. The lab directly off the main deck has double doors so that large items can be slid directly into the lab.



On the main deck is a 6000-lb cap A-frame and utility hoist, a crane with reach up to 22 ft (capacity of 1320 lbs at that reach, and up to 5000 lbs close in). The folding swim step 12 ft wide. Two generators produce the electrical power necessary for on-board research activities — one 55-kW unit for large loads (e.g., winches) and another 20-kW unit for general work along with a 4-kW sine wave inverter and generous house batteries and battery charging equipment.

The main engine and/or auxiliary AC driven hydraulics will power the bow thruster, the crane, bow anchor, double stern anchors, A-frame, utility winch, and the general purpose deck winch. There are two hull wells below — a 10" and a 19" diameter with access through the lab floor for long items. The primary engine room access is from the lower level through a watertight door. There is interior and exterior access between all levels for safety and convenience.

Plans

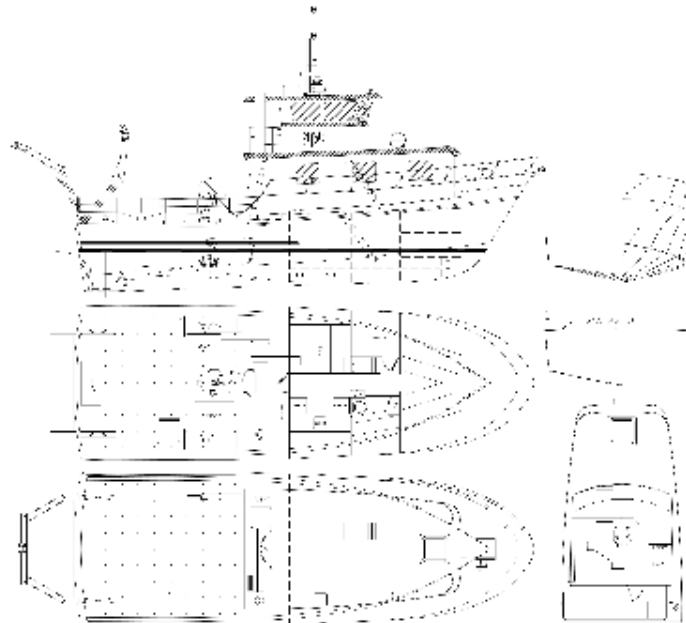

[R/V Jack Robertson specifications \(double click to open PDF file\)](#)

8. APPENDIX E. Non-Recurring Engineering for Baseline Build and Test

8.1. Sensor integration, control and monitoring software development

When the system hardware components are received, they will be assembled onto the towbody. We have included fabrication of non-operational dummy acoustic elements and arrays to demonstrate initial fitting, mounting, installation, and handling without risk to the exposed sonar parts.

All standard FOCUS-3 peripheral sensors, customer added sensors, and sonars will be connected and the interfaces tested. Once the system is fully assembled and connected, lab bench testing will confirm proper operation of all sensors and subsystems.

All FOCUS-3 sensor monitoring and control functions will be lab tested and any additional software functions and control algorithms will be developed. The software necessary to acquire, process, and communicate the cable angle encoder data will be developed.

8.2. Low-frequency processing and classification development

The NRE here is focused on implementing the classification methods developed to date within the DCL towbody environment and developing user friendly displays that allow the operator to examine the processed data and make initial detection, regions of interest decisions. Post-mission processing that allows final DCL decisions on detected objects will be developed.

Quantifying performance of low-frequency classifiers was the subject of SERDP MR-2231 and the ongoing MR-2505. The data acquired and models used to test classifiers are discussed in the final reports of MR-1665 and MR-2231. Transitioning the results of those efforts into classification algorithms and visualization methods tailored to operational use with the eBOSS sonar system will require significant effort. Separately funded SERDP tasks to take full advantage of ongoing classification studies are also envisioned.

The objective here is to lay groundwork that gives near-term capability and accommodates integration of classification improvements developed under other SERDP efforts.

8.3. Engineering tests

Engineering tests of the MuST system will be four 1-week, in-water tests at the APL-UW acoustic test facility (ATF, 1 week), the UW School of Oceanography salt water test tank (1 week), and vessel-based testing in the local waters of Lake Washington and Puget Sound (two 1-week efforts).

Engineering tests objectives:

1. Confirm water-tight integrity of all enclosures and connections
2. Confirm operation of all vehicle functions
3. Confirm operation of all vehicle engineering sensors
4. Confirm operation of all payload sensors
5. Confirm operation, characterize, and calibrate the low- and high-frequency sonars

6. Characterize the performance of the vehicle positioning components and methods
7. Develop basic vehicle launch and recovery procedures
8. Determine preliminary system performance parameters (e.g., swath coverage vs. vehicle altitude, bottom coverage vs. speed) and modify operational parameters (e.g., vehicle altitude range, survey speed range, survey track line spacing)

8.3.1. Acoustic test facility

The APL-UW ATF is housed on the R/V *Henderson*, a 70-ft steel-hulled catamaran vessel with a large interior lab space, a traveling overhead hoist, and a large wet well between the hulls. It is equipped with full instrumentation for calibration of underwater acoustic equipment. Accurate measurements can be made of transmit and receive responses, radiation patterns, and all transducer parameters. The MuST transducers will be mounted to the FOCUS-3, the FOCUS-3 mounted to the ATF extendable arm, and then the source transmission voltage response, receive sensitivity, and beam patterns for both sources and receivers will be measured. This on-board calibration is needed to assure transducer health and for the subsequent processing to obtain absolute target scattering strength as a function of frequency and angle.

8.3.2. Salt water test tank

The UW School of Oceanography salt water test tank is 7.3 m long x 3 m wide x 4 m deep. An overhead hoist will be used to lower the towbody into the tank and then recover it. All subsystems will be tested while the towbody is in the tank.

Towbody trimming and ballasting will be performed in the salt water test tank. Testing in salt water will locate ground faults, which will confirm the integrity of all electrical housings, cables, and connectors. All the towbody moving parts, including the horizontal and vertical towbody active control surfaces, will be tested to confirm integrity of the shaft and other seals.

The sonar and acoustic devices will be operated to test for cross-talk and interference between the various acoustic sensors. Different timing and triggering configurations can be tested to remove and/or minimize the acoustic interference. The small size of the tank and reverberation from the tank walls will prevent full acoustic testing, but these tests will be useful.

8.3.3. Lake Washington and Puget Sound

The MuST system will be loaded on the R/V *Robertson* (Appendix D) for tests in Lake Washington (fresh water, 30 min from the APL-UW dock) and Puget Sound (salt water, 1 h from the APL-UW dock). The system will be deployed, lowered to an appropriate water depth and height above the bottom, and then towed with the planned operational configuration, speed, altitude, and other towing parameters. Sonar imaging of the seabed will be done on naturally occurring features and targets. Lake Washington has test sites with soft mud bottoms and Puget Sound has sites with sand and gravel bottoms, which will allow testing with a variety of seafloor types.

These tests will also demonstrate the vessel and towbody positioning and navigation methods.

8.4. In-field demonstration

The R/V *Robertson* with the MuST system on board will transit to the Sequim Bay test site (6–8 h from the APL-UW dock) for two 1-week operational demonstrations over a munitions field placed in Sequim Bay by divers from the Pacific Northwest National Laboratory (PNNL).

8.4.1. Munitions placement

The Marine Sciences Laboratory (MSL), headquartered at PNNL, is located at the entrance to Sequim Bay on the Washington State Olympic Peninsula (Figure 21). MSL operates the 28-ft R/V *Strait Science*, a rigid hull inflatable dive boat, and has a team of six certified scientific divers.

Sequim Bay has an average water depth of approximately 20 m with a relatively flat bottom and a variety of bottom types (Figure 22). Several dummy munitions shapes will be placed by the MSL divers in a variety of depths and bottom types – soft mud, clean sand, gravel – in Sequim Bay. The types, positions, orientations, and burial depths of the dummy munitions will be recorded and entered into a layer of a geographical information system (GIS).



Figure 21. Aerial photo of the PNNL Marine Sciences Laboratory

8.4.2. Munitions operational tests

After the dummy munitions are placed, one or more survey areas will be established in the area (Figure 22, red square). Survey track lines will be set up with an initial spacing of 15 m and the DCL survey will be conducted along the track lines. The real-time sonar data, sonar imagery, and engineering sensor data will be monitored and logged for off-line processing. The survey operations will be run during daylight hours. The data from the previous day will be processed and analyzed by personnel on shore.

Operational tests objectives:

1. Demonstrate the DCL capabilities of the MuST system
2. Continue characterization of system performance parameters (e.g., swath coverage vs. vehicle altitude, bottom coverage vs. speed) and optimization of operational parameters (e.g., vehicle altitude range, survey speed range, survey track line spacing)

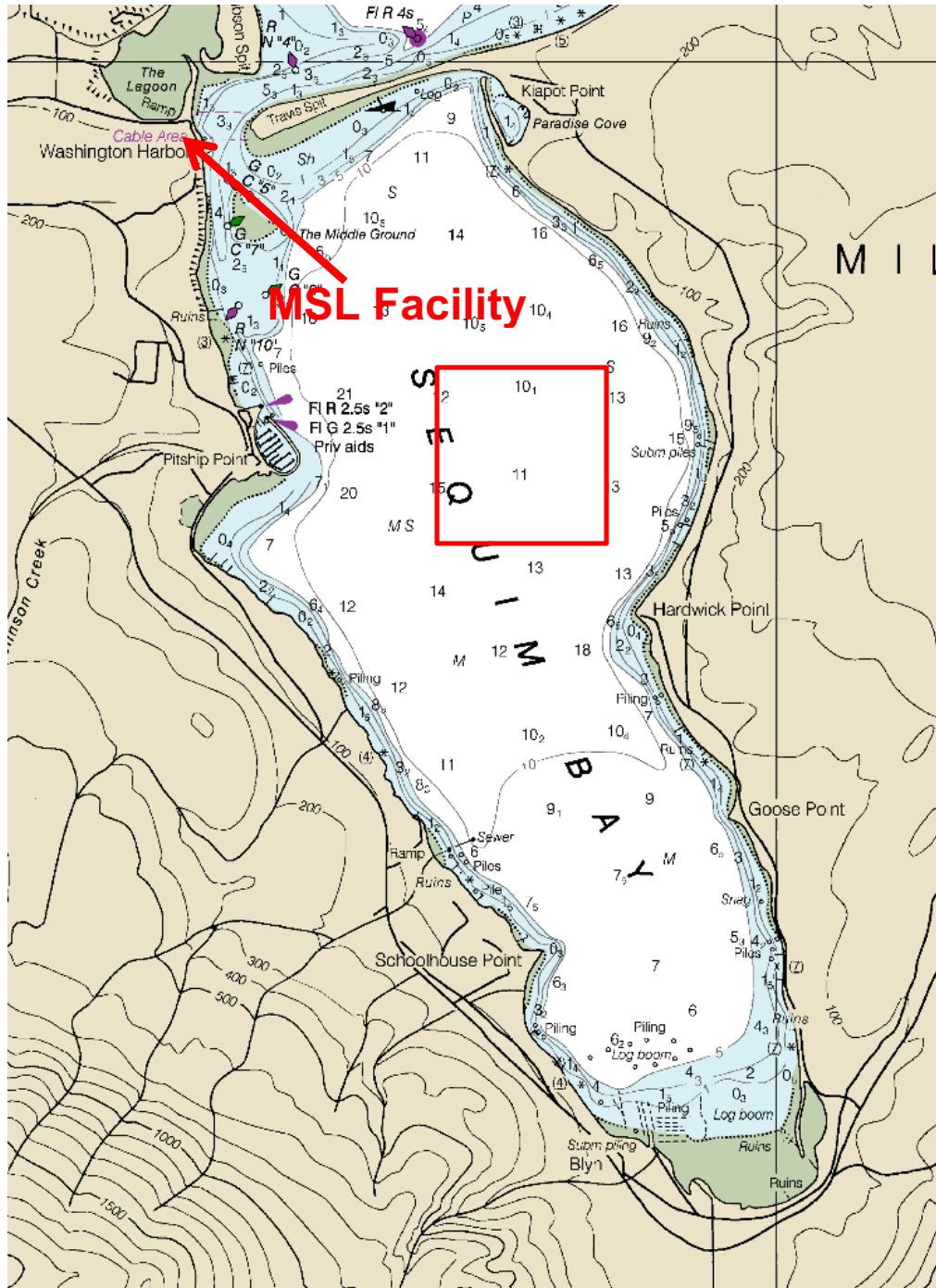

Figure 22. Chart of Sequim Bay (depth in fathoms) with a 0.5 nm² survey area bounded by a red square