

Staff Summary Sheet

	To	Action	Signature (Surname), Grade, Date		To	Action	Signature (Surname), Grade, Date
1	DFEM	Approve	<i>S. Kelly</i> , 0-6, 22 May 2013	6			
2	DFER	Review	<i>Kraus, Col</i> 23 May 13	7			
3	DFEM	Action		8			
4				9			
5				10			

Grade and Surname of Action Officer Dr. Lubov P. Andrusiv	Symbol DFEM	Phone 333-9095	Suspense Date 30 May 2013
--------------------------------------------------------------	----------------	-------------------	------------------------------

Subject Clearance of Material for Public Release Case Number: <i>USAFA-DF-PA-3583</i>	SSS Date 20 May 2013
-----------------------------------------------------------------------------------------------	-------------------------

Summary

1. Purpose: To provide security and policy review on the document at Tab 1 prior to release to the public.

2. Background:

- *Author(s):* Dr. Lubov P. Andrusiv, USAFA, DFEM/DFRL

Dr. Amy Courtney and Dr. Michael Courtney, BTG Research, PO Box 62541

- *Title:* A Test of the Acoustic Impedance Model of Blast Wave Transmission

- *Abstract:* This paper represents the acoustic impedance model which was used to estimate blast wave transmission of some armor materials experimentally. The results show that transmitted pressures are much higher than model prediction, and increasing the acoustic impedance does not ensure a decrease in peak transmitted blast pressure when selecting armor material.

- *Release information:* To be submitted to the Journal of Battlefield Technology

- *Previous clearance information:* 1. Article (DF-PA-366) for publishing in Journal of Fracture Mechanics, 2010. 2. The conference paper (DF-PA-367) for presenting on the VIII Int'l Conference in Ukraine, 2010. 3. Article (DF-PA-527) for ASME Journal of Vibration and Acoustics, 2011. 4. DF-PA-287, Configuration Control of Telescoping Beams with Three or More Segments, for publication in Journal of Sounds and Vibrations, April 2013

- *Recommended distribution statement:* Distribution A, Approved for public release, distribution unlimited.

3. Discussion:

4. Recommendation:

Dr. Lubov P. Andrusiv
Department of Engineering Mechanics

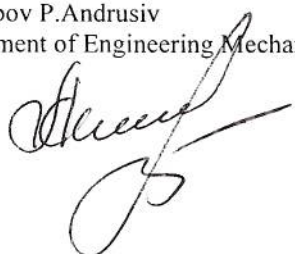

Tab
1. Copy of article

A TEST OF THE ACOUSTIC IMPEDANCE MODEL OF BLAST WAVE TRANSMISSION

Amy C. Courtney,* Lubov P. Andrusiv,** and Michael W. Courtney*

Abstract. The ability of armor to minimize blast wave transmission is key in mitigating blast related injuries. The acoustic impedance model is commonly employed to estimate blast wave transmission of candidate armor materials even though the model assumes semi-infinite material thickness. The applicability of the acoustic impedance model to blast wave transmission through plates has not been experimentally verified. In this study, a 79 mm diameter, oxy-acetylene driven shock tube was used to generate a blast-like wave with a peak pressure of 1173 kPa. The pressure wave transmitted through 6.35 mm thick plates of ten different materials spanning a range of acoustic impedance was measured and compared with predictions of the acoustic impedance model. The magnitude of the peak transmitted blast pressure averaged over five trials for each material was well correlated with both the acoustic impedance of the material (correlation coefficient, $r = -0.709$) and with the predicted peak transmitted blast pressure ($r = 0.844$). However, in all cases, the acoustic impedance model predicted significantly lower peak blast pressure transmission than was actually observed, with the peak transmitted pressure varying from 9 to 90 times greater than the prediction of the model, with an average transmission of 41 times the prediction of the model. These results show that even though plate materials with higher acoustic impedance tend to transmit lower peak blast pressure, transmitted pressures are much higher than model predictions, and increasing the acoustic impedance does not ensure a decrease in peak transmitted blast pressure when selecting armor materials.

INTRODUCTION

Improvised explosive devices are commonly encountered in modern military operations, and the injury potential of both improvised and conventional explosives is well documented. Blast waves can cause injuries independently of penetrating fragments or impact injuries, and injuries attributable to the blast wave itself are called primary blast injuries [1]. Risk and severity of primary blast injuries are believed to increase with the increasing blast wave magnitude reaching the body [2-3]; therefore, decreasing the blast wave magnitude transmitted through armor materials is one goal of armor design [4].

Element based numerical modeling of blast transmission through candidate armor designs is still in the developmental stages. Numerical modeling techniques of blast wave transmission that have been experimentally validated with a variety of materials and geometries are not yet widely available, and even when models become available, the accuracy of material properties at the very high strain rates associated with blast (~10,000/s) remain an open question. Consequently, armor designers often employ the acoustic impedance model to predict blast wave transmission through materials [4-6]. Various approaches to layering and mismatching impedances have been used under the assumption that greater impedance mismatch necessarily leads to reduced blast wave transmission and resulting injury risk [6, 7].

However, the acoustic impedance transmission model assumes semi-infinite volumes of material and requires independent knowledge of the wave propagation velocity [5]. In practice, plate-based armor designs are not reasonable experimental realizations of semi-infinite volumes, and the speed of sound may not be a reasonable estimate to the shock/blast wave propagation velocity in a material. The application of acoustic impedance ideas in selection and consideration of armor materials seems to be based more in the simplicity and availability of the model than in rigorous justification and reasonable expectation of accurate predictions. To the authors' knowledge, the accuracy of predictions based on application of the acoustic impedance

model to blast wave transmission through simple plate geometries have not been experimentally verified beyond a small number of cases where blast wave transmission and resulting injury were observed to be decreased with a significant increase in the impedance mismatch [4]. The present study quantitatively tests the applicability of the acoustic impedance model for predicting transmission of air blast through materials in a simple plate geometry.

The stress wave propagation impedance in a material is the product of the material density and the wave propagation speed [4, 5]. In the absence of other information, shock and blast wave speeds are often approximated by the speed of sound in a material, so that the stress wave impedance is approximated by the acoustic impedance, Z . For wave propagation normal across one plane interface of two semi-infinite media, the predicted transmission ratio, T , is given by

$$T_{one} = \frac{2Z_2}{Z_1 + Z_2}, \quad (\text{Eqn. 1})$$

where Z_1 is the acoustic impedance of the material the wave from which the wave propagates, and Z_2 is the acoustic impedance of the material into which the wave is transmitted. It is clear from Eqn. 1 that the wave is perfectly transmitted in the case that the two materials have the same impedance. In the case of a wave transmitted through a material in air, the combined transmission is the product of the transmission ratios from air into the material and then from the material back into air (through two plane interfaces),

$$T_{two} = \frac{4Z_1 Z_2}{(Z_1 + Z_2)^2}, \quad (\text{Eqn. 2})$$

where Z_1 and Z_2 are the impedances of air and the intervening material, respectively.

The present study employs a laboratory scale shock tube and high speed pressure transducers to measure the blast wave transmission in air through ten different homogeneous materials of the same thickness. Results are compared with

* BTG Research, PO Box 62541, Colorado Springs, CO 80962, Michael_Courtney@alum.mit.edu

** United States Air Force Academy, 2354 Fairchild Drive, USAF Academy, CO 80840

the predictions of the acoustic impedance model both in absolute terms and in terms of correlations between the acoustic impedance and predicted transmission ratios with the experimentally measured transmission ratios. It is determined that the acoustic impedance model significantly underestimates blast wave transmission through plates of material by factors ranging from 9 to 90, but that the predictions of the model are reasonably well correlated with the experimental transmission ratios ($r = 0.844$).

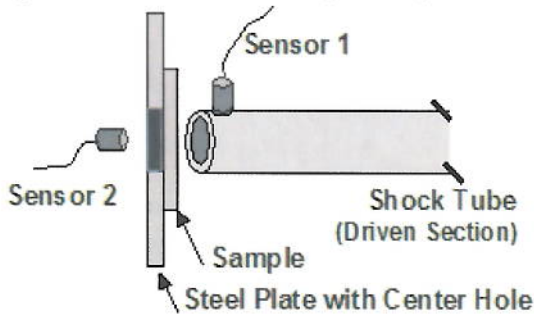

Figure 1: Experimental test setup showing the relative locations of the 79 mm diameter shock tube, sample and pressure sensors.

METHODS

The shock tube and experimental method have been described previously [8, 9]. Briefly, an oxy-acetylene driven, 79 mm diameter shock tube was used to simulate the blast waves. The shock tube was a 305 cm long piece of steel pipe. The driving section, which was filled with the fuel-oxygen mixture, was 30.5 cm long [8]. A piezoelectric pressure sensor (PCB 102B15), sensor 1, was mounted near the opening of the shock tube with its face parallel to the direction of the blast wave. Pressure sensor 2 (PCB 102B18) was placed behind the test sample with its face perpendicular to the direction of the blast wave. It was used to measure the transmitted blast wave (Figure 1). Sensor 2 was placed so that the total distance between it and the shock tube opening was 40 mm, with the sample centered in between. The applied blast wave with peak magnitude of 1173 kPa and duration close to 2 ms corresponds with realistic battlefield parameters which are expected to present a significant risk of brain and lung injuries [3, 4, 8], while being small enough that it is reasonable to employing the sonic velocities to estimate acoustic impedances.

The test samples were 152.4 mm square by 6.35 mm thick pieces of cast acrylic, polycarbonate, aluminum oxynitride (ALON, [10]), steel, aluminum, copper, brass, magnesium, and zinc and a 304.8 mm square by 6.35 mm thick piece of tempered glass. The test materials were chosen to represent a span of impedances from $\sim 2 \text{ kg/sm}^2$ to $\sim 50 \text{ kg/sm}^2$. Each test sample was placed in front of the shock tube and mounted on a 304.8 mm square by 6.35 mm thick mild steel plate with a 76.2 mm diameter hole in the center. The mild steel plate was used to minimize any influence on the pressure measurements of components of the blast wave that may have diffracted around the samples [7].

Peak transmitted pressures were recorded and pressure-time profiles were plotted for each trial. Since the peak pressure decreases with distance from the shock tube opening, the transmission ratio was calculated as the peak transmitted pressure divided by the peak unobstructed pressure at the face of the sensor, which was measured in separate trials [8]. The blast waves coming from the shock tube have a steep shock front, a near exponential decay, and a positive pulse duration of about 2 milliseconds. Five trials were conducted for each sample tested; mean peak transmitted pressure and standard error of the mean (SEM) were computed for each sample. Acoustic impedances are computed from material properties obtained from reference literature and are given in Table 1 along with the predicted transmission ratios calculated with Eqn. 2.

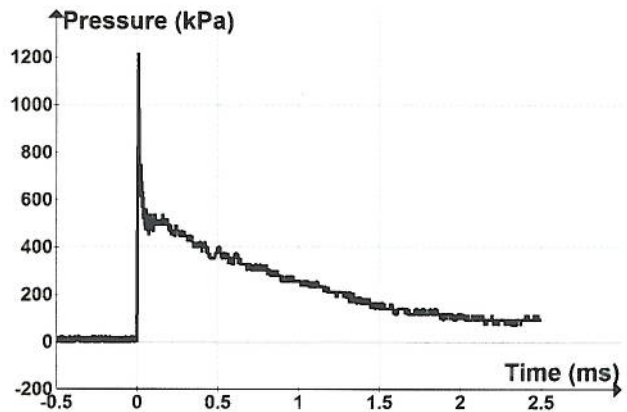

Figure 2: Unobstructed blast wave showing typical steep shock front followed by near exponential decay.

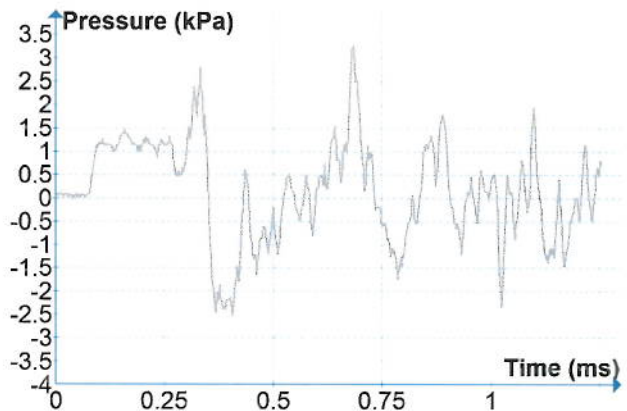

Figure 3: Blast wave transmitted through 6.35 mm thick magnesium plate.

RESULTS

Representative pressure-time curves for the unobstructed blast wave and blast wave transmitted through a plate of magnesium are shown in Figures 2 and 3, respectively. The general characteristics of the transmitted blast wave were similar for other materials, though the peak transmitted pressures were different. Note that contrary to the

expectation of Meyers [10] for transmission across a planar boundary in semi-infinite materials, transmission through a plate does not nearly preserve the original wave shape. Not only is the wave attenuated, its shape is completely different with both positive and negative pressures of comparable magnitude with the peak transmitted pressure.

The experimental transmission ratio of each trial is defined as the peak transmitted pressure divided by the peak unobstructed blast pressure measured at the same location (1173 kPa). The average of five trials is shown in Table 1 and in Figure 4 for each material. The uncertainty is the standard error of the mean for the five trials.

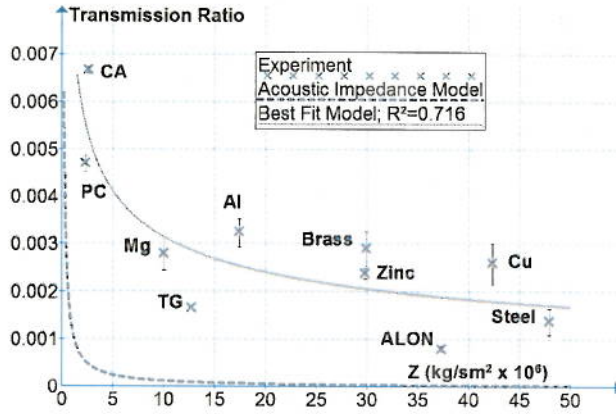

Figure 4: Blast transmission ratios through 6.35 mm plates of ten different materials plotted vs. acoustic impedance along with the predicted transmission ratio of the acoustic impedance model and a best fit empirical model.

The measured transmission ratios are much larger (by factors of 9 to 90) than those predicted by the acoustic impedance model, as shown in Figure 4 and Table 1. There is a definite negative correlation ($r = -0.709$, $p = 0.022$) between the measured transmission ratio and the acoustic impedance and a definite positive correlation ($r = 0.844$, $p = 0.002$) between the measured and predicted transmission ratios of the ten materials. A best fit empirical model for transmission ratio vs. acoustic impedance is also shown in Figure 4. The model that fits the equation the best is

$$T = a \frac{4Z_1 Z_2}{(Z_1 + Z_2)^b}, \quad (\text{Eqn. 3})$$

where $a = 6.207$ and $b = 1.389$ are the best fit parameters. $Z_1 = 0.00031 \times 10^6 \text{ kg/m}^2\text{s}$ is the acoustic impedance of air at the altitude where the experiments were performed, and Z_2 is acoustic impedance of the plate material as the independent variable. The best fit to this model had a coefficient of determination $R^2 = 0.716$. Clearly, there is a trend of decreasing transmission with increasing acoustic impedance, but the acoustic impedance does not explain all of the observed variation in blast transmission observed in different materials.

Material	Z (Kg/m ² s x 10 ⁶)	T measured	T predicted
6061 Aluminum (Al)	17.4	3.25E-003	7.07E-005
B36 Brass	29.9	2.91E-003	4.12E-005
B152 Copper (Cu)	42.3	2.60E-003	2.91E-005
AZ31B Magnesium (Mg)	10	2.80E-003	1.23E-004
A36 Steel	47.9	1.39E-003	2.57E-005
99.997% Zinc	29.8	2.39E-003	4.13E-005
Cast Acrylic (CA)	2.6	6.68E-003	4.73E-004
Polycarbonate (PC)	2.3	4.71E-003	5.35E-004
Tempered Glass (TG)	12.7	1.67E-003	9.69E-005
ALON	37.3	8.10E-004	3.30E-005

Table 1: Acoustic impedance, measured transmission ratio and predicted transmission ratio for each of the ten materials tested.

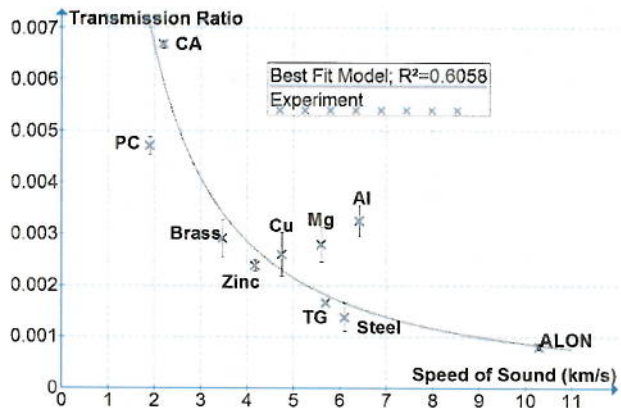

Figure 5: Blast transmission ratios through 6.35 mm plates of ten different materials plotted vs. material speed of sound.

Correlations between the measured blast transmission ratio and other material properties can also be considered. The strongest correlation of the measured blast transmission ratios is with the speeds of sound in the materials at $r = -0.778$ ($p = 0.008$). Blast transmission is not as strongly correlated with material density or elastic modulus with correlation coefficients of $r = -0.443$ ($p = 0.200$) and $r = -0.747$ ($p = 0.013$), respectively. Figure 5 shows the measured blast transmission ratio plotted against the speed of sound in each material along with a best fit line. The best fit function has the form

$$T(u) = \frac{a}{(1 + u/c)^b}, \quad (\text{Eqn. 4})$$

where u is the speed of sound in the material in km/s. The best fit yields $a = 0.0868$, $b = 1.376$, and $c = 0.366 \text{ km/s}$. It may be notable that c is close to the speed of sound in air and that the exponent b is close to that obtained in the best fit model using acoustic impedance as the independent variable.

* BTG Research, PO Box 62541, Colorado Springs, CO 80962, Michael_Courtney@alum.mit.edu

** United States Air Force Academy, 2354 Fairchild Drive, USAF Academy, CO 80840