

“BENDING THE EAGLE’S WING”

HOW ADVANCED AIR DEFENSES PUT THE ENEMY’S VITAL CENTERS
BEYOND THE REACH OF AMERICAN AIRPOWER

BY

MAJOR JOHN V. BARTOLI

A THESIS PRESENTED TO THE FACULTY OF
THE SCHOOL OF ADVANCED AIR AND SPACE STUDIES
FOR COMPLETION OF GRADUATION REQUIREMENTS

SCHOOL OF ADVANCED AIR AND SPACE STUDIES
AIR UNIVERSITY

MAXWELL AIR FORCE BASE, ALABAMA

4 JUNE 2010

APPROVAL

The undersigned certify that this thesis meets masters-level standards of research, argumentation, and expression.

DR. JAMES W. FORSYTH (Date)

DR. THOMAS A. HUGHES (Date)

DISCLAIMER

The conclusions and opinions expressed in this document are those of the author. They do not reflect the official position of the US Government, Department of Defense, the United States Air Force, or Air University.

ABOUT THE AUTHOR

Major John V. Bartoli received his commission in 1997 through the Air Force Reserve Officer Training Corps. He entered active duty as an air battle manager and has flown more than 400 combat and combat support hours in Operations Southern Watch, Northern Watch, and Iraqi Freedom as an E-3B/C Sentry Weapons Director and Electronic Combat Officer. Major Bartoli graduated Magna Cum Laude from King's College, Pennsylvania with a Bachelor of Science degree in Accounting. In 2007, he was awarded a Master of Business Administration degree from Touro University International, graduating Summa Cum Laude, and a Master of Military Operational Art and Science with recognition as a Distinguished Graduate from Air Command and Staff College in 2009.

ACKNOWLEDGEMENTS

I owe the men and women of SAASS a great debt of gratitude for their guidance and their patience during the research. Their suggestions regarding my research were enormously beneficial to the completion of this project. I also must recognize the professionalism and generosity of the men and women of the 552d Air Control Wing at Tinker Air Force Base, Oklahoma. I would not have been afforded this opportunity without the encouragement and confidence demonstrated by those fine warriors. But above all, I am indebted to my family for their love, patience, understanding and perseverance.

ABSTRACT

This study examines the relationship between advanced integrated air defense systems and coercive airpower. Improvements in air defenses and the proliferation of air defense systems among states adversarial to the US threatens to degrade the effectiveness of airpower as a coercive instrument. SAM designers appear to have learned more effectively from airpower victories in the Bekaa Valley, Libya, and Desert Storm than the US and have made improvements to their systems that provide credible defense against stealthy aircraft. An adversary who possesses these systems may be able to dissuade the US from using airpower to coerce them for fear of suffering prohibitive losses. These systems make aerial coercion too risky and expensive to be considered an attractive option for national leaders. To reverse this trend, the US Air Force must restructure its force, acquiring large numbers of cheap, unmanned vehicles to swarm an enemy IADS instead of relying on a small force of gold-plated manned strike aircraft that may not be able to operate in the envelope of these lethal air defense systems.

CONTENTS

Chapter		Page
	DISCLAIMER.....	ii
	ABOUT THE AUTHOR.....	iii
	ACKNOWLEDGEMENTS.....	iv
	ABSTRACT.....	v
	INTRODUCTION.....	1
1	THE IADS.....	5
2	TRENDS AND EFFECTIVENESS OF AIR DEFENSE SYSTEMS.....	25
3	BACK TO THE FUTURE: COULD THE USAF BREAK THE IRAQI IADS AGAIN?.....	48
4	RESETTING THE CONTEXT.....	59
5	RECOMMENDATIONS.....	74
	APPENDIX – ACRONYM LIST.....	80
	BIBLIOGRAPHY.....	82

Illustrations

Figure		Page
1	SIMPLE C2 STRUCTURE.....	19
2	SECTOR CONTROL SYSTEM.....	20
3	ENGAGEMENT ZONES.....	21
4	SAMPLE IDENTIFICATION MATRIX.....	22
5	KARI ARCHITECTURE.....	35
6	DESERT STORM SEAD PLAN.....	37
7	DESERT STORM SEAD PLAN.....	42
8	F-35 RADAR SIGNATURE DIAGRAM.....	65

Introduction

The United States is the world's air power in the same sense that colonial Great Britain was a sea power. Both of these great states reigned supreme over a domain with such dominance that they could exert tremendous influence on the land domains. During the 20th century, airpower became an integral, if controversial, part of the American military identity. At Pearl Harbor, Japanese airpower inflicted a grievous wound on the American psyche. The US responded with astonishing rage and power, in large part delivered by long-range bombers escorted by long-range fighters and swarms of carrier-based dive bombers. American airpower in World War II (WWII) originated in the bosom of a burgeoning industrial behemoth and played a significant role in bringing the Axis Powers to their knees, culminating with the delivery of two atomic bombs to Japan that repaid the debt incurred during the ignominy of Pearl Harbor many times over.

In the wake of WWII, airpower shaped by the vision of Curtis LeMay and his vaunted Strategic Air Command (SAC) provided the first and most visible sign of American might during the Cold War. It was fitting that a global power separated by its adversary by two huge oceans grew into the mantle of the world's preeminent aerial power. By the 1990s, air power appeared to have become America's coercive weapon of choice.¹ Beginning with the remarkable display of aerial dominance during Operation Desert Storm and continuing through strikes against Bosnia and Kosovo, American leaders routinely sought to influence the behavior of adversaries via the use, or threatened use, of air power. These events reinforced the idea that the overwhelming might of American airpower ensured air superiority against any potential enemy. Massive investment of economic and intellectual gave us the unparalleled B-2 Spirit and F-22 Raptor as the manifestation of that assumption.

Despite such impressive machinery, however, the proliferation of advanced air defense systems have invalidated the assumption that air superiority and the ability to

¹ In *Arms and Influence*, Thomas C. Schelling defines "compellence" as the administration of punishment against a target until the target acts in the way the coercing state desires. In essence, Schelling's concept of compellence is offensive coercion, while deterrence is defensive coercion. Robert A. Pape uses the term "coercion" in a manner synonymous with Schelling's compellence. In this study, the term "coercion" is synonymous with "compellence."

compel an adversary into or out of certain behaviors are American birthrights. An integrated air defense system (IADS) composed of an overlapping, redundant network of modern active and passive sensors and advanced air-to-air and surface-to-air weapons integrated by robust digital command and control (C2) provide near peer competitors a credible defense against American airpower. As a result of IADS improvements, the fall of the Soviet Union, and a decade of low intensity conflict against enemies with obsolete IADS, the US Air Force is today structured poorly to conduct a coercive air operation against an enemy protected by state-of-the-art air defenses. China is the only strategic competitor of the US who currently possesses such an IADS, however Russia continues to improve its air defense technology and export this equipment to states unfriendly to the US like Iran and Venezuela. To regain the advantage in the struggle between offensive airpower and the IADS, the US Air Force must restructure itself to meet the threat.

Several factors contributed to the decline in coercive airpower's capability relative to the IADS. To begin tracing these factors, Chapter 1 of this study takes a reductionist approach to studying the IADS, examining each of its components: sensors, weapons, and C2 architecture. This chapter delves into the principal functions and organization of an IADS, though this examination is mostly in the context of a legacy IADS. Such an approach is necessary to demonstrate the linkages within the system that enable an IADS to engage and repel a threat.

A system is more than the sum of its parts, however. Chapter 2 abandons the reductionist approach and evaluates five conflicts of the 20th century in which air defenses and air power featured prominently. Examination of trends in Suppression of Enemy Air Defenses (SEAD) and IADS in the Yom Kippur War, the battle in the Bekaa Valley, Operation Linebacker II in Vietnam, and Operation El Dorado Canyon against Libya set the stage for an in-depth analysis of the destruction of the Iraqi IADS during Operation Desert Storm. Three trends emerge from these operations that indicate when SEAD and its supported offensive air operations should triumph over an IADS. The first of these trends is a high degree of integration between SEAD assets and their plan of attack with the rest of the strike package, including offensive counterair (OCA) and interdiction assets. The second trend is well-developed SEAD doctrine and training that enables the integration sought in the first trend. The final trend is the importance of

investing in the correct technology to defeat an IADS. Air defense is manifestly a highly technical undertaking.

As in any facet of warfare, human imagination and the genius of the commander can compensate for many technological shortcomings. Technology is extremely important, however, and a capable leader commanding a superbly trained and equipped force will normally defeat a capable adversary commanding superbly trained but inadequately equipped forces. It is the development of SEAD technology relative to that of air defense technology that has tipped the scales in favor of the defense in the game of aerial coercion. Humbled by the reverses of their air defense systems in the Bekaa Valley and the humiliation of watching their equipment dominated by American stealth and SEAD in Desert Storm, Russian SAM designers closed gaps in capabilities for dealing with American airpower, even as that fearsome air fleet contracted in the wake of the Cold War. The resultant technological improvements in air defenses have rendered existing SEAD equipment, doctrine, and tactics relatively obsolete. Technology is the linchpin in the IADS/SEAD contest.

Chapter 3 examines the repercussions of the Air Force's reduction in force after Desert Storm and evaluates the capability of the 2010 force structure against the operational problem posed by the 1991 Iraqi IADS. Despite the increased potency of the weapons in the US Air Force arsenal, the loss of standoff jammers, specialized SEAD assets, fighters, and bombers leaves the 2010 US Air Force in a weaker relative position than the 1991 Air Force against Saddam's IADS. This conclusion is sobering, considering the chasm between the capability of the Iraqi IADS and that of a modern IADS with a robust blend of active and passive sensors, double-digit SAMs and fourth and fifth generation fighters.

Chapter 4 examines the specific advancements in IADS technology and evaluates the impact of these systems on the efficacy of the US Air Force as a coercive instrument. The mastery of low-frequency emitters, cooperative engagement capability, digital data links, passive radar, and highly lethal mobile SAMs gives the IADS a pronounced advantage over American coercive airpower. The US Air Force could still defeat such an IADS, but at prohibitive cost that would leave the service a mere shell of itself at the conclusion of hostilities. This is far too high a price to pay to use airpower as a coercive

tool, except under the most dire circumstances. Until and unless the US restructures its Air Force to cope with these systems, adversaries who possess these air defenses will enjoy a period of strategic advantage during which they can advance national priorities such as a nuclear weapons program within their borders safely beyond the reach of American airpower.

Just as Russian air defense designers learned their lessons and closed the gap with stealth-enabled American airpower, the designers that fuel American airpower can do the same to restore the advantage. Such measures, however, will require a shift in the Air Force's organizational identity and approach to weapons system procurement. In order to close the gap, the US must invest heavily in producing the very systems capable of defeating stealth. It will take a commitment of that magnitude to learn how to defeat and exploit new air defense systems to enable stealthy aircraft like the F-22 and B-2 to do their work in the name of American interests. The US must also invest in stealthy ISR platforms that can operate closer to the enemy IADS and contribute to its disruption and degradation. More radically, the US Air Force must break with its infatuation for small numbers of gold-plated manned weapons systems and embrace large numbers of cheaper unmanned systems with the ultimate goal of being able to swarm an enemy air defenses, increasing the latent friction within the IADS and the accompanying noise level to mask stealth aircraft operations.

Finally, and probably most importantly, the Air Force should cancel or curtail procurement of the F-35. The F-35 will be obsolete before the first squadron declares its initial operational capability. The huge cost of this program, estimated at \$300 billion now and likely to climb higher, represent an opportunity cost too high to pay. Those funds must be redirected to more survivable, effective platforms for projecting airpower.

The US Air Force is at a crossroads. It must accept the looming sunset of the effectiveness of manned strike aircraft and structure itself to defeat the advanced air defense systems that are proliferating.

Chapter 1

The IADS

Introduction

The proliferation of advanced air defense systems threatens the ability of the US and its allies to gain and maintain air superiority. Since air superiority is a precondition for successful conventional military operations, these air defense systems jeopardize American airpower's value as a coercive instrument.¹ The modern IADS is an asymmetric response to American dominance of the air. In other words, a state need not develop better aircraft and man them with better pilots to defend against an enemy. The IADS constitutes a different option. By combining an array of sensors with weapons on the land and air, and then lashing them together with a robust C2 system, a state can degrade an adversary's ability to exploit the speed, flexibility, and if one believes Douhet, the inherent offensive nature of airpower.

This chapter examines the components of the IADS and the synergy that a state achieves when it properly integrates sensors, C2, and weapons systems. After examining the components and principles of integrated air defense, this chapter places the IADS in the context of a struggle between the dissuasive defensive power of the IADS and the compellent quality of airpower.

Air Superiority

Joint Publication 1-02, *Department of Defense Dictionary of Military and Associated Terms* defines air superiority as “that degree of dominance in the air battle of one force over another which permits the conduct of operations by the former and its related land, sea, and air forces at a given time and place without prohibitive interference

¹ In this context, the term “instrument” is a means by which something is done. A state can attempt to coerce a target state by applying pressure with a variety of economic, military, or diplomatic instruments. Airpower is one military instrument a head of state can choose to apply against a target state. This term implies that any coercive method will ordinarily be one of multiple instruments applied to coerce a target.

by the opposing force.”² The concept of prohibitive interference is essential. States will tolerate varying degrees of interference or losses depending on the circumstances. A war of survival, like that waged by Israel against a coalition of Arab states during the Yom Kippur War, implies a much higher tolerance for losses than a coercive air operation, like the NATO air operations against Serbia in 1999.

In recent decades, American forces have enjoyed an unparalleled degree of air superiority. Since Vietnam, the US has routinely achieved air supremacy against every adversary it has faced.. Air supremacy is a degree of air superiority “wherein the opposing air force is incapable of effective interference.”³ This level of dominance belies far less risk to American aircraft than that which might prevail under conditions of air superiority, and makes airpower a very attractive coercive instrument for American decision-makers.

The proliferation of advanced IADS increases the risk of conducting coercive air operations. Today, lesser powers like Venezuela and Iran can acquire highly capable air defenses that provide a credible defense against American airpower previously available only to peer or near-peer competitors like Russia or China. Defensive capability of this quality can make lesser powers unattractive targets for aerial coercion. This is a significant shift in relative advantage between offensive airpower and air defenses compared to the halcyon days of coercive airpower during the 1990s.

The IADS

Before examining the relationship between airpower and IADS, one must understand what capabilities are inherent to an IADS and how the system integrates different subsystems to defend against an air attack. The basic IADS consists of sensors, weapons, and C2. The sensors consist of active sensors and passive sensors, with the active sensors being the more important, diverse, and pervasive. These active sensors are radars and a basic IADS employs different radars for early warning, target acquisition, target tracking, and missile guidance.

In sequential terms, the IADS’ early warning radar is the part of the system that makes first contact with the enemy. These radars are typically powerful sensors capable

² Joint Publication 1-02, *Department of Defense Dictionary of Military and Associated Terms*, 12 April 2001, 21.

³ JP 1-02, *DoD Defense Dictionary*, 21.

of detecting targets at long range and their purpose is to alert the IADS to the position and direction of the enemy aircraft. Early warning radars achieve long range detection through high power output and relatively low frequencies. These characteristics, however, limit the accuracy of target information derived from the radar.⁴

To engage attacking aircraft, the IADS relies on ground control intercept (GCI) radars or target acquisition radars to obtain more accurate target information. GCI radars are designed to provide azimuth, range, and target information accurate enough for C2 operators to vector air defense fighters to intercept attacking aircraft. Any early warning radar system that can derive azimuth, range, and altitude information on a target and is integrated with the communications equipment to pass this information to other air defense assets can function as a GCI radar. Such radars can augment early warning coverage.⁵

Target acquisition radars, on the other hand, normally operate at higher frequencies than GCI or early warning radars and provide more accurate azimuth and range information for target tracking radars. In some weapons systems, the acquisition radar is a distinct radar from the other components, while in other systems, it is incorporated into the target tracking radar. The target tracking radar provides even more refined information. They tend to have higher frequencies, narrow beamwidths, and enough computer processing to provide continuous target updates that guide a missile or direct antiaircraft artillery to a target. The high frequency and the narrow beamwidth of these systems typically reduce the effective range and the scan volume of the sensor. The significance of the narrow beamwidth and reduced scan volume means that target tracking radars rely on other radars to find the target. A common analogy for trying to detect and acquire a target with a target tracking radar's beam is "scanning the sky for a bird while you're looking through a soda straw."⁶ Therefore, while a target tracker is effective for directing fire against a specific target, it does a poor job of detecting an incoming aircraft or strike package.

Once a target has been detected by the IADS, then acquired and tracked by a weapons system within the IADS, missile guidance radars come into play. Guidance

⁴ Air Combat Command Training Manual, *Electronic Warfare Fundamentals*, November 2000, 1-6.

⁵ ACC, *Electronic Warfare Fundamentals*, 1-7.

⁶ ACC, *Electronic Warfare Fundamentals*, 1-9.

radars are considered direct-threat sensors because they are communicating directly with a missile fired at the target. For the purposes of this description, there are two general types of guidance sensors: remote control missile guidance (MG) and homing guidance.

Remote control MG radars are ground-based radars that communicate with the missile and direct it to maneuver based on target information obtained by a target tracking radar and processed by a fire control computer. The MG might physically be part of a target tracking radar or be a separate piece of hardware. MGs transmit commands to the missile to alter its yaw, pitch, and roll as it maneuvers to intercept the target. MG radars can also provide fusing commands to the missile. The missile has an antenna and receiver/transmitter assembly in it to receive these commands. As the missile approaches a target, the tracking radar and fire control computer will continue to update the range, bearing, speed, altitude, and heading of the target, which will generate additional commands for the missile to be transmitted by the MG.⁷ Often, the radio frequency used by a MG is widely separated from the frequencies used by the tracking radar so the MG and tracking radars do not interfere with each other. There are multiple hybrids of remote control MG. For the purposes of this work, however, it is only necessary to understand MG as described above.

Unlike remote control MG, homing guidance involves the illumination of the target by a radar. The missile employed by a system that uses homing guidance differs greatly from the missile employed by the remote control MG system. Homing missiles possess on-board seekers and fire control computers that enable the missile to generate its own maneuver and fusing commands. Two general types of homing guidance are semi-active homing and active homing.

Semi-active homing missiles typically operate in conjunction with a continuous wave (CW) radar transmitter. CW radars do not send out pulses of electromagnetic energy. Instead the radar transmits constantly, “painting” or illuminating the target for the missile. The seeker and computer in the missile normally use the relative velocity between the target and the CW transmitter to guide to the target. Changes in this relative velocity create small shifts in frequency of the radar energy reflected by the target. Based on the difference between the original frequency and the reflected frequency, the seeker

⁷ ACC, *Electronic Warfare Fundamentals*, 8-1.

and computer command the missile to maneuver. When the missile is on an intercept course with the target, the difference in these signals will be close to zero. There will be a small difference because the missile will lead the target, attempting to meet the target at a point in space. This increases the range of the missile and decreases the engagement time, giving the target less time to evade. Once the missile computes its intercept path, it homes in on the radar energy reflected by the target and corrects for the target's evasive maneuvers.⁸

Active radar homing techniques improve on semi-active homing during the terminal phase of the intercept. Missiles associated with this type of system possess their own on-board radars. As the missile approaches the target, guided initially by either MG or semi-active homing, the missile active radar activates and guides the missile to the intercept. Active radar homing is typically associated with air-intercept missiles launched by fighter aircraft. Such missiles include the now-retired AIM-54 Phoenix, the AIM-120 AMRAAM, and the Russian AA-12 Adder. Active homing guidance has two major advantages relative to semi-active homing. First, the presence of an on-board radar improves the accuracy of these missiles during long range engagements. Second, they allow the fighter to turn away from the target as the missile enters the terminal guidance phase, increasing its odds of survival against a target that can shoot back.

Radar in these forms has been the most important sensor of any IADS. The combination of all of the radar types discussed above gives the IADS the vision required to defend its territory from an air attack. With the advent of the stealth aircraft used to devastating effect by the United States Air Force (USAF), passive sensors will become a more important component of an effective IADS. Passive sensors do not emit a signal. Rather, they act as receivers for emissions from a target. The passive sensors most relevant to an IADS are passive electronic sensors, infrared (IR) sensors, acoustic sensors, and optical sensors. Of these, passive electronic sensors are the most relevant to the IADS.

Passive electronic sensors are receivers that detect, identify, and locate a target by intercepting radio emissions made by the target. Emissions from an aircraft's multifunction radar, radar altimeter, data link, or voice radio are all subject to

⁸ ACC, *Electronic Warfare Fundamentals*, 8-10.

interception, and thus detection, by these systems. Passive electronic systems may have multiple networked locations separated by many miles to locate a target by simple direction finding (DF) techniques. The probability of a passive electronic system detecting a signal is affected by the location and sensitivity of the receivers and the emission's strength, and polarization.

The location of the receivers must provide for line-of-sight to incoming aircraft. Terrain featuring large mountains or deep valleys creates radar shadows that might mask attacking aircraft from active or passive sensors. Placement of the receivers must account for that challenge. Additionally, the receivers must be placed far enough apart and oriented perpendicularly to probable threat axes to increase the volume of area the system can cover and to produce enough angular displacement to enable DF.

Once a passive electronic system detects an emission, it identifies it by either automatic or manual means. Automatic identification involves the comparison to the parameters of the intercepted signal to a database of known electronic signals and their parameters. Manual systems normally operate in conjunction with an automatic system. Common methods for manual identification include visual identification via oscilloscope or auditory identification by a skilled operator. It is important to note that these systems identify emitters, not platforms. The identification of an emitter common to many platforms will not aid substantially in the identification of an aircraft. Generally, the proper identification of a platform requires the intercept of an emitter unique to a certain platform. For example, a signal identified as an APG-63 airborne interceptor (AI) radar would reliably indicate an F-15C. That emitter is unique to that platform. A signal identified as an APN-59, however, would not reliably indicate any platform. It is a common weather/navigation radar found on many different types of aircraft, from cargo transports to bombers.

While detection of a signal is critical, and identification of it is useful, it is the location of a signal that is most actionable for an IADS, for it is the location of an attacking aircraft that is required to direct ordnance at it. Passive electronic systems locate a target in one of three usual ways: triangulation, interferometry, and time of arrival (TOA).⁹ Triangulation is accomplished by taking direction measurements of an

⁹ ACC, *Electronic Warfare Fundamentals*, 17-15.

emission from multiple sources. When these measurements are consolidated and plotted, the lines of bearing will intersect. The intersection of those lines of bearing represents the probable location of the target.¹⁰

Compared to triangulation, interferometry is more complicated and technical. In simple terms, an interferometer uses at least two different receivers to intercept an emission. A computer compares the differences in the phase of the intercepted signal's waveform from each receiver. Based on the phase differential, the computer can compute an angle of arrival for the signal. If a piece of equipment has an array of interferometers that can measure and compare multiple samples of the same waveform simultaneously, it can rapidly determine the location of an emitter.¹¹

The TOA method of emitter location is similar to interferometry in that it requires two different receivers to intercept and compare characteristics of a waveform. Whereas interferometry measures a waveform's phase, TOA compares the time of arrival of a signal at different receivers to compute the distance of the emitter. Such a system can derive bearing information if it has at least one other receiver that is not in line with the first two receivers.¹²

Whereas passive electronic sensors intercept radio emissions from a target, IR sensors detect its heat emissions, or IR radiation. These heat emissions emanate from an aircraft's exhaust plume, engine parts, and skin. Taking these heat sources into account, an aircraft's vulnerability to IR detection depends on its aspect angle, airspeed, altitude, and afterburner state. With respect to aspect angle, an aircraft has a higher relative IR signature from the tail because the exhaust plume and engine parts are less obstructed by the body of the aircraft. Increased airspeed increases relative IR intensity because of greater engine temperature and friction between the air and the skin of the aircraft. At higher altitudes the aircraft's relative IR intensity increases from all aspect angles because thinner air results in less atmospheric attenuation of the IR emissions. Finally, if an aircraft is in afterburner, its exhaust plume will have a higher IR intensity.¹³

¹⁰ ACC, *Electronic Warfare Fundamentals*, 17-15.

¹¹ ACC, *Electronic Warfare Fundamentals*, 17-17.

¹² ACC, *Electronic Warfare Fundamentals*, 17-19

¹³ ACC, *Electronic Warfare Fundamentals*, 14-18.

Next to passive electronic sensors, IR sensors are the most relevant passive sensor in an IADS and are normally associated with weapons systems. Normally IR sensors are detection and guidance mechanisms for short-range air-intercept and surface-to-air missiles. Of the IR-guided SAMs, most are shoulder-launched, portable air-defense systems. IR systems are problematic for attacking aircraft because, unlike active radar sensors, IR sensors give aircrews no warning that a threat has acquired and tracked them. This greatly reduces the time an aircrew will have to react to the threat. For that reason, aircrews and planners should consider passive IR sensors to be a direct threat akin to target tracking or missile guidance radars.

Passive IR and radar sensors are relatively complex technical instruments that, when networked by effective C2, can give an IADS excellent situational awareness of the battlespace. With respect to air defense, the most relevant acoustic and optical sensors are human. More technologically advanced optical and acoustic instruments aid different military missions and roles. Advanced acoustic sensors, for example, have long been a vital part of naval warfare, particularly for submarines and the ships and aircraft that hunt them. Listening posts consisting of a man and a radio can report jet noise. Recent technology in acoustic sensors has profoundly affected the capability of ground troops to locate incoming artillery fire and facilitate counterbattery fire. In terms of air defense, however, the most effective acoustic sensors are people on the ground who hear and report jet noise. Attacking aircraft, particularly those executing low-altitude ingress, can use terrain to evade early warning radar, therefore delaying detection and frustrating the IADS ability to track and engage them. Listening posts can help the C2 of the IADS to fill in the gaps by establishing enough of a track for air defense fighters to attempt to intercept low flying, or even stealthy aircraft.

While acoustic detection of attacking aircraft tends to support the IADS by detecting targets, optical sensors, manifestly the Mark-1 eyeball, factor prominently in acquisition and tracking. Some SAM systems such as the Former Soviet Union (FSU)-manufactured SA-6 Gainful have the capability to optically track a target. Additionally, many older types of anti-aircraft artillery (AAA), notably the FSU-produced S-60 57mm, rely on optical tracking in the absence of an off-carriage fire control radar. Optical guidance is inferior in key respects to radar-guided weapons. For example, radar tracking

tends to be far more accurate than optical tracking. However, radar tracking will normally trigger a target aircraft's radar warning receiver (RWR), thereby warning the aircrew that a threat system is targeting its aircraft. This can give the aircrew ample time to deploy countermeasures such as chaff or a decoy as it maneuvers to evade the weapon. Optical guidance, on the other hand, gives no such warning. A SAM launched optically at target can delay illuminating its target with radar until the terminal phase of the engagement. This tactic will allow the target aircraft very little time to react to the incoming missile. Acoustic and optical detection and acquisition of target aircraft give the IADS added capability to engage attacking aircraft.

All of these sensors form what may be reasonably described as the eyes of the IADS. Air defenses also have weapons systems that act as the IADS' teeth. Air defense fighters, SAMs, and AAA use the information collected by the IADS to destroy attacking aircraft. Fighter aircraft are probably the IADS weapon of choice for most long-range engagements. Certainly, different countries have different orders of battles, and proficiency within their defense forces may differ. These factors will obviously affect the structure and tactics of different IADS. All things being equal, however, the fighter has the speed, range, and flexibility to engage attacking aircraft at greater ranges than surface-to-air weapons.

Effective air defense fighters tend to have six general characteristics: range/loiter, rapid deployment, agility, speed, avionics/sensors, and weapons.¹⁴ Clearly, range is an important characteristic for an air defense fighter. The goal of any such defensive weapon is to defeat an enemy before he can release his weapons. This implies the need for range to engage the enemy beyond his weapons engagement envelope. By engaging attacking aircraft at the most extreme range possible, fighters can begin to attrite them beyond the range of the IADS' SAMs and may be able to mount subsequent attacks on the leading edge of the incoming aircraft. A fighter with good range can establish a combat air patrol (CAP) far from the point it is defending to enable these engagements. For any aircraft, range is a compromise between speed and endurance. It is the optimal tradeoff between transiting between points in space and using as little fuel as possible in

¹⁴ M.B. Elsam, *Air Defence* (London: Brassey's, Maxwell Pergamon Publishing, 1989), 36.

doing so. Endurance is the characteristic that enables a fighter to loiter for the longest interval possible on CAP.¹⁵

While the ability to range about the battlespace and maintain an acceptable station time is important for an air defense fighter, the ability to deploy rapidly from a ground alert status is equally critical. Such rapid deployment is better known as a “scramble.” Rapid deployment of fighter aircraft could allow the direct engagement of incoming attackers or the relief of fighters who have exhausted fuel or ordnance during the course of an engagement. Additionally, fighters may rapidly deploy to reestablish a CAP if air defense fighters have been shot down by an offensive fighter sweep.

Two characteristics almost automatically ascribed to fighter aircraft are agility and speed. These are the hallmarks of the vaunted dogfighter, blazing across the sky to meet the enemy then rolling, banking, and diving in a deadly dance. For the purposes of a fighter, agility is essentially the possession of enough thrust and wing area to execute high performance turns. Most fourth generation fighters can achieve an instantaneous turn of nine times the centrifugal force of level flight, or nine “g’s.” These fighters can also sustain a turn of seven to eight g’s. Accompanying this remarkable agility is high speed. The air defense fighter needs to be fast to close quickly with attacking aircraft and engage them before they can attack their targets. Additionally, greater speed tends to increase the maximum range of air-to-air missiles. A faster fighter imparts more energy to its weapon merely by virtue of its speed than would a slower aircraft. At least as important as raw speed is the ability of an air defense fighter to rapidly accelerate to match the speed of maneuvering targets as they try to escape or deliver their ordnance.

The high speeds involved in modern aerial combat make integrated avionics and sensors essential for an air defense fighter. An air-to-air engagement could happen with astonishing speed, allowing the air defense fighter only seconds to maneuver into weapons release parameters. Capable sensors for attack, such as radar, and for defense, such as an RWR, aid the pilot in quickly acquiring and attacking targets while evading threats from enemy fighters. The three advancements in sensors and avionics pertaining to the IADS are pulse Doppler radar, improved computer processing, and data links. Pulse Doppler radar give an air defense radar “look down” capability. Obsolete pulse

¹⁵ Elsam, *Air Defence*, 38.

radars could not detect targets flying at significantly lower altitudes than the fighter. The relatively simple pulse radars would get huge returns from the ground, masking any radar return from the fighter. Because pulse Doppler radars discriminate radar returns based on the frequency shift caused by relative velocity of the target from the sensor, they are far more effective at detecting low-flying targets. This allows air defense fighters at high or medium altitudes to detect attacking aircraft attempting a low-altitude ingress.

While the capability of the pulse Doppler AI radar was a boon to fighter aircraft, it had its weaknesses. Vast improvements in computer processing allowed the integration of pulse radar with the Doppler radar to improve detection and tracking capability when the relative velocity of the target approaches zero. As the relative velocity of the target approaches zero, a Doppler radar will have trouble distinguishing the target from background clutter. The range of low relative velocity where this problem occurs is called the clutter notch. Another weakness of the Doppler radar that improved computer processing and pulse radar integration has fixed is poor range discrimination. Using pulse radar, radar processors can extract raw velocity and range information and convert it into target tracks.¹⁶

Pulse Doppler radars, pulse radar interleaving, and improved data processing have greatly increased the situational awareness a pilot can derive from his aircraft's sensors. The advent of data links have taken situational awareness to the next level and allowed pilots and air commanders at the operational level of war to gain awareness from offboard sensors. Data links are digital communications between stations and provide information for air defense entities at the tactical and operational levels. At the tactical level, data links allow fighters to share target information, and weapons and fuel state among flight members. Additionally, tactical data link between fighters and tactical C2 elements such as airborne early warning (AEW) aircraft or GCI stations give the fighters the benefit of a near real time picture of the air situation from the offboard surveillance radar. A link between tactical C2 elements and the fighters minimizes verbal radio communication because, as the adage goes, a picture is worth a thousand words. In addition to carrying a surveillance picture to the fighters, the link allows the fighters to digitally communicate their targeting responsibility to tactical C2.

¹⁶ Elsam, *Air Defence*, 46.

The value of datalinks is even more pronounced at the operational level. An Air Defense Operations Center (ADOC) or Sector Operations Center (SOC) can view an integrated air picture from a series of radars and tactical C2 units. They can also monitor the weapons, fuel, and engagement status of the air defense fighters and direct the deployment of additional fighters, tanker aircraft, or engagement direction to subordinate tactical units.

The final essential characteristic of the air defense fighter is air-to-air weaponry, and its employment depends on the successful leverage of the other essential fighter characteristics. Currently, the universe of air-to-air weapons for air defense consists of missiles and guns. The former category is subdivided into radar-guided missiles and IR missiles, with radar missiles divided further into semi-active homing missiles and active radar homing missiles. Radar-guided missiles have the longest range of these air-to-air weapons. In operational parlance, they are beyond-visual-range (BVR) weapons. Active radar homing missiles give the fighter the option of launching, then leaving the engagement before the missile impacts the target. Once the missile's radar activates, the fighter no longer needs to support that missile and can turn away from the target to preserve room for a subsequent commit, escape from an offensive fighter's engagement zone, or simply flow onto another target.

IR missiles also give the fighter launch and leave capability, although this advantage is diminished since they are typically short range weapons. Modern IR missiles are very resistant to IR countermeasures like flares and are deadly weapons, however, an air defense fighter in employment parameters for IR missile launch risks falling into the engagement zone of an enemy fighter's radar missiles. Additionally, when an air defense fighter has to close to within range of a target to launch an IR missile, the fighter will probably have forfeited a lot of space to allow for follow-on intercepts. In a defensive counterair scenario, a circumstance that demands the employment of an IR missile is less than desirable. However, the IR missile is a valuable tool for a fighter during such a less than optimal situation. The considerations for employing a gun in an air defense engagement are similar to those of the IR missile, but even less optimal. Air-to-air gunnery occurs at very short ranges, meaning that it may be

even more difficult for air defense fighters to flow to additional targets at the conclusion of the intercept.

SAMs have distinct advantages and disadvantages relative to air defense fighters. For example, a single SAM is far cheaper than the attacking aircraft it is intended to shoot down. A well-equipped SA-20 battery consisting of a C2 module, engagement, acquisition, and low-level early warning radar, and eight transporter-launchers with four missiles each costs about \$100 million. This system can defend an area with a radius of approximately 100 nautical miles.¹⁷ By comparison, the unit cost of a single F-35 is currently estimated to be \$120 million.¹⁸ Therefore, a robust air defense system would likely enjoy a numerical advantage in terms of missiles to targets. Additionally, SAMs are more persistent than air defense fighters. An enemy can position SAMs around high value targets or in defensive belts astride the attacker's probable axis of attack without its station time limited by fuel.¹⁹ Mobile short-range SAMs like the SA-8 Gecko, SA-11 Gadfly, or Roland can rapidly reposition to avoid interdiction by attacking fighter-bombers and are easily camouflaged. Therefore, they can avoid being targeted themselves while lying in wait for their targets.

Despite these advantages, SAMs will probably have shorter engagement ranges than fast air defense fighters. Even long-range SAMs like the American Patriot or FSU SA-5 Gammon and SA-10 Grumble family have a maximum engagement range shorter than a fighter able to traverse long distances rapidly and launch air-to-air missiles at long range. SAMs are either tied to a fixed point or certain area.

SAMs are excellent options for a defending nation to achieve defense in depth against an air attack.²⁰ Most SAMs are radar-guided and exploit either semi-active homing guidance, remote MG, or a hybrid of the two.²¹ Other systems, most notably portable, shoulder-fired missiles, are IR-guided missiles. IR-guided missiles have much

¹⁷ Carlo Kopp, "Almaz S-300P/PT/PS/PMU/PMU1/PMU2, Almaz-Antey S-400 Triumf, SA-10/20/21 Grumble/Gargoyle," Technical Report APA-TR-2006-1201, March 2009. <http://www.ausairpower.net/APA-Grumble-Gargoyle.html#mozTocId106894> (Accessed 4 May 2010). (*Chicago* 17.198)

¹⁸ US Air Force, FY 2011 Budget Estimates, "Aircraft Procurement, Air Force, Volume 1," February 2010, 1-1.

¹⁹ Elsam, *Air Defence*, 57.

²⁰ Michael Fiszer and Jerzy Gruszczynski, "Castles in the Sky," *Journal of Electronic Defense*, February 2002, 25, 2, P 46.

²¹ Elsam, *Air Defence*, 59.

shorter ranges than their radar-guided cousins. Belts of these weapons can combine long-range SAMs with shorter range variants whose interceptors offer better maneuverability or low-altitude performance. Combining systems in such a manner complicate a strike package's suppression plan by presenting numerous frequencies to jam and multiple sites to target. Furthermore, it also makes the strike package's ingress more difficult by denying it any sanctuary at extreme low or high altitude. A strike package that evades a medium range, high-altitude SAM like the SA-2 by maneuvering vertically will enter the engagement envelope of a shorter range system with better low-altitude capability such as the SA-3 or SA-6. As the strike package is forced to evade these additional threats, it faces an array of short range threats like AAA and short range, highly-maneuverable SAM systems.

Some advanced SAMs like the Patriot and SA-10, SA-12, and SA-20 family are extremely lethal. They employ advanced, multifunction phased array radars that scan large volumes of airspace rapidly, operate on multiple frequencies simultaneously, and possess extremely robust data processing capability. They tend to be very difficult to jam and possess missiles that are exceptionally agile, destructive, and impossible for existing aircraft to overfly.²² Modern SAMs like these are a component of advanced air defense systems that create serious problems for air planners.

Like its more advanced surface-to-air cousins, AAA also provides defense in depth. Normally, these shorter range weapons have lower engagement ceilings and are used to defend fixed points. Modern AAA systems like the ZSU-23-4 Shilka, a self-propelled, radar-guided system, are devastating against low-flying targets when the weapons are arranged effectively around small point-targets. AAA weapons generally represent the last line of defense of an IADS.²³

Thus far, discussion has focused on the eyes of the IADS and on its teeth. Continuing with the analogy, the nervous system of the IADS allows it to process the picture captured by its eyes and coordinate a response that involves fighting the attackers

²² Overflying a SAM site can mean one of two things. One meaning is the transit of an aircraft at an altitude that exceeds the maximum engagement ceiling of the system. Most modern systems have engagement ceilings that enable them to engage any air-breathing threat. The second meaning is that an aircraft can approach at low altitude, fly over the site at high speed, and recede too rapidly for the SAM to compensate and engage it. Many modern SAMs that store their missiles in vertical launch tubes may have little difficulty in engaging and destroying such a target.

²³ Elsam, *Air Defence*, 66.

with its weapons. The central nervous system of the IADS is its C2 network. It is an IADS' C2 that lashes the entire system together and makes the system much more than merely the sum of its parts. Before engaging in a description of what an IADS C2 structure is and does, it is worthwhile to address some similar terms, such as C3, which adds communications to command and control, and C4, which adds computers. For the purposes of this argument, all of these terms are interchangeable. Indeed, the terms communications and computers add nothing to the discussion. Communications and computers are so thoroughly assimilated into the command and control of military operations that the term C2 must imply the leveraging of communications and computers of many kinds.

Returning to the idea of C2 as an IADS central nervous system, it helps to describe the C2 in its most basic form: communications links among different components of the system that allow the air defense commander to concentrate dispersed resources and achieve mass at the decisive time and place. These communications links originally carried verbal communications or Morse code to an air defense operations center (ADOC) that technicians plotted on a board with grease pencil. Today, the

communications may be verbal via satellite communication (SATCOM) or digital communication that carries an integrated air picture to the ADOC and subordinate units.²⁴

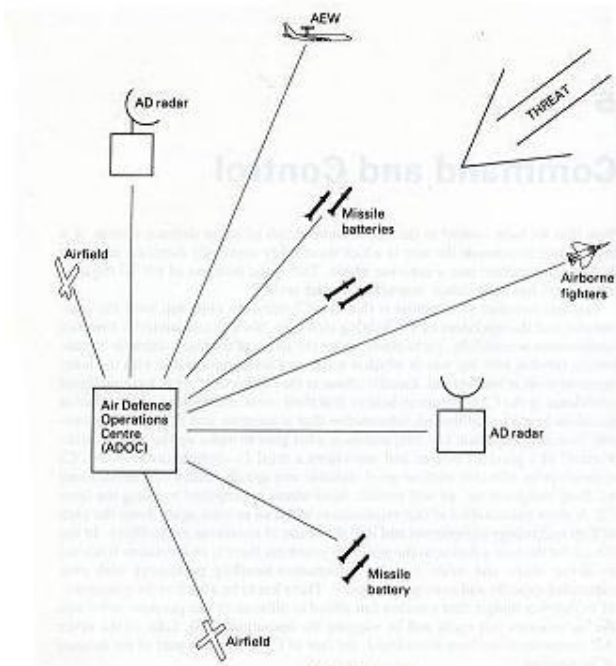

Figure 1. Simple C2 Structure

Source: Reprinted from M.B. Elsam's *Air Defence*

²⁴ Ibid., 68.

picture. In this graphic, the ADOC is a node that directs missile batteries and fighters to engage an incoming threat. The links between the ADOC and the airfields imply scramble authority for the air defense commander at the ADOC, as well as air raid warning from the ADOC to the fields.

The small, simple C2 structure shown in Figure 1 gives short shrift to the concept of decentralized execution. Most states possess far greater land mass with more vital centers requiring defense and a correspondingly vast volume of airspace for such a simple system to

work. Large, modern states will probably require many more sensors to monitor their air space and more airfields and air defense artillery sites with which to defend it. The ADOC assumes great risk of stifling initiative at the tactical level if it involves itself in detailed, local decision-making. The information from dozens or hundreds of sensors and the coordination with many surface-to-air and air-to-air weapons systems could overwhelm a single C2 node.

Figure 2 illustrates a more realistic C2 structure using a sector control system. In this C2 architecture, the battlespace is divided into geographically designated sectors. Each of these sectors has a SOC to direct air defense activities within its area of responsibility. In this arrangement, the ADOC will supervise the SOCs by providing direction on air defense priorities and allocating resources.²⁵ This allows for central control of national or regional-level air defense issues, but decentralized execution of air defense activities within a particular sector such as identifying unknown aircraft, committing fighters to an engagement, and resolving conflicts between SAM engagements and friendly aircraft. It is important to note that these sectors do not merely

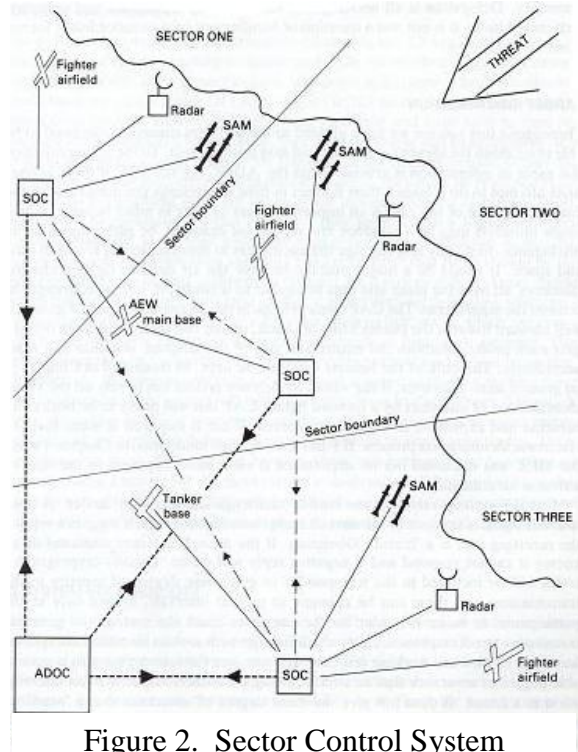

Figure 2. Sector Control System

Source: Reprinted from M.B. Elsam's *Air Defence*

²⁵ Elsam, *Air Defence*, 72

interact with the ADOC. They are very much integrated with each other and coordinate laterally with each other on operations that affect two or more sectors simultaneously.

On manner in which coordination between sectors is likely is in the management of a hostile aircraft transiting from one sector to another. Managing fighter or missile resources and being aware of adjacent sectors' resources add to the complexity of air defense operations. A C2 system must have a clearly defined airspace plan to cope with these issues. An essential piece of an air defense airspace plan is the management of fighter, joint, and missile engagement zones.

In a notional modern IADS, the ADOC, usually via a subordinate C2 unit such as an AEW platform, will direct air defense fighters on combat air patrol to engage an incoming threat. Figure 3 shows the air defense plan for this notional IADS. The fighter engagement zones (FEZ) are far to the East of the defended point and are situated to allow patrolling air defense fighters the first engagement opportunity. SAMs will not engage any attackers in the FEZ, mostly because of the extreme range from the missile batteries to their targets and the lower probability of kill (P_k) maximum range SAM shots. The air defense fighter, as directed by C2, will attempt to attrite the leading edge of an attacking force. Attackers that survive the air defense fighters will enter the shaded area labeled "Joint Engagement Zone."

Joint engagement zones (JEZ), according to Joint Publication 3-52, *Joint Doctrine for Airspace Control in the Combat Zone*, “involve the employment and integration of multiple air defense systems to simultaneously engage enemy targets in the operational area.”²⁶ The specific capabilities of the defending force and the threat it combats will shape the tactics and priorities for actual air defense operations. However, “successful JEZ operations depend on correctly identifying friendly, neutral, and enemy aircraft.”²⁷ In a high intensity air defense environment featuring large attacking forces, multiple strike packages, or multi-axis attacks, the IADS will have a better chance for success if it uses a positive control structure. Positive control means that C2 units will operate in conjunction with each other to provide targeting information, threat warning, and direction to the weapons systems. An IADS operating under procedural control, on the other hand, emphasizes detailed rules of engagement (ROE). In theory, procedural control measures allow air defense weapons to operate with relative autonomy. To be effective, however, the IADS must have weapons systems capable of correctly and consistently discriminating among friendly, neutral, and hostile aircraft. The shutdown

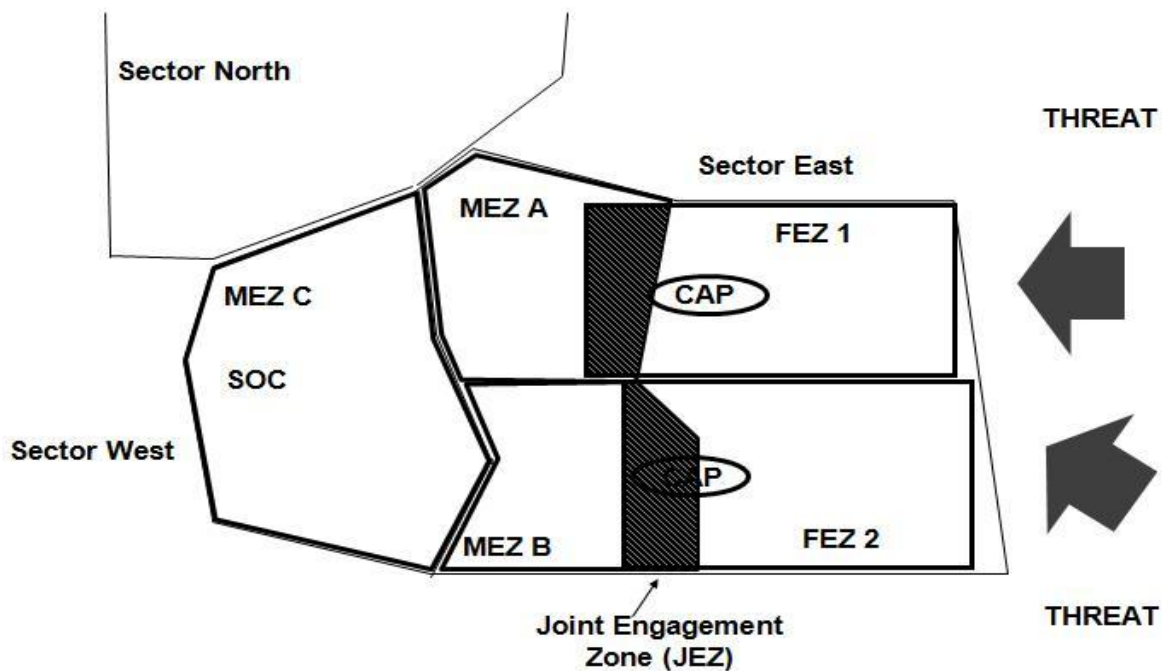

Figure 3. Engagement Zones

²⁶ Joint Publication 3-52, *Joint Doctrine for Airspace Control in the Combat Zone*, 30 August 2004, III-5.

²⁷ JP 3-52, *Joint Doctrine for Airspace Control*, III-5.

of two friendly fighters during Operation Iraqi Freedom in a relatively benign, permissive air-to-air environment indicates significant shortcomings in an approach using procedural control.

An effective C2 system can accelerate the pace of engagements to the benefit of the defenders. Using a vast array of radars, transponder interrogation, and a variety of electronic identification systems, the IADS can identify incoming targets and transmit those identities to the weapons systems in the battlespace, saving fighters and missile systems the trouble of identifying the tracks on their own.²⁸

Identifying tracks correctly is challenging in a high-intensity air defense scenario, but is essential to avoid fratricide and maximize scarce air defense resources, specifically irreplaceable fighters that require significant time to exit the battlespace, land, refuel, and rearm. Figure 4 is a notional identification matrix a C2 system might use in an air defense scenario. An IADS can employ any sensor or subsystem it possesses to advance through the identification matrix. In most cases, the IADS can cooperatively identify a target long

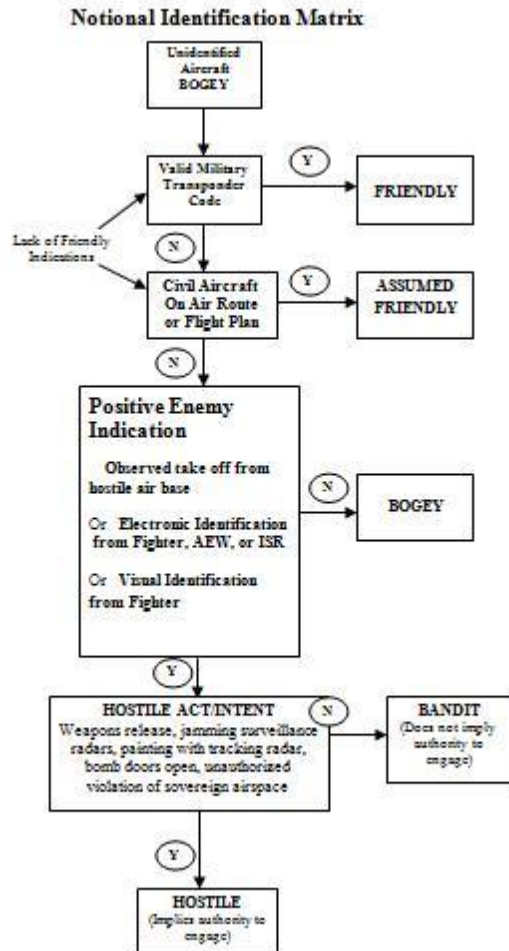

Figure 4. Sample Identification Matrix

before any single weapons system or sensor can do the same by itself. Following the matrix, IADS EW radars, including AEW, will interrogate an unknown aircraft for a

²⁸ Electronic identification (EID) is a term that encompasses a wide range of capabilities. Some fighters possess their the ability to interrogate a target for its military transponder code. Other types of EID include systems that measure the acoustic, thermal, radio, or radar emissions of a target against a database of known characteristics to identify a target. ISR aircraft like the US RC-135V/W Rivet Joint and the E-3 Sentry AWACS aircraft have some ability to EID targets. Ground-based passive sensors also have the capability to identify aircraft based on emissions.

military transponder. Also called Identify Friend or Foe (IFF), this system will reply with a valid encrypted response when interrogated. A positive reply indicates a friendly military aircraft. Another transponder mode will reply with a specific 4-digit octal code, allowing C2 to identify the aircraft not only as friendly, but as a specific aircraft by correlating the coded reply to the code and the aircraft to which it is assigned from an air tasking order (ATO).

The matrix accommodates the likelihood of civilian or neutral air traffic that may be in the field of fire between defending and attacking aircraft by interrogating civil transponders. These transponder checks are done to verify the presence or absence of friendly indications. To identify an engage an aircraft, the notional IADS must verify not only the lack of friendly indications, but also a positive enemy indication. IADS possess sensors such as passive electronic detection that can identify airborne emitters and determine the specific emitter type. Only by determining a lack of friendly indications and a positive enemy indication, can this IADS identify the aircraft as an enemy, or in USAF parlance, a “bandit.” Once a bandit commits a hostile act or demonstrates hostile intent, air defense weapons are authorized to engage it. By combining intelligence on enemy capabilities, intentions, and actions with the air picture, the ADOC may be able to determine that an enemy intends to attack and can establish ROE that establish a positively identified enemy aircraft or formation approaching from a particular bearing that violates sovereign airspace as hostile. Such operations require a high degree of integration and coordination.

Despite effective coordination and integration, attacking aircraft might penetrate the JEZ and reach the missile engagement zone, or MEZ. In Figure 2, the MEZs lie to the West of the JEZ and FEZ. A MEZ is an area in which SAMs are the primary weapon. Joint Publication 3-52 states that MEZ operations are “ideal for point defense of critical assets, protection of maneuver units in the forward area, and area coverage of rear operations.”²⁹ The SAM systems that defend the MEZ will receive the integrated air picture via data link. This allows the missile batteries to keep their sensors in stand-by, using the data link picture to monitor incoming threats. Only when the attacking aircraft enter their missile engagement envelopes, will the SAM radars activate to acquire and

²⁹ JP 3-52, *Joint Doctrine for Airspace Control*, III-5.

track attacking aircraft. This delayed radiation by the SAMs protects them from effective jamming, geolocation by enemy ISR aircraft for targeting, and anti-radiation missiles. Delayed activation also gives attacking aircraft less time to react to SAM launches.

Summary

The real defensive value of the IADS lies in the synergy it achieves by tying together sensors and weapons with C2. It enables a defending state to concentrate dispersed air defense fighters against an attacking aerial force and attrite the attackers in a manner consistent with the Jominian dictate to concentrate force at the decisive point. Surviving attackers must then cope with fixed surface-to-air weapons arranged in either defensive belts or clustered around high-value targets.

A well-integrated IADS with a dense array of radar sensors operating across a wide-range of frequencies can create significant problems for an attacking force. It is more difficult to jam the EW radars of such a system, because the jammers are not able to concentrate their jamming on a few specific frequency sets or waveforms. More significantly, a dense sensor array will provide cueing to weapons systems via a C2 network that will allow SAMs and AAA to delay activation of their radars, while still gaining situational awareness through data links or voice reports of incoming tracks. By minimizing their radar emissions, SAM and AAA sites will deny electronic support aircraft the ability to locate mobile or recently-established batteries. Furthermore, antiradiation missiles will find fewer signals they can follow to their targets.

The mere possession of an IADS, however, does not mean that a state can dissuade or defeat potential attackers. Effective SEAD plans have disrupted or destroyed IADS and enabled the attacking force to strike vital targets in some conflicts. So, too, IADS have indeed inflicted painful enough losses on attacking air forces to force them to change how they operate. In a kinetic fight, the admixture of these opposing forces often determines who wins and loses the battle.

Chapter 2

Trends and Effectiveness of Air Defense Systems

Introduction

The disparate Israeli experiences during the Yom Kippur War of 1973 and over the Bekaa Valley in 1982 illustrate two important features of IADS. First, during the Yom Kippur War, the Arab IADS demonstrated how much damage air defenses with a technological edge could do to an air force which lacked a coherent SEAD doctrine. Second, in the Bekaa Valley, Israel illustrated how an air force can successfully operate against a formidable IADS when it tightly integrates SEAD activity with counterair and interdiction and makes the destruction of the IADS a priority. Those two conflicts juxtapose effective integrated air defense and an emphatic response because they feature the same combatants operating against each other in the same battlespace with a mere nine year interval between conflicts.

For Israel, these conflicts were matters of survival. For the United States, any conventional military operation it undertakes in the near future will probably be a matter of compellence. Therefore, while the Israeli examples isolate the variables of integrated air defense and a response to it, the cases of American B-52s during Linebacker II in Vietnam and the 1986 Eldorado Canyon raid against Libya are relevant because they extend the trend revealed in the Israeli cases to operations in which the US used its airpower to compel an enemy.

These events provide superb background for evaluating the destruction of the Iraqi IADS during the preeminent coercive campaign in recent military history: Operation Desert Storm. Saddam's impressive Kari C2 system integrated an impressive array of weapons and sensor. Indeed, the planners of Desert Storm considered the Iraqi IADS to be one of the most formidable on the planet and it was one of the four centers of gravity identified by Colonel John Warden, father of the original concept for the Desert Storm strategic air operation.¹

¹ *Gulf War Air Power Survey*, vol. 1, *Planning and Command and Control*, part 1, *Planning* (Washington DC: US Government Printing Office, 1993), 141.

Three general trends emerge from the Israeli and American experiences with IADS. First, an attacker is more likely to defeat an IADS when his SEAD plan is well integrated with the attacking force. Second, successful SEAD operations require proper doctrine and training, if not outright rehearsal, which in turn requires a vast collection and analysis of intelligence. Third, technology, while not the final arbiter, is incredibly important. Advanced jamming equipment and techniques, precision guided munitions, and state-of-the-art antiradiation missile technology tend to tilt the scales in favor of the attacker.

Offense Versus Defense: The Yom Kippur War

During the Yom Kippur War of 1973, the Israeli Air Force became aware that advanced IADS could swing the pendulum in favor of the defensive. During the first three days of the war, it lost approximately 150 aircraft to Egyptian and Syrian radar-guided SAMs and AAA. These losses amounted to more than a quarter of its combat force. The Israelis were unprepared for the new SA-6 Gainful SAM and its Straight Flush Target racking radar which was undetectable by Israeli passive electronic detection equipment or anti-radiation missiles.²

Fortunately for the Israelis, they retained air superiority over most of their own air space and neither side possessed air superiority over the battlespace. Within their SAM umbrella, the Arabs denied the Israelis access to the sky and denied Israeli ground forces close air support (CAS). Outside that umbrella, the superior skill of Israeli pilots denied Arab air forces access to the battlespace. Beyond the range of Arab SAMs and AAA, the Israelis exacted a gruesome toll of 456 losses from the Arab air forces. Eventually, the Israelis destroyed or exhausted 27 of 36 of the Syrian missile batteries in the Golan Heights, but at very high cost to its air force.

Lack of discipline on the part of Syrian SA-6 operators provided the Israelis with the reprieve needed to score this victory. The profligate firing of missiles at Israeli aircraft exhausted their stockpiles and resupply was not prompt enough to keep the batteries armed. But it had been a close call. Hanoch Bartov, the biographer of Israeli Chief of Staff David Elazar concluded, “if another four to five days of erosion are

² James R. Brungess, *Setting the Context: Suppression of Enemy Air Defenses and Joint War Fighting in an Uncertain World* (Maxwell Air Force Base, AL: Air University Press, 1994), 16.

allowed to pass before the counter-attack commences, the air force may reach its ‘red line.’” As it was, by denying the Israelis the ability to operate in the air, without prohibitive interference from enemy forces, the Arabs denied Israeli ground forces the CAS to which the army was accustomed. Eventually, the shortage of Arab missiles, savage artillery bombardment of SAM sites by the IDF, and the moral imperative accompanying a war of national survival helped the IDF carry the day.

The Pendulum Swings: The Bekaa Valley, 1982

The Israeli air operation in the Bekaa Valley during the 1982 war in Lebanon indicated how well the Israelis internalized the lessons of the Yom Kippur War. Lt Gen Kelly H. Burke, USAF, Retired, former US Air Force Deputy Chief of Staff for Research, Development and Acquisition claimed that Bekaa Valley “was the war of the future—a war in which electronic combat was a central and dominant theme, featuring drones to deceive and saturate the IADS, improved anti-radiation missiles, and extensive jamming of Syrian radar and communications. During the 10-day air operation, the IDF smashed 20 Syrian SAM sites, including SA-2s, SA-3s, SA-6s, and SA-8s.³ Israel lost two aircraft; one to an SA-6 battery, the other to an unidentified ground system.⁴ In the air, the Israeli Air Force dominated, claiming an 87:0 kill ratio.”⁵

The reason for this reversal of fortune stems from a profound doctrinal shift. In the Yom Kippur War, suppression of enemy air defenses (SEAD) was a support role performed through piecemeal commitment of specialized resources to a larger mission. SEAD training was minimal and not integrated very well with other operations. During the Lebanon war, however, the destruction of the IADS in the Bekaa Valley was the top priority. Israeli forces trained exhaustively to take down the IADS and integrated SEAD thoroughly with other mission sets like interdiction and counterair.

Israel developed a complex three-phase plan to destroy the IADS. The first phase used decoys, jamming, and feints from multiple axes to confuse and saturate the IADS. The second phase involved harassment and minor kinetic engagement of some sites to increase pressure on the system. Finally, the third phase was the destruction in earnest of

³ Brungess, *Setting the Context*, 17.

⁴ Greenhous, “The Israeli Experience,” 601.

⁵ Brereton Greenhous, a 25-year veteran historian of the Canadian Department of National Defense, acknowledges that this 87:0 kill ratio is impossible to verify but is “very likely correct.”

the IADS sites. Syrian error aided Israeli preparation by placing their mobile systems in fixed site locations, which made targeting easier. Moreover, the deception phase induced the Syrians to commit against the feints. SOC controllers were quickly overwhelmed by the combination of feints, false targets, drones, and jamming. Syrian fighters blundered into ambushes in which they pursued false targets into an area vulnerable to air-to-air attack, only to have the Israelis jam their GCI communications. The Israelis then slaughtered the suddenly-abandoned GCI-dependent fighters. Within the first hour, the Bekaa Valley IADS was decisively broken.⁶ What a difference nine years had made.

The Trend Continues: Linebacker II

As with the Israeli experience, the cat and mouse game between IADS and airpower pitched back and forth, with different combinations of tactics and technology granting temporary advantage to one side before a countermove reversed their fortunes. Earlier in the war, improved North Vietnamese IADS C2 more thoroughly integrated more sophisticated Soviet-made radars, passive sensors, communications, fighters, SAMs and AAA. This increased IADS efficiency reduced the American air-to-air kill ratio from 2.2:1 to 2:1.5, and even less than 1:1 for short periods. America countered with improved integrated tactics, specialized SEAD aircraft, jamming techniques, precision guided munitions (PGM), and improved anti-radiation missiles.⁷ US forces seized air superiority again, paving the way for SAC's B-52s to help compel the Vietnamese to negotiate.

During the Vietnam War, the 11-day air operation in December 1972 known as Linebacker II saw SAC's mighty B-52 bombers join the fray. SAC was the preeminent Cold War force, maintaining an armada of nuclear bombers and nuclear-tipped intercontinental ballistic missiles (ICBM) poised to rain nuclear hell on the Soviet Union. SAC was not, however, a force accustomed to conducting tactical operations in a jungle environment.

SAC B-52s possessed electronic warfare capability and aircrews who had honed their readiness and skill at delivering nuclear weapons to targets deep inside the Soviet Union. Unfortunately, their electronic warfare capability was designed to counter

⁶ Brungess, *Setting the Context*, 22.

⁷ Brungess, *Setting the Context*, 15.

specific threat systems and not against integrated air defenses. Additionally, the strategic bombing mission required B-52s to penetrate Soviet airspace unescorted. They did not train to operate as part of an integrated air attack. As a result, it was very difficult for them to cope with the formidable North Vietnamese IADS. Poor tactics, coupled with unprepared, yet overconfident aircrews, and the failure to integrate tactical SEAD assets with the strategic bombers led to 11 B-52 kills for North Vietnamese SA-2s.⁸

Faced with such grievous losses, American air planners adopted the same plan that Israeli planners would employ a decade later in the Bekaa Valley. They made the destruction of the North Vietnamese IADS a priority to pave the way for the B-52s to punish the North Vietnamese and compel them to return to the negotiating table in good faith. The results of integrating tactical SEAD assets with the B-52s were startling. In April 1973, the US launched a series of B-52 strikes against North Vietnam. During this period, integrated packages of counterair fighters and SEAD assets escorted the bombers. A typical support package contained eight counterair fighters, ten SEAD fighters, four stand-off jammers blinded North Vietnamese radars, and twenty laying a huge chaff corridor to conceal the bombers' approach. The strikes targeted petroleum facilities and military airfield and inflicted relatively modest damage. The psychological impact on the North Vietnamese military, however, was profound. They were "appalled at the ineffectiveness of their defenses. The air defenders did not even know that B-52s had been in the attack force until the following day, when a team from the Air Defense Headquarters...analyzed the bomb craters."⁹ Once the North Vietnamese IADS was broken, it took three days for the North Vietnamese to return to negotiations.¹⁰

Small Scale Compellence: El Dorado Canyon

The April 1986 raid against Libya by US forces represents an evolution of the direct kinetic attack tactics American and Israeli SEAD professionals employed in Vietnam and Lebanon. There are two reasons why the evolution evidenced in the Operation El Dorado SEAD-IADS contest is noteworthy. The first reason is a political factor that helps explain in part why American leaders favored airpower as a compellent

⁸ Brungess, *Setting the Context*, 9.

⁹ Stephen P. Randolph, *Powerful and Brutal Weapons* (Cambridge, MA: Harvard University Press, 2007) 121.

¹⁰ Brungess, *Setting the Context*, 9.

instrument. The bitter experience of the Vietnam War, according to retired Air Force Lt Col James R. Brungess, winner of the Air Force Historical Foundation's 1992 Colonel James Cannell Memorial Award for his book *Setting the Context: Suppression of Enemy Air Defenses and Joint Warfighting in an Uncertain World*, created an unspoken objective of American combat to avoid casualties.¹¹ The USAF honored this objective by developing robust SEAD capabilities that made its tactical forces more survivable in the face of formidable enemy IADS.

The second reason is that this raid was the clearest example of joint SEAD. It was a deliberate effort to integrate Air Force and Navy SEAD capabilities against an impressive IADS that consisted of Soviet and Western equipment. While lacking the most formidable Soviet SAM of the day, the SA-10, Libya's IADS boasted the SA-2, SA-3, SA-6, SA-8, as well as the Crotale, a formidable French short-range SAM.¹² Furthermore, the early warning and naval surface search radars that could detect and cue Libyan weapons in targeting the American raid were of Soviet, German, British, and French origins. By integrating Air Force and Navy SEAD assets, the Americans would be able to maximize jamming coverage of the Libyan EW net. Additionally, this plan made best use of the limited number of antiradiation missiles available for the strike.

The Libyans, however, had learned their own lessons from the Bekaa Valley and assembled an IADS with a technical structure to counter US strengths. After all, the Israeli SEAD equipment and tactics used to devastating effect in Lebanon were of American origin. To assemble their IADS, the Libyans built a dense EW net in which the loss of a single EW radar would not create a gap. Also, they used selected systems for their IADS that used a very diverse set of frequencies that required an attacking force to spread jamming power across a broad swath of the electromagnetic spectrum and make it difficult to concentrate jamming power to blind Libyan EW. The diversity of the systems also had the potential to complicate the self-protection jamming scheme of an attacking force because of a variety of waveforms. Finally, the Libyans used multiple radio links

¹¹ Brungess, *Setting the Context*, 28.

¹² Joseph T. Stanik, *El Dorado Canyon* (Annapolis, MD: Naval Institute Press, 2003), 184.

as well as hardened land lines for redundancy to mitigate the possibility of an enemy decapitating its command structure.¹³

The joint SEAD plan was predicated more on jamming Libyan radars than on bombing missile sites, although the Navy did bomb radar sites to enable the attack on Benghazi. By concentrating jamming capability on EW radars, the US strike package would stimulate the IADS, forcing the SAMs to activate the radars and making them more susceptible to American antiradiation missiles. The attacking aircraft approached at very low altitude to delay detection by Libyan EW radars, then began jamming the EW radars while launching a hailstorm of antiradiation missiles at known SAM sites. The SEAD plan was devastating. Libyan EW radars could not acquire targets, delaying launch decisions because one glaring flaw in the Libyan IADS was highly centralized control and execution. The antiradiation missiles hit numerous radars, blasting gaps in the IADS. SAM and AAA operators did launch many projectiles to counter the raid, but most were unguided and totally ineffective. The strike package lost only one aircraft, an F-111 shot down by an undetermined surface-to-air system.¹⁴

The lopsided results of the SEAD-IADS contest in the El Dorado Canyon raid resulted from excellent planning and execution from the Americans and a few serious flaws in the Libyan IADS. Clearly, the Americans effectively integrated Navy and Air Force assets to blast some holes in the Libyan phalanx and enable the successful raid. The US military invested heavily in the superb AGM-88 High-Speed Antiradiation Missile (HARM) and sophisticated jamming gear that proved more than a technical match for the older Libyan sensors and weapons. However, the defeat of the Libyan IADS was made more certain by limited proficiency in its air defense pilots, AAA and SAM operators, and C2. The highly-centralized IADS could not react quickly enough to the loss of its EW coverage and the SAM operators failed to take initiative and operate autonomously.

Desert Storm and the IADS Take-Down

The destruction of Saddam's IADS was essential to the achievement and maintenance of air superiority. According to Volume 1 of the Gulf War Air Power

¹³ Brungess, *Setting the Context*, 28.

¹⁴ Stanik, *El Dorado Canyon*, 190.

Survey (GWAPS), planning for the opening phases of Desert Storm was replete with mentions of suppressing or destroying the IADS.¹⁵ Phase III of the campaign plan also prominently mentioned the suppression of the IADS. This phase required attacks against Iraqi combat units, with an accompanying shift in coalition airpower efforts to cut Iraqi supply lines and C2 in southern Iraq and Kuwait. The commencement of Phase III, however, was contingent on the neutralization of Saddam's air defenses.¹⁶ The imperative to suppress or destroy the IADS was expressed in US Central Air Force's target list. Of 218 targets for the first 48 hours of the war, 123 were air defense targets, airfield targets, or C2 targets that supported the IADS. Most of the remainder was sites believed to store chemical or biological weapons.¹⁷

Kari

At the center of the fearsome Iraqi IADS was the French-built C2 system called Kari, which is simply the French word for Iraq spelled backwards. Figure 5 shows Kari's basic structure. It was highly centralized, with an ADOC

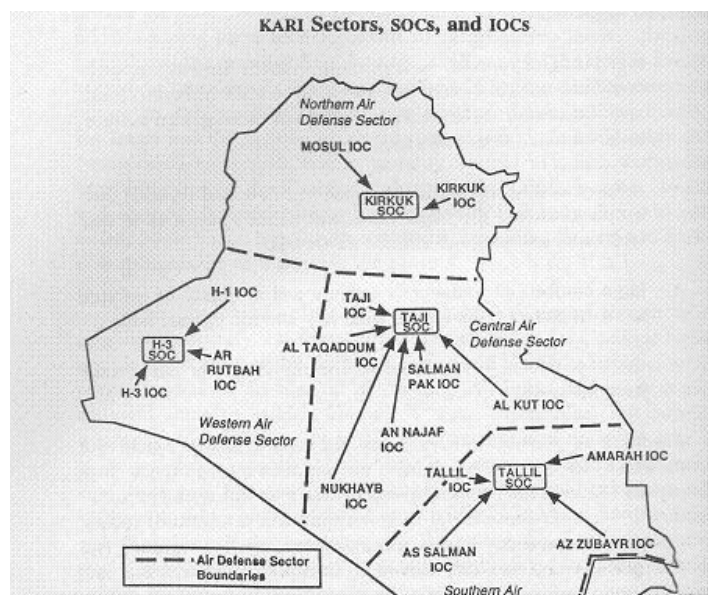

Figure 5. KARI Architecture

Source: Reprinted from Gulf War Air Power Survey

located in Baghdad and 4 SOCs controlling air defense assets. A 5th SOC was to be established in Kuwait, but was never completed. The system was focused on meeting long-distance Israeli threats and Iranian threats. Intercept Operations Centers (IOC) subordinate to SOCs supervised GCI, SAM, and AAA activity, and coordinated the flow of information from individual radar stations and visual-reporting sites to the SOCs. Information then flowed down to AAA units, bases, and SAMs. The Baghdad ADOC made the crucial decisions while the Kari system

¹⁵ GWAPS, Vol 1, Part 1, 5.

¹⁶ GWAPS, Vol 1, Part 1,6.

¹⁷ GWAPS, Vol 1, Part 1,48.

connected the network's elements together. It possessed land-line and microwave communications to lower echelons with redundant land lines between SOCs and the ADOC. The Iraqis established IOCs near telecommunications hardware that had voice and data communications capability. These SOCs and ADOCs resided in hardened shelters.¹⁸ Kari was more complex in terms of C2 structure, extensive in terms of sensor coverage, and networked with far more weapons systems than the Libyan IADS blitzed so effectively by the joint force that executed the El Dorado Canyon raid.¹⁹

Iraqi leadership thought Kari would give them the ability to weather an air campaign. Their plan was to inflict heavy enough losses on attacking air forces to convince the enemy to abandon air operations and commence a ground campaign. According to the GWAPS, "Iraqi air and air defense planners operated on the assumption that while its air force could not contest coalition control of the skies, its ground-based air defenses could neutralize or degrade the coalition's effectiveness. While ground-based air defenses would provide point defense of vital civilian and military targets, the air force would conduct hit and run or suicide operations against high value targets such as AWACS aircraft and large naval vessels in the Gulf, and attempt to pick off straggling coalition aircraft."²⁰ The primary weapons of the Iraqi IADS were SAMs and AAA. On paper, defenses were impressive, with 500 radars in more than 100 sites and SA-2, SA-3, SA-6, SA-8, and Roland coverage. Iraq possessed more than 8000 AAA pieces. They placed approximately 4,000 fixed and mobile AAA pieces and SAMs around Baghdad.²¹

Saddam rested his hopes of repelling a coalition air armada on these surface-to-air weapons. He lacked faith in the capability of his air defense fighter pilots to contest the skies with American pilots, and wanted to spare his fighter fleet. Saddam's trend of reticence to risk his air force originated during the Iran-Iraq War. The Iraqi aircraft were incapable of distinguishing friendly aircraft from hostile ones and did not engage Iranian aircraft ranging the skies over Iraq. Saddam thought that withholding his aircraft from combat with the Iranians was an intelligent strategic calculation. "We will not use our air force," he said. "We will keep it. Two years hence our air force will still be in a position

¹⁸ *Gulf War Air Power Survey*, vol. 2, *Operations and Effectiveness*, part 1, *Operations*, (Washington DC: US Government Printing Office, 1993), 82.

¹⁹ GWAPS, vol 2, part 1, 117.

²⁰ GWAPS, vol.1, part 1, 70.

²¹ GWAPS, vol 2, part 2, 79.

to pound Bani-Sadr [then prime minister of Iran] and his collaborators.”²² While his air force would improve, by the time the coalition commenced Desert Storm, Iraqi pilots did not excel in air-to-air training and lacked proficiency in dynamic tactical situations. Soviet trainers assessed less than half the students whom they passed as possessing the ability to fly in line Soviet

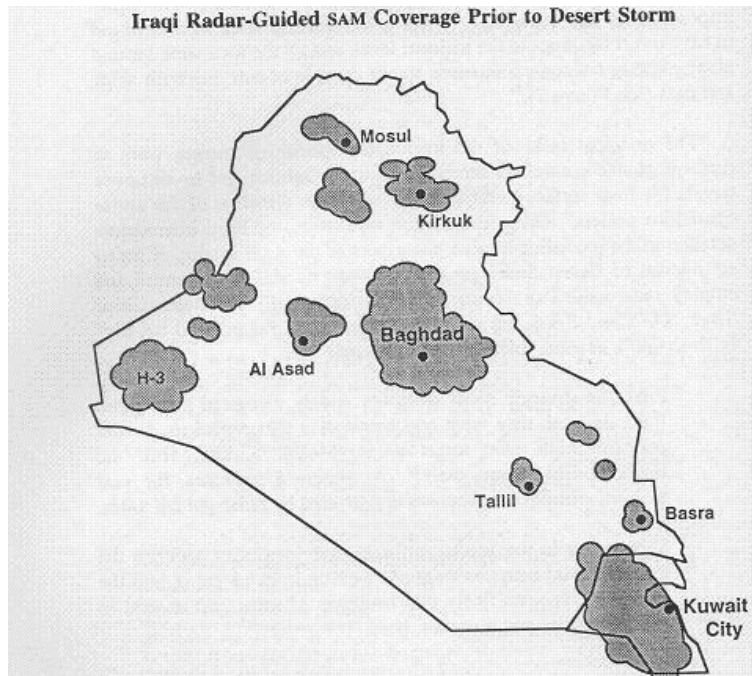

Figure 6. Pre-Desert Storm Radar SAM Coverage
Source: Reprinted from Gulf War Air Power Survey

fighter units which were inferior to their adversaries in the USAF. The Desert Storm air planners assessed that no more than 50% of Iraqi pilots would even qualify to be pilots in the USAF and many thought the real number of Iraqi pilots capable of meeting minimum US standards was closer to 20%. This lack of air-to-air proficiency stemmed from the Iran-Iraq War, in which Saddam’s best pilots were assigned to aircraft charged with performing CAS.²³ The Iran-Iraq War taught the Defense Intelligence Agency (DIA) that Saddam’s air force could not and would not make a serious effort to defend its airspace. Just as importantly, the DIA also recognized another key vulnerability in the Iraqi IADS: its tendency toward highly-centralized operations.²⁴

While the surface-to-air portion of the IADS was undoubtedly its strong suit, the Kari system had significant weaknesses. French developers oriented it to repel attack from Iran in the east and Israel in the west. Coverage toward Saudi Arabia was weak. Additionally, there were large gaps in SAM coverage. As Figure 6 shows the Iraqi IADS clustered most SAMs and AAA around key cities, making some sectors very well-defended. Others were relatively undefended, with much open airspace allowing the

²² Saddam Hussein quoted in GWAPS, vol 2, part 2, 74.

²³ GWAPS, vol 2, part 2, 77.

²⁴ GWAPS, vol 1, part 1, 206.

coalition to mount an multi-axis attack. Most glaring was a dead zone in the western and central sectors that created an avenue of approach from Saudi Arabia right to Baghdad. Finally, the system was designed to deal with threats in terms of number and quality from other Middle Eastern force structures. The threat that coalition airpower posed to far exceeded the threats Kari was designed to repel.²⁵

While the C2 capability was impressive within the context of the threat it was designed to defeat, Kari had to contend with other handicaps imposed upon it from Saddam himself. The IADS was not only centrally controlled, it executed centrally, as well. The ADOC coordinated all activities among the SOCs, and was believed by coalition intelligence analysts to be under the direct control of Saddam.²⁶ This degree of micromanagement permeated the entire IADS. Violations of radio discipline invited punishment such as death or imprisonment. As a result, commanders issued only very general mission type orders to subordinates, such as “defend your sector,” yet the training regimens for subordinate units featured detailed direction for local employment. This created a gap in substantive coordination between echelons or adjacent units in a high-stress combat situation. Thus, Saddam’s extreme micromanagement caused the operators of the Kari system to perform in a manner that did not take advantage of the full capabilities of the system.²⁷ Another significant problem that plagued the IADS was the impact of economic sanctions. By the time the war began, approximately 20% of Iraq’s combat aircraft were grounded because of maintenance. The surface-to-air weapons systems were not immune to the sanctions, either. Both a shortage of spare parts and the exodus of Soviet and other foreign maintenance personnel who maintained the Iraqi military forces prevented the maintenance of vehicles and equipment that were already deployed to the field and destined to meet coalition forces.²⁸

The most significant weakness of the Iraqi IADS, however, was the inability of Iraqi operators and pilots to deal with the technological and tactical competence of their coalition adversaries. Despite combat experience with Iran and a reasonably capable IADS, Iraq was facing a vastly superior military force. The GWAPS boldly stated “No

²⁵ GWAPS, vol 1, part 1, 81.

²⁶ GWAPS, vol. 1, part 1, 152.

²⁷ GWAPS, vol. 1, part 1, 71.

²⁸ GWAPS, vol. 1, part 1, 79.

single, numerical comparison can convey the balance between the opposing sides in the Gulf War. The crucial factors determining the outcome mainly concerned issues such as military preparation, peace-time training, doctrinal conceptions, and the complex interrelationships among training, technological capabilities, and the educational sophistication of those who did the fighting.”²⁹

It did not take long for coalition air planners to exploit these weaknesses. Lieutenant General Chuck Horner, the Combined Force Air Component Commander for Desert Storm, established a Special Planning Group to build an offensive air operation plan. In the early stages of planning, this group identified the IADS’ highly-centralized C2 system as a key vulnerability.³⁰ The suppression of the IADS was key to the coalition’s achievement of air superiority.

Volume 1 of the GWAPS, which recounts in detail the considerations involved in crafting the Desert Storm air operation, states “Air campaign planners needed air superiority for several reasons. First, air operations to eliminate the Iraqi Integrated Air Defense system and render its air force ineffective were essential before most coalition aircraft could attack the centers of gravity with low losses.”³¹ Supporting Brungess’ argument that minimizing casualties had become an unspoken requirement in the wake of Vietnam, a presidential objective for the Desert Storm air operation flatly stated that planners should strive to avoid any unnecessary loss of aircraft and men. CENTAF planners expected to lose between 115 and 140 aircraft to the Iraqi IADS in the first three phases of the war. The prospect of absorbing such a gruesome kill total created a major imperative for coalition air power to eliminate the Iraqi IADS as a threat as soon as possible. Coalition ground forces, believed the air planners, would also benefit directly from coalition air superiority. They assumed that Saddam’s forces could not acquire intelligence on coalition movements through aerial reconnaissance if the coalition owned the skies. Additionally, even if Iraqi forces became aware of Schwarzkopf’s now-legendary Left Hook maneuver, air power could smash the forces as the redeployed to meet the coalition ground advance.³² Additionally, air superiority kept the elite ground

²⁹ GWAPS, vol. 2, part 1, 53.

³⁰ GWAPS, vol. 1, part 1, 152.

³¹ GWAPS, vol. 1, part 1, 151.

³² GWAPS, vol. 1, part 1, 150.

attack pilots of the Iraqi air force from interfering with the coalition ground force's scheme of maneuver.

In a September 1991 speech, Horner described how his planning group designated two specific target categories to defeat the Iraqi IADS: strategic air defense and airfields. Under the first category, they listed targets such as Iraqi command-and-control centers, communications nodes, and radars to, in Horner's words "induce the maximum amount of shock and violence against enemy air defenses."³³ The goal of the Desert Storm SEAD plan was to allow coalition aircraft to operate with little risk at medium altitude, defined by the 2006 US Air Force Tactics, Techniques, and Procedures Manual 3-1, Volume 1, Attachment 1 as 10 thousand to 40 thousand feet.³⁴ More probably, the Desert Storm planners desired unfettered access to Iraq's skies above 20,000 feet, which is the upper limit of most IR missile and AAA systems.

The Desert Storm plan for defeating the IADS originated with Warden's Instant Thunder plan, which aimed to suppress the IADS instead of destroying it detail. Suppression of the IADS involves disrupting and degrading the IADS with jamming and antiradiation missiles and destroying runways to ground Iraq's air force. The destruction of the entire IADS, including the multitude of SAMs and AAA pieces was not Warden's intent.³⁵ Coalition intelligence planners did, however, identify 26 radar sites inside Kuwait requiring destruction and not merely suppression.³⁶ Instead of wholesale destruction of the entire IADS, Checkmate planners wanted to knock the IADS off balance, depriving it of information from its EW sensors and degrading the ability of its leadership to make decisions and transmit guidance to subordinate units. Warden's Checkmate team and Horner's planning group believed that the timing and sequence of air strikes could have a significant impact on the success of the air operation and decided to target air defenses first.³⁷

The coalition planned to attack Kari during the first 48 hours of the war. Targets included the Baghdad ADOC, as well as SOCs and IOCs located throughout southern

³³ GWAPS, vol. 1, part 1, 151.

³⁴ Air Force Tactics, Techniques, and Procedures Manual 3-1, 2006, A1-21.

³⁵ GWAPS, vol 1, part 1, 120.

³⁶ Diane T. Putney, *Airpower Advantage: Planning the Gulf War Air Campaign 1989-1991* (Washington, DC: Air Force History and Museums Program, 2004), 242.

³⁷ GWAPS, vol 1, part 1, 123.

Iraq and Kuwait. Planners thought these C2 nodes could be rendered inoperative without completely destroying them and that targeting Iraq's electrical grid would disrupt air defense activities. The plan also called for strikes on the main operating bases, active dispersal fields, and associated runways, support facilities, and hangars to keep Iraqi fighters on the ground. Coalition counterair fighters would establish CAPs near these fields and pounce on any aircraft that managed to take off.³⁸

The plan relied on American F-4G Wild Weasels, EA-6B Prowlers, and EF-111 Ravens to suppress SAM sites with jamming and antiradiation missiles, while F-117s, acting without support from SEAD packages, would penetrate the Baghdad area and strike targets within the clustered SAM defenses.³⁹ It was believed at this time that the F-117s operated most effectively without support, since SEAD or escort fighter activity would only serve to warn air defenses of impending attack. Instead, the F-117s relied on their stealth to approach relatively unnoticed by the defenders. The impact of their laser-guided bombs would be the first reliable indicator of their presence.

The weight of effort devoted to the defeat of the IADS at the beginning of the war was significant. 48% of the targets planned for the first day of the war were air superiority targets, consisting of air defense and airfields, and communications targets essential for the effective functioning of the IADS.⁴⁰ 43% of the targets scheduled for the second day were air defense targets. Furthermore, 70% of targets determined important enough to warrant second strikes to ensure destruction were IADS targets.⁴¹ These second day targets were concentrated heavily in air defenses in western, central, and eastern Iraq. From the very beginning, coalition planners demonstrated that SEAD was a top priority. Following the trend established by the Israelis in the Bekaa Valley and the American raid on Libya in 1985, operations against the IADS featured prominently in this massive, integrated combined air operation. By August, 22 F-15Es, 46 F-15Cs, 44 F-16s, and 14 B-52G arrived in theater, and another 72 A-10s, 18 F-117s, 24 F-4Gs, and 6 B-52Gs were on their way. The coalition targeting cell leveraged these assets to support Horner's plan for offensive counterair with an emphasis on freedom of mobility and

³⁸ GWAPS, vol. 1, part 1, 152.

³⁹ GWAPS, vol. 1, part 1, 155.

⁴⁰ GWAPS, vol. 1, part 1, 187.

⁴¹ GWAPS, vol. 1, part 1, 193.

action against the ground-based IADS. Saddam would soon see his Kari system crushed beneath the weight of this incredible air armada.⁴²

Execution

The coalition fired the first shots of the war in the early morning hours of 17 January 1991 during the famous attack by Apache helicopters with MH-53s as pathfinders on Iraqi EW radars. The Apaches destroyed two radars, opening up a corridor for the initial strikes on scuds in the west. EF-111s flying in trail jammed Iraqi radars and F-117s struck targets in Baghdad.⁴³ The stealth fighters hit the Iraqi Air Force Headquarters twice, the ADOC, Tallil SOC, and Salman Pak IOC, in conjunction with Navy Tomahawk strikes in and around Baghdad that disrupted the electrical grid, amplifying friction within the Iraqi IADS.⁴⁴

Desert Storm's "first wave featured F-117 Stealth fighters flying as individual attack aircraft, a handful of F-15Es, and some thirty U.S. Navy Tomahawk missiles. Sorties were directed against command and control and leadership facilities in Baghdad, Tallil, and south central Iraq—specifically designed to cripple Iraqi air defense."⁴⁵ Coalition SEAD aircraft attacked the heart of Iraqi defenses, breaking connections between nodes in Kari and swamping defenses built to repel smaller air forces. Iraqi weapons operators had to operate autonomously, but were not trained to operate without guidance in an astoundingly adverse jamming environment. The coalition attack maximized inefficiencies and friction inherent in the Kari system, which had been gradually desensitized by huge coalition CAPs during the months before the attack.⁴⁶ They attacked Kari from the inside out, paralyzing the C2 and decision-making apparatus and collapsing the whole system with a massive parallel attack instead of a gradual approach to rollback the IADS.

⁴² GWAPS, vol. 1, part 1, 137.

⁴³ GWAPS, vol. 2, part 1, 121.

⁴⁴ GWAPS, vol. 2, part 1, 124.

⁴⁵ GWAPS, vol. 1, part 1, 14.

⁴⁶ GWAPS, vol. 2, part 1, 119.

After a series of strikes against the ADOC, the Tallil and Taji SOCs, communications centers, and electrical plants, “the full weight of US SEAD forces attacked the Baghdad area to break the capabilities and morale of the defenders.” Planners assumed the initial TLAM and F-117 strikes would bring the IADS to full alert. Former Air Force Chief of Staff General Michael Dugan’s infamous, career-killing remarks about massive bombardment of Baghdad to decapitate the regime also worked to the coalition’s advantage. Planners correctly assumed the Iraqis would expect an all-out air assault on Baghdad. This fear was supported by radar detection of coalition aircraft massing south of the Saudi Arabia-Iraq border.

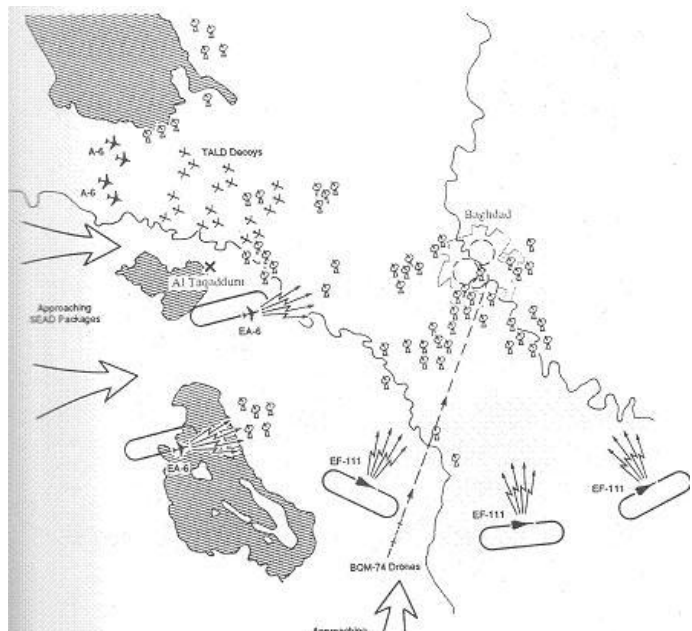

Figure 7. Desert Storm SEAD Plan

Source: Reprinted from Gulf War Air Power Survey

In reality, these massing aircraft were part of two large SEAD packages. One included three EA-6B Prowler stand-off jammers, three F-14s for escort, and ten F/A-18s, two A-6 Intruders, eight A-7 HARM shooters. This package attacked the Iraqi IADS from the west. Adding to the Iraqis difficulties were four A-6s and four British GR-1 Tornado attack aircraft targeting the Al Taqaddum airfield. Four additional A-6s supported the attack on the airfield with tactical air-launched decoys (TALD) to overwhelm and confuse the Iraqi IADS C2 operators. The second package, composed of 12 F-4G Wild Weasels and some EF-111 jammers would target Baghdad’s southern air defenses, supported by an EC-130H Compass Call, which jammed Iraqi communications as it orbited just south of the border.⁴⁷ Figure 7 is an illustration of this SEAD attack.

Twenty-five TALDs flooded Iraqi radar scopes. This intense IADS stimulation resulted in constant, high-power radiation from Iraqi sensors. The drones drew

⁴⁷ GWAPS, vol. 2, part 1, 127.

significant attention from Iraqi target acquisition and tracking radars. The western SEAD package launched forty-five HARMs at known sites and six more at targets of opportunity. The southern package loosed twenty-two HARMs, ten of which appeared to be successful. The GWAPS cited a lack of evidence regarding the exact damage the HARMs did kinetically. Nevertheless, intelligence sources report “significant numbers of radars that ceased operating when incoming HARMs would have impacted.” Approximately half the HARMs fired seemed to force Iraqi radars out of action, whether through destruction or intimidation. As an F-4G wing commander observed:

The key is that very early on while the F-15s maintained air superiority, the weasels maintained suppression of enemy air defense[s] as far as I am concerned, because they beat them down quickly, efficiently and the enemy knew if he turned his radar on, he'd be dead. As a result of that, they are not turning their radars on. If they do anything, they are blinking them off and on just to be able to say they are doing it and to maybe get some cuts on where the strikers are coming in. They're firing their missiles off ballistically. For the most part they are completely ineffective, and I hold that almost exclusively at the value of the suppression of the enemy air defenses during that first week.⁴⁸

SEAD attacks and another F-117 strike attacked and re-attacked SOCs and IOCs, along with other nodes in the IADS. Further frustrating Iraqi air defense, B-52s and Tornados struck Iraqi forward bases near the Saudi border, dissuading Saddam from deploying fighters to these bases.⁴⁹ Finally, American F-15C and F-14 air superiority fighters established CAPs near Iraqi main operating bases, shooting down Iraqi fighters in the immediate vicinity of their airfields. These victories discouraged the Iraqis from flying against the coalition forces. The battle between coalition SEAD and the Iraqi IADS was a rout. At the end of the first night, the Iraqis' only kill was a single US Navy F/A-18.⁵⁰

After the first 48 hours, Kari no longer operated as an integrated system. Many of its radars and SAMs were non-functional. None of the four SOCs functioned and the

⁴⁸ GWAPS, vol. 2, part 1, 133.

⁴⁹ GWAPS, vol. 2, part 1, 135.

⁵⁰ GWAPS, vol. 2, part 1, 136.

effectiveness of the IOCs, or at least those that survived the first two days, “no longer matched their original capabilities.”⁵¹ A-10s continued to attack Iraqi EW radars to “eliminate the ends of the tentacles, so that the enemy would lose his sense as to what was coming.”⁵² By the end of the second week, Kari “no longer functioned except fitfully” and on 27 January, scarcely 10 days after the war began, the coalition possessed air supremacy, “meaning that the Iraqi air force no longer existed as a combat-effective force.”⁵³ From 17 January through 27 February, coalition airpower conducted 11,610 strikes against twelve strategic target sets, excluding Saddam’s vaunted Republican Guard. Of those 11,610 strikes, 6110 struck the IADS or leadership, electrical, or telecommunications targets deemed critical to IADS operation.⁵⁴ While the Iraqis could cobble together a few disjointed components to defend against coalition aircraft, effective contention of Iraqi air space was impossible. Coalition aircraft ranged throughout the whole of Iraqi airspace at medium altitude at only slight risk. A prime indication of the extent to which coalition aircraft owned the sky over Iraq was the approval of KC-135 tanker aircraft to fly into Iraq to refuel strike aircraft.⁵⁵ Only in the heart of Baghdad did the Iraqi air defense remain formidable. The loss of two F-16s striking targets in the Baghdad area during daylight highlighted that some SAM units in the capital still functioned effectively. The coalition leadership simply adapted, sending only F-117s to strike targets in the Baghdad area.⁵⁶

Conclusion

Historical examples from Israel’s experience during the 1970s and 1980s and American operations in Vietnam and Libya reveal a typical pattern of move-countermove common to military innovation throughout time. Though airpower generally succeeded in these examples, formidable IADS exacted a toll that demanded intense investment in SEAD technology and development of doctrine, tactics, and training. At the very least, the presence of a strong IADS and the required SEAD response represents an opportunity cost for nation states that rely heavily on airpower as an instrument of national policy.

⁵¹ GWAPS, vol. 2, part 1, 138.

⁵² GWAPS, vol. 2, part 1, 142.

⁵³ Thomas A. Keaney and Eliot A. Cohen, *Revolution in Warfare? Air Power in the Persian Gulf* (Annapolis, MD: Naval Institute Press, 1993), 48.

⁵⁴ Putney, *Airpower Advantage*, 351.

⁵⁵ GWAPS, vol. 2, part 1, 202.

⁵⁶ GWAPS, vol. 2, part 1, 176.

The Desert Storm IADS takedown demonstrated how an integrated joint SEAD operation could break a formidable IADS. In many respects, the destruction of the Iraqi Kari system represents a best case scenario for SEAD operators attacking a truly formidable IADS. All of the conditions identified in the Yom Kippur, Bekaa Valley, Linebacker II, and El Dorado Canyon scenarios strongly favored the US-led coalition. The American forces invested in SEAD technology and developed excellent SEAD tactics that proceeded from sound doctrine. The coalition leadership and planners made the neutralization of the IADS a top priority and committed a tremendous amount of combat power to accomplishing the task.

The success of the coalition forces relative to the Iraqi IADS transcends the lessons that Brungess made in *Setting the Context*, however. The lopsided defeat of the Iraqi IADS during Operation Desert Storm was the result of a confluence of factors unique to that operation. These factors include the size of the USAF, its technological advantage over the Iraqi forces, the near-unanimous international condemnation of Saddam's invasion of Kuwait, and a desert environment most accommodating of coalition airpower and its sensors and weapons. The USAF was at the acme of its Cold War power, combining the supreme might of SAC with unparalleled tactical capability that included PGMs and stealth technology. The USAF was not only tactically and technically superb, it was a huge. It overwhelmed the Iraqi IADS with a quantity of attackers with which the Kari system simply could not cope.

From a technological perspective, the coalition outclassed the Iraqis. The air armada that hammered Iraq had been conceived to defeat the finest Soviet military hardware such as the SA-10 SAM family and advanced fighters such as the Su-27 and MiG-31. These supreme FSU weapons systems existed only in the Soviet Union during Desert Storm, yet the countermeasures for these formidable threats travelled to the Middle East to confront the less-advanced weapons of Saddam's air defense system. Thus, the mismatch between coalition airpower and Iraqi defenses extended from quantity to quality, making an already-prohibitive advantage even more pronounced.

The context of the international environment in which this force was operating also favored the coalition. Saddam's brazen invasion of Kuwait terrified or enraged nearly every state on the planet. Tremendous diplomatic pressure could be brought to

bear on Iraq while Iraq lacked the diplomatic footing to gain assistance from other states to repel invasion or pressure the US to scale back its operations. Established as the leader of an international coalition with a just cause, the US could bring the full measure of its conventional might and rage down on an isolated Iraq.

The geographic environment favored attacking airpower over the IADS as well. Iraq is a relatively flat, open country with a minimum of topographical features that could limit the prying eyes of coalition sensors or the reach of its weapons. All of the country was accessible to coalition airpower. In summary, Iraq was an ideal venue for the kind of air operation the coalition assembled.

Before addressing matters such as today's emerging defensive technology that might have made a difference for Iraq in 1990, it is useful to consider if American airpower, as currently constituted, could achieve the same result against the Iraqi IADS as the massive 1991 force. In many respects, today's USAF is more potent than the version that helped eject Saddam from Kuwait. In some respects, however, the USAF compares unfavorably to the 1991 juggernaut, especially in terms of numbers of aircraft and aircrews and a greatly reduced number of stand-off jammers in the wake of the retirement of the EF-111. The next chapter will examine the current force structure that provides America her air power and will assess if the current force could defeat that Iraqi IADS of 1991.

Chapter 3

Back to the Future: Could the USAF Break the Iraqi IADS Again?

Introduction

The next adversary that America attempts to coerce through airpower will not face the air armada of Desert Storm. Today, the US possesses a smaller, but more technologically advanced force with weapons and platforms that have proven themselves since the first Gulf War. This chapter argues that today's USAF force structure would have been adequate to destroy the Iraqi IADS, but not in the same manner the larger 1991 force was able to defeat it. The critical factors that led to decisive coalition victory provide an excellent gauge for comparing the forces. These factors are the size of the attacking force, technological advantage over the Iraqi forces, international condemnation of Saddam's invasion of Kuwait.

Size of the Force

The USAF and US Navy of 2010 could defeat Saddam Hussein's formidable IADS of 1991, but not in the same way as the Cold War air colossus that blitzed the Iraqi defenses two decades ago. The 1991 force overwhelmed the IADS with a massive suppression operation based on radar jamming and anti-radiation employment in the opening days of the war. The 2010 force would have to destroy radar sites that the 1991 force jammed, making the air superiority plan more destructive than John Warden's Checkmate planners intended. The plan would also require the lion's share of the current Air Force fleet, leaving little in reserve for other missions such as air defense of North America and South Korea.

During Desert Storm, the USAF was at the acme of its Cold War power, combining the supreme might of SAC with unparalleled tactical capability that included PGMs and stealth technology. The USAF was exceptionally trained and equipped, blending high quality with overwhelming numbers. It flooded the Iraqi IADS with a

quantity of attackers with which the Kari system simply could not cope. After Desert Storm and the final collapse of the Soviet Union, the US reduced the size of its military as worries of a reconstituted Soviet threat receded. The absence of the Soviet threat is an important factor in assessing the capability of today's Air Force to defeat the Iraqi IADS. Cold War imperatives required substantial American forces in Europe and the Pacific to remain in place. The vast majority of forces deployed to the Persian Gulf were from bases in the Continental United States (CONUS). The Air Force deployed 693 fighters to the Persian Gulf for Operation Desert Storm, including 18 RF-4s and 18 EF-111s.¹ The Air Force also deployed 11 E-3A Sentries, 7 RC-135V/W Rivet Joints, and 5 EC-130H Compass Calls to support the IADS takedown with tactical C2, electronic support, and communications jamming.² The deployed fighters included 96 F-15Cs for counterair, 42 F-117s for interdiction, and 49 F-4Gs and 18 EF-111s for SEAD—the most important strike aircraft for the destruction of the Iraqi IADS.³ That large fighter force represented less than 23% of the 3,076 fighters of the active duty and reserve components of the USAF and the Air National Guard.⁴

SEAD

Because the Iraqi IADS relied much more on its surface-to-air weapons than air defense fighters to repel air attacks, SEAD aircraft like the EF-111 and F-4Gs did the lion's share of the IADS disruption. These specialized aircraft are no longer in the USAF inventory. The Air Force retired the EF-111 in 1998 because the aircraft was considered redundant, expensive to maintain, and less capable than the EA-6B because it did not employ the HARM. In a period of shrinking defense budgets because of the collapse of the Soviet Union, the EF-111 was an unjustifiable luxury, despite its excellent service during Desert Storm.⁵ The Navy's EA-6B force filled the role of stand-off jammer for the entire joint force admirably. The Navy, however, has begun retiring its Prowler fleet in favor of the EA-18G Growler, an electronic attack version of the F/A-18F Super Hornet and is only buying enough for fleet operations. It will not provide jamming

¹ *Gulf War Air Power Survey*, vol. 5, *A Statistical Compendium and Chronology*, part 1, *A Statistical Compendium*, (Washington DC: US Government Printing Office, 1993), 27.

² GWAPS, vol. 5, 28.

³ GWAPS, vol. 5, 27.

⁴ GWAPS, vol. 5, 16.

⁵ Michael W. Ackerman, "Future of Airborne Tactical Jamming," US Navy report. (accessed 24 March 2010) (*Chicago*, 17.198)

support for the entire joint force.⁶ When the USAF cancelled its attempt at a new jammer, the EB-52 standoff jammer based on the venerable B-52 bomber, it found itself without jamming support once the Prowler retirement is complete.⁷ Therefore, the 2010 USAF is inferior to the 1991 force in terms of standoff jamming.

The lack of standoff jamming capability means that today's force could not replicate the 1991 IADS takedown plan that John Warden developed. That plan heavily emphasized suppression and disruption of the defenses and not the wholesale destruction of the system. Electronic jamming was essential. In lieu of the large jamming force, today's force would have to take a more destructive approach to defeating the Iraqi IADS. The destruction of EW radars and weapons systems that comprised the IADS have serious implications for a coercive air operation. First, suppression implies a transient state of disruption, after which an air defense system would still be fairly intact. Destruction, on the other hand, is more permanent. The total destruction of Iraqi air defenses could have left the country far more vulnerable to its rival Iran after the coalition forces terminated Desert Storm. If Iran took advantage of a defenseless Iraq, the US would bear some responsibility for the hardship that befell the Iraqi people in the wake of Desert Storm. If the US is faced with the need to apply coercive airpower on a large scale in the future and its only option of gaining access to enemy airspace is to permanently destroy the IADS, the obligation to restore some air defense capability or assume responsibility for the target state's air defense in the future will affect the decision-making of American leaders. It creates the possibility of having to choose between a "too-soft" approach of very limited air strikes with stealth assets or a "too-hard" approach that blasts large permanent holes in the target's defensive perimeter without any "just-right" option.

Fortunately, the USAF did not outsource its HARM-shooting capability as it did its standoff jamming. In December 1995, the final F-4G retired and the F-16C Block 50/52 assumed the mantle as the USAF's HARM shooter. The Air Force currently possesses approximately 194 of these aircraft for operational employment. There are two squadrons at Misawa Air Base, Japan, two squadrons at Spangdahlem Air Base,

⁶ Allen Li, "Electronic Warfare: Option of Upgrading Additional Ea-6bs Could Reduce Risk in Development of Ea18g: Gao-06-446," in *GAO Reports* (U.S. Government Accountability Office, 2006).

⁷ David A. Fulghum, "Pentagon Jam Up," *Aviation Week & Space Technology* 164, no. 15 (2006).

Germany, three at Shaw Air Force Base, South Carolina, and one at McEntire Joint Air National Guard Base, South Carolina. There are 40 F-16Cs at Misawa that may be assumed to be reserved for the defense of the South Korea, leaving 154 F-16C Block 50/52s in combat-ready squadrons available for deployment.⁸

This force is capable of deploying enough HARM-shooting capability equal to the capability of the 49 F-4Gs deployed for Desert Storm.⁹ The way in which the F-4G and F-16C employ the HARM differs, however. The F-4G preferred to launch HARMs reactively. That is, they fired their HARMs at emitters that they detected. These aircrews tallied a success rate of 46% during Operation Desert Storm.¹⁰ The F-16C prefers to pre-emptively target its HARMs to suppress, rather than destroy an emitter. In the coercive air operation over Kosovo, pre-emptive HARM launches successfully hit its target in only 1 of 86 shots.¹¹ Against the robust Iraqi IADS of 1991, the F-16C would certainly have suppressed the Iraqi threat, but its proclivity for pre-emptive shots would probably have required more aircraft to achieve the same effects as the F-4Gs. The current inventory of 194 F-16C Block 50/52s could handle the demand and still maintain enough aircraft in reserve to handle another crisis that would require SEAD support.

Interdiction

⁸ Raymond F. Moschler, Air Combat Command, Combat Forces Branch, in discussion with the author, 24 March 2010.

⁹ Experts interviewed for this chapter offer conflicting assessments of the capabilities of the F-16C Block 50/52 relative to the F-4G. The two weapons systems perform the same mission, but have different and distinct strengths and weaknesses. The F-4Gs deployed for Desert Storm were a highly specialized SEAD asset operated by a two-man crew consisting of a pilot and an Electronic Warfare Officer (EWO). EWOs are highly-trained electronic warfare experts charged with finding, identifying, and countering enemy electronic radars. F-4G EWOs had the ability to listen to the audio signature of a radar and identify the radar with exceptional accuracy. A two-person crew also has an inherent advantage in coping with extreme task loads. The F-4G also had 360 degree coverage, whereas the F-16's HARM Targeting System (HTS) has only a 90 degree view. Finally, the F-4G was capable of carrying up to 4 HARMs, although those aircraft flying to Iraq required external fuel tanks that limited them to 2 HARMs, which is the same capacity as the F-16C. There was consensus among experts interviewed for this thesis that the F-4G was the superior SEAD asset for the first 15 years of the F-16C Block 50/52's existence. Recent technological upgrades, however, give the F-16 unique SEAD capabilities, including the ability to use an advanced targeting pod that has electro-optical, infrared, and radar capability in conjunction with the HTS to rapidly locate and identify emitters. This unique synergy also enables F-16s to kill radars or SAM control nodes with PGMs. This author has determined that the most advanced F-16C Block 50/52 aircraft are as capable as the F-4G in the SEAD role.

¹⁰ GWAPS, vol. 2, part 1, 133.

¹¹ Lt Col Michael "Starbaby" Pietrucha, USAFR, F-4G EWO, Member of Operation Allied Force planning and post-strike analysis teams, in discussion with author, 23 March 2010.

The SEAD assets of Desert Storm received significant assistance in defeating the Iraqi IADS from the 42 stealthy F-117s deployed to the Persian Gulf. The stealth fighters struck 39 C2 nodes on the first night of the war to disrupt the IADS.¹² They penetrated the dense air defenses protecting Baghdad and hit vital targets like a huge telecommunications node, the ADOC, and various SOCs and IOCs inside the capital and outside it.¹³ These targets lay in the most heavily defended part of the Iraqi IADS, an area far too lethal for any non-stealthy interdictor. The contribution of the F-117s to the defeat of the IADS was profound, given the desire to minimize losses in the US military's first major combat operation since the Vietnam War. In 2008, the USAF retired the last of these aircraft.

The 2010 USAF could compensate for the retirement of the 42 F-117s with its 16 B-2 stealth bombers and F-22s, with a significant caveat. Today, the USAF is in a stealth trough with the F-117s retired and only 141 of the authorized 182 F-22s acquired. Of these 141 F-22s, approximately 90 are in combat units, with remainder reserved for training or testing. Furthermore, a significant portion of the aircraft at Elmendorf Air Force Base, Alaska would probably have to remain in place for homeland defense operations. The F-35 Lightning II strike fighter, the stealthy fifth generation strike fighter that will constitute the bulk of USAF and Naval strike aviation, is not scheduled to declare initial operational capability until at least 2013.¹⁴ With a very small, but very capable force of 16 B-2s in combat units, the USAF would have to commit the bulk of its limited stealth fleet to defeat the Iraqi IADS.

There are three primary limitations that this stealth trough would inflict on today's force. First, the F-22s deployed to support this operation would be stretched very thin. Despite the Iraqi Air Force's poor readiness and proficiency and Saddam's pattern of reluctance to risk his fighter fleet, they present an air-to-air threat that US forces must honor. The Iraqi air order of battle consisted of several formidable fighter aircraft and, while Saddam's reluctance to use them to defend Iraq was expected, it could not be assumed. Therefore, the many of the F-22s would probably be flying counterair missions

¹² GWAPS, vol. 5, part 1, 405.

¹³ GWAPS, vol. 2, part 1, 124.

¹⁴ Michael C. Sirak, "Not Date Driven," *airforce-magazine.com*, 19 February 2010, <http://www.airforce-magazine.com/Features/modernization/Pages/box021910fraser.aspx> (accessed 26 March 2010). (Chicago, 17.198)

in the opening days of the war. This would leave the small B-2 force to strike most of the targets that F-117s serviced during the opening days of the war.

The second limitation derives from the occupation of the F-22s with the counterair mission and the small B-2 fleet. This limitation is the inability to strike geographically separated targets in parallel. While each F-117 could only carry two bombs, compared to the 80 500 lb. bombs a B-2 can carry, the greater number of aircraft allowed these bombs to strike targets across Iraq at the same time.¹⁵ The B-2 force has the payload to strike all of the targets the F-117s hit, but the small force cannot strike them simultaneously. Instead, the B-2s would have to strike these targets in sequence, with each subsequent strike more likely to be anticipated and detected by IADS and increasing the risk to each irreplaceable aircraft. The B-2 could mitigate this risk by overflying its targets at altitudes above dense Iraqi AAA fire. Nevertheless, the sequence of the targets in the opening days of the war was an important factor for Desert Storm planners, and the retirement of the F-117 would make the parallel attack that crippled the IADS in the opening days of the war much more difficult to achieve.

The third limitation is the B-2's lack of laser designation capability. The PGMs dropped by the B-2 would be guided by GPS or inertial navigation systems, which are less accurate than the laser-guided bombs loosed by the F-117s. These bombs, however, are accurate enough to hit most of the targets struck by the F-117s in the first few days of the war.¹⁶ After the critical opening days of the war, however, B-2s involved in destroying SAM components would have to drop more ordnance to ensure that the equipment was destroyed. The shortage of standoff jamming capability described above would greatly increase the risk of conventional strike assets engaging some SAM sites, so it air planners would rely on either the B-2 or the F-22 to attack some of these targets. This limitation affects joint air operations less than the other two and would be mitigated entirely if the F-35 force was available to target this particular IADS.

Much of the interdiction required to defeat the Iraqi IADS could be performed by aircraft in the current inventory, though the USAF's lack of standoff jamming capability

¹⁵ USAF, "B-2 Spirit," USAF Fact Sheet, <http://www.af.mil/information/factsheets/factsheet.asp?id=82> Accessed on 26 March 2010. (Chicago, 17.198)

¹⁶ William Fry, Major, USAF, Intelligence Officer and US Air Force Weapons School graduate and instructor. In discussion with author 4 March 2010.

means assuming greater risk for all strike aircraft. The loss of an F-22 or a B-2 to the 1991 Iraqi IADS would be unlikely. However, losing even one of these aircraft, particularly a B-2, would have strategic repercussions. With such a small force, the permanent loss of a single B-2 is a loss of 6.25% of the B-2 inventory. Such a loss would be permanent. B-2s are horrifically expensive, with a unit cost of more than \$2 billion according to the GAO.¹⁷ Considering that the small fleet already lacks the numbers to service targets in a parallel attack of the Iraqi IADS, the loss of a B-2 would seriously diminish the global attack capability of the USAF. This is especially true considering that low observable platforms will be in higher demand, and at higher risk, against an IADS more robustly equipped than the 1991 Iraqi system.

Counterair

Despite Saddam's strategy to repel coalition airpower with his surface-to-air weapons, the counterair requirements of the coalition for defeating the IADS are still important to evaluate. The 2010 USAF differs significantly in its air-to-air capability than the 1991 force. In 1991, the F-15C was America's premier air superiority fighter and its weapons consisted of the AIM-7 Sparrow semi-active radar homing missile, the heat-seeking AIM-9 Sidewinder, and the 20-mm cannon; 96 of these fighters deployed to the Persian Gulf for Desert Storm, representing about 11% of the total USAF and ANG F-15 inventory.¹⁸ This large force featured a corps of highly-skilled aviators training at very high levels.

In contrast to the 1991 force, the 2010's projected USAF and ANG F-15C inventory is 120 aircraft in combat units.¹⁹ As of March 2010, many F-15 units have closed or are preparing to close as the F-22 approaches its full operational capability. The 2010 F-15Cs are more capable than the 1991 versions, having been upgraded with improved radars and avionics, the AIM-120 active radar homing missile, and a data link that improves situational awareness among F-15Cs in flight and E-3s supporting them with tactical C2. These technological advantages make each individual F-15C more

¹⁷ United States General Accounting Office, "B-2 Bomber: Cost and Operational Issues," Letter Report, 14 August 1997, GAO/NSIAD-97-181 (Washington DC: General Accounting Office), <http://www.fas.org/man/gao/nsiad97181.htm>. Accessed March 15 2010.

¹⁸ GWAPS, vol. 5, part 1, 16.

¹⁹ This F-15C inventory is the result of interviews with Major Nicholas O. Guttman, USAF, an F-15C pilot and USAF Weapons School Graduate, and Mr. Raymond Moschler, Combat Forces Branch, Air Combat Command.

lethal than it was in 1991. However, these advancements do not mean that the US would be able to deploy fewer F-15Cs for this operation because maintaining air superiority requires launching a counterair fleet large enough to support air operations throughout Iraq and Kuwait and defend Saudi Arabian airspace. This counterair operation would require constant presence of air superiority fighters in the battlespace in sufficient numbers to defeat a substantial Iraqi air defense effort. The limiting factor for coalition airpower in this scenario would be the number of air-to-air missiles available to shoot down Iraqi aircraft and enough fighters in the battlespace to allow the timely engagement of any threatening Iraqi aircraft.

The presence of the F-22 in the American arsenal has an even more pronounced effect on the lethality of each individual air superiority fighter. The fifth-generation fighter is far more capable than the F-15C or any other fighter in the world. However, it can only carry six AIM-120s, compared to the F-15C's eight. Despite the capability of the remarkable fighter, the need for missiles at the ready to destroy a potentially large attacking force mean that the presence of the F-22 does not reduce the number of air superiority fighters in the theater. Therefore, the US would have to deploy a combination of roughly 96 F-15Cs and F-22s to defeat the Iraqi IADS, despite the fact that the 96 air superiority fighters of 2010 are far more lethal than the 96 deployed in 1991. There is no doubt that the 2010 USAF would seize and maintain total air superiority over Iraq, Kuwait, and Saudi Arabia.

Nevertheless, defeating the Iraqi IADS would carry with it significant opportunity costs. Assuming that the upgraded F-15Cs will remain in the inventory for the next five years and the F-22 acquisition is not reduced below the current buy of 182, the USAF will have approximately 250 F-22s and F-15Cs in combat units. Deploying 96 of these fighters to the Middle East for a coercive air operation against Iraq would leave only about 150 air superiority fighters in the total force for every other counterair need, and there are competing counterair requirements. For instance, fighters remain on alert in the US to defend against a terrorist threat similar to the 9/11 attack. Additionally, American air defenses remain postured to intercept Russian aircraft transiting close to US airspace during the Russian air force's annual deployment of bombers to its northern bases. The route of these bombers typically runs close to Alaskan airspace. Finally, air superiority

fighters based at Kadena Air Base on Okinawa would support any combat operation conducted in defense of Taiwan or South Korea. The US possesses, if only barely, enough counterair fighters to defeat Iraq and satisfy these other missions. It is significant, however, that US leaders would assume the risk of being unable to meet requirements for air superiority in the Pacific or, in a less likely scenario, air defense of the United States homeland.

Conclusion

With its current structure, the USAF could defeat the Iraqi IADS. There are two significant factors that would complicate such an operation, however. First, the 2010 USAF force structure lacks the standoff jamming capability of the 1991 force. The Desert Storm SEAD operation disrupted the Iraqi IADS by striking C2 nodes, jamming radars, and suppressing SAM sites with antiradiation missiles. By electing to suppress and disrupt the IADS, the 1991 coalition force left large portions of the Iraqi C2 system intact and many SAMs, AAA pieces, and fighter aircraft serviceable. At the conclusion of Desert Storm, Iraq was not defenseless against a potential air attack by Iran.

Today's USAF could easily overwhelm the IADS with a combination of stealthy aircraft, standoff weapons, exceptional air-to-air capability, and a barrage of HARMs. It is a much smaller, but far more lethal force. The greater destructive capability of today's USAF, however, is in some respects a liability. The ability of the force to suppress an IADS with a jamming-intensive SEAD operation has given way to the ability to destroy it kinetically with PGMs. Today's USAF would wage a destructive operation of the Iraqi IADS, executing an operation more accurately called Destruction of Enemy Air Defenses (DEAD) instead of SEAD. A SEAD/DEAD operation of this magnitude would most likely lay waste to the IADS, leaving a post-war Iraq quite vulnerable to air attack. The idea of leaving Iraq defenseless would probably cause trepidation on the part of some coalition members. Such circumstances would make it difficult to maintain the kind of international consensus that isolated Iraq during Desert Storm. Indeed, it is unlikely the US could count on such near-unanimous international support for an operation that could destabilize the Middle East by leaving Iraq without the means to defend itself from air attack. Indeed, present-day American hegemony itself makes it more difficult to achieve the same level of international support for such a coercive operation.

In the current international environment, American hegemony has prompted balancing behavior among nations like Russia, Venezuela, Iran, and to some extent, the European Union. Venezuela has purchased Russian Su-30 Flanker aircraft. Even if Venezuelan pilots lack proficiency in employing these aircraft, the mere presence of the Su-30 in the Western Hemisphere is significant because the Russian fighter would be the most advanced combat aircraft in the region. Similarly, Iran has purchased the SA-10 SAM system as tensions between it and the US escalate over its nuclear weapons program. Russia herself is resurgent, resurrecting its long range bomber aviation program. The renewed vigor of this capability was conspicuous when Venezuelan President Hugo Chavez to offer to host bombers in the Western Hemisphere as a sign of friendship with Russia. Balancing against American hegemony by regional powers makes it perhaps unlikely that the US could diplomatically isolate an adversary as it was able to do to Iraq in 1991.

Despite these challenges, confronting Saddam's IADS with the 2010 force really stacks the deck in favor of the US. Even so, there are some very ominous indications here for American airpower. In this notional engagement that pits the most technologically advanced air force in history against a flawed IADS designed to repel small regional threats instead of superpowers, there are areas for concern for the USAF. First, the smaller force structure means that the US would assume risk in other geographic regions, as discussed. Concentrating so much airpower in one region of the world is bound to stretch the remaining forces very thin and a large coercive air operation in the Middle East would leave very little in reserve for combat action in the Pacific or in the Western Hemisphere.

Second, this smaller force indicates an assumption by American leaders that the remarkable technology and training of today's USAF will enable all of its aircraft to survive to fight the next battle. Attrition reserves are very small for some of the weapons systems on which American hopes for air dominance rest. The current force of 141 F-22s includes an attrition reserve of 2 aircraft. More startlingly, the 21 B-2s include a few aircraft for test and evaluation, but none for attrition reserve.²⁰ Against aging weapons,

²⁰ Moschler, in discussion with author, 24 March 2010.

this is a major assumption, especially considering that the F-117 shot down during Operation Allied Force was lost to a 1960s-era SA-3.

Against more modern IADS with innovative active and passive sensors like multistatic radars, multispectral imagery, and advanced weapons like the SA-10 family of SAMs and the Su-30 Flanker family of fighters, such an assumption seems imprudent. Russian SAM designers have designed the latest variants of their weapons systems to detect and engage stealth aircraft, cruise missiles, and even HARMs and PGM employed against the site itself. These air defense systems demonstrate that the relative advantage has shifted away from offensive airpower and back to the defensive. In terms of coercive airpower, the question the US must answer is not merely, “Can we gain access to enemy airspace and hit the target?” It is now “Is it worth a few B-2s and F-22s to try to compel an enemy shielded by such formidable defenses?”

Chapter 4

Resetting the Context

Introduction

This study has examined the principles of the IADS and identified certain conditions under which IADS have successfully defended against aerial offensives. It has also identified what conditions allow offensive airpower to defeat the IADS, laying bare the defender's centers of gravity and allowing the attacker to defeat or coerce the defender. When an aerial offensive has an integrated SEAD plan, effective SEAD doctrine and training, and the right technology, the offensive enjoys excellent prospects for success. Conversely, when one or more of these conditions are absent, the IADS tends to inflict serious damage on the attacker.

Certainly, all of these conditions were present in 1991 during Desert Storm. Chapter 2 covered in detail the defeat of the Iraqi IADS by coalition forces. These three conditions of the IADS/SEAD contest were all stacked very heavily in favor of the United States. There were other strategic factors that stacked the deck even more heavily in favor of coalition military forces in general and their SEAD forces in particular. These factors were the overwhelming size of the air force arrayed against Iraq, flat, open terrain, and near-unanimous international consensus that prevented maintenance and repair of the IADS preceding and during hostilities. There is no reason to assume these factors will present themselves in future conflicts. The US Air Force is much smaller. Many states the US may confront have mountainous or forest terrain that will frustrate sensor coverage and provide concealment for enemy IADS components, and a global hegemon must not assume it will command the same degree of consensus in future military operations.

In the last chapter, this study evaluated the differences between the 1991 force structure and the 2010 force structure, using the operational problem of the Iraqi IADS

destruction as a barometer. One additional conclusion demands consideration alongside the three conditions that set the context of the IADS/SEAD contest. This conclusion is that the size of a force matters. As Joseph Stalin said, “Quantity has a quality all its own.” The US Air Force has decided to procure weapons systems of the highest quality, even if that the expense of superb aircraft like the F-22 and B-2 meant the Air Force could only procure them in relatively small numbers. Against legacy threats like those possessed by Iraq, that acquisitions strategy is sound.

Against advanced systems like the SA-10 family of SAMs, 4.5 or 5th generation fighters, and emerging sensors and electronic countermeasures, however, the strategy is flawed and the current force structure inadequate for aerial coercion of a well-defended adversary. These systems are no longer sequestered deep within the Soviet Union. They are making their way to states like Iran, a sponsor of terrorism with aspirations of nuclear weapons and regional hegemony.

This chapter will examine some of the emerging technologies that threaten American air dominance, the balancing behavior between Russia, Iran, and Venezuela, and the vulnerabilities of the US Air Force inventory these adversaries could exploit to dissuade the US from launching a coercive air operation against them. Since 1990, improvements to US air power have not kept pace with technological advancements in air defense technology. As a result, the US Air Force, with its emphasis on small numbers of stealthy aircraft and long-range precision munitions, is now at a decided disadvantage in terms of the ability to compel an adversary to acquiesce to American demands. These weapons have the potential to place the enemy’s centers of gravity beyond the reach of American air power.

Advances in Air Defenses

IADS technology has improved in all three major components of the IADS: sensors, C2, and weapons. The improvements in each area are significant. The IADS, however, as a system, is greater than the sum of its parts. Likewise, the impact of the improvements in sensors, C2, and technology is profound. As a result of these improvements, the modern IADS has the potential to be more formidable than Saddam’s 1991 IADS by an order of magnitude.

Modern sensor technology easily surpasses the eyes of the 1991 Iraqi IADS. Stealth aircraft ranged the skies over Iraq with impunity, striking the most heavily-defended targets in Iraq. An emerging technology called passive radar has the potential to uncloak stealthy aircraft, making the F-117s forays into the teeth of the enemy IADS a relic instead of a harbinger. Passive radar exploits transmitters of opportunity such as commercial radio signals, television, cellular phone signals, and digital audio/video broadcasts to track aircraft.¹ Using powerful commercial off the shelf (COTS) computers, passive radar could exploit cell phone towers as a dense series of receiver/transmitters. This would turn the cell phone network into a dense, multi-static early warning network.²

Advanced signal processing techniques and increased computational power make it possible for a IADS C2 node to detect interference caused by aircraft as the radio waves are reflected. Stealth defeats a conventional mono-static radar by reflecting the radar signal away from the receiver/transmitter. In this multi-static system, the waves bounce off the stealth aircraft, but other receivers intercept the signals. Computers can monitor and plot these minute disruptions in the cell phone transmissions to determine the position of an aircraft. Accuracy increases proportionally with the number of receivers and minute Doppler shifts in the reflected signals can reveal the aircraft's speed and heading.³ Dr. Carlo Kopp, a prominent Australian defense analyst, wrote that this kind of surveillance, made possible with advancements in data processing, is appearing in Russian radar designs and that track fusion algorithms that compile sensor contacts from multiple systems and computes highly accurate position data on targets are available in at least one Russian design, the Salyut Poima E.⁴

Another trend in sensor technology is the employment of very low frequencies in acquisition radars. Many of the commercial emitters exploitable as part of a passive

¹ Arend G. Westra, "Radar Versus Stealth: Passive Radar and the Future of US Military Power," *Joint Force Quarterly* 55, 4th Quarter 2009, 139.

² A multi-static radar system is one in which multiple transmitters and receivers are located apart from each other.

³ Tao Yue, "Detection of the B-2 Bomber and a Brief History on Stealth," *The Tech: Online Edition*, 30 November 2001, <http://tech.mit.edu/V121/N63/Stealth.63f.html> (accessed 23 April 2010). (Chicago, 17.198)

⁴ Carlo Kopp, "Surviving the Modern IADS", Air Power Australia Analysis 2009-02, 3 February 2009. <http://www.ausairpower.net/APA-2009-02.html> (accessed 1 January 2010). (Chicago, 17.237)

radar network operate at very low frequencies. The long wavelength of these frequencies are inherently counterstealth because they create resonance with large sections of aircraft fuselage, regardless of shape.⁵ Recent Russian acquisition radars operate in this frequency band. These low frequencies not only defeat stealth contouring and radar-absorbent material, they render self-protection jammers ineffective as well. These jammers cannot operate at frequencies low enough to interfere with the radar because of antenna size limitations.⁶ These trends in surveillance strike directly at one of America's most vital pillars of military strength: stealth. The counterstealth potential promised by the surveillance techniques above have migrated to direct threat systems, as well. Russian SAM manufacturer Almaz claims that its S-400 Triumph system, referenced in NATO as the SA-21 Growler, possesses the capability to destroy cruise missiles, ballistic missiles, and low observable aircraft.⁷

Similar trends in direct threat sensors like target tracking and missile engagement radars significantly weaken another pillar of American air supremacy: SEAD. Modern engagement and tracking radars are exceptionally difficult to jam. They are remarkably frequency agile, shifting to different frequencies with each pulse. Most of these radars are active electronically scanned phased arrays with digital signal processing which mask waveform characteristics more easily measured in legacy SAM systems.⁸ This makes detection, identification, location, and jamming very difficult, granting these systems relative immunity from anti-radiation missiles and stand-off and self-protection jamming.⁹ These radars can emit many individual radar beams at once and can scan very large volumes of the sky very rapidly, which blurs the line between acquisition radar and target tracking radar and makes it even more difficult to break the SAM kill chain. Even

⁵ Westra, "Radar Versus Stealth," 140.

⁶ Kopp, "Surviving the Modern IADS."

⁷ Jane's Land-Based Air Defence, "S-400 Triumph," 21 April 2010, http://search.janes.com/Search/documentView.do?docId=/content1/janesdata/yb/jlad/jlad0593.htm@current&pageSelected=allJanes&keyword=S-400&backPath=http://search.janes.com/Search&Prod_Name=JLAD&#toclink-j0010230054663. Accessed 25 April 2010. (*Chicago* 17.237)

⁸ Lt Col Michael "Starbaby" Pietrucha, USAFR, F-4G EWO, Member of Operation Allied Force planning and post-strike analysis teams, in discussion with author, 23 March 2010.

⁹ Kopp, "Surviving the Modern IADS."

if an aircraft can successfully jam or evade the target tracking beam, the system will still maintain contact with the target using a beam operating on a different frequency.¹⁰

Many of these advancements in sensors, signal processing, C2, and mobility are appearing in older SAM systems. This concept is known as “hybridization” and enables backward compatibility among older and newer versions of similar systems as well as extensive retrofitting of modern phased array radars to legacy systems like the SA-2.¹¹ A concurrent trend has been the emergence of self-propelled mobility upgrades for old systems like the SA-2 and SA-3.¹²

Adding to the difficulty of suppressing modern air defense sensors are the increased ranges of these sensors and their associated weapons. This poses a two-fold problem for SEAD aircraft. First, the additional power required to guide the longer-range missile also makes it more difficult to jam the engagement radar. Second, systems like the SA-10 family of SAM systems have extended the range of their missiles past 120 nautical miles, forcing jamming aircraft like the EA-6B and EA-18G equipped with the ALQ-99 jamming suite outside of their effective range and denying the strike aircraft they accompany any jamming support.¹³ Therefore, not only are the sensors of the modern IADS capable, at least to some extent, of detecting stealth aircraft, they are also inherently difficult to suppress.

Recall from the last chapter that the 2010 force structure has regressed in its ability to suppress an IADS, but is more capable of destroying IADS components. Unfortunately for American airmen, DEAD operations against modern IADS are more difficult, as well. These systems possess different types of decoys that make it more difficult for attacking aircraft to conduct SEAD/DEAD. Some of these emitters are radio frequency emitting decoys that transmit a waveform difficult to distinguish from the

¹⁰ Sidelobes are essentially wasted radar energy that radiates from the side and rear of the antenna. Jammers exploit these lobes because they are exposed for longer periods of time than the more tightly focused main beam. Interference targeted at sidelobes can create intense visual cluttering of the operator’s scope, masking actual targets.

¹¹ Two examples Kopp gives of backward compatibility are the SA-6/SA-11 systems and the SA-10/SA-20 systems. The SA-11 is a newer version of the SA-6, but the old and new components are compatible, so the old missile launchers could couple with the newer radar and vice versa. The same is true of the SA-10/20 family.

¹² Carlo Kopp, “SAM System Mobility: Russian and PLA Air Defence System Vehicles,” Technical Report APA-TR-2008-0601, Air Power Australia, June 2008. <http://www.ausairpower.net/APA-SAM-Support-Vehicles.html> Accessed 20 April 2010. (Chicago 17.237)

¹³ Kopp, “Surviving the Modern IADS.”

actual radar. Other decoys are inflatable visual decoys accompanied by smoke generators, chaff dispensers, and flares to frustrate enemy sensors.¹⁴ As a result, it is extremely difficult to locate these systems with sufficient accuracy to employ ordnance against them. The most relevant factor for the survivability of these IADS components is mobility.

The mobility of advanced SAM batteries is the key to their survivability and lethality. The SA-10 family of weapons needs approximately 5 minutes to transition from transit to firing a missile. Within another five minutes, these weapons can be on the move again.¹⁵ This makes it exceptionally difficult to target these highly lethal systems with standoff weapons like cruise missiles, including new variants like the Joint Air-to-Surface Standoff Missile (JASSM) or the Standoff Land Attack Missile-Extended Range (SLAM-ER). These missiles, assuming they reach the target, will probably be hitting a point where the SAM used to be. Standoff weapons like these rely on intelligence to provide very accurate location information for targets. In most cases, this information will come from satellite surveillance and will be at least several minutes old by the time the analysts process the data. Even if target location is passed to an airborne strike aircraft, the time consumed by processing, vetting by C2 agencies like the US Air Force Air Operations Center, and the time of flight of the weapon will provide ample time for the SAM to depart the launch site. Furthermore, these SAMs would not have to move very far to defeat a missile shot. A SAM component moved more than 500 feet would escape any damage from most munitions employed against it.¹⁶ The aforementioned decoys and countermeasures would make it difficult for an attacking air force to strike the SAM even with a promptly launched weapon.

Improved C2 technology contributes to the survivability and lethality of advanced air defense systems. New Russian systems make extensive use of data links and wireless networks between supporting echelons of the IADS and between self-propelled components of the SAM battery. The data links between the SAMs and supporting C2 agencies allow the SAM to minimize radiation that enemies might be able to exploit to

¹⁴ Kopp, "Surviving the Modern IADS."

¹⁵ Carlo Kopp, "Assessing Joint Strike Fighter Defence Penetration Capabilities," Air Power Australia Analysis, 7 January 2009. <http://www.ausairpower.net/APA-2009-01.html> Accessed 13 March 2010. (Chicago 17.273)

¹⁶ Pietrucha, discussion, 23 March 2010.

locate it. Recall from the first chapter of this study that this minimizes the chances of the SAM being destroyed and makes it difficult for aircraft to take evasive maneuvers in the case of a SAM launch since it will have little warning before the missile intercepts it.¹⁷

Mobility also changes the way stealth strike aircraft plan their operations. This is especially true of the F-35 Joint Strike Fighter. The F-35 is a low-end complement to the F-22 and will constitute the bulk of American strike aircraft. Secretary of Defense Robert Gates called the F-35 “the heart of the future of our tactical combat aviation.”¹⁸ With such a ringing endorsement by the sitting Secretary of Defense, it is not surprising that the US will purchase more than 2,000 of these aircraft.¹⁹ The problem is that the F-35 is not as stealthy as the F-22 or B-2. Unlike those platforms, the F-35 is only stealthy against radar frequencies commonly associated with target tracking radars and only from a head-on aspect, as depicted in Figure 8.²⁰ For this aircraft to penetrate an IADS, it will have to know the precise locations of the SAMs and approach from virtually head-on angles. Mobile SAMs deprive the F-35 of high-confidence threat locations for such an approach. This uncertainty seriously compromises the survivability of the “heart of the future of American combat tactical aviation.” Unfortunately, even this tactic will

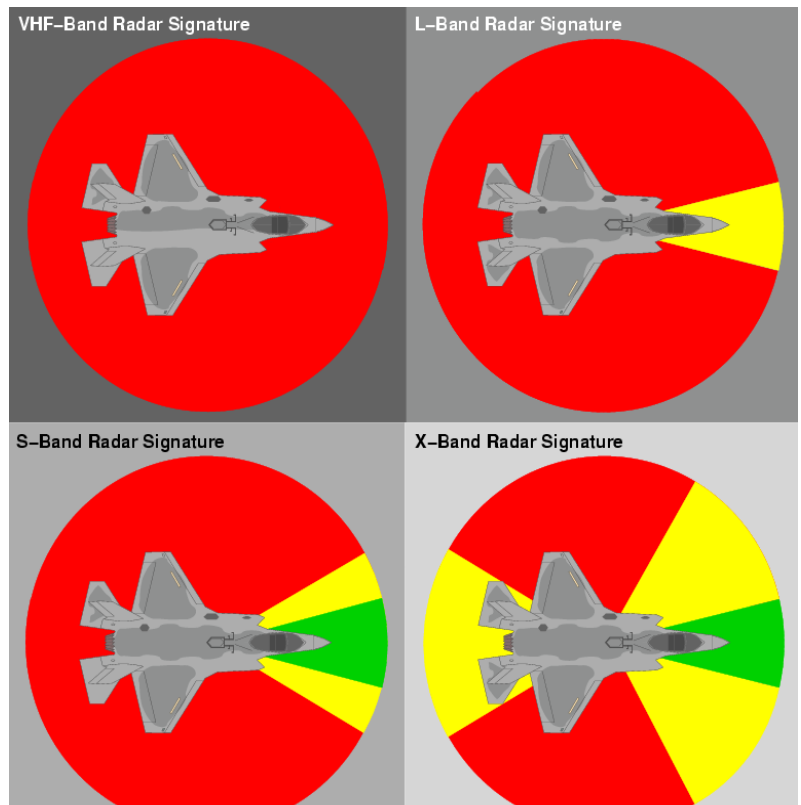

Figure 8. F-35 Radar Signature Diagram

Source: Reprinted from Carlo Kopp’s *Assessing JSF Penetration Capabilities*

¹⁷ Kopp, “Surviving a Modern IADS.”

¹⁸ Donna Miles, “Gates Touts F-35 as Heart of Future of Combat Tactical Aviation,” United States Department of Defense, 31 August 2009. <http://www.defense.gov/news/newsarticle.aspx?id=55684> Accessed 24 April 2010. (Chicago 17.198)

¹⁹ “Joint Strike Fighter,” http://www.jsf.mil/contact/con_faqs.htm Accessed 25 April 2010. (Chicago 17.237)

²⁰ Kopp, “Assessing JSF Penetration Capabilities.”

be ineffective against an IADS that uses overlapping sensors with low frequencies as described above. As an F-35 passes through airspace monitored by a low frequency multi-static radar system, the receivers will acquire echoes from the fighter from multiple aspect angles, subjecting it to engagement.

The weapons that an IADS could bring to bear against detected F-35s or any other strike asset have improved significantly, as well. The missiles fired by some advanced SAM systems are incredibly capable. Some of these systems, according to a GlobalSecurity.org fact sheet on the SA-10 family of SAM, are capable of withstanding acceleration and maneuvering up to 60 g, or 60 times the force of gravity. Additionally, some of these weapons possess directional fragmentation warheads that increase the lethal radius of the missile by discharging its lethal payload directly at the target instead of exploding and distributing the fragmentation spherically.²¹ Adding to the conundrum of engineers and aircrews trying to solve the new IADS problem, Russian SAM manufacturer Agat has experimented with using alternative types of missile guidance and seeker heads, mating IR, active radar, or antiradiation seeker heads to existing missile airframes to overcome defensive radar jamming.²² These features, combined with peak velocities in excess of mach 6, give each missile shot a kill probability of 90%. That figure increases radically as they are fired at the target in a salvo.²³

Finally, Russian SAM manufacturers have developed short range point defense SAM systems like the SA-15 and SA-22 that are allegedly capable of shooting down munitions targeting SAM battery missiles and radars. The SA-15 and SA-22 have been re-equipped with superb phased array radars capable of simultaneously tracking many inbound targets, including cruise missiles, antiradiation missiles, and PGMs.²⁴ If the excellence of recent Russian air defense systems are any indication, these point defense systems would be extremely potent. Any SEAD or DEAD operation targeting the longer range SAMs would have to expend many more weapons To saturate the point defense systems and strike their intended targets.

²¹ GlobalSecurity.org, "S-300 Tactical and Technical Performance," <http://www.globalsecurity.org/military/world/russia/s-300-list.htm> Accessed 25 April 2010. (Chicago 17.237)

²² Kopp, "Surviving the Modern IADS."

²³ Global Security.org, S-300 Tactical and Technical Performance."

²⁴ Kopp, "Surviving the Modern IADS."

These systems radically change the context of the SEAD/IADS struggle. A modern IADS composed of these systems, including more advanced fighters like the Su-30, could fiercely contest their airspace against the best the US Air Force could throw at it. The countermeasures available to the attackers in a confrontation with an IADS like this are not promising. It is possible that passive radar early warning networks could detect even stealthy aircraft. Standoff jamming against these systems would be very difficult because of the low radio frequencies involved. These ubiquitous sensors would feed a very accurate air picture to ADOCs and other C2 units, which distribute the information along with direction to formidable SAM systems lying in wait. Escort jammers cannot support the strike packages adequately because they cannot get close enough to the radars without being shot down by the very systems they attempt to jam. Even if they could get close enough, it is doubtful that their jamming would be effective against the advanced signal processors of these systems.

Standoff weapons like cruise missiles are of limited value because of the ability of these systems to rapidly relocate. Even if a strike aircraft can ingress low enough to launch on a SAM system, it cannot be sure it is even targeting a real threat. Perhaps it has been seduced by one of the many decoys or concealed by smoke or camouflage. Assuming the DEAD weapons are correctly targeted against an actual weapons system, the SAM is protected by highly capable point defense missile systems that knock down the munitions as they approach their target.

This is the modern IADS.

The Context Revisited

Chapter 2 of this study identified three conditions present when SEAD defeats an IADS. These conditions are a high degree of integration between SEAD and the rest of the force, proper doctrine and rigorous training, and technology. The advanced IADS represents significant technological advances in defensive technology that neutralize much of the advantage produced by the American monopoly on stealthy aircraft. The technological changes simultaneously tip the scale heavily against traditional SEAD equipment and tactics like jamming and antiradiation missile employment and the survivability of non-stealthy aircraft in the operating envelope of modern ground-based air defenses.

The shift in technology and the radical effect it has had on the effectiveness of US SEAD doctrine, tactics, and training creates something of paradox with respect to the first condition dealing with the importance of integrating SEAD forces and the plan for suppressing the IADS. Against these double-digit SAMs and their supporting sensors, much of the American SEAD portfolio is ineffective. Yet, the lethality and survivability of the advanced SAMs makes their elimination a litmus test of for modern American airpower. If an SA-20 or similar system is active in the area of operations, air operations cannot commence.

It is difficult to prove a specific reason for this evolution, but the measure-countermeasure technological chess game between airpower and air defense appear to validate social constructivist theory of technological development. The essential point here is that political and social needs lie behind and directs the growth and adoption of technology.²⁵ American airpower developed stealth because of a sociopolitical need for aircraft able to penetrate Soviet airspace and strike targets. Soviet, and later Russian, air defense designers apparently felt sociopolitical pressure to innovate and develop a technological response to American airpower.

During the 1990s, however, American SEAD capabilities like improvements in jamming, geolocation, and counter-IADS munitions seemed geared toward the remnants of Iraqi air defenses, “single-digit SAMs” like the SA-2, SA-3, SA-6, and SA-8. During this period, the US Air Force was heavily involved in patrolling the two no-fly zones in Northern and Southern Iraq. When the Soviet Union dissolved, the need to penetrate an IADS with advanced fighters and SAMs found only within the former USSR took a back seat to equipping more effectively for the ongoing operations in Iraq. This is understandable.

Russian SAM designers had different motivations. The destruction of fixed Soviet-manufactured air defenses during the Yom Kippur War created an imperative to produce mobile components. The size limitations of such hardware drove Soviet designers to produce emitters with smaller antennas. These systems operated in

²⁵ John Law, “Portuguese Expansion,” *The Social Construction of Technological Systems: New Directions in the Sociology and History of Technology*, ed. by Wiebe E. Bijker, Thomas P. Hughes, and Trevor Pinch (Cambridge, MA: The MIT Press, 1987), 113.

relatively high frequency ranges against which stealth technology is highly effective.²⁶ The humiliating performance of Russian hardware against the F-117 during Desert Storm inspired a large investment in air defenses to rectify weaknesses in previous air defense design. When Russia began exporting these systems, the gap between American SEAD and Russian IADS became very relevant to the future of coercive airpower.

The emergence of advanced IADS casts stealth in the light of an evolutionary, rather than revolutionary technology. Stealth is not invincible, as the F-117 shot down over Kosovo by an aging SA-3 indicates.²⁷ Air defenses throughout history have also been evolutionary. Therefore, one can infer that offensive airpower will eventually develop some sort of countermeasure for these fearsome IADS. Until then, however, the US has entered a time of strategic disadvantage in terms of the ability to successfully apply aerial coercion against a nation protected by an advanced IADS. Conversely, American adversaries who arm themselves with advanced IADS are entering a period of strategic opportunity in which they can advance their interests beyond the reach of American coercive airpower.

How Advanced IADS Affect Coercive Airpower

Kenneth N. Waltz wrote “Dissuasion, whether by defense or deterrence, is easier to accomplish than ‘compellence,’ to use an apt term invented by Thomas C. Schelling. Compellence is more difficult to achieve, and its contrivance is a more intricate affair.”²⁸ Waltz’s assertion harmonizes with Clausewitz’s dictum that “defense is the stronger form of waging war” when pursuing a negative objective.²⁹ These two great minds capture the essence of the struggle between coercive airpower and the IADS. Coercive airpower must inflict enough pain to force the target state into changing its behavior in accordance with the will of the coercing state with relatively few losses among the coercer’s forces. The IADS needs only to deprive coercive airpower of a decision to be effective. A stalemate is tantamount to a victory for the defender.

²⁶ Kopp, “Assessing JSF Penetration Capabilities.”

²⁷ Zord Gabor Laszlo, “Secrets of the F-117 Shootdown Revealed,” *The Journal of Electronic Defense*, January 2006, 24.

²⁸ Kenneth N. Waltz, *Theory of International Politics* (Boston, MA: McGraw-Hill, 1979), 189.

²⁹ Carl von Clausewitz, *On War*, ed. and trans. Michael Howard and Peter Paret (Princeton, NJ: Princeton University Press, 1976), 358.

More so than either Clausewitz or Waltz, however, Robert Pape identified the single most important reason that today's modern IADS may have negated airpower's value as a coercive instrument. Pape wrote that one reason strategic bombing persists as an attractive coercive instrument is the desire of civilian and military leaders for cheap, easy solutions to difficult international confrontations.³⁰ Advanced IADS make aerial coercion very difficult, extremely risky, and prohibitively expensive.

Modern IADS makes airpower an unattractive method of coercion in three ways. First, they raise to unacceptably high levels the price a coercing state must pay to change a target's behavior. Second, they drastically increase the uncertainty that airpower can succeed at all. Third, the price of using airpower to coerce an enemy shielded by an advanced IADS and failing to break through the defenses are ghastly and carry with it dire strategic consequences.

To successfully inflict enough pain to bend an enemy's will, the US Air Force will have to penetrate the IADS. The Air Force can approach this task in two ways. First, it can try to evade detection through all-aspect stealth. The potential counterstealth capability of emerging early warning sensors makes this option too risky. The alternative is to blast gaps in the defenses and exploit them, just like conventional, non-stealthy strike aircraft must do.³¹ The ranges of the "double-digit" SAMs deny the employment of relatively inexpensive smart bombs. Long before the aircraft could get close enough to release its bombs, the SAM would have shot it down. That leaves standoff weapons like cruise missiles or glide bombs as alternatives. Many of these bombs cost between \$500,000 and \$1 million a piece. The Air Force would have to expend large numbers of these expensive weapons to try to engage IADS components. The mobility of these systems, their robust arsenal of deception techniques, and terminal point defenses will soak up many of the released weapons. Kopp estimated that a strike package penetrating an area defended by a single SA-21 battery would need to deliver at least 32 weapons merely to exhaust the point defense magazines protecting the SA-21.³² Overlapping SAM systems would greatly compound the number of munitions and the cost of the

³⁰ Robert A. Pape, *Bombing to Win: Air Power and Coercion in War* (Ithaca, NY: Cornell University Press, 1996), 327.

³¹ Kopp, "Assessing JSF Penetration Capabilities."

³² Kopp, "Assessing JSF Penetration Capabilities."

strike, involving potentially hundreds of these expensive munitions in a single strike, making such strikes difficult to support in terms of dollars and production capacity.

That aerial coercion in the face of the modern IADS will be costly is certain. What is not certain is the probability of success. “Coercion,” wrote Pape, “is very hard...the requirements for successful coercion are very high. Even when coercion succeeds, moreover, it rarely gains very much.”³³ Successful or unsuccessful coercion depends on the target’s perception and decision making logic regarding the costs and benefits of resistance.³⁴ States tend to evaluate costs and military performance poorly, resulting in recalcitrance even when the costs of continued resistance obviously outweigh any possible benefits.³⁵

The possession of advanced IADS will probably make this tendency even more pronounced because they inspire tremendous confidence at the outset of the conflict. At the beginning of Desert Storm, Saddam was highly confident his fixed IADS composed of relatively old weapons systems cued by relatively few overlapping EW radars would withstand the coalition strategic air operation and force a bloody ground war that offered him his best chance for victory. In a confrontation between American airpower and a top-notch, Russian-produced IADS, the defender’s belief that his IADS could repel an air attack would be far more justifiable than Saddam’s optimism. As result, expectations of the effectiveness of his IADS would predispose him to resistance, even if the attacking aircraft did manage to inflict damage. As Jervis wrote, “People are predisposed to see what they expected to be present.”³⁶ The defender’s IADS is almost certain to retain significant capability. Even if the attacker manages to sever C2 links through a combination of kinetic and non-kinetic tactics, the double-digit SAM systems described in this chapter are capable enough of autonomous operations to blunt offensive air power and buy time to turn defeat into stalemate. For the defender, this is enough. For the coercer, it may be too much to overcome.

If the price tag associated with victory against these systems and the elusiveness of achieving that victory are not enough to give the US pause, the cost of failure surely

³³ Pape, *Bombing to Win*, 315.

³⁴ Pape, *Bombing to Win*, 16.

³⁵ Pape, *Bombing to Win*, 32.

³⁶ Robert Jervis, *Perception and Misperception in International Politics* (Princeton, NJ: Princeton University Press, 1976), 145

will. The current high-low composition of the US Air Force is predicated on the assumption that its aircraft are exceptionally survivable.³⁷ Decades of operating against overmatched adversaries with thin or obsolete IADS provide false indications that such an assumption is correct. After all, if every F-22 and B-2 launched returns safely, a small force of each would indeed be sufficient to defeat any adversary in the world. The modern IADS makes this assumption a poor one.

Against double-digit SAMs with kill probabilities of approximately 90% against non-stealthy aircraft and an advertised capability against stealth, it is implausible that the small inventories of B-2s and F-22s will not suffer losses. These inventories cannot absorb losses and continue to exist as a meaningful force-in-being. Within the context of an Iran, China, and Venezuela shielded by these systems, the smallness of the high-end stealth force is a strategic liability. Quantity matters as much as quality.

To put the smallness of modern air forces into perspective, one need only juxtapose American airpower from WWII and Desert Storm. In WWII, bomber and fighters were replaced by the Allied war machines in tremendous numbers. Compare the 693 American fighters *deployed* to the Middle East for Desert Storm to the 4,754 B-17 bombers *lost* in World War II. The mighty American air armada that hammered Iraq in 1991 was comparatively small. The modern IADS would not have to destroy many aircraft to inflict losses that would be considered prohibitive, especially in the context of a B-2 fleet of 20 aircraft. The loss of a few B-2s or F-22s to air defenses would quickly call into question the survivability of these fleets. American decision makers may decide not to break their high-end stealth capability against these systems. Under these circumstances, these aircraft would become liabilities instead of the silver bullets in the American military arsenal.

The real strategic cost of a failed mission against an advanced IADS transcends the loss of a few billion dollars' worth of stealth aircraft and their highly-trained aircrews. In a single stroke, failure would pierce the aura of American air dominance cultivated carefully since the end of the Vietnam War. Consider the measures that enemies of the US have taken to protect certain vital centers. Saddam built underground bunkers.

³⁷ An example of the high-low mix is the use of 182 F-22s acting as an enabling element for more than 2,000 less capable F-35s. The F-15/F-16 relationship is another high-low mix.

Similarly, Iran has hidden vital components of its nuclear program such as the uranium enrichment facility at Natanz, beneath the earth. In response to the development of more effective penetrating munitions, these enemies have had to dig deeper in an attempt to escape airpower. Such countermeasures are unquestionably shrewd, but are also a tacit admission of American air dominance and recognition that the American bomber will get through. Until now. Iran, Venezuela, Syria, China, and Russia are arming themselves with incredibly capable air defense systems engineered with the benefit of observing decades of American air dominance. Each advancement discussed in this chapter chipped away at some facet of American air dominance, culminating in an asymmetric defense that is a credible countermeasure to American airpower. By putting the decision in doubt and demanding a steep cost in blood and treasure, these air defense systems have bent the wing of coercive airpower, because the US would be able or willing to pay the price of fighting these systems only in the most dire of circumstances that warrant the risk of the US Air Force as a combat force.

In the final chapter, this study will present a series of recommendations to restore the capability of the US Air Force to operate against these IADS. The crux of the matter is the recognition of an emergent presumptive anomaly with respect to the IADS and manned aircraft. Against sensors that can detect stealth and weapons that demand evasive maneuvers requiring speed and acceleration that greatly exceed the tolerances of human anatomy and physiology, the sunset of manned strike aircraft has arrived.

Chapter 5

Recommendations

Just as stealth aircraft did not represent the last word in the struggle between airpower and air defense, there is no reason to assume that advanced air defenses possess an unassailable advantage over coercive airpower. Many of the technological and tactical advancements the Russians made were brilliant strategic countermeasures to mitigate the advantage of stealth. With its own bold strategic countermoves, it is possible for the US to regain the upper hand in this battle.

Three assumptions influenced the development of this chapter and its recommendations for countering the threat posed by advanced IADS. First, the US will strive to regain and maintain the capability to operate in enemy airspace which is protected by advanced IADS. Second, the counterstrategy for operating against these IADS must involve hardware that is cheap and or reusable. Third, the US and its allies do not have the political will to sustain many casualties in the course of aerial combat operations.

Within the constraints of these assumptions, four recommendations have taken shape. First, the US should invest in passive radar systems. Second, the development of a stealthy, persistent ISR platform is essential. Third, the US must adjust its force structure and acquire large numbers of affordable unmanned aircraft to swarm and enemy IADS. Fourth, the US should cancel or curtail the acquisition of the F-35.

The US developed stealth technology to defeat conventional radar systems. American expertise in developing and employing radar is impressive, especially in terms of integrated air defense. The vast NORAD network of early warning radars provided excellent coverage of the airspace over and around North America during the Cold War. An intimate understanding of these sensors certainly paid dividends in the development of stealth. It is logical that a deep understanding of a target system, in this case radar, is useful in figuring out a way to defeat it.

American mastery of active radar technology does not currently face a credible threat from a nation equipped with low-observable aircraft. As a result, it has largely neglected passive radar. This situation threatens to undermine the immense investment the US has made in stealth technology. Stealth is an important pillar of American airpower. However, advanced IADS end the era of low-observable aircraft operating alone against the air defenses. Stealth retains its value if the US Air Force recognizes the need to provide stealthy aircraft with support that enables its mission. A deep knowledge of passive radar is one such enabler. It is foolish to continue to invest billions of dollars in the maintenance of existing stealth platforms and the development of new ones without gaining a deep understanding of the systems a near-peer enemy could use to defeat low observable technology.

The US must make a serious, sustained effort to build passive radar networks. One obvious benefit of mastering passive radar technology is the ability to assess the effectiveness of these systems against different stealth technologies and vice versa. A facility like the Nevada Test and Training Range north of Nellis Air Force Base could build a passive radar, allowing aircrews to practice countermeasures and tactics to defeat these systems and maximize the effectiveness of stealth against these systems. Another obvious benefit from becoming a leader in the arena of passive radar is the acquisition of knowledge that could lead to the disruption or destruction of an enemy passive radar surveillance system.¹

The second recommendation of this study would also be an enabling force for stealth strike aircraft. The US should develop stealthy C2ISR platforms to provide real-time threat warning and target-cueing to attacking aircraft. The expectation of stealthy C2ISR aircraft is not to penetrate deep within enemy territory alongside stealthy fighter-bombers. Instead, these systems could stand-off from highly-defended areas, but remain close enough to provide support to the penetrating strike package. It is unlikely that stealthy ISR systems could allow SEAD/DEAD assets to dominate an IADS as in the past. However, threat-warning could spare some strike aircraft and the possibility of persistent ISR and time-sensitive prosecution of IADS components could greatly increase

¹ Arend G. Westra, "Radar Versus Stealth: Passive Radar and the Future of US Military Power," *Joint Force Quarterly* 55, 4th Quarter 2009, 142.

the pressure on the IADS as a whole as more nodes are forced to rapidly relocate. An SA-21 in transit is one unable to shoot down an aircraft. The effect of a persistent, stealthy ISR capability in this scenario would be the degradation and disruption of the IADS contributing to local air superiority.

One severe limitation of current air-breathing C2ISR assets is the common Boeing 707 or similar C-135 platform carrying the mission system. Stealth was the last thing the engineers of these aircraft had in mind. They have massive visual, IR, and radar signatures and are relatively slow, non-maneuvering targets that have no chance of surviving in the operating envelope of the modern IADS. The long maximum ranges of advanced Russian SAMs would deny these aircraft the opportunity to operate within their effective ranges to the threat and friendly forces. In essence, many of these aircraft would be forced out of the fight by the mere presence of a long-range double-digit SAM. A stealthy ISR platform should allow some crucial support to stealthy strike aircraft operating against a formidable IADS.

The acquisition of large numbers of unmanned aircraft armed with enough ordnance to attack IADS nodes or other targets is another way to increase pressure on an advanced air defense system. To do this, however, the US Air Force will have to seriously change its institutional approach to procuring aircraft. Instead of a few gold-plated, phenomenally capable fighters and bombers, the Air Force will have to turn its eye toward acquiring many cheaper, unmanned systems to overwhelm the IADS with sheer numbers. Under this model, the small, inexpensive unmanned aircraft, networked with the stealthy ISR aircraft, could swarm an IADS. The swarm would rapidly attack SAM batteries that reveal their positions by firing or by leaving concealed positions for new locations. The swarming unmanned aircraft would either engage and destroy point defense systems or absorb their missiles, leaving the long-range SAMs more vulnerable to attack. In the near term, a less ambitious scenario would involve dozens or hundreds of drones or decoys saturating the IADS, creating enough chaos and background noise while stealth aircraft like the F-22, B-2, or NGB strike the enemy's CoG. In either scenario, the acquisition of cheap, unmanned strike aircraft and their thorough integration with manned aircraft is a necessary step toward defeating an advanced IADS and achieving local air superiority.

The final recommendation is to cancel or curtail the F-35 program. The F-35 is the weapon system to which the US and many of its allies have staked their air combat fortunes for the foreseeable future. That decision is a strategic error. This aircraft appears to be ill-suited to operate in a combat environment that includes an advanced IADS. Advertised as a stealth fighter, the F-35's radar cross section is actually aspect angle and frequency dependent. It is designed to break the SAM kill chain of systems that rely on relatively high frequency radars. The assumption appears to be that the F-22 will have destroyed area defense systems like the SA-20 or SA-21, leaving only the point defense systems or legacy single-digit SAMs for the F-35 to confront. As demonstrated in Chapter 4, this assumption is wishful thinking at its worst. The F-35 was designed to defeat an IADS threat that the existing legacy fighter force is capable of defeating, but with a much higher price tag than legacy fighters.

According to the US Air Force Fiscal Year 2011 Budget Estimate, the unit price of the F-35 is approximately \$120 million through fiscal year 2014.² In recent months, the program has come under fire for rising costs and a series of delays as a result of immature technology rushed to production.³ In contrast, Boeing's F-15SE Silent Eagle, a semi-stealthy variant of the F-15E Strike Eagle marketed to states who balk at the F-35's price tag, has a unit cost of approximately \$100 million.⁴ Given the mechanics of the sensors and weapons of the modern IADS, it is difficult to see how the F-35 offers greater survivability than a platform like the F-15SE.

The problem with the F-35 is the sheer size of the program and the opportunity cost associated with it. The US will buy more than 2,000 F-35s at a total cost of approximately \$300 billion. That is money that ought to be committed to revamping the new force structure based on a long-range penetrating bomber, passive radar, swarm technology, and stealthy ISR capability. The strategic bind in which the US finds itself currently is not due to strategic miscalculation per se. Stealthy aircraft have performed brilliantly in several conflicts. The adversary merely made a series of superb

² US Air Force, FY 2011 Budget Estimates, "Aircraft Procurement, Air Force, Volume 1," February 2010, 1-1.

³ Christopher Drew, "Gates Tries to Get F-35 Program Back on Track," New York Times, 3 February 2010, <http://www.nytimes.com/2010/02/03/business/03fighter.html> (accessed 3 May 2010). (*Chicago*, 17.198)

⁴ Alon Ben-David, "Boeing Unveils Silent Eagle," *Jane's Defence Weekly*, 18 March 2009, http://www.janes.com/news/defence/systems/jdw/jdw090318_1_n.shtml Accessed 3 May 2010. (*Chicago*, 17.187)

countermoves to balance the equation. The F-35, on the other hand, represents a strategic blunder of the first magnitude, representing squandered treasure for little gain against a threat that no longer meaningfully exists.

Modern IADS have changed the equation. The creators of these systems boldly pursued technology bound in a reverse salient and generated impressive leaps in sensor technology, C2 connectivity, and weapon lethality. If the US is to maintain its ability to wield airpower as a coercive instrument, it will have to commit itself to a larger force structure that features many cheap, replaceable unmanned systems to enable high-end stealth strike aircraft. Half-measures and middleweight capabilities like the F-35 will not suffice. Should the US fail to pursue these bold recommendations to adapt meaningfully to the IADS threat, it will be an American President who echoes Saddam Hussein: “We will not *use* our Air Force. We will *keep* it.”

APPENDIX

ACRONYM LIST

AA-	Air-to-Air (prefix for FSU weapon system)
AAA	Antiaircraft Artillery
ADOC	Air Defense Operations Center
AEW	Airborne Early Warning
AGM	Air-to-Ground Missile
AI	Air Intercept
AIM	Air Intercept Missile
AMRAAM	Advanced Medium Range Air-to Air Missile
ANG	Air National Guard
ATO	Air Tasking Order
AWACS	Airborne Warning and Control System
BVR	Beyond Visual Range
C2	Command and Control
CAP	Combat Air Patrol
CAS	Close Air Support
CENTAF	Central Air Forces
CONUS	Continental United States
COTS	Commercial Off-The-Shelf
CW	Continuous Wave
DEAD	Destruction of Enemy Air Defenses
DF	Direction Finding
DIA	Defense Intelligence Agency
EW	Early Warning
FEZ	Fighter Engagement Zone
FSU	Former Soviet Union
GAO	General Accounting Office
GCI	Ground Controlled Intercept
GPS	Global Positioning System
GWAPS	Gulf War Air Power Survey
HARM	High-Speed Antiradiation Missile
IADS	Integrated Air Defense System
ICBM	Intercontinental Ballistic Missile
IDF	Israeli Defense Force
IFF	Identification Friend or Foe
IOC	Initial Operational Capability
IR	Infrared
ISR	Intelligence, Surveillance, and Reconnaissance
JASSM	Joint Air-to-Surface Stand-off Missile
JEZ	Joint Engagement Zone
MEZ	Missile Engagement Zone
MG	Missile Guidance

NGB	Next Generation Bomber
OCA	Offensive Counterair
P_k	Probability of Kill
PGM	Precision Guided Munition
ROE	Rules of Engagement
RWR	Radar Warning Receiver
SA-	Surface-to-Air (prefix for FSU weapon system)
SAC	Strategic Air Command
SAM	Surface-to-Air Missile
SATCOM	Satellite Communications
SEAD	Suppression of Enemy Air Defenses
SLAM-ER	Stand-off Land Attack Missile – Extended Range
SOC	Sector Operations Center
TALD	Tactical Air-Launched Decoy
TLAM	Tomahawk Land Attack Missile
TOA	Time of Arrival
USAF	United States Air Force

BIBLIOGRAPHY

- Ackerman, Michael W. *Future of Airborne Tactical Jamming*. US Navy report. Accessed 24 March 2010.
- Air Combat Command Training Manual. *Electronic Warfare Fundamentals*. November 2000.
- Air Force Tactics, Techniques, and Procedures Manual 3-1, 2006.
- Axelrod, Robert. *The Evolution of Cooperation*. New York: Basic Books, 1984.
- Bousquet, Antoine. *The Scientific Way of Warfare: Order and Chaos on the Battlefields of Modernity*. New York: Columbia University Press, 2009.
- Brungess, James R. *Setting the Context: Suppression of Enemy Air Defenses and Joint War Fighting in an Uncertain World*. Maxwell Air Force Base, AL: Air University Press, 1994.
- Clausewitz, Carl von. *On War*. Edited and Translated by Michael Howard and Peter Paret. Princeton, NJ: Princeton University Press, 1976.
- Clodfelter, Mark. *The Limits of Airpower: The American Bombing of North Vietnam*. Lincoln, NE: The University of Nebraska Press, 2006.
- Cohen, Eliot A and Thomas A. Keaney, eds. *Gulf War Air Power Survey*. 5 vols. Washington DC: US Government Printing Office, 1993.
- David, Alon Ben. "Boeing Unveils Silent Eagle." *Jane's Defence Weekly*. 18 March 2009, http://www.janes.com/news/defence/systems/jdw/jdw090318_1_n.shtml
- Douhet, Giulio. *Command of the Air*, Edited by Joseph Patrick Harahan & Richard H. Kohn, Translated by Dino Ferrari. Tuscaloosa, AL: The University of Alabama, 1942.
- Drew, Christopher. "Gates Tries to Get F-35 Program Back on Track." *New York Times*, 3 February 2010, <http://www.nytimes.com/2010/02/03/business/03fighter.html>
- Elsam, M.B. *Air Defence*. London: Brassey's Maxwell Pergamon Publishing, 1989.
- Fiszer, Michael and Jerzy Gruszczynski. "Castles in the Sky." *Journal of Electronic Defense*, 25, no. 2 (February 2002): 46-51.
- Fulghum, David A. "Pentagon Jam Up." *Aviation Week & Space Technology*. 164, no. 15, 2006.
- Gentile, Gian P. *How Effective is Strategic Bombing*. New York: New York University Press, 2001.
- Gertler, Jeremiah. *Air Force Next-Generation Bomber: Background and Issues for Congress*. Congressional Research Service Report. Washington DC: Congressional Research Service, 22 December 2009.
- GlobalSecurity.org. "S-300 Tactical and Technical Performance." <http://www.globalsecurity.org/military/world/russia/s-300-list.htm>
- Greenhous, Brerton, "The Israeli Experience." *Case Studies in the Achievement of Air Superiority*. Edited by Benjamin Franklin Cooling. Washington DC: US Government Printing Office, 1991.

- Hufbauer, Gary Clyde, Jeffrey J. Schott, Kimberly Ann Elliott, and Barbara Oegg. *Economic Sanctions Reconsidered*. Washington, DC: Peterson Institute for International Economics, 2007.
- Jane's Land-Based Air Defence, "S-400 Triumph," 21 April 2010, http://search.janes.com/Search/documentView.do?docId=/content1/janesdata/yb/jlad/jlad0593.htm@current&pageSelected=allJanes&keyword=S-400&backPath=http://search.janes.com/Search&Prod_Name=JLAD&#toclink-j0010230054663
- Jervis, Robert. *Perception and Misperception in International Politics*. Princeton, NJ: Princeton University Press, 1976.
- Joint Publication 3-01, *Countering Air and Missile Threats*, 5 February 2007.
- Joint Publication 3-52. *Joint Doctrine for Airspace Control in the Combat Zone*, 30 August 2004.
- "Joint Strike Fighter," http://www.jsf.mil/contact/con_faqs.htm
- Keaney, Thomas A. and Eliot A. Cohen. *Revolution in Warfare? Air Power in the Persian Gulf*. Annapolis, MD: Naval Institute Press, 1993.
- Kopp, Carlo. "Assessing Joint Strike Fighter Defence Penetration Capabilities." Air Power Australia Analysis, 7 January 2009. <http://www.ausairpower.net/APA-2009-01.html>
- Kopp, Carlo. "SAM System Mobility: Russian and PLA Air Defence System Vehicles." Technical Report APA-TR-2008-0601, Air Power Australia, June 2008. <http://www.ausairpower.net/APA-SAM-Support-Vehicles.html>
- Kopp, Carlo. "Almaz S-300P/PT/PS/PMU/PMU1/PMU2, Almaz-Antey S-400 Triumph, SA-10/20/21 Grumble/Gargoye." Technical Report APA-TR-2006-1201. March 2009. <http://www.ausairpower.net/APA-Grumble-Gargoye.html#mozTocId106894>
- Kopp, Carlo. "Surviving the Modern IADS." *Air Power Australia*. February 2009, <http://www.ausairpower.net/APA-2009-02.html>
- Laszlo, Zord Gabor. "Secrets of 1999 F-117 Shootdown Revealed." *The Journal of Electronic Defense*, 29, no. 1 (January 2006): 24-26.
- Law, John. "Portuguese Expansion." *The Social Construction of Technological Systems: New Directions in the Sociology and History of Technology*. Edited by Wiebe E. Bijker, Thomas P. Hughes, and Trevor Pinch. Cambridge, MA: The MIT Press, 1987.
- Li, Allen. "Electronic Warfare: Option of Upgrading Additional Ea-6bs Could Reduce Risk in Development of Ea18g: Gao-06-446." *GAO Reports*. U.S. Government Accountability Office, 2006.
- Lord, Kristin M., *The Perils and Promise of Global Transparency*. Albany, NY: State University of New York Press, 2006.
- Miles, Donna. "Gates Touts F-35 as Heart of Future of Combat Tactical Aviation," United States Department of Defense, 31 August 2009. <http://www.defense.gov/news/newsarticle.aspx?id=55684>
- Mukherjee, Somnath. "Passive Sensors Using RF Backscatter." *Microwave Journal*, November 2004, 96-108.
- Olsen, John Andreas. *John Warden and the Renaissance of American Air Power*. Washington, DC: Potomac Books, Inc., 2007.

- Olsen, John Andreas. *Strategic Air Power in Desert Storm*. London: Routledge Taylor and Francis Group, 2003.
- Overy, Richard J. *The Air War 1939-1945*. Washington DC Potomac Books, 1980.
- Pape, Robert A. "Air Force Strikes Back." *Security Studies* 7, no.2 (Winter 1997-1998): 191-214.
- Pape, Robert A. *Bombing to Win*. Ithaca, NY: Cornell University Press, 1996.
- Pape, Robert A. "Coercive Airpower in the Vietnam War." *International Security* 15, no. 2 (Autumn, 1990): 103-146.
- Putney, Diane T. *Airpower Advantage: Planning the Gulf War Air Campaign 1989-1991*. Washington, DC: Air Force History and Museums Program, 2004.
- Randolph, Stephen P. *Powerful and Brutal Weapons*. Cambridge, MA: Harvard University Press, 2007.
- Sagan, Scott D. and Kenneth N. Waltz. *The Spread of Nuclear Weapons: A Debate Renewed*. New York: W.W. Norton and Company, 2003.
- Schelling, Thomas C. *Arms and Influence*. New Haven, CT: Yale University Press, 1966.
- Sirak, Michael C. "Not Date Driven," *airforce-magazine.com*, 19 February 2010, <http://www.airforce-magazine.com/Features/modernization/Pages/box021910/fraser.aspx>
- Stanik, Joseph T. *El Dorado Canyon*. Annapolis, MD: Naval Institute Press, 2003.
- United States General Accounting Office. *B-2 Bomber: Cost and Operational Issues*. Letter Report, 14 August 1997, GAO/NSIAD-97-181. Washington DC: General Accounting Office. <http://www.fas.org/man/gao/nsiad97181.htm>.
- USAF. "B-2 Spirit." USAF Fact Sheet. <http://www.af.mil/information/factsheets/factsheet.asp?id=82>
- USAF. "FY 2011 Budget Estimates: Aircraft Procurement, Air Force, Volume 1," February 2010
- USAF. "RC-135V/W Rivet Joint." USAF Fact Sheet. <http://www.af.mil/information/factsheets/factsheet.asp?fsID=121>
- Waltz, Kenneth N. *Theory of International Politics*. Boston, MA: McGraw-Hill, 1979.
- Warden, John A. *The Air Campaign*. Research Report. Washington DC: National War College, February 1986.
- Westermann, Edward B. *Flak*. Lawrence, KS: University of Kansas Press, 2001.
- Westra, Arend G. "Radar Versus Stealth: Passive Radar and the Future of US Military Power." *Joint Force Quarterly*, no. 55, 4th Quarter 2009: 136-143.
- Xudong, Wang. "The Essential Solution for the People's Liberation Army to Defeat F-22 Raptor: Boost of Systems' Combat Power." *Ordnance Knowledge Magazine*, 12 May 2008.
- Yue, Tao. "Detection of the B-2 Bomber and a Brief History on Stealth." *The Tech: Online Edition*, 30 November 2001, <http://tech.mit.edu/V121/N63/Stealth.63f.html>