



ARL-TR-7837 • SEP 2016



# Evaluation of Thermoelectric Devices by the Slope-Efficiency Method

by Patrick J Taylor, Jay R Maddux, and Adam Wilson

Approved for public release; distribution is unlimited.

## **NOTICES**

### **Disclaimers**

The findings in this report are not to be construed as an official Department of the Army position unless so designated by other authorized documents.

Citation of manufacturer's or trade names does not constitute an official endorsement or approval of the use thereof.

Destroy this report when it is no longer needed. Do not return it to the originator.



# **Evaluation of Thermoelectric Devices by the Slope-Efficiency Method**

**by Patrick J Taylor**

*Sensors and Electron Devices Directorate, ARL*

**Jay R Maddux**

*General Technical Services, LLC, 3100 Route 138 West, Wall Township, NJ 07719*

**Adam Wilson**

*Department of Mechanical, Aerospace and Nuclear Engineering, Rensselaer Polytechnic Institute 110 8th Street, Troy, NY 12180-3590*

**REPORT DOCUMENTATION PAGE**

*Form Approved*  
*OMB No. 0704-0188*

Public reporting burden for this collection of information is estimated to average 1 hour per response, including the time for reviewing instructions, searching existing data sources, gathering and maintaining the data needed, and completing and reviewing the collection information. Send comments regarding this burden estimate or any other aspect of this collection of information, including suggestions for reducing the burden, to Department of Defense, Washington Headquarters Services, Directorate for Information Operations and Reports (0704-0188), 1215 Jefferson Davis Highway, Suite 1204, Arlington, VA 22202-4302. Respondents should be aware that notwithstanding any other provision of law, no person shall be subject to any penalty for failing to comply with a collection of information if it does not display a currently valid OMB control number.

**PLEASE DO NOT RETURN YOUR FORM TO THE ABOVE ADDRESS.**

|   |                                    |   |   |  |  |
|---|------------------------------------|---|---|--|--|
| <b>1. REPORT DATE (DD-MM-YYYY)</b><br>September 2016  |                                    | <b>2. REPORT TYPE</b><br>Technical Report |   | <b>3. DATES COVERED (From - To)</b><br>09/2016                     |  |
| <b>4. TITLE AND SUBTITLE</b><br>Evaluation of Thermoelectric Devices by the Slope-Efficiency Method   |                                    |   |   | <b>5a. CONTRACT NUMBER</b>   |  |
|   |                                    |   |   | <b>5b. GRANT NUMBER</b>  |  |
|   |                                    |   |   | <b>5c. PROGRAM ELEMENT NUMBER</b>                                  |  |
| <b>6. AUTHOR(S)</b><br>Patrick J Taylor, Jay R Maddux, and Adam Wilson  |                                    |   |   | <b>5d. PROJECT NUMBER</b>  |  |
|   |                                    |   |   | <b>5e. TASK NUMBER</b>   |  |
|   |                                    |   |   | <b>5f. WORK UNIT NUMBER</b>  |  |
| <b>7. PERFORMING ORGANIZATION NAME(S) AND ADDRESS(ES)</b><br>US Army Research Laboratory<br>ATTN: RDRL-SED-E<br>2800 Powder Mill Road<br>Adelphi, MD 20783-1138   |                                    |   |   | <b>8. PERFORMING ORGANIZATION REPORT NUMBER</b><br><br>ARL-TR-7837 |  |
| <b>9. SPONSORING/MONITORING AGENCY NAME(S) AND ADDRESS(ES)</b>  |                                    |   |   | <b>10. SPONSOR/MONITOR'S ACRONYM(S)</b>                            |  |
|   |                                    |   |   | <b>11. SPONSOR/MONITOR'S REPORT NUMBER(S)</b>                      |  |
| <b>12. DISTRIBUTION/AVAILABILITY STATEMENT</b><br>Approved for public release; distribution is unlimited.   |                                    |   |   |  |  |
| <b>13. SUPPLEMENTARY NOTES</b>  |                                    |   |   |  |  |
| <b>14. ABSTRACT</b><br>Thermoelectric power generation is the premier solid-state technology for low-temperature, greater than approximately 900 K, conversion of heat energy into electrical energy. However, the evaluation, interpretation, and analysis of thermoelectric devices is not straightforward. In this work, we introduce a new device analysis that provides a simple new experimental method to obtain the usual quantifiable metric for device performance, $ZT_{\text{maximum}}$ . The significance of this new method is that it provides a fast experimental method to confirm the validity of basic materials measurements. The new method directly connects basic materials properties to conversion efficiency and, employing differential measurements, minimizes systemic error. We demonstrate the efficacy of this method by 3 separate cases of thermoelectric power generation modules fabricated from different materials; a low-cost technology demonstrates $ZT = 0.4$ , a commercial module shows $ZT = 0.7$ , and a precommercial lead telluride/TAGS technology has $ZT = 0.7$ by the proposed technique. |                                    |   |   |  |  |
| <b>15. SUBJECT TERMS</b><br>thermoelectric device characterization, efficiency, $ZT$ , slope efficiency, power generation   |                                    |   |   |  |  |
| <b>16. SECURITY CLASSIFICATION OF:</b>  |                                    |   | <b>17. LIMITATION OF ABSTRACT</b><br><br>UU | <b>18. NUMBER OF PAGES</b><br><br>18                               | <b>19a. NAME OF RESPONSIBLE PERSON</b><br>Patrick J Taylor       |
| <b>a. REPORT</b><br>Unclassified  | <b>b. ABSTRACT</b><br>Unclassified | <b>c. THIS PAGE</b><br>Unclassified       |   |  | <b>19b. TELEPHONE NUMBER (Include area code)</b><br>301-394-1475 |

## Contents

---

---

|   |           |
|---|-----------|
| <b>List of Figures</b>  | <b>iv</b> |
| <b>1. Introduction</b>  | <b>1</b>  |
| <b>2. Slope-Efficiency Method: Rapid Measurement of Device <math>ZT_{\text{maximum}}</math></b> | <b>1</b>  |
| <b>3. Experimental Configuration</b>  | <b>5</b>  |
| 3.1 Case I: Analysis of a Precommercial Module  | 6         |
| 3.2 Case II: Analysis of Commercial Bismuth-Antimony-Selenide-Telluride Module                  | 8         |
| 3.3 Case III: Analysis of Precommercial Lead Telluride (PbTe)/TAGS Module                       | 9         |
| <b>4. Conclusions</b>   | <b>9</b>  |
| <b>5. References</b>  | <b>11</b> |
| <b>Distribution List</b>  | <b>12</b> |

## List of Figures

---

|        |   |   |
|--------|---|---|
| Fig. 1 | Schematic experimental apparatus for measuring the current-voltage data, the maximum electrical power, and efficiency of thermoelectric generator .....   | 5 |
| Fig. 2 | Current-voltage load lines (left) and current-power curves (right) obtained with $T_{\text{cold}} = 70\text{ }^{\circ}\text{C}$ . The highest $T_{\text{hot}} = 300\text{ }^{\circ}\text{C}$ for which $\Delta T = 229\text{ }^{\circ}\text{C}$ . ..... | 7 |
| Fig. 3 | Slope efficiency to determine $ZT_{\text{max}}$ . $T_{\text{cold}} = 343\text{ K}$ and $T_{\text{hot}}$ limit = $873\text{ K}$ .....  | 7 |
| Fig. 4 | Slope of efficiency from $(\text{Bi,Sb})_2(\text{Te,Se})_3$ to determine $ZT_{\text{max}}$ .....  | 8 |
| Fig. 5 | Slope of efficiency from precommercial PbTe/TAGS to determine $ZT_{\text{max}}$ .....   | 9 |

## 1. Introduction

---

---

Thermoelectric power generation is the premier solid-state technology for low-temperature, greater than approximately 900 K, conversion of heat energy into electrical energy. However, the evaluation, interpretation, and analysis of thermoelectric devices is not straightforward.

The efficiency with which thermoelectric power generation can convert heat energy to electricity can be predicted, in part, by making individual measurements of the basic thermoelectric properties of the constituent materials: the Seebeck coefficient,  $\alpha$ ; the electrical resistivity,  $\rho$ ; and the thermal conductivity,  $\kappa$ . However, experimental measurement of those properties usually results in significant error, greater than  $\pm 20\%$ .<sup>1</sup> That error leads to significant overestimates of actual device performance.

For example, efforts to quantify the error of one property, thermal conductivity, showed it can be as large as  $\pm 15\%$ . There have been initiatives to characterize these properties with significantly improved accuracy.<sup>2-4</sup>

What is lacking in the field of thermoelectrics research is a straightforward method of confirming measurements and validating ZT claims. Therefore, one goal of this work is to demonstrate a simple method of confirming measurements and validating ZT claims. A secondary goal is the description of a straightforward technique for accurately measuring output power and efficiency of thermoelectric power generator modules.

In this work, we introduce a new device analysis that provides a simple new experimental method to obtain the usual quantifiable metric for device performance,  $ZT_{\text{maximum}}$ . The significance of this new method is that it provides a fast experimental method to confirm the validity of basic materials measurements. The new method directly connects basic materials properties to conversion efficiency and employing differential measurements minimizes systemic error.

## 2. Slope-Efficiency Method: Rapid Measurement of Device

### $ZT_{\text{maximum}}$

---

---

The maximum electrical power output,  $P_{\text{max}}$ , of any thermoelectric generator module is obtained when it is operated in an impedance-matched condition. The impedance matched condition occurs when internal device electrical resistance,  $R_{\text{int}}$ , exactly equals to the electrical resistance of an external load,  $R_{\text{load}}$ . When  $R_{\text{int}} = R_{\text{load}}$ , then total system resistance is equal to  $2R_{\text{int}}$  and open-circuit voltage,  $V_{\text{oc}}$ , drops by half leading to

$$P_{\max} = \frac{V_{oc}^2}{4R_{int}}. \quad (1)$$

For a thermoelectric generator consisting of some number “i” of individual “thermocouples” connected in series and each having n-type thermoelement and p-type thermoelement, the Seebeck effect relates  $V_{oc}$  to the temperature difference,  $\Delta T$ , induced by the heat source as described:

$$V_{oc} = \sum_0^i (\alpha_n + \alpha_p)_i \Delta T, \quad (2)$$

where  $\alpha_n$  and  $\alpha_p$  are values of n-type and p-type Seebeck coefficients from each individual thermoelement, respectively. Thus, the sum of Seebeck coefficients from i thermocouples is the ensemble-average proportionality between  $V_{oc}$  and  $\Delta T$ . Likewise,  $R_{int}$  is the sum of resistances from i thermocouples, and it is the ensemble-average electrical resistivity of n-type ( $\rho_n$ ) and p-type ( $\rho_p$ ) thermoelements times their respective area (A)-to-length ( $\ell$ ) values:

$$R_{int} = \sum_0^i \left( \rho_n \frac{\ell}{A} + \rho_p \frac{\ell}{A} \right)_i \quad (3)$$

Thus,  $P_{\max}$  can be expressed in terms of Seebeck coefficients:

$$P_{\max} = \frac{(\sum_0^i (\alpha_n + \alpha_p)_i)^2 \Delta T^2}{4R_{int}}. \quad (4)$$

This expression highlights the first important point:  $P_{\max}$  increases as  $\Delta T^2$ . So, for large electrical power output, the largest possible  $\Delta T$  is required.

The efficiency,  $\Phi$ , with which a thermoelectric generator can convert heat flow,  $Q$ , to electrical power is also important because the most electrical power possible from a given amount of heat flow is desirable. A new expression for the efficiency of a thermoelectric generator can be obtained starting with expression for  $P_{\max}$ . The ratio of electrical power generated per amount of input heat flow is the definition of efficiency:

$$\Phi = \frac{P_{\max}}{Q}. \quad (5)$$

Equation 5 can be rewritten, assuming for simplicity a solitary p-n couple ( $i=1$ ), as

$$\Phi = \frac{(\alpha_n + \alpha_p)^2 \Delta T^2}{4R_{int}Q}. \quad (6)$$



The flow of heat is dominated by thermal conductivity of the materials from which a thermoelectric generator is constructed, so Fourier's law can be used to express Q:

$$\Phi = \frac{(\alpha_n + \alpha_p)^2 \Delta T^2}{4R_{\text{int}}([\kappa_n + \kappa_p] \frac{A}{\ell} \Delta T)}. \quad (7)$$

Then expressing  $R_{\text{int}}$  as described earlier,

$$\Phi = \frac{(\alpha_n + \alpha_p)^2 \Delta T^2}{4(\rho_n \frac{\ell}{A} + \rho_p \frac{\ell}{A})([\kappa_n + \kappa_p] \frac{A}{\ell} \Delta T)}. \quad (8)$$

For planar thermoelectric generator devices, the values of  $\ell$  of both n- and p-type thermoelements are equal; however, cross-sectional areas of n- and p-type may be quite different. Identifying cross-sectional area of n-type as  $A_n$  and that of p-type as  $A_p$  allows a simplification, yielding  $\Phi$  in terms of measurable materials properties and  $\Delta T$ :

$$\Phi = \frac{1}{4} \left( \frac{(\alpha_n + \alpha_p)^2}{\left(\frac{\rho_n}{A_n} + \frac{\rho_p}{A_p}\right)(\kappa_n A_n + \kappa_p A_p)} \right) \Delta T. \quad (9)$$

The proportionality between  $\Phi$  and  $\Delta T$  is termed “ $Z_{\text{device}}$ ”:

$$Z_{\text{device}} = \left( \frac{(\alpha_n + \alpha_p)^2}{\left(\frac{\rho_n}{A_n} + \frac{\rho_p}{A_p}\right)(\kappa_n A_n + \kappa_p A_p)} \right). \quad (10)$$

Note that when area-to-length ratios are optimized for maximum efficiency, this relationship reduces to the common, well-known expression for device ZT:

$$Z_{\text{max}} = \left( \frac{(\alpha_n + \alpha_p)}{(\sqrt{\kappa_n \rho_p} + \sqrt{\kappa_p \rho_n})} \right)^2. \quad (11)$$

The thermoelectric generator efficiency can be measured as function of  $\Delta T$ , and the slope of that data should equal to

$$\frac{\partial \Phi}{\partial \Delta T} = \frac{1}{4} \left( \frac{(\alpha_n + \alpha_p)^2}{\left(\frac{\rho_n}{A_n} + \frac{\rho_p}{A_p}\right)(\kappa_n A_n + \kappa_p A_p)} \right) = \frac{Z_{\text{device}}}{4}. \quad (12)$$

This expression highlights a second important point, that  $\Phi$  should linearly increase as a function of  $\Delta T$  according to the slope indicated by 1/4 of the quantity in parentheses. This makes sense, because the  $\Phi$  function increases linearly with  $\Delta T$ ,

and  $P_{\max}$  increases as  $\Delta T^2$ . Taking the ratio yields a simple linear dependence on  $\Delta T$ .

It is important to note that the materials properties are all temperature-dependent, so taking the derivative would necessarily yield higher-order terms. However, we make use of the following simplifications:

- 1) The temperature dependence of the electrical component of thermal conductivity depends on the mobility of charge carriers, and the electrical resistivity depends on the inverse of that mobility, so these dependencies cancel.
- 2) The Seebeck coefficient does have a relatively small, but finite temperature dependence; however, the derivative of the Seebeck coefficient should yield a temperature dependence of  $T^{-1}$ , and that approximately cancels with the  $T^{-1}$  temperature dependence of lattice thermal conductivity in the denominator.

The remaining terms are essentially constant over the operational temperature window of interest such that the derivative of Eq. 12 would have a solution that is constant. Thus, a linear slope ought to be expected. The linearity of that slope is in fact experimentally observed over a window of temperature, as we show.

A new index to determine maximum ZT of any thermoelectric generator device can be obtained by measuring the slope of the efficiency as a function of  $\Delta T$ . To calculate maximum ZT, 4 times the slope of efficiency multiplied by maximum temperature,  $T_{\max}$ , under which the thermoelectric generator displays linear behavior with respect to  $\Delta T$ . When the thermoelectric generator is operated outside this linear regime, the basic materials properties can no longer be described by these functions and the efficiency degrades. Therefore, the slope-efficiency method yields a measure of maximum  $Z_{\text{device}}T$  as per Eq. 13:

$$Z_{\text{device}}T = 4 \left( \frac{(\alpha_n + \alpha_p)^2}{\left(\frac{\rho_n}{A_n} + \frac{\rho_p}{A_p}\right)(\kappa_n A_n + \kappa_p A_p)} \right) T_{\max}. \quad (13)$$

The significance of this analysis is it allows unique means to rapidly obtain  $ZT_{\max}$  and confirm properties and individual measurements. Measurements can be confirmed by measuring slope of efficiency as function of  $\Delta T$  and ZT can be obtained and compared to theoretical ZT as calculated by individual measurements.

### 3. Experimental Configuration

The temperature difference across a thermoelectric module, as defined by a hot-side temperature,  $T_{hot}$ , and a cold-side temperature,  $T_{cold}$ , causes electrical power output from the resulting heat flow through the device. The magnitude of that power is directly measured by collecting  $V_{oc}$ , and the current-voltage data ranging from the  $V_{oc}$  condition until the short-circuit current condition. The slope of the current-voltage curve yields  $R_{int}$ . The experimental  $V_{oc}$  and  $R_{int}$  data are used with Eq. 1 to exactly determine the electrical power output.

To characterize the thermodynamic conversion efficiency, the magnitude of the heat flow through the thermoelectric module must be known. The specific strategy employed in this work for determining the heat flow through the device is schematically shown in Fig. 1. In this specific strategy, the heat flow through the device is given as the sum of the heat flow that passes through a heat flow meter after it leaves the module,  $Q_{heat-flow-meter}$ , *added to* the magnitude of the generated electrical power output, Eq. 1. All other heat flows are negligible because the test is performed in vacuum, and the small temperature difference between the cold side and the environment eliminates radiative heat loss at the cold side.

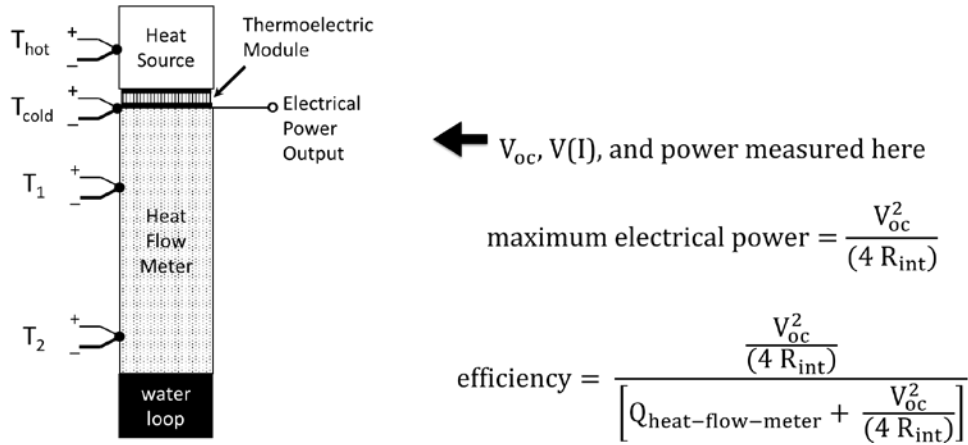

**Fig. 1 Schematic experimental apparatus for measuring the current-voltage data, the maximum electrical power, and efficiency of thermoelectric generator**

Having eliminated heat flow errors at the cold side, the Fourier heat flow law can characterize that heat by the steady-state temperature difference ( $T_1 - T_2$ ) along the length of a heat flow meter made of a material of known thermal conductivity, in this case oxygen-free, high-purity copper. The efficiency is defined, then, as the power output divided by the sum of the Fourier heat flow plus the power output.

By increasing the heat input from the heat source in Fig. 1, a range of temperature differences across the thermoelectric device can be investigated. The temperature

difference data can be self-consistent if the cold-side temperature  $T_{\text{cold}}$  is maintained constant. In the present strategy, a constant  $T_{\text{cold}}$  is easily preserved by a cooling water loop at the base of the heat flow meter.

In the individual cases that follow, we measure the power and efficiency of some currently available thermoelectric modules. Each module was measured using the experimental strategy as described. The obtained data were then used to demonstrate the efficacy of the new slope-efficiency methodology to analyze and quantify the performance of the modules in terms of ZT.

### **3.1 Case I: Analysis of a Precommercial Module**

---

A precommercial module assembled from unspecified thermoelectric materials was subjected to the present analysis. The materials are designed to be extremely low cost, not high performance. According to the supplier, the module technology has a hot-side temperature limit of 873 K beyond which slope linearity breaks down, so a hot-side temperature of 573 K is sufficient to fully capture the linear slope of interest. In this test, the cold side was maintained at a constant 343 K (70 °C).

Shown in Fig. 2 are the current-voltage and current-power data sets that were collected with  $T_{\text{cold}} = 343$  K with a maximum temperature difference  $\Delta T$  of 229 K to capture the linear slope. On the left panel of Fig. 2, the slopes indicated by the best-fit equations of the current-voltage data are the  $R_{\text{int}}$  values as a function of the  $T_{\text{hot}}$ . The y-intercepts are  $V_{\text{oc}}$ . The right-side panel shows the collected power output from the module ranging from open circuit, passing through the parabolic power at maximum efficiency, and stopping at short circuit. There are 3 separate  $\Delta T$  values of 135, 179, and 229 K.

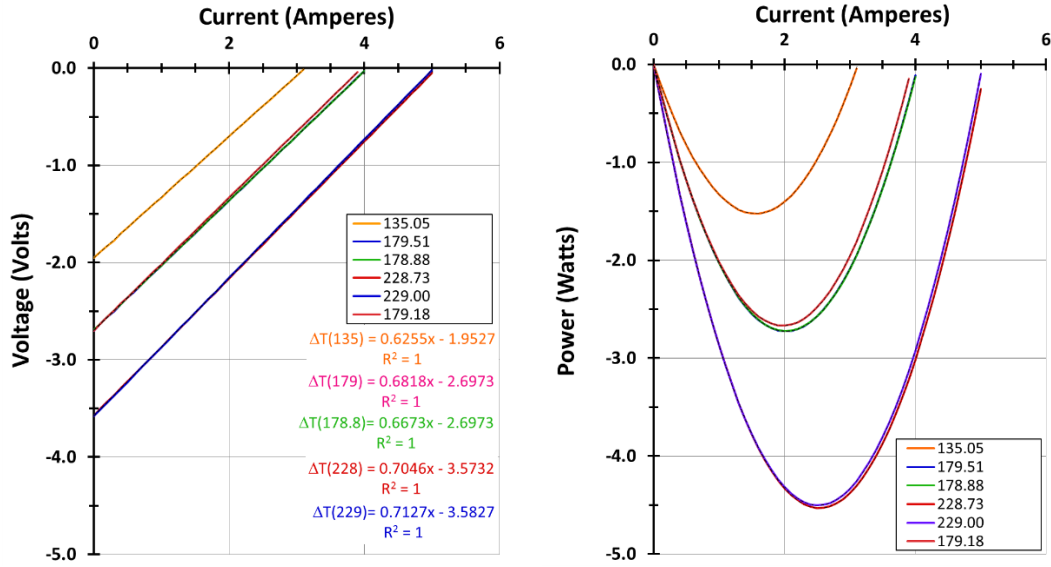

Fig. 2 Current-voltage load lines (left) and current-power curves (right) obtained with  $T_{\text{cold}} = 70 \text{ }^{\circ}\text{C}$ . The highest  $T_{\text{hot}} = 300 \text{ }^{\circ}\text{C}$  for which  $\Delta T = 229 \text{ }^{\circ}\text{C}$ .

The efficiency was determined and is plotted in Fig. 3. In this range, the efficiency is linear, and the slope is 0.0001/K. Therefore, for this module, the determined  $ZT_{\text{maximum}} = 0.4$ .

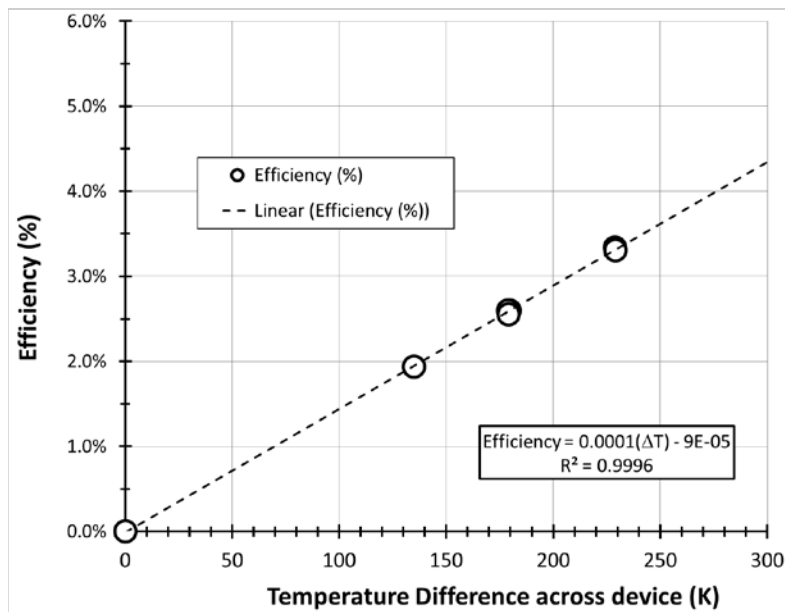

Fig. 3 Slope efficiency to determine  $ZT_{\text{max}}$ .  $T_{\text{cold}} = 343 \text{ K}$  and  $T_{\text{hot}} \text{ limit} = 873 \text{ K}$

### 3.2 Case II: Analysis of Commercial Bismuth-Antimony-Selenide-Telluride Module

The efficiency measured from a commercial bismuth-antimony-selenide-telluride— $(\text{Bi,Sb})_2(\text{Te,Se})_3$ —device is presented in Fig. 4. This device is designed for high performance for applications requiring an especially large value of thermal impedance, such as energy harvesting. The result of high thermal impedance is that the maximum hot-side temperature is a relatively low value causing a relatively narrow optimum performance window: roughly room temperature to 425 K.

The current-voltage data, current-power data, and efficiency were collected as a function of  $\Delta T$ . The slope efficiency of 0.0004/K is shown in inset in Fig. 4. As expected, the slope is highly linear function of  $\Delta T$  until deviation from nonlinearity begins at 405 K. The  $ZT_{\text{maximum}}$  can be obtained by the simple relationship, and observed maximum temperature of roughly 405 K:

$$Z_{\text{device}} T_{\text{maximum}} = 4 \left( \frac{\partial \Phi}{\partial \Delta T} \right) T_{\text{maximum}}. \quad (14)$$

The obtained value of  $ZT_{\text{maximum}} = 0.7$  is consistent with established values for such commercial devices designed for high performance.

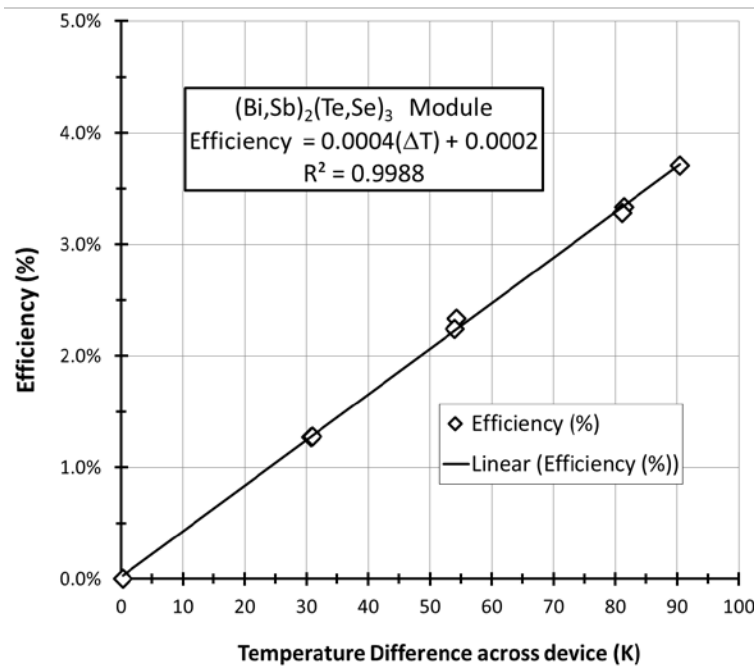

Fig. 4 Slope of efficiency from  $(\text{Bi,Sb})_2(\text{Te,Se})_3$  to determine  $ZT_{\text{max}}$

### 3.3 Case III: Analysis of Precommercial Lead Telluride (PbTe)/TAGS Module

The temperature dependence of the efficiency of a precommercial lead telluride (PbTe)/TAGS device is presented in Fig. 5. TAGS is a chemical acronym that stands for  $(\text{GeTe})_{85}(\text{AgSbTe})_{15}$ . For this measurement, the  $T_{\text{cold}}$  was constant at 300 K, and the hot-side temperature was increased to 600 K. Thus, the  $\Delta T$  across the device was as high as 300 K. For  $\Delta T$  values  $>150$  K, the slope is small and a somewhat nonlinear function of  $\Delta T$ . That temperature range is outside the normal operation window for PbTe/TAGS, which is in the range from 450 to 700 K. A true measure of the representative slope efficiency is determined where the efficiency is linear, greater than 500 K.

A representative value of  $ZT_{\text{maximum}}$  can therefore be obtained by using Eq. 14 and observed maximum temperature for linear device behavior, which for the device being measured is equal to 873 K. The obtained slope is 0.0002/K resulting in value  $ZT_{\text{maximum}} = 0.7$ , which is consistent with established values for well-known PbTe/TAGS modules.

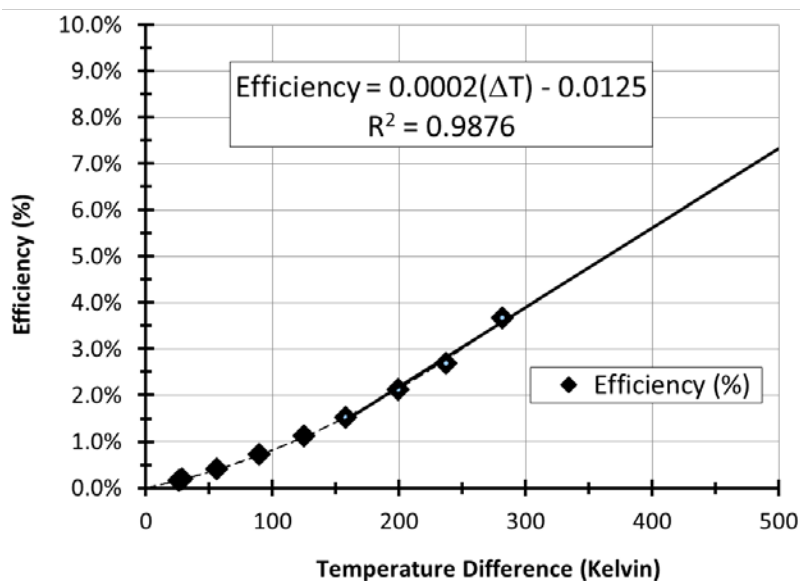

Fig. 5 Slope of efficiency from precommercial PbTe/TAGS to determine  $ZT_{\text{max}}$

## 4. Conclusions

We have developed a new, simple method for analyzing thermoelectric device performance. The significance of this method is that the usual quantifiable metric for device performance,  $ZT_{\text{maximum}}$ , can be obtained in a more straightforward manner. The new method more directly connects basic materials properties to observed conversion efficiency and, employing differential measurements, helps

minimize systemic error. We demonstrate the efficacy of this method by 3 separate cases of thermoelectric power generation modules fabricated from different materials. A low-cost technology demonstrates  $ZT = 0.4$ , a commercial module shows  $ZT = 0.7$ , and a precommercial PbTe/TAGS technology has  $ZT = 0.7$ .



## 5. References

---

1. Wang H, Bai S, Böttner H, Chen L, Harris F, Kiss L, Kleinke H, König J, Lo J, Mayolet A, Porter W, Sharp J, Smith C, Tritt T. International energy agency report: transport properties of bulk thermoelectrics. Oak Ridge (TN): Oak Ridge National Laboratory; 2011. Report No.: 32716.
2. Taylor PJ, Maddux J, Uppal P. *J Electr Mater.* 2012;41(9):2307.
3. Castillo EE, Hapenciuc C, Borca-Tasciuc T. *Rev Sci Instrum.* 2010;81:044902.
4. Buist RJ. A new method for testing thermoelectric materials and devices. Proceedings of the 11th International Conference on Thermoelectrics, 1992; Arlington, TX.

1 DEFENSE TECHNICAL  
(PDF) INFORMATION CTR  
DTIC OCA

2 DIRECTOR  
(PDF) US ARMY RESEARCH LAB  
RDRL CIO L  
IMAL HRA MAIL & RECORDS  
MGMT

1 GOVT PRINTG OFC  
(PDF) A MALHOTRA

1 DIRECTOR  
(PDF) US ARMY RESEARCH LAB  
RDRL SED E  
P TAYLOR