



10th Annual Small Business Conference

“Army & Small Business: Partners for Success”

McLean, Virginia

November 1 - 2, 2006

Agenda

Wednesday, November 1, 2006

Welcome & Introduction to the Conference - Lt Gen Lawrence P. Farrell, Jr., USAF (Ret), President & CEO, NDIA

Opening Remarks - GEN Benjamin S. Griffin, USA, Commanding General (AMC)

Continuing Opportunities for Small Businesses - Hon Claude M. Bolton, Jr., Assistant Secretary of the Army (Acquisition, Logistics and Technology)

Update on the State of the Army Small Business Program - Ms. Tracey L. Pinson, Director, Small and Disadvantaged Business Utilization, Office of the Secretary of the Army

The Outlook for Small Business - Mr. Joel Szabat, Chief of Staff, US Small Business Administration

Thursday, November 2, 2006

PANEL: “Industry Insights”

- Mr. Randy Gardiner, President, Red Dot Corporation
- Mr. Vikram Verma, President & CEO, Savi Technology, a Lockheed Martin Company

PANEL: “Assistance & Opportunities”

- Ms. Elaine C. Duke, Chief Procurement Officer, Department of Homeland Security (DHS)
- Mr. Lee Thompson, Assistant Deputy Assistant Secretary of the Army (Policy & Procurement) - Iraq/Afghanistan, HQs, Department of the Army
- Ms. Wendy Despres, Mentor-Protégé Program & Subcontracting, Office of Small & Disadvantaged Business Utilization, HQs, Department of the Army
- Mr. Steve Marion, Senior Program Director, Supplier Management, FCS, The Boeing Company

PANEL : “Open Question Period”

Moderator: Mr. Jeffrey Parsons, Director, Command Contracting, US Army Materiel Command

Panelists:

- Ms. Marlene Cruze, Executive Director, Acquisition Center, US Army Aviation and Missile Command
- Mr. Edward Elgart, Principal Assistant Responsible for Contracting (PARC), US Army Communications-Electronics Command
- Mr. Martin Green, Acting PARC, US Army Tank-Automotive and Armaments Command
- Mr. James Loehrl, PARC, US Army Field Support Command
- Mr. James Warrington, Director of Contracting, US Army Research, Development and Engineering Command Acquisition Center

Matching Your Personnel Requirements with Available Talent - Mr. Steven R. Clark, Director, Military Severely Injured Center, Pentagon Detachment, Department of Defense

Breakout Sessions - Special Interest Topics

“Industry Insights”

- “A Lean Management Journey” - Mr. Randy Gardiner, President, Red Dot Corporation
- “Perspectives of a Small Business and Large Business CEO” - Mr. Vikram Verma, President & CEO, Savi Technology, a Lockheed Martin Company

“Assistance & Opportunities”

- “Business Opportunities with DHS” - Ms. Elaine Duke, Chief Procurement Officer, Department of Homeland Security (DHS)
- “Support of Operations in Iraq & Afghanistan” - Mr. Lee Thompson, Assistant Deputy Assistant Secretary of the Army (Policy & Procurement) - Iraq/Afghanistan, HQs, Department of the Army
- “Opportunities Through the Army Mentor-Protégé Program” - Ms. Wendy Despres, Mentor-Protégé Program & Subcontracting, Office of Small & Disadvantaged Business Utilization, HQs, Department of the Army
- “Business Opportunities with Future Combat Systems” - Mr. Steve Marion, Senior Program Director, Supplier Management, FCS, The Boeing Company

“Open Question Period”

Moderator:

Mr. Jeffrey Parsons, Director, Command Contracting, US Army Materiel Command

Panelists:

- Ms. Marlene Cruze, Chief Procurement Officer, Department of Homeland Security (DHS)
- Mr. Edward Elgart, Principal Assistant Responsible for Contracting (PARC), US Army Communications-Electronics Command
- Ms. Martin Green, Acting PARC, US Army Tank-Automotive and Armaments Command
- Mr. James Loehrl, PARC, US Army Field Support Command
- Mr. James Warrington, Director of Contracting, US Army Research, Development and Engineering Command Acquisition Center

CONCURRENT ACTIVITIES: BUSINESS OPPORTUNITIES FAIR AND BREAKOUT SESSIONS

Breakout Sessions - Special Interest Topics

10th Annual Small Business Conference

Theme: "Army & Small Business: Partners For Success"

November 1 - 2, 2006 • Hilton McLean Hotel at Tysons Corner • McLean, Virginia

Featured Speakers:

- Mr. Steven Preston, Administrator, US Small Business Administration
- Hon Claude M. Bolton, Jr., Assistant Secretary of the Army (Acquisition, Logistics and Technology)
- **GEN Benjamin S. Griffin, USA**, Commanding General, AMC
- Ms. Elaine C. Duke, Chief Procurement Officer, Department of Homeland Security
- Ms. Tracey L. Pinson, Director, Small and Disadvantaged Business Utilization, Office of the Secretary of the Army
- Mr. Steven Marion, Senior Program Director, Future Combat Systems, The Boeing Company
- Mr. Randy Gardiner, President, Red Dot Corporation
- Mr. Vikram Verma, President & CEO, Savi Technology, a Lockheed Martin Company

ONSITE AGENDA

Key Benefits of Attending:

- Meet Government decision makers who set policies & conduct acquisitions
- Learn firsthand about available business opportunities with Government & leading large businesses
- Exchange information & ideas directly with senior leaders of Government & small businesses
- Find out what's new or changed that affects small businesses

Sponsored by the National
Defense Industrial
Association

Objective & Scope

Providing for the Nation's security requires an effective partnership between the Federal Government and the small business community. Small business is "big business" in the Army. Last year the Army awarded \$20.4 billion in direct contracts. Small businesses received an even greater amount in contracts with major defense firms. Despite having the smallest budget of the three military departments, the Army has awarded the highest dollar amount of prime contracts to small businesses for each of the last six years.

This conference brings together leaders of the industry small business community and the government (Small Business Administration and Army) to discuss timely topics, including recent changes affecting small businesses. Participants will include key Government decision makers from Washington to field commanders who conduct acquisitions. The conference provides a forum for open exchange of information and ideas between senior government officials and small business leaders.

The Business Opportunities Fair is an important part of the conference. Representatives from the Army's major buying commands will be present to discuss future opportunities for small businesses in their respective commands. In addition, representatives from the top 50 large business defense contractors will be there to discuss small business opportunities with their firms. Army personnel will be available to address individual contractor's questions and concerns.

Breakout sessions will be presented on timely subjects of special interest. The agenda offers a variety of topics designed to meet the varying needs of contractors present.

In this Brochure....

Conference At-A-Glance.....	p. 3
Panel/Breakout Session Topics & Information	p. 4 - 6
Schedule of Breakout Sessions	p. 6
Speaker/Panelist/Breakout Biographies	p. 7 - 16
Promotional Partner Information	p. 17



10th Annual Small Business Conference
"Army & Small Business: Partners for Success"

10th Annual Small Business Conference “Army & Small Business: Partners for Success” Conference-At-A-Glance

Wednesday, November 1, 2006

1:00 PM	Registration Opens, Displayer Set-Up Begins
3:00 PM	Administrative Remarks
3:05 PM	Welcome & Introduction to the Conference - Lt Gen Lawrence P. Farrell, Jr., USAF (Ret), President & CEO, NDIA
3:10 PM	Opening Remarks - GEN Benjamin S. Griffin, USA, Commanding General (AMC)
3:40 PM	Continuing Opportunities for Small Businesses - Hon Claude M. Bolton, Jr., Assistant Secretary of the Army (Acquisition, Logistics and Technology)
4:15 PM	Afternoon Break
4:30 PM	Update on the State of the Army Small Business Program - Ms. Tracey L. Pinson, Director, Small and Disadvantaged Business Utilization, Office of the Secretary of the Army
5:00 PM	The Outlook for Small Business - Mr. Joel Szabat, Chief of Staff, US Small Business Administration
5:45-7:45 PM	Networking Reception in the Display Area

Thursday, November 2, 2006

7:00 AM	Registration & Continental Breakfast		
7:50 AM	Administrative Remarks		
8:00 AM	Recognition of AMC Small Business Person of the Year - Presented by: GEN Benjamin S. Griffin, USA, Commanding General, (AMC)		
8:05 AM	<p>PANEL: “Industry Insights”</p> <ul style="list-style-type: none"> • Mr. Randy Gardiner, President, Red Dot Corporation • Mr. Vikram Verma, President & CEO, Savi Technology, a Lockheed Martin Company 		
8:55 AM	<p>PANEL: “Assistance & Opportunities”</p> <ul style="list-style-type: none"> • Ms. Elaine C. Duke, Chief Procurement Officer, Department of Homeland Security (DHS) • Mr. Lee Thompson, Assistant Deputy Assistant Secretary of the Army (Policy & Procurement) - Iraq/Afghanistan, HQs, Department of the Army • Ms. Wendy Despres, Mentor-Protégé Program & Subcontracting, Office of Small & Disadvantaged Business Utilization, HQs, Department of the Army • Mr. Steve Marion, Senior Program Director, Supplier Management, FCS, The Boeing Company 		
10:15 AM	Morning Break in the Display Area		
10:30 AM	<p>PANEL : “Open Question Period” - Moderator: Mr. Jeffrey Parsons, Director, Command Contracting, US Army Materiel Command</p> <p>Panelists:</p> <ul style="list-style-type: none"> • Ms. Marlene Cruze, Executive Director, Acquisition Center, US Army Aviation and Missile Command • Mr. Edward Elgart, Principal Assistant Responsible for Contracting (PARC), US Army Communications-Electronics Command • Mr. Martin Green, Acting PARC, US Army Tank-Automotive and Armaments Command • Mr. James Loehr, PARC, US Army Field Support Command • Mr. James Warrington, Director of Contracting, US Army Research, Development and Engineering Command Acquisition Center 		
11:35 AM	Matching Your Personnel Requirements with Available Talent - Mr. Steven R. Clark, Director, Military Severely Injured Center, Pentagon Detachment, Department of Defense		
11:50 AM - 1:00 PM	Luncheon (Ballroom C and Martinique’s)		
1:00 PM - 4:00 PM	CONCURRENT ACTIVITIES		
	<table border="0" style="width: 100%;"> <tr> <td style="width: 50%; vertical-align: top;"> <p>Business Opportunities Fair</p> <p>Representatives of each AMC major subordinate command, the National Guard, Army Contracting Agency; Corps of Engineers; Medical Command; and the Defense Contracting Command-Washington, will be present to discuss future business opportunities, and to address individual contractor concerns.</p> </td> <td style="width: 50%; vertical-align: top;"> <p>Breakout Sessions - Special Interest Topics</p> <p>The Special Interest Topics will be presented during the afternoon. Presentations will begin at 1:00 pm with multiple topics running concurrently, each in a separate room and repeated. Each session will take about 40 minutes with the time evenly divided for presentation comments/questions. Breakout Session Topics descriptions are listed on page 4.</p> </td> </tr> </table>	<p>Business Opportunities Fair</p> <p>Representatives of each AMC major subordinate command, the National Guard, Army Contracting Agency; Corps of Engineers; Medical Command; and the Defense Contracting Command-Washington, will be present to discuss future business opportunities, and to address individual contractor concerns.</p>	<p>Breakout Sessions - Special Interest Topics</p> <p>The Special Interest Topics will be presented during the afternoon. Presentations will begin at 1:00 pm with multiple topics running concurrently, each in a separate room and repeated. Each session will take about 40 minutes with the time evenly divided for presentation comments/questions. Breakout Session Topics descriptions are listed on page 4.</p>
<p>Business Opportunities Fair</p> <p>Representatives of each AMC major subordinate command, the National Guard, Army Contracting Agency; Corps of Engineers; Medical Command; and the Defense Contracting Command-Washington, will be present to discuss future business opportunities, and to address individual contractor concerns.</p>	<p>Breakout Sessions - Special Interest Topics</p> <p>The Special Interest Topics will be presented during the afternoon. Presentations will begin at 1:00 pm with multiple topics running concurrently, each in a separate room and repeated. Each session will take about 40 minutes with the time evenly divided for presentation comments/questions. Breakout Session Topics descriptions are listed on page 4.</p>		
4:15 PM	Conference Adjourns		

Panel Topics & Breakout Session Topics

PANELS

8:05 AM: **“Industry Insights”**

- “A Lean Management Journey”
- **Mr. Randy Gardiner**, President, Red Dot Corporation
- “Perspectives of a Small Business and Large Business CEO”
- **Mr. Vikram Verma**, President & CEO, Savi Technology, a Lockheed Martin Company

8:55 AM: **“Assistance & Opportunities”**

- “Business Opportunities with DHS”
- **Ms. Elaine Duke**, Chief Procurement Officer, Department of Homeland Security (DHS)
- “Support of Operations in Iraq & Afghanistan”
- **Mr. Lee Thompson**, Assistant Deputy Assistant Secretary of the Army (Policy & Procurement) - Iraq/Afghanistan, HQs, Department of the Army
- “Opportunities Through the Army Mentor-Protégé Program”
- **Ms. Wendy Despres**, Mentor-Protégé Program & Subcontracting, Office of Small & Disadvantaged Business Utilization, HQs, Department of the Army
- “Business Opportunities with Future Combat Systems”
- **Mr. Steve Marion**, Senior Program Director, Supplier Management, FCS, The Boeing Company

10:30 AM: **“Open Question Period”**

Moderator:

- **Mr. Jeffrey Parsons**, Director, Command Contracting, US Army Materiel Command

Panelists:

- **Ms. Marlene Cruze**, Chief Procurement Officer, Department of Homeland Security (DHS)
- **Mr. Edward Elgart**, Principal Assistant Responsible for Contracting (PARC), US Army Communications-Electronics Command
- **Ms. Martin Green**, Acting PARC, US Army Tank-Automotive and Armaments Command
- **Mr. James Loehrl**, PARC, US Army Field Support Command
- **Mr. James Warrington**, Director of Contracting, US Army Research, Development and Engineering Command Acquisition Center

CONCURRENT ACTIVITIES: BUSINESS OPPORTUNITIES FAIR AND BREAKOUT SESSIONS

Breakout Sessions - Special Interest Topics

The following topics will be presented during the afternoon. Presentations will begin at 1:00 pm with multiple topics running concurrently, each in a separate room and repeated. Each session will take about 40 minutes with the time evenly divided for presentation comments/questions.

1:00 PM

- **“What You Need to Know Before You Team/Partner”**
- **Ms. January Dennison**, President, Technology Resource Consultants, Inc.

Synopsis - Alliances are formed for a variety of reasons: an increased complexity in the customer base; increased complexity of the channels used to produce products or sell them to customers; lack of knowledge or capabilities in computer applications or operating systems; the desire to achieve a wide choice of options in labor management issues; a desire to minimize investments by shifting them off the balance sheet; the ability to acquire new, dedicated assets such as warehouse facilities or transportation equipment; the need to improve customer performance levels, such as fill order rate or on-time deliveries; a desire to outsource new products or services to minimize/reduce downside risks; the need to compress the product or service development process to gain competitive advantage; a desire to gain new process or product/service technologies by relying on partner’s expertise; the ability to access or enter new markets immediately due to the partner’s core competencies, expertise and local knowledge; a desire to shift operations that are difficult to perform or subject to complex administrative work; the ability to release employees from non-core activities so that the firm can concentrate on the activities that it does best; or, the desire to downsize staffs or departments.

Therefore, when exploring opportunities for forming an alliance, it’s important to explore every facet of the business. This presentation will provide an overview on the process, questions and implementation strategies that can effectively integrate one or more activities, processes or services across companies. Areas of interest will include: Business Re-engineering, Partnership Drivers, Partner Selection Methods and Managing a Long Term Partnership.

Panel Topics & Breakout Session Topics

- **“Tips and Opportunities Available for Small Businesses”**

- *Mr. Jim Regan*, Executive Director, Procurement Technical Assistance Program, George Mason University

Synopsis - An overview of local and Internet based resources which can help companies more effectively pursue their government business objectives. In addition to how to find local resources and the services available through nationwide programs, such as Small Business Development and Procurement Technical Assistance Centers, the presentation will highlight a number of sites that any company interested in government procurement must have as part of their knowledge base. Many of these, such as GSA's Federal Supply Schedule Virtual University and Federal Procurement Data Base, are extracted from one of the more popular George Mason University's PTAP seminars entitled "Internet for Government Contractors."

- **“Small Business Innovative Research (SBIR) Opportunities”**

- *Ms. Susan Nichols*, Program Manager, SBIR, US Army Research, Development and Engineering Command

Synopsis - This session provides attendees with the description of, and the means to, participate in R&D opportunities funded through the two Army programs with an annual budget of approximately \$260M. SBIR funds high impact, dual-use technology projects deemed critical to the Army in ten broad areas of Science and Technology. The overall objectives of SBIR are to stimulate technological innovation, increase small business participation in federal R&D, increase private sector commercialization of technological advances developed with federal R&D, and increase participation by woman-owned and socially and economically disadvantaged small businesses. STTR joins the talents of small businesses and research institutions to quickly move ideas from the laboratory to the marketplace. SBIR and STTR projects are funded in two phases: Phase I (feasibility) lasts about six months with a budget not exceeding \$70K for SBIR and \$100K for STTR, and Phase II (product development) lasts about two years with a maximum total budget of \$750K.

- **“The Route to ISO 9000 Qualification”**

- *Ms. Joan Ales*, Chief, Weapons Product Quality Management Branch, US Army Research, Development and Engineering Command
 - *Mr. Jay Jacobowitz*, Team Leader, National Logistics Qualification Office, AMC

Synopsis - This session provides attendees an overview of what the ISO 9000 series is all about. It will also indicate why a firm should be ISO qualified, how it can help your competitive position, what is involved in qualifying, along with the time required to qualify and the costs involved.

- **“Industry Partnership Opportunities with AMC”**

- *Mr. Ronald Davis*, Deputy Chief of Staff for Business Transformation, G7, HQs, AMC

Synopsis - This session will provide information on the Army Materiel Command (AMC) Partnership Program to include defining a partnership, the goal and objectives of the program, examples of current partnerships, and how your firm might participate in the program. AMC has significant industrial capabilities in its depots and manufacturing arsenals, which can be used to supplement work by private sector firms in meeting defense requirements and performing some commercial work. These capabilities include facilities, specialized equipment and tooling, and an available trained workforce. AMC's goal is to develop mutually beneficial relationships that build on the strengths of each partner and create increased value.

- **“Preparing Your Proposals to Win More Contracts”**

- *Mr. Robert Spitzbarth*, Procurement Analyst, Acquisition Center, US Army Tank-Automotive and Armaments Life Cycle Management Command

Synopsis - This breakout session is designed to help Small Businesses compete more effectively under RFPs where award will be made on a Source Selection Trade-off basis. Topics include: (a) how to better read and understand the RFP evaluation criteria and basis of award, (b) responding to evaluation criteria involving assessments of Proposal Risk (e.g. Technical Approach) and Performance Risk (Past Performance), (c) when to expect the conduct of Discussions, (d) understanding the Government's Source Selection decision making process for selecting the winner, and (e) top messages and tips for competing more effectively.

- **“Future Combat Systems - Business Opportunities & Supplier Management”**

- *Mr. Audry Musgrove*, Lead Systems Integrator, Future Combat Systems, The Boeing Company

Synopsis - This breakout session will build on and provide more detail than the formal presentation on Thursday morning. It will enable small businesses to learn more about current and upcoming business opportunities by talking directly to representatives from firms now engaged in FCS activities. Technology areas of interest include, but are not limited to, Embedded Training Software, Network Intrusion Detection, Advanced Data Mining, Advanced Robotic Controls, and Modeling & Simulation Tools.

Schedule of Breakout Sessions

November 2, 2006

Topics	Time 1:00 pm - 1:40 pm	Time 1:50 pm - 2:30 pm	Time 2:40 pm - 3:20 pm	Time 3:30 pm - 4:10 pm
“What you need to Know Before you Team/ Partner” - Ms. January Dennison	McLean Room		McLean Room	
“Preparing Your Proposals to Win More Contracts” - Mr. Robert Spitzbarth		McLean Room		McLean Room
“Tips and Opportunities Available for Small Businesses” - Mr. Jim Regan		Fairfax Room	Fairfax Room	
“Industry Partnership Opportunites with AMC” -Mr. Ron Davis	Amphitheater	Amphitheater		Amphitheater
“The Route to ISO 9000 Qualification” - Ms. Joan Ales - Mr. Steve Terronez	Gunston Room		Gunston Room	
FCS Business Opportunities and Supplier Management - Ms. Audry Musgrove	Sully Room	Sully Room	Sully Room	Sully Room
“SBIR Opportunities” - Ms. Susan Nichols		Ballroom B	Ballroom B	Ballroom B
Visit our Business Opportunities Fair	Ballroom A	Ballroom A	Ballroom A	Ballroom A

**McLean, Fairfax Rooms, Ballroom A & B are located on the lobby level.
All other breakout rooms are on the lower level.**

Speaker Biographies

GEN BENJAMIN S. GRIFFIN, USA, COMMANDING GENERAL, (AMC)

General Benjamin S. Griffin assumed the duties of Commanding General, US Army Materiel Command on November 5, 2004. Prior to this assignment, he served as the Department of the Army Deputy Chief of Staff, G-8.

General Griffin began his career when he was commissioned as an Infantry Officer in July 1970 following graduation from Officer Candidate School, Fort Benning, Georgia. He served two tours at Fort Bragg, North Carolina in the 82nd Airborne Division: in the 1st Battalion (Airborne), 508th Infantry as a rifle platoon leader and company executive officer, and in the 3rd Battalion (Airborne), 325th Infantry as a commander of Company C and a S-3 Air (Operations) officer. General Griffin also worked as a G3 operations officer, Headquarters, 82nd Airborne Division.

General Griffin's overseas assignments included a tour in Korea as a Company Commander and Brigade S-2 in the 2nd Infantry Division. He served two tours in Germany in the 8th Infantry Division as Secretary of the General Staff and Mechanized Infantry Battalion Executive Officer in the 2nd Battalion (Mechanized), 87th Infantry. He was also Commander of the 3rd Battalion, 8th Infantry Regiment.

His later assignments included: Special Assistant to the Chief of Staff of the Army in Washington, D.C., and Commander of the 2nd Brigade, 6th Infantry Division (Light) in Alaska. In August 1994, he served as Executive Officer to the Commanding General, US Army Forces Command, Fort McPherson, Georgia.

Following his assignment in Georgia, General Griffin took command of Joint Task Force 6, Fort Bliss, Texas. He then served as the Assistant Division Commander (Support), 1st Cavalry Division in Fort Hood, Texas.

In July 1997, he became the Director of Force Programs, Office of the Deputy Chief of Staff for Operations and Plans in Washington, D.C. General Griffin returned to Fort Hood from June 1999 to October 2001 to command the 4th Infantry Division.

General Griffin's awards and decorations include the Distinguished Service Medal, the Defense Superior Service Medal, the Legion of Merit (with three Oak Leaf Clusters), the Meritorious Service Medal (with four Oak Leaf Clusters), the Army Commendation Medal (with one Oak Leaf Cluster), the Army Achievement Medal (with one Oak Leaf Cluster), the Joint Meritorious Unit Award, the Master Parachutist Badge, the Expert Infantry Badge, and the Army General Staff Badge.

General Griffin received a Bachelor's Degree in Business Management from Old Dominion University in 1969 and a Master's Degree in Business Administration from Mercer University in 1981.

His military education includes the Infantry Officer Advanced Course, Command and General Staff College, and the Industrial College of the Armed Forces at the National Defense University.



HON CLAUDE M. BOLTON, JR., ASSISTANT SECRETARY OF THE ARMY

Claude M. Bolton was sworn in Wednesday, January 2, 2002, as Assistant Secretary of the Army (Acquisition, Logistics and Technology) (ASA(ALT)).

In this position, Mr. Bolton serves as the Army Acquisition Executive, the Senior Procurement Executive, and the Science Advisor to the Secretary. Also, he serves as the senior research and development official for the Department of the Army. Among his responsibilities as ASA(ALT) are: appointing, managing and evaluating Program Executive Officers and Program Managers; managing the Army Acquisition Corps; and overseeing research, development, test, evaluation and acquisition programs.

Formerly Mr. Bolton was Commander, Air Force Security Assistance Center, Headquarters Air Force Materiel Command, Wright-Patterson Air Force Base, Ohio. He managed foreign military sales programs with totals exceeding \$90 billion that support more than 80 foreign countries. As AFMC's center of excellence for international affairs, his responsibilities also included managing the command's international cooperative programs and its foreign disclosure policy.

Mr. Bolton received his commission in the Air Force in 1969 through the University of Nebraska's Air Force ROTC program, where he was honored as a distinguished graduate. He has served in a variety of positions during his career. His duties include squadron and wing safety officer, instructor pilot, wing standardization and evaluation flight examiner, scheduler, test pilot and acquisition professional. He is a command pilot with more than 2,700 flying hours in more than 30 different aircrafts. During the Vietnam War he flew 232 combat missions, 40 over North Vietnam. He was a test pilot for the F-4, F-111 and the F-16, and the first program manager for the Advanced Tactical Fighter Technologies Program which evolved into the F-22 System Program Office.

Speaker & Panelist Biographies

MRS. TRACY L. PINSON, DIRECTOR, SMALL AND DISADVANTAGED BUSINESS UTILIZATION

Ms. Tracey L. Pinson became the Director for Small and Disadvantaged Business Utilization, Office, Secretary of the Army in May 1995. Ms. Pinson advises the Secretary of the Army and the Army Staff on all small business procurement issues and is responsible for the implementation of the Federal acquisition programs designed to assist small businesses. She provides management and oversight for the Army's Mentor-Protégé Program as well as the Historically Black Colleges and Universities and Minority Institutions (HBCU/MI) Program, and develops policies and initiatives to enhance HBCU/MI participation in Army funded programs. As one of the top females in the Army's acquisition career field, she is responsible for the integration of small businesses, HBCUs and MIs in acquisition strategies developed at the Army Headquarters.

From 1986 - 1995, Ms. Pinson served as Assistant to the Director, Office of Small and Disadvantaged Business Utilization, Office of the Secretary of Defense. During this time frame she served as the program manager of the DoD Small Disadvantaged Business Program and the HBCU/MI Program. She developed the implementation strategy for the DoD Mentor-Protégé Program resulting in over 250 participants with a budget allocation as high as \$120 million. This program has served as the model-mentoring program for all Federal Government Agencies.

Ms. Pinson was born in Washington, D.C. She received a Bachelor of Science Degree in Political Science from Howard University. She also received a law degree from Georgetown University Law Center. She is a member in good standing of the Maryland Bar Association and the National Contract Management Association.

MR. JOEL SZABAT, CHIEF OF STAFF, US SMALL BUSINESS ADMINISTRATION

Mr. Joel Szabat serves Administrator Steve Preston as SBA's Chief of Staff, helping to administer an agency which provides \$76 billion in loans and financial support for America's small business owners. Joel joined SBA from the Department of Transportation, where he led department-wide initiatives such as the President's Management Agenda, Pandemic Flu planning, Hurricane Katrina lessons learned, and interagency research coordination.

In 2005 Joel was on detail to the US Embassy in Baghdad, as the Transportation Counselor to the Ambassador directing the US government's \$544 million transportation reconstruction program in Iraq. Joel joined DOT in 2002, as the Deputy Assistant Secretary (DAS) for Transportation Policy, then as DAS for Management and Budget.

From 1993 through 2001, Joel was the Principal Consultant for Transportation for Republicans in the California State Assembly.

From 1990 to 1993 Joel served as a management and budget aide to the Administrator of the US Environmental Protection Agency. Before joining EPA, Joel worked in a management consulting firm in the private sector.

Joel received a B.A. in Economics and Government from Georgetown University in 1981, and an MBA from Harvard Business School in 1988. Between Georgetown and Harvard, Joel was in the United States Army during the Cold War, commanding tank units patrolling the East-West German border.

Joel is from Sacramento, California. He is the founder of the International Leadership Foundation, a non-profit organization providing public service scholarships for Asian American college students. His wife, Chiling Tong, also serves President Bush, in the Commerce Department.

MR. RANDY GARDINER, PRESIDENT, CHIEF EXECUTIVE OFFICER, AND CHAIRMAN, RED DOT CORPORATION

Randy Gardiner joined Red Dot Corporation 29 years ago in the accounting department and has since been involved in nearly every aspect of the business. In his 16 years as Red Dot's President, Randy helped the company establish operations in Europe and Memphis, Tennessee.; invest in one of the most sophisticated and busiest climate-control research and test facilities in the industry; and adopt a lean manufacturing philosophy focusing on productivity, product quality, continuous training, and shorter lead customer times.

In 2000, Randy led the company's transfer of ownership to an Employee Stock Ownership Program, creating a 100% employee-owned company. On the strength of a more diversified customer base, Red Dot's revenues have increased from \$60 million a year in 2000 to almost \$115 million in 2005.

A native of Seattle, Randy earned his Business Degree at Pacific Lutheran University in Tacoma, Washington.

Positions held at Red Dot:

2000 - present: President, CEO and Chairman; 1990-2000: President; 1988-1990: Vice President, Aftermarket Sales; 1982-1988: Marketing Manager; 1980-1982: Personnel Manager; 1977-1979: Cost Accountant.

Panelist Biographies

MR. VIKRAM VERMA, PRESIDENT AND CEO, SAVI TECHNOLOGY, A LOCKHEED MARTIN COMPANY

Vikram Verma, President and Chief Executive Officer of Savi Technology, Inc., has combined a distinguished and highly credentialed career in both academia and business to transform Savi into a leading provider of real-time solutions for the visibility, management and security of supply chain assets. In 1999, he led a management buyout of Savi from Raytheon. Since then, Savi has raised more than \$100 million in venture capital while the company's valuation has increased more than 2,000 percent on revenue growth of more than 500 percent. Under Mr. Verma's direction, Savi has expanded its network software platform and Radio Frequency Identification (RFID) product solutions on sales to a growing diversity of government and commercial customers worldwide.

He was a co-founder of the company in 1989 and has held a succession of progressively responsible technical, management and executive positions since then. As COO, he was instrumental in negotiating the acquisition of the privately held company to Texas Instruments in 1995. In 1997, the unit was sold to Raytheon and in 1999 he led the management buyout of Savi from Raytheon.

Mr. Verma holds eight patents, and early in his career his DF/Tag product was recognized as the "Most Innovative Technology Developed by a Small Business" by the White House Office of Science and Technology. He has won numerous industry accolades, including being named as one of 40 "Technology Innovators" by the World Economic Forum. He has been the recipient of the "Distinguished Achievement Award" by the Florida Institute of Technology, where he earned his undergraduate degree and now sits on its Board of Trustees. He holds a seat on the Board of Governors of the National Center to the Asia Pacific Economic Coalition (APEC).

Mr. Verma graduated at the top of his class in 1987 with a B.S. degree from the Florida Institute of Technology, earned an M.S.E. degree from the University of Michigan in 1989, and an Advanced Engineer's degree from Stanford University in 1990, all in electrical engineering. In 1986, he was awarded the Eta Kappa Nu Norman R. Carson Award as the Outstanding Junior Electrical Engineering student in the United States (runner up). In 1987, he won the Tau Beta Pi Williams Fellowship as one of the top five engineering students in the United States and the Eta Kappa Nu Alton Zerby Award as the Outstanding Senior in Electrical Engineering (runner up). He completed all the coursework and passed the qualifying exam for his Ph.D. candidacy in electrical engineering from Stanford University before leaving to join Savi. In addition, he attended the executive management program for CEOs at Harvard Business School, the AEA Executive Institute at Stanford University, and the Financial Management Program at the University of California-Berkeley.

MS. ELAINE C. DUKE, CHIEF PROCUREMENT OFFICER, DEPARTMENT OF HOMELAND SECURITY (DHS)

Elaine C. Duke is the Chief Procurement Officer for the Department of Homeland Security. She provides leadership over the department's \$14 billion in contracts and \$11 billion in financial assistance programs. Ms. Duke was the department's Deputy Chief Procurement Officer from October 2004 to December 2005, when she assumed duties as the acting Chief Procurement Officer. In January 2006, Ms. Duke took over full responsibilities as the department's second procurement chief. Before coming to the headquarters, she served for two years as the Deputy Assistant Administrator for the Transportation Security Administration.

Ms. Duke spent the majority of her career in acquisition with the US Navy. She completed her final tour with the Navy at the Naval Sea Systems Command in Washington, D.C. She was Director, Office of Contract Policy as well as the Deputy Director, Hull, Mechanical, and Electrical Division in the Contracts Directorate. Prior to her tour with Naval Sea Systems Command, Ms. Duke served on the staff of the Assistant Secretary of the Navy (Installations & Environment), working the base closure and realignment program.

Ms. Duke also held various positions with the Naval Facilities Engineering Command. She began her career as a contracting officer for the US Air Force. In addition to her work in the Department of Defense, Ms. Duke served as the Deputy Director of Contracting and Property Management for the Smithsonian Institution and Director of Acquisition and Grant Services for the Federal Railroad Administration.

Ms. Duke has a Bachelor of Science degree in Business Management and a Master's degree in Business Administration.

MR. LEE THOMPSON, ASSISTANT DEPUTY ASSISTANT SECRETARY OF THE ARMY (POLICY & PROCUREMENT) - IRAQ/AFGHANISTAN, HQs, DEPARTMENT OF THE ARMY

Mr. Lee Thompson is the Assistant Deputy Assistant Secretary of the Army (Policy and Procurement), Iraq/Afghanistan. Mr. Thompson directly supports the Deputy Assistant Secretary for Policy and Procurement and the Assistant Secretary of the Army (Acquisition, Logistics and Technology), on contract matters pertaining to Iraq and Afghanistan. Mr. Thompson directs a staff responsible for the analysis and evaluation of contracting matters and the initiation, development and recommendations of contracting policies, procedures, guidance and control for subordinate contracting activities in Iraq and CONUS. In this position Mr. Thompson oversees and monitors reach-back procurements and in concert with the Commander, Joint Contracting Command/Head Contract Activity-Iraq/Afghanistan provides advice and guidance on contracting matters to project managers and contracting activities in support of combat operations.

Panelist Biographies

Prior to his current appointment Mr. Thompson served in various senior level management positions in the private sector where his responsibilities included the analysis of business policies, practices and procedures, delivery of logistics and procurement software solutions, and program management of acquisition and logistics projects. His military assignments included various procurement positions including command of Defense Contract Management Command District in Chicago, senior Army Staff level positions in procurement and logistics where he developed and analyzed procurement policies and practices, Department of Defense Depot Maintenance policies and methodologies, and aviation policy implementation.

M S. WENDY DESPRES, MENTOR-PROTEGE PROGRAM & SUBCONTRACTING, OFFICE OF SMALL & DISADVANTAGED BUSINESS UTILIZATION, HQS DEPARTMENT OF THE ARMY

Wendy Despres became the Mentor-Protégé/Subcontracting Program Manager for the US Army Office of Small Business Programs in January 2005. Ms. Despres advises the Director, US Army Office of Small Business Programs and the Secretary of the Army on matters related to management of the Army's Mentor-Protégé Program. She also advises acquisition personnel and industry on matters related to the Army's Mentor-Protégé Program, as well as ensuring successful program execution. Ms. Despres also serves as the primary point of contact for Small and Disadvantaged Business Subcontracting for the Army.

Ms. Despres entered civil service in June 1987. She served in several other appointments throughout her career, most recently, as the Chief, Center for Health Care Contracting for the US Army Medical Command (MEDCOM). She has achieved Contracting Level III Certification and is a member of the Army Acquisition Corps. Her professional training includes the Sustaining Base Leadership Management Course at the Army Management Staff College. She has earned numerous awards including two Achievement Medals for Civilian Service and the Outstanding Operational Contracting Civilian for Fiscal Year 1990 for the Air Force Logistics Command.

Ms. Despres earned a Bachelor of Business Administration in Accounting from Our Lady of the Lake University in 1987. She earned a Master of Business Administration from the University of Texas in San Antonio in 1994.

M R. STEVE MARION, SENIOR PROGRAM DIRECTOR, SUPPLIER MANAGEMENT, FCS, THE BOEING COMPANY

Steve S. Marion is Senior Program Director, Supplier Management, Future Combat Systems. In this position, Steve leads all Subcontract Activity representing sub-contracts in excess of \$9 billion dollars. As the Supplier Management representative of the Office of the Program Management, Steve leads the development and execution of our Acquisition Strategy in a fire walled environment, as Boeing is operating as a Lead Systems Integrator. Steve has personnel in six different Boeing/SAIC sites supporting this complex system of system program for the Army.

Steve joined McDonnell Douglas in 1980 and has held increasing levels of responsibility in all aspects of materiel and project management. Steve has rotated through all West Coast Divisions of Boeing in various capacities of materiel and has extensive process knowledge in military, space and commercial. Steve worked many corporate initiatives, and led a leveraging group that made a major change in our buying practices and provided significant savings to the company.

Education: Steve is a graduate of University of Redlands, with a Bachelor's Degree in Business Administration. He received a Master's Degree in Business at Pepperdine University.

M R. JEFFREY PARSONS, DIRECTOR, COMMAND CONTRACTING, US ARMY MATERIEL COMMAND

Mr. Jeffrey P. Parsons is the Director of Contracting, Office of Command Contracting, Headquarters, US Army Materiel Command, Fort Belvoir, Virginia. He is the principal advisor to the Commanding General and members of his staff on all contracting matters. Mr. Parsons works with the Deputy Assistant Secretary of the Army (Policy and Procurement) and the US Army Materiel Command Principal Assistants Responsible for Contracting to efficiently and effectively accomplish the AMC Contracting mission. He is the AMC Career Program Manager for the Contracting and Acquisition Career Program, and as such, is responsible for the recruitment, training, education, and professional development of the contracting professionals who are part of the acquisition workforce. Mr. Parsons was appointed to the Senior Executive Service on December 15, 2003.

Prior to his current appointment, Mr. Parsons was the Director of Contracting, Headquarters, US Air Force Materiel Command, Wright-Patterson Air Force Base, Ohio, where he retired from active duty as an Air Force Colonel after 26 years of service. He was responsible for developing and implementing contracting policies and processes to annually acquire \$34 billion in research and development, production, test, and logistics support for Air Force weapon systems. He was directly responsible for the training, organizing, and equipping of more than 3,000 contracting professionals.

Mr. Parsons' contracting career began in 1977 as a base procurement officer supporting the 90th Strategic Missile Wing at F. E. Warren Air Force Base, Wyoming. He held a variety of positions as a contracting officer with a wide range of experience

Panelist Biographies

touching on all aspects of systems, logistics, and operational contracting. He was the Director of Contracting for a multi-billion dollar classified satellite program operated by the National Reconnaissance Office and served twice as a plant commander in the Defense Contract Management Agency. Mr. Parsons also held several key staff positions at Headquarters, US Air Force, the Air Force Secretariat, and with the Office of the Secretary of Defense, in which he was responsible for the development, implementation, and management of integrated, coordinated, and uniform policies and programs to govern DoD procurement world-wide.

Mr. Parsons received his Bachelor's Degree in Psychology from St. Joseph's University, Philadelphia, Pennsylvania, and holds two Masters Degrees - one in Administration with a concentration in Procurement and Contracting from George Washington University, Washington, DC, and the other in National Resource Strategy from the National Defense University. He is a graduate of the Industrial College of the Armed Forces and the Defense Systems Management College Executive Program Management Course. Mr. Parsons holds the Acquisition Professional Development Program's highest certifications in contracting and program management. He also is a Certified Professional Contracts Manager, National Contract Management Association.

MS. MARLENE CRUZE, EXECUTIVE DIRECTOR, ACQUISITION CENTER, US ARMY AVIATION AND MISSILE COMMAND

Ms. Cruze is currently the Executive Director of the US Army Aviation and Missile Command Acquisition Center (AMCOM AC) managing 600 contracting personnel with annual obligations exceeding \$10 billion and \$160 billion of active contracts. The AMCOM AC acquires aircraft and missiles along with their research, development, engineering, total logistical support, and the base operations contracting for Redstone Arsenal, Alabama.

Ms. Cruze was selected for the above SES position in March 1995. Previously, Ms. Cruze held positions with US Army Communications and Electronics Command (CECOM) and the US Navy, Naval Sea Systems Command (NAVSEA) and Naval Air Systems Command (NAVAIR). As the CECOM Associate Director for Contract Operations, Ms. Cruze managed the acquisition personnel at Vint Hill Farms Station and Fort Belvoir Research and Development Center in Virginia. In this capacity, Ms. Cruze provided direction for the execution of Army, joint agency electronic warfare, satellite communications, and other intelligence gathering agencies.

When Ms. Cruze worked for the NAVSEA in Washington, DC, she managed the contracting officers for the Navy's largest acquisitions, i.e., the construction of nuclear powered ships to include US NIMITZ class aircraft carriers, TRIDENT submarines, LOS ANGELES nuclear class submarines, the Navy's battleship reactivation program, and public-private competition for the overhaul of nuclear submarines and overhaul of aircraft carriers. Ms. Cruze was the Navy's contracting officer for acquisition planning and execution of the new class submarine SEAWOLF Program. She has negotiated and awarded many multi-billion dollar contracts for Navy ships supra and Navy aircraft at NAVAIR in Washington, DC, i.e., OV-10 Broncos, T-2 training jets, KFIR aircraft manufactured by the Israeli Aircraft Corporation, the E-6A aircraft, prototype AH-1 COBRA, SH-60B LAMPS MK III, CV-HELO (SH-60F), and TH-57 training helicopters. Ms. Cruze was a Presidential Management Intern from 1982 through 1984.

Ms. Cruze has held offices in the Federal Executive Women's Association and the National Contract Management Association. Additionally, she plays Dobro (resophonic guitar), pedal steel and Hawaiian style guitars; and is a charter member of the Virginia Bluegrass Association. Ms. Cruze is a native of Thomasville, Georgia. She received her Baccalaureate Degree from Auburn University and her Master's Degree from Georgia College. She has three grown children; twin daughters, Cindy and Wendy; and son, Scott.

MR. EDWARD ELGART, PRINCIPAL ASSISTANT RESPONSIBLE FOR CONTRACTING (PARC), US ARMY COMMUNICATIONS-ELECTRONICS COMMAND

Edward G. Elgart is the Director of the Acquisition Center, US Army Communications-Electronics Life Cycle Management Command (C-E LCMC) with locations at Fort Monmouth, New Jersey, Fort Huachuca, Arizona, and Alexandria, Virginia. He also serves as the Principal Assistant Responsible for Contracting for that activity, Tobyhanna Army Depot and TAO. He is responsible for the acquisition and support of Army and joint command, control, communications, computers, intelligence, surveillance, and reconnaissance systems, estimated in excess of \$11 billion annually. Twice during his tenure, Mr. Elgart has served as the Acting Deputy Assistant Secretary of the Army for Procurement from August 2000 - January 2002 and May 1997 - May 1998. In that capacity, he was responsible for oversight and policy for all Army procurements, acquisition excellence and reform, and advocacy for the industrial base, as well as the proponent for the Army contracting career field. He completely revised Army procurement regulations and source selection policies during that assignment. Additionally, in partnership with the user community, he helped define doctrine for contractors on the battlefield. He also acted as the Army's Competition Advocate General during that time. Mr. Elgart was instrumental in directing resources to reconstitute Army procurement operations in the Pentagon following the September 11, 2001 attack.

From 1985-1989, Mr. Elgart served in a variety of management positions with the Defense Logistics Agency, first at DCASPRO Teledyne CAE, then at DCASMA Detroit, and culminating as the Director of Contract Management for Defense Contract Administration Services Region Chicago. In that position, he was responsible for the administration of 18,000 defense contracts valued in excess of \$19 billion.

Panelist Biographies

Mr. Elgart began his career in government service in 1976 as a Contract Specialist intern. As a Contracting Officer he was responsible for the negotiation and award of the \$4.3 billion contract for the Mobile Subscriber Equipment battlefield communications system.

Mr. Elgart entered the Senior Executive Service in June 1989, and has twice been a recipient of the Presidential Meritorious Executive Rank Award (in 1996 and 2002). He is a Fellow of the National Contract Management Association and a previous Fort Monmouth Chapter President and Executive Director. He was appointed to the National Board of Advisors in 2005. His awards and decorations include the Decoration for Exceptional Civilian Service, two Meritorious Civilian Service awards, the Honorable Order of Saint Barbara, the Signal Corps Regimental Association Bronze Order of Mercury and the Army Staff Identification Badge. He was the first recipient of the Acquisition Career Management Advocate of the Year award and was presented with the Secretary of the Army Professionalism in Contracting Award (Civilian) in 2000. He is Level III Certified in Contracting and in Program Management Oversight.

Mr. Elgart holds membership in numerous professional associations and is a member of the Army Acquisition Corps and the American Mensa Society. He has published numerous articles on the field of Government contracting and has taught graduate courses in that field at Fairleigh Dickinson University. In 2004, he was named a Distinguished Alumni by Brookdale Community College.

Mr. Elgart is a graduate of the Federal Executive Institute and the Command and General Staff Officer Course. He is also a graduate of the Brookings Institute-University of North Carolina Leadership 2000 program and the Center for Creative Leadership. He has a Bachelor's Degree in Biology from Kean College and a Masters Degree in Business Administration from Fairleigh Dickinson University.

He is married to the former Mary Ellen Reed of Deal, New Jersey. They have two children, Lindsay (Ensign, USNR), a graduate of the US Merchant Marine Academy, and Stephen, a College student.

M R. MARTIN GREEN, ACTING PARC, US ARMY TANK-AUTOMOTIVE AND ARMAMENTS COMMAND

Martin J. Green, born in Port Huron, Michigan in 1955, holds a BA degree in Criminal Justice from Michigan State University. Mr. Green's government background includes 29 years of acquisition with the government and began in 1977 as a Contract Specialist in TACOM's Acquisition Center. He is currently the Acting Director of the TACOM LCMC Acquisition Center.

Since 1977, Mr. Green has served in various positions with the US Army Tank-automotive and Armaments Command (TACOM). His experience includes acquisition and leadership on the prototype and initial production phases of the HMMWV, M939 and FMTV truck programs. From 1999-2002, he served as Deputy Director of the Light Combat Commodity Business Unit (a multi-functional unit consisting of logistics, supply and contracting).

Since February 2002, Mr. Green has served as the Associate Director for the TACOM Acquisition Center. Mr. Green has demonstrated a keen ability to lead the Acquisition Center in significant procurement efforts including: support for the Coalition Provisional Authority (CPA), to include execution of the Iraqi Armed Forces Battalion Sets, the Iraqi Civilian Ministries non-tactical vehicles contracts and the Afghanistan light and medium tactical vehicle contracts; the continued focus on the Future Combat Systems Program; and significant support to the Global War on Terrorism to include armoring of thousands of light, medium and heavy wheeled vehicles.

Mr. Green is the recipient of 1997 Commander's Award for Public Service, the 1999 Superior Civilian Service Award, and the 2004 John W. Macy, Jr., Award.

Mr. Green is married to Nancy Green. They have two daughters, Stephanie and Danielle.

M R. JAMES LOEHL, PARC, US ARMY FIELD SUPPORT COMMAND

Mr. James G. Loehrl serves as Director of the Acquisition Center and Principal Assistant Responsible for Contracting (PARC) for the US Army Sustainment Command. As such, he acts as the Command's senior civilian procurement and production authority, and advises the Commanding General on the total acquisition process, including policy development, compliance and review, contract pricing, contract management, and associated support. Mr. Loehrl has oversight of about 275 contracting personnel and more than \$25 billion worth of contracts. As PARC, Mr. Loehrl is responsible for staff supervision and management of major contracting areas such as chemical demilitarization, installation support, garrison operations, and Army Prepositioned Stocks (APS), as well as the contract support staff. On November 29, 2005, Mr. Loehrl became a member of the Senior Executive Service. The SES is a corps of federal executives appointed to key leadership positions just below the level of Presidential appointees. Mr. Loehrl's past assignments include serving as Chief of the Ammunition and Installation Division, which was responsible for procuring conventional ammunition in support of all US armed services. From February 1992 to April 2001, Mr. Loehrl served as Chief of the Chemical Demilitarization program, a \$12 billion mission that was new to the Command. His

Panelist Biographies

responsibilities included researching the mission, preparing staffing plans, and the award and administration of contracts for the construction, operation, and closure of eight chemical munitions disposal facilities. Mr. Loehrl began his federal career in 1979 as a contract specialist with the US Army Armament, Munitions and Chemical Command (AMCCOM) at Rock Island Arsenal, Illinois. A native of Cheyenne, Wyoming, Mr. Loehrl was raised in Silvis, Illinois. He received a Bachelor of Arts degree in Accounting in 1975 from St. Ambrose University in Davenport, Iowa, and a Master of Business Administration in Procurement in 1984 from the Florida Institute of Technology. He has received the Department of the Army Exceptional Civilian Service Award and two Superior Civilian Service Awards, and was named one of the US Army Materiel Command's top ten employees for fiscal year 1998.

Mr. Loehrl and his wife, Patricia O'Connor, reside in Moline.

MR. JAMES WARRINGTON, DIRECTOR OF CONTRACTING, US ARMY RESEARCH, DEVELOPMENT & ENGINEERING COMMAND ACQUISITION CENTER

Mr. Warrington currently serves as the Executive Director of the US Army RDECOM Acquisition Center. The organization is centered at Aberdeen Proving Ground with various satellites throughout the country. The center provides contracting support to RDECOM, DTC, ARL, and ARO sites.

Mr. Warrington previously served as the Program Director for Domestic Preparedness and Homeland Defense from November 1996 until September 2001. The Domestic Preparedness program was a nationally recognized interagency program with DoD as the lead and Department of the Army acting as the Executive Agent. The program transitioned to the Department of the Justice on October 1, 2000.

Having worked for the Department of the Army for 34 years, Mr. Warrington spent the bulk of his time in the procurement arena, progressing from Procurement Analyst to Principal Assistant Responsible for Contracting (PARC). He served as the Director of Procurement from 1989 to 1995 and as the PARC from 1995 until November 1996. He served as the PARC, Contracting Activity, Baghdad, from April thru September 2004.

Mr. Warrington has a B.A. degree from Towson University, an M.B.A. from Florida Institute of Technology, and a J.D. from the University of Baltimore School of Law. He is a member of the Maryland Bar, the Court of Military Appeals, and has been admitted to the bar of the Supreme Court of the United States. He is a retired JAG Corps Naval Reserve Officer. He is also a graduate of the Logistics and Acquisition Management Program (LOGAMP) and graduated from the Program Manager's Course at Fort Belvoir in 1986. He is Level III certified in both Program Management and Contracting and Acquisition.

He lives in Baltimore, Maryland, and has a daughter, Kim.

MR. STEVEN R. CLARK, DIRECTOR, MILITARY SEVERELY INJURED CENTER, PENTAGON DETACHMENT, DEPARTMENT OF DEFENSE

Steve Clark was born in Louisville, Kentucky, and raised in Bloomington, Indiana. In 1990, following High School, Steve enrolled at the University of South Florida and graduated in 1994 with a Bachelor of Arts degree. Subsequently, Steve accepted employment with the University of South Florida, where he worked as the Outdoor Recreation Coordinator, and Adjunct Faculty member.

Following the terrorist attacks on September 11, 2001, Steve answered our Nation's call to duty. He abandoned a safe 9 to 5 job, and enlisted in the United States Army. Steve's leadership and dedication quickly led to his advancement to the rank of Sergeant. He was stationed in Germany as a gunner on a Multiple Launch Rocket System and was deployed with his unit to Iraq. While performing combat operations there in October 2003, he sustained severe injuries, which resulted in the amputation of his right arm. Steve underwent multiple surgeries, physical therapy, and rehabilitation at Walter Reed Army Medical Center, for nearly a year. President George Bush presented Steve a Purple Heart Medal. During his three year Army career, Steve earned the Purple Heart Medal, Combat Action Badge, Army Good Conduct Medal, four (4) Army Achievement Medals, two (2) Army Commendation Medals, the Global War On Terrorism Medal, the National Defense Medal, and the Iraqi Service Medal. He was medically discharged from the Army in August 2004.

His desire to work with and assist his fellow soldiers, who had been severely injured, was uppermost. He began work at Headquarters, US Army Materiel Command (AMC) where he led the "Always a Soldier Program". This program's objective is to assist severely injured soldiers in getting a civilian job in AMC. After successfully leading this program for a year, he joined the staff of the Severely Injured Soldier Support Center, Pentagon Detachment. This is a pilot program developed to assist disabled veterans in securing meaningful employment and to help them transition back into the civilian community. Steve is now the Director of this program and is currently assigned as a Program Analyst at the Pentagon's Severely Injured Center, part of the Office of the Under Secretary for Personnel & Readiness, US Department of Defense. Steve continues to serve as a Peer Counselor, for wounded soldiers, at the Walter Reed Army Medical Center.

Breakout Session Biographies

MS. JANUARY DENNISON, PRESIDENT, TECHNOLOGY RESOURCE CONSULTANTS, INC.

SYNOPSIS:

January Dennison, Chief Executive Officer and President of Technology Research Consultants, Inc. (TRC), brings a robust resume of Engineering, Manufacturing, Sourcing and Business Development Management expertise. Mrs. Dennison is a recognized business strategist throughout Department of Defense Hardware market segments. Most recently, Mrs. Dennison has been responsible for planning, facilitating and managing key Strategic Alliances between TRC and the University of Alabama and the University of South Florida. These partnerships integrate system design, engineering, fabrication, test, integration and assembly competencies into single Turn-Key Business Modernization Solutions for Department of Defense customers. TRC is a 2005 Best Places to Work awardee. Mrs. Dennison was awarded the Small Business Administration 2006 Florida Small Business Person of the Year. TRC annual revenues exceed \$15M.

SIGNIFICANT EXPERIENCE:

1998-Present: Technology Research Consultants, Inc., CEO/President. Responsible for establishing and managing key strategic alliances throughout Department of Defense Hardware market segments to assist in the mitigation of Avionic Component and Subassembly Obsolescence. TRC is an innovative Small Disadvantaged Business that couples our design, electronics fabrication, assembly, test, and logistics services capabilities with Florida based University Laboratory capacity and Systems Engineering competencies. Product lines include Legacy System Obsolescence Mitigation, Automated Test Equipment, Instrumentation Repair and Return, and Systems Integration.

1996-2001: Teledyne Brown Engineering, General Manager, Team Millennium. Responsible for reestablishing TBE Systems Engineering Defense market position due to shakeout of Large Business acquisition/alliances and increasing Small Business prime contract awards. Responsible for the award and management of a Systems/Hardware Integration Business Unit supporting \$56M in contract awards.

1994-1996: General Electric Transportation-Director, Sourcing. As the Director of Sourcing for General Electric Transportation-Grove City Diesel Division, Mrs. Dennison was responsible for managing an annual \$100M Supply Chain, and evaluating/ implementing Sourcing/Outsourcing decisions affecting inventory management of the Diesel Engine Product Line. Mrs. Dennison, a Six-Sigma Master Black Belt, supported the Six-Sigma launch across multiple GE global manufacturing centers thereby significantly reducing manufacturing and sourcing costs.

1986-1994: Consolidated Industries, Program Manager, Automated Test Systems Branch. Responsible for business development, design, and manufacturing of automated test equipment for the US Army and US Marine Corps. Supported Development and Integration, Validation & Verification (IV&V) of Test Program Sets and emerging Automated Test Equipment platforms. Recognized as an Automated Test Equipment subject matter expert, and authored/presented various IEEE AUTOTESCON white papers on Digital/Hybrid testing applications.

EDUCATION: Bachelor of Science (Electrical Engineering/Mathematics), University of Alabama in Huntsville; Master of Business Administration, University of Alabama; Six Sigma Master Black Belt Certification; Korean Linguist.

PERSONAL: Hispanic-American US Army Veteran; Florida Enterprise Workforce 2020 Board Of Directors; University of South Florida Women in Leadership and Philanthropy Founding Member; 2004 Florida Small Business Woman of the Year; Married (John), two daughters (Jessica and Jocelyn), Running and Bowling enthusiast.

MR. JIM REGAN, EXECUTIVE DIRECTOR, PROCUREMENT TECHNICAL ASSISTANCE PROGRAM, GEORGE MASON UNIVERSITY

Jim Regan, Director of the Virginia Procurement Technical Assistance Program, at the George Mason University School of Public Policy Mason Enterprise Center, has over 25 years of experience in commercial and government business development and management with both small and large corporations. As PTAP Director he applies these qualifications in assisting businesses in pursuit of their government business objectives.

Mr. Regan possesses in depth experience in corporate strategic and tactical planning, and plan execution to achieve objectives. His activities in systems integration and services business development have developed broad knowledge of the government acquisition process and organizations in both the Federal and vendor community.

Prior to joining George Mason University's PTAP, Jim held senior business development management positions in Unisys, CSC and IBM in the Washington area. He also served as Senior Vice President of Corporate Development with American Coastal Industries, a diversified small business involved in manufacturing and systems integration. These positions have provided in depth experience in a variety of functional business areas including subcontractor and program management, systems engineering and business development.

Mr. Regan graduated from the US Naval Academy and the US Naval Postgraduate School at Monterey, California, where he earned his MS in Computer Systems Management. He spent a number of years on active duty as a naval aviator and retired from the Naval Reserve with the rank of Captain. In addition to carrier aviation, he flew as an international pilot with Pan American Airways on overseas routes.

M S. SUSAN NICHOLS, PROGRAM MANAGER, SBIR, US ARMY RESEARCH, DEVELOPMENT & ENGINEERING COMMAND

Ms. Susan Nichols began her career with the Federal government in the US Army Corps of Engineers. In the Corps of Engineers she worked in the Civil Works Dredging Division and the US Army Engineering and Housing Support Center (EHSC) where she became a DA Intern under the Comptroller career program in 1990.

During her participation in this program, she attended resource management and budget courses at the US Army Management Engineering College, US Army Finance School, US Army Logistics Management College, Center for Army Leadership and OPM. She completed developmental assignments in budget and manpower functions at the EHSC; HQDA Staff Programming Division; Deputy Chief of Staff for Personnel (DCSPER); MACOM Staff Manpower Management Division, US Army Corps of Engineers; Fort Belvoir Garrison, Resource Management Office in the budget, manpower and finance and accounting sections; and the Humphreys Engineer Center Support Activity finance and accounting office. She graduated from the DA Intern Program in 1993 and continued her career with the US Army Center for Public Works, Resource Management Office as a Budget Analyst.

Ms. Nichols was selected for a Budget Analyst position in the Resource Management Office in 1994 and selected for a Program Analyst position in the Technical Plans and Programs Office at the Topographic Engineering Center in 1998. This is when she first became involved with the Army SBIR program as one of her duties. She continued in this position until 2001, when the Corps of Engineers laboratories underwent reorganization.

The US Army Corps of Engineers restructured all of its laboratories under one consolidated command called the Engineer Research and Development Center (ERDC) in 2001. Ms. Nichols was selected for a Program Analyst position at ERDC headquarters, which resulted in expanded oversight of the SBIR program to the seven ERDC laboratories. She continued in this position until she was selected for the Army SBIR Program Manager position in May 2004.

Ms. Nichols has a Bachelor of Science degree in Management/Computer Information Systems from Park University.

M S. JOAN ALES, BUSINESS INTERFACE OFFICE, CUSTOMER ACCOUNT MANAGER, US ARMY RESEARCH, DEVELOPMENT & ENGINEERING COMMAND

Joan C. Ales serves as a Customer Account Manager at the Armament Research Development Engineering Center part of the US Army Research, Development and Engineering Command. She works with Product Managers and Life Cycle Management Commands concentrating on acquisition of munitions and armament systems for the Army. This includes assuring the processes for specifying the quality requirements included in Army contracts, and the performance of audits of contractor's and Government facilities producing new material or repairing existing systems are implemented and maintained. These responsibilities cover equipment and systems as diverse as training devices, tanks, tools, diving equipment, artillery and small arms, both hardware and related software and munitions.

Ms. Ales received a Bachelor's Degree in education from William Penn College, Oskaloosa, IA and a Master's in Business Administration from St. Ambrose University, Davenport, IA. She began her federal career in 1984 in the Army Quality Assurance and Reliability Intern program and has remained in the quality assurance field during her years of Government employment.

She has received ASQ certification for Quality Technician and Quality Auditor. She is a member of the Army Acquisition Corp.

M R. STEVEN M. TERRONEZ, CHIEF, WEAPONS PRODUCT QUALITY MANAGEMENT BRANCH, RESEARCH, DEVELOPMENT & ENGINEERING COMMAND - ARMAMENTS RESEARCH, DEVELOPMENT & ENGINEERING CENTER (RDECOM-ARDEC)

Steven M. Terronez serves as Chief of the Large Weapons Product Quality Management Branch, part of REDCOM-ARDEC. In his present position as Branch Chief, he is responsible for the successful performance of his branch as related to the application of quality assurance requirements throughout the acquisition life cycle of various weapons systems/platforms such as the ABRAMS Tank, Bradley Fighting Vehicle, M119 Howitzer, etc. In addition to his Branch Chief duties, Mr. Terronez, achieved his Six Sigma Green Belt certification and is close to completing his Lean Six Sigma Black Belt project. Mr. Terronez was very active in the early 1990s through 2003 conducting ISO Quality System Management audits as a RAB certified lead assessor. In December of 1997, Mr. Terronez took and successfully passed the QS9000 auditor examination, and did have the opportunity to participate on QS9000 audits. Mr. Steven M. Terronez is a 1980 graduate of St. Ambrose University, Davenport, IA where he received his Bachelor of Arts degree in Biology. He began his federal career in 1985 in the Army Quality Assurance and Reliability Intern program and has remained in the quality assurance field during his years of Government employment. He is a member of the Army Acquisition Corp, and a member of American Society For Quality.

M R. RONALD DAVIS, DEPUTY CHIEF OF STAFF FOR BUSINESS TRANSFORMATION, G7, HQs AMC

Mr. Davis is the Deputy Chief of Staff for Business Transformation (G-7), Headquarters, Army Materiel Command. His responsibilities include industrial base policy, public-private partnerships, standardization, diminishing manufacturing sources, product data policy and programs for continuous improvement including Lean Six Sigma. Ongoing actions include implementation of the Army's Industrial Base Strategic Plan and Partnership Business Development Plan. Mr. Davis entered the Senior Executive Service in June of 2004 as the Deputy G-3 for Industrial Operations, Headquarters, Army Materiel Command.

Mr. Davis began his DoD career at Norfolk Naval Shipyard as a Naval Architect in the Engineer Development Program. He left in 1984 to work for the Supervisor of Shipbuilding, Jacksonville, Florida as the Supervisory Naval Architect and later as Chief Engineer. While in Jacksonville, Mr. Davis led the engineering effort for battle damage repair on USS STARK (FFG 31) and USS SAMUEL B ROBERTS (FFG 58). In 1998 Mr. Davis went to the Supervisor of Shipbuilding, New Orleans, Louisiana as the Chief Engineer. There he participated in lead ship design for amphibious transport dock ships and construction of strategic sealift ships.

In 2000, Mr. Davis became the first civilian deputy to the commanding officer at the Supervisor of Shipbuilding, Pascagoula, Mississippi. There he led over \$1 billion per year in major acquisition including guided missile destroyers, amphibious assault ships and oceanographic research vessels, as well as reconstruction of the USS COLE (DDG 67) following a terrorist attack in Yemen. In 2004, Mr. Davis served as Director, Supervisor of Shipbuilding Management Group, Naval Sea Systems Command headquarters.

Mr. Davis completed his undergraduate engineering studies at the Georgia Institute of Technology. He is also a graduate of National Defense University's Industrial College of the Armed Forces. While at ICAF Mr. Davis earned a Master of Science degree in National Resource Strategy, completed the Senior Acquisition Course and earned recognition as a Distinguished Academic Graduate.

MR. ROBERT SPITZBARTH, PROCUREMENT ANALYST, ACQUISITION CENTER, US ARMY TANK-AUTOMOTIVE AND ARMAMENTS LIFE CYCLE MANAGEMENT COMMAND

Mr. Spitzbarth began his career with the Department of the Army in 1979 as a Contract Specialist at the Tank Automotive Readiness Command in Warren, Michigan where, from 1986 to 1994, he served as Contracting Officer or SSEB Deputy Chairman on numerous Source Selections.

In 1994, he was re-assigned to the newly established System Acquisition Assistance Office (SAAO), within the TACOM Acquisition Center. The SAAO was formed primarily as a service organization to assist Program Managers, PCOs, Source Selection Evaluation Boards and Source Selection Authorities in the planning and execution of Best Value Source Selections. While in the SAAO, Mr. Spitzbarth also served as an SSEB Deputy Chairman on a number of acquisitions, including the joint United States/United Kingdom Future Scout and Cavalry System.

Mr. Spitzbarth was the TACOM representative on the Army Materiel Command's Past Performance IPT at its inception in 1989, and also represented the Department of the Army on the Department of Defense's 1997 IPT to develop an execution strategy for DoD implementation of FAR Part 42 requirements to collect and maintain "Contractor Performance Information".

During the period 1999-2000, Mr. Spitzbarth participated nearly full time in the Army's Transformation objective to equip Brigade Combat Team's with Stryker Interim Armored Vehicles. In this role, he was directly involved in the development of the acquisition strategy, evaluation criteria, and preparation of the Source Selection decision documentation during selection phase of the acquisition. He also served as the SSEB Management Area Team Chief.

Since 2000, and beyond his TACOM related Source Selection activities, Mr. Spitzbarth has also participated extensively in a series of Army-wide Source Selections including the Aberdeen Proving Grounds A-76, Restore Iraq Oil (RIO), the USAREUR Support Contract, and full time assignment to the Department of Army's Orchestration & Coordination Committee (OCC) responsible for managing the Source Selection award of 10 contracts for the Reconstruction of Iraq's basic public services infrastructure. The Source Selection process for the 10 Iraq Reconstruction awards, from proposal receipt to award, was completed in 50 days without protest.

Mr. Spitzbarth is currently assigned to Acquisition Center at the TACOM LCMC, where he continues to serve in the System Acquisition and Assistance Office. Mr. Spitzbarth is a 1979 graduate of the University of Michigan with a Bachelors Degree in History.

MS. AUDRY MUSGROVE, LEAD SYSTEMS INTEGRATOR, FUTURE COMBAT SYSTEMS, THE BOEING COMPANY

Audry Musgrove is Small Business Liaison Officer, Supplier Diversity, Future Combat Systems. In this position, Audry develops and implements unique strategies to augment the utilization of small businesses, small disadvantaged businesses, women-owned small business, historically black colleges and university/minority institutions, and other business concerns identified by the FCS Program. In addition to coordinating the performance reports from 23 subcontractors, Audry also is the FCS prime interface with the Army Small business office on all matters regarding Supplier Diversity.

Audry joined the Douglas Aircraft Company in 1985 as a manufacturing capacity planner in Fabrication. In this position she developed capacity plans for fabrication and assembly. Audry also developed integrated schedules to support the F-15 program. In 1992, Audry was promoted to senior manager of MD11 Aft Fuselage. In this capacity, she led 13 managers and more than 400 collective bargaining union employees in delivering fully stuffed fuselage barrels to final assembly. Audry also initiated, coordinated and managed producibility improvements, policy and procedures, and manufacturing cost improvements. After serving various assembly managerial positions with increasing responsibility, Audry was named senior manager of electrical sub-assemblies, one of the largest departments.

She was also very active on division/corporate level improvement teams, including lean manufacturing, diversity council, HBCU/ME corporate committee, and division-level strategy team. Audry has received numerous awards including a 2003 National Women of Color in Technology Award.

Promotional Partners

BAE SYSTEMS

BAE Systems Land and Armaments is a global leader in the design, development, production and service support of armored combat vehicles, major and minor caliber naval guns and missile launchers, canisters, artillery systems and intelligent munitions. Our trans-atlantic business has operations in the UK, South Africa, Sweden and the US, with markets in more than two dozen countries.

Land and Armaments employs 11,000 employees dedicated to providing superb performance and meeting customer requirements with on-time, on-schedule delivery of advanced combat armament solutions. We maintain industry leadership in advanced technologies that focus on enhancing survivability, lethality, and mobility.

Our strategy is to provide the broadest product line of systems and components in our markets, breakthrough technology solutions, world-class systems integration capabilities, flexible manufacturing capabilities and superior integrated logistics support throughout the product life-cycle.

Our goal is to provide our customers with the finest combat capability in the world.

GENERAL DYNAMICS

Ordnance and Tactical Systems

General Dynamics Ordnance and Tactical Systems (GD-OTS) is a world leader in the manufacture of large, medium- and small-caliber direct and indirect-fire munitions, mortar weapons and systems, artillery projectiles, bomb bodies and BALL POWDER® Propellant. The company also manufactures precision metal components; provides explosive load, assemble and pack services for a variety of munitions, tactical missile and rocket programs; and designs and produces shaped charge warheads and control actuator systems.

GD-OTS is commitment to providing the Armed Forces of the US and its allies with the highest quality, “best value” solutions for 21st century combat. As one of the oldest and largest manufacturer of conventional ammunition in the United States and a continuous Department of Defense contractor, we continue a century-long heritage of setting the quality and innovation standards in medium and large caliber ammunition design, development and manufacturing. GD-OTS has participated in the development and/or production of every US kinetic energy projectile since 1960. We are rewriting medium caliber ammunition performance standards with new, more effective kinetic energy, multi-purpose and airburst munitions. We are a world leader in munitions dispensing technology, high-performance propulsion and propellant systems, shaped-charge and explosive formed penetrator development and air-to-air warhead design.

As a leading systems contractor to the US government, we offers a diverse array of capabilities including engineering, manufacturing and weapon system program management; technical support capabilities; high-volume load, assemble and pack; precision metal parts fabrication; forging and composite fabrication; and quality and testing services. Our vast systems contracting experience enables us to extend our capabilities to the global market.

GD-OTS capitalizes on the synergy created by more than 100 years of proven success and expertise in supporting the defense and aerospace industries. To that end, both US and international customers continue to look to General Dynamics Ordnance and Tactical Systems for their total ammunition solutions.

NORTHROP GRUMMAN



10th Annual Small Business Conference
*“Army & Small Business:
Partners For Success”*

November 1 - 2, 2006 • Hilton McLean Hotel at Tysons Corner • McLean, Virginia



**Thank You to Our
Promotional Partners!**

BAE SYSTEMS

GENERAL DYNAMICS
Ordnance and Tactical Systems

NORTHROP GRUMMAN



10th Annual Small Business Conference

Army & Small Business: Partners For Success

**The Honorable Claude M. Bolton, Jr., DSc
Assistant Secretary of the Army
(Acquisition, Logistics and Technology)
And Army Acquisition Executive
November 1, 2006**



Trivia Question

What Current Multi-Billion Dollar Company Started Off As A Small Business Financed By The Sale Of A VW Bus And An HP Scientific Calculator?



Trivia Question

Apple



Focus

- **Right Product**
 - **Right Time**
 - **Right Place**
 - **Right Price**

Rapid Fielding Initiative

Weapon Light



M4/M16 Improved
Cleaning Kit



M145 Machine Gun
Optic



Rapid Fielding Initiative



M249 Soft
Ammo Pack



Spare Barrel
Bag



3-Point Sling

Equipment Items Fielded to *All* Soldiers

Rapid Equipping Force

TACMAV



Translators



PILAR



Rapid Equipping Force



Magnetometer

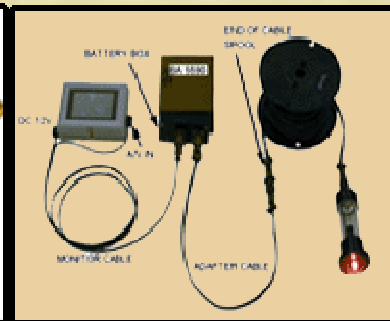

Well-Cam

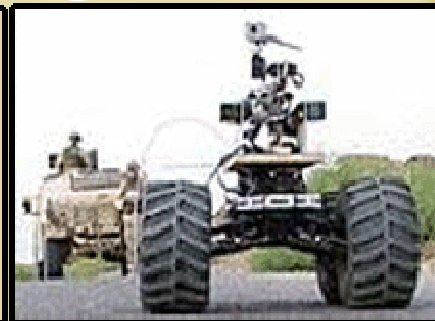

MARCBOT

Stryker Family of Vehicles



SUCCESS



Future Combat System

Manned Systems

Unmanned Aerial Vehicles

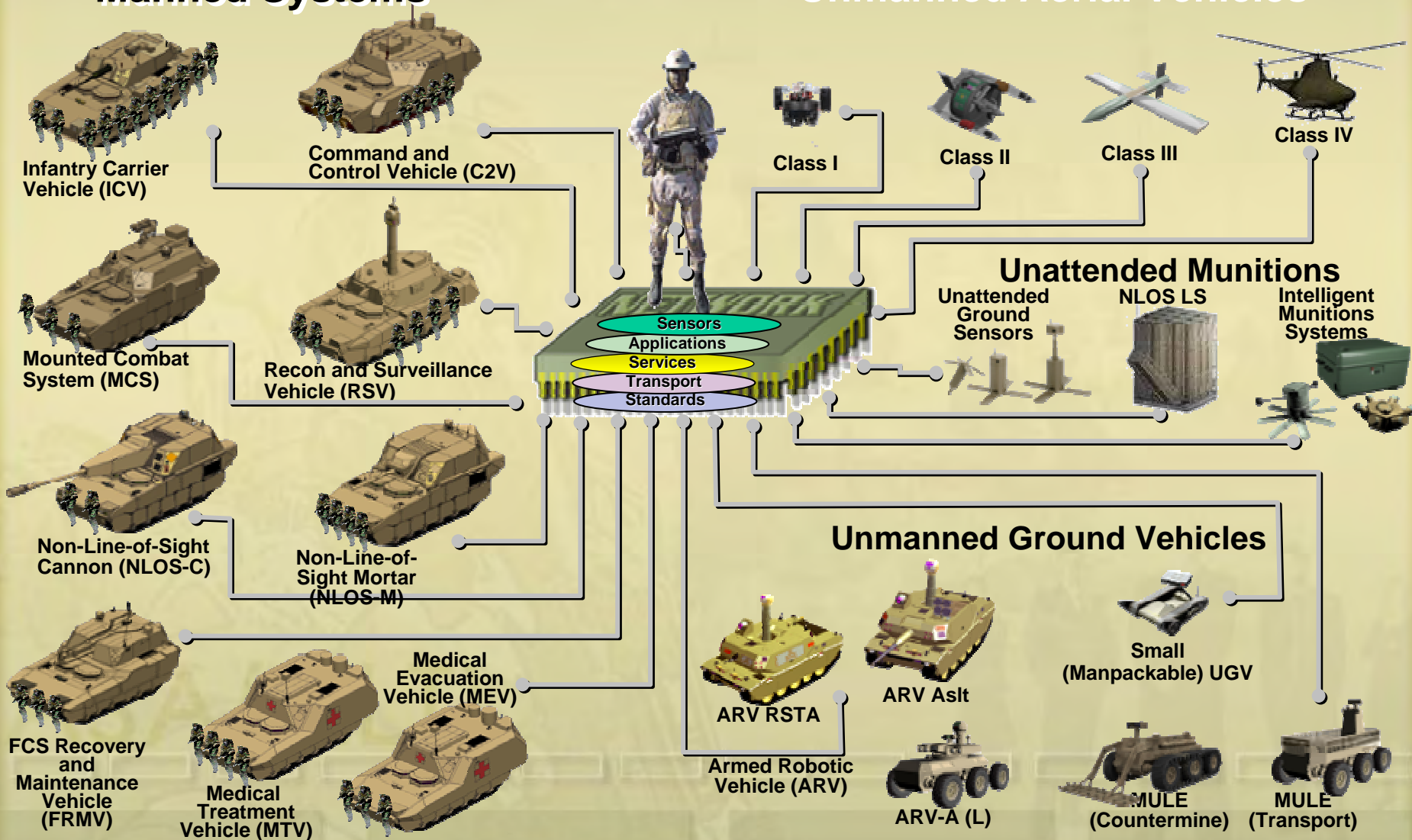

PM UA System of Systems Schedule

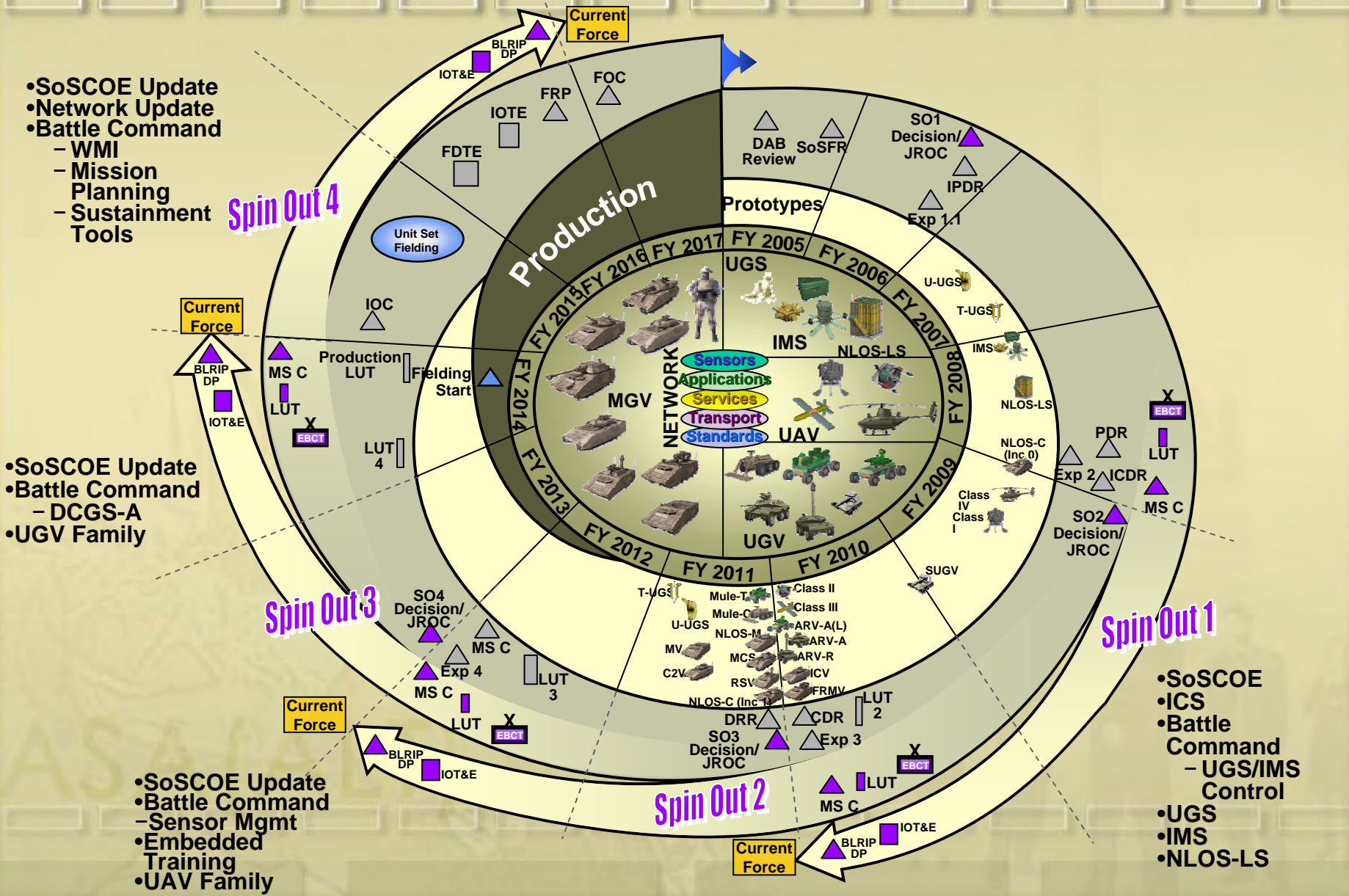

Future Combat Systems Supply Base

**42 States plus the District of Columbia
232 Congressional Districts, 631 Suppliers**

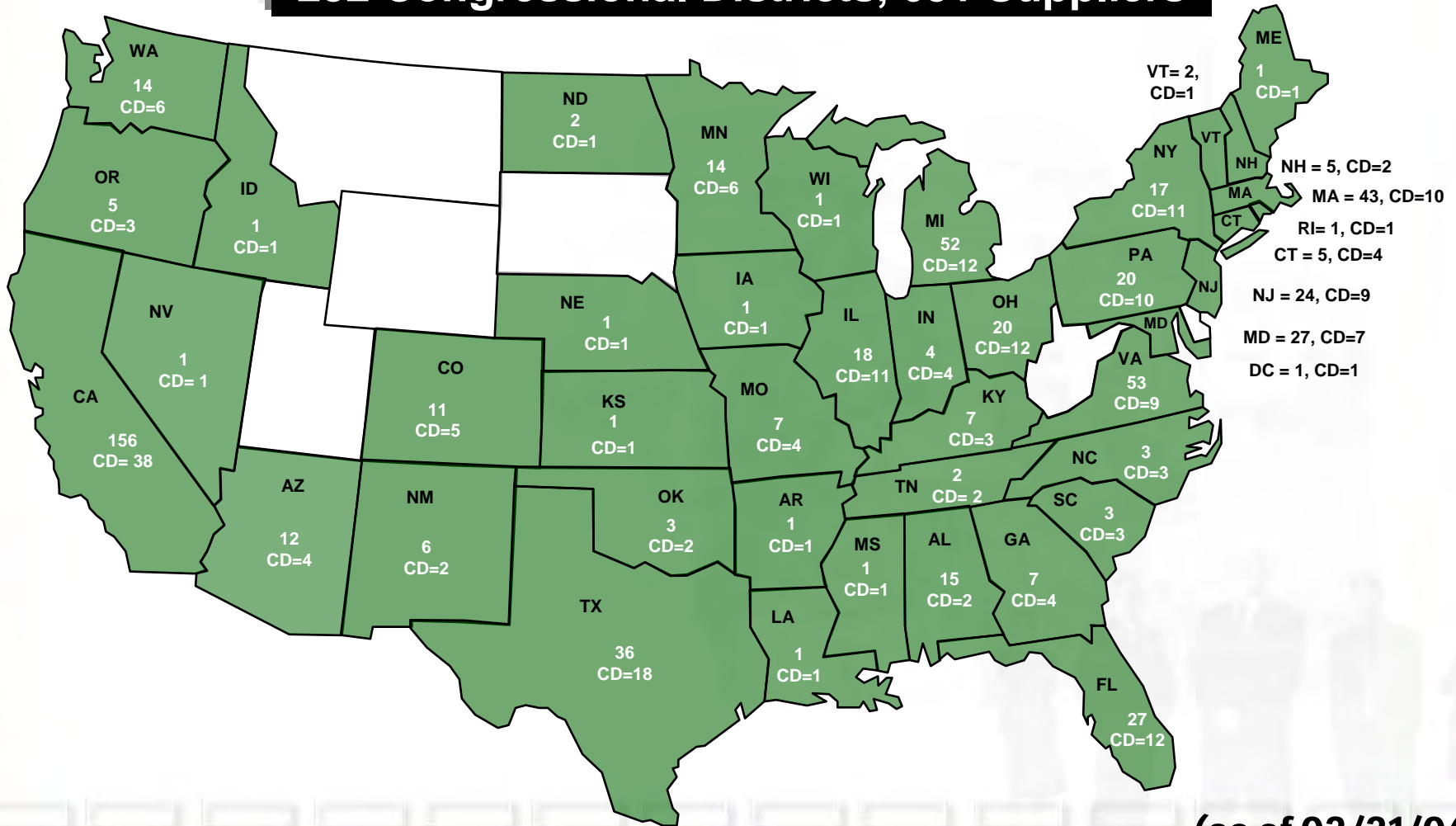

(as of 03/31/06)

Future Combat Systems Small Business Supply Base

38 States, 193 Congressional Districts, 420 Suppliers

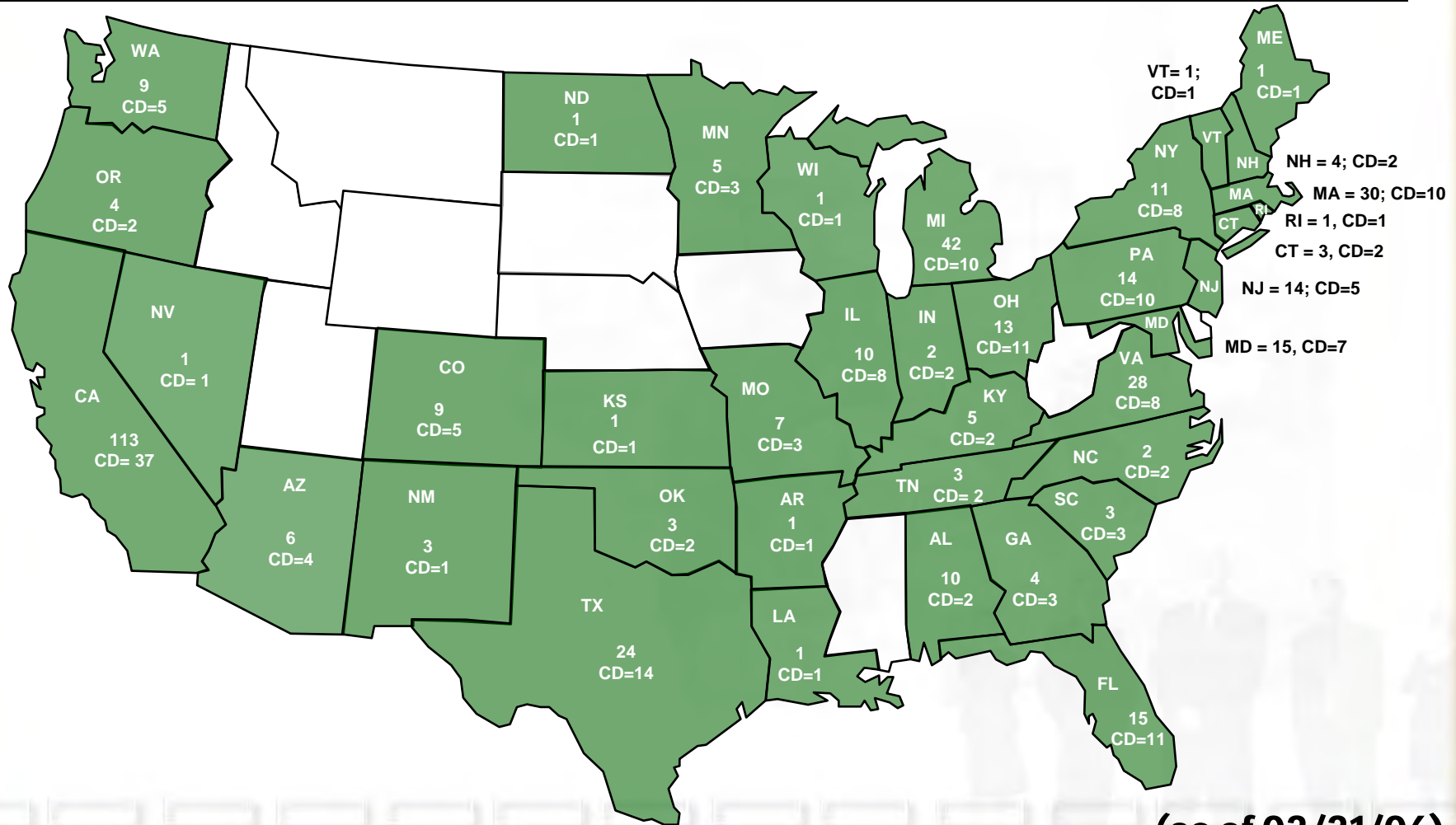

(as of 03/31/06)

Army SBIR Facts and Figures FY00-06

- 1,656 research topics...
- 21,067 proposals from industry...
- 3,408 contract awards...
- Over \$1.2 billion in research...
- 26 participating organizations...



Army SBIR = Improved Operational Capability

Cockpit Air Bag System

Simula, Inc.

Phoenix, AZ

- Over \$42M in DoD sales

UH-60A/L production contract; OH-58D completed qualification; AH-64D & CH-47D study programs



Innovative Communications and Electronic Warfare Antenna

FIRST RF Corporation

Boulder, CO

- \$247K in DoD R&D

- Over \$70M in DoD Sales

Over 12,500 units delivered through March 06.



FIDO Lightweight Integrated Explosives Detection System

Nomadics –
Stillwater, OK

-Over \$10M in non-SBIR investment

Fielded on 8 Nov 2005 in Baghdad, Iraq



Small Business in OIF & OEF



**HemCon Bandage:
HemCon, Inc.**

PACK BOT: iRobot



ATACS: Cybernet

Army Prime Contract Awards

	DOLLARS (M\$)		NAT'L GOAL		% ACHIEVED	
	FY04	FY05	FY04	FY05	FY04	FY05
US Business	\$55,493	\$70,802				
Small Business	\$15,471	\$20,381	23.00%	23.00%	27.90%	28.80%
Small Disadvantaged Business	\$5,005	\$6,658	5.00%	5.00%	9.00%	9.40%
Women-Owned SB	\$2,029	\$2,625	5.00%	5.00%	3.70%	3.70%
HUBZone Small Business	\$1,573	\$2,226	3.00%	3.00%	2.80%	3.10%
Service Disabled Veteran-Owned SB	\$233	\$501	3.00%	3.00%	0.40%	0.70%

Things On My Mind

Are We Better Off Today Because of Small Business?

- More Than 25 Million Small Businesses In America
- Creates Two Out Of Every Three New Jobs And Accounts For Nearly Half Of America's Overall Employment
- Produced 13 To 14 Times More Patents Per Employee Than Large Patenting Firms
- Employs 41 Percent Of High Tech Workers
- Pays 45 Percent Of Total U.S. Private Payroll



Back-Ups

ASA (ALT)

Atair Aerospace, Inc.
Brooklyn, NY
Autonomous Aerial Delivery System



\$11.7 M

Thermoanalytics, Inc.
Calumet, MI
Vehicle Thermal Design Tool

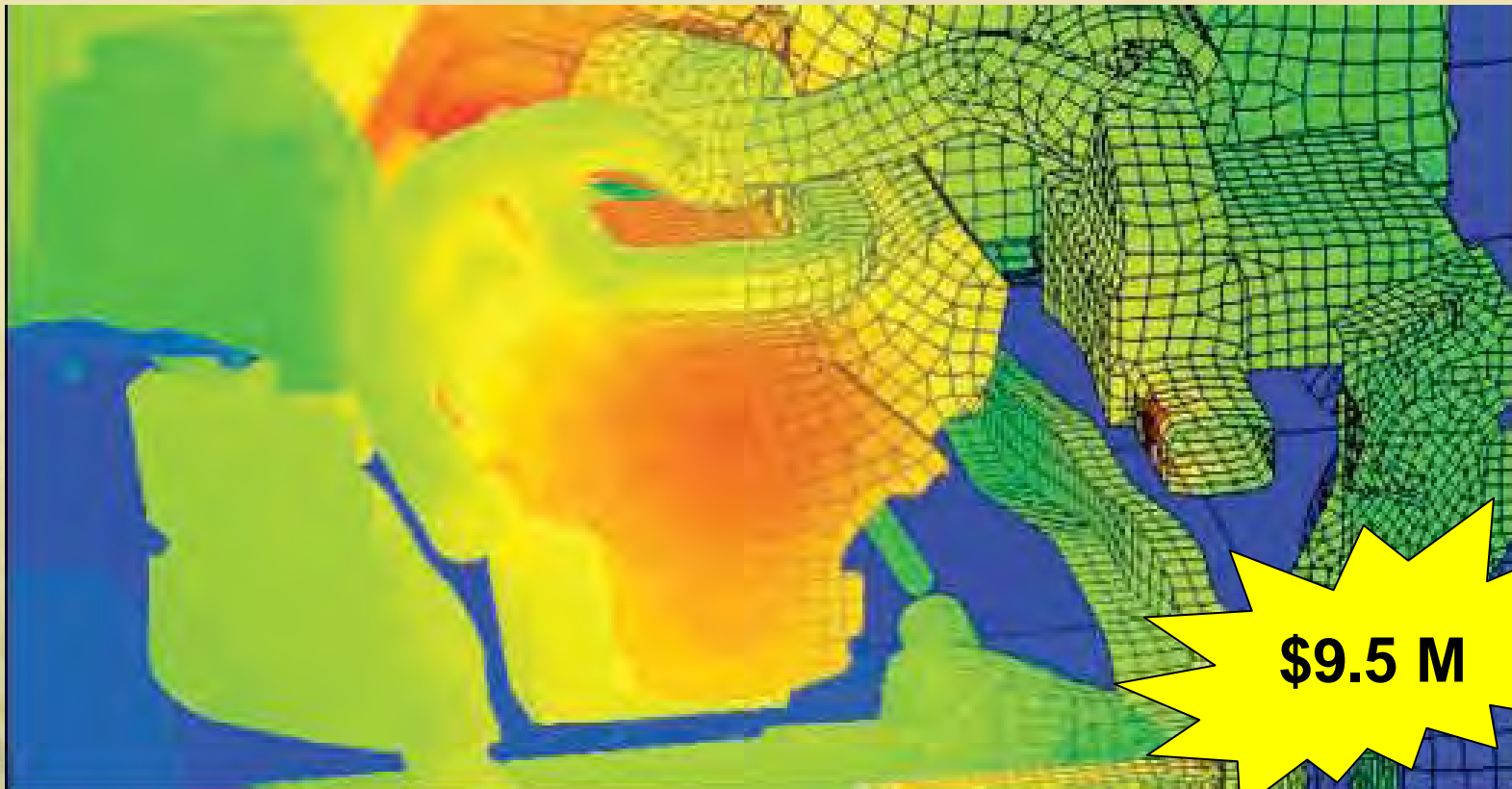

Universal Display Corporation
Ewing, NJ
Flexible Color Displays



\$5.2 M

21st Century Systems Inc. Herndon, VA Single Integrated Space Picture

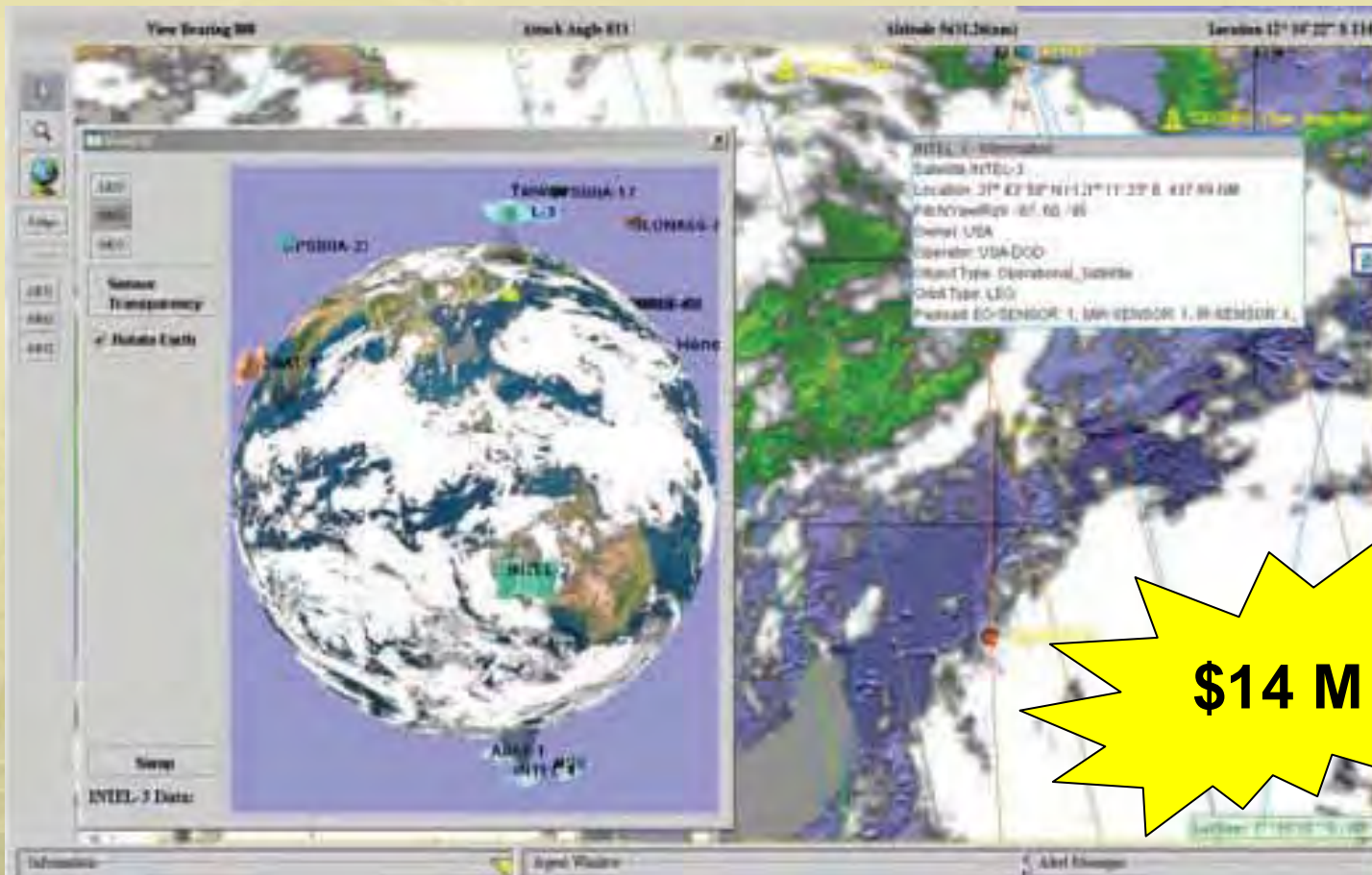

FCS Small Business Performance to Goals

FCS Cumulative Small Business Commitment Dollars

Report Period:	1	2	3	4	5	6	7	8	9
Data Through:	3/31/2004	9/30/2004	3/31/2005	9/30/2005	3/31/2006	9/30/2006	3/31/2007	9/30/2007	3/31/2008
Small Business (SB)	\$ 48,170,426	\$ 125,980,861	\$ 228,671,813	\$345,827,443	\$ 502,399,884				
Large Business	\$ 237,164,342	\$ 636,535,766	\$ 1,548,116,305	\$ 2,012,094,199	\$ 2,932,164,049				
Total Commitments	\$ 285,334,768	\$ 762,516,627	\$ 1,776,788,118	\$ 2,357,921,642	\$ 3,434,563,933				
Disadvantaged SB	\$ 8,412,789	\$ 15,982,605	\$ 35,221,523	\$ 46,480,946	\$ 57,151,799				
Woman-Owned SB	\$ 4,622,229	\$ 12,016,365	\$ 25,243,369	\$ 41,551,065	\$ 55,595,164				
HUB Zone SB	\$ 605,973	\$ 2,309,963	\$ 4,332,551	\$ 8,196,691	\$ 14,817,637				
Veteran-Owned (VO) S	\$ 16,598,747	\$ 35,440,225	\$ 56,533,528	\$ 75,214,625	\$ 106,133,223				
Service-Disabled VOS	\$ 5,226,250	\$ 11,979,935	\$ 23,524,760	\$ 28,733,870	\$ 35,126,740				

FCS Cumulative Small Business Commitment Percentages

Report Period:	1	2	3	4	5	6	7	8	9
Data Through:	3/31/2004	9/30/2004	3/31/2005	9/30/2005	3/31/2006	9/30/2006	3/31/2007	9/30/2007	3/31/2008
Small Business (SB)	16.9%	16.5%	12.9%	14.7%	14.6%				
Disadvantaged SB	2.9%	2.1%	2.0%	2.0%	1.7%				
Woman-Owned SB	1.6%	1.6%	1.4%	1.8%	1.6%				
HUB Zone SB	0.2%	0.3%	0.2%	0.3%	0.4%				
Veteran-Owned (VO) S	5.8%	4.6%	3.2%	3.2%	3.1%				
Service-Disabled VOS	1.8%	1.6%	1.3%	1.2%	1.0%				

FCS Small Business Goals

Small Business (SB)	17.5%
Disadvantaged SB	3.5%
Woman-Owned SB	2.5%
HUB Zone SB	0.3%
Veteran-Owned (VO) S	1.5%
Service-Disabled VOS	0.2%

Committed Dollars are defined as dollars used to procure goods or services that can be tracked back to a prime contract via a valid contractual document.

The contractual document can be fully or incrementally funded.

Funding for subcontracts generally fall into two categories (Per FAR Subpart 32.7):

1. Fully Funded – funds obligated to cover the full or estimated price at subcontract completion.
2. Incrementally Funded (aka. "Fund(s) Limited") – Funds obligated to cover the amount allotted and any corresponding increment of fee for identified contract effort.

Formula used for percentages: Numerator includes committed dollars placed with diverse suppliers (e.g. SB, SDB, WOSB, HUBZ, VOSB, SDVOSB) during a reporting period. Denominator includes ALL committed dollars (including both large and small business suppliers) for the same reporting period.

Please note: In some cases, a pro-rata portion of indirect dollars may be included in both the numerator and denominator. Some Partners have a dollars threshold of \$500K for reporting small business dollars.

Break Out Sessions

- What You Need to Know Before You Team / Partner
- Tips and Opportunities Available for Small Businesses
- Small Business Innovative Research (SBIR) Opportunities
- The Route to ISO 9000 Qualification
- Industry Partnership Opportunities with AMC
- Preparing Your Proposals to Win More Contracts



Matching Your Personnel Requirements with Available Talent

Steve Clark
Program Analyst
DOD Military Severely Injured Center



NDIA
10th Annual Small Business Conference
Nov 2, 06

DOD Military Severely Injured Center (MSIC)



MSIC opened on Feb 1, 2005. It ties together military and other government programs to assist severely injured service members.

Mission:

Prepare severely injured Service members to return to duty or to reintegrate into civilian communities.

Objectives:

Ensure all severely service members and their families receive proper assistance.

To provide assistance, tailored to an individual's needs during recovery and rehabilitation.

Includes

- Medical care & rehabilitation
- Education, training and job placement
- Personal mobility and functioning
- Home, transportation and workplace accommodations
- Personal, couple and family issues counseling
- Financial resources assistance

Availability:

- 24/7, worldwide

Employing the Severely Injured is Good Business for You and the Veteran



1. The wounded veteran has skills, training and character to meet tough challenges.
2. They are experienced in working side by side with others and performing under pressure.
3. They are accountable and have respect for following procedures.
4. They understand an "honest days work."
5. Severely injured veterans can bring a diverse set of skills to your organization.

How You Can Help



1. Call Me: Steve Clark 703-692-2054, email-steve.clark@osd.mil.
2. Visit our website at www.militaryhomefront.dod.mil for more information.

Questions?

Department of the Army Small Business Program



"Our Army at War - Relevant & Ready"

Army Mentor-Protégé Program

November 2, 2006

Ms. Wendy Despres
Mentor-Protege Program Manager
U.S. Army Office of Small Business Programs

Army Small Business Office



Mentor Protégé Program *Agenda*



- ❑ Background
- ❑ Participants
- ❑ Types of Agreements
- ❑ Program Benefits
- ❑ Program Status
- ❑ How to Participate
- ❑ Army Requirements



Mentor Protégé Program *Background*



- ❑ Established in 1991 - P.L. 101-510 to provide incentives to prime contractors to develop the technical and business capabilities of eligible protégés to increase their participation in both prime contracts and subcontracts
- ❑ The National Defense Authorization Act for FY 2005 extended the MPP until **30 Sep 2010** for approval of new agreements, and until **30 Sep 2013** for incurred costs



Mentor Protégé Program



Who is Eligible?

Mentors

- ❑ Have at least one active approved subcontracting plan negotiated with DoD
- ❑ Be eligible for award of Federal contracts
- ❑ May be an 8(a) Graduate
- ❑ Committed to small business & protégé
- ❑ Can mentor more than 1 protégé under separate agreements



Mentor Protégé Program

Who is Eligible?



Protégé's

- ❑ Certified Small Disadvantaged Business
- ❑ Qualified organizations employing the severely disabled
- ❑ Women-Owned Small Business
- ❑ Indian-Owned Small Business
- ❑ Native Hawaiian Organization-Owned Small Business
- ❑ Qualified HUB zone Small Business
- ❑ Service-Disabled Veteran-Owned Small Business
- ❑ Be eligible for award of Federal contracts



Mentor Protégé Program

Types of Agreements



- ❑ **Credit** – Allows mentor to receive credit against their SDB subcontracting goals for costs incurred due to development assistance provided to the protégé.
- ❑ **Direct Reimbursement** – Allows mentor to receive monetary reimbursement of costs incurred due to development assistance provided to the protégé.

Army Small Business Office



Mentor Protégé Program

Mentor Benefits



- ❑ Long-term relationship with business partner
- ❑ Qualified source at competitive prices
- ❑ Ability to award subcontracts directly
- ❑ Help achieve subcontracting goals
- ❑ Subcontracting opportunities
- ❑ Source of qualified employees from HBCU/MI

Army Small Business Office



Mentor Protégé Program

Protégé Benefits



- ❑ Technology Transfer
- ❑ Technical Management Skills
- ❑ Long-term Relationship
- ❑ Enhanced Competitiveness (prime contract opportunities)
- ❑ Subcontracting Opportunities
- ❑ Source of Qualified Employees from HBCU/MI

Army Small Business Office



Mentor Protégé Program



Why MP Program?

- ❑ Army is looking for agreements that will develop small disadvantaged manufacturers (strong technology transfer)
- ❑ Large firms are seeking to improve small business diversity in their subcontracting programs
- ❑ Large firms are seeking small disadvantaged companies to team with and MP Program offers a way to train and partner
- ❑ The DFARS now requires evaluation of small business participation in all awards >\$550,000 so large firms are looking to increase small business participation on specific contracts



Army Mentor-Protégé Program



□ Army

- Application Process using specific evaluation criteria
- Agreements through **modifications** to existing contracts
- New contracts can be approved with compelling justification
- Non-Manufacturing Agreements **< \$500,000**, Manufacturing may be higher but cannot exceed **\$1 Million** a year



Mentor Protégé Program

Program Status



- ❑ **Number of agreements fluctuates**
 - Currently, 36 agreements are in place
 - 23 Mentors (4 are graduated 8a firms)
 - Protégés (can have only 1 mentor under the DOD program)
- ❑ **Protégé Statistics***
 - 26 Small Disadvantaged Businesses
 - 25 8(a) firms
 - 11 Woman-Owned Small Businesses
 - 8 Service Disabled Veteran-Owned Small Business
 - 9 HUB Zone Small Businesses
 - 3 firms owned by Indian Tribes

*Various protégés qualify under more than one category

Army Small Business Office



Mentor Protégé Program

How to Apply



- ❑ For credit only agreements, apply directly to DCMA
- ❑ DOD delegated approval authority to Services beginning FY 2004 for cost reimbursement agreements
- ❑ For Army, 2 rounds of proposals each Fiscal Year -- Proposal due dates: **15 Nov and 15 Apr**
- ❑ Review Army Mentor-Protégé Policies & Procedures and proposal instructions

Army Small Business Office



Mentor Protégé Program Conclusion



*"The Army's Mentor-Protégé Program is specifically designed to engage industries to shape and expand the industrial base to support the **war fighter!**"*



www.sellingtoarmy.info

Our Army at War - Relevant & Ready

Army Small Business Office



Department of Defense Mentor-Protégé Programs



- DOD Mentor-Protégé Program (MPP)
 - 1-800-540-8857
 - www.acq.osd.mil/osbp/mentor_protege/
- Army MPP
 - Wendy Despres, Program Mgr/703-697-2868
 - www.sellingtoarmy.info
- DCMA MPP
 - Melba (Sunny) Thompson, Program Mgr/877-662-3960

Department of Homeland Security

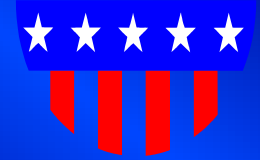

Office of Small and Disadvantaged Business Utilization (OSDBU)

Elaine C. Duke



Homeland
Security

Department of Homeland Security Mission

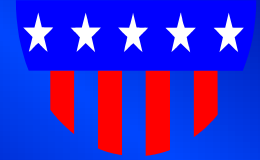

“We will lead the unified national effort to secure America. We will prevent and deter terrorist attacks and protect against and respond to threats and hazards to the nation. We will ensure safe and secure borders, welcome lawful immigrants and visitors, and promote the free-flow of commerce.”

DHS Acquisition Regulation Small Business Policy

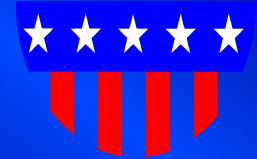

- ★ “DHS is committed to a unified team approach involving senior management, small business specialists, acquisition personnel and program staff to support both critical homeland security missions and meet public policy objectives concerning small business participation on departmental procurements.”

Three Major Types of Business Opportunities at DHS

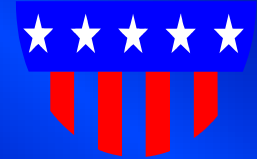

- ★ **Contracts and Subcontracts**
- ★ **Research and Development**
- ★ **Grants to State and Local Governments**

8 Major DHS Buying Activities

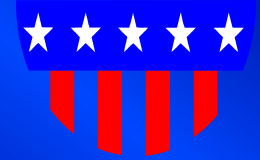

- ★ **Customs & Border Protection**
- ★ **DHS Headquarters Office of Procurement Operations**
- ★ **Federal Emergency Management Agency**
- ★ **Federal Law Enforcement Training Center**
- ★ **Immigration & Customs Enforcement**
- ★ **Transportation Security Administration**
- ★ **U.S Coast Guard**
- ★ **U.S. Secret Service**

Customs and Border Protection (CBP)

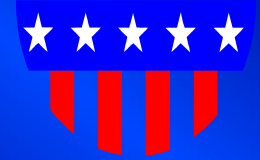

- ★ Protects America's borders against terrorists and other criminals, while facilitating trade and travel.
- ★ Oversees 2,000 miles of border with Mexico, 5,000 miles of border with Canada, 317 "ports of entry" (official crossing points) and 136 Border Patrol stations with 33 interior checkpoints.

HQ Office of Procurement Operations

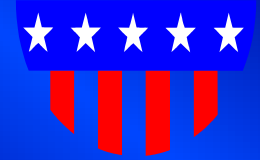

Provides a full range of acquisition support to 35 program offices within Homeland Security such as:

Science & Technology

Citizenship & Immigration Services

US-Visit

Center for Domestic Preparedness

CFO

CIO

HQ Office of Procurement Operations

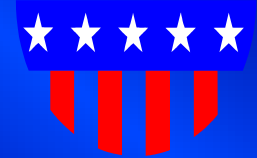

Provides a full range of acquisition support to 35 program offices within DHS such as:

- ★ Office of the Secretary (USM, CPO, CIO, CFO)
- ★ US VISIT Program Office
- ★ Office of Preparedness
- ★ Office of Intelligence & Analysis
- ★ Domestic Nuclear Detection Office
- ★ Science & Technology (HSARPA)
- ★ Citizenship & Immigration Services
- ★ Center for Domestic Preparedness

Federal Emergency Management Agency (FEMA)

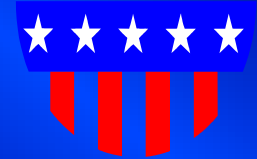

- ★ **Manages Federal response and recovery efforts following any national disaster**
- ★ **Provides disaster assistance in the form of housing and financial assistance caused by disaster**
- ★ **Manages the National Flood Insurance Program**
- ★ **Coordinates 4,000 standby disaster assistance employees available for deployment after disasters**

Federal Law Enforcement Training Center (FLETC)

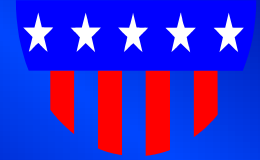

- ★ Provides training that enables federal, state and local law enforcement partners to accomplish their missions (training is provided by in-house trainers)

- ★ Provides mission-responsive infrastructure

Immigration and Customs Enforcement (ICE)



- ★ Investigates issues such as human smuggling, export enforcement, contraband smuggling, and financial and immigration crimes
- ★ Ensures the departure from the U.S. of all removable aliens
- ★ Collects and analyses intelligence data for use by ICE and DHS
- ★ Reduces threats posed against the more than 8,800 federal facilities nationwide (FPS)

Transportation Security Administration



- ★ Protects the nation's transportation systems
- ★ Screens all airline passengers
- ★ Deploys Federal air marshals to detect, defeat, and deter hostile acts targeting all transportation modes
- ★ Screens 100% of 1 billion pieces of luggage checked annually
- ★ Detects and deters the use of explosive devices in transportation systems

U.S. Coast Guard (USCG)

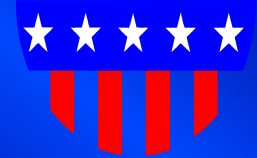

- ★ Protects ports, waterways, & flow of commerce from terrorism
- ★ Provides maritime border security against illegal drugs, illegal aliens, firearms and WMD
- ★ Provides protection of natural resources
- ★ Provides maritime safety, including search & rescue efforts, commercial and recreational boating safety

U. S. Secret Service



- ★ Protects the President, Vice President, visiting heads of state, and other government leaders
- ★ Protects U.S. currency from counterfeiters and safeguards Americans from financial crimes
- ★ Plans, coordinates, and implements security for designated national special security events (NSSE)
- ★ Emphasizes prevention through protective intelligence and threat assessment

Role of the OSDBU

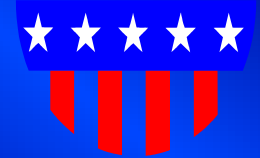

- ★ The OSDBU serves as the focal point for small business acquisition matters, and works closely with all DHS organizations to implement the program.
- ★ The OSDBU strives to create an environment in which small businesses have a meaningful opportunity to obtain DHS prime and subcontracts.
- ★ OSDBU and small business procurement information: please visit www.dhs.gov/openforbusiness

Role of the OSDBU

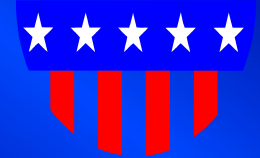

Major Activities

- ★ **FY 2007 Forecast of Contract Opportunities (includes a point of contact for each project)**
- ★ **Listing of DHS large business prime contractors with small business prime contracting opportunities**
- ★ **Links to DHS acquisition offices, small business specialists, and FedBizOpps**
- ★ **Outreach Programs**
- ★ **DHS Mentor-Protégé Program**

Small Business Considerations

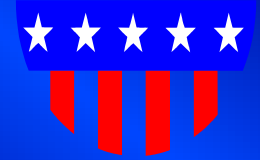

- ★ 8(a)
- ★ HUBZone
- ★ Service Disabled Veteran Owned Small Business
- ★ Traditional Small Business Set-Asides
- ★ Small Business Teams or Joint Ventures
- ★ Full and Open Competition –
Subcontracting and DHS Mentor-Protégé Program

DHS Mentor-Protégé Program

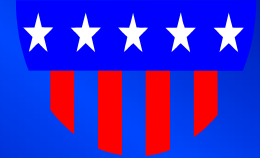

- ★ **Mentor-protégé program features three incentives: pre-award, post-award, and annual recognition**
- ★ **Mentor-Protégé Program is open to all small businesses**
- ★ **Details and application format available on the DHS small business website**

Small Business Goals for FY 2006 / 2007

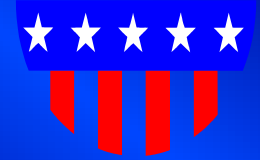

- ★ SB prime - 30.0%
- ★ 8(a) – 4.0%
- ★ SDB [non-8(a)] prime – 4.0%
- (note: 8(a) + SDB [non-8(a)] = 8.0%)
- ★ WOSB prime – 5.0%
- ★ HUBZone prime – 3.0%
- ★ SDVOSB prime – 3.0%
- ★ SB sub – 40.0%
- ★ SDB sub – 5.0%
- ★ WOSB sub – 5.0%
- ★ HUBZone sub – 3.0%
- ★ SDVOSB sub – 3.0%

Preliminary FY 2006 Small Business Prime Contracting Accomplishments

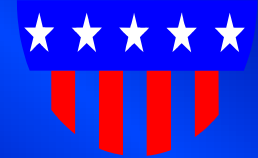

(Preliminary Results)

Category	Goal (%)	Accomplishment (\$)	Accomplishment (%)
Total Procurement Dollars	N/A	\$11,273,368,778	N/A
SB Prime Contracts	30.0%	\$3,782,663,412	33.6%
SDB Prime Contracts [overall; including 8(a) contracts]	8.0%	\$1,325,545,985	11.7%
8(a) Contracts	4.0%	\$622,170,135	5.5%
SDB Prime Contracts [other than 8(a)]	4.0%	\$703,375,850	6.2%
HUBZone SB Prime Contracts	3.0%	\$442,453,654	3.9%
SDVOSB Prime Contracts	3.0%	\$195,954,755	1.7%
WOSB Prime Contracts	5.0%	\$761,102,602	6.7%

Strategic Positioning

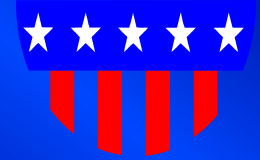

- ★ **Marketing tips from small businesses that have been successful in the federal marketplace:**
 - **Review all background information**
 - **Understand difference between use of pre-existing contract vehicles and open market buying – and position your firm accordingly**
 - **Participate in small business outreach/networking activities**
 - **Teaming**

Other DHS Programs

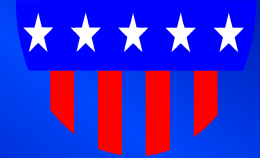

- ★ **Research and Development Opportunities (featuring Broad Agency Announcements from the DHS Science and Technology Division)**
- ★ **Small Business Innovation Research (SBIR) Program**
- ★ **DHS Grants to State and Local Governments (potentially resulting in a state or local government procurement opportunity)**
- ★ **For more information on DHS programs of interest to the business community, please visit www.dhs.gov/openforbusiness**



Homeland Security

Red Dot's Lean Journey

Randy Gardiner

President



Red Dot Corporation

***“We Create and Deliver
Innovative Climate Control
Solutions”***



Facilities



\$100 Million In Sales World-wide

- **Seattle**
- **Memphis**
- **Ipswich**



Core Customers



JOHN DEERE



TAKEUCHI



PACCAR



Diverse Product Applications



Army & Marine Kits

**DESIGNED AND BUILT LIKE SOMEONE'S LIFE
DEPENDS ON IT!**



**BUILT TO SURVIVE
RED DOT CORPORATION**



Red Dot's Lean Journey



Why?

**Red Dot's business landscape has
changed.....**

**Red Dot must change to survive
and....THRIVE!**



NEW LANDSCAPE

- **More Products**
- **Shorter Deliver Schedules**
- **Smaller Runs....More Set-ups**
- **More Inventory....More Cash**
- **More Competition = Lower Prices**
- **Lower Prices = Cost Pressure**
- **Employee Ownership**



Employee Ownership



MYTH

**“We’re just in a
down cycle.....**

**things will be better
when the economy
picks up”**



"VALUE-ADDED" SALES PER EMPLOYEE

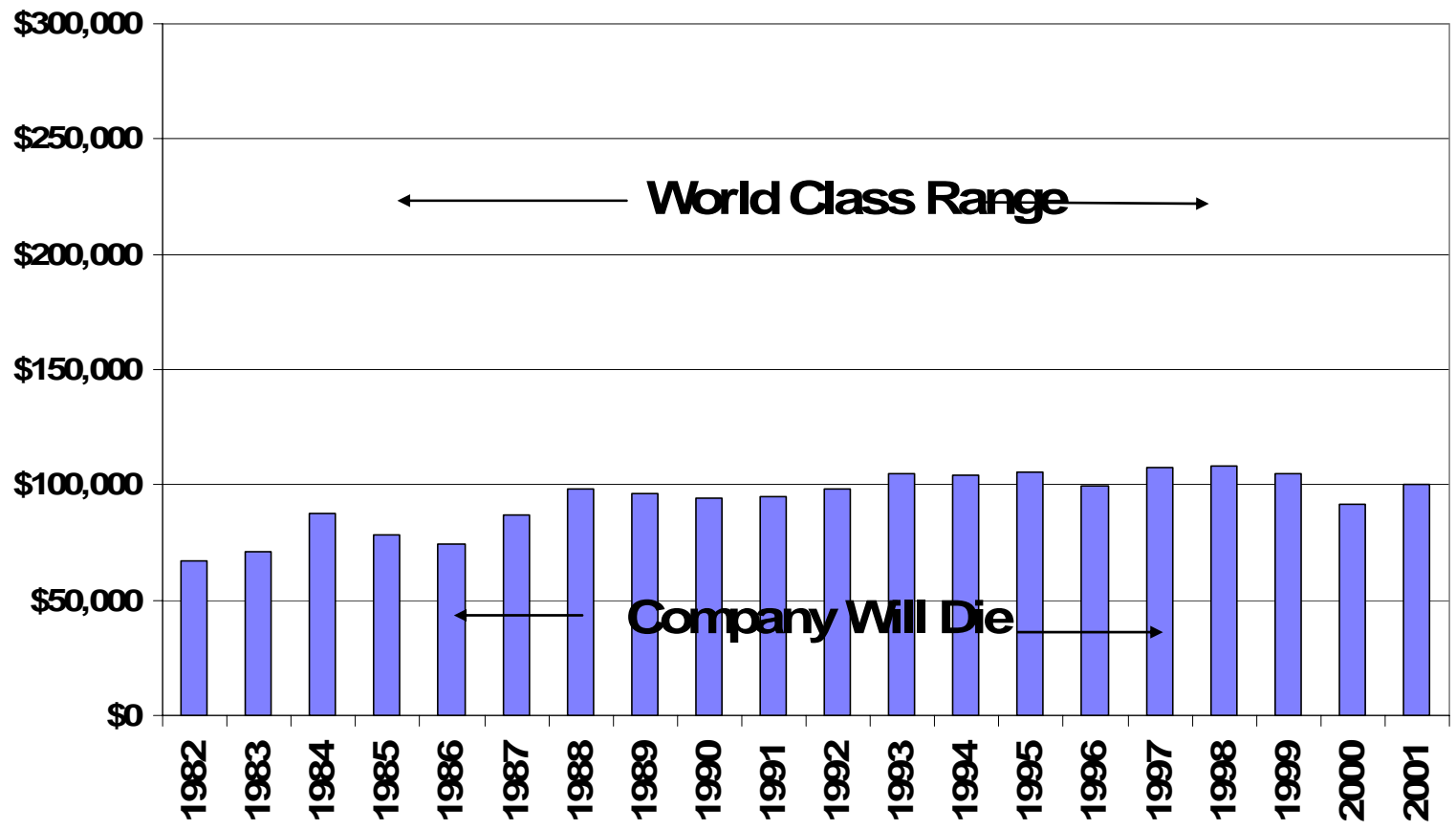



INVENTORY TURNS

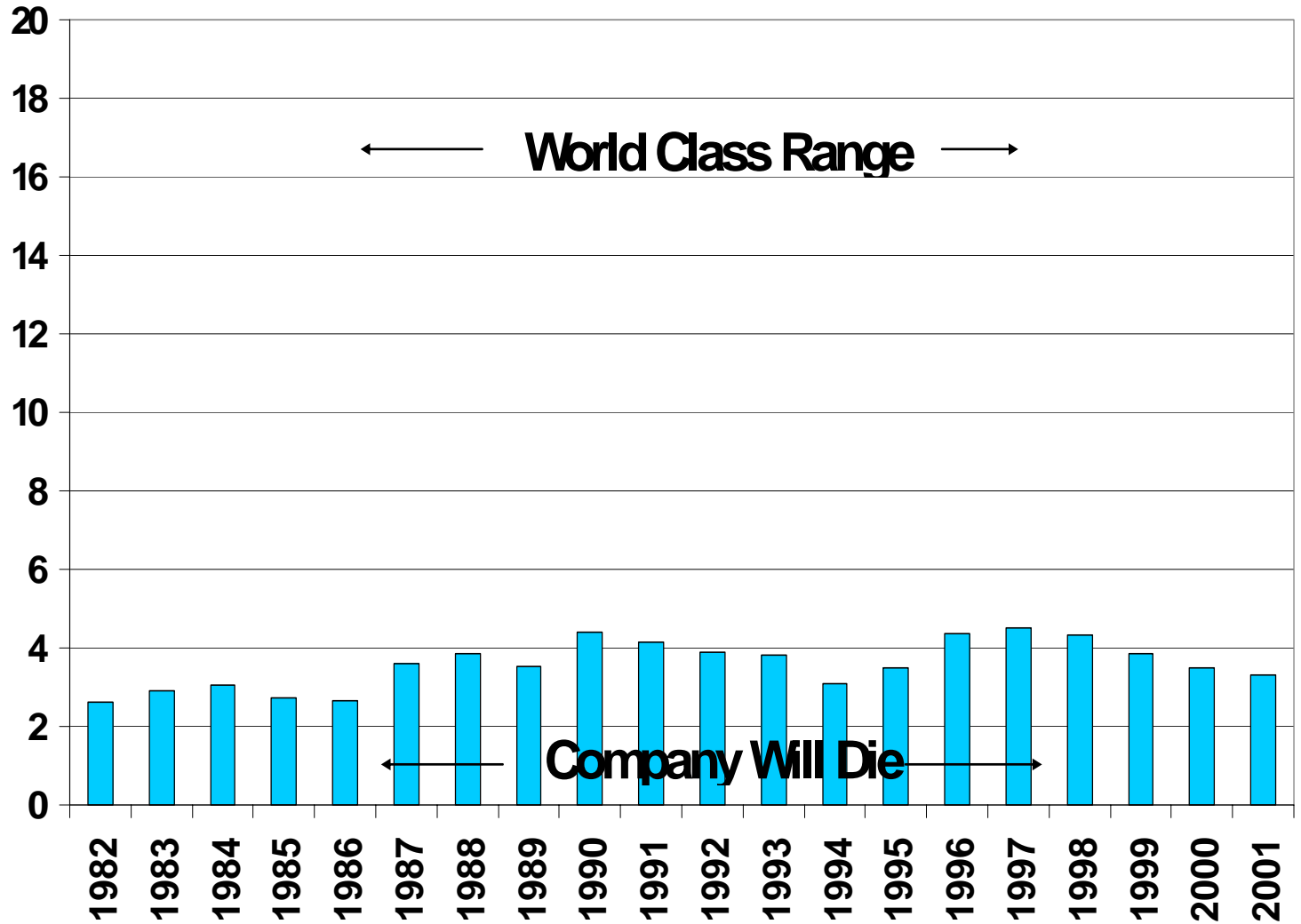



ASSET UTILIZATION

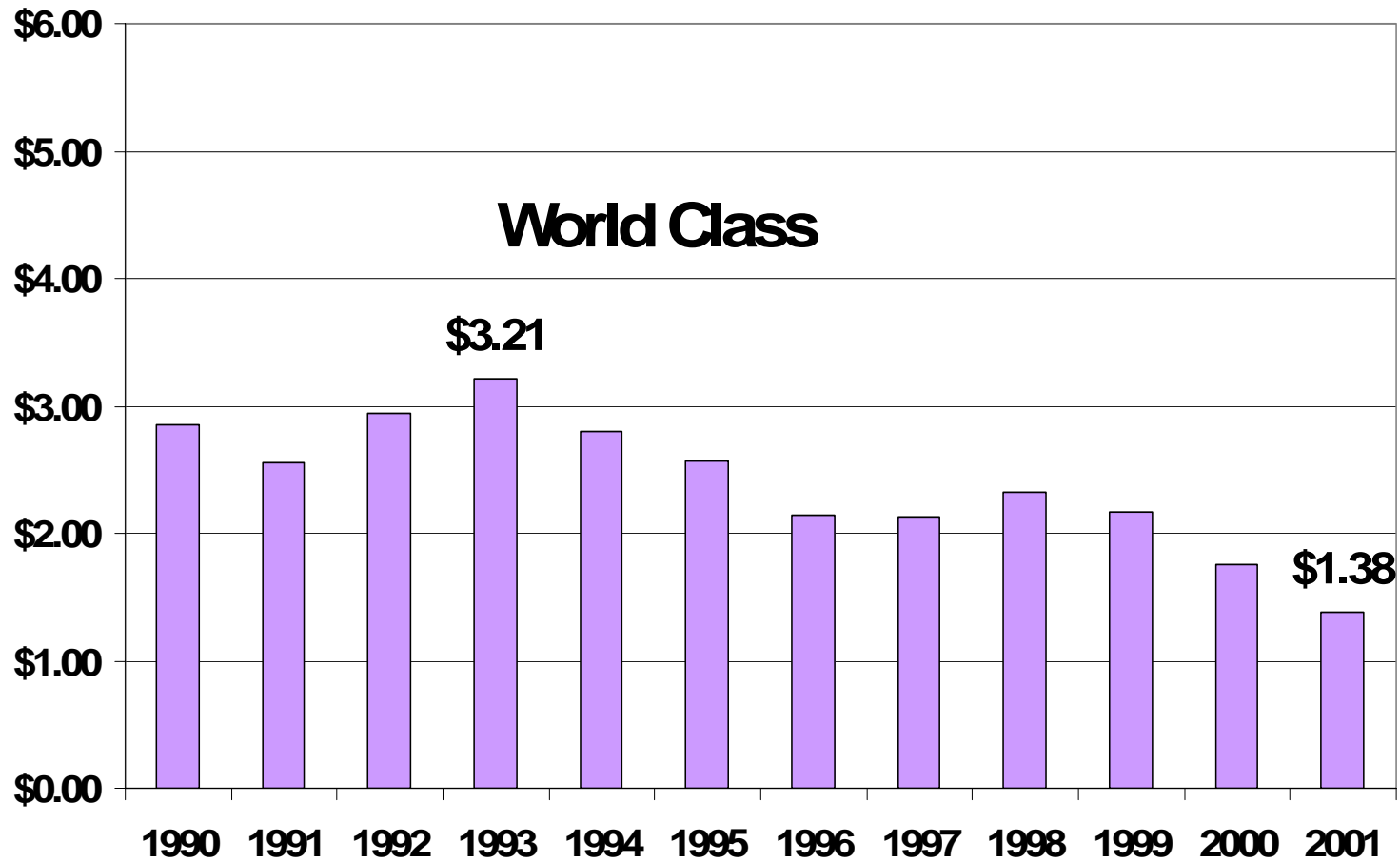

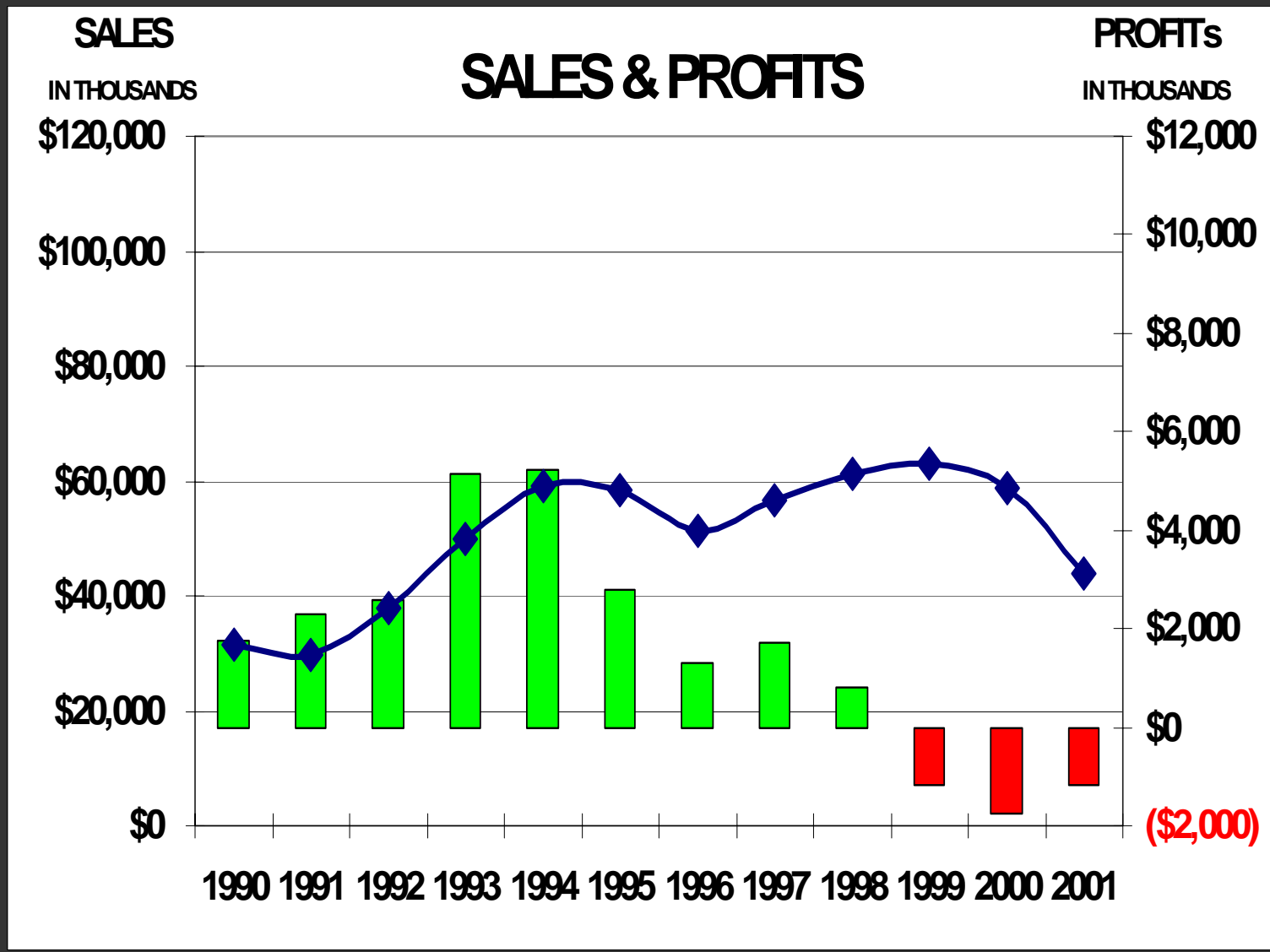

**Red Dot must change to
survive**

and....THRIVE!



RED DOT "LEAN" PRODUCTION SYSTEM

What did we do?

- **Hired A Lean Consultant**
- **Committed Ourselves Entirely**
- **Held Monthly "Kaizen Events"**



RED DOT "LEAN" PRODUCTION SYSTEM

What is it?

- **Elimination of Waste**
- **Creating Continuous "Flow"**
- **"Pull vs Push" Toyota Production**
- **Cellular Manufacturing**
- **Continuous Improvement System**
- **"Kaizen Events"**



The "Lean" Journey

60 Kaizen Events since December 2001



The "Lean" Journey

Over 1,000 Kaizen Ideas Implemented



The "Lean" Journey

Assembly Lines Revamped

- Continuous Flow – Moving Belts
- Work balancing
- Running Change Over – Zero Set-up

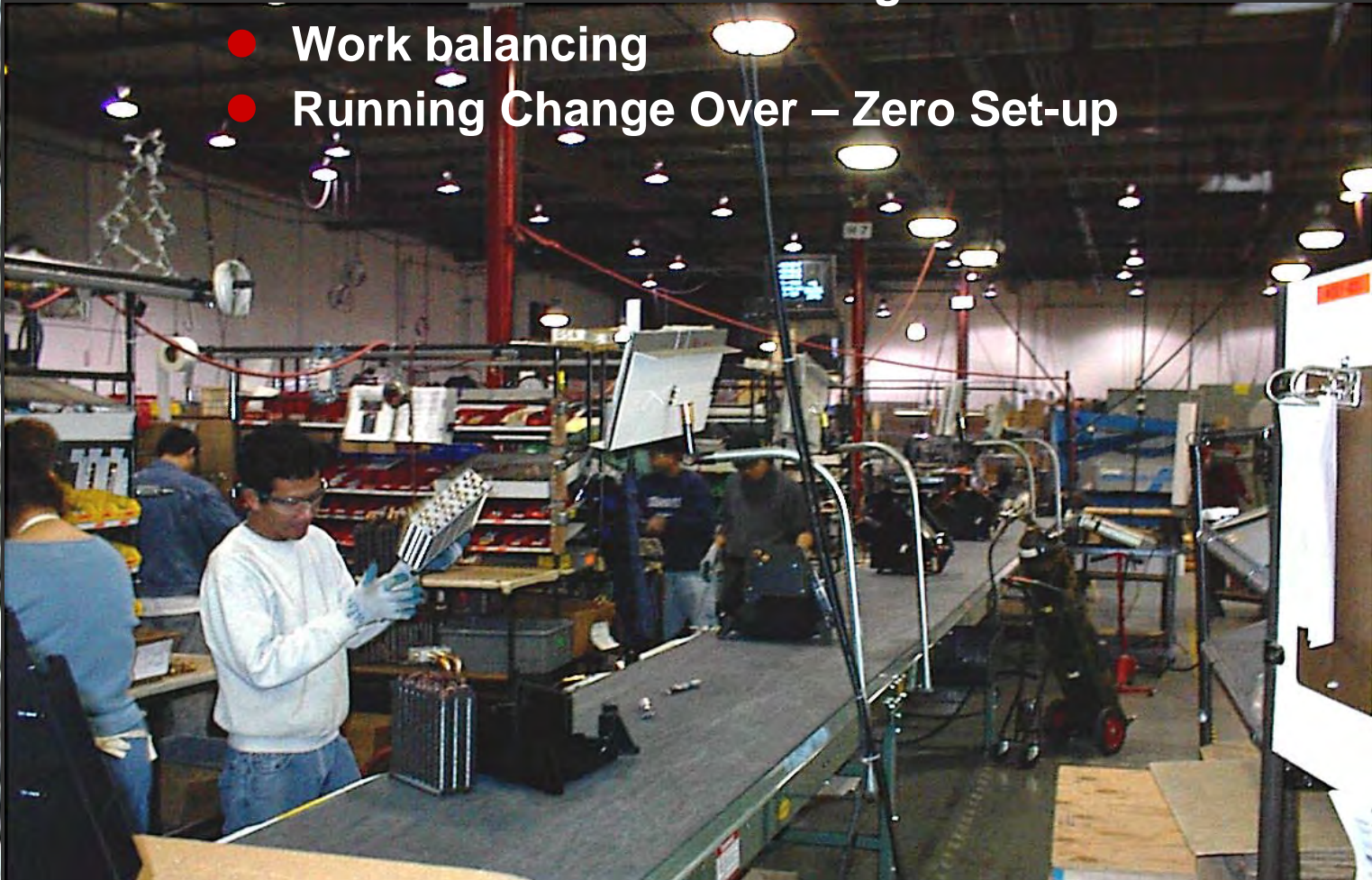

The "Lean" Journey

Coil Production Revamped to a Line

- Continuous Flow vs Batch
- Reduced space from 7,000sq.ft. to 1,700sq.ft.



The "Lean" Journey

Sheet Metal Cells Developed

- Reduced Part Travel
- Improved Cycle Times - Responsiveness



The "Lean" Journey

Set-up Time Reductions



The "Lean" Journey

Management Involvement





Target Progress Report and Results Sheet

Kaizen Event #: 60
 Team Name: TELEFLEX COMPRESSOR CELL
 Department/Area: WC/SSO
 Product/Process: _____

Team Number: 2
 Date: 10-16-06
 TAKT Time: _____
 Team Leader: LINDA YANTZER

Measures	Baseline	Target	Day 1	Day 2	Day 3	Final	Percent (to target)
Space (Sq. Ft.)	1,161	580					
Inventory	75	19					
Walking Distance	483	212					
Parts Travel Distance	321	160					
Lead-time	4.1	1.1					
Quality (# Defects)	12	0					
Productivity Gain (# People)	8	-					
Environmental, Health & Safety (5S)	-	-					
Set-Up	-	-					
Cycle Time	1032	774					

Results: _____

225

Standard Work Sheet

TELEFLEX

Event # 60 Team # 2 Team Name COMPRESSOR CELL Before After

Process Name ASSEMBLY
Part Name TELEFLEX COMPRESSOR

Process Boundaries From WC/550
To WC/550

Date Prepared Or Revised 10-02-06

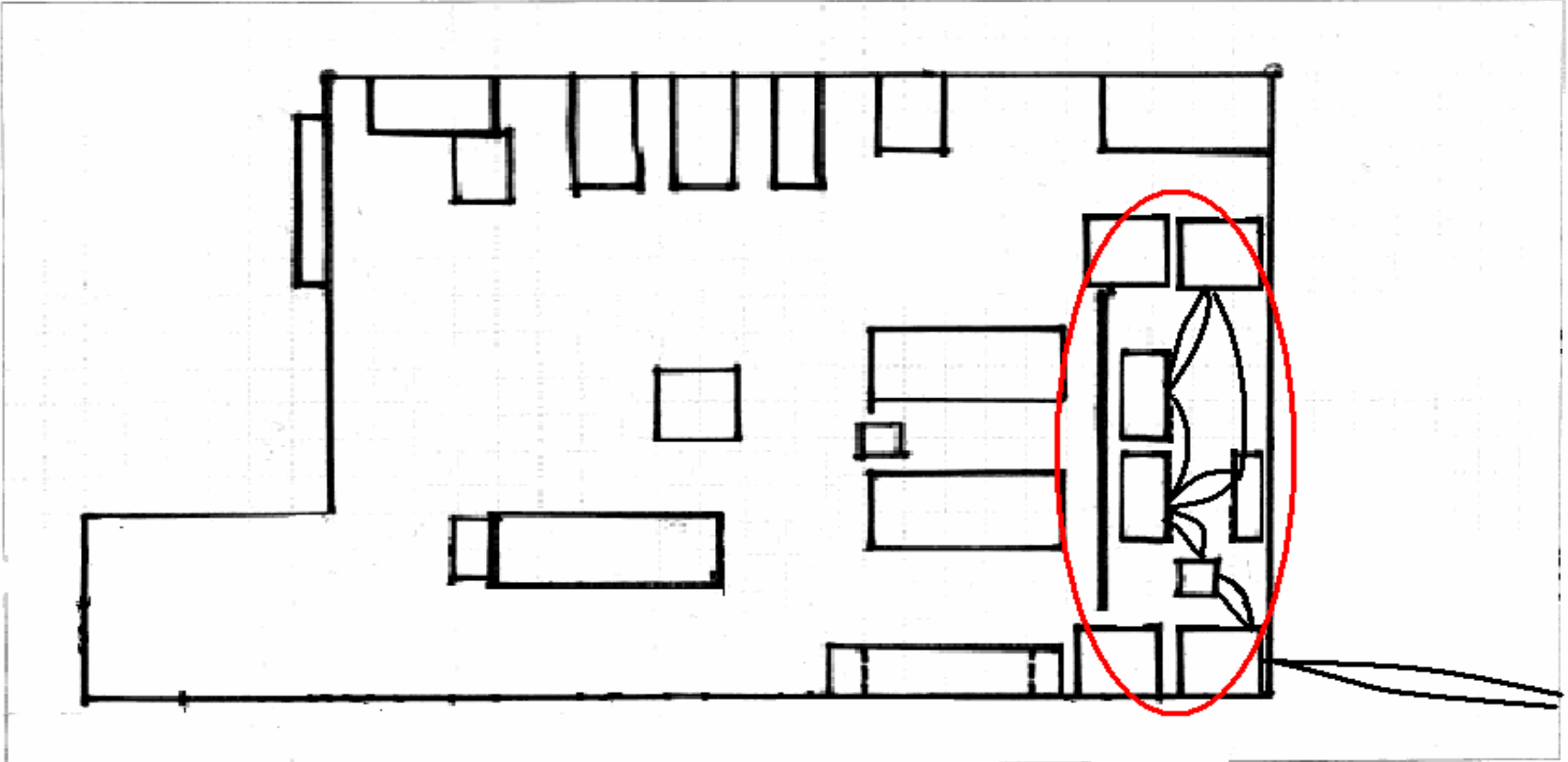

Quality Check	Safety Precautions	TAKT Time	Cycle Time	Operator Number
◇	+	○		

AFTER

CT 7:10"
T/T 3:42" - MP 3

Percent Loading Chart

Event # _____ Team # _____ Team Name _____

Time
500
480
460
440
420
400
380
360
340
320
300
280
260
240
220
200
180
160
140
120
100
80
60
40
20

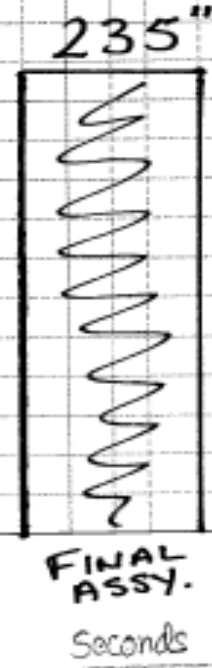
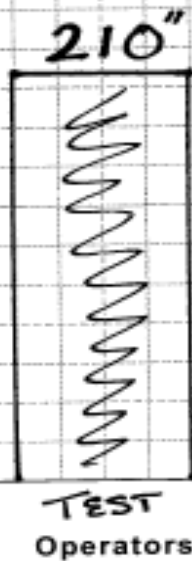
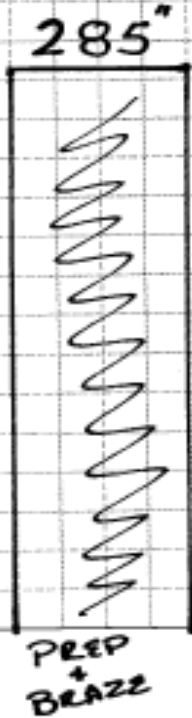



Target Progress Report and Results Sheet

Kaizen Event #: 60
 Team Name: TELEFLEX COMPRESSOR CELL
 Department/Area: WC/550
 Product/Process: _____

Team Number: 2
 Date: 10-19-06
 TAKT Time: _____
 Team Leader: LINDA YANTZER

Measures	Baseline	Target	Day 1	Day 2	Day 3	Final	Percent Change
Space (Sq. Ft.)	1,161	580	1,161	1,161	1441	280	75%
Inventory	75	19	229	230	75	7	90%
Walking Distance	483	242	402	—	—	24	95%
Parts Travel Distance	321	160	—	—	—	20ft	94%
Lead-time	4.1	1.1	—	—	—	1 day	77%
Quality (# Defects)	12	0	0	0	0	0	0
Productivity Gain (# People)	8	—	—	—	—	3 people	50%
Environmental, Health & Safety (5S)	—	—	—	—	—	—	—
Set-Up	—	—	—	—	—	—	—
Cycle Time	1032"	774	1289	1289	740	740"	29%

Results: _____

Lean Results Since 2001

20,000sq.ft. in floor space cleared



Lean Results Since 2001

PRODUCTION LEAD
TIME

WAS 12 DAYS

NOW 4 DAYS!!



Lean Results Since 2001

Value Added Sales Per Employee

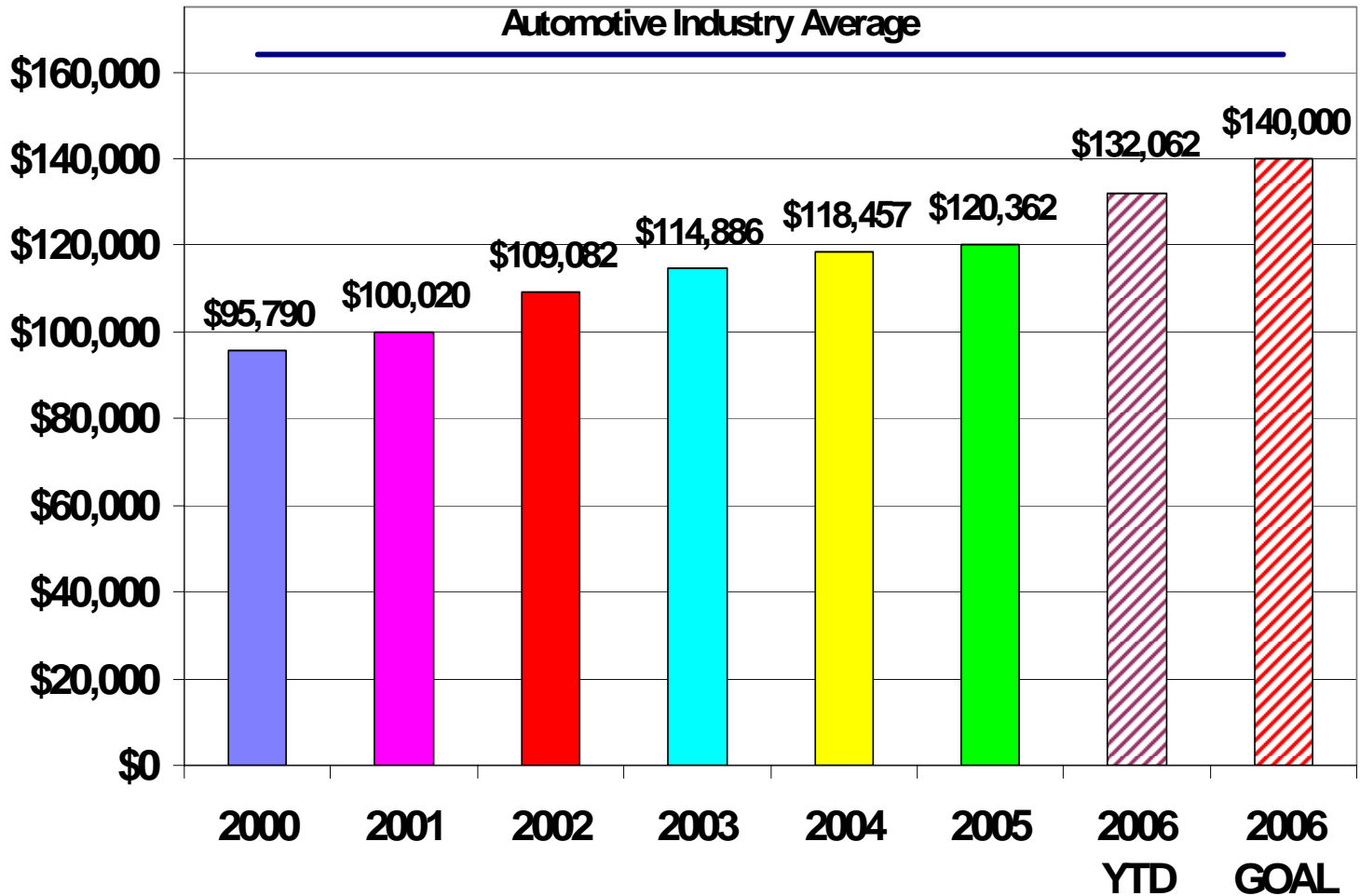

Lean Results Since 2001

Company Inventory Turns

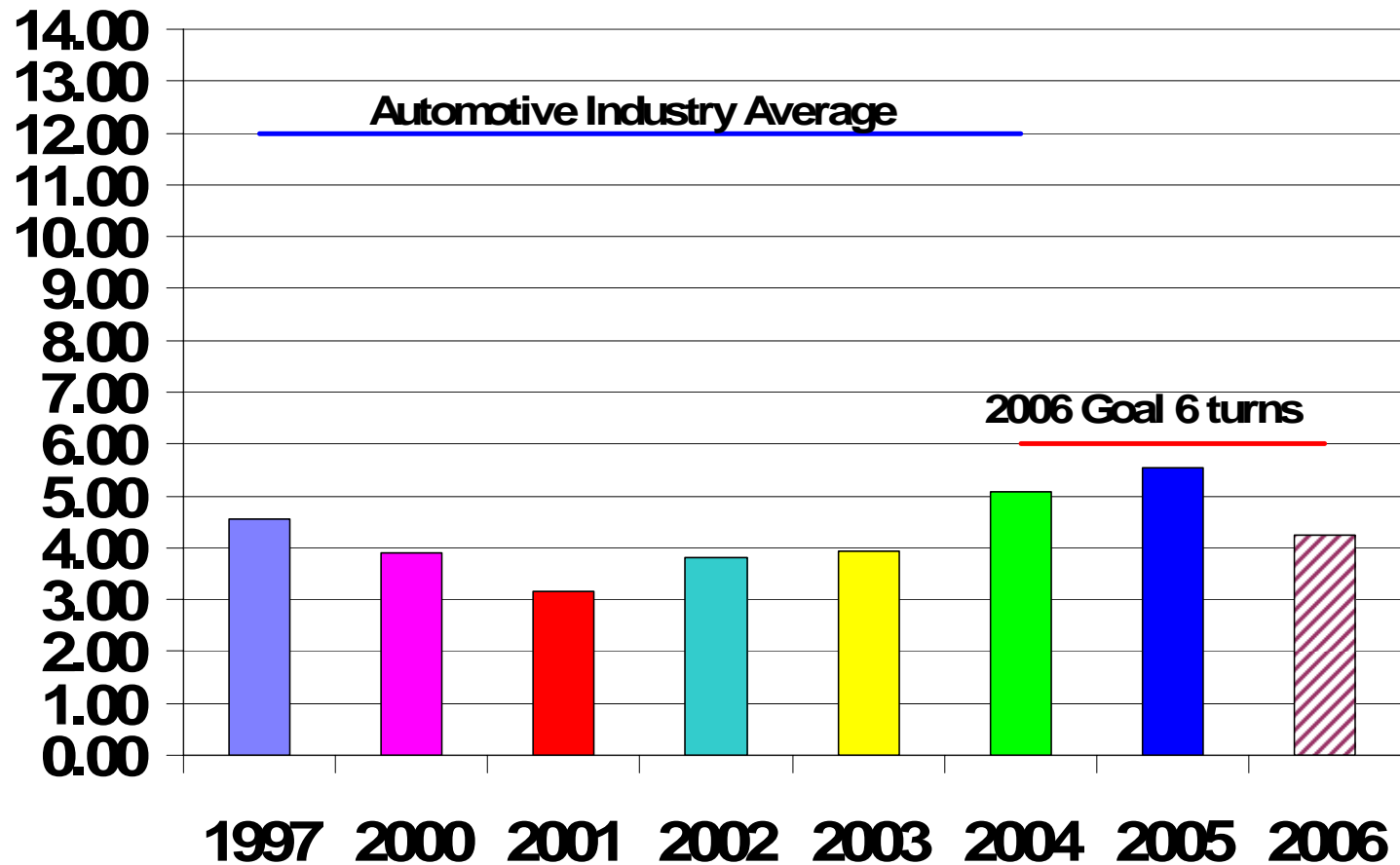

Lean Results Since 2001

ASSET UTILIZATION

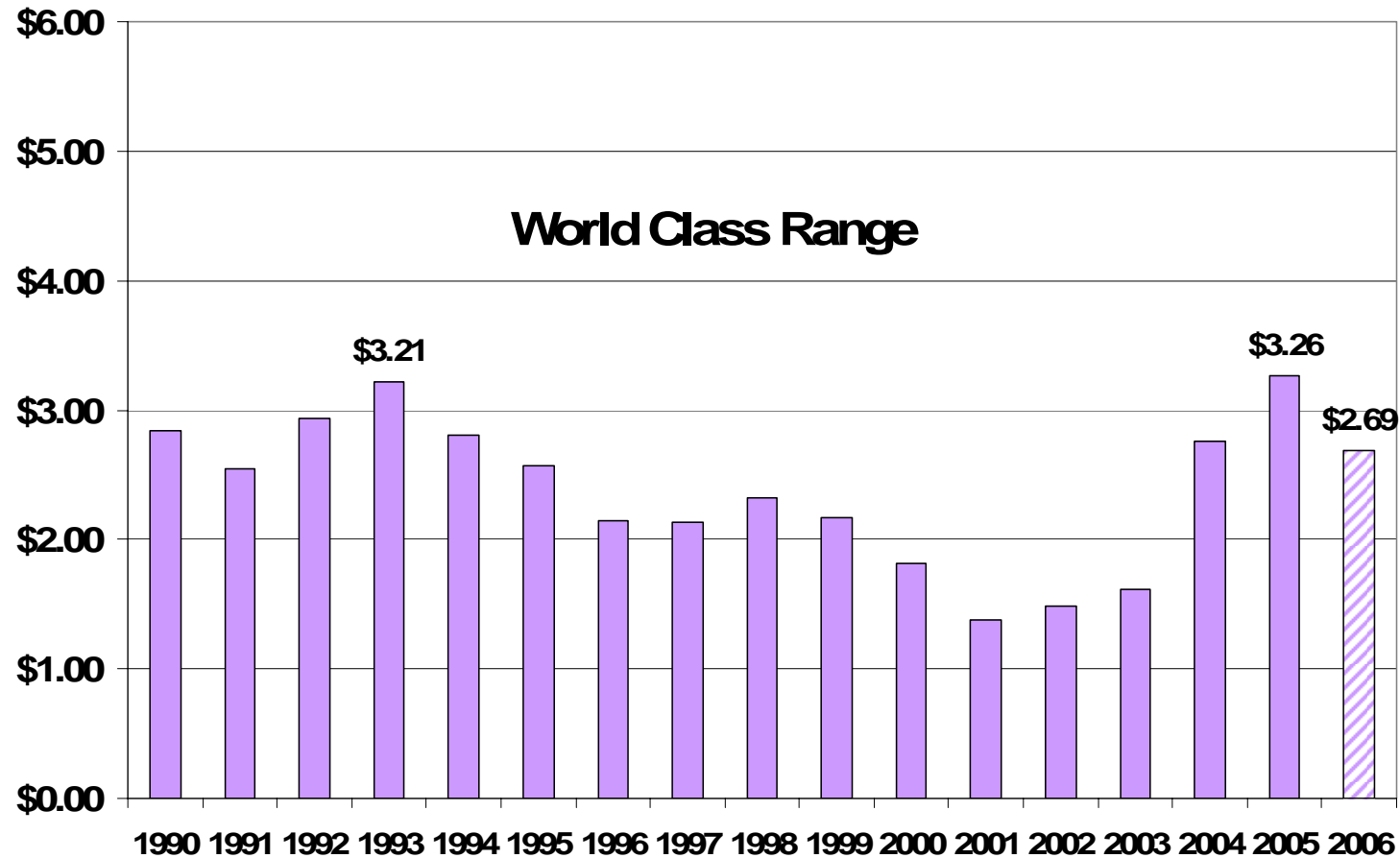

Lean Results Since 2001

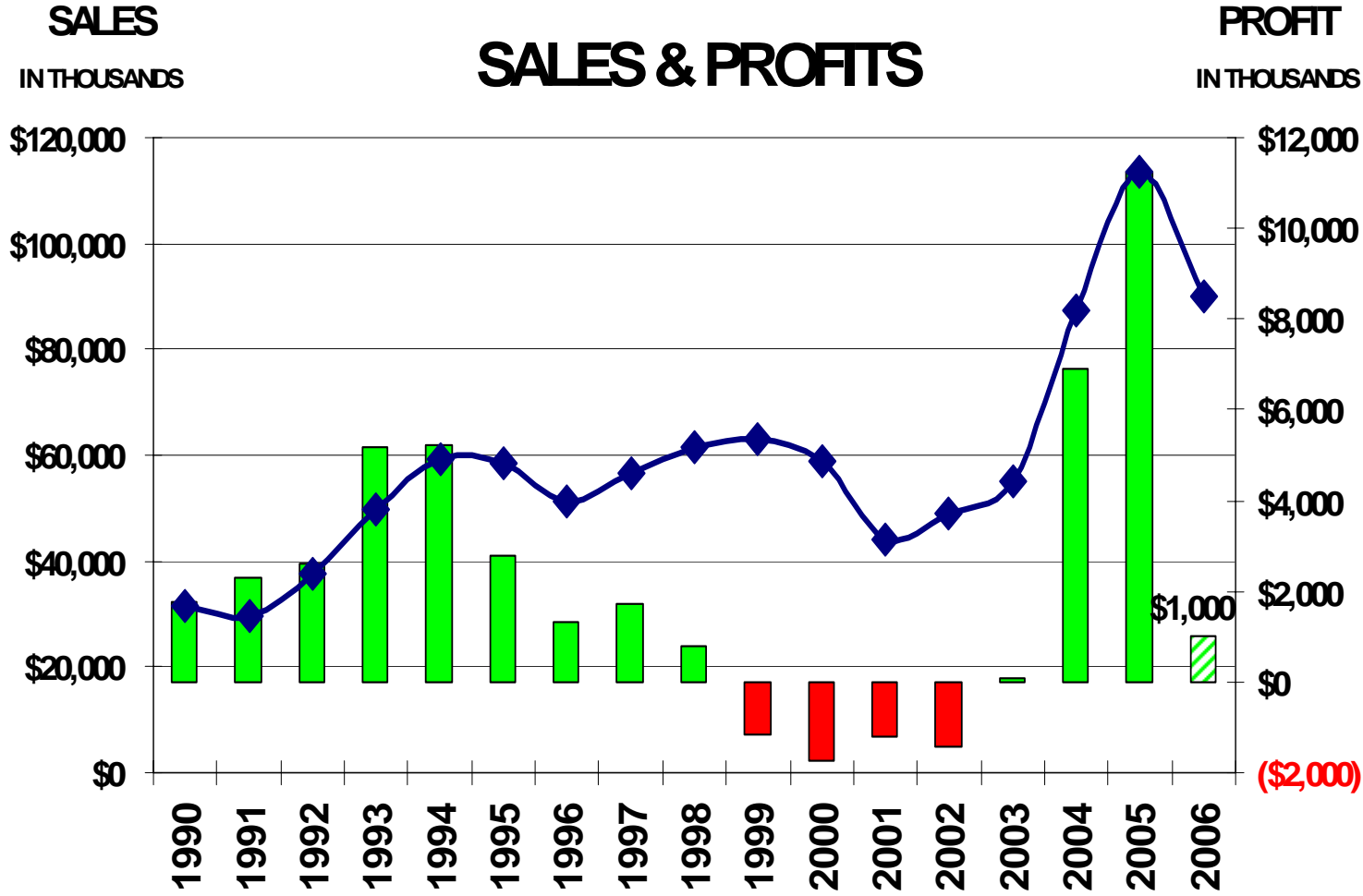

Lean Results Since 2001

- **20,000sq.ft. in floor space redeployed (Added 4 assembly lines; totaling 7)**
- **Inventory Turns Increased 46%**
- **Productivity (VASPE) up 32%**
- **Asset Utilization up 95%**
- **Production Lead time reduced from 12 to 4 days**



Lean Lessons

- **Use a consultant**
- **Create a sense of urgency**
- **Commit “Full Time” Resources**
- **Demand Management Involvement**
- **Implement “5S” First**
- **Anticipate Passive Resistance
Remove “Concrete Heads”**
- **It’s A “Never Ending Journey”
Stay The Course!!**



Questions
Thank You
Welcome!





U.S. ARMY MATERIEL COMMAND

AMC Small Business Program

Supporting the Warfighter
GEN Benjamin S. Griffin



10th Annual Small Business Conference
1-2 November 2006



“Need to be faster, more agile, less bureaucratic... Need to fight this every day”



MISSION



As of 18 Oct 06

Provide superior technology, acquisition support and logistics to ensure dominant land force capability for Soldiers, the United States and our Allies.



“If a Soldier shoots it, drives it, flies it, wears it, or eats it, Army Materiel Command provides it.”



“Need to be faster, more agile, less bureaucratic... Need to fight this every day”



AMC Commanders and Deputies



As of 19 Oct 2006

Tank-automotive & Armaments Command LCMC

MG Mike Lenaers	Mr. Jack Dugan
Civilian 13,089 Military 97	

Army Materiel Command

LTG William E. Mortensen	Ms. Kathryn A. Condon	CSM Daniel K. Elder
Civilian 820 Military 62		

Communications-Electronics LCMC

MG Michael R. Mazzucchi	Mr. Victor J. Ferlise
Civilian 7,192 Military 85	

Joint Munitions & Lethality LCMC

BG Paul S. Izzo	Mr. James Sutton	BG James Rogers
Civilian 4,206 Military 15		

Presence:

- Locations – 149
- States – 43
- Countries – 55
- Personnel: 53,181
- Contractors: 38,000+
- Total AMC in SWA – 57,279

Research, Development & Engineering Command

MG Roger Nadeau	Mr. David J. Shaffer
Civilian 11,814 Military 245	

Army Sustainment Command

MG Jerome Johnson	Mr. Scott Welker
Civilian 1,183 Military 696	

Aviation and Missile Command LCMC

MG James Pillsbury	Dr. Richard W. Amos
Civilian 8,623 Military 107	

Military Surface Deployment & Distribution Command

MG Kathleen Gainey	Ms. Patricia Young
Civilian 1,670 Military 204	

Chemical Materials Agency LCMC

Mr. Michael Parker	Mr. Kevin Flamm
Civilian 2,432 Military 18	

US Army Security Assistance Command

BG Clinton Anderson	Mr. Rick Alpaugh
Civilian 560 Military 49	



Life Cycle Management Commands... Soldier Focused

Depots, Arsenal, Ammunition Plants

TACOM, AMCOM, C-E LCMC, **CMA, JM&L**

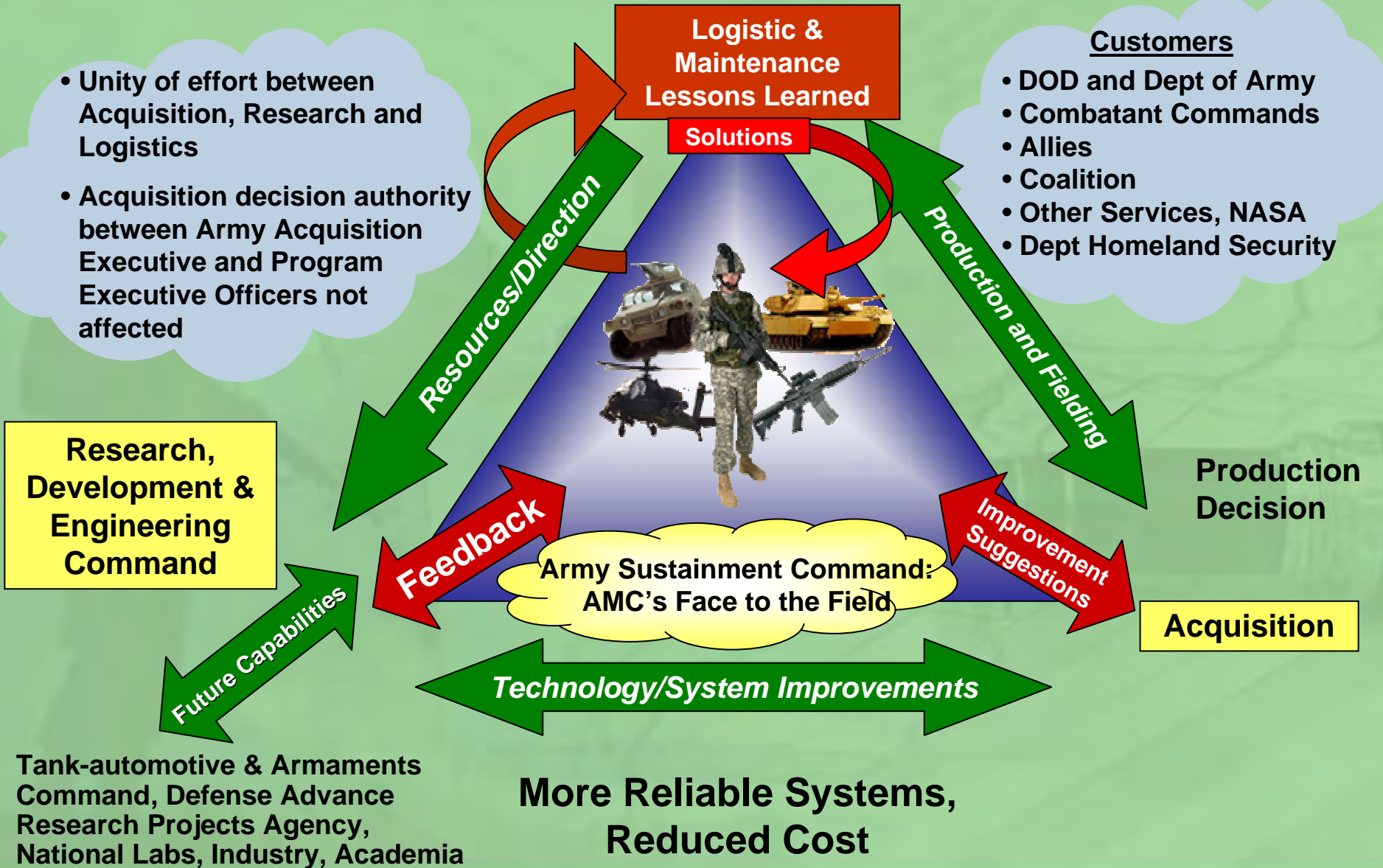



"Providing Support to the Joint Warfighter"



As of 18 Oct06

Transforming Army Materiel Command from an organization that is "Production-based, commodity-focused, and platform-centric" to one that is

"Service-based, capabilities-focused, and unit-centric" -- GWOT

ORGANIZATIONAL CHANGE

- Life-Cycle Management Commands
- Army Sustainment Command
- Army Field Support Brigades
- Brigade Logistic Support Teams
- Base Realignment and Closure (BRAC)
- Surface Deployment and Distribution
- Installation Maintenance and Ammunition Facilities
- Security Assistance

End State

"Cradle-to-Grave Capabilities Support"

CULTURE OF INNOVATION

- Safety
- Lean Six Sigma
- Depot Commanders Course
- Outreach to Industry
- Partnerships
- Performance Based Logistics
- Rapid Review Teams
- Research & Development/Technology to the Warfighter
- Army's Greatest Inventions
- Human Capital Strategy

End State

"Efficient Production Processes"

COMPLEX SERVICES

- Support to ARFORGEN
- Forward Repair Activities
- Unit-focused RESET
- Small Arms Repair Teams
- Left-Behind Equipment
- Theater Provided Equipment
- Add-on-Armor / Safety
- LOGCAP & Contingency Contracting
- Fleet Management
- Industrial Capabilities
- Ammunition Enterprise
- Chemical Storage & Demil

End State

"Customer Focused Solutions"

KNOWLEDGE MANAGEMENT

- Condition Based Maintenance
- Global Help Desk
- Central Technical Support Facility (CTSF)
- Logistic Automation Test Bed at Sierra Depot
- Factory-to-Foxhole Visibility
- Single Army Logistics Enterprise
- Lessons Learned
- Quantitative Metrics and Analysis

End State

"Data Driven Decisions"



Mission

Ensure that a fair portion of contract awards is placed with small business enterprises

Achieving **optimum** small business participation by seeking small business solutions first

AMC contracts for:

- Weapon systems and equipment
- R&D
- Spare parts
- Maintenance
- Other services (eg. IT, Engineering Support, Logistics, etc.)



Deputy Commander HQ A M C EDCG



Scott Crosson
Civ 800 Mil 72

T A C O M



Civ Mil
11,241 99
Patricia Redding

C E C O M

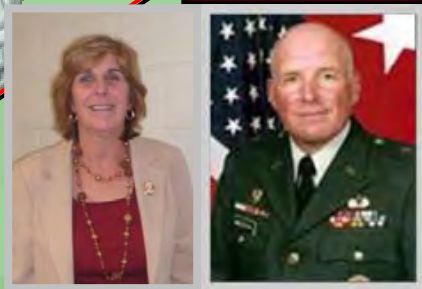

Marcia Easton



AMC Associate & Assistant Directors with Commanders

A F S C



Civ Mil
5,530 209
Robert Matthys

A M C O M



Civ Mil
8,246 208
David Seitz

R D E C O M



Civ Mil
12,046 246
John O'Brien



AMC Small Business Offices

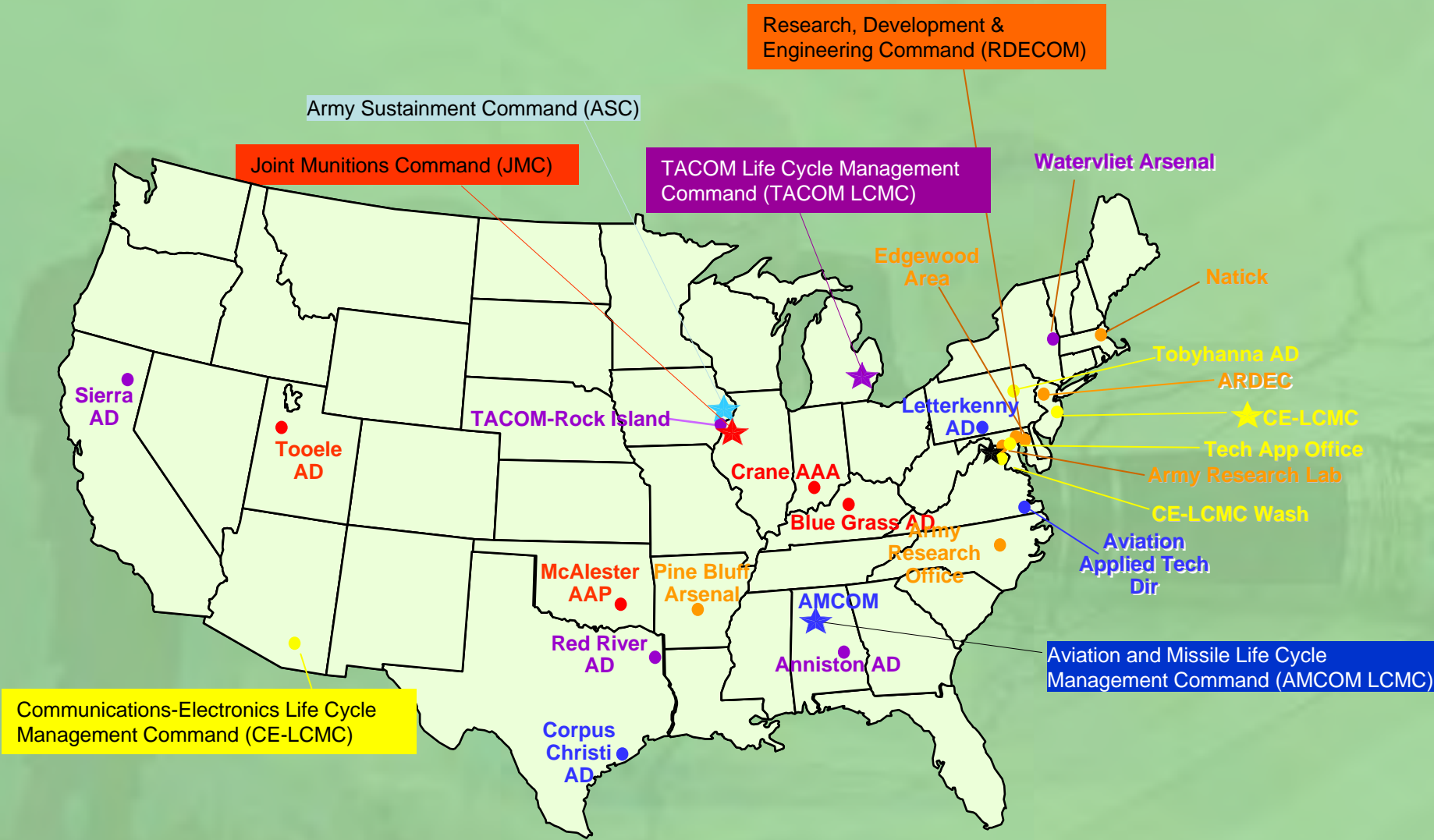



Small Business is Big Business At AMC

Total Contracts \$ 41 Billion

Small Business \$ 6.1 Billion

Total 2006 as of 12 Oct



Small Business

A Critical Component of our Defense Industrial Base



Supporting America's Warfighters ... *in Army Transformation*

- Small Business Innovative Research

and on the battlefield today

- Unmanned systems, mine detectors
- Uniforms, body armor, ballistic blankets, munitions
- Air beam maintenance shelters and lightweight tactical tents
- Batteries, antennas, night vision components, hand-held signal devices



CAPABILITY, CAPABILITY, CAPABILITY!



Success Stories



- 40MM Grenade Family of Munitions
- Full Spectrum Active Protection Close-In Layered Shield (FCLAS) System
- Army Prototype Integration Facility
- SATCOM Transportable Terminals
- Dual band Antenna
- Multi-Function Controlled Robot
- Micro Fuel Cell Systems for Portable Devices



40MM Grenade Family of Munitions

Empowering Small Business



Critical Munition for the Warfighter!

- Small Business Is the 40MM Industrial Base
- PM Maneuver Ammunition Systems (PM MAS) Empowering Small Business:
 - Implemented a Systems Approach With Contractors Leading
 - Two Joint Venture Small Business Teams
 - Two 8A Team Members
 - Approached Products as a Family Not as Individual Items

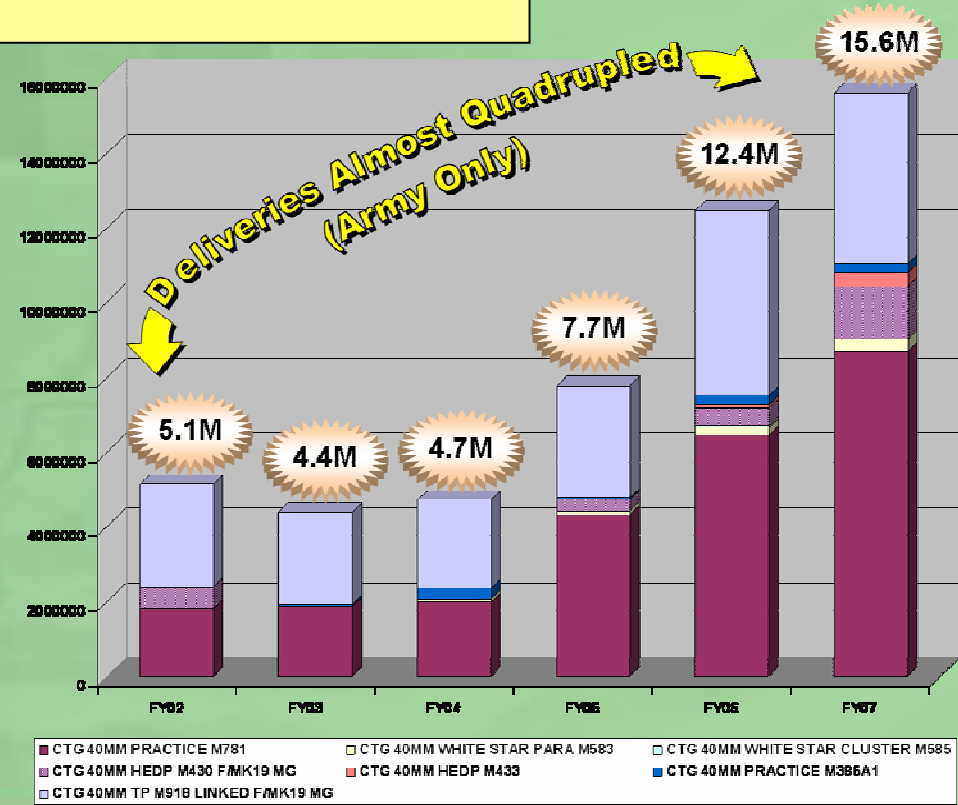



FCLAS



(Full Spectrum Active Protection Close-In Layered Shield) System

FCLAS System
(Full Spectrum Active Protection Close-In Layered Shield)

FCLAS Test Results

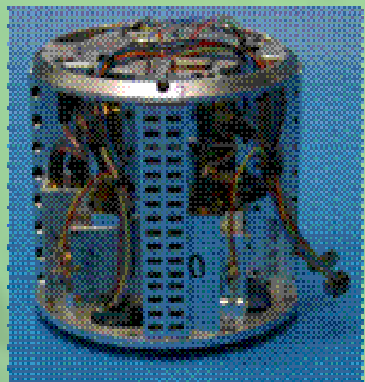

FCLAS Sensor
Detects inbound missiles, triggers detonation of FCLAS countermeasure
Developed by **Chang Industry**

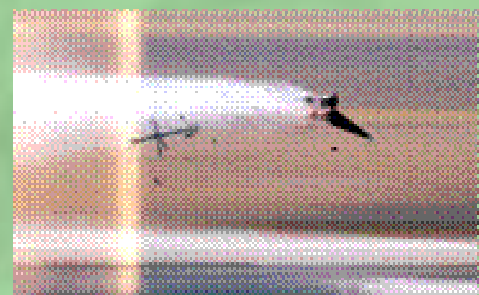

Interception of threat by countermeasure

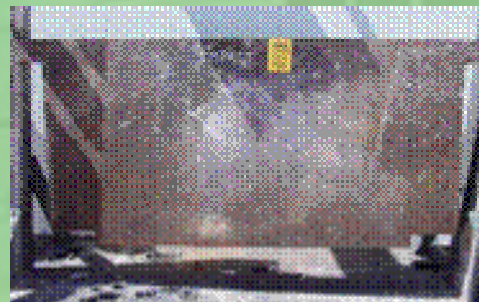

Steel target plate indicating no penetration



Army Prototype Integration Facility



(AMCOM Receives 100% Credit as 8(a) Obligations - \$641M To Date)



- **Small Business Support:** Joint Venture Yulista, an 8(a) Company, and Science & Engineering Services Inc. have established An Aggressive Small Business Subcontracting Program with 123 Small Businesses Participating
- **Scope:** Manufacturing, Technical & Hardware Support As Prime Contractor Supporting the U.S. Army Prototype Integration Facility (PIF), Redstone Arsenal, AL
- **Contract Ceiling:** \$1.4 Billion (10 year – 2002 to 2012)
- **Obligations To Date:** \$641 Million



SATCOM TRANSPORTABLE TERMINALS

- Provided by **Datapath, Inc., Duluth, GA**
- Provides intra-theater satellite communications transmission for the Modularized Force Structure supporting UE/AU communications
- Ku-Band trailer designed for future Ka-Band upgrade
- Trailer chassis equipment common to High Mobility Multi-Purpose Wheeled Vehicle (HMMWV) and High Mobility Trailers (HMT)



Part of
Commercial SATCOM
Terminal Program



Small Multi-decade Communications and Electronic Warfare (EW) Antenna

- **First RF Corporation**, Boulder, Colorado developed Passive Antenna technology
- Two basic antenna approaches utilizing First RF antenna technology
 - Monopole technology
 - Slot technology





Multi-function Controlled Robot



Low-cost platform intended as a disposable-type asset to address otherwise problematic technical support/logistics of complex, expensive robots

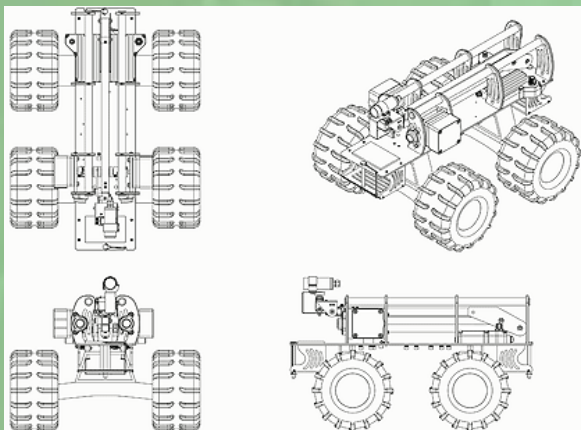

Developed by:

Exponent





Ultracell Corporation (Livermore, CA)

- Micro fuel cell systems for portable devices.
- UltraCell is delivering complete fuel cell systems to OEM customers in mobile computing, military, and ruggedized portable applications.
- The Communications-Electronics Research, Development, and Engineering Center has been working with Ultracell on the development of the XX25, a 25W Reformed Methanol Fuel Cell for Soldier Power applications.



The Ultracell XX25 units will be extensively evaluated against Military-Standard testing specifications by CERDEC



Army Focus Areas

Potential Business Opportunities



- FCS technologies
- Force Protection
- Weight/cube reductions
- Power management
- Advanced sensor development
- Thermal imaging & optics
- Miniaturization & nanotechnology
- Unmanned/autonomous systems/robotics
- Wireless network technologies
- Logistics & supply chain management
- IT Support



How You Can Help



- Provide effective responses to sources sought notices
- On time delivery on all contracts
- Feedback on how to work smarter together
- Small Business Innovation Research- Maintain situational awareness of current and emerging needs and respond
- Identify alternative technology solutions to those currently being pursued
- Continue to become more effective and efficient – Lean your processes



Large Business Participants



- **AAI Corporation**
- **Alliant Techsystems**
- **Armor Holdings**
- **BAE Systems**
- **CSC**
- **DRS Technologies**
- **EDS**
- **General Dynamics**
- **Lockheed Martin**
- **Northrop Grumman Corporation**
- **Oshkosh Truck Corporation**
- **ITT**
- **SAIC**
- **The Boeing Company**
- **VSE Corporation**



FOCUSED ON THE
WARFIGHTER

FCS Program Overview

10th Annual Army Small Business Conference

Steve Marion
Sr. Program Director
Combat Systems Supplier Management

FCS Program Status

- **Program keeping pace with Army needs**
 - Accelerating needed capabilities to our soldiers
 - Completed Initial Preliminary Design Review (IPDR)
 - Evaluation Brigade Combat Team at Fort Bliss
- **On cost, On schedule, On performance**
- **FY07 is critical execution year**
 - Execute Integration Phase 1 (Experiment 1.1, Software Build 1)
 - Initial Integration of Spin Out 1 – Deliver First B-Kit
 - Platform Preliminary Design Reviews and Critical Design
 - Develop, Validate, & Deliver DOTL Products for EBCT Training and T&E Activities
 - Complete OSD and Joint Staff review of Main Program and Spin Out
 - Conduct Engineering Maturity 1 Program Milestone
 - Define Integration Phases 2 & 3 and Initiate Required Tasks



Program Momentum is Strong... Maintain Velocity

Benefits of FCS

- **FCS will be Dominant across the Entire Range of Military Operations**
 - Optimized to respond in an uncertain future
 - Sized for Urban operations
 - Traditional / Irregular / Disruptive / Catastrophic
 - Networked situational awareness to the soldier

Dominant Force for all Military Operations including Urban Ops

Operational Environment Demands Integration

Conventional

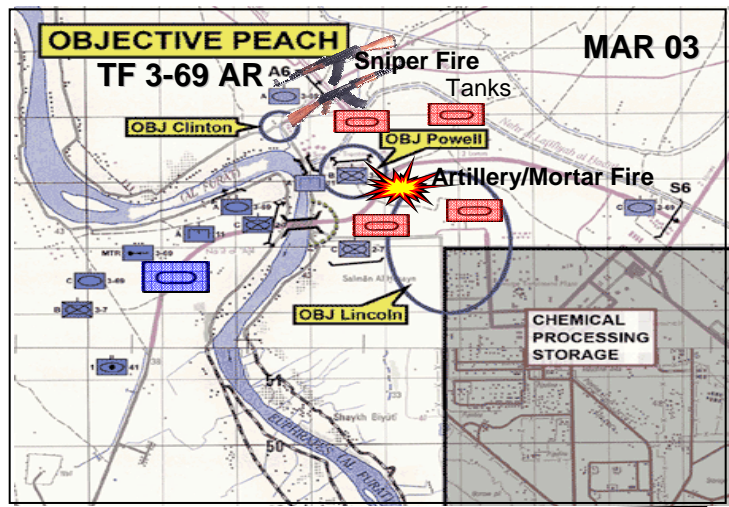

Complex

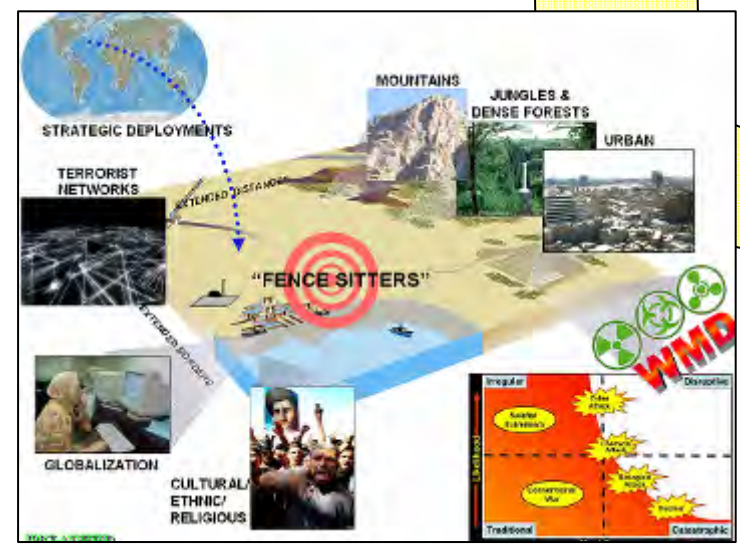

Multiple Data Sets

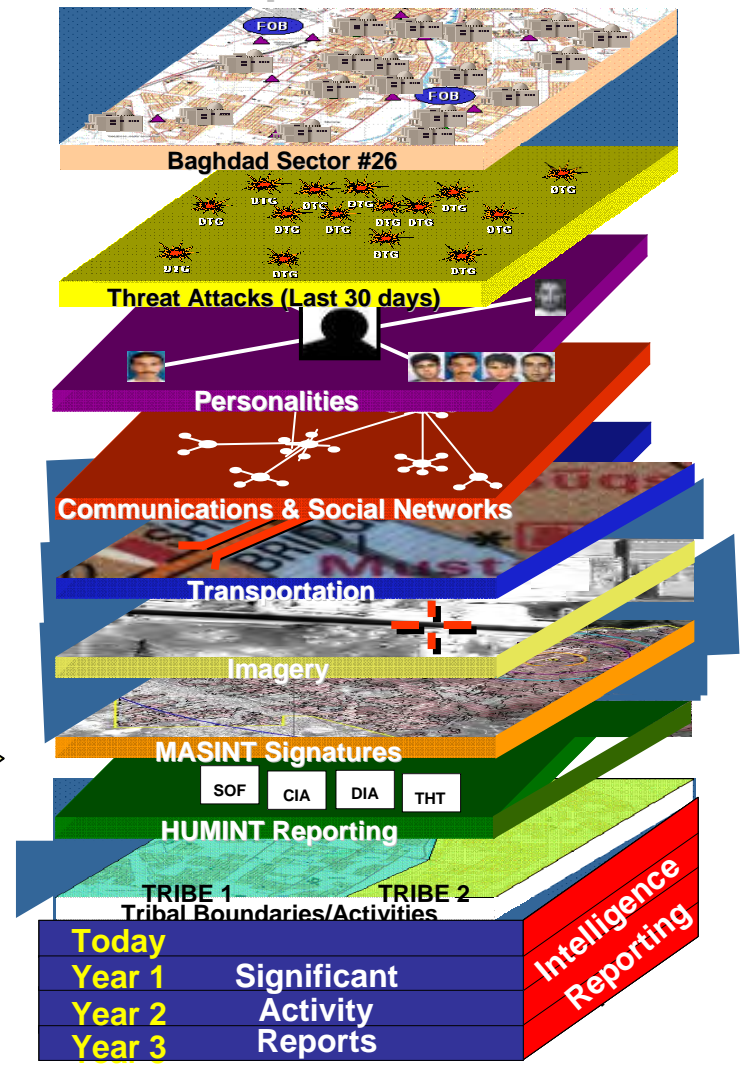

Recent Significant Events



Demonstrations and Technologies On Track

Approved for Public Release, Distribution Unlimited, TACOM 27 OCT 2006, case 06-234.

FCS “Best of Industry” Partner Team

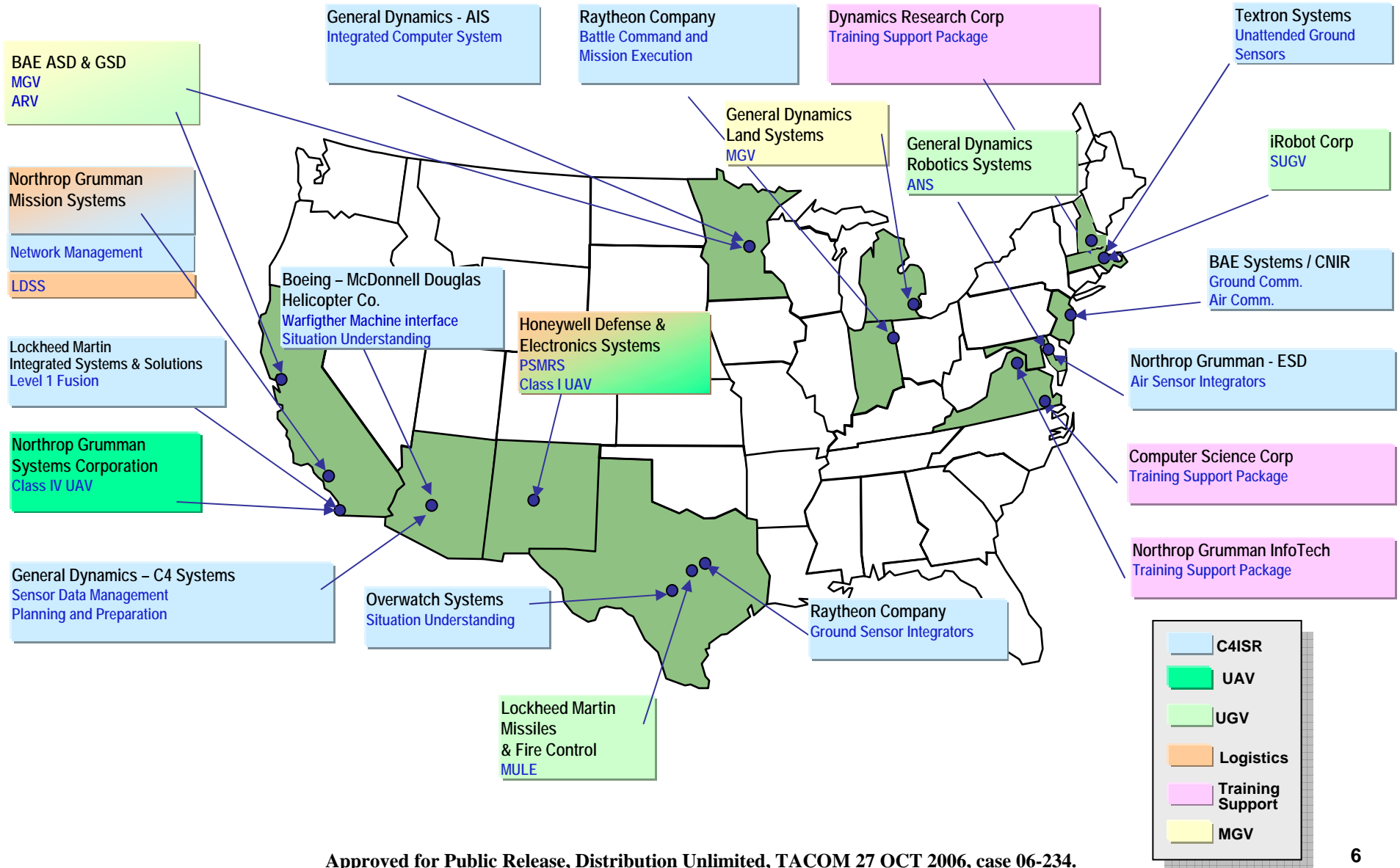

FCS Small Business Involvement

- Small Business is a critical element of the FCS Program
- One Team Partners are initiating Mentor Protégé projects to promote Small Business participation
 - LSI has one project in place and one in work
- Ongoing FCS presence at numerous conferences, symposia, and science & technology demonstrations
- Supplier Showcase
 - Technology forum for current & potential suppliers to present capabilities to the LSI & One Team Partners sponsored by DART

***Over 400 Small Businesses currently supporting FCS
and the number is increasing***

What Small Businesses are doing on FCS

- **iRobot is a Tier One Supplier to the LSI**
- **Mission: Provide extended reconnaissance of MOUT and subterranean battlespace/network node**
- **Armament: Non-Lethal specific to MOUT**
- **Gross Weight: 30 lbs.**
- **Sensors: EO/IR, Seismic, Acoustic, Target designation, NBC**

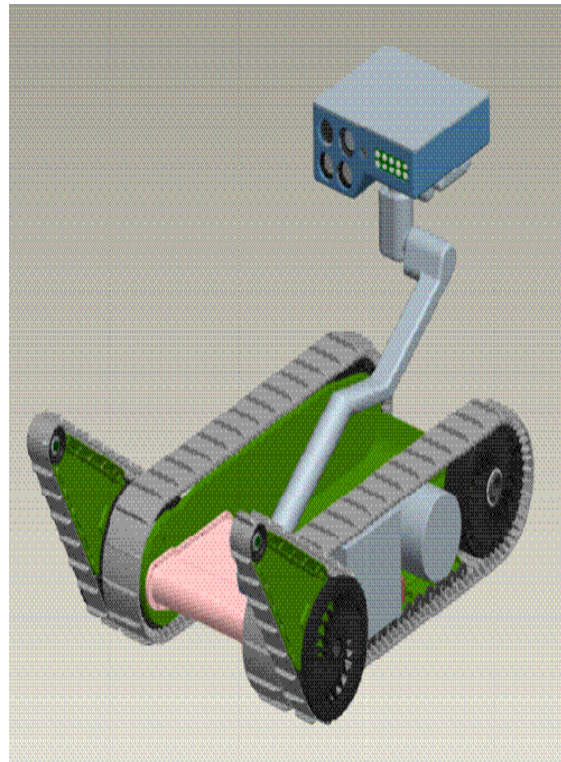

Legend:
Platform Unique Subsystem
Complementary Program Subsystem
Common Distributed Subsystem

The iRobot pre-prototype Small Unmanned Ground Vehicle (SUGV) was exhibited at the AUSA show (Oct. 9-11). In addition to being on static display, it demonstrated its mobility (over small rubble objects/debris), stair climbing ability (climbing up and down stairs), and ability to look around corners without exposing itself to potential hostile fire. This demo was unscripted and intended to provide a general capabilities presentation of this new pre-prototype part of the FCS Brigade Combat team.

The SUGV provides an extension of the soldier in high risk reconnaissance operations

What Small Businesses are doing on FCS

- **Overwatch Systems is a Tier One Supplier to the LSI for Situation Understanding**
- **Tier Two Supplier for Battle Command Mission Execution, Planning & Prep and Level 1 Fusion**

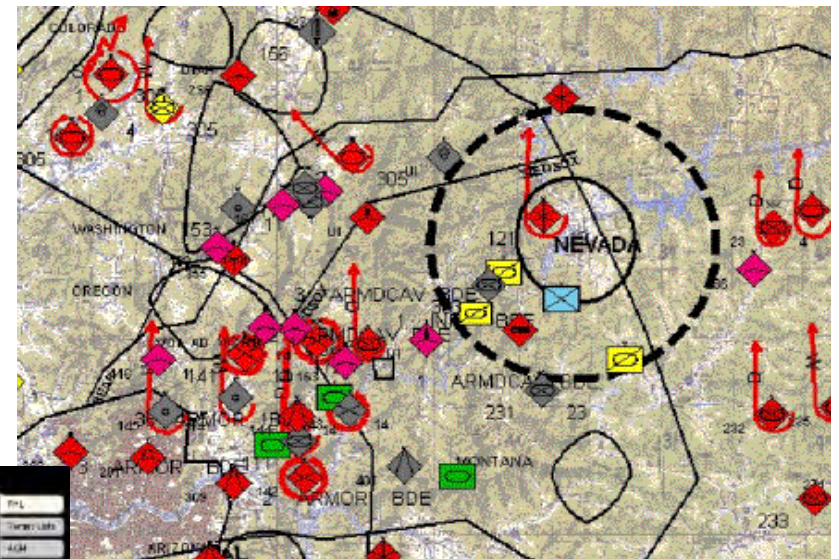

- Responsible for portraying the friendly and enemy forces on the Common Operating Picture (COP)
- Semi-autonomous Level 1 – 4 Fusion software will reduce the warfighter's workload
- COP will help the warfighter achieve the "Quality of Firsts"

What Small Businesses are doing on FCS

- **Phacil Incorporated** – SDB/HUBZone
 - FCS Mentor Protégé (Credit Only Agreement) provides C4ISR information technology, systems integration, and logistics services
- **Sparta** – Small Business Concern
 - Modeling support to the development of collective tasks for the FCS BCT
- **Milvets Systems Technology, Inc** – SB/SDB/HUBZone/SVO/SDVO
 - Army training and operations support in the areas of Fire Support and CBRN operations
- **Visual Purple** – Small Business Concern
 - Expertise on design and development of computer based training materials
- **LynuxWorks** – Small Business Concern
 - Objective embedded operating system to increase functionality and support of evolving hardware

How to Get Involved with FCS



- Regularly check the FCS Website Home Page at: www.boeing.com/fcs
- Located on this website:
 - FCS Business Opportunities of the LSI and its Partners (contacts with websites)
 - Information on Submitting Unsolicited Proposals and Questions
 - Partners' Requests for Quotations / Information
 - Supplier Diversity information (specific LSI / Partner Small Business contacts provided in FCS Business Opportunities Brochure)
 - FCS calendar with upcoming conferences and events
 - On-line registration form
- Reach out to the LSI and Partners to express your interest and capability
- Focus on areas of technology and express interest across the One Team

FCS External Web Site

- **Website for program information to engage all segments of Industry**
 - Business opportunities across the team including RFI's/RFP's & Industry Day Announcements
 - Notification of opportunities sent to suppliers
 - 695 registered suppliers
 - LSI/Partner contact information
 - Small business event calendar
 - Industry inquiries

Quick Links:

- ▶ [Partners](#)
- ▶ [Unsolicited Proposals](#)
- ▶ [Request for Information/Proposal](#)
- ▶ [FCS Business Opportunities](#)

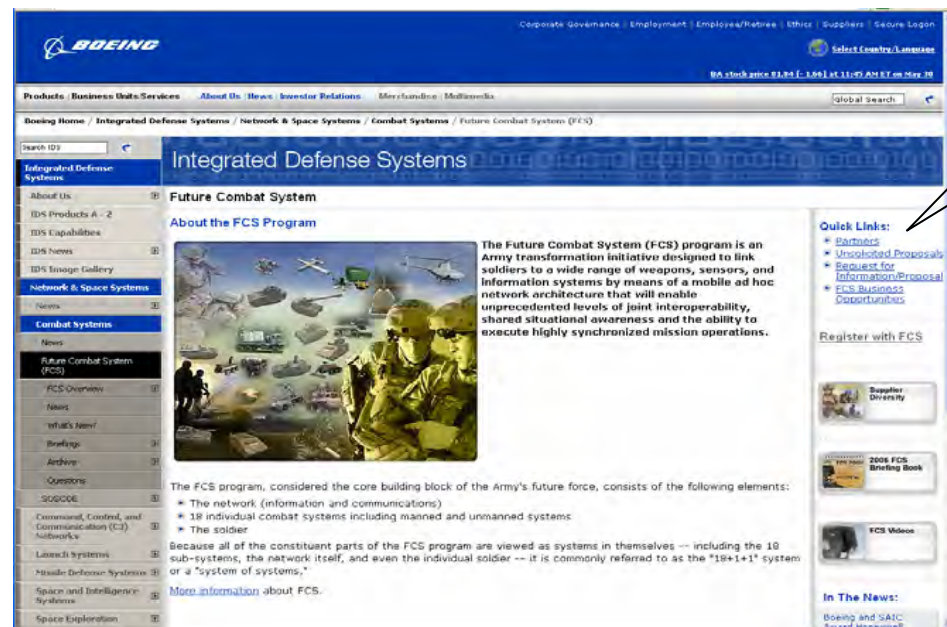

Examples of Business Opportunities

• Supportability

- General Purpose Processors
- Secure Wireless Fidelity, Zigbee, or other Wireless communications technology
- Chemical/Biological/Radiological/ Nuclear micro-sensors and sensor fusion
- Advanced ruggedized display technology (OLED, micro cube projection, etc.)
- Perception Systems
- Advanced Robotic Controls
- High Bandwidth Transmission techniques
- Advanced micro-turbine or heavy fuel micro-diesel engine technology
- Simulation and Modeling Tools/Model Development for Rapid Prototyping
- Advanced Data Mining Functionality
- Reasoning Technology

• C4ISR Network Systems

- General Purpose Processors
- Graphics Processors
- Fixed and Removable Storage Media
- Storage Controllers
- Network Switches and Routers
- Firewalls
- Network Intrusion Detection

• C4ISR Battle Command

Level 1 Fusion

- Distributed Fusion Management
- Fusion Engine
- Exploitation Tools
- Embedded Training Software

Examples of Business Opportunities (Continued)



• Unmanned Ground Vehicles

- Perception Sensors
 - IR Camera
 - Low Light Monochrome Camera
 - Millimeter Wave Radar
 - Optics/Lenses
- Core Navigation System
 - Integrated GPS/INS System
 - GPS Antenna
- Perception Computer Subsystem
 - Computer System Enclosure
 - Power Supply
 - Heat Exchanger

• Manned Ground Vehicles

- M240 Remote Operation Kit
- Light Weight Track
- Energy Storage System
- Close Combat Armament System Sight Sensor
- Digital Imaging Devices
- Laser Warning Receiver
- External Power Converter

In Summary...



- Small Businesses are important to the FCS Program
- Our Outreach and Supplier Diversity initiatives are in place and we are making good progress
- Continuing to foster an environment that increases Small Business awareness and opportunities
- To date over 400 Small Businesses have been involved with FCS, representing more than \$500M of total commitments across 38 States and 184 Congressional Districts
- Please visit the FCS Small Business Team (DART) during the Breakout Sessions for more business opportunity information (Sully Room - lower level)

FUTURE COMBAT SYSTEMS



One Team-The Army/Defense/Industry

Questions and Answers



Strength through Industry & Technology



National Defense

Industrial Association



*America's leading Defense Industry
association promoting National Security*

The Voice of the Industrial Base



Mission

- ✓ **ADVOCATE:** cutting-edge technology and superior weapons, equipment, training, and support for the War-Fighter and First Responder
- ✓ **PROMOTE:** a vigorous, responsive, Government-Industry National Security team
- ✓ **PROVIDE:** a forum for exchange of information between Industry and Government on National Security issues

"If I were inviting a colleague to join, I'd say the most compelling reason is the prestige of NDIA membership." -- NDIA member

Department of the Army Small Business Program



"Our Army at War - Relevant & Ready"

U.S. Army Materiel Command 10th Annual Army Small Business Conference

November 1-2, 2006 McLean, Virginia

MS. TRACEY PINSON
DIRECTOR, OFFICE OF SMALL BUSINESS PROGRAMS
OFFICE OF THE SECRETARY OF THE ARMY



VISION

**To Be The Premier Advocacy Organization
Committed To Maximizing Small Business
Opportunities In Support Of The Warfighter
And The Transformation Of The Army.**



MISSION

- Advise the Secretary of the Army and the Army Leadership on Small Business Related Matters
- Spearhead Innovative Initiatives that Contribute to Expanding the Small Business Industrial Base Relevant to the Army Mission and Priorities
- Leverage the Use of Minority Serving Educational Institutions in Support of Army Science and Technology Programs



ARMY PRIME CONTRACT AWARDS FY 05



	Total Dollars	Achieved	Army Target	Nat'l Goal
US Business	\$70,802			
Small Business	\$20,381	28.8%	27.0%	23.0%
Small Disadvantaged Business	\$ 6,658	9.4%	8.8%	5.0%
Women-Owned SB	\$ 2,625	3.7%	4.1%	5.0%
HUBZone SB	\$ 2,226	3.1%	3.0%	3.0%
Veteran-Owned SB	\$ 1,946	2.8%	n/a	n/a
Service-Disabled Veteran-Owned SB	\$ 501	0.7%	0.9%	3.0%

Dollars Shown in Millions



INSIDE THE NUMBERS

- Small Business: \$20.4B (Exceeded Target)
- Small Disadvantaged Business: \$6.7B (Exceeded Target)
- Women Owned: \$2.6B (First Federal Agency)
- HUBZone: \$2.2B
Target/Goal: 3.1% (Highest in Federal Government)
- SDVOSB (FY03 – FY05):
Increased dollars from \$100M to \$501M
Increased percentage of dollars by 400%



Army US Business Prime Contract Awards-FY 05



Total Awards (\$70.8B)

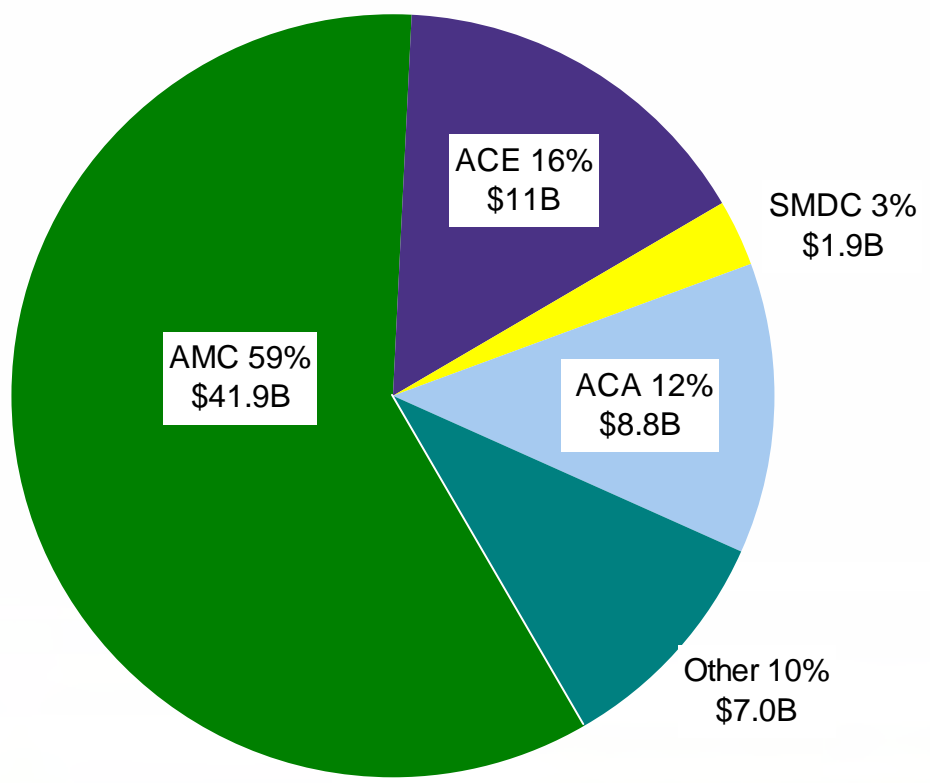



Army Small Business Prime Contract Awards FY 05



Small Business Awards (\$20.3B)

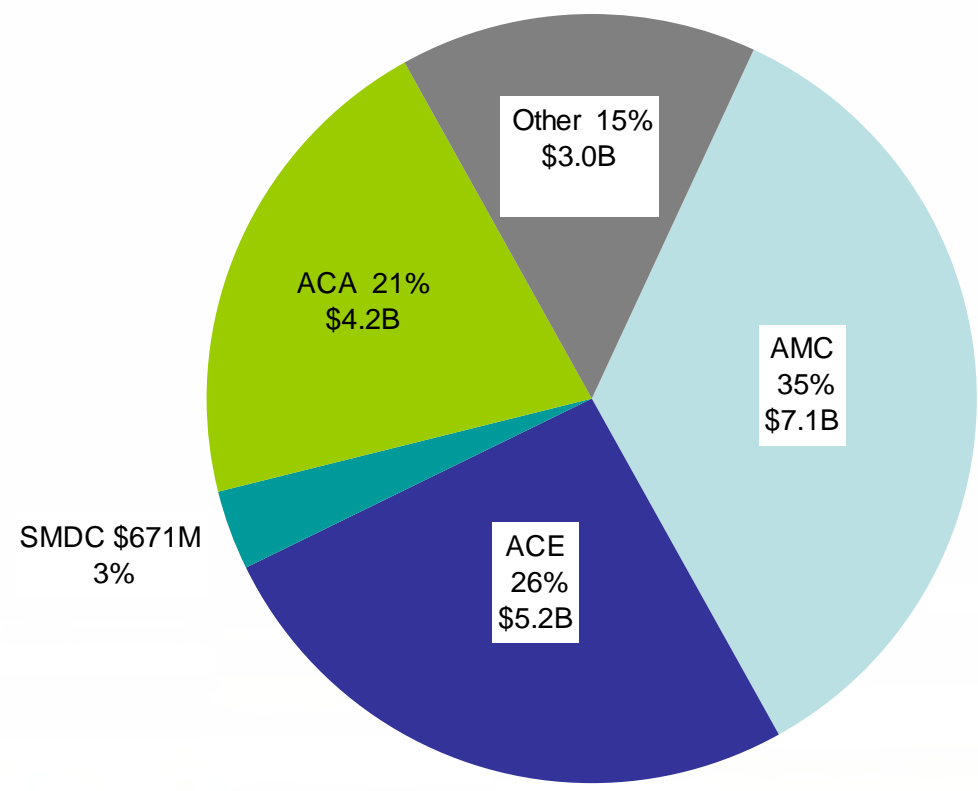



Army SDB Prime Contract Awards FY 05



SDB Awards (\$6.6B)

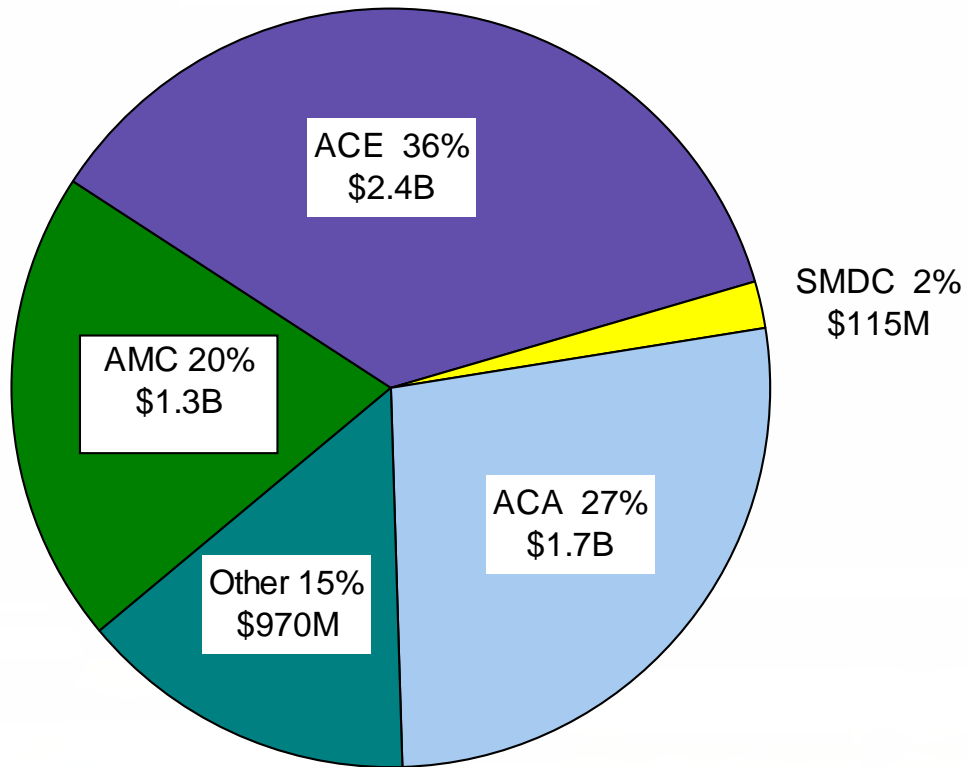



Army WOSB Prime Contract Awards FY 05



WOSB Awards (\$2.6B)

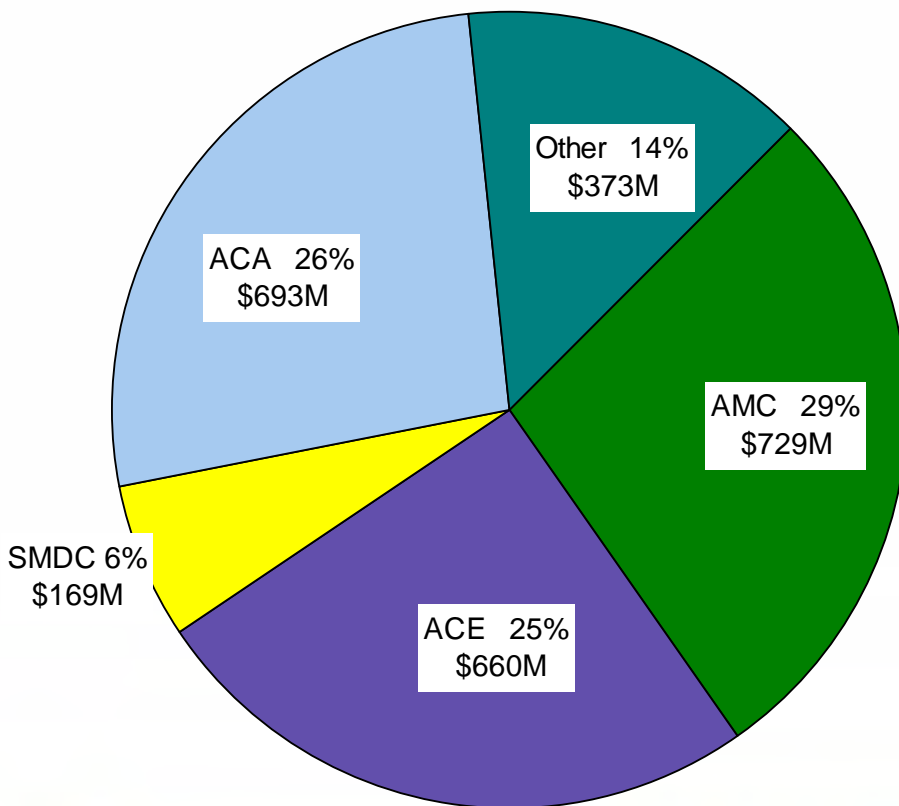



Army HUBZone Prime Contract Awards FY 05

HUBZone Awards (\$2.2B)

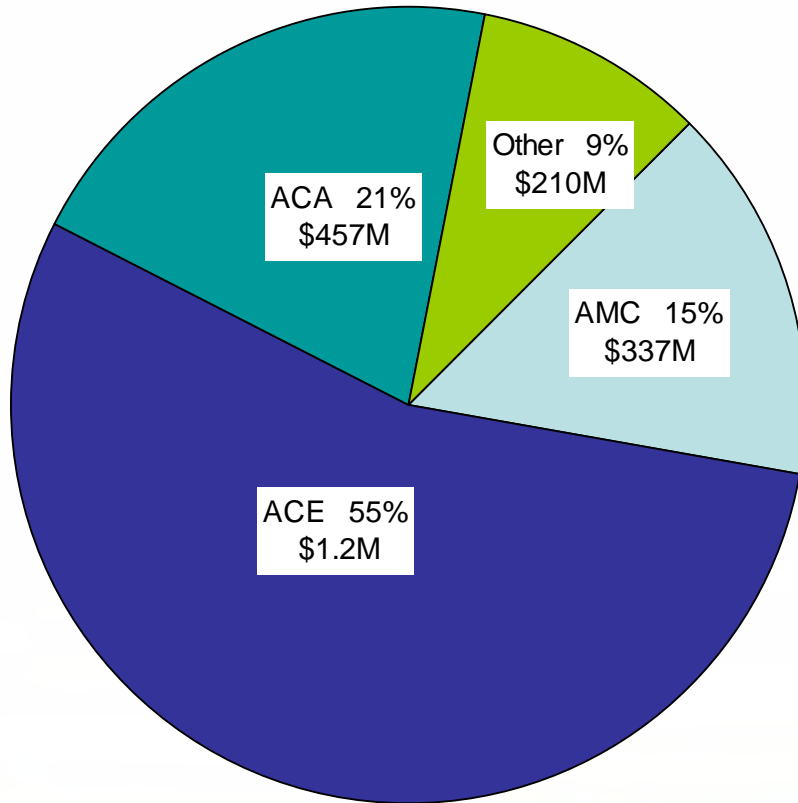



Army SDVOSB Prime Contract Awards FY 05

SDVOSB Awards (\$501M)

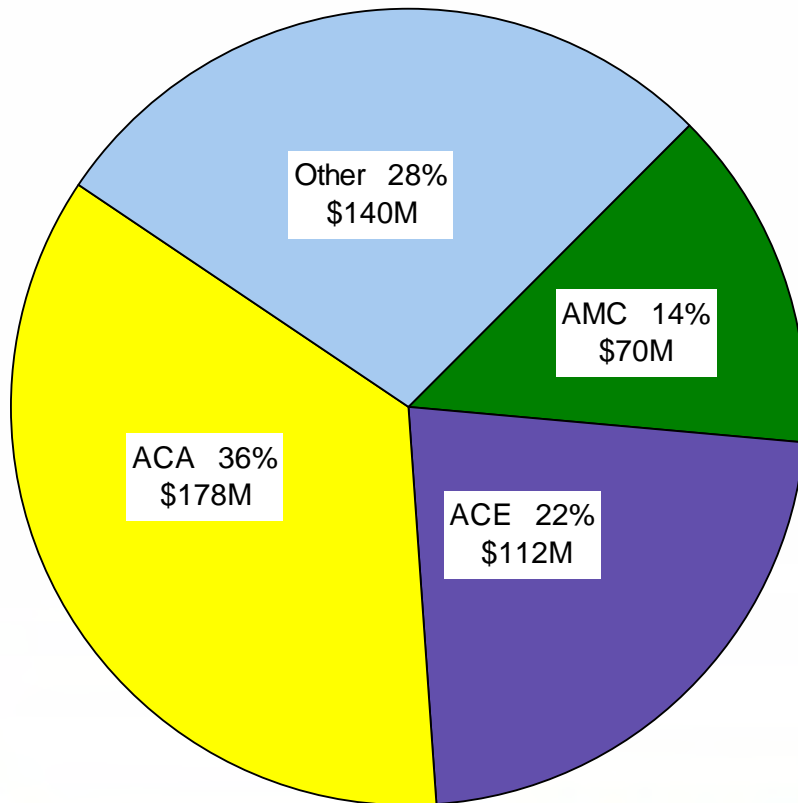



ARMY SADBUC FOCUS FY 07



- Small Business Participation in FCS and Major Army Programs
- Promote Greater Involvement of SBs in Army Contracts for Services
- Support of BRAC through HUBZone Initiatives
- Service-Disabled Veteran-Owned Small Business Opportunities
- Contract Bundling and Consolidation
- Increased role of HBCUs & MIs in the Acquisition Process
- Residential Communities Initiative
- Subcontracting Policy and Enforcement



ARMY FCS PROGRAM

Subcontract Goals Based Upon Boeing Comprehensive Goals

FCS SDD Goals	(% of Boeing Subcontract Dollars)
Small Business	17.5%
Small Disadvantaged Business	3.5%
Woman Owned Small Business	2.5%
Historically Underutilized Business Zone	0.3%
Veteran Owned Small Business	1.5%
Service Disabled Veteran Owned	0.2%

Note: These goals are based on dollars going to small business through and including the third tier of subcontracts



Army Subcontract Awards FY 05

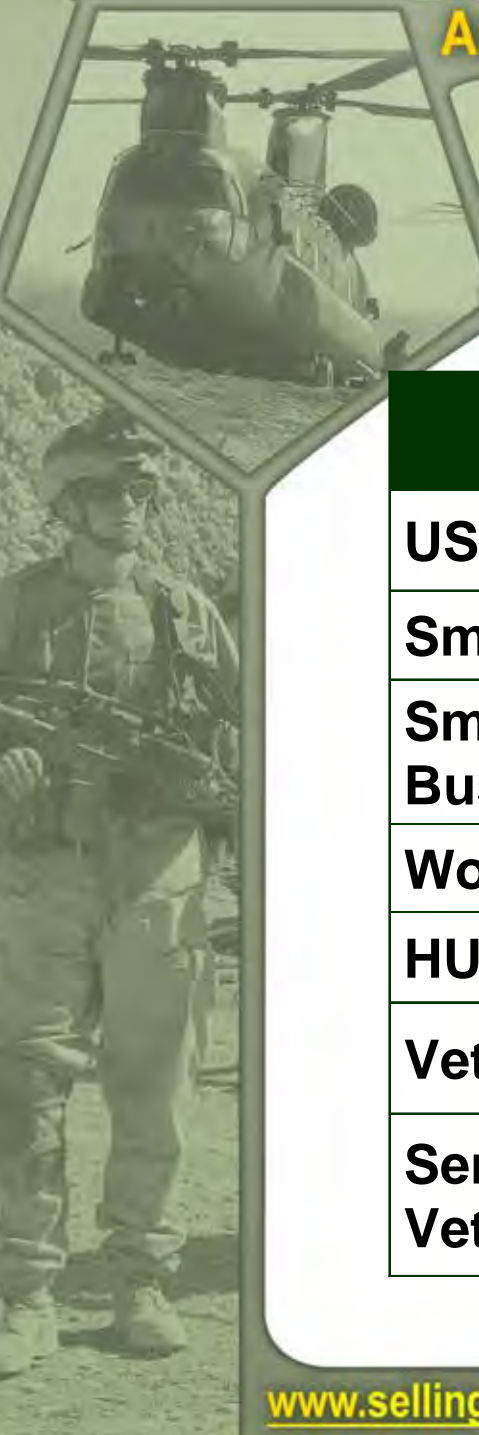

	TOTAL DOLLARS	ACHIEVED	TARGET
US Business	\$6,890		
Small Business	\$3,403	49.4%	49.9%
Small Disadvantaged Business	\$ 444	6.4%	7.7%
Women-Owned SB	\$ 487	7.1%	7.0%
HUBZone SB	\$ 240	3.5%	2.4%
Veteran-Owned SB	\$ 280	4.1%	
Service-Disabled Veteran-Owned SB	\$ 39	0.6%	0.5%

Dollars Shown in millions



MENTOR-PROTÉGÉ PROGRAM



- DoD delegated approval authority to services beginning FY 2004
- Army goal is to engage industries to shape and expand the industrial base to support the Warfighter
- Seeking agreements with strong technical component, or focus on innovative transfer of state of the art technology
- Army Agreements Should Focus on High-Tech Solutions for the Warfighter
- 36 Active Agreements
 - 22 Mentors
 - 36 Protégés (Can Have Only 1 Active Agreement)
- 7 Mentors are Graduated 8(a) Firms



HBCU/MI PROGRAM FY 05

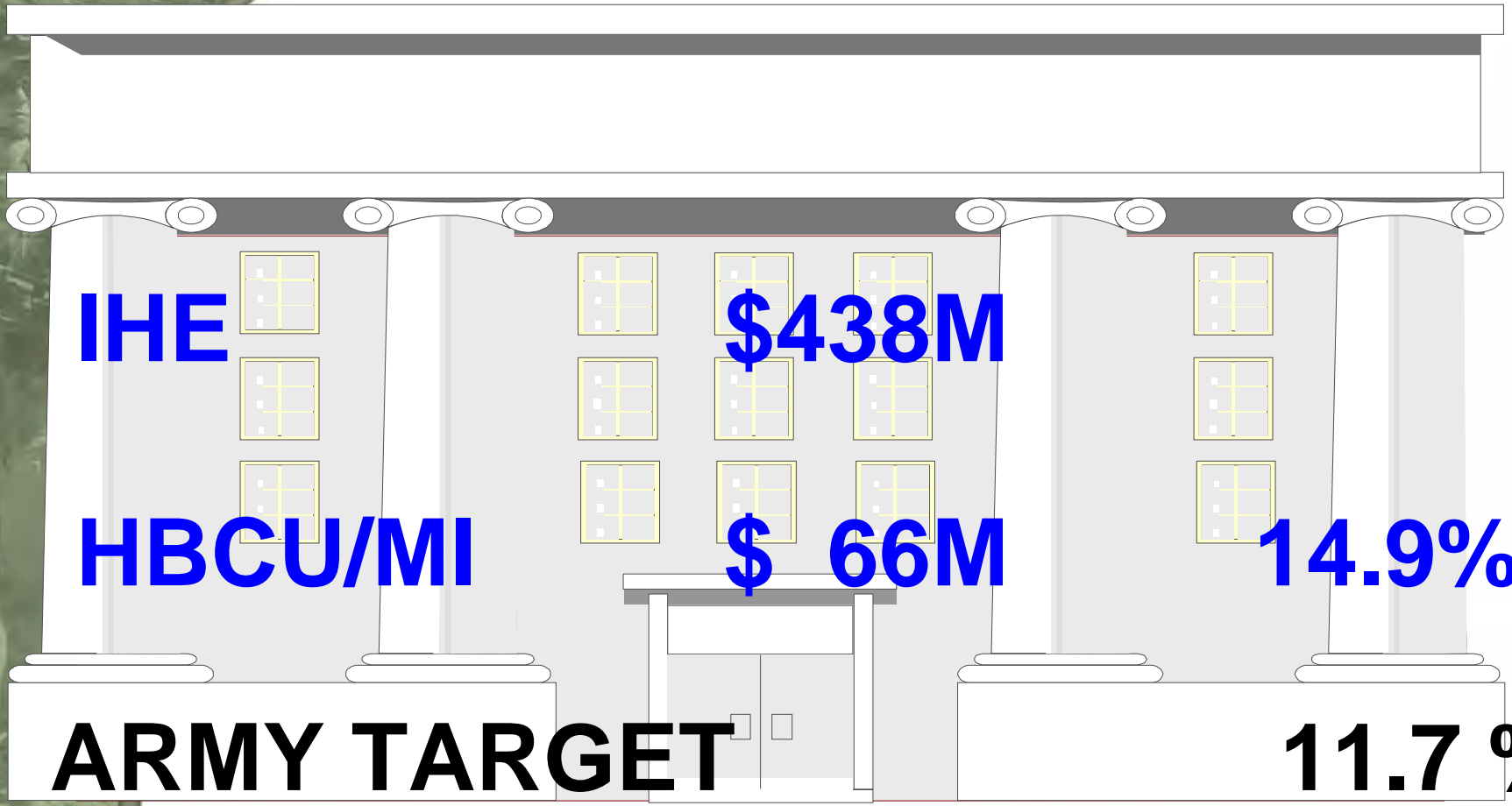



CHALLENGES

- Consolidation / Bundling
- Subcontracting plan enforcement
- Staffing of SADBUs offices

www.sellingtoarmy.info



Open Question Period

Mr. Jeff Parsons
Moderator

Ms. Marlene Cruze

Mr. Edward Elgart

Mr. Martin Green

Mr. James Loehrl

Mr. James Warrington

THE OUTLOOK FOR SMALL BUSINESS

Mr. Joel Szabat

Chief Of Staff

U.S. Small Business Administration



Assistance and Opportunities Iraq - Afghanistan

Mr. Lee Thompson
Assistant Deputy Assistant Secretary of the Army
Policy & Procurement –
Iraq/Afghanistan

“Army Contracting: One Community Serving Our Soldiers, Serving Our Nation”



Agenda

- Organizational Structures
- Joint Contracting Command –
Iraq/Afghanistan
 - Mission
 - Evolution
 - Programs going forward
- Opportunities

“Army Contracting: One Community Serving Our Soldiers, Serving Our Nation”



Post -War Iraq Reconstruction



(\$13B of \$18.4B Iraq Relief & Reconstruction Fund (IRRF*))

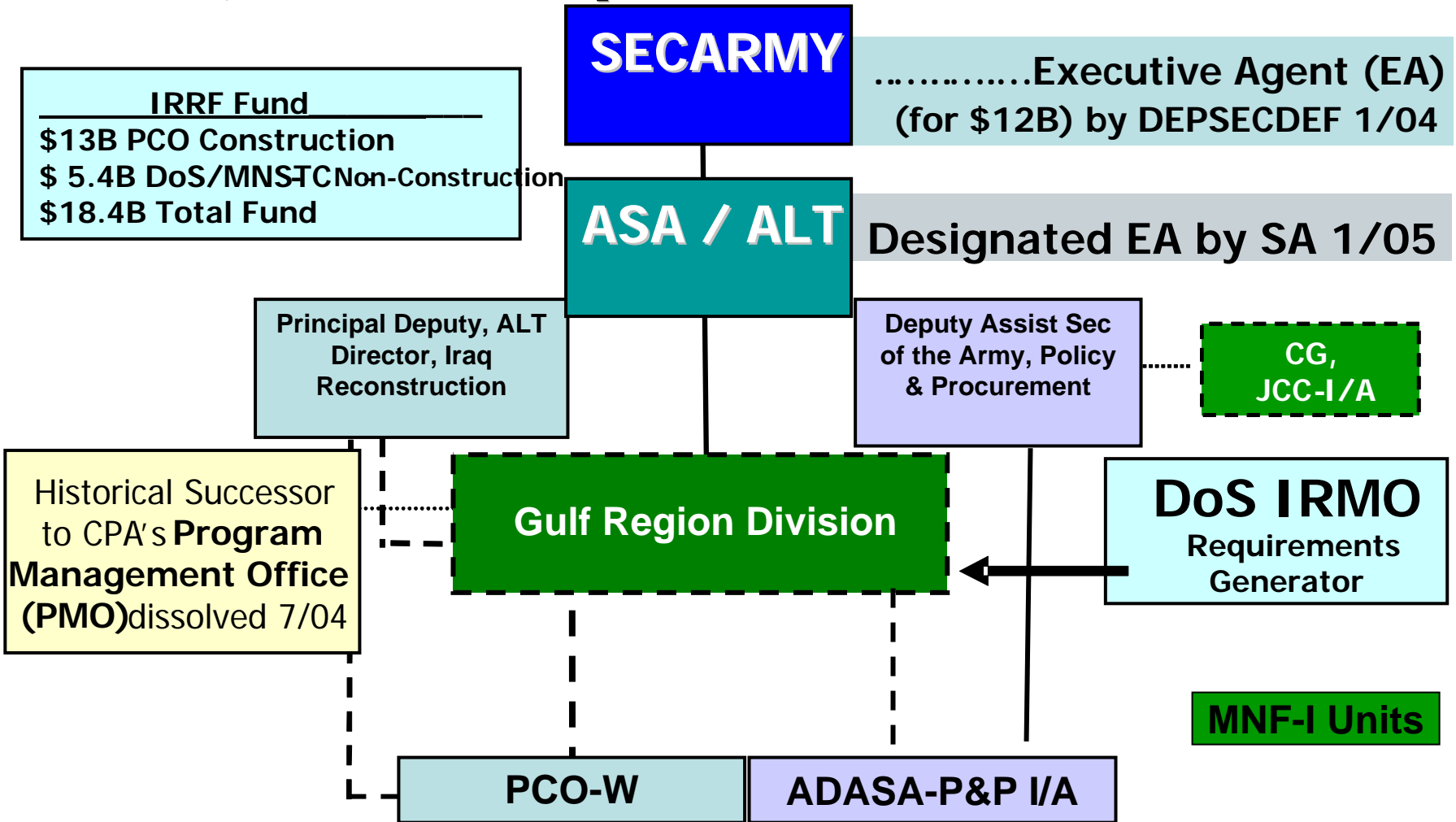



Deputy Assistant Secretary of the Army Policy & Procurement



OADASA-(P&P)-Iraq/Afghanistan

L. Thompson
1LT B. Mason
T. Heide

ADASA-P&P
Executive Officer (XO)
Congressional Liaison

Support Office

T. Mapp	Office Manager
C. Williams	Security/Deployment Specialist
Vacant	Information Management Specialist
R. Bergmann	Archive Specialist*
J. Neal	Document Specialist*

Human Resources

MAJ P. Shields	Military Personnel
C. Creamer	Civilian Personnel

JCC-I/A Support (Duty assignment: JCC-I/A in Iraq)

D. Packard	PARC-Iraq
Contract Specialists	17 Personnel

Policy & Procurement Operations Directorate

COL T. Harrison	Director
Vacant	Policy
D. Salter	Budget /Special Projects
J. Williams	Procurement Analyst
A. Kartchner	Procurement Analyst
Vacant	Procurement Analyst
R. Veney	Admin Ass't*

* Contractor

JCC-I/A Mission



MNF-I

Joint Contracting Command
Iraq / Afghanistan

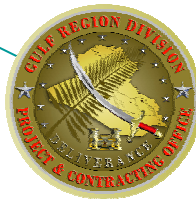

*Provide responsive **operational contracting support** to the Chiefs of Mission, Multi-National Forces - Iraq and Combined Forces Command – Afghanistan to efficiently acquire vital supplies, services and construction **in support of the Coalition Forces** and the relief and reconstruction of Iraq and Afghanistan; provide **capacity building** to establish effective contracting and procurement processes within the Iraqi and Afghani Ministries to build and sustain self-sufficient security forces.*



JCC-I/A – Evolution

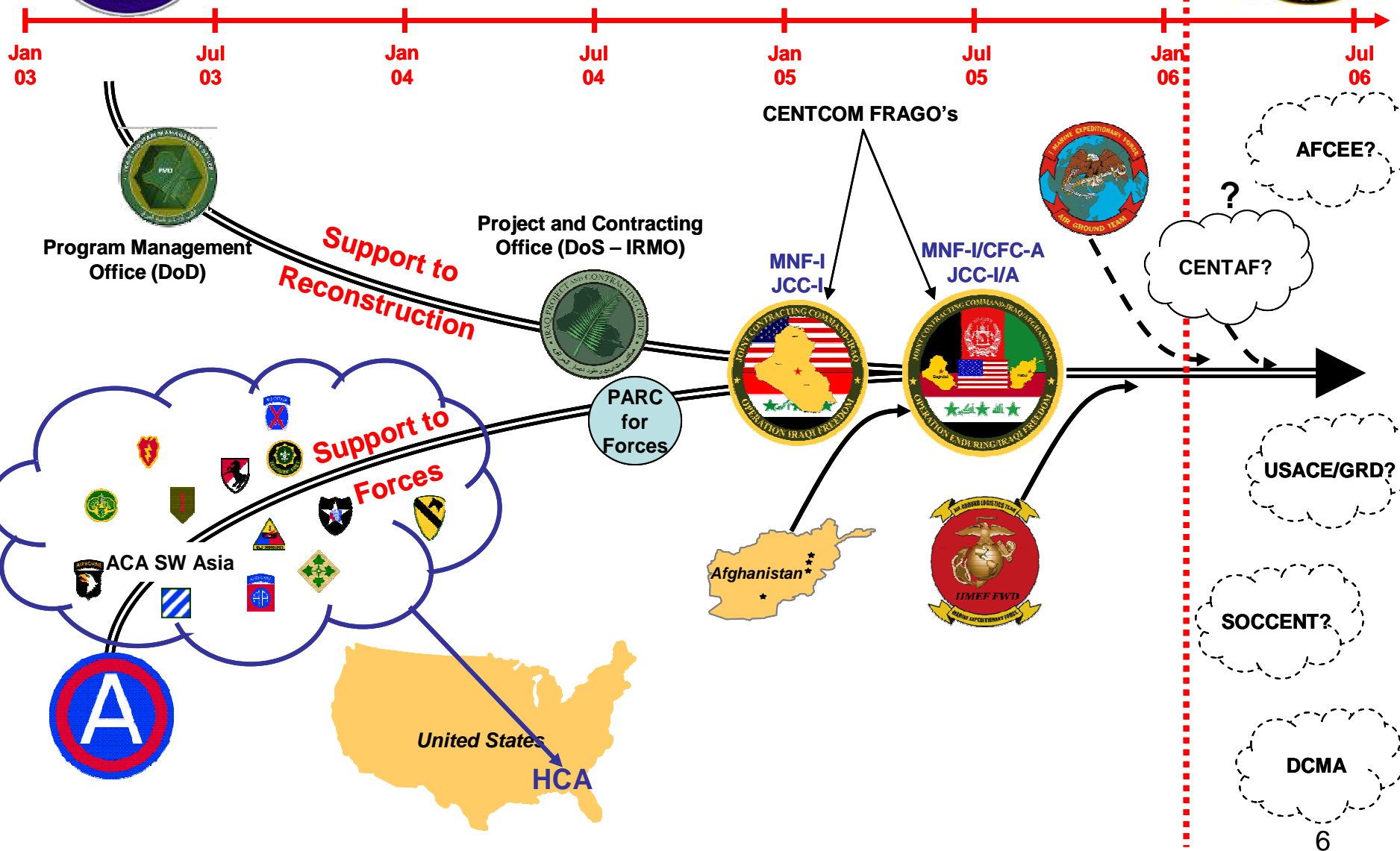

JCC-I/A Today



Embassy
Iraqi Reconstruction Management Office

MNF-I

**ASA(ALT)
DASA-P&P**

CFC-A

GRD

MNSTC-I

MNC-I

OSC-A

CJTF-76

**Joint Contracting Command
Iraq / Afghanistan**

***PARC- RECONSTRUCTION**

Iraq Operations

***PARC-
AFGHANISTAN**

*Creating PARC
Iraq Nov 06*

**MNSTC-I
SUPPORT
DIVISION**

**SPECIALIZED
CONTRACTS
DIVISION**

PARC-F

**PLANS &
POLICY**

AFGHANISTAN

Reconstruction Offices

- BAGHDAD RCO
- BASRAH RCO
- HILLAH RCO

OIL SECTOR

ELECTRICAL SECTOR

PUBLIC WORKS / WATER SECTOR

FACILITIES & TRANSPORTATION SECTOR

Regional Contracting Centers

VICTORY	BALAD
BAGHDAD	TIKRIT
ECHO	MOSUL
TAJI	KIRKUK
FALLUJAH	TALLIL

KABUL

BAGRAM

SALERNO

KANDAHAR

***PARC: Principal Assistant Responsible for Contracting**



FY06 Small Business \$



- USAF - \$947,478,920.00
- USN - \$236,318.00
- USA – \$197,072,780.00
- Design Build - \$469,000,000.00

“Army Contracting: One Community Serving Our Soldiers, Serving Our Nation”



FY07 Opportunities

- FY06 Supplemental \$1.1b
 - Expires Sep 07
- Iraq Security Forces Funds - \$3b
 - Expires Sep 07
- Economic Stability Funds - \$1b
- OMA-\$1.5b



Business Opportunities



www.baghdadbusinesscenter.org

www.rebuilding-iraq.net

www.iraqiarmedforces.org

“Army Contracting: One Community Serving Our Soldiers, Serving Our Nation”

PERSPECTIVES OF A SMALL BUSINESS & LARGE BUSINESS CEO

Mr. Vikram Verma

President & CEO

Savi Technology a Lockheed Martin Co.