



11th Annual Systems Engineering Conference

San Diego, CA

20-23 October 2008

Agenda

TUESDAY, 21 OCTOBER 2008

Keynote Addresses:

- HON Charles McQueary, Director, Operational Test & Evaluation;

Plenary Session: Executive Panel

Moderator:

Ms. Kristin Baldwin, Deputy Director, Software Engineering & System Assurance

Panelists:

- Mr. Terry Jagers, Director, SAF/AQR (Science, Technology & Engineering)
- Mr. Carl Siel, Chief Systems Engineer; ASN(RDA)CHENG
- Mr. Ross Guckert, Assistant Deputy, Acquisition & Systems Integration ASA(ALT)

Luncheon with Speaker in the Regatta Pavilion

- Dr. Ronald Jost, Deputy Assistant Secretary of Defense, C3, Space & Spectrum

BAYVIEW III: SYSTEMS ENGINEERING EFFECTIVENESS

Session 2C1

- 7099- DoD's Systems and Engineering Revitalization Efforts- An Update Mr. Nicholas M. Torelli, OSD/SSE/ED
- 7475 - The Effectiveness of Systems Engineering on Federal (DoD) System Development Programs - Update 2008, Mr. Ken Ptack
- 7153- Systems Engineering Plan (SEP) and Systems Engineering Management Plan (SEMP) Unification Mr. Chet Bracuto, OSD
- Naval Power 21 Integration & Interoperability Improvement, Mr. Kevin Smith
- 7089 - Systems Engineering for Systems of Systems, Dr. Judith Dahmann, The MITRE Corporation

BAYVIEW II: TEST & EVALUATION IN SYSTEMS ENGINEERING

Session 2C2

- 7100- Implementation of the 2007 Developmental Test & Evaluation Defense Science Board Results: Mr. Chris DiPetto, OUSD/SSR/
- 7101 - Test and Evaluation Value Metrics at Acquisition Decision Points: Ms. Darlene Mosser-Kerner, OUSD/SSE/DTE
- 6979 - Integration of Software Intensive Systems: Mr. Tom Wissink, Lockheed Martin
- 6996 - Modeling & Simulation in the Test & Evaluation Master Plan, Mr. Michael Truelove
- 7103 – “New....Improved” Test & Evaluation Master Plan, Ms. Darlene Mosser-Kerner
- 7290 – Mission Based T&E Strategy, Mr. Chris Wilcox

BAYVIEW I: PROGRAM MANAGEMENT

Session 2C3

- 7096 - New Acquisition Policy and Its Impact on Defense Systems Engineering: Ms. Sharon Vannucci, ODUSD/SSE/ED
- 6919- Improving the Quality of DoD Weapon Systems: Ms. Cheryl K. Andrew, U.S. Government Accountability Office
- An Air Force S&T Directorate's View on Applying Systems Engineering Principles to its Programs
- High Confidence Technology Transition Planning Through the Use of Stage-Gates (TD-13), Dr. Claudia Kropas-Hughes, HQ, AFMC
- 7002 - Systems Engineering Re-vitalization at the Defense Contract Management Agency: Mr. Lawrence F. Cianciolo, Defense Contract Management Agency

MISSION I SYSTEM SAFETY- ESOH & HSI

Session 2C4

- 6997 - Human Systems Integration and Model Based Systems Engineering: Dr. Abraham W. Meilich, Lockheed Martin
- 7084 - Human Reliability Analysis and the Advanced Man Portable Air Defense System: A Case Study: Mr. Christopher A. Brown, Naval Surface Warfare Center, Crane
- 7092- Systems Engineering to Ensure Aircraft Airworthiness, Mr. Jim Miller
- 7161 – ESOH In Acquisition OSD Expectations For Implementing DODI 5000.02, Ms. Karen Gill
- ESOH Challenges in Commissioning an Aircraft Carrier, Mr. Doug Parrish, Booz Allen Hamilton

MISSION II MODELING & SIMULATION

Session 2C5

- 7172 - Execution of the Acquisition M&S Master Plan- A Progress Report: Mr. James W.. Hollenbach, Simulation Strategies, Inc.
- Update on Survey on Modeling and Simulation Support for the Systems Engineering of Systems of Systems, Ms. Judith Dahmann, Simulation Strategies, Inc
- 7440 - Synchronizing Modeling and Simulation Plans Across Navy Acquisition: Dr. Ivar Oswald, VisiTech
- 7085 - Modeling and Simulation Resource Reuse Business Model: Mr. Dennis P. Shea, Center For Naval Analyses
- Joint Rapid Scenario Generation (JRS) System Engineering, Mr. Ralph O’Connell, US Joint Forces Command, Joint Capability Development (J8)
- Cross-Command Collaboration Effort (3CE)

MISSION III: NET CENTRIC OPERATIONS

Session 2C6

- 7461-Network Centric Engineering use of the NCOIC (Network Centric Operations Industry Consortium) Processes and Tools in a Logistics Example: Mr. Thomas M. Dlugolecki, SenseResponder LLC
- 7128 - Changing the Value Equation in Engineering and Acquisition to Align Systems of Systems with Dynamic Mission Needs: Mr. Philip J. Boxer, Software Engineering Institute
- 7341 - Crucial Factors in the Design of Net-Centric Systems: Dr. David Hernandez, Tactronics Holdings, LLC
- 7330 – Creating a Systems Architecture for an SOA-based IT System as Part of a Systems Engineering Process, Mr. Robert S. Elinger
- A Service-Oriented Architecture (SOA) Business Model for the U.S. Department of Defense (DoD)

PALM I: REQUIREMENTS DEVELOPMENT & MANAGEMENT

Session 2C7

- 7444- Acquisitions Requirements of Capabilities in a Netcentric Enterprise - Creating a Capabilities Engineering Framework: Mr. Jack M. Van Kirk, SFAE-AV-AS
- 7138- Implications of Capability-based Planning on Requirements Engineering: Mr. Leonard Sadauskas, DoD CIO, IT Investment & Commercial Policy
- 7191- System Concept of Operations: Standards, Practices, and Reality: Ms. Nicole Roberts, L-3 Communications
- 7066 - Two-Step Methodology to Reduce Software System Requirements Defects, Mr. Robert J. Kosman
- 7451 - Why Design for Testability Sooner?, Mr. Bruce Bardell, BAE Systems
- 7399 – The Challenges of Requirements Decomposition, Ms. Eliza Siu, Northrop Grumman Corporation

PALM II: SOFTWARE

Session 2C8

Panel

- 7137 - DoD Software Engineering and System Assurance: Moderator: Ms. Kristen J. Baldwin, Systems and Software Engineering
- 7139 - A Framework for Integrating Systems and Software Engineering: Dr. Richard Turner, Stevens Institute of Technology
- 7041 - Software Process Improvement for Acquisition of Naval Software Intensive Systems: Mr. Carl Siel, U.S. Navy, ASN (RDA) CHENG
- 7119 - Architecting Systems to Meet Expectations – Managing Quality Characteristics To Reduce Risk, Mr. Paul R. Croll, CSC
- 7156 – New Concepts and Trends – How Future Trends in Systems and Software Technology Bode Well for Enabling Improved Acquisition and Performance in Defense Systems, Dr. Kenneth E. Nidiffer
- 7239 – Systems and Software Design Principles for Large-Scale Mission-Critical Embedded Products from Aerospace and Financial Problems Domains, Mr. Rick Selby, Northrop Grumman Space Technology

WEDNESDAY, 22 OCTOBER 2008

Luncheon with Speaker in the Regatta Pavilion

- Ms. Shannon Cunniff, Director, Emerging Containments: Office of Under Secretary of Defense (Installations and Environment)

BAYVIEW III: SYSTEMS ENGINEERING EFFECTIVENESS

Session 3A1

- 7405 - Systems Engineering: Application in Complex Organizations: Mr. Kevin Roney, Booz Allen Hamilton
- 7065 - Establishing a Systems Engineering Center of Excellence in PEO Ground Combat Systems: Mr. Michael H. Phillips, Jacobs
- 7423- Systems Engineering Capability Development: Mr. Edward Andres, TARDEC

Session 3B1

- 7436- A Process Decision Table for Integrated Systems and Software Engineering: Dr. Barry Boehm, USC-CSSE
- 7190 - A Tool to Enhance Systems Engineering Planning: Ms. Sue O’Brien, The University of Alabama in Huntsville
- 6945- The Role of Chaos and Complexity in Systems Development: Dr. Robert J. Monson, Lockheed Martin

Session 3C1

- 6878 - Reduction of Total Ownership Costs (R-TOC) and Value Engineering (VE) in Defense System's Life Cycle: Mr. Chet Bracuto, OSD
- 7007 - Using Performance-Based Earned Value(R) for Measuring Systems Engineering Effectiveness: Dr. Ronald S. Carson, Boeing
- 7017-KBAD- A Cost-Effective Way to Conduct Design and Analysis: Dr. Steven Dam, Systems and Proposal Engineering Company
- 6886 - Air Force Systems Engineering Assessment Model, Mr. Randy Bullard
- 7030 – Defining 100 Best Practices for SE, Mr. Ian Talbot, AAC/EN
- 7204 – Advancing Systems Engineering Practice within the Department of Defense: Overview of DoD's Newest University Affiliated Research Center (UARC), Ms. Sharon Vannucci, ODUSD
- 7093 – Systems Engineering Performance Measures, Mr. Jim Miller

BAYVIEW II: TEST & EVALUATION IN SYSTEMS ENGINEERING

Session 3A2

- 6937 - Systems Engineering for Testing in a Joint Mission Environment: Mr. Earl Reyes, OSD/JTEM
- 7209- Joint Mission Environment Test Capability (JMETC): Mr. Chip Ferguson, JMETC
- 7351 - End to End System Test Architecture: Dr. Masuma Ahmed, Lockheed Martin

Session 3B2

- 7011 - Implementing a Methodology to Incorporate Operational Realism in CONOPS & Testing: Mr. William R. Lyders, ASSETT, Inc.
- 6928 - The Role of T&E in the Requirements Process for System of Systems: Mr. Walter C. Reel, Naval Surface Warfare Center - Dahlgren
- 7372 - Integrated T&E Process and Tools in the Joint High Speed Vessel Program: Mr. Stephen F. Randolph, Alion Science and Technology

BAYVIEW II: BEST PRACTICES & STANDARDIZATION

Session 3C2

- 6874 - Why CMMI Isn't Enough: Ms. Anita Carleton, Software Engineering Institute
- 6888 - Value Engineering: Enhance DMSMS Solutions: Dr. Jay Mandelbaum, Institute for Defense Analysis
- 7761- Applying Business Process Modeling to Develop Systems Engineering Guidance for New DoD Acquisition Regulations: Dr. Judith Dahmann, OSD

Session 3D2

- 7003 - How to Specify Applicable Documents: Mr. James R. van Gaasbeek, Northrop Grumman
- 7014 - Systems Engineering in the Science and Technology Environment – Best Practices and other Lessons Learned from the Air Force Research Laboratory: Mr. William P. Doyle, General Dynamics
- 7031-Lessons Learned Doing Systems Engineering Assessments on the Government: Mr. Ian Talbot, AAC/EN

BAYVIEW I: PROGRAM MANAGEMENT

Session 3A3

- 7438 - The Incremental Commitment Model and Competitive Prototyping: Dr. Barry Boehm, USC
- 7070 - An Integrated, Knowledge-based Approach to Developing Weapon System Business Cases could Improve Acquisition Outcomes: Mr. Travis J. Masters, U.S. Government Accountability Office
- 7258 – Joint Service Safety Testing Study Phase II Final Presentation, Ms. Paige V. Ripani, Booz Allen Hamilton

Session 3B3

- 7340 - “Integrated Management Operating Model (iMOM)”, An E-2D Advanced Hawkeye SD&D Program Case Study: Mr. Douglas J. Shaffer, Northrop Grumman
- 7269- Closing the Gap Between Systems Engineering and Project Management: Mr. Robert W. Ferguson, Software Engineering Institute
- 7349- The Death of Risk Management: Mr. Michael P. Gaydar, Naval Air Systems Command

Session 3C3

- 7095 - Evaluating Complex System Development Maturity- The Creation and Implementation of a System Readiness Level for Defense Acquisition Programs: Mr. Eric Forbes, Northrop Grumman
- 7023- Program Management of Concurrently Developed Complex Systems - Lessons Learned: Mr. Alexander Polack, The Aerospace Corporation

Session 3D3

- 7385 - Enabling More Effective Weapons Systems Acquisition and Sustainment through an Enterprise Approach: Mr. John Stewart, Oracle
- 7462 - Applying the Tenets of Military Planning and Execution to Project and Systems Engineering Management: Mr. Philip Lindeman, SAIC
- 7479 - 360 Degree View of the Technology, Strategy and Business: Mr. Min-Gu Lee, Lockheed Martin

MISSION I: SYSTEM SAFETY- ESOH & HSI

Session 3B4

- 7211 - Defining a Generic Hazard Tracking Database for Future Programs: Mr. Jeff Walker, Booz Allen Hamilton
- 7215 - DoD Energy Demand: Addressing the Unintended Consequences: Mr. Thomas Morehouse, Booz Allen Hamilton
- 7258 - Joint Service Safety Testing Study: Ms. Paige Ripani, Booz Allen Hamilton

Session 3C4

- Update on Revisions to MIL-STD 882: Mr. Robert “Bob” Smith, Booz Allen Hamilton

MISSION II: MODELING & SIMULATION

Session 3A5

- 7347 - Deployment of SysML in Tools and Architectures: an Industry Perspective: Mr. Rick Steiner, Raytheon
- 7073 - Standardized Documentation for Verification, Validation, and Accreditation — An Update to the Systems Engineering Community: Mr. Kevin Charlow, Space and Warfare Systems Center-Charleston
- 7052 - Architecture and Model Based Systems Engineering for Lean Results: Mr. Tim Olson, Lean Solutions Institute, Inc.

Session 3B5

- 7026 - Rapid Assessment Approach Using Commander’s Intent to Identify Promising Force Structure Architectures for System Trade Studies: Mr. David A. Blancett, Northrup Grumman
- 7082 - Domain Modeling: A Roadmap to Convergence: Mr. Nathaniel C. Horner, The Johns Hopkins University Applied Physics Laboratory
- 7364 - Predictive Modeling: Principles and Practice: Dr. Rick Hefner, Northrop Grumman

Session 3C5

- 7144 - Systems Engineering Analysis of Threat Reduction Systems using a Collaborative Constructive Simulation Environment: Dr. James E. Coolahan, Johns Hopkins University Applied Physics Laboratory
- 7393 - Systems Engineering Approach to Total Vehicle Design and Integration: Mr. Walter J. Budd, BAE Systems

Session 3D5

- 7228 - Total System Modeling: A System Engineering Application of the Higraph Formalism: Mr. Kevin Fogarty, SAIC
- 7077 - Near-field RCS and Fuze Modeling and Simulation: Mr. David Hall, Survice Engineering Company
- 7174 - Virtual Battlespace Center for Systems Engineering: Mr. James Hollenbach, Simulation Strategies, Inc.

MISSION III: NET CENTRIC OPERATIONS

Session 3A6

- 6954 - SOAs and Net-Centric Warfare-Similarities, Differences and Conflicts: Mr. James A. Mazzei, The Aerospace Corporation
- 7374 - Capitalizing in Migrating Web Service Environments: Mr. Brian Eleazer, South Carolina Research Authority

Session 3B6

- 6972 - A System Engineering Approach to Develop a Service-Oriented Perspective: Mr. Rob Byrd, SI International
- 7413 - Systems Engineering Approach for Assessing a Warfighter’s Cognitive Performance: Mr. James Buxton, U.S. Army

Session 3C6

- 7105 - Building Net-Ready Information Interoperability Performance Indicator Widgets For DoDAF 2.0 Dashboards: Mr. William B. Anderson, Software Engineering Institute
- 7088 - The Benefit of Collaboration: Integration between the DoDAF and Systems Engineering Communities: Mr. Tim Tritsch, Vitech Corporation
- 7337 - Modeling Cognition in the DoD Architecture Framework for Early Concept Development: Dr. John M. Colombi, Air Force Institute of Technology
- 7046 – Survivable Network Design Framework, Mr. Dennis Moen, Lockheed Martin
- 7377 – Joint Surface Warfare Joint Capability Technology Demonstration – Maturing Weapon Data Link Concepts into Operational Capability, Mr. Robert Finlayson, John Hopkins University

PALM I: REQUIREMENTS DEVELOPMENT & MANAGEMENT

Session 3A7

- 7047-Stop the Pain: Take Some Requirements Definition and Management for Project Success: Mr. Scott Derby, AVISTA Incorporated
- 7068-Daily Challenges in Requirements Engineering: Mr. Frank J. Salvatore, High Performance Technologies, Inc.
- 7593- Correlation of Types of Requirements to Verification Methods: Dr. William G. Bail, The MITRE Corporation

Session 3B7

- 7548- Mission Analysis and its Impact on SE Fundamentals: Mr. John T. McDonald, Raytheon
- 7055- How to Write ‘Lean and Mean’ Requirements: Mr. Tim Olson, Lean Solutions Institute, Inc.

PALM I: LOGISTICS, SUPPORTABILITY & SUSTAINMENT

Session 3C7

- 7180-A Continuous Process View of Systems Engineering for the Sustainment Phase: Mr. Paul d. Ratke, OC - ALC
- 7183- Progress Toward the Development of a Reliability Investment Cost Estimating Relationship: Mr. Andy Long, LMI
- 7235- Future Combat Systems (FCS) Logistics Systems: Ms. Soo R. Yoon, Boeing

Session 3D7

- 7390 - Systems Engineering of Deployed Systems: Mr. Robert K. Finlayson, Johns Hopkins University, Applied Physics Laboratory
- 7383 - Extending Enterprise Systems for an Integrated Logistics Management Environment: Mr. Mike Korzenowski, General Dynamics Land Systems

7455- The Seven Affordability Sins of Logistics System Integration: Dr. Thomas E. Herald, Lockheed Martin

PALM II: SOFTWARE

Session 3A8

- 7114- Building the Next Generation of Software Engineers - Benchmarking Graduate Education: Dr. Arthur Pyster, Stevens Institute of Technology
- 7135 - Improving Work Breakdown Structure (WBS) Guidance for Weapons Systems with Substantial Software Content: Mr. Christopher Miller, OUSD/SE/SSA
- 7232 - ASN (RD&A) Initiatives to Improve Integration of Software Engineering into Defense Acquisition Related Systems Engineering: Dr. John F. Miller, The MITRE Corporation

Session 3B8

- 7198- Software Reuse Readiness Levels: A Framework for Decision Making: Mr. Steven Wong, Northrop Grumman
- 7195 - Counting Software Size: Is it as easy as Busyng a Gallon of Gas?: Ms. Lori Vaughan, Northrop Grumman

PAM II: ARCHITECTURE

Session 3C8

- 7136- Architecture Trade-off Analysis Method® (ATAM®) for System Architecture Evaluation: Mr. Michael Gagliardi, Software Engineering Institute
- 7243 - Method for Aligning Architecture Frameworks and System Requirements: Mr. Richard L. Eilers, IBM

Session 3D8

- 7428- Adaptable Architecture for System of Systems: Mr. Bruce Schneider, Applied Physics Lab Johns Hopkins University
- 7285 - Universal Architecture Description Framework: Mr. Jeffrey O. Grady, JOG System Engineering
- 7109 - Applying Open Architecture Concepts to Mission and Ship Systems: Mr. John M. Green, Naval Postgraduate School
- 7273 - US Air Force Global Persistent Attack Architecture, Process, & Risk Analysis: Maj Jeffrey D. Havlicek, Air Force Center for Systems Engineering

THURSDAY, 23 OCTOBER 2008

BAYVIEW III: SYSTEMS ENGINEERING EFFECTIVENESS

Session 4A1

- 7697 - Enhancing Systems Engineering in the Department of Defense: Mr. Cesar Sharper, ODUSD /SSE
- 7186 - Air Force Implementation of NRC "Pre-A SE" Study Committee Recommendations: Mr. Jeff Loren, AF/AQRE
- 7281-A Holistic Approach to System Development: Mr. Douglas T. Wong, NASA Johnson Space Center

Session 4B1

- 7004 - Operational Concepts: Mr. James R. van Gaasbeek, Northrop Grumman
- 7296 - The Dangers of Oversimplifying Availability: Dr. Jeffrey M. Harris, General Dynamics
- 7214-Developing and Maintaining the Technical Baseline: Mr. Michael G. Uchino, Air Force Institute of Technology

Session 4C1

- 7289 - Process Tailoring Patterns and Frameworks for Accelerating Systems Engineering Processes: Mr. Larry J. Earnest, Northrop Grumman
- 7054 - Using Lean Principles and Process Models to Achieve Measurable Results: Mr. Tim Olson, Lean Solutions Institute, Inc.
- 7265- Rocket Motor Development Cycle Time - Business Process Review: Mr. Jose Gonzalez, OUSD/PSA/LW&M

BAYVIEW II: BEST PRACTICES & STANDARDIZATION

Session 4A2

- 7076 - Systems and Software Life Cycle Process Standards: Foundation for Integrated Systems and Software Engineering: Ms. Teresa Doran, TECHSOFT
- 7111 - Improving Process Utilizations with Tools: Mr. Frank J. Salvatore, High Performance Technologies, Inc.
- 7179 - Integration of Systems and Software Engineering: Implications from Standards and Models Applied to DoDs' Acquisition Programs: Mr. Donald Gantzer, ODUSD/SSE

Session 4B2

- 7325 - Applying CMMI High Maturity Practices and Leveraging LEAN Six Sigma: Mrs. Ann Hennon, BAE Systems
- 7422 - NDIA CMMI Working Group: Status and Plans: Mr. Geoff Draper, Harris Corporation
- 7441 – Process Enrichment Boot Camp, Mr. Victor Elias, High Performance Technology, Inc
- 7446 – Best Practices Clearinghouse: Making Lessons Learned Come Alive and Be Practical, Mr. Forrest Shull, Fraunhofer Center, Maryland

MISSION II: EDUCATION & TRAINING

Session 4A5

- 6944 - Establishing the Need for Functional Analysis in Systems Development: Dr. Robert J. Monson, Lockheed Martin
- 6946 - Improving Systems Engineering Execution and Knowledge Management: Mr. Steven C. Head, Boeing

Session 4B5

- 7094 - Development and Validation of a Systems Engineering Competency Model: Dr. Don Gelosh, SAIC
- 7098 - Accelerate Performance Improvements: Systems Engineering Skills Competency Analysis and Training Program Development: Mr. Steven A. Diebold, General Dynamics,
- 7130 - Concept Definiti- A Historical Perspective: Dr. David R. Jacques, Air Force Institute of Technology

MISSION III: ENTERPRISE HEALTH MANAGEMENT

Session 4A6

- 7580 - Engineering Solutions for Fleet Readiness Centers utilizing an Avionics Rapid Action Team Innovation Cell: Mr. Bill Birurakis, PIDESO
- 7447 - Prognostics as an Approach to Improve Mission Readiness and Availability: Mr. Sony Mathew, Center for Advance Life Cycle Engineering
- 7613 - Prognostics Based Health Assessment System Approaches: Mr. Ronald D. Newman, VSE Corporation

Session 4B6

- 7520 - NDIA ID Electronic Prognostics (E-Prog) Task Follow-on Study to Quantify Weapon System Benefits: Mr. Paul Howard, Paul L. Howard Enterprises
- 7597 - Enterprise Health Management Emerging Technology Transition Enabling Plan: Mr. Chris H. Reisig, Boeing

LRU Prognostics Demonstration Video MPEG Video RealPlayer

PALM I: LOGISTICS, SUPPORTABILITY & SUSTAINMENT

Session 4A7

- 7481- Defining the Prognostics Health Management Enterprise Architecture: Mr. Ethan Xu, Raytheon
- 7131- Sustaining Systems Engineering - The A-10 Example: Dr. David R. Jacques, Air Force Institute of Technology
- 7188- Reliability Centered Maintenance Applied to the CH-47 Chinook Helicopter–Universal Principles that go beyond Equipment Maintenance: Ms. Nancy Regan, The Force, Inc.

Session 4B7

- 7207- Sustainment Engineering versus Systems Engineering, Is There A Difference?: Ms. Karen B. Bausman, AF Center for Systems Engineering
- 7064- Reliability Growth Analysis of Mobile Gun System during PVT: Dr. Dmitry Tananko, GDLS

PALM II: ARCHITECTURE

Session 4A8

- 7401- Enabling Systems Engineering with an Integrated Approach to Knowledge Discovery and Architecture Framework: Mr. Michael R. Collins, Advantage Development, Inc.
- 7453 - Open Architecture in Electronics Systems: Mr. Bruce R. Bardell, BAE Systems
- 7069 - The Value of Architecture: Mr. Frank J. Salvatore, High Performance Technology, Inc.

Session 4B8

- 7365 - Enabling the Successful Transition from Architecture to Concept Design: Mr. Chris Ryder, Johns Hopkins University Applied Physics Laboratory
- 7079 - The Benefits of Synergizing Naval Open Architecture Practices and Principles with Systems Engineering Processes: Mr. Mike Dettman, PEO C4I - NAVSEA
- 7029 - Concurrent Increment Sequencing and Synchronization with Design Structure Matrices in Software-Intensive System Development: Dr. Peter Hantos, The Aerospace Corporation



11TH ANNUAL **SYSTEMS ENGINEERING CONFERENCE**



IN CONJUNCTION WITH:



CONFERENCE OBJECTIVES

This conference seeks to create an interactive forum for Program Managers, Systems Engineers, Software Engineers, Chief Scientists, and Engineers and Managers from government, industry, and the academic communities whose interests converge on Defense acquisition, from capabilities analysis through operations and disposal. This conference will provide the opportunity to learn from one's peers on latest techniques and methodologies, and help shape policy and guidance through the exchange of innovative procedures and lessons learned to address the following current issues:

- Effectiveness of Systems Engineering
- Program Management
- Architectures
- Requirements Development & Management
- Interoperability & Systems Integration
- Software & Software-intensive Systems
- Network Centric Operations
- System-of-Systems Engineering
- Modeling & Simulation
- Integrated Risk Management
- Aging Aircraft
- Logistics & Supportability including Performance Based Logistics
- Life Cycle Systems Management
- Improved Cycle Times for Design, Manufacture, & Repair Process
- Sustainment & Upgrade of Legacy Systems
- Application of Government & Industry “Best Practices” Tools, Methodologies, & Technologies
- System Safety – Environment, Safety & Occupational Health & Human Systems Integration
- Improved Mission Readiness & Systems Availability
- Enterprise Health management & Integrated Diagnostics
- Systems Engineering Training & Education
- Capability Maturity Model Integration (CMMI)
- Integrated Systems Engineering, Test, & Supportability Discipline
- Application of DoD Initiatives:
 - Performance Based Business Environment
 - System Safety
 - Open Systems
 - Simulation Based Acquisition
 - COTS Integration



BACKGROUND

The Department of Defense has been undertaking a major transformation of our military capability over the past few years in response to the new world environment and unforeseen, ever-changing threats. The ability to effect this transformation can only be realized if our Defense Systems—space, air, land, sea, and under sea—can effectively satisfy mission area and capability requirements, and achieve and sustain a high degree of interoperability, systems integration, readiness, availability, and systems safety, with affordable cost. We believe that the greatest opportunity to achieve these objectives for new and legacy systems is through strong technical management embodied in systems

engineering methodologies and processes, on the part of both industry and the DoD, in not only the technical arms but the management & program management arms. Strong emphasis on systems engineering across the full acquisition life cycle, from concept development & refinement through deployment & sustainment, is a key enabler of improved performance in the overall acquisition process and effectiveness. The Systems Engineering Conference is an annual event targeted at exploring the role of technical planning and execution in Defense programs and systems from a variety of perspectives, academic and pragmatic, by the entire Defense systems engineering community.

GENERAL INFORMATION

CONFERENCE ATTIRE

Appropriate dress for this conference is business casual for civilians and class B uniform for military.

During conference registration and check-in, each participant will be issued an identification badge. Please be prepared to present a picture ID. Badges must be worn at all conference functions.

CONFERENCE PROCEEDINGS

Proceedings will be available on the web through the Defense Technical Information Center (DTIC), and will be available one to two weeks after the conference. You will receive notification via e-mail once proceedings are posted and available on the web.

OTHER INFORMATION

Conference Chair: Mr. Bob Rassa, Raytheon

Conference Technical Program Co-Chairs: Dr. Thomas Christian, USAF, Technical Advisor, Systems Engineering, USAF AFMC/ASC; Mr. Steve Henry, Northrop Grumman

Plenary: Ms. Kristen Baldwin, OSD/SSE

Systems Engineering Effectiveness: Mr. Al Brown, Boeing; Ms. Sharon Vannucci, OSD

Logistics Supportability & Sustainment: Mr. Joel Moorvich, Raytheon

Involving Test & Evaluation in SE: John Lohse, Raytheon; Darlene Mosser-Kerner, OSD

Program Management: Mr. Hal Wilson, Northrop Grumman

Modeling & Simulation: Mr. Jim Hollenbach, SIMSTRAT, Inc.; Mr. Gary Belie, Lockheed Martin

Net Centric Operations: Mr. Jack Zavin, ASD(NII); Dr. Rich Eilers, IBM

Best Practices & Standardization: To be announced

Software: Mr. Paul Croll, CSC

Education & Training in SE: Mr. Mike Uchino, USAF/AFIT/CSE

Enterprise Health Management: Mr. Dennis Hecht, Boeing; Mr. Howard Savage, Savage Consulting

System Safety, ESOH & HIS: Mr. Sherman Forbes, USAF; Ms. Paige Ripani, Booz Allen Hamilton

Requirements Development & Management: Mr. Bob Scheurer, Boeing

Architecture: Mr. Joe Kuncel, Northrop Grumman; Mr. John Palmer, Boeing

Practical SE Experience: To be Announced

CONFERENCE AGENDA

SUNDAY, OCTOBER 19, 2008

5:00 pm - 7:00 pm Registration for Tutorials and General Conference
(Tutorials are an additional \$250.00 registration fee)

MONDAY, OCTOBER 20, 2008

7:00 am - 5:00 pm Registration
7:00 am - 8:00 am Continental Breakfast for Tutorial Attendees ONLY
(Tutorials are an additional \$250.00 registration fee)
8:00 am - 12:00 pm Tutorial Tracks
(Please refer to the following pages for Tutorial Schedule)
12:00 pm - 1:00 pm Lunch for Tutorial Attendees ONLY
1:00 pm - 5:00 pm Tutorial Tracks Continued
5:00 pm - 6:00 pm Reception in the Regency Annex (Open to All Participants)

TUESDAY, OCTOBER 21, 2008

7:15 am - 5:00 pm Registration
7:15 am - 8:15 am Continental Breakfast
8:15 am - 8:30 am Introductions & Opening Remarks:
Mr. Sam Campagna, *Director, Operations, NDIA*;
Mr. Bob Rassa, *Director, Systems Supportability, Raytheon; Chair, Systems Engineering Division*
8:30 am - 9:45 am Keynote Addresses:
HON Charles McQueary, *Director, Operational Test & Evaluation*;
Gen Les Lyles, *USAF (Ret)*
9:45 am - 10:15 am Break
10:15 am - 12:15 pm Plenary Session: Executive Panel
Moderator:
Ms. Kristin Baldwin, *Deputy Director, Software Engineering & System Assurance*
Panelists:
Mr. Terry Jagers, *Director, SAF/AQR (Science, Technology & Engineering)*
Mr. Carl Siel, *Chief Systems Engineer, ASN(RDA)CHENG*
Mr. Kelly Miller, *Director, Systems Engineering, NSA*
Mr. Ross Guckert, *Assistant Deputy, Acquisition & Systems Integration ASA(ALT)*
12:15 pm - 1:30 pm Luncheon with Speaker in the Regatta Pavilion
Dr. Ronald Jost, *Deputy Assistant Secretary of Defense, C3, Space & Spectrum*
1:30 pm - 5:15 pm Concurrent Sessions
(Please refer to the following pages for session schedule)
5:15 pm - 6:30 pm Reception in the Regatta Pavilion

CONFERENCE AGENDA, CONTINUED

WEDNESDAY, OCTOBER 22, 2008

7:00 am - 5:00 pm	Registration
7:00 am - 8:00 am	Continental Breakfast
8:00 am - 12:00 pm	Concurrent Sessions (Please refer to the following pages for session schedule)
12:00 pm - 1:30 pm	Luncheon with Speaker in the Regatta Pavilion Ms. Shannon Cunniff, <i>Director, Emerging Containments: Office of Under Secretary of Defense (Installations and Environment)</i>
1:30 pm - 5:15 pm	Concurrent Sessions (Please refer to the following pages for session schedule)

THURSDAY, OCTOBER 23, 2008

7:00 am - 3:00 pm	Registration
7:00 am - 8:00 am	Continental Breakfast
8:00 am - 12:00 pm	Concurrent Sessions (Please refer to the following pages for session schedule)
12:00 pm - 1:00 pm	Awards Lunch in the Regatta Pavilion
1:00 pm - 3:00 pm	Concurrent Sessions (Please refer to the following pages for session schedule)
3:00 pm	Conference Adjourns

Tuesday, October 21, 2008

1:30 pm - 3:15 pm

3:30 pm - 5:15 pm

Bayview III Systems Engineering Effectiveness Session 2C1	7099 - DoD's Systems and Engineering Revitalization Efforts - An Update <i>Mr. Nicholas M. Torelli, OSD/ SSEED</i>	7475 - The Effectiveness of Systems Engineering on Federal (DoD) System Development Programs - Update 2008 <i>Mr. Ken Prack</i>	7153 - Systems Engineering Plan (SEP) and Systems Engineering Management Plan (SEMP) Unification <i>Mr. Chet Bracato, OSD</i>
Bayview II Test & Evaluation in Systems Engineering Session 2C2	7100 - Implementation of the 2007 Developmental Test & Evaluation Defense Science Board Results <i>Mr. Chris DiPietro, OUSD/SSR</i>	7101 - Test and Evaluation Value Metrics at Acquisition Decision Points <i>Ms. Darlene Moser-Kerner, OUSD/SSB/DTE</i>	7103 - New Test and Evaluation Master Plan Guidance <i>Ms. Darlene S. Moser-Kerner, OUSD/SSB/DTE</i>
Bayview I Program Management Session 2C3	7096 - New Acquisition Policy and Its Impact on Defense Systems Engineering <i>Ms. Sharon Vannucci, ODUSD/ SSEED</i>	6919 - Improving the Quality of DoD Weapon Systems <i>Ms. Cheryl K. Andrews, U.S. Government Accountability Office</i>	7002 - Systems Engineering Re-vitalization at the Defense Contract Management Agency <i>Mr. Lawrence F. Cianciolo, Defense Contract Management Agency</i>
Mission I System Safety - ESOH & HSI Session 2C4	6997 - Human Systems Integration and Model Based Systems Engineering <i>Dr. Abraham W. Mellich, Lockheed Martin</i>	7035 - The Special Operational Airworthiness Release (SOAR) Process, A Systems Engineering Approach <i>Dr. Thomas Christian, ASCIEN</i>	7161 - ESOH in Acquisition - OSD Expectations for Implementing DoD 5000.02 <i>Ms. Patricia Hulbey, ODUSD/IC&E</i>
Mission II Modeling & Simulation Session 2C5	7172 - Execution of the Acquisition M&S Master Plan - A Progress Report <i>Mr. James W. Hollenbach, Simulation Strategies, Inc.</i>	7440 - Synchronizing Modeling and Simulation Plans Across Navy Acquisition <i>Dr. Ivar Osuvald, VisiTech</i>	7404 - Joint Rapid Scenario Generation Systems Engineering Vision <i>Mr. Ralph O'Connell, JFCOM</i>
Mission III Net Centric Operations Session 2C6	7461 - Network Centric Engineering use of the NCOIC (Network Centric Operations Industry Consortium) Processes and Tools in a Logistics Example <i>Mr. Thomas M. Dlugolecki, SenseResponder LLC</i>	7128 - Changing the Value Equation in Engineering and Acquisition to Align Systems of Systems with Dynamic Mission Needs <i>Mr. Philip J. Boxer, Software Engineering Institute</i>	7016 - A Service-Oriented Architecture (SOA) Business Model for DoD <i>Dr. Steven H. Dam, Systems and Proposal Engineering Company</i>
Palm I Requirements Development & Management Session 2C7	7444 - Acquisitions Requirements of Capabilities in a Netcentric Enterprise - Creating a Capabilities Engineering Framework <i>Mr. Jack M. Van Kirk, SPAE-AV-AS</i>	7138 - Implications of Capability-based Planning on Requirements Engineering <i>Mr. Leonard Sudauskas, DoD C/O, IT Investment & Commercial Policy</i>	6998 - Quantifying the Impact of System Engineering Changes <i>Dr. Mark Blkbburn, Systems and Software Consortium</i>
Palm II Software Session 2C8	7137 - DoD Software Engineering and System Assurance <i>Moderator: Ms. Krisen J. Baldwin, Systems and Software Engineering</i>	7139 - A Framework for Integrating Systems and Software Engineering <i>Dr. Richard Turner, Stevens Institute of Technology</i>	7119 - Architecting Systems to Meet Expectations - Managing Quality Characteristics to Reduce Risk <i>Mr. Paul Groll, Computer Sciences Corporation</i>
Panel			

Break in the Registry Annex

Bayview III Systems Engineering Effectiveness Session 2D1	7042 - Establishing a Departmental-Level Systems-Management Construct for the Department of Navy <i>Mr. Carl Stiel, Asst. Secretary of the Navy/RDA</i>	7089 - Systems of Systems: Update on the DoD Systems of Systems SE Guide and Future Direction <i>Dr. Judith S. Dahmann, The MITRE Corporation</i>	6986 - Technology Readiness Assessments for Systems of Systems <i>Dr. Jay Mandelbaum, Institute for Defense Analyses</i>
Bayview II Test & Evaluation in Systems Engineering Session 2D2	7103 - New Test and Evaluation Master Plan Guidance <i>Ms. Darlene S. Moser-Kerner, OUSD/SSB/DTE</i>	6996 - Modeling & Simulation in the Test & Evaluation Master Plan <i>Mr. Michael R. Truelove, SAIC</i>	7290 - Mission - Based Test and Evaluation Strategy: An Interagency Developed Process to Link Mission Capability with System Functional Requirements <i>Mr. Christopher M. Wilcox, U.S. Army Test and Evaluation Command</i>
Bayview I Program Management Session 2D3	7002 - Systems Engineering Re-vitalization at the Defense Contract Management Agency <i>Mr. Lawrence F. Cianciolo, Defense Contract Management Agency</i>	7223 - An Air Force S&T Directorate's View on Applying Systems Engineering Principles to its Programs <i>Dr. James C. Malas, Air Force Materiel Command++</i>	7320 - Air Force Initiative - High Confidence Technology Transition Planning Through the Use of Stage-Gate <i>Dr. Claudia V. Kropas-Hughes, Air Force Materiel Command</i>
Mission I System Safety - ESOH & HSI Session 2D4	7092 - Systems Engineering to Ensure Aircraft Airworthiness <i>Mr. James C. Miller, USAF</i>	7161 - ESOH in Acquisition - OSD Expectations for Implementing DoD 5000.02 <i>Ms. Patricia Hulbey, ODUSD/IC&E</i>	ESOH Challenges in Pre-commissioning a Naval Aircraft Carrier <i>Dr. Doug Parrish, Booz Allen Hamilton</i>
Mission II Modeling & Simulation Session 2D5	7467 - Systems Engineering Across my Modeling and Simulation <i>LTC Fabio Lopez,</i>	7404 - Joint Rapid Scenario Generation Systems Engineering Vision <i>Mr. Ralph O'Connell, JFCOM</i>	7175 - LVC Architecture Roadmap - A Path Forward for Distributed Simulation <i>Mr. James W. Hollenbach, Simulation Strategies, Inc</i>
Mission III Net Centric Operations Session 2D6	7414 - An IT Government Solution <i>Mr. Paul Byrnes, Integrated System Diagnostics, Inc.</i>	7016 - A Service-Oriented Architecture (SOA) Business Model for DoD <i>Dr. Steven H. Dam, Systems and Proposal Engineering Company</i>	7330 - Creating a Systems Architecture for an SOA-based IT System as Part of a Systems Engineering Process <i>Dr. Robert Ellinger, Northrop Grumman</i>
Palm I Requirements Development & Management Session 2D7	7451 - Why Design for Testability Earlier? <i>Mr. Bruce R. Baradell, BAE Systems</i>	7066 - Two-Step Methodology to Reduce Software Requirements Defects <i>Mr. Robert J. Kosman, Naval Undersea Warfare Center Division Newport</i>	7399 - The Challenges in Requirements Decomposition <i>Mrs. Eliza Sira, Northrop Grumman Corporation</i>
Palm II Software Session 2D8	7156 - How Future Trends in Systems and Software Engineering Boke Well for Enabling Improved Acquisition and Performance of Defense Systems <i>Dr. Kenneth E. Nidloff, Software Engineering Institute</i>	7239 - Systems and Software Design Principles for Large-Scale Mission-Critical Embedded Products from Aerospace and Financial Problem Domains <i>Dr. Richard W. Selby, Northrop Grumman Space Technology</i>	7119 - Architecting Systems to Meet Expectations - Managing Quality Characteristics to Reduce Risk <i>Mr. Paul Groll, Computer Sciences Corporation</i>

Wednesday, October 22, 2008

8:00 am - 9:45 am

10:15 am - 12:00 pm

Bayview III Systems Engineering Effectiveness Session 3A1	7405 - Systems Engineering: Application in Complex Organizations <i>Mr. Kevin Roney, Booz Allen Hamilton</i>	7065 - Establishing a Systems Engineering Center of Excellence in PEO Ground Combat Systems <i>Mr. Michael H. Phillips, Jacobs</i>	7423 - Systems Engineering Capability Development <i>Mr. Edward Andres, TARDEC</i>
Bayview II Test & Evaluation in Systems Engineering Session 3A2	6937 - Systems Engineering for Testing in a Joint Mission Environment <i>Mr. Earl Reyes, OSD/JTEM</i>	7209 - Joint Mission Environment Test Capability (JMETC) <i>Mr. Chip Ferguson, JMETC</i>	7351 - End to End System Test Architecture <i>Dr. Masuma Ahmed, Lockheed Martin</i>
Bayview I Program Management Session 3A3	7438 - The Incremental Commitment Model and Competitive Prototyping <i>Dr. Barry Boehm, USC</i>	7116 - Exploration of Customer Capability Gaps Through Experimentation <i>Mr. Michael E. Groff, Lockheed Martin</i>	7070 - An Integrated, Knowledge-based Approach to Developing Weapon System Business Cases could Improve Acquisition Outcomes <i>Mr. Travis J. Masters, U.S. Government Accountability Office</i>
Mission I Program Management Session 3A4	7721 - Systemic Analysis and Developing System Issues <i>Mr. Pete Noble, OSD</i>	7720 - Systemic Root Cause Task Group Results <i>Mr. Dave Casadamo, US Army RDECOM-ARDEC</i>	System Root Cause Task Group Recommendations Implementation <i>Mr. Nicholas M. Torelli, OSD/SSE/ED</i>
Mission II Modeling & Simulation Session 3A5	7347 - Deployment of SysML in Tools and Architectures: an Industry Perspective <i>Mr. Rick Steiner, Raytheon</i>	7073 - Standardized Documentation for Verification, Validation, and Accreditation — An Update to the Systems Engineering Community <i>Mr. Kevin Charlton, Space and Warfare Systems Center-Charleston</i>	7052 - Architecture and Model Based Systems Engineering for Lean Results <i>Mr. Tim Olson, Lean Solutions Institute, Inc.</i>
Mission III Net Centric Operations Session 3A6	6954 - SOAs and Net-Centric Warfare-Similarities, Differences and Conflicts <i>Mr. James A. Mazzei, The Aerospace Corporation</i>	7477 - Service Oriented Architecture - The good, Bad, and Ugly of the World's Largest SOA Attempt (DoD NECC) <i>Mr. Allen L. Mink, SRA International</i>	7374 - Capitalizing in Migrating Web Service Environments <i>Mr. Brian Eleazer, South Carolina Research Authority</i>
Palm I Requirements & Development Session 3A7	7047 - Stop the Pain: Take Some Requirements Definition and Management for Project Success <i>Mr. Scott Derby, AVISTA Incorporated</i>	7068 - Daily Challenges in Requirements Engineering <i>Mr. Frank J. Salvatore, High Performance Technologies, Inc.</i>	7593 - Correlation of Types of Requirements to Verification Methods <i>Dr. William G. Bail, The MITRE Corporation</i>
Palm II Software Session 3A8	7114 - Building the Next Generation of Software Engineers - Benchmarking Graduate Education <i>Dr. Arthur Pyter, Stevens Institute of Technology</i>	7135 - Improving Work Breakdown Structure (WBS) Guidance for Weapons Systems with Substantial Software Content <i>Mr. Christopher Miller, OUSD/SE/SSA</i>	7232 - ASN (RD&A) Initiatives to Improve Integration of Software Engineering into Defense Acquisition Related Systems Engineering <i>Dr. John F. Miller, The MITRE Corporation</i>

Break in the Registry Annex

Bayview III Systems Engineering Effectiveness Session 3B1	7436 - A Process Decision Table for Integrated Systems and Software Engineering <i>Dr. Barry Boehm, USC</i>	7190 - A Tool to Enhance Systems Engineering Planning <i>Ms. Sue O'Brien, The University of Alabama in Huntsville</i>	6945 - The Role of Chaos and Complexity in Systems Development <i>Dr. Robert J. Monson, Lockheed Martin</i>
Bayview II Test & Evaluation in Systems Engineering Session 3B2	7011 - Implementing a Methodology to Incorporate Operational Realism in CONOPS & Testing <i>Mr. William R. Lyders, ASSETT, Inc.</i>	6928 - The Role of T&E in the Requirements Process for System of Systems <i>Mr. Walter C. Reed, Naval Surface Warfare Center - Dahlgren</i>	7372 - Integrated T&E Process and Tools in the Joint High Speed Vessel Program <i>Mr. Stephen F. Randolph, Alion Science and Technology</i>
Bayview I Program Management Session 3B3	7340 - "Integrated Management Operating Model (IMOM)", An E-2D Advanced Hawkeye SD&D Program Case Study <i>Mr. Douglas J. Shaffer, Northrop Grumman</i>	7269 - Closing the Gap Between Systems Engineering and Project Management <i>Mr. Robert W. Ferguson, Software Engineering Institute</i>	7349 - The Death of Risk Management <i>Mr. Michael P. Gaydon, Naval Air Systems Command</i>
Mission I System Safety- ESOH & HSI Session 3B4	7211 - Defining a Generic Hazard Tracking Database for Future Programs <i>Mr. Jeff Walker, Booz Allen Hamilton</i>	7215 - DoD Energy Demand: Addressing the Unintended Consequences <i>Mr. Thomas Morhouse, Booz Allen Hamilton</i>	7258 - Joint Service Safety Testing Study <i>Ms. Paige Ripani, Booz Allen Hamilton</i>
Mission II Modeling & Simulation Session 3B5	7026 - Rapid Assessment Approach Using Commander's Intent to Identify Promising Force Structure Architectures for System Trade Studies <i>Mr. David A. Blametz, Northrop Grumman</i>	7082 - Domain Modeling: A Roadmap to Convergence <i>Mr. Nathaniel C. Horner, The Johns Hopkins University Applied Physics Laboratory</i>	7364 - Predictive Modeling: Principles and Practice <i>Dr. Rick Heffner, Northrop Grumman</i>
Mission III Net Centric Operations Session 3B6	6972 - A System Engineering Approach to Develop a Service-Oriented Perspective <i>Mr. Rob Byrd, SI International</i>	7122 - Department of Defense Architecture Frameworks: Delivering Architectures to the World <i>Mr. Walt Okon, OSD/NIIAe/I</i>	7413 - Systems Engineering Approach for Assessing a Warfighter's Cognitive Performance <i>Mr. James Buxton, U.S. Army</i>
Palm I Requirements & Development Session 3B7	7548 - Mission Analysis and its Impact on SE Fundamentals <i>Mr. John T. McDonald, Raytheon</i>	7055 - How to Write 'Lean and Mean' Requirements <i>Mr. Tim Olson, Lean Solutions Institute, Inc.</i>	7055 - How to Write 'Lean and Mean' Requirements <i>Mr. Tim Olson, Lean Solutions Institute, Inc.</i>
Palm II Software Session 3B8	7198 - Software Reuse Readiness Levels: A Framework for Decision Making <i>Mr. Steven Wong, Northrop Grumman</i>	7195 - Counting Software Size: Is it as easy as Busying a Gallon of Gas? <i>Ms. Lori Vaughan, Northrop Grumman</i>	7195 - Counting Software Size: Is it as easy as Busying a Gallon of Gas? <i>Ms. Lori Vaughan, Northrop Grumman</i>

Wednesday, October 22, 2008

1:30 pm - 3:00 pm

3:30 pm - 5:15 pm

Bayview III Systems Engineering Effectiveness Session 3C1	6878 - Reduction of Total Ownership Costs (R-TOC) and Value Engineering (VE) in Defense System's Life Cycle <i>Mr. Chet Brucato, OSD</i>	7007 - Using Performance-Based Earned Value(R) for Measuring Systems Engineering Effectiveness <i>Dr. Ronald S. Carson, Boeing</i>	7017-KBAD - A Cost-Effective Way to Conduct Design and Analysis <i>Dr. Steven Dam, Systems and Proposal Engineering Company</i>
Bayview II Best Practices & Standardization Session 3C2	6874 - Why CMMI Isn't Enough <i>Ms. Anita Carleton, Software Engineering Institute</i>	6888 - Value Engineering: Enhance DMSMS Solutions <i>Dr. Jay Mandelbaum, Institute for Defense Analysis</i>	7761- Applying Business Process Modeling to Develop Systems Engineering Guidance for New DoD Acquisition Regulations <i>Dr. Judith Dahmann, OSD</i>
Bayview I Program Management Session 3C3	7095 - Evaluating Complex System Development Maturity- The Creation and Implementation of a System Readiness Level for Defense Acquisition Programs <i>Mr. Eric Forbes, Northrop Grumman</i>	7023- Program Management of Concurrently Developed Complex Systems - Lessons Learned <i>Mr. Alexander Polack, The Aerospace Corporation</i>	7344 - Complex System Development Program Assessments and Support: A Forensics Perspective <i>Mr. Dinesh Verma, Stevens Institute of Technology</i>
Mission I System Safety - ESOH & HSI Session 3C4	7378- A Culture Shift- Strengthening the "jointness" in Weapon Safety Reviews <i>Ms. Mary Ellen Caro, Naval Ordnance Safety and Security Activity</i>	Update on Revisions to MIL-STD 882 <i>Mr. Bob Smith, Booz Allen Hamilton</i>	7442 - What Systems Engineers Need to Know About System Environmental Noise <i>Ms. Lynn Engelman, USAF</i>
Mission II Modeling & Simulation Session 3C5	7144 - Systems Engineering Analysis of Threat Reduction Systems using a Collaborative Constructive Simulation Environment <i>Dr. James E. Coolahan, Johns Hopkins University Applied Physics Laboratory</i>	7335 - Model-Based Specification for Legacy Networks <i>Mr. Robert M. Kane, SAIC</i>	7228 - Total System Modeling: A System Engineering Application of the Higraph Formalism <i>Mr. Kevin Fogarty, SAIC</i>
Mission III Net Centric Operations Session 3C6	7105 - Building Net-Ready Information Interoperability Performance Indicator Widgets For DoDAF 2.0 Dashboards <i>Mr. William B. Anderson, Software Engineering Institute</i>	7088 - The Benefit of Collaboration: Integration between the DoDAF and Systems Engineering Communities <i>Mr. Tim Tritsch, Vitech Corporation</i>	7046 - Cost-Effective Survivable Network Design Framework <i>Dr. Dennis M. Moen, Lockheed Martin</i>
Palm I Logistics, Supportability & Sustainment Session 3C7	7180-A Continuous Process View of Systems Engineering for the Sustainment Phase <i>Mr. Paul d. Ranke, OC - ALC</i>	7183- Progress Toward the Development of a Reliability Investment Cost Estimating Relationship <i>Mr. Andy Long, LMI</i>	7383 - Extending Enterprise Systems for an Integrated Logistics Management Environment <i>Mr. Mike Korzenowski, General Dynamics Land Systems</i>
Palm II Architecture Session 3C8	7081 - Littoral Combat Ship (LCS) Mission Modules Integration: An Open Architecture Approach <i>Mr. Cecil Whitfield, NAVSEA SYSCOM</i>	7136- Architecture Trade-off Analysis Method* (ATAM*) for System Architecture Evaluation <i>Mr. Michael Gagliardi, Software Engineering Institute</i>	7273 - US Air Force Global Persistent Attack Architecture, Process, & Risk Analysis <i>Major Jeffrey D. Havlicek, Air Force Center for Systems Engineering</i>

Break in Display Area

Bayview III Systems Engineering Effectiveness Session 3D1	7030 - Defining 100 Best Practices for Systems Engineering <i>Mr. Ian Talbot, AAC/EN</i>	6886 - Air Force Systems Engineer Assessment Model (AF SEAM) <i>Mr. Randall Ballard, AF Center for Systems Engineering</i>	7093 - Systems Engineering Performance Measures <i>Mr. James C. Miller, OC-ALC</i>	7204 - Advancing Systems Engineering Practice within the Department of Defense: Overview of DoDs Newest University Affiliated Research Center <i>Ms. Shann Vanucci, ODUSD/ SSE/ED</i>
Bayview II Best Practices & Standardization Session 3D2	7003 - How to Specify Applicable Documents <i>Mr. James R. van Gaisbeek, Northrop Grumman</i>	7014 - Systems Engineering in the Science and Technology Environment - Best Practices and other Lessons Learned from the Air Force Research Laboratory <i>Mr. William P. Doyle, General Dynamics</i>	7031- Lessons Learned Doing Systems Engineering Assessments on the Government <i>Mr. Ian Talbot, AAC/EN</i>	7377 - The Joint Surface Warfare JC2D: Mating Weapon Data Link Concepts into Operational Capability <i>Mr. Robert K. Finlayson, Johns Hopkins University, Applied Physics Laboratory</i>
Bayview I Program Management Session 3D3	7385 - Enabling More Effective Weapons Systems Acquisition and Sustainment through an Enterprise Approach <i>Mr. John Stewart, Oracle</i>	7462 - Applying the Tenets of Military Planning and Execution to Project and Systems Engineering Management <i>Mr. Philip Lindeman, SAIC</i>	7479 - 360 Degree View of the Technology, Strategy and Business <i>Mr. Min-Gu Lee, Lockheed Martin</i>	7216 - Acquisition and Technology Programs Task Force Funded Initiatives <i>Ms. Lucy Rodriguez, Booz Allen Hamilton</i>
Mission I System Safety - ESOH & HSI Session 3D4	7442 - What Systems Engineers Need to Know About System Environmental Noise <i>Ms. Lynn Engelman, USAF</i>	7515 - The Intersection of System Safety, Lean Engineering and Ergonomics <i>Dr. Lee Ostrom, GDIT</i>	7216 - Acquisition and Technology Programs Task Force Funded Initiatives <i>Ms. Lucy Rodriguez, Booz Allen Hamilton</i>	7174 - Virtual Battlespace Center for Systems Engineering <i>Mr. James Hollenbach, Simulation Strategies, Inc.</i>
Mission II Modeling & Simulation Session 3D5	7228 - Total System Modeling: A System Engineering Application of the Higraph Formalism <i>Mr. Kevin Fogarty, SAIC</i>	7077 - Near-field RCS and Fuze Modeling and Simulation <i>Mr. David Hall, Sunrise Engineering Company</i>	7174 - Virtual Battlespace Center for Systems Engineering <i>Mr. James Hollenbach, Simulation Strategies, Inc.</i>	7377 - The Joint Surface Warfare JC2D: Mating Weapon Data Link Concepts into Operational Capability <i>Mr. Robert K. Finlayson, Johns Hopkins University, Applied Physics Laboratory</i>
Mission III Net Centric Operations Session 3D6	7046 - Cost-Effective Survivable Network Design Framework <i>Dr. Dennis M. Moen, Lockheed Martin</i>	7280- Multiple Information Agents for Real-Time, Dynamic Situational Awareness: Architectures for Real-Time WAirfighter Support <i>Dr. James A. Crowder, Raytheon</i>	7377 - The Joint Surface Warfare JC2D: Mating Weapon Data Link Concepts into Operational Capability <i>Mr. Robert K. Finlayson, Johns Hopkins University, Applied Physics Laboratory</i>	7455 - The Seven Affordability Sins of Logistics System Integration <i>Dr. Thomas E. Herald, Lockheed Martin</i>
Palm I Logistics, Supportability & Sustainment Session 3D7	7390 - Systems Engineering of Deployed Systems <i>Mr. Robert K. Finlayson, Johns Hopkins University, Applied Physics Laboratory</i>	7383 - Extending Enterprise Systems for an Integrated Logistics Management Environment <i>Mr. Mike Korzenowski, General Dynamics Land Systems</i>	7383 - Extending Enterprise Systems for an Integrated Logistics Management Environment <i>Mr. Mike Korzenowski, General Dynamics Land Systems</i>	7455 - The Seven Affordability Sins of Logistics System Integration <i>Dr. Thomas E. Herald, Lockheed Martin</i>
Palm II Architecture Session 3D8	7273 - US Air Force Global Persistent Attack Architecture, Process, & Risk Analysis <i>Major Jeffrey D. Havlicek, Air Force Center for Systems Engineering</i>	7109 - Applying Open Architecture Concepts to Mission and Ship Systems <i>Mr. John M. Green, Naval Postgraduate School</i>	7285 - Universal Architecture Description Framework <i>Mr. Jeffrey O. Grady, JOG System Engineering</i>	7428 - Adaptable Architecture for System of Systems <i>Mr. Bruce Schneider, Applied Physics Lab Johns Hopkins University</i>

Thursday, October 23, 2008

8:00 am - 9:45 am

10:15 am - 12:00 pm

Bayview III Systems Engineering Effectiveness Session 4A1	7697 - Enhancing Systems Engineering in the Department of Defense <i>Mr. Caesar Sharper, ODUSD/ISSE</i>	7186 - Air Force Implementation of NRC "Pre-A SE" Study Committee Recommendations <i>Mr. Jeff Loren, SAF/AQRE</i>	7281-A Holistic Approach to System Development <i>Mr. Douglas T. Wong, NASA Johnson Space Center</i>
Bayview II Best Practices & Standardization Session 4A2	7076 - Systems and Software Life Cycle Process Standards: Foundation for Integrated Systems and Software Engineering <i>Ms. Teresa Doran, TECHSOFT</i>	7111 - Improving Process Utilizations with Tools <i>Mr. Frank J. Salvatore, High Performance Technologies, Inc.</i>	7179 - Integration of Systems and Software Engineering: Implications from Standards and Models Applied to DoDs' Acquisition Programs <i>Mr. Donald Ganizer, ODUSD/ISSE</i>
Bayview I Program Management Session 4A3	7113 - Lessons Learned in EVM Control Account Analysis and Design <i>Mr. Thomas R. Conole, Raytheon Space and Airborne Systems</i>	7158 - Achieving Success for Program Managers: Integrating Work Breakdown Structure, Schedule, and Work Packages <i>Mr. Philip J. Simpkins, Vitach Corporation</i>	7010 - Integrating Systems Engineering with Earned Value Management <i>Mr. Paul Solomon, Performance-Based Earned Value</i>
Mission I Practical Systems Engineering Experience Session 4A4	6881 - A Systems Engineering Approach For Balancing Powered Trailer Requirements <i>Mr. Dana F. Peterson, DRS-SSI</i>	6984 - Evaluation of an Immersive Virtual Collaboration Environment for System Development <i>Mr. Rudge Bartholomew, Becknell Collins</i>	7028 - Semi Autonomous Unmanned Aerial Systems with Collaborating Behaviors <i>MAJ Edward B. Teague, United States Military Academy</i>
Mission II Education & Training Session 4A5	6944 - Establishing the Need for Functional Analysis in Systems Development <i>Dr. Robert J. Monson, Lockheed Martin</i>	6946 - Improving Systems Engineering Execution and Knowledge Management <i>Mr. Steven C. Head, Boeing</i>	7034 - Modeling and Simulation Education for the Acquisition/T&E Community <i>Dr. David Olvaell, Naval Postgraduate School</i>
Mission III Enterprise Health Management Session 4A6	7580 - Engineering Solutions for Fleet Readiness Centers utilizing an Avionics Rapid Action Team Innovation Cell <i>Mr. Bill Birunakis, PIDESO</i>	7447 - Prognostics as an Approach to Improve Mission Readiness and Availability <i>Mr. Samp Mathews, Center for Advance Life Cycle Engineering</i>	7613 - Prognostics Based Health Assessment System Approaches <i>Mr. Ronald D. Newman, VSE Corporation</i>
Palm I Logistics, Supportability & Sustainment Session 4A7	7481 - Defining the Prognostics Health Management Enterprise Architecture <i>Mr. Ethan Xu, Raytheon</i>	7131 - Sustaining Systems Engineering - The A-10 Example <i>Dr. David R. Jacques, Air Force Institute of Technology</i>	7188 - Reliability Centered Maintenance Applied to the CH-47 Chinook Helicopter - Universal Principles that go beyond Equipment Maintenance <i>Ms. Nancy Regan, The Force, Inc.</i>
Palm II Architecture Session 4A8	7401 - Enabling Systems Engineering with an Integrated Approach to Knowledge Discovery and Architecture Framework <i>Mr. Michael R. Collins, Advantage Development, Inc.</i>	7453 - Open Architecture in Electronics Systems <i>Mr. Bruce R. Barrdell, BAE Systems</i>	7069 - The Value of Architecture <i>Mr. Frank J. Salvatore, High Performance Technology, Inc.</i>

Break in the Regency Annex

Bayview III Systems Engineering Effectiveness Session 4B1	7004 - Operational Concepts <i>Mr. James R. van Gasbeek, Northrop Grumman</i>	7296 - The Dangers of Oversimplifying Availability <i>Dr. Jeffrey M. Harris, General Dynamics</i>	7214-Developing and Maintaining the Technical Baseline <i>Mr. Michael G. Uchino, Air Force Institute of Technology</i>
Bayview II Best Practices & Standardization Session 4B2	7325 - Applying CMMI High Maturity Practices and Leveraging LEAN Six Sigma <i>Mrs. Ann Hennon, BAE Systems</i>	7400 - Systems Engineering Initiative - How do you Implement a New Lessons Learned Process and Tool on a Legacy Program? <i>Mr. Rey A. Polo, Boeing</i>	7422 - NDIA CMMI Working Group: Status and Plans <i>Mr. Geoff Draper, Harris Corporation</i>
Bayview I Program Management Session 4B3	7363 - Integrated Risk and Opportunity Management <i>Ms. Audrey Dorofoe, Software Engineering Institute</i>	7459 - Multi-Factor Risk Management <i>Ms. Laura West, BAE Systems</i>	7255- Integrated Change Control for the Concurrently Developed Complex Systems - Lessons Learned <i>Mr. Alexander J. Polack, The Aerospace Corporation</i>
Mission I Practical Systems Engineering Experience Session 4B4	7063 - Product Platforms in Support of Rapid Response to DOD In-Theatre Force Protection Needs <i>Dr. Steven B. Shooter, Bucknell University</i>	7102 - Reengineering Electronic Warfare: Shifting From Platform - To Capability - Centric Engineering <i>Mr. William B. Anderson, Software Engineering Institute</i>	7278 - Integrating Metrics with Qualitative Temporal Reasoning for Constraint-Based Expert Systems <i>Dr. James A. Crowder, Raytheon</i>
Mission II Education & Training Session 4B5	7094 - Development and Validation of a Systems Engineering Competency Model <i>Dr. Don Gelosh, SAIC</i>	7098 - Accelerate Performance Improvements: Systems Engineering Skills Competency Analysis and Training Program Development <i>Mr. Steven A. Diebold, General Dynamics</i>	7130 - Concept Definition - A Historical Perspective <i>Dr. David R. Jacques, Air Force Institute of Technology</i>
Mission III Enterprise Health Management Session 4B6	7520 - NDIA ID Electronic Prognostics (E-Prog) Task Follow-on Study to Quantify Weapon System Benefits <i>Mr. Paul Howard, Paul L. Howard Enterprises</i>	7597 - Enterprise Health Management Emerging Technology Transition Enabling Plan <i>Mr. Chris H. Reising, Boeing</i>	7029 - Concurrent Increment Sequencing and Synchronization with Design Structure Matrices in Software-Intensive System Development <i>Dr. Peter Flantos, The Aerospace Corporation</i>
Palm I Logistics, Supportability & Sustainment Session 4B7	7207 - Sustaining Engineering versus Systems Engineering. Is There A Difference? <i>Ms. Karen B. Baumann, AF Center for Systems Engineering</i>	7064 - Reliability Growth Analysis of Mobile Gun System during PVT <i>Dr. Dmitry Tamanko, GDLS</i>	7079 - The Benefits of Synchronizing Naval Open Architecture Practices and Principles with Systems Engineering Processes <i>Mr. Mike Datman, PEO CAI - NAVSEA</i>
Palm II Architecture Session 4B8	7365 - Enabling the Successful Transition from Architecture to Concept Design <i>Mr. Chris Ryder, Johns Hopkins University Applied Physics Laboratory</i>		

Thursday, October 23, 2008

1:30 pm - 3:00 pm

Bayview III Systems Engineering Effectiveness Session 4C1	7289 - Process Tailoring Patterns and Frameworks for Accelerating Systems Engineering Processes <i>Mr. Larry J. Earnest, Northrop Grumman</i>	7054 - Using Lean Principles and Process Models to Achieve Measurable Results <i>Mr. Tim Olson, Lean Solutions Institute, Inc.</i>	7265- Rocket Motor Development Cycle Time - Business Process Review <i>Mr. Jose Gonzalez, OUSD/PSA/ LW&M</i>
Bayview II Best Practices & Standardization Session 4C2	7441 - Process Enrichment Boot Camp - An Intensive Introduction to a Generic, Enterprise-wide, Strategic Communication and Continuous Improvement Methodology <i>Mr. Victor Elias, High Performance Technologies Inc.</i>	7446- Making Lessons Learned Come Alive and be Practical <i>Mr. Forest Shull, Fraunhofer Center Maryland</i>	
Bayview I Program Management Session 4C3	7067- Estimating Systems Engineering Level Of Effort <i>Mr. Frank Salvatore, High Performance Technologies, Inc.</i>	7189- The Integrated Natural Environment Authoritative Representation Process (INEARP) and Beyond <i>Maj James Everett, Air & Space Natural Environment M&S Executive Agent</i>	
Mission I Practical SE Experience Session 4C4	7417 - VIRGINIA (SSN-774) Class Systems Engineering to Reduce Total Ownership Cost <i>Mr. Steve Lose, Naval Sea Systems Command</i>	7463 - The C-17 PIO Team <i>Mr. David Murray, Boeing</i>	7497- Accuracy Control Tools, Technology, and Processes used for Addressing Hull Fairness <i>Mr. Stephan H. Hankins, Northrop Grumman</i>
Mission II Education & Training Session 4C5	7308 - PeaceKeeper Intercontinental Ballistic Missile Systems Engineering Case Study <i>Mr. Charles M. Garland, Air Force Center for Systems Engineering</i>	7474 - CAPTURE of Critical Engineering Skills and Knowledge <i>Mrs. Ann Hennon, BAE Systems,</i>	

Promotional Partner

Thank You to Our Promotional Partner!

LOCKHEED MARTIN



LOCKHEED MARTIN CORPORATION

Lockheed Martin is a premier systems integrator and global security enterprise principally engaged in the research, design, development, manufacture, integration and sustainment of advanced technology systems, products and services.

With growth markets in Defense, Homeland Security, and Systems/Government Information Technology, Lockheed Martin delivers innovative technologies that help customers address complex challenges of strategic and national importance.

Headquartered in Bethesda, Maryland, Lockheed Martin employs 140,000 people worldwide. Distinguished by whole-system thinking and action, a passion for invention and disciplined performance, Lockheed Martin strives to earn a reputation as the partner of choice, supplier of choice and employer of choice in the global marketplace.

Lockheed Martin is led by Robert J. Stevens, Chairman, President and Chief Executive Officer. The Corporation reported 2007 sales of \$41.9 billion.

Governments worldwide are involved in meeting vital strategic goals to defend the peace, make their borders and homeland secure or manage large Information Technology infrastructure projects. Lockheed Martin has more than 300 alliances, joint ventures and other partnerships in 75 countries.

In our approach to global partnerships, Lockheed Martin seeks to establish a long-term presence, provide quality jobs in-country, earn the trust of customers, develop industrial alliances for growth, and match corporate breadth with customer priorities.

Lockheed Martin's operating units are organized into four broad business areas with diverse lines of business.

- Electronic Systems: missiles and fire control, maritime systems/sensors, platform integration, simulation/training, and energy programs
- Aeronautics: combat aircraft, air mobility, special mission and reconnaissance aircraft, advanced development programs, and sustainment operations/services
- Space Systems: launch services, satellites, and strategic/defensive missile systems.
- Information Systems & Global Services: Information Systems, Global Services, and Mission Solutions.

ADDITIONAL AUTHORS

Track	Abstract	Paper Title	Author
1A1, 1C1	7025	Introduction to SysML & Object Oriented Systems Engineering Methodology (OOSEM)	Dr. Abe Meilich
1A2	7033	ULCM (Unified Life Cycle Modeling) for Defense Acquisition	Dr. Peter Hantos
1A3	7050	How to Define Practical Metrics Using NASA JPL as an Example	Mr. Tim Olson Dr. Jairus Hihn
1A4	7071	Introduction to the Capability Test Methodology: Methods and Processes for Testing in a Joint Environment Tutorial	Lt Col Jay R. Gendron
1A5	7209	Joint Mission Environment Test Capability (JMETC), Providing efficiency and cost savings with a distributed test infrastructure	Mr. Chip Ferguson
1A6	7294	FMESA: The Method Framework for Engineering System Architectures	Mr. Donald G Firesmith
1A7, 1C7	6877	(TUTORIAL 8 HOURS) Gap Analysis and Its Conceptual Foundations: Integrating Sound Management Methods with Systems Engineering Best Practices	Mr. Gary Langford
1A8	6975	Early Verification: The Road to Program Success - A Tutorial	Mr. Stephen J Scukanec Mr. James R Vangaasbeek
1C2	7044	A Model-Based Systems Engineering Roadmap for Developing DoDAF Architectures	Mr. Tim Tritsch
1C3	6987	Development and Configuration Management of Requirements	Mr. Al Florence Dr. Bill Bail
1C5	7210	Engineering Systems of Systems	Mr. Soumya Simanta Ms. Grace Lewis Mr. Dennis Smith Pat Place Mr. Ed Morris
1C6	7366	Tutorial: Systems Engineering Applications in supporting the Joint Capabilities Integration and Development System (JCIDS)	Mr. Chris Ryder
1C8	6970	Universal Architecture Description Framework Tutorial	Mr. Jeffrey O Grady
2B8	7198	Software Reuse Readiness Levels: A Framework for Decision Making	Mr. Steven Wong Mr. Dean Caccavo
2C1	7099	DoD's Systems and Software Engineering Revitalization Efforts—An Update	Mr. Nicholas (Nic) M. Torelli, Jr.
2C1	7153	Systems Engineering Plan (SEP) and Systems Engineering Management Plan (SEMP) Unification	Mr Chet Bracuto Mr. Robert Scheurer
2C1	7475	The Effectiveness of Systems Engineering: on Federal (DoD) System Development Programs – Update 2008	Mr. Ken Ptack
2C2	7100	Implementation of the 2007 Developmental Test & Evaluation Defense Science Board Results	Mr. Chris DiPetto
2C2	7101	Test and Evaluation Value Metrics at Acquisition Decision Points	Ms. Darlene Mosser-Kerner Mr. William Eischens
2C2	6979	Integration of Software Intensive Systems	Mr. Tom Wissink
2C3	7418	DON Acquisition Reform and its Impact on CANES System Engineering	CDR Philip Turner Mr. Dennis Almazan Mr. Jose Davila
2C3	6919	Improving the Quality of DOD Weapon Systems	Ms. Cheryl K Andrew Mr. Michael J Sullivan
2C3	7096	New Acquisition Policy and Its Impact on Defense Systems Engineering	Ms. Sharon Vannucci

ADDITIONAL AUTHORS
CONTINUED

2C4	6997	Human Systems Integration and Model Based Systems Engineering	Dr. Abraham W Meilich
2C4	7035	The Special Operational Airworthiness Release (SOAR) Process, A Systems Engineering Approach	Dr. Thomas F Christian Mr. Gary L. Bailey Mr. Al E Owens
2C4	7084	Human Reliability Analysis and the Advanced Man Portable Air Defense System: A Case Study	Mr. Christopher A Brown
2C5	7172	Execution of the Acquisition M&S Master Plan - A Progress Report	Mr. James W Hollenbach Mr. Michael R Truelove
2C5	7085	Modeling and Simulation Resource Reuse Business Model	Mr. Dennis P Shea
2C5	7440	Synchronizing Modeling and Simulation Plans Across Navy Acquisition	Dr. Ivar Oswalt Dr. Robert R Tyler
2C6	7461	Title of Abstract: Network Centric Engineering use of the NCOIC (Network Centric Operations Industry Consortium) Processes and Tools in a Logistics Example	Mr. Thomas M Dlugolecki Mr. John Yanosy Mr. Hans Polzer
2C6	7341	Crucial Factors In The Design Of Net-Centric Systems	Dr. David Hernandez
2C6	7128	Changing the value equation in engineering and acquisition to align systems of systems with dynamic mission needs	Mr. Philip J Boxer Ms. Suzanne Garcia Mr. William Anderson Mr. Patrick Kirwan
2C7	7444	Acquisition Requirements for Capabilities in a Netcentric Enterprise -- Creating a Capabilities Engineering Framework	Mr. Jack M Van Kirk Mr. Ira A Monarch
2C7	7191	System Concept of Operations: Standards, Practices, and Reality	Ms. Nicole Roberts
2C7	7138	Implications of Capability-based Planning on Requirements Engineering	Mr. Leonard Sadauskas
2C8	7041	Software Process Improvement for Acquisition of Naval Software Intensive Systems	Mr. Carl Siel
2C8	7137	DoD Software Engineering and System Assurance	Ms. Kristen J. Baldwin
2C8	7139	A Framework for Integrating Systems and Software Engineering	Dr. Arthur Pyster Dr. Richard Turner
2D1	6986	Technology Readiness Assessments for Systems of Systems	Dr. Jay Mandelbaum
2D1	7042	Establishing a Departmental-Level Systems-of-Systems Engineering Management Construct for the Department of the Navy	Mr. Carl Siel Mr. John Kevin Smith
2D1	7089	Systems of Systems: Update on the DoD Systems of Systems SE Guide and Future Direction	Dr. Judith s Dahmann
2D2	7290	Mission-Based Test and Evaluation Strategy: An Interagency Developed Process to Link Mission Capability with System Functional Requirements	Mr. Christopher M Wilcox Mr. John W Beilfuss
2D2	6996	Modeling & Simulation in the Test & Evaluation Master Plan	Mr. Michael R Truelove
2D2	7103	New Test and Evaluation Master Plan Guidance	Ms. Darlene S Mosser-Kerner
2D3	7002	Systems Engineering Re-Vitalization At The Defense Contract Management Agency	Mr. Lawrence F Cianciolo Mr. Shaun Lanham

2D3	7223	An Air Force S&T Directorate's View on Applying Systems Engineering Principles to its Programs	Dr. James C Malas Mr. Robert L Rapson Capt Ronald Pendleton Mr. Bryan DeHoff Ms. Carol Ventresca
2D3	7320	Air Force Initiative – High Confidence Technology Transition Planning Through the Use of Stage-Gates	Dr. Claudia V Kropas-Hughes Ms. Lynda T Rutledge Mr. George H Sarmiento
2D4	7092	Systems Engineering to Ensure Aircraft Airworthiness	Mr. James C Miller
2D4	7161	ESOH in Acquisition – OSD Expectations for Implementing DoDI 5000.02	Ms. Patricia Huheey Ms. Karen Gill
2D4	7222	What the Systems Engineer Needs to Know About Integrating Environment, Safety, and Occupational Health (ESOH) into Systems Engineering (SE) Using the System Safety Methodology	Mr. Sherman G. Forbes
2D5	7404	Joint Rapid Scenario Generation Systems Engineering Vision	Mr. Ralph O'Connell Mr. Warren Bizub Mr. Ken Goad Mr. Michael Winslow Ms. Leslie Winters
2D5	7467	Systems Engineering Across Army Modeling and Simulation	Mr. Van Sullivan LTC Favio Lopez
2D5	7175	LVC Architecture Roadmap - A Path Forward for Distributed Simulation	Mr. James W Hollenbach
2D6	7016	A Service-Oriented Architecture (SOA) Business Model for DoD	Dr. Steven H Dam
2D6	7330	Creating a Systems Architecture for an SOA-based IT System as Part of a Systems Engineering Process	Dr. Robert S. Ellinger Mr. Gabriel Hoffman
2D6	7414	An IT Governance Solution	Mr. Paul Byrnes
2D7	7451	Why Design for Testability Earlier?	Mr. Bruce R Bardell
2D7	7399	The Challenges in Requirements Decomposition	Mrs. Eliza Siu
2D7	6998	Quantifying the Impact of System Engineering Changes	Dr. Mark R Blackburn
2D7	7066	Two-Step Methodology to Reduce Software Requirement Defects	Mr. Robert J Kosman
2D8	7119	Architecting Systems to Meet Expectations - Managing Quality Characteristics To Reduce Risk	Mr. Paul Croll
2D8	7156	How Future Trends in Systems and Software Engineering Bode Well for Enabling Improved Acquisition and Performance of Defense Systems	Dr. Kenneth E Nidiffer
2D8	7239	Systems and Software Design Principles for Large-Scale Mission-Critical Embedded Products from Aerospace and Financial Problem Domains	Dr. Richard W Selby
3A1	7065	Establishing a Systems Engineering Center of Excellence in PEO Ground Combat Systems	Mr. Michael H Phillips
3A1	7405	Systems Engineering: Application in complex organizations	Mr. Kevin Roney Mr. Robert Parrish

ADDITIONAL AUTHORS
CONTINUED

3A1	7423	Systems Engineering Capability Development	Mr. Edward Andres Mr. Troy Peterson Ms. Harsha Desai Mr. Scott Welles
3A2	7351	End to End System Test Architecture	Dr. Masuma Ahmed
3A2	6937	Systems Engineering for Testing in a Joint Mission Environment	Mr. Earl Reyes
3A3	7438	The Incremental Commitment Model and Competitive Prototyping	Dr. Barry Boehm Ms. Jo Ann Lane
3A3	7116	Exploration of Customer Capability Gaps Through Experimentation	Mr. Michael E. Groff
3A3	7070	An integrated, knowledge-based approach to developing weapon system business cases could improve acquisition outcomes	Mr. Travis J Masters Mr. Michael J Sullivan Mr. John E Oppenheim
3A4	7720	Systemic Root Cause Analysis Leads to Acquisition Improvement Recommendations	Ms. Laura M Dwinnell Mr. David R Castellano Mr. Hal Wilson
3A4	7721	Systemic Root Cause Analysis Leads to Acquisition Improvement Recommendations (Part 2)	Mr. Peter Nolte
3A5	7073	Standardized Documentation for Verification, Validation, and Accreditation — An Update to the Systems Engineering Community	Mr. Kevin Charlow Mr. Curtis Blais Mr. David Broyles Ms. Marcy Stutzman
3A5	7052	Presentation: “Architecture and Model Based Systems Engineering for Lean Results”	Mr. Tim Olson
3A5	7347	Deployment of SysML in Tools and Architectures: an Industry Perspective	Mr. Rick Steiner
3A6	6954	SOAs and Net-Centric Warfare-Similarities, Differences and Conflicts	Mr. James A Mazzei Ms. Camille O Keely Mr. James L Ayers
3A6	7477	Service Oriented Architecture - The good, bad, and ugly of the world's largest SOA attempt (DoD NECC)	Col Allan L Mink, II, USAF (Ret)
3A6	7374	Capitalizing in Migrating Web Service Environments	Mr. Brian Eleazer
3A7	7047	Stop the Pain: Take Some Requirements Definition and Management for Project Success	Mr. Scott Derby
3A7	7593	Correlation of Types of requirements to Verification Methods	Dr. William G Bail
3A7	7068	Daily Challenges in Requirements Engineering	Mr. Frank J Salvatore
3A8	7232	ASN (RD&A) Initiatives to Improve Integration of Software Engineering into Defense Acquisition Related Systems Engineering	Dr. John F Miller Mr. Archibald McKinlay, VI
3A8	7135	Improving Work Breakdown Structure (WBS) Guidance for Weapons Systems with Substantial Software Content	Mr. Christopher Miller
3A8	7714	Building the Next Generation of Software Engineers - Benchmarking Graduate Education	Dr. Arthur Pyster Dr. Richard Turner
3B1	6945	The Role of Chaos and Complexity in Systems Development	Dr. Robert J. Monson
3B1	7190	A Tool to Enhance Systems Engineering Planning	Ms. Sue O'Brien Dr. Dawn Sabados Dr. James Snider, Maj. Gen., ret.

3B1	7436	A Process Decision Table for Integrated Systems and Software Engineering	Dr. Barry Boehm Ms. Jo Ann Lane
3B2	7372	Integrated T&E process and tools in the Joint High Speed Vessel Program	Mr. Stephen F Randolph
3B2	7011	Implementing a Methodology to Incorporate Operational Realism in CONOPS & Testing	Mr. William R Lyders
3B2	6928	The Role of T&E in the Requirements Process for System of Systems	MSG Walter C. Reel, Jr
3B3	7269	Closing the gap between systems engineering and project management	Mr. Robert W Ferguson
3B3	7349	The Death of Risk Management	Mr. Michael P Gaydar
3B3	7340	“Integrated Management Operating Model (iMOM)”, An E-2D Advanced Hawkeye SD&D Program Case Study	Mr. Douglas J Shaffer
3B4	7215	DoD Energy Demand: Addressing the Unintended Consequences	Mr. Thomas Morehouse
3B4	7216	Acquisition and Technology Programs Task Force Funded Initiatives	Ms. Lucy Rodriguez
3B4	7211	Defining a Generic Hazard Tracking Database for Future Programs	Mr. Jeff Walker
3B5	7364	Predictive Modeling: Principles and Practice	Dr. Rick Hefner Mr. Philip Paul Mr. Rasheed Baqui Prem Daniel Arun Durairaj
3B5	7082	Domain Modeling: A Roadmap to Convergence	Mr. Nathaniel C Horner Mr. J. Stephen Topper
3B5	7026	Rapid Assessment Approach Using Commander’s Intent to Identify Promising Force Structure Architectures for System Trade Studies	Mr. David A Blancett Mr. Kurt Dittmer
3B6	7048	Requisite EcoSystem alterations for SOA in the DoD/IC domain	Mr. Charles Long
3B6	6972	A System Engineering Approach to Develop a Service-Oriented Perspective	Mr. Rob Byrd
3B6	7122	Department of Defense (DoD) Architecture Framework (DoDAF); Delivering Architectures to the World	Mr. Walt Okon
3B7	7548	Mission Analysis and its Impact on SE Fundamentals	Mr. John T McDonald Mr. David W Rhodes
3B7	7055	Presentation: “How to Write ‘Lean and Mean’ Requirements”	Mr. Tim Olson
3B8	7195	Counting Software Size: Is it as easy as buying a gallon of gas?	Ms. Lori Vaughan Mr. Dean Caccavo
3C1	7007	Using Performance-Based Earned Value(R) for Measuring Systems Engineering Effectiveness	Dr. Ronald S Carson Mr. Bojan Zlicaric
3C1	7017	KBAD – A Cost-Effective Way to Conduct Design and Analysis	Dr. Steven Dam
3C1	6878	Reduction of Total Ownership Costs (R-TOC)	Mr. Chet Bracuto Dr. Jay Mandelbaum
3C2	6888	Value Engineering: Enhance DMSMS Solutions	Dr. Jay Mandelbaum Dr. Danny L. Reed

ADDITIONAL AUTHORS
CONTINUED

3C2	6874	Why CMMI isn't enough	Mr. Timothy A Chick Mrs. Anita D Carleton
3C2	7761	Applying Business Process Modeling to Develop Systems Engineering Guidance for New DoD Acquisition Regulations	Dr. Judith S Dahmann Aumber Bhatti
3C3	7023	Program Management of Concurrently Developed Complex Systems – Lessons Learned	Mr. Alexander Polack
3C3	7095	Evaluating Complex System Development Maturity – The Creation and Implementation of a System Readiness Level for Defense Acquisition Programs	Mr. Eric Forbes Mr. Kenneth Michaud Mr. Peter Gentile
3C3	7344	Complex System Development Program Assessments and Support: A Forensics Perspective	Dr. Dinesh Verma Ms. Laura Dwinell Mr. Mark Weitekamp Mr. Glynn James Mr. Tom Parry
3C4	7378	A Culture Shift – Strengthening the “Jointness” in Weapon Safety Reviews	Ms. Mary Ellen Caro
3C4	7433	Learning From NASA Mishaps: What Separates Success From Failure?	Ms. Faith Chandler
3C4	7226	Way Ahead for DoD Acquisition Efforts to Integrate Environment, Safety, and Occupational Health (ESOH) Considerations into Systems Engineering Using the DoD Standard Practice for System Safety	Mr. Sherman G Forbes
3C5	7393	Systems Engineering Approach to Total Vehicle Design and Integration	Mr. Walter J Budd
3C5	7144	Systems Engineering Analysis of Threat Reduction Systems using a Collaborative Constructive Simulation Environment	Dr. James E. Coolahan Dr. Andrew C. K. Wiedlea Dr. Roger L. West Dr. Joseph G. Kovalchik
3C5	7335	Model-Based Specification for Legacy Networks	Mr. Robert M Kane Mr. Martin A Kane
3C6	7105	Building Net-Ready Information Interoperability Performance Indicator Widgets For DODAF 2.0 Dashboards	Mr. William B Anderson Mr. Jayson Durham Dr. David Zubrow
3C6	7337	Modeling Cognition in the DoD Architecture Framework for Early Concept Development	Dr. John M Colombi Dr. Joseph W Carl
3C6	7088	The Benefit of Collaboration: Integration between the DoDAF and Systems Engineering Communities	Mr. Tim Tritsch
3C7	7180	A continuous process view of systems engineering for the sustainment phase	Mr. Paul D Ratke
3C7	7183	Progress Toward the Development of a Reliability Investment Cost Estimating Relationship	Mr. E. Andrew Long Dr. David A. Lee Mr. James Forbes
3C7	7235	Future Combat Systems (FCS) Logistics Systems	Ms. Soo R. Yoon
3C8	7243	Method for Aligning Architecture Frameworks and System Requirements	Mr. Richard L Eilers Mr. Mark Rhaodes Mr. Kevin Hall Dr. Samer Minkara

3C8	7136	Architecture Trade-off Analysis Method® (ATAM®) for System Architecture Evaluation	Mr. Michael Gagliardi Mr. William Wood Mr. John Klein
3C8	7081	Littoral Combat Ship (LCS) Mission Modules Integration: An Open Architecture Approach	Mr. Cecil Whitfield Mr. Jose Casals Mr. Kenneth Montgomery
3D1	6886	Air Force Systems Engineer Assessment Model (AF SEAM)	Mr. Randall Bullard Mr. George Freeman
3D1	7204	Advancing Systems Engineering Practice within the Department of Defense: Overview of DoD's Newest University Affiliated Research Center (UARC)	Ms. Sharon Vannucci Mr. Dennis Barnabe
3D1	7030	Defining 100 Best Practices for Systems Engineering	Mr. Ian Talbot
3D1	7093	Systems Engineering Performance Measures	Mr. James C Miller
3D2	7003	Applicable Documents	Mr. James R van Gaasbeek
3D2	7014	Systems Engineering in the Science and Technology Environment – Best Practices and other Lessons Learned from the Air Force Research Laboratory	Mr. William P Doyle Mr. Michael C Bartmess
3D2	7031	Lessons Learned Doing Systems Engineering Assessments on the Government	Mr. Ian Talbot
3D3	7462	Applying the Tenets of Military Planning and Execution to Project and Systems Engineering Management	Mr. Philip Lindeman
3D3	7479	360 degree view of the technology, strategy and business	Mr. Min-Gu Lee
3D3	7385	Enabling More Effective Weapons Systems Acquisition and Sustainment through an Enterprise Approach	Mr. John Stewart Mr. Pat Morris Mr. John Liss Mr. Rich Fredricks Dr. Iraj Hirmanpour
3D4	7515	The Intersection of System Safety, Lean Engineering, and Ergonomics	Dr. Lee Ostrom Ms. Cathy Rothwell
3D4	7258	Joint Service Safety Testing Study	Ms. Paige Ripani
3D4	7442	What Systems Engineers Need to Know About System Environmental Noise	Ms. Lynn Engelman
3D5	7228	Total System Modeling: A System Engineering Application of the Higraph Formalism	Mr. Kevin Fogarty Dr. Mark Austin
3D5	7174	Virtual Battlespace Center for Systems Engineering	Mr. James W Hollenbach
3D5	7077	Near-field RCS and Fuze Modeling and Simulation	Mr. David Hall Ms. Dorothy L Saitz
3D6	7413	Systems Engineering Approach for Assessing a Warfighter's Cognitive Performance	Mr. James Buxton Mr. Kevin Roney Mr. Albert A Sciarretta
3D6	7280	Multiple Information Agents for Real-Time, Dynamic Situational Awareness: Architectures for Real-Time Warfighter Support	Dr. James A Crowder
3D6	7046	Cost-Effective Survivable Network Design Framework	Dr. Dennis M Moen

ADDITIONAL AUTHORS
CONTINUED

3D6	7377	The Joint Surface Warfare JCTD: Maturing Weapon Data Link Concepts into Operational Capability	Mr. Robert K. Finlayson, III
3D7	7383	Extending Enterprise Systems for an Integrated Logistics Management Environment	Mr. Mike Korzenowski Mr. Kurt Hansen Mr. James Garrity
3D7	7390	Systems Engineering of Deployed Systems	Mr. Robert K. Finlayson, III Mr. Bryan E. Herdlick
3D7	7455	The Seven Affordability Sins of Logistics System Integration	Dr. Thomas E Herald, Jr. Mr. Joseph S. Bobinis, PMP
3D8	7428	Adaptable Architecture for System of Systems	Mr. Bruce Schneider Mr. Joe Wolfrom
3D8	7109	Applying Open Architecture Concepts to Mission and Ship Systems	Mr. John M Green Mr. Gregory A. Miller
3D8	7273	US Air Force Global Persistent Attack Architecture, Process, & Risk Analysis	Major Jeffrey D Havlicek Major Brian Hazel Major John Eller Mr. Brendan Rooney
3D8	7285	Universal Architecture Description Framework	Mr. Jeffrey O. Grady, CSEP
4A1	7186	Air Force Implementation of NRC "Pre-A SE" Study Committee Recommendations	Mr. Jeff Loren
4A1	7697	Enhancing Systems Engineering in the Department of Defense	Mr. Ceasar Sharper
4A1	7281	A Holistic Approach to System Development	Mr. Douglas T Wong
4A2	7179	Integration of Systems and Software Engineering: Implications from Standards and Models Applied to DoDs' Acquisition Programs	Mr. Donald J Gantzer Ms. Lisa Reuss
4A2	7076	Systems and Software Life Cycle Process Standards: Foundation for Integrated Systems and Software Engineering	Ms. Teresa Doran
4A2	7111	Improving Process Utilizations with Tools	Mr. Frank J Salvatore Mr. Richard Swanson
4A3	7158	Achieving Success for Program Managers: Integrating Work Breakdown Structure, Schedule, and Work packages	Mr. Philip J Simpkins
4A3	7113	Lessons Learned in EVM Control Account Analysis and Design	Mr. Thomas R Cowles
4A3	7010	Integrating Systems Engineering with Earned Value Management	Mr. Paul Solomon
4A4	6984	Evaluation of an Immersive Virtual Collaboration Environment for System Development	Mr. Redge Bartholomew
4A4	6881	A Systems Engineering Approach For Balancing Powered Trailer Requirements	Mr. Dana F Peterson, CSEP
4A4	7028	Semi Autonomous Unmanned Aerial Systems with Collaborating Behaviors	MAJ Edward B Teague
4A5	6944	Establishing the Need for Functional Analysis in Systems Development	Dr. Robert J. Monson Mr. David Lindstrom
4A5	6946	Improving Systems Engineering Execution and Knowledge Management	Mr. Steven C Head Mr. Bill Virostko

4A5	7034	Modeling and Simulation Education for the Acquisition/T&E Community	Dr. David H. Olwell Ms. Jean M. Johnson
4A6	7613	Prognostics Based Health Assessment System Approaches	Mr. Ronald D Newman Ms. Mary Nolan Mr. Greg DeMare
4A6	7447	Prognostics as an Approach to Improve Mission Readiness and Availability	Mr. Sony Mathew Dr. Michael G Pecht
4A6	7580	Engineering Solutions for Fleet Readiness Centers utilizing an Avionics Rapid Action Team Innovation Cell	Mr. William Birurakis, Jr. Mr. Stu Paul
4A7	7481	Defining the Prognostics Health Management Enterprise Architecture	Mr. Ethan Xu
4A7	7131	Sustaining Systems Engineering - The A-10 Example	Dr. David R Jacques
4A8	7069	The Value of Architecture	Mr. Frank J Salvatore
4A8	7401	Enabling Systems Engineering with an integrated Approach to Knowledge Discovery and Architecture Framework	Mr. Michael R Collins Mr. John M. Green
4A8	7453	Open Architecture in Electronics Systems	Mr. Bruce R Bardell
4B1	7004	Operational Concepts	Mr. James R van Gaasbeek
4B1	7214	Developing and Maintaining the Technical Baseline	Mr. Michael G Uchino
4B1	7296	The dangers of oversimplifying availability	Dr. Jeffrey M Harris
4B2	7325	Applying CMMI High Maturity Practices and Leveraging LEAN Six Sigma	Mrs. Ann Hennon
4B3	7363	Integrated Risk and Opportunity Management	Ms. Audrey Dorofee Mr. Christopher Alberts
4B3	7459	Multi-Factor Risk Management	Ms. Laura West Ms. Felicia Hong
4B4	7063	Product Platforms in Support of Rapid Response to DOD In-Theatre Force Protection Needs	Dr. Steven B Shooter Mr. Stephen Luckowski Mr. Thomas Kiel
4B4	7102	Reengineering Electronic Warfare: Shifting From Platform- To Capability-Centric Engineering	Mr. William B Anderson Mr. Joseph Elm Lt. Michael Thompson Mr. John Hawrylak Mr. Ray Williams
4B4	7278	Integrating Metrics with Qualitative Temporal Reasoning for Constraint-Based Expert Systems	Dr. James A Crowder
4B5	7094	Development and Validation of a Systems Engineering Competency Model	Dr. Don Gelosh
4B5	7098	Accelerate Performance Improvements: Systems Engineering Skills Competency Analysis and Training Program Development	Mr. Steven A Diebold Mr. Wendell Mullison
4B5	7130	Concept Definiti - A Historical Perspective	Dr. David R Jacques
4B6	7520	NDIA ID Electronic Prognostics (E-Prog) Task Follow-on Study to Quantify Weapon System Benefits.	Mr. Paul L Howard

ADDITIONAL AUTHORS
CONTINUED

4B6	7597	Enterprise Health Management Emerging Technology Transition Enabling Plan	Mr. Chris M Reisig Mr. Thomas Dabney Dr. James Dill
4B7	7188	Reliability Centered Maintenance applied to the CH-47 Chinook Helicopter–Universal principles that go beyond Equipment Maintenance	Ms. Nancy Regan
4B7	7207	Sustainment Engineering versus Systems Engineering, Is There A Difference?	Ms. Karen B Bausman
4B7	7064	Reliability Growth Analysis of Mobile Gun System during PVT	Dr. Dmitry Tananko Mr. Sharad Kumar Mr. John Paulson Ms. Jenny Chang
4B8	7079	The Benefits of Synergizing Naval Open Architecture Practices and Principles with Systems Engineering Processes	Mr. Mike Dettman
4B8	7029	Concurrent Increment Sequencing and Synchronization with Design Structure Matrices in Software-Intensive System Development	Dr. Peter Hantos
4B8	7365	Enabling the Successful Transition from Architecture to Concept Design	Mr. Chris Ryder
4C1	7054	Presentation: “Using Lean Principles and Process Models to Achieve Measurable Results”	Mr. Tim Olson
4C1	7265	Rocket Motor Development Cycle Time - Business Process Review	Mr. Jose Gonzalez
4C1	7289	Process Tailoring Patterns and Frameworks for Accelerating Systems Engineering Processes	Mr. Larry J Earnest
4C2	7400	Systems Engineering Initiative – How do you implement a new lessons learned process and tool on a legacy program?	Mr. Ray A Polo Mr. Christian A Stillings Ms. Marybeth Catoline Mr. Dale Retrum
4C2	7422	NDIA CMMI Working Group: Status and Plans	Mr Geoff Draper
4C2	7441	Process Enrichment Boot Camp - An intensive introduction to a generic, enterprise-wide, strategic communication and continuous improvement methodology	Mr. Victor A. Elias
4C2	7446	Making Lessons Learned Come Alive and be Practical	Mr. Forrest Shull Ms. Michele A Shaw Mr. Raimund L Feldmann
4C4	7417	VIRGINIA (SSN-774) Class Systems Engineering to Reduce Total Ownership Cost	Mr. George M. Drakeley, III Mr. Steve Lose Mr. George L Becker
4C4	7497	Accuracy Control Tools, Technology, and Processes used for Addressing Hull Fairness	Mr. Stephan H Hankins Mr. Jimmy R. Sharp
4C4	7463	The C-17 PIO Team	Mr. David Murray
4C5	7308	PeaceKeeper Intercontinental Ballistic Missile Systems Engineering Case Study	Mr. Charles M Garland
4C5	7474	Capture of Critical Engineering Skills and Knowledge	Mrs Ann Hennon

Promotional Partner

LOCKHEED MARTIN



Why CMMI Isn't Enough?

Systems Engineering Conference
October 20-23, 2008

Anita Carleton
Tim Chick



Performance Results of CMMI – Based Process Improvement

Performance Category	Median Improvement
Cost	34%
Schedule	50%
Productivity	61%
Quality	48%
Customer Satisfaction	14%
Return on Investment	4:1

WARNING: Results may vary!

Source: <http://www.sei.cmu.edu/pub/documents/06.reports/pdf/06tr004.pdf>



Why results vary - 1

Two different approaches to CMMI based Process Improvement:

- Bureaucratic improvement that comes to life only when assessments are to be performed
- Improvement efforts that are based on achieving business objectives which are embedded into the culture of an organization and actively supported by the entire staff



Why results vary - 2

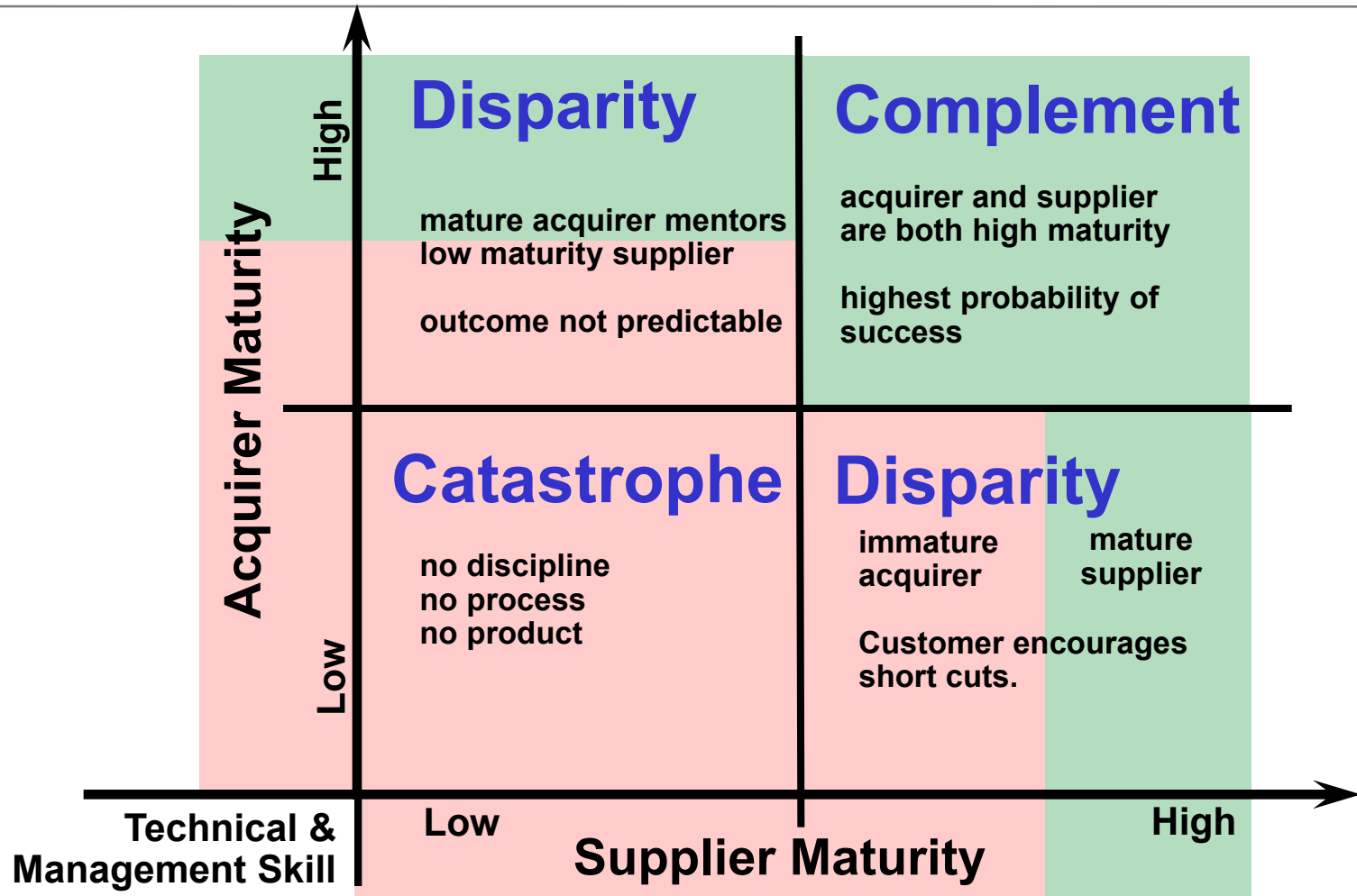

Source: http://www.dau.mil/pubs/dam/11_12_2006/11_12_2006_chi_nd06.pdf



Bureaucratic Improvement

Bureaucratic Improvements can be very successful in changing the organizational culture. However it doesn't fundamentally change the developers individual behavior or processes.

Resulting in continued quality, cost and schedule issues. Because ultimately only the developers can control the quality of the product, which directly impacts the cost and schedule.

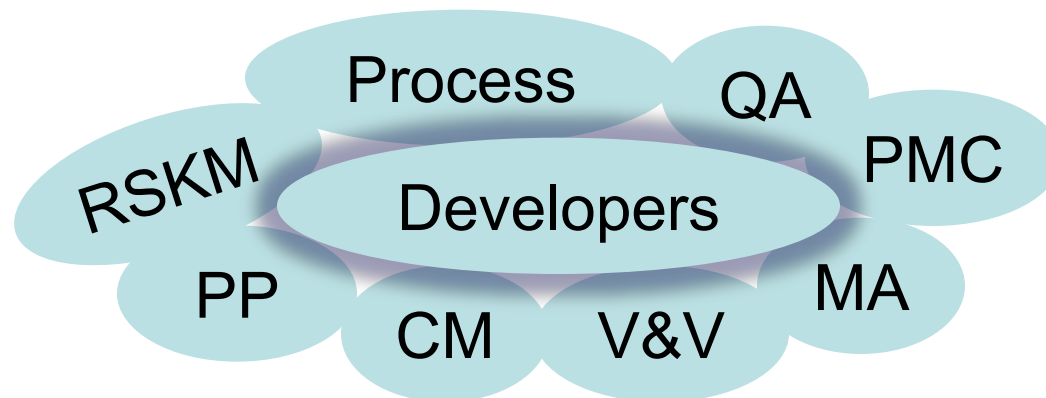

How to get the performance you expect using CMMI

Improvement efforts that are based on achieving business objectives which are embedded into the culture of an organization and actively supported by the entire staff:

Achieving a maturity rating doesn't guarantee improved performance

To get high performance, you need to build a solid foundation from the beginning

Performance becomes an enabler for high maturity

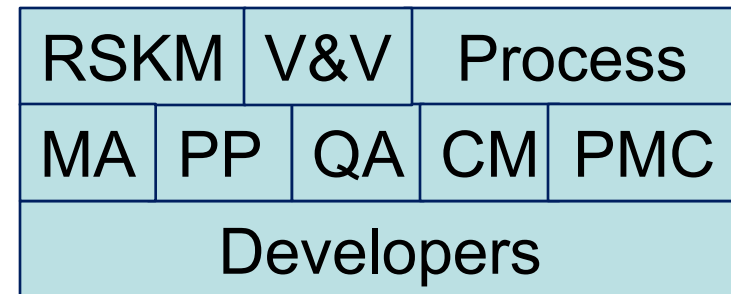

Definitions

High Performance –

High performance means obtaining superior outcomes.

High Maturity –

Implementing the concepts and practices at levels 4 and 5 of CMMI.

High Maturity Practices –

The "specific practices" and "generic practices" at levels 4 and 5 of CMMI.



Align Business Objectives

Are we getting more business moving to a higher maturity?

Are we shipping (releasing) higher quality products?

Do we have better performance?

Do our products have more functionality?

Are we reducing our costs?

Are we meeting our schedules?

How do we get high performance from high maturity?



Prerequisites for High Performance

Before an organization can perform high maturity activities, it must:

- Gather and use data at all organizational levels
- Defined operational processes that specify how and when the data are gathered
- Faithfully execute the defined processes

This implies that individuals and teams gather data on their own and use the data to plan and perform work



To Get High Performance, Address Team and Individual Discipline

A high-performing **organization** must be built of high performing teams.

High performing **teams** must be built of high-performing individuals.

High-performing **individuals** must be disciplined to gather and use their own data.

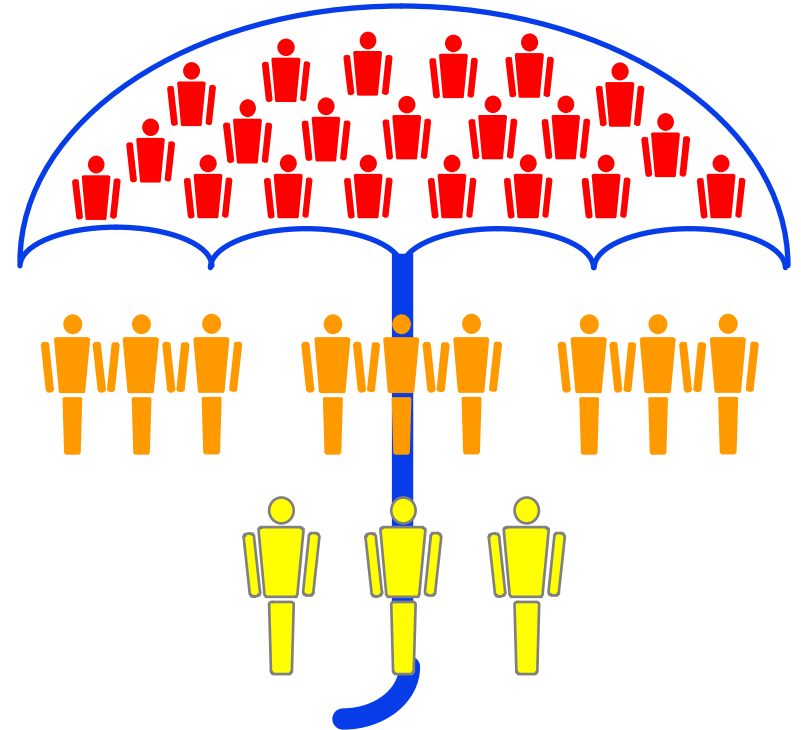

For a successful case study showing the integration of CMMI and TSP, please see —“CMMI Level 5 and the Team Software Process” by Webb, Miluk, and Van Buren in CrossTalk April 2007.

<http://www.stsc.hill.af.mil/crosstalk/2007/04/0704WebbMilukVanBuren.html>



Operationalizing CMMI Practices

What does operationalize mean?

- To put something to use

What are characteristics of an “operationalized” process?

- The people who use the process own the process and have the authority to adapt and improve it.
- The “process owners” are in the best position to understand the process strengths and weaknesses.
- If people “own the process,” they will be more willing to fairly evaluate process changes.



Once you collect data, what do you do with it?

Discussion:

- Why do you need to periodically review your process data?
- How often should you review your process data?
- What happens if you review your process data too often? too seldom?

If you have already set goals, you start by understanding your performance against those goals.



Analyzing Performance



Analyze your performance with respect to size estimation, effort estimation, and quality management to:

- understand your current performance
- identify your highest-priority areas for improvement
- establish challenging but achievable goals, and
- define corresponding improvement actions to meet those goals
- define actions to address challenges you will face in making those changes



Analysis of Size Estimating Accuracy



Review your performance on size estimating accuracy. For example:

- How much did your size estimating accuracy change? Why?
- Do I have a tendency to add/miss entire parts?
- Do I have a tendency to misjudge the relative size of parts?
- Do I need to calculate relative size range data using my historical data?
- Based on my historical size-estimating accuracy data, what is a realistic size-estimating goal for me?
- How can I change my process to meet that goal?



Analysis of Time Estimating Accuracy



Review your performance on effort estimating accuracy. For example:

- How much did your effort estimating accuracy change? Why?
- Is my productivity stable? Why or why not?
- How can I stabilize my productivity?
- How much are my time estimates affected by the accuracy of my size estimates? (Would multiple regression help me?)
- Based on my historical time-estimating accuracy data, what is a realistic time-estimating goal for me?
- How can I change my process to meet that goal?



Defect and Yield Analysis



For example:

- What type of defects do I inject during design and coding?
- What trends are apparent in defects per size unit (e.g., KLOC) found in reviews, compile, and test?
- What trends are apparent in total defects per size unit?
- How do my defect removal rates (defects removed/hour) compare for design review, code review, compile, and test?
- What are my review rates for design review and code review?
- What are my defect-removal leverages for design review, code review, and compile versus unit test?
- Is there any relationship between yield and review rate for design and code reviews?



Leading vs. Lagging Indicators



Case Study - 1

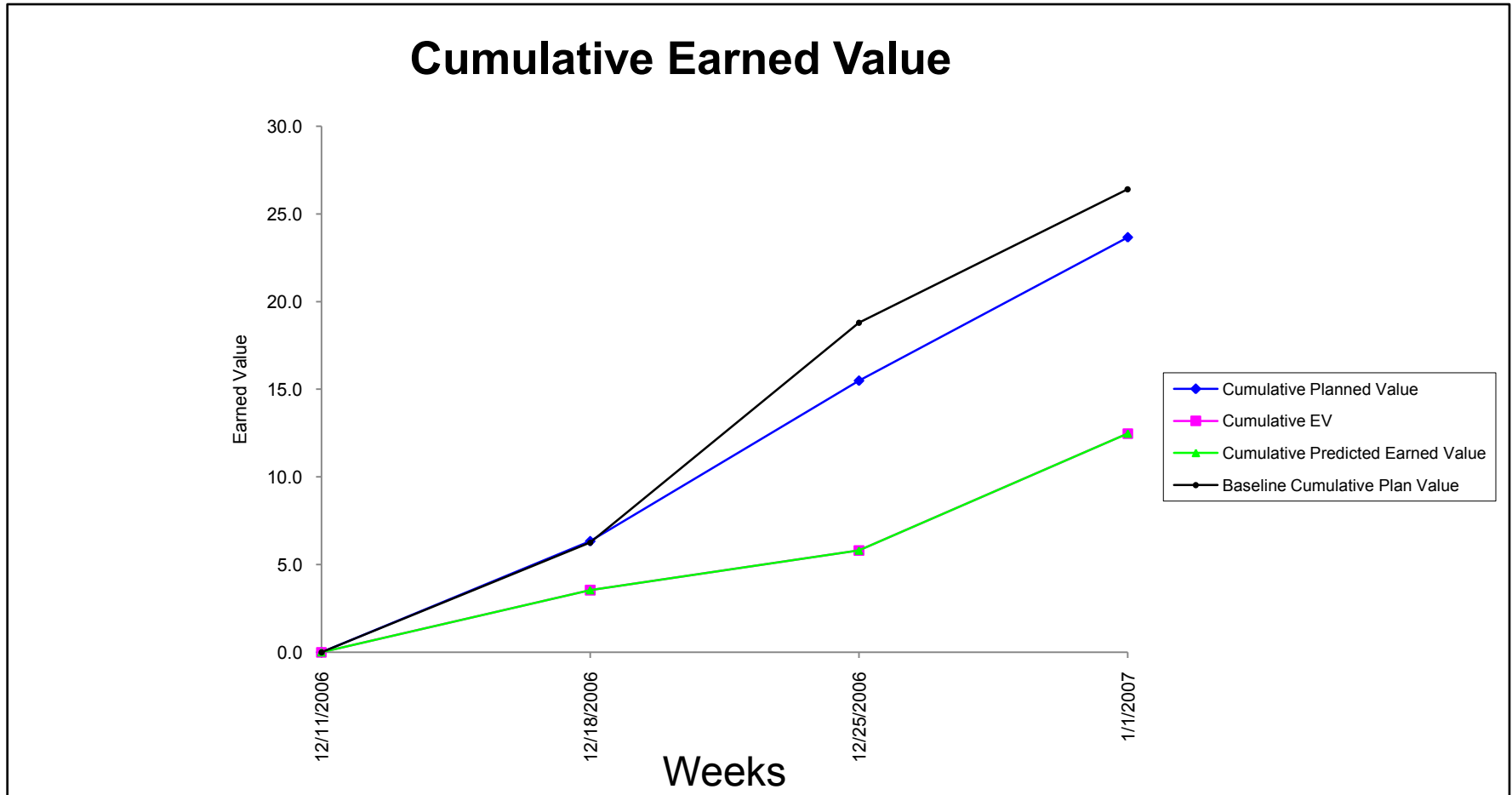

Case Study - 2

TSP Week Summary - Form WEEK										
Name	Consolidation				Date	11/8/2007				
Team	Example week									
Status for Week	2		Selected Assembly			Cycle	1			
Week Date	7/2/2007		SYSTEM							
Task Hours	%Change		Weekly Data	Plan	Actual	Plan / Actual	Plan - Actual	Project End Dates		
Baseline		1280.1	Schedule hours for this week	45.5	26.9	1.69	18.6	Baseline	2/4/2008	
Current		1332.1	Schedule hours this cycle to date	86.9	48.6	1.79	38.3	Plan	2/4/2008	
%Change		4.1%	Earned value for this week	1.3	0.7	1.86	0.6	Predicted	11/16/2009	
			Earned value this cycle to date	3.7	3.4	1.10	0.3			
			To-date hours for tasks completed	44.7	31.9	1.40				
			To-date average hours per week	43.4	24.3	1.79				
			EV per completed task hour to date	0.075	0.105					

A team is in week 2 of 7 month plan.

The team is behind 10% in Earned Value but the projected date for project completion is 2 years late— what is the problem?

The team on average is only getting a little more than half of their planned on-project task hours.

- (1) Understand why the predicted project completion is two years late?
- (2) Why aren't team members achieving planned on-project task hours?



Case Study – How Do You Get This Information?

From having operationally, defined processes (e.g., development process)

From basic, measurement data

- Operational measures (size, effort, schedule, quality)
- Measurement Definitions (task hour, defect, ...)

From tools

- To record and analyze data

From having a realistic plan

- Developed by team members who use their own data for estimating and planning



Operational Definition

Task Hour

- Count effort applied to a specific project task
- Do not count
 - Break time
 - Project tasks not in the earned value plan
 - Non-project tasks



Operational Definition

Earned Value

- Planned Value for task = estimated effort (cost) for task divided by sum of estimated effort for all project tasks
- Earned Value credited when task is complete
- In this definition Earned value always approaches 1.0 as the project nears completion



Each Week: (Actual – Planned) Effort [hours]

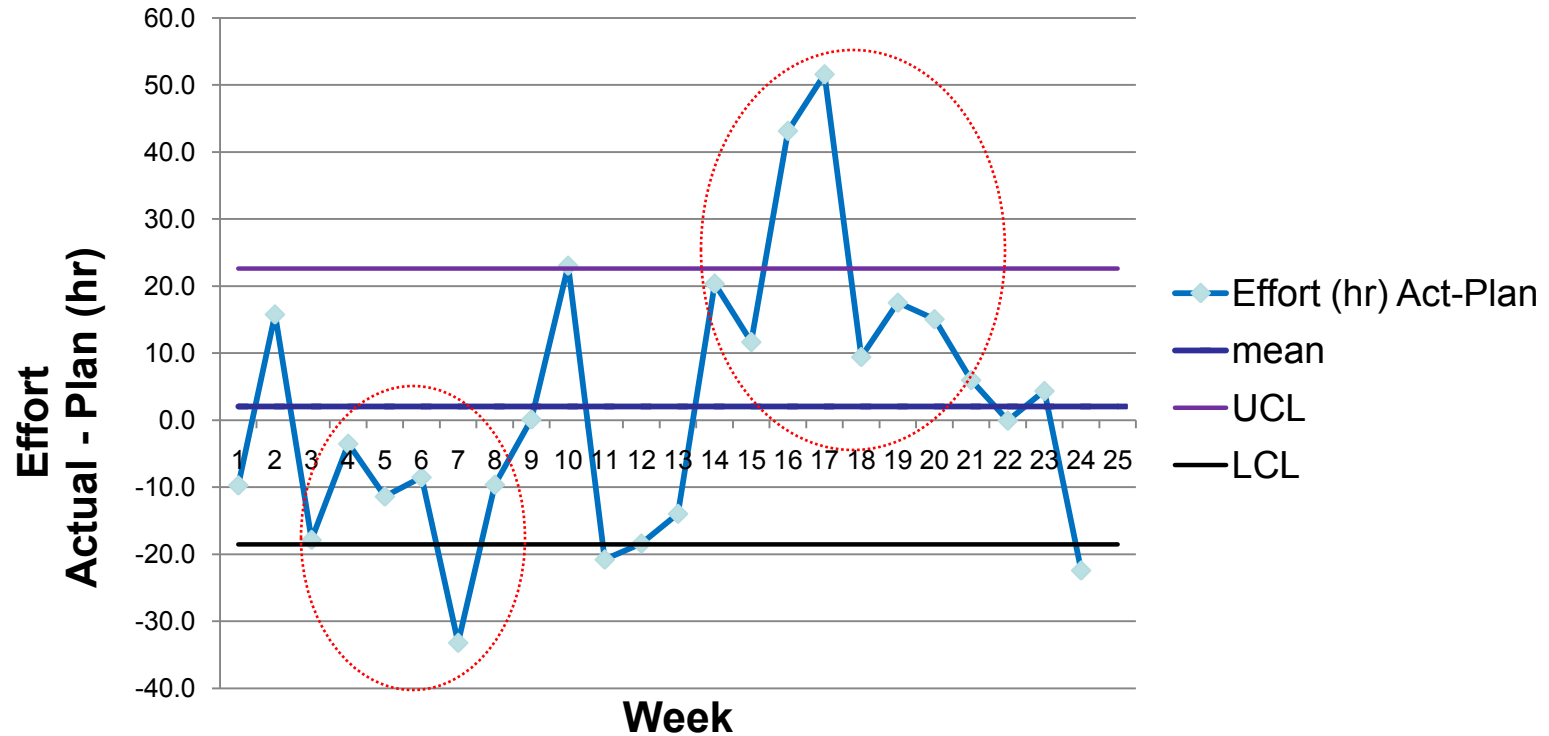

The team addressed the project effort problem.



Variation

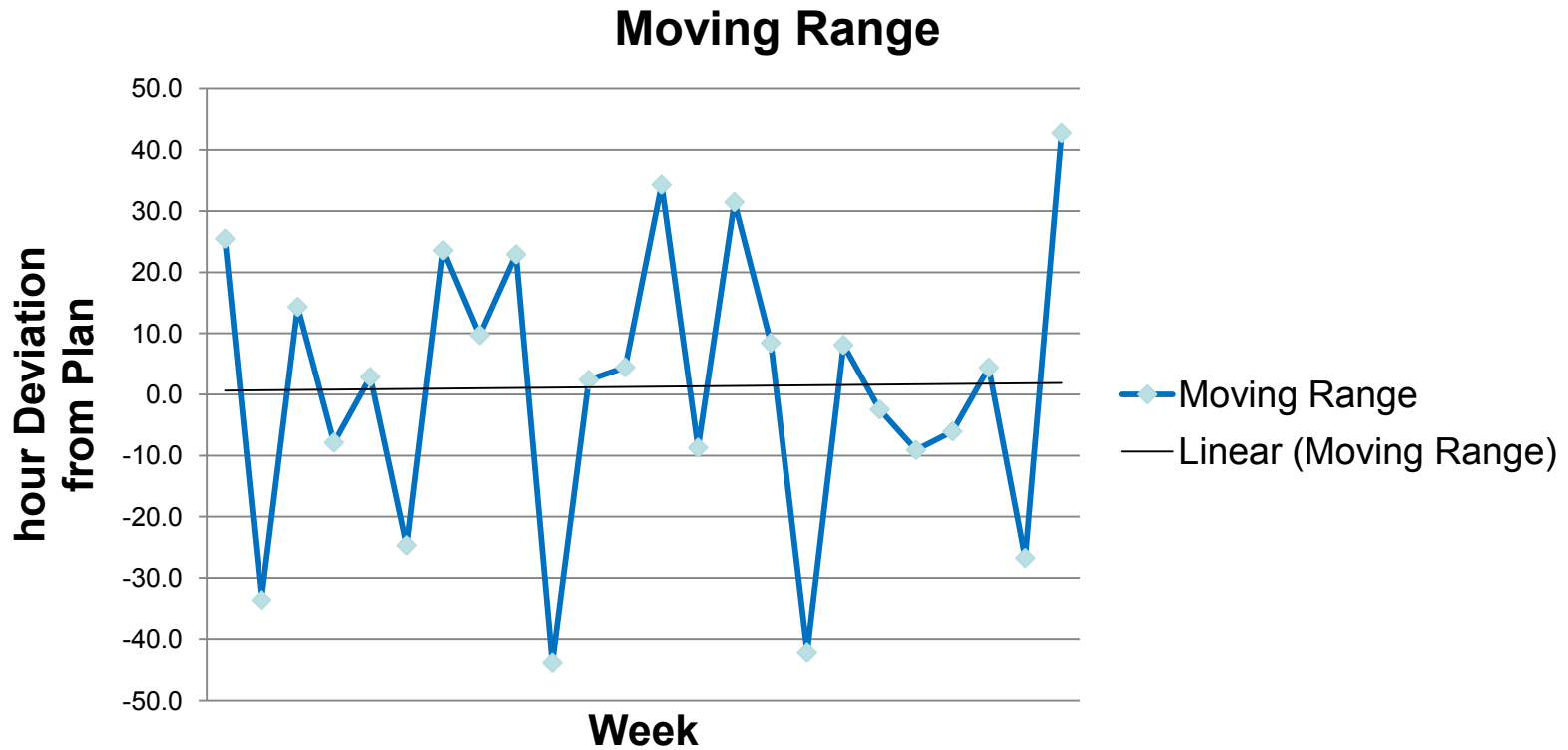

Week 8, Schedule Progress (Earned Value)

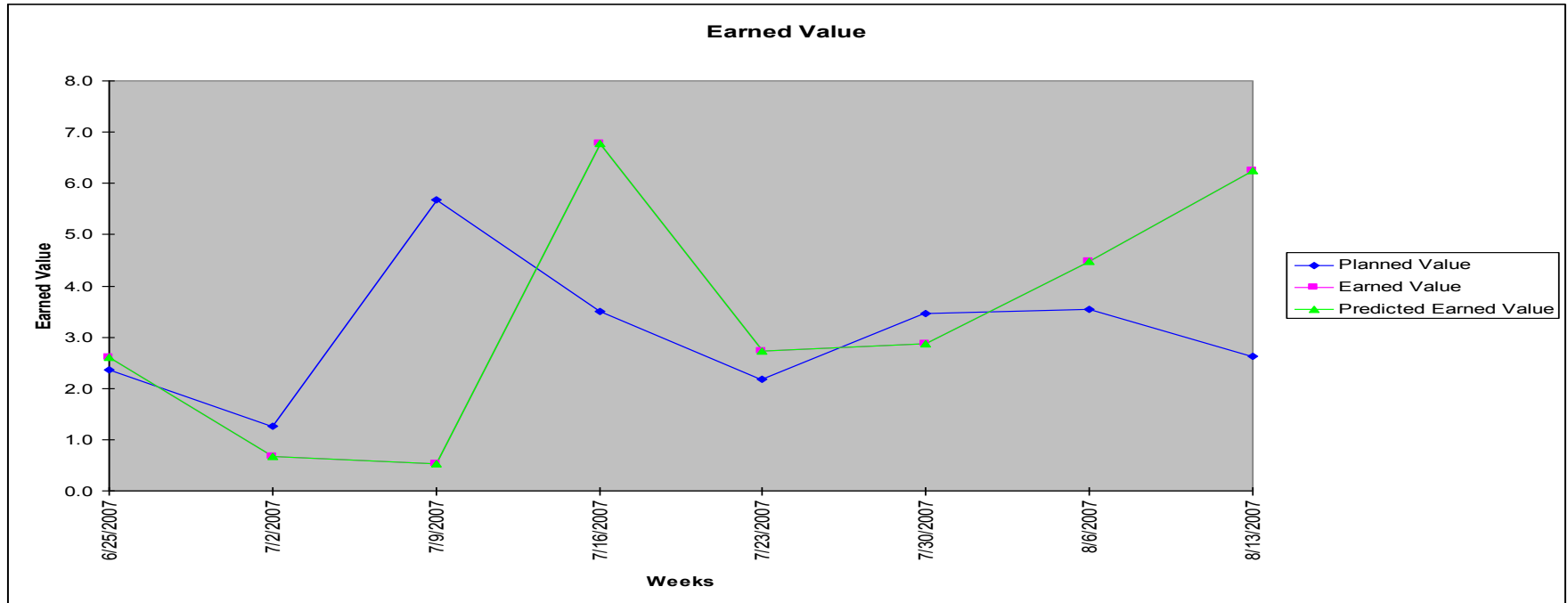

After initially falling farther behind, weekly progress stabilizes.



Weekly Status Report

Weekly status reviews:

- Plan assumptions
 - Effort plan
 - Upcoming work tasks
- Project status
 - Actual effort
 - Earned Value
 - Cost Performance
- Projections based on status and history



Week 8 Team Report

TSP Week Summary - Form WEEK							
Name	Consolidation			Date	11/8/2007		
Team	Example week 8						
Status for Week	8	Selected Assembly		Cycle	1		
Week Date	8/13/2007	SYSTEM					
Task Hours	%Change	Weekly Data	Plan	Actual	Plan / Actual	Plan - Actual	Project End Dates
Baseline	1280.1	Schedule hours for this week	47.3	43.8	1.08	3.4	Baseline 2/4/2008
Current	1358.8	Schedule hours this cycle to date	364.1	306.7	1.19	57.3	Plan 2/4/2008
%Change	6.1%	Earned value for this week	2.6	6.3	0.42	-3.6	Predicted 4/21/2008
		Earned value this cycle to date	24.6	26.9	0.91	-2.3	
		To-date hours for tasks completed	365.7	293.1	1.25		
		To-date average hours per week	45.5	38.3	1.19		
		EV per completed task hour to date	0.074	0.092			

The team actions have been effective:

- Cumulative hours have not caught up
- The team is 9% ahead of schedule
- The predicted end date is now 2 months late rather than 2 years



Are They Following Their Process?

Plan and Actual Time in Phase

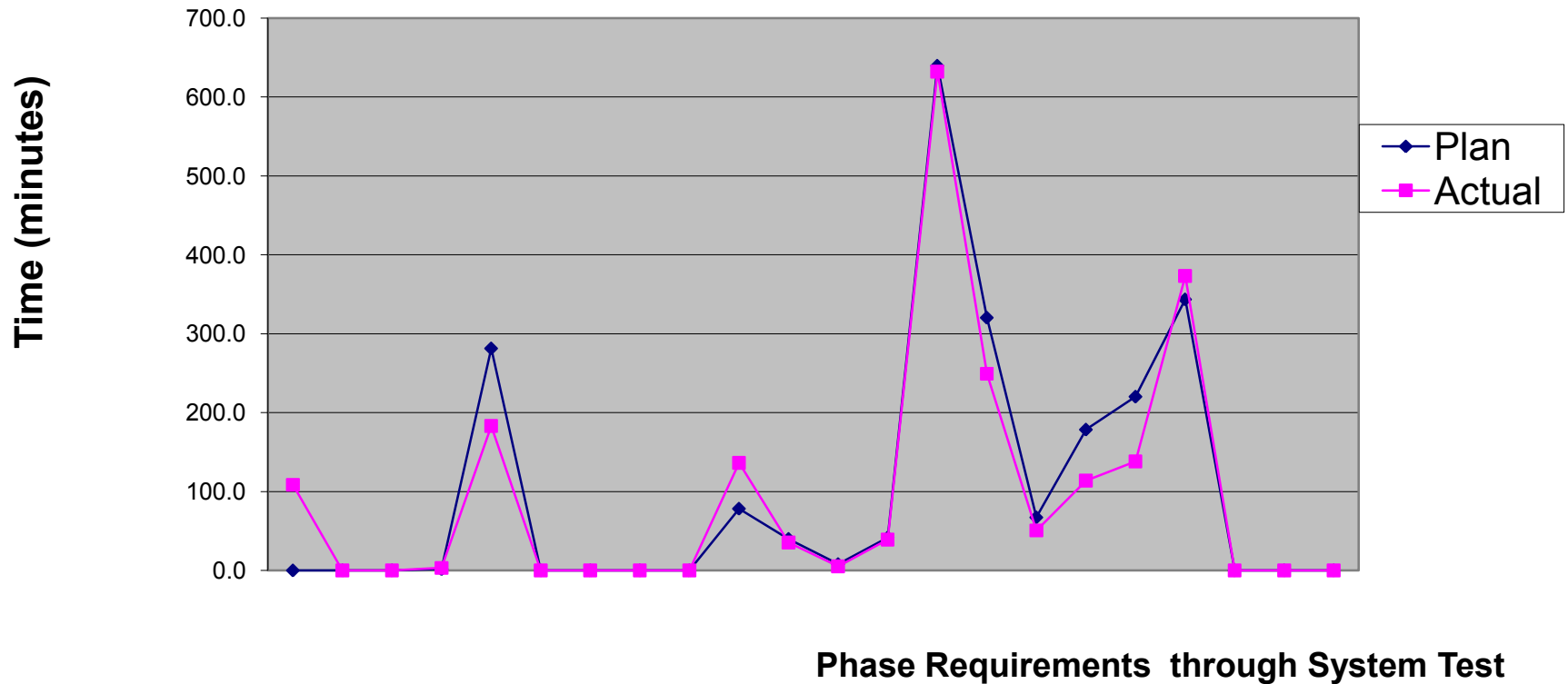

Size Estimation

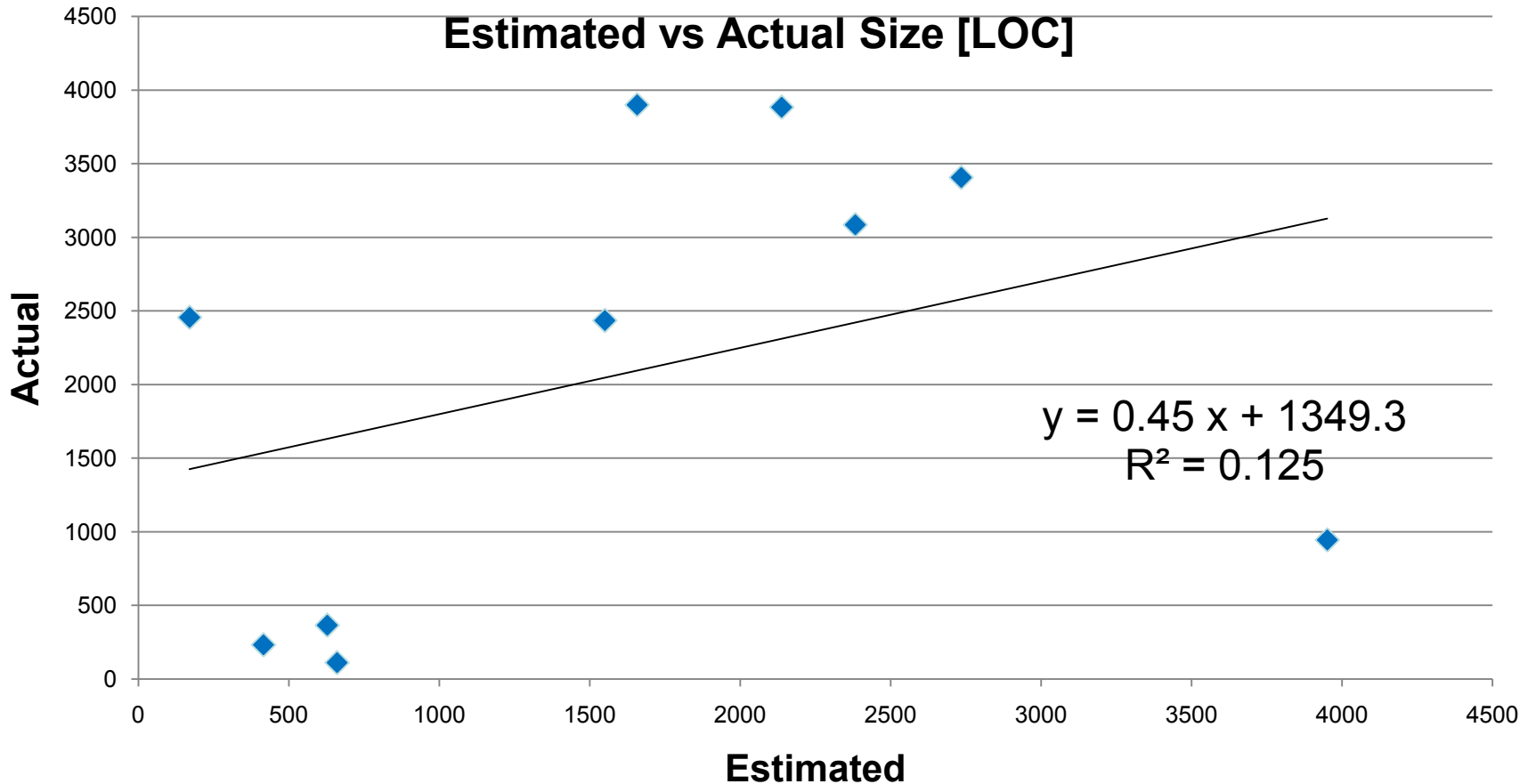

Case Study Wrap-up

Teams and individuals need to assess performance with respect to goals:

- Did we achieve our performance goals? Why or why not?
- Where do we need to improve? What could we do differently?
How would it change our performance?
- What kind of analyses need to be performed?



Summary

Build high performance through teams

Enable high maturity capabilities by building a solid foundation

CMMI and TSP are mutually reinforcing—

- CMMI provides the principles for process improvement and organizational focus
- TSP can be useful for providing team discipline and operationalizing CMMI practices



Questions?

Tim Chick

tchick@sei.cmu.edu

412-268-1473

PSP/TSP website:

<http://www.sei.cmu.edu/tsp>

TSP SYMPOSIUM 2009

4th Annual Software Engineering Institute
Team Software Process Symposium

 Software Engineering Institute | Carnegie Mellon

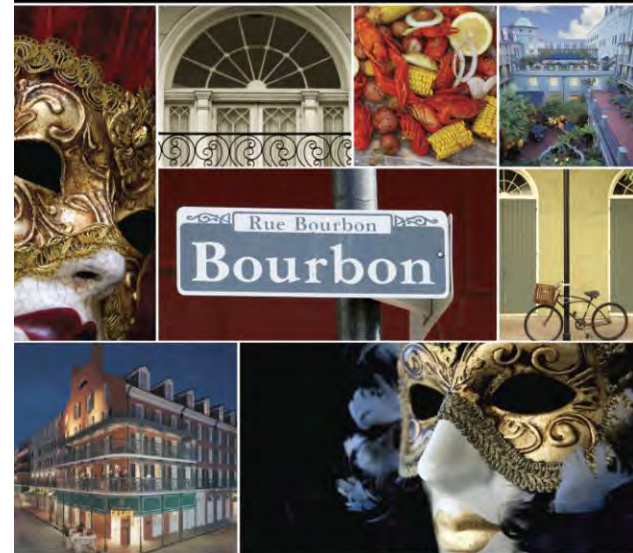

→ **SAVE THE DATE**

September 21-24, 2009 • New Orleans, LA →

www.sei.cmu.edu/tsp/symposium.html



Software Engineering Institute

Carnegie Mellon

Why CMMI isn't enough
© 2008 Carnegie Mellon University

NAVAIR Benefits from TSP

Program	Size of Program	Defect Density (Defects/KSLOC)	Cost Savings from Reduced Defects
AV JMPS	443 KSLOC	0.59	\$2,177,169
P-3C	383 KSLOC	0.6	\$1,478,243

Program	Schedule Variance	Cost Variance
AVJMPS	0.5% overrun	1.5% overrun
H2.0	1.1% overrun	6.9% overrun



Quality Benefits

- TSP dramatically reduces the effort and schedule for system test.
- Most defects are removed during reviews and inspections at a cost of 2 to 25 minutes per defect.
- System test removal costs run from to 2 to 20 hours per defect.
- These benefits continue after delivery.
 - lower support costs
 - satisfied customer
 - better resource utilization

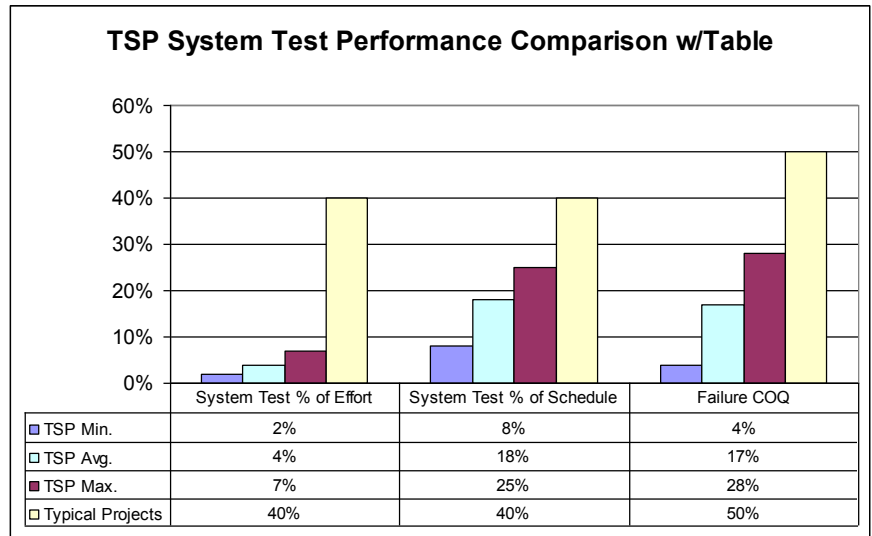

Reviews and Inspections Save Time

- Xerox found that TSP quality management practices reduced the cost of poor quality by finding and removing defects earlier when costs are lower.

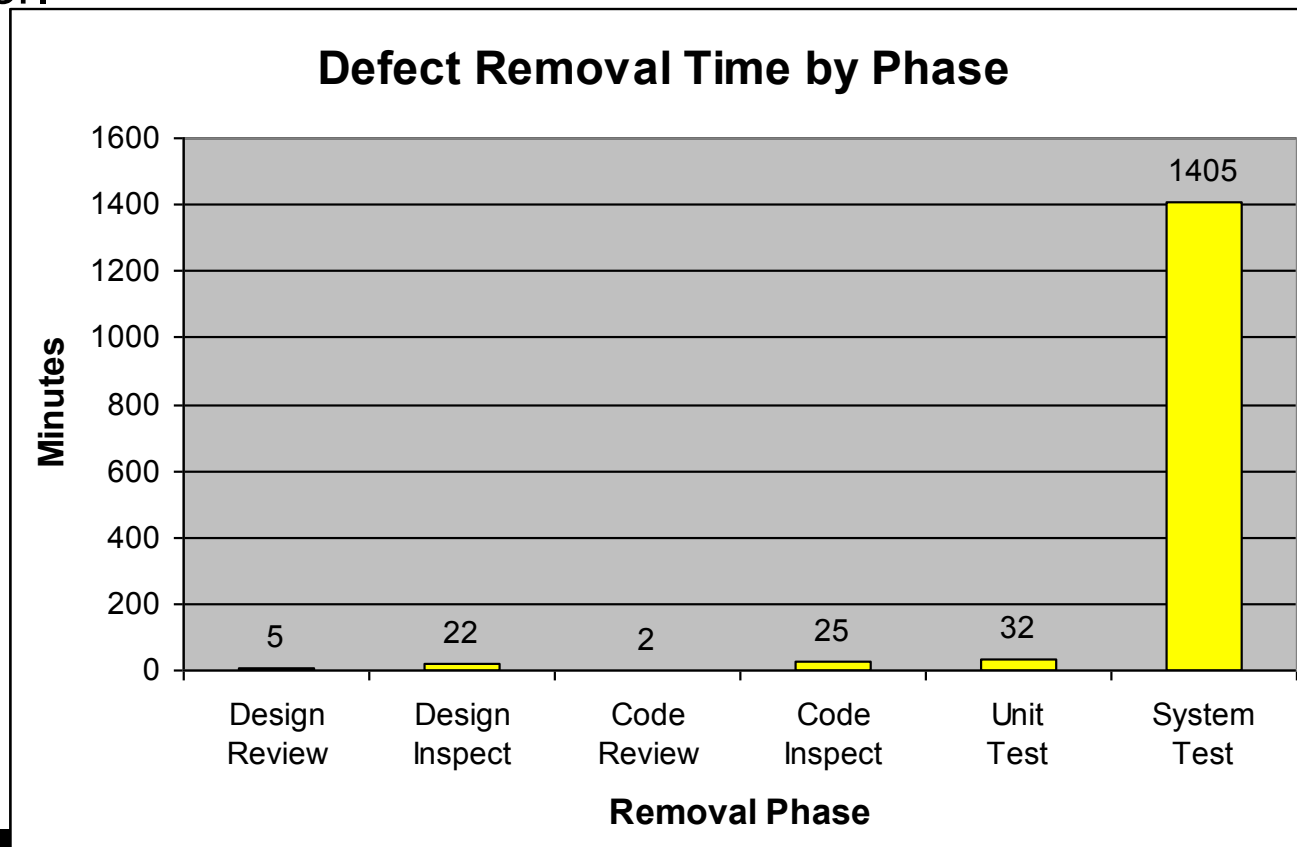

Intuit Quality Improvement

- TSP reduced defects found in system test by 60% over the previous two releases of QuickBooks 2007 release.
- Intuit has also recently reported a savings of \$20M from a reduction in customer support calls on QuickBooks 2007.

Results at Intuit: Improved Quality

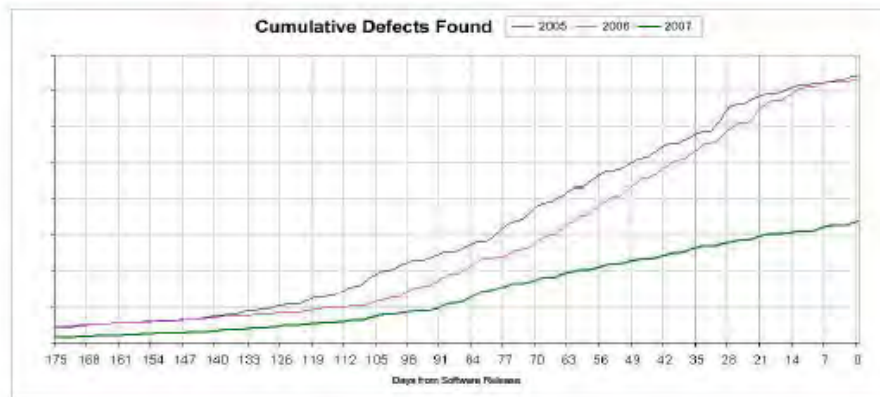

In 2007 ~60% fewer defects were found in System Test than the previous two releases

Intuit Productivity Improvement

- By putting a quality product into system test Intuit improved productivity and reduced cost while delivering 33% more functionality than planned.

Results at Intuit: Productivity

- During 2007 over 60% of Intuit's Small Business Division used TSP
- TSP was a major contributor to the QuickBooks 2007 release
- It was the smoothest release anyone can remember:
 - On time delivery of all planned scope
 - 13 new features were added during the cycle(33% of initial scope)
 - Saved \$700K in temporary testing staff expenses
 - Level of automated testing coverage was doubled compared to previous year

Focused improvements helped deliver a great release



Improving Task Hours

- At Allied Signal average task hours per developer per week were improved from 9.6 hours to 15.1 hours through quiet time, process documentation, more efficient meetings, etc.
- This is equivalent to a 57% increase in productivity.
- If you didn't have such detailed information, would you even know that you had a problem? Or an opportunity for such dramatic improvement?

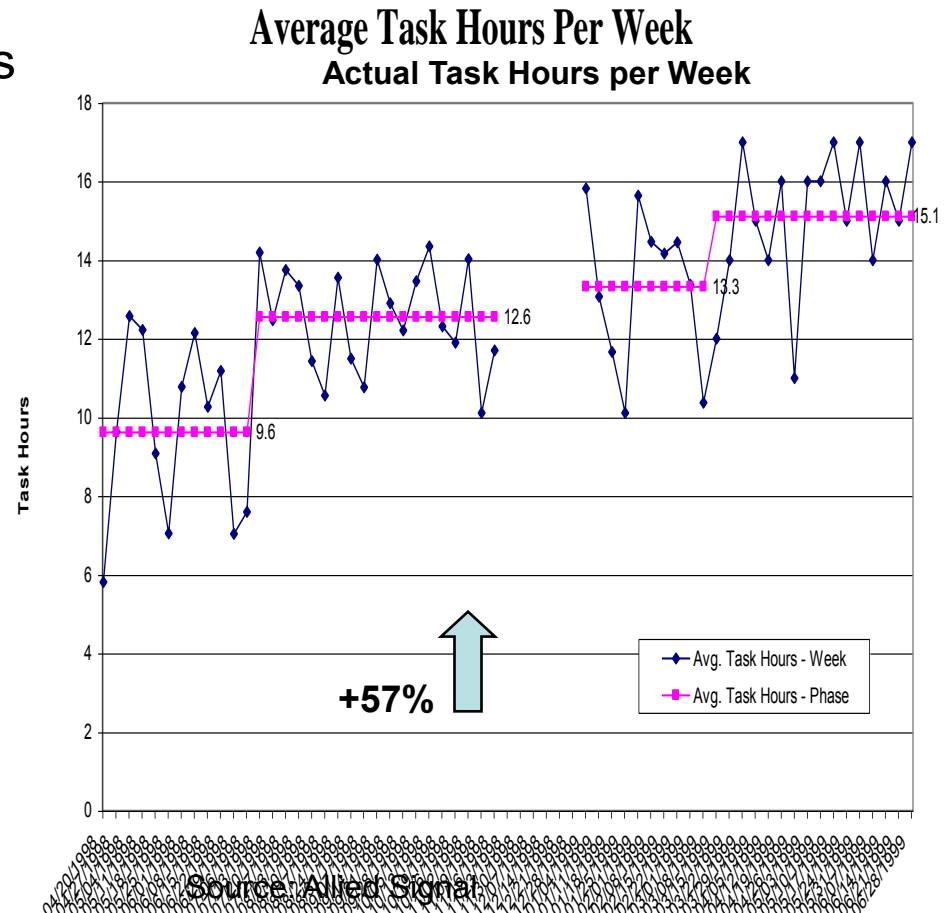

Intuit Test Schedule Reduction

- From data on over 40 TSP teams, Intuit has found that
 - post code-complete effort is 8% instead of 33% of the project
 - for TSP projects, standard test times are cut from 4 months to 1 week
- Testing time is reduced from four months to one month.

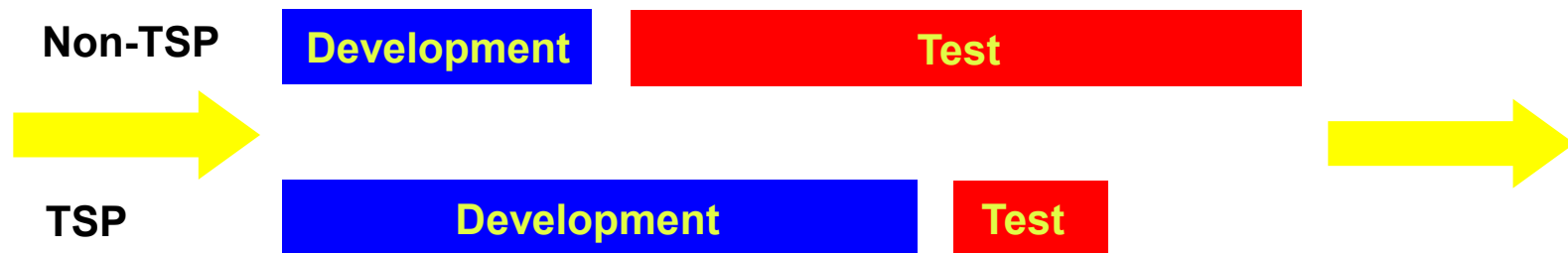

Microsoft Schedule Improvement

- First-time TSP projects at Microsoft had a 10 times better mean schedule error than non-TSP projects at Microsoft as reflected in the following table.

Microsoft Schedule Results	Non-TSP Projects	TSP Projects
Released on Time	42%	66%
Average Days Late	25	6
Mean Schedule Error	10%	1%
Sample Size	80	15



Work-Life Balance

- People are your most important resource.
- Finding and retaining good people is critical to long-term success.
- Intuit found that TSP improved work-life balance, a key factor in job satisfaction.

Results at Intuit: Improved Work-Life Balance

- Half as many weekend source check-ins (<3%)
- Reduced \$ on dinners as measured by PSS - "Pizza Slices Served"

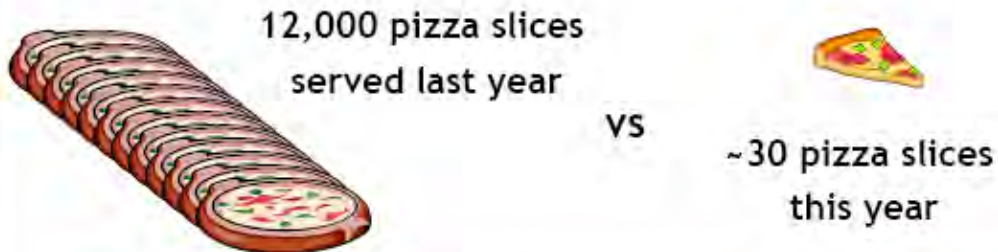

TSP helped improved employee work life balance



Intuit TSP Survey Results

- Improved work-life balance with TSP is reflected in job satisfaction surveys.

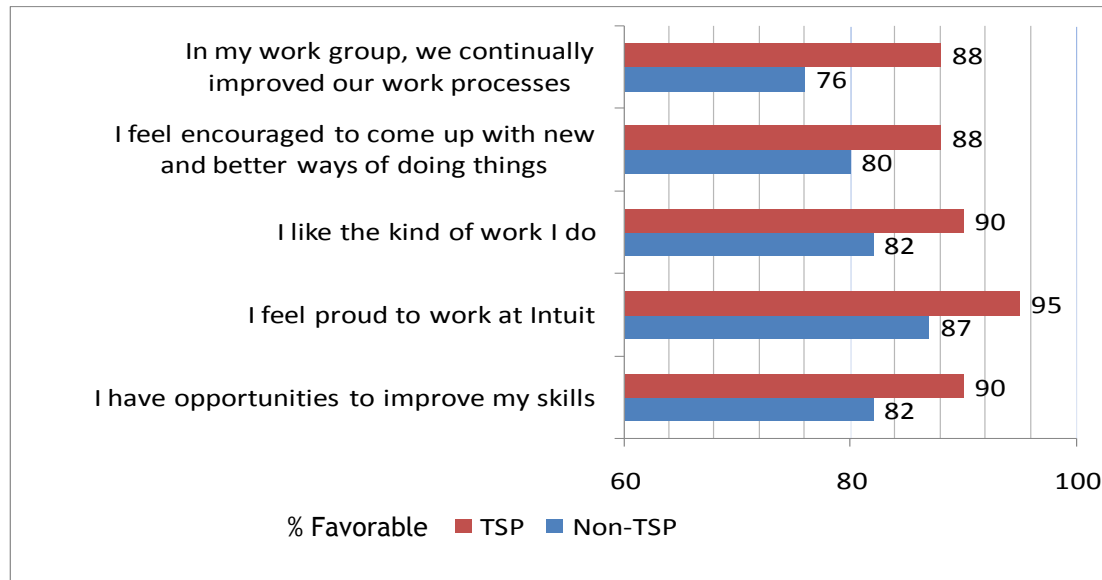

“Engineers love it... Once they adopt it they can’t imagine going back”

Source: Intuit





11th Annual Systems Engineering Conference

Reduction of Total Ownership Costs (R-TOC) and Value Engineering (VE) in the Defense System's Life Cycle

Mr. Chet Bracuto
Office of the Secretary of Defense
Acquisition, Technology & Logistics
Systems and Software Engineering

Dr. Danny Reed
Institute for Defense Analyses

October 22, 2008

R-TOC Genesis

- Initiated in 1999 by the USD(AT&L) to address:
 - **O&S cost growth** at expense of force modernization and readiness
 - O&S budget constraints limit programs to near-term, critical solutions only
 - R-TOC program seeks to seed O&S cost avoidance solutions that have broader impact
 - Thirty Pilot Programs

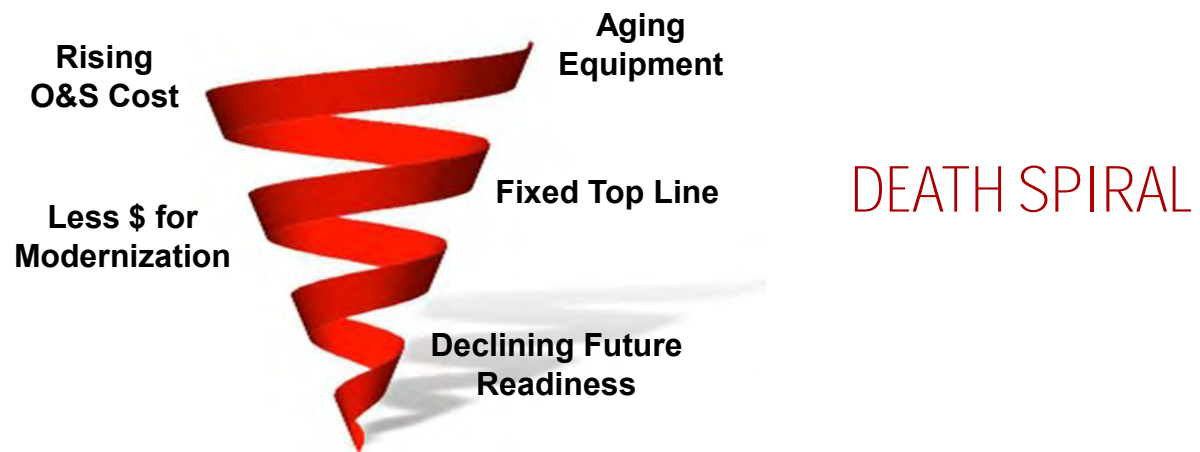

USD(AT&L) FY 2005 R-TOC Goal

- USD(AT&L) Goal: “...reduce the O&S cost of fielded systems (excluding manpower and fuel) by 20% (compared to current FY 1998 levels) by the year 2005.”
- “Overall, each Service’s O&S reduction plans will be based on tradeoffs among these three areas for savings:
 1. **Reduced demand** from weapon systems via reliability and maintainability improvements
 2. **Reduced supply chain response times**, leading to reduced spares, system support footprint, and depot needs
 3. **Competitive sourcing** of product support, leading to streamlining and overhead reductions”

FY 2005 O&S Savings

- FY 2005 cost avoidances exceeded \$2.1B
- Projected life cycle cost avoidances will exceed \$76B, for the R-TOC Pilot Programs

O&S Costs Can Be Reduced!!

**Life Cycle Savings Provides a Focus
on Long Term Benefits**

New Strategic Direction

- With the successful completion of the Pilot Programs FY 2005 goal, a new direction was needed
- Strategic Directions:
 - New goal for FY 2010
 - Focus on life cycle O&S cost reductions
 - Focus on institutionalization
 - Direct funding for long-term savings projects

USD(AT&L) FY 2010 R-TOC Goal

- USD(AT&L) Goal: “Maximize cost avoidance on total defense systems FY 2010 O&S costs from an FY 2004 baseline, by offsetting 30% of predicted inflation.”
 - Goal extends to **all** defense systems on program-by-program basis
 - 15 Special Interest Programs (SIPs) designated lead programs to “show the way” towards achieving the goal
 - SIPs are monitored through semi-annual reports and quarterly R-TOC Forums
 - Services will include this goal in their reviews
- Ultimately expand to **all** defense systems
- \$25M/year R-TOC PE created

R-TOC

Special Interest Programs (SIPs)

Army

- Bradley A3 Upgrades
- UH-60M – Upgrade
- Stryker
- UAVS
- Guardrail

Air Force

- Global Hawk
- Engines (2)
- F-16

Navy

- H-1 Upgrades
- V-22
- F/A-18E/F
- H-60
- ASE
- Common Ship

Joint

- F-35 (JSF)

Status of R-TOC SIP Program Savings

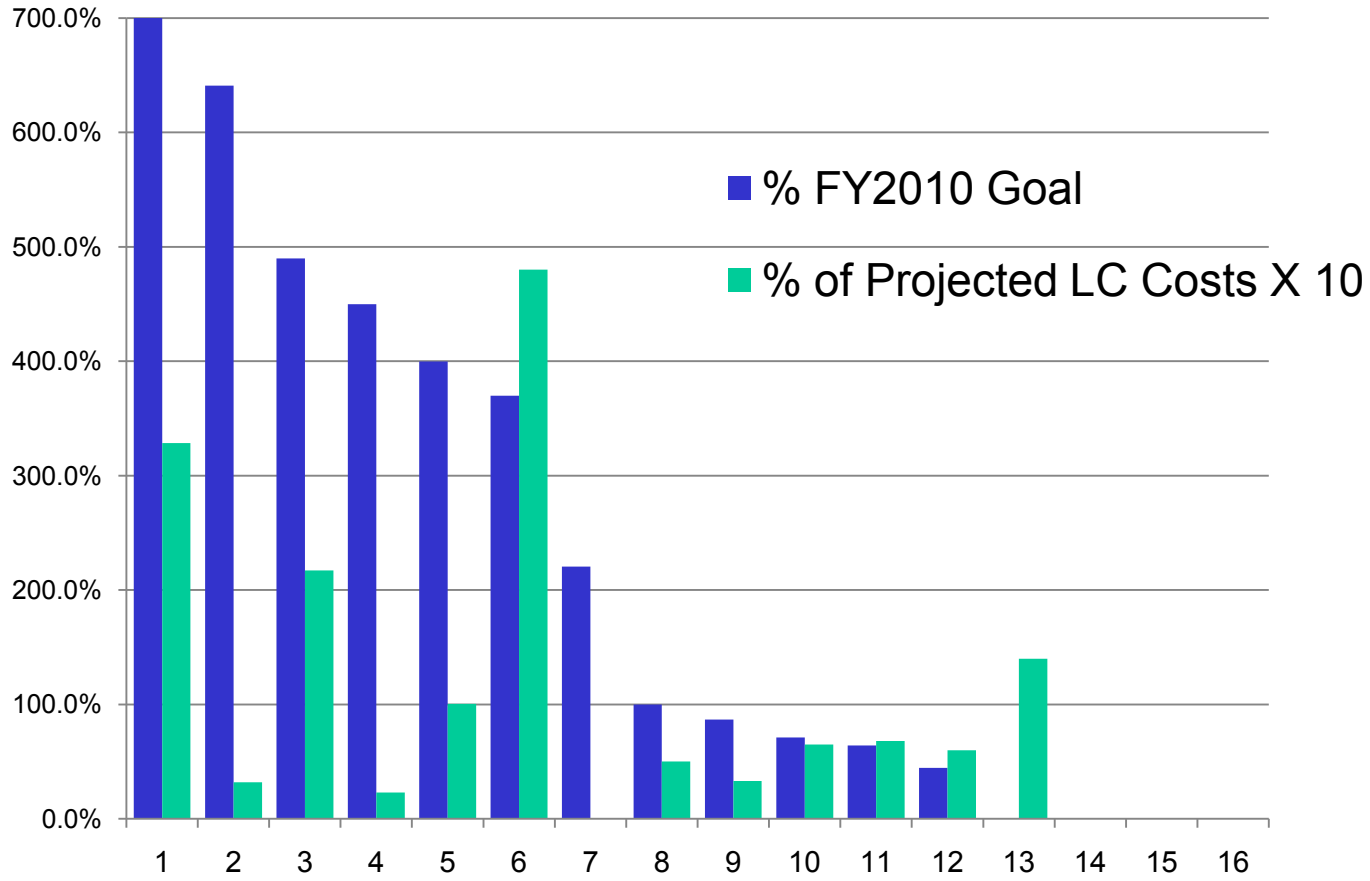



UH-60M Composite Tailcone

Program Description

Problem: The currently proposed metal tailcone for the UH-60M's, MH-60S's and MH-60R's are labor intensive to manufacture and require thousands of parts and fasteners.

Solution: Incorporate a composite tailcone into the UH-60M, MH-60S and MH-60R fleets.

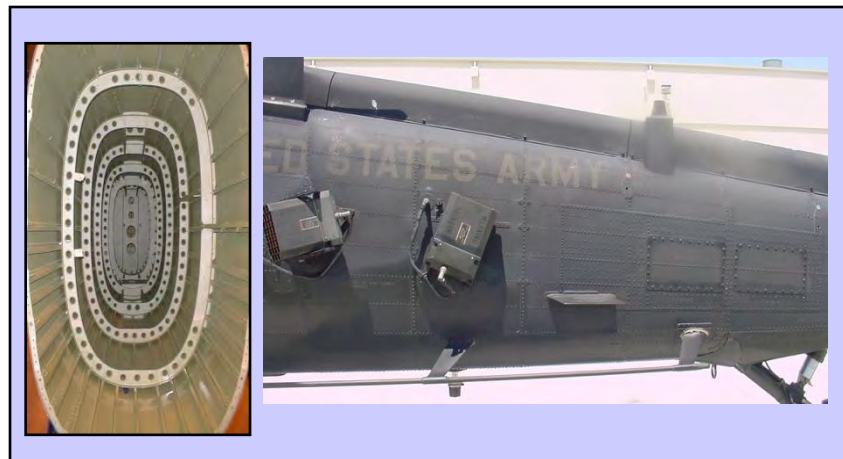

Benefits

- Cost savings of \$60,000.00 per new production aircraft.
- Fewer parts and fasteners
- No corrosion or fatigue maintenance
- Weight Reduction (50 pounds)

Investment/ROI

Investment: \$2.35M

Life Cycle ROI: 33:1



Ship's Material Condition Model

Overview/Problem

- USN does not have a consistent objective method to determine material condition and its impact on mission / warfare area
- USN has multiple antiquated software tools and systems to validate, screen and broker work candidates depending on platform type and coast
- USN has no objective method to determine future material condition readiness when routine maintenance is not performed

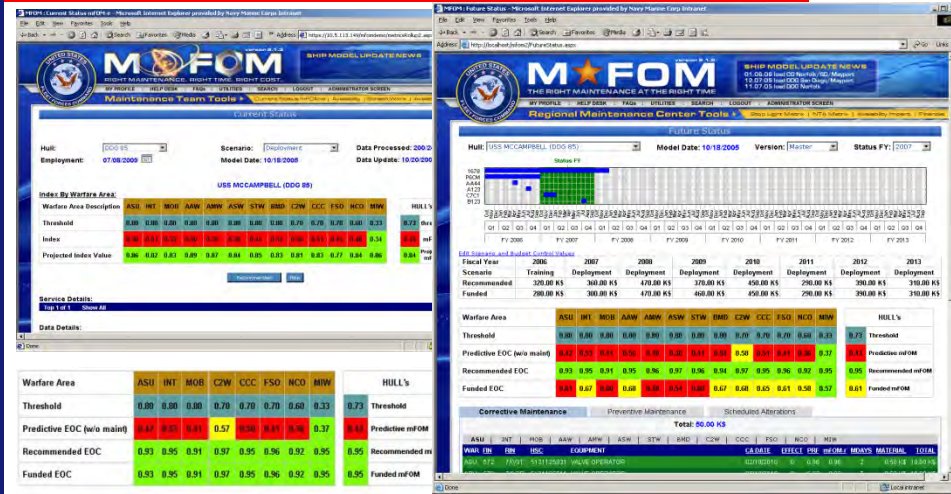

Solution

- Model each ship using a hierarchical structure that will show the impact of each shipboard equipment on material condition readiness
- Provide a single validation, screening and brokering tool for use across all ship platforms
- Allow for a near term predictive nature in modeling accounting for failure to perform routine maintenance

Investment/ROI

Investment: \$0.5M

Life Cycle ROI: 34:1

Intermittent Fault Detection & Isolation System (IFDIS)

Overview/Issue

- Unable to duplicate discrepancy on No Fault Found (NFF) LRU's
- Bad Actor LRU's continued to be recycled through the repair cycle process

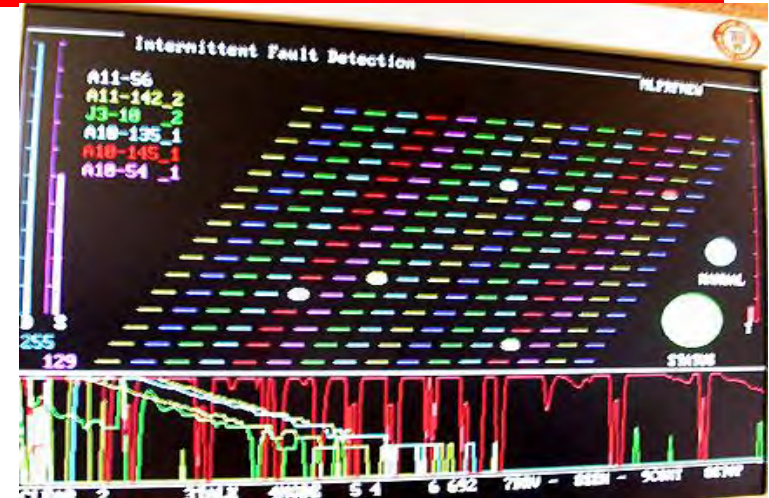

Solution

- Develop maintenance tool to augment traditional testing methods
- Will identify and isolate intermittent faults on end items
- Repeats Vigorous Test scenario

Investment/ROI

Investment: \$2.20M

Life Cycle ROI: 22:1

R-TOC Projects Cost Reductions

	FY2006	FY2007	FY2008	FY2009	FY2010
Army					
LC ROI	34:1	48:1	27:1	64:1	32:1
LC Savings	\$1,730M	\$179M	\$295M	\$714M	\$345M

DoN					
LC ROI	60:1	35:1	21:1	50:1	61:1
LC Savings	\$155M	\$95M	\$359M	\$735M	\$463M

Air Force					
LC ROI	100:1	108:1	33:1	100:1	68:1
LC Savings	\$2,205M	\$261M	\$522M	\$557M	\$718M

DoD Total ROI	71:1	75:1	28:1	69:1	58:1
DoD Total Savings	\$4,090M	\$535M	\$1,176M	\$2,006M	\$1,527M

DoD TOTAL FY06-10	
Life Cycle Savings	\$9,334M
Average LC ROI	80:1

Initiatives Contributing to R-TOC

- Lean Enterprise Value
- Six Sigma
- Supply Chain Management
- DoD Manufacturing Technology (ManTech)
- Value Engineering
 - Law Requires
 - FAR provisions offer contractual incentives
 - OMB Directs Implementation
 - Strategic Plan guides DoD
 - Methodology offers an approach to partner with industry

Value Engineering is an R-TOC Best Practice

- VE provides:
 - Cost reduction (VEPs and VECPs)
 - Product or process improvement
 - Higher quality
 - Reduced cycle time
 - Better means and materials for maintenance
 - Increased reliability
 - Greater safety
 - Less environmental impact

Definition

- **Value Engineering** - *An organized effort directed at analyzing the functions of systems, equipment, facilities, services, and supplies for the purpose of achieving the essential functions at the lowest life cycle cost consistent with required performance, reliability, quality, and safety. OMB Circular A-131*

VE Goal: Lower the government's costs, improve value & provide cost effective solutions to problems in design, development, fielding, support, & disposal

VE Authority

- Office of Federal Procurement Policy Act 41 USC 432 – Each executive agency shall establish & maintain cost-effective VE procedures & processes
- Public Law Implemented by OMB Circular A-131
- All Agencies Will:
 - Establish and maintain a VE Program
 - Develop annual plans
 - Budget for VE
 - Encourage VECPs
 - Encourage VEPs
 - Identify and report results
 - Provide training
- OMB Circular A-131 implemented by the DoD through VE Strategic Plan

DoD VE Strategic Plan

- Signed by USD (AT&L)
- Objectives
 1. Improve the Value Proposition for Defense Systems
 2. Align Industry and Government Value Propositions in Defense Systems
 3. Increase Value Engineering Expertise

SAVINGS GOAL = 1.5% OF TOA ANNUALLY

DoD VE Savings and Cost Avoidance

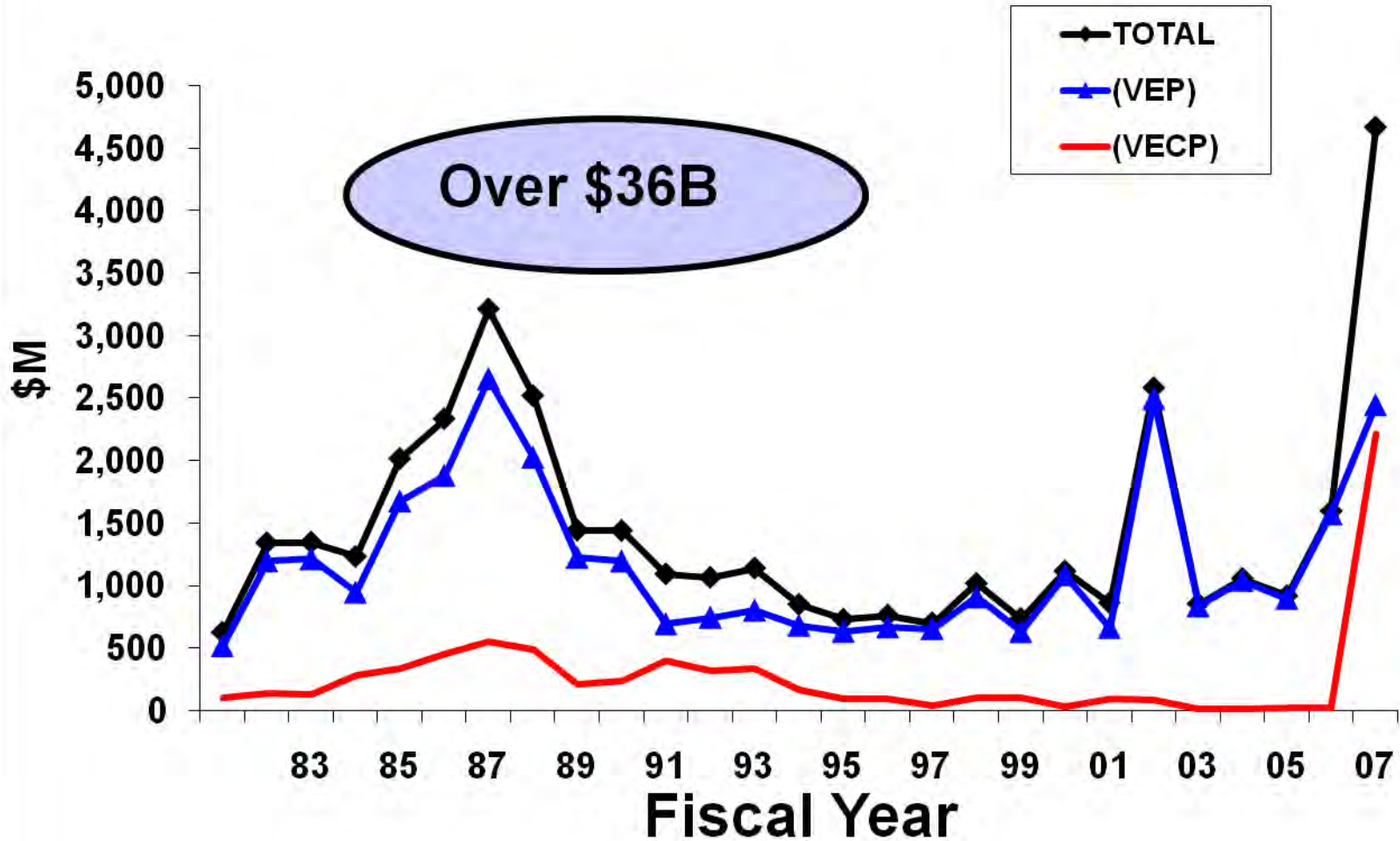

VE – An Industry Example

1998 Toyota Corolla - VE Project

- **Problems: Increased material costs, production time issues**
- **Objective: Correct problems using VE**
 - **Lighter by 10%**
 - **25% Fewer engine parts**
 - **Faster production**
 - **Better fuel economy**
 - **Decreased emissions**
 - **15% Horsepower increase**
 - **Costs \$1,000 less to make than in 1997**



Impulse Red Pearl with Stone or Pebble Beige (CE/LE)
or Charcoal (S) Interior

COROLLA

The Defense Acquisition System

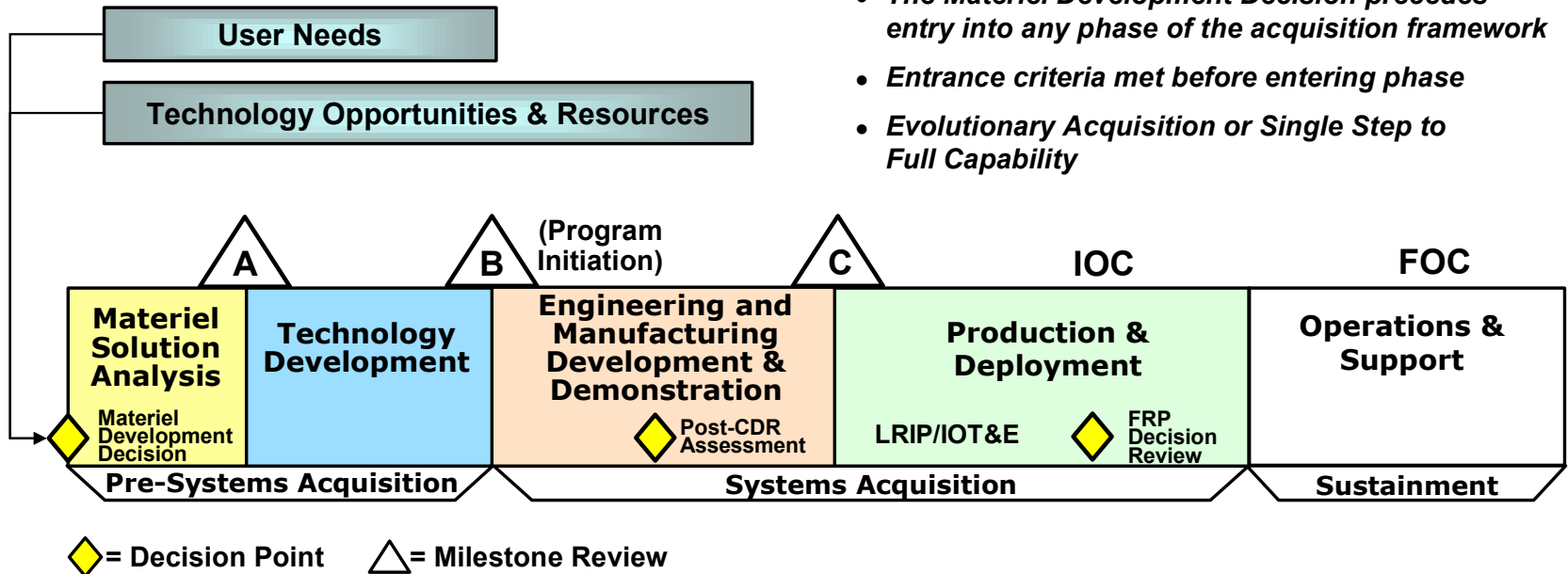

VE in Systems Engineering

- **VE methodology is an effective tool for making systems engineering decisions**

- Reduce cost
- Increase productivity
- Improve quality related features

While...meeting or exceeding functional performance capabilities

- **VE is applicable at any point in the life cycle**

How...making SE trades

VE and R-TOC in Systems Engineering

- **VE and R-TOC Early in the Life Cycle – Material Solution Analysis**
 - Analysis of Alternatives – evaluate functions vs. requirements
 - Challenge needs/ensure requirements are valid
 - SE trades
 - Develop cost of alternatives
 - Consider life cycle cost implications – (R-TOC)

Savings For All Production Units

VE and R-TOC in Systems Engineering

- **VE and R-TOC During Technology Development**
 - Analyze value of requirements/specifications
 - Can these be tailored?
 - Cost as an independent variable
 - Compare function, cost and worth of technologies
 - Consider life cycle cost implications of new technologies – R-TOC

VE and R-TOC in Systems Engineering

- **VE and R-TOC During Engineering and Manufacturing Development and Demonstration**
 - Identify technical approaches
 - Eliminate unnecessary design restrictions
 - Estimate cost of functions
 - Identify alternatives
 - Evaluate design concepts – O&S life cycle concepts (R-TOC)
 - Search for new technologies
 - Simplify designs

VE and R-TOC in Systems Engineering

- **VE and R-TOC During Production and Deployment**
 - Evaluate and improve manufacturing processes, methods and materials
- **VE and R-TOC During Operations and Support**
 - Analyze advances in technologies
 - Evaluate modifications
 - Reduce repair costs – R-TOC
 - Analyze packaging requirements
 - Improve RM&S – R-TOC
 - Analyze/Improve supply chain/logistics footprint – R-TOC
 - Implement CBM – R-TOC
 - Reduce manpower – R-TOC

SUMMARY

- R-TOC and VE provide savings/cost avoidances for DoD
- VE is a tool for Systems Engineering – All Life Cycle Phases
- R-TOC provides a focus on O&S considerations - All Life Cycle Phases
- DoD VE documents: 1) VE Contractor's Guide, 2) VECP Contracting Guide, and 3) VE Handbook
- VE revitalization effort in-work –
 - USD(A&T) memo on compliance with OMB Circular A-131 guidance
 - Joint Analysis Team (JAT)
- OMB A-131 update needed

- R-TOC/VE websites: <http://rtoc.ida.org> or <http://ve.ida.org>
- R-TOC / VE Points of Contact: Chet Bracuto: Chet.Bracuto@osd.mil and Danny Reed: dreed@ida.org



AF CSE



Air Force Systems Engineering Assessment Model (AF SEAM)



Randy Bullard
AF Center for Systems Engineering
Randy.bullard@afit.edu



Outline



AF CSE

1. Background

- AF SEAM Pedigree
- AF SEAM Goals

2. Model Contents (What is Included)

- Process Areas (PAs)
- Practices (Specific)
- Practices (Generic)
- References (What)
- Other Information/Elaboration
- Typical Work Products
- Methodology





AF SEAM Background

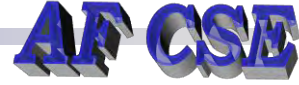

- **In 2006, AFMC Engineering Council Action Item to:**
 - Provide an AF-wide SE Assessment Model
 - Involve AF Centers (product and logistics)
 - Leverage current CMMI®-based models in use at AF Centers
 - Baseline Process capability & usage
- **Definition of AF Systems Engineering Assessment Model:**
 - **A single AF-wide tool which can be used for the assessment and improvement of systems engineering processes in a program/project.**



AF SEAM Goals



- Goals
 - Ensure a Consistent Understanding of SE
 - Ensure Core SE Processes are in Place and Being Practiced
 - Document repeatable SE “Best Practices” across AF
 - Identify Opportunities for Continuous Improvement
 - Clarify Roles and Responsibilities
 - Improve Program Performance & Reduce Technical Risk



Why We Need SE Assessment

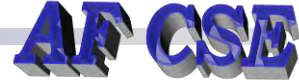

- Lack of Disciplined System Engineering (SE) has been a major contributor to poor program performance
- Many Problems Have Surfaced Repeatedly with AF Programs
 - Missed or Poorly Validated Requirements
 - Poor Planning Fundamentals
 - Lack of Integrated Risk Management
 - Lack of Rigorous Process
 - Lack of Process Flow Down
- Restoring SE Discipline in AF Programs Is Key to Improved Performance and Credibility



Benefits



AF CSE

- Restoring Disciplined SE
 - Clear Definition of Expectations
 - Well Aligned with Policy
- Established Assessment Methods & Tools
 - Best Practices Baseline
 - Driving Improvement
- Moving towards
 - Deeper Understanding of SE Processes
 - More Efficient Programs



Why AF SEAM



- **AF SEAM is a composite of Industry & DoD SE best practices**
 - Maps to CMMI -ACQ 1.2 & -DEV 1.2
 - Consistent w/ Industry and DoD guidance
- **Advantages to using AF SEAM**
 - Streamlining of CMMI process areas to AF programs
 - AF-centric w/ end-to-end life cycle coverage
 - More focused document requires less program overhead
 - Does not require SEI certified assessors
- **Impact to AF programs**
 - Assure programs are achieving desired outcomes
 - Ensure program teams have adequate resources
 - Qualified People, Process Discipline, Tools/Technology



AF SEAM Pedigree

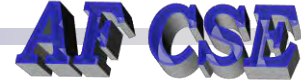

- All AF product Centers selected and tailored some version of the Software Engineering Institute (SEI) Capability Maturity Model Integration (CMMI®) to baseline process institutionalization
- SEI CMMI® is the Defense Industry-wide accepted method for process appraisal and improvement
- The SEI CMMI® incorporates principles and practices from recognized industry and US Government system engineering and related standards such as:
 - **AFI 63-1201** **Life Cycle Systems Engineering**
 - **Defense Acquisition Guidebook, Chapter 4**
 - **MIL-STD 499B** **System Engineering**
 - **ANSI/EIA 632** **Processes for Engineering a System**
 - **IEEE/EIA 731** **Systems Engineering Capability Model**
 - **ISO/IEEE 15288** **Systems Engineering-System Life Cycle Processes**
 - **INCOSE** **System Engineering Standard**
 - **IEEE 1220** **Application and Management of the Systems Engineering Process**



AF SEAM Content



AF CSE

- Process Areas (PAs)
- Goals
- Practices
- Informative Material
 - Description
 - Typical Work Products
 - Reference Material
 - Other Considerations

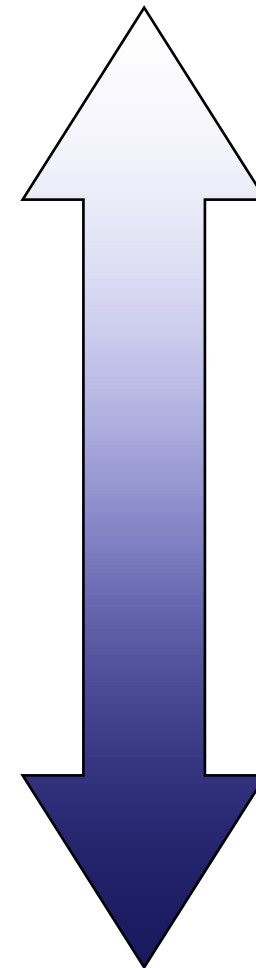

Broadest

*Level of
Specificity*

Most Detailed



Principles & Objectives



AF CSE

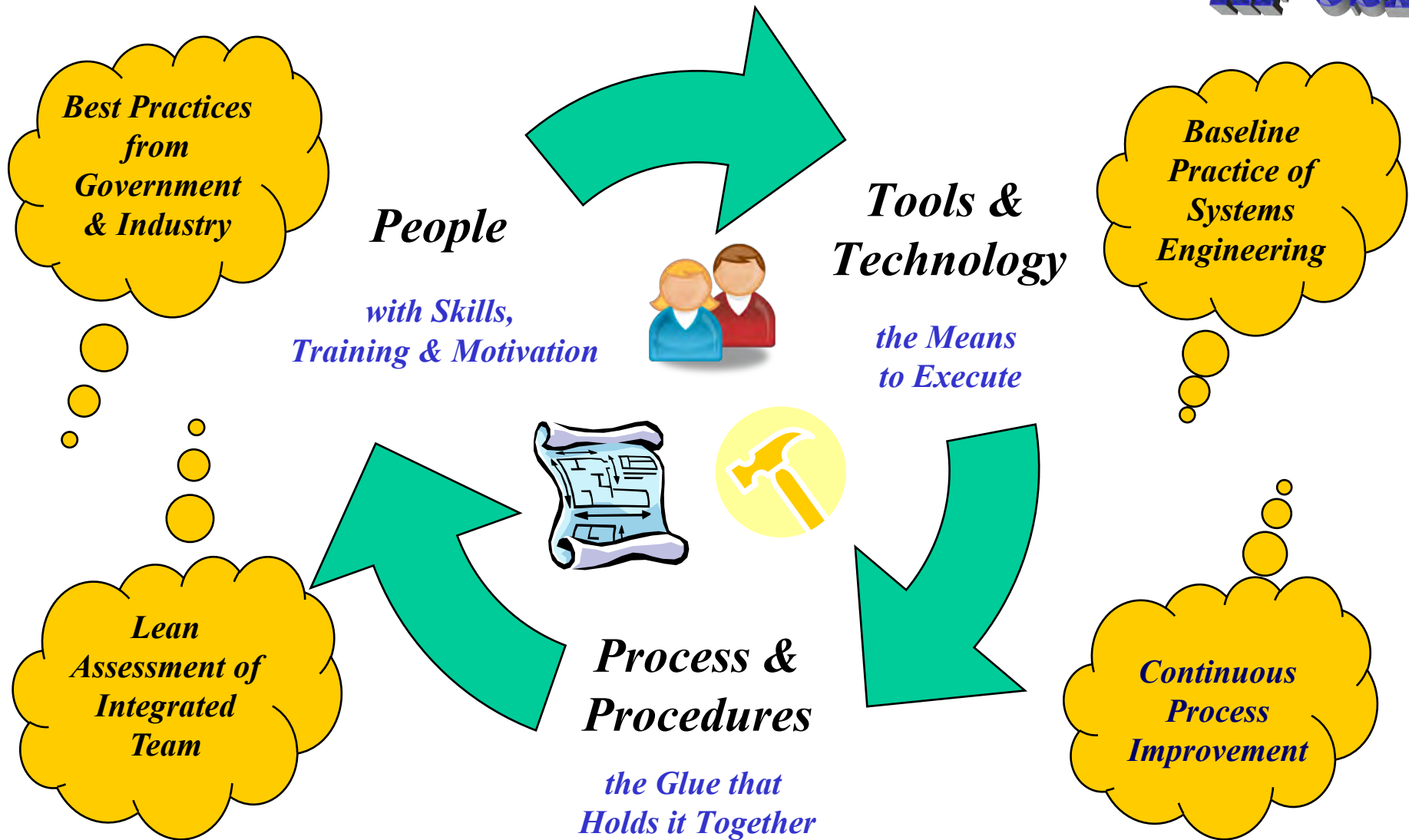



Why Focus on Process?



"If you can't describe what you are doing as a process, you don't know what you are doing."

- **W. Edwards Deming**



AF SEAM Elements

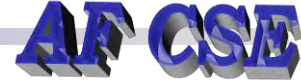

- **10 Process Areas (PAs)**
 - Based in CMMI process area construct
 - Conforms with AFI 63-1201 & DAG Chapter 4

Process Areas (PAs)

- Configuration Mgmt (CM)
- Decision Analysis (DA)
- Design (D)
- Manufacturing (M)
- Project Planning (PP)
- Requirements (R)
- Risk Mgmt (RM)
- Sustainment (S)
- Tech Mgmt & Ctrl (TMC)
- Verification & Validation (V)

- 34 Goals - *Are Accomplished through the Specific Practices*
- 120 Specific Practices
- 7 Generic Practices (Apply to each Process Area)



AF SEAM Practices



AF CSE

- **Specific Practices – Each one applies to only one Process Area**
- **Each Practice has Informative Material**
 - Description
 - References
 - Typical Work Products
 - Other Considerations
- **Generic Practices**
 - Must be accomplished for each Process Area
 - Ensures specific practices are executed
 - Involves stakeholders



AF SEAM Practices



AF CSE

<i>Process Area</i>	<i>Goals</i>	<i>Specific Practices</i>	<i>Generic Practices</i>	<i>Total Practices</i>
Configuration Mgmt	3	8	7	15
Decision Analysis	1	5	7	12
Design	3	14	7	21
Manufacturing	4	12	7	19
Project Planning	3	15	7	22
Requirements	4	13	7	20
Risk Mgmt	3	7	7	14
Sustainment	4	15	7	22
Tech Mgmt & Control	4	15	7	22
V & V	5	16	7	23
Total	34	120	70	190



Sample Specific Practice

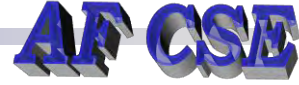

- **RMG1P1 Determine risk sources and categories**
- **Description:** Establish categories of risks and risk sources for the project initially and refine the risk structure over time (e.g., schedule, cost, supplier execution, technology readiness, manufacturing readiness, product safety, and issues outside control of team), using Integrated Product Teams. Quantify the risk probability and consequence in terms of cost and schedule.
- **Typical Work Products:**
 - Risk matrix
 - Risk management plan
- **Reference Material:** [USAF Operational Risk Management, AFI 90-901](#)
- **Other Considerations:** Consider using Acquisition Center of Excellence Risk Management Workshops when needed. For manufacturing risks consider the capability of planned production processes to meet anticipated design tolerances. Include the supplier's capacity and capabilities in the analysis.



Generic Practices

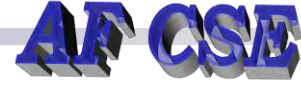

- 1. Establish and maintain the description of a defined process**
- 2. Establish and maintain plans for performing the process**
- 3. Provide adequate resources for performing the process, developing the work products, and providing the services of the process**
- 4. Assign responsibility and authority for performing the process, developing the work products, and providing the services of the process**
- 5. Train the people performing or supporting the processes needed**
- 6. Monitor and control the process against the process plan and take appropriate corrective action**
- 7. Review the activities, status, and results of the process with higher level management and resolve issues**



Process Detail Outline



AF CSE

A - B

- Roles/Responsibilities
- Training
 - Leadership
 - Self Assessment

C - D

- Build Team
- Train team
- Logistics support
- Set schedule

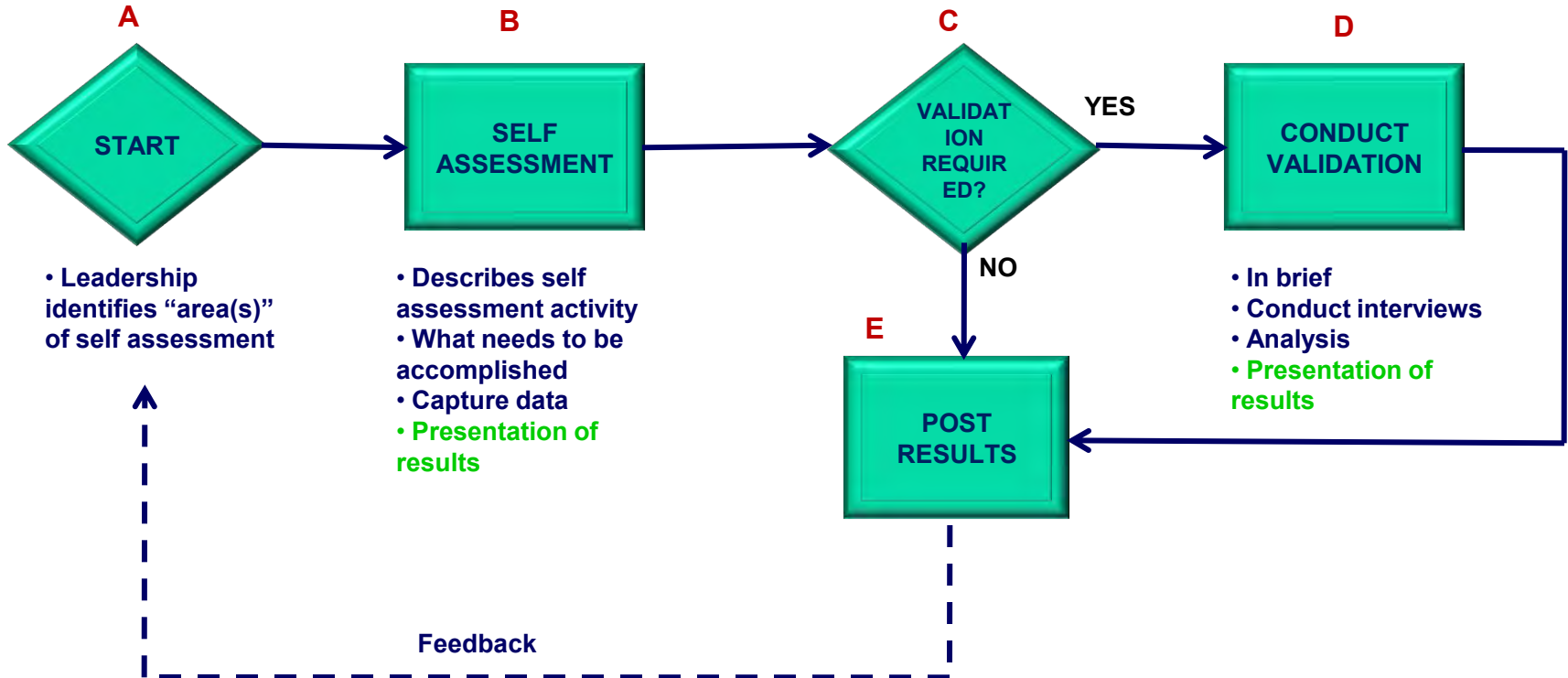



Criteria for Methodology



- Facilitate Self Assessment
- Facilitate Continuous Improvement
- Provide insight into Program/Project Processes & Capability
- Objective Assessment
- Consistent Near and Far Term Approach
- Provide Results that are meaningful for leadership
 - **Relevant to PM/PEO/CC**
 - **Simple**
 - **Understandable**
 - **Graphical**
- **Support Multi-level Measurement & Reporting**
 - **Program/Project, Squadron, Group, Wing, Center**
 - **Resource Allocation**
 - **SE Process Improvement**



Defining the Methodology



AF CSE

Low

Assessment Continuum

High

- Hands Off
- Promulgate Policy
 - Directives
 - Instructions
 - Checklists
 - Guidance
- Expect Compliance

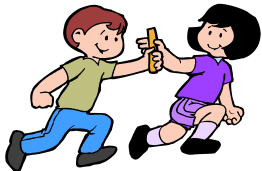

- **AF SEAM**
 - Collaborative & inclusive
 - Leanest Possible Best Practices “Must Dos”
 - Clearly Stated Expectations
 - Program Team & Assessor Team
 - Training
- Self Assessment of Program with Validation Assessment



- Hands On
- Comprehensive Continuous Process Improvement
 - Highly Detailed Process Bibles
 - Training
- Validation Assessment
 - Deep Dives



Assessment Methods that Balance Time and Effectiveness



SE Assessment Activities



AF CSE

Phase I Planning

- Read Ahead Package
- Logistics Planning
- Training

Phase II Self-Assessment

- Self Assessment Training
- Project performs self-assessment
- Provide self - assessment to review team

Phase III Independent Validation

- Team In-Brief
- Project Brief
- Review Self-Assessment
- Collaborative Interviews
- Document Reviews

Phase IV Report Results

- Consolidate Results
- Prepare final report / outbrief
- Deliver Final Results



Assessment Outputs



- Feedback
 - Lessons learned from assessment tool
 - Collaborative review
- Findings
 - Completed assessment tool
 - Strengths
 - Improvement opportunities
 - Output metrics
- Recommendations
- Final outbrief



Generic Practices Summary



PA/GP	GP1	GP2	GP3	GP4	GP5	GP6	GP7	GP Overall
CM	1	1	1	1	1	1	1	7
DA	0	0	1	1	1	1	1	5
D	1	1	1	1	1	1	1	7
M	1	1	1	1	1	1	1	7
PP	0	1	1	0	1	0	1	4
R	1	1	1	1	1	1	1	7
RM	1	1	1	1	1	1	0	6
S	1	1	1	1	1	1	1	7
TMC	0	1	1	1	1	1	1	6
V	1	1	1	1	1	1	1	7

GP LEGEND
1
0

PA LEGEND
6-7
4-5
<4



Summary



- **Goal is to Continue to Improve Program Performance**
 - Too many examples of program performance/issues being tracked back to lack of SE discipline
- **Long Term Goal – *Revitalize & Institutionalize Systems Engineering***
 - **Use SE “Best Practices”**
 - **Assist programs in achieving desired outcomes**
 - **Assist program teams in resource planning**
 - **Qualified People**
 - **Disciplined Processes**
 - **Tools/Technology**



AF CSE

Back Up Slides



Team Members

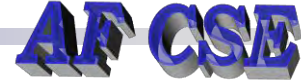

Center	Members
AAC	Ian Talbot
AEDC	Neil Peery, Maj Mark Jenks
ASC	Gary Bailey
AF CSE	Rich Freeman, Randy Bullard
HQ AFMC	Caroline Buckey
ESC	Bob Swarz, Bruce Allgood
OC-ALC	Cal Underwood, Bill Raphael
OO-ALC	Jim Belford, Mahnaz Maung
SMC	Linda Taylor
WR-ALC	Jim Jeter, Ronnie Rogers



Spiral 2



- Capability Enhancement
 - Re-look process areas for improvements
 - Further refine assessment methodology
 - Strengthen inclusion of software
 - Capture and promulgate best practices/lessons learned
 - Review scoring
 - Examine potential use for SE health assessment
 - Migrate to web-based platform
- Resources
 - Funding
 - People
 - Computer Based Training
- Schedule
 - Estimated 1-year effort
 - One member from each Center
 - Working Group meetings held approximately bi-monthly
- Lead POC/Steering Group
 - Staff support
 - Community of Interest
 - Model sustainment (continuous improvement)



Scoring Roll-Up

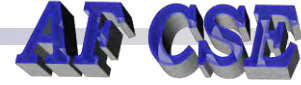

Specific Practice Assessment Results XXX Center

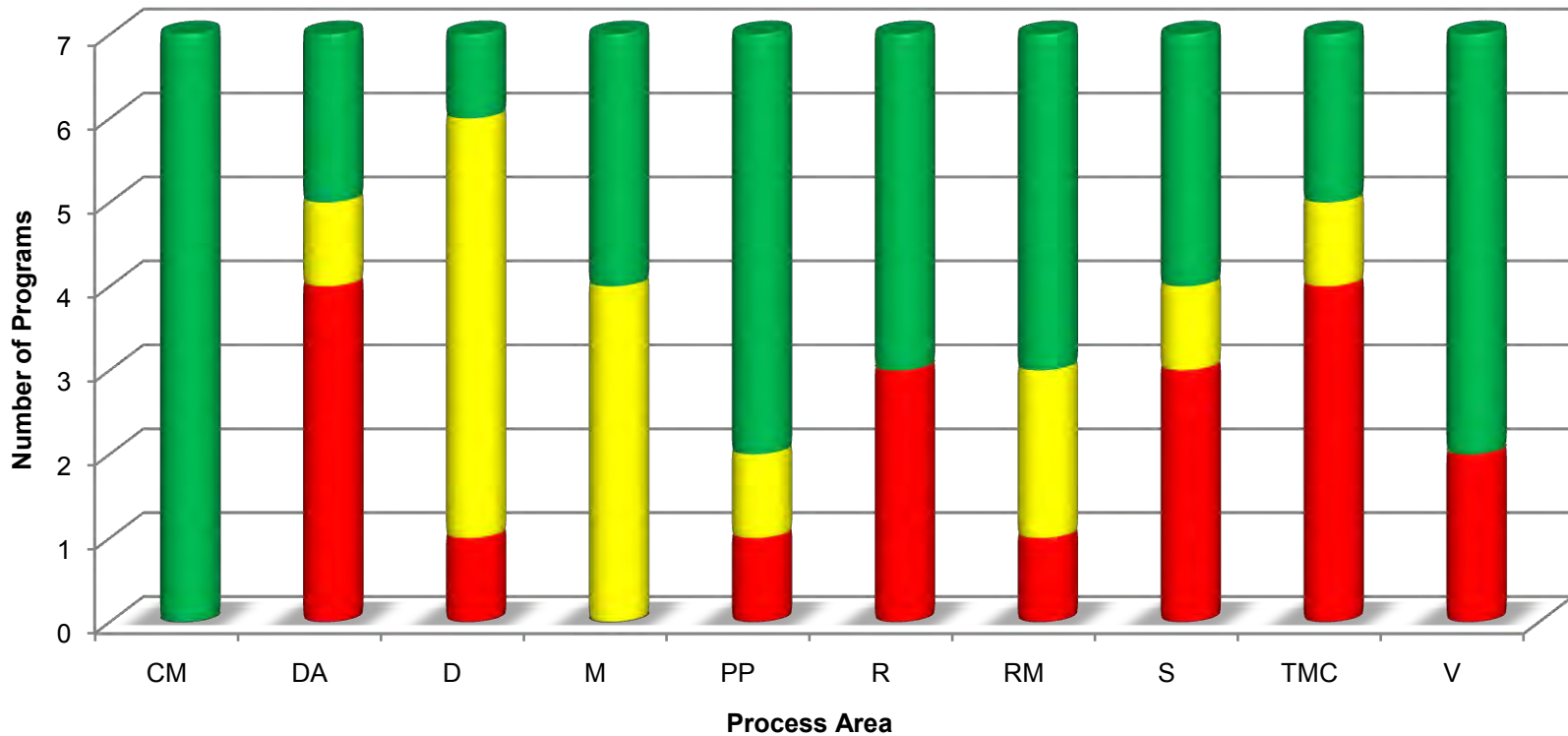



Scoring Roll-Up



Generic Practice Assessment Results XXX Center

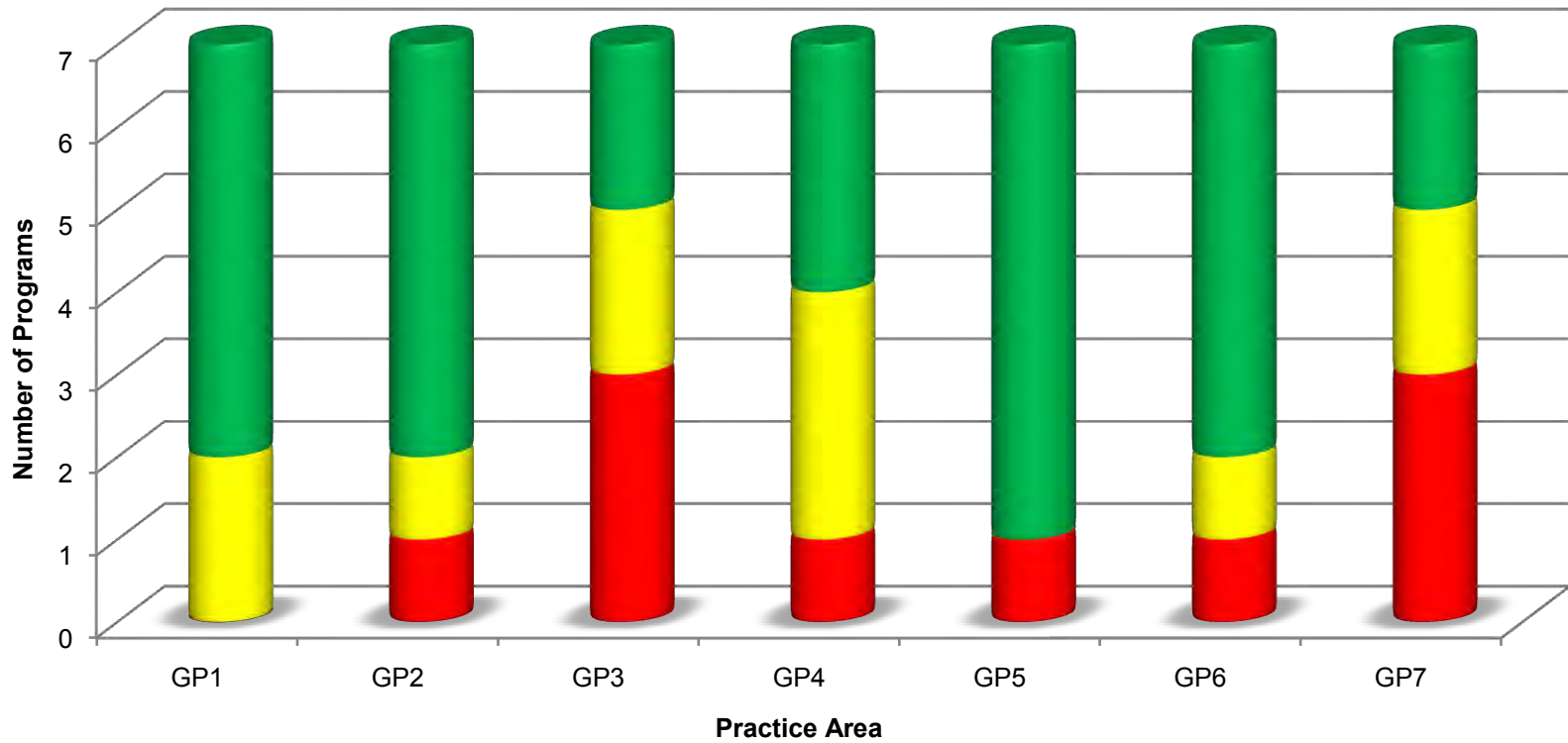



Implementation By Center



CENTER	5 AUG 08 - FEEDBACK
✓ AAC	"AAC began integrating AF SEAM in our established program assessment process in January 2008 and expects to complete this integration in FY09."
✓ AEDC	"We will begin implementing AF SEAM in October."
✓ ASC	"We are creating a plan to migrate from our current tool to SEAM, tailored with AFMC and ASC specific areas of interest."
✓ ESC	"We have initiated tailoring efforts to implement AF SEAM by the end of the calendar year. We will be working closely with SMC, our acquisition partner, on the tailoring and implementation effort."
✓ OC-ALC	"Strongly support, have plans in place, ready to go!"
✓ OO-ALC	"We are implementing now."
✓ SMC	"SMC plans to adopt AF SEAM and comply with related policies."
✓ WR-ALC	"We'll begin implementation at Robins with pilot assessments in F-15 and Avionics."

Development process yielded 100% buy-in



**How Value Engineering (VE) Enhances
Diminishing Manufacturing Sources and
Material Shortages (DMSMS) Solutions**

**2008 National Defense Industrial Association
11th Annual Systems Engineering Conference
October 22, 2008**

Dr. Jay Mandelbaum

Institute for Defense Analyses

4850 Mark Center Drive • Alexandria, Virginia 22311-1882



Outline

- **Introduction to DMSMS**
- **Introduction to VE**
- **Relationship of the VE methodology to the DMSMS risk management process**
- **Real VE examples for DMSMS resolution options**
- **Conclusions and next steps**

Problems DMSMS Addresses

- ***Technology improvements:*** As new products are developed, the technology used in predecessor products becomes outdated, making it more difficult to maintain the older equipment
- ***Decreasing demand:*** The parts needed to repair products may become more difficult and expensive to acquire because fewer are produced as demand for them decreases
- ***Non-availability of materials:*** The materials required to manufacture products may no longer be available, or they may be uneconomical to procure

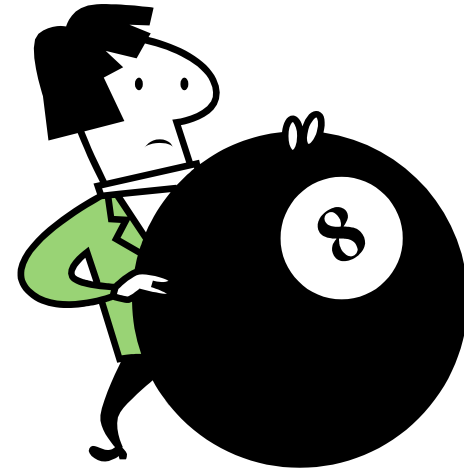

DMSMS Risk Management Process

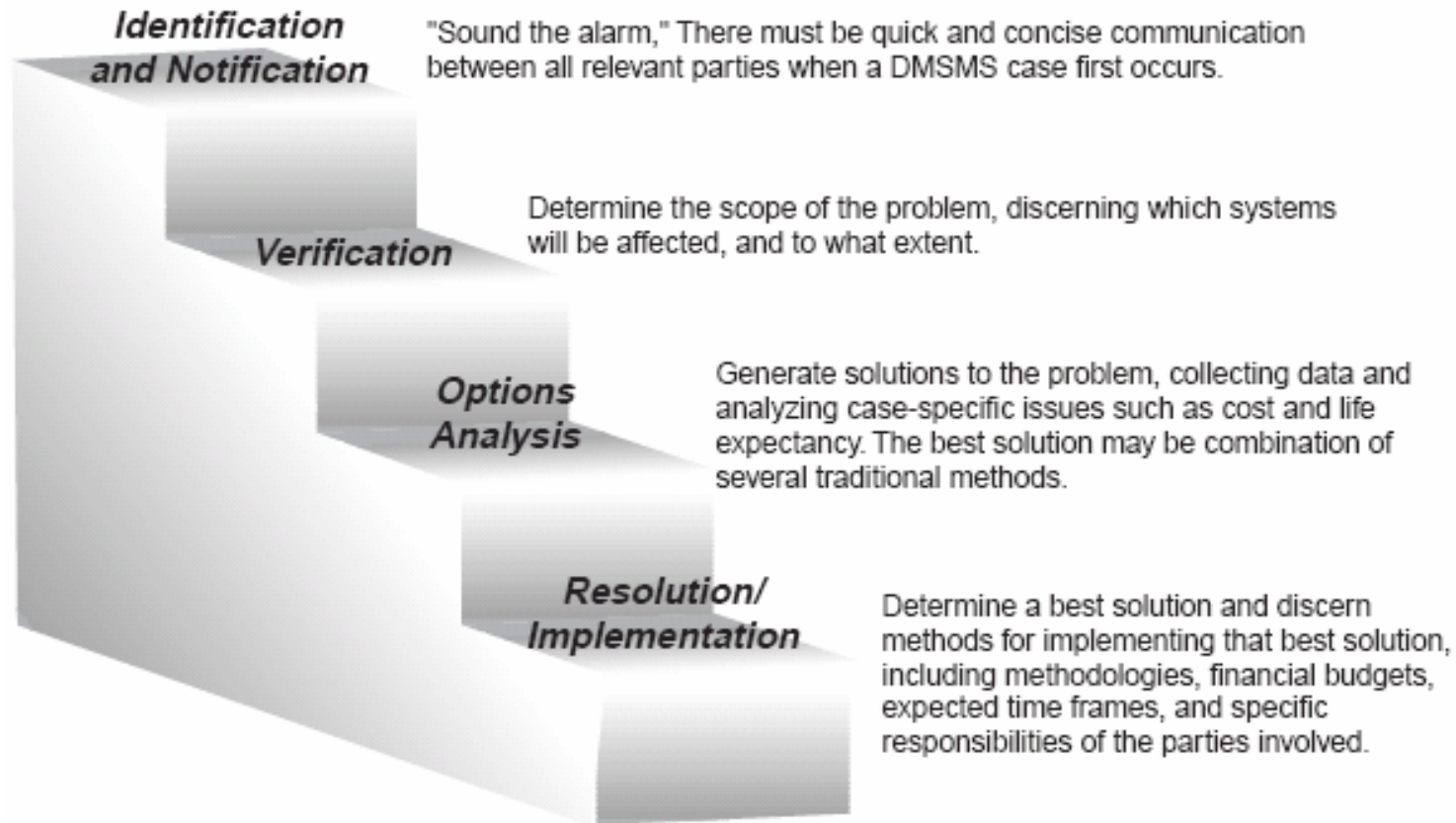

Source: DMSMS Guidebook, p. 3-1.

Outline

- **Introduction to DMSMS**
- **Introduction to VE**
- **Relationship of the VE methodology to the DMSMS risk management process**
- **Real VE examples for DMSMS resolution options**
- **Conclusions and next steps**

What is VE?

- **According to Public Law 104-106 value engineering means an analysis of the functions of a program, project, system, product, item of equipment, building, facility, service, or supply of an executive agency, performed by qualified agency or contractor personnel, directed at improving performance, reliability, quality, safety, and life cycle costs.**
- **Characteristics**
 - **Systems engineering tool**
 - **Contractually authorized**
 - **Employs a simple, flexible and structured methodology**
 - **Promotes innovation and creativity**
 - **Incentivizes contractor to help government's value proposition**



An Actual VECP for the Evolved Sea Sparrow Missile (ESSM)

- **Background**

- The ESSM is an advanced a radar-guided missile with a high explosive warhead used for surface-to-air anti-missile defense
- A missile safe and arm fuze prevents an unintended launch and, once launched, arms the warhead when the proper stimuli (e.g., speed, gravitational force) are received

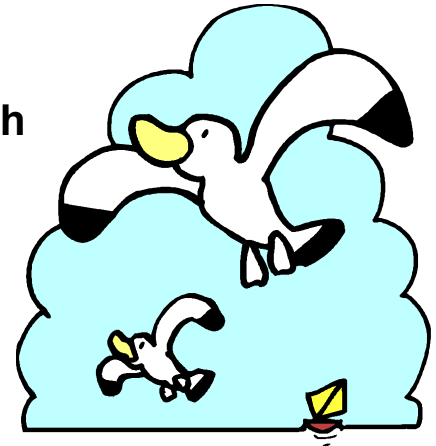

- **DMSMS situation**

- ESSM design called for an obsolete mechanical safe and arming fuze
- Number of suppliers was limited and costs were high
 - Highly skilled artisans were needed for the manufacturing process, and much of the world fuze market had adapted to electronic fuzes

- **The contractor proposed a VECP to replace the mechanical safe and arm fuze with an electronic one adapted from the Sidewinder missile**

- Development and implementation costs were \$1,873,911; took approximately 2 years to offset
- Total recurring cost savings equaled \$6,832,000, which, when spread over the 1,600 units involved, resulted in a net savings per unit of \$4,270
- Savings shared equally between the Navy and the contractor

Factors Leading to VE Solutions

- Advances in technology
- Excessive cost
- Questioning specifications
- Additional design effort
- Changes in user's needs
- Feedback from test/use
- Opportunities for design improvements
- Miscellaneous



Problems DMSMS Addresses

- *Technology improvements:* As new products are developed, the technology used in predecessor products becomes outdated, making it more difficult to maintain the older equipment
- *Decreasing demand:* The parts needed to repair products may become more difficult and expensive to acquire because fewer are produced as demand for them decreases
- *Non-availability of materials:* The materials required to manufacture products may no longer be available, or they may be uneconomical to procure

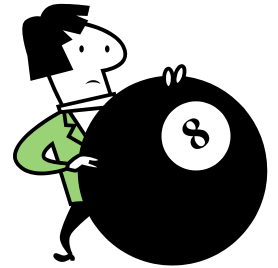

Phases of the VE Methodology (Job Plan)

- Orientation Phase
- Information Phase
- Function Analysis Phase
- Creative Phase
- Evaluation Phase
- Development Phase
- Presentation Phase
- Implementation Phase



Often carried out in a Workshop format

Outline

- Introduction to DMSMS
- Introduction to VE
- **Relationship of the VE methodology to the DMSMS risk management process**
- Real VE examples for DMSMS resolution options
- Conclusions and next steps

Linking the two Methodologies

Phases of the VE Methodology

- Orientation
- Information
- Function analysis
- Creative
- Evaluation
- Development
- Presentation
- Implementation

Steps in the DMSMS Risk Management Process

- Identification and notification
- Verification
- Options analysis
- Resolution/implementation

There is a strong synergy

Potential VE Contributions to DMSMS

- Finds innovative approaches to problem solving that might not otherwise be considered using the creative elements of the VE methodology
- Incentivizes DoD participants and their industry partners to increase their joint value proposition in achieving best value solutions as part of a successful business relationship
 - Provides businesses with a strong profit-based incentive for using its skilled engineering workforce to mitigate DoD's DMSMS issues
- Rewards contractors for making investments in DMSMS resolution options
- Allows the DoD to spread non-recurring engineering costs over time, making them far easier to fund

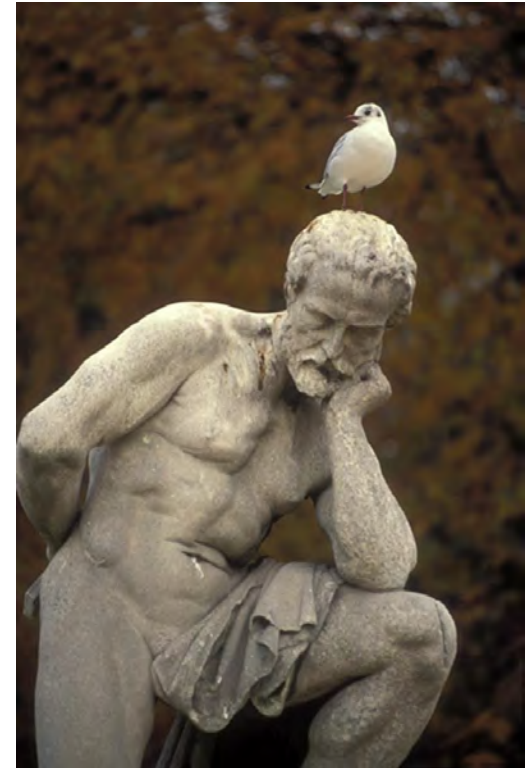

Benefits Realized Regardless of the DMSMS Resolution Option

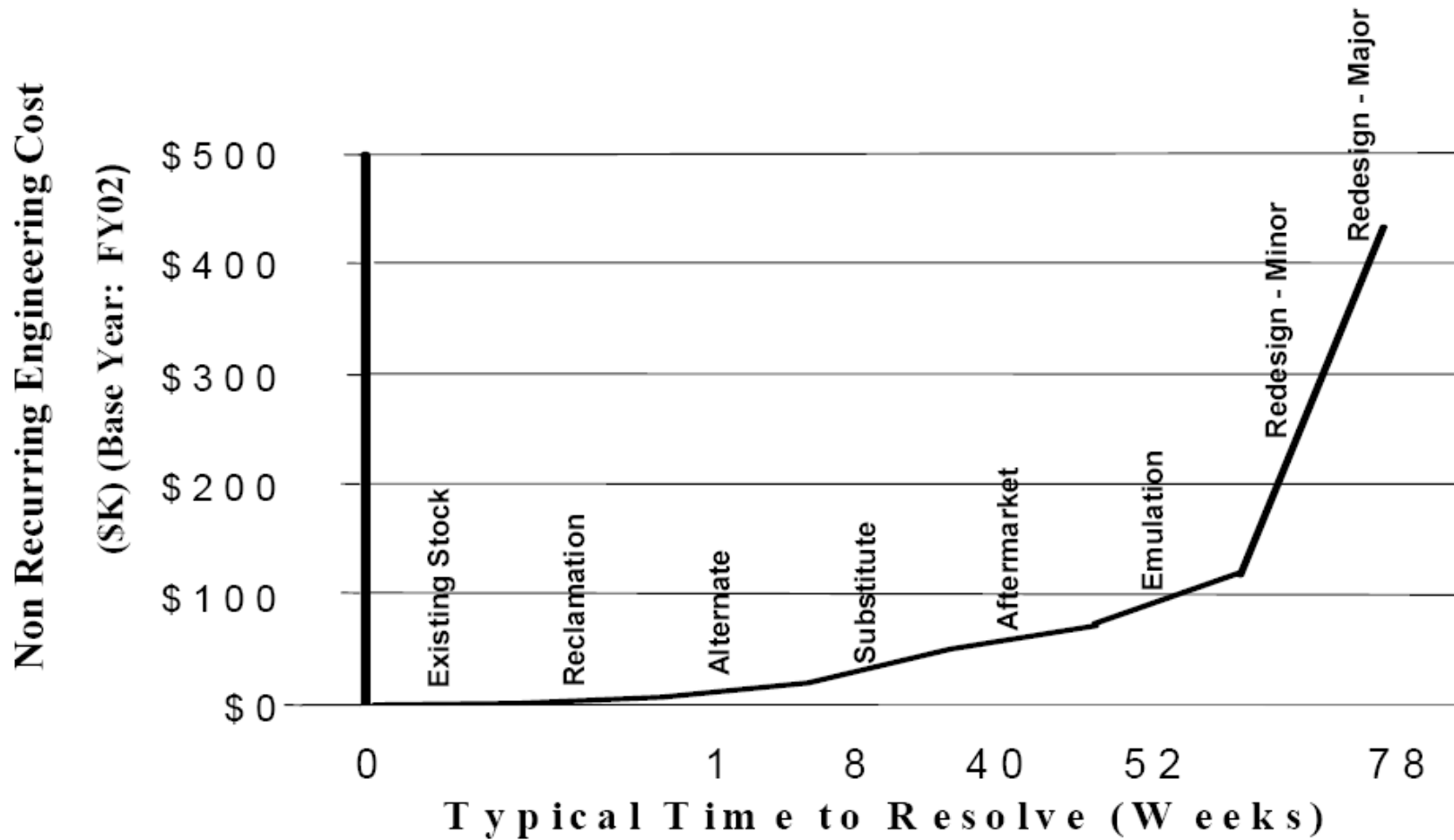

Source: DMSMS Guidebook p. 4-11

Outline

- **Introduction to DMSMS**
- **Introduction to VE**
- **Relationship of the VE methodology to the DMSMS risk management process**
- **Real VE examples for DMSMS resolution options**
- **Conclusions and next steps**

VE Contributions to an Existing Stock Approach

- **Definition**
 - The *current* supplier utilizes *on-hand* inventories or agrees to continue to produce the item in question
 - Typically use a life-of-type or bridge purchase
- **Drawbacks to this approach**
 - Costs for material management including packaging, storage, transportation, shelf life, and upkeep of the inventory
 - Difficult to estimate demand
- **How VE can help**
 - Value engineering incentivizes the contractor to perform the material management function and solves short-term budget problems associated with a quantity purchase



Standard Missile Radome VE Example for Existing Stock Approach

- **Background**

- The Standard Missile is a surface-to-air air defense weapon is a fleet area air defense and ship self defense weapon
- The radome is a dome that covers the radar on the outside of the missile

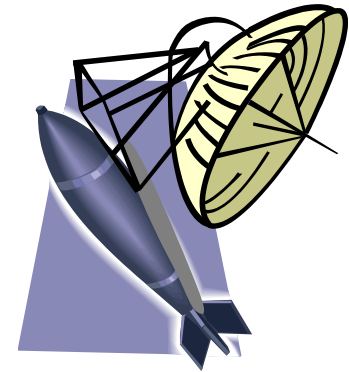

- **DMSMS situation**

- There are few radome suppliers because of the complexity involved in finishing them to both withstand high heat and acceleration and allow signals to penetrate without distortion
- Due to reduced program funding, the Navy halved its Standard Missile procurement rate
- If the radomes were to be purchased on the revised procurement schedule, the unit price would increase by 50 percent due to production slow down
- The Navy wanted to make a quantity purchase to reduce the overall cost, however it did not have the resources in the current fiscal year

- **The contractor used a VECP to make the quantity radome purchase and sell future radome lots back to the Navy at the lower price, thus leading to significant savings**

- Total savings was \$1,153,500 shared equally by the contractor and the Navy

VE Contributions to a Reclamation Approach

- **Definition**

- Examines marginal or out-of-service equipment or supplies as a potential source of DMSMS parts
- Equipment that is in a long supply, perhaps as a result of a planned product improvement or modernization effort where baseline equipment could be cannibalized

- **Drawbacks to this approach**

- Reclaimed parts may be unserviceable or damaged
- Probably represents only a short-term solution

- **How VE can help**

- Value engineering can play an important role in making reclamation feasible



Artillery VE Example for Reclamation Approach

- **Background**
 - The M795 is a 155-millimeter high-explosive artillery projectile with a high-fragmentation steel body
 - It provides increased effectiveness against major ground-force threats at greater ranges for anti-personnel and anti-materiel targets
- **DMSMS situation**
 - Because of a world-wide scrap steel shortage, it was difficult to maintain a source for M795 steel
- **A VE study was initiated to develop a process to reutilize the steel from a large demilitarization stockpile of surplus M106 8-inch projectile shells**
 - The steel could not be reclaimed directly since the projectiles contained trace amounts of explosives
 - A process was developed to decontaminate and mill the surplus M106 projectiles to reclaim the steel
 - M795 production costs were decreased
 - The demilitarization stockpile was reduced
 - Total cost avoidance savings in FY 2006 for the 197,000 projectiles processed amounted to \$9.2 million



VE Contributions to an Alternative Source Approach

- **Definition**
 - Items currently in production that are form, fit, function, and interface qualified replacements such as a superseding part listed in a specification or standard
 - May apply to aftermarket or reverse-engineered sources (discussed later)
- **Drawbacks to this approach**
 - Same as existing stock
- **How VE can help**
 - VE can increase the efficiency of the new suppliers's production process



VE Contributions to an Existing Substitute Approach

- **Definition**
 - A different part that is *currently* being produced for a different application but is (or can be made) capable of performing fully (in terms of form, fit, and function) in place of the DMSMS item
- **Drawbacks to this approach**
 - Non-recurring engineering expenses
 - Market conditions may not have a favorable outcome for the new source
 - Qualifying and testing the replacement item
 - The unit cost may be higher
- **How VE can help**
 - Value engineering function analysis identifies viable options for items to be used as an existing substitute and incentivizes the prime contractor to invest in them
 - represents probably the most prevalent use of VE for DoD weapon systems

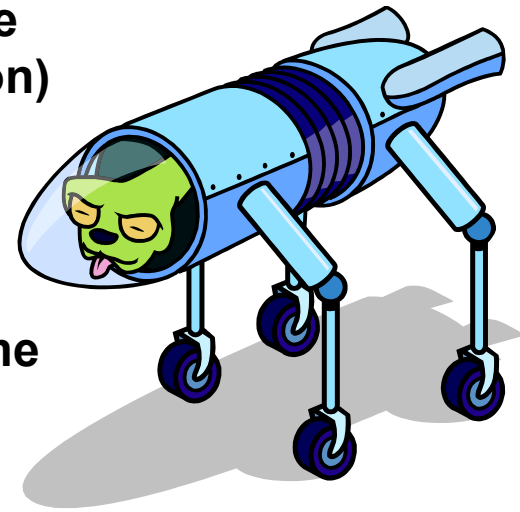

Phalanx VE Example for Existing Substitute Approach

- **Background**

- The Phalanx Close-In-Weapon-System is a fast-reaction, rapid-fire 20-millimeter gun system that provides Navy ships with a terminal defense against anti-ship missiles, fixed-wing aircraft, small gunboats, and helicopters
- A contract was awarded to retrofit Phalanx with a manual controller to direct fire against targets of opportunity

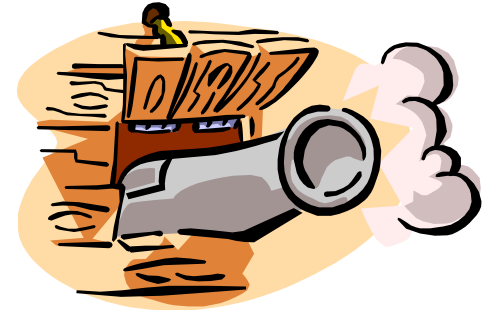

- **The contractor submitted a VECF to replace the standard military controller with a ruggedized commercial derivative**
 - On its own initiative, the contractor produced a modified unit
 - Based on the test results, the contractor had confidence that the commercial derivative met all of the technical requirements at a lower cost
 - The military standard controller would cost \$7,600, while the commercial derivative was only \$2,100
 - Since each gun required three controllers, net savings was \$16,500 per system
 - Approximately \$2 million in savings were shared by the Navy and the contractor

VE Contributions to an Aftermarket Approach

- **Definition**
 - The original equipment manufacturer authorizes the assembly of an obsolete part and provides necessary tech data
 - A smaller company might undertake production that is no longer sufficiently profitable for a larger company at a lower price; competition also leads to lower cost
- **Drawbacks to this approach**
 - Market conditions may not have a favorable outcome for the new source
 - Non-recurring engineering expenses will be incurred
 - The unit cost may be higher
- **How VE can help**
 - Value engineering enables the development of viable aftermarket sources



AMRAAM VE Example for Aftermarket Approach

- **Background**

- AMRAAM is a fire-and-forget air-to-air missile capable of attacking beyond-visual-range targets
- The Inertial Reference Unit (IRU) accurately measures the missile vertical velocity and position enabling in-flight steering and targeting adjustments



- **DMSMS situation**

- Originally, there was only one source for this expensive item
- The contractor was aware that others were interested in furnishing this item, so the contractor provided the requirements and helped encourage others in the development of the IRU

- **The contract contained a mandatory VE program and DoD recognized the value of having a second source for the IRU**

- Approximately \$4 million in non-recurring engineering costs were required
- These efforts saved \$2,000 per unit
- The existence of a second source through the VECP probably prevented the price of the IRU from increasing

VE Contributions to a Reverse Engineering Approach

- **Definition**
 - A producer obtains and maintains the design, equipment, and process rights to manufacture a replacement item by analyzing the part's structure, function, and operation
- **Drawbacks to this approach**
 - Market conditions may not have a favorable outcome for the new source
 - Non-recurring engineering expenses
 - The new unit cost may be higher
 - Intellectual property rights
- **How VE can help**
 - Value engineering function analysis identifies viable options for reverse engineering parts



Missile VE Example for Reverse Engineering Approach

- **Background**
 - A defense missile contractor had a sole-source subcontractor for a costly warhead
 - The subcontractor was having problems meeting “insensitive munitions capability” requirements for the warhead to not explode in a fire or if dropped
- **With DoD cooperation, a VECP was submitted to develop an alternative, and less expensive, source for the warhead by reverse engineering**
 - Insensitive munitions capability improved by using a different process for making the explosive portion of the warhead
 - Approximately \$12 million is being invested to develop the new source
 - Estimated savings is \$15,000 per warhead
 - Second source also expected to control future cost increases

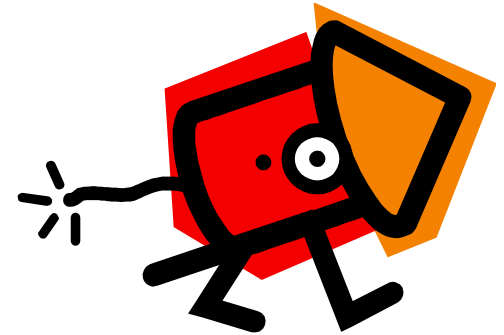

VE Contributions to a Redesign Approach

- **Definition**

- **Either eliminate the need for the part in question or replace it with another – may occur at many levels**
 - The DMSMS part itself
 - The next higher level configuration item
 - An entire subsystem
 - The end item itself



- **Drawbacks to this approach**

- **Non-recurring engineering expenses for building and testing the new production capability**
- **Qualification and certification to meet requirements**

- **How VE can help**

- **Value engineering function analysis identifies viable minor redesign options and it systematically identifies economically viable opportunities for a major redesign when there is a high degree of interdependence among parts**

AMRAAM VE Example for a Major Redesign Approach

- **Early in its production, the AMRAAM missile used an Analog Range Correlator**
 - The unit was scheduled to be replaced by a Digital Range Correlator as a pre-planned product improvement
 - With implementation several years in the future, the contractor was faced with producing the missile using a very difficult to build and extremely sensitive Analog Range Correlator
- **The contractor submitted a VECP to use an Interim Digital Range Correlator**
 - Implementation occurred four years in advance of the pre-planned version
- **Savings**
 - \$13,000 per unit
 - Government shared exceeded \$100 million
 - Contractor received over \$20 million in VE incentives after being reimbursed for approximately \$9 million in NRE

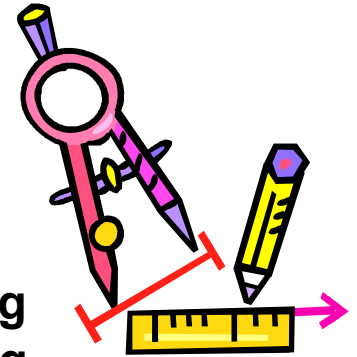

Outline

- **Introduction to DMSMS**
- **Introduction to VE**
- **Relationship of the VE methodology to the DMSMS risk management process**
- **Real VE examples for DMSMS resolution options**
- **Conclusions and next steps**

VE Enriches DMSMS Resolution Options

- **VE is an extremely powerful tool and methodology for**
 - Identifying a large number of resolution options
 - Evaluating their potential for solving the problem
 - Developing recommendations
 - Providing incentives for the investments needed for successful implementation

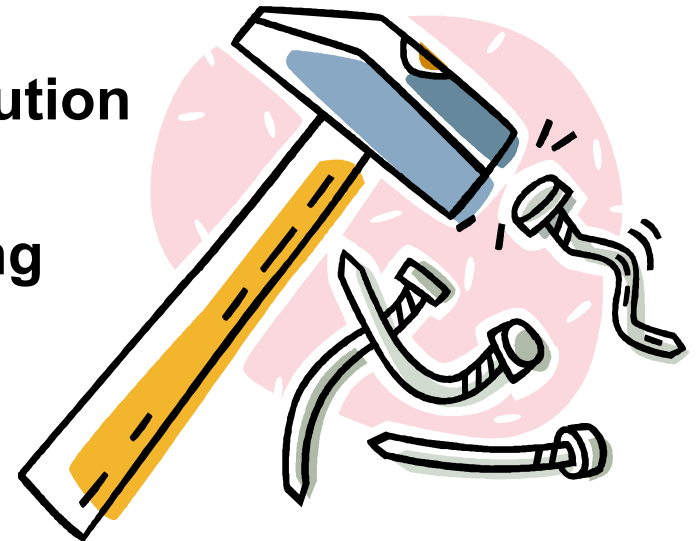

Using the VE methodology provides *greater opportunity* for developing and implementing innovative solutions to DMSMS problems

A VE / DMSMS Partnership Would be Beneficial

- **Nature of the partnership**
 - DMSMS community identifies problems
 - VE provides and incentivizes alternative solutions
- **Potential actions to develop a partnership**
 - Update the DMSMS Guidebook with a comprehensive treatment of VE and its application to DMSMS
 - Incorporate DMSMS examples into the DAU VE distance learning course
 - Incorporate DMSMS into the introductory VE certification training
 - Establish a DMSMS track at the annual VE professional society conference
 - Maintain and strengthen the VE track at the annual DMSMS conference
 - Augment the DAU DMSMS distance learning courses to include a section on VE
 - Include VE lessons in appropriate DAU DMSMS classroom material



Additional Actions

- **Outreach to contractors and program managers**
- **Outreach to the PBL community**
 - **Use of Value Engineering Program Requirement clause**
- **Potential DFARS changes**

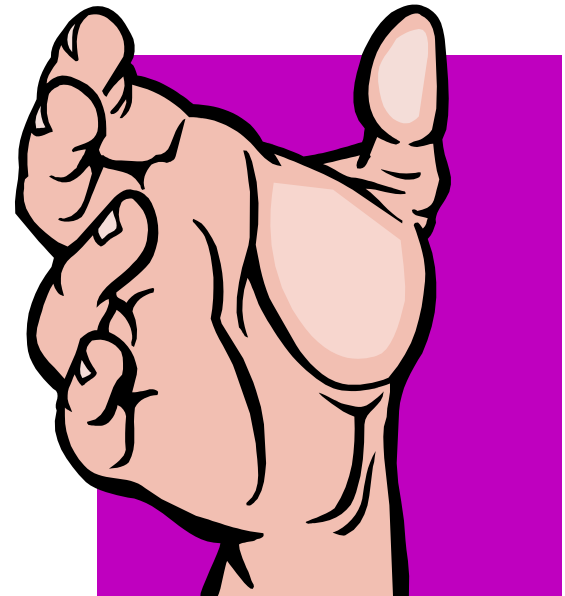

Sources of More Information

- **Contractual aspects of value engineering**
 - DAU CON 236 (online course)
 - Value Engineering Proposal Training Course – Ball Associates, www.ballassociates.com
- **VE methodology**
 - SAVE International <http://www.value-eng.org/>
 - Certified facilitators and consultants
- **Publications**
 - Value Engineering Handbook
 - Contracting Guide to Value Engineering
 - Value Engineering Change Proposals in Supplies or Services Contracts
 - Value Methodology Pocket Guide www.goalqpc.com
- **R-TOC/VE websites:** <http://rtoc.ida.org> or <http://ve.ida.org>



GAO Review of Best Practices for Quality Assurance

**11th Annual Systems Engineering Conference
October 21, 2008**

Cheryl Andrew
Senior Defense Analyst

Agenda

- GAO Audit Objectives
 - Background
 - Scope
 - Findings
 - Conclusions
 - Recommendations
-

Objectives

- Identify the impact of quality problems on selected DOD weapon systems and defense contractors' practices that contributed to the problems
 - Identify practices used by leading commercial companies that can be used to improve the quality of DOD weapon systems
 - Identify problems DOD faces in terms of improving quality
 - Identify recent DOD initiatives that could improve quality
-

Background

- A quality product is one that is delivered
 - on time
 - performs as expected
 - performs when need
 - can be obtained at an affordable cost
 - MIL-Q-9858A guided DOD quality efforts from the mid-1960's to the mid-1990's
 - DOD adopted commercial standards (i.e., ISO 9001) in mid-1990's
-

Scope

Commercial Manufacturers

- Boeing Commercial
- Cummins, Inc.,
- Kenworth Truck Company
- Siemens Medical Solutions
- Space Systems/Loral

Commercial Customers

- American Airlines
- Intelsat

DOD Weapon Systems –Prime*

- ASDS - Northrop Grumman
- ATIRCM/CMWS - BAE
- EFV - General Dynamics
- F-22A – Lockheed Martin
- Global Hawk – Northrop Grumman
- JASSM - Lockheed Martin
- LPD-17 – Northrop Grumman
- MH-60S – Sikorsky
- PAC-3 – Lockheed Martin
- V-22 – Bell/Boeing
- WGS – Boeing

* These contractors are involved with over \$1 trillion, or about 76 percent of the \$1.5 trillion DOD plans to spend on weapon systems in its current portfolio

Objective 1: DOD Quality Problems and Prime Contractor Practices that Contributed to Problems

- For the 11 programs we reviewed, quality problems resulted in
 - Over \$1.5 billion in cost overruns
 - Up to 5 years of schedule delays
 - Reduced weapon system availability
 - Military personnel deaths
 - Prime contractor practices that contributed to problems:
 - Poor systems engineering practices related to requirements analysis, design, and testing
 - Manufacturing processes not in control
 - Supplier quality problems
-

Objective 1: Expeditionary Fighting Vehicle Example of Systems Engineering Problem

- Contractor was only able to demonstrate 7.7 hours between operational mission failures during pre-production testing, well short of the 17 hour goal
- Primary problem was part and subsystem interferences
- Root causes
 - subassembly teams claiming the same space
 - inconsistent computer model checks
 - lack of design engineer experience
 - tight engineering model release schedules



Source: EFV Program Office.

- **4-year extension to SDD**
- **\$750 million cost growth**

Objective 1: LPD-17 Example of Manufacturing Problems

Over 5,000 quality problems were found

- Faulty hydraulics piping welds due to inexperienced workers and improper documentation
 - Some rework was required
 - All welds had to be re-inspected
 - Could have resulted in injuries
- Peeling non-skid coating due to unclean surfaces and high humidity
 - Rework was required
 - Long-term solution has not been identified



- **3-year delay**
- **\$846 million cost growth**

Objective 1: Patriot Advanced Capability-3 Example of Supplier Quality Problem

- Program has experienced a number of problems with the seeker portion of the missile
- A sub-tier supplier accepted non-conforming hardware without authority
 - seeker contractor identified quality problem
 - resulted in rework
 - re-inspection of components
- Same supplier also had poor workmanship and inadequate manufacturing controls
 - Operated in a development rather than a production environment
 - Facility was temporarily shut-down to address management and production problems



Source: PAC-3 Product Office, Lower Tier Project Office.

- **6-month schedule slip**
- **Delivery delay of 100 missiles**

Objective 2 – Commercial Best Practices – Systems Engineering

Ensure that a product's requirements are achievable with available resources and technologies

- Siemens Medical Solutions
 - Clear, precise, measurable, comprehensive requirements
 - Quality and reliability requirements prior to commitment
 - Boeing Commercial Airplanes
 - “Mistake-proof” designs
 - Rating tool on critical designs
 - Space Systems/Loral
 - Reliability assessments
 - Highly accelerated life testing
-

Commercial Best Practices - Manufacturing

Ensure that a product's requirements can be produced consistently with high quality and low variability

- Cummins, Inc.
 - Capability growth plan for manufacturing processes
 - Prototypes to validate design and production processes
 - Kenworth Truck Company
 - Electronic system for process documents
 - Pictures and engineering specifications
 - Training audits
-

Commercial Best Practices – Supplier Quality

Ensure that suppliers have the ability to deliver high-quality parts

- Kenworth Truck Company
 - Hold first-tier suppliers accountable for quality problems attributed to lower-tier suppliers
 - Boeing Commercial Airplanes
 - 99% part conformance expectations for suppliers
 - Retain higher-performing suppliers
 - Siemens Medical Solutions
 - 98% part conformance expectations for suppliers
 - Levy financial penalties against non-conforming suppliers
-

Objective 3 – Problems DOD Faces When Trying to Improve Quality

- Environment
 - DOD awards cost reimbursement contracts assumes most of the financial risks
 - Reliability is not emphasized at development start
 - Requirements are set without adequate systems engineering knowledge
 - Oversight
 - Risk-based approach used to oversee contractors
 - DCMA and service oversight varies by program
 - Information is not aggregated in a manner that would allow DOD to determine overall weapon system quality, prime contractor performance, or systemic problems
-

Objective 4 – DOD Initiatives that Could Improve Quality

- Concept Decision Reviews
 - Time-Defined Acquisition
 - Configuration Steering Boards
 - Key Performance Parameters/Key System Attributes
 - Award and Incentive Fees
 - Establishing Reliability Goal and Demonstrating Reliability Prior to Production
 - New Reliability, Availability, and Maintainability Policy (7/08)
-

Conclusions

- Despite adopting commercial quality standards and implementing new requirements and systems engineering policies, DOD still has difficulty acquiring high-quality weapon systems in a cost-efficient and timely manner
- Poor systems engineering, manufacturing control, and supplier quality are the underlying problems
- Improvements in analyzing requirements and successful implementation of several new initiatives could improve outcomes

It is going to take a **joint effort** between DOD and prime contractors to improve weapon system quality

Recommendations

- As part of the concept decision review initiative, require systems engineering analysis be completed by the prime contractor prior to entering into a development contract
 - Establish measures to gauge the success of the concept decision review, time-defined acquisition, and configuration steering board initiatives
 - Identify and collect data that provides metrics about the effectiveness of prime contractors' quality management system by weapon system and business area over time
 - Develop evaluation criteria that would allow DOD to score the performance of contractors' quality management systems based on actual performance
-

The Problem



Charlie Chaplin in "Modern Times"

How do we define testable requirements for System of Systems (SoS) when no one understands *exactly* how the complex system will operate and integrate once it comes on-line and the human in the loop is added to the equation?

The Problem

<http://thinkingproblemmanagement.blogspot.com/2008/03/differences-between-problems-and.html>



Most problems with SoS designs, (as with most designs), lead us back to the requirements phase.

The synthesis of these very large systems often results in different problems than those presented by the design of a single, but complex, system.

Historical Approach

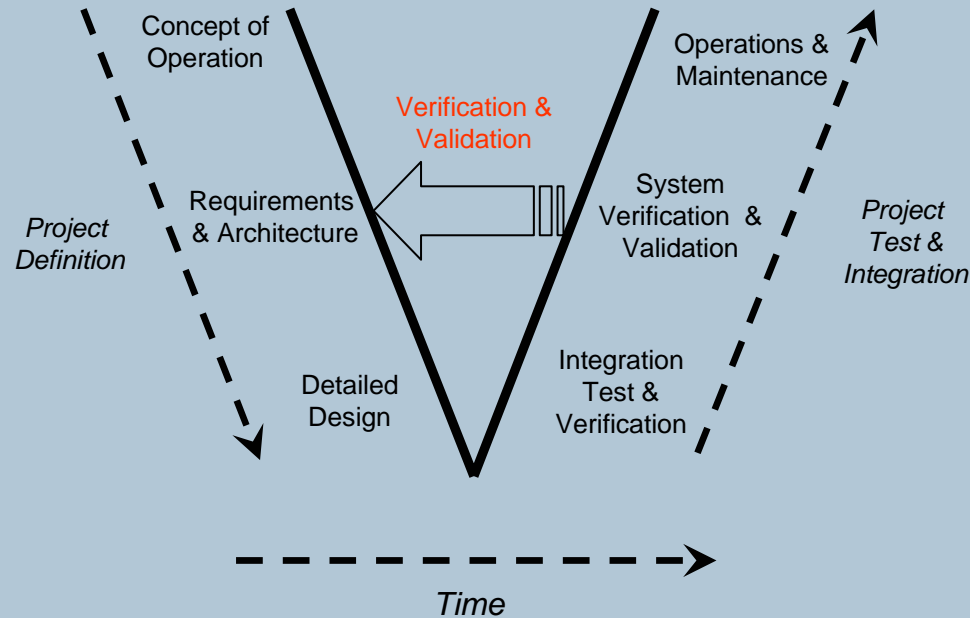

In the past the contribution of Test and Evaluation professionals has not come until after the system Detailed Design phase.

It is our recommendation that this be changed and T&E personnel be involved from the beginning of the Requirements and Architecture phase.

The Problem Continued



What do we want the SoS to be able to do?

This is often a very complex question that can have multiple and vague answers that have little meaning when it comes to defining measurable metrics for later testing of our system.

We usually end up with requirements that are too detailed and “Pie in the Sky” requirements that are too vague to implement.

“The system CPU will operate at 500 megahertz.”

“The system will create synergy among multiple sensor systems and enable data fusion at all levels.”

End User Example



Primitive Need Statement for C2 Cell of a C4ISR System

“I need to be able to visualize what my Intel guys are collecting and analyzing so that my understanding of the battle area is current and my decisions are based on accurate, comprehensive, up to date information. I also need to have an understanding of what is changing now, how long things can be expected to remain the same (Dwell Time) and the status of the enemy’s assets as well as my own, and I need this to be a simple process.”

End User Example

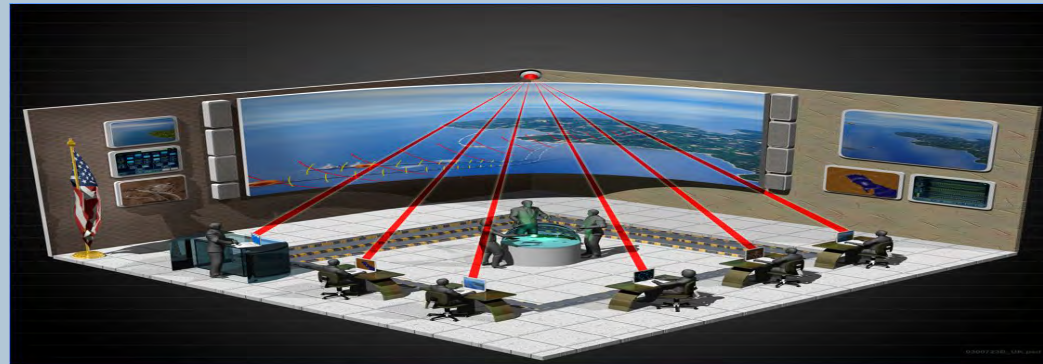

<http://www.optemax.com/html/productmilindoor.html>

Seems to be a reasonable request, right?

Well let's look at this primitive need statement and try to do a quick and dirty breakdown of what functionality the Commander is looking for us to incorporate into our C4ISR system to provide these required Command and Control capabilities.

- *Situational Awareness:*

- Visualization of the Battlespace
- Near/Real Time Information
- Sensor Availability
- Data Fusion
- Predictive Intelligence
- Blue Force Intel
- Order of Battle (OOB)
- Advanced HSI

End User Example

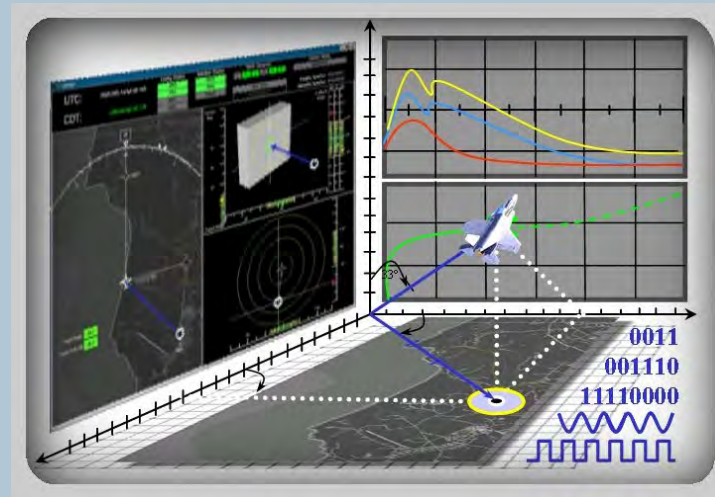

<http://www.cctcorp.com/>

Now let's break down each of these major functionalities into some of their supporting functions.

- Visualization:

- Maps
- Overlays
- Terrain information
- Weather Information
- Symbology
- Movement Representation (Vector)
- Detail Drill Down
- Information Filtering and Manipulation
- DATA Handling

End User Example

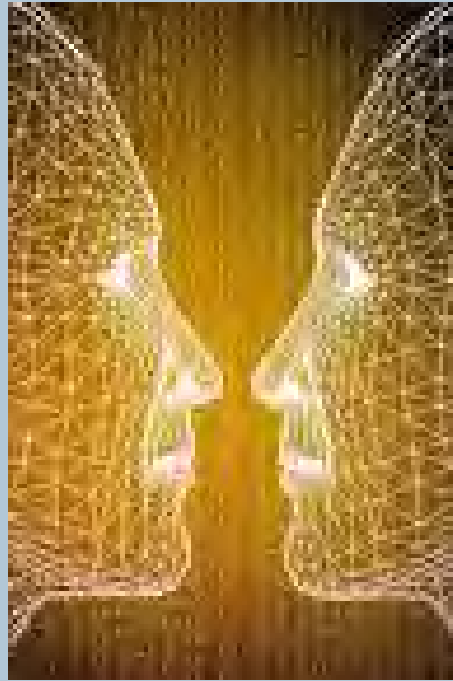

http://blog.businessquests.com/marketing_marketing_x0/index.html

- Near/Real Time Information:

- Direct Sensor feed
- Single Step Data Sharing
- Prioritization of Information
- Latency of Information

End User Example

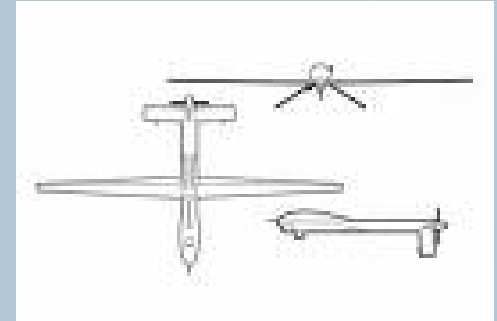

- Sensor Availability:

- Multiple Sensors
- On Station Time
- Full Spectrum of Sensor Types
- Local Sensor Tasking
- Live Sensor Data Feeds
- Information on Data Accuracy/Latency

End User Example



<http://www-vis.lbl.gov/Vignettes/>

- Data Fusion:

- Autonomous Data Fusion
- Selectable Data Fusion
- Fusion C2 Products
- Fusion C2 Symbology
- Information Reliability Ratings

End User Example



<http://www.berrizbeitia-design.com/art-play.html>

- Predictive Intelligence:
 - Dwell Time
 - Probable Destination for Moving Units
 - Probable Unit Strength
 - Probable Unit Type
 - Probable Unit Action
 - Predicted Unit Weaknesses
 - Information Reliability Ratings

End User Example

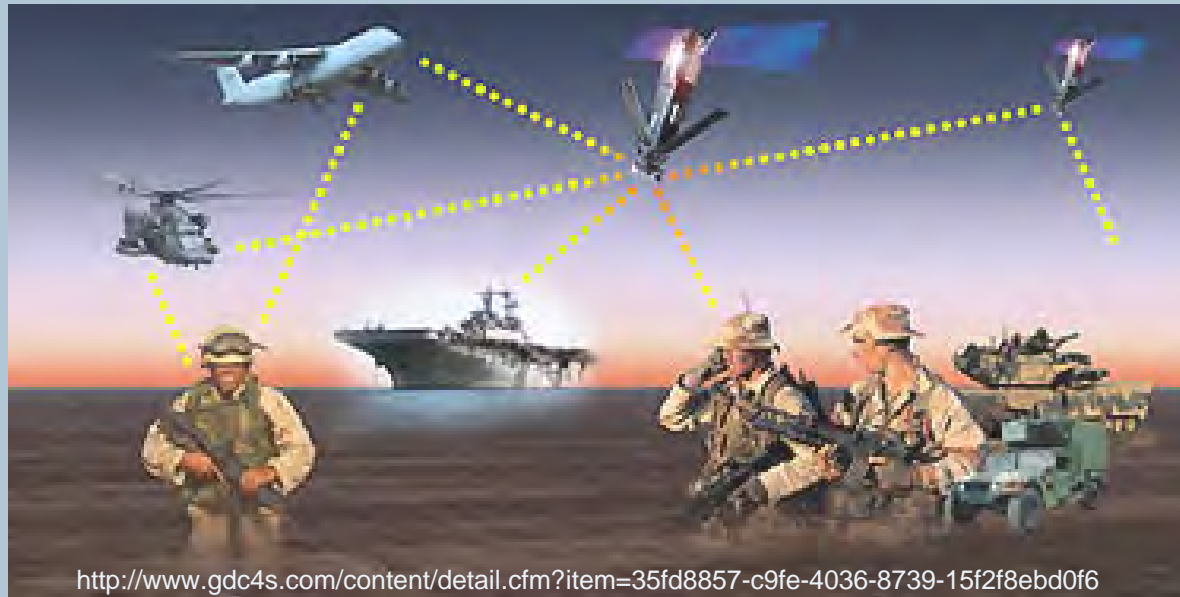

- Blue Force Intel:
 - Unit Location
 - Unit Movement
 - Unit SITREP
 - Latency of Information

End User Example

航空団の組織

航空団の組織は、一般的に次のようになっています。

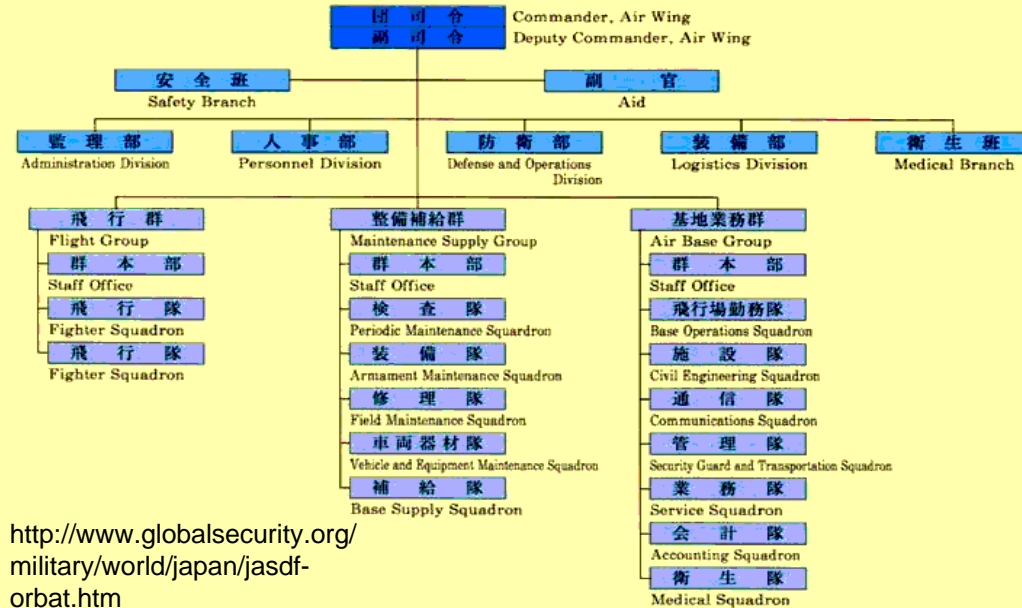

<http://www.globalsecurity.org/military/world/japan/jasdf-orbat.htm>

•OOB:

- Known Enemy Unit Locations
- Known Enemy Unit Equipment
- Known Enemy Unit Strength
- Known Enemy Unit Weaknesses
- Known Enemy Unit Range and Speed
- Latency and reliability of Information

End User Example

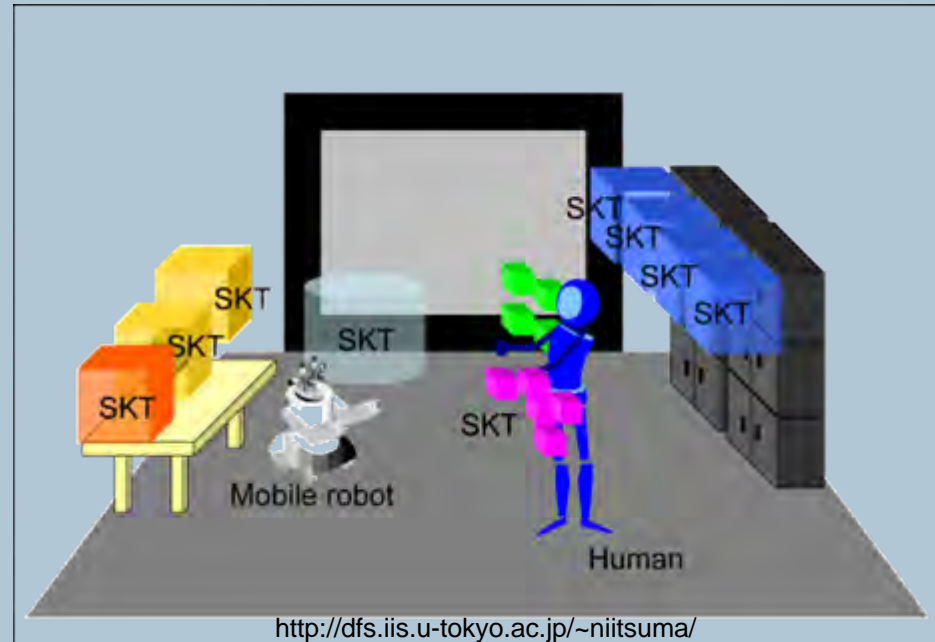

- Advanced HSI:

- Operators Control Visual Clutter
- Simple HSI Actions for Data Manipulation, Retrieval, and Storage

We can readily see that many systems will be involved in providing these capabilities to the Command and Control Cell to meet the user's needs.

End User Example

Generate an Effective Need Statement

“A Command and Control System is required that integrates Near/Real Time Information from Enemy OOB, all deployed Sensors, ISR Data Fusion, Intelligence Analysis, Predictive Intelligence, Blue Force Intel, enemy unit location, and all unit movement data. The system will allow Visualization of this information within the defined Battlespace and allow the operator to manipulate and request information updates and details utilizing simple HSI functionality. The system will be able to filter, store, and transfer information for detailed scrutiny to limit visual clutter.”

What's Next

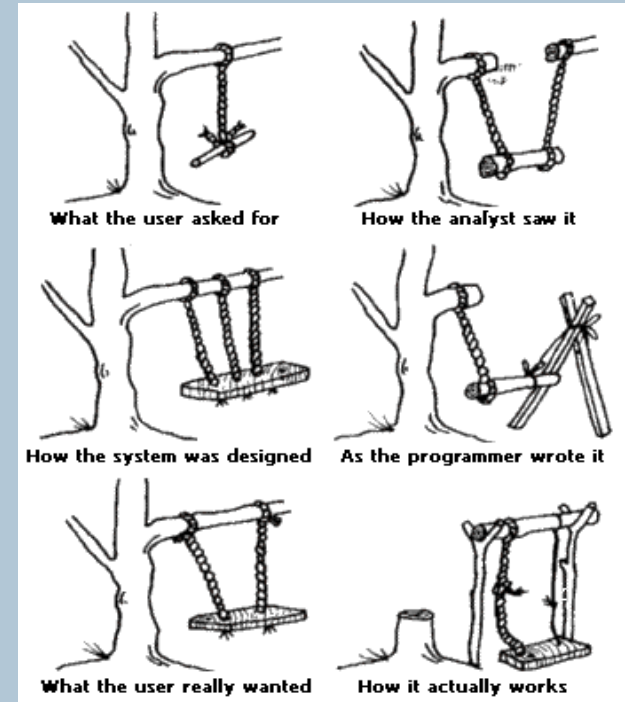
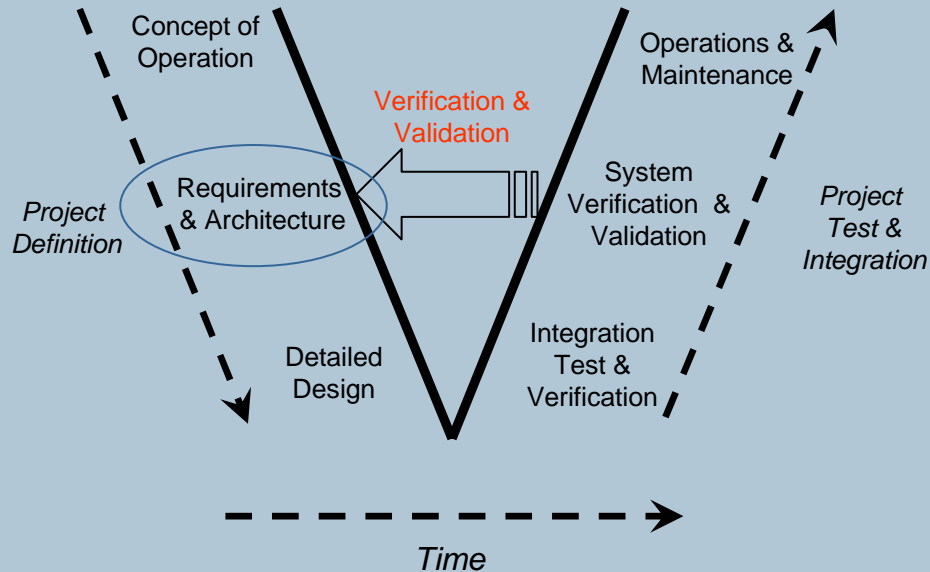

The Requirements Definition process now becomes our primary mission

This process should be conducted utilizing the Integrated Product Team approach and should include all Stakeholders.

If the requirements are too vague System Design will suffer as will construction, test and evaluation.

If the requirements are too specific the ability of the contractor to build a better mousetrap will be hindered and system functionality may suffer

Requirements Generation



What approach will ensure that the requirements are written so that they properly support the user's needs and also provide design and testing adequate information to do their job?

Requirements should be written and then evaluated and then re-written and then re-evaluated and then re-written and re-evaluated, etc..., until a consensus is reached by ALL Stakeholders.

We are reminded of the old carpenter's adage, "measure twice and cut once."

Collaborating System Interactions



In a SoS world, requirements may already be established for the systems that you will integrate with.

This can often require great negotiating skills, if you are the new kid on the block it is very likely that you will have to make most of the concessions if there are issues with interfacing with fielded systems.

Requirements Generation



Here we see an inherent problem with SoS design and Acquisition:

If we have to incorporate or modify existing systems in order to achieve the desired functionality to fill the user's need our process will become more time and coordination intensive.

This fact has driven the requirements for Net-Centric Design and Service Oriented Architecture that could ease the integration of multiple Inter/Intra-network systems into a SoS framework

Requirements Generation



Let's get back to our discussion and look at Information Exchange Requirements (IERs). In a SoS acquisition IERs become much more important than in most system designs.

IERs tell us who exchanges what information with whom, why the information is necessary, how the information is used, and defines the metrics for the IER.

In SoS there may be hundreds of IERs and to imagine having the resources to test and evaluate all of them is unrealistic. Just as we cannot possibly test all possible combinations of inputs and pre-conditions in a complex software program we will not be able to test all IERs in a complex SoS. Therefore, as with software, we must evaluate the SoS's states and behaviors against a specification.

Requirements Generation

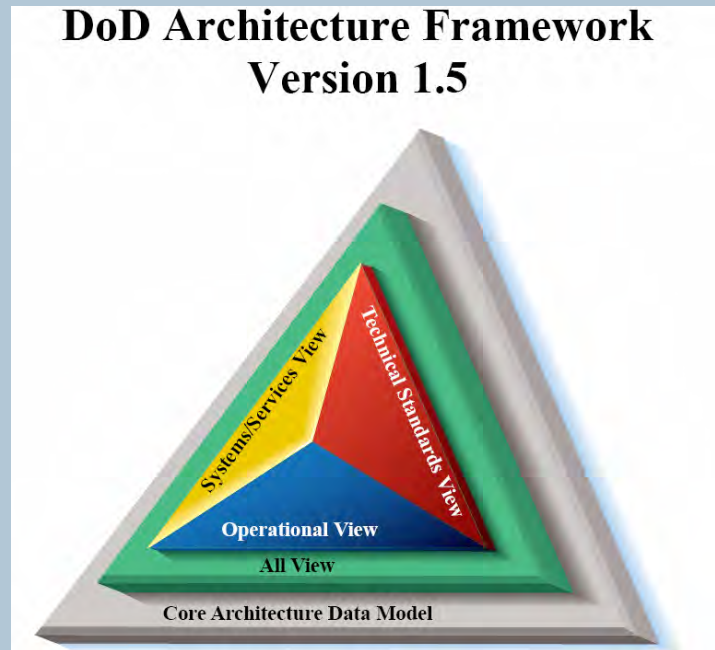

A key tool for the definition of how a System of Systems will interface, who it will interface with and what data will be exchanged and the rules for exchanging information among systems is the Department of Defense Architectural Framework (DODAF). The major product areas are defined in the figure above.

Input in the generation of these documents by Test and Evaluation personnel would help to insure that they can be realistically tested and also provide T&E experience to the sponsor during the early generation of system capability definition.

The Role of Test and Evaluation



T&E personnel must be involved from the beginning of the Requirements Definition Phase

Test personnel will be responsible for designing the developmental and operational testing of the system and need to have input into whether or not the requirements being generated can be tested.

The Role of Test and Evaluation

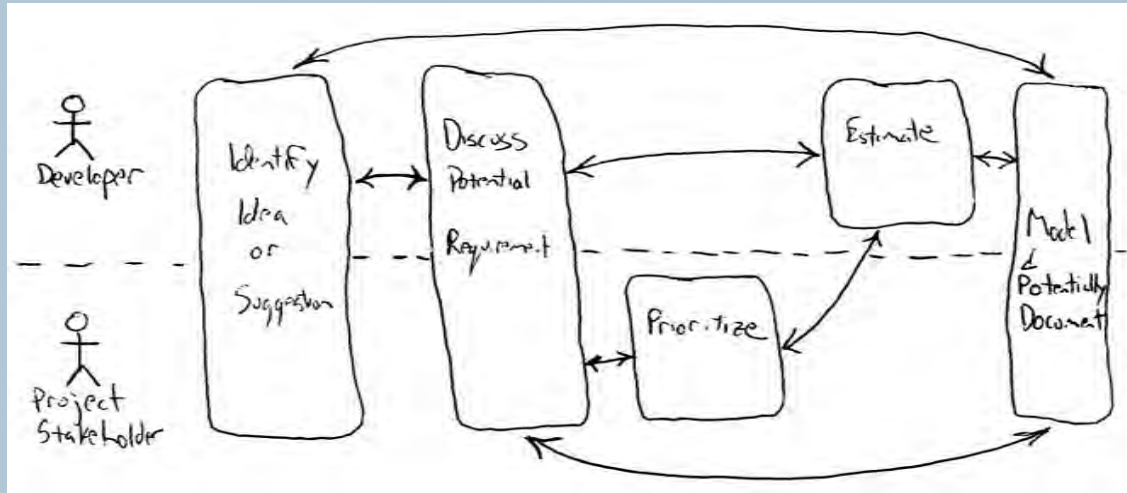

<http://www.agilemodeling.com/essays/agileRequirementsBestPractices.htm>

Requirements come from many sources;

Sponsors put them in the Acquisition Capabilities documents when defining for the acquisition Program Manager their Key Performance Parameters (KPPs) and other attributes.

Requirements may be determined by the Joint Chiefs of Staff (JCS) as overarching requirements for all programs.

Requirements are derived from discussion with stakeholders and users and they evolve from the process of defining the required system performance.

The Role of Test and Evaluation

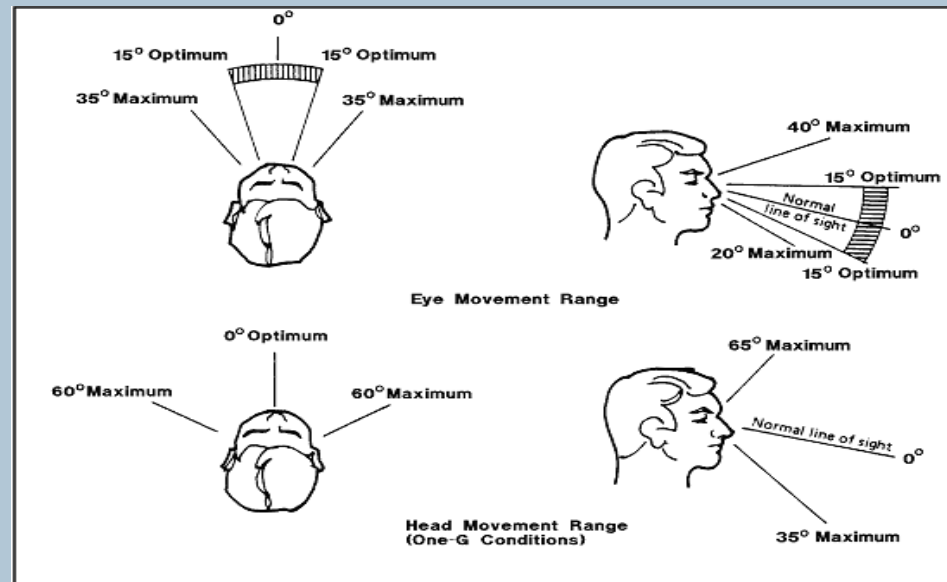

Requirements are transformed;

They become Critical Technical Parameters (CTPs) and Software Design or System Specifications (SDS/SS).

Systems are built and tested based on specifications, whether they be software or system.

Specifications define how a system must function and support system requirements.

If requirements are so vague that they cannot be supported by specifications how can the requirement be met or tested?

The Role of Test and Evaluation

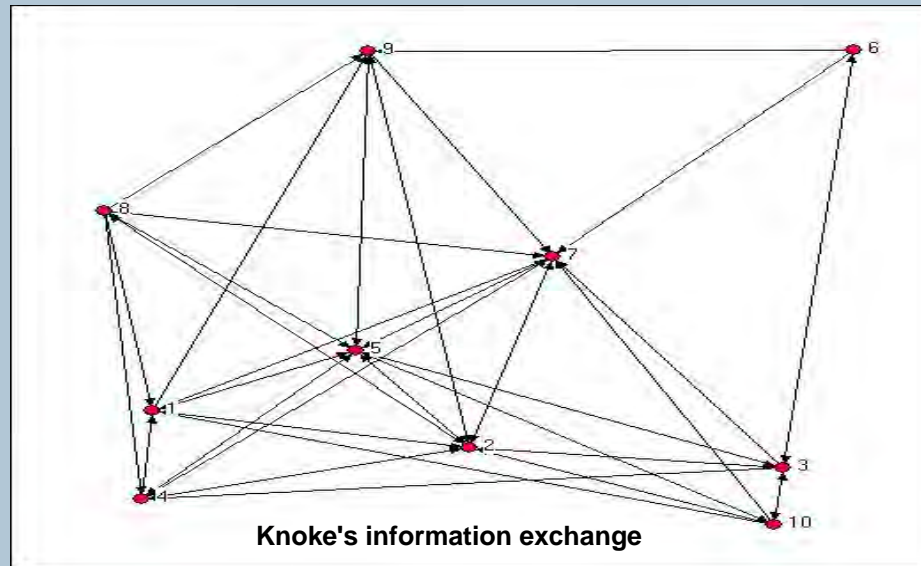

Testing SoS requires that the system be evaluated for acceptability by the end users, the target audience, the purchasers, and other stakeholders.

It is resource intensive to test all individual IERs, we must rely on testing the outcome of their contribution to the system, as defined in our specifications, to evaluate the systems overall acceptability.

We must know what will not be tested as part of our evaluation in order to examine whether this imposes risk to the performance, or our stakeholders acceptance of the system.

The Role of Test and Evaluation



http://www.toronto.drdc-rddc.gc.ca/facilities/specialized_e.html

Other areas for requirements that need to be addressed are the Humans in the Loop (HITL) and Human System Interfaces (HSI).

These provide a whole set of other requirements and can be resource intensive to evaluate. If our SoS require HITL at several different systems' locations the complexity of the testing is increased greatly.

The performance of most systems, however; is tied to the performance of HITL and to ignore these requirements would add risk to the systems acceptability.

The Role of Test and Evaluation



Another dimension of HITL that is not normally designed into testing is the ability of personnel to utilize the system in ways that had not been imagined when the system was designed.

This can be a positive or a negative factor but is a valuable input into the systems' readiness.

It is important that testing is not always strictly scripted to give the operators latitude when conducting their portion of the evaluation. Doing this will often lead to discoveries testers had not anticipated!

Summary

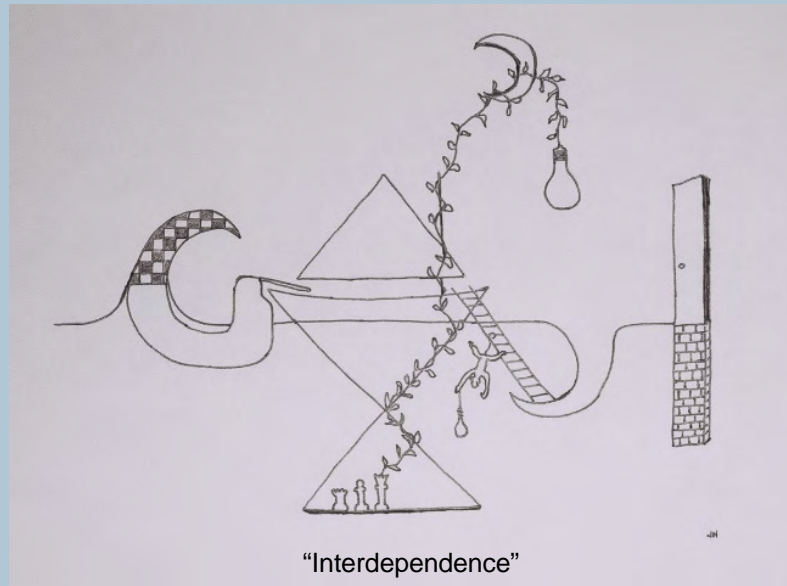

http://www.modernartwork.net/gallery_Modern_Art_Work_drawings.htm

The interdependence of Requirements Definition, Test, and Evaluation takes place throughout the program cycle.

To exclude T&E from the beginning stages of requirements development is to preclude more opportunity for synergy.

To operate in an efficient manner all components of a system must work together; this is a basic definition of a system. Why would we as the systems engineers want to deny this basic truth and eliminate the T&E capability of our acquisition system?



Joint Test and Evaluation Methodology (JTEM)



Systems Engineering for Testing in a Joint Mission Environment (JME)

National Defense Industrial Association
11th Annual Systems Engineering Conference

Test & Evaluation in Systems Engineering Track
October 22, 2008

Earl Reyes
Senior Systems Engineer
757.638.6014
earl.reyes@jte.osd.mil



Overview



- JTEM Problem Statement
- Capability Test Methodology (CTM)
- CTM Systems Engineering Thread
- Summary



Overview



- **JTEM Problem Statement**
- Capability Test Methodology (CTM)
- CTM Systems Engineering Thread
- Summary



JTEM Problem Statement



Processes and methods for designing and executing tests of systems of systems in the joint mission environment are not well defined or understood. Nor is there a clear understanding of how to assess system performance as it pertains to capabilities supporting joint missions.

Overall Goal: Recommended Best Practices for a consistent approach to describing, building, and using an appropriate representation of a particular Joint Mission Environment across the acquisition lifecycle.



Overview



- JTEM Problem Statement
- **Capability Test Methodology (CTM)**
- CTM Systems Engineering Thread
- Summary



JTEM Capability Test Methodology (CTM) v2.0

6 Steps
14 JTEM
Processes

1. Characterize Test

Program Introduction Document (PID)	Statement of Capabilities (SOC)
-------------------------------------	---------------------------------

Capability Subset Focus

- Develop Test Concept
- Refine Evaluation Strategy
- Technical Assessment

2. Plan Test

Analysis & Evaluation	Planning	Execution
<ul style="list-style-type: none"> Problem Statement Issue 1 Issue 2 Issue 3 FRD (previously PO) <ul style="list-style-type: none"> Test purpose Objectives Scope Operational context Support & Schedule constraints 	<ul style="list-style-type: none"> Statement of Capability Measure Measure Measure Measures & SDRs Data Requirements Data Source Review Scenarios Test Analysis 	<ul style="list-style-type: none"> Test Plan

- Develop Test Design
- Perform LVC Distributed Environment Analysis
- Develop Test Plan

0. Develop T&E Strategy

T&E Strategy (TES)	T&E Master Plan (TEMP)
--------------------	------------------------

- Develop Capability/SoS Description
- Develop Joint Operational Context for Test (JOC-T)
- Develop Evaluation Strategy
- Develop/Refine Capability Crosswalk

Test Concept

Joint Operational Context for Test



Integrated Vignettes

LVC Distributed Environment Design

Joint Mission Environment

Test Control & Monitoring

3. Implement LVC-DE

	System Design Document (SDD)
--	------------------------------

- Design LVC Distributed Environment Configuration
- Integrate LVC Distributed Environment

Capability Set Focus

5. Evaluate Capability

	Joint Capability Evaluation (JCE)
--	-----------------------------------

- Analyze Data
- Evaluate SoS Performance & Joint Mission Effectiveness

4. Manage Test Execution

	Event Management Plan
--	-----------------------

Event Focus

LVC – Live, Virtual, Constructive
LVC-DE – Live, Virtual, Constructive Distributed Environment
SoS – System of Systems



Overview



- JTEM Problem Statement
- Capability Test Methodology (CTM)
- **CTM Systems Engineering Thread**
- Summary



What is the Joint Mission Environment?

OSD/JS J7

Analytic Agenda
DPS, MSFD, FYAB

JOpsC Family
JOC, JFC, JIC

JS J8/J7
"Capability Lead"

JCIDS
JCD, ICD, CDD, JCIDS DoDAF Views (e.g., OV, SVs)

AOA

USJFCOM J8/J7

JCAs

UJTL/Service Task Lists

AT&L/
Service/Joint Acq Programs

TES/TEMP
STAR

JTEM **Methods and Processes**

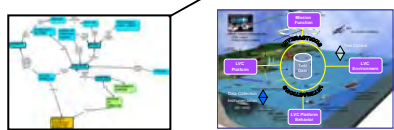

JMETC



Components

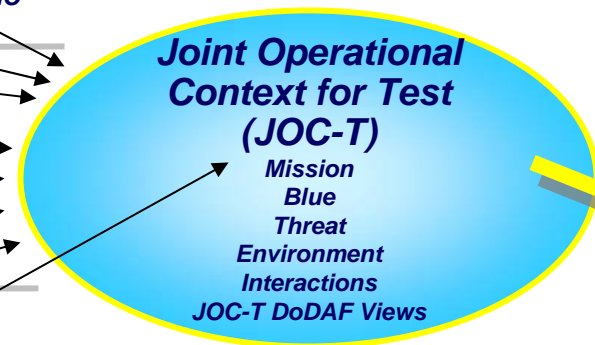
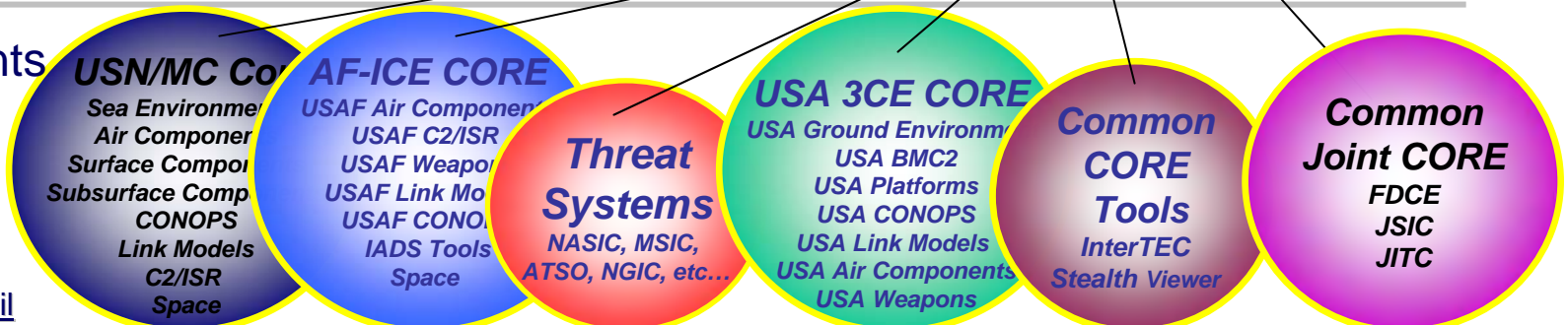



System Engineering Process

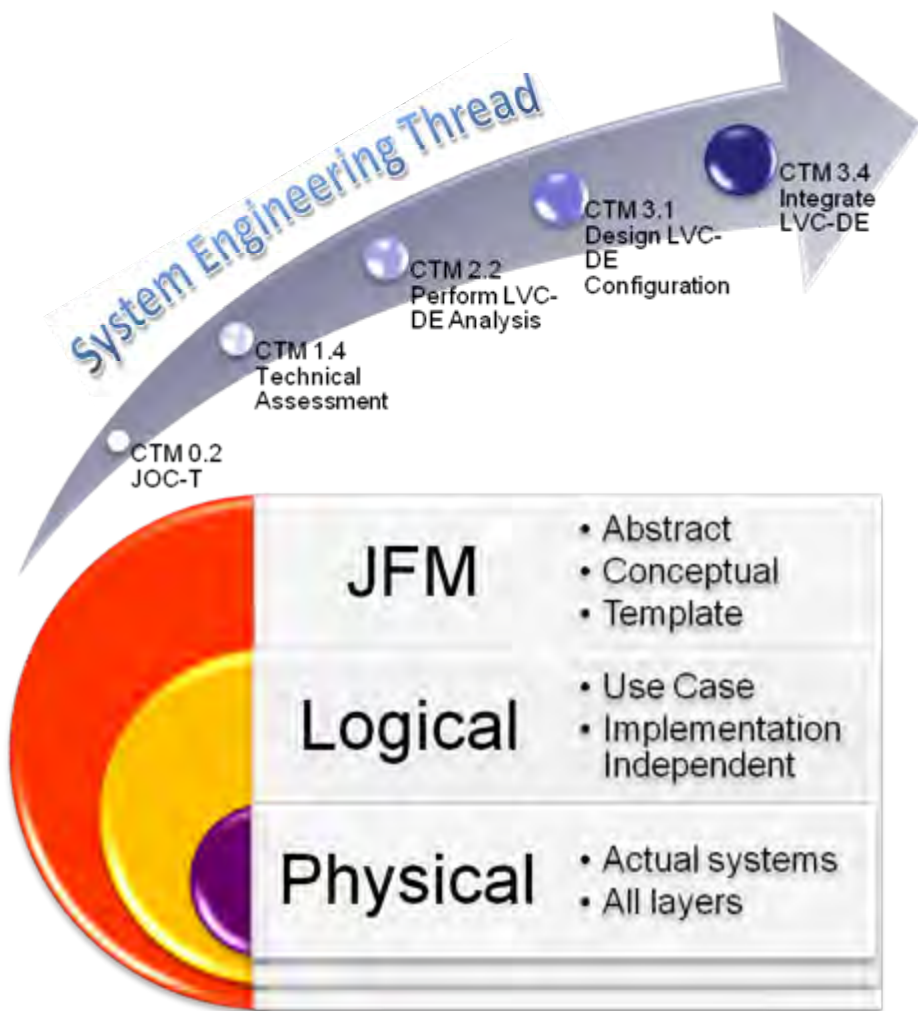

- JFM identifies generic capabilities, environments, behaviors, and tasks
- Logical Design applies the JFM to a use case (e.g., JCAS, JFIRES, etc.) independent of implementation
- Logical Design is transformed into a physical design
- Physical interfaces transformed to executable software
- Physical Design solutions are integrated into a JME (moves to LVC-DE repository for reuse)



JTEM Capability Test Methodology (CTM) v2.0

**6 Steps
14 JTEM
Processes**

1. Characterize Test

Program Introduction Document (PID)	Statement of Capabilities (SOC)
-------------------------------------	---------------------------------

Capability Subset Focus

- Develop Test Concept
- Refine Evaluation Strategy
- Technical Assessment

2. Plan Test

Analysis & Evaluation	Planning	Execution
<ul style="list-style-type: none"> Problem Statement Issue 1 Issue 2 Measure FRD (previously PO) - test purpose, characteristics, scope, operational context, support & schedule constraints Hypothesis Test Deficiency Analysis Hour Analysis 	<ul style="list-style-type: none"> Statement of Capability Subset Capabilities Measure Measures & SDRs Data Requirements Data Source Review Scenarios Test-Test Analysis 	<ul style="list-style-type: none"> Test Plan

- Develop Test Design
- Perform LVC Distributed Environment Analysis
- Develop Test Plan

0. Develop T&E Strategy

T&E Strategy (TES)	T&E Master Plan (TEMP)
--------------------	------------------------

- Develop Capability/SoS Description
- Develop Joint Operational Context for Test (JOC-T)
- Develop Evaluation Strategy
- Develop/Refine Capability Crosswalk

Capability Set Focus

3. Implement LVC-DE

<ul style="list-style-type: none"> Mission Prediction LVC Platform Data Collection Instrumentation Scenario Development LVC Platform Behavior 	<ul style="list-style-type: none"> System Design Document (SDD)
---	--

- Design LVC Distributed Environment Configuration
- Integrate LVC Distributed Environment

5. Evaluate Capability

	<ul style="list-style-type: none"> Joint Capability Evaluation (JCE)
--	---

- Analyze Data
- Evaluate SoS Performance & Joint Mission Effectiveness

4. Manage Test Execution

<ul style="list-style-type: none"> Client Systems 	<ul style="list-style-type: none"> Event Management Plan
--	---



LVC – Live, Virtual, Constructive
LVC-DE – Live, Virtual, Constructive Distributed Environment
SoS – System of Systems



JME Foundation Model (JFM)

- Conceptual model to enable implementation-independent reasoning in an idealized framework
- Provides abstract interface descriptions and the logical and quantitative relationships between those interfaces
- The goal of the JFM is to provide a frame of reference for LVC-DE configuration design
- The JFM Description is an evolutionary document that will be modified over time to promote the robustness of the JME

The JFM is a design template to guide the development and reuse of LVC-DE systems.



CTM 0.2: Develop JOC-T

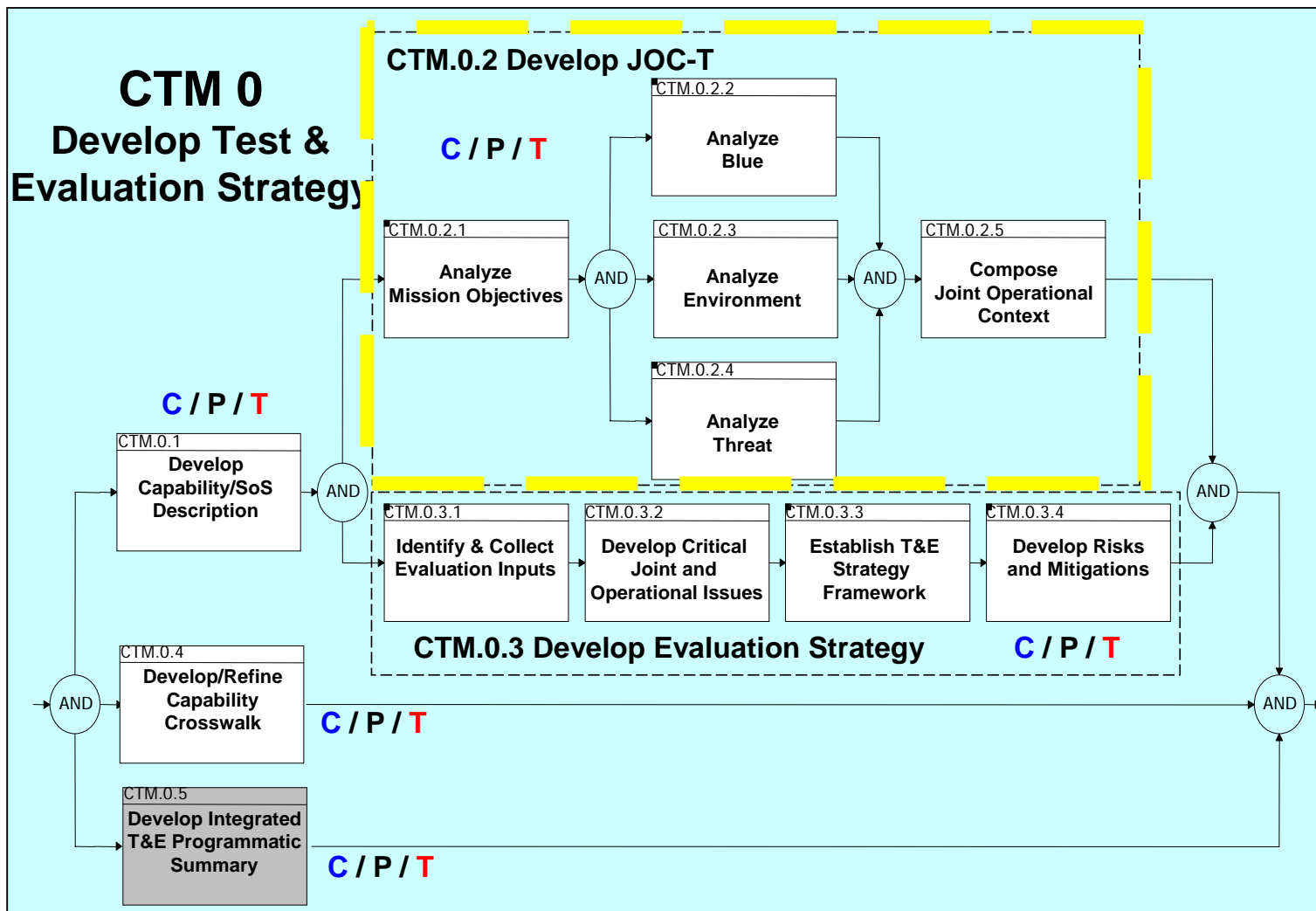



CTM 0.2.1: Analyze Mission Objectives

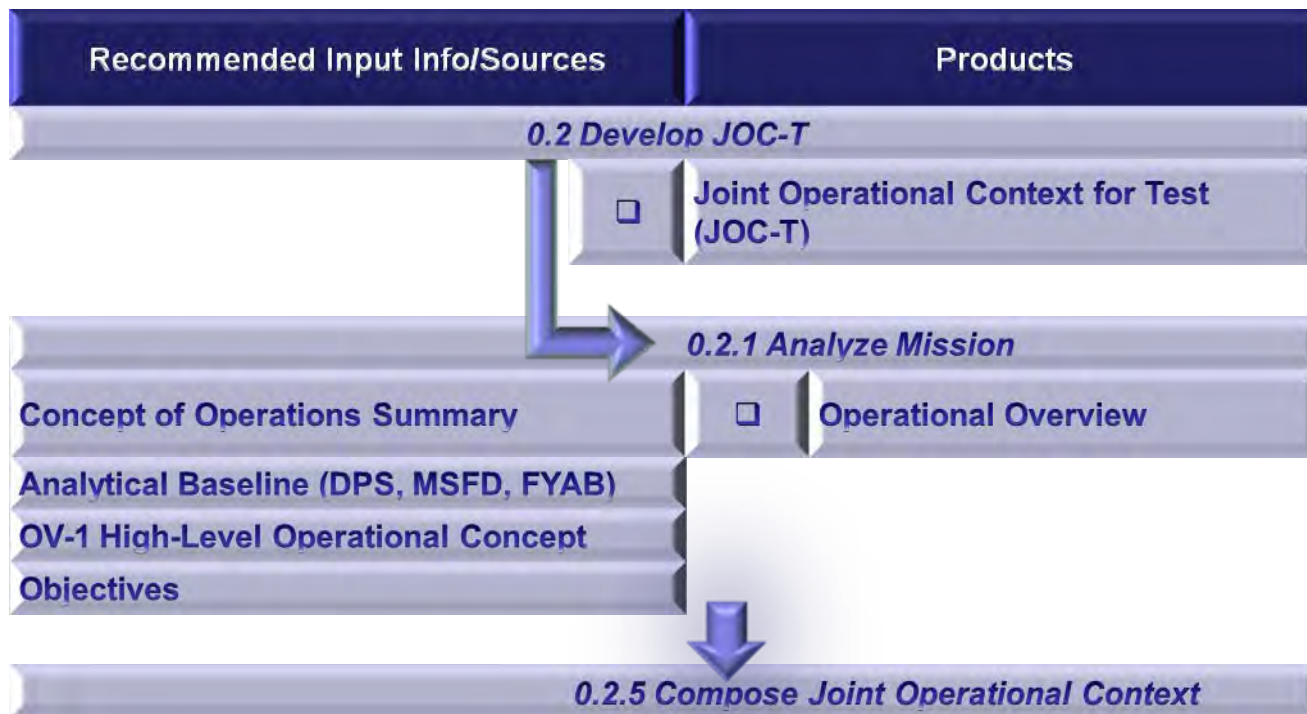



CTM 0.2.2: Analyze Blue



Recommended Input Info/Sources	Products	Example
0.2 Develop JOC-T		
	<input type="checkbox"/> Joint Operational Context for Test (JOC-T)	
0.2.2 Analyze Blue		
Joint Tasks	<input type="checkbox"/> Blue Forces	
Forces and Related Conditions	<input type="checkbox"/> Blue Actions	
Tasks Steps/Mission Threads (JTA, other sources)	<input type="checkbox"/> Blue Interactions	
Capability Discussion		
System/SoS Capabilities Required for Current Increment		
SoS Synchronization		
OV-1 High-Level Graphic	<input type="checkbox"/> Blue High-Level Graphic (BOV-1)	A
OV-5 Operational Activity Model	<input type="checkbox"/> Blue Operational Node Connectivity Model (BOV-5)	B
OV-2 Operational Node Connectivity Description	<input type="checkbox"/> Blue Operational Node Connectivity Description (BOV-2)	C
OV-4 Organizational Relationship Chart	<input type="checkbox"/> Blue Notional Relationship Chart/Task Organization (BOV-4)	D
SV-1 System/SoS Interface Description	<input type="checkbox"/> Blue SoS Interface Description (BSV-1)	E
SV-5 Operational Activity to System/SoS Function Traceability Matrix	<input type="checkbox"/> Blue SoS Operational Activity to System/SoS Function Traceability Matrix Description (BSV-5)	F
SV-4 System/SoS Functionality Description	<input type="checkbox"/> Blue SoS Functionality Description (BSV-4)	G
SV-6 System/SoS Data Exchange Matrix	<input type="checkbox"/> Blue SUT Information Exchange Matrix (BSV-6)	H
0.2.5 Compose Joint Operational Context		



CTM 0.2.3/4: Analyze Environment/Analyze Threat

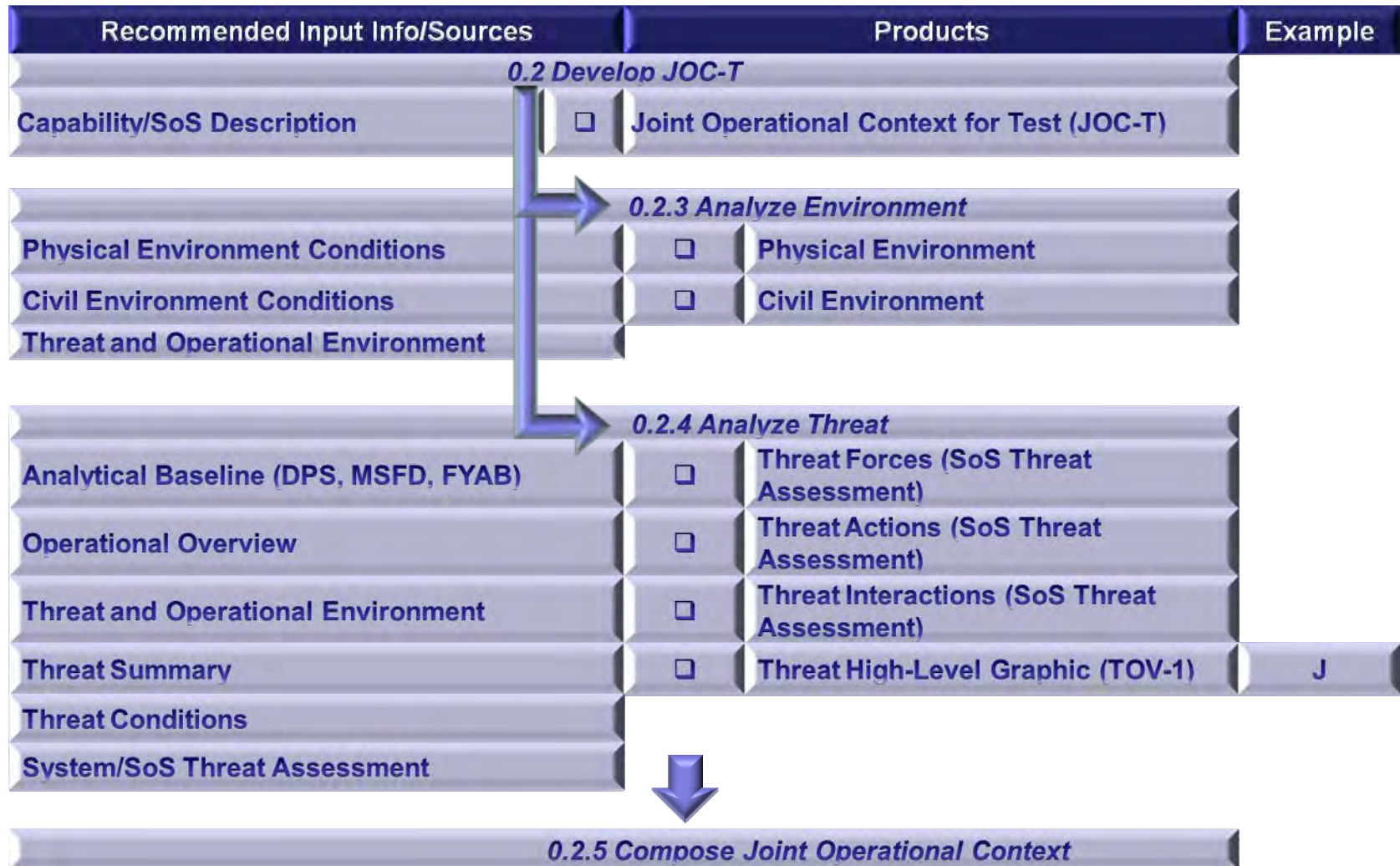



JTEM Capability Test Methodology (CTM) v2.0



6 Steps
14 JTEM
Processes

1. Characterize Test

Program Introduction Document (PID) | Statement of Capabilities (SOC)

Capability Subset Focus

- Develop Test Concept
- Refine Evaluation Strategy
- Technical Assessment

2. Plan Test

Analysis & Evaluation | Planning | Execution

Test Plan

- Develop Test Design
- Perform LVC Distributed Environment Analysis
- Develop Test Plan

0. Develop T&E Strategy

T&E Strategy (TES) | T&E Master Plan (TEMP)

- Develop Capability/SoS Description
- Develop Joint Operational Context for Test (JOC-T)
- Develop Evaluation Strategy
- Develop/Refine Capability Crosswalk

Capability Set Focus

3. Implement LVC-DE

System Design Document (SDD)

- Design LVC Distributed Environment Configuration
- Integrate LVC Distributed Environment

5. Evaluate Capability

Joint Capability Evaluation (JCE)

- Analyze Data
- Evaluate SoS Performance & Joint Mission Effectiveness

Capability Set Focus

4. Manage Test Execution

Event Management Plan

Event Focus



LVC – Live, Virtual, Constructive
 LVC-DE – Live, Virtual, Constructive Distributed Environment
 SoS – System of Systems



CTM 1.4: Technical Assessment

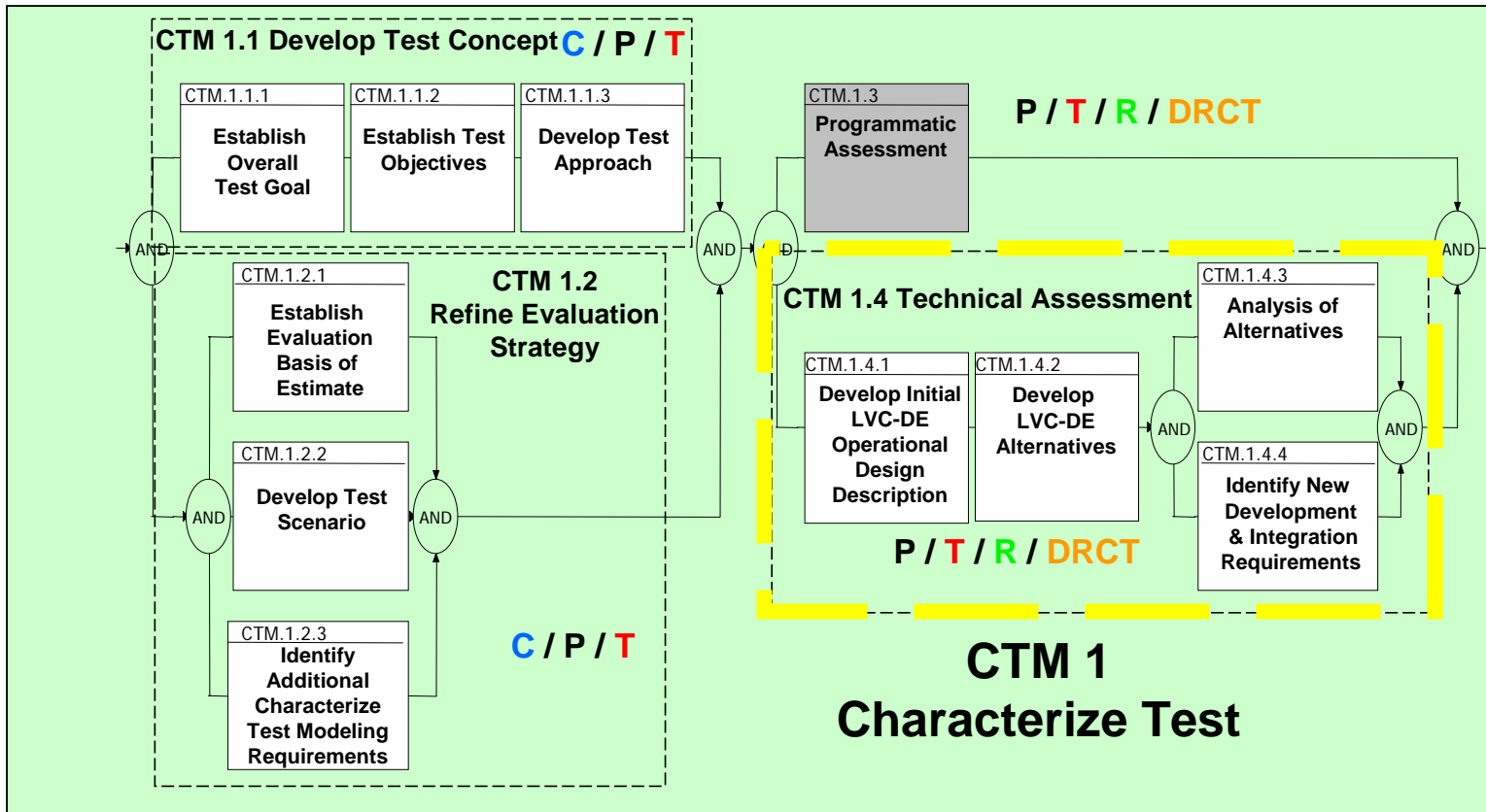



CTM 1.4: Technical Assessment

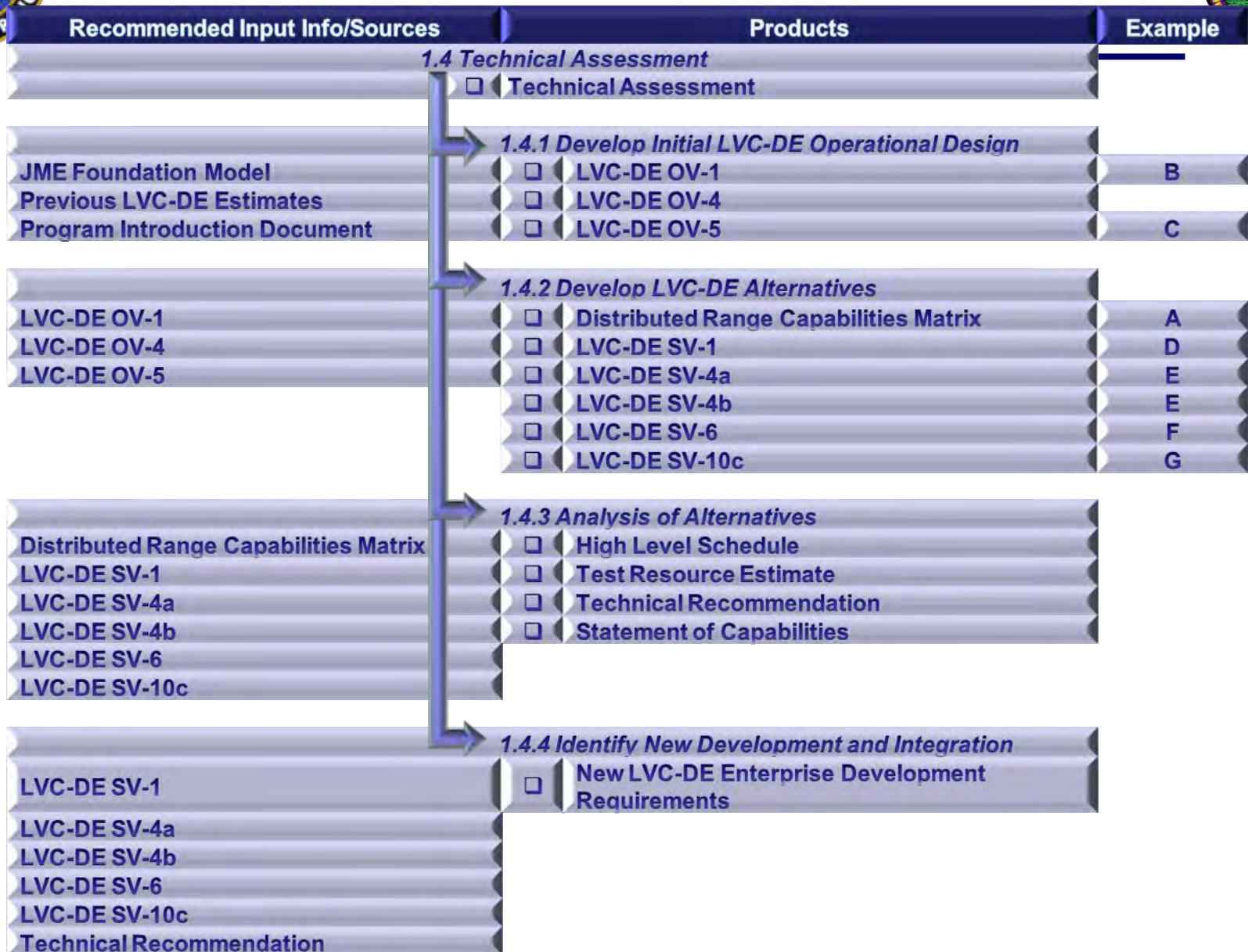



JTEM Capability Test Methodology (CTM) v2.0

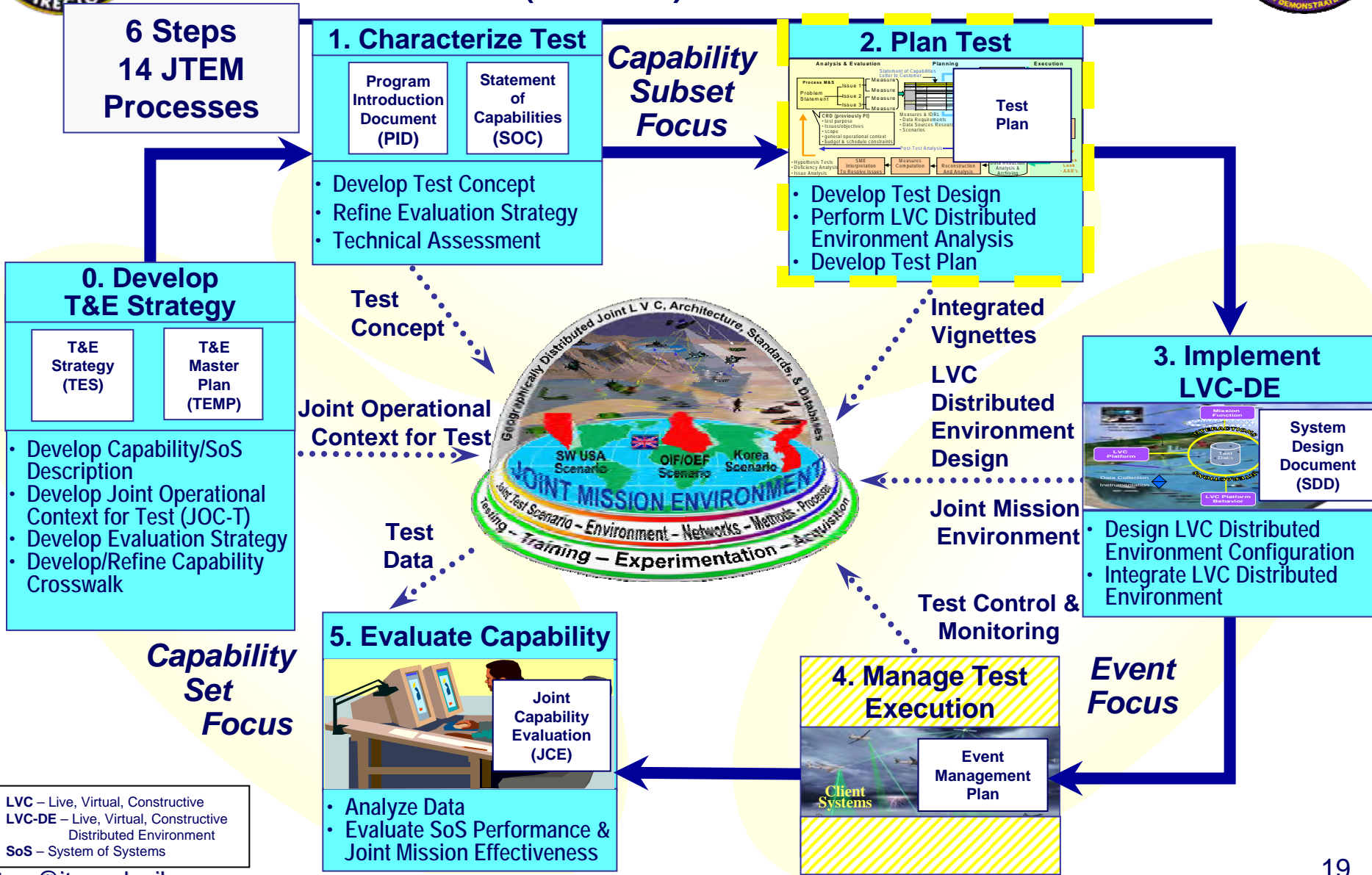

LVC – Live, Virtual, Constructive
 LVC-DE – Live, Virtual, Constructive Distributed Environment
 SoS – System of Systems



CTM 2.2: Perform LVC-DE Analysis

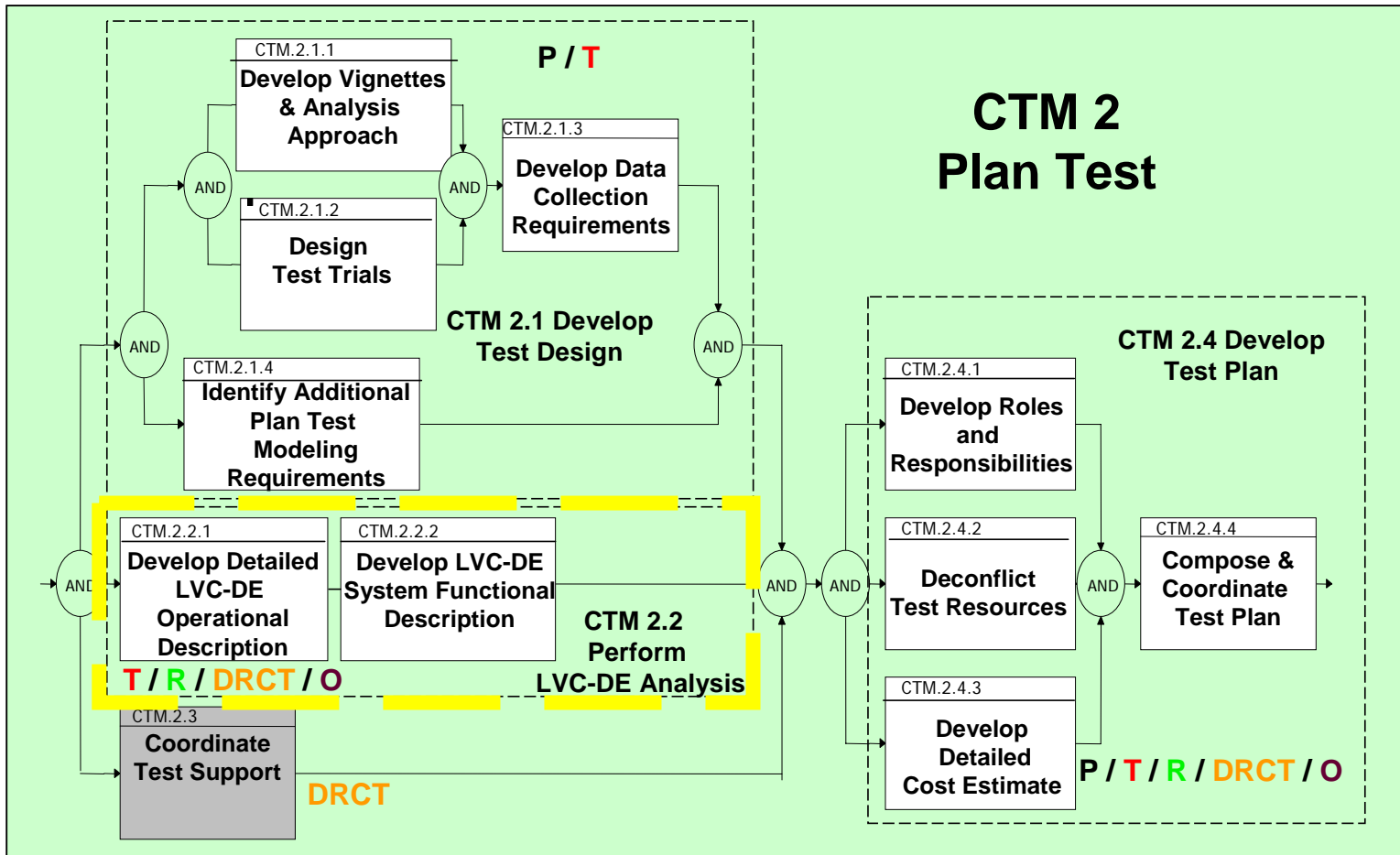



CTM 2.2: Perform LVC-DE Analysis



Recommended Input Info/Sources	Products	Example
2.2 Perform LVC-DE Analysis		
	<input type="checkbox"/> LVC-DE Analysis	
	2.2.1 Develop Detailed LVC-DE Operational Description	
JME Foundation Model	<input type="checkbox"/> LVC-DE OV-1 (Refined)	
Data Analysis Plan	<input type="checkbox"/> LVC-DE OV-2	A
Test Concept	<input type="checkbox"/> LVC-DE OV-4 (Refined)	
System and Joint Mission Evaluation Strategy	<input type="checkbox"/> LVC-DE OV-5 (Refined)	
LVC-DE OV-1 High Level Operational Concept	<input type="checkbox"/> LVC-DE OV-6c	B
	<input type="checkbox"/> LVC-DE OV-7	C
	2.2.2 Develop LVC-DE System Functional Description	
LVC-DE OV-1	<input type="checkbox"/> LVC-DE SV-4a (Refined)	
LVC-DE OV-2	<input type="checkbox"/> LVC-DE SV-4b (Refined)	
LVC-DE OV-4	<input type="checkbox"/> LVC-DE SV-6 (Refined)	
LVC-DE OV-6c	<input type="checkbox"/> LVC-DE OV-10c (Refined)	
LVC-DE OV-7	<input type="checkbox"/> Environmental Specifications	
LVC-DE SV-4a (Initial)	<input type="checkbox"/> Refined Configuration Mgt Plan	
LVC-DE SV-4b (Initial)	<input type="checkbox"/> Refined V&V Plan	
LVC-DE SV-6 (Initial)		
LVC-DE OV-10c (Initial)		



JTEM Capability Test Methodology (CTM) v2.0

6 Steps
14 JTEM
Processes

1. Characterize Test

Program Introduction Document (PID) | Statement of Capabilities (SOC)

Capability Subset Focus

- Develop Test Concept
- Refine Evaluation Strategy
- Technical Assessment

2. Plan Test

Analysis & Evaluation | Planning | Execution

Test Plan

- Develop Test Design
- Perform LVC Distributed Environment Analysis
- Develop Test Plan

0. Develop T&E Strategy

T&E Strategy (TES) | T&E Master Plan (TEMP)

- Develop Capability/SoS Description
- Develop Joint Operational Context for Test (JOC-T)
- Develop Evaluation Strategy
- Develop/Refine Capability Crosswalk

Capability Set Focus

3. Implement LVC-DE

System Design Document (SDD)

- Design LVC Distributed Environment Configuration
- Integrate LVC Distributed Environment

5. Evaluate Capability

Joint Capability Evaluation (JCE)

- Analyze Data
- Evaluate SoS Performance & Joint Mission Effectiveness

Capability Set Focus

4. Manage Test Execution

Event Management Plan

Event Focus



LVC – Live, Virtual, Constructive
LVC-DE – Live, Virtual, Constructive Distributed Environment
SoS – System of Systems



CTM 3.1: Design LVC-DE Configuration

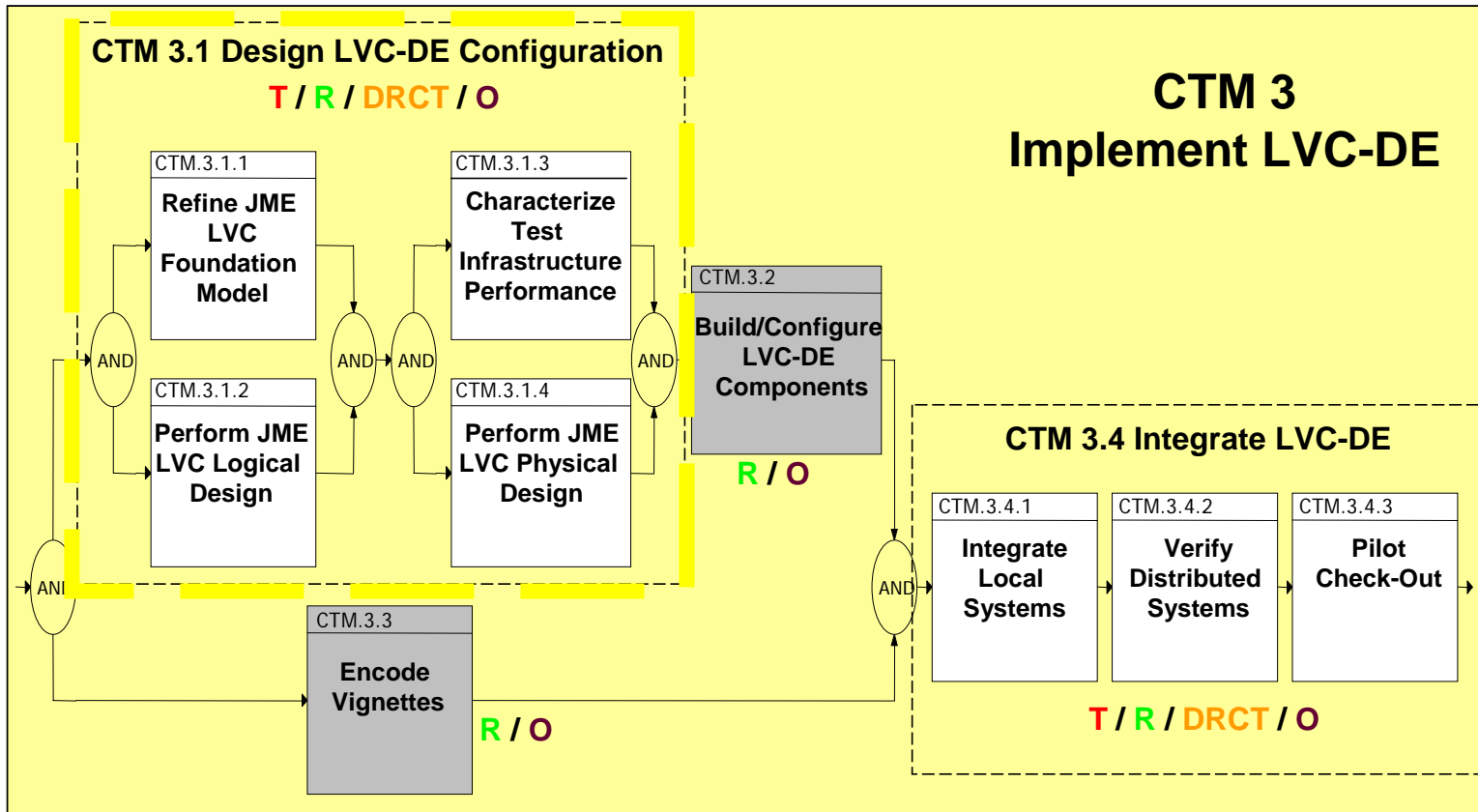



CTM 3.1: Design LVC-DE Configuration

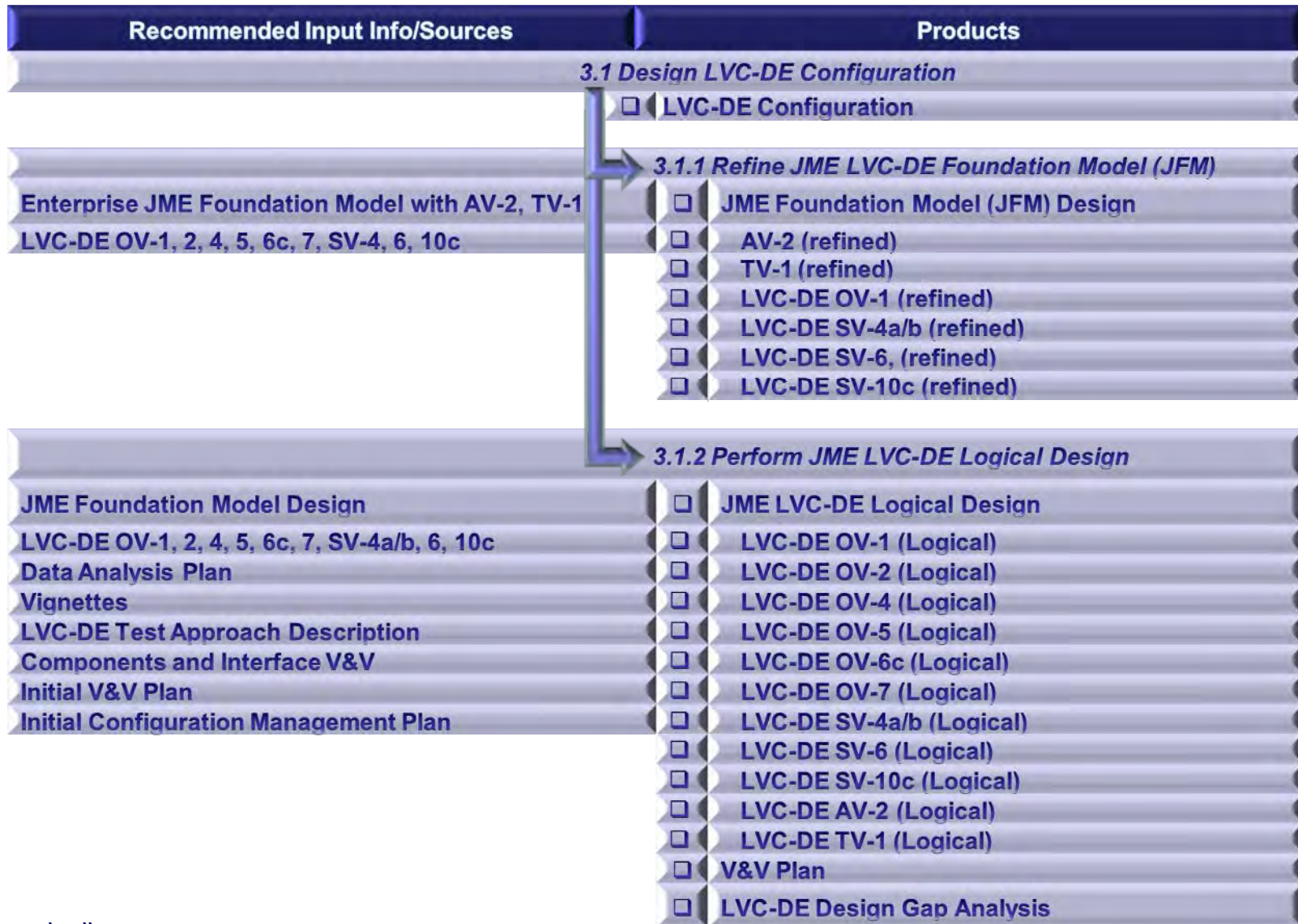



CTM 3.1: Design LVC-DE Configuration

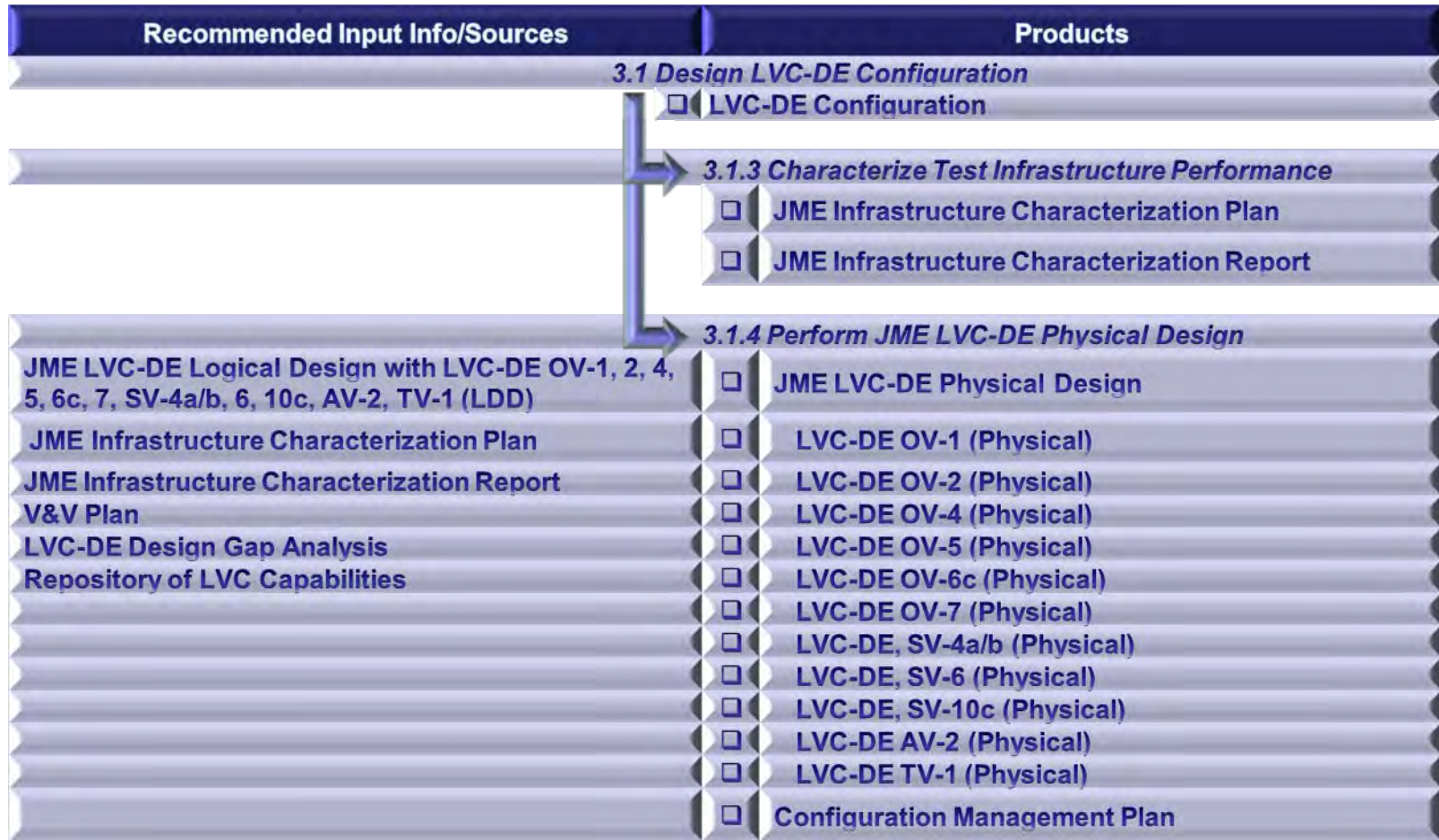



Instantiated JME

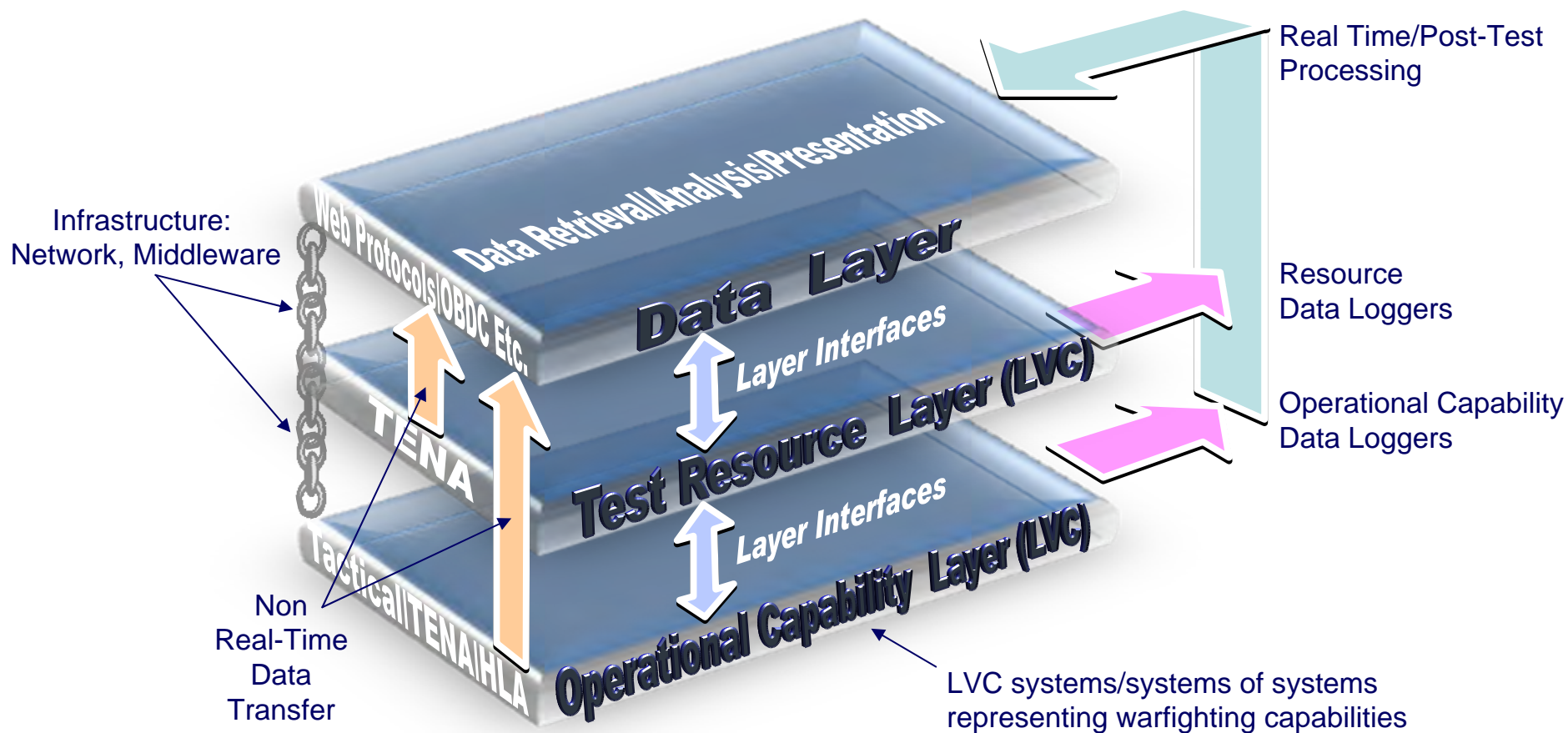

Physical Design configuration includes systems in Operational, Test, and Data layers



CTM 3.4: Integrate LVC-DE

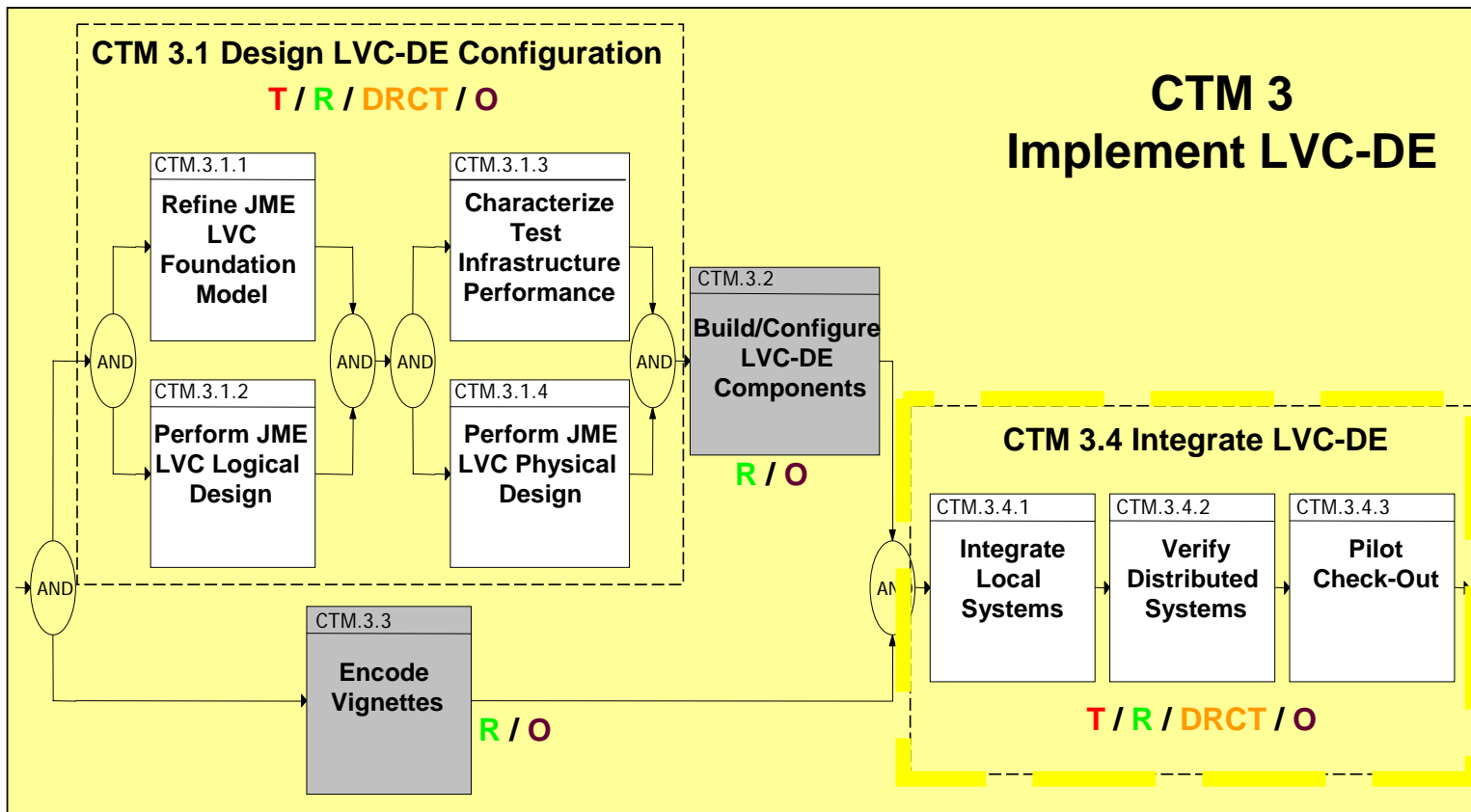



CTM 3.4: Integrate LVC-DE

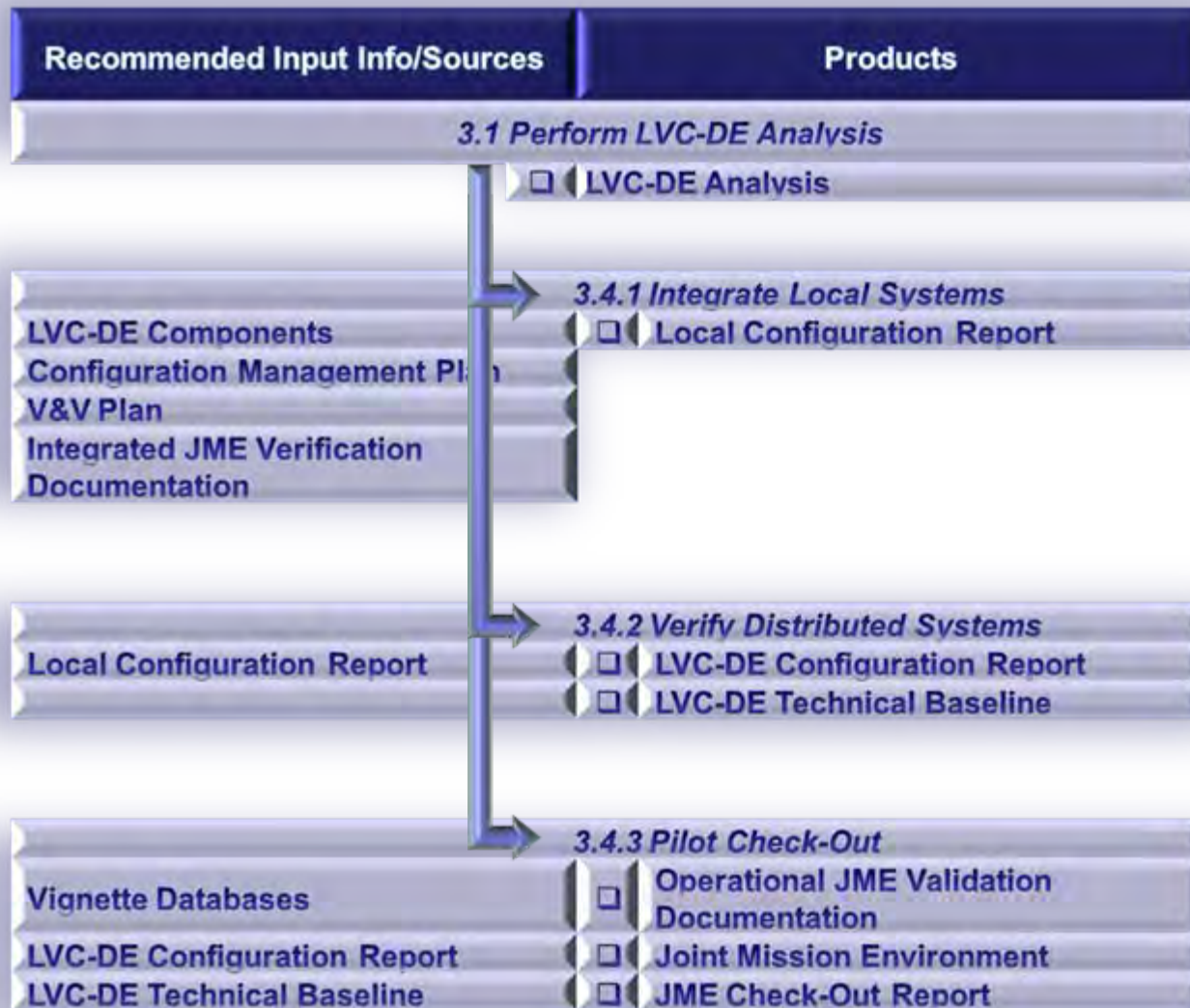



Overview



- JTEM Problem Statement
- Capability Test Methodology (CTM)
- CTM Systems Engineering Thread
- **Summary**



Summary



- JTEM mission is to develop methods and processes (M&P) for realistic testing in a live, virtual, constructive distributed environment (LVC-DE)
- CTM systems engineering process provides an effective building block approach to JME development - “Design Once - Use Many”
 - JFM
 - Logical Design
 - Physical Design



Mr. Max Lorenzo
Joint Test Director
757.638.6079

max.lorenzo@jte.osd.mil

Mr. Tim Beach
Chief, Analysis & Methods & Processes Division
757.638.6088

timothy.beach@jte.osd.mil

Mr. Earl Reyes
Senior Systems Engineer
757.638.6014

earl.reyes@jte.osd.mil

Email: jtem@jte.osd.mil

Website: <https://www.jte.osd.mil/jtemctm/>

Serving the testing, acquisition, and warfighting communities



The Role of Chaos and Complexity in Systems Development

Robert J. Monson, Ph.D.
Lockheed Martin MS2 Tactical Systems
Eagan, Minnesota

Chaos and Complexity

★ The Bak Sandpile model

- ★ Defines the behavior of a simple system
- ★ Representative of many physical and organizational systems
- ★ Provides insight into an appropriate method to plan and manage systems

Why do we care?

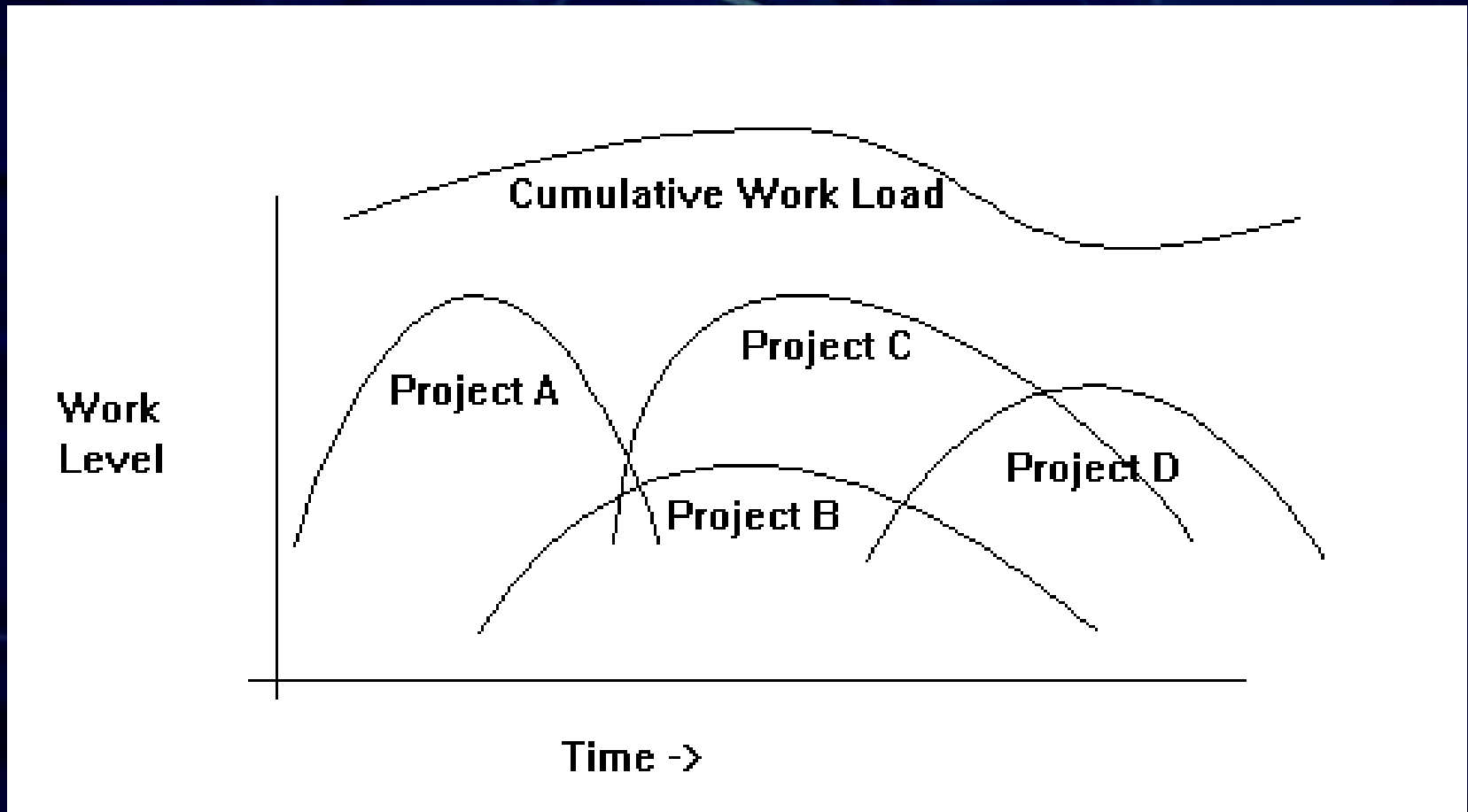

How does the model work?

- ★ Complex Systems are frequently governed by simple rules

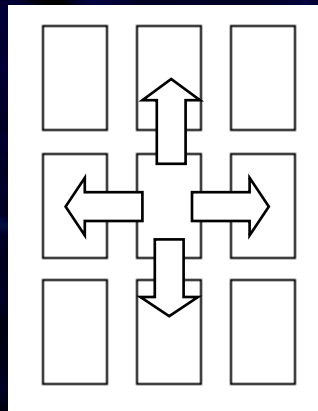
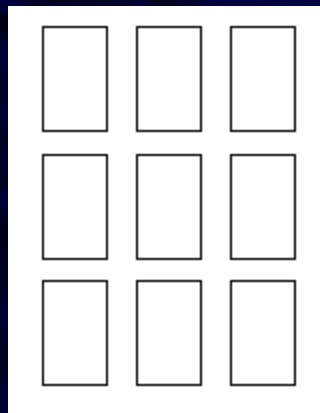

1. Add 1 item randomly to any pile
2. If any pile ≥ 4 items, distribute 4 items

Typical Results

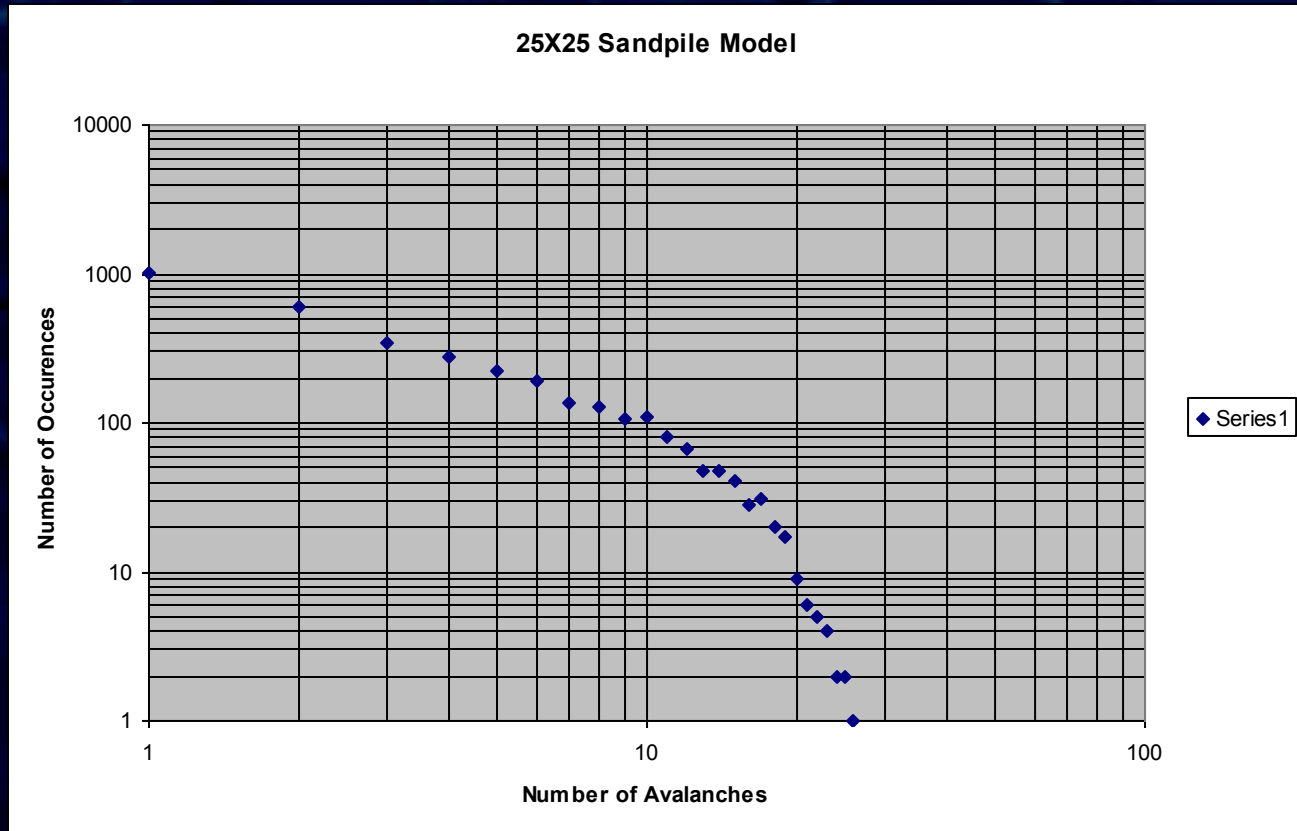

The Sandpile Model

- ✦ Examples utilizing a 3 X 3 matrix
 - ✦ Previous example
- ✦ Larger examples do not exhibit such a dramatic edge effect
 - ✦ 25 X 25 model used most commonly
 - ✦ Use simulation to provide behavior information

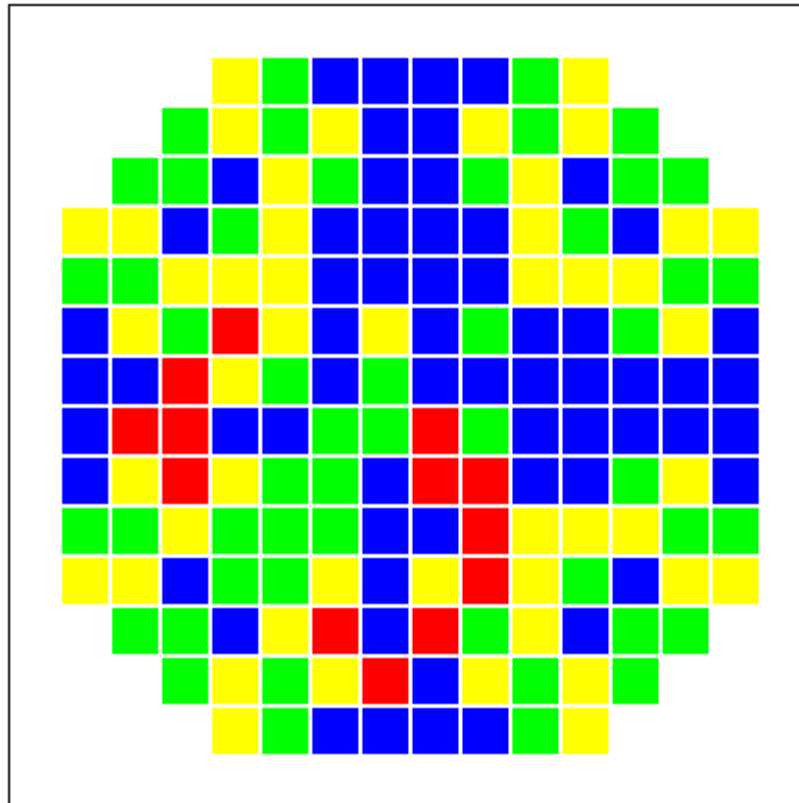

Ready..

Go!

One Step

Reset

Slow Animation

Select view:

Histogram

System Size:

16

Avalanches: N/A

Aval. size: N/A

- yellow box -- one particle
- green box -- two particles
- blue box -- three particles
- red box -- four particles, critical (unstable) state

3 X 3 matrix 100 points

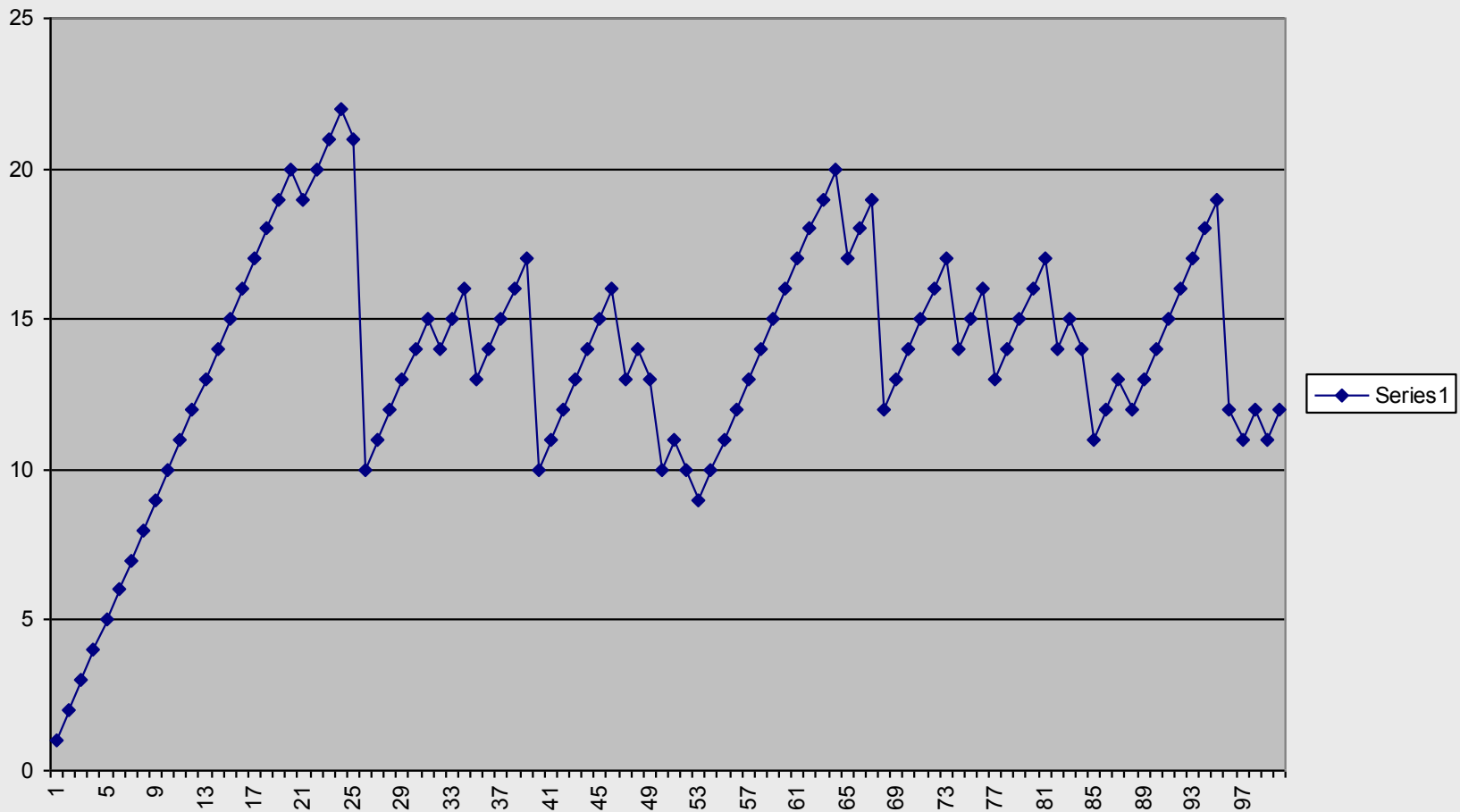



25 X 25 matrix, 2000 pts

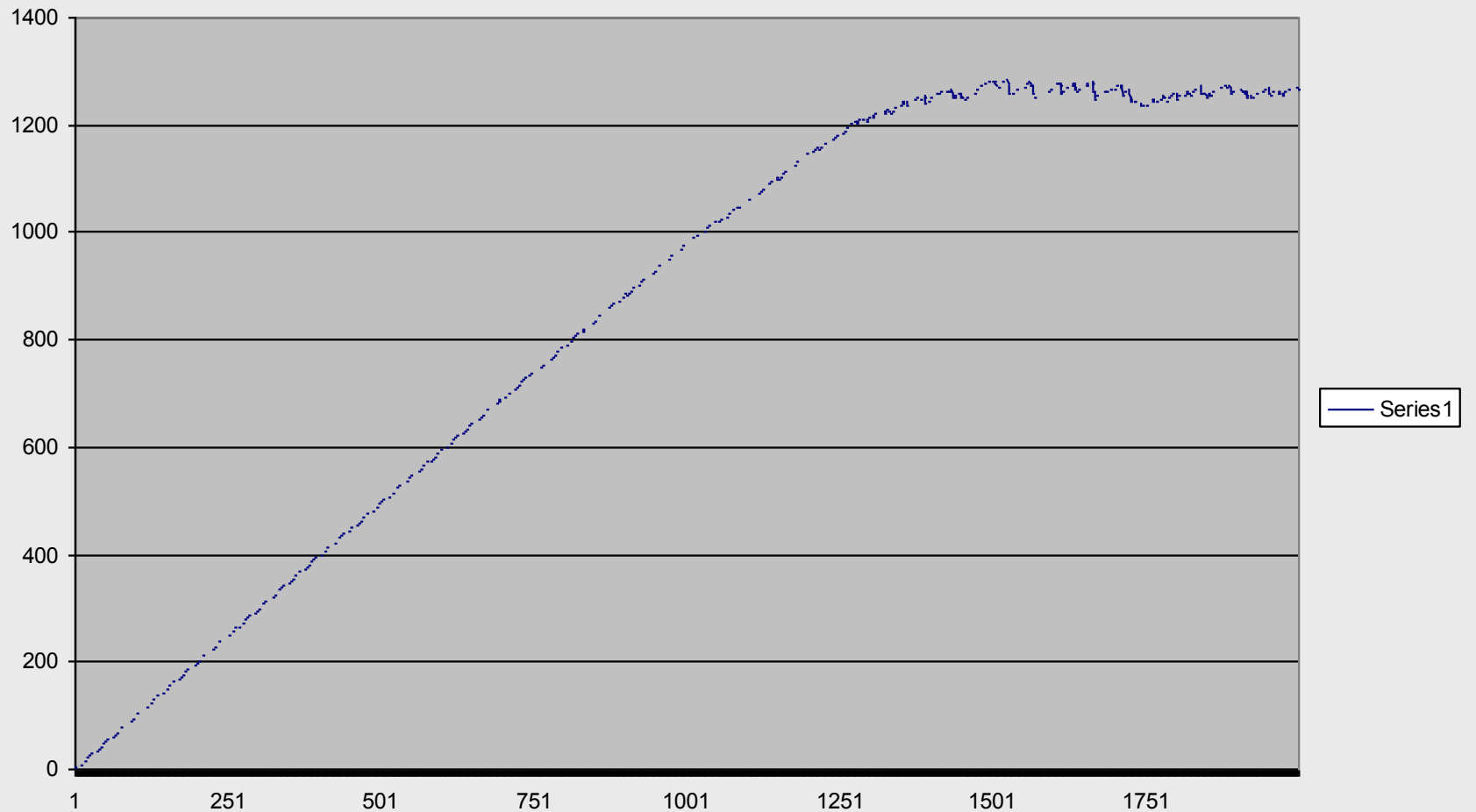

25 X 25, 2M points, 1875 Normalized

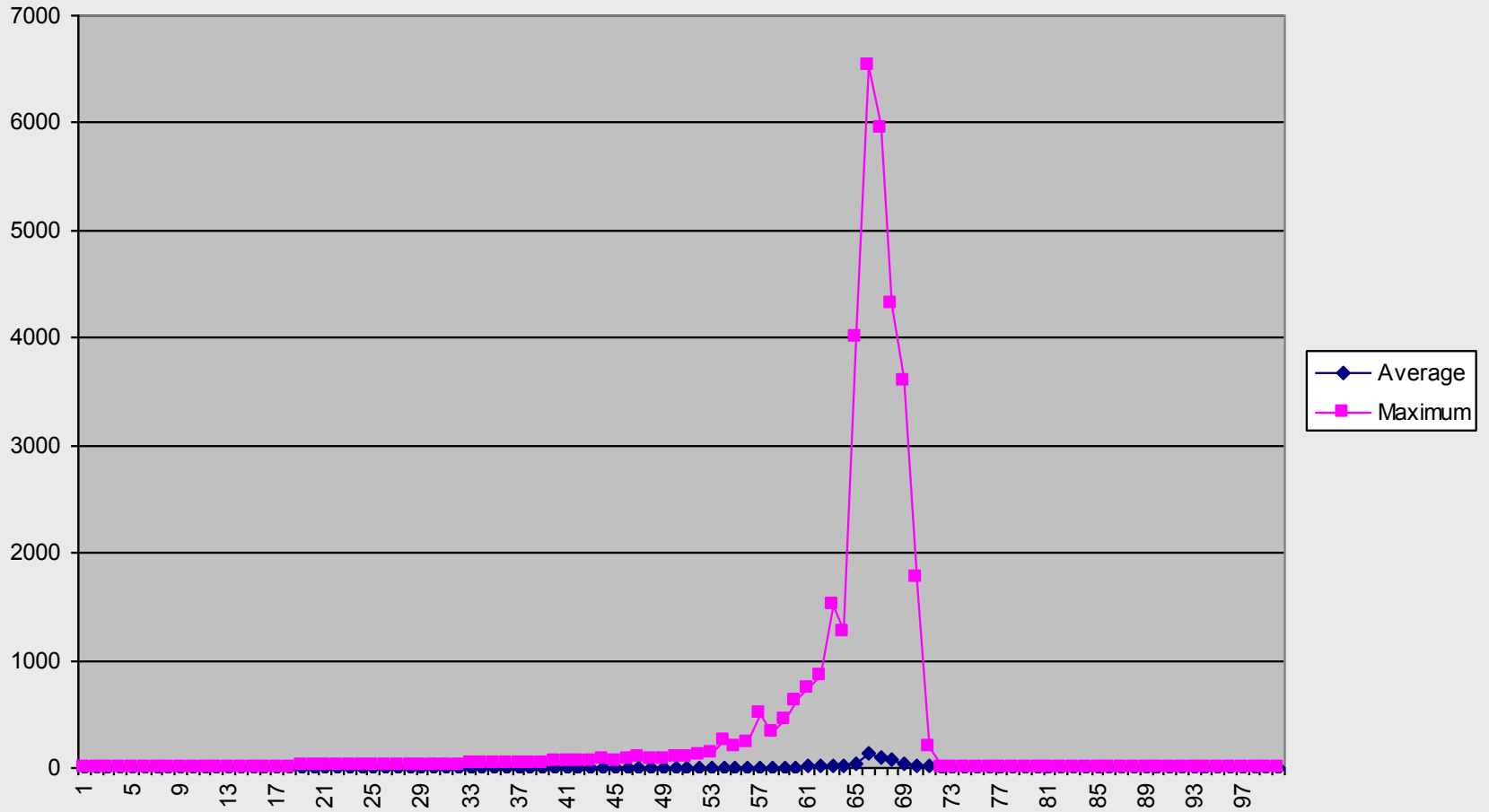

25 X 25, 2M points, 1875 Normalized

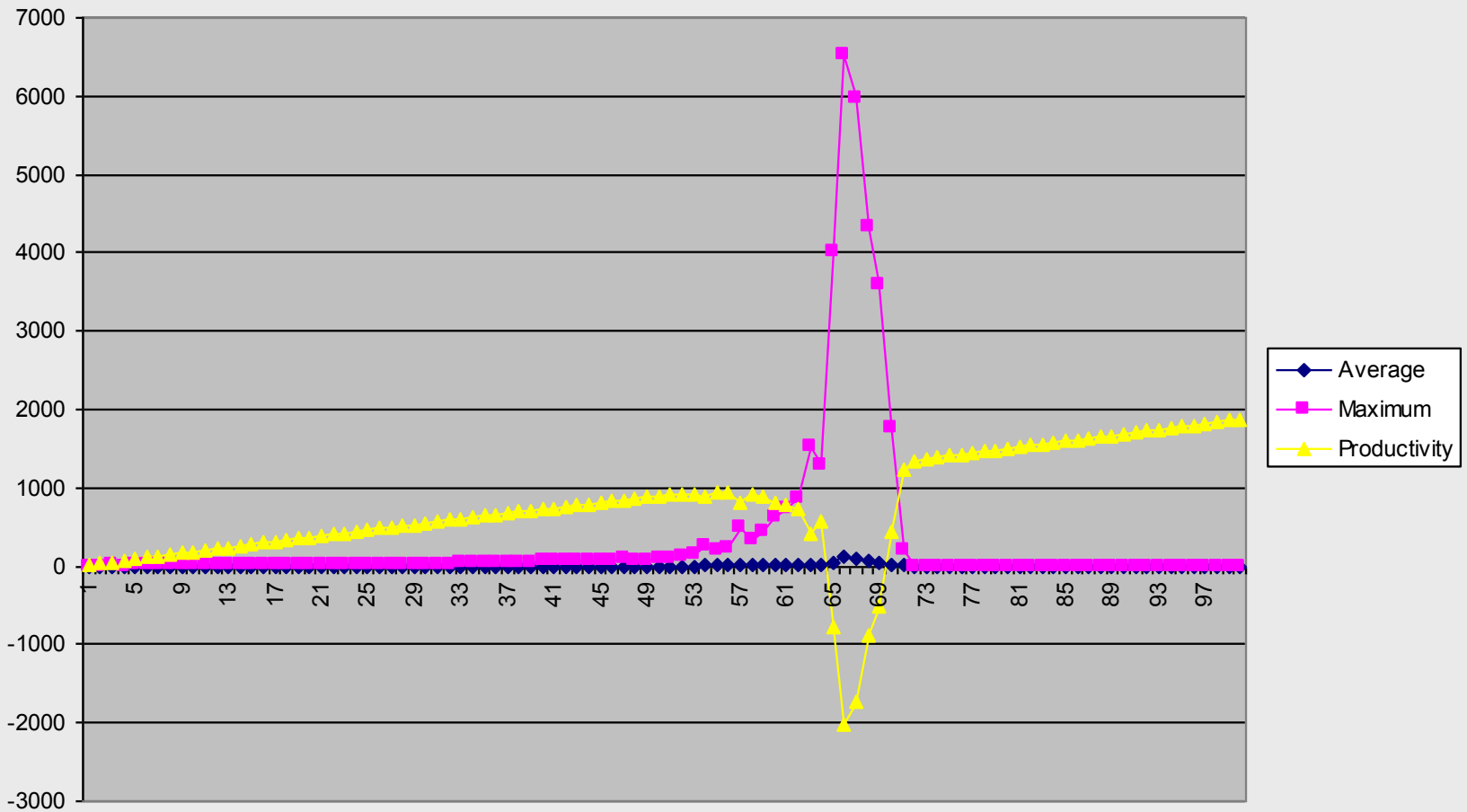

25 X 25, 2M points, 1875 Normalized

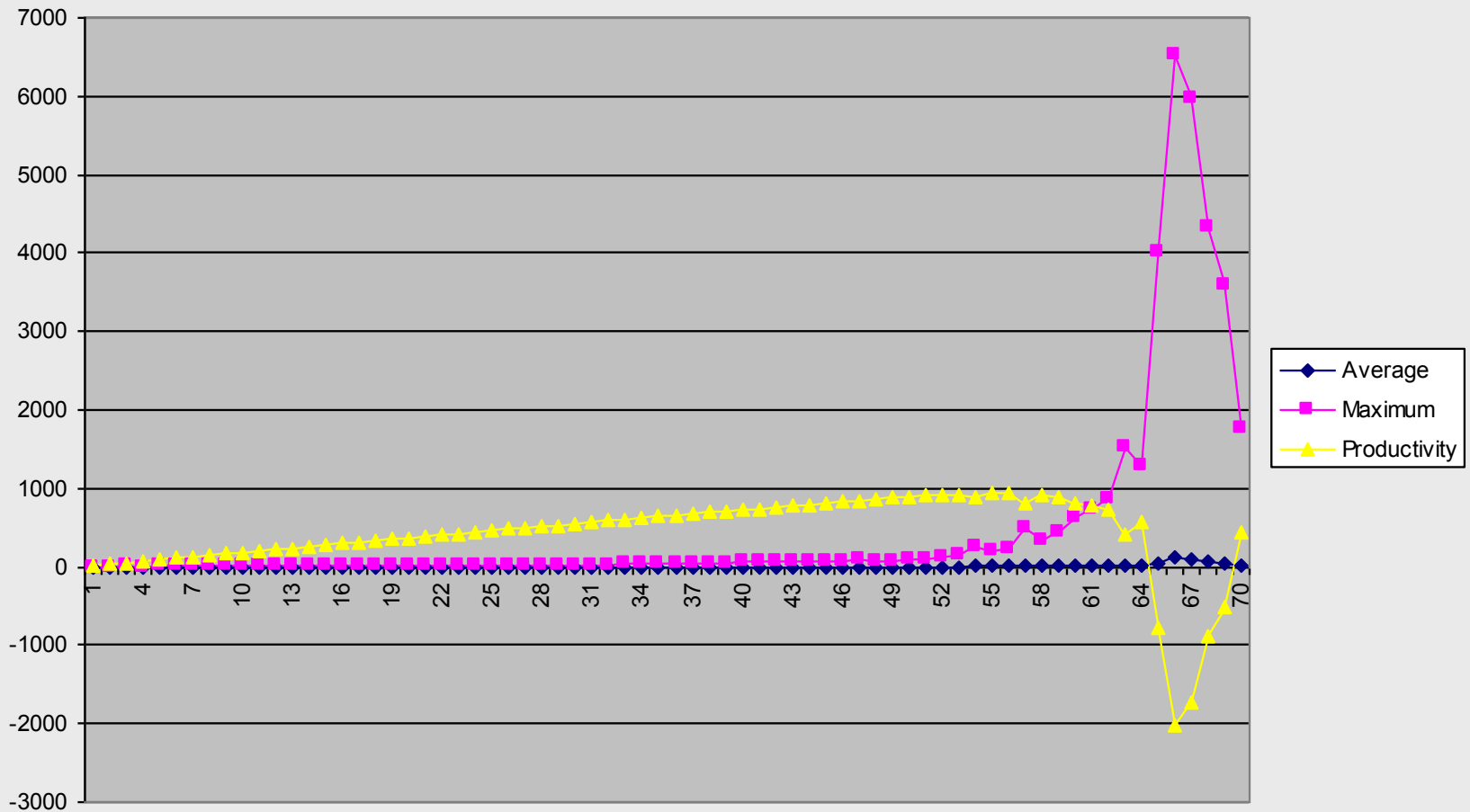

25 X 25, 2M points, 1875 Normalized

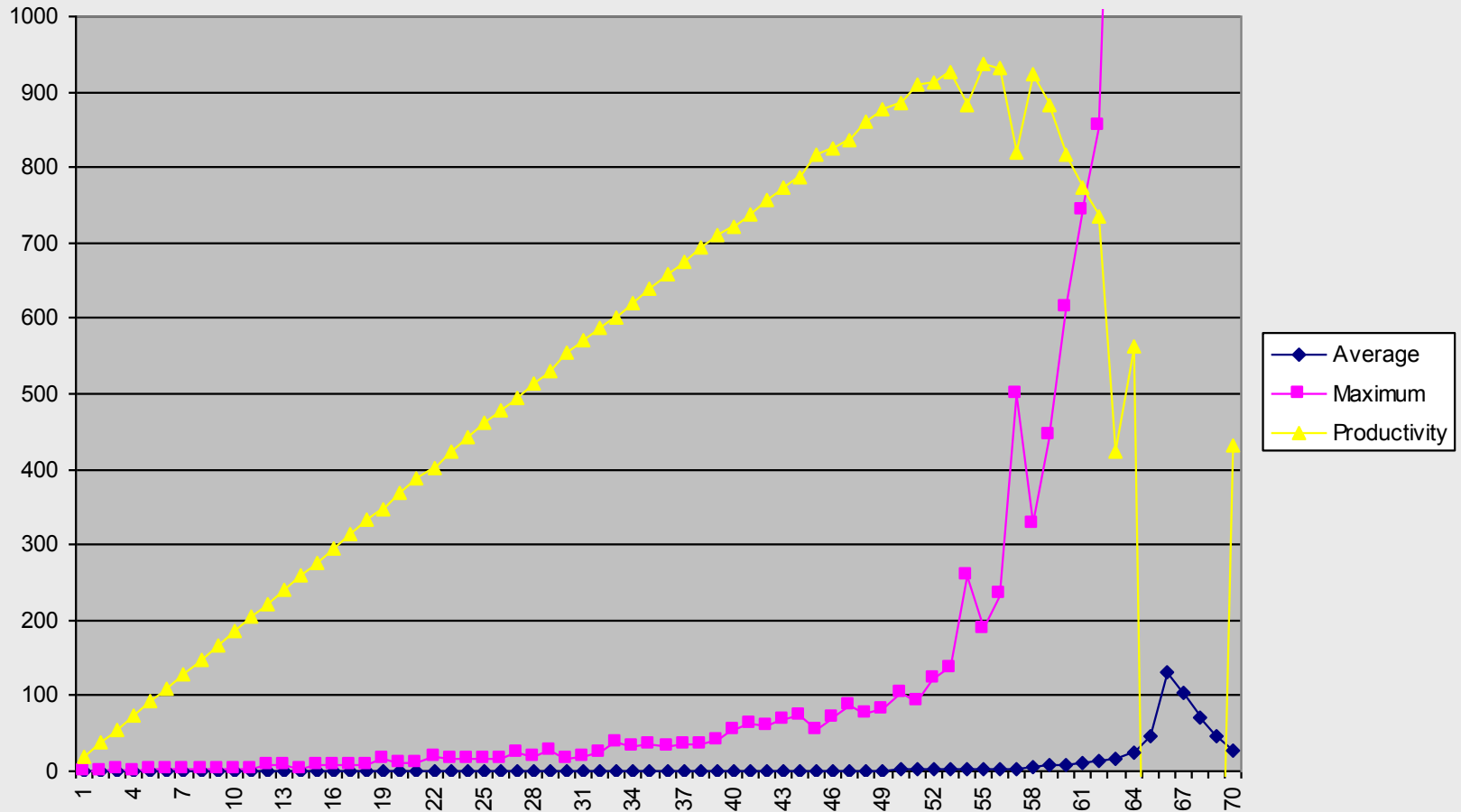

Some Examples

- ✱ Physical Models
- ✱ Traffic Patterns
- ✱ Complex Interactions in
Organizational Systems /
Systems Development

Physical Models

- ★ Fish Schooling
- ★ Oslo Experiment
 - ★ Rice grains between sheets of glass
- ★ Avalanches monitored



Traffic Patterns

Microsimulation of road traffic with a time-continuous model

Start	1: Ring Road	3: Lane closing
Stop	2: On-Ramp	4: Uphill Grade

Time 0:27

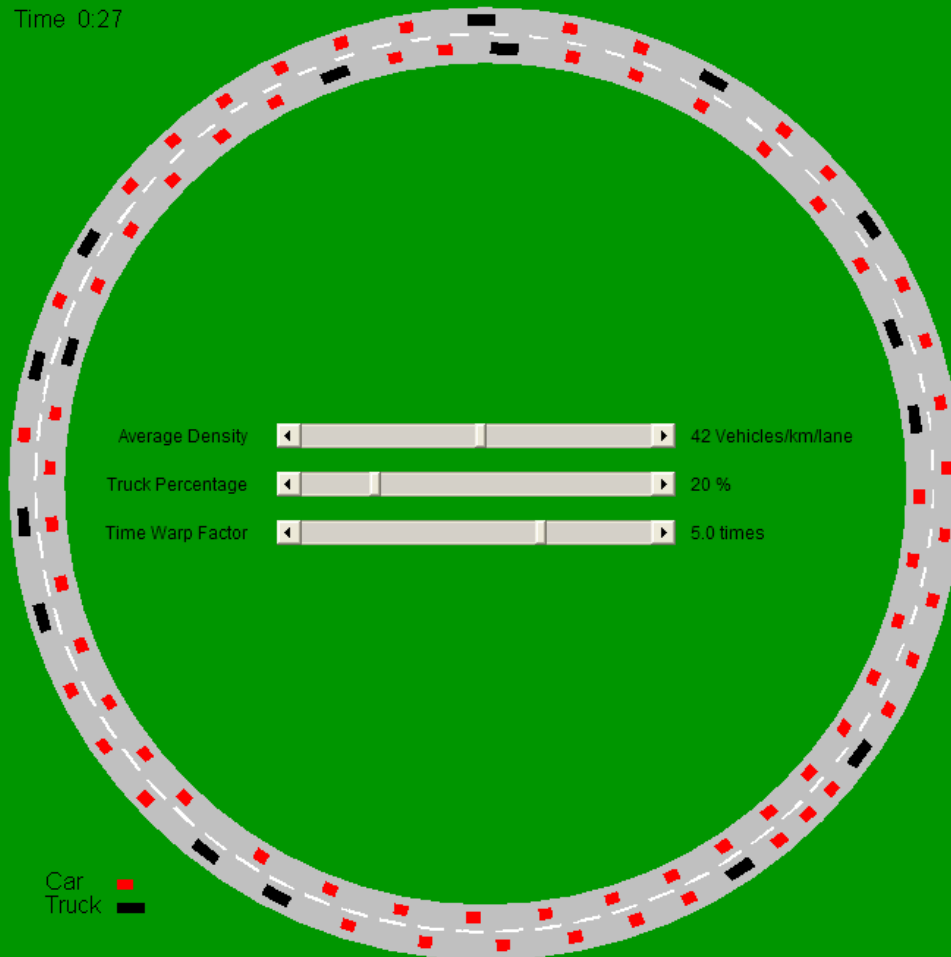

Traffic Patterns

Microsimulation of road traffic with a time-continuous model

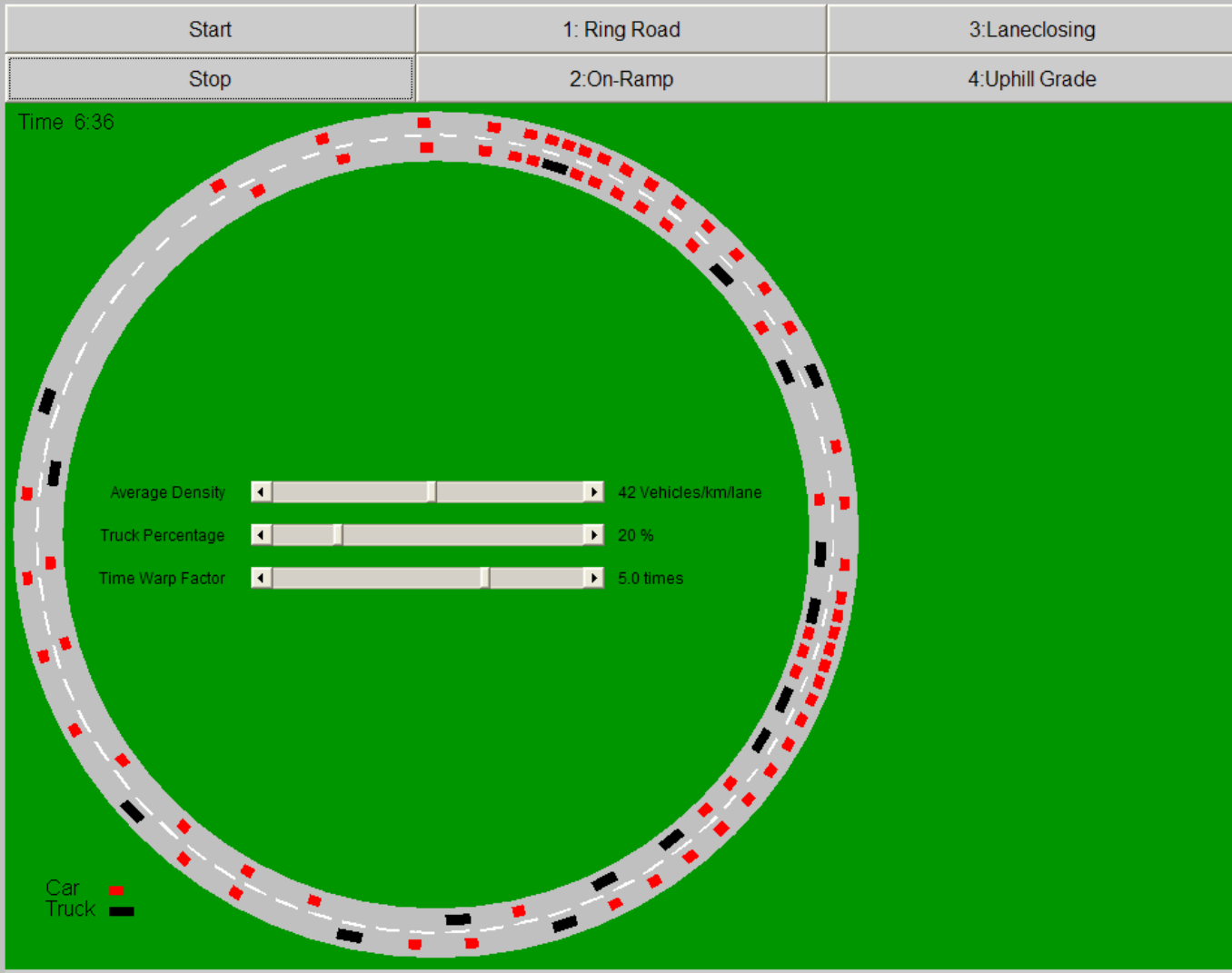

Organizational Systems

- ✦ Predictability of complex systems is effective in a generalized sense
 - ✦ I cannot know when and where earthquakes will occur, but I can know approximately how many to expect and typical magnitudes
 - ✦ Overall I will have a good idea what energy will be imparted by the earthquakes
 - ✦ This is good enough to know how to design structures for the region
- ✦ Systems Design requires predictability in order to achieve plans and projections

Systems Design

- ★ To increase probability of success, we need to dramatically increase operational predictability
- ★ Scheduling work with a consideration for 75% efficiency provides this added predictability
 - ★ Since we do not know what specific disturbances will occur
 - ★ We do not know when they will occur or what magnitude they will be
 - ★ But we know that on average that 25% of our time will be consumed by them

Conclusions

- ✦ A complex system will organize itself into a critical (or unstable) state
- ✦ We know that a certain amount of disturbances and resultant avalanches within our Systems Development is unavoidable
- ✦ We don't know specifics, but we know 25% of our time will be consumed by interdependencies in the system
- ✦ We can increase our probability of success by planning personnel at 75% capacity, which should be treated as our maximum productivity
- ✦ This purposeful detuning of the system results in fewer catastrophes with less catastrophic Systems Development results

References

- ✱ Bak, Per (1999) How Nature Works. Springer-Verlag Telos. 1st edition.
- ✱ <http://www.cmth.bnl.gov/~maslov/soc.htm>
- ✱ <http://vwisb7.vkw.tu-dresden.de/~treiber/MicroApplet/>
- ✱ www.santafe.edu/~ole/oslo.html
- ✱ www.mindware.com



Ground Support Systems
Integrated Defense Systems

Improving Systems Engineering Execution and Knowledge Management

Steve Head

Objective

- **Refocus programs back to basic objectives of Systems Engineering execution including oversight of product developmental life cycle**
 - Requirements, design, implementation, test, delivery, product feedback and sustainment
- **Identify methods of simplifying and presenting key domain knowledge (need to know) to the engineer**
 - Processes, procedures, and technical
- **Provide simplified approaches to improve communication and better manage products and teams**
 - Use of web, database tools and improvement focals
- **Provide ability to better understand and manage products in an age of sometimes overwhelming conditions**
 - Reduce the apparent bottleneck caused by engineering teams interpreting the overlapping requirements and mandates

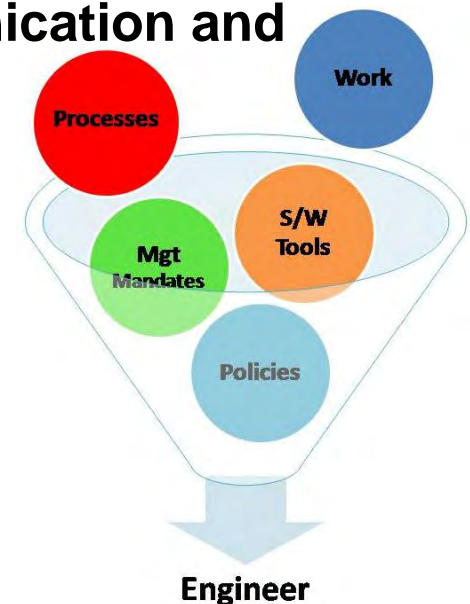

Traditional Systems Engineering

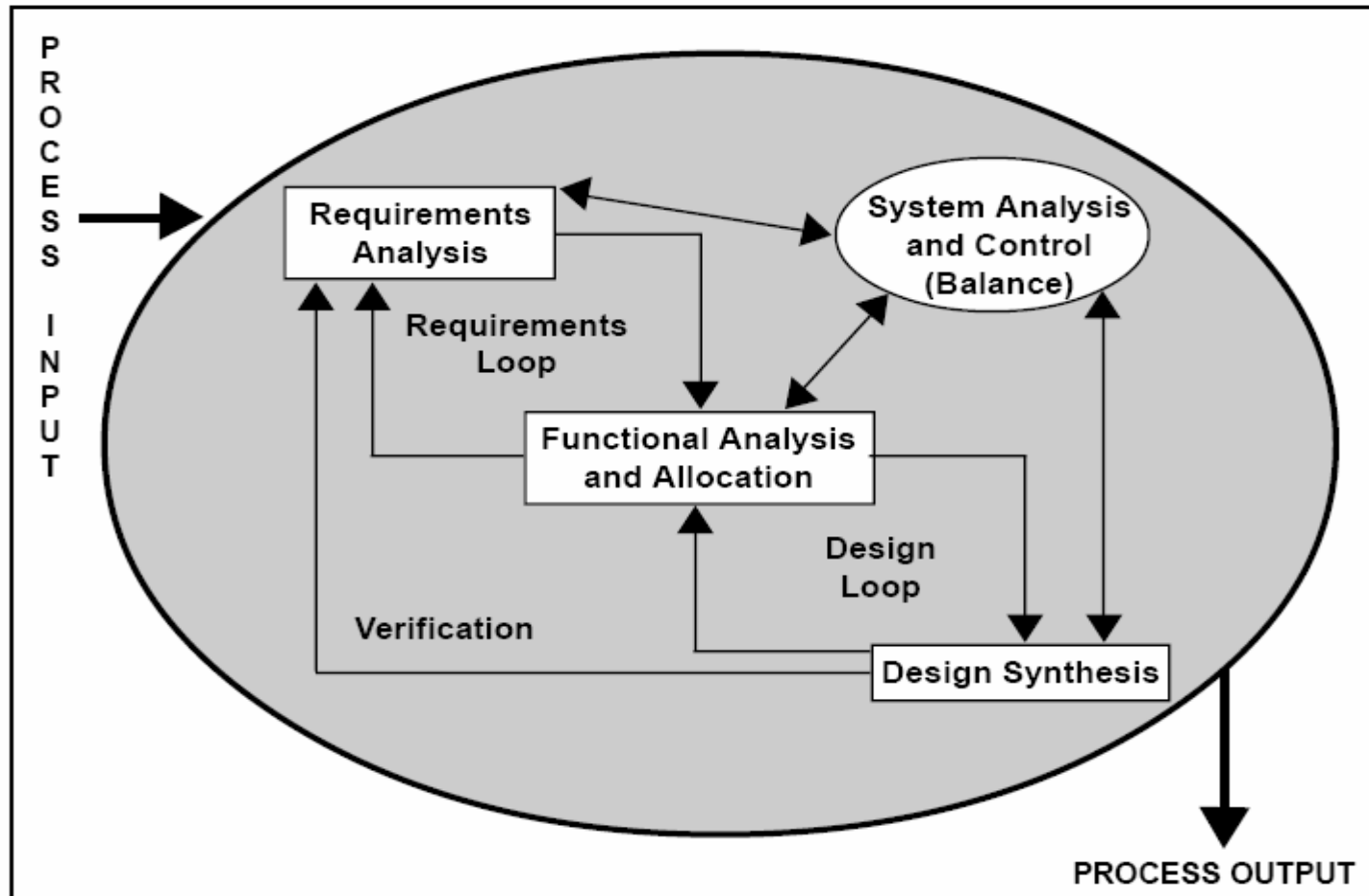

Source: Systems Engineering Fundamentals – DOD Publication, Defense Acquisition University Press

Traditional Systems Engineering Activities

■ Fundamental Systems Engineering Activities

- Requirements Analysis
- Functional Analysis and Allocation
- Design Synthesis

■ All balanced by techniques and tools called System Analysis and Control

- Track Decisions and Requirements
- Manage Interfaces
- Manage Risks
- Track Cost and Schedule
- Track Technical Performance
- Verify Requirements
- Review and audit progress

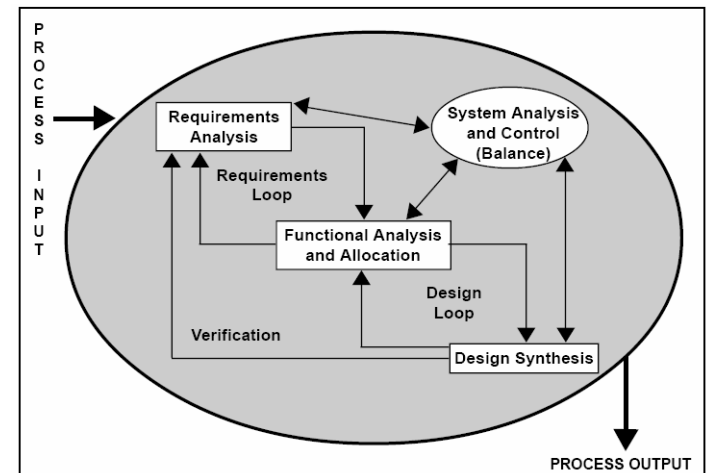

Can we improve Systems Engineering?

■ Processes, Procedures and Technical Information

- Decrease excess of supporting documentation including variations of same?
 - SEI CMM®, SEI CMMI®, corporate, program, team, etc
- Legacy programs struggle?
 - Baseline to one set, then an “improved” set is flowed down (sometimes before the initial baseline is completed)
- Identify specific information related to engineering role?
 - Easy to get lost and confused

■ Systems Engineering Oversight

- Provide oversight during code/build to decrease chances of major rework down the road?
- Evaluate metrics at developmental stages and post delivery?
 - Build upon successful program practices and lessons learned
 - Continuous improvement
- Utilize Improvement Councils with dedicated focals?

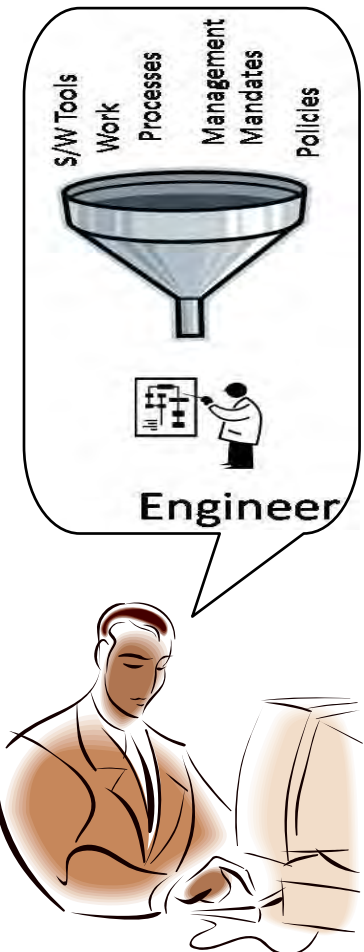

Previous Assessment Findings

■ Quick Assessment Guidelines

- Begin with quick assessment of group developmental status
- Identify common and unique enterprise software tools
- Identify artifacts, processes, procedures and supporting documentation
- Identify all change boards and other review boards
- Identify methods for group communication and status

■ Results of Evaluation

- Determined that many processes, procedures, and documentation were already in use accessible via program only
- Programs were collecting some information (give credit where credit is due)
- Included common and unique tools such as Finance/Budgeting, Earned Value System, Risk Tracking, Quality and Selloff documentation, Requirements tracking, Change Process/CCB, and some levels of metrics
- Big picture of program not always apparent to team members

Focus on Following Standard Work Flow

- Engineering development should follow a basic work flow
- Problems occur when basic development steps are marginalized, minimized, or omitted

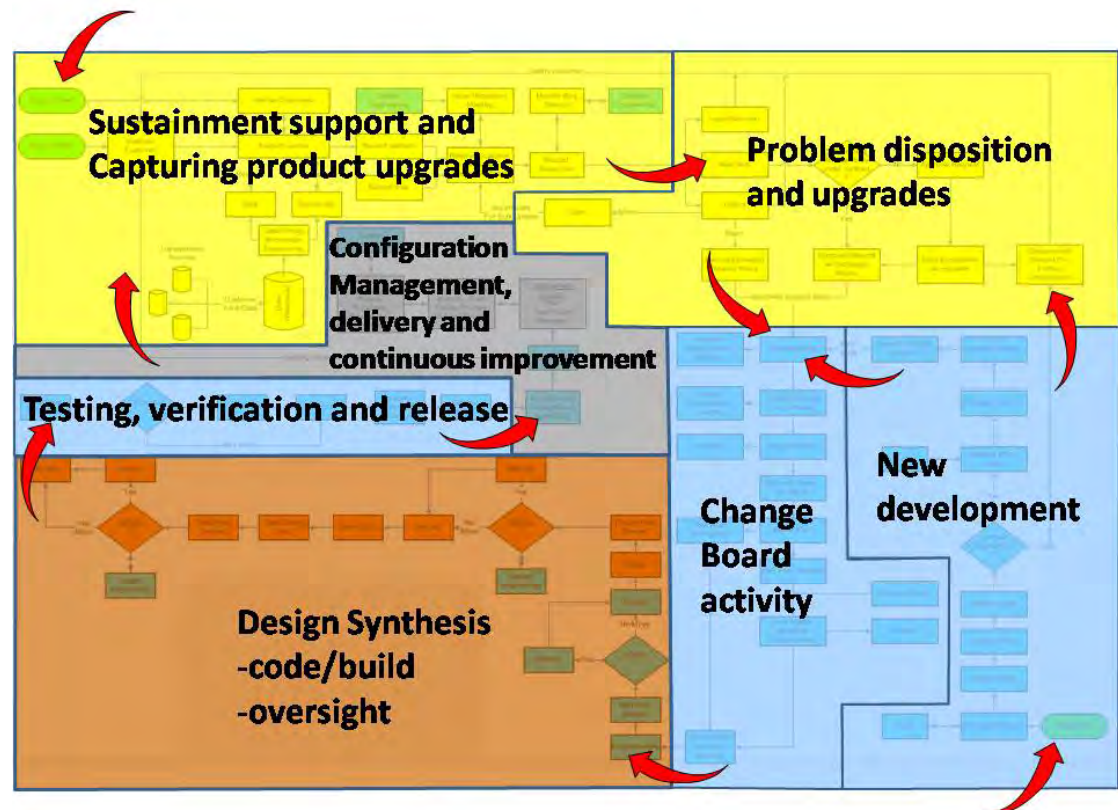

Work Flow Visualization

- Provides the stakeholders with complete color coded work flow of both new products and sustainment of existing products
- Visually enhances ability of the stakeholders to better understand dynamics of how to improve systems engineering execution and business discipline knowledge management

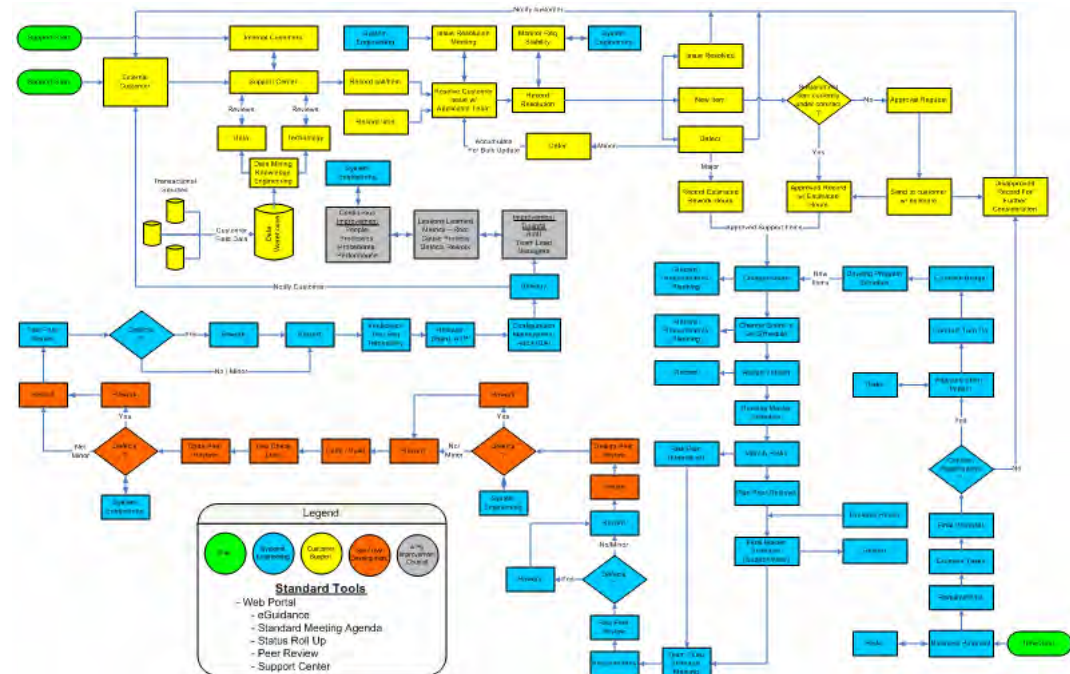
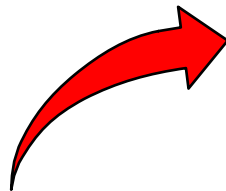

Work Flow Visualization (cont)

- Legend provides color coded element identifiers
- Standard tools - lists web-based methods for maintaining same information gathering throughout the organization



Work Flow Visualization (cont)

■ Start for new development Section

- Entry point for new business

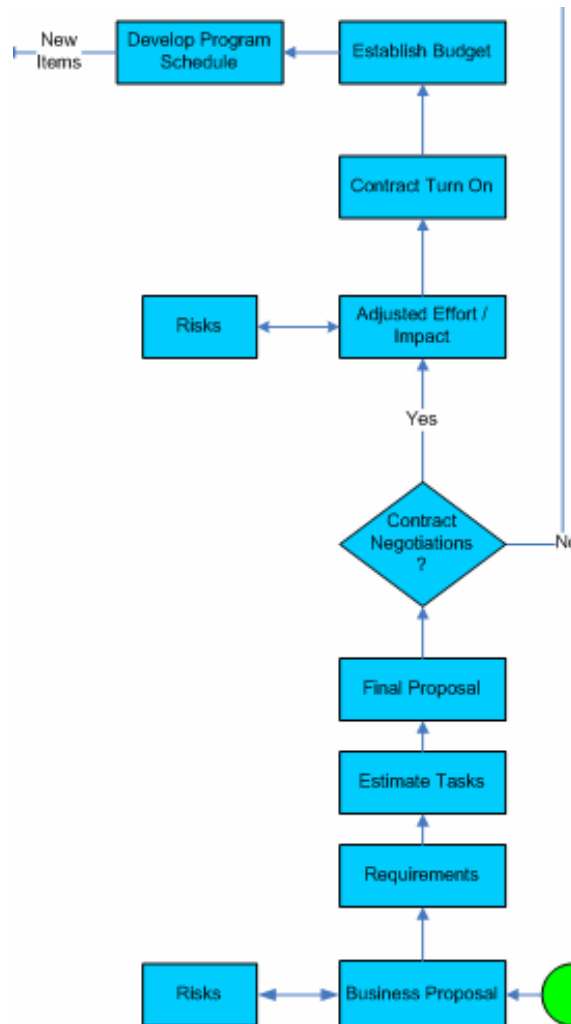

Work Flow Visualization (cont)

- **Sustainment support and capturing product upgrades**
 - Represents methodology for acquiring follow-on business

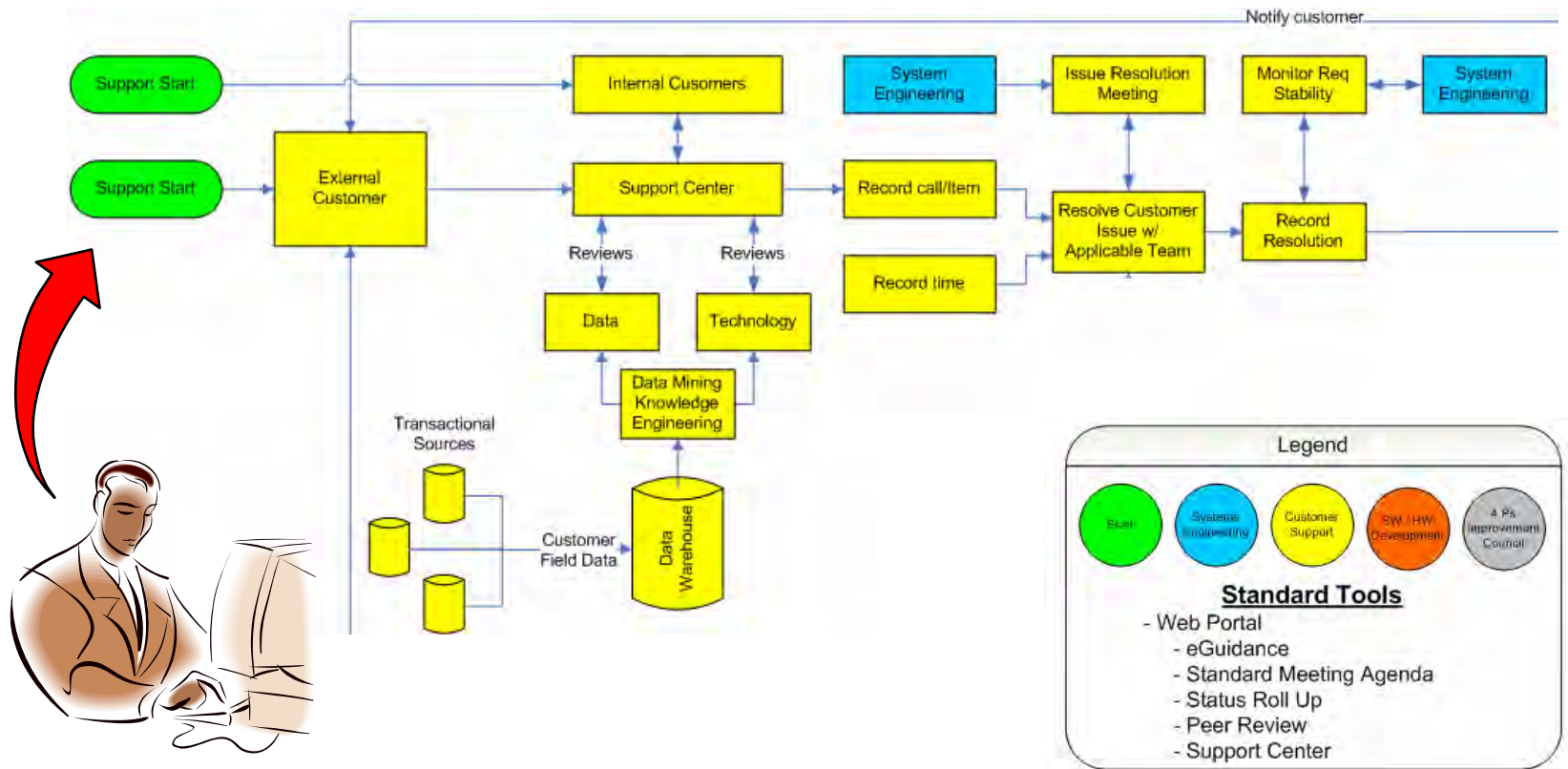

Work Flow Visualization (cont)

- Section addresses support center, problem disposition and upgrade funding

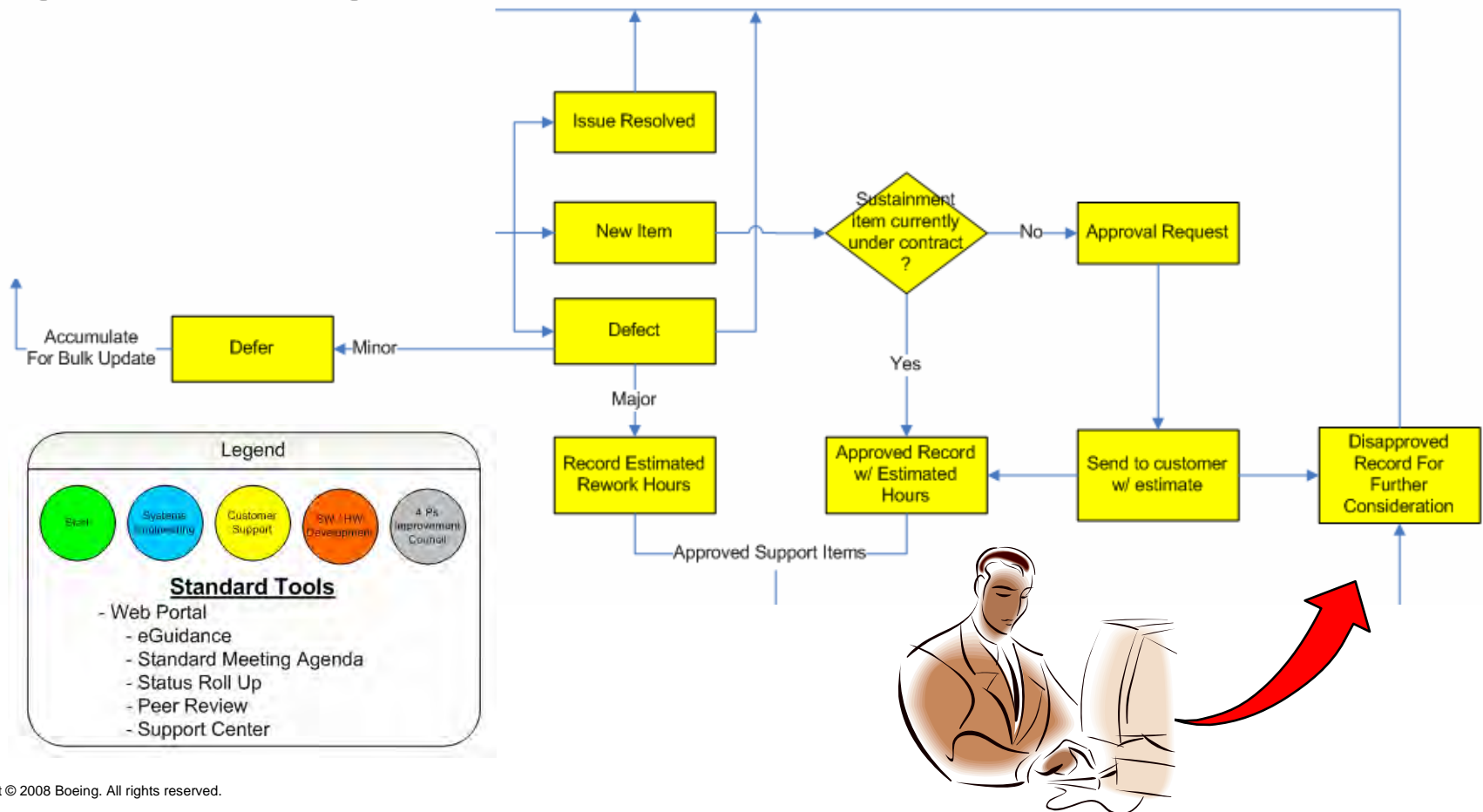

Work Flow Visualization (cont)

■ Section for Change Board activity

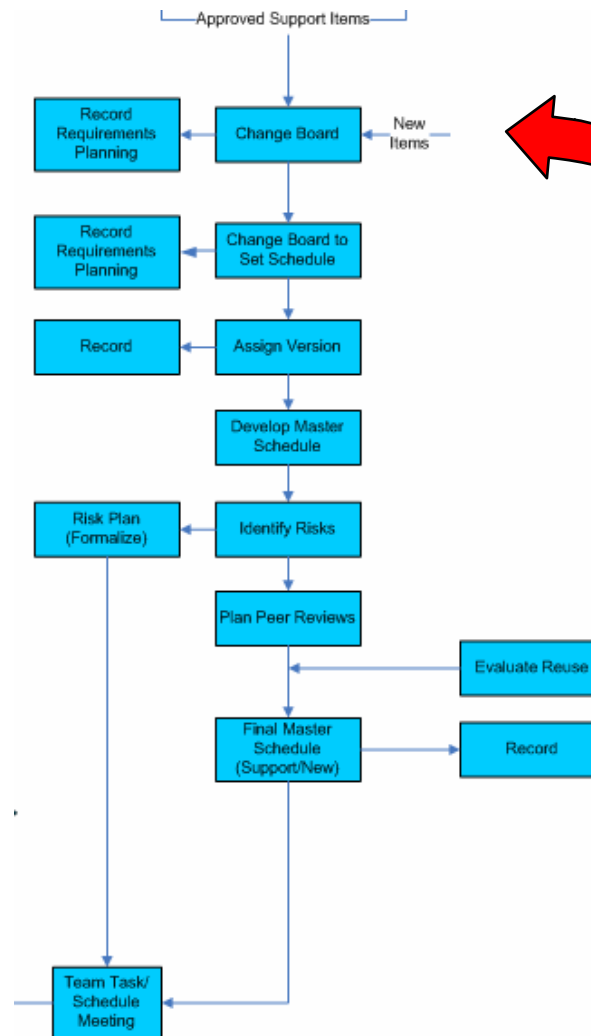

Work Flow Visualization (cont)

■ Design Synthesis - code/build oversight

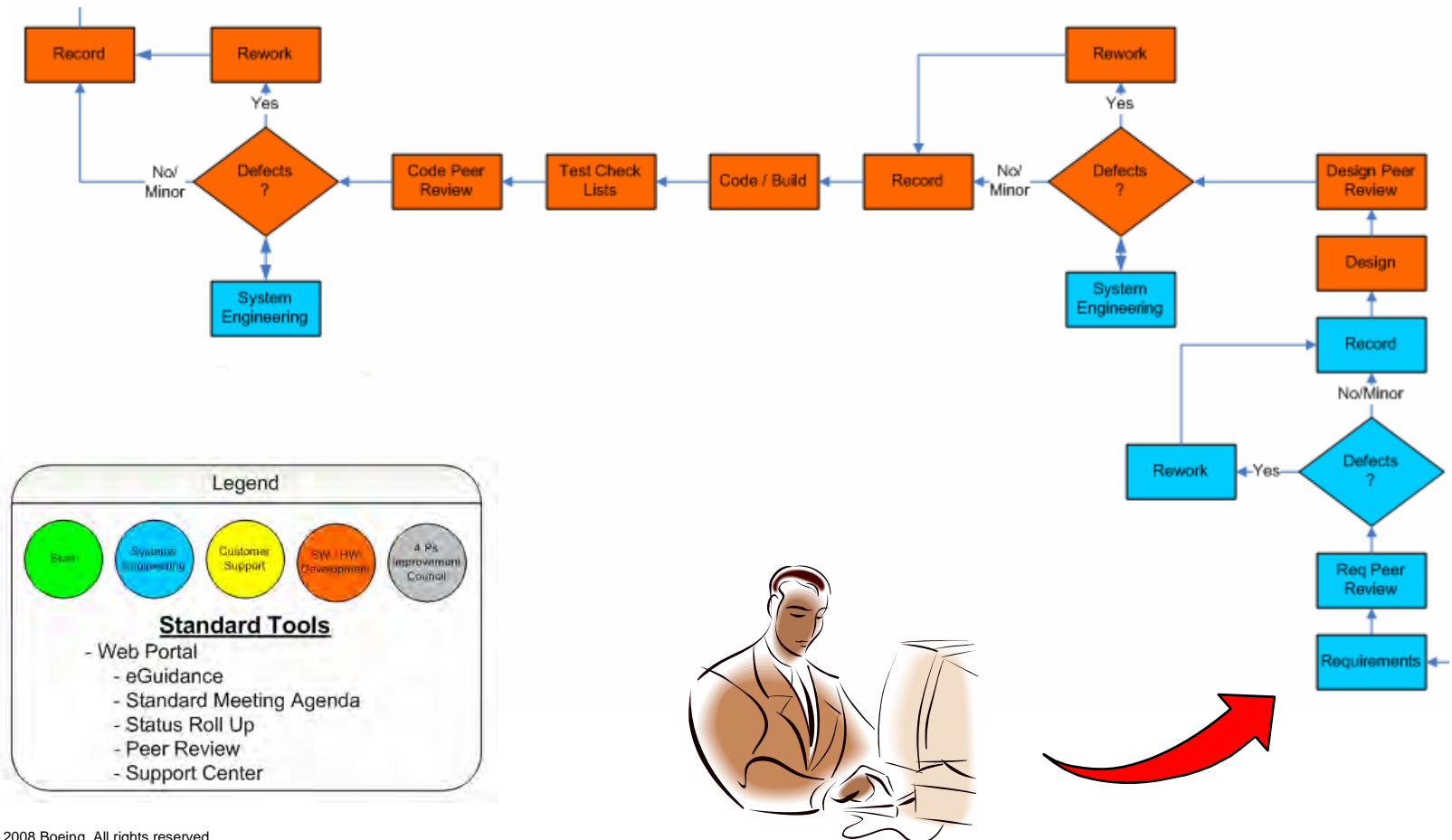

Work Flow Visualization (cont)

■ Testing, verification and release

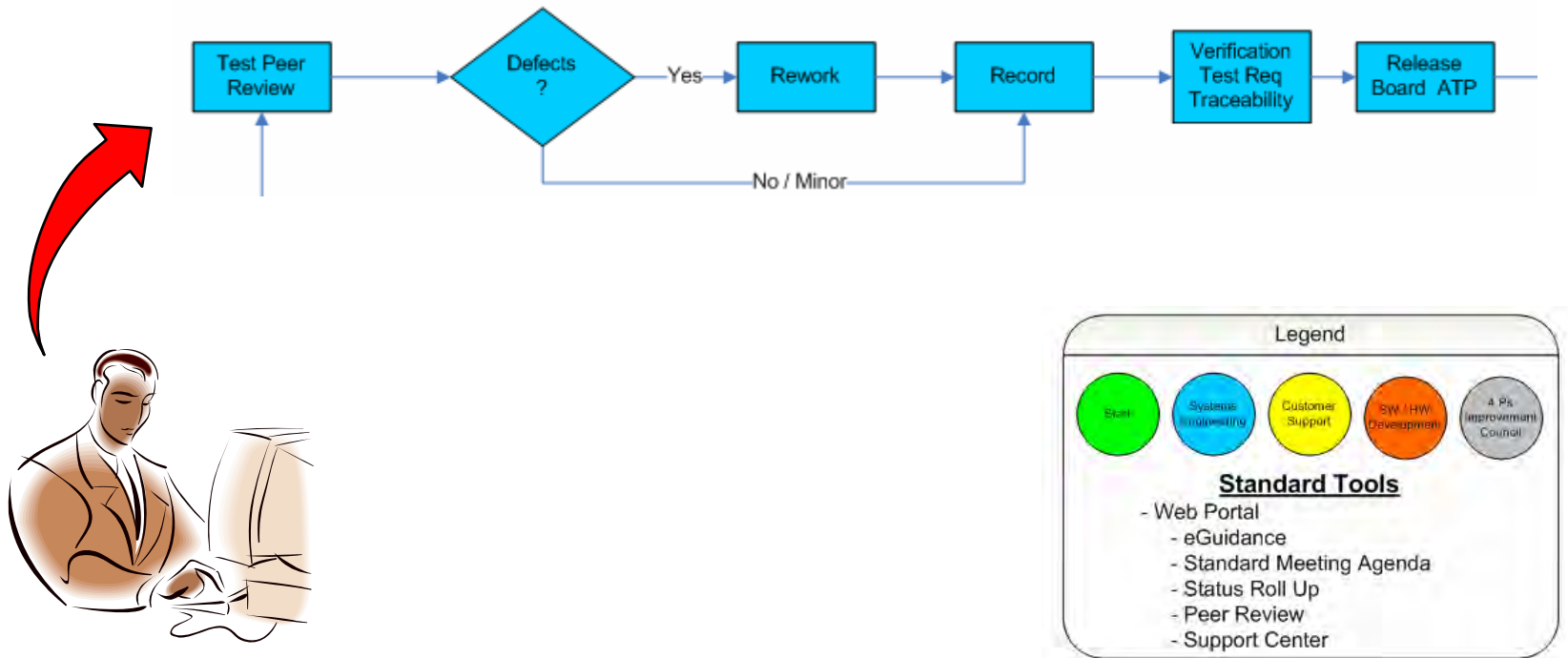

Work Flow Visualization (cont)

- Configuration Management, delivery and continuous improvement
- Improvement Council

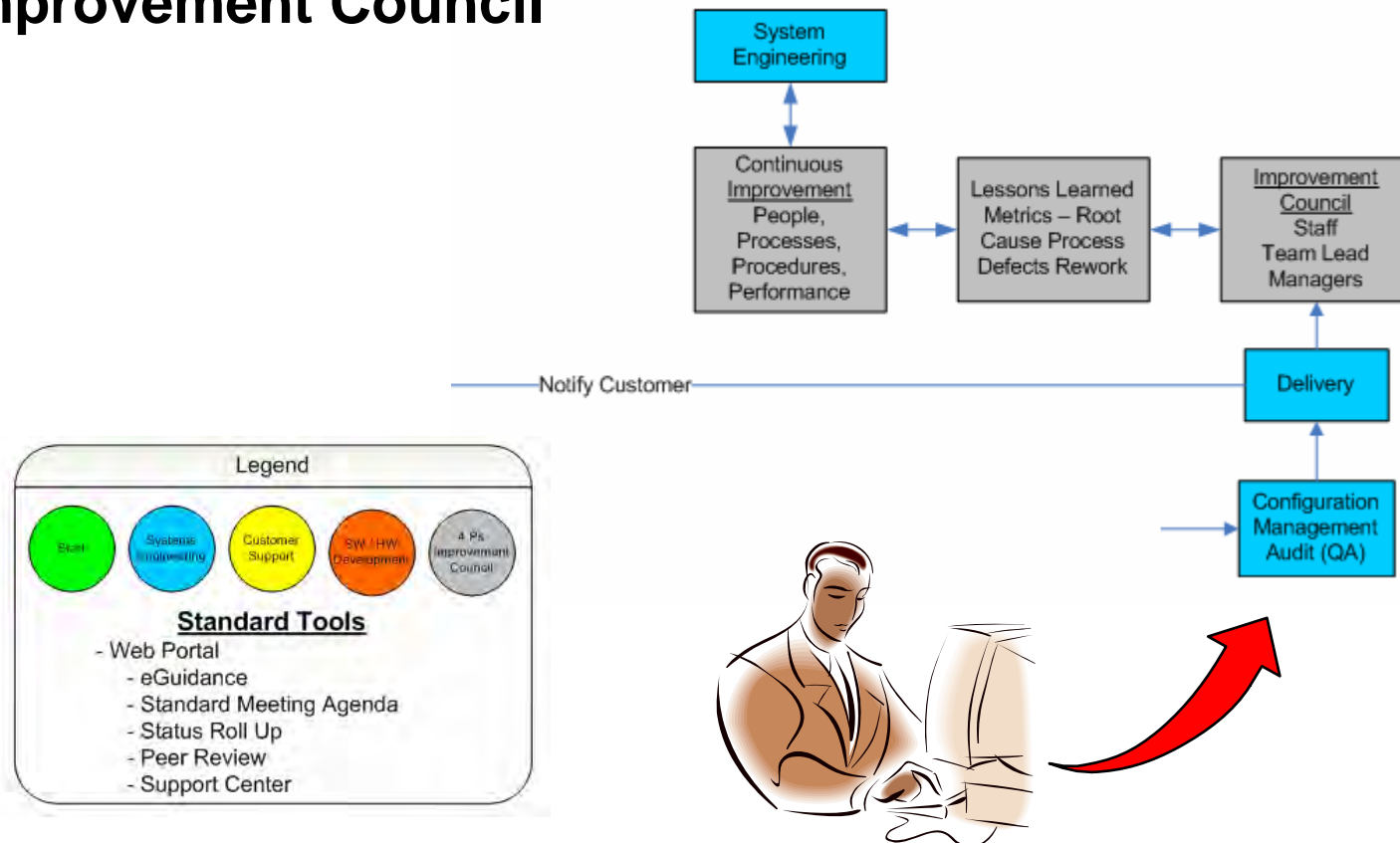

Work Flow Visualization Benefits

- **Identifies major steps in development that will remain during organizational process change activity**
 - Engineer better informed as to what his or her role is for product development
 - Influence to product delivery
- **Associated processes may change, but work flow stays consistent**
 - Minor adjustments made for that role for that task
- **Communication across specialties improved**
 - Work flow task
- **Importance of work flow task provides increased importance on work product artifact, at that stage**
 - Improve peer review effectiveness
 - Decreases chance of out of phase defects
 - Increases chance of in phase defects found

Knowledge Management

- **Linking and sharing of related information between business disciplines**
 - Improves systems engineering influence and maturity
 - Improves oversight of quality
 - Increases timeliness of applicable decision making processes
 - Directs engineer to key “need to know” information
 - Protects engineer from overwhelming sensation of “nice to know” information
 - Reduces bottleneck

Knowledge Management (cont)

- **Electronic guidance or eGuidance**
- **Key “need to know” information provided by a web based tool**
 - Procedures, Processes, and tools required to do the job
 - E-Guidance is a tool designed to provide an employee relevant reference information regarding his/her role and responsibilities within the organization and current assignment
 - Intent of e-Guidance is for the employee focus learning of necessary tools, procedures, and product documents in an expeditious manner

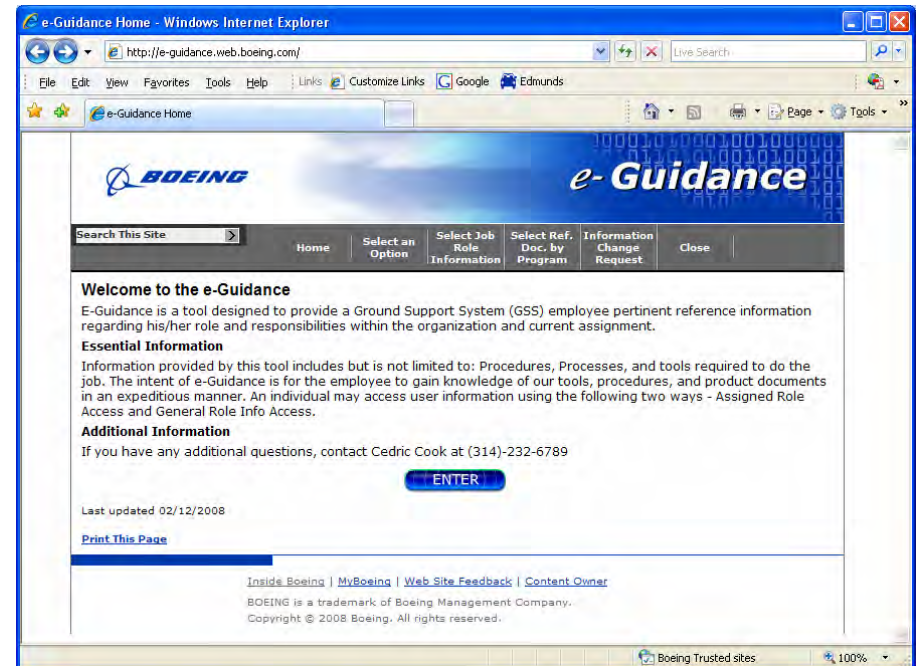

Standard Tools to Consider

■ **Common Web Portal**

- Meeting Agenda
- Meeting Minutes
- Status with applicable roll up to various levels of leadership
- eGuidance
- Peer Review
- Support Center

Summary

■ Challenge

- Implement an effective method of improving systems engineering execution and knowledge management across specialties
- Maintain control of chaotic situations that impact base lined work flow
- Insure communication of activities are readily available up and down the organizational chain

■ Solution

- Build on past studies and lessons learned for continuous improvement
- Develop visualizations of major business work flow elements
- Map the employee role to the documentation that is needed
- Develop standard meeting agendas that represent full process compliance
- Utilize the latest technology to lessen the bottle neck affect of key domain technical documentation of the team and specific roles

■ Future Benefits

- More robust program managers
- Knowledge builds upon knowledge





Service Oriented Architectures (SOA) and Net-Centric Warfare: Similarities, Differences and Conflicts

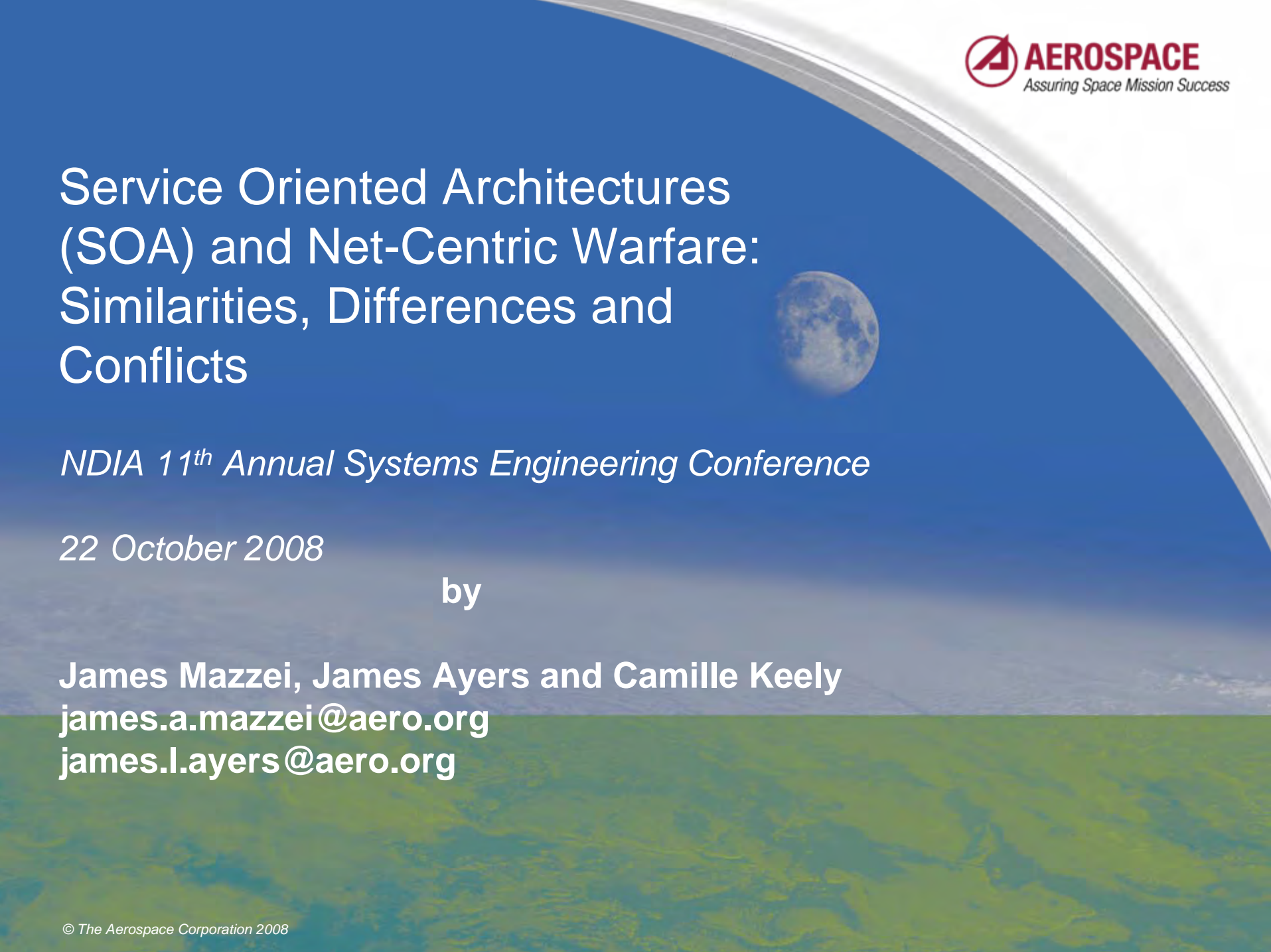

NDIA 11th Annual Systems Engineering Conference

22 October 2008

by

James Mazzei, James Ayers and Camille Keely

james.a.mazzei@aero.org

james.l.ayers@aero.org

Outline

- Introduction
- Objectives of SOA
- Advantages & Implementations of SOAs
- Objectives of Net-Centric Warfare
- Implementations of Net-Centric Warfare
- Common Features
- Fundamental Considerations
- Baseline Architecture Questions
- Conclusions



Introduction

SOAs provide agility by giving users:

- Open & interoperable system design
- A structure for problem & requirement resolution
- Common best practices & systems engineering techniques
- Consistency across the industry
- A vehicle for sharing strategies and proven approaches



Objectives of SOA

SOA's principal objectives are to provide:

- Application reuse
- Fast response to business needs



Advantages & Implementations of SOA

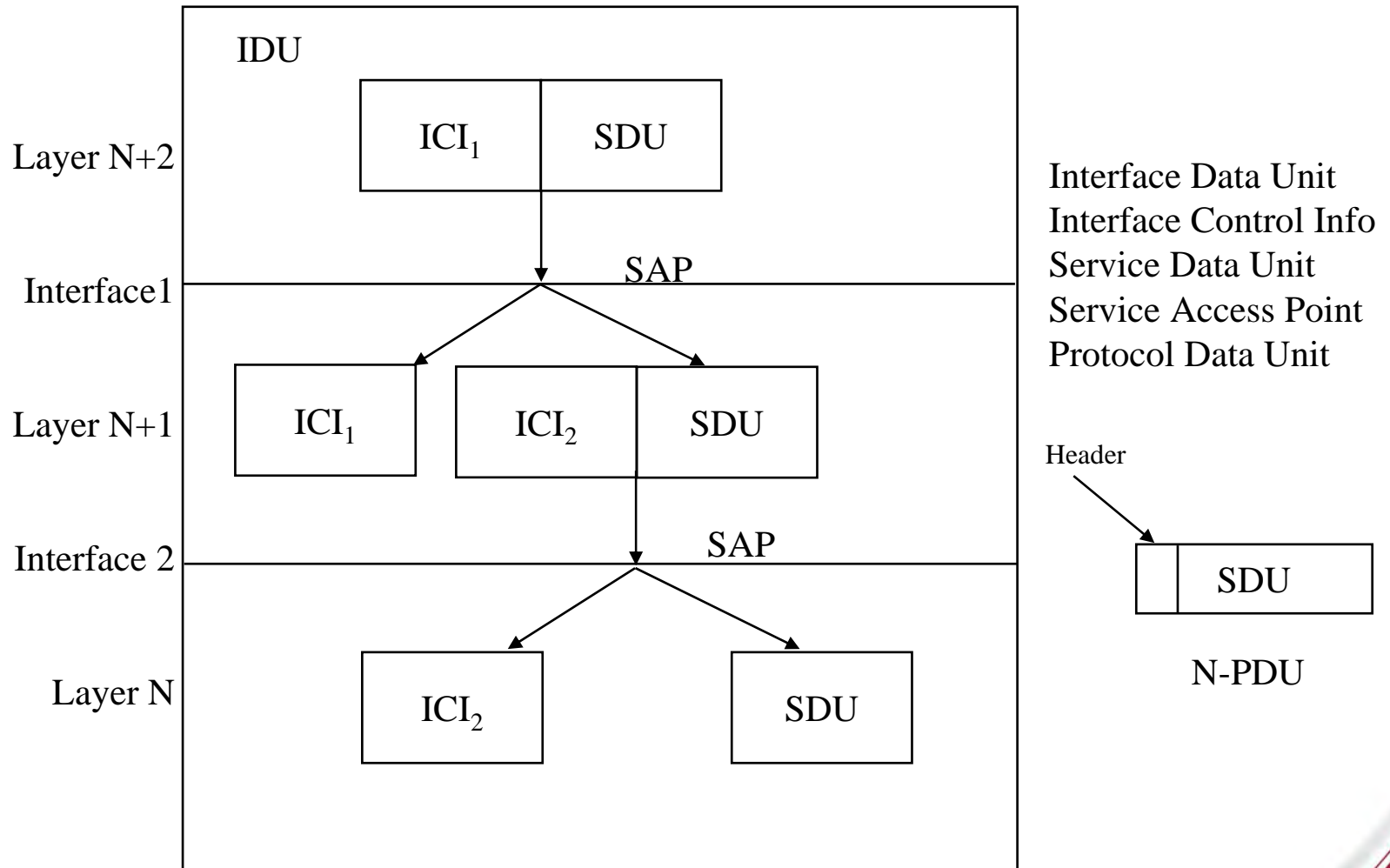

Objectives of Net-Centric Warfare

Net-Centric Warfare's Holy Grails:

- Timeliness
- Availability
- Throughput



Implementations of NCW

IP
Asynchronous Transfer Mode (ATM)
SONET/SDH
Interface for OTN, G.709
Optical Fiber/OTN (WDM)



Common Features

Both SOAs and Net-Centric Warfare require:

- Stable Requirements
- Correlation of Disparate Stakeholders
- Strong Management



Fundamental Considerations

IP Layer	OSI Layer	SONET Layer	ATM Layer	ATM Sublyr	Functionality
	3/4		AAL	CS	Providing standard interface
				SAR	Segmentation and reassembly
4	2/3	2	ATM		Flow control Cell header generation & extraction Virtual circuit path management
3	2		Phys	TC	Cell multiplexing & demultiplexing Cell rate decoupling, Cell generation, header, Checksum, Frame generation, Packing and unpacking cells from enclosing envelope
	1	1	Phys	PMD	Bit timing and physical network access



Baseline Architecture Questions

- Should Architecture Be Software Based?
- Is an Enterprise Service Bus Appropriate?
- Should the SOA Be Implemented By a Single Vendor/Integrator?



Conclusions

- The SOA can either compliment or impede Net-Centric Principles
- Implementations should be pursued with adequate prototyping and testing



Abbreviations

- AAL – ATM Adaptation Layer
- ATM – Asynchronous Transfer Mode
- CS – Convergence Sublayer
- ICI – Interface Control Info
- IDU – Interface Data Unit
- IP – Internet Protocol
- NCW – Net-Centric Warfare
- OSI – Open System Interconnection
- OTN – Optical Transport Network
- PDU – Protocol Data Unit
- PMD – Physical Medium Dependent
- SAP – Service Access Point
- SAR – Segmentation and Reassembly
- SDH – Synchronous Digital Hierarchy
- SDU – Service Data Unit
- SOA – Service Oriented Architecture
- SONET – Synchronous Optical Network
- TC – Transmission Convergence
- WDM – Wave Division Multiplexing



A System Engineering Approach to Develop a Service-Oriented Perspective

Rob Byrd
robert.byrd@si-intl.com
719-235-4408
<http://ea.si-intl.com>

Today's SOA Challenge

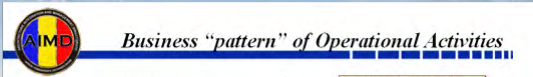
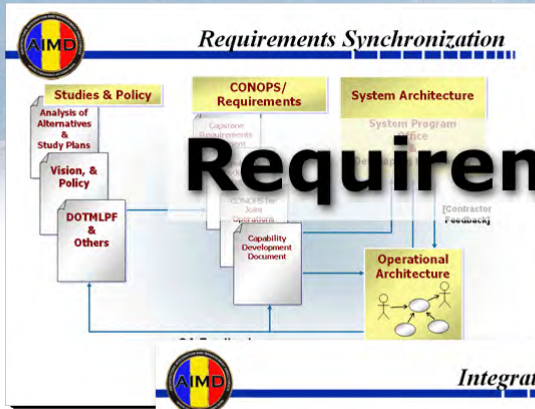

Requirements Understanding

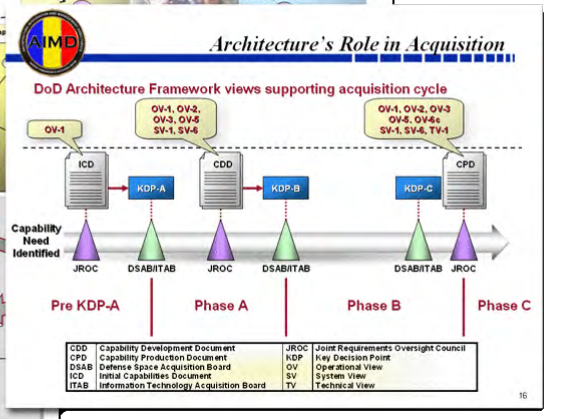
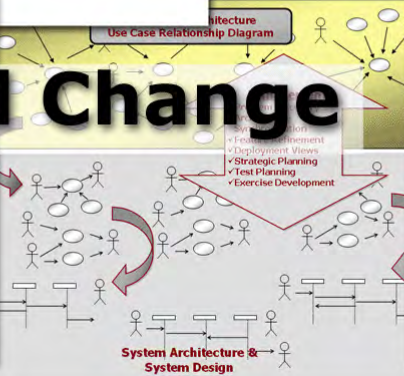
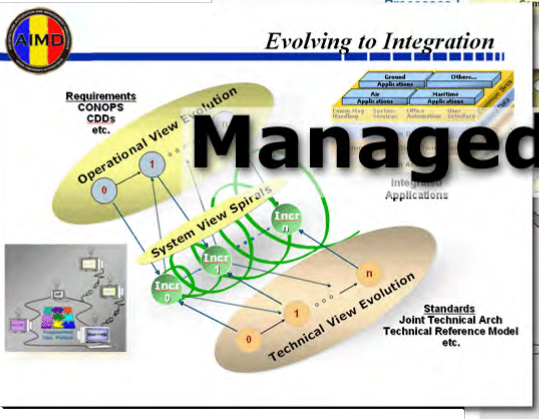
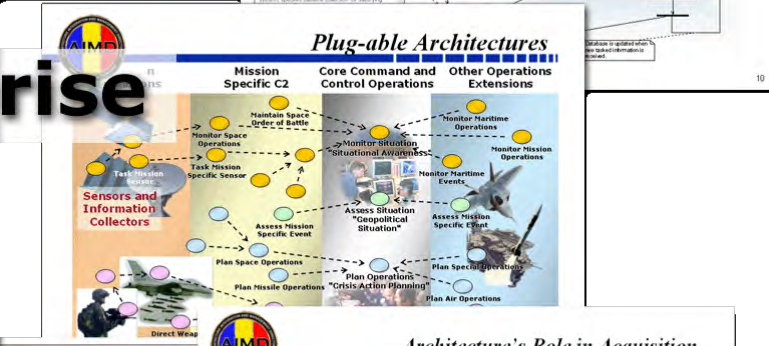
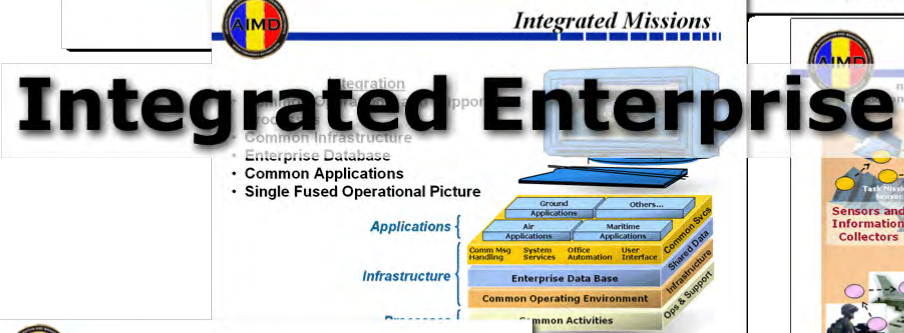

Today's Stovepipes

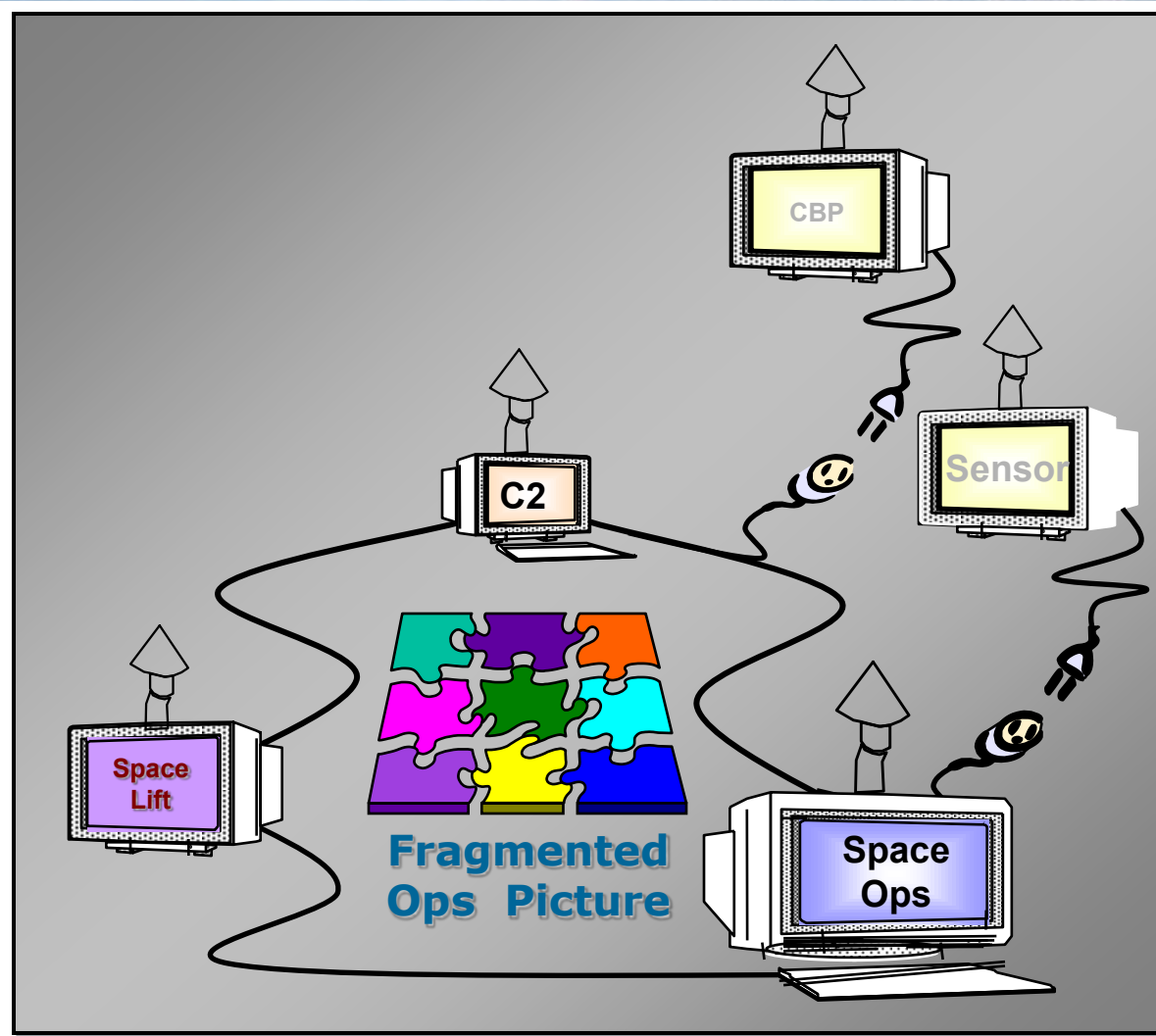

Organizing SOA for Success

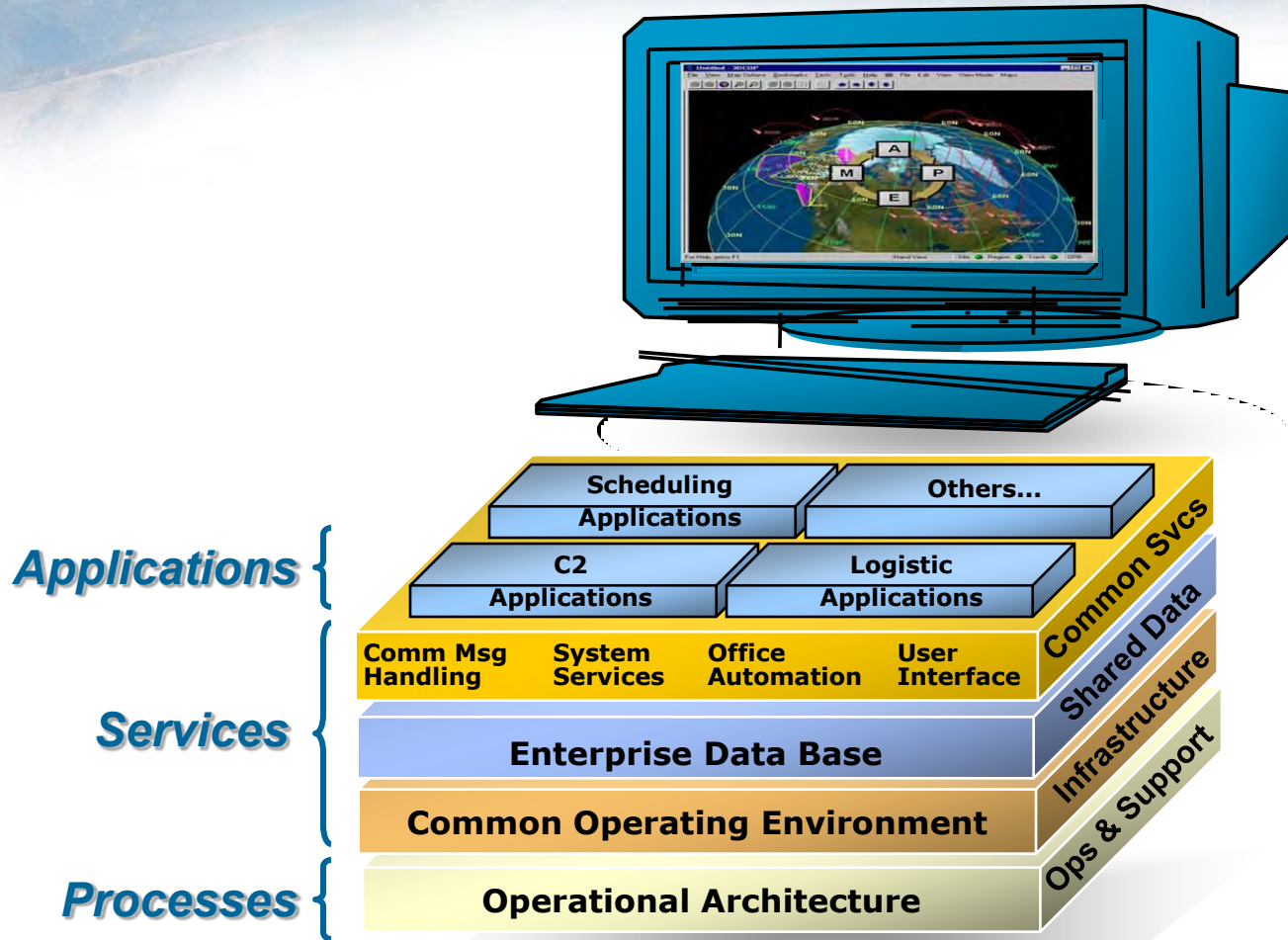

Operational Architecture Process to SOA Perspective

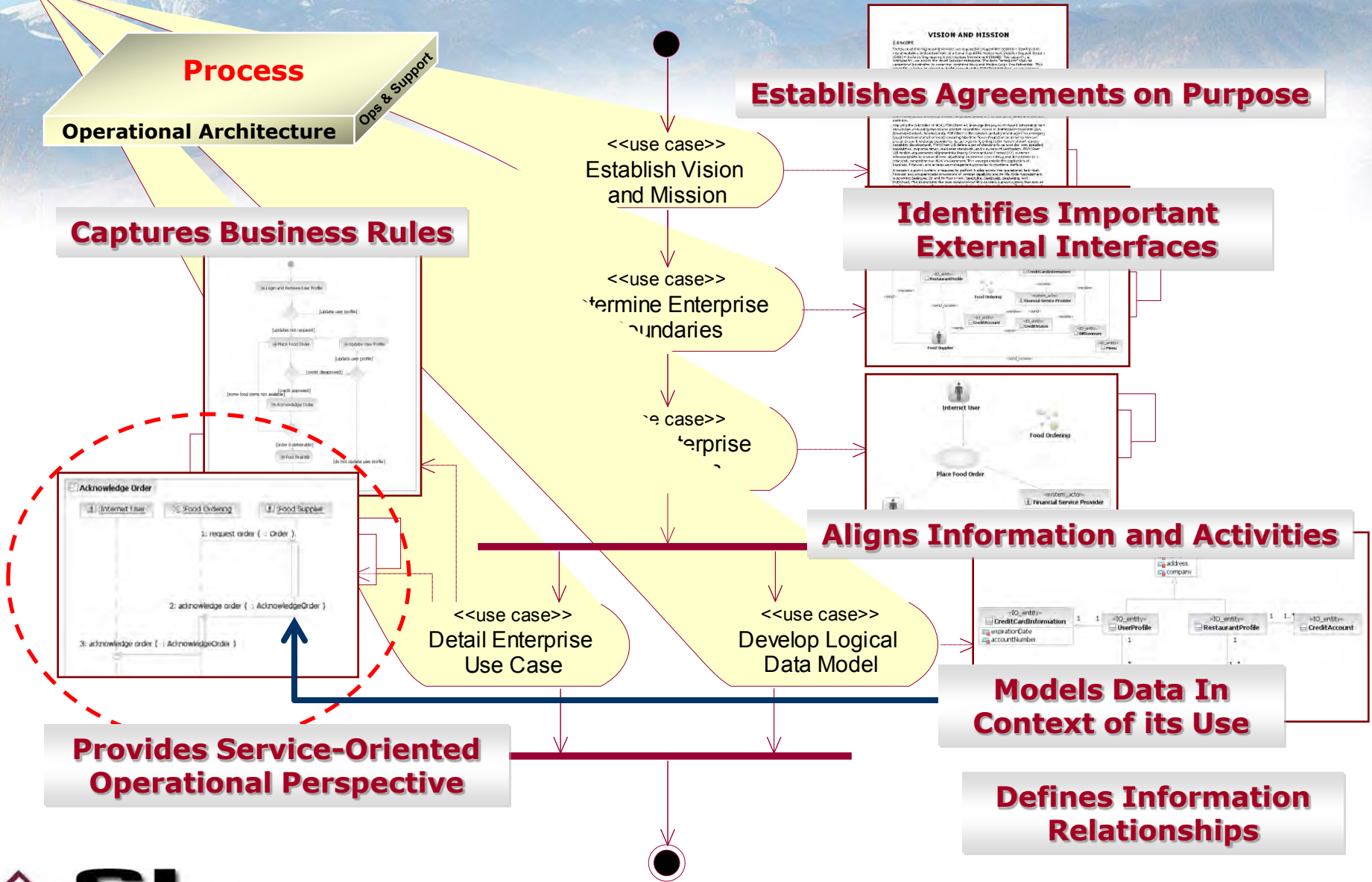

Managing Service Frameworks in UML

DoD Architecture Framework

Operational View

System View

Technical View

Operational Capabilities
(value [data] driven processes)

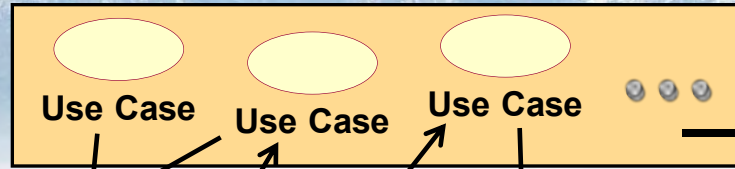

Role—System Interaction



Activity Groups
(organizational)

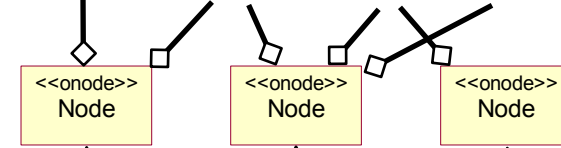

Physical Facilities
(people, systems, resources)

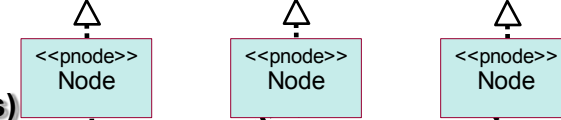

Function Groups

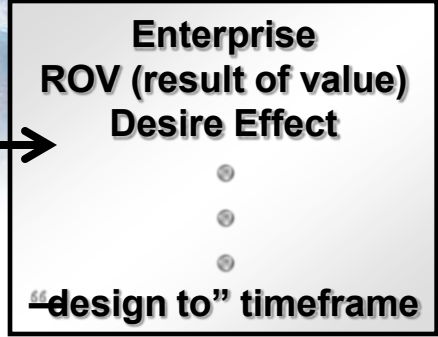
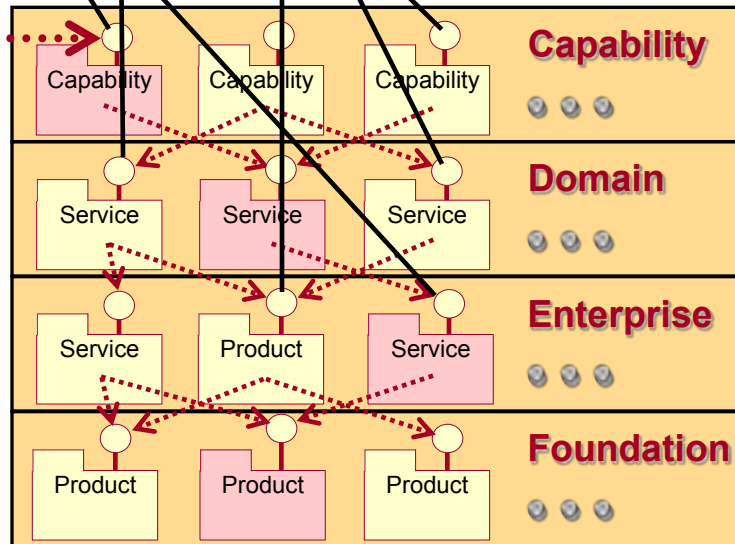
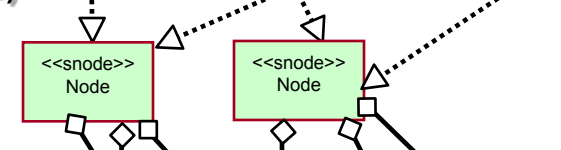

Capabilities

Domain Services

Infrastructure

Commercial and Government



Operational Trace Sequence (OV-6c)

UNCLASSIFIED

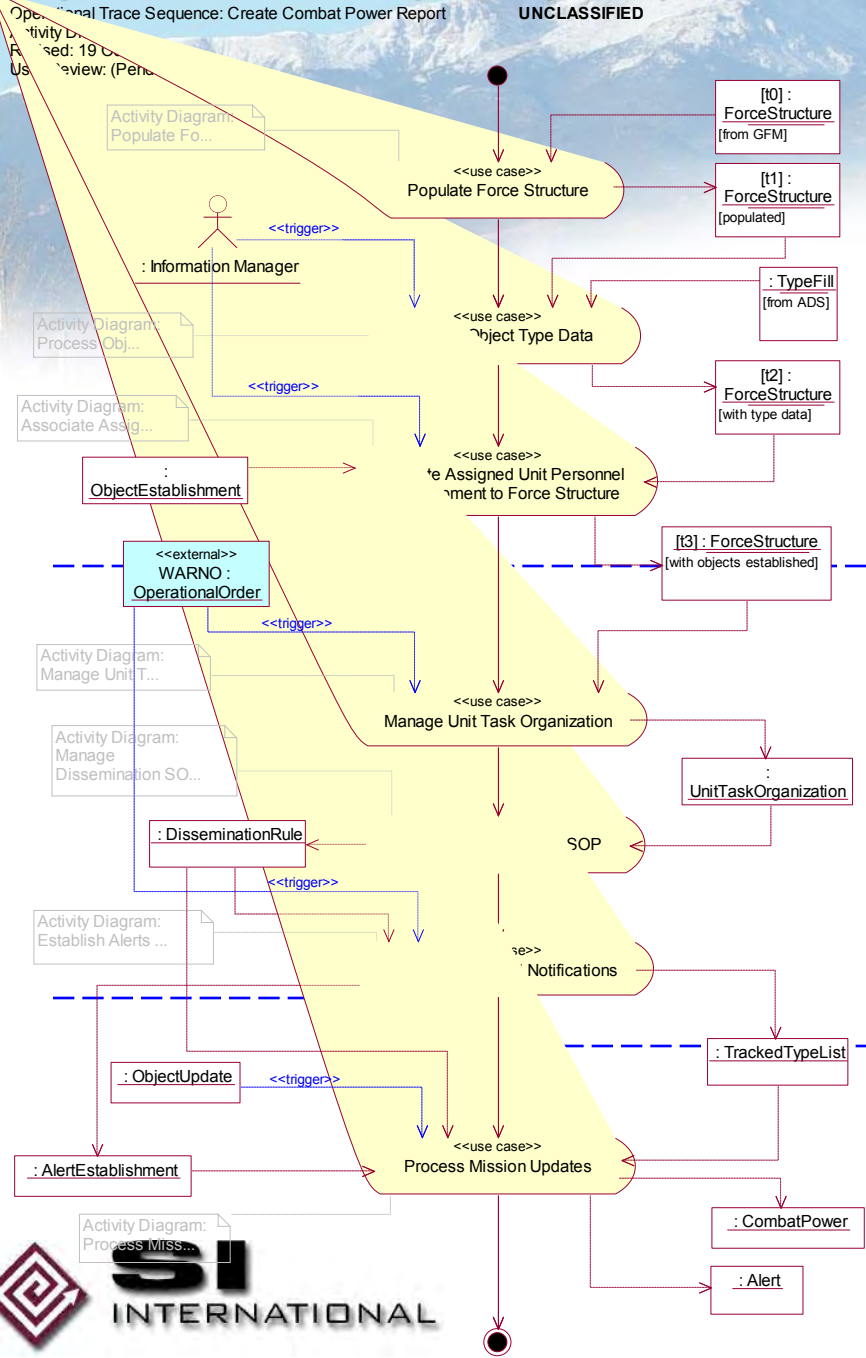

JC3IEDM SOA Prototype Overview

UNCLASSIFIED

JC3IEDM SOA Prototype
Scenario Use Case Diagram
Revised: 19 Oct 2006
User Review: (Pending)

Phase 1

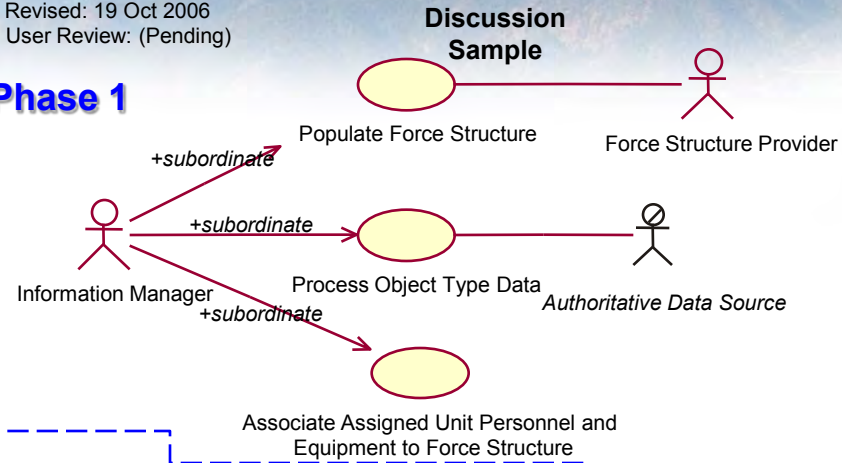

Phase 2

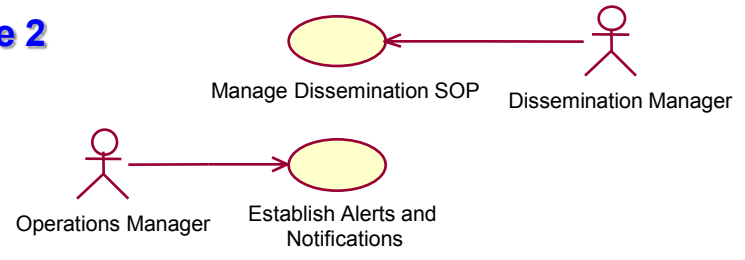

Phase 3



UNCLASSIFIED Use Case Relationship Diagram (OV-5)

Business Model – OV-5

UNCLASSIFIED

Populate Force Structure
Use Case Diagram
Revised: 19 Oct 2006
User Review: (Pending)

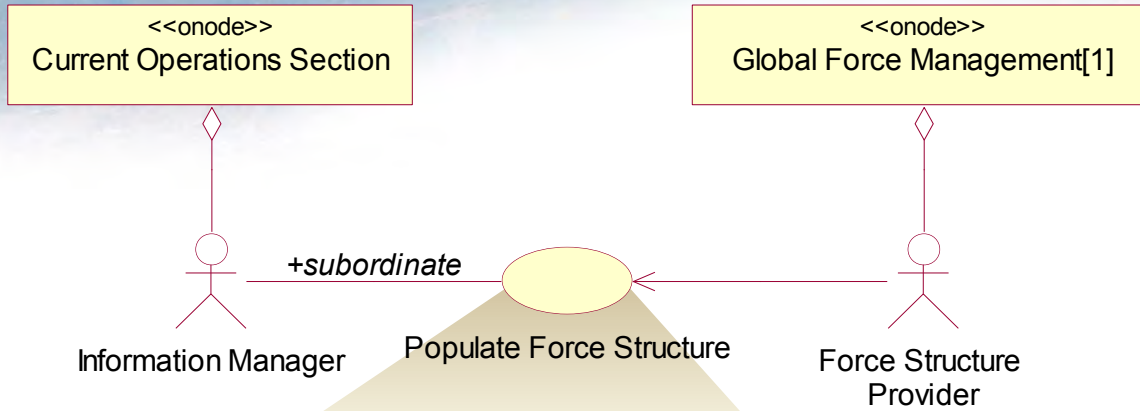

Important I/O entities for OV-7 development

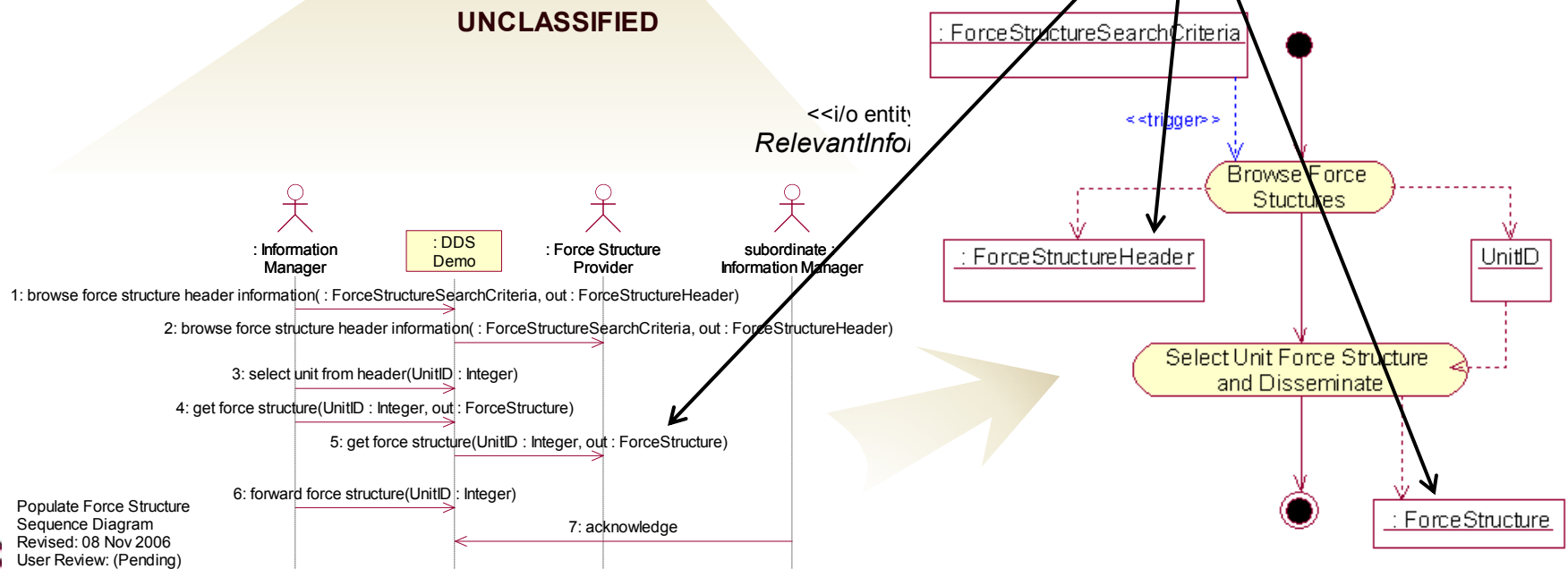

Populate Force Structure
Sequence Diagram
Revised: 08 Nov 2006
User Review: (Pending)

Business Model – Part of OV-5

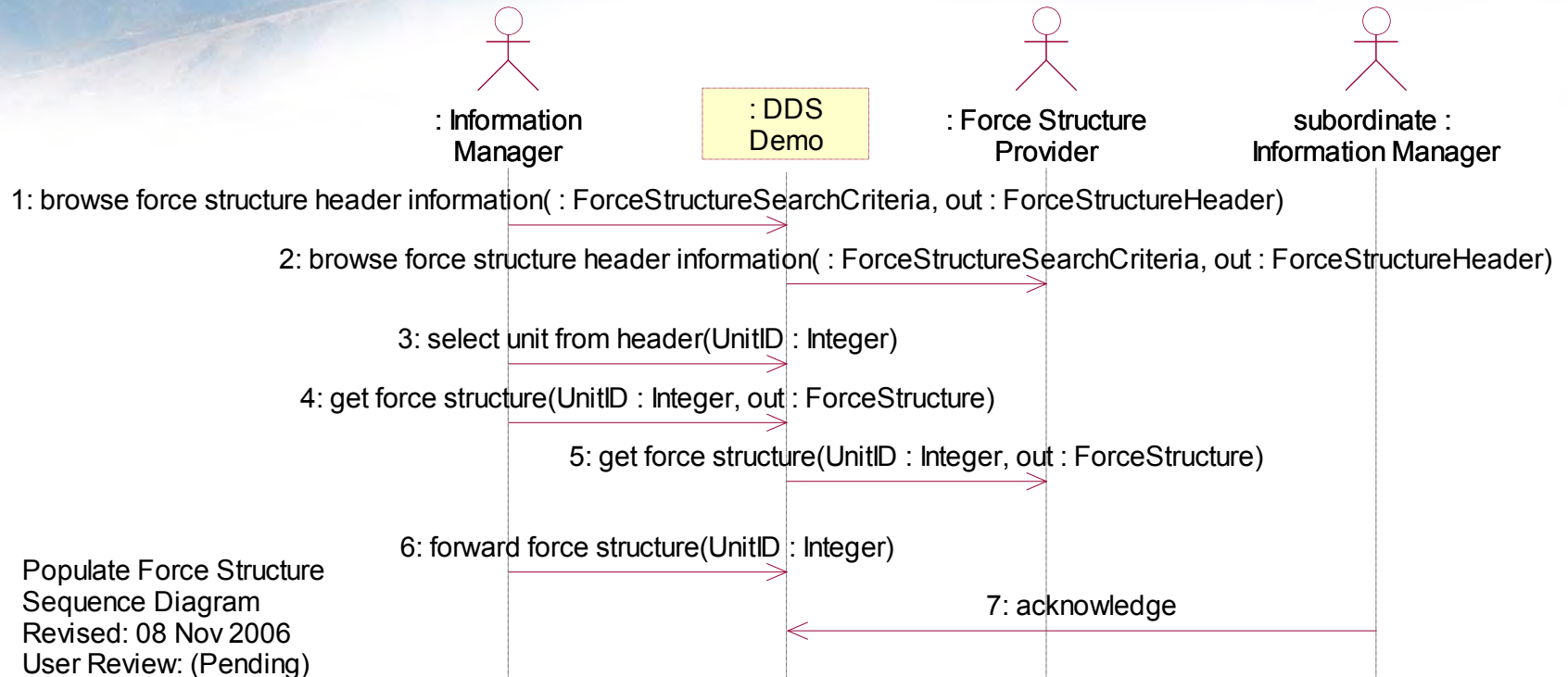

Force Structure Logical Structure – OV-7

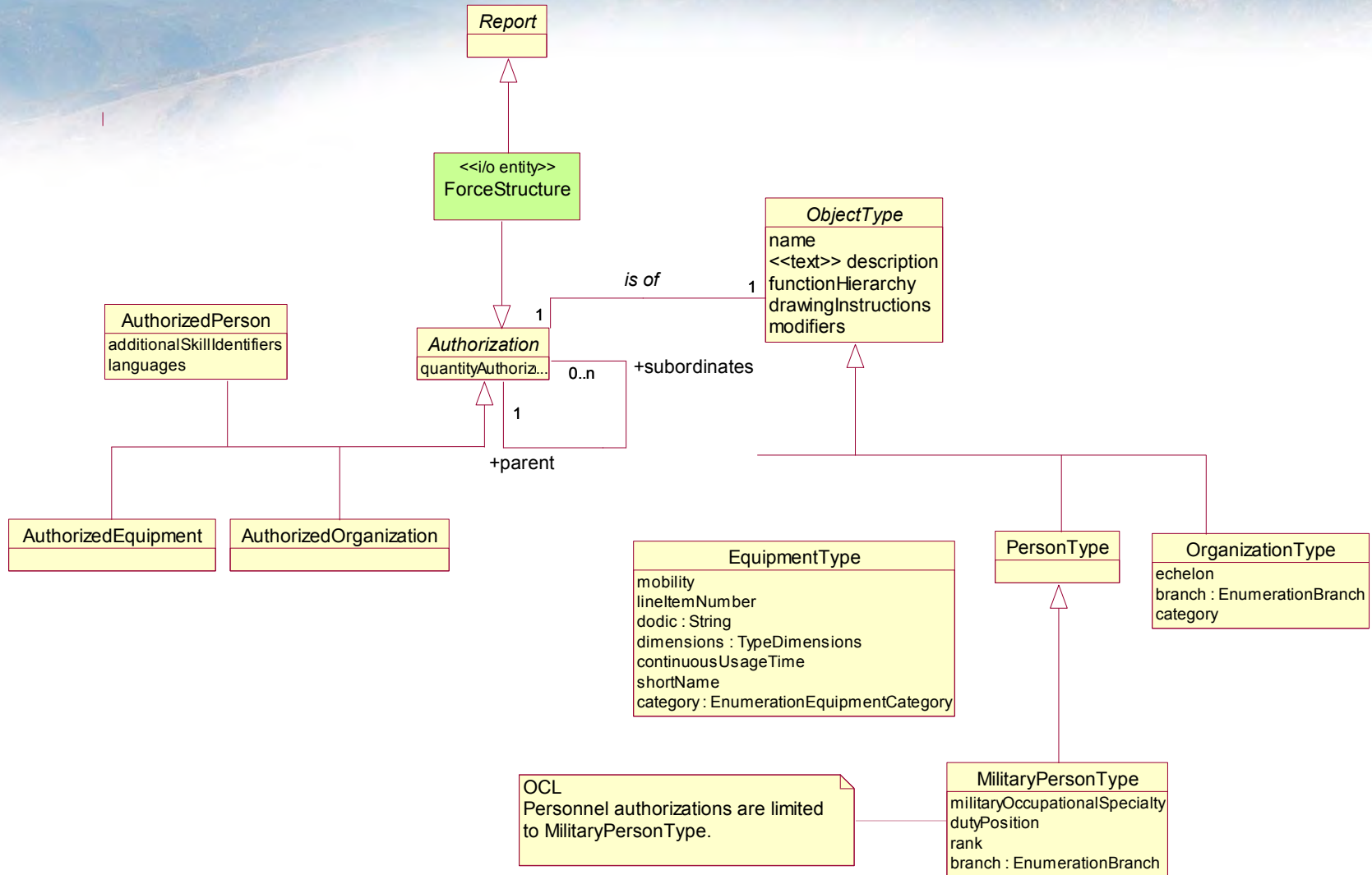

Physical Architecture (SV-2)

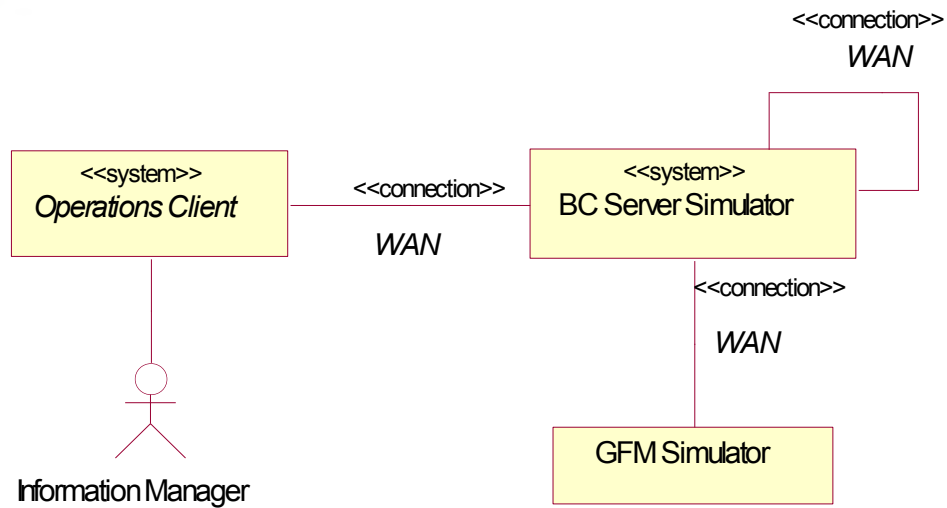

Business Model – Part of OV-5

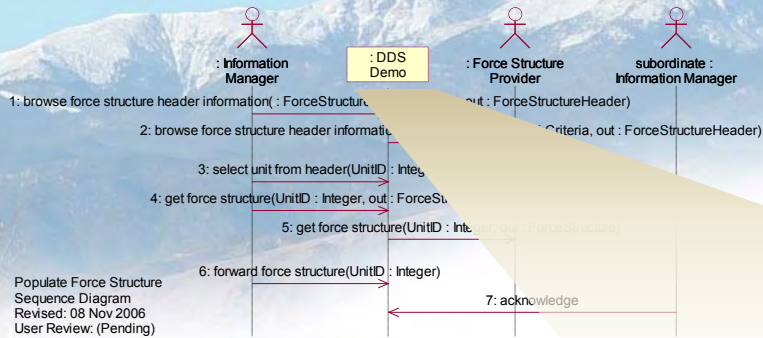

Physical Realization Model – Part of SV-6

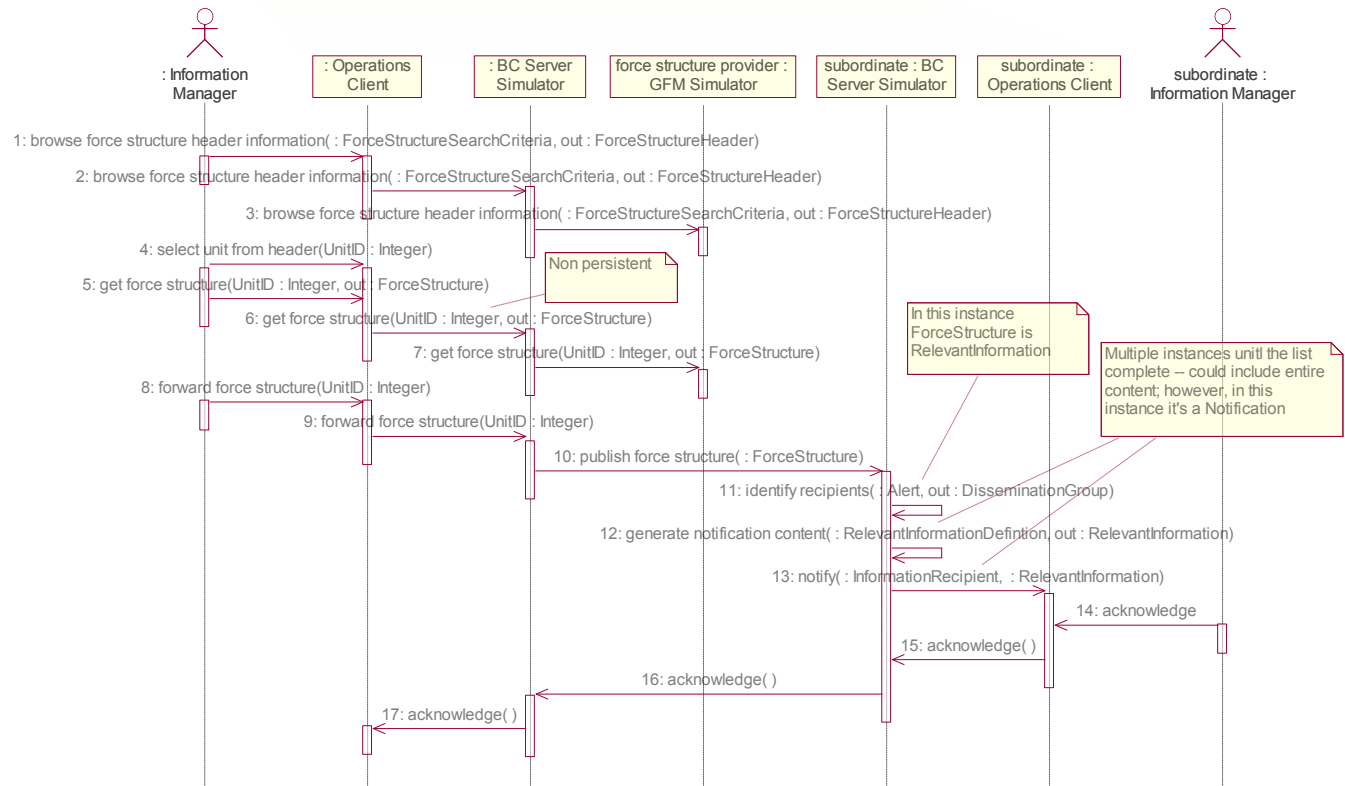

Populate Force Structure (SV-6)
Physical Realization Diagram (Sequence Diagram)
Revised: 08 Nov 2006
User Review: (Pending)

Physical Realization Model – Part of SV-6

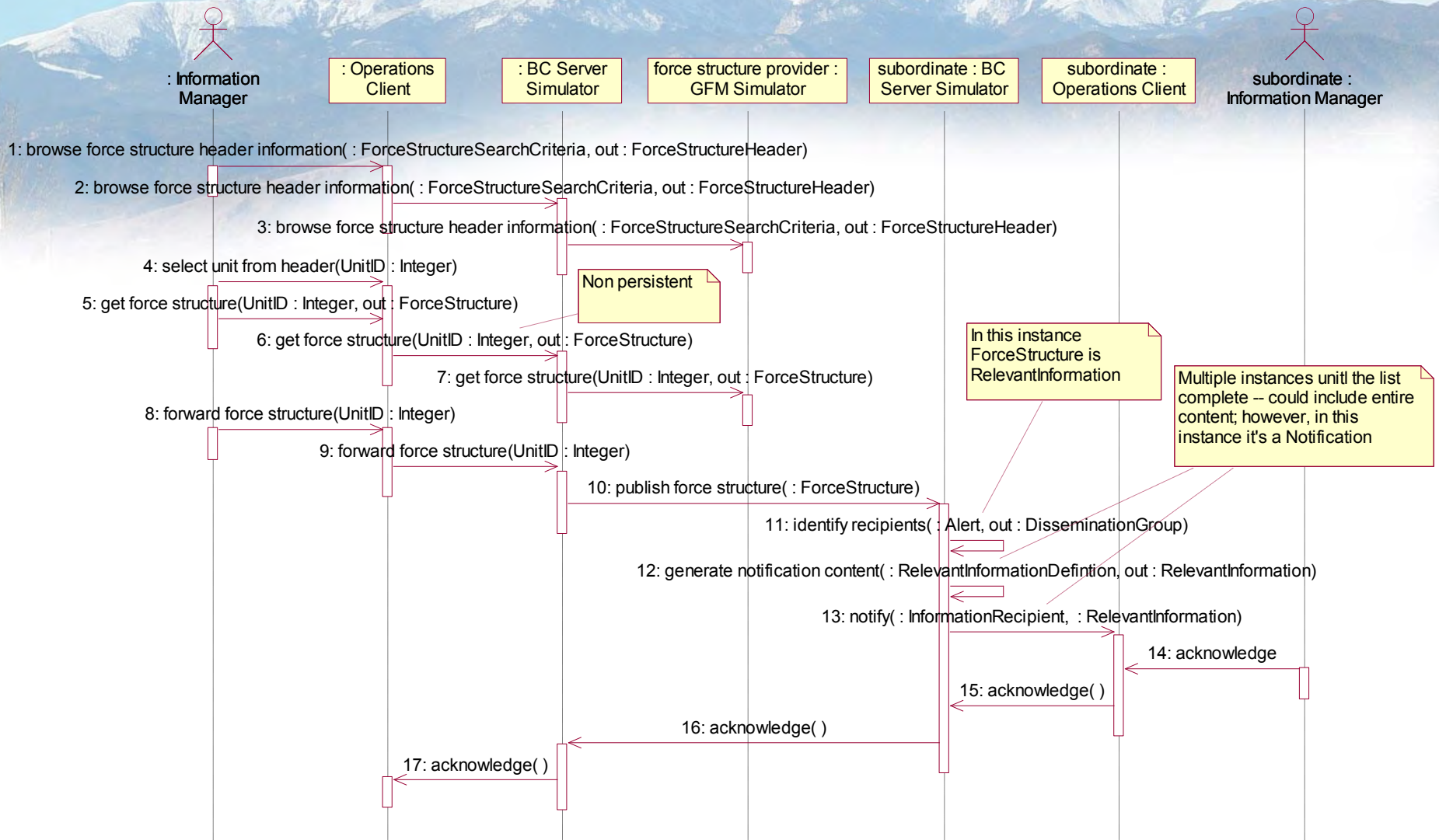

Non persistent

In this instance ForceStructure is RelevantInformation

Multiple instances until the list complete -- could include entire content; however, in this instance it's a Notification

Populate Force Structure (SV-6)
 Physical Realization Diagram (Sequence Diagram)
 Revised: 08 Nov 2006
 User Review: (Pending)

UNCLASSIFIED

OV-7

Compartmented view abstractly describes the i/o entity used on the sequence diagram and activity diagram – defines the interface data requirements

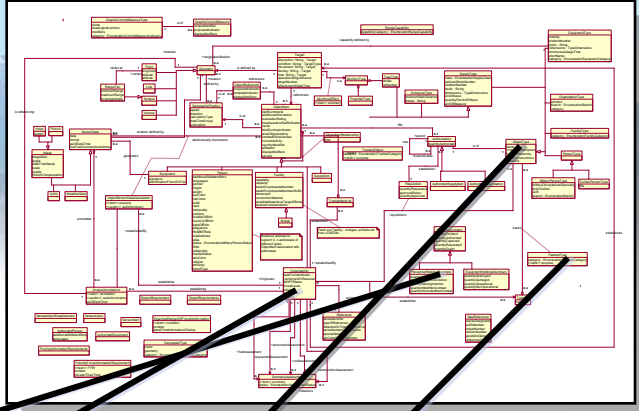
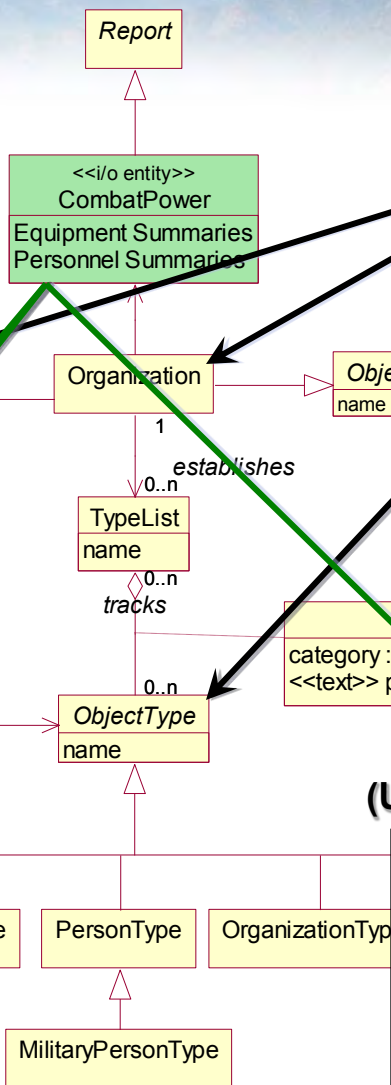
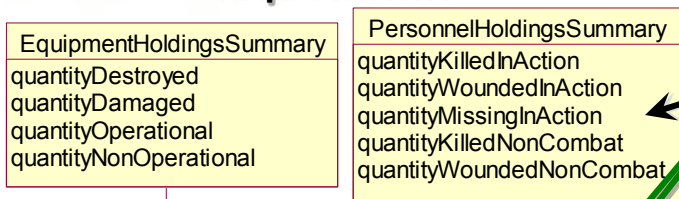

Purpose attribute in TrackedType on the Slant Report will always equal "CombatPower."

category : EnumerationTrackedCategory
 <<text>> purpose

Determine Combat Power - SAUC03
 Activity Diagram
 Revised: 17 Apr 06
 User Review: (Pending)

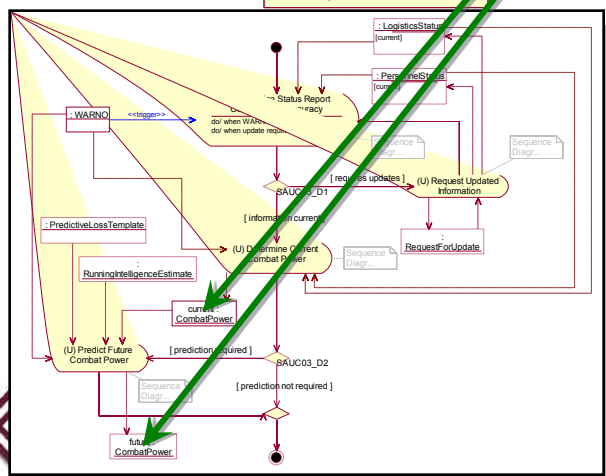

(U) Determine Current Combat Power

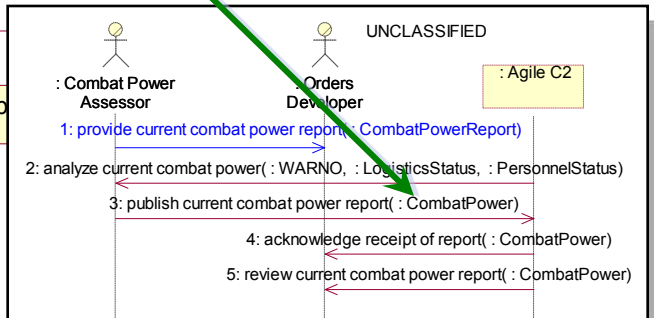

UNCLASSIFIED

UNCLASSIFIED

OV-5, OV-6c

(U) Mechanisms and procedures are in place allowing various reporters to send status information

Binds the OV-5 to the OV-6c – defines “instantiatable” use cases

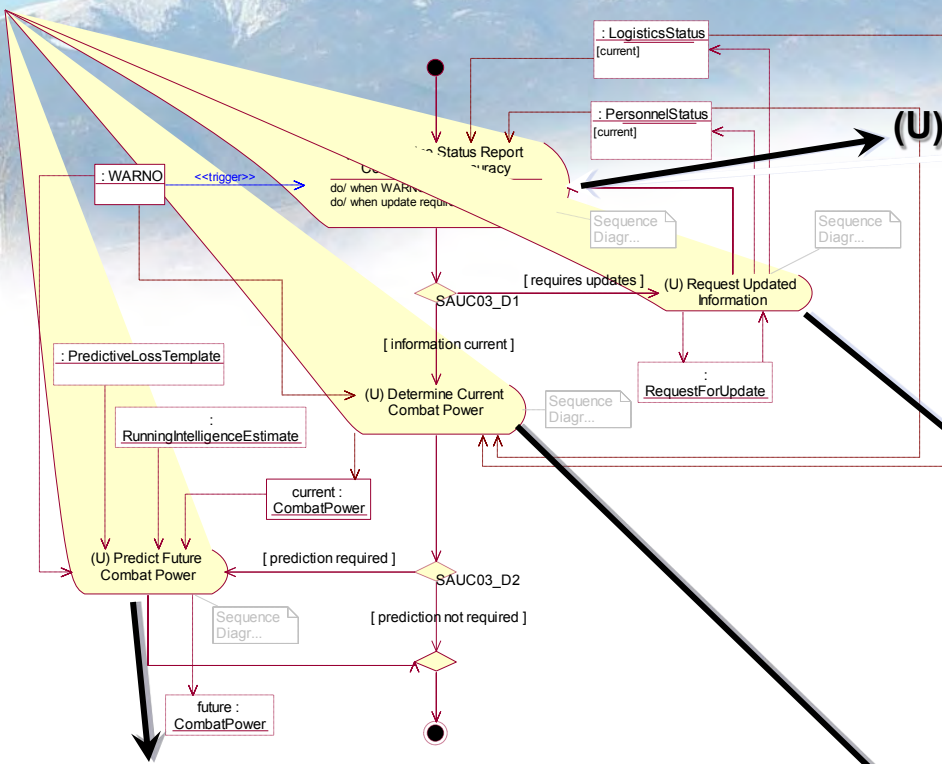

(U) Determine Status Report Condition and Accuracy

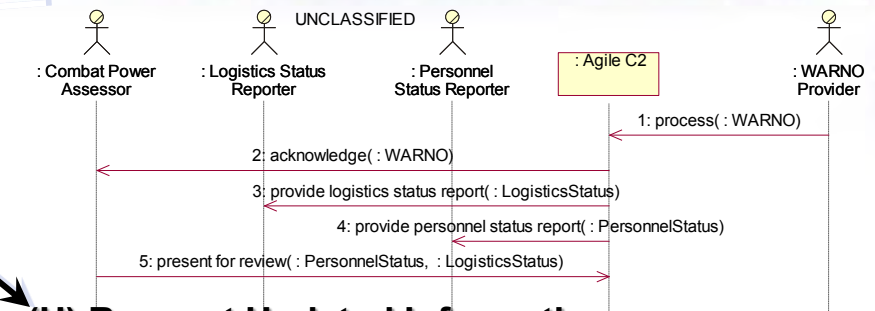

(U) Request Updated Information

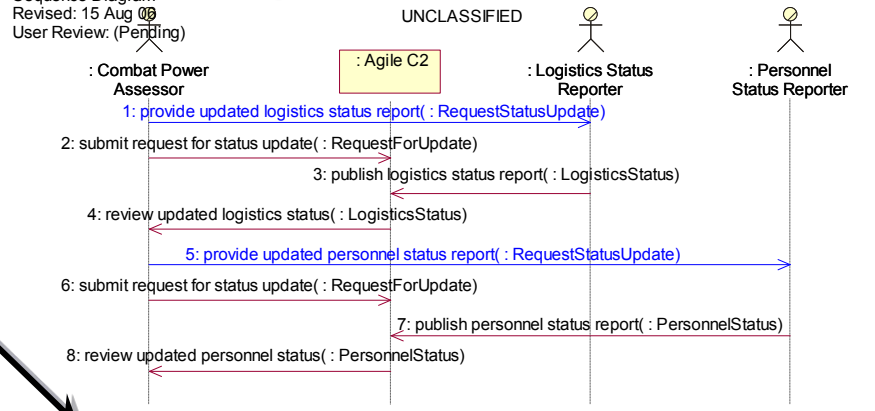

(U) Predict Future Combat Power

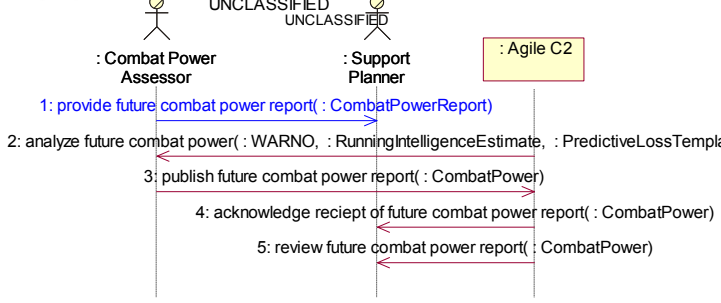

(U) Determine Current Combat Power

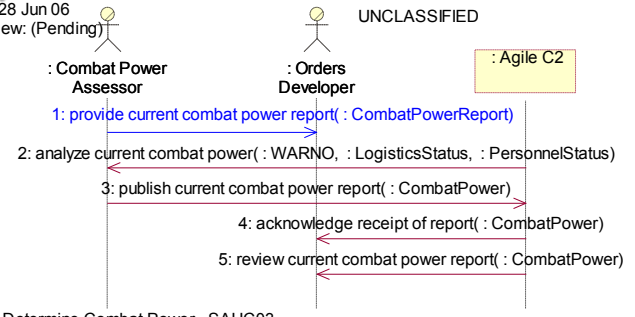

Determine Combat Power - SAUC03
Sequence Diagram
Revised: 16 Jun 06
User Review: (Pending)

Determine Current Combat Power - SAUC03
Sequence Diagram
Revised: 28 Jun 06
User Review: (Pending)

- One use case may modify (& inherit) behavior of a second
- Use cases capture data interaction among operators, nodes, and systems
- Interaction is allocated to systems, their elements, and their objects

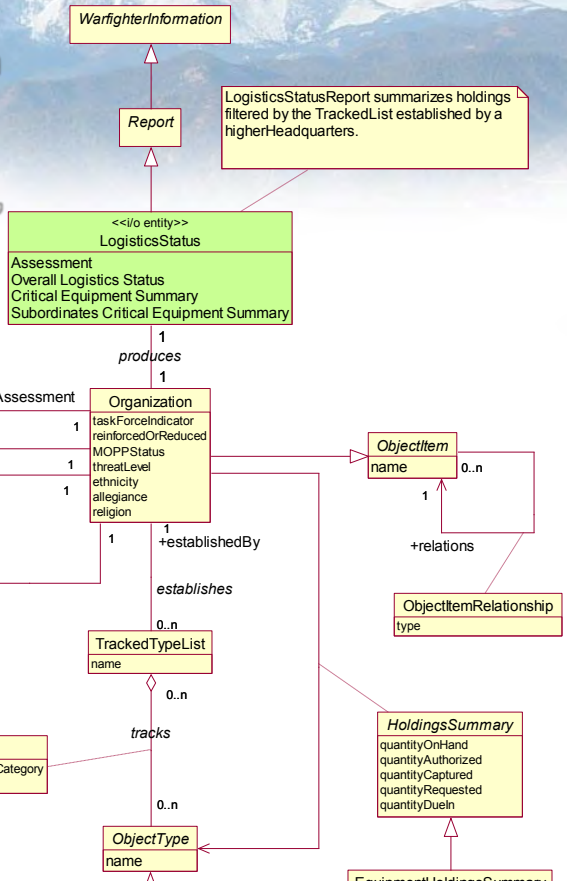
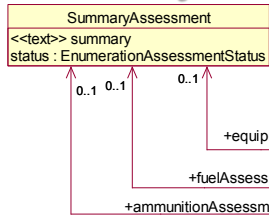
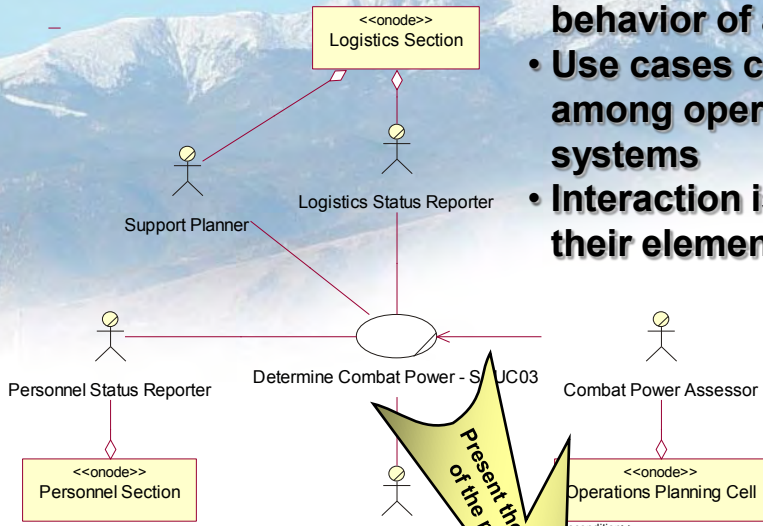

LogisticsStatusReport summarizes holdings filtered by the TrackedList established by a higher-Headquarters.

Defines the data in a reusable way

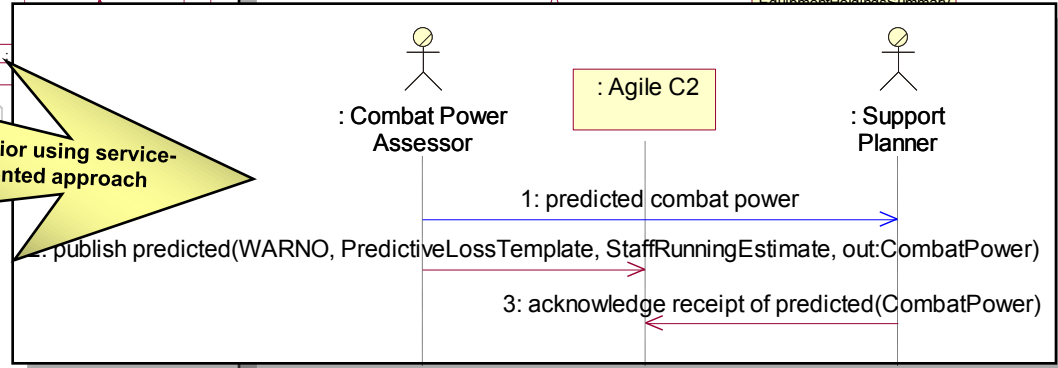
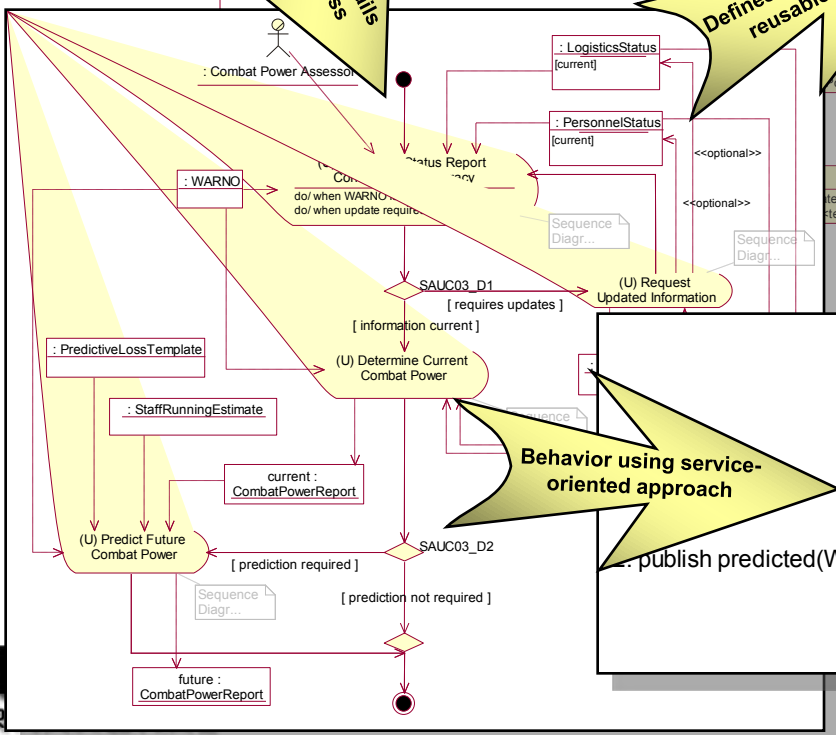

Managing Service Frameworks in UML

DoD Architecture Framework

Operational View

System View

Technical View

Operational Capabilities
(value [data] driven processes)

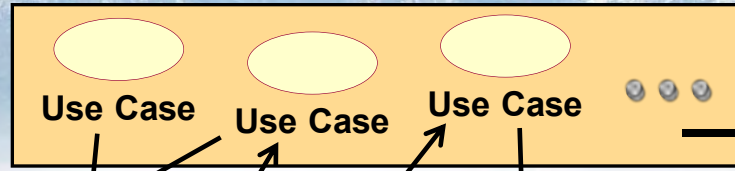

Role—System Interaction



Activity Groups
(organizational)

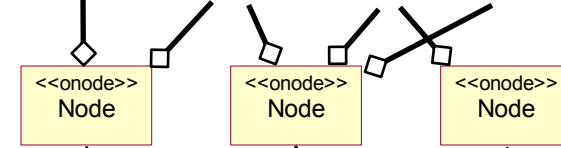

Physical Facilities
(people, systems, resources)

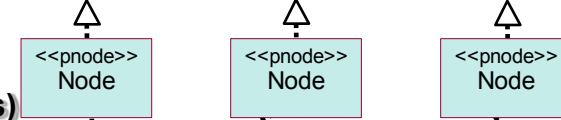

Function Groups

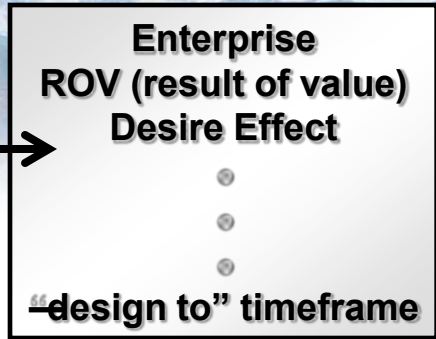
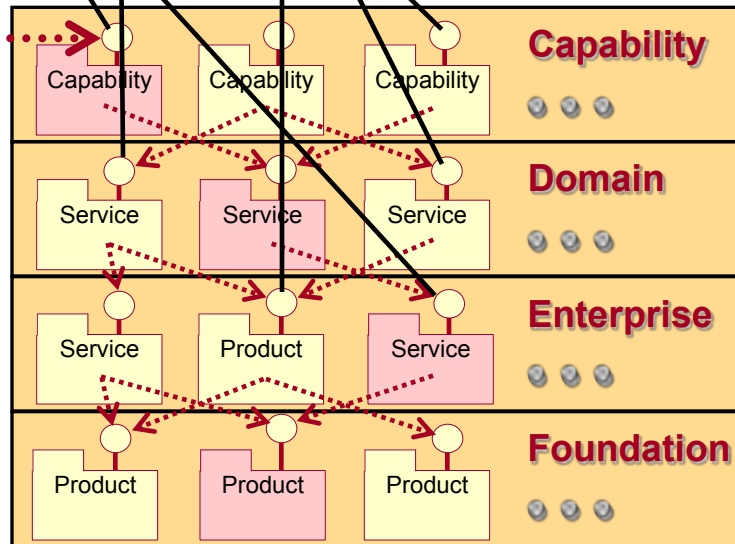
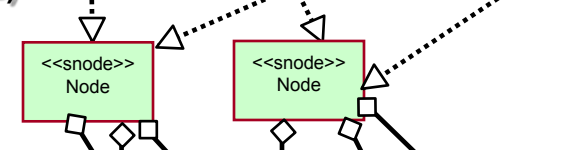

Capabilities

Domain Services

Infrastructure

Commercial and Government

Verify and Validate Architecture Through Animation

UML Architecture Data Drives Mission Thread Animations

UML Architecture

Architecture Animator

C2 Operational Nodes
USSTRATCOM HQ – Headquarters for US Strategic Command
JFCC GS – USSTRATCOM Joint Functional Component Global Strike, Barksdale AFB, LA
TACC – Tanker Airlift Control Center, Scott AFB, MO
JCS – Joint Chiefs of Staff (Current Ops / Plans)
CAOC – Combined Air Operations Center (Notional)
**Note – Multiple additional information exchanges and C2 nodes are involved in this scenario; these are critical nodes/IEs only.*

Way Point Specifications
Name: c130_WP1
Show Name
Set Way Point location: [874, 715] (Starting Location)
Select Way Point to Travel to: c130_WP1a
Speed: 250
Estimated time to next way point: 32

Spirally Evolving Guided by OA



Capabilities
CONOPS
ICDs
etc.

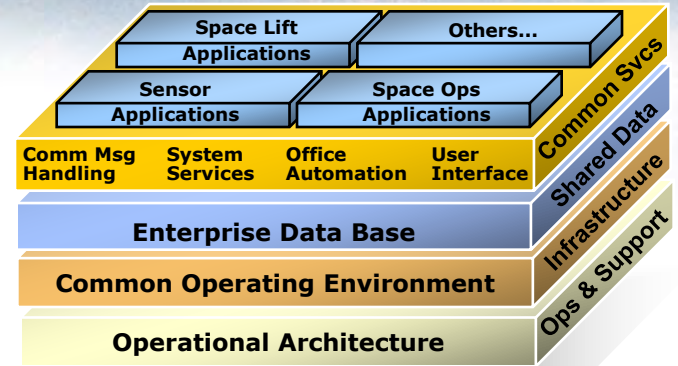
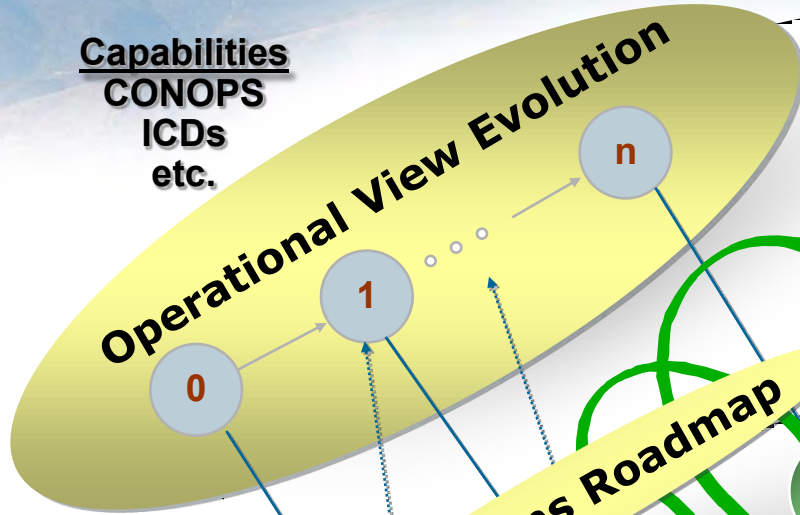

Integrated Capabilities

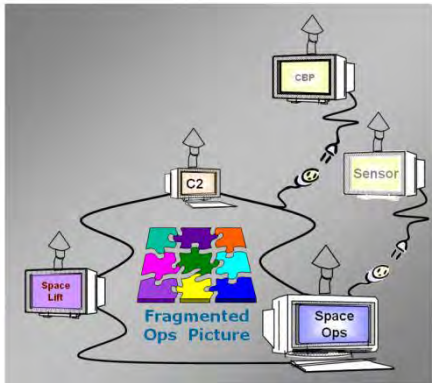

A Legacy of Stovepipes

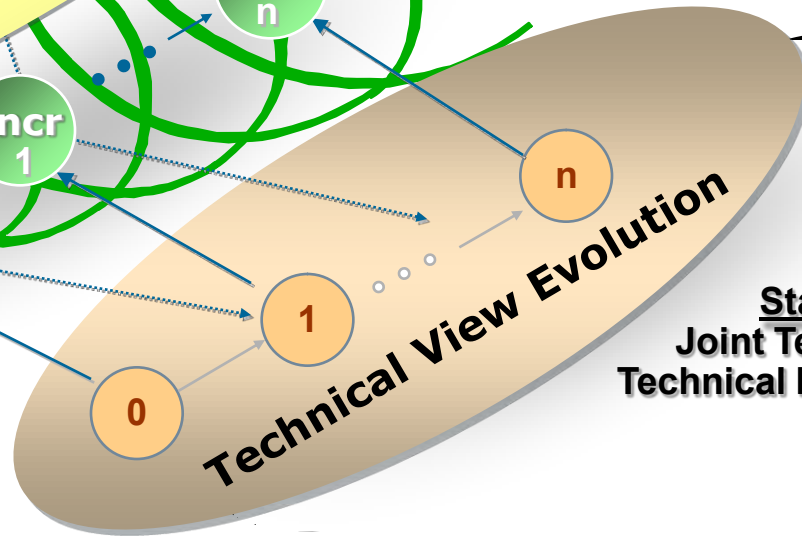

Standards
Joint Technical Arch
Technical Reference Model
etc.

Solution Requires More than Architecture



Train Architects
 • Train to think object-oriented



VISION AND MISSION

At the beginning of the project, it is essential to define the vision and mission of the project. This is a key element of the project management process. The vision and mission statements provide a clear direction for the project and help to align the team's efforts. They also serve as a benchmark for measuring progress and success.

The vision statement describes the long-term goals and aspirations of the organization. It is a statement of the organization's purpose and its commitment to its stakeholders. The mission statement, on the other hand, describes the organization's primary objectives and the actions it will take to achieve them.

Both the vision and mission statements should be clear, concise, and measurable. They should also be communicated to all members of the organization and reviewed regularly to ensure they remain relevant and effective.

Clarify/Link Vision and Mission

- Develop agreed goals and objectives
- Research guidance and direction
- Establish enterprise boundaries
- Establish COI consensus on architecture purpose and uses
- Develop architecture strategy
- Determine strategic effects
- Determine governance approach
- Establish buy-in

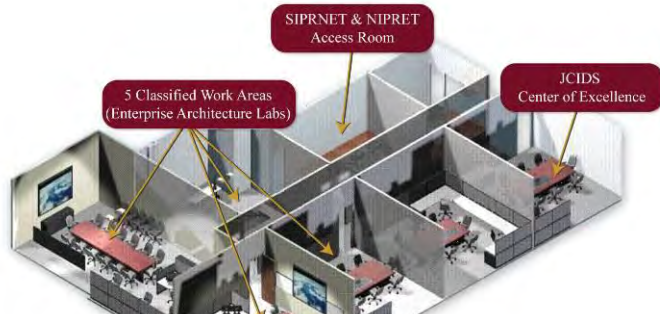

Develop Infrastructure

- Assessment and recommendations
- Collaboration laboratories
- Reference materials
- Procedures
- Computers / software / communications
- Configuration management



Identify Knowledge Management Needs

- Architecturally based CONOPS development
- Develop architecture data mining requirements
- Identify portfolio managers

Architecture Value to CBP

Enterprise Domain

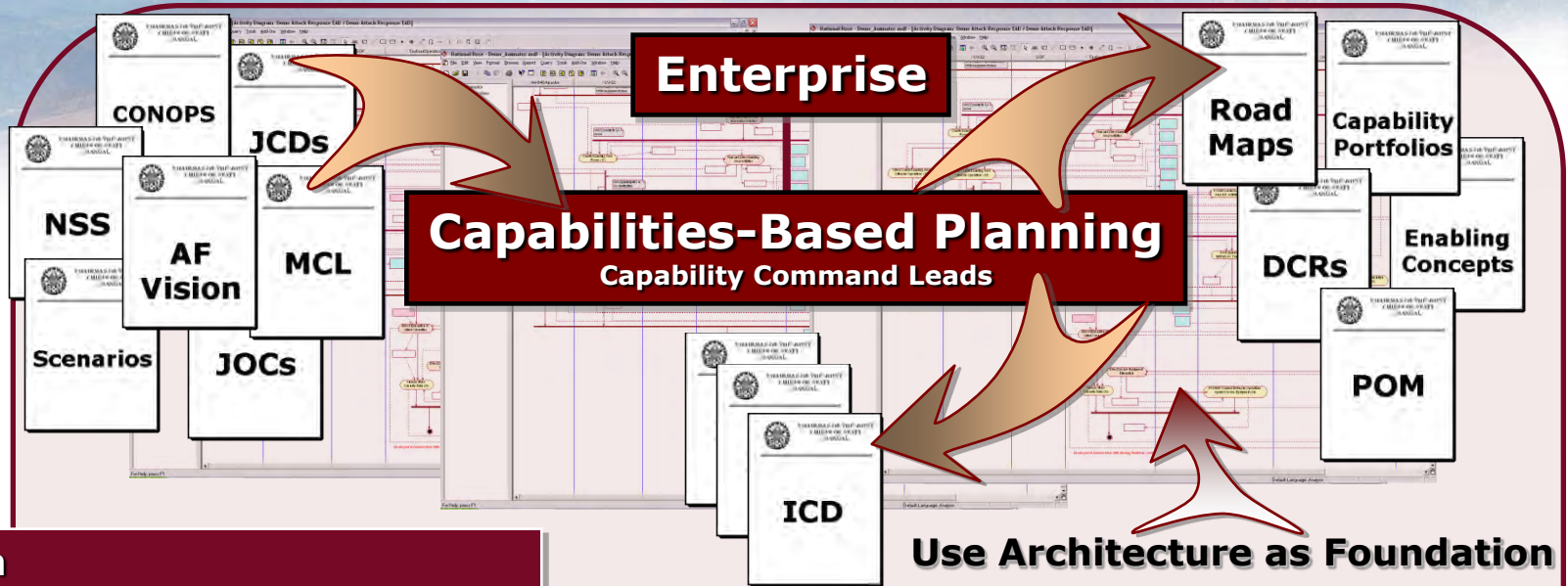

Approach

- Leverage existing architectures
- Model operational processes
 - Discover cross-mission common activities
 - Provides basis for business process reengineering
- Extend architecture describing mission-specific needs
 - e.g., Intel, Surveillance, Recon, etc.
- Capture critical information exchange needs
- Graphically depict FNA capability gaps
- Data-mine domain architecture supporting CBP products

Value Gained

- Answer operational capability "questions"
- Better deals with complexity
 - Mission and organizational relationships
- Clear understanding of roles and responsibilities among stakeholders
- Rapid identification of gaps/overlaps among capability areas
- Responsive to inevitable changes in threats, organizations, tasks, technology
- Defensible foundation for:
 - JCS CBA products
 - HQ AF CBP products
 - Resource allocation decisions
- Powerful analysis capabilities to support portfolio management using advanced visualization tools

Architecture Provides Tool to Manage Capability

Enterprise Domain

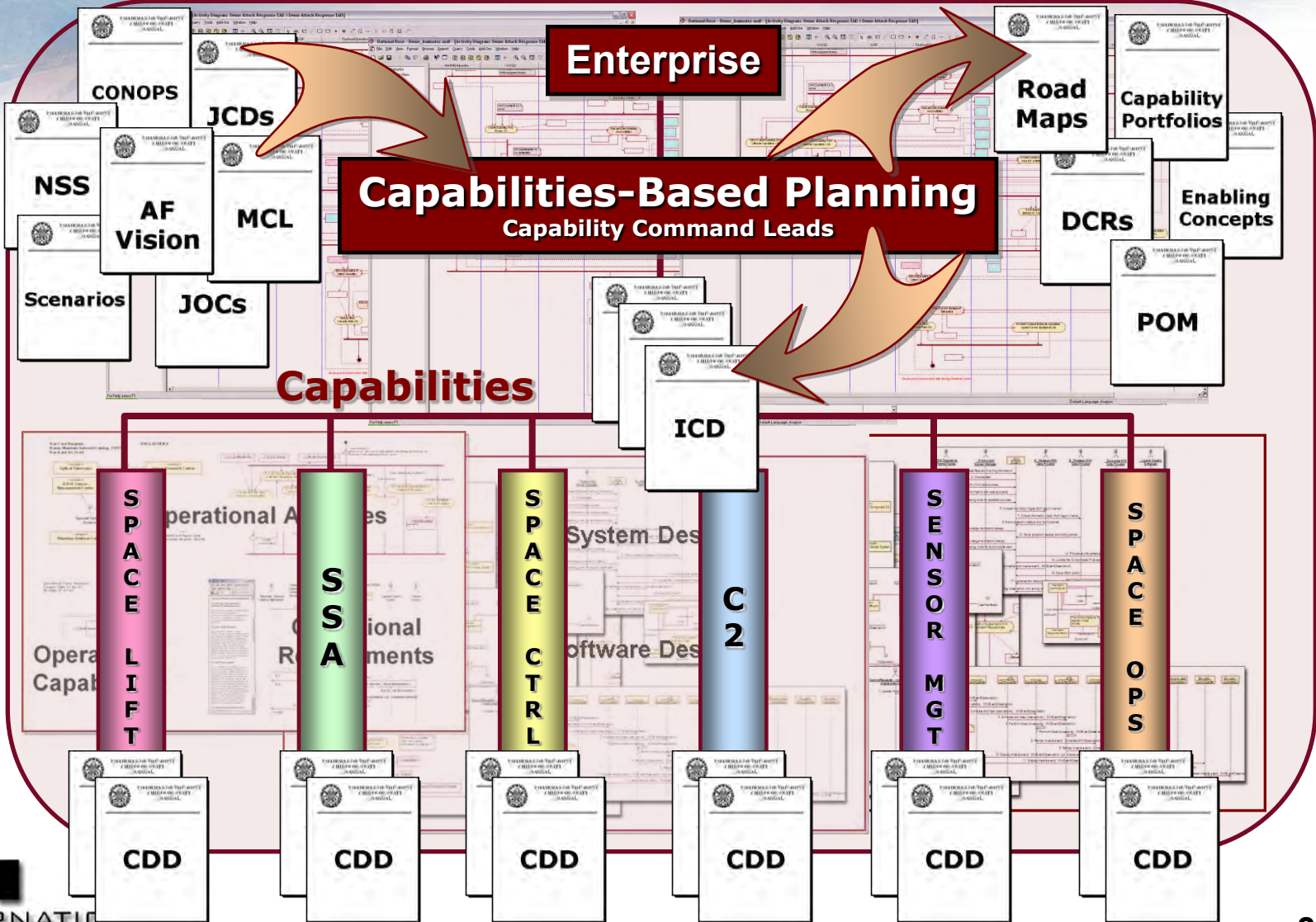

SOA Key to Portfolio Management

Allows non Architects to understand the architecture

Validation and Verification using SI Animator

Architecture Animator

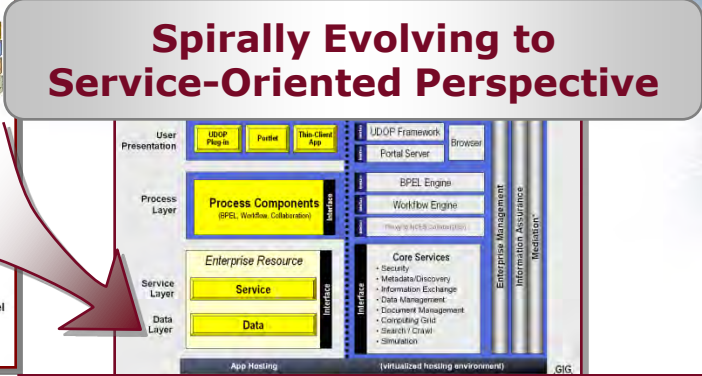
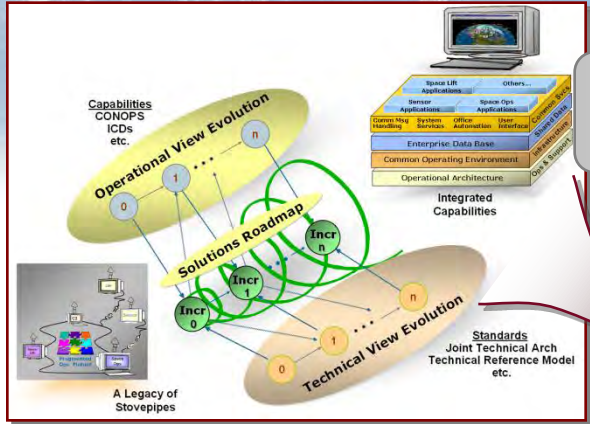

Development using Architecture

Effects Oriented...

Operational Activities

Requirements in Operational Context...

Operational Requirements

Operational Capabilities

SI Specialized Tools

Data Mine Architecture

Interfaces with COTS IBM Rational Suite

CONOPS

FAA

- Operational Tasks
- Conditions
- Standards

FNA

- Shortfalls
- Deficiencies
- Tradespace Studies

FSA

- COAs
- Solution Set Development
- Capabilities-Based Requirements Documents
- Roadmap
- Strategic Plan
- Etc...

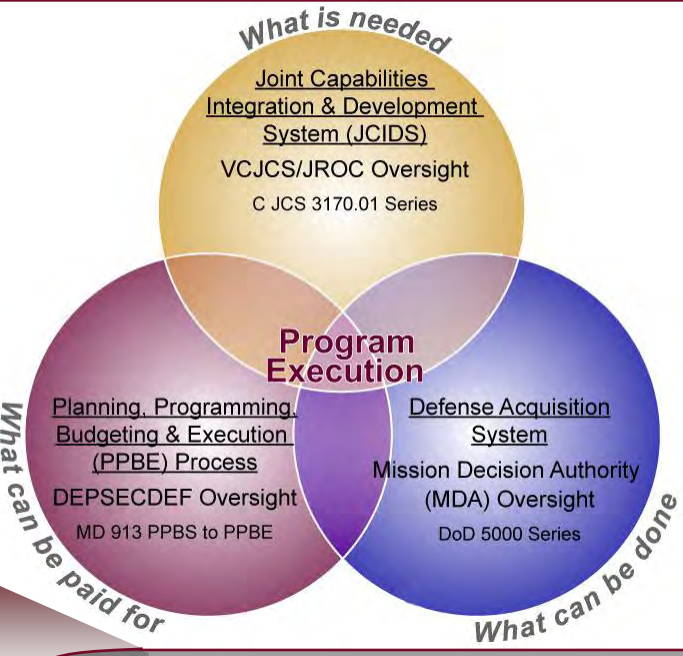

Portfolio Management (PfM) – Knowledge Management



Integration of Software Intensive Systems

Tom Wissink

Lockheed Martin Fellow
IS&GS, Gaithersburg, MD

301-240-6244

tom.wissink@lmco.com

October2008

Agenda

- Introduce the Problem
- Integration Definitions
- Integration throughout a Development Lifecycle
- Integration: Techniques, Methods
- Integration Support Activities
- Wrap-Up

Introduce the Problem

- No consistent definition & process:
 - Results of a Web Search “System Integration is the successful integration of a new technology into the system by analyzing the technology's system effects and resolving any negative impacts that might result from its broader use.”
 - From the International Council on System Engineering (INCOSE) web site – “Integrate: . . . Systems, businesses and people must be integrated so that they interact with one another. Integration means bringing things together so they work as a whole. . . .”



Introduce the Problem (cont'd)

- My favorite published definition:
 - Integration is defined as the act of mating hardware and/or software components, subsystems, systems or elements at their respective interfaces and verifying the compatibility and proper operation of the integrated units.
 - From a paper entitled “Integration Challenges of Complex Systems” written by Bill Haskins and Jack Striegel for the 16th Annual INCOSE International Symposium,
- No complete guidance on how to do Integration



Integration throughout the Lifecycle

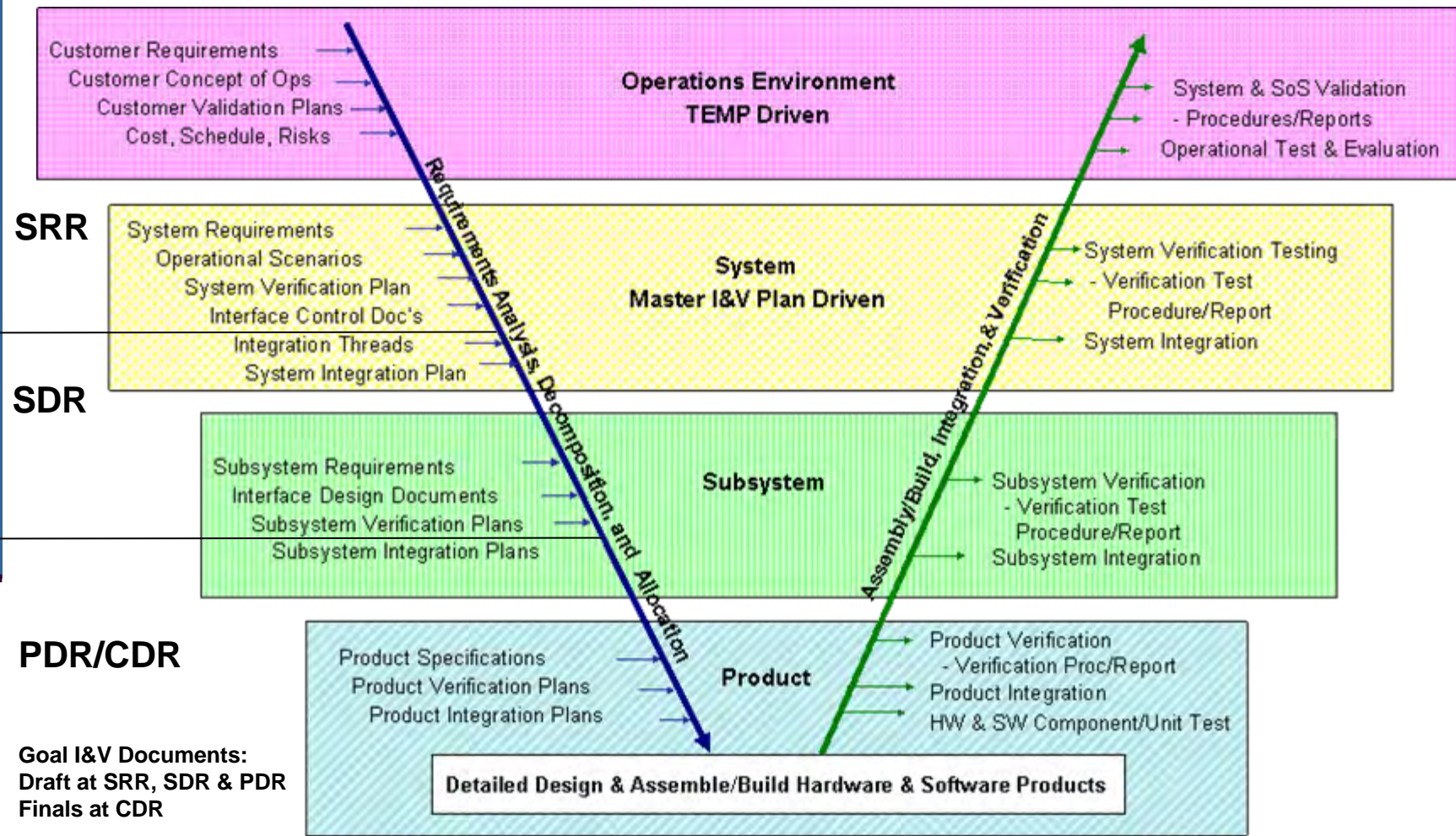

Integration: Techniques, Methods & Tools

Two Techniques:

- Non-Incremental* (Big Bang) vs Incremental*
 - Incremental is the way to go for most systems and large applications
 - Integrate/Build-Up – starting small and continually increasing capability/complexity

* References for Techniques and Methods

Kit, Edward. 1995. *Software Testing in the Real World*, Addison-Wesley

Myers, Glenford. 1979. *The Art of Software Testing*, John Wiley & Sons, Inc.

Integration: Techniques, Methods & Tools

Three Methodologies:

- Top-Down*, Bottoms-Up* & Thread-Based

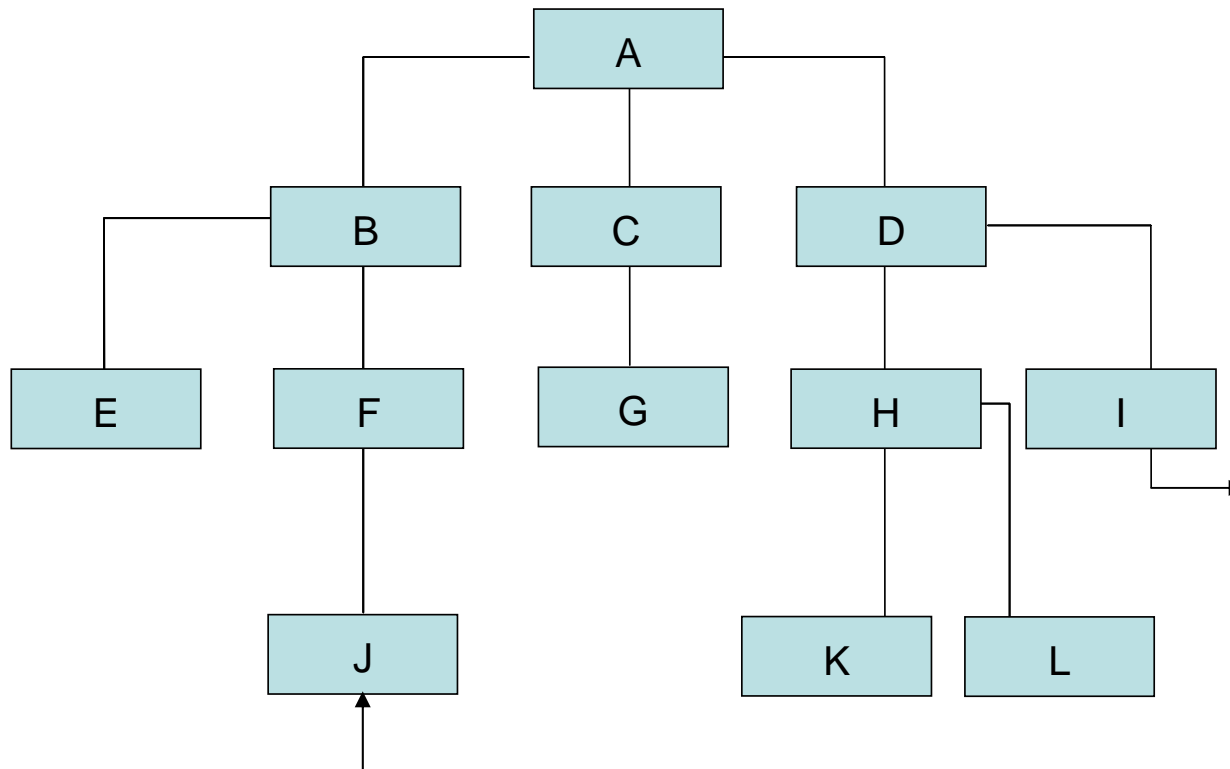

Integration: Techniques, Methods & Tools

Three Methodologies:

- Top-Down

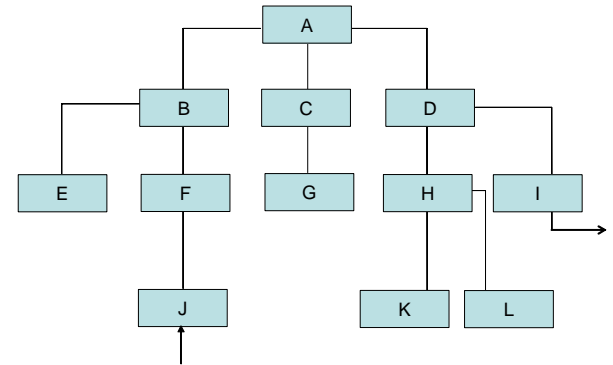
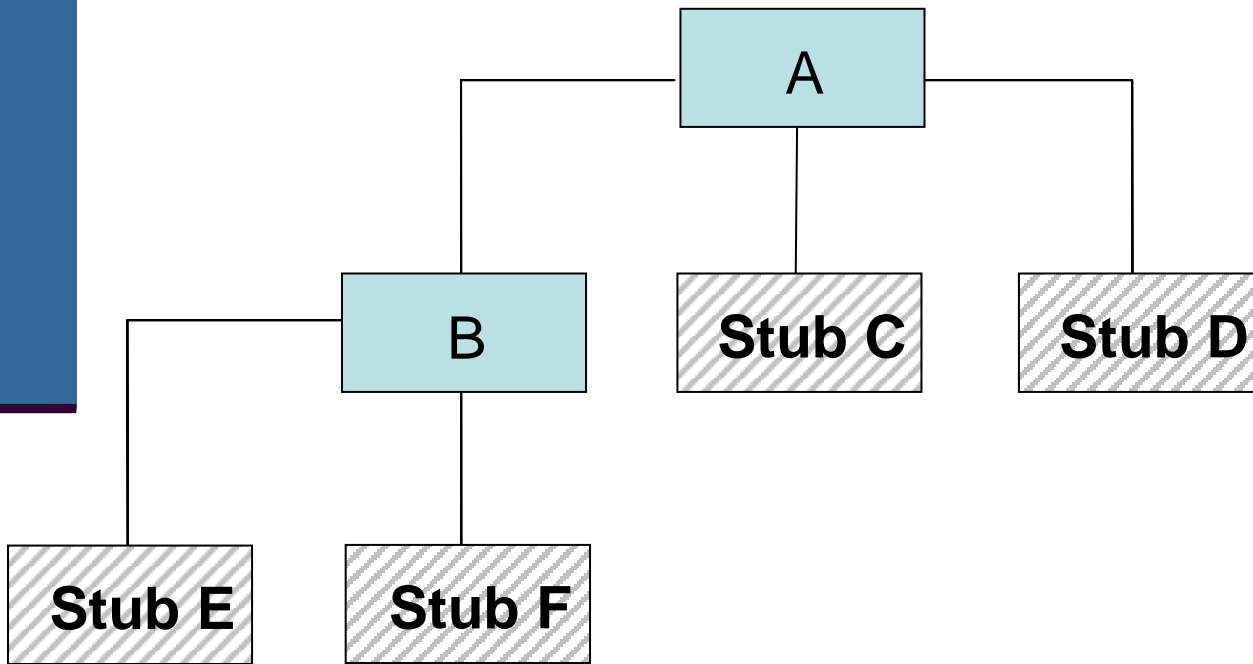

Integration: Techniques, Methods & Tools

Three Methodologies:

- Bottom-Up

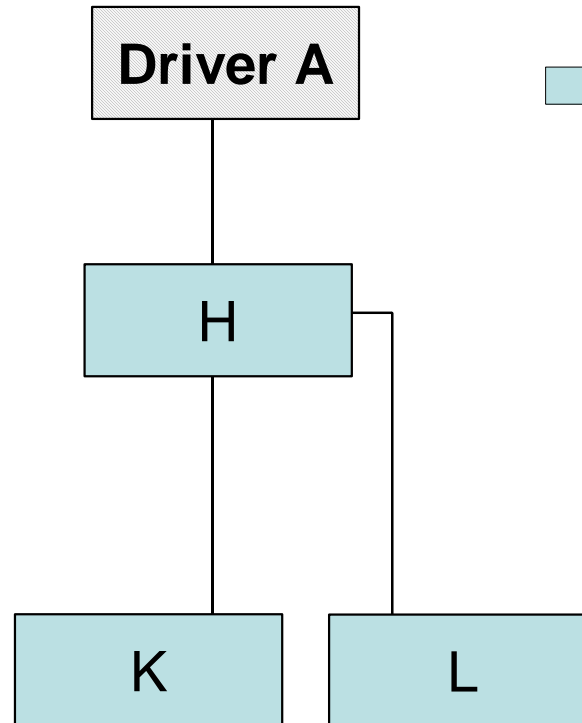
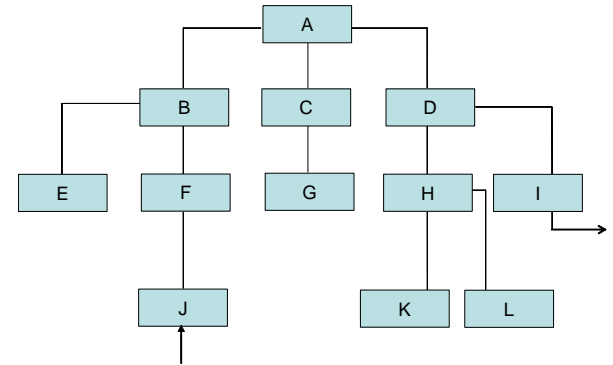

Integration: Techniques, Methods & Tools

Three Methodologies:

- Thread-Based

- Experience indicates this is the preferred method for most large complex applications and or systems

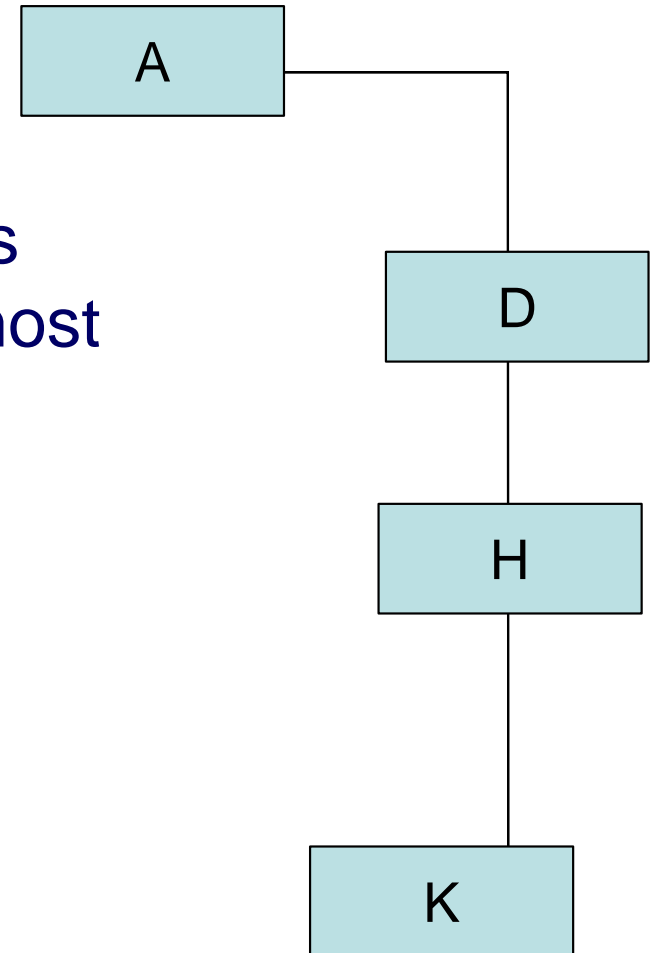
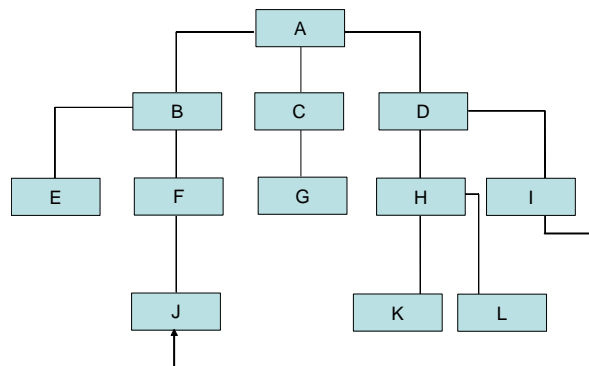

Integration Support Activities

- Interface Matrices (Interface Coverage)
 - Account for all internal & external interfaces
- Hardware/Software/System Build Plan
 - Thread based and negotiated with the developers
- Dedicated Integration Laboratories
 - Separate from Test Laboratories
- Early “ilities” Checkout during integration phases
 - Stability
 - Reliability
 - Performance
 - Capacity

Wrap-Up

- Integration requires a different skill set than Testing.
- Lessons learned have shown that Integration is a key weakness on most medium to large software intensive projects
- Perform the Top Ten Integration steps and you will have a robust Integration process

Top Ten Integration Steps

1. Document the Integration and Test process
2. Hire and train the right staff for the role of Integrator
3. Review and analyze requirements to ensure testability and included requirements to ensure visibility into system data while it is operating
4. Ensure all interfaces at all levels of the architecture have been identified and are implemented, tested, tracked, and statused
5. Identify & plan other testing activities to start during the integration test conduct phase (i.e. stability, performance, reliability, etc)
6. Develop and maintain a Project “Build Plan”
7. Define and ensure sufficient Integration and Test laboratories available
8. Design integration tests and test data for all levels of the architecture
9. Ensure functional testing is also being conducted at each level of the architecture
10. Ensure sufficient simulation/stimulation capabilities are available



**Technology Readiness
Assessments (TRAs) for
Systems of Systems (SoS)**

**2008 National Defense Industrial Association
11th Annual Systems Engineering Conference
October 21, 2008**

Dr. Jay Mandelbaum

Institute for Defense Analyses

4850 Mark Center Drive • Alexandria, Virginia 22311-1882



Outline

- **Background**

- **Complexity of the problem**
- **The TRA process for a SoS**
 - **Describing the SoS**
 - **Identifying the SoS environment(s) and interfaces**
 - **Identifying SoS CTEs and their associated relevant/operational environments**
 - **Conducting the SoS TRA**
 - **Documenting and coordinating the SoS TRA**
- **SoS TRA updates**

What is a TRA?

- **Systematic, metrics-based process that assesses the maturity of Critical Technology Elements (CTEs)**
 - Uses Technology Readiness Levels (TRLs) as the metric
- **Regulatory information requirement for *all* acquisition programs**
 - Submitted to DUSD(S&T) for ACAT ID and IAM programs

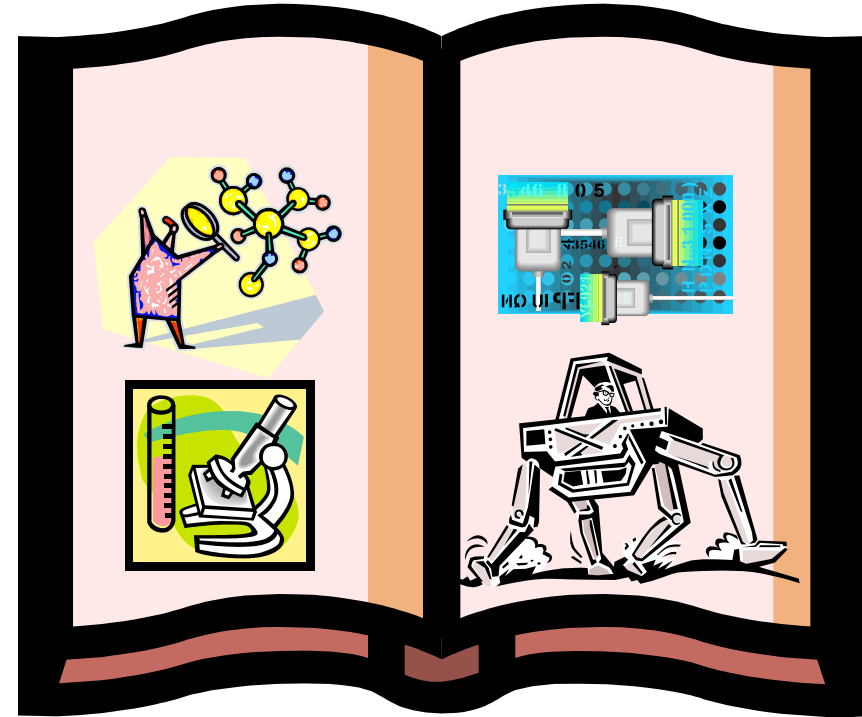

- ≠ **Not a risk assessment**
- ≠ **Not a design review**
- ≠ **Does not address system integration**

Why is a TRA Important? (1 of 2)

- **The Milestone Decision Authority (MDA) uses the information to support a decision to initiate a program**
 - Trying to apply immature technologies has led to technical, schedule, and cost problems during systems acquisition
 - TRA established as a control to ensure that critical technologies are mature, based on what has been accomplished

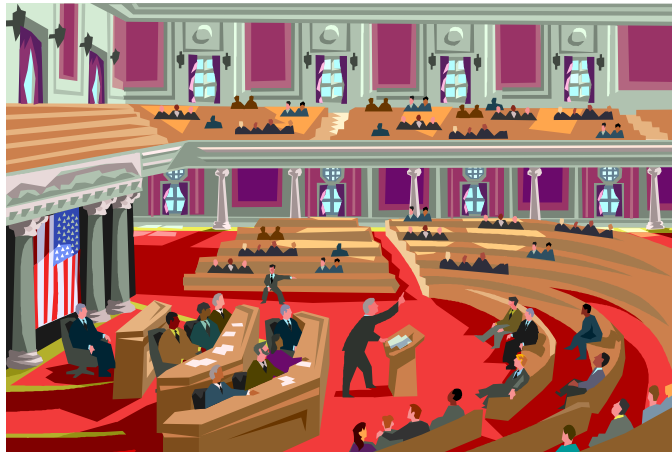

- **Congressional interest**
 - MDA must certify to Congress that the technology in programs has been demonstrated in a relevant environment at program initiation
 - MDA must justify any waivers for national security to Congress

TRL Overview

- **Measures technology maturity**
- **Indicates what has been accomplished in the development of a technology**
 - Theory, laboratory, field
 - Relevant environment, operational environment
 - Subscale, full scale
 - Breadboard, brassboard, prototype
 - Reduced performance, full performance
- **Does not indicate that the technology is right for the job or that application of the technology will result in successful development of the system**



Critical Technology Element (CTE) Defined

A technology element is “critical” if the system being acquired depends on this technology element to meet operational requirements with acceptable development cost and schedule and with acceptable production and operation costs and if the technology element or its application is either new or novel or **in an area that poses major technological risk during detailed design or demonstration or provides unprecedented functionality**



CTEs may be hardware, software, manufacturing, or life cycle related at the subsystem or component level

Changes Anticipated for New Deskbook

- **Reflects new DoDI 5000.02 and other policy changes**
- **Rigor and robustness added to processes in chapter 3**
- **Chapter 5 on technology maturity rewritten**
 - **Early evaluation of technology maturity**
 - **Reflect 10 USC 2366a**
- **New appendices**
 - **Interfaces with S&T community**
 - **Space, SoS, and ships**



**The following material is preliminary.
Feedback is welcome.**

Outline

- **Background**
- **Complexity of the problem**
- **The TRA process for a SoS**
 - **Describing the SoS**
 - **Identifying the SoS environment(s) and interfaces**
 - **Identifying SoS CTEs and their associated relevant/operational environments**
 - **Conducting the SoS TRA**
 - **Documenting and coordinating the SoS TRA**
- **SoS TRA updates**

Complexity of SoS TRAs

- **SoS definition:**
a set or arrangement of systems that results when independent and useful systems are integrated into a larger system that delivers unique capabilities
- **Why there is a special section in the Deskbook**
 - In a SoS, individual systems are integrated with each other to achieve a capability
 - An individual system's performance is changed by its linkage to other systems
 - This affects both CTE identification and CTE assessment . . .



Complexities with CTE Identification

CTEs must be considered tentative prior to completion of overall SoS engineering and then individual system(s) engineering

- **SoS operational/performance requirements for a capability are not easily allocated to individual systems and their subsystems**
- **Some of the interactions among systems are not predictable in advance and the individual systems may change when they are joined together**
- **The allocation of SoS operational and performance requirements for a capability may evolve over time**



Complexities with CTE Assessment in a Relevant SoS Environment

- **There are difficulties in allocating SoS requirements to associated systems or subsystems**
- **The relevant environment may not be fully understood because other systems are part of it:**
 - **Modeling and simulation may not be adequate**
 - **Test and evaluation environments may not be fully understood**
 - **System performance and the relationships among systems change over time**
 - **Testing all permutations is not possible**



Complexities with SoS Management

DoDI 5000.02 does not prescribe an overarching process for managing SoS acquisition that includes legacy systems, developmental systems, and system modernization

- Each of these systems is often managed independently**
- Control of resources may not be collocated with those management responsibilities**
- The associated systems' acquisition activities may not be on the same time line as the SoS development effort**



Outline

- **Background**
- **Complexity of the problem**
- **The TRA process for a SoS**
 - **Describing the SoS**
 - **Identifying the SoS environment(s) and interfaces**
 - **Identifying SoS CTEs and their associated relevant/operational environments**
 - **Conducting the SoS TRA**
 - **Documenting and coordinating the SoS TRA**
- **SoS TRA updates**

Getting Started



- **Normal TRA best practices apply**
 - A series of meetings between the program office, the Component S&T Executive office, and DUSD(S&T) should be conducted to determine the scope and conduct of the SoS TRA
 - Panel members should be independent of the program and include a wider range of relevant subject matter expertise

Describing the SoS

- Identify the boundaries that encompass the required capability to be delivered
- Identify SoS spirals/blocks or other expected increments and their timeframes including spirals/blocks of specific systems of the SoS
- Identify how component systems must be modified (and new interfaces developed) to be integrated into the SoS
- Identify SoS specific operational and performance requirements, including those for each system comprising the SoS
- Clearly delineate the interface requirements, externally controlled/managed capabilities, and SoS dependencies and interdependencies, within a context of the capabilities provided and operating limits of the SoS under evaluation



Identifying the SoS Environment(s) and Interfaces

- **Focus on what makes the SoS environment unique**
 - **Consider execution time or data throughput and information exchange requirements to/from other systems**
 - **Include information assurance considerations**
 - **Identify functional dependencies and the technologies that enable these functions**
- **If no documentation exists or is still in development, involve the SoS end users or customers for determining SoS behavior(s)**

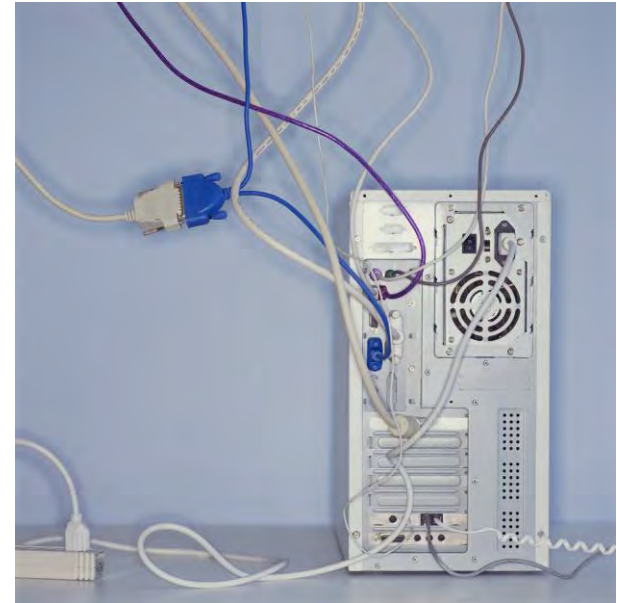

Identifying SoS CTEs and their Associated Relevant/Operational Environments (1 of 4)

- **Identify the SoS WBS, ... well in advance of the CTE selection and systematically examine all elements of the WBS for determining CTEs**

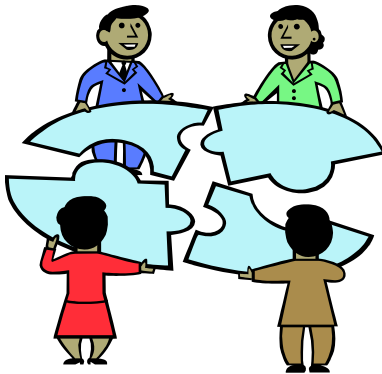

- **When conducting a TRA for the SoS**
 - **Include all CTEs required to meet SoS operational requirements**
 - **Include SoS unique CTEs and system unique CTEs required for a system to participate in the SoS regardless of who is responsible for funding or development**
 - **Internal and external dependencies should be treated equally and all associated CTEs should be formally assessed in the SoS TRA against the SoS requirements**

Identifying SoS CTEs and their Associated Relevant/Operational Environments (2 of 4)

- **When conducting a TRA for a system that is part of the SoS**
 - **Include all system specific technologies that meet the CTE criteria**
 - **Assess SoS CTEs that are in the system undergoing the TRA even if they are not system specific CTEs**
- **In either case, take into account situations where a capability in one system is dependent on a technology in another system for its functionality**
- **Consider any TRA completed or being conducted on a system within the SoS for identification of relevant CTEs**



Identifying SoS CTEs and their Associated Relevant/Operational Environments (3 of 4)

Expand upon CTE identification questions, e.g.,

- **Does the technology directly impact an operational requirement?**
 - Is the technology contributing to a more effective performance of the SoS in development?
 - Is an increase or change in capability being required from currently fielded systems?
 - Is the technology enabling a new concept of operation?



Identifying SoS CTEs and their Associated Relevant/Operational Environments (4 of 4)

Expand upon CTE identification questions, e.g.,

- **Is the technology new or novel (or being used in a new or novel way)?**
 - Is this technology creating new relationships between systems?
 - Is this technology dependent upon new relationships between systems?
- **Has the technology been modified?**
 - Are technologies fielded on the associated systems being modified to meet new requirements of the SoS?
 - Are current technologies dealing with the relationships among systems being modified for the SoS?



Conducting the SoS TRA

- **CTEs in a component system whose environments are not dependent on the rest of the SoS should be assessed in the normal way**
- **The Program Manager and/or Chief Engineer for the SoS should conduct technology demonstrations/validations for the SoS-related CTEs**
- **The program should provide the necessary documentation to the Independent Panel to enable independent assessment of the CTE performance within the SoS**
- **The Independent Review Panel should determine the TRLs for each SoS-related CTE**
- **CTEs for future spirals are not expected to be TRL 6 at Milestone/KDP B**



Documenting and Coordinating the SoS TRA

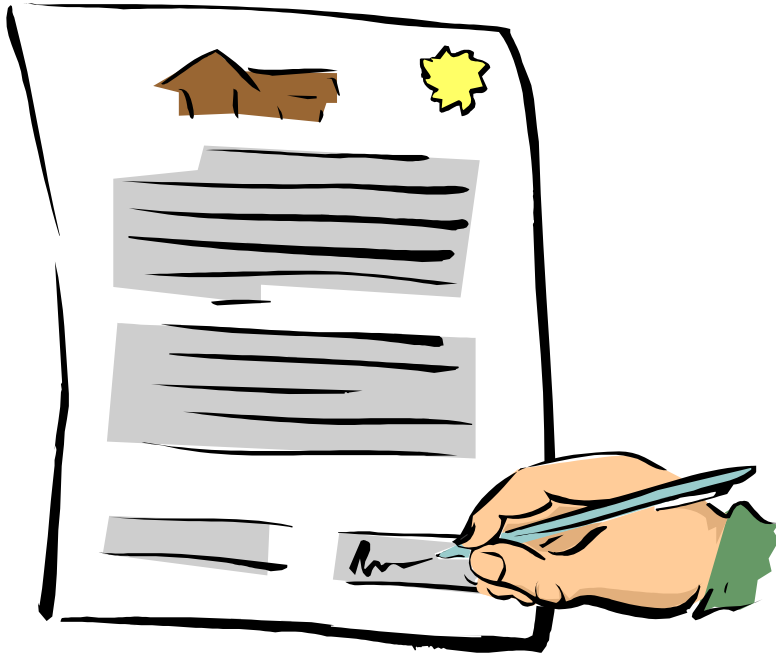

- **Reference other pertinent material**
- **Ensure proper coordination is conducted on the SoS technology maturation plans especially between interdependent acquisition development efforts**
- **The Component Acquisition Executive should communicate the TRA results with each program management echelon which is part of the SoS**

Outline

- **Background**
- **Complexity of the problem**
- **The TRA process for a SoS**
 - **Describing the SoS**
 - **Identifying the SoS environment(s) and interfaces**
 - **Identifying SoS CTEs and their associated relevant/operational environments**
 - **Conducting the SoS TRA**
 - **Documenting and coordinating the SoS TRA**
- **SoS TRA updates**

SoS TRA Updates

- Because of the inherent difficulties associated with SoS TRAs in identifying CTEs and assessing their maturity in the relevant environment, it is possible that even a rigorously done TRA at Milestone B could be found, in hindsight, to be incomplete
- Update at SoS CDR and initiation of new spiral in any of the systems

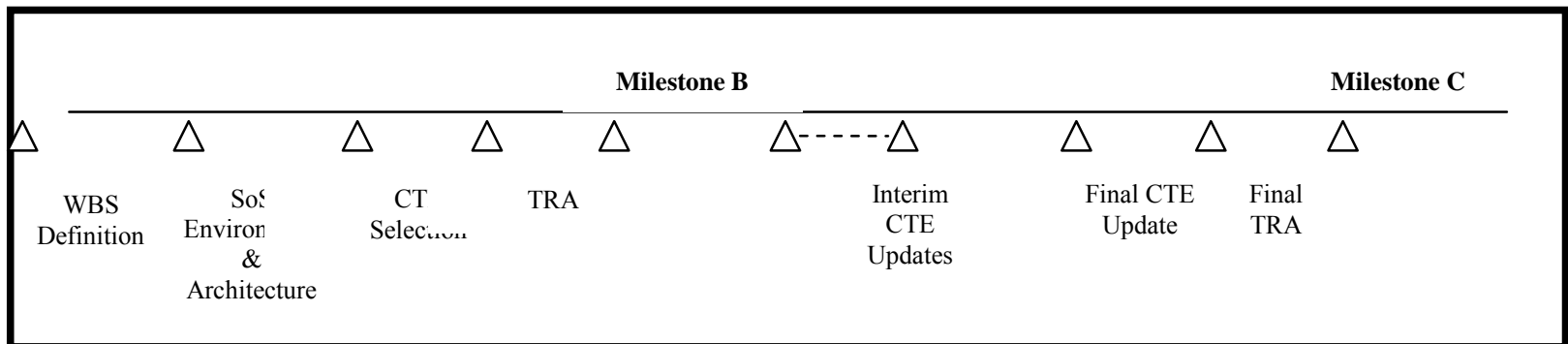
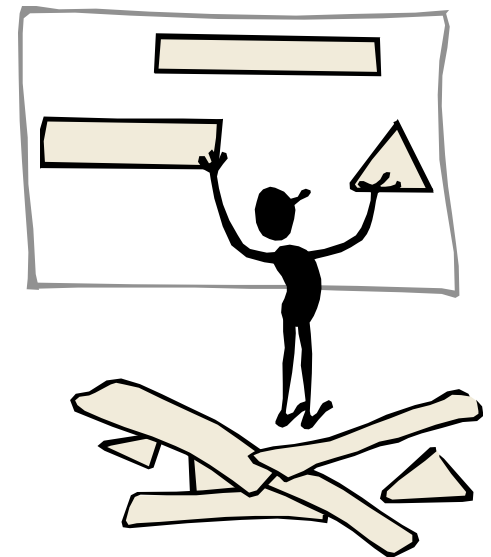

References and Resources

- **Defense Acquisition Resource Center** <http://akss.dau.mil/darc/darc.html>
 - DoD Directive 5000.1 (DoDD 5000.1), *The Defense Acquisition System*, dated May 12, 2003
 - DoD Instruction 5000.2 (DoDI 5000.2), *Operation of the Defense Acquisition System*, dated May 12, 2003
 - *Defense Acquisition Guidebook*
- **DAU Continuous Learning Module CLE021**
 - <https://learn.dau.mil/html/clc/Clc.jsp> to browse it
- **TRA Deskbook**
 - http://www.defenselink.mil/ddre/doc/tra_deskbook_2005.pdf
- **DDR&E**
 - Mr. Jack Taylor jack.taylor@osd.mil
- **Institute for Defense Analyses**
 - Dr. Dave Sparrow dsparrow@ida.org
 - Dr. Jay Mandelbaum jmandelb@ida.org
 - Dr. Michael May mmay@ida.org

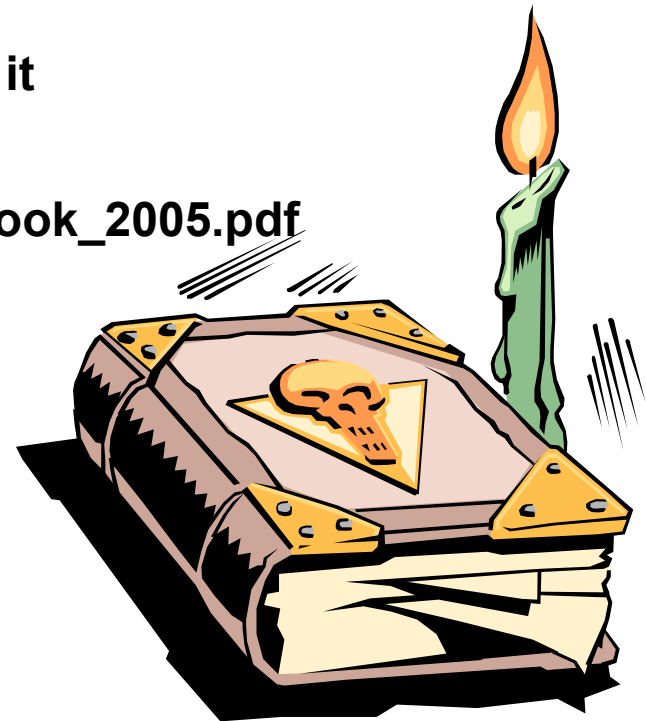





***Modeling & Simulation
in the
Test & Evaluation Master Plan***

**NDIA Systems Engineering Conference
October 2008**

**Michael Truelove – SAIC Support
Office of the Deputy Under Secretary of Defense (A&T)
Developmental Test & Evaluation
1550 Crystal Drive, Suite 1004
Arlington, VA 22202
Phone: 703-412-3683**

Acquisition M&S Governance Structure

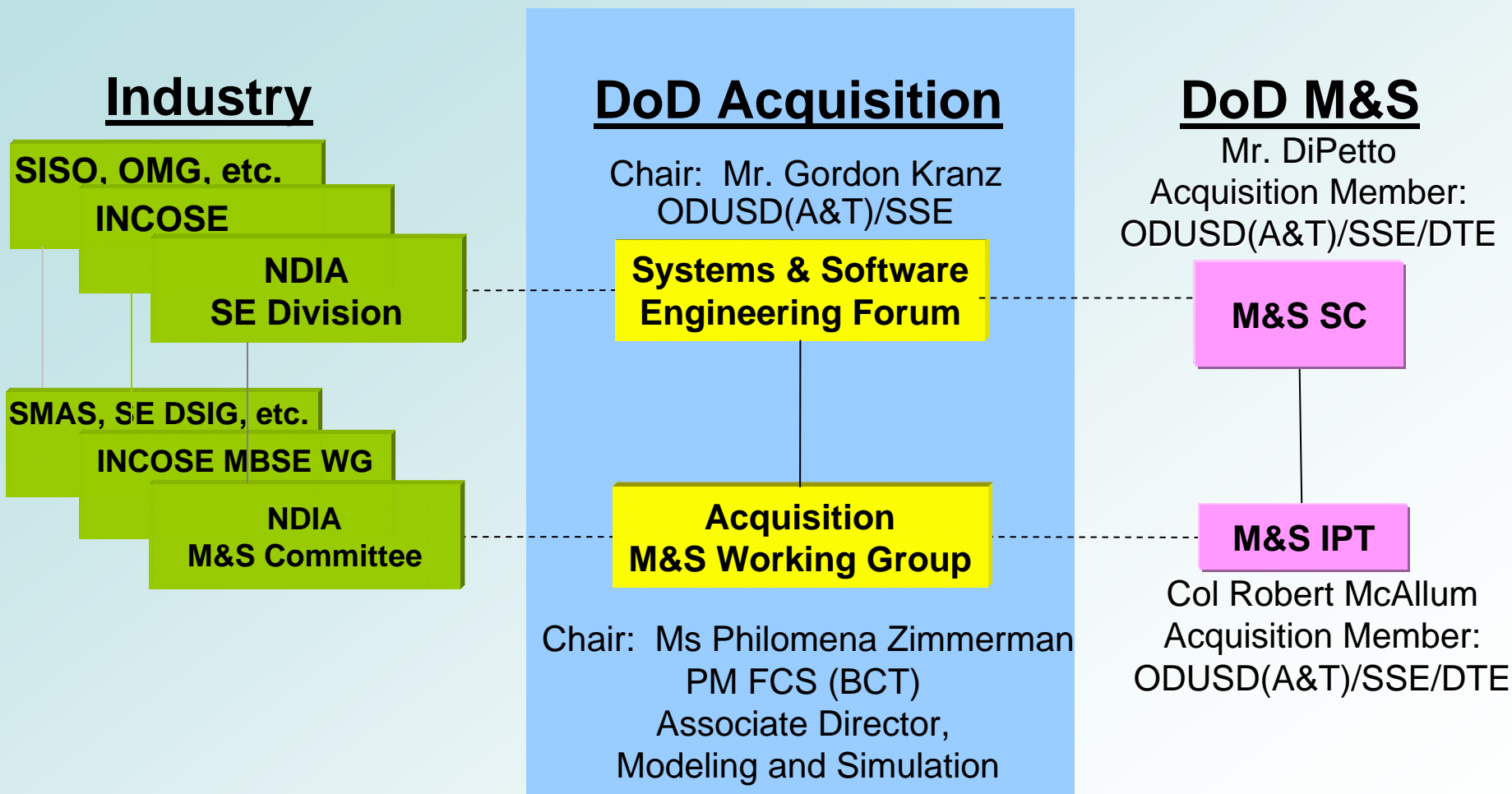

AMSWG is anchored in acquisition community and linked to industry and the DoD M&S community

Content of Acquisition M&S Master Plan



Department of Defense
**Acquisition Modeling and
Simulation Master Plan**

Issued by the
DoD Systems Engineering Forum
April 17, 2006

- **Foreword**
- **Introduction**
 - Purpose
 - Vision
 - Scope
- **Objectives (5)**
- **Actions (40)**
 - Action
 - Rationale (why it's needed)
 - Discussion (implementation guidance)
 - Lead & supporting organizations
 - Products (what is expected)
 - Completion goal (year)
- **Execution Management**

A Decade of Studies on M&S Support to Acquisition

1. *Final Report of the Acquisition Task Force on M&S, 1994*
Sponsor: DDR&E (Dr. Anita Jones); Chair: VADM T. Parker, USN (Ret.)
2. *Naval Research Advisory Committee Report on M&S, 1994*
Sponsor: ASN(RDA); Chair: Dr. Delores Etter
3. *Collaborative Virtual Prototyping Assessment for Common Support Aircraft, 1995*
Sponsor: Naval Air Systems Command; conducted by JHU APL and NSMC
4. *Collaborative Virtual Prototyping Sector Study, 1996*
North American Technology & Industrial Base Organization; sponsor: NAVAIR
5. *Application of M&S to Acquisition of Major Weapon Systems, 1996*
American Defense Preparedness Association; sponsor: Navy Acqn. Reform Exec.
6. *Effectiveness of M&S in Weapon System Acquisition, 1996*
Sponsor: DTSE&E (Dr. Pat Sanders); conducted by SAIC (A. Patenaude)
7. *Technology for USN and USMC, Vol. 9: M&S, 1997*
Naval Studies Board, National Research Council; sponsor: CNO
8. *A Road Map for Simulation Based Acquisition, 1998*
Joint SBA Task Force (JHU APL lead); sponsor: Acquisition Council of EXCIMS

A Decade of Studies on M&S Support to Acquisition

9. *M&S for Analyzing Advanced Combat Concepts*, 1999
Defense Science Board Task Force (Co-chairs: L. Welch, T. Gold)
10. *Advanced Engineering Environments*, 1999
National Research Council; sponsor: NASA
11. *Survey of M&S in Acquisition*, 1999 and 2002
Sponsor: DOT&E/LFT&E; conducted by Hicks & Associates (A. Hillegas)
12. *Test and Evaluation*, 1999
Defense Science Board Task Force (Chair: C. Fields)
13. “*SIMTECH 2007*” *Workshop Report*, 2000
Military Operations Research Society (Chair: S. Starr)
14. *M&S in Manufacturing and Defense Systems Acquisition*, 2002
National Research Council; sponsor: DMSO
15. *M&S Support to the New DoD Acquisition Process*, 2004
NDIA Systems Engineering Div. M&S Committee; sponsor: PD, USD(AT&L)DS
16. *Missile Defense Phase III M&S*, 2004
Defense Science Board Task Force (Chair: W. Schneider)

Five Objectives, 40 Actions

Objective 1

Provide necessary policy and guidance

- 1-1 M&S management
- 1-2 Model-based systems engineering & collaborative environments
- 1-3 M&S in testing
- 1-4 M&S planning documentation
- 1-5 RFP & contract language
- 1-6 Security certification

Key

Broader than Acquisition

Objective 2

Enhance the technical framework for M&S

- 2-1 Product development metamodel
- 2-2 Commercial SE standards
- 2-3 Distributed simulation standards
- 2-4 DoDAF utility
 - a) DoDAF 2.0 Systems Engineering Overlay
 - b) Standards for depiction & interchange
- 2-5 Metadata template for reusable resources

Objective 3

Improve model and simulation capabilities

- 3-1 Acquisition inputs to DoD M&S priorities
- 3-2 Best practices for model/sim development
- 3-3 Distributed LVC environments
 - a) Standards
 - b) Sim/lab/range compliance
 - c) Event services
- 3-4 Central funding of high-priority, broadly-needed models & sims
 - a) Prioritize needs
 - b) Pilot projects
 - c) Expansion as warranted

Objective 4

Improve model and simulation use

- 4-1 Help defining M&S strategy
- 4-2 M&S planning & employment best practices
- 4-3 Foster reuse
 - a) Business model
 - b) Responsibilities
 - c) Resource discovery
- 4-4 Info availability
 - a) Scenarios
 - b) Systems
 - c) Threats
 - d) Environment
- 4-5 VV&A
 - a) Documentation
 - b) Risk-based
 - c) Examination
- 4-6 COTS SE tools
- 4-7 M&S in acqn metrics

Objective 5

Shape the workforce

- 5-1 Definition of required M&S competencies
- 5-2 Harvesting of commercial M&S lessons
- 5-3 Assemble Body of Knowledge for Acqn M&S
- 5-4 M&S education & training
 - a) DAU, DAG & on-line CLMs
 - b) Conferences, workshops & assist visits
- 5-5 MSIAC utility

Acquisition M&S Master Plan: Actions 1-3 & 1-4

ACTION 1-3. Establish policy and guidance on appropriate use of M&S to plan tests, complement system live tests, and assess joint capabilities.

ACTION 1-4. Establish policy to require documented M&S planning as part of the Systems Engineering Plan, T&E Strategy, and T&E Master Plan.

PRODUCTS: Revised policy and guidance in DoDI 5000.2, DAG, and TEMP guidance

**This is not a recommendation to replace testing
with models and simulations**

Current Policy Regarding the use of Models & Simulations

DoDI 5000.2; Enclosure 5

E5.1 The PM, in concert with the user and test and evaluation communities, shall coordinate developmental test and evaluation (DT&E), operational test and evaluation (OT&E), LFT&E, family-of-systems interoperability testing, information assurance testing, and [modeling and simulation \(M&S\)](#) activities, into an efficient continuum, closely integrated with requirements definition and systems design and development. The T&E strategy shall provide information about risk and risk mitigation, provide empirical data to validate [models and simulations](#), evaluate technical performance and system maturity, and determine whether systems are operationally effective, suitable, and survivable against the threat detailed in the System Threat Assessment.

Adequate time and resources shall be planned to support pre-test predictions and post-test reconciliation of [models](#) and test results, for all major test events.

E5.3.1 Projects that undergo a Milestone A decision shall have a T&E strategy that shall primarily address [M&S](#), including identifying and managing the associated risk, and that shall evaluate system concepts against mission requirements.

E5.4.7 Appropriate use of accredited [models and simulation](#) shall support DT&E, IOT&E, and LFT&E.

Recent Test & Evaluation Policy

Reference: December 22, 2007 Memorandum

Signed by:

Dr. Charles McQueary; Director, Operational Test & Evaluation

Mr. John Young, Jr.; Under Secretary of Defense for Acquisition, Technology & Logistics

T&E must be brought to bear at the beginning of the system life cycle.

Developmental and operational [test activities](#) shall be integrated and seamless throughout the systems life cycle.

Evaluations shall include a comparison with current mission capabilities using existing data, so that measurable improvements can be determined. If such evaluation is considered cost prohibitive the Service Component shall propose an [alternative evaluation strategy](#).

To realize the benefits of [modeling and simulation](#), T&E will be conducted in a continuum of [live, virtual, and constructive](#) system and operational environments.

Deputy, Director Developmental Test & Evaluation Initiative

Examine the formats for the Test and Evaluation Strategy (TES) and the Test & Evaluation Master Plan (TEMP)

Either establish a single format for both documents or make the transition from one to the other seamless with a direct correlation

Revise the format for the TES/TEMP

Provide a recommended TES/TEMP format to adequately consider M&S

Deputy, Director Developmental Test & Evaluation Initiative

A T&E Working Group worked the initiative:

Co-Leads: Darlene Mosser-Kerner, OUSD (AT&L)
Tom Carter, DOT&E

Participating Organizations:

OSD (AT&L) DT&E

OSD DOT&E

JFCOM

DISA

OPNAV 912

HQ Department of the Army (DUSA-TEO)

COMOPTEVFOR

HQ Air Force (AQXA)

How Documentation Can Help:

Help a program manager think about how to plan for and incorporate M&S into the T&E process by identifying:

- how M&S can contribute to the T&E process
- high payoff areas in which to invest testing resources
- the most cost effective way of conducting T&E
- when it is too impractical or too costly to incorporate real world assets into a test and M&S may provide insight
- opportunities for M&S to support the T&E of a system in a SoS environment

Original M&S Input to the TEMP Format Rejected

Submitted a full page for inclusion in the new TEMP format

Proposed new guidance for the Defense Acquisition
Guidebook (DAG) Chapter 9

The full page submission was deemed too long and
the input was rejected in total.

Convinced the T&E Working Group to include a short
paragraph in the TEMP Format with a reference and link to
new guidance in the DAG.

Current M&S Input for the New TEMP Format

2 .5 Modeling & Simulation (M&S) –

Describe the key models and simulations and their intended use.

Include the test objectives to be addressed using M&S to include operational test objectives.

Identify data needed and the planned accreditation effort.

(Additional guidance for planning for the use of M&S can be found at the DT&E web page which DAG Sections 4.5.7 and DAG Section 9.3.4 will link to.)

<http://www.acq.osd.mil/sse/dte/docs/M-S-Guidance-Acquisition-Workforce.pdf>

Proposal for DAG Section 9.3.4 of TEMP Recommended Format:

- Document the intended use of models & simulations
- Identify key models & simulations intended to support T&E
- Identify the modeling & simulation data needed to support T&E
- For each model & simulation and its data describe the planned accreditation effort based on the assessment of the risk of using the model & simulation results for decisions being made
- Describe the standards (both government and commercial) with which the models & simulations and associated data must comply

Proposal for DAG Section 9.3.4 T&E Documentation Planning

Document the intended use of models & simulations by documenting:

- Question(s) to be answered
- Decisions that will be made based on the results of the models & simulations
- The test objectives/critical operational issues the models & simulations will address
- The requirements for the use of the models & simulations
- Consequences resulting from erroneous outputs from the models & simulations
- Support resources required

Proposal for DAG Section 9.3.4 T&E Documentation Planning (cont.)

Identify all M&S intended to support T&E (1 of 2):

- Live, virtual, and constructive simulations; distributed simulations and associated architecture; federates and federations; emulators; prototypes; simulators; and stimulators
- Legacy systems, new developments, and modified or enhanced legacy models & simulations
- Models & simulations managed by Federally Funded Research and Development Centers, industry, academia, and other Federal or non-Federal government organizations
- Commercial-off-the-shelf and government-off-the-shelf models & simulations
- Model & simulation test resources including hardware-in-the loop, human-in-the-loop, and software-in-the-loop simulators; land-based, sea-based, air-and space-based test facilities

Proposal for DAG Section 9.3.4 T&E Documentation Planning (cont.)

Identify all M&S intended to support T&E (2 of 2):

- Threat models, simulations, simulators, stimulators, targets, threat systems, & surrogates
- Synthetic countermeasures, test beds, environments, and battlespaces
- Models & simulations whether embedded in weapon systems, implemented as stand-alone systems, or integrated with other distributed simulations
- Test assets, test planning aids, and post-test analysis tools that address other than real time characteristics
- Infrastructure needed to conduct a (the) test(s) to include networks, integration software, data collection tools, etc.
- Provide descriptive information for each model & simulation resource:
 - Title, acronym, version, date, proponent
 - Assumptions, capabilities, limitations, risks, and impacts of the M&S
 - Availability for use to support T&E
 - Schedule for obtaining

Proposal for DAG Section 9.3.4: T&E Documentation Planning (cont.)

Identify the modeling & simulation data needed to support T&E:

- Describe the input data the models & simulations need to accept
- Describe the output data the models & simulations should generate
- Describe the data needed to verify & validate the models & simulations
- Provide descriptive information for each data resource:
 - Data title, acronym, version, date
 - Data producer (organization responsible for establishing the authority of the data)
 - Identify when, where, and how data was or will be collected
 - Known assumptions, capabilities, limitations, risks, and impacts
 - Availability for use to support T&E
 - Schedule for obtaining

Proposal for DAG Section 9.3.4 T&E Documentation Planning (cont.)

For each model & simulation and its data describe the planned accreditation effort based on the assessment of the risk of using the model & simulation results for decisions being made

- Explain the methodology for establishing confidence in the results of models & simulations
- Document historical source(s) of verification, validation and accreditation (VV&A) in accordance with DoDI 5000.61
- Provide the schedule for accrediting prior to their use to support T&E

Proposal for DAG Section 9.3.4 T&E Documentation Planning (cont.)

Describe the standards (both government and commercial) with which the models & simulations and associated data must comply

- Information technology standards identified in the DoD Information Technology Standards Registry (<https://disonline.disa.mil/>)
- Standards identified in the DoD Architecture Framework Technical Standards Profile (TV-1) and Technical Standards Forecast (TV-2)
- Modeling & Simulation Standards and Methodologies (<http://assist.daps.dla.mil/>)
- Data standards
- VV&A standards:
 - IEEE Std 1516.4TM -2007, IEEE Recommended Practice for VV&A of a Federation—An Overlay to the High Level Architecture Federation Development and Execution Process
 - IEEE Std 1278. 4TM -1997(R2002), IEEE Recommended Practice for Distributed Interactive Simulation - VV&A
 - **MIL-STD-3022 DoD Standard Practice for Model & Simulation VV&A Documentation Templates**

Summary

Incorporating the use of modeling & simulation planning into the TEMP:

- Responds to new T&E policy to plan for using models & simulations in support of the testing process.
- Supports the DT&E initiative to incorporate planning for modeling & simulation in the TEMP.
- Addresses recognized needs in the Acquisition M&S Master Plan
- Provides a thought process for a program manager to think about planning for the use of models and simulations to support the testing process

Currently this is still work in progress.

Back Ups

Current Recommended TEMP Format (DAG 9.10)

2. PART II-INTEGRATED TEST PROGRAM SUMMARY

b. Management

- (2) Identify the T&E WIPT structure, to include the sub-T&E WIPTs, such as a M&S or Reliability, with their participating organizations.

3. PART III-DEVELOPMENTAL TEST AND EVALUATION OUTLINE

b. Future Developmental Test and Evaluation.

- (3) List all M&S to be used to help evaluate the system's performance, explain the rationale for their credible use and provide their source of verification, validation and accreditation (VV&A).

4. PART IV-OPERATIONAL TEST AND EVALUATION OUTLINE

c. Future Operational Test and Evaluation

- (3) Whenever M&S are to be used: identify the planned M&S; explain how they are proposed to be used; and provide the source and methodology of the VV&A underlying their credible application for the proposed use.

5. PART V-TEST AND EVALUATION RESOURCE SUMMARY

a. ... Identify the following test resources:

- (4) *Threat Representation*: Subject each representation of the threat (target, simulator, model, simulation or virtual simulation) to validation procedures to establish and document a baseline comparison with its associated threat and to determine the extent of the operational and technical performance differences between the two throughout the life cycle of the threat representation.
- (7) *Simulations, Models and Testbeds*: ... Identify the M&S to be used, including computer-driven simulation models and hardware/software-in-the-loop test beds. However, provide the discussion of how these M&S will be used in Parts III and IV. Identify the resources required to accredit their usage. Identify the M&S Proponent, the V&V Agent, and the Accreditation Agent for intended user.

Current Defense Acquisition Guidance Regarding the use of Models & Simulations

9.1 Introduction to Test and Evaluation (T&E): DT&E supports: the systems engineering process to include providing information about risk and risk mitigation; assessing the attainment of technical performance parameters; providing empirical data to validate models and simulations and information to support periodic technical performance and system maturity evaluations.

The program manager, in concert with the user and test communities, without compromising rigor, is required to integrate modeling and simulation (M&S) activities with government and contractor DT&E, OT&E, LFT&E, system-of-systems interoperability and performance testing into an efficient continuum.

9.1.5. Integrated T&E Philosophy: Live testing might be integrated with verified, validated, and accredited simulators or computer driven models and simulations, to optimize the amount of live testing required. Another aspect is integrating developmental test and evaluation with operational test and evaluation into a continuum that reduces testing resource requirements and time, or conducting concurrent DT and OT when objectives and realism are compatible.

9.3.2.T&E Working Integrated Product Team: Program managers should also consider forming lower level functional working groups, who report to the T&E WIPT, whose focus is on specific areas such as reliability scoring, M&S development and VV&A, threat support, etc.

9.3.4. Modeling and Simulation in DT&E

9.3.5. System Readiness for IOT&E

9.4.1. OT&E Guidelines

9.4.2. Validation of Threat Representations (targets, threat simulators, or M&S)

9.5.3. Early LFT&E

9.5.4. Full-Up, System-Level Testing (FUSL) and Waiver Process

9.6.1.1. TES Description

9.6.2.2. Test and Evaluation Master Plan (TEMP) Format



Integration of MBSE and HSI

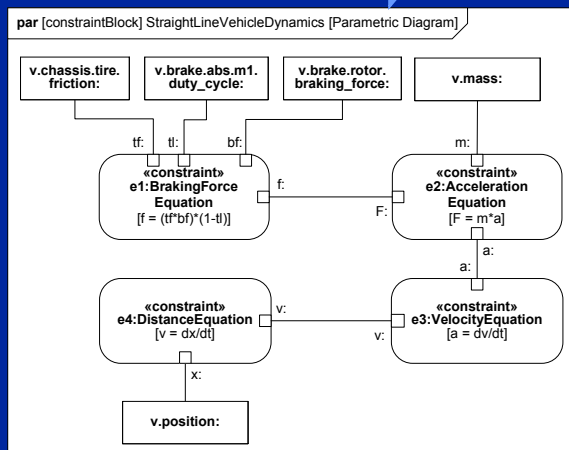

Abe Meilich, Ph.D.
Lockheed Martin Corporation
abraham.w.meilich@lmco.com

Agenda



- **Objective of INCOSE Research activity related to HSI/MBSE Integration**
 - **What Is The problem?**
 - **Why Should You Care?**
 - **What Is Included in HSI**
 - **Issues in Modeling the Human Influence on System Design**
 - **What Is Being Done Under the INCOSE MBSE/HSI Activity?**
- **Summary of selected HSI modeling and System Architecture Frameworks**
- **Definition of HSI tasks applied to SE process**
- **Examples of Application of HSI linked to MBSE using SysML**
- **Discussion plans in 2009 for Industry, Government, and INCOSE collaboration in improving the HSI/MBSE interface**

A View Into the Future

Erosion of the people/system boundary:

“People will not just be users of the system of Ultra-Large-Scale (ULS) system; they will be elements of the system, affecting its overall emergent behavior”

Source: Ultra-Large Systems; The Software Challenge of the Future, SEI-CMU, June 2006,



What is the problem?



- **Complex, revolutionary socio-technical systems pose a design problem that does not succumb to linear, de-compositional techniques**
 - Do we have SE processes to deal with this?
 - Predict one person ? Predict group behavior?
 - Two Air Force Science Advisory Board (AF SAB) studies have recognized there is weakness in our ability to better leverage human-to-human interaction in the battlespace ¹
 - The Potomac Institute also highlighted the lack of HSI tools to tackle the Future of Human in the Loop ²
 - Ring³ (2004) argues that although current Systems Engineering practice can be applied effectively to the design of inanimate systems, it faces significant obstacles in the design of human intensive, socio-technical systems.

¹ AF SAB 2005 "System-of-Systems Engineering for Air Force Capability Development", SAB-TR-05-04

² Potomac Institute Study, "New Concepts in Human Systems Integration", March 2008

³ Ring, Jack (2004). Beyond the System Operator Paradigm; Systems Engineering as a Sociotechnical System. Conference on Systems Engineering Research, USC/SIT/INCOSE, April, 2004, Paper #120

What is the problem?



- **Our evolving system of systems environment demand more attention to the human dimension**
 - the elements of such systems can together provide capabilities not achievable in isolation – **leveraging the power of networking**
 - definitions of the boundaries of these elements create dependencies and interaction activities – **emergent behavior (both bad and good)**
 - the mission performance of such systems is greatly improved through attention to the resulting human communication and coordination efforts – **often overlooked**
- **Why are the products of cognitive engineering ignored in the systems development process?**
 - It is not because the challenges of Human-System Integration (HSI) are unrecognized but because the products of cognitive engineering do not resonate with the design community at large¹

¹ Lintern, Gavan, "Human Performance Modeling for Enterprise Transformation, Proceedings of the 16th Annual International Symposium of the International Council on Systems Engineering, 2006

Another recommendation



- **Use of scenario based analysis advocated***

Recommendation: Adapt existing or develop new methods and tools that facilitate capture and traccability of HSI design objectives, design rationale, and constraints across design phases. Specifically:

Adapt existing and develop new methods for generating scenarios that reflect the range of complexities uncovered by context of use analyses. This corpus of scenarios can be used to support development and evaluation of designs, procedures, and training, including human reliability and safety analyses. They could also be used to exercise models and simulations as part of the system development process. The goal would be to ensure that the systems have been explicitly designed and tested to support performance across a comprehensive range of representative situations, as identified by context of use analyses. Context of use scenarios are also essential to the meaningful definition of such key performance parameters as response time, reliability, and accuracy.

One of several recommendations

* "Human-System Integration in the System Development Process: A New Look", Committee on Human-System Design Support for Changing Technology, Richard W. Pew and Anne S. Mavor, *Editors*, Committee on Human Factors, National Research Council, The National Academy Press, p 306, 2007.

Human Systems Integration: Mandate



AFSAB Report, SAB-TR-04-04



U.S. AIR FORCE

Study Overview



Increased demands on human operators

- Volume and complexity of information
- Changing job demands
- Manpower constraints

Impact on system effectiveness

- Accuracy and timeliness of decisions
- Operational safety
- Acquisition cost and schedule
- Total system life cycle cost

Study Assessment:

Shortfalls in HSI Practices

- Lack of organizational focus & advocacy
- No definitive AF policy/program guidance
- Lack of measurable requirements
- Resources below critical mass
- Inconsistent planning and execution

PROPOSED ACTIONS

- Elevate leadership focus
- Fix policy and S&T gaps
- Educate program management
- Strengthen HSI in System Engineering processes

Potential Solution?



- **Potential Solution: Leverage and adapt new methods of SE modeling (MBSE) techniques to help the construction of a bridge between cognitive engineers, as well as all HSI domains, and systems engineers**

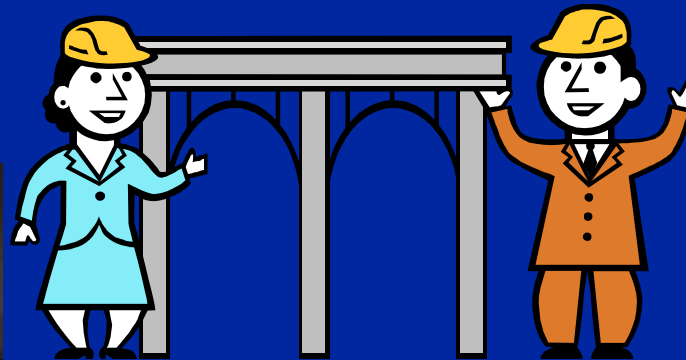

What is included in HSI?



Traditional HSI Domains	Focus of analysis/evaluation
Manpower	Staff count and composition; total cost.
Personnel	Required and available personnel skills and aptitudes; physical abilities; security clearances; retention or attrition rates; total cost.
Training	Types of training and lengths of training; recurrent training requirements; impact of training on readiness; total cost of training.
Human Factors Engineering (HFE)	Required human capabilities; usability of proposed system; task performance times; accuracy (error rates) and efficiency (number of tasks performed in a given time period); cognitive and physical workloads; stress; organizational impact; effectiveness of communications.
Safety	Potential for errors that cause injury; potential for loss of use of system; potential for loss of personnel; cost of implementing reasonable safety precautions.
Occupational Health	Health hazards; severity and risks associated with hazards; total cost to minimize hazards or their consequences.
Survivability	Probability of being detected, attacked, or mistaken for enemy; ability to minimize injury; ability to minimize physical or mental fatigue; total cost of reducing risks.
Verification and Validation	Human system requirements met; functionality exists to accomplish the tasks or functions required; results compared to other sources to confirm accuracy within acceptable tolerances.

Note: most recently more areas have been proposed under the HSI umbrella >>>>>

HSI needs to communicate and inform SE



-Differences in terminology¹-

Term	SE interpretation	HSI interpretation
Task	A high level description of what an Enterprise needs to achieve.	A duty that individuals carry out as part of their job.
Activity	A high-level description of what needs to be achieved, before individual resources are specified.	A low-level description of what individual people may do as part of their tasks.
Function	A specific description of what individual resources are designed or designated to do (e.g. human, machine, animal).	A generic description of what needs to be done at a high level of task descriptions – often resource-independent.
Role	Something to be done that is defined independently of whether a human or a machine will carry it out – since these allocations may change.	Something to be done by people (mostly one) who take responsibility for the outcomes. This is closely related to job definitions.

Bruseberg A (In press) "Human Views for MODAF as a Bridge between Human Factors Integration and Systems Engineering". Cognitive Engineering and Decision Making Journal. (Special Section on: Integrating Cognitive Engineering in the Systems Engineering Process: Opportunities, Challenges and Emerging Approaches.) Publisher: Human Factors and Ergonomics Society, 2008

Integration of Hardware, Software, & Human Life Cycles

Design Requirements (criteria)*

- Design for:
- Performance
 - Cost-system effectiveness
 - Reliability
 - Maintainability
 - Political, Social, & Tech Feasibility
 - **Human Factors**
 - **Safety**
 - **Environment**
 - **Occupational Health**
 - **Manpower**
 - **Personnel**
 - **Training**
 - **Survivability**
 - **Habitability**
 - Vulnerability
 - Supportability
 - Producibility
 - Reconfigurability
 - Affordability
 - Disposability
 - Flexibility (growth)

* applicable to all levels in the system structure and tailored to specific program needs

Design task (tools/methods)

- Design accomplished through:
- Requirements analysis
 - Quality function deployment
 - Feasibility analysis
 - Operational requirements & maintenance concept
 - Functional analysis
 - Design trade-off studies
 - Simulation & modeling
 - Requirements allocation
 - Reliability & maintainability analyses
 - Human system integration
 - Supportability analysis
 - Test and evaluation
 - Risk analysis
 - Other supporting analyses

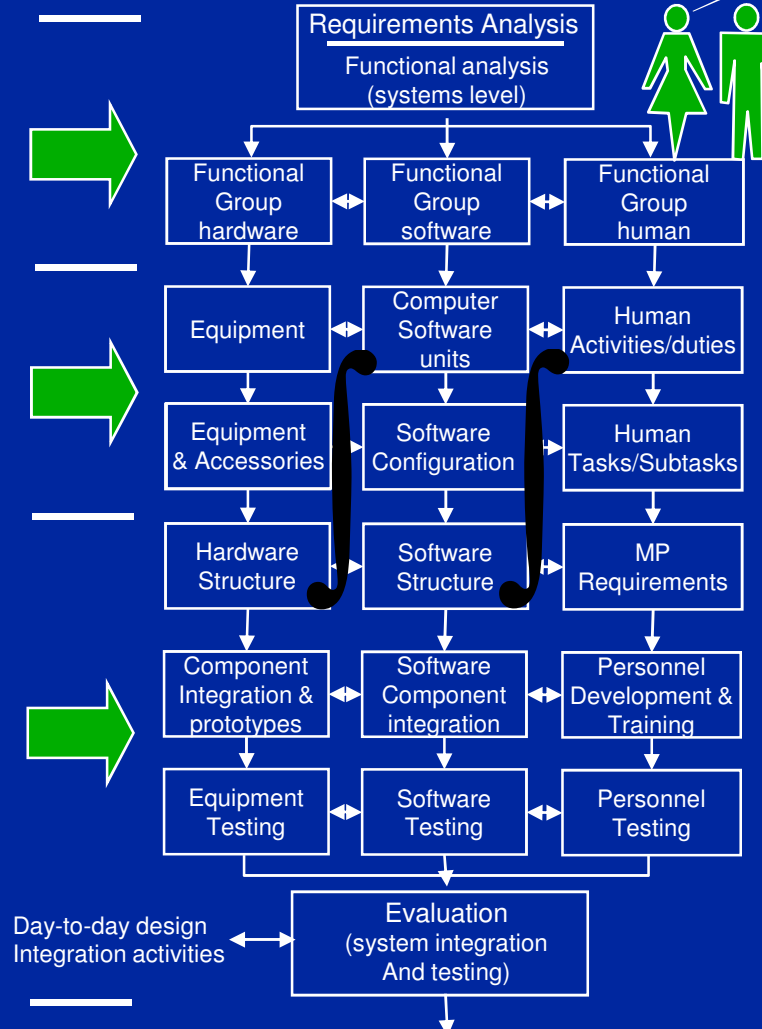

Source: Modified graphic from Blanchard & Fabrycky, Systems Engineering and Analysis, 2006, pp. 106

Human-Centered Tasks in System Life Cycle

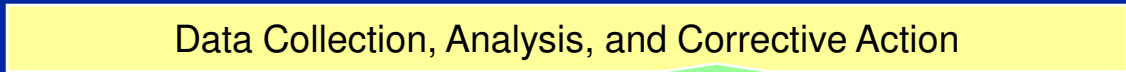
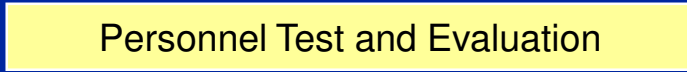
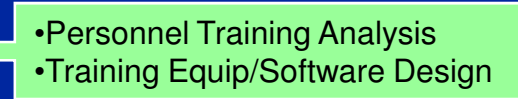
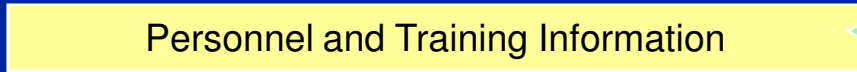
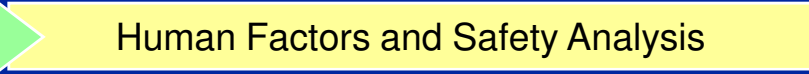
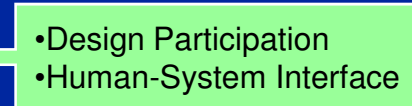
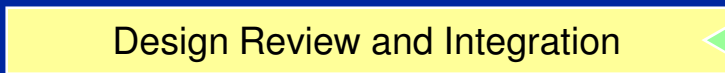
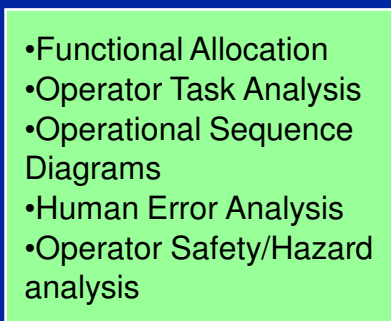
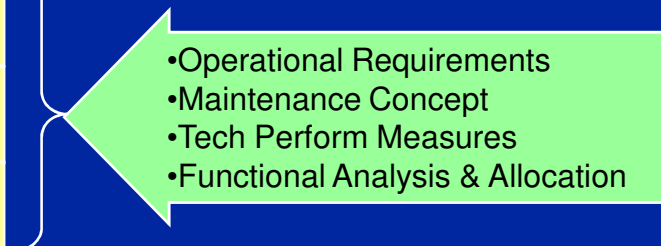
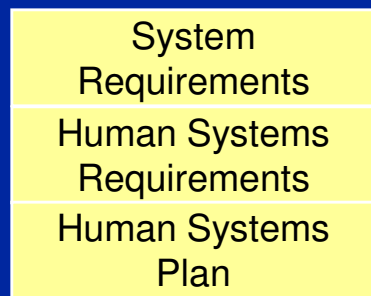

Issues in Modeling the Human Influence on System Design



- **HSI modeling has remained in the HSI domains**
 - No way of linking HSI models to SE models due to domain languages and lack of relevant taxonomy linkage to SE needs
- **It is challenging to link the soft behaviors of the human to the predictable behaviors of machines**
 - Human performance modeling issue - cognitive capability and capacity can change with stress, fatigue and experience. Sometimes the direction of change can be unexpected (e.g., team performance under high workload can exhibit emergent behavior)
- **There is lack of awareness of what attributes of human behavior can be linked to system effectiveness as it relates to overall mission effectiveness; thus limiting the ability of an SE to perform trade studies**
- **Note this issue as discussed by the AF SAB *:**
 - “Whenever the Air Force generates a system-of-systems, interaction among the systems often includes human-to-human interactions. If the machine-to-machine aspect of SoS is weak, then it falls upon the humans to achieve the interaction. This can, and often does, create a very challenging environment for the human; sometimes leading to missed opportunities or serious mistakes. The lack of sound Human System Interface designs can exacerbate this. Coordinated situation awareness is difficult to manage if the individual systems miss or convey confusing or conflicting information to their operators.”

* AF SAB 2005 “System-of-Systems Engineering for Air Force Capability Development”, SAB-TR-05-04
Lockheed Martin Copyright 2008

What is being Done Under the INCOSE/HSI Tasking?



- **Evaluate how present MBSE artifacts can be related to SE artifacts from various HSI modeling approaches (including cognitive model applications) in practice today**
 - **Leverage HSI WG at INCOSE and other industry forums**
 - **Link to systems models in SysML**
 - **Link to dynamic models from system dynamics theory**
 - **Link to experimentation techniques**
 - **Link to executable cognitive architecture representations**

Initial findings



- **Many tools and computational engines used to perform HSI analysis**
 - In process of negotiating prototypes of linking (automatically or semi-automatically) HSI data with SE data in a MBSE environment
 - IMPRINT™ to be used in conjunction with SysML for first prototype. Others are being investigated for prototypes
- **LMC developing a HSI/SE methodology that can leverage MBSE modeling techniques to perform more “human centric” SE**
 - Results to be reported at Winter 2009 INCOSE Workshop

What modeling techniques are out there for integrating HSI with SE



Initial Research:

- IMPRINT (Dynamic modeling of human performance characteristics in a system – US Army tool)
- SysML (common standards based SE language for modeling)
- Architecture Frameworks (Human Views)
- SOA Services and Standards (BPEL4People)

MBSD Encompasses Multiple Modeling Domains

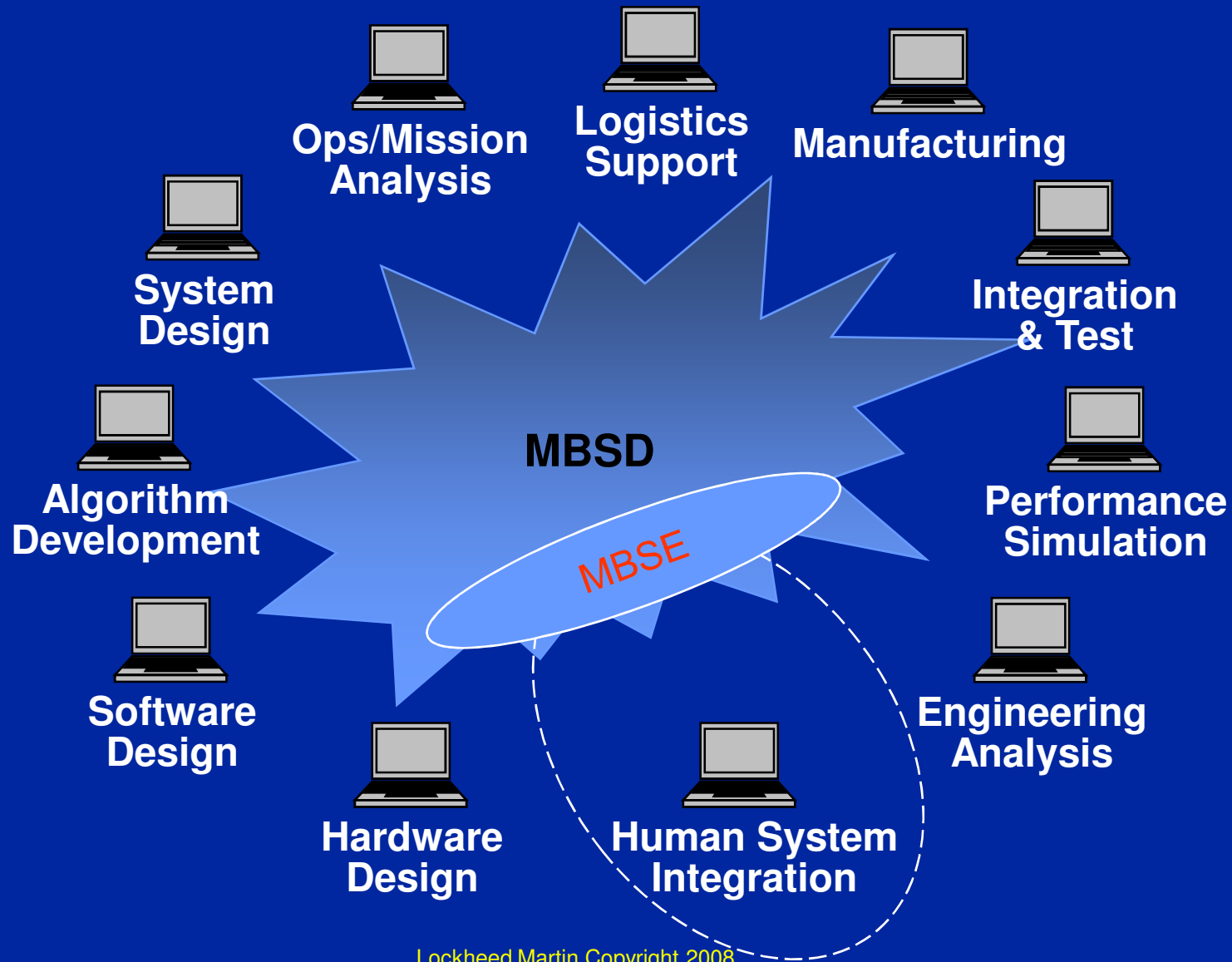

MBSD Integration

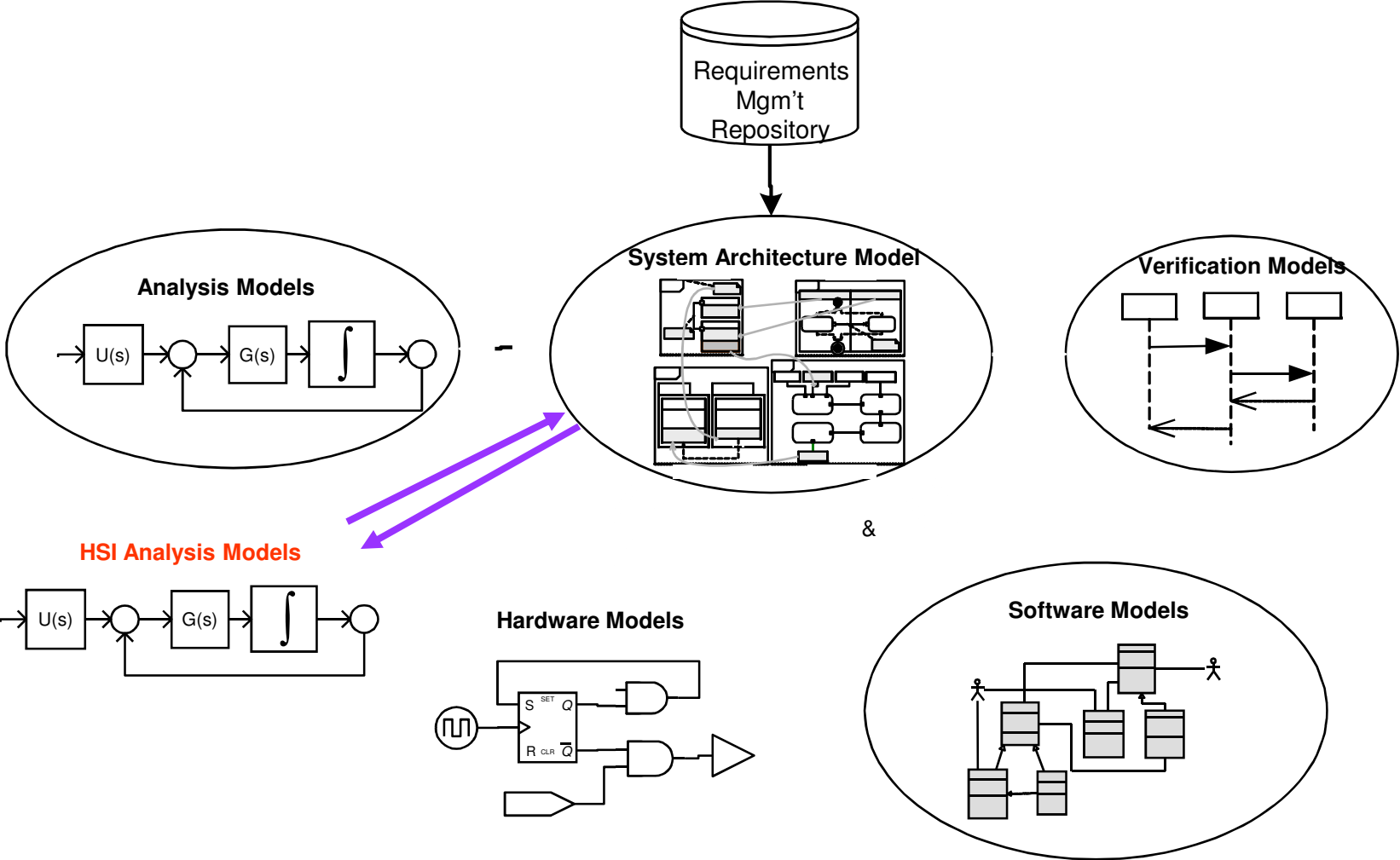

System Engineering Technical Life Cycle Processes

•ISO/IEC JTC1/SC7 15288, Systems and Software Engineering - System Life Cycle Processes

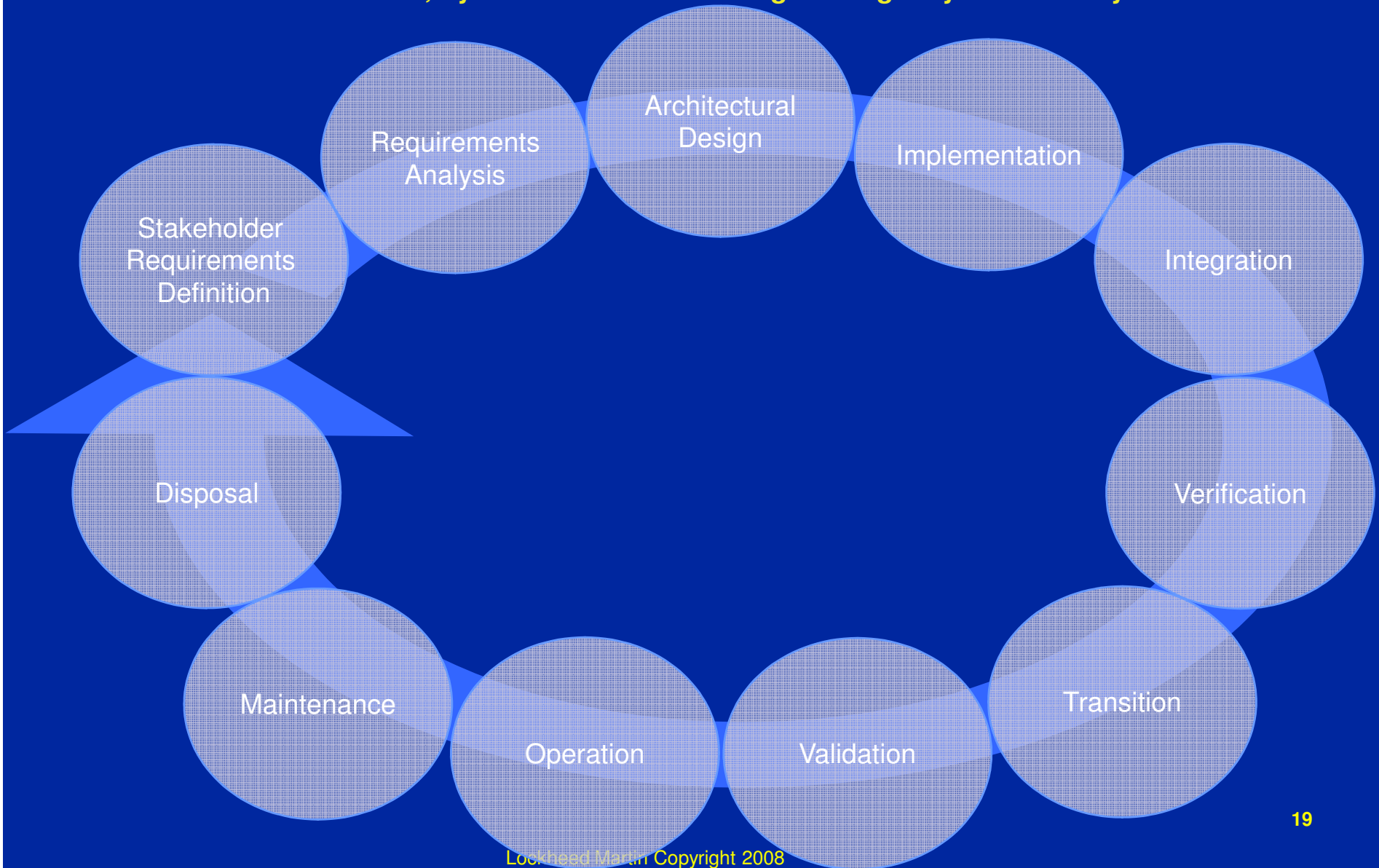

HSI: A Cornerstone of Human Performance

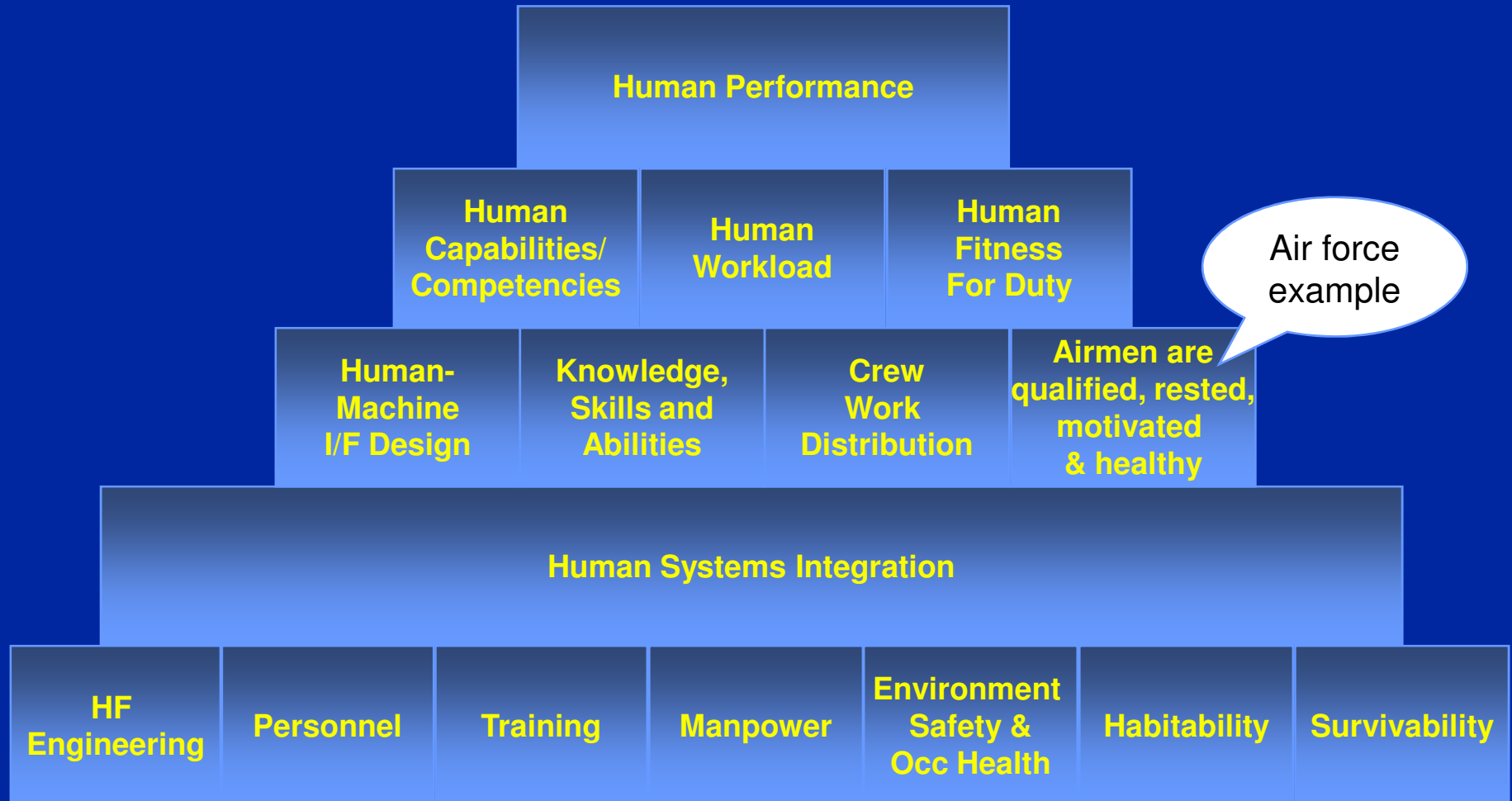

Inputs and Outputs to SE/HSI Models

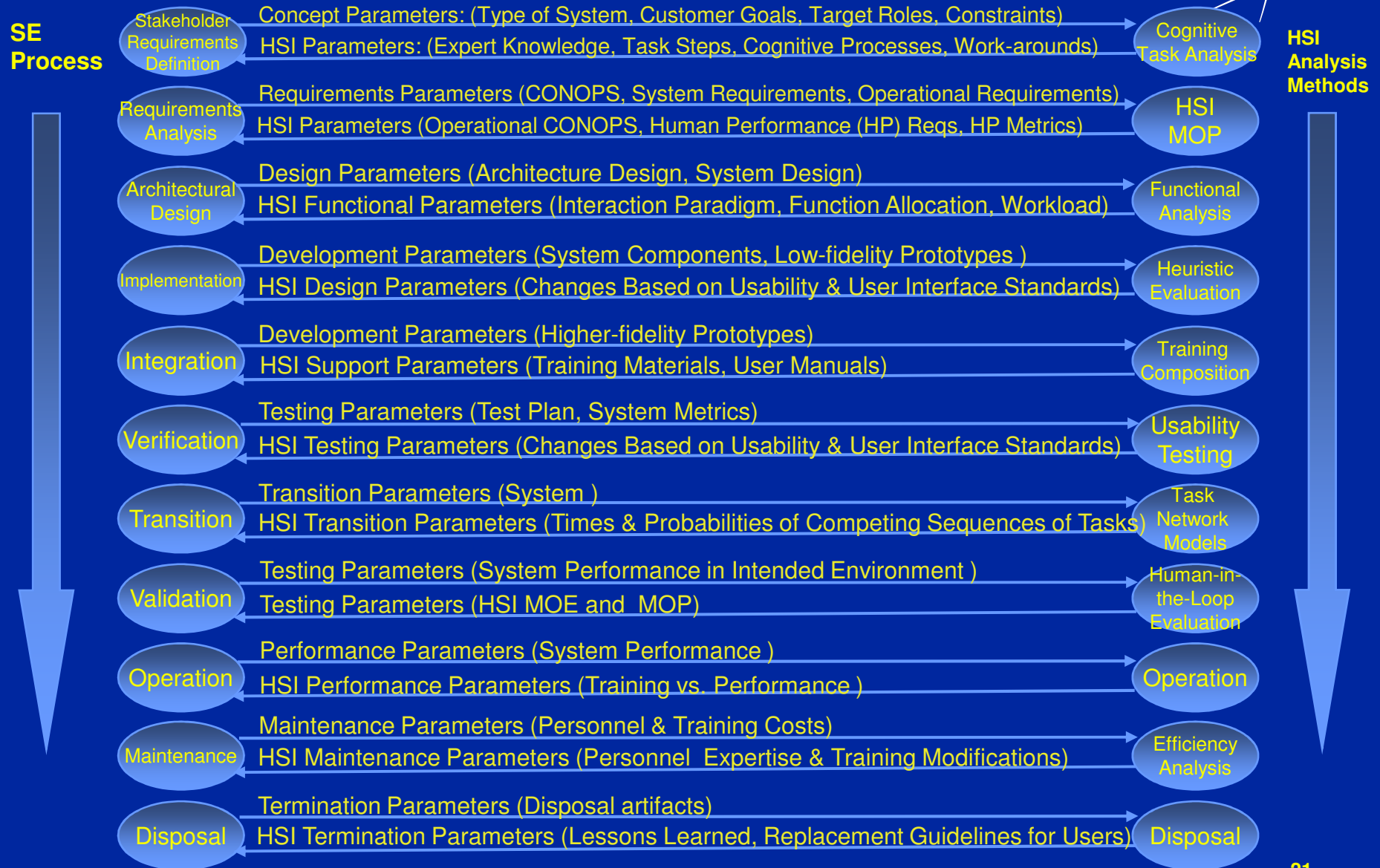

Ongoing UML – IMPRINT Pilot Study Project

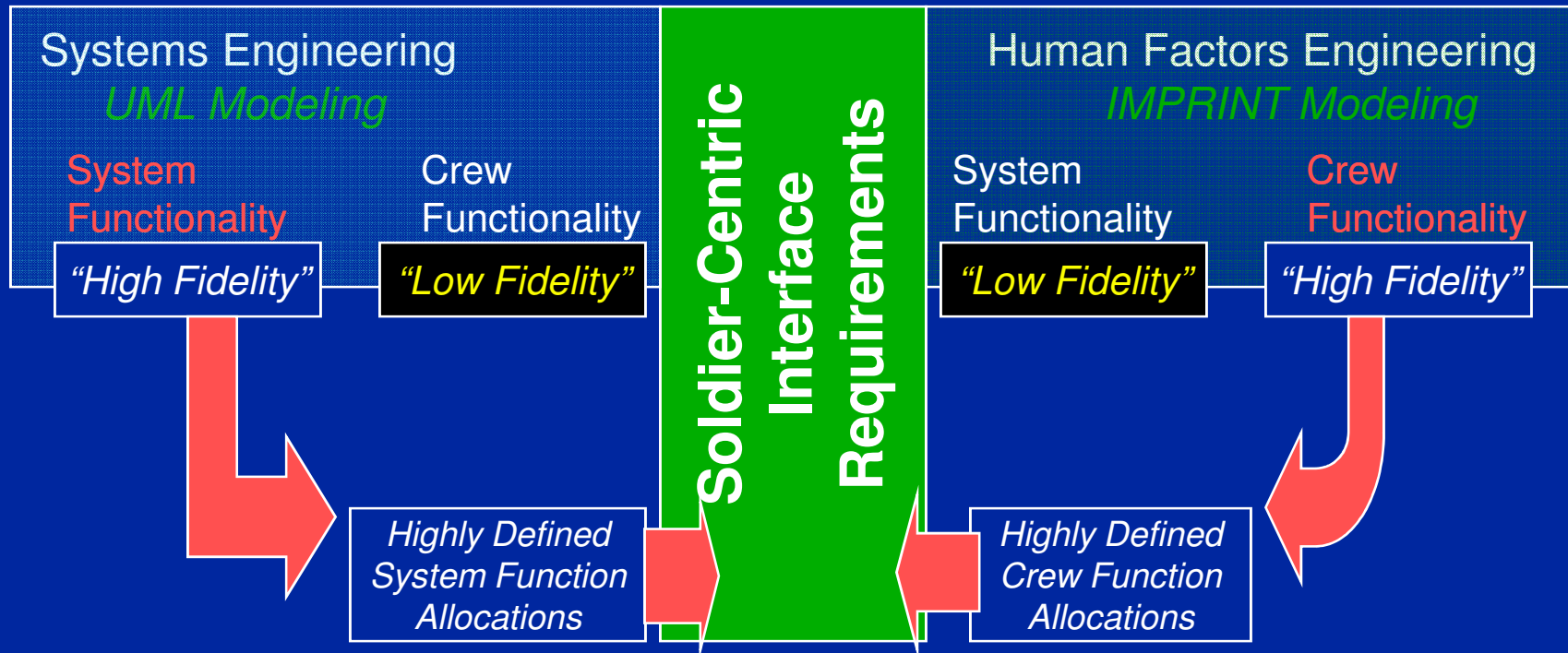

Source: Presentation: "Enhancing System Design by Modeling IMPRINT Task Workload Analysis Results in the Unified Modeling Language", Diane Mitchell, Operations Analysis Team Leader, Integration Methods Branch, US Army Research Laboratory, diane@arl.army.mil, 2008.

Architecture Framework Products Supporting HSI/MBSE

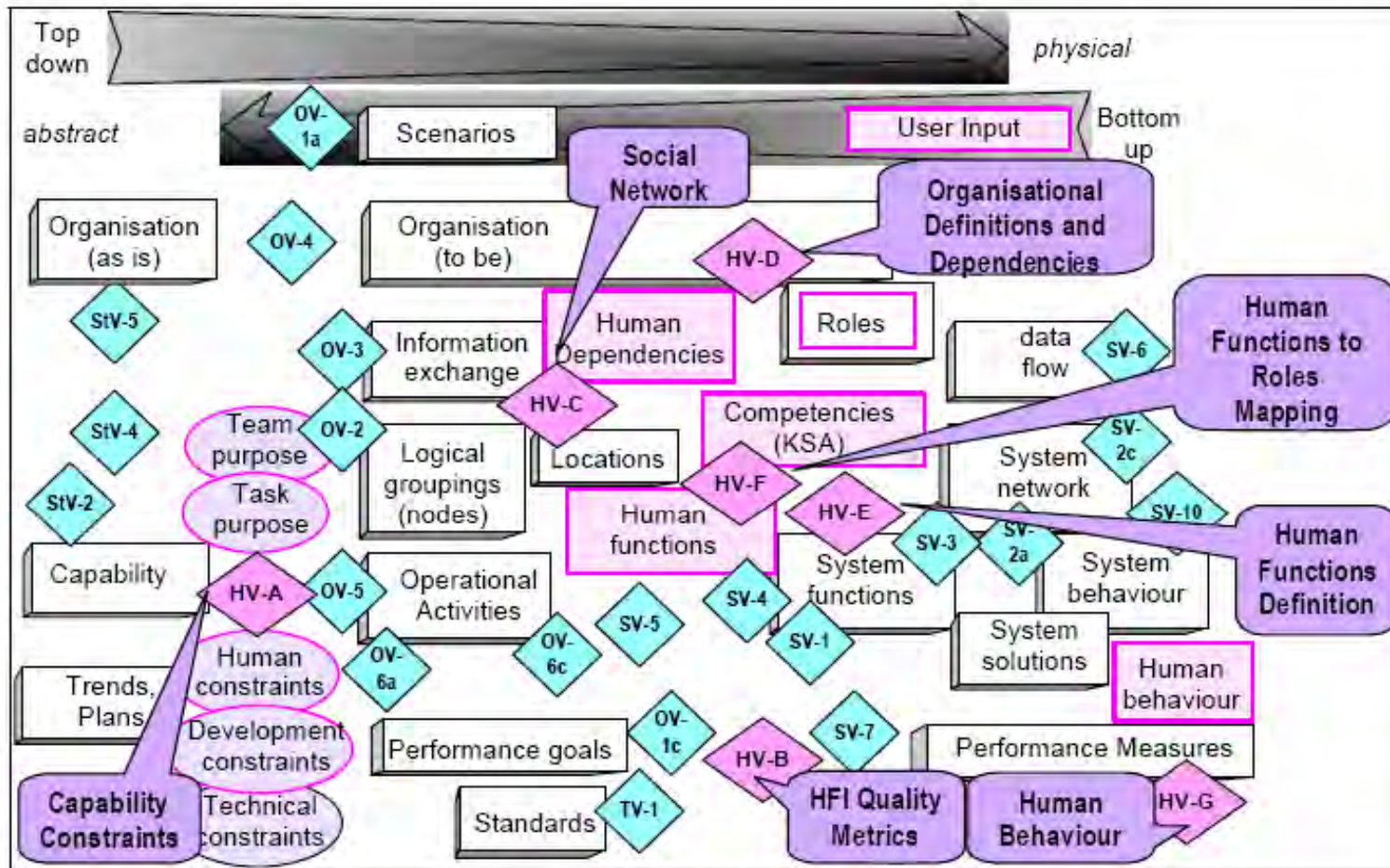

Figure 4: Human Views in Context.

Source: "Human Factors Integration for MODAF: Needs and Solution Approaches",

A. Bruseberg & G. Lintern, INCOSE Annual Symposium 2007

B. Also see: Bruseberg A (In press) "Human Views for MODAF as a Bridge between Human Factors Integration and Systems Engineering". Cognitive Engineering and Decision Making Journal.

(Special Section on: Integrating Cognitive Engineering in the Systems Engineering Process: Opportunities, Challenges and Emerging Approaches.) Publisher: Human Factors and Ergonomics Society, 2008

Lockheed Martin Copyright 2008

Architecture Framework Products Supporting HSI/MBSE (Another view of MODAF/HV)

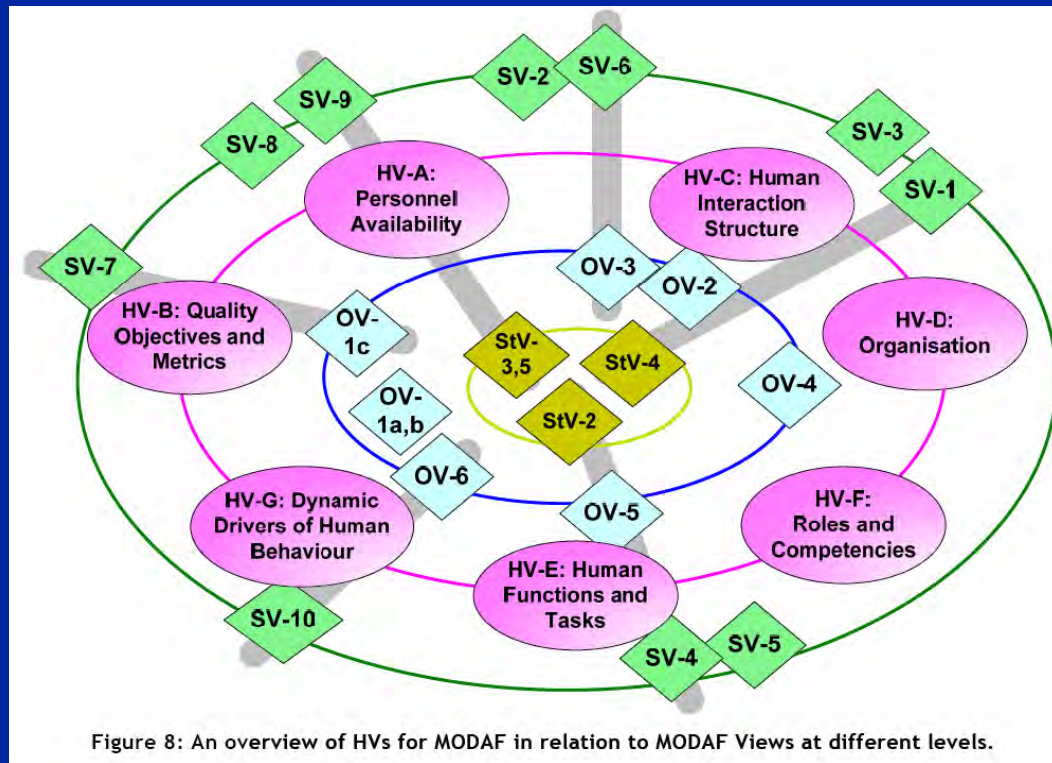

Figure 8: An overview of HVs for MODAF in relation to MODAF Views at different levels.

The Human View Handbook for MODAF”, Systems Engineering & Assessment, Ltd,
Produced on behalf of the MoD HFI DTC, © Crown Copyright, Bristol, UK, 15 July 2008

[http://www.hfidtc.com/MoDAF/HV Handbook First Issue.pdf](http://www.hfidtc.com/MoDAF/HV_Handbook_First_Issue.pdf)

SOA Services And Human-in-the-Loop



Process Improvement	OMG - Business Process Maturity Model (BPMM)
Process Modeling	OMG - Business Process Modeling Notation (BPMN) OMG - Business Process Definition Meta-Model (BPDM) WFMC –XML Process Definition Language (XPDL)
Task Management	WS-HumanTask
Process Execution	OASIS – Business Process Execution Language WS BPEL 2.0 WS-BPEL Extension for People (http://www-128.ibm.com/developerworks/webservices/library/specification/ws-bpel4people)

Orchestrate people, systems, content, and business rules into streamlined end-to-end processes that are accessible to process participants through engaging user interfaces, online or offline.

BPEL4People features

Features addressed by WSHumanTask



Human Task Behavior

- Normal Processing of a Human Task
- Releasing a Human Task
- Delegating or Forwarding a Human Task
- Suspending and Resuming a Human Task
- Skipping a Human Task
- Termination of a Human Task
- Error Handling for Human Task

Other considerations:

•Scope of users (i.e., operators, management, stakeholders, etc.)

•User Interfaces to Applications

•Portability and Interoperability Considerations

- The portability and interoperability aspects Features addressed by WSHumanTask:
 - Portability - The ability to take human tasks and notifications created in one vendor's environment and use them in another vendor's environment.
 - Interoperability - The capability for multiple components (task infrastructure, task list clients and applications or processes with human interactions) to interact using well-defined messages and protocols. This enables combining components from different vendors allowing seamless execution.

How can MBSE and SysML help?



- **Various efforts are underway to leverage SysML as part of Systems Engineering analyses**
 - **SysML is a System Engineering Modeling Language – a superset of UML**

Example Integration of HSI and MBSE

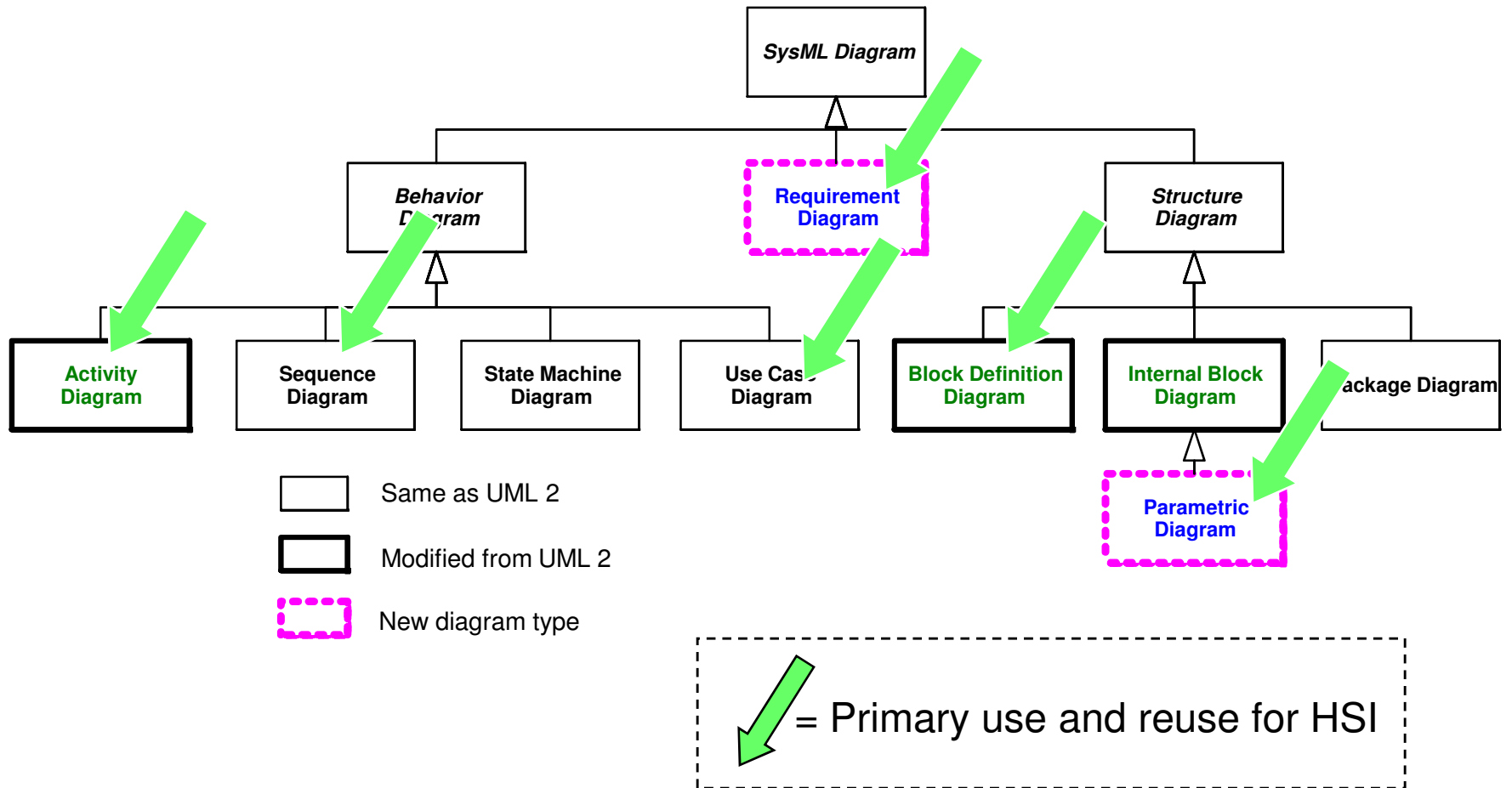

IMPRINT™ Example - OV-6b Operational State Transition Diagram

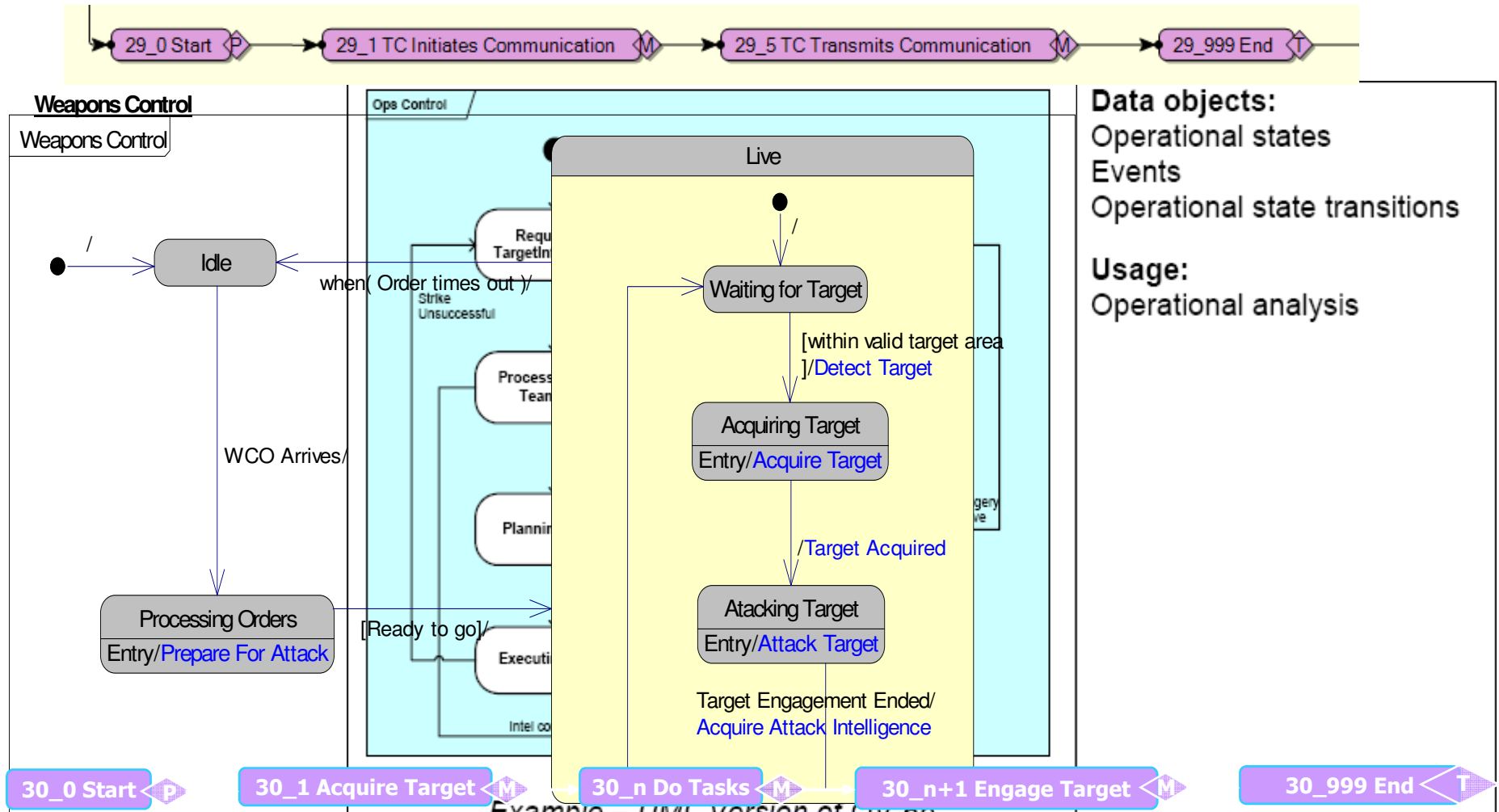

Example - UML version of OV-6b

Description:

Graphical method of describing how an operational node or activity responds to various events by changing its state

Alternative Views:

UML Statechart Diagram

User Characteristics

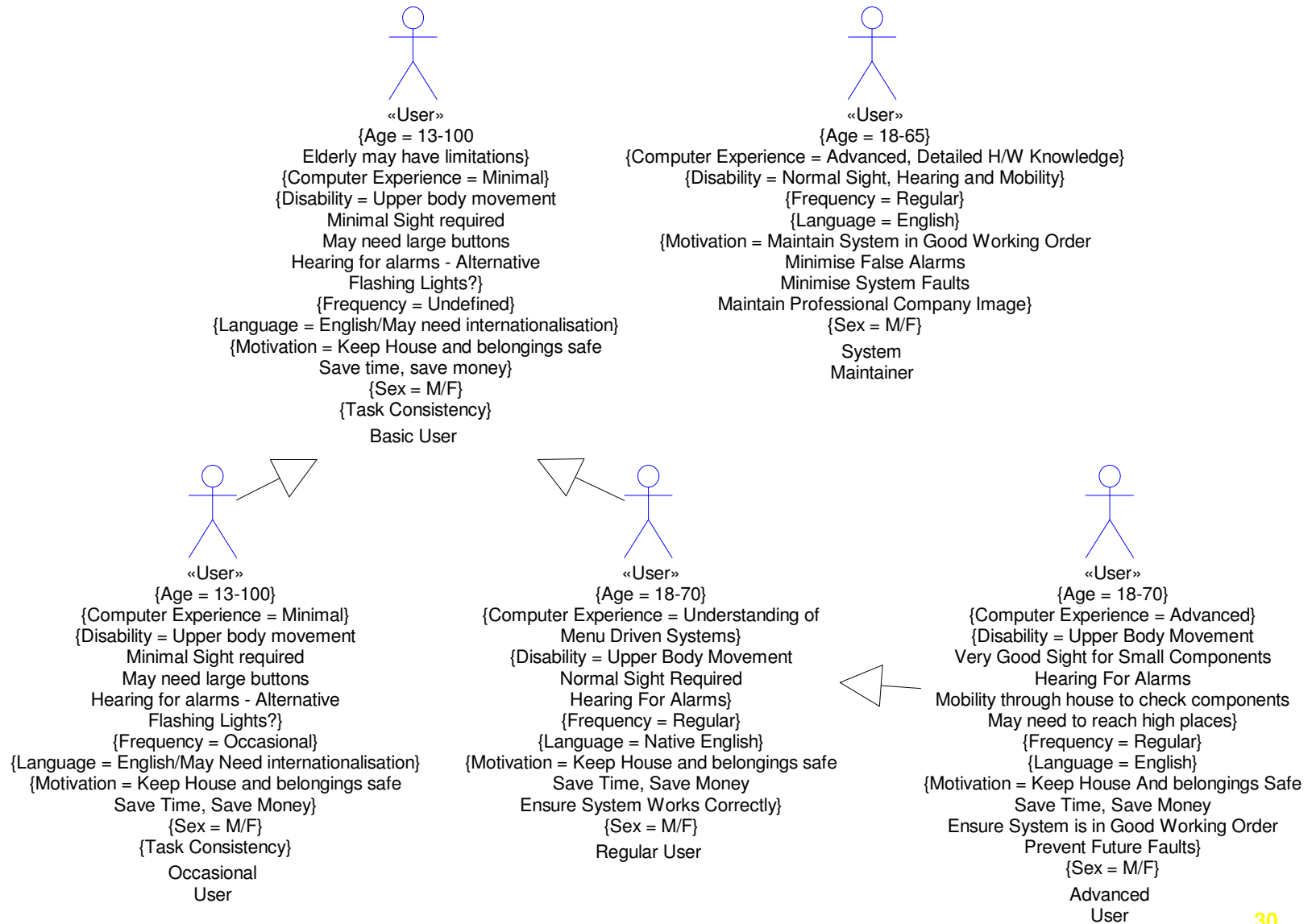

Task Characteristics

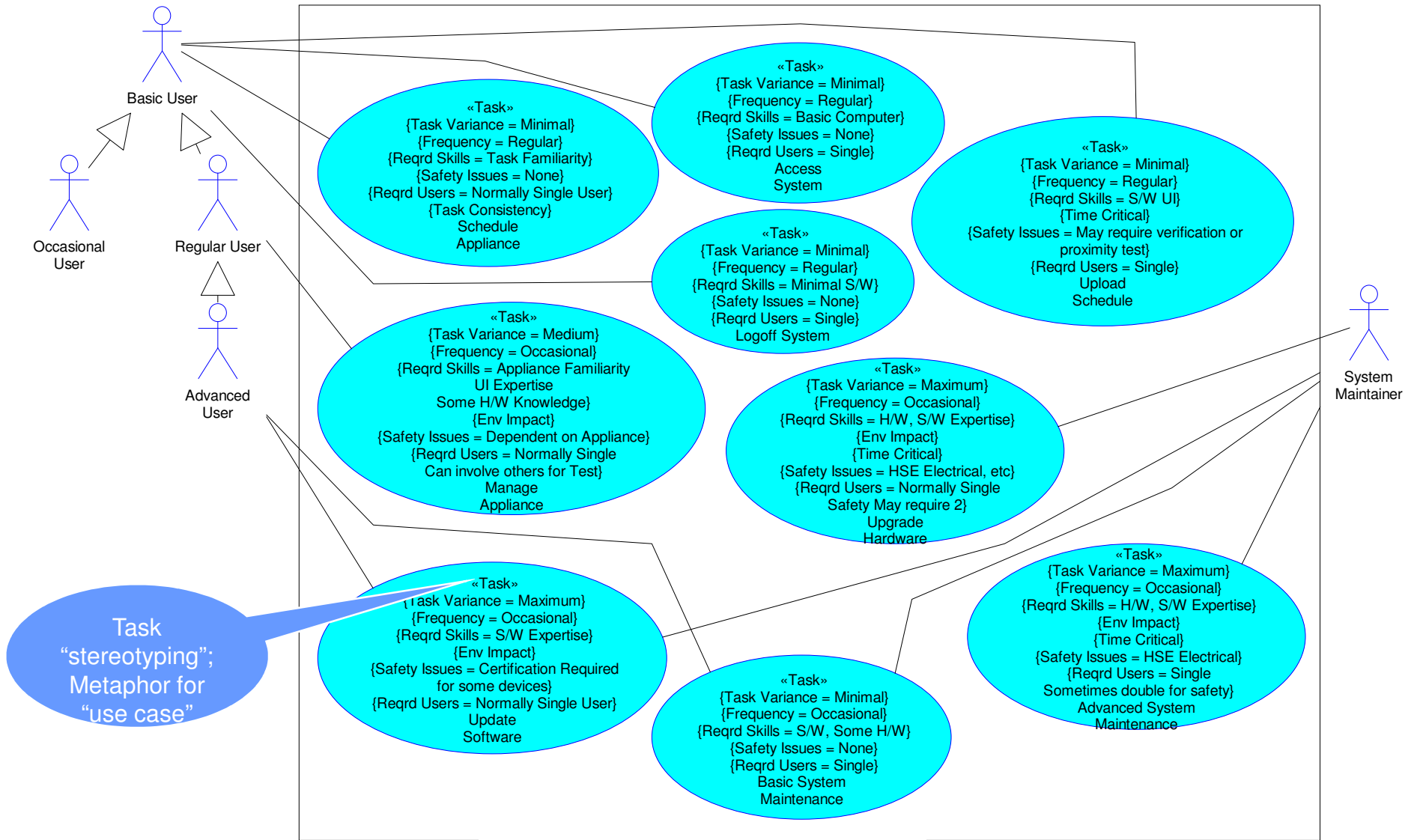

Parametrics

- **Used to express constraints (equations) between value properties**
 - **Provides support for engineering analysis (e.g., performance, reliability)**
 - **Facilitates identification of critical performance properties**
- **Constraint block captures equations**
 - **Expression language can be formal (e.g., MathML, OCL) or informal**
 - **Computational engine is defined by applicable analysis tool and not by SysML**
- **Parametric diagram represents the usage of the constraints in an analysis context**
 - **Binding of constraint usage to value properties of blocks (e.g., vehicle mass bound to $F = m \times a$)**

Parametrics Enable Integration of Engineering Analysis with Design Models

Vehicle Dynamics Analysis (example)

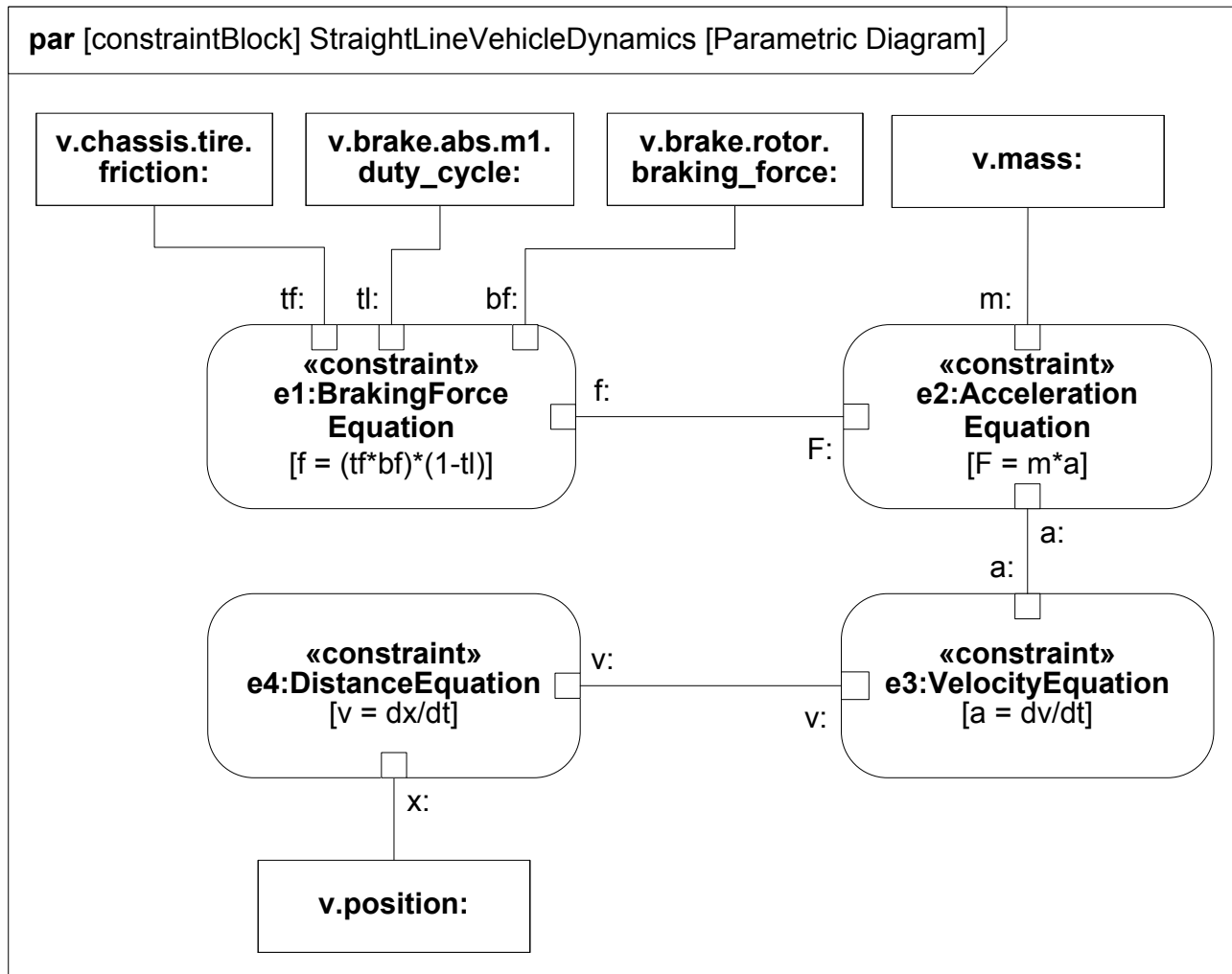

Using the Equations in a Parametric Diagram to Constrain Value Properties

Future Plans for INCOSE HSI/MBSE Collaboration in 2009



- **Develop an initial mapping between the artifacts produced in SE Process to HSI Process/analysis**
- **Map HSI artifacts into static structural modeling framework including interdependency across systems.**
- **Comprehensive Example Architecture: Using MBSE approach with an exemplar architecture using the outcomes of 2008 effort**
- **Develop example integration of HSI tool to MBSE environment (e.g., using SysML)**
- **Work with HSI/SE community to help peer review approaches developed under our INCOSE activity**



DCMA
Defense Contract Management Agency



Systems Engineering Re-Vitalization at the Defense Contract Management Agency

Presented By:

Mr. Lawrence Cianciolo

October 20-23, 2008

DCMA
Defense Contract Management Agency

DCMA
Defense Contract Management Agency

Charter

Feedback

**DCMA Systems Engineering Value to the DoD Acquisition
Enterprise**

DCMA Systems Engineering Functions and Influence Areas

DCMA Systems Engineering Core Processes

Recommended Path Forward

- **Baseline Skills Assessment**
- **Competency Training**
- **Develop Policy/Tools/Guidance**
- **Recommended Training Track/Curriculum**
- **SE Standard Surveillance Operating Guide (SSOG) Outline**

Intent is to define expectations and prioritize processes, functions, and efforts of DCMA engineers in providing the best guidance, support, and life-cycle balanced system solutions that satisfy customer needs, goals, objectives, requirements, and specific outcomes in DoD weapon systems acquisition management

Defining the Future of DCMA Systems Engineering!

Feedback

Feedback on our recommendations - provided by OSD (AT&L), PEO, DCMA Division Director, CMO Commander, and CMO Engineers:

“...a sound approach with a great explanation...” - Dr. Don Gelosh, Senior Systems Engineer, OSD (AT&L) SSE / ED

“...you have a good handle on this...” - Col Rich Hoeferkamp, Acting Deputy Director, OSD (AT&L) SSE / ED

“...you are on the right track...” - Alex Levi, PEO Staff Engineer, Space and Missile Systems Center, Los Angeles AFB

“...this initiative is much needed...” - Col Warren Anderson, DCMA Dayton Commander - OSD (AT&L) SE Instructor

“I like the Engineering Core Processes listed...” - Gregory Lehn, P.E., DCMA NASA Product Operations

- **Primary Result of OSD (AT&L) Study**
 - **A lack of Systems Engineering process capability and process compliance were primary contributors to poor program performance**
- **Revitalizing DCMA Systems Engineering efforts would help to improve program performance**
- **Aligns with OSD (AT&L) Mission to Revitalize Systems Engineering Throughout the DoD**

DCMA Systems Engineers

- **Ensure that the contractor has effective processes**
- **Ensure that the contractor delivers products that meet requirements and are delivered on schedule and within cost**
- **Track cost, schedule and technical performance, perform risk analysis, perform predictive analysis of program impacts, and recommend improvements to contractor performance**
- **Influence the contractor to improve performance**
- **Provide needed recommendations to the PMO**

- **Ensure Products Meeting Customer Requirements in a Timely Manner (Satisfied Customer)**
- **Support Major Program Performance Commitments (PCs)**
- **Perform Mandated DCMA Systems Engineering Activities in Support of Certain MOAs**

**These Functions are Implemented via the
DCMA Systems Engineering Core Processes**

Engineering Core Processes

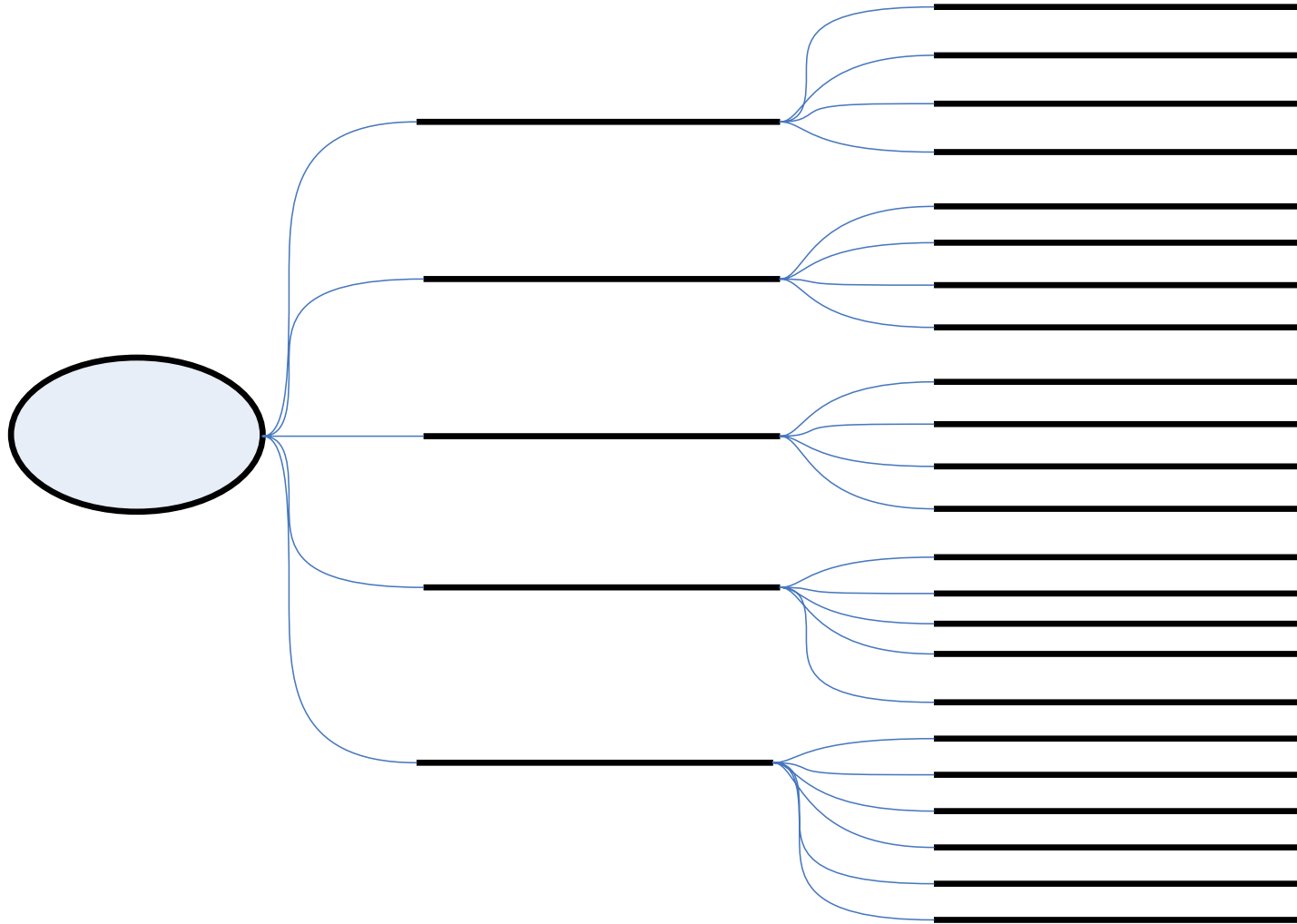

Establish DCMA HQ Sys Eng Competency Team

- **Baseline Skills Assessment**
 - **Assess Core Processes, roles and responsibilities - continuously review for modifications**
 - **Baseline core competency skills needed by commodity**
 - **Identify skills needed to implement new technology in future programs**
 - **Identify skills needed to sustain legacy systems**
 - **Align with AT&L Competency Assessment Efforts**

Engineering Disciplines are Unique

Establish DCMA HQ Sys Eng Competency Team

- **Develop Competency Training Program**
 - **Consolidate and prioritize Division training inputs**
 - **Secure Systems Engineering training funding**
 - **Execute Systems Engineering training**
 - **Define training standards and timelines**
 - **Measure Agency training success (Metrics)**
- **Develop measures of success to achieve core competencies**
- **Integrate results with the following recommended training path/curriculum:**

Recommended Training Path/Curriculum

Training Type	Course(s)
Education	Appropriate ABET Accredited Degree
DAWIA	Level II in appropriate field Level III in appropriate field for CMO Engineer Lead
Core	DCMA New/Advanced Engineering Courses
Commodity	Appropriate Licenses or Certifications for Commodity (e.g. Airframe Powerplant (A&P) License for Aero Work)
Specialty	As needed (e.g. EMI)

Recommended Training Path/Curriculum

Training Type	Course(s)
Developmental	Leadership, PBM, Six Sigma, Predictive Analysis
Professional Certification	Certified by Professional Society Aligned with the Individual's Career Field (as desired)
Additional Recommended Training	<p><u>Acquisition:</u> DCMA Integrated Master Schedule Class DCMA Systems Engineering Course BCF 102,203 (Earned Value) LOG 101, 204 PQM 101, 201 TST 102</p> <p><u>Engineering:</u> e.g., TSNs, NDT, ANSI Y-14.5M Geometric Dimensioning & Tolerancing (all as needed)</p> <p><u>Product Specific:</u> Determined by DCMA Divisions Based on Knowledge Gap Analysis</p>

Recommended Path Forward

Establish DCMA HQ Sys Eng Competency Team

- **Develop Policy/Tools/Guidance**
 - **Perform/Evaluate Enterprise Planning to include:**
 - **Staffing/Organization**
 - **Succession Planning**
 - **Appropriate Skills Matching**
 - **Policy and Tools**
 - **Training**
 - **System Engineering Guide Development**
 - **Develop Standard Surveillance Operating Guide (SSOG)**
 - **Develop Systems Engineering Influence Guide**
 - **Develop Systems Engineering Evaluation Guide and associated metrics**

Chapter 1: Concept Development Phase

Perform Program Management Oversight

Perform Engineering Process Reviews

Evaluate Engineering/Resource Schedule Estimates

Evaluate Program Performance

Perform Engineering Product Examinations

Chapter 2: Technology Development Phase

Perform Program Management Oversight

Perform Engineering Process Reviews

Evaluate Engineering/Resource Schedule Estimates

Evaluate Program Performance

Perform Engineering Product Examinations

Chapter 3: System Development and Demonstration Phase

Perform Program Management Oversight

Perform Engineering Process Reviews

Evaluate Engineering/Resource Schedule Estimates

Evaluate Program Performance

Perform Engineering Product Examinations

Chapter 4: Production and Deployment Phase

Perform Program Management Oversight

Perform Engineering Process Reviews

Evaluate Engineering/Resource Schedule Estimates

Evaluate Program Performance

Perform Engineering Product Examinations

Chapter 5: Operations and Support Phase

Perform Program Management Oversight

Perform Engineering Process Reviews

Evaluate Engineering/Resource Schedule Estimates

Evaluate Program Performance

Perform Engineering Product Examinations

**Appendices: DCMA Systems Engineering Influence Guide,
Surveillance Plan Template, Report Results and
Recommendations, Metrics, and Test and Evaluation**

Shaun Lanham	DCMAG-OCT
Larry Cianciolo	DCMAM-OCT
Thuyhong Tran	DCMAS-OCT
David Kiewit, P.E., JD	DCMAM-OCT
Mike Sheridan, P.E.	DCMAM-OCT
Bruce Heim	DCMA Boeing LB
Terry Taylor	DCMA AIMO
Capt Mark Fienhold	DCMA SSO Sunnyvale
Dr. Ram Sinha	DCMA-HQ



NORTHROP GRUMMAN

DEFINING THE FUTURE

How to Specify Applicable Documents

11th Annual Systems Engineering
Conference

National Defense Industrial Association
San Diego, California
22 October, 2008

James R van Gaasbeek
Associate Technical Fellow, Systems Engineering
Northrop Grumman Corporation

- **Abstract**
- **Context and Definitions**
- **Disclaimer**
- **Citation in Sections 3, 4 or 5**
- **Citation in Section 2**
- **Precedence**
- **Tiering**
- **Flowdown to Subcontractors**
- **References**
- **Biography**

A space-themed background featuring a view of Earth from space on the left, with a bright sun and lens flare effects in the upper left quadrant. The rest of the background is a deep blue space filled with stars.

NORTHROP GRUMMAN

DEFINING THE FUTURE

Abstract

It is a common practice to refer to applicable documents in both programmatic and product-specification documents in contracted development. The practice permits inclusion of a vast amount of lessons-learned and best practices can be referenced without the need to include the information directly in the document, nor to maintain the referenced information. Product requirements documents often specify interfaces and interoperability characteristics by reference to interface control documents included in the list of applicable documents. Benefits accruing to the product from the use of applicable documents are reduced overall cost, better products and better interoperability. Costs accruing to the product development effort are the cost of maintaining visibility on changes to applicable documents outside the control of the Program and the cost of verification of all included requirements.

Experience on many Programs and with several customers has shown that there is a wide variation in the manner in which applicable documents are incorporated in product specifications. The observed differences fall into several broad categories, such as: the method of citation of applicable documents; the difference between compliance and reference documents; the methods of referencing the documents in the requirements statements; and the approach to sub-tiering of the applicable documents.

This paper will discuss the different approaches to utilizing applicable documents within product documents and the issues and risks that arise, illustrated with examples. Using lessons learned across the program and customer experience, a robust, standardized approach is recommended that should increase the benefit of using applicable documents while reducing the cost.

A space-themed background featuring a view of Earth from space on the left, with a bright sun and lens flare effects in the upper left quadrant. The rest of the background is a deep blue space filled with stars.

NORTHROP GRUMMAN

DEFINING THE FUTURE

Context and Definitions

- Typical specification formats utilized in US Department of Defense contracting provide for the citation of applicable documents.
- “Judicious referencing of other documents in specifications is a valuable tool that eliminates the repetition of requirements and [eliminates the repetition of] tests adequately set forth elsewhere. However, unnecessary or untailored referencing of other documents can lead to increased costs, excessive tiering, ambiguities, and compliance with unneeded requirements.” (MIL-STD-961E, 4.19)
- Method for incorporating lessons learned in the field
- Method for including commercial standards and practices

- The applicable documents are of two types:
 - **Compliance – the cited document contains requirements included in the citing document by reference**
 - **Reference – the cited document provides data or information useful in enhancing the understanding of the citing document**
- Documents can be referenced in product specifications and in programmatic documents (e.g., Statement of Work). This presentation will address citation in product specifications only.
- Compliance documents can be found in functional, performance, interface, environmental and design and construction requirements. Reference documents can be found throughout Sections 3, 4 and 5 and Appendices.

- **Various standard specification formats exist (MIL-STD-490A, MIL-STD-961E, JSSG-2000A, various DIDs). A typical format is:**

1.0 Scope

2.0 Applicable Documents

3.0 Requirements

4.0 Verification

5.0 Packaging

6.0 Notes

10.0 Appendix

Citations of all documents cited in sections 3, 4 and 5, and Appendices, with full attribution, by type and source

Document citations within specific requirements

- Citation of a reference document as a compliance document
- Citation of a compliance document as a reference document
- Unnecessary citation of a complete document
- Incomplete citations in Section 2
- Failure to state precedence
- Failure to address tiering
- Failure to flowdown applicable documents to subcontractors

A space-themed background featuring a view of Earth from space on the left, with a bright sun or star in the upper left quadrant creating a lens flare effect. The rest of the background is a deep blue space filled with numerous small white stars.

NORTHROP GRUMMAN

DEFINING THE FUTURE

Disclaimer

- The author has found no discussions of the use of applicable documents in the literature.
- Some examples of requirements that can be improved are given in this presentation. There is no intent to criticize the original author, as there is no standard way to handle applicable documents.

A background image of space featuring a view of Earth from the left, a bright sun with a lens flare in the upper left, and a field of stars in the dark blue void.

NORTHROP GRUMMAN

DEFINING THE FUTURE

Citation in Sections 3, 4 or 5

The <System> shall limit orbital debris generation in compliance with NSS1740.14, Guidelines and Assessment Procedures for Limiting Orbital Debris.

- NSS1740.14 defines parameters for assessing a design to determine the minimization of orbital debris generation.
- This could be a programmatic requirement inadvertently included in a product specification.
- Alternatively, one can derive several product requirements from the Guidelines, in which case the requirement should be stated as:

The <System> shall limit orbital debris generation using NSS1740.14, Guidelines and Assessment Procedures for Limiting Orbital Debris for guidance.

- NSS1740.14 should then be listed in the "Reference Documents" section.

The <System> shall meet MIL-STD-1472 for all 1-g human-machine interfaces.

The <System> shall meet NASA-STD-3000 for all micro-g and 0-g human-machine interfaces.

- Both requirements are valid product requirements.
- Both MIL-STD-1472 and NASA-STD-3000 contain some explicit requirements (“shalls”) and numerous implicit requirements in the form of design guidance.
- It has been estimated that each of the documents may contain approximately 3000 requirements. By inclusion of the entire document, all the cited requirements will have to be verified.
- Should only cite a complete document if the intent is to include all of its requirements. Otherwise, cite specific sections.

The <System> shall operate after temperature and humidity diurnal cycling During transportation and storage as defined in MIL-STD-810F, Method 507.

- MIL-STD-810F is not a product requirements document – it addresses methods for environmental testing.
- The requirement should be rewritten as a product requirement for Section 3 and a verification requirement Section 4:

The <System> shall operate after temperature and humidity diurnal cycling During transportation and storage in the natural environment defined in MIL-HDBK-310.

Verification of the <System's> operation after temperature and humidity diurnal cycling during transportation and storage using Method 507 in MIL-STD-810F.

- Both MIL-STD-810F and MIL-HDBK-310 should then be referenced in the "Reference Documents" section.

The <System> shall operate during and after exposure to rain at a rate of 100 millimeters (mm) per hour for a 1 hour duration at +24 degrees Celsius (C) and with a 64-knot wind as defined in MIL-HDBK-310.

The <System> shall be sealed to prevent water incursion as defined in MIL-STD-810F, Method 506, Section 2.2.2b (Water Tightness).

- The first requirement is a good example.
- The second requirement should be rewritten as a product and a verification requirement:

The <System> shall be sealed to prevent water incursion (Water Tightness).

Verification that the <System> is sealed to prevent water incursion shall be conducted using Method 506, Section 2.2.2b of MIL-STD-810F.

A space-themed background featuring a view of Earth from space on the left, with a bright sun and lens flare effects in the upper left quadrant. The rest of the background is a deep blue space filled with stars.

NORTHROP GRUMMAN

DEFINING THE FUTURE

Citation in Section 2

2.0 APPLICABLE DOCUMENTS

2.1 APPLICABLE DOCUMENTS

The following documents are applicable to the <Item> requirements:

2.2 REFERENCE DOCUMENTS

The following are reference documents:

- The first problem is the use of the same title for sections 2.0 and 2.1. Section 2.1 should be called “COMPLIANCE DOCUMENTS”.
- The introductory text in Section 2.1 places no restrictions on the cited documents – if a document is updated at some point during the product life cycle, then the product must be updated to agree with the compliance documents.

2.0 APPLICABLE DOCUMENTS

The documents listed in this section are specified in sections 3, 4, or 5 of this document. This section does not include documents cited in other sections of this document or recommended for additional information or as examples. While every effort has been made to ensure the completeness of this list, Document users are cautioned that they must meet all specified requirements of Documents cited in sections 3, 4, or 5 of this document, whether or not they are listed here. Failure to include a cited document in this section does not mean that it is not included in this Document. Inclusion of a document in this section without a citation in the text does not include that document in this Document.

2.1 APPLICABLE DOCUMENTS

The following documents of the exact revision and date listed below form a part of this specification to the extent specified herein.

2.2 REFERENCE DOCUMENTS

The following documents of the exact revision and date listed below are referenced herein.

- **The statements force exact attribution of the applicable documents and ensure that any update to an applicable document will force a formal explicit review and possible change to the specification.**

- **The format for Sections 2.0, 2.1 and 2.2 shown on the previous chart are the “short” form.**
- **MIL-STD-490 and MIL-STD-961 recommend listing the documents within Sections 2.1 and 2.2 by source.**
- **See Section 5.7.2 – 5.7.3 of MIL-STD-961E for an example of the “long” form. Note that it makes no distinction between compliance and reference documents.**

- **A standard format is to reference the documents (compliance and reference) in a tabular format, as follows:**

MIL-DTL-15090D
6 November 1996

Detail Specification, *Enamel, Equipment, Light Gray, (Navy Formula No. 111)*, Department of Defense

MIL-STD-1399-300A
Notice 1
11 March 1992

Military Standard, Interface Standard for Shipboard Systems, Section 300A, Electric Power, Alternating Current, Department of Defense

MIL-STD-1472F
Notice 1
5 December, 2003

Department of Defense Design Criteria Standard, Human Engineering, Department of Defense

- **Decide if the citation in the requirement statement should have the full attribution, or just the base number (i.e., MIL-STD-130M or MIL-STD-130). The full attribution must be provided in Section 2.**



NORTHROP GRUMMAN

DEFINING THE FUTURE

Precedence

- There can be conflicts between the cited documents and requirements in the citing specification.
- Add a subsection to Section 2 with the following text:

2.X Order of precedence

In the event of a conflict between the text of this specification and the references cited herein, the text of this specification takes precedence. Nothing in this specification, however, supersedes applicable laws and regulations unless a specific exemption has been obtained.

Quoted from JSSG-2000A, paragraph 2.5.

A space-themed background featuring a view of Earth from space on the left, with a bright sun and lens flare effects in the upper left quadrant. The rest of the background is a deep blue space filled with stars.

NORTHROP GRUMMAN

DEFINING THE FUTURE

Tiering

- **Control of document tiering has become a primary way of controlling contractual applicability of cited documents. Care must be taken to ensure that each cited document is appropriate to the first-tier references or compliance documents (including those references or compliance documents cited in the contract, which themselves would become first-tier references or compliance documents and, thus, their second tier would become contractually applicable as well).**
- **Exceptions to tiering applicability are generally defined by DoD policy. For example, in the Perry memo previously cited, the direction on tiering of specifications and standards includes, “Approval of exceptions may only be made by the Head of the Departmental or Agency Standards Improvement Office and the Director, Naval Nuclear Propulsion for specifications and drawings used in nuclear propulsion plants in accordance with Pub. L. 98-525 (42 U.S.C. fl7158 Note).”**

Based on JSSG-2000A, paragraph 2.4.

- Cited applicable documents can, themselves, cite additional applicable documents which can, also, cite applicable documents:

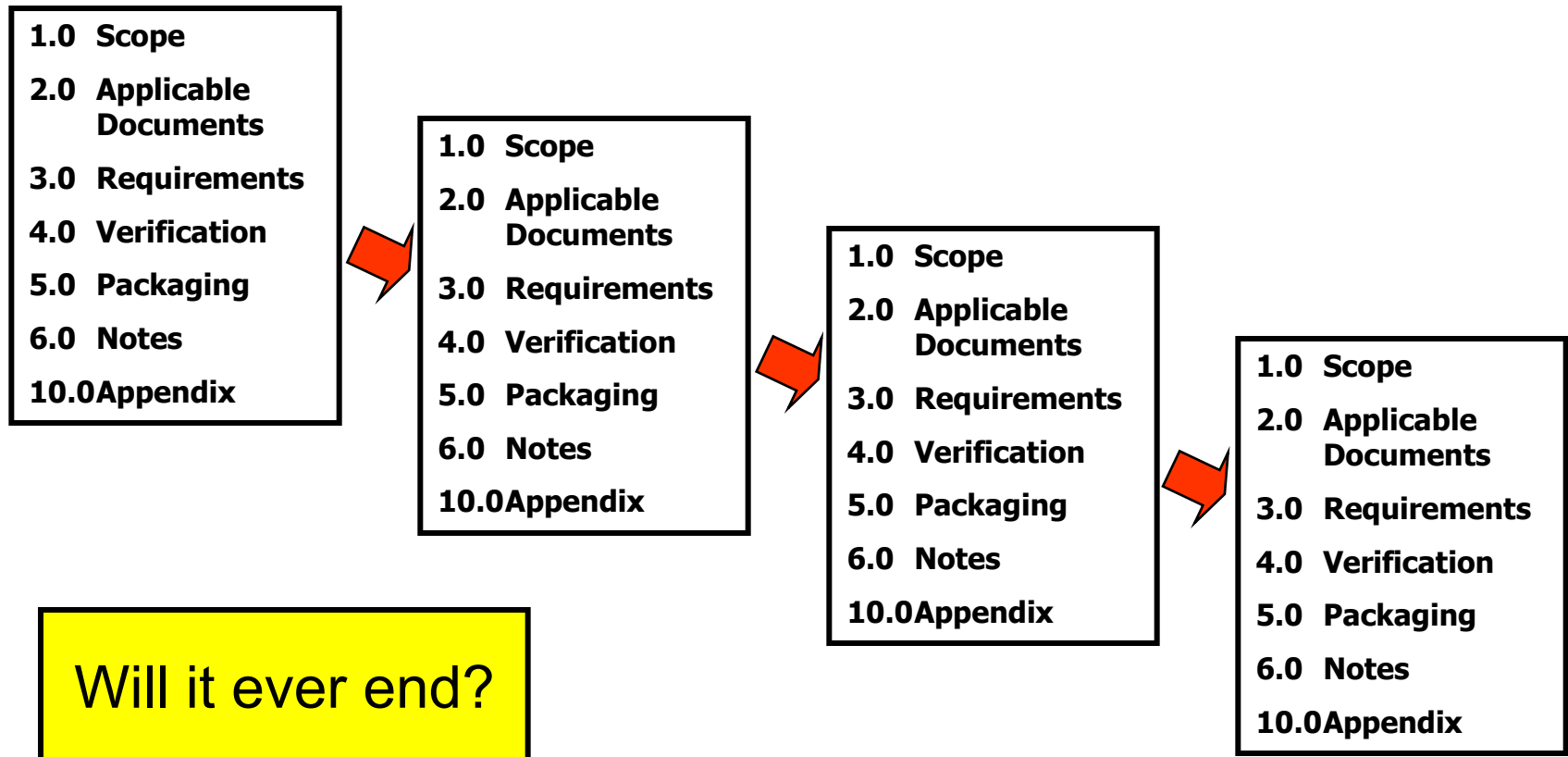

- Need to include a tiering statement such as:

When the <item> specification is directly referenced in the contract, it is a first-tier specification and is applicable. Documents referenced in the first-tier specification are applicable as follows:

- a. Second Tier - All documents directly referenced in the first-tier specification are only applicable to the extent specified.**
- b. Lower Tier - All documents directly referenced in second- or lower-tier documents are for guidance only unless otherwise directed by the contract.**

Based on JSSG-2000A, paragraph 2.4.

A space-themed background featuring a view of Earth from space on the left, with a bright sun or star in the upper left quadrant creating a lens flare effect. The rest of the background is a deep blue space filled with numerous small white stars.

NORTHROP GRUMMAN

DEFINING THE FUTURE

Flowdown to Subcontractors

Cleared for Public Release, Control No. 08-103, dtd. 9/30/08

- The specifications provided to the subcontractors for the items that they are to provide should also contain a Section 2, and the flowed-down requirements should cite the portion of the applicable document in the parent document that corresponds to the flowed-down requirement

A space-themed background featuring a view of Earth from space on the left, with a bright sun and lens flare effects in the upper left quadrant. The rest of the background is a deep blue space filled with stars.

NORTHROP GRUMMAN

DEFINING THE FUTURE

References

- **MIL-STD-490A, Military Standard Specification Practices, 4 June 1985 (now cancelled)**
- **MIL-STD-961E, Department of Defense Standard Practice Defense and Program-Unique Specifications Format and Content, 1 August 2003**
- **JSSG-2000A, Department of Defense Joint Service Specification Guide Air System, 15 March, 2000**
- **MIL-STD-810F, Department of Defense Test Method Standard, Environmental Engineering Considerations and Laboratory Tests, 1 January 2000, Department of Defense.**
- **MIL-STD-1472F, Notice 1, Department of Defense Design Criteria Standard, Human Engineering, 5 December, 2003, Department of Defense.**
- **MIL-HDBK-310, Department of Defense Handbook, Global Climatic Data for Developing Military Products, 23 June 1997, Department of Defense.**

A space-themed background featuring a view of Earth from space on the left, with a bright sun and lens flare effects in the upper left quadrant. The rest of the background is a deep blue space filled with stars.

NORTHROP GRUMMAN

DEFINING THE FUTURE

Biography

- Jim van Gaasbeek has 35 years experience analyzing and developing rotary-wing and fixed-wing aircraft, launch vehicles and spacecraft, both in the United States and European defense environments. Beginning as a rotor aeroservoelastician, his career has progressed with experience in constructive and virtual simulation, accident investigation, vehicle-management system design and systems engineering, concentrating in risk management and requirements development, management and verification.

NORTHROP GRUMMAN

DEFINING THE FUTURE



NORTHROP GRUMMAN

DEFINING THE FUTURE

Operational Concepts

11th Annual Systems Engineering
Conference

National Defense Industrial Association
San Diego, California
23 October, 2008

James R van Gaasbeek
Associate Technical Fellow, Systems Engineering
Northrop Grumman Corporation

A recognized systems engineering best practice is early development of operational concepts during system development and documentation of those operational concepts in one or more Operational Concept Documents. Recognizing this best practice, United States Department of Defense and NASA standard procedures require that information relating to system operational concepts be prepared in support of the specification and development of systems. In the past, the DoD has published Data Item Descriptions (DIDs), and NASA has published Data Requirements Documents (DRDs), which describe the format and content of the information to be provided.

The abstract model of the concept of operations is focused on operations, with reference to specific systems only as needed. A definition of “operational concept” has not been found. For the purposes of this presentation, it will be taken to mean an abstract model of the operations of a specific system or group of systems, usually developed as part of the acquisition process and used throughout the design, development, test and evaluation (DDT&E) phases of the system life cycle.

While various Government standards require the generation of operations concept information and Data Item Descriptions (DIDs) are available, little information is typically provided which clearly describes the manner in which an OCD should be used in support of a system development. Few guidelines exist regarding which information is most useful, how to develop that information, which developer and customer personnel should participate, or how to document it have been provided.

This presentation will address the nature of the operations concept, how it is developed and by whom, and how it is used in the development, deployment, operations and support of a new or upgraded system.

- What is an OpsCon
- Relationships with Use Cases and DoDAF
- OpsCon Preparation
- Scenarios
- Requirements Definition from the Operational Concept
- Use of the Operational Concept for Validation
- References
- Author Biography

- **Concept of Operations:** A verbal and graphic statement, in broad outline, of an enterprise's assumptions or intent in regard to an operation or series of operations. The concept of operations frequently is embodied in long-range strategic plans and annual operational plans. In the latter case, the concept of operations in the plan covers a series of connected operations to be carried out simultaneously or in succession. The concept is designed to give an overall picture of the enterprise operations. It is also called the CONOPS.
 - (Based on Department of Defense Dictionary of Military and Associated Terms, JP 1-02, 12 April 2001 (as amended through 23 March 2004))
- **Operational Concept:** A verbal and graphic statement of an enterprise's assumptions or intent in regard to an operation or series of operations of a system or a related set of systems. The operational concept is frequently developed as part of a system development or acquisition program. The operational concept is designed to give an overall picture of the operations using one or more specific systems, or set of related systems, in the enterprise's operational environment from the users' and operators' perspective. It is also called the OpsCon. It is defined in an Operational Concept Document.
- These definitions will be used in this presentation. They are arbitrary – define the terms for your Program at the beginning of the Program and use them consistently.

ConOps and OpsCon Relationship

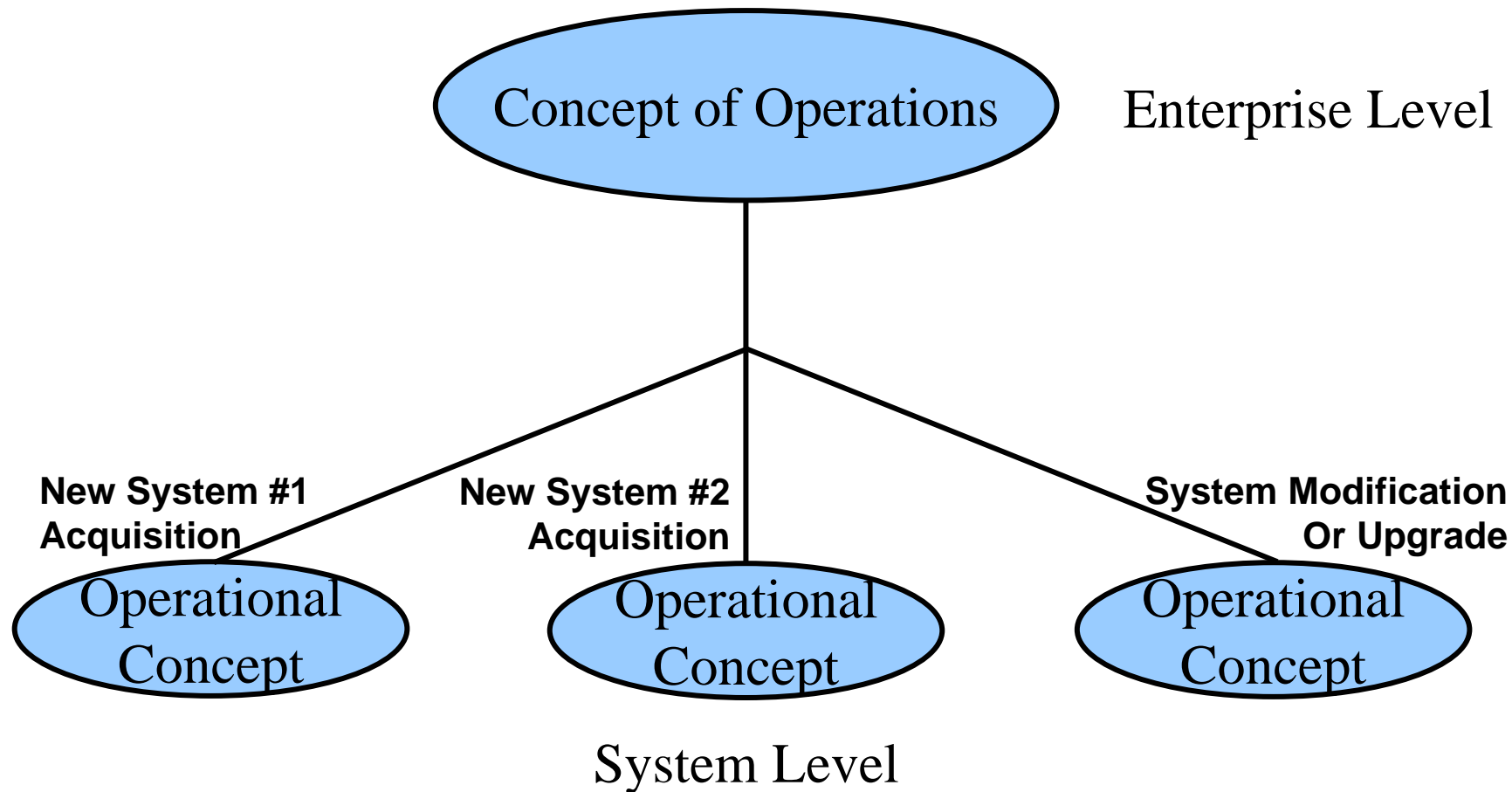

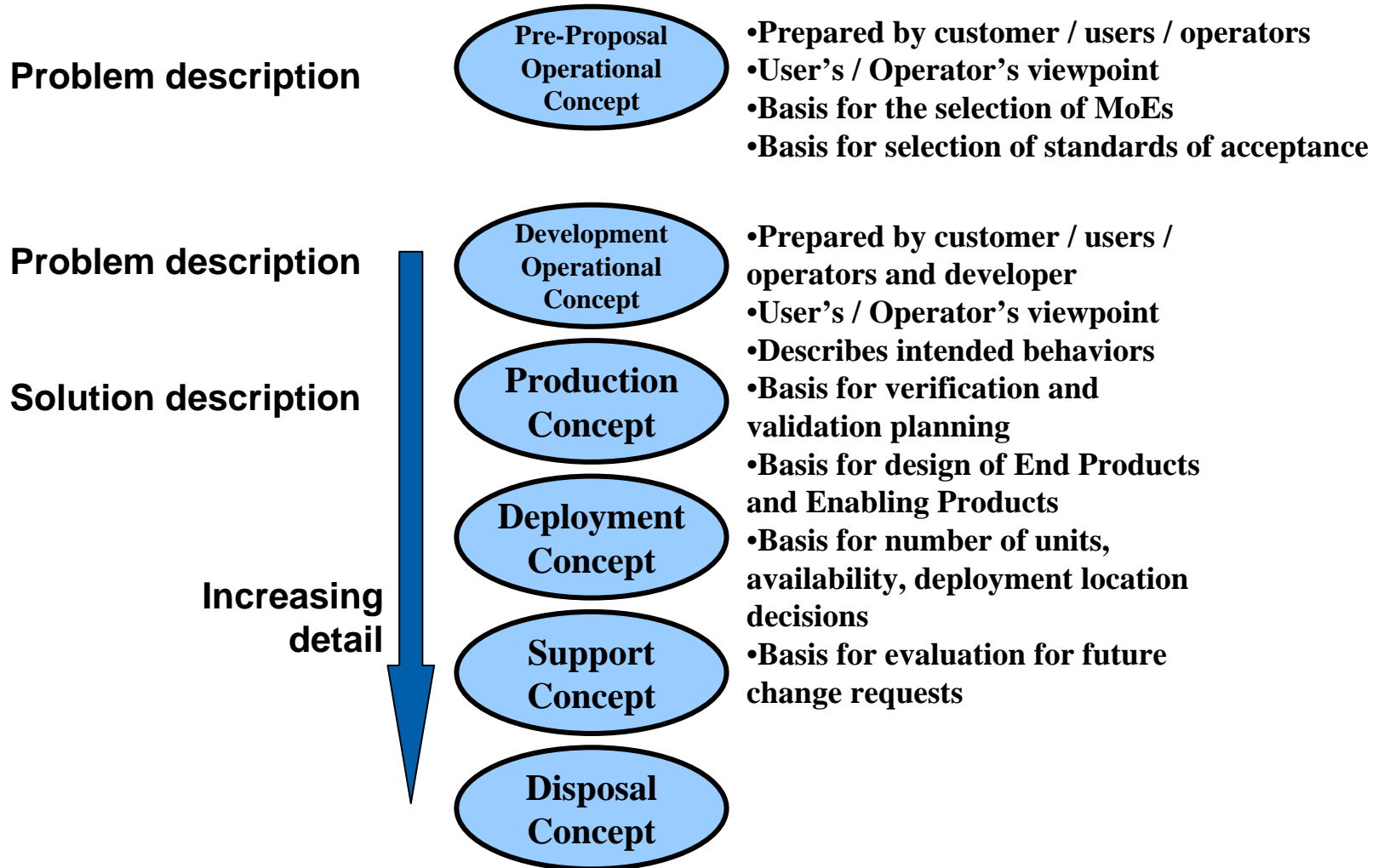

OpsCon in the DoD Acquisition Life Cycle

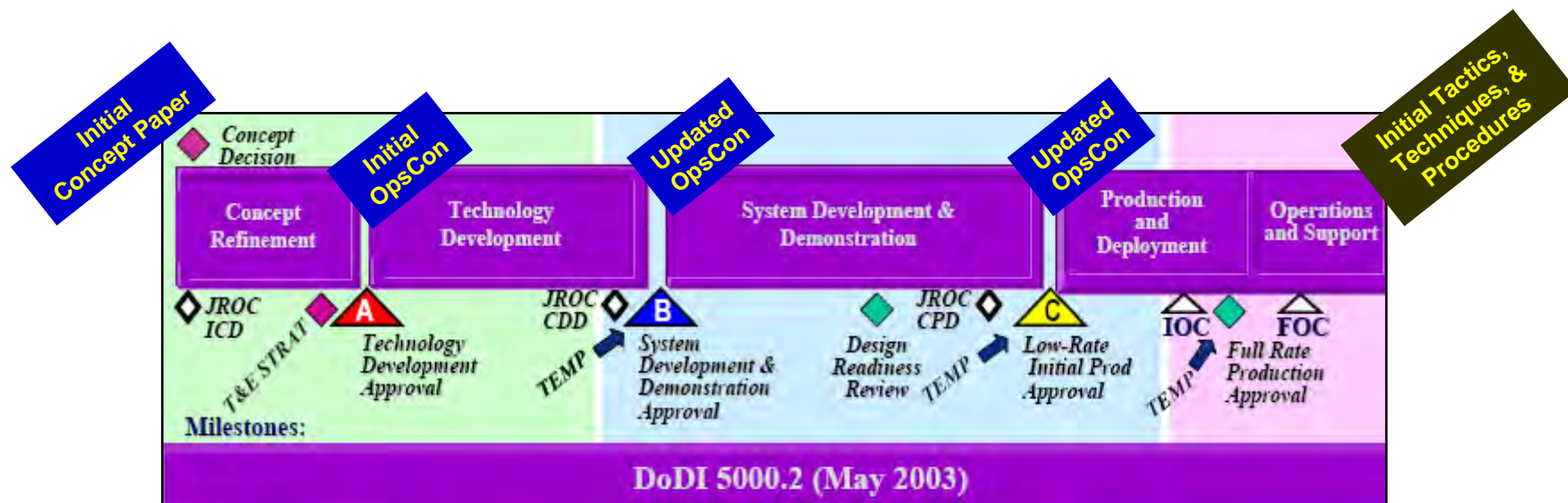

ConOps and OpsCon in Development

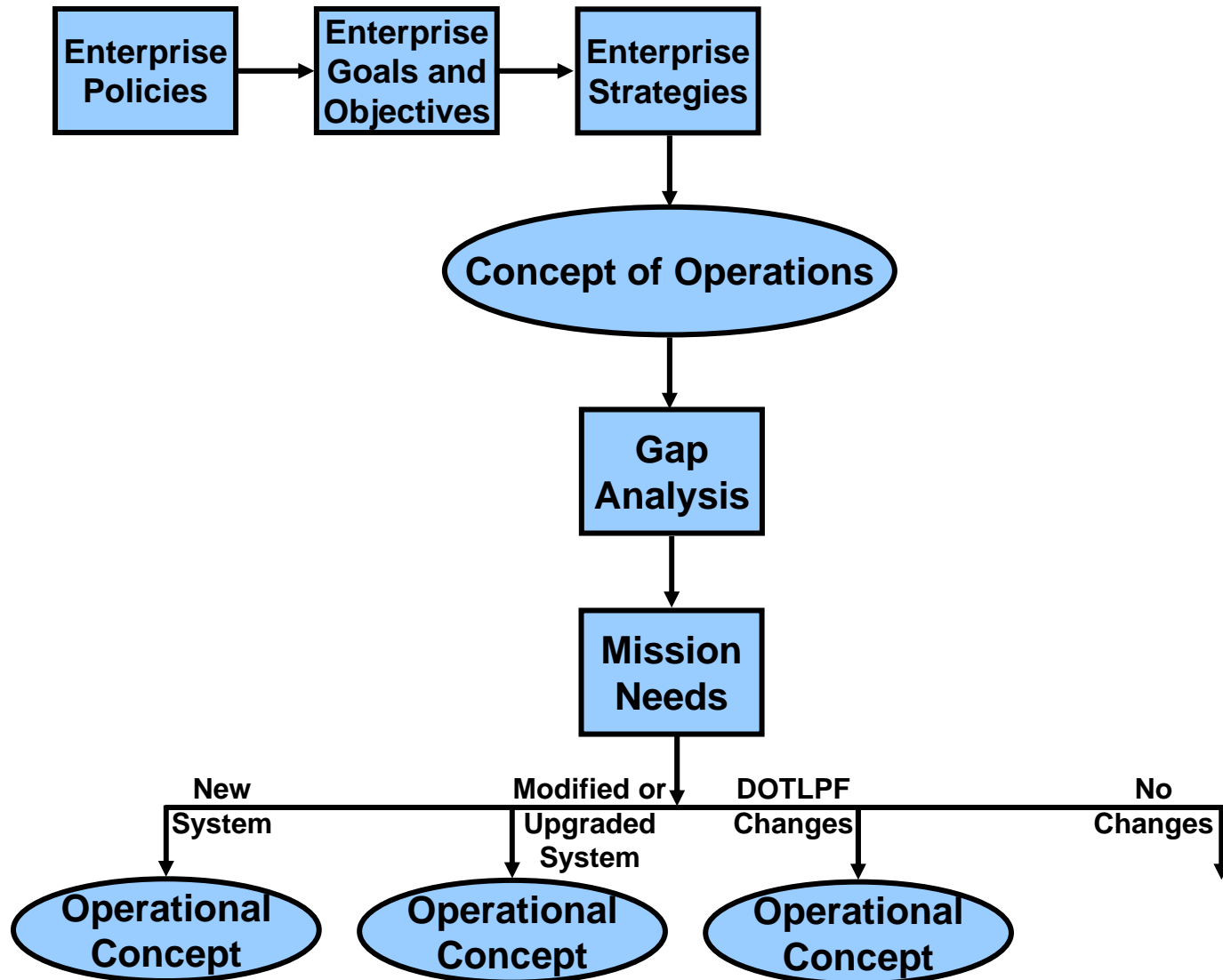

OpsCon Purposes

- The Operational Concept provides contextual information for the development of the requirements and the system – details of the intended use and benefits of the system.
- The Operational Concept provides the basis for the system validation.

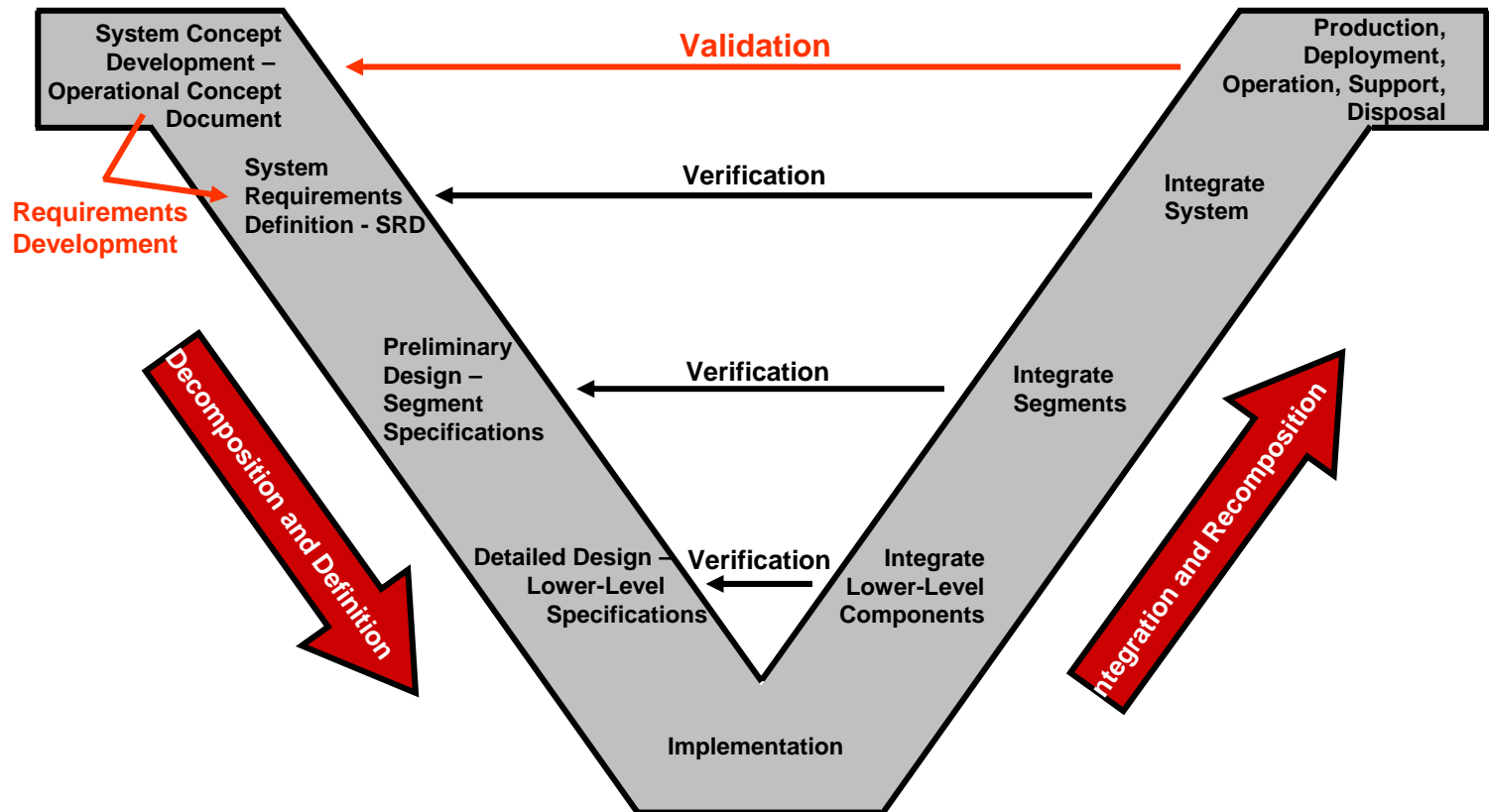

- **The Use Case, part of the Unified Modeling Language (UML), and now part of the System Modeling Language (SysML) as well, is limited in scope relative to an Operational Concept Document (OCD).**
- **Use Case analysis is extremely useful in elicitation of operator, maintainer and user requirements.**
- **The Use Case does not discuss the operational context or environment, for example.**
- **Another valuable feature of Use Cases, which can be included in the OCD, is the Use Case scenario pre- and post-conditions.**
- **The set of Use Case descriptions and the scenarios can be included in the OCD, but they do not form a complete OpsCon**
- **The use of Use Cases in the OpsCon should be carefully considered and balanced with the use of narrative and graphics for the remainder of the OCD. A collection of Use Cases and Scenarios can not, in itself, constitute an OCD.**

- OV-1, High-Level Operational Concept Graphic
- The High- Level Operational Concept Graphic describes a mission and highlights main operational nodes (see OV-2 definition) and interesting or unique aspects of operations. It provides a description of the interactions between the subject architecture and its environment, and between the architecture and external systems. **A textual description accompanying the graphic is crucial. Graphics alone are not sufficient for capturing the necessary architecture data.**
- The Operational Concept Document, which documents the Operational Concept, is ideal to provide the textual description for the OV-1 Graphic.

- **There are two documents that provide guidance in the development of Operational Concepts and their documentation:**
 - **ANSI/AIAA G-043-1992, Guide for the Preparation of Operational Concept Documents, American Institute of Aeronautics and Astronautics, Washington, D.C., January 22, 1993 (being updated)**
 - **FHWA-HOP-07-001, Developing and Using a Concept of Operations in Transportation Management Systems, Federal Highway Administration, August 2005**
 - **Note that the report is actually addressing the Operational Concept as defined on Chart 4**
- **There are two additional documents that provide outlines and a discussion of the contents of an OpsCon**
 - **IEEE Standard 1362, IEEE Guide for Information Technology – System Definition – Concept of Operations Document, 19 March 1998**
 - **ISO 14711:2002(E), Space systems – Unmanned mission operations concepts – Guidelines, 2002**
- **US Government guidance documents are listed in the References.**

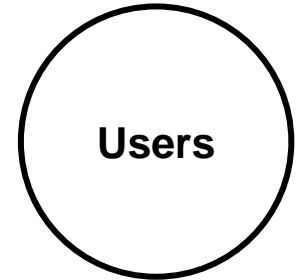
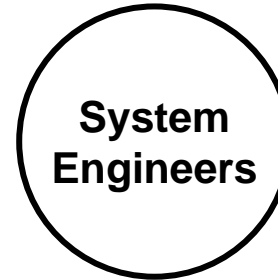
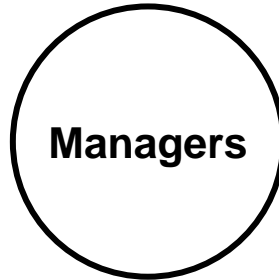
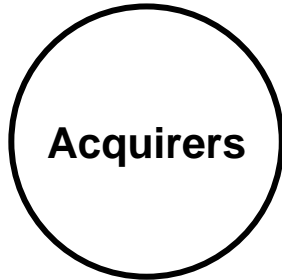

Operators, Maintainers and Users should be the authors of the OpsCon. In the event that they have not developed an OpsCon, then the developer community should develop it in cooperation with the operators, maintainers and users. It is possible that some stakeholders are not available (e.g., regulators), in which case the authors must work with stakeholder surrogates.

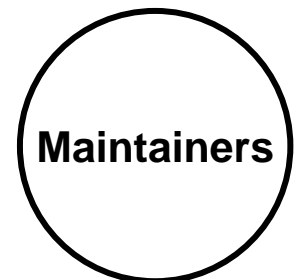
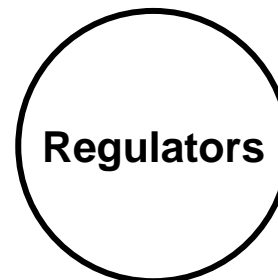
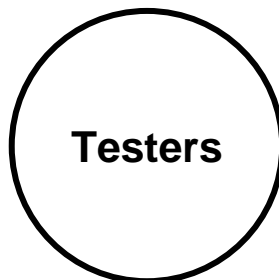
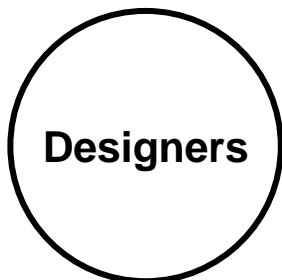
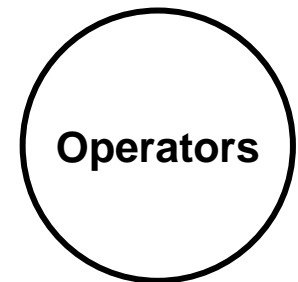

When to Write the OpsCon

- The OpsCon should be written before or during the concept development phase.
- The OpsCon should be updated throughout the product lifecycle, at major milestones, to support the Program phase:
 - System Development
 - Production
 - Deployment
 - Operations and Support
 - Disposal

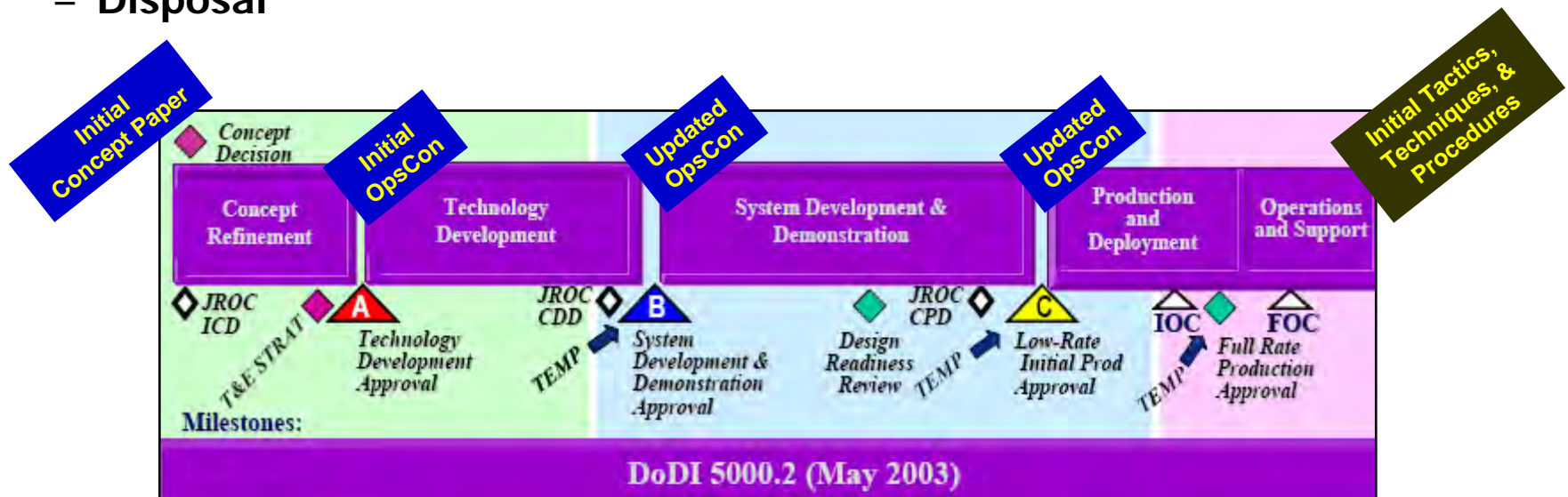

Users of the OpsCon

- Operators / Maintainers / Users
- Systems Engineers and Architects
- System Implementers
- Acquirers
- Testers
- Regulators
- In short, the stakeholders

- Operations Concept - describes the way the system works from the operator's perspective.
- Production Concept - describes the way the system will be manufactured.
- Deployment Concept - describes the way the system will be delivered and installed.
- Support Concept - describes the desired support infrastructure and manpower considerations for maintaining the system after it is deployed. This includes specifying equipment, procedures, facilities and operator training requirements.
- Disposal Concept - describes the way the system will be removed from operation and retired.
 - **Based on the INCOSE Systems Engineering Handbook**

- The OpsCon describes the various environments in which the system will be deployed, operate and be maintained:
 - **Physical**
 - **Natural**
 - **Induced**
 - **Self-induced**
 - **Threat**
 - **Cooperative**
 - **Political**
 - **Social**
 - **Economic**
 - **etc**

- 1. Scope
- 2. Referenced Documents
- 3. Background Information
- 4. Existing Systems and Operations
- 5. Operational Overview
- 6. System Overview
- 7. Operational Processes
- 8. Other Operational Needs
- 9. Analysis of the Proposed System
- Appendix A: Acronyms, Abbreviations and Glossary
- Appendix B: System Operational Scenarios

- Scenarios consist of both a textual and graphical description of a single end-to-end thread of operation of the system
- Need to have the major, critical, normal operational scenarios (“happy day”) described
- Need to have the important off-design or degraded-mode operational scenarios described as well (“rainy day”)
- Some examples of the graphical representation follow
 - **Typically, would use Functional Flow Block Diagrams, Enhanced Functional Flow Block Diagrams, Activity Diagrams or Sequence Diagrams**
 - **Have used a non-standard notation for simplicity**

Example Scenario – “Happy Day”

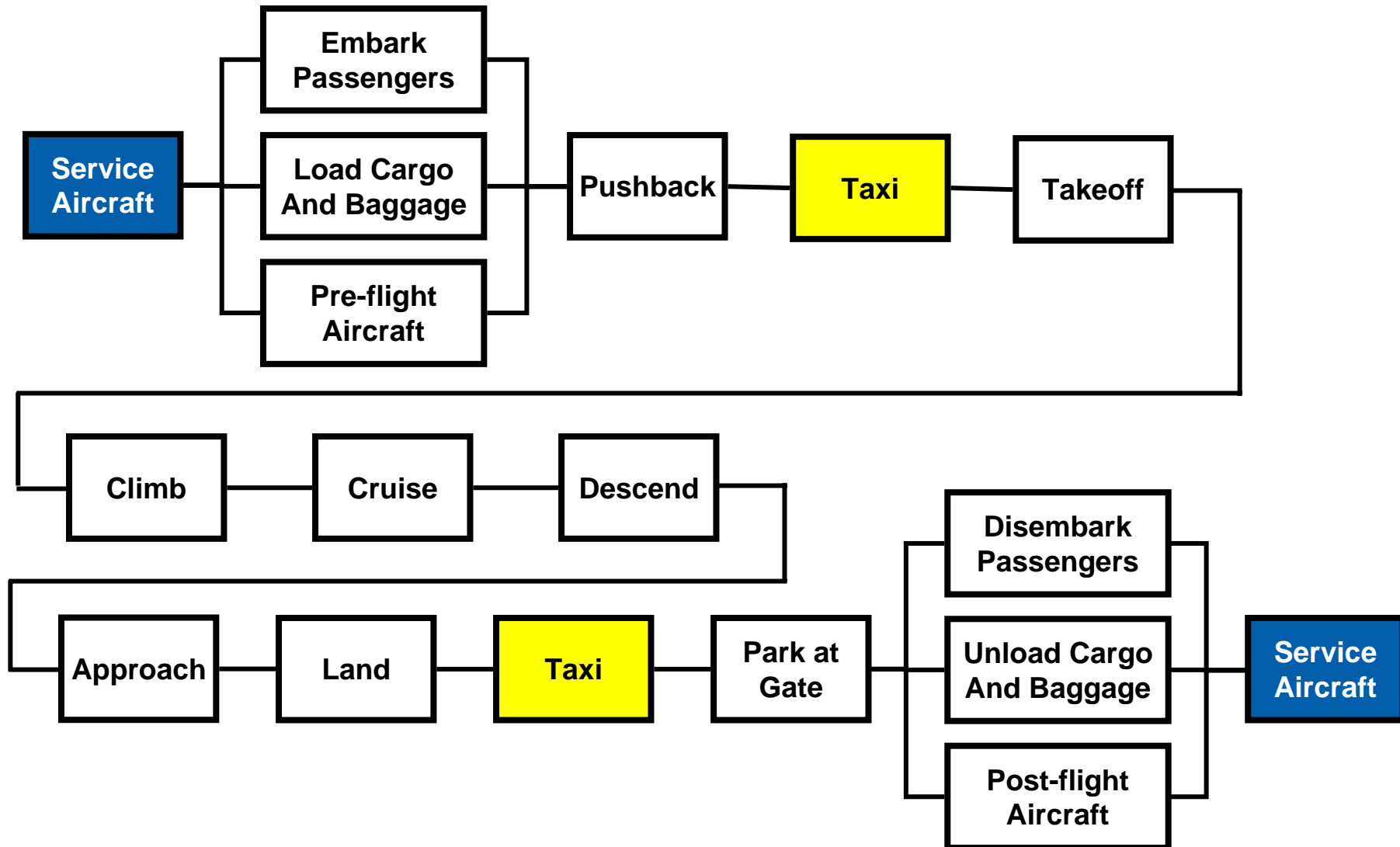

Example Scenario – “Rainy Day 1”

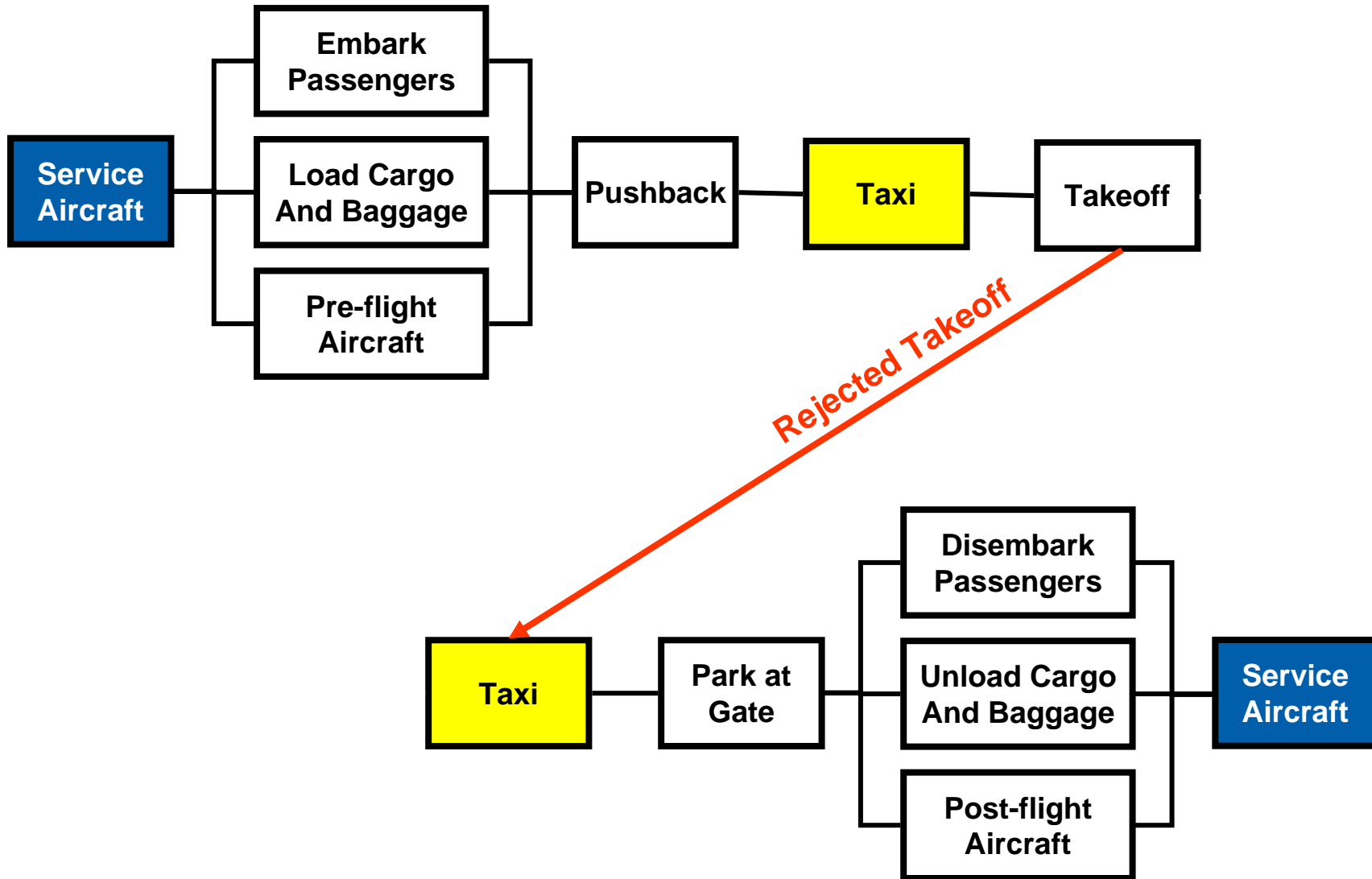

Example Scenario – “Rainy Day 2”

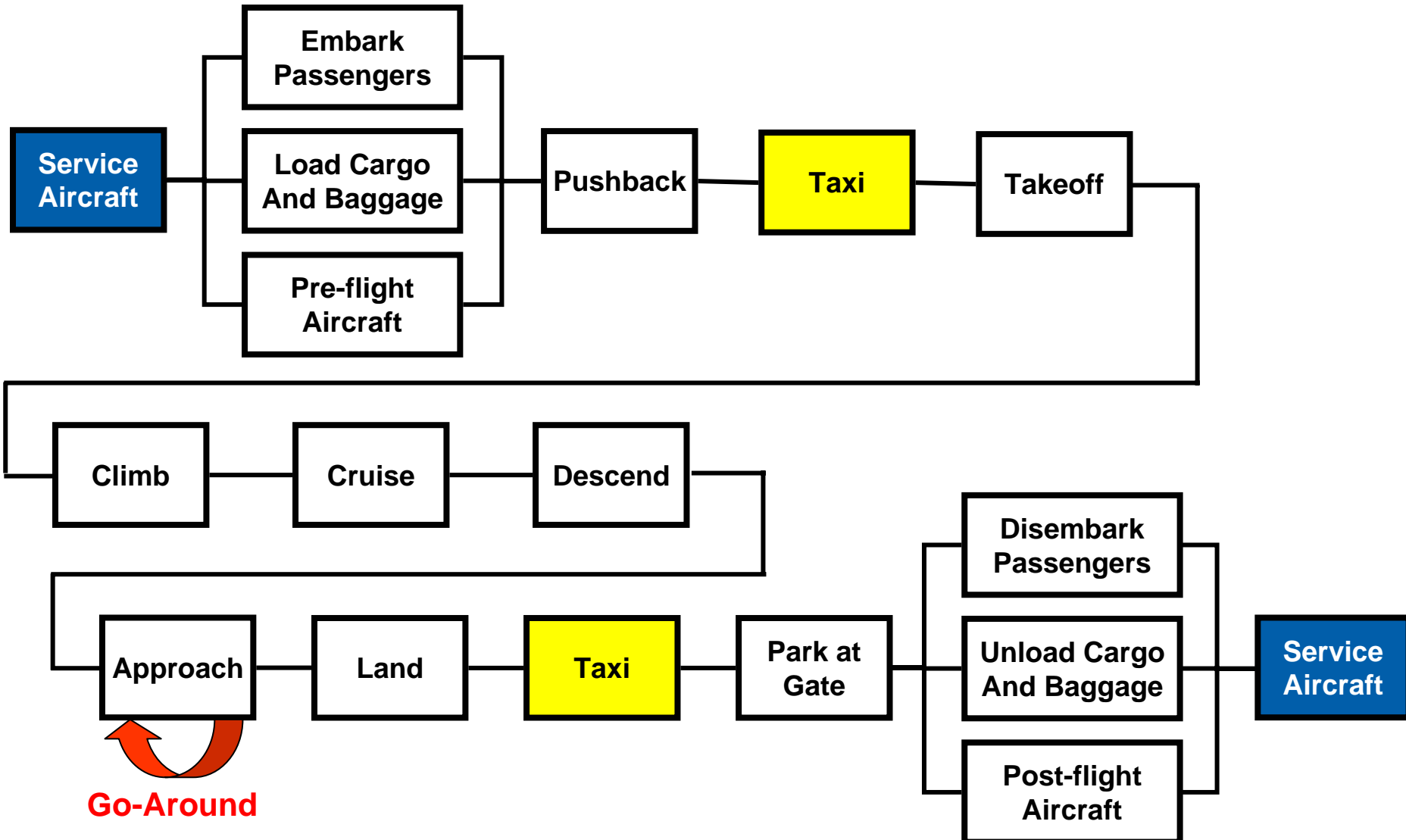

Example Scenario – “Rainy Day 3”

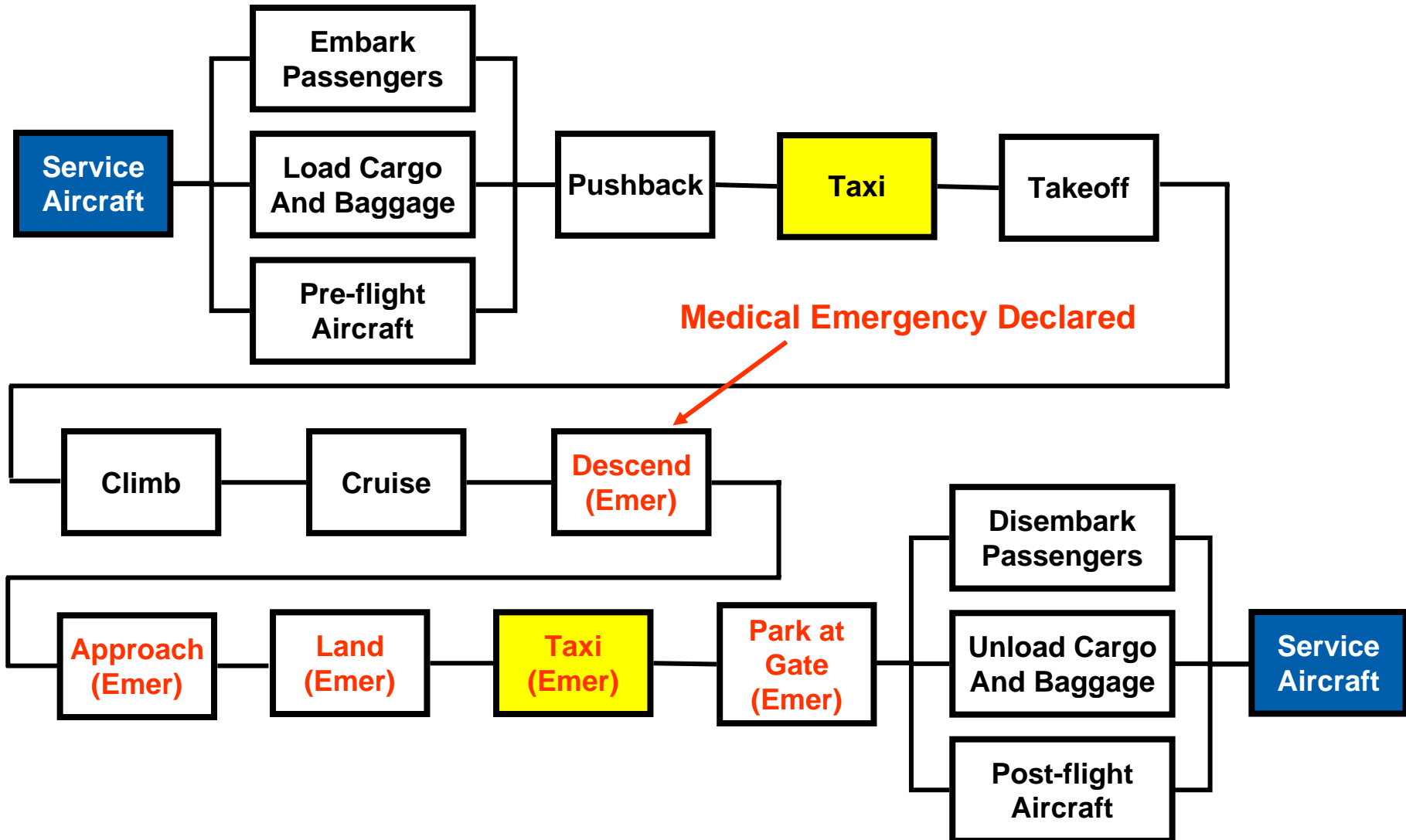

Developing Requirements from the Operational Concept

- The Operational Concept defines:
 - the context of the product, leading to a definition of its boundaries and the external interfacing and inter-operating systems, leading to identification of interface requirements;
 - the normal and other operational environments, leading to definition of the environmental requirements;
 - scenarios of normal and degraded operations, from which Product functionality can be derived;
 - and scenarios showing a “day in the life” of the product which help to develop the logistics, maintenance and support requirements, and identify the personnel requirements for the product operator.

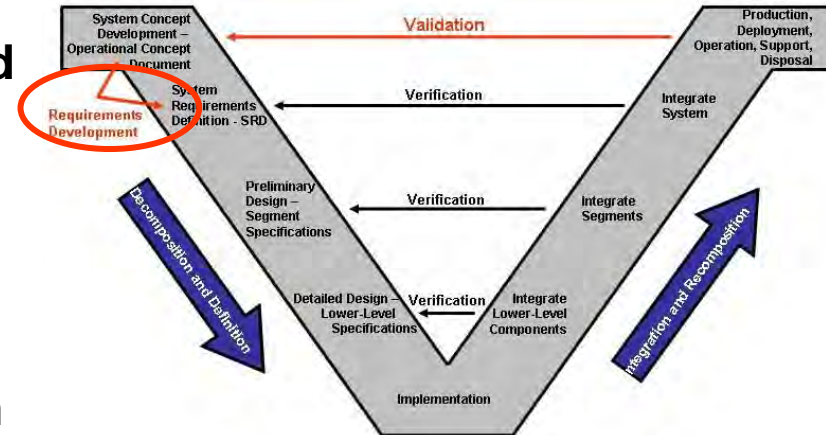

Use of the Operational Concept for Validation

- Requirements Validation is the task of showing that the Product as developed satisfies the customer needs in its intended operational environment.
- The Operational Concept provides:
 - A summary of the customer needs
 - A description of the normal and other operational environments
 - Various operational scenarios that can be used to define validation test procedures
 - Scenarios of degraded operations

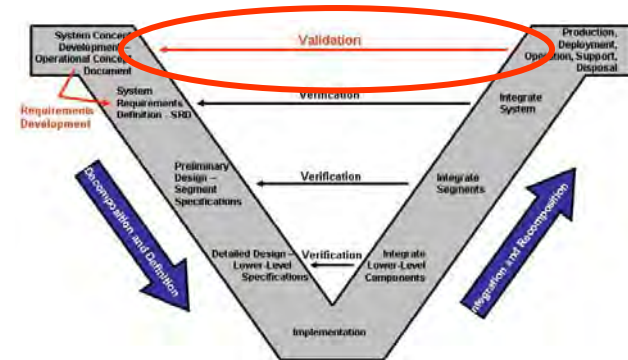

- **JP 1-02, Department of Defense Dictionary of Military and Associated Terms, 12 April 2001 (as amended through 23 March 2004)**
- **ANSI/AIAA G-043-1992, Guide for the Preparation of Operational Concept Documents, American Institute of Aeronautics and Astronautics, Washington, D.C., January 22, 1993**
- **FHWA-HOP-07-001, Developing and Using a Concept of Operations in Transportation Management Systems, Federal Highway Administration, August 2005**
- **IEEE Standard 1362, IEEE Guide for Information Technology – System Definition – Concept of Operations Document, 19 March 1998**
- **ISO 14711:2002(E), Space systems – Unmanned mission operations concepts – Guidelines, 2002**
- **ACC Instruction 10-650, Development and Use of Concepts of Operations, Department of the Air Force, 11 September 1998**
- **SMA-DID-P100, Concept Data Item Description, NASA Product Specification Document Standard, Release 4.3, 28 February, 1989**

- **Structured Approach for Operational Concept Formulation (OCF), TRW Defense and Space Systems Group, T-031-979, Redondo Beach, California, January, 1980**
- **Lano, Robert J, "A Structured Approach for Operational Concept Formulation", reprinted in Thayer, Richard H and Dorfman, Marlin, System and Software Requirements Engineering, IEEE Computer Society Press Tutorial, IEEE Computer Society Press, Los Alamitos, California, 1990.**
- Strengers, George, Development of Operational Concept Descriptions (Analyzing what the customer needs), Proceedings of the 2000 Systems Engineering / Test and Evaluation Conference, Australia, 2000
- DID DI-MCCR-80023, Operational Concept Documents, SDS Documentation Set – Data Item Descriptions for DoD-STD-2167, Department of Defense, 4 June 1985.
- DID DI-IPSC-81430, Operational Concept Description (OCD)
- DoD Architecture Framework, Version 1.0, Volume II: Product Descriptions, 15 August 2003

References (Concluded)

- **CJCSM 3170.01C Joint Capabilities & Integration Develop Sys (JCIDS), 01 May 07**
- **CJCSI 3010.02B, Joint Operations Concepts Development Process, 27 Jan 06**
- **COMUSFLTFORCOM Instruction 5401.1, Fleet CONOPS Development, Sep 07**
- **AF Instruction 10-2801, AF Concept of Operations Development, 24 Oct 05**
- **Army Strategic Planning Guidance 2005: Annex B Concept Development & Experimentation Guidance, 15 Jan 05**
- **Air Force Policy Directive 10-28, AF Concept Development, 15 Sep 03**
- **AF Space Command Instruction 10-102, Concept Development, 15 Nov 07**

- Jim van Gaasbeek has 35 years experience analyzing and developing rotary-wing and fixed-wing aircraft, launch vehicles and spacecraft, both in the United States and European defense environments. Beginning as a rotor aeroservoelastician, his career has progressed with experience in constructive and virtual simulation, accident investigation, vehicle-management system design and systems engineering, concentrating in risk management and requirements development, management and verification.

NORTHROP GRUMMAN

DEFINING THE FUTURE

Using Performance-Based Earned Value[®] for Measuring Systems Engineering Effectiveness

**Dr. Ron Carson
Bojan Zlicaric**

The Boeing Company

NDIA SE Conference – 20 October 2008

Outline

- **Performance-Based Earned Value®**
- **SE Effectiveness**
- **SE Metrics Architecture**
- **Example Metrics for Requirements**

The Scope of Earned Value is Limited

- ***ANSI/EIA-748B, 3.8**
 - “Earned value is a direct measurement of the quantity of work accomplished. The quality and technical content of work performed is controlled by other processes.” [emphasis added]
- **Need another method to assess quality of work accomplished**

* “Standard for Earned Value Management Systems”

Easy PBEVSM Example

- **Task: wash windows**
- **Desired outcome: clean windows**
- **Quality measure: cannot see anything on window surface (no distortion or obscuration of reflections)**
- **Earned Value: Window was washed**
 - “I washed the window”
- **PBEVSM: Window is clean**
 - “But it’s not clean” – PBEVSM less than EV
- **Difference (PBEVSM – EV) = “Unearned value” = Quality criteria for the product delivered by the activity, or the *cost of rework***

What is Quality?

- **“Quality is conformance to requirements” (Crosby, “Quality is Free”, 1979)**
- **Therefore, “quality” of work accomplished is composed of**
 - **Inherent quality of work product (conformance to work product standards, e.g., specs, drawings, plans, reports)**
 - **Conformance of work product to technical requirements associated with the system (e.g., design satisfies requirements)**

SE Quality Example - Specifications

- **A major SE work product is a specification containing all requirements for a system**
- **Requirements Specification Quality – 2 parts**
 - **Specification structure and syntax**
 - **Conforms to template standards (quality of specification)**
 - **Completeness, outline, format**
 - **Requirements are well-stated (quality of requirements)**
 - **Clarity, verifiability, etc.**
 - **Specification content**
 - **System described satisfies user needs and/or contract requirements, e.g., weight, speed, availability, etc.**

SE Effectiveness

- **“Effectiveness” is an ability to produce the needed result using the committed resources**
 - Resource commitments based on planning
 - EV measures execution vs. plan
 - Resource utilization: money, people, facilities, time
 - **What are the “needed results” or products of SE?**
 - Specific SE work products
 - Program outcomes
 - Cost – Budgeted cost
 - Schedule – Committed schedule
 - Technical Performance – Systems satisfying requirements and needs
- **Leads to PBEVSM***

*PBEV and Performance-Base Earned Value are registered trademarks of Paul Solomon

SE Effectiveness Decomposition

- **Define contributors to SE Effectiveness**
 - Leads to SE Metrics Architecture
- **Three contributing streams**
 - **Product Quality – Satisfying needs and requirements**
 - **Cost and**
 - **Schedule** } Collectively measured by Earned Value
 - **Planning (basis for product definition and EV)**
- **Essential elements**
 - **Work product quality and completeness – fitness for use by downstream “customer”**
 - **Timeliness – available when needed**
 - **Defined by coordinated schedule; measured by EV**

SE Measures Architecture

- Top level of measures architecture shows decomposition of SE Effectiveness and PBEVSM

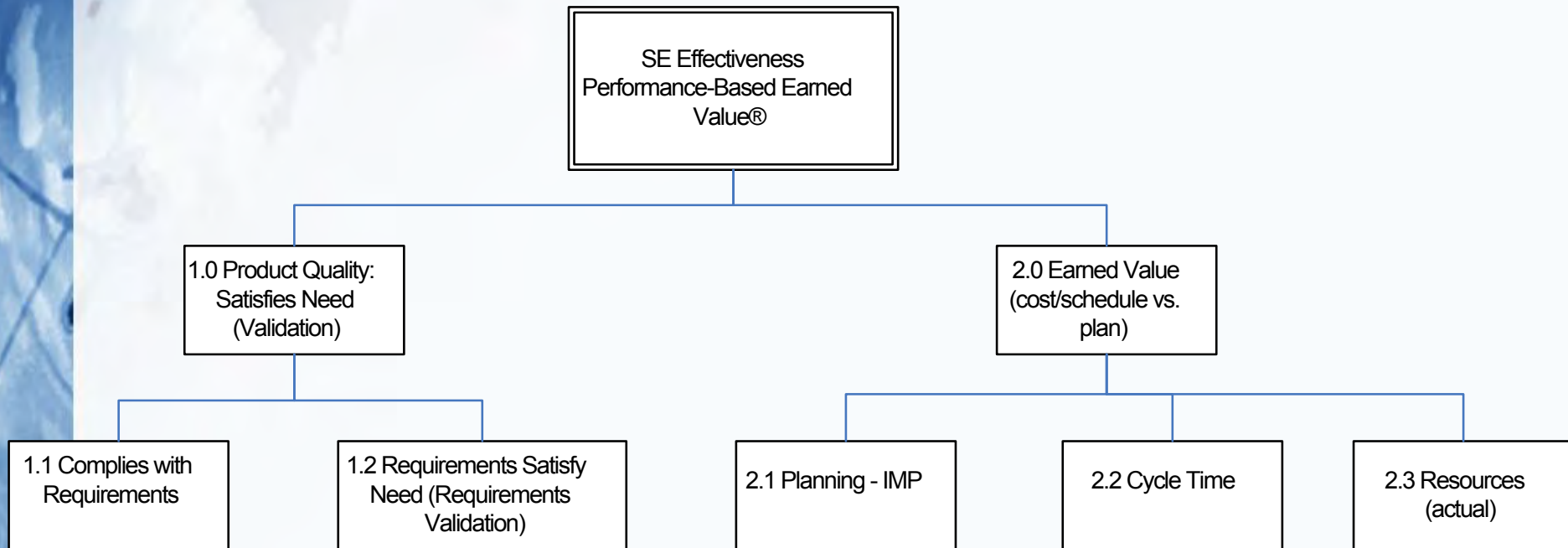

Using PBEVSM for SE Effectiveness

■ Work definition – IMP/IMS

- Define work products for every scheduled activity (evidence of completion)
 - Plans, requirements, design, interfaces, verification
- Define objective quality standards for work products
- Define technical content requirements for work products

■ Progress assessment

- Value is earned (EV) based on
 - Satisfying work product quality standard
 - Satisfying technical requirements associated with work product
 - Technical maturity per plan – % of planned TPM achieved (Solomon)
- “Unearned value” is cost of rework: the work not-yet-accomplished

Decomposition of Compliance of Design with Requirements

- **Measure Quality and Completeness of**
 - **Design Analysis and Verification (Compliance)**
 - **Design and Implementation**
 - **Requirements**

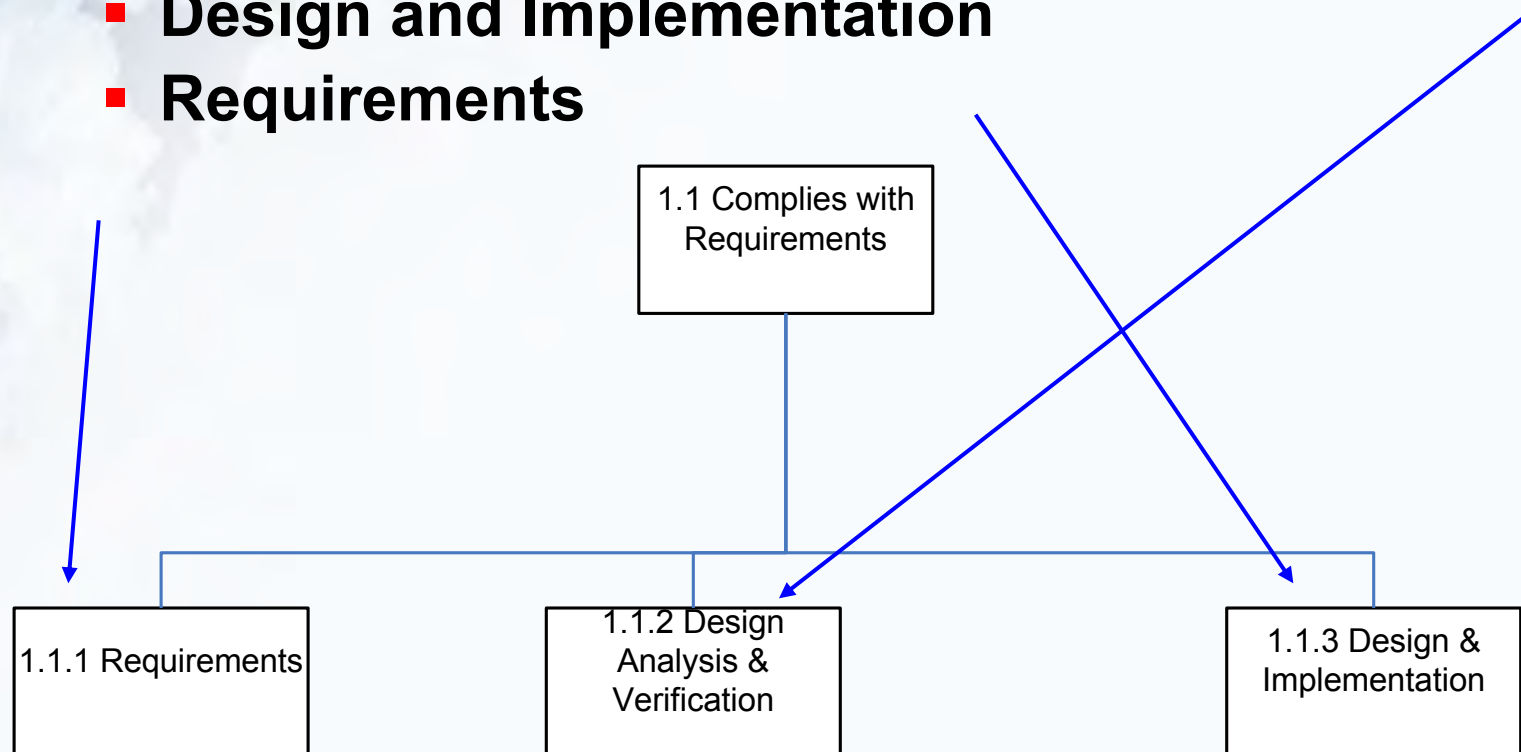

Technical Compliance Metric

- At each major review, assess % requirements for which design is compliant, with associated risk level of non-compliance*

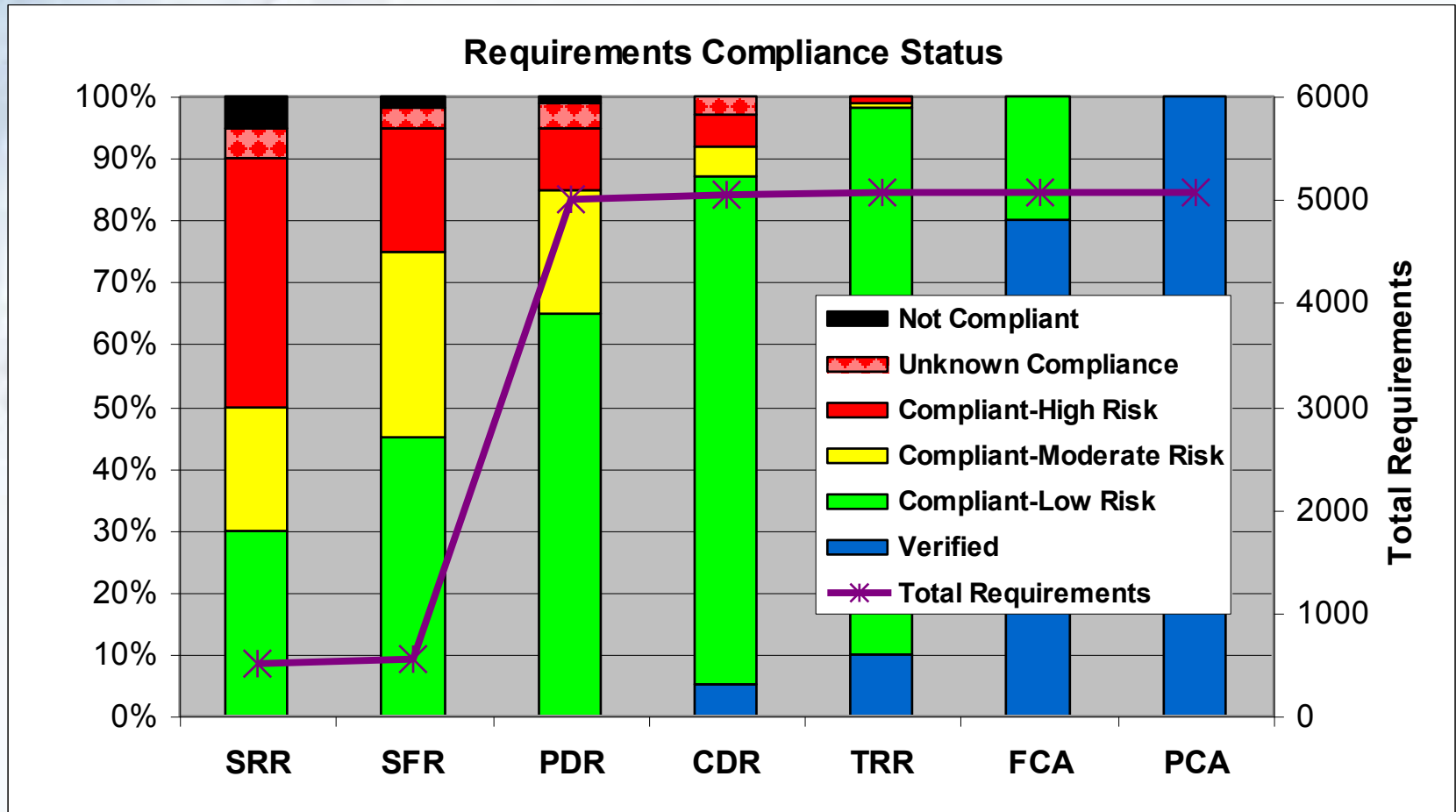

*Notional data

Requirements Quality Assessments (RQA)

- Assess quality of requirements vs. objective quality standard

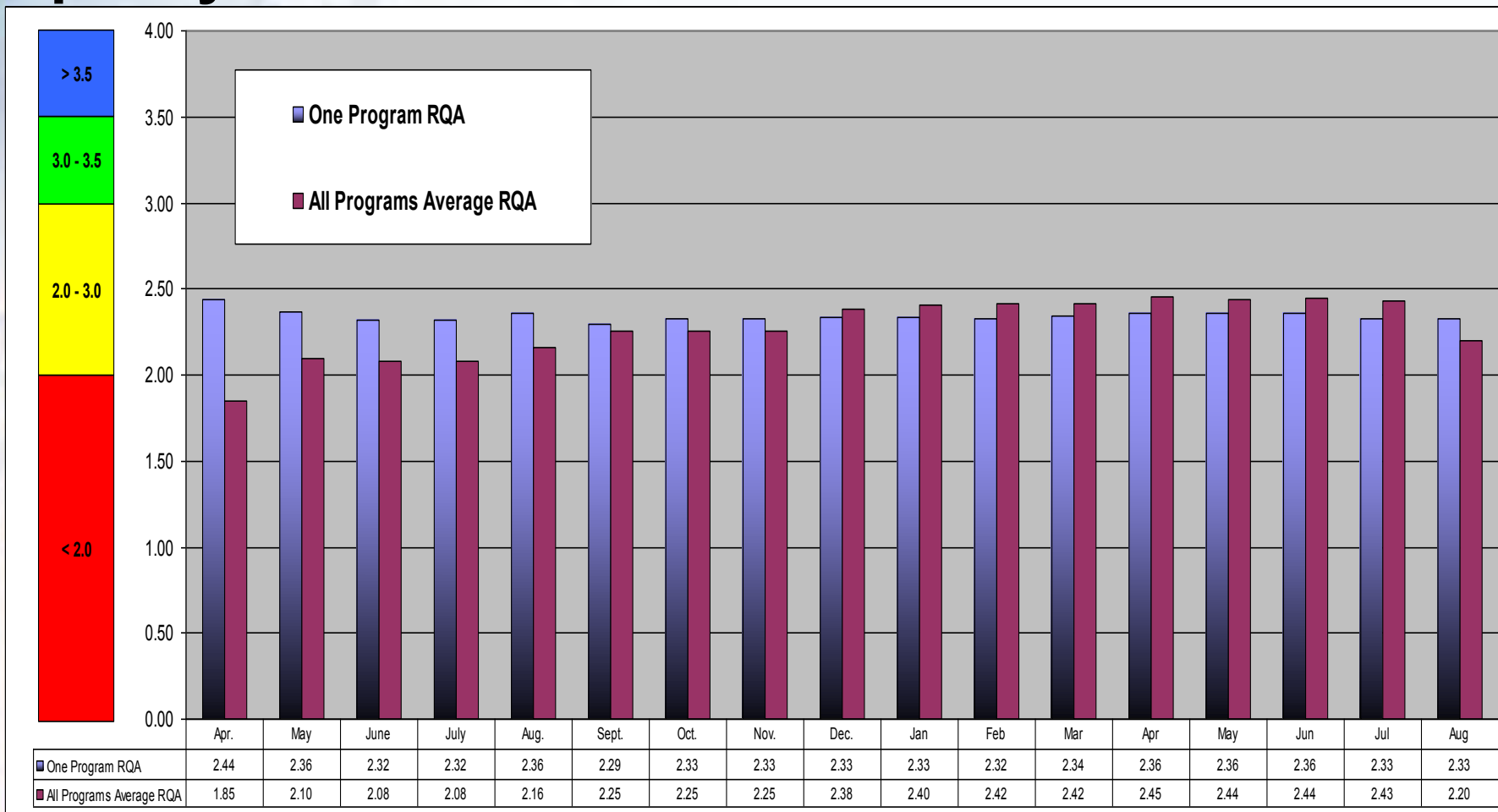

Summary

- **EV alone is inadequate to assess technical progress**
- **Program goals include satisfying cost, schedule, technical requirements**
- **PBEVSM offers a method to integrate these**
- **Architecture of SE measures enables decomposition and allocation of PBEVSM contributors to measurements of common SE work products**



Advanced Systems & Supportability Engineering Technology and Tools

Implementing a Methodology to Incorporate Operational Realism in CONOPS & Testing

National Defense Industrial Association (NDIA)
11th Annual Systems Engineering Conference
October 20-23, 2008

Test & Evaluation in Systems Engineering Track,
Wednesday October 22, 2007

William Lyders, ASSETT Inc.

Agenda

- Challenge: Incorporate Operational Realism Early in Life Cycle – Today!**
 - What products & when in life cycle
 - Two current projects that address challenge

- Double Helix Methodology involving CONOPS/Technology Trade-offs**

- The Methodology Captures Key Acquisition Information**
 - Inputs for TES, TDS, and TDS
 - Use Case involvement
 - Incorporating operations in Test Architecture

- Lessons Learned at ASSETT**

- Summary and Conclusions**

- Q&A**



SSETT Challenge: Operational Realism Early in Cycle

- Challenge – NDIA SE Division DT&E Report [April 2008]:
 - **Finding:** Operational realism is often not included or detailed in the earliest phases of acquisition, such as during generation of the CONOPS, ICD, TDS, and TES
 - **Recommendations:**
 - Operational realism must be given due diligence during the generation of the CONOPS, then flowed into the ICD, TDS, and TES
 - CONOPS should have iterative updates beginning when technology constraints are identified...
 - These updates need to flow into the ICD, TDS, and TES or their respective follow-on documentation.

- *In the following charts, the approach being done by a small business, ASSETT, is shown to be accomplishing the recommendations.*

Operational Realism and CONOPS

- Operational Realism – The tasks and activities, operational elements, and information exchanges required to conduct operations
 - DODAF Operational View in a System Architecture
 - Includes high level operational concepts [e.g. CONOPS],
 - Operational activities sequence and timing descriptions
 - Activity and Logical data models
 - Trade-offs between operations and technologies

- CONOPS – *A Concept of Operations is defined as a description of how a set of capabilities may be employed to achieve mission objectives or a particular end state for a specific scenario*
 - A CONOPS for critical mission segments should be in place for all mission scenarios
 - Currently, a CONOPS is not updated for a platform even though a technology improvement is installed or a new capability made available...CONOPS should change

Operational Realism Products Evolve Early in Acquisition and SE Process

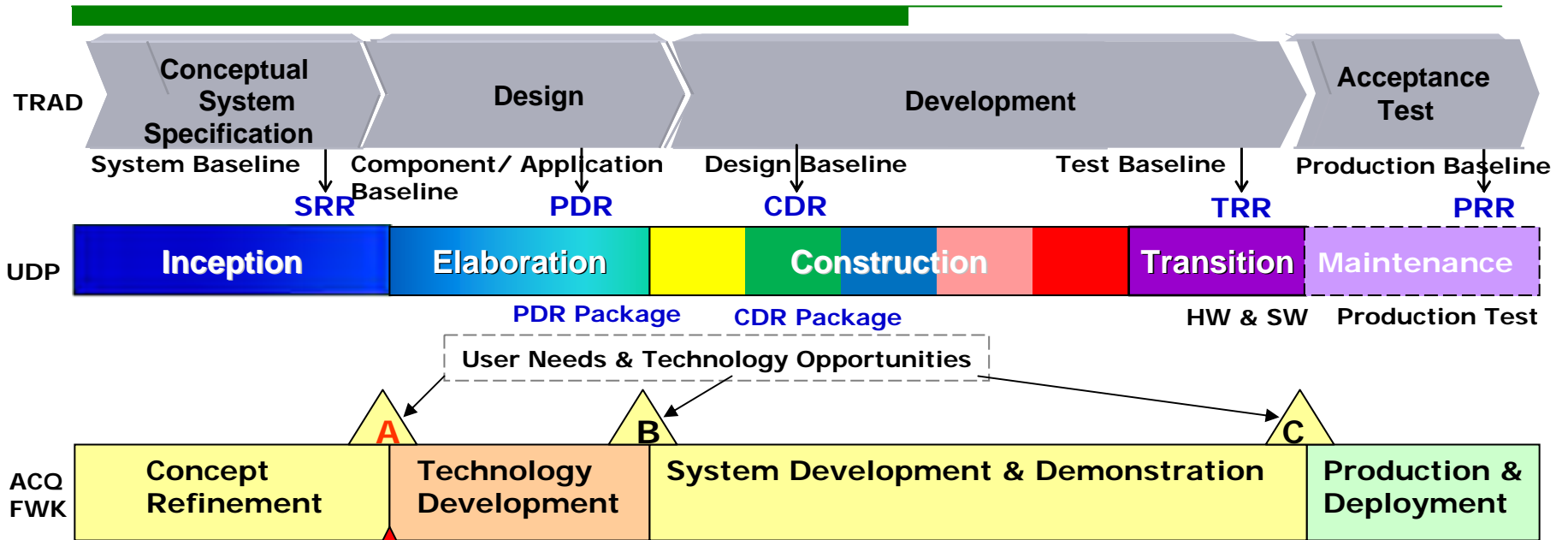

- ICD - Initial Capabilities Document
- TDS - Technology Development Strategy
- TES - Test & Evaluation Strategy [for TEMP]

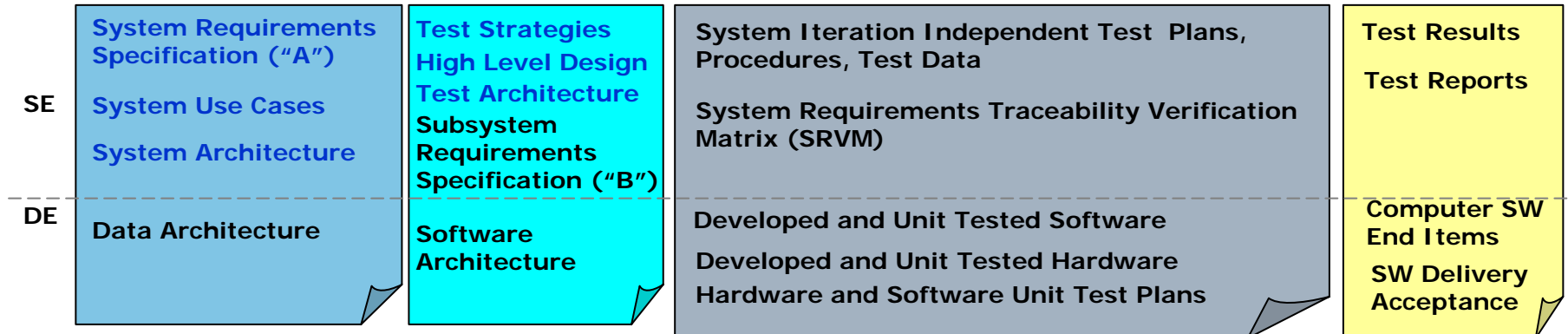

Two Current ASSETT Projects Address Operational Realism

□ SBIR N05-149 Combat System of the Future

■ Non-Traditional View of the Submarine

□ Provide the Basis for Ship Design

■ HSI Impacts Manning Reduction that Drives Stores, Accommodations, and Supplies

■ Maximum Use of Technology that Drives Power, Cooling, Volume, and Footprint Requirements

□ Identify Changes in CONOPS and Training

■ Allow CONOPS to Change as a Function of Technology

■ Develop Confidence in New Analysis Tools and Automation

□ ONR Capable Manpower Initiative

■ BAA 007-013 – Improved Manning and Optimized Personnel (IMOP)

□ Top-Down Approach to Estimating the Manning Requirements for a Platform

□ Searches for an Optimum Manning Solution Among Number of Operators, System Resource Requirements and Mission Tasking

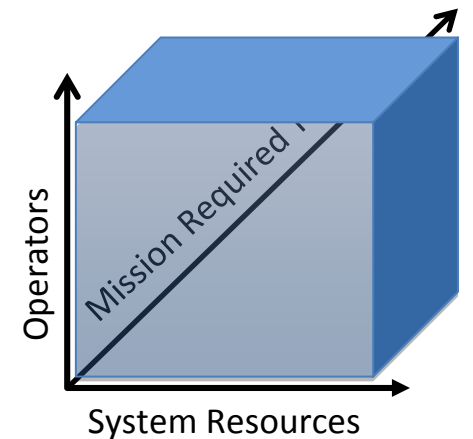
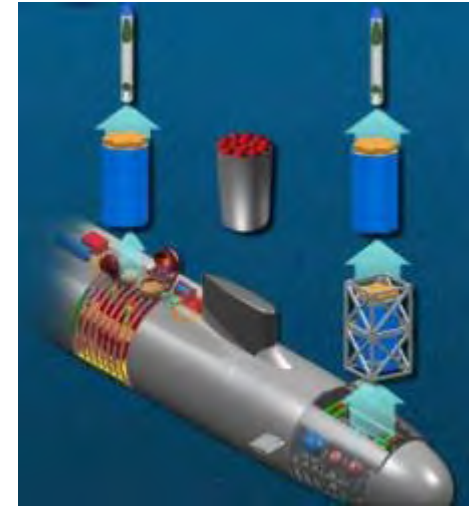

Our CSoF Methodology Incorporates Operational Concepts and Technology

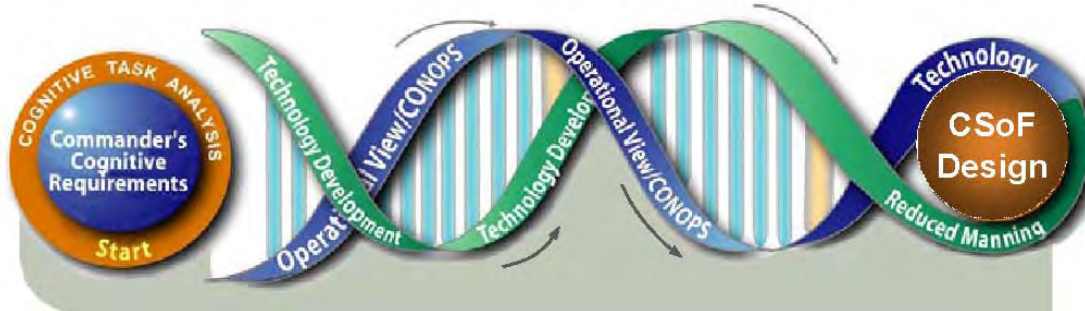

**Double Helix Approach
Leveraged from the DARPA
Command Post of the
Future [CPoF])**

- **Technology (Helix 1) and CONOPS (Helix 2 - Operator's View) Evolve and Over the Life Cycle of the System (Concept Through Disposal)**
 - **Understanding the Operator's View and What Is Needed for Effective Decision Making Is Necessary In Order to Apply New Technologies Effectively**
 - **Conversely, the Operator Needs to Be Made Aware of New Technologies and How They May Impact His Decision Making**
 - **The Blue Vertical Bars Represent Points in Time When an Exercise Is Run to Determine if Changes in Technology or CONOPS Would Enhance the Operator's Ability to Make Accurate Decisions. Typically this Exercise Is Via the Web or Video Conferencing**
 - **The Orange Vertical Bars Represent Point in Time When Actual Experiments Are Run to Analyze the Benefits of New Technology or Changes in CONOPS.**

Mission Driven Design

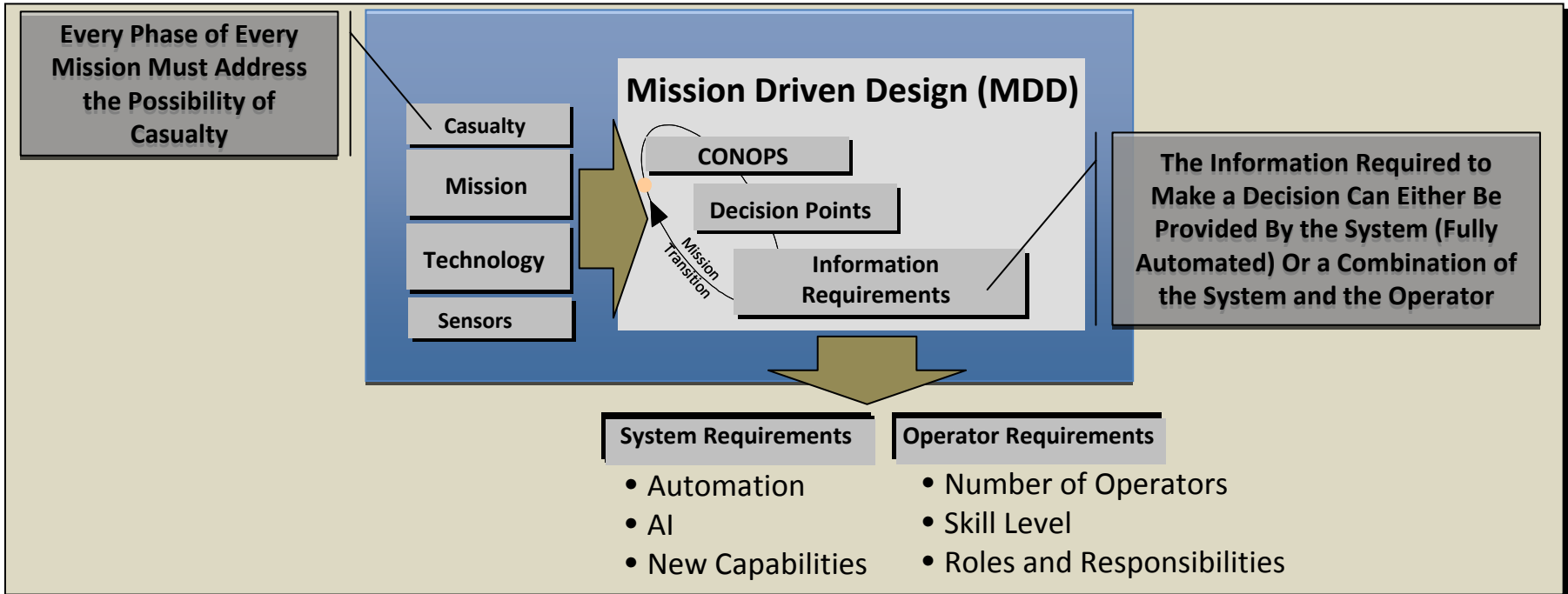

□ Top Down Approach that Focuses On Ensuring Mission Success

- Develop Mission Scenarios
- Determine Alternatives for Presenting Information to Operator (s)
- The ASSETT Team Executes Web Exercises, Interviews, & Team Experiments
 - SMEs Identify the Decision Points and the Information Required
- System Engineers Determine Technologies and Capabilities Necessary to Provide the Required Information

Operations & Technology Analyses Driven by Missions to Optimize Manning – Data Gathering

- Personnel/ Roles of Current Submarines (CSoF)
- An initial CONOPS identifying Candidate Operators to Eliminate or Redefine
- Manning Goal of current crew size
- Zero-based double helix manning analysis (CSoF)

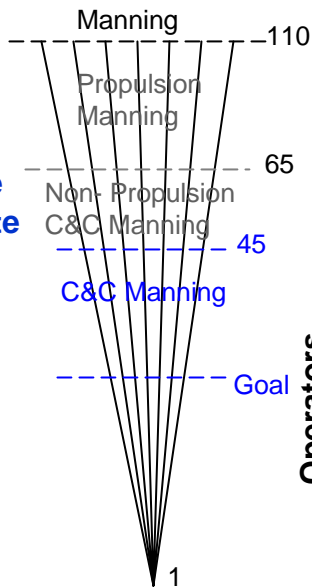

Operational Scenarios

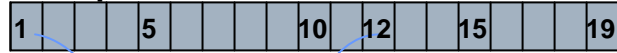

Navigation, Contact Avoidance, and Covert Transit (Port Egress & Submerged Transit Mission Phases)

Initial Decision/Task Flows

- Operational Sequences
- Relationships
- Timelines

CONOPS

Rethink the NWP for Decisions/Tasks

Initial Decision Hierarchy

- Decision Levels
- Map Decisions/Tasks

CTA Analysis & Reports

- Decisions & Manning Implications
- Decision Information

Decisions & Task Timeline

Tasks & Attributes

Operators

(System) Resources

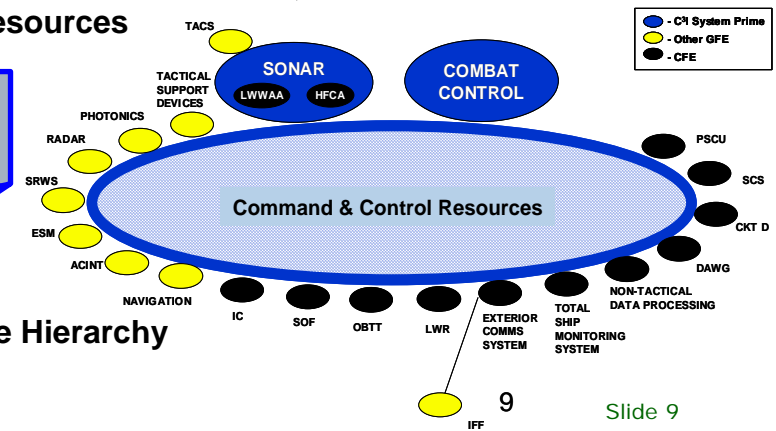
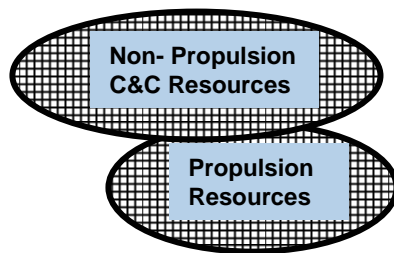

An Initial Basis for a Resource Hierarchy

Tasks are defined in the IMOP Manning Model with Trade-offs between Operators & Resources

Building with the Combat System of the Future (CSoF) Process

Missions: (Representative mission phases from the CSoF Operational Scenarios: Port Egress, Submerged Transit, and Intelligence Surveillance and Reconnaissance (ISR))

Decisions:
To support Missions

Objective: Formulate data to define operational decisions & capture technology for TDS & ICD inputs

Double Helix process

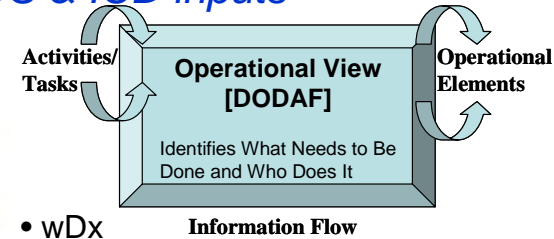
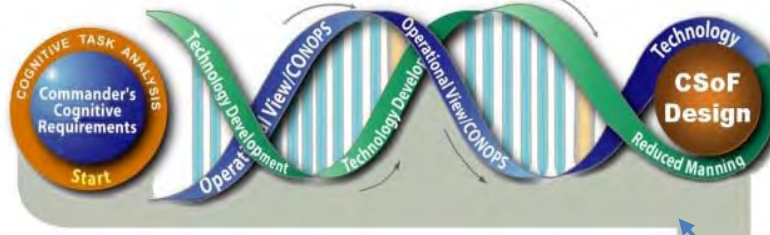

- wDx
- SME Interviews

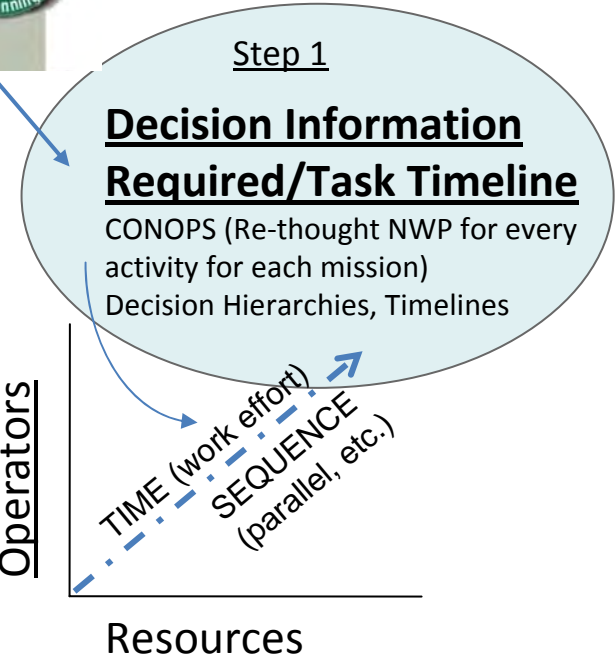
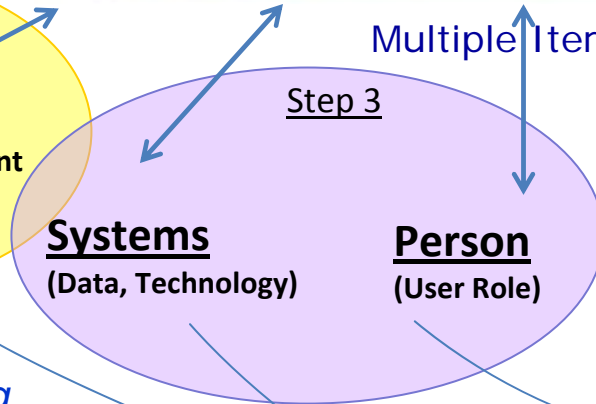
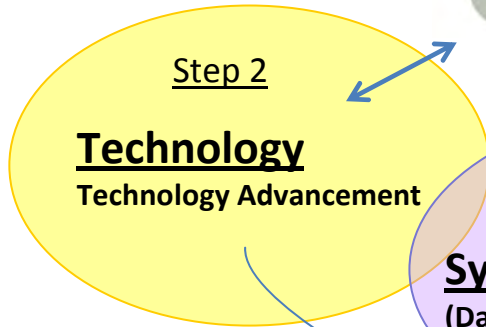

Proceeding Ahead:
Refocus Data Gathering to narrow search and expand data attributes for modeling

Our Process Would Drive Operational Needs Into the TES, ICD, and TDS

(Page 1 of 2)

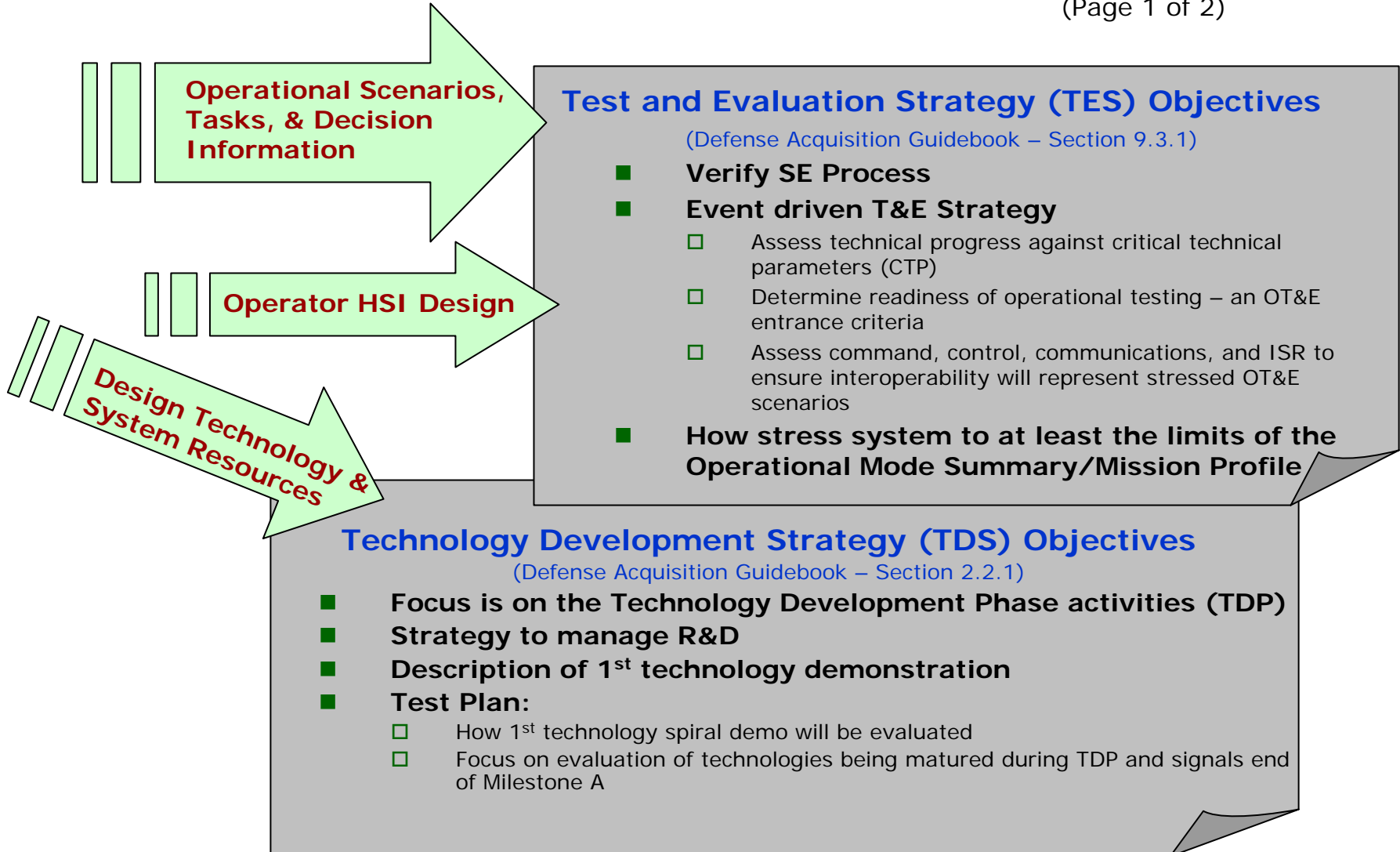

Our Process Would Drive Operational Needs Into the TES, ICD, and TDS

(Page 2 of 2)

Operational Scenarios,
Tasks, & Decision
Information

Design Technology &
System Resources

Initial Capabilities Document (ICD) Objectives

(Defense Acquisition Guidebook – Section 9.1.3.1 + Other Sources)

- Broad Operational Goals and Requisite Mission Capabilities that drive the TES
- Addresses specific capability gaps in terms of
 - Functional areas
 - Range of Military Operations
 - Desired Effects and Time
- Description of 1st technology demonstration
- Describes materiel and non-materiel approach to satisfy capability gap
- Used for Milestone A decisions

An important effort to define Initial Capabilities is to perform a demonstration of conceptual designs including Command & Control Display Concepts for operational scenarios – such as those done by the CPoF and CSoF projects.

Use Cases provide a good Link to Operational Test Validations

UC 127 Analyze the Downloaded Contact Picture

UC 57 Generate an External Communication Message

UC 41 Import a Weapon System Configuration

UC24 Generate an Alternate Navigation Path Plan

Purpose – To generate an alternative by identifying certain attributes of the baseline plan in accordance with the defined set of navigation path rules

Main Flow

1. System displays list of available path options
2. User chooses path options to review
3. System displays path plan option details
4. User identifies & changes path option attributes
5. System displays impact assessment of change adjustment
6. User chooses to save alternate navigation path plan
7. System saves alternate navigation path plan

Example UC

- **Use Case (UC) Definition:** *A use case is a single [operational] task, performed by the end user of a system, that has some useful outcome.*

- **Use cases (UC) are a popular way to express operational & system requirements**

- **A UC spans between the user needs and system functionality**
- **The UC directly states the user intention and system response of each step in a particular interaction.**

- **Mission Analyses result in defining tasks in an operational scenario that needs to be completed.**

- **These tasks become the basis for defining use cases**
- **A system design that satisfies a UC meets an operational need.**

A good Test Strategy includes a Test Plan that performs Test Cases involving Uses Cases for both DT&E and OT&E.

Test Architecture incorporates Methodology Outputs



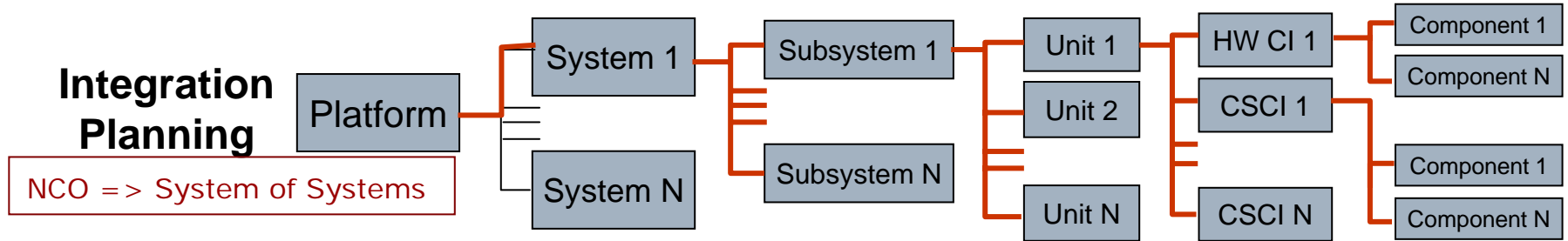

- The System Integration Planning Must Address All Levels of Test – Operational testing done at each level
 - Results in Multiple Test Plans
- Minimize risks of meeting Operational requirements



• Integrating DT&E Events with early OT&E Events

- DT&E is Laboratory level testing – little or no human environment
- DT&E uses simulators for operating environment conditions
- OT&E includes the human element in testing
- OT&E has the real platforms and real operating environments
- **Early OT&E Alignment in DT&E environment can be done**

- **Plan long duration operability demonstration tests with real system operators**
- **Schedule regular test shifts for 3-6 months for real system operators**

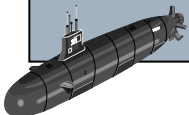

- **Get testable operational requirements [e.g. use cases] defined early and agreed upon with the Customer**

- **Getting the users involved early and often results in you building what the operational users want, not what they asked for**
 - **Often when asked to clarify a requirements, the real need is uncovered...not the “design” they “required”**
 - **Results in fleet buy-in and more likely for operational acceptance**

- **The Navy ARCI project has CONOPS groups to address capabilities gaps currently not being supported now.**
 - **After group meets, then they meet with contractors**
 - **Initially a new capability could be requested and implemented without broad need. The group solves that.**

- **Often involving an operational crew in laboratory testing will identify design improvements and improve acceptance later**

Summary & Conclusions

- 1. Incorporating operational realism early will result in building something that be used and verified in DT&E and OT&E**
- 2. A methodology exists and is being performed by contractors that addresses operational realism early in the design process**
- 3. Conducting the operational modeling, designs, and technology trade-offs will result in requirements, strategies, and technology candidates for including in the TES, TDS, and ICD.**

Systems Engineering provides a structured approach to managing the technical solution over the full life cycle from concept to deployment to retirement...

...Test and Evaluation complements this approach with support for defining requirements and integration planning...and conducting many levels of integration tests with systems engineering support to achieve customer acceptance of a system...

Q&A



Implementing a Methodology to Incorporate Operational Realism in CONOPS & Testing

Session: Test and Evaluation in Systems Engineering

Operational realism, a key piece of an Operational View in a System Architecture, is today being implemented as part of a Double Helix Methodology. The methodology, developed, tested, and validated by the DARPA Army Command Post of the Future is being used by ASSETT for a future Navy Combat System of the Future. The methodology incorporates iterations of CONOPS and Technology trade-offs using Subject Matter Experts (SME), web exercises, interviews, team experiments, and display simulations in developing and testing evolving conceptual system designs prior to a system acquisition. This presentation will identify how ASSETT Inc. has successfully implemented this approach within its system engineering process and how it will eventually lead to better acquisition development and test strategies.

The Double Helix Methodology and the CONOPS/Technology Trade-offs: In the 2008 NDIA DTE Committee Study Task Report, one of the key findings/recommendation was “to include operational realism in early phases of acquisition of a new system during generation of the CONOPS, ICD, TDS, and TES”. Our Mission Driven Design process uses the Double Helix Methodology, beginning with a conceptual CONOPS and an eye for the future. New automated capabilities are envisioned based on a decision centered design approach to defining tasks, their sequence, and any associated time constraints. The CONOPS is synchronized iteratively with the technology team to address the CONOPS expectations for the future technologies & promising capabilities. From mission phases in operational scenarios, many different uses cases can be defined to test this new operational realism in DT&E and OT&E.

Outputs of the Approach Feed System Capabilities and Strategy Documents: The new capabilities, technologies, and mission driven conceptual designs will derive requirements to be captured in the acquisition development and testing documentation. This presentation will provide an insight into the methodology, the Decision Centered Design process that drives the operational and system architecture views, how the decisions are used in defining the tasks and events in each evolving CONOPS/Technical iteration, and how the Testing & Simulations of the HSI displays using operational personnel will focus the designs for a system to be acquired.

Author Biography

William Lyders
Senior Systems Engineer
Bill.lyders@assett.net

703-365-0969

11220 Assett Loop
Manassas, VA 20109

Session: Test and Evaluation in Systems Engineering

Author Biography – Mr. Lyders is currently a Systems Engineering Manager and Lead Systems Engineer/Test Director for multiple projects at ASSETT, Inc. He has over 39 years of both systems engineering & project management experience in both federal software and commercial Information Technology (IT) development projects. He has significant complex system test and integration expertise, dockside, and at-sea testing experience developed through his federal work with multiple Sonar, Combat Control, and Submarine Combat Systems and multiple SBIR projects for the Navy. He was a Test Team Lead on large commercial projects for both domestic/international companies.



Systems Engineering in the S&T Environment

Best Practices and Other Lessons Learned from the Air Force Research Laboratory



October 2008



Overview



- **AFRL's SE Problem**
- **The TASE Study**
- **TASE Assessment Results – Best Practices**
- **TASE Recommendations**
- **Conclusions**



AFRL's SE Problem



- **Technology development and maturation are a contributing element to the acquisition process**
- **Recent acquisition “failures” have resulted in an increased DoD focus on systems engineering**
- **AFRL is also being asked to do more with fewer resources**

So – why shouldn't AFRL apply systems engineering in its activities?



AFRL's SE Problem - Continued



- **Because...**
 - **“SE is acquisition oriented, and we do research”**
 - **“AFRL programs are small with limited budgets, and SE adds a resource burden”**
 - **“SE focuses on customers and requirements satisfaction, and research programs don't have either”**
 - **“Structured approaches like systems engineering will stifle creativity in research”**

“We don't need no stinking SE!”



The TASE Study



- **AFRL commissioned the Transformational Activities in Systems Engineering (TASE) study in 2006**
- **3 Phases**
 - **Assess AFRL's current SE state of practice: determine DoD/AF requirements; assess current SE policy, practices, and tools (2006)**
 - **Recommend improvements to AFRL's SE policy and practices (2007)**
 - **Implement and sustain an approved AFRL SE process (2008+)**



TASE Assessment Process



- **Assessment based on:**
 - Review of DoD and AF SE guidance
 - Interviews with AFRL Advanced Technology Demonstration (ATD) and other high-priority program personnel (52 programs assessed)
- **Facilitated by GD-AIS contractor team**
 - 5 senior systems engineers
 - Former Director of the AF Center for Systems Engineering



TASE Assessment Results



- **Intent** of DoD guidance *encourages* use of SE in research activities
- SE was not foreign to AFRL personnel, but few programs used a full set of processes
- The S&T environment is “different”
 - Variable program size
 - “Soft” requirements (aka “desirements”)
 - Complex (vs hierarchical) relationships
 - Instability in customer base

These factors drive the tailoring of SE to S&T



AFRL S&T Systems Engineering Example: Requirements Development and Roadmapping



- **AFRL use of the Integrated Product and Process Development (IPPD) process**
 - High Energy Laser on a Large Tactical Platform (HELLTP)
 - Next Generation Unmanned Aerial System
 - Multiple small programs
- **SE Successes**
 - Increased understanding of “customer” needs
 - Better focus on which technology areas to pursue
 - Increased potential for successful transition



AFRL Systems Engineering Example: Full Systems Engineering Implementation



- **The Advanced Tactical Directed Energy System (ATADS) ATD used SE processes to successfully meet its program objectives**
 - Result was up to an order of magnitude reduction in weight and cost from the existing airborne infrared countermeasures system with increased performance
- **SE Successes:**
 - Lab-led requirements development and management including IPT with user, PO, and contractor resulted in responsive but controlled requirements that balanced user needs with technical realities
 - Continuous risk management successfully responded to technology and program issues
 - Model-based decision analysis improved both requirements and design choices
 - Strong contractor SE processes, monitored by Lab managers, ensured matured technologies and integration met Lab needs



AFRL Science & Technology Systems Engineering Best Practices



- **Requirements Development and Decision Analysis**
 - Formal IPPD process tailored to AFRL’s environment and “Standardized” between Directorates
 - Strong Integrated Product Teams (IPTs)
- **Risk Management**
 - Continuous process involving AFRL and contractor
- **AFRL/Contractor Relationship**
 - Strong contractor SE with AFRL understanding and oversight
- **Senior Leadership Support**
 - Designated Chief Engineers and SE Branches



AFRL S&T SE Best Practice: IPPD Process

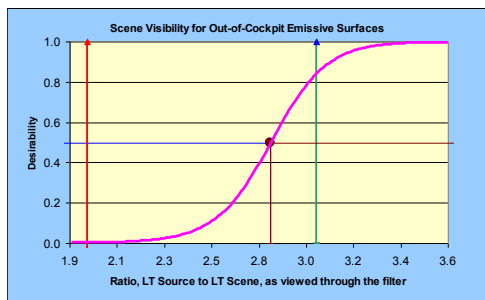

Customer Requirements



Technology Alternatives



Value Analysis

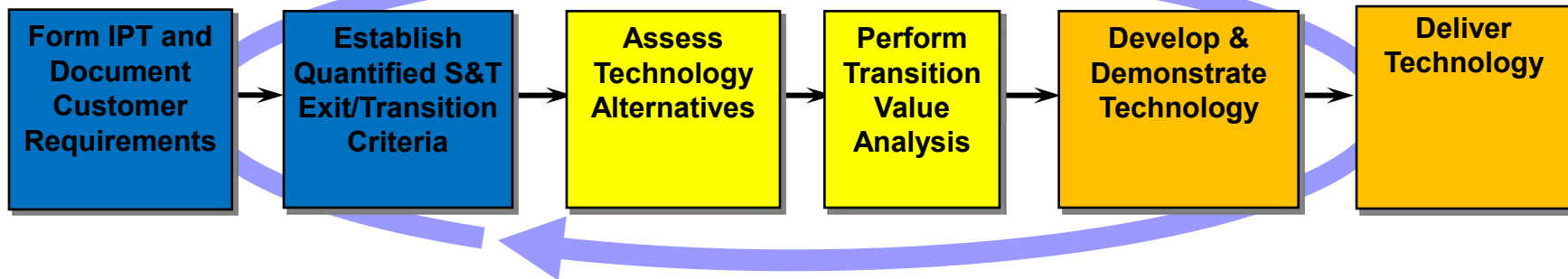
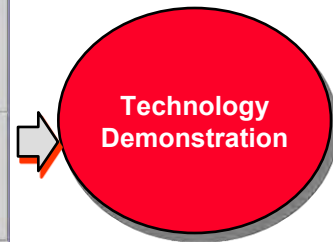

Transition Focused:

- Measurement-based methods
- Balanced tech trades/options
- Quantify desirability & risk



IPPD Revisited



Phase 1:
Expand the
problem
space

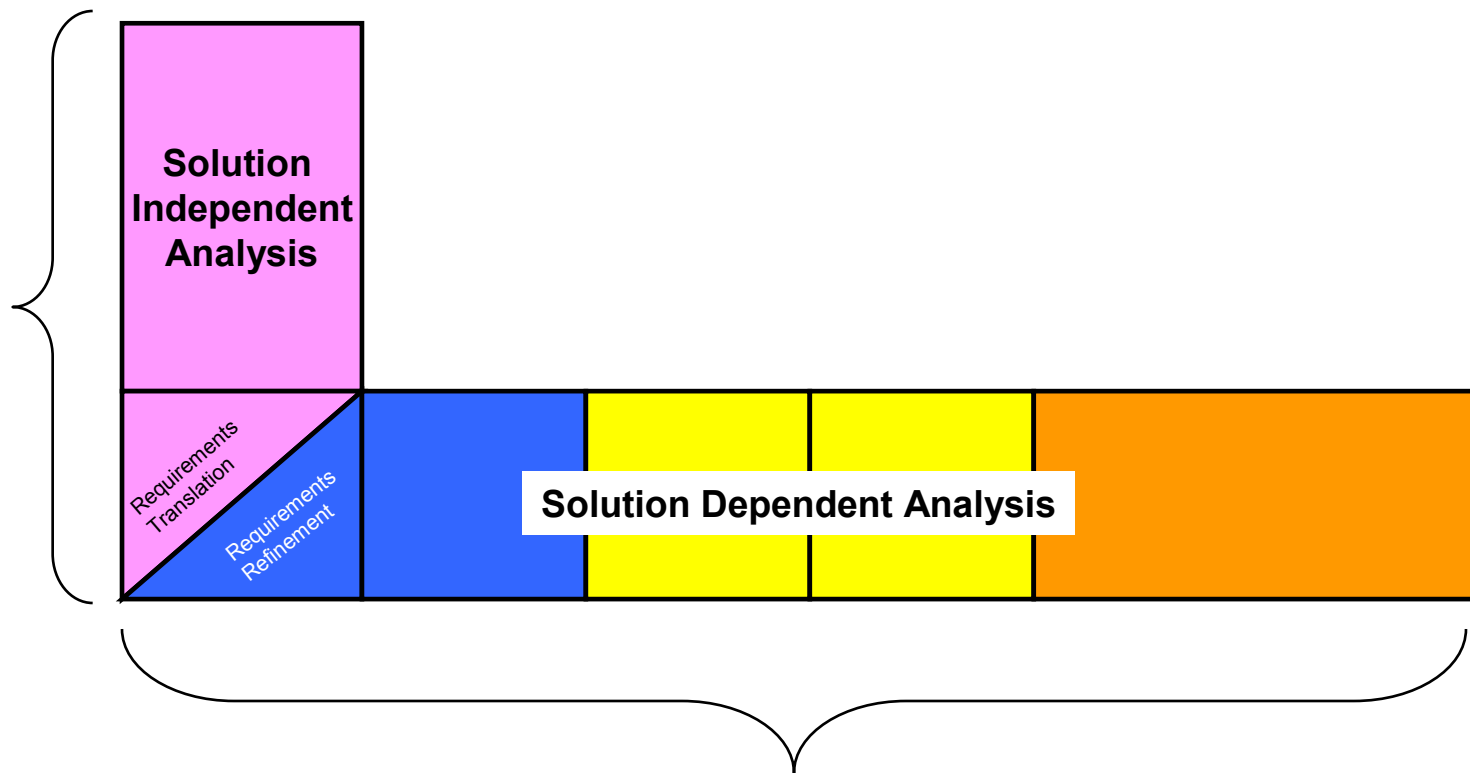

Phase 2: Expand the solution space



TASE Recommendation: Attack the Problem on 2 Fronts



- **Cultural Change:**
 - **Build upon current SE Best Practices in AFRL**
 - **Implement a tailored, consistent, and complete SE framework that is a part of everyday operations (not a “burden”)**
 - **Provide training on fundamental SE practices tailored to the research environment**
 - **Champion the S&T SE framework and supporting organization at the highest level of leadership**



TASE Recommendation: Attack the Problem on 2 Fronts



- **Cultural Change and**
- **Process Improvement:**
 - Institute strong requirements development and decision analysis processes
 - Employ continuous technical management processes
 - Ensure AFRL technology program managers understand and have visibility into contract SE
 - Reduce program risk:
 - Foster customer intimacy, recognizing customer changes as a key factor in transition risk
 - Investigate technology alternatives early in the program



Conclusions



- **AFRL has discovered that Systems Engineering is a good idea for S&T work**
- **AFRL has learned that implementing SE processes must be attacked on 2 fronts: cultural change and process improvement**
- **AFRL is implementing process and culture improvement efforts base on Best Practices**



Questions?



- **AFRL POCs:**
 - **Dr. Ken Barker (Deputy Director for Program Management and Systems Engineering)**
kenneth.barker@wpafb.af.mil
 - **Mr. Bill Nolte (Assistant to Dr. Barker for SE)**
william.nolte@wpafb.af.mil
- **General Dynamics POC:**
 - **Mr. Bill Doyle, PMP (TASE Project Lead)**
william.doyle@gd-ais.com (719-641-3758)

Systems and Proposal Engineering Company

SOA Business Model for DoD

**A Service-Oriented Architecture
(SOA) Business Model for the
US Department of Defense (DoD)**

Presented October 21, 2008

Overview of presentation

- **How is DoD viewed today?**
- **How is SOA related to net-centricity?**
- **What would be a more SOA-like approach look like?**
- **Conclusions**

How Is DoD Viewed Today?



• This “systems view” divides activities into various “mission areas”

- Warfighting
- Intelligence
- Business
- Infrastructure

• In doing so, this complicates the interfaces between areas

• Also, “business” occurs in all these areas

See *Global Information Grid Architectural Vision*, June 2007

How Is SOA Related to Net-Centricity?

- **DoD defines net-centricity as “the realization of a networked environment, including infrastructure, systems, processes, and people, that enables a completely different approach to warfighting and business operations.”***
 - The idea is to use the global network to provide warfighters and decision makers with the information they need, when they need it, in a secure environment
- **Service-Oriented Architectures provides a means to package business processes as interoperable services**
 - Hence, it is seen as a means to implement net-centricity

See DoD Net-Centric Data Strategy, May 9, 2003

So does the current model lend itself easily to SOA?

Simple Example: A Basic SOA

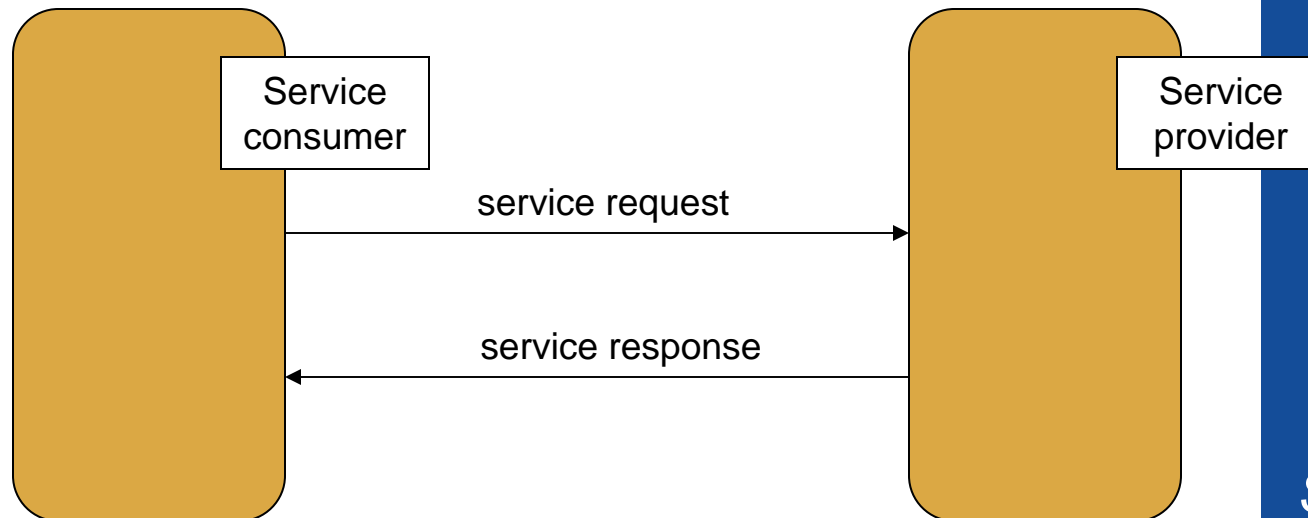

*So how
can we
apply this
to DoD's
needs?*

Proposed SOA Business Model for DoD

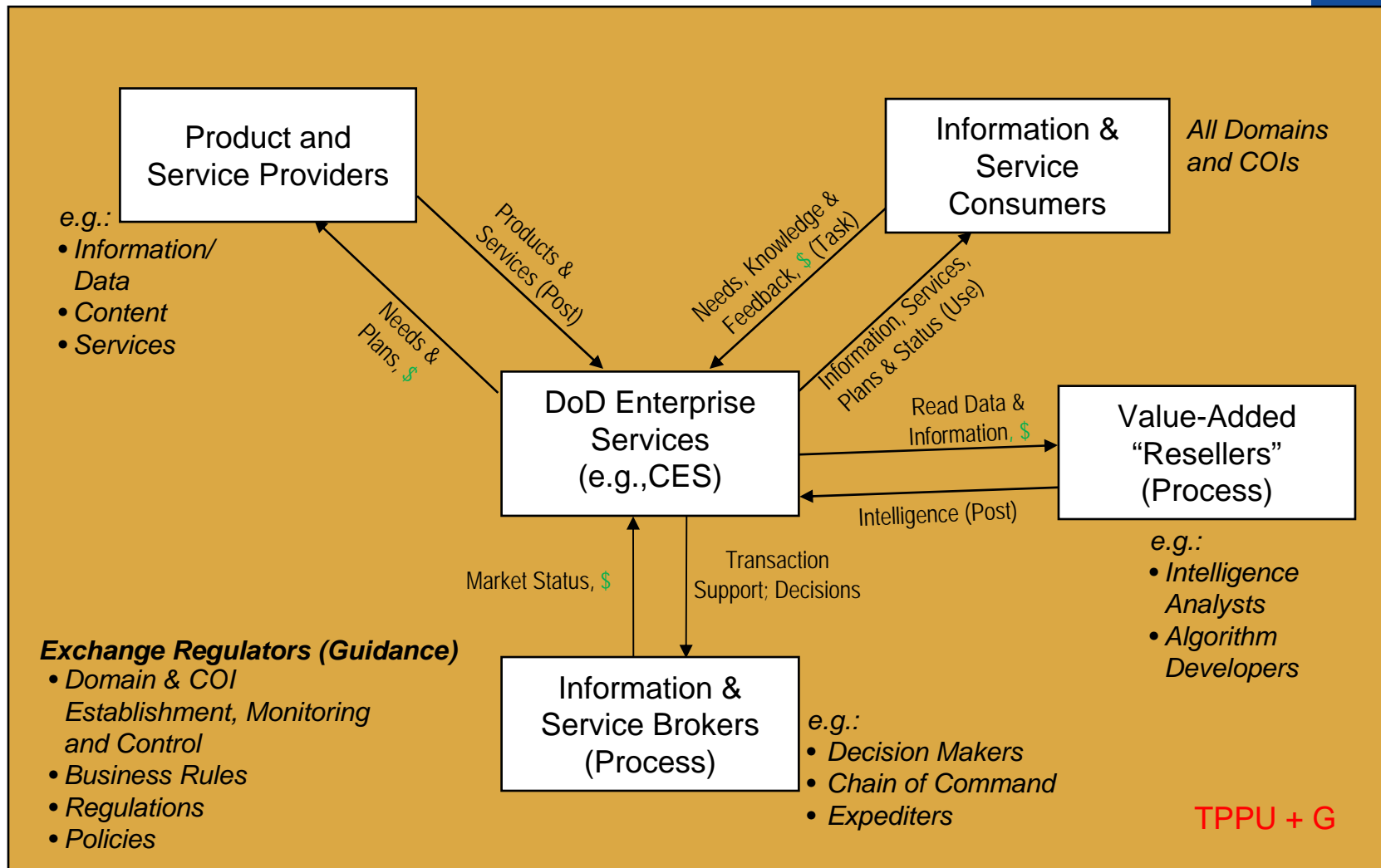

Conclusions

- **Net-centricity can provide significant benefits to warfighters and decision makers**
- **SOA can provide an effective means for implementing net-centric principles**
- **By adopting a business model that cuts across the organizational boundaries, we can reap the benefits of DoD's vision for net-centricity**

Systems and Proposal Engineering Company

Knowledge-Based Analysis and Design (KBAD)

A methodology for rapid, cost-effective system engineering and architecture development

Presented October 22, 2008

Overview of presentation

- **Why yet another “methodology?”**
- **What is KBAD?**
- **What theory underlies KBAD?**
- **What kind of tools work with KBAD?**
- **What process does KBAD implement?**
- **What kind of people do we need to execute KBAD?**
- **How do we move from drawing pictures to building a knowledgebase?**

Why Yet Another Methodology?

- **We have the DoD Architecture Framework ...**
 - But DoDAF isn't a methodology, its just a description of necessary products
- **We have UML ...**
 - But UML is only a software engineering technique. You have to come up with the process and tools for implementing it
- **We now have SysML ...**
 - But SySML is just another technique and still needs more definition to create complete, executable designs
- **What's missing?**
 - A complete, coherent technique, process, and tool set that results in a knowledge base that can be used for full lifecycle decision making

Knowledge-Based Analysis and Design

- **KBAD combines system engineering and program management disciplines to enable the development of a knowledgebase that can enable cost-effective decision making**
- **KBAD spans the acquisition lifecycle enabling support for design, development, integration, test, operations and sustainment**
- **KBAD focuses on using a variety of techniques and tools, brought together in a common database using special software to migrate data between tools**
- **The KBAD process links the technique and tools together in an executable, cost-effective way to support decision making at all levels**

KBAD reduces costs and increases speed of delivery by simplifying the data captured and focusing on the analyses needed for design. The result: a knowledge-base for decision making.

What makes up KBAD?

- **Technique**

- Modified Model-Based System Engineering (MBSE)

- **Process**

- SPEC's Middle-Out Process for Architecture Development and System Engineering

- **Tools**

- A variety of COTS tools tailored to the MBSE modifications and special needs of DoDAF

- **People**

- Trained, experienced professionals who bring a wealth of different backgrounds and knowledge in architecture, system engineering, modeling & simulation, physics, computer science, test & evaluation, operations & support

KBAD was developed over the past 15 years and brings lessons learned from those years of experience.

The technique: refined MBSE

- **Various forms of model-based system engineering have been developed**
- **SPEC uses the one developed by TRW in the late 1960s, which has been successfully used since then**
- **SPEC has refined this technique by simplifying the information collected (entities, relationships and attributes) and adding a number of key elements missing from the original development**

MBSE Models

1. Logical architecture (behavior) model
 - Functional sequencing
 - Data flow and size
 - Resource model
 - Evolution in time

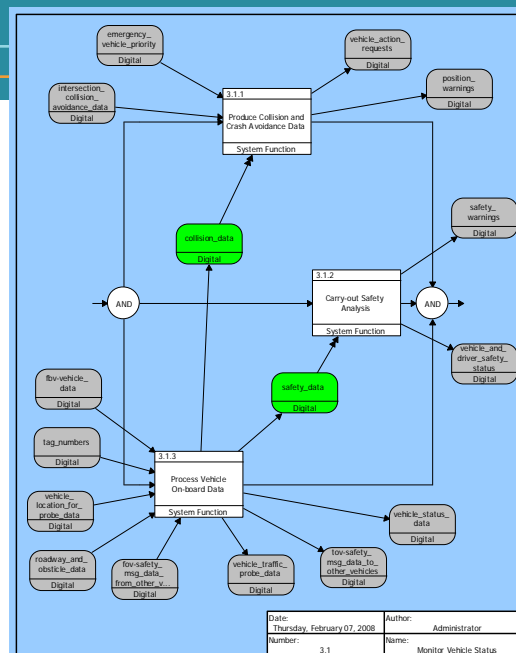

2. Physical architecture (asset) model
 - Interface definition (bandwidth and latency)
 - Actions allocated to Assets
 - Data allocated to interfaces

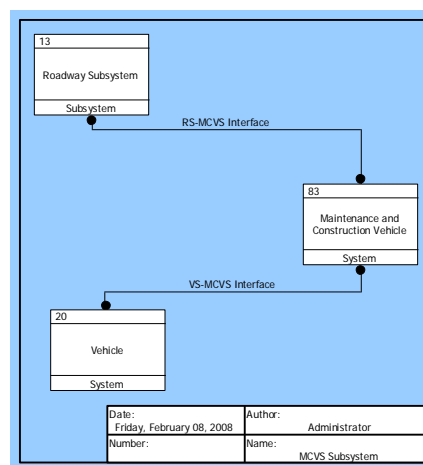

Models are based on language

Language Elements	English Equivalent	KBAD Schema Example
Element	Noun	<ul style="list-style-type: none"> • Statement • Action • Asset • ...
Relationship	Verb	<ul style="list-style-type: none"> • Statement is the <u>basis of</u> an Action • An Action is <u>performed by</u> an Asset • ...
Attribute	Adjective	<ul style="list-style-type: none"> • Description • Type (e.g., Operational Activity is a type of Action) • ...
Attribute of Relationship	Adverb	<ul style="list-style-type: none"> • <u>amount of</u> Resource consumed by an Action • <u>acquire available</u> (hold partial) Resource for Action • ...
Structure Enables Executability	Graphics/ Drawings	<ul style="list-style-type: none"> • Graphic Views: Behavior, Hierarchies, Physical Block

We modified Vitech's schema

KBAD Element	CORE Elements	Rationale
Action	Function/Operational Activity	Provide overall class for actions
Artifact	Document	Recognized not just documents
Asset	Component/Operational Element	Provide overall class for assets
Characteristic	type of Requirement	Way to capture metrics and other characteristics of an element
Cost	attribute of Component	Broadens capture of costs
Input/Output	Item/Operational Information	Clearer name
Issue	Issue	Same
Link	Link/Needline	Provide overall class for transmission
Location	none	Captures geolocation information
Risk	Risk	Same
Statement	type of Requirement	Clearer name
Time	attribute of Function	Broadens capture of times

The goal was to simplify and clarify the language.

We related all the KBAD schema elements

	Action	Cost	Characteristic	Artifact	Asset	Input/Output	Link	Statement	Issue	Risk	Time	Location	CORE Equivalent	DoDAF Equivalent
Action	decomposed by	incurs	specified by	documented by	performed by utilizes	inputs outputs triggered by	-	based on	generates	resolves	occurs	located at	Function	Operational Activity/ System Function
Cost	incurred by	decomposed by	specified by	documented by	incurred by	incurred by	incurred by	based on	generates	incurred by	occurs	located at	New	N/A
Characteristic	specifies	specifies	decomposed by	documented by	specifies	specifies	specifies	based on	generates	causes	occurs	located at	New	N/A
Artifact	documents	documents	documents	decomposed by	documents	documents	documents	source of	generates	causes	occurs	located at	Document	N/A
Asset	performs utilized by	incurs	specified by	documented by	decomposed by	-	connected by	based on	generates	causes	occurs	located at	Component	Operational Node/ System Node
Input/Output	input to output from triggers	incurs	specified by	documented by	-	decomposed by	transferred by	based on	generates	causes	occurs	located at	Item	Operational Information/Data
Link	-	incurs	specified by	documented by	connects	transfers	decomposed by	based on	generates	causes	occurs	located at	Link	Needline/Interface
Statement	basis of	basis of	basis of	stated in	basis of	basis of	basis of	decomposed by	generates	causes	occurs	located at	Requirement	N/A
Issue	generated by	generated by	generated by	documented by	generated by	generated by	generated by	generated by	decomposed by	causes	occurs	located at	Issue	N/A
Risk	caused by resolved by	incurs	caused by	documented by	caused by	caused by	caused by	caused by	caused by	decomposed by	occurs	located at	Risk	N/A
Time	occurred by	occurred by	occurred by	occurred by	occurred by	occurred by	occurred by	occurred by	occurred by	occurred by	decomposed by	located at	New	N/A
Location	locates	locates	locates	locates	locates	locates	locates	locates	locates	locates	occurs	decomposed by	New	N/A

Reduced number of elements from 21* to 12, while adding time, location and cost

*CORE's DoDAF schema

A key attribute – *type*

- **We added a “type” attribute to all classes**
- **Each “type” attribute contains different designators for the parent class**
- **Examples:**
 - Assets can have types that include:
 - Operational Node, System, Component, Resource, Subsystem, System of Systems, Component, ...
 - Actions can have types that include:
 - Operational Activity, System Function, Task, Mission, ...
- **You can expand these lists to characterize anything in that class**
- **When we display the element, we use the type**

Using the type attribute we reduce the complexity and ease changes in perspective from requirements to implementation.

Benefits of the KBAD Schema

- **Reducing the number of primary data elements means less complexity for analysts to deal with**
 - Less complexity enables quicker capture and presentation of the information for analysis and decision making
- **Covers programmatic, as well as technical, elements of information**
 - Enables the trade off between cost, schedule and performance necessary for good design and decision making
- **Eliminates overlap between similar data elements**
 - Reduces potential for duplication of information which cuts the time and cost of data gathering

The result is a more cost-effective means for describing an architecture or system design.

MBSE Describes Behavior

- **Typical data/activity modeling only works in the data dimension (e.g. IDEF0 or Data Flow Diagrams)**
- **For simple systems with sequential flow, this is sufficient**
- **However, for more complex systems, which all architecture are, it can be very misleading**
- **We need to be able to predict how system will behave**

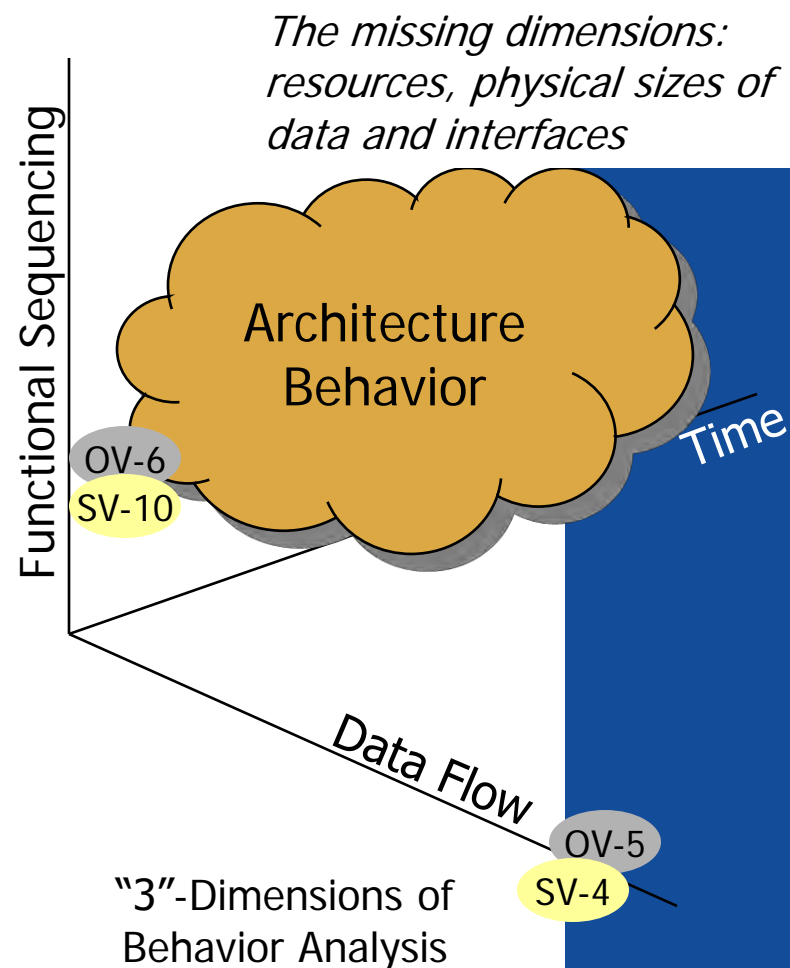

Why is sequencing important?

- **In software the mantra is: data, data, data**
 - Why? Because a tremendous amount of software programming has to do with input/output, hence the need to understand the data very well
 - The functional sequencing for individual software modules is relatively simple and many algorithms exist for complex methods (e.g., sorting algorithms)
- **In architecture development (or system engineering or business process modeling ...) sequencing is actually more important than the data**
 - We want to know how the data affects the functional sequencing – we call these triggers
 - We want to control the behavior to avoid having significant failures
 - We also need sequencing for the human side

Hence the real answer is we need both if we are to develop systems and services with predictable behavior.

MBSE provide a robust set of constructs

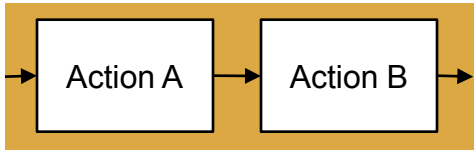

SERIAL

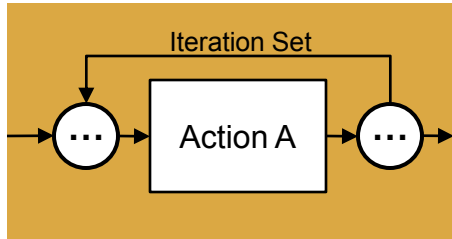

ITERATIVE

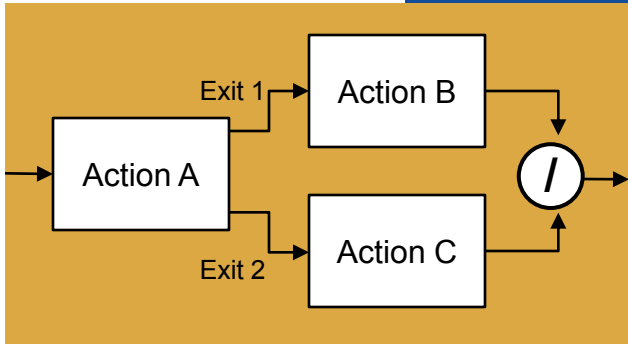

MULTIPLE-EXIT

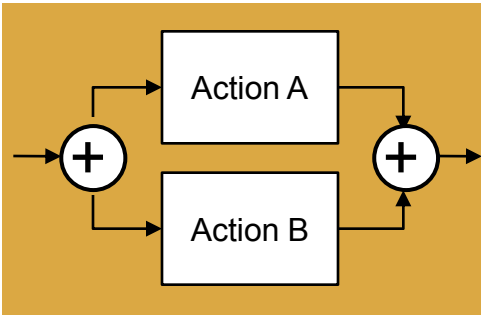

PARALLEL

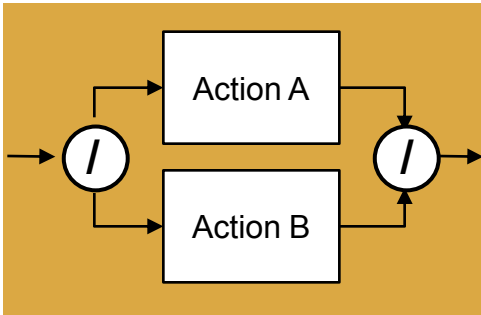

SELECTIVE

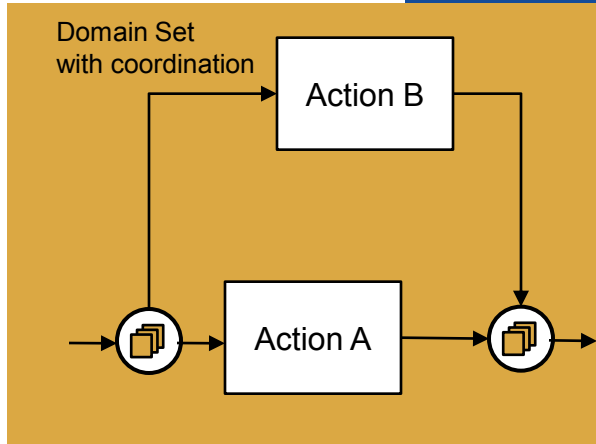

REPLICATE

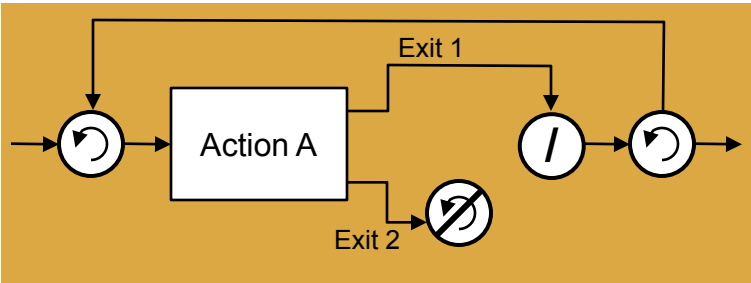

LOOP

One diagram gives many products

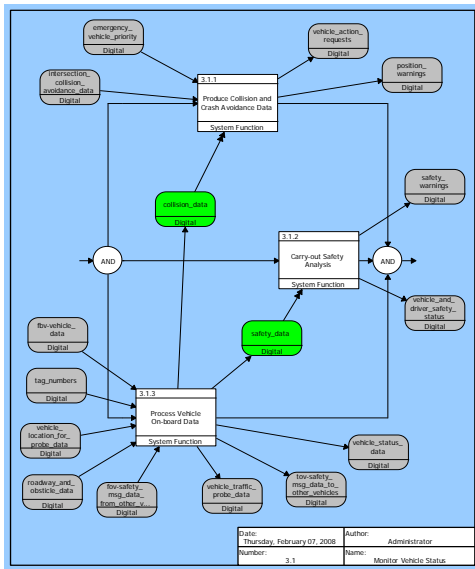

EFFBD:
complete and executable

IDEF0:
lacks constructs

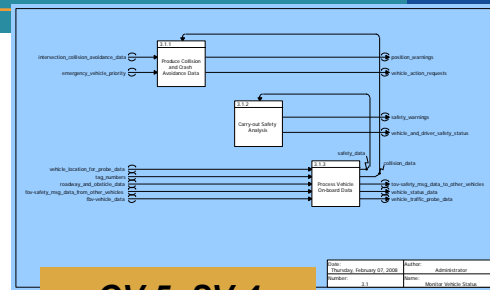

OV-5; SV-4

N2 Chart:
lacks constructs

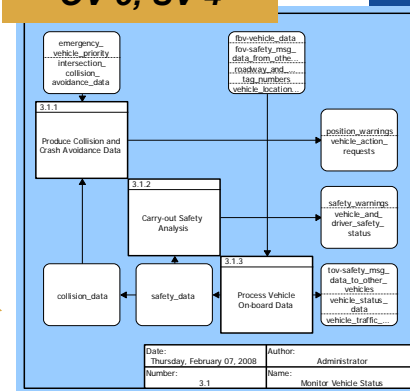

FFBD:
lacks data

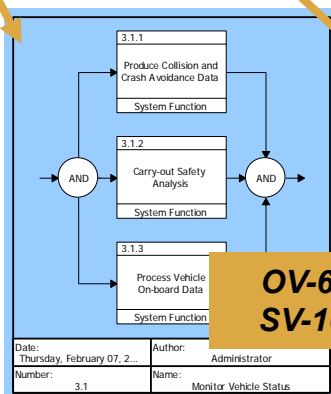

**OV-6c;
SV-10c**

Hierarchy: only parent to child

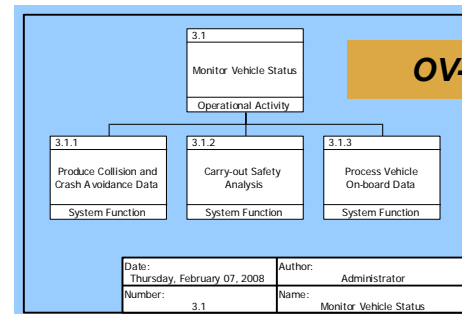

OV-5; SV-4

Text

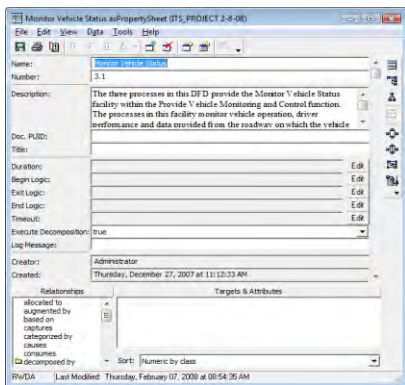

MBSE also diagrams the physical elements

Physical Hierarchy

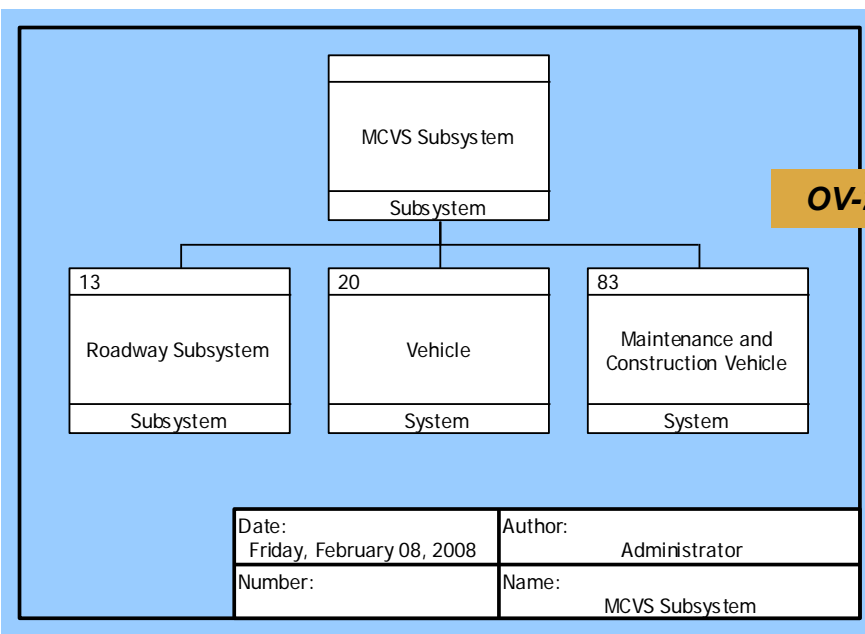

OV-2; SV-1; SV-2

Physical Block Diagram

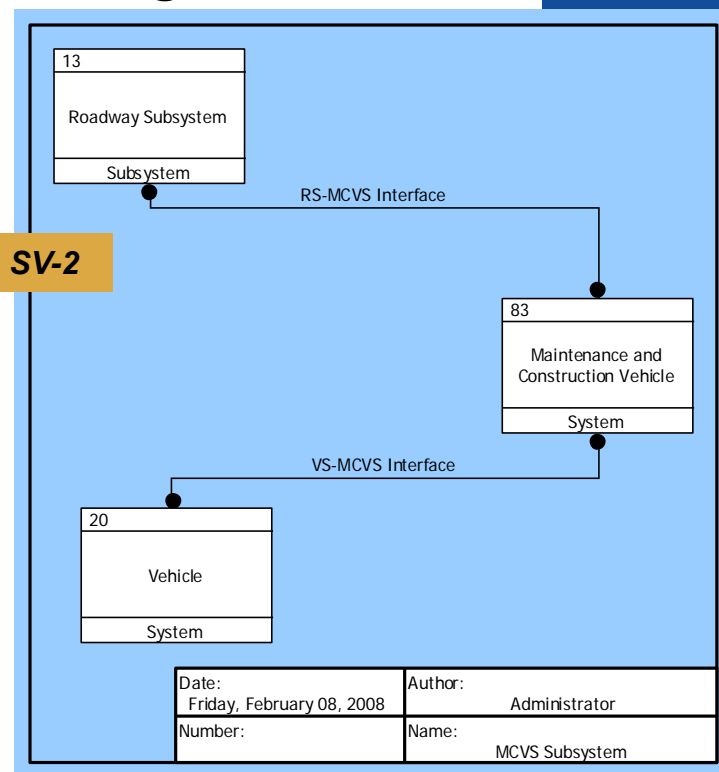

Traceability is a key to success

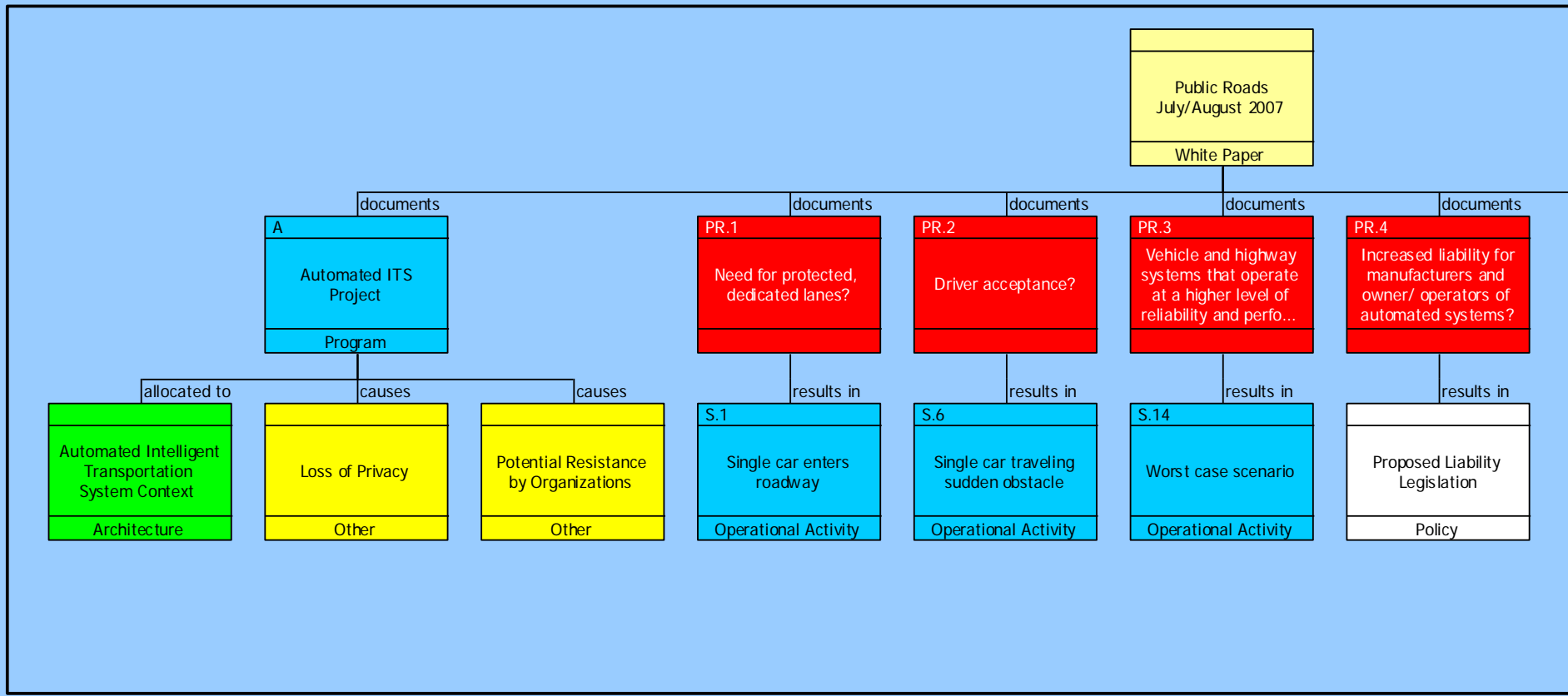

Tools support the technique and process

Most Programs
Require Tools in
All These
Domains, but ...

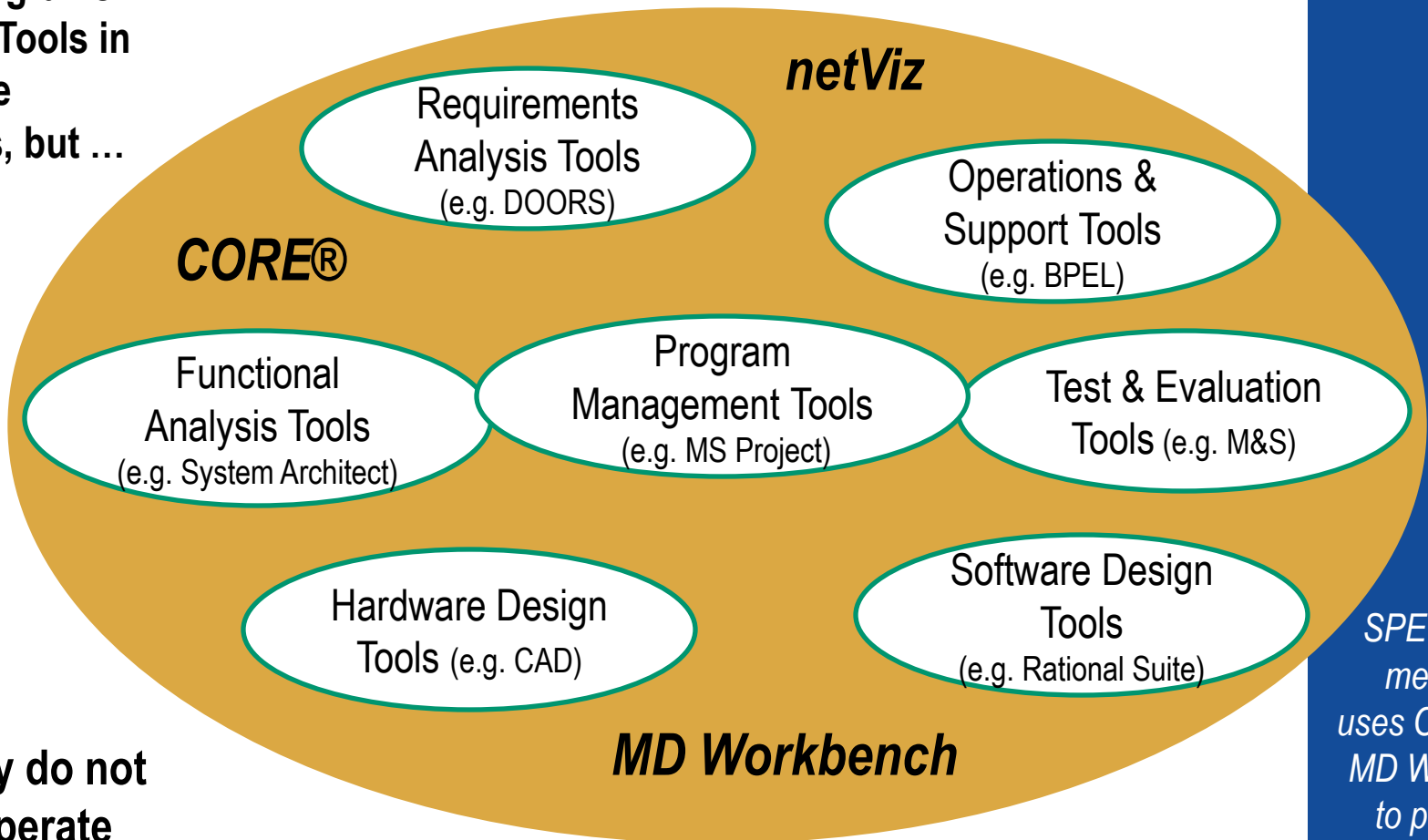

... they do not
interoperate
well together.

SPEC's KBAD methodology uses CORE and MD Workbench to provide the underlying tool interoperability.

Tools used: CORE



- CORE's system engineering tools maintain an integrated design repository that provides traceability between requirements, functional models and system design elements
- CORE's database schema may be modified to support customer needs and facilitate tool integration
- Executable diagrams
- Special schemas and reports
- Powerful scripting language for your own report generation

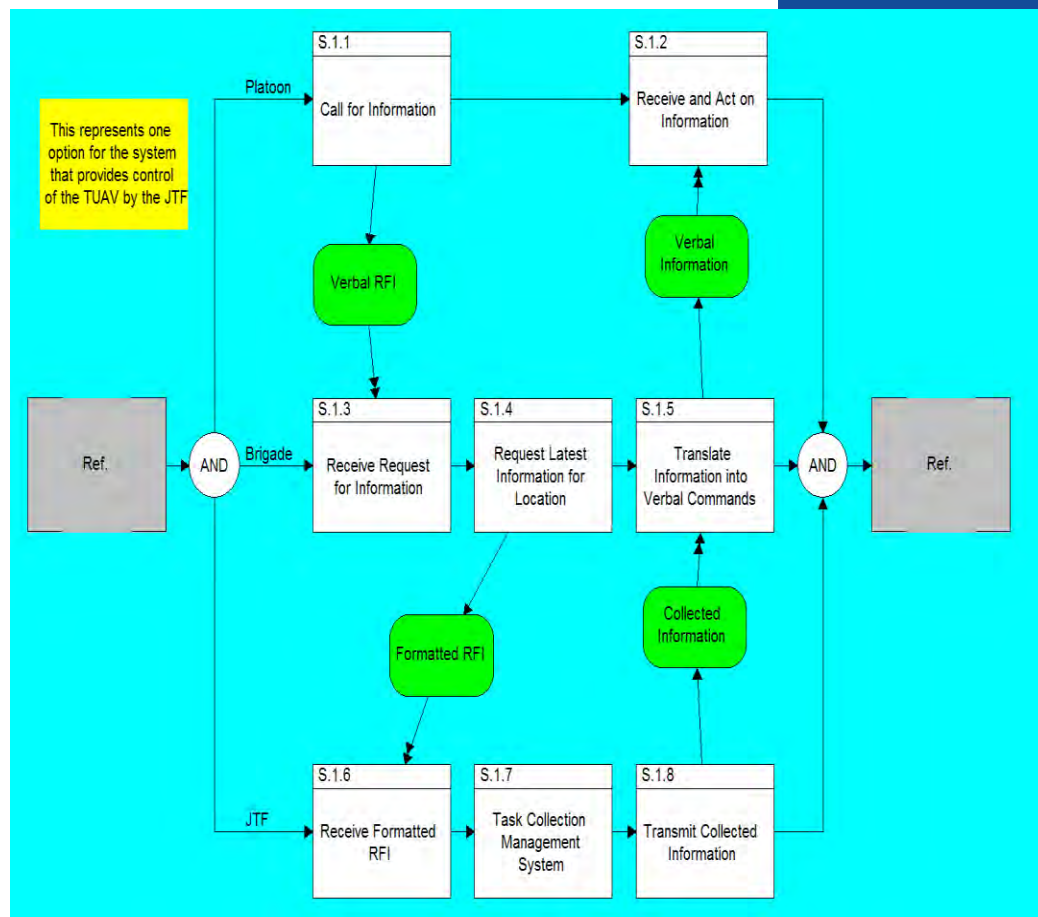

Version 5.1 released with updated schema and reports

www.vitechcorp.com

Tools used: MD Workbench

Eclipse-based IDE for code generation and model transformation, devoted to implementing MDA/MDE strategies. It provides:

- code generation (via text template engine and optionally Java)
- model manipulation through dedicated languages
- (imperative rules, declarative ATL modules to support QVT transformations, Java)
- model and metamodel management, including UML support
- customizable model connectors (XMI 1.0 to 2.1, XML, Hibernate, COM, etc.)



NEW MS ready 2007

MDWorkbench 2.1
download

- > [Document generation](#)
- > [RCP/Command line](#)
- > [Navigation history](#)
- > [On-demand reload](#)
- > [Multiline text dialog](#)
- > [UML 2.1 upgrade](#)
- > [Improved reader](#)
- > [Rose model reader](#)

2.1 is a major release! New features of MDWorkbench 2.1 includes:

→ Microsoft Word® Document generation

Doc Templates enable you to easily generate Microsoft Word® documents (Word 2003 or 2007).

A doc template is edited in Word, using all the functions, formatting, and styles available, with the addition of MDWorkbench constructs to access model data. A doc template brings the power and ease of use of text templates into Microsoft Word®.

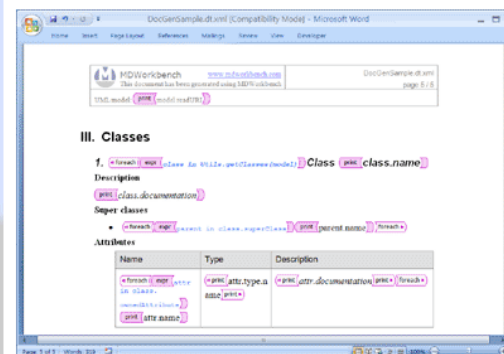

You can generate rich documents to describe models, to report metrics, to report QA validation results. etc...

<http://www.mdworkbench.com>

A great way to move data between different tools.

Tools used: NetViz

netViz®

- Personnel all over the world use netViz to graphically depict operational architectures and logistical scenarios
- With NetViz you can create the SV-1 and SV-2 diagrams, with its intuitive graphical workspace, drill down capability, and connectivity views
- You can use the data embedded in your netViz projects to create other critical elements of a comprehensive C4I documentation project, like OV-1s (Operational Concept Diagrams) and OV-3s (Information Exchange Matrices)

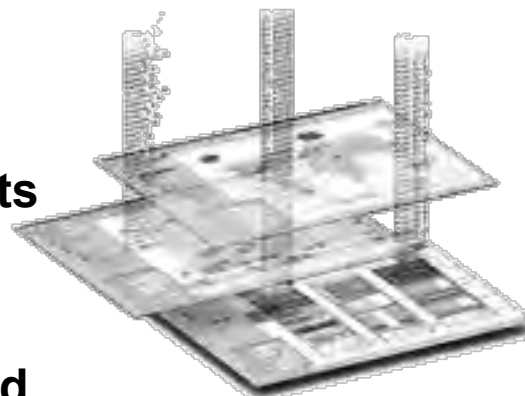

Version 7.1 released; Available in Client Server or Enterprise Web editions as well

SPEC processes – full lifecycle

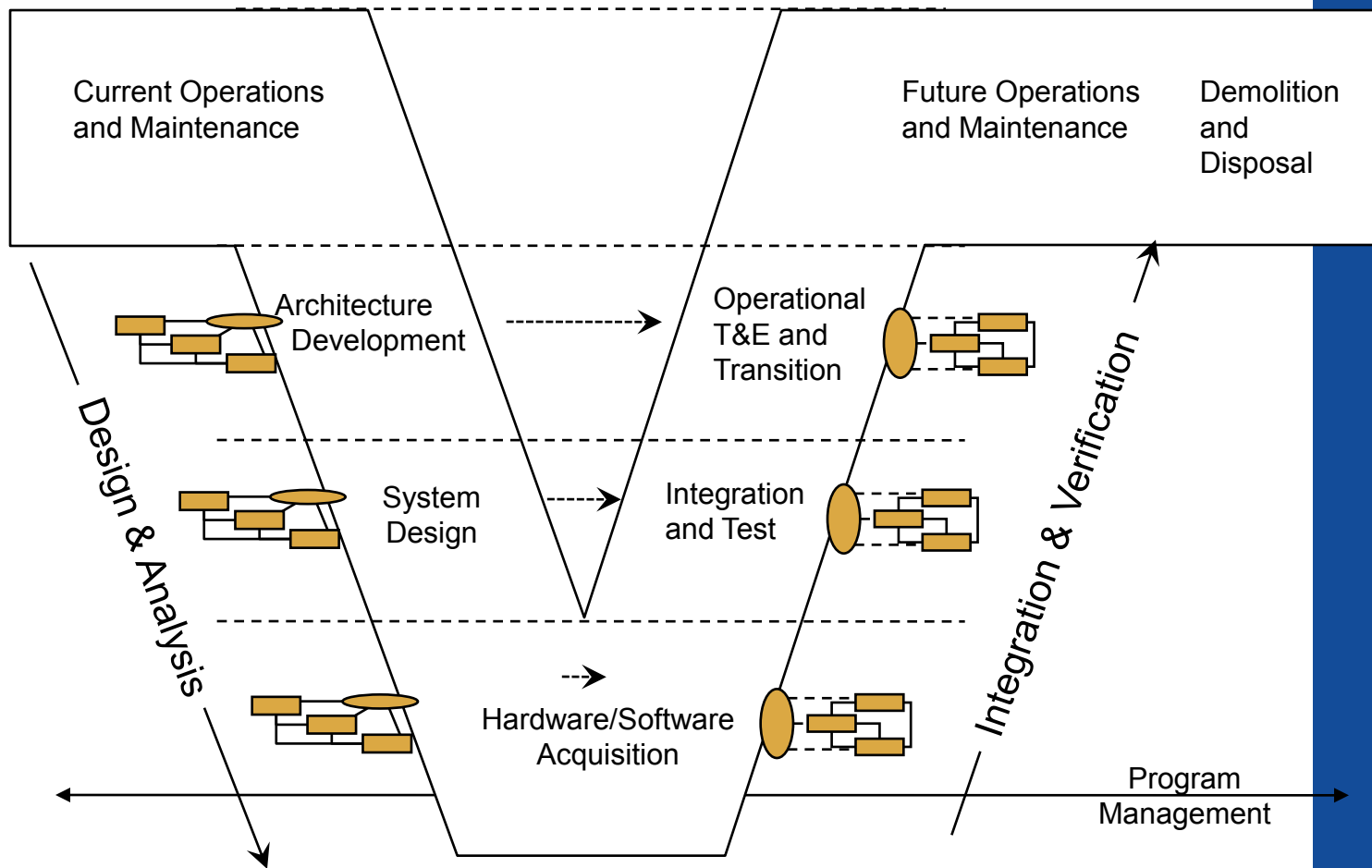

Design and analysis phase

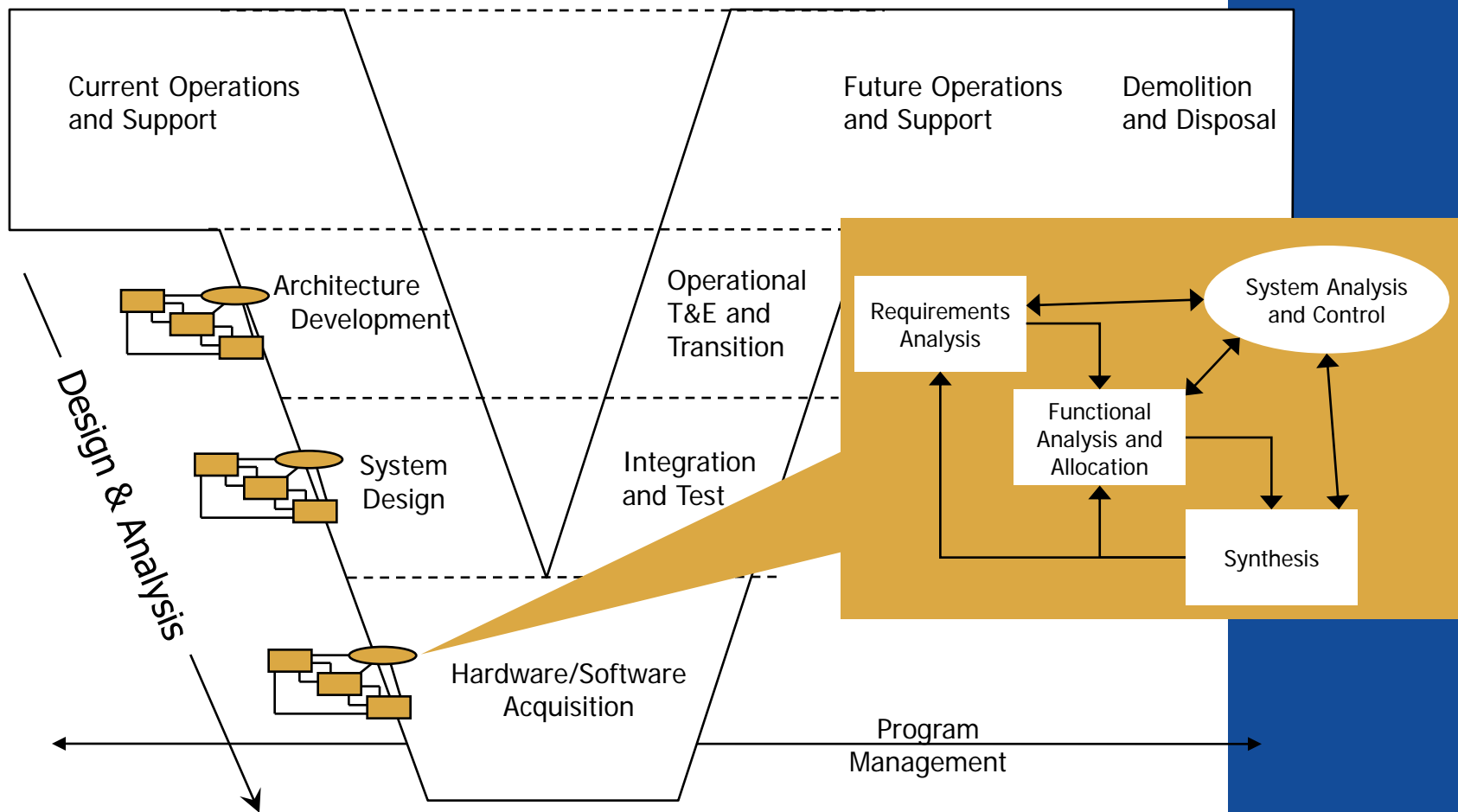

SPEC's middle-out process

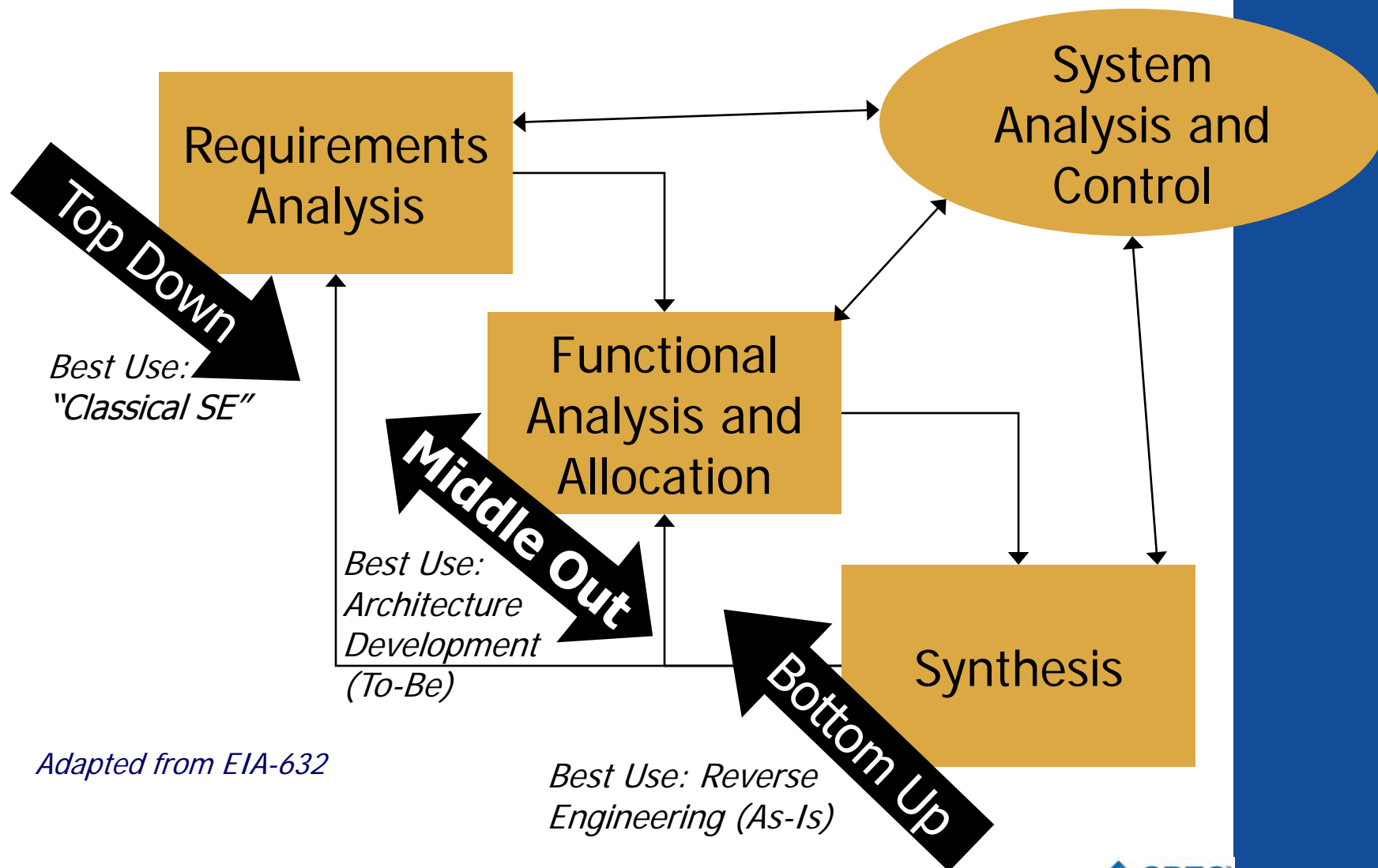

Middle-out timeline with products

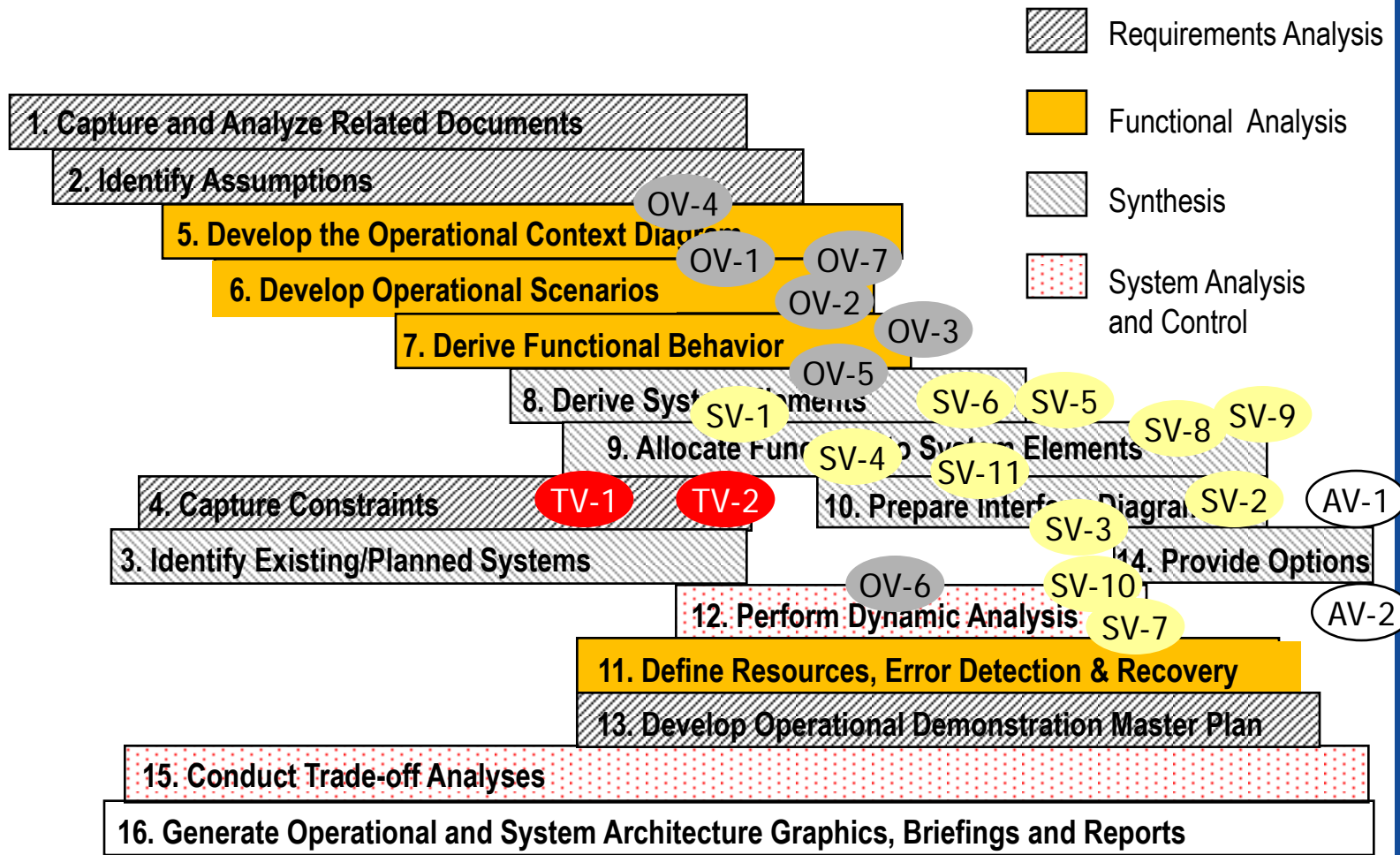

The middle-out approach has been proven on a variety of projects.

Time →

People Considerations

- **Large teams make organization and focus on a vision very difficult**
- **You need people with a wide variety of skills and personalities**
 - Someone with vision
 - Someone who can perform the detailed system engineering
 - Someone who understands the domain
 - Someone familiar with the technique and tools
 - Someone who understands the process
- **They need to be trained as a team – including the government personnel**

How Do We Move from Drawing Pictures to Building a Knowledgebase?

- **Apply a proven, model-based technique that results in executable diagrams**
- **Use a process that implements the technique**
- **Use industrial-strength system engineering tools**
- **Make sure the personnel who use the methodology have the proper knowledge, skills and abilities to implement the approach**

Questions & Discussion

Integrated Change Control for the Concurrently Developed Complex Systems – Lessons Learned



Alexander J. Polack
The Aerospace Corporation

22 October 2008

Before We Begin...

There were many contributors to this effort.
Thank you everyone who helped!



Advanced Extremely High Frequency (AEHF) System



Reprinted courtesy of the United States Air Force



Reprinted courtesy of the United States Air Force

- Mission – Provide protected satellite communications for strategic and tactical defense missions
- Designed to augment and eventually replace the Milstar system
- AEHF Program Office is located at the Space Missile Center (SMC), Los Angeles Air Force Base



AEHF Program Challenges

- Concurrent development and acquisition of major AEHF system elements
- Concurrent development of interfaces
- Most elements have different
 - *Contracts*
 - *Contracting agencies*
 - *Contract schedules*
 - *Development teams*
- Backward compatibility requirements with existing operational systems
- Operational systems are in the process of changing while in sustainment mode
- New, post contract award requirements
- International Partners
- Budgetary and regulatory requirements and constraints



Change Dilemma...

- Change is inevitable on a large, multi-year, concurrent development program
- Change is disruptive by its nature
- Managing change is not easy
- Having a well defined and understood process for managing change is imperative
- Processes need to be constantly adjusted to reflect the needs at hand



In the Beginning...

- AEHF Program Office Change Process existed since the beginning of the program
- December 2003 – SMC/CMMI Program Office Assessment recommends review of the existing change process
- September 2004 – Comprehensive review of the AEHF Change Process is initiated
- July 2005 – “New and Improved” AEHF Change Process makes its debut



What We've Learned About the AEHF Change Process Since...

- Define, document, and implement the process
 - *Identify what needs to be accomplished, e.g., Engr. Change vs. Contr. Change*
 - *Know your stakeholders*
 - *Provide enough detail to map it into the process above (e.g. Group to Wing)*
 - *Define Entry and Exit criteria for each step*
 - *Identify Artifacts created and modified*
 - *Define realistic, nominal timelines*
 - *Apply a “KISS” principle at every opportunity*
- Train, train, and train again
- Execute and measure process performance
- Implement Process Volume controls
 - *Addresses multiple, simultaneous changes and resource contention*
- Adjust the process as needed
 - *Conduct process improvement activity (e.g., VSM)*
 - *Implement changes as needed and as possible*
 - *Avoid “Big Bang” approach to changes, “evolutionary” vs. “revolutionary”*
- Be vigilant about your process



AFSO21 VSM

AEHF Change Process Current State – July 2006

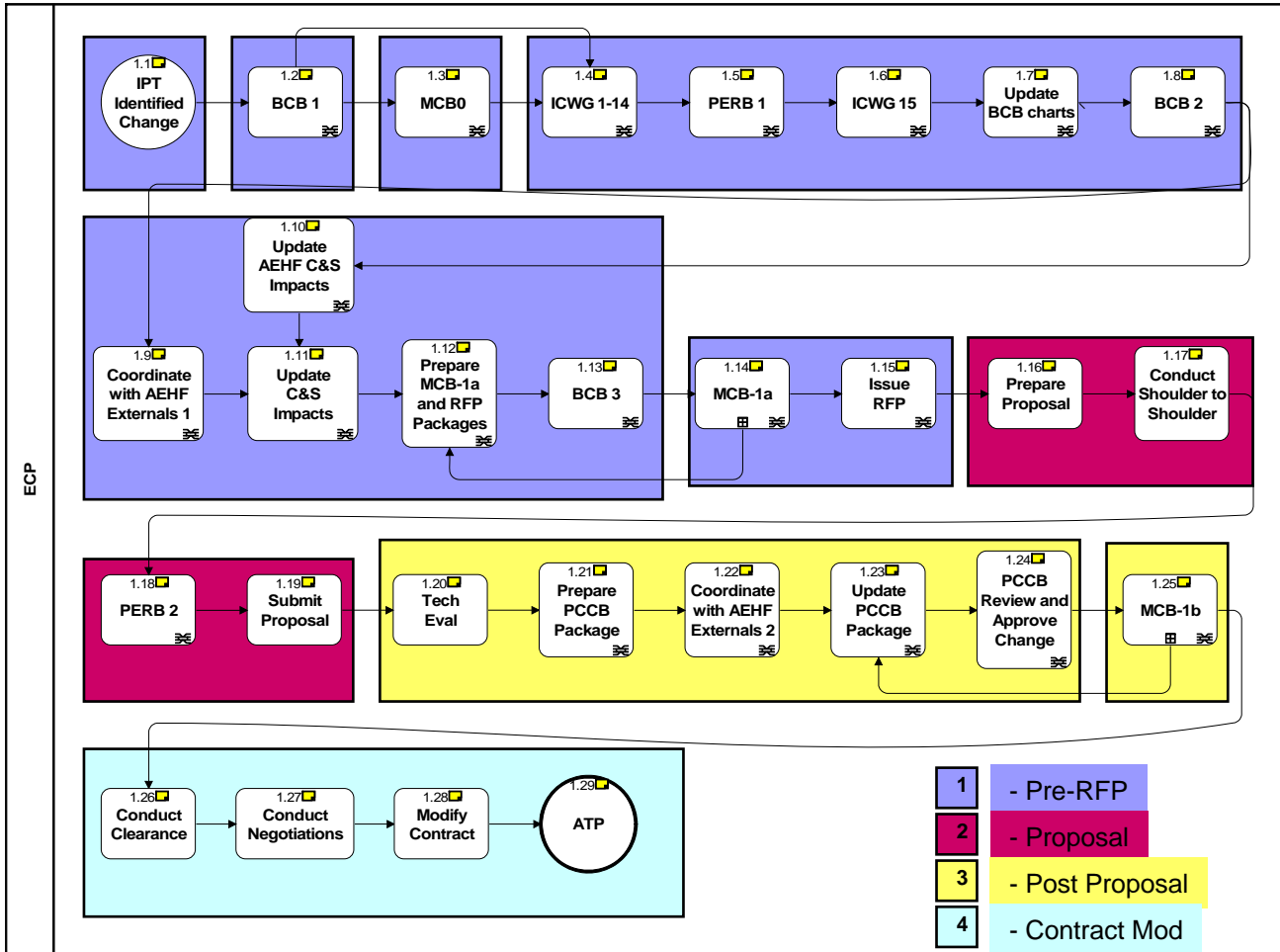

- 1 – Pre-RFP
- 2 – Proposal
- 3 – Post Proposal
- 4 – Contract Mod



AFSO21 VSM Process Activity Value Definitions

Pure Value Activities

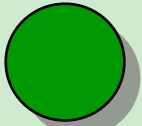

- Activities that change the form, fit or function of the product/service and
- Activities that, when asked, the customer is willing to pay for and
- Activities done right the first time.

Business Value Activities

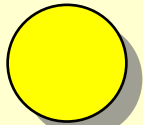

- Activities causing no value to be created but that cannot be eliminated based on current state of technology or thinking
- Required (regulatory, customer mandate, legal)
- Necessary (due to non-robustness of process, currently required)

Non Value Activities

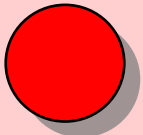

- Activities that consume resources but create no value in the eyes of the customer
- Pure waste
- If you can't get rid of the activity, it turns to yellow.



AFSO21 AEHF CP Initial State VSM Analysis

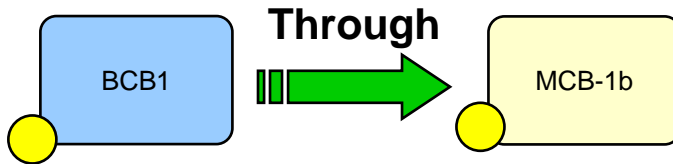

TOTAL	
Task	
Trigger	
Done	
Cycle Time (days)	321
Touch Time (days)	40.25
TAKT Time	
No. of People	492
Items in In-Box	
No. of Approvals	143
Distance Item Travels	
ESH Issue	
% Rework	
Top 3 Rework Issues	

25 STEPS	
10 GREENS	40%
8 YELLOWS	32%
7 REDS	28%

Wait Time (%)	87%
---------------	-----



AFSO21 VSM AEHF Change Process Future State – July 2006

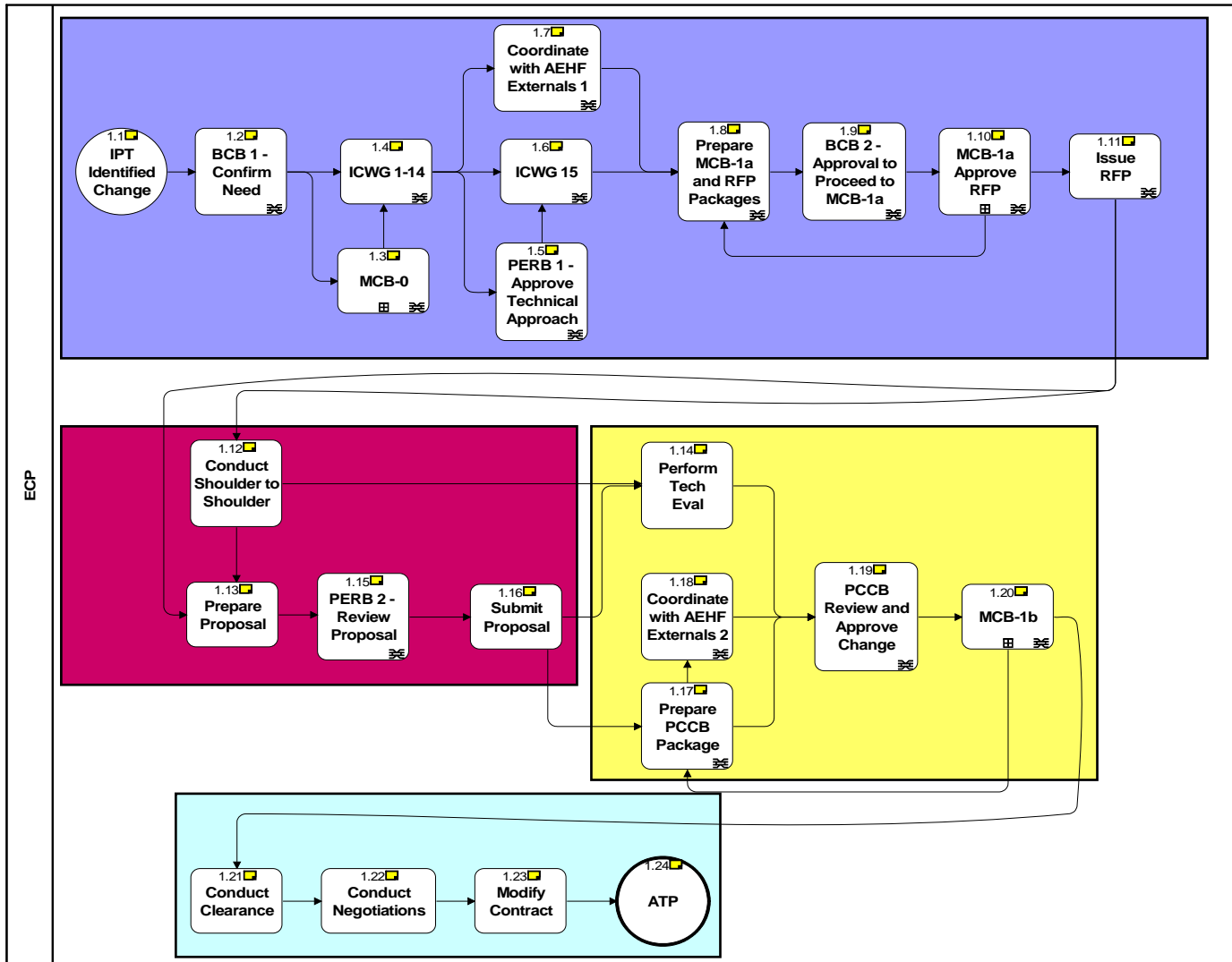

- 1 - Pre-RFP
- 2 - Proposal
- 3 - Post Proposal
- 4 - Contract Mod



AFSO21 Value Stream Mapping Event – July 2006

AEHF Change Process



Reprinted courtesy of the United States Air Force

- What Existed
 - 25 Steps, 321 Days of cycle time (Excluding Mod Phase)
- What We Did
 - Eliminated steps – Consolidated board meetings
 - Optimized Process Flow
 - Performing technical and programmatic coordination in parallel
 - Improved Organizational Impact Analysis
 - Started Activities Earlier – Improved Shoulder-to-Shoulder (StS) process to allow the Tech Evaluation to begin during the Proposal preparation phase
- Results
 - Excluding Mod Phase
 - 19 steps – 24% Improvement
 - Cycle time 196 days – 39% Improvement



Reprinted courtesy of the United States Air Force



Metrics – How Are We Doing?

Start through Contract Modification

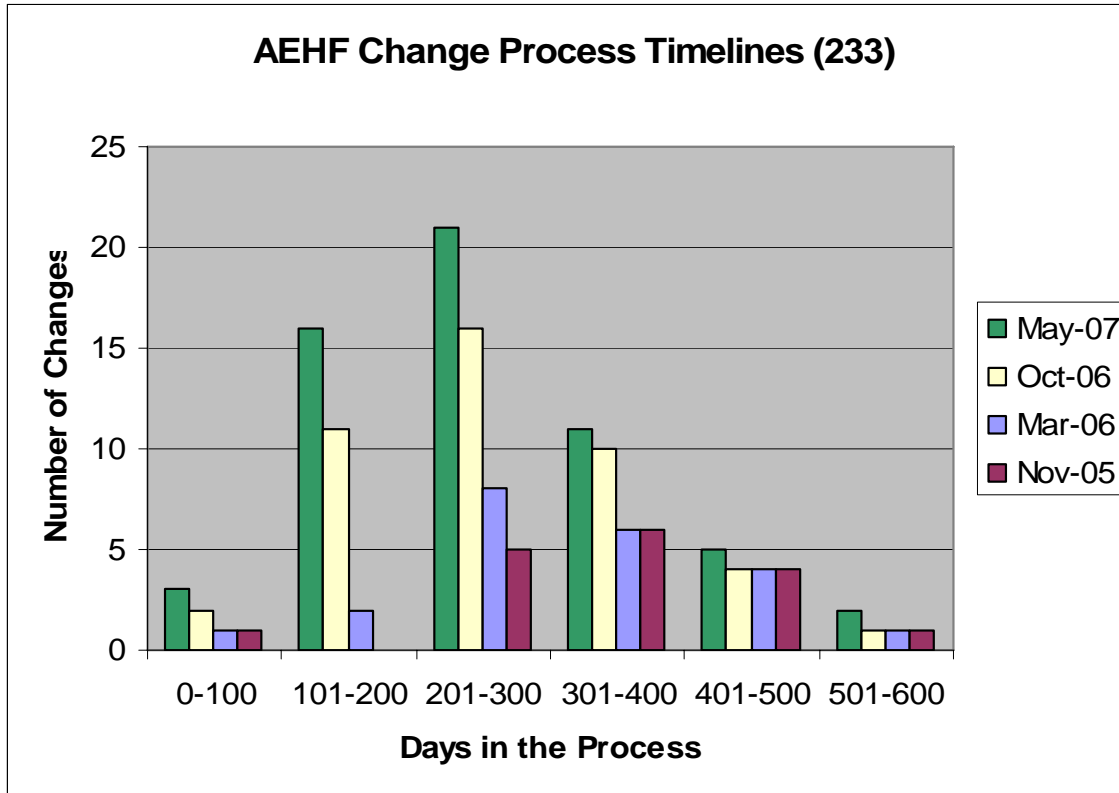

- 17 ECPs/CCPs put on contract (05/05 – 10/05)
- 23 ECPs/CCPs put on contract (05/05 – 03/06)
- 44 ECPs/CCPs put on contract (05/05 – 10/06)
- 58 ECPs/CCPs put on contract (05/05 – 05/07)
- Median
 - 11/05 – 303 days ~ 43 weeks
 - 03/06 – 252 days ~ 36 weeks
 - 10/06 – 243 days ~ 35 weeks
 - 05/07 – 233 days ~ 33 weeks
- 30% Improvement including Mod Phase



VSM Lessons Learned

- VSM technique is a valuable tool in identifying “waste” in a process
- Keep the team lean and effective – 10-15 people
- Must have representation from all stakeholders
- Participants need to know the current process
- Participants need to have basic training in process improvement techniques
- Need experienced event facilitators
- Do not allow changes in team membership once the event starts
- Team leaders need to stay engaged throughout the event, especially during the “heavy lifting” activities
- Team leaders must be careful not to dominate the discussion
- Team leaders must make sure the discussion does not deviate to far from the plans
- Be vigilant to keep the “out-of-bounds” items out of discussions
- Have fun!



CMMI AEHF Program Office Assessment 2007 – Excerpts

- SMC Tailored CMMI® / Acquisition models, no numerical rating or process quality
- AEHF Best Practices – Within the Model
 - *A rigorous Change Management process is used to baseline and maintain requirements*
 - *All types of program changes are analyzed via the Change Management process*
 - *A rigorous Change Management System of boards and reviews includes the relevant stakeholders*
- Strengths Above the Model
 - *Baseline ECO Board (BEB) Master Matrix and waterfall chart are used to regulate change management process flow*



Summary

- A comprehensive Change Process has successfully supported the AEHF program for the past 3 years
- Further improvements are possible, necessary, and are being implemented

Any Questions?

All trademarks, service marks, and trade names are the property of their respective owners



NORTHROP GRUMMAN

DEFINING THE FUTURE

Rapid Force Structure Analysis

Capability Effectiveness Tool

October 22, 2008

David Blancett

Mgr, Systems Analysis & Simulation

Kurt Dittmer

Dir, Advanced CONOPS

Northrop Grumman Corporation

- Large trade spaces limit M&S effectiveness for force structure architecture studies
 - Problem of interest was Layered Intelligence, Surveillance and Reconnaissance (LISR) with Integrated Air and Space
 - Solution spaces ranged from 10,000 to 450,000+ possible architectures
- Historically, addressed with a combination of common sense and expert opinion
 - This in no way guaranteed most cost effective solution was truly identified
- Three-part structured, traceable process was developed to address this limitation
 - Capture commander's intent for a given operation and translate into collection requirements
 - Assess force structure effectiveness as the percentage of collection requirements met and calculate wartime and life-cycle costs
 - Identify highest potential architectures and key elements
- Three tools used to support the upfront process:
 - Collaborative Reasoning Tool (CRT)
 - Capability Effectiveness Tool (CET)
 - Analyst's Workbench

Process Goal: Identify Limited Set of Architectures with the Highest Cost Effectiveness Potential As Starting Point for Detailed Studies

Layered ISR Problem Definition

Collection capabilities change with each scenario and phase of war

Joint air, space, maritime and ground ISR assets have varied and overlapping capabilities

National leadership must integrate Irregular, Catastrophic and National Collection capabilities to make informed deployment decisions

Group Force Mixes by Effectiveness/Cost

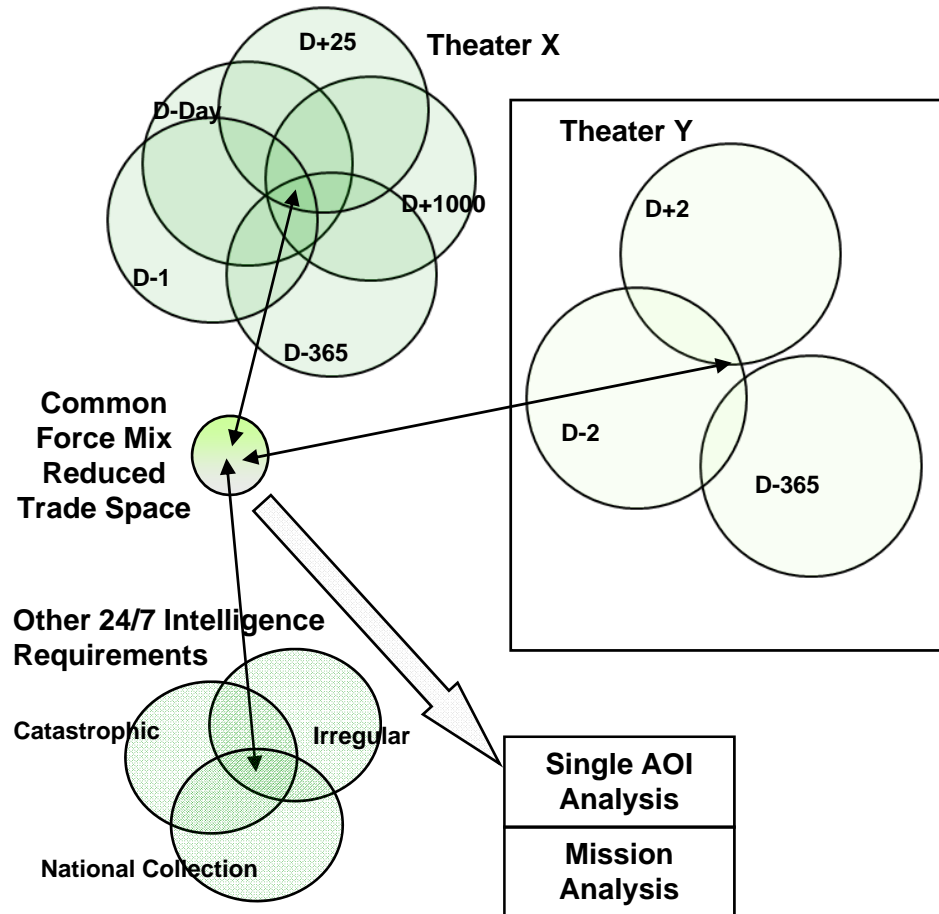

Where We Started

- Investigate Surveillance Capabilities Within 10 Year Horizon That Could Provide Ubiquitous, Near Real Time, Theater-Wide Coverage
 - Consider Manned, Unmanned, Satellites, Ships, Ground Based Systems
 - Multi-Spectral
- What Force Mix Provides Most Cost Effective Means of Accomplishing Goals?

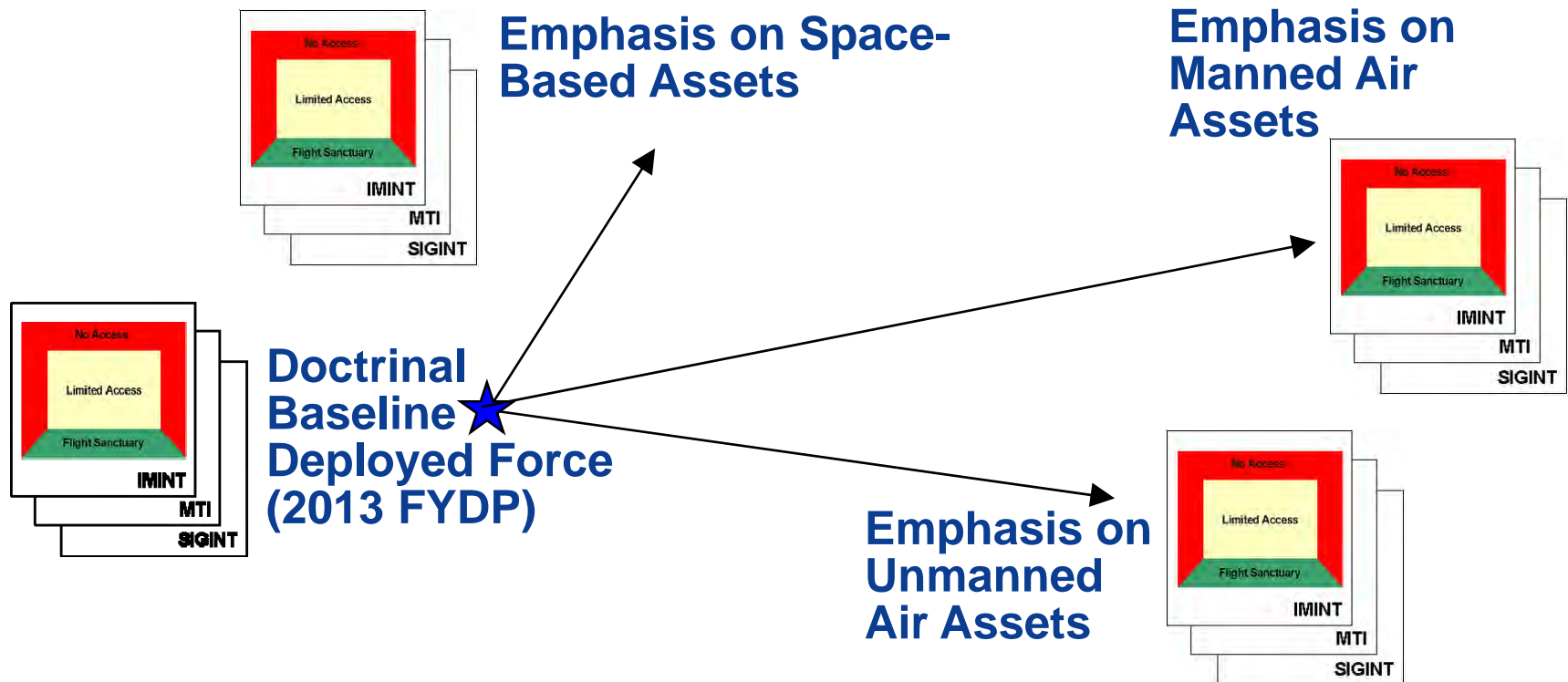

Assessed 57 Cases Out of ~450,000 Possibilities

Developed Toolset to Address Solution Space Size

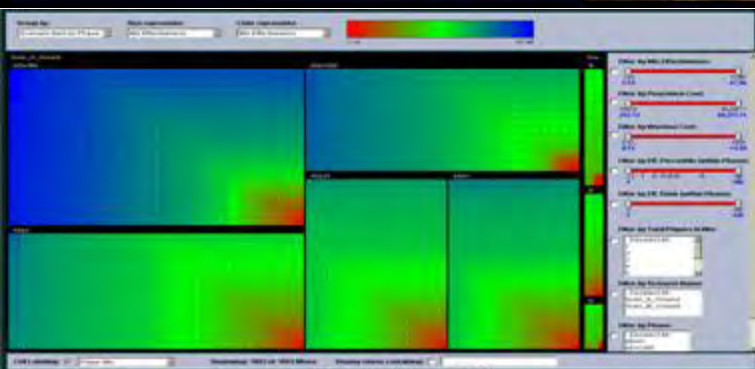
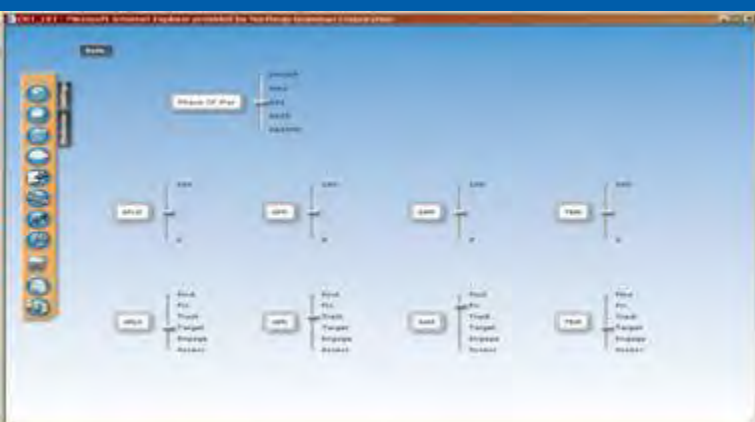

- Collaborative Reasoning Tool
 - Means to easily capture commander's intent for each phase of an operation
 - Single Joint Forces Commander (JFC), or consensus of a group
 - Distributed Capability
- Capability Effectiveness Tool
 - Assess alternative force structure options in terms of potential effectiveness and cost
 - Graphical User Interface (GUI)
- Analyst Workbench
 - Means to quickly review and understand a large database
 - Filters, tagging and other tools to support data analysis

Capability Effectiveness Tool

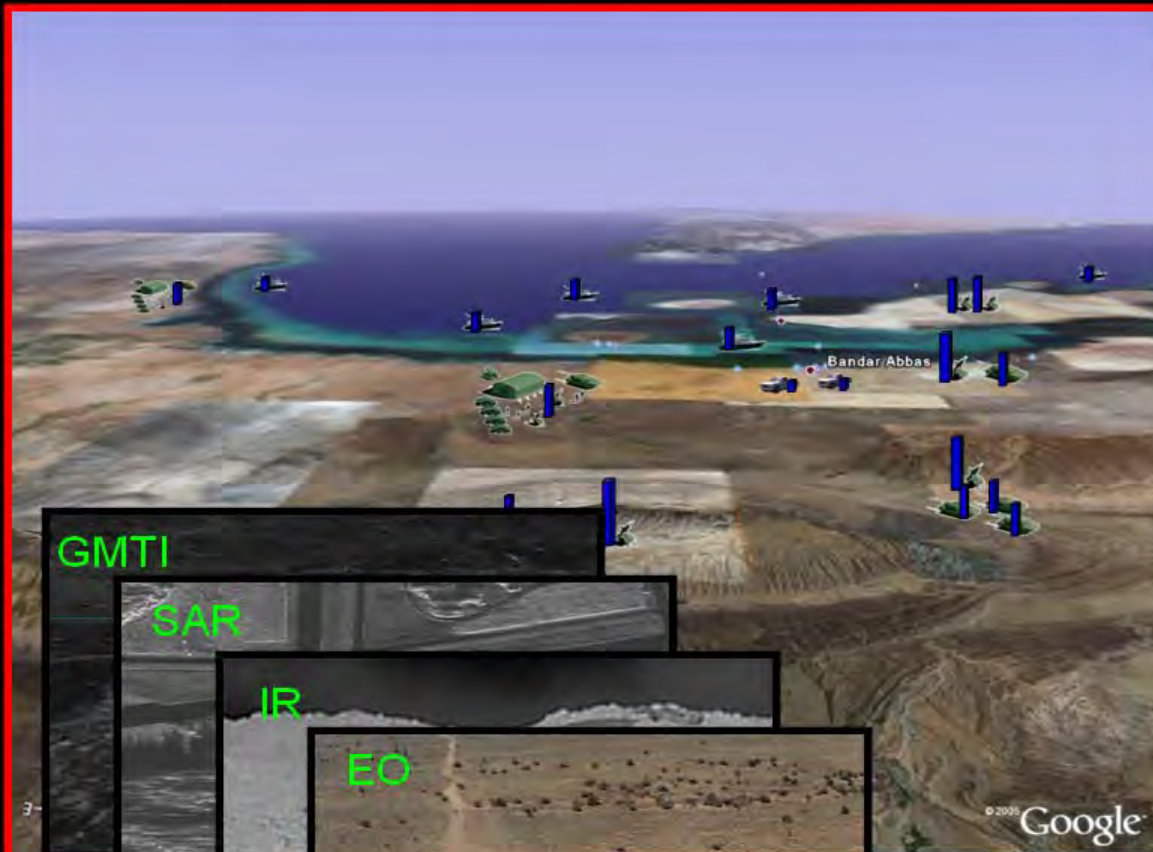

JFC Intent determines type and quality of required sensor information by target

Commander's Intent

Joint Target Prioritization by Phase

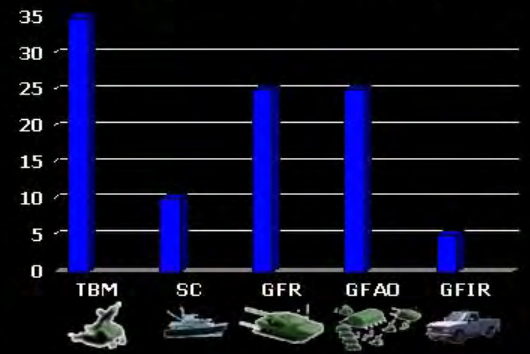

Determine JFC Intent by Target

	TBM	SC	GFR	GFAO	GFIR
FIND		•			
FIX					
TRACK				•	
TARGET			•	•	
ENGAGE	•				•
ASSESS					

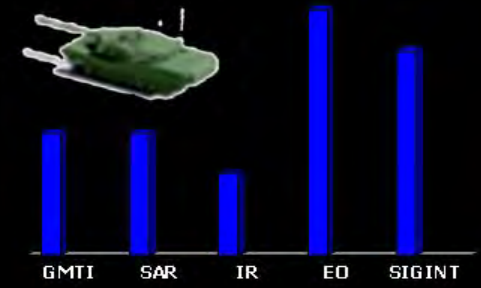

Collaborative Reasoning Tool

The screenshot shows a web browser window titled "CRT_CET - Microsoft Internet Explorer provided by Northrop Grumman Corporation". The interface is set against a blue background and includes a "Vote" button in the top left. A vertical toolbar on the left side, labeled "Moderator Settings", contains icons for various moderation actions such as mouse, chat, ban, and mute. The main content area features a "Phase Of War" control with a slider and a list of options: Dm365, Dm1, Dp1, Dp25, and Dp1000. Below this are four sets of controls for different systems: AFLD, GFR, SAM, and TBM. Each system has a slider ranging from 0 to 100 and a vertical list of actions: Find, Fix, Track, Target, Engage, and Assess.

- Assesses the ability of alternate force structures to achieve the commander's intent
- Static assessment of potential capability over 12 hr or 24 hr period
- ISR force mix effectiveness defined as percent of commander's collection priorities achieved
- Exhaustive assessment, or greedy algorithm
- Also provides
 - Relative contribution of each potential element
 - Collection gaps by sensor and by target
 - Comms throughput and reach-back
 - Wartime operating costs
 - Peacetime life cycle costs

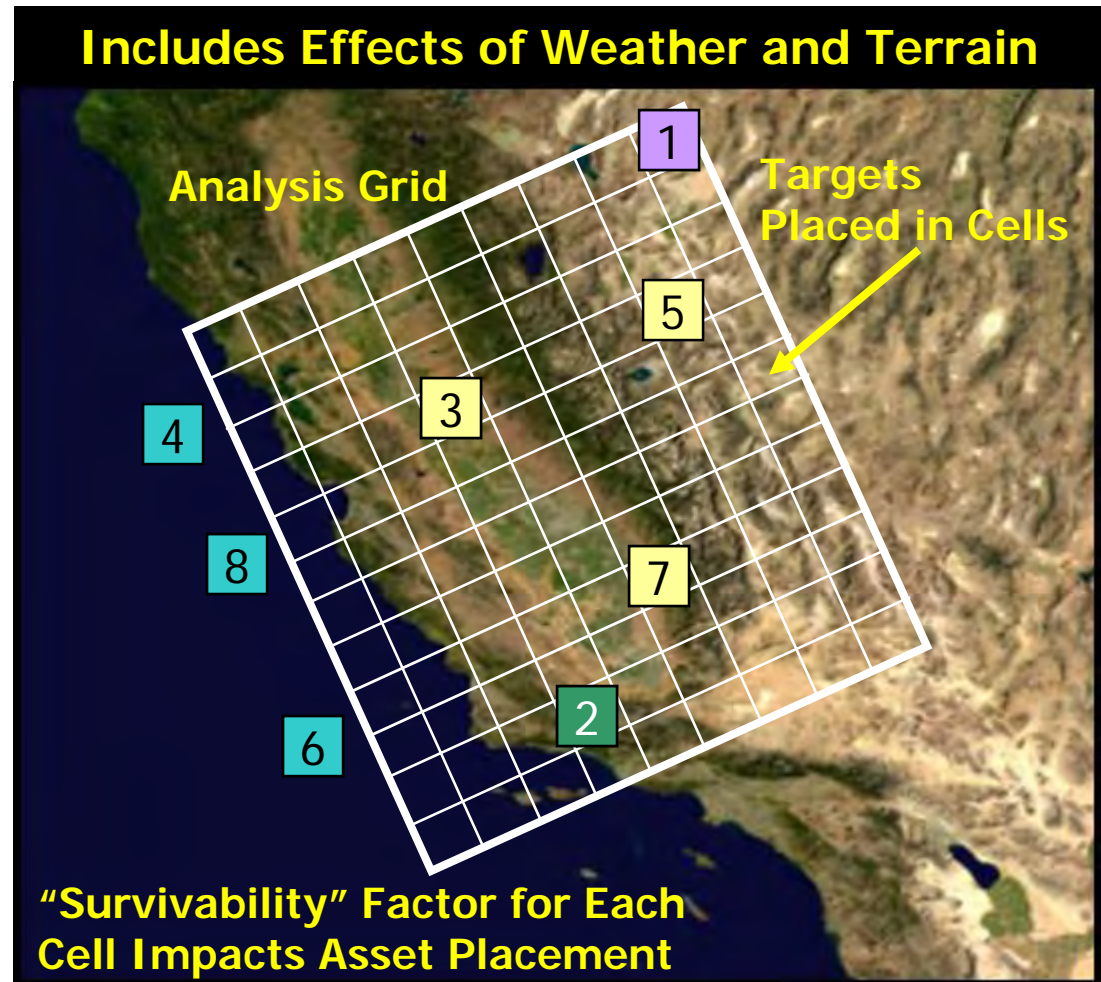

GUI Interface: Scenario and Spectrum

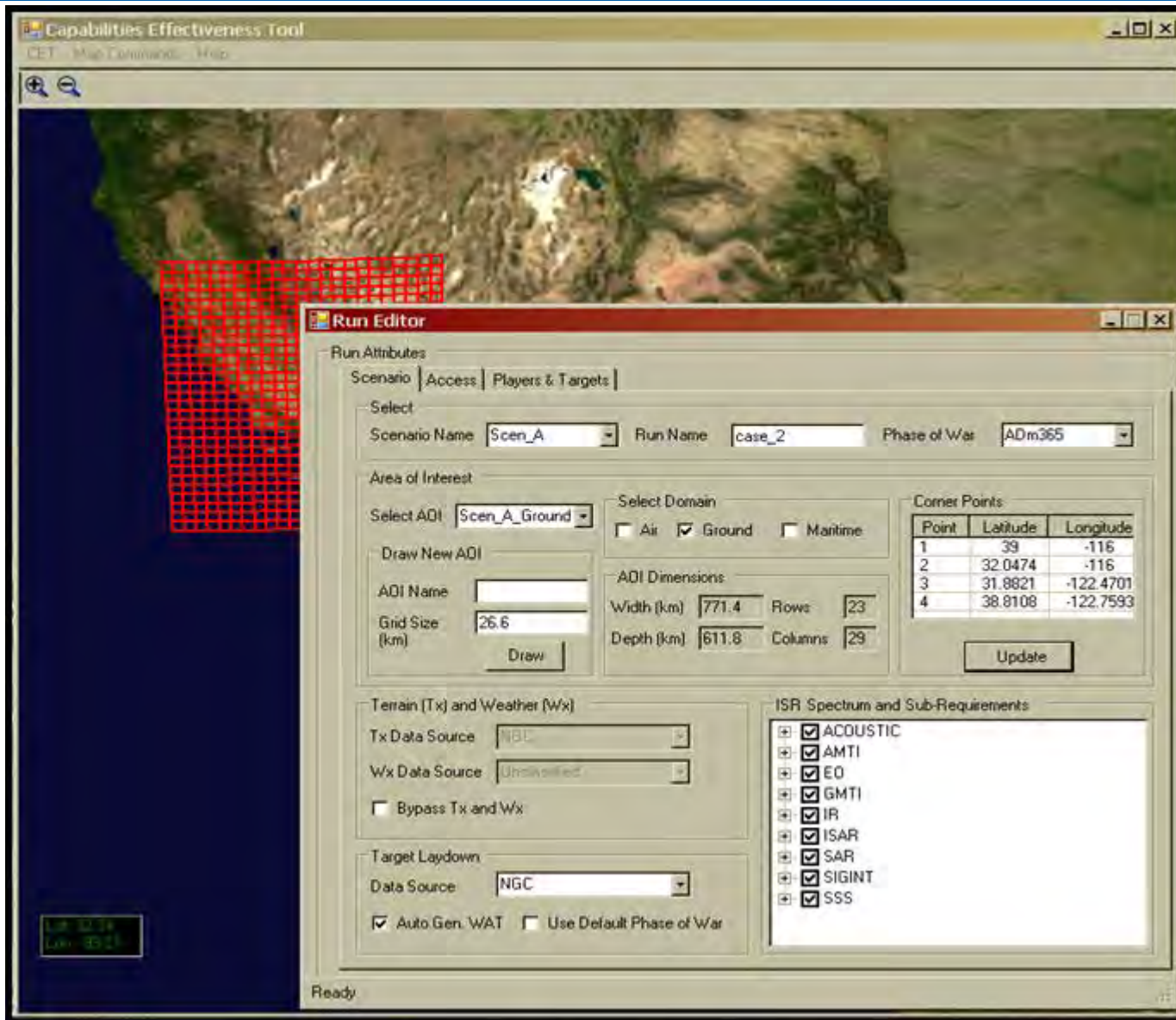

NOTIONAL RESULTS

Multi-Domain Force Mix Gap Analysis

◆ 1 Satellite_A; 1 Satellite_B; 3 VehA; 1 VehB

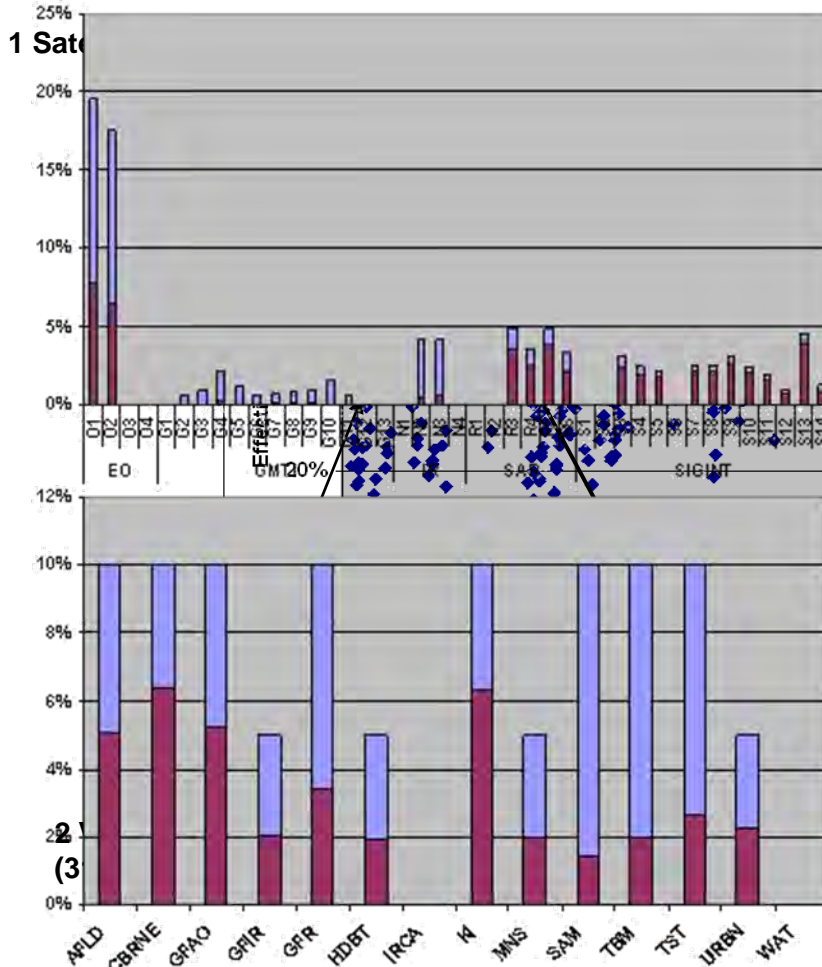

Label	Spectrum	Requirement
01	EO	EO_GEO_LOC_ACCURACY
02		EO_NIIRS
03		HAS_EO
04		PLATFORM_REVISIT
G1	GMTI	GMTI_DETECTIONS
G2		GMTI_ELECTRONICALLY_SCANNED_ARRAY
G3		GMTI_RESOLUTION
G4		GMTI_GEO_LOC_ACCURACY
G5		GMTI_LONG_TERM_TRACKS
G6		GMTI_MIN_DETECTABLE_VELOCITY
G7		GMTI_MTI_HRR
G8		GMTI_NEAR_SIMO_MTI_HRR
G9		GMTI_NEAR_SIMO_SAR_GMTI
G10		GMTI_RESOLUTION
G11		GMTI_SENSOR_ONLY_REVISIT_RATE
G12		HAS_GMTI
G13		PLATFORM_REVISIT
N1	IR	HAS_IR
N2		IR_GEO_LOC_ACCURACY
N3		IR_NIIRS
N4		PLATFORM_REVISIT
R1	SAR	HAS_SAR
R2		PLATFORM_REVISIT
R3		SAR_ELECTRONICALLY_SCANNED_ARRAY
R4		SAR_GEO_LOC_ACCURACY
R5		SAR_RESOLUTION
R6		SAR_SIMO_SAR_GMTI
S1	SIGINT	HAS_SIGINT
S2		PLATFORM_REVISIT
S3		SIGINT_COMINT_GEO_LOC_ACCURACY
S4		SIGINT_COMMERCIAL_COMINT
S5		SIGINT_CONVENTIONAL_COMINT
S6		SIGINT_DETECTIONS
S7		SIGINT_ELINT_SIMPLE
S8		SIGINT_ELINT_GEO_LOC_ACCURACY
S9		SIGINT_ELINT_SIMPLE
S10		SIGINT_FREQ_RANGE
S11		SIGINT_LPI
S12		SIGINT_MILITARY_COMINT
S13		SIGINT_MILITARY_COMINT
S14		SIGINT_UEE

1 Satellite_A; 1 Satellite_B; 3 VehA; 1 VehB (50%)

UNCLASSIFIED

1 Satellite_A; 1 Satellite_B; 1 Satellite_C; 2 VehA (48%)

3 VehC (38%)

Analyst Workbench

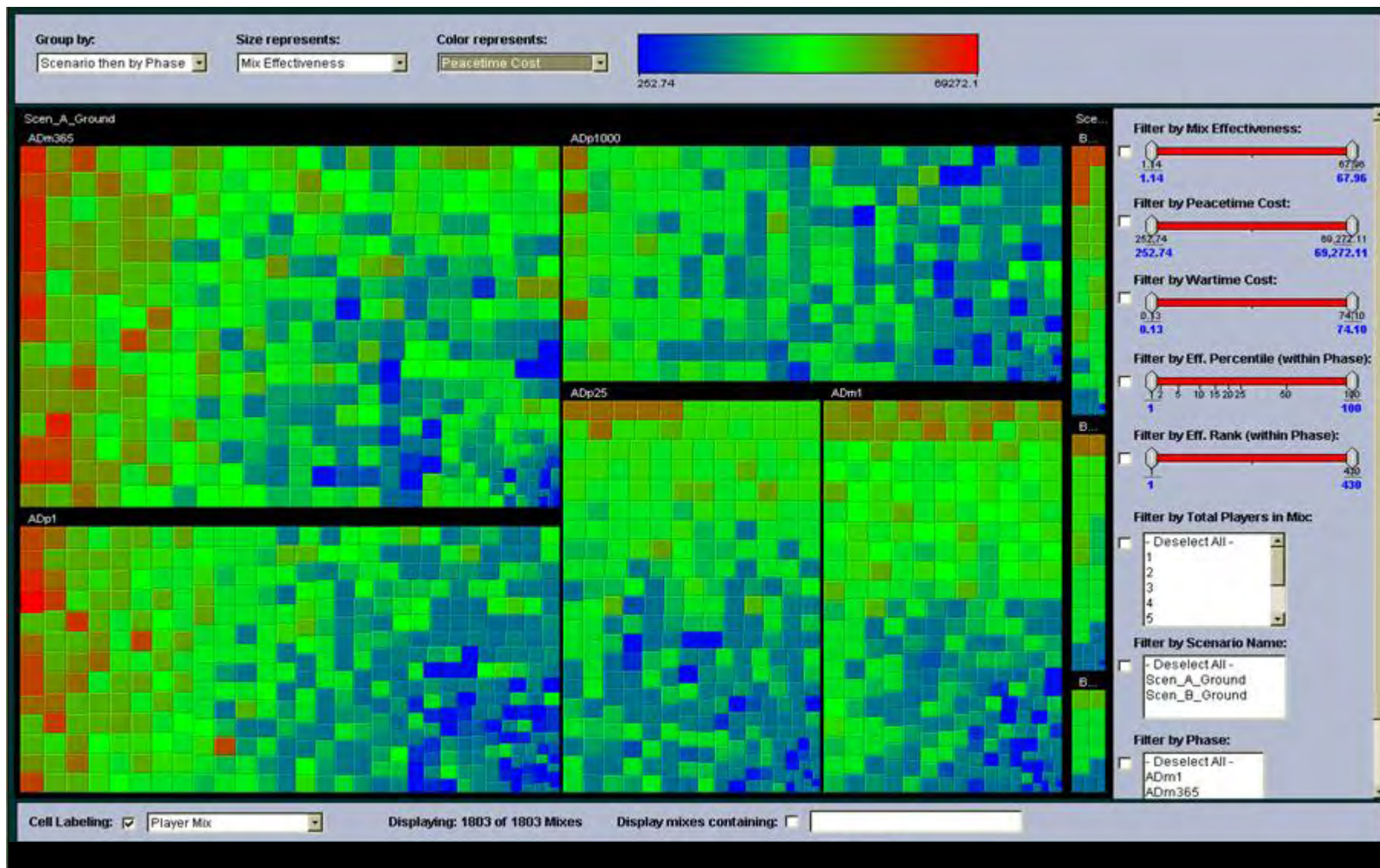

CET Results Feed Into Detailed Analysis

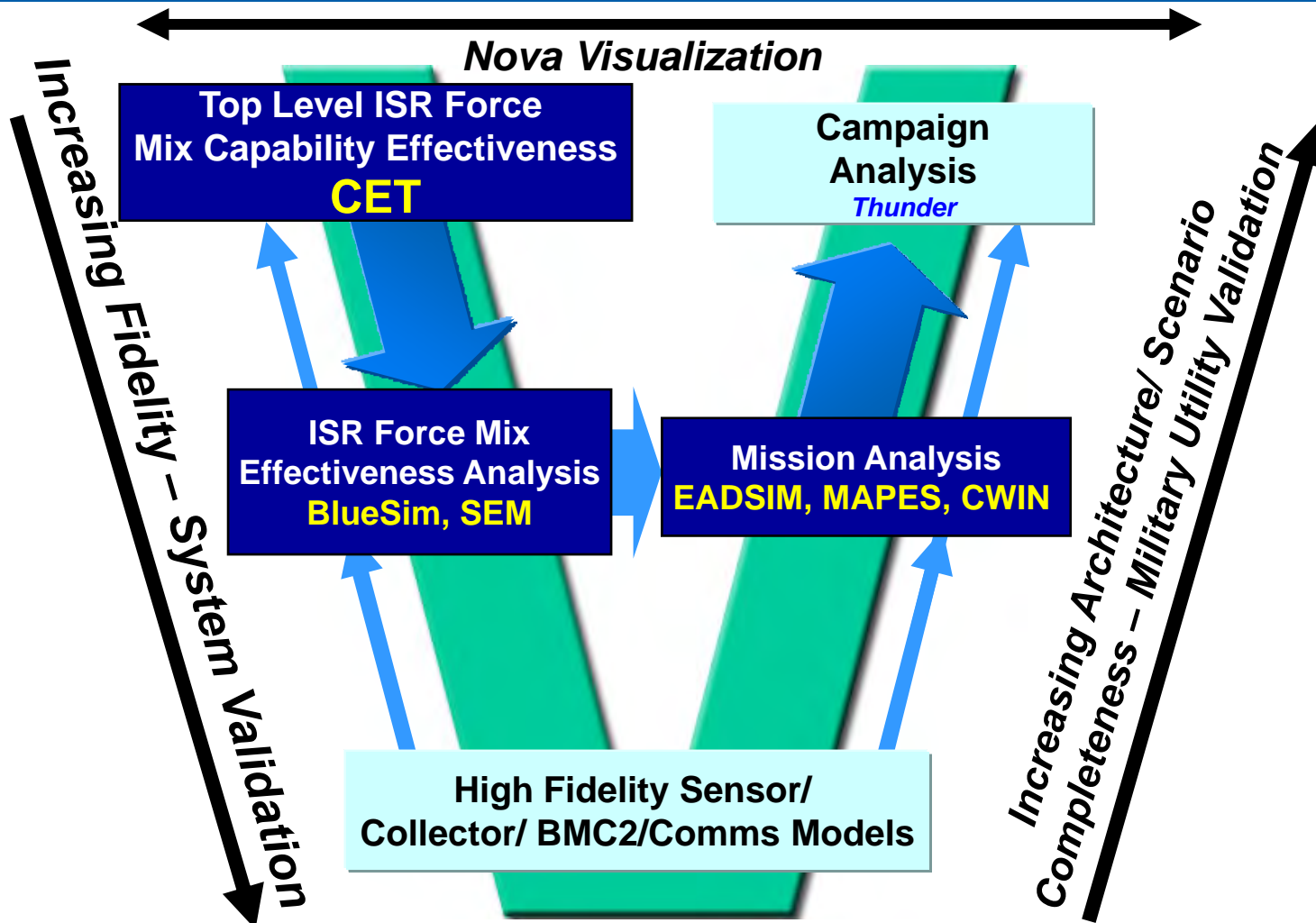

CET Does Not Optimize – It Assesses All Force Mixes to Feed Physics Based Analysis...

Force Structure Validation: CWIN, A Distributed/Collaborative Virtual M&S Enterprise



**CWIN Western Region
El Segundo, CA**



**CWIN Washington Node
Rosslyn, VA**



**CWIN Eastern Region
Bethpage, NY**

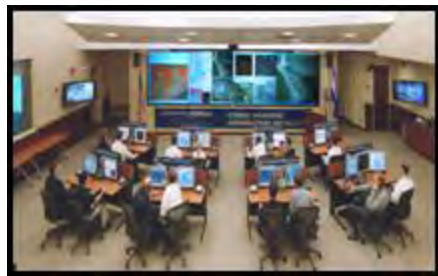

**CWIN Western Region
Rancho Bernardo, CA**



**CWIN Eastern Region
Melbourne, FL**



Deployable Mobile CWIN Services & Systems

Expanded CET Applications

- CET has been adopted by USSTRATCOM
- Other CET applications under consideration:



DIA/STRATCOM Joint Functional Component Command ISR - Assessment Tool for Theater Apportionment



NRO: Integrating CET with Northrop Grumman Corporation ISR Test Bed Incorporate National Intel Priority Framework



J-2 and OSD: Capabilities Assessment Tool for Battlespace Awareness Functional Capabilities Board Program Objective Memorandum Decisions



USSTRATCOM: ISR Global Force Management/ Global Force Posture



- Means to rapidly identify high potential solutions within a large problem set
- Provides understanding of the contribution of each potential element
- Provides understanding of the capability gaps
- Effective use of analyst time and simulation resources

Structured, traceable process providing the means to support LISR force structure architecture studies:

Stand-alone and as a lead-in to detailed work

NORTHROP GRUMMAN

DEFINING THE FUTURE

Concurrent Increment Sequencing and Synchronization with Design Structure Matrices in Software- Intensive System Development



Dr. Peter Hantos
The Aerospace Corporation

NDIA Systems Engineering
Conference
October 23, 2008

Acknowledgements

- This work would not have been possible without the following:
 - *Feedback:*
 - Suellen Eslinger, Software Engineering Subdivision
 - Dr. Leslie J. Holloway, Software Acquisition and Process Department
 - Mary A. Rich, Software Engineering Subdivision
 - *Sponsor*
 - Michael Zambrana, USAF Space and Missile Systems Center, Directorate of Systems Engineering
 - *Funding sources*
 - Mission-Oriented Investigation and Experimentation (MOIE) Research Program (Software Acquisition Task)
 - *Inspiration*
 - Dr. Barry W. Boehm, University of Southern California



Presentation Objectives

- Introduce a research platform to address concurrent engineering concerns of software-intensive system development
- Propose new metrics to characterize increment coupling and cohesion in complex, aggregate life cycle models



Agenda

- Wisdom
- Introduction
- ULCM[®] (Unified Life Cycle ModelingSM)
- Challenges of Concurrent Engineering
- DSM (Design Structure Matrix)
- Mapping Anchor Points to DSM
- CICM (Concurrent Increment Coupling Metric)
- Relationship Between CICM and Schedule/Cost Risk
- Next Steps – Direction of Future Research
- Summary
- Acronyms
- References

[®] ULCM is registered in the U.S. Patent and Trademark Office by The Aerospace Corporation
SM Unified Life Cycle Modeling is a Service Mark of The Aerospace Corporation



Wisdom

“To understand a subject, one must tear it apart and reconstruct it in a form intellectually satisfying to oneself, and that (in the view of the differences between individual minds) is likely to be different from the original form. This new synthesis is of course not an individual effort; it is the result of much reading and of countless informal discussions, but for it one must in the end take individual responsibility. “

Quote from J.L. Synge, “Relativity: The Special Theory” (1956), p. vii



Introduction

- The National Security Space Defense Acquisition Challenge
 - *Chronic cost/schedule overruns in space acquisitions*
 - *Difficulty with validating the contractors' plans*
 - *Difficulty with implementing proper controls*
 - *Difficulty with successfully executing Evolutionary Acquisition and Spiral Development-related policies*
- One of the Most Significant Root-Causes Identified
 - *Concurrent Engineering is pursued without proper models and tools to manage concurrent process streams*
- Proposed solutions involve the use of ULCM[®] (Unified Life Cycle ModelingSM) and DSM (Design Structure Matrix)
 - *ULCM[®] is an Aerospace-developed research framework and methodology*
 - *DSM is a widely used, visual system representation tool*



ULCM[®] – The 64 Thousand Mile View

- ULCM[®] is an intuitive, pattern-based approach for specifying, constructing, visualizing and documenting the life cycle processes of software-intensive system development
- ULCM[®] is aspiring to become the “Occam’s Razor” of Life Cycle Modeling
 - *The medieval rule of parsimony: “Plurality shouldn’t be assumed without necessity”*
 - William of Ockham, 14th century philosopher
 - *The Life Cycle Modeling (LCM) rule of parsimony: All life cycle models are constructs or derivatives of a small number of basic life cycle modeling patterns*
- ULCM[®] is also a research platform
 - *It provides a foundation for a consistent and universal system development methodology*



The First Principles of Unified Life Cycle Modeling*

1. Covered process domains are acquisition and development of software-intensive systems
2. The fundamental building block of life cycle models is an increment
3. All life cycle models are constructs or derivatives of a small number of basic LCM patterns
4. LCM is synergistic with architecture, architectural concepts and architecture modeling
5. Proper representation of life cycle models requires multiple views
6. Concurrent processes are synchronized via anchor points

* **Source:** [Hantos 2007]



Principles #1, #2, and #3

- Principle #1: Covered process domains are acquisition and development of software-intensive systems
 - *ULCM[®] might be applicable in other domains as well, but such use was neither pursued nor verified*
- Principle #2: The fundamental building block of life cycle models is an increment
 - *Increment is a conceptual term, refers to the difference between two subsequent releases of the product*
 - Delivering any useful functionality requires the creation of at least one increment of a system
- Principle #3 : All Life Cycle Models are constructs or derivatives of a small number of basic LCM patterns
 - *Since the fundamental building block is an increment, the ULCM[®] definition of all LCM patterns must address their relationship to the creation and sequencing of increments*



Principles #4 and #5

- Principle #4: Life cycle modeling is synergistic with architecture, architectural concepts, and architecture modeling
 - *Product Architects answer the “What” question*
 - *Process Architects/Project Managers answer the “How” question*
 - *However, both activities are concurrently iterated during the life cycle*
- Principle #5: Proper representation of life cycle models requires multiple views
 - *Based on related experience with architecture modeling, it is clear that having multiple views is always necessary when modeling complex entities*
 - *The question is how many is necessary and sufficient?*
 - Currently ULCM[®] assumes two views of any life cycle model
 - *However, only one of them, the Enactment View, will suffice to demonstrate concerns related to increment coupling and cohesion*



Principle #6

- Principle #6: Concurrent processes are synchronized via Anchor Points
 - *What are Anchor Points (APs)?*
 - Intermediate milestones with specific, focused objectives

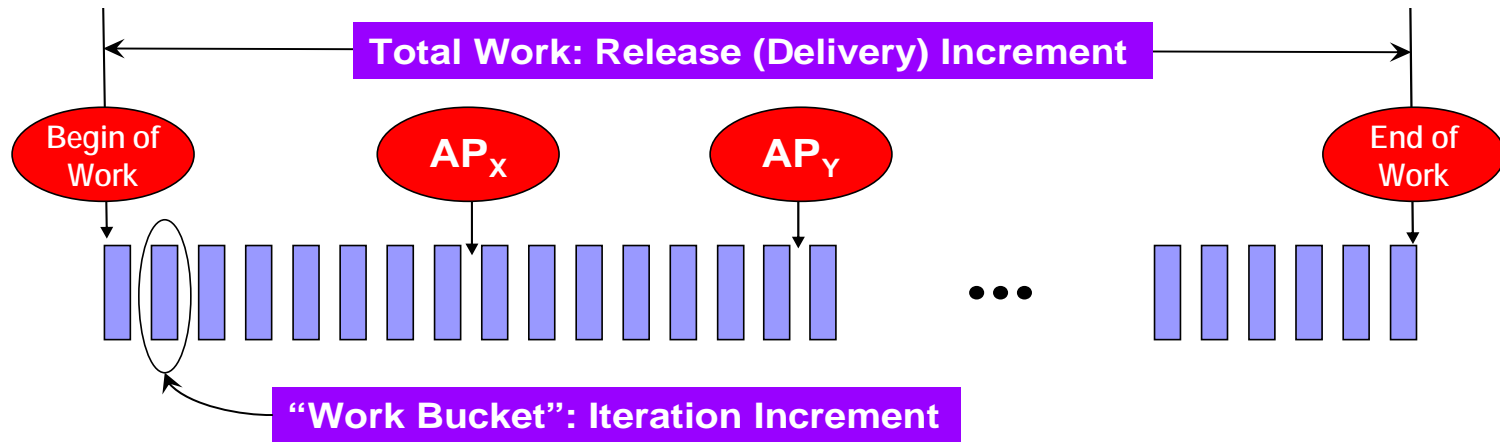

- *The idea behind Anchor Points*
 - “Extreme” Planning and Monitoring & Control Approaches
 - *Ad-hoc, “code-and-fix”*: Planning horizon is the next iteration
 - *Waterfall*: Planning horizon is the end of the Increment
 - “Stop, Stabilize, and Regroup” Approach
 - *Iterative with APs*: Planning horizon is the next Anchor Point



ULCM[®] Enactment View of an Increment

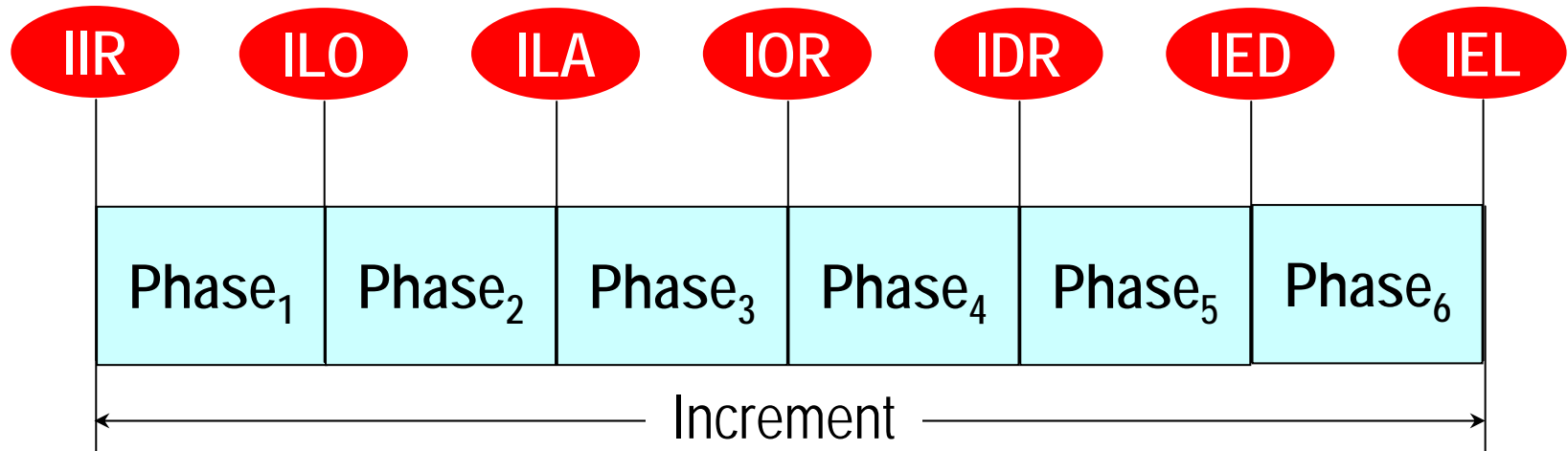

- In ULCM[®], life cycle phases of an increment are intentionally not named
 - *Specifying both phase content and anchor points is redundant*
 - *Phase content stays flexible; phase activities are not pre-determined*
 - *Focus is on achieving anchor point objectives*

Legend:

IIR – Increment Inception Readiness
ILO – Increment Life Cycle Objectives
ILA – Increment Life Cycle Architecture
IOR – Increment Operational Readiness
IDR – Increment Delivery Readiness
IED – Increment End-Of-Life Decision
IEL – Increment End-Of-Life



Product-related AP Objectives During Development

- **IIR** – Increment Inception Readiness
 - *Its sole purpose is to mark the beginning of an increment*
- **ILO** – Increment Life Cycle Objectives
 - *Definition of operational concept, scope, and top-level requirements*
 - *Architectural and design options*
- **ILA** – Increment Life Cycle Architecture
 - *Refinement of operational concept, scope, and top-level requirements*
 - *Resolution of ILO option-explorations, commitment to a feasible architecture and technology solutions*
- **IOR** – Increment Operational Readiness
 - *Operation and quality is demonstrated in development environment*
- **IDR** – Increment Delivery Readiness
 - *The work product created in this phase is ready for*
 - Delivery to the end-user/customer, or
 - Higher-level integration and test



Challenges of Concurrent Engineering

- The usual HW/SW dialog
 - *Traditional SW Position: Give me the working hardware, and leave me alone!*
 - *Traditional HW Position: Here are the specs, see you at final integration. Now leave me alone!*
 - *What Really Takes Place: HW is frequently changing during design. SW people are frustrated and inefficient. SW always ends up being the bottleneck*
- Similar situation in case of concurrently developed software components
- Challenges, challenges ...
 - *The Project Manager's Challenge:*
 - Managing (estimating, planning, monitoring, and controlling) concurrent engineering processes
 - *The Process Architect's Challenge:*
 - Dealing with life cycle modeling complexity
 - *Concurrent engineering of hardware and software*
 - *Iterative/incremental processes*



Anchoring Concurrent Engineering Processes in ULCM[®]

Hardware-Software Streams

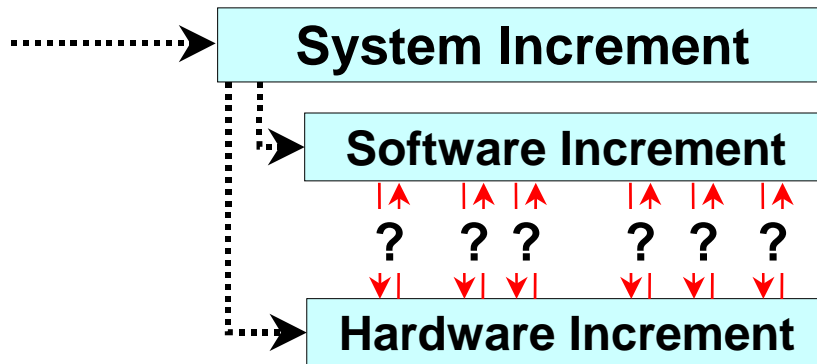

Software-Software Streams

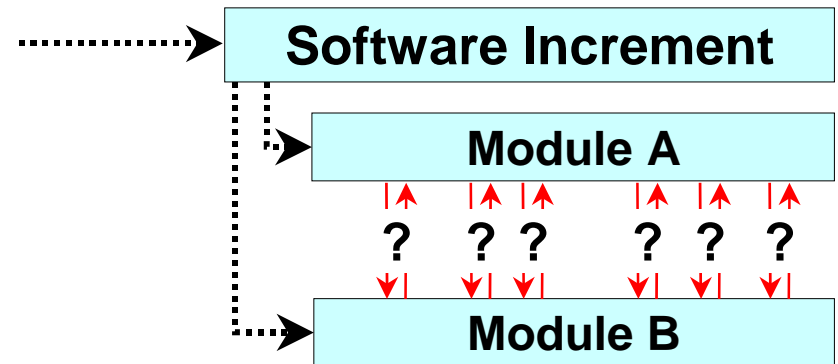

- Specific Challenges Addressed
 - Design of interfaces and the tuning of Technical Performance Measures (TPMs) related to dependent, concurrently developed components
 - For concurrent engineering process streams, the determination of
 - Optimal number of interactions between concurrent streams, and
 - The optimal place of interactions in the life cycle (solved by using APs)



Synchronization Via Anchor Points

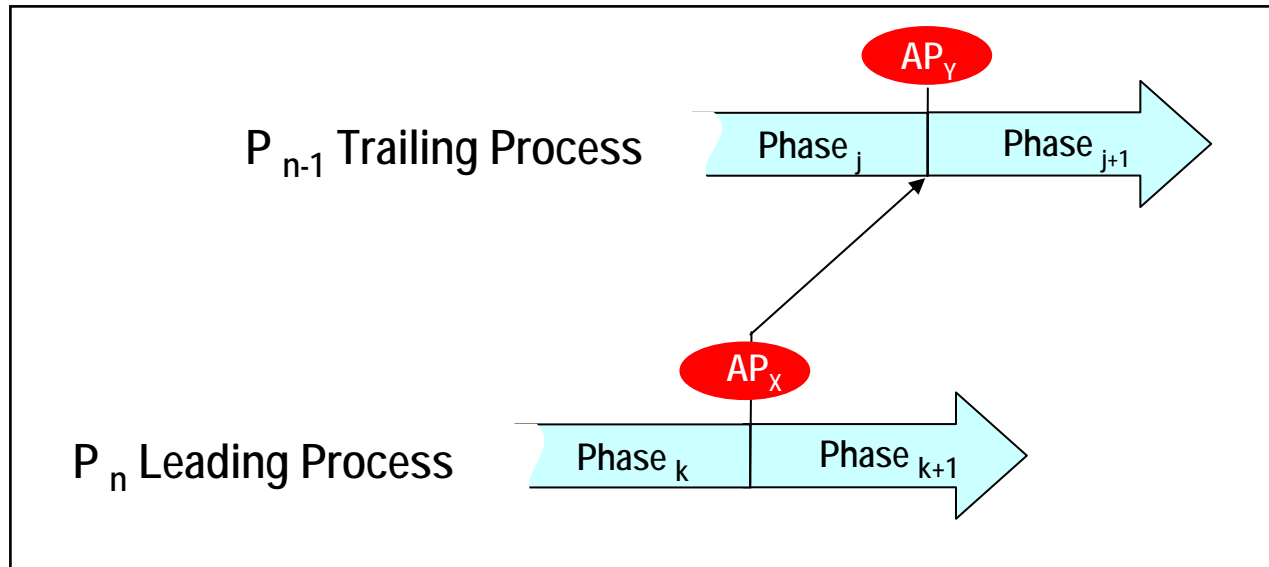

- How Anchor Points are used
 - *Concurrent process streams should not be arbitrarily shifted or overlapped*
 - *Connection is only planned at Anchor Points*
- Stakeholders of the process streams collaborate at Anchor Points
 - P_{n-1} stakeholders rely on P_n stakeholder deliveries at AP_x to satisfy AP_y objectives



Example Use of Anchor Points for a Product Line

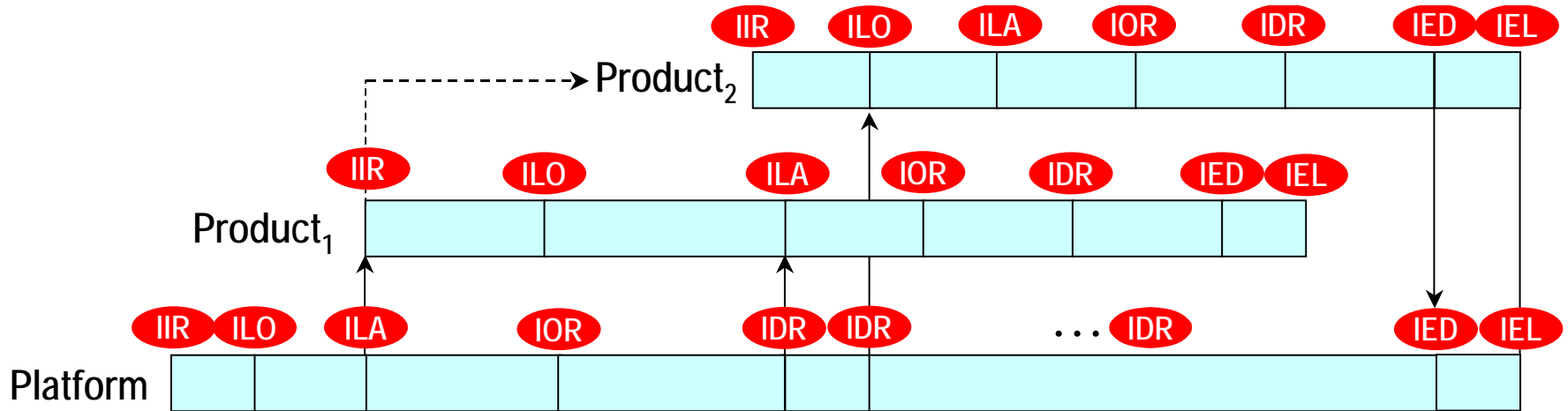

- What is a product line?
 - A *product line* represents a product family, a set of related systems that are built from and leveraging off a common set of core assets*
- Product line challenges
 - *Technical considerations* – selecting/distributing product features
 - *Business constraints* – balancing cost and Time-to-Market
 - *Development strategy challenges* – determination of architectural structuring, development and production order
- LCM Challenge: Manipulating a complex, aggregate life cycle model

* **These core assets are also called the elements of the Product Line Platform**



DSM (Design Structure Matrix)

- The DSM method is widely used to design and optimize complex systems in various domains
 - *DSM describes the relationships between architectural elements of a system in a concise format*
 - *In each cell we might have simply a marker (like a circle) or, in more complex cases some kind of indicator characterizing the relationship between system design elements*
 - *A wide range of tools are available to manipulate DSM [Browning 2001]*
- Basic DSM Examples:

	D1	D2	D3	D4
D1				●
D2	●			
D3				
D4		●		

	D1	D2	D3	D4
D1				m_{14}
D2	m_{21}			
D3				
D4		m_{42}		

Legend: *D1 ... D4* – System Design Elements;
m_{ij} – Relationship between *D_i* and *D_j* Elements



Mapping Anchor Points to DSM

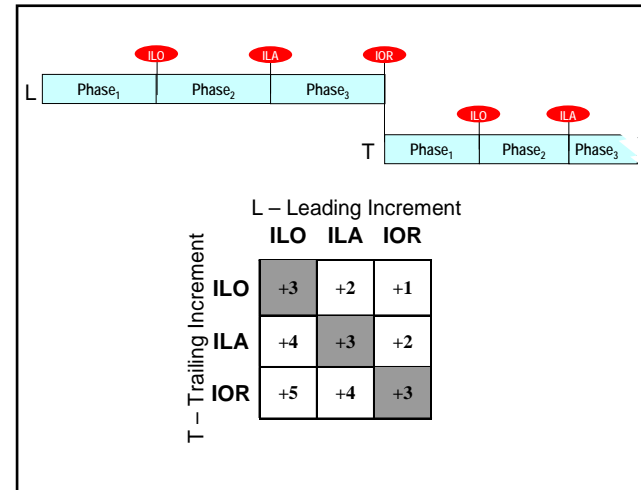
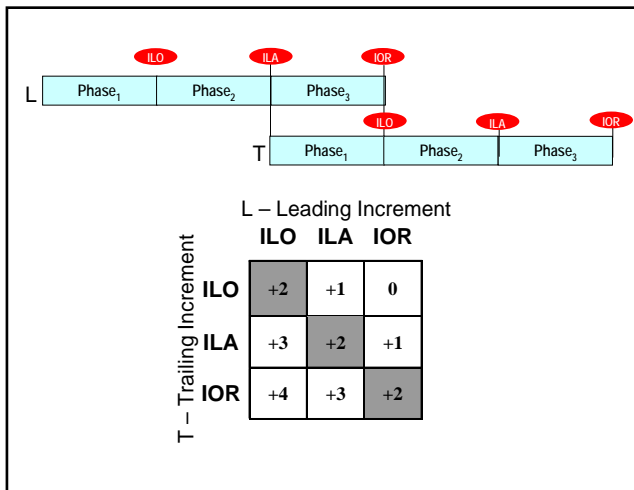
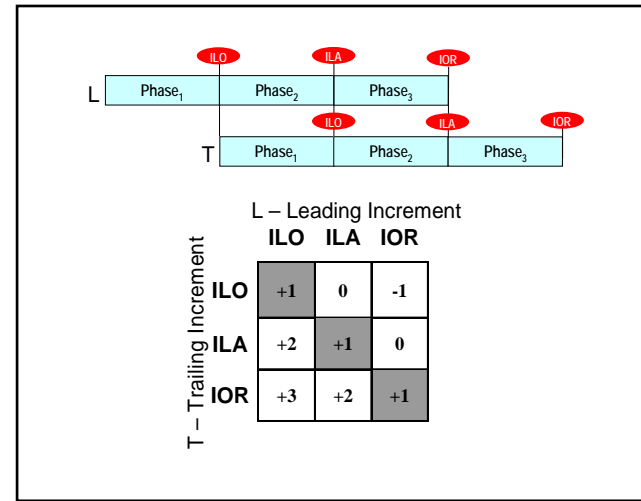
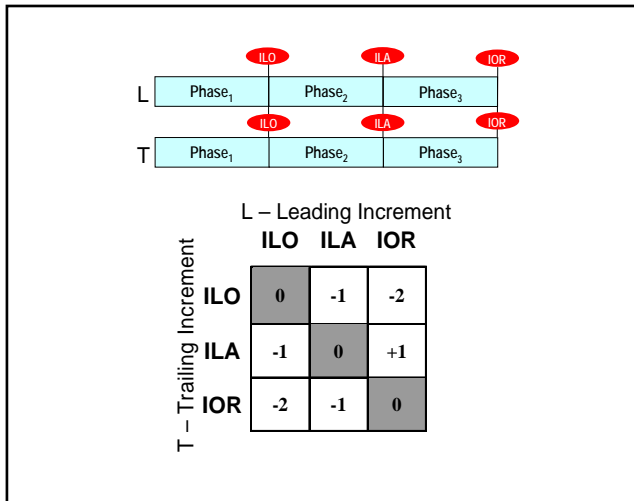

Concurrent Increment Coupling Metric (CICM)

- Coupling is a measure of strength of interconnection
 - *Uncoupled modules are independent*
- High or Low coupling is not “good” or “bad”
 - *Various pro’s and con’s are associated with different coupling levels*
 - *Author’s hypothesis is that for any concurrent engineering situation an optimal coupling exists*
- DSM-based CICM definition

$$\mathbf{CICM} = f(m_{11}, m_{12}, \dots, m_{ij}, \dots, m_{nn})$$

- For the shown DSM matrices a simple CICM definition

$$\mathbf{CICM} = 4 - m_{nn}$$

where m_{nn} is the value from the diagonal of the matrix



CICM Values for the DSM Examples

m_{nn}	CICM	
	Numeric Value	Ordinal Rating
0	4	Very High
1	3	High
2	2	Medium
3	1	Low
	0	No coupling (Independent)



The Relationship Between CICM and Schedule/Cost Risk

- Definitions
 - *Schedule risk in this context is risk to complete the project in the estimated timeframe due to unexpected rework*
 - *Cost risk in this context is risk to complete the project within estimated cost due to unexpected rework*
- A main source of these risks is architecture volatility stemming from concurrent engineering
 - *However, the relationship between concurrent increment process stream coupling and architecture volatility is not straightforward*
 - *For example, the classic “Iron Triangle” of Cost-Schedule-Performance does not apply anymore*
 - Depending on the chosen concurrency configuration of the increments, drastically different schedules are expected even though performance and cost are supposed to stay the same



Discussion Based on the Examples

- Very High Coupling (CICM=4)

- *Positive:*

- Increment phases overlap, all APs are aligned
 - The architecture of both increments is basically planned together, at the same time
 - *Being able to change both architectures provides flexibility that is considered positive*
 - This configuration promises the shortest schedule

- *Caveats:*

- Both architectures are volatile
 - No “hardening” provided for the leading increment
 - No learning from the development of the leading increment
 - There will not be any opportunity for early detection of defects in the leading increment
 - *This configuration results in the most costly rework*



Discussion Based on the Examples (Cont.)

- High Coupling (CICM=3)

- *Positive:*

- Architectural options for the leading increment are known when the design of the trailing increment starts
 - Actual architecture of the leading increment is known when the determination of the trailing increment architecture starts
 - The actual code of the leading increment is available when the implementation of the trailing increment starts

- *Caveat:*

- Increased cost of rework when correcting any problems with the leading increment that are discovered during the design of the trailing increment



Discussion Based on the Examples (Cont.)

- Medium Coupling (CICM=2)
 - *Positive:*
 - Actual architecture of the leading increment is known when the work on the trailing increment starts
 - The actual code of the leading increment is available when the architectural design of the trailing increment starts
 - *Caveats:*
 - Increased difficulty in correcting any problems with the leading increment that are discovered during the design of the trailing increment due to the fact that the leading increment's architecture has been determined
 - Final integration is further removed; correcting any problems with the leading increment that are discovered during final integration is becoming increasingly more expensive



Discussion Based on the Examples (Cont.)

- Low Coupling (CICM=1)
 - *Positive:*
 - The actual code of the leading increment is available when the planning of the trailing increment starts
 - Leading increment's code is considered sufficiently tested
 - *Caveats:*
 - High level of difficulty in correcting any problems with the leading increment that are discovered during the development of the trailing increment due to the fact that the leading increment has already been coded and tested
 - Final integration is further removed; Correcting any problems with the leading increment that are discovered during final integration is becoming very expensive



Next Steps – Direction of Future Research

- Extend CICM to cover more realistic increment positioning situations
 - *The shift involves more than one phase*
 - *Phase-lengths are not equivalent*
- Define LCPC (Life Cycle Plan Cohesion) Metric
 - *Cohesion is a measure of how tightly bound or related the concurrent increments are to one another*
 - *Coupling is one key factor, but not the only factor*
 - It seems to be plausible that tightly coupled increments create a life cycle plan with high cohesion
 - *However, the relationship needs to be researched and quantified.*

$$\mathbf{LCPC = f(CICM)}$$

- Develop quantitative evaluation guidance for LCPC
 - *Quantify metrics*
 - *Develop a methodology that allows the comprehensive evaluation of schedule, rework, and quality dimensions of different life cycle plans*



Summary

- A promising Aerospace research platform, ULCM[®] has been used to model concurrent engineering process streams of software-intensive system development
- DSM has been introduced to facilitate the easy manipulation of ULCM[®] models of concurrently engineered complex systems
- Two new metrics, CICM and LCPC has been proposed to characterize increment coupling and cohesion in complex life cycle models



Acronyms

AP	Anchor Point
CICM	Concurrent Increment Coupling Metric
DSM	Design Structure Matrix
IDR	Increment Delivery Readiness
IED	Increment End-of-Life Decision
IEL	Increment End-of-Life
IIR	Increment Inception Readiness
ILA	Increment Life Cycle Architecture
ILO	Increment Life Cycle Objectives
IOR	Increment Operational Readiness
IR&D	Independent Research & Development
LCM	Life Cycle Modeling
LCPC	Life Cycle Plan Cohesion
MOIE	Mission-Oriented Investigation and Experimentation
TPM	Technical Performance Measure
ULCM	Unified Life Cycle Modeling



References

- [**Browning 2001**] Browning, R. T., “Applying the Design Structure Matrix to System Decomposition and Integration Problems: A Review and New Directions,” IEEE Transactions on Engineering Management, 48(3):292-306
- [**Hantos 2007**] Hantos, P., “Unified Life Cycle Modeling Tutorial, Version 1.0,” Aerospace Report No. TOR-2007(8550)-6966, August 31, 2007



Contact Information

Peter Hantos

The Aerospace Corporation

P.O. Box 92957-M1/112

Los Angeles, CA 90009-2957

Phone: (310) 336-1802

Email: peter.hantos@aero.org



All trademarks, service marks, and trade names are the property of their respective owners



Air Armament Center

War-Winning Capabilities...On Time, On Cost



Defining 100 Best Practices for SE

Ian Talbot

AAC/EN

ian.talbot@eglin.af.mil

<https://afkm.wpafb.af.mil/EglinSE>

U.S. AIR FORCE



Product Portfolio



AFMCC

AMRAAM



HTS



MALD



BQM-167A



SDB



JASSM

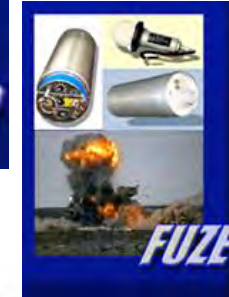

FUZE



JDAM



SFW



UMT



ARTS



B-2 Shelter



Outline



- **Air Armament Center
Systems Engineering
Assessment Model**
 - Why
 - How
 - What
 - Excerpts



Today is a Discussion not a Lecture – Please Stop me Anytime!



Direction & Goals



- In 2006, Tasked to:
 - Perform a Center-wide SE Assessment
 - Found Out Where We Are?
 - Baseline Enterprise Process Improvement

- Goals
 - Improve Program Performance & Reduce Technical Risk
 - Ensure a Consistent Understanding of SE
 - Ensure Core SE Processes are in Place and Being Practiced
 - Identify Opportunities for Continuous Improvement
 - Clarify Roles and Responsibilities
 - Institutionalize “Best Practices”





Why We Need Change?



- **Too Many Problems Have Surfaced**
 - Missed or Poorly Validated Requirements
 - Poor Planning Fundamentals
 - Lack of Integrated Risk Management
 - Lack of Rigorous Process
 - Lack of Process Flow Down
- **We Must Regain Our Credibility**
- **Restoring SE Discipline in AAC Projects Is a Key Initiative**

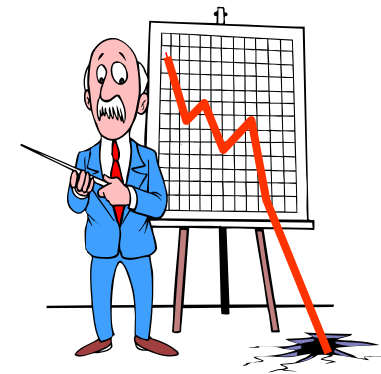

*Lack of Disciplined Systems Engineering
has been a Major Contributor to Poor Program Performance*



Our Approach



- **Define Systems Engineering Best Practices**
- **Benchmark Systems Engineering Implementation**
- **Establish a Baseline for Continuous Improvement**
 - **Begin Changing the Culture to Kaizen**
- **Phased Approach – 3 Phases**



2006



2007-2008



2008-2009



SE Models & Frameworks

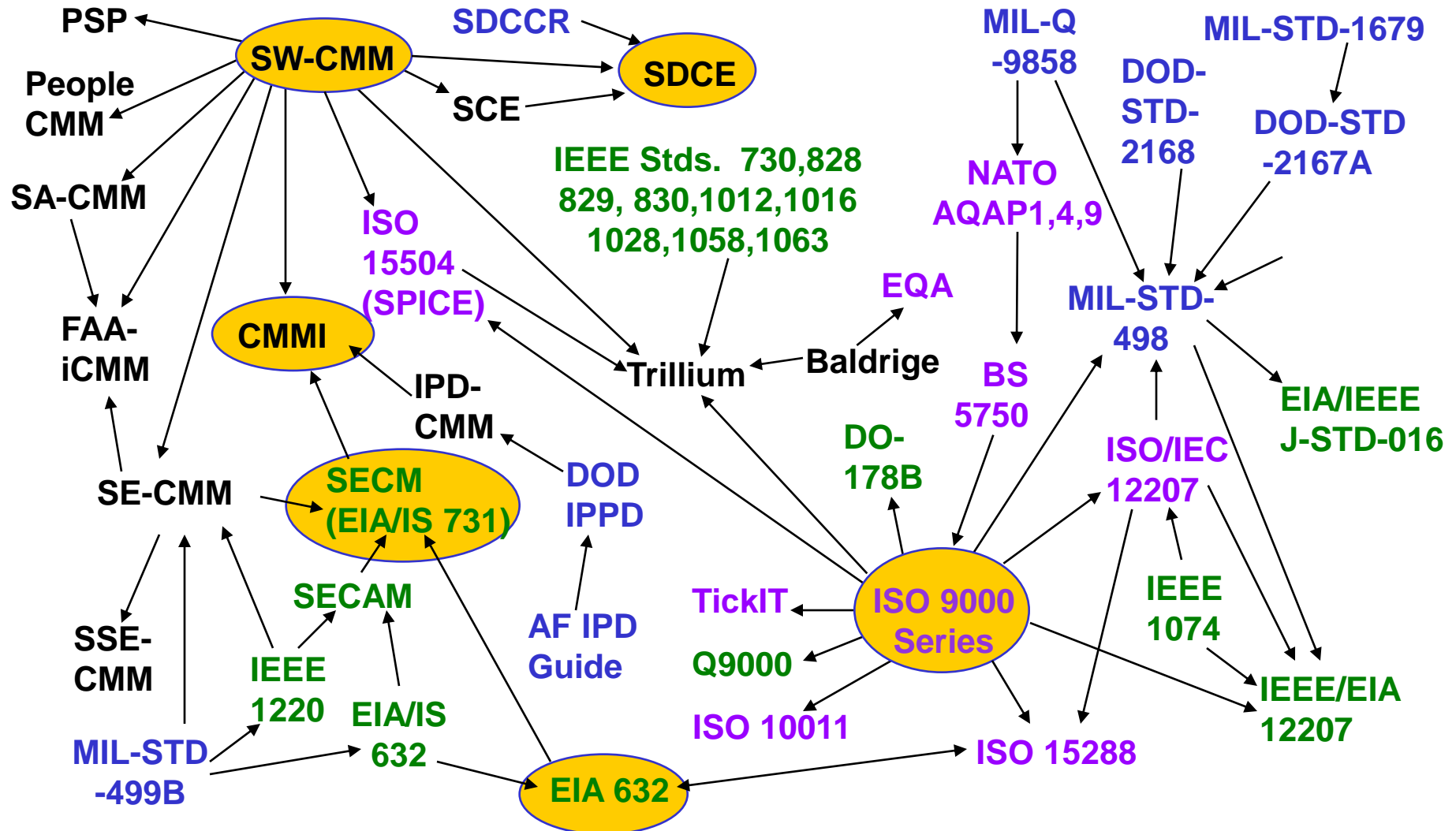



Defining SE



- **Center Engineering Steering Council**
 - **Defined Criteria**
 - **Approved Module & Approach**

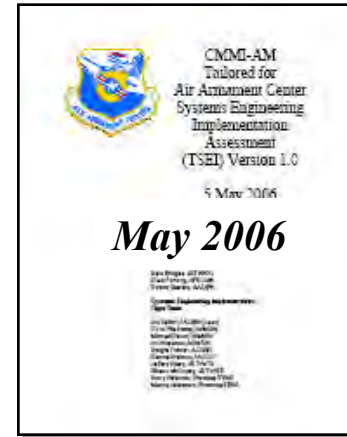
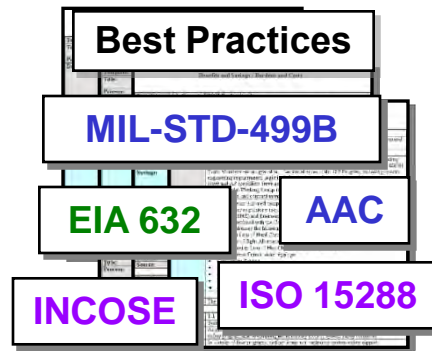
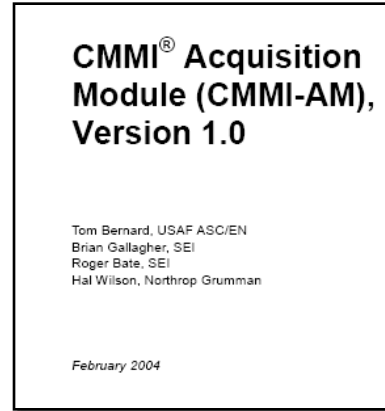

- **9 Key Process Areas**
- **29 Goals**
- **117 Practices**
- **9 Generic Practices**
- **Qualifying Questions**
- **43 Pages**



Industry/Academia

- SEI, NDIA, Boeing, Raytheon, etc.
- USC, AFIT, etc.

OSD Guidance

- DAG
- SEP Guidance

AF Guidance

- AFI 63-1201
- AFPD OSS&E

AFMC Guidance

- AFMCI 63-1201
- OSS&E

Other Centers

- ESC
- SMC

AAC Assessment Module Based on International, Industry and DoD Best Practices



Benchmarking the Enterprise



Process Area Criteria*

- >90% of Practices
- 65-89% of Practices
- <65% of Practices

Program Criteria

- >90% of Practices, No Red
- 65-89% of Practices, NTE 1 Red
- <65% of Practices, 2 or More Red

as of 8 Jan 07	Key Process Areas									Pgm
	R	D	V	T	P	TA	RM	CM	DA	
Program #1	Yellow	Green	Green	Yellow	Yellow	Yellow	Green	Green	Red	Green
Program #2	Green	Green	Green	Green	Yellow	Yellow	Green	Green	Yellow	Green
Program #3	Yellow	Green	Green	Green	Yellow	Yellow	Red	Green	Red	Red
Program #4	Yellow	Green	Red	Yellow	Yellow	Yellow	Green	Green	Yellow	Yellow
Program #5	Green	Green	Green	Green	Yellow	Yellow	Yellow	Green	Yellow	Yellow
Program #6	Yellow	Green	Green	Green	Red	Yellow	Yellow	Green	Red	Red
Program #7	Yellow	Green	Green	Yellow	Red	Yellow	Yellow	Yellow	Red	Red
Program #8	Red	Red	Red	Red	Yellow	Yellow	Red	Red	Red	Red
Program #9	Yellow	Green	Green	Yellow	Yellow	Yellow	Yellow	Green	Yellow	Yellow
Program #10	Yellow	Green	Green	Yellow	Yellow	Yellow	Yellow	Green	Red	Yellow
Program #11	Yellow	Green	Green	Yellow	Yellow	Yellow	Yellow	Green	Red	Yellow
Program #12	Yellow	Green	Green	Yellow	Yellow	Yellow	Yellow	Green	Red	Yellow
Program #13	Green	Green	Green	Yellow	Yellow	Yellow	Green	Green	Yellow	Green
Program #14	Yellow	Green	Green	Green	Yellow	Yellow	Yellow	Green	Red	Yellow
Program #15	Yellow	Green	Green	Green	Yellow	Yellow	Yellow	Green	Yellow	Yellow
Program #16	Yellow	Green	Green	Green	Yellow	Yellow	Yellow	Green	Yellow	Yellow
Program #17	Yellow	Green	Green	Red	Red	Yellow	Yellow	Green	Red	Red
Program #18	Red	Yellow	Green	Yellow	Yellow	Yellow	Green	Green	Red	Red
Center Average	Yellow	Green	Green	Yellow	Yellow	Yellow	Green	Green	Red	Red

* Weighting
SPs 75%
GPs 25%

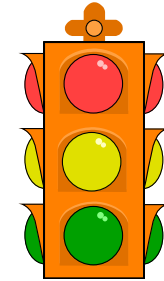

Portfolio Criteria

- 95% Programs Green
- 75%-95% Programs Green, <10% Programs Red
- <75% Programs Green or >10% Programs Red





AAC SE Assessment Model



- Engineering Council Provided Steering
- Working Level Team Did Heavy Lifting
 - Defined SE
 - Established Expectations
 - Facilitated Assessments
 - Training Benefits

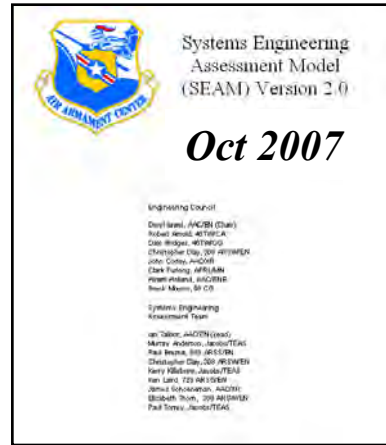

AAC-SEAM v2.09

- 10 Process Areas
- 34 Specific Goals
- 120 Practices
- 6 Generic Practices
- Qualifying Questions
- 50 Pages

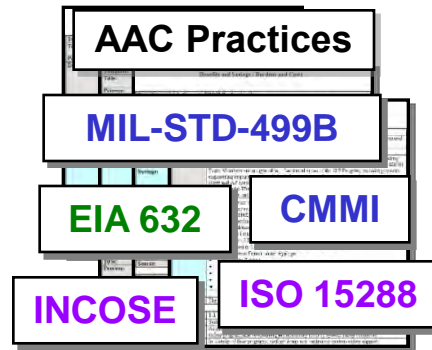

Industry/Academia

- SEI, NDIA, Boeing, Raytheon, etc.
- USC, AFIT, etc.

OSD Guidance

- DAG
- SEP Guidance

AF Guidance

- AFI 63-1201
- AFPD OSS&E

AFMCI Guidance

- AFMCI 63-1201
- OSS&E

Other Centers

- ESC
- SMC

AAC Assessment Model Based on International, Industry and DoD Best Practices



Process Area Evolution



• Technical Processes

- Requirements
- Design
- Verification/Validation
- Transition

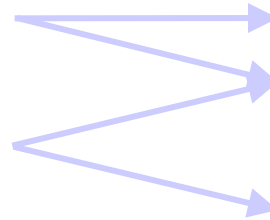

• Technical Processes

- Requirements
- Design
- Manufacturing
- Verification/Validation
- Sustainment

• Technical Management Processes

- Planning
- Risk Management
- Configuration Management
- Decision Analysis
- Technical Assessment

• Technical Management Processes

- Planning
- Risk Management
- Configuration Management
- Decision Analysis
- Technical Assessment

*Consistent with OSD Policy, Defense Acquisition Guidebook,
Draft AFI on Systems Engineering & AFMCI 63-1201*

Version 1

Version 2



Collaboration & Refinement



- **2007-2008 Goals**
 - Reduce Burden on Execution
 - Refine Alignment Between Module and DoD, AF, AFMC Guidance
 - **Formed AAC Tiger Team to Work on:**
 - Streamlining
 - Expanded Coverage
 - **Collaboration with OSD and Software Engineering Institute on Future of CMMI**
 - **AF Wide Collaboration to Develop Common SEA Model**
 - **Industry Collaboration**
- AAC-SEAM v2.4**
- 10 Process Areas
 - 33 Specific Goals
 - 115 Practices
 - 7 Generic Practices
 - 67 Qualifying Questions
 - 47 Pages

Compliant with AF-SEAM v1.0



Current Process Areas



- **Technical Process Areas**
 - Requirements
 - Design
 - Manufacturing
 - Verification & Validation
 - Fielding & Sustainment
- **Project Process Areas**
 - Project Planning
 - Risk Management
 - Configuration Management
 - Decision Analysis
 - Technical Assessment
- **Introduction**
- **Goal**
 - Practices
 - Grey Matter
 - Question(s)
- **Goal...**
 - Generic Practices
- **Question(s)**

AAC-SEAM v2.4



Requirements Process Area



- **Purpose: Develop and analyze operational user, product, and product-component requirements**
- **Goals:**
 - **RG1: Stakeholder needs, expectations, constraints, and interface requirements are collected and translated into a definition of needed product capabilities/characteristics**
 - **RG2: Requirements are refined, elaborated and allocated to support product design**
 - **RG3: Iteratively analyze and validate operational and derived requirements throughout the product life cycle**
 - **RG4: Requirements are managed and controlled, and inconsistencies with technical plans and work products are identified**
 - **RG5: Generic practices are applied to the requirements process area**
- **13 specific & 7 generic practices to be assessed**



Example Practice



Key Process Area: Requirements

Goal: RG4 - Requirements are managed and controlled, and inconsistencies with technical plans and work products are identified.

Practice:

P1 Use a disciplined process for accepting, vetting, approving and providing requirements and changes to the developer through a single focal point.

This process should prevent developers from receiving requirements changes from unauthorized sources that are outside the flow of the acquirer's established configuration management process. Each change to a controlled requirement should be assessed for impact to the program's performance, cost, and schedule baselines and to program risk. The existing cost, schedule, and performance baselines should be changed, as required, to accommodate the requirements change. "Requirements creep" must be avoided. A new requirement must be backed with money and vetted through a control process.

Self Assessment Consists of Answering Yes, No or Not Applicable with Supporting Rationale to each Practice – No Partial Credit



Requirements



- **Design Mission Reference Profiles (RG1P2)**
 - **Comprehensive Definition of Product Characteristics in Engineering Terms and Documentation of the Interaction of the Product with the Environment, Other Systems, and Operational Users [Willoughby].**

Do we understand the edges of the technical performance envelope?

- **Validate Requirements (RG2P3)**
 - **Ensure the Evolving Product will Perform as Intended in the Operational Environment [CMMI].**

Do the derived requirements accurately and completely represent what is needed? and no more... How were they validated?

Reference: AAC SEAM v2.4



Planning



- **Integrated Plans for Managing (PPG2)**
 - Plan for Engineering, Data, Resources, Stakeholders, Technology, Reliability and Supportability. Maintain Integrated Master Schedule and Plans [CMMI].

Are all technical plans integrated and consistent? How do you know?

- At the fundamental level, planning includes understanding **what** must be done (scope of effort), **who** needs to do it (staffing and skills), **when** it needs to be done (life cycle and schedule), **how** it is to be done (reviews, methodology, tools, meetings etc...) and **how much** it will cost.

Reference: AAC SEAM v2.4



Manufacturing



- **Plan for Transition to Production (RG1P2)**
 - **Establish Comprehensive Management Plans that Describe All Production Related Activities that Must Be Accomplished During Design, Test and Low-rate Initial Production [Willoughby].**

Are all tiers of suppliers are involved in production planning?

- **Implement Quality Management (MG4P1)**
 - **Monitor and Control Manufacturing Processes and Product Variation in all Tiers of Manufacturing [Willoughby].**

How are process changes considered, authorized and implemented?

Reference: AAC SEAM v2.4



Testing and Sustainment



- **Verification and Validation (VG3 & VG5)**
 - Analyze and document the results of the verification & validation activities, identify issues, initiate and document corrective actions [CMMI].

Is information on issues and corrective actions widely known?

- **Plan for Logistic Support (SG1P1)**
 - Comprehensive Life Cycle Plan for Ensuring a Safe, Suitable and Effective Product [AFMCI].

Are the critical failure modes addressed in maintenance activities?

Reference: AAC SEAM v2.4



Decision Analysis



- **Guidelines For Decision Making (DAG1P1)**
 - Determine Which Issues Are Subject To Formal Evaluation [CMMI].

Do we understand when a formal analysis of alternative courses is indicated? Do we have the discipline to comply? ...

- **Document Decision Rationale (DAG1P6)**
 - Including Dissenting Opinions [NASA]
 - Support Future Analysis [CMMI]

Have we documented the decision including any concerns/issues? ... Sufficiently to support a re-examination in the next phase?

Reference: AAC SEAM v2.4



Final Thoughts



“The Air Force is not funded to do everything that everybody wants us to do.”

-- Hon Michael Wynne, SECAF

So let's agree in AFMC we are done with the phrase "more with less."

*Instead, I'd like us each to focus on doing the right things with the available resources. I want you to ask yourself the question, "with the resources I have at my disposal (time, funding, people, equipment, etc.) **what are the most important things I have to do?** " The corollary question then becomes, "**what must I stop doing so I can do those things?**" I recognize there are valuable things you might have to stop doing. I need each of you to take a hard look at your organization and determine what those things are.”*

-- Gen Bruce Carlson, Commander AFMC

*This is Great News for Systems Engineering Because we are All About Optimizing Systems!
but We Must Have the Discipline and the Integrity to Make the Trades...*

改善

Kai-zen

The Art of Continuous Improvement

*Kai-zen must operate with three principles in place:
process and results, systemic thinking, and non-blaming
(because blaming is wasteful).*

Air Armament Center

War-Winning Capabilities...On Time, On Cost

Lessons Learned Doing Systems Engineering Assessments on the Government



U.S. AIR FORCE

Ian Talbot
AAC/EN
ian.talbot@eglin.af.mil

<https://afkm.wpafb.af.mil/EglinSE>



Product Portfolio



AMRAAM



HTS



MALD



BQM-167A



SDB



JASSM

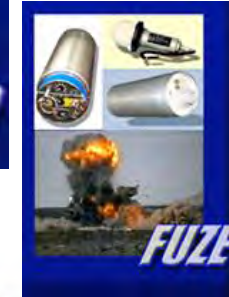

FUZE



JDAM



SFW



UMT



ARTS



B-2 Shelter



Outline



- **Air Armament Center Systems Engineering Assessments**
 - Why
 - How
 - What we Learned
 - Futures



Today is a Discussion not a Lecture – Please Stop me Anytime!



Direction & Goals



- In 2006, EN Tasked to:
 - Perform a Center-wide SE Assessment
 - Found Out Where We Are?
 - Baseline Enterprise Process Improvement

- Goals
 - Improve Program Performance & Reduce Technical Risk
 - Ensure a Consistent Understanding of SE
 - Ensure Core SE Processes are in Place and Being Practiced
 - Identify Opportunities for Continuous Improvement
 - Clarify Roles and Responsibilities
 - Institutionalize “Best Practices”





Our Approach



- **Define Systems Engineering Best Practices**
- **Benchmark Systems Engineering Implementation**
- **Establish a Baseline for Continuous Improvement**
 - **Begin Changing the Culture to Kaizen**
- **Phased Approach – 3 Phases**



2006



2007-2008



2008-2009



Focus on Process



- **The Quality of a System or Product is Highly Influenced by the Quality of the Process Used to Develop and Maintain It**

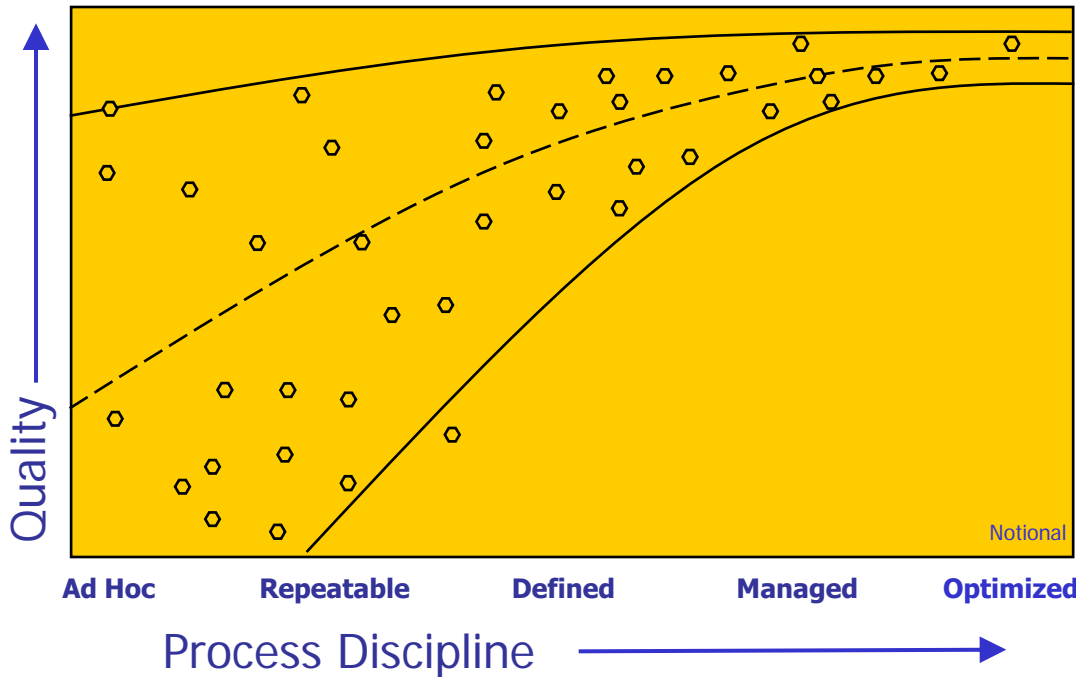

CMMI Performance Results Summary		
	Median Improvement	Number of Data Points
Cost	34%	29
Schedule	50%	22
Productivity	61%	20
Quality	48%	34
Customer Satisfaction	14%	7
ROI	4.0 : 1	22

CMU/SEI-2006-TR-004

- **Process Discipline Leads to:**
 - **Predictable Program Performance**
 - **Ability to Deliver on our Commitments**

Institutionalized Process Driven SE » Lower Risk Technical Programs



AAC SEA Model Development



CMMI® Acquisition Module (CMMI-AM), Version 1.0

May 2006
CMMI-AM Tailored for Air Armament Center Systems Engineering Implementation Assessment

Oct 2007
Systems Engineering Assessment Model (SEAM) Version 2.0
1 October 2007

30+ Assessments

Systems Engineering Assessment Model
Aug 2008

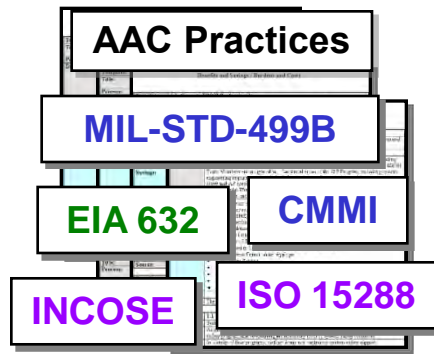

Systems Engineering Assessment Model v2.4

- 10 Process Areas
- 33 Specific Goals
- 115 Practices
- 7 Generic Practices
- 67 Qualifying Questions
- 47 Pages

Streamlined CMMI
Compliant with AF-SEAM v1.0

Industry/Academia
• SEI, NDIA, Boeing, Raytheon, etc.
• USC, AFIT, etc.

OSD Guidance
• DAG
• SEP Guidance

AF Guidance
• AFI 63-1201
• AFPD OSS&E

AFMC Guidance
• AFMCI 63-1201
• OSS&E

Other Centers
• ESC
• SMC

AAC Assessment Model Based on International, Industry and DoD Best Practices



Current Process Areas



- **Technical Process Areas**
 - Requirements
 - Design
 - Manufacturing
 - Verification & Validation
 - Fielding & Sustainment
- **Project Process Areas**
 - Project Planning
 - Risk Management
 - Configuration Management
 - Decision Analysis
 - Technical Assessment
- **Introduction**
- **Goal**
 - Practices
 - Grey Matter
 - Question(s)
- **Goal...**
 - Generic Practices
- **Question(s)**

AAC-SEAM v2.4



Criteria for Methodology



- **Objective Assessment**
- **Provide insight into Government, Prime Contractors and Subs Process & Capability**
- **Facilitate Self Assessment & Continuous Improvement**
 - **Lean & Six Sigma**
- **Consistent Near and Far Term Approach**
- **Provide Results that are meaningful for leadership**
 - **Relevant to PM/PEO**
 - **Simple**
 - **Understandable**
 - **Graphical**
- **Support Multi-level Measurement & Reporting**
 - **Program, Group, Wing, Enterprise**





SEA Methodology



Training & Preparation...

Acquirer & Supplier

Project Team
Self-Assessment

Leadership
Review Board

High Value

SEA Team
Peer Review

Co-chaired by Chief of Systems Engineering and Line Engineering Functional

Team Chaired by Senior Systems Engineer
Members from Across Multiple Programs

Assessment Process Time Required
Leadership – 8 person hrs
Project Team – 60-100 person hrs
SEA Team – <50 person hrs

*SEA Assess What Practices are Implemented NOT How Well Executed
Future: Begin to Shift Focus to “How To” and Quality of SE Implementation*



Products Provided to Program



- **Training & Self Assessment**
- **Peer Review Collaboration & Feedback**
- **Validated Assessment**
- **Summary Memorandum**
 - **Findings & SE Improvement Recommendations**





Benchmarking the Enterprise



Process Area Criteria*

- >90% of Practices
- 65-89% of Practices
- <65% of Practices

Program Criteria

- >90% of Practices, No Red
- 65-89% of Practices, NTE 1 Red
- <65% of Practices, 2 or More Red

as of 8 Jan 07

	Key Process Areas									
	R	D	V	T	P	TA	RM	CM	DA	Pgm
Program #1	Yellow	Green	Green	Yellow	Yellow	Yellow	Green	Green	Red	Green
Program #2	Green	Green	Green	Yellow	Yellow	Yellow	Green	Green	Yellow	Green
Program #3	Yellow	Green	Green	Yellow	Yellow	Yellow	Red	Green	Red	Red
Program #4	Yellow	Green	Red	Yellow	Yellow	Yellow	Green	Green	Yellow	Yellow
Program #5	Green	Green	Green	Yellow	Yellow	Yellow	Yellow	Green	Yellow	Yellow
Program #6	Yellow	Green	Green	Yellow	Red	Yellow	Yellow	Green	Red	Red
Program #7	Yellow	Green	Green	Yellow	Red	Yellow	Yellow	Yellow	Red	Red
Program #8	Red	Red	Red	Red	Yellow	Yellow	Yellow	Red	Red	Red
Program #9	Yellow	Green	Green	Yellow	Yellow	Yellow	Yellow	Green	Yellow	Yellow
Program #10	Yellow	Green	Green	Yellow	Yellow	Yellow	Yellow	Green	Red	Yellow
Program #11	Yellow	Green	Green	Yellow	Yellow	Yellow	Yellow	Green	Red	Yellow
Program #12	Yellow	Green	Green	Yellow	Yellow	Yellow	Yellow	Green	Red	Yellow
Program #13	Green	Green	Green	Yellow	Yellow	Yellow	Green	Green	Yellow	Green
Program #14	Yellow	Green	Green	Yellow	Yellow	Yellow	Yellow	Green	Red	Yellow
Program #15	Yellow	Green	Green	Yellow	Yellow	Yellow	Yellow	Green	Yellow	Yellow
Program #16	Yellow	Green	Green	Yellow	Yellow	Yellow	Yellow	Green	Yellow	Yellow
Program #17	Yellow	Green	Green	Red	Red	Yellow	Yellow	Green	Red	Red
Program #18	Red	Yellow	Green	Yellow	Yellow	Yellow	Green	Green	Red	Red
Center Average	Yellow	Yellow	Green	Yellow	Yellow	Yellow	Yellow	Green	Red	Red

* Weighting
SPs 75%
GPs 25%

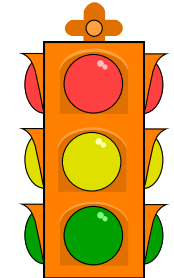

Portfolio Criteria

- 95% Programs Green
- 75%-95% Programs Green, <10% Programs Red
- <75% Programs Green or >10% Programs Red





Lessons Learned



- **Personnel Resources are Stretched and Need SE Training & Experience**
- **Process and Procedures are Needed to Ensure More Repeatable/Consistent Application of SE**
- **Product Line Specific Guidebook Capturing Eglin Experience in Weapons Desired**



The Good



- **Requirements Control & Verification Working Group**
- **Iterative Requirements & Design Trade-off Working Group**
- **Concurrent Engineering to Ensure Successful Transition to Production**
- **Contract Incentives for Reducing Cost and Increasing Reliability**
- **Full Trust Integrated Teaming**
- **Integrated & Overarching Risk Management Strategy**

“Following MIL-STDs was Better than Having No Process at All”



The Bad

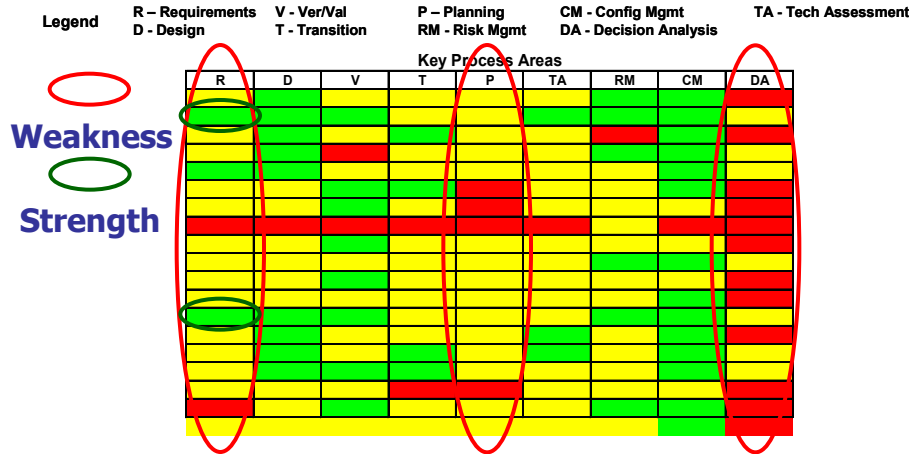

Decision Analysis	RED
Planning	YELLOW
Requirements	
Risk Management	
Verification & Validation	
Transition	
Technical Assessment	
Design	
Configuration Management	GREEN

Better ↓

- Areas that Need Work
 - Requirements
 - Decision Analysis
 - Planning
 - Process Integration Particularly Risk Management
- Model Expansion Needed
 - Manufacturing (Transition to Production)
 - Sustainment

Added in Version 2.0



Requirements Weaknesses



- **Design Mission Reference Profiles (RG1P2)**
 - **Comprehensive Definition of Product Characteristics in Engineering Terms and Documentation of the Interaction of the Product with the Environment, Other Systems, and Operational Users [Willoughby].**

Do we understand the edges of the technical performance envelope?

- **Validate Requirements (RG2P3)**
 - **Ensure the Evolving Product will Perform as Intended in the Operational Environment [CMMI].**

Do the derived requirements accurately and completely represent what is needed? and no more... How were they validated?

Reference: AAC SEAM v2.4



Some Solutions



- **Develop Valid Mission Reference Profiles to Support Design**
 - **Validate** Concepts of Employment
 - Obtain **Accredited** Simulation Capability Including Carriage, Separation, Fly-out
 - Engage Independent Subject Matter Experts
 - Discover & Examine Stressing Conditions
 - **Anchor** the Models with Data
 - Test Prototypes in Wind Tunnel
 - Test Instrumented Flight Vehicles in Carriage, Separation and Fly-out Modes
- **Test** Sample Conditions of All Configurations With Representative Hardware Early and Allow Schedule for Issue Resolution

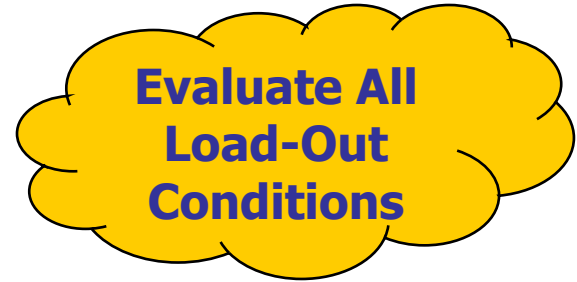

**Evaluate All
Load-Out
Conditions**

Vibration

Acoustics

Temperature

Electromagnetic

Aerodynamic



Sustainment Weaknesses



- **Establish Operational, Suitability and Effectiveness Baselines (SG4P1)**
 - **Conduct Health Monitoring and Verification to Ensure Fielded Product Matches Baseline Performance [AFMCI]**

How do we assure the products continued safety & performance?

- **Perform Audits to Maintain Integrity (CMG3P2)**
 - **Ensure Processes for Maintaining the Integrity of the Fielded Configuration are Effective [CMMI].**

How do you know if Time Critical Technical Orders are compete?

Reference: AAC SEAM v2.4



AF-SEAM Background



- **In 2006, USAF Material Command Engineering Council Action Item to:**
 - **Provide an USAF-wide SE Assessment Model**
 - **Involve USAF Centers (product and logistics)**
 - **Leverage current CMMI®-based models in use at AF Centers**
 - **Baseline Process Capability & Usage**
- **AF Systems Engineering Assessment Model:**
 - **A single AF-wide tool which can be used for the assessment and improvement of systems engineering processes in a program/project.**

Version 1.0 Completed August 2008



AF-SEAM SP Roll-Up



Specific Practice Assessment Results XXX Center

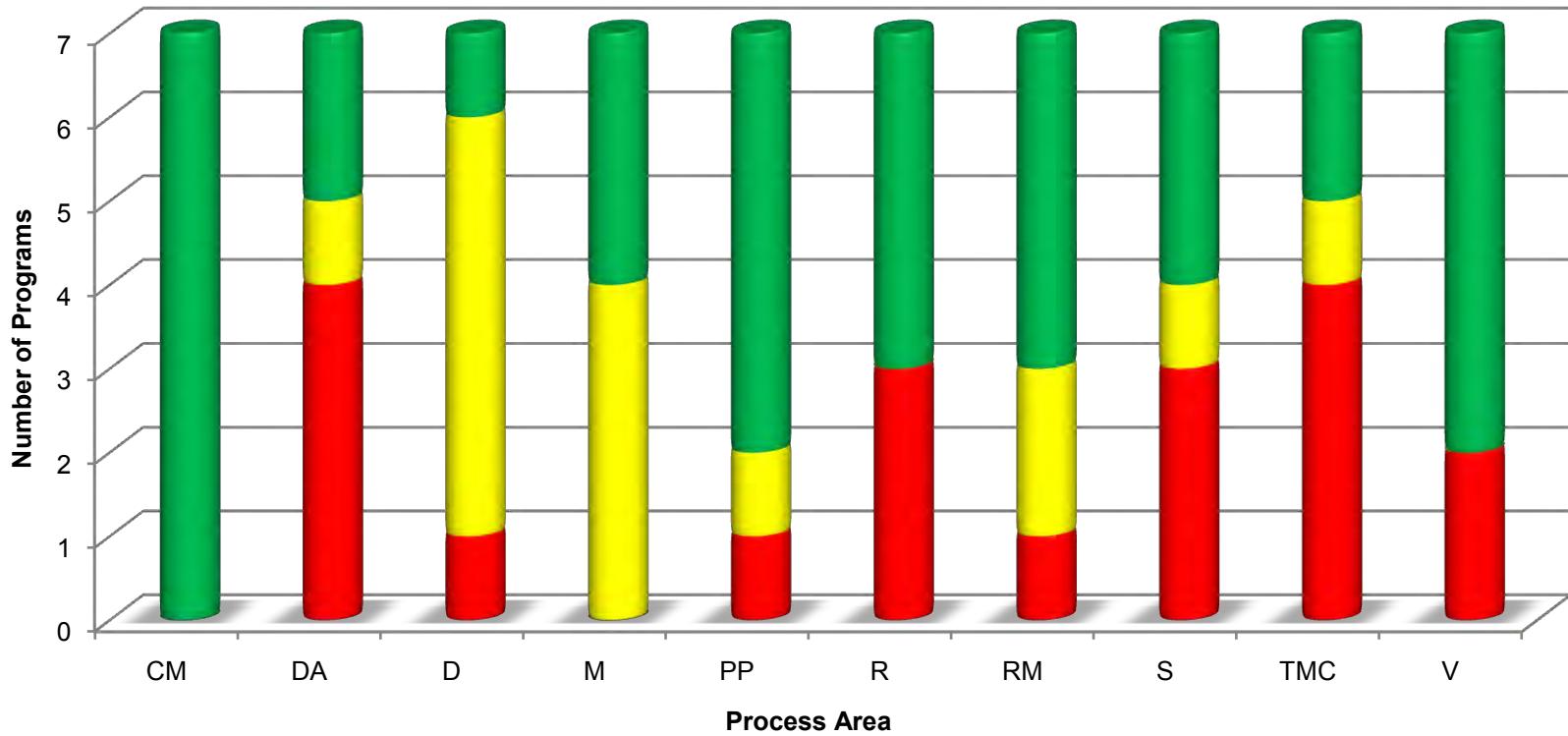



AF-SEAM GP Roll-Up



Generic Practice Assessment Results XXX Center

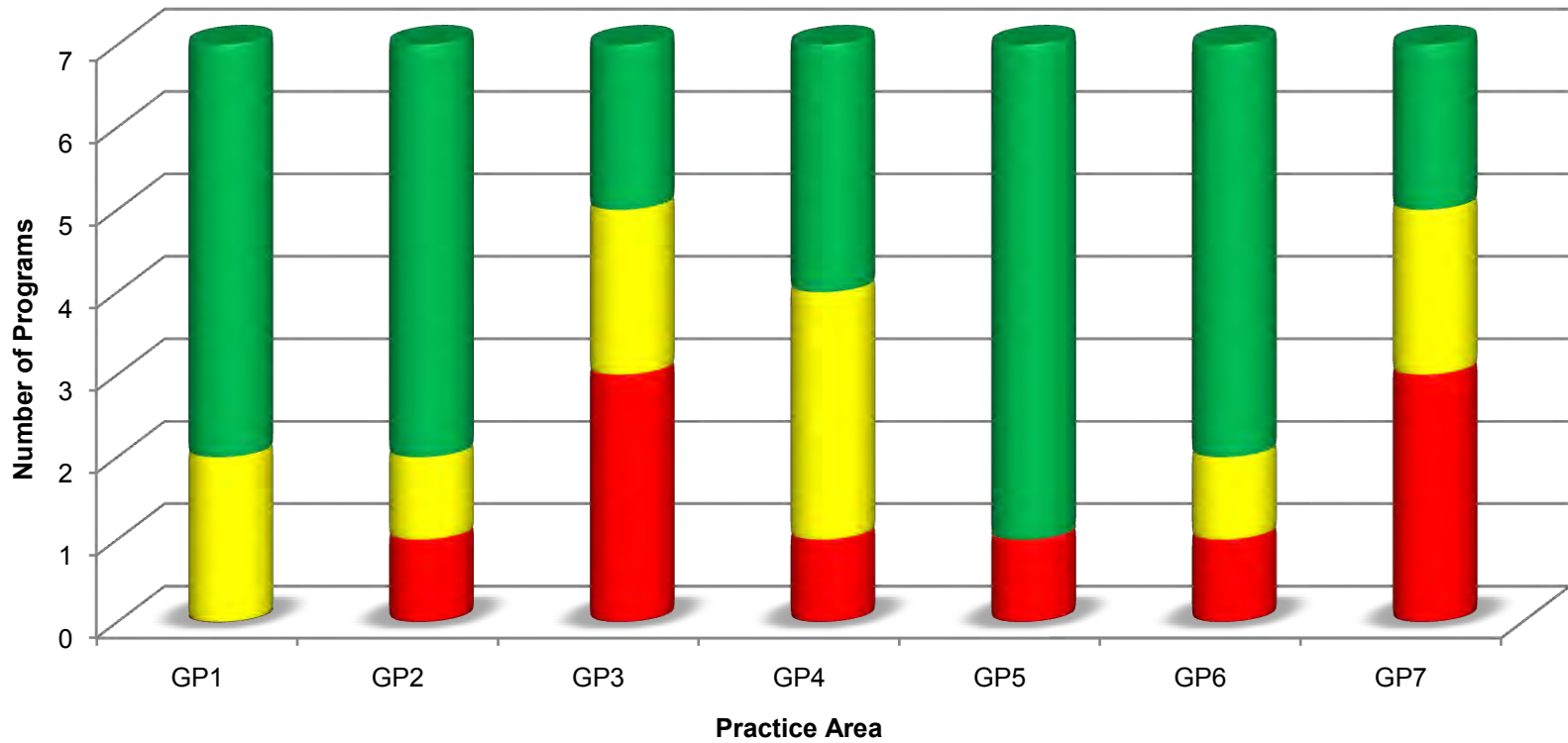



Future Concept



Key Process Area: Manufacturing or TMC

Goal: – Product and process quality is assessed and improved.



Practice:

Notional

P1 Establish and maintain a quality management system.

- 5: *The developer and major suppliers have an ISO 9000/AS9100 certified operation with recent AS9101 audit at relevant locations.*
- 4: *The developer has an ISO 9000/AS9100 certified operation with recent AS9101 audit at relevant locations.*
- 3: *The developer is meeting the intent of ISO 9000/AS9100 with a recent independent quality audit at relevant locations.*
- 2: *The developer has an effective quality management system that includes suppliers with no recent independent audit.*
- 1: *The developer has not demonstrated an effective quality management system.*

Rungs Facilitate 1) Self Assessment, 2) Training and 3) Steps for Improvement



Summary



- **Goal is to Continue to Improve Program Performance**
 - Too Many Examples of Program Performance/ Issues Being Tracked Back to Lack of Systems Engineering Discipline
- **Long Term Goal – Revitalizing Systems Engineering**
 - Need to Follow “Best Practices”
 - Need to Do them “Well”
 - Need to Ensure that Our Program Teams Have What they Need
 - Qualified People, Process Discipline, Tools/Technology



1. What to do?

2. How to do it?

3. How to Sustain it?

Where there is no standard there can be no Kaizen

– Taiichi Ohno

改善

Kai-zen

The Art of Continuous Improvement

*Kai-zen must operate with three principles in place:
process and results, systemic thinking, and non-blaming
(because blaming is wasteful).*

ASN (RDA) Chief Systems Engineer

Software Process Improvement Initiative

October 21, 2008

Mr. Carl Siel
ASN(RDA) Chief Systems Engineer
carl.siel@navy.mil



Navy Software Process Improvement Initiative (SPII)

RDA
CHIEF
SYSTEMS
ENGINEER

- ENVIRONMENT**
(Jan 2006 Offsite)
- Lack Of Government SW Expertise
 - New Requirements- No New Cost, ASN/RDA SW Policies
 - Requirements Testing
 - CMM Level Improvements
 - SW Certification
 - ASN (RDA) Software Policies
 - Non-standard Interfaces
 - Spiral Development
 - Resistance To Change
 - COTS
 - Immature Costing Models
 - EVMS
 - External Drivers
 - Security
 - Processes For Requirements/ Budget Determination
 - Non-standard Processes
 - Enterprise Licenses
 - OA & Standards/ IDDs
 - Releaseability Concerns
 - Industrial Base Concerns

ENVIRONMENT
(Jan 2006 Offsite)

OBJECTIVES

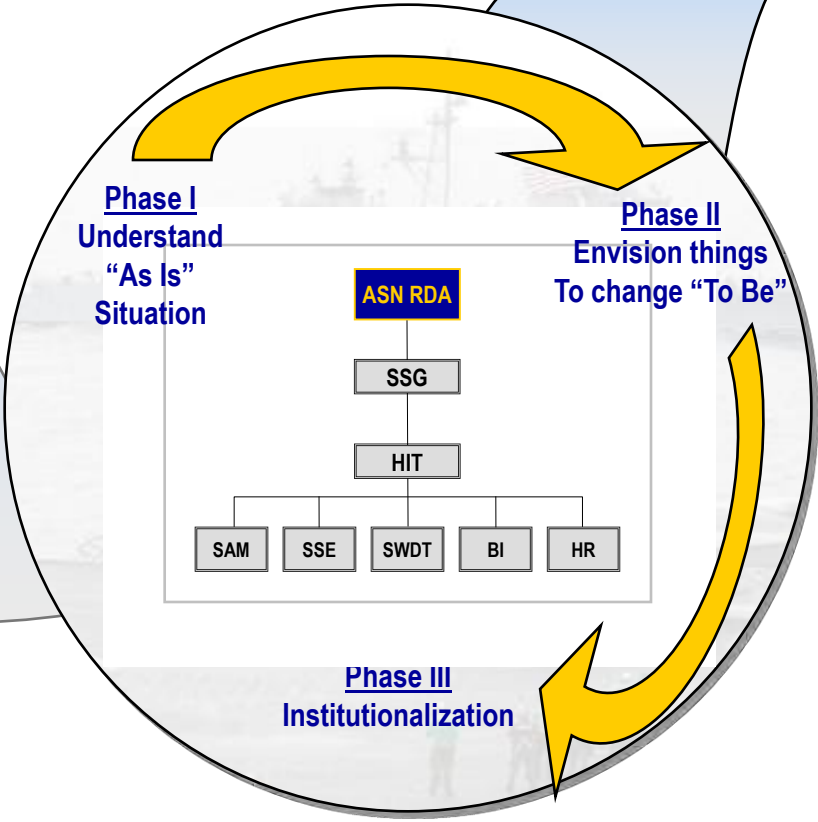

- ◆ Increase leadership awareness and accountability
- ◆ Better align Naval acquisition with our industry partners
- ◆ Develop a skilled acquisition force
- ◆ Holistic Systems Engineering Approach focused on key functional areas:
 - Software Acquisition Management
 - Software Engineering Practices
 - Business Implications
 - Software Development Techniques
 - Human Resources

SSG: Senior Steering Group
 HIT: Horizontal Integration Team
 SAM: Software Acquisition Management
 SSE: Software Systems Engineering
 SWDT: Software Development Techniques
 BI: Business Implications
 HR: Human Resources

SPII Charter: 15 May 2006 ASN RDA Memo



The Plan

RDA
CHIEF
SYSTEMS
ENGINEER



5 Focus Areas

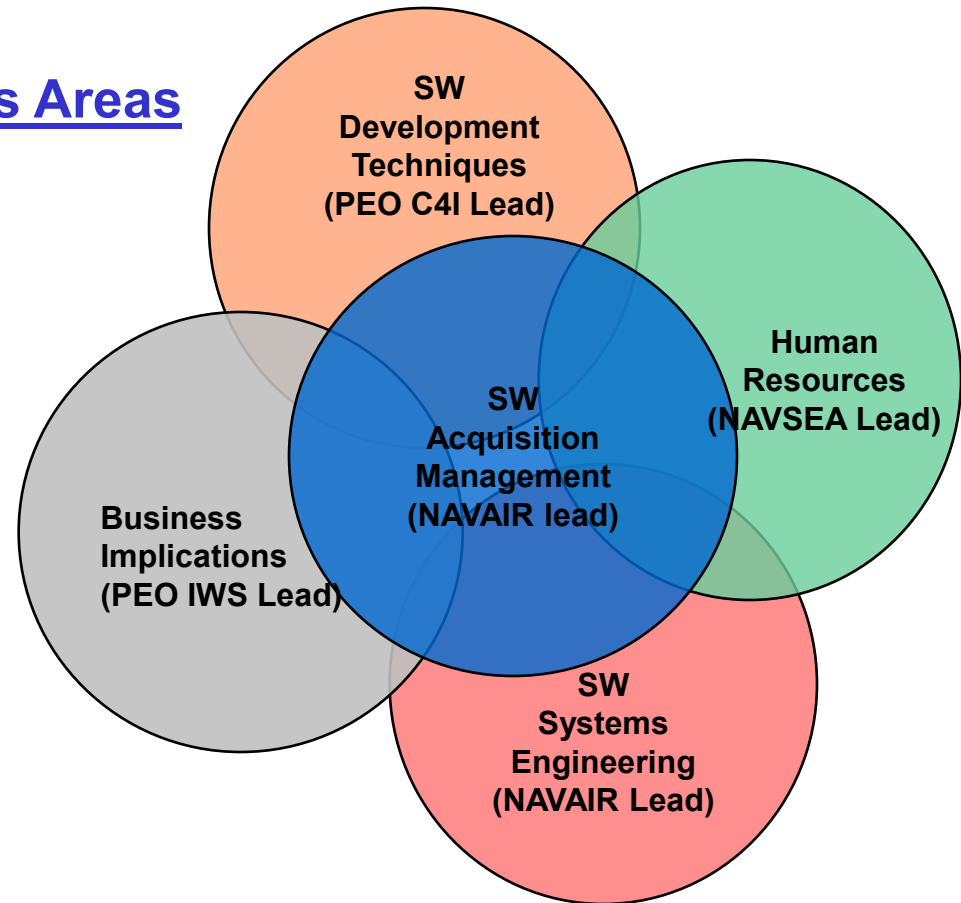

Institutionalize

Overarching Policy and Guidebook for Acquisition of SW Intensive Systems



Step-wise Accomplishments

RDA
CHIEF
SYSTEMS
ENGINEER

- ◆ **As Is” Report signed 17 May 2007**
 - Uncovers the current environment for the acquisition of software intensive systems across the Naval Enterprise
 - Findings are consistent with past DSB and NRAC findings
- ◆ **“Software Development Techniques Phase 1 Report” signed 10 Jul 2007**
 - Provides an overview of existing software development techniques and suggestions for evaluating emerging software development techniques
- ◆ **Program Office Survey Findings Report promulgated July 2007**
 - Report verifies the findings of previous studies (e.g., Defense Science Board (DSB)-2000 and Naval Research Advisory Committee (NRAC)-2006) by tracking them directly to current programs of record
- ◆ **Contract Language Guidance policy memo signed 13 Jul 2007**
 - Provides amplifying guidance information on the 17 Nov 2006 Contract Language policy memo



Accomplishments (cont.)

RDA
CHIEF
SYSTEMS
ENGINEER

- ◆ **Software Metrics White Paper – identified 4 core metrics**
- ◆ **“To Be” Report signed 6 Nov 2007**
 - Assists acquisition professionals with a preview of key considerations for major problems having been found to be most troublesome and most commonly documented
- ◆ **“Role Base Right Fit Training” Report signed 6 Nov 2007**
 - Addresses the training issues highlighted by the SAM focus team “As Is” state report, SSE focus team “Program Management Office Survey Findings,” DSB, and NRAC findings
- ◆ **Contract Language policy memo signed 17 Nov 2006**
 - Directs standardized contract language for all contracts containing software development, acquisition and life cycle support beginning with RFPs issued after 1 Jan 2007
 - Requires developers to submit Software Development Plan (SDP)



Core Software Metrics

- ◆ **The four required core metrics**
 - Software Size/Stability
 - Software Cost/Schedule
 - Software Quality
 - Software Organization
- ◆ **All metrics to be provided during key phases of the system acquisition lifecycle and DoN 2Passes/6Gates**

ID	Phase	Milestone-Related Period
I	Concept Development	Pre-Concept Decision (CD)
II	Concept Refinement	Post-CD, Leading to Milestone (MS)-A
III	Technology Development	Post MS-A, Leading to MS-B
IV	System Development and Demonstration (SDD) (System Integration)	Post MS-B, Leading to Design Readiness Review (DRR)
V	SDD (System Demonstration)	Post DRR, Leading to MS-C
VI	Production and Deployment	Post MS-C, Leading to Full Rate Production (FRP) Decision
VII	Operations and Support	Post FRP Decision Review



Status Reporting Based on Metrics

RDA
CHIEF
SYSTEMS
ENGINEER

- ◆ **Examples of basic and general usage of metrics:**
 - Scope creep and software stability based on software size metrics/trends
 - Software cost and schedule variances, trends, and performance indexes
 - Software defects, trouble reports, and other quality trends
 - Software personnel staffing actuals vs. planned, including training and turnover metrics

- ◆ **Software 4 Core Metrics infused into Naval Probability of Program Success (PoPS) - Complete**



SPII is Institutionalized!

RDA
CHIEF
SYSTEMS
ENGINEER

- ◆ **Software Process Improvement Initiative completed – Sept 2008**
 - **Software Measurement for Naval Software Intensive Systems**
 - 4 core metrics
 - **Overarching Software Process Improvement Policy for Acquisition of Naval Software Intensive Systems**
 - Software Process Management Improvement
 - Contract Language
 - Software Measurement
 - Personnel experience or training
 - Ensure implementation and adherence to processes Software Measurement for Acquisition of Naval Software Intensive Systems
 - **Guidebook for Software Process Improvement for Acquisition of Naval Software Intensive Systems**
 - Provide support to acquisition stakeholder team
 - Organize to capture focus teams products
 - Structure follows acquisition process timeline



“Should-Be” Software Environment

RDA
CHIEF
SYSTEMS
ENGINEER

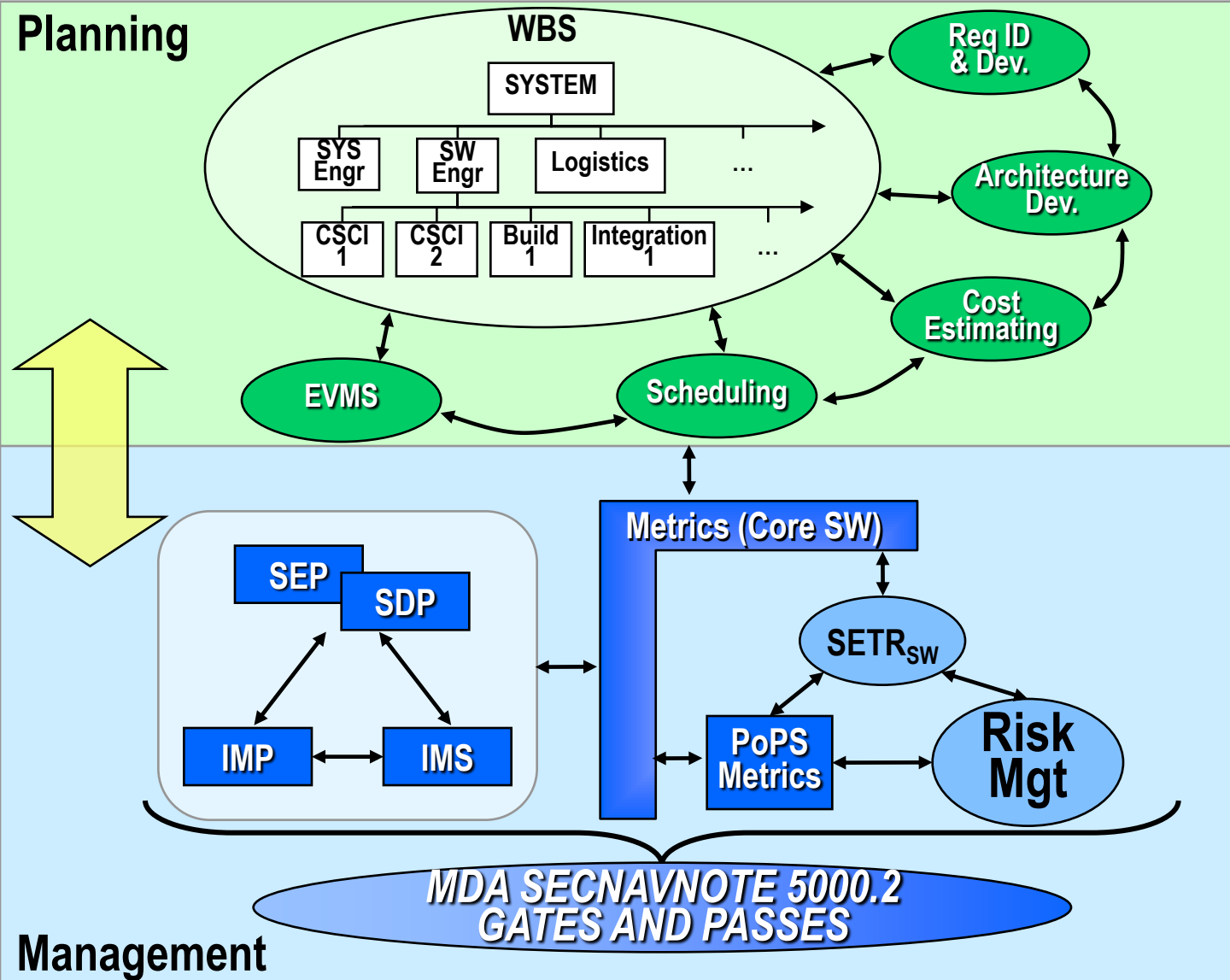

Historical Software Data

- Domain
 - Similar systems
- Key attributes
 - E.g.,
 - Accurate
 - Normalized
 - Etc.

Legend:

Process (oval)

Product (rectangle)



Institutionalization Next Steps

RDA
CHIEF
SYSTEMS
ENGINEER

- ◆ **Infuse software into SE Planning, SE Management, and SE Technical Reviews processes**
 - **Systems Engineering Technical Review (SETR)**
 - **Systems Assurance**
 - **Work Breakdown Structure friendly to Software**
- ◆ **Continue working with USD(AT&L), Services, and DAU to meet human resources and training needs**
- ◆ **RDA CHSENG sponsor next updates to:**
 - **Software development techniques**
 - **Contract language guidance, when required**

Back-up slides



Infusion Into PoPS for Gate Reviews

RDA
CHIEF
SYSTEMS
ENGINEER

- ◆ **Mapping of software metrics-related timeline phases to Gate Reviews**

Lifecycle Phases	SECNAVNOTE 5000
I: Concept Development	Gate 1
II: Concept Refinement	Gates 2 & 3
III: Technology Development	Gates 4 & 5
IV: System Development	Gate 6
V: System Demonstration	Gate 6 (Phase 2)
VI: Production & Deployment	Gate 6 (Phase 3)
VII: Operations & Support	Gate 6 (Phase 4)

- **See Backup slides for overview/description of each Gate Review and policy memos for use of PoPS methodology at Gate Reviews**



SPII Core Measurement and Metrics Update

RDA
CHIEF
SYSTEMS
ENGINEER

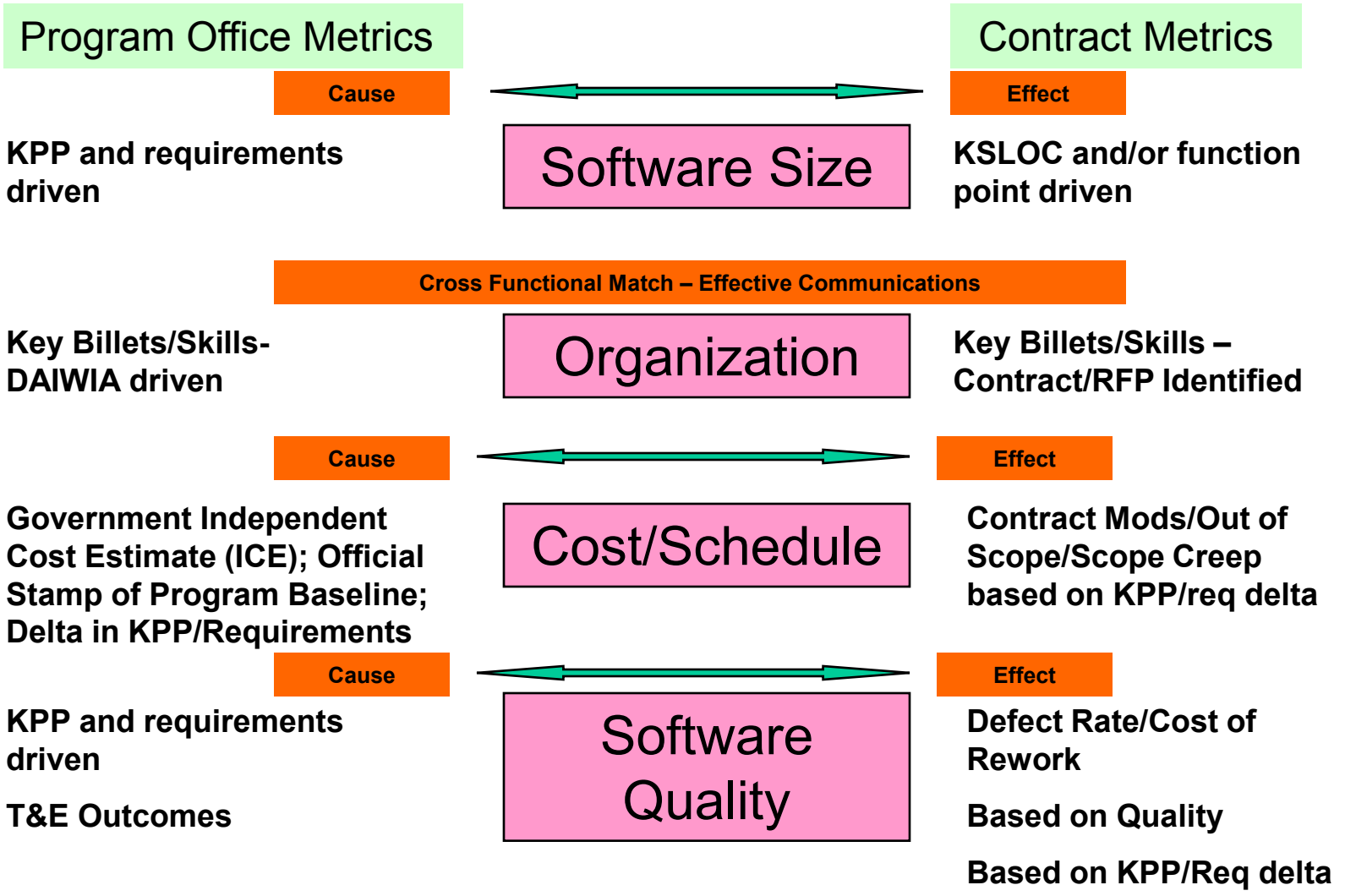

Details are dependent on SAM organization micro-product, HR skills and capability micro-product; BI contract language review



Motivation for SPI Core Metrics

RDA
CHIEF
SYSTEMS
ENGINEER

Efforts to develop appropriate metrics for performance measurement and continual process improvement.

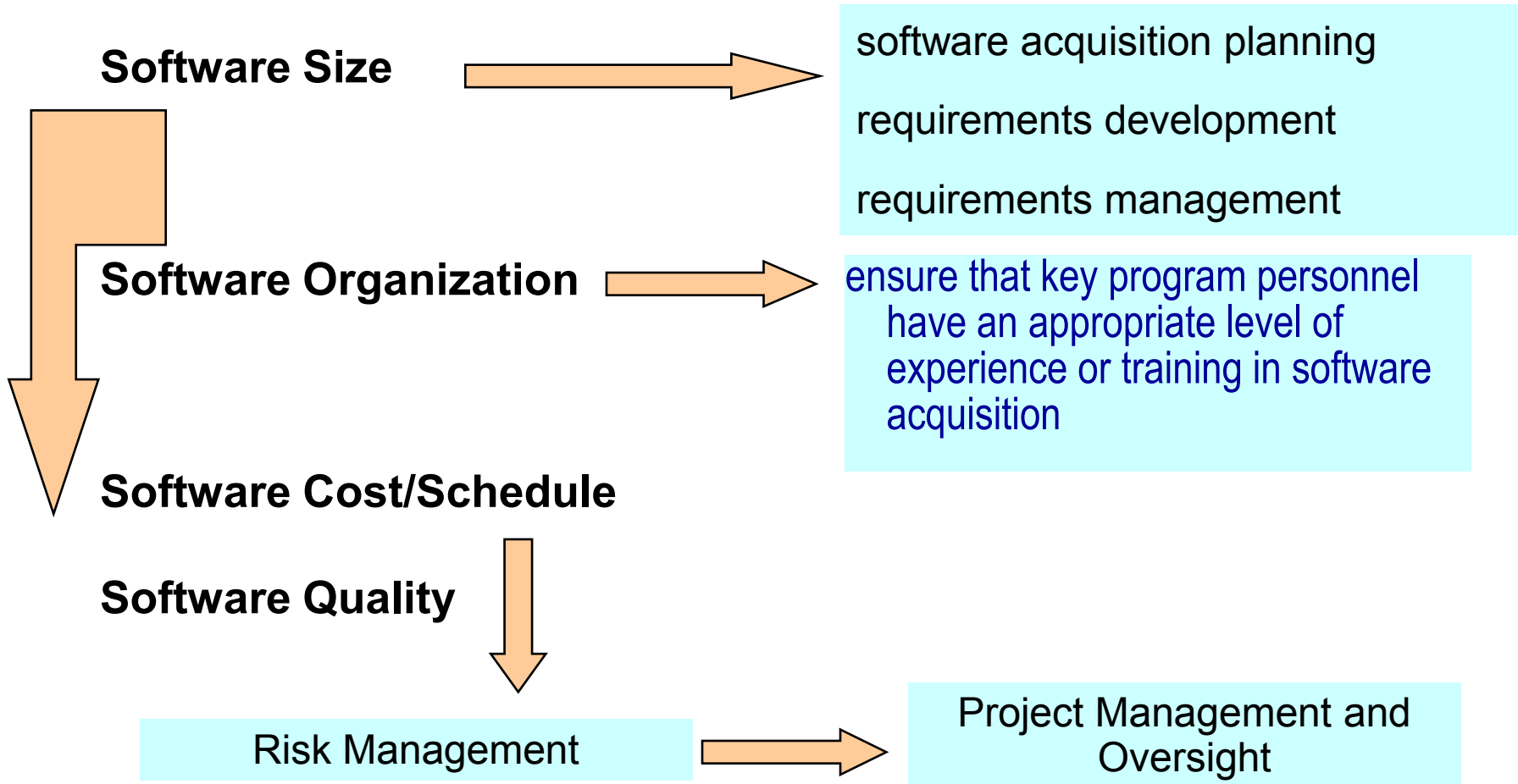



May 2006 SPII Charter

**RDA
CHIEF
SYSTEMS
ENGINEER**

“Successful development and acquisition of software is paramount for acquiring Naval Warfighting and business systems. There are many parallel and related efforts underway that address improvement in the acquisition of software products: mandates such as Public Law 107-314 Section 804 and the Clinger-Cohen Act; initiatives such as Software Assurance and Open Architecture (OA); and the development of best practice models such as the Capability Maturity Model Integration (CMMI) for Acquisition. To consolidate these efforts into a focused initiative, I have formed a steering group composed of my senior engineering professionals and led by the ASN (RD&A) Chief Engineer. This group will evaluate existing policies and implement process improvements to enhance our ability to develop and acquire software without sacrificing the cost, schedule and performance goals of our acquisition programs.

Additionally, five focus teams, led by department software engineering professionals, have been established to achieve our strategic software goals (see attachment):

- Software Acquisition Management (SAM) Focus Team
- Software Systems Engineering (SSE) Focus Team
- Software Development (SWDEV) Techniques Focus Team
- Business Implications Focus Team
- Human Resources Focus Team”

ASN RDA Memo dtd May 15, 2006, subj: Software Process Improvement Initiative



Business Implications (BI)

RDA
CHIEF
SYSTEMS
ENGINEER

- ◆ **Accomplished – As Is and To Be**
 - **Contract Language policy memo signed 17 Nov 2006**
 - Directs standardized contract language for all contracts containing software development, acquisition and life cycle support beginning with RFPs issued after 1 Jan 2007
 - Requires developers to submit Software Development Plan (SDP)
 - **Contract Language Guidance policy memo signed 13 Jul 2007**
 - Provides amplifying guidance information on the 17 Nov 2006 Contract Language policy memo
- ◆ **Institutionalize**
 - Re-enforced in the overarching Policy and Guidebook for Acquisition of Naval Software Intensive Systems – signed September 16, 2008
 - Update Contract Language based on future need



Software Development Techniques (SWDT)

RDA
CHIEF
SYSTEMS
ENGINEER

- ◆ **Accomplished – As Is and To Be**
 - “Software Development Techniques Phase 1 Report” signed 10 Jul 2007
 - Provides an overview of existing software development techniques and suggestions for evaluating emerging software development techniques
 - Facilitates program managers software risk management
- ◆ **Institutionalize**
 - Guidebook for Acquisition of Naval Software Intensive Systems – signed September 16, 2008
 - Annual update to reflect maturity of existing techniques and emergence of new techniques



Software Systems Engineering (SSE)

RDA
CHIEF
SYSTEMS
ENGINEER

- ◆ **Accomplished – As Is and To Be**
 - Program Office Survey Findings Report promulgated July 2007
 - Report verifies the findings of previous studies (e.g., Defense Science Board (DSB)-2000 and Naval Research Advisory Committee (NRAC)-2006) by tracking them directly to current programs of record
 - Software Metrics White Paper – identified 4 core metrics
 - Develop software reviews for inclusion in Systems Engineering Technical Review (SETR)
- ◆ **Institutionalize**
 - Software Measurement for Naval Software Intensive Systems Policy – signed July 22, 2008
 - Provides a set of software metrics to assess program performance
 - Incorporate software reviews into SETR (planned March 2009)
 - Executing under Systems Engineering Stakeholders Group (SESG)



Software Acquisition Management (SAM)

RDA
CHIEF
SYSTEMS
ENGINEER

- ◆ **Accomplished – As Is and To Be**
 - “As Is” Report signed 17 May 2007
 - Uncovers the current environment for the acquisition of software intensive systems across the Naval Enterprise
 - Findings are consistent with past DSB and NRAC findings
 - “To Be” Report signed 6 Nov 2007
 - Assists acquisition professionals with a preview of key considerations for major problems having been found to be most troublesome and most commonly documented
- ◆ **Institutionalize**
 - Tailorable Organization Structure (included in Guidebook Sept 2008)
 - Tool for assessing organizational structure, software expertise, and staffing requirements for software intensive systems program offices
 - Software Measurement for Naval Software Intensive Systems Policy July 22, 2008
 - Provides a set of software metrics to assess program performance
 - Use the Systems Engineering Plan (SEP) and SETR (planned March 2009)
 - On-going effort through the SESG



Human Resources (HR)

RDA
CHIEF
SYSTEMS
ENGINEER

- ◆ **Accomplished – As Is and To Be**
 - **“Role Base Right Fit Training” Report signed 6 Nov 2007**
 - **Addresses the training issues highlighted by the SAM focus team “As Is” state report, SSE focus team “Program Management Office Survey Findings,” DSB, and NRAC findings**
- ◆ **Institutionalize**
 - **“Establishment of DAWIA Software Acquisition Training and Education Working Group” draft memo by OUSD(AT&L)**
 - **The “Role Base Right Fit Training” report serves as Naval input to OSD sponsored reviews of software acquisition management competencies for six acquisition disciplines (Program Management, Contracting, Acquisition Logistics, Systems & Software Engineering, and Legal)**



Institutionalize – Guidebook

RDA
CHIEF
SYSTEMS
ENGINEER

- ◆ **Signatory: ASN RDA**
- ◆ **Audience:**
 - **Primary: Government acquisition community**
 - **Secondary: Stakeholder community (e.g, developers)**
- ◆ **Objective:**
 - **To provide support to acquisition stakeholder team**
 - **Organize to capture focus teams products**
 - **Structure follows acquisition process timeline**
- ◆ **Status: Signed September 16, 2008**



Institutionalize – Policy









RDA
CHIEF
SYSTEMS
ENGINEER

- ◆ **Signatory: ASN RDA**
- ◆ **Audience:**
 - Primary: Government acquisition community
 - Secondary: Stakeholder community (e.g, developers)
- ◆ **Objective:**
 - Improve software acquisition processes
- 1. **Software Measurement for Naval Software Intensive Systems**
 - 4 core metrics
- 2. **Overarching Software Process Improvement Policy for Acquisition of Naval Software Intensive Systems**
 - Software Process Management Improvement
 - Contract Language
 - Software Measurement
 - Personnel experience or training
 - Ensure implementation and adherence to processes
- ◆ **Status: signed July 22, 2008 & September 16, 2008**

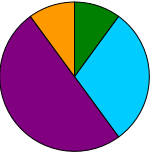
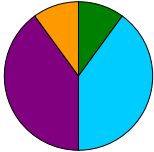

Weighting of Core Metrics Across Gates

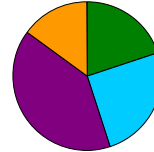
**RDA
CHIEF
SYSTEMS
ENGINEER**

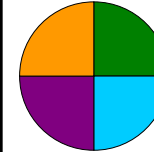
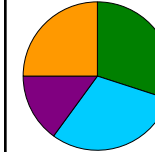
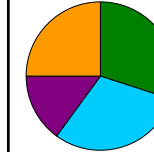
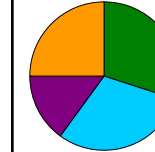
Core Metric	Gate 1 / Ph I: Concept Development	Gate 2 / Ph II: Concept Refinement	Gate 3 / Ph II: Concept Refinement	Gate 4 / Ph III: Technology Development	Gate 5 / Ph III: Technology Development	Gate 6 / Ph IV: System Development	Gate 6 Phase 2 / Ph V: System Demonstration	Gate 6 Phase 3 / Ph VI: Production & Deployment	Gate 6 Phase 4 / Ph VII: Operations & Support
Size/ Stability 	10%	10%	10%	20%	30%	25%	30%	30%	30%
Organization 	50%	40%	50%	40%	30%	25%	15%	15%	15%
Cost / Schedule 	30%	40%	30%	25%	25%	25%	30%	30%	30%
Quality 	10%	10%	10%	15%	15%	25%	25%	25%	25%
TOTAL	100%	100%	100%	100%	100%	100%	100%	100%	100%
									



Software Size/Stability Metric

RDA
CHIEF
SYSTEMS
ENGINEER

Phase	I	II	III	IV	V	VI	VII
Baseline/ Basis of Metric	Concept expectation of %-age of system functionality to be delivered by SW (vice, e.g., HW)	Concept expectation of %-age of system functionality to be delivered by SW (vice, e.g., HW)	SW Size Estimates	SW Size Baseline	SW Stability	SW Stability	SW Stability
Who Collects Measure- ments	Program Office	Program Office	Program Office / Bidders	SW developer/ integrator	SW developer/ integrator	SW developer/ integrator	Program Office / SW developer/ integrator
Who Analyzes	Program Office	Program Office	Program Office	Program Office / SW developer/ integrator	SW developer/ integrator	SW developer/ integrator	Program Office
Metric	%-age of functionality in SW	%-age of functionality in SW	Estimated SLOC, FP, or Req'ts.	ESLOC, FP, or Req'ts.	ESLOC, FP, or Req'ts.	ESLOC, FP, or Req'ts.	ESLOC, FP, or Req'ts.
Use of Metrics	Risk, Lessons Learned	Risk, Lessons Learned, Concept Selection	Risk, Lessons Learned, Source Selection	Risk, Lessons Learned, Performance	Risk, Lessons Learned, Performance	Risk, Lessons Learned, Performance	Risk, Performance, Lessons Learned, Database/ Archival



Software Cost/Schedule Metric

RDA
CHIEF
SYSTEMS
ENGINEER

Phase	I	II	III	IV	V	VI	VII
Baseline/ Basis of Metric	SW related IERs, SDXs	SW related IERs, SDXs	Actual SW cost & schedule data	Actual SW cost & schedule data	Actual SW cost & schedule data	Actual SW cost & schedule data	Actual SW cost & schedule data
Who Collects Measure- ments	Sponsors & Advocates	Sponsors & Advocates	Program Office /SW developer/ integrator	Program Office / SW developer/ integrator	Program Office / SW developer/ integrator	Program Office / SW developer/ integrator	Program Office / SW developer/ integrator
Who Analyzes	Sponsors & Advocates	Sponsors & Advocates	Program Office	Program Office	Program Office	Program Office	Program Office
Metric	# IERs/SDXs produced by SW	# IERs/SDXs produced by SW	Cost/Schedule Variance/ Performance index	Cost/Schedule Variance/ Performance index	Cost/ Schedule Variance/ Performance index	Cost/ Schedule Variance/ Performance index	Cost/ Schedule Variance/ Performance index
Use of Metrics	Risk, Lessons Learned	Risk, Lessons Learned	Risk, Lessons Learned	Risk, Performance , Lessons Learned	Risk, Performance , Lessons Learned	Risk, Performance , Lessons Learned	Risk, Performance Lessons Learned



Software Quality Metric

Phase	I	II	III	IV	V	VI	VII
Baseline/ Basis of Metric	SW related IERS & SDXs	SW related IERS & SDXs	Defects per SLOC	Defects per SLOC, Defects per system interface	Defects per SLOC, Defects per system interface, Defects per system interface	Defects per SLOC, Defects per system interface, Defects per system interface	Defects per SLOC, Defects per system interface, Defects per system interface
Who Collects Measure- ments	Sponsors & Advocates	Sponsors & Advocates	Program Office / SW developer/ integrator	Program Office / SW developer/ integrator	Program Office / SW developer/ integrator	User/Tester	User/Tester
Who Analyzes	Sponsors & Advocates	Sponsors & Advocates	Program Office	Program Office	Program Office	Program Office	Program Office
Metric	% SW generated IERS/SDXs	% SW generated IERS/SDXs	Qty performance index/ variance	Qty performance index/ variance	Qty performance index/ variance	Qty performance index/ variance	Qty performance index/ variance
Use of Metrics	Risk, Lessons Learned	Risk, Lessons Learned	Risk, Lessons Learned	Risk, Performance , Lessons Learned	Risk, Performance , Lessons Learned	Risk, Performance , Lessons Learned	Risk, Performance , Lessons Learned



Software Organization Metric

Phase	I	II	III	IV	V	VI	VII
Baseline/ Basis of Metric	Effort/KSA	Effort/KSA	Effort/KSA/ Turnover	Effort/KSA/ Turnover	Effort/KSA/ Turnover	Effort/KSA/ Turnover	Effort/KSA/ Turnover
Who Collects Measure- ments	Program Office	Program Office	Program Office / Bidders	Program Office / Contractor	Program Office / Contractor	Program Office / Contractor	Program Office / Contractor
Who Analyzes	Program Office	Program Office	Program Office	Program Office / SW developer/ integrator	Program Office / SW developer/ integrator	Program Office / SW developer/ integrator	Program Office / SW developer/ integrator
Metric	Planned # of people or planned # of labor hours, KSA	# of people or # of labor hours/actual trng vs required trng	# of people or # of labor hours/actual trng vs required trng/# of people lost & gained	# of people or # of labor hours/actual trng vs required trng/# of people lost & gained	# of people or # of labor hours/actual trng vs required trng/# of people lost & gained	# of people or # of labor hours/actual trng vs required trng/# of people lost & gained	# of people or # of labor hours/actual trng vs required trng/# of people lost & gained
Use of Metrics	Risk, Lessons Learned	Risk, Lessons Learned	Risk, Lessons Learned, Source Selection	Risk, Lessons Learned	Risk, Lessons Learned	Risk, Lessons Learned	Risk, Lessons Learned

ASN (RDA) Chief Engineer

Naval Power 21 Integration & Interoperability Improvement

21 October 2008

Mr. Carl Siel

ASN(RDA) Chief Engineer
carl.siel@navy.mil

Mr. J. Kevin Smith

Technical Director
ASN(RDA) Chief Engineer's Office
kevin.k.smith1@navy.mil

Unclassified



Purpose

- ◆ Provide an information briefing on the ASN(RDA) CHSENG initiative to improve integration, interoperability, and net-centricity across the Department of the Navy.



Agenda

- ◆ **Background**
- ◆ **Overview of I&I Management**
- ◆ **Centralized Planning Processes**
- ◆ **Decentralized Execution Processes**
- ◆ **Capability Package Assessments**
- ◆ **Configuration Capture**
- ◆ **Role of Integrated Architectures**
- ◆ **Governance Structure**



Background

- ◆ In February 2006, ASN(RDA) Chief Systems Engineer (CHSENG) undertook to improve systems engineering across the department in the area of integration and interoperability of “information-handling” systems.
 - “Information-handling system” is the term used by RDA CHSENG to cover every data system within the Department, including both IT systems, national security systems, and everything else.

- ◆ After reviewing the existing systems engineering organizations under the ASN(RDA), CHSENG determined that the best value-added for the CHSENG was to accept the role of systems-of-systems engineer at the Naval mission level.
 - PEO systems engineers and technical directors already coordinated systems engineering within their organizations.
 - PMO system engineers held responsibility for program-level systems engineering.



Background

- ◆ But a gap existed at the echelon above where any PEO had the authority to operate and, as a result, PEO-to-PEO collaboration was unsupervised and haphazard.
 - ASN(RDA) CHSENG assumed the role of coordinator for issues which cross PEO boundaries.



Background: DoN Systems Engineering Hierarchy

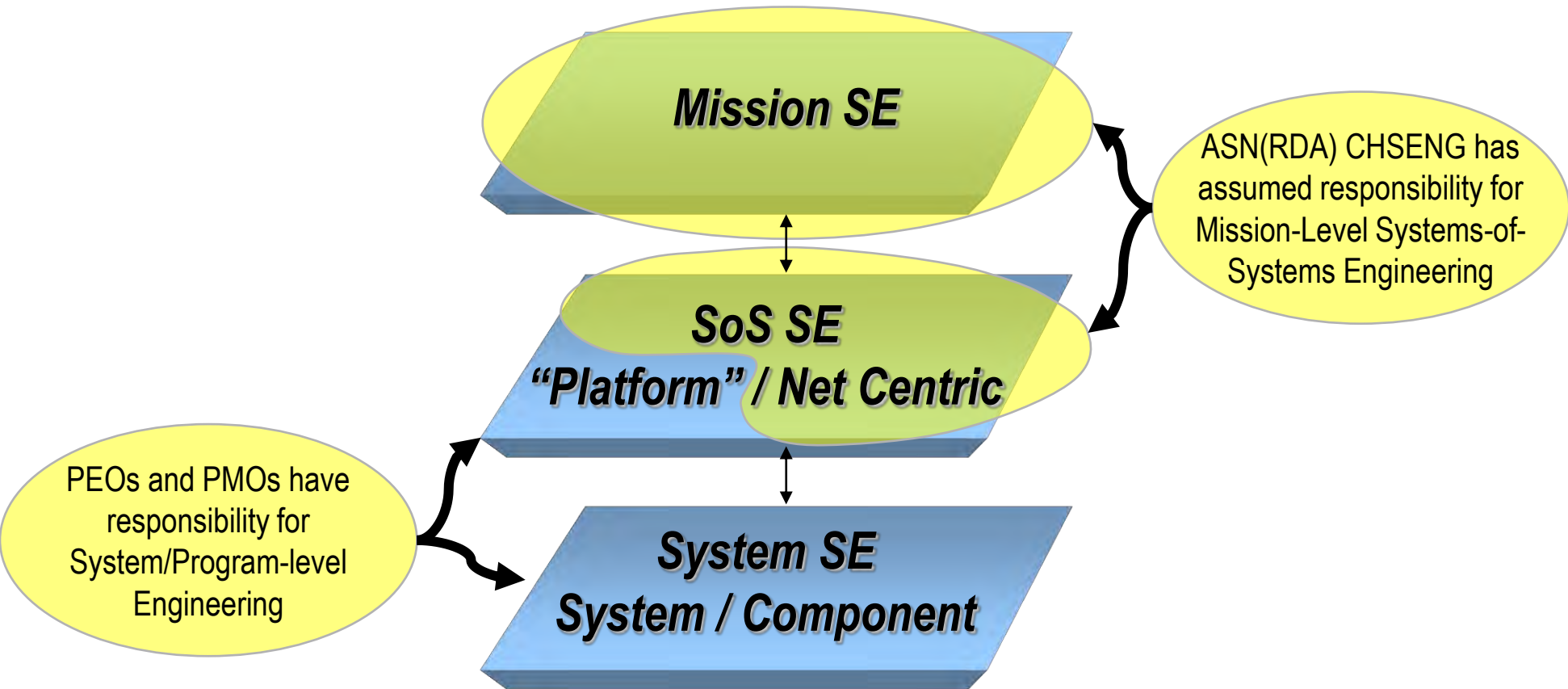

To do Enterprise & SoS / FoS SE need to Execute Sound System SE Practices



Background

- ◆ However, to establish the boundaries within which the RDA CHSENG would operate, it was necessary to define the systems-of-systems for which RDA CHSENG would take responsibility.
 - We created the DON Enterprise Architecture Hierarchy to establish those boundaries.
 - Aligns Mission-Level SOSs to the Joint Capability Areas.
 - Resulting mission-level architectures will describe the Secretariat, U.s. Navy, and U.S. Marine Corps' contributions to each JCA.
 - Approved for use across DON on 22 September 2008.

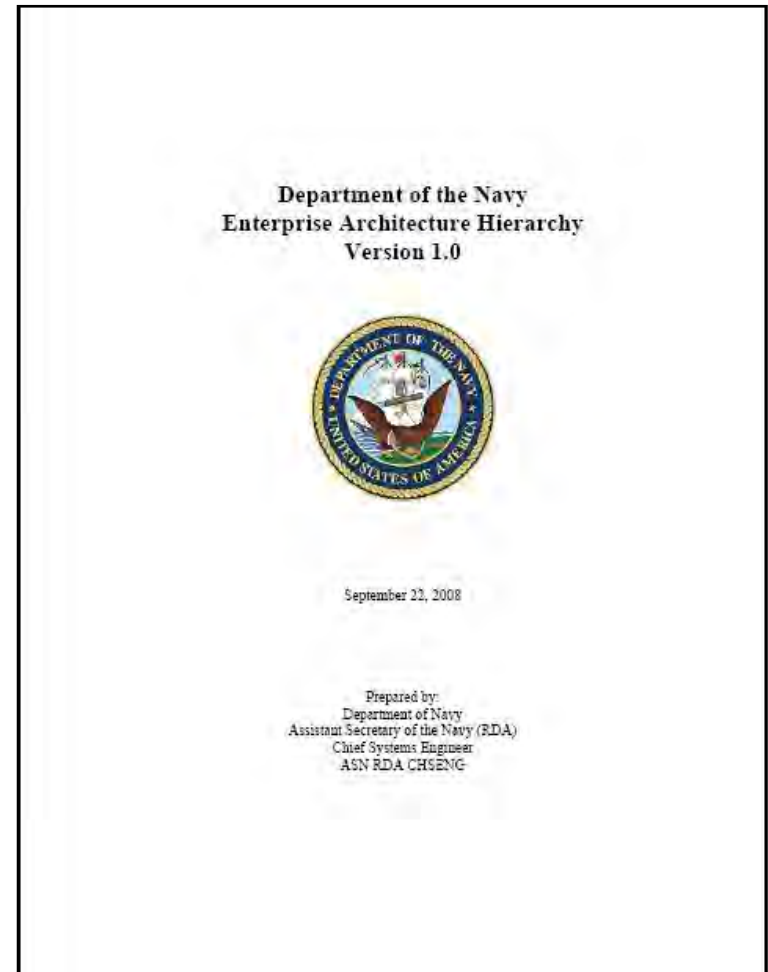



Background

- ◆ Sample page from DON EA Hierarchy.

DON Enterprise Architecture Hierarchy Booklet 9/22/08

Hierarchy Identifier	Joint Capability Area/DON Segment Reference Architecture (Marine Corps Essential Task/Navy Required Operational Capability)	NP 21 Pillar/ MA CHENG	Existing Principle Mission- Level Architecture	Existing Supporting Mission- Level Architectures
04.05.02	Computer Network Operations	SS/S(Land) SS/S(Air) SS/S(SEA) FORCenet EMFTS	EMFTS - C2	
04.05.02.MCT5.4.2.1	Conduct Computer Network Operations (CNO)	EMFTS	EMFTS - C2	
04.05.02.01	Computer Network Attack	SS/S(Land) SS/S(Air) SS/S(SEA)		
04.05.02.02	Computer Network Defense	FORCenet	F ₂ - C&N	
04.05.02.03	Computer Network Exploitation	SS/S(Land) SS/S(Air) SS/S(SEA)		
04.05.03	Operations Security (OPSEC)	See Shield EMFTS	EMFTS - C2	
04.05.03.MCT5.4.2	Conduct Operations Security (OPSEC)	EMFTS	EMFTS - C2	
04.05.03.C2W4	Plan and Implement Operations Security Measures	See Shield		
04.05.03.C2W6	Plan and Conduct Countersurveillance, Countertargeting and Military Deception Operations	See Shield		
04.05.03.AMW36	Conduct Counterintelligence Operations	See Shield		
04.05.03.AMW37	Conduct Counterintelligence Operations with Local/Allied Agencies	See Shield		
04.05.04	Military Deception (MILDEC)	SS/S(Land) EMFTS	EMFTS - C2	
04.05.04.MCT5.4.1.1	Conduct Deception Operations	EMFTS	EMFTS - C2	
04.05.04.C2W6	Plan and Conduct Countersurveillance, Countertargeting, and Military Deception Operations	SS/S(Land) SS/S(Air) SS/S(Sea)		
04.05.05	Psychological Operations (PSYOP)	SS/S(Land) EMFTS		
04.05.05.MCT5.4.1.3	Conduct Psychological Operations (PSYOPS)	EMFTS	EMFTS - C2	

Version 1.0 page F-25



Integrated Architectures

- ◆ Integrated architectures provide the means for defining the details of the operational and system requirements.

- ◆ Integrated architectures are needed for multiple echelons:
 - DON Enterprise Architecture.
 - Mission-level integrated architectures (244)
 - Program/Systems: ADNS, AEGIS, CVN, LHA-6, F/A-18

- ◆ Each tier of integrated architectures as a subset of the tier above it.



Integrated Architectures (continued)

- ◆ How do we use integrated architectures?

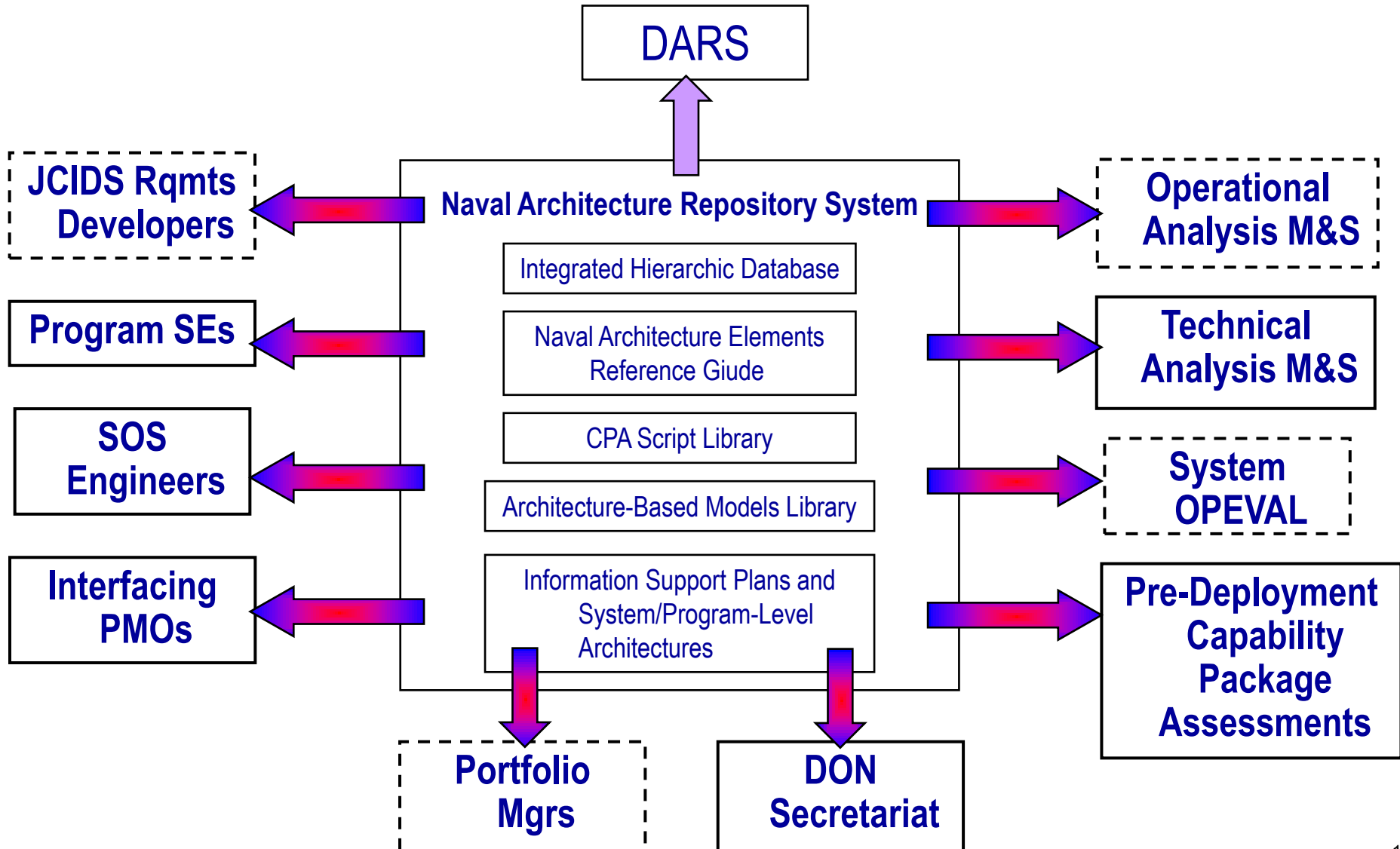



Overview of I&I Management

- ◆ First order of business was to identify ALL of the missions in the Department of the Navy (DON).
 - Requires a definition of a Naval mission.
- ◆ Naval missions are defined as the Navy, Marine Corps, and Secretariat contributions to the Joint Capability Areas (JCAs).
 - Results in 244 mission areas, based on 2007 JCAs.
 - These are listed and collated in the DON Enterprise Architecture Hierarchy.
 - Will be updated following revisions to the JCAs scheduled for November 2008.

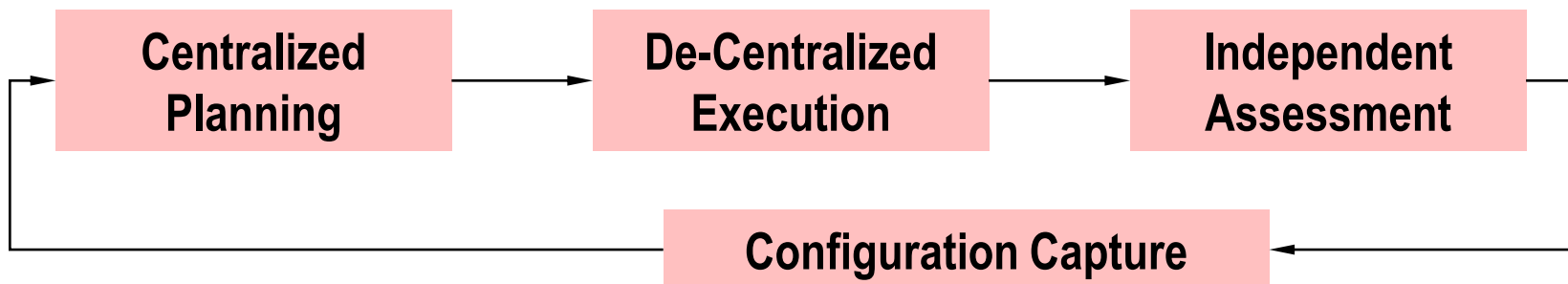



Overview of I&I Management (continued)

- ◆ Because of the complexity of the Department of the Navy (DON), RDA CHSENG relies on assistance provided by Mission-Area Chief Engineers who are experts in particular systems-of-systems and/or mission areas.
 - FORCEnet: SPSWARSCOM 5.1
 - Sea Shield: NAVSEASYSYSCOM 05W
 - Sea Strike/Shaping (Air, Sea, Land, INFO OPS, SPECWAR)
 - Sea Basing: To be determined.
 - Expeditionary Maneuver Warfare (MARCORSYSCOM DEP for ENG)
 - Manpower, Personnel, Training, Education: To be determined.
 - Sea Enterprise: To be determined.

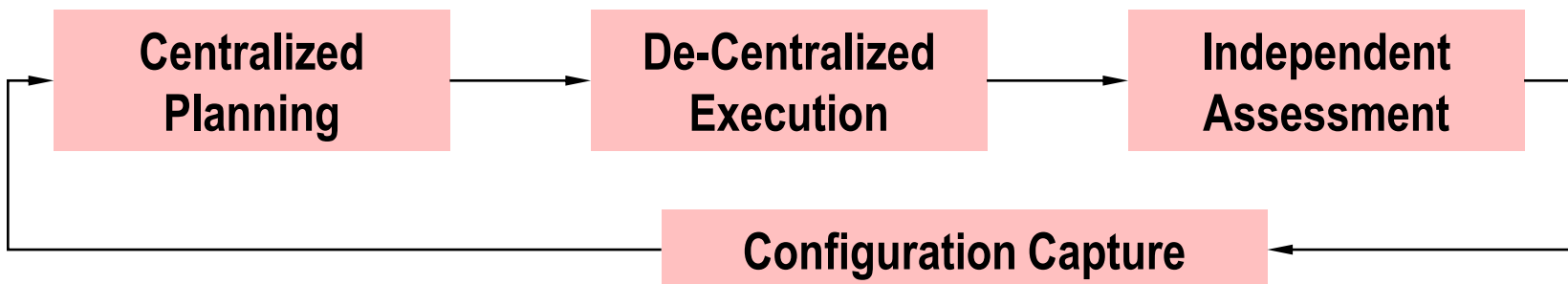



Overview of I&I Management (continued)

- ◆ We are implementing an end-to-end management process for I&I of information systems which is based on the systems engineering needed by the mission-level system-of-systems.
- ◆ Uses a philosophy of Centralized Planning – Decentralized Execution – Independent Assessments – Configuration Capture.
- ◆ Relies on multi-tiered integrated architectures to set technical requirements and to communicate among engineers.

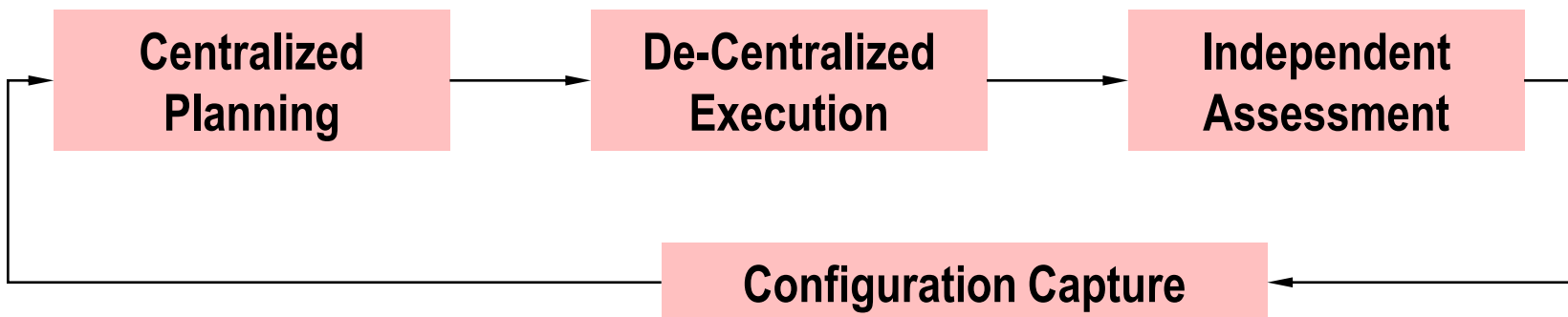



Centralized Planning

- ◆ Objectives for Centralized Planning include:
 - Consistent application of standards across PEOs/SYSCOMs.
 - Ensuring full understanding of the role of a single system within the SoSs where it participates. Overseeing the resolution of issues among PEOs/SYSCOMs.
 - Conduct initial evaluations of the operational effectiveness and technical performance of the mission-level SoSs.
- ◆ The Information Support Plan provides the means for accomplishing Centralized Planning across PEOs/SYSCOMs and with higher authorities.
 - Reviewed at each acquisition milestone and each major upgrade.

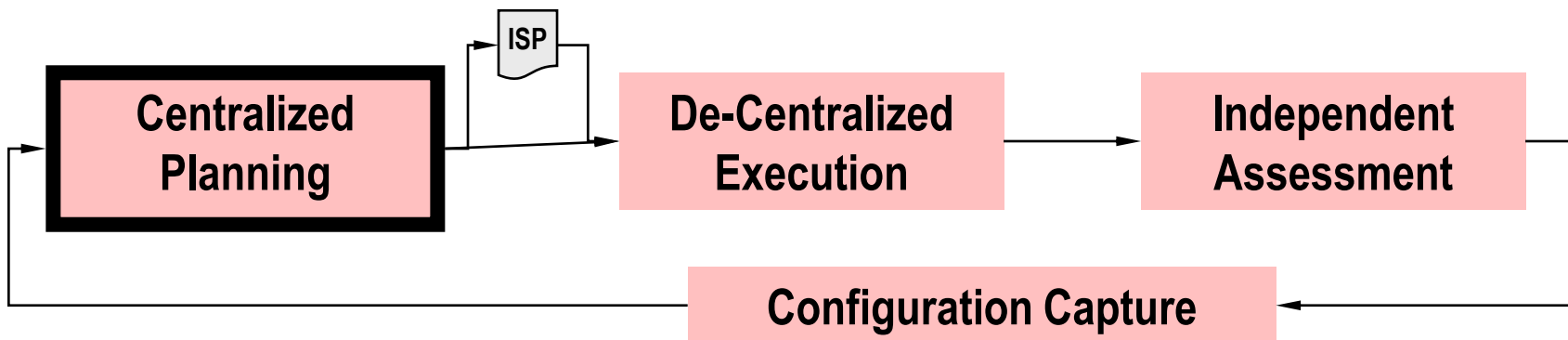



Centralized Planning Methods:

- ◆ Establishment of system-level and mission-level integrated architectures.
- ◆ Comparison of architectures of new systems with mission architectural baselines.
- ◆ Review of other ISP and NR-KPP requirements.
- ◆ Concurrence from PMOs of interfacing systems.
- ◆ Concurrence from CIO/DCIO(N)/DCIO(MC).
- ◆ Concurrence from NNWC, MCCDC and operational agents.
- ◆ Use existing processes for reviews of ISPs.
 - DON-level review.
 - DOD-level review using JCPAT-E

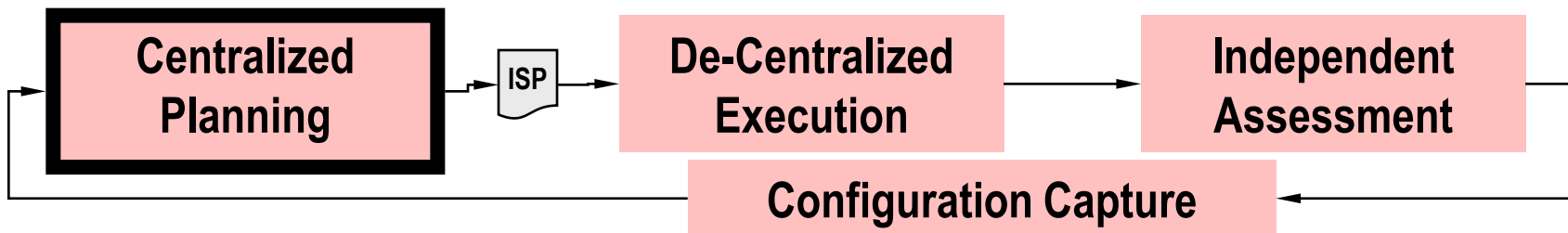



De-Centralized Execution

- ◆ PMs and PEOs execute their acquisition programs according to plans (SEP, ISP).
- ◆ ASN(RDA) CHENG, coordinating with the DON Engineering community, assists by:
 - Providing a venue for coordinating across PEOs, especially to resolve cross-PEO/SYSCOM issues,
 - Providing common dictionaries,
 - Developing and distributing mission-level integrated architectures.
 - Developing and interpreting policies of higher headquarters,
 - Supporting program representation to higher headquarters,
 - Providing a communications link to authoritative sources within the operational agents.

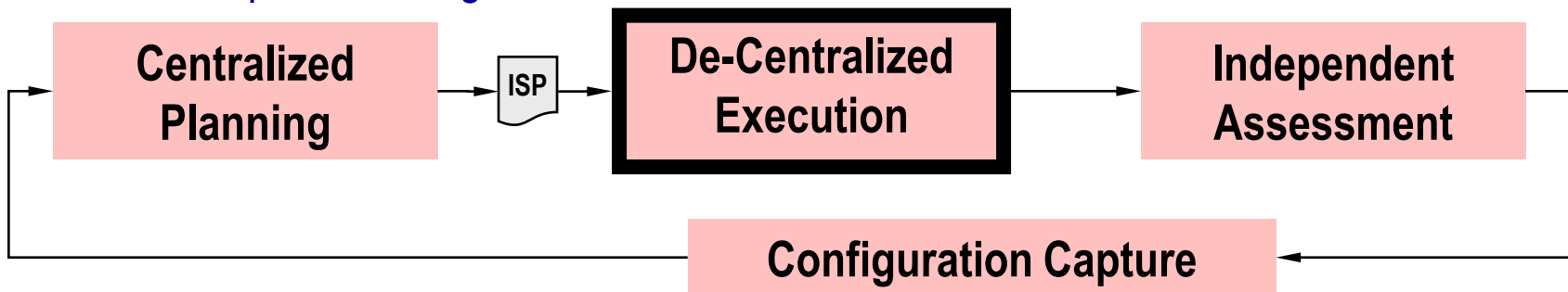



De-Centralized Execution (continued)

- ◆ Revised ISPs and system-level DT/OT test reports provide the means for oversight of De-Centralized Execution.

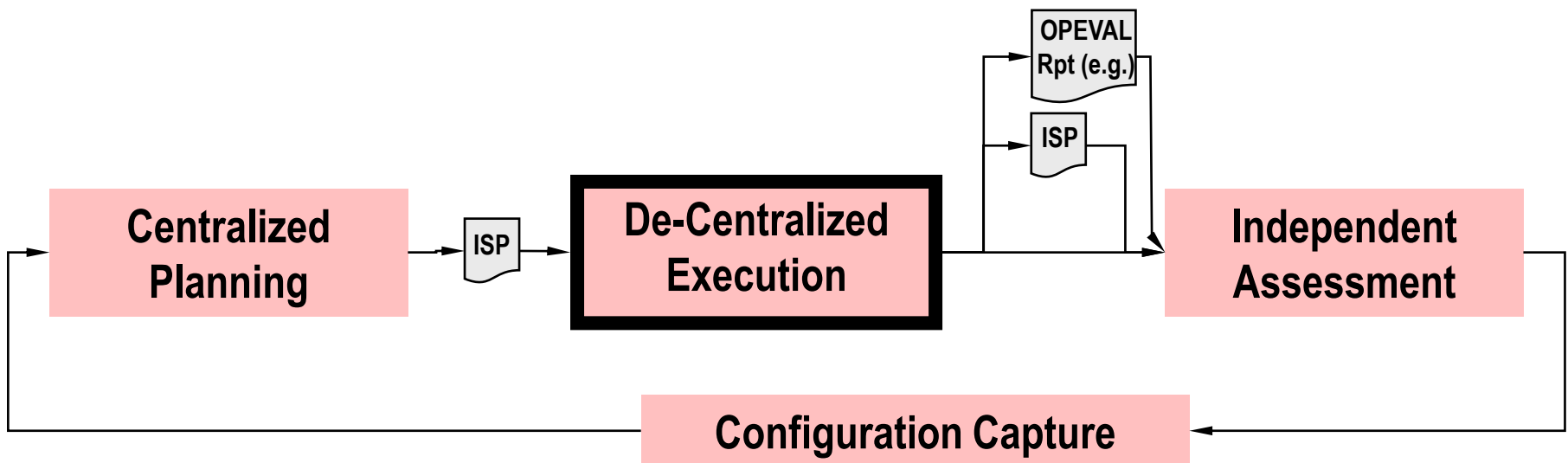



Independent Assessments

- ◆ There is a need for formal evaluation of the performance of mission-level systems-of-systems.
 - OPEVAL concentrates on single systems only.
 - Evaluation needs to be done in an operationally-relevant context.
- ◆ Capability Package Assessments (CPAs) will become the means for independent testing of SOSs.
 - Based on a process prototyped by MCSC/MCTSSA since FY02.
 - Aligns with NNWC desire for more relevant SOS assessments.
- ◆ Evaluation criteria are defined by the mission-level integrated architecture.

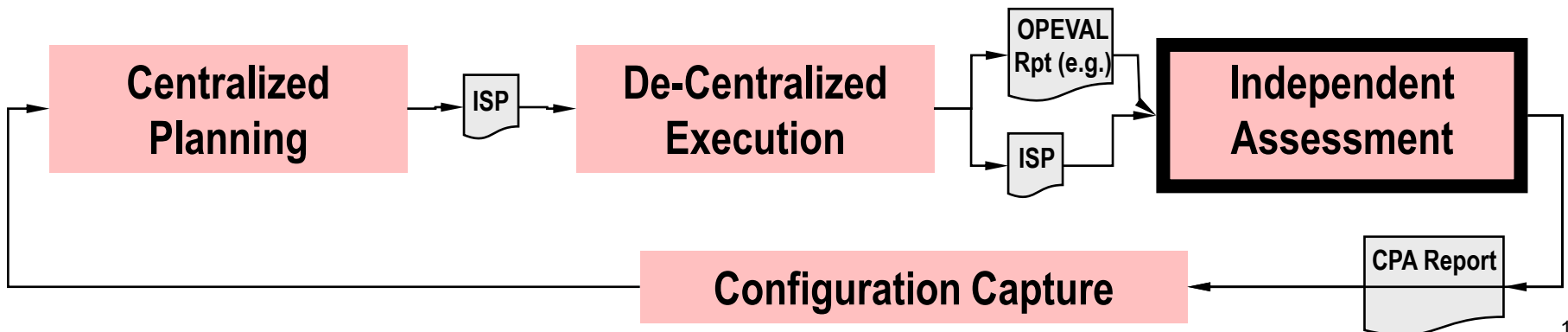



Independent Assessments (continued)

- ◆ Test scripts are developed for CPAs from the following MCP-level architectural views:
 - OV-5 Activity Model,
 - OV-6C Operational Event Trace Description,
 - SV-1/2 Systems Interface and Communications Description,
 - SV-5 Operational Activity to Systems Function Matrix,
 - SV-10C Systems Event Trace Description
- ◆ Initial test thread is Close Air Support.
- ◆ We are coordinating with NNWC for access to conduct CPAs during battle group pre-deployment work-ups.

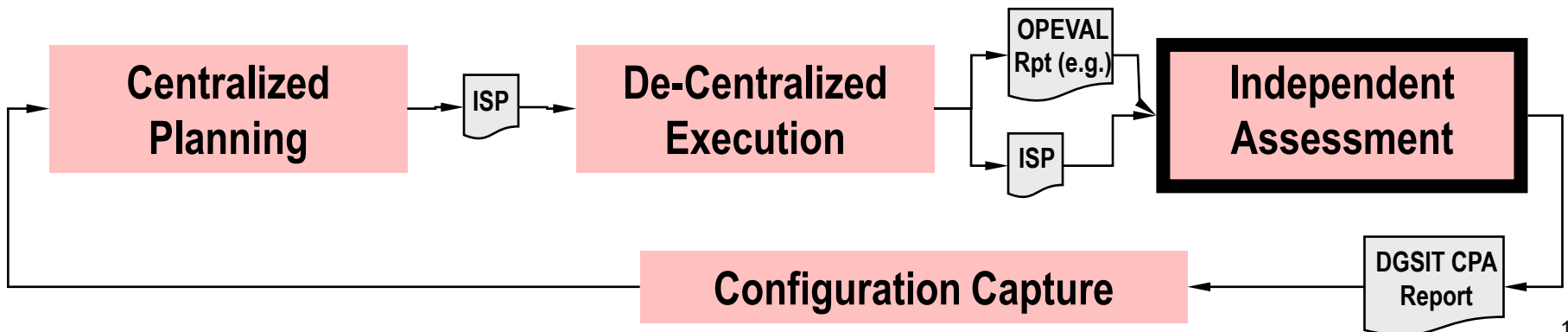



Configuration Capture

- ◆ The configuration observed aboard the battlegroup during the CPAs will be incorporated into the architecture repository as the “As-Is” configuration for the afloat portion of the DON Enterprise Architecture.
 - CPA configurations and results inform the mission-level integrated architectures of real-world conditions.

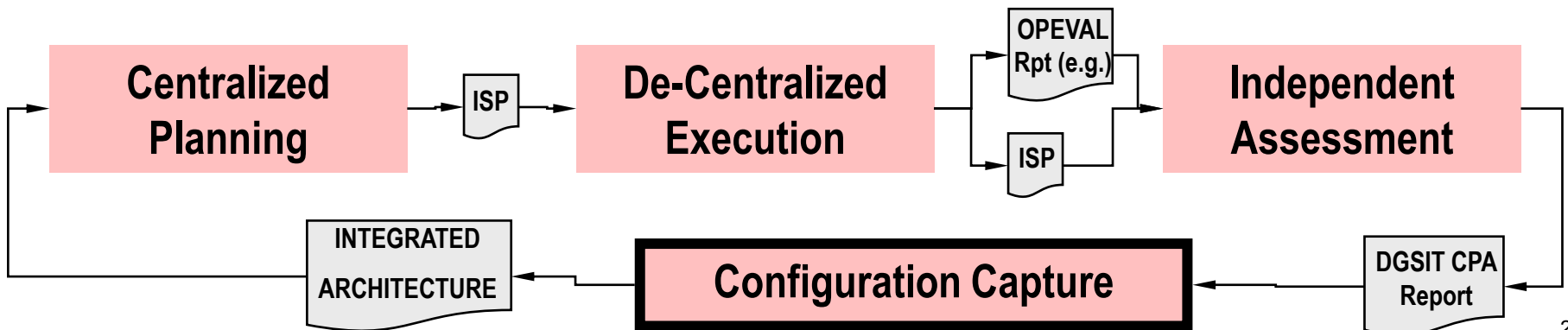



ASN(RDA) View of I&I - Sea Strike: STOM Example

Navy Component
Commander (COCOM)

USMC Component
Commander (COCOM)

JTFHQ

JFMCC

OTC

JFACC

JFLCC

CVTG:

CVN(s)
CG-47
DDG-51
SSN

Not Shown:
MNW, LSG,
Sea shield
functions.

GIG and FORCEnet Systems/Services:
Comms & Networking Infostructure
C2/DS Systems
ISR/BA Systems

CAS Aircraft:

JSF
AV-8
F-18C/D/E/F
AH-1

NFSG:

DDG-51
FFG-7
LCS
SSGN

ATG Escorts:

DDG-51
FFG-7
SSN

Landing Craft:

EFV-C/P
AAVC/P-7
LCAC
LCU

ATG:

LHA-1/6
LHD-1/4/8
LPD-17/18
LSD-42/49

Transport
Aircraft:

OV-22
CH-53
CH-46
UH-1

TDN/WIN-T Systems
MAGTF C2 Systems

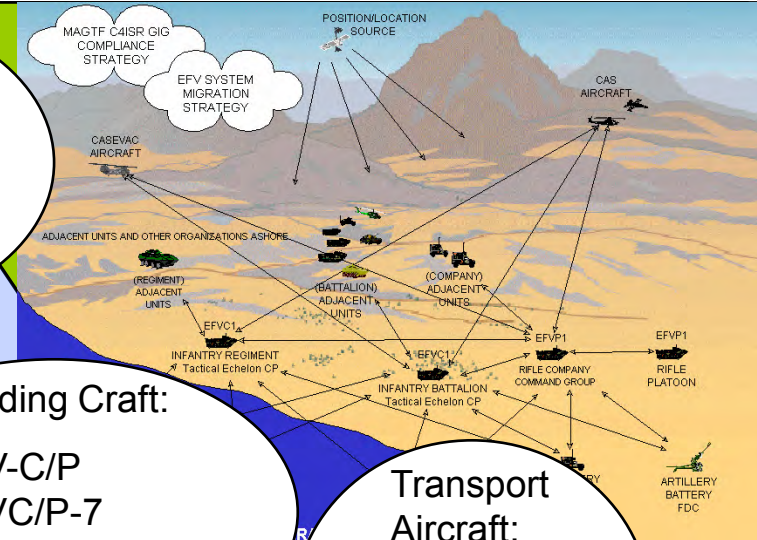



I&I Management Structure

MA CHENGs

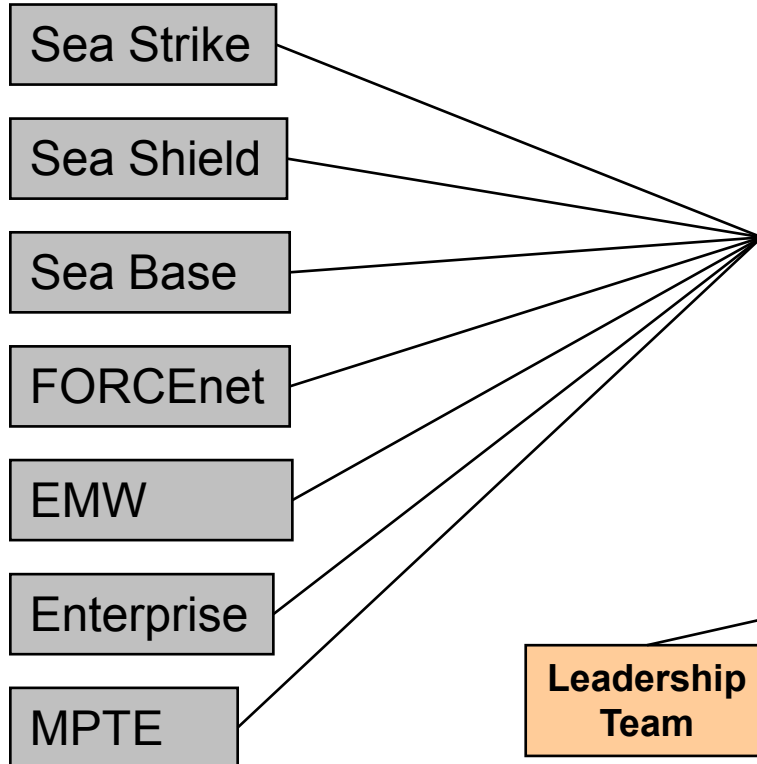

NNFE

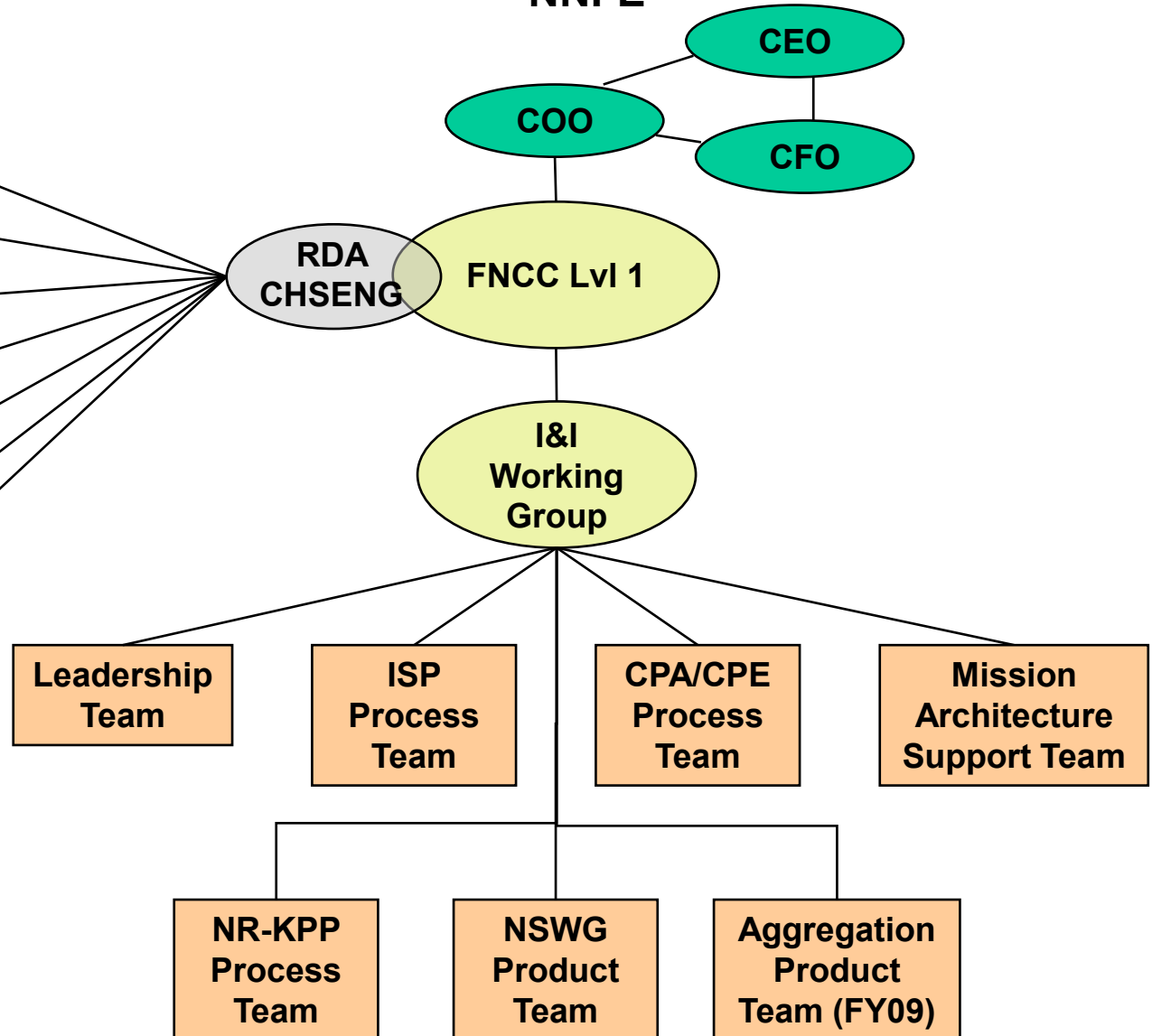

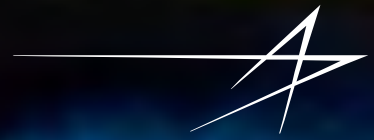

Survivable Network Design Framework

Dennis M. Moen, Ph.D., P.E.
Lockheed Martin MS2 Tactical Systems
Advanced Technology
Eagan, MN

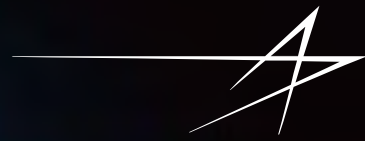

- ***MS2 Tactical Systems***
- ***Motivation for Survivable Networks: C4ISR***
- ***A Framework for cost-effective survivable network design***
- ***Summary/Discussion***

MS2 Tactical Systems – C4ISR Products and Solutions

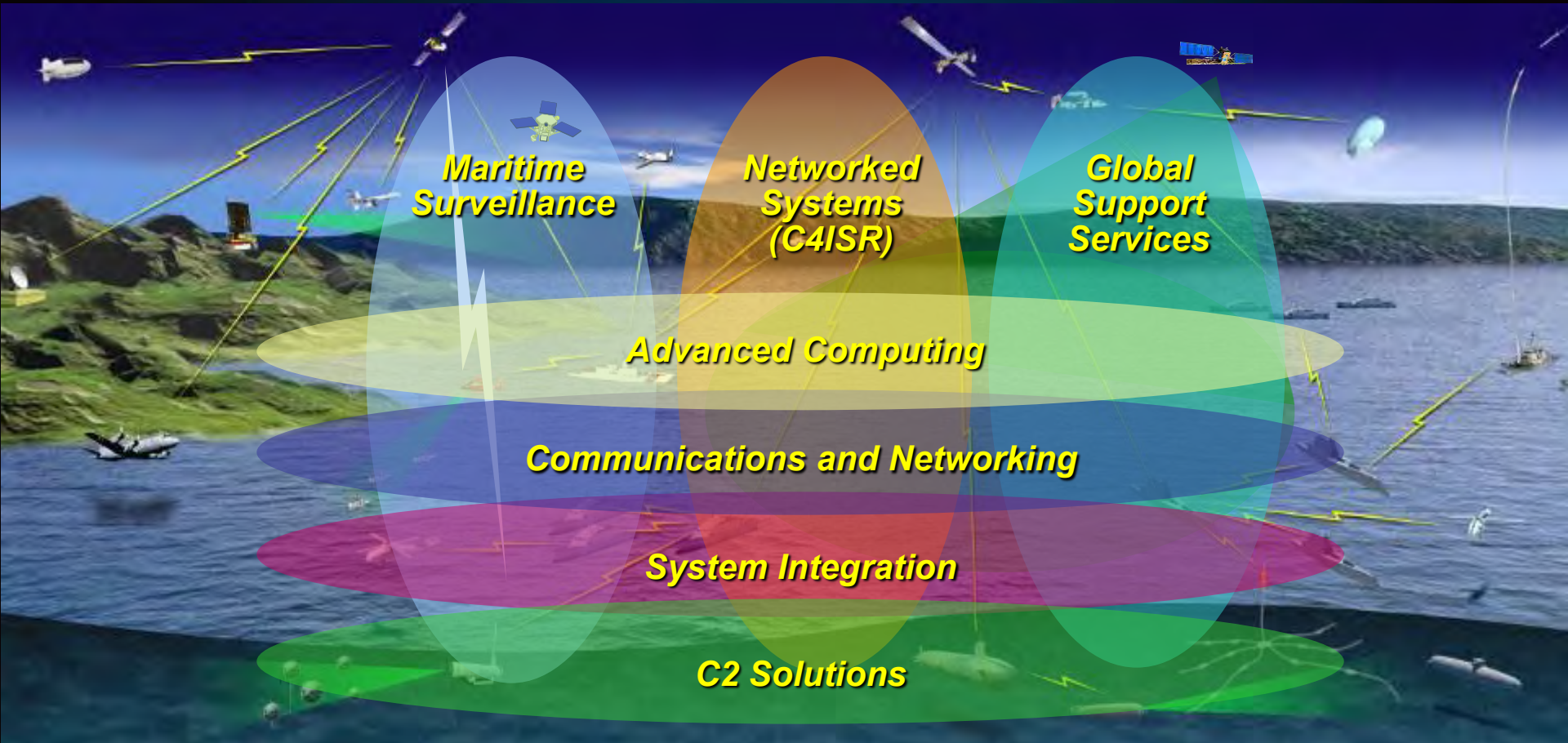
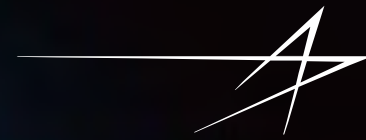

**Maritime
Surveillance**

**Networked
Systems
(C4ISR)**

**Global
Support
Services**

Advanced Computing

Communications and Networking

System Integration

C2 Solutions

MS2 Tactical Systems Delivers and Supports Complex C4ISR Solutions

Motivation: Complexity of C4ISR and Battle Management

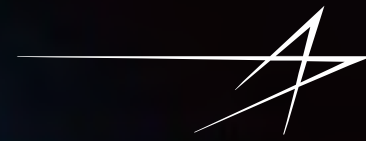

- **Sensors: They are everywhere on many networks**
 - *Lots of data in many types and formats*
 - *Diverse capabilities: range, modality, maneuverability*
 - *Networks are poorly integrated*
- **Communications and dissemination**
 - *Inter and intra networking*
 - *Networking platforms have different characteristics: mobility, power, line-of-sight, latency, bandwidth*
 - *Network-to-network adaptation: adaptive data rate and waveforms*
- **“Always-on”: Connectivity anytime, anywhere, anyhow**

Objective: Reliable information transfer under dynamic conditions with QoS

What is a Survivable Network?

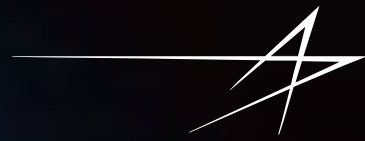

A survivable network has the characteristic that essential services are preserved under disruption and recover full services in a timely manner

- ***Disruption can result from many factors***
 - *Congestion resulting from excess offered load*
 - *Protocol Interworking failure (configuration)*
 - *Physical disruption*
 - *Security failure (Denial of service)*
- ***Service recovery***
 - *Priority of restoral*
 - *Automated vs manual*
 - *Efficiency (recover full service in a timely manner)*

Survivability Framework: Three levels of Network Integrity during undesirable events



- **Network availability (planned)**

- Normally associated with maintenance and configuration faults (single fault)
- Represents the majority of faults
- Automated recovery or inherent reliability in the design

- **Single, worst case failure (node, link, etc)**

- Environmental failure
- Accident
- Manual recovery (minutes/hours)

- **Disaster-based event: Several links or nodes fail simultaneously**

- Natural or man-made event
- Manual recovery (lengthy-hours/days/weeks)

Logical Layer recovery
(Application and traffic layer)

Physical Layer recovery



- ***System Requirements need to be integrated with survivability requirements at node and network level***
 - *Organize into essential and non-essential services*
 - *Organize by user or business function*
- ***Survivability imposes new types of requirements***
 - *Emergent behavior: collective behavior of node services communicating across the network*
 - *Adaptive behavior, function, and resource allocation*

Example: Functions and resources devoted to non-essential services could be reallocated to essential services

Sample Survivability Measures

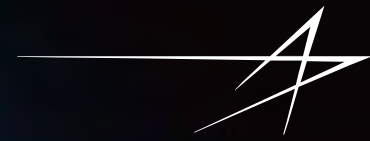

- **Connectivity based measures**
 - *Route availability ratio*
 - *Probability of node isolation*
- **Traffic based measures**
 - *Average network blocking given a failure*
 - *Average number of lost calls given a failure*
- **Desirable characteristics of measures**
 - *Technology independent*
 - *Measure survivability under the three described levels of failure*
 - *Can be applied to a subnetwork of the network*
 - *Can measure the customer/user impact*

Survivability Framework: Analysis



Survivability Level System Criteria	Level 1 Network Availability	Level 2 Single, Worst Case Event	Level 3 Disaster-based Event
Performance (Fault Tolerance + Security)			
Availability (System Reliability)			
Recovery Time (Modifiability)			
Life Cycle Cost			

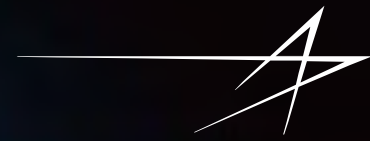

- **Architectural trade analysis using design patterns and styles**
 - *DoDAF modeling*
 - *Exhibit 300*
- **Formal methods using Markov modeling and simulation**
 - *Hamiltonian Cycle based analysis*
 - *Generalized graph methods for clustering*
 - *Minimum-cost vertex-connectivity analysis*
- **Scenario based methods**

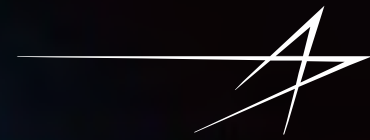

- **Maintainability: Fewer unique installations**
 - *Default configurations*
 - *Training*
 - *Logistic support*
- **Operational availability**
 - *Faster restoral*
 - *Swap like components*
 - *Priorities: Know when I need a service*
- **Life cycle cost management**

Objective: Commonality across the Enterprise

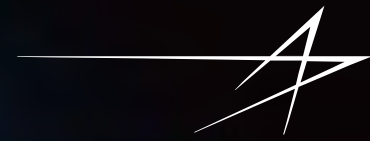

- ***The emphasis on net-centric operations makes it essential that we create effective methods for survivable network design***
- ***We can apply system engineering methodologies similar to those we apply to other systems in order to define “essential” services***
- ***We can use spiral model of analysis and design with appropriate measures to obtain desired properties***

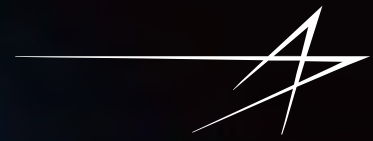

Questions?

Dennis.moen@lmco.com
(651)456-2421

Stop the Pain: Effective Requirements Definition and Management for Project Success

Scott Derby, Esterline AVISTA

NDIA Systems Engineering Conference
October 20-23, 2008



Agenda

- » Why are good requirements so important?
- » What makes a good requirement?
- » Requirements definition
- » Managing change
- » Advantages in modeling
- » Effective prototyping
- » Summary
- » Q & A



Why Are Good Requirements So Important?

Change Impact vs. Project Phase

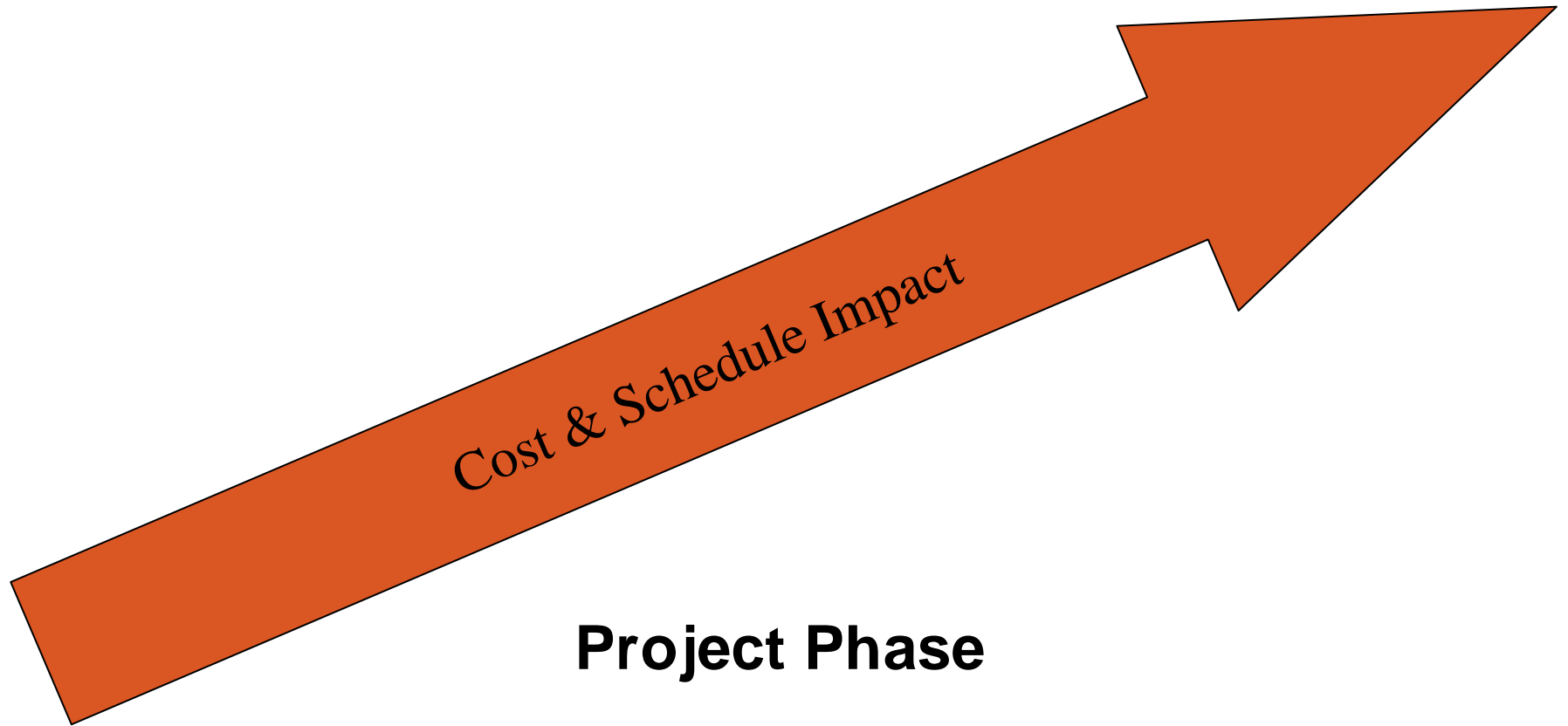

Why Are Good Requirements So Important? (cont.)

- » Requirements can be:
 - » Unrealistic
 - » Incomplete
 - » Ambiguous
 - » Contradictory
 - » Un-testable
 - » Poorly managed
- » This leads to:
 - » Rework, delays, budget over-runs, unhappy customers



What Makes a Good Requirement?

- » Be S.M.A.R.T.*
 - » Specific (concise, clear, unique)
 - » Measurable
 - » Achievable
 - » Relevant
 - » Testable
- » What vs. How
- » This leads to:
 - » Less rework, shorter schedules, lower costs, happy customers

» [*http://www.win.tue.nl/~wstomv/edu/2ip30/references/smart-requirements.pdf](http://www.win.tue.nl/~wstomv/edu/2ip30/references/smart-requirements.pdf)



Requirements Definition

- » Consider interests of ALL stakeholders
- » Include all users in reviews
 - » End user
 - » Development/Safety Team
 - » Production/Maintenance Team
 - » Verification/Validation Team
- » Don't forget:
 - » Traceability
 - » Interface requirements



Requirement Layers

- » Start with high level concept and technical requirements
- » Drill down adding more detail with each layer
 - » Highest level – capabilities
 - » Next n levels – subsystems, architecture, high level design, low level design
 - » The number is subjective - depends on complexity
 - » Stop when you have enough detail to build it, buy it, code it, and test it



Requirements Layers

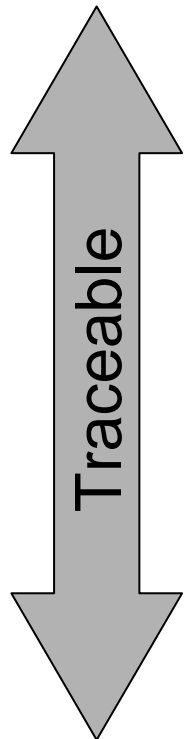

Customer Requirements

System Requirements

Subsystem Requirements

Component/Part (H/W & S/W) Req.

Verif./Valid. Procedures

Managing Change

- » During initiation:
 - » Define and formalize change control process (internal and external)
 - » Define how legacy issues will be handled
- » Get to know the “customer” and learn their true priorities
- » Good communications with stakeholders is key (include Contract Administrators)



Managing Change (cont.)

- » Effectively and formally evaluate and control proposed changes
- » Hold the line even on small impact changes
- » Requirements vs. desirements (what is in the contract?)
- » Identify and address errors/issues as early as possible



Advantages of Model Based Development

- » Early detection of errors in requirements and design
- » Proof of concept
- » Repeatable
- » Reduces impact of changes
- » Reduces cost of downstream activities (design, code)



Rapid Prototyping

- » Formalize the process to provide proof of concept
- » Make it repeatable – what if it works?
- » Emphasis of testing on core functionality, doesn't address capabilities such as operational environment



Summary

- » Create S.M.A.R.T. requirements
- » Communicate with stakeholders and dig deeper for clarification of requirements
- » Formalize the change management process
- » Identify legacy issues at the start of the project
- » Leverage modeling to detect errors early and reduce downstream costs
- » Use prototyping to help test functionality



Questions?

Contact Info:

Scott Derby

Programs Manager

Esterline AVISTA

Phone (608)348-8815

Fax (608)348-8819

Email Scott.Derby@avistainc.com

www.avistainc.com





Architecture and Model Based Systems Engineering For Lean Results

NDIA Systems Engineering Conference - October 2008

**Timothy G. Olson, President
Lean Solutions Institute, Inc.**

(760) 804-1405 (Office)

Tim.Olson@lsi-inc.com

www.lsi-inc.com

**Chris Armstrong, President
Armstrong Process Group**

Chris.Armstrong@aprocessgroup.com

www.aprocessgroup.com

Copyright © 1994-2008 by Process Assets, LLC (PAL). All Rights Reserved.



**“I have made this letter
longer than usual
because I lack the time
to make it shorter”**

Blaise Pascal



Objectives

Provide some “lean results” motivation.

Describe some engineering problems from industry.

Describe motivation and advantages of architectures.

Describe motivation and advantages of models.

Provide some examples.

Answer any of your questions.



Outline

Lean Results

Some Problems in Engineering

Systems Engineering Processes

Why Focus on Architectures?

Why Focus on Models?

The Future: Industry Standards and Tools

Summary



The Quality Crisis

The cost of poor quality:

- **“In most companies the costs of poor quality run at 20 to 40 percent... In other words, about 20 to 40 percent of the companies’ efforts are spent in redoing things that went wrong because of poor quality” (*Juran on Planning for Quality*, 1988, pg. 1)**
- **Crosby’s Quality Management Maturity Grid states that if an organization doesn’t know it’s cost of quality, it’s probably at least 20%. (*Crosby, Quality is Free*, 1979, pg. 38-39)**

What is Lean?

Lean has its roots in quality and manufacturing, and is a recent popular movement in quality.

“Lean Production” is the name for the Toyota Lean Production System.

The following are major lean references (see references in back of presentation for full references):

- **“The Machine That Changed The World”**
- **“Learning to See”**
- **“The Toyota Way”**
- **“The Toyota Product Development System”**
- **“Lean Thinking”**



Some Lean Principles - (1)

Establish customer defined value (i.e., identify the “value stream”). Process = “value”.

Continuously eliminate non-value added activities (e.g., waste, rework, defects).

Use leadership and standardization to create a lean culture.

Align your organization through visual communication.

Create an optimized process flow (e.g., “Flow”, “Pull”, “Just-In-Time”, “Leveled”).



Some Lean Principles - (2)

Use lean metrics to manage the value stream.

Front-Load the process for maximum design space.

Build a learning organization to achieve lean and continuous improvement.

Adapt technology to fit your people and processes.

Strive for perfection through continuous improvement.



Some Lean Results

MEASUREMENT	WORLD-CLASS BENCHMARK
Costs of Poor Quality (COPQ)	Reduced from ~33% to ~15% (e.g., cut COPQ in half)
Defect Removal Efficiency	70-90% defect removal before test
Post-Release Defect Rate	Six Sigma (i.e., 3.4 Defects Per Million)
Productivity	Doubled (e.g., in 5 years at ~20% a year)
Return on Investment	7:1 - 12:1 ROI
Schedule / Cycle Time	Reduced by 10-15% (e.g., per year)



Outline

Lean Results

Some Problems in Engineering

Systems Engineering Processes

Why Focus on Architectures?

Why Focus on Models?

The Future: Industry Standards and Tools

Summary



Some Engineering Problems

Numerous problems with requirements.

Too many defects (i.e., quality problems).

Lack of metrics (e.g., process improvement).

Major decisions made made subjectively or without data.

Management problems (e.g., poor risk management).

Lack of product integrity.

Example Problem: Requirements

A research report from the Standish Group highlighted the continuing quality and delivery problems in our industry and identified three leading causes:

- **Lack of user input**
- **Incomplete requirements and specifications**
- **Changing requirement specifications**

• Reference: “Chaos”, Compass, The Standish Group, 1997, used with permission.



Problems with Requirements

According to the SEI [Christel 92], problems of requirements elicitation can be grouped into 3 categories:

- 1. Problems of Scope: the requirements may address too little or too much information.**
- 2. Problems of Understanding: problems within groups as well as between groups such as users and developers.**
- 3. Problems of Volatility: the changing nature of requirements.**



Outline

Lean Results

Some Problems in Engineering

Systems Engineering Processes

Why Focus on Architectures?

Why Focus on Models?

The Future: Industry Standards and Tools

Summary

CMMI[®] Process Areas

Engineering:

- Requirements Management (REQM)
- Requirements Development (RD)
- Technical Solution (TS)
- Product Integration (PI)
- Verification (VER)
- Validation (VAL)

Support:

- Measurement and Analysis (MA)
- Process & Product Quality Assurance (PPQA)
- Configuration Management (CM)
- Decision Analysis and Resolution (DAR)
- Causal Analysis and Resolution (CAR)

® CMMI is registered in the U.S. Patent and Trademark Office by Carnegie Mellon University



CMMI[®] Process Areas

Project Management:

- **Project Planning (PP)**
- **Project Monitoring and Control (PMC)**
- **Supplier Agreement Management (SAM)**
- **Risk Management (RSKM)**
- **Integrated Project Management + IPPD (IPM)**
- **Quantitative Project Management (QPM)**

Process Management:

- **Organizational Process Definition + IPPD (OPD)**
- **Organizational Process Focus (OPF)**
- **Organizational Training (OT)**
- **Organizational Process Performance (OPP)**
- **Organizational Innovation and Deployment (OID)**

® CMMI is registered in the U.S. Patent and Trademark Office by Carnegie Mellon University



NASA Systems Engineering Requirements (NPR-7123)

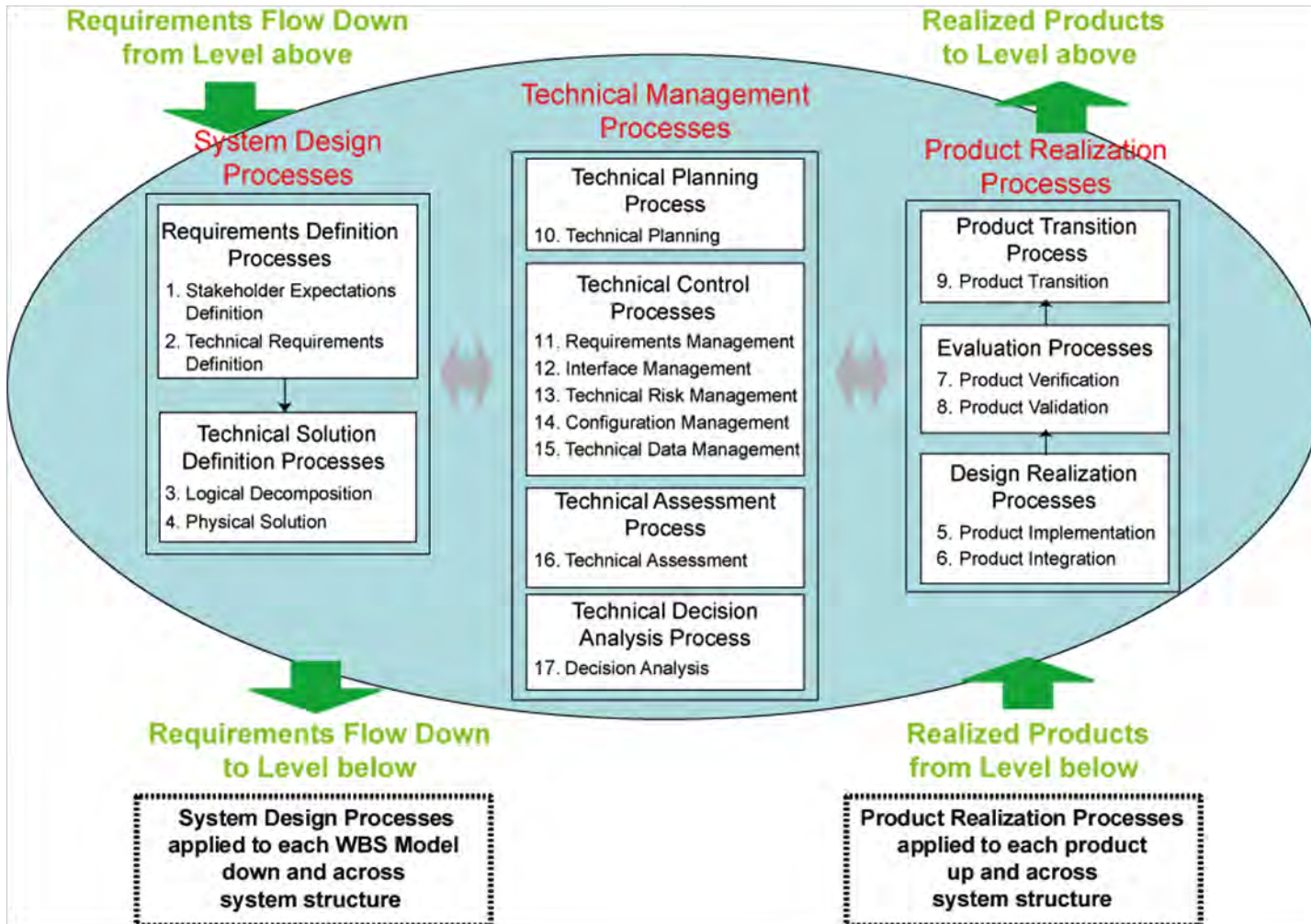



Outline

Lean Results

Some Problems in Engineering

Systems Engineering Processes

Why Focus on Architectures?

Why Focus on Models?

The Future: Industry Standards and Tools

Summary



Why Architectures?

Architectures are very powerful because they:

- **Are graphical (a picture is worth a 1000 words) and can be powerful communication tools.**
- **Provide a framework for how components are related (e.g., interfaces, interdependencies, relationships) and how components fit together.**
- **Promote reuse (e.g., products, components, requirements, designs, tests, interfaces, etc.) and can improve productivity and quality.**
- **Can be modeled in an automated tool.**



Architectures

Architectures consist of:

- **Components**
- **Interfaces, interdependencies, and other relationships among components**
- **Ordering and rules for putting components together**

Simple Architecture Example: Lego's

Numerous Types of Architectures:

- **Product and Domain Specific Architectures**
- **Business, Data, Technology, etc. Architectures**
- **Discipline Specific Architectures (e.g., software)**
- **Process Architectures**
- **Documentation Architectures**



Example Product Architecture

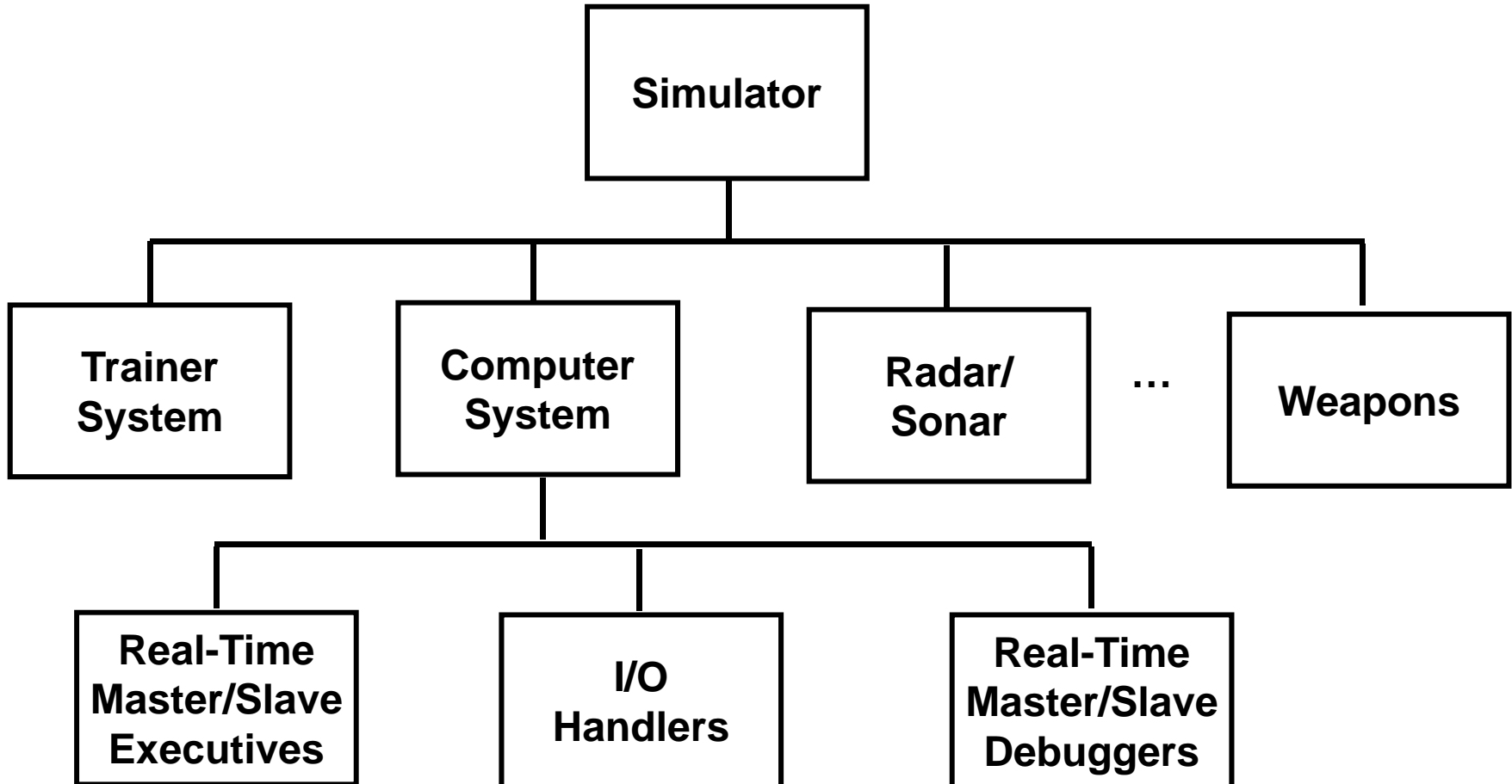



Example Process Architecture

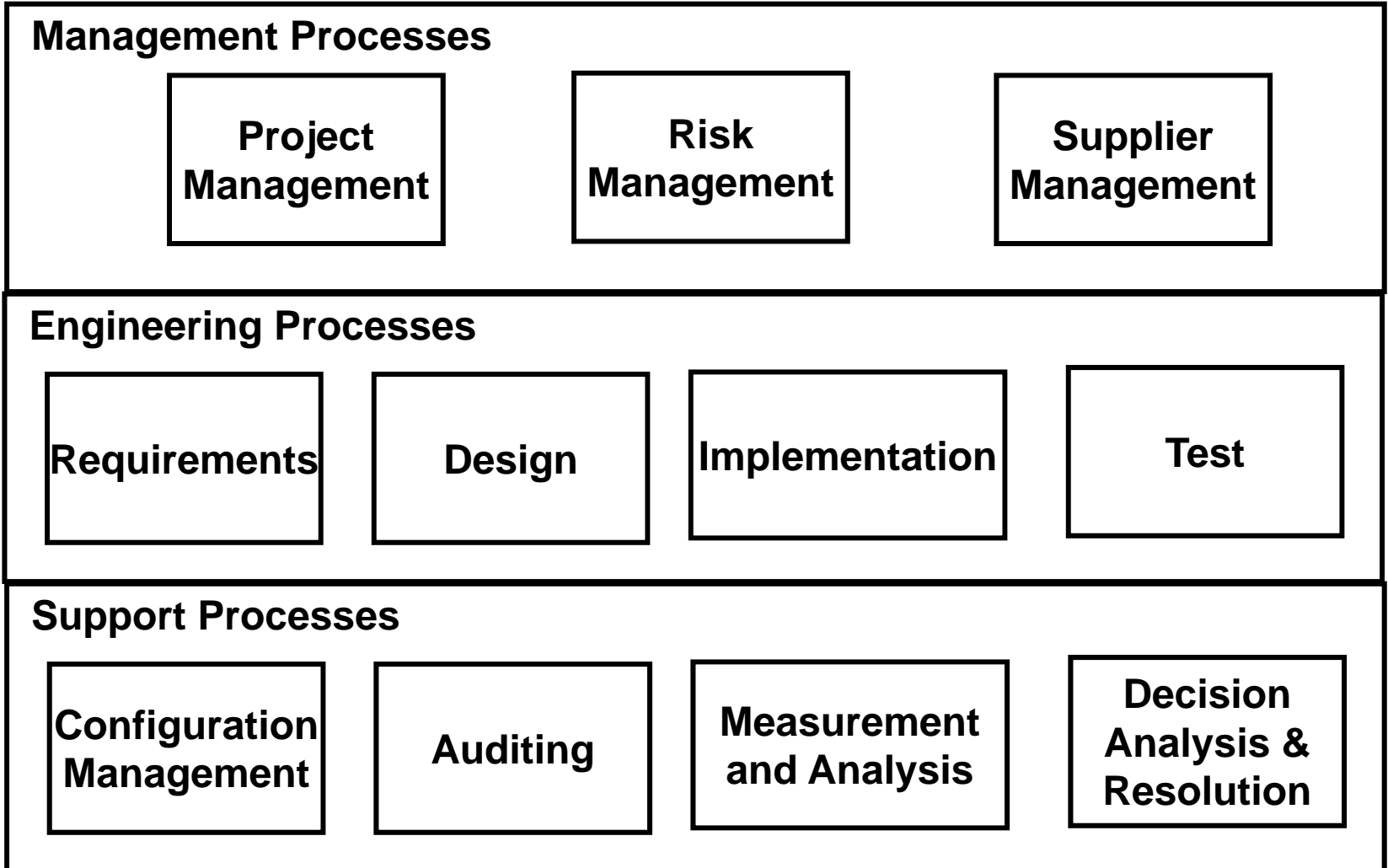



Documentation Architecture

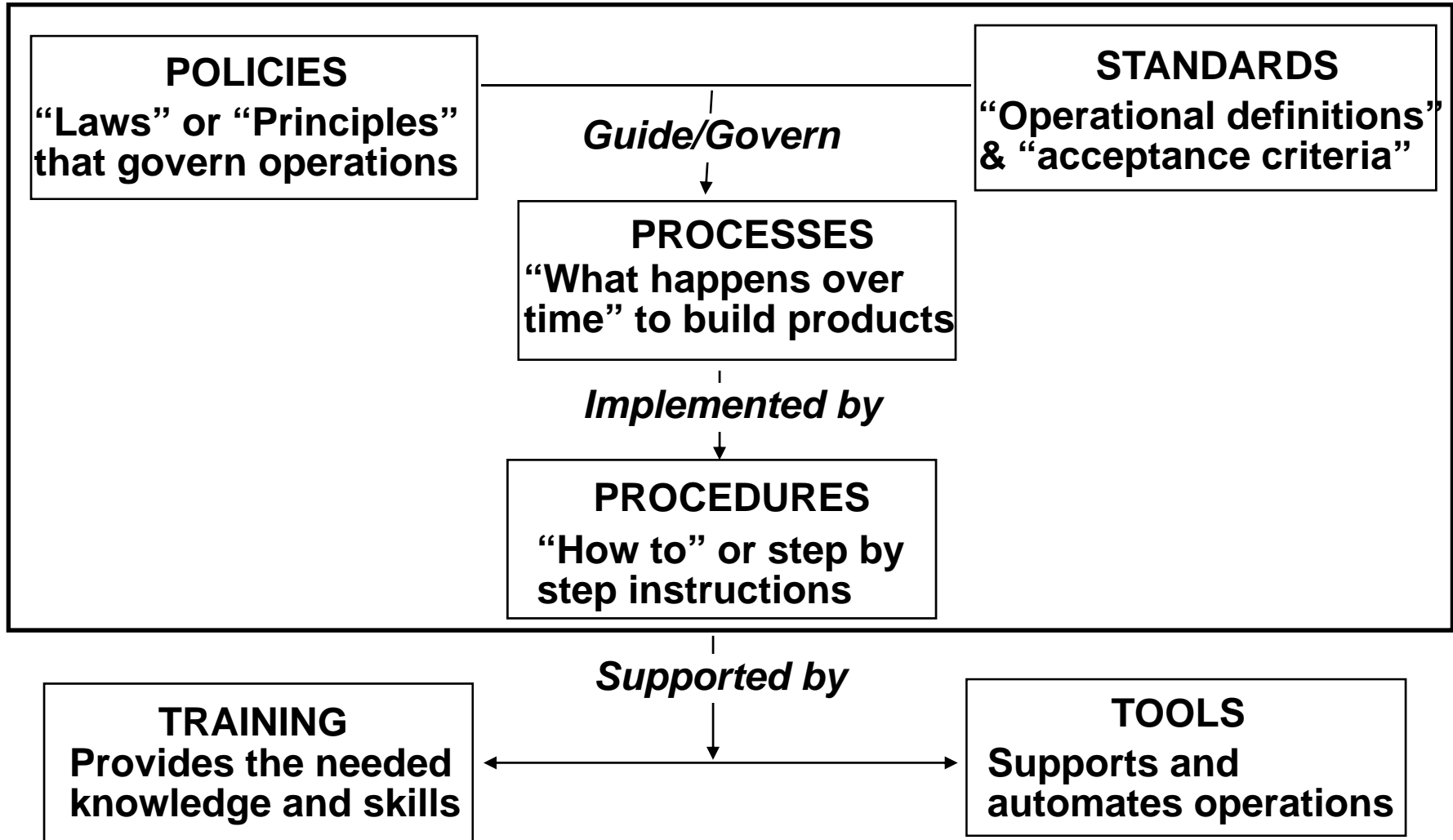

• Slide adapted from “A Software Process Framework for the SEI Capability Maturity Model”, CMU/SEI-94-HB-01



Outline

Lean Results

Some Problems in Engineering

Systems Engineering Processes

Why Focus on Architectures?

Why Focus on Models?

The Future: Industry Standards and Tools

Summary



Why Models?

Models are very powerful because they:

- **Are graphical (a picture is worth a 1000 words) and can be powerful communication tools.**
- **Can scale up to complex systems and provide a tool to analyze complex relationships and dependencies.**
- **Promote reuse (e.g., products, components, requirements, designs, tests, interfaces, etc) and can improve productivity and quality.**
- **Can be represented in an automated tool, and simulated.**



Models

Models are abstractions of reality constructed for a (useful) purpose consisting of:

- **Formal notations and rules for representations**
- **Model components or building blocks**
- **Ways to model interfaces, interdependencies, and other relationships among the model components**

There are numerous modeling languages and tools.

A Few Modeling Examples:

- **Behavioral Models (e.g., timing, states)**
- **Structural Models (e.g., hierarchy, order)**
- **Functional Models (e.g., input, function, output)**
- **Process Models (e.g., the 5 W's)**



What is a Process Model?

Process Model:

- An abstraction of a process typically characterized by formal notations for representing roles, activities, and/or work products, and the relationships (e.g., events, transformations) among them.

Types of process models:

- Descriptive (as-is): describes what is actually done
- Prescriptive (to-be): prescribes what to do (e.g., by new policies, standards, process guidelines, etc.)
- Mixed (both): most process models are a mixture of prescriptive and descriptive processes



Popular Process Models: CMM/CMMI

SADT: Structured Analysis and Design Technique (SADT) is a graphical systems modeling language developed at Softech/MIT by Doug Ross in early 1970's. Used extensively to document all manner of systems including manufacturing processes. Has automated tool support (e.g., IDEF).

ETVX: Entry criteria/Tasks/Verification/eXit criteria (ETVX). Developed at IBM in the mid 1980's. Simple to use, but no automated tool support.

Role/Flow or Swim-Lane Models: Like flow charts, but have swim-lanes for roles and are formal process models. Have become very popular in the last decade. [Example Handout].



Example Requirements Process: NASA Onboard Shuttle Project

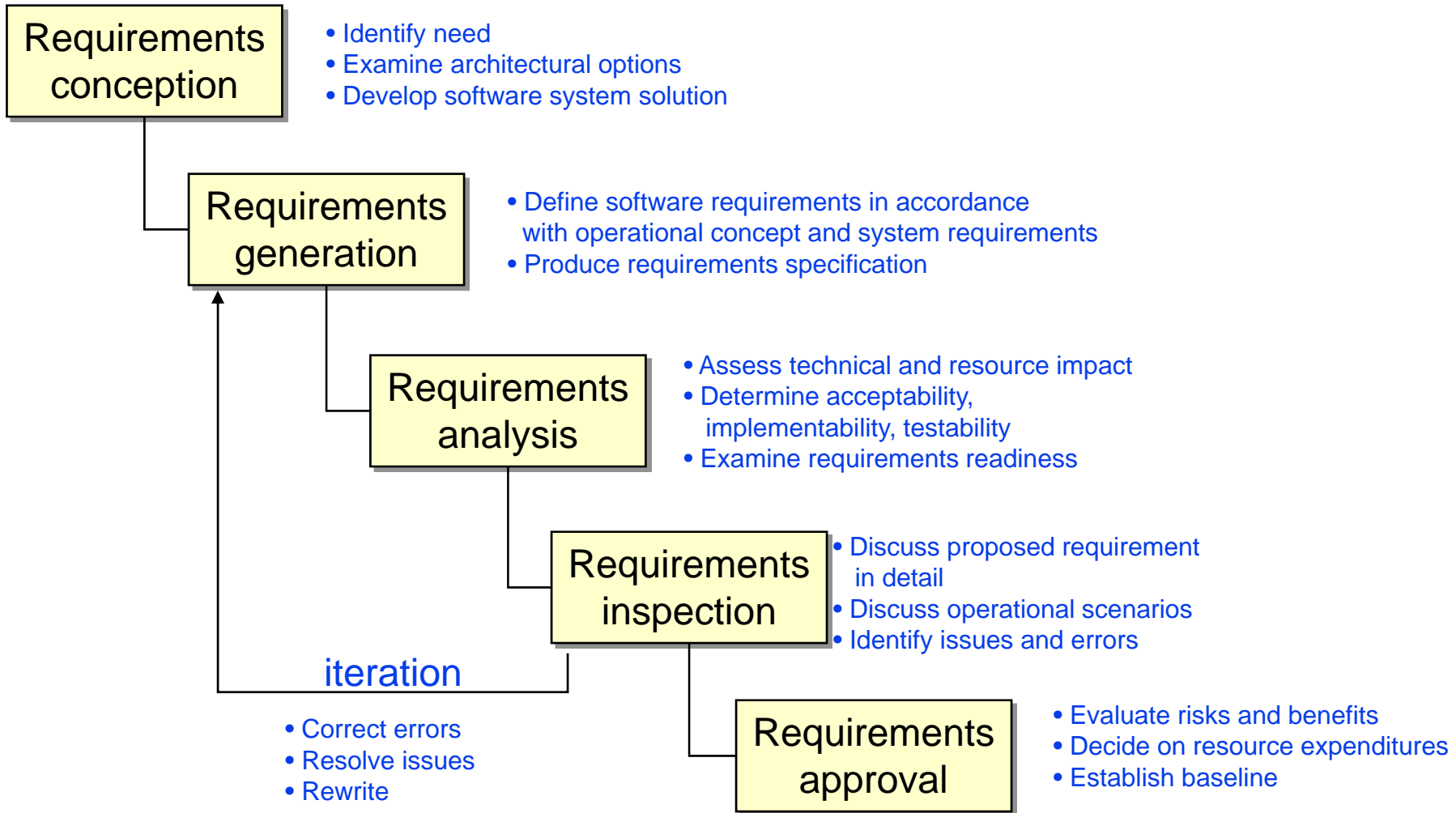



Outline

Lean Results

Some Problems in Engineering

Systems Engineering Processes

Why Focus on Architectures?

Why Focus on Models?

The Future: Industry Standards and Tools

Summary

State of the Industry – Process Management

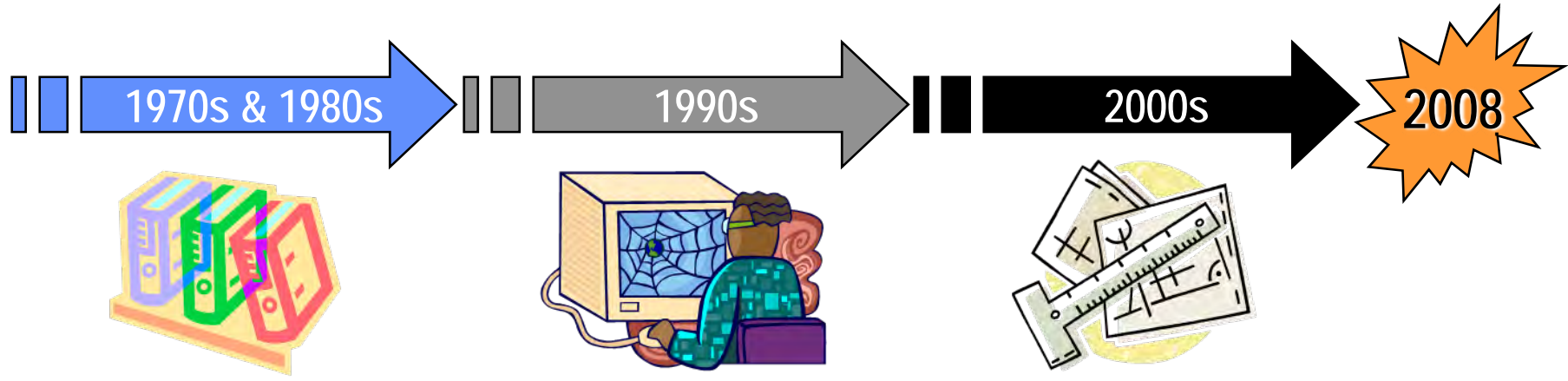

Three-Ring Binders

- Demonstrated organization commitment
- Often became shelfware

Websites

- More accessible by practitioners
- Often difficult to navigate and maintain

Model-Driven

- Access to industry standard frameworks
- Integration of multiple lifecycles
- Formal process asset management

Benefits of a Standards-Based Approach

Increased sustainability:

- Lower cost and shorter time of initial adoption
- Widespread availability of knowledgeable employee, contractor, and vendors
- Lower cost of maintenance

Lower risk:

- Apply proven best practices
- Widespread adoption across industry



Some Industry Standards

OMG: Object Management Group

UML: Unified Modeling Language

SysML: Systems Modeling Language

**SPEM: Software and Systems Process Engineering
Metamodel**

**Eclipse Process Framework (EPF) Composer: Open
Source based on SPEM: www.eclipse.org/epf.**

OpenUP: Open Unified Process - process framework

TOGAF: The Open Group Architecture Framework

DoDAF: DoD Architecture Framework

**IEEE 1471: Recommended Practice for Architecture
Description of Software Intensive Systems**



Outline

Lean Results

Some Problems in Engineering

Systems Engineering Processes

Why Focus on Architectures?

Why Focus on Models?

The Future: Industry Standards and Tools

Summary



Summary

There are many industry engineering problems.

Systems engineering needs to focus on improving those engineering problems.

Organizations need lean measurable results (e.g., 7:1 ROI).

Architectures and models are powerful tools to help improve engineering and obtain measurable results.

The future of architectures and models is industry standards and tools. Architectures can also be represented with models.



Architecture and Model Based Systems Engineering For Lean Results

NDIA Systems Engineering Conference - October 2008

**Timothy G. Olson, President
Lean Solutions Institute, Inc.**

(760) 804-1405 (Office)

Tim.Olson@lsi-inc.com

www.lsi-inc.com

**Chris Armstrong, President
Armstrong Process Group**

Chris.Armstrong@aprocessgroup.com

www.aprocessgroup.com

GENERAL DYNAMICS

Land Systems

Reliability Growth of Mobile Gun System during PVT

Dmitry E. Tananko, Ph.D., Reliability and Robust Engineering, GDLS
Sharad Kumar, Senior Director, System Engineering, GDLS
John Paulson, Director, Stryker Program, GDLS
Jenny Chang, PM SBCT, TACOM
LTC David J. Rohall, PM SBCT, TACOM
James Ruma, VP, Engineering Programs, GDLS

Agenda

- **What is MGS**
- **Success Factors of MGS PVT**
 - ↗ Program Management – Integrated Team
 - ↗ System Engineering and Reliability Attainment
 - ↗ Reliability Data Analysis – RGA
 - FDSC – Failure Definition Scoring Criteria
 - Failure Categories
 - Inherent vs. Induced Reliability
 - Mission Profile and Life Variable
 - Data Grouping and Modeling
 - Instantaneous vs. Cumulative Reliability
- **MGS Lesson Learned - DFR**

Agenda

- **What is MGS**
- **Success Factors of MGS PVT**
 - Program Management – Integrated Team
 - System Engineering and Reliability Attainment
 - Reliability Data Analysis – RGA
 - FDSC – Failure Definition Scoring Criteria
 - Failure Categories
 - Inherent vs. Induced Reliability
 - Mission Profile and Life Variable
 - Data Grouping and Modeling
 - Instantaneous vs. Cumulative Reliability
- **MGS Lesson Learned - DFR**

Stryker Family of Vehicles



**Infantry Carrier Vehicle
(ICV) 130**



**Commander's Vehicle
(CV) 28**



**Fire Support Vehicle
(FSV) 14**



Mobile Gun System (MGS) 27



**Reconnaissance Vehicle
(RV) 52**



**Medical Evacuation Vehicle
(MEV) 16**



**Engineer Squad Vehicle
(ESV) 13**



**Anti Tank Guided Missile
(ATGM) 10**



**120mm Mounted Mortar Carrier
(MC-B) 37**



**NBC Reconnaissance Vehicle
(NBCRV) 3**

Mobile Gun System – The Bunker Buster



BLUF – Key Factors for Successful Reliability Growth Program

- **Program Management – Integrated Team**
 - The systems, tools, and practices now in place between the US Government and General Dynamics Land Systems allowed the system's reliability to grow (repeatable process)
 - Reliability growth requires commitments from Material Developer Team, Combat Developer, and Independent Test and Evaluation Communities (requirements, test, data, methodology, tools)
- **System Engineering – Reliability Backbone**
 - Integrates All Reliability Tasks
 - Redirects Tasks Toward a Single Objective
 - Crosses Boundaries Affecting Operational Reliability
 - Provides Program Manager Authority, Funding, and Focus on Engineering, Processes, Documentation, Training, Manufacturing, and Testing for Reliability
- **Reliability Data Analysis – Reliability Assessment**
 - FDSC – Failure Definition Scoring Criteria
 - Failure Categories
 - Inherent vs. Induced Reliability
 - Mission Profile and Life Variable
 - Data Grouping and Modeling
 - Instantaneous vs. Cumulative Reliability

Agenda

- **What is MGS**

- **Success Factors of MGS PVT**

- Program Management – Integrated Team

- System Engineering and Reliability Attainment

- Reliability Data Analysis – RGA

- FDSC – Failure Definition Scoring Criteria

- Failure Categories

- Inherent vs. Induced Reliability

- Mission Profile and Life Variable

- Data Grouping and Modeling

- Instantaneous vs. Cumulative Reliability

- **MGS Lesson Learned - DFR**

MGS Program Management

Plan

- Phase I - Conduct an Additional Reliability Test (ART)
 - Validate effectiveness of 216 PQT and Post-PQT corrective actions
- Phase II - Implement changes to Government and GDLS Systems Engineering Processes
 - Management and process changes
- Phase III - Redesign of Sub-System components and integration

Tests

- Additional Reliability Testing (DEC 2004 – MAR 2005)
 - 2 vehicles
 - Pre-ART – XXX rounds & X00 miles
 - ART – XXX rounds & X,000 miles
 - Reliability Point Estimate XX MRBSA
- Reliability Growth Test (JUL-AUG 2005)
 - 2 Vehicles
 - XXX rounds
 - X,000 miles
 - Reliability Point Estimate XX MRBSA
- Production Verification Testing (APR 2006 - DEC 2007)
 - 3 Vehicles
 - XXXX rounds
 - XX,000 miles
 - On-going – Current estimate XXX MRBSA

MGS Idealized Growth Curve

MGS Rebaselined MEP Idealized Growth Curve
RGT Demonstrated Reliability

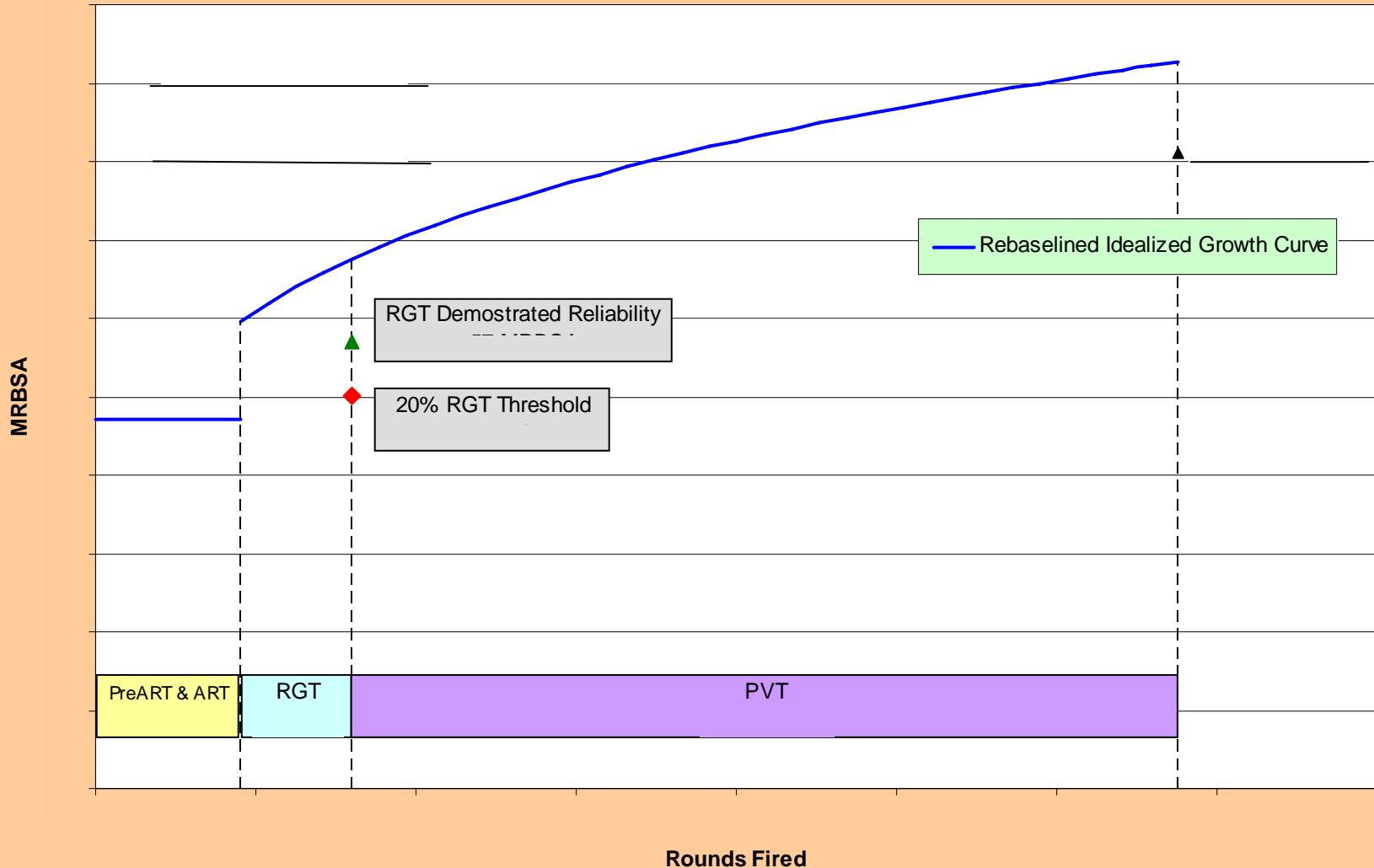

Agenda

- **What is MGS**
- **Success Factors of MGS PVT**
 - ↗ Program Management – Integrated Team
 - ↗ System Engineering and Reliability Attainment
 - ↗ Reliability Data Analysis – RGA
 - FDSC – Failure Definition Scoring Criteria
 - Failure Categories
 - Inherent vs. Induced Reliability
 - Mission Profile and Life Variable
 - Data Grouping and Modeling
 - Instantaneous vs. Cumulative Reliability
- **MGS Lesson Learned - DFR**

MGS - Systems Engineering Approach

- Integrates All Reliability Tasks
- Redirects Tasks Toward a Single Objective
- Crosses Boundaries Affecting Operational Reliability
- Provides Program Manager Authority, Funding, and Focus on Engineering, Processes, Documentation, Training, Manufacturing, and Testing for Reliability
- Approach Provides Metrics that can be Measured

SE Approach to Reliability

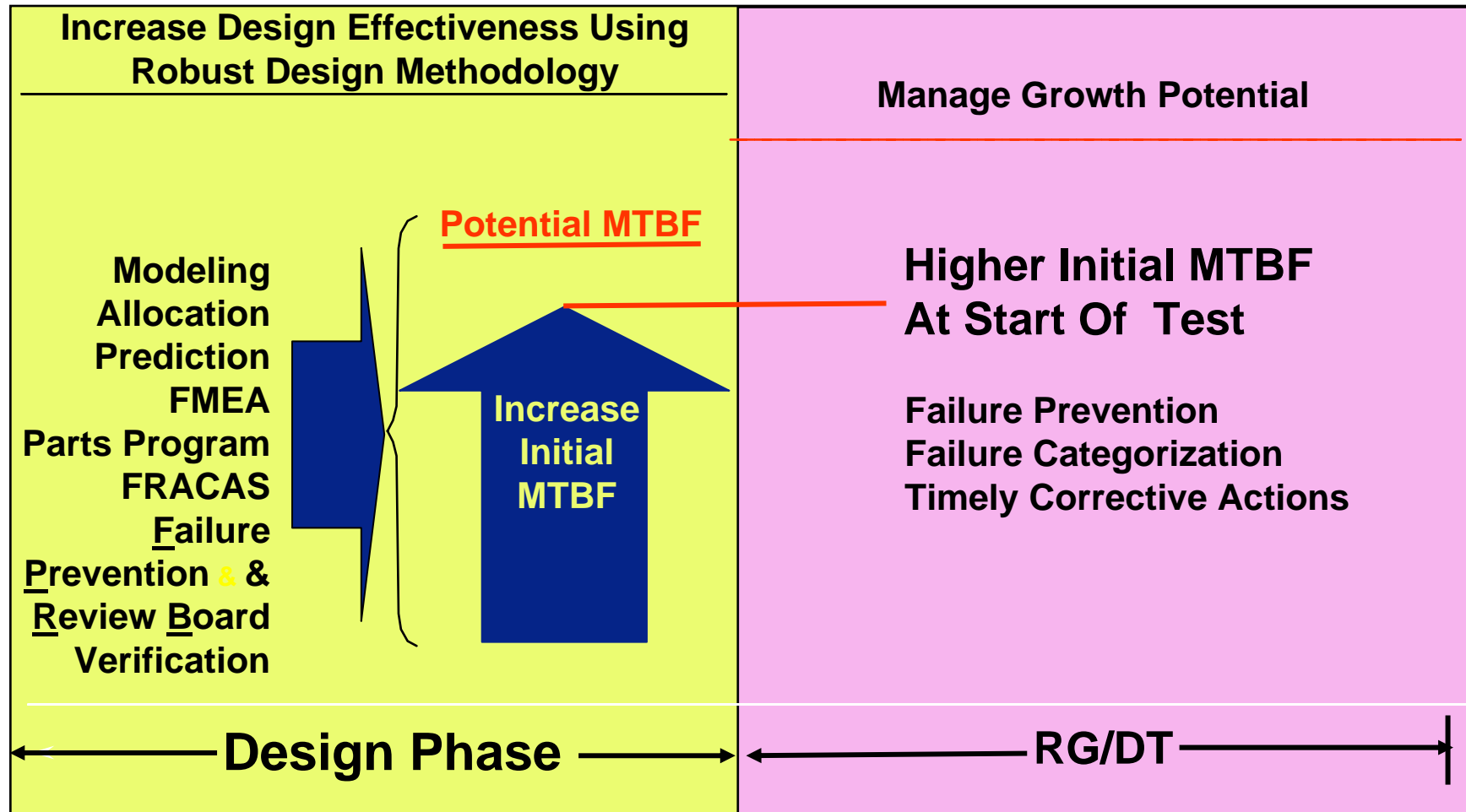

Design for Reliability Management Focuses on Failure Prevention

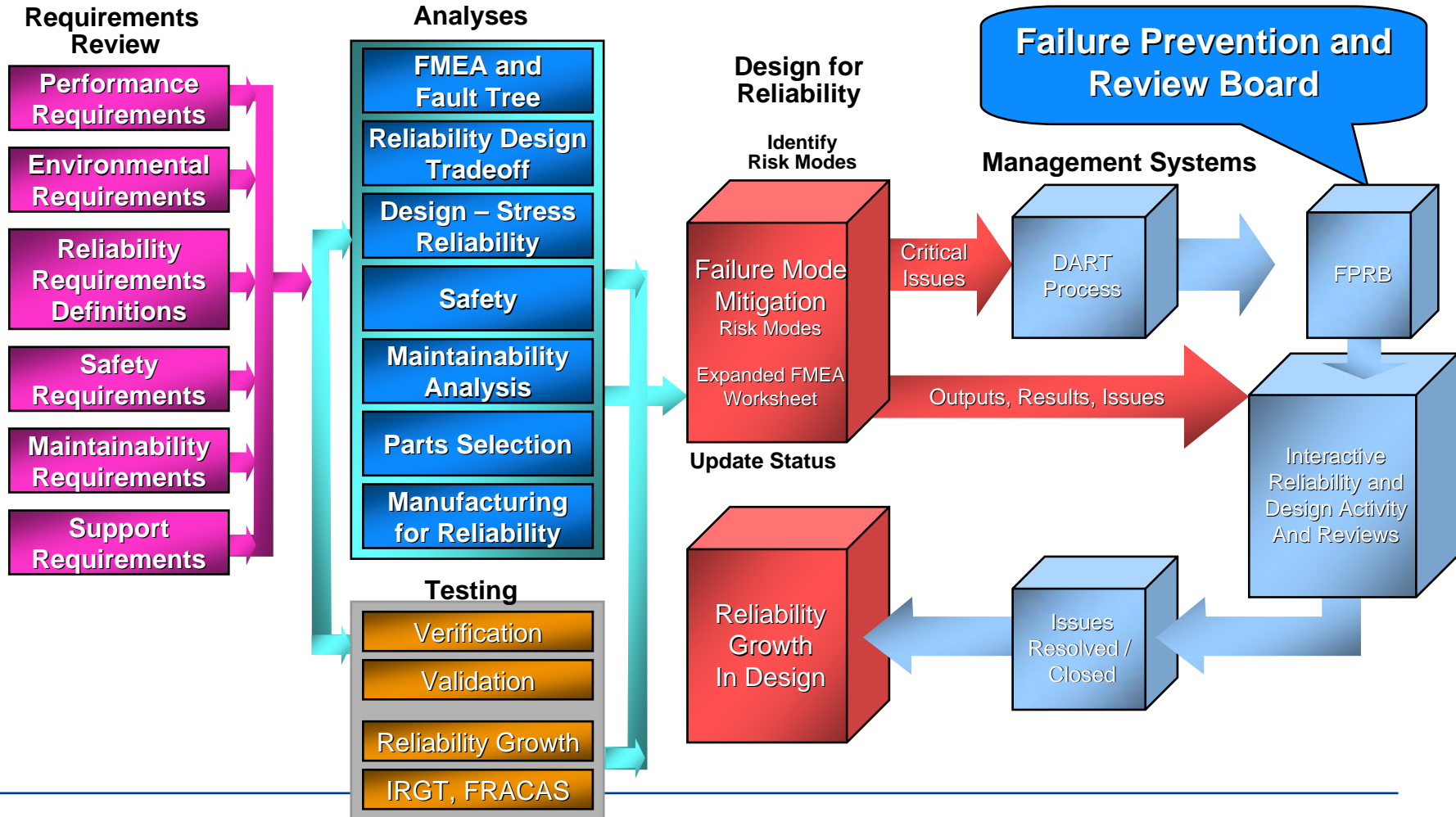

Stryker – Mobile Gun System

Failure Prevention and Resolution Implementation

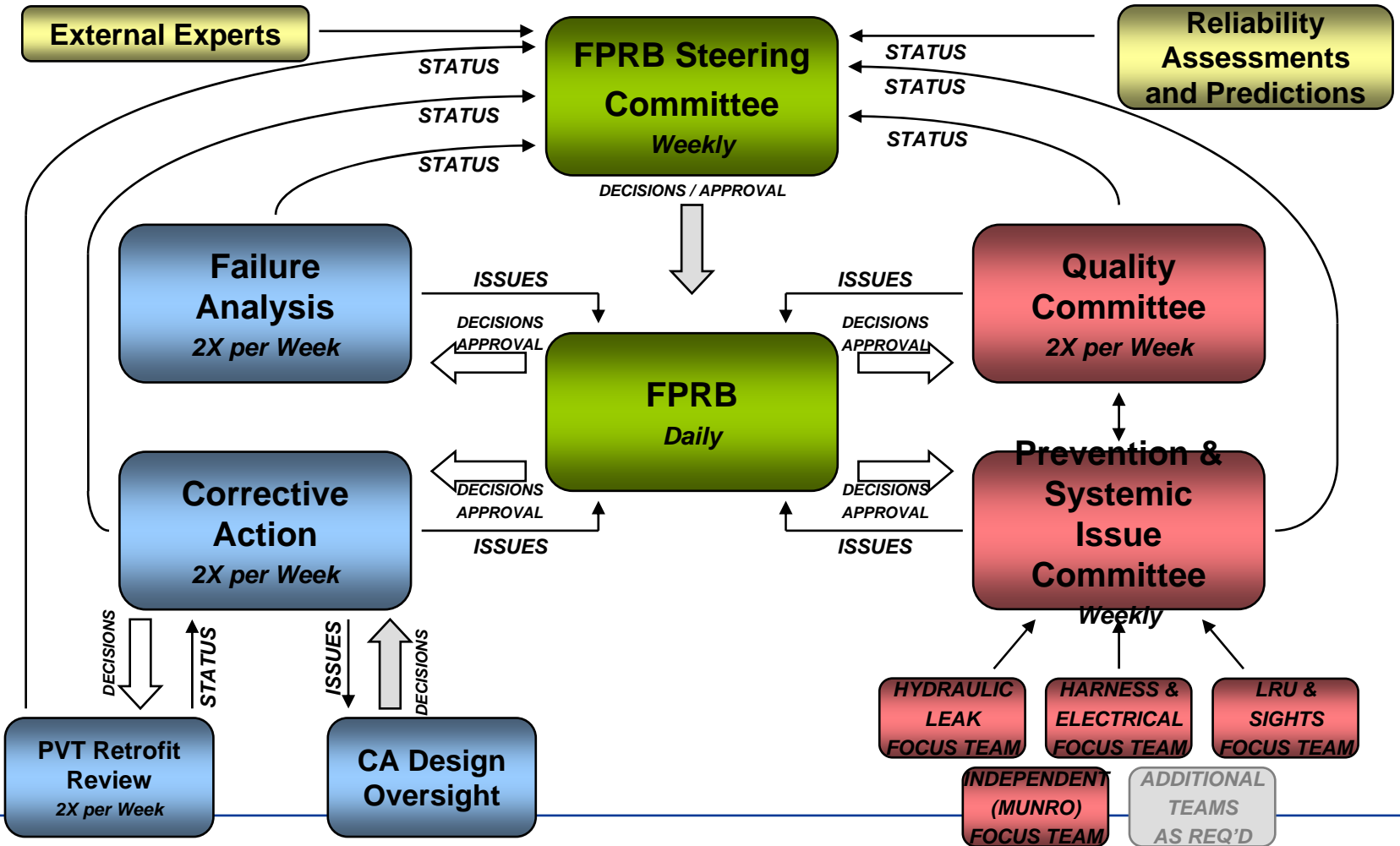

Agenda

- **What is MGS**
- **Success Factors of MGS PVT**
 - Program Management – Integrated Team
 - System Engineering and Reliability Attainment
 - Reliability Data Analysis – RGA
 - FDSC – Failure Definition Scoring Criteria
 - Failure Categories
 - Inherent vs. Induced Reliability
 - Mission Profile and Life Variable
 - Data Grouping and Modeling
 - Instantaneous vs. Cumulative Reliability
- **MGS Lesson Learned - DFR**

Reliability Data Analysis

- Proper Reliability Assessment is a key for the program success at PVT
- Reliability Assessment must be discussed up front and consensus should be reached on:
 - FDSC – Failure Definition Scoring Criteria
 - Failure Categories
 - Inherent vs. Induced Reliability
 - Mission Profile and Life Variable
 - Data Grouping and Modeling
 - Instantaneous vs. Cumulative Reliability

FDSC – Failure Definition Scoring Criteria

- FDSC is Contractual Document that defines
 - Failure/non-Failure Event
 - Test related Event
 - Severity of Failure as it relates to the Mission
 - Cause of the Failure
- FDSC is prepared as required by Army Regulation 70-1, Army Acquisition Policy.
- FDSC is being used through out the test for Scoring purposes, hence it is a major document for Reliability Assessment

Failure Categories

- Performance FM – FM is repeatable with 100% probability of failure for the given procedure/conditions. (Example: TDS overheating)
- Software FM – same as above, but software related.
- Quality FM – happens when vehicle is not built/maintained/operated as designed and is not repeatable after fixing (probability of failure =0%). Can be broken down into Initial Quality, Maintenance, Operator error, etc. (Example: Improperly installed harness, turret lock bended, etc.)
- Potential Reliability FM – happens when vehicle was built/maintained/operated as designed/intended; probability of failure is greater than 0% and less than 100%; usually happens due to wear out, environment, insufficient design, manufacturing variability, etc.

Failure Mode Categorization Process

Inherent vs. Induced Failure

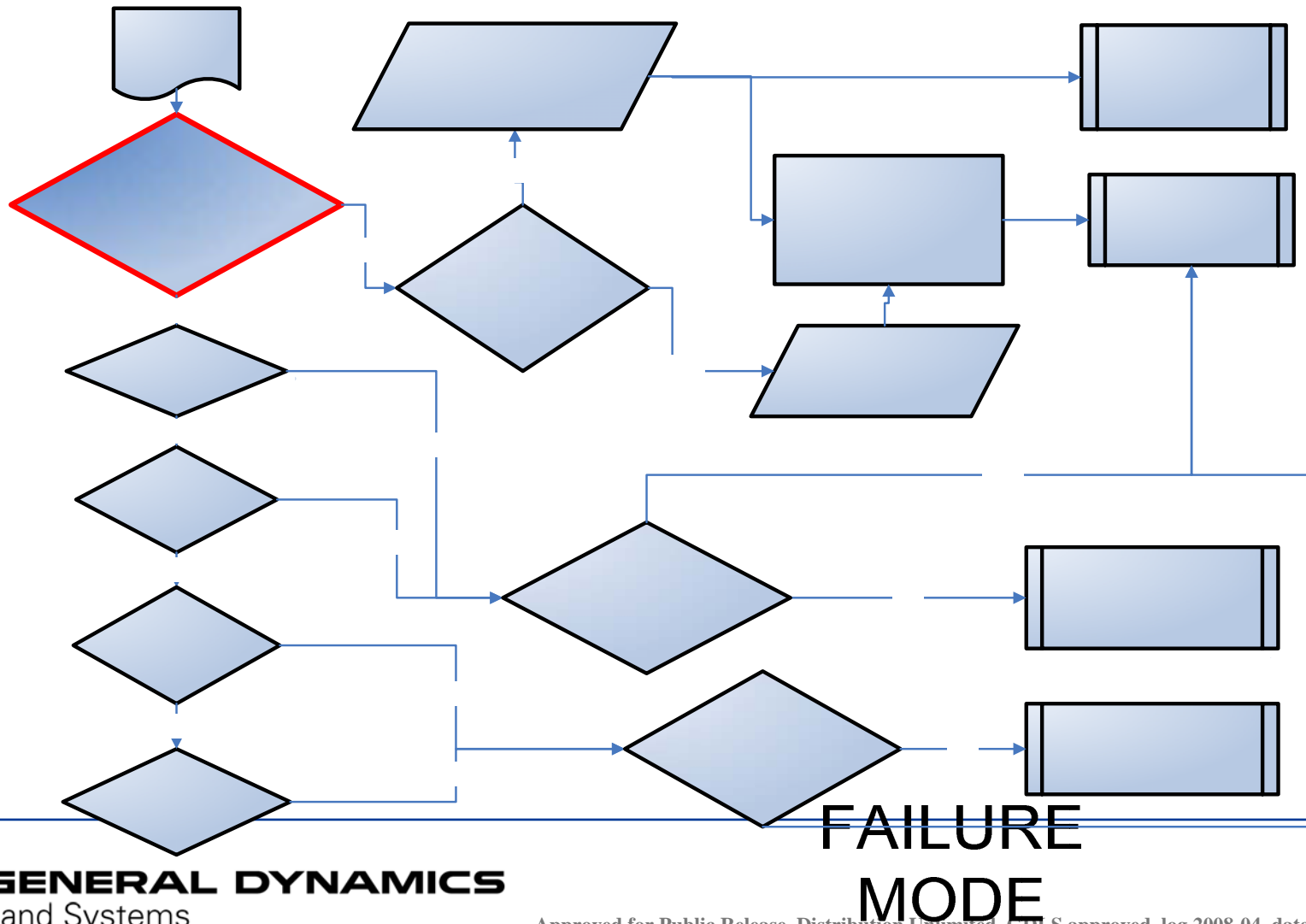

Categorize Failures and take Relevant Management Actions

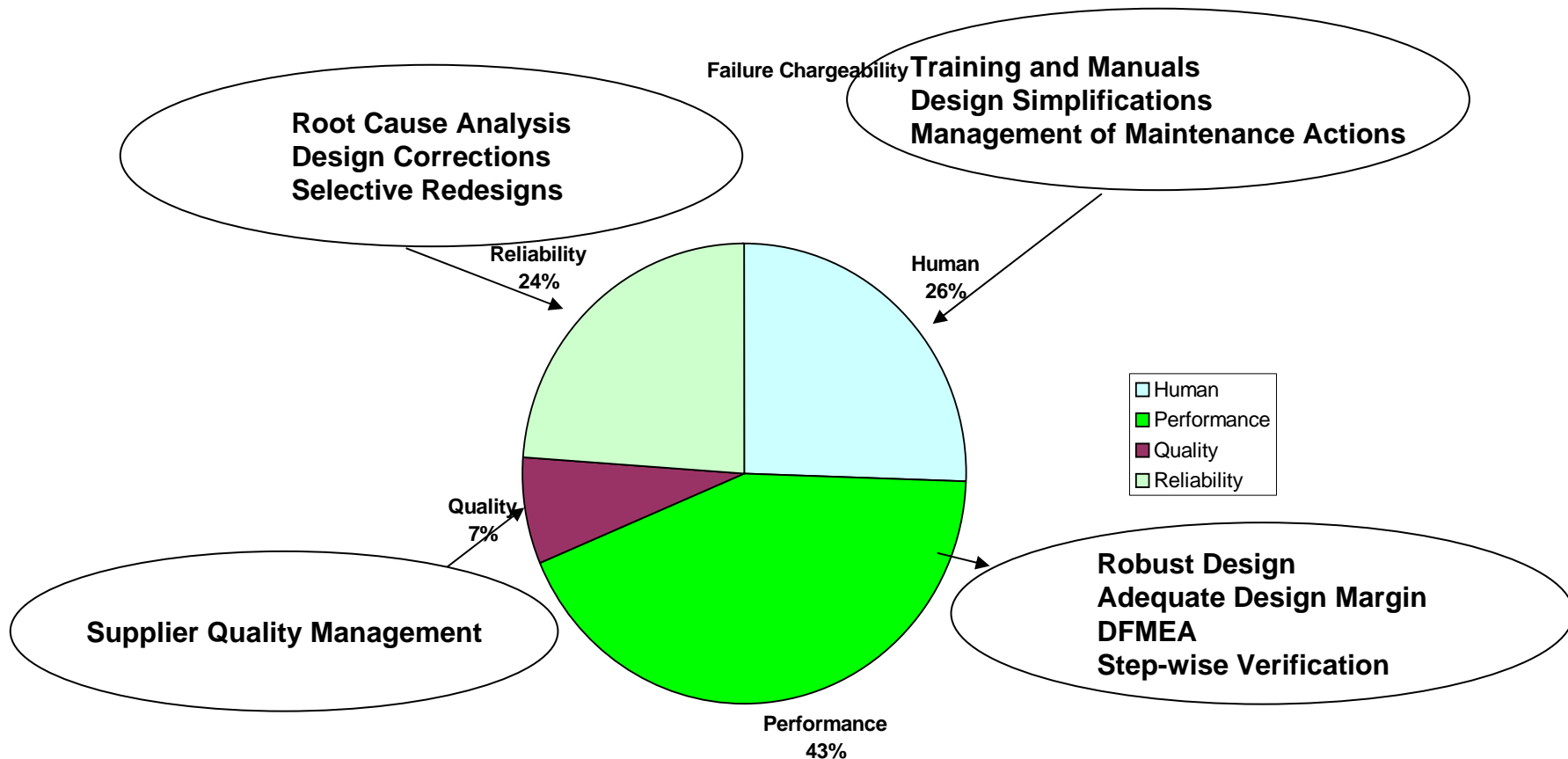

Data Grouping

Known Equivalent Time

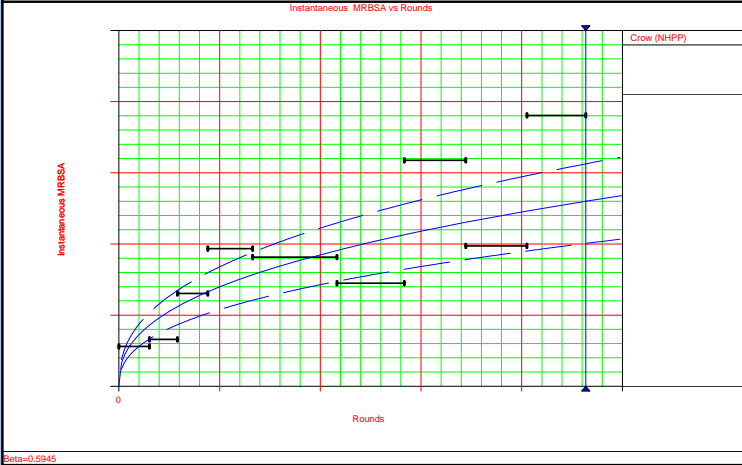
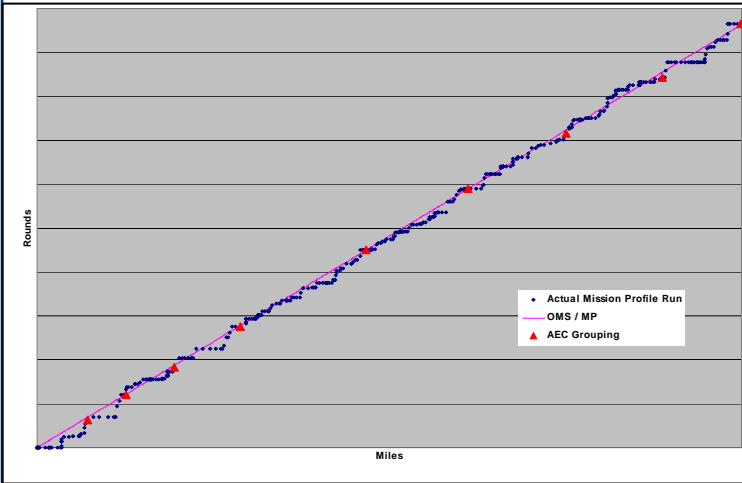

Unknown Equivalent Time

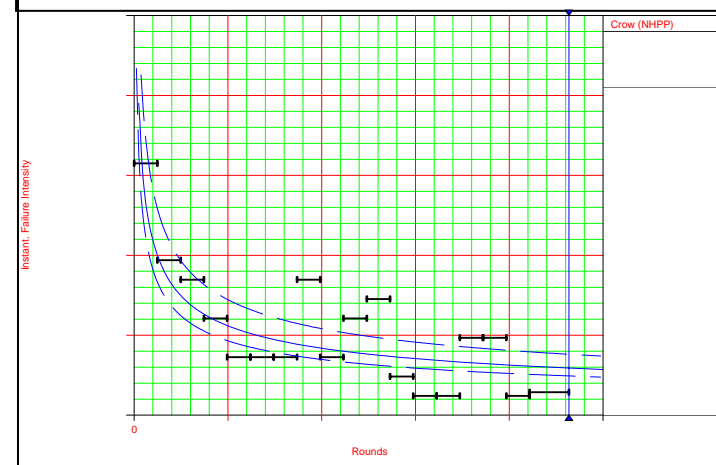
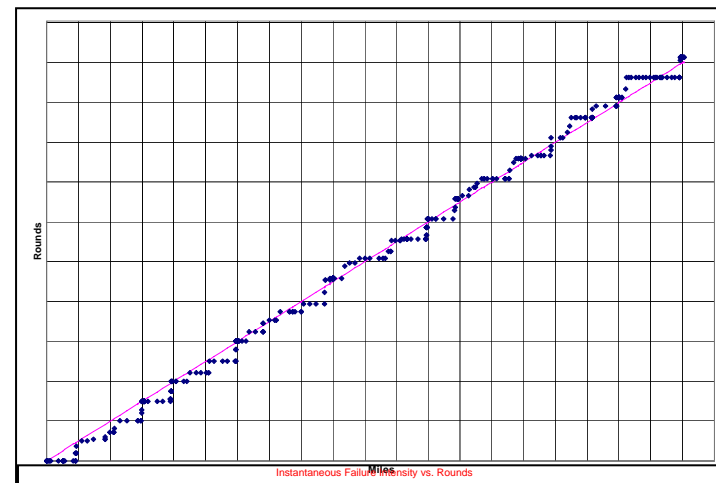

Rounds and Miles Accumulation per Vehicle vs. Calendar Time

Cum Miles vs Calendar Time

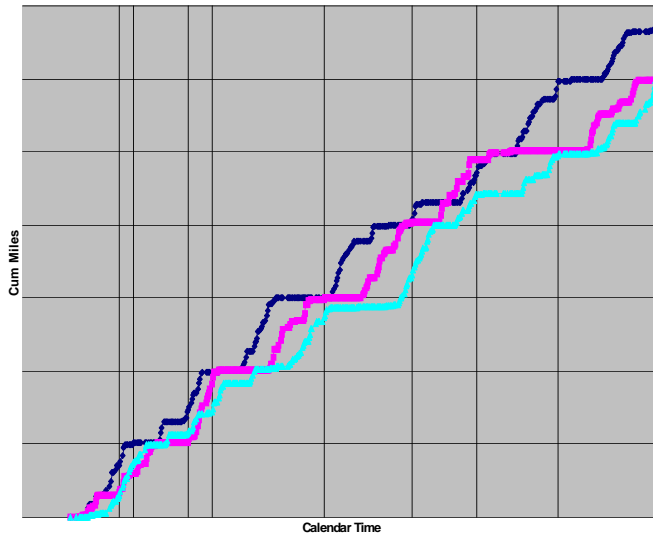

KET Model can be useful in the beginning of the test when vehicles have not accumulated enough mileage and rounds.

UET model takes into account any discrepancies between different vehicles following through the test in calendar time

Cum Rounds vs Calendar Time

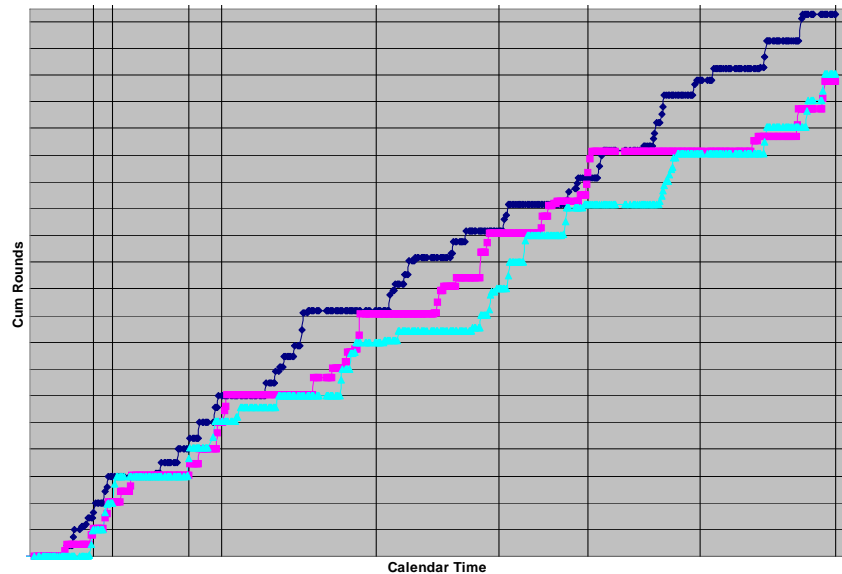

Crow/AMSAA Model

ReliaSoft's RGA 6 PRO - RGA.ReliaSoft.com

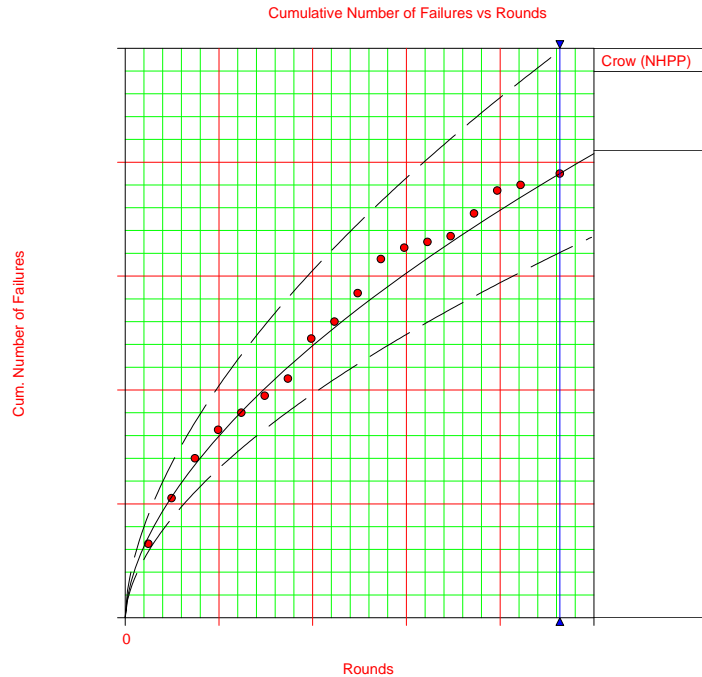

Beta=0.5827

Cum Number of Failures

$$E(N) = \lambda \cdot T^\beta$$

Cum Failure Rate

$$r_c = \frac{E(N)}{T} = \lambda \cdot T^{\beta-1}$$

Cum MTBF

$$MTBF_c = (r_c)^{-1} = (\lambda \cdot T^{\beta-1})^{-1}$$

Inst Failure Rate

$$r_i = \frac{d(E(N))}{dt} = \frac{d(\lambda \cdot t^\beta)}{dt} = \lambda \cdot \beta \cdot t^{\beta-1}$$

Inst MTBF

$$MTBF_i = (r_i)^{-1} = (\lambda \cdot \beta \cdot T^{\beta-1})^{-1}$$

Cumulative vs. Instantaneous Reliability

- Reliability growth on the Development test is the result of Corrective Actions.
- Estimating Reliability of the product by taking the Cumulative reliability (total number of failures / total time on the test) does not take into account the growth on the test.

Idealized Growth Curve and Observed Parametric Curve for Demonstrated Instantaneous MRBSA

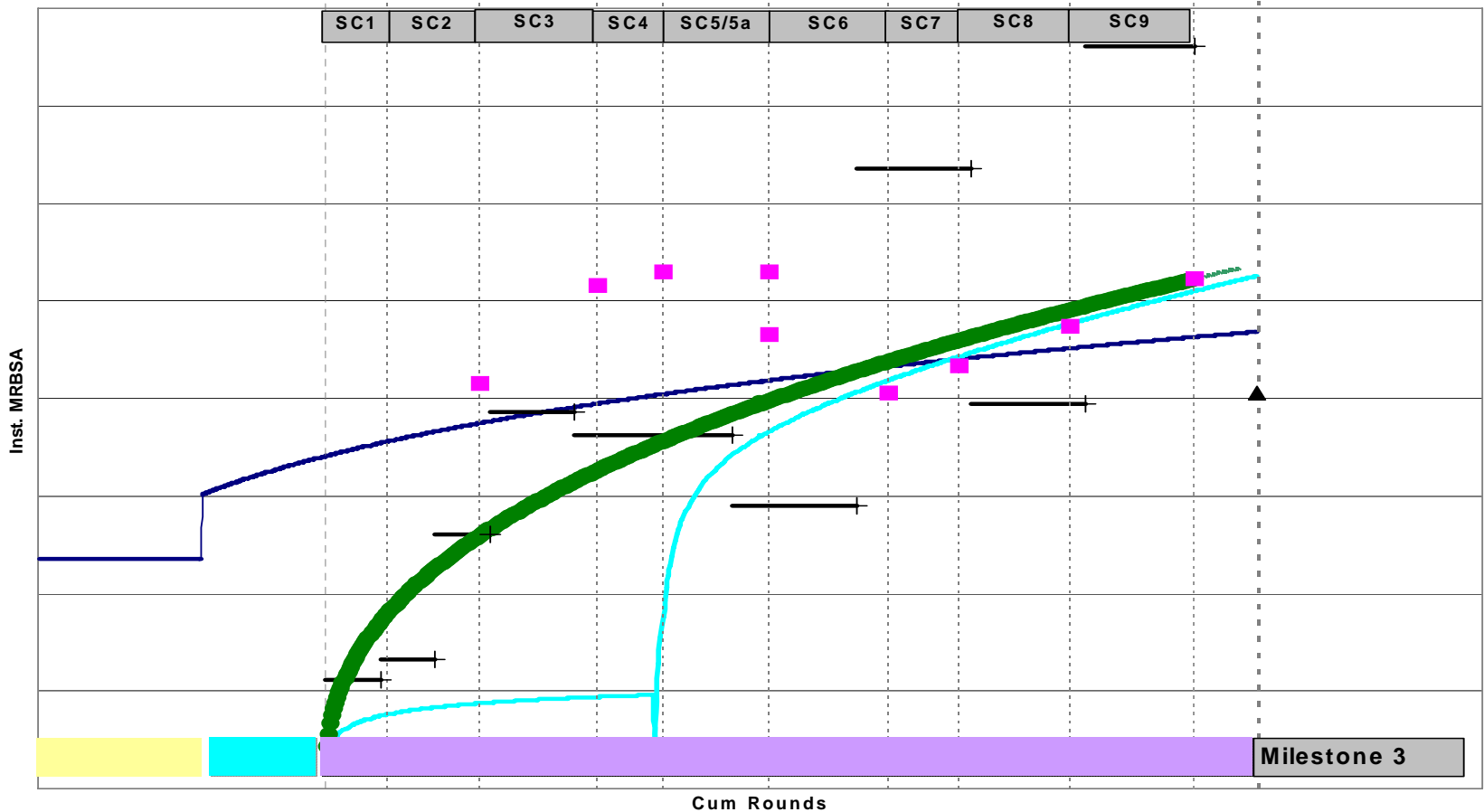

Agenda

- **What is MGS**
- **Success Factors of MGS PVT**
 - Program Management – Integrated Team
 - System Engineering and Reliability Attainment
 - Reliability Data Analysis – RGA
 - FDSC – Failure Definition Scoring Criteria
 - Failure Categories
 - Inherent vs. Induced Reliability
 - Mission Profile and Life Variable
 - Data Grouping and Modeling
 - Instantaneous vs. Cumulative Reliability
- **MGS Lesson Learned - DFR**

DFR Process Elements

- **Boundary Diagram / System Block Diagram**
- Interface matrix
- **P-Diagram**
- **DFMEA**
- Reliability & Robustness Metrics
- **DVP&R**
- **Reliability Demonstration Metrics**

DFSS (DCOV) Flow of Analysis & Tools

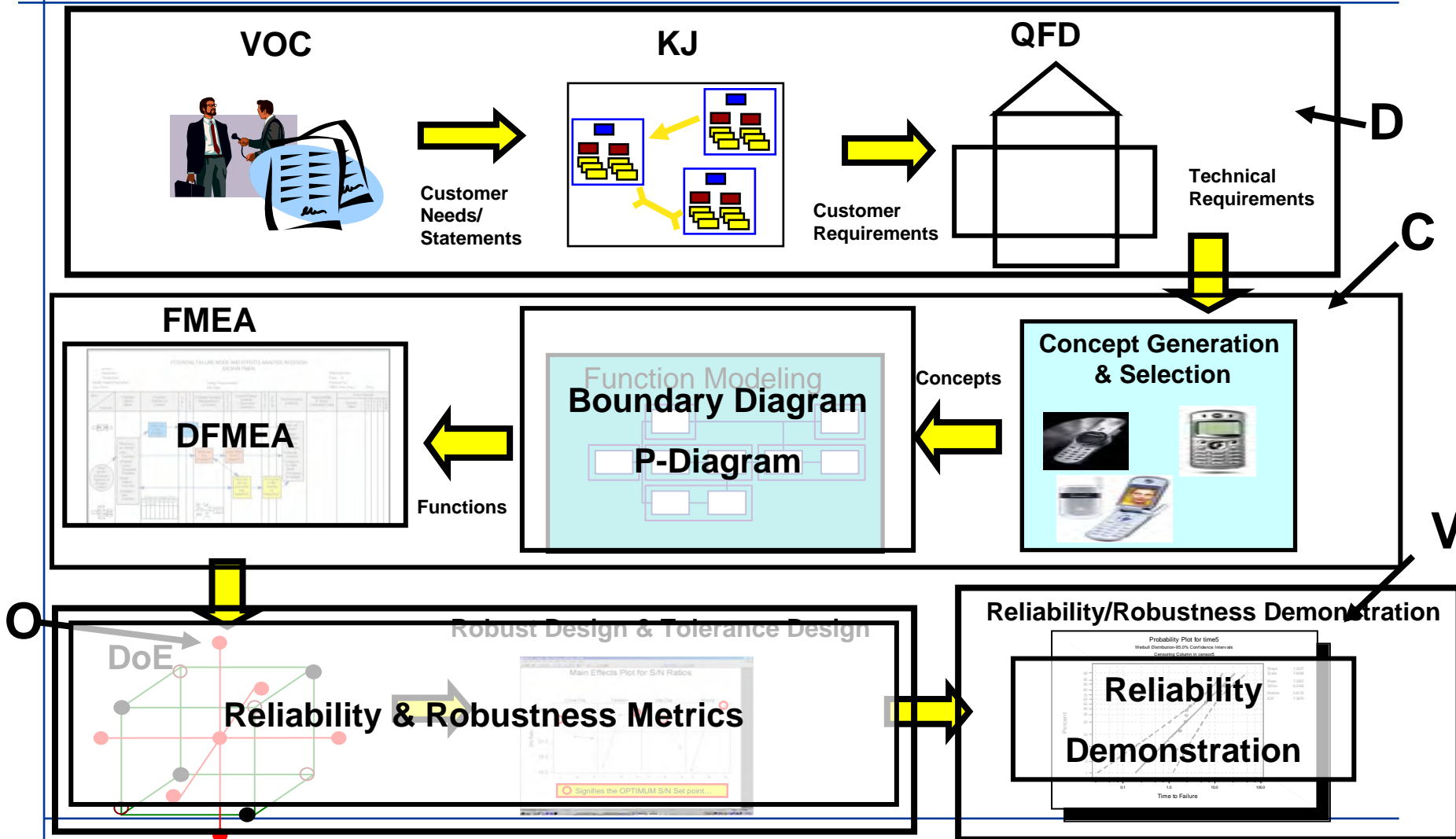

Design For Reliability Map

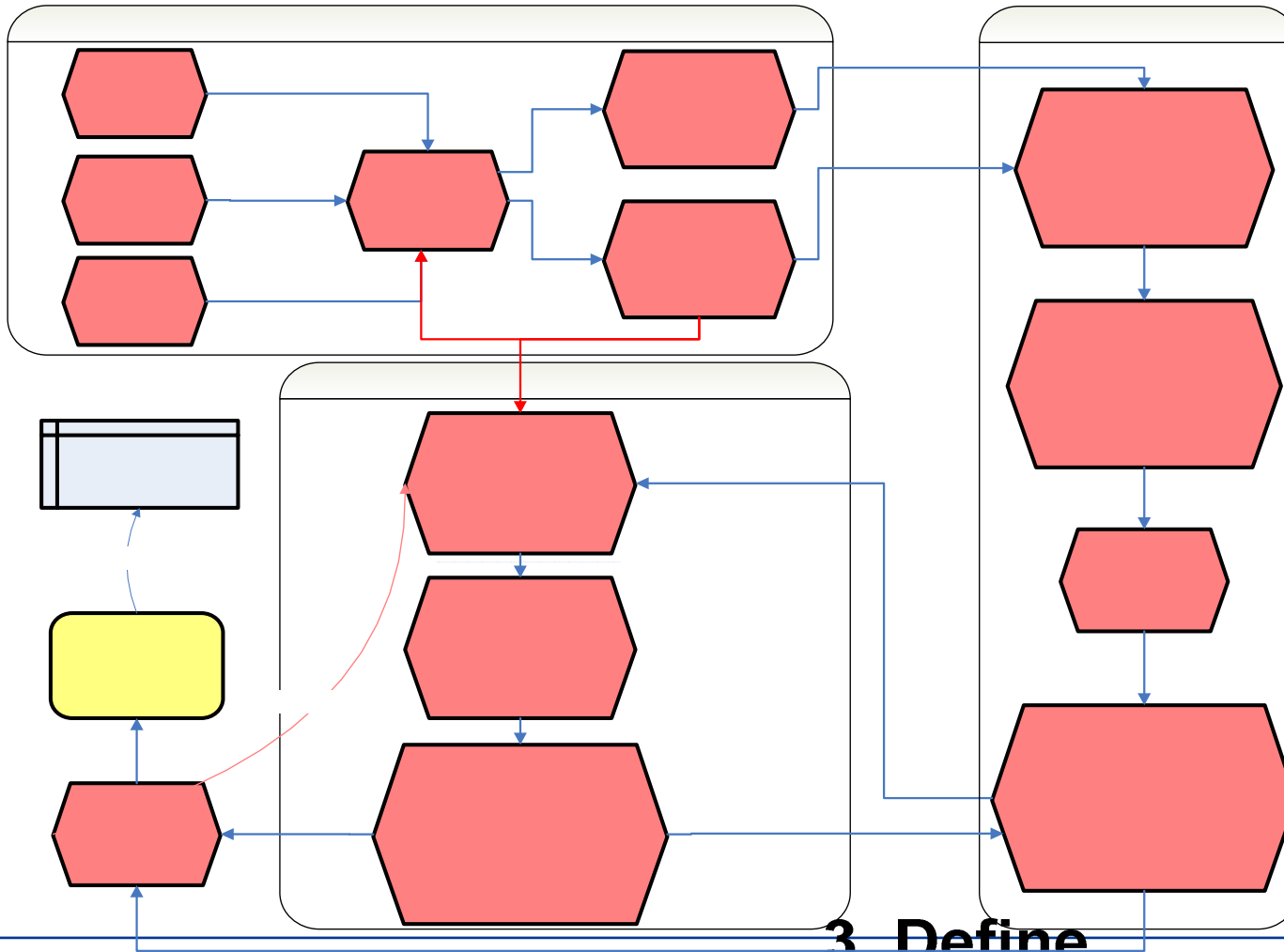

**3. Define
Control
Factors**

MIL-HDBK-189 RGA Method

MGS MEP PVT Instantaneous MRBSA

- Demonstrated Instantaneous MRBSA for decision-makers
- Growth Rate is 0.4
- RGA Methodology was developed and agreed by RAM-T Community

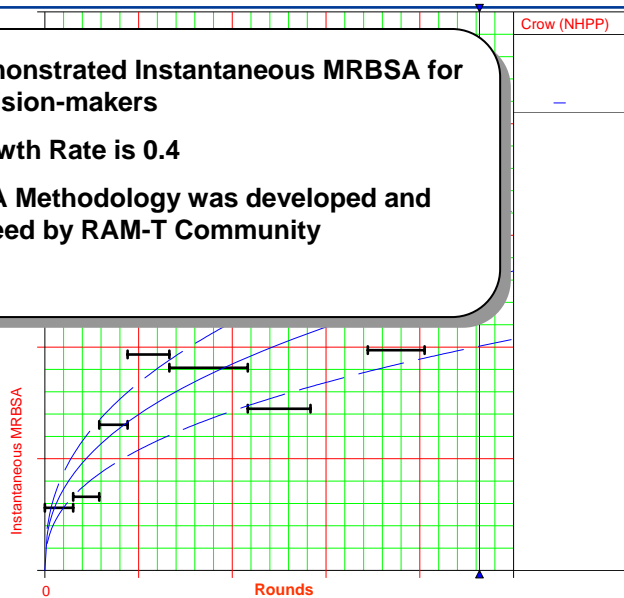

- Failure Rate continues to decrease, thus demonstrating substantial reliability growth in PVT
- Sustained decrease of MGS Failure Rate suggests infant mortality region is passed and design is maturing

ReliaSoft's RGA 6 PRO - RGA.ReliaSoft.com

Instantaneous Failure Intensity vs. Rounds

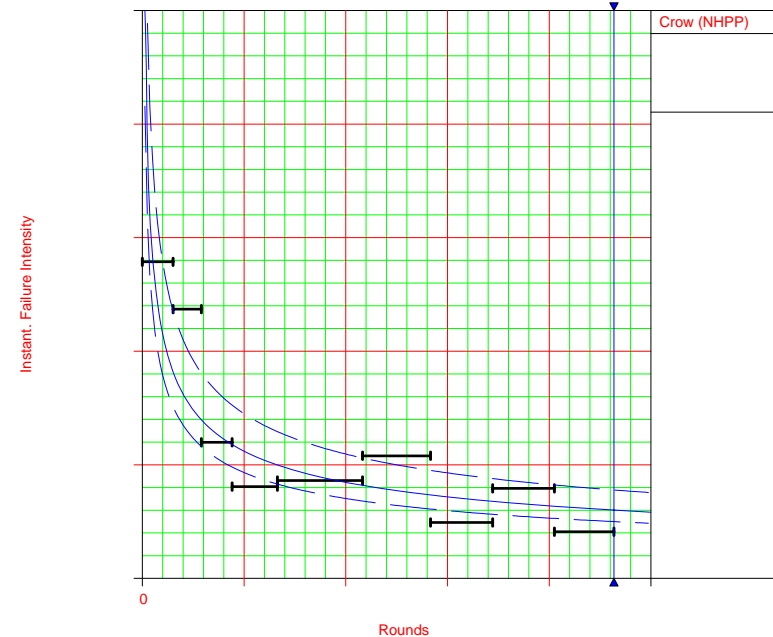

Beta=0.5945

Continuing the effort to ensure MGS reliability growth

- Systems Engineering Process continues to be worked “24/7”
- GDLS Senior Leadership briefed on a daily basis
- Focus on implementation of Corrective actions on both the Test Vehicles and the Fielded vehicles
- GDLS teams at our vendors to work failure analysis and ensure MGS gets their top priority
- Outside experts on reliability and quality regularly review our processes in engineering and Manufacturing so we keep getting better

Keys to Success

- Program Management forms Integrated Team (Material Developers, Tester/Evaluators, User) that has clear priority and focus on Reliability with clear understanding of Evaluation Criteria and Test Methods up front.
- System Engineering assembles Reliability tools into Disciplined processes and Working Organizations
- Reliability Assessment is reached through in-depth analysis and consensus between all involved parties

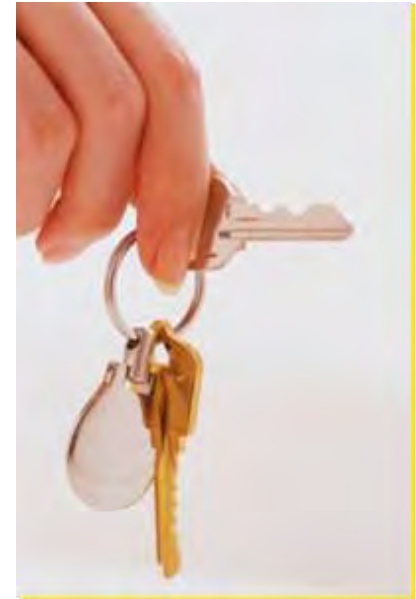

Program Management + System Engineering + Reliability = Success

Questions and Discussion



GENERAL DYNAMICS

- Dmitry Tananko, Ph.D.
 - ↗ General Dynamics Land Systems
 - ↗ Tel.: (586) 634-5071
 - ↗ E-mail: tanankod@gdls.com



NDIA 11th Annual
Systems Engineering
Conference

22 Oct 2008

Establishing a Systems Engineering Center of Excellence within PEO GCS

Mike Phillips

*PM MBE Systems Engineer
Jacobs*

Distribution approved for Public Release; distribution Unlimited, per AR 380-5.
OPSEC Review conducted per AR 530-1 and HQ TACOM OPSEC SOP.



TACOM LCMC

TACOM Life Cycle Management Command

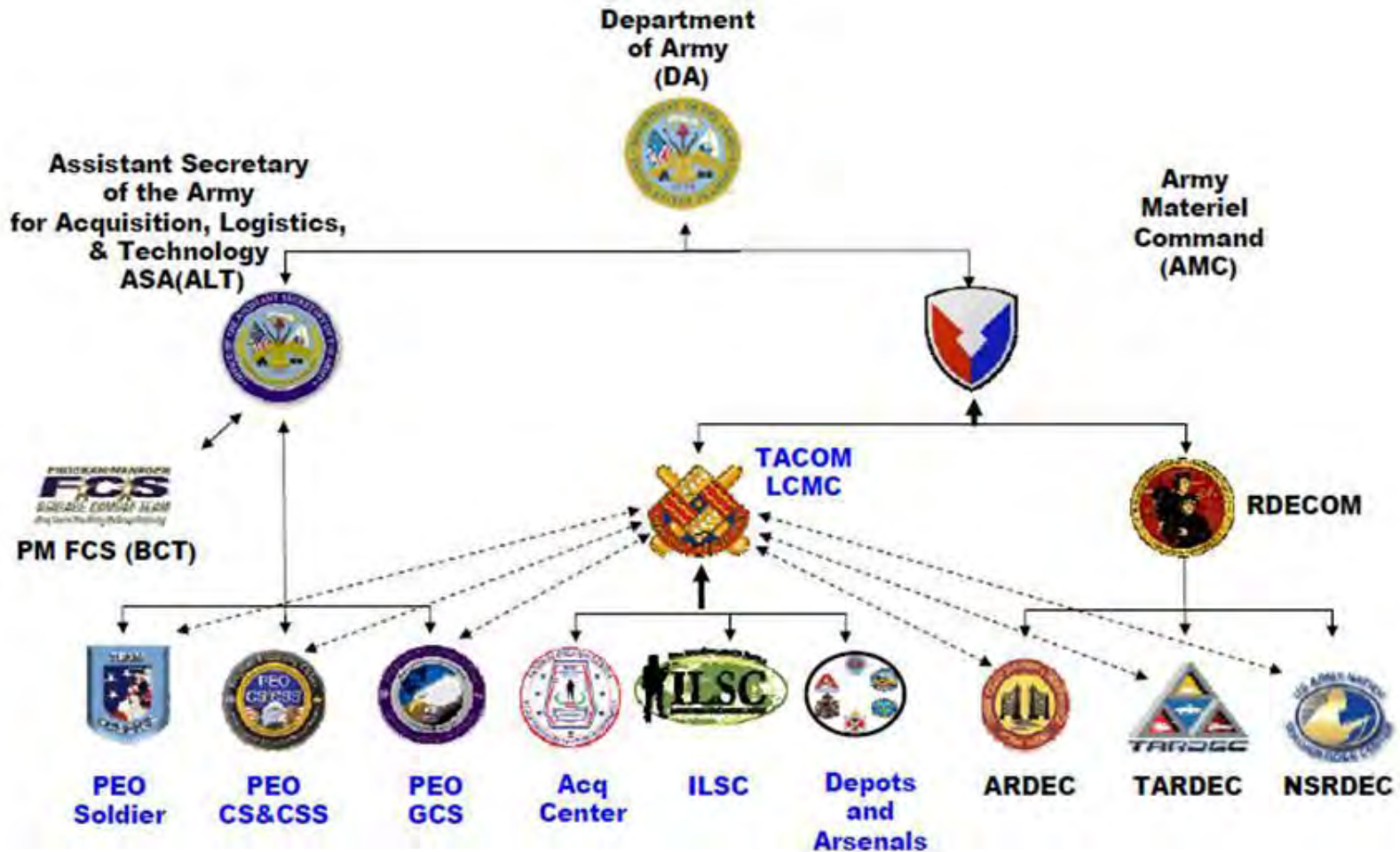

The TACOM LCMC unites all of the organizations that focus on Soldier and Ground Systems. The PEOs and PMs are able to work as an integral part of the Logistics and Technology efforts of the LCMC, while enterprise level partnerships are maintained with the Research, Development, and Engineering Centers (RDECs).

TACOM LCMC Playbook

TACOM LCMC Vision

Providing our warfighters with overwhelming lethality, survivability, mobility, and sustainment for battlefield dominance, now and in the future.



TACOM LCMC Mission

Develop, acquire, field, and sustain soldier and ground systems for the warfighter through the integration of effective and timely acquisition, logistics, and cutting-edge technology.

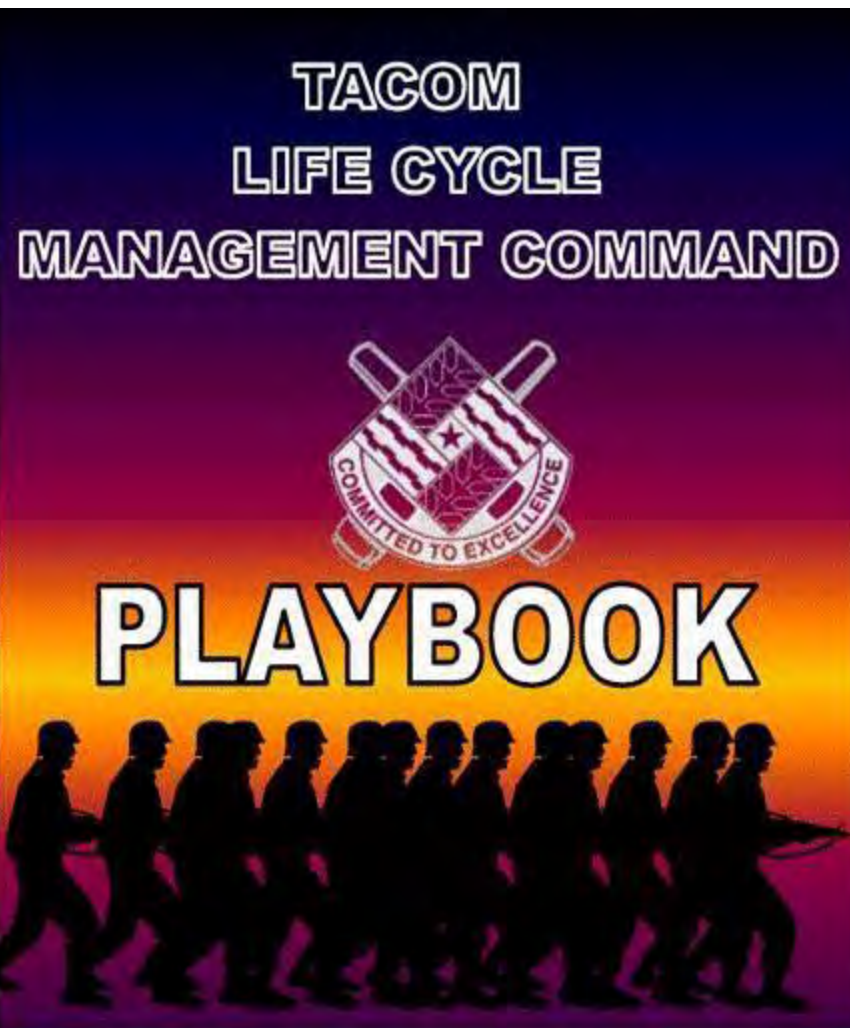



PEO GCS

Program Executive Office Ground Combat Systems



Mr. Kevin Fahey



Heavy Brigade
Combat Team

COL P. Lepine



Stryker Brigade
Combat Team

COL R. Schumitz



Joint Robotics Systems
(Army & Marine)

Col J. Braden (USMC)



Mine Resistant
Ambush Protection

COL K. Peterson



Joint LWH 155mm
(Army & Marine)

Mr. J. Shields



Modular Brigade
Enhancements

COL J. Wendel

Vision

Exceed Warfighter expectations as the Army's Lifecycle Manager and systems integrator for current and future Ground Combat Systems.

Mission

Manage the development, systems integration, acquisition, testing, fielding, sustainment and Improvement of ground combat systems in accordance with the Army's initiatives to provide mission-capable systems to the Warfighter while meeting cost, schedule and Performance goals.

Supporting the Army Vision Requires Synchronized Modernization **WHY?**

WHAT WORKED BEFORE...



- GCS Platform infrastructure has remained relatively constant since the last development/improvement program
- Requirements are evolving and expanding which requires integration of new capabilities
 - New/Updated CDDs/CPDs under development
 - Integrating new capability to already strained power, space, and weight claims
- Integrating more in current vehicle configuration impacts crew and vehicle capability



...DOESN'T NECESSARILY WORK NOW!

We are at the degradation point



SECOE

Systems Engineering Center of Excellence

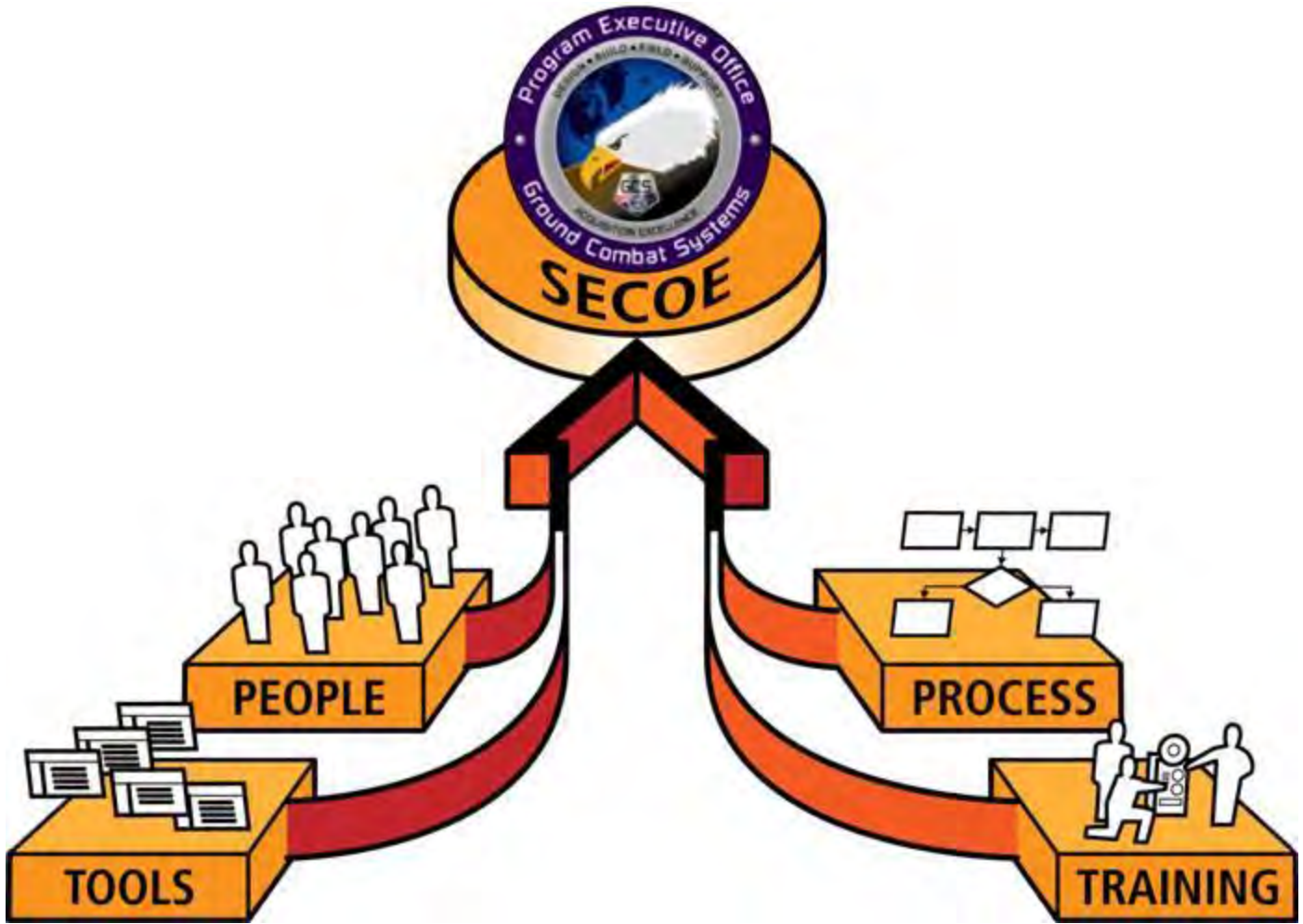



SECOE Description

Systems **E**ngineering **C**enter **O**f **E**xcellence is an operational organization infused with common SE processes and tools to optimize execution of acquisition programs

DEVELOPMENT TENETS:

- Comprehensive system-of-systems integration methodologies
- Support senior management fact-based decision making
- End-to-end processes that are tailorable, scalable, & portable
- Focus on PEO-wide problem sets
- Maximize common tools and processes

Systems Engineering

A branch of engineering whose responsibility is creating and executing an interdisciplinary process to ensure that customer and stakeholder's needs are satisfied in a high quality, trustworthy, cost efficient and schedule compliant manner throughout a system's entire life cycle, from development to operation to disposal.

- International Council on Systems Engineering (INCOSE)



SE Capability Growth

The transition plan brings a PEO from its initial SE capability to a mature capability

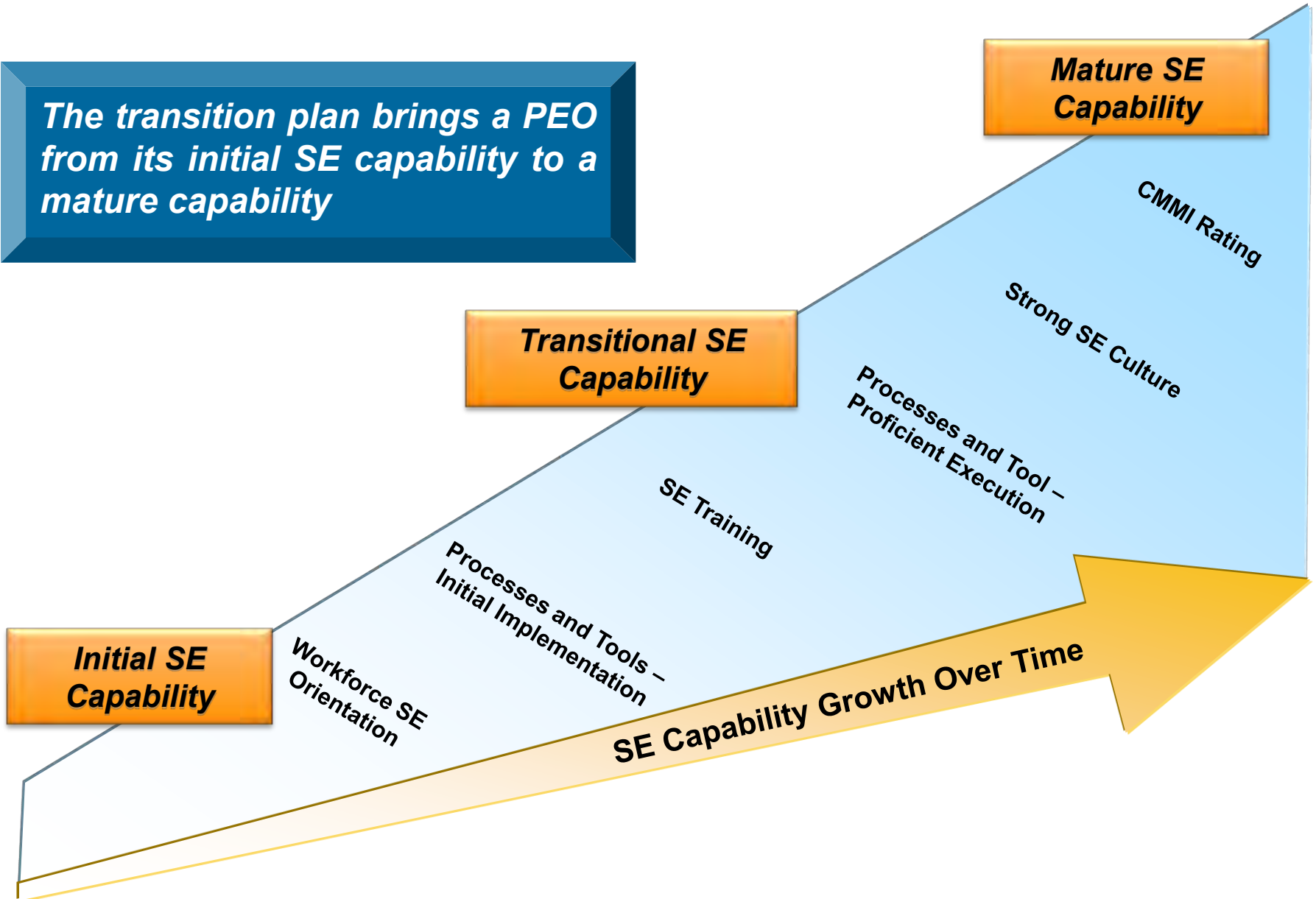

SECOE COMPONENTS

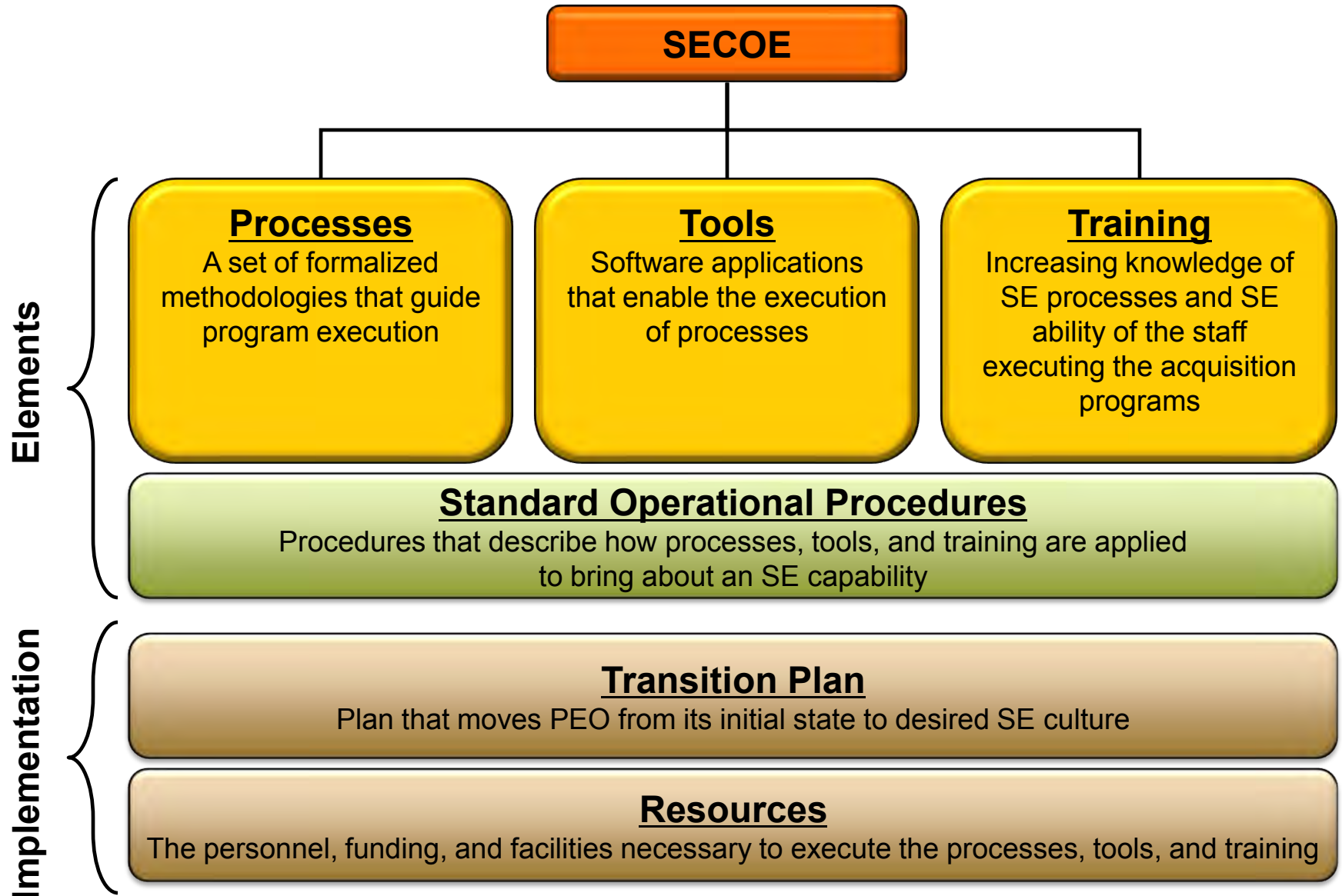



Growing Core Capabilities

Current Efforts

Near Term Plans

PROCESSES

- IMP/IMS Development
- IMS Maintenance
- Capability Alignment
- SEP Development
- Risk Management

TOOLS

- Tools Plan
- Risk Management Tool
- Requirements Mgmt
- Integrated Scheduling

TRAINING

- Training Plan
- SE Curriculum

STANDARD OPERATIONAL PROCEDURES

- Systems Engineering Integration Team Review and Approval SOP
- Risk Management Process/Tool Application SOP
- PEO IMP/IMS SOP

- Technical Reviews
- Requirements Mgmt
- Unit Set Fielding
- Tech Readiness Assmnt
- Mfg Readiness Assmnt

- Fielding Management
- Automated IMP Template
- Configuration Mgmt
- Data Management
- Modeling and Simulation
- Architecture Tools
- Reliability Tools

- Workforce SE Orientation
- Pilot Training Program
- Professional Affiliations
- SE Training Coordinator
- Academic Partnerships
- SE Library



Integrated Scheduling

Aligning Across Platforms

Individual Schedules

Differing formats
Differing detail
Differing software

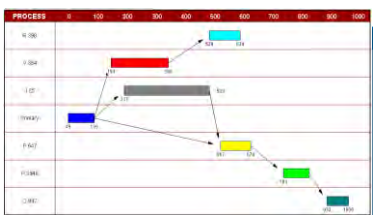
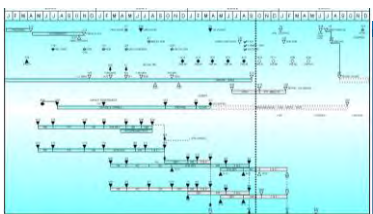
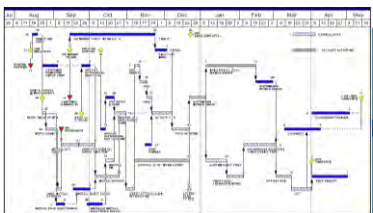

Scheduling Tools

Built using off-the-shelf software SOPs being developed

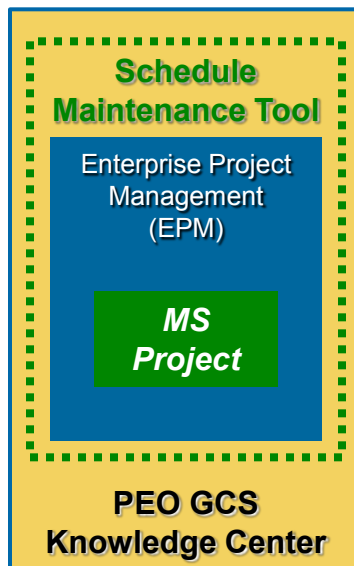

HBCT
SBCT
MRAP
JLWH
RS JPO

PEO GCS

Integrated Master Schedule

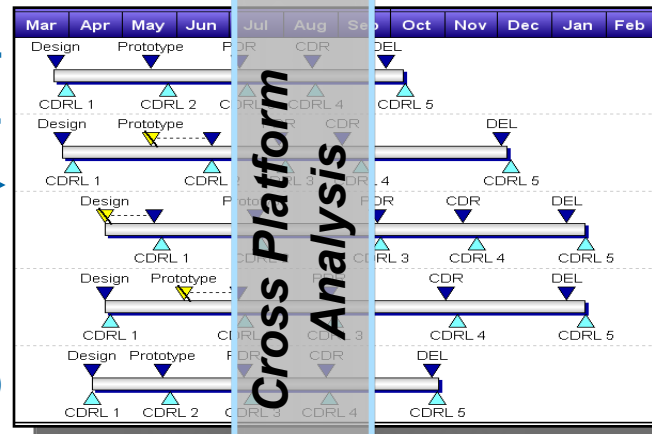

Cross Platform Analysis

Scheduling Opportunities

- PEO and PMs gaining better insight across programs
- Focusing on sustainment & modernization
- Managing Schedule Risk
- Identifying Commonality Opportunities
- Supporting "What If Drills"
- Synchronizing/Standardizing schedules across PEO



Risk Management

PEO GCS Risk Management Process

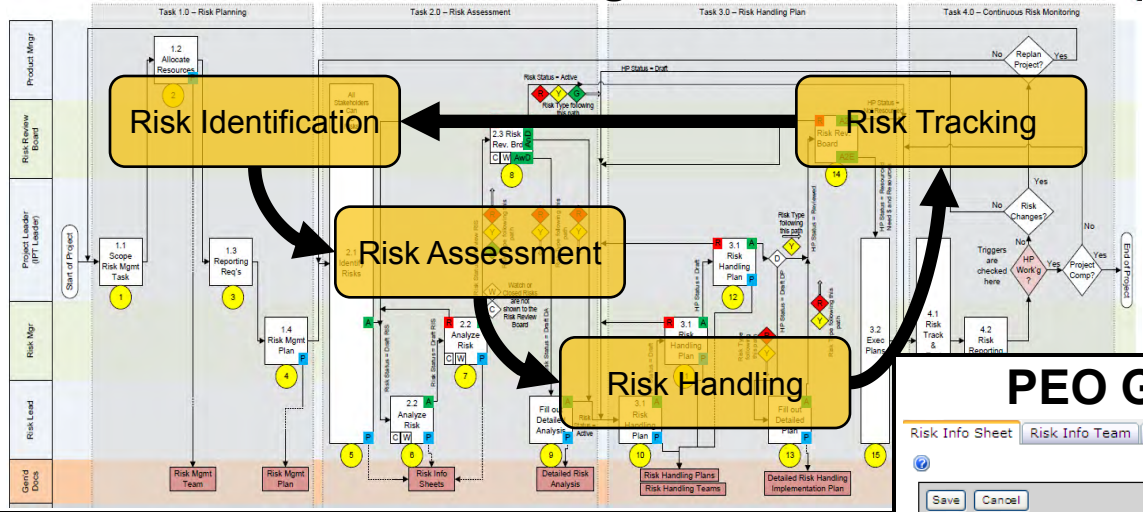

Improving Risk Management

- Proactively Managing Risk
- PEO and PMs using a common understanding of program risk
- Supporting "What If Drills"

PEO GCS Risk Management Tool

Risk Info Sheet | Risk Info Team | Detailed Risk Analysis | Handling Plan(s) | Related Projects

Save Cancel

Risk ID:

Risk Title: RISK-2008-Engineering - Widget Form Factor Exceeds Available Spaceclaim *

Status: Baselined

Open Date: 8/17/2008 *

Last Reviewed On Date: 10/3/2008

WBS #: N/A

IMP #: CDR-003-002

Risk Lead: Phillips, Mike H *

* required field

Risk Assessment

Likelihood	5	4	3	2	1
Consequence	1	2	3	4	5

- PEO GCS risk management tool is being used to automate the risk management process
- Integrated in the PEO GCS Knowledge Center
- The process is based on and aligns with DOD risk guidance
- The tool is portable and tailorable to other PEOs



SE Analyses Processes & Tools

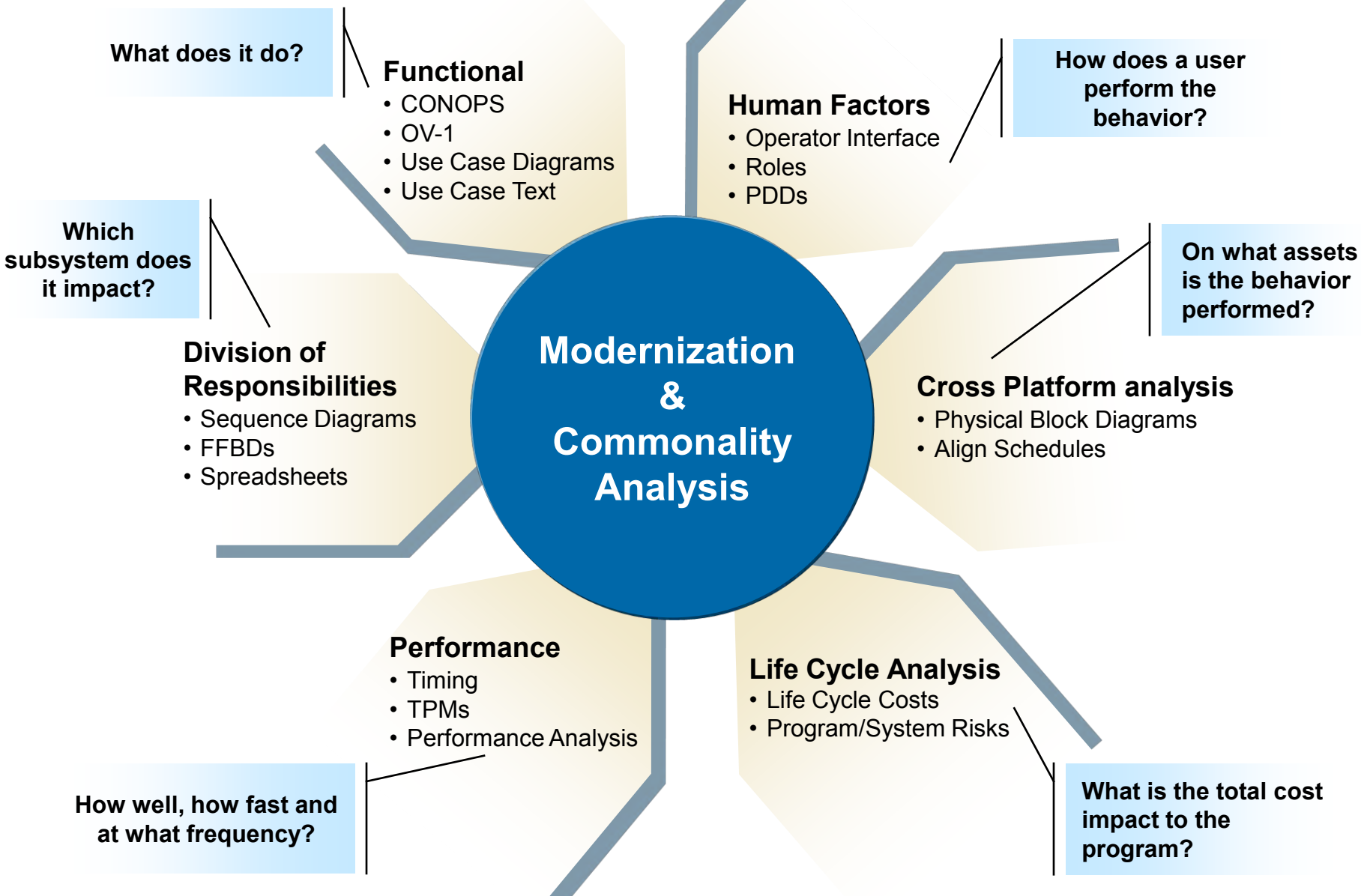

Systems Engineering-Based Analysis Processes Being Improved

Two-Level Platform Analysis

System Wide Analysis of Potential Components



Component

Performance/
Capability

Needed
Power
Space Claim
Thermal

Vehicle

Performance
Needs

Available
Power
Space Claim
Thermal Limits







Needed Vehicle
Infrastructure
Improvements



Component
Mods to support
vehicle needs

Coordinated
Vehicle
Modernization
Plans
&
Component
Development
Plans

Commonality Analysis

					
Move	X			X	X
Shoot	X	X			
Comm	X	X	X		X
Survive	X				X

Commonality Optimization



SE Training

World-Class
SE
Organization

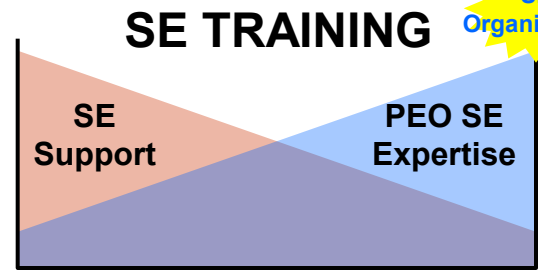

*Evolving the
Workforce Over Time*

- SECOE Training Objectives:
 - Train a SE qualified workforce
 - Trained to understand systems engineering
 - Trained to manage systems engineering
 - Increase visibility into available SE training and certifications
 - Establish single training tracking tool for SE training & certifications
 - Working with DAU to customize & implement PEO GCS training
 - Available to PEO CS/CSS, TARDEC, and TACOM
 - Focusing on growing number of Level III certified SPRDE, Program Systems Engineers
 - Working with professional organizations, academia
 - Aligning and educating workforce on available SE certifications and degree programs for those interested
 - Utilize existing TACOM training databases (e.g., TEDS) to implement

- Near Term Timeline:
 - Sep 08: Draft Training Plan
 - Sep 08: Draft Training Curriculum
 - Nov 08: SE Workforce Briefing Complete
 - Nov 08: Pilot Training Delivery
 - Dec 08: SE Library Initiated
 - Jan 09: Professional Development Opportunities Identified
 - Feb 09: SE Training Process Approved

PEO GCS System Engineering Curriculum 2008				SE ROLES																				
Category	Course	Course #	Hrs	Type	New Engineer	Chief Systems Engineer	Technical Decider	Program/Chief Systems Eng	Level Systems Engineer	Systems Engineer	System Process Engineer	System Cert Analyst	Program Controller	System Architecture	Modeling & Simulation	Hardware Support & Flight	Integration & Test & Eval/Arch	Test & Eval/Arch	Technical Reviews	System Eng Planning (SEP)	Reliability	Human Factors	SE Task	
Process	Cost Analysis	CLE 007	4	online																				
	Intro to Earned Value	CLE 016	1	online																				
	Performance Measurement Baseline	CLE 017	1	online																				
	Earned Value & Financial Reports	CLE 018	1	online																				
	Technical Reviews	CLE 003	3	online																				
	System Safety in SE	CLE 009	4	online																				
	Modeling & Simulation for SE	CLE 011	3	online																				
	Modular Open Sys Approach to Acquisition	CLE 013	4	online																				
	Technical Planning	CLE 017	3	online																				
	Technology Readiness Assessment	CLE 021	3	online																				
	Modeling & Simulation for Test & Evaluation	CLE 023	3	online																				
	Trade Studies	CLE 028	4	online																				
	Engineering Change Proposals for Engineers	CLE 035	5	online																				
	Readiness & Maintainability	CLE 301	4	online																				
	Scheduling	CLM 012	8	online																				
	Work Breakdown Structure	CLM 015	6	online																				
	Unit Signs & Leadership	CLM 014	8	online																				
	Risk Management	CLM 017	6	online																				
	Improved Statement of Work - Rights Mgmt	CLM 051	4	online																				
	PEO GCS SE Overview	PEO-GCS-SE		instruct																				
	Cost As an Independent Variable	C-APP001	8	Instruct																				
	Logistics Support Training	LS-5100	24	Instruct																				
	Reliability Engineering Overview	REL-101	3	Instruct																				
	Production Reliability Engineering	REL-102	6	Instruct																				
	Design Development Reliability Engineering	REL-103	18	Instruct																				
	Decision Analysis and Resolution	MC-SEP0001	1	Instruct																				
	Design to Cost	DTX-100	6	Instruct																				
	Design Load Requirements	DL-1000	8	Instruct																				
	Processes of System Engineering	SEP-100	40	Instruct																				
	Applied Statistics	STAT-150	24	Instruct																				
	Tasking of Equipments	STAT-210	24	Instruct																				
	Earned Value Management (EVMS) 100	F-EVM100WB	8	online																				
	EVMS - Program Execution	F-EVM200WB	6	online																				
	SEP-100																							

Approval Process

Process Flow

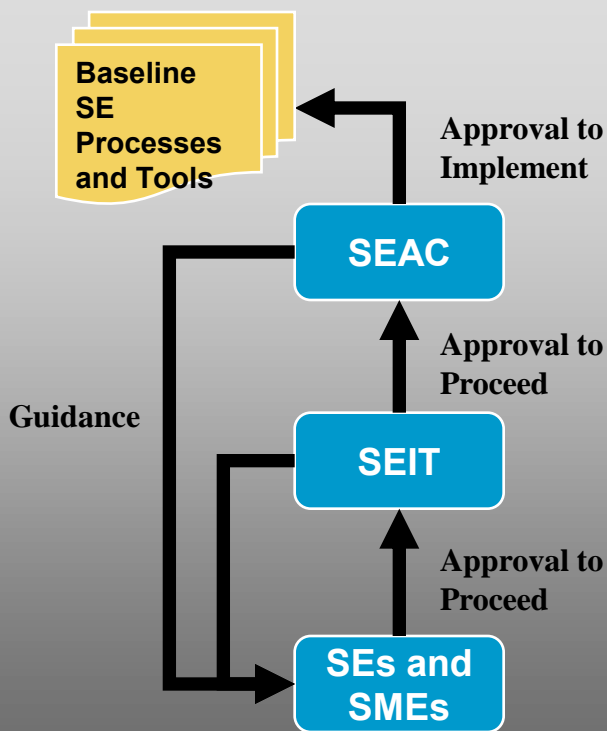

Process Steps

Phase 1: Need and Concept	Phase 2: Draft Development	Phase 3: Final Development	Phase 4: Implementation
1.1 Identify SE Product Need	2.1 Form IPT to Develop Product	3.1 Develop Final Product	4.1 Add Product to the PEO GCS Baseline
1.2 Define Scope and High-level Solution Concept	2.2 Develop Draft Product	3.2 Develop Associated Training	4.2 Deliver Training to the User
1.3 Present Draft SE Project Directive to SEIT for Approval	2.3 Present Draft Product to SEIT for Guidance	3.3 Present Final Product to SEIT for Approval	4.3 User Execution
1.4 Present Draft SE Project Directive to SEAC for Approval		3.4 Present Final Product to SEAC for Approval	4.4 Maintain and Continuously Improve Product
		3.5 Present Final Product to PEO GCS for Approval	

Systems Engineering & Integration (SEIT) Membership: *PEO Lead SE (chair), PM Lead SEs, CIO*

Systems Engineering Advisory Council (SEAC) Membership: *PEO Lead SE (chair), PMs, CIO*

SECOE Steady State

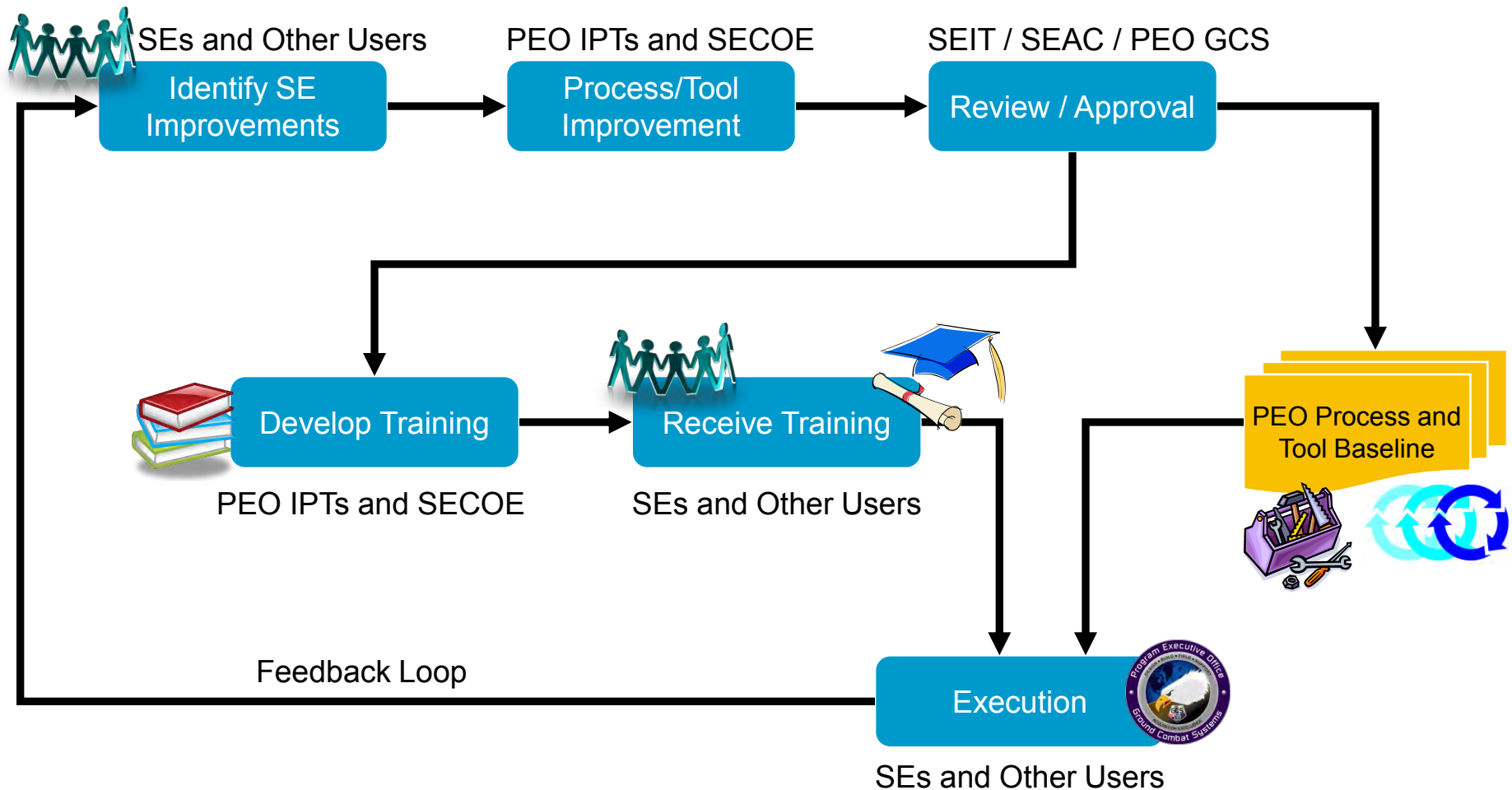

A Lifecycle of Continuous Improvement



SECOE Stakeholder Benefits

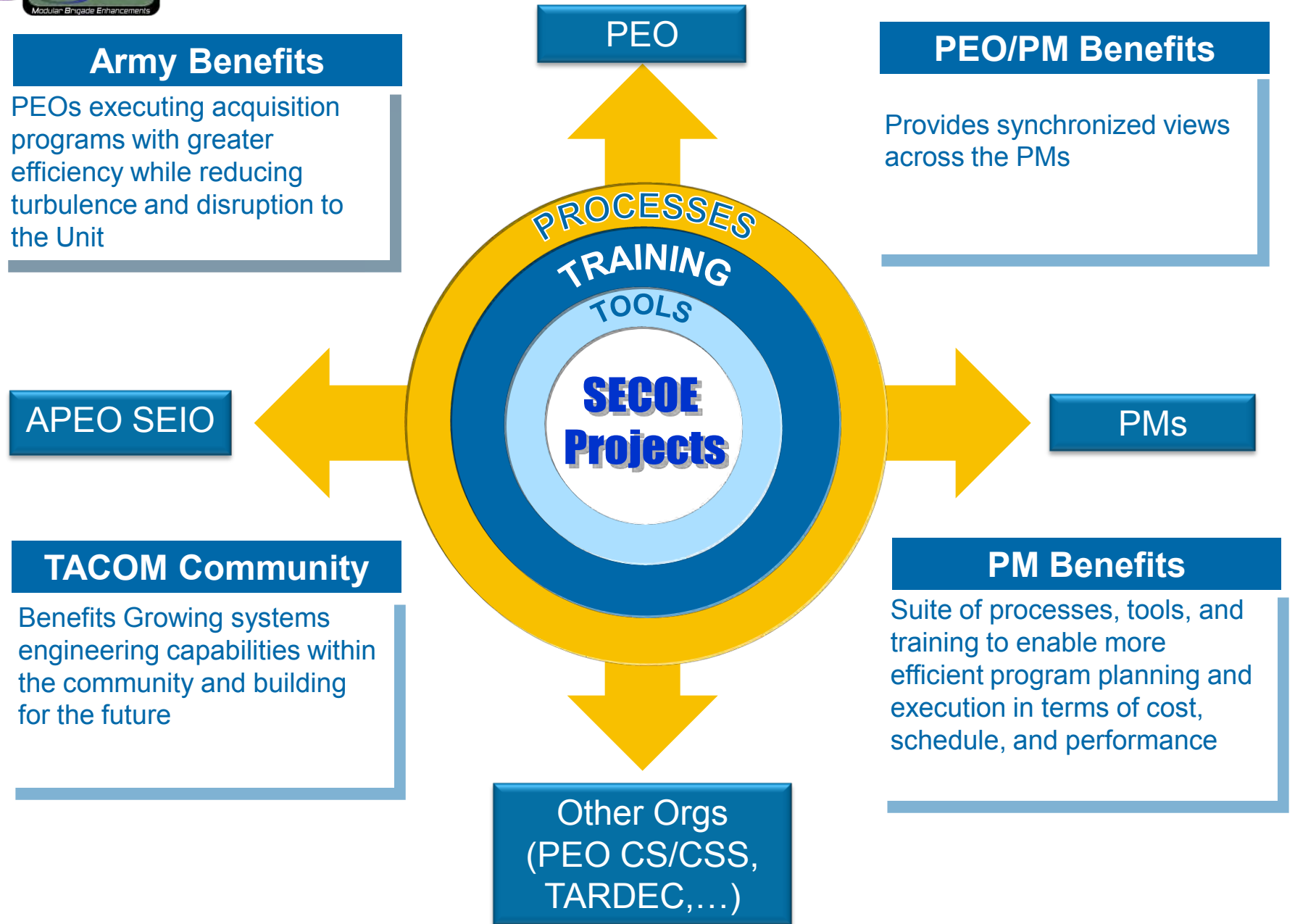



The Future

- Update on PEO GCS progress will be provided at NDIA 12th Annual Systems Engineering Conference
- In the meantime, contact me if you want to:
 - Contribute good ideas to our effort
 - Steal good ideas from our effort

Mike Phillips

mike.h.phillips@us.army.mil

586.574.8879



Sensors & SONAR Systems

DEPARTMENT

Two-Step Methodology to Reduce Software System Requirement Defects

Presented to

NDIA Systems Engineering Conference

21 October 2008

Presented by

Robert J. Kosman

Operational Systems Division/1552

(401) 832-8571, robert.kosman@navy.mil

APPROVAL FOR PUBLIC RELEASE; DISTRIBUTION IS UNLIMITED

Naval Undersea Warfare Center Division, Newport, RI

Software System Development

"Typical" Software System Development

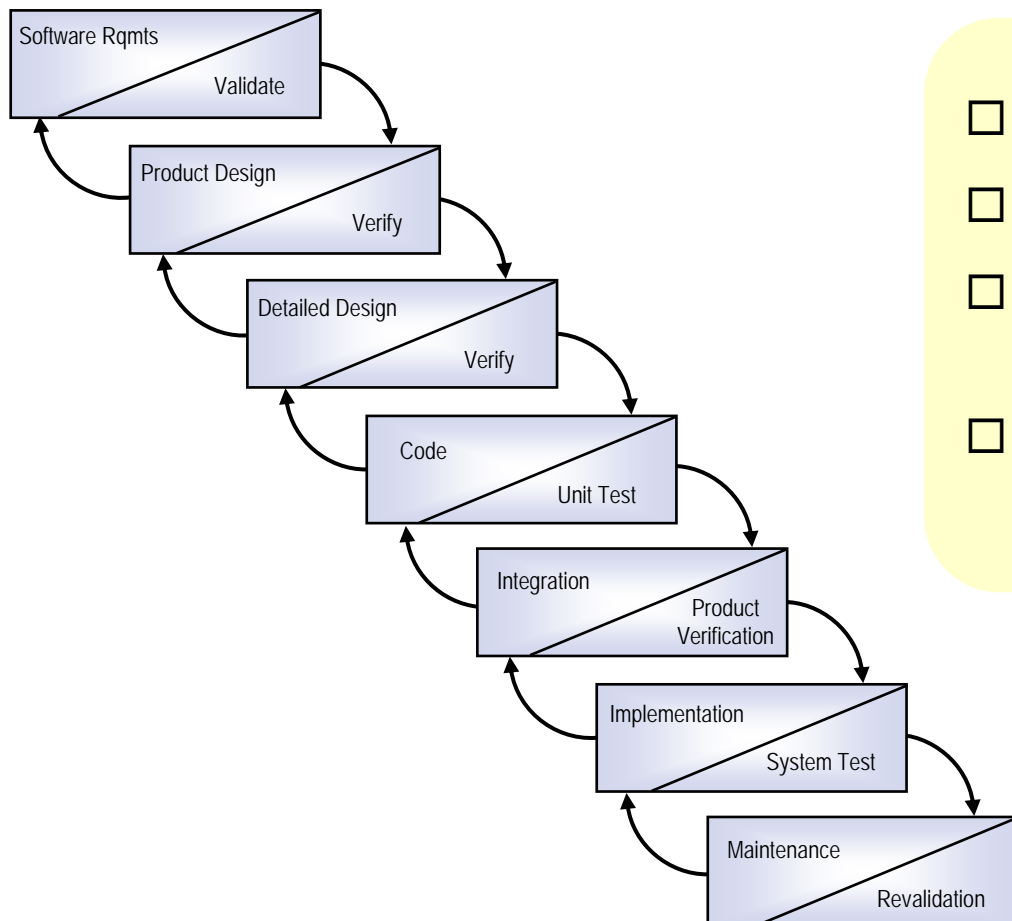

- Waterfall / Incremental model**
- Spiral model similar for a spiral**
- Implies a sequential process to resolve problems (defects)**
- Does not provide an adequate illustration of defect impacts**

Software System Development

"Realistic" Software System Development

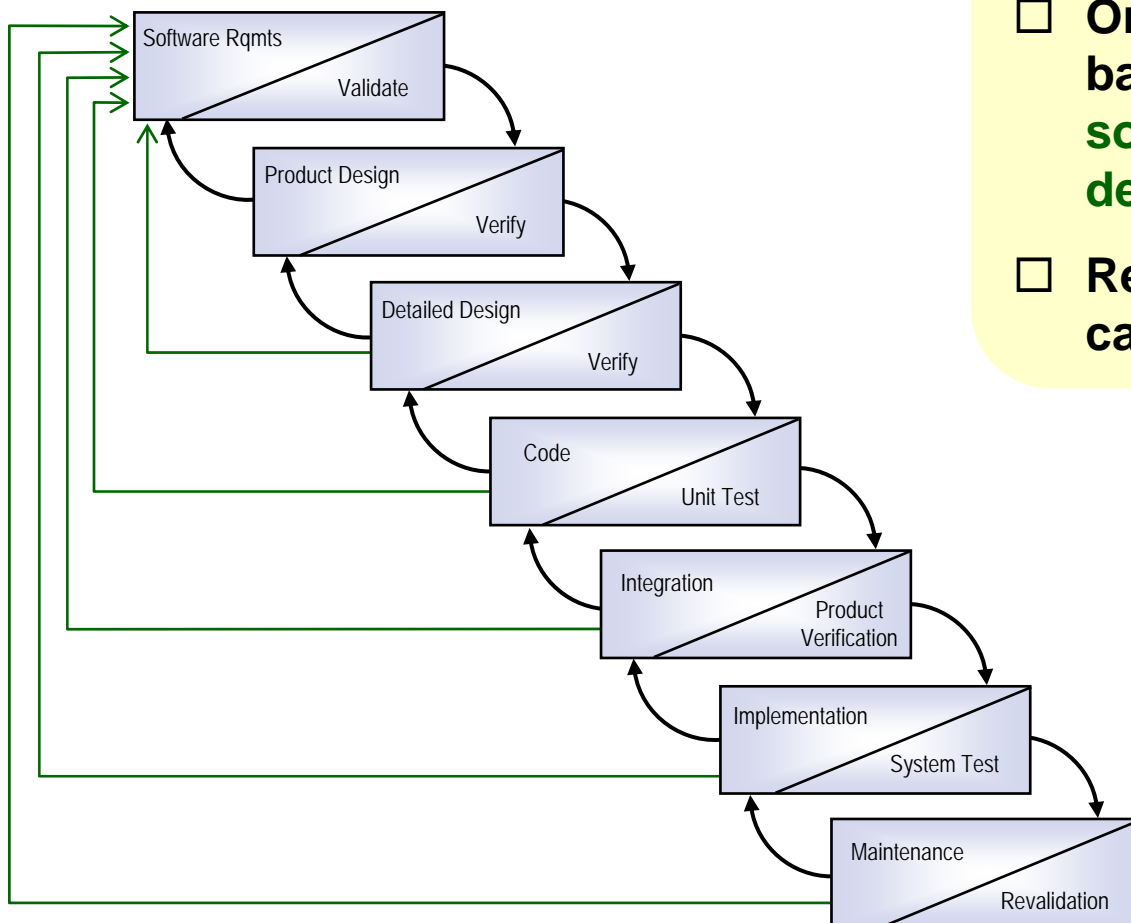

- Added links backwards to reflect origin of defects
- Omitted links other than those back to the first phase – **software system requirements development**
- Rework caused by defects can impact cost and schedule

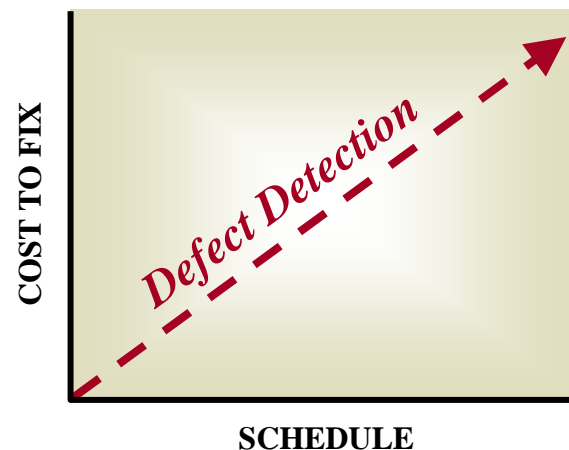

Software System Development

DEFECTS AND REWORK

- \$ Rework caused by defects can impact cost and schedule
- \$ The later a defect is found, the greater the cost to correct
- \$ Defects found and fixed in later phases of development can cost up to 100x the cost to correct if detected in early phases
 - Software Specifications
 - S/W designs, code, test, documentation
 - Integration, T&E plans and procedures
 - Integrated Logistics Support (ILS) products (Operator / User manuals, Training materials, etc)
 - Distribution costs
 - Change documentation

REQUIREMENT DEFECTS

- *Impacts all phases and products (“Negative Ripple Effect”)*
- *Most costly to correct*
- *Cause delays in schedule and product delivery*
- *Initial system may have reduced capability and functionality, and most likely operational limitations*
- *Usually require formal documentation to correct, e.g., Engineering Change Proposal (ECP)*

**DEFECT CORRECTION EXPENDS RESOURCES AND FUNDS
REQUIRED FOR PLANNED SYSTEM CAPABILITIES**

S/W System Requirement Defects

PROPOSED METHOD TO REDUCE SOFTWARE SYSTEM REQUIREMENT DEFECTS

□ When:

- Focus on software development phase of acquisition; initial development or maintenance phase
- Prior to Software Specification Review (SRR) and Preliminary Design Review (PDR)
 - » Low-level, defect detection process prior to high-level, program milestone review
 - » Process generates better products input to SRR and PDR, or an Engineering Change Proposal (ECP) during life-cycle maintenance phase
- Used during system software specification generation, i.e., during translation of high level Performance Specification and user requirements (CONOPS) or User Requirements Document into low-level Software Requirement Specifications (SRSs)
- Systems Engineering (SE) organizes and runs the **defect detection process**
 - » SE oversees technical aspects of the entire system acquisition, including processes to find defects in **ALL** products

S/W System Requirement Defects

PROPOSED METHOD TO REDUCE SOFTWARE SYSTEM REQUIREMENT DEFECTS

□ How:

- Analysis on past defects identifies two basic types of s/w system requirement defects
- The defect that is unintentionally introduced into the s/w system requirement specifications during specification generation
 - » Ambiguous text
 - » Equation errors (algorithms)
 - » Figure errors (functional and processing flows)
 - » Table errors (wrong units, input ranges, etc.)
 - » Connectivity and inconsistency issues
 - » Missing or incomplete requirements
- The defect that causes effort to be expended producing unnecessary, incorrect or unwanted functionality
 - » “Bells and whistles”
 - » Inadequate graphical user interface (GUI)
 - Systems are becoming more user interface driven (COTS) so the proposed GUI should be included in the s/w specification

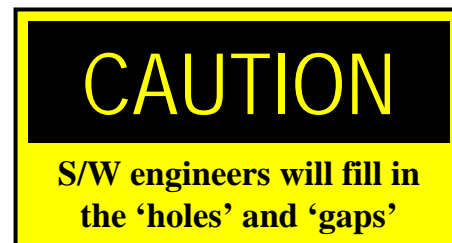

Need to eliminate user comments like, “system should work this way”

S/W System Requirement Defects

PROPOSED METHOD TO REDUCE SOFTWARE SYSTEM REQUIREMENT DEFECTS

□ How:

- Develop methodology/process to address both types of s/w system requirement defects
- First, tackle the mistakes made translating P-Spec and User specifications/CONOPS into functional flows and the GUI
 - » “Bells and whistles”
 - » Unnecessary, incorrect or unwanted functionality
- Second, tackle the mistakes made generating the s/w system requirements specifications
 - » Usual mistakes made producing specifications, e.g., ambiguous text, etc.

S/W System Requirement Defects

PROPOSED METHOD TO REDUCE SOFTWARE SYSTEM REQUIREMENT DEFECTS

□ Introduce a two-step methodology for s/w system requirements clean-up

1: Operational Demonstration (OP-DEMO) of the User Requirements

- » Visual demonstration of proposed GUI and functional flows
- » Allows evaluation of system functionality prior to development

2: S/W Inspection conducted on software requirement specifications

- » Rigorous review originally developed for s/w but can be applied to any “readable” products

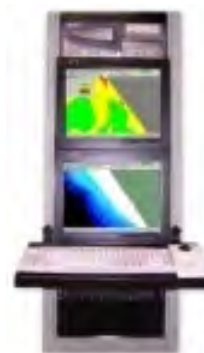
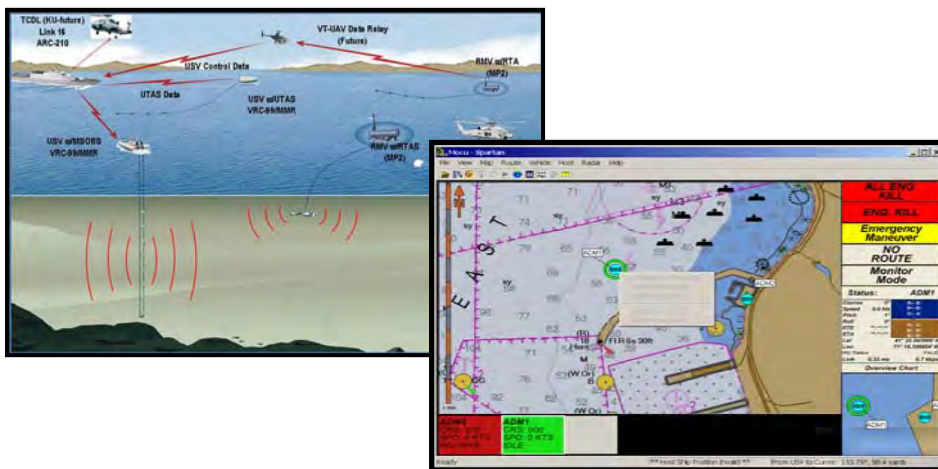

Step 1: OP-DEMO

PROPOSED METHOD TO REDUCE SOFTWARE SYSTEM REQUIREMENT DEFECTS

□ Visualization of the User Requirements

- Operability and functional flow
- Graphical User Interface (GUI)
- Target Machine or other

□ Different levels of OP-DEMO

- Operability features and functional flow
- Operability features and functional flow with limited processing (e.g., algorithms)

□ Form of Software Rapid Prototyping

- Disposable code
- Developed FAST using appropriate tools
- User involvement early – during s/w requirements phase

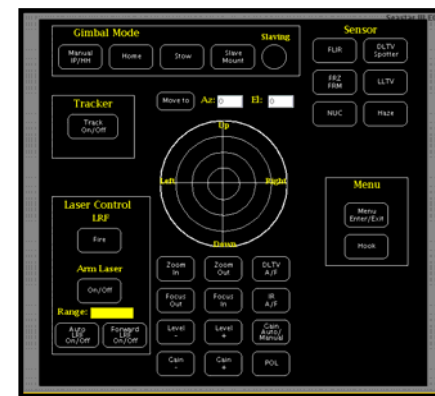
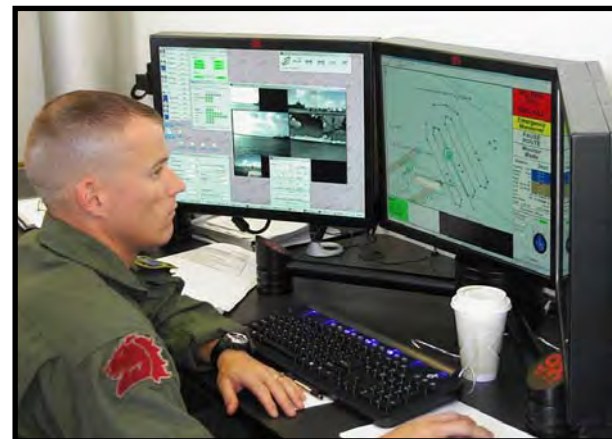

Step 1: OP-DEMO

PROPOSED METHOD TO REDUCE SOFTWARE SYSTEM REQUIREMENT DEFECTS

Wrong Concept of OP-DEMO (prototyping)

- Target machine is always utilized
- Deliverable code
- Considered 'full' system operability
- User involvement in later phases
- Fix problems in maintenance phase

CAUTION

OP-DEMO is Similar to Prototyping and Prototyping Means Different Things to Different People

PROPOSED METHOD TO REDUCE SOFTWARE SYSTEM REQUIREMENT DEFECTS

- Involves the User during the early phases, as opposed to the later phases or after system delivery**
- Eliminates unnecessary and incorrect functionality and helps prioritize remaining functionality**
- Provides a working model of intended operation for reference, as well as tool to allow parallel development of operator/training materials**
- Identifies areas of uncertainty for risk management**
- Promotes faster and more accurate s/w system specification writing**

Step 2: Requirement Inspection (RI)

PROPOSED METHOD TO REDUCE SOFTWARE SYSTEM REQUIREMENT DEFECTS

- “Software Inspection” applied to the Software System Specifications**
- Not like an informal ‘Code Walkthrough’**
- Formal, intensive review process designed to detect errors**
 - Ambiguous text
 - Equation errors (algorithms)
 - Figure errors (functional and processing flows)
 - Table errors (wrong units, input ranges, etc.)
 - Connectivity and inconsistency issues
 - Missing or incomplete requirements
- Basic characteristics**
 - Team approach, with assigned roles (reader, moderator, author)
 - Standards of conduct
 - Collect metric data
 - Criteria for Quality

Documented results indicate up to 85% of design and code errors can be detected by “Software Inspections”

Step 2: Requirement Inspection (RI)

PROPOSED METHOD TO REDUCE SOFTWARE SYSTEM REQUIREMENT DEFECTS

Team Members

- Software Engineer (Lead)
- System Engineer
- User (or ILS person)
- Test Engineer

Multiple teams (2 or 3) detect more defects (N-Fold Inspection)

- Small % of duplicate defects found between multiple teams

Multiple discipline involvement ensures consistent interpretation of software system requirements across phases

Requirement Inspection Benefits

PROPOSED METHOD TO REDUCE SOFTWARE SYSTEM REQUIREMENT DEFECTS

- Ensures User requirements are accurately specified
- Ensures developer requirements are accurately specified
- Real-time metric data collection identifies areas of improvement w/ specification generation
- Errors corrected in single pass versus iterative correction process
- Detects errors associated with all phases of the Development
- Low cost / defect ratio
- Reduces software development costs by detecting errors early, avoids **REWORK**

Requirement Inspection Benefits

PROPOSED METHOD TO REDUCE SOFTWARE SYSTEM REQUIREMENT DEFECTS

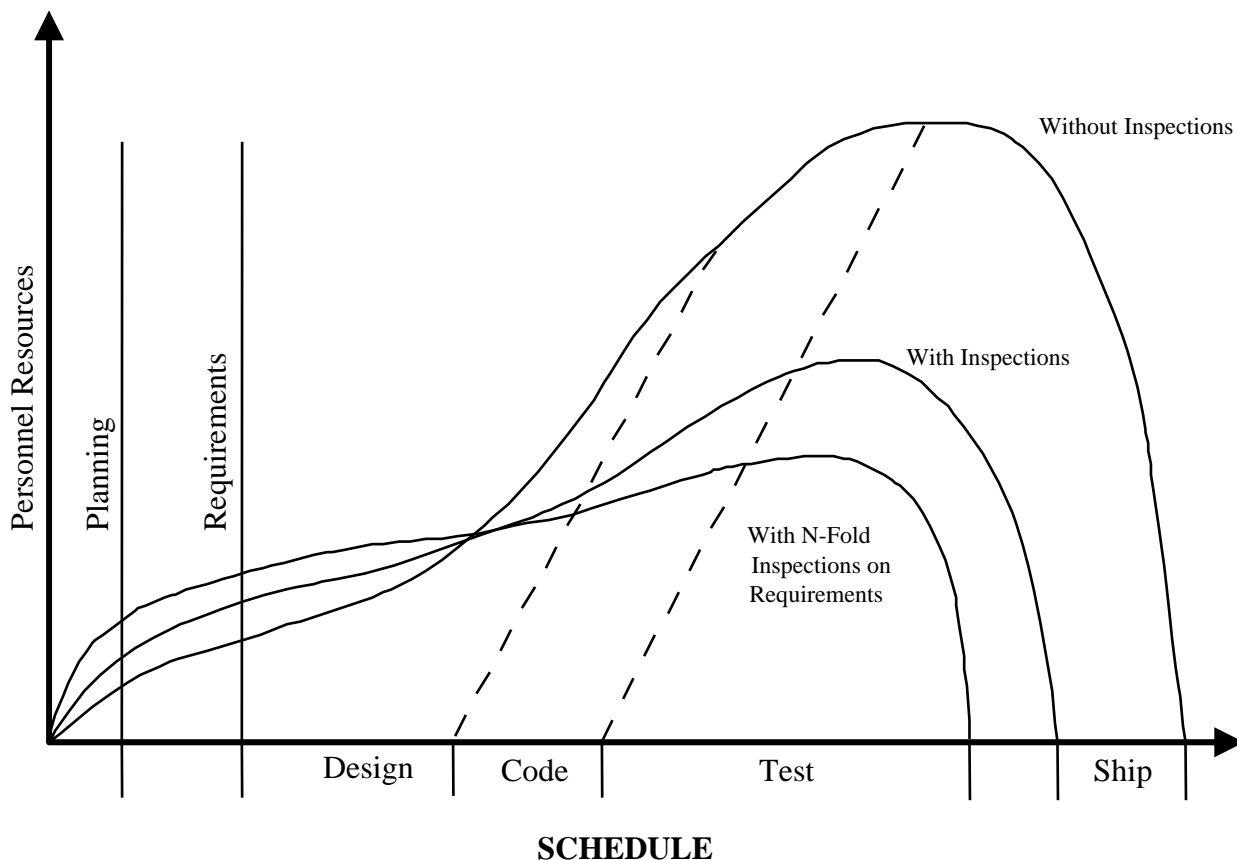

Impact of RI on Development (modified from [1])

[1] Fagan, M.E., "Advances in Software Inspections," *IEEE Transactions on Software Engineering*, Vol SE-12, No. 7, July 1986

PROPOSED METHOD TO REDUCE SOFTWARE SYSTEM REQUIREMENT DEFECTS

- **Two extensive upgrades to an existing system – approx 100 KSLOC each**
 - Existing system was really a “prototype/experimental” system delivered as a production system; so had to fix in Maintenance phase via ECPs
 - First upgrade did not use 2-Step Methodology to reduce Software System Requirement Defects; second upgrade did
 - Software System Specifications for first upgrade were developed by SE with only informal reviews, and significant portion of user interface was “TBD/TBS”
 - Software development team was already using Software Inspection during development so extensive defect metric data was collected during both upgrades
 - Causal analysis was conducted on all defects found to determine origin of defect
 - Both types of OP-DEMO were utilized on second upgrade (algorithms); 2-Fold RI also used on second upgrade

PROPOSED METHOD TO REDUCE SOFTWARE SYSTEM REQUIREMENT DEFECTS

Upgrade 1 Observations

Requirement Defects By Phase - UPGRADE 1

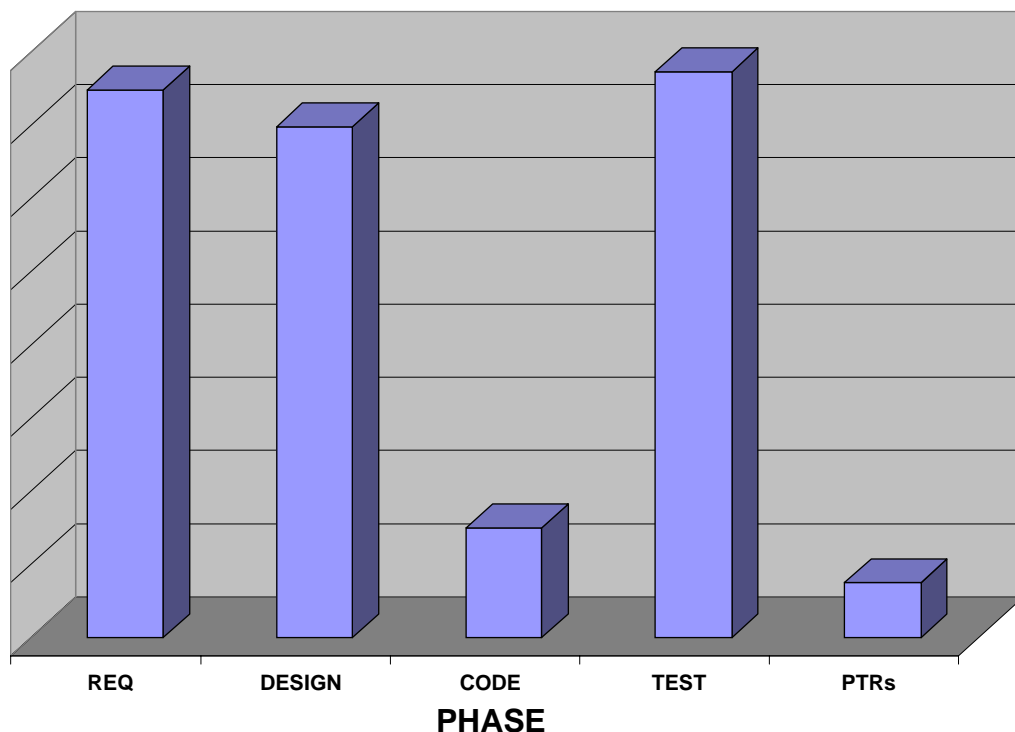

- \$ Informal reviews found some defects but not enough
- \$ Defects found during Design and Code could have been found by RI
- \$ Defects found during computer-based Test and Post-delivery could have been found by OP-DEMO
- \$ Rework caused schedule delays and end product had reduced functionality
- \$ Defects required multiple updates to s/w system spec

PROPOSED METHOD TO REDUCE SOFTWARE SYSTEM REQUIREMENT DEFECTS

Upgrade 2 Observations

Requirement Defects By Phase - BOTH

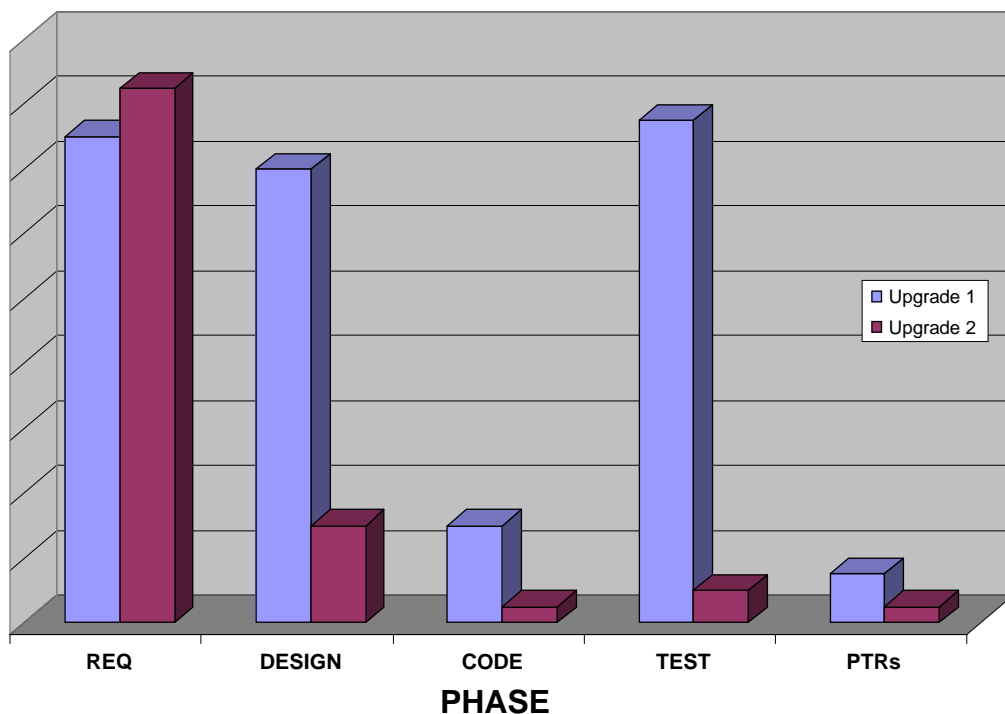

- \$ OP-DEMO significantly reduced defects in computer-based Test and post-delivery phases
- \$ RI significantly reduced defects in Design and Code phases
- \$ S/W Requirement Spec had a “positive ripple effect” on development
- \$ Significantly less rework for 2nd upgrade and product was delivered on schedule w/ full functionality
- \$ Req defects were less severe and were easily fixed

PROPOSED METHOD TO REDUCE SOFTWARE SYSTEM REQUIREMENT DEFECTS

- ❑ **Software system requirement defects can impact cost, schedule, and delivered functionality due to REWORK**
- ❑ **OP-DEMOS are useful in reducing defects that would be identified during computer-based Test and Deployment phases**
- ❑ **Requirement Inspections are useful in reducing defects that would be identified during Design & Code phases**
- ❑ **Improved s/w requirement specifications can cut costs in ALL s/w system development phases, including life-cycle maintenance**
- ❑ **Combining OP-DEMO and Requirement Inspection is a low-tech approach to reducing s/w requirement defects; is simple to apply and requires minimal training**

NDIA 11th Annual Systems Engineering Conference

“Daily Challenges of Requirements Engineering”

October 22, 2008

Frank Salvatore
High Performance Technologies, inc.
3159 Schrader Road
Dover NJ, 07801
(973) 442-6436 ext 249
fsalvatore@hpti.com

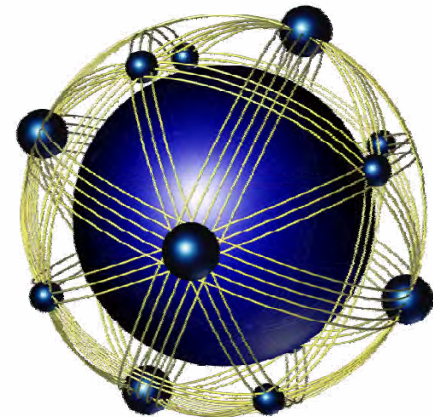

Outline

- Requirements Elicitation**
- Requirements Capture and Management**
- Requirements Traceability**
- Requirements Control**
- Reaching Consensus**
- Eliciting Verifications**
- Communicating Requirements**
- Metrics**

Requirements Elicitation

How do you gather the requirements?

- Interviews
- QFD Workshops
- Web Based Surveys
- Vignettes and Scenarios
- Questionnaires
- Brainstorming and Mind Mapping
- Analysis/Derivation
 - ✓ Hazard
 - ✓ Fault Tree
 - ✓ Sensitivity
 - ✓ Trade Studies
- Existing Documentation and or Policies
- Quality Assurance Provisions

It involves a lot of research and is evolutionary!

Don't forget to Document Rational. It will save you time latter when you will need to defend the requirements.

Interview Based Elicitation

Using an Enterprise Architecture approach one can first probe into Business Goals and Architecture Principles by asking questions to understand:

- Mission and Values of your organization
- Understand importance (PM Level)
- Understand organization structure
- Understand Products
- Understand Customers and Stakeholders
- Understand Daily Activities

Mostly used for Business Systems

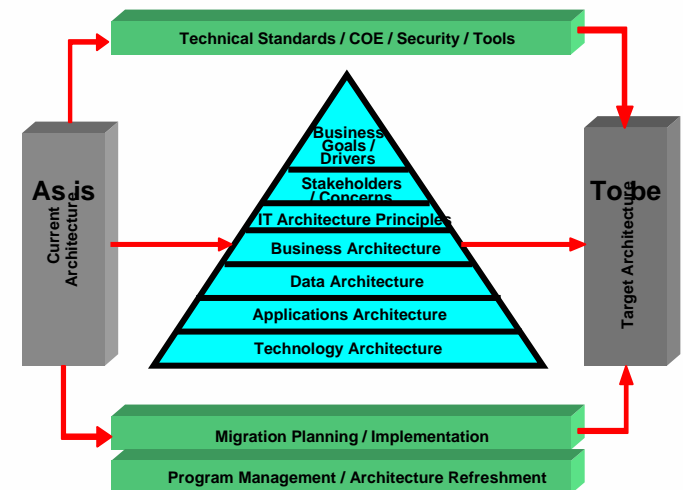

Interview Based Elicitation

Project and Product Data can be understood by asking these leading questions

- What are the Projects/Products that the organization manages?
- Who do you interact with?
- What data types do you manage?
- How do you organize your data?
- What data do you view as being most important?
- Who are the Customers for each product?
- Who are the stakeholders for each product?
- What are the day to day activities that go on for the projects you choose?

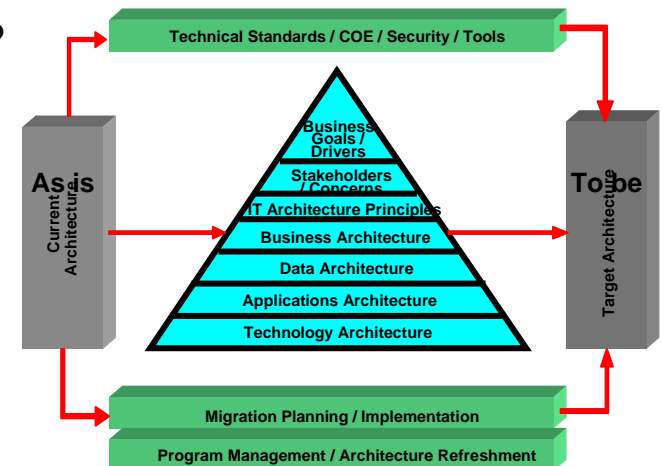

QFD Based Elicitation



		Engineering Metrics											Customer Importance	Relative Importance	
		Engineering Measur 1	Engineering Measur 2	Engineering Measur 3	Engineering Measur 4	Engineering Measur 5	Engineering Measur 6	Engineering Measur 7	Engineering Measur 8	Engineering Measur 9	Engineering Measur 10	Engineering Measur 11			
USER NEEDS	User Needs	Customer Need 1.0	9	9	0	0	0	9	9	9	0	0	9	5.00	26%
	Customer Need 2.0	0	0	9	9	9	9	9	3	0	0	9	3.00	16%	
	Customer Need 3.0	0	0	0	0	0	3	9	1	9	0	3	5.00	26%	
	Customer Need 4.0	0	0	0	0	0	1	3	9	0	0	1	4.00	21%	
	Customer Need 5.0	0	0	0	0	0	1	1	1	0	5	1	2.00	11%	

USER RATING									
Absolute Score					Relative Score				
Concept A	Concept B	Concept C	Concept D	Concept E	Concept A	Concept B	Concept C	Concept D	Concept E
3	5	1	3	2	0.79	1.3	0.3	0.8	0.5
3	2	3	3	3	0.47	0.3	0.5	0.5	0.5
3	5	5	3	4	0.79	1.3	1.3	0.8	1.1
3	2	5	3	5	0.63	0.4	1.1	0.6	1.1
3	1	5	3	4	0.32	0.1	0.5	0.3	0.4

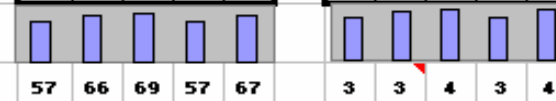

Organizational Difficulty												
Absolute importance	45	45	27	27	27	93	131	97	45	10	93	
Relative Importance	7%	7%	4%	4%	4%	15%	20%	15%	7%	2%	15%	

ENGINEERING RATING		Raw Score														
		Concept A	Concept B	Concept C	Concept D	Concept E	Concept A	Concept B	Concept C	Concept D	Concept E	Concept A	Concept B	Concept C	Concept D	Concept E
Weighted Score	Concept A	3	3	3	3	3	3	3	3	3	3	3	3	3	3	3
	Concept B	4	3	2	4	3	5	3	2	1	3	3	3	3	3	3
	Concept C	4	3	3	4	5	4	1	2	4	3	2	2	2	2	2
	Concept D	3	3	3	3	3	3	3	3	3	3	3	3	3	3	3
	Concept E	2	5	3	4	5	5	5	4	3	3	4	3	3	4	4

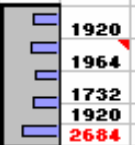

RISK	Technical											
	Schedule											
	Cost											

Also helps to Build Consensus and Understanding of complex relationships as well as importance.

Requirements are Discovered Thru The SW Safety Process

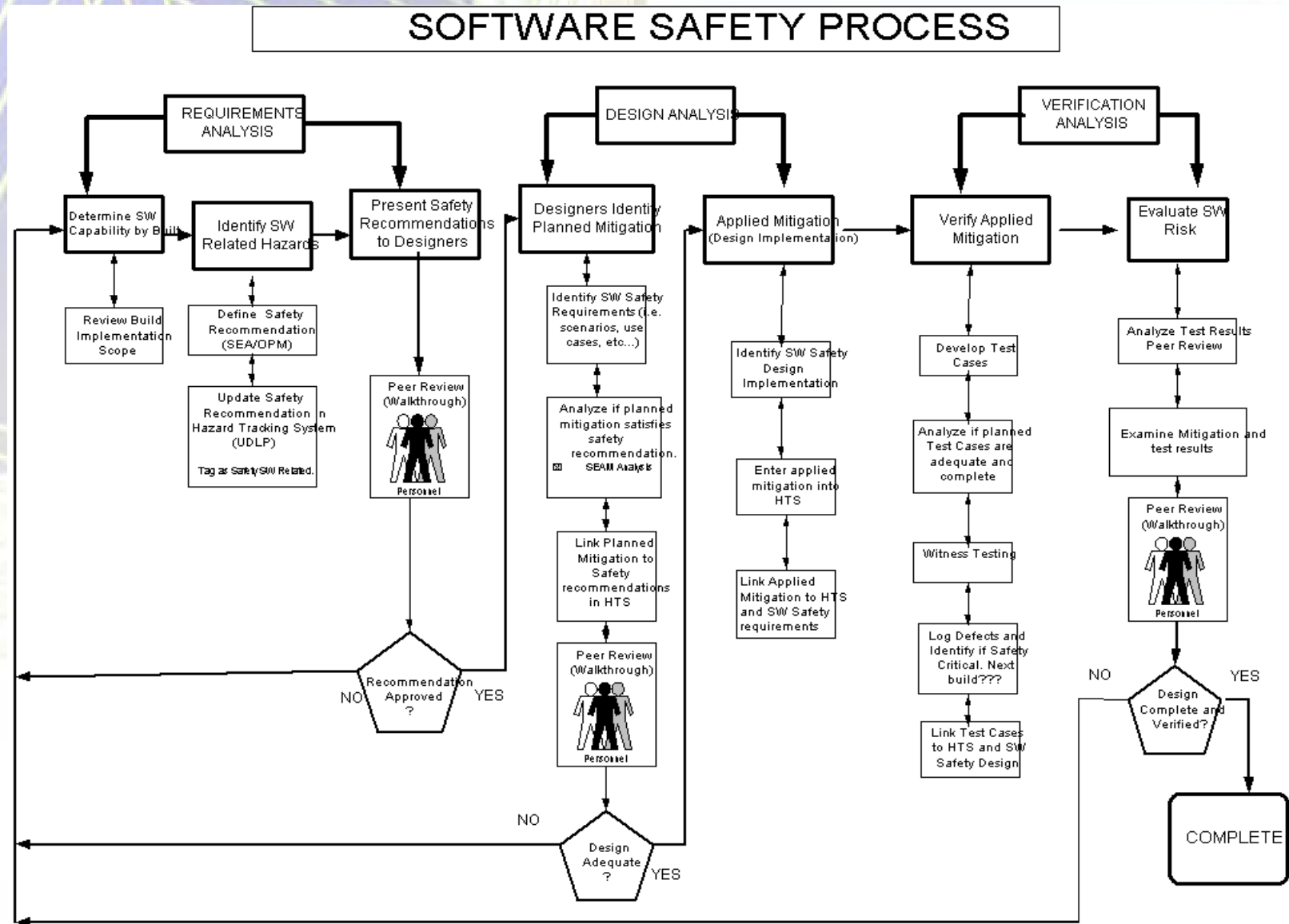

Eliciting Verification Methods

Similar to Requirements. Stakeholders are different. Methods are typically thru Analysis, Test, Inspection, Measurement.

- Use Interview**
- Use Questionnaires**
- Include Stakeholders Early and Often.**
- Have Stakeholders Peer Review Requirements**
- Use a JCCB**

Graph: Interface Definition

TRL: TRL5
 TRL6
 TRL7

IPT Name: Ammo Handling
Module Name: AHR

ion: 3.1.2.0-1

Requirements: The Ammo Handling Subsystem will interface with the Turret Structure, Gun Assembly, Fire Control, Ammo Suite and Secondary Armament.

ATD/Objective Force:

This enables and disables the required field warning:

Switch to View Mode

TRL 5 Verification Method:

~~~Please Select a Method~~~

Responsibility:

- Analysis
- Inspection
- Measurement
- Test
- N/A

(e.g.: IPT Name, Subcontractor, System Integrator)

Critical Test:

Location of Verif:

(e.g.: Picatinny, Contractor Facility, Proving Ground)

~~~Please Select a Test~~~

Verification Procedure: Briefly describe the procedure you recommend at this TRL level to validate or confirm the requirement.

If the requirement will not be verified at this time please indicate so:

~~~Please Select a Method~~~

[Empty text box for verification procedure]

Data Collected:

[Empty text box for data collected]

Clear

Reset

**TRL 6** Verification Method:

~~~Please Select a Method~~~

Responsibility:

[Empty text box]

(e.g.: IPT Name, Subcontractor, System Integrator)

Critical Test:

Location of Verif:

[Empty text box]

(e.g.: Picatinny, Contractor Facility, Proving Ground)

~~~Please Select a Test~~~

Verification Procedure: Briefly describe the procedure you recommend at this TRL level to validate or confirm the requirement.

If the requirement will not be verified at this time please indicate so:

[Empty text box for verification procedure]

Data Collected:

[Empty text box for data collected]

Clear

Reset

**TRL 7** Verification Method:

~~~Please Select a Method~~~

|< << >> >|

Record [] of []

Exit

Requirements Capture and Management

How and where do you store the requirements?

Word Documents are standard. Tools are useful and can Help. But try to get everyone to use them consistently!!!!

- Access**
- Excel**
- DOORS**
- RTM**
- Requisite Pro**
- RM Calibre**
- etc....**

Use Document Templates Based On Standards. Also IM is Important for Efficiency.

Requirements Management Specification Hierarchy

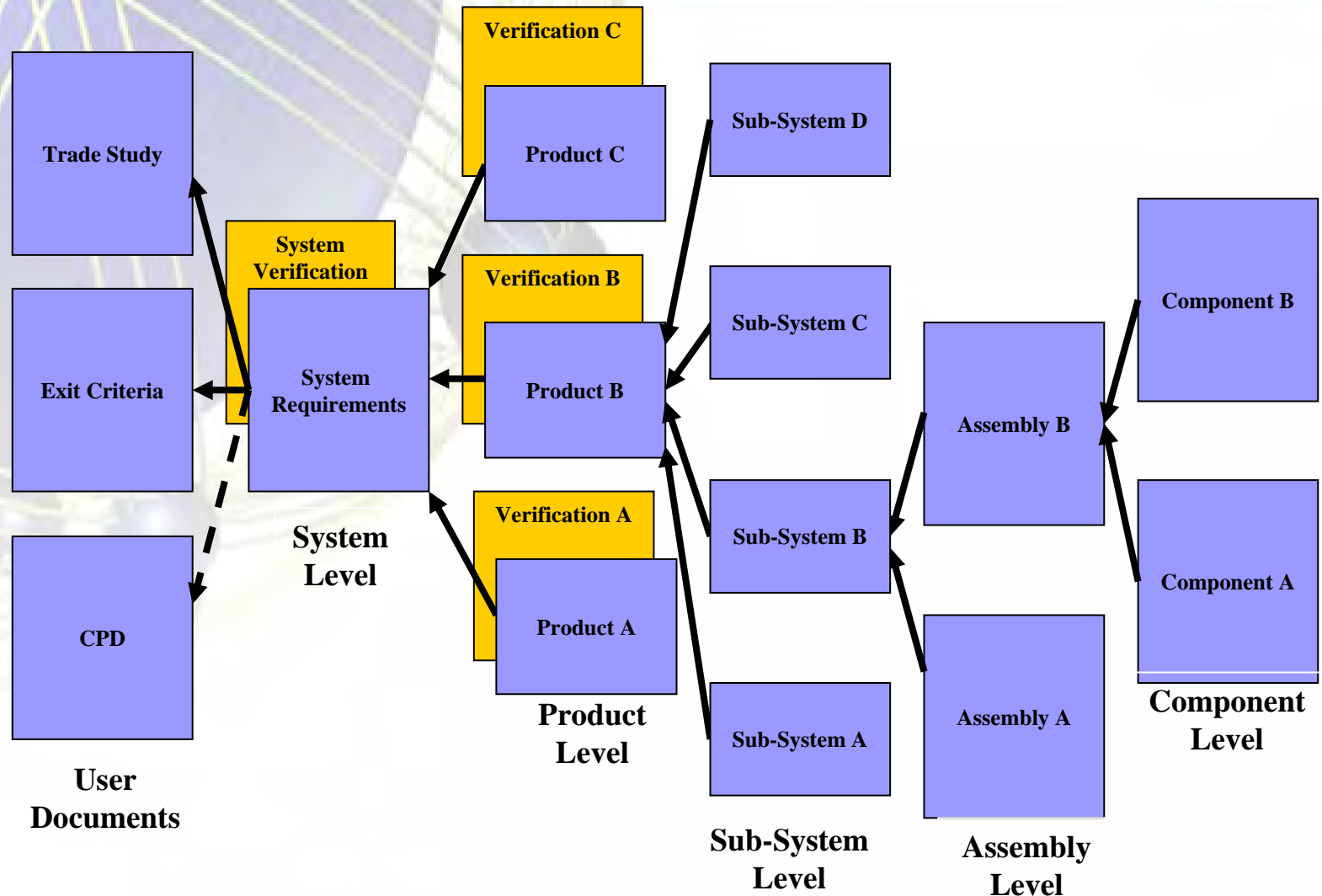

Establish Hierarchy and Naming Convention, Follow IEEE Standard

Document Outline is Standard Throughout Project.

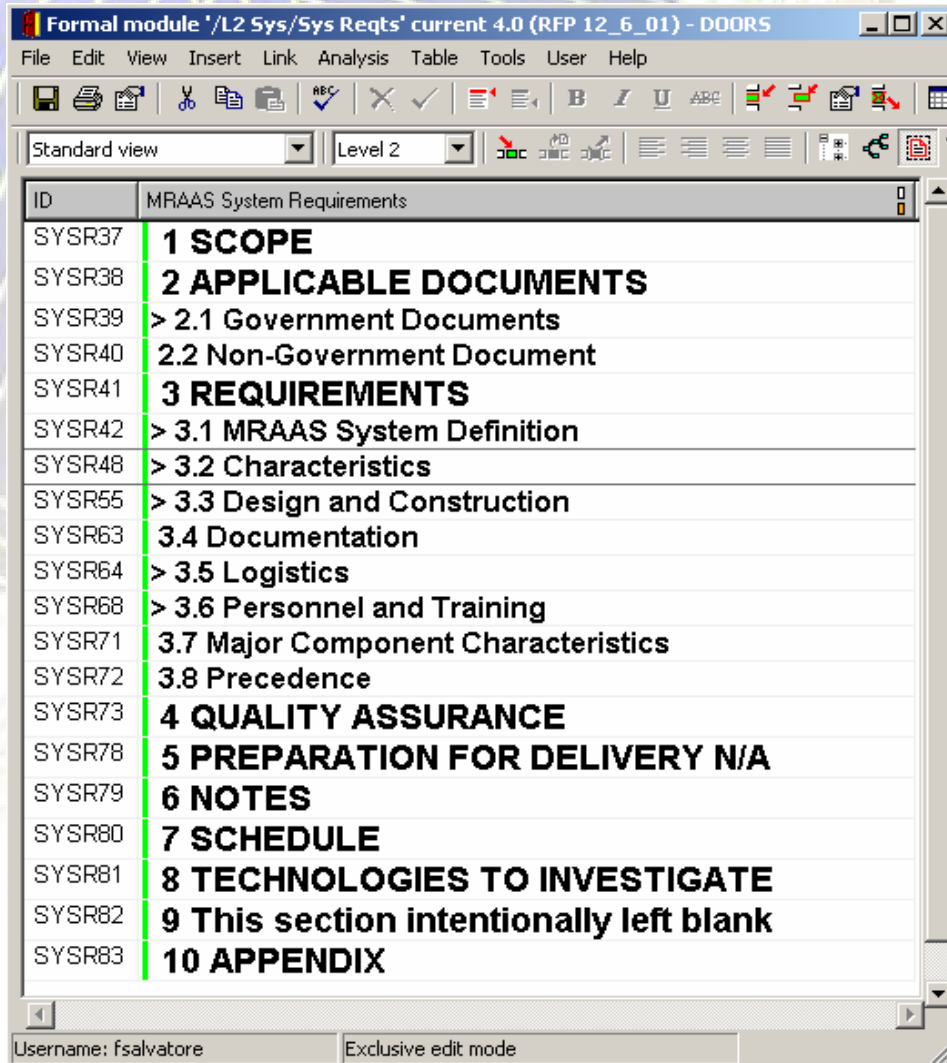

The screenshot shows a software application window titled 'Formal module "/>

| ID | MRAAS System Requirements |
|--------|--|
| SYSR37 | 1 SCOPE |
| SYSR38 | 2 APPLICABLE DOCUMENTS |
| SYSR39 | > 2.1 Government Documents |
| SYSR40 | 2.2 Non-Government Document |
| SYSR41 | 3 REQUIREMENTS |
| SYSR42 | > 3.1 MRAAS System Definition |
| SYSR48 | > 3.2 Characteristics |
| SYSR55 | > 3.3 Design and Construction |
| SYSR63 | 3.4 Documentation |
| SYSR64 | > 3.5 Logistics |
| SYSR68 | > 3.6 Personnel and Training |
| SYSR71 | 3.7 Major Component Characteristics |
| SYSR72 | 3.8 Precedence |
| SYSR73 | 4 QUALITY ASSURANCE |
| SYSR78 | 5 PREPARATION FOR DELIVERY N/A |
| SYSR79 | 6 NOTES |
| SYSR80 | 7 SCHEDULE |
| SYSR81 | 8 TECHNOLOGIES TO INVESTIGATE |
| SYSR82 | 9 This section intentionally left blank |
| SYSR83 | 10 APPENDIX |

Username: fsalvatore Exclusive edit mode

- ☑ Using Mil-STD-490/961C standard template
- ☑ Standardized Documentation format makes it easier to find what you are looking for

Level 1 User Requirements

3159 DOORS Database: /L1 User - DOORS

File Edit View Tools Help

3159 DOORS Database

- Crusader
- FSAC
 - AAN
 - Armaments Server
 - ASSM
 - FCMRAAS
 - FCS
 - MRAAS
 - Analysis
 - Change Proposal
 - Design
 - Discussions
 - Links
 - Management
 - Procedures
 - Reqts
 - L1 User**
 - L2 Sys
 - L3 Prod
 - L4 Subsys
 - L5 Asmby
 - L6 Comp
 - Templates

| Name | Type | Description |
|------------------------|--------|-------------------------|
| Change Proposal System | Folder | System Information |
| ATD Reqts | Formal | ATD Reqts |
| MNS | Formal | Mission Needs Statement |
| Trade Study | Formal | Trade Study |

Username: fsalvatore User type: Database Manager

- This is where the User Requirements would be stored.
- Everyone on the project can read only few can change.

Level 2 System Requirements

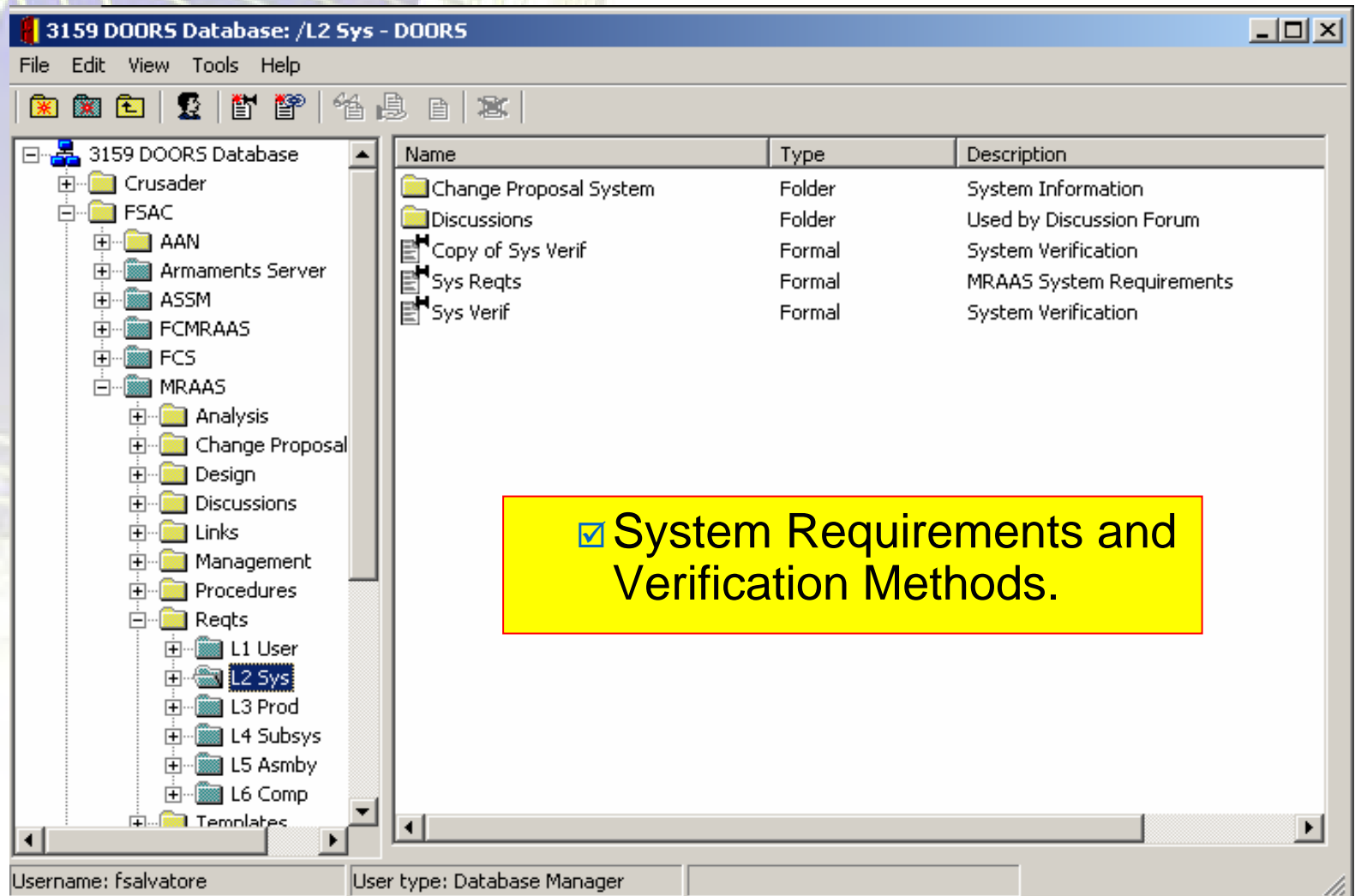

The screenshot shows the 3159 DOORS Database interface. The left pane displays a tree view of the database structure, with the 'L2 Sys' folder selected under the 'MRAAS' folder. The right pane displays a table of the contents of the 'L2 Sys' folder.

| Name | Type | Description |
|------------------------|--------|---------------------------|
| Change Proposal System | Folder | System Information |
| Discussions | Folder | Used by Discussion Forum |
| Copy of Sys Verif | Formal | System Verification |
| Sys Reqts | Formal | MRAAS System Requirements |
| Sys Verif | Formal | System Verification |

System Requirements and Verification Methods.

Username: fsalvatore User type: Database Manager

Level 3 Product Requirements

3159 DOORS Database: /L3 Prod - DOORS

File Edit View Tools Help

3159 DOORS Database

- Crusader
- FSAC
 - AAN
 - Armaments Server
 - ASSM
 - FCMRAAS
 - FCS
 - MRAAS
 - Analysis
 - Change Proposal
 - Design
 - Discussions
 - Links
 - Management
 - Procedures
 - Reqts
 - L1 User
 - L2 Sys
 - L3 Prod**
 - L4 Subsys
 - L5 Asmbly
 - L6 Comp
 - Templates

| Name | Type | Description |
|------------------------|--------|----------------------------------|
| Change Proposal System | Folder | System Information |
| Discussions | Folder | Used by Discussion Forum |
| ASR | Formal | Ammo Suite Requirements |
| ASV | Formal | Ammo Suite Verification |
| MAR | Formal | Main Armaments Requirements |
| MAV | Formal | Main Armament Verification |
| SAR | Formal | Secondary Armaments Requirements |
| SAV | Formal | Secondary Armament Verification |

Username: fsalvatore User type: Database Manager

Product Requirements and Verification Methods.

IPT's Manage and communicate changes to SEIT.

Level 4-6 Subassembly to Component Requirements

3159 DOORS Database: /AS - DOORS

File Edit View Tools Help

FSAC

- AAN
- Armaments Server
- ASSM
- FCMRAAS
- FCS
- MRAAS
 - Analysis
 - Change Proposal
 - Design
 - Discussions
 - Links
 - Management
 - Procedures
 - Reqts
 - L1 User
 - L2 Sys
 - L3 Prod
 - L4 Subsys
 - AS
 - Discussio
 - MA
 - SA
 - L5 Asmbly

| Name | Type | Description |
|------------------------|--------|----------------------------------|
| Change Proposal System | Folder | System Information |
| AKR | Formal | Adv KE Reqts |
| AKV | Formal | Adv KE Verification |
| PR | Formal | Propulsion Assembly Requirements |
| PV | Formal | Propulsion Verification |
| SSR | Formal | Smart Suite Reqts |
| SSV | Formal | Smart Suite Verification |
| WHR | Formal | Warhead Reqts |
| WHV | Formal | Warhead Verification |

Username: fsalvatore User type: Database Manager

- ✓ IPT's Own and work to requirements
- ✓ Designers communicate Changes and assess impact.
- ✓ Everyone works together to achieve a common goal.

Requirements Traceability

How do you understand how the requirements are being satisfied, are complete, are accurate, etc.....

- Trace Matrices are Typical and require constant care and feeding to maintain.**
- Use a tool to manage your requirements and capture traceability so you can search and query when doing impact analysis.**
 - ✓ **More accurate**
 - ✓ **More efficient**
 - ✓ **More complete**

No tool will automatically generate but they will preserve it once you do it the first time.

If a requirement isn't traceable to anything it doesn't belong!!!

This is Important when performing Impact Analysis, doing FCA and PCA, etc....

Requirements Change Control

If a Requirement is changed, how do we determine effects on other Requirements, Verifications or Schedule Events?

- Use Inter-IPT Coordination**
- Use Impact Analysis & Visualization Tools**
- Use Formal Change Control Procedures**
- Attributes**

With a tool you have better and more efficient ways of controlling the requirements.

Follow a Change Proposal Process

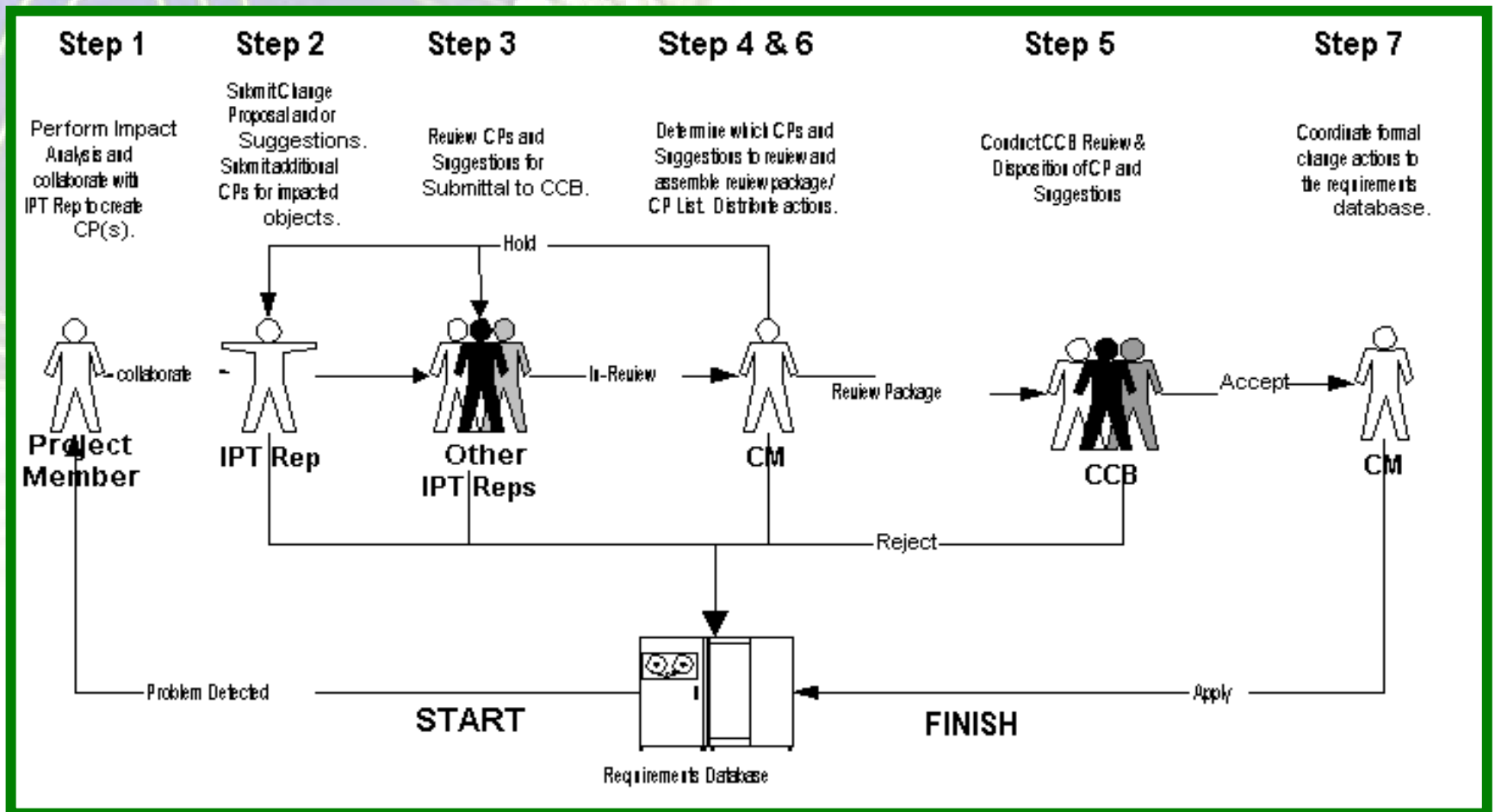

Starting the Change Process

IPT Member brings an issue to attention of IPT Lead

IPT Lead makes an initial determination:

PURSUE – Proposed change has merit and is worth further investigation

DISCARD – Proposed change does not have merit or is not worth further investigation at this time

If you choose to PURSUE the potential change:

- 1. Coordinate with other IPT's to discuss**
- 2. Initiate working group(s) as needed**

COMMUNICATE !!!

Starting the Change Process

Still think a change is needed? Perform an “Impact Analysis”

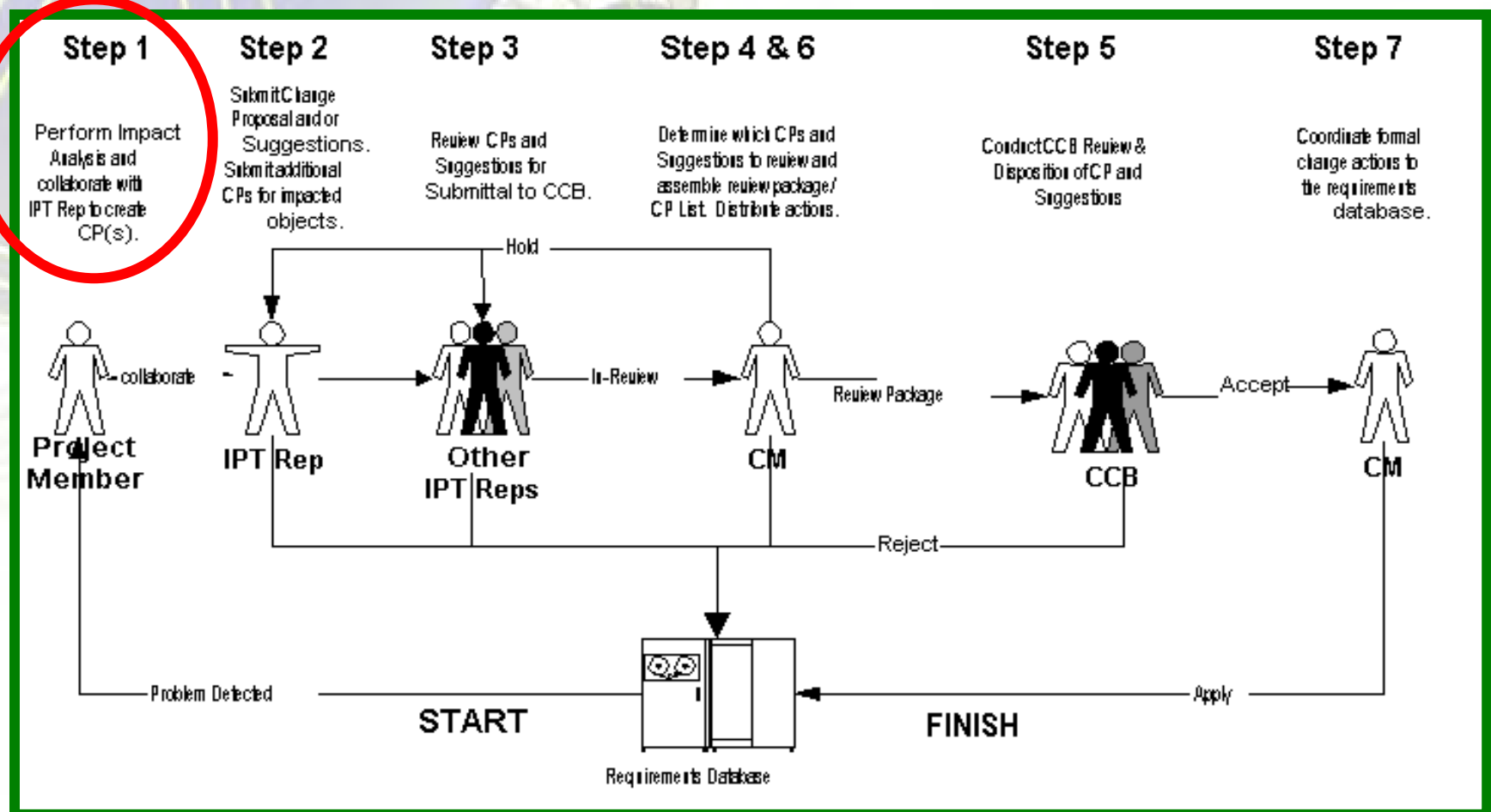

Impact Analysis Complete... Submit a Change Proposal

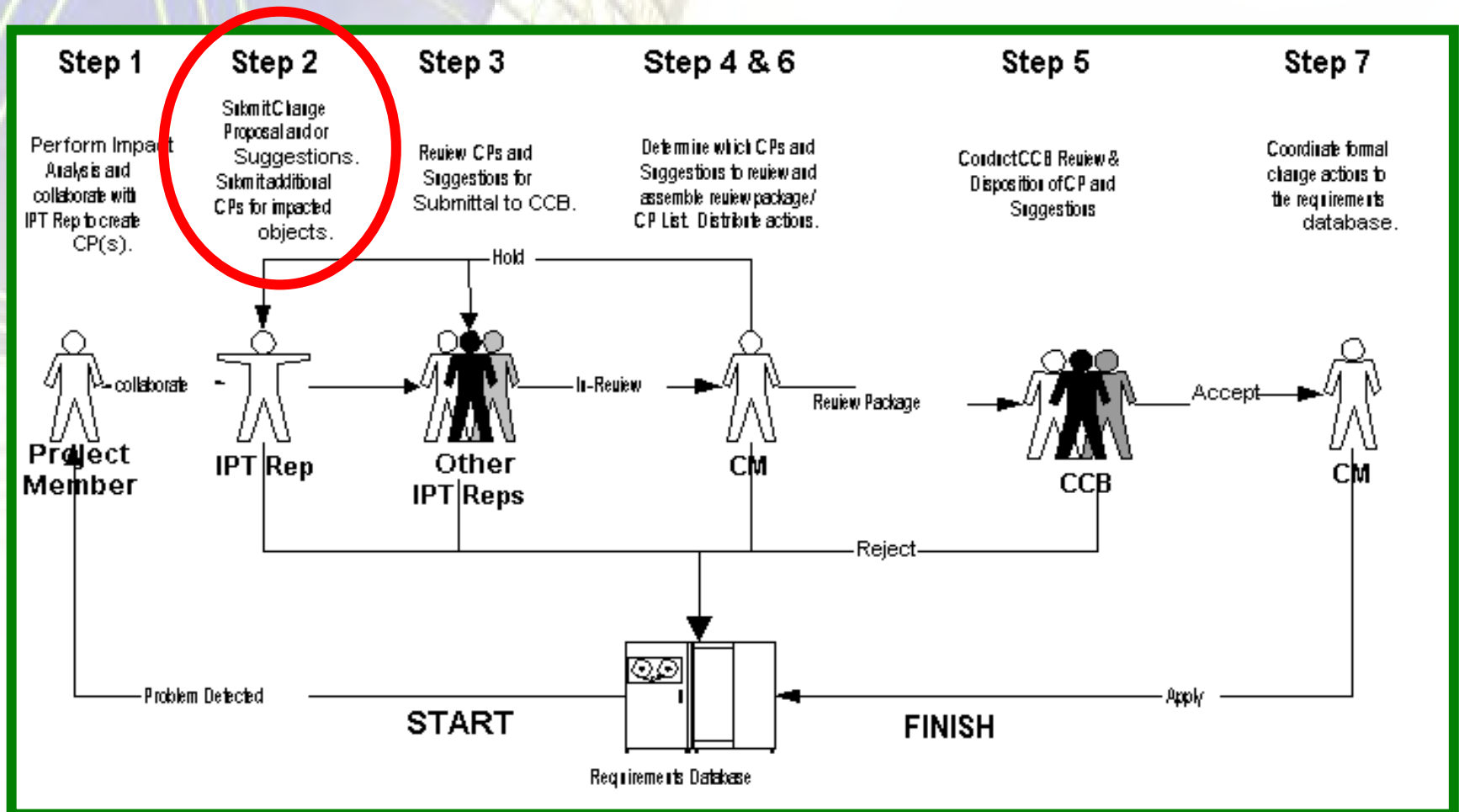

Submit Change Proposal

Fill out appropriate fields in the 'Proposed' half of the Change proposal Form. Remember to address any affected attributes.

Change Proposal for module "LAR" - DOORS

Change proposal for object: LAR360 In-links: 0

Pending change proposals for this object: 1 Out-links: 1

Current

Object Heading

Object Text

The muzzle brake shall not generate a muzzle exit pressure above 12ksi.

ATD

Proposed

Object Heading

Object Text

The muzzle brake shall not generate a muzzle blast overpressure above TBD. (Driven by muzzle exit pressure of 12 ksi)

Show attribute: ATD/0

ATD

Reason for change:

Muzzle blast overpressure is correct term. Muzzle Brake will be designed to minimize blast overpressure.

Other impacted requirements are:

Change type: Priority:

Submit

Select
Change
Type

Make adjustments to the
Reason for change as needed.
**BE SURE TO NOTATE ANY
CONTRACTUAL
IMPLICATIONS!!!**

Select **Very High**, **High**, **Medium** or **Low**
(refer to **CPP Document** for details)

When satisfied with
form, press **Submit** to
create the new Change
proposal

Submit Change Suggestion

When 5 or more actions need to occur (I.e., Change proposals) in order to fully satisfy a Change Proposal, a Change Suggestion should be created instead of a change proposal.

Suggestion for project 'MRAAS' - DOORS

Suggestion:

[r-ids.] [The total Gun Assembly imbalance is equal to 6063 r-ids. Gun mount is 63 r-ids.] - ATD/Objective Attribute = ATD, TRL Attribute = TRL 7. Link requirement to GAR new requirement 1.

GAR242: The Gun Assembly shall have an imbalance of no more than 1.011 x e7 N-mm. (7457 ft-lbs.) - Change TRL Attribute to read TRL 5 & 6 Only. De-link from MAR 281, MAR282, MAR283, MAR284 (Weapon Pt. Errors), MAR89 (The Main Armament shall be capable of elevating and depressing at a rate of 400 mils/sec), MAR133 (The Main Armament shall be capable of elevation in the range of -10 to 55 degrees.) and link to MAR new requirement 1 below.

GAR new requirement 1: GAR242: The Gun Assembly shall have an imbalance of no more than 8.22 x e6 N-mm. (6063 ft-lbs.) - ATD/Objective Attribute = ATD, TRL Attribute = 7. Link requirement to MAR new requirement 2.

MAR new requirement 1: The Gun Assembly shall have an imbalance of no more than 1.011 x e7 N-mm. (7457 ft-lbs.)

Reason for change:

Currently the imbalance requirement (LAR 335) of 7394 ft-lbs for Launcher is the same for TRL 5, 6, 7. Need a different imbalance requirement for TRL 7 of 6000 ft-lbs. Need to flow up the new requirement to GAR and MAR. The old requirement must also flow-up to MAR. Need imbalance requirement in MAR to link gun imbalance to FC requirements.

Suggestion type: Priority:

Fill out fields as needed and press **Submit** to create a new suggestion. The JCCB will approve and apply suggestions via the Change Proposal System.

Review CP's and Suggestion

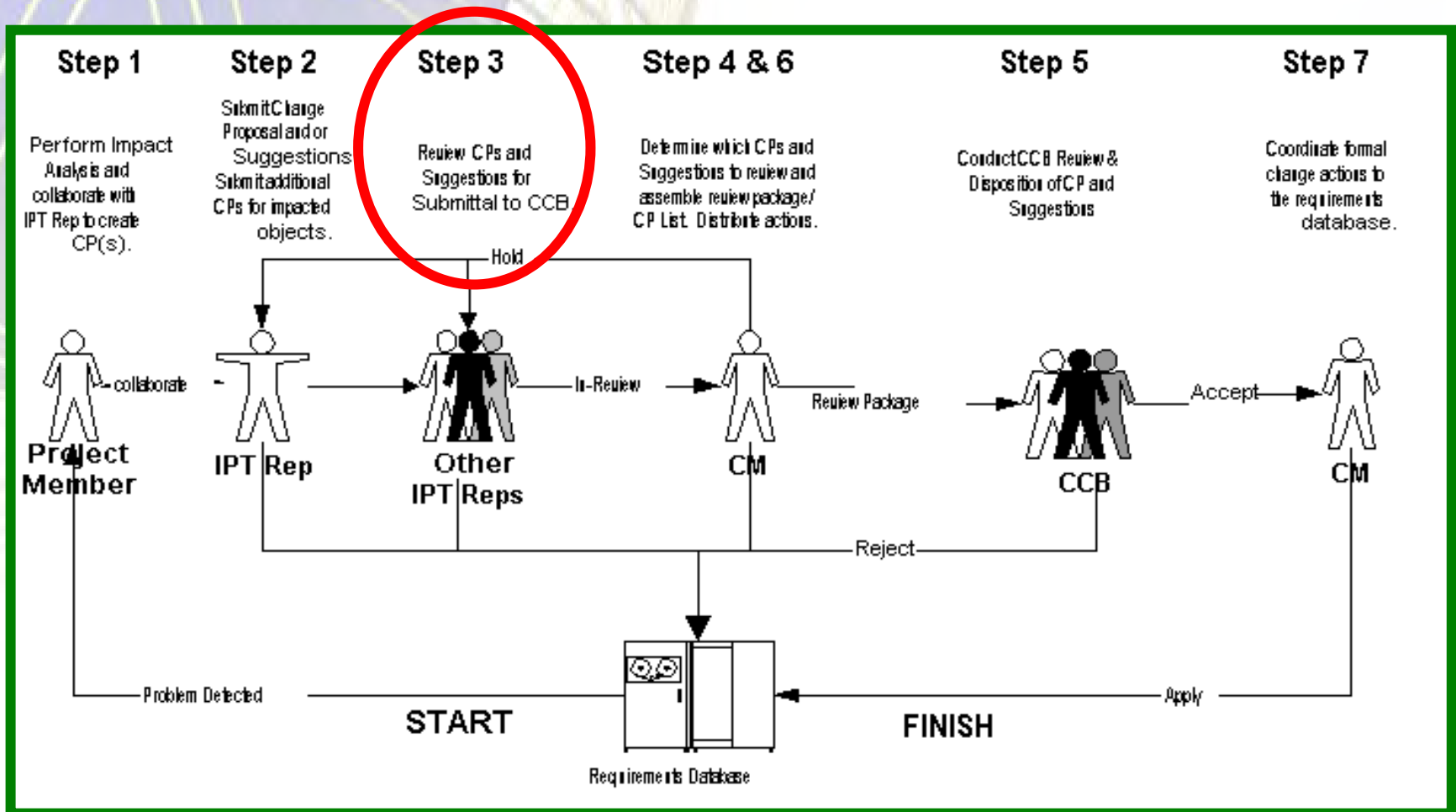

Predefined Views Can Help

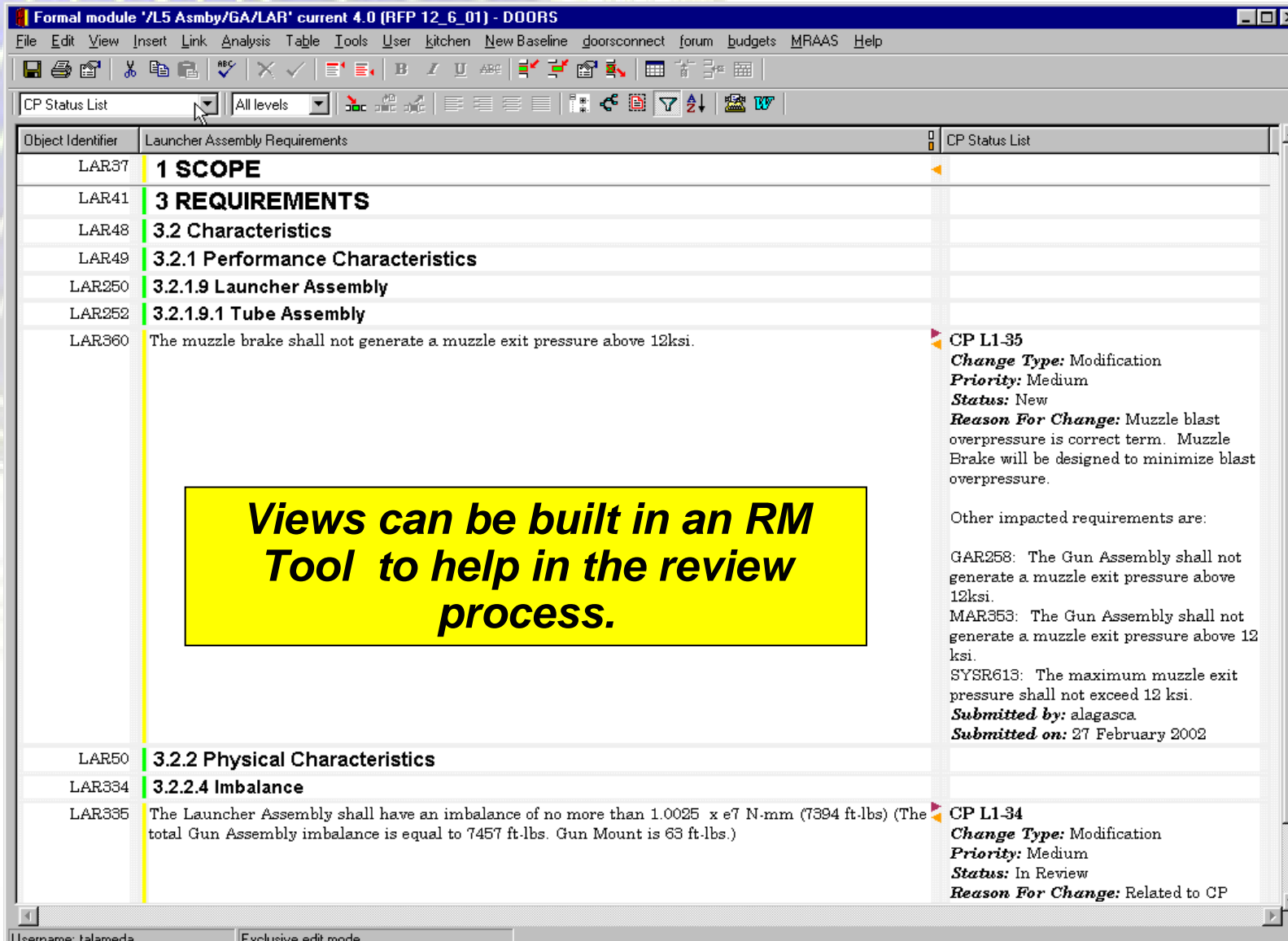

The screenshot displays a software window titled "Formal module 'L5 Asmbly/GA/LAR' current 4.0 (RFP 12_6_01) - DOORS". The interface includes a menu bar (File, Edit, View, Insert, Link, Analysis, Table, Tools, User, kitchen, New Baseline, doorsconnect, forum, budgets, MRAAS, Help) and a toolbar with various icons. A "CP Status List" dropdown menu is set to "All levels".

| Object Identifier | Launcher Assembly Requirements | CP Status List |
|-------------------|--|---|
| LAR37 | 1 SCOPE | |
| LAR41 | 3 REQUIREMENTS | |
| LAR48 | 3.2 Characteristics | |
| LAR49 | 3.2.1 Performance Characteristics | |
| LAR250 | 3.2.1.9 Launcher Assembly | |
| LAR252 | 3.2.1.9.1 Tube Assembly | |
| LAR360 | The muzzle brake shall not generate a muzzle exit pressure above 12ksi. | CP L1-35
Change Type: Modification
Priority: Medium
Status: New
Reason For Change: Muzzle blast overpressure is correct term. Muzzle Brake will be designed to minimize blast overpressure.

Other impacted requirements are:

GAR258: The Gun Assembly shall not generate a muzzle exit pressure above 12ksi.
MAR353: The Gun Assembly shall not generate a muzzle exit pressure above 12 ksi.
SYSR613: The maximum muzzle exit pressure shall not exceed 12 ksi.
Submitted by: alagasca
Submitted on: 27 February 2002 |
| LAR50 | 3.2.2 Physical Characteristics | |
| LAR334 | 3.2.2.4 Imbalance | |
| LAR335 | The Launcher Assembly shall have an imbalance of no more than 1.0025 x e7 N-mm (7394 ft.-lbs.) (The total Gun Assembly imbalance is equal to 7457 ft.-lbs. Gun Mount is 63 ft.-lbs.) | CP L1-34
Change Type: Modification
Priority: Medium
Status: In Review
Reason For Change: Related to CP |

At the bottom of the window, the status bar shows "Username: talameda" and "Exclusive edit mode".

Views can be built in an RM Tool to help in the review process.

Forms Can Also Help

Review Change Proposals - DOORS

CP L1-35 submitted by 'alagasca' on 27 February 2002.

Current

Object Heading:

Object Text:

Show attribute:

Proposed

Object Heading:

Object Text:

Show attribute:

Reason for change:

Other impacted requirements are:

Priority:

Status:

Reviewer comments:

Show proposals:

Forms are another way of stepping thru changes and suggestions made by the IPT.

ID CP's and Suggestions and Schedule JCCB

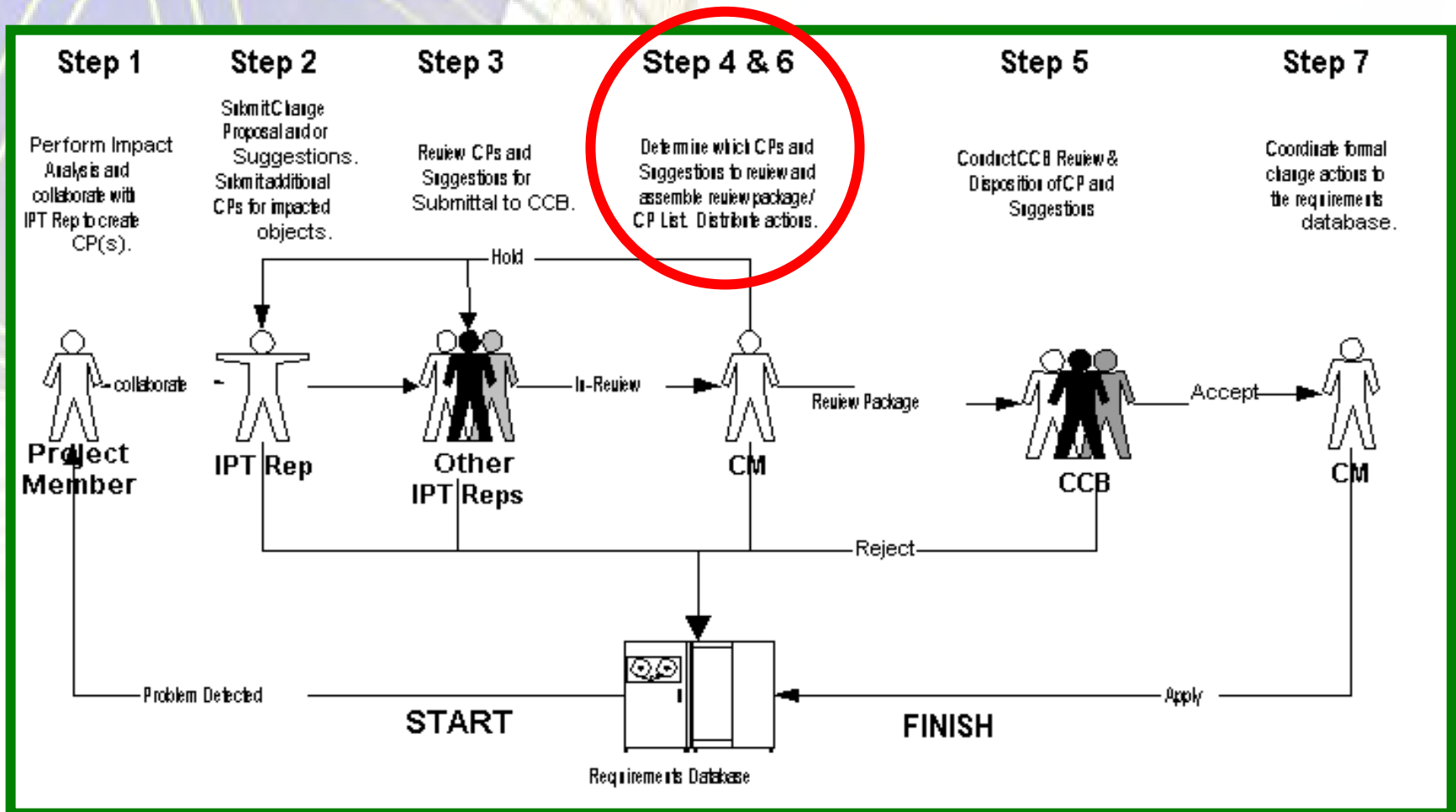

Perform JCCB and Update dB with Results.

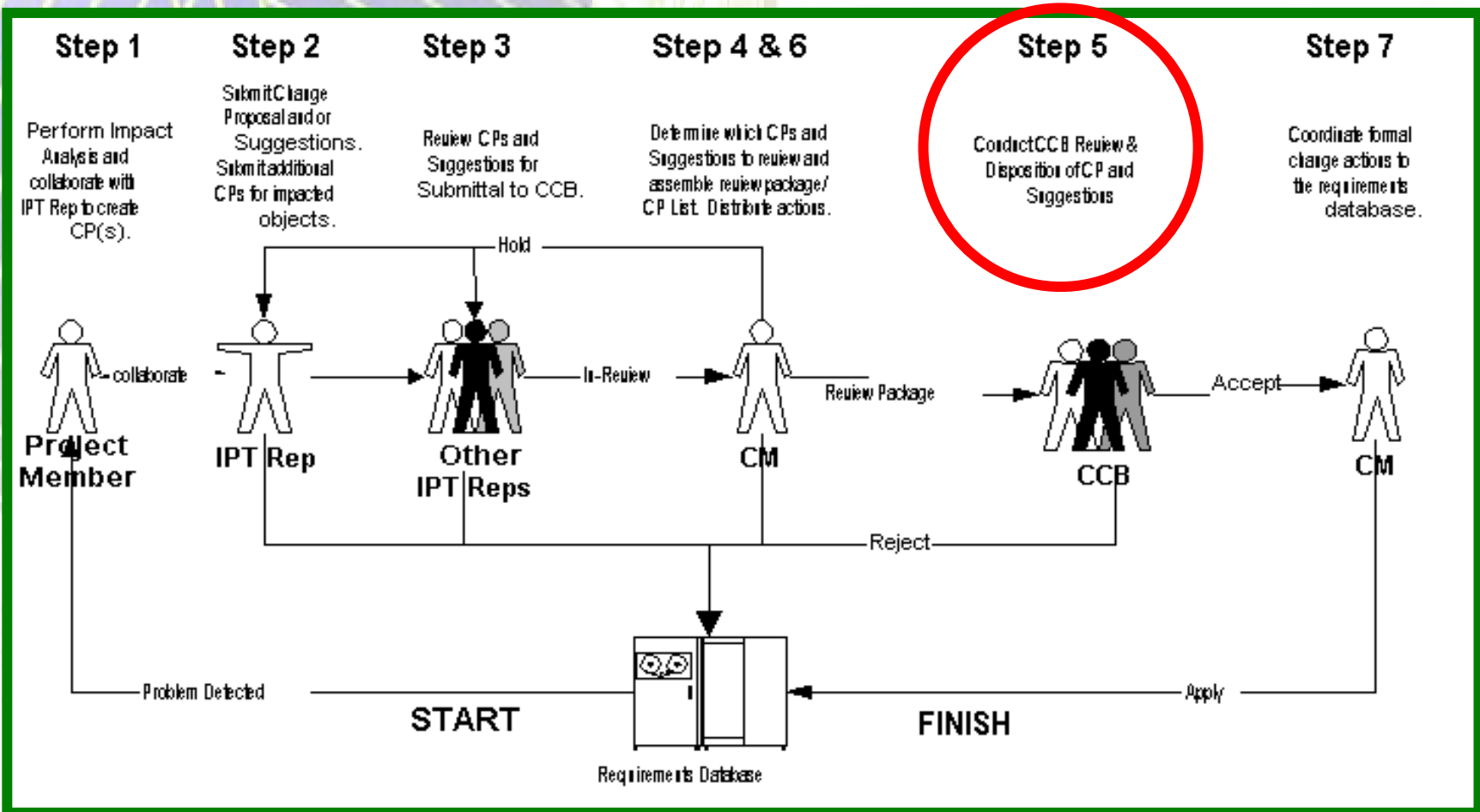

Approved (ready for implementation)

On-Hold (further investigation needed)

Rejected (requested change discarded)

Reaching Consensus

Use IPT forum to Elicit Requirements.

- Include Stakeholders Early and Often.**
- Have Stakeholders Peer Review Requirements**
- Document Rational. It will save you time latter when you will need to defend the requirements.**
- Use a JCCB**
- Try using QFD Method to Build Consensus**

Communicating Requirements

Use of DOORS has helped BUT!!

- Culture shock is hard to overcome.**
- Revert back to WORD and EXCEL documents.**
 - ✓ **Not so efficient and may introduce errors.**
- May need to hold hands**
- Provide Training and Tailor it to the project.**
- Need to pay close attention to Permission and database administration details.**
- JCCB has forced communication to happen and has made it mandatory.**
- Will need good IT support to reach remote locations when using a tool.**

Requirements Metrics

Select metrics you will use.

Don't try to many or they won't be managed.

You can build them into an RM tool.

Some Examples Include:

Volatility

Requirements

TBD

Verified

***Using a tool will produce
metrics naturally.***

Requirements Attributes

Attributes are additional defined characteristics of a requirement and they provide essential information in addition to requirement text

| | |
|----------------------|--|
| Source | Who specified this requirement? |
| Priority | What is the priority of this requirement? |
| Verifiability | Is the requirement verifiable? |
| Accepted | Has this requirement been accepted by the developers? |
| Review | Review status of this requirement |
| Safety | Is this a safety-critical requirement? |
| Comments | Any comments on the requirement to clarify its meaning |
| Questions | Any questions that must be clarified with the source |

You can define attributes that will support your process and make your database more productive for you

Summary

The use of an RM tool is an enabling technology to achieve greater accuracy and efficiency when engineering requirements.

There are definite skills and disciplines required to do requirements engineering

Not only will One need to understand how to:

- Elicit Requirements**
- Capture and Control Them**
- Establish and maintain Traceability**
- Reach Consensus**
- Elicit Verification Methods**
- Communicate Requirements**
- Defined some Metrics and Attributes**

They will also need to be proficient in using and tailoring an RM Tool



Questions?

NDIA 11th Annual Systems Engineering Conference

“The Value of Architecture”

October, 2008

Frank Salvatore
High Performance Technologies, inc.
3159 Schrader Road
Dover NJ, 07801
(973) 442-6436 ext 249
fsalvatore@hpti.com

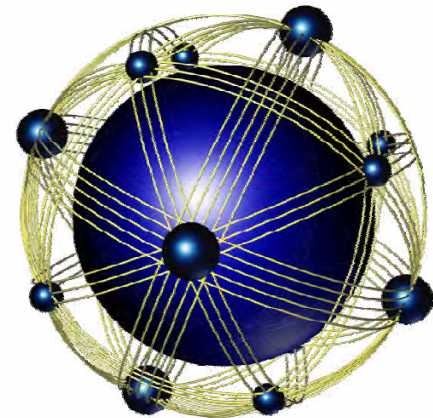

Outline

- Architecture**
- Operational View**
- Goal Hierarchy**
- Process Flow**
- 7.0 Identify and Define Alternatives**
- Tools Architecture**
- Summary**

Architecture

- ❑ **During the systems engineering process architectures are generated to better describe and understand the system**
- ❑ **Architectures provide a description of how subsystems join together to form a system.**
 - **The Functional Architecture identifies and structures the allocated functional and performance requirements.**
 - **The Physical Architecture depicts the system product by showing how it is broken down into subsystems and components.**
 - **The System Architecture identifies all the products (including enabling products) that are necessary**
 - **Operational Views provide a frame of reference that the project work can be related to.**

Operational View

Identify, define, and evaluate potential Universal (Objective) Active Protection System (APS) approaches for the Future Combat System (FCS).



Provide decision makers the tools/data to help identify RDECOM's Science and Technology investments needed to get to an objective APS system.

An Operational View was key. It gave everyone a common frame of reference to work from when executing their part of the analysis.

Goal Hierarchy

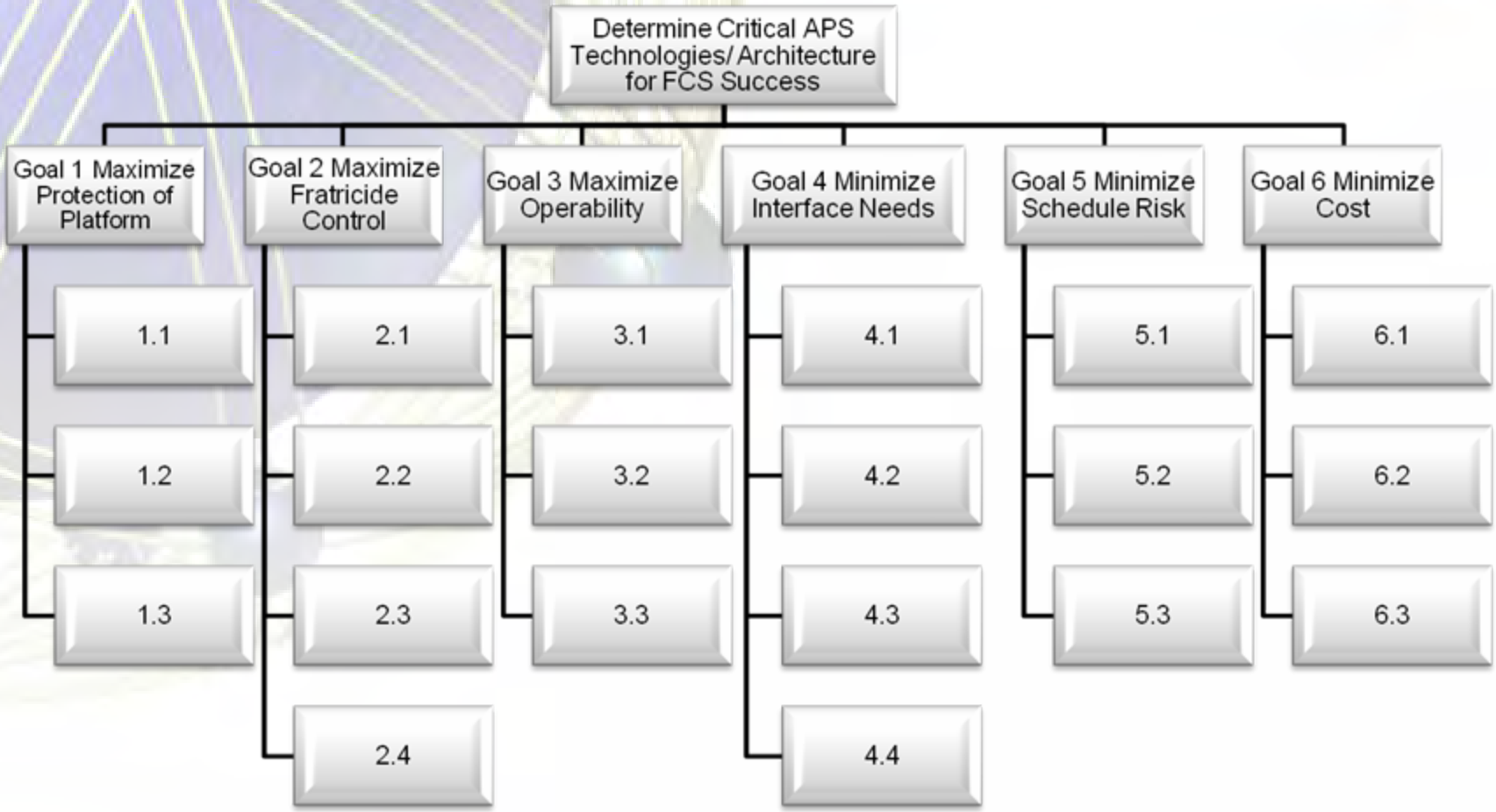

This was the Goal Hierarchy. Essentially an Architecture. Without it we were not focused on what was important to consider in the trade study

Process Flow

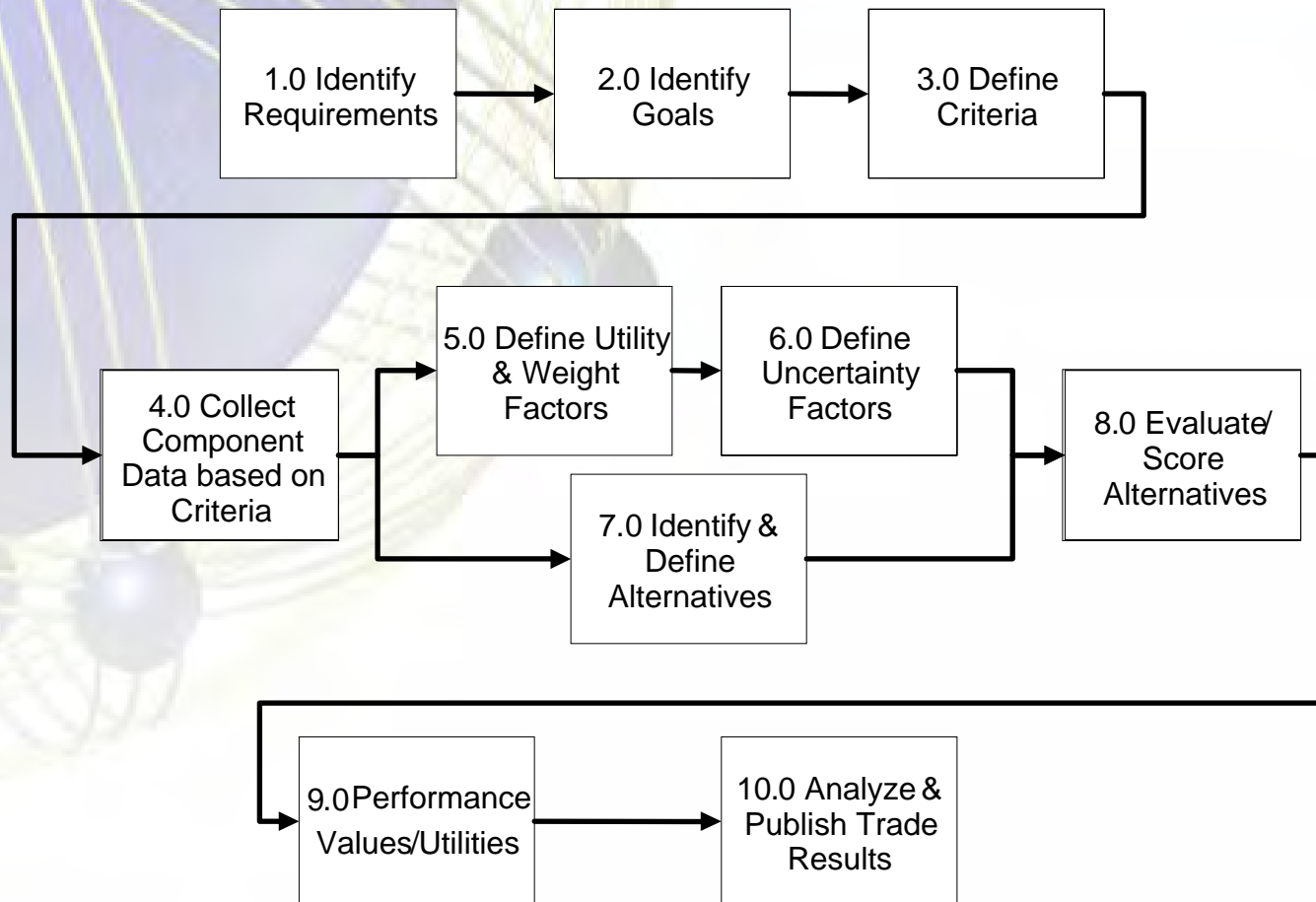

Trade Study Process Flow Diagram was the Process Architecture used. It kept the team aligned and was a central communication tool

7.0 Identify & Define Alternatives

- List Systems/Components
- Previous Trades
- Component Data
- Requirements

- Existing Systems
- Analysis Method, Tools
- System Assumptions

- System Alternatives
- System ID

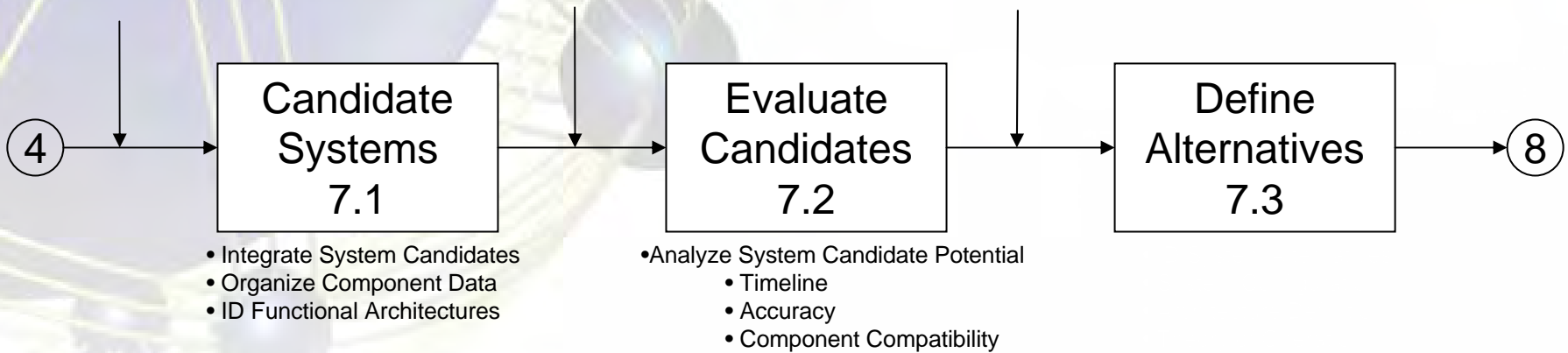

Subject Matter Experts



System and Technology Architectures Required!!!!

7.1 Candidate Systems (Physical Architecture)

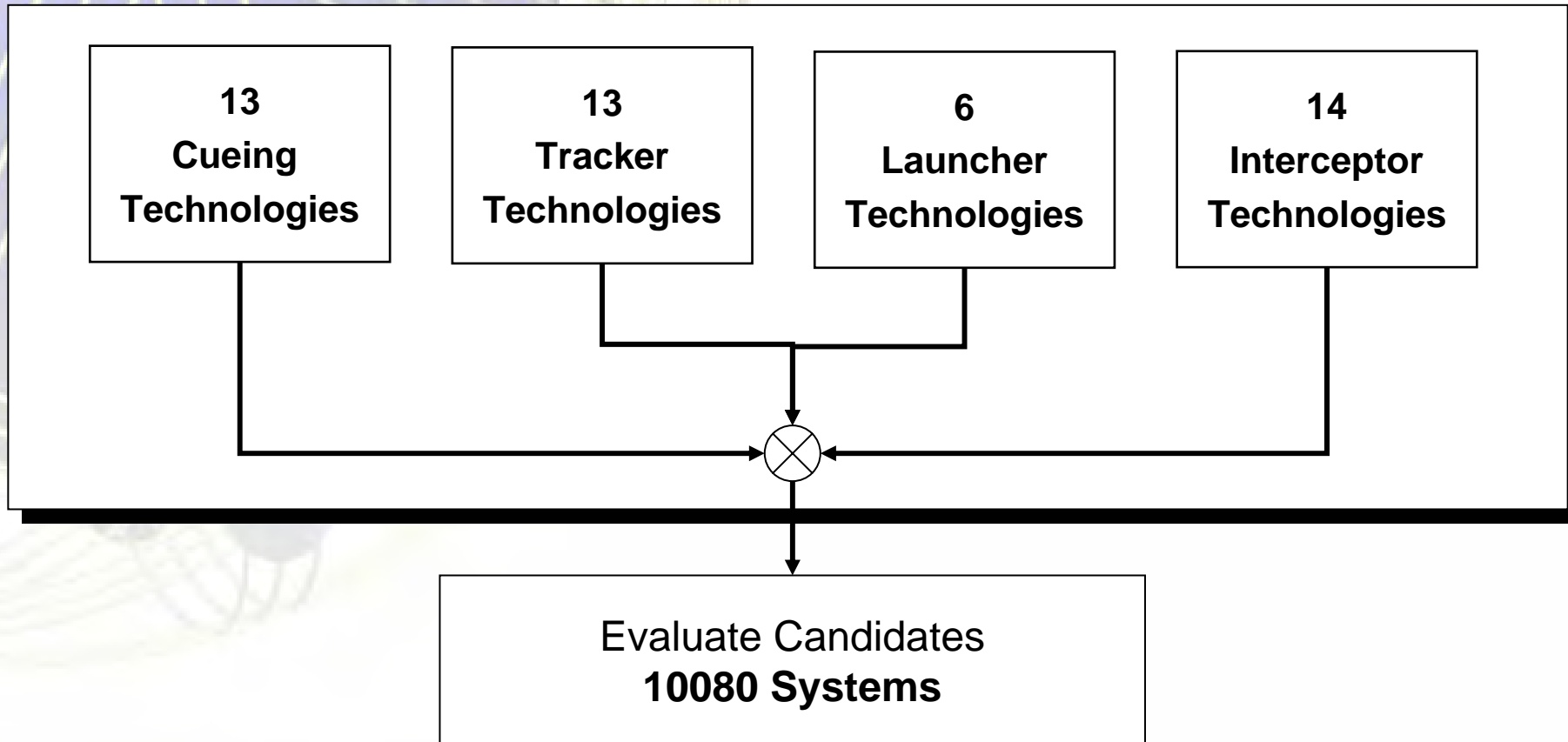

The Physical Architecture was core to understanding the basic construct of an Active Protection System. All 10,080 Systems Evaluate had the same Physical Architectures

7.2 Evaluate Candidates (Functional Analysis and Allocation)

- ❑ Major component of the trade study was the Functional Analysis and Allocation (FAA).
 - It allowed for a better understanding of what the technologies could and had to be able to do to satisfy the performance requirements of the system, in what ways they could do it, and to some extent, the priorities and conflicts associated with lower-level functions.
 - It provided information essential to optimizing physical solutions.
 - Key tools were Functional Flow Block Diagrams, and the Time Line Analysis

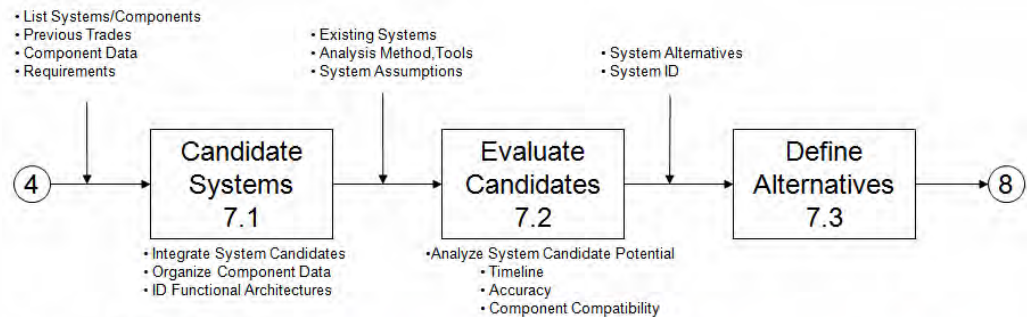

Subject Matter Experts



7.2 Evaluate Candidates (System Functions)

| Function | Definition |
|--|--|
| Detect, Acquire | Measure and report an event not due to ambient noise |
| Declare | Measure and report an persistent object that should be tracked |
| Classify | Measure and report what the persistent object is either by class or specific type/item. |
| Coarse Track | Measure and report an object and determine that it's trajectory point of closest approach to our platform is threatening. Classify and coarse track may be based on the same measured data set and completed at the same time |
| Initial Slew | Initial slew of launcher to launch position using fire control solution based on coarse track |
| Initial Tube Selection | Initial designation of launch tube or tubes in fixed system that need to be "warmed up" using fire control solution based on coarse track |
| Fine Track | Measure and report a target to enable calculation of a fire control solution |
| Fine Slew & Fire Control | Slew launcher to final position and launch an interceptor loaded with any required flight path, terminal guidance, and fuzing information |
| Final Tube Selection & Fire Control | Final designation of launch tube in fixed system and launch an interceptor loaded with any required flight path, terminal guidance, and fuzing information |

Established a common vocabulary for understanding and describing how each for the systems studies operated.

7.2 Evaluate Candidates System Functions (cont.)

| Function | Definition |
|-------------------------------------|---|
| In-Flight Track | Measure and report a target trajectory to provide in-flight guidance to an interceptor |
| No-Op | “No operation” - used to designate function not performed |
| In-Flight Guidance | Propulsion to change flight path of interceptor |
| Terminal Track | Measure and report a target trajectory to provide terminal guidance & fuzing updates to an interceptor |
| Terminal Guidance & Fuze | Orient (focus) the warhead to produce the desired effect & initiate the effect at the prescribed time and / or the prescribed distance from target |
| Warhead Effect | Target negation |

Established a common vocabulary for understanding and describing how each for the systems studies operated.

7.2 Evaluate Candidates

Functional Flow Block Diagram (Unguided Interceptor)

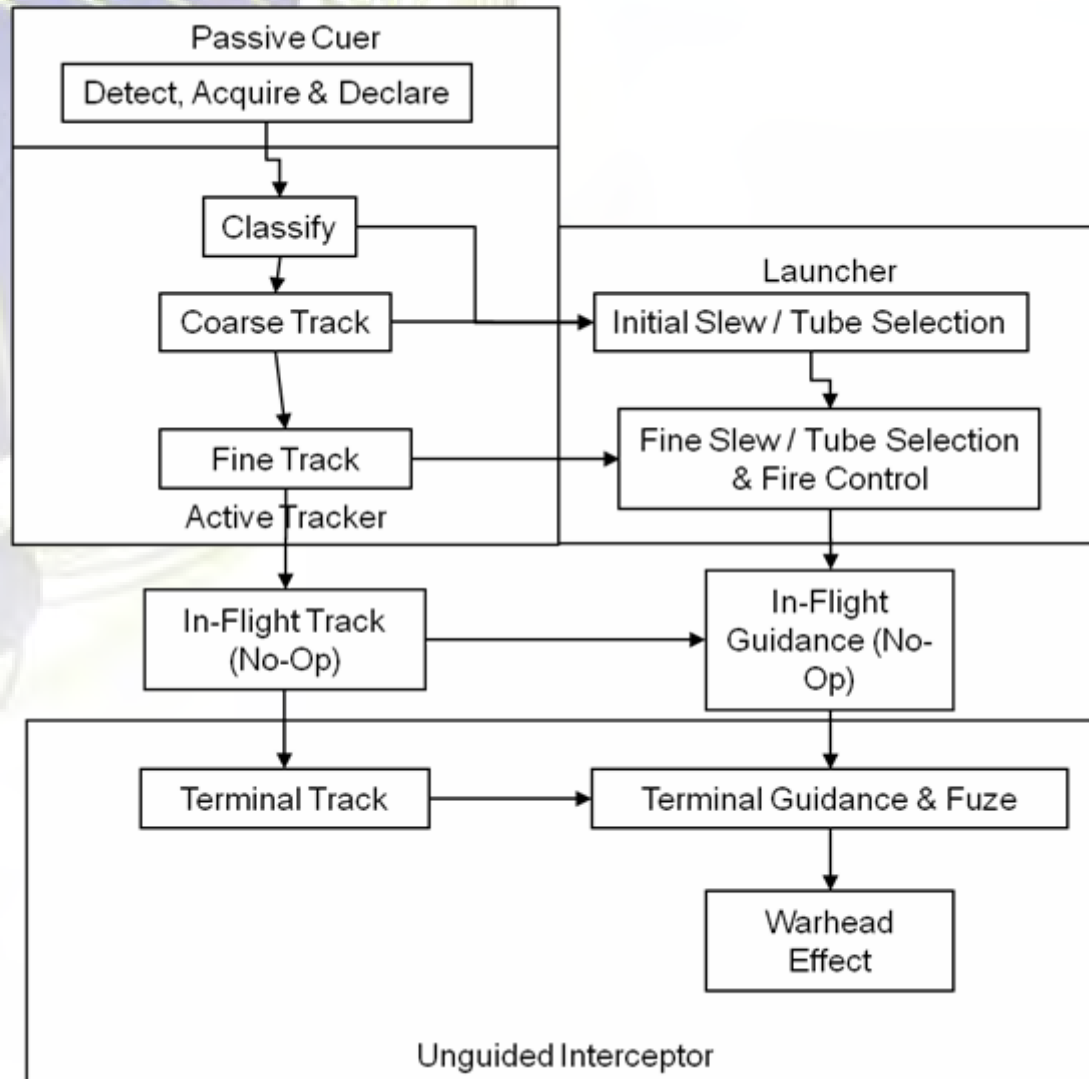

7.2 Evaluate Candidates

Functional Flow Block Diagram (Guided Interceptor)

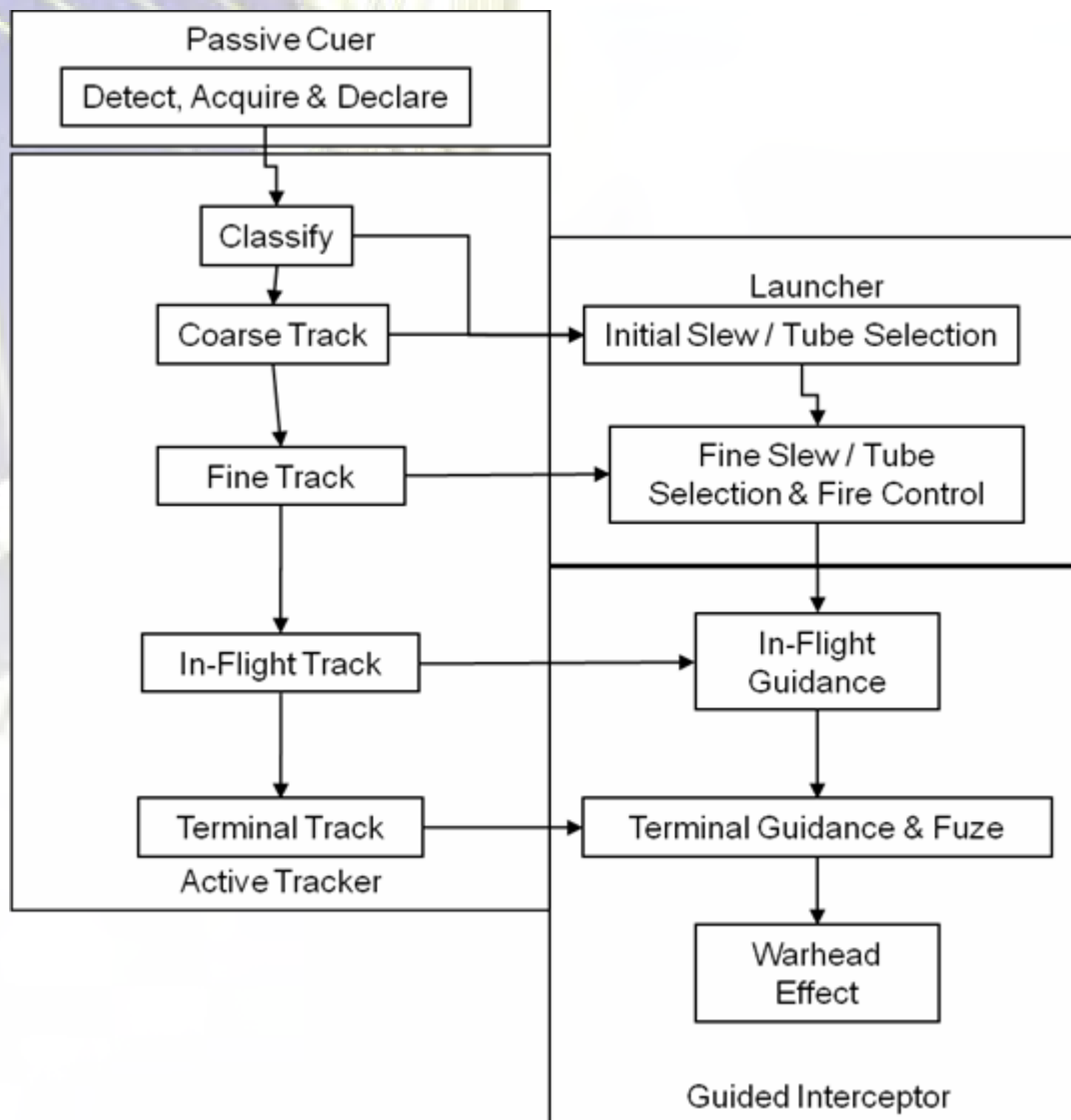

7.2 Evaluate Candidates (Functional to Physical Allocation)

| | | Architectures for Unguided Interceptors | | | | Architectures for Guided Interceptors | | | |
|------------------|--|---|-------------------------------|----------------------------------|-----------------------|---------------------------------------|-------------------------------|----------------------------------|-----------------------|
| | | U1 | U2 | U3 | U4 | G1 | G2 | G3 | G4 |
| System Functions | Detect, Acquire & Declare | Passive Cuer | Passive Cuer / Coarse Tracker | Passive Cuer | Active Cuer / Tracker | Passive Cuer | Passive Cuer / Coarse Tracker | Passive Cuer | Active Cuer / Tracker |
| | Classify | Active Tracker | | Passive or Active Coarse Tracker | | Active Tracker | | Passive or Active Coarse Tracker | |
| | Coarse Track | | Launcher | Launcher | Launcher | Launcher | Launcher | Launcher | Launcher |
| | Initial Slew / Tube Selection | Active Tracker | Active Fine Tracker | Active Fine Tracker | Active Cuer / Tracker | Active Tracker | Active Fine Tracker | Active Fine Tracker | Active Cuer / Tracker |
| | Fine Track | Launcher | Launcher | Launcher | Launcher | Launcher | Launcher | Launcher | Launcher |
| | Final Slew / Tube Selection & Fire Control | None | None | None | None | Active Tracker | Active Fine Tracker | Active Fine Tracker | Active Cuer / Tracker |
| | In-Flight Track | Unguided Interceptor | Unguided Interceptor | Unguided Interceptor | Unguided Interceptor | Guided Interceptor | Guided Interceptor | Guided Interceptor | Guided Interceptor |
| | In-Flight Guidance | | | | | Active Tracker | Active Fine Tracker | Active Fine Tracker | Active Cuer / Tracker |
| | Terminal Track | Guided Interceptor | Guided Interceptor | Guided Interceptor | Guided Interceptor | Active Tracker | Active Fine Tracker | Active Fine Tracker | Active Cuer / Tracker |
| | Terminal Guidance & Fuze | | | | | Guided Interceptor | Guided Interceptor | Guided Interceptor | Guided Interceptor |
| | Warhead Effect | | | | | | | | |

Functional allocation to physical components provided context for data provided on specific components and was critical in both the Timeline and Accuracy Analysis.

7.2 Evaluate Candidates Timeline Analysis



Threat



Interceptor

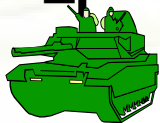

| | | | |
|--------|--------------------------------|---------|---------------|
| Threat | Threat Launch Range | 1500.00 | Meters |
| | Threat Average Velocity | 1500.00 | Meters/Second |
| | Time to impact Platform | 1.00 | Seconds |
| | Threat Time to Intercept Point | 0.87 | Seconds |

| | | | |
|-------------|------------------------------|---------|---------------|
| Interceptor | Min Range to Defeat Threat | 200.00 | Meters |
| | Time to Min Range | 0.20 | Seconds |
| | Interceptor Average Velocity | 1000.00 | Meters/Second |

| System Functions | | Function Time | Timeline | Threat Range to Platform | Interceptor Range to Threat |
|------------------|-----------------------|---------------|----------|--------------------------|-----------------------------|
| Threat Launch | | 0.000 | 0.00 | 1500 | |
| Cue | Cue | 0.030 | 0.03 | 1455 | |
| | Track Handoff | 0.000 | 0.03 | 1455 | |
| Track | Track Established | 0.030 | 0.06 | 1410 | |
| | Min Fire Control Time | 0.000 | 0.06 | 1410 | |
| Margin | | 0.607 | 0.67 | 501 | |
| Launch | Slew | 0.030 | 0.70 | 456 | |
| | Stabilize | 0.030 | 0.73 | 411 | |
| Intercept | Initiate Interceptor | 0.000 | 0.73 | 411 | 0 |
| | Launch & Fly Out | 0.200 | 0.93 | 111 | 200 |
| Platform Defeat | | 0.073 | 1.00 | 9.48E-13 | 273.33 |

Range vs Time

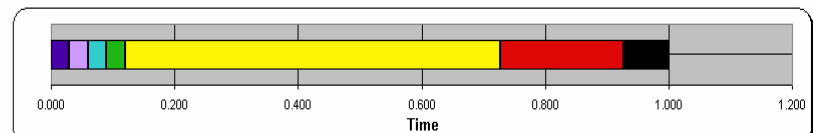
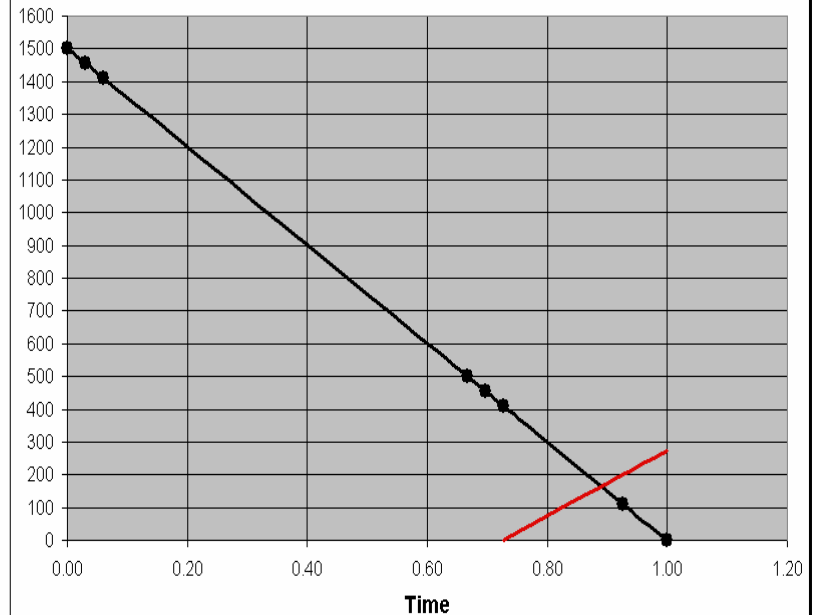

Pass Screen

The results of the Functional Analysis and Allocation effort provided the basis for how time was to be calculated for each of the 10K plus systems to be evaluated.

7.2 Evaluate Candidates

Interface Compatibility Analysis

SCORING INSTRUCTIONS

| Level | Component Compatibility Description |
|-------|---|
| 9 | - Significant software integration with concurrently developed hardware. |
| 3 | - Hardware and/or software interfaces defined and analyzed so complexity is |
| 1 | - Software and/or hardware interfaces known but need to be revised with as |
| 0 | - Interfaces exist and no changes are required. |

[Cue - Track Results](#)

[Launch - Intercept Results](#)

Hardware interface c

- Mechanical – envelope, attachment, obscuration, alignment
- Hydraulic and pneumatic - flow rates, pressures
- Mass – weight, moments of inertia, centers of gravity
- Environment – mechanical shock and vibration, particulate, etc
- Thermal - temperature limits, temperature control
- Electrical – signals, voltage, power

Software interface considerations include added requirements for

- Data encryption and encoding
- Data structures
- Data storage
- Data transfer rates
- Data communication protocols
- Data processing and algorithms

Experties

| | |
|---|--|
| 0 | No experties, Don't fill out scores for anything you have no exp |
| 1 | If you have seen a briefing on the technology or have only rece |
| 3 | If you have a working knowledge (understand underlying physid |
| 9 | If you are intimately involved in designing, developing, and or in |

| | | Launchers | | | | | | |
|--------------|----------------|------------|------------|------------|------------|------------|------------|------------|
| | | Launcher 1 | Launcher 2 | Launcher 3 | Launcher 4 | Launcher 5 | Launcher 6 | Launcher 7 |
| Interceptors | Interceptor 1 | 1 | 1 | 1 | 1 | 9 | 9 | 0 |
| | Interceptor 2 | 1 | 0 | 0 | 3 | 9 | 9 | 1 |
| | Interceptor 3 | 0 | 2 | 0 | 9 | 1 | 9 | 2 |
| | Interceptor 4 | 1 | 1 | 1 | 1 | 1 | 1 | 1 |
| | Interceptor 5 | 0 | 4 | 3 | 1 | 1 | 1 | 4 |
| | Interceptor 6 | 0 | 4 | 3 | 1 | 1 | 1 | 4 |
| | Interceptor 7 | 3 | 9 | 3 | 3 | 3 | 0 | 3 |
| | Interceptor 8 | 3 | 9 | 3 | 3 | 3 | 0 | 3 |
| | Interceptor 9 | 1 | 9 | 3 | 1 | 0 | 1 | 1 |
| | Interceptor 10 | 3 | 9 | 3 | 3 | 0 | 3 | 3 |
| | Interceptor 11 | 1 | 9 | 1 | 1 | 1 | 1 | 1 |
| | Interceptor 12 | 1 | 9 | 1 | 1 | 1 | 1 | 1 |
| | Interceptor 13 | 0 | 9 | 9 | 0 | 0 | 3 | 3 |

Physical to Functional Allocations helped in determining what the interfaces would be and gave us a way to make subjective evaluations of their maturity

7.3 Define Alternatives

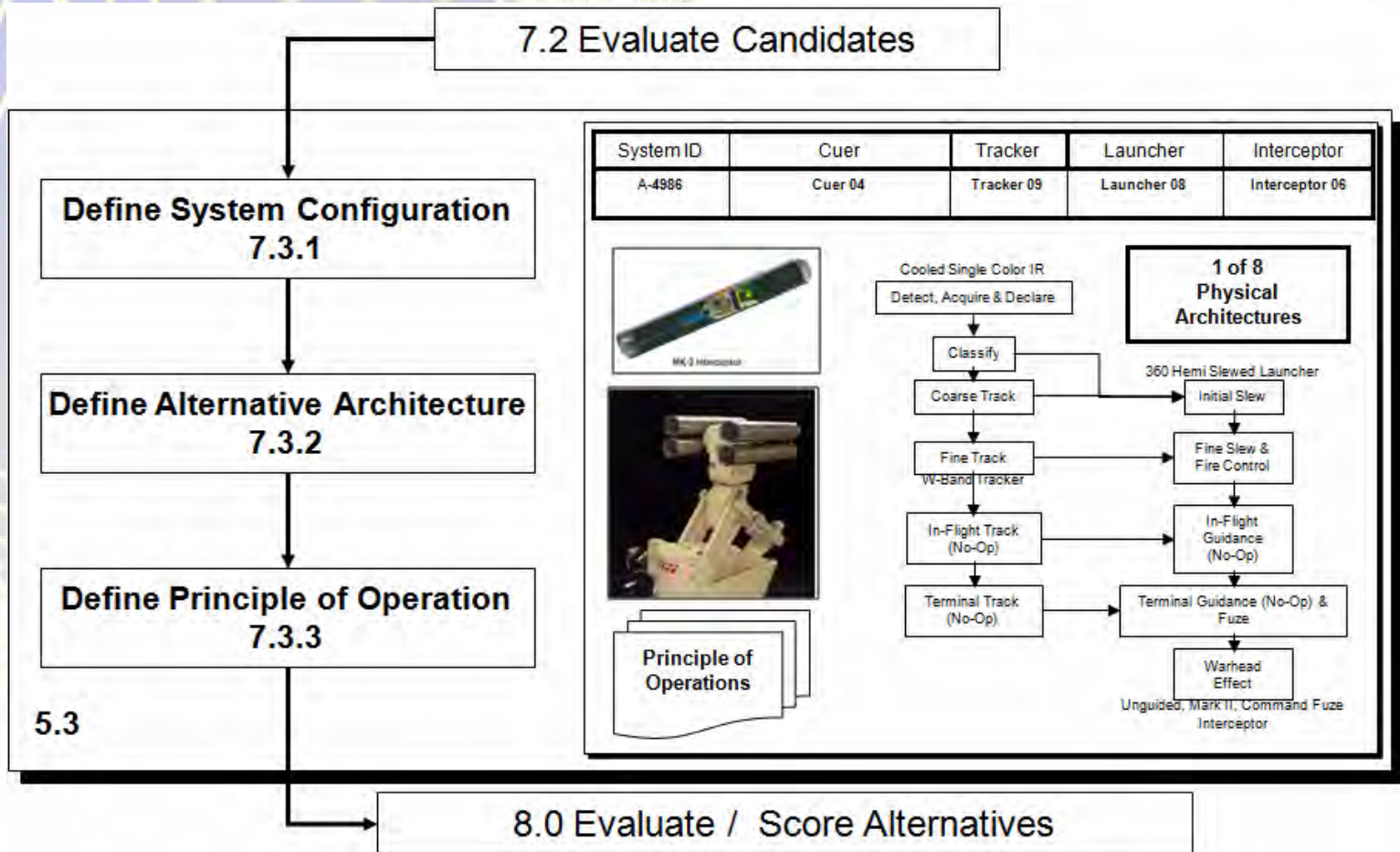

Physical to Functional Allocation allowed us to define the system configuration, system architecture, and principle of operation of each system analyzed.

Tools Architecture

Abstract Architecture

□ Schematic Block Diagrams

- Physical Architecture
- Interfaces
- Data Flow
- Easy to Read
- Hard to Maintain

Formal Architecture

□ IDEF0, FFBD, EFFBD, Hierarchy

- Physical Architecture
- Functional Architecture
- Interfaces
- Data Flow
- Easy to Maintain
- Hard to Read

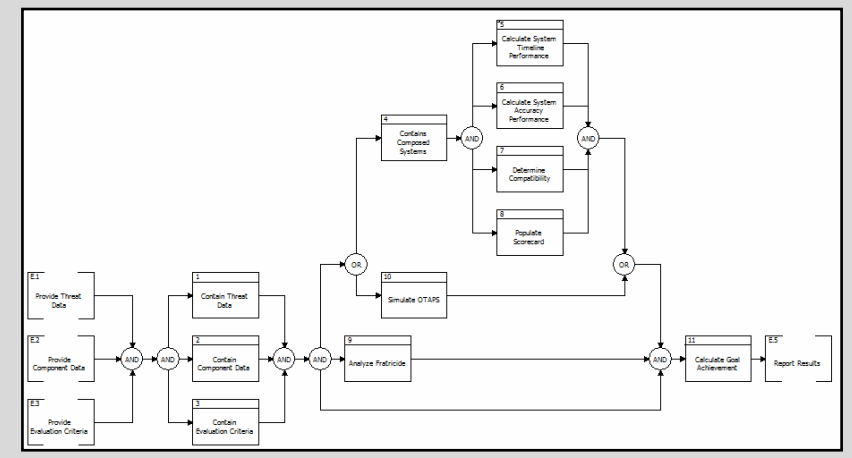
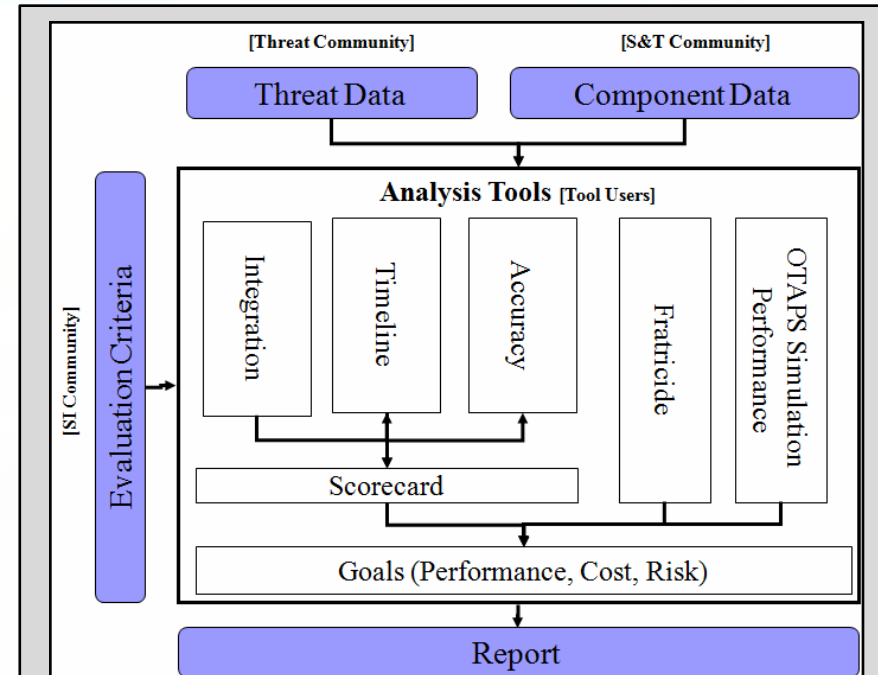

Schematic Block Diagram

- Home
- Threat Data
- Component Data
- Evaluation Criteria
- Timeline
- Accuracy
- Integration
- Fratricide
- OTAPS Simulation
- Scorecard
- Goal
- Report

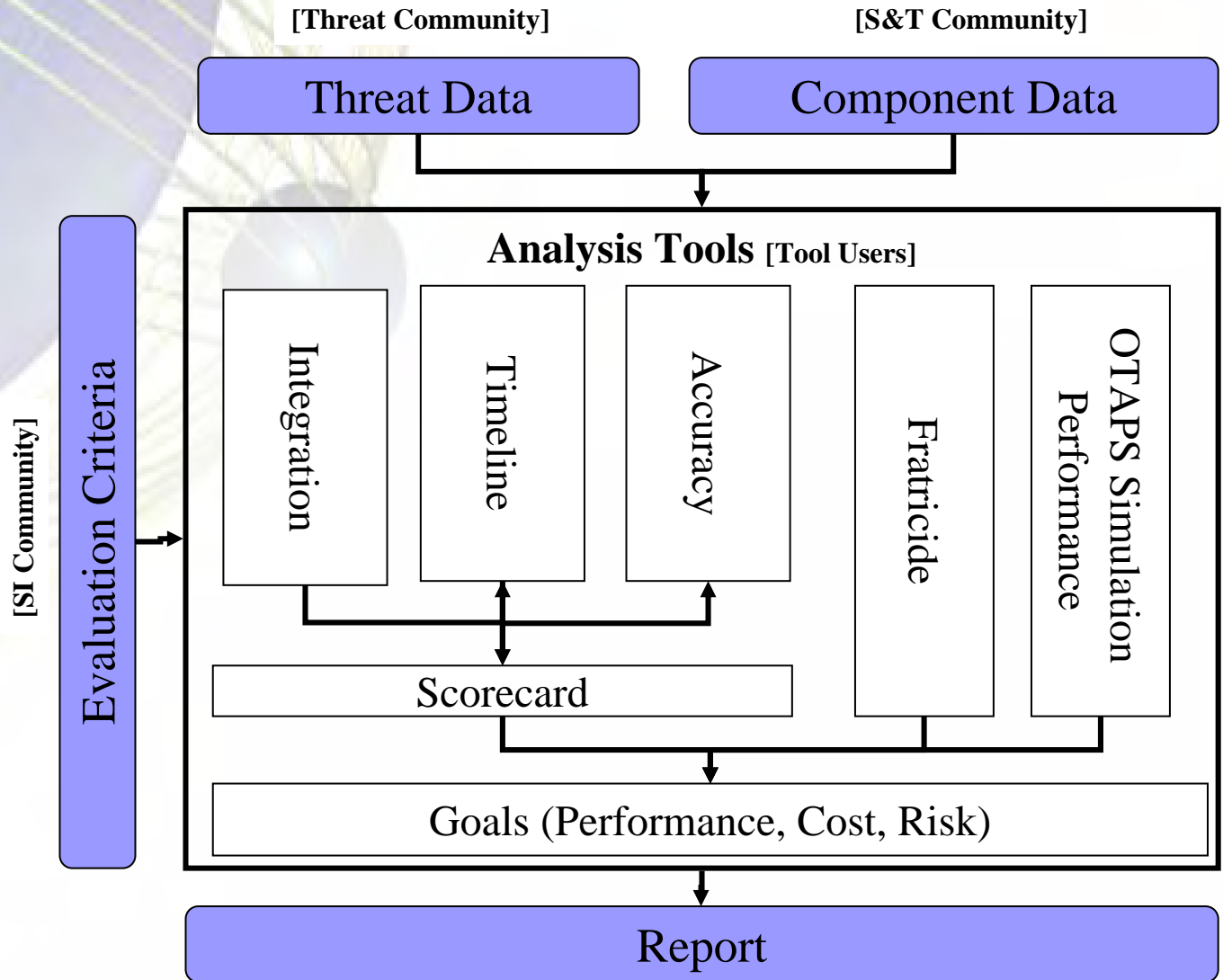

Perform APS Analysis

Functional Flow Block Diagram (FFBD)

The FFBD (Function Flow Block Diagram) of the APS Tool shows the sequencing and control flow of the functions of the integrated set of trade study tools

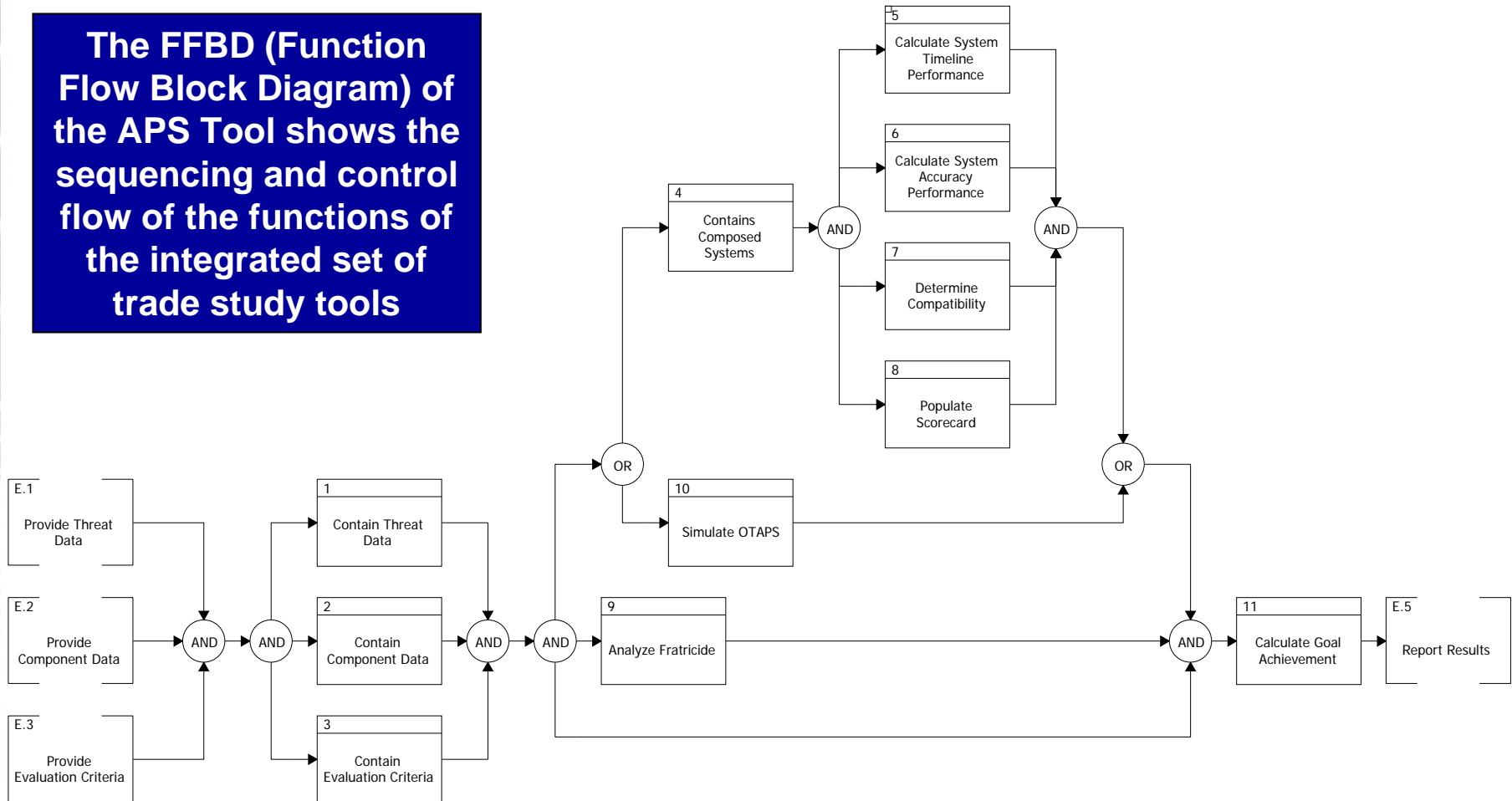

Hierarchy Diagram

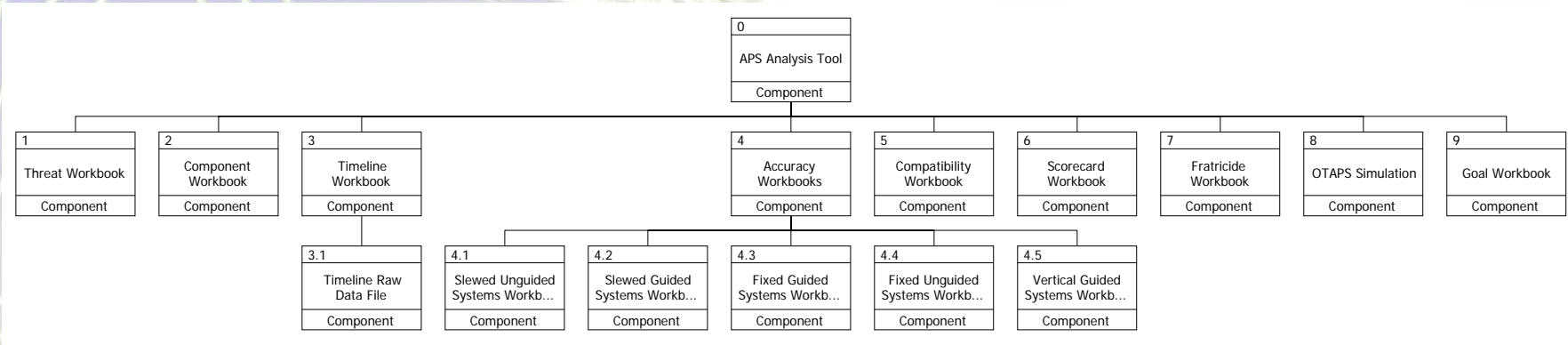

The Hierarchy Diagram was a quick way to quickly capture all the Trade Study Tools and their Hierarchical relationships. These ultimately became the configuration items that were kept under version control.

Summary

- ❑ Use of Business Process Models helped everyone to understand the trade study approach that was being used.
- ❑ Using Hierarchy Diagrams helped the trade study team stay focused on the goals and criteria being evaluated.
- ❑ Physical Architecture, Functional Architectures provided the trade study team and the rest of industry a common language to work from. It also was core to defining systems, organizing data
- ❑ Functional Flow Block Diagrams and Functional To Physical Allocation was instrumental to establishing rules used to automating the evaluation of 10K plus system alternatives. More importantly it allowed the entire APS community to agree it was being done correctly in all 10k plus cases.
- ❑ Capturing System Architectures was essential to understand how to model system time function and communicate it to the community.
- ❑ Structured Physical and Functional decomposition made establishing a System ID scheme simple.
- ❑ Tool Architecture helped to communicate how each tool was used in the trade study process
 - ✓ many tool interface gaps were identified and fixed.

Improving Weapon System Investment Decisions

A Knowledge-based Approach to Weapon System Acquisitions Could Improve Outcomes

Travis Masters
Senior Defense Analyst
U.S. Government Accountability Office
Wright-Patterson AFB, OH

DOD Framework vs. Knowledge-based Best Practices Model

DOD's Framework

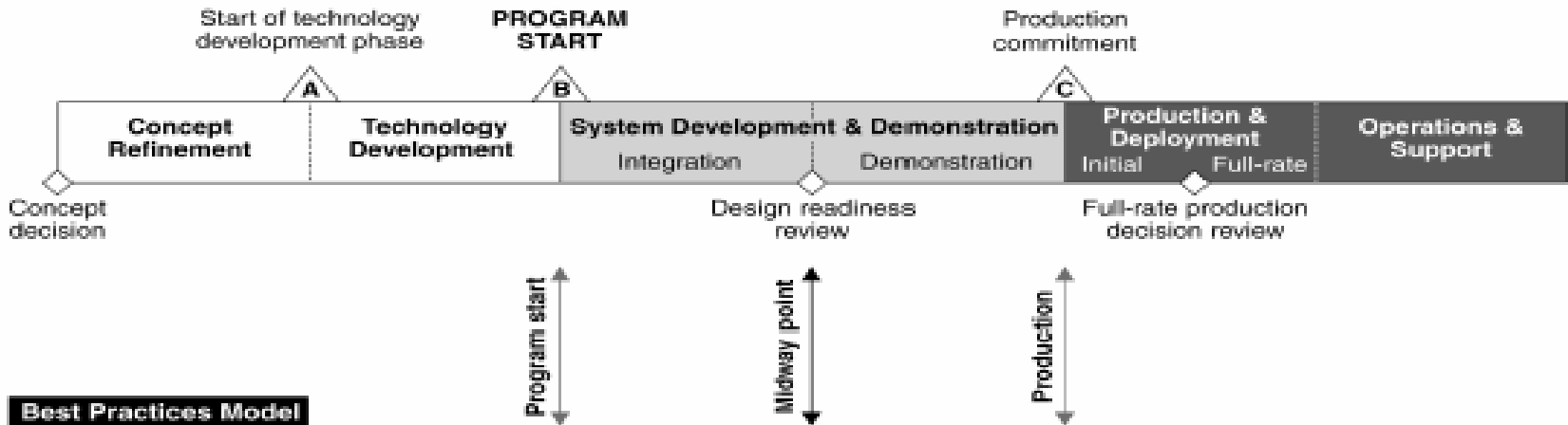

Best Practices Model

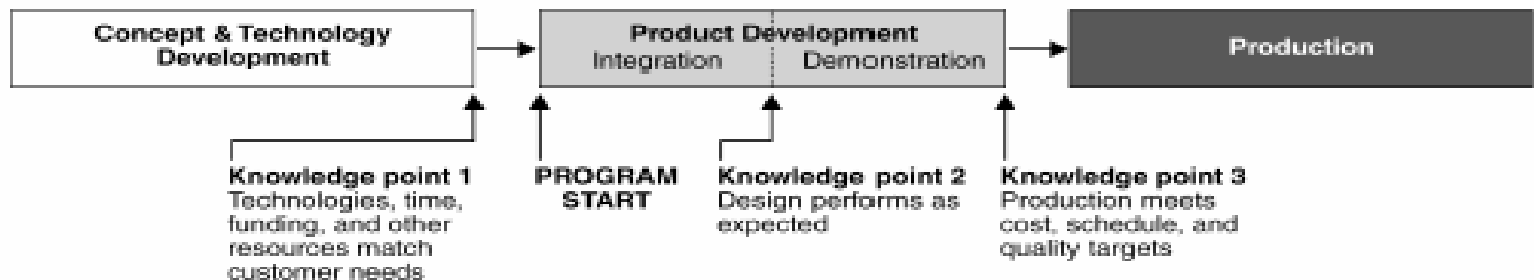

Sources: DOD and GAO.

Major Determinant Of Program Outcomes Is The Level Of Knowledge Attained At Key Junctures

Knowledge Point 1: At milestone B, a match is achieved between the user's needs and the developer's resources (indicator: technology readiness level)

Knowledge Point 2: At critical design review, the product design demonstrates its ability to meet user needs and is stable (indicator: % of engineering drawings released)

Knowledge Point 3: At milestone C, it is demonstrated that the product can be produced within cost, schedule, and quality targets (indicator: % of key processes in statistical control)

Making a Business Case that a Product Can Be Developed Within Resource Constraints

At milestone B programs should present a business case that provides evidence that:

- (1) Warfighter needs are valid and can be met with chosen concept, and
 - (2) The chosen concept can be developed and produced within resources-technologies, funding, design knowledge, and time
-

Resolving Gaps Between Requirements and Resources Before Program Start

Early systems engineering enables a developer to identify and resolve gaps between resources and requirements before product development begins

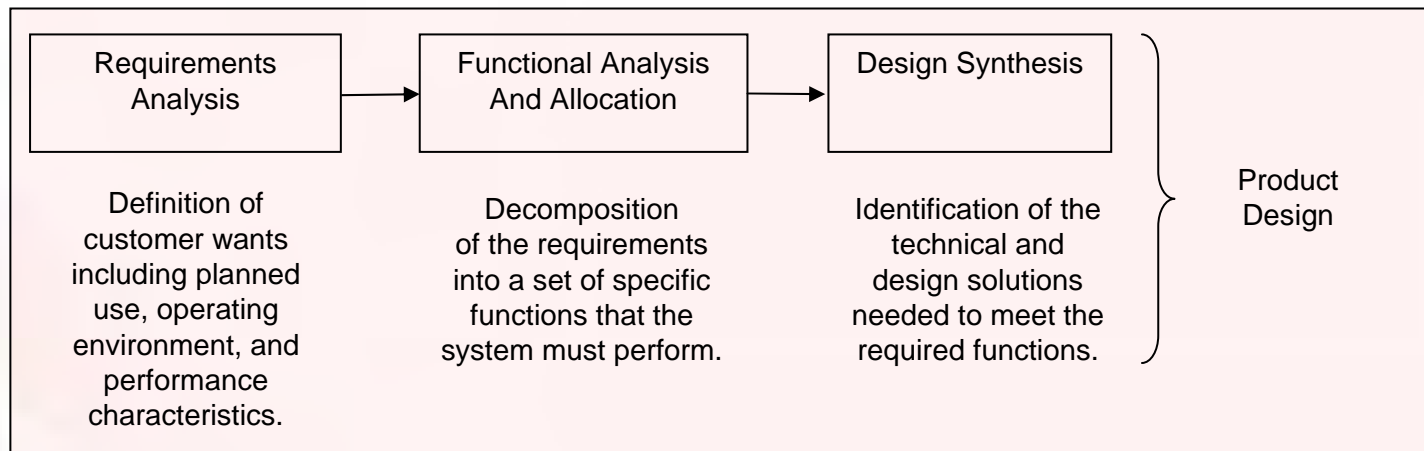

DOD Programs Continue to Experience Cost and Schedule Problems

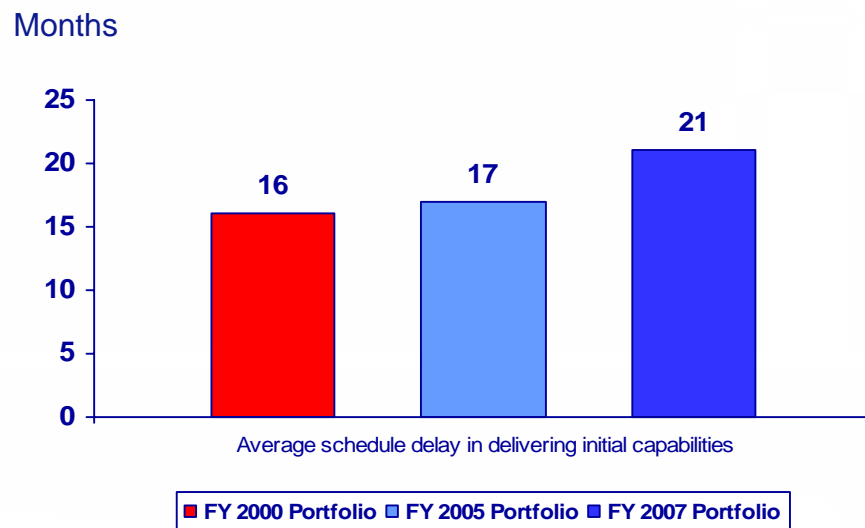
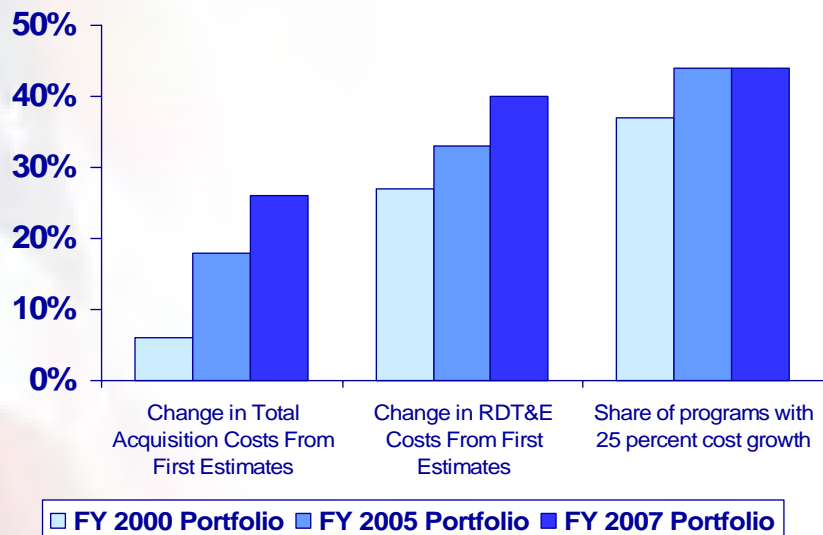



Source: GAO analysis of DOD data.

GAO Continues to Find That Programs Begin Without Key Knowledge

- Requirements are not well understood
 - Quantum leaps in capability not incremental changes
 - Technologies are not mature
 - Cost and schedule estimates are overly optimistic
 - Program cycle times are too lengthy
-

Little Evidence of Widespread Adoption of Knowledge-based Acquisition Process

- DOD’s acquisition practices necessary to ensure effective implementation of knowledge-based process are not always followed despite policies and guidance to the contrary.

| Key junctures | Development start | Design review | Production start |
|---------------------------------|---|---|---|
| | Knowledge point 1 | Knowledge point 2 | Knowledge point 3 |
| Best practices | Mature all critical technologies | Achieve knowledge point 1 on time and complete 90 percent of engineering drawings | Achieve knowledge points 1 and 2 on time, and have all critical processes under statistical control |
| DOD outcomes^a |  12 percent of programs |  4 percent of programs |  0 percent of programs ^b |

Source: GAO presentation of DOD data.

a Not all programs provided information for each knowledge point or had passed through all three key junctures.

b In our assessment of two programs, the Light Utility Helicopter and the Joint Cargo Aircraft, are depicted as meeting all three knowledge points when they began at production start. We excluded these two programs from our analysis because they were based on commercially available products and we did not assess their knowledge attainment with our best practices metrics.

GAO's Review of the Acquisition Decision Support Systems

GAO has done a lot of work looking at the DAS

Congress directed GAO to initiate a body of work looking at the funding and requirements processes and how they could support better program outcomes

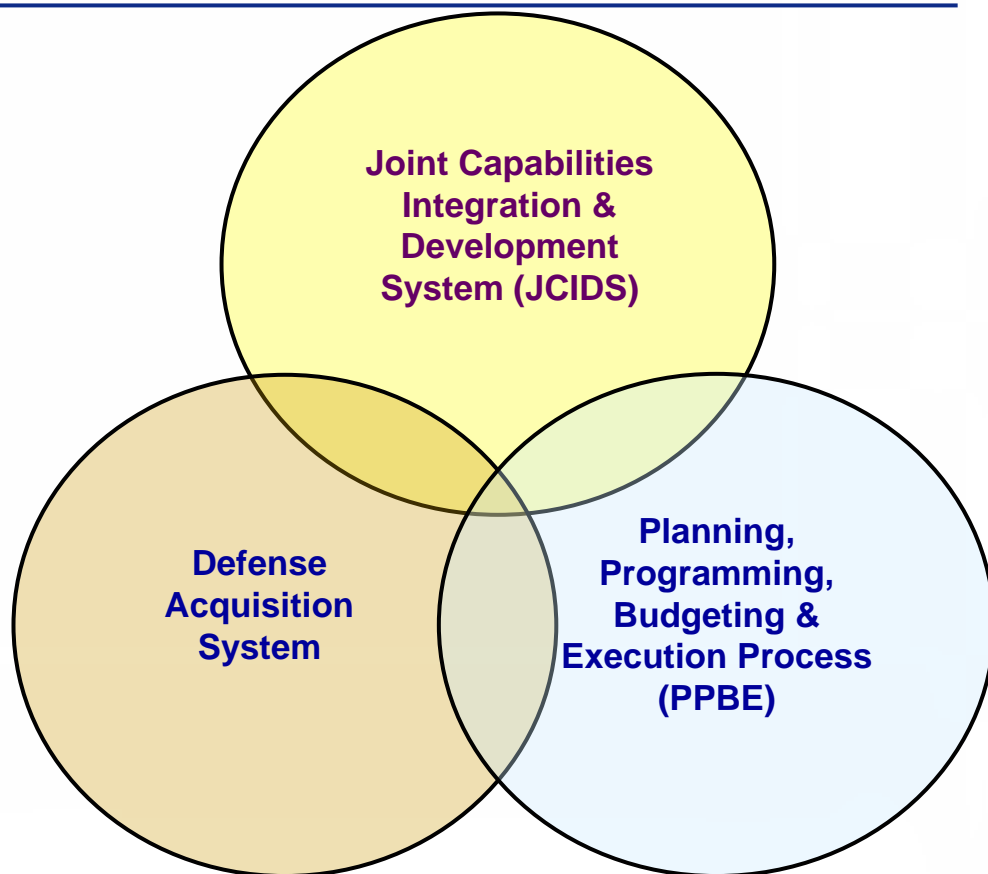

Portfolio Management: A Successful Commercial Model

- Each investment must be viewed from an enterprise level as contributing to the collective whole, rather than independent and unrelated
 - Identify and Prioritize Market Opportunities to Lay the Foundation for Achieving the Right Mix of Products
 - Use a Disciplined Process to Identify New Products and Achieve a Balanced Portfolio
 - Ensure strong governance, committed leadership, empowered decision makers, and effective accountability

The Portfolio Management Funnel

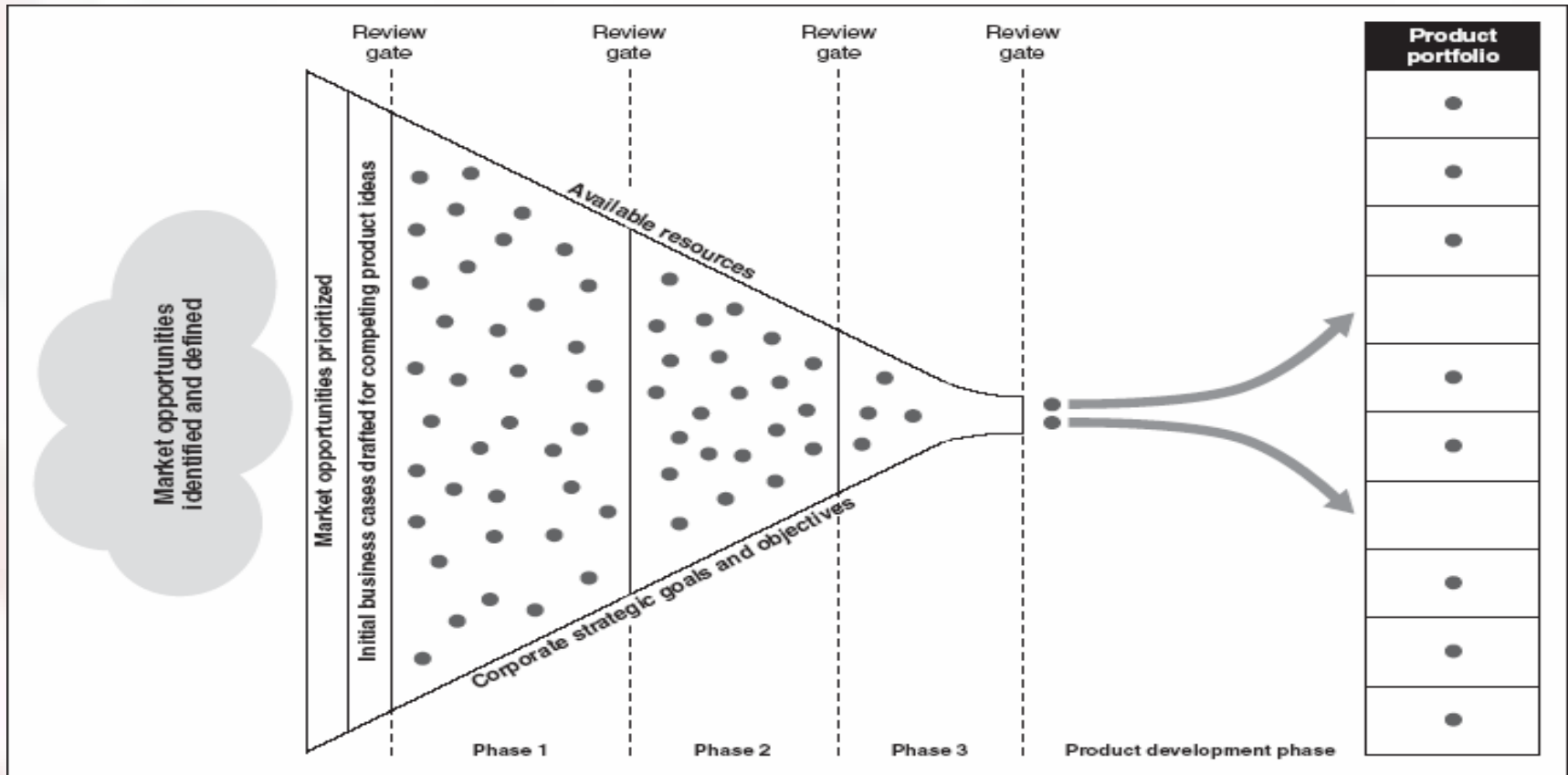

DOD's Decision Making Processes are Service-centric and Fragmented

- Services identify needs and budget for solutions
 - FCBs don't have the resources to effectively evaluate the service assessments within the context of the broader portfolio
 - FCBs don't have the authority to allocate resources
 - Service funding appears to be allocated according to historical percentages
 - 40% AF, 20% Army, 30% Navy, and 10% DOD Wide
 - JCIDS, PPBE, and DAS led by different organizations
 - Joint Staff, USD(AT&L), OSD (PA&E and Comptroller)
-

Fragmented Processes With Adverse Incentives

***PRESSURE ON
DECISION MAKER TO ...***

Requirements Process

**... promise high
performance**

Budgeting Process

**... promise low
resource demands**

Acquisition Process

**... move forward,
get knowledge later**

DOD Commits to Solutions Early and With Limited Knowledge

- Review points prior to milestone B are “optional” and typically by-passed
 - Key processes are not integrated early to provide insight into cost and feasibility
 - ICDs don’t address cost or technical feasibility
 - AOAs often make the case for a specific solution vs. identifying the preferred solution
 - Programs don’t have sound business cases
 - Undefined requirements
 - Immature technology
 - Optimistic cost and schedule estimates
-

DOD's Funding Process Contributes to Poor Acquisition Outcomes

- Assessed cost and funding data for 20 major acquisition programs, and conducted detailed analysis of five of those programs:
 - Global Hawk
 - Joint Strike Fighter (JSF)
 - Future Combat Systems (FCS)
 - Warfighter Information Network – Tactical (WIN-T)
 - Multi-mission Maritime Aircraft (MMA)
- Leveraged work GAO has been doing in cost estimating and earned value best practices (*GAO Cost Assessment Guidebook*)
- Leveraged prior best practices work and obtained additional input from several of the companies that contributed to our prior work

Accurate Cost Estimates Are Needed Before Adequate Funding Can Be Allocated

- Without accurate estimates it is not realistic to assume that funding will be adequate
 - Cost estimating best practice is to assess risk and uncertainty and present estimate as range of potential costs
 - Conduct sensitivity analysis and identify the range of likely costs
 - Ranges will be “broader” as knowledge is limited but as knowledge is gained (before development begins) the range should “narrow” until
 - Ranges allow decision makers to make more informed decisions—they can test the estimate’s reasonableness and decide on what level of funding risk they want to take)
-

The Cone of Uncertainty

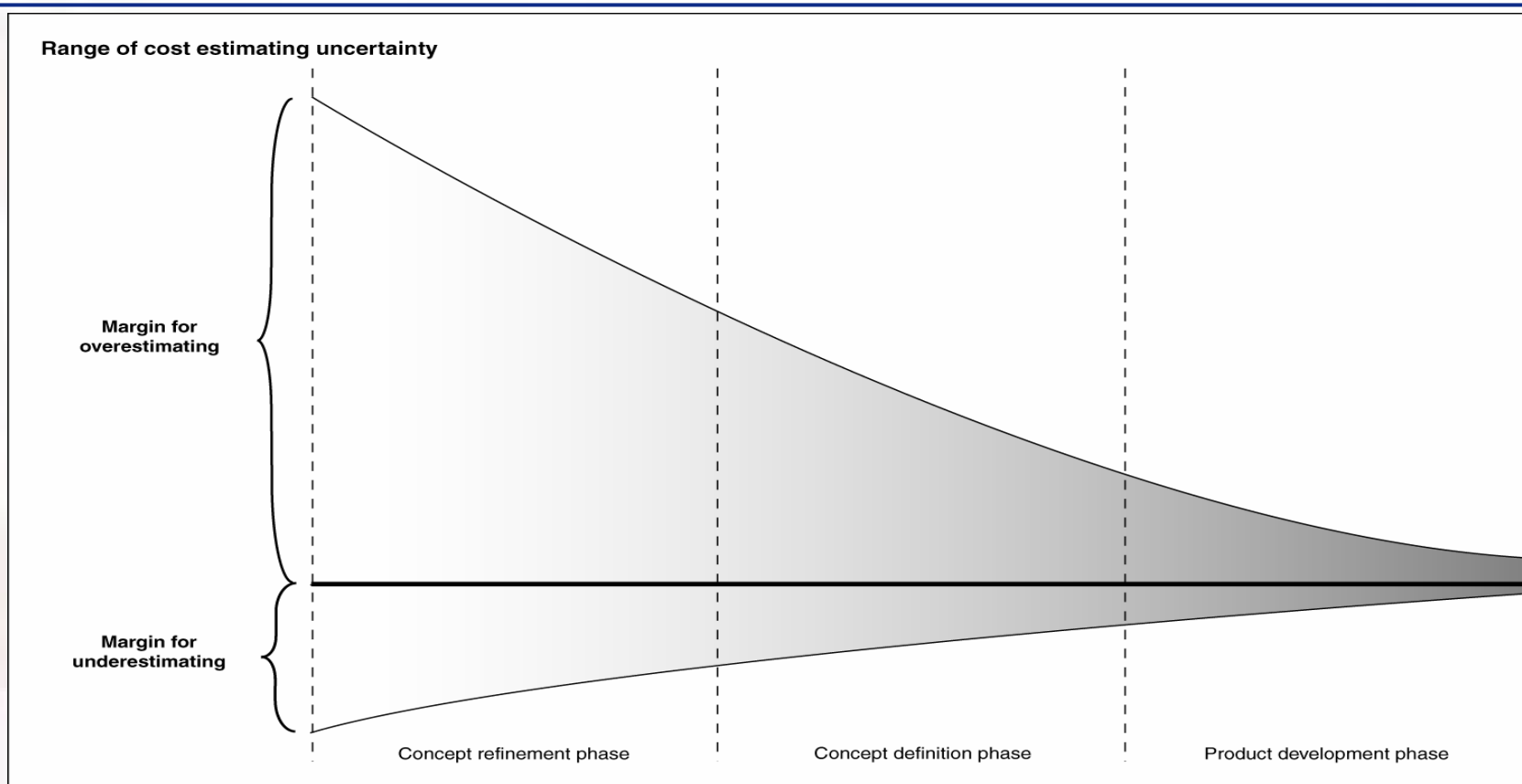

Source: GAO.

Built-in Funding Instability

- DOD programs often initiate development with funding that does not reflect true costs
 - 75% of the programs we reviewed were under-funded in the FYDP when they began development
 - The FYDP doesn't cover the entire development program
 - DOD makes unplanned and inefficient adjustments to compensate for poor planning / projections
 - Creates / perpetuates instability
 - Pushes costs into the future
 - "Robs Peter to pay Paul"
 - Reduces procurement quantities
-

Unrealistic Cost Estimates Hinder Accurate Funding Commitments

- Estimates are often based on limited knowledge about requirements and technologies and optimistic assumptions—lack of systems engineering analysis up front
 - Our analysis of 20 programs found that both CAIG and Service estimates tended to be too low
 - Estimates are presented as point estimates representing “most likely cost” and do not depict risk and uncertainty
 - Program cycle times are longer than the FYDP timeframe
-

DOD's Failure to Balance Needs with Resources Promotes Unhealthy Competition

- Relying on unrealistically low estimates, DOD has committed to more programs than its resources can support
 - In a zero-sum game, increases in one program will impact other programs
 - Pressure to make a program stand out from others
 - Pressure to appear affordable (fit within the FYDP)
 - When “reality” hits and things don’t go as planned, instability is the inevitable result
-

Recommended Steps to Improve Program Funding

- Balance the current portfolio (to reduce the pressures of unhealthy competition)
 - Require programs to have short, manageable development cycles (5 to 6 years long)
 - Require cost estimates to be presented as a range of likely costs (wider at a milestone A point and more narrow at milestone B)
-

DOD's Requirements Process (JCIDS) Has Not Been Effective in Prioritizing Joint Capabilities

- JCIDS is not meeting its objective to prioritize joint warfighting needs
 - Military services, not the joint warfighting community continue to sponsor most JCIDS proposals
 - Almost 70% of initial capability proposals submitted to JCIDS since 2003 were sponsored by a military service
 - Virtually all capability proposals that go through the JCIDS process are validated—or approved
 - Of 140 capability proposals since 2003 that completed the process, only 6 were not validated
 - Process is also lengthy and cumbersome, making it difficult to respond to near-term needs
- DOD is losing opportunities to strengthen joint warfighting capabilities and constrain its portfolio of weapon system programs to match available resources

DOD Lacks An Approach and Alignment of Resources to Prioritize and Balance Capability Needs

- JCIDS largely responds to capability proposals that are submitted by sponsors on a case-by-case basis
 - Lacking a more proactive and analytic approach, JCIDS has been ineffective at integrating and balancing needs
 - The military services continue to drive the determination of capability needs, in part because they retain most of DOD's analytic capacity and resources
 - Without an approach and entity in charge to determine what capabilities are needed, all proposals tend to be treated as priorities within the JCIDS process
-

Recommended Steps To Improve JCIDS

- Develop an analytic approach within JCIDS to better prioritize and balance capability needs department-wide, and
 - Determine and allocate appropriate resources for conducting joint capabilities development planning
-

Related GAO Products

- *Defense Acquisitions: DOD's Requirements Determination Process Has Not Been Effective in Prioritizing Joint Capabilities.* GAO-08-1060. September 25, 2008.
 - *Defense Acquisitions: A Knowledge-Based Funding Approach Could Improve Major Weapon System Program Outcomes.* GAO-08-619. July 2, 2008.
 - *Defense Acquisitions: Better Weapon Program Outcomes Require Discipline, Accountability, and Fundamental Changes in the Acquisition Environment.* GAO-08-782T. June 3, 2008.
 - *Defense Acquisitions: Assessments of Selected Weapon Programs.* GAO-08-467SP. March 31, 2008.
 - *Cost Assessment Guide: Best Practices for Estimating and Managing Program Costs.* GAO-07-1134SP. July 2, 2007.
 - *Best Practices: An Integrated Portfolio Management Approach to Weapon System Investments Could Improve DOD's Acquisition Outcomes.* GAO-07-388. March 30, 2007.
-



National Defense Industrial Association
11th Annual Systems Engineering Conference
San Diego, California

**Standardized Documentation for
Verification, Validation, and
Accreditation -
An Update to the Systems Engineering
Community**

Mission II
M&S Session 3A5
Wednesday, October 22, 2008
8:00 am - 9:45 am

Presented by
DoD M&S Project
Project Management Team



Outline

- Why VV&A Background
- DoD M&S Project Overview
- Policy, Guidance & Standards
- Discoverable Metadata
- DoD VV&A Documentation Tool (DVDT)
- Data Discovery Mechanisms
- Summary



VV&A - where it all started ...

"Those who cannot remember the past are condemned to repeat it."

- 1980 By the Comptroller General Report to the Congress of the United States, *Models, Data, and War: A Critique of the Foundation for Defense Analyses*, March 12, 1980 (PAD-80-21) (<http://archive.gao.gov/f0202/111782.pdf>)
- 1987 United States General Accounting Office Report to the Chairman, Legislation and national Security Subcommittee, Committee on Government Operations, House of Representatives. *DoD Simulations: Improved Assessment Procedures Would Increase the Credibility of Results* (<http://archive.gao.gov/d30t5/134959.pdf>)
- 1990, 1992, 1994, 1999 Military Operational Research Society (MORS) Simulation Validation Mini-Symposiums and Workshops (<http://www.mors.org/reports.htm>)
- 1993 Report of the Defense Science Board Task Force on Simulation, Readiness and Prototyping. *Impact of Advanced Distributed Simulation on Readiness, Training and Prototyping*, January 1993 (<http://www.acq.osd.mil/dsb/reports/srp.pdf>)
- 1994 DoDD 5000.59 *DoD M&S Management*, January 4, 1994
- 1996 DoDI 5000.61 *DoD M&S VV&A*, April 29, 1996



Everything Is Simulation Except Combat*

- Modeling and Simulation (M&S) is a key enabler for systems engineers in the acquisition process
- Using M&S that provide credible results is crucial to fielding defense weapon systems to the warfighter
- Credibility and confidence in the use of M&S results are achieved through implementation of Verification, Validation, and Accreditation (VV&A) processes
- VV&A is critical for ensuring M&S is correct, is used correctly, and can produce results a systems engineer can trust

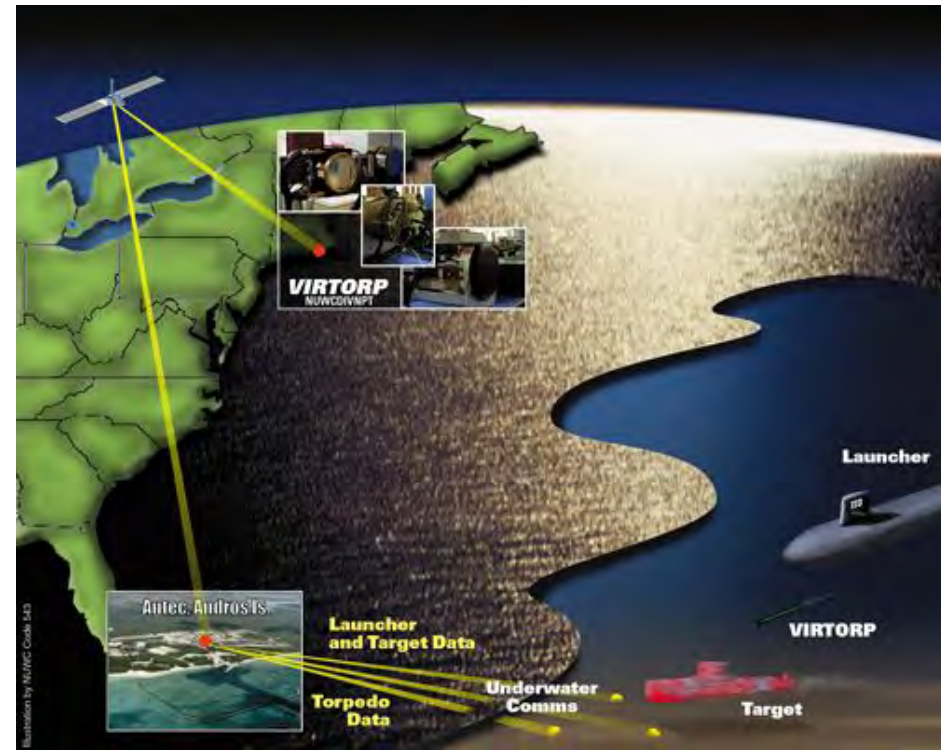

Naval Undersea Warfare Center Newport
Synthetic Environment Tactical Integration
Virtual Torpedo Project
HLA federation linking live submarines to high-fidelity
torpedo hardware-in-the-loop facility

*Defense Science Board, January 1993



Three Methods of Simulation

*Defense Science Board, January 1993

***Findings - Continued**
DoD investment required in VV&A: *“Techniques routinely used for VV&A of single models or simulations face new challenges in a multi-source, highly interactive, internetted M&S environment where complex software modules are required to interoperate. New techniques of VV&A are likely required.”*

“The important task of verifying, validating, and accrediting battlefield behavior, modeled in some form, should receive greater attention in all DoD M&S programs.”

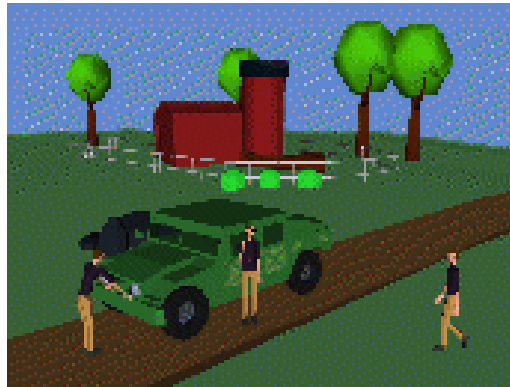

LIVE

Real people operating real systems in real environments in the air and space, on the ground, on and below the sea

VIRTUAL

Real people operating simulated systems in simulated environments included are wargames, models and analytic tools

CONSTRUCTIVE

Simulated people operating simulated systems in simulated environments



DoD M&S Project

- Project title: Standardized Documentation for VV&A
- Sponsor: Department of Defense (DoD) M&S Steering Committee (M&S SC)
- Oversight: Acquisition Community Lead





Project Organization

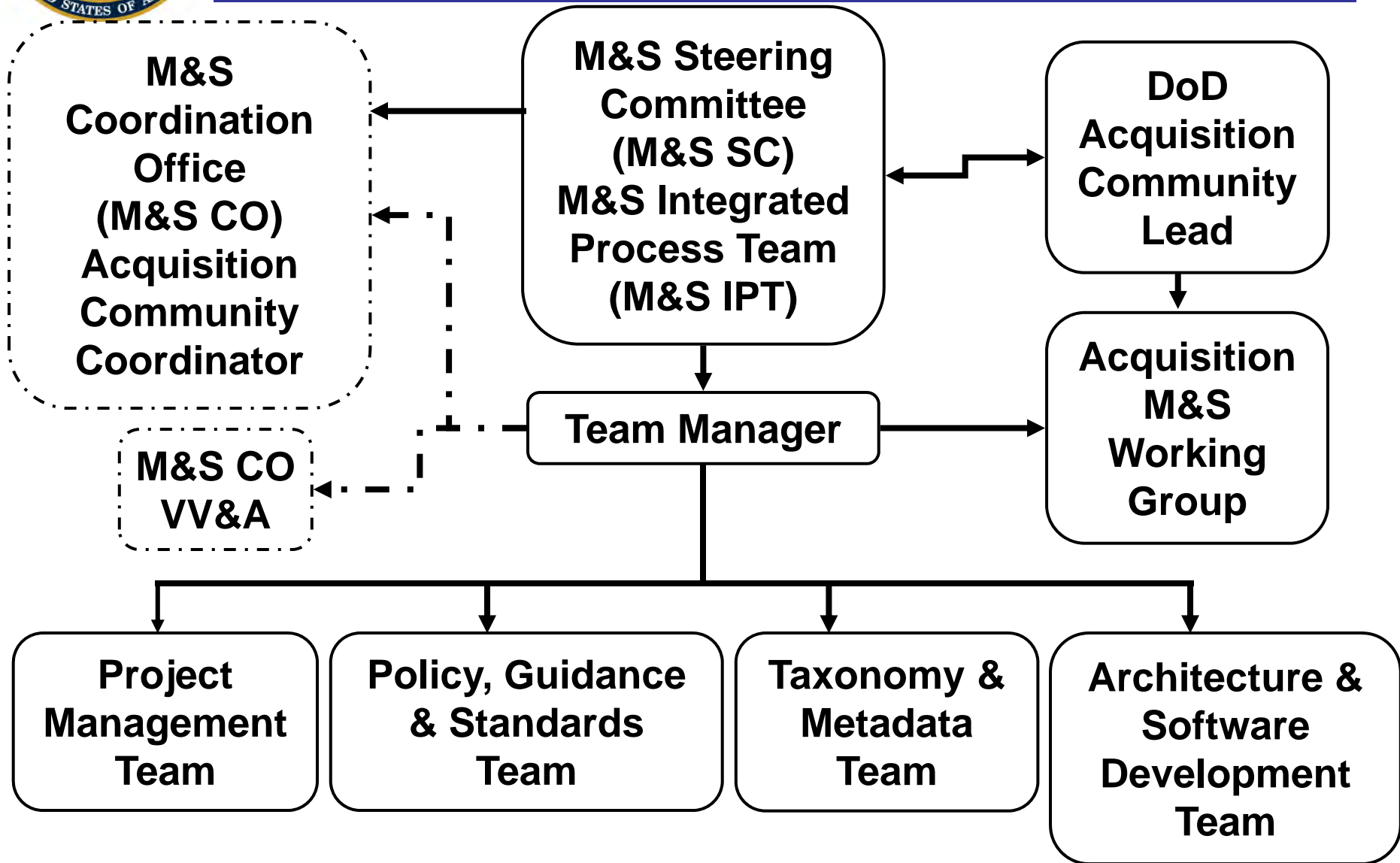



Project Scope

- Three major tasks and associated deliverables:
 - recommend updates to associated policy, guidance, and standards documents
 - design, describe, and register VV&A XML schemas
 - design, develop, test, and deploy the DVDT



Plan of Action and Milestones

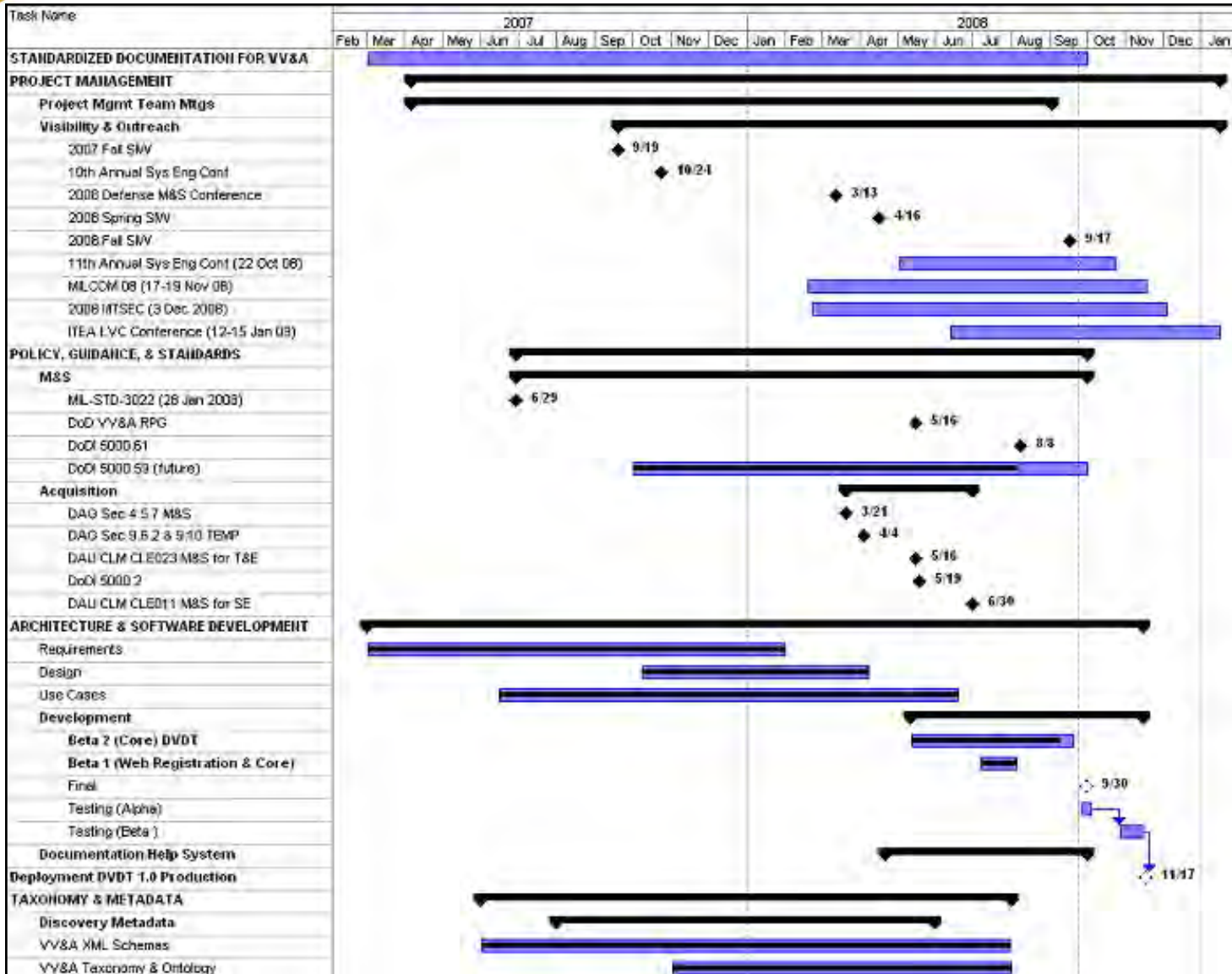



Concept of Operations

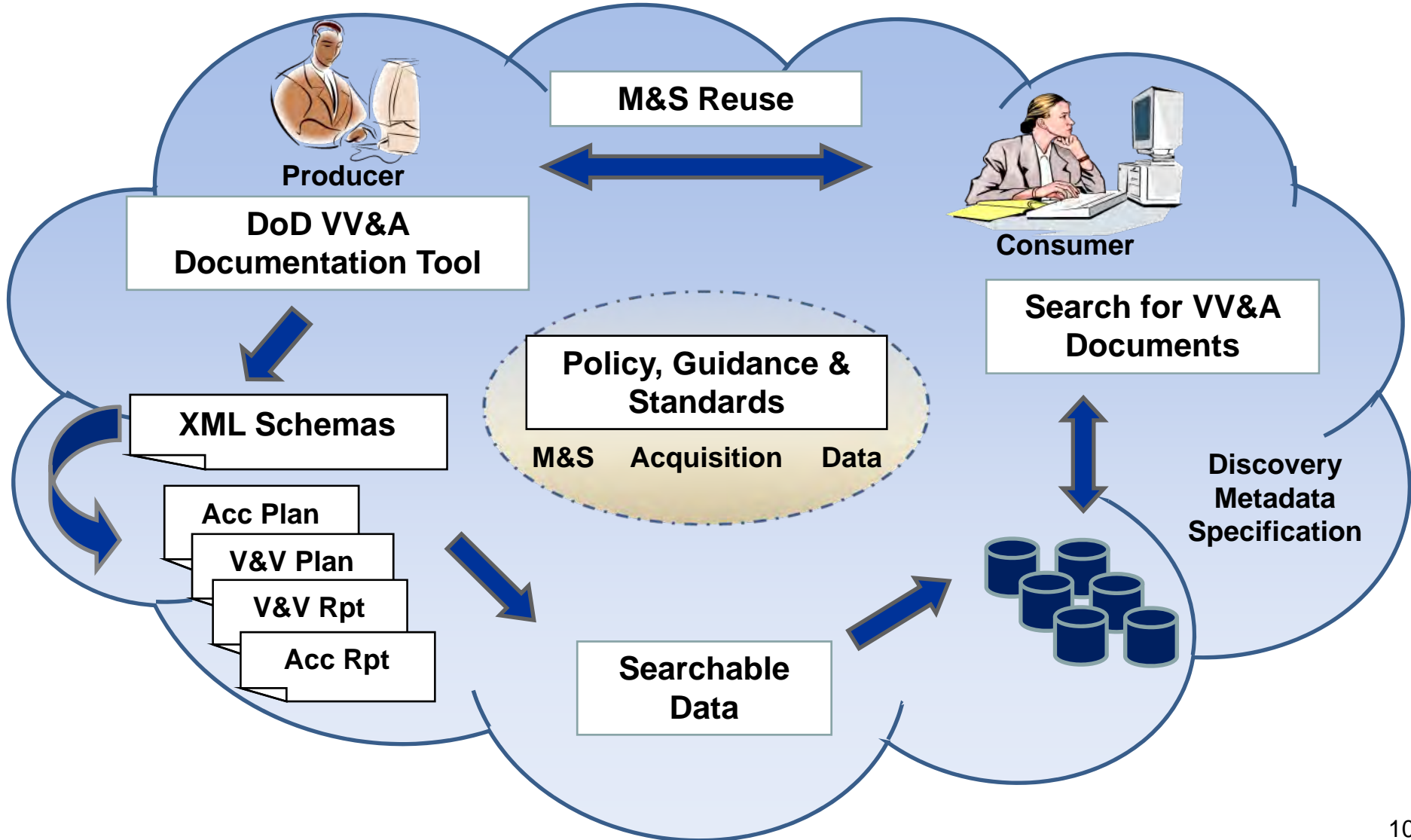



Policy, Guidance & Standards

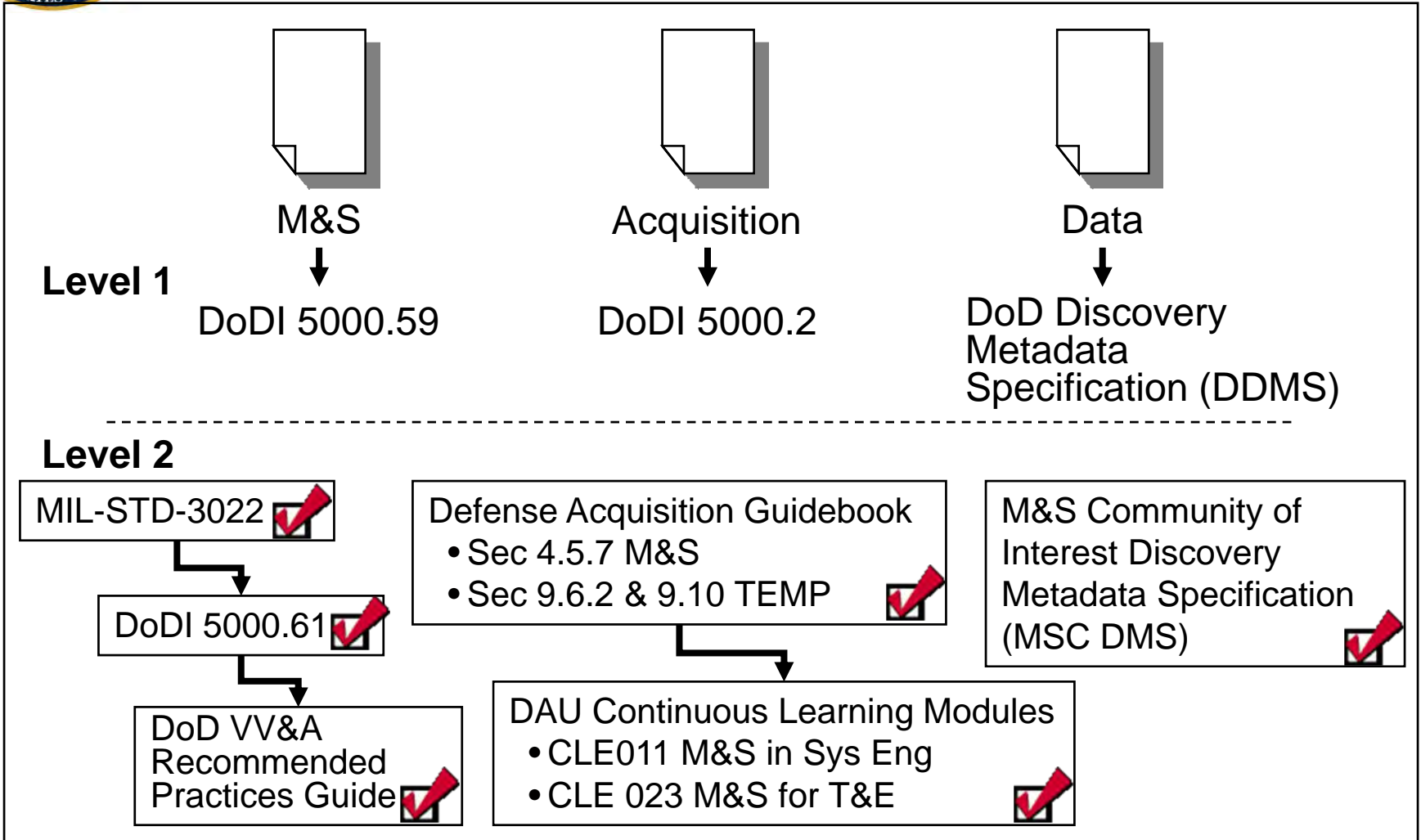



MIL-STD-3022

28 January 2008

- **2008:** Approved as a DoD Standard Practice with four associated Data Item Descriptions (DIDs)
 - DI-MSSM-81750 DoD M&S Accreditation Plan
 - DI-MSSM-81751 DoD M&S V&V Plan
 - DI-MSSM-81752 DoD M&S V&V Report
 - DI-MSSM-81753 DoD M&S Accreditation Report
- MIL-STD-3022 may be cited as a solicitation requirement and DIDs included on Contract Data Requirements List
- Available at Acquisition Streamlining and Standardization Information System (ASSIST) - <http://assist.daps.dla.mil/>

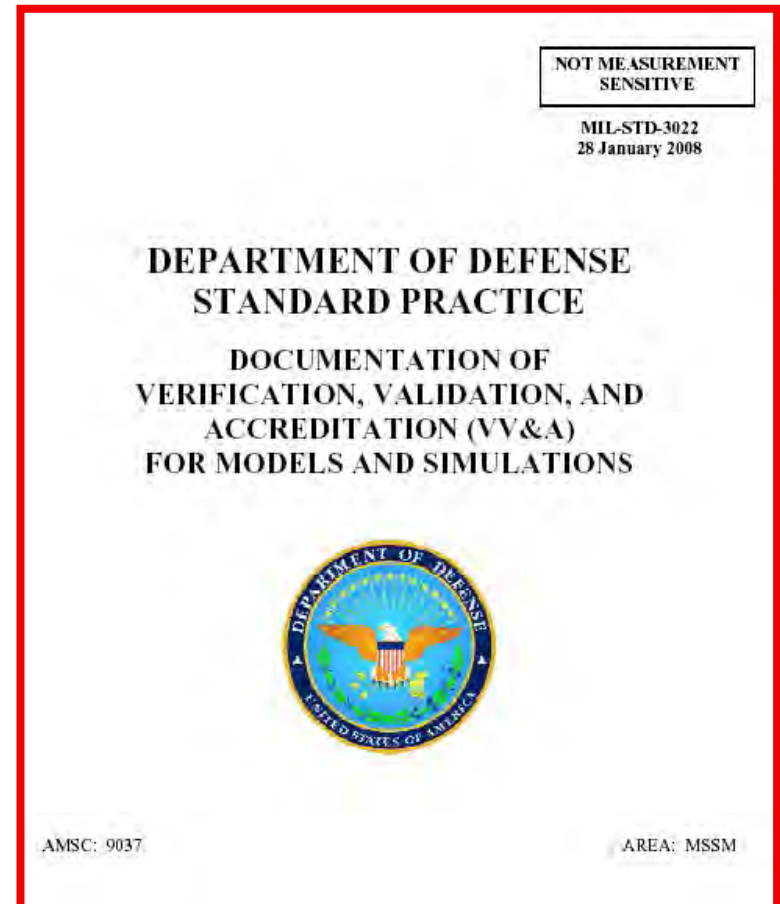

DVDT automates standard templates enabling sharing of VV&A information across Global Information Grid (GIG) enterprise



DoD Instruction 5000.61

M&S VV&A, 13 May 2003

- M&S SC directed a 5-year review in 2008
- Working Group kickoff meeting (21 Feb 2008)
 - Drafting Group formed
- M&S IPT informal review of draft revision (25 Jul-8 Aug 2008)
- Comment Resolution Panel (CRP) (Aug-Sep 2008)
- USD(AT&L) Review Process
 - Not begun
- DoD Directives Program Coordination Process (SD-106)
 - Signature authorities for DoD issuances include Presidentially Appointed, Senate-confirmed (PAS) officials
 - Processing might wait for new administration

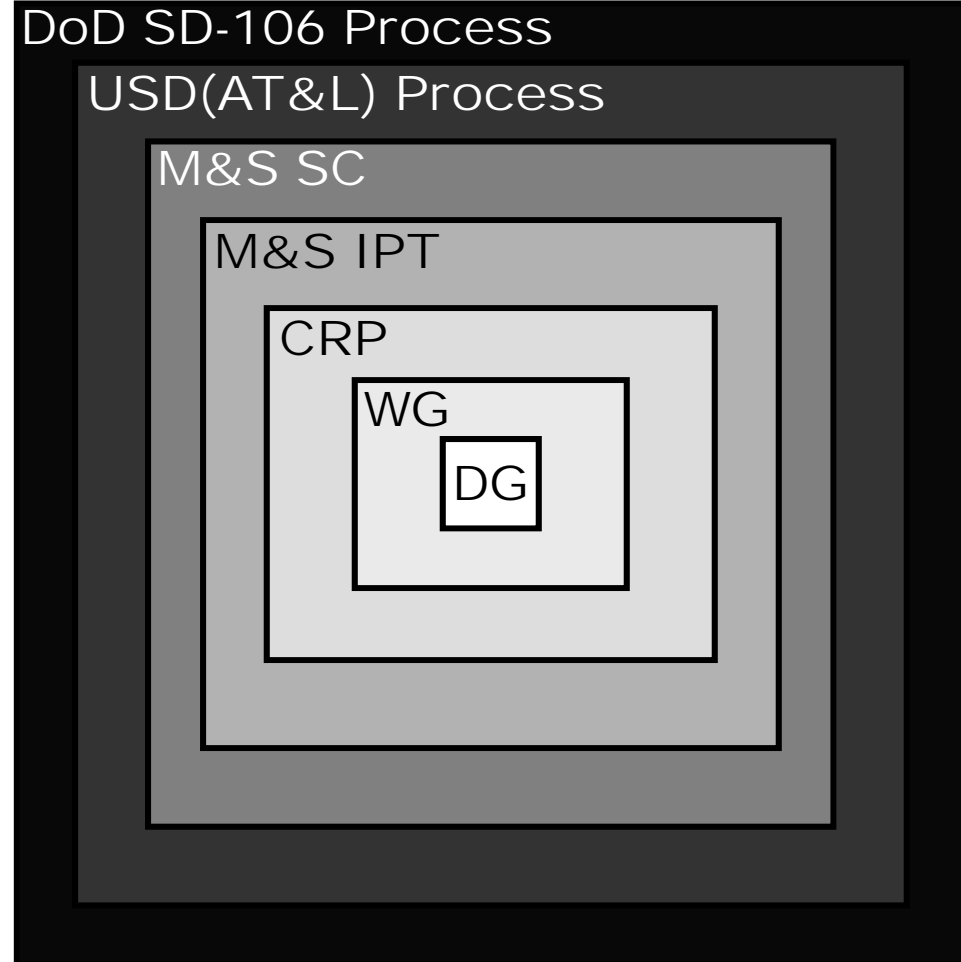



Discovery Metadata

DoD Discovery Metadata Specification (DDMS) describes DoD resources
- is very broad

M&S Community of Interest Discovery Metadata Specification (MSC DMS) provides more detail to describe resources in the M&S domain
- is more precise

VV&A metadata describes VV&A resources
- is most precise

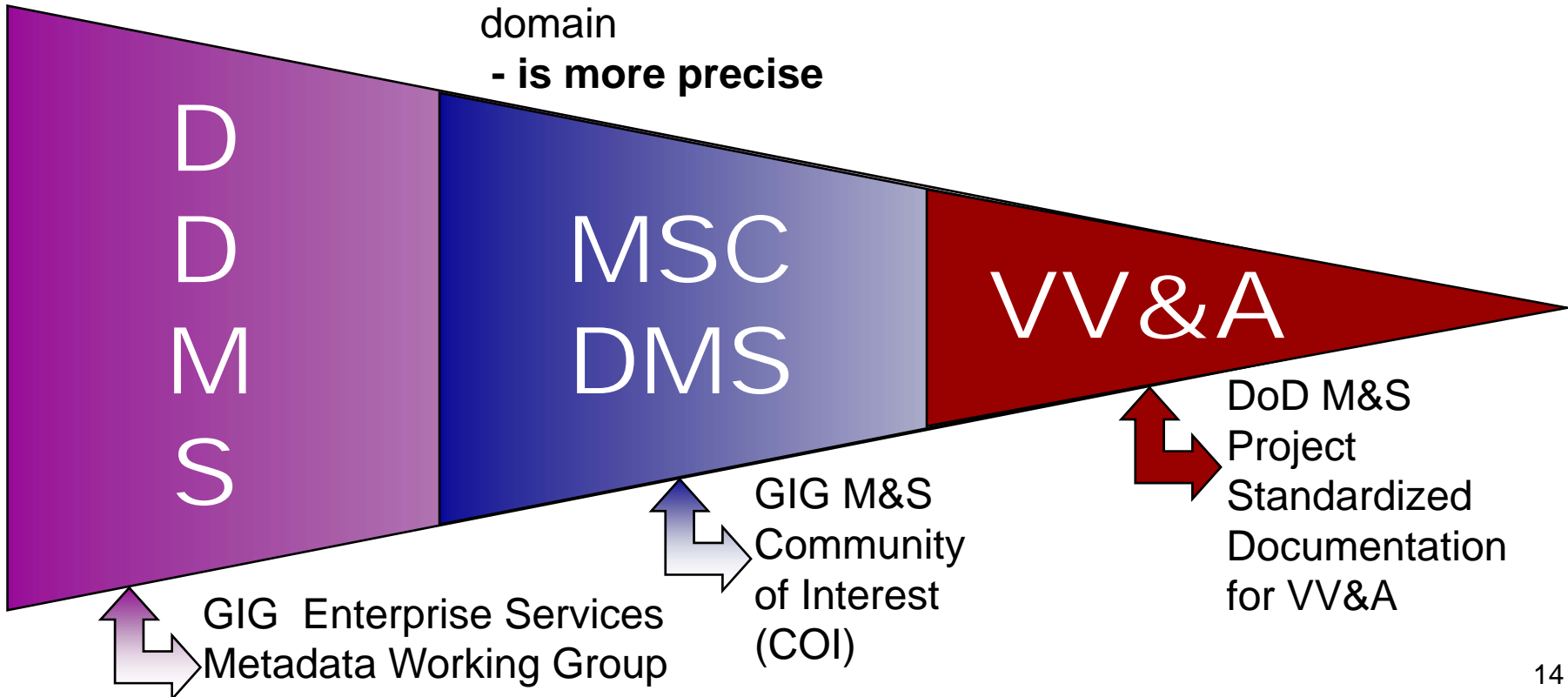



DoD Metadata Registry

**VV&A
Project
Metadata
XML
Schema**

**VV&A
Document
Base
Types
XML
Schema**

**Accreditation
Plan
XML
Schema**

**Accreditation
Report
XML
Schema**

**V&V
Plan
XML
Schema**

**V&V
Report
XML
Schema**

The DoD Metadata Registry and metadata registration process together collect, store, and disseminate structural metadata information resources, e.g.:

- schemas
- data elements
- attributes
- document type definitions
- style-sheets
- data structures

The project's XML products will be registered and available for use by industry and government.



<http://metadata.dod.mil>



DVDT

- Automates production of VV&A documentation in compliance with MIL-STD-3022
- Enables search and discovery of VV&A document information via the GIG enterprise
- Produces documents that enable DoD data sharing in compliance with:
 - DoD Directive 8320.02, Data Sharing in a Net-Centric DoD
 - DoD Discovery Metadata Specification
 - M&S Community of Interest Discovery Metadata Specification
- Helps organizations
 - produce documents more efficiently and consistently
 - organize information
 - output documents in a common format
 - share discovery metadata about VV&A documents across GIG enterprise



Architecture Focus

- In January 2008 focus turned
 - to an architecture that would allow offline document production and storage
 - from one that would provide an online capability to produce documents
- Offline production and storage capability assists producer in managing information common to all four documents identified in MIL-STD-3022
- DVDT populates the four documents with the common information when documents are stored together
- Coordination on production of each individual document by disparate organizations will occur through means used by those organizations
 - e.g., integrated digital environment, engineering environment, knowledge sharing environment, or sharing files through email
- Decisions where to retain the documents under control left to producers



DVDT Architecture

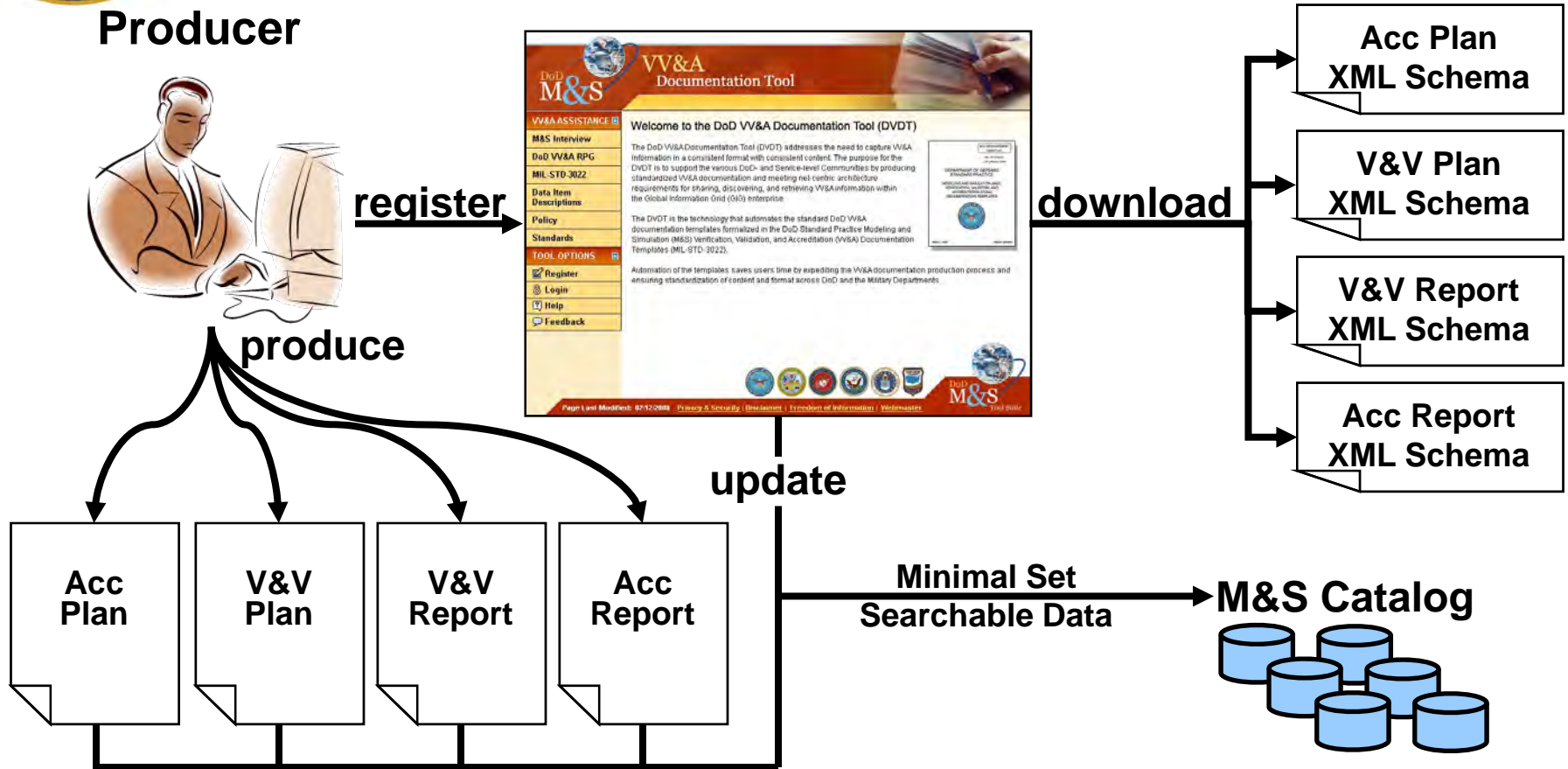



DVDT Screenshots

{Placeholder for tool demonstration or screenshots}



My Projects

My Projects - DoD VV&A Documentation Tool (DVDT)

DoD M&S VV&A Documentation Tool

VV&A ASSISTANCE

- M&S Interview
- DoD VV&A RPG
- MIL-STD-3022
- Data Item Descriptions
- Policy
- Standards

TOOL OPTIONS

- My Profile
- My Projects
- Submit a Project
- Search
- Log Out
- Help
- Feedback

MY PROJECTS

| Name | Version | Date Submitted |
|------------------------|---------|----------------------|
| MODSIM | 1.3 | 8/8/2008 10:45:46 AM |

After submitting VV&A project information a list of projects with versioning information is provided.

DoD M&S Tool Suite

Last Modified: 9/30/2008 11:10:13 AM



Project Information

The screenshot displays the 'VV&A Documentation Tool' interface. On the left is a navigation menu with sections for 'VV&A ASSISTANCE' (including M&S Interview, DoD VV&A RPG, MIL-STD-3022, Data Item Descriptions, Policy, and Standards) and 'TOOL OPTIONS' (including My Profile, My Projects, Submit a Project, Search, Log Out, Help, and Feedback). The main content area is titled 'MODIFY A PROJECT' and includes a 'Download Templates' button. A warning message states: 'You must complete all fields marked with a [R] in ALL TABS before submitting.' Below this, a form titled 'M&S Entity on Which VV&A Is Being Performed' contains the following fields:

- [R] Name: MODSIM
- [R] Version: 1.3
- Description: This year, the conference focus is on Decision-Making in Complex Environments. Speakers, educational tracks, presentations, and product demonstrations will center on using modeling and simulation tools and practices in decision-making in today's challenging operating environments. attendees will learn about new applications and practices and have an opportunity to network with other industry professionals. One conference fee enables exhibitors and attendees to attend the pre-conference on Monday, September 15 and all educational tracks. An exciting cross-cutting Gaming Track is featured throughout each of the education tracks and will offer the most up-to-date developments in "Serious Gaming". MODSIM World 2008 will be held at the Virginia Beach Convention Center in Virginia Beach, Virginia.
- [R] Intended Use: In this workshop, attendees will be introduced to using simulations and Stella to teach Earth science as a system. Drs. S. Raj Chaudhury (CNU) and Lin H. Chambers (NASA Langley) will demonstrate how to utilize these tools in a classroom, "system dynamics modeling" environment. They will also demonstrate system dynamics as a computer modeling technique that can be used to produce dynamic simulation models for teaching and learning earth science as a system. The basics of a system dynamics software package called Stella will be introduced and modeling exercises that utilize the Stella software will be undertaken in the workshop. No prior modeling experience or use of Stella is necessary, however, participants are required to bring a lap top to the workshop.

At the bottom of the form, there is an 'Organization' field and a 'Name' field with the value 'David H. Bunker'.

Project information provides configuration management as well as discoverable Metadata



Download Offline Tool and/or Templates



The screenshot shows a web application interface for the VV&A Documentation Tool. The header features the DoD M&S logo and the text 'VV&A Documentation Tool'. A left-hand navigation menu includes sections for 'VV&A ASSISTANCE' (with sub-items: M&S Interview, DoD VV&A RPG, MIL-STD-3022, Data Item Descriptions, Policy, Standards) and 'TOOL OPTIONS' (with sub-items: My Profile, My Projects, Submit a Project, Search, Log Out, Help, Feedback). The main content area is divided into two primary sections: 'DOWNLOAD PROJECT TEMPLATES' and 'DOWNLOAD VV&A DOCUMENTATION TOOL'. The first section includes a button labeled 'Download Project Templates Only'. The second section includes a button labeled 'Download VV&A Documentation Tool and Project Templates'. Below this, there are three numbered steps: 'STEP 1: DOWNLOAD VV&A DOCUMENTATION TOOL', 'STEP 2: INSTALL VV&A DOCUMENTATION TOOL', and 'STEP 3: START USING THE PROJECT TEMPLATES', each with detailed instructions on how to use the tool and templates.

DoD M&S **VV&A Documentation Tool**

VV&A ASSISTANCE

- M&S Interview
- DoD VV&A RPG
- MIL-STD-3022
- Data Item Descriptions
- Policy
- Standards

TOOL OPTIONS

- My Profile
- My Projects
- Submit a Project
- Search
- Log Out
- Help
- Feedback

DOWNLOAD PROJECT TEMPLATES

If you have misplaced the project templates for "MODSIM", you can download them again. Each of these document templates will only be populated with data you provided during your registration for this specific project.

[Download Project Templates Only](#)

DOWNLOAD VV&A DOCUMENTATION TOOL

If you need to reinstall the VV&A Documentation Tool, you can do so by downloading the tool below and following the instructions provided.

STEP 1: DOWNLOAD VV&A DOCUMENTATION TOOL

If you need to reinstall the VV&A Documentation Tool, you can do so by downloading the tool below and following the instructions provided.

[Download VV&A Documentation Tool and Project Templates](#)

STEP 2: INSTALL VV&A DOCUMENTATION TOOL

After download, unzip/extract wadoctool.zip to a folder on your computer. Locate SETUP.EXE within the folder you extracted to and double-click it to run the program.

Upon install a word template file (.dot) from the VVA Documentation Tool will be copied to your computer and if not already installed, Visual Studio Tools for Office (VSTO) will be added. The VSTO simply supports the customized task pane used amongst the documents.

STEP 3: START USING THE PROJECT TEMPLATES

After installation, locate the folder DODMS-VVA-2008-3 within the area you extracted the wadoctool.zip to and move it to an area on your computer that you will work on the VVA project at (such as My Documents).



XML via MS Word Interface

The screenshot displays the Microsoft Word interface for a document titled "AccreditationPlan.doc (Read-Only)". The document is structured as follows:

- 1.1 Intended Use
- 1.2 M&S Overview
- 1.3 M&S Application
- 1.4 Accreditation Scope
- 2 M&S REQUIREMENTS AND ACCEPTABILITY CRITERIA

The document content includes several placeholder boxes labeled "[enter table or figure here]". At the bottom of the document, there are three tables with the following headers:

| Priority | REQ# | M&S Requirement |
|----------|----------|-----------------|
| [Add] | [Remove] | |

| REQ# | AC# | Acceptability Criterion |
|-------|----------|-------------------------|
| [Add] | [Remove] | |

| AC# | M/M# | Metric/Measure |
|-----|------|----------------|
|-----|------|----------------|

The left sidebar shows the "Document Actions" pane with a tree view of the document structure, including sections like "Accreditation Plan", "Title Page", "Record of Changes", "Executive Summary", "1. Problem Statement", "1.1 Intended Use", "1.2 M&S Overview", "1.3 M&S Application", "1.4 Accreditation Scope", "2. M&S Requirements and Acceptability", "3. M&S Assumptions, Capabilities, Limit", "4. Accreditation Methodology", "5. Accreditation Issues", "6. Key Participants", "7. Planned Accreditation Resources", and various Appendices (A-F). A "Guidance" section provides an overview of the M&S for which the document is written and discusses the level of configuration control that currently exists for the M&S.



Standardized Outputs

Standards driven user interface

Produces MS Word documents
(view in print-preview)

And discoverable metadata

```
1 <ns1:AccreditationPlan xmlns:ns1="http://metadata.dod.mil/mdr/ns/VVADocumentation/1.0"
2 <ns1:ProjectReferenceID>DODMS-VVA-2008-3</ns1:ProjectReferenceID>
3 <ns1:DocumentReferenceID>DODMS-VVA-2008-3-9</ns1:DocumentReferenceID>
4 <ns1:AccreditationPlanTitlePage>
5 <ns1:ProgramIdentification>
6 </ns1:ProgramIdentification>
7 <ns1:SponsoringOrganizationOrPM>
8 </ns1:SponsoringOrganizationOrPM>
9 <ns1:MSName>MODSIM
10 </ns1:MSName>
11 <ns1:MSVersion>1.3
12 </ns1:MSVersion>
13 <ns1:DocumentType userEnteredDocumentType="&#xA; " >Accreditation Plan</ns1:
14 <ns1:DocumentTitle>MODSIM Accreditation Plan
```



Consumer Side - M&S Catalog

VV&A Documentation Tool

MODIFY A PROJECT

Download Templates

You must complete all fields marked with a [R] in ALL TABS before submitting.

M&S Entity on Which VV&A Is Being Performed

[R] Name: MODSIM

[R] Version: 1.3

VV&A Project information is discoverable as MSC-DMS compliant XML. The VV&A XML schema is an extension of the DDMS.

Search result with Metadata from DVDT Alpha .01

Description:

This year, the conference focus is on Decision-Making. Speakers, educational tracks, presentations, and pre-conference modeling and simulation tools and practices in operating environments. attendees will learn about new an opportunity to network with other industry professional exhibitors and attendees to attend the pre-conference educational tracks. An exciting cross-cutting Gaming the education tracks and will offer the most up-to-date MODSIM World 2008 will be held at the Virginia Beach, Virginia.

[R] Intended Use:

In this workshop, attendees will be introduced to using Earth science as a system. Drs. S. Raj Chaudhury (Langley) will demonstrate how to utilize these tools in a "modeling" environment. They will also demonstrate simulation modeling technique that can be used to produce dynamic and learning earth science as a system. The basic package called Stella will be introduced and modeling software will be undertaken in the workshop. No prior experience is necessary, however, participants are required to bring a laptop.

Simple Search

Search

Results 1 - 4 of 4 for MODSIM

Search... Modeling & Simulation Catalog

MODSIM Search

- Title
- References
- Type
- POC
- Description
- Keywords
- Dates
- Acronym
- Version
- Media
- Rights
- Security

MODSIM Accreditation Plan

Title: MODSIM Accreditation Plan. ... Sponsoring Organization or PM: MODSIM. Project Reference ID: DODMS-VVA-2008-3. Document Reference ID: DODMS-VVA-2008-3-9. version: 1.3
xdodwadocool.crata.ucf.edu/-2k--cached

- Title: MODSIM Accreditation Plan
- Description: In this workshop, attendees will be introduced to using simulations and Stella to teach Earth science. Drs. S. Raj Chaudhury (CNU) and Lin H. Chambers (NASA Langley) will demonstrate how to utilize these tools in a classroom, and how to utilize these tools in a modeling environment. They will also demonstrate...
- Version: 1.3

Naval Mine Warfare Simulation

... Input: Systems performance characteristics, environmental data, and operation plans and scenarios. Source Code: MODSIM III, Visual Basic, C. ...
nmsa.navy.mil/index.cfm%3Frid%3DMNS_N_1010064-5k--cached

- Title: Naval Mine Warfare Simulation
- Description: NMWS was developed by PEO (MIW) to support MS II Analysis of Alternatives in the acquisition process. This event-driven simulation was developed using the Shlaer/Mellor object-oriented methodology.
- Sponsor: NAVSEASYSCOM
- Acronym: NMWS
- Releaseability: This resource is UNCLASSIFIED



Beta Testing

- Alpha testing (internal) conducted 29 Sep-3 Oct 2008
- Beta testing (external) scheduled to start 3-7 Nov 2008





Why is VV&A Information Important?

- VV&A information tells consumers about
 - M&S assumptions (simplifications and potential failure points)
 - M&S capabilities (what the M&S can be used to do)
 - M&S limitations (what it should not be used to do)
- Consistently documenting VV&A information across DoD yields many returns
 - Discoverable VV&A information saves time and money finding an M&S to satisfy a need
 - VV&A documents provide evidence to determine credibility of M&S results to support an intended use
 - Credible M&S results can be defended and used with confidence





Discoverable VV&A Document Metadata

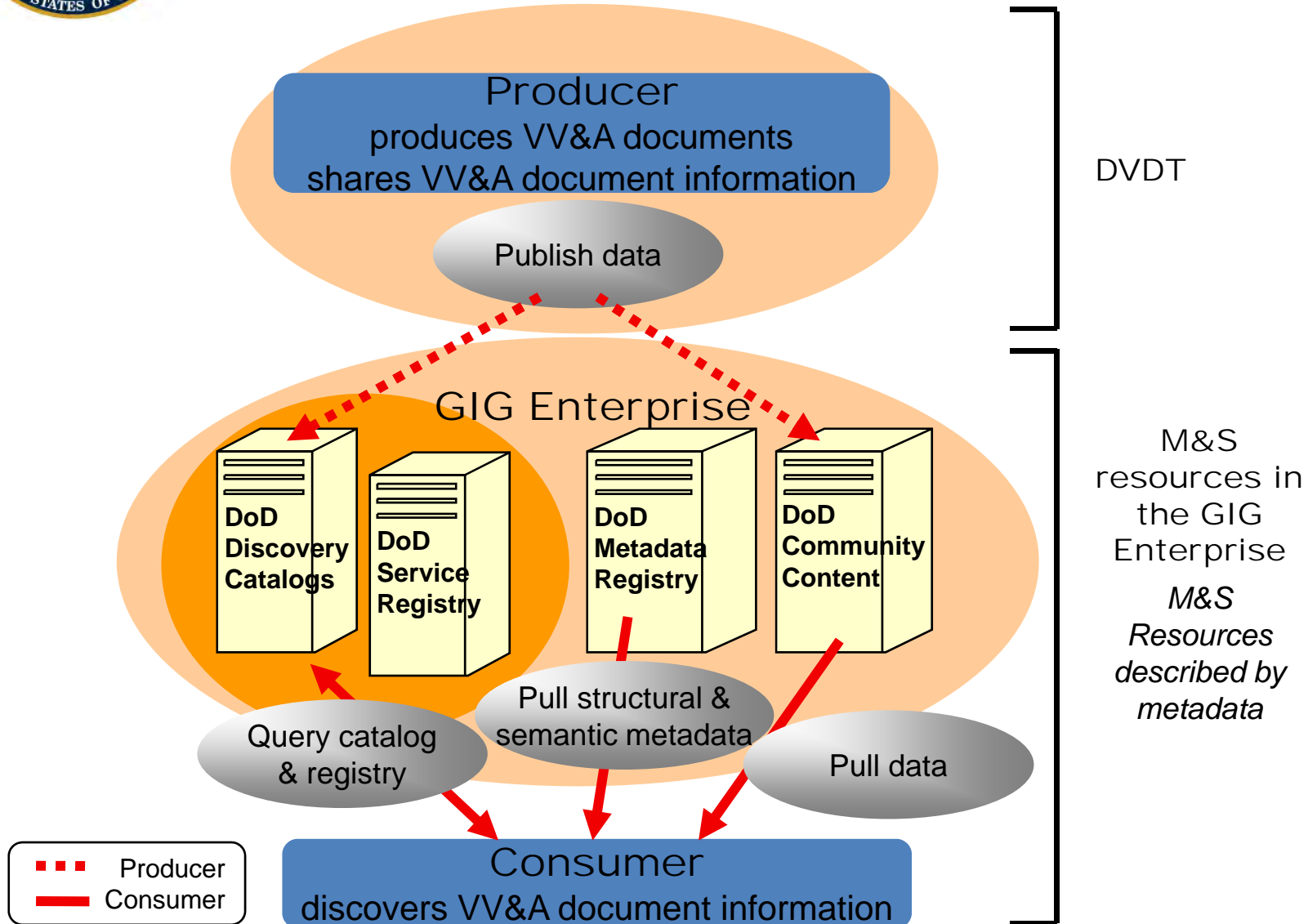



M&S Search Tool

Need VV&A information?



+

search

=

**VV&A
information**

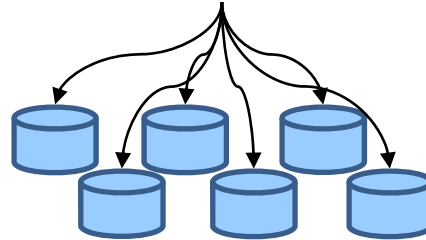

**Using the power of search and discovery capability
to conduct focused federated searches for
information about VV&A documents**



Summary

- Updated the Systems Engineering Community on the DoD M&S Project, *Standardized Documentation for VV&A*
- Provided information about related policy, guidance, and standards
- Discussed Discovery Metadata and discovery mechanisms
- Described and demonstrated DVDT

Using the DVDT to document implementation of VV&A processes enables systems engineers to use M&S results with confidence



Point of Contact

Kevin Charlow

Space and Naval Warfare Systems Center
Atlantic

P.O. Box 190022

North Charleston, SC 29419

843-218-5372

kevin.charlow@navy.mil



Published Papers

- Broyles, D. H., Blais, C., and Stutzman, M.: "Automating Standardized Information for the Verification, Validation, and Accreditation Process: An Acquisition Community Sponsored M&S Project," Paper 07F-SIW-068, Proceedings of the Fall Simulation Interoperability Workshop, Simulation Interoperability Standards Organization, Orlando, Florida, September 2007.
- Charlow, K., Broyles, D. H., Blais, C., and Stutzman, M.: "Acquisition M&S Community Sponsored M&S Project: Standardized Documentation for Verification, Validation, and Accreditation - A Status Report to the Systems Engineering Community," Paper 5431, Proceedings of the 10th Annual Systems Engineering Conference, National Defense Industrial Association, San Diego, California, October 2007.
- Project Management Team: "DoD M&S Project: Standardized Documentation for Verification, Validation, and Accreditation," Proceedings of the 2008 Department of Defense Modeling and Simulation Conference, Orlando, Florida, March 2008.
- Charlow, K., Broyles, D. H., Blais, C., Daehler-Wilking, R., and Stutzman, M.: "Standardized Documentation for Verification, Validation, and Accreditation," Paper 08S-SIW-003, Proceedings of the 2008 Spring Simulation Interoperability Workshop, Simulation Interoperability Standards Organization, Providence, Rhode Island, April 2008.
- Charlow, K., Blais, C., Daehler-Wilking, R., and Stutzman, M.: "Standardized Documentation for Verification, Validation, and Accreditation," Paper 08F-SIW-003, Proceedings of the 2008 Fall Simulation Interoperability Workshop, Simulation Interoperability Standards Organization, Orlando, Florida, September 2008.
- Charlow, K., Broyles, D., Blais, C., and Stutzman, M.: "Standardized Documentation For Verification, Validation, And Accreditation (VV&A) — Helping Assure Mission Success," Paper 330, Proceedings of MILCOM 2008, San Diego, California, November 2008.



Acronyms

| | |
|-----------|--|
| CRP | Comment Resolution Panel |
| DDMS | DoD Discovery Metadata Specification |
| DG | Drafting Group |
| DID | Date Item Description |
| DMSP | DoD M&S Project |
| DoD | Department of Defense |
| DVDT | DoD VV&A Documentation Tool |
| GIG | Global Information Grid |
| M&S | Modeling and Simulation, model(s) and simulation(s) |
| M&S CO | M&S Coordination Office |
| M&S IPT | M&S Integrated Product Team |
| M&S SC | M&S Steering Committee |
| MIL-STD | Military Standard |
| MORS | Military Operational Research Society |
| MSC DMS | M&S Community of Interest Discovery Metadata Specification |
| USD(AT&L) | Under Secretary of Defense for Acquisition, Technology and Logistics |
| VV&A | Verification, Validation, and Accreditation |
| WG | Working Group |
| XML | Extensible Markup Language |



Systems and Software Life Cycle Process Standards: Foundation for Integrated Systems and Software Engineering

For: ***NDIA Systems Engineering Conference***

Date: **23 October 2008**

Presented By: **Teresa Doran**

- Purpose
- TECHSOFT
- Standards-based Process Improvement Success
- Why Harmonize?
 - Issues
 - Impacts to you
- SE/SW LCP Alignment and Integration
 - Path
 - Concepts
 - Where we are today
 - How we got here – Key changes in 15288 & 12207
- Large Scale Harmonization
- Benefits Summary

Show how the key changes in the alignment of a foundational systems/software standards set (ISO/IEC/IEEE 15288 and ISO/IEC/IEEE 12207) facilitates integrated systems and software engineering, project management, and acquisition

Who We Are

- Founded in 1990
- Based in Pensacola, Florida
 - Presence in Charleston, SC
- Primarily, a DoD Contractor
- Experienced Staff
 - High % Masters level personnel
 - Majority with Security Clearances
 - SEI-Authorized CMMI® Lead Appraisers
 - SEI-Authorized CMMI® Instructors
 - International SE/SW Standards Expertise

What We Do

- Systems & Software Development
- Database Applications
- Security / IA
- Web Development
- Network Engineering/Hosting
- Training
- Process Engineering/Process Improvement
 - CMMI®
 - SEI Partner

Standards-based Process Improvement

Example of a Successful Approach



Process Improvement and Systems Engineering Strategy - 2003

- **Vision**

- Develop and maintain a World Class Systems Engineering Organization

- **Approach**

- Achieve Command-wide operational consistency
- Based on ISO 15288 – systems engineering
- Based on ISO 12207 – software engineering
- Measure using best practices of CMMI®

- **Goals**

- CMMI® Maturity Level 2 by April, 2005
- CMMI® Maturity Level 3 by April, 2007



Both Goals attained on schedule

1st SPAWAR Systems Center to Achieve ML2 and ML3

New Goal: Maturity Level 4 & 5

Full OPD, But Today's Focus: 15288/12207

This SSC has 15288 and 12207-based SE/SWE Technical Processes

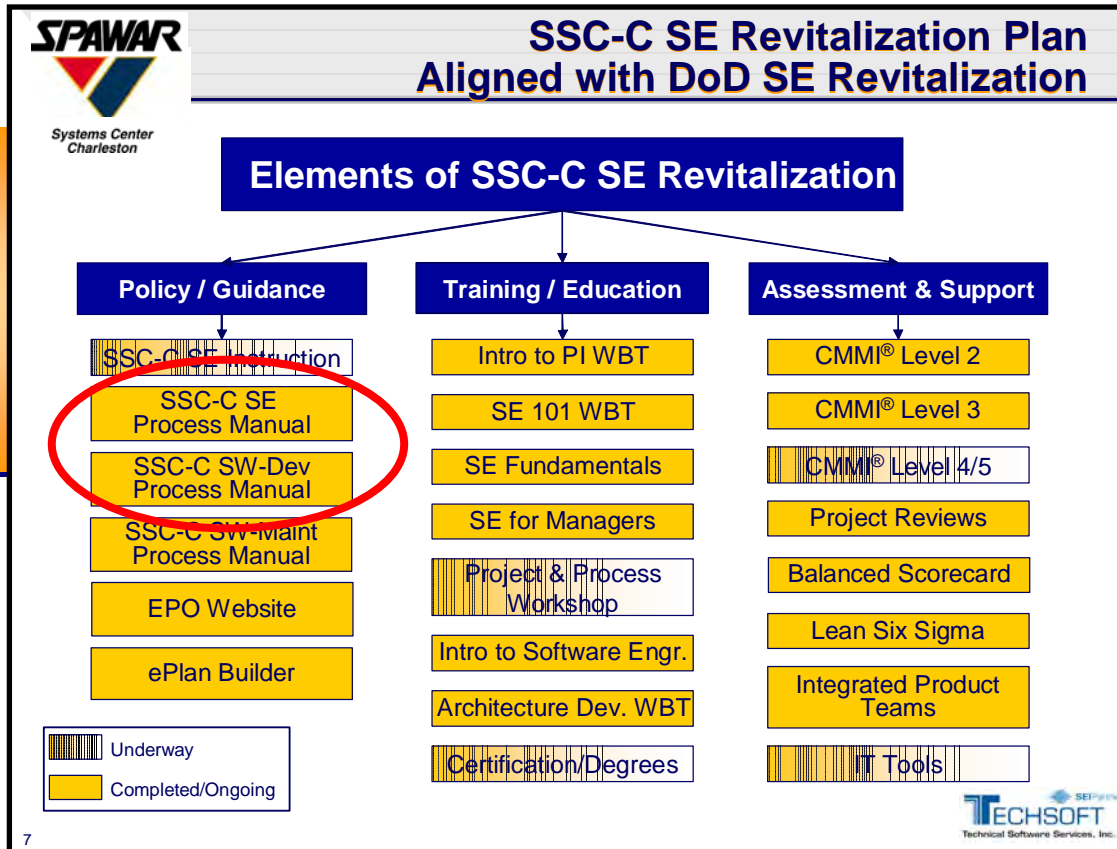

Process Asset Library

With Extensive OPA Support

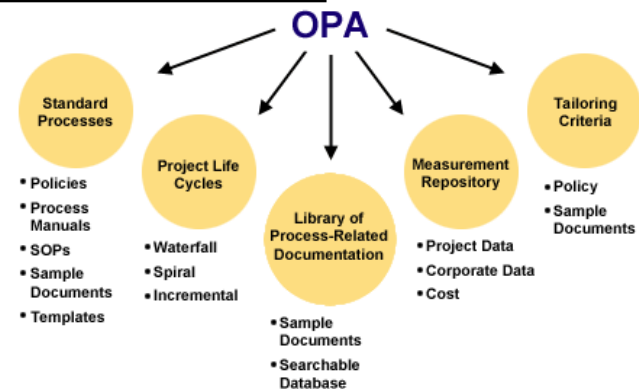

Source: N65236-ENGOPS-BRIEF-0048-1.2, Tools and Resources to Enable Systems Engineering Improvement, M.T. Kutch, Jr. & M. Knox, NOV07

So what's the problem with 15288 and 12207

ISO/IEC 15288:2002

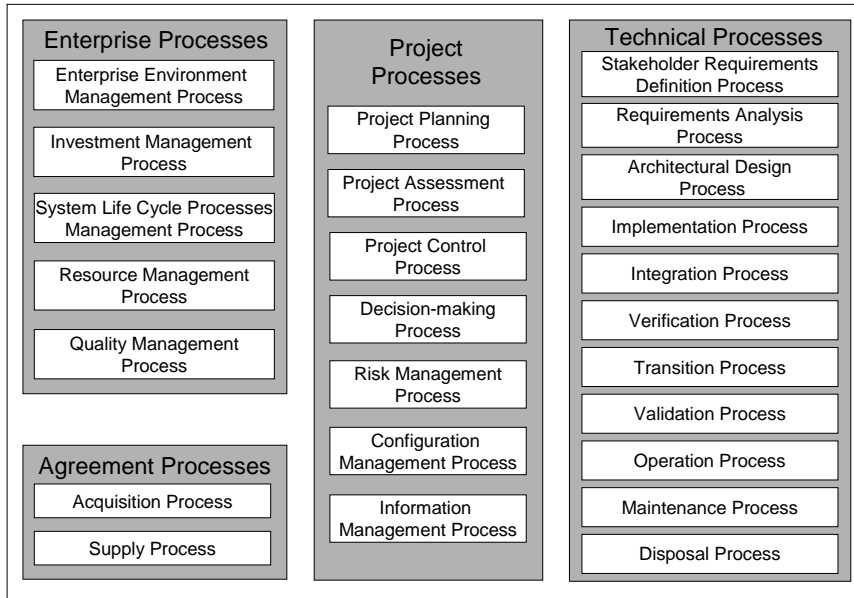

ISO/IEC 12207:1995

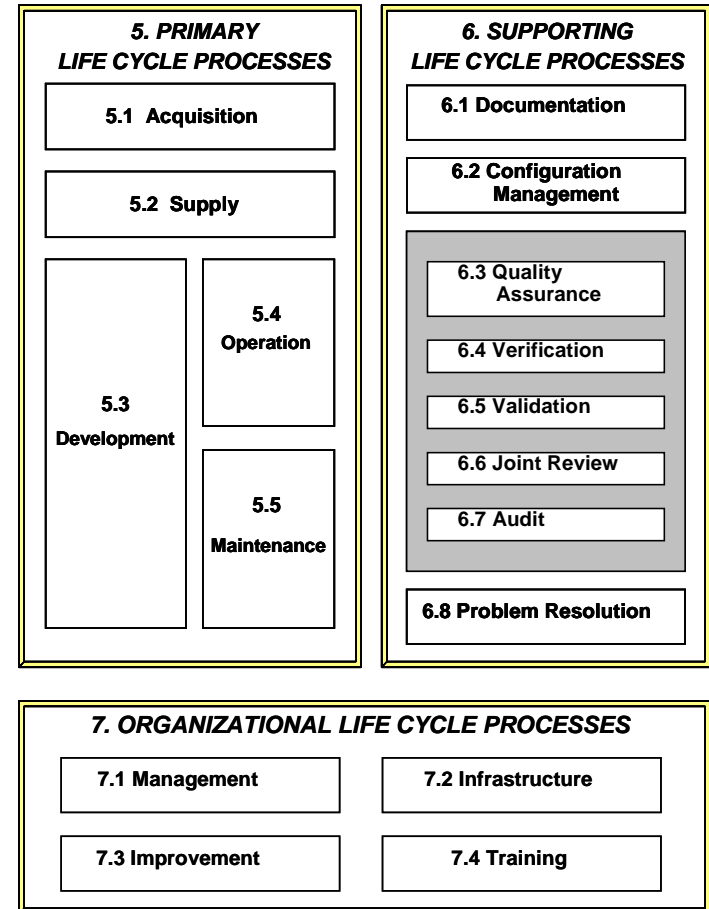

Using Them Together!

- Conflicting terms and definitions
- Overlapping, yet distinct processes
- Different process architectures
- Different levels of prescription

Unintegrated 12207 amendments from 2002 and 2004 are difficult to use and also not adopted by IEEE

Why You Should Care

- Leverage the Commonalties
 - Identify and explain the differences
 - Use the interfaces
- Promote Communication and Team Integration
 - Identify strengths, views, and appropriate focused implementations
 - Reduce us/them, finger-pointing, stove-piping
- Improve Resource Performance
 - Personnel, Processes, Tools, Services
- Lower Costs
 - Reduce redundancy and inefficiency

Benefits of Standards Harmonization
Supports Integration, Facilitates Management, Simplifies Acquisition

15288-12207 Harmonization Path

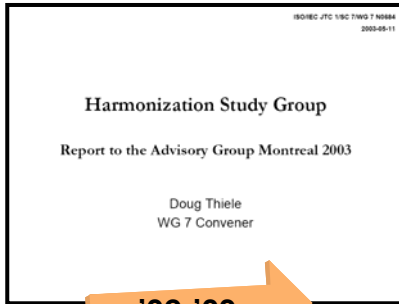

Studies

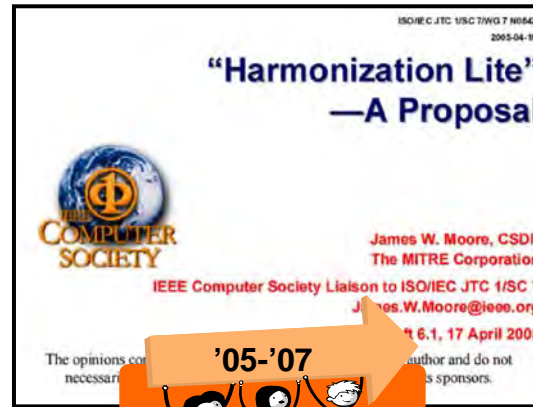

Eat that elephant one bite at a time!



Implementation hits a snag

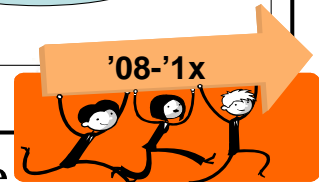
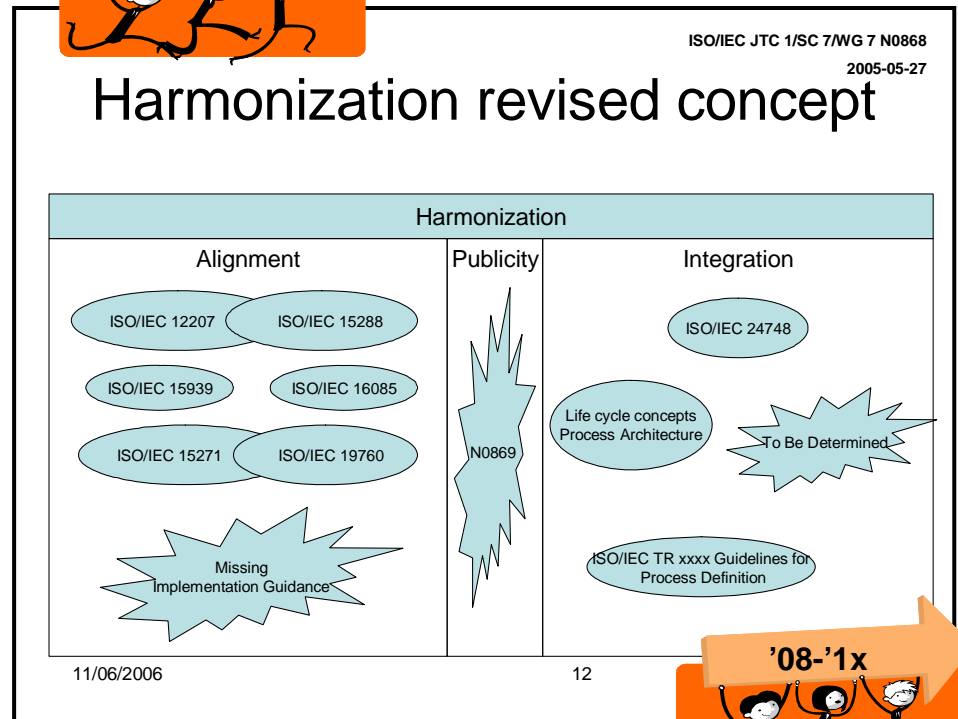

Align – Publicize - Integrate

Concept for the Harmonized Set

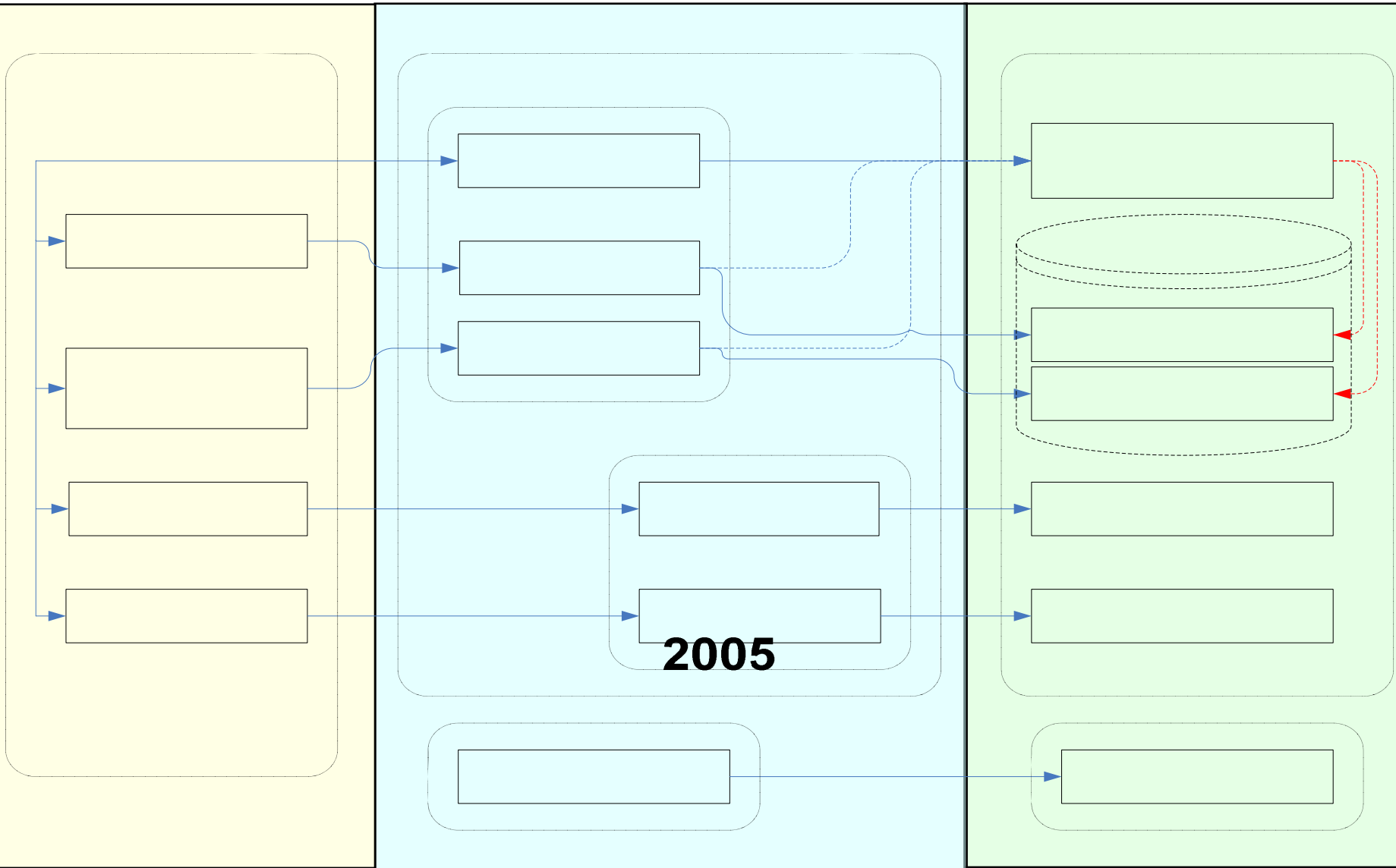

Where We Are Today

Nearly identical process models

System Level Processes

INTERNATIONAL STANDARD

ISO/IEC 15288

IEEE Std 15288-2008

Second edition
2008-02-01

Systems and software engineering — System life cycle processes

Ingénierie des systèmes et du logiciel — Processus du cycle de vie du système

INTERNATIONAL STANDARD

ISO/IEC 12207

IEEE Std 12207-2008

Second edition
2008-02-01

Systems and software engineering — Software life cycle processes

Ingénierie des systèmes et du logiciel — Processus du cycle de vie du logiciel

System Processes Specialized To Software and Software-Specific Processes

Life Cycle Concepts
Process Concepts
LC Models, Stages

ISO/IEC JTC 1/SC 7
Date: 2008-08-11

ISO/IEC DTR 24748-1
ISO/IEC JTC 1/SC 7/WG 7 N1140
Secretariat: SCC

DRAFT

Systems and software engineering — Guide for life cycle management

Ingénierie systèmes et logiciel — Guide pour gestion du cycle de vie

It is the intention of this project to create a Technical Report of Type 3 that may be made freely available in accordance with the provisions of JTC 1 N 7269 and Sendai Resolution 32. In particular, the document has the following

LC Adaptation Domains, Disciplines, & Specialties
Prior Version Transition



Technical Software Services, Inc.

Relations of Process Constructs among ISO/IEC 12207:1995 and its Amendments, 15288:2002, 15288:2008 & 12207:2008

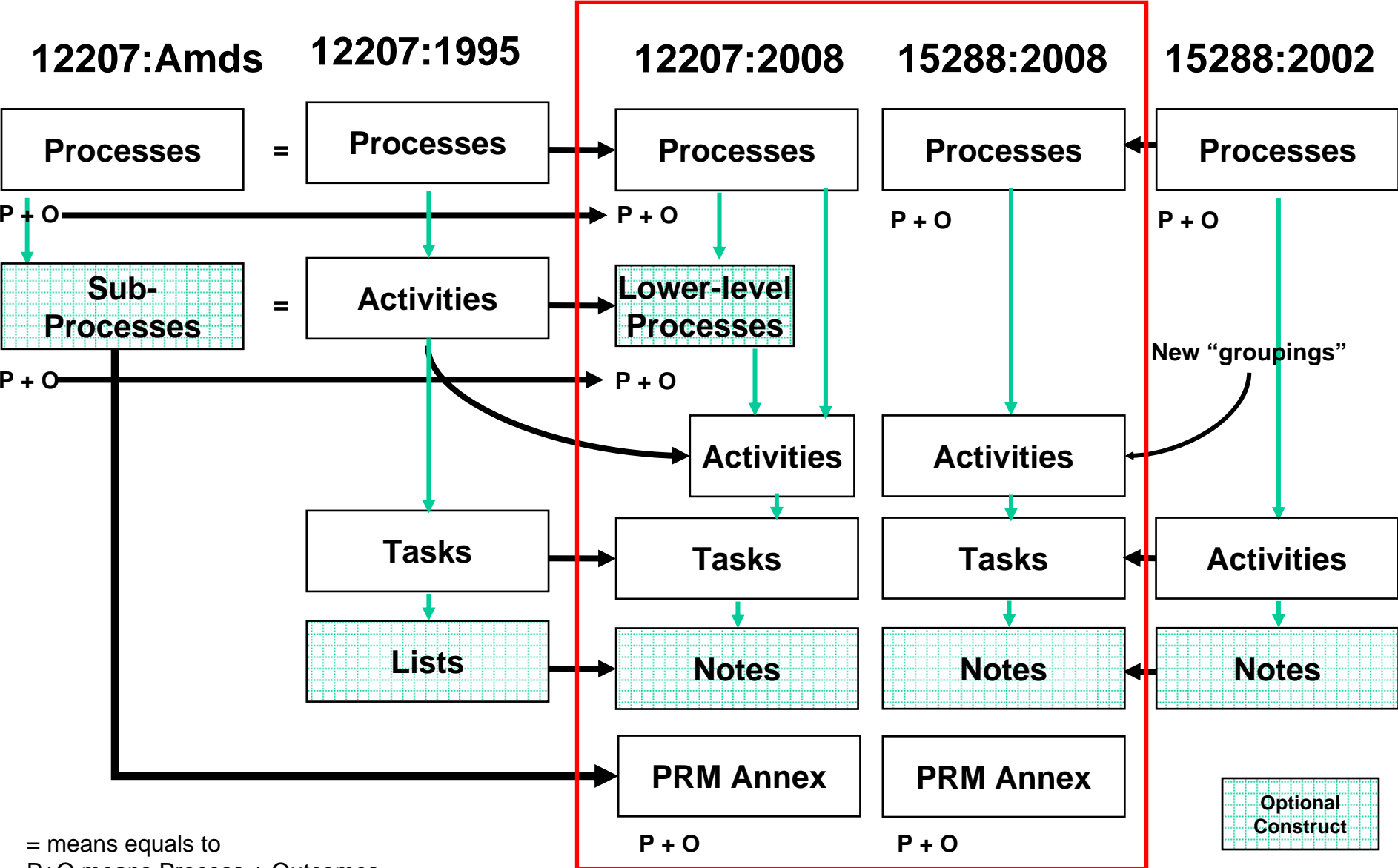

Adapted from ISO/IEC JTC1/SC7 WG7 N1111 briefing material
Source: Anatol Kark, National Research Council, Canada

12207/15288:2008 Process Constructs

Processes require a purpose and outcome. All processes have at least one activity. The processes, with their statements of purpose and outcomes, constitute a Process Reference Model (PRM).

Activities are constructs for grouping together related tasks. The activities provide a means to look at related tasks within the process to improve understanding and communication of the process. If an activity is cohesive enough, it can be converted to a (lower level) process by defining a purpose and a set of outcomes.

A task is a detailed provision for implementation of a process. It may be a requirement (“shall”), a recommendation (“should”), or a permission (“may”).

Notes are used when there is a need for explanatory information to better describe the intent or mechanics of a process. Notes provide insight regarding potential implementation or areas of applicability such as lists, examples and other considerations.

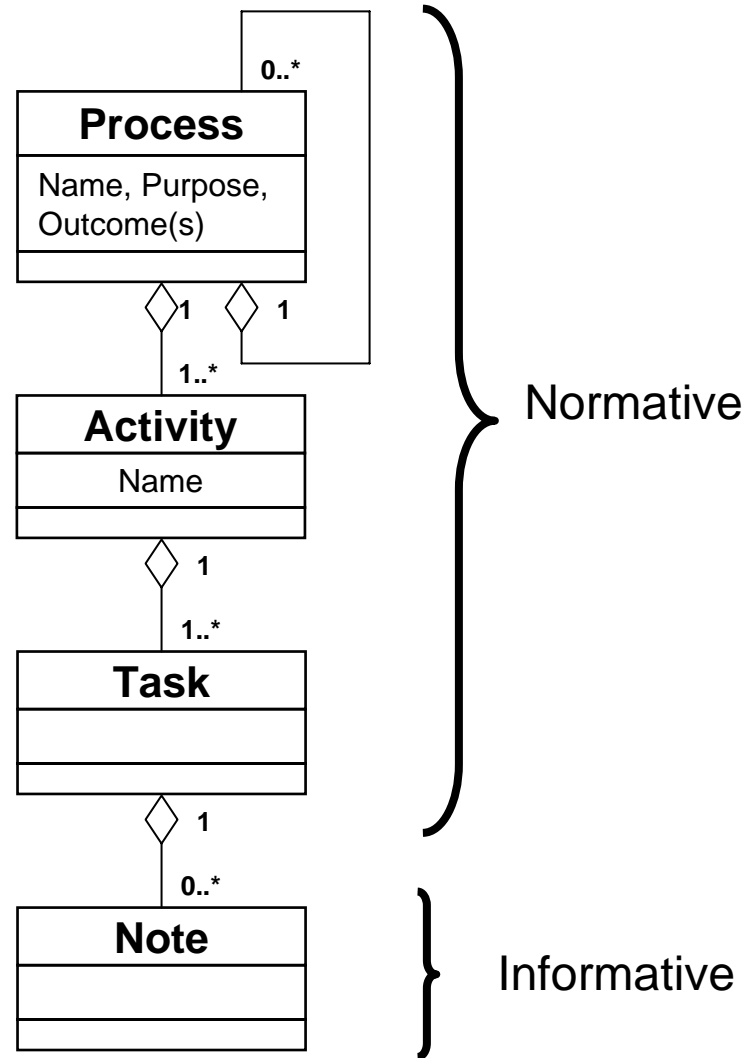

The Life Cycle Processes of 15288:2002

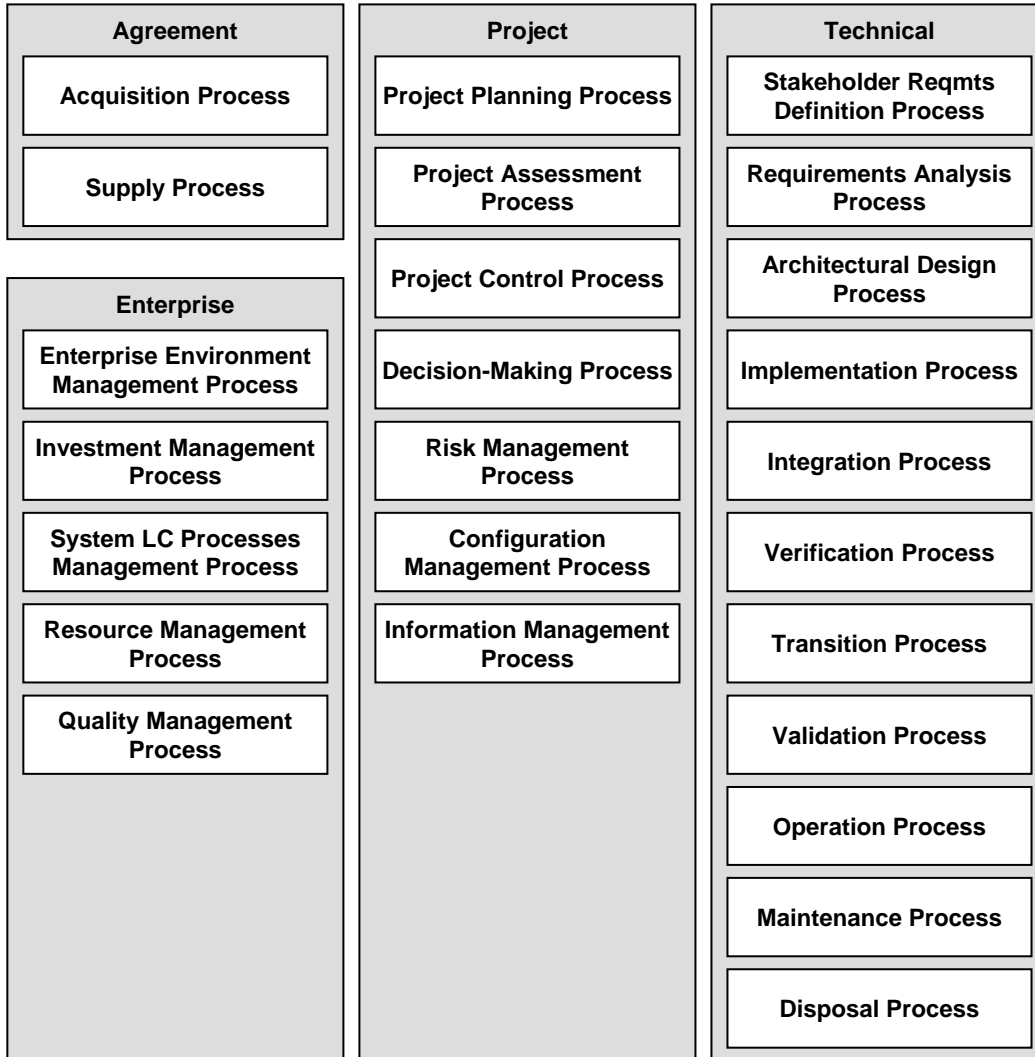

Source: WG7 N1111; Adapted by Jim Moore, MITRE Corporation from chart by Anatol Kark, National Research Council, Canada

Building 15288:2008 – Activities and Tasks

Activity-Task allocation is new to 15288:2008

Provides structural alignment with 12207

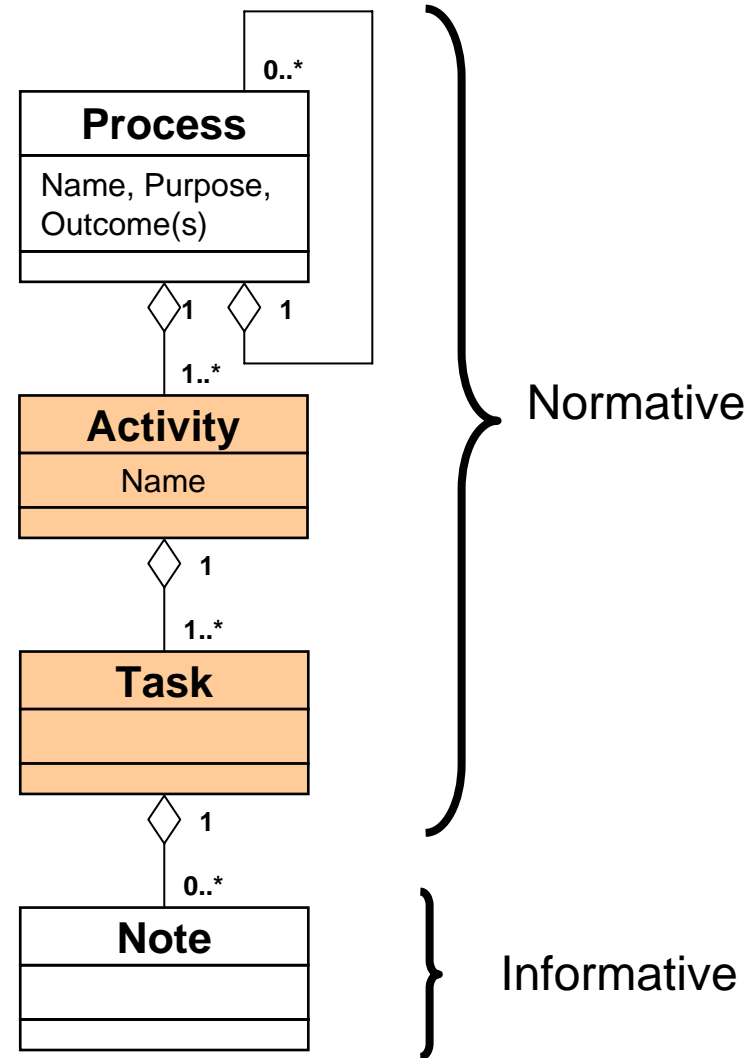
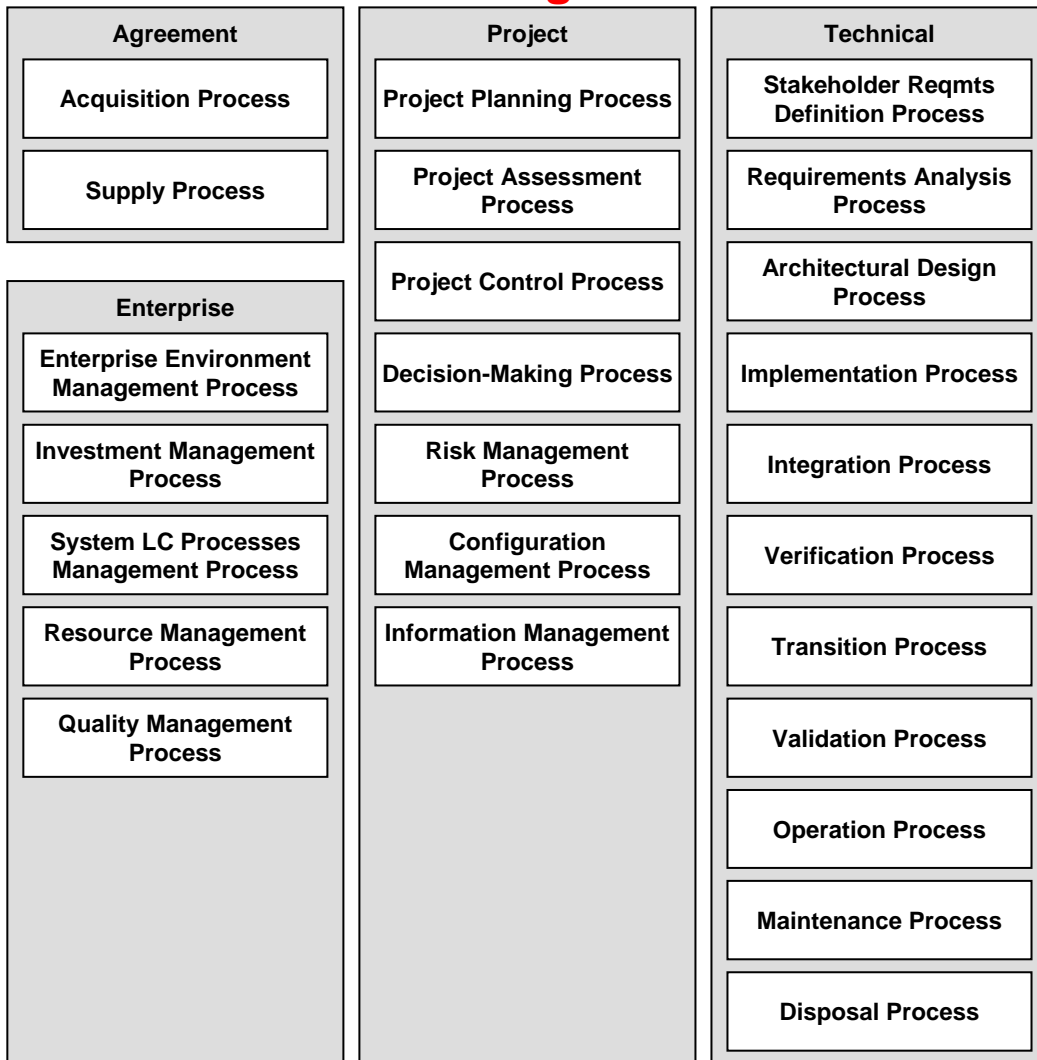

Building 15288:2008 – Technical Processes

15288:2008 has the same set of technical processes as 15288:2002

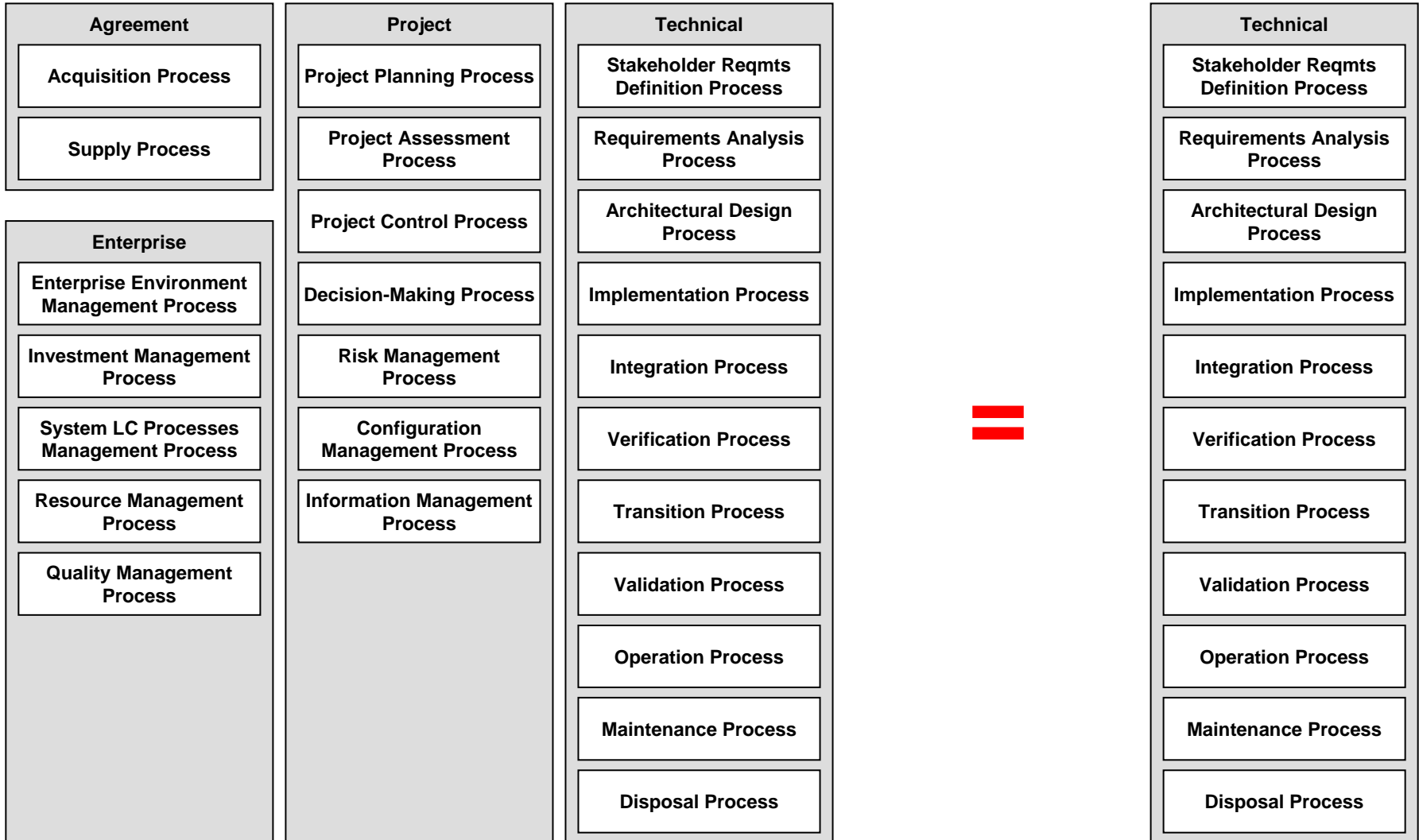

Source: WG7 N1111; Adapted by Jim Moore, MITRE Corporation from chart by Anatol Kark, National Research Council, Canada

Building 15288:2008 – Project Processes

15288:2008 has a similar set of project processes as 15288:2002

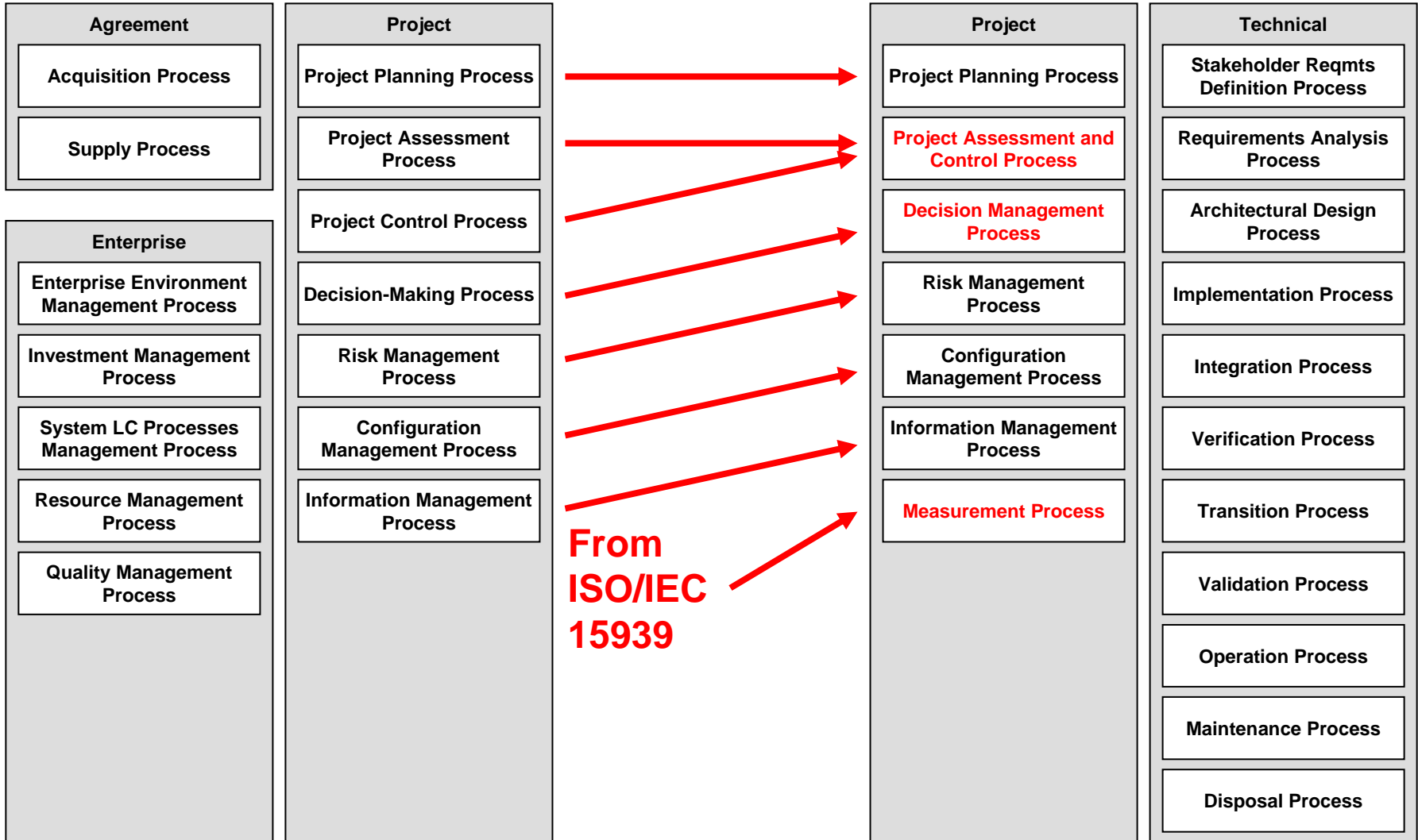

Source: WG7 N1111; Adapted by Jim Moore, MITRE Corporation from chart by Anatol Kark, National Research Council, Canada

Building 15288:2008 – Project-Enabling Processes

15288:2008 has a similar set of project-enabling processes as 15288:2002

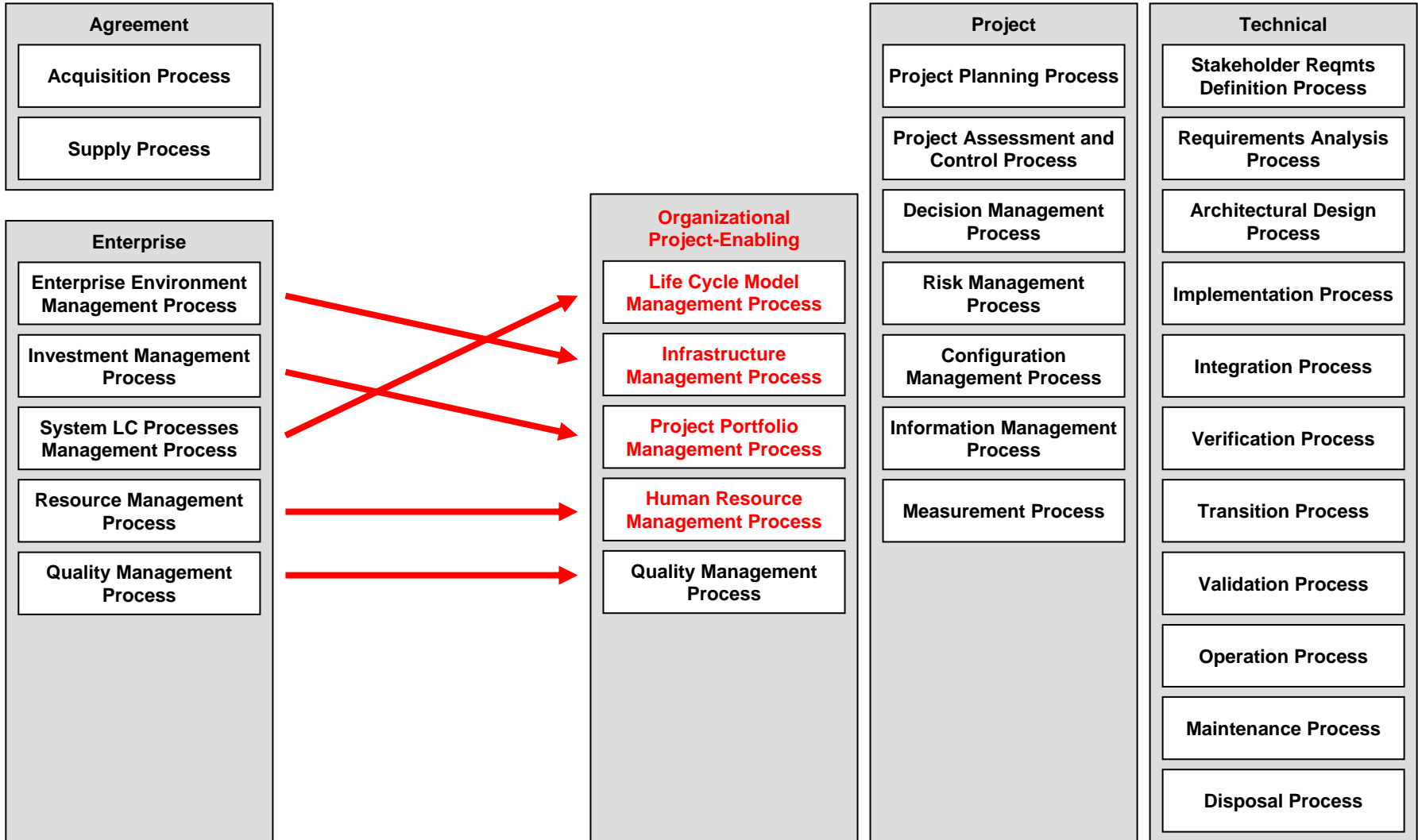

Source: WG7 N1111; Adapted by Jim Moore, MITRE Corporation from chart by Anatol Kark, National Research Council, Canada

Building 15288:2008 – Agreement Processes

15288:2008 has the same set of agreement processes as 15288:2002

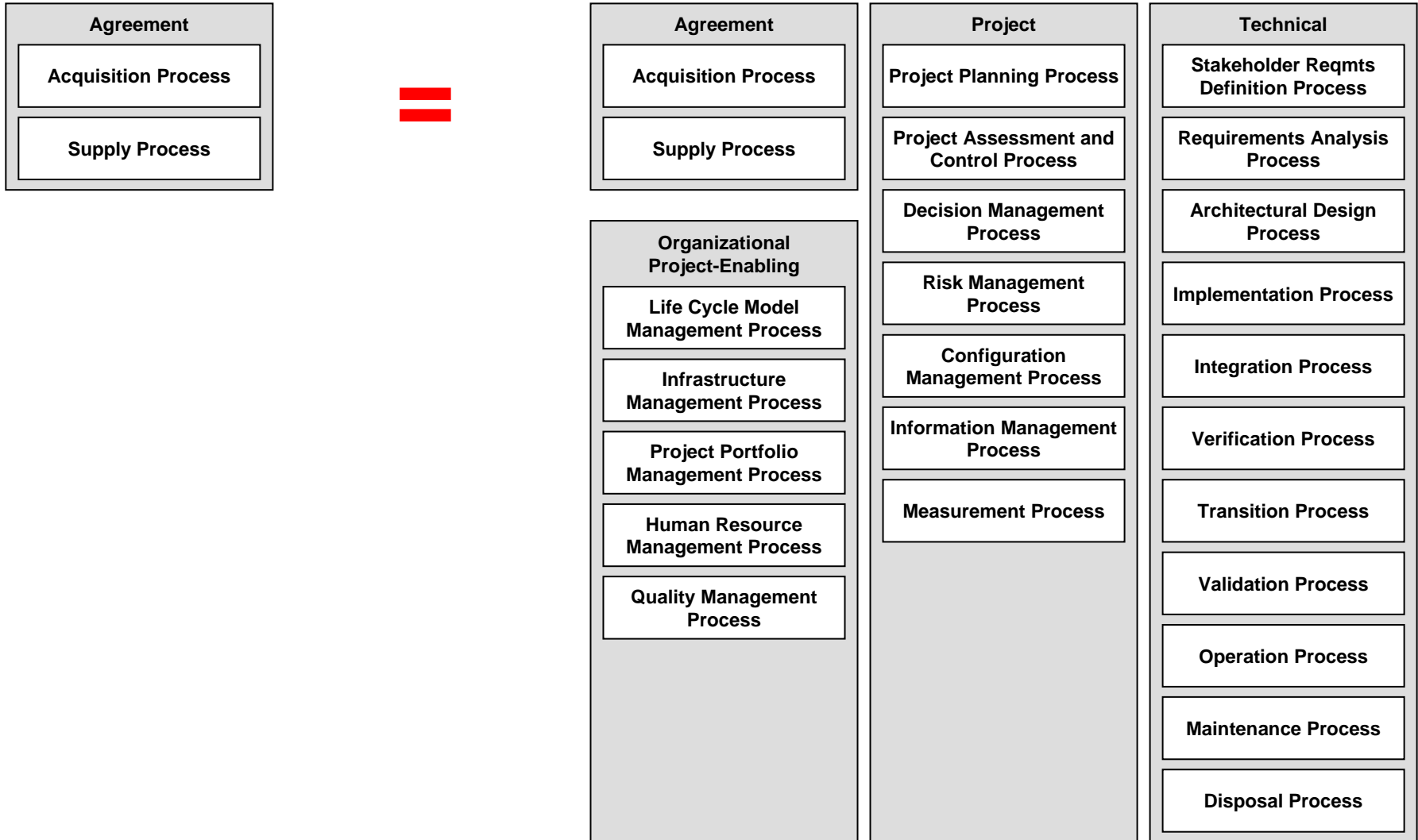

Source: WG7 N1111; Adapted by Jim Moore, MITRE Corporation from chart by Anatol Kark, National Research Council, Canada

The Life Cycle Processes of 15288:2008

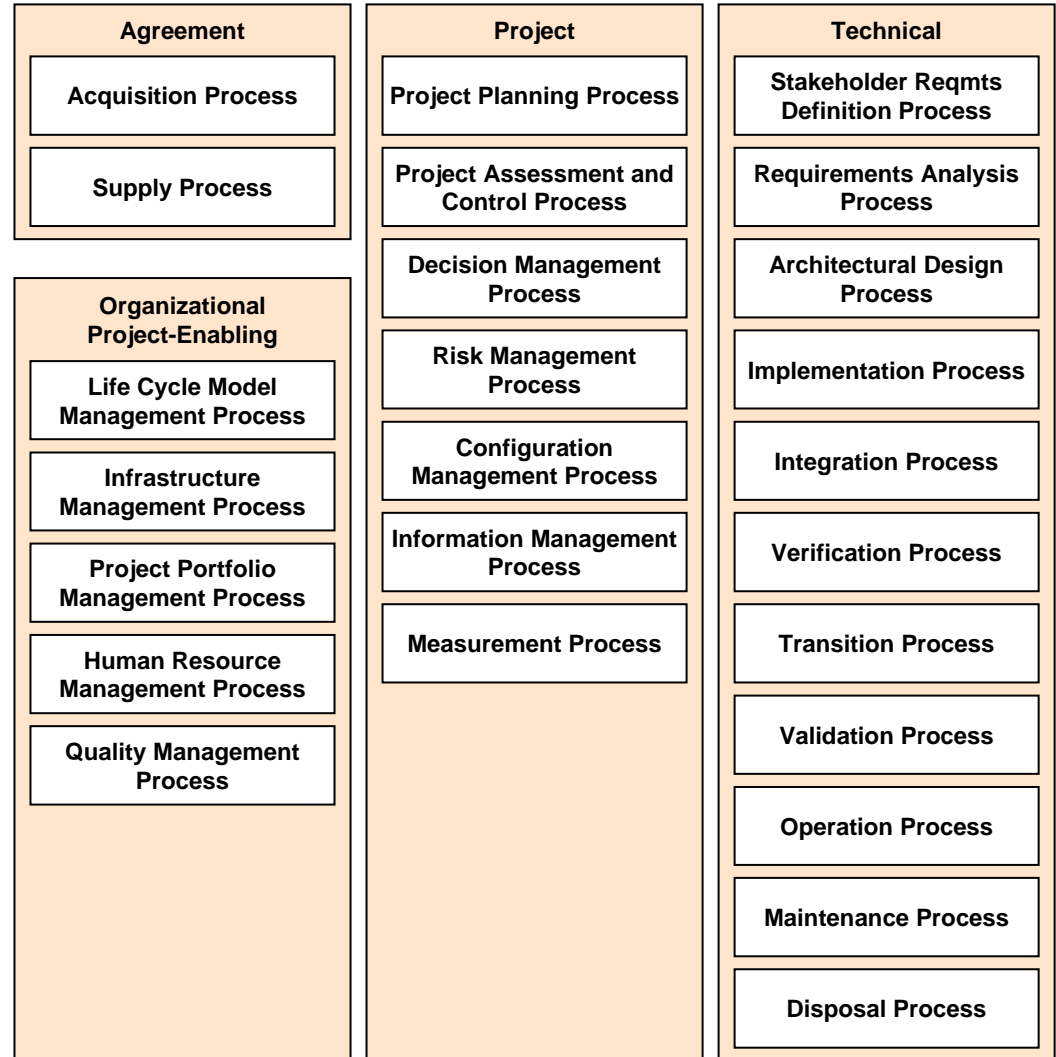

Source: WG7 N1111; Adapted by Jim Moore, MITRE Corporation from chart by Anatol Kark, National Research Council, Canada

The Life Cycle Processes of 12207:1995

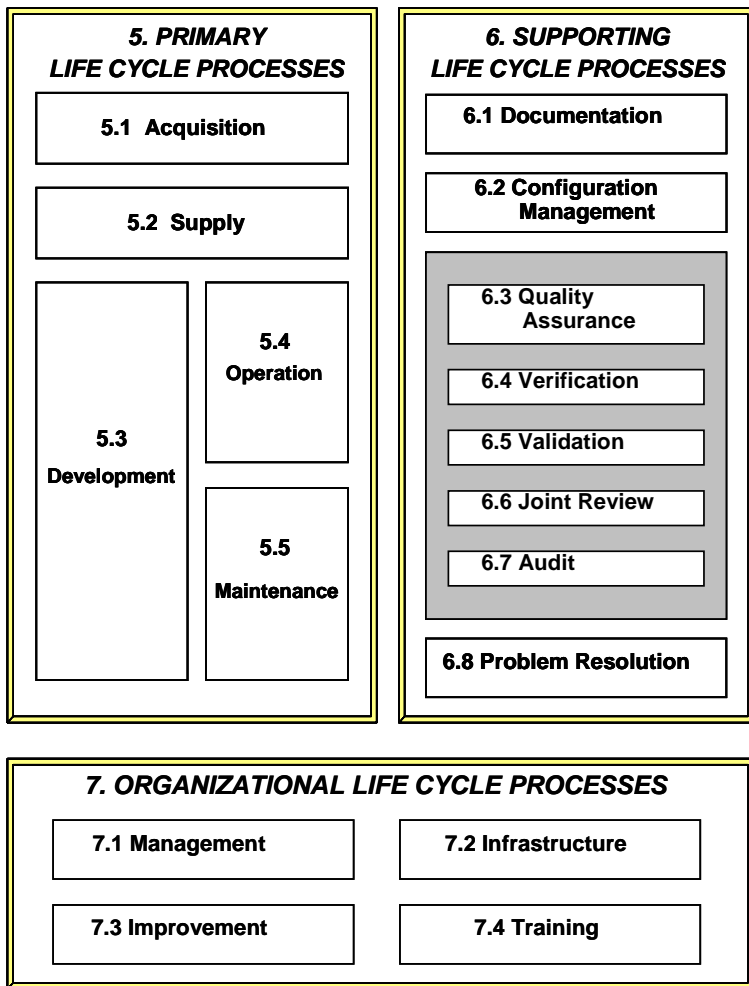

**The Familiar 1995
LCP Categories
Process Structure
and Titles**

The Life Cycle Processes of 12207:1995

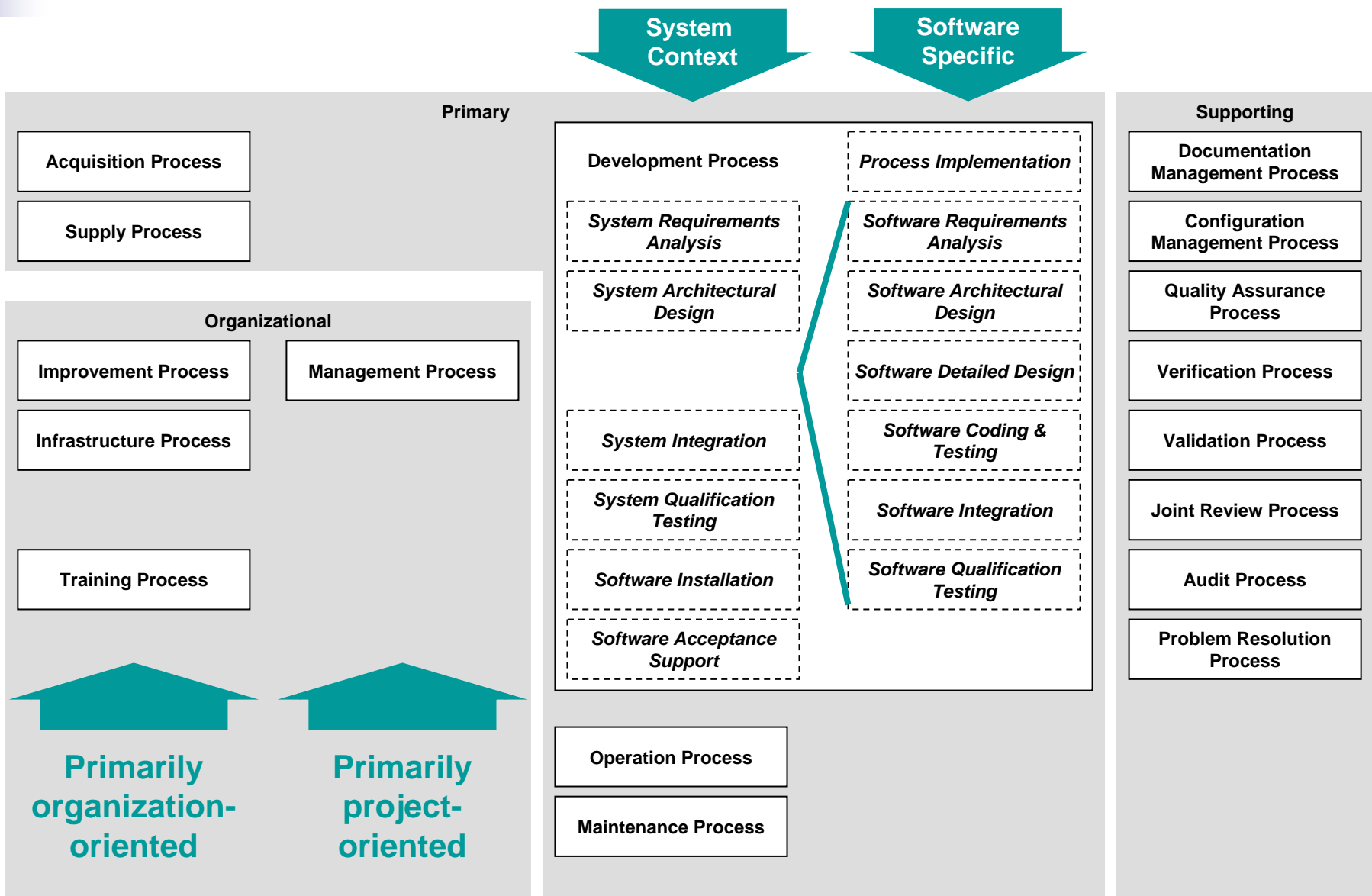

Adapted from WG7 N1111; Source: Jim Moore, MITRE Corporation

Box with dashed border was an Activity in 1995

12207 Amd.1:2002 and Amd.2:2004

- Defined a Process Reference Model (PRM) for 12207
 - Process Name, Purpose, and Outcomes
- Restructured processes to provide higher granularity
 - Introduced sub-processes (e.g based on Development activities)
 - Improvement, Human Resource, Acquisition, Supply, Development, Operation, Management
- Introduced extensions, elaborations and new processes
 - e.g. to better support process assessment (15504-2), usability(13407), measurement (15939), product evaluation(14598), and reuse/asset management (IEEE 1517)
- Added activities and tasks for 8 new processes
- Made some corrections

Generally aligned and incorporated in body of revised 12207
Several sub-processes allocated as lower-level PRM only processes

The Life Cycle Processes of 12207:2008

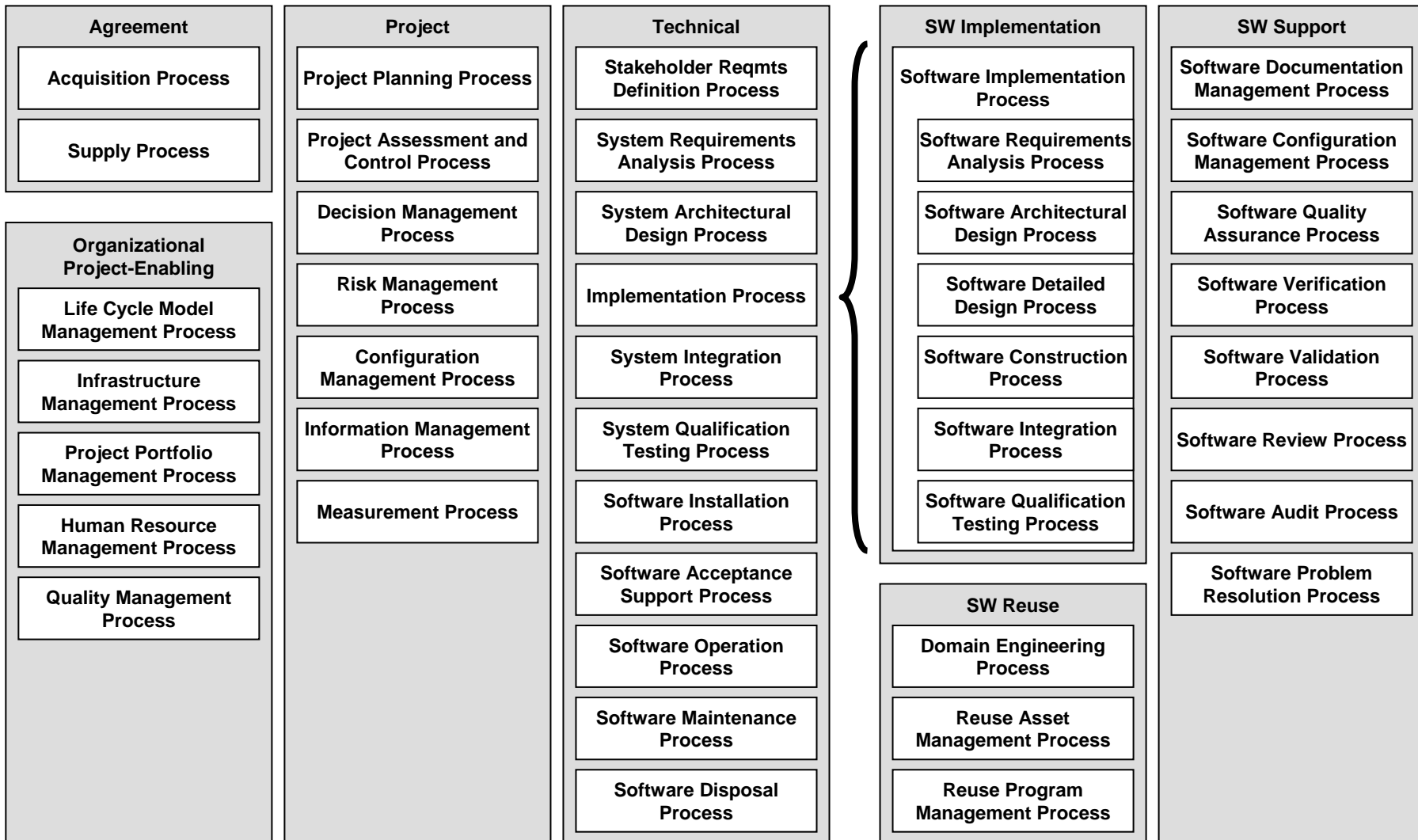

Building 12207:2008 – System Context

Structural alignment with 15288 system level categories

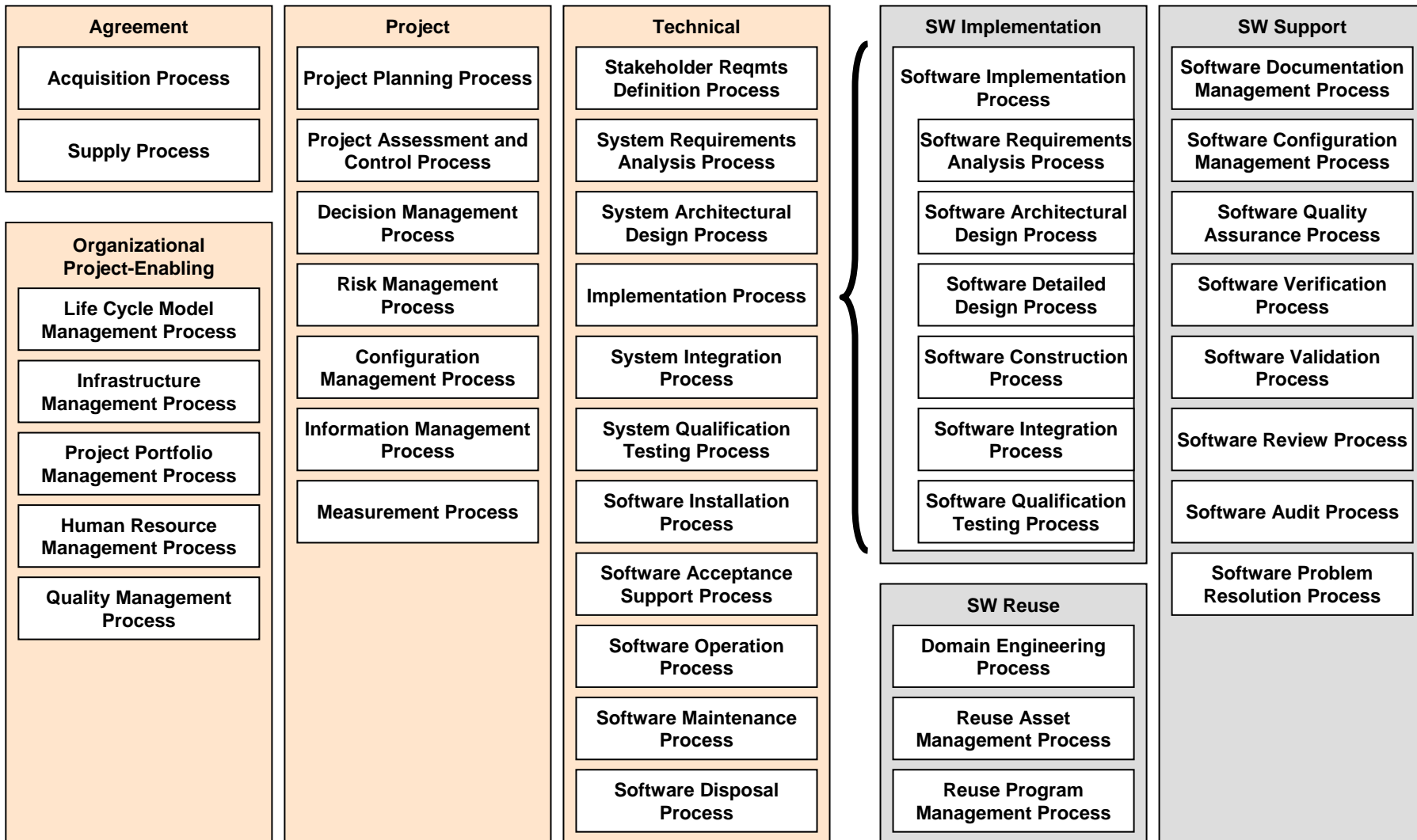

Adapted from WG7 N1111;

Building 12207:2008 – System Context

System Context Processes based on 15288 Processes

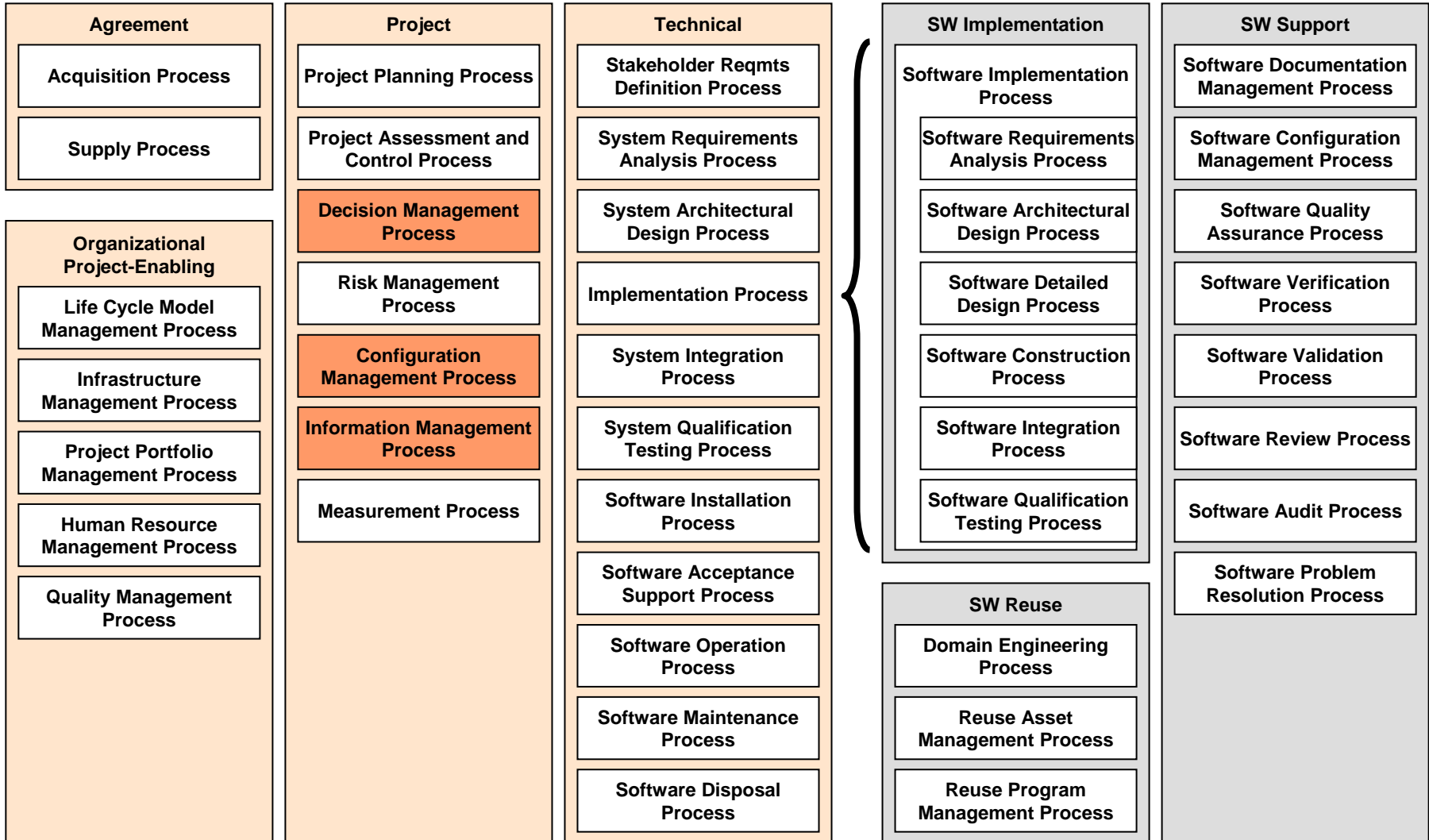

Adapted from WG7 N1111;

Adapted 15288 Outcome/s
Activities, Tasks

Building 12207:2008 – System Context

Include 12207 Organizational Processes: Improvement, Infrastructure, Human Resource/Training, Management

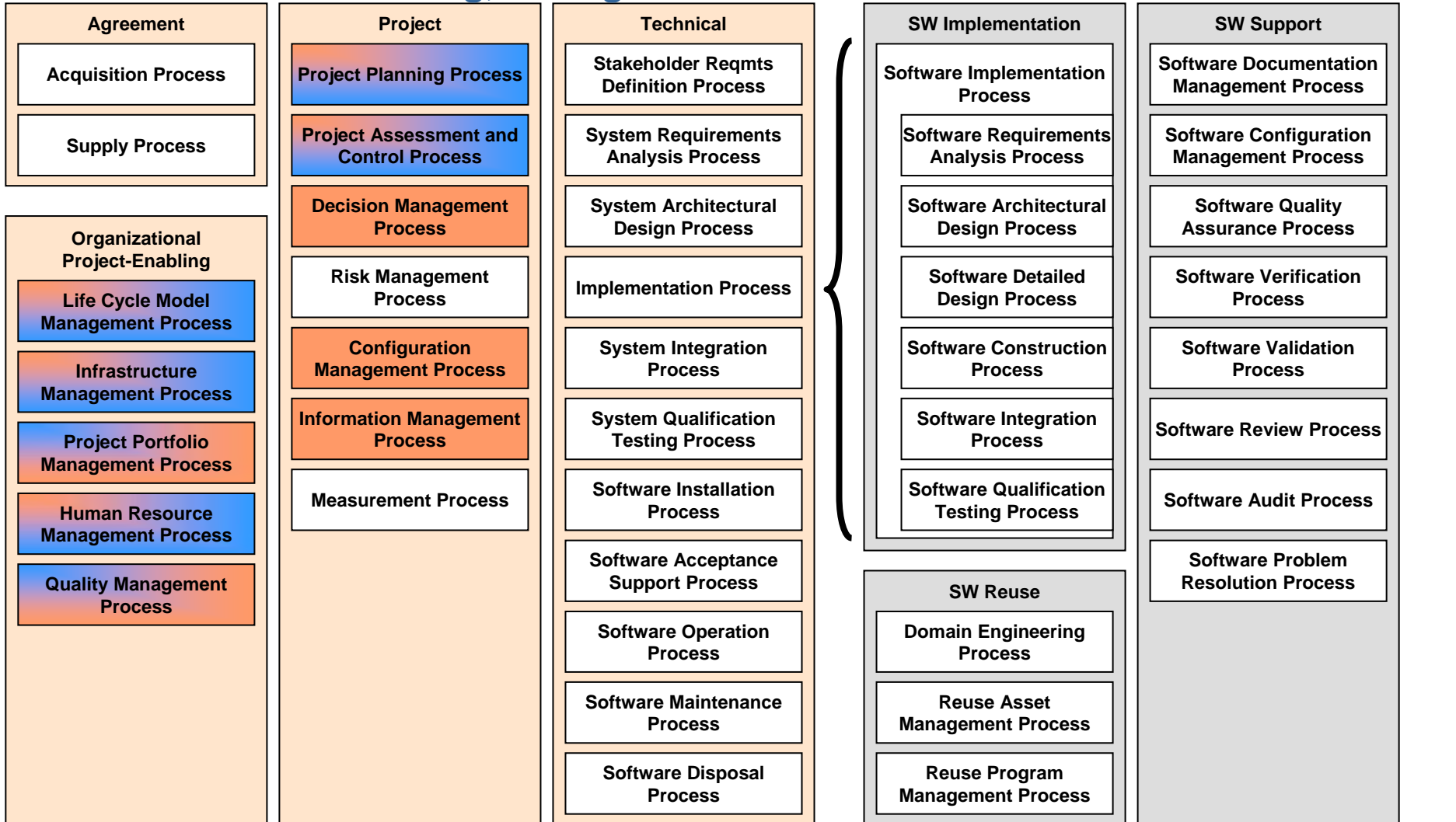

Adapted from WG7 N1111;

TSDoran-NDIA-SE_23OCT08_v1.0

Adapted 15288 Outcome/s Activities, Tasks

One or more 12207 Outcomes

Blended 12207 & 15288 Activities and Tasks

One or more 15288 Outcomes

12207-based Outcome/s Activities, Tasks

Building 12207:2008 – System Context

Risk Management from 16085 and Measurement from 15939 are added

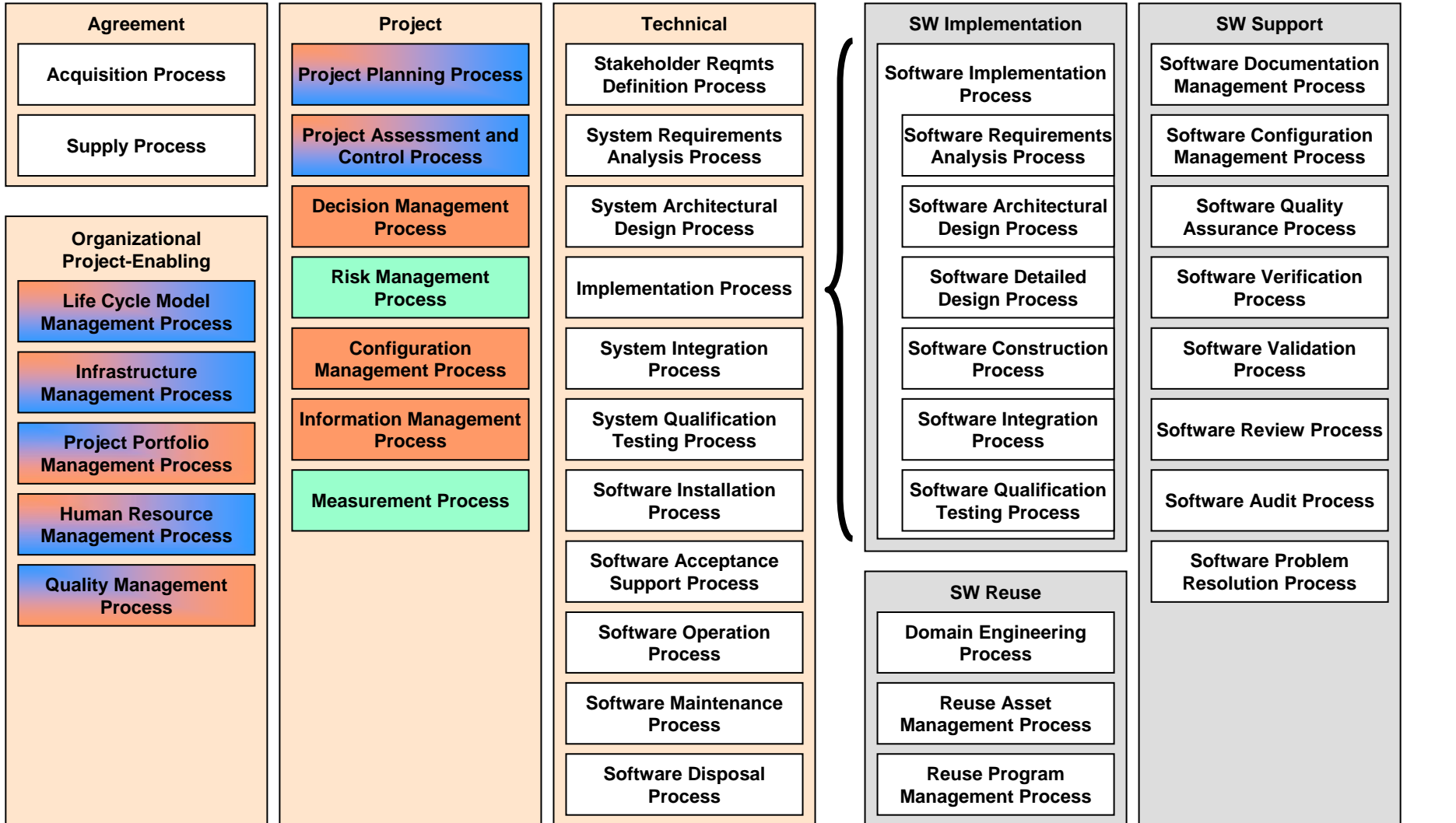

Adapted from WG7 N1111;

TSDoran-NDIA-SE_23OCT08_v1.0

Adapted 15288 Outcome/s Activities, Tasks

One or more 12207 Outcomes

Blended 12207 & 15288 Activities and Tasks

One or more 15288 Outcomes

12207-based Outcome/s Activities, Tasks

Building 12207:2008 – System Context

Risk Management and Measurement are now almost identical to 15288

12207 Acquisition and Supply are blended with 15288 Agreement Processes

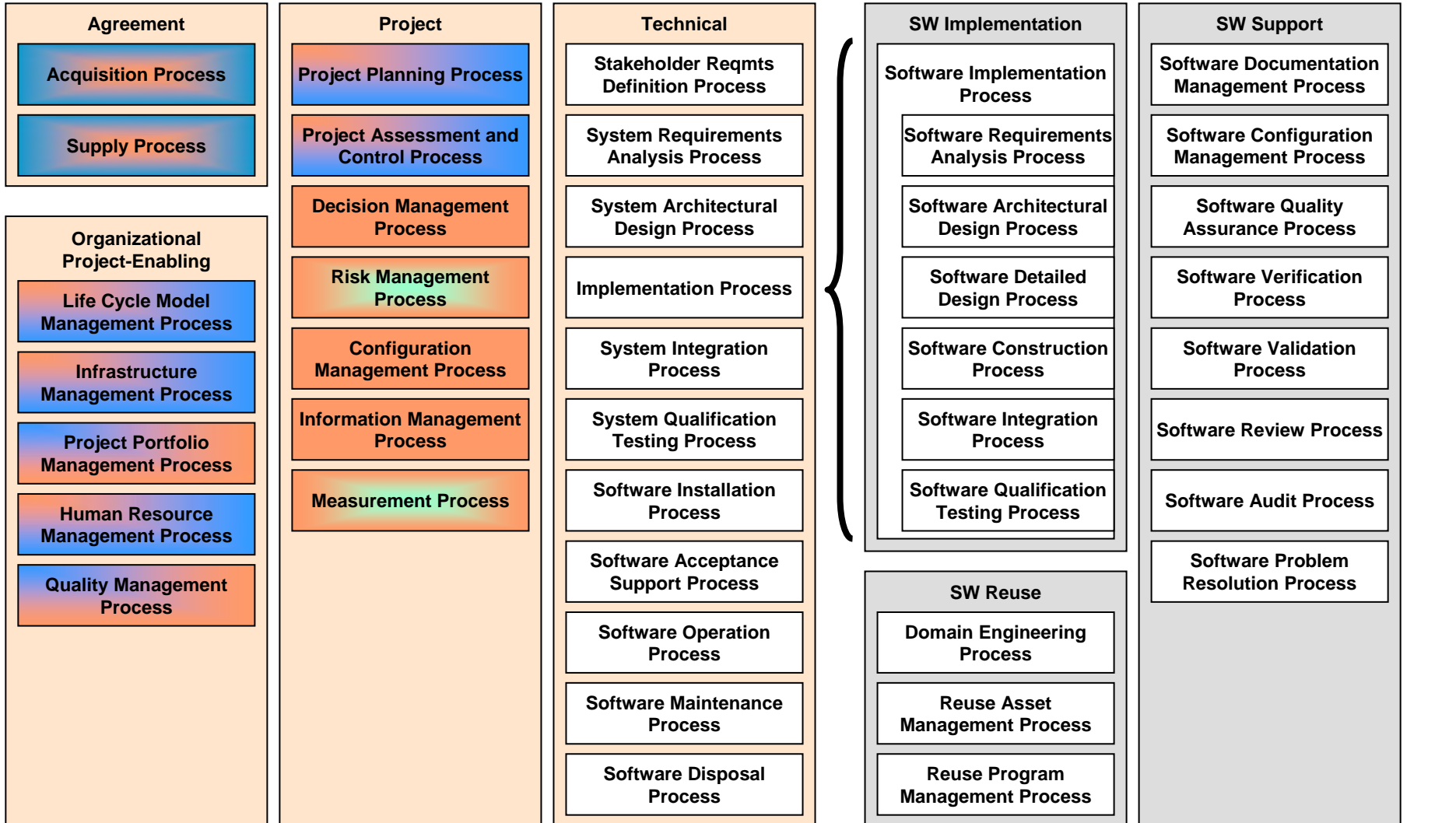

Adapted from WG7 N1111;

TSDoran-NDIA-SE_23OCT08_v1.0

Adapted 15288 Outcome/s Activities, Tasks

One or more 12207 Outcomes

Blended 12207 & 15288 Activities and Tasks

One or more 15288 Outcomes

12207-based Outcome/s Activities, Tasks

Building 12207:2008 – System and Software

Development Activities form System Context and Software Specific Processes

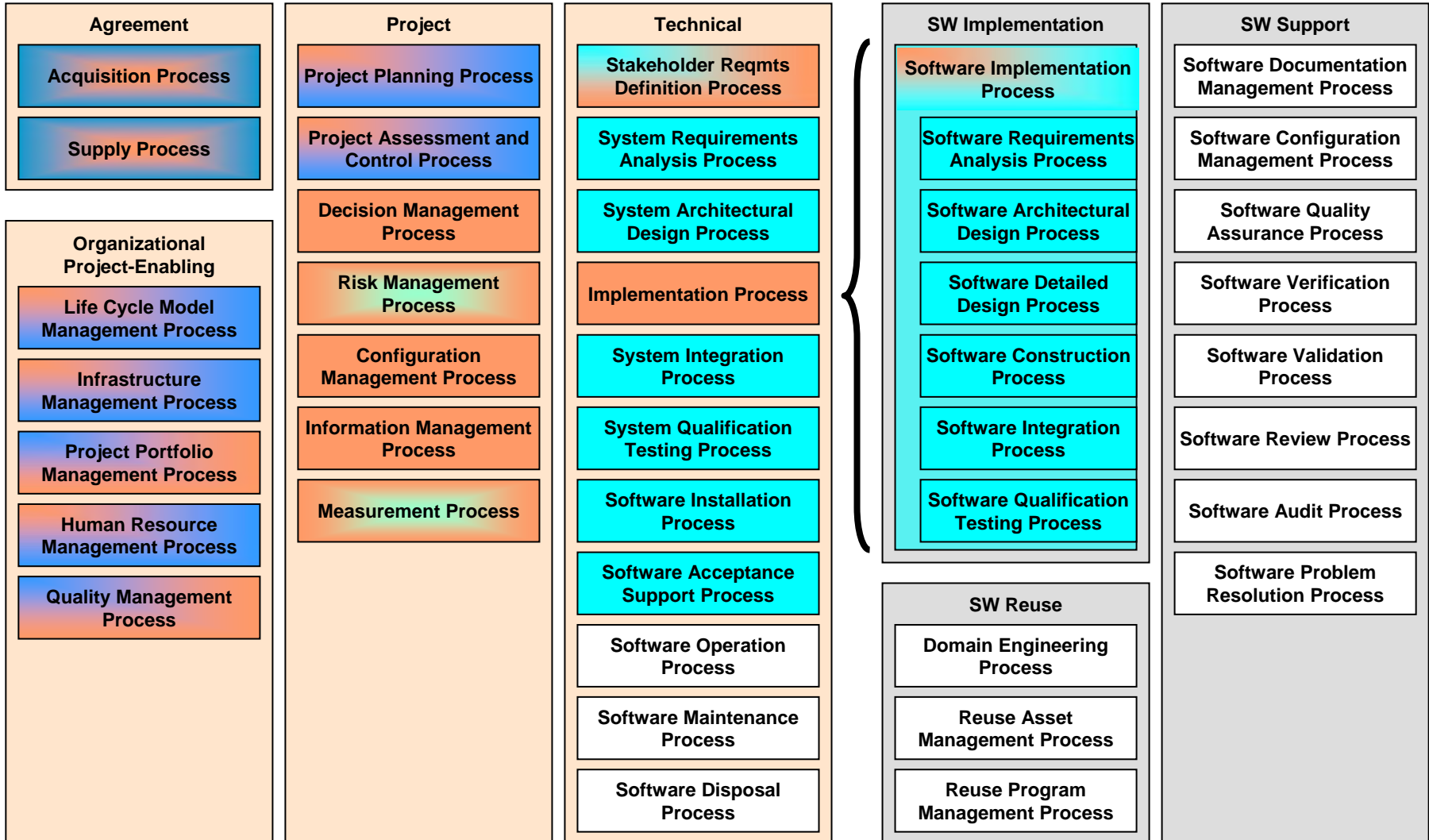

Adapted from WG7 N1111;

TSDoran-NDIA-SE_23OCT08_v1.0

Adapted 15288 Outcome/s Activities, Tasks

One or more 12207 Outcomes

Blended 12207 & 15288 Activities and Tasks

One or more 15288 Outcomes

12207-based Outcome/s Activities, Tasks

Building 12207:2008 – System Context

12207 Operation and Maintenance Processes complete the System Context

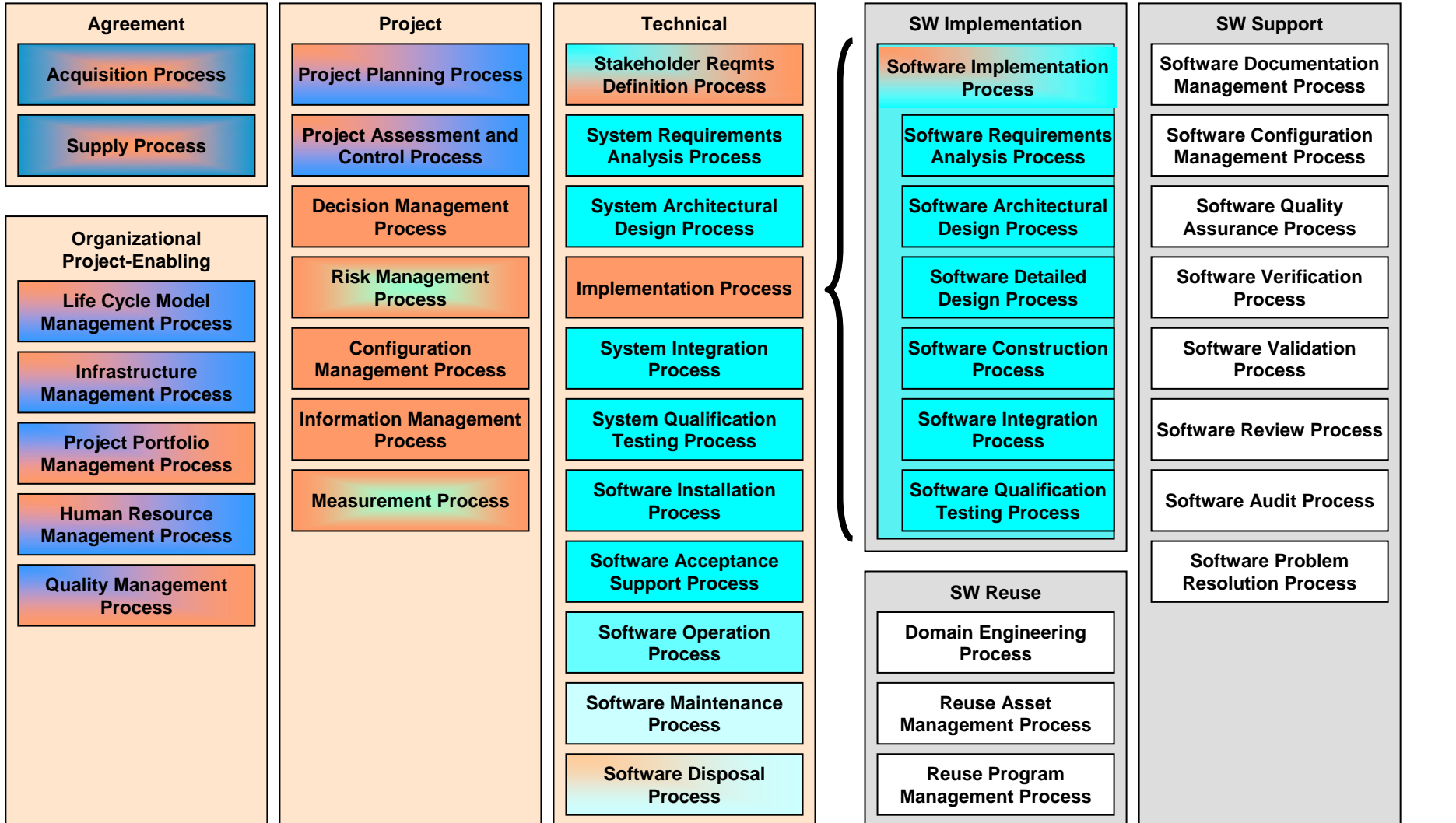

Adapted from WG7 N1111;

TSDoran-NDIA-SE_23OCT08_v1.0

Adapted 15288 Outcome/s
Activities, Tasks

One or more
12207 Outcomes

Blended 12207 & 15288
Activities and Tasks

One or more
15288 Outcomes

12207-based Outcome/s
Activities, Tasks

Building 12207:2008 – Software Specific

Software Specific Support almost the same as 12207 Supporting Processes

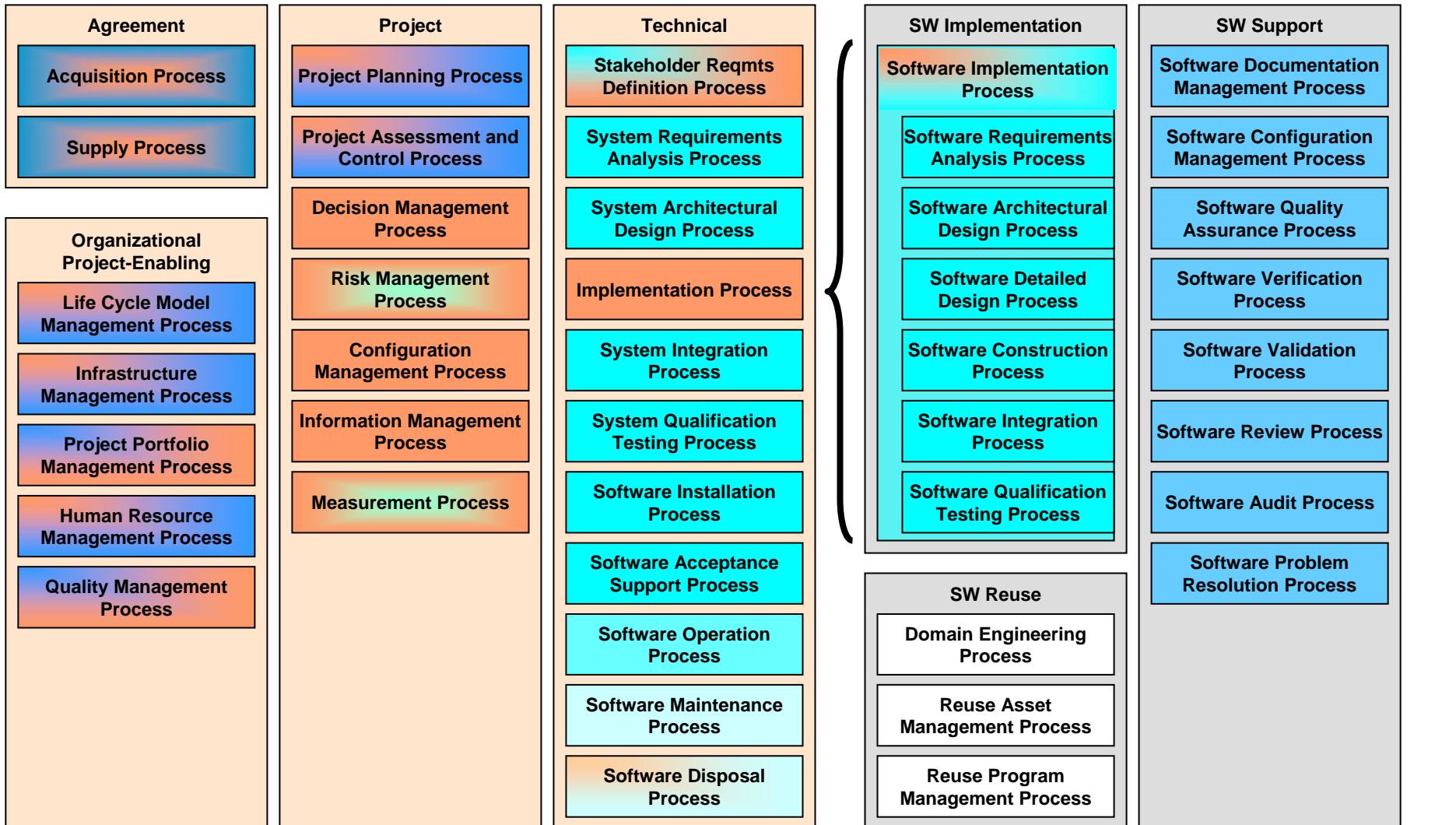

Adapted from WG7 N1111;

TSDoran-NDIA-SE_23OCT08_v1.0

Adapted 15288 Outcome/s
Activities, Tasks

One or more
12207 Outcomes

Blended 12207 & 15288
Activities and Tasks

One or more
15288 Outcomes

12207-based Outcome/s
Activities, Tasks

Building 12207:2008 – Software Specific

12207 Organizational Processes for Reuse conclude the Software Specific set

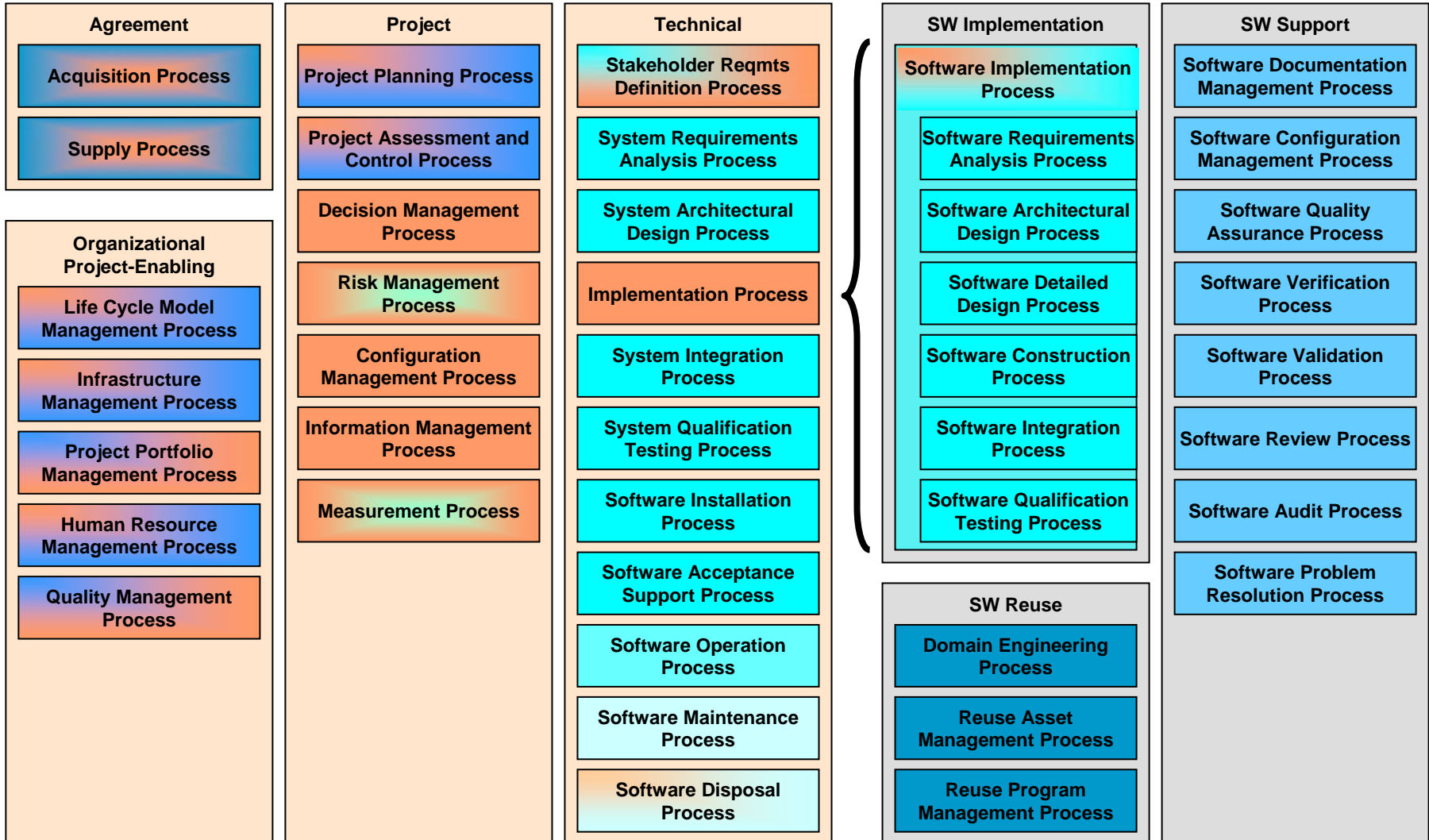

Adapted from WG7 N1111;

TSDoran-NDIA-SE_23OCT08_v1.0

Adapted 15288 Outcome/s Activities, Tasks

One or more 12207 Outcomes

Blended 12207 & 15288 Activities and Tasks

One or more 15288 Outcomes

12207-based Outcome/s Activities, Tasks

Another Way of Looking at It

1. Processes common to both

2. Processes similar between the two

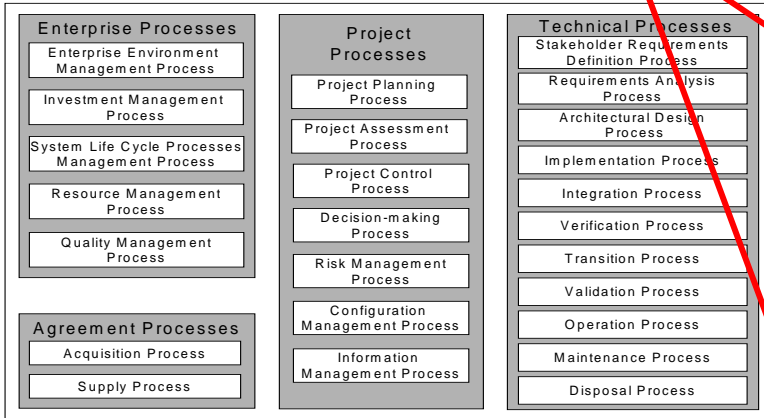

15288

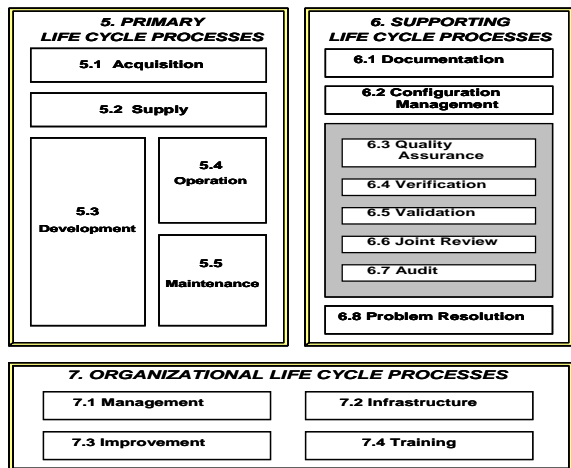
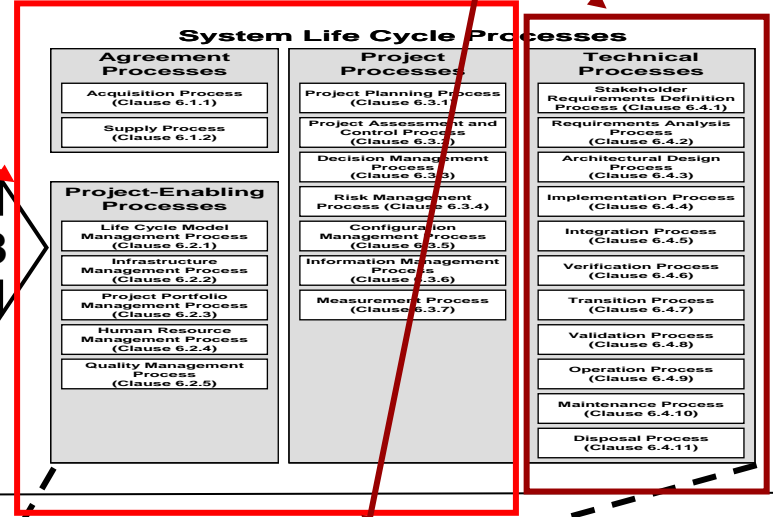

12207

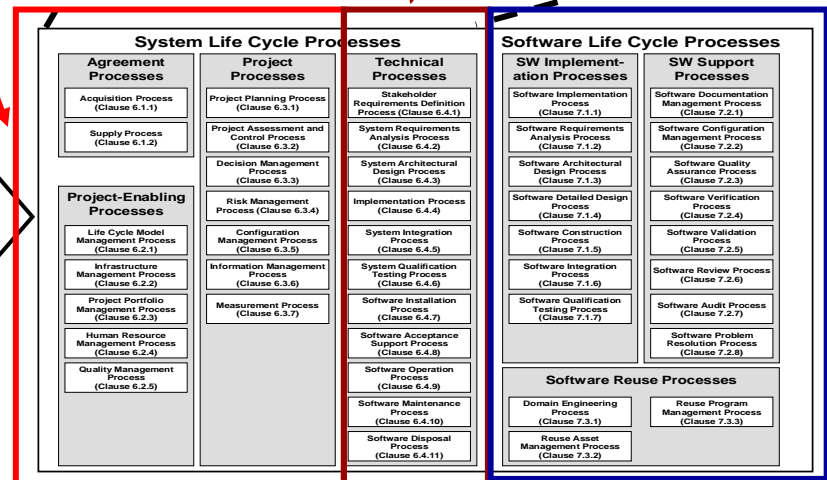

3. Processes unique to domain

Revised Content (Viewed from 12207)

Revised Standards

- Front Matter
- 1. Scope
- 2. Conformance
- 3. Normative References
- 4. Terms and Definitions
- 5. Application of this International Standard
- 6. System Life Cycle Processes
- 7. *Software Life Cycle Processes {Italicized indicates 12207 Only}*

The 12207 Annexes (12207 and 15288 differ somewhat in format and content here)

- A. Tailoring (Normative)
- B. Process Reference Model (Normative)
 - 15504-2 Conformance, *PRM Lower Level Processes for Acquisition, Supply, Life Cycle Model Management, Human Resource Management, and Software Operation*
- C. History and Rationale (Informative)
 - *History, Process Integration/Constructs and Usage, Relationships, Process Definition Sources*
- D. Process Alignment of 12207-15288 {Clause 6} (Informative)
- E. Process Views (Informative)
 - Concepts, and *Process View for Usability Example*
- F. *Some Example Process Descriptions (Informative)*
- G. Relationship to other IEEE standards (Informative)
- H. Bibliography (Informative)
- I. List of {IEEE} participants (Informative)

Aligned 15288 and 12207 Set Provides

- Coordinated Terms and Definitions
- Integrated Process Structure
- Coordinated Process Sets
 - Backward compatible
 - Usable stand alone or jointly by systems and software teams
 - System Context processes are nearly identical or the 12207 processes provide software-appropriate specializations of, or contribute to the outcomes of, the corresponding 15288 processes
 - Especially on Agreement and Project Processes
- Common Conformance/Tailoring
- Common Life Cycle Model and Stage Concepts
- Free Guidance (Annexes and Plan for TR 24748-1)

**Easier Joint Use – Improved Efficiency – Reduced Costs
Common Acquisition, Supply and Management Views**

Towards Full LCP Integration

- WG7 Study Group on Harmonization Integration Strategy Report
 - SC7 Life Cycle Process Harmonization Advisory Group (LCPHAG)
 - Work with SWG5 across SC7 and externally for analyses and recommendations
 - Model SC7's current LCPs and supporting standards
 - Study Process Repository and Electronic Publishing Concepts
 - Rigorous review of SC7 Vocabulary (WG22)
 - Start revision to 15289 (Documentation) to reflect aligned set.

- Some 15288-12207 Integration Considerations:
 - Common purpose and outcomes
 - Architecture of the standards
 - Level of prescription of activities and tasks
 - Life cycle treatments
 - Application to services and operations
 - Common verification and validation concepts
 - Common configuration management concepts
 - Alignment with other applicable standards
 - Rationalization of application guides

Source: WG 7 N1103 – Strategy for Integration Study Group Final Report, 22APR08



Technical Software Services, Inc.

SC7's Large Scale Harmonization Efforts

SWG1

- Business Planning
- Standards Management

- ## Study Groups, e.g.
- Relationships
 - Integration

LCPHAG

- Modeling
- Architectural Analysis
- Process Repository

Overview of the SC 7 collection

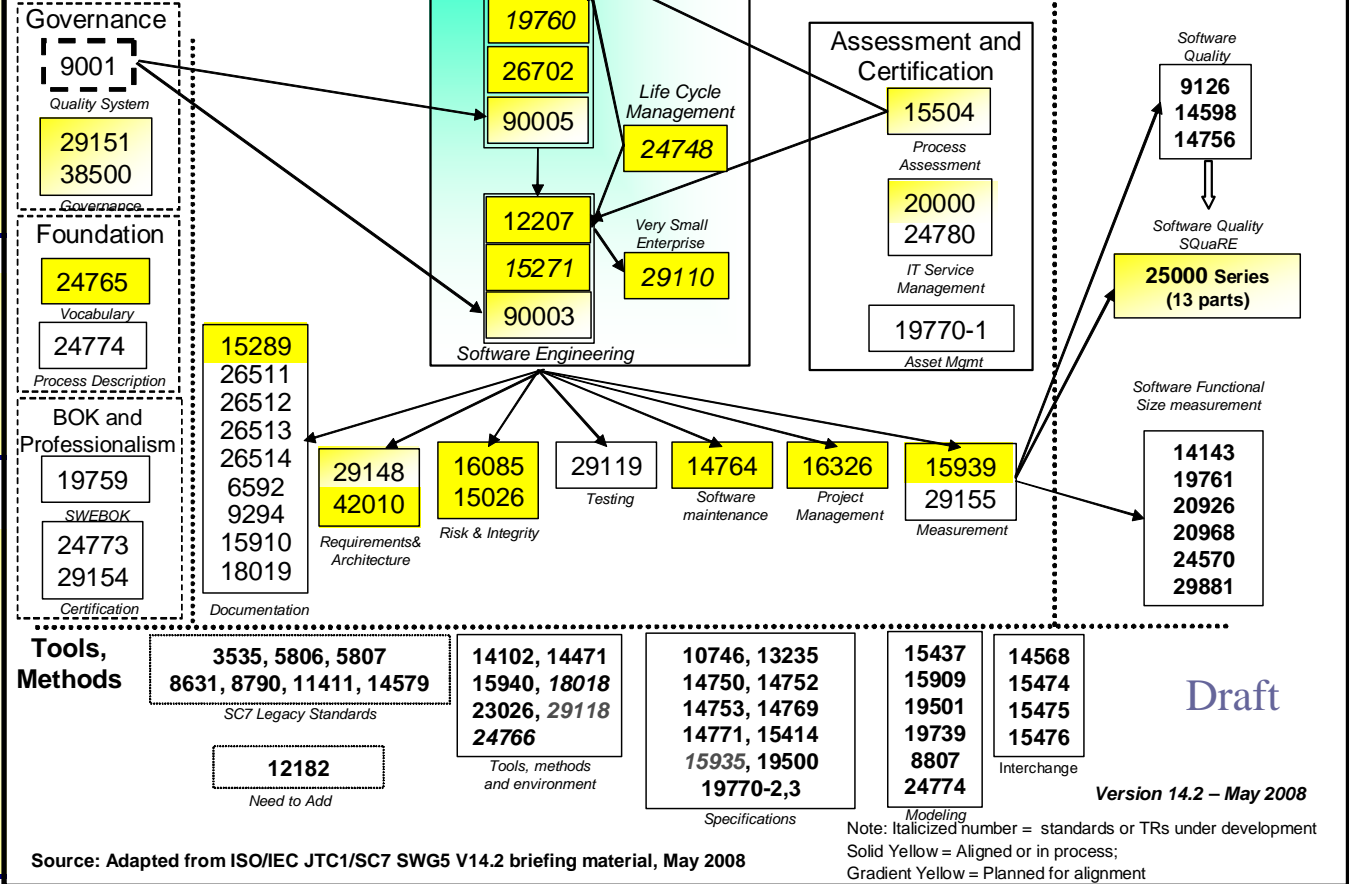

Source: Adapted from ISO/IEC JTC1/SC7 SWG5 V14.2 briefing material, May 2008

Harmonization Across Collections

The State of Harmonization ... Today

| Topic | Status | Remarks |
|--|----------|--|
| Terminology & Concepts | Yellow ↑ | Shared BOK, joint vocabulary project, potential certification framework |
| Quality management | Yellow | IEEE is adopting ISO/IEC 90003 approach. |
| Testing | Orange ↑ | Both IEEE and BSI will harmonize with SC7 processes |
| Architecture description | Green | SC7 adopted IEEE standard and will harmonize with processes. |
| Product quality | Yellow ↑ | ISO/IEC 12119 was revised as 25061. IEEE will withdraw its standard. |
| Life cycle processes | Green | |
| Systems engineering | Green | Shared SE process standard; harmonization with other LC processes underway |
| SW maintenance | Green | Project to merge IEEE and ISO standards is completed |
| Measurement | Yellow ↑ | IEEE will adopt 15939 after its current revision. Some details remain. |
| Risk management | Green | SC7 adopted IEEE standard and is now extending it to the systems level. |
| Project management | Yellow ↑ | Project is merging the incompatible standards. |
| Verification and validation | Red | Fundamentally different approaches. Good intentions, but no action yet. |
| Configuration management | Yellow | SC7 withdrew its standard; systems issues remain. IEEE is about to revise. |
| SW process assessment | Yellow ↑ | Harmonization with LC process standards is underway |
| Requirements engineering | Orange ↑ | Joint project has been approved; mashup of relevant standards is being prepared. |
| SW life cycle data | Yellow ↑ | IEEE is adopting 15289 to replace 12207.1 |
| User documentation | Yellow ↑ | IEEE 1083 has been incorporated into 26514. IEEE will adopt it. |
| CASE tools | Yellow | Minor incompatibilities |
| Notations | Harmless | Distinct standards for distinct notations |
| Internet | Green | Shared standard |
| IT Services, Management, Governance | Yellow | IEEE will adopt 20000 standards |
| Specialty Engineering (Safety, Security) | Orange ↑ | Unrelated approaches will be addressed in part by coordination revision of 15026 |
| Others | Yellow | Many unrelated standards |

The State of Harmonization in 1995

| Topic | Status | Remarks |
|--|----------|--|
| Terminology & Concepts | Red | Different vocabulary standards |
| Quality management | Orange | ISO: Driven down from ISO 9001. IEEE: traditional QA approach. |
| Testing | Orange | IEEE standards unrelated to SC7 processes. |
| Architecture description | Harmless | SC7 didn't have architecture standards. |
| Product quality | Yellow | Unrelated standards |
| Life cycle processes | Red | Incompatible standards |
| Systems engineering process | Yellow | Unrelated standards |
| SW maintenance | Red | Incompatible standards |
| Measurement | Yellow | Unrelated standards |
| Risk management | Harmless | No standards at all |
| Project management | Red | Incompatible standards |
| Verification and validation | Red | Fundamentally different approaches; minor incompatibilities in details |
| Configuration management | Red | Incompatible standards |
| SW process assessment | Yellow | Nothing in IEEE. ISO process assessment incompatible with ISO LC. |
| Requirements engineering | Orange | IEEE standards unrelated to SC7 processes |
| SW life cycle data | Red | Incompatible standards |
| User documentation | Red | Incompatible standards |
| CASE tools | Yellow | Minor incompatibilities |
| Notations | Harmless | Distinct standards for distinct notations |
| Internet | Harmless | No standards |
| IT Services, Management, Governance | Harmless | No standards |
| Specialty Engineering (Safety, Security) | Orange | Unrelated approaches |
| Others | Yellow | Many unrelated standards |

**IEEE CS May 2008
Status Report to SC7**

**Stoplight charts
show marked
improvement
between the
IEEE and SC7
Standards
Collections**

Harmonization Benefits Summary

Alignment

- Achieves short term objectives
- Maintains backward compatibility
- Starts disparate users towards goal

Integration

- Tackles the 'religious' issues
 - Technical and Political
- Achieves long term goals in a set

Large Scale Harmonization

- Solves big picture issues within and across SDOs

Each Level Brings You

- Easier process definition and implementation
- Better team communication and integration
- Improved performance at lower cost
- Increased benefit and usefulness of implementing these standards in your organization

Eases Your Integration, Management, and Acquisition Burden



Technical Software Services, Inc.



Questions?

For More Information Contact

- Teresa 'Terry' Doran
TECHSOFT

31 West Garden Street, Suite 100

Pensacola, FL 32502-5685

Internet: www.techsoft.com

NY Office Tel: 1 631-266-2191

Email: tsdoran@techsoft.com

- ISO/IEC/IEEE 12207 Project Editor
- 15288-12207-24748 Editorial Team Member
- IEEE Std 1220™-2005 Project Editor (aka ISO/IEC 26702:2007)
- ISO/IEC JTC1/SC7 Life Cycle Process Advisory Group Chair



Technical Software Services, Inc.

| | |
|----------------|---|
| ANSI | – American National Standards Institute |
| CMMI | – Capability Maturity Model Integration |
| CMU | – Carnegie Mellon University |
| IEC | – International Electrotechnical Commission |
| IEEE | – Institute of Electrical and Electronics Engineers |
| IEEE CS | – IEEE Computer Society |
| INCOSE | – International Council on Systems Engineering |
| ISO | – International Organization for Standardization |
| IT | – Information Technology |
| JTC1 | – ISO/IEC Joint Technical Committee 1: Information Technology |
| LCP | – life cycle process |
| NWIP | – new work item proposal |
| OPA | – organizational process assets |
| OPD | – organizational process definition |
| SC | – subcommittee |
| SG | – study group |

- SC7** – ISO/IEC JTC1 SC 7: Software and Systems Engineering
- SE** – systems engineering
- SEI** – Software Engineering Institute (at CMU)
- S2ESC** – Software and Systems Engineering Standards Committee (IEEE CS)
- SEP** – SE process
- SWE** – software engineering
- SWG** – special WG
- WG** – working group
- WG7** – ISO/IEC JTC1 SC7 WG 7: Life Cycle Management
- VSE** – very small enterprise

For ISO and ISO/IEC Standards (Current and Withdrawn):

http://www.iso.org/iso/iso_catalogue.htm

- 1) **ISO 9001:2005, *Quality management systems — Requirements***
- 2) **ISO/IEC 12207:2008, *Systems and software engineering — Software life cycle processes***
- 3) **ISO/IEC 15288:2008, *Systems and software engineering — System life cycle processes***

For ISO/IEC documents and in-process standards and technical reports (TRs): <http://www.jtc1-sc7.org/>

- 4) **SC7 N4143: ISO/IEC DTR 24748.2:2009, *Systems and software engineering — Guide for life cycle management***

For IEEE Standards:

<http://www.ieee.org/web/standards/home/index.html>

IEEE Std 1220™-2005, *IEEE Standard for Application and Management of the Systems Engineering Process*

Or related information:

<http://standards.computer.org/s2esc/>

**IEEE CS Software and Systems Engineering Standards Committee
– for on-going SE/SW standards activities**

http://pascal.computer.org/sev_display/index.action

SEVOCAB: An IEEE CS and ISO/IEC JTC 1/SC7 project, SEVOCAB includes definitions from international standards; This database is issued periodically as a formal, published International Standard (ISO/IEC 24765) reflecting a "snapshot" of the database.



Systems and Software Life Cycle Process Standards: Foundation for Integrated Systems and Software Engineering

For: ***NDIA Systems Engineering Conference***

Date: **23 October 2008**

Presented By: **Teresa Doran**

- Purpose
- TECHSOFT
- Standards-based Process Improvement Success
- Why Harmonize?
 - Issues
 - Impacts to you
- SE/SW LCP Alignment and Integration
 - Path
 - Concepts
 - Where we are today
 - How we got here – Key changes in 15288 & 12207
- Large Scale Harmonization
- Benefits Summary

Show how the key changes in the alignment of a foundational systems/software standards set (ISO/IEC/IEEE 15288 and ISO/IEC/IEEE 12207) facilitates integrated systems and software engineering, project management, and acquisition

Who We Are

- Founded in 1990
- Based in Pensacola, Florida
 - Presence in Charleston, SC
- Primarily, a DoD Contractor
- Experienced Staff
 - High % Masters level personnel
 - Majority with Security Clearances
 - SEI-Authorized CMMI® Lead Appraisers
 - SEI-Authorized CMMI® Instructors
 - International SE/SW Standards Expertise

What We Do

- Systems & Software Development
- Database Applications
- Security / IA
- Web Development
- Network Engineering/Hosting
- Training
- Process Engineering/Process Improvement
 - CMMI®
 - SEI Partner

Standards-based Process Improvement

Example of a Successful Approach



SPAWAR
Systems Center
Charleston

Process Improvement and Systems Engineering Strategy - 2003

- **Vision**
 - Develop and maintain a World Class Systems Engineering Organization
- **Approach**
 - Achieve Command-wide operational consistency
 - Based on ISO 15288 – systems engineering
 - Based on ISO 12207 – software engineering
 - Measure using best practices of CMMI®
- **Goals**
 - CMMI® Maturity Level 2 by April, 2005
 - CMMI® Maturity Level 3 by April, 2007



WORLD CLASS SYSTEMS ENGINEERING
SPAWAR
Maturity Level 3
Maturity Level
April 27, 2007
Capability Maturity Model Integration (CMMI®)
SYSTEMS CENTER CHARLESTON

Both Goals attained on schedule
1st SPAWAR Systems Center to Achieve ML2 and ML3
New Goal: Maturity Level 4 & 5

33

Approved for public release; distribution is unlimited (15 JUL 2008)

Source: N65236-ENGOPS-BRIEF-0068-1.1, Standardization of Systems Engineering & Project Management Using CMMI, M.T. Kutch, Jr., 17JUL08

Full OPD, But Today's Focus: 15288/12207

This SSC has 15288 and 12207-based SE/SWE Technical Processes

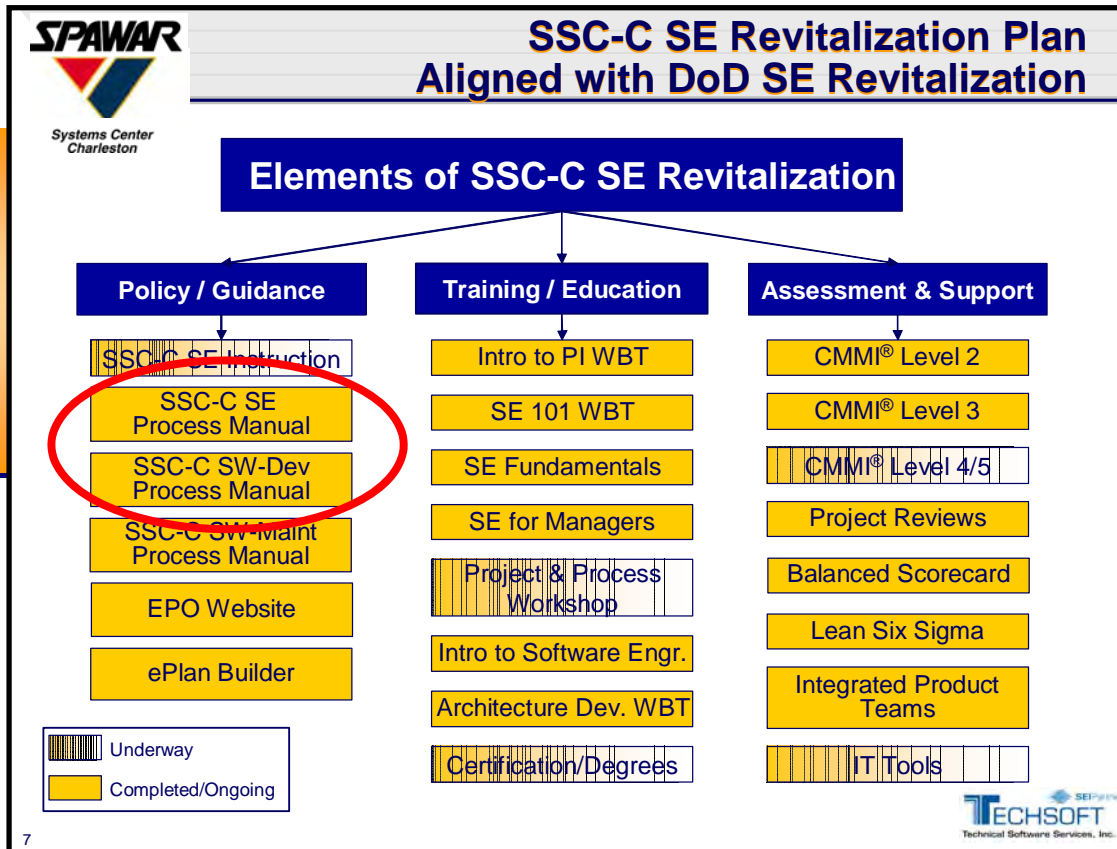

Process Asset Library

With Extensive OPA Support

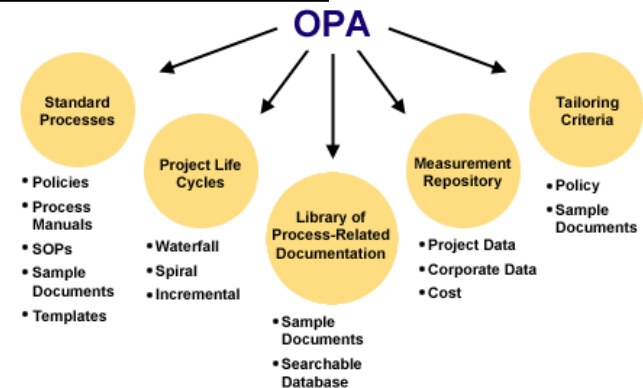

Source: N65236-ENGOPS-BRIEF-0048-1.2, Tools and Resources to Enable Systems Engineering Improvement, M.T. Kutch, Jr. & M. Knox, NOV07

So what's the problem with 15288 and 12207

ISO/IEC 15288:2002

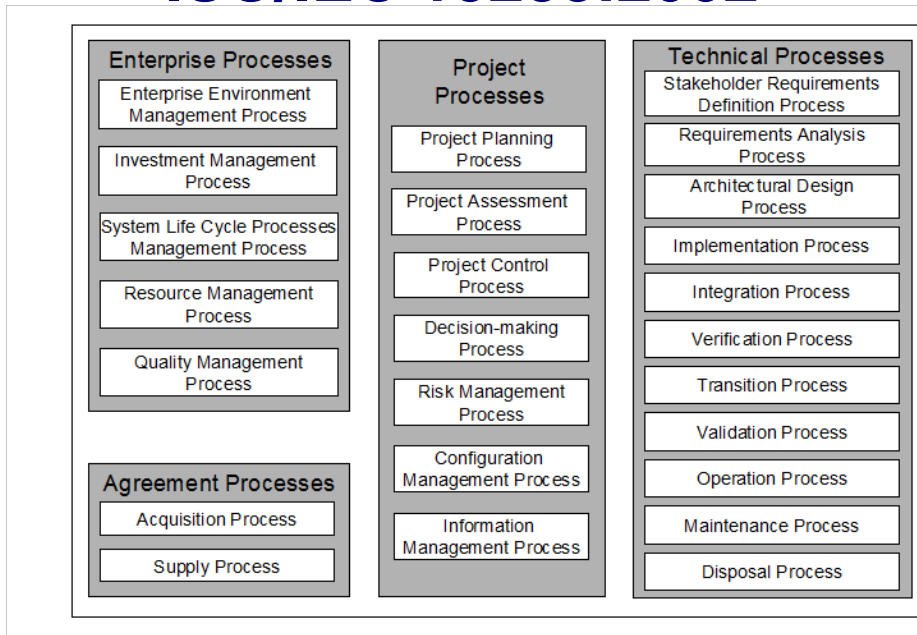

ISO/IEC 12207:1995

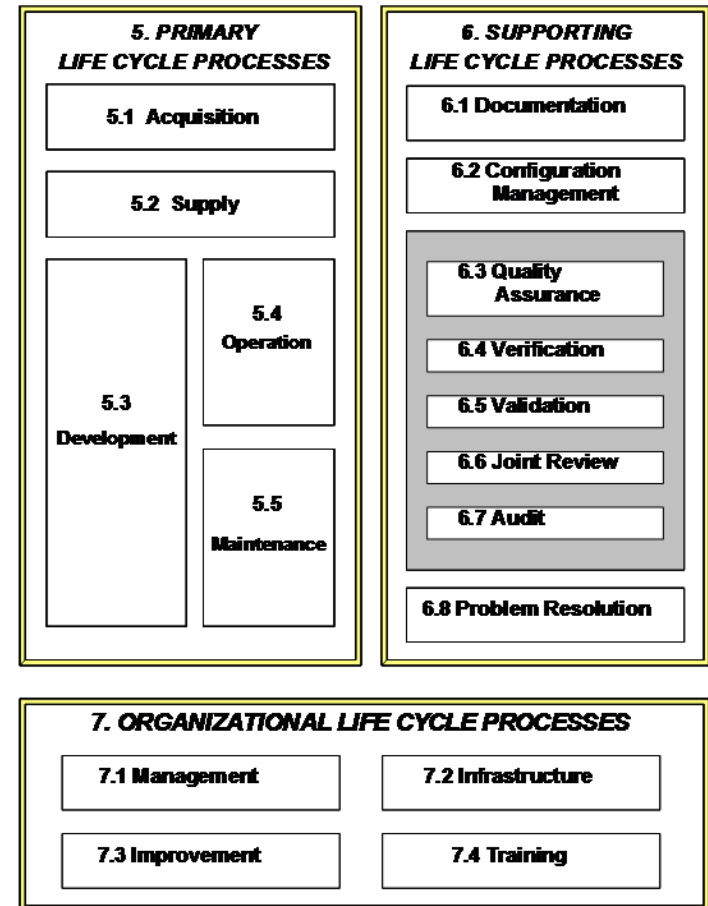

Using Them Together!

- Conflicting terms and definitions
- Overlapping, yet distinct processes
- Different process architectures
- Different levels of prescription

Unintegrated 12207 amendments from 2002 and 2004 are difficult to use and also not adopted by IEEE

Why You Should Care

- Leverage the Commonalties
 - Identify and explain the differences
 - Use the interfaces
- Promote Communication and Team Integration
 - Identify strengths, views, and appropriate focused implementations
 - Reduce us/them, finger-pointing, stove-piping
- Improve Resource Performance
 - Personnel, Processes, Tools, Services
- Lower Costs
 - Reduce redundancy and inefficiency

Benefits of Standards Harmonization

Supports Integration, Facilitates Management, Simplifies Acquisition

15288-12207 Harmonization Path

ISO/IEC JTC 1/SC 7/WG 7 N0864
2003-09-11

Harmonization Study Group

Report to the Advisory Group Montreal 2003

Doug Thiele
WG 7 Convener



Studies

ISO/IEC JTC 1/SC 7/WG 7 N0842
2005-04-15

"Harmonization Lite"
—A Proposal

James W. Moore, CSDP
The MITRE Corporation
IEEE Computer Society Liaison to ISO/IEC JTC 1/SC 7
James.W.Moore@ieee.org
Draft 6.1, 17 April 2005

The opinions expressed herein are those of the author and do not necessarily represent those of the sponsors.



Eat that elephant one bite at a time!

ISO/IEC JTC 1/SC 7/WG 7 N0822
2004-10-18

Harmonization
ISO/IEC 15288 & ISO/IEC 12207 Revisions

STOCKHOLM meeting

Project Editor report

Harmonization Project Editor



Implementation hits a snag

ISO/IEC JTC 1/SC 7/WG 7 N0868
2005-05-27

Harmonization revised concept

| Harmonization | | |
|---|-------------------------------|--|
| <p>Alignment</p> <p>ISO/IEC 12207 ISO/IEC 15288</p> <p>ISO/IEC 15939 ISO/IEC 16085</p> <p>ISO/IEC 15271 ISO/IEC 19760</p> <p>Missing Implementation Guidance</p> | <p>Publicity</p> <p>N0869</p> | <p>Integration</p> <p>ISO/IEC 24748</p> <p>Life cycle concepts
Process Architecture</p> <p>To Be Determined</p> <p>ISO/IEC TR xxxx Guidelines for
Process Definition</p> |
| 11/06/2006 | | 12 |

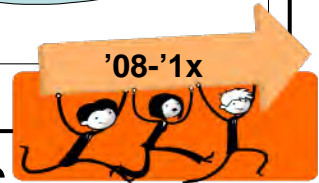

Align – Publicize - Integrate

Concept for the Harmonized Set

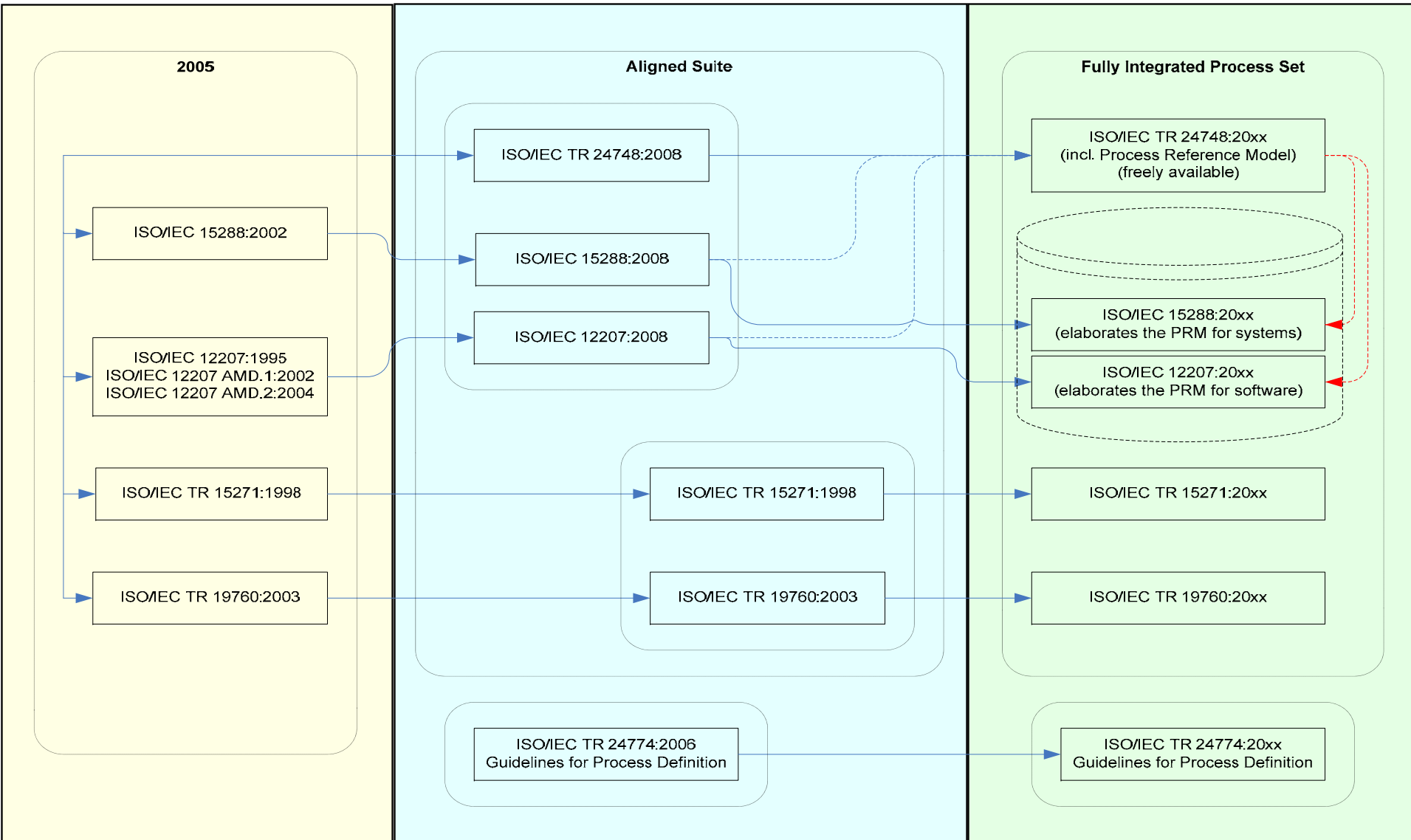

Where We Are Today

Nearly identical process models

System
Level
Processes

INTERNATIONAL STANDARD

ISO/IEC 15288

IEEE
Std 15288-2008

Second edition
2008-02-01

**Systems and software engineering —
System life cycle processes**

Ingénierie des systèmes et du logiciel — Processus du cycle de vie du système

INTERNATIONAL STANDARD

ISO/IEC 12207

IEEE
Std 12207-2008

Second edition
2008-02-01

**Systems and software engineering —
Software life cycle processes**

Ingénierie des systèmes et du logiciel — Processus du cycle de vie du logiciel

System
Processes
Specialized
To Software
and
Software-
Specific
Processes

Life Cycle Concepts
Process Concepts
LC Models, Stages

ISO/IEC JTC 1/SC 7
Date: 2008-08-11

ISO/IEC DTR 24748-1
ISO/IEC JTC 1/SC 7/WG 7 N1140
Secretariat: SCC

DRAFT

Systems and software engineering — — Guide for life cycle management

Ingénierie systèmes et logiciel — — Guide pour gestion du cycle de vie

It is the intention of this project to create a Technical Report of Type 3 that may be made freely available in accordance with the provisions of JTC 1 N 7269 and Sendai Resolution 32. In particular, the document has the following

LC Adaptation
Domains, Disciplines,
& Specialties
Prior Version Transition

Relations of Process Constructs among ISO/IEC 12207:1995 and its Amendments, 15288:2002, 15288:2008 & 12207:2008

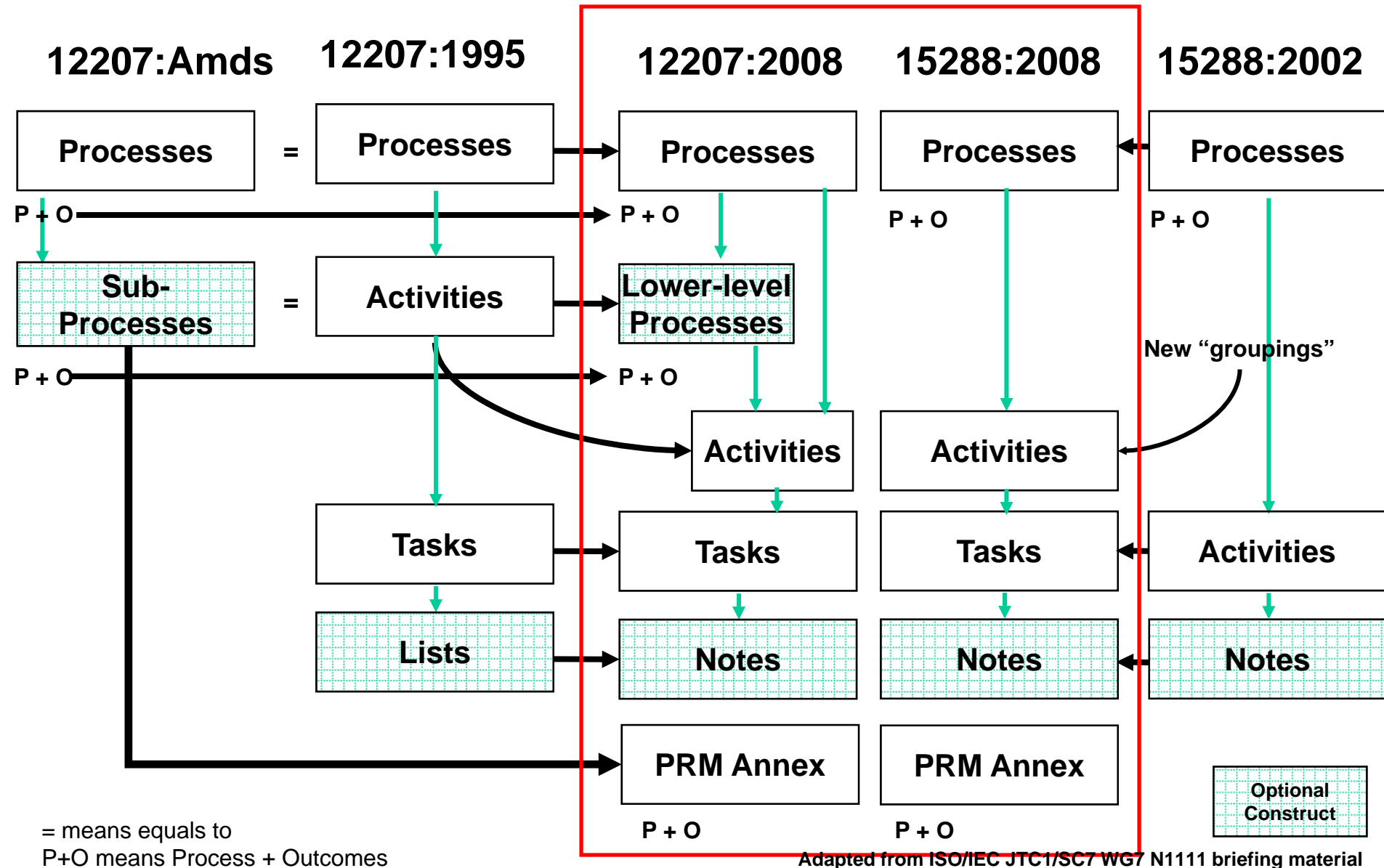

12207/15288:2008 Process Constructs

Processes require a purpose and outcome. All processes have at least one activity. The processes, with their statements of purpose and outcomes, constitute a Process Reference Model (PRM).

Activities are constructs for grouping together related tasks. The activities provide a means to look at related tasks within the process to improve understanding and communication of the process. If an activity is cohesive enough, it can be converted to a (lower level) process by defining a purpose and a set of outcomes.

A task is a detailed provision for implementation of a process. It may be a requirement (“shall”), a recommendation (“should”), or a permission (“may”).

Notes are used when there is a need for explanatory information to better describe the intent or mechanics of a process. Notes provide insight regarding potential implementation or areas of applicability such as lists, examples and other considerations.

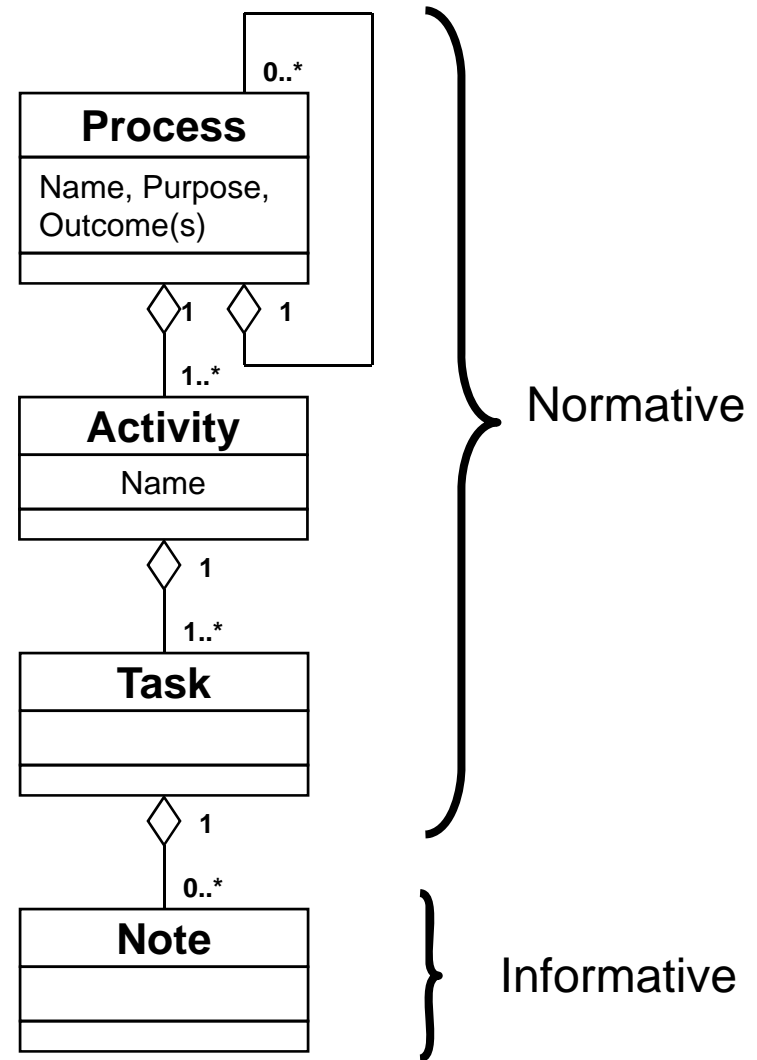

The Life Cycle Processes of 15288:2002

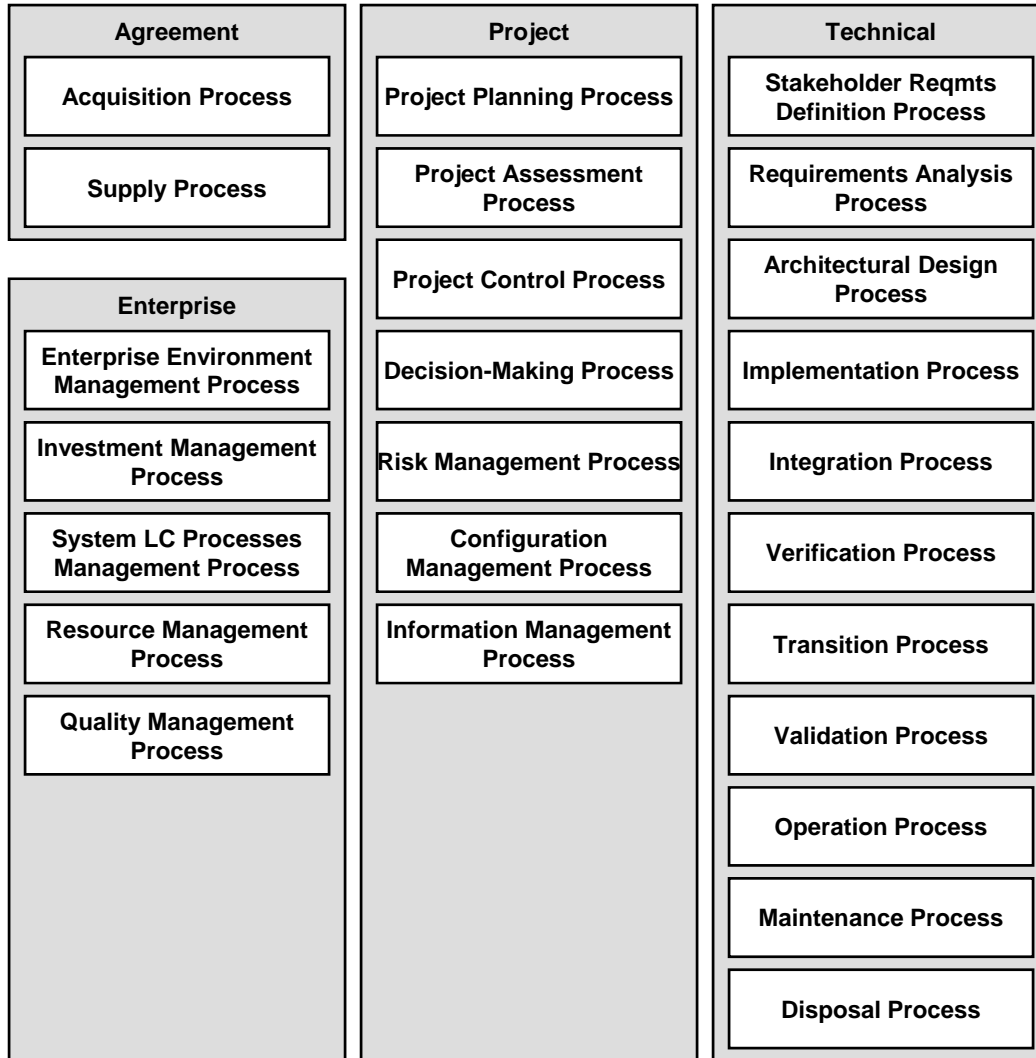

Source: WG7 N1111; Adapted by Jim Moore, MITRE Corporation from chart by Anatol Kark, National Research Council, Canada

Building 15288:2008 – Activities and Tasks

Activity-Task allocation is new to 15288:2008
Provides structural alignment with 12207

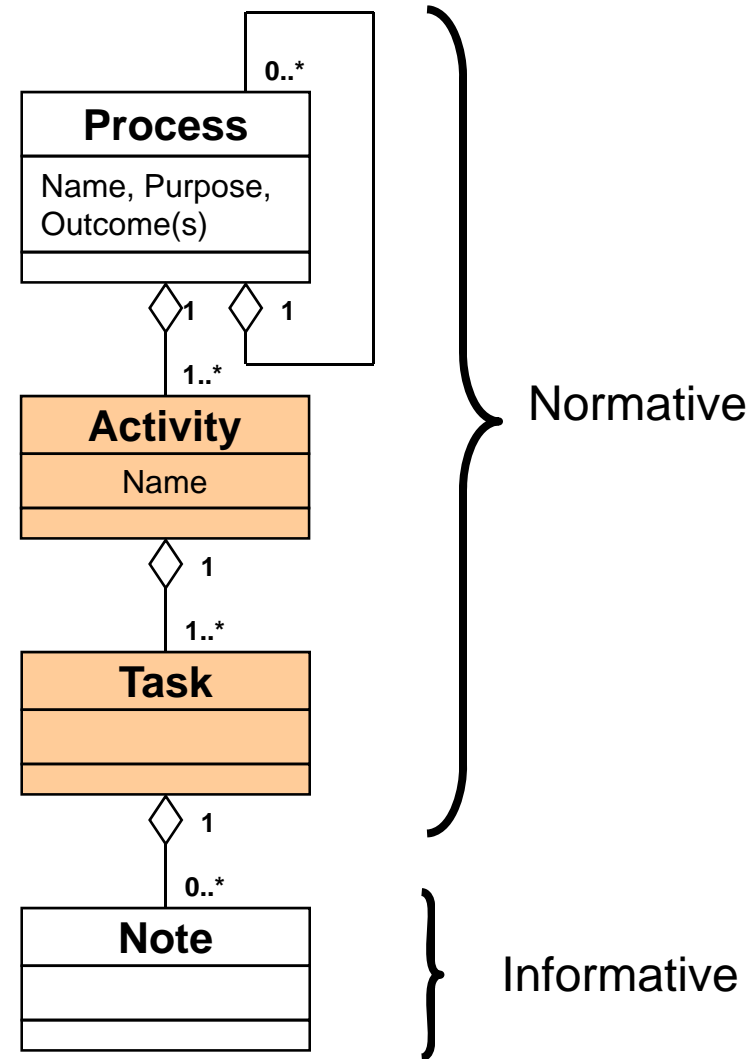
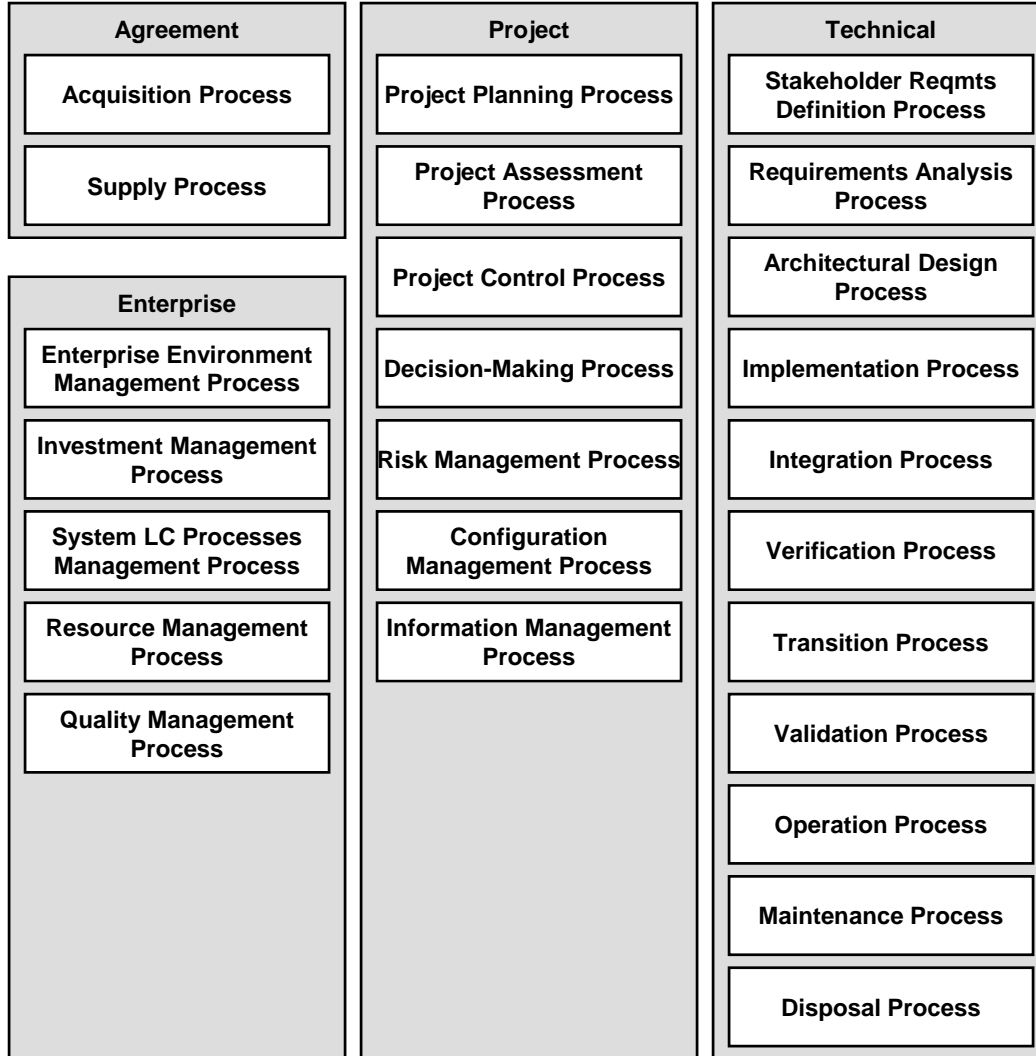

Building 15288:2008 – Technical Processes

15288:2008 has the same set of technical processes as 15288:2002

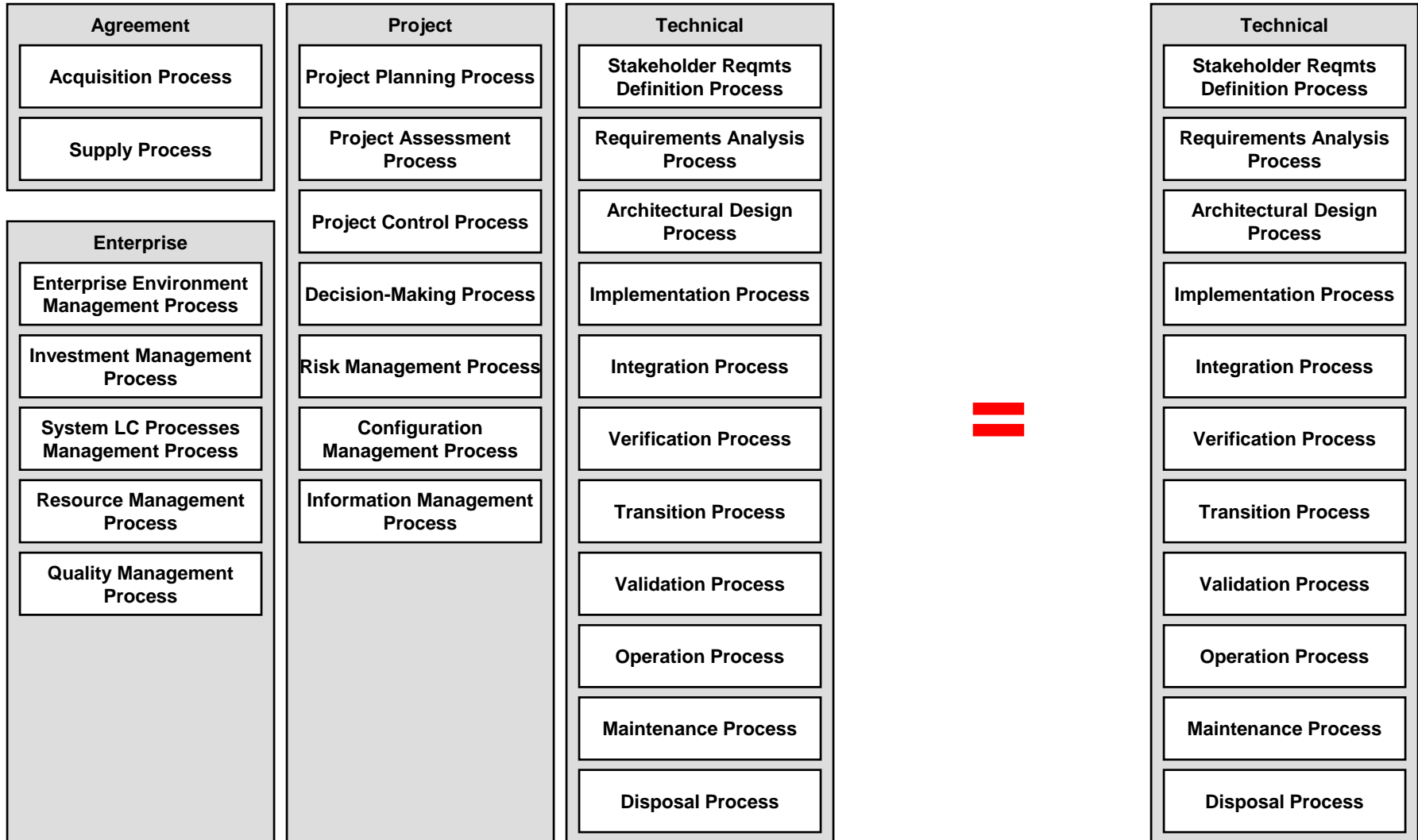

Source: WG7 N1111; Adapted by Jim Moore, MITRE Corporation from chart by Anatol Kark, National Research Council, Canada

Building 15288:2008 – Project Processes

15288:2008 has a similar set of project processes as 15288:2002

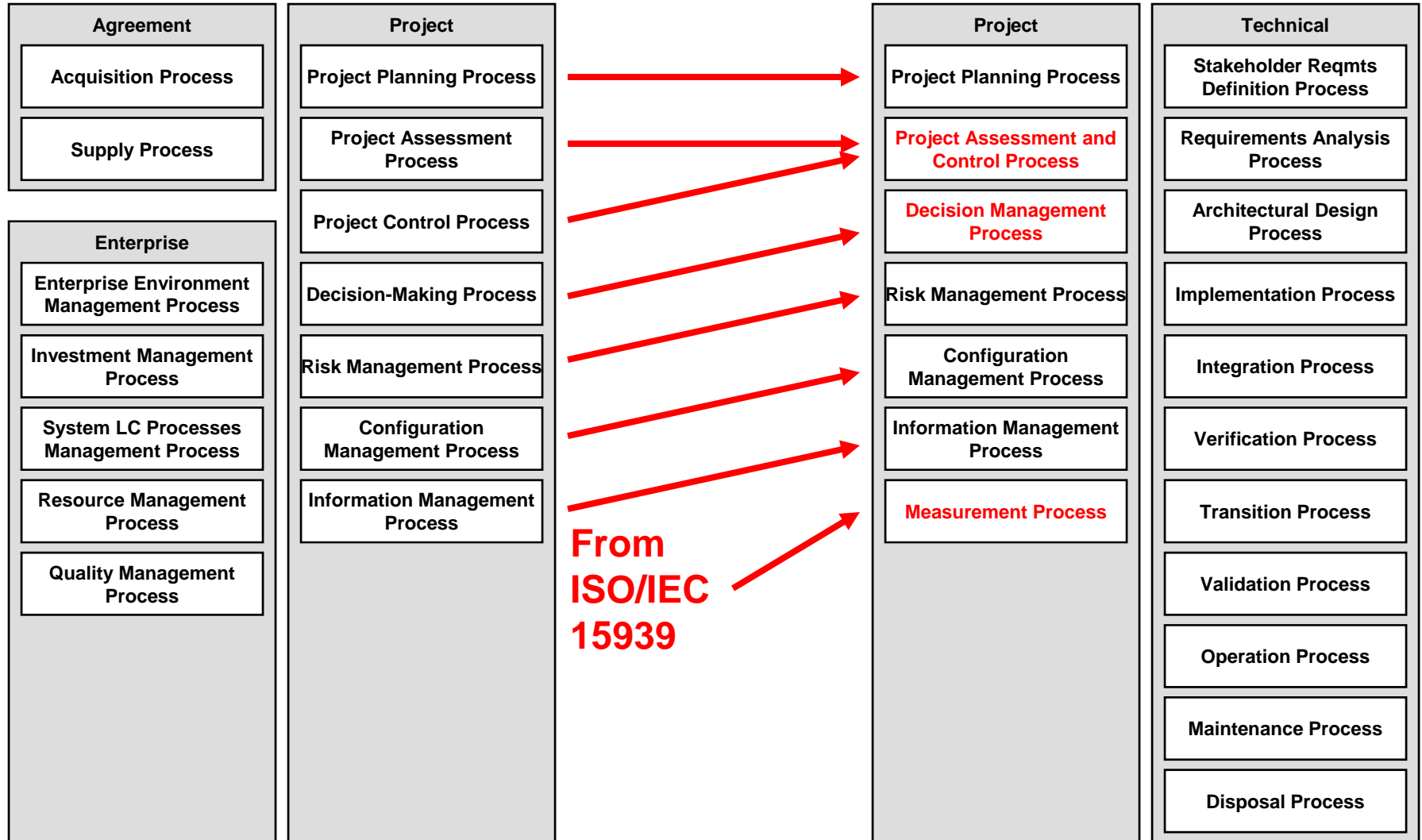

Source: WG7 N1111; Adapted by Jim Moore, MITRE Corporation from chart by Anatol Kark, National Research Council, Canada

Building 15288:2008 – Project-Enabling Processes

15288:2008 has a similar set of project-enabling processes as 15288:2002

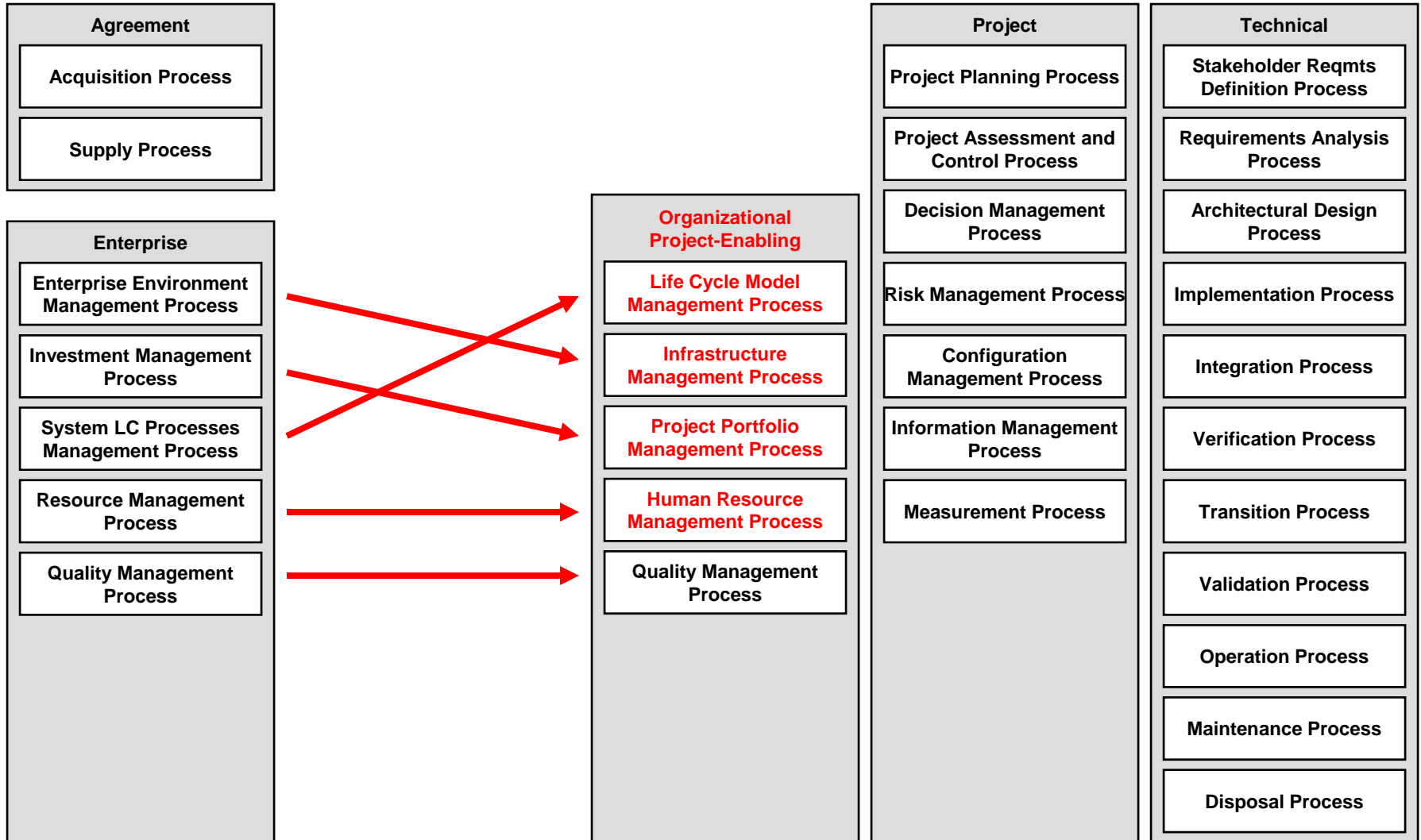

Source: WG7 N1111; Adapted by Jim Moore, MITRE Corporation from chart by Anatol Kark, National Research Council, Canada

Building 15288:2008 – Agreement Processes

15288:2008 has the same set of agreement processes as 15288:2002

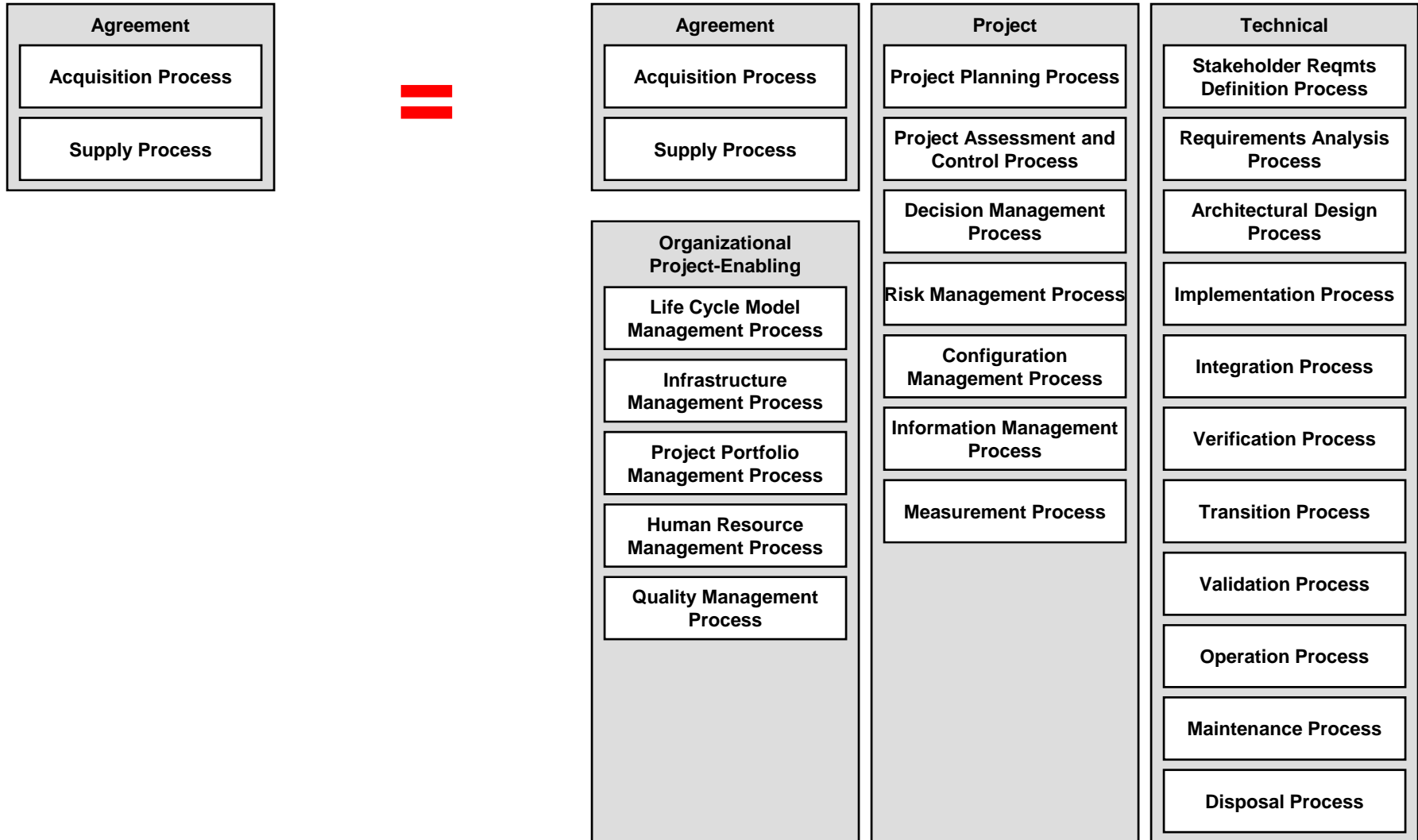

Source: WG7 N1111; Adapted by Jim Moore, MITRE Corporation from chart by Anatol Kark, National Research Council, Canada

The Life Cycle Processes of 15288:2008

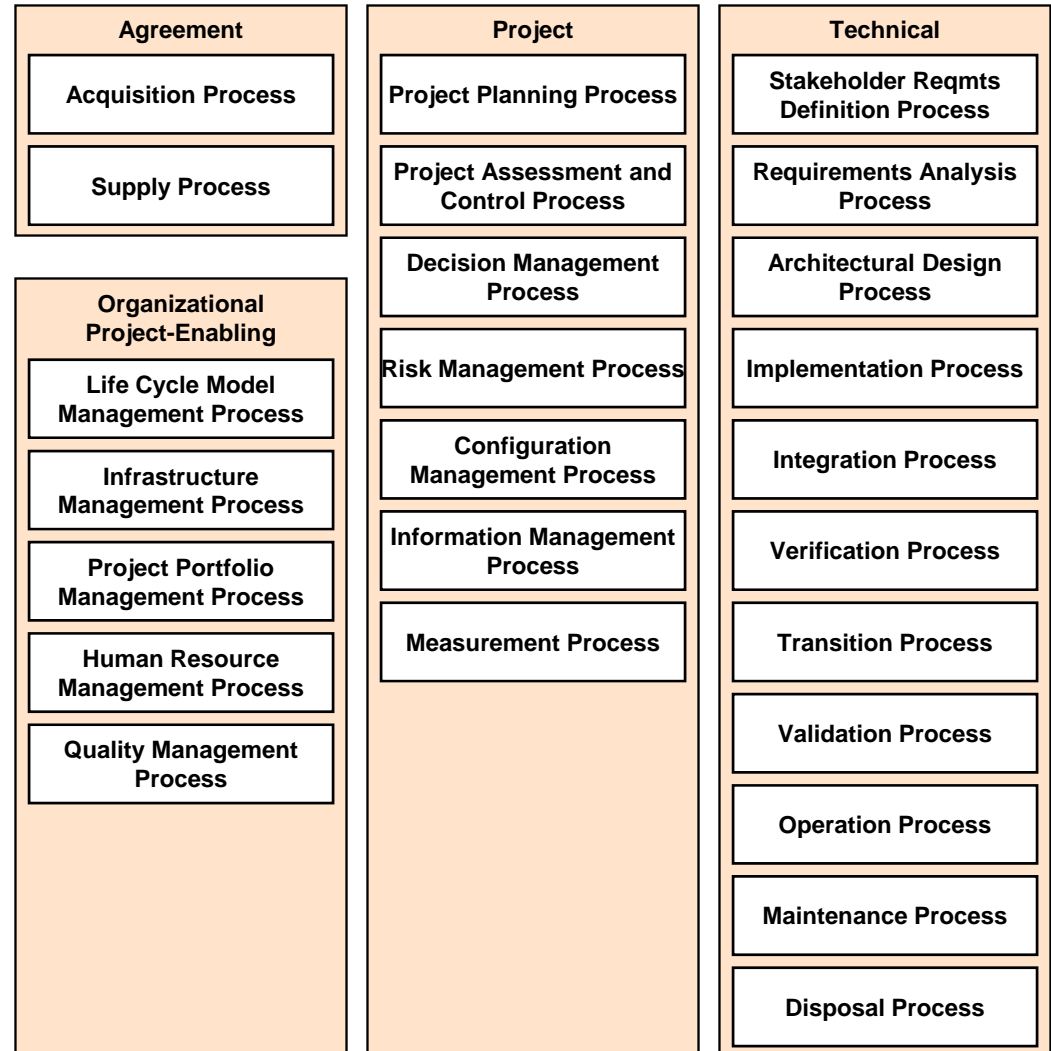

Source: WG7 N1111; Adapted by Jim Moore, MITRE Corporation from chart by Anatol Kark, National Research Council, Canada

The Life Cycle Processes of 12207:1995

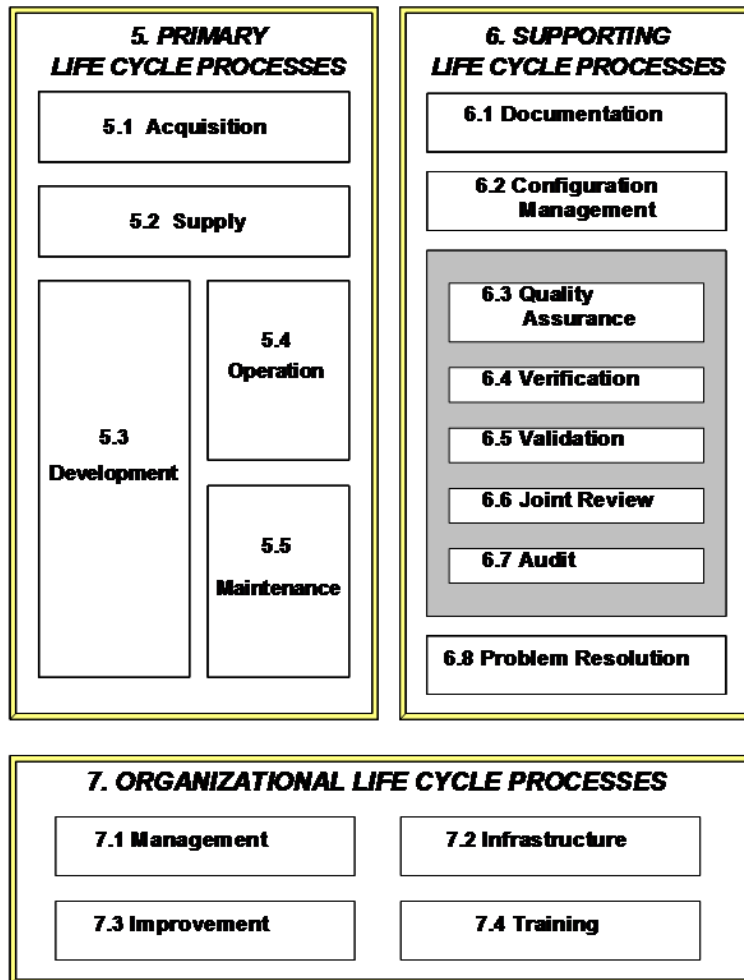

**The Familiar 1995
LCP Categories
Process Structure
and Titles**

The Life Cycle Processes of 12207:1995

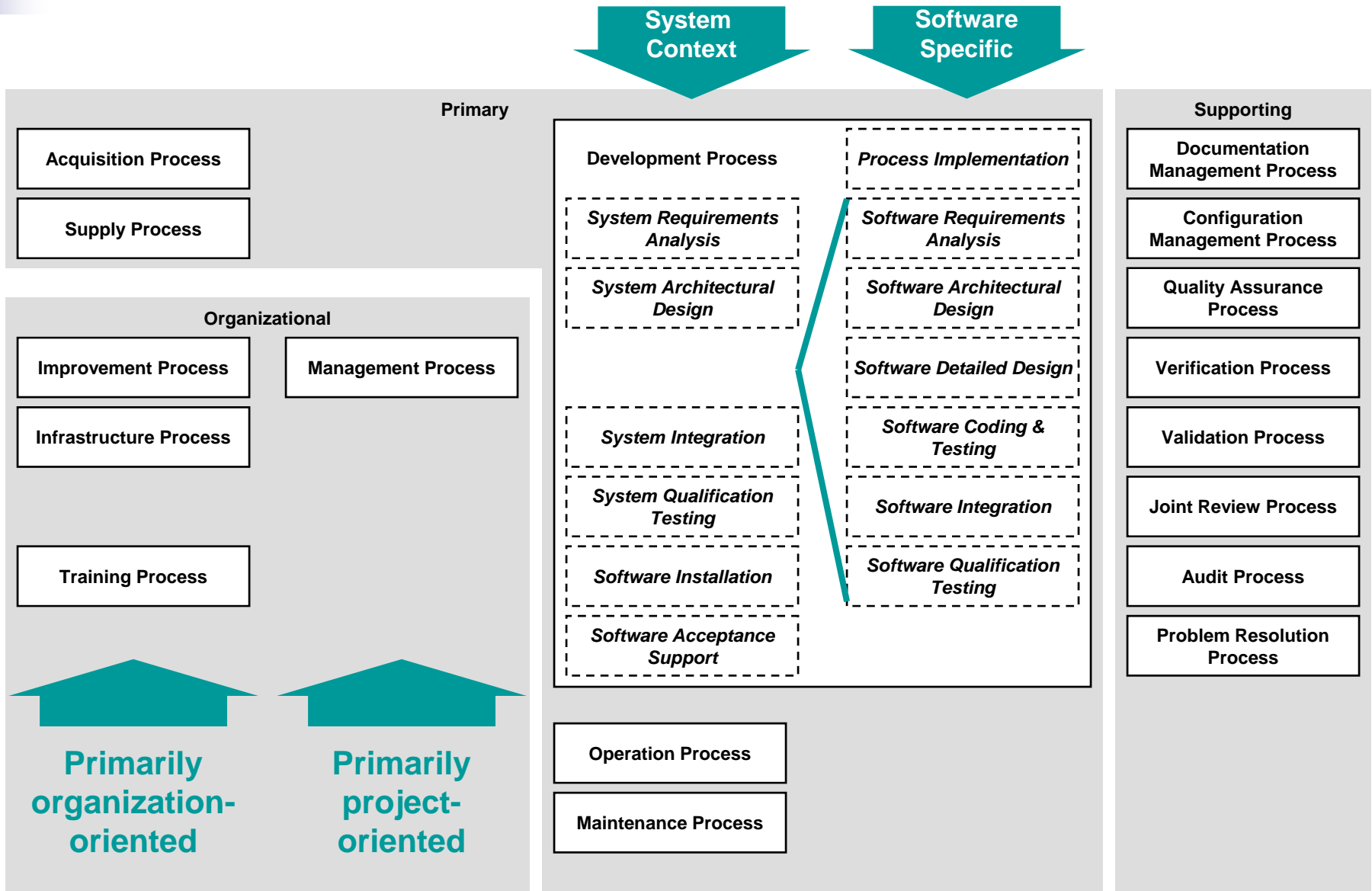

12207 Amd.1:2002 and Amd.2:2004

- Defined a Process Reference Model (PRM) for 12207
 - Process Name, Purpose, and Outcomes
- Restructured processes to provide higher granularity
 - Introduced sub-processes (e.g based on Development activities)
 - Improvement, Human Resource, Acquisition, Supply, Development, Operation, Management
- Introduced extensions, elaborations and new processes
 - e.g. to better support process assessment (15504-2), usability(13407), measurement (15939), product evaluation(14598), and reuse/asset management (IEEE 1517)
- Added activities and tasks for 8 new processes
- Made some corrections

Generally aligned and incorporated in body of revised 12207
Several sub-processes allocated as lower-level PRM only processes

The Life Cycle Processes of 12207:2008

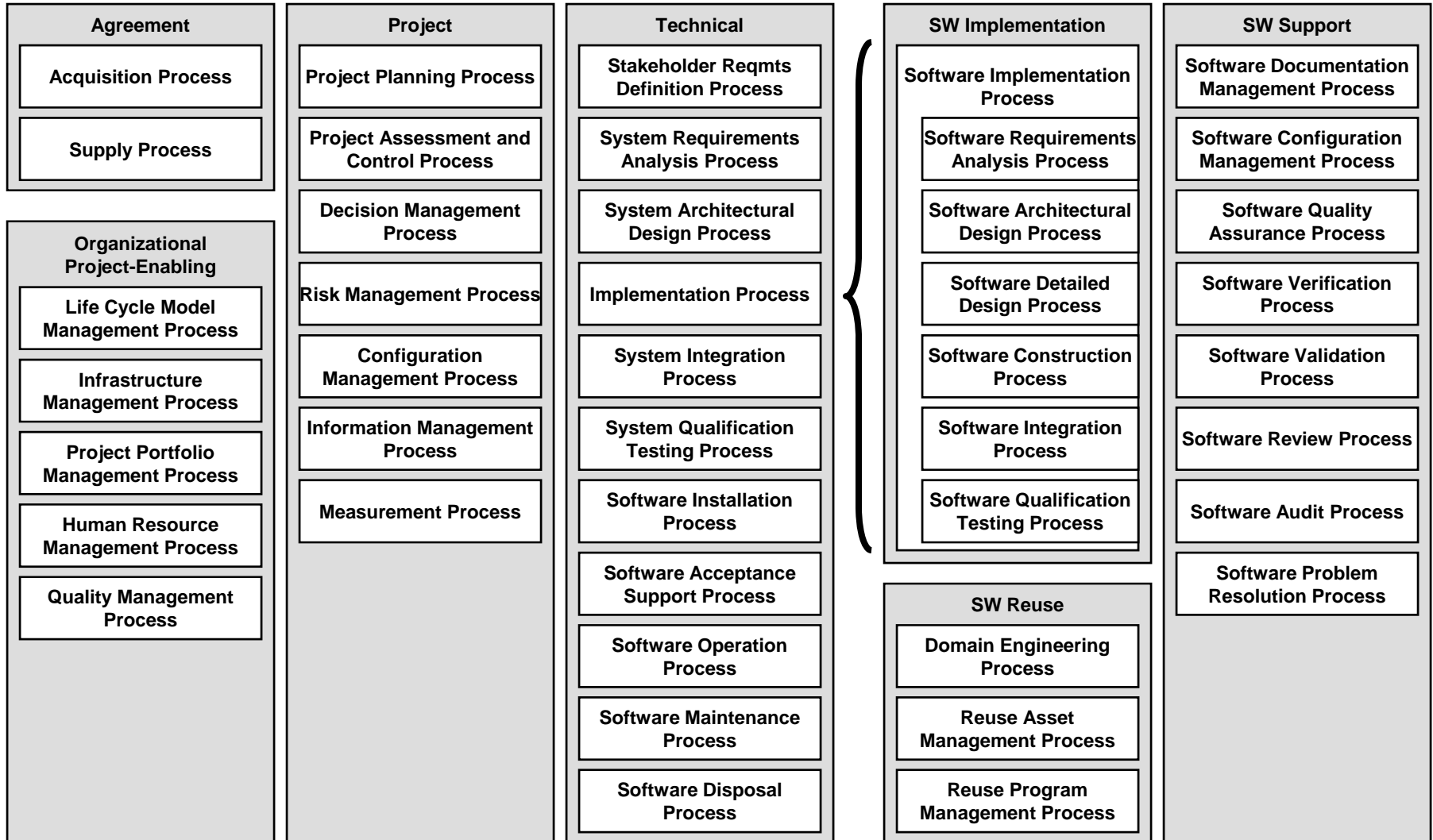

Adapted from WG7 N1111; Source: Jim Moore, MITRE Corporation

Building 12207:2008 – System Context

Structural alignment with 15288 system level categories

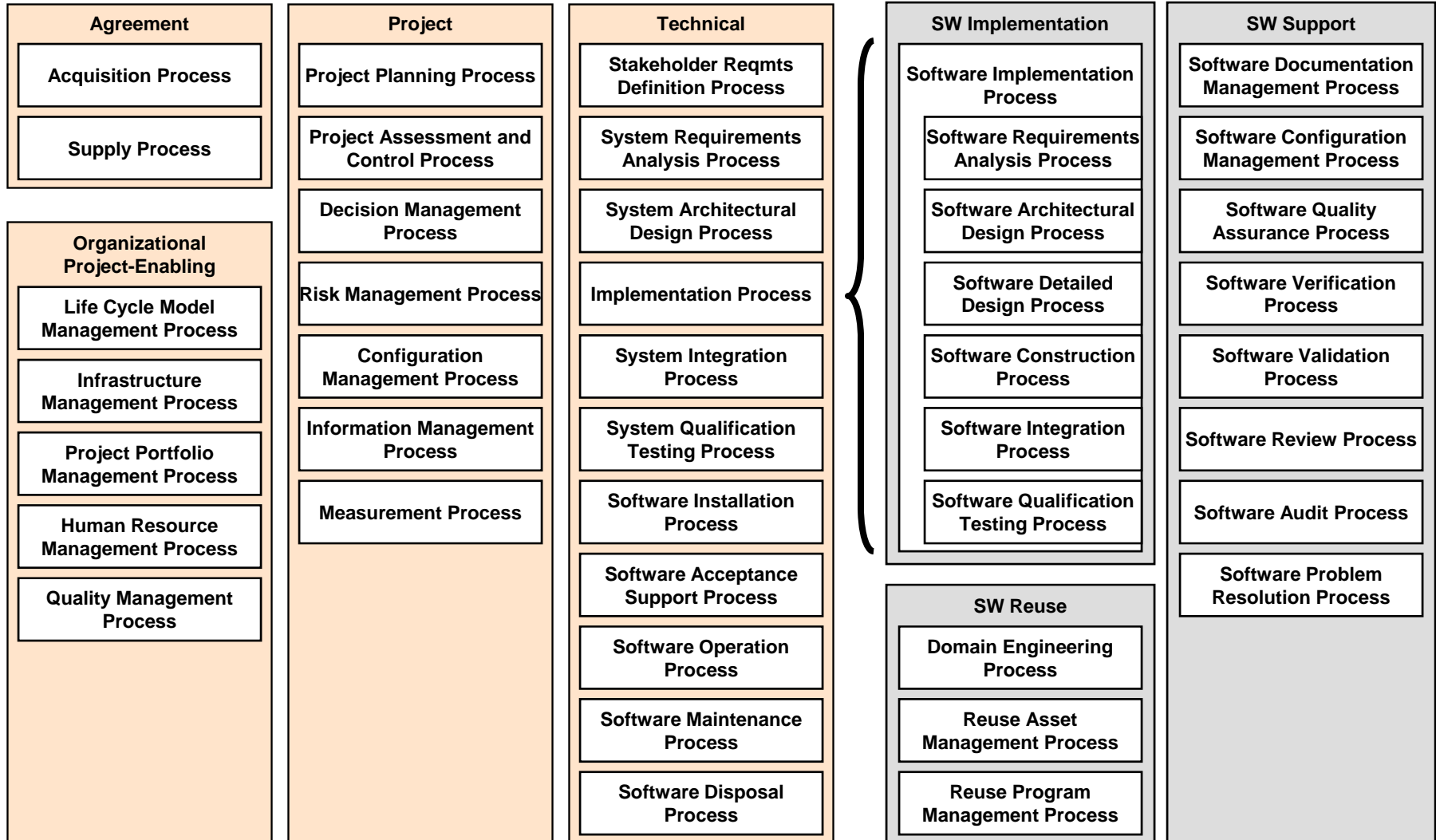

Adapted from WG7 N1111;

TSDoran-NDIA-SE_23OCT08_v1.0

Building 12207:2008 – System Context

System Context Processes based on 15288 Processes

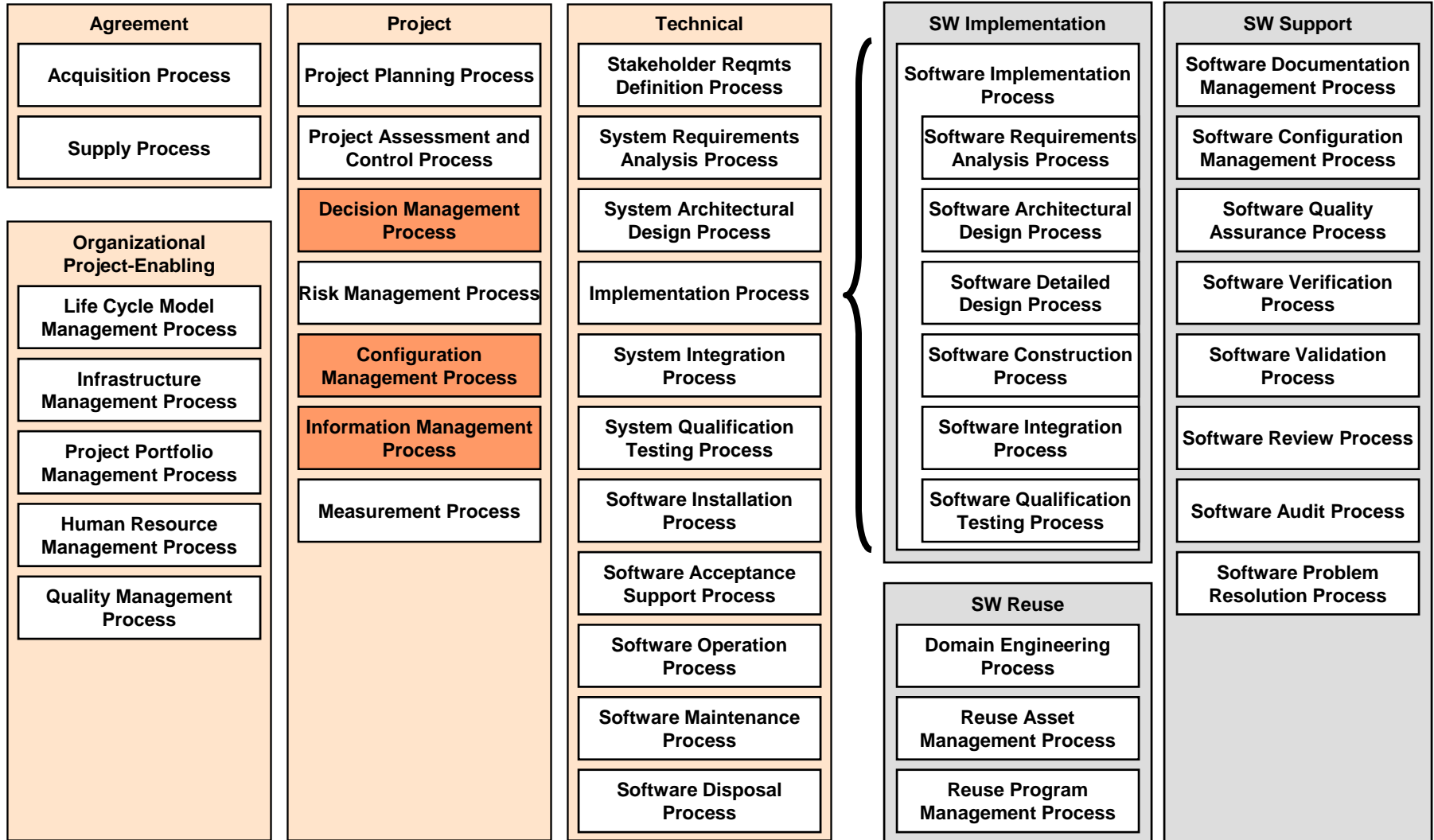

Building 12207:2008 – System Context

Include 12207 Organizational Processes: Improvement, Infrastructure, Human Resource/Training, Management

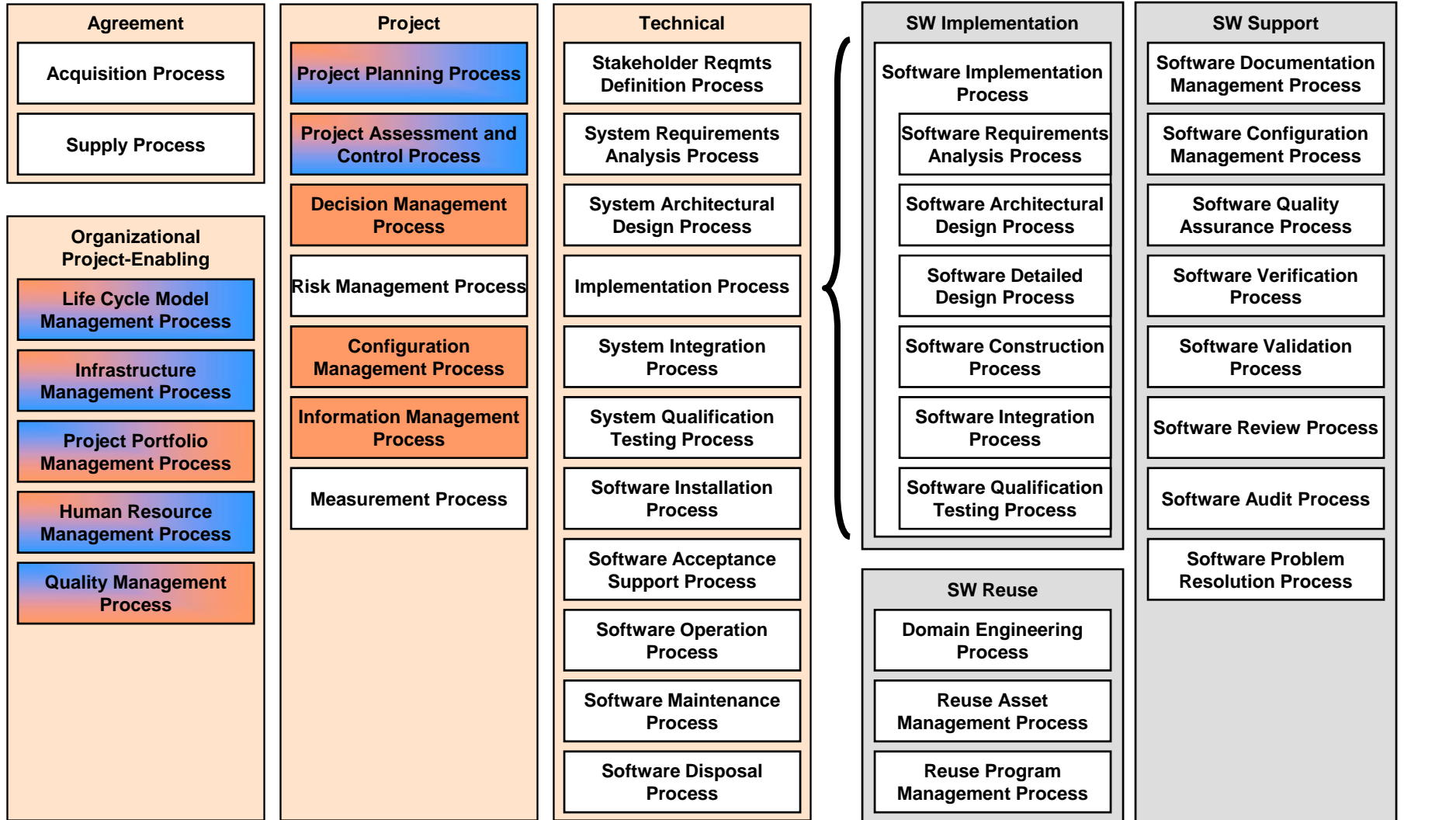

Adapted from WG7 N1111;

TSDoran-NDIA-SE_23OCT08_v1.0

Adapted 15288 Outcome/s Activities, Tasks

One or more 12207 Outcomes

Blended 12207 & 15288 Activities and Tasks

One or more 15288 Outcomes

12207-based Outcome/s Activities, Tasks

Building 12207:2008 – System Context

Risk Management from 16085 and Measurement from 15939 are added

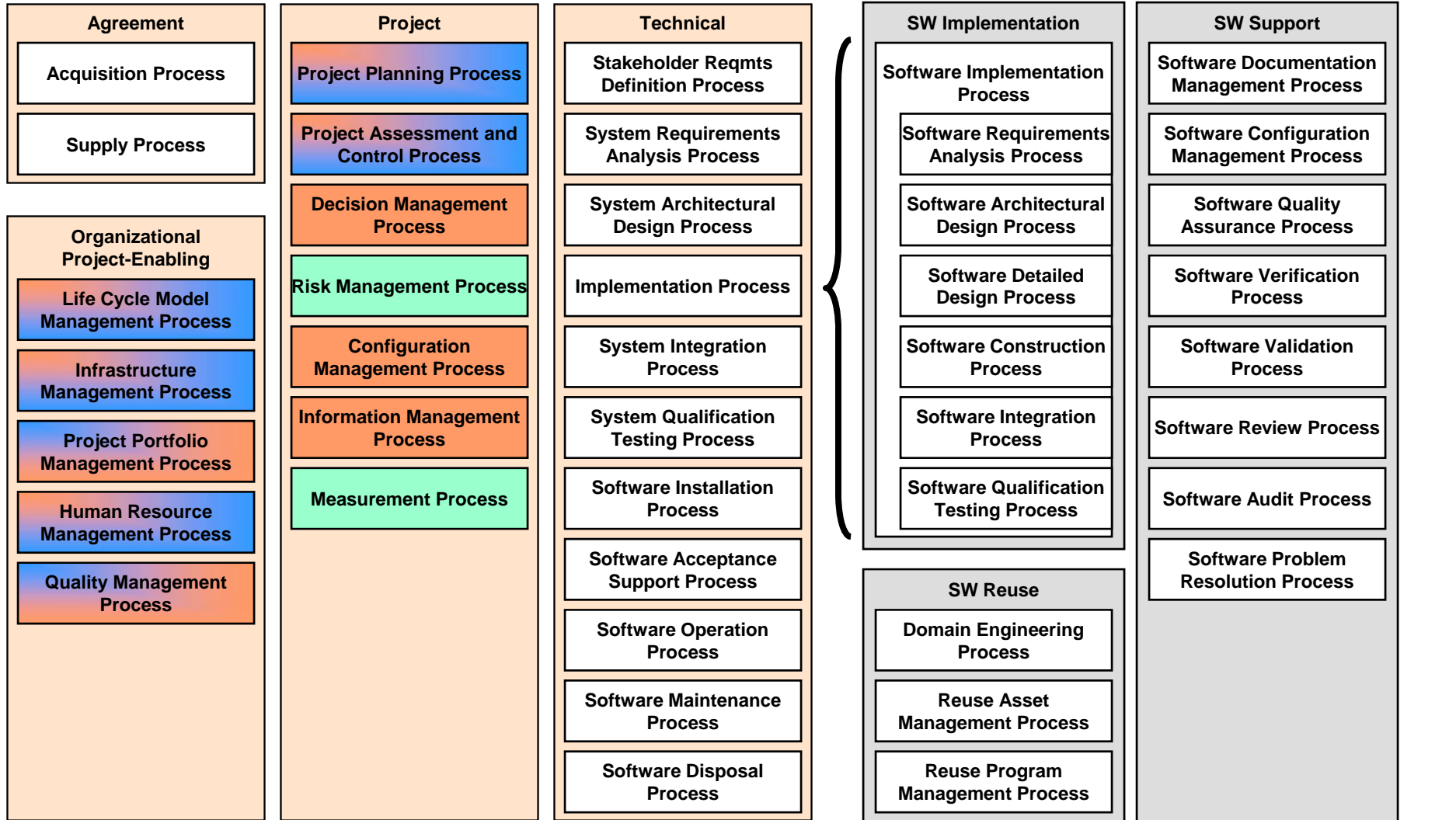

Adapted from WG7 N1111;

TSDoran-NDIA-SE_23OCT08_v1.0

Adapted 15288 Outcome/s Activities, Tasks

One or more 12207 Outcomes

Blended 12207 & 15288 Activities and Tasks

One or more 15288 Outcomes

12207-based Outcome/s Activities, Tasks

Building 12207:2008 – System Context

Risk Management and Measurement are now almost identical to 15288

12207 Acquisition and Supply are blended with 15288 Agreement Processes

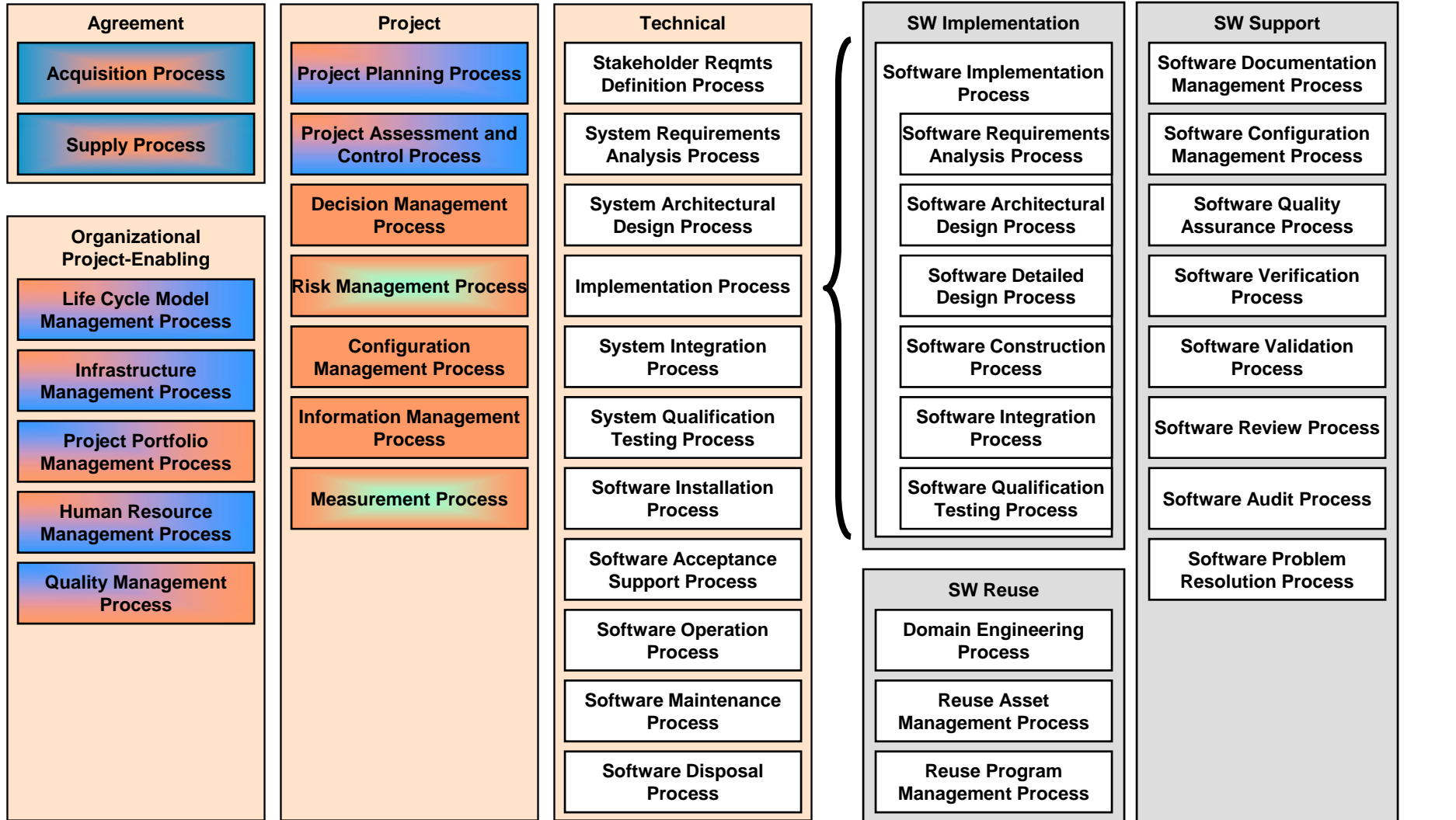

Adapted from WG7 N1111;

TSDoran-NDIA-SE_23OCT08_v1.0

Adapted 15288 Outcome/s Activities, Tasks

One or more 12207 Outcomes

Blended 12207 & 15288 Activities and Tasks

One or more 15288 Outcomes

12207-based Outcome/s Activities, Tasks

Building 12207:2008 – System and Software

Development Activities form System Context and Software Specific Processes

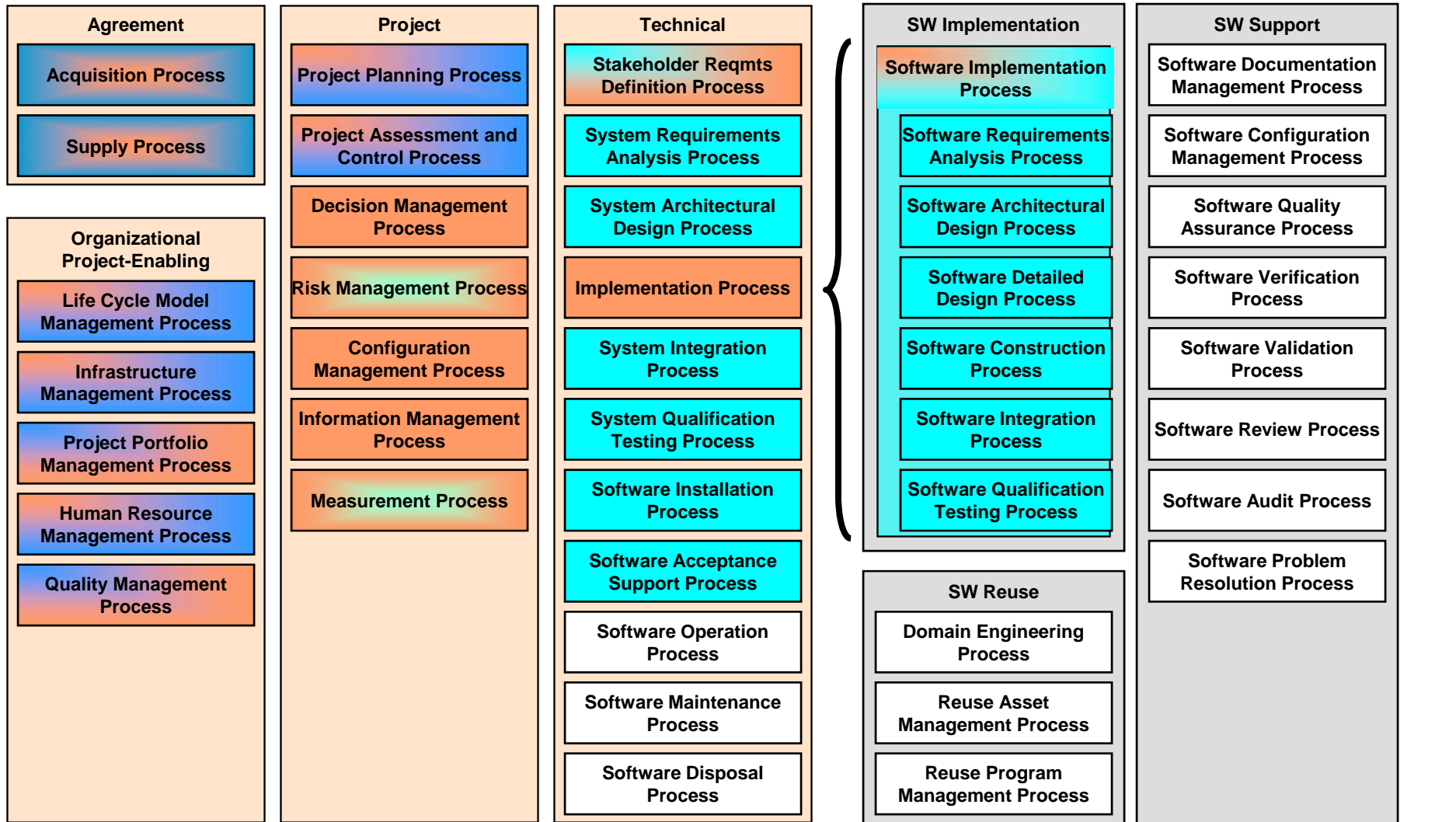

Adapted from WG7 N1111;

TSDoran-NDIA-SE_23OCT08_v1.0

Adapted 15288 Outcome/s Activities, Tasks

One or more 12207 Outcomes

Blended 12207 & 15288 Activities and Tasks

One or more 15288 Outcomes

12207-based Outcome/s Activities, Tasks

Building 12207:2008 – System Context

12207 Operation and Maintenance Processes complete the System Context

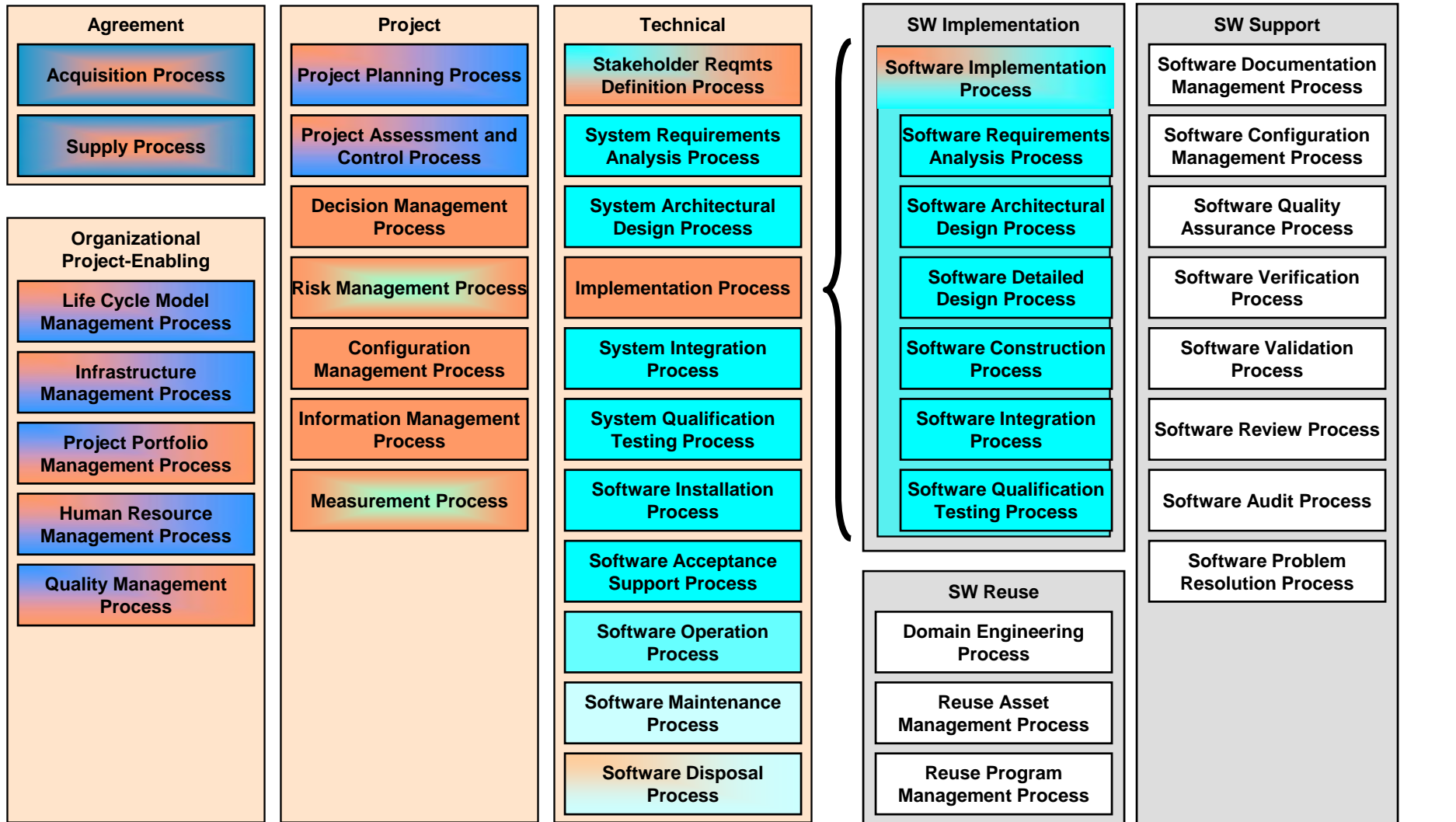

Adapted from WG7 N1111;

TSDoran-NDIA-SE_23OCT08_v1.0

Adapted 15288 Outcome/s
Activities, Tasks

One or more
12207 Outcomes

Blended 12207 & 15288
Activities and Tasks

One or more
15288 Outcomes

12207-based Outcome/s
Activities, Tasks

Building 12207:2008 – Software Specific

Software Specific Support almost the same as 12207 Supporting Processes

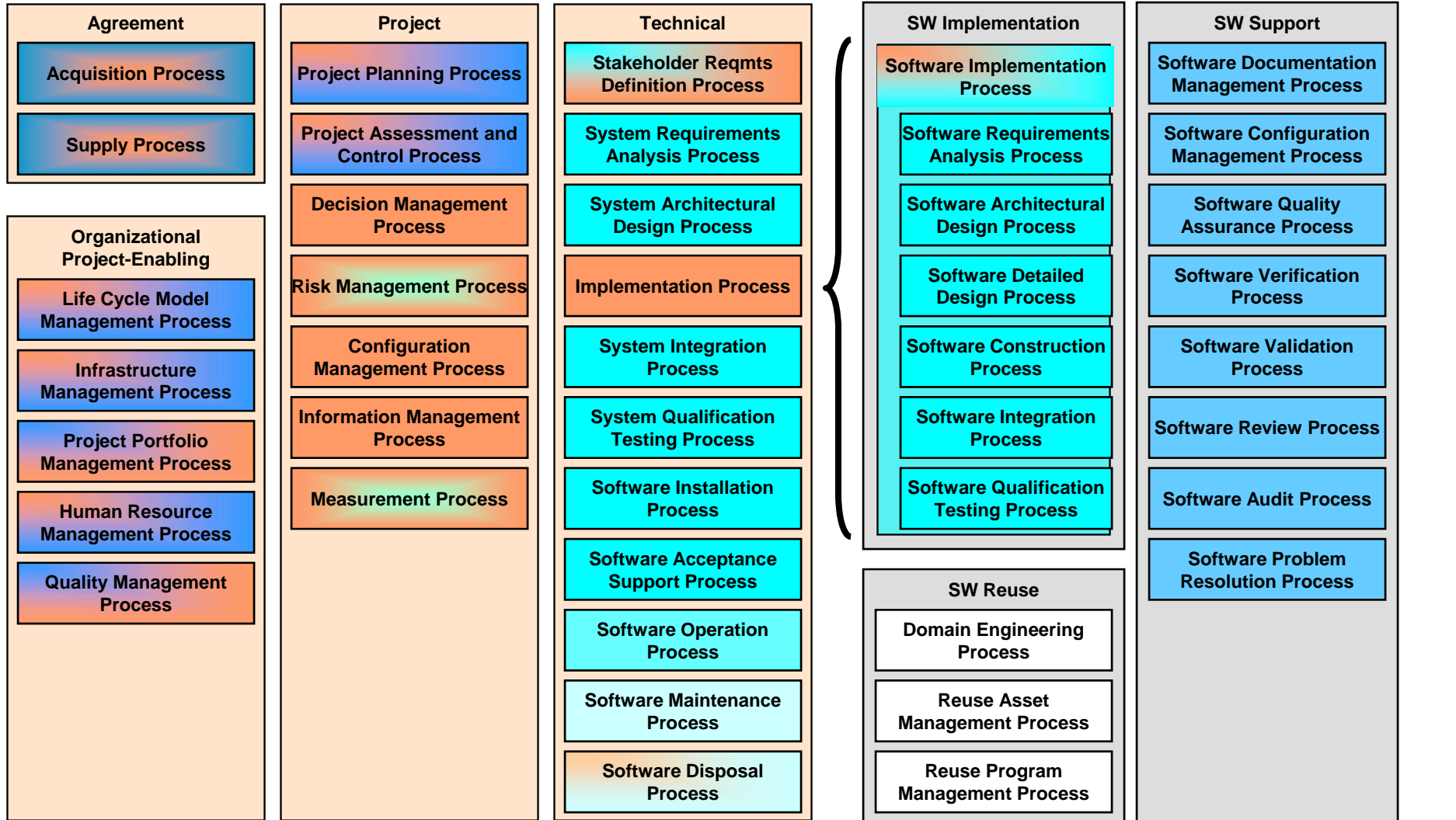

Adapted from WG7 N1111;

TSDoran-NDIA-SE_23OCT08_v1.0

Adapted 15288 Outcome/s
Activities, Tasks

One or more
12207 Outcomes

Blended 12207 & 15288
Activities and Tasks

One or more
15288 Outcomes

12207-based Outcome/s
Activities, Tasks

Building 12207:2008 – Software Specific

12207 Organizational Processes for Reuse conclude the Software Specific set

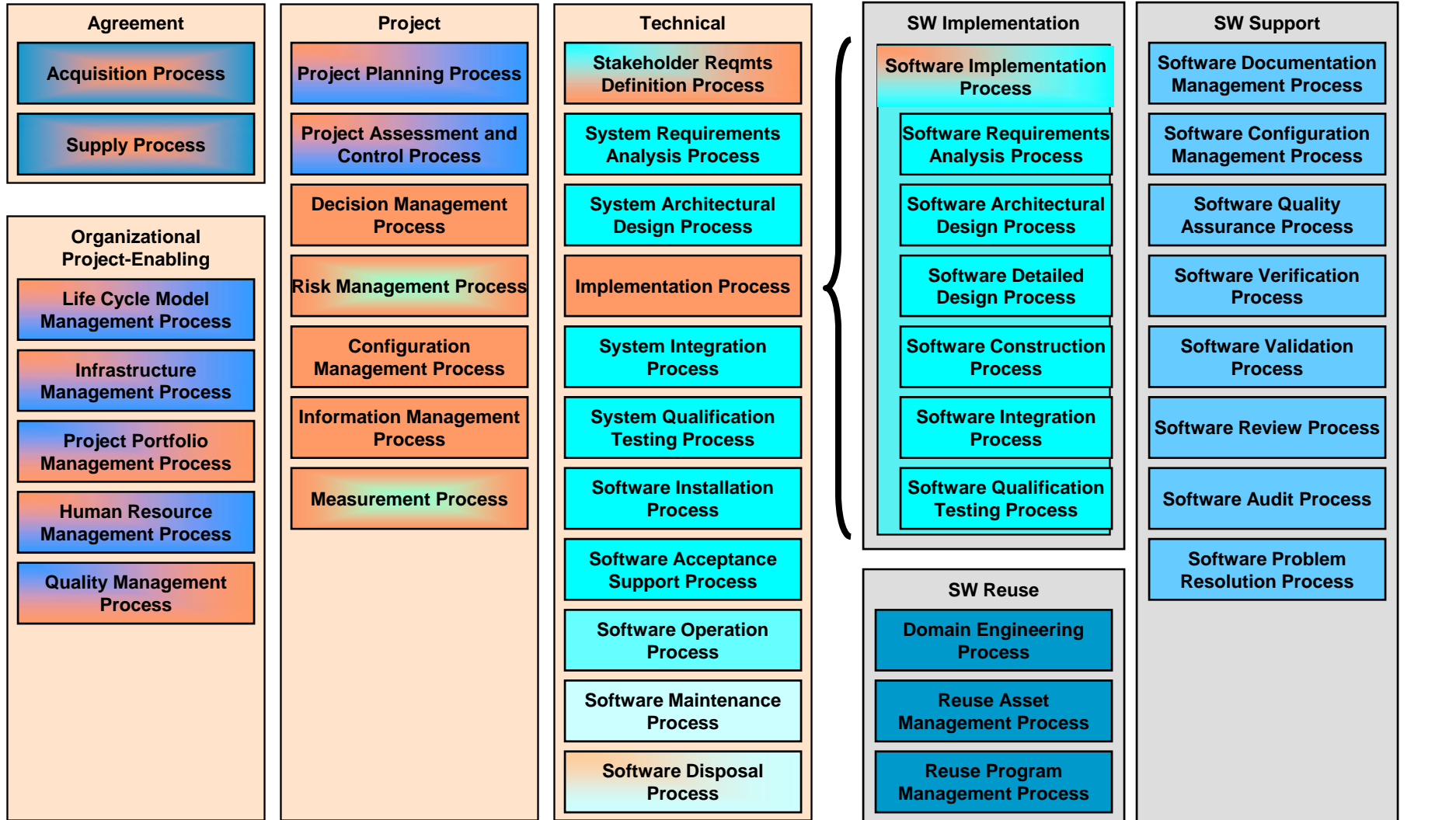

Adapted from WG7 N1111;

TSDoran-NDIA-SE_23OCT08_v1.0

Adapted 15288 Outcome/s
Activities, Tasks

One or more
12207 Outcomes

Blended 12207 & 15288
Activities and Tasks

One or more
15288 Outcomes

12207-based Outcome/s
Activities, Tasks

Another Way of Looking at It

1. Processes common to both

2. Processes similar between the two

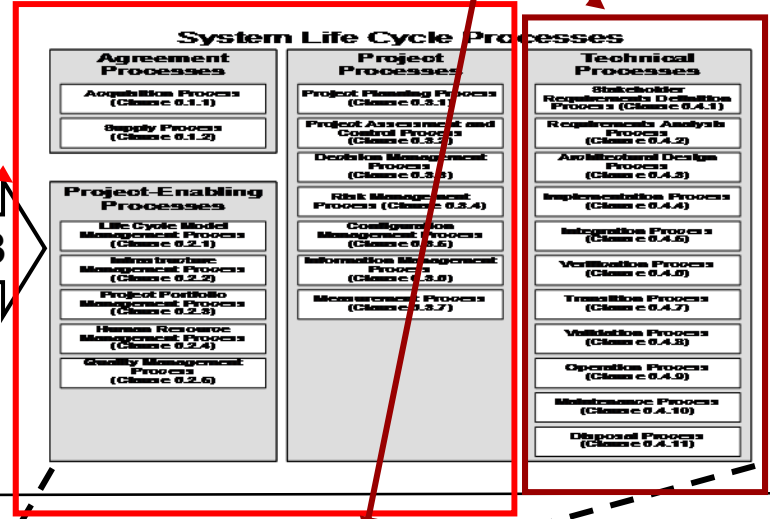
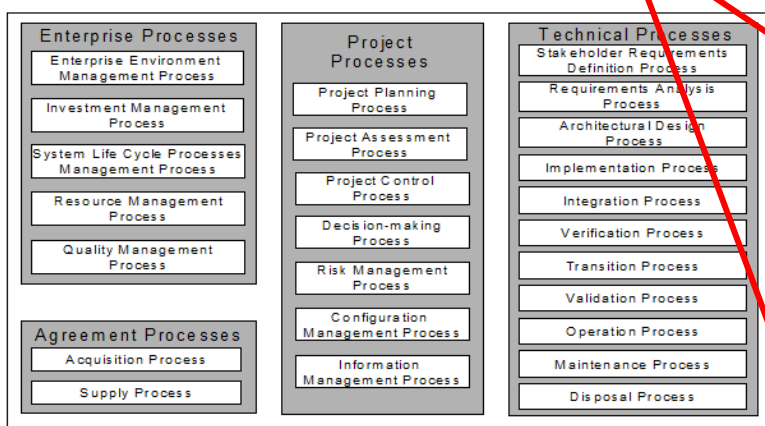

15288

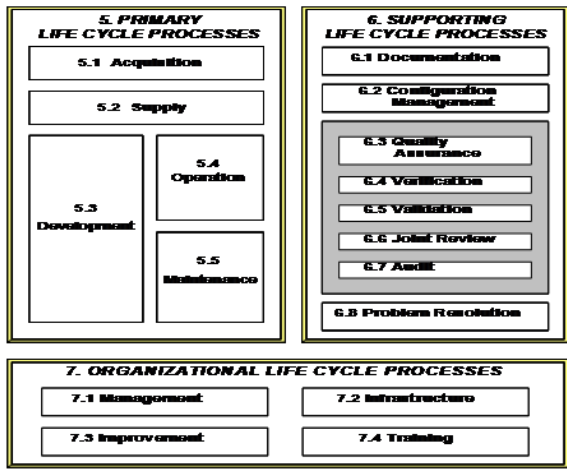

12207

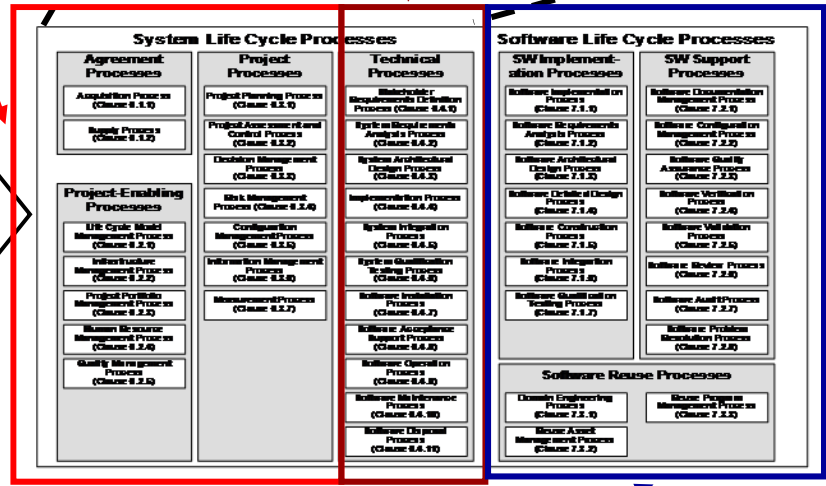

3. Processes unique to domain

Revised Content (Viewed from 12207)

Revised Standards

- Front Matter
- 1. Scope
- 2. Conformance
- 3. Normative References
- 4. Terms and Definitions
- 5. Application of this International Standard
- 6. System Life Cycle Processes
- 7. *Software Life Cycle Processes {Italicized indicates 12207 Only}*

The 12207 Annexes (12207 and 15288 differ somewhat in format and content here)

- A. Tailoring (Normative)
- B. Process Reference Model (Normative)
 - 15504-2 Conformance, *PRM Lower Level Processes for Acquisition, Supply, Life Cycle Model Management, Human Resource Management, and Software Operation*
- C. History and Rationale (Informative)
 - *History, Process Integration/Constructs and Usage, Relationships, Process Definition Sources*
- D. Process Alignment of 12207-15288 {Clause 6} (Informative)
- E. Process Views (Informative)
 - Concepts, and *Process View for Usability Example*
- F. *Some Example Process Descriptions (Informative)*
- G. Relationship to other IEEE standards (Informative)
- H. Bibliography (Informative)
- I. List of {IEEE} participants (Informative)

Aligned 15288 and 12207 Set Provides

- Coordinated Terms and Definitions
- Integrated Process Structure
- Coordinated Process Sets
 - Backward compatible
 - Usable stand alone or jointly by systems and software teams
 - System Context processes are nearly identical or the 12207 processes provide software-appropriate specializations of, or contribute to the outcomes of, the corresponding 15288 processes
 - Especially on Agreement and Project Processes
- Common Conformance/Tailoring
- Common Life Cycle Model and Stage Concepts
- Free Guidance (Annexes and Plan for TR 24748-1)

**Easier Joint Use – Improved Efficiency – Reduced Costs
Common Acquisition, Supply and Management Views**

Towards Full LCP Integration

- WG7 Study Group on Harmonization Integration Strategy Report
 - SC7 Life Cycle Process Harmonization Advisory Group (LCPHAG)
 - Work with SWG5 across SC7 and externally for analyses and recommendations
 - Model SC7's current LCPs and supporting standards
 - Study Process Repository and Electronic Publishing Concepts
 - Rigorous review of SC7 Vocabulary (WG22)
 - Start revision to 15289 (Documentation) to reflect aligned set.

- Some 15288-12207 Integration Considerations:
 - Common purpose and outcomes
 - Architecture of the standards
 - Level of prescription of activities and tasks
 - Life cycle treatments
 - Application to services and operations
 - Common verification and validation concepts
 - Common configuration management concepts
 - Alignment with other applicable standards
 - Rationalization of application guides

Source: WG 7 N1103 – Strategy for Integration Study Group Final Report, 22APR08

SC7's Large Scale Harmonization Efforts

- SWG1**
- Business Planning
- SWG5**
- Standards Management

- Study Groups, e.g.**
- Relationships
 - Integration

- LCPHAG**
- Modeling
 - Architectural Analysis
 - Process Repository

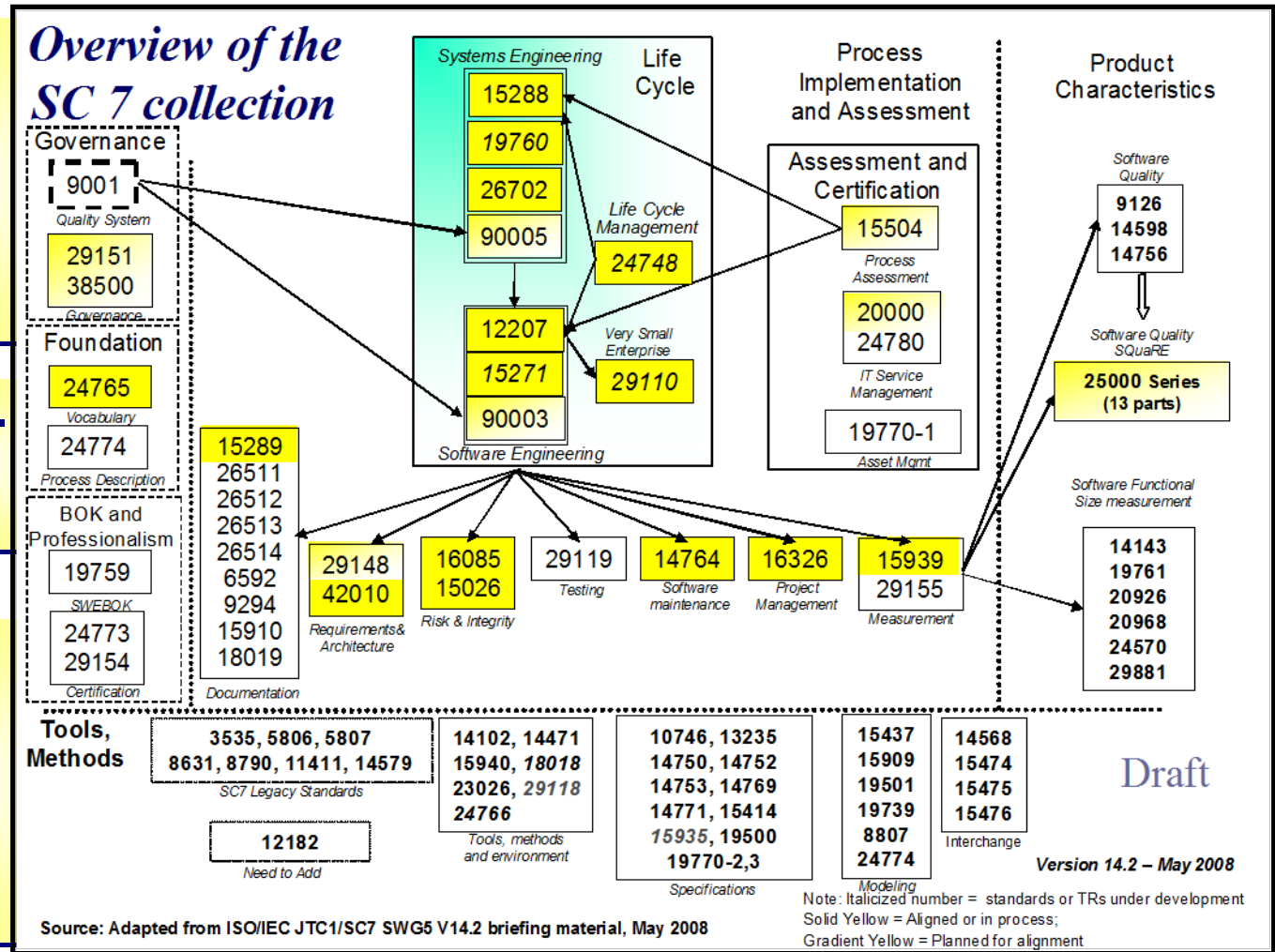

Harmonization Across Collections

The State of Harmonization ... Today

| Topic | Status | Remarks |
|--|----------|---|
| Terminology & Concepts | Yellow ↑ | Shared BOK, joint vocabulary project, potential certification framework. |
| Quality management | Yellow | IEEE is adopting ISO/IEC 90003 approach. |
| Testing | Orange ↑ | Both IEEE and BSI will harmonize with SC7 processes. |
| Architecture description | Green | SC7 adopted IEEE standard and will harmonize with processes. |
| Product quality | Yellow ↑ | ISO/IEC 12119 was revised as 25051. IEEE will withdraw its standard . |
| Life cycle processes | Green | |
| Systems engineering | Green | Shared SE process standard, harmonization with other LC processes underway. |
| SW maintenance | Green | Project to merge IEEE and ISO standards is completed. |
| Measurement | Yellow ↑ | IEEE will adopt 15020 after its current revision. Some details remain. |
| Risk management | Green | SC7 adopted IEEE standard and is now extending it to the systems level. |
| Project management | Yellow ↑ | Project is merging the incompatible standards. |
| Verification and validation | Red | Fundamentally different approaches. Good intentions, but no action yet. |
| Configuration management | Yellow | SC7 withdrew its standard; systems issues remain. IEEE is about to revise . |
| SW process assessment | Yellow ↑ | Harmonization with LC process standards is underway. |
| Requirements engineering | Orange ↑ | Joint project has been approved. masup of relevant standards is being prepared . |
| SW life cycle data | Yellow ↑ | IEEE is adopting 15289 to replace 12207.1. |
| User documentation | Yellow ↑ | IEEE 1083 has been incorporated into 26514. IEEE will adopt it . |
| CASE tools | Yellow | Minor incompatibilities. |
| Notations | Harmless | Distinct standards for distinct notations. |
| Internet | Green | Shared standard. |
| IT Services, Management, Governance | Yellow | IEEE will adopt 20000 standards . |
| Specialty Engineering (Safety, Security) | Orange ↑ | Unrelated approaches will be addressed in part by coordination revision of 15025 . |
| Others | Yellow | Many unrelated standards. |

The State of Harmonization in 1995

| Topic | Status | Remarks |
|--|----------|---|
| Terminology & Concepts | Red | Different vocabulary standards. |
| Quality management | Orange | ISO: Driven down from ISO 9001. IEEE: traditional QA approach. |
| Testing | Orange | IEEE standards unrelated to SC7 processes. |
| Architecture description | Harmless | SC7 didn't have architecture standards. |
| Product quality | Yellow | Unrelated standards. |
| Life cycle processes | Red | Incompatible standards. |
| Systems engineering process | Yellow | Unrelated standards. |
| SW maintenance | Red | Incompatible standards. |
| Measurement | Yellow | Unrelated standards. |
| Risk management | Harmless | No standards at all. |
| Project management | Red | Incompatible standards. |
| Verification and validation | Red | Fundamentally different approaches; minor incompatibilities in details. |
| Configuration management | Red | Incompatible standards. |
| SW process assessment | Yellow | Nothing in IEEE. ISO process assessment incompatible with ISO LC. |
| Requirements engineering | Orange | IEEE standards unrelated to SC7 processes. |
| SW life cycle data | Red | Incompatible standards. |
| User documentation | Red | Incompatible standards. |
| CASE tools | Yellow | Minor incompatibilities. |
| Notations | Harmless | Distinct standards for distinct notations. |
| Internet | Harmless | No standards. |
| IT Services, Management, Governance | Harmless | No standards. |
| Specialty Engineering (Safety, Security) | Orange | Unrelated approaches. |
| Others | Yellow | Many unrelated standards. |

**IEEE CS May 2008
Status Report to SC7**

**Stoplight charts
show marked
improvement
between the
IEEE and SC7
Standards
Collections**

Harmonization Benefits Summary

Alignment

- Achieves short term objectives
- Maintains backward compatibility
- Starts disparate users towards goal

Integration

- Tackles the 'religious' issues
 - Technical and Political
- Achieves long term goals in a set

Large Scale Harmonization

- Solves big picture issues within and across SDOs

Each Level Brings You

- Easier process definition and implementation
- Better team communication and integration
- Improved performance at lower cost
- Increased benefit and usefulness of implementing these standards in your organization

Eases Your Integration, Management, and Acquisition Burden



Questions?

For More Information Contact

- **Teresa 'Terry' Doran**
TECHSOFT

31 West Garden Street, Suite 100

Pensacola, FL 32502-5685

Internet: www.techsoft.com

NY Office Tel: 1 631-266-2191

Email: tsdoran@techsoft.com

- **ISO/IEC/IEEE 12207 Project Editor**
- **15288-12207-24748 Editorial Team Member**
- **IEEE Std 1220™-2005 Project Editor (aka ISO/IEC 26702:2007)**
- **ISO/IEC JTC1/SC7 Life Cycle Process Advisory Group Chair**

| | |
|----------------|---|
| ANSI | – American National Standards Institute |
| CMMI | – Capability Maturity Model Integration |
| CMU | – Carnegie Mellon University |
| IEC | – International Electrotechnical Commission |
| IEEE | – Institute of Electrical and Electronics Engineers |
| IEEE CS | – IEEE Computer Society |
| INCOSE | – International Council on Systems Engineering |
| ISO | – International Organization for Standardization |
| IT | – Information Technology |
| JTC1 | – ISO/IEC Joint Technical Committee 1: Information Technology |
| LCP | – life cycle process |
| NWIP | – new work item proposal |
| OPA | – organizational process assets |
| OPD | – organizational process definition |
| SC | – subcommittee |
| SG | – study group |

- SC7** – ISO/IEC JTC1 SC 7: Software and Systems Engineering
- SE** – systems engineering
- SEI** – Software Engineering Institute (at CMU)
- S2ESC** – Software and Systems Engineering Standards Committee (IEEE CS)
- SEP** – SE process
- SWE** – software engineering
- SWG** – special WG
- WG** – working group
- WG7** – ISO/IEC JTC1 SC7 WG 7: Life Cycle Management
- VSE** – very small enterprise

For ISO and ISO/IEC Standards (Current and Withdrawn):

http://www.iso.org/iso/iso_catalogue.htm

- 1) ISO 9001:2005, *Quality management systems — Requirements*
- 2) ISO/IEC 12207:2008, *Systems and software engineering — Software life cycle processes*
- 3) ISO/IEC 15288:2008, *Systems and software engineering — System life cycle processes*

For ISO/IEC documents and in-process standards and technical reports (TRs): <http://www.jtc1-sc7.org/>

- 4) SC7 N4143: ISO/IEC DTR 24748.2:2009, *Systems and software engineering — Guide for life cycle management*

For IEEE Standards:

<http://www.ieee.org/web/standards/home/index.html>

IEEE Std 1220™-2005, *IEEE Standard for Application and Management of the Systems Engineering Process*

Or related information:

<http://standards.computer.org/s2esc/>

**IEEE CS Software and Systems Engineering Standards Committee
– for on-going SE/SW standards activities**

http://pascal.computer.org/sev_display/index.action

SEVOCAB: An IEEE CS and ISO/IEC JTC 1/SC7 project, SEVOCAB includes definitions from international standards; This database is issued periodically as a formal, published International Standard (ISO/IEC 24765) reflecting a "snapshot" of the database.

Near-field RCS and Fuze Modeling: Assessment and Strategy

*NDIA Systems Engineering Conference
Oct 22, 2008*

David H. Hall, Dorothy L. Saitz, Dr. David L. Burdick
SURVICE Engineering Company
Ridgecrest, CA

Objectives

- In an encounter between an aircraft and a missile, fuze function is one of the most important endgame elements in determining the probability of kill (Pk)
- In recent years, proximity fuze modeling and the required near-field RCS modeling do not appear to have received adequate attention
- This effort is investigating the state-of-the-art of proximity fuze modeling
 - Our goal is to help determine the need for resurrecting and improving this capability
 - We are actively seeking information on who's doing what with which kinds of models
 - We're interested in all kinds of fuzes:
 - RF
 - Active Optical
 - IR
 - Guidance Integrated

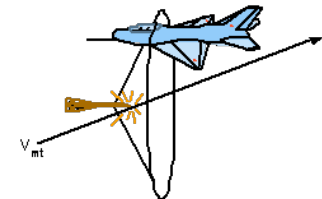

Applications

- **SYSTEM LETHALITY**
 - U.S. Missile Systems
- **SURVIVABILITY**
 - Threat Missile Systems

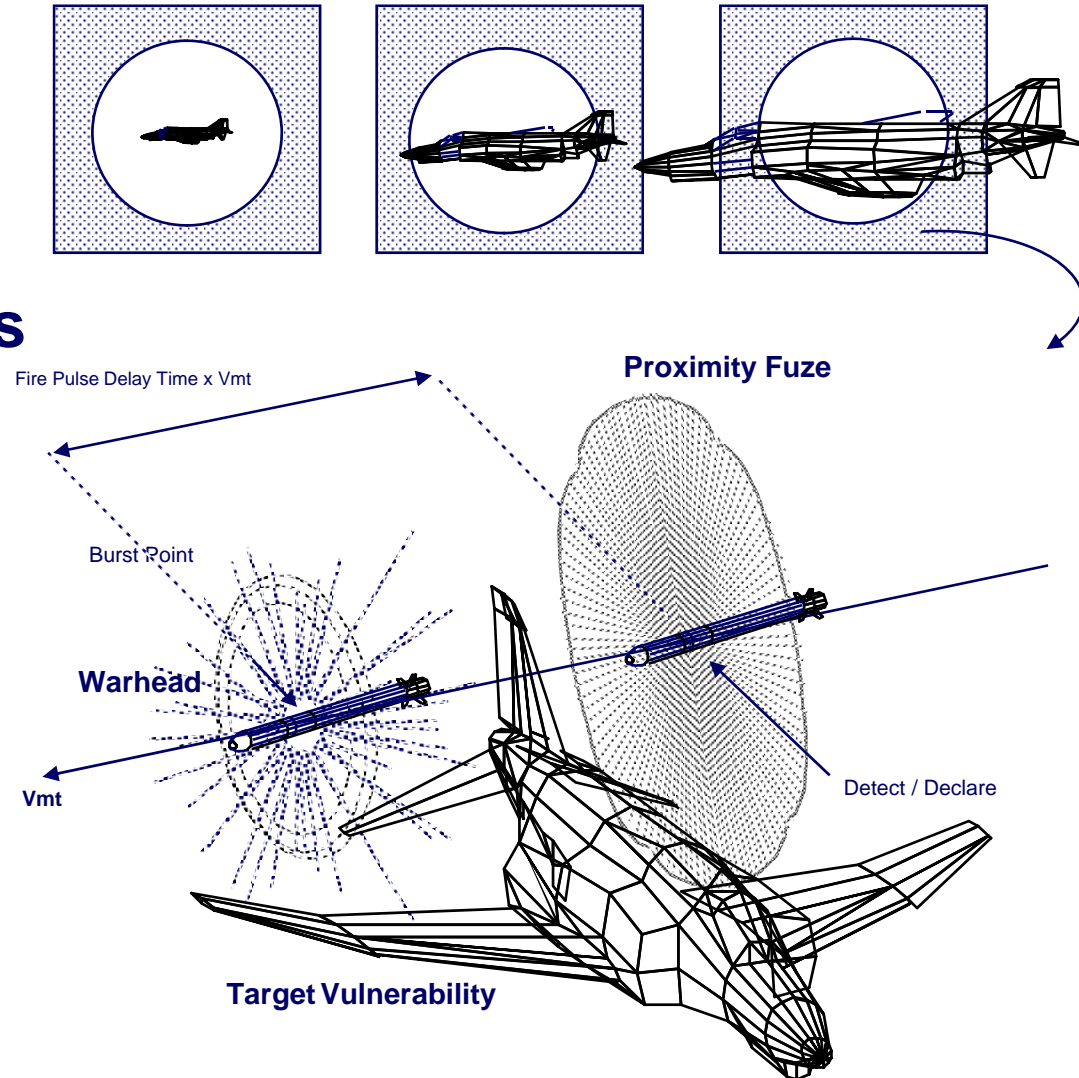

Typical Surface-to-Air Missile Engagement

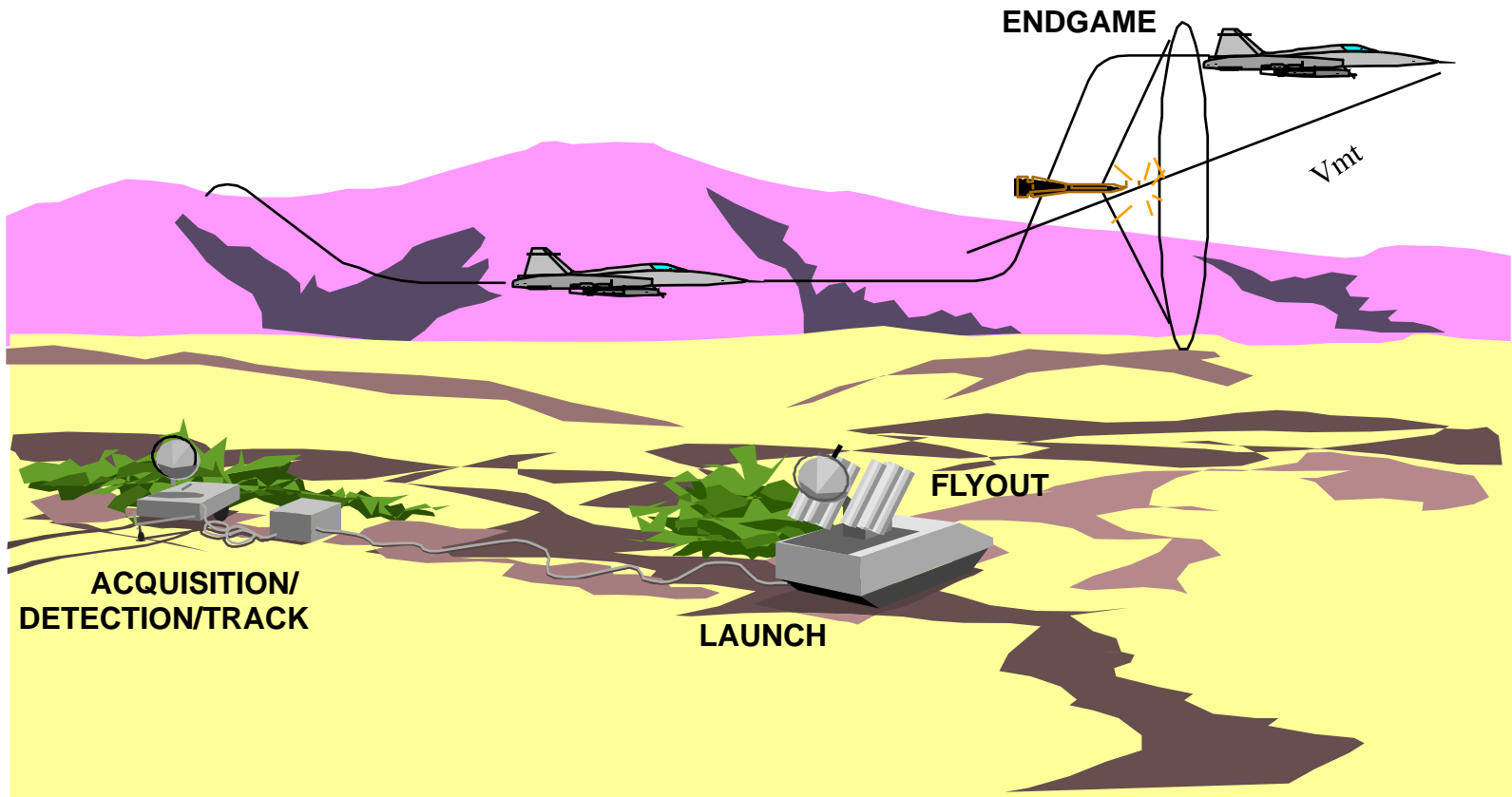

Endgame Models

OUTPUT FROM FLYOUT

- MISSILE VEL COMPONENTS
- TARGET VEL COMPONENTS
- MISSILE POSITION
- TARGET POSITION
- ANGLES OF ATTACK

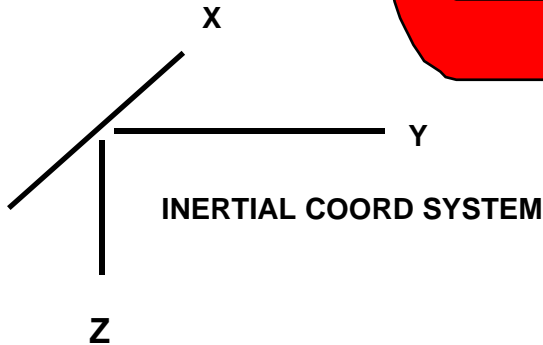
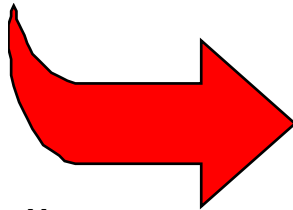

INPUTS TO ENDGAME

- APPROACH ANGLES
 - MISS DISTANCE
- RELATIVE VELOCITY
- ANGLES OF ATTACK

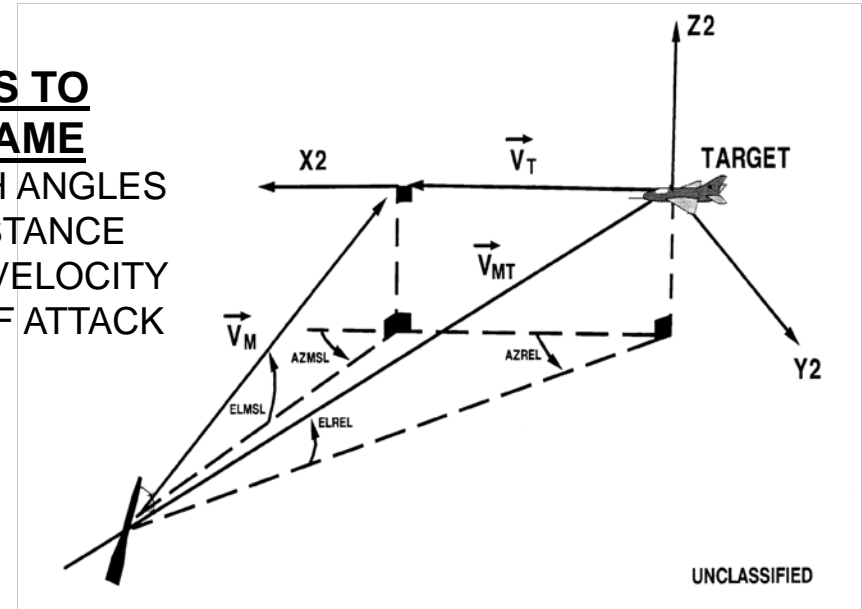

- What happens after the last missile guidance time-constant before intercept
 - Everything is assumed to be a straight line
 - Acceleration is assumed to have little or no effect during endgame
- Calculate events along the relative missile-target velocity vector (V_{mt})
 - Fuze Declaration Position
 - Warhead Burst Point
 - Impact with Target (if direct hit)

Fuze Determines Burst Point

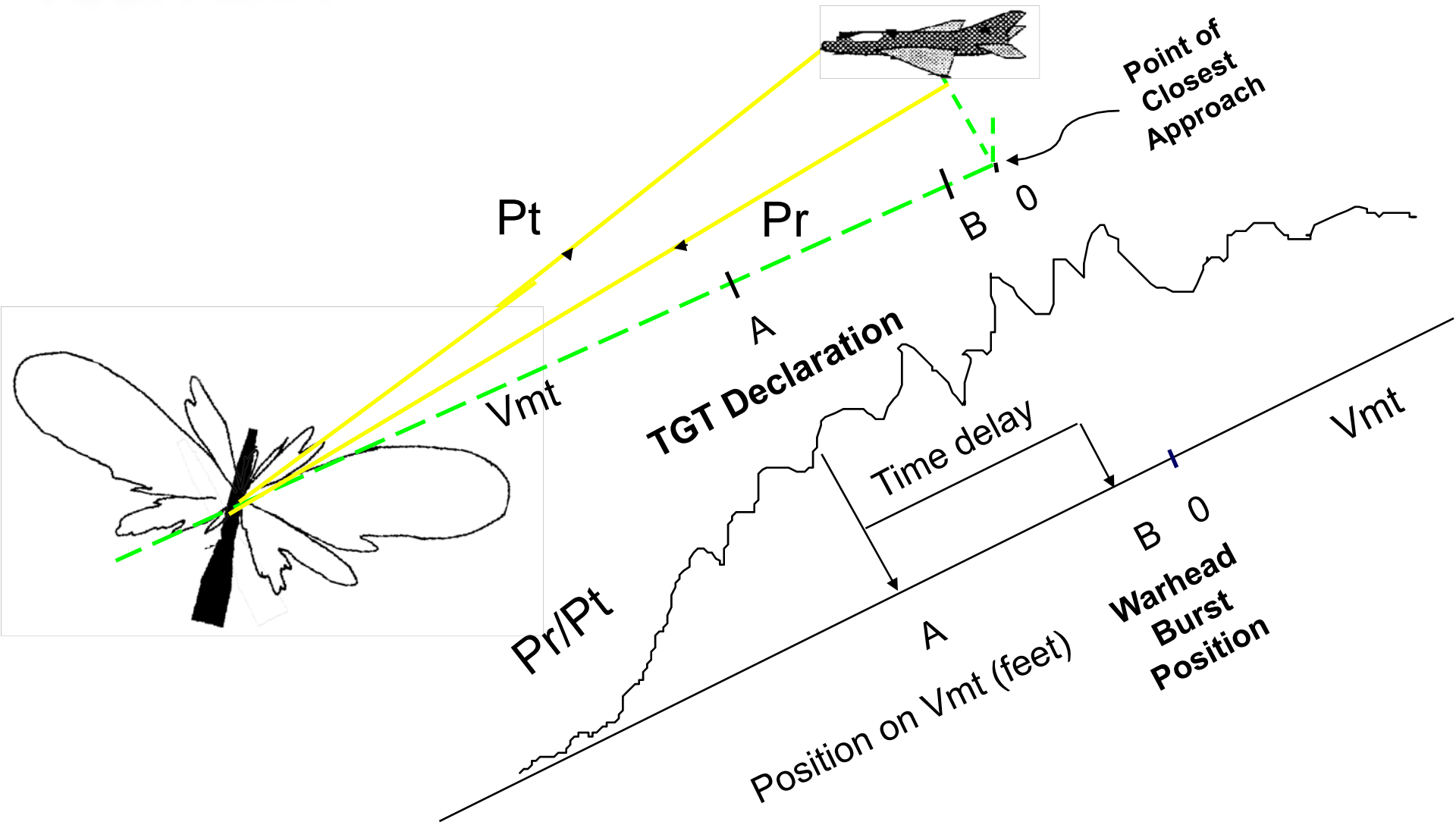

Fuzeze Model Within the Endgame

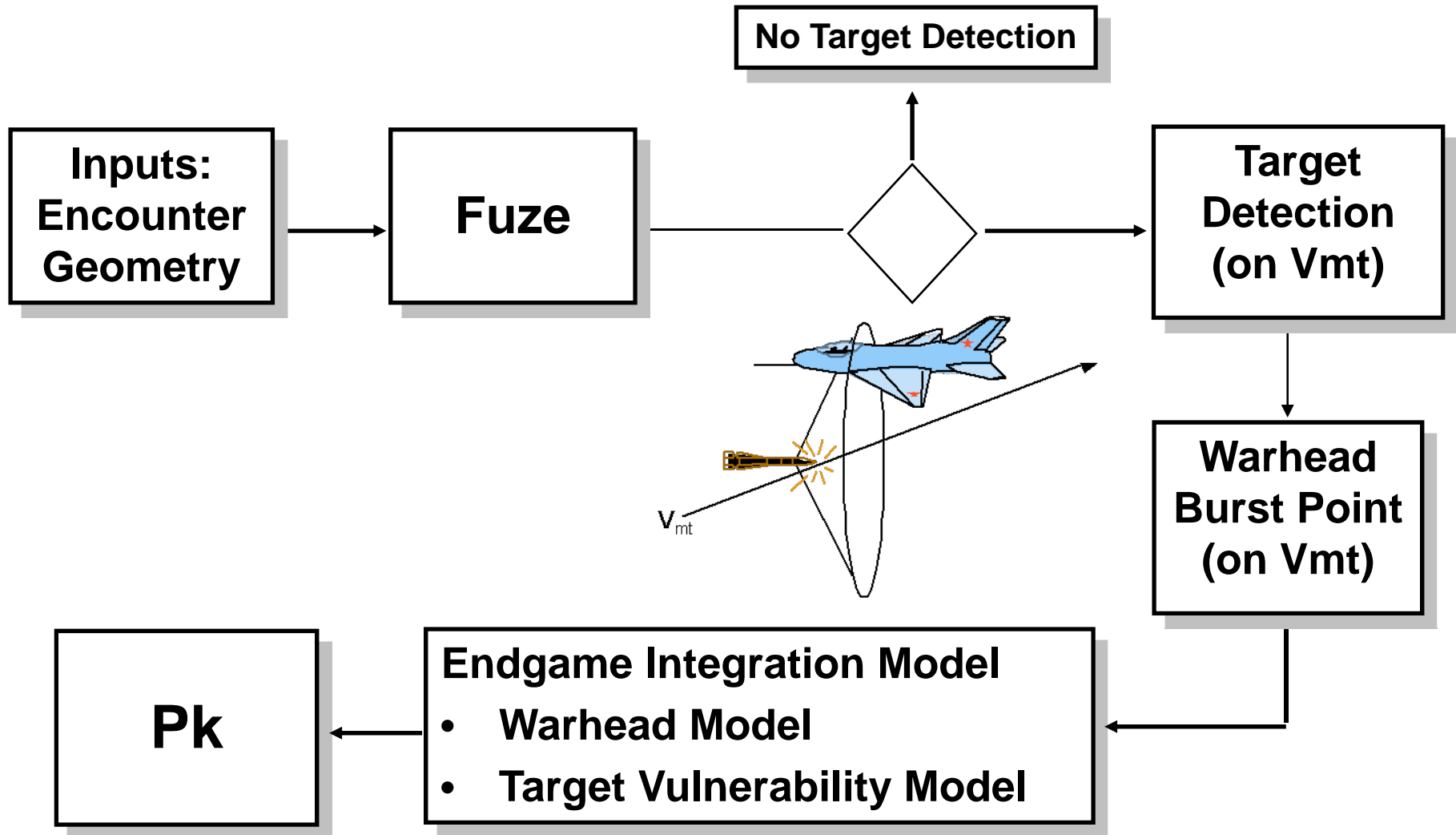

Fuze Model Elements

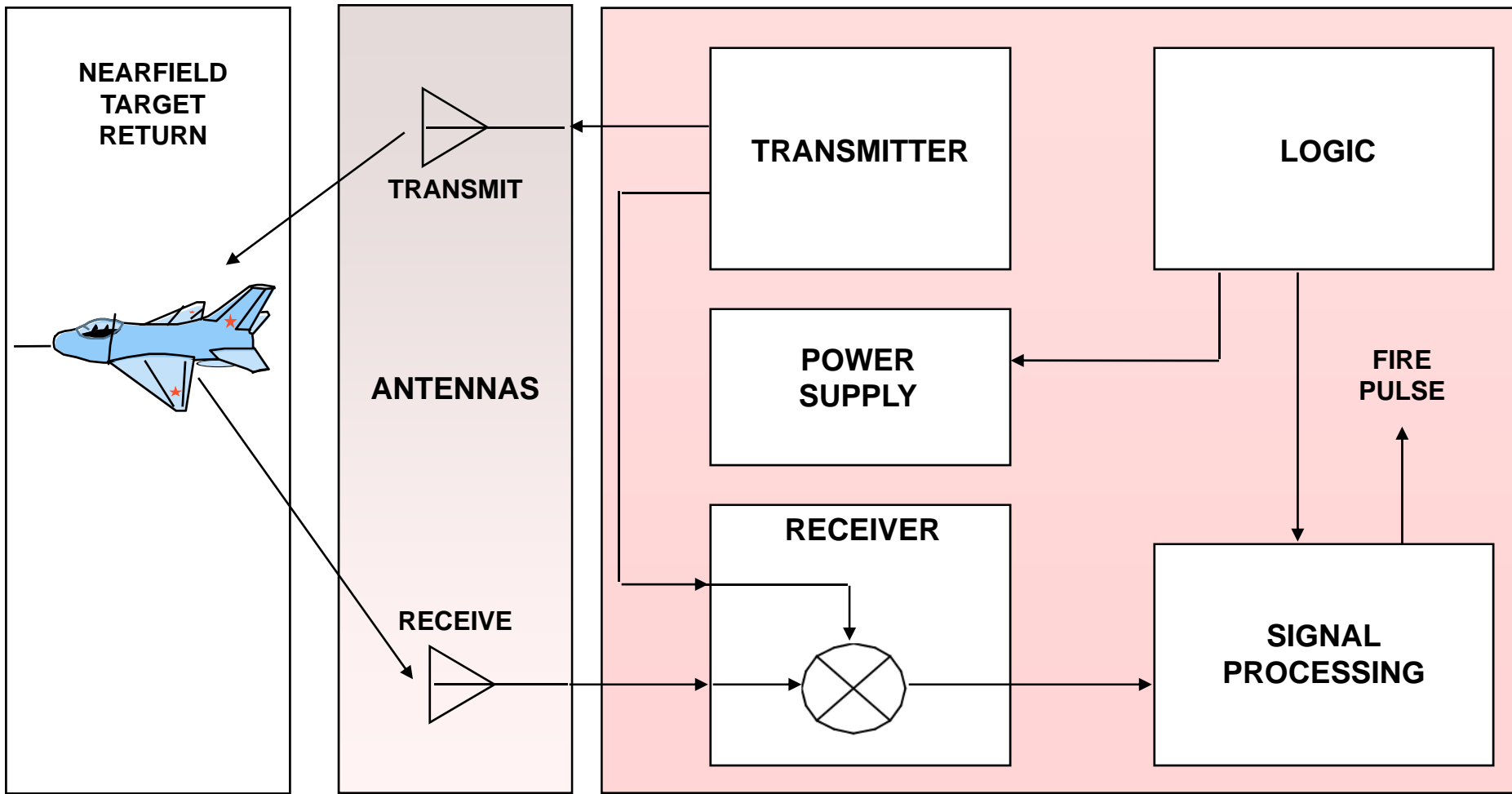

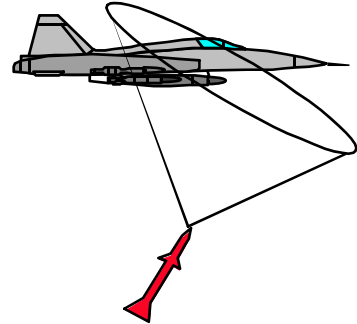

Modeling a Proximity Fuze

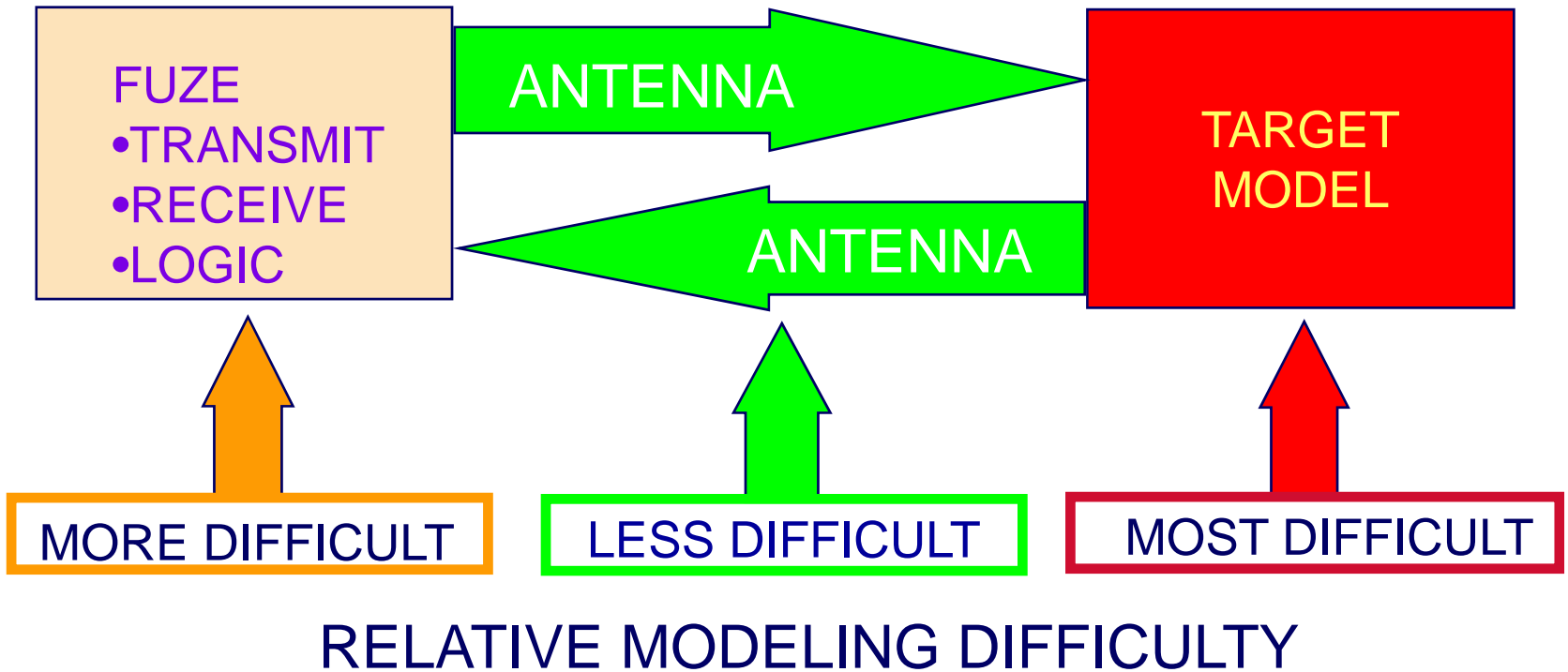

Example Near Field Signature Methodology: Geometrical Theory of Diffraction (GTD)

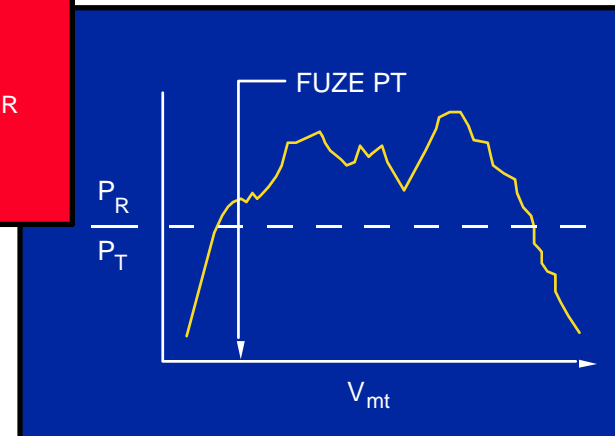
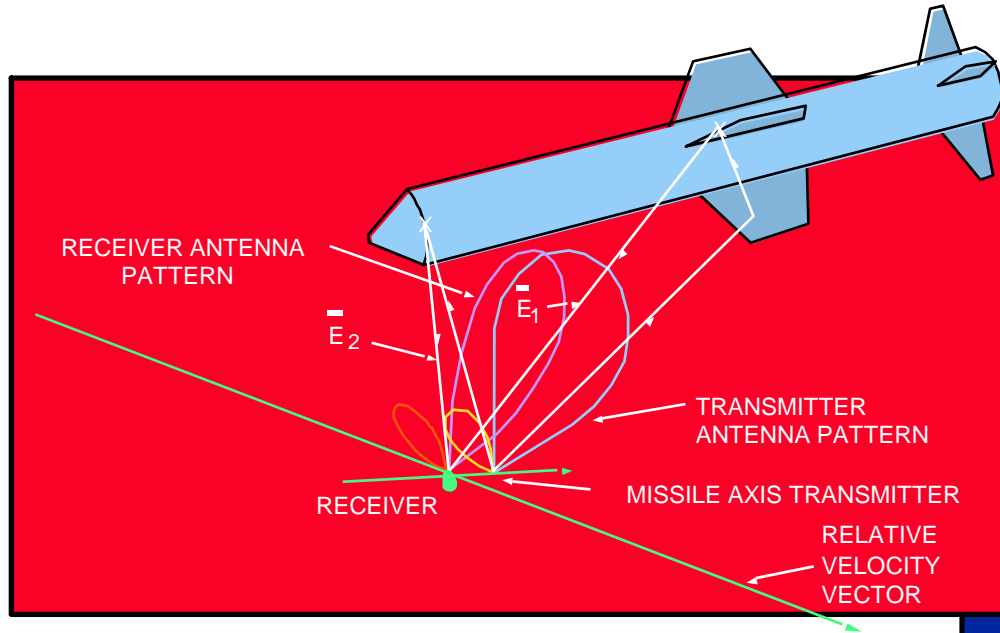

TOTAL FIELD AT RECEIVER LOCATION $E_T = E_1 + E_2$

- CONVERTED TO $\frac{P_R}{P_T}$
- $\frac{P_R}{P_T}$ COMPARED TO THRESHOLD LEVEL

Missile Engagement Simulation Arena (MESA)

- Unique China Lake Facility for Evaluation of Missile Proximity Fuzes Against Full Scale Targets
- Effects of Near Field Signatures (Aircraft or Missile) on Threat Missile Fuze Performance

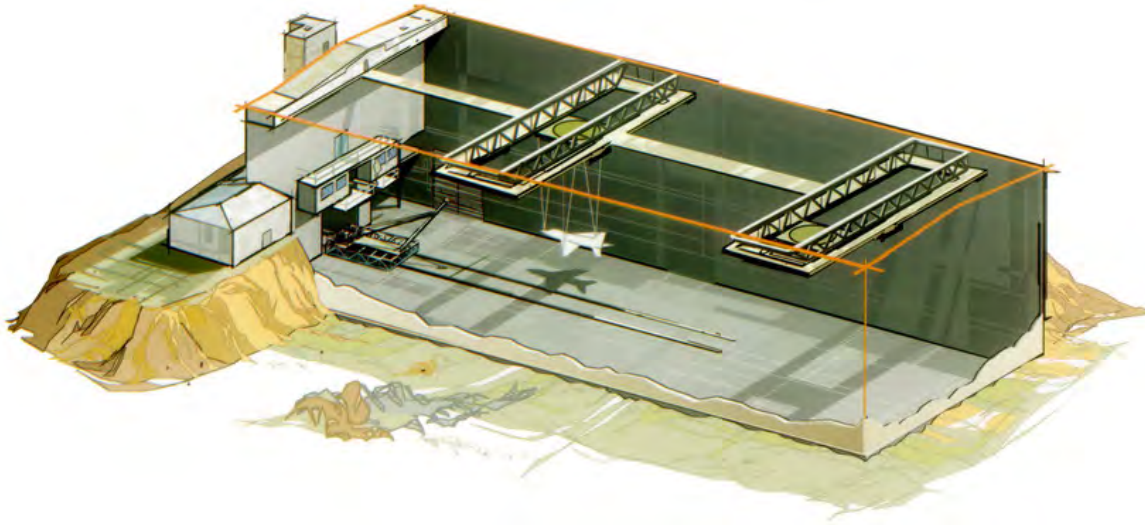

- Realistic Encounter Simulations Provide:
 - Fuze Performance (Pd)
 - Warhead Burst Point
 - Countermeasures Effects
 - Overall Missile Performance
 - Effectiveness Analysis Support
 - **M&S Validation Data**

Example Measurements vs. GTD Model "Crayola" Target

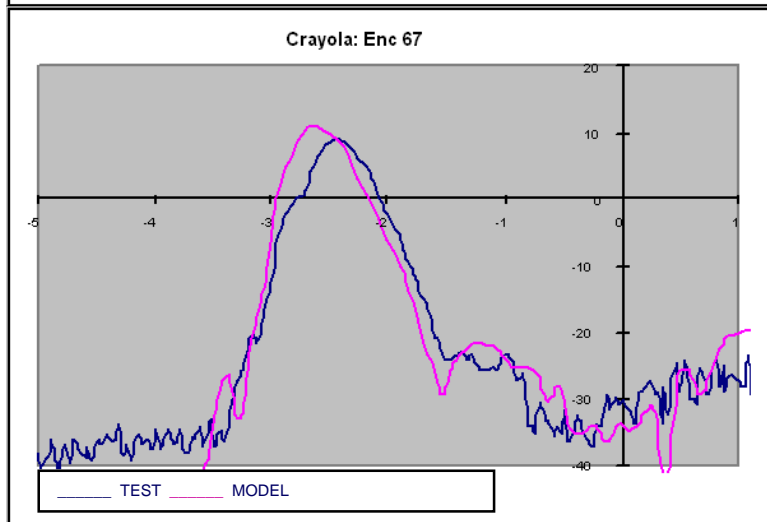
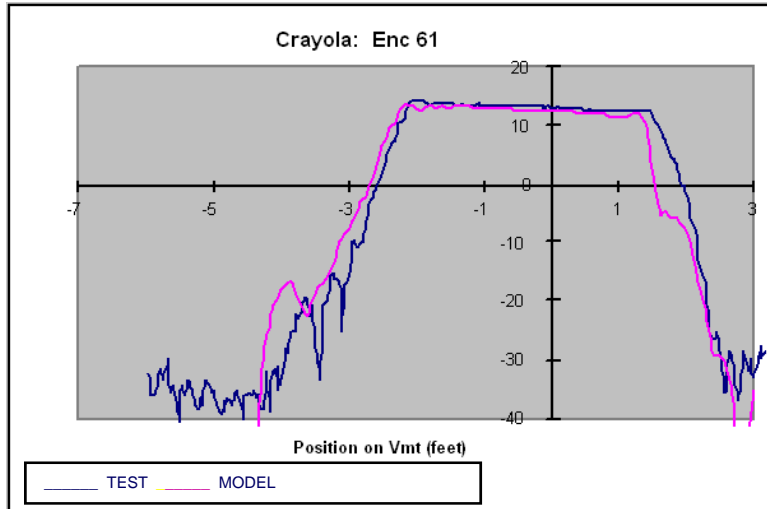

What Drives Pk the Most?

How Good Does the Fuze Model Need to Be?

- **Sensitivity Analysis Can Support the answers:**
 - **Determine Effect on Pk Caused by Errors in Inputs to the Endgame**
 - **Compare results to Pk accuracy requirements for specific applications**
 - **Example: Net Reduction in Lethality (NRL) for ECM**

$$\text{NRL} = 1 - \frac{\text{Pk(wet)}}{\text{Pk(dry)}}$$

Endgame Parameters Affecting Pk

- **Primary parameters**
 - **Intercept geometry parameters**
 - » **Miss distance, direction**
 - » **V_m , V_t**
 - » **Approach angles**
 - » **Angles of attack**
 - **Fuze declaration position [on V_{mt}]**
 - **Target Vulnerability**
- **Secondary parameters**
 - **Fuze parameters: detection thresholds, etc.**
 - **Warhead parameters: ejection angle, etc.**
 - **Fault trees: redundancies, etc.**

Example $P(K)$ Sensitivity to Fuze Detection Position

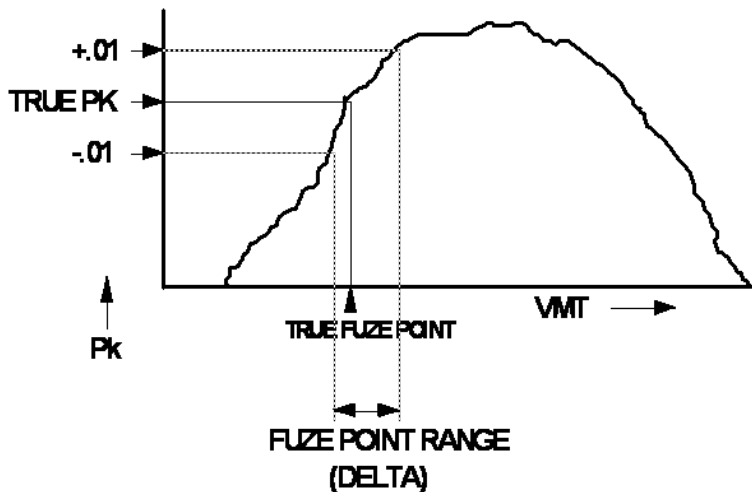

Figure I-2. $P(K)$ Profile Along V_{MT}

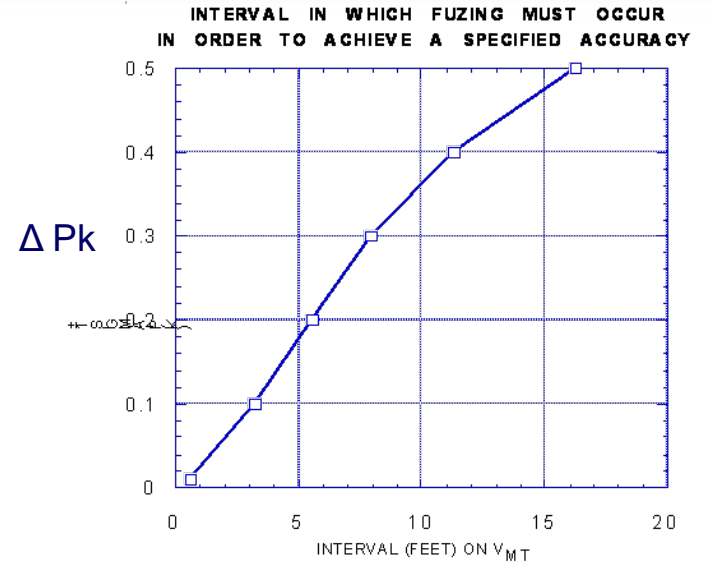

Figure I-3. Interval in Which Fuzing Must Occur To Achieve A specified $P(K)$ Accuracy

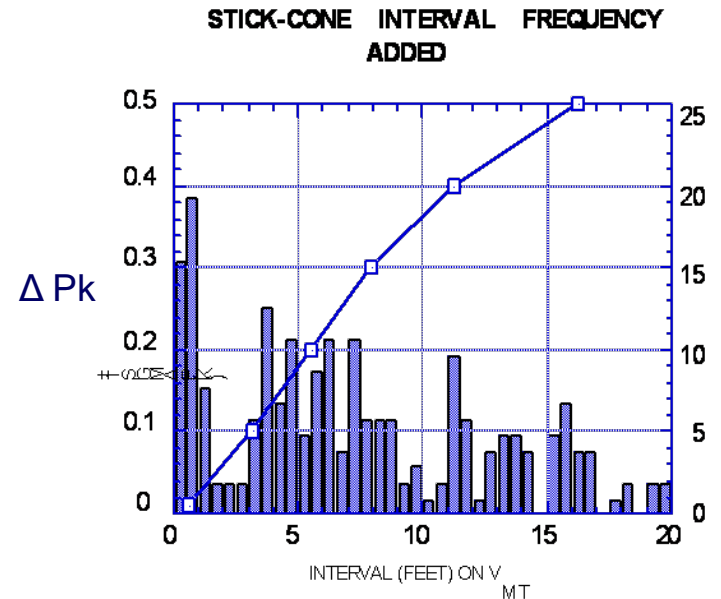

Figure I-3A. Interval in Which Fuzing Must Occur (on V_{MT}) To Achieve a Specified $P(K/F)$ Accuracy

Sensitivity Analysis Results

Primary Drivers of Pk (in order):

- 1. Fuzing (Burst Position)**
- 2. Miss Distance**
- 3. Az**
- 4. EI**
- 5. Yaw**
- 6. Pitch**

Relative importance depends on specific intercept conditions, type of missile and type of target

It Is Impossible to Know the Validity of Simulated Pk Without Knowing the Validity of the Fuze Model

- Errors in fuzing prediction can change the predicted Pk from zero to one or vice versa**

Modeling Fuze Performance

- **Models of proximity fuzes require simulation of near field signatures as well as fuze system (sensors, processing)**
 - **Some options include:**
 - » **Simple geometric model (stick-cone model)**
 - » **“Advanced Fuze Model” in models like ESAMS, SHAZAM**
 - » **Near field signature models (GTD, PTD)**
- **Risk Areas:**
 - **Some elements of threat fuzes not well understood**
 - » **Burst Control Logic**
 - » **Detection algorithms**
 - **Stick-cone model does not well represent threat fuze characteristics**
 - **Models like ESAMS advanced fuze model have little or no usage history nor any documented V&V**
 - **GTD, PTD signature models require development for use with fuze models**

Project Objectives

- **ID current approaches to Proximity Fuze modeling**
 - **Government and Industry**
 - **Document the “State-of-the-Art”**
- **Determine/Examine needs for improvement**
 - **Methodology**
 - **Data**
 - **Verification and/or Validation**
- **Develop a strategy for improvement**
 - **Develop a plan for filling methodology, data & V&V gaps**
 - **ID potential funding sources**

**We are actively seeking information on the current status of fuze modeling in Government and Industry (and in other countries)
Please let us know if you have any information!**



Naval Open Architecture

NDIA 11th Annual

Systems Engineering Conference

AIR



C4I



SPACE



SUBS

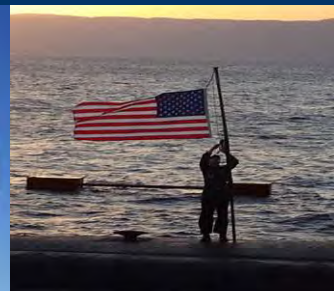

SURFACE



MARINES



October 23, 2008

***Distribution Statement A: Approved for Public Release;
distribution is unlimited***

***Mr. Mike Dettman
Associate Technical Director (Policy & Guidance)
PEO C4I***



Agenda

- The Open Architecture Imperative
- Open Architecture Policy and Requirements
- Benefits of Open Architecture
- Open Architecture Business and Technical Practices
- Examples of Open Architecture Implementation across the Navy
- Importance of Acquiring and Exercising Intellectual Property Rights
- Conclusion



The Navy must build a fleet where our systems ...



... are modular, interoperable, and affordable to upgrade



To accomplish this, ASN (RD&A) in 2003 commissioned a Red Team to assess the Navy's plan to adopt Open Architecture

The Red Team Made 13 Recommendations to leadership:

1. Develop and promulgate a clear Navy policy
2. Develop a Navy-wide business strategy to support OA goals
3. Redirect the OA implementation by defining architectures for domains based on their unique needs
4. Assign one PEO to be accountable for managing OA in each domain
5. Investigate alternate strategies for budgeting and contracting for ships and their combat systems to maximize benefits of open architectures
6. Evaluate DDX, AEGIS, LCS, and CVN/large deck L-ships combat system requirements and analyze architecture/cost trades to exploit a common architecture for surface ship command and decision systems
7. Review all applicable programs to determine how OA is actually being implemented and what changes in the program of record are required



Red Team Recommendations (continued)

8. Reaffirm the role of PEO IWS in the Navy-wide OA Initiative
9. Modify and enforce the OA architecture definition and standards selection processes within and across communities
10. Implement and sustain a proactive education and information exchange program across the Industrial and Government communities
11. Modify testing and certification processes to exploit OA
12. Regarding JTM and its development by JSSEO:
 - Determine whether the technical approach and the transition strategy to Navy programs is appropriately risked
 - Determine whether the Navy programs have sufficient, coordinated off-ramps
13. Consider using the basic framework of these recommendations for Navy OA to address Joint interoperability and network centric warfare requirements

The Red Team included several technical recommendations



These recommendations acknowledge that many pieces of the acquisition puzzle are required to become “truly open”

Open Architecture

The confluence of business and technical practices yielding modular, interoperable systems that adhere to open standards with published interfaces.

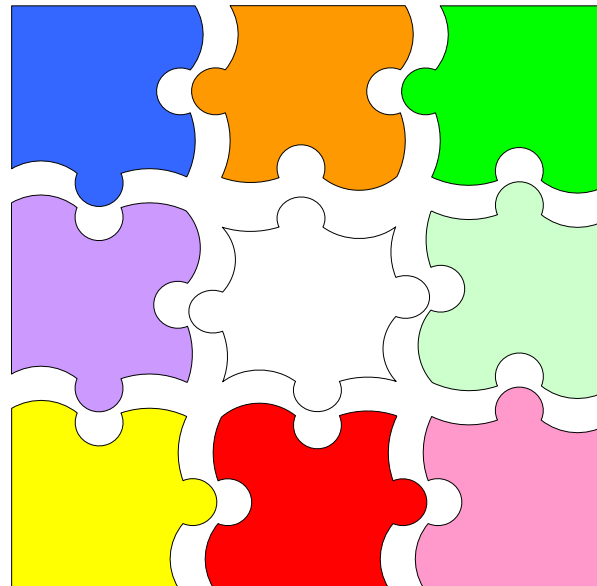



So, leadership mandated *Open Architecture* implementation across the Naval Enterprise and provided some guidance

1 Aug 2004 ASN RDA mandates open architecture

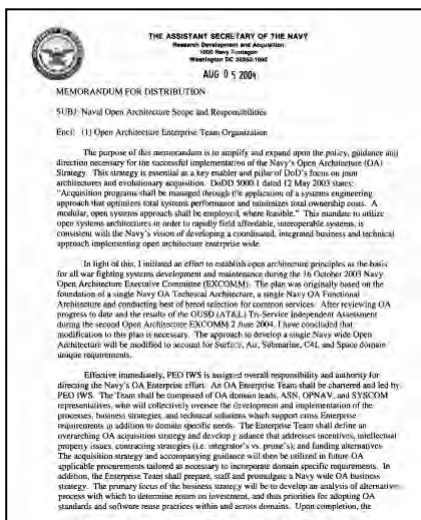

Naval OA Policy

2 Dec 2005 OPNAV issues OA Requirements letter

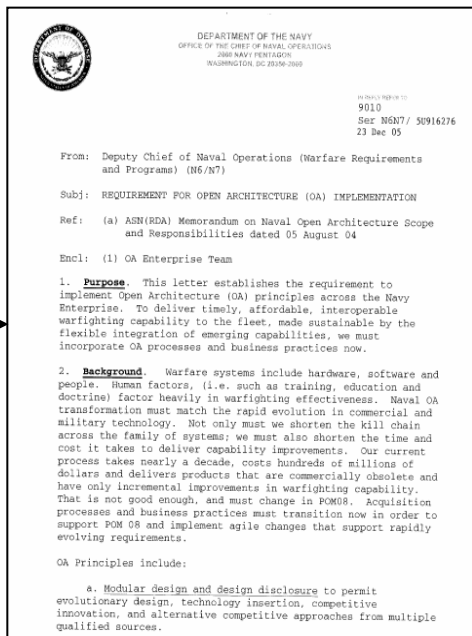

Naval OA Requirements

OA CORE PRINCIPLES

Modular design and design disclosure

Reusable application software

Interoperable joint warfighting applications and secure information exchange

Life cycle affordability

Encouraging competition and collaboration



From this guidance, the OA Enterprise Team (OAET) developed a Naval OA Strategy that includes goals, objectives, practices, and tools ...

OA STRATEGY

OA GOALS

OA PRACTICES

Statement A: Approved for Public Release, distribution is unlimited

Naval OA Strategy

"Probably the biggest challenge I have is to get the ship building key right, to get the future capabilities right. We are at 281 ships today. We have come down, and I believe are projected to go up - and we need to sustain that projection in a positive direction."
- ADM Muller, Chief of Naval Operations, 26 Oct 2007

The Navy leadership is faced with building future combat systems and a fleet capable of meeting emerging threats and evolving national security requirements while at the same time controlling the rising costs of our weapon systems and aging platforms. In order to build combat systems capable of countering emerging threats in sufficient numbers needed to support our warfighters, we must be able to quickly introduce new or upgraded technologies into the Fleet. Changing the way we do business today is imperative if we are to gain the added flexibility required to capitalize on these technologies and deliver the right capabilities.

Naval Open Architecture (OA) is an enterprise-wide, multifaceted business and technical strategy for acquiring and maintaining National Security Systems as interoperable systems that adopt and exploit open system design principles and architecture. This initiative is a key enabler and pillar of the Department of Defense's (DoD) focus on joint architecture and evolutionary acquisition. DoD Directive 5000.1 dated 12 May 2003 states: "Acquisition programs shall be managed through the application of a systems engineering approach that optimizes total system performance and minimizes total ownership cost. A modular, open systems approach shall be employed, where feasible."

By adopting OA principles throughout the naval enterprise today, we can build modular, affordable, future combat systems designed to meet the future needs of our Sailors. These systems will also be able to readily incorporate insertion of new technologies from a broad range of industry partners. However, as the CNO states, we must become leaders of innovation and change to make this happen. We must identify our path forward. This strategy lays out the Navy's vision, goal, and objectives for institutionalizing OA across the enterprise.

Naval OA Vision

To meet the CNO's promise to sustain combat readiness, build a fleet for the future and develop 21st century leaders, the Naval OA vision is to:

Transform our organization and culture and align our resources to adopt and institutionalize open architecture principles and processes throughout the naval community, in order to deliver more warfighting capabilities to counter current and future threats.

Institutionalizing Naval OA throughout the Naval community will require that the enterprise:

| Align | Share | Collaborate |
|---|---|---|
| <ul style="list-style-type: none"> Align Requirements & Acquisition Communities Align Domains across the Enterprise and with Joint Service Partners Align Industry and Academic Partners | <ul style="list-style-type: none"> Share Products and assets across the enterprise Share services to products and assets through government intellectual property rights Share knowledge and ideas through communities of interest | <ul style="list-style-type: none"> Collaborate thru sub-to-unit experiments to reduce risk Collaborate to harmonize standards and guidance Collaborate to reduce T&E expenses through common modular designs and standard interfaces |

1. Change the Naval processes and **business** practices to "utilize open systems architectures in order to rapidly field affordable, interoperable systems."
2. Provide **OA Systems Engineering** leadership to field common, interoperable capabilities more rapidly at reduced costs
3. Change the Naval and Marine Corps **Cultures** to Institutionalize OA Principles

- Disclose design artifacts
- Negotiate appropriate data rights
- Foster enterprise collaboration
- Reuse GOTS products
- Institute Peer Reviews
- Develop new business models
- Incorporate OA in contracts

- Publish interfaces
- Isolate proprietary components
- Use widely adopted standards
- Modularize systems

- DAU OA Training Outreach
- Government Symposia & Industry Days
- NPS Research

TOOLS TO ASSIST

OA Contract Guidebook



OA Assessment Tool

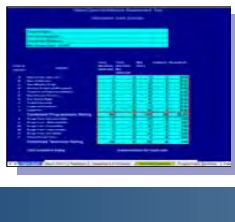

Reuse Licensing Agreement



OA/FORCENet Experiment



SHARE Repository



OA Training Module

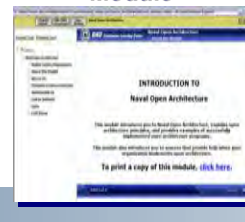

Industry Days



OA Website





... and found that implementing OA yields many benefits

Reduction in Time to Field

- Decreased development and acquisition cycle times to field new warfighting capabilities
- Faster integration of open standards based systems

Increased Performance

- Improved operator performance thru delivery of cutting edge technologies and increased bandwidth capabilities from spiral developments and technology insertions

Improved Interoperability

- Use of common services (e.g. common time reference)
- Use of common warfighting applications (e.g. track mgr)
- Use of published interfaces to standardize collaboration

More Competition

- Modular architectures enable competition at the component level
- Sharing data rights allows third parties to compete

Cost Avoidance

- Cost avoidance from software reuse and use of commodity COTS products at optimum prices
- Reduced training and streamlined lifecycle support



Therefore, the Navy is changing its business and technical practices to take advantage of OA's benefits

Business Practices

- Disclose design artifacts
- Negotiate appropriate data rights
- Increase enterprise collaboration
- Institute reviews of solutions
- Develop new business models
- Change contracts
- Increase competition
- Design for lifecycle affordability

Technical Practices

- Modularize systems
- Publish interfaces
- Isolate proprietary components
- Use widely adopted standards
- Re-use software components
- Build interoperable applications
- Ensure secure data exchange
- Implement common solutions



For example, PEO IWS is building a modular, common combat system architecture ...

Aligning platform combat systems ...



... to one open, objective architecture ...

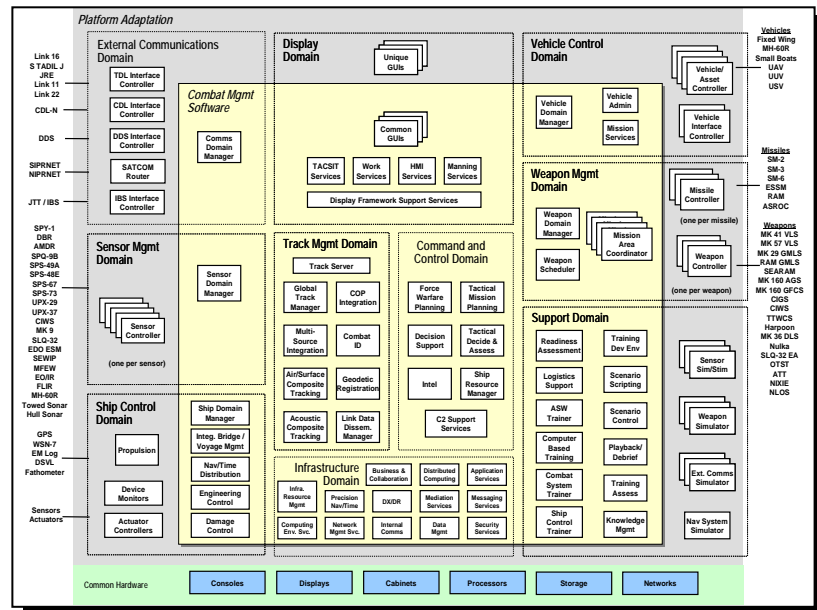

"I expect us to compete whenever possible. Competition provides us with options to seek the best solution for the fleet and the taxpayer. ... I also expect us to foster an environment in which competition can be sustained over time. Competition once does not serve our interests."
 —VADM Paul E. Sullivan

... to achieve commonality across multiple ship classes where the business case supports it

... to help increase competition



PEO C4I is developing new business models ...

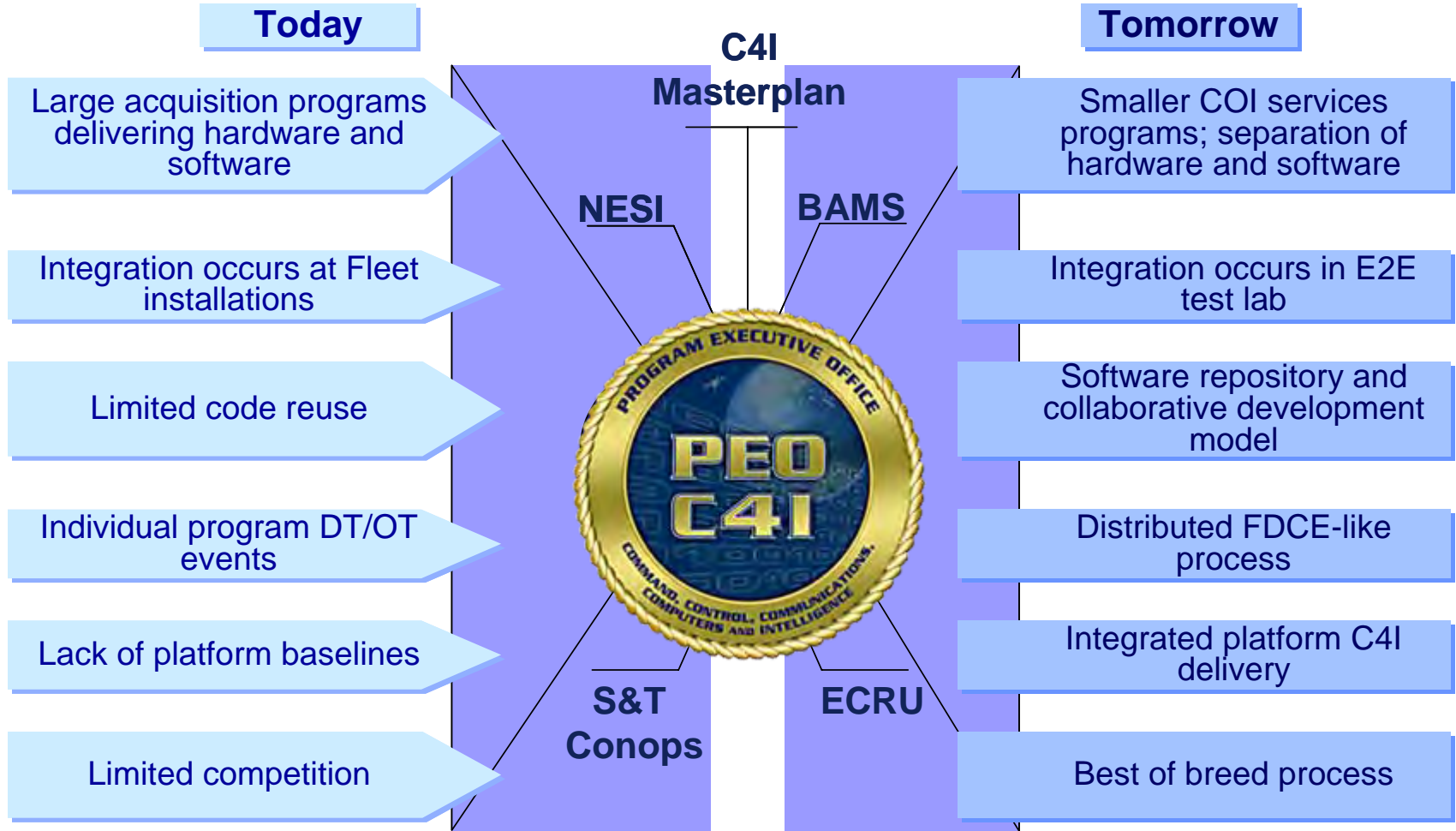

... to neck down and move towards common services



Another significant cultural change is that the Navy now understands the importance of exercising its intellectual property rights

- A key aspect to implementing OA is for the Government to **exercise** the intellectual property (IP) rights it acquires
- Under the Federal Acquisition Regulations (FAR) and Defense Federal Acquisition Regulation Supplement (DFARS):
 - The Government gets **Unlimited Rights** in both Technical Data (TD) and Computer Software (CS) for noncommercial items **developed exclusively at the Government's expense**.
 - For noncommercial items developed with **mixed funding**, the Government gets **Government Purpose Rights (GPR)** in TD and CS.
- If a contractor asserts more restrictive rights over a system/component's IP and the Government fails to challenge such an assertion by exercising its rights, the contractor obtains the asserted rights
- It is imperative that the Government assert and exercise the IP rights it acquires because it may lose those rights after a period of time





For example, acquiring, asserting, and exercising IP rights enables Naval programs to disclose designs to foster collaboration ...

- Design artifacts from AEGIS, LCS, DDG 1000, SSDS, SIAP, IABM are available to qualified vendors in IWS's SHARE repository



IWS SHARE REPOSITORY



- Project artifacts from CLIP, XCOP, and NITES-Next are available to qualified vendors in the C4I NESI collaboration site



C4I NESI COLLABORATION SITE



... and improve interoperability



In conclusion, over the four year span of this enterprise transformation, lessons learned have emerged

OA Enterprise Transformation Requires...

- Clear vision and strategy
- Top leadership support & commitment
- Quick wins to get momentum
- Enterprise governance & ownership
- Identified Change Agents
- Consistent OA Communications
- Accountability at all levels
- Performance metrics
- Fleet driven requirements
- Industry / Academia Involvement
- Training / Research

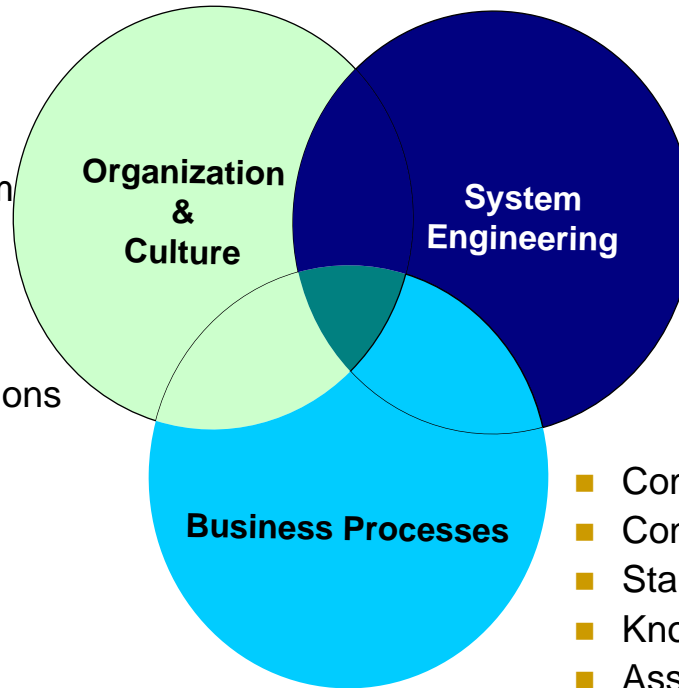

- Operational Capability Roadmap
- Open / Scalable architectures
- Aligned architectures
- Access to design artifacts
- Published interfaces
- Enterprise collaboration
- Threat / data driven performance evaluation
- Tech refresh process

- Compliance checkpoints – six gate
- Consistent assessment approach
- Standardized contract language
- Knowledge of upcoming contracts
- Asset user licensing agreements
- Software asset repositories
- Changed acquisition bus model
- Viable sourcing alternatives
- Transparency -Third Party Reviews
- Streamlined acquisition processes

UNCLASSIFIED

Domain Modeling

Roadmap to Convergence

Nathaniel Horner ↔ Steve Topper

22 October 2008

"You got to be careful if you don't know
where you're going, because you might not
get there."

- Yogi Berra

The logo for Applied Physics Laboratory (APL) at Johns Hopkins University, consisting of the letters 'APL' in a large, bold, blue serif font.

The Johns Hopkins University
APPLIED PHYSICS LABORATORY

UNCLASSIFIED

Overview

- **Introduction**
- **Conceptual Modeling Process Overview**
- **Domain Modeling as the Foundation of the Conceptual Model**
- **Domain Modeling Application Across the Project**
 - **Analysis**
 - **M&S, Software Engineering**
 - **Systems Engineering / Architecting**
 - **Business Processes**
- **Domain Modeling “Goods and Others”**

Why are we here?

- Initial activities on a modeling and simulation (M&S) project for a large, complex, integrated system attempted:
 - To develop generic DoDAF artifacts,
 - To link these artifacts more closely to developed models,
 - To provide a basis for new M&S development across a wide community of stakeholders.
- Issues
 - Legacy tool challenges for complex systems-of-systems analysis (configuration/preparation time, fidelity, and interoperability).
 - Lack of standardized foundation.
 - Traditional architectures often difficult to assess using M&S (lacked underlying referential structure).
 - Activities difficult to accurately plan and estimate.

How can we fix it?

Introduction

Problem Domain:

The real-world things and concepts related to the problem that the system is being designed to solve.

Domain Modeling:

The task of discovering “objects” (classes) representing things and concepts, and the relationships between them.

[Rosenberg and Scott 2001]

Problem Statement:

Develop efficient techniques to support complex system analysis

Given:

Complex systems, lots of components, subsystems, sophisticated behaviors, networks, information processing, collaboration

Organizations involved in design & development of these systems

Analysis, requirements, architecture, systems engineering, software engineering, testing, operations.

Approach:

Understand the problem Domain and progress from there...

Conceptual Modeling Process

- Based on standard software and systems engineering processes.*
- Translates informal, generalized information from disparate sources into formal system models.
- Maintains focus on understanding and standardizing the problem space before moving on to the solution.
- Allows iteration and feedback until it's "right."
- Produces documentation allowing traceability throughout the process.

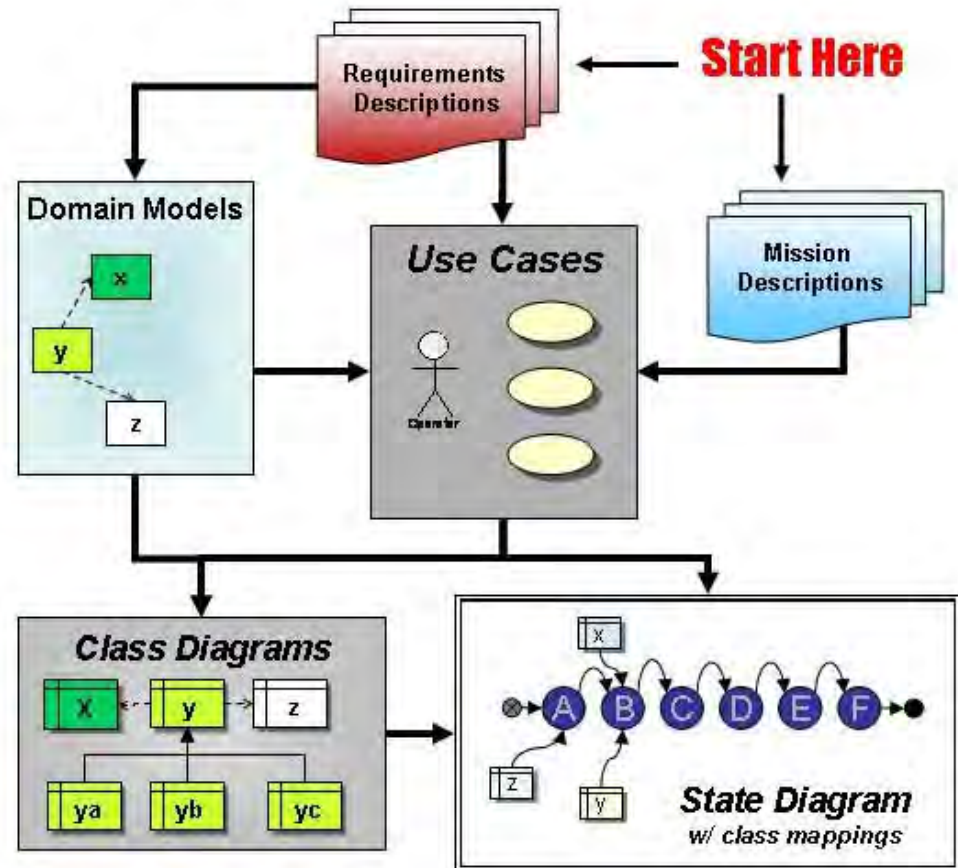

- * Though significantly changed, this conceptual modeling process is informed by ICONIX, a software engineering process falling between RUP and XP with respect to rigor and flexibility. ICONIX is documented in Rosenberg and Stephens [2007].

Conceptual Modeling Importance

“Conceptual modeling is almost certainly the most important aspect of the simulation modeling process A well-designed model significantly enhances the possibility that a simulation will meet its objectives within the required time-scale. What sets truly successful modelers apart is their effectiveness in conceptual modeling.”

[Robinson 2004]

The first, crucial step in conceptual modeling is ***Domain Modeling.***

Domain Model

What it is: A “10,000-foot view,” a live “project glossary,” a simplified class diagram.

How to do it:

- Create list of candidate domain entities by extracting nouns from input documents.
- Review list, standardizing and defining terms.
- Deploy entities in a simplified class diagram (no attributes or operations) and draw important relationships (generalization, composition/aggregation).
- *Iterate as needed with all stakeholder groups and revisit throughout the project.*

What it is for:

- Answers the question, “What makes up the system and its environment?”
- Defines the scope of the project, standardizes terms.
- *Provides foundation for static structural model.*

Domain Model Input

What it is: Known information about the system and its environment.

How to do it:

- Informal requirements descriptions and mission descriptions.
 - ***NOT*** detailed, formal system requirements.
 - Generalized statements about system and what it does.
- CONOPS.
- Existing documentation.
- Stakeholder brainstorming sessions.

What it is for: Nouns extracted from these documents form a list of candidate domain entities.

Domain Model (Example)

- High Level Domain covers environment, mission and systems-of-systems representations →→→→
- Expands to increasingly detailed system representations ↓↓

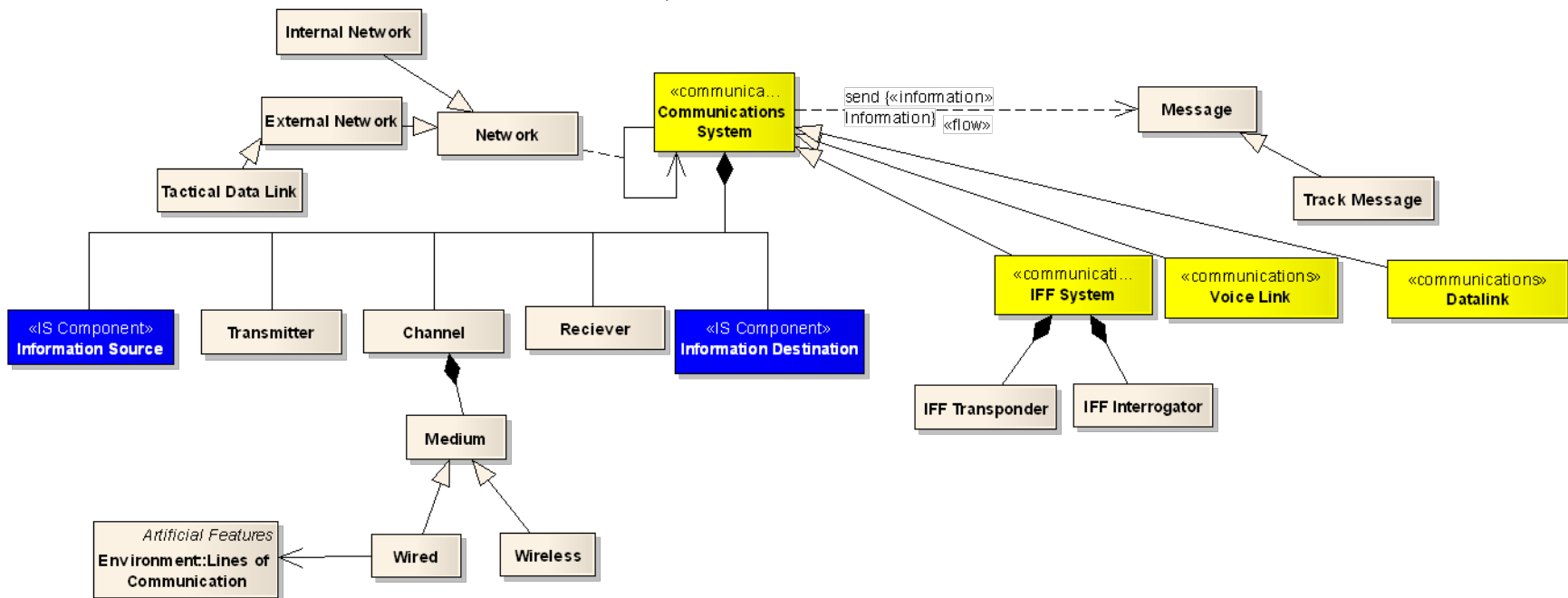
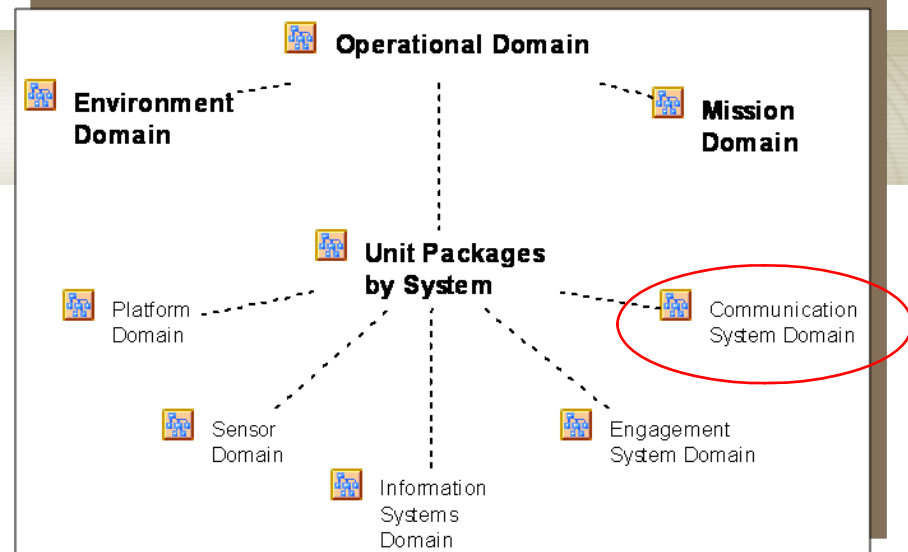

Why Use Domain Modeling?

- **Standardize and define the problem space.**
 - **Use as a project glossary/naming convention.**
 - **Focus on real-world (problem domain) objects.**
- **Document domain structure.**
 - **Organize around key problem domain factors.**
 - **Encapsulate (sub) systems.**
 - **Simplify and/or standardize interfaces.**
 - **Identify systems and their interrelationships.**
 - **Enable analysis of the concepts.**
- **Provide critical foundation for follow-on conceptual modeling artifacts (e.g., use cases, activity models, state diagrams, M&S software design, etc.).**

Complex systems-of-systems require a design approach that formalizes the mapping between behaviors and entities and remains flexible and resilient to change.

Domain Modeling and Other Project Tasks

- **The domain model is critical to the conceptual modeling tasks, through which it has important application across analysis and development projects:**
 - **Research, Development, and Analysis**
 - **M&S, Software Engineering**
 - **Systems Engineering, Architecture**
 - **Business Processes, Project Management**

Why It Matters: Research, Development & Analysis

- **Establishes framework for factor identification and selection including:**
 - **Structure: defines systems and capabilities.**
 - **Behavior: defines functional processes.**
- **Defines the domain entities each group must focus on to achieve their objectives.**
 - **There will be overlap identified – requiring coordination.**
- **Provides the terminology and factors for development of:**
 - **Tests and experiments including specification of alternatives and trades, and scenario development requirements.**
 - **System functions which emerge from domain entities: methods, attributes, and interfaces.**
- **Supports analysis at different levels of abstraction/fidelity without changing the underlying model/architecture.**

Analysis Example

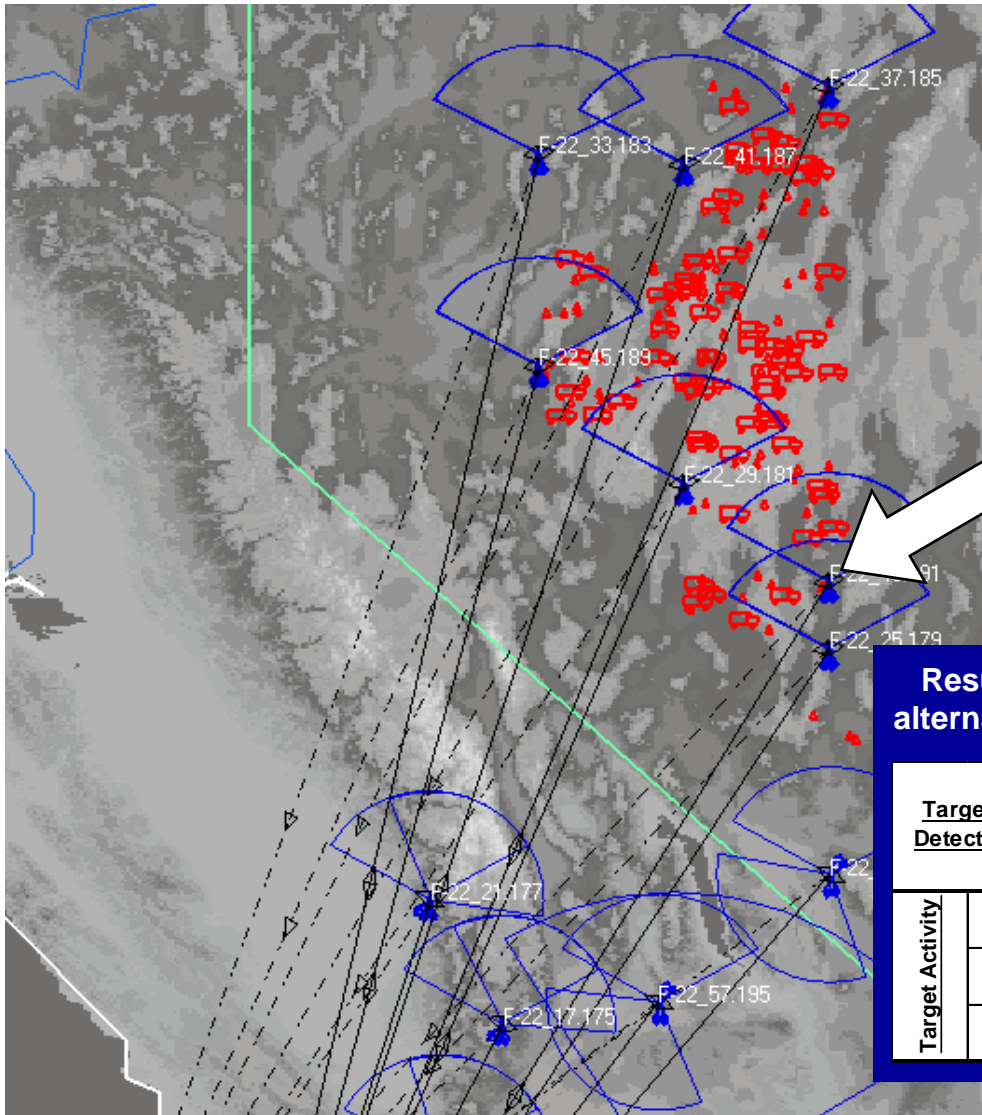

- Analysis factors are selected using domain entities and derived artifacts.
- Selection is independent of simulation tool.

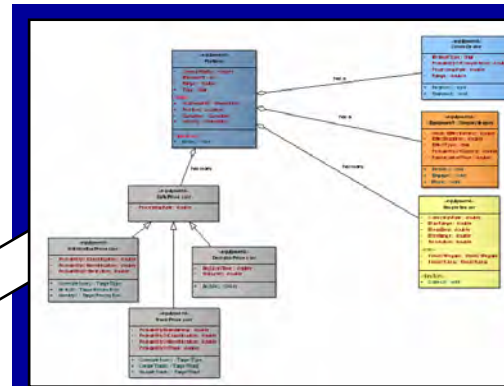

Simulation implementation is defined by the class structure based on the domain model.

Results provide assessment of the efficacy of the system alternatives and the sensitivity of the factors on one another.

| Targets Detected | | Comm Throughput | | | | | | | | |
|------------------|----|-----------------------|-----|-----|-----|-----|-----|-----|-----|-----|
| | | 0.3 | | | 0.5 | | | 0.7 | | |
| | | Collection Capability | | | | | | | | |
| Target Activity | | 0.3 | 0.5 | 0.7 | 0.3 | 0.5 | 0.7 | 0.3 | 0.5 | 0.7 |
| | 10 | 60 | 60 | 55 | 61 | 52 | 53 | 56 | 61 | 64 |
| | 20 | 58 | 66 | 80 | 69 | 80 | 65 | 75 | 69 | 76 |
| 30 | 73 | 62 | 61 | 74 | 73 | 71 | 73 | 75 | 75 | |

Why It Matters: Model and Simulation, S/W Eng.

- **Helps identify where M&S software should be developed.**
- **Represents the top level classes and associations for M&S design.**
 - **Forms a foundation for software design model (UML).**
 - **Models are derived, developed, or specified from the domain-level superclasses.**
- **Enables assessment of complex network-centric issues via reusability, extensibility, and re-configurability of models.**
- **Identifies M&S needs/requirements for potential assignment to available tools (including legacy simulations).**
 - **i.e., once a simulation need is identified, existing tools can be evaluated against it.**

M&S Example

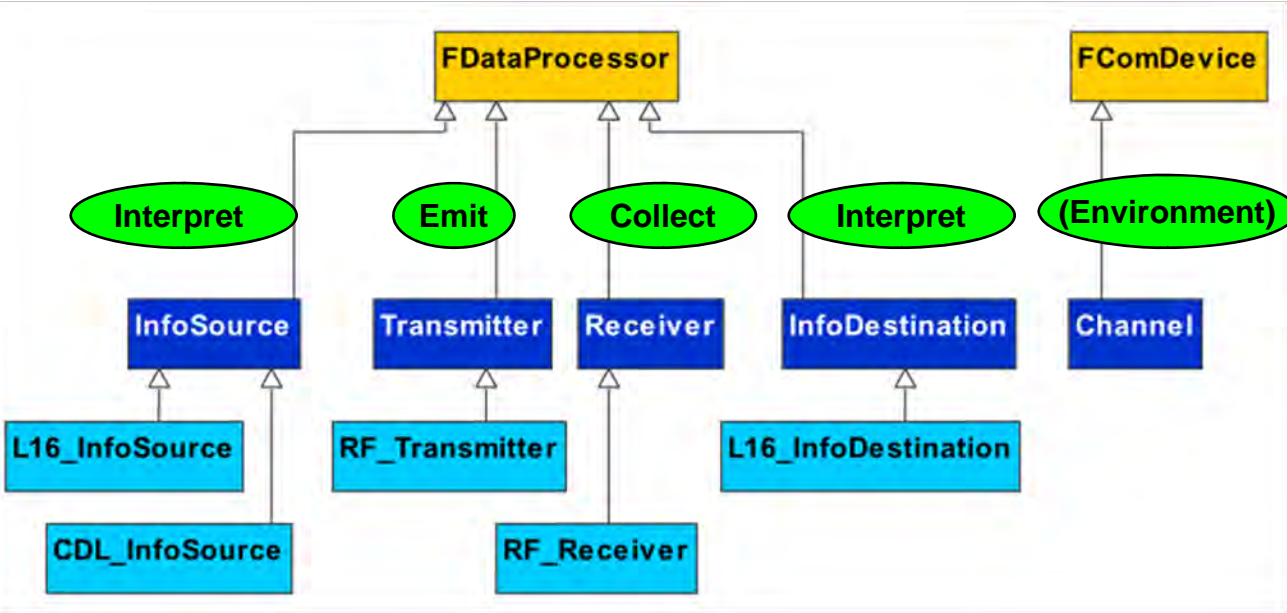
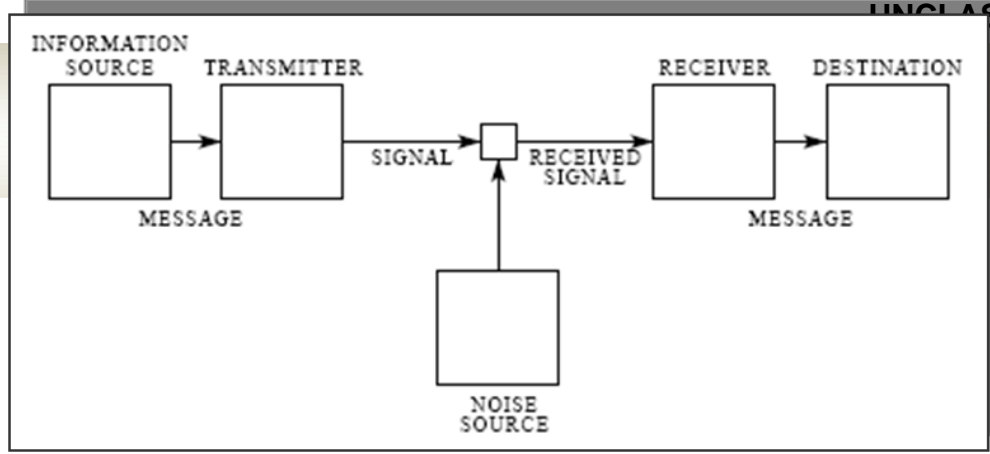

Sim Framework Basic Types

Metamodel Activities

Generic Model Classes

Inherited Model Classes

- Domain entity becomes class for model implementation.
- Model parameters used to compose system representation.
- Domain artifacts provide basis for evaluation of existing simulations.

Why It Matters: Systems Engineering

- Tracks overall system-of-systems development and interactions.
- Provides insight into the system/subsystem alternatives.
- Useful as a foundation for system architectures.
- Supports requirements development/refinement.
- Identifies redundant or superfluous systems/processes.
- Simplifies design.
- Identifies capability shortfalls.
- Identifies program risks:
 - Technical readiness,
 - Interoperability challenges,
 - Critical technologies.
- Stored in a database, which can be linked to other SE products.

Systems Engineering Example

Requirement: The system will engage advanced air-to-air and surface-to-air threats based on the rules of engagement.

Program Database:
Requirements, domain model and other artifacts, MS&A information, project management info, etc.

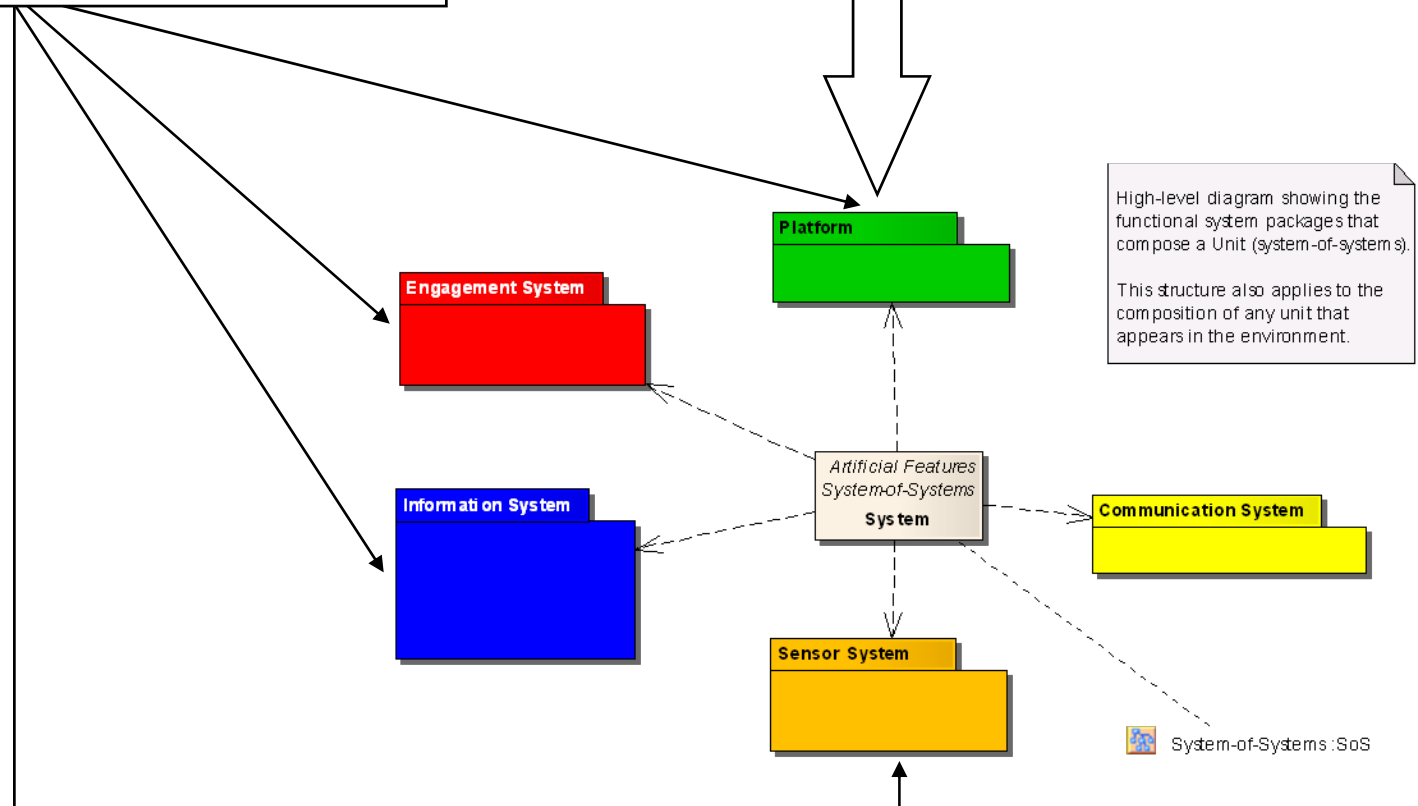

Why It Matters: Business Processes

- **Identifies:**
 - **Areas of responsibility for different stakeholders.**
 - **Maps to project Work Breakdown Structure.**
 - **Shortfalls in coverage/investments.**
 - **Return on investment and related tech maturity of individual systems.**
 - **Risks to the overall goals of the program.**
- **How is this done?**
 - **Each domain entity is related to activities supporting development of applications, data or products needed to accomplish objectives and goals.**
- **Represents a unified simulation-based acquisition process with all components interconnected via the UML-based architecture.**

Business Process Example

| Task Name | Duration | Start | Finish |
|---|----------------|--------------------|--------------------|
| Project X | 56 days | Wed 2/27/08 | Wed 5/14/08 |
| Scenario Development | 56 days | Wed 2/27/08 | Wed 5/14/08 |
| + Identify Target Sets | 42 days | Wed 2/27/08 | Thu 4/24/08 |
| + Assess TCT characteristics | 4 days | Thu 4/24/08 | Tue 4/29/08 |
| + Scenario development | 11 days | Wed 4/30/08 | Wed 5/14/08 |
| + Intelligence Collection Process Design | 1 day | Thu 4/24/08 | Thu 4/24/08 |
| Command and Control Process Design | 1 day | Thu 4/24/08 | Thu 4/24/08 |
| Develop Baseline Processes/Metrics | 1 day | Thu 4/24/08 | Thu 4/24/08 |
| Develop Advanced Processes | 1 day | Thu 4/24/08 | Thu 4/24/08 |
| + Engagement System Development | 1 day | Thu 4/24/08 | Thu 4/24/08 |
| + Develop assessment process | 1 day | Thu 4/24/08 | Thu 4/24/08 |
| Model and Simulation Development | 1 day | Thu 4/24/08 | Thu 4/24/08 |
| Select Model Environment | 1 day | Thu 4/24/08 | Thu 4/24/08 |
| Unit Development | 1 day | Thu 4/24/08 | Thu 4/24/08 |
| System Development | 1 day | Thu 4/24/08 | Thu 4/24/08 |
| Sensor Development | 1 day | Thu 4/24/08 | Thu 4/24/08 |
| Communications Development | 1 day | Thu 4/24/08 | Thu 4/24/08 |
| Information System Development | 1 day | Thu 4/24/08 | Thu 4/24/08 |
| Engagement System Development | 1 day | Thu 4/24/08 | Thu 4/24/08 |
| + Conduct Analysis | 1 day | Wed 2/27/08 | Wed 2/27/08 |
| + Write Report | 1 day | Wed 2/27/08 | Wed 2/27/08 |

- Project's WBS and activities based on domain entities and follow-on artifacts.
- Enables improved governance.
- Enhances task estimation and risk assessment.

Domain Modeling Assessment

Goods

- Replacement of legacy applications (incremental implementation)
- Gain understanding of current capabilities, analyze costs, compare w/ proposed replacement systems
- Make future programs more efficient
- Better risk management
- Potential for program-wide database or knowledge management system
- Reuse across portfolio
- Common foundation/linkages for program tasks (s/w and system engineering, analysis, business processes)
→ **CONVERGENCE**
- Standardization
- Greater accessibility to stakeholders
- Lasting documentation (domain longevity)
- Tool/simulation/code agnostic

Others

- Up-front costs
- Understanding new tools, language, processes
- Personnel and skillset availability
- Inertia of DoD acquisition practices
- Cultural resistance

Summary -- Domain Modeling:

- Is fundamental to conceptual model development, which itself is a crucial activity in large and complex projects.
- Is not a new idea, though it is (perhaps) under-utilized in the DoD community.
- Enables discovery of relationships between entities within the domain and analysis of technical problems.
- Results in a robust, relatively invariant model applicable across related domains.
- Facilitates linkage of diverse projects and processes into a unified portfolio.
- Increases efficiency of acquisition processes through flexibility and reusability.
- Provides a common foundation for M&S, architecture, analysis, and project management tasks . . .

→ ***Convergence***

Sources

ROBINSON, S. 2004. *Simulation: The Practice of Model Development and Use*. John Wiley & Sons, Ltd, West Sussex, England.

ROSENBERG, D., AND SCOTT, K. 2001. Driving Design: The Problem Domain. *Dr. Dobb's Journal*.

ROSENBERG, D., AND STEPHENS, M. 2007. *Use Case Driven Object Modeling with UML*. Apress, Berkeley, CA.

Questions?

Contact Info:

Nathaniel Horner

Nathaniel.Horner@jhuapl.edu
(240) 228-2908

Steve Topper

Steve.Topper@jhuapl.edu
(240) 228-2701

“It is far better to grasp the Universe as it really is than to persist in delusion, however satisfying and reassuring.”

- *Carl Sagan*
(1934-1996)

UNCLASSIFIED

Backups

The logo for Applied Physics Laboratory (APL) consists of the letters 'APL' in a large, bold, blue, sans-serif font.

The Johns Hopkins University
APPLIED PHYSICS LABORATORY

UNCLASSIFIED

Use Cases

What it is: Descriptions of interactions between the system and its users.

How to do it:

- **Identify**
 - **The actors – users of the system, including other systems.**
 - **The tasks facilitated by the system.**
 - **The actors' participation in the tasks, including alternate courses of events.**
- ***Use vocabulary previously defined in domain model.***
- ***Go back and alter the domain model as errors are uncovered through use case exploration.***

What it is for:

- **Answers the question, “What are the user experiences with the system?”**
- **Helps define scope and provides general basis for more formal modeling.**
- ***Provides foundation for the dynamic behavioral model.***

Use Case (Example)

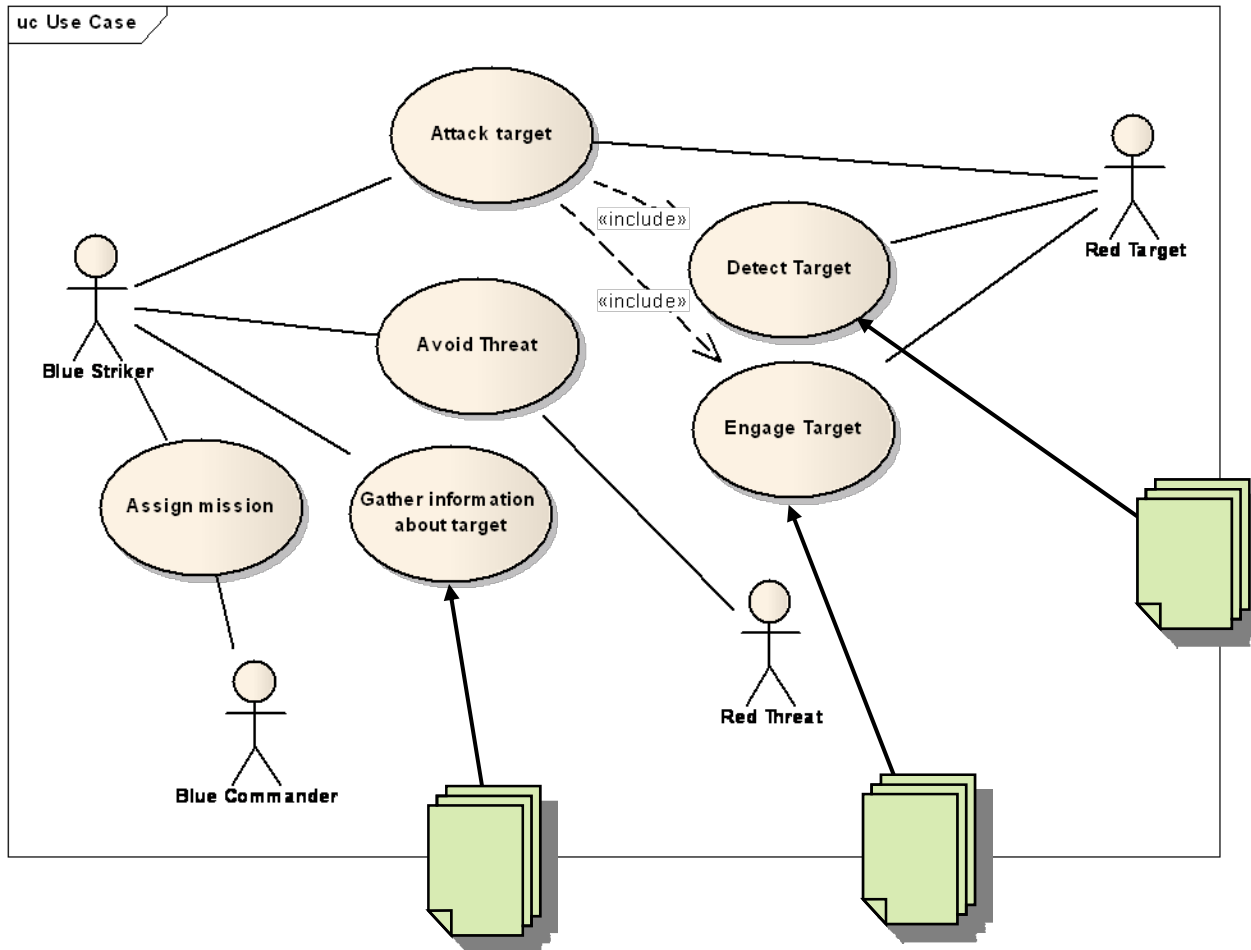

- Use cases are listed in a diagram showing the participating actors.
- Each use case is expanded into a document describing the flow of events involved, including:
 - Actors involved
 - Preconditions
 - Event sequences
 - Exceptions
 - Participants
 - Alternatives
 - Unresolved issues

Class Model

What it is: A more detailed static representation of the domain.

How to do it:

- ***Extend the domain model.***
- **Allocate behaviors to domain model entities based on use case descriptions.**
- **Add attributes and operations to domain model entities.**
- **Add classes to the solution space as necessary.**
- **Work iteratively, going back and forth between static model and behavioral model (e.g., activity, sequence diagrams).**

What it is for: Begins to translate general descriptions into more formal system design.

Class Model (Example)

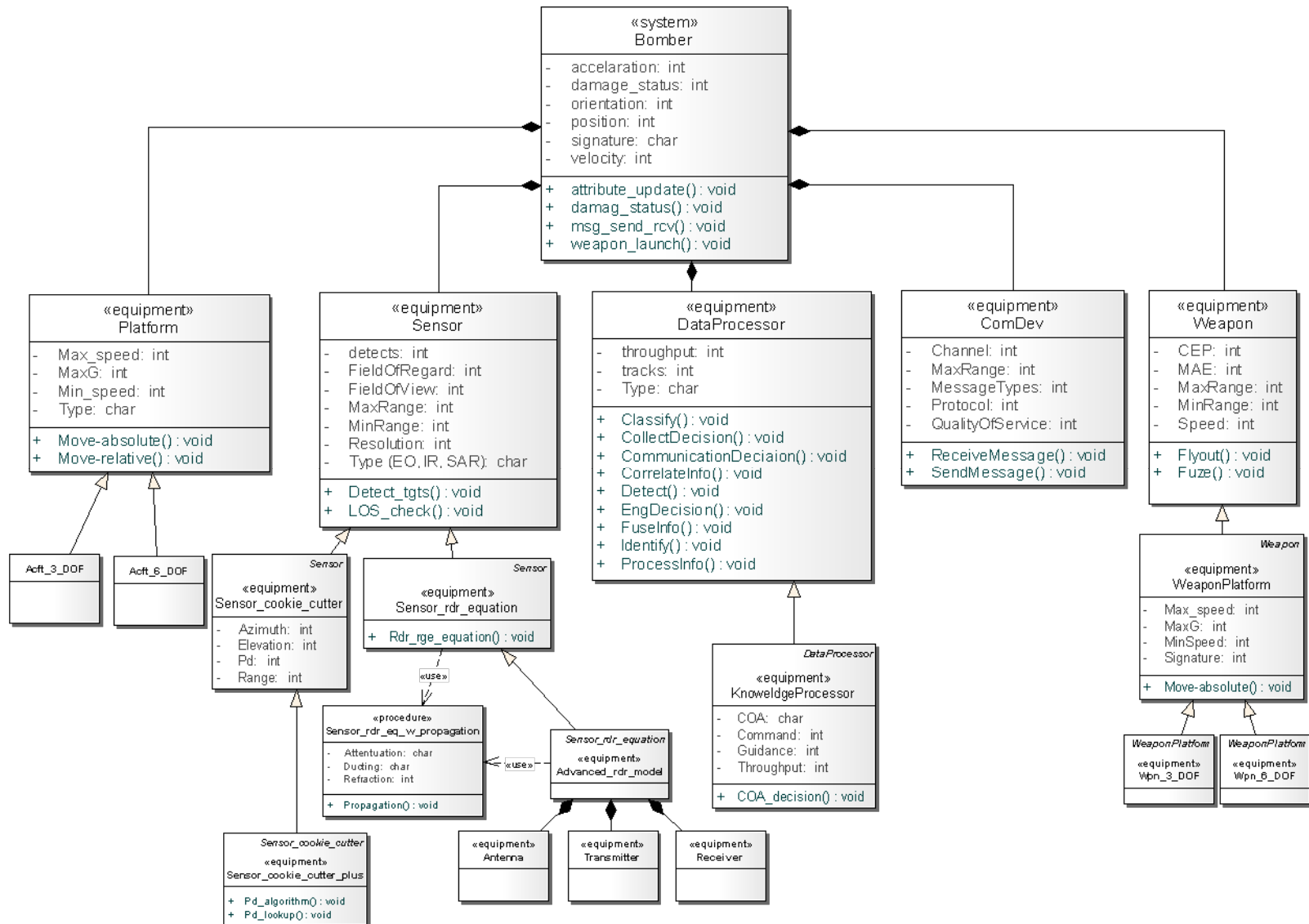

Activity, State, other Behavioral Diagrams

What it is: A more detailed dynamic representation of the system.

How to do it:

- Create activity diagrams:
 - Break up use cases into component transactions or activities.
 - Sequence the activities.
 - Assign responsibility for each activity to a domain entity via swimlanes.
- Create state diagrams:
 - Define atomic states for each domain entity.
 - Sequence the states.
 - Define conditions and constraints governing state transitions.
- Use the use cases as a primary input.
- Work iteratively, going back and forth between the behavioral model and the static model (domain and class model), ensuring compatibility.

What it is for: Begins to formalize use cases into more detailed system behaviors and activities.

Behavioral Model (Example)

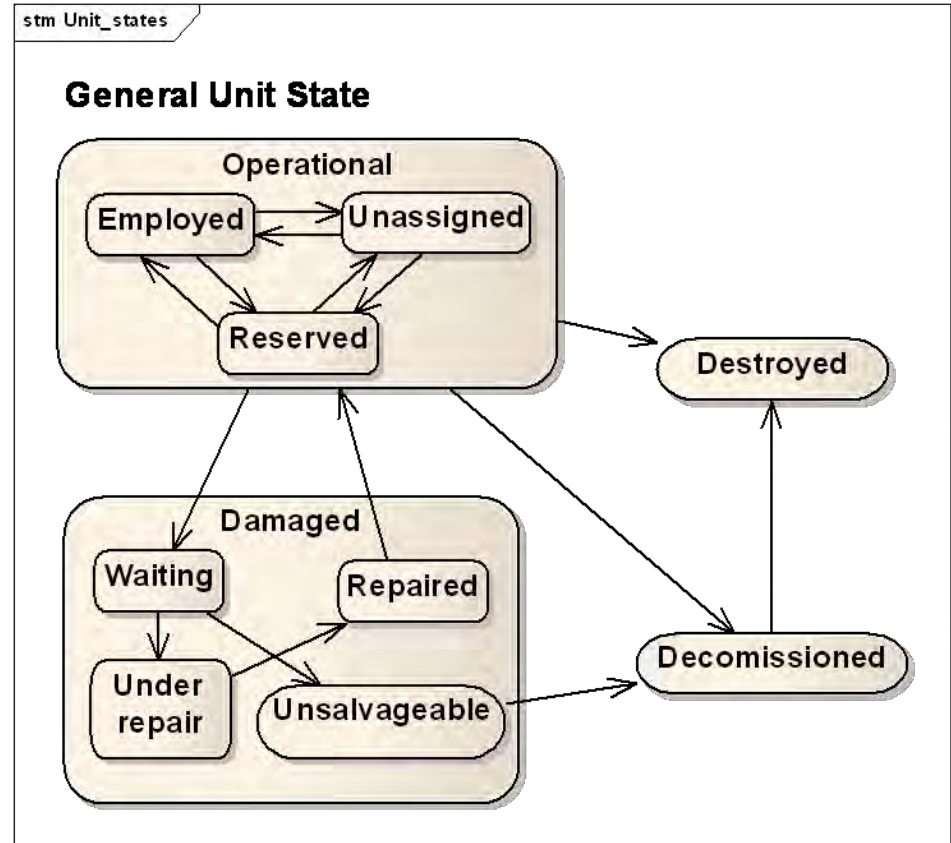
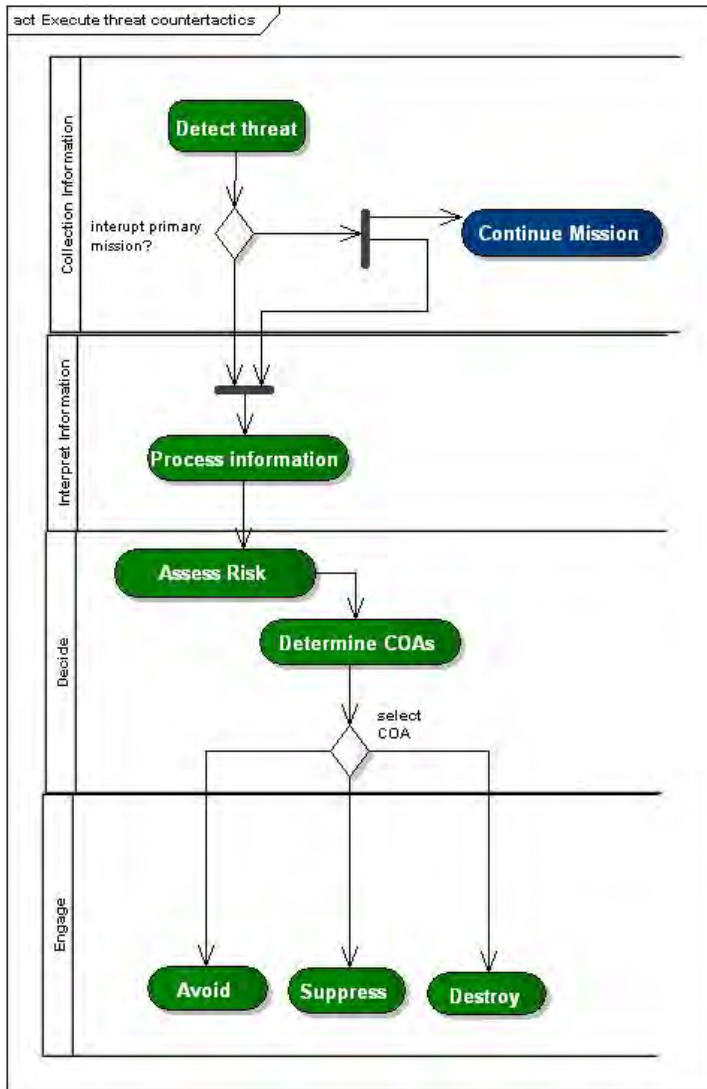

- 📌 State Diagram
- 📌 Activity Diagram

Naval Surface Warfare Center Crane



Human Reliability Analysis and the Advanced Man Portable Air Defense System: A Case Study

Christopher Brown
21 October 2008

A-MANPADS



- The Advance Man Portable Air Defense System (A-MANPADS) allows the Marines of Low Altitude Air Defense (LAAD) battalions to successfully meet their primary mission.
 - Marine Corps LAAD units deploy in one of two primary missions; convoy support or local area defense. In both roles, LAAD units provide primary air defense.
- The A-MANPADS provides a means to safely and expeditiously transport 4 Stinger missiles in WRCs and ancillary equipment.
- The installation of the weapons station allows the Marines the option of mounting a crew served weapon such as the 7.62 machine gun, M240B, or the .50-caliber machine gun, M2 Heavy Barrel (HB). The crew served weapon could be utilized for self-protection against both air and ground threats within the inner launch boundary of the missile.



A-MANPADS with 240B Machine Gun



- In the case of the A-MANPADS, the crew served weapon is flexible therefore the pintle needs to be flexible.
 - The Mk 93 Universal Pintle provides the ability to switch between all crew served weapons in the Marine Corps' arsenal with a minimum of effort.
 - The Mk93 includes an adjustable safety stop for restricting the depression angle. This allows the pintle to not only adjust depending upon the weapon system, but also the vehicle load out.

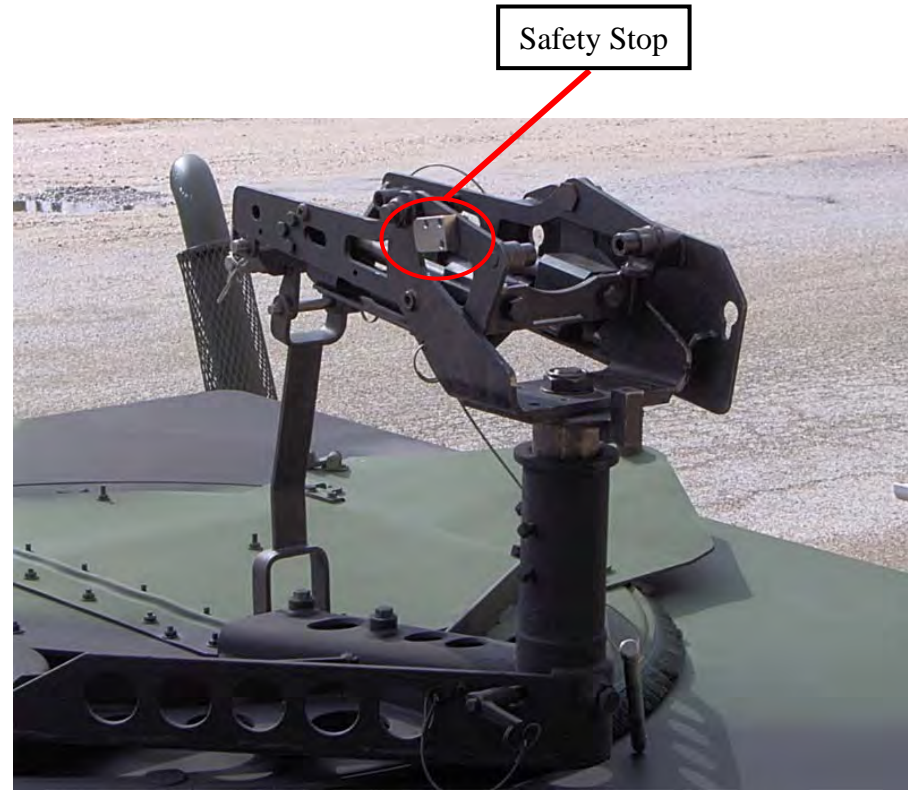

Mk 93 Pintle Installed on an A-MANPADS

Safety Hazard



- The Mk 93 pintle utilized with the HMMWV weapons station and a crew served weapon allows for a maximum declination angle of 27°. In the standard configuration with the M1025/M1043 slant-back HMMWV, this angle does not present an issue. The trajectory of the round would pass through the HMMWV outer shell in an area where no gear is stowed. However, the addition of the WRCs adds height to the rear dimension. If allowed to fire at maximum depression the round would impact the WRC as demonstrated by the figure.

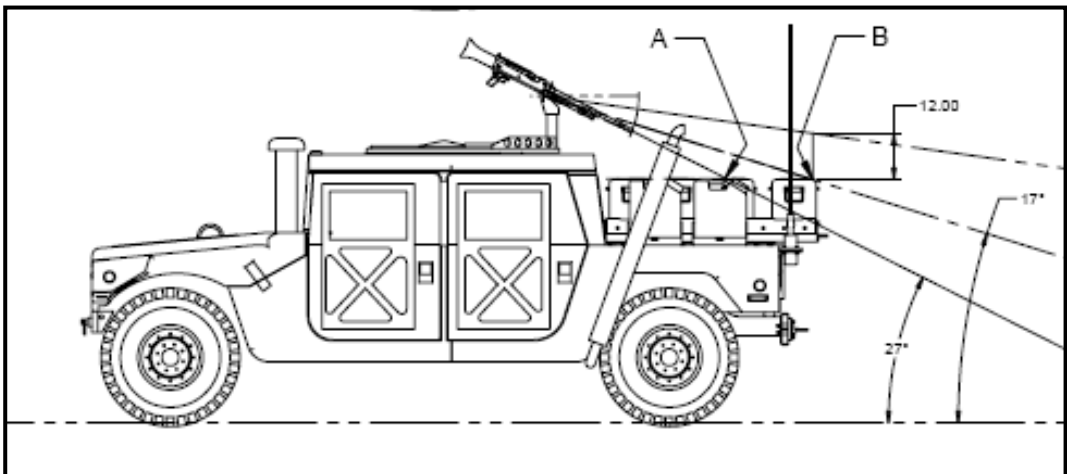

Trajectory of Crew Served Weapon Round



Safety Assessment

(U) UNCLASSIFIED



- The methodology used to classify and rank mishap risks is based upon criteria and guidelines specified in MIL-STD-882
 - A combat loaded A-MANPADS is valued at less than \$300k. With this in mind the dollar values were removed and system damage was evaluated with the MIL-STD-882C criteria.
- A group of independent system safety engineers determined that an impingement incident was both catastrophic and likely to occur several times during the life of the A-MANPADS.
 - The Hazard was assessed a Risk Level of High, IC. Thus requiring the Assistant Secretary of the Navy to accept the risk.
- The Program Manager requested an in-depth review of the Hazard.

| HAZARD RISK INDEX | RISK LEVEL | ACCEPTANCE AUTHORITY |
|--------------------------------|------------|---|
| I A/B/C, II A/B, IIIA | High | Component Acquisition Executive (Assistant Secretary of the Navy for Research, Development and Acquisition) |
| I D, II C, III B | Serious | Program Executive Officer (Commanding General, Marine Corps Systems Command) |
| I E, II D/E, III C/D/E, IV A/B | Medium | Program Manager (Program Manager, Air Defense Weapon Systems) |
| IV C/D/E | Low | Program Manager (Program Manager, Air Defense Weapon Systems) |

Risk Acceptance Levels as stated in MIL-STD-882C



Severity Assessment

- An accurate assessment of the severity of a round striking a Stinger missile can be garnered from a simple evaluation of the end results.
 - The Stinger Missile costs less than \$100k
 - The missile is a mission critical component.
 - If the missile is rendered inoperable, the A-MANPADS becomes non-mission capable, temporarily resulting in a de facto combat loss.

- The Hazard is assessed a Severity of Category I, Catastrophic.

| SEVERITY | CATEGORY | RESULT CRITERIA |
|--------------|----------|--|
| Catastrophic | I | Could result in death, permanent total disability, system loss, or irreversible severe environmental damage that violates law or regulation. |
| Critical | II | Could result in permanent partial disability, injuries or occupational illness that may result in hospitalization of at least three personnel, major system damage, or reversible environmental damage causing a violation of law or regulation. |
| Marginal | III | Could result in injury or occupational illness resulting in one or more lost workdays, minor system damage, or mitigatable environmental damage without violation of law or regulation where restoration activities can be accomplished. |
| Negligible | IV | Could result in injury or illness not resulting in a lost workday, less than minor system damage, or minimal environmental damage not violating law or regulation. |

Mishap Severity Categories as stated in MIL-STD-882C



Probability Assessment

- The original Safety Analysis assessed a Probability level of C, Occasional, based on the following criteria:
 - Properly setting the adjustable depression stop is a training issue.
 - Training issues are a result of human error.
 - Human error has a probability of 1×10^{-3}

| DESCRIPTIVE WORD | LEVEL | INDIVIDUAL ITEM | FLEET OR INVENTORY |
|--|-------|--|---|
| Frequent ($X > 10^{-1}$) | A | Likely to occur frequently | Continuously experienced |
| Probable ($10^{-1} > X > 10^{-2}$) | B | Will occur several times in life of an item | Will occur frequently |
| Occasional ($10^{-2} > X > 10^{-3}$) | C | Likely to occur sometime in life of an item | Will occur several times across fleet |
| Remote ($10^{-3} > X > 10^{-6}$) | D | Unlikely, but possible to occur in the life of an item | Unlikely, but can reasonably be expected to occur |
| Improbable ($10^{-6} > X$) | E | So unlikely, it can be assumed occurrence may not be experienced | Unlikely to occur, but possible |

Mishap Probability Levels as stated in MIL-STD-882C

Probability Quantification

- ***Weapon System Explosives Safety Review Board (WSESRB) has stated***

“programs need to be utilizing one of the various methods (of human error prediction) and not use a blanket number (1×10^{-3})”

Human Error Quantification, WSESRB Executive Session, November 2005





(U) UNCLASSIFIED

Human Error

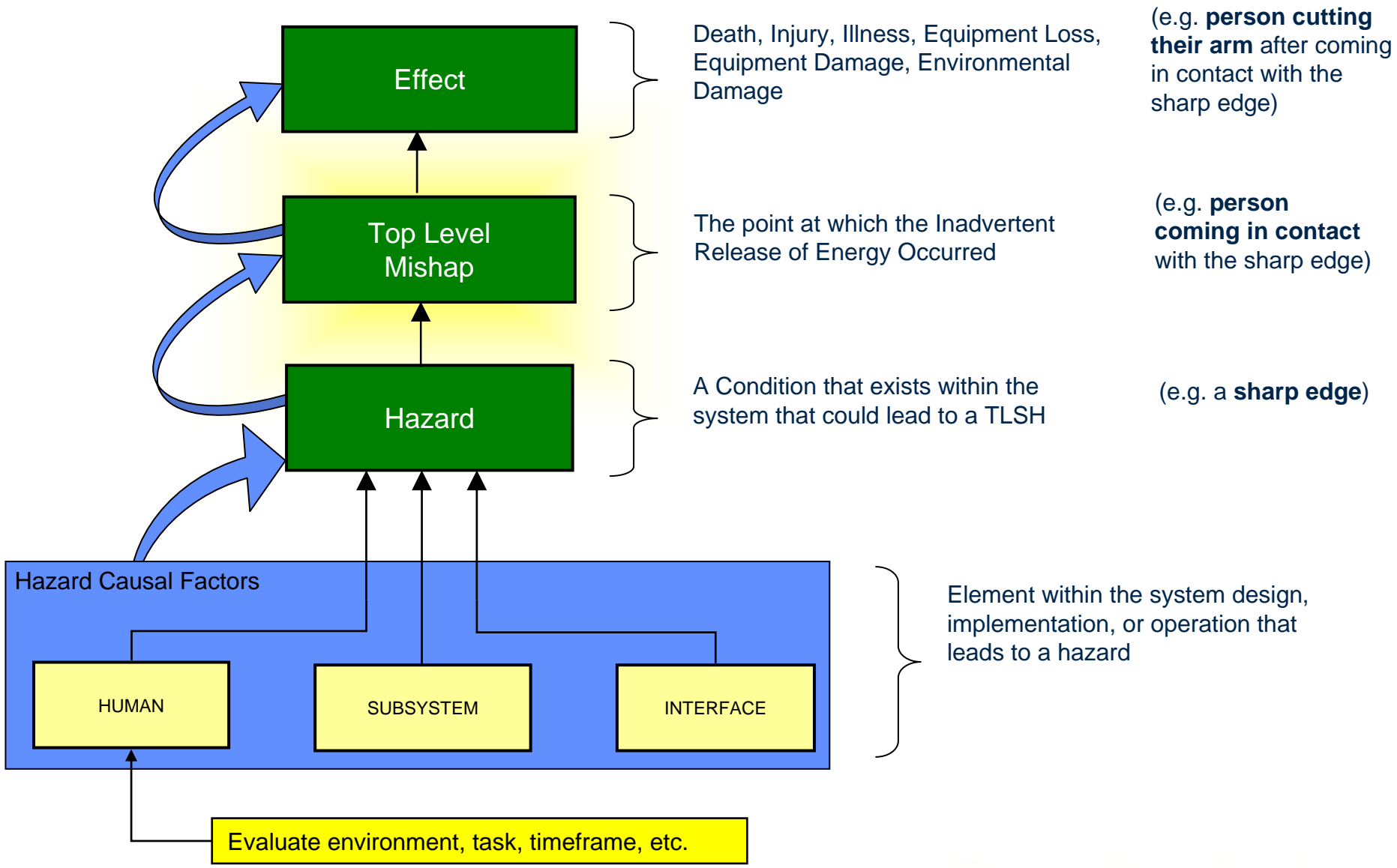



Fault Tree Analysis

- The original assessment had only considered the final action that would lead to the mishap.
- Assessing a probability of failure for a situation starts by determining the series of actions that the operator undertakes for the particular situation. The methodology to determine the actions is known as a fault tree analysis (FTA).
- An FTA begins with the selection of an undesirable outcome, the root. Then, each situation that could cause that outcome is added to the tree. Further branches are added by assessing possible causes for each successive layer of contributing factors.



- The Human Factors Analysis and Classification System (HFACS) was selected for the A-MANPADS due to the inclusion of environmental, psychological, emotional, and physical influences on the operator, in addition to the active faults of the operator.
- HFACS was originally developed by the Federal Aviation Administration (FAA) and has been adopted by the US Navy for investigating the underlying reasons for human error in aviation accidents.
- HFACS was developed based on the “Swiss Cheese” model of human error described by James Reason (Reason, 1990). Most investigations only focus on the operator’s final error(s) that lead to the mishap. However, the “Swiss Cheese” model states that it is the alignment of many factors at many levels of the organization that align perfectly to allow or lead to the final error, much like the holes of many layers of Swiss cheese aligning to allow light through.

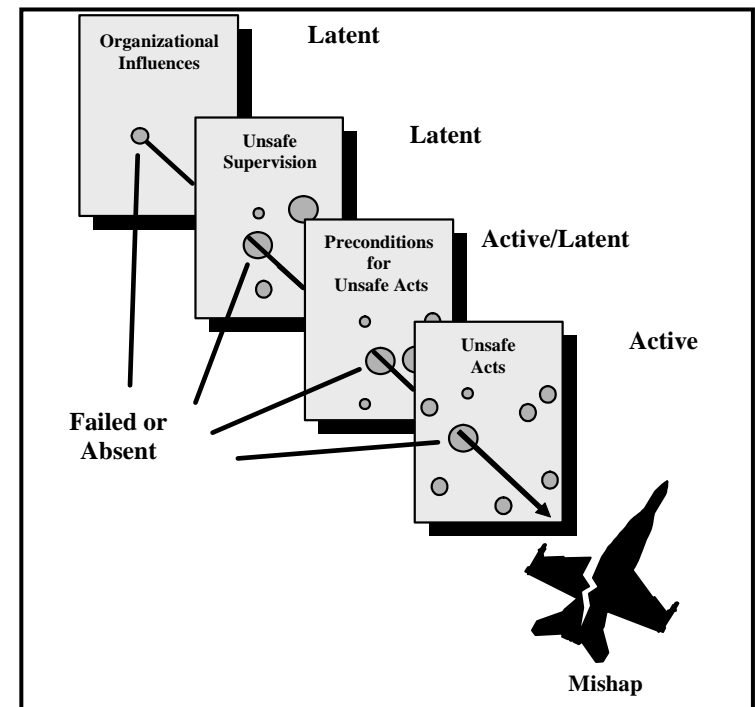

Reason "Swiss Cheese" Model



HFACS Analysis

- Not only were the actions of the Marine firing the weapon evaluated, but also the preexisting environmental conditions and the organizational doctrine required to initiate the chain of events.





- **Human Error Assessment and Reduction Technique (HEART) Method**
 - The HEART Method provides two tables to find the human error rate. A factor from the first table is multiplied by chosen factors from the second table.
 - Based on expert opinion – cannot be validated
 - There is the difficulty in dealing with the many variables which contribute to the probability of error occurrence at any point in time.
- **SPAR-H Method**
 - Provides a simple worksheet with multipliers for stress, complexity, experience, etc.
 - Computationally intensive
- **Operator HEP Estimate**
 - The Reactor Safety Study lists Operator Human Error Probability (HEP) Estimates for each scenario description
 - Has a limited number of scenarios. Expert judgment must be used in selecting a scenario that can be used as a substitute.
- **Human Reliability Table**
 - Lists Operator HEP Estimates for each general scenario description.
 - Generalized scenarios limit fidelity. Expert judgment must be used in selecting a scenario that can be used as a substitute.
- **WSESRB Guidebook Worksheets**
 - Supply complex tables of factors that take into account fatigue, stress, training, complexity, etc. These factors are used in a series of binomial equations which derive a final error rate.
 - Computationally intensive





(U) UNCLASSIFIED

SPAR-H

- **The Standardized Plant Analysis Risk Human Reliability Analysis (SPAR-H) developed by the US Nuclear Regulatory Commission (NRC) takes into account performance shaping factors (PSFs). SPAR-H makes allowance for the following factors:**
 - Available Time
 - Stress and Stressors
 - Experience and Training
 - Complexity
 - Ergonomics
 - Procedures
 - Fitness for Duty
 - Work Processes
- **Not only does SPAR-H account for a greater number of influences, but it also takes into account positive benefits derived from some PSFs.**
- **SPAR-H makes a distinction between diagnosis (i.e., the processing of information) and action (i.e., the response).**
- **It assigns a base value to the HEP for basic processes. A multiplier for each of the eight PSFs is then factored into determining the overall HEP.**
- **SPAR-H allows for the occasion where the diagnosis, and the action are so interrelated that they can not be separated. Likewise, SPAR-H includes a correction factor for cases where the influence of PSFs is so great that an inaccurate HEP is produced.**



SPAR-H Multipliers

- **Available Time:** Available time refers to the time the operator has to make a diagnosis and act upon the diagnosis. When time is short an operator tends to analyze fewer possible alternatives.
- **Stress/Stressors:** Stress is broadly defined as motivating forces that have both positive and negative effects on human performance. Small amounts of stress can lead to increased work performance, however, as the level of stress increases the ability to successfully complete tasks decreases.
 - The previous work that SPAR-H derived from allowed a multiplier of 25 when the operator believed himself to be in a life-threatening situation. When in combat the operator knows that he is in a life-threatening situation. Therefore a multiplier of 25 will be utilized for combat situations.
- **Complexity:** Complexity incorporates both the difficulty and the ambiguity of a task. If the task is mentally or physically difficult to perform the likelihood of failure increases noticeably.
- **Experience/ Training:** Formal schooling, on the job training, years of experience with the system, and previous exposure to similar events are all factors taken into consideration when determining the value of this PSF.

| Category | SPAR-H Value | | Combat Adjustment |
|----------------------|------------------------------------|---------|-------------------|
| | Inadequate | Failure | |
| Available Time | Time Available = Time Required | 10 | N/A |
| | Nominal Time | 1 | |
| | Time Available > 5x Time Required | 0.1 | |
| | Time Available > 50x Time Required | 0.01 | |
| Stress/ Stressors | Extreme | 5 | 25 |
| | High | 2 | |
| | Nominal | 1 | |
| Complexity | Highly Complex | 5 | N/A |
| | Moderately Complex | 2 | |
| | Nominal | 1 | |
| Experience/ Training | Low | 3 | N/A |
| | Nominal | 1 | |
| | High | 0.5 | |



SPAR-H Multipliers

- **Procedures:** This PSF accounts for the existence and usage of formalized procedures.
- **Ergonomics:** Ergonomics considers the ease of interaction between the human and the machine. Such factors include, availability of instrumentation, positioning of instrumentation, ease of understanding the information presented, and the layout of the controls.
- **Fitness for Duty:** This PSF considers the physical and mental capacity of the operator to properly perform the task. Considerations include drug usage, illness, fatigue, distractions, and personal problems.
 - While combatants are generally physically fit, the conditions surrounding combat not only equalize this advantage but often degrade the fitness of the operator beyond that of a fever or some cough syrup. To account for this a multiplier of 10 is utilized for combat situations.
- **Work Process:** Work Process captures the company culture and “way of doing business”. It considers how the work is planned and communicated, how management supports or enforces policies, and how the company as a whole values safety, quality, and the individual worker.

| Category | SPAR-H Value | | Combat Adjustment |
|------------------|---------------------|-----------|-------------------|
| | Value | Weight | |
| Procedures | Not Available | 50 | N/A |
| | Incomplete | 20 | |
| | Available but Poor | 5 | |
| | Nominal | 1 | |
| Ergonomics | Missing/ Misleading | 50 | N/A |
| | Poor | 10 | |
| | Nominal | 1 | |
| | Good | 0.5 | |
| Fitness for Duty | Unfit | Failure | 10 |
| | Degraded Fitness | 5 | |
| | Nominal | 1 | |
| Work Process | Poor | 2 | N/A |
| | Nominal | 1 | |
| | Good | 0.8 – 0.5 | |



SPAR-H Calculations

$$HEP_{No\ min\ al} = HEP_{Base} \bullet PSF_{Time} \bullet PSF_{Stress} \bullet PSF_{Comp} \bullet PSF_{Train} \bullet PSF_{Proc} \bullet PSF_{HMI} \bullet PSF_{Fit} \bullet PSF_{Work}$$

- The multipliers are utilized by multiplying the base HEP for action or diagnosis by the 8 PSF multipliers.
- The Base Multipliers are:
 - 0.01 for diagnosis
 - The user is required to decide what the correct action should be based on external stimuli.
 - 0.001 for action
 - The user implements the action as stated in a procedure or that they have chosen based on their diagnosis.
- If the PSFs are significantly negative, the HEP can become inordinately large. To help adjust the HEP in the event of overwhelming negative influences a simple mathematical formula is provided below:

$$HEP_{Adjusted} = \frac{HEP_{No\ min\ al} \bullet PSF_{Composite}}{HEP_{No\ min\ al} \bullet (PSF_{Composite} - 1)} + 1$$



- **Conservative assumptions made.**
 - All armored A-MANPADS and only armored A-MANPADS
 - Used a quarter of their life cycle in combat
 - Loaded with live missiles half of the time.
 - Under attack every time they went to combat

$$P_{\text{Combat}} = \frac{AMANPADS_{\text{Armored}}}{AMANPADS_{\text{Total}}} \cdot P_{\text{Life}} \cdot P_{\text{Missiles}} \cdot P_{\text{Attack}}$$

$$0.0266 = \frac{40}{188} \cdot 0.25 \cdot 0.5 \cdot 1$$

2.66% chance of an A-MANPADS transporting missiles while being attacked

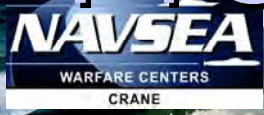

Probability of Shooting into the Danger Zone

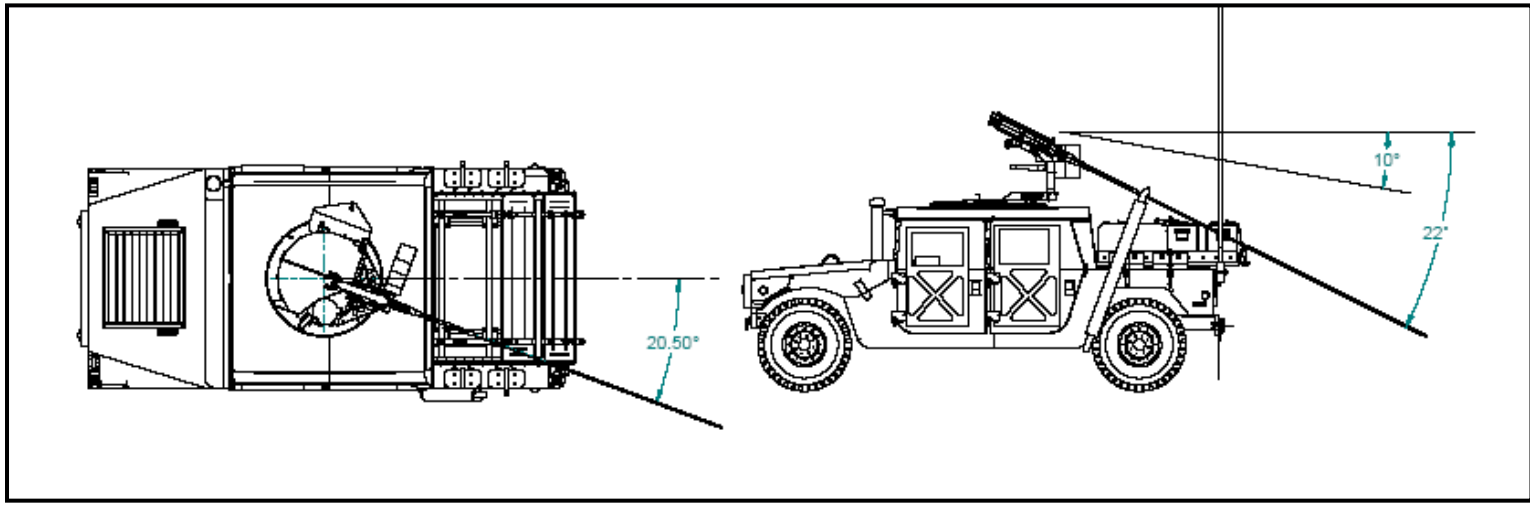

- Just because the Marine returns fire does not guarantee the rounds are traveling towards the missiles.
- In lieu of data representing the number of attacks to the rear of vehicles, the percentage of the area on the vehicle considered to be the danger zone will be calculated.
 - The assumption is made that the operator never fires the machine gun elevated.

$$P_{DZ} = \frac{DZ_{AZ}}{360^\circ} \bullet \frac{DZ_{EL}}{22^\circ}$$

$$0.0621 = \frac{41^\circ}{360^\circ} \bullet \frac{12^\circ}{22^\circ}$$

6.21% chance of being attacked from the rear

Probability of Armorer Failing to Set Depression Stop



(U) UNCLASSIFIED

- When the armorer receives a new pintle, a new mission role with a load out that requires a depression angle change, or a misaligned pintle is returned, the armorer sets the depression angle.
- A **0.005%** chance that the armorer will fail to complete the adjustment is reasonable.
 - It is a required step of a procedure, ample time is supplied to complete the process, a follow on procedure performed by an independent person checks for the completion of this task, and the steps are well documented and simple.

| Category | Level | Value | Reason |
|----------------------|---------|---------|--|
| Base HEP | Action | 0.001 | Action only |
| Available Time | 5x Req | 0.1 | Armorer completes the task offline with more than ample time. |
| Stress/ Stressors | Nominal | 1 | With ample time to complete and no dependency on outcome, armorer is not stressed. |
| Complexity | Nominal | 1 | Steps are straight forward and easy to follow |
| Experience/ Training | Nominal | 1 | The job is simple but the armorer only does it. |
| Procedures | Nominal | 1 | The procedure is well documented and clearly written. |
| Ergonomics | Nominal | 1 | Ergonomics neither impede nor help |
| Fitness for Duty | Nominal | 1 | The armorer is more than fit enough. |
| Work Process | Good | 0.5 | The expectations are well defined and communicated clearly. |
| Nominal HEP | | 0.00005 | |

(U) UNCLASSIFIED



Probability of Marine Failing to Check Depression Stop

- As the Marine is installing the pintle and the machine gun, the procedures instruct the Marine to check the depression angle using available components and tools.
 - The Marine is instructed to alert the armorer if the pintle is misaligned.
 - Before leaving on the mission, the senior Marine in the vehicle ensures that preoperational checks were preformed.
- A **0.05%** chance that the operator will fail at the check is reasonable.
 - It is a required step of a procedure completed often, a person in a supervisory role checks for completion, and the steps are well documented and simple.

| Category | Level | Value | Reason |
|----------------------|---------|--------|---|
| Base HEP | Action | 0.001 | Action only |
| Available Time | Nominal | 1 | Part of the installation of the weapon and sufficient time is provided |
| Stress/ Stressors | High | 2 | Operator is preparing for combat, anticipation and fear begin to increase stress |
| Complexity | Nominal | 1 | Steps are straight forward and easy to follow |
| Experience/ Training | High | 0.5 | The same procedure is followed every time the weapon is installed |
| Procedures | Nominal | 1 | The procedure is well documented and clearly written. |
| Ergonomics | Nominal | 1 | Ergonomics neither impede nor help |
| Fitness for Duty | Nominal | 1 | The operator may be uncomfortable but their fitness is not degraded. |
| Work Process | Good | 0.5 | The expectations are well defined. Additionally the supervisor ensures that the process is completed. |
| Nominal HEP | | 0.0005 | |

Probability of Marine Shooting WRC

- When the Marine identifies a threat and begins firing, there is a probability that he will continue to fire even if the rounds are going to impact the WRC.
- An adjusted value of **47.39%** is a reasonable percentage to expect.
 - When in combat and under attack, operators are likely to experience tunnel vision and fixate on the threat until it is eliminated.
 - The adjustment equation was utilized to correct for the overwhelming multipliers.

| Category | Level | Value | Reason |
|----------------------|-------------|------------|--|
| Base HEP | Action | 0.001 | Action only |
| Available Time | Avail = Req | 10 | In combat Oper. Always has just enough time |
| Stress/ Stressors | Combat | 25 | Life threatening situation |
| Complexity | Nominal | 1 | Firing the weapon is relatively easy |
| Experience/ Training | Above Avg | 0.6 | Even the newest member of the squad trains on the system rigorously. However, rear attacks and shooting around the WRC are not well rehearsed. |
| Procedures | Nominal | 1 | Procedures are well established and followed explicitly. |
| Ergonomics | Nominal | 1 | Ergonomics neither impede or help |
| Fitness for Duty | Combat | 10 | Even the most physically fit personnel suffers from degradation of fitness in combat |
| Work Process | Above Avg | 0.6 | While fog of war impedes the process; expectations are clear, concise, well communicated, and strictly enforced. |
| Nominal HEP | | 0.9 | |
| Adjusted HEP | | 0.47393365 | Due to the large number of negative multipliers the adjustment was used. |



Probability of Most Likely Scenarios

- **WRC Shot When No Depression Stop is Present:**
 - The A-MANPADS is in combat
 - The weapon enters the “danger zone”
 - The Marine fires the weapon while in or around the “danger zone”.

$$P_{NoStop} = P_{Combat} \bullet P_{DZ} \bullet HEP_{Shoot}$$

$$7.8301 \times 10^{-4} = 2.6596 \times 10^{-2} \bullet 6.2121 \times 10^{-2} \bullet 4.7393 \times 10^{-1}$$

With no stop present and conservative representations of the likelihood of the A-MANPADS being in combat with a live missile and attacked from behind, the probability of shooting the WRC is 7.8301×10^{-4} or 7.83 chances in one thousand.





Probability of Most Likely Scenarios

- **The Depression Stop is Misaligned by the Marine:**
 - The A-MANPADS is in combat
 - The weapon enters the “danger zone”
 - The Marine fires the weapon while in or around the “danger zone”.
 - The operator misaligns the pintle

$$P_{Check} = P_{NoStop} \bullet HEP_{Check}$$

$$3.9151 \times 10^{-7} = 7.8301 \times 10^{-4} \bullet 5 \times 10^{-4}$$

With the addition of a depression stop the probability of shooting the WRC is 3.9151×10^{-7} or approximately one in 250,000.



Probability of Most Likely Scenarios

- **The Depression Stop is Misaligned by the Armorer:**
 - The A-MANPADS is in combat
 - The weapon enters the “danger zone”
 - The Marine fires the weapon while in or around the “danger zone”.
 - The armorer misaligns the pintle or fails to align the pintle at all
 - The operator does not find the misalignment.

$$P_{Misalign} = P_{Check} \bullet HEP_{Misalign}$$

$$1.9575 \times 10^{-11} = 3.9151 \times 10^{-7} \bullet 5 \times 10^{-5}$$

By making the armorer responsible for the adjustment of the safety stop, the probability of shooting the WRC becomes **1.9575x10⁻¹¹** or approximately one in 50 Billion.



Final Assessment

| Scenario | Severity | Probability | Acceptability | Authority |
|----------------------------|----------|-------------|---------------|---------------------------|
| No Depression Stop | I | D | ID | Program Executive Officer |
| Adjustable Depression Stop | I | E | IE | Program Manager |
| Armorer Adjusts Pintle | I | E | IE | Program Manager |

- **The risk associated with the A-MANPADS operating with the adjustable stop provided with the Mk 93 pintle is of a level acceptable by the Program Manager.**
 - **Based upon**
 - **The condition that all controls and procedures are complied with**
 - **The A-MANPADS will be operated within stated parameters**



(U) UNCLASSIFIED



Conclusion

- After the study was conducted, the Program Manager was able to accept the risk associated with the hazard, the Program received a full rate production decision, and all systems were fielded on schedule.
- The use of a fault treat analysis such as HFACS for Safety Assessment Probability Levels is crucial to capturing a true picture of all the factors leading to a hazard.
- While the use of SPAR-H requires computational effort, I have demonstrated that the math is uncomplicated and relatively concise.
- SPAR-H includes the flexibility to be utilized for any Program. It does not depend upon predetermined scenarios, but rather considers 8 performance shaping factors that are crucial to success in any action or diagnosis.
- With the comparative ease of applying SPAR-H, there is no need for a program to arbitrarily apply a blanket number (1×10^{-3}) to their Safety Assessment Probability Levels.

(U) UNCLASSIFIED

Questions?



Modeling and Simulation Resource Reuse Business Model

Dennis P. Shea

Outline

- **Problem statement**
 - Inefficient use of M&S resources
 - Barriers to reuse
 - Multiple perspectives on reuse
- **Study approach**
- **Review federal laws, DoD regulations and policies on intra-government business transactions**
- **M&S may contain intellectual property**
- **Proprietary M&S and reuse**
- **Lessons learned from successful M&S reuse**
- **Framework for a business model**
- **Business model actions to spur reuse**

The Problem:

Inefficient Use of M&S Resources

Few M&S resources are *reused* – either during a single program’s lifecycle or across acquisition programs.

| <u>Tools</u> | <u>Data</u> | <u>Environment</u> | |
|-------------------------------|----------------------|--------------------|---------------------|
| - Models | - Input datasets | - Architectures | - Network resources |
| - Simulations | - Scenarios | - Interfaces | - SME expertise |
| - Federations | - CONOPs | - Protocols | |
| - Utilities (post-processors) | - Threat data | - VV&A templates | |
| | - Algorithms | | |
| | - Environmental info | | |

Absence of incentives for Gov’t M&S managers and industry developers

Reuse doesn't mean necking down to a single model or database

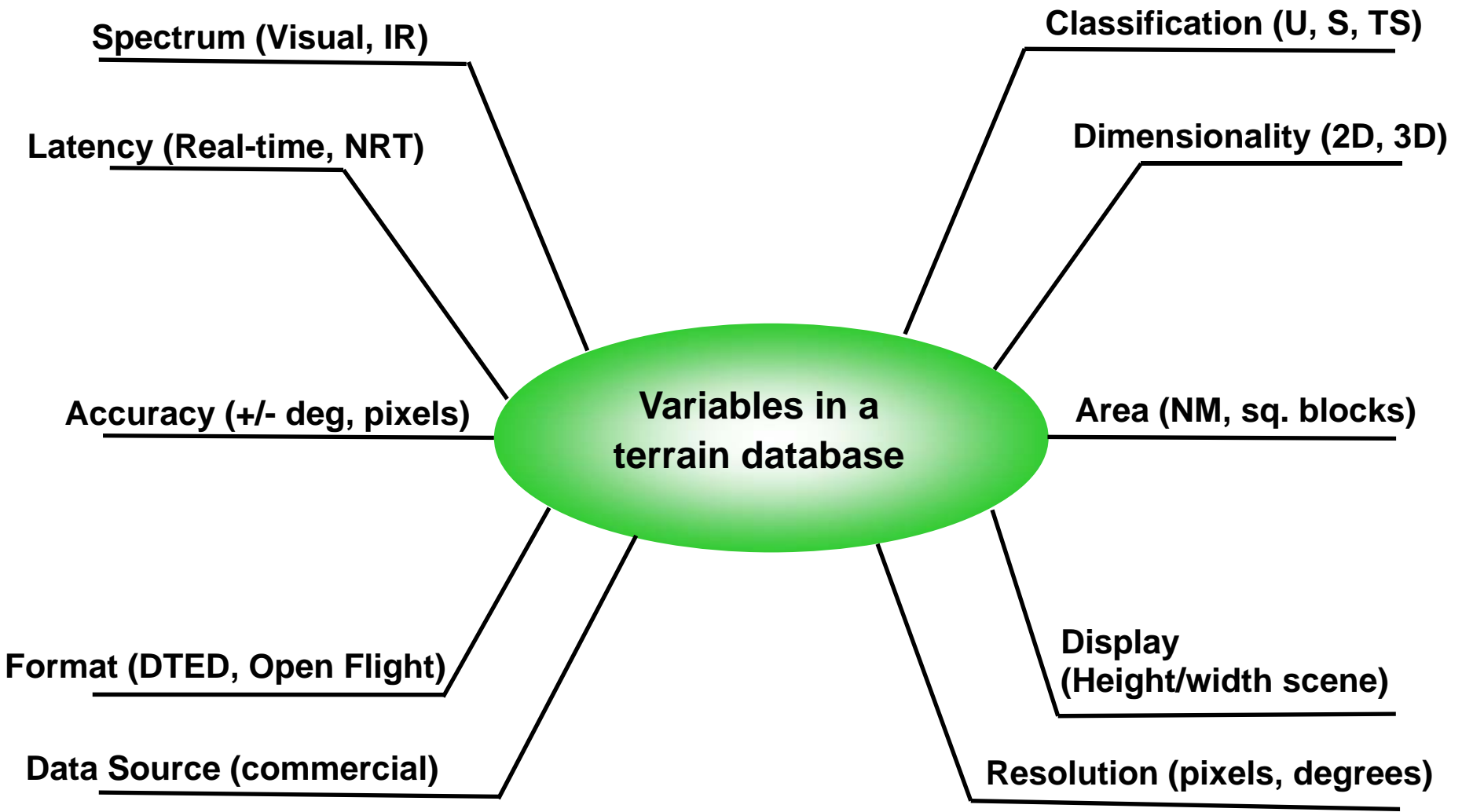

Barriers to M&S Resource Reuse

- **Users lack awareness of reusable resources**
- **Insufficient details about reusable resources**
- **Hard to assess the true capabilities and limitations of existing resources**
- **Resources not in a form suitable for reuse**
- **Users lack trust in resources developed by others/ NIH**
- **Model is available but not the data**
- **M&S components don't work well together**
- **Repositories are incomplete and not current**
- **Little insight into how resources have been used in the past, including successfully and failures**
- **Difficult to access the actual resource**
- **Difficult to adapt existing resources to new problems**
- **No mechanism to compensate developer for resource investment and guidance on use**
- **No mechanism to protect developer from mischievous uses**

Multiple perspectives on M&S reuse

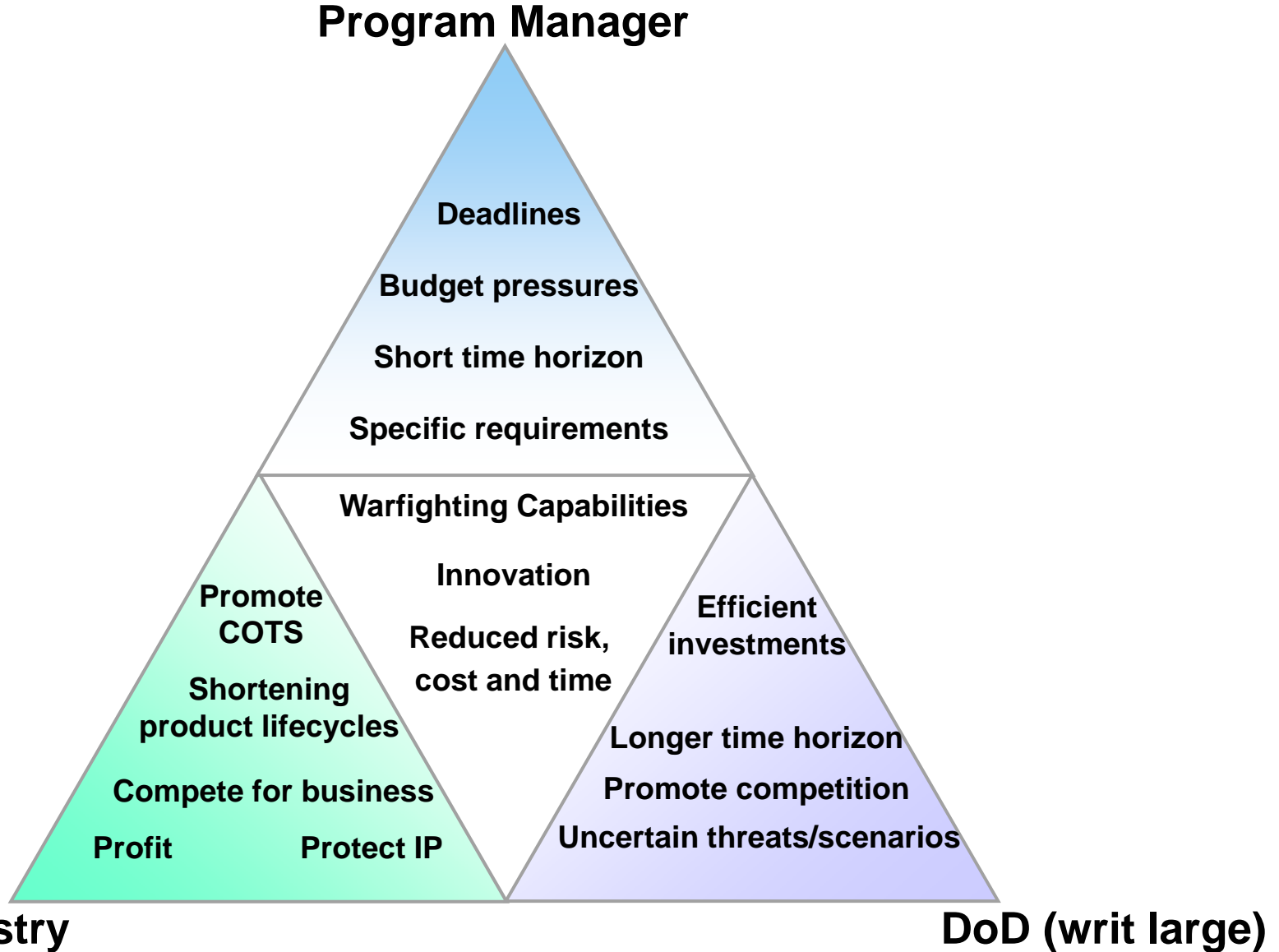

Objective

- **Develop an economic business model that will make the reuse of M&S resources an attractive option for both consumers and providers of resources**
 - **Puts the best M&S resources in the hands of users**
 - **Fosters collaboration and sharing**
 - **Leads to cost efficiency and minimal duplication of effort**
 - **Protects IP rights of industry**
 - **Ensures profitability of M&S industry**

M&S Reuse Puzzle

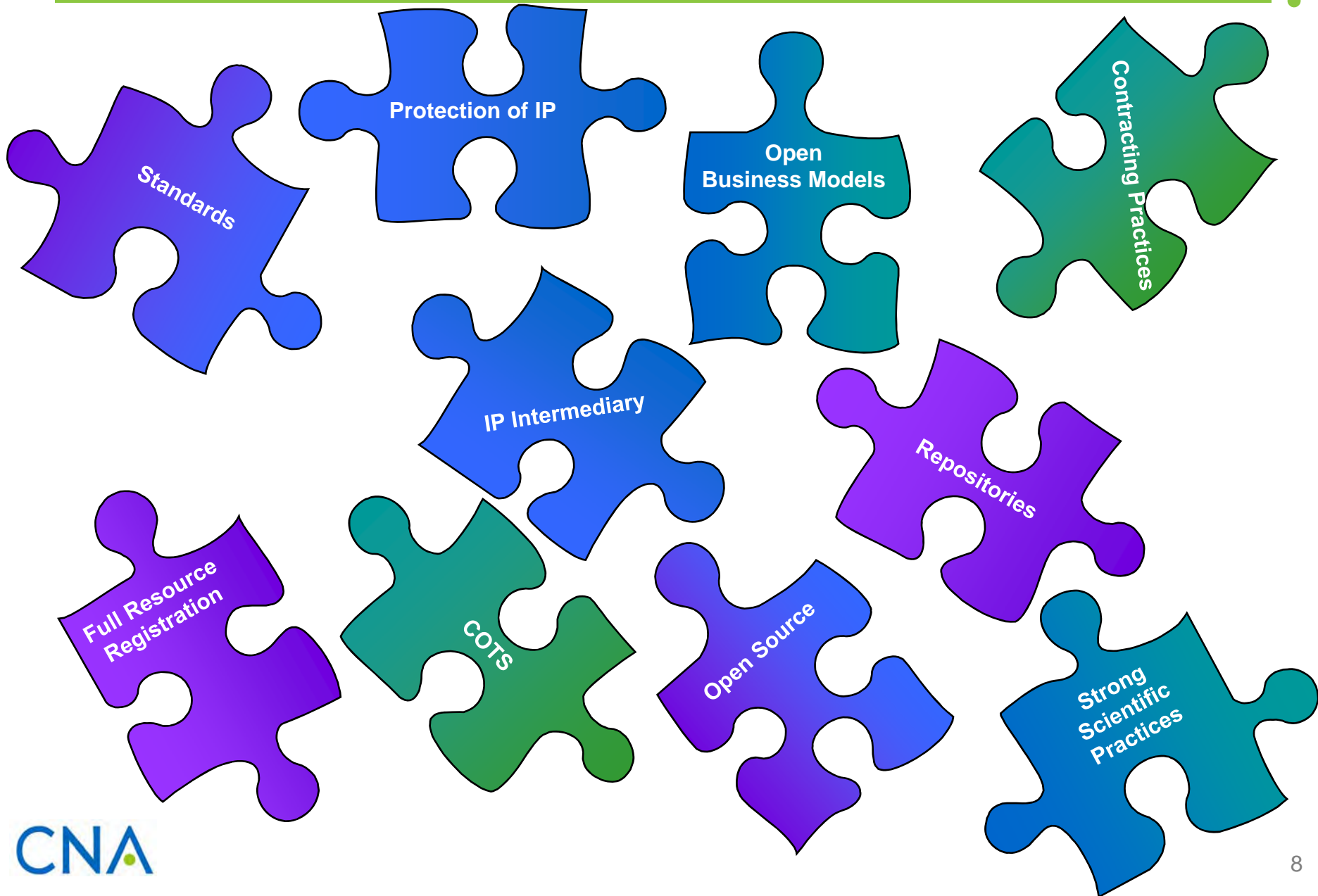

Approach

- Reviewed existing policy documents, DoD instructions, guidance, interagency agreements, FAR, DFARS, prior reports, ...
- Prepared case studies
 - SIMDIS, Linux, EADSIM, ICT, NIH/OTT, ...
- Used a variety of survey instruments, interviews, e-mail dialogue with industry and government
 - Where is reuse occurring today?
 - What “business factors” help to motivate reuse?
 - What are the challenges to reuse and how might these be overcome?

Who we have spoken to:

Northrop Grumman
Aegis Technology
MAK Technologies
PM FCS AD M&S
NGA
NAVAIR Portable Source Initiative
OSD-JDS
BreakAway, LTD
MSIC, DIA TMAP
USJFCOM J9
USAF Common Data Set
M&S EA (Ocean, Air&Space, Terrain)
IWS General Council (SEA00)
Pitch Technologies
MMA M&S

Boeing
Soar Technology
Lockheed Martin
MOVES/NPS
Metron
NAVMSMO
JSF M&S
IWS M&S
USN IWS SHARE
SAF/XC
OPNAV N814
NRL
JASP
MSIAC

Key issue for a business model

Under what conditions can a DoD program manager or other government official invest in M&S today

- to satisfy both current and future requirements,
- including perhaps requirements of another yet unknown government user,
- Including additional investment to make the M&S resource reusable,
- and be compensated in a future intra-government business exchange?

Federal laws and DoD regulations affecting intra-government business transactions

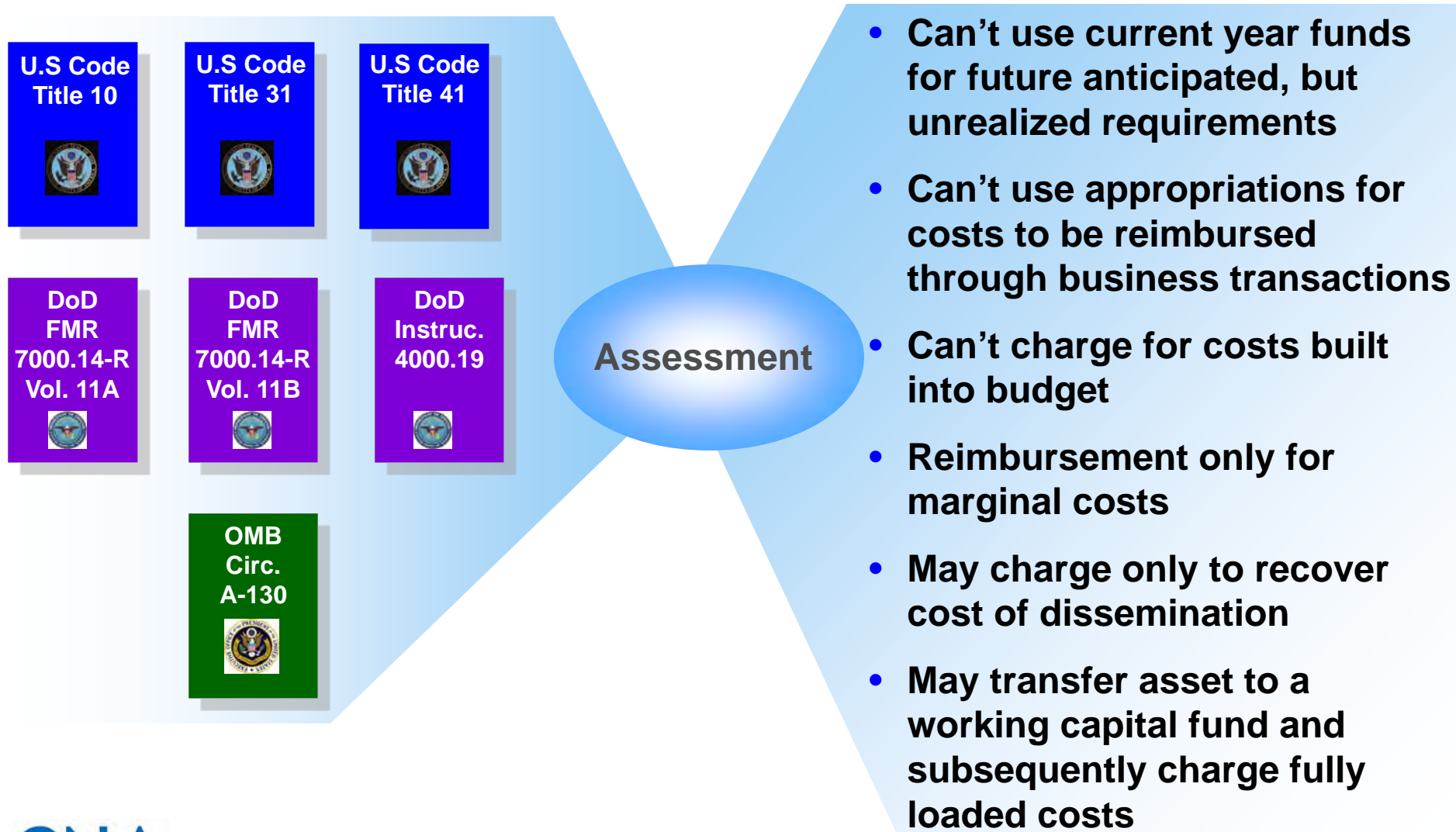

Interagency Acquisition of M&S

Servicing agency

- (1) Existing GOTS or COTS with Gov't Purpose Rights**
- (2) Same as (1) + Gov personnel or contract support**
- (3) Same as (1) + model enhancements**
- (4) COTS M&S with license requirements**
- (5) New M&S with joint requirements**

Requesting agency

- (1) No compensation allowed**
 - Congress has appropriated funds to servicing agency
 - No increase in support supplier's costs
- (2) Fund incremental cost of labor**
- (3) Fund model enhancements**
- (4) Fund incremental license fees**
- (5) Jointly fund new M&S**

M&S resources often contain valuable intellectual property

- Intellectual property refers to *creations of the mind*: inventions, literary and artistic works, and symbols, names, and images used in commerce.
 - In M&S the IP is often encapsulated in the source code and data sets
- DOD's access to M&S IP developed under contract is governed by both copyright law, patent law, and the procurement regulations contained in the DFARS
 - These laws affect the Government's ability to use, reproduce, modify, and release the resource to one or more potential users
- Control of IP is determined, in part, by who funded development
 - Government, Industry, or Mixed
 - But formal title is generally retained by the contractor-developer regardless of funding source
 - DoD acquisitions that involve a mix of government and IRAD funded technologies pose a challenge in determining control "rights"

Proprietary M&S and reuse

- **COTS provides DoD with access to leading-edge M&S that otherwise would not be available**
- **COTS supports a broader market than DoD and thus capabilities should continue to improve over time**
 - **But a challenge to maintain legacy systems**
- **COTS enables “agile” M&S investment decisions by eliminating long-term O&M**
- **Developer may earn a short-term monopoly**
 - **Until the next wave of innovation**
- **Decouple the M&S from the original developer?**
 - **Yes-- a source license and/or tech data rights will promote 3rd party competition and encourage DoD to develop in-house talent to extend the M&S**
- **DoD may also require source license simply to “look under the hood”**
- **Enterprise license may reduce overall DoD costs of COTS**
- **Decision on negotiating for source or enterprise license depends on reuse potential (and willingness of developer)**

Lessons learned from successful M&S reuse

Keep within a small, well-informed community

- V&V guides use
- MOU if needed

Keep within a small, well-informed community

Rely on standards

- V&V
- database formats (OpenFlight, Shape, GeoTIFF)

GPR license and proper Sys Eng to reduce costs

Government Purpose Rights

MIPR to cover Additional costs:

- Personnel
- Model enhancements
- incremental license fee

Assume knowledgeable user

- User funds integration

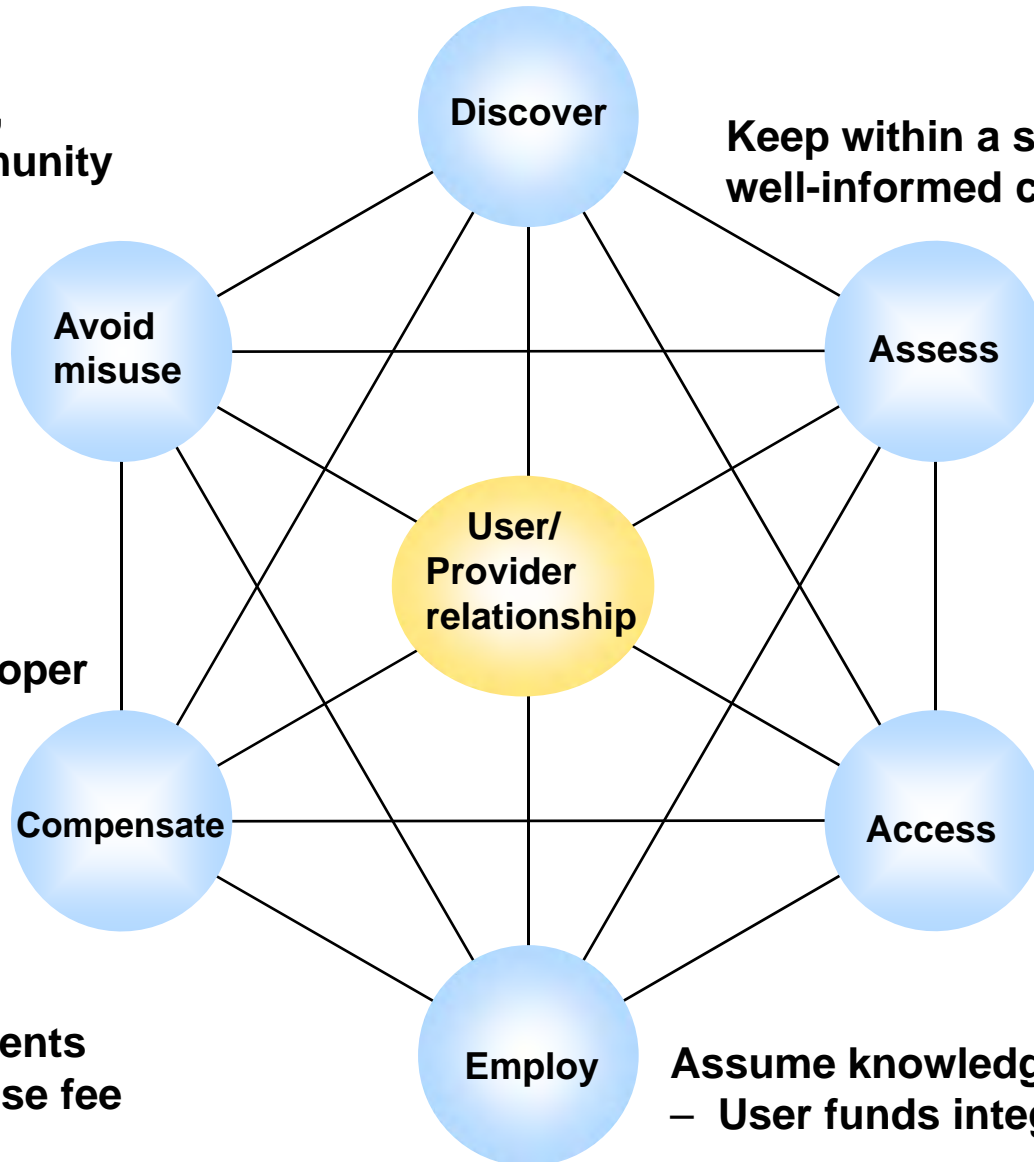

M&S Resource Reuse Business Model

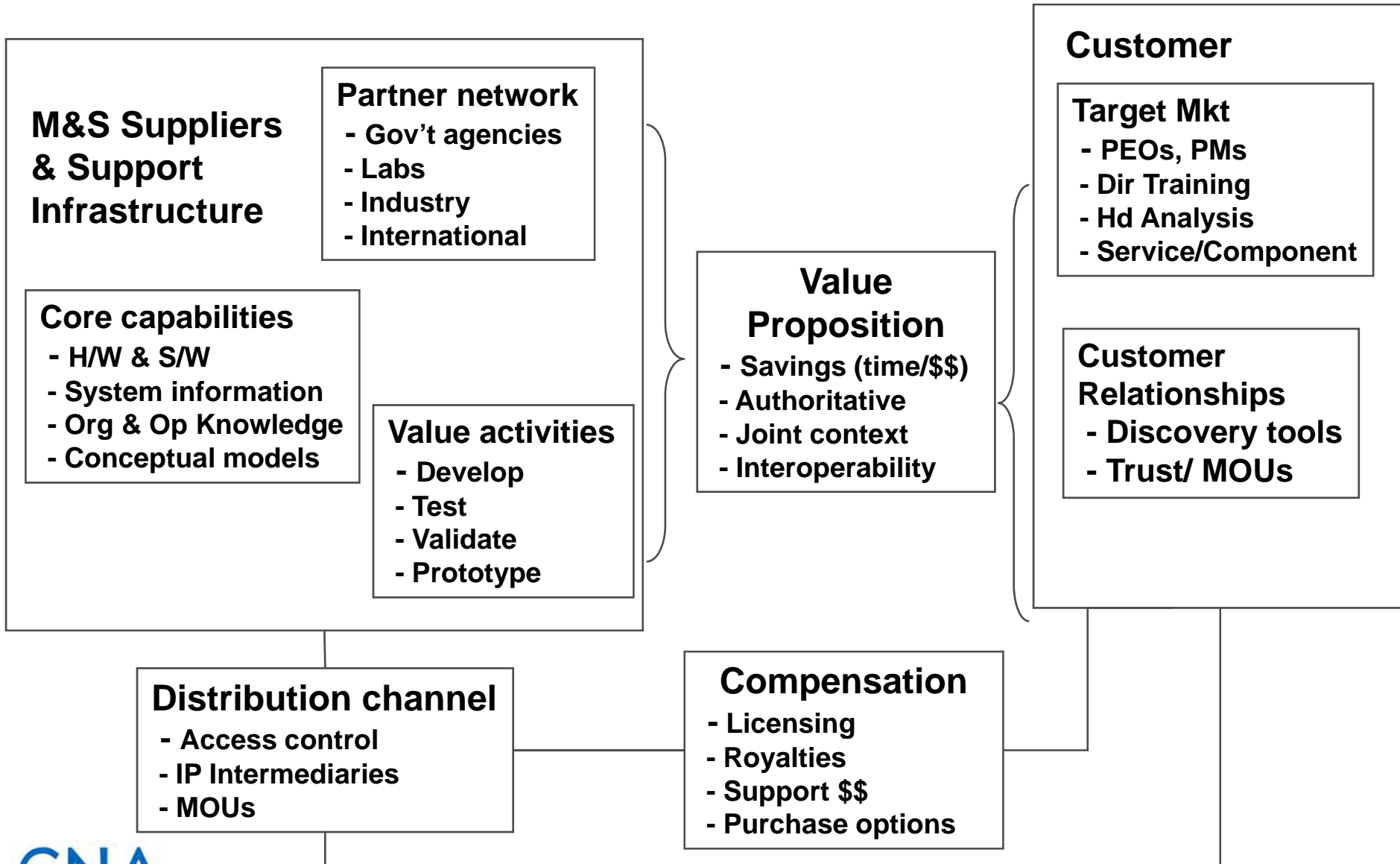

Business model actions to spur M&S reuse

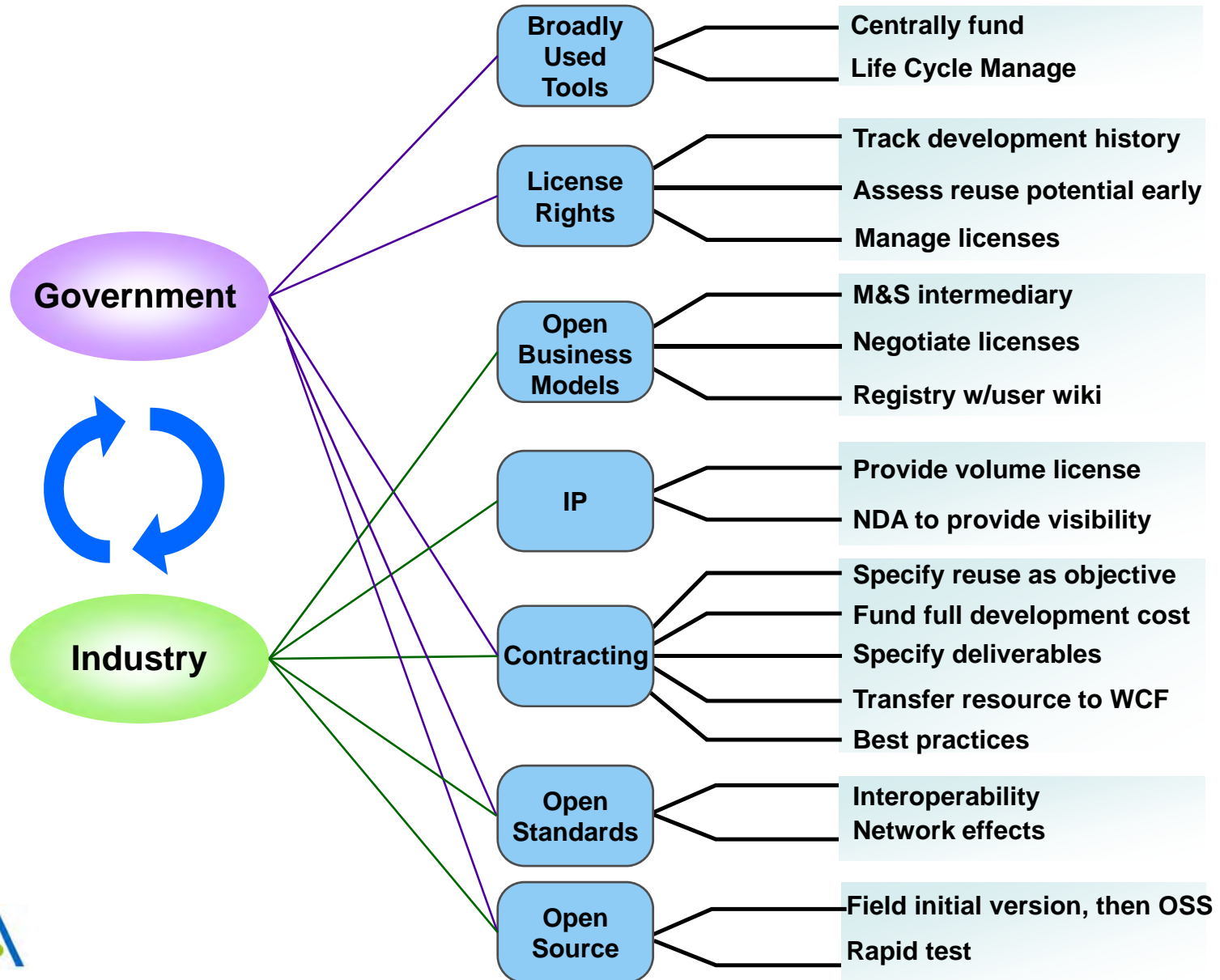

Backup

Business model actions that will spur M&S reuse (1 of 7)

- **Improved contracting practices**
 - Specify software, tech data, documentation as a deliverable
 - Price contract to include full cost of making M&S reusable (licenses, documentation, V&V, interfaces, ...)
 - Include expectations for software reuse in solicitations (and incentives for achieving reuse)
 - Implement stronger oversight of M&S development process
 - When was it developed and who paid for it?
 - Is contractor entitled to restricted or limited rights?
 - Standard contract language requiring GPR on all datasets
 - Require registration of all M&S resources (with metadata)

Business model actions that will spur M&S reuse (2 of 7)

- **Implement improved training for contract officers and program managers**

Contract Officers

- **Goals and strategies for M&S reuse**
- **Form and function of alternative deliverables:**
 - **Computer programs, source code, object code, algorithms, flow charts, computer databases, documentation, etc.**

Program managers / DoD decision makers

- **Goals and strategies for M&S reuse**
- **Software licenses and tech data rights:**
 - **Unlimited, limited, restricted, government purpose, commercial license, nonstandard rights**
- **Negotiating strategies**
- **Develop a “Best Practices Guide” for contracting M&S resources**

Business model actions that will spur M&S reuse (3 of 7)

- **For broadly used GOTS M&S, use central funding to make the resource reusable and to manage Life Cycle Costs**
 - **No single organization can be responsible**
- **Similar approach for common databases**
 - **Environment, threat models, scenarios, current and future forces (Blue, Red, White)**
- **Negotiate volume or enterprise license for proprietary M&S**

Emerging tenets for an M&S business model (4 of 7)

M&S intermediary to create a secondary market

- Patterned after IP intermediary (Innovation Xchange, InnoCentive)
- Functions as an honest broker
 - Helps PMs locate suitable M&S resources
 - Helps developers find a market for established M&S resources
 - Independent of developers and users – Free to sign NDAs
- Documents legal status of each M&S resource within DoD
- Facilitates license agreements
- Manages tiers of licenses across DoD
- Builds and maintains the knowledge base
 - How resources have been used in the past
 - V&V histories
- Handles MOUs to guide appropriate use and avoid liability

Virtual collaboration through electronic registries alone will be insufficient to achieve desired levels of reuse

Business model actions that will spur M&S reuse (5 of 7)

- **Establish enablers for open business model transactions for both government and industry**
 - Register reusable M&S assets (Gov't and industry)
 - Include license rights
 - Include info on previous applications
 - Allow user-wiki comments on experiences with the M&S

Business model actions that will spur M&S reuse (6 of 7)

- **Explore the transfer of reusable M&S resources to a working capital fund (e.g., major test range)**
 - **Compensate M&S provider with test range services**
- **Develop methods to assess downstream and cross-program reuse potential**
- **Adopt strong scientific practices to ensure credibility of M&S products**

Business model actions that will spur M&S reuse (7 of 7)

- **Promote the use of open source software**
- **Grant industry access to approved government models and databases**
- **Add reuse as performance objective for Gov't stewards of M&S funds**
 - **Examine registry/repository first**
 - **Fund to make new M&S reusable for others**
- **Pursue balanced acquisition strategy**
 - **M&S COTS with tier-based licenses, GOTS, GPR, and proprietary non-commercial where needed**
- **Publicize DoD M&S reuse objectives and strategy)**
 - **Use keynote address at conferences/ articles in trade journals and professional societies**

Integrating Architecting and Systems Engineering

**NDIA SE Conference
22 October 2008**



Intro/Topics





Background: What is the Problem? Why is An Architecture Framework Needed?

Organizations are developing major systems that need to interface and interact

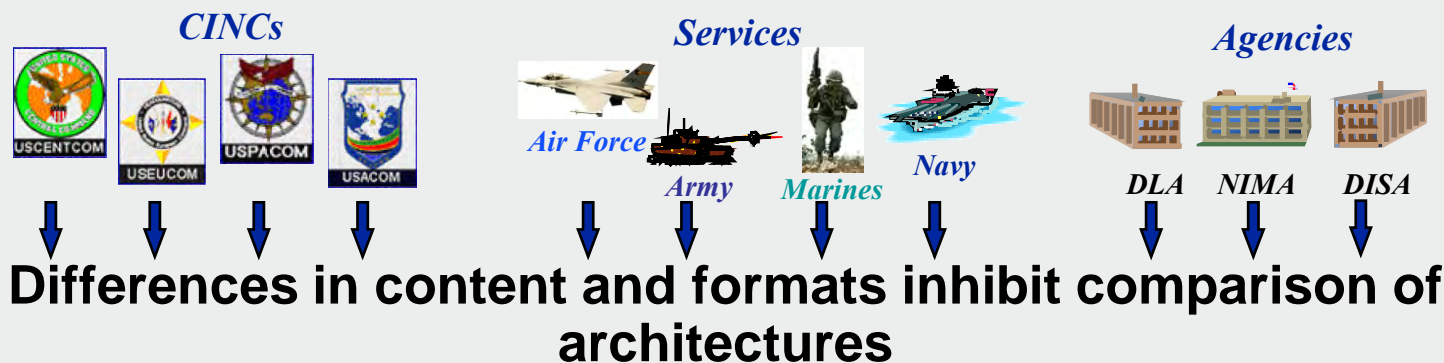

Disparate and unrelatable architecture products lead to non-integrated, non-interoperable, and non-cost effective capabilities in the field

Reprinted from "C4ISR INCOSE Tutorial", A.H. Levis and L.W.Wagenhals, March 2001



Evolution DoDAF

1996 1997 1998 1999 2000 2001 2002 2003 2004 2005 2006 2007 2008 2009?

Clinger-Cohen

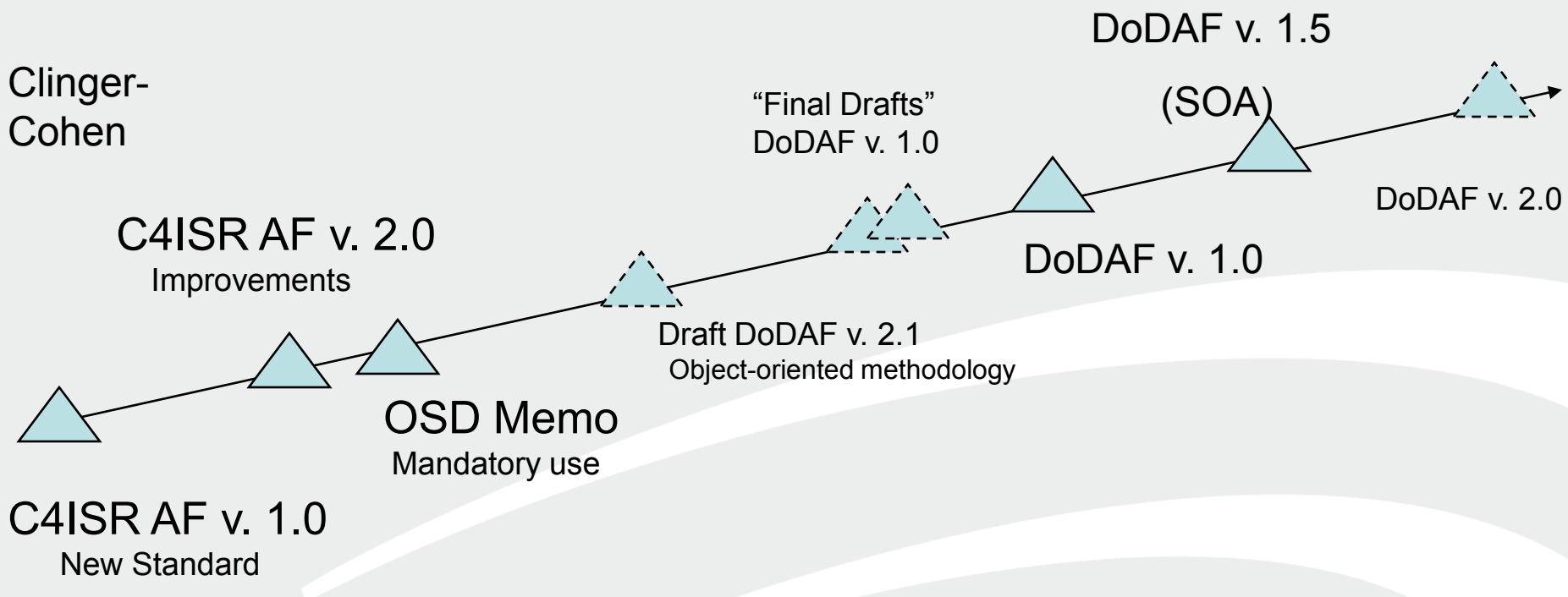



Motivations for DoDAF

- Architectures required by law (Clinger-Cohen, etc.)
- Structured, repeatable *method* for investments and investment alternatives
- Influence and guide organizational change
- Create New Systems (*i.e.*, define System Requirements)
- Deploy (plan for) new technologies
 - Ex., Net-Centric Warfare



Typical DoDAF Taxonomy

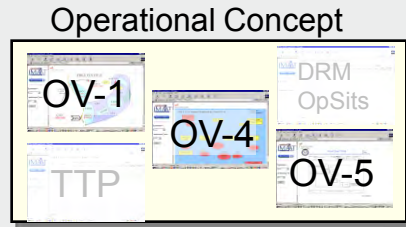

DRM: Design Reference Mission
 OpSit: Operational Situation
 TTP: Tactics, Techniques, Procedures
 FoS: Family of Systems
 SoS: System of Systems

- OV-1 High-level Operational Concept Graphic
- OV-2 Operational Node Connectivity Description
- OV-3 Operational Information Exchange Matrix
- OV-4 Command Relationships Chart
- OV-5 Activity Model
- OV-6C Operational Event/Trace Description
- SV-1 System Interface Description
- SV-2 Systems Communication Description
- SV-3 Systems Matrix
- SV-4 System Functionality Description
- SV-5 Operational Activity to System Function Traceability Matrix
- SV-6 System Information Exchange Matrix
- SV-7 System Performance Parameters Matrix
- SV-8 System Evolution Description
- SV-9 System Technology Forecast
- SV-10 System Activity Sequence & Timing
- TV-1 Technical Architecture Profile
- TV-2 Standards Technology Forecast

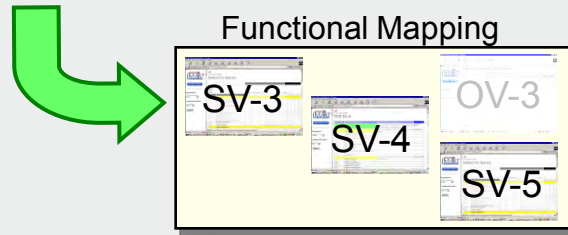

1st Order Analysis:
Functionality

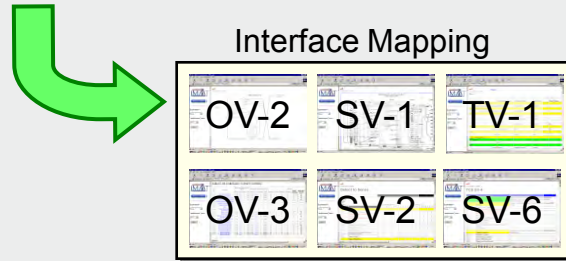

2nd Order Analysis:
Static Interoperability

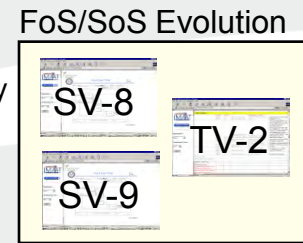

Note: There are dependencies between the Architecture products that are not shown in the System Engineering flow. Many of the products are developed concurrently.

Architectures Provide the Framework for FoS/SoS Systems Engineering & Acquisition

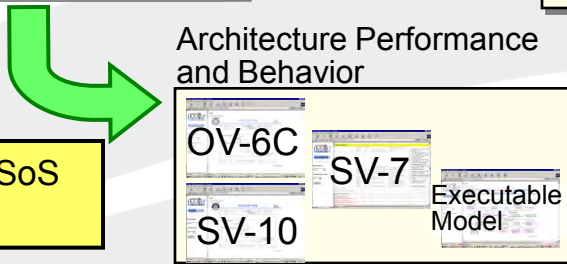

3rd Order Analysis:
Dynamic Interoperability

Ref: "Naval Collaborative Environment", Dr. Harry Crisp, 2002



Integrated Architectures – Defined

- Architecture data elements uniquely defined and consistently used
- Accomplished through the mapping of standardized terms, definitions, and relations
 - Objects used in more than one view are identical
 - Objects linked between views are linked within an underlying data base.
- *Common points of reference* linking different views of the architecture
- Examples



View Creation Not Complete System Architecture

- No Requirements
- Need for integration with other SE related activities – (Test Planning)
- Representations of Traceability lacking



- **Model-driven approach to capture and integrate:**
 - Requirements Development
 - Logical Analysis
 - Design Solution
 - Implementation
 - Integration
 - Verification
 - Validation
- **System Specification is the model, Model is the System Specification**



Example MBSE Taxonomy

Source Requirements Domain

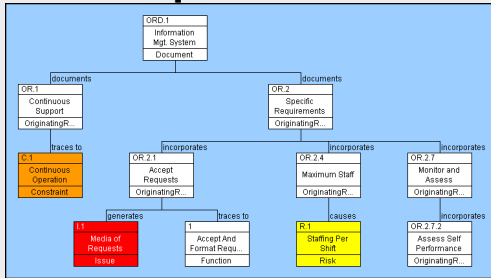

Originating requirements trace to behavior

Behavior Domain

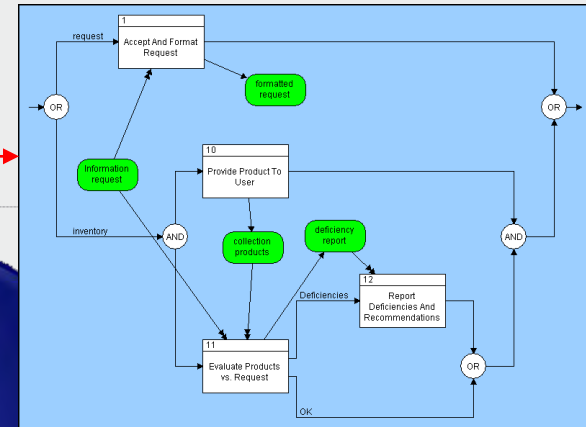

Behavior is allocated to physical components

verified by

V&V Domain

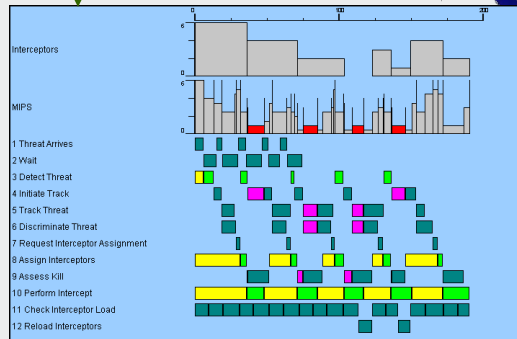

verified by

verified by

Originating requirements trace to physical components

Physical Architecture Domain

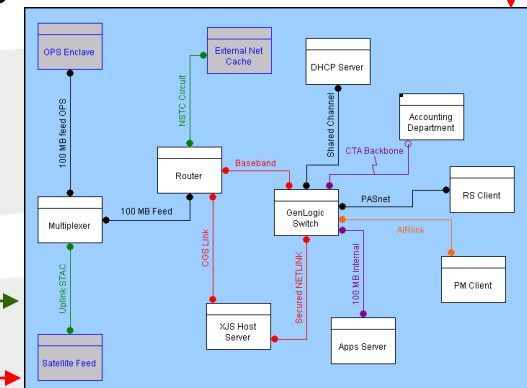



Example MBSE taxonomy (cont.)

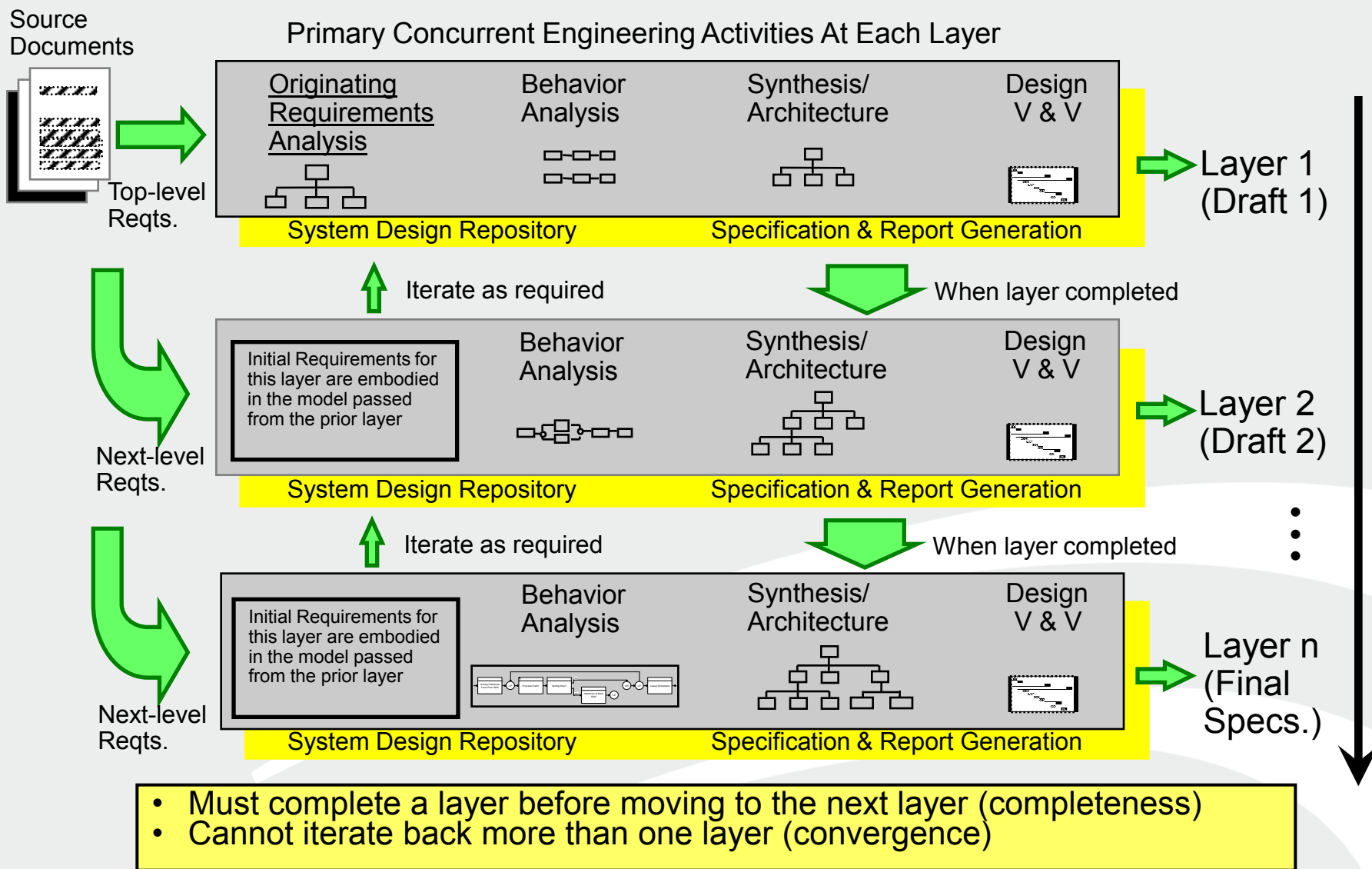

MBSE and Integrated Architecture Common Traits



DoDAF Integrated Data Layer

Architecture Framework Structure

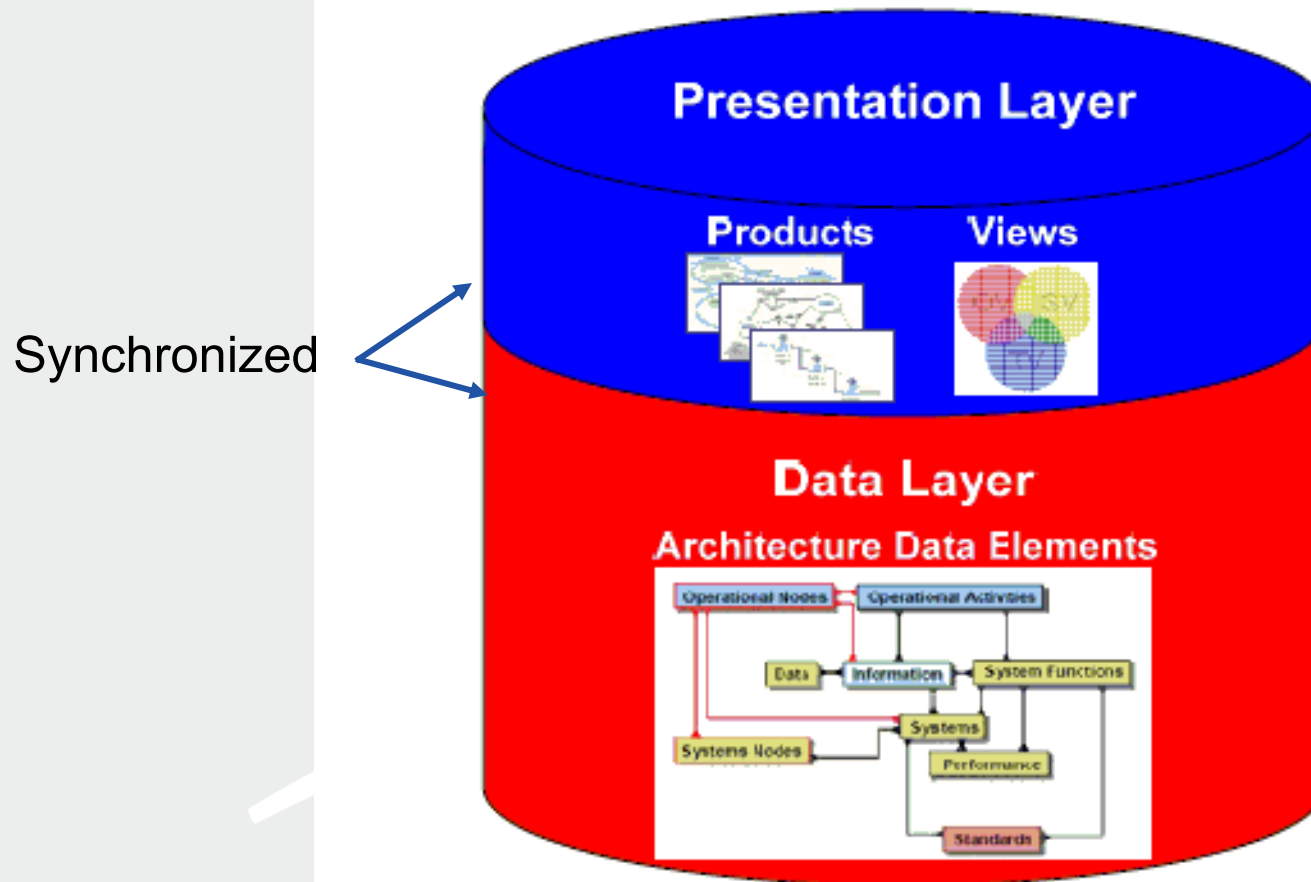



MBSE Integrated Data Layer

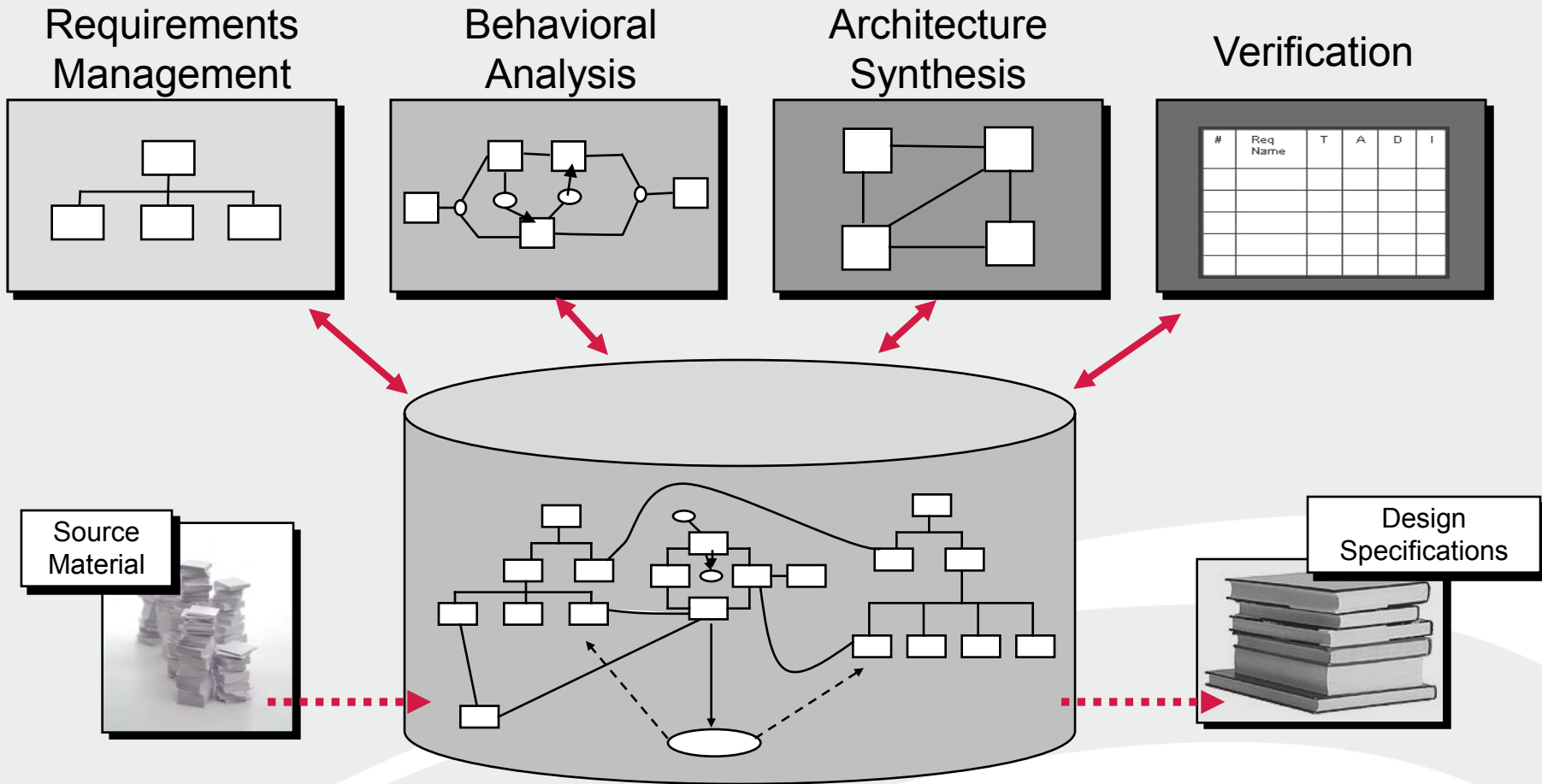

Integrated, Consistent Analysis: Complete Specifications, Project Documentation, Queries & Models



Integrated DoDAF Data Model

Operational
Architecture
Domain

System
Architecture
Domain

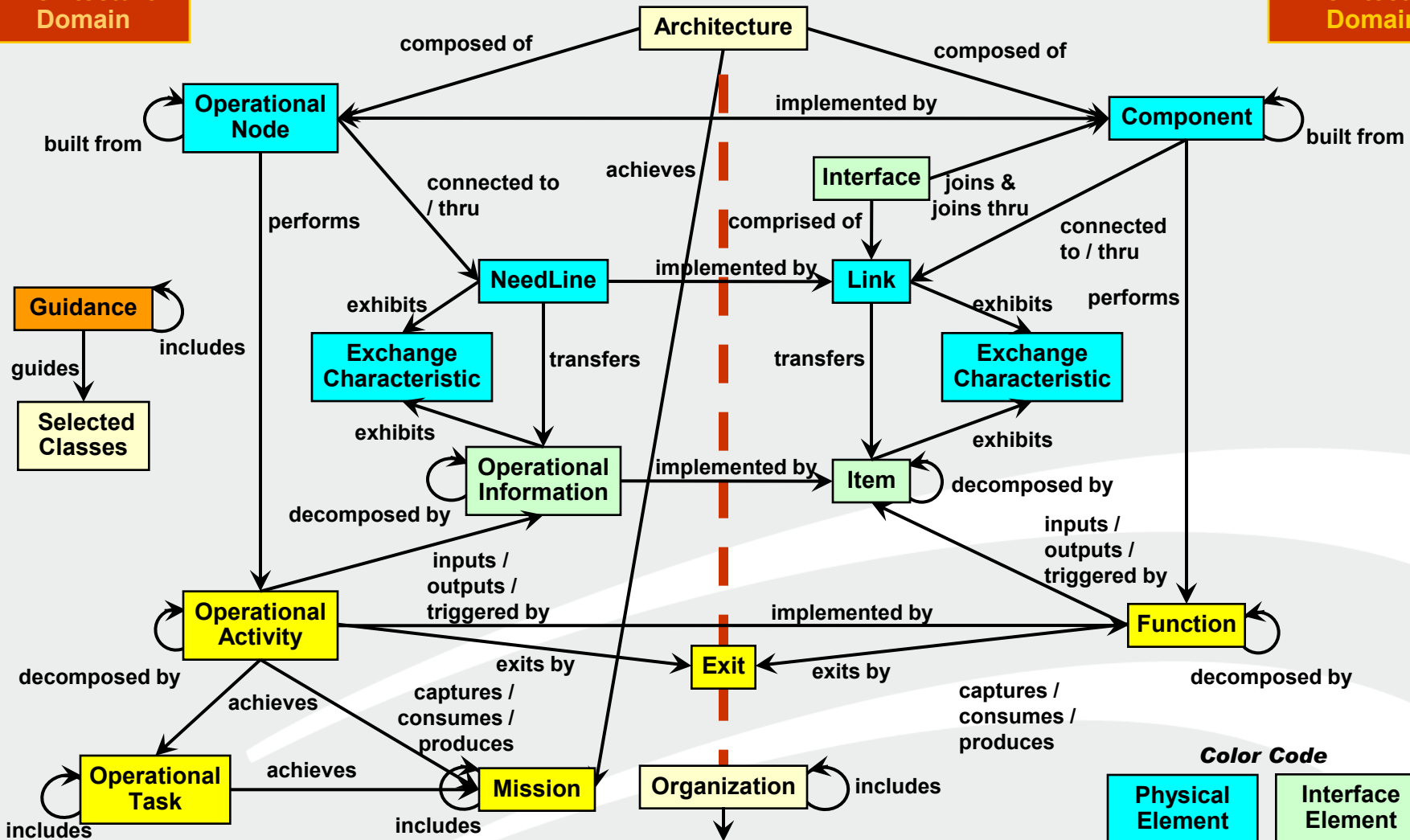



Systems Engineering Data Model (partial)

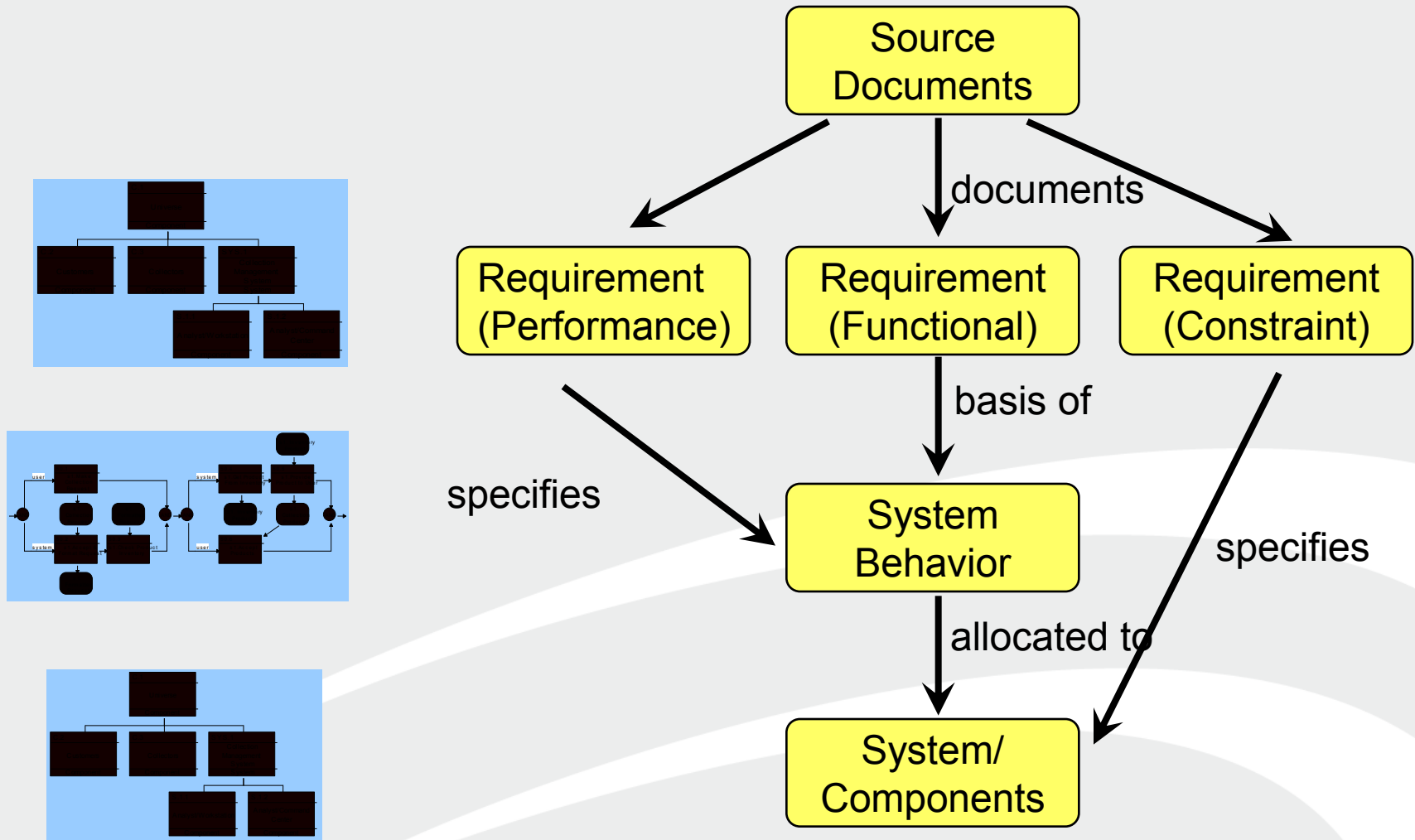



Integrated Data Model: Complete Traceability Between the Operational Architecture and System Engineering Domains

Operational Architecture Domain

System Architecture Domain

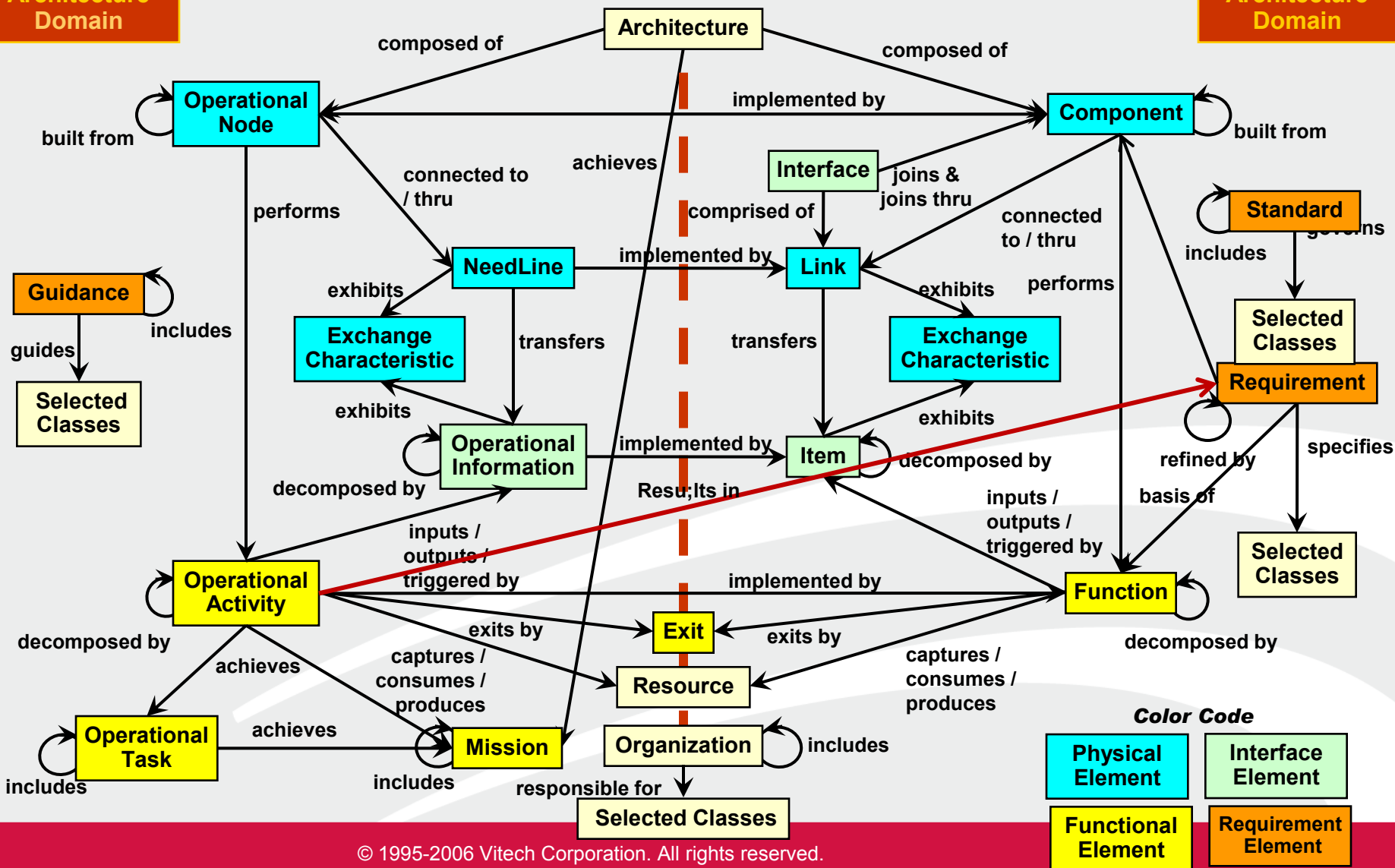

DoDAF and MBSE System Model Overlap - Examples



Sample Project Tactical Imagery Gathering

Description: The Tactical Image Management Architecture is composed of both an operational element and an image management system which supports the architecture. The tactical scenario models an army platoon which is advancing over a hill and requires information about the tactical environment on the other side of hill. The platoon makes an image information request which is transferred back to joint task force. The joint task force has access to an image management system which checks to see if the information required is already available in its inventory. If the information is not in the inventory, a tactical UAV, in this case a Predator, is tasked to collect an image of the other side of the hill, send it back to the image management system, and then the requested tactical information is communicated to the platoon.

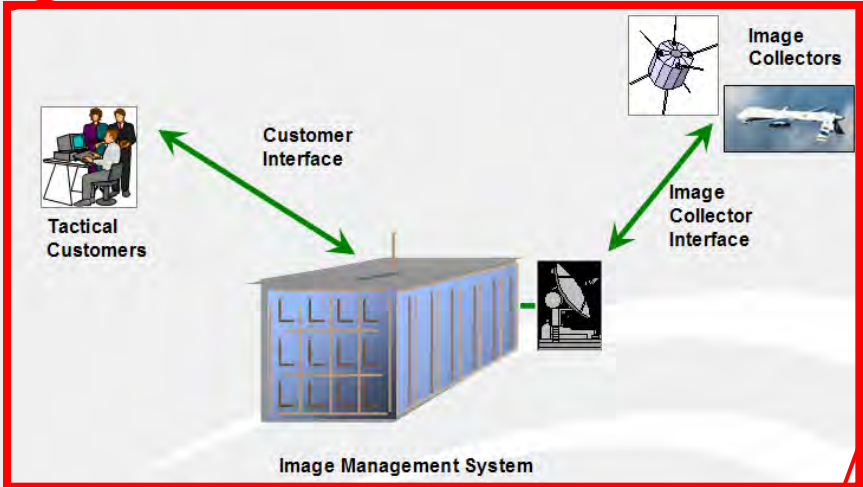
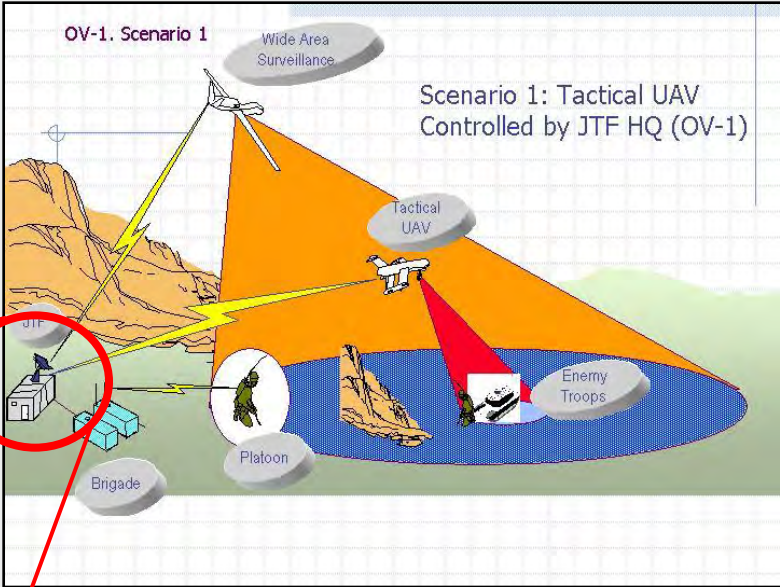

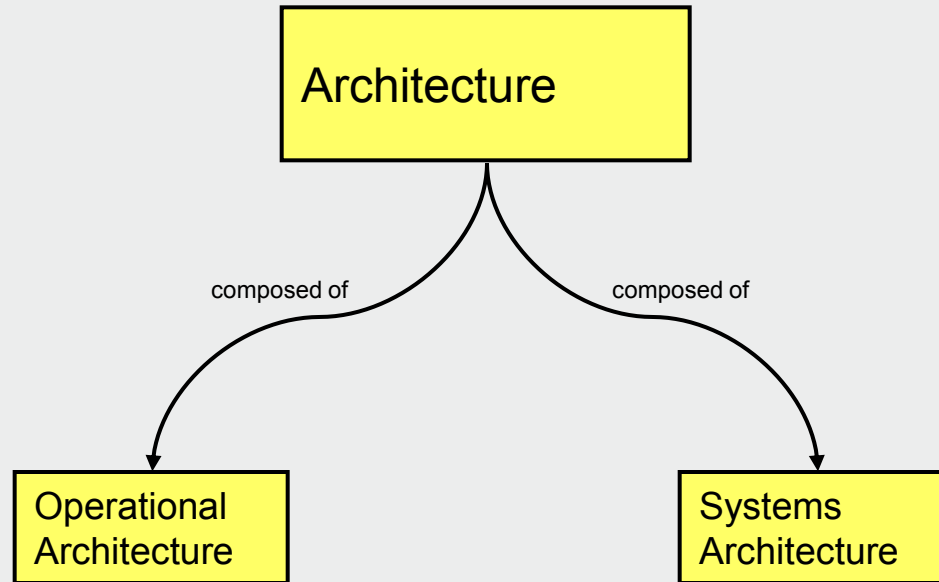



Modeled Relationships

Tactical Image Management asPropertySheet (Tactical Image Management NDIA (DoDAF v1.5))

File Edit View Data Tools Help

Name: Tactical Image Management
Number: Mod
Description: The Tactical Image Management Architecture is composed of both an operational element and an image management system which supports the architecture.
Purpose: The tactical scenario models an army platoon which is advancing over a hill and requires information about. The purpose of this architecture model is to serve as a sample application of the CORE DoDAF v1.5 schema.
Scope: This architecture demonstrates two specific ideas:
1) How to express capabilities within the operational architecture
2) How to express services in a system architecture

Time Frame: To Do

| Relationships | Targets & Attributes |
|--------------------|---|
| achieves | Component S.1 Image Management System with Services |
| assigned to | OperationalNode IM TACIM Op Scenario Participants |
| augmented by | |
| categorized by | |
| composed of | |
| documented by | |
| guided by | |
| reported by | |
| specified by | |

Sort: Numeric by class

RWDA Last Modified: Friday, August 03, 2007 at 04:12:05 PM



Architecture Traced to Guidance Documents

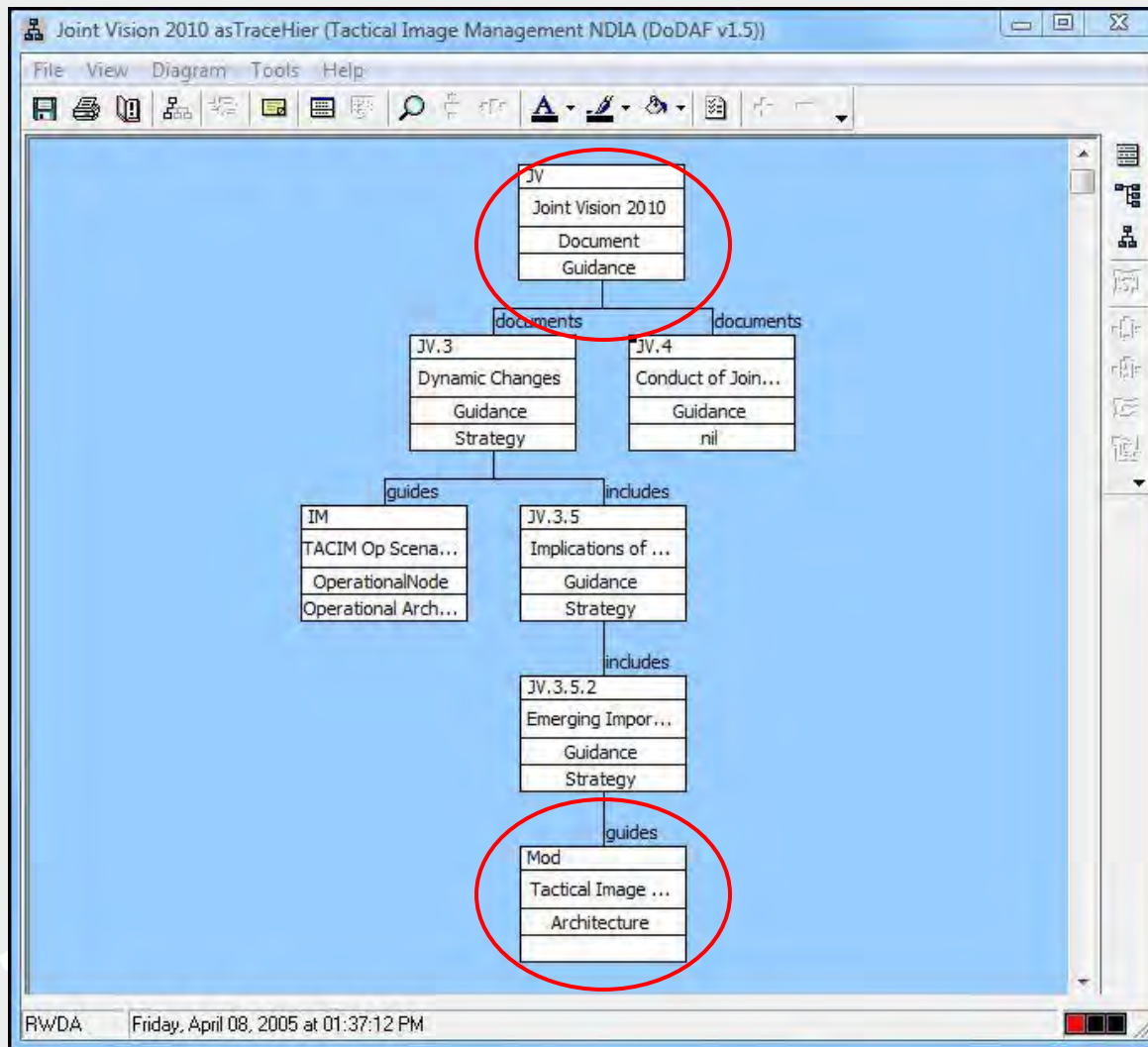



As seen in the produced AV-2

ARCHITECTURE DESCRIPTION DOCUMENT
FOR
Tactical Image Management

Wednesday, October 15, 2006

Prepared For:

Tutorial Participants
1441 Quivera Rd
San Diego, CA 92109

Prepared By:

NDIA Presenter
125 Main Street
SpringLake, NJ 08736

Joint Vision 2010

Includes Subordinate Guidance:

JV.3.5 Implications of Technological Advances

Guides:

OperationalNode: IM TACIM Op Scenario Participants

JV.3.5.2 Emerging Importance of Information Superiority

Description:

We must have information superiority: the capability to collect, process, and disseminate an uninterrupted flow of information while exploiting or denying an adversary's ability to do the same.

Type:

Strategy

Source Document(s):

Joint Vision 2010

Included In Higher-Level Guidance

JV.3.5 Implications of Technological Advances

Guides:

Architecture: Mod Tactical Image Management

JV.4 Conduct of Joint Operations

Description:

Pages 17 through 31 of JV 2010.

Source Document(s):

Joint Vision 2010

Includes Subordinate Guidance:

JV.4.1 New Operational Concepts



Architectures - Example

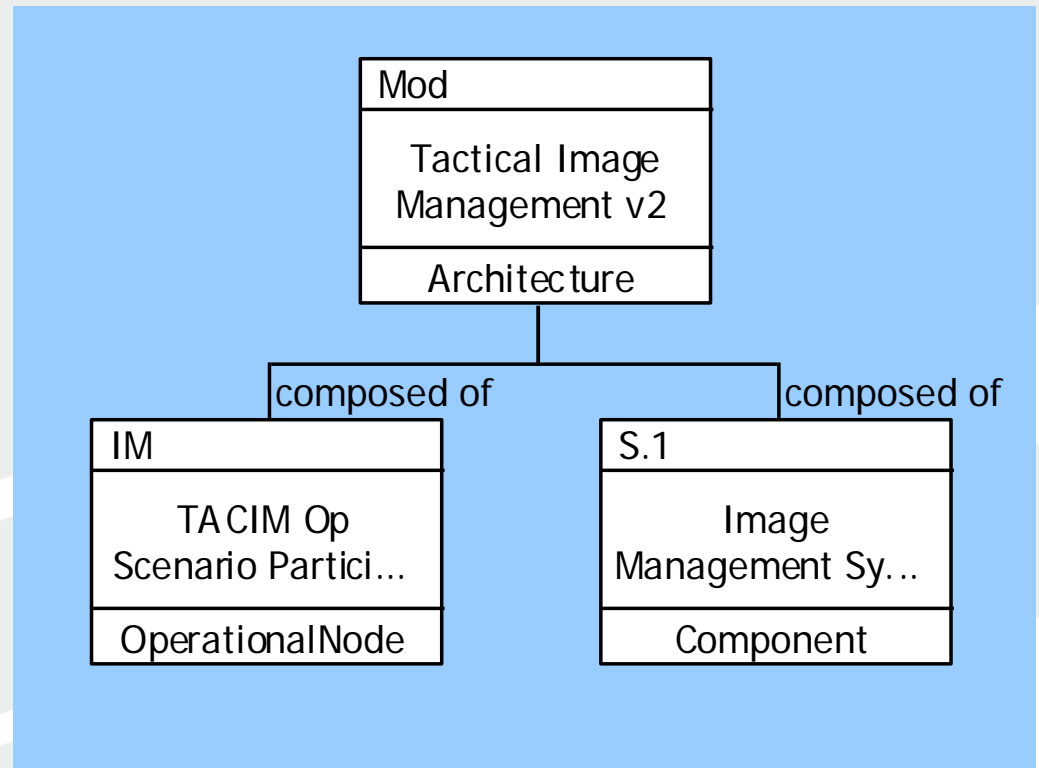
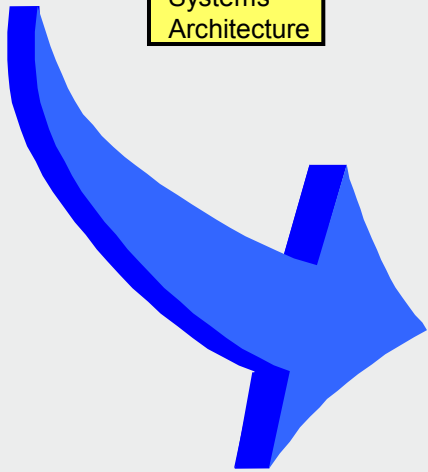
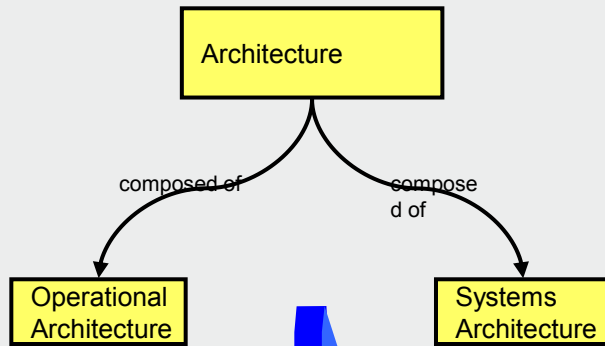



Capability – Support External Users

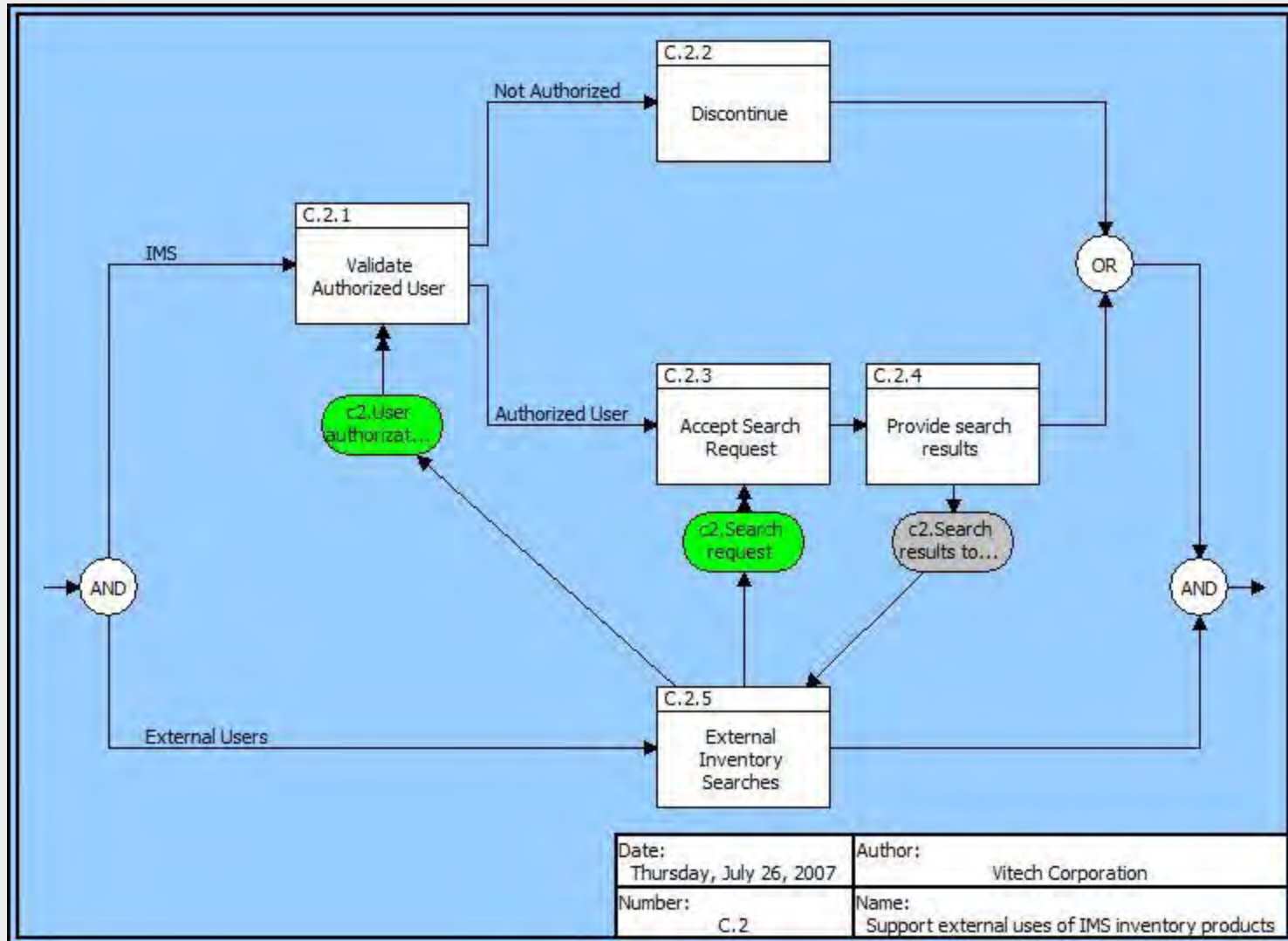



Support External Users as an OV-5

Support external uses of IMS inventory products Operational Activity Model (OV-5)

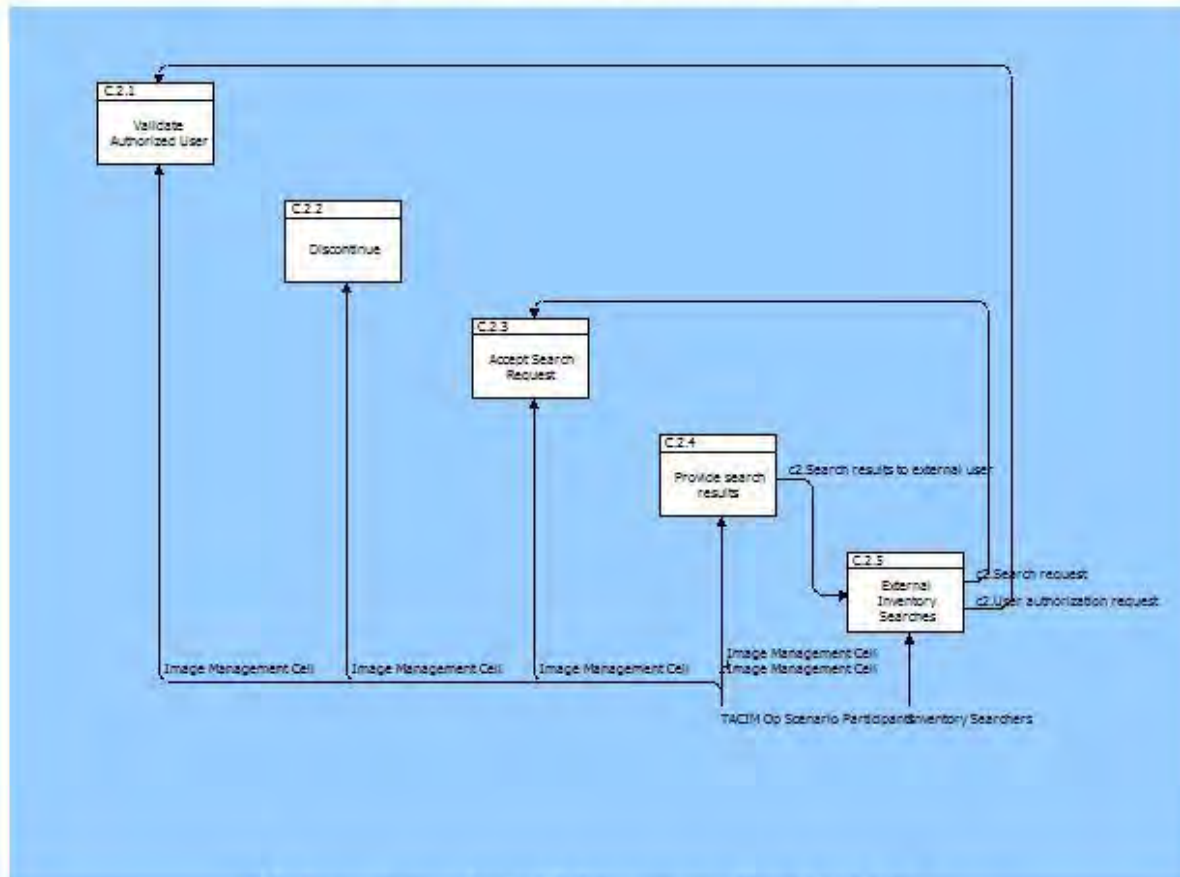

C.2 Support external uses of IMS inventory products IDEF0 Diagram



Architectures & Domains

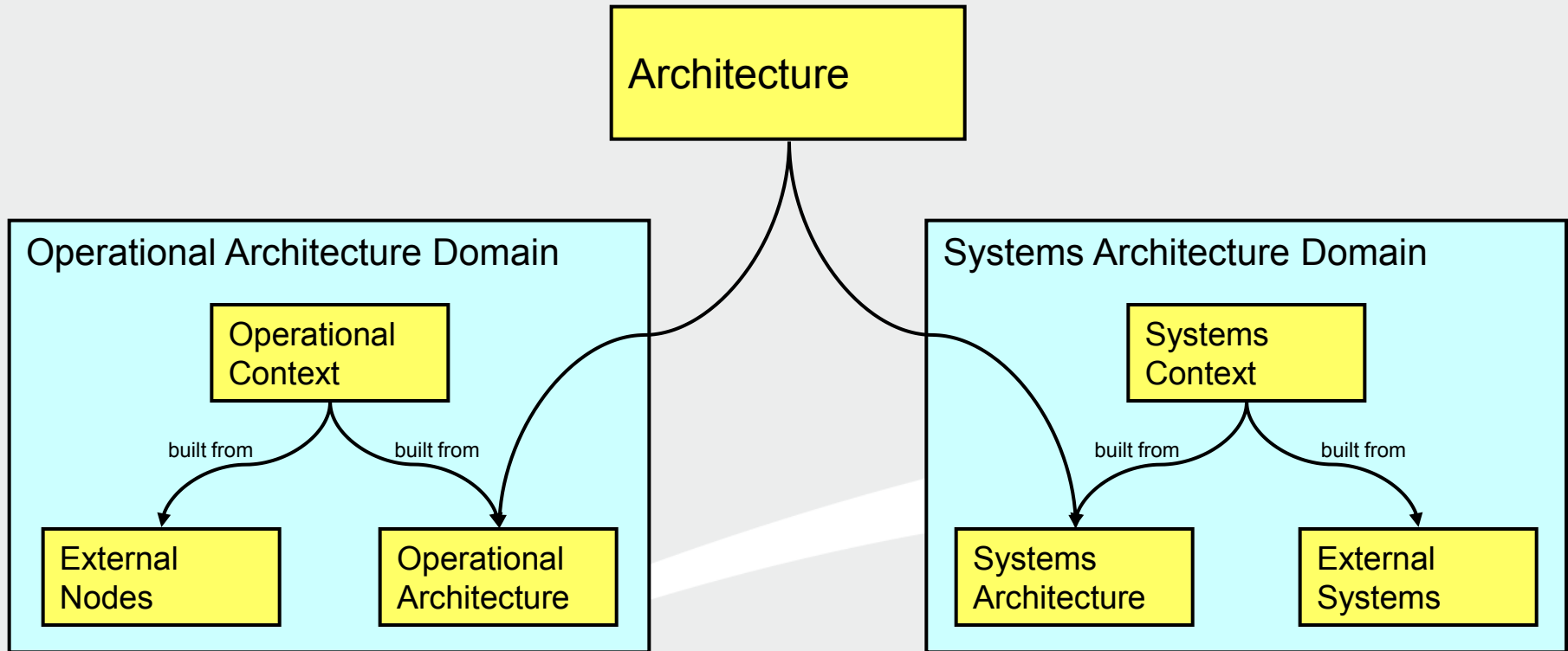



Hierarchy of Operational Nodes

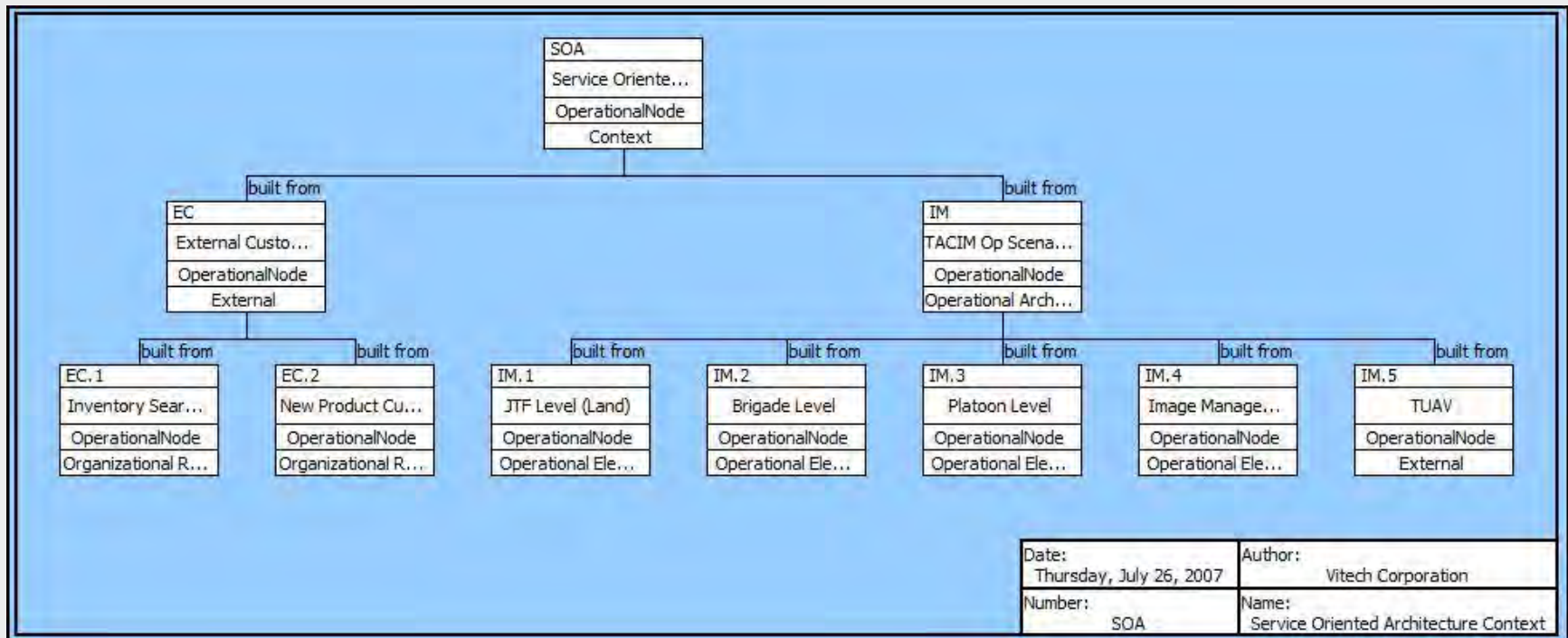



... Relates to the Next ...

I/O of Operational Activities

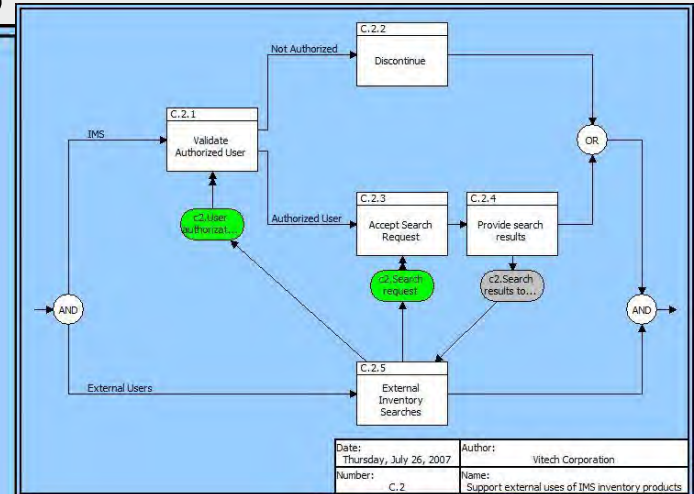
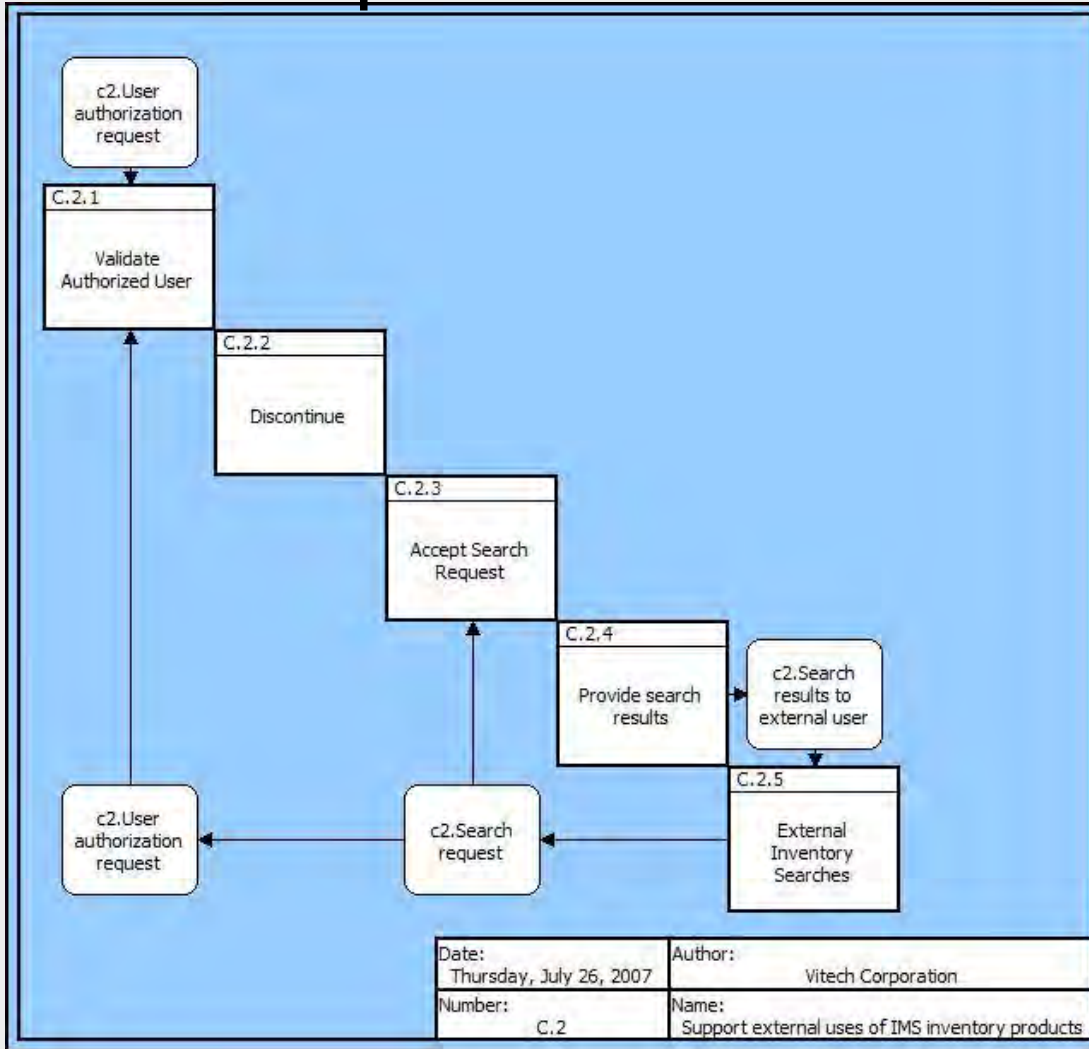



... Relates to the Next ...

TACIM Op Scenario Participants Operational Node Connectivity (OV-2)

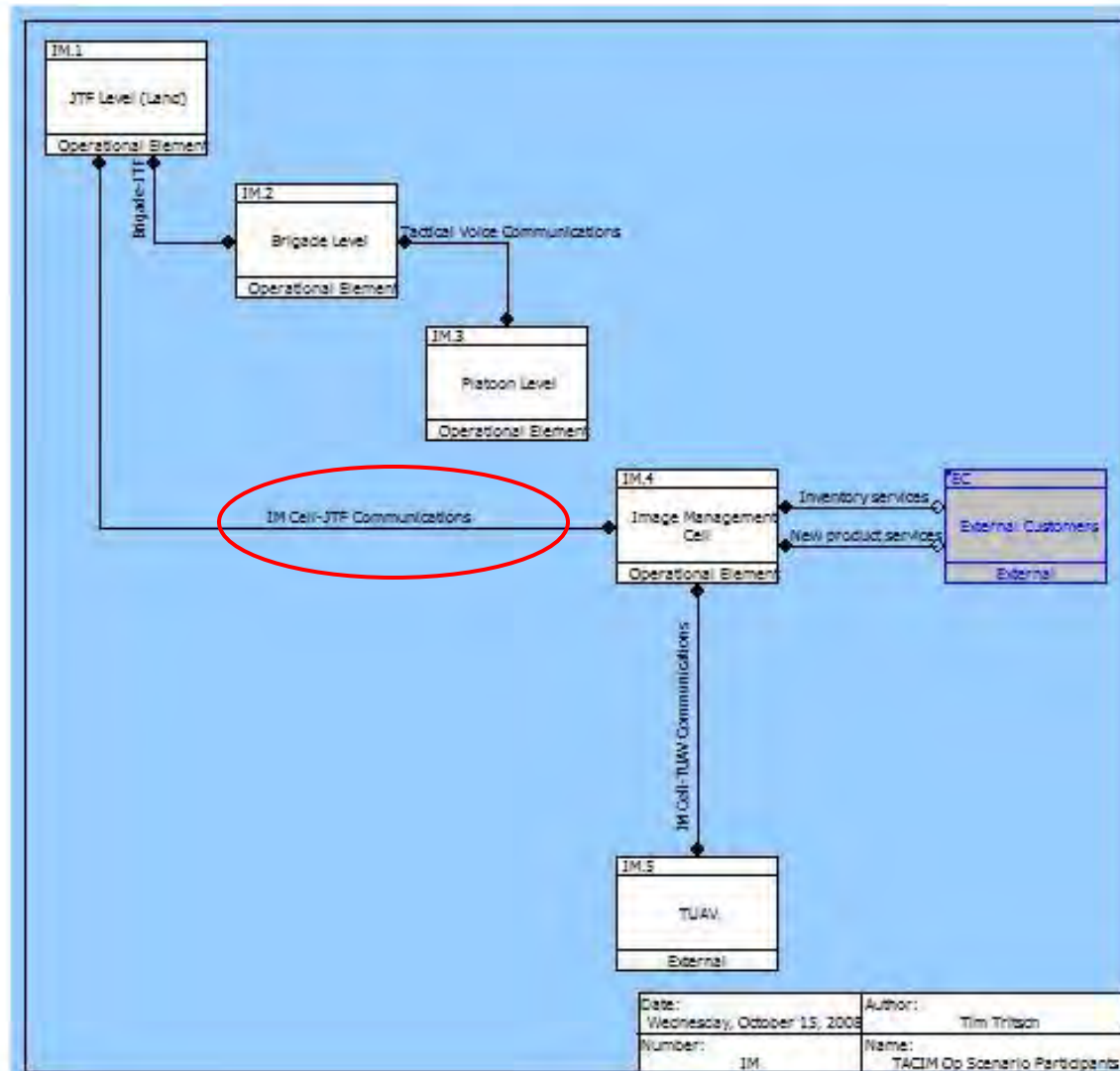



... And From Our Integrated Architecture ...

The screenshot displays the 'Project Explorer' window for 'Tactical Image Management NDIA (DoDAF v1.5)'. The interface includes a menu bar (File, Edit, View, Project, Data, Schema, Utilities, Diagram, Tools, Help) and a toolbar. The 'Project' pane on the left shows a tree view of classes, with 'Needline (6/6)' circled in red. The 'Elements' pane in the center lists 'All Elements' and 'IM Cell-JTF Communications', which is selected. The 'IM Cell-JTF Communications' property sheet on the right shows fields for Name, Number, Description, Doc. PUID, Title, Capacity, Capacity Units, Delay, and Delay Units. The 'Name' field is circled in red. Below the property sheet, the 'Relationships' pane shows a list of relationships, with 'exhibits' circled in red. The 'Targets & Attributes' pane shows a relationship between 'ExchangeCharacteristic' and 'IM Cell - JTF Exchange Characteristics'. The status bar at the bottom indicates 'RWDA' and 'Last Modified: Wednesday, June 06, 2007 at 08:27:45 AM'.



. . . The Resulting OV-3

Tactical Image Management Operational Information Exchange Matrix (OV-3)

| PART I | | | | |
|-----------------------------|--|--|---|---|
| Needline | Information Exchange | Operational Information Element | Information Source | Information Destination |
| Brigade-JTF Communications | Brigade - JTF Exchange Characteristic | c1. Collected Information
Description: Package of imaging information and augmenting material returned to the customer.
Accuracy: Medium | JTF Level (Land)
<i>Transmit Collected Information(As-Is)</i> | Brigade Level
<i>Translate Information into Verbal Commands(As-Is)</i> |
| | | c1. Formatted RFI
Description: Formatted Request for Information requesting intelligence on a target at a specified location.
Accuracy: High | Brigade Level
<i>Request Latest Information for Location(As-Is)</i> | JTF Level (Land)
<i>Receive Formatted RFI(As-Is)</i> |
| IM Cell-JTF Communications | IM Cell - JTF Exchange Characteristics | c1. Tactical Image Products
Description: Processed imaging products.
Accuracy: Medium | Image Management Cell
<i>Provide Current Target Imaging Product(As-Is)</i> | JTF Level (Land)
<i>Process Tactical Operational Information(As-Is)</i> |
| | | c1. Tactical Tasking Imaging Request
Description: Tasking request to acquire imaging intelligence for tactical commanders.
Accuracy: High | JTF Level (Land)
<i>Receive Formatted RFI(As-Is)</i> | Image Management Cell
<i>Accept Tasking for Tactical Operations(As-Is)</i> |
| IM Cell-TUAV Communications | | c1. Target Imaging | TUAV
<i>TUAV Ops(As-Is)</i> | Image Management Cell
<i>Acquire Target Imaging(As-Is)</i>
Image Management Cell
<i>Subscriber(s) for this</i> |



Architectures & Requirements

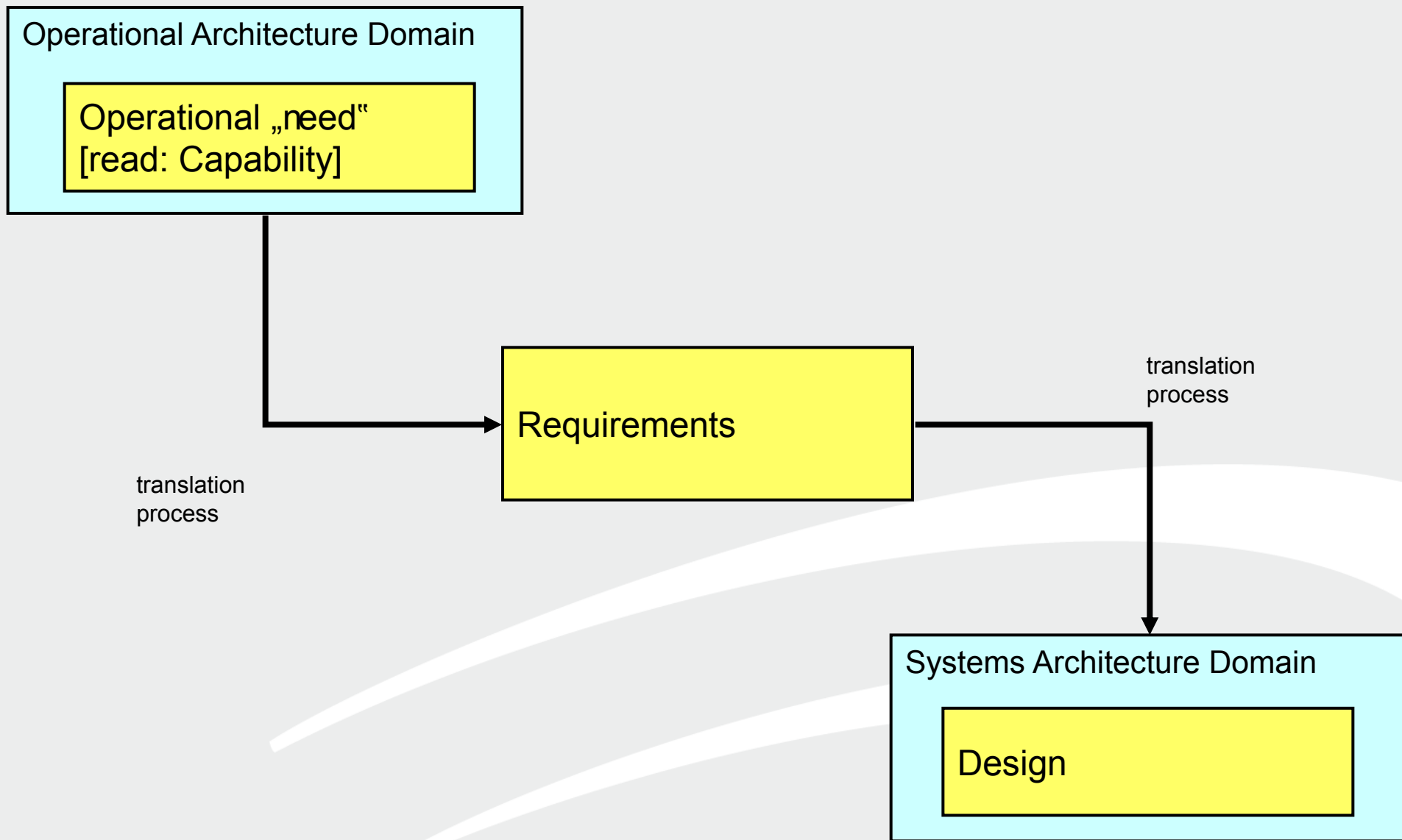



Capability to Requirement Traceability

Support external uses of IMS inventory products asPropertySheet (Tactical Image Management NDIA (Do...

File Edit View Data Tools Help

Name: Support external uses of IMS inventory products

Number: C.2

Description: Allow authorized external [outside the boundary of existing TUAV] customers to query for existing image products.

Doc. PUID:

Title:

Duration: Edit

Exit Logic: Edit

Relationships

- decomposes
- documented by
- exits by
- guided by
- implemented by
- inputs
- outputs
- performed by
- produces
- relates to
- reported by
- results in
- services
- specified by
- triggered by

Targets & Attributes

- Requirement MR.3 Provide Inventory Search Capability

Sort: Numeric by class

RWDA Last Modified: Thursday, July 26, 2007 at 12:32:52 PM



Requirement to Function Traceability

Provide Inventory Search Capability asPropertySheet (Tactical Image Management NDIA (DoDA...

File Edit View Data Tools Help

Name: Provide Inventory Search Capability

Number: MR.3

Description: The system shall provide the capability for non-tactical customers to search existing product inventory and retrieve existing products.

Doc. PUID:

Title:

Type: Functional

Value:

Relationships

- augmented by
- basis of**
- categorized by
- causes
- documented by
- generates
- guided by
- refined by
- refines
- reported by
- result of
- specifies
- utilized by
- verified by

Targets & Attributes

..... Function Inv Inventory Search

Sort: Numeric by class

RWDA Last Modified: Sunday, August 26, 2007 at 09:45:28 PM



Op Activities implemented by System Functions

The screenshot displays the Project Explorer interface for Tactical Image Management NDIA (DoDAF v1.5). The main window shows the definition of the function "Support external uses of IMS inventory products asPropertySheet".

Function Definition:

| Property | Value |
|------------------------|---|
| Name: | Support external uses of IMS inventory products |
| Number: | C.2 |
| Description: | Allow authorized external [outside the boundary of exist TUAV] customers to query for existing image products. |
| Doc. PUID: | |
| Title: | |
| Duration: | |
| Exit Logic: | |
| Timeout: | |
| Execute Decomposition: | true |

Relationships:

- decomposed by
- decomposes
- documented by
- exits by
- guided by
- implemented by**
- inputs
- outputs
- performed by
- produces
- relates to
- reported by

Targets & Attributes:

- Function IMS.16 Validate User (Status: Planned)
- Function IMS.17 Authorize User (Status: Planned)
- Function IMS.21 Get Search Parameters (Status: Planned)
- Function IMS.22 Perform Inventory Search (Status: Planned)
- Function IMS.23 Return Search Results (Status: Planned)

At the bottom of the window, the status bar shows "RWDA" and "Last Modified: Thursday, July 26, 2007 at 12:32:52 PM".



SV-5a Operational Activity to Systems Function Traceability Matrix

Support external uses of IMS inventory products to
Operational Activity to Systems Function Traceability Matrix (SV-5)

| Function | Operational Activity | | | | |
|-------------------------------|-----------------------|-------------|-----------------------------|------------------------|--------------------------|
| | Accept Search Request | Discontinue | External Inventory Searches | Provide search results | Validate Authorized User |
| Accept and Format Request | | | | | |
| Authorize User | | | | | X |
| Check Product Inventory | | | | | |
| Check Subscriber Requests | | | | | |
| Determine Sensor Mix | | | | | |
| Distribute New Product | | | | | |
| Existing Subscriptions? | | | | | |
| Fly to Surveillance Position | | | | | |
| Get Product From Inventory | | | | | |
| Get Search Parameters | X | | | | |
| Get Subscription Parameters | | | | | |
| New Product Received | | | | | |
| Not Authorized | | X | | | X |
| Perform Inventory Search | X | | | | |
| Perform Predator Surveillance | | | | | |
| Prioritize Request | | | | | |



SE Traceability

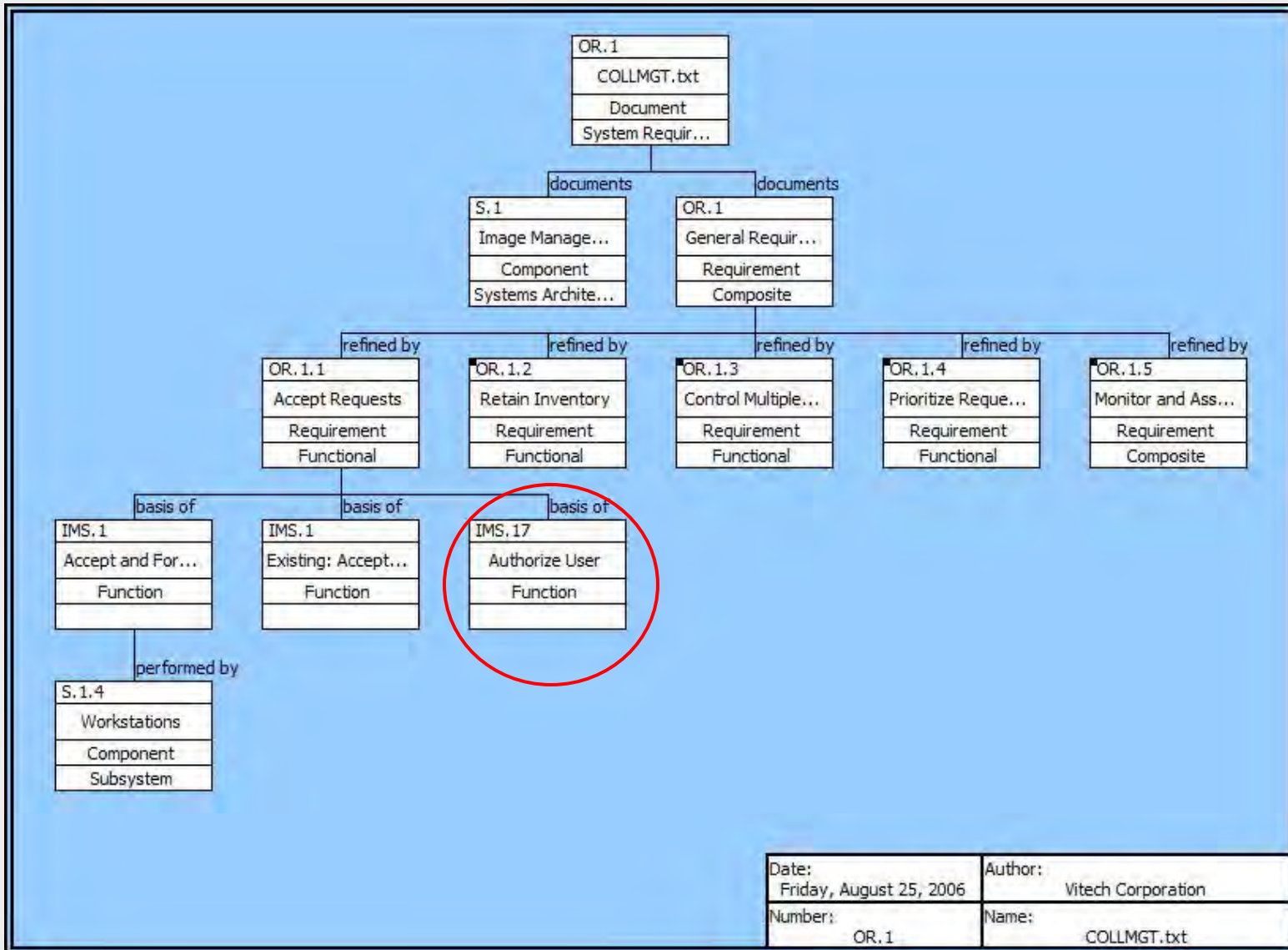



Function Appears in the SSS

Wednesday, October 15, 2008

SYSTEM SPECIFICATION FOR THE IMAGE MANAGEMENT SYSTEM WITH SERVICES

Prepared For:

Tutorial Participants
1441 Quivera Rd
San Diego, CA 92109

Prepared By:

NDIA Presenter
123 Main Street
SpringLake, NJ 08736

Authorized by: _____ Approved by: _____

Date: _____ Date: _____

3.2.1.16.7 Send User Access Rights

This function responds with the user's access rights.

3.2.1.16.8 Send Unknown User

This function notifies the interfacing service that the user is unknown.

3.2.1.17 Authorize User

Supplied credentials indicate the user is authorized access, so acknowledge the access.

3.2.1.18 Get Subscription Parameters

This function receives user inputs for a subscription to new products.



Function As Part Of SV-4

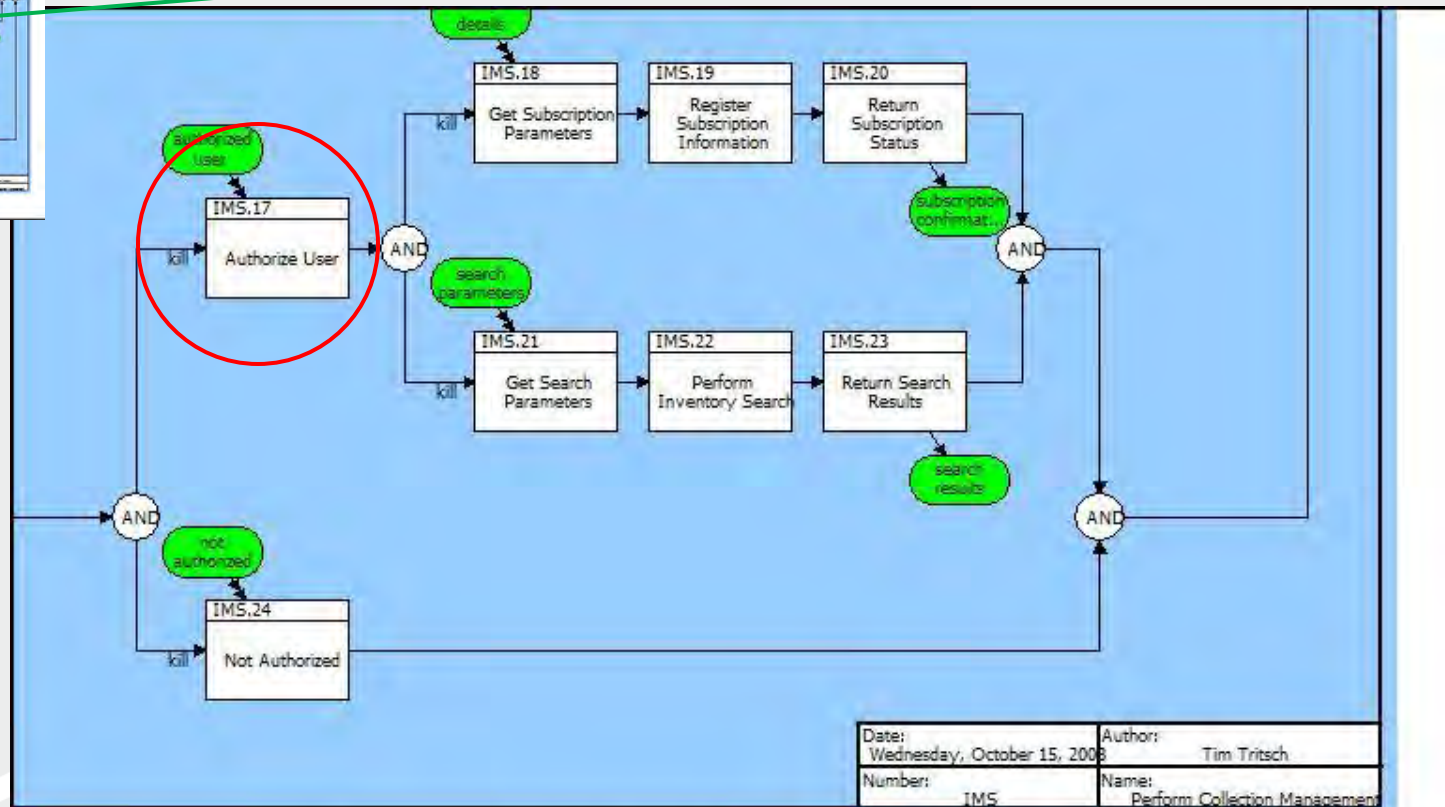
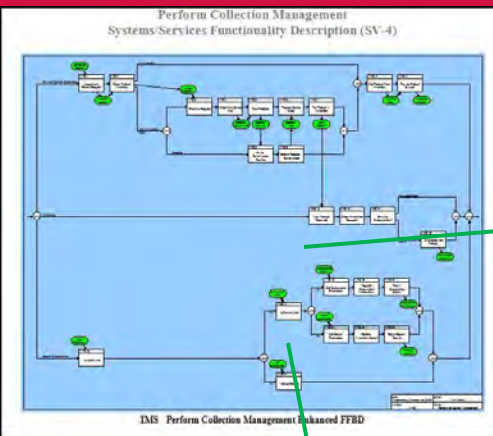

Management Enhanced FFBD



Inside the Data Model . . .

The screenshot displays the Project Explorer (Tactical Image Management NDIA / D&DAF v1.5) interface. The 'Project' pane on the left shows a tree structure with 'Function (51/134)' circled in red. The 'Elements' pane in the center lists various IMS elements, with 'IMS.17 Authorize User' circled in red. The main pane on the right shows the 'Authorize User asPropertySheet' for the 'Authorize User' class, with 'Number: IMS.17' and 'Description: Supplied credentials indicate the user is authorized access, so acknowledge the access.' circled in red. Below the main pane, the 'Relationships' pane lists various relationships, with 'triggered by' circled in red. The 'Targets & Attributes' pane shows 'Item authorized user' circled in red. The bottom status bar indicates 'RWDA' and 'Last Modified: Monday, October 20, 2008 at 09:37:34 AM'.



N2 Diagram Provides a Snapshot of System I/O

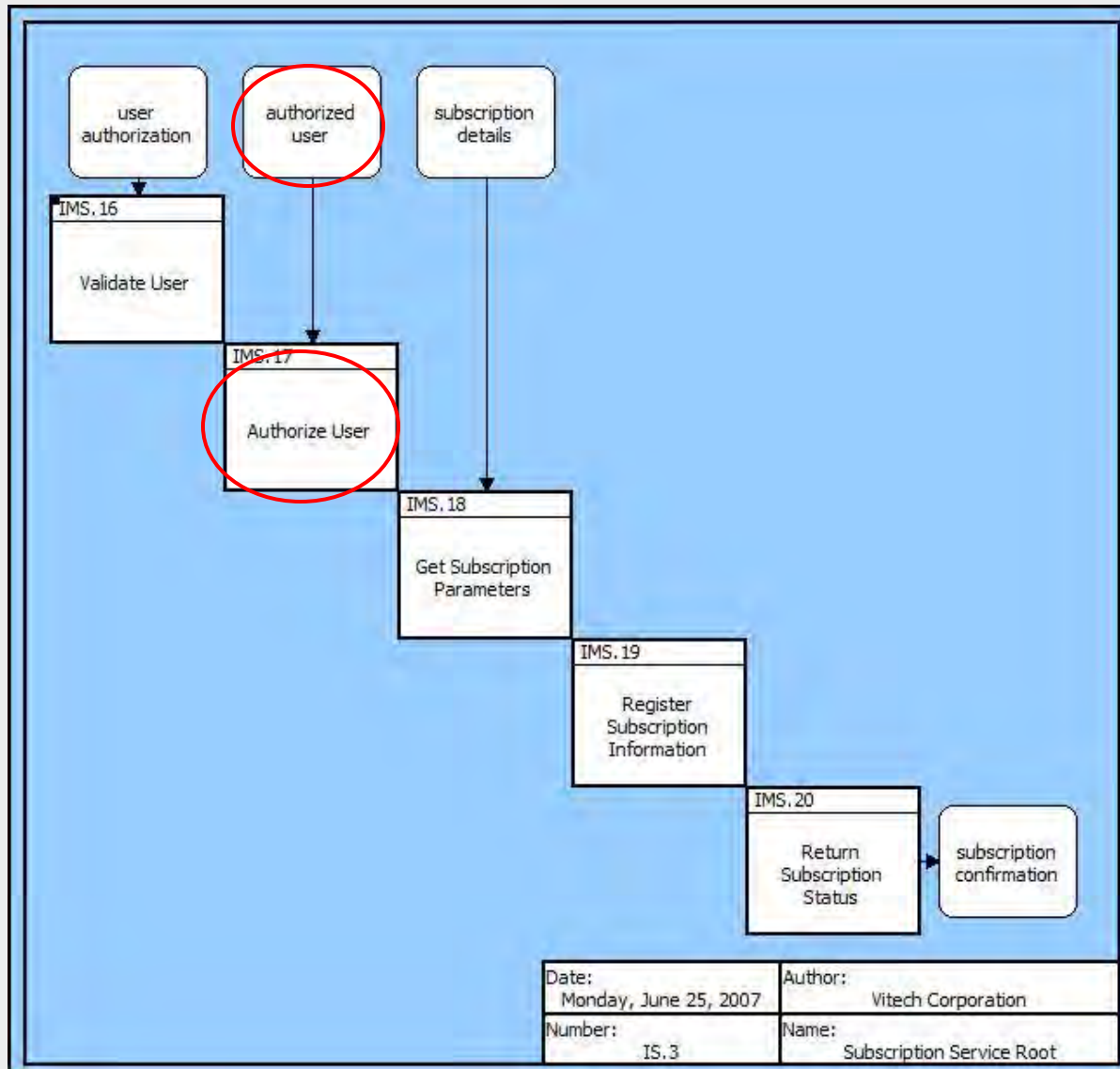



Functional Allocation to System Components Reveals Required Connectivity

Image Management System with Services
Systems/Services Communications Diagram (SV-2)

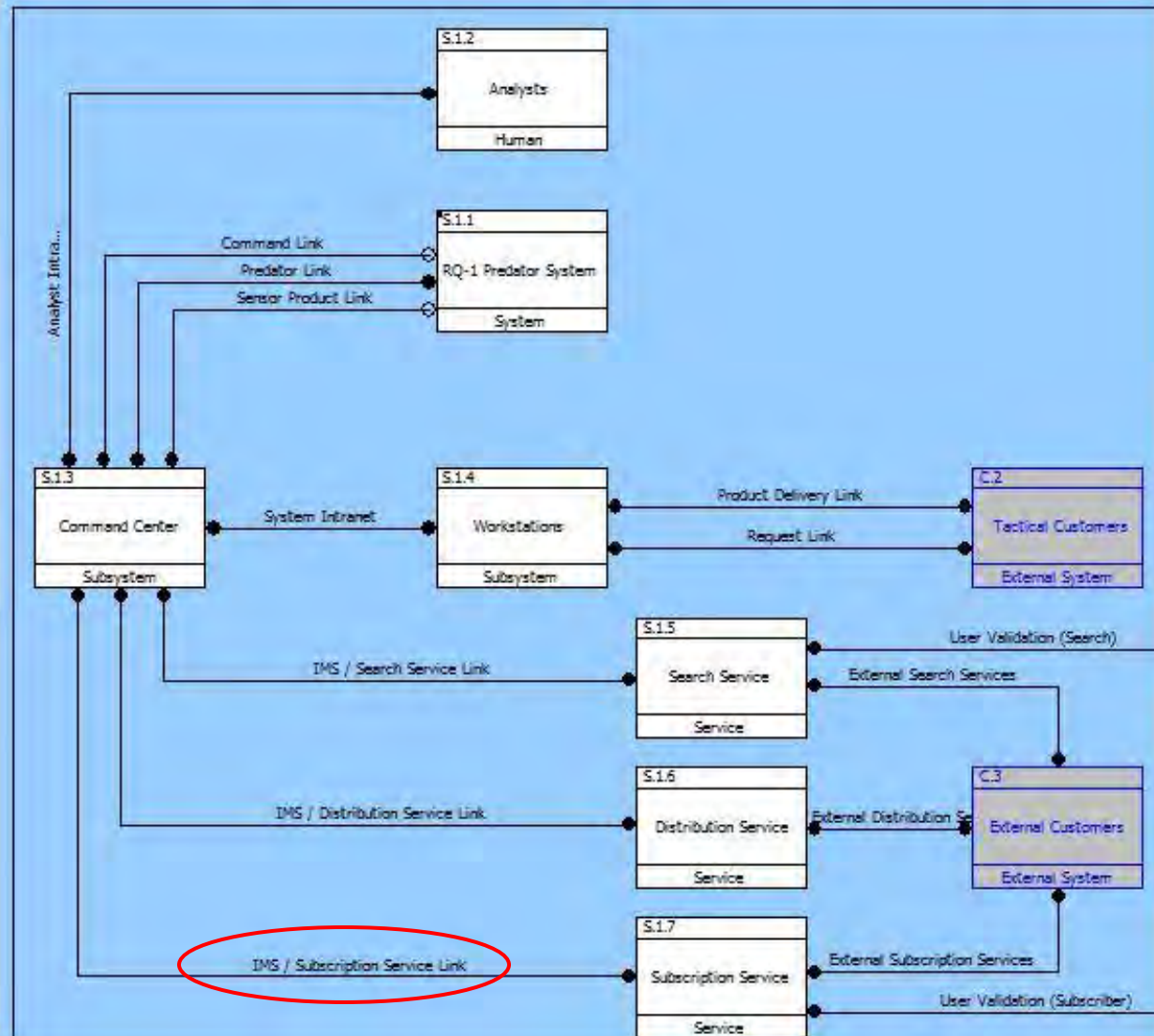



System Interoperability Also Used In Interface Requirement Specifications

Wednesday, October 15, 2008

INTERFACE REQUIREMENTS SPECIFICATION FOR THE NEW PRODUCTS / IMS INTERFACE

Prepared For:

Tutorial Participants
1441 Quiviera Rd.
San Diego, CA 92109

Prepared By:

NDIA Presenter
123 Main Street
Spring Lake, NJ 08736

Authorised by: _____ Approved by: _____

Wednesday, October 15, 2008

Table 3 - IMS / Subscription Service Link Item Definitions

| Name and Description | Source / Destination | Characteristics |
|--|---|-----------------|
| authorized user
User authorized status. | Source: Subscription Service
Destination: Command Center | Accuracy: High |
| not authorized
User is not authorized. | Source: Subscription Service
Destination: Command Center | |
| subscription confirmation
Subscription details returned for verification. | Source: Subscription Service
Destination: Command Center | |
| subscription details
Subscription request details provided. | Source:
Destination: | |
| user authorization
User authorization status. | Source:
Destination: | |



SV-3 Systems-Systems Matrix

Image Management System
Systems-Systems Matrix (SV-3)

| | Analysis | Command Center | Ground Control Station (GCS) | Predator Crew | Predator Vehicle | Work Stations | Tactical Customers |
|------------------------------|----------|----------------|------------------------------|---------------|------------------|---------------|--------------------|
| Analysts | | X | | | | | |
| Command Center | X | | X | | | X | |
| Ground Control Station (GCS) | | X | | X | X | | |
| Predator Crew | | | X | | | | |
| Predator Vehicle | | | X | | | | |
| Work Stations | | X | | | | | X |
| Tactical Customers | | | | | | X | |



Test Planning In

3.2.1 Accept Request Test

a) SCHEDULE:

| Estimated Duration | Start Date | End Date |
|--------------------|------------|----------|
|--------------------|------------|----------|

b) TEST CONFIGURATION:

The Accept Request configuration consists of one or more tactical customers connected to the system and entering new product requests.

Test Equipment

System Context

Description

A reference component used to incorporate the system and a system under one physical representation.

c) TEST TEAM:

d) TEST PROCEDURES:

1. TP.Accept Request Test steps are documented here:
 1. View active job log
 - a. Document existing IMS jobs in progress
 2. Enter new product request
 3. Ensure product request is entered into IMS
 - 3.1 View active job log
 - 3.2 Document new IMS job has been entered into active list

TEST AND EVALUATION PLAN
FOR THE
IMAGE MANAGEMENT SYSTEM WITH SERVICES

Prepared For:
Tutorial Participants
1441 Quivvers Rd
San Diego, CA 92109

Prepared By:
NDIA Presenter
123 Main Street
Spring Lake, NJ 08758

Reviewed by: _____ Approved by: _____

Date: _____ Date: _____

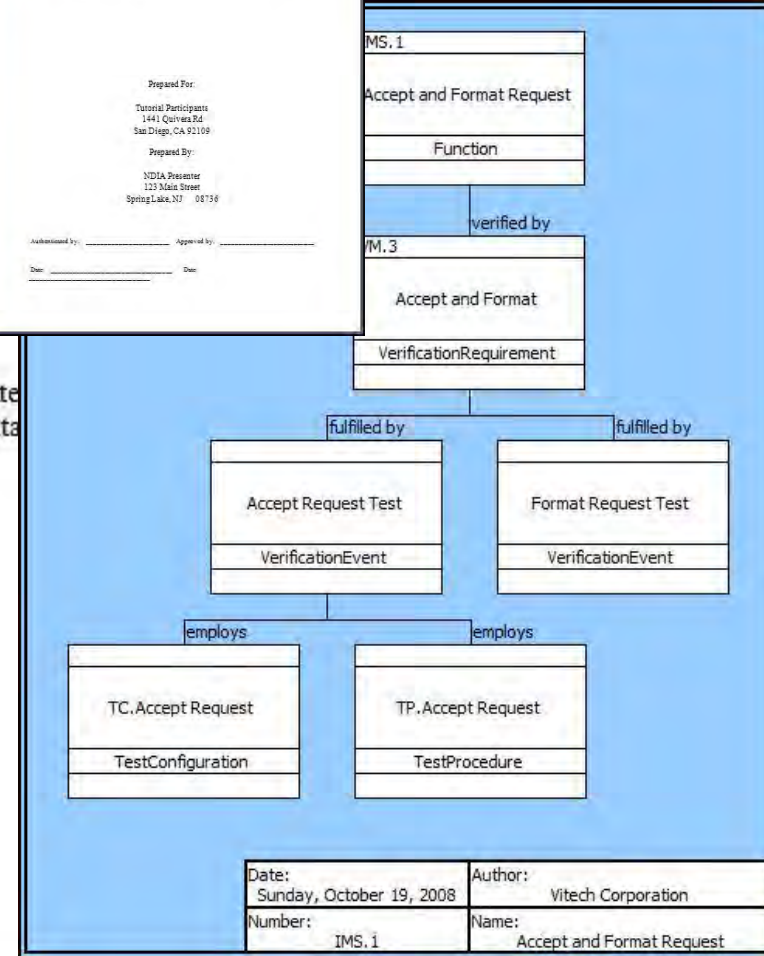



Integrated Model Benefits

- Synchronization between DoDAF views and systems Engineering products
- Traceability of Operational Doctrine to System-level Functional Requirements
 - Can be establish through Operational Scenarios
 - Supports Operational Testing



- Implications for CADM (?)
- DoDAF Views lend themselves to analysis, not system development
- Migration from C4ISR to DoDAF
 - Typical modeling techniques limited to computer stuff
 - Much discovery work goes straight to software
 - Traced from TOGAF?



- TOGAF – The Open Group Architecture Framework
 - TOGAF ADM – Architecture Development Method, limited to amorphous, distributed computer gunk
- SE principles applicable to all levels of analysis
- Why is the DoD “Chief Information Officer” dictating methods and tools by which we develop systems?
- “Interoperability” issues not limited to “purple”
 - Including “disadvantaged” or “tactical edge” users (the real war fighters)



The End

Systems Engineering for Systems of Systems

**NDIA
SE Conference
October 2008**

**Dr. Judith Dahmann
The MITRE Corporation**

SoS SE Challenge

- US DoD builds and fields large systems employed to support Joint and Coalition operations
 - Conceived and developed independent by Military Services
 - Acquisition (and SE) on a system by system basis
- Focus of DoD investment shifting to broad user capabilities implemented in a networked environment
 - Mix of material and non-material assets which must work together to meet capability objectives
 - Individual systems are no longer considered as individual bounded entities and are evolved based on extant capabilities
 - Components in larger, more variable, ensembles of interdependent systems which interact based on end-to-end business processes and networked information exchange
- Increasingly SoS of various types proliferate despite continued focus on individual systems

What are the implications for SE?

DoD System of Systems SE Guide

SoS Guide Version .9

- Effort led by the Office of the Secretary of Defense
- Collaborative Approach with DoD, Industry, Academia
- Purpose
 - 6 month effort addressing areas of agreement across the community
 - Focus on technical aspects of SE applicable across SoS management constructs
 - Vehicle to *capture* and *debate* current SoS experience
- Audience
 - SoS and Program Managers and Lead/Chief Engineers

Version 1.0

- Develop 'Boots on the Ground' basis for Version 1.0
 - Structured reviews with practitioners
 - Refine early draft guide content, identify areas for future study
- Update findings and release Version 1.0
 - Draft released for comment December 2007
 - ~600 comments received in February 2008 (Industry, FFRDCs, Gov't)
 - Revision reviewed by Senior SE leadership in July 2008
 - Final release in August 2008

What does SoS Look Like in the DoD Today?

- Typically an **overlay to ensemble of individual systems** brought together to satisfy user capability needs
- Are **not new acquisitions** per se
 - Cases like FCS are extremely rare and, in practice, still must integrate with legacy systems
- SoS 'manager' **does not control the requirements or funding for the individual systems**
 - May be in a role of **influencing** rather than directing, impacts SE approach
- Focus of SoS is on **evolution of capability over time**
- A functioning SoS takes start-up time but, in steady state, seems well-suited to **routine incremental updates**

Most military systems are part of an SoS operationally
Only by exception do we manage and engineer at SoS level

Definitions

SoS: *A set or arrangement of systems that results when independent and useful systems are integrated into a larger system that delivers unique capabilities* [DoD, 2004(1)].

Accepted Taxonomy of SoS [Maier, M. 1998]

- Directed
 - SoS objectives, management, funding and authority; systems are subordinated to SoS
- Collaborative
 - No objectives, management, authority, responsibility, or funding at the SoS level; Systems voluntarily work together to address shared or common interest
- Virtual
 - Like collaborative, but systems don't know about each other

US DoD Pilots identify a new SoS type:

- Acknowledged
 - SoS objectives, management, funding and authority; however systems retain their own management, funding and authority in parallel with the SoS

SoS SE Guidebook focuses on 'Acknowledged' SoS

Characteristics of Acknowledged SoS

- Top-down direction for an SoS capability concurrent with independent direction and autonomy in system operation and development
 - Multiple levels of objectives
 - Multiple management authorities with independent priorities, funding and development plans
 - Multiple technical authorities
- Much of SoS functionality is in extant capabilities of the systems
- SoS manager and SE do not have control over all the parts of the SoS
 - In fact, they may not be aware of all the systems which may impact their objectives and both the systems and the objectives may change over time.

Management of Acknowledged SoS

- Independent, concurrent management and funding authority pose management issues
- In defense, a solid governance & management approach is seen as key for SoS
 - Independent authorities are unlikely to accept direction from a systems engineer they do not control
 - Argue to make 'acknowledged' into 'directed' made difficult by 'multi-mission' systems which are important to multiple SoS
- Beyond defense 'acknowledged' SoS exist and evolve without top down management
 - Systems or services are designed to be broadly useful and have as their business objective to support numerous user applications
 - They naturally retain authority over decisions regarding their development and are not likely to agree to limit themselves to one specific customer

Management issues have technical implications for SE

A Comparison

| | System | System of Systems |
|--|--|---|
| Management & Oversight | | |
| Stakeholder Involvement | Clearer set of stakeholders | Two levels of stakeholders with mixed possibly competing interests |
| Governance | Aligned PM and funding | Added levels of complexity due to management and funding for both SoS and systems; No SoS does over all systems |
| Operational Environment | | |
| Operational Focus | Designed and developed to meet operational objectives | Called upon to meet operational objectives using systems whose objectives may or may not align with the SoS system's objectives |
| Implementation | | |
| Acquisition | Aligned to established acquisition processes | Cross multiple system lifecycles across acquisition programs, involving legacy systems, developmental systems, and technology insertion; Capability objectives but may not have formal requirements |
| Test & Evaluation | Test and evaluation the system is possible | Testing more challenging due systems' asynchronous life cycles and given the complexity of all the moving parts |
| Engineering & Design Considerations | | |
| Boundaries & Interfaces | Focuses on boundaries and interfaces | Focus on identifying systems contributing to SoS objectives and enabling the flow of data, control and functionality across the SoS while balancing needs of the systems |
| Performance & Behavior | Performance of the system to meet performance objectives | Performance across the SoS that satisfies SoS user capability needs while balancing needs of the systems |

SE Model for SoS Based on 7 Core Elements of SoS SE

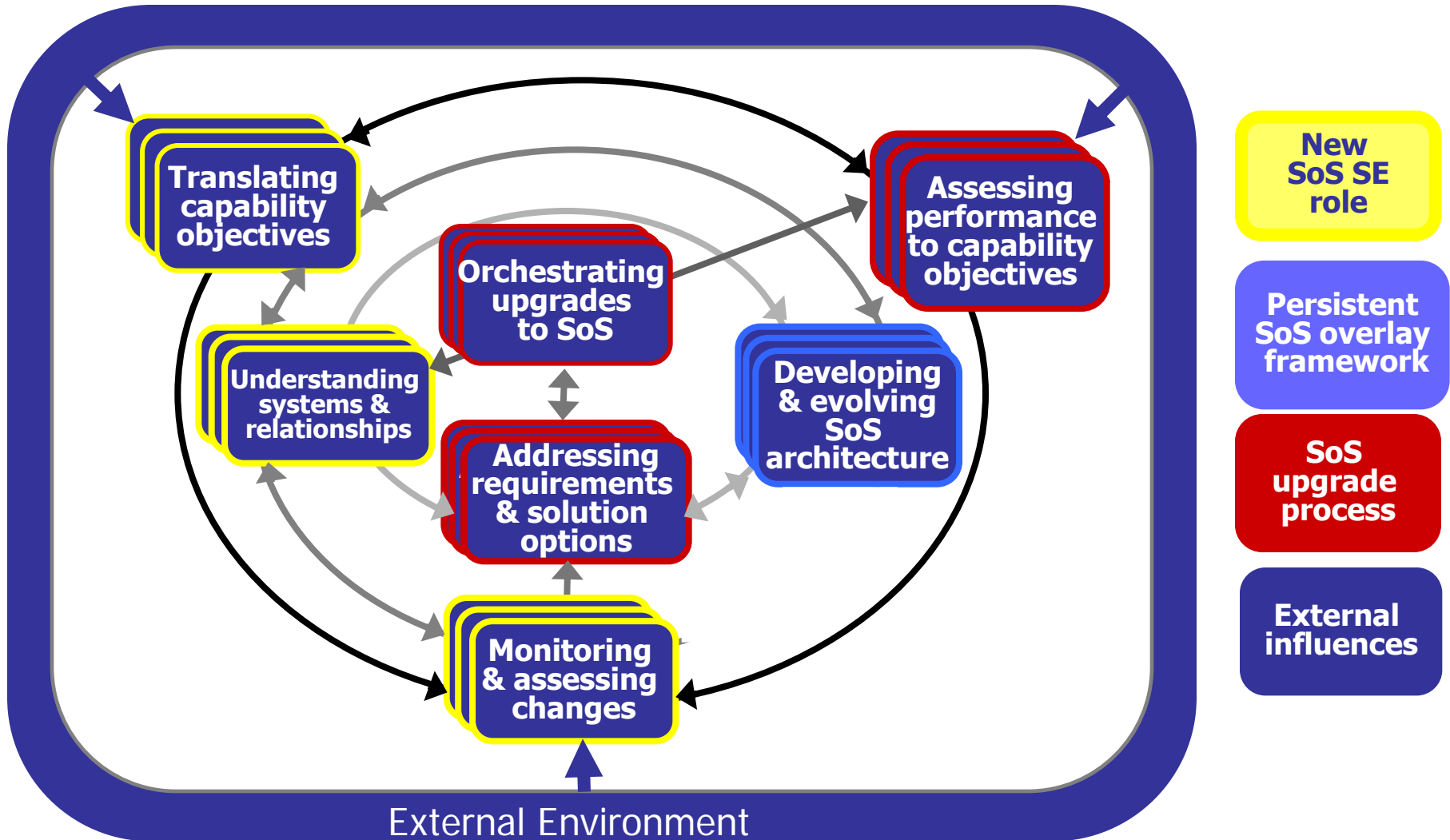

Core Elements of SoS SE (1 of 3)



Translating capability objectives

- Translating SoS capability objectives into high level requirements over time
 - SoS objectives based on broad capability objectives
 - SE team plays strong role in establishing requirements and understanding dynamics of the environment



Understanding systems & relationships

- Identifying and understanding the systems that impact SoS objectives
 - Focus on components and dynamics vs boundaries
 - Extends beyond technical to broader context of management, organizational, development plans, funding, etc.



Monitoring & assessing changes

- Anticipating and assessing impacts of potential changes on SoS performance
 - Given scope of SoS authority, key to SoS SE is identifying and addressing changes in systems and other areas (e.g. threat) which may impact the SoS

Core Elements of SoS SE (2 of 3)



- Developing and evolving SoS architecture
 - This includes
 - Concept of operations
 - Systems, functions and relationships and dependencies, both internal and external
 - End-to-end functionality, data flow and communications within the SoS.
 - Provides the technical framework for assessing options and implications for meeting requirements over time
 - Persistence, tolerance for change
- An **architecture** is the structure of components, their relationships, and the principles and guidelines governing their design evolution over time (IEEE Std 610.12 and DoDAF).
- The architecture of an SoS is a persistent technical framework for governing the evolution of an SoS over time.

Core Elements of SoS SE (3 of 3)

Addressing requirements & solution options

- SoS requirements and solution options
 - Requirements addressed at both SoS & systems
 - Recommend SoS requirements based on both priority and practicality
 - SoS and system SE teams identify and assess options
 - Result is plan for development for next increment

Orchestrating upgrades to SoS

- Orchestrating SoS Upgrades
 - Upgrades implemented by systems under system SE teams
 - SoS SE team plans, facilitates, integrates and tests upgrades to the SoS
 - Development based on incremental approaches (bus stop, wave) which accommodate asynchronous system developments

Assessing performance to capability objectives

- Assessing SoS Performance
 - Based on measures of SoS user results applied in different settings (test, exercises, M&S, operations)
 - Opportunity to identify changes and emergent behavior

View of SoS Upgrade (1 of 2)

For each increment

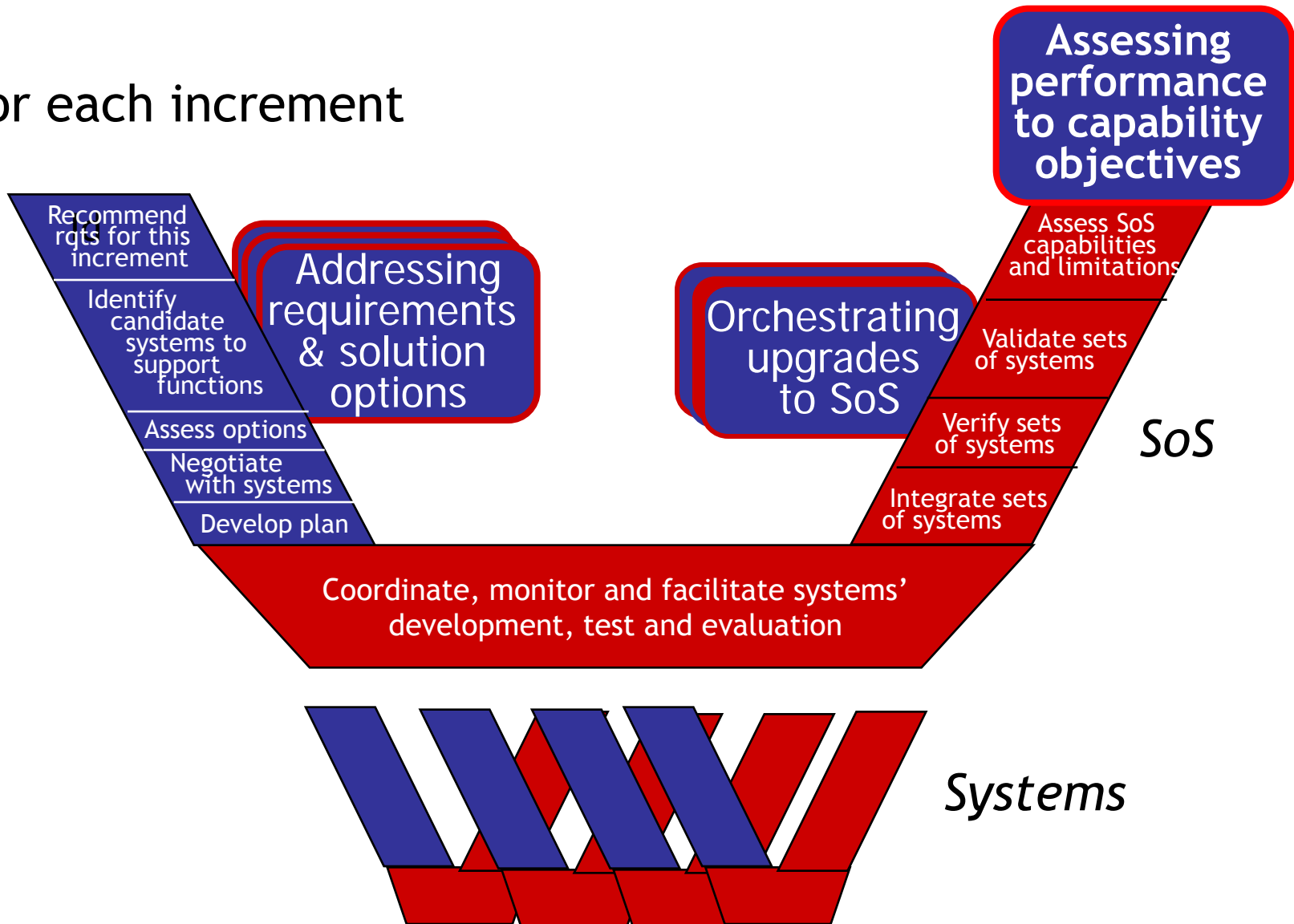

View of SoS Upgrade (2 of 2)

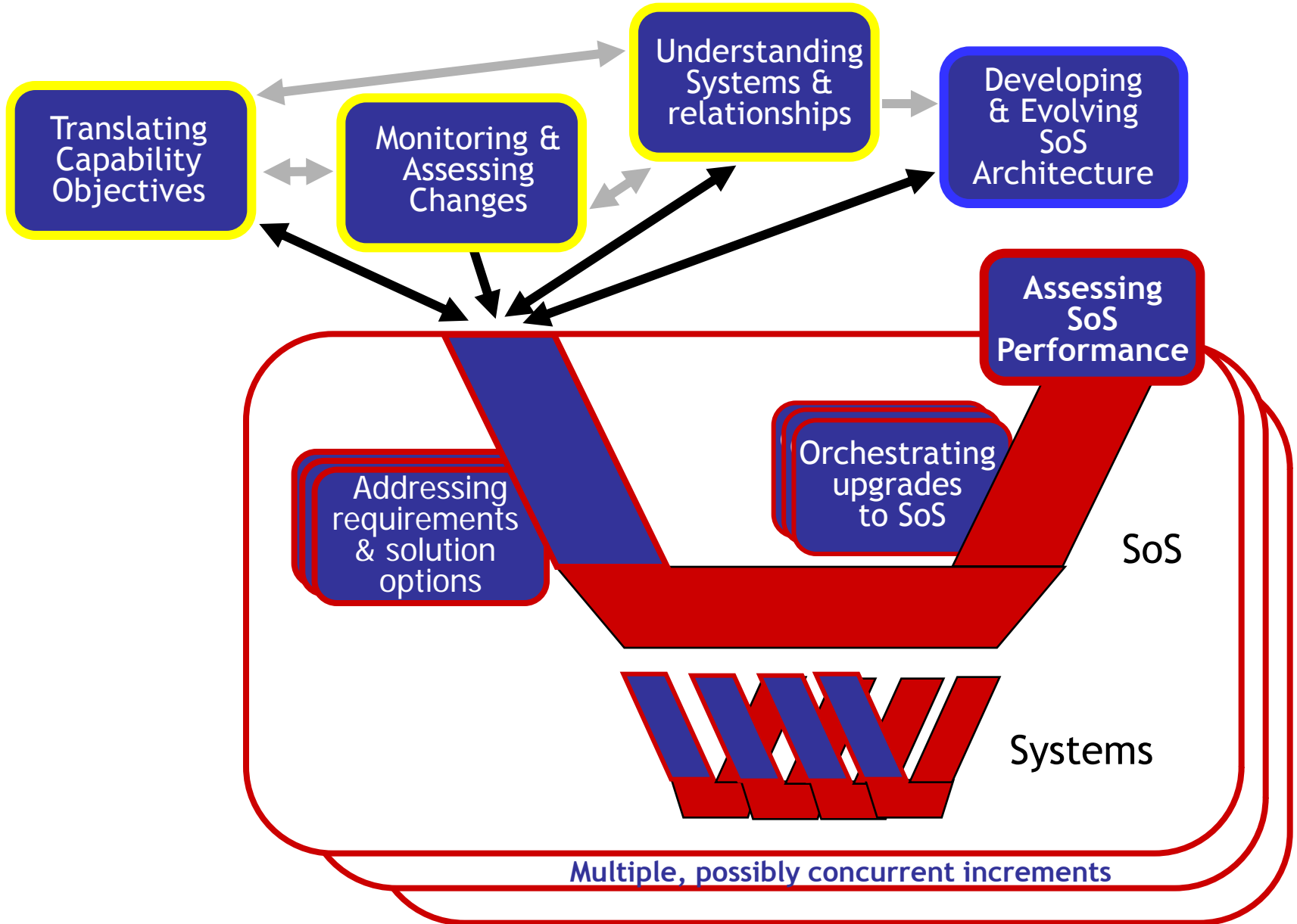

Guide Extract

Relationships Among the Core Elements

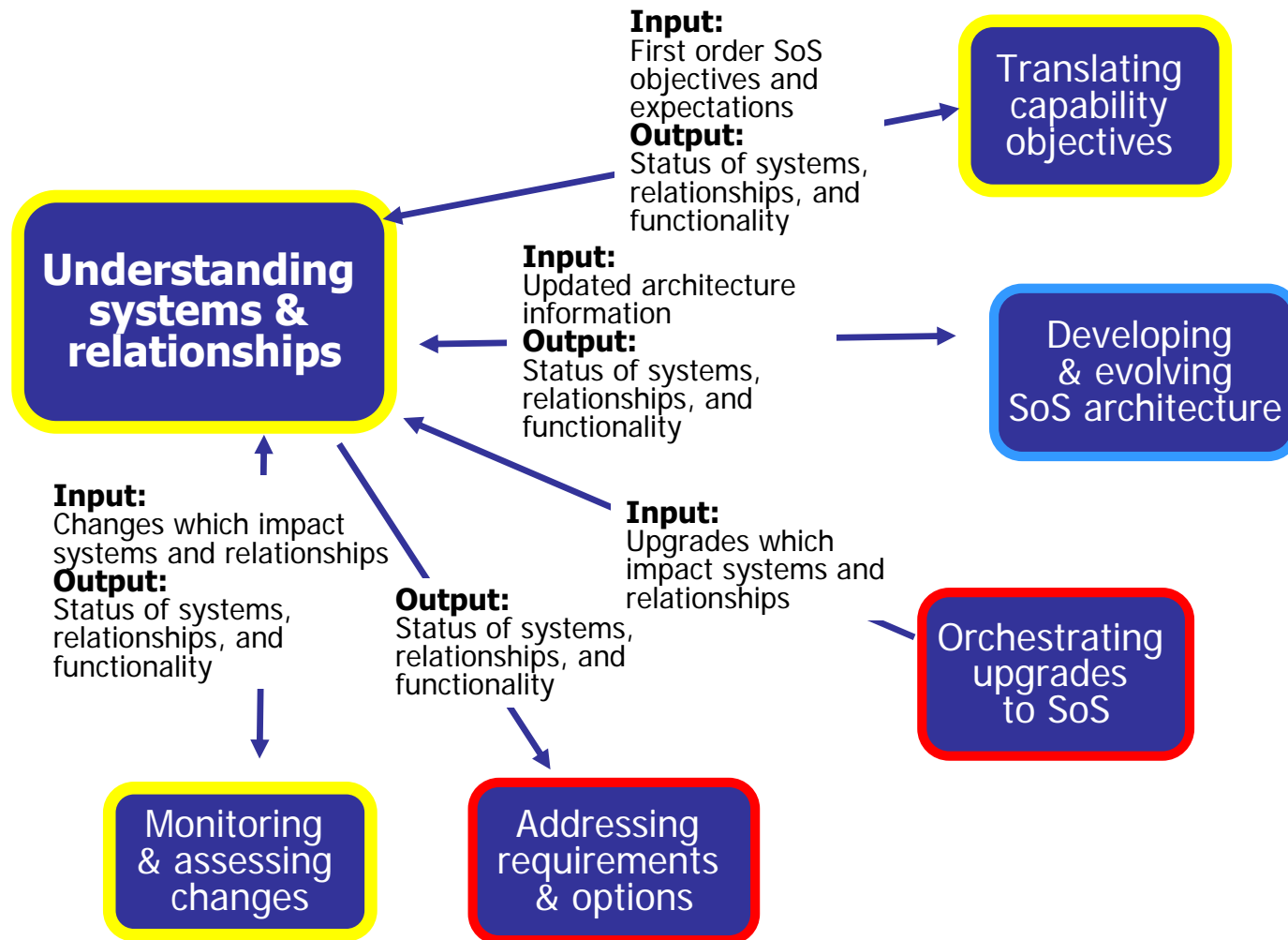

Guide Extract: SE Processes Supporting Each SoS SE Element

| Technical or Technical Management Process | Relationship to SoS SE Core Element |
|--|--|
| <p>Logical Analysis is the process of obtaining sets of logical solutions to improve understanding of the defined requirements and the relationships among the requirements (e.g., functional, behavioral, temporal).</p> | <p>Logical Analysis is a key part of Understanding Systems and Relationships. Basic to engineering an SoS is understanding how systems support SoS functionality. In developing a new system, the systems engineer allocates functionality to system components based on a set of technical considerations. In an SoS, the systems engineer develops an understanding of the functionality extant in the systems and how that functionality supports SoS objectives, as a starting point for SoS architecture and evolution. ...</p> |
| <p>Risk Management ... helps ensure program cost, schedule, and performance objectives are achieved at every stage in the life cycle and to communicate to all stakeholders the process for uncovering, determining the scope of, and managing program uncertainties.</p> | <p>Risk management is a core function of SE at all levels. In Understanding Systems and Relationships, the systems engineer assesses the current distribution of functionality across the systems and identifies risks associated with either retaining the status quo or identifying areas where changes may need to be considered. The systems engineer also considers approaches to monitor, mitigate, or address risks. Such risks might include ...</p> |
| <p>Configuration Management is the application of sound business practices to establish and maintain consistency of a product's attributes with its requirements and product configuration information.</p> | <p>Understanding Systems and Relationships is where the CM process for the “as is” SoS resides and is maintained as the SoS product baseline. In a system the CM process addresses all of the ‘product’s’ features where the system itself is the product. In an SoS, the ensemble of systems and their functionality is the product; the SoS CM depends on the CM of the systems to maintain much of the product information, since the system owner, PM, and system systems engineer normally retain responsibility for their systems. The SoS CM focuses on the linkage to the system CM and crosscutting attributes which pertain to the SoS not addressed by the CM of the systems....</p> |



What is Working? SoS SE Principles

- Address **organizational** as well as technical perspectives
 - Factor in broader set of consideration into trade space and technical planning
- Focus on **areas critical to the SoS**
 - Leave the rest to the systems engineers of the systems
- Technical management approach reflects need for **transparency and trust** with focused active participation
- SoS designs are best when **open and loosely coupled**
 - Impinge on the existing systems as little as possible
 - Are extensible, flexible, and persistent overtime
- **Continuous** ('up front') analysis which anticipates change
 - Design strategy and trades performed upfront and throughout
 - Based on robust understanding of internal and external sources of change

Way Ahead

- Guide is out and in use, offers a **first step**
 - Highlights the issues of SoS in DoD today
 - Provides some support for SE teams operating in SoS today
 - Plan for outreach and educational materials
 - Assess added guidance for areas such as Systems Engineering Plans
- Efforts are underway to support **update** to the guide
 - A follow-up data collection to get an understanding of ‘how to’ level of information from ongoing SoS SE efforts
 - Cooperative effort with NDIA M&S Committee to examine promise and experience with M&S to support SoS SE
 - Series of industry exchanges on SoS topics of common interest
 - International cooperative efforts are being initiated
 - Expansion into broader areas
 - SE for Capability Portfolio Management
 - Net Centric Enterprise Systems/Services

Backup

Active SoS SE Practitioners

| Name | Acronym | Owner | Approach |
|---|-----------------------|--------------|------------------------------|
| Army Battle Command System | ABCS | Army | Acquisition Program |
| Air Operations Center | AOC | Air Force | Acquisition Program |
| Ballistic Missile Defense System | BMDS | Joint | Acquisition Program |
| USCG Command & Control Convergence | C2 Convergence | Coast Guard | Strategy |
| Common Aviation Command & Control System | CAC2S | Marine Corps | Acquisition Program |
| Distributed Common Ground Station | DCGS-AF | Air Force | Program Office |
| DoD Intelligence Information System | DoDIIS | Intel | DIA CIO Initiative |
| Future Combat Systems | FCS | Army | Program Office |
| Ground Combat Systems | GCS | Army | Program Executive Office PEO |
| Military Satellite Communications | MILSATCOM | Joint | AF Wing |
| Naval Integrated Fire Control – Counter Air | NIFC-CA | Navy | SE Integrator in PEO |
| National Security Agency | NSA | Intel | Agency |
| Naval Surface Warfare Center Dahlgren | NSWC | Navy | Warfare Center |
| Single Integrated Air Picture | SIAP | Joint | Acquisition Program |
| Space and Missile Systems Center | SMC | Air Force | SE Authority |
| Space Radar | SR | Joint | Acquisition Program |
| Theater Joint Tactical Networks | TJTN | Joint | PEO |
| Theater Medical Information Systems – Joint | TMIP | Joint | Acquisition Program |

Provided a basis for understanding SoS in DoD Today



Systems Engineering to Ensure Aircraft Airworthiness

21 Oct 08

Jim Miller
Director of Engineering
727 ASW/EN
Phone: (405) 736-4101
james.c.miller@tinker.af.mil

Sustainment Environment



727th Aircraft Sustainment Wing

Col. Paul Waugh
Commander

Mr. Bob Valdez
Deputy Director

Mr. James Miller
Director of Engineering

PROVIDING EFFECTIVE & EFFICIENT WEAPON SYSTEM SUPPORT

OC-ALC Wing Structure

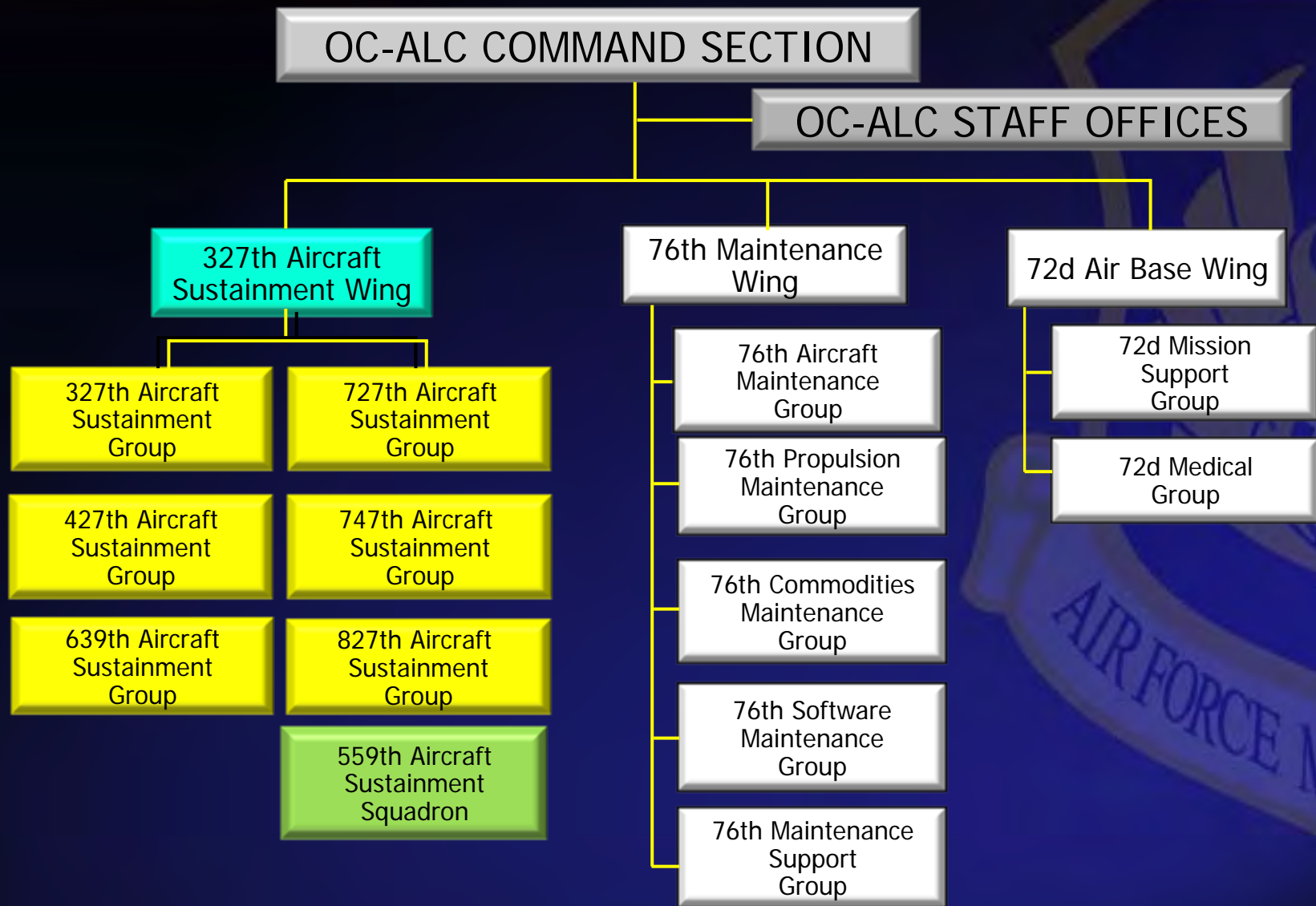

327th Aircraft Sustainment Wing

327th Aircraft Sustainment Wing

Col Paul Waugh, 736-5865

Bob Valdez, 736-5865

Jim Miller, 736-4101

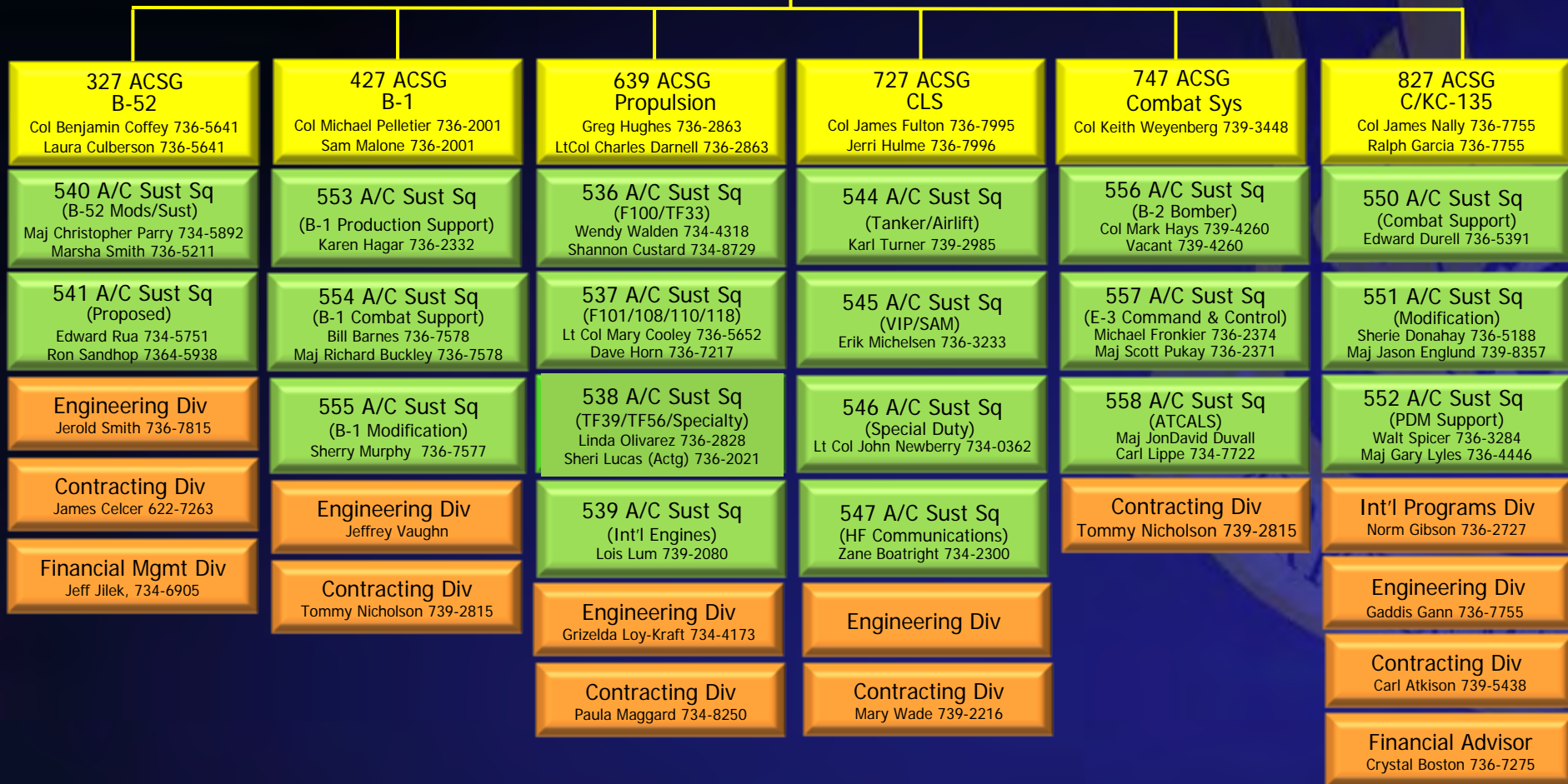
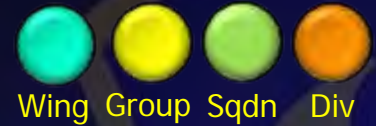

327th ASW Responsibilities

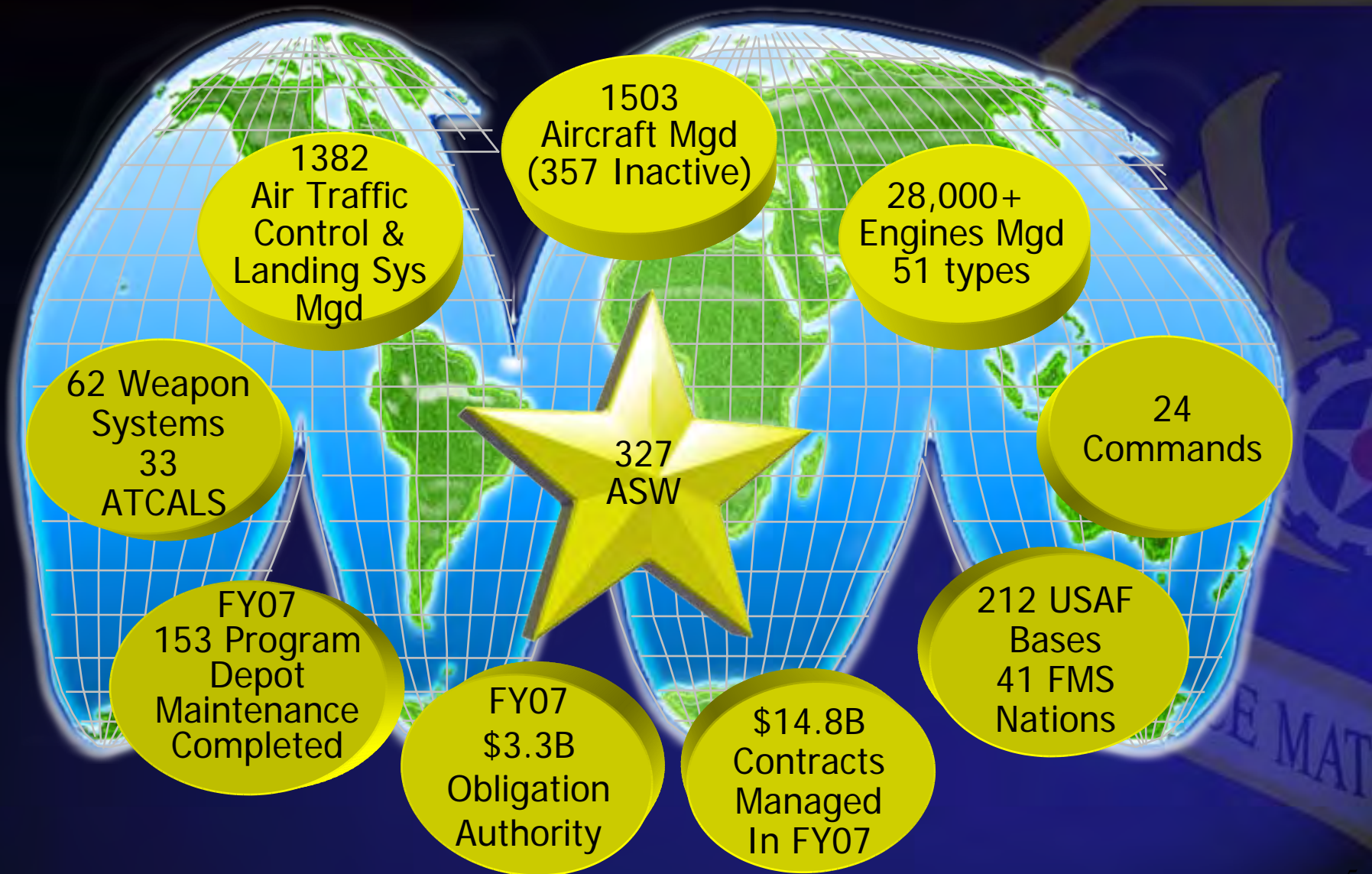

So What is the Airworthiness Problem?

- Airworthiness is a requirement for all aircraft, whether FAA or DoD
- Tinker AFB manages 20-plus different types of CDA
 - Aircraft use a mixture of FAA and Air Force criteria and methods of compliance to verify airworthiness when modifying the aircraft
- Modifying a CDA by a process that combines both FAA Certification and Air Force Certification could result in a hybrid safety standard.
 - Such a standard is unproven by either the FAA or the DoD, and could therefore put the aircraft and crew at risk
- No planning and implementation process to ensure comprehensive and complete airworthiness of all designs and parts
- No tracking the organization's progress regarding airworthiness for upper management in a fleet of over 400 aircraft throughout the entire lifecycle of the CDA

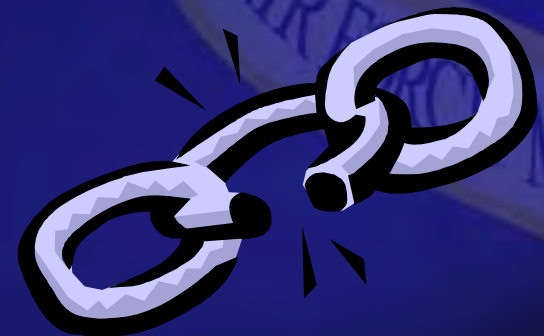

Airworthiness Project Overview

- **Problem Statement**
 - Current practices do not ensure 100% of CDA modification design/parts are correctly certified for airworthiness.
- **Project Definition and Scope**
 - 727 ACSG aircraft (CDA) sustained by Boeing
 - Airworthiness certification to cover various (FAA & Military) compliance methods
 - Review and “Walk” the entire process in both orgs
 - Define Responsibility Accountability Authority (RAA) for any process decision pts
 - Ensure certification means supports lifecycle sustainment
 - Must include metrics for upper management visibility

Current Process

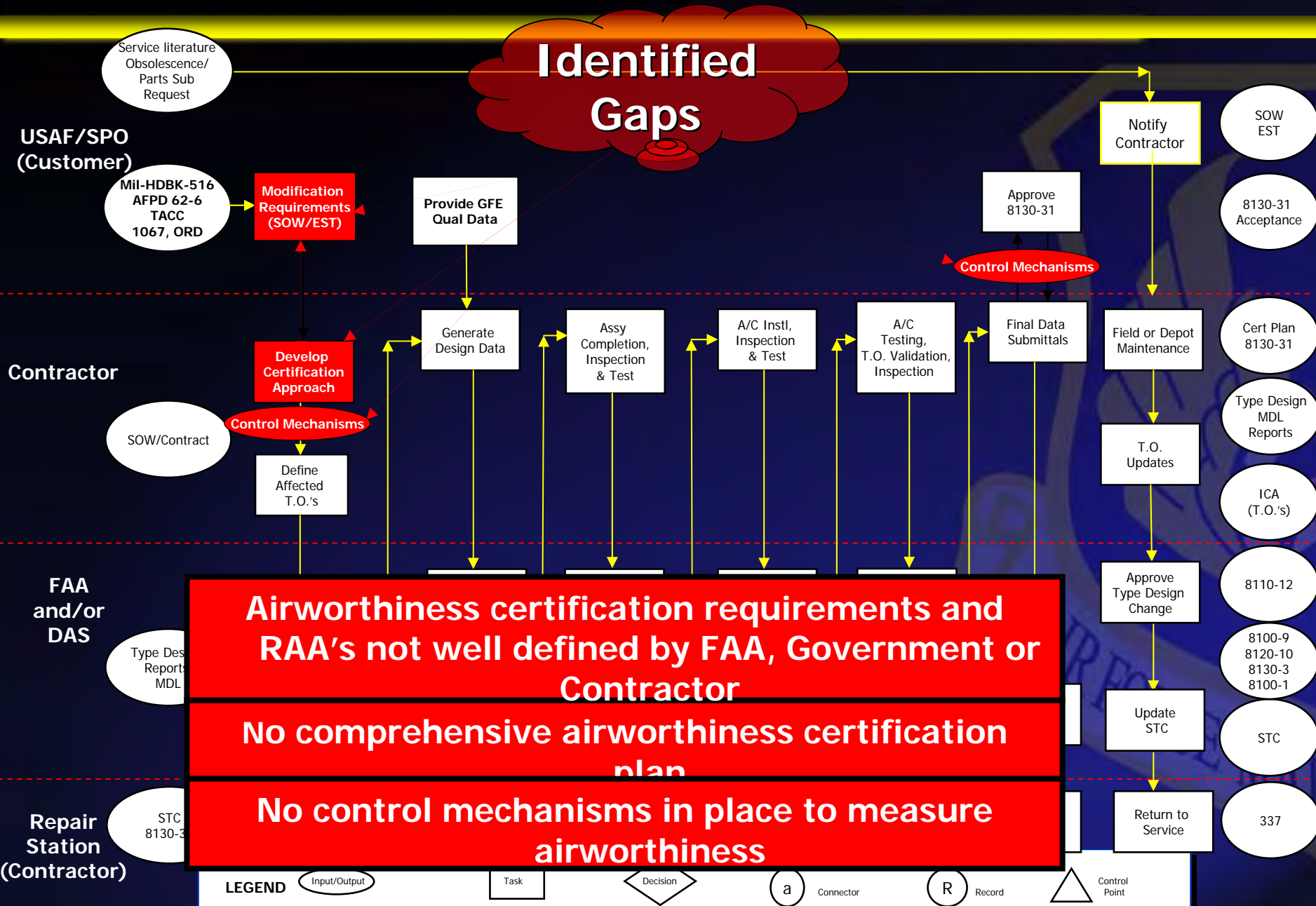

GAPS

- **Government does not clearly state airworthiness requirement to contractors**
- **Responsibility, Accountability and Authority (RAA) not well defined by FAA, Government or Contractor**
- **No comprehensive airworthiness certification plan**
 - Plan not done early in modification process
 - Plan not coordinated between Government, FAA and Contractor
- **No control mechanisms in place to measure airworthiness**

Gap #1: Requirements Not Clear

- Airworthiness very briefly mentioned
- Rarely states what type airworthiness certification required
- Rarely addresses parts
- Rarely addresses life cycle cost/sustainment aspects
- Does not address who/when airworthiness decisions will be made
- Examples....



Airworthiness SOW Language Examples

- **“The contractor shall-obtain FAA approval for this modification...”**
- **“Any equipment installed as part of this modification not covered with full FAA certification must be...”**
- **“Obtain FAA approval for engineering drawings...”**
- **“This SOW directs the contractor to provide an FAA approved modification...”**
- **“Contractor shall obtain FAA approval where applicable...”**
- **“Contractor shall obtain FAA where practical...”**

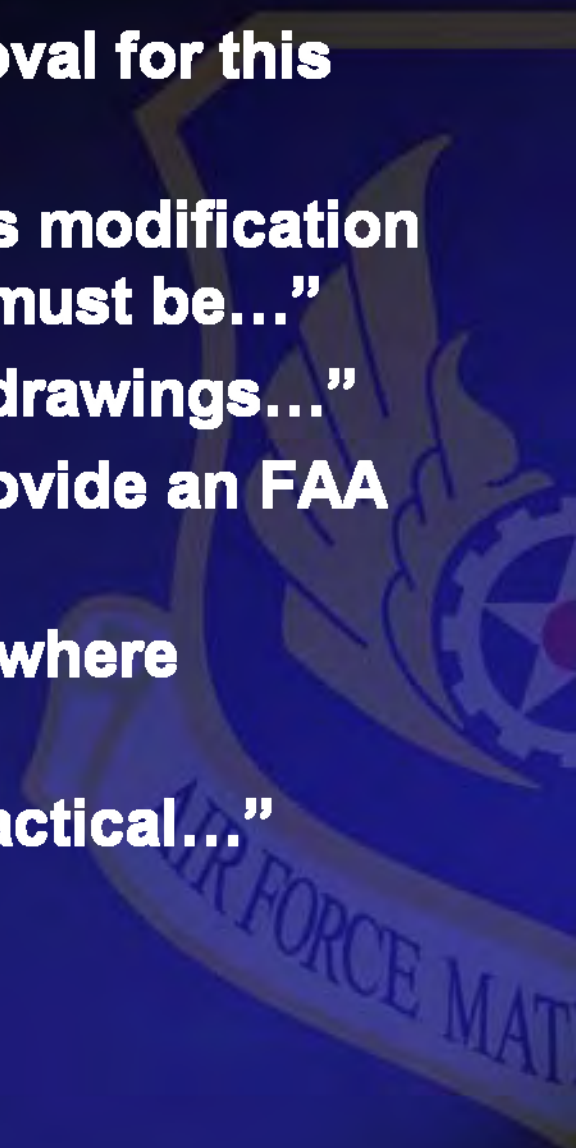

Gap #2: RAA Not Well Defined

- **Responsibility, Accountability and Authority (RAA) not well defined by FAA, Government or Contractor**
- **Neither Gov't nor Contractor have policy in place defining who makes airworthiness decisions throughout process**
 - **Design: Not clear who decides which of design cert will be followed**
 - **Parts: Decisions made at various levels, part “pedigree” often assumed, or not given consideration to life cycle cost**



GAP #3: No Certification Plan

- MIL-HDBK-516B describes criteria, but not implementation and planning
- Currently no certification plan required for modification
- No plan provided up-front regarding all designs and all parts
- Government usually does not find out until end what the certification is

The logo of the Air Force Materiel Command is visible in the background on the right side of the slide. It features a stylized eagle with its wings spread, holding a gear in its talons. Below the eagle is a banner with the text "AIR FORCE MAT".

AIR FORCE MAT

GAP #4: No Control Measures

- **How much FAA certified and how much Military certified?**
- **Which design certification methods used?**
- **What are the pedigrees of all the parts?**
- **Does the actual delivered modification match the planned?**
- **How can you keep your SPM and Chief Engineer informed of this important topic before the signing of the DD Form 250?**

So What Are Doing About It?

- Instigated a step-by-step Operating Instruction to implement air worthiness management throughout the organization
- Implemented tangible approach that is:
 - Aimed at the working level
 - Applies to both contractor and Air Force
 - Applicable throughout entire organization
 - Accounts for status/progress through metrics
 - Always starts with requirements



4 Solution Recommendations

- **Improve SOW wording (Requirements)**
- **Complete airworthiness approach/certification plan for both design and parts early**
- **Clearly define decision making authority for each airworthiness condition**
- **Establish control measures to verify 100% certification of designs and parts and keep upper management informed**

Sol'n #1: Improved SOW Words

- **OI contains decision tree which will drive appropriate level of airworthiness requirements**
- **Airworthiness certification requirements expanded and clarified to contractor**
- **OI contains “cut-and-paste” template SOW language for modification contracts**
- **Templates available for:**
 - **FAA Airworthiness Certification**
 - **Non-FAA Airworthiness Certification**
 - **Airworthiness Sustainment Requirements (Parts)**
 - **Airworthiness Documentation**



Sol'n #2: Airworthiness Cert. Plan

- **The Airworthiness Certification Plan Must:**
 - Be delivered NLT System Requirements Review
 - Cover 100% of planned design
 - Cover 100% of planned parts
 - Instructions for Continued Airworthiness (ICA)
 - Sustainment plan to ensure availability of airworthy parts throughout life cycle
 - For all non-FAA parts or design, must have SPM or Chief Engineer approval
 - Account for life cycle maintenance
 - Deliver applicable airworthiness certification documentation
 - Include specific control measures (metrics) to track health

Sol'n #3: Decisions at Right Level

- **Clearly define decision making authority for each airworthiness condition**
 - OI contains detailed matrix for each certification method, part certification and documentation requirement
 - OI clearly defines for each condition what level has approval authority
 - Chief Engineer or Single Manager
 - Engineering Flight Director
 - Lead engineer or program manager
 - Boeing make similar changes to their internal processes

Sol'n Gap #4: Developed Metrics

- **Establish control measures to track the following:**
 - Design/part certification method
 - Design certification breakout
 - Part certification breakout
- **Start tracking at beginning and continue through delivery**
 - Brief to Upper Management Quarterly
 - Metrics must have ability to roll-up
 - For a collection of modifications
 - For entire aircraft
 - For entire organization

Design/Part Certification Method

DESIGN

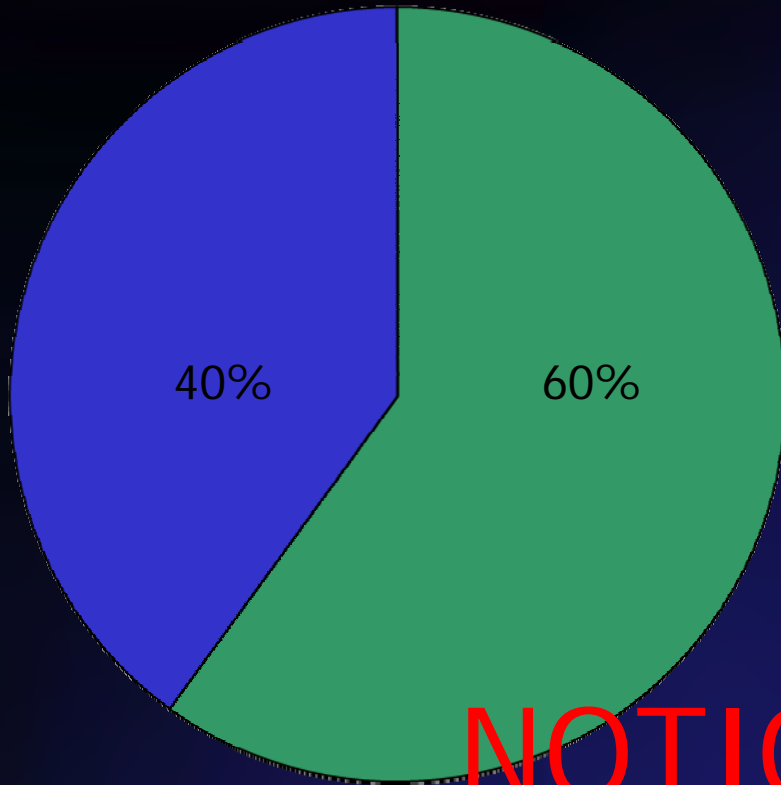

PARTS

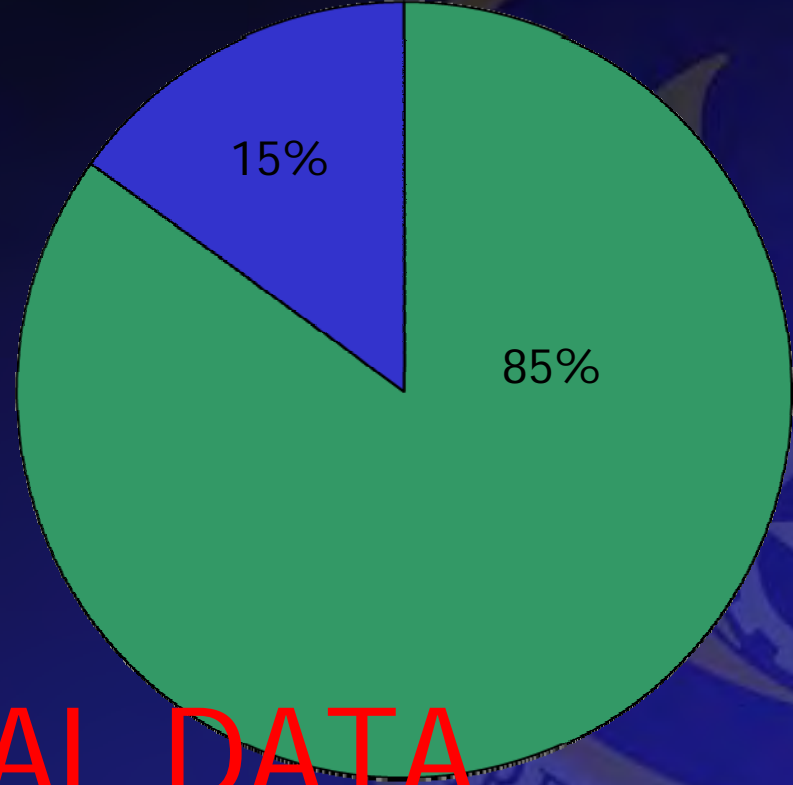

NOTIONAL DATA

■ FAA
■ Military

■ FAA
■ Military

- FAA represents fully commercial compliant
- Military is anything but fully commercial compliant

Design Certification Breakout

Total Mods

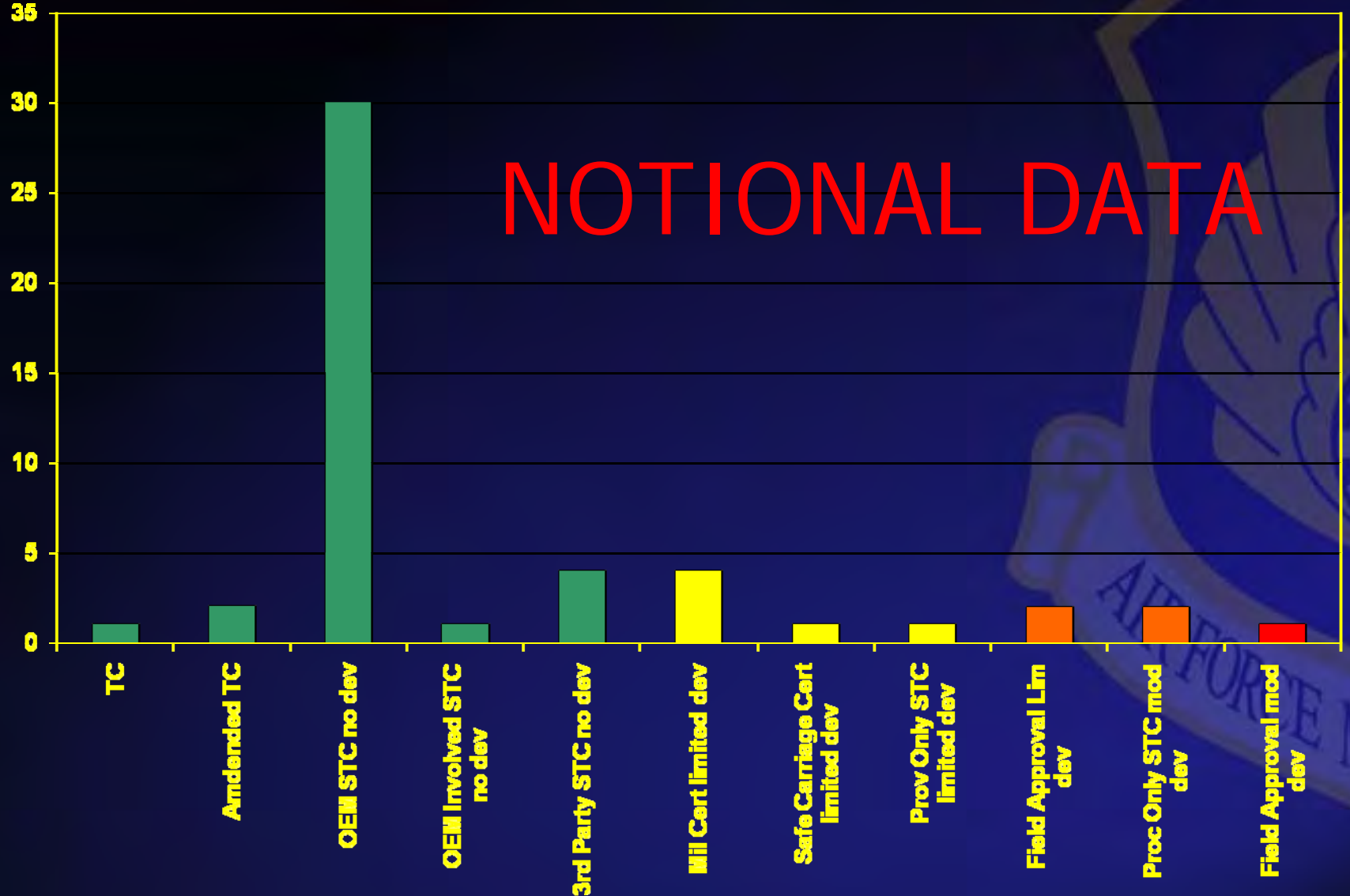

Part Certification Breakout

NOTIONAL DATA

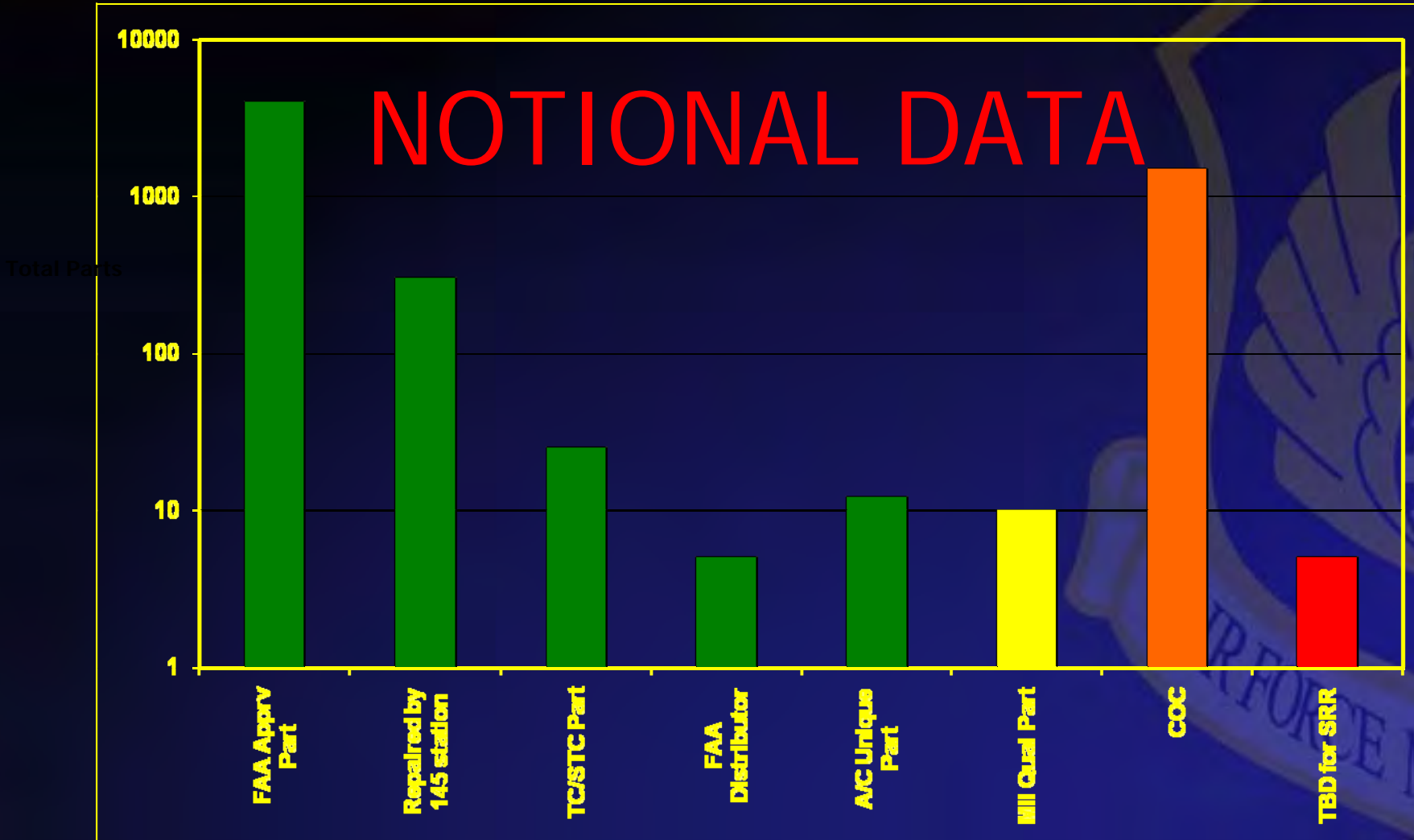

New Process to Ensure Airworthiness

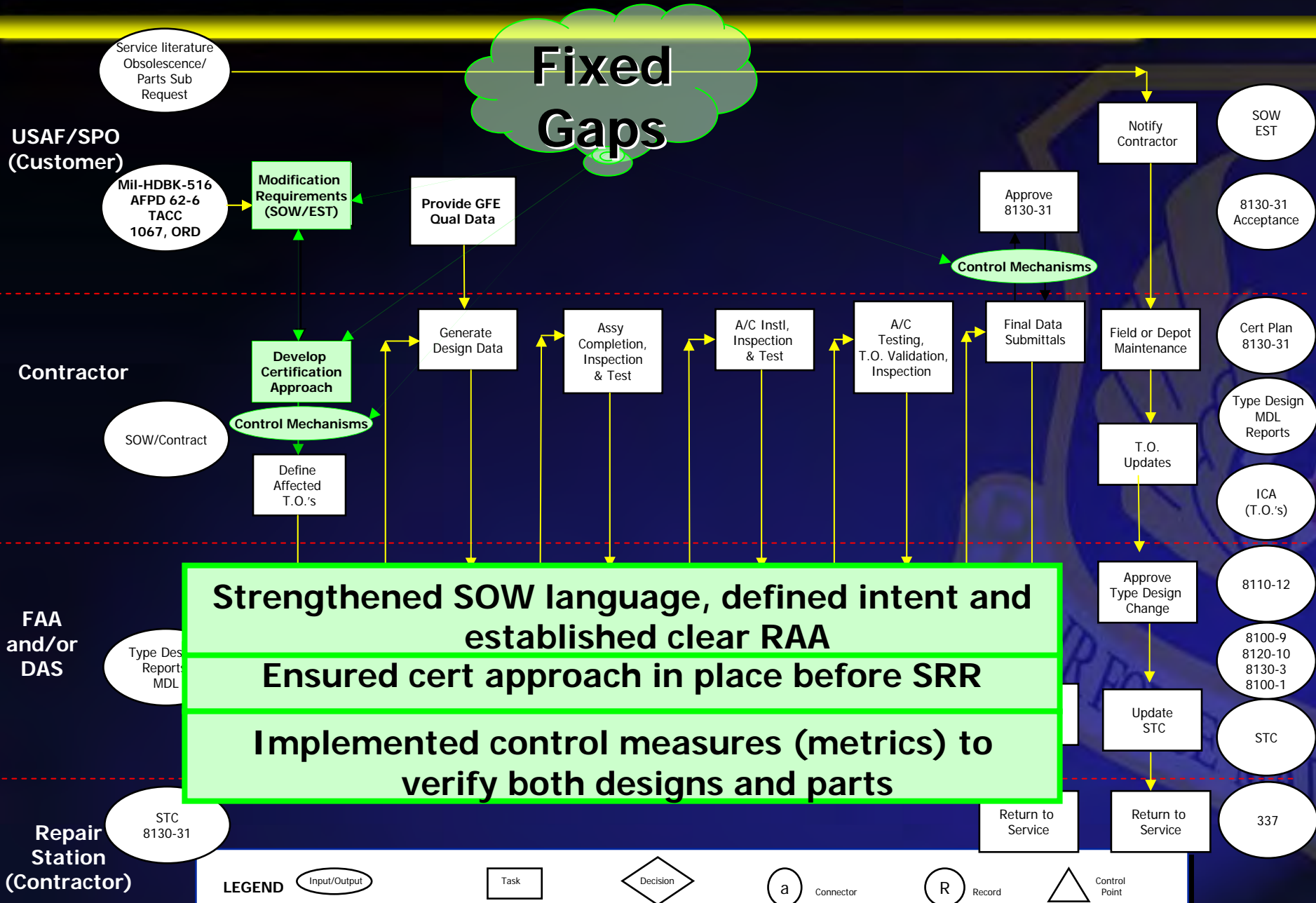

Summary

- **Focuses on airworthiness certification planning and implementation rather than establishment of airworthiness certification criteria**
- **Provides a standardized proactive airworthiness certification management process consistent with Air Force policy**
- **Provides a process to ensure airworthiness certification requirements are an integral part of program management—contractor and DoD**
- **Ensures “the right” airworthiness certification requirements, for both design and parts, are identified, implemented, monitored, controlled, and reported.**

Questions ?



Current Process

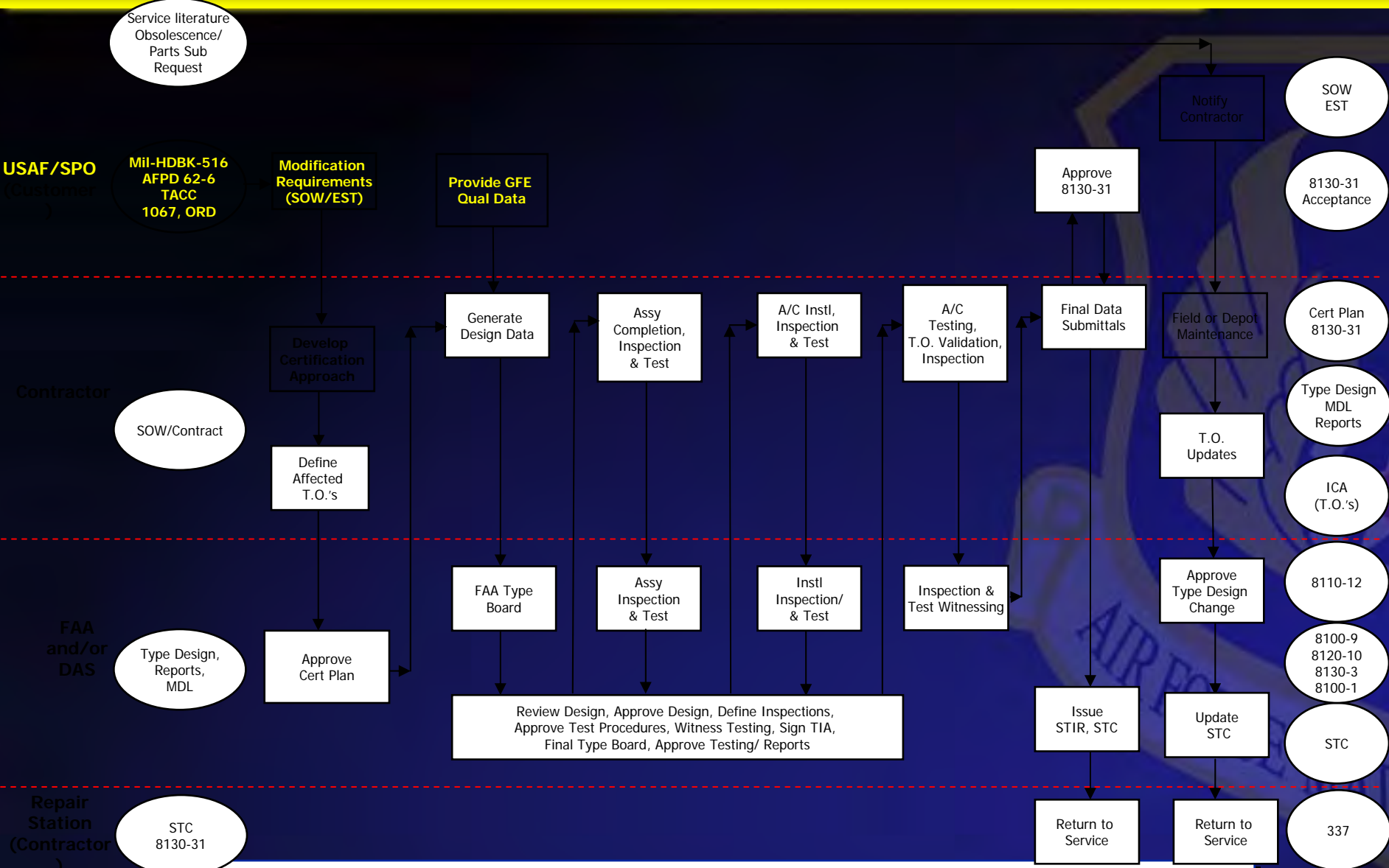

Parking Lot Gaps

| Gap | 727 ACSG | Boeing | ASC/FAA |
|---|----------|--------|---------|
| (G1) MACC's not being prepared for each modification | X | | |
| (G1a) Cert plans that are generated by contractor are not coordinated with Government | | X | |
| (G2) No approach in 727 ACSG for military certification path | X | | |
| (G2a) Contractor processes do not support military certification path or have firm understanding of military airworthiness requirements (i.e. AFPD 62-6, AFPD 62-4, AFPD 62-5, MIL-HDBK 516B) | | X | |
| (G3) User and contractual requirements provide insufficient details to ensure airworthiness certification for 100% of designs/parts | X | | |
| (G3a) Definitive definition of correct level of certification has not been provided by FAA | | | X |
| (G3b) Definitive definition of correct level of certification has not been provided by ASC/EN | | | X |
| (G3c) Contractor processes do not support different methods of airworthiness certification or incorporate FAA order 8110 | | X | |
| (G4) Responsibility, Accountability, Authority (RAA) is not defined or documented on Government or contractor side resulting in Program Managers, Equipment Specialists making airworthiness decisions on designs/parts | X | | |
| (G4a) Contractor does not have defined and documented RAA's for airworthiness decisions | | X | |
| (G4b) FAA has not defined and documented RAA's for airworthiness decisions | | | X |
| (G4c) ASC/EN has not defined and documented RAA's what airworthiness decisions should be made at what level for the different methods of certification | | | X |
| (G5) Airworthiness certification for entire provisions only installation not attained | X | | |
| (G6) Methods of maintaining continued airworthiness not fully understood | X | | |
| (G6b) Sustainment and modification teams on ASC/EN team not integrated | | | X |
| (G6a) Sustainment and modification teams on contractor team not integrated | | X | |
| (G7) Contract requirements impact on existing airworthiness decisions not understood | X | | |
| (G8) Sustainment (parts or services procurement and repair) not necessarily in accord with design/certification basis | X | | |
| (G8a) Contractor sustainment teams are not involved with new mod development | | X | |
| (G9) FAA certification of COTS do not play well together | X | | |
| (G9a) Air Force customer mission requirements and airworthiness requirements do not support each other | 28 | | X |

RCM Template

| Event | | Requirement | | |
|-------|--|---|---------|---------|
| 0 | Effort kickoff or major review/change | <ul style="list-style-type: none"> Identify scope of modification, including functions/ capabilities affected/incorporated, major hardware elements and LRUs, areas of a/c affected, and system or systems involved. | Step 1 | Step 1 |
| 1 | Overall Certification | <ul style="list-style-type: none"> R1 – Prepare an integrated airworthiness certification plan to accomplish comprehensive design certification. R2 – Provide Instructions for Continued Airworthiness to permit aircraft sustainment in accordance with certified design R22 – Provide control measures (metrics) to track design/part certification method, part certification breakout and design certification breakout on or before SRR with updates to metrics throughout modification program R23 – Provide delivery dates for metrics and supporting data in program integrated master schedule | Step 2 | Step 2 |
| 2 | <p>Are there portions of the modification which can/should be fully FAA certified? That is elements (A) which are:</p> <ul style="list-style-type: none"> Similar/identical to widespread commercial requirements Similar to private initiatives in effects on airworthiness, flight characteristics, operational characteristics, or pilot technique Are similar to private initiatives in aircraft usage or implementation of mission or interior accommodations Can meet all applicable FAA regulations and the same requirements for a commercial modification | <ul style="list-style-type: none"> R3 – Obtain FAA approval/certification for (A) equipment/ capability implementation in accordance with requirements applicable to aircraft operating under FAR Part (91, 121, etc. as applicable). | Step 3 | Step 5 |
| 3 | Are there adaptations or alterations of commercial aviation equipment required to suit military or mission requirements? | <ul style="list-style-type: none"> R4 – Modify (E) to provide capabilities (Z) R5 – Obtain FAA certification for (E), as modified | Step 3a | Step 3a |
| 3 | Will existing STCs (S) be partially changed as a result of this modification? | <ul style="list-style-type: none"> R18 – Obtain FAA approval of changes to (S) <p>Gov't note: Military a/c primarily don't maintain the airworthiness certificate (from the strict FAA stance). Recommend that a technical risk</p> | | |

RCM Template

| Event | Requirement | | |
|---|---|---------|---------|
| <p>5 Are there elements of the modification which cannot be approved for carriage by the FAA (B)?
Examples include:</p> <ul style="list-style-type: none"> •Hazardous materials or equipment •Equipment which cannot be demonstrated to be safe even when not operating | <ul style="list-style-type: none"> •R6 – Obtain Provisions Only FAA approval/certification of interfaces/provisions for (B). | Step 6 | Step 6 |
| <p>6 Will military qualified equipment (C) be needed/used in the modification?</p> | <ul style="list-style-type: none"> •R7 – Obtain FAA installation certification/approval for (C) using military qualification and operational data. •R8 – Perform necessary analysis to support FAA certification/approval for (C) •R9 – Perform additional testing required to support FAA certification/approval for (C) | Step 7 | Step 7 |
| <p>7 Will the modification use/apply non-aviation commercial- or consumer-grade equipment</p> | <ul style="list-style-type: none"> •R10 – Perform safety analyses covering use and operation of (L) •R11 – Obtain FAA certification/approval for (J) •R 12 – Identify any equipment in (L) which is unsafe or hazardous when applied to this modification (H) | Step 8 | Step 8 |
| <p>8 Is there hazardous commercial/consumer equipment?</p> | <ul style="list-style-type: none"> •R13 – Design enclosures and/or accommodations to control hazards posed by (H) •R14 – Obtain FAA certification/approval for enclosures and/or accommodations for (H) | Step 9 | Step 9 |
| <p>9 Is there doubt that sustainment parts and repairs can be readily obtained for FAA certified design, throughout the life of the modification?</p> | <ul style="list-style-type: none"> •R15 – Develop a sustainment plan to ensure availability of FAA parts repair capability throughout the life of the modification •R16 – Develop a sustainment plan to ensure availability of FAA replacement parts throughout the life of the modification <p>Gov't note: Requires a Logistics Support Analysis to determine right path FAA or not – don't assume pure FAA is the right approach.</p> | Step 10 | Step 10 |

RCM Template

Event

Requirement

| | | | | |
|----|--|--|---------|---------|
| 10 | Are there elements (M) that will not be FAA certified? | <ul style="list-style-type: none">•R17 – Develop a comprehensive plan to certify (M) in accordance with military airworthiness certification requirements (MIL-HDBK-516) | Step 11 | Stop |
| 11 | Are there elements B? | <ul style="list-style-type: none">•R18 – Conduct analyses, tests, and demonstrations to qualify (B)•R19 – Prepare and submit data to support certification of (B) for airworthiness, including operation in-flight | Step 12 | Step 12 |
| 12 | Are there elements K? | <ul style="list-style-type: none">•R20 – Conduct analyses, tests, and demonstrations to demonstrate/develop safe installation and use of (K)•R21 – Prepare and submit data to support certification or approval of (K) for installation and use | Step 13 | Step 13 |
| 13 | Military Certification | <ul style="list-style-type: none">•R21 - Conduct necessary analyses, test, and demonstrations to support airworthiness and operations approval for (M) | | |

RCM Template Key

- **A** Elements of modification which may receive full FAA certification/approval
- **B** Military only elements of the modification – those which cannot be approved for installation by FAA and require provisions only approval
- **C** Military qualified equipment for which FAA certification may be obtained
- **E** Commercial aviation equipment which must be altered or adapted to meet military requirements (subset of A)
- **H** Non aviation commercial or consumer equipment which is unsafe or poses hazards which cannot be mitigated (subset of L)
- **J** Non aviation commercial or consumer equipment which may be FAA certified (subset of L)
- **K** Non aviation commercial or consumer equipment which cannot be FAA certified or for which accommodations cannot be designed to permit certification (subset of L and possibly H)
- **L** Non aviation commercial or consumer equipment needed/used as part of modification
- **M** Elements requiring military airworthiness certification (Includes B and K)
- **S** Existing STCs modified in the course of the current modification
- **Z** Capabilities or features for military purposes which must be incorporated into commercial aviation equipment

Basic Systems Engineering Process

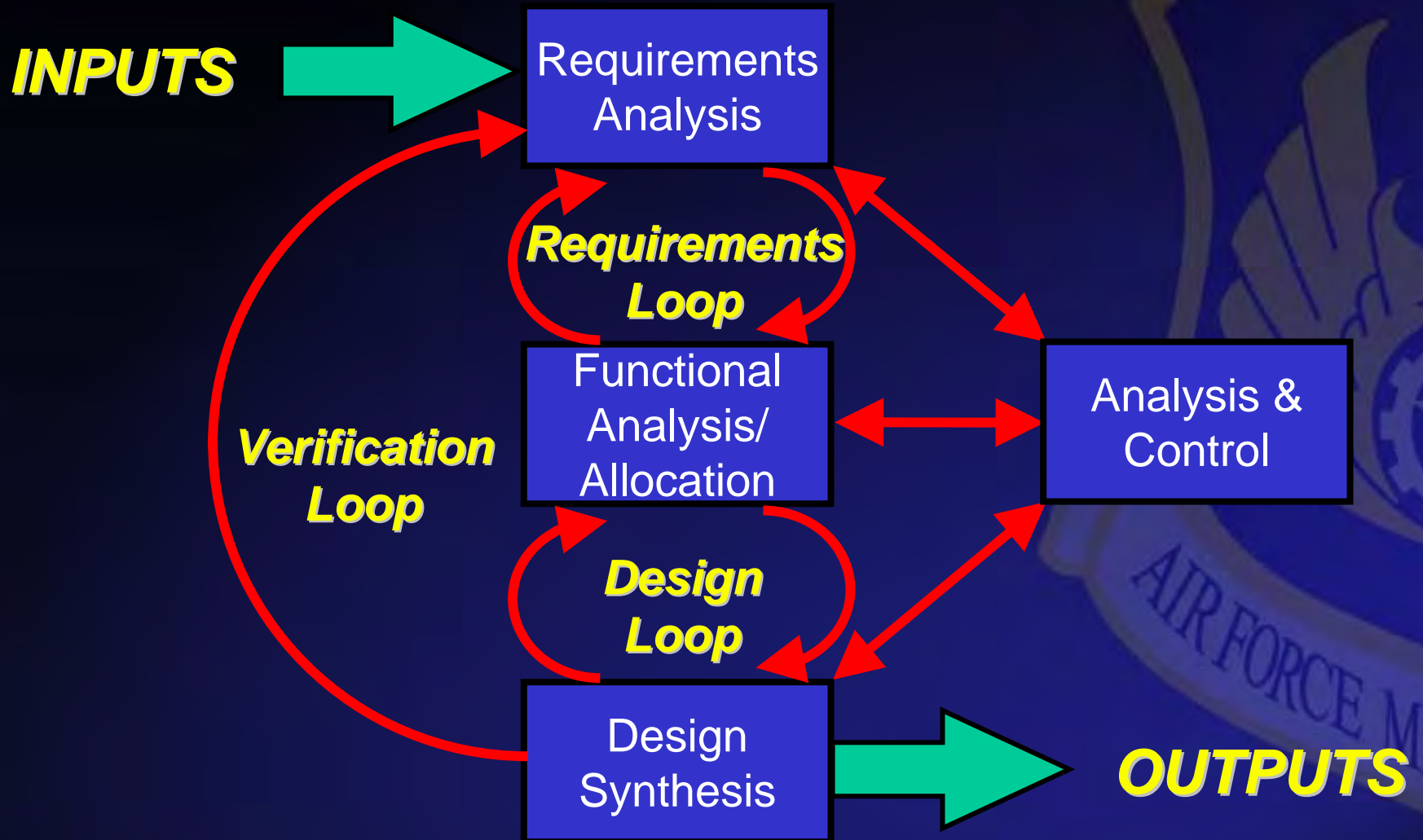

Major Modification Programs

17 Current Programs

| | | |
|---|--|----------|
| Y | KC-10 AMP – ASC Lead (ACAT II) | \$1.03B |
| G | KC-10 Dual 406 MHz ELT Upgrade (ACAT III)* | \$2.4M |
| G | KC-10 Iridium Phone (ACAT III)* | \$2.7M |
| G | KC-10 UHF SATCOM Antenna (ACAT III)* | \$2.6M |
| G | VC-25 Forward Lower Lobe (FLL) Cooling (ACAT III) | \$14.4M |
| G | VC-25 Presidential Data System (PDS) (ACAT III)* | \$223.3M |
| G | VC-25 CNS/ATM (ACAT III)* | \$41.8M |
| G | C-20 Gulfstream Test Vehicle (GTV) (ACAT III)* | \$8.7M |
| G | E-9 Telemetry Sys Upgrade (ACAT III)* | \$5.9M |
| G | E-4B Mod Block I (ACAT II) * | \$421.4M |
| G | E-4B 256 Kbps High Speed Data via INMARSAT (ACAT III)* | \$8.4M |
| R | C-12 EFIS (ACAT III) | \$77.7M |
| Y | HFGCS Network Control Station – West (ACAT III)* | \$23.2M |
| Y | HFGCS AFSPC Test Range HF Modernization (ACAT III)* | \$3.9M |
| G | HFGCS Network Optimization – Spiral II (ACAT III)* | \$7.1M |
| G | HFGCS Navy Consolidation (ACAT III)* | \$6.4M |
| G | HFGCS Audit Log Upgrade (ACAT III)* | \$189K |

*Program is fully funded



Systems Engineering Performance Measures

22 Oct 08

Jim Miller
Director of Engineering
727 ASW/EN
Phone: (405) 736-4101
james.c.miller@tinker.af.mil

Sustainment Environment



727th Aircraft Sustainment Wing

Col. Paul Waugh
Commander

Mr. Bob Valdez
Deputy Director

Mr. James Miller
Director of Engineering

PROVIDING EFFECTIVE & EFFICIENT WEAPON SYSTEM SUPPORT

OC-ALC Wing Structure

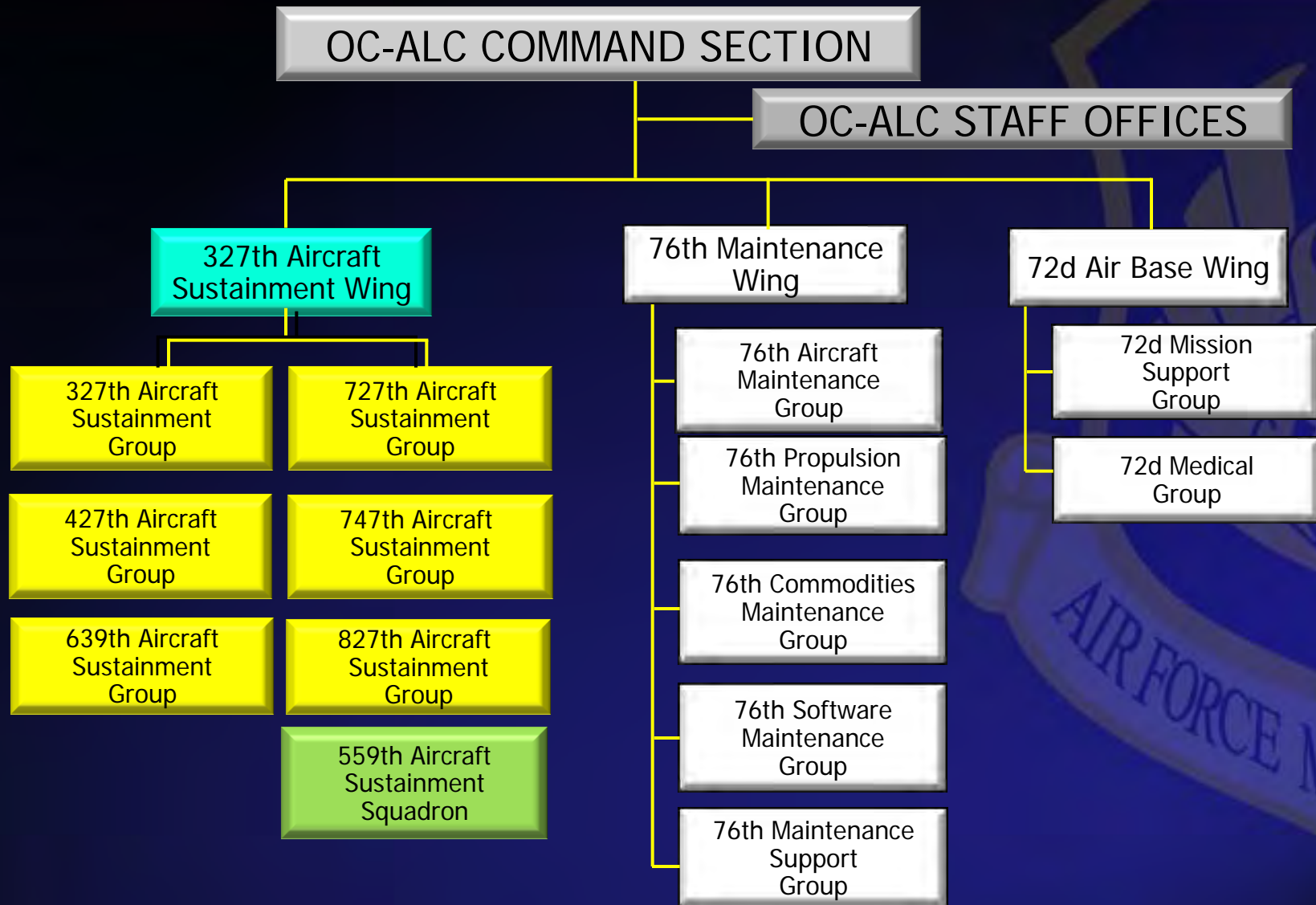

327th Aircraft Sustainment Wing

327th Aircraft Sustainment Wing

Col Paul Waugh, 736-5865

Bob Valdez, 736-5865

Jim Miller, 736-4101

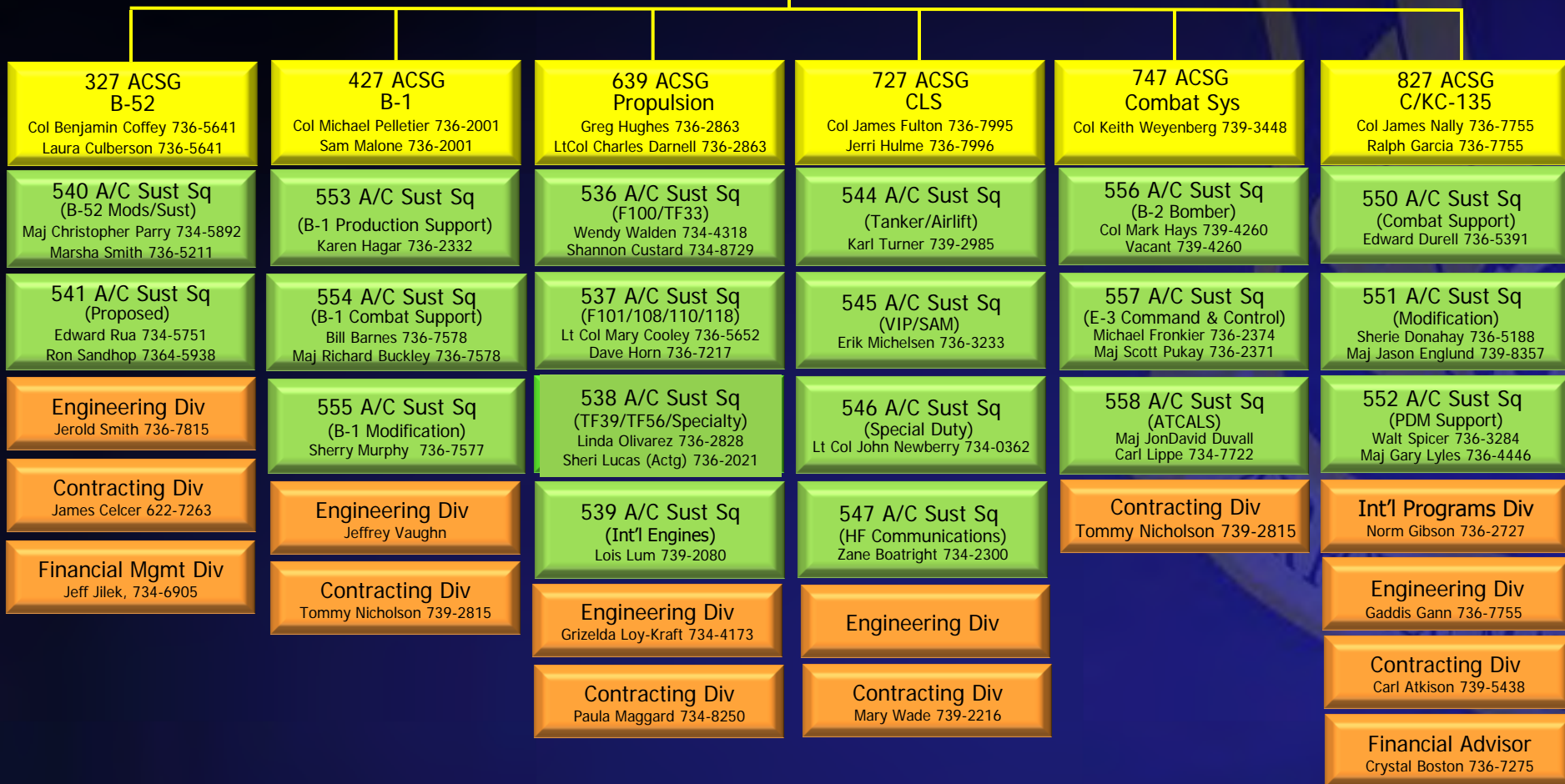

327th ASW Responsibilities

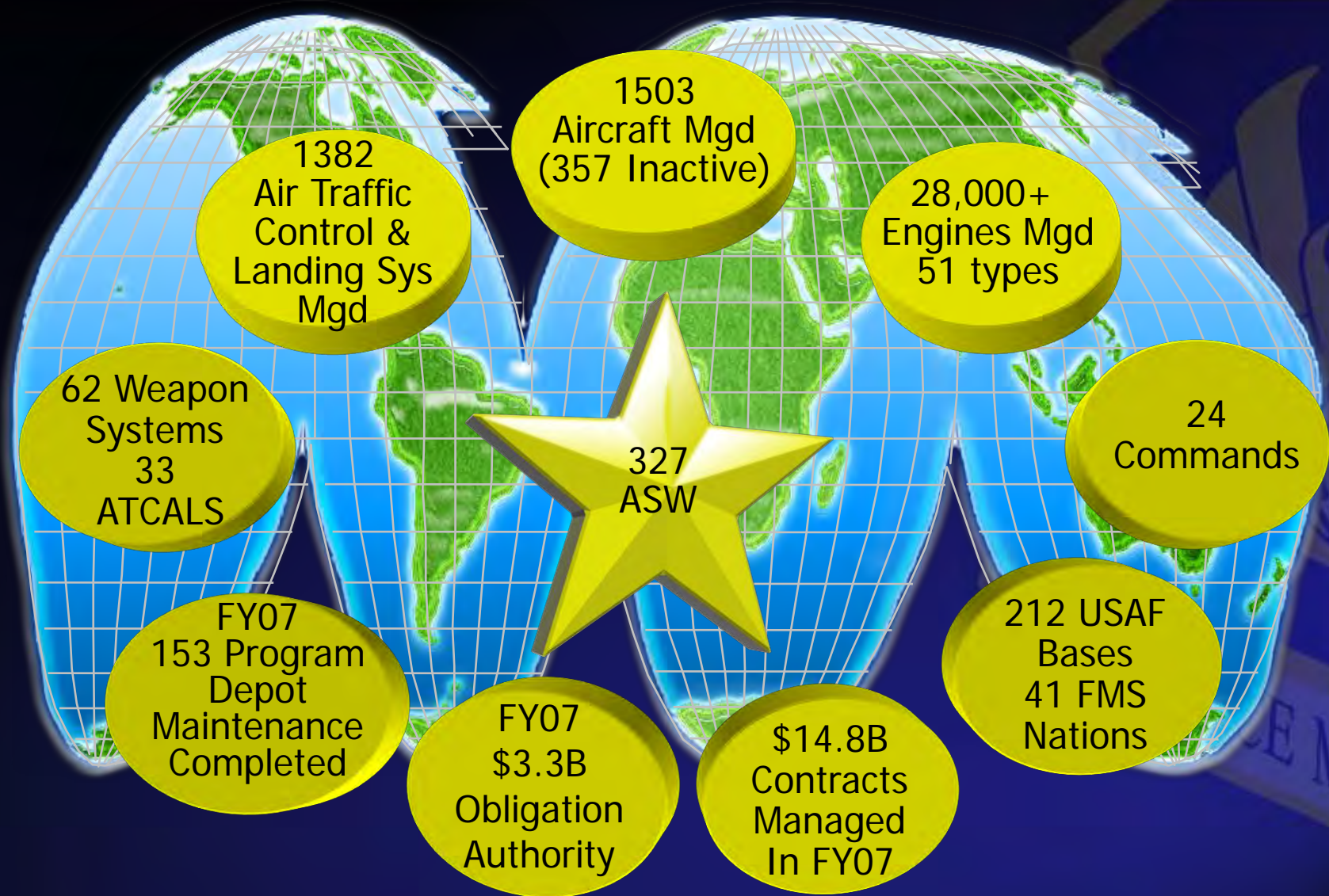

So What is System Engineering?

...Everything Can Be System Engineering

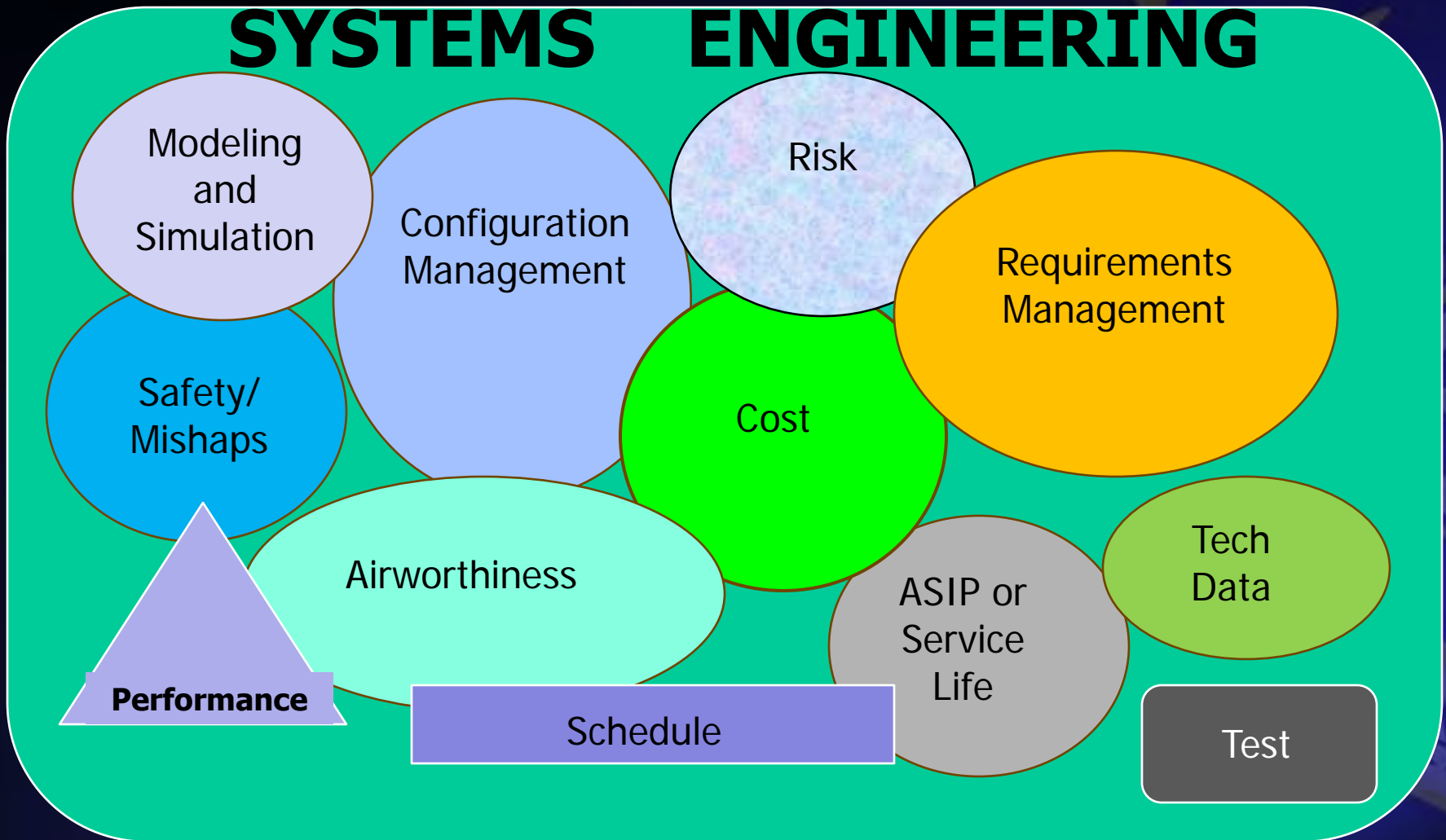

AF and DoD Sys Eng Policy

THE UNDER SECRETARY OF DEFENSE
3010 DEFENSE PENTAGON
WASHINGTON, DC 20301-3010
FEB 28 2004

MEMORANDUM FOR: SEE DISTRIBUTION

SUBJECT: Policy for Systems Engineering in DoD

Application of rigorous systems engineering discipline is paramount to the Department's ability to meet the challenge of developing and maintaining needed warfighting capability. This is especially true as we strive to integrate increasingly complex systems in a family-of-systems, system-of-systems, networked warfare context. Systems engineering provides the integrating technical processes to define and balance system performance, cost, schedule, and risk. It must be embedded in program planning and performed across the entire acquisition life cycle.

Toward that end, I am establishing the following policy, effective immediately and to be included in the next revision of the DoD 5000 series acquisition documents:

Systems Engineering (SE). All programs responding to a competition or requirements document, regardless of acquisition category, shall apply a systems SE approach that ensures total system performance and total interoperability within the family-of-systems, systems-of-systems context. Programs shall develop a Systems Engineering Plan (SEP) for all...

h. Assess the adequacy of current Department-level SE related policies, processes, practices, guidance, tools, and education and training and recommend any necessary changes.

Requires renewed emphasis on systems engineering
Implementation of SE Plans

THE UNDER SECRETARY OF DEFENSE
3010 DEFENSE PENTAGON
WASHINGTON, DC 20301-3010
MAY 12 2004

MEMORANDUM FOR: SEE DISTRIBUTION

SUBJECT: Policy Addendum for Systems Engineering

Per the direction in my systems engineering policy memorandum (February 20, 2004), the Director, Defense Systems established the Systems Engineering Forum. Your expertise readily available to program managers throughout the system life cycle. Consequently, I establish the following additional policy, effective immediately, and to be included in the next revision of DoD Instruction 5000.2.

Each Program Executive Office (PEO), or equivalent, shall have a lead or chief systems engineer on the program responsible to the PEO for the application of systems engineering across the PEO's portfolio of programs. The PEO lead or chief systems engineer shall review and approve all Systems Engineering Plans (SEPs) and oversee their implementation. The PEO lead or chief systems engineer shall also assess the performance of subordinate lead or PEO and program manager.

Requires PEO chief engineer
Conduct of technical reviews

MEMORANDUM FOR: SEE DISTRIBUTION
ACTING

FORCE MAT

SE Policy Addendum

Signed by the Marvin R. Sambour, Asst. SecAF (Acquisition) Apr 03 & Jan 04

- **Policy Memo 03A-005, 9 Apr 03**
 - **Subj: Incentivizing contractors for Better Systems Engineering**
 - “An immediate transformation imperative for all our programs is to focus more attention on the **application of Systems Engineering principles...**”
 - **Directing the following:**
 - **A. Assess ability to incentivize contractors to perform robust SE**
 - **B. Develop SE performance incentives**
 - **C. Include SE processes/practices during all program reviews**
- **Policy Memo 04A-001, 7 Jan 04**
 - **Subj: Revitalizing Air Force and Industry Systems Engineering (SE) – Increment 2**
 - “...intended to institutionalize key attributes of an **acceptable SE approach** and outcome...”
 - “...must focus on an end state...”

Systems Engineering Policy in DoD

Signed by the Honorable Mike Wynne, USD(AT&L) (Acting) Feb 20, 2004

- All programs, regardless of ACAT shall:
 - Apply an SE approach
 - Develop a Systems Engineering Plan (SEP)
 - Describe technical approach, including processes, resources, and metrics
 - Detail timing and conduct of SE technical reviews
- Director, DS tasked to provide SEP guidance for DoDI 5000.2
 - Recommend changes in Defense SE
 - Establish a senior-level SE forum
 - Assess SEP and program readiness to proceed before each DAB and other USD(AT&L)-led acquisition reviews

So What is the Problem?

- **High-level policy is there, But ...**
 - How do you know if you are doing it?
 - How do you measure so you drive the behavior?
- **Sys Eng scope can be huge, So ...**
 - What tenets should be measured?
 - What are the key characteristics?
 - How can it apply across different programs and organizations?
- **Sys Eng is important, Yet ...**
 - No accepted, standard metrics
 - No measure of sys eng current status
 - No metrics for both PM and upper management

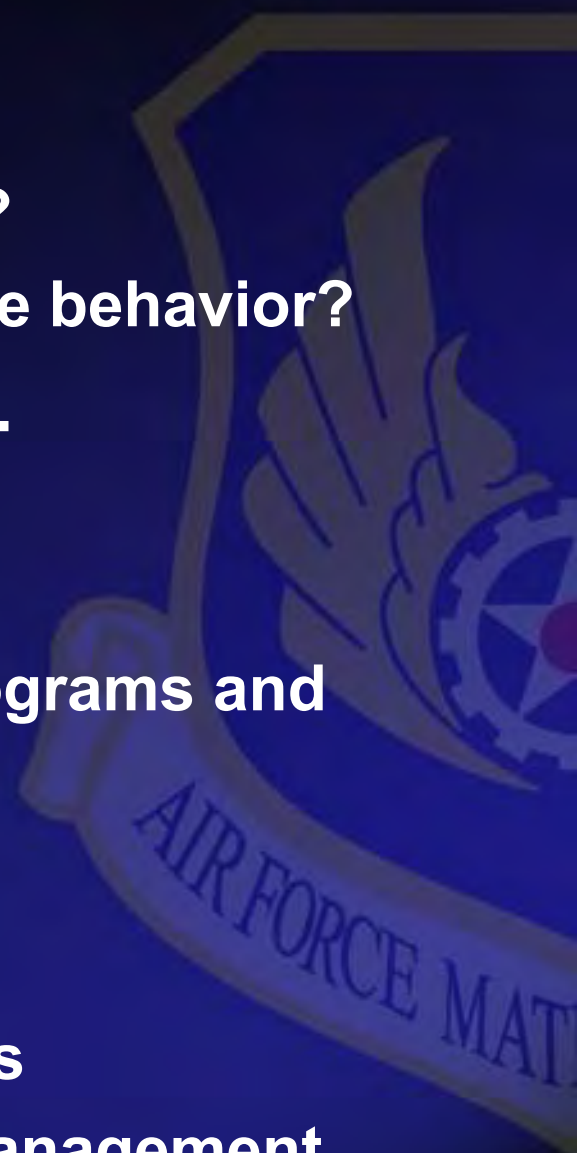

Why Measure Systems Engineering?

- When performance is measured ... **performance improves**
- When performance is measured and reported ... **the rate of performance improves**
- When performance is measured, reported, and compared ... **the rate of performance continues to improve**

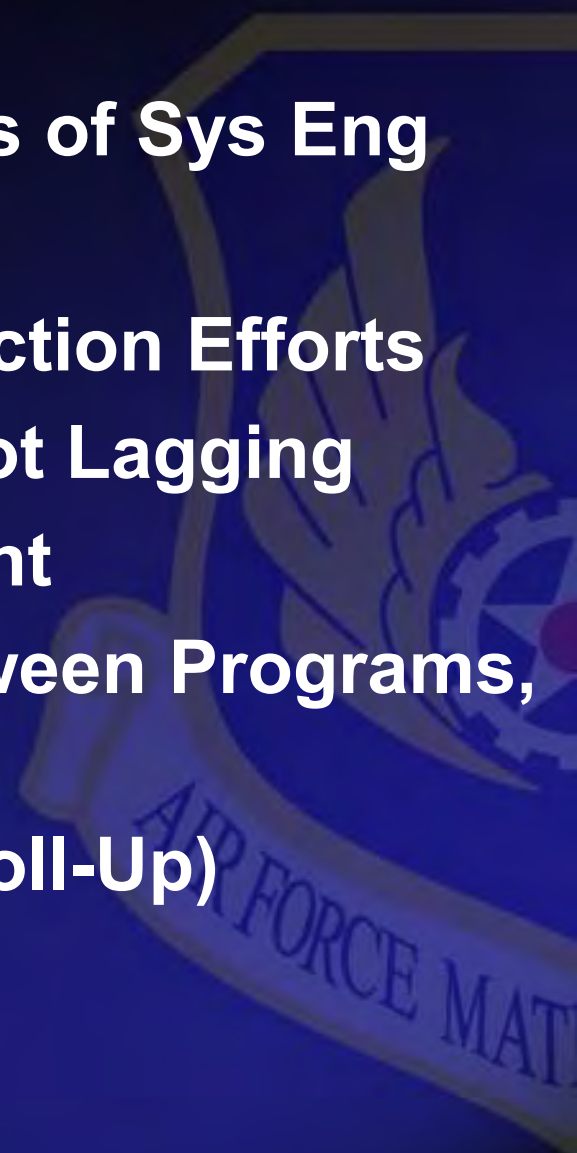

Sys Eng Metrics Key Characteristics

- **Must Measure Major Components of Sys Eng**
 - **Must Be Few in Number**
 - **Must Avoid Extensive Data Collection Efforts**
 - **Must Describe Current Status, Not Lagging**
 - **Must Be Targeted for Management**
 - **Must Allow For Comparison Between Programs, Organizations, and Time**
 - **Must Be Cumulative (Ability to Roll-Up)**
- 
- A large, semi-transparent watermark of the Air Force Materiel Command logo is visible in the background on the right side of the slide. The logo features a stylized eagle with its wings spread, holding a gear in its talons. Below the eagle is a banner with the text "AIR FORCE MATERIEL".

What Was Our Approach?

- **Defined first 5 Sys Eng Tenets**
- **Step-by-step implemented systems engineering throughout the organization**
- **Is a tangible approach that is:**
 - Aimed at the working level
 - Affects all phases of a program's lifecycle
 - Applicable throughout entire organization
 - Accounts for organization's progress through metrics
- **Documented clearly in Operating Instructions (OIs)**



What Each OI Has

- **Brief and to the point**
- **Pictorially defined process flow**
- **Specific instructions for each process step aimed at working level**
- **Clearly outlines approval levels**
- **Defines specific metrics**
- **States when/where show to upper management**



Tenets of Sys Eng

- **Our first-cut tenet selection of Systems Engineering:**
 - Requirements Management
 - Risk Management
 - Test Management
 - Airworthiness
 - Training



Tenets of Sys Eng

- Our first-cut tenet selection of Systems Engineering:
 - **Requirements Management**
 - Risk Management
 - Test Management
 - Airworthiness
 - Training



Requirements Mngt Process Flowchart

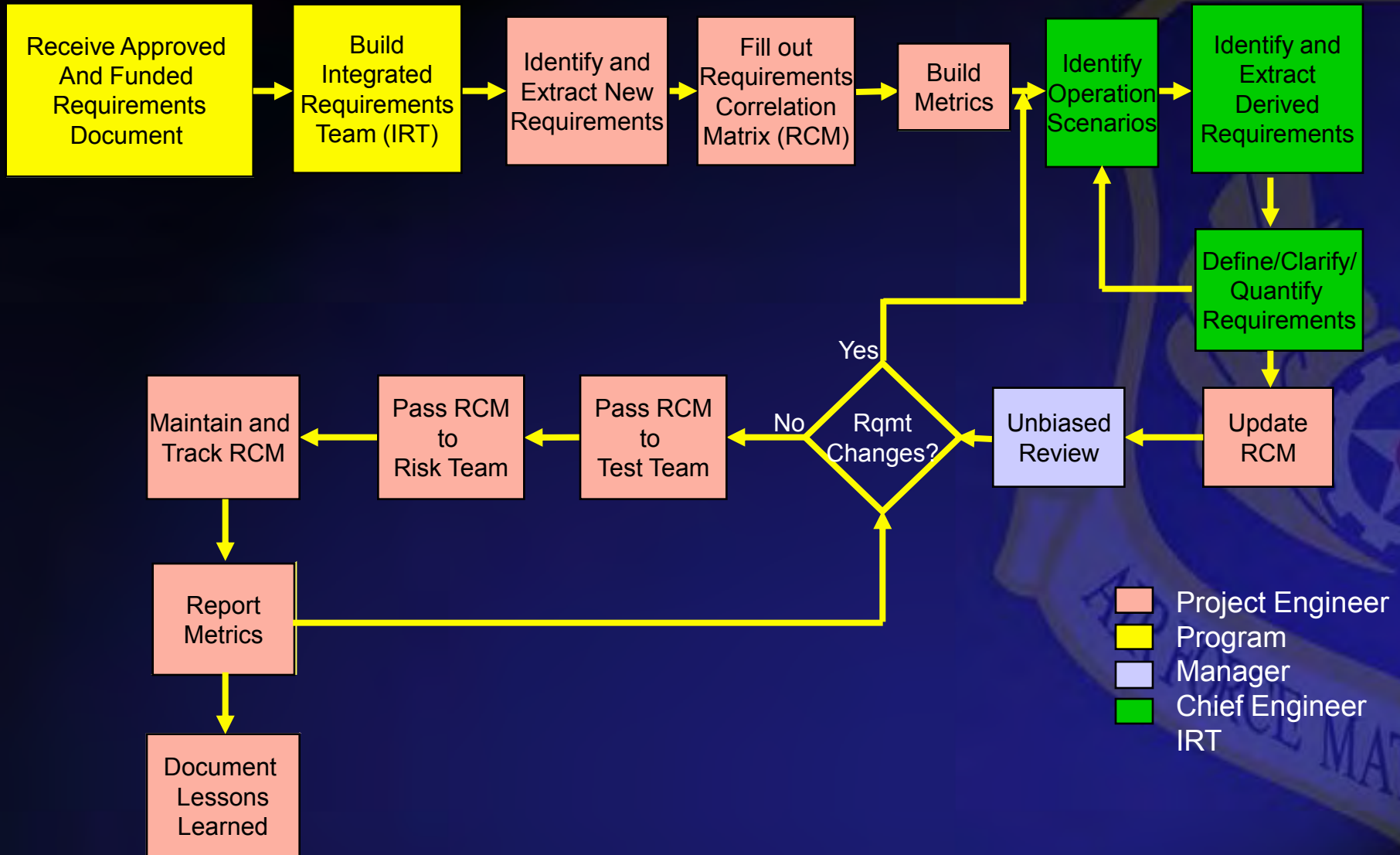

Requirements Management Metric

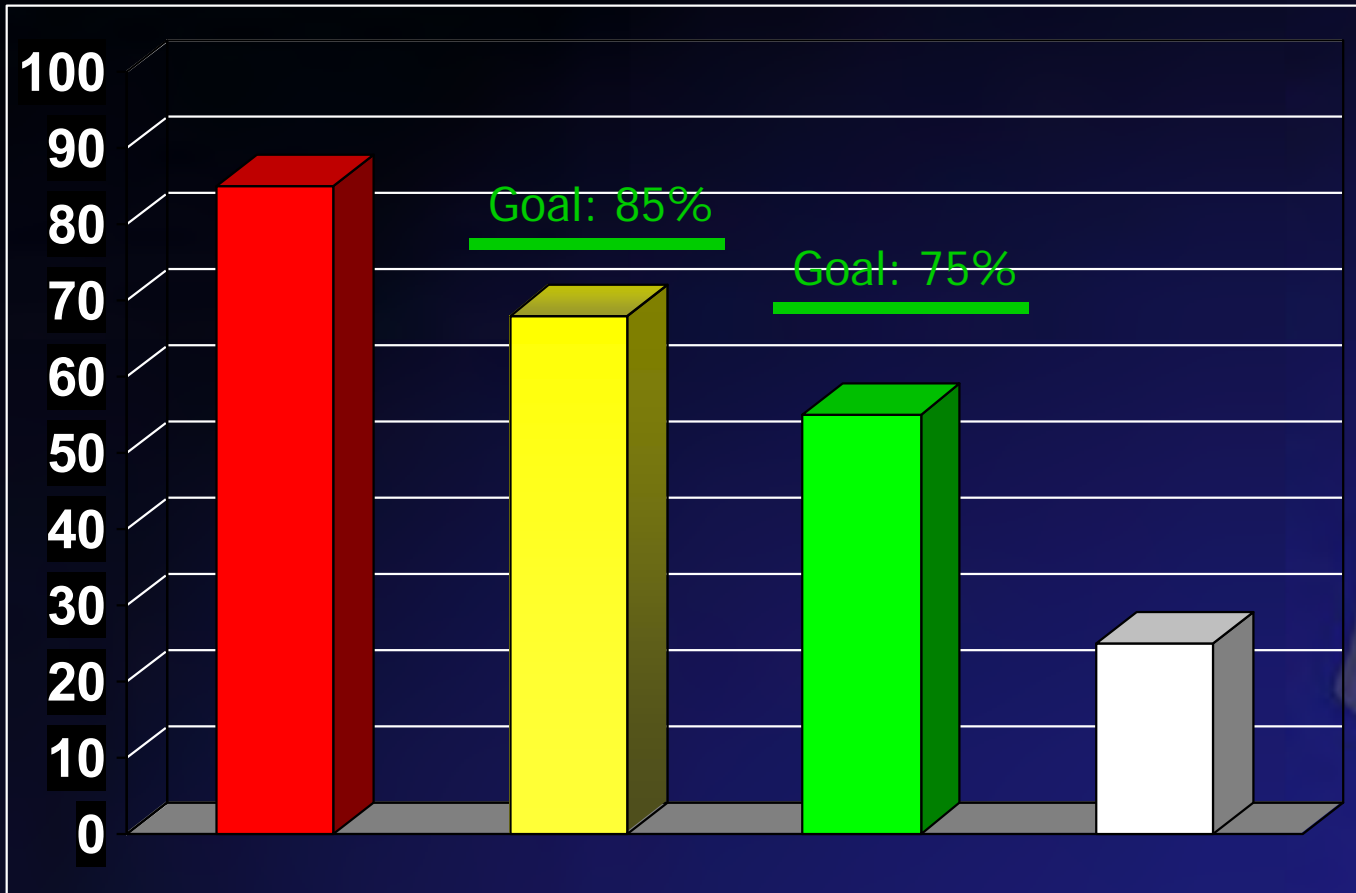

Total Requirements = Stated Requirements + Derived Requirements

Requirements Growth Metric

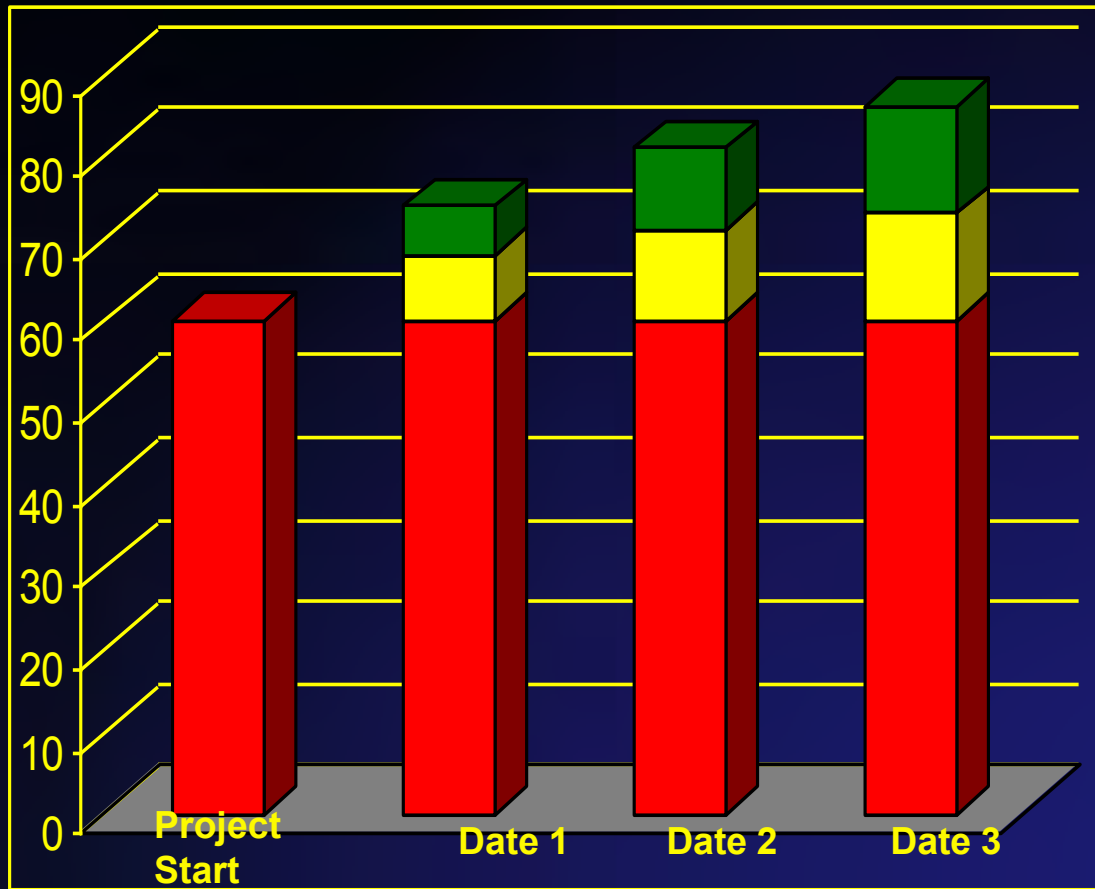

- Requirements Added
- Requirements Derived
- Baseline Requirements

AIR FORCE MAT

Tenets of Sys Eng

- Our first-cut tenet selection of Systems Engineering:
 - Requirements Management
 - **Risk Management**
 - Test Management
 - Airworthiness
 - Training

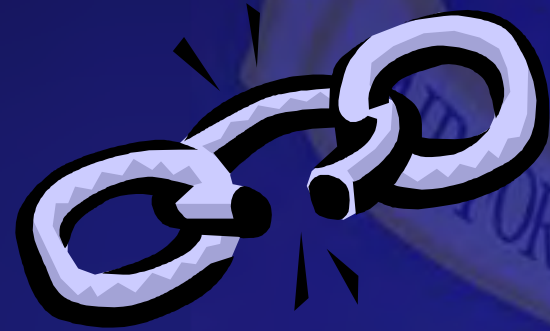

Risk Management Process Flowchart

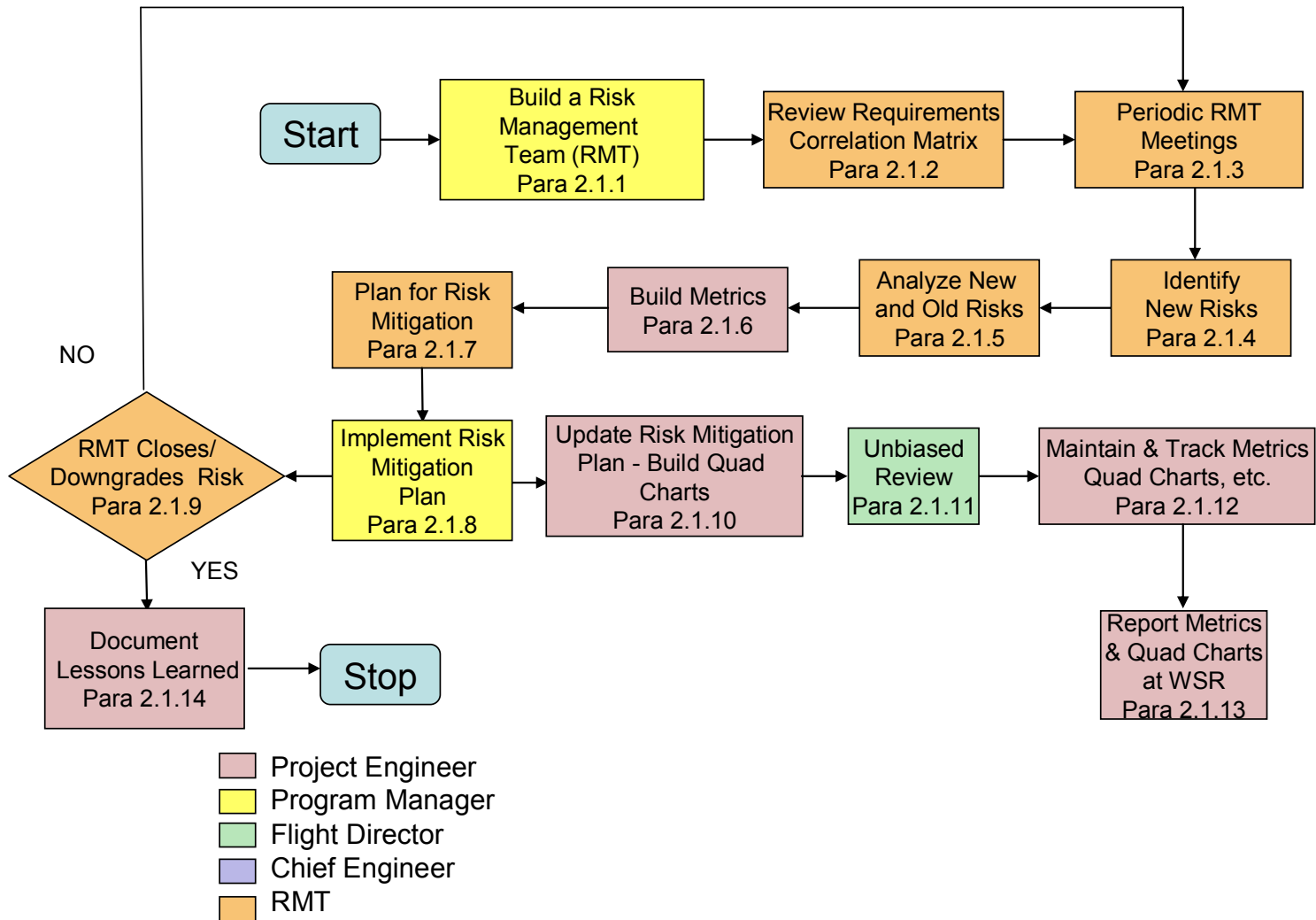
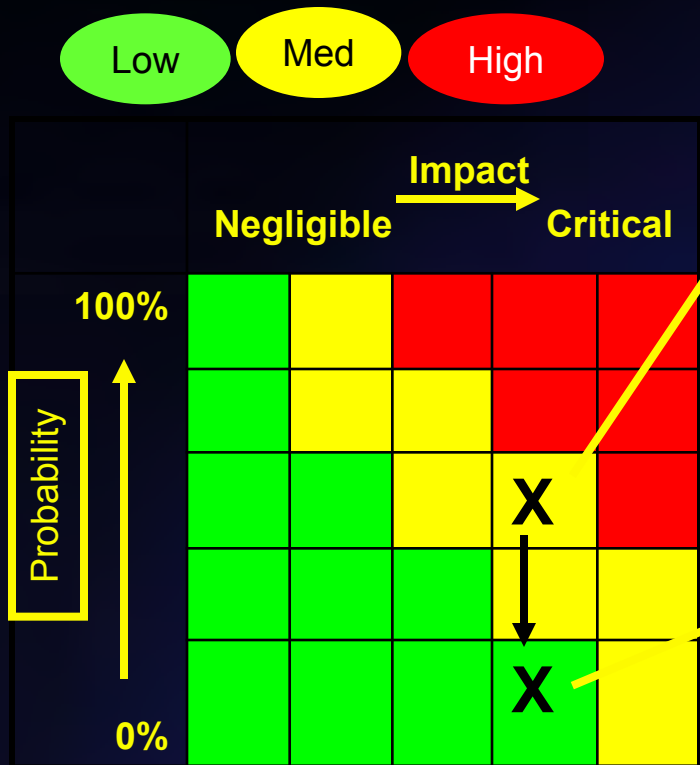

Figure 1. Flowchart for Risk Management Process

Risk #1 Assessment Matrix



Risk Workshop Completed –
14 Mar 07

Technical Risk: If software complexity increases on MCS then failure of modifications could result.

Mitigation Plan:

- Contractor is currently Capabilities Maturity Model Integration (CMMI) software level 3 certified and has plan to reach level 5 by contract award
- Government will ensure contractor will work with ground agencies to ensure software is interoperable
- Government will follow disciplined requirement matrix process outlined in 727 ACSG Operating Instruction (O.I.) to prevent unplanned requirements/complexity increases & track via established metrics

Risk Quad Chart

Risk Title

Risk Tracking Number

G

Risk
Color
Code

Background

Description of problem

- Item 1
- Item 2
- Item 3

Risk Mitigation Plan

- Proposed solution for implementation and risk mitigation.

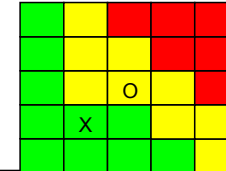

Actions to Date

- | | Date |
|---|--------|
| • Established Risk Assessment | Date 1 |
| • Completed Mitigation Plan | Date 2 |
| • Completed details of mitigation incorporation with contractor | Date 3 |
| • Received effort impact (cost and schedule) | Date 4 |

Future Action

- Proj.Date
Contract Award for implementation Date 1
- Mitigation Plan Completion (or any significant milestones) Date 2
- Etc...



Technical Risk Summary

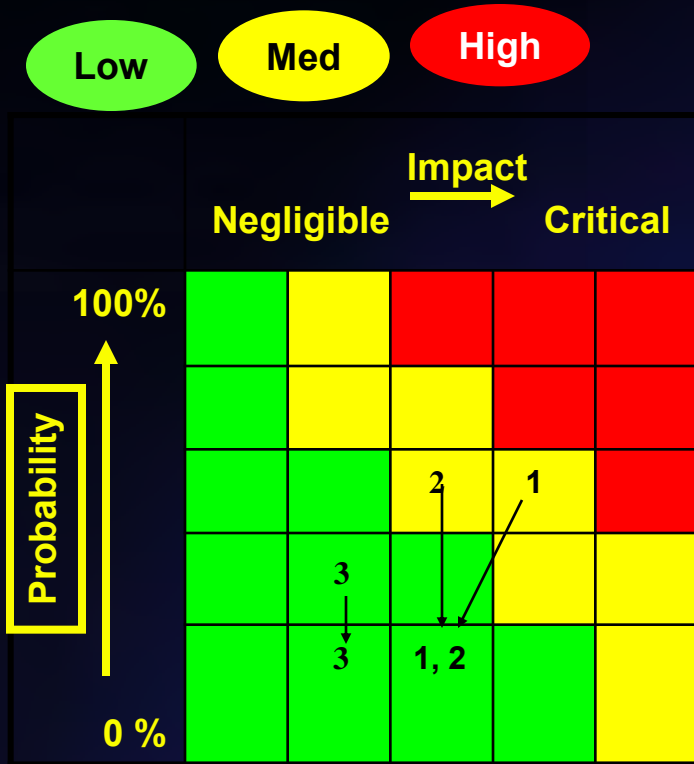

OVERALL TECHNICAL
RISK IS LOW

Risk Workshop Completed –
14 Mar 07

Tenets of Sys Eng

- Our first-cut tenet selection of Systems Engineering:
 - Requirements Management
 - Risk Management
 - **Test Management**
 - Airworthiness
 - Training



Test Management Process Flowchart

2.2 Planning Phase

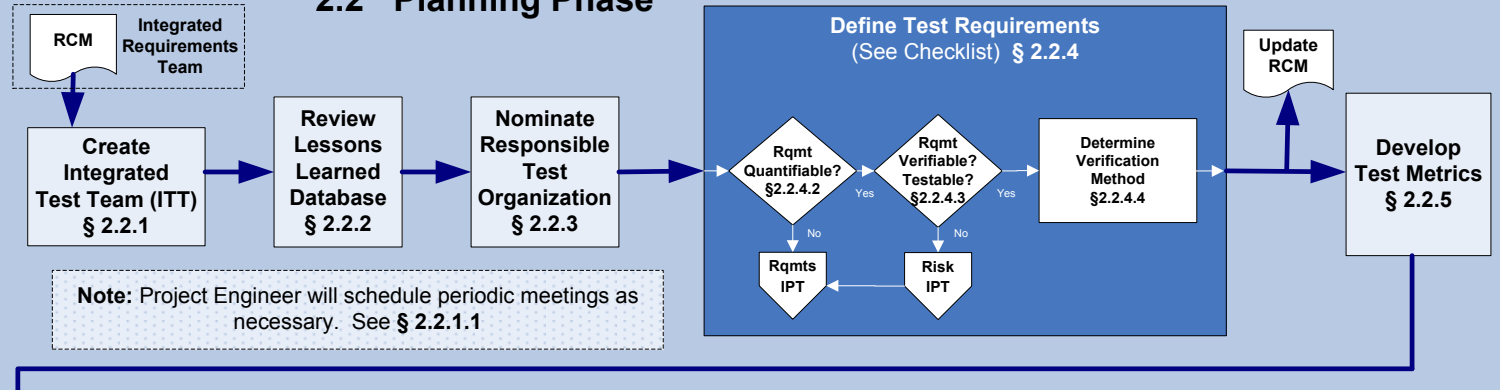

2.3 Design Phase

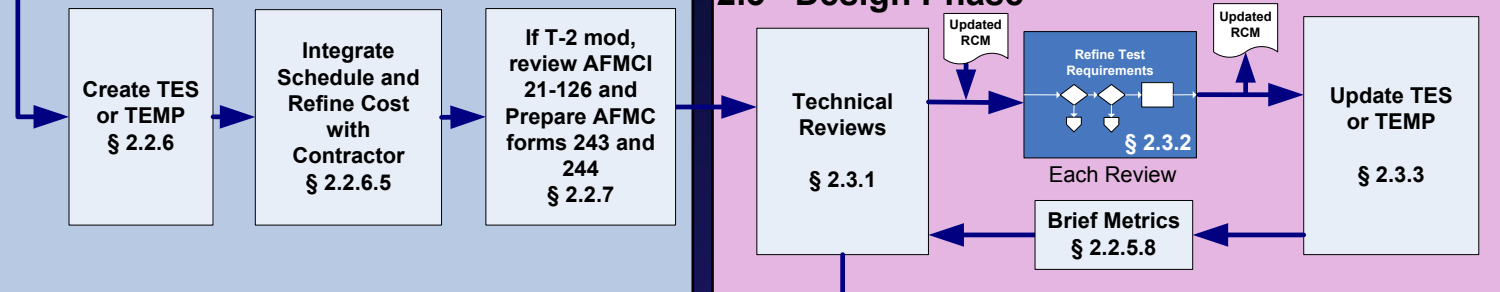

2.3 Execution Phase

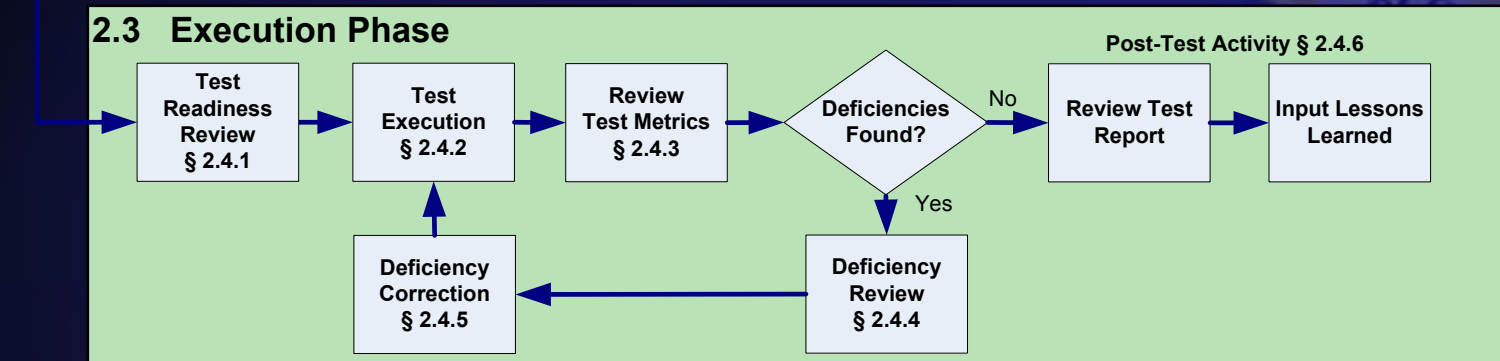

Test Requirements Metric

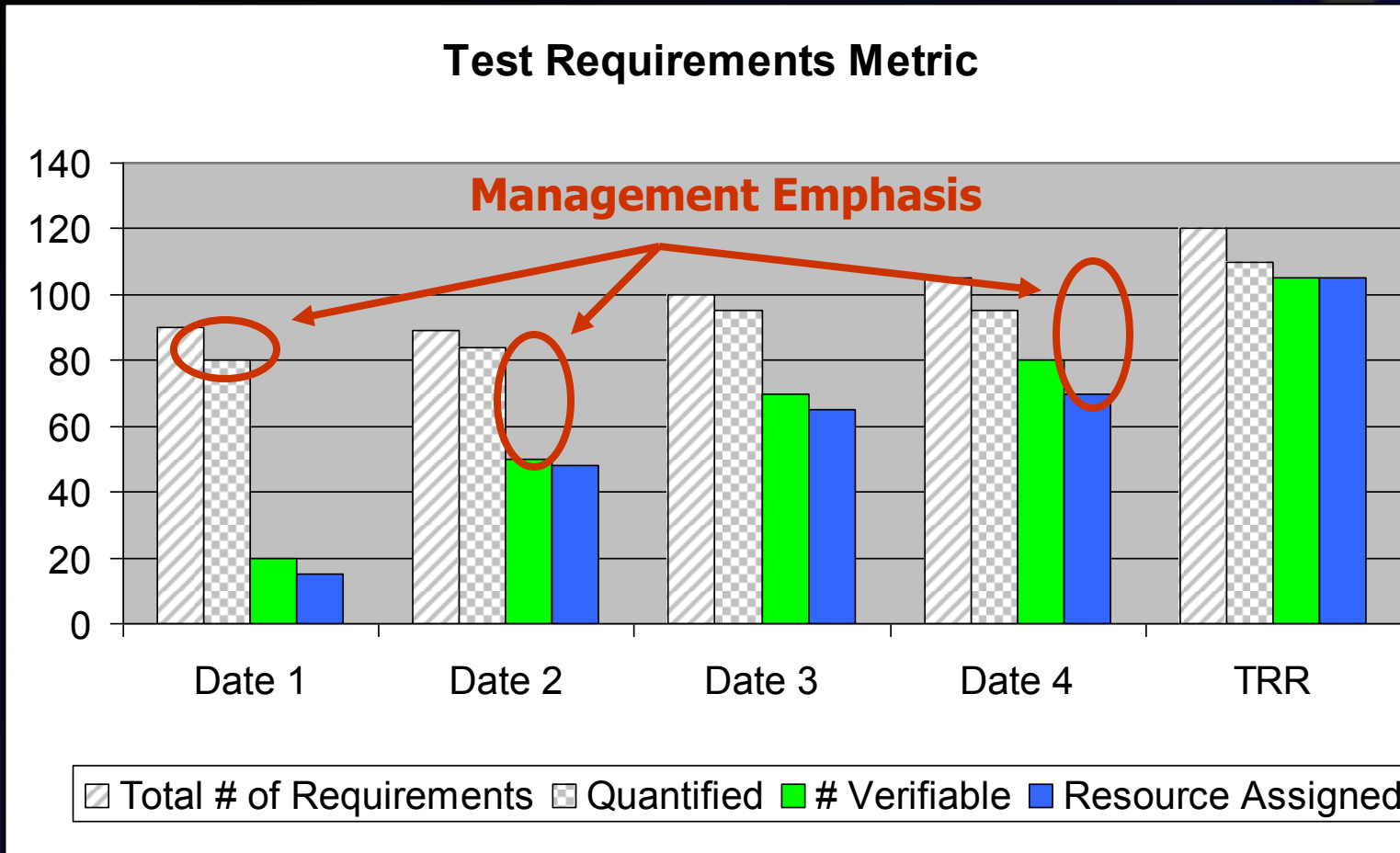

Test Risks Management Metric

Test Risks Management Metric

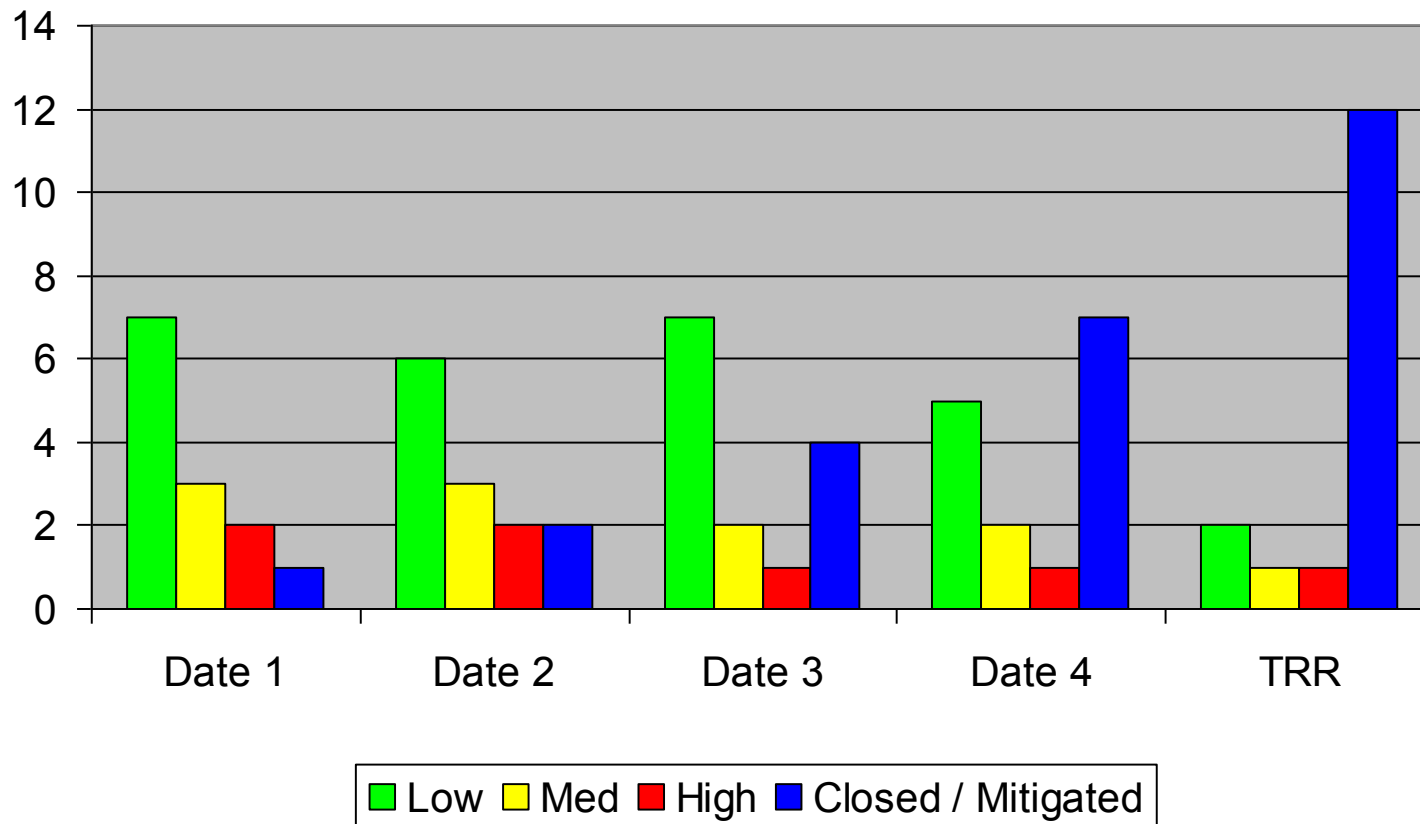

Deficiency Metric Report

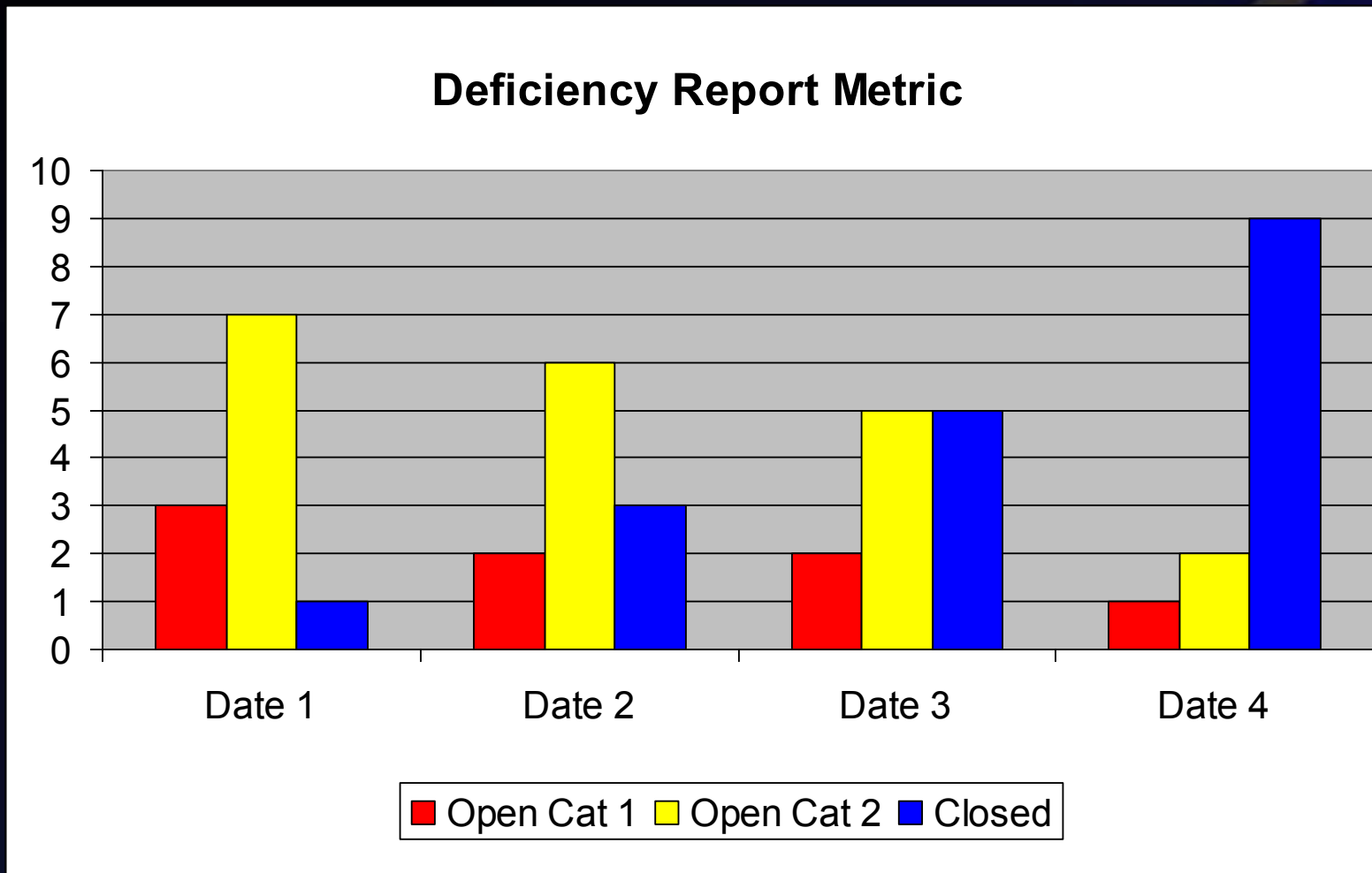

Tenets of Sys Eng

- Our first-cut tenet selection of Systems Engineering:
 - Requirements Management
 - Risk Management
 - Test Management
 - **Airworthiness**
 - Training

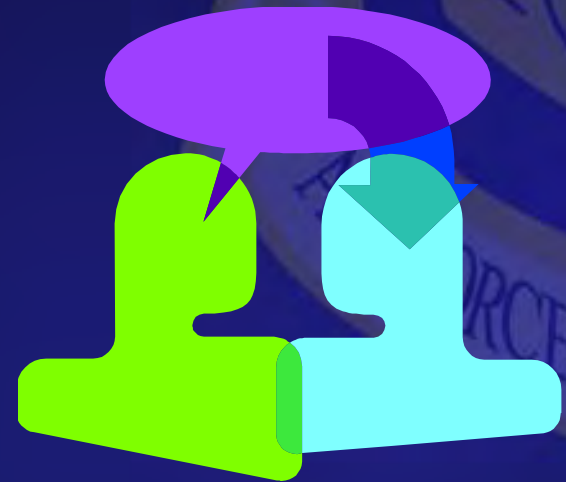

New Process to Ensure Airworthiness

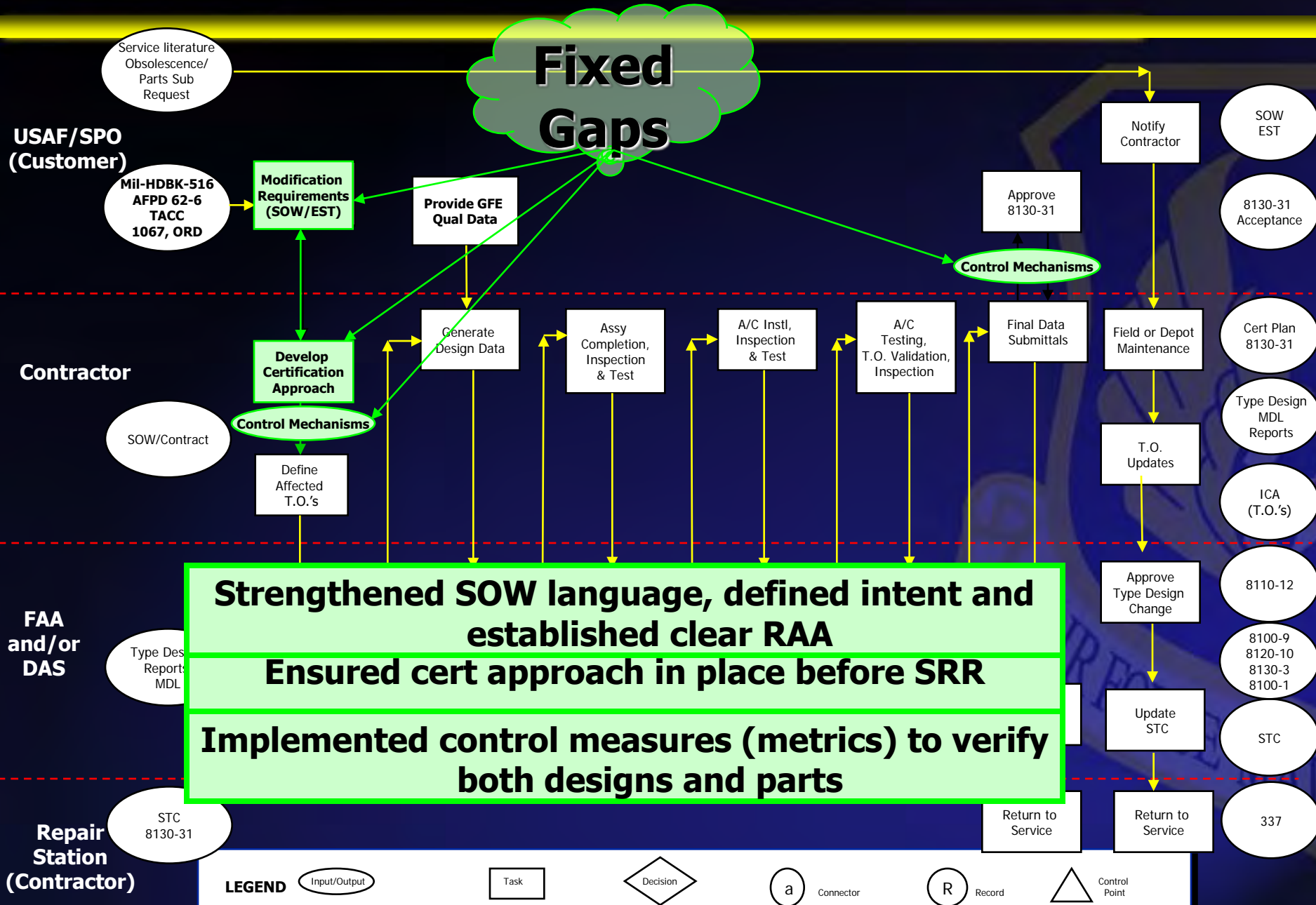

Design/Part Certification Method

DESIGN

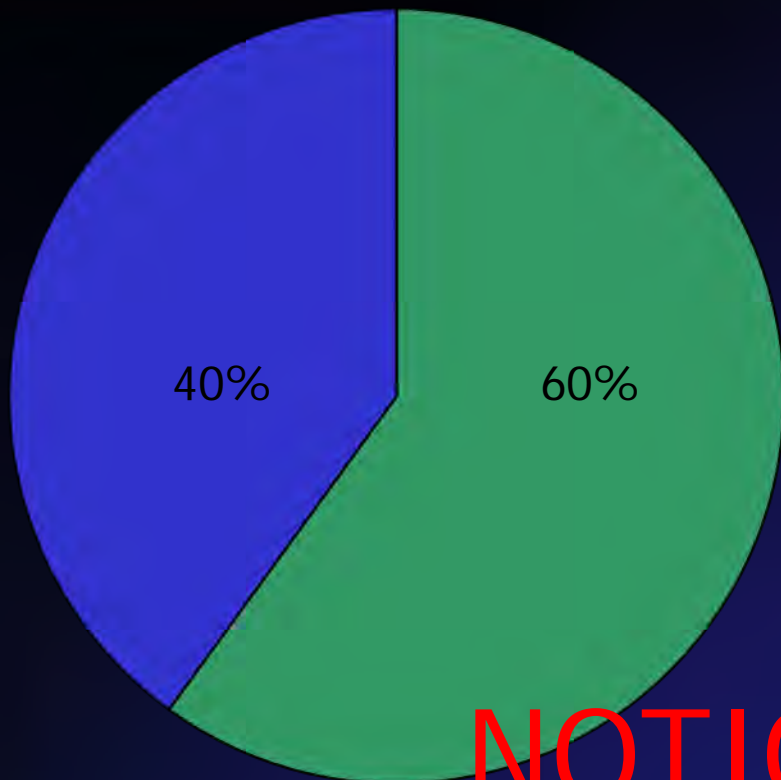

PARTS

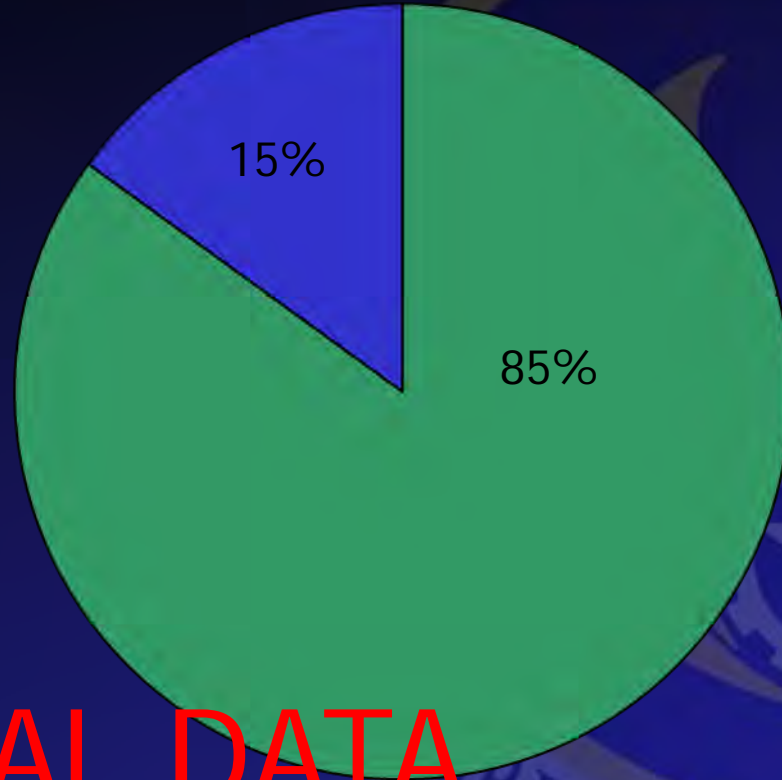

NOTIONAL DATA

■ FAA
■ Military

■ FAA
■ Military

- FAA represents fully commercial compliant
- Military is anything but fully commercial compliant

Design Certification Breakout

Total Mods

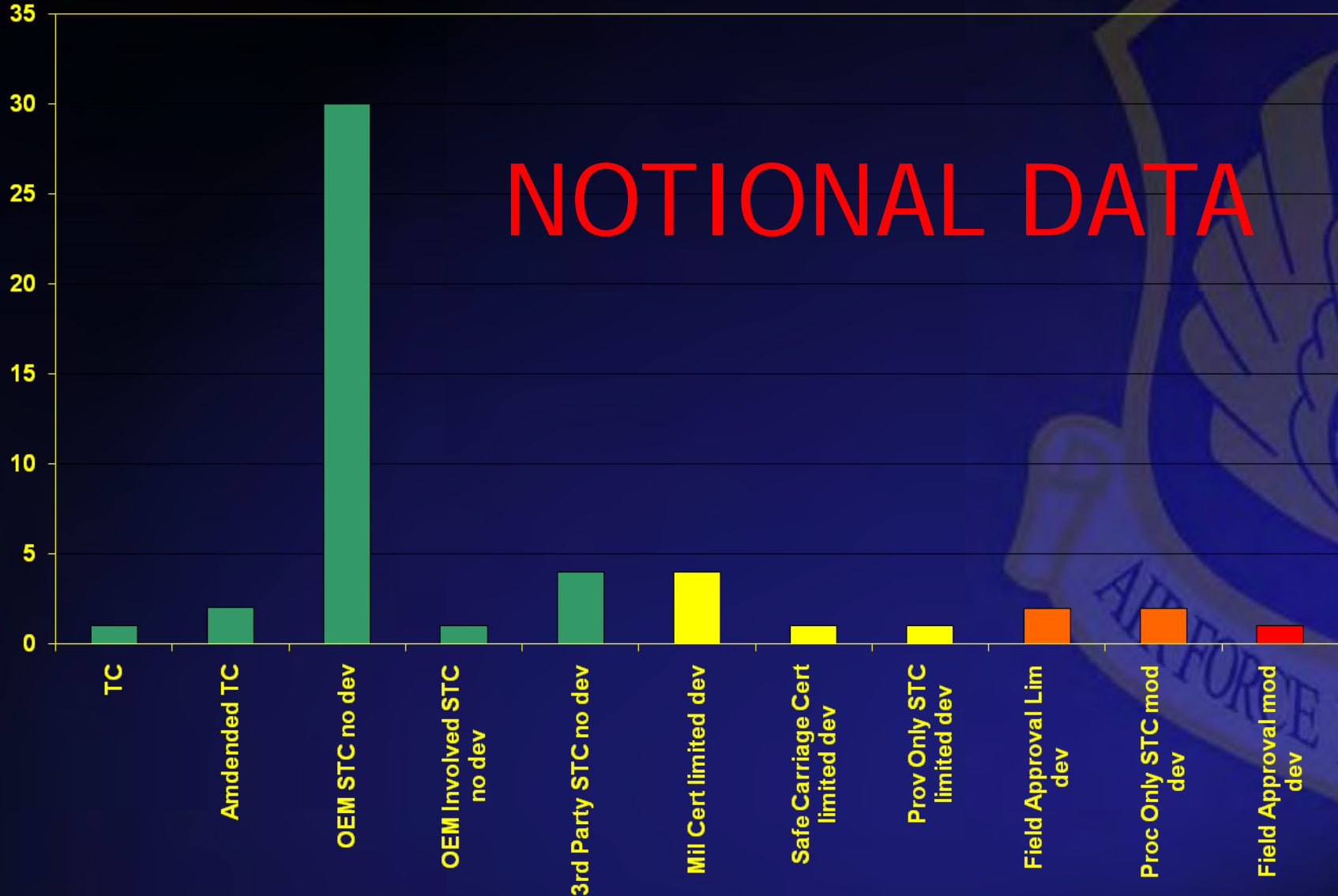

Part Certification Breakout

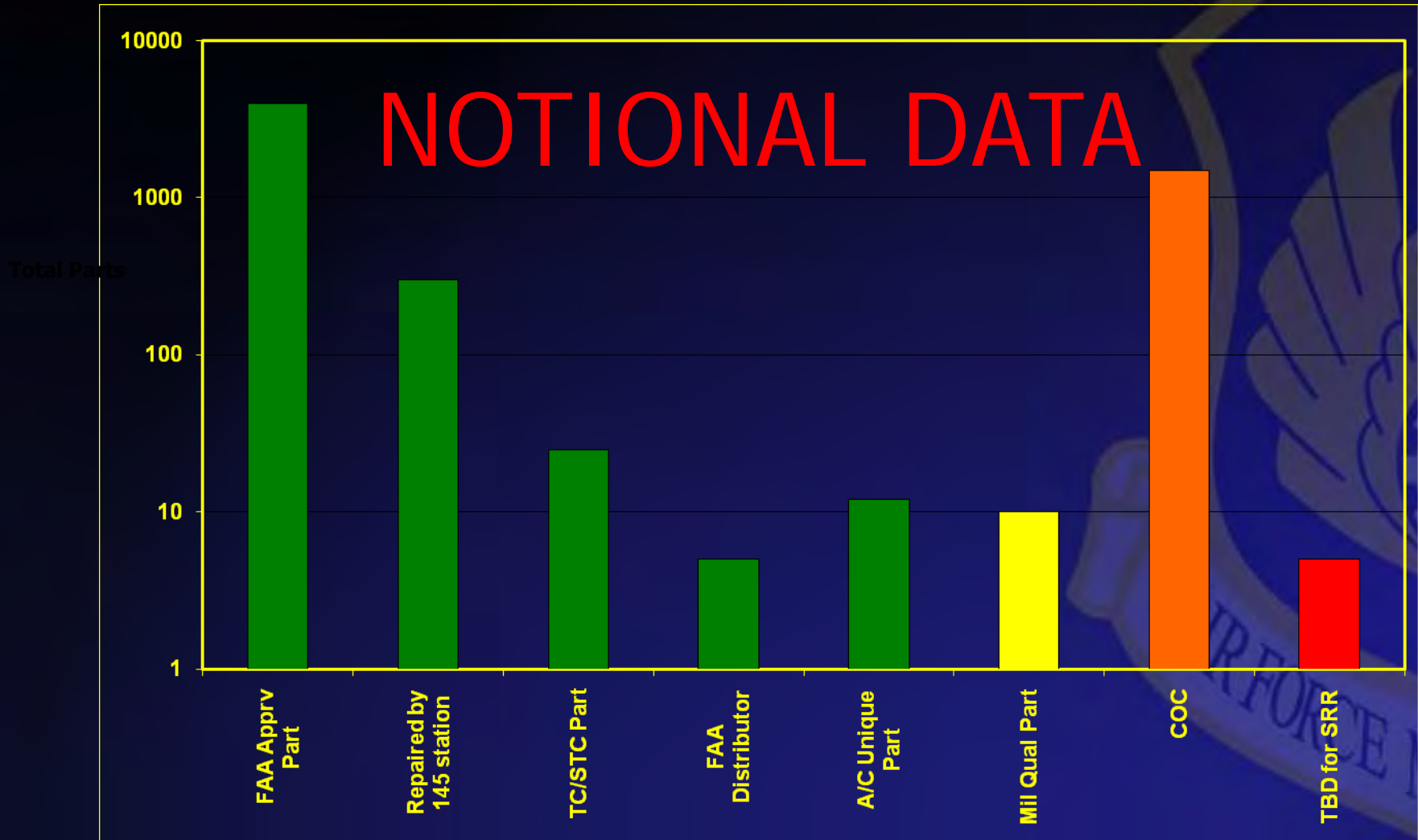

Tenets of Sys Eng

- Our first-cut tenet selection of Systems Engineering:
 - Requirements Management
 - Risk Management
 - Test Management
 - Airworthiness
 - **Training**

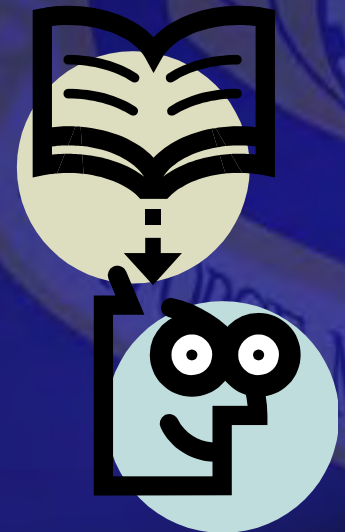

Workforce Training Metric

Org A Training Progress (45 People)

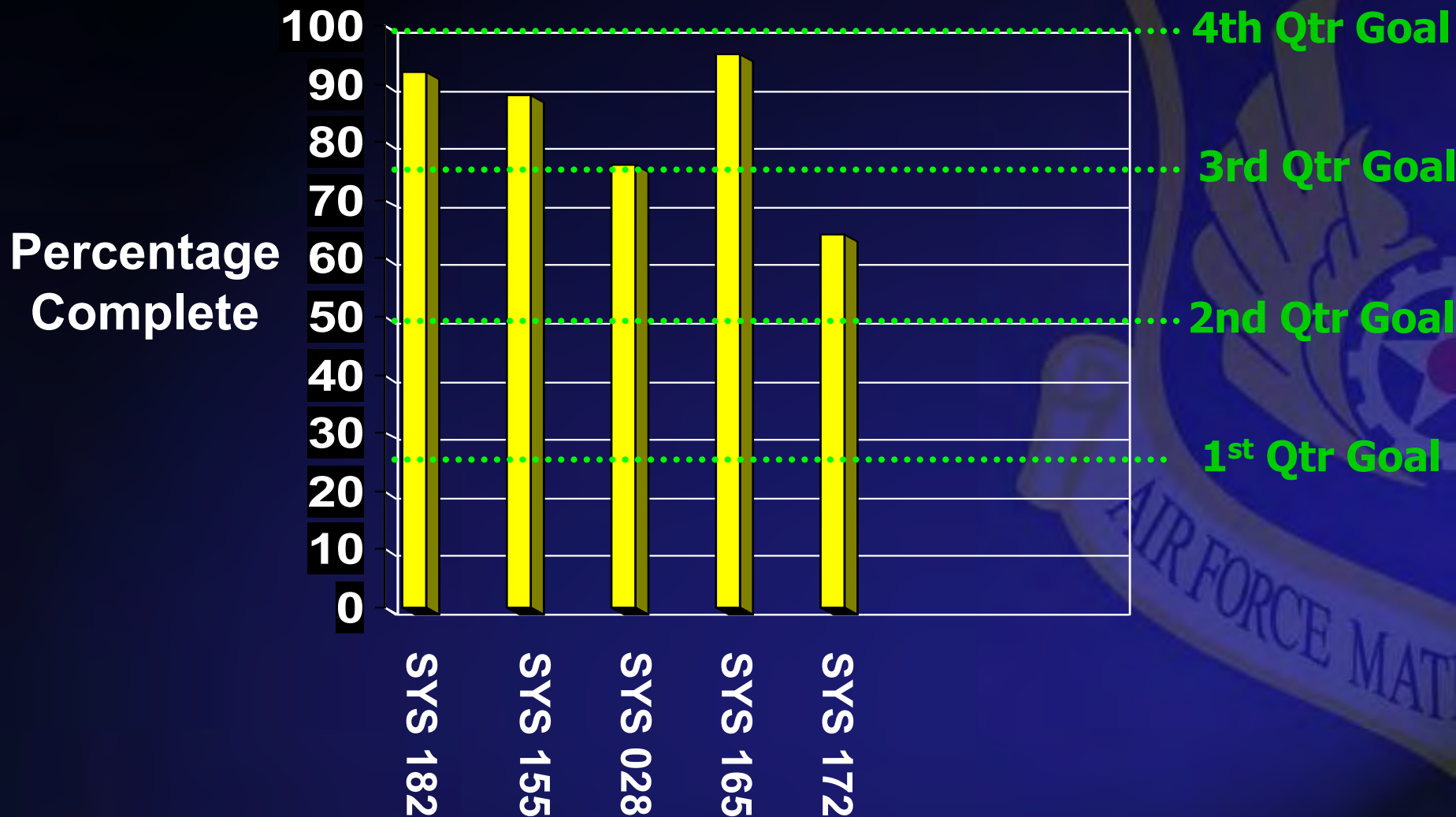

What's Next

- **Aircraft Structural Integrity Program (ASIP)**
- **Configuration Control**
- **Service Life**
- **Mishaps**
- **Obsolescence**
- **Safety**
- **Incentivizing contractors**



Summary

- **Measuring systems engineering can be a daunting task**
- **327th ASW developed a means to do this:**
 - **Broke up sys eng into its components**
 - **Devised metrics for each component**
 - **Institutionalized by codifying in OIs**
 - **Regularly brief to upper management**
- **Driving behavior, but takes time**
- **Have plans to do more...**

**Performance measures are being implemented,
driving behavior AND making a difference**

Questions ?



Incentivizing Contractors Metric



**% of Contracts with
Sys Eng Incentives**



Risk Handling Plan - "Waterfall"

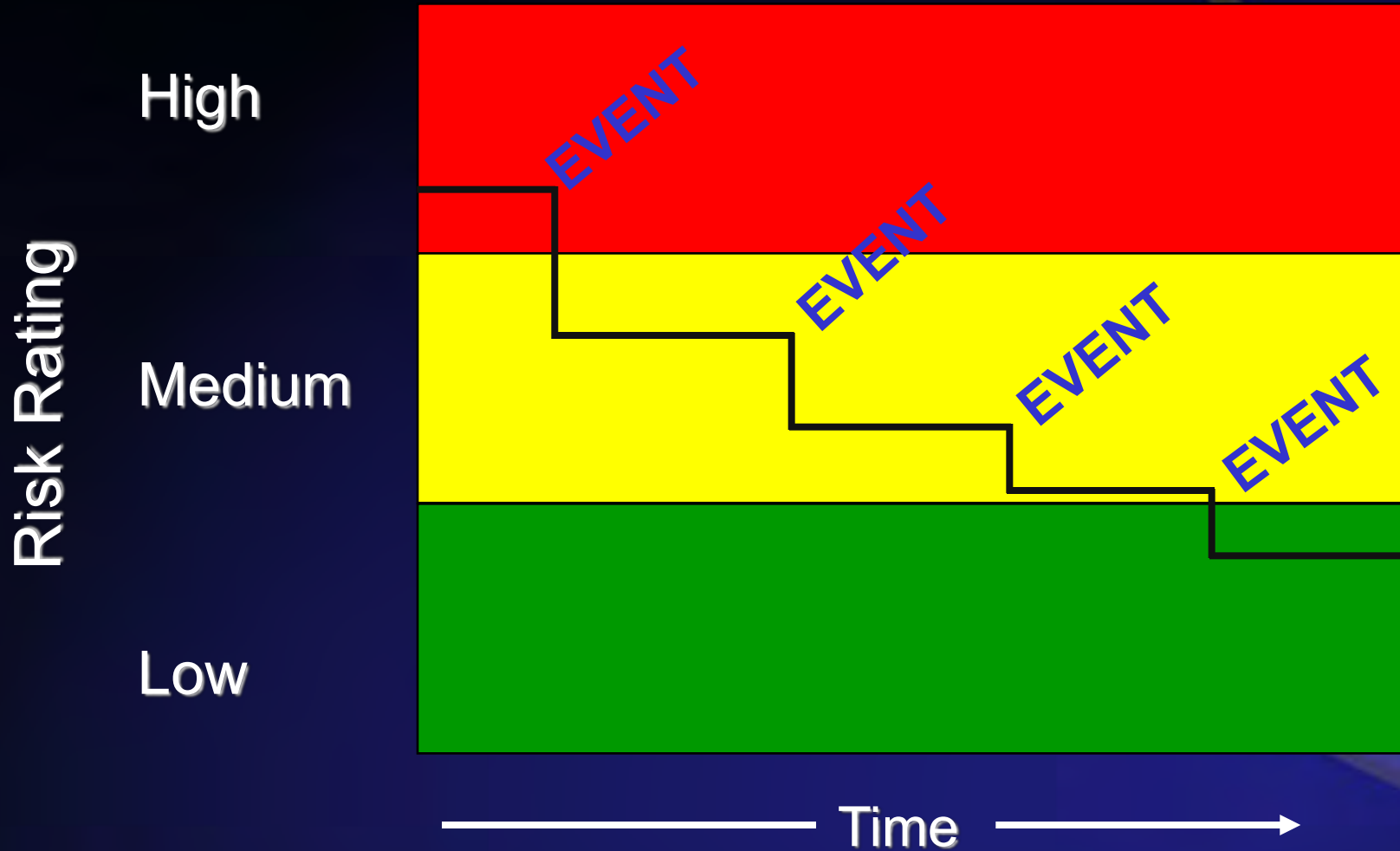

Sample: 5 - Level Risk Rating Chart

| LIKELIHOOD: | |
|-------------|--|
| Level | What Is The Likelihood The Risk Will Happen? |
| a | Remote |
| b | Unlikely |
| c | Likely |
| d | Highly Likely |
| e | Near Certainty |

ASSESSMENT GUIDE

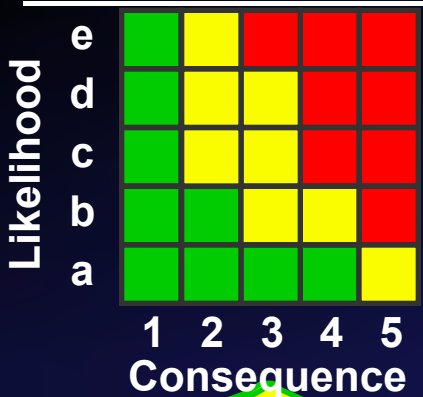

RISK ASSESSMENT

- **HIGH** - Unacceptable. Major disruption likely. Different approach required. Priority management attention required.
- **MODERATE** - Some disruption. Different approach may be required. Additional management attention may be needed.
- **LOW** - Minimum impact. Minimum oversight needed to ensure risk remains low.

CONSEQUENCE:
Given The Risk Event is Realized, What is the Magnitude of the Impact?

| Level | Technical Performance | and/or | Schedule | and/or | Cost | and/or | Impact on Other Teams |
|-------|---|--------|--|--------|----------------------|--------|-----------------------|
| 1 | Minimal or no impact | | Minimal or no impact | | Minimal or no impact | | None |
| 2 | Acceptable with some reduction in margin | | Additional resources required; able to meet need dates | | < 5% | | Some impact |
| 3 | Acceptable with significant reduction in margin | | Minor slip in key milestone; not able to meet need dates | | 5 - 7% | | Moderate impact |
| 4 | Acceptable, no remaining margin | | Major slip in key milestone or critical path impacted | | > 7 - 10% | | Major impact |
| 5 | Unacceptable | | Can't achieve key team or major program milestone | | > 10% | | Unacceptable |

Major Modification Programs

17 Current Programs

| | | |
|---|--|----------|
| Y | KC-10 AMP – ASC Lead (ACAT II) | \$1.03B |
| G | KC-10 Dual 406 MHz ELT Upgrade (ACAT III)* | \$2.4M |
| G | KC-10 Iridium Phone (ACAT III)* | \$2.7M |
| G | KC-10 UHF SATCOM Antenna (ACAT III)* | \$2.6M |
| G | VC-25 Forward Lower Lobe (FLL) Cooling (ACAT III) | \$14.4M |
| G | VC-25 Presidential Data System (PDS) (ACAT III)* | \$223.3M |
| G | VC-25 CNS/ATM (ACAT III)* | \$41.8M |
| G | C-20 Gulfstream Test Vehicle (GTV) (ACAT III)* | \$8.7M |
| G | E-9 Telemetry Sys Upgrade (ACAT III)* | \$5.9M |
| G | E-4B Mod Block I (ACAT II) * | \$421.4M |
| G | E-4B 256 Kbps High Speed Data via INMARSAT (ACAT III)* | \$8.4M |
| R | C-12 EFIS (ACAT III) | \$77.7M |
| Y | HFGCS Network Control Station – West (ACAT III)* | \$23.2M |
| Y | HFGCS AFSPC Test Range HF Modernization (ACAT III)* | \$3.9M |
| G | HFGCS Network Optimization – Spiral II (ACAT III)* | \$7.1M |
| G | HFGCS Navy Consolidation (ACAT III)* | \$6.4M |
| G | HFGCS Audit Log Upgrade (ACAT III)* | \$189K |

*Program is fully funded



Development and Validation of a Systems Engineering Competency Model

Don Gelosh, Ph.D., CSEP-Acq

Senior Systems Engineer

Systems Engineering Support Office

Enterprise Development/Systems and Software Engineering

Office of the Deputy Under Secretary of Defense (A&T)

23 October 2008



Overview



- ***Why Competency Management?***
- ***Senior Leadership Support***
- ***Competency Management Process***
- ***Proposed Next Steps***
- ***Summary***





Why Competency Management for AT&L and Systems Engineering?



Competencies are observable, measurable patterns of knowledge, skills, abilities, behaviors and other characteristics that an individual needs to perform work roles or occupational functions successfully.

Competency management helps:

- **Assess** and **refine** the requisite competencies within the current workforce
- Develop appropriate **strategies** to shape the skill sets and capabilities needed by the **future workforce**
- Identify overall **capabilities** we need to execute the **acquisition mission**
- Evaluate which competencies are **mission critical** and **highest priority**
- Develop solutions that will help us **mitigate risk** and **respond** to the challenges



Competency Model Applications

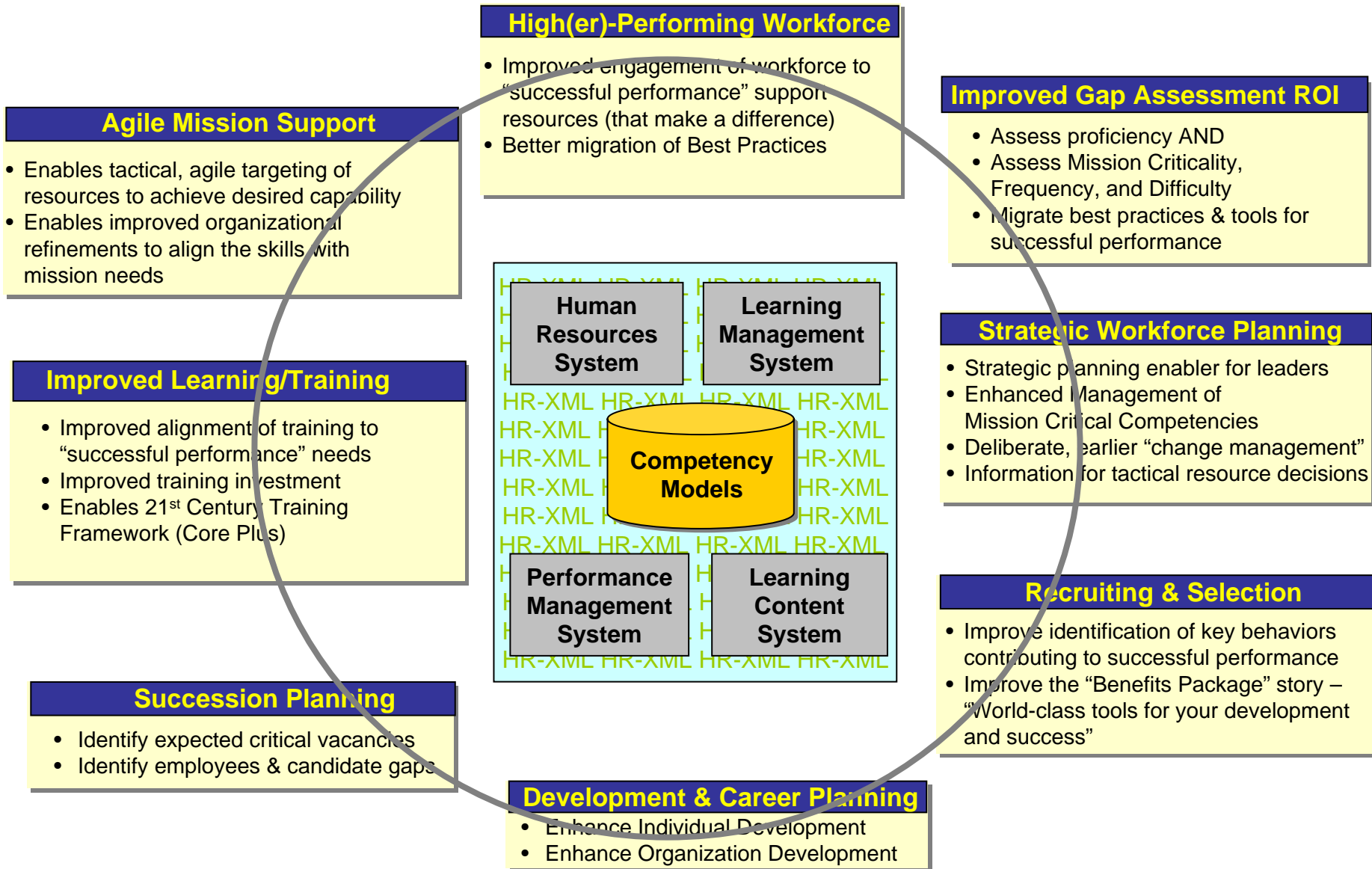



Senior Leadership Support is Critical!!!



Align with Senior Leadership

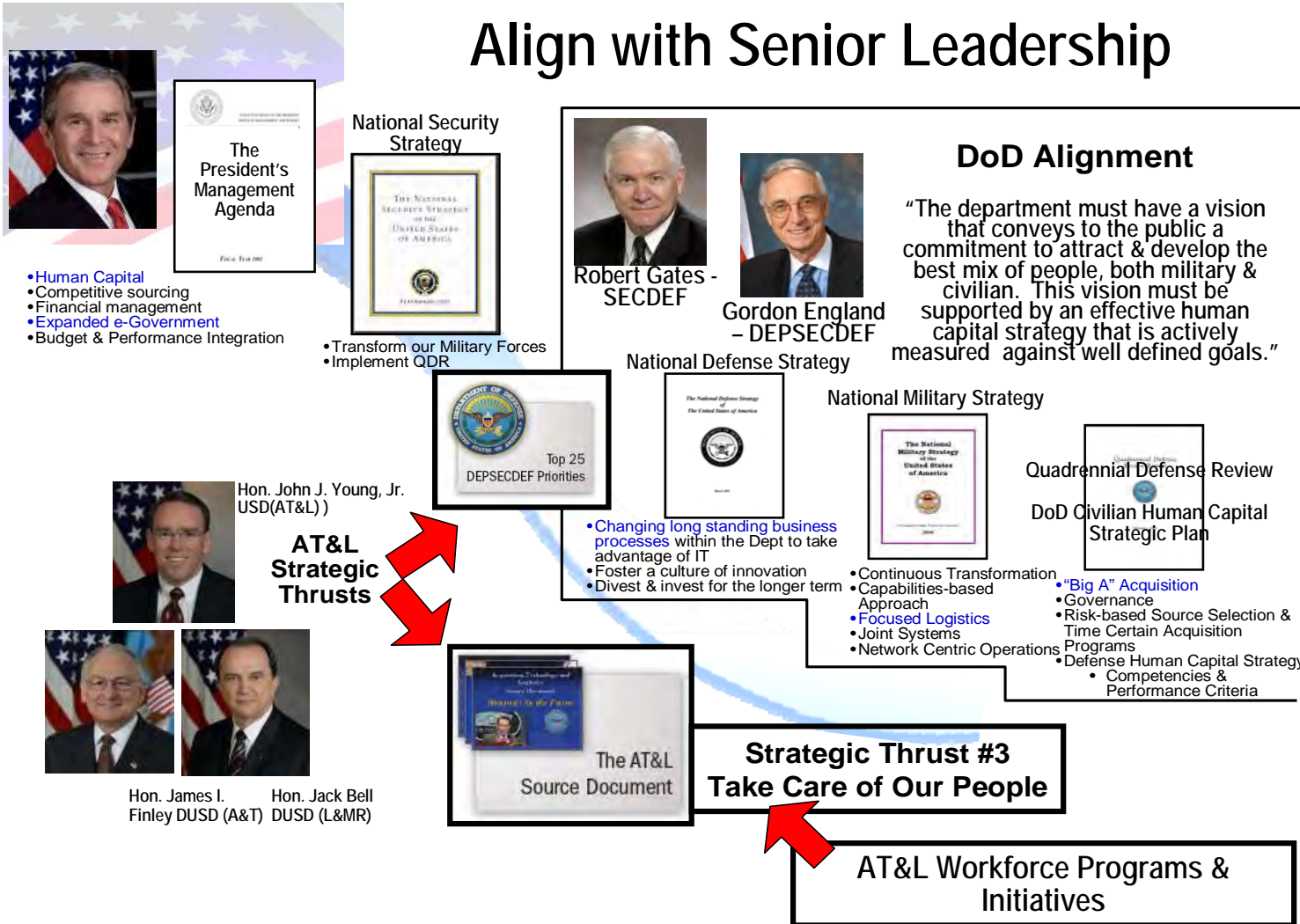



AT&L Competency Management Process



Collect Existing Competency Data

Framework Development

Model Development

Model Testing & Refinement

Competency Validation, Assessment, and Sustainment

Phase I - Convene an expert panel (EP)

Actions:

- Develop a competency framework & input model
- EP identifies Subject Matter Experts (SMEs)
- EP communicates competency effort to the SMEs
- Develop communications package

Goal:

- Establish baseline of existing competency model.
- Communicate effort

Products:

- FA provides list of targeted high-performing SMEs
- Obtains expert panel concurrence on baseline competency framework
- Obtain approval from Dir, HCI and FA on competency model input

Approved Input Competency Model

Phase II - Develop the model

Actions:

- SMEs review the competency framework and provide essential job data through structured interviews and online data collection tools.
- SMEs engaged to identify key "work" situations and competencies contributing to successful performance
- Analyze results and develop competency model content

Goal:

- Model development and identification of key behaviors

Products:

- Deliver Proposed Model Report to Dir, HCI and FA for review

Proposed Competency Model Report

Phase III - Perform a beta test & refine model

Actions:

- Collect and synthesize feedback from proposed model report
- Pre-assessment communications to workforce
- Identify stratified workforce sample

Goal:

- Further refine model to include input from functional leads
- Obtain FA and Dir, HCI approval for validation assessment

Products:

- Obtain concurrence from FIPT on competency model
- Obtain approval from Dir, HCI and FA on competency model

Approved Initial Competency Model V 0.5

Phase IV - Validate and Assess

Actions:

- Launch competency assessment tool
- Analyze results to evaluate model validity and generalizability to the workforce

Goal:

- Identify competencies required for superior performance
- Evaluate proficiency gaps for validated competencies
- Plan for continual updates and use of competency model

Products:

- Deliver proven (validated) competency model in HR XML format
- Provide competency validation and assessment and obtain Dir, HCI and FA approval

V 1.0 Competency Model

Competency Validation & Assessment Report



Phase I: Expert Panel and Competency Model Framework Development

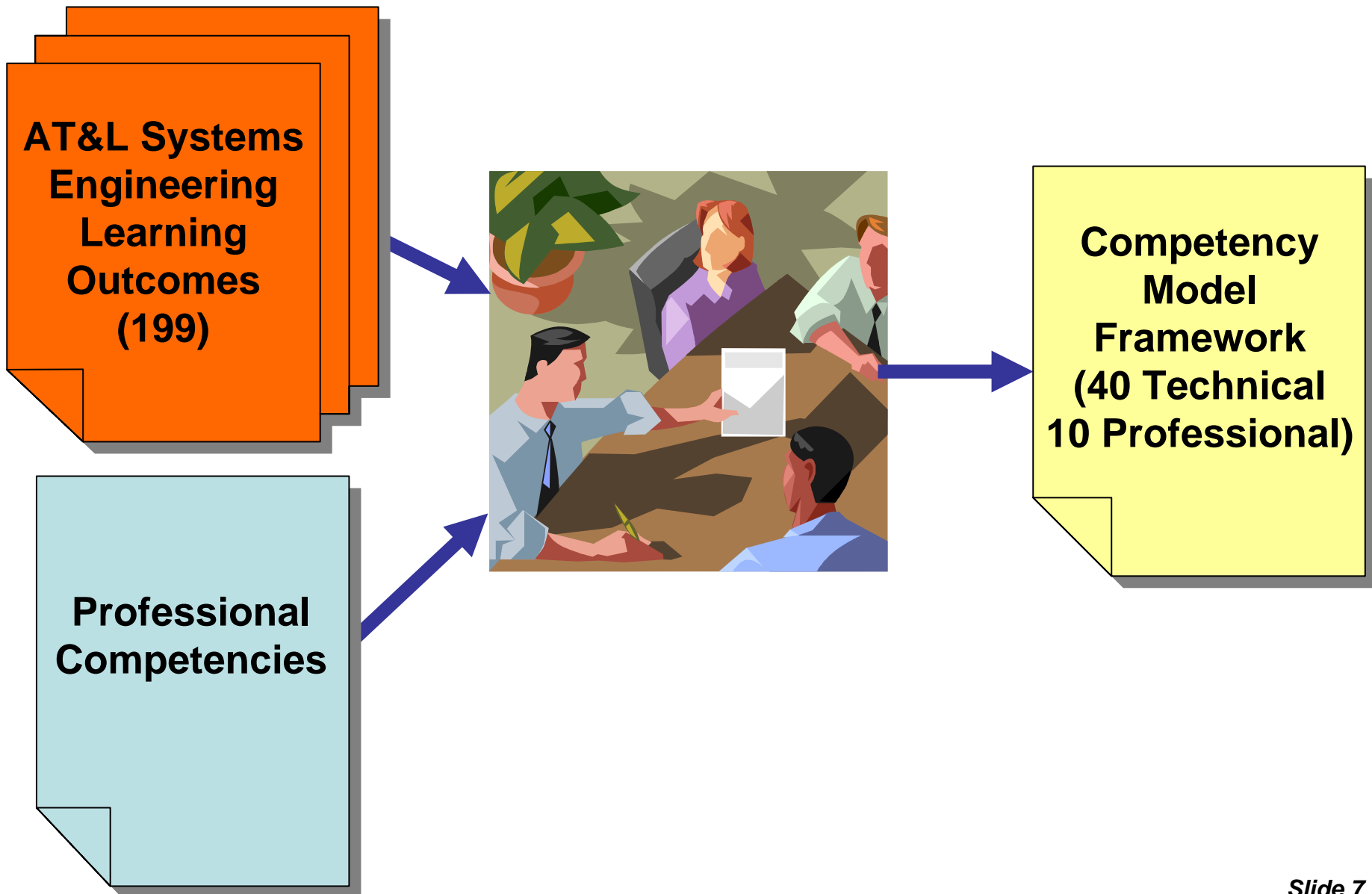



Competency Model Example



Unit of Competence Riding a Bicycle

Competency 1 Mount the Bicycle

- Element 1** – Position the Peddle
- Element 2** – Swing leg/Take seat
- Element 3** – Transition to Motion

Competency 2 Dismount the Bicycle

- Element 1** – Slow Down
- Element 2** - Support at Stop
- Element 3** – Swing Leg to Ground

Competency 3 Pedal the Bicycle

- Element 1** – Maintain Balance
- Element 2** – Peddle Fast
- Element 3** – Peddle Slow

Competency 4 Maintain the Bicycle

- Element 1** – Tire Pressure
- Element 2** – Brake Operation
- Element 3** - Wheel Balance



SE Competency Model Framework



| Technical Competencies | | | | | | | | | | | | | | | | | | | | | | | | | | | |
|--|---|---|-------------------------------|---|---------------------------|---------------------------|--|----|---------------|----|-------------------|----|-----------------|----|-----------------|----|-----------------------|----|---------------|----|-----------------------------|----|----------------------|----|--------------------|----|---|
| Analytical
<i>SE Tools & Techniques Design Considerations</i> | | Technical Management
<i>Technical Management Processes</i> | | General
<i>Total Systems View</i> | | | | | | | | | | | | | | | | | | | | | | | |
| 1 | Technical Basis for Cost | 21 | Decision Analysis | 36 | Acquisition | | | | | | | | | | | | | | | | | | | | | | |
| 2 | Systems Engineering Plans | 22 | Technical Planning | 37 | IPPD | | | | | | | | | | | | | | | | | | | | | | |
| 3 | Work Breakdown Structure | 23 | Technical Assessment | 38 | Leadership | | | | | | | | | | | | | | | | | | | | | | |
| 4 | Value Engineering | 24 | Requirements Management | 39 | International Acquisition | | | | | | | | | | | | | | | | | | | | | | |
| 5 | Technical Performance Measurement | 25 | Risk Management | 40 | Professional Ethics | | | | | | | | | | | | | | | | | | | | | | |
| 6 | Trade Studies | 26 | Configuration Management | <table border="1"> <thead> <tr> <th colspan="2">Professional Competencies</th> </tr> </thead> <tbody> <tr> <td>41</td> <td>Communication</td> </tr> <tr> <td>42</td> <td>Analytical Skills</td> </tr> <tr> <td>43</td> <td>Decision Making</td> </tr> <tr> <td>44</td> <td>Problem Solving</td> </tr> <tr> <td>45</td> <td>Technology Management</td> </tr> <tr> <td>46</td> <td>Team Building</td> </tr> <tr> <td>47</td> <td>Influencing and Negotiating</td> </tr> <tr> <td>48</td> <td>Interpersonal Skills</td> </tr> <tr> <td>49</td> <td>Strategic Thinking</td> </tr> <tr> <td>50</td> <td>Understanding Attributes of Evidence and Rational Decisions</td> </tr> </tbody> </table> | | Professional Competencies | | 41 | Communication | 42 | Analytical Skills | 43 | Decision Making | 44 | Problem Solving | 45 | Technology Management | 46 | Team Building | 47 | Influencing and Negotiating | 48 | Interpersonal Skills | 49 | Strategic Thinking | 50 | Understanding Attributes of Evidence and Rational Decisions |
| Professional Competencies | | | | | | | | | | | | | | | | | | | | | | | | | | | |
| 41 | Communication | | | | | | | | | | | | | | | | | | | | | | | | | | |
| 42 | Analytical Skills | | | | | | | | | | | | | | | | | | | | | | | | | | |
| 43 | Decision Making | | | | | | | | | | | | | | | | | | | | | | | | | | |
| 44 | Problem Solving | | | | | | | | | | | | | | | | | | | | | | | | | | |
| 45 | Technology Management | | | | | | | | | | | | | | | | | | | | | | | | | | |
| 46 | Team Building | | | | | | | | | | | | | | | | | | | | | | | | | | |
| 47 | Influencing and Negotiating | | | | | | | | | | | | | | | | | | | | | | | | | | |
| 48 | Interpersonal Skills | | | | | | | | | | | | | | | | | | | | | | | | | | |
| 49 | Strategic Thinking | | | | | | | | | | | | | | | | | | | | | | | | | | |
| 50 | Understanding Attributes of Evidence and Rational Decisions | | | | | | | | | | | | | | | | | | | | | | | | | | |
| 7 | Modeling and Simulation | 27 | Technical Data Management | | | | | | | | | | | | | | | | | | | | | | | | |
| 8 | Failure, Modes, Effects & Criticality Analysis | 28 | Interface Management | | | | | | | | | | | | | | | | | | | | | | | | |
| 9 | Requirements Traceability Matrix | 29 | Technical Data Packages | | | | | | | | | | | | | | | | | | | | | | | | |
| 10 | Safety Analysis | 30 | Specifications | | | | | | | | | | | | | | | | | | | | | | | | |
| 11 | SE Design Considerations | 31 | Earned Value Management | | | | | | | | | | | | | | | | | | | | | | | | |
| 12 | Requirements Development | 32 | IMP/IMS | | | | | | | | | | | | | | | | | | | | | | | | |
| 13 | Logical Analysis | 33 | Technical Reviews | | | | | | | | | | | | | | | | | | | | | | | | |
| 14 | Design Solution | 34 | Software Engineering | | | | | | | | | | | | | | | | | | | | | | | | |
| 15 | Implementation | 35 | Systems Engineering by Phases | | | | | | | | | | | | | | | | | | | | | | | | |
| 16 | Integration | | | | | | | | | | | | | | | | | | | | | | | | | | |
| 17 | Verification | | | | | | | | | | | | | | | | | | | | | | | | | | |
| 18 | Validation | | | | | | | | | | | | | | | | | | | | | | | | | | |
| 19 | Transition | | | | | | | | | | | | | | | | | | | | | | | | | | |
| 20 | System Assurance | | | | | | | | | | | | | | | | | | | | | | | | | | |



SE Competency Model Examples



| Unit of Competence | Competency | Elements | Knowledge Items |
|---------------------------|---------------------------|--|---|
| #1 Analytical | Technical Basis for Cost | Apply knowledge of cost drivers to develop cost estimates and program budgets that reflect program phase requirements and best practices. | Knowledge of cost drivers and cost estimating techniques and best practices |
| #1 Analytical | Systems Engineering Plans | Identify the proper points within a program's lifecycle to generate a Systems Engineering Plan (SEP) that describes the program's SE processes, resources, metrics, and technical review process. | Knowledge of SEP preparation guidance |
| #1 Analytical | Requirements Development | Apply the Requirements Development process to translate inputs from relevant stakeholders into technical requirements. | Knowledge of requirements management tools |
| #1 Analytical | Verification | Apply the Verification process to confirm that the system element meets the design specifications as defined in the functional, allocated, and product baselines and to answer the question: 'Did you build it right?' | Knowledge of verification (test and evaluation) techniques |
| #1 Analytical | Validation | Apply the Validation process to test the performance of systems within their intended operational environment and to answer the question 'Did you build the right thing?' | Knowledge of validation (operational test and evaluation) techniques |



Phase II: Subject Matter Expert (SME) Validation



- **SMEs review the competency model framework and provide essential job data through an online data collection tool.**
- **SMEs can add/delete competencies and associated elements and knowledge items.**
- **SMEs must identify at least two key “work” situations and associated competencies that contribute to successful performance.**
- **Results are analyzed and used to develop a complete competency model.**





SME Competency Review



SMEs review each competency element and provide information on:

- Frequency
- Importance
- Level First Used



| Unit of Competence #1 Analytical | | | |
|--|---|---|--|
| Includes the analytical and technical processes of systems engineering with a full understanding of tools and techniques and all design considerations. | | | |
| Competency Element | Frequency | Importance | Level First Used |
| Technical Basis for Cost - Element 1. Apply knowledge of cost drivers to develop cost estimates and program budgets that reflect program phase requirements and best practices. | <input type="radio"/> 1 Never
<input type="radio"/> 2 Sometimes
<input type="radio"/> 3 Often
<input type="radio"/> 4 Frequently
<input type="radio"/> 5 Very Frequently
<input type="radio"/> N/A | <input type="radio"/> 1 Not Important
<input type="radio"/> 2 Less Important
<input type="radio"/> 3 Moderately Important
<input type="radio"/> 4 Important
<input type="radio"/> 5 Very Important
<input type="radio"/> N/A | <input type="radio"/> 1 Entry Level
<input type="radio"/> 2 Mid-Level
<input type="radio"/> 3 Expert/Senior Level
<input type="radio"/> N/A |
| Systems Engineering Plans - Element 1 of 3 - Element 2. Identify the proper points within a program's lifecycle to generate a Systems Engineering Plan (SEP) that describes the program's SE processes, resources, metrics, and technical review process. | <input type="radio"/> 1 Never
<input type="radio"/> 2 Sometimes
<input type="radio"/> 3 Often
<input type="radio"/> 4 Frequently
<input type="radio"/> 5 Very Frequently
<input type="radio"/> N/A | <input type="radio"/> 1 Not Important
<input type="radio"/> 2 Less Important
<input type="radio"/> 3 Moderately Important
<input type="radio"/> 4 Important
<input type="radio"/> 5 Very Important
<input type="radio"/> N/A | <input type="radio"/> 1 Entry Level
<input type="radio"/> 2 Mid-Level
<input type="radio"/> 3 Expert/Senior Level
<input type="radio"/> N/A |
| Systems Engineering Plans - Element 2 of 3 - Element 3. Develop the critical contents of a SEP including government and contractor SE processes, the technical baseline approach, program control tools, and the role of SE to guide all technical aspects of an acquisition program. | <input type="radio"/> 1 Never
<input type="radio"/> 2 Sometimes
<input type="radio"/> 3 Often
<input type="radio"/> 4 Frequently
<input type="radio"/> 5 Very Frequently
<input type="radio"/> N/A | <input type="radio"/> 1 Not Important
<input type="radio"/> 2 Less Important
<input type="radio"/> 3 Moderately Important
<input type="radio"/> 4 Important
<input type="radio"/> 5 Very Important
<input type="radio"/> N/A | <input type="radio"/> 1 Entry Level
<input type="radio"/> 2 Mid-Level
<input type="radio"/> 3 Expert/Senior Level
<input type="radio"/> N/A |
| Systems Engineering Plans - Element 3 of 3 - Element 4. Determine what enterprise, system and software architectures are needed to reason about the system, to inform recommendations and decisions regarding software implementations in the context of the system being acquired and to allow effective communication across the stakeholders throughout the system life cycle. | <input type="radio"/> 1 Never
<input type="radio"/> 2 Sometimes
<input type="radio"/> 3 Often
<input type="radio"/> 4 Frequently
<input type="radio"/> 5 Very Frequently
<input type="radio"/> N/A | <input type="radio"/> 1 Not Important
<input type="radio"/> 2 Less Important
<input type="radio"/> 3 Moderately Important
<input type="radio"/> 4 Important
<input type="radio"/> 5 Very Important
<input type="radio"/> N/A | <input type="radio"/> 1 Entry Level
<input type="radio"/> 2 Mid-Level
<input type="radio"/> 3 Expert/Senior Level
<input type="radio"/> N/A |
| Work Breakdown Structure - Element 5. Translate the system design (including all products and services) into a Work Breakdown Structure (WBS) to ensure that all of the appropriate SE activities are implemented. | <input type="radio"/> 1 Never
<input type="radio"/> 2 Sometimes
<input type="radio"/> 3 Often
<input type="radio"/> 4 Frequently
<input type="radio"/> 5 Very Frequently
<input type="radio"/> N/A | <input type="radio"/> 1 Not Important
<input type="radio"/> 2 Less Important
<input type="radio"/> 3 Moderately Important
<input type="radio"/> 4 Important
<input type="radio"/> 5 Very Important
<input type="radio"/> N/A | <input type="radio"/> 1 Entry Level
<input type="radio"/> 2 Mid-Level
<input type="radio"/> 3 Expert/Senior Level
<input type="radio"/> N/A |



Key Situation Interviews

- **Key Situations:** a method of data collection from subject matter experts regarding “**what it takes**” to perform effectively on your job.
- Using the STARR Method of Description

Situation/Task

What was the situation or context? What were you doing? What task were you working on?



Action

What did you do? What were the steps you took to get to that effective outcome?



Reasoning

What was the reasoning/rationale that led to the action?



Results

What was the result/outcome of the key situation?



Additional SME Questions



- 1. Do you identify yourself to others as a systems engineer?**
- 2. Do you have the appropriate resources to do your job?**
- 3. Are you allowed to apply new skills acquired through recent education and training to perform your job?**
- 4. Does your organizational culture encourage the application of new skills?**
- 5. Do you believe additional advanced or senior level training in systems engineering is needed?**
- 6. Have you received training associated with integrating software into warfare related systems?**
- 7. If you answered yes to Question 6, has this training provided you with an adequate understanding of potential issues associated with integrating software into warfare related systems?**
- 8. What do you see as the primary community wide SPRDE workforce capability challenge?**



Phase III: Test and Refine the Model



- **Collect and synthesize feedback, refine the model.**
- **Further refine model to include input from Expert Panel and functional leads.**
- **Send pre-assessment communications to workforce.**
- **Identify stratified workforce sample.**

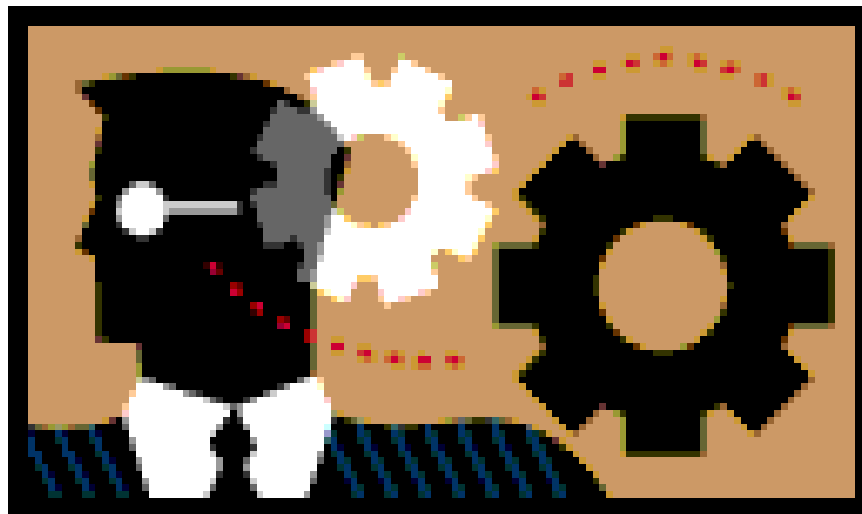



Phase IV: Workforce Assessment

- **Launch competency assessment tool.**
- **Analyze results to evaluate model validity and general applicability to the workforce.**
- **Identify competencies required for superior performance.**
- **Evaluate proficiency gaps for validated competencies.**
- **Plan for continual updates and use of competency model.**

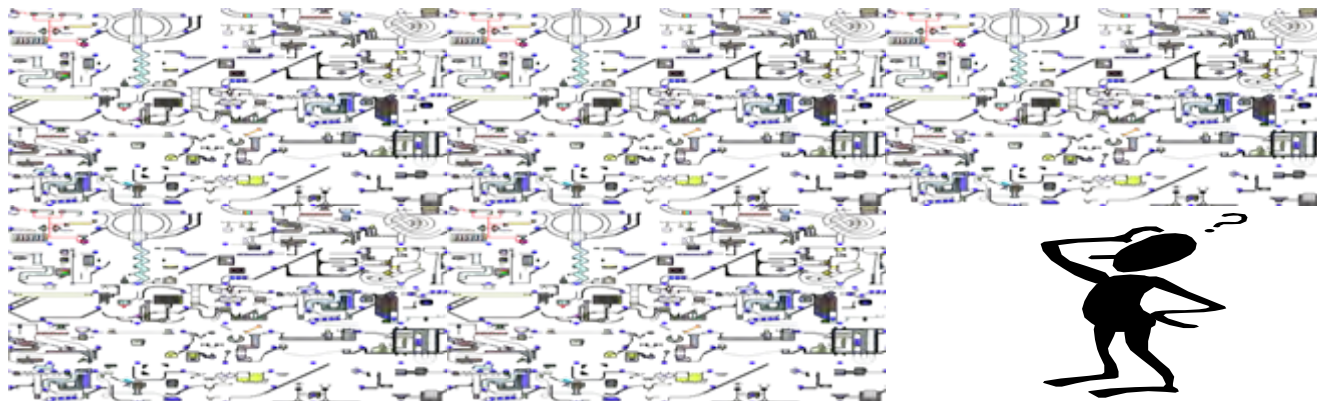



Proposed Next Steps



Improve the Competency Model:

- **Compare and contrast with other competency models – leverage best of the best**
- **Incorporate results from SE education and research efforts**
- **Develop a sub-set of “Core SE Competencies” that define the true Systems Engineers**

Apply the Competency Model:

- **Use the Core Competency sub-set to help identify the true SEs in the SPRDE career field**
- **Use the model to develop criteria for hiring Entry-level, Journeyman-level, and Highly Qualified Experts**
- **Use the model to drive SE education, training, and experience opportunities – a guide to where you should apply resources**



Summary

To successfully develop and implement a competency management program, you should:

- 1. Develop a competency management plan.**
- 2. Solicit and obtain senior leadership support.**
- 3. Develop a competency assessment model framework.**
- 4. Validate the model with high-performing subject matter experts.**
- 5. Test and refine the model with input from the functional leaders.**
- 6. Assess the target workforce against the competency model to identify competencies required for superior performance and to evaluate proficiency gaps.**
- 7. Update the plan and apply the competency model as needed.**
- 8. Provide reports.**



Questions?

Don Gelosh, Ph.D., CSEP-Acq
Senior Systems Engineer
OSD (AT&L) SSE/ED

1851 SOUTH BELL STREET
CRYSTAL MALL 3 SUITE 102
ARLINGTON, VA 22202

OFFICE: 703-602-0851 EXT 194
FAX: 703-602-3560





Backup Slides



INCOSE UK SE Competencies



INCOSE UK Advisory Board Systems Engineering Competencies Framework

Systems Thinking

- Systems concepts
- Super-system capability issues
- Enterprise and technology environment

Systems Engineering Management

- Concurrent engineering
- Enterprise Integration
- Integration of specialisms
- Lifecycle process definition
- Planning, monitoring and controlling

Holistic Lifecycle view

- Determine and manage stakeholder requirements

System Design:

- Architectural design
- Concept generation
- Design for ...
- Functional analysis
- Interface Management
- Maintaining Design Integrity
- Modeling and Simulation
- Select Preferred Solution
- System Robustness
- Integration & Verification
- Validation
- Transition to Operation



INCOSE SE Handbook



INCOSE Systems Engineering Handbook v. 3.1, August 2007

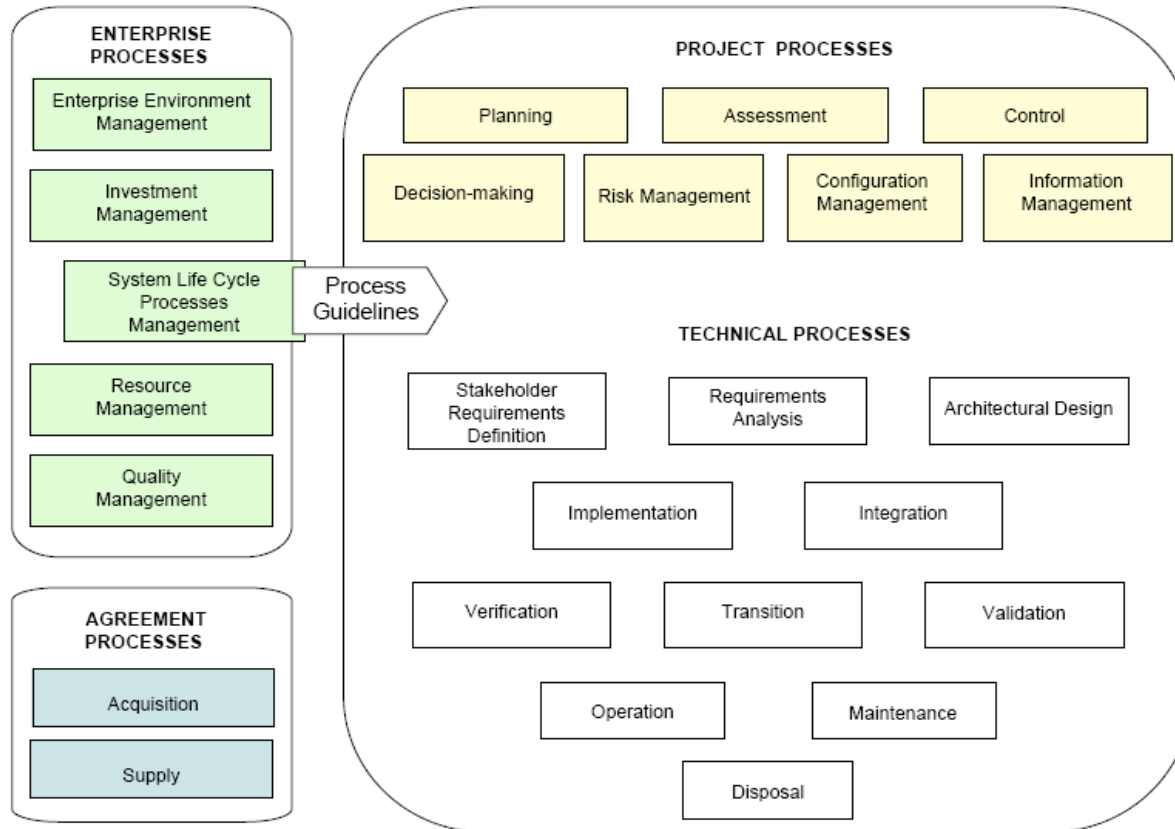

Figure 1-1 System Life Cycle Processes Overview per ISO/IEC 15288



Paper Reference Number: 7095
Session: Program Management

Evaluating Complex System Development Maturity

The Creation and Implementation of a System Readiness Level for Defense Acquisition Programs

NDIA Systems Engineering Conference
22 October 2008

Kenneth Michaud
NAVSEA PEO LMW / PMS 420

Eric Forbes
Northrop Grumman Corporation

Brian Sauser, Ph.D.
Stevens Institute of Technology

Peter Gentile
Northrop Grumman Corporation

Overview

- Defining the Need
- SRL Methodology
- Refinement, Verification and Validation
- Implementation / Application
- Next Steps

The Complex System Development Problem

- A 2006 Government Accountability Office study of DOD technology development practices concluded:
 - A lack of insight into the technical maturity of complex systems during development has contributed to an environment of:
 - Significant cost overruns
 - Schedule slips leading to program delays
 - Canceled acquisition efforts
 - Reduced system performance at fielding
- These symptoms will only grow worse as demands for rapid development and quick delivery increase
- DOD needs to strengthen its technology development monitoring and gate review processes



“Over the next 5 years, many of the programs in our assessment plan to hold design reviews or make a production decisions without demonstrating the level of technology maturity that should have been there before the start of development.”

U.S. Government Accountability Office on the Department of Defense, 1999

Defining Program Office Needs

- PEO LMW / PMS 420 is responsible for the development and integration of a series of Mission Modules to be used on the Littoral Combat Ship
- Modules leverage considerable amounts of technology from existing programs of record while also conducting new development
- Key aspects of the project include not only monitoring the status of technology development, but also the maturity of the numerous integrations between those technologies
- This has resulted in a very complex and diverse system of systems engineering activity with a need to obtain quick and accurate snapshots of program status, risks, and issues





Methodology

TRL Shortcomings

- Application of TRL to systems of technologies is not sufficient to give a holistic picture of complex system of systems readiness
 - TRL is only a measure of an individual technology
- Assessments of several technologies rapidly becomes very complex without a systematic method of comparison
- Multiple TRLs do not provide insight into integrations between technologies nor the maturity of the resulting system
 - Yet most complex systems fail at the integration points

Individual Technology



Can TRL be applied?

Yes

System of Technologies

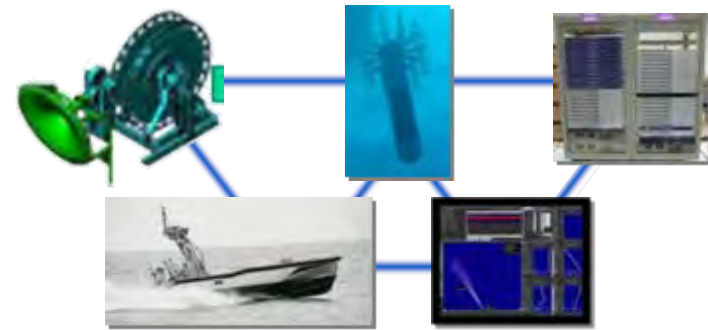

Can TRL be applied?

NO

Methodology Development Overview

GOAL: Institute a robust, repeatable, and agile method to monitor / report system development and integration status

APPROACH → *Create a System Readiness Level (SRL) that utilizes SME / developer input on technology and integration maturity to provide an objective indication of complex system development maturity*

*DOD-Standard
Evaluation System*

**Technology Readiness
Levels (TRL)**

*Status of technologies
making up the system*

Newly Created

**Integration Readiness
Levels (IRL)**

*Status of connections
between the technologies*

**System Readiness
Levels (SRL)**

*Overall system maturity
appraisal*

- Provides a **system-level** view of development maturity with opportunities to drill down to element-level contributions
- Allows managers to evaluate system development in real-time and take **proactive** measures
- Highly **adaptive** to use on a wide array of system engineering development efforts
- Can be applied as a **predictive** tool for technology insertion trade studies and analysis

SRL Methodology and Analysis Flow

Step 1: Identify hardware and software components

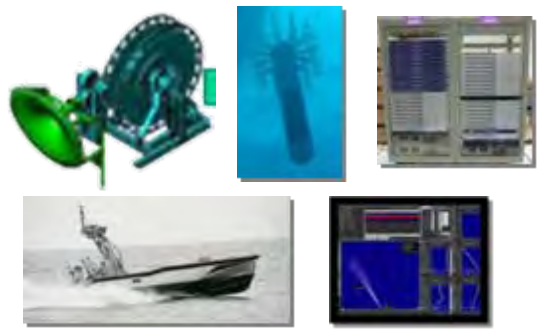

Include all technologies that make-up the overall system

Step 2: Define network diagram for systems

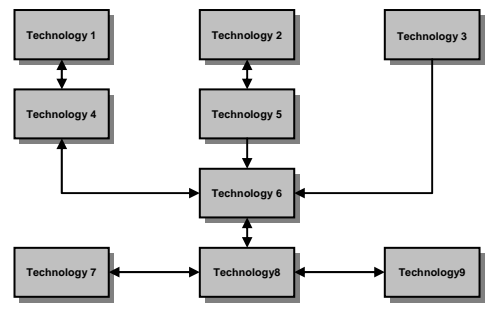

Emphasis is on the proper depiction of hardware and software integration between the components

Step 3: Define system operational strings (If applicable)

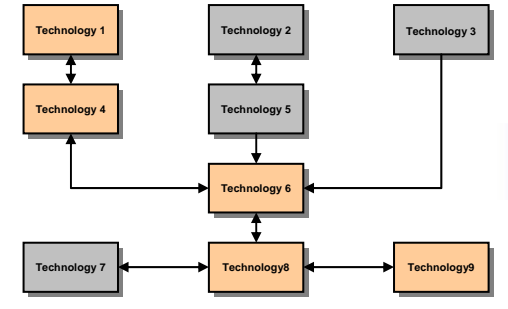

String analysis allows for the option of weighting the most important components and evaluation of alternate operational states

Initial Architecture Definition and Setup

Step 4: Apply detailed TRL and IRL evaluation criteria to components and integrations

| Integration Maturity Level 1 | |
|------------------------------|--|
| 100 | Components to be integrated are selected |
| 100 | Component interface points are identified |
| 100 | Documented phase/build plan for component availability |
| 100 | Data types identified |

| Technology Readiness Level 1 | |
|------------------------------|--|
| 100 | Physical laws and assumptions used in new technologies defined |
| 50 | Have some concept in mind that may be realizable in software |
| 25 | Know what software needs to do in general terms |
| 30 | Paper studies confirm basic principles and system concepts |
| NA | Mathematical formulations of concepts that might be realizable in software |
| 100 | Have an idea that captures the basic principles of a possible algorithm |
| 0 | Basic scientific principles observed |
| 100 | Research hypothesis formulated |
| 75 | Identify who will perform research and where it will be done |
| 60 | Readiness Level Percent Complete (non-weighted) |

Checklist style evaluation allows for the ability to "take-credit" for steps that have taken place beyond the current readiness level

Step 5: Calculate individual and composite SRLs

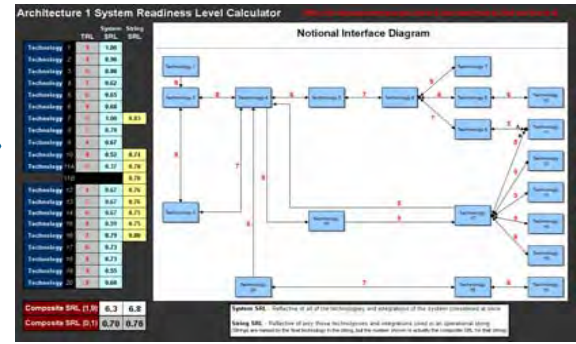

Input TRL and IRL evaluations into algorithm to compute an assessment of overall system status via SRLs

Step 6: Document status via roll-up charts

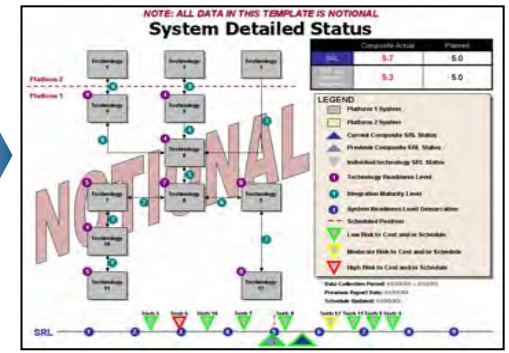

Populate reporting chart templates with evaluation and calculation outcomes to highlight both current status and performance over time

SRL Calculation

- The SRL is not user defined, but is instead based on the outcomes of the documented TRL and IRL evaluations
- Through mathematically combining these two separate readiness levels, a better picture of overall complex system readiness is obtained by examining all technologies in concert with all of their required integrations

$$\mathbf{SRL} = \mathbf{IRL} \times \mathbf{TRL}$$

$$\begin{pmatrix} \mathbf{SRL}_1 & \mathbf{SRL}_2 & \mathbf{SRL}_3 \end{pmatrix} = \begin{pmatrix} \mathbf{IRL}_{11} & \mathbf{IRL}_{12} & \mathbf{IRL}_{13} \\ \mathbf{IRL}_{12} & \mathbf{IRL}_{22} & \mathbf{IRL}_{23} \\ \mathbf{IRL}_{13} & \mathbf{IRL}_{23} & \mathbf{IRL}_{33} \end{pmatrix} \times \begin{pmatrix} \mathbf{TRL}_1 \\ \mathbf{TRL}_2 \\ \mathbf{TRL}_3 \end{pmatrix}$$

$$\begin{aligned} \text{Composite SRL} &= 1/n \left(\mathbf{SRL}_1/n + \mathbf{SRL}_2/n + \mathbf{SRL}_3/n \right) \\ &= 1/n^2 \left(\mathbf{SRL}_1 + \mathbf{SRL}_2 + \mathbf{SRL}_3 \right) \end{aligned}$$

- These values serve as a decision-making tool as they provide a prioritization guide of the system's technologies and integrations and point out deficiencies in the maturation process

SRL Calculation Example

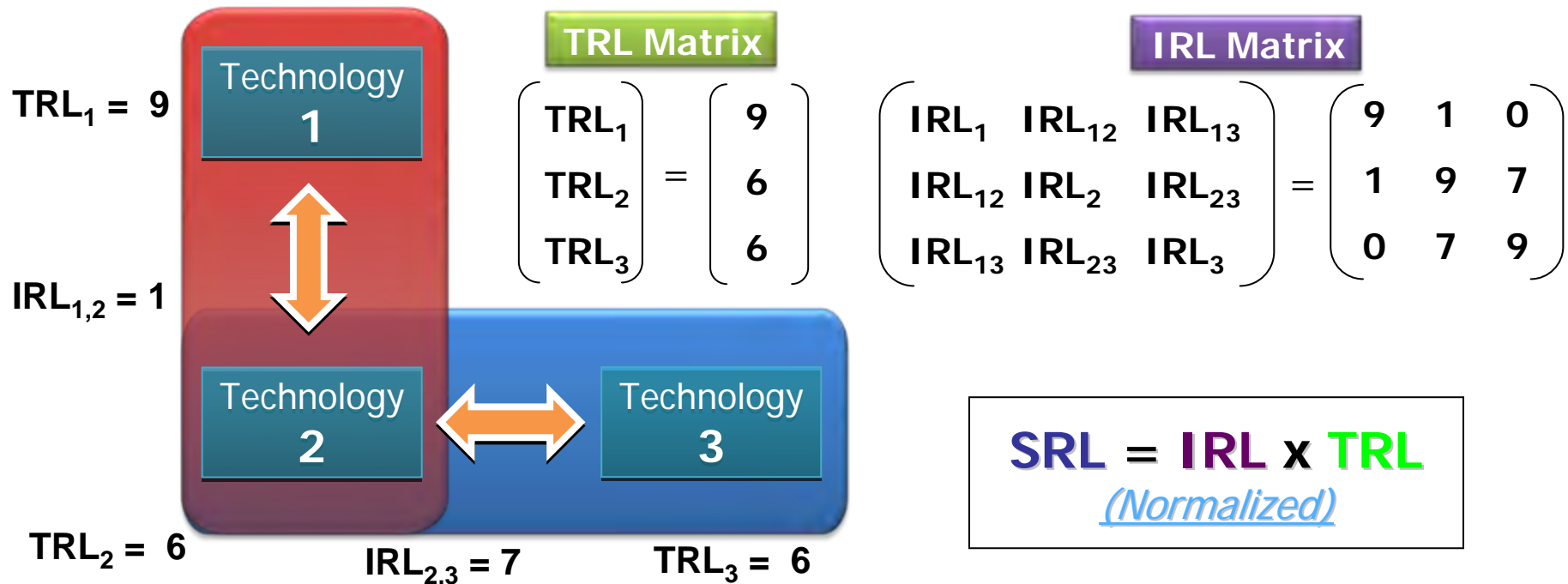

$$\text{Component SRL} = \begin{pmatrix} \text{SRL}_1 & \text{SRL}_2 & \text{SRL}_3 \end{pmatrix} = \begin{pmatrix} 0.54 & 0.43 & 0.59 \end{pmatrix}$$

Component SRL_x represents Technology "X" and its IRLs considered

$$\text{Composite SRL} = 1/3 (0.54 + 0.43 + 0.59) = 0.52$$

The Composite SRL provides an overall assessment of the system readiness

SRL Reporting Method

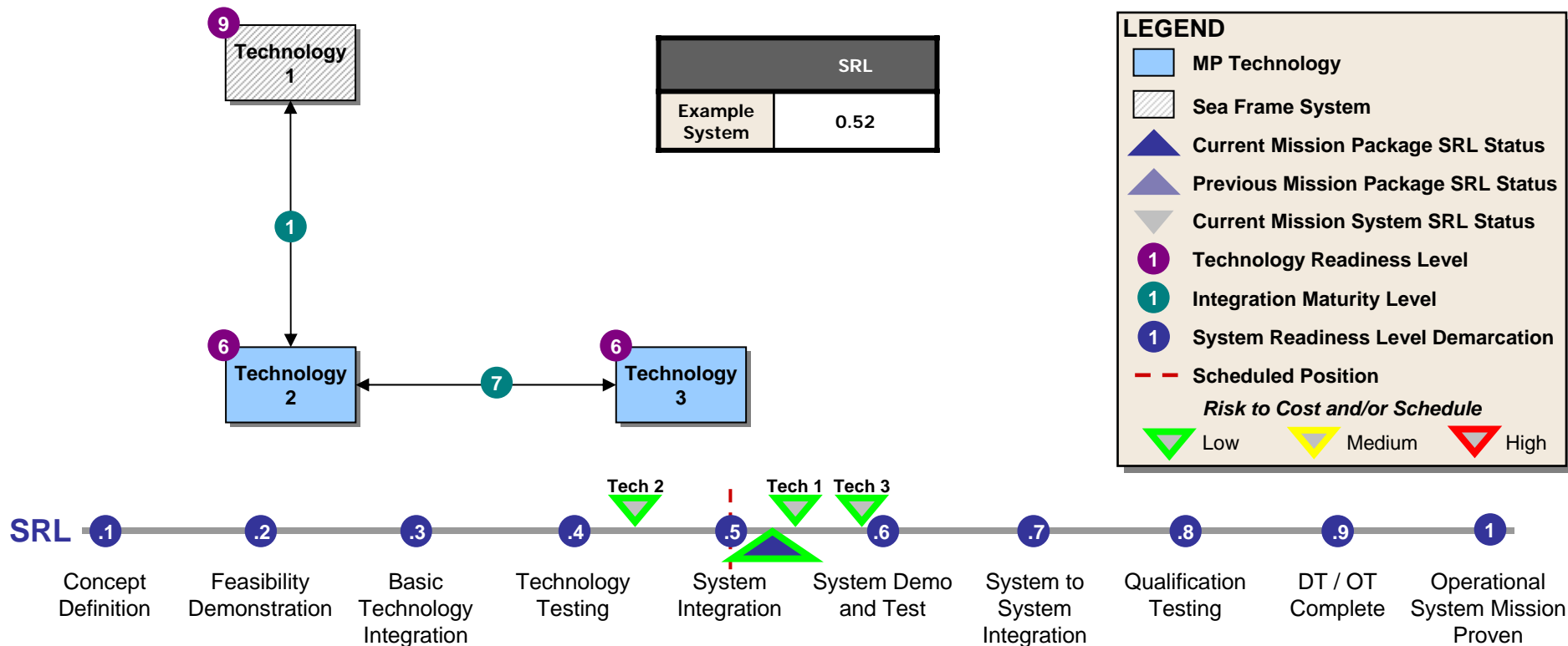

- For complex systems, the amount of information obtained from the SRL evaluation can be overwhelming
- To maximize applicability SRL outputs are tied to key, program- specific development milestones
- Progress against these milestones provide key insight to the user regarding current program status, risk and progress



Refinement, Verification and Validation

"String" Analysis Incorporated

Complex systems often offer numerous options for conducting operations



- Operational strings were created that identified the components required to utilize a single function of the system
- Assessment of the SRL for each of these options allows for a better understanding of the maturity of each operating configuration
- Understanding the true status of the system on an operational string level allows for the opportunity to field initial capability earlier and then add to it as other strings mature

SRL Calculators Developed

- Calculators are developed and defined for the system being evaluated
- Allows for real-time updates to TRL and IRL inputs and the resulting SRL evaluation providing decision-makers with instant feedback on “what if” scenarios
- Intuitive interface removes the need for the user to manipulate and deal with the mathematics of the SRL calculation

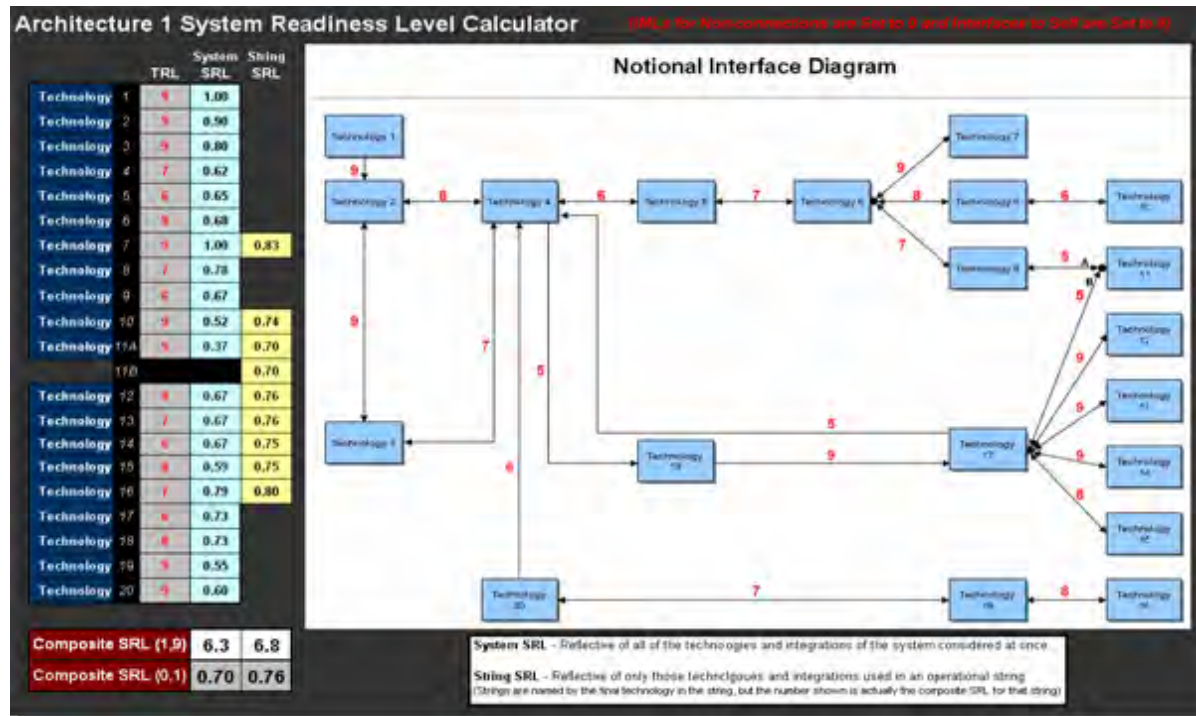

Verification and Validation Activities

IRL Criteria

- Created expanded list of IRL criteria for each readiness level
- Goal was to capture the key elements of the integration maturation process
- Presented to 30 integration SMEs from across government, academia, and industry
- Asked to assess importance of each criterion
- Results show solid buy-in among SMEs that identified criteria are key factors in successful integration

SRL Evaluation Process

- Conducted a “blind trial” of SRL methodology and evaluation process
- User’s Guide and evaluation criteria were sent to key system SMEs
- From just these resources SMEs were asked to conduct the evaluation and report on the results
- Compiled results and iterated on lessons learned to improve the process



Implementation / Application

Trading Off Technology Options

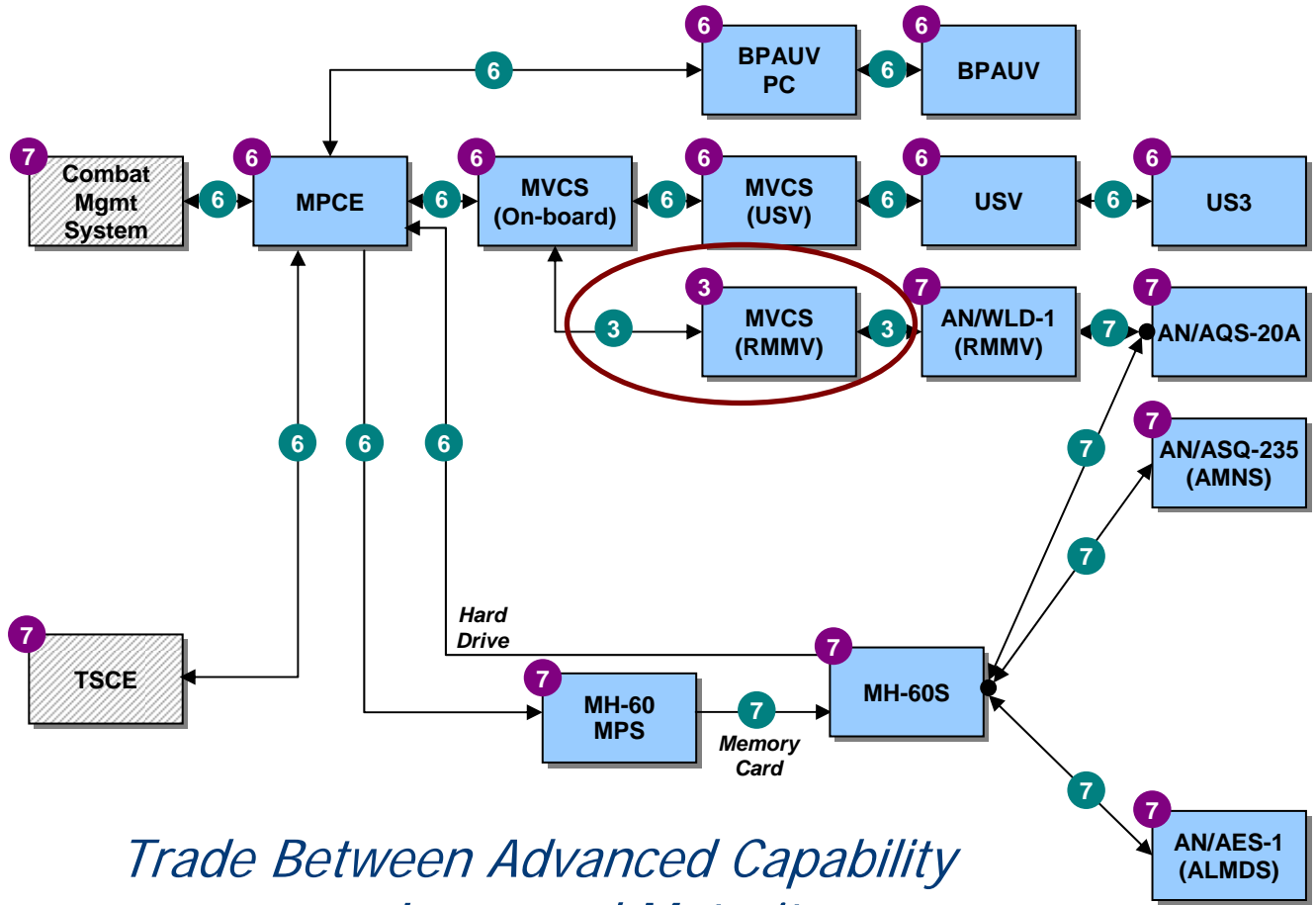

| | MP SRL | MP SRL
w/o Sea Frame |
|------|--------|-------------------------|
| MP 1 | 0.60 | 0.57 |

LEGEND

- MP Technology
- Sea Frame System
- Current Mission Package SRL Status
- Previous Mission Package SRL Status
- Current Mission System SRL Status
- 1 Technology Readiness Level
- 1 Integration Maturity Level
- 1 System Readiness Level Demarcation
- Scheduled Position

Risk to Cost and/or Schedule

- Low
- Medium
- High

Trade Between Advanced Capability or Increased Maturity

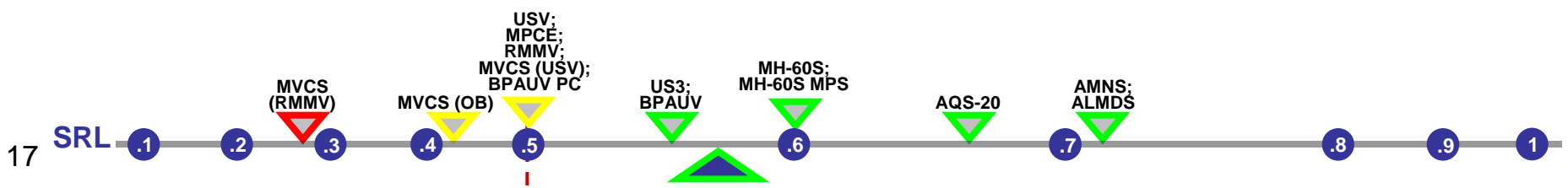

Taking Action to Mitigate Risk

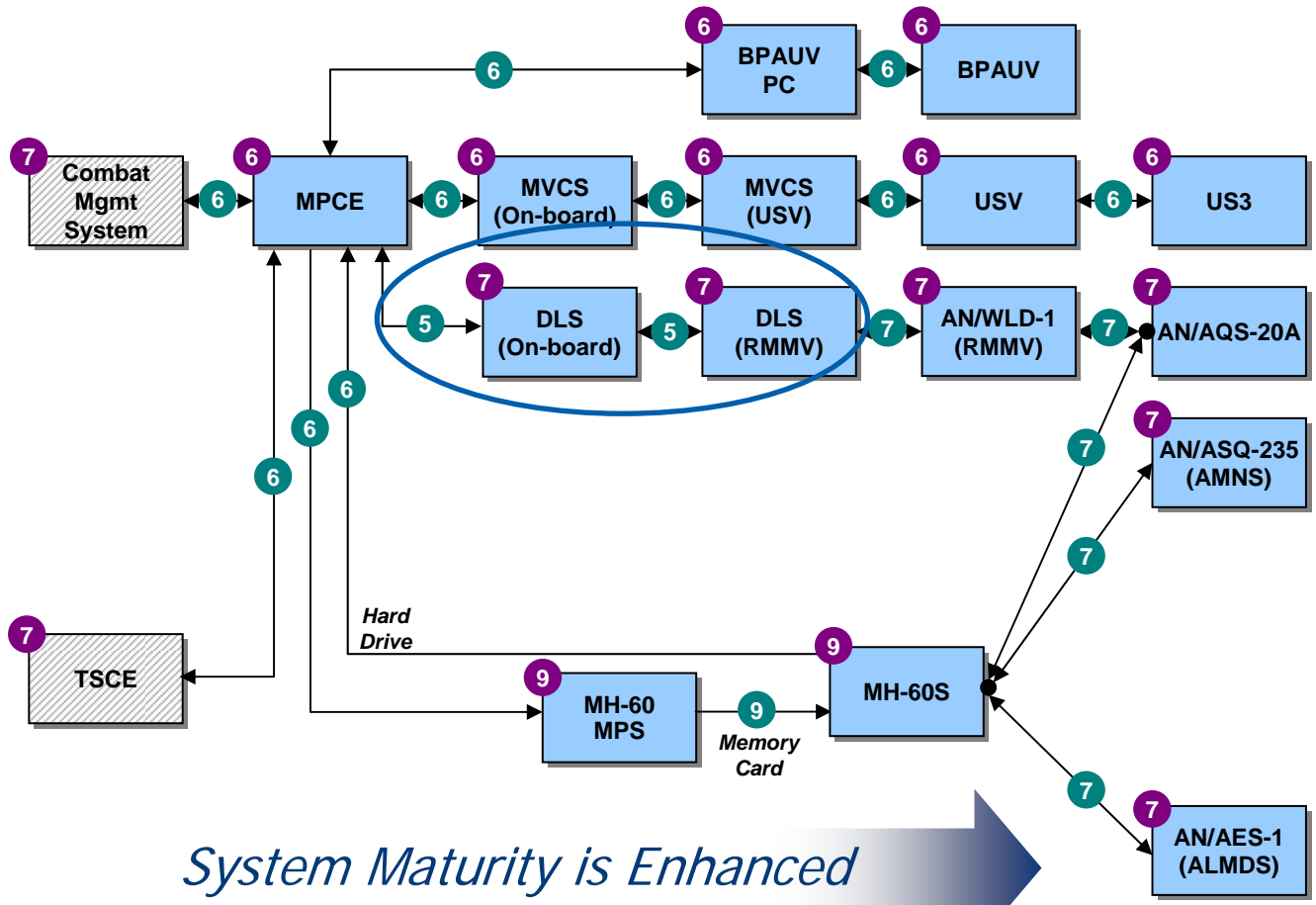

| | MP SRL | MP SRL
w/o Sea Frame |
|------|--------|-------------------------|
| MP 1 | 0.64 | 0.67 |

LEGEND

- MP Technology (Blue box)
- Sea Frame System (Hatched box)
- Current Mission Package SRL Status (Blue triangle)
- Previous Mission Package SRL Status (Purple triangle)
- Current Mission System SRL Status (Grey triangle)
- Technology Readiness Level (Purple circle)
- Integration Maturity Level (Green circle)
- System Readiness Level Demarcation (Blue circle)
- Scheduled Position (Red dashed line)

Risk to Cost and/or Schedule

- Low (Green inverted triangle)
- Medium (Yellow inverted triangle)
- High (Red inverted triangle)

System Maturity is Enhanced

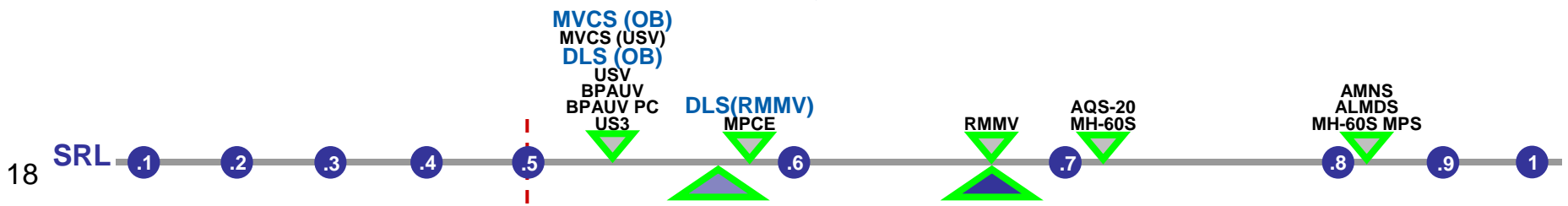

Planning for the Unexpected

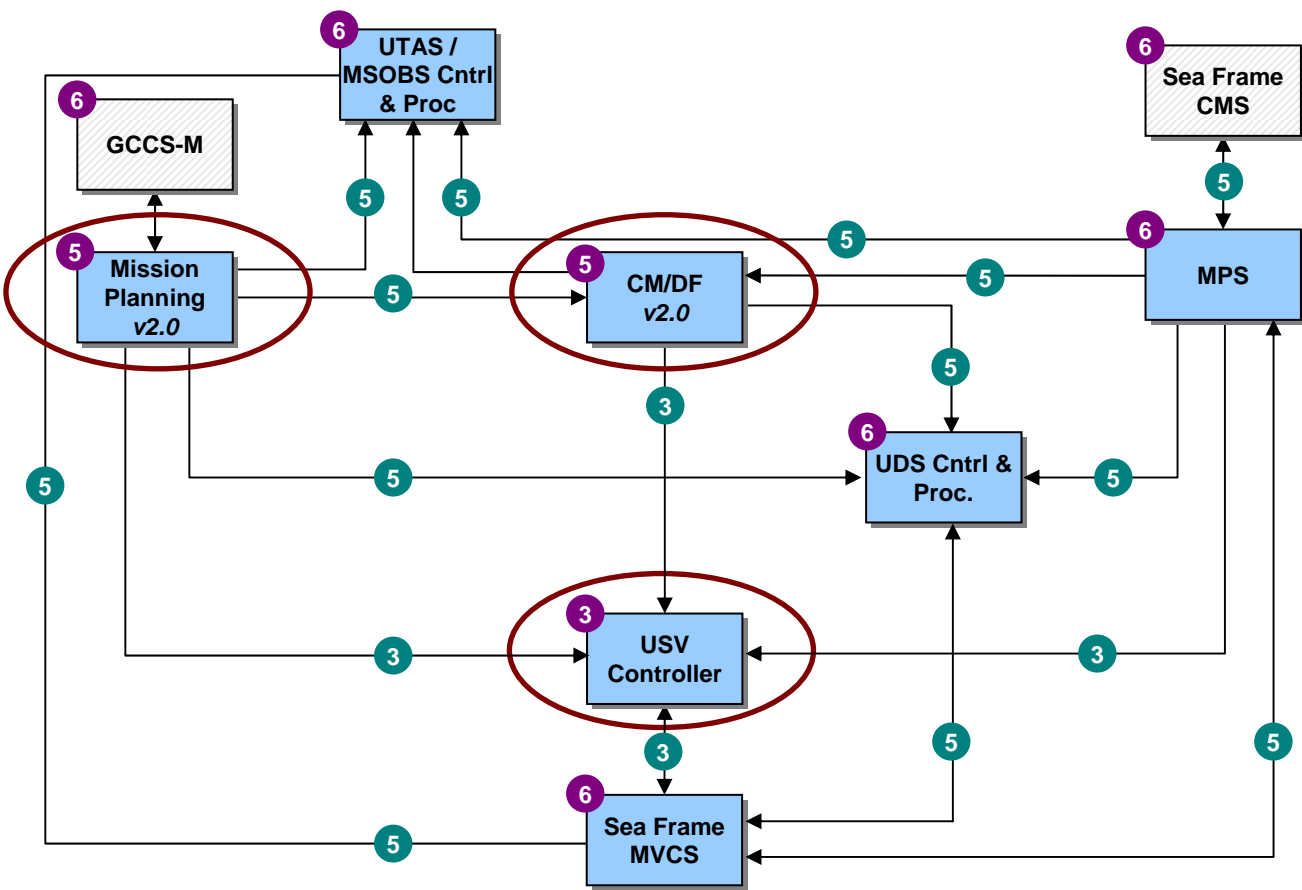

| | MP SRL | MP SRL
w/o Sea Frame |
|-------|--------|-------------------------|
| MP SW | 0.39 | 0.35 |

LEGEND

- MP Technology (Blue box)
- Sea Frame System (Hatched box)
- ▲ Current Mission Package SRL Status
- ▲ Previous Mission Package SRL Status
- ▼ Current Mission System SRL Status
- 1 Technology Readiness Level
- 1 Integration Maturity Level
- 1 System Readiness Level Demarcation
- - - Scheduled Position
- Risk to Cost and/or Schedule**
- ▼ Low (Green)
- ▼ Medium (Yellow)
- ▼ High (Red)

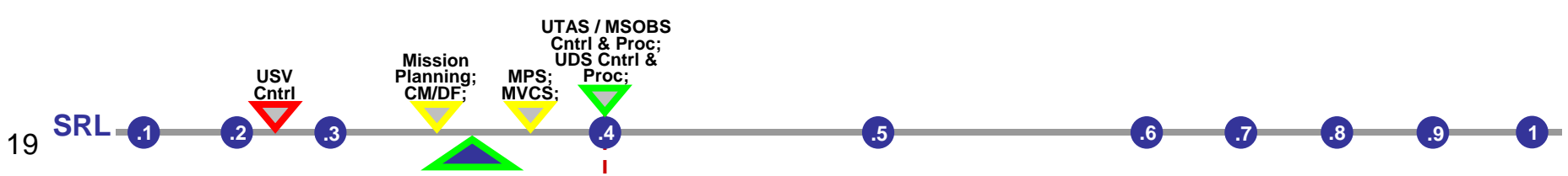

Effectively Channeling Resources

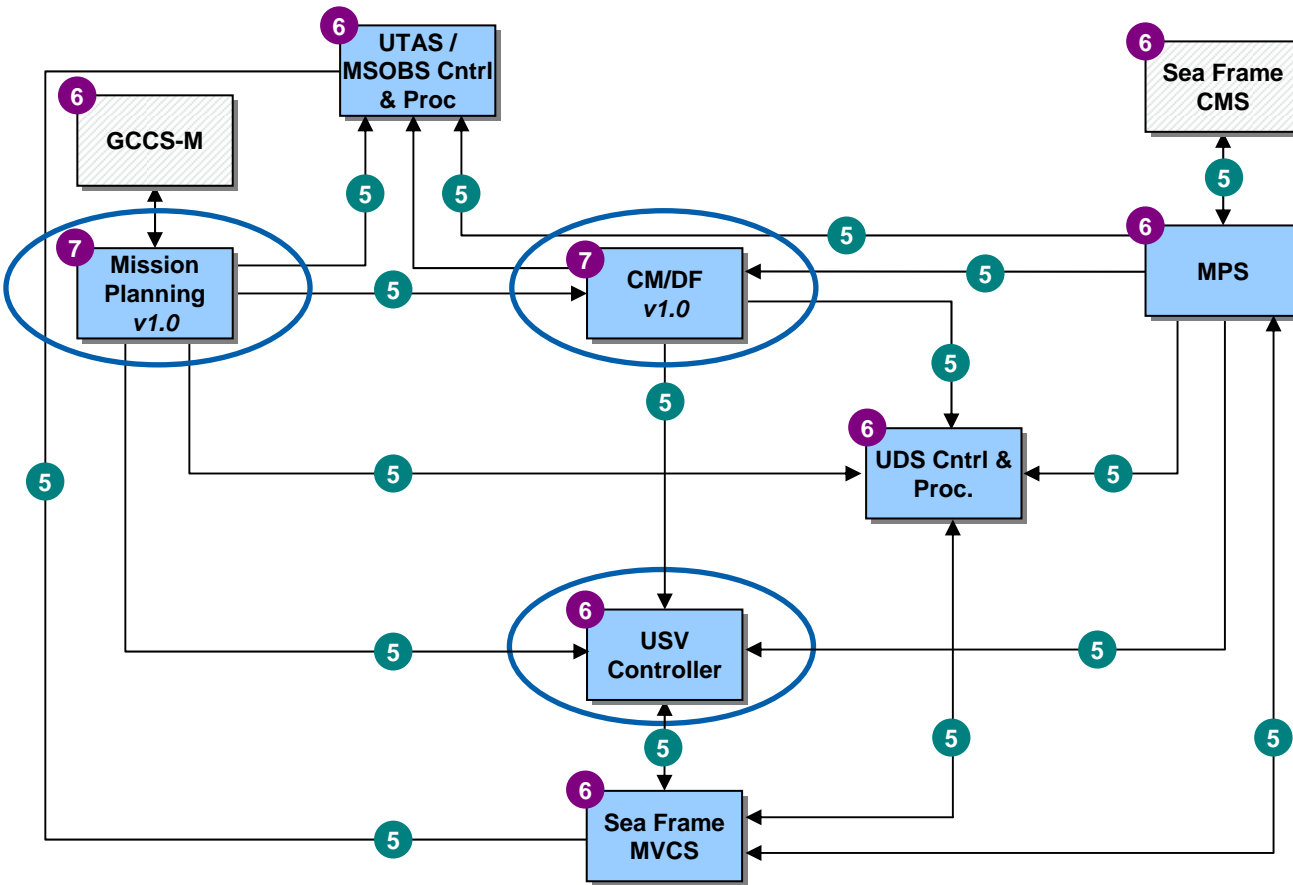

| | MP SRL | MP SRL
w/o Sea Frame |
|-------|--------|-------------------------|
| MP SW | 0.46 | 0.45 |

LEGEND

- MP Technology
- Sea Frame System
- Current Mission Package SRL Status
- Previous Mission Package SRL Status
- Current Mission System SRL Status
- 1 Technology Readiness Level
- 1 Integration Maturity Level
- 1 System Readiness Level Demarcation
- Scheduled Position

Risk to Cost and/or Schedule

- Low
- Medium
- High

6 months later...

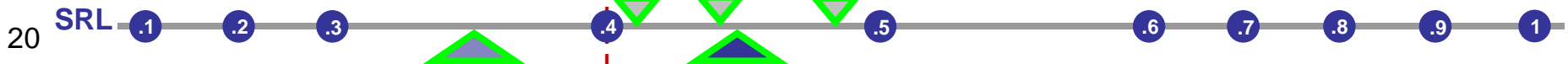

Lessons Learned

- Methodology is highly adaptable and can be quickly applied to a wide variety of development efforts
- Programs tend to minimize the importance of system and subsystem integration and thus overestimate the maturity of their development
- Widespread familiarity with TRL makes acceptance and utilization of TRL and IRL easier
- Formulating the system architecture early in development is a key step and leads to an enhancement of the overall systems engineering effort
- System architecture formulation also provides the opportunity to bring together SMEs from both the physical and logical realms and necessitates insightful discussions across the team
- The decision maker is afforded the ability to assess program status from a system of systems perspective

The SRL methodology delivers a holistic evaluation of complex system readiness that is robust, repeatable, and agile



Next Steps

Future Work and Applications

SRL methodology can be used not only to assess current program performance against plan, but also to roadmap and assess future development options

Future work will focus on the creation of an interactive technology insertion options tradeoff and decision environment

Key Aspects:

- Development of a tool to assess technology options and architectures
- Incorporation of a semi-automated tradeoff capability that considers SRL, cost, risk, schedule, and performance impact
- Gathering of data from potential suppliers detailing how they fit into the defined architecture and the maturity of their product

Applications:

- Future technology, obsolescence, and upgrade planning



QUESTIONS?



Back-up

Abstract

A 2006 Government Accountability Office study of Department of Defense (DoD) technology transition processes concluded that a lack of insight into the technical maturity of complex systems during development has led to an environment of program cost overruns, schedule slips, and reduced performance. A key aspect of current development practices is the reliance on the Technology Readiness Level (TRL) as a core provider of maturity assessments. While the TRL has been well proven for its effectiveness in gauging individual technology maturity in research and development applications, its extrapolation to the complex systems of systems integration dictated by emerging DoD requirements brings about a host of issues. Principally, by looking only at the status of individual component technical maturity, TRL fails to account for the complexities involved in the integration of these components into a functional system and creates the opportunity for performance gaps to remain hidden until late in the development cycle.

To address this lack of a true system-level maturity analysis process, the Northrop Grumman Corporation, the Stevens Institute of Technology, and NAVSEA have collaborated to create and implement a methodology known as the System Readiness Level (SRL). The SRL is a composite rating system relying on input from the traditional TRL scale as well as a new readiness gauge known as the Integration Maturity Level (IRL). These two scales are combined analytically to provide a systems readiness indicator that yields a holistic assessment of both the maturity of individual technologies within a system as well as the status of their corresponding integrations and interdependencies. This presentation will detail the application and value of this methodology to complex DoD integration efforts as well as the theory behind the SRL concept and the steps taken to minimize ambiguity and subjectivity in the evaluation process. Through this it will be shown that the SRL is an effective tool for system maturity and risk monitoring and contributes greatly to enhancing development program performance for complex systems.

Detailed SRL Calculation Example

Matrix Setup

- The computation of the SRL is a function of two matrices:
 - The TRL Matrix provides a blueprint of the state of the system with respect to the readiness of its technologies. That is, TRL is defined as a vector with n entries for which the k th entry defines the TRL of the k th technology.
 - The IRL Matrix illustrates how the different technologies are integrated with each other from a system perspective. IRL is defined as an $n \times n$ matrix for which the element IRL_{ij} represents the maturity of integration between the i th and j th technologies.
- Populate these matrices with the appropriate values from the previously documented TRL and IRL component evaluations and then normalize to a (0,1) scale by dividing through by 9
- For an integration of a technology to itself (e.g. IRL_{nn}) a value of "9" should be placed in the matrix
- For an instance of no integration between technologies a value of "0" should be placed in the matrix

$$[TRL]_{n \times 1} = \begin{bmatrix} TRL_1 \\ TRL_2 \\ \dots \\ TRL_n \end{bmatrix} \quad [IML]_{n \times n} = \begin{bmatrix} IML_{11} & IML_{12} & \dots & IML_{1n} \\ IML_{21} & IML_{22} & \dots & IML_{2n} \\ \dots & \dots & \dots & \dots \\ IML_{n1} & IML_{n2} & \dots & IML_{nn} \end{bmatrix}$$

Detailed SRL Calculation Example

Calculation

- Obtain an SRL matrix by finding the product of the TRL and IRL matrices

$$[SRL]_{n \times 1} = [IML]_{n \times n} \times [TRL]_{n \times 1}$$

- The SRL matrix consists of one element for each of the constituent technologies and, from an integration perspective, quantifies the readiness level of a specific technology with respect to every other technology in the system while also accounting for the development state of each technology through TRL. Mathematically, for a system with n technologies, [SRL] is:

$$[SRL] = \begin{bmatrix} SRL_1 \\ SRL_2 \\ \dots \\ SRL_n \end{bmatrix} = \begin{bmatrix} IML_{11}TRL_1 + IML_{12}TRL_2 + \dots + IML_{1n}TRL_n \\ IML_{21}TRL_1 + IML_{22}TRL_2 + \dots + IML_{2n}TRL_n \\ \dots \\ IML_{n1}TRL_1 + IML_{n2}TRL_2 + \dots + IML_{nn}TRL_n \end{bmatrix}$$

Detailed SRL Calculation Example

Analysis

- Each of the SRL values obtained from the previous calculation would fall within the interval $(0, \# \text{ of Integrations for that Row})$. For consistency, these values of SRL should be divided by the number of integrations for that row of the matrix to obtain the normalized value between $(0,1)$. (e.g. if there are four non-zero numbers in the IRL matrix for that row, divide by four)
- This number should then be multiplied by 9 to return to the familiar $(1,9)$ scale
- For Example:

$$\begin{pmatrix} \text{IRL}_1 & \text{IRL}_{12} & \text{IRL}_{13} \\ \text{IRL}_{12} & \text{IRL}_2 & \text{IRL}_{23} \\ \text{IRL}_{13} & \text{IRL}_{23} & \text{IRL}_3 \end{pmatrix} = \begin{pmatrix} 0 & 1 & 0 \\ 1 & 0 & 7 \\ 0 & 7 & 0 \end{pmatrix}$$

← **1 Integration** (Divide SRL for that Row by 1 and multiply by 9)

← **2 Integrations** (Divide SRL for that Row by 2 and multiply by 9)

← **1 Integration** (Divide SRL for that Row by 1 and multiply by 9)

Detailed SRL Calculation Example

Analysis



$$SRL = \left[SRL_1 \quad SRL_2 \quad SRL_3 \right]$$

- These individual values serve as a decision-making tool as they provide a prioritization guide of the system's technologies and integrations and point out deficiencies in the maturation process
- The composite SRL for the complete system is the average of all normalized SRL values. (Note that weights can be incorporated here if desired.)

$$SRL_{Composite} = \frac{\left(\frac{SRL_1}{n} + \frac{SRL_2}{n} + \dots + \frac{SRL_n}{n} \right)}{n}$$

- A standard deviation can also be calculated to indicate the variation in the system maturity

SRL Calculation Example

Normalizing the TRLs and IRLs

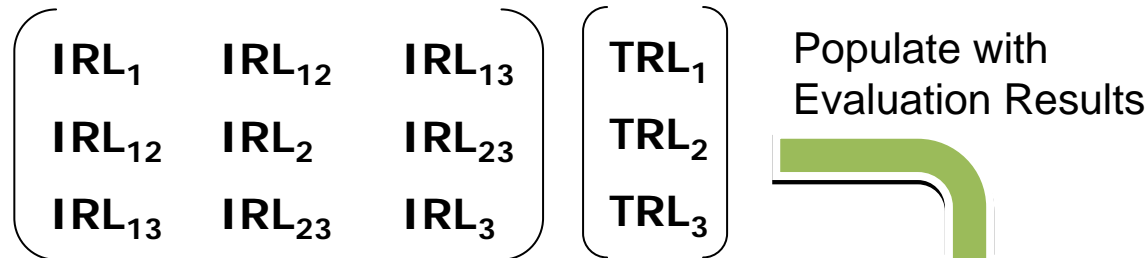

Non-Normalized [(1,9) scale]

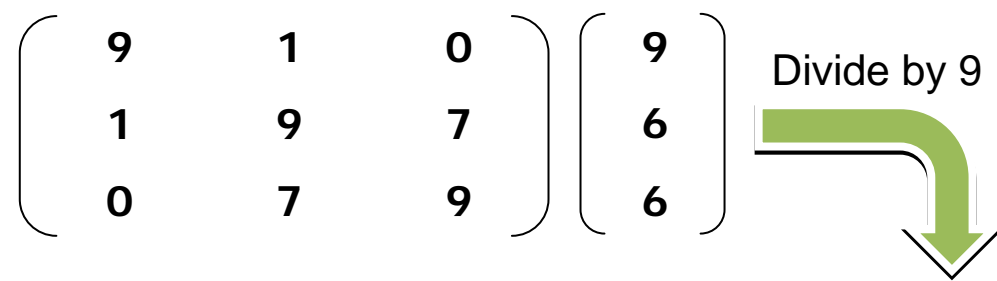

Normalized [(0,1) scale]

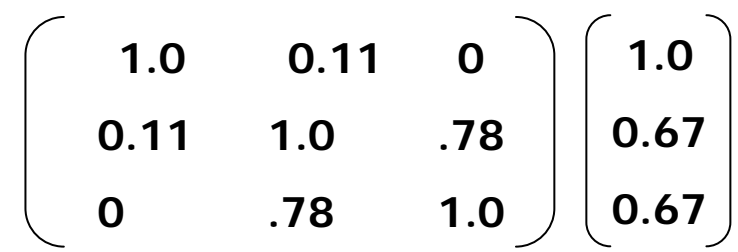

Remember... a technology integrated with itself receives an IRL value of 9 (e.g. IRL₁₁), while technologies for which there is no connection between them receive a value of 0 (e.g. IRL₁₃).

SRL for System Alpha

Calculating the SRL and Composite Matrix

$$\text{SRL} = \text{IRL} \times \text{TRL}$$

Component SRL

$$\begin{bmatrix} \text{SRL}_1 & \text{SRL}_2 & \text{SRL}_3 \end{bmatrix} = \begin{bmatrix} 1.07 & 1.30 & 1.19 \end{bmatrix} \quad \text{(0,n) scale}$$

Where "n" is equal to the number of integrations for that technology

$$\begin{bmatrix} \text{SRL}_1 & \text{SRL}_2 & \text{SRL}_3 \end{bmatrix} = \begin{bmatrix} 0.54 & 0.43 & 0.59 \end{bmatrix} \quad \text{(0,1) scale}$$

Component SRL_x represents Technology "X" and its IRLs considered

Composite SRL

$$\begin{aligned} \text{Composite SRL} &= 1/3 (0.54 + 0.43 + 0.59) \\ &= \boxed{0.52} \end{aligned}$$

The Composite SRL provides an overall assessment of the system readiness

Both individual and composite scores provide key insights into the actual maturity of the system as well as where risk may lie and attention directed for greatest benefit

NOTE: ALL DATA IN THIS TEMPLATE IS NOTIONAL

System Detailed Status

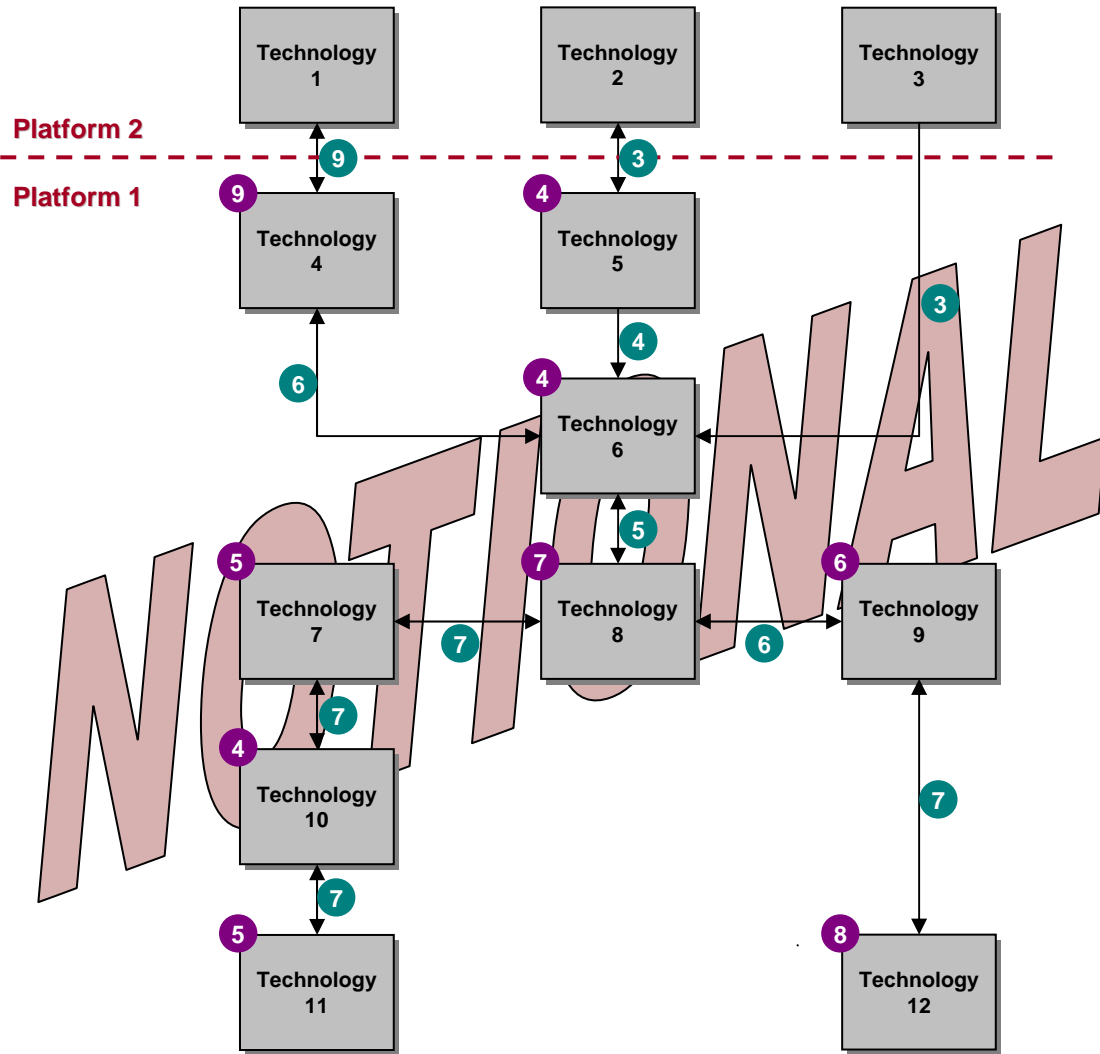

| | Composite Actual | Planned |
|---------------------------------|------------------|------------|
| SRL | 5.7 | 5.0 |
| SRL w/o Platform 1 Integrations | 5.3 | 5.0 |

LEGEND

- Platform 1 System
- Platform 2 System
- Current Composite SRL Status
- Previous Composite SRL Status
- Individual technology SRL Status
- Technology Readiness Level
- Integration Maturity Level
- System Readiness Level Demarcation
- Scheduled Position
- Low Risk to Cost and/or Schedule
- Moderate Risk to Cost and/or Schedule
- High Risk to Cost and/or Schedule

Data Collection Period: XX/XX/XX – X/XX/XX

Previous Report Date: XX/XX/XX

Schedule Updated: XX/XX/XX

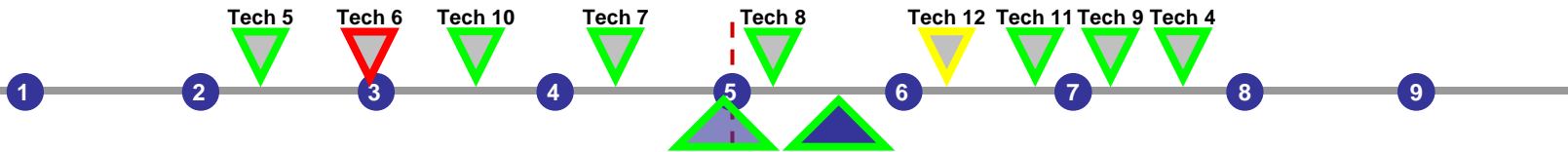

NOTE: ALL DATA IN THIS TEMPLATE IS NOTIONAL

Program Status Roll-up

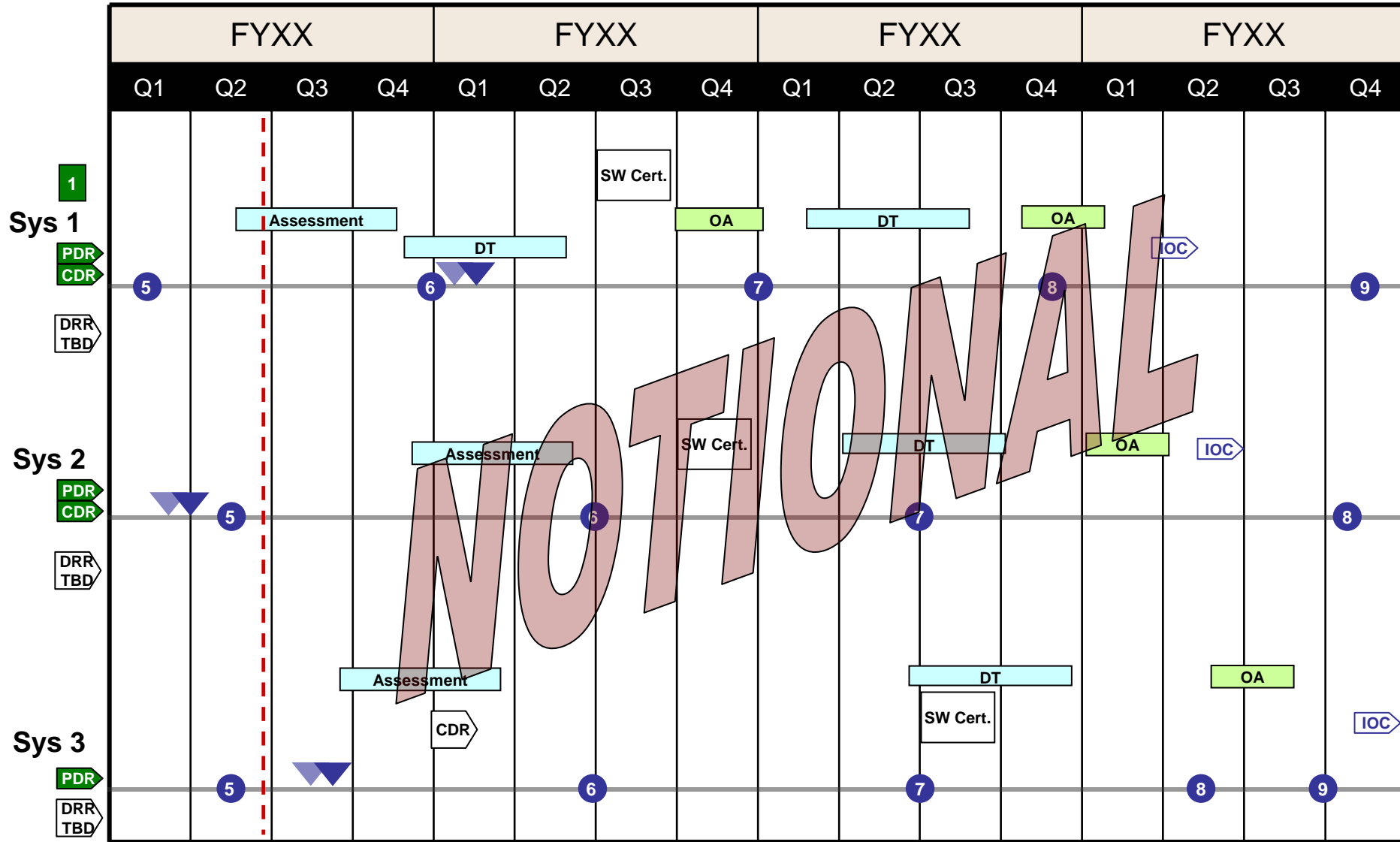

LEGEND

- ▼ Current Reporting Period Status
- ▼ Previous Reporting Period Status
- Scheduled Position
- 7 System Readiness Level

Data Collection Period: XX/XX/XX – X/XX/XX
Previous Report Date: XX/XX/XX
Schedule Updated: XX/XX/XX

What is an IRL?

A systematic measurement reflecting the status of an integration connecting two particular technologies

| | IRL | Definition |
|-----------|-----|---|
| Pragmatic | 9 | Integration is Mission Proven through successful mission operations. |
| | 8 | Actual integration completed and Mission Qualified through test and demonstration, in the system environment. |
| | 7 | The integration of technologies has been Verified and Validated with sufficient detail to be actionable. |
| Syntactic | 6 | The integrating technologies can Accept, Translate, and Structure Information for its intended application. |
| | 5 | There is sufficient Control between technologies necessary to establish, manage, and terminate the integration. |
| | 4 | There is sufficient detail in the Quality and Assurance of the integration between technologies. |
| Semantic | 3 | There is Compatibility (i.e. common language) between technologies to orderly and efficiently integrate and interact. |
| | 2 | There is some level of specificity to characterize the Interaction (i.e. ability to influence) between technologies through their interface. |
| | 1 | An Interface between technologies has been identified with sufficient detail to allow characterization of the relationship. |

SRL Algorithm Sensitivity Evaluated

- Observed that the SRL algorithm did not take into account the varying levels of “importance” between technologies
- Examined the sensitivity of the algorithms to changes in the TRL and IRL ratings of systems with varying levels of importance
- Modified the methodology to automatically include weightings for those technologies that are most important by looking at operational “strings” or mission threads

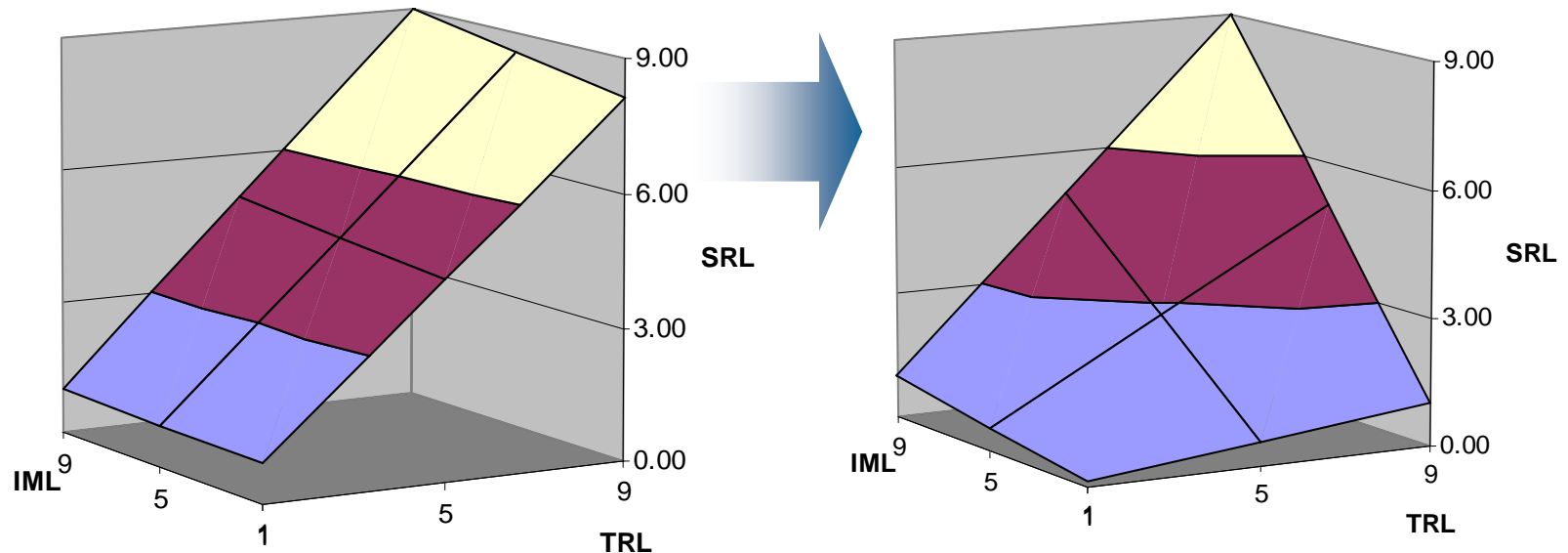

SRL Response Analysis

IML = 1

* Indicates unreasonable combination

IML = 4

Components to be integrated are selected and interfaces identified

Integration and data requirements are defined; low fidelity experimentation

| TRL | Composite SRL |
|-----|---------------|
| 1 | 0.06 |
| 3 | 0.17 |
| 5 | 0.28 |
| 7 | 0.39 |
| 9 | 0.51* |

| TRL | Composite SRL |
|-----|---------------|
| 1 | 0.08 |
| 3 | 0.23 |
| 5 | 0.38 |
| 7 | 0.54 |
| 9 | 0.69* |

IML = 7

End-to-end system integration accomplished; prototype demonstrated

IML = 9

System installed and deployed with mission proven operation

| TRL | Composite SRL |
|-----|---------------|
| 1 | 0.10* |
| 3 | 0.29* |
| 5 | 0.49 |
| 7 | 0.68 |
| 9 | 0.88 |

| TRL | Composite SRL |
|-----|---------------|
| 1 | 0.11* |
| 3 | 0.33* |
| 5 | 0.56* |
| 7 | 0.78 |
| 9 | 1.00 |

Algorithms Evaluated for Sensitivity

TRL Variation Analysis

All TRLs in the system are set to 9 with the exception of the one corresponding to the system in each row, which was set to 1.

| | Standard Methodology | | Non-connected, Self IRLs = 0 | |
|--|----------------------|--------|------------------------------|--------|
| | Sys | String | Sys | String |
| MPCE
6 Connections
Used by all Threads | 8.6 | 7.9 | 7.9 | 7.2 |
| Radar
1 Connections
Used by all Threads | 8.6 | 7.9 | 8.8 | 8.5 |
| MH-60S
7 Connections
Used by 5 Threads | 8.6 | 8.4 | 7.7 | 8.1 |
| COBRA
1 Connections
Used by 1 Thread | 8.6 | 8.9 | 8.8 | 8.9 |

NOTE: There are 9 total threads

IRL Variation Analysis

All IRLs in the system are set to 9 with the exception of the one corresponding to the link in each row, which was set to 1

| | Standard Methodology | | Non-connected, Self IRLs = 0 | |
|---|----------------------|--------|------------------------------|--------|
| | Sys | String | Sys | String |
| MPCE - CMS
Used by all Threads | 9.0 | 8.7 | 8.6 | 8.0 |
| Radar - CMS
Used by all Threads | 9.0 | 8.7 | 8.6 | 8.0 |
| MH-60S - MPCE
Used by 5 Threads | 9.0 | 8.8 | 8.6 | 8.4 |
| COBRA - VTUAV
Used by 1 Thread | 9.0 | 9.0 | 8.6 | 8.9 |

NOTE: There are 9 total threads

Comparative Sensitivity – A look at how the algorithms penalized the SRL rating relative to one another (1 is most severe)

| | Standard Methodology | | Non-connected, Self IRLs = 0 | |
|------------|----------------------|--------|------------------------------|--------|
| | Sys | String | Sys | String |
| 1.) MPCE | 1,4 | 1,2 | 2 | 1 |
| 2.) MH-60S | 1,4 | 3 | 1 | 2 |
| 3.) Radar | 1,4 | 1,2 | 3,4 | 3 |
| 4.) COBRA | 1,4 | 4 | 3,4 | 4 |

| | Standard Methodology | | Non-connected, Self IRLs = 0 | |
|-------------------|----------------------|--------|------------------------------|--------|
| | Sys | String | Sys | String |
| 1.) MPCE - CMS | 1,4 | 1,2 | 1,4 | 1,2 |
| 2.) MH-60S - MPCE | 1,4 | 3 | 1,4 | 3 |
| 3.) Radar - CMS | 1,4 | 1,2 | 1,4 | 1,2 |
| 4.) COBRA - VTUAV | 1,4 | 4 | 1,4 | 4 |



New Acquisition Policy and Its Impact on Systems Engineering

NDIA 11th Annual Systems Engineering Conference

October 21, 2008

Sharon Vannucci

Systems and Software Engineering/Enterprise Development

Office of the Deputy Under Secretary of Defense

(Acquisition & Technology)



Subtle, But Substantial Changes

Old Life Cycle

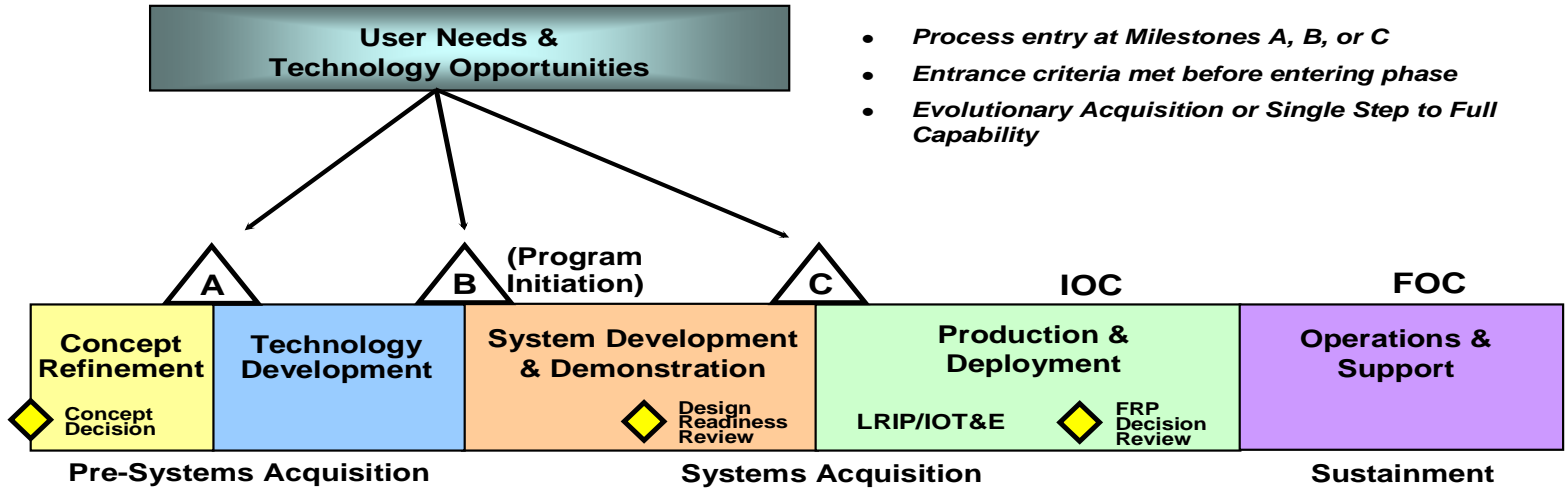

New Life Cycle

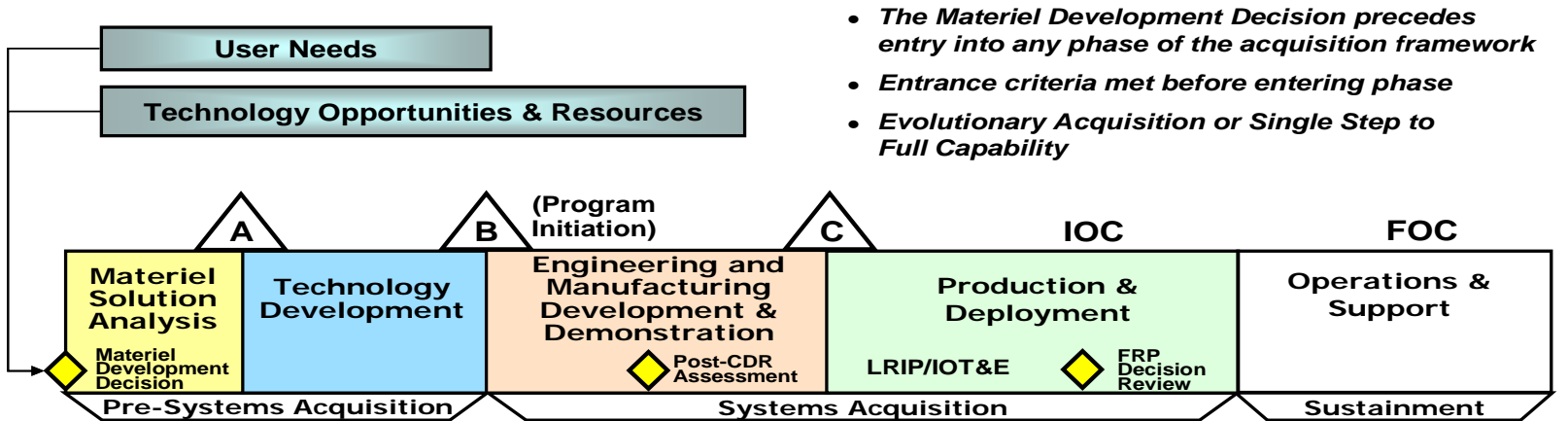

◆ = Decision Point ▲ = Milestone Review



Overview of Draft Acquisition Policy Changes*

- ❖ Mandatory Materiel Development Decision (MDD)
- ❖ Mandatory competing prototypes before MS B
- ❖ Mandatory PDR and a report to the MDA before MS B (*moves MS B to the right*)
- ❖ Configuration Steering Boards at Component level to review all requirements changes

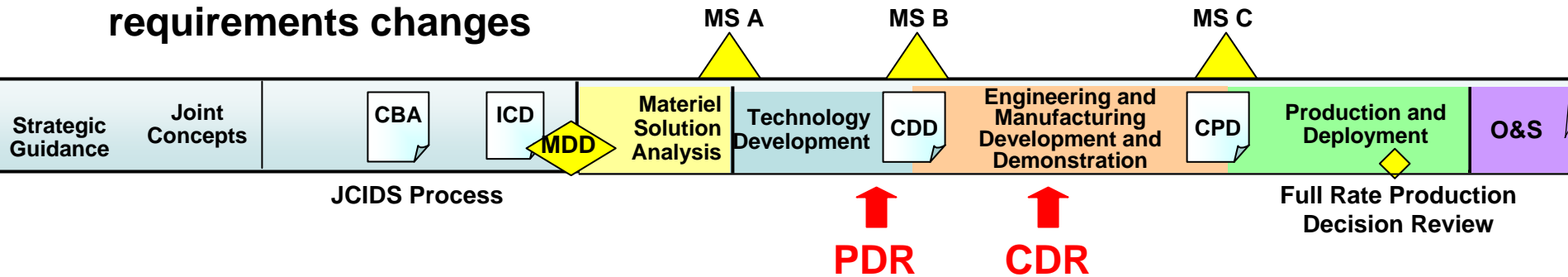

- ❖ Renewed emphasis on manufacturing during system development:
 - Re-titles SDD phase to EMDD with two sub phases: Integrated System Design and System Capability and Manufacturing Process Demonstration
 - Establishes consideration of manufacturing maturity at key decision points
- ❖ Mandatory system-level CDR with an initial product baseline and followed by a Post-CDR Report to the MDA
- ❖ Post-CDR Assessment by the MDA between EMDD sub phases



Mandatory “Materiel Development Decision”

- ❖ *Materiel Development Decision precedes entry into any phase of the acquisition framework*
- ❖ *Entrance criteria met before entering phase*
- ❖ *Evolutionary Acquisition or Single Step to Full Capability*

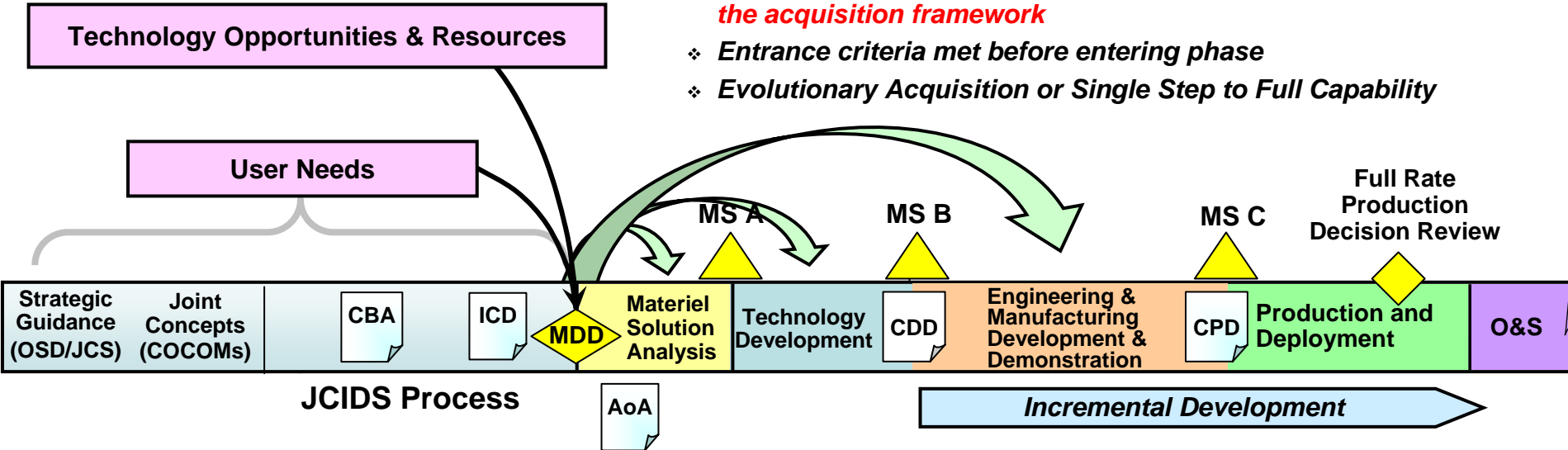

“ When the ICD demonstrates the need for a materiel solution, the JROC will recommend that the MDA consider potential materiel solutions. The MDA, working with appropriate stakeholders, shall determine whether it is appropriate to proceed with a Materiel Development Decision. . . . If the MDA decides that additional analysis is required, a designated office shall prepare, and the MDA shall approve, study guidance to ensure that necessary information is available to support the decision. . . . The Materiel Solution Analysis Phase begins with the Materiel Development Decision (MDD) Review. The MDD Review is the formal entry point into the acquisition process and shall be mandatory for all programs. . . . At the MDD Review, the Joint Staff shall present the JROC recommendations and the DoD Component shall present the ICD including: the preliminary concept of operations, a description of the needed capability, the operational risk, and the basis for determining that non-materiel approaches will not sufficiently mitigate the capability gap. The Director, PA&E, shall propose study guidance for the AoA. . . . The MDA shall approve the AoA study guidance; determine the acquisition phase of entry; identify the initial review milestone; and designate the lead DoD Component(s). The MDA decisions shall be documented in an Acquisition Decision Memorandum (ADM).”



FY08 National Defense Authorization Act

- ❖ Mandates Milestone A approval prior to technology development for a major weapon system
- ❖ Requires MDA Certification prior to Milestone A for MDAPs
- ❖ Changed Milestone B Certification Requirements
- ❖ Mandates reporting and notification of program cost changes

H. R. 4986

One Hundred Tenth Congress
of the
United States of America

AT THE SECOND SESSION

*Begun and held at the City of Washington on Thursday,
the third day of January, two thousand and eight*

SEC. 943. REQUIREMENT FOR CERTIFICATION OF MAJOR SYSTEMS
PRIOR TO TECHNOLOGY DEVELOPMENT.

(a) REQUIREMENT FOR CERTIFICATION.—
(1) IN GENERAL.—Chapter 139 of title 10, United States
Code, is amended by inserting after section 2366a the following
new section:

“§ 2366b. Major defense acquisition programs: certification
required before Milestone A or Key Decision
Point A approval

“(a) CERTIFICATION.—A major defense acquisition program may
not receive Milestone A approval, or Key Decision Point A approval
in the case of a space program, until the Milestone Decision
Authority certifies, after consultation with the Joint Requirements
Oversight Council on matters related to program requirements and
military needs—

“(1) that the system fulfills an approved initial capabilities
document;

“(2) that the system is being executed by an entity with
a relevant core competency as identified by the Secretary of
Defense under section 118b of this title;

“(3) if the system duplicates a capability already provided
by an existing system, the duplication provided by such system
is necessary and appropriate; and

“(4) that a cost estimate for the system has been submitted
and that the level of resources required to develop and procure
the system is consistent with the priority level assigned by
the Joint Requirements Oversight Council.



Prototyping and Competition

“Evolutionary acquisition requires . . . Technology development preceding initiation of an increment shall continue until the required level of maturity is achieved, prototypes of the system or key system elements are produced, and a preliminary design is completed. . . .”

“The TDS and associated funding shall provide for two or more competing teams producing prototypes of the system and/or key system elements prior to, or through, Milestone B.”



ACQUISITION,
TECHNOLOGY
AND LOGISTICS

THE UNDER SECRETARY OF DEFENSE

3010 DEFENSE PENTAGON
WASHINGTON, DC 20301-3010

19 SEP 2007

MEMORANDUM FOR SECRETARIES OF THE MILITARY DEPARTMENTS
CHAIRMAN OF THE JOINT CHIEFS OF STAFF
COMMANDER, U.S. SPECIAL OPERATIONS COMMAND
DIRECTORS OF THE DEFENSE AGENCIES

SUBJECT: Prototyping and Competition

Many troubled programs share common traits – the programs were initiated with inadequate technology maturity and an elementary understanding of the critical program development path. Specifically, program decisions were based largely on paper proposals that provided inadequate knowledge of technical risk and a weak foundation for estimating development and procurement cost. The Department must rectify these situations.

Lessons of the past, and the recommendations of multiple reviews, including the Packard Commission report, emphasize the need for, and benefits of, quality prototyping. The Department needs to discover issues before the costly System Design and Development (SDD) phase. During SDD, large teams should be producing detailed manufacturing designs – not solving myriad technical issues. Government and industry teams must work together to demonstrate the key knowledge elements that can inform future development and budget decisions.

To implement this approach, the Military Services and Defense Agencies will formulate all pending and future programs with acquisition strategies and funding that provide for two or more competing teams producing prototypes through Milestone (MS) B. Competing teams producing prototypes of key system elements will reduce technical risk, validate designs, validate cost estimates, evaluate manufacturing processes, and refine requirements. In total, this approach will also reduce time to fielding.

Beyond these key merits, program strategies defined with multiple, competing prototypes provide a number of secondary benefits. First, these efforts exercise and develop government and industry management teams. Second, the prototyping efforts provide an opportunity to develop and enhance system engineering skills. Third, the programs provide a method to exercise and retain certain critical core engineering skills in the government and our industrial base. Fourth, prototype efforts can attract a new generation of young scientists and engineers to apply their technical talents to the needs of our Nation's Warfighters. Finally, these prototype efforts can inspire the imagination and creativity of a new generation of young students, encouraging them to pursue technical educations and careers.





Preliminary Design Review Precedes MS B

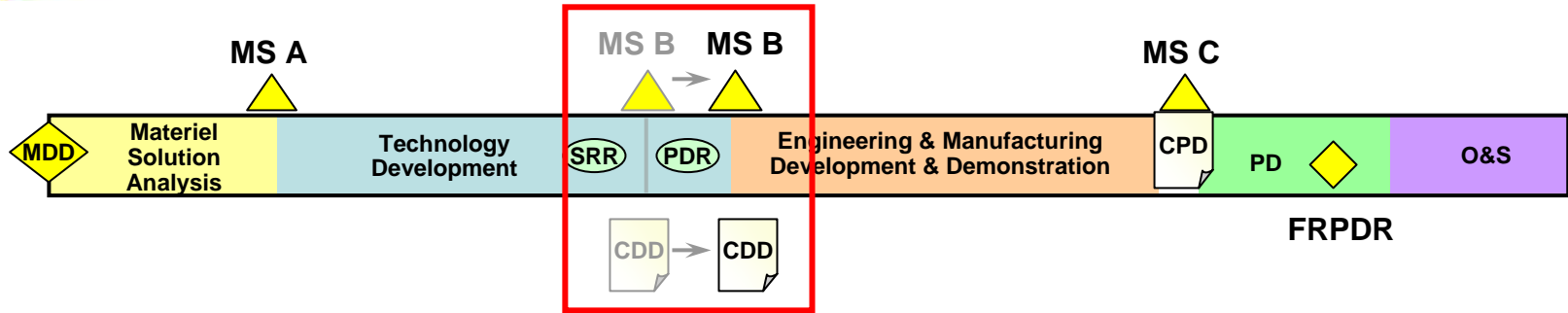

| | |
|-------------------------------|---|
| CHARACTERISTICS | MS B moved “to the right” to allow contractor preliminary design to inform requirements, estimated costs, and schedule. |
| PROCESS | Technology Development extended through formal Preliminary Design Review (PDR). Preliminary design based on DRAFT CDD to facilitate trades before JROC approval. Competitive environment sustained up to and perhaps through MS B. MDA conducts MS B review as described in current policy. |
| SUPPORTING INFORMATION | PDR Report from PM.
Current statutory and regulatory information |

BENEFITS

- ❖ Ties program decision to event-based (product-based) technical review
- ❖ Most derived requirements surfaced
- ❖ Better understanding of cost, schedule, and performance risk when the APB is approved and SAR reporting begins
- ❖ Opportunity for MDA to defer (in coordination with requirements authority) unachievable requirements to next increment
- ❖ Final requirements informed by detailed design
- ❖ Early indicator of manufacturing and production issues
- ❖ Logical extension of prototyping and competition policy



Preliminary Design Review

§ 3.5.11. A Preliminary Design Review (PDR) shall be conducted for the candidate design(s) to establish the allocated baseline (hardware, software, human/support systems) and underlying architectures and to define a high-confidence design. All system elements (hardware and software) shall be at a level of maturity commensurate with the PDR entrance and exit criteria. A successful PDR will inform requirements trades; improve cost estimation; and identify remaining design, integration, and manufacturing risks. The PDR shall be conducted at the system level and include user representatives and associated certification authorities. The PDR Report shall be provided to the MDA at Milestone B and include recommended requirements trades based upon an assessment of cost, schedule, and performance risk.



Re-Titled Engineering and Manufacturing Development and Demonstration Phase

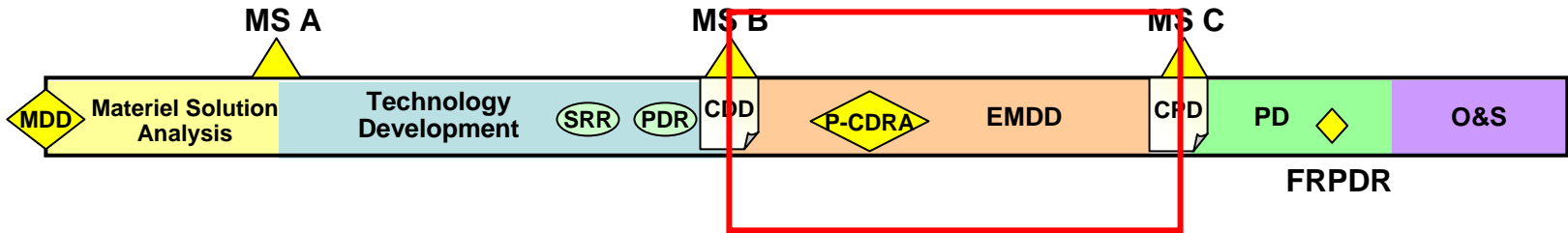

“The purpose of the EMDD phase is to develop a system or an increment of capability; complete full system integration (technology risk reduction occurs during Technology Development); develop an affordable and executable manufacturing process; ensure operational supportability with particular attention to minimizing the logistics footprint; implement human systems integration (HSI); design for producibility; ensure affordability; protect CPI by implementing appropriate techniques such as anti-tamper; and demonstrate system integration, interoperability, safety, and utility. The CDD, Acquisition Strategy, Systems Engineering Plan (SEP), and Test and Evaluation Master Plan (TEMP) shall guide this effort.”

“**Integrated System Design.** This effort is intended to define system and system-of-systems functionality and interfaces, complete hardware and software detailed design, and reduce system-level risk. Integrated System Design shall include the establishment of the product baselines for all configuration items.”

“**System Capability and Manufacturing Process Demonstration.** This effort is intended to demonstrate the ability of the system to operate in a useful way consistent with the approved KPPs and that system production can be supported by demonstrated manufacturing processes. The program shall enter System Capability and Manufacturing Process Demonstration upon completion of the Post-CDR Assessment and establishment of an initial product baseline. This effort shall end when the system meets approved requirements and is demonstrated in its intended environment using the selected production-representative article; manufacturing processes have been effectively demonstrated; industrial capabilities are reasonably available; and the system meets or exceeds exit criteria and Milestone C entrance requirements.”



MDA Conducts Post-CDR Assessment

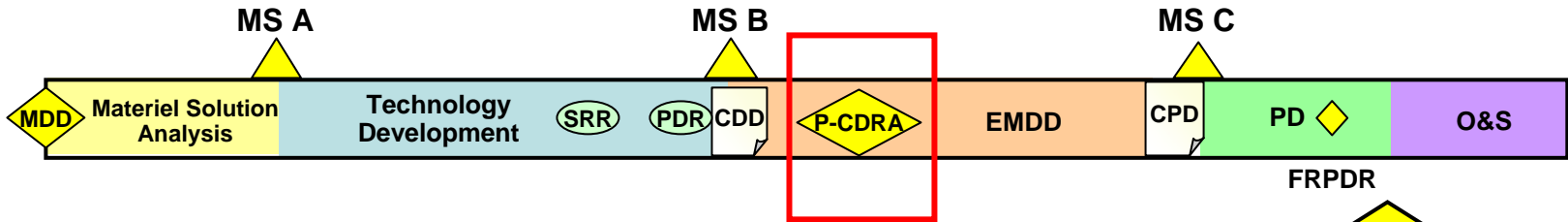

| | |
|-------------------------------|--|
| CHARACTERISTICS | Post-CDR Assessment replaces Design Readiness Review. |
| PROCESS | Post-CDR Assessment is a formal, Milestone Decision Authority (MDA)-conducted decision event. PM describes product baseline, completed build-to packages, a summary of issues and an assessment of program risk based on the CDR report and summarized EVM data. Review considers whether, based on the Program Manager’s report, the program is able to provide capability consistent with the Acquisition Program Baseline approved at Milestone B. The MDA determines whether (1) an adjustment should be made, or (2) the program should be permitted to proceed without change. |
| SUPPORTING INFORMATION | System-Level CDR Report |

| BENEFITS | |
|-----------------|---|
| ❖ | Capitalizes on a well-defined, event-based, technical review |
| ❖ | Decisions based on enhanced knowledge of program and associated contract, all derived requirements surfaced, design uncertainties resolved, development and production costs well defined |
| ❖ | Opportunity for MDA to assess design maturity, e.g., drawings complete |
| ❖ | May provide opportunity to update “current” baseline if consistent with statute (“re-structure”) |
| ❖ | An opportunity to defer “derived” requirements if inconsistent with cost / schedule thresholds |



Post-CDR Assessment

§3.6.4.2. Post-Critical Design Review (CDR) Assessment. The MDA shall conduct a formal program assessment following system-level CDR. The system-level CDR, which shall be conducted as soon as practicable after program initiation, provides an opportunity to assess design maturity as evidenced by measures such as: successful completion of subsystem CDRs; the percentage of hardware and software product build-to specifications and drawings completed and under configuration management; planned corrective actions to hardware/software deficiencies; adequate developmental testing; an assessment of environment, safety and occupational health risks; a completed failure modes and effects analysis; the identification of key system characteristics, manufacturing feasibility, and critical manufacturing processes; an estimate of system reliability based on demonstrated reliability rates; etc.



Post-CDR Report

§ 3.6.4.2.1. The PM shall provide a **Post-CDR Report to the MDA** that provides an overall assessment of design maturity and a summary of the system-level CDR results which shall include, but not be limited to:

§ 3.6.4.2.1.1. The names, organizations, and areas of expertise of independent subject matter expert participants and CDR chair;

§ 3.6.4.2.1.2. A **description of the product baseline** for the system and the percentage of build-to packages completed for this baseline;

§ 3.6.4.2.1.3. A **summary of the issues and actions** identified at the review together **with their closure plans**;

§ 3.6.4.2.1.4. An **assessment of risk by the participants against the exit criteria for the EMDD Phase**; and

§ 3.6.4.2.1.5. **Identification of those issues/risks that could result in a breach to the program baseline or substantively impact cost, schedule, or performance.**

§ 3.6.4.2.2. The MDA shall review the Post-CDR Report and the PM's resolution/mitigation plans and determine whether additional action is necessary to satisfy EMDD Phase exit criteria and to achieve the program outcomes specified in the APB. The results of the MDA's Post-CDR Assessment shall be **documented in an ADM.**



Codifies OSD SE Role in Program Oversight

§ 3.9.6. Program Support Reviews (PSR). PSRs are a means to inform an MDA and Program Office of the status of technical planning and management processes by identifying cost, schedule, and performance risk and recommendations to mitigate those risks. PSRs shall be conducted by cross-functional and cross-organizational teams appropriate to the program and situation. PSRs for ACAT ID and IAM programs shall be planned by the Director, Systems and Software Engineering to support OIPT program reviews, at other times as directed by the USD (AT&L), and in response to requests from PMs.

Enclosure 5. § E5.7.2. The DUSD(A&T) shall conduct an independent Assessment of Operational Test Readiness (AOTR) for all ACAT ID programs and special interest programs designated by the USD(AT&L). Each AOTR shall consider the risks associated with the system's ability to meet operational suitability and effectiveness goals. This assessment shall be based on capabilities demonstrated in DT&E, and OAs, and criteria described in the TEMP. The AOTR report shall be provided to the USD(AT&L), D,OT&E, and Component Acquisition Executive (CAE).

§ E5.7.3. The CAE shall consider the results of the AOTR prior to making a determination of materiel system readiness for IOT&E.



New Systems Engineering Enclosure

- ❖ **Codifies three previous SE policy memoranda**
- ❖ **Codifies a number of SE-related policies and Statutes since 2003:**
 - **Environment, Safety, and Occupational Health**
 - **Corrosion Prevention and Control**
 - **Modular Open Systems Approach**
 - **Data Management and Technical Data Rights**
 - **Item Unique Identification**
 - **Reliability, Availability, and Maintainability**
- ❖ **Introduces new policy on Configuration Management**



Enclosure 12. Systems Engineering

E12.1. Systems Engineering Across the Acquisition Lifecycle.

E12.2. Systems Engineering Plan (SEP).

E12.2.1. PMs shall prepare a SEP for each milestone review, beginning with Milestone A. At Milestone A, the SEP shall support the TDS; at Milestone B or later, the SEP shall support the Acquisition Strategy.

E12.2.2. The DUSD (A&T) shall be the SEP approval authority for programs that will be reviewed by the DAB/ITAB.

E12.3. Systems Engineering Leadership. Each PEO, or equivalent, shall have a lead or chief systems engineer on his or her staff responsible to the PEO for systems engineering across the PEO's portfolio of programs. ... and shall:

E12.3.1. Review assigned programs' SEPs and oversee their implementation.

E12.3.2. Assess performance of subordinate lead or chief system engineers ...

E12.4. Technical Reviews. Technical reviews shall be event driven, conducted when documented entrance criteria are met, and include participation by subject matter experts who are independent of the program.



New SE Policy in *Draft DoDI 5000.02*

Enclosure 12. Systems Engineering

E12.5. Configuration Management. The PM shall use a configuration management approach to establish and control product attributes and the technical baseline across the total system life cycle. This approach shall identify, document, audit, and control the functional and physical characteristics of the system design; track any changes; provide an audit trail of program design decisions and design modifications; and be integrated with the SEP and technical planning. At completion of the system level Critical Design Review, the PM shall assume control of the initial product baseline for all Class 1 configuration changes.

E12.6. Environment, Safety, and Occupational Health (ESOH). The PM shall use the methodology in MIL-STD-882D to assess ESOH risk, eliminate ESOH hazards where possible, manage the risks that cannot be eliminated, and report on the status of ESOH risk at technical reviews.

E12.6.1. Programmatic ESOH Evaluation (PESHE). The PM for all programs, regardless of ACAT level, shall prepare a PESHE and summarize it in the acquisition strategy.

E12.5.2. NEPA/EO 12114. The PM shall conduct and document NEPA/EO 12114 analyses, to be approved by the CAE, for which the PM is the action proponent.

E12.6.3. Mishap Investigation Support. The PM will support system-related Class A and B mishap investigations.



New SE Policy in *Draft DoDI 5000.02*

Enclosure 12. Systems Engineering

- E12.7. Corrosion Prevention and Control. Each ACAT I program shall document its strategy in a Corrosion Prevention Control Plan at Milestones B and C.
- E12.8. Modular Open Systems Approach (MOSA). Program managers shall employ MOSA.
- E12.9. Data Management and Technical Data Rights. Program Managers for ACAT I and II programs, regardless of planned sustainment approach, shall assess the long-term technical data needs of their systems and reflect that assessment in a Data Management Strategy (DMS).
- E12.10. Item Unique Identification (IUID). To enhance life-cycle management of assets in systems acquisition and sustainment, and to provide more accurate asset valuation, all PMs shall plan for and implement IUID to identify and track applicable major end items, configuration-controlled items, and Government-furnished property. IUID planning and implementation shall be documented in an IUID Implementation Plan and summarized in the program's Systems Engineering Plan (Reference (an) and DoD Directive 8320.03, Reference (bv)).
- E12.11. Reliability, Availability, and Maintainability (RAM). PMs for all programs shall formulate a viable RAM strategy that includes a reliability growth program as an integral part of design and development. RAM shall be integrated within the Systems Engineering processes, documented in the program's SEP and LCSP, and assessed during technical reviews, T&E, and PSRs.



Implications for Systems Engineering



New Opportunities for Enhanced SE – Starting Programs Right

- What's relevant:**
- **Mandatory Materiel Development Decision**
 - **Mandatory Milestone A for all “major weapon systems”**
 - **MS B after system-level PDR* and a PDR Report to the MDA***

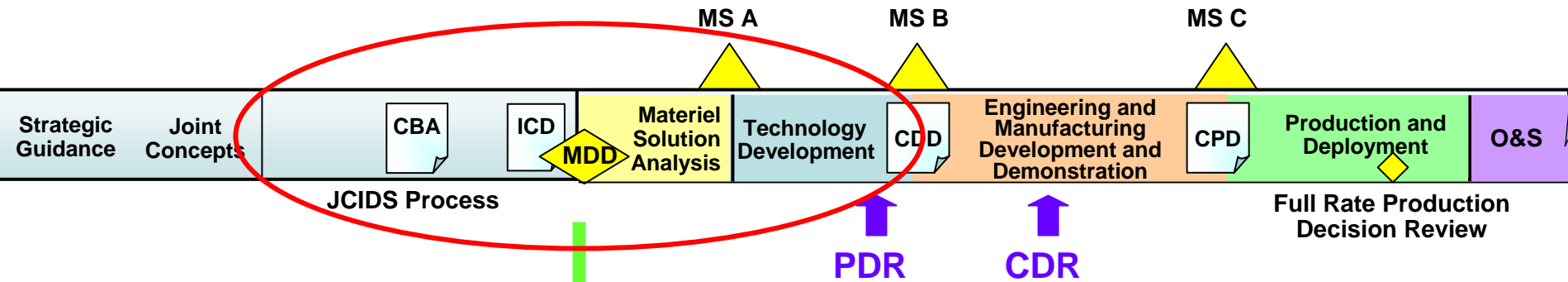

Pre-MDD “SE Touch Points”

- Initial Capabilities Document (ICD)
- Analysis of Alternatives study plan

Pre-Milestone A “SE Touch Points”

- Systems Engineering Plan
- Technology Development Strategy
- Test and Evaluation Strategy
- Analysis of Alternatives

* PDR – Preliminary Design Review

* CDR – Critical Design Review

* MDA - Milestone Decision Authority



SE Focus: Materiel Solution Analysis

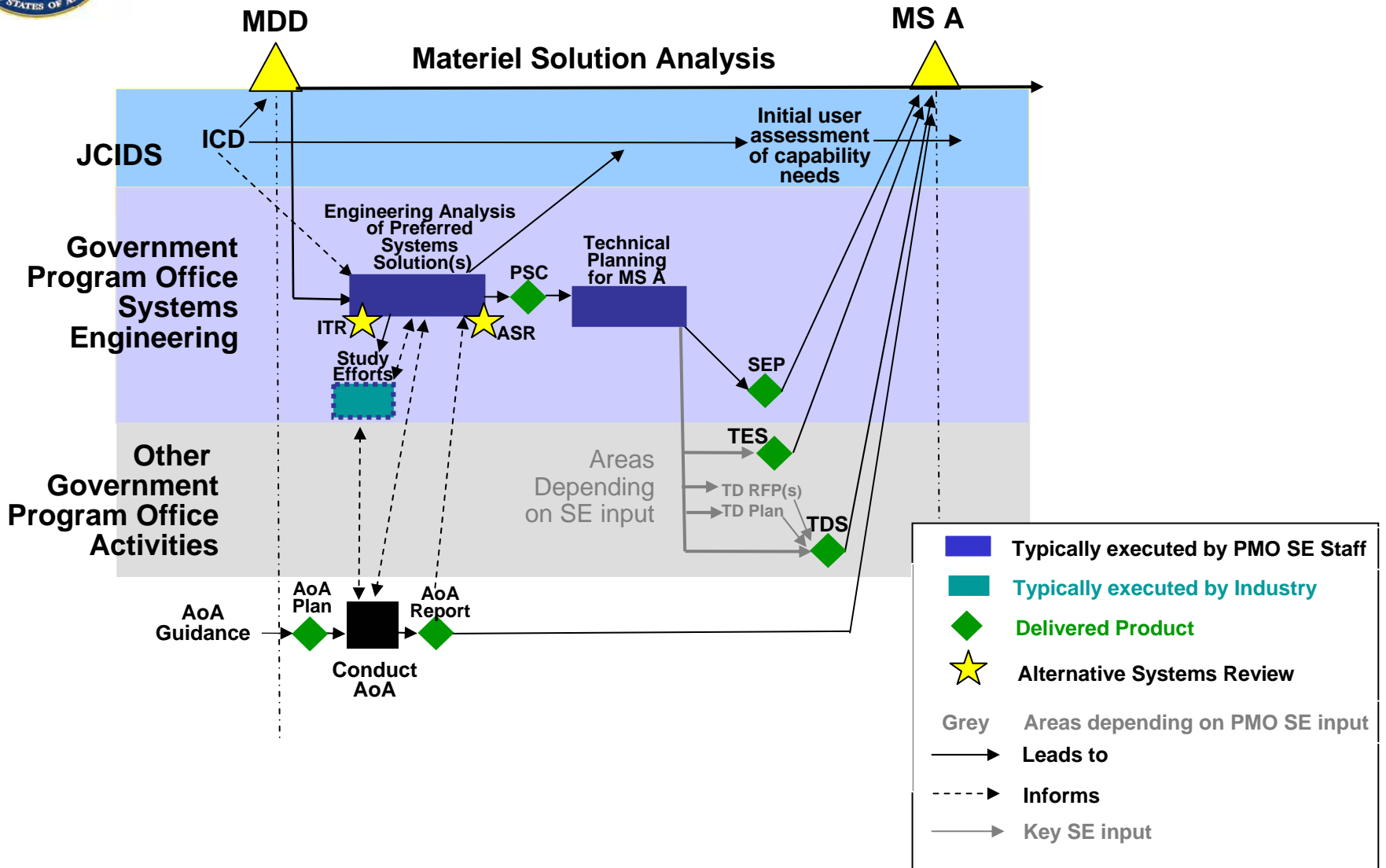



SE Focus: Technology Development

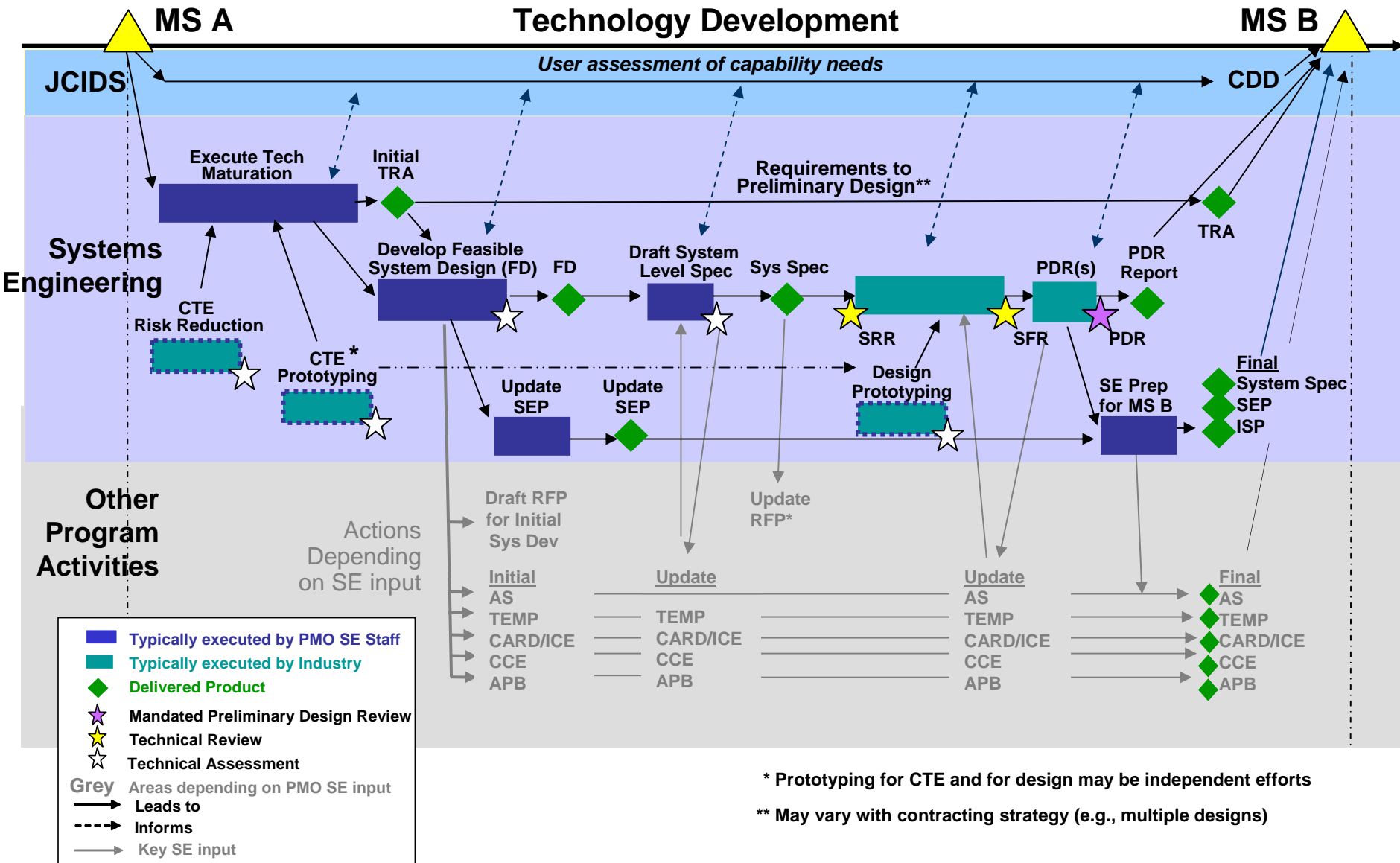



New Opportunities for Independent Reviews

- What's relevant:**
- **Mandatory Milestone A** for all “major weapon systems”
 - **MS B** after system-level PDR* and a PDR Report to the MDA
 - **EMDD with Post-CDR*** Report and MDA Assessment
 - **PSR and AOTR** in policy

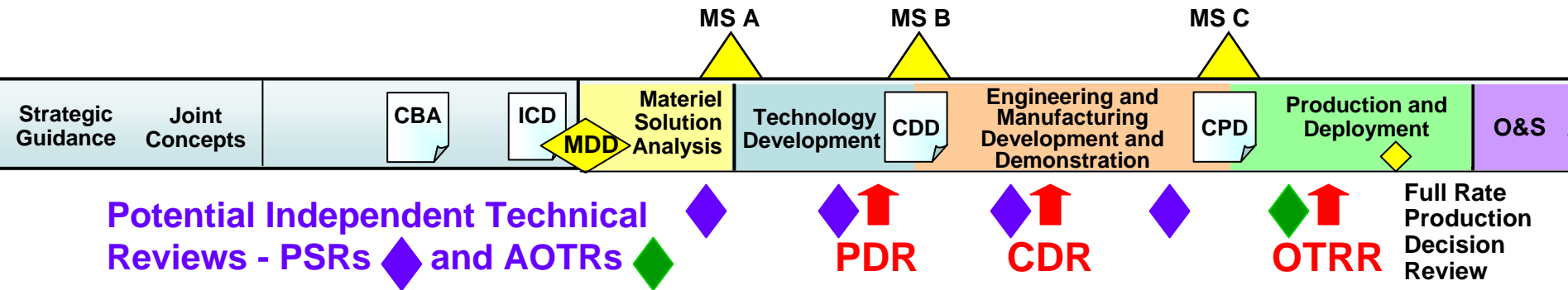

Potential Independent Technical Reviews - PSRs and AOTRs

Program Support Reviews (PSRs)

- ❖ All ACAT ID & IAM
- ❖ To inform the MDA on technical planning and management processes thru risk identification and mitigation recommendations
- ❖ To support OIPT program reviews and others as requested by the MDA

Assessments of Operational Test Readiness (AOTRs)

- ❖ All ACAT ID and special interest programs
- ❖ To inform the MDA, DOTE, & CAE of risk of a system failing to meet operational suitability and effectiveness goals
- ❖ To support CAE determination of materiel readiness for IOT&E

* PDR – Preliminary Design Review

* CDR – Critical Design Review

* OTRR – Operational Test Readiness Review



Backup



Draft DoD Instruction 5000.02 Extract

Milestone A (per FY'08 NDAA Sec. 943)

“The project shall enter the Technology Development Phase at Milestone A when the MDA has approved the TDS. The tables in Enclosure 3 identify all statutory and regulatory requirements applicable to Milestone A. . . . The MDA shall comply with the certification requirements at Milestone A as described in Enclosure 10 of this Instruction. This effort normally shall be funded only for the advanced development work. **Technology development for a major weapon system shall not proceed without Milestone A approval.** For business area capabilities, commercially available solutions shall be preferred. A favorable Milestone A decision DOES NOT mean that a new acquisition program has been initiated.”



Configuration Steering Boards

Configuration Steering Boards (CSB). The Acquisition Executive of each DoD Component shall establish a CSB with broad executive membership including senior representatives from the Office of the USD(AT&L) and the Joint Staff.

- **The CSB shall review all requirements changes and any significant technical configuration changes for ACAT I and IA programs in development which have the potential to result in cost and schedule impacts to the program. Such changes will generally be rejected, deferring them to future blocks or increments. Changes shall not be approved unless funds are identified and schedule impacts mitigated.**
- **Program Managers shall, on a roughly annual basis, identify and propose a set of descoping options to the CSB that reduce program cost or moderate requirements. The CSB shall recommend to the MDA (if an ACAT ID or IAM program) which of these options should be implemented. Final decisions on de-scoping option implementation shall be coordinated with the Joint Staff and military department requirements officials.**

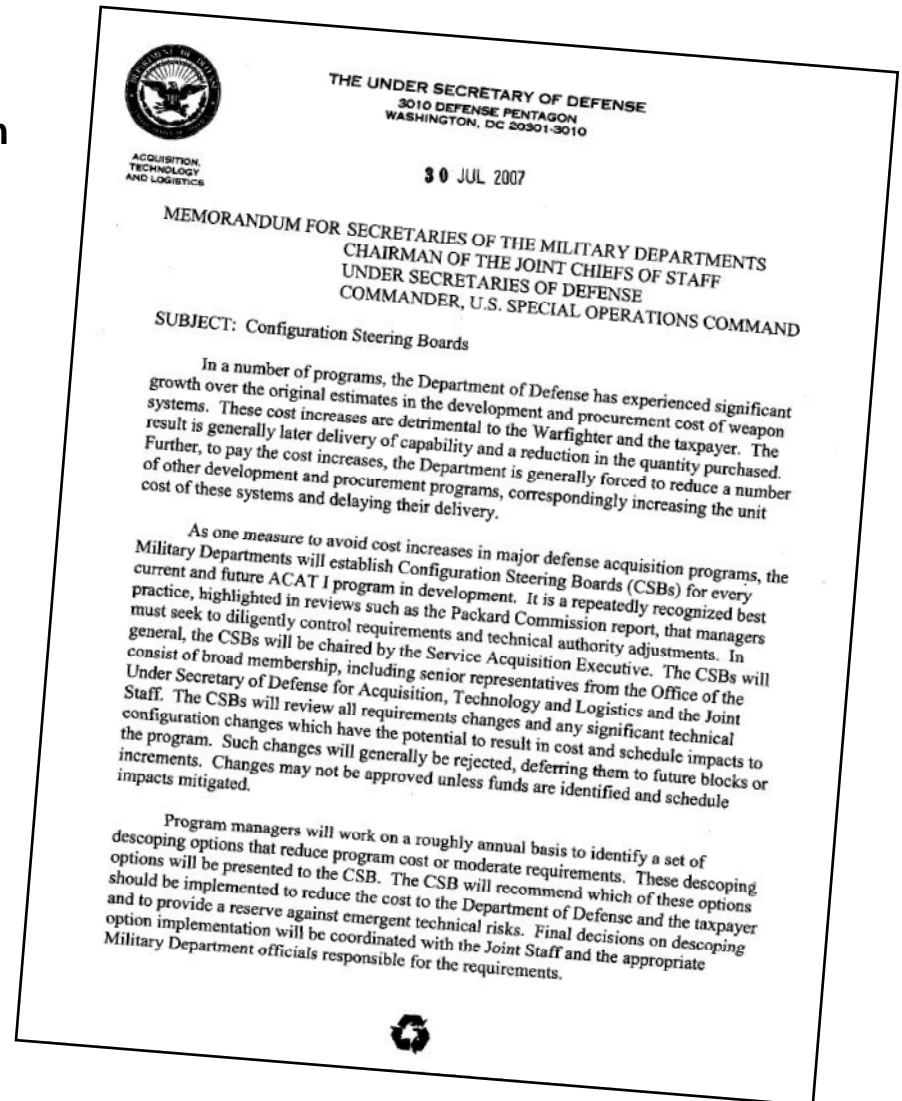



Test and Evaluation

- ❖ Integrated DT&E / OT&E activities
- ❖ Evaluations include comparison with current capability
- ❖ Evaluations conducted in the expected “mission context”

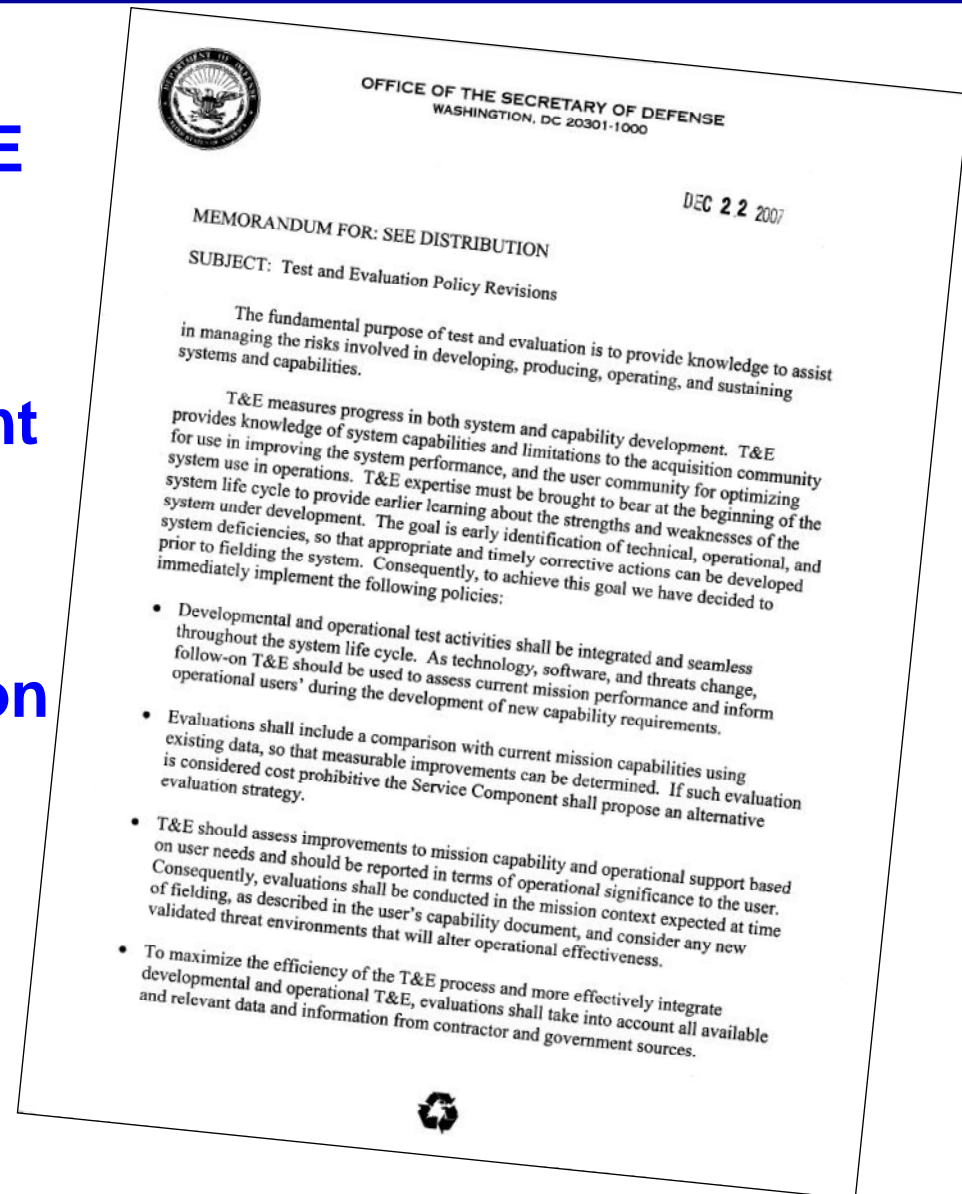

Accelerate Performance Improvements: Systems Engineering Skills Competency Analysis and Training Program Development

**Steven A. Diebold
Director, Future Force Systems Engineering
General Dynamics, Land Systems**

Agenda

- GDLS Overview
- SE Training & Education Program Overview
- Competency Assessment
- Gap Analysis
- Curriculum Development
- Results to Date
- Future Activities

GDLS Mission



General Dynamics Land Systems provides a full spectrum of land and amphibious combat systems, subsystems and components worldwide

Our strengths are world-class design and systems integration, superior production and innovative life cycle support

We will deploy these strengths to meet our customers' needs in a changing world

U.S. Locations

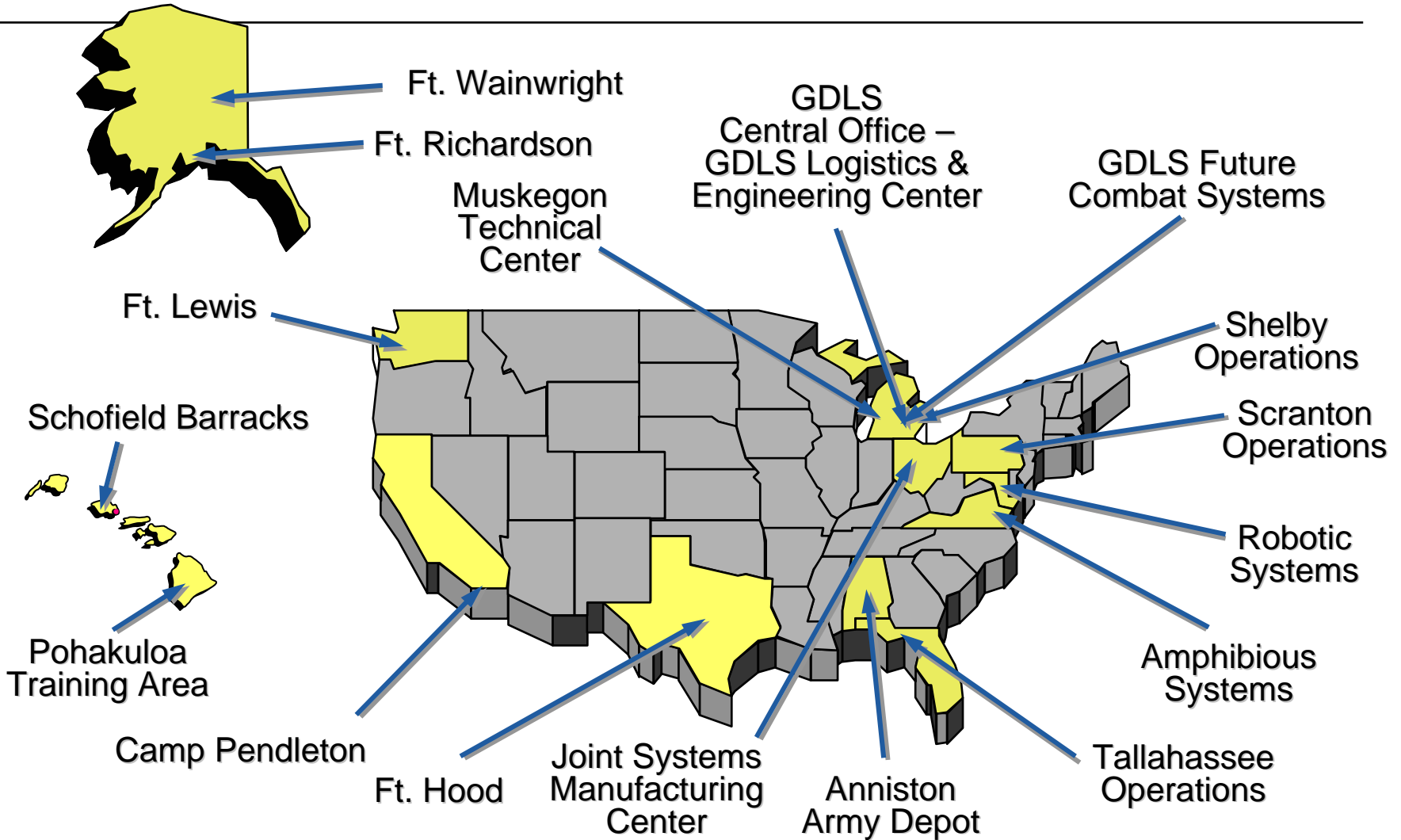

Major Contributors to Poor Program Performance*

- Lack of technical planning and oversight
- Inadequate understanding of requirements
- Incomplete, obsolete, inflexible and Stovepipe Physical and Functional architectures
- Stovepipe developments with late integration
- Lack of subject matter expertise at the integration level
- Low visibility of software risk

Lack of systems engineering discipline, authority, and resources

* DoD-directed Studies/Reviews, 2005

GDLS's Response

- Organize along Product Centers
 - Voice of customer
- 'One Engineering Design and Development Team' for GDLS
 - Integrated Process System across all Locations
 - CMMI Level 3/5
- Revitalize Systems Engineering
 - Process Improvements
 - Gate Reviews, Six Sigma, DFR
 - SE Training & Education Program

Today's Topic

SE Training & Education Program Development Overview

- Roles identified for Systems Engineering
- For each role, required competencies established
- Employees assessed against required competencies for their assigned roles
- Results of competency assessments analyzed to identify gaps
- SE Curriculum developed to address high and medium gaps and to further develop employees with low or no gaps
- Training Plan developed to incorporate SE Curriculum, mandatory courses, and Seminars/Conferences
- Progress to goals and training effectiveness measured by Level 1 evaluations

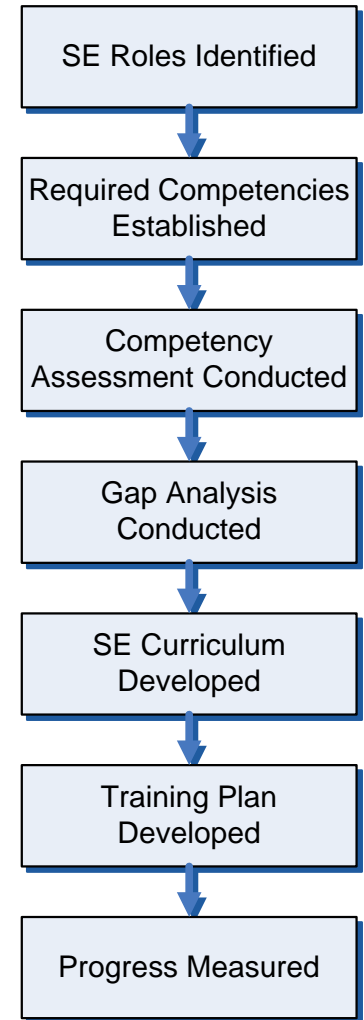

Competency Assessment

- Supervisor verifies that correct roles are assigned to Employee
- Employee conducts self-assessment of competency levels for each required competency
 - Basic** - Trained or understands basic concepts of the competency, however still needs help in applying the competency
 - Qualified** - Has a good command of the competency, no help needed in applying the competency
 - Advanced** - Has advanced understanding of the competency, can lead and/or teach others in applying the competency
 - None** – Does not meet basic competency level
- Supervisor verifies assessment
- Training Coordinator compiles all completed assessments
- Training Coordinator evaluates roles to determine which roles represent 80% of the Systems Engineering population

Gap Analysis Methodology

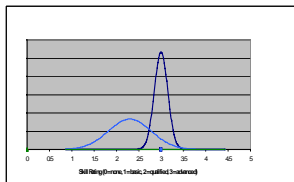
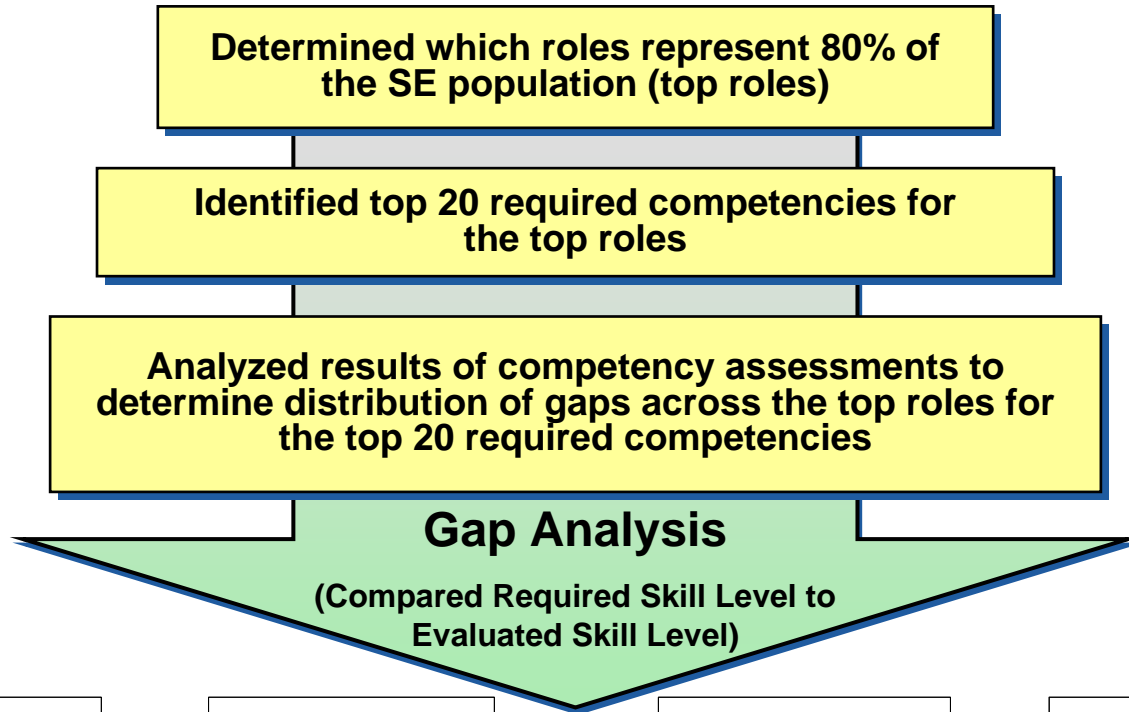

High Gap

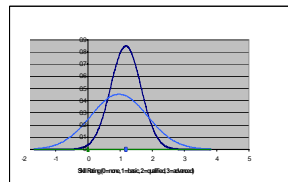

Medium Gap

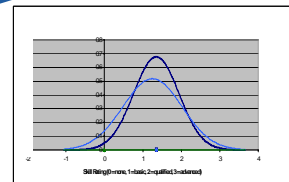

Low Gap

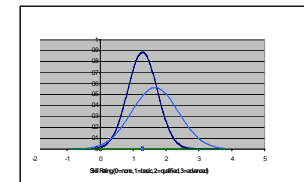

No Gap

Competency Assessment Results

- Highest Gap
 - SE Principles
 - Project Management
 - Domain Specific Skills
- Medium Gap
 - Risk Analysis
 - Test & Validation Planning
 - Baseline Management (CM)
- Lowest Gap
 - Requirements Management
 - Trade Studies
 - Reliability
 - Design Integration

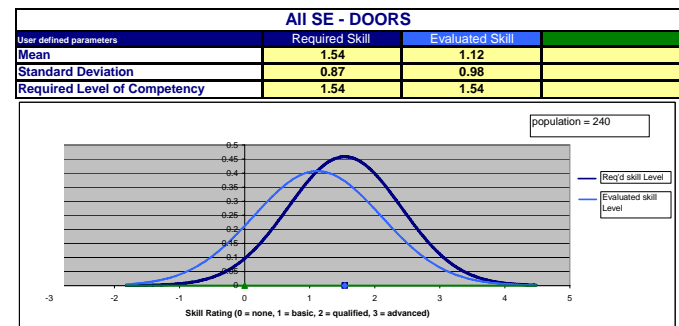
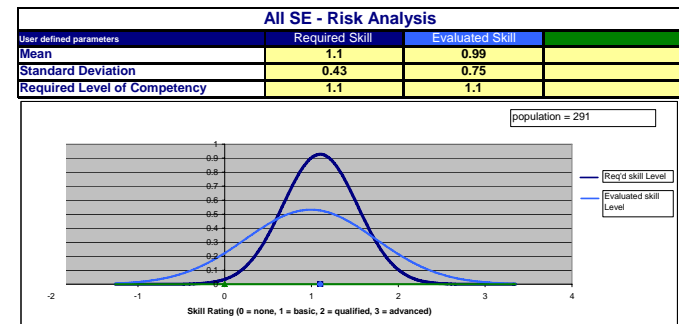
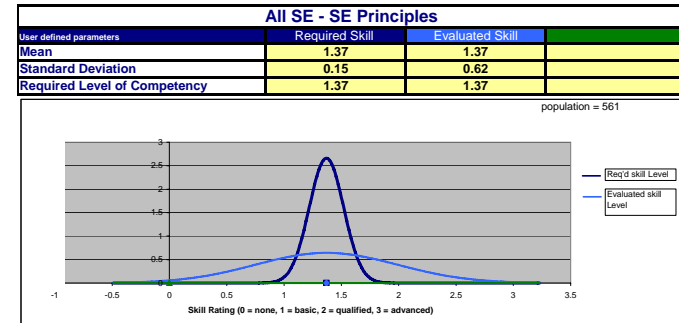

SE Curriculum

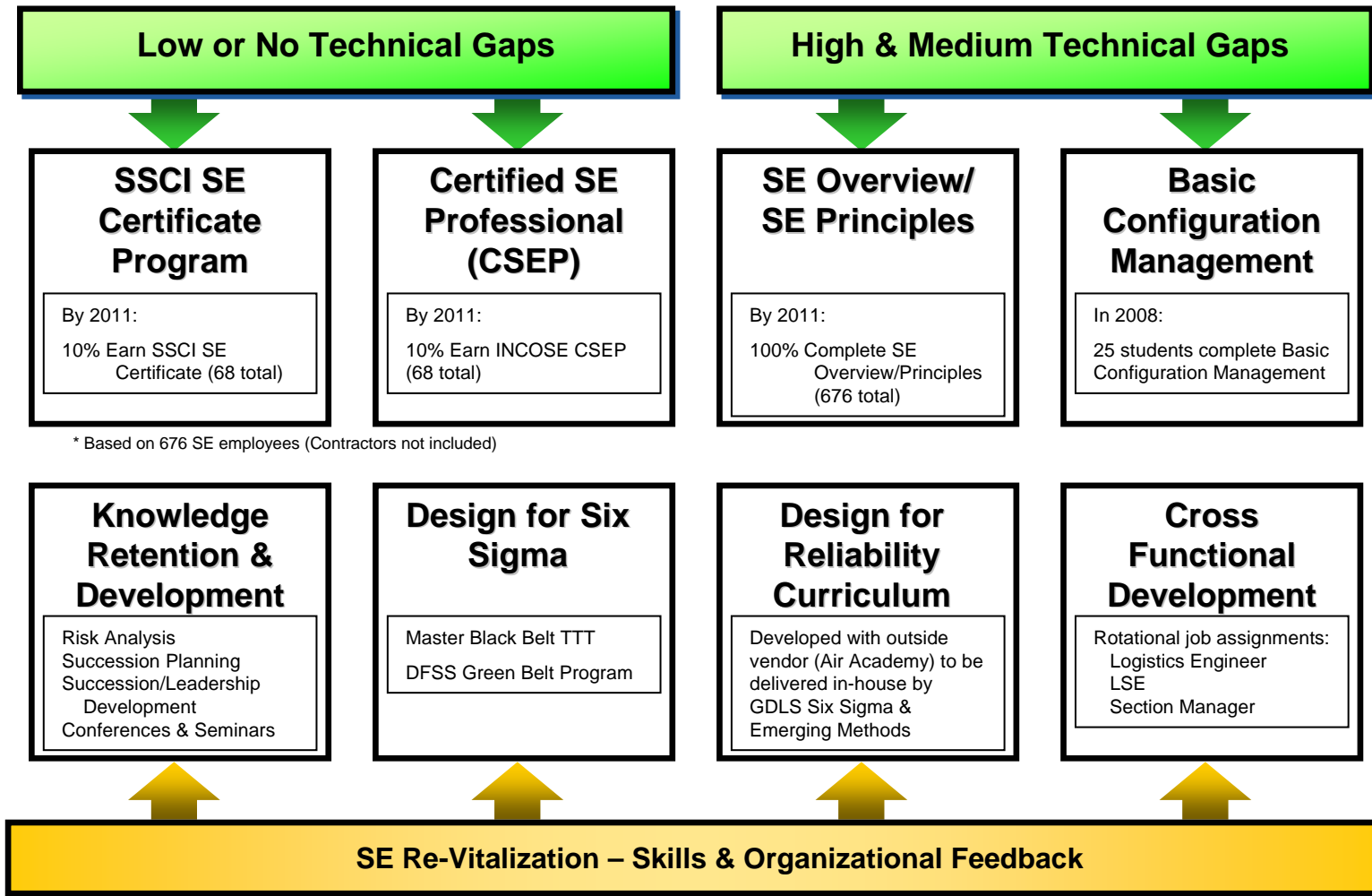

Development of SE Training Plan

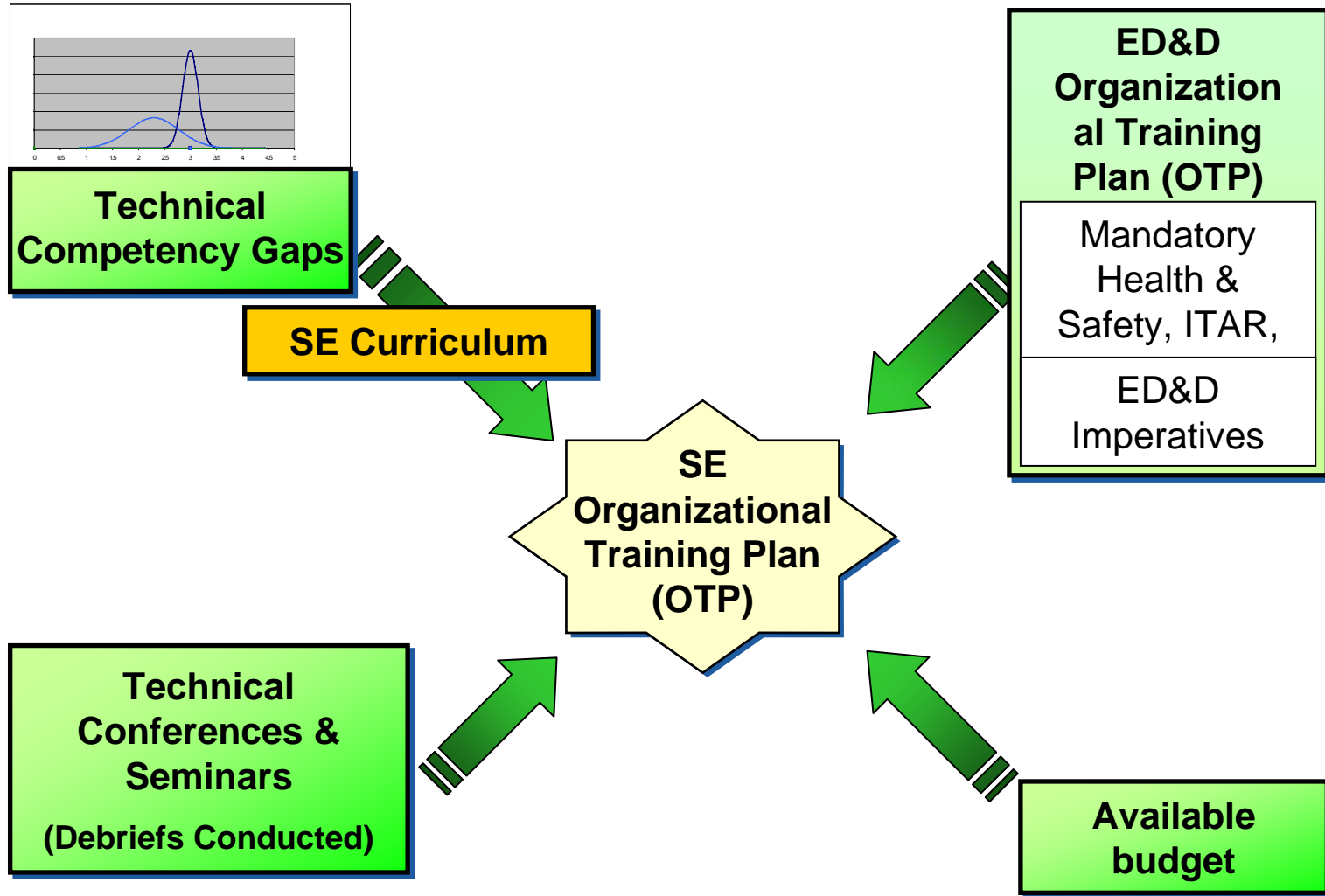

Training Budget Distribution

- Training represents 6% of the Systems Engineering overhead budget.

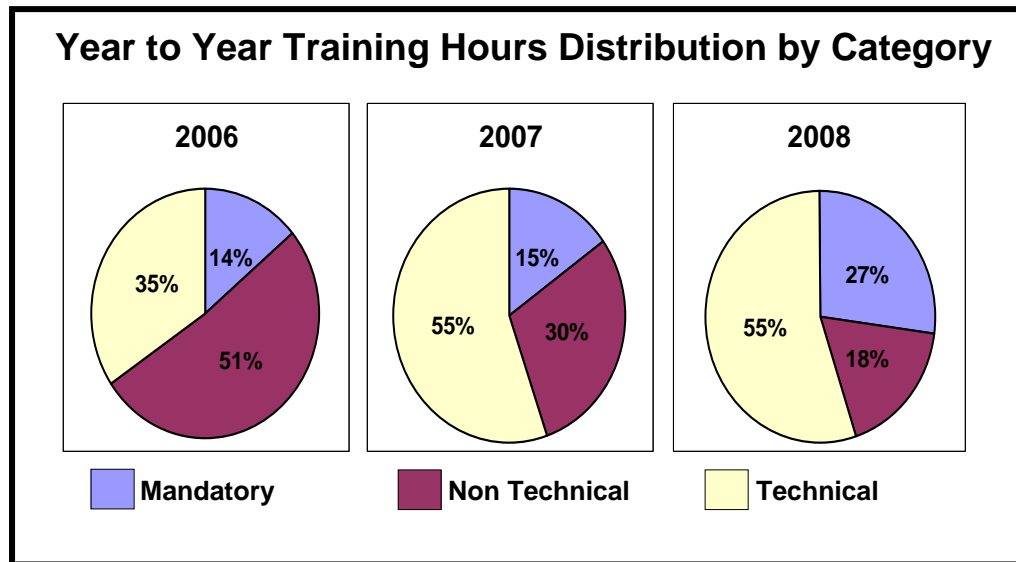

- **Mandatory Training** includes health, safety and security courses.
- **Non Technical Training** includes courses such as leadership development, teaming, CMMI and ISO.
- **Technical Training** includes courses such as SE Certificate Program/Overviews, GD&T, Soldering and Welding.

Development of SE Courses

2006

- Training Gap Analysis of Systems Engineering employees revealed need for Systems Engineering courses.
- Completed trade study and selected Center for Systems Management (CSM) based largely on their affiliation with Stanford University.
- Delivered first sessions of SE courses with CSM.

2007

- CSM/Stanford University no longer affiliated.
- Second trade study conducted to determine if vendor change best option for future course delivery.
- Systems and Software Consortium (SSCI) selected based on reputation and prior relationship.
- Collaborated with SSCI to tailor standard course materials for GDLS.
- Delivered first sessions of 12-day SE Certificate Program (SECP).

2008

- Continued offerings of SECP and added 5-day and 2-day SE Overview course to training plan.
- Utilized Michigan Economic Development Grant

Training Goals

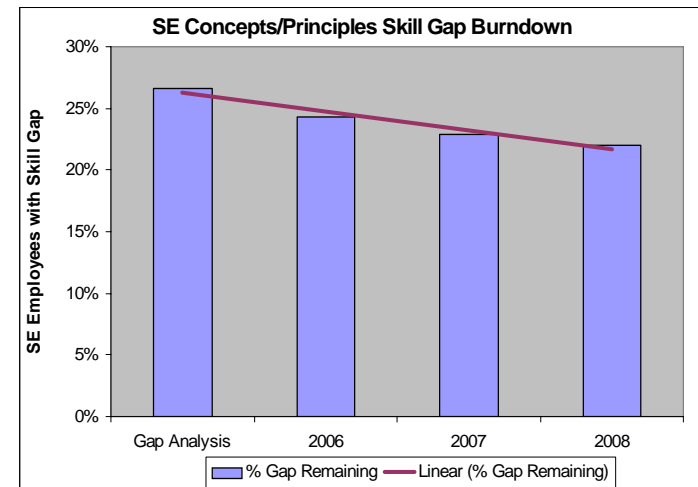
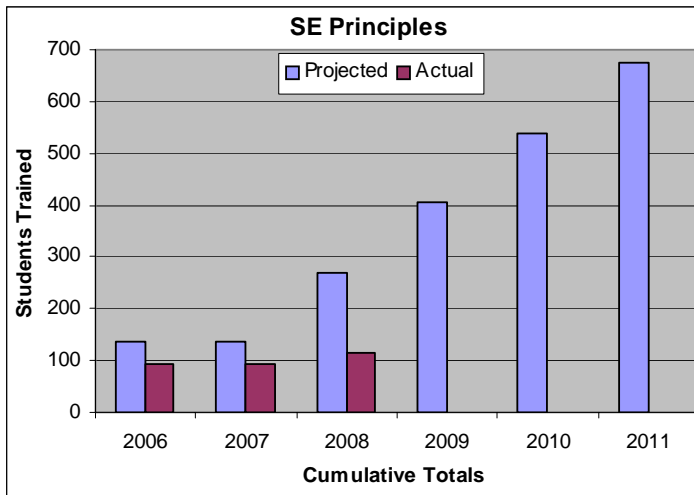
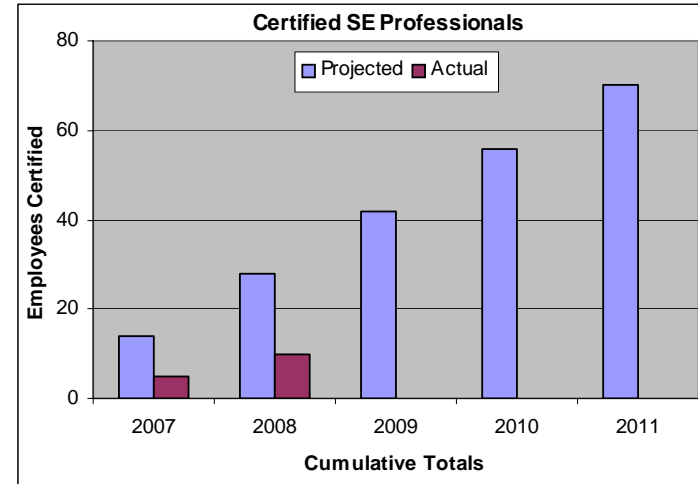
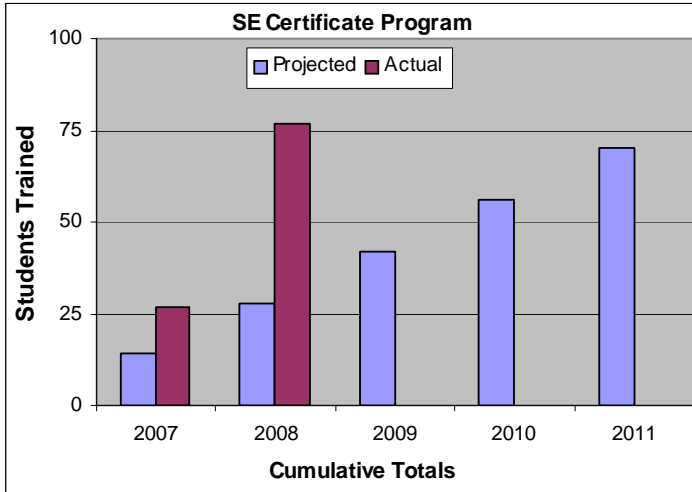

Training Evaluation

Levels of Evaluation

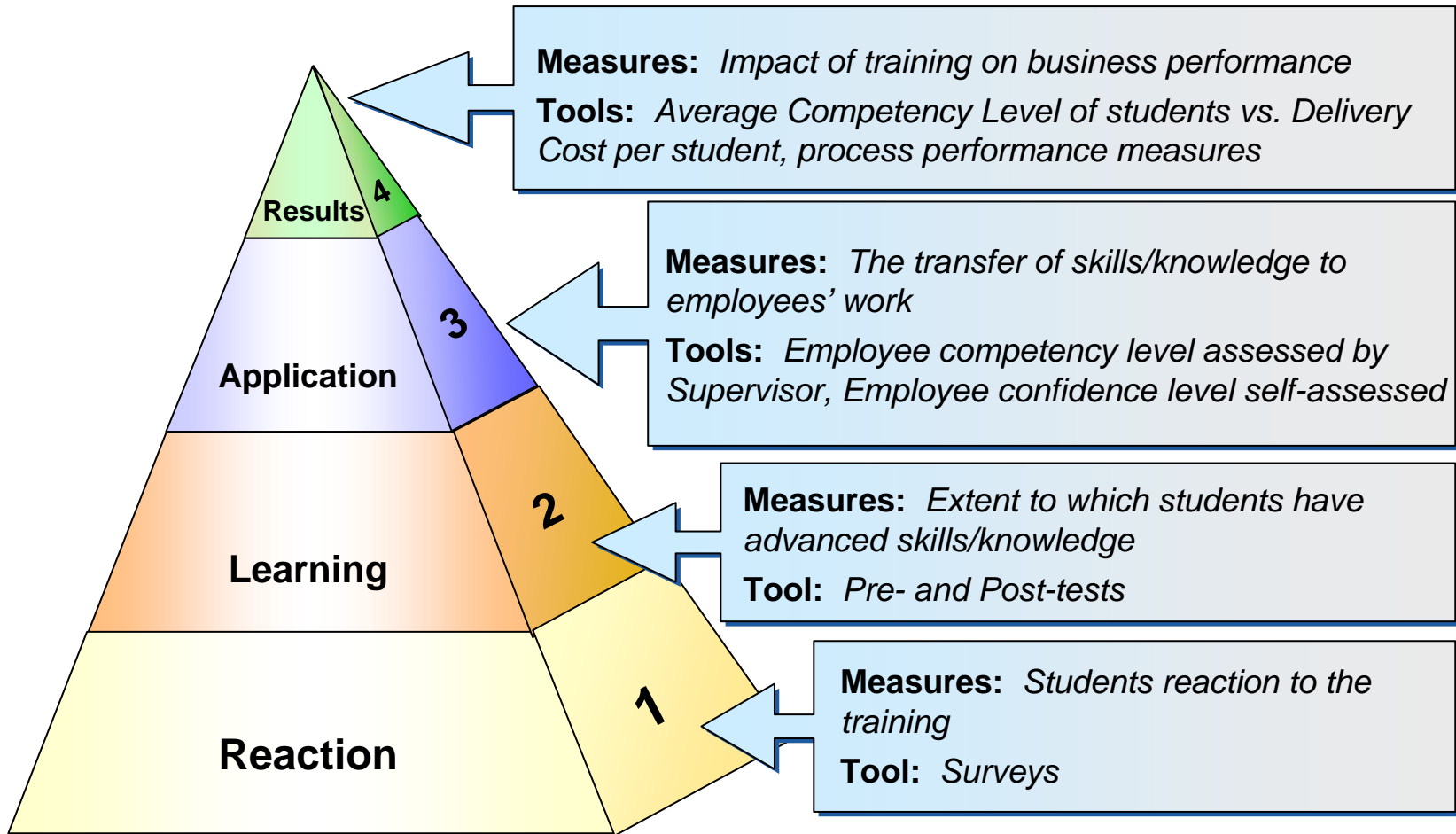

Results to Date

- Development of evaluation methods: surveys, pre/post testing, 90-day evaluations
- Evaluations reveal effectiveness of courses
- Student comments used to improve future course delivery
- Modest changes to 2006 SE Training Gap

SE Training Effectiveness

- Level 1 Evaluation: Course Surveys administered at end of class
17 question survey used to evaluate students' satisfaction with the course content, instructor, resources, and relevance of course to their jobs.

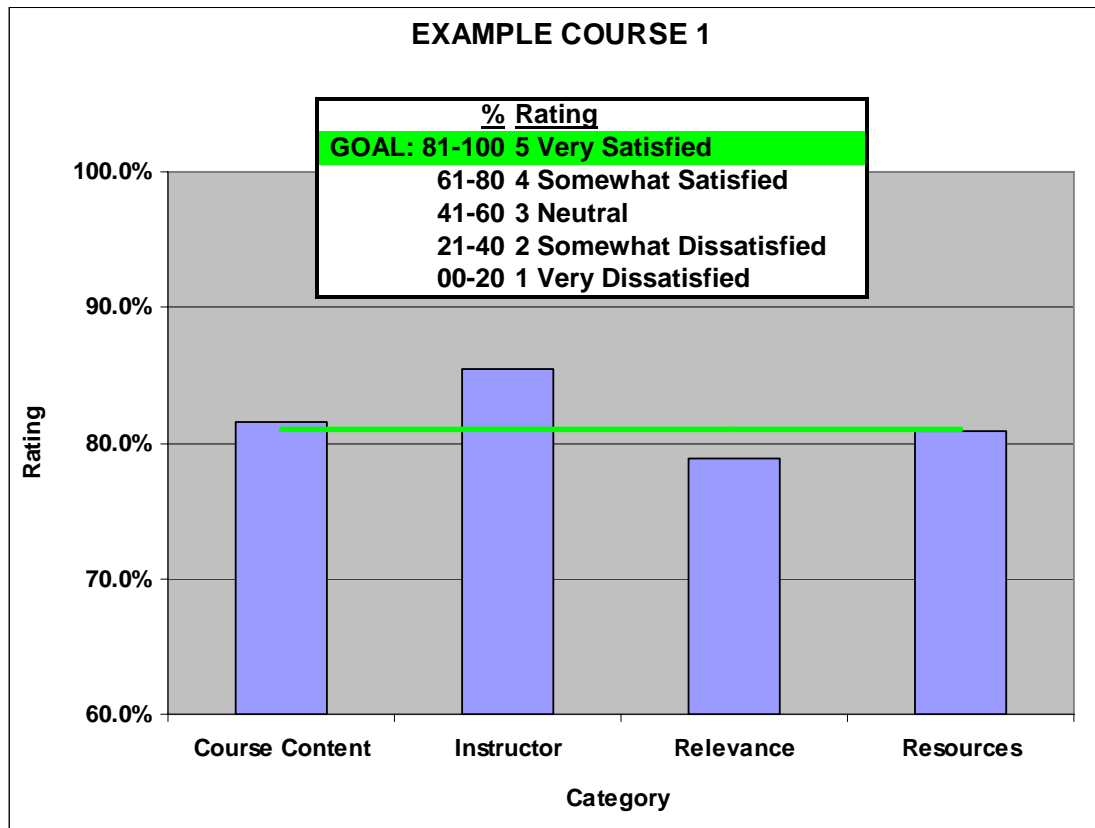

EXAMPLE COURSE 1: ANALYSIS

- Some attendees were employees with many years of experience and felt that the course was not relevant to them.
- Course material needs to be made more relevant to SE. Too much focus on Software.

CORRECTIVE ACTION

- One time offering. No action to be taken at this time. If future offerings to be scheduled, consider tailoring course material to SE and use updated gap analysis data to identify attendees.

SE Training Effectiveness

Level 2 Evaluation: Pre/Post Testing

Test of 10 questions based on course content administered at start and end of courses to measure initial effectiveness of course delivery.

SE Overview 5 Day Pre/Post-Test
Class Held: 8-18-22-08 – VIS Room

Employee # _____ Pre-Test Post-Test

Please take a few minutes to answer the questions below to the best of your ability. This is a two-part exercise with the purpose of measuring the basic skills/knowledge gained through this course. You will be asked to complete this same test at the end of the course. There is no penalty for wrong answers.

| | | | |
|--------------------------|---------------------------|-----------------|---------------------|
| <i>Possible Answers:</i> | Maintenance | Process Control | State |
| | Measures of Effectiveness | Quality | Systems Engineering |
| | Mode | Reliability | Validation |
| | Planning | SEMP | Verification |

Fill in the blanks using the choices above.

1. _____ is an interdisciplinary approach and means to enable the realization of successful systems.
2. _____ are used to quantify the performance of system products and processes.
3. _____ is the condition of the system.
4. _____ is the manner in which the system operates.
5. _____ and _____ are elements of Logistics Support.
6. _____ answers the question, "Did we build the right thing?"
7. _____ describes engineering specialty integration, the SE work to be done, and the management of this work.
8. _____ and _____ are engineering specialties.

9. How would you rate your current knowledge of Systems Engineering? (*Check one.*)

| | |
|--|--|
| <input type="checkbox"/> Advanced – Have an advanced understanding of the skill, can lead and/or teach others in applying it.
<input type="checkbox"/> Qualified – Have a good command of the skill, no help needed in applying it.
<input type="checkbox"/> Basic – Understand basic concepts, but still need help applying it.
<input type="checkbox"/> None – Have no knowledge of this skill/topic. | <input type="checkbox"/> New ideas related to Systems Engineering
<input type="checkbox"/> Build on my existing knowledge of Systems Engineering
<input type="checkbox"/> Basic knowledge of Systems Engineering
<input type="checkbox"/> Nothing |
|--|--|
10. What did you gain from this course? (*Check one.*)

Please return this test to the instructor when you have completed it.

EXAMPLE COURSE 2: ANALYSIS

- Few students scored higher on Post Test
- Focus of course did not match pre/post test questions well.

CORRECTIVE ACTION

- Prior to next course offering, work with course instructor to develop a Pre/Post test that is more relevant to the topics reviewed during the course.

SE Training Effectiveness

- Level 3 Evaluation: Application – Post-Course Evaluation**

Use standardized evaluation form to collect data.

Send via email to students 60-90 days following course.

Measures frequency of skill use, value of skill on job, self-assessed proficiency rating, barriers to use on job.

EXAMPLE COURSE 3: ANALYSIS

- Analysis of preliminary data shows course is well received and is perceived by attendees to have value in their day to day activities. Most students would recommend this course to coworkers and managers.

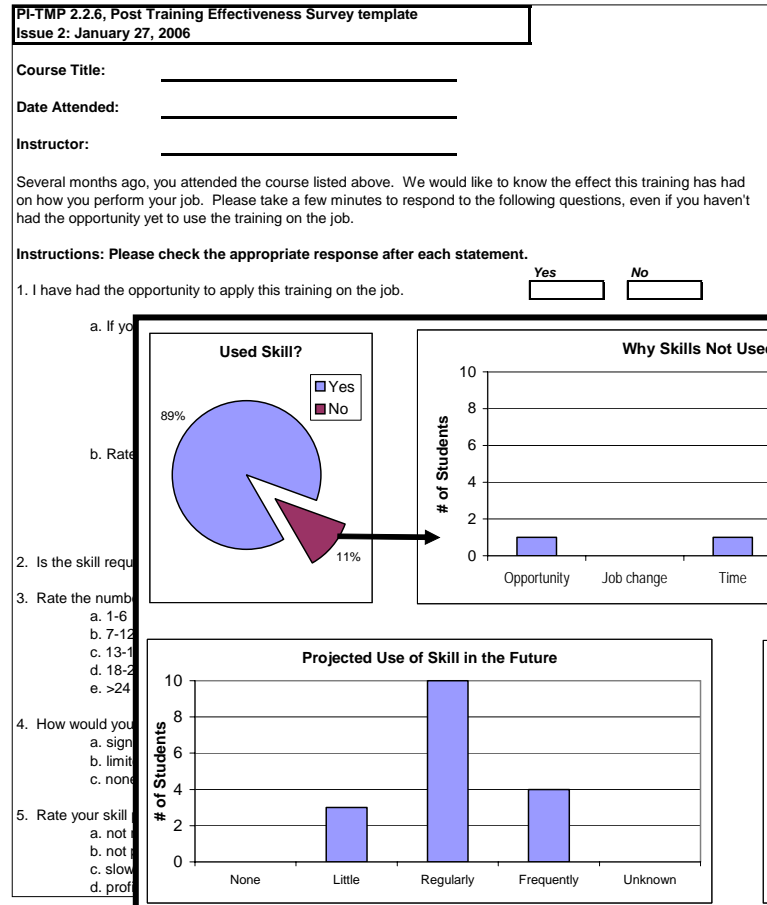

Path Forward

- Complete follow up Training Gap Analysis by year-end
- Renew focus on closing identified training gaps
- Continue to tailor/modify course delivery based on student feedback
- Continue to develop and improve evaluation methods to assess improved business performance

Contact Information

Steven A. Diebold
Director, Future Force System Engineering
38500 Mound Road
Sterling Heights, MI 48310
(586) 825-5869
diebold@gdls.com

Wendell Mullison
Manager, System Engineering Process Tools and Architecture
38500 Mound Road
Sterling Heights, MI 48310
(586) 825-4118
mullison@gdls.com

Kimberly Swierpel
SE Measurement Analysis & Process Architecture
38500 Mound Road
Sterling Heights, MI 48310
(586) 825-4779
swierpel@gdls.com

BACKUP

Roles & Competencies

| ROLES REPRESENTING 80% OF SE POPULATION | | |
|---|--|--|
| Requirements Engineer | Configuration Management (CM) Engineer | Specialty Engineer - Embedded Training Analyst |
| Section Manager | Team Lead | Administrative Assistant |
| Systems Analysis Engineer | Corrective Action Engineer | Environmental Test Technician |
| Physical Architect | CM (Configuration Management) Analyst | Process Engineer |
| Specialty Engineer | System Integration Engineer | Provisioning Analyst |
| Field Test Engineer - Vehicle Test Engineer | Environmental Test Engineer | Training Content Developer |
| System Architect | CM Technician | Requirements Management Analyst |
| Logistics Engineer | Field Material Supply Specialist | Field Test Engineer - Supply Support Engineer |
| Lead System Engineer | Maintenance Engineer | Logistics Engineering Liaison |
| Reliability Engineer | Department Manager | System Safety Engineer |
| Technical Writer - Operations and Maintenance | Diagnostics Engineer - Troubleshooting Developer | |

| TOP 20 COMPETENCIES | |
|---------------------|---|
| 1 | System Engineering Principles |
| 2 | Job Specific Process knowledge |
| 3 | Product knowledge - (Tracked, Wheeled or FCS as applicable) |
| 4 | Customer Satisfaction |
| 5 | Communication |
| 6 | Effective meeting / reviews |
| 7 | EVMS |
| 8 | Risk Analysis |
| 9 | Trade Studies |
| 10 | Reliability theory |
| 11 | Pro E |
| 12 | DOORS |
| 13 | Requirements Generation & Documentation |
| 14 | Metric development |
| 15 | Program Management |
| 16 | Test & validation plan development |
| 17 | Cost estimating / proposal development |
| 18 | DFMEA principles & techniques |
| 19 | XFMEA (reliasoft suite of tools - Vmetric, Weibull, blocksim) |
| 20 | Project Planning |

SE Certificate Program (SECP)

- Is an on-site program leading to a **Systems Engineering Certificate** from the Systems and Software Consortium, Inc. (SSCI).
- Is an intensive, graduate-level learning curriculum for experienced, practicing engineers.
- Is a 12 day program delivered in a building block approach of four 3-day modules over a two to three month period with self-study, classroom, and team project work.
- Is a program that integrates INCOSE SE Handbook material in an effort to help participants who are interested in pursuing the INCOSE Certified Systems Engineering Professional (CSEP) certificate.
- Provides the ability to address skill/competency gaps through training
- Supports SE Revitalization

SE Certificate Program (SECP)

SE Certificate Curriculum
(4 classes, 3 days each)

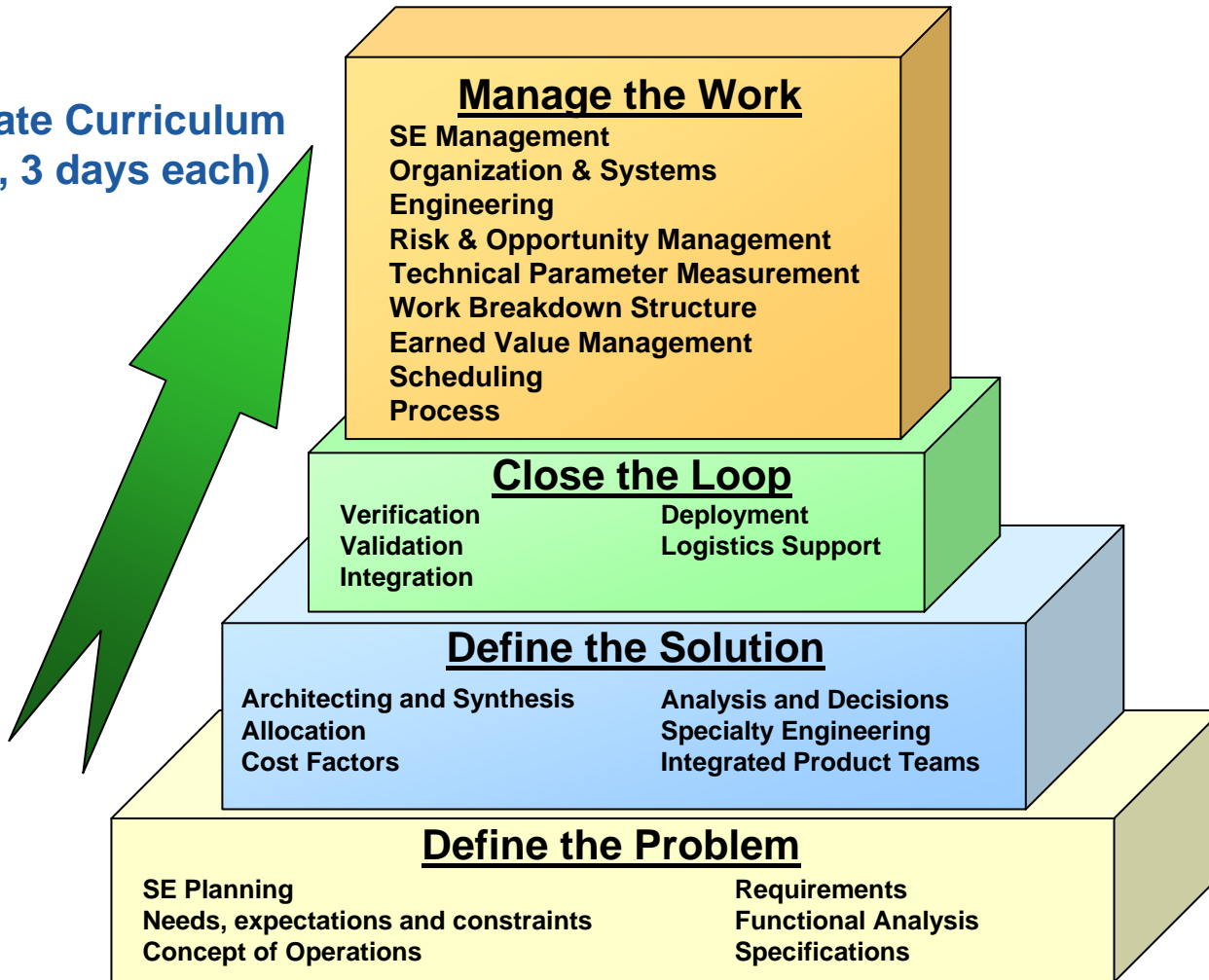

Other SE Courses

SE Principles

- Is an on-site courses developed by the Systems and Software Consortium, Inc. (SSCI).
- Offered as 2 and 5 day courses
- Provides overview of SE for inexperienced engineers (high or medium technical competency gap).
- Describes the basics of systems engineering – what it is, how it proceeds through the life cycle and why it needs to be done.

Basic Configuration Management

- Is a two-day, on-site course developed by the Systems and Software Consortium, Inc. (SSCI).
- Provides a foundation in basic Configuration Management principles and skills

Certified SE Professional

Certified Systems Engineering Professional is a recognized certification that confirms that an individual has the basic skills to perform fundamental Systems Engineering tasks and is able to make a productive contribution to work efforts.

Benefits of CSEP Certification

- Formally recognizes SE capabilities
- Distinguishes CSEP holder from others within a professional field
- Provides a competitive advantage
- Furthers professional SE development
- Helps advance the art and practice of SE

Certification Process

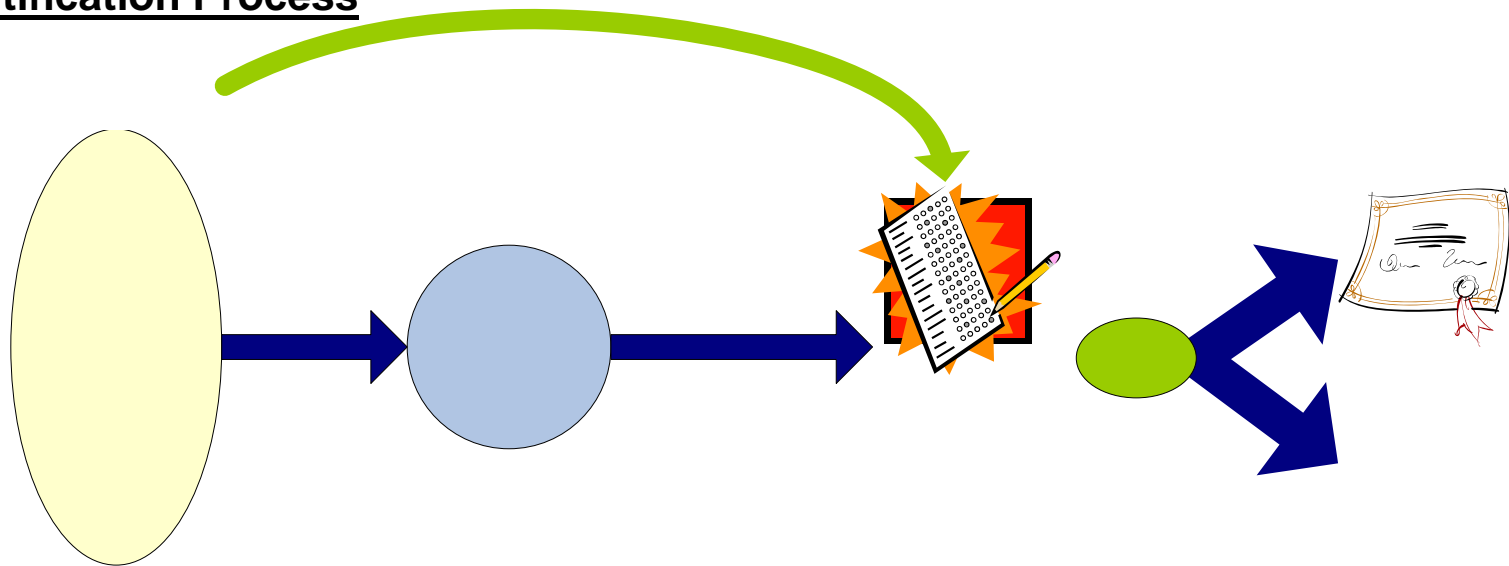



Systems Engineering in DoD

Nicholas Torelli

**SYSTEMS & SOFTWARE ENGINEERING
Office of the Deputy Under Secretary of Defense
for Acquisition and Technology**

21 October 2008



The Problem and Root Causes



- Problem Statement: Defense Acquisition programs are experiencing significant problems:
 - over cost
 - behind schedule
 - not operationally suitable or effective
- Root Causes:
 - The Defense Acquisition workforce has experienced significant “peace dividend” and “baby boomer” losses in critical personnel
 - Implementation of Acquisition Reform went too far in terms of streamlining or reducing policies and processes
 - The Department lacks adequately defined and enforceable criteria to assess program maturity at milestones with direct linkage to technical reviews
 - Incomplete, ineffective and/or unrealistic acquisition strategies and plans have resulted in poor program performance
 - Poor or incomplete Requirements development process



Proposed Solutions



- Solutions:
 - Early / Enhanced Life Cycle Engagement in Systems Engineering
 - Human Capital Strategic Plan
 - Systems Engineering Research



Enhanced Systems Engineering



- Actions:
 - Fostered Enhanced Systems Engineering Policy in DoDI 5000.02
 - Refined SE content through out the Acquisition Life Cycle (Milestones / Mandatory Technical Reviews)
 - Detailed SE uniquely, in DoDI 5000.02 - Enclosure 12
 - Established new policy on key SE Design Considerations (Reliability, Availability, Maintainability (RAM))
 - Promulgated focused and expanded SE Guidance IAW Policy
 - Formalized design reviews and SE Processes for accountability
 - Authored sections of Defense Acquisition Guidebook update
 - Partnered in establishing RAM-C Guidebook and Contract Language
 - Continuing updates to Defense Acquisition Program Support methodology supporting Program Support Reviews

“Implement the right activities at the right time in the right way”



Human Capital Strategic Plan



- Actions:
 - Improving the Defense Acquisition Workforce by:
 - Recruiting and Hiring Qualified Personnel / Highly Qualified Experts
 - Training and Developing Defense Acquisition Personnel
 - Retaining and Recognizing Qualified Personnel
 - Evaluating and Improving SE Competencies through:
 - Education (Universities and associated Service Colleges)
 - Training (DAU)
 - Experience Opportunities (e.g., rotations, OJT)



Systems Engineering Research



- Actions:
 - Systems Engineering Research
 - Established SE Research University Affiliated Research Center (UARC) at Stevens Institute of Technology
 - Technical Task Order-based research opportunities
 - » OSD / Components fund desired research
 - » Knowledge shared across all associated universities



Systems Engineering Knowledge Map

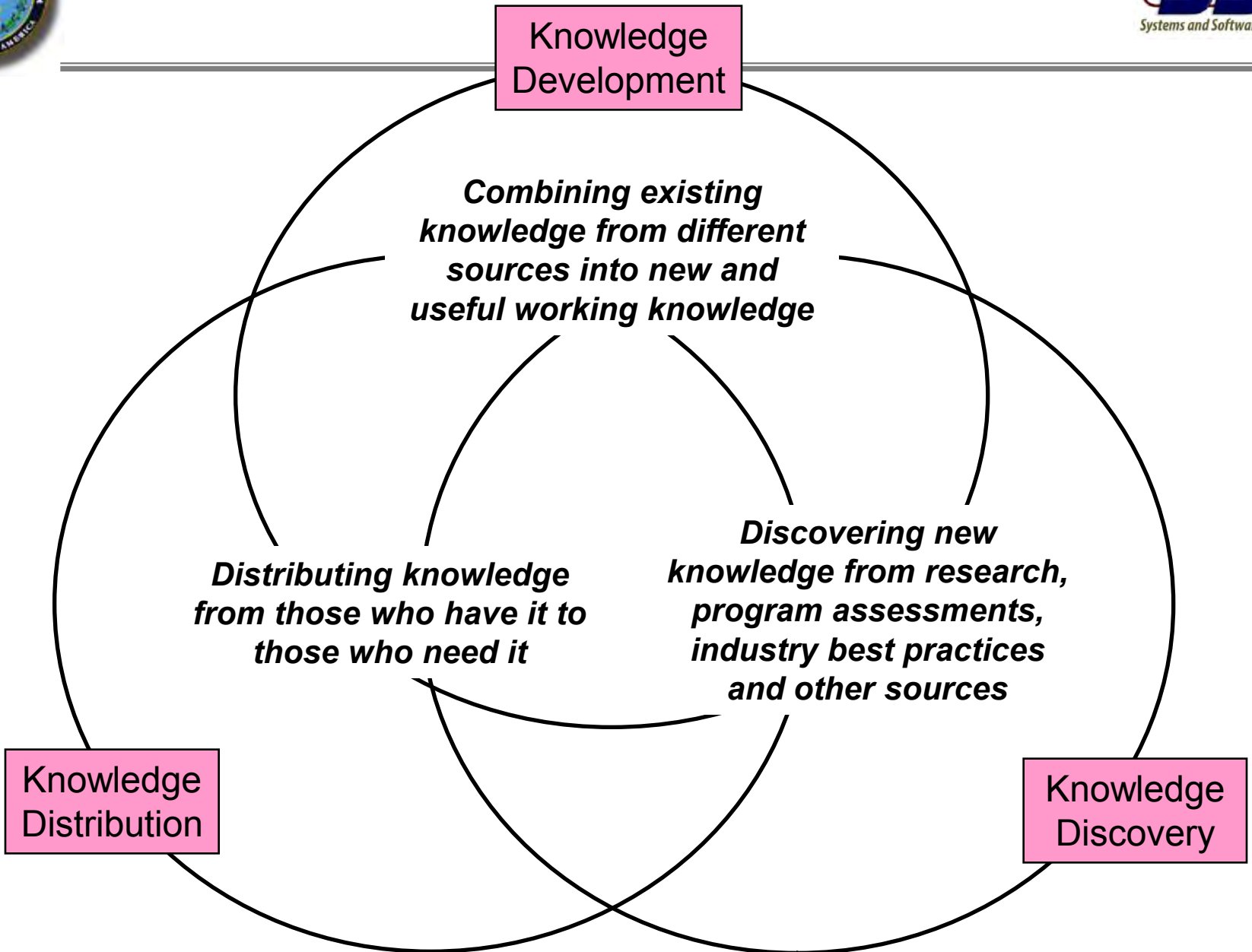



Systems Engineering Knowledge Map

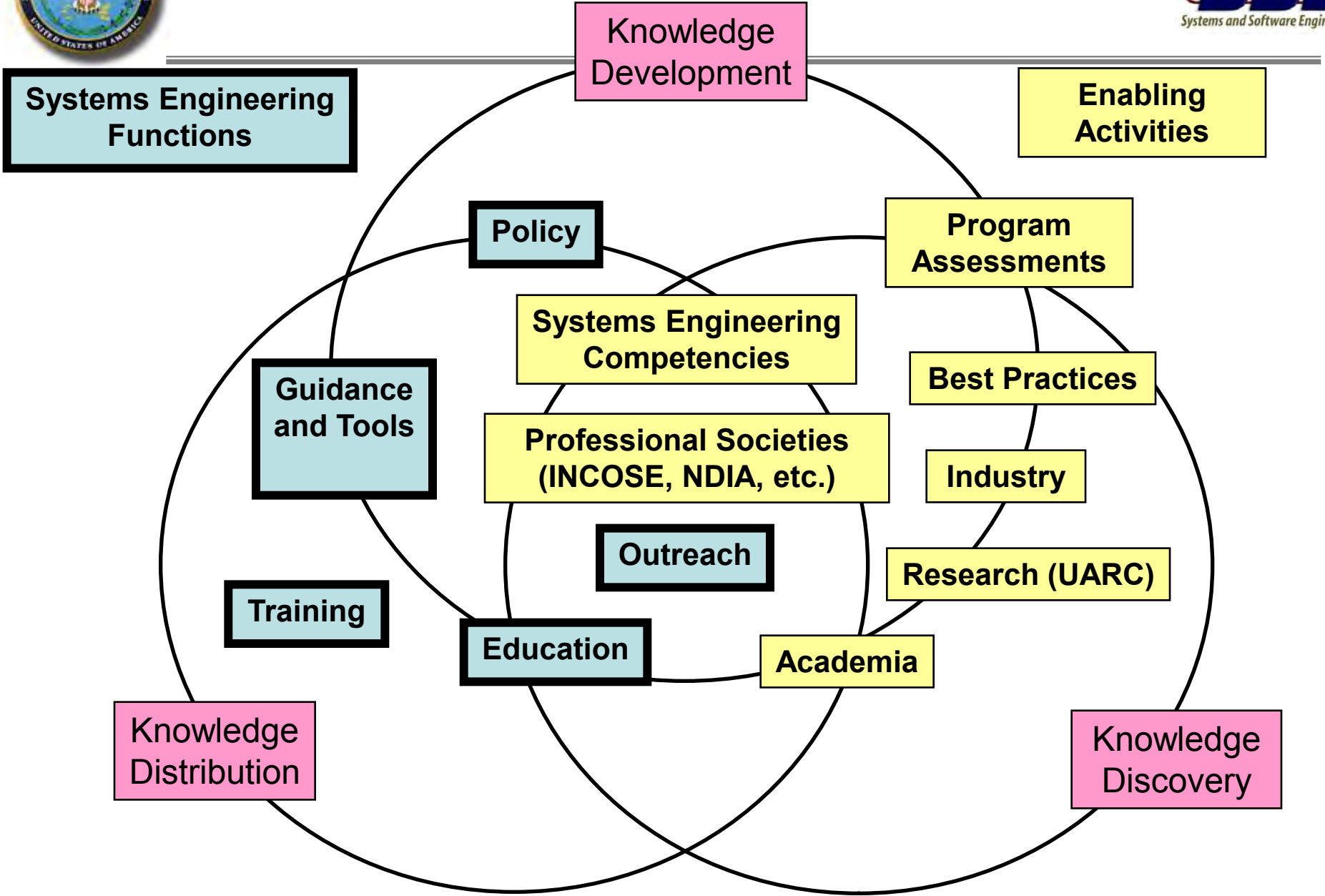

Systems Engineering Knowledge Flow

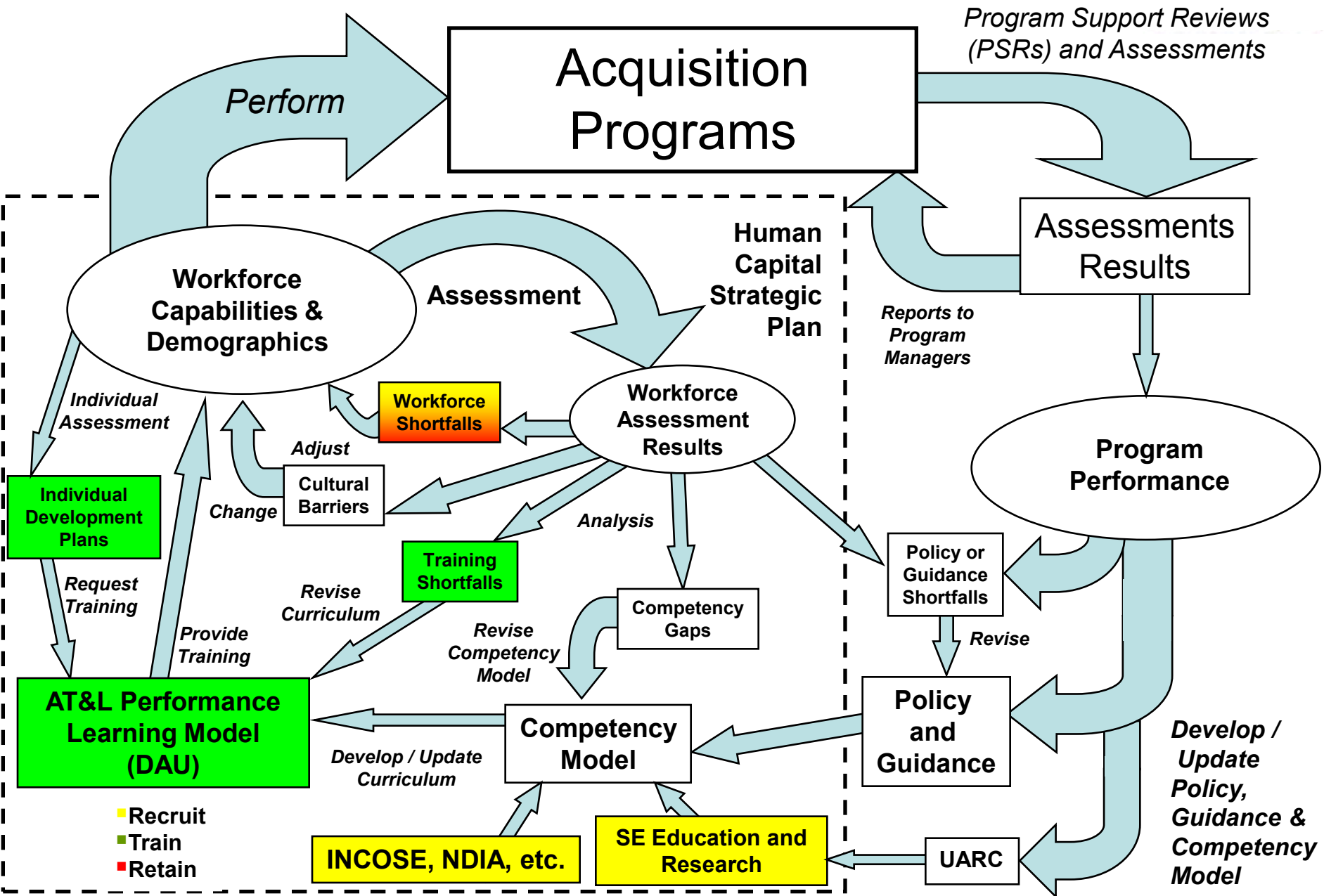



Systems Engineering Policy



- Draft OSD Acquisition Policy (DoDI 5000.02) is in for final signature ... substantial changes to the early acquisition process (in consonance with NRC Study), including
 - Mandatory Materiel Development Decision (MDD)
 - Mandatory competing prototypes before MS B
 - **Mandatory PDR and report to the MDA before MS B**
 - Configuration Steering Boards at Component level to review all requirements changes
 - Mandatory government control of Class I changes no later than CDR for Configuration Management
- Renewed emphasis on manufacturing during system development:
 - Re-titles SDD phase to EMDD with two sub phases: Integrated System Design and System Capability and Manufacturing Process Demonstration
 - Establishes consideration of manufacturing maturity at key decision points
- Mandatory system-level CDR with an initial product baseline followed by a Post-CDR Report to the MDA
- Post-CDR Assessment by the MDA between EMDD sub-phases

This includes explicit recognition of Systems Engineering in all phases, but especially early in the acquisition life cycle



Systems Engineering Guidance



- Plans are underway to complete the update of all Systems Engineering (SE) documentation based on the updated Policy:
 - Defense Acquisition Guidance (DAG) Chapter 4 (SE)
 - Systems Engineering Plan (SEP)
 - Integration of Systems Engineering into Contracts
 - Defense Acquisition Program Support (DAPS) methodology
- Impacting Requirements Generation earlier through Joint Staff recommendation for Capability Description Document early in the Technology Development phase to influence system design
- Published System of Systems Guide, Modeling & Simulation Guide, Test & Evaluation Contracts Guide
- Tools
 - Acquisition Guidance Model



Human Capital Initiatives (SE Education and Training)



- Re-coding of program level engineering specialty positions to Program Systems Engineer (PSE) is in progress across the Services.
 - Added additional training and experience requirements
 - Focus on enhancing SE in the early phases of acquisition
 - Broaden the competency set to include other career fields (e.g., PM, Logistics, Contracting)
 - Double the years of experience required for each DAWIA certification level
- Conducting Systems Engineering Competency Assessment in late 2008 / early 2009 (based on SME validation of competency model, to be completed in November 2008)
- Key contributors to DAU's "Requirements Manager" training curriculum for Joint Staff / Services personnel who develop and manage requirements
- Surveying SE Education curricula and programs for future leverage



Human Capital Initiatives (SE Education and Training)



Defense Acquisition Workforce Development Fund (based on NDAA Section 852, Defense Acquisition Workforce Development Act)

- Recruiting and Hiring:
 - Intern Programs.
 - Recruiting Incentives.
 - Outreach Programs.
 - Journeyman Hiring Programs.
 - Hiring Expert Knowledge – Highly Qualified Experts (HQE).
- Training and Development:
 - Training Enhancement and Capacity Expansion.
 - Comprehensive Acquisition Workforce and Student Information System.
 - Competency Management and Assessments.
 - Workforce Planning Pilot Program.
- Retention and Recognition:
 - Retention and Recognition Incentives.
 - Career Broadening and Academic Programs.



Human Capital Initiatives

(Defense Acquisition Workforce Development Fund ¹)

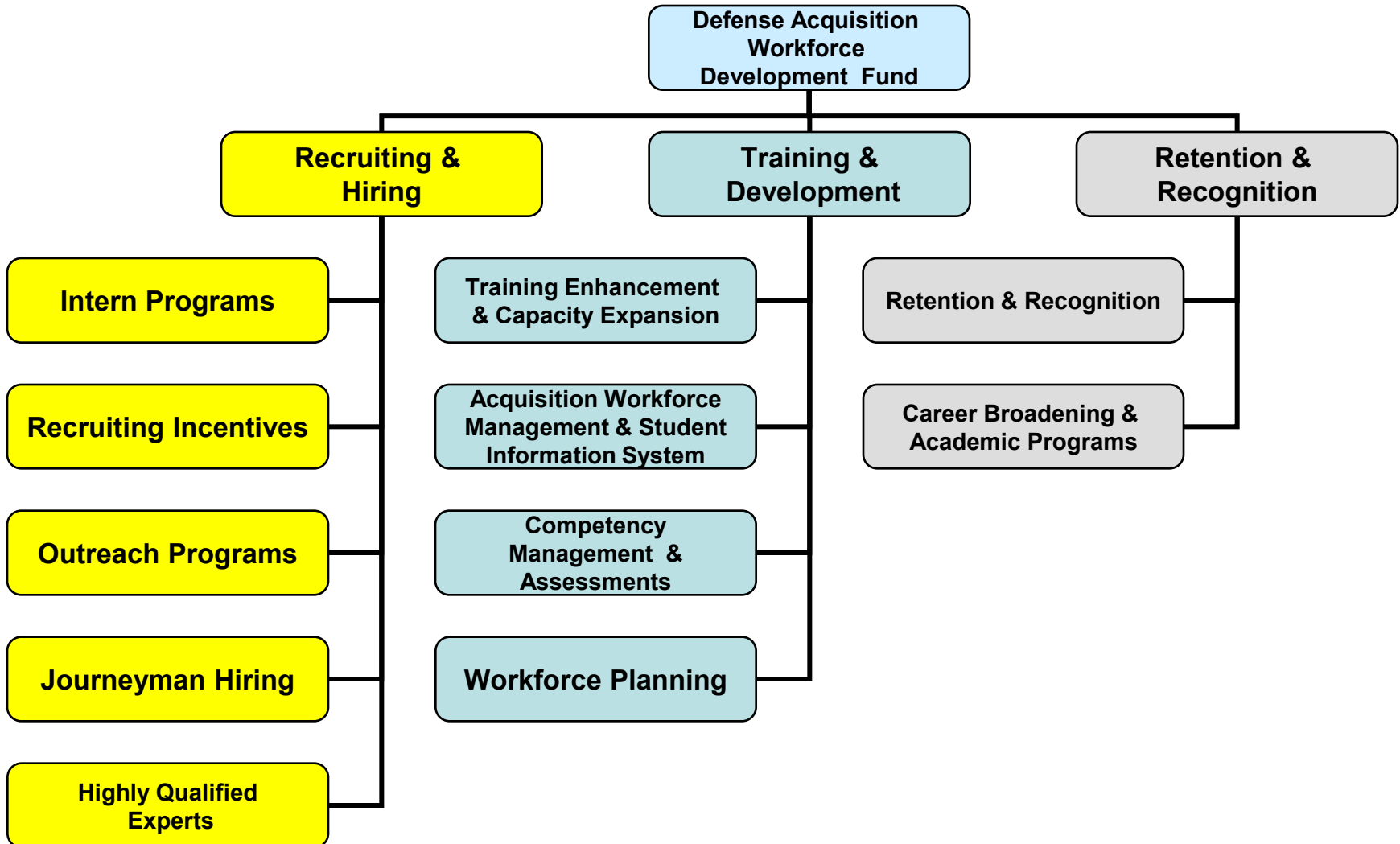

¹ Based on NDAA Section 852, Defense Acquisition Workforce Development Act



Examples of SSE Outreach (1)



- Conducted cross-Service / OSD PDR Workshop, examining the impact of the movement of PDR prior to Milestone B decision point.
 - Developed updates / improvements to the draft Guidance based on the results
- Defense Acquisition Program Support (DAPS) methodology used by SSE for Program Support Reviews is being shared with the Services
- Best Practices Clearinghouse - focused effort to leverage this Defense Acquisition University asset to provide an accessible repository of lessons learned and best practices across DoD and other agencies (e.g., NASA)
- Co-Chair of NDIA SE Division Education and Training Committee



Examples of SSE Outreach (2)



- Assisted INCOSE (International Council on Systems Engineering) in development of a certification program for Systems Engineers who work on DoD Acquisition programs, based directly on the Defense Acquisition Guidance (DAG). The designation is "CSEP - Acq"
 - Approval for DAU SYS-101 and -202 equivalency in work
- Working with Naval Postgraduate School SE Department and Air Force Institute of Technology / Center for Systems Engineering to help align their SE curriculum with Service and OSD policy and to facilitate equivalency with similar DAU SE courses
- Lead for 2009 Singapore-US Exchange Forum on Systems Engineering; focus will be on international SE competencies



DEVELOPMENTAL TEST & EVALUATION

Implementing the 2007 Developmental Test & Evaluation Defense Science Board Results

Oct 2008 NDIA SE Conference

Mr. Chris DiPetto

Deputy Director

Developmental Test & Evaluation
OUSD(AT&L)/Systems & Software Engineering



Problem Definition

DEVELOPMENTAL TEST & EVALUATION

- Approximately 50% of programs completing Initial Operational Test and Evaluation (IOT&E) have not been evaluated as operationally effective and operationally suitable. These results in IOT&E suggest deficiencies in our DT&E processes.
 - Substantial increase in the number of systems not suitable during IOT&E
 - Suitability failures are as high as 80% for some commodities
 - Reliability, Availability and Maintainability (RAM) deficiencies comprise the primary shortfall areas



Tasking: Terms of Reference

DEVELOPMENTAL TEST & EVALUATION

Review, assess and recommend changes to improve:

- OSD T&E organization, roles, and responsibilities
- DT&E oversight and facilitate integrated T&E
- DT&E Title 10 authority
- DT&E process improvements to discover suitability problems earlier

Additional Task Force Objectives:

- Conduct root cause analysis of suitability problems
- Recommend changes to correct systemic problems



Summary of Major DSB Findings

DEVELOPMENTAL TEST & EVALUATION

- RAM shortfalls are identified during DT, but program constraints (schedule and funding) often preclude incorporating fixes and delaying IOT&E
 - Recent studies have reconfirmed that improving RAM lowers Life Cycle Costs (LCCs)
- Service acquisition programs are incorporating Integrated Testing to a limited degree through varying approaches
 - Additional emphasis on Integrated Testing will result in greater T&E process efficiency and program cost reductions
- Large government acquisition personnel reductions combined with industry/government retirements have had a severe adverse impact on acquisition program support



DEVELOPMENTAL TEST & EVALUATION

Selected Findings and Recommendations

T&E – From Concept to Combat



RAM Findings

DEVELOPMENTAL TEST & EVALUATION

- Acquisition Reform implementation detrimental to RAM
 - With some exceptions, reliability growth discontinued during SDD and deferred until production
 - Relevant military specs and standards cancelled and not, in all cases, replaced with industry standards
 - Gvmt Technical/managerial workforce reduced in most PMs and test organizations
- RAM shortfalls are frequently identified during DT
 - Program constraints (schedule and funding) often preclude incorporating fixes and delaying IOT&E
- Examples of programs with such serious RAM concerns that they were precluded from proceeding to production until the problems could be corrected.



RAM Recommendations

DEVELOPMENTAL TEST & EVALUATION

The single most important step necessary to correct high suitability failure rates is to ensure programs are formulated to execute a viable systems engineering strategy from the beginning, including a robust RAM program, as an integral part of design and development. No amount of testing will compensate for deficiencies in RAM program formulation.

To this end, the following RAM-related actions are required as a minimum:

- Develop a military standard for consistent RAM development and testing that can be readily referenced in future DoD contracts
- Identify and define RAM requirements in JCIDS and incorporate into RFP
- Make RAM, to include a robust reliability growth program, a mandatory contractual requirement and document progress as a part of every major program review
 - Flow-down RAM requirements to subcontractors
- Ensure an adequate cadre of experienced RAM personnel are part of the Service acquisition and engineering office staffs



Integrated Test and Evaluation Findings

DEVELOPMENTAL TEST & EVALUATION

- Service acquisition programs are incorporating integrated testing to a limited degree through varying approaches
 - Army has integrated DT and OT organizations into one command
 - Navy utilizes a full-spectrum RDT&E approach to conducting Test & Evaluation
 - Air Force employs Combined Test Force concept which consolidates test execution
- Additional emphasis on integrated testing can result in greater T&E process efficiency and program cost reductions



Integrated Test and Evaluation Recommendations

DEVELOPMENTAL TEST & EVALUATION

- Mandate integrated DT and OT planning and execution throughout the program
 - Require sharing and access to all appropriate system-level and selected component-level test and model data by government DT and OT organizations as well as the prime contractor, where appropriate
 - Incorporate data access requirements in contract
 - Integrate test events, where practical, to satisfy OT and DT requirements
 - Define which testing will be accomplished by the prime contractor, government DT lead, and OT as the lead agency prior to award of contract
 - Require an operational evaluation framework as a part of the Milestone B TEMP
- Make available a cadre of operational personnel to support DT for ACAT I and special interest programs, as a minimum
- Better integrate OTAs into the DR process to include participation on Joint Reliability Maintainability Evaluation Team (JRMET) or Corrective Action Review Board throughout DT



DEVELOPMENTAL TEST & EVALUATION

Implementing Actions



RIWG Chartered Feb 2008

DEVELOPMENTAL TEST & EVALUATION

- DUSD(A&T) and DOT&E February memo established working group to implement recommendations to improve RAM
- Specific Tasks:
 - Ensure execution of a viable SE strategy as an integral part of design and development
 - Ensure government orgs reconstitute cadre of experienced T&E and RAM personnel
 - Integrated DT and OT
 - ensure data access
 - conduct T&E in an operationally representative environment as early as possible
- Report issued September 5, 2008

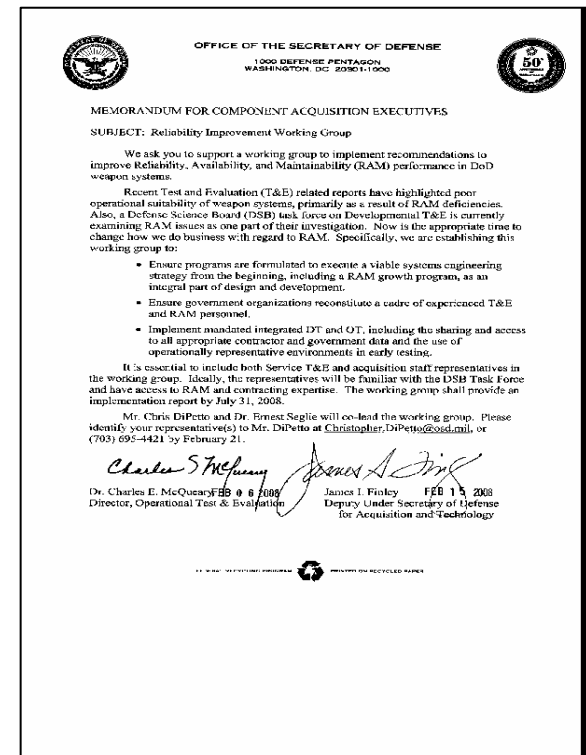



RIWG Accomplishments/Recommendations

DEVELOPMENTAL TEST & EVALUATION

1. SE strategy as an integral part of design and development
 - Developed contract reliability guidance; RFP language
 - ✓ Based on GEIA-STD-0009 – On DAU ACC website
 - Drafted RAM planning template
 - ✓ RIWG Report, Appendix 1.3.2
 - Updated Reliability scorecard in DAG
 - ✓ On DAU ACC website
 - AT&L RAM Policy Memo (July 21, 2008)



AT&L Reliability Policy Memo – July 2008

•DEVELOPMENTAL TEST & EVALUATION

- Services directed to establish a reliability improvement acquisition policy
 - Report back to AT&L w/in 30 days w/ plan to implement policies
- Effective immediately, it is DoD policy for programs to execute a RAM strategy that includes a reliability growth program as an integral part of design and development
 - RAM shall be integrated w/in SE, documented in SEP and Life Cycle Sustainment Plan
 - Assessed during technical reviews, T&E, and Program Support Reviews

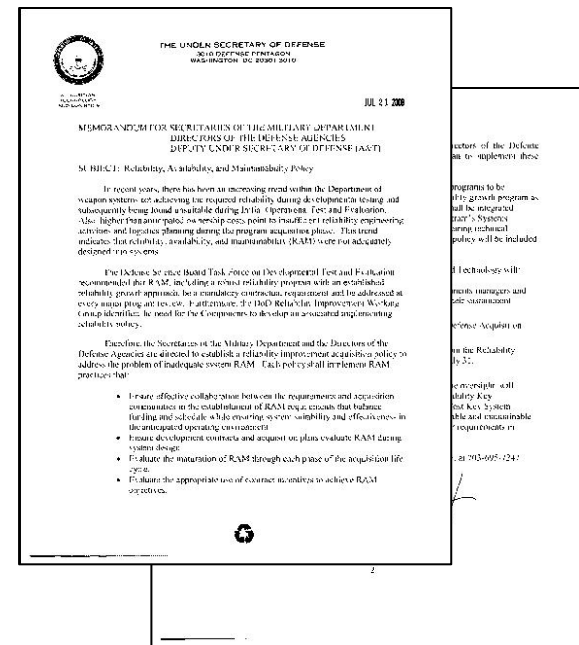

•USD(AT&L) Memo, Jul 21, 2008



RIWG Accomplishments/Recommendations cont.

DEVELOPMENTAL TEST & EVALUATION

2. Reconstitute cadre of experienced T&E and RAM personnel
 - ✓ Provided DAU course material recommendations for RAM and T&E
 - ✓ Recommendations provided to DAU O-FIPT
 - ✓ Curriculum/certification recommendations under review by each FIPT
 - ✓ Also addressing courses for Requirements Officers
 - ✓ OSD/AT&L initiative to recruit RAM and T&E expertise
 - ✓ NDAA SECT 852 Workforce Development fund
 - ✓ Considering competency alignment as an alternative to Centers of Excellence



RIWG Accomplishments/Recommendations cont.

DEVELOPMENTAL TEST & EVALUATION

3. Implement mandated Integrated DT and OT

- ✓ Published DoD-common Integrated Testing definition
- ✓ Revised TEMP format – In DAG update
- ✓ Guide on Incorporating T&E in Acquisition Contract
 - ✓ Approval coordination for publication in process
 - ✓ Located at: <http://www.acq.osd.mil/sse/dte/docs>
- ✓ Updated DAG with integrated test implementation guidance



Integrated Test Implementation

DEVELOPMENTAL TEST & EVALUATION

Impediments To Full Implementation:

- Common Understanding - Definition
- Lack Of Guidance - Updating DAG and TEMP Content
- Culture Change - Leadership Needs To Engage

Definition Signed By DUSD(A&T) And DOT&E
Coordinated Across Components and Services

“Integrated testing is the **collaborative planning** and **collaborative execution** of test phases and events to provide **shared data** in support of **independent analysis**, evaluation and reporting by all stakeholders particularly the developmental (both contractor and government) and operational test and evaluation communities.”



Revised TEMP Concept

DEVELOPMENTAL TEST & EVALUATION

Part I Introduction

Brief mission description paragraph

System description

Brief Threat Assessment

Program Background

Key Capabilities

Part II Mgmt & Sched

Describe T&E management

Common Data

Deficiency Reporting

TEMP Updates

Overarching integrated schedule that includes sequencing of T&E activities (CT, DT, OT, LFT, M&S)

Part III T&E Strategy

The philosophy recognizes a T&E continuum & emphasizes evaluations

Evaluation Framework ties T&E knowledge to decisions, requirements, etc

Developmental

Live Fire

IOT&E Readiness Cert

Operational

Certifications

Reliability Growth

Future Testing

Part IV Resources

Include in para form or table:

- Test articles needed/event
- Special equip/ instr costs
- Target / expendable costs
- Threat representation costs
- Manpower needs
- M&S costs

Linkage of decisions to evaluations, requirements, test phases, and resources

What

Who, When

Why, How

Resources required

Include Joint requirements throughout

T&E – From Concept to Combat



T&E in DoDI 5000.02

DEVELOPMENTAL TEST & EVALUATION

- Integrated Testing
 - IOT&E still separate
- Assessment of Operational Test Readiness
 - Independent DUSD(A&T) assessment – informs OTRR
- Capability Comparison
 - Additional perspective for programmatic decisions
- Data Sharing
 - Goal is common data set (contractor, government) for evals
 - Establishing & maintaining data “pedigree” is key
- TES/TDS at MS-A
 - Tailor content to competitive prototyping and preps for PDR (now prior to MS B)
 - Focus on TDS & ICD



Summary

DEVELOPMENTAL TEST & EVALUATION

- 2007 DT&E DSB
 - Results published June 2008
 - Beginning to address the systemic issues with DT&E
- RIWG Progress Update
 - Report available
 - Follow-up in December
- T&E in 5000.02
 - In final SD 106 review for approval
 - Publication expected Fall 2008



Questions and Discussion

DSB Report: <http://www.acq.osd.mil/dsb/reports.htm>

OSD/DT&E: <http://www.acq.osd.mil/sse/dte/index.html>



T&E Metrics for Acquisition Phases & Decisions

**Developmental Test & Evaluation
OUSD(AT&L)/Systems & Software Engineering**



Purpose

DEVELOPMENTAL TEST & EVALUATION

- **Define T&E metrics for decision points and phases across the acquisition life cycle**
 - **Define appropriate T&E execution and reporting measures**
 - **Standardize metrics to assess progress in T&E planning and execution**
 - **Convey value-added role of T&E**



Precepts

DEVELOPMENTAL TEST & EVALUATION

- **The purpose of T&E is to develop and deliver knowledge**
 - **Knowledge = actionable information**
- **T&E developed knowledge informs decisions to reduce risk in requiring, acquiring, and employing systems / capabilities**
- **T&E knowledge is used to:**
 - **Assess system capabilities / limitations**
 - **Assess program progress**
 - **Assess technical progress**
 - **Improve the product and processes**



Attributes Measured

DEVELOPMENTAL TEST & EVALUATION

- **The metrics required are related to:**
 - **Resources (\$, people, ranges, test assets)**
 - **Errors / Problems (#, discovery / correction rates, criticality)**
 - **Process characteristics (uniqueness, complexity)**
 - **Project Characteristics (size, complexity, schedule)**
 - **Project Dynamics (Reqt chg, Sched chg, Resource chg)**



Sample Integrated Schedule

DEVELOPMENTAL TEST & EVALUATION

How are you doing?

How do you know?

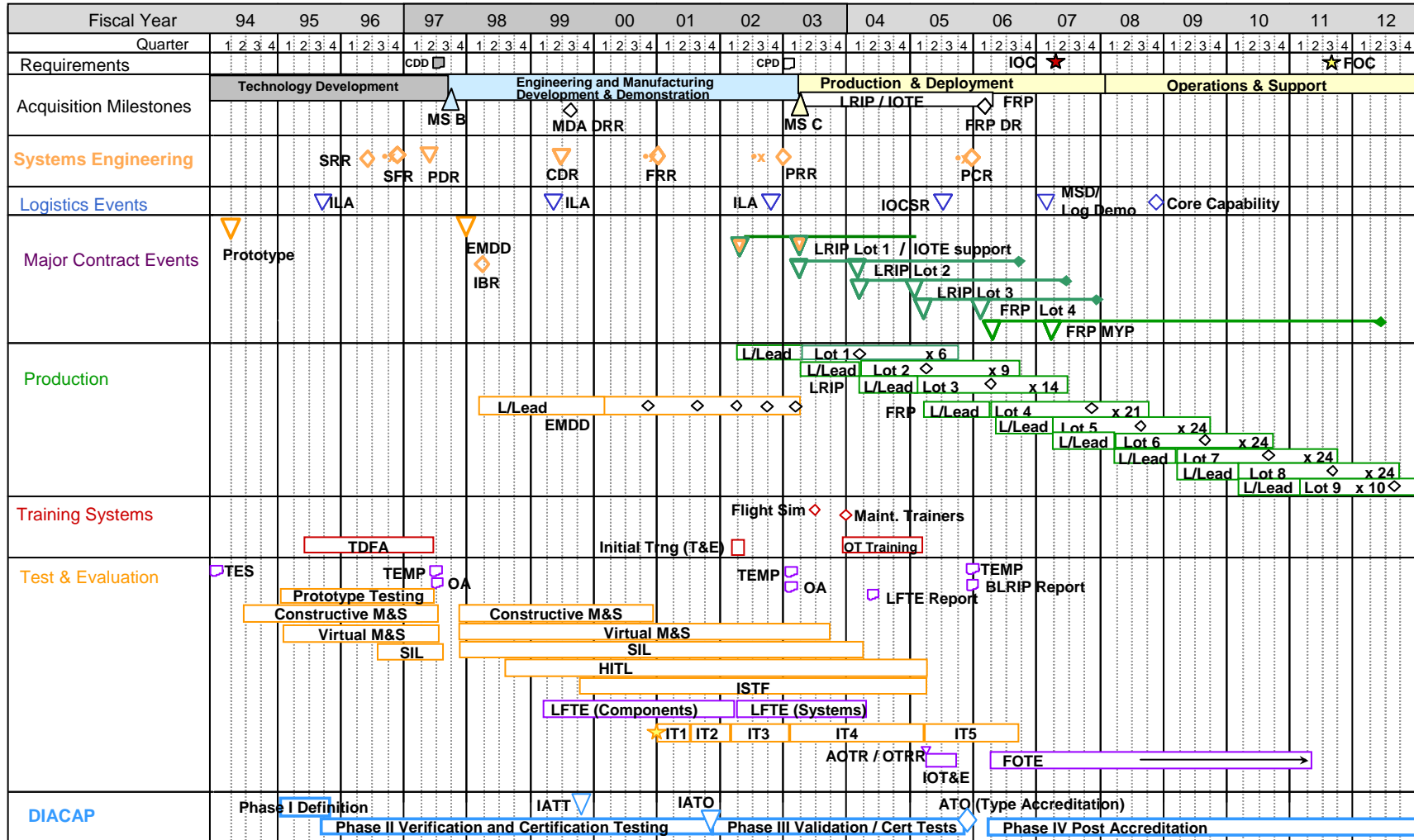

T&E - From Concept to Combat



Acquisition Life Cycle and Phases

Material Solution Analysis

DEVELOPMENTAL TEST & EVALUATION

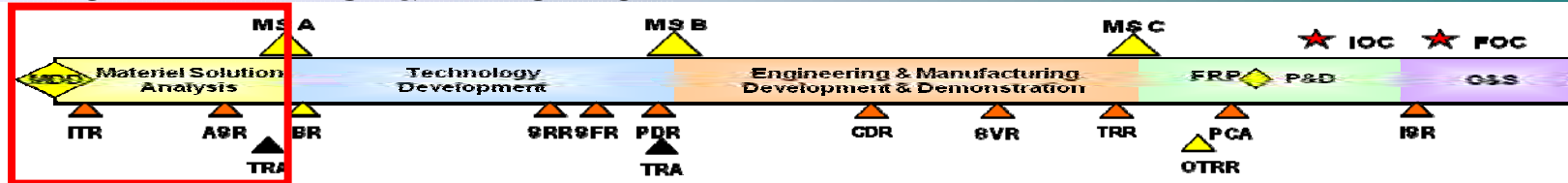

- **Focus:** Assess potential materiel solutions
- **Decision Points:** MDD, ITR, ASR, TRA, MS-A
- **T&E Activity:**
 - Review AoA for evaluatability, identify discriminators
 - M&S to evaluate alternatives, sensitivity analyses
- **T&E Products:** TES
- **Measures / Metrics:**
 - T&E Strategy defined
 - CARD input



Acquisition Life Cycle and Phases

Technology Development

DEVELOPMENTAL TEST & EVALUATION

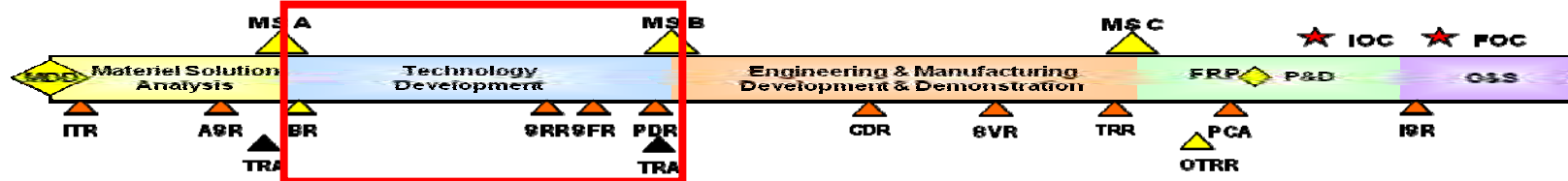

- **Focus:** Reduce technology risk, determine technologies for system integration
- **Decision Points:** IBR, SFR, SRR, TRA, PDR, MS-B, EMDD RFP
- **T&E Activity:**
 - Risk identification & investigation
 - Technology maturation, integration, & demonstration in relevant environment



Acquisition Life Cycle and Phases

Technology Development cont.

DEVELOPMENTAL TEST & EVALUATION

- **T&E Products:** Technology evaluation, TEMP, CARD update
- **Measures / Metrics:**
 - T&E WIPT charter status
 - TEMP status (KPP/KSAs incorporated, design risks, resources)
 - M&S, SIL capabilities relative to desired level
 - Test point burn-down (M&S, SIL)
 - Test time vs schedule (M&S, SIL)
 - TRLs achieved
 - Risk mitigation (Initial & current risk level)



Acquisition Life Cycle and Phases Engineering & Manufacturing Dev & Demo

DEVELOPMENTAL TEST & EVALUATION

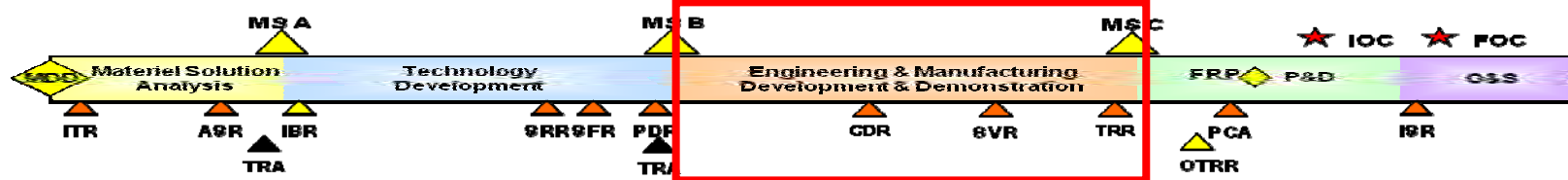

- **Focus:** Develop a system or increment of capability, reduce manufacturing risk, & ensure supportability. Also demonstrate system integration, interoperability, safety, & utility
- **Decision Points:** IBR, CDR, SVR, TRR, FCA, MS-C
- **T&E Activity:**
 - Risk reduction – System, manufacturing
 - Assess design maturity
 - Determine system capability & limitations
 - Demonstrate spec performance
 - Estimate reliability
 - Assess information assurance
 - Ensure supportability



Acquisition Life Cycle and Phases

Engineering & Manufacturing Dev & Demo cont.

DEVELOPMENTAL TEST & EVALUATION

- **T&E Products:** Developmental evaluation reports, OA, TEMP
- **Measures / Metrics:**
 - DR quantity vs time (M&S, SIL, HITL, OAR, manufacturing)
 - DR rate of discovery/correction (design & manufacturing)
 - Test point burn-down (M&S, SIL, HITL, OAR)
 - Test time vs schedule (M&S, SIL, HITL, OAR)
 - Configuration status (M&S, SIL, HITL, OAR)
 - CTP results vs thresholds
 - CTP results vs time
 - System capabilities (mission context) characterized
 - System Certifications (Interoperability, IA, Safety)
 - TRLs



Metric Examples

DEVELOPMENTAL TEST & EVALUATION

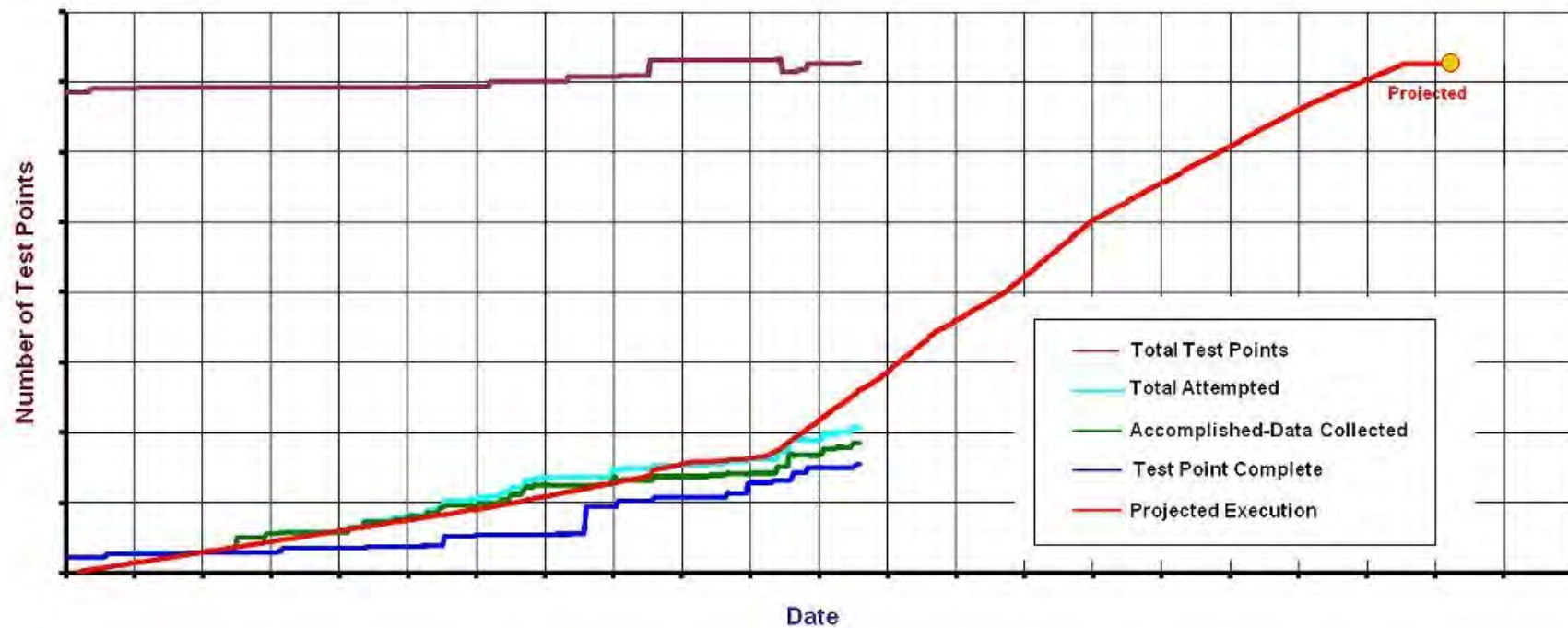



Acquisition Life Cycle and Phases

Production & Deployment

DEVELOPMENTAL TEST & EVALUATION

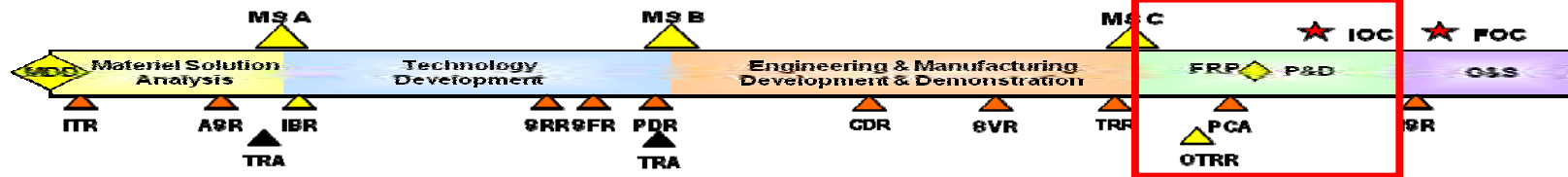

- **Focus:** Achieve an operational capability
- **Decision Points:** PCA, OTRR, PRR, FRP, IOC
- **T&E Activity:**
 - Operational effectiveness & suitability
 - Vulnerability / Lethality
 - Production acceptance & Manufacturing process control
 - Deficiency correction
 - Reliability



Acquisition Life Cycle and Phases

Production & Deployment cont.

DEVELOPMENTAL TEST & EVALUATION

- **T&E Products:** Developmental evaluation report, AOTR, IOT&E report (BLRIP), LFT&E report, TEMP
- **Measures / Metrics:**
 - DR rate of discovery/correction (design & manufacturing)
 - Test point burn-down (OAR)
 - Test time vs schedule (OAR)
 - TOV&V (O-level, I-level, D-level)
 - System Certifications (Interoperability, IA, Safety)
 - MRLs
 - Configuration status (M&S, OAR, Trainers)
 - Operational Effectiveness & Operational Suitability
 - Survivability, Vulnerability, & Lethality
 - System capabilities (mission context) characterized



Acquisition Life Cycle and Phases

Operations & Support

DEVELOPMENTAL TEST & EVALUATION

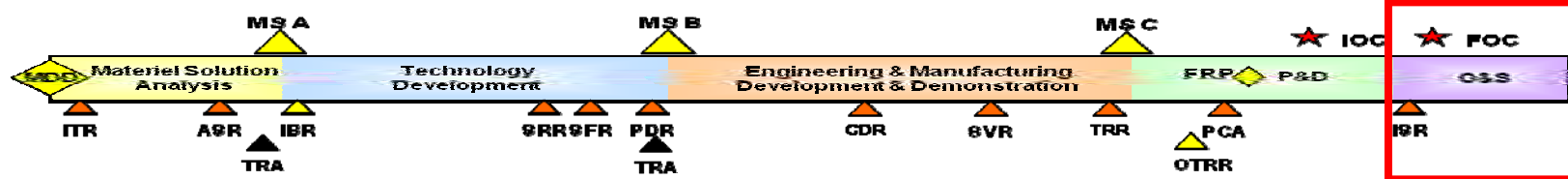

- **Focus:** Sustain the system
- **Decision Points:** ISR, FOC
- **T&E Activity:**
 - Assess availability, reliability, maintainability
 - Identification of new capabilities, improved supportability
- **T&E Products:** Deficiency Reports, TTP updates
- **Measures / Metrics:**
 - DR discovery & resolution
 - Operating time (periodic & cumulative)



Summary

DEVELOPMENTAL TEST & EVALUATION

- **Product of T&E is knowledge for decisions across the life cycle**
- **Value of T&E – informed decisions (acquisition & operational)**
- **No single set of metrics applicable to all decisions or phases**
- **Metrics assess how well T&E is:**
 - Planning
 - Executing
 - Evaluating
 - Reporting



Next Steps

DEVELOPMENTAL TEST & EVALUATION

- **Engage with T&E and program management communities**
- **Continue to develop & evolve metrics**
- **Request your inputs to make the metrics meaningful & useful**



Contact Info

DEVELOPMENTAL TEST & EVALUATION

Darlene Mosser-Kerner

[darlene.mosser-kerner \(at\) osd.mil](mailto:darlene.mosser-kerner@osd.mil)

Visit our website:

<http://www.acq.osd.mil/sse/dte>

Contact us to provide feedback and share your experience

Back-up



Metric Examples

DEVELOPMENTAL TEST & EVALUATION

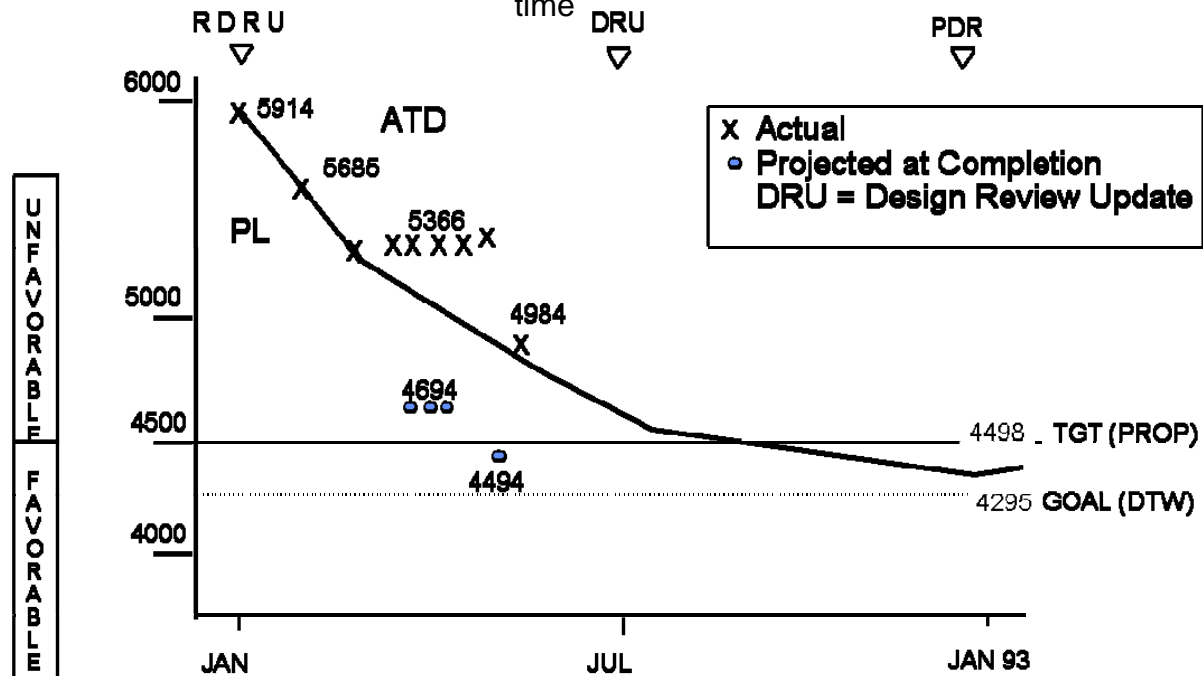
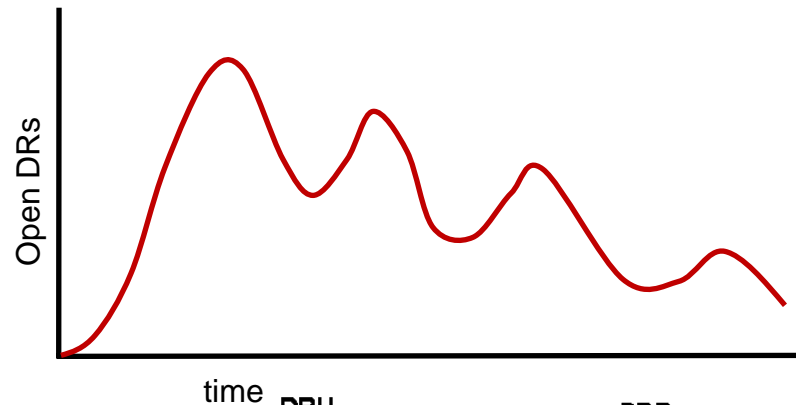
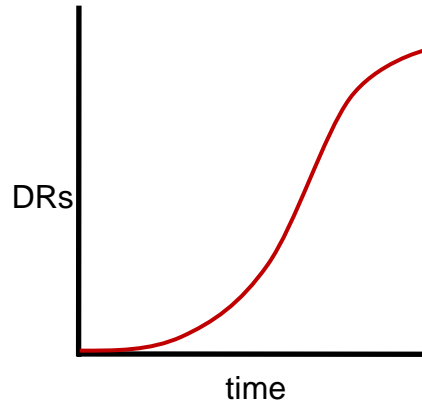

T&E - From Concept to Combat



“New ... Improved”

Test & Evaluation Master Plan

Ms. Darlene Mosser-Kerner

Developmental Test & Evaluation
OUSD(AT&L)/Systems & Software Engineering



New TEMP Content & Format

DEVELOPMENTAL TEST & EVALUATION

- **Current TEMPs have become bloated bureaucratic packages**
 - Excessive detail
 - Late to need – frequently completed after testing has started
 - Limited discussion of evaluation
 - Allowed “stovepiping” within T&E community
- **Need to improve TEMP relevance, utility, and timeliness**
 - Focus on *evaluations*
 - Facilitate integrated testing
 - Show support for Acq Strategy & SE linkage
 - Elevate discussion level to T&E strategy
- **New TEMP Content & Format in DAG update**



Revised TEMP Concept

DEVELOPMENTAL TEST & EVALUATION

| Part I
Introduction | Part II
Mgmt & Sched | Part III
T&E Strategy | Part IV
Resources |
|-------------------------------------|---|---|--|
| Brief mission description paragraph | Describe T&E management | The philosophy recognizes a T&E continuum & emphasizes evaluations | Include in para form or table: <ul style="list-style-type: none"> •Test articles needed/event •Special equip/ instr costs •Target / expendable costs •Threat representation costs •Manpower needs •M&S costs |
| System description | Common Data | Evaluation Framework ties T&E knowledge to decisions, requirements, etc | |
| Brief Threat Assessment | Deficiency Reporting | Developmental | |
| Program Background | TEMP Updates | Live Fire | |
| Key Capabilities | Overarching integrated schedule that includes sequencing of T&E activities
(CT, DT, OT, LFT, M&S) | IOT&E Readiness Cert | |
| | | Operational | |
| | | Certifications | |
| | | Reliability Growth | |
| | | Future Testing | |

Linkage of decisions to evaluations, requirements, test phases, and resources

What

Who, When

Why, How

Resources required

Include Joint requirements throughout

T&E – From Concept to Combat



Test Planning Hierarchy

DEVELOPMENTAL TEST & EVALUATION

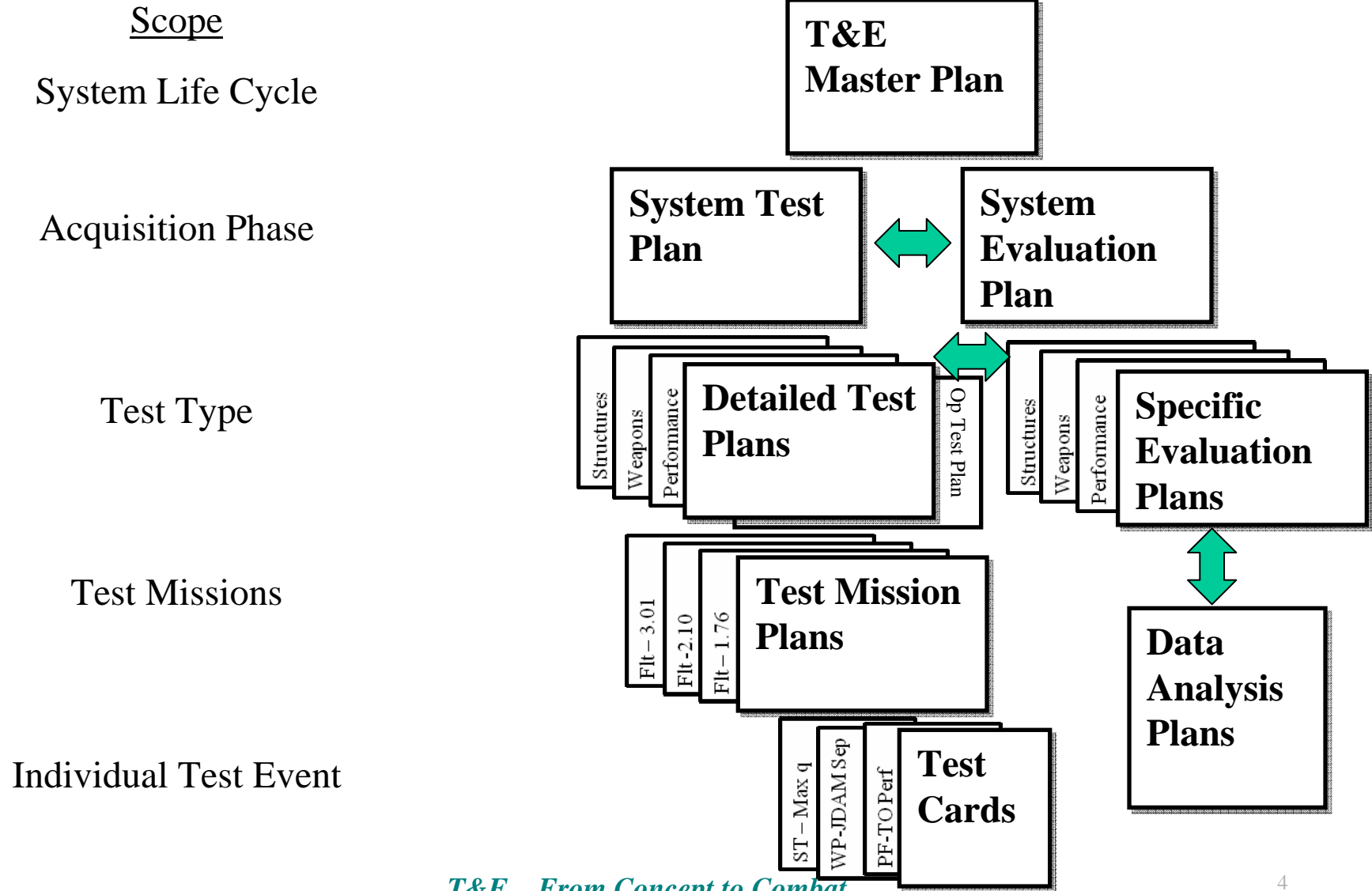



Current vs New Outline

DEVELOPMENTAL TEST & EVALUATION

Current

PART I: SYSTEM INTRODUCTION

- Mission Description
- System Description
- System Threat Assessment
- Measures of Effectiveness and Suitability
- Critical Technical Parameters

PART II: INTEGRATED TEST PROGRAM SUMMARY

- Integrated Test Program Schedule
- Management

New

PART I: INTRODUCTION

- 1.1. Purpose
- 1.2. Mission Description
- 1.3. System Description
 - Sys Threat Assessment
 - Program Background
 - Key Capabilities

PART II: T&E PROGRAM MANAGEMENT & SCHEDULE

- 2.1. T&E Management
- 2.2. Common T&E Data Base Requirements
- 2.3. Deficiency Reporting
- 2.4. TEMP Updates
- 2.5. Integrated Test Program Schedule



Sample Integrated Schedule

DEVELOPMENTAL TEST & EVALUATION

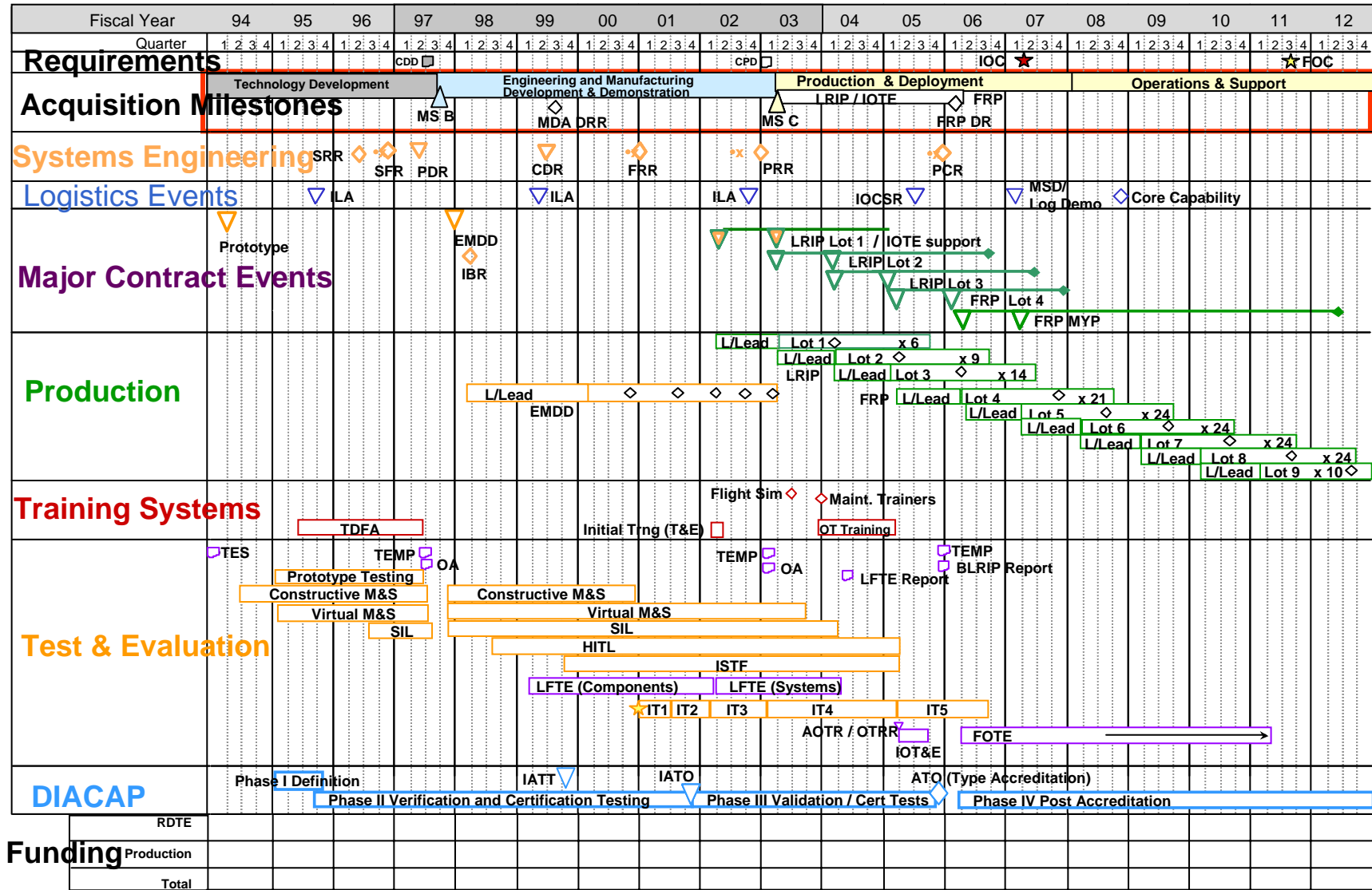

T&E - From Concept to Combat



Current vs New Outline

DEVELOPMENTAL TEST & EVALUATION

Current

PART III: DEVELOPMENT TEST AND EVALUATION OUTLINE

- Development Test and Evaluation Overview
- Future Developmental Test and Evaluation Limitations

PART IV OPERATIONAL TEST AND EVALUATION OUTLINE

- Operational Test and Evaluation Overview
- Critical Operational Issues
- Future Operational Test and Evaluation Limitations
- Live Fire Test and Evaluation

New

PART III: T&E STRATEGY

- 3.1 Introduction
- 3.2 Evaluation Framework
 - Evaluation Framework Matrix (Annex)
- 3.3 Developmental Evaluation Approach
 - Mission Oriented Context
 - Test Objectives
 - M&S
 - Test Limitations
- 3.4 Live Fire Evaluation Approach
 - Test Objectives, M&S, Limitations
- 3.5 Certification for IOT&E
- 3.6 Operational Evaluation Approach
 - Test Objectives, M&S, Limitations
- 3.7 Other Certifications
- 3.8 Reliability Growth
- 3.9 Future Testing



Example Evaluation Framework

DEVELOPMENTAL TEST & EVALUATION

| Key Requirements and T&E Measures | | | | Test Methodologies/Key Resources
(M&S, SIL, MF, ISTF, HITL, OAR) | Decisions Supported |
|-----------------------------------|---|-------------------|---------------------|---|---------------------|
| Key Reqs | COIs | Key MOEs/
MOSs | CTPs &
Threshold | | |
| Combat Radius
KPP#1: | COI #1. Can the UAV locate and engage the XXX enemy threat at a range and time that will ensure survivability of friendly troops? | MOE 1.1.
Range | Fuel Consumption | Aero + Propulsion M&S
Engine stand
Performance profiles – OAR | PDR
CDR
MS-C |
| | | MOE 1.2.
Speed | Airspeed | Wind Tunnel
Performance M&S
Performance Flt Test - OAR | PDR
CDR
MS-C |
| | COI #2. Is the XXX suitable for... | MOE 1.3. | | | Post-CDR
FRP |
| KPP #2 | | MOS 2.4. | Data link | | MS-C
SR |



Current vs New Outline

DEVELOPMENTAL TEST & EVALUATION

Current

New

PART V TEST AND EVALUATION RESOURCE SUMMARY

PART IV: RESOURCE SUMMARY

4.1 Introduction

- Test Articles
- Test Sites and Instrumentation
- Test Support Equipment
- Threat Representation
- Test Targets and Expendables
- Operational Force Test Support
- Simulations, Models, and Test Beds
- Special Requirements
- Test and Evaluation Funding Requirements
- Manpower/Personnel Training

- Test Articles
- Test Sites and Instrumentation
- Test Support Equipment
- Threat Representation
- Test Targets and Expendables
- Operational Force Test Support
- Models, Simulations, and Test Beds
- Joint Operational Test Environment
- Special Requirements

4.2 Federal, State, Local Requirements

4.3 Manpower/Personnel Training

4.4 Test Funding Summary

- Resource Summary Matrix



Critical Technical Parameters

DEVELOPMENTAL TEST & EVALUATION

- **CTPs are not well defined or productively implemented**
- **A short review**
 - **What are they?**
 - **How should they be determined?**
 - **How should they be used?**



Critical Technical Parameters Definition

DEVELOPMENTAL TEST & EVALUATION

- **Pick the CTPs -**

- Radar Target Location Error

- Interoperability

- MTBF

- Software Functionality

- Support Internet Protocol

- Range Safety

- Position Accuracy

- Operational Availability

- Critical field length

- Jammer Duty Cycle

- Range

- Single Mission Sortie

- Open Architecture Certification

- Interoperability Certification

- Handling Qualities

- **Definition:** A CTP is a measurable critical system characteristic that, if not achieved, preclude the fulfillment of desired operational performance capabilities.
- CTPs are technical measures derived from desired user capabilities.
- CTPs are NOT a percentage of KPPs!



Critical Technical Parameters

How Derived?

DEVELOPMENTAL TEST & EVALUATION

- CTP development process is the responsibility of the program test manager
- Lead Systems Engineer plays a key role in determining CTPs

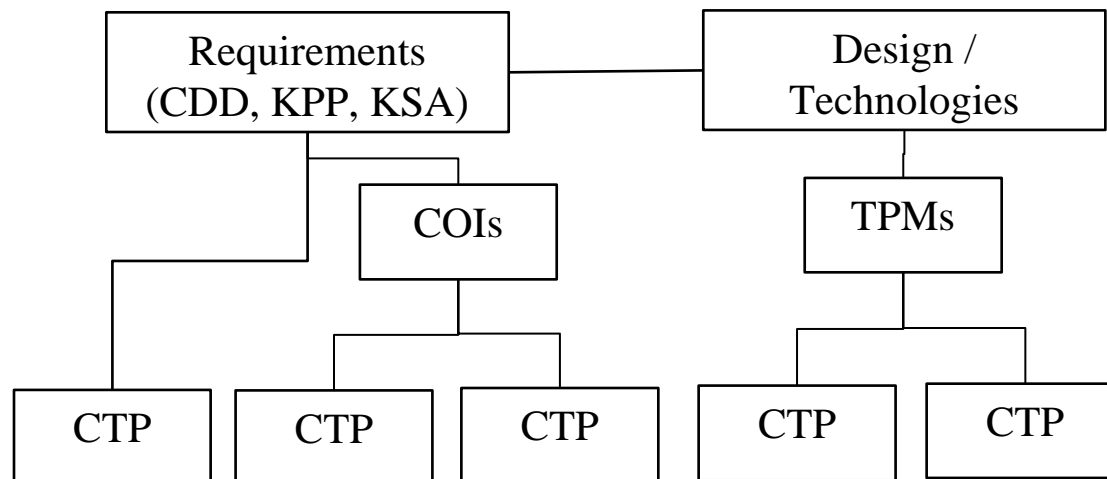



Critical Technical Parameters

How Used?

DEVELOPMENTAL TEST & EVALUATION

- **While not user requirements, CTPs are technical measures derived from desired user capabilities.**
- **Testers use CTPs as reliable indicators that the system is on (or behind) the planned development schedule or will likely (or not likely) achieve an operational capability.**
- **CTPs should be significant from a T&E program perspective – should drive scope / magnitude of the T&E program.**



New Terminology

DEVELOPMENTAL TEST & EVALUATION

- Mission-oriented context:
 - Ability to relate evaluation results to an impact on the warfighters' ability to execute their tasks
 - More robust test environment allows ID of design issues that may not be discovered in a pure DT environment
 - Opportunity to influence design, increase reliability, performance
- Integrated Testing:

“Integrated testing is the **collaborative planning** and collaborative **execution** of test phases and events to provide **shared data** in support of **independent analysis, evaluation**, and reporting by all stakeholders particularly the developmental (both contractor and government) and operational test and evaluation communities”



Mission-Oriented Context

DEVELOPMENTAL TEST & EVALUATION

Mission-oriented DT&E is not a dress rehearsal that is conducted just prior to IOT&E. It is the focus throughout the DT program to ensure the design of the system will meet the user's needs.

- Part of policy to emphasize robust DT&E
 - Discover operational failure modes in time to fix them
- Mission-oriented DT and Integrated Testing will increase efficiencies and reduce risk



Bonus – New TES Sneak Peak

DEVELOPMENTAL TEST & EVALUATION

- **T&E Strategy required at Milestone A**
- **TEMP format – 4 parts**
- **Less detail – similar to “draft” TEMP**
- **Includes T&E life cycle concept**
- **Includes TDS test plan**



Summary

DEVELOPMENTAL TEST & EVALUATION

- **New TEMP Content**
 - **Brings evaluation focus into TEMP**
 - **Assumes a continuum of T&E**
 - **Life cycle view versus scoping to next milestone**
 - **Facilitates Integrated Testing & Mission-oriented context**
 - **Additional test plan details shifted to System Test Plan**
- **In next revision to DAG – Chapter 9**
 - **Applies to new programs, restructured programs, & others if desired**



Contact Info

DEVELOPMENTAL TEST & EVALUATION

Darlene Mosser-Kerner

[darlene.mosser-kerner \(at\) osd.mil](mailto:darlene.mosser-kerner@osd.mil)

Visit our website:

<http://www.acq.osd.mil/sse/dte>

Contact us to provide feedback and share your experience



NDIA 2008 Systems Engineering Conference

*Building net-ready information interoperability
performance indicator widgets for DoDAF 2.0
dashboards*

Jayson Durham
NAERG/ELS Project Lead (ASN RDA CHSENG)
SPAWAR Systems Center Pacific, Code 56150
jayson.durham@navy.mil

Bill Anderson & David Zubrow
Carnegie Mellon, Software Engineering Institute
wba@sei.cmu.edu, dz@sei.cmu.edu



Agenda

Motivation

Goal Driven Measurement – GQIM

Workshop Outcomes

Case Example: Mission-Architecture IPT

Next Steps

HSDII Committee Objective

Information Technology Association of America

Benefit ITAA/GEIA members, government sponsors, builders, developers, and users of ...

Products, Processes and Tools related to ...

Information Interoperability by ...

***Filling critical gaps,
Improving performance, and
Reducing costs.***

But How Do We Judge?

Information Technology Association of America

Measurement!

peaks from palpating back

CONVERSION EXCHANGE
DEPOSIT FEET HERE
PICK UP METERS HERE

Glass Me-LPPP

Pump laser

| | |
|-----------------|-------------|
| Flemish Ell | Yard |
| Cubit | English Ell |
| Span | French Ell |
| Fathom | |
| 18 Handbreadths | |
| 6 Feet | |



Agenda

Motivation

Goal Driven Measurement – GQIM

Workshop Outcomes

Case Example: DODAF 2.0

Next Steps



Goal-Driven Measurement

When using goal-driven measurement,
the primary question is not:

“What metrics should I use?”

rather, it is:

“What do I want to know or learn?”



Measuring Goal Achievement

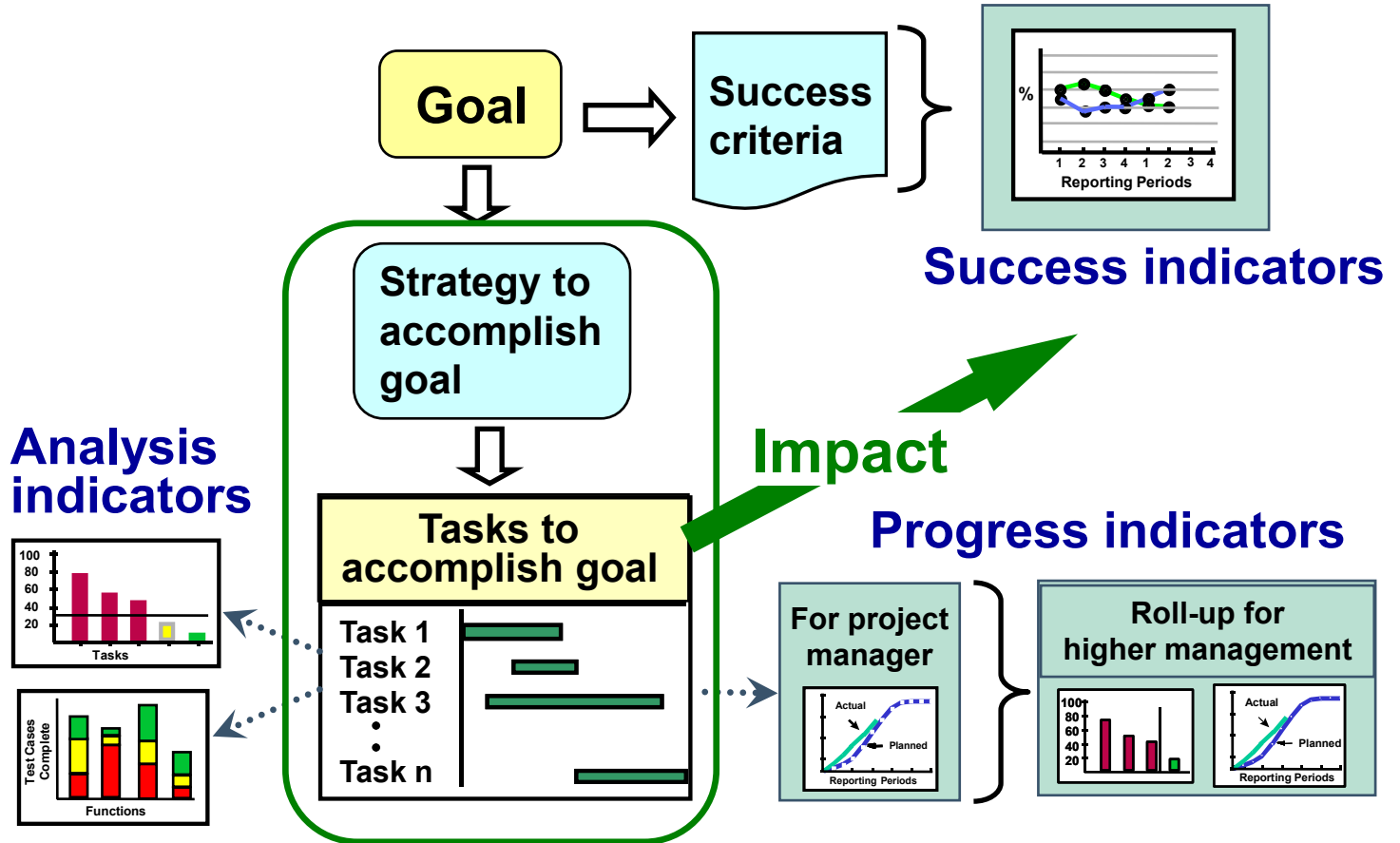



Workshop Steps

Indicator Template

Indicator Template

Goal ID: _____
Objective: _____
Question: _____



Inputs: _____
Algorithm: _____
Assumptions: _____

Step ①: Goals

Components of good goal statements

Step ②: Clarify Questions to refine the goal

Step ③: Decomposing Goals

Subgoals by perspective

Step ④: Operationalize Goals

Operationalize goal statement

Step ⑤: Success Criteria

Clear articulation of the criteria you will use to decide if the goal has been met.

Step ⑥: Success Indicators

Postulate Success Indicators

Step ⑦: Strategies & Activities

Step ⑧: Identify the data elements

| Data Elements | Avail | Source |
|---------------|-------|--------|
| Size | + | QA |
| Defects | 0 | CM |
| | - | ? |
| | 0 | Etc. |
| | + | . |
| | -- | . |

Step ⑨: Identify the actions needed to implement your measures

| Planning Tasks | Data Elements | | | | |
|----------------|---------------|---|---|---|---|
| | 1 | 2 | 3 | 4 | 5 |
| Task 1 | 50 | N | | Y | |
| Task 2 | | Y | | Y | Y |
| Task 3 | Y | | Y | | |
| Task n | | N | | Y | |

Step ⑩: Prepare a plan

Verification and action plans



Agenda

Motivation

Goal Driven Measurement – GQIM

Workshop Outcomes

Case Example: Mission-Architecture IPT

Next Steps

Workshop Outcomes: Top Three Goals

Information Technology Association of America

- Enable precision information sharing among stakeholders
 - Minimal ambiguity
- Measure the “goodness” for information interoperability standards
 - Then standards in general
 - “Goodness” for information interoperability
 - How effectively are users getting & using information exchanges
- Systems and enterprise“s achieve more effective collaboration and/or achieve greater success by enabling inter-enterprise collaboration

Enable information sharing among stakeholders with minimal ambiguity.

| ID | Theme (Stakeholder, Info, Std) | Type of Indicator (Success, Progress, Analysis) | Questions | Atomic Indicator | Roll-up Indicator | DoDAF Product & Other Sources | CADM Data Elements |
|----|--------------------------------|---|---|---|---|---|---|
| | Stakeholder | | Who are the stakeholders? | | | OV-2, OV-3 | OperationalNode |
| | Stakeholder | | What information do the stakeholders need? | Completeness
Is there an information architecture that defines the stakeholders and context for the information sharing? | Completeness
What percentage of information exchanges (IERs) are defined in the information architecture? | OV-2, OV-3 | InformationExchangeRequirement/
InformationExchange/
Needline |
| 11 | Information | Success | Was the correct information provided where and when needed? | Visibility
Did the Info Provider publish availability of the info?
Can the Info Consumer discover needed info? | Visibility
What percentage of IERs are published? | SV-4a/b, Enterprise Catalog Service (ECS) & Service Registry, Content Discovery and Delivery (CD&D) | InformationExchange/
Information Element |
| 12 | Information | Success | Does the info exchange enable traceability back to the original context? | Understandable
Is metadata published with the information that defines its source/context/pedigree? | Understandable
What percentage Info Providers create and publish metadata for IERs/Services? | AV-2, SV-11, DDMS, Metadata Registry (MDR) | InformationExchange/
Information Element |
| 13 | Information | Success | Can we verify information integrity? | Unambiguous
Does the Info Provider claim/advertise that the information conforms to a 'verifiable' standard? | Unambiguous
What percentage of IERs conformed to adopted Standard(s)? | TV-1, MDR | Information Element, Operational Nodes, Technology Areas, Technical Standards, Performance Parameters |
| 14 | Information | Progress | Is the information standardized? | Extensible
Does the standard contain normative statements that define conformance to compliance points?
Implementable
Do normative statements in the standards conflict?
Testable
Are the normative statement verifiable? | | | |
| | Standard | Analysis | Are technical requirements in the standard stated clearly and understandable? | | | DISR, TV-1 | Technology Areas, Technical Standards, Performance Parameters |
| | Standard | Analysis | Are the requirements in the standard(s) implementable? | | | DISR, TV-1 | Technology Areas, Technical Standards, Performance Parameters |
| | Standard | Analysis | Does the standard define verification of conformance? | | | DISR, TV-1 | Technology Areas, Technical Standards, Performance Parameters |
| | Standard | | Will the standard support sharing with unanticipated stakeholders? | | | | |

Quality Evaluation

Information Technology Association of America

Standard Quality Evaluation

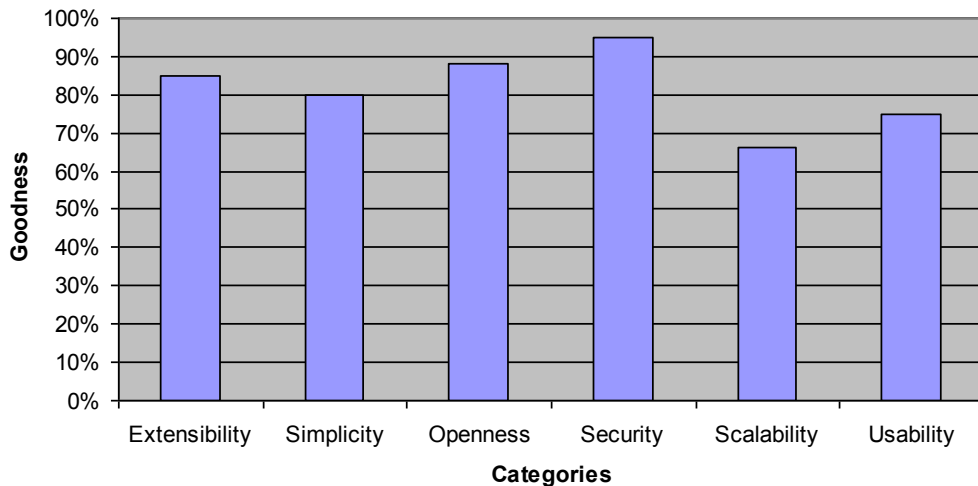

Notes:

Each category is graded on a scale of 1-5 and weighted to a total of 100%.
Data is based on a survey of stakeholders.

Users of the indicator include:

- standard developers and associated marketing
- potential adopters
- actual users

Scalability means across multiple domains

Usability means by multi-functions (non-IT experts)

Interface Maintenance

Information Technology Association of America

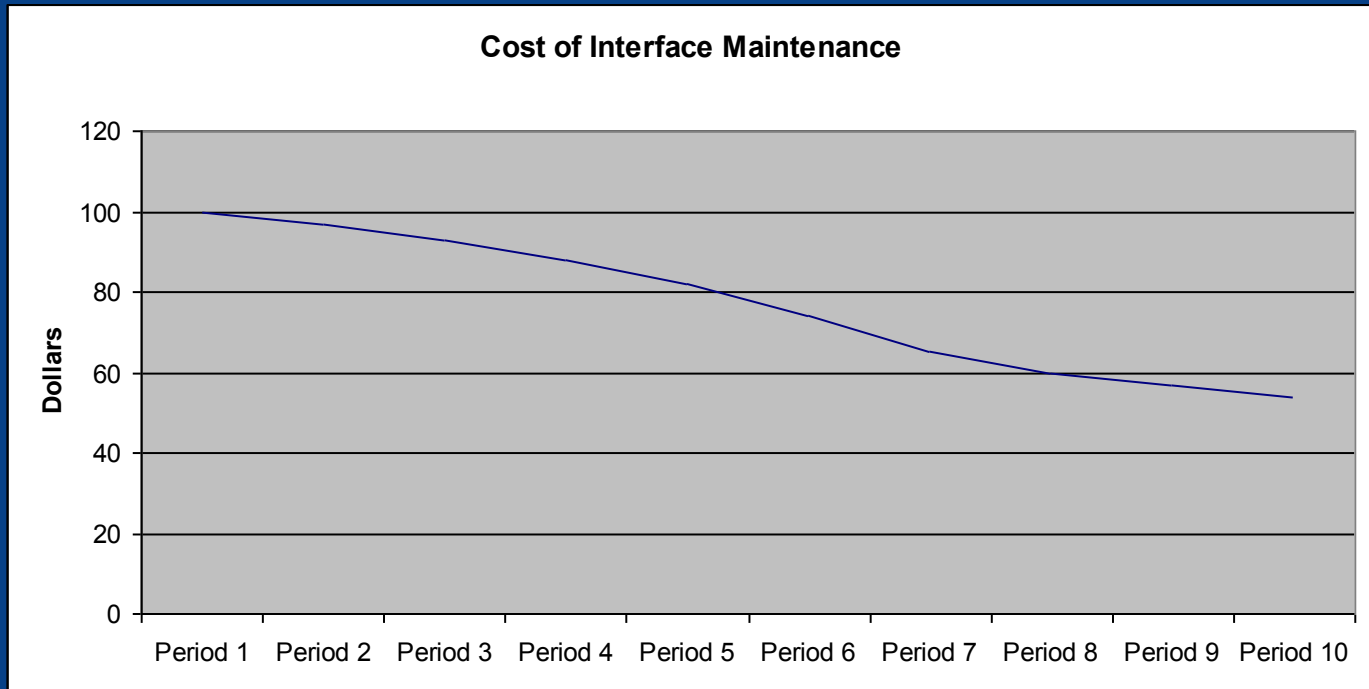

Adoption

Information Technology Association of America

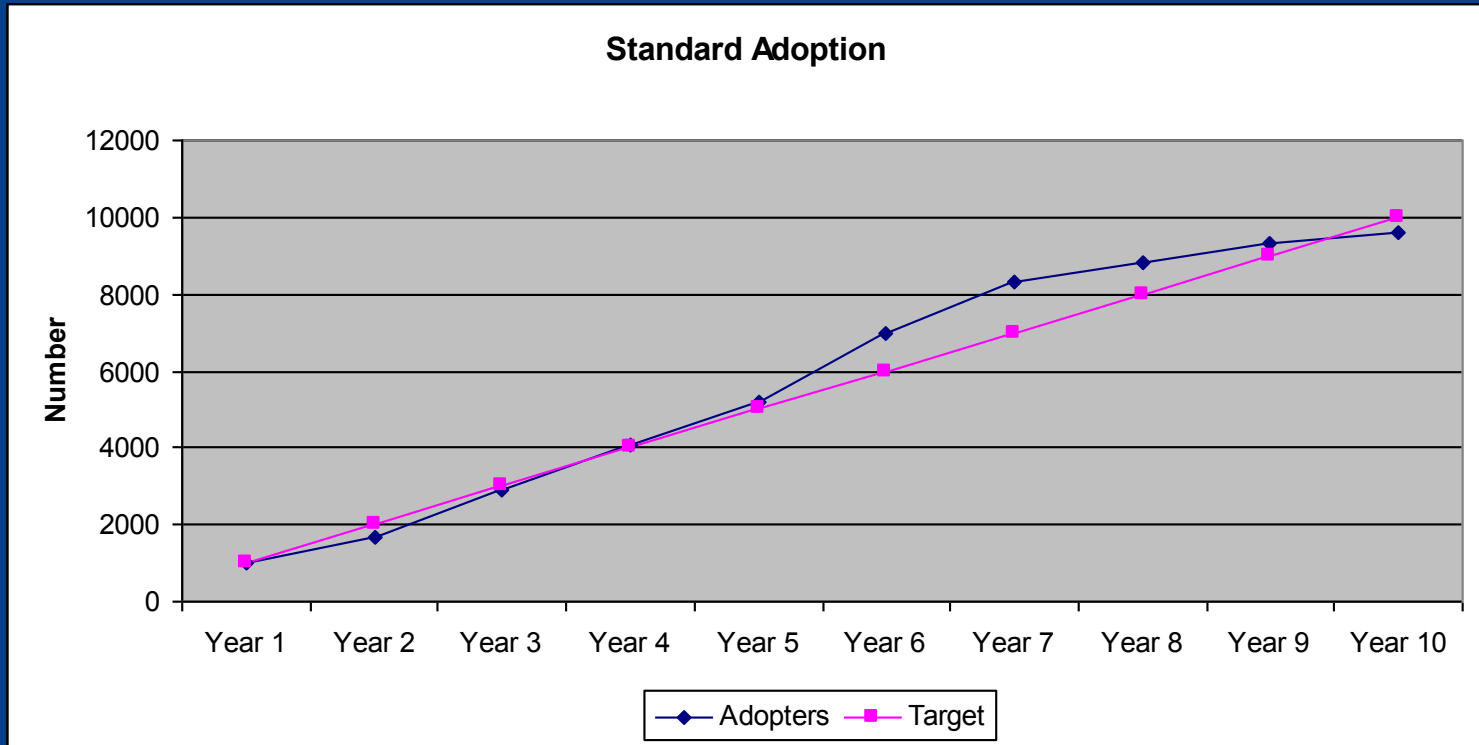

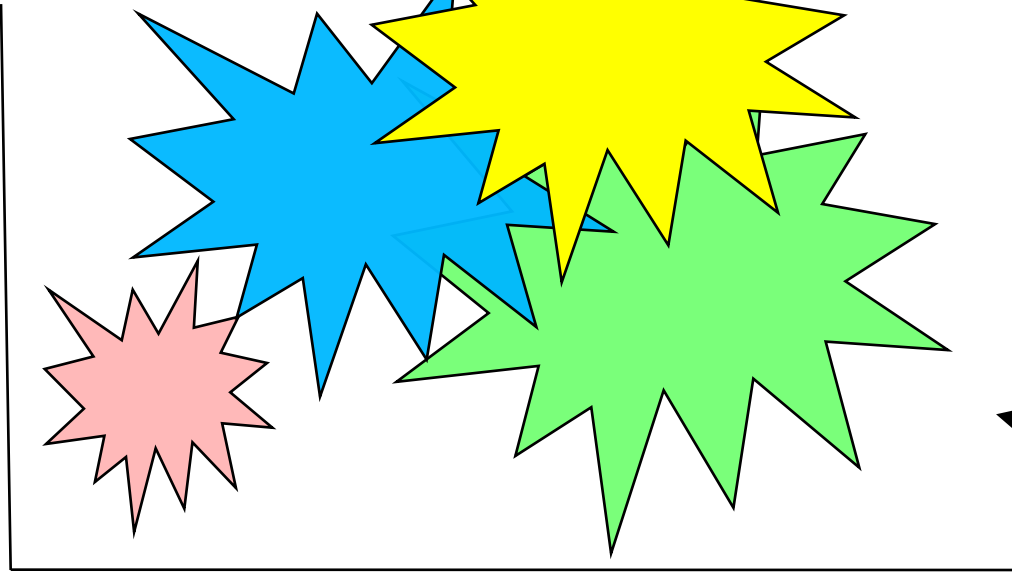

← WordNet
Cyc

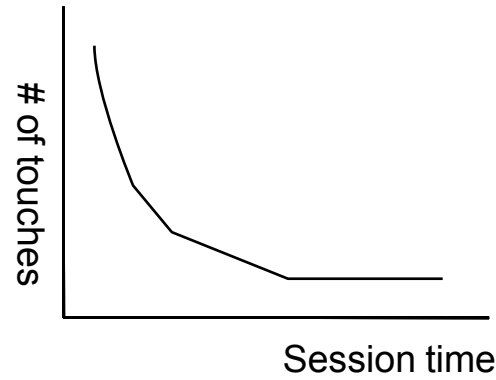
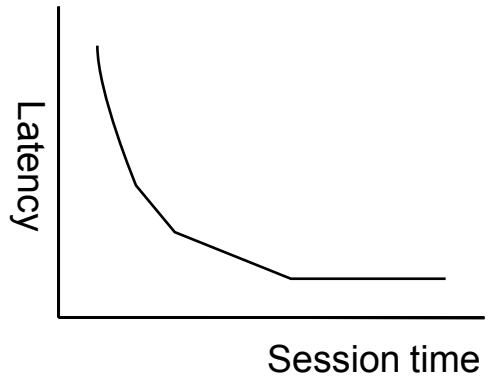

DoDAF 2.0 “Dashboards”

Information Technology Association of America

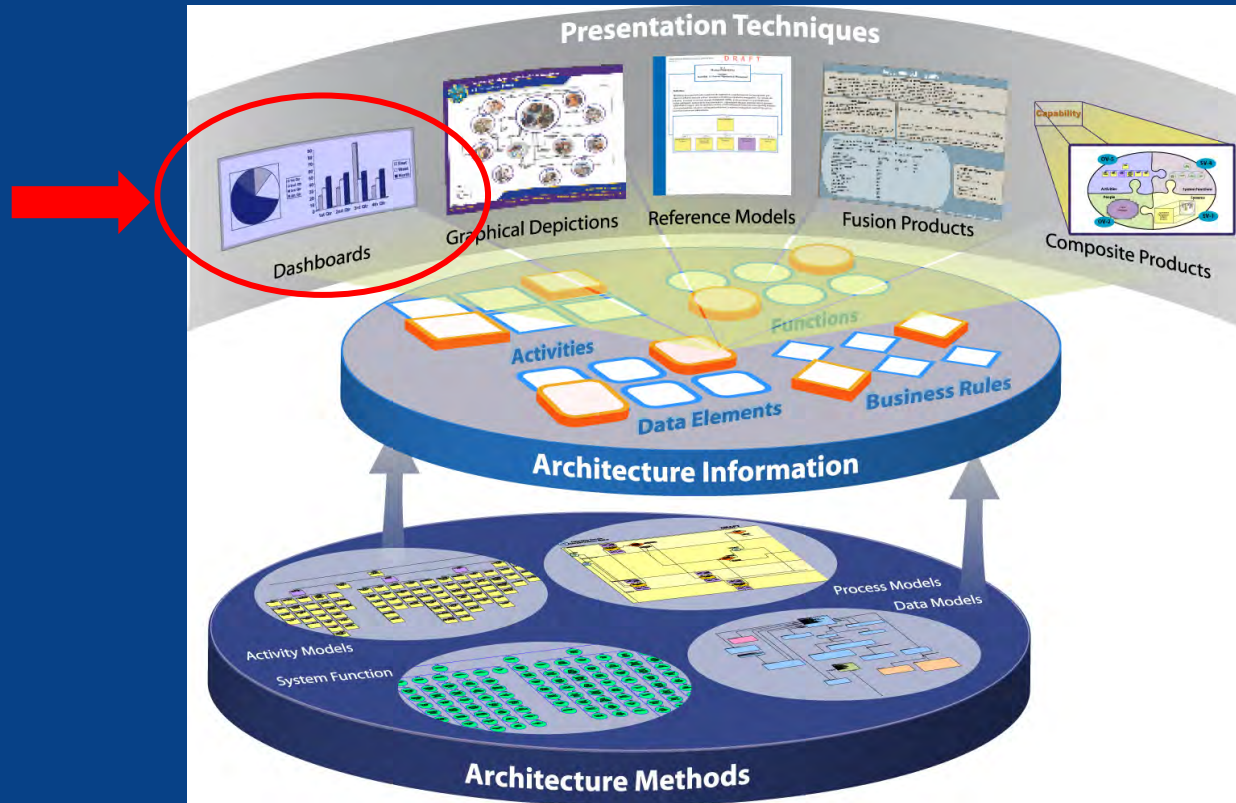

Defining indicator widgets for dashboards

Workshop Outcomes: Conclusions

Information Technology Association of America

- The SEI GQ(I)M provides a viable methodology to develop information interoperability indicators
- We identified a preliminary set of indicators for measuring the “goodness” of information exchange standards relative to business goals
- We concluded
 - Enterprise architecture frameworks with an explicit focus on services (transactions) provide a means of implementing and improving Information Interoperability
 - Indicators provide a means for establishing a standardized set of reusable dashboard elements („indicator widgets“) in these frameworks

Workshop Outcomes: Observations

Information Technology Association of America

- The DoDAF 2.0 presentation technology working group has set forth dashboards as a category of presentation views
- Baseline indicators for information interoperability need to be developed (similar to baseline KPI"s for enterprise architecture frameworks)
- Existing work from assessment, performance, and other model based efforts provide valuable resources for developing information interoperability (as well as other) indicator widgets



Agenda

Motivation

Goal Driven Measurement – GQIM

Workshop Outcomes

Case Example: Mission-Architecture IPT

Next Steps



Architecture Models: Background Tenets of Network Centric Warfare (NCW)

RDA
CHIEF
SYSTEMS
ENGINEER

(Networked Force, Quality Information, Information Sharing, etc.)

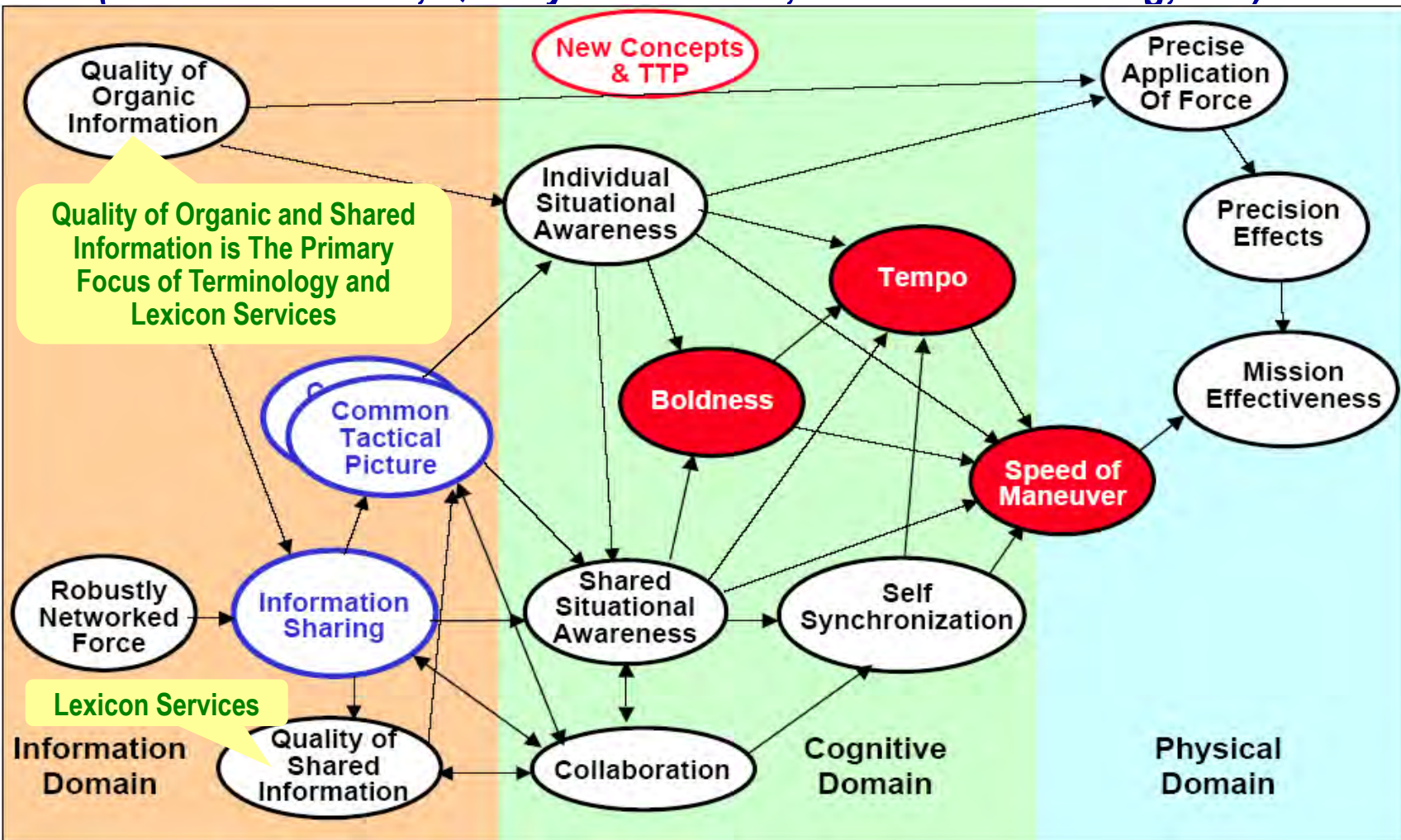



Terminology Services: Challenge Semantic Interoperability Scoping

RDA
CHIEF
SYSTEMS
ENGINEER

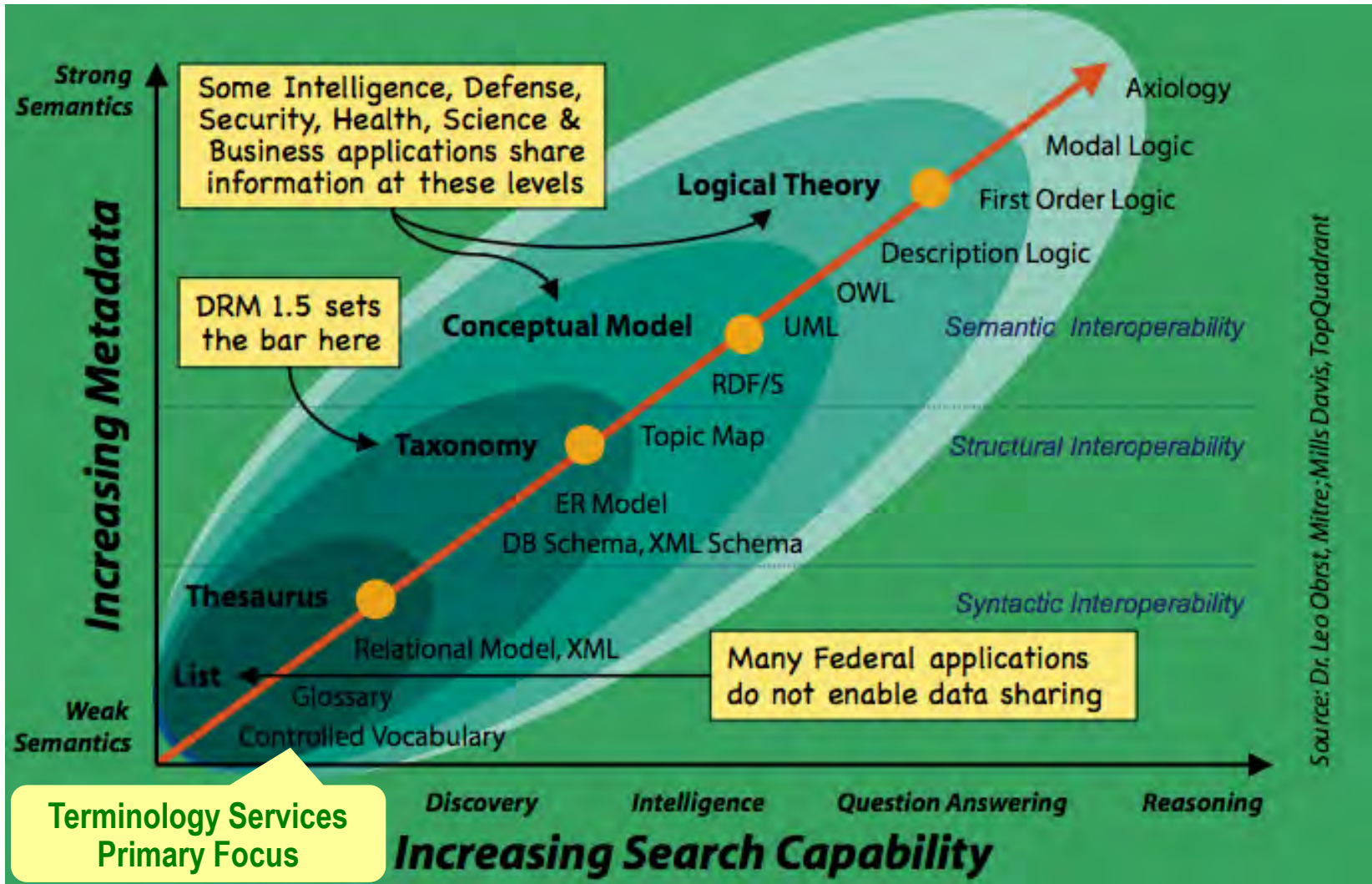



Terminology Services: Challenge Information Interoperability

RDA
CHIEF
SYSTEMS
ENGINEER

Common Lexicon vs Ad-Hoc Reverse Engineering

Common Terminology Makes Information Interoperability Possible

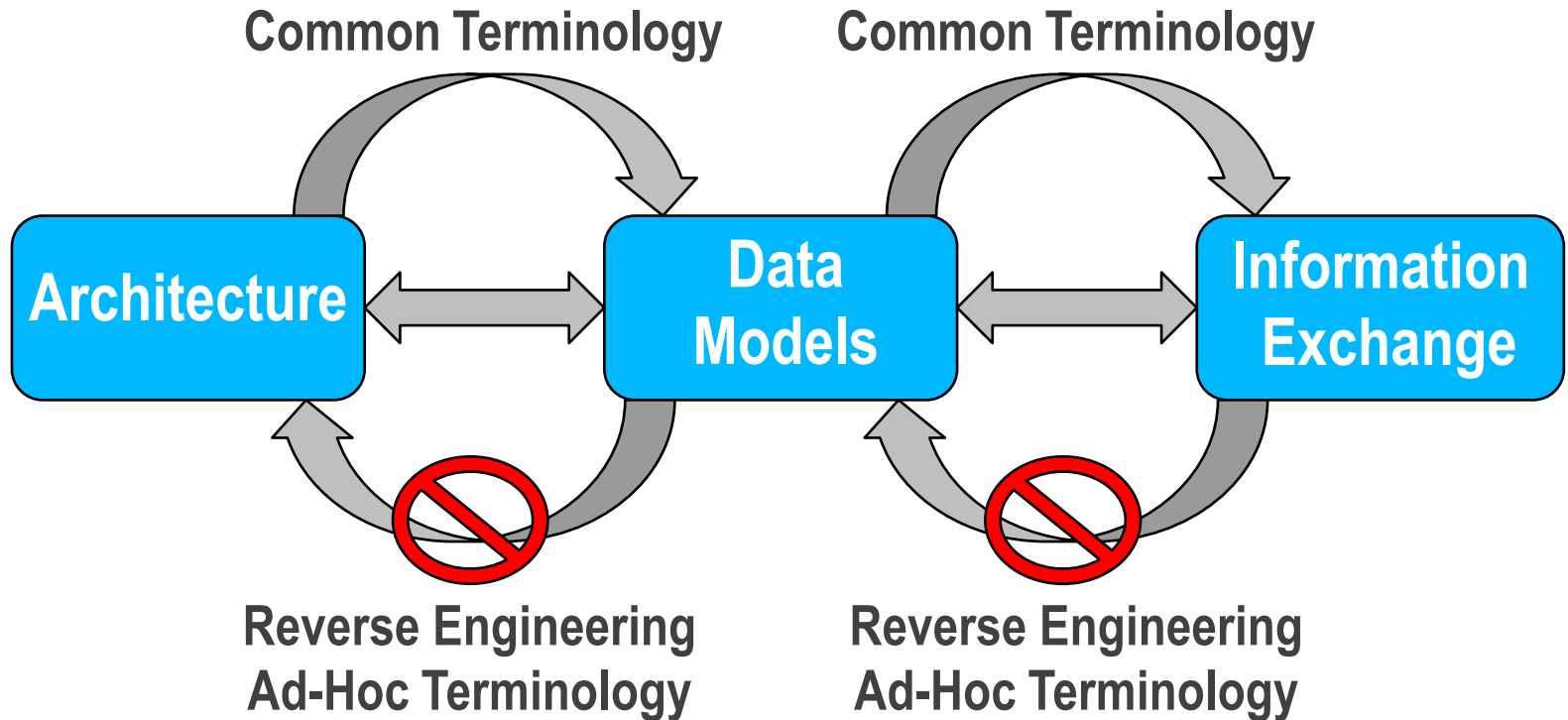

Reverse Engineering is Expensive, Difficult, and Often Not Feasible



Terminology Services: Related Work Capability-Based Systems-of-Systems Engineering (SOSE)



NCEE

NAERG

Naval Collaborative Engineering Environment (NCEE)

NAERG Link at CHSENG NCEE Home Page

The screenshot shows the NCEE website with a yellow callout box highlighting a link in the 'Links of Interest' section. The link text is 'The Naval Architecture Elements Reference Guide'.

Naval Architecture Element Reference Guide (NAERG)

The Naval Architecture Elements Reference Guide

The screenshot shows the NAERG website with a table of architecture elements. The table has columns for 'Operational View (OV)' and 'System View (SV)'. The rows list various elements like 'Operational Nodes', 'Operational Tasks', etc.

| ARCHITECTURE ELEMENTS | Operational View (OV) | | | | | | | System View (SV) | | | | | | | | | | | |
|------------------------|-----------------------|---|---|---|---|---|--------|------------------|---|---|---|---|---|---|---|---|----|----|--------|
| | 1 | 2 | 3 | 4 | 5 | 6 | 7 | 1 | 2 | 3 | 4 | 5 | 6 | 7 | 8 | 9 | 10 | 11 | 12 |
| Operational Nodes | ● | ● | ● | ● | ● | ● | (B) | | | | | | | | | | | | |
| Operational Tasks | | | | | | | (B, C) | | | | | | | | | | | | |
| Operational Activities | | | | | | | (B, C) | | | | | | | | | | | | |
| Information Elements | | | | | | | | ● | ● | ● | ● | ● | ● | ● | ● | ● | ● | ● | ● |
| System Nodes | | | | | | | | | | | | | | | | | | | |
| Systems | | | | | | | | | | | | | | | | | | | (B, C) |
| System Functions | | | | | | | | | | | | | | | | | | | (B, C) |
| Triggers/Events | | | | | | | (B, C) | | | | | | | | | | | | (B, C) |
| Performance Parameters | | | | | | | | | | | | | | | | | | | |
| Technical Standards | | | | | | | | | | | | | | | | | | | ● ● |

Common Access Card (CAC) Enabled Websites

<https://ncee.navy.mil/Pages/default.aspx>

<https://stalwart.spawar.navy.mil/naerg>



Architecture Frameworks: Current Work

Mission Architecture Dashboard

RDA
CHIEF
SYSTEMS
ENGINEER

Capability Tracing, Assessment, Validation, and Gap Analysis

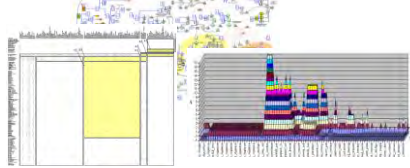

Threat Scenarios

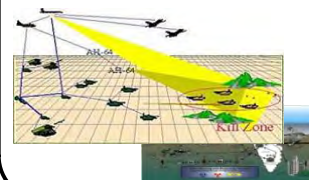

Inter-Agency Cross-Domain Information-Sharing Supply-Chain



Mission Architecture Dashboard

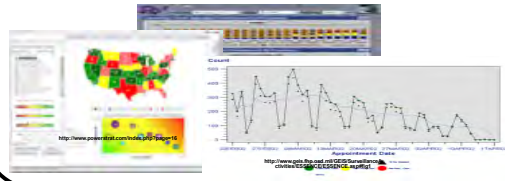

Integrated AT&L Life Cycle Management Framework

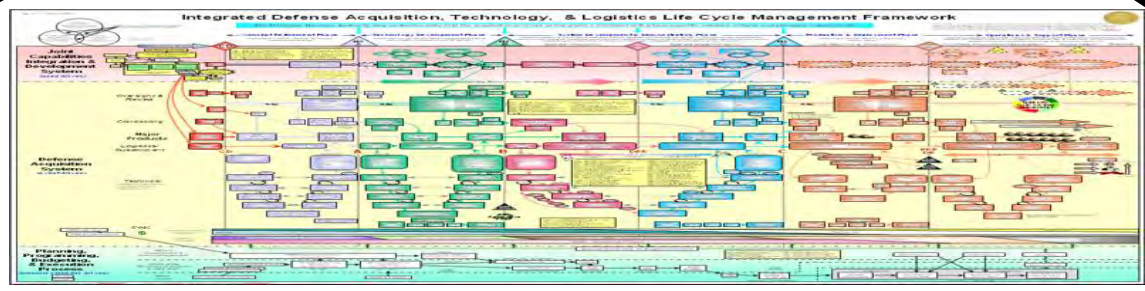

Operational Mission-Threads



Operational Plans (OPlans)



Mission Operations

Systems

Devices

Enterprise Framework - Policies, Rules, Metrics Processes, Architectures, ...





Architecture Models: Emerging Standards DoD Architecture Framework 2.0 Example

RDA
CHIEF
SYSTEMS
ENGINEER

Standardized Dashboard Views, Data Elements, Business Rules, etc.

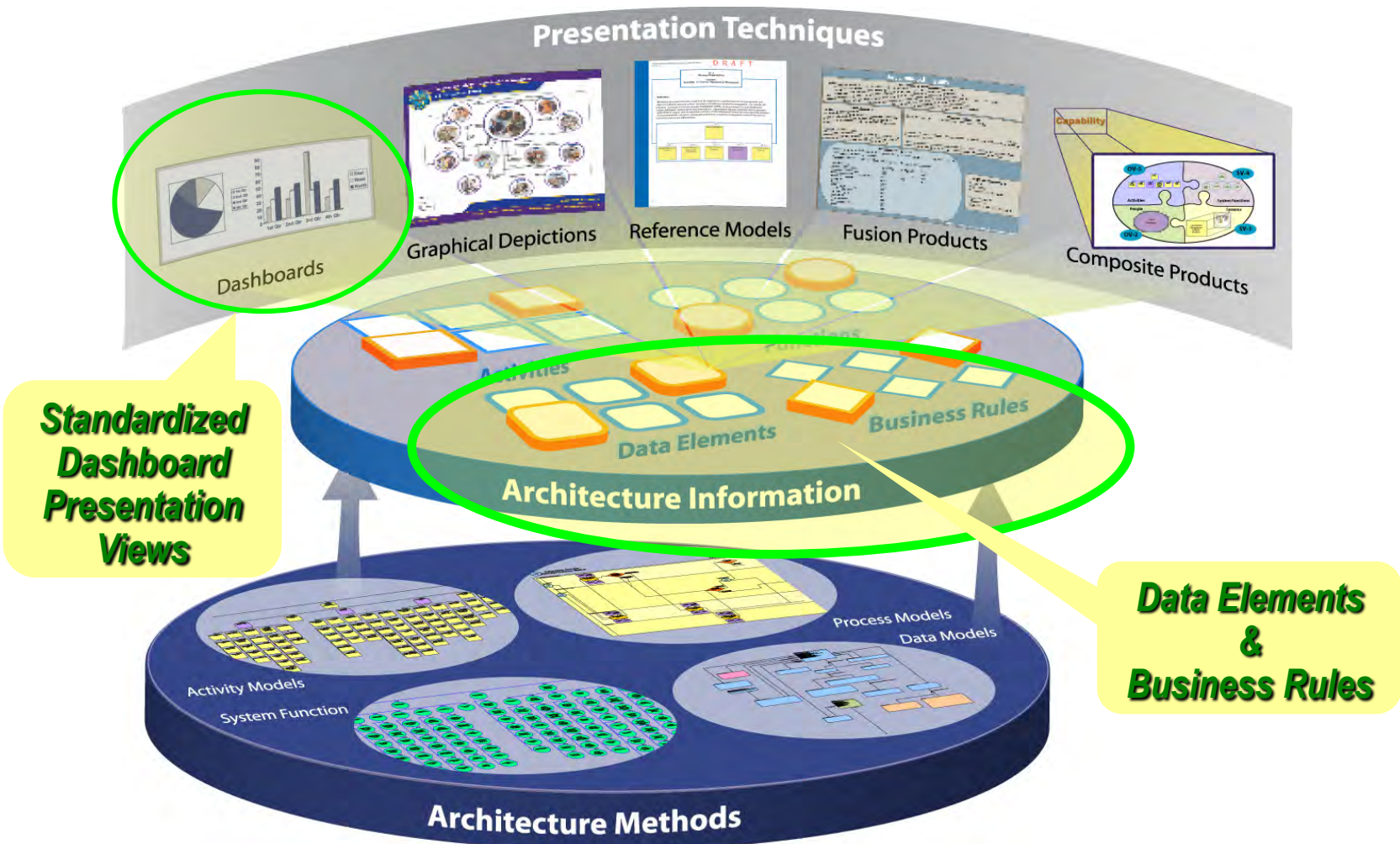



Agenda

Motivation

Goal Driven Measurement – GQIM

Workshop Outcomes

Case Example: Mission-Architecture IPT

Next Steps

Way Ahead

- Further explore leveraging DoDAF 2.0 to help define an open standard for indicator widgets
- Produce an exemplar reference implementation for a set of indicator widgets
- Produce guidance on how to go from existing standards to the indicator widget paradigm



Questions?

- DOD Net-Centric Checklist, Version 2.1.4, July 30, 2004
 - Assists program managers in understanding the net-centric attributes that their programs need to implement to move into the net-centric environment as part of a service-oriented architecture in the Global Information Grid.
- NCIOC Network Centric Analysis Tool (NCAT) & SCOPE model
 - NCAT is a metric measurement tool developed by the NCOIC for use in evaluating the ability of a system/subsystem/component to operate in a network centric environment. Designed to leverage complementary tools developed by DISA and others, the NCAT is highly flexible, easily adaptable, and can be tailored for specific requirements.
- DOD's Modular Open Systems Approach (MOSA) Program Assessment and Rating Tool (PART)
 - An analytical tool to aid DoD Program Managers assess their approach to open systems throughout the acquisition life cycle.
- Navy Open Architecture Assessment Tool (OAAT)
 - A Navy tool to assess the openness of a systems or program.
- DOD's Data and Service Exposure Verification Tracking Sheets
 - Used to measure net-centricity in support of the DOD's Net-Centric Data Strategy.

A catalog of reusable indicators can be readily derived

NO WARRANTY

ANY CARNEGIE MELLON UNIVERSITY AND SOFTWARE ENGINEERING INSTITUTE MATERIAL CONTAINED HEREIN IS FURNISHED ON AN "AS-IS" BASIS. CARNEGIE MELLON UNIVERSITY MAKES NO WARRANTIES OF ANY KIND, EITHER EXPRESSED OR IMPLIED, AS TO ANY MATTER INCLUDING, BUT NOT LIMITED TO, WARRANTY OF FITNESS FOR PURPOSE OR MERCHANTABILITY, EXCLUSIVITY, OR RESULTS OBTAINED FROM USE OF THE MATERIAL. CARNEGIE MELLON UNIVERSITY DOES NOT MAKE ANY WARRANTY OF ANY KIND WITH RESPECT TO FREEDOM FROM PATENT, TRADEMARK, OR COPYRIGHT INFRINGEMENT.

Use of any trademarks in this presentation is not intended in any way to infringe on the rights of the trademark holder.

This Presentation may be reproduced in its entirety, without modification, and freely distributed in written or electronic form without requesting formal permission. Permission is required for any other use. Requests for permission should be directed to the Software Engineering Institute at permission@sei.cmu.edu.

This work was created in the performance of Federal Government Contract Number FA8721-05-C-0003 with Carnegie Mellon University for the operation of the Software Engineering Institute, a federally funded research and development center. The Government of the United States has a royalty-free government-purpose license to use, duplicate, or disclose the work, in whole or in part and in any manner, and to have or permit others to do so, for government purposes pursuant to the copyright license under the clause at 252.227-7013.





NAVAL
POSTGRADUATE
SCHOOL

Applying Open Architecture Concepts to Mission and Ship Systems

John M. Green Gregory Miller
Senior Lecturer Lecturer
Department of Systems Engineering

The Nation's Premier Defense Research University

Monterey, California
WWW.NPS.EDU

- Purpose: *to introduce a simulation based methodology to facilitate development of a software product line architecture concept for the Navy's C5ISR systems.*
- Two key advantages to the proposed methodology:
 1. it provides a formal systems approach to the verification of the product line architecture requirements consistent with the Department of Defense Architecture Framework.
 2. it provides a medium for the iterative development of architectures that blend the operational concepts of FORCEnet with the system and technical imperatives of Open Architecture and Services-Oriented Architecture (SOA).

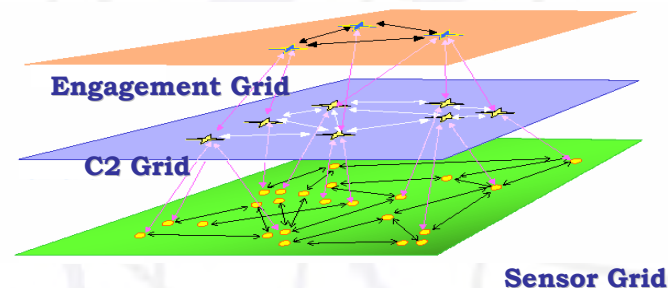



What I'm Going to Tell You

- Background
- Technical Approach
 - Key Concepts
 - Open Architecture
 - Domain Modeling
 - Formal Methods
 - H-P Method
 - Details of the Technical Approach
- Conclusion



- The last 15 years (or thereabouts) has seen a number of interesting developments in the technologies that support C4ISR system development.
 - For example, the advent of CEC and GPS provided the impetus for the conceptual development of Network-Centric Warfare (NCW), Network-Centric Operations (NCO) and FORCENet [Alberts, Garstka, and Stein 2000].
 - Yet, despite all that has been written about the concepts of FORCENet and Open Architecture (OA), there has been little written on how these two concepts will come together in the naval C4ISR systems of the future.
- The main emphasis has been on technologies such as Internet Protocol version 6 (IPv6), not the architecture.
- *As a result, there is no commonly shared or understood model of what this end state may look like.*

- There is a tendency to view the system architecture using existing paradigms that were used to develop the “stove-piped” systems that are now proving to be limited in their capability.
- This is a “paving the cow paths” approach and has made developing FORCENet capable systems difficult.
- European firms such as Thales, Saabtech and Terma have already validated the concepts of open architecture, software product lines, and software reuse as applied to combat systems



- In addition to lessons learned from European firms, the proposed Technical approach is built upon lessons learned from Lockheed Martin's Norwegian Frigate Project and a predecessor program, Taiwan's PFG-2 Class Frigate project
- Valuable lessons were also learned from the predecessor program to OA, the Common Command and Decision (Common C&D) project.
- Common C&D resulted in the development of several FORCEnet related concepts that were briefed to the Assistant Secretary of the Navy for Research and Development.





- The key Open Architecture principles espoused by the Navy are [Naval OA Strategy]:
 - *Modular design and design disclosure*
 - *Reusable application software*
 - Interoperable joint warfighting applications and secure information exchange
 - Life-cycle affordability
 - Encouraging competition and collaboration through development of alternative solutions and sources
- The first two principles are especially relevant to this paper. It is the authors' belief that proper attention to these principles will result in *software product lines* that provide *domain specific solutions*.



- The ability to make good design decisions early in the process is a significant driver in effectively lowering life-cycle cost and system development time.
- There are two key issues to be addressed with the use of the Open Architecture concept:
 - What is the structure of the various product lines required to support the various warfare domains, and
 - What is the technical approach?

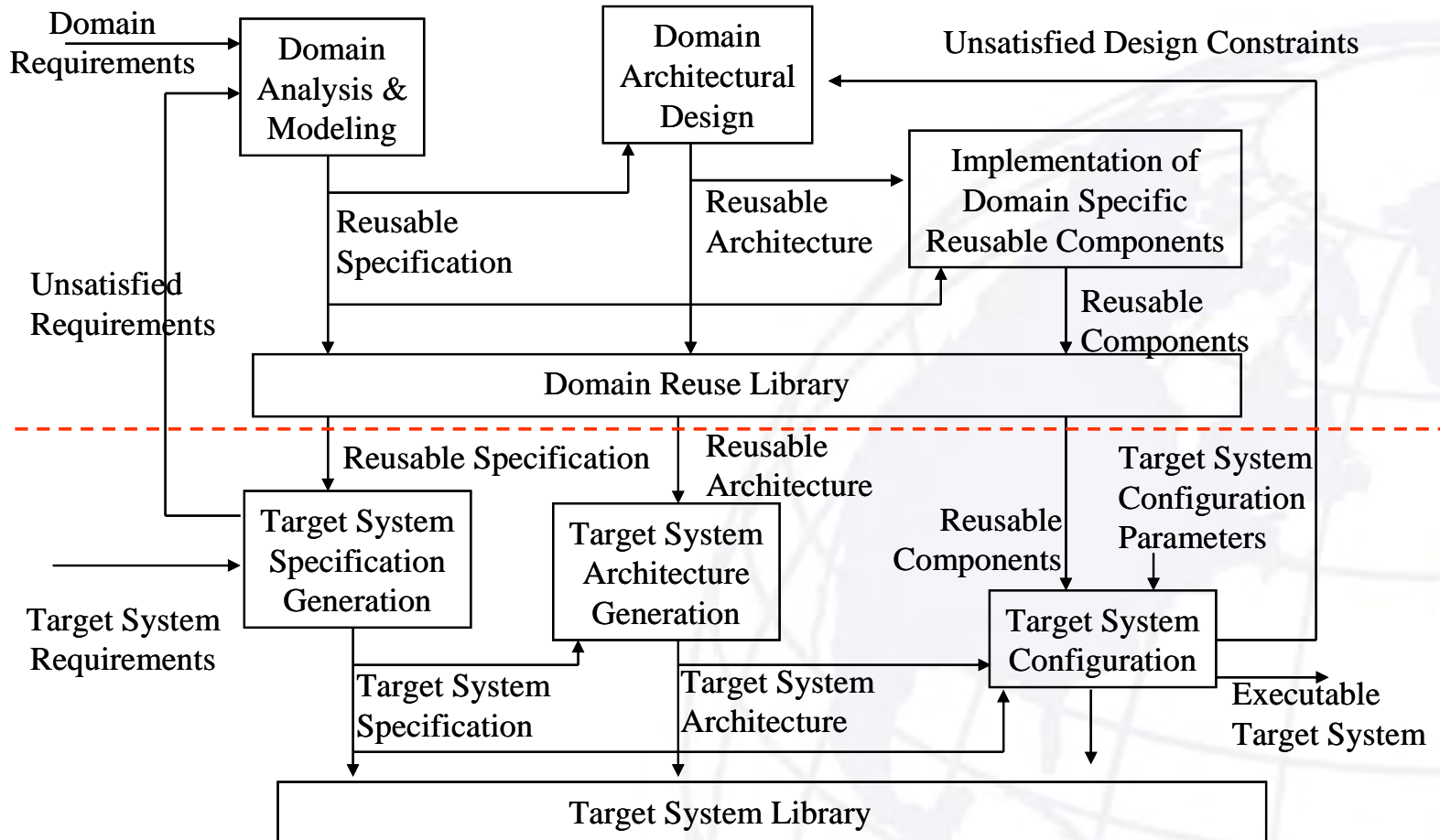



- Formal methods are mathematically-based techniques for the specification, development and verification of software and hardware systems.
- *Natural language specifications tend to get out of hand as the document grows and with growth comes ambiguity.*
- The use of formal methods for software and hardware design is motivated by the expectation that, as in other engineering disciplines, performing appropriate mathematical analyses can contribute to the reliability and robustness of a design.
- *Formal methods are appropriate for the design of discrete-event real-time systems because they can be used to specify system behavior without ambiguity.*

- The following approach uses two formal methods as a foundation:
 - *Finite State Machines (FSM)* →
 - *Petri Nets* ↙

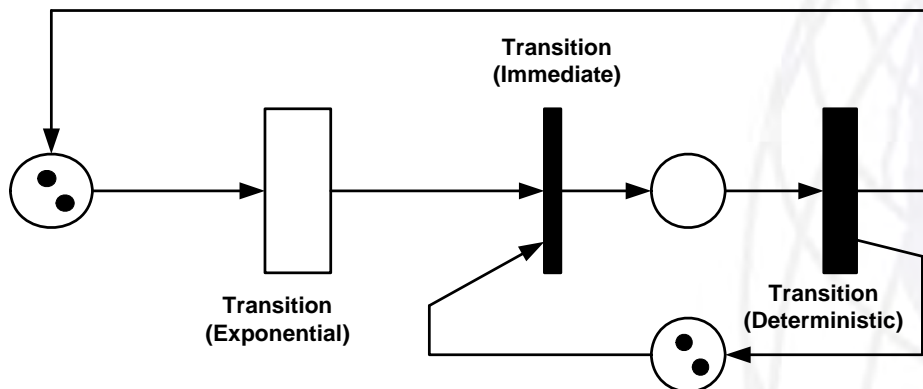

A Petri net consists of *places*, *transitions*, and directed arcs

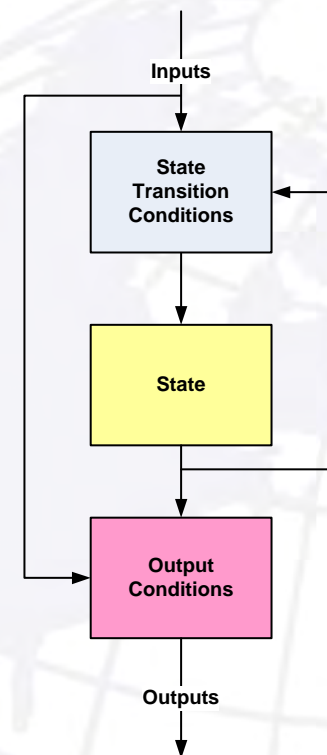



- Centered around the Hatley-Pirbhai “*Process for Systems Architecture and Requirements Engineering*” (PSARE)
 - Model-based process that uses FSM & Petri Nets
 - Accommodates HW, SW & PW
 - Can be described using SYSML/UML or EFFBD’s (to name two) (not tool dependent)
 - Results in both a functional and architectural specification model
 - Can be captured with Clymer’s OpEMCSS modeling approach which represents both FSM and Petri Nets
- *Core elements are the process/control model and the architecture template*

Hatley-Pirbhai Process/Control Model

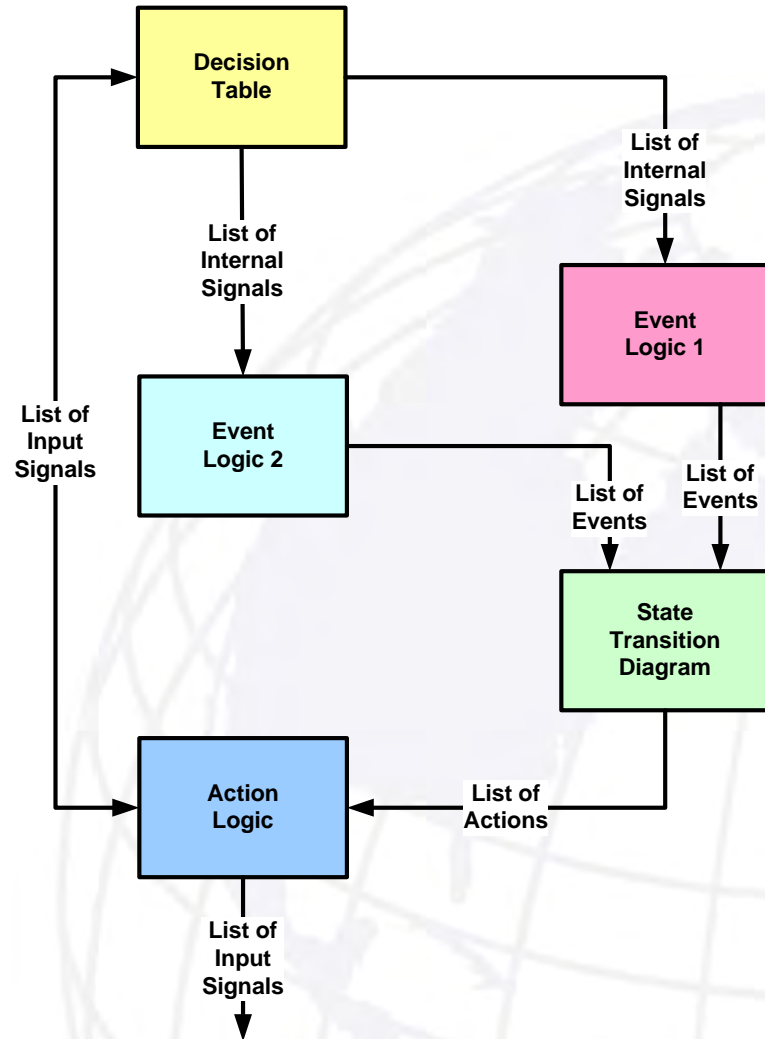
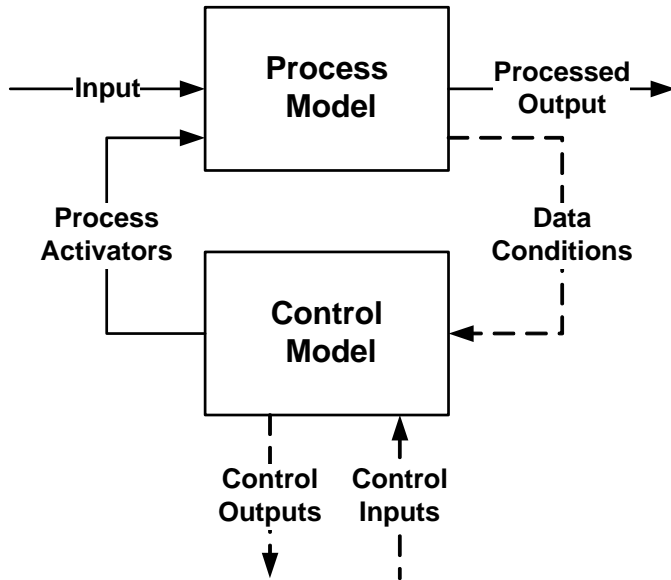

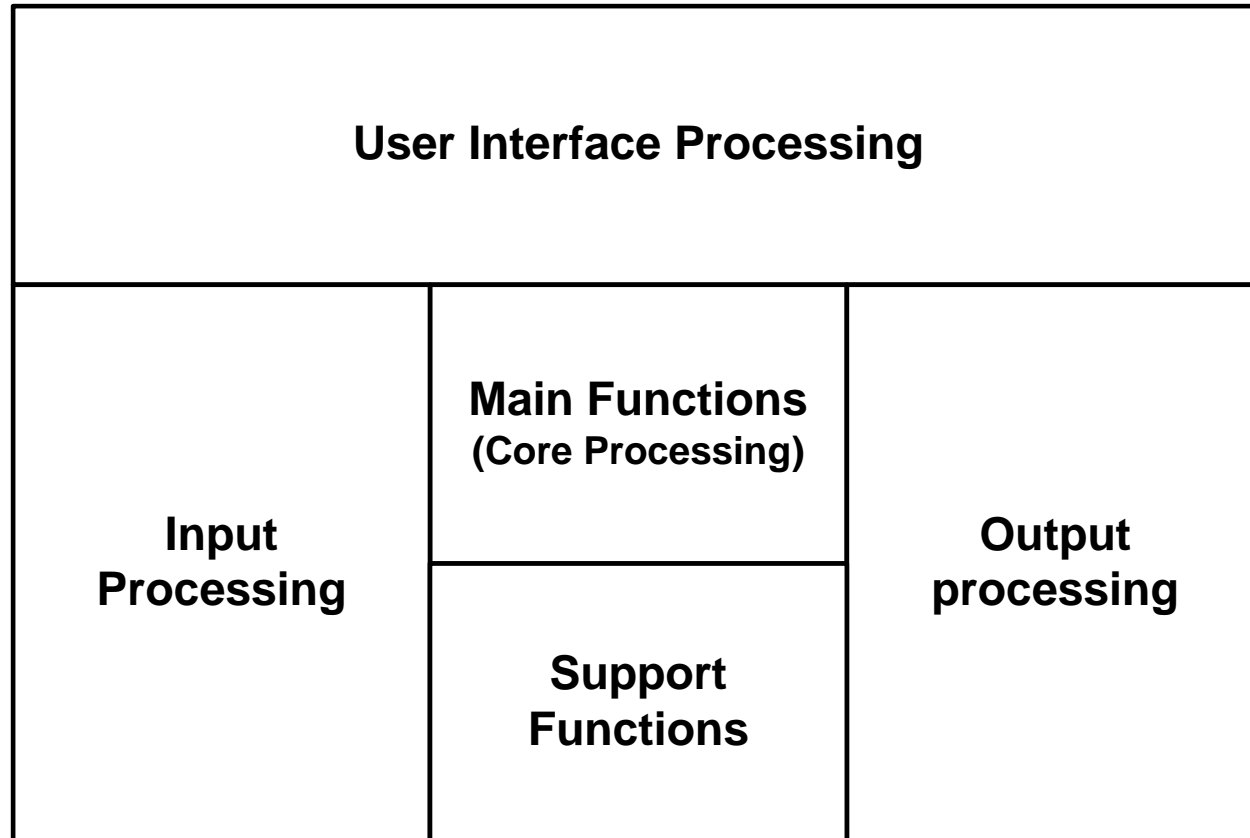

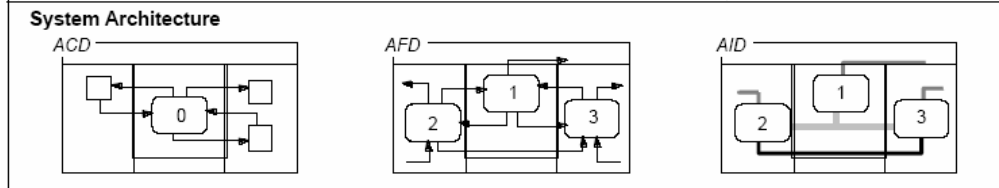
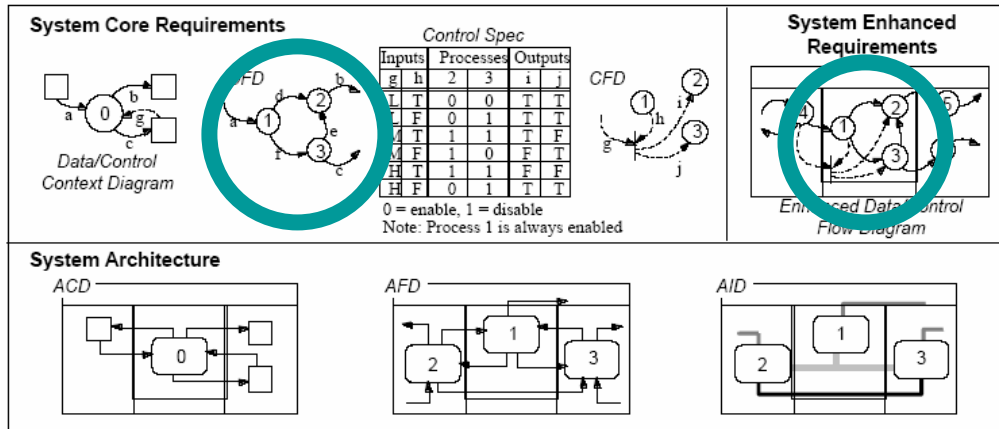

The elements

*H-P originally used
Yourdon-DeMarco
notation*

The steps

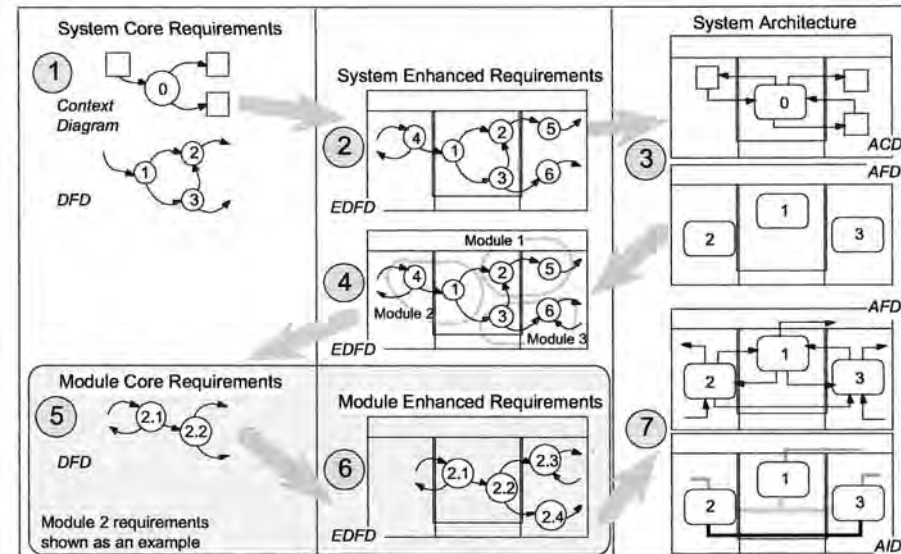

Figure 1 Model development process. Enhancing requirements models for each architecture module before drawing flows on the AFD provides consistent allocation of architecture flows to interconnects.

Figures used with permission
from H&A Systems Engineering
<http://www.hasys.com/>

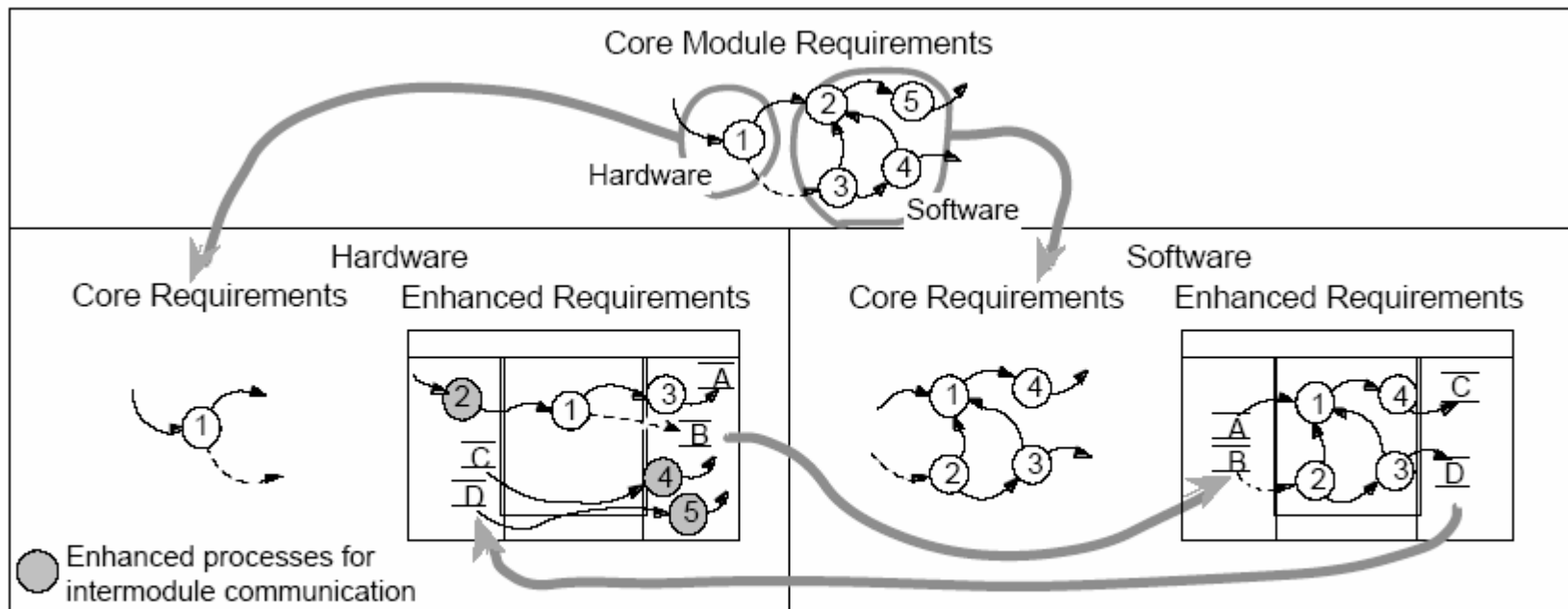

Figure 2 Hardware/software interface modeling using stores. Hardware processes produce flows into stores which are accessed by software processes. Software processes produce flows into stores which are accessed by hardware processes and transformed for intermodule communication.

Figure used with permission
from H&A Systems Engineering
<http://www.hasys.com/>

Clymer's OpEMCSS Approach

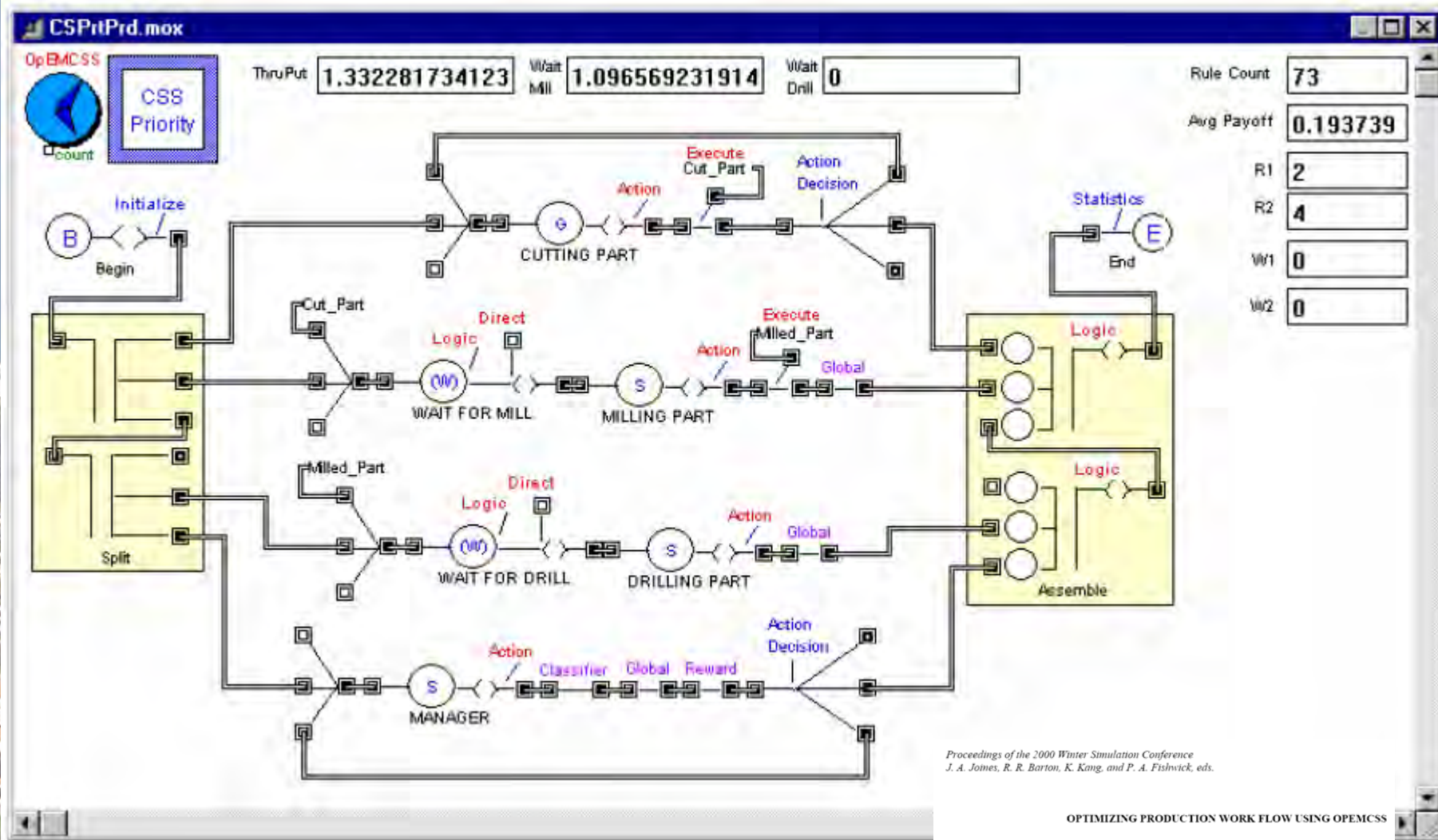

Figure 11: OpEMCSS Directed Graph Model of a Part Production System

Table 1 HPM Features and Benefits. The rigor and hierarchical nature of HPM provide specific benefits.

| Features | Benefits |
|--|--|
| Hierarchical model | <ul style="list-style-type: none"> • Specifies requirements at appropriate level • Depicts manageable amount of information at one time |
| Graphical and text representation of functionality | <ul style="list-style-type: none"> • Clearly shows interfaces (functional and physical) • Graphics depict abstract aspects of system • Text defines details |
| Allocation of functions to physical entities | <ul style="list-style-type: none"> • Greatly improved interface consistency |
| Rigorous method | <ul style="list-style-type: none"> • Promotes thorough design • Identifies gaps early |

Figure used with permission from H&A Systems Engineering
<http://www.hasys.com/>

- Another advantage of a simulation-based approach using H-P can be seen by reference to the figure.
- As system development proceeds down the left side of the “Vee” the models developed provide the foundation and guidance for the steps as integration proceeds up the right side of the “Vee”.
- It should be noted that the “Vee” model has been demonstrated to be consistent with spiral development

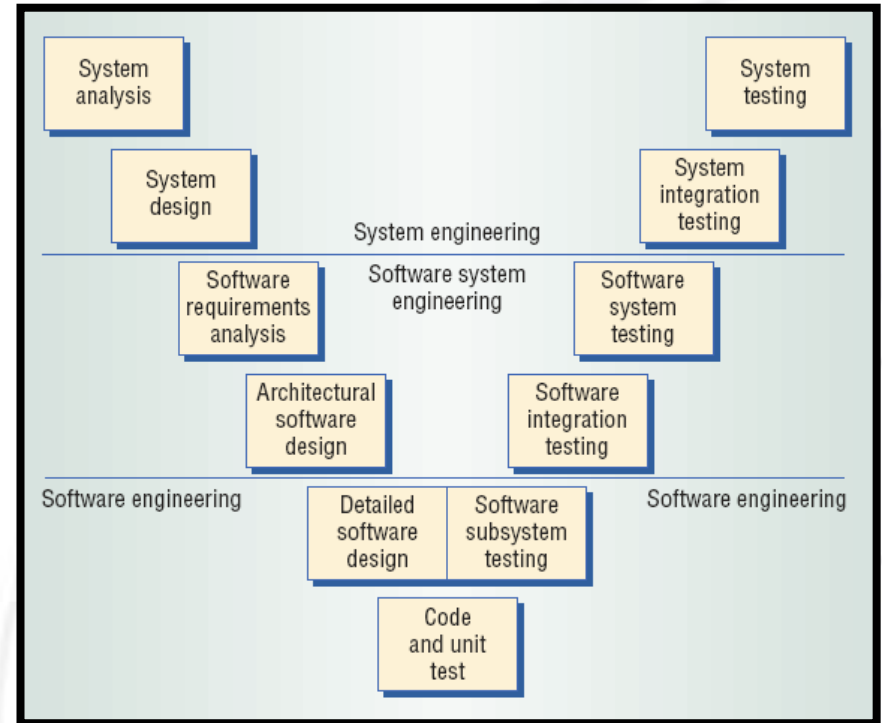



- The presented work gives emphasis to the value of a formal process in architecture development.
- In this case formal will mean that the architecture requirements will be validated through the use of simulation as part of a defined methodology as described.
- Specifically, the model driven architecture approach has the following advantages:
 - It is a formal method for tying the architecture requirements process to the architecture verification process.
 - It is consistent with acquisition policy
 - It provides a methodology to test Network Centric Operations concepts such as MDA, CMD, and TCT.
- The use of a simulation-based methodology will result in the requisite DODAF artifacts required for both requirements capture and the description of the system functional behavior.
- In addition, it supports the development of architectures that incorporate modular design and the identification of reusable and interoperable modules/applications.
- This approach is consistent with the development of a capability/systems-based architecture using a spiral or “Vee” approach.



- Incorporation of the use case paradigm
- Mapping to DoDAF
- Incorporation of Clymer's work
- Merging notations/languages into a universal architecture descriptive framework

NDIA 11th Annual Systems Engineering Conference

“Improving Process Utilization with Tools”

October 22, 2008

Frank Salvatore
High Performance Technologies, inc.
3159 Schrader Road
Dover NJ, 07801
(973) 442-6436 ext 249
fsalvatore@hpti.com

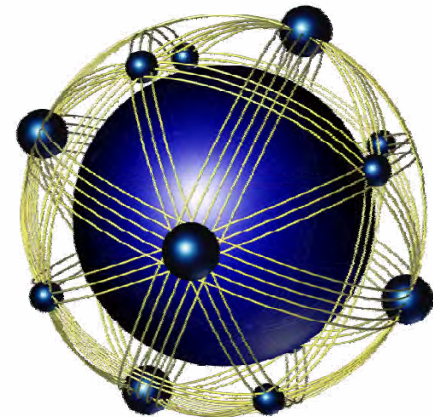

Overview

- Introduction**
- The Process Problem**
- Tools are a solution**
- Examples**
- Substantiating Data**
- Conclusion**

Introduction

The US Army Armament Research Development and Engineering Center (ARDEC) Systems Engineering Directorate (SED) Systems Engineering Infrastructure Division (SEID) has a completely documented Systems Engineering Process.

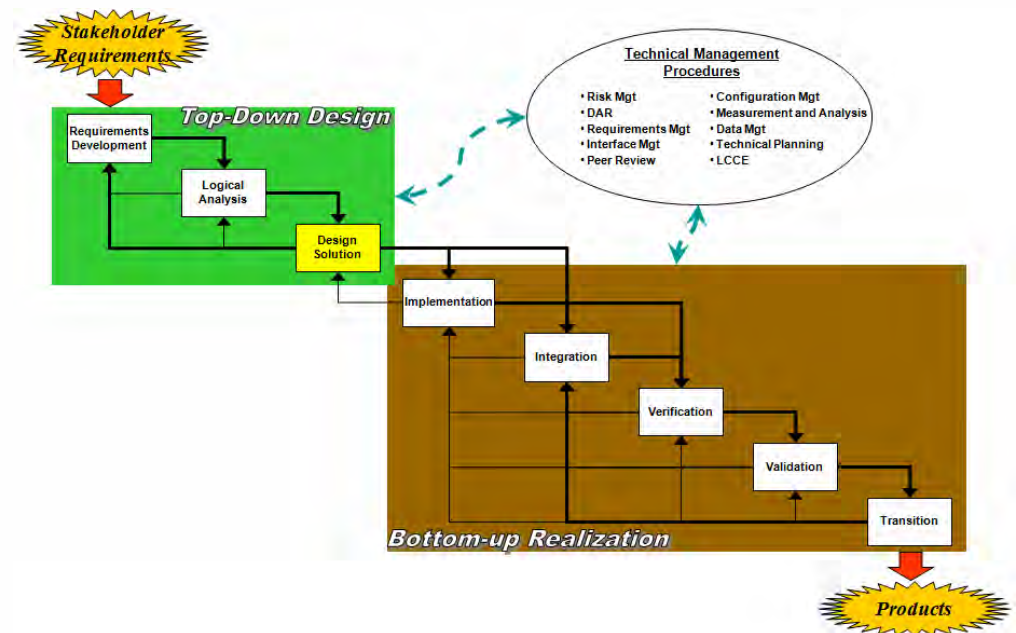



The Process Problem

All the “best” processes in the world are useless if they are not accepted, understood and implemented by the workforce

Difficulties with Process Acceptance

- Hard to understand/implement the process**
- Don't know what's available to help process implementation**
- No common method of implementation**
- Uncertainty on the part of the user and the advocate on whether implementation is being done correctly.**

Tools are a solution

- ❑ **The US Army ARDEC Systems Engineering Directorate (SED) has been investing in its infrastructure via tools that facilitate proper use of its processes**
 - Many are simple Excel/Access tools that were developed in <100 man hours

- ❑ **Tools that:**
 - Guide the user through the process and document the results of each step (DAR, Peer Review, Roadmap)
 - Evaluate a project's compliance to process(es) (PP Eval)
 - Guide the user towards additional resources to assist them (PP Eval, IPPD, PAL)
 - Get the user started with some instruction (Requirements Management Plan Template, System Spec Template)
 - Provide the user with examples to choose from (Technical Engineering Database (TED), Example Project Plans)

- ❑ **Feedback has shown that they improve process utilization**

ARDEC SE Roadmap

The SE Roadmap Tool encompasses **17 ARDEC SE process areas** that describe key aspects of SE tasks covered by projects during the complete product lifecycle

Project Planning

Requirements Development

Logical Analysis

Design Solution

Implementation

Integration

Verification

Validation

Transition

**Decision Analysis and
Resolution (DAR)**

Technical Assessment

Requirements Management

Risk Management

Data Management

Configuration Management

Interface Management

Peer Review

SE Roadmap Implementation

SE Roadmap provides basis for technical planning, feeds the Project Plan/Schedule, allows technical assessment versus planned activities and supports multiple reporting needs

Project Plan



IMS or Project Schedule

| Task | FY2008 | | | FY2009 | | | FY2010 | | |
|---------|--------|----|----|--------|----|----|--------|----|--|
| | 1Q | 2Q | 3Q | 4Q | 1Q | 2Q | 3Q | 4Q | |
| Task 1 | █ | █ | █ | █ | █ | █ | █ | █ | |
| Task 2 | █ | █ | █ | █ | █ | █ | █ | █ | |
| Task 3 | █ | █ | █ | █ | █ | █ | █ | █ | |
| Task 4 | █ | █ | █ | █ | █ | █ | █ | █ | |
| Task 5 | █ | █ | █ | █ | █ | █ | █ | █ | |
| Task 6 | █ | █ | █ | █ | █ | █ | █ | █ | |
| Task 7 | █ | █ | █ | █ | █ | █ | █ | █ | |
| Task 8 | █ | █ | █ | █ | █ | █ | █ | █ | |
| Task 9 | █ | █ | █ | █ | █ | █ | █ | █ | |
| Task 10 | █ | █ | █ | █ | █ | █ | █ | █ | |

| Roadmap SE Level | 1 | 2 | 3 | End State (Highest Level to be Achieved) | Planned Accomplishments (SE Accomplishments to get to Next Level) | Schedule (Timeframe) | Product (Associated Product(s)) | Status |
|--|---|--|---|--|--|----------------------|--|--------|
| SE Processes | | | | | | | | |
| 1.0 Project Plan (ARDEC-200) | Tailor Template, Prepare Draft PP for Initial Review
Submit PP to PI | Project Plan Approved | Project Plan Maintenance | 3 | Finalize the PP/SEP for approval | March, 2008 | PP/SEP | ~ ~ ~ |
| 2.0 Requirements Development (ARDEC-200) | Identify Stakeholders | Elicit Stakeholder Requirements | Get Stakeholder Commitment | 3 | Support development of TR5 requirements | commence 1QFY09 | Draft stakeholder performance specification | ~ ~ ~ |
| 3.0 Logical Analysis (ARDEC-200) | Analyze Scope of Technical Problem | Define TR5 Technical Requirements | Define TR6 Technical Requirement | 3 | Support translation of stakeholder requirements | 1QFY08 | Draft TR5 performance specification | ~ ~ ~ |
| 4.0 Design (ARDEC-200) | Document system functions and logical alternative | Develop, Allocate, Refine Logical Analysis Models | Support the resolution of derived technical requirement conflicts | 3 | Complete/finalize updated logical analysis | March, 2008 | Logical description, States and modes diagrams as defined by the IPT | ~ ~ ~ |
| 5.0 Integration (ARDEC-200) | Document alternative design solutions as researched by the IPT | Support IPT analysis and selection of the preferred solution | Generate Full Design Solution Description and Baseline | 3 | Support design solution process and ensure solutions are traceable to technical requirements | June, 2008 | Physical architecture with design solution | ~ ~ ~ |
| 6.0 Design (ARDEC-200) | Document what components will be reused or bought | Identify Interfaces, Plan for Enabling Products | Acquire all Components | 3 | Document all platform interface requirements | 1QFY09 | Platform interface requirements per product baseline | ~ ~ ~ |
| 7.0 Integration (ARDEC-200) | Confirm validation of received products | Prepare for assembly & integration | Document lessons learned | 3 | Document subsystem integration | 1QFY09 | Draft Integration Plan/procedure | ~ ~ ~ |
| 8.0 Design (ARDEC-200) | Prepare to conduct TR5 | Perform Verification | Analyze Verification Results | 3 | Develop verification plan | 1QFY09 | Draft verification Plan/procedure | ~ ~ ~ |

Project Plan – SE portion of project plan describes how project will achieve specified SE levels for each process area

Project Schedule reflects SE activities and events needed to develop technology/product and satisfy roadmap transition criteria

Roadmap Implementation Guide:

- Planning** → 1. Coordinate with APO/IPT to baseline current SE activities
- Planning** → 2. Based on the project objectives, define with APO/IPT the required SE End State (use SE procedures to assist with tailoring as appropriate)
- Planning** → 3. Work with APO/IPT to determine what SE Tasks will satisfy transition criteria to achieve next SE level & complete Roadmap accordingly
- Planning** → 4. Develop or update Project Plan/Schedule using Roadmap input to complete SE sections of plan
- Tracking** → 5. Verify that IMS/Project Schedule reflects accomplishments, schedule and products contained in Roadmap
- Assessment** → 6. Assess Project's performance against Roadmap details and provide status in the Roadmap Column title "status". Describe any corrective actions as required.
- Reporting** → 7. Use tech assessment from Roadmap to address reporting requirements (MAPR, Level 1, Level 2, Level 3 Briefings, etc.)

Reporting Processes

MAPR format includes SE Status (tech assessment), project rating, and corrective action plan (if needed)

Level 1 Briefing summarizes SE status of project

U.S. Army Research, Development & Engineering Center
Fort Belvoir, NJ

<Project Name>
Level 1 Review

<date>

PRESENTED BY
<Presenter Name>

Previous Review date:

| (Project Name) SE Status | | | |
|--------------------------|-----------------|-----------------------|--------|
| SE Planned Activities | Time Associated | Associated Product(s) | Status |
| ~ ~ ~ | ~ ~ ~ | ~ ~ ~ | ~ ~ ~ |
| ~ ~ ~ | ~ ~ ~ | ~ ~ ~ | ~ ~ ~ |
| ~ ~ ~ | ~ ~ ~ | ~ ~ ~ | ~ ~ ~ |
| ~ ~ ~ | ~ ~ ~ | ~ ~ ~ | ~ ~ ~ |

Project Plan Evaluation Tool

- ❑ **The Project Plan (PP) is a key piece of the ARDEC Project Management process**
 - Originally developed for Project Plan (PP) evaluators to perform an assessment of a PP which lead to PP approval and project funding
 - Quickly became a key instructional document provided to projects who were writing/updating their PP
 - Also used to capture the Ownership Matrix for every PP section (who the SME is for each PP section). This provides key contact for further assistance
 - Process Flow
 - Automatically tailors the Evaluation Criteria based on project details that are used to “seed” the tool. (project scenario, phase etc.)

Project Plan Evaluation Tool

| | |
|--------------------------|------------------------|
| Project Name: | EXAMPLE Project |
| PP Version #: | <PP Version Number> |
| Project Scenario: | <PP Scenario> |
| Project Phase: | Technology Development |
| APO Name: | <APO Name> |

| | |
|-------------------------------|--------------------------------|
| Date Received: | <Date Received> |
| PI Name: | <Name of PI> |
| PIO Evaluator Name: | <Enter PI Evaluator Name Here> |
| SEAL Name: | <Enter SEAL Name Here> |
| Process Advocate Name: | <Enter Name Here> |

The Questions are tailored based on the Project Details above

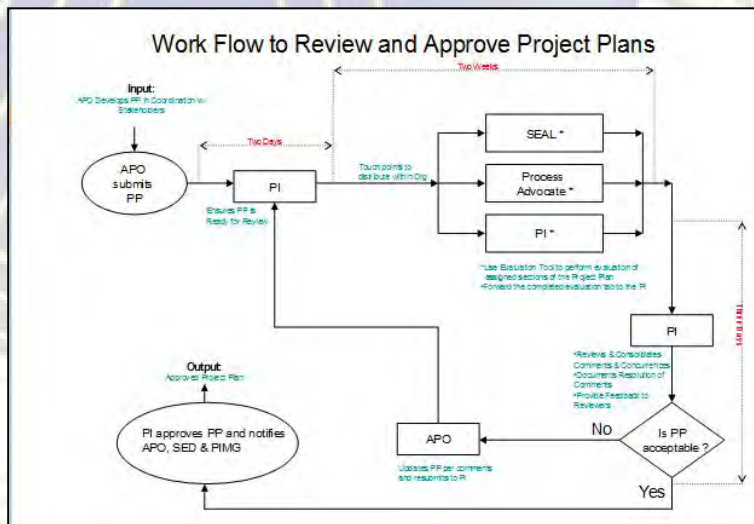

Process Flow

| | | |
|--|--|---|
| 15 System Engineering Process | | 0 |
| 1. Does the PP describe the overall SE process to be used on the project and the basis for selection (e.g., commercial standard, organizational process, etc.), including the purpose and objectives of the process? | | 0 |
| 2. Does the PP describe the technical authority responsible for implementation of the SE process? | | 0 |
| 15.1 Requirement Development | | 1 |
| 1. Does the PP specify the approach and methods used to define the performance and functional requirements (including all product and component functional requirements, performance requirements, interface requirements, and other detailed requirements)? | | 1 |

Each Project Plan section is evaluated

| PP Sect. # | Project Plan Section | PIMG | SED | PIO |
|------------|------------------------------------|------------------|------------------------|--------------------|
| 19 | Interface Management | | Rob Bernard | |
| 20 | Process Assurance Plan | Process Advocate | | |
| 21 | Configuration Management | | Paula Baselinesa-Versi | |
| 22 | Data Management | | Petro Librariano | |
| 23 | Project Deliverables/Work Products | | | Project Integrator |
| 24 | Simulation Support Planning | | Modello Simulato Jr. | |
| 25 | Risk Management Plan | | | Project Integrator |

Ownership Matrix details SMEs for each section

| Feedback |
|---|
| We welcome feedback on the Evaluation Criteria and this Evaluation Tool itself. Please use the link below to send feedback to Frank J. Salvatore (SED), Humisar Sianpar (PIO) and Dan Crowley (PIMG). |
| Click to Send Feedback |

Decision Analysis and Resolution

- Process is nested within the tool**
 - Each Process Step has a corresponding section of the tool.
- Use of the tool provides a project with “self documenting” input data and results**
- Provides the user with some standard graphical forms of output that assist with both making the decision and capturing its rationale**
- Use of the tool follows the DAR Procedure**

Decision Analysis and Resolution

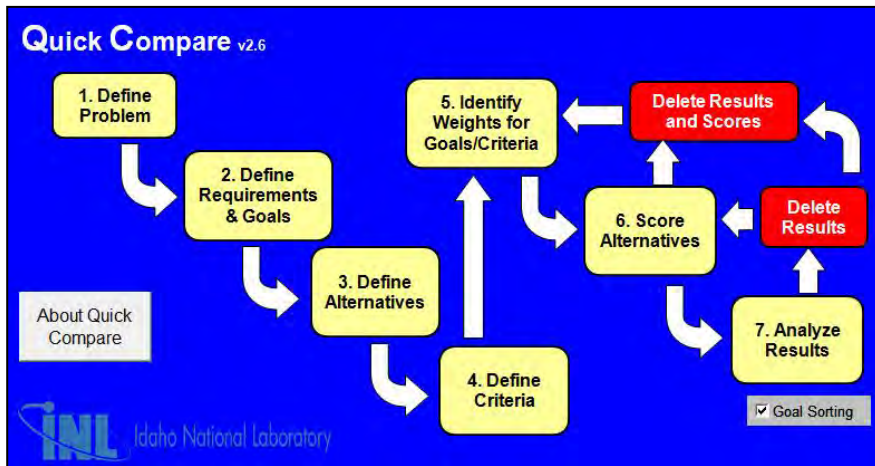

Follow the process steps in the tool



| | Criteria Weight | Alt 1 | Alt 2 | Alt 3 | Alt 4 |
|--------------|-----------------|-------|-------|-------|-------|
| Cost | 0.563 | 30000 | 50000 | 25000 | 80000 |
| Schedule | 0.100 | 5 | 3 | 1 | 7 |
| Safety | 0.150 | Good | Fair | Bad | Great |
| Startup Risk | 0.188 | 4 | 3 | 9 | 1 |

Raw Input for each Alternative

| Goal Number | Goal Name | Goal Weight Factor | Normalized Weight Factor | Criteria Name | Criteria Weight (within each goal) |
|-------------|---------------|--------------------|--------------------------|---------------|------------------------------------|
| 1 | Reduce Cost | 9 | 0.563 | Cost | 10 |
| 2 | Meet Schedule | 4 | 0.250 | Schedule | 2 |
| | | | | Safety | 3 |
| 3 | Reduce Risk | 3 | 0.188 | startup risk | 9 |

Identify and Weight Goals + Criteria

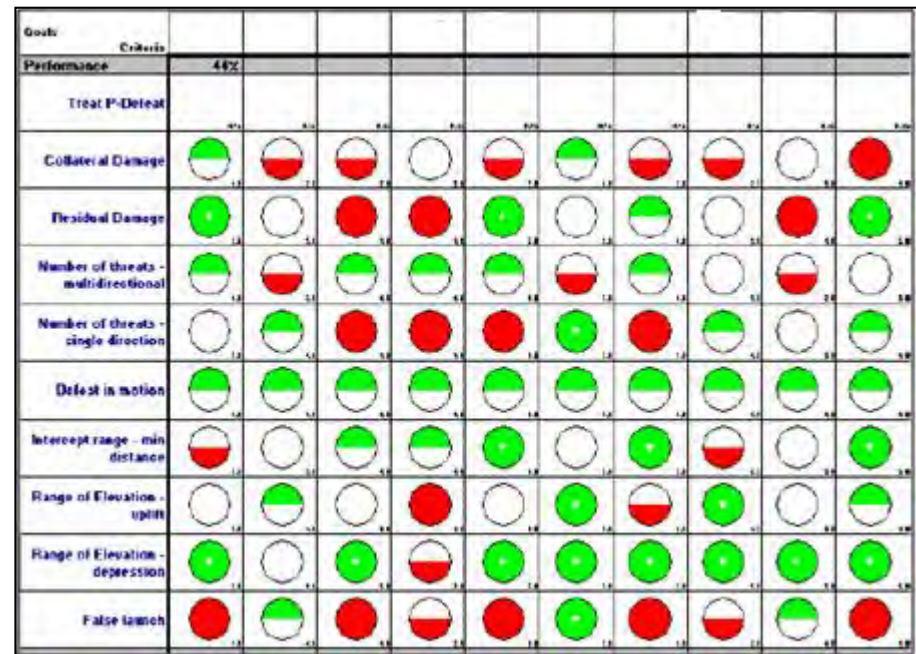

Utility applies to the Raw Input to Score the Alternatives against the Criteria

Integrated Process & Product Development Tool

- database of available resources (procedures, tools, templates etc.)**
- search based on different “languages” (DOD lifecycle, Six Sigma, SED SE Process...), and the sub-steps within that language**

Integrated Processes and Tools

Help You Find the Best Processes and Tools to Support IPPD

Use Drop Down Lists to Generate Report

1) Select Process/Method

2) Select Procedure/Step

3) Select Resource Type (optional)

Process/Method ▼
Systems Engineering Process

Procedure/Step ▼
Technical Planning

Resource Type ▼
Tool

| Resource | Type | User | Purpose | Reference | Reference Location | POC | Applies to |
|--------------------------------|------|------|---|---|---|------------|--|
| Work Breakdown Structure (WBS) | Tool | APO | To better define and organize the total scope of a project, using a hierarchical tree structure | Para. 7.1 Phase A Project Initiation Step A4
WBS Template 1 Oct 2007 | ARDEC 101 Project Management Procedure | PIO | Project Planning, Technical Planning, |
| Earned Value Management (EVM) | Tool | APO | To better ensure the total integration of cost, schedule, and work scope aspects of the contract. | | | PIO | Project Planning, Technical Planning, Risk Management, |
| Project Plan Evaluation Tool | Tool | ALL | To better evaluate the quality of the Project Plan | | Project Plan Evaluation Tool 21 Sept 2007 | PIO
SED | Project Planning, Technical Planning, |

Report provides tailored list of Resources

Verification Tool

- Use Interview**
- Use Questionnaires**
- Include Stakeholders Early and Often.**
- Have Stakeholders Peer Review Requirements**
- Use a JCCB**

Paragraph: Interface Definition TRL: TRL5 IPT Name: Ammo Handling
Section: 3.1.2.0-1 TRL6 Module Name: AHR
Requirements: The Ammo Handling Subsystem will interface with the Turret Structure, Gun Assembly, Fire Control, Ammo Suite and Secondary Armament. ATD/Objective Force: This enables and disables the required field warning:

Switch to View Mode

TRL 5 Verification Method:
Responsibility: (e.g.: IPT Name, Subcontractor, System Integrator) Critical Test:
Location of Verif: (e.g.: Picatinny, Contractor Facility, Proving Ground)
Verification Procedure: Briefly describe the procedure you recommend at this TRL level to validate or confirm the requirement.
If the requirement will not be verified at this time please indicate so:

Data Collected:

TRL 6 Verification Method:
Responsibility: (e.g.: IPT Name, Subcontractor, System Integrator) Critical Test:
Location of Verif: (e.g.: Picatinny, Contractor Facility, Proving Ground)

Verification Procedure: Briefly describe the procedure you recommend at this TRL level to validate or confirm the requirement.
If the requirement will not be verified at this time please indicate so:

Data Collected:

TRL 7 Verification Method:

Templates



Listing of some Templates:

- Project Plan Template
- Requirements Management Plan Template
- System Specification Template
- Interface Control Document Template
- Etc....

Substantiating Data

- this year we are working on metrics and measures that will provide greater insights into what is and isn't working**
- here is a whole suite of metrics and measurement tools that have been developed.**

What makes a “good” tool?

- onfiguration Management built into the tool for Change History, versioning etc.**
- nstructions on how to use the tool**
 - Instruction sheet, pop-up comments
- rocess Flow**
- eedback Form**
- ie the tool into the process they are seeking to implement (language, steps etc.)**

Conclusion

- Tools are common focal points for discussion.**
- Management expects them to be used**
- We are starting to capture metrics to help guide future changes and to build a case to develop and make improvements to tools.**



Questions?



Educating the Next Generation of Software Engineers



Art Pyster

**Distinguished Research Professor
Stevens Institute of Technology and
Deputy Executive Director, SER-UARC**

October 22, 2008

art.pyster@stevens.edu



Agenda

- How the world has changed
- The current state of software engineering education
- A new reference curriculum

A stylized, wireframe world map is positioned in the top right corner of the slide. It is rendered in a light blue color and is partially obscured by the blue wavy lines that sweep across the top of the slide.

A History Lesson - 1996

Resolved: Software Should Lead in Systems Engineering

Jim Armstrong vs. Art Pyster

The systems engineering community has long debated the extent to which software disciplines, processes, and practitioners should influence systems engineering. In August 1996, the authors held a lively debate at a meeting of the Washington Metropolitan Area Chapter of INCOSE on the proper role of software engineering within systems engineering. The particular issue debated was the proposal that software ideas, process, and people should be in the lead when building complex systems. Pyster favored that view while Armstrong opposed it.



Software will be the center of
systems design.

*Eberhardt Rechtin,
1993*



Twenty years from now, software people will be sitting at the table and the other disciplines will be sitting around the sides of the room.

*Eberhardt Rechtin,
1993*

What do we teach for a master's degree in software engineering?

- The last effort to create a reference curriculum for graduate software engineering education was by the SEI in the early 1990s.
- There are, in effect, no current community-endorsed recommendations on what to teach software engineers – nothing that recognizes how the world has changed.
- Response: create a project to create a new reference curriculum in software engineering



The Integrated Software and Systems Engineering Curriculum Project

- Begun in May 2007 at Stevens Institute of Technology
- Sponsored by DoD Director of Systems and Software Engineering
- Three products planned:
 1. A modern reference curriculum for a master's degree in software engineering that integrates an appropriate amount of systems engineering
 2. A modern reference curriculum for a master's degree in systems engineering that integrates an appropriate amount of software engineering
 3. A truly interdisciplinary degree that is neither systems nor software engineering – it is both



1st Project – Graduate Software Engineering Reference Curriculum

1. Understand the current state of SwE graduate education (November 2007)
2. Create GSwERC 0.25 with a small team, suitable for limited review (February 2008)
3. Publicize effort through conferences, papers, website, etc (continuous)
4. Obtain endorsement from INCOSE, NDIA, ACM, IEEE, and other professional organizations (continuous)
5. Create GSwERC 0.50 suitable for broad community review and early adoption (October 2008)
6. Create GSwERC 1.0 suitable for broad adoption (2009)

The evolving author team

- Rick Adcock, *Cranfield University and INCOSE*
- Edward Alef, *General Motors*
- Bruce Amato, *Department of Defense*
- Mark Ardis, *Rochester Institute of Technology*
- Larry Bernstein, *Stevens Institute of Technology*
- Barry Boehm, *University of Southern California*
- Pierre Bourque, *Quebec University and SWEBOK volunteer*
- John Bracket, *Boston University*
- Murray Cantor, *IBM*
- Lillian Cassel, *Villanova and ACM volunteer*
- Robert Edson, *ANSER*
- Richard Fairley, *Colorado Technical University*
- Dennis Frailey, *Raytheon & Southern Methodist University*
- Gary Hafen, *Lockheed Martin and NDIA*
- Thomas Hilburn, *Embry-Riddle Aeronautical University*
- Greg Hislop, *Drexel University and IEEE Computer Society participant*
- Dave Klappholz, *Stevens Institute of Technology*
- Philippe Kruchten, *University of British Columbia*
- Phil Laplante, *Pennsylvania State University, Great Valley*
- Qiaoyun (Liz) Li, *Wuhan University, China*
- James McDonald, *Monmouth University*
- John McDermid, *University of York, UK*
- Ernest McDuffie, *National Coordination Office for NITRD*
- Bret Michael, *Naval Postgraduate School*
- William Milam, *Ford*
- Ken Nidiffer, *Software Engineering Institute*
- Art Pyster, *Stevens Institute of Technology*
- Doug Schmidt, *Vanderbilt University*
- Mary Shaw, *Carnegie Mellon University*
- Robert Suritis, *IBM*
- Richard Thayer, *California State University at Sacramento*
- Barrie Thompson, *Sunderland University, UK*
- Richard Turner, *Stevens Institute of Technology*
- Joseph Urban, *Texas Technical University*
- Ricardo Valerdi, *MIT & INCOSE*
- David Weiss, *Avaya*
- Mary Jane Willshire, *Colorado Technical University*



Methodology to understand current state of SwE education

- Diverse set of universities with Masters programs in SWE
 - Vary in size, geography, maturity, resources, target market, ...
 - Focused on programs with degree in SWE or Computer Science with a SWE specialization - not degrees in information technology and related areas
- Used Software Engineering Body of Knowledge (SWEBOK) as the primary framework for SWE competencies
- Collected data from school websites
 - Degree, faculty size, student population, target market, ...
 - Degree structure, individual course descriptions
 - Map between courses and SWEBOK
- Validated data with one or more professors from each school
- Analyzed for commonalities and uniqueness



Schools studied

1. Air Force Institute of Technology
2. Brandeis University
3. California State University – Fullerton
4. California State University – Sacramento
5. Carnegie Mellon University
6. Carnegie Mellon University West
7. DePaul University
8. Drexel University
9. *Dublin City University (Ireland) **
10. Embry-Riddle Aeronautical University
11. George Mason University
12. James Madison University
13. Mercer University
14. Monmouth University
15. Naval Postgraduate School
16. Penn State University – Great Valley
17. *Quebec University (Canada) **
18. Rochester Institute of Technology
19. Seattle University
20. Southern Methodist University
21. Stevens Institute of Technology
22. Texas Tech University
23. University of Alabama – Huntsville
24. University of Maryland University College
25. University of Michigan – Dearborn
26. University of Southern California
27. *University of York (UK) **
28. Villanova University

Non-US Schools



Observations from 28 schools

1. SWE is largely viewed as a specialization of Computer Science - much as systems engineering was often viewed as specialization of industrial engineering or operations research years ago
2. Faculty size is small - few dedicated SWE professors, making programs relatively *brittle*
3. Student enrollments are generally small compared to CS and to other engineering disciplines
4. Many programs specialize to specific markets such as defense systems or safety critical systems
5. The target student population varies widely - anyone with Bachelors and B average to someone with CS degree and 2+ years of experience
6. Online course delivery is popular



More observations

7. Objective for graduates vary widely - software developer to researcher to software manager
8. Wide variation in depth and breadth of SWEBOK coverage in required and semi-required* courses
9. Many programs have required or semi-required courses that cover material that is either not in the SWEBOK at all or is not emphasized in the SWEBOK
10. Some significant topics are rarely mentioned - agility, software engineering economics, systems engineering
11. Some topics are ubiquitous - formal methods and architecture
12. “Object-oriented” is the standard development paradigm - creating a “clash” with many systems engineering programs that emphasize structured methods

*A student has a 50% or greater probability of taking a *semi-required* course.



Diverse focuses

1. Development of defense systems
2. Acquisition of defense systems
3. Embedded real-time systems
4. Entrepreneurial technology companies
5. Quantitative software engineering
6. Software economics
7. Safety critical systems
8. Secure software engineering
9. Highly dependable software systems

No focus
dominated



Entrance requirements

Most programs offer leveling courses for students lacking entrance requirements

Many programs routinely waive academic requirements for students with industrial experience

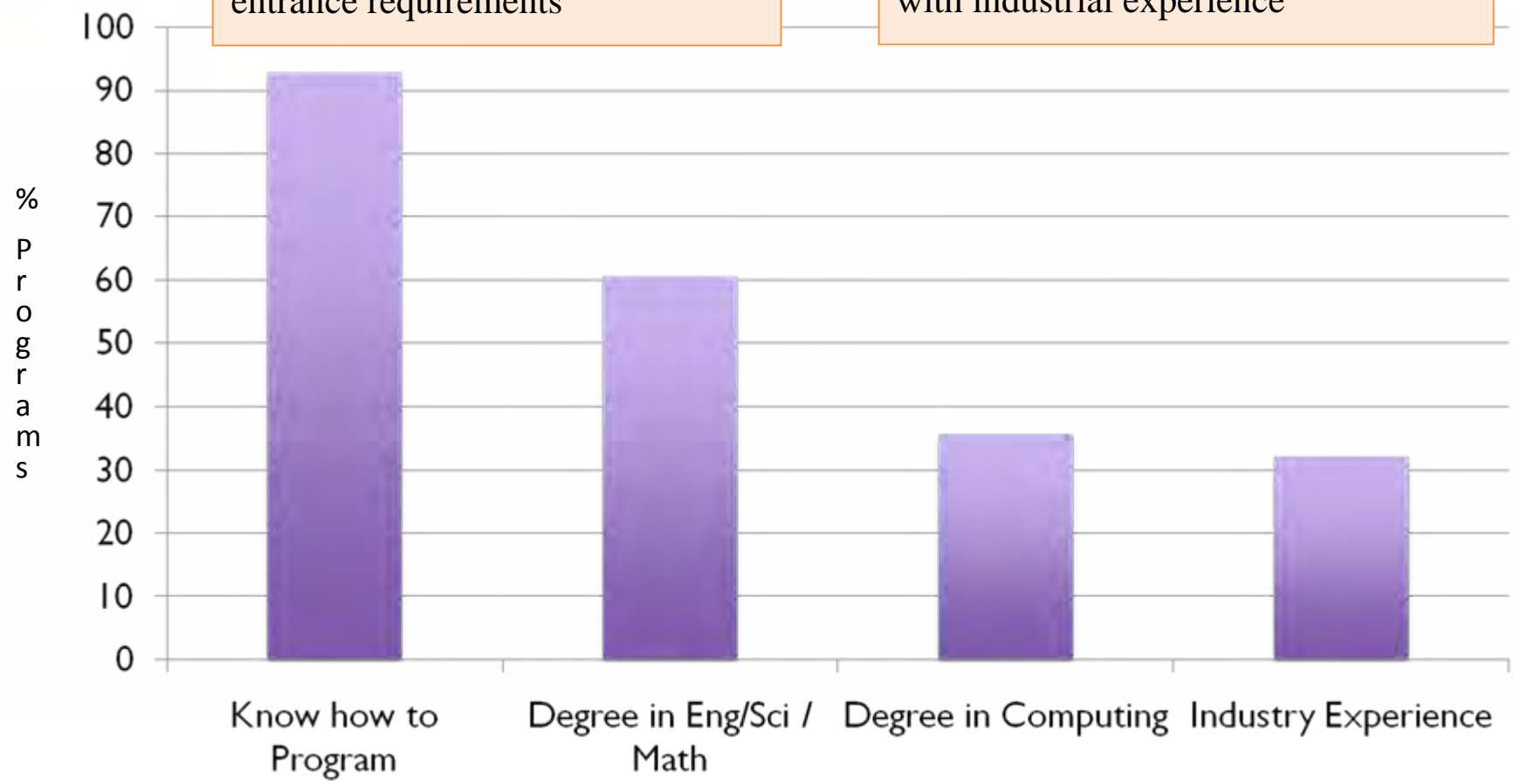



SWEBOK coverage in required and semi-required courses

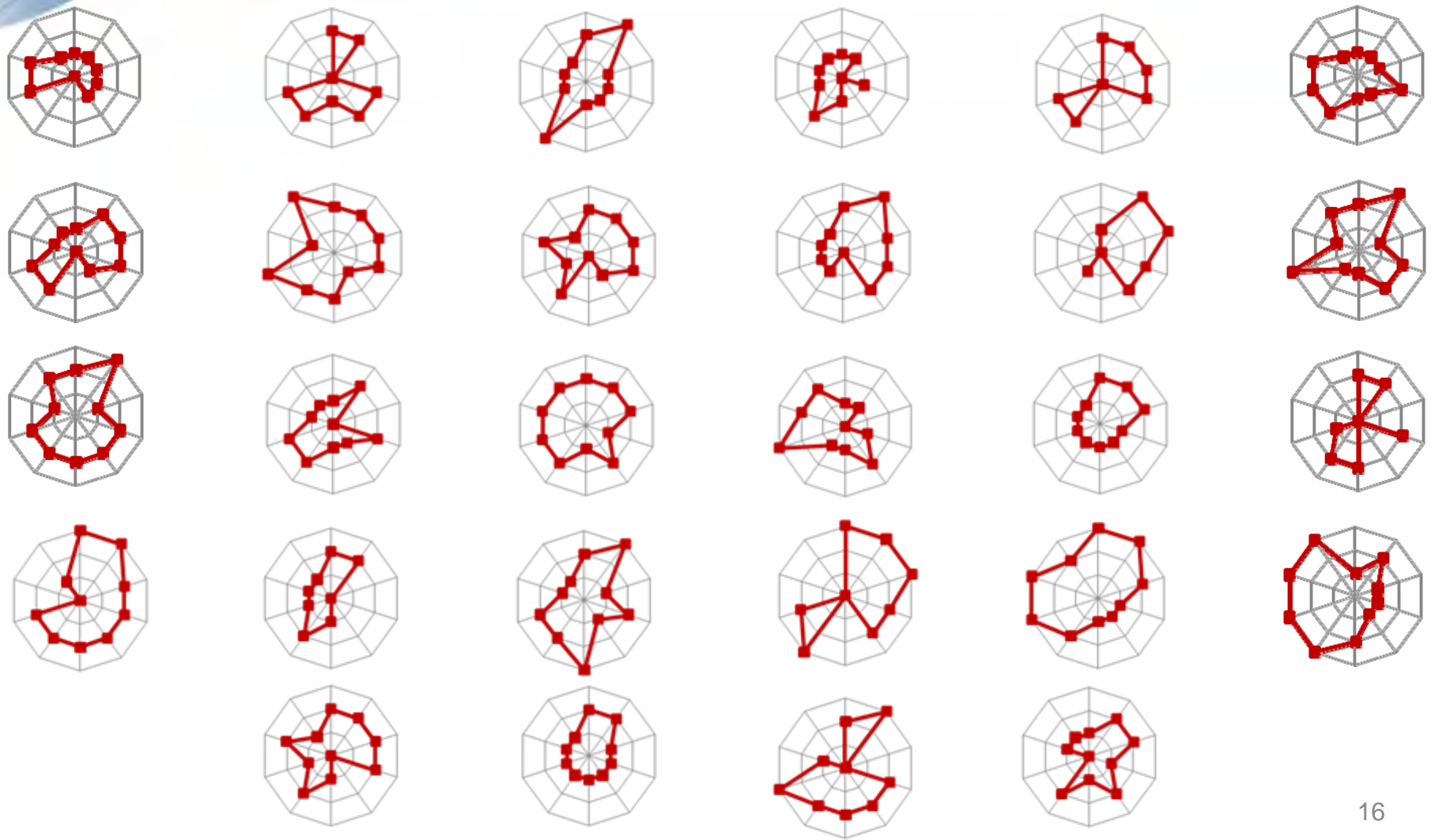

The approach – GSwERC 0.50

1. Understand the current state of SWE graduate education (November 2007)
2. Create GSwERC 0.25 with a small team, suitable for limited review (February 2008)
3. Publicize effort through conferences, papers, website, etc. (continuous)
4. Obtain endorsement from ACM, IEEE, INCOSE, NDIA, and other professional organizations (continuous)
5. ***Create GSwERC 0.50 suitable for broad community review and early adoption (October 2008)***
6. Create GSwERC 1.0 suitable for broad adoption (2009)



Expectations at entry

1. The equivalent of an undergraduate degree in computing or an undergraduate degree in an engineering or scientific field and a minor in computing
2. The equivalent of an introductory course in software engineering
3. At least two years of practical experience in some aspect of software engineering or software development.



Outcomes 1 to 4 at graduation

1. Mastered the Core Body of Knowledge
2. Mastered at least one application domain, such as finance, medical, transportation, or telecommunications, and one application type, such as real-time, embedded, safety-critical, or highly distributed systems. That mastery includes understanding how differences in domain and type manifest themselves in both the software itself and in their engineering, and includes understanding how to learn a new application domain or type.
3. Mastered at least one knowledge area or sub-area from the CBOK to at least the Bloom Synthesis level.
4. Demonstrated how to make ethical professional decisions and practice ethical professional behavior.



Outcomes 5 to 7 at graduation

5. Understand the relationship between software engineering and systems engineering and be able to apply systems engineering principles and practices in the engineering of software.
6. Be able to work effectively as part of a team, including teams that may be international and geographically distributed, to develop quality software artifacts, and to lead in one area of project development, such as project management, requirements analysis, architecture, construction, or quality assurance.
7. Show ability to reconcile conflicting project objectives, finding acceptable compromises within limitations of cost, time, knowledge, existing systems, and organizations.



Outcomes 8 to 10 at graduation

8. Understand and appreciate the importance of feasibility analysis, negotiation, effective work habits, leadership, and good communication with stakeholders in a typical software development environment.
9. Understand how to learn new models, techniques, and technologies as they emerge, and appreciate the necessity of such continuing professional development.
10. Be able to analyze a current significant software technology, articulate its strengths and weaknesses, and specify and promote improvements or extensions to that technology.



Curriculum architecture

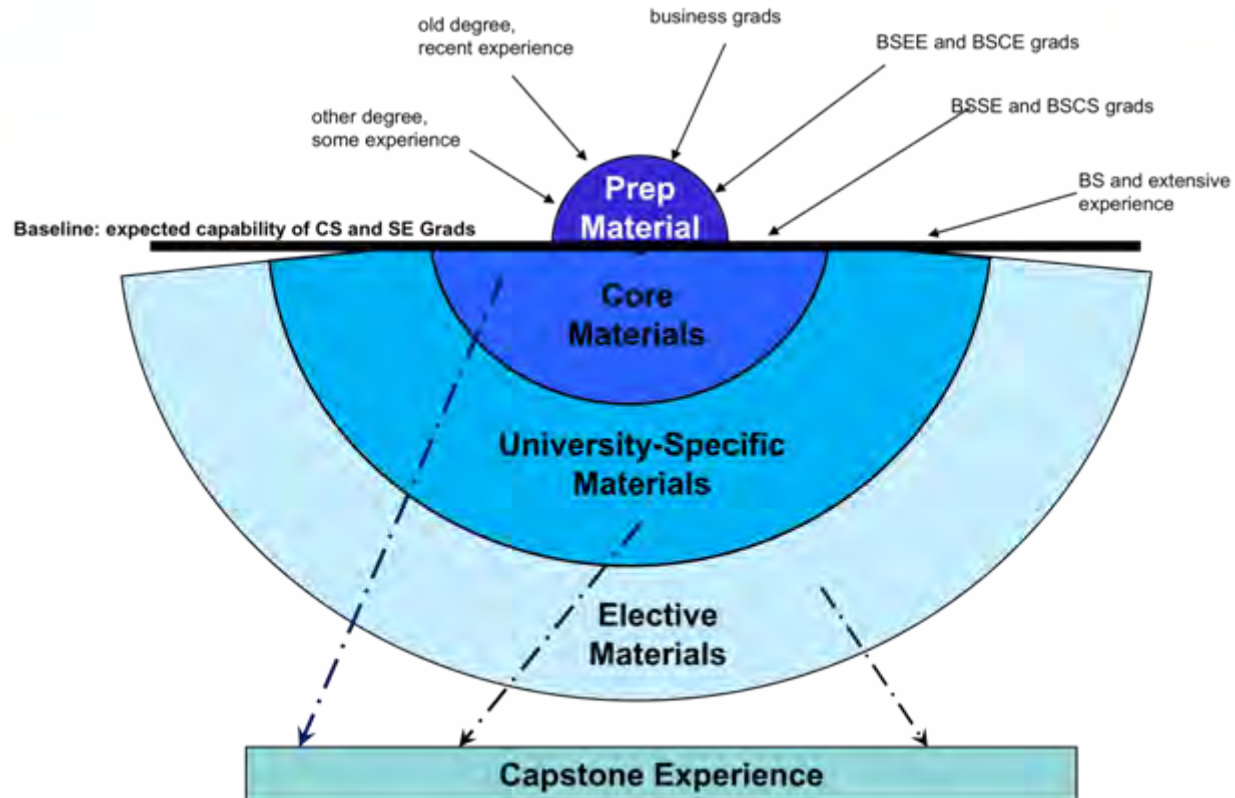



Additional material in GSwERC

- Comparison of existing graduate software engineering programs with GSwERC recommendations – know how big the gap is between recommendations and practice
- Strategies recommended by the authors to implement GSwERC
- Hypothetical modifications of existing programs to more fully satisfy GSwERC

Reviewers, authors, and early adopters

SEEKING AUTHORS, REVIEWERS AND EARLY ADOPTERS FOR VERSION 0.5



A New Reference Curriculum for Graduate Studies Leading to a Master's Degree in Software Engineering

Since August 2007, a group of more than 30 professionals from academia, industry, and government have been developing a new reference curriculum leading to a Master's Degree in Software Engineering. The new reference curriculum will integrate systems engineering into the education of software engineers and reflect the dramatic changes in how software is used and developed since the last major graduate reference curriculum was published in the early 1990's. The effort is endorsed by the International Council on Systems Engineering (INCOSE), and the U.S. National Defense Industrial Association (NDIA) Systems Engineering Division. The IEEE Computer Society has a participating author and the ACM has a volunteer contributor. Sponsorship and funding for this effort are being provided by the U.S. Department of Defense.

Version 0.25 of the Graduate Software Engineering Reference Curriculum (GSwERC) was released in February 2008 for a limited review. Version 0.5 is being readied for world-wide release at the end of October 2008. The document will be posted on the GSwERC website (www.GSwERC.org). Review comments from all interested professionals are being sought. Version 1.0 baseline is expected sometime in 2009.

A clear limitation of the effort so far has been the demographics of the author team. While the team is extraordinarily talented and dedicated, the authors of these first two drafts were mainly from the United States. The first round of reviewers was more international, but still dominated by professionals from the U.S. In order to ensure that GSwERC has global applicability, we seek to further broaden both the reviewers for the second draft and the author team for Version 1.0.

One of the novel features of GSwERC is the inclusion of explicit comparisons of existing graduate software engineering programs to GSwERC recommendations and the inclusion of hypothetical modifications to two of those programs to better match GSwERC. These comparisons and modifications offer a window on how well GSwERC aligns with existing practice and will help faculty understand how to adopt GSwERC in their own universities. We welcome additional comparisons and hypothetical modifications from other universities to provide more insight into the gap between GSwERC and current practice and how to close that gap.

The Graduate Software Engineering Reference Curriculum (GSwERC) is ready for early adoption. Several of the current authors are now integrating portions of GSwERC in their own programs. We are also interested in helping universities begin to adopt GSwERC in 2009.

Please visit our website at
www.GSwERC.org
for more information.

Dr. Art Pyeter, Distinguished Research
Professor, from Stevens Institute of
Technology in the United States, is the
project leader for GSwERC.

Please contact him at
art.pyeter@stevens.edu if you are
interested in participating.

STEVENS
Institute of Technology



www.GSwERC.org

Architecting Systems to Meet Expectations - Managing Quality Characteristics To Reduce Risk



Paul R. Croll
CSC
pcroll@csc.com



*Chair, NDIA Software Industry
Experts Panel*

*Co-Chair, DoD Software in
Acquisition Working Group on
Software Quality Attributes*

Outline

- The Systems Quality Challenge
- Architecture And Quality Defined
- Quality Attribute-Based Approaches To Architecting Systems
- Making The Case For Architectural Quality
- Customer Implications Of Quality-Attribute-Based Architectural Approaches
- Process Maturity And Product Quality
- A Current Concern: Architecting For System Assurance
- Summary

It's About The Architecture . . .

One of the top ten emerging systemic issues, from fifty-two in-depth program reviews since March 2004, was inadequate software architectures

Source: D. Castellano. Systemic Root Cause Analysis. NDIA Systems Engineering Division Strategic Planning Meeting, December, 2007.

It's Also About Quality . . .

- The NDIA Top Software Issues Workshop examined the current most critical issues in software engineering that impact the acquisition and successful deployment of software-intensive systems
- Two issues emerged that were focused specifically on the relationship between software quality and architecture:
 - Ensure defined quality attributes . . . are addressed in requirements, architecture, and design.
 - Define software assurance quality attributes that can be addressed during architectural trade-offs

Source: G. Draper (ed.), Top Software Engineering Issues Within Department of Defense and Defense Industry. National Defense Industrial Association, Arlington, VA, August 2006.

The Systems Quality Challenge

- If we are successful in managing risk for the systems we build, and meet stakeholder expectations, we must:
 - Start as early as possible in the design process to understand the extent to which those expectations might be achieved
 - Develop candidate system architectures and perform architecture trade-offs
 - Define and use a set of quantifiable system attributes tied to stakeholder expectations, against which we can measure success

The Systems Quality Challenge Is A Software Quality Challenge

- Most systems we encounter today contain software elements and most depend upon those software elements for a good portion of their functionality
- Modern systems architecture issues cannot be adequately addressed without considering the implications of software architecture

Architecture Defined

- *The fundamental organization of a system embodied in its components, their relationships to each other, and to the environment, and the principles guiding its design and evolution.*

Source: IEEE 1471-2000, IEEE Recommended Practice for Architectural Description of Software-Intensive Systems. The Institute of Electrical and Electronics Engineers, Inc., New York, NY, 2000.

- *The set of all of the most important, pervasive, higher-level, strategic decisions, inventions, engineering trade-offs, assumptions, and their associated rationales concerning how the system meets its allocated and derived product and process requirements*

Source: D. Firesmith, P. Capell, D. Falkenthal, C. Hammons, D. Latimer, and T. Merendino. The Method-Framework for Engineering System Architectures (MFESA): Generating Effective and Efficient Project-Specific System Architecture Engineering Methods. November, 2008. CRC Pr I Llc,

Quality Defined

- *Software quality: The degree to which software possesses a desired combination of attributes.*

Source: IEEE Standard 1061-1992. Standard for a Software Quality Metrics Methodology. New York: Institute of Electrical and Electronics Engineers, 1992.

- *Software product quality: The totality of characteristics of an entity that bear on its ability to satisfy stated and implied needs.*

Source: ISO/IEC 9126-1: Information Technology - Software product quality - Part 1: Quality model. ISO, Geneva Switzerland, 2001.

Quality Attribute-Based Approaches To Architecting Systems

- *Developing systematic ways to relate the software quality attributes of a system to the system's architecture provides a sound basis for making objective decisions about design tradeoffs and enables engineers to make reasonably accurate predictions about a system's attributes that are free from bias and hidden assumptions. The ultimate goal is the ability to quantitatively evaluate and trade off multiple software quality attributes to arrive at a better overall system.*

Source: M. Barbacci, M. Klein, T. Longstaff, and C. Weinstock. Quality Attributes, CMU/SEI-95-TR-021. Software Engineering Institute, Carnegie Mellon University, December 1995.

Relationships Between Attributes

■ Collaboration

- Increasing the degree to which one attribute is realized increases the realization of another

■ Damage

- Increasing the degree to which one attribute is realized decreases the realization of another

■ Dependency

- The degree to which one attribute is realized, is dependent upon the realization of at least some sub-characteristics of another

Source: X. Franch and J. Carvalho. "Using Quality Models in Software Package Selection", IEEE Software, pp. 34-41. New York: Institute of Electrical and Electronics Engineers, 2003.

Optimization Among Quality Attributes

- Example: A large telecommunication application
 - Good optimization (Collaboration)
 - balance among multiple quality attributes, such as maintainability, performance and availability
 - Poor optimization (Damage)
 - Focusing solely on maintainability often results in poor system performance
 - Focusing on performance and availability alone may result in result in poor maintainability
- Explicit architectural decisions can facilitate optimization among quality attributes

Source: D. Häggander, L. Lundberg, and J. Matton, "Quality Attribute Conflicts - Experiences from a Large Telecommunication Application," Proceedings of the Seventh International Conference on Engineering of Complex Computer Systems (ICECCS'01), New York: Institute of Electrical and Electronics Engineers, 2001.

Understanding Quality In The Context Of Architectural Structures

- Structures for describing architectures
 - *Functional structure* is the decomposition of the functionality that the system needs to support
 - *Code structure* is the code abstractions from which the system is built
 - *Concurrency structure* is the representation of logical concurrency among the components of the system
 - *Physical structure* is just that, the structure of the physical components of the system
 - *Developmental structure* is the structure of the files and the directories identifying the system configuration as the system evolves
- Using architectural structures to understand quality
 - *Concurrency and Physical* structures are useful in understanding system Performance
 - *Concurrency and Code* structures are useful in understanding system Security
 - *Functional, Code, and Developmental* structures are useful in understanding system Maintainability

Source: L. Bass and R. Kazman, *Architecture-Based Development*, CMU/SEI-99-TR-007. Software Engineering Institute, Carnegie Mellon University, April 1999.

Attribute-Driven Design

- Attribute-Driven Design (ADD) produces an initial software architecture description from a set of design decisions that show:
 - Partitioning of the system into major computational and developmental elements
 - What elements will be part of the different system structures, their type, and the properties and structural relations they possess
 - What interactions will occur among elements, the properties of those interactions, and the mechanisms by which they take place
- In the very first step in ADD, *quality attributes requirements* are expressed as the system's desired measurable quality attribute response to a specific stimulus
- Knowing these requirements for each *quality attribute* supports the selection of design patterns and tactics to achieve those requirements

Source: R. Wojcik, F. Bachmann, L. Bass, P. Clements, P. Merson, R. Nord, and B. Wood, *Attribute-Driven Design (ADD)*, Version 2.0, CMU/SEI-2006-TR-023. Software Engineering Institute, Carnegie Mellon University, November 2006.

Understanding The Consequences Of Architectural Decisions With Respect To Quality Attributes

- The Architecture Tradeoff Analysis MethodSM (ATAMSM) is dependent upon quality attribute characterizations, like those produced through ADD, that provide the following information about each attribute:
 - The stimuli to which the architecture must respond
 - How the *quality attribute* will be measured or observed to determine how well it has been achieved
 - The key architectural decisions that impact achieving the *attribute requirement*
- ATAM takes proposed architectural approaches and analyzes them based on quality attributes
 - generally specified in terms of scenarios addressing stimuli and responses
 - Use case scenarios, describing typical uses of the system
 - Growth scenarios, addressing planned changes to the system
 - Exploratory scenarios, addressing any possible extreme changes that would stress the system
- ATAM also identifies sensitivity points and tradeoff points

Source: R. Kazman, M. Klein, and P. Clements, ATAM: Method for Architecture Evaluation, CMU/SEI-2000-TR-004, Software Engineering Institute, Carnegie Mellon University, August 2000.

Some Real World Architecture Review Issues

- Results from four AT&T companies
Between 1989 and 2000
- More than 1,000 issues
- Six classes of issues
 - Product architecture and design, 29–49%
 - Management controls, 14–26%
 - Problem definition, 10–18%
 - Process, 4–19%
 - Technology, 3–14%
 - Domain knowledge, 2–5%

Source: J. Maranzano, S. Rozsypal, G. Zimmerman, G. Warnken, P. Wirth, and D. Weiss, Architecture Reviews: Practice and Experience, IEEE Software, March/April 2005.

Making The Case For Architectural Quality

■ The Quality Case

- The set of claims, supporting arguments, and supporting evidence that provide confidence that the system will in fact demonstrate its expected *quality characteristics*
- Common types of quality cases include:
 - *safety cases*
 - *security cases*
 - *assurance cases*

■ The Architectural Quality Case

- The *architectural* claims, supporting arguments, including architectural decisions and tradeoffs, architectural representations, and demonstrations that the architecture will exhibit its expected *quality characteristics*

Source: D. Firesmith, P. Capell, D. Falkenthal, C. Hammons, D. Latimer, and T. Merendino. *The Method-Framework for Engineering System Architectures (MFESA): Generating Effective and Efficient Project-Specific System Architecture Engineering Methods*. November, 2008. CRC Pr I Llc,

Risk Management Implications Of Quality-Attribute-Based Architectural Approaches

- Stakeholder *quality requirements* will have been distilled into *architectural drivers* which will have shaped the system architecture
- Tradeoffs will have been made to optimize the realization of important *quality characteristics*, in concert with stakeholder expectations
- The level of confidence that the resultant architecture will meet those expectations will be known
- Stakeholders will be knowledgeable of any *residual risk* they are accepting by accepting the delivered system

Source: R. Wojcik, F. Bachmann, L. Bass, P. Clements, P. Merson, R. Nord, and B. Wood, *Attribute-Driven Design (ADD), Version 2.0, CMU/SEI-2006-TR-023. Software Engineering Institute, Carnegie Mellon University, November 2006.*

Process Maturity Does Not Guarantee Product Quality

- The CMMI[®] embodies the process management premise that, *the quality of a system or product is highly influenced by the quality of the process used to develop and maintain it*

Source: CMMI[®] for Development, Version 1.2, CMU/SEI-2006-TR-008, Software Engineering Institute, Carnegie Mellon University, August 2006

- However:
Several recent program failures from organizations claiming high maturity levels have caused some to doubt whether CMMI[®] improves the chances of a successful project

Source: R. Hefner. CMMI Horror Stories: When Good Projects Go Bad. SEPG Conference, March 2006

. . . But Engineering Discipline Might

- Process maturity can in many cases improve project performance, but special attention to the engineering processes is required to ensure that stakeholder quality expectations are realized in resultant products.

A Current Concern: Architecting For System Assurance

■ The challenge:

Integrating a heterogeneous set of globally engineered and supplied proprietary, open-source, and other software; hardware; and firmware; as well as legacy systems; to create well-engineered integrated, interoperable, and extendable systems whose security, safety, and other risks are acceptable – or at least tolerable.

Source: P. Croll, “Engineering for System Assurance – A State of the Practice Report,” Proceedings of the 1st Annual IEEE Systems Conference. New York: Institute of Electrical and Electronics Engineers, April 2007

■ The vision:

The requirements for assurance are allocated among the right systems and their critical components, and such systems are designed and sustained at a known level of assurance.

Source: K. Baldwin. DOD Software Engineering and System Assurance New Organization – New Vision, DHS/DOD Software Assurance Forum, March 8, 2007

Architectural Principles For Assurance

- Isolate critical components from less-critical components
- Make critical components easier to assure by making them smaller and less complex
- Separate data and limit data and control flows
- Include defensive components whose job is to protect other components from each other and/or the surrounding environment
- Understanding the interrelationships between components and their linkages
- Use defense-in-depth measures where appropriate
- Beware of maximizing performance to the detriment of assurance

Source: Engineering For System Assurance, Version 1.0. National Defense Industrial Association, System Assurance Committee, Arlington, Virginia October 2008.

Summary

- If we are to be successful in managing risk for the systems we build, and meet stakeholder expectations, we must:
 - Start as early as possible in the design process to understand the extent to which those expectations might be achieved
 - Define a set of *quantifiable quality attributes* tied to stakeholder expectations, against which we can measure success and understand the residual risk stakeholders are being asked to accept
 - Develop candidate system architectures and perform architecture trade-offs using those attributes

For More Information . . .

Paul R. Croll
CSC
10721 Combs Drive
King George, VA 22485-5824

Phone: +1 540.644.6224
Fax: +1 540.663.0276
e-mail: pcroll@csc.com

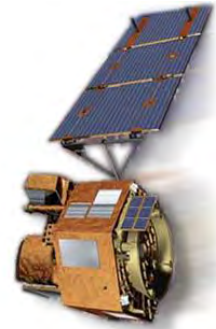



**Changing the value equation
in engineering and
acquisition to align systems
of systems with dynamic
mission needs:
*The Value Stairs***

Philip Boxer, Suzanne Garcia, William
Anderson, Pat Kirwan

October 21st 2008



Agenda

- ➔ The demand for agility
 - Managing alignment
 - Creating value for the defense enterprise
 - Changing the value equation



Modernization AND Stability/Counterinsurgency

I've spent much of the last year talking about irregular or asymmetric warfare, and making the argument in favor of institutionalizing counterinsurgency skills, and our ability to conduct stability and support operations.

The need for the state of the art systems – particularly longer range capabilities – will never go away, as we strive to offset the countermeasures being developed by other nations. But at a certain point, given the types of situations we are likely to face, it begs the question whether specialized, often relatively low-tech equipment for stability and counterinsurgency missions is also needed.

- **How do we institutionalize procurement of such capabilities – and the ability to get them fielded quickly?**
- **Why do we have to go outside the normal bureaucratic process** to develop counter-IED technologies, to build MRAPs, and to quickly expand our ISR capability? In short, why did we have to bypass existing institutions and procedures to get the capabilities we need to protect our troops and pursue the wars we are in?

Our conventional modernization programs seek a 99 percent solution in years. Stability and counterinsurgency missions – the wars we are in – require 75 percent solutions in months.

- **The challenge is whether in our bureaucracy and in our minds these two different paradigms can be made to coexist.**
- The issue then becomes how we build this kind of innovative thinking and flexibility into our rigid procurement processes here at home. **The key is to make sure that the strategy and risk assessment drives the procurement, rather than the other way around.**

I believe we must do this. The two models can – and do – coexist.

*Extracted from speech delivered by Secretary of Defense Robert M. Gates,
National Defense University, Washington, D.C. September 29, 2008*
<http://www.defenselink.mil/speeches/speech.aspx?speechid=1279>



There are three diverging tempos

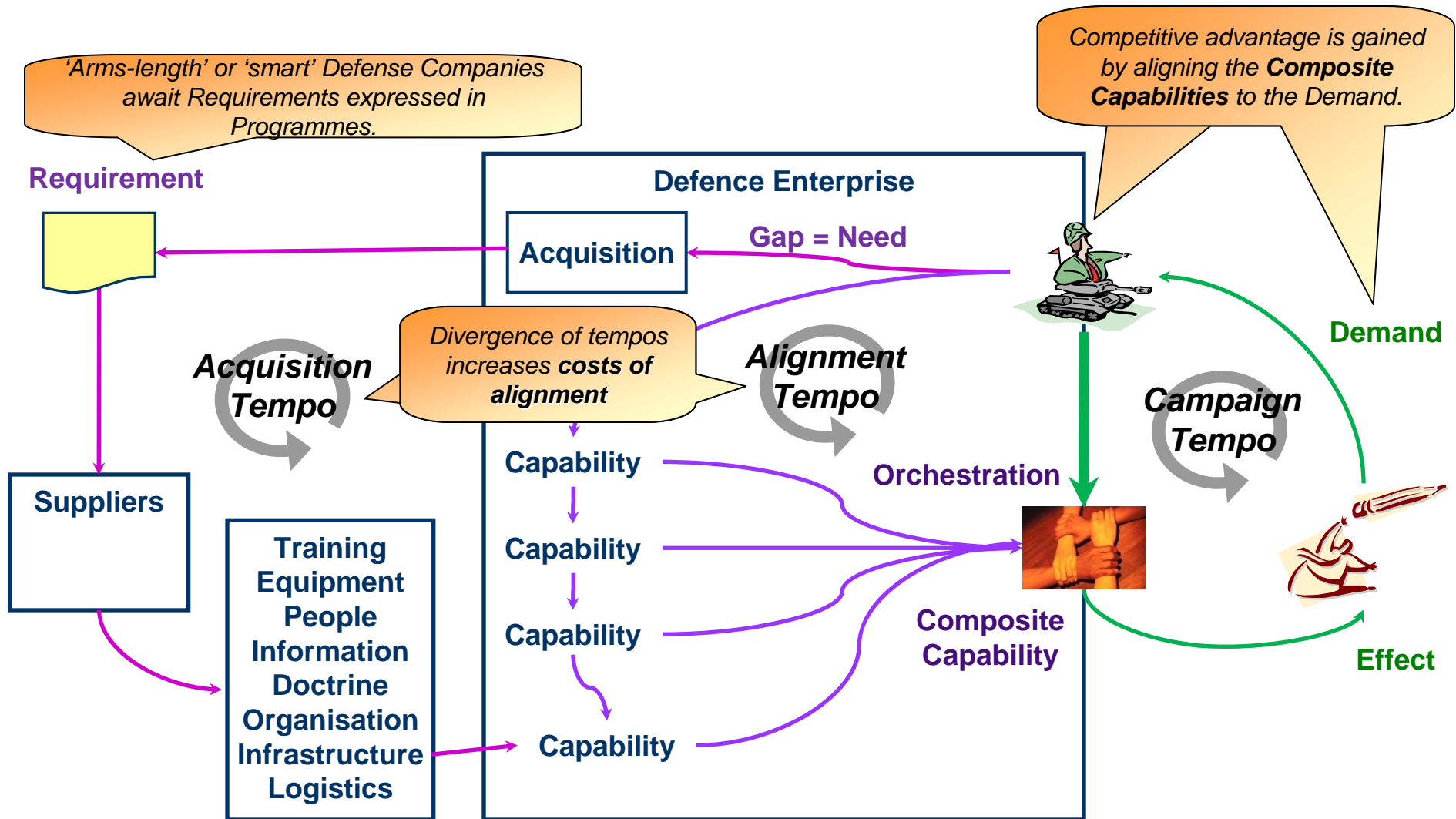

Adapted from: *Appropriate Collaboration and Appropriate Competition in C4ISTAR Transformation*, Dr Nicholas Whittall RUSI 2007



The divergence of tempos challenges the supplier to support Type III Agility

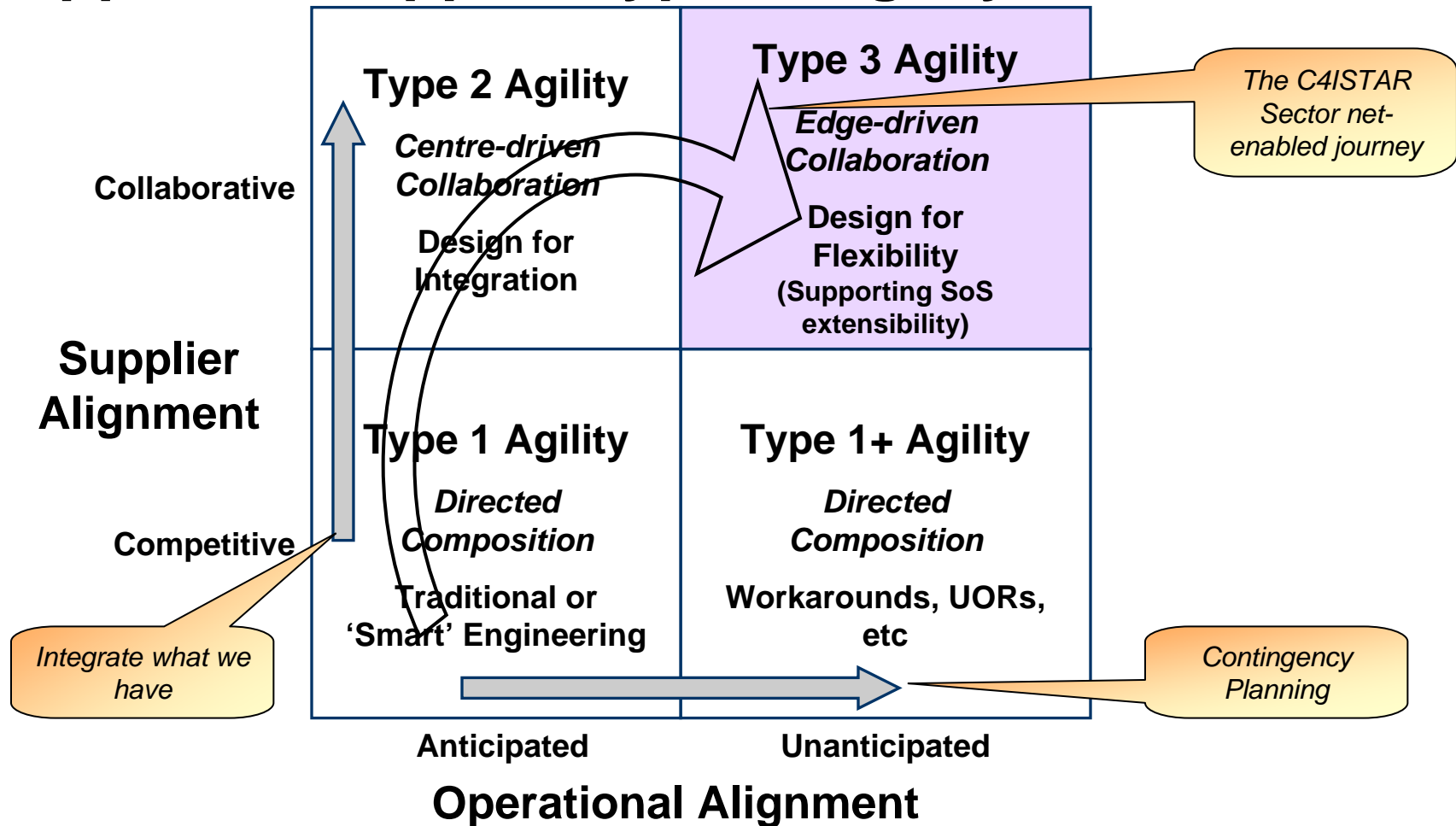

Derived from 'The Double Challenge', in Boxer, P.J. et al. (2008) *SoS Navigator 2.0: A Context-Based Approach to System-of-Systems Challenges* (CMU/SEI-2008-TN-001). Software Engineering Institute, Carnegie Mellon University, 2008. <http://www.sei.cmu.edu/publications/documents/08.reports/08tn001.html>



Agenda

The demand for agility

➔ Managing alignment

Creating value for the defense enterprise

Changing the value equation



The approach to alignment is 'stratified'

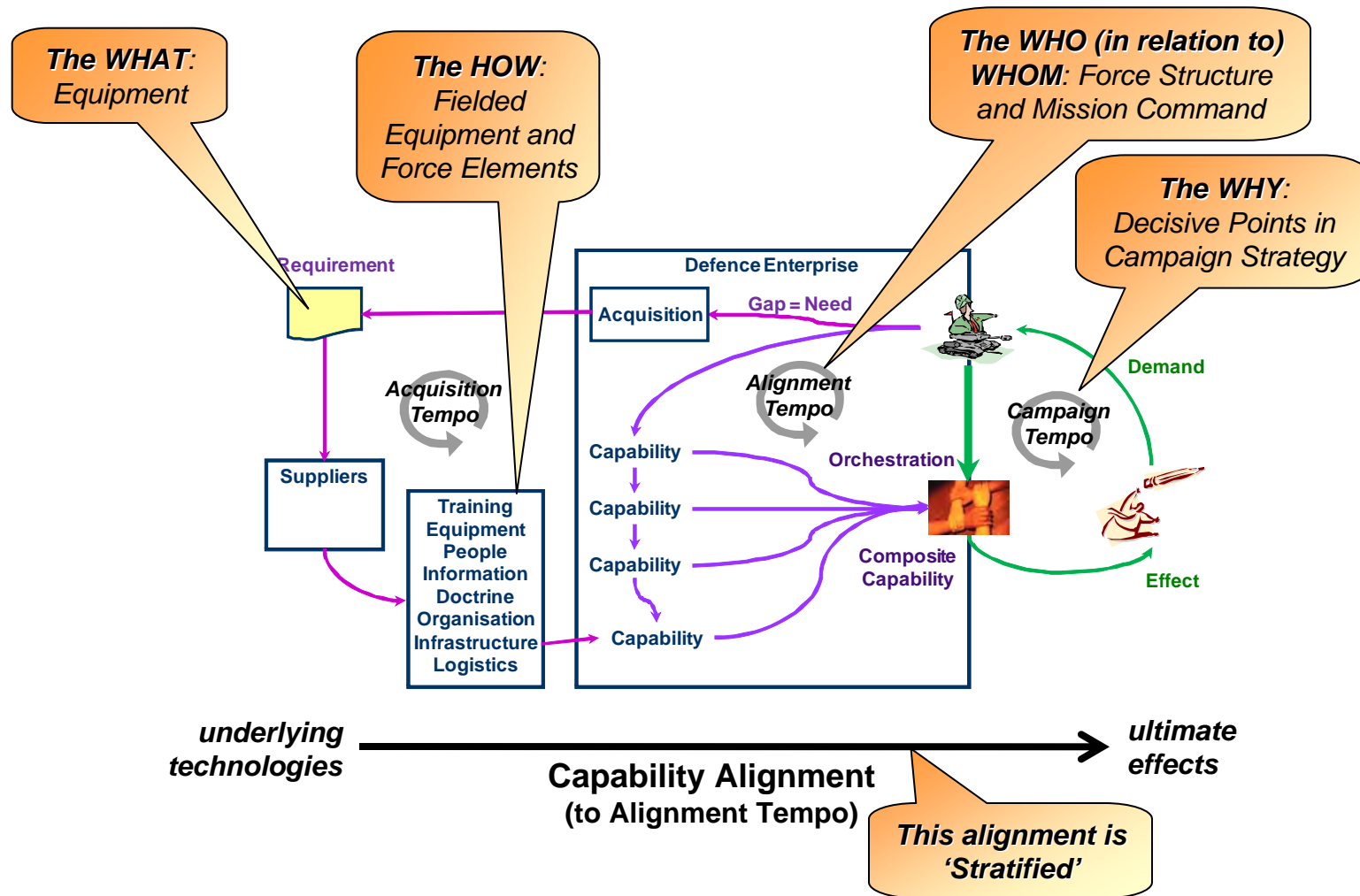

The divergence of these tempos creates new challenges for the Defense Enterprise

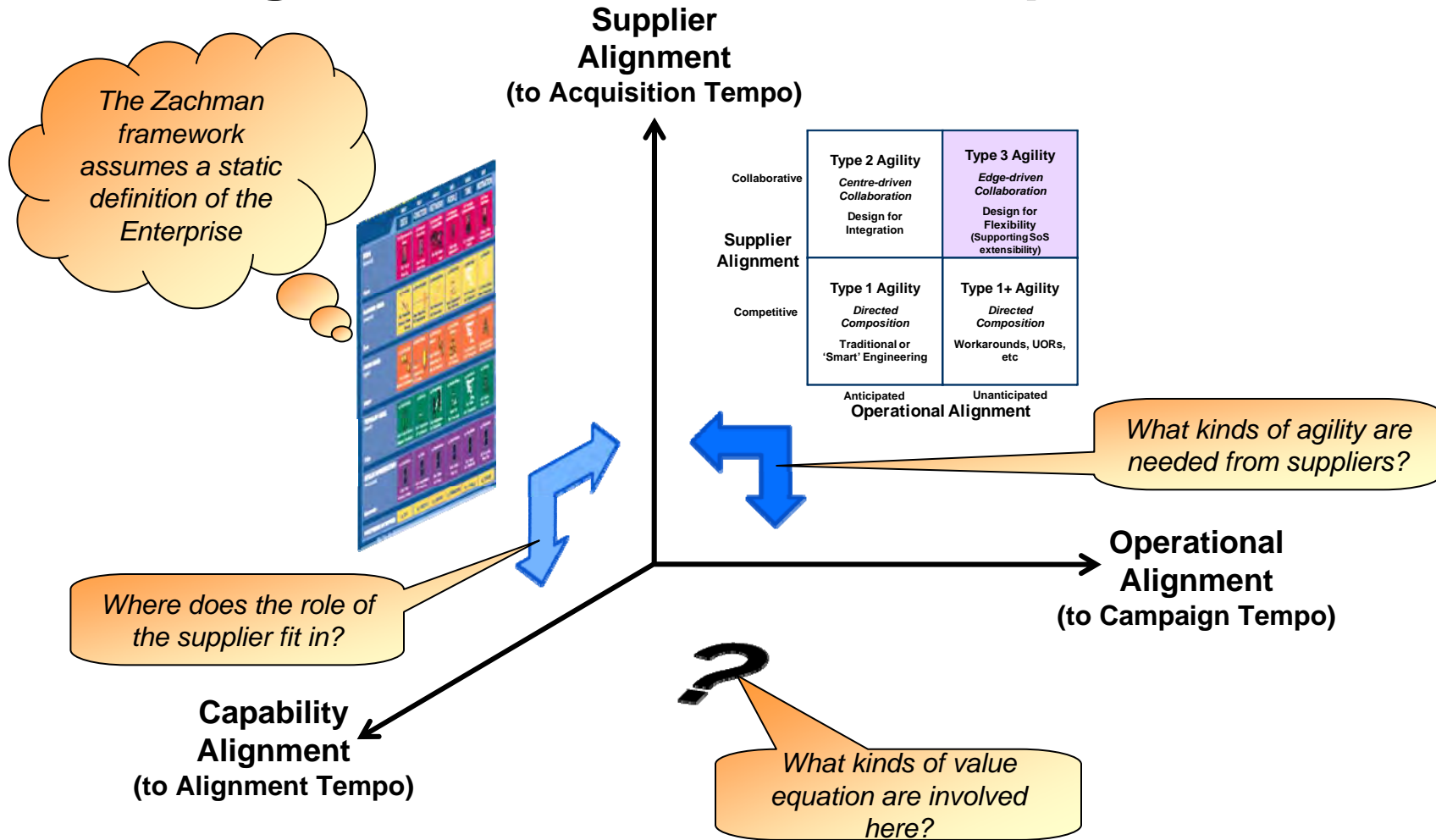

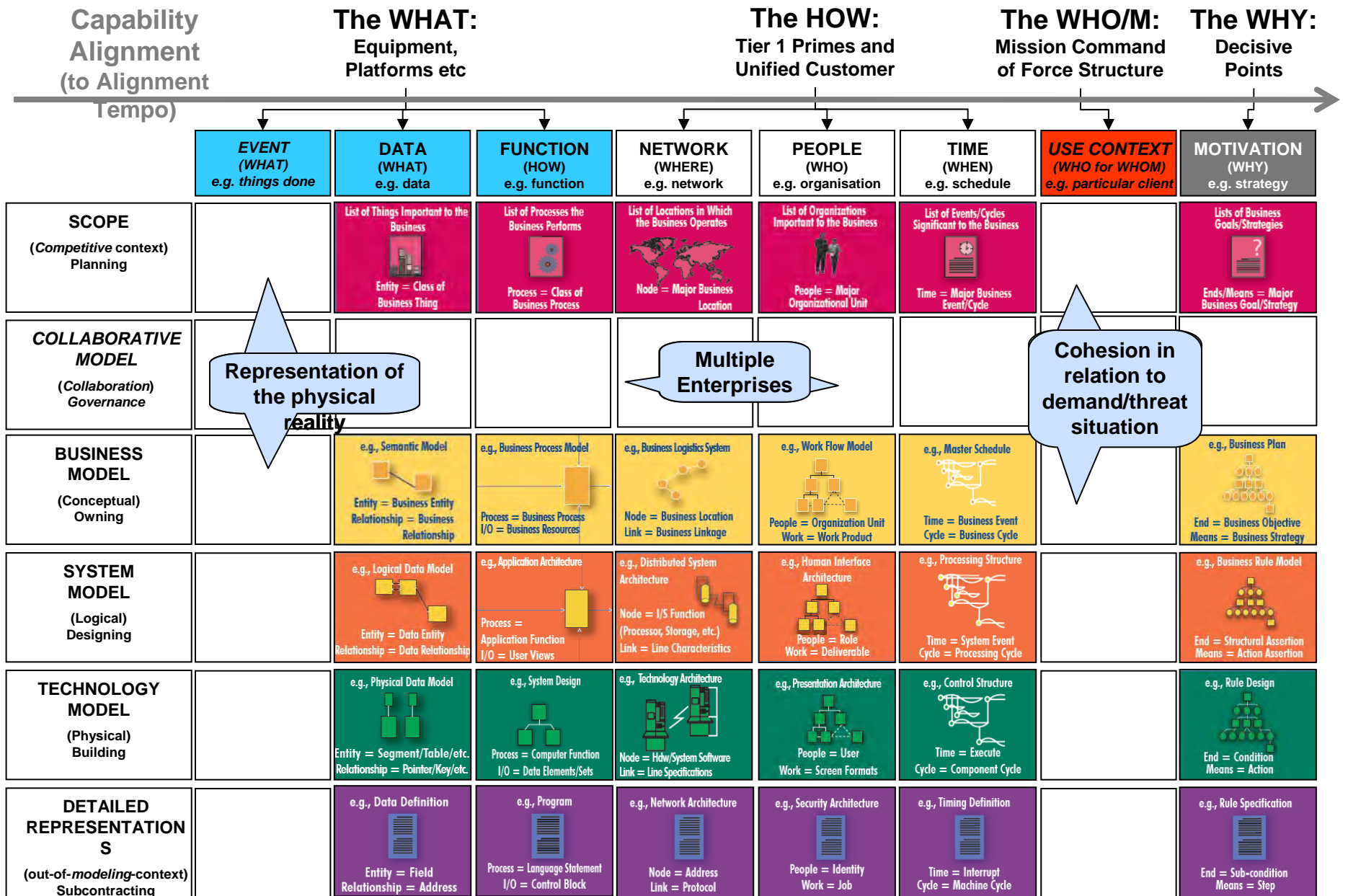

Source of coloured squares: Zachman Framework, www.zifa.com



The divergence of these tempos creates new challenges* for the Defense Enterprise

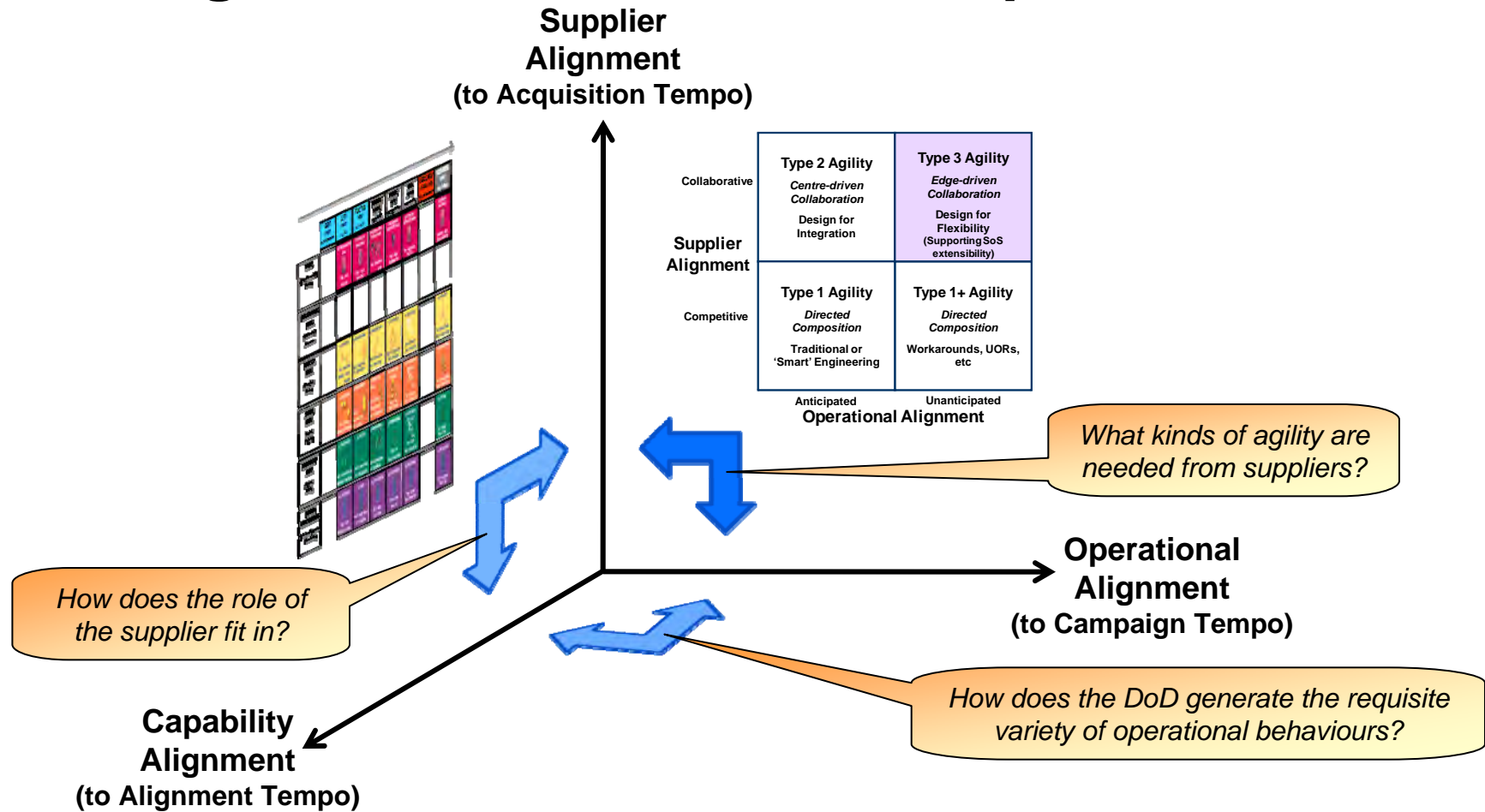

* For more on these, see Boxer, P.J. (2008) *SoS Navigator Principles for Sustaining Dynamic Alignment: The Example of U. S. Army Acquisition Strategies and Operational Realities*, Special Report, Software Engineering Institute, Carnegie Mellon University, CMU/SEI-2008-SR-027, September 2008



Agenda

The demand for agility

Managing alignment

➔ Creating value for the defense enterprise

Changing the value equation



Value for Defense comes from managing a Double 'V'

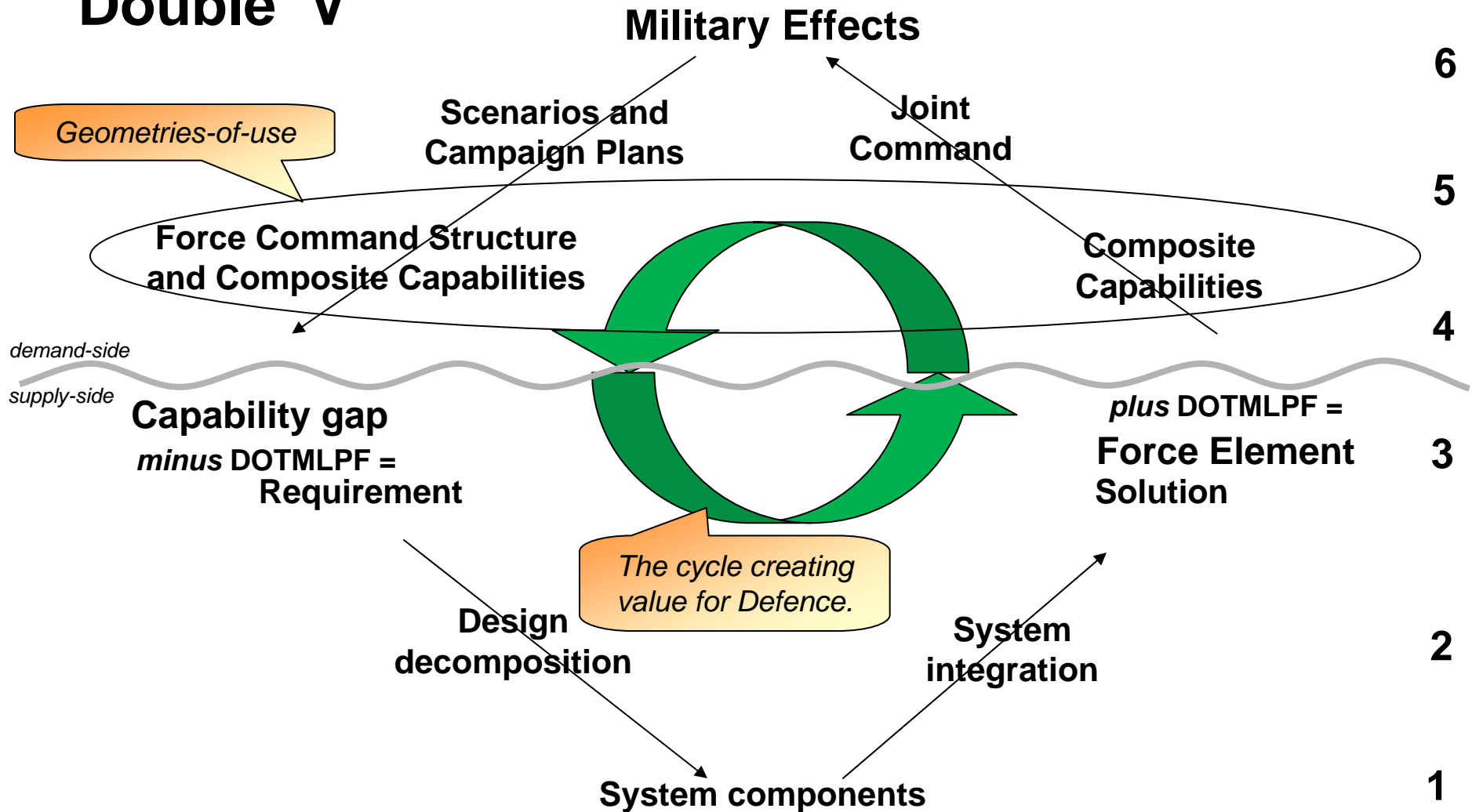

Boxer, P.J. (2007) *Managing the SoS Value Cycle*, January 2007, <http://www.asymmetricdesign.com/archives/85>



This double 'V' is layered, spanning the three different kinds of tempo

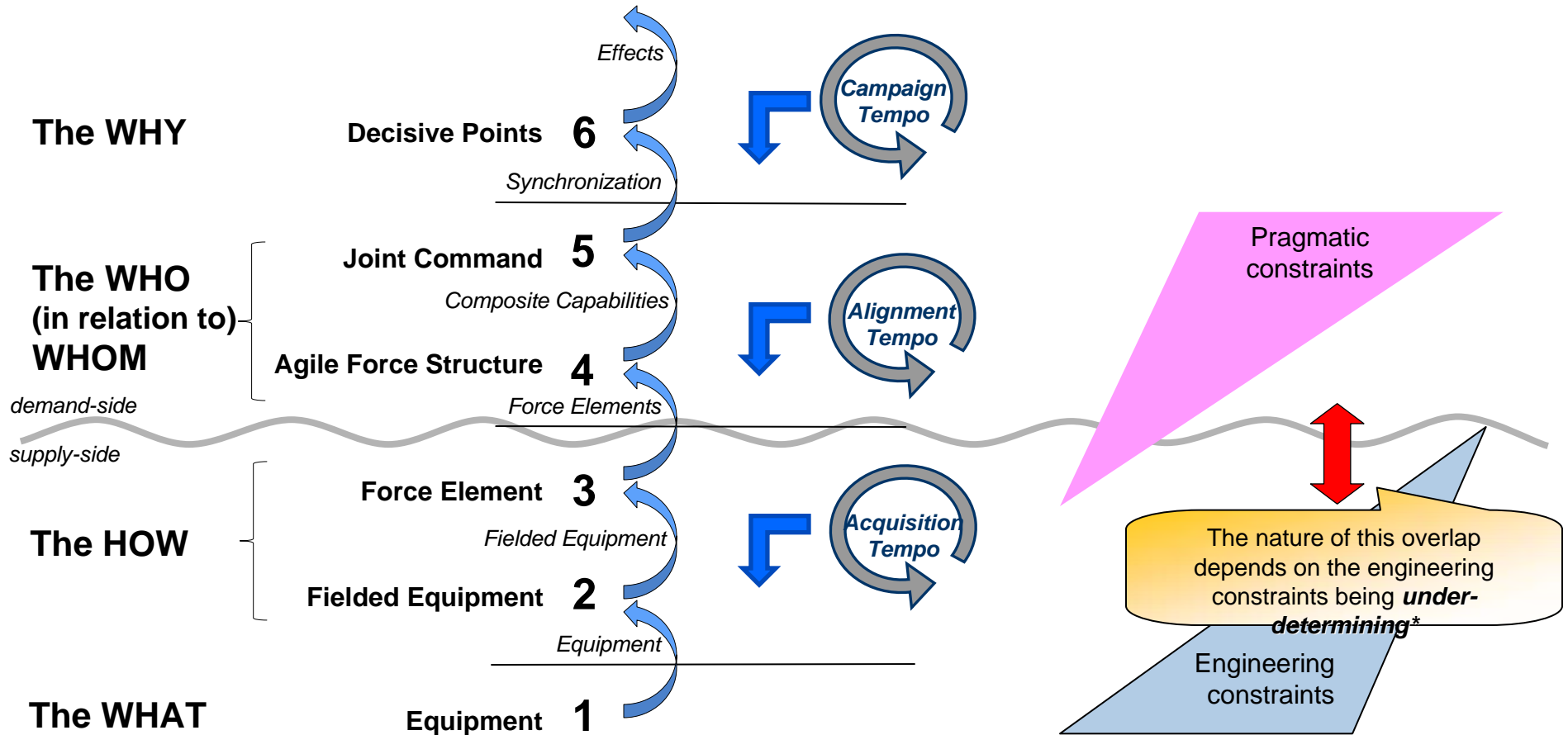

* Boxer, P.J. (2008) *Framework Architectures*, Navigator White Paper, Software Engineering Institute, Carnegie Mellon University, June 2008



These contexts-of-use have to be related to the individual capabilities

↔ Many-to-many composition

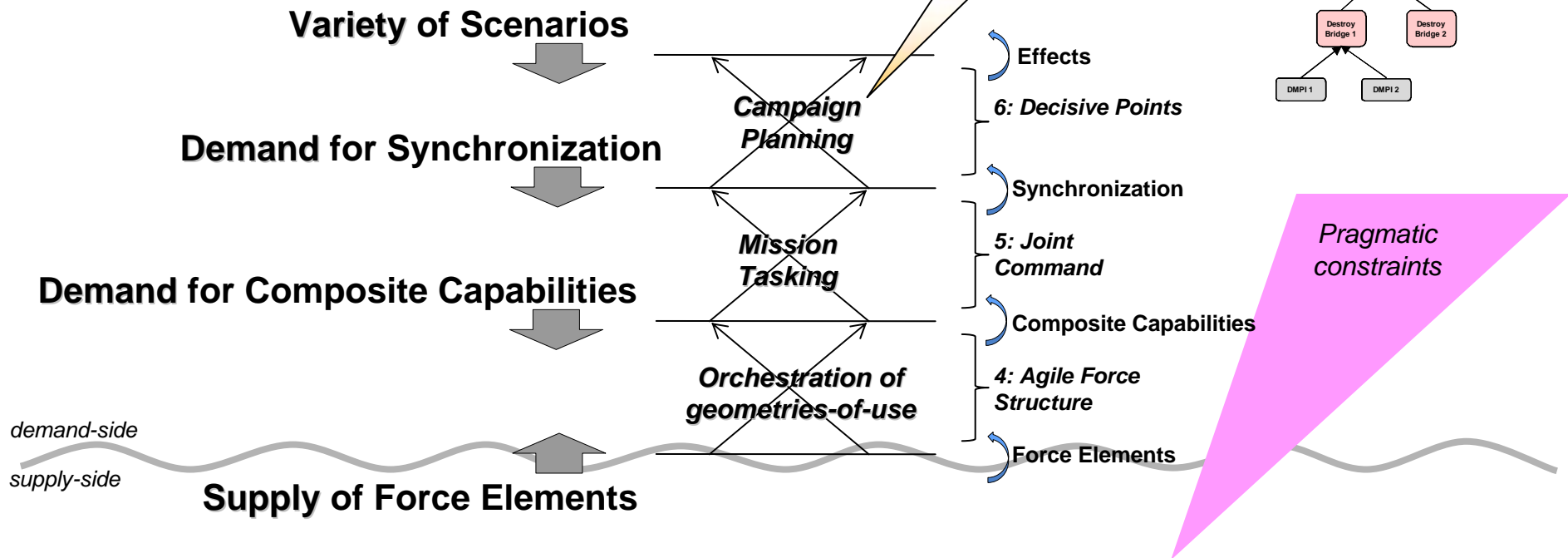

Boxer, P.J. et al (2008) "Systems-of-Systems Engineering and the Pragmatics of Demand," Proceedings of the Second Annual IEEE Systems Conference pp107. Montréal, Québec, Canada, April 7-10, 2008. IEEE, 2008.
http://www.ieeeexplore.ieee.org/xpl/freeabs_all.jsp?isnumber=4518971&arnumber=4519030&count=89&index=58



Adding the socio-technical perspective in relation to demand extends the analytical space

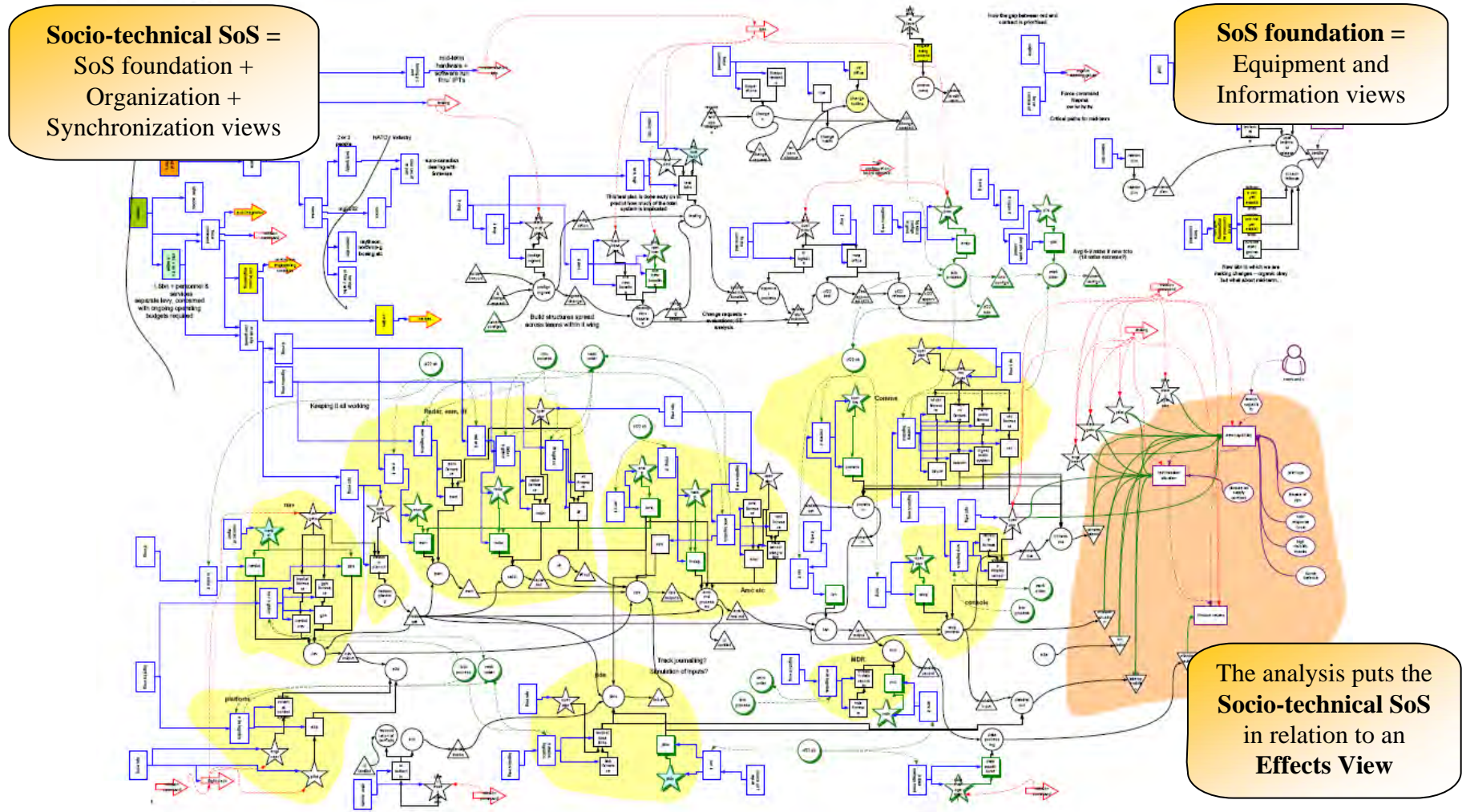

This leads to a different kind of analysis of interoperability...

Socio-technical SoS in relation to Demand

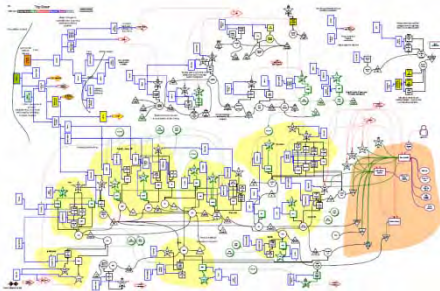

Distinguishing three different kinds of path

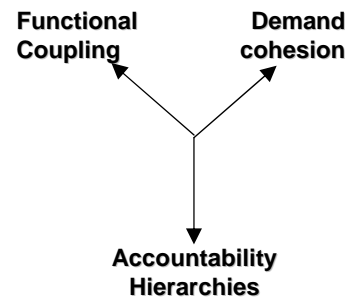

Analyzing alignment of strata

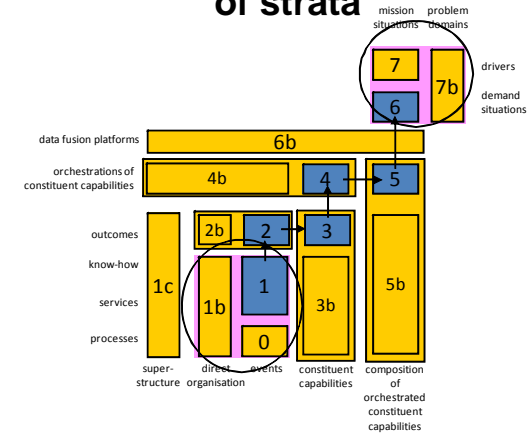

Analysis of Stratification

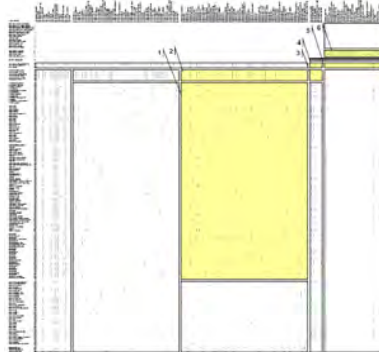

Identifying Interoperability Gaps in the different strata

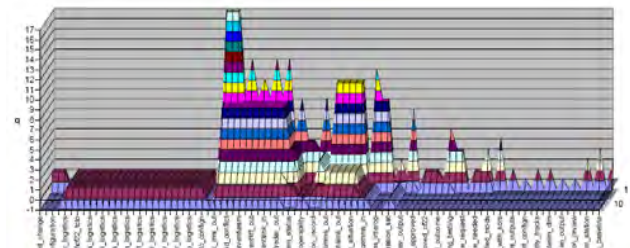

Source: Anderson, Boxer & Broward (2006) *An Examination of a Structural Modeling Risk Probe Technique*, Special Report, Software Engineering Institute, Carnegie Mellon University, CMU/SEI-2006-SR-017, October 2006. <http://www.sei.cmu.edu/publications/documents/06.reports/06sr017.html>
 Special permission to use PAN in this Technical Probe was granted by Boxer Research Limited.



Agenda

The demand for agility

Managing alignment

Creating value for the defense enterprise

➔ Changing the value equation



Spanning the layers means managing different kinds of value equations

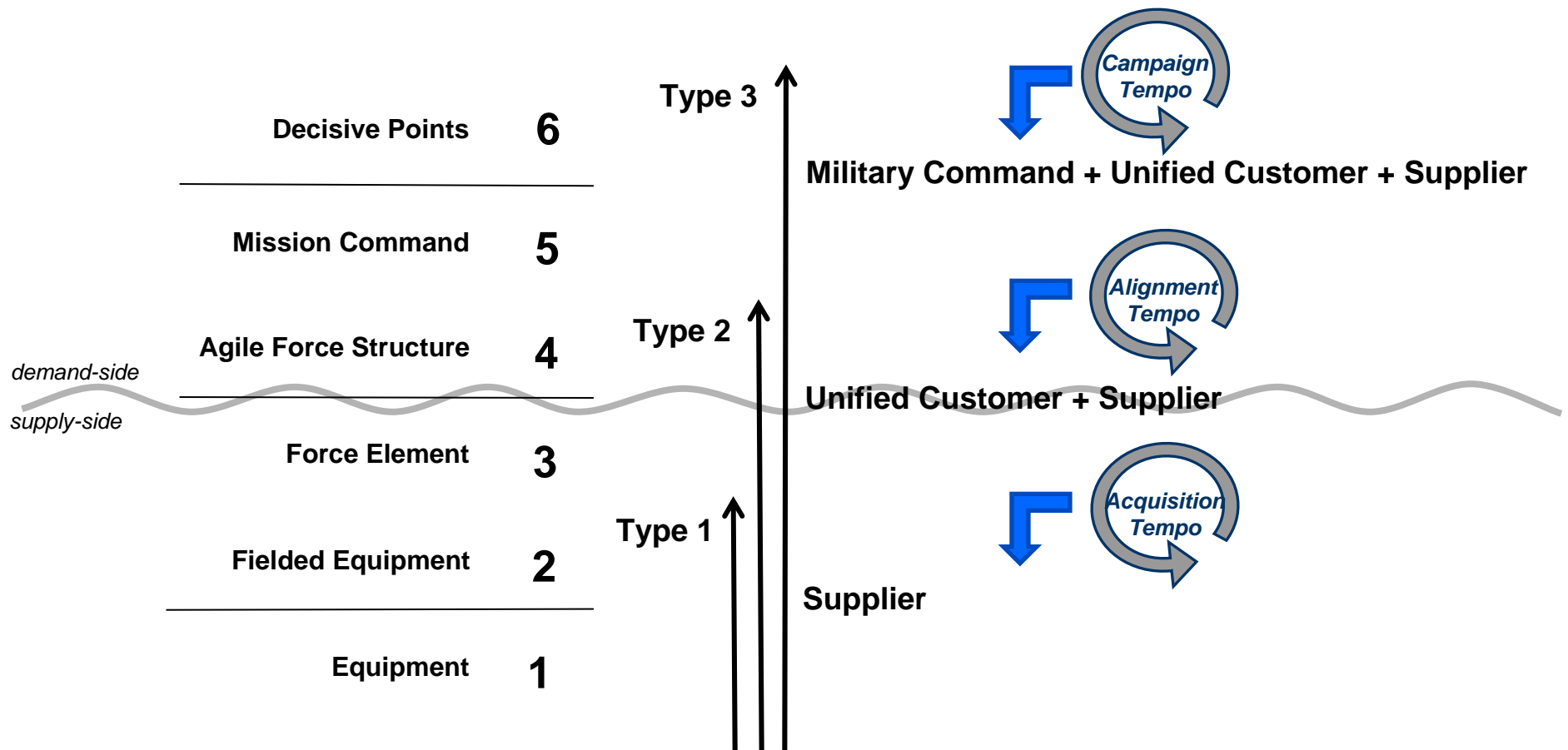

The Value Stairs: a progressive development of the value equation model

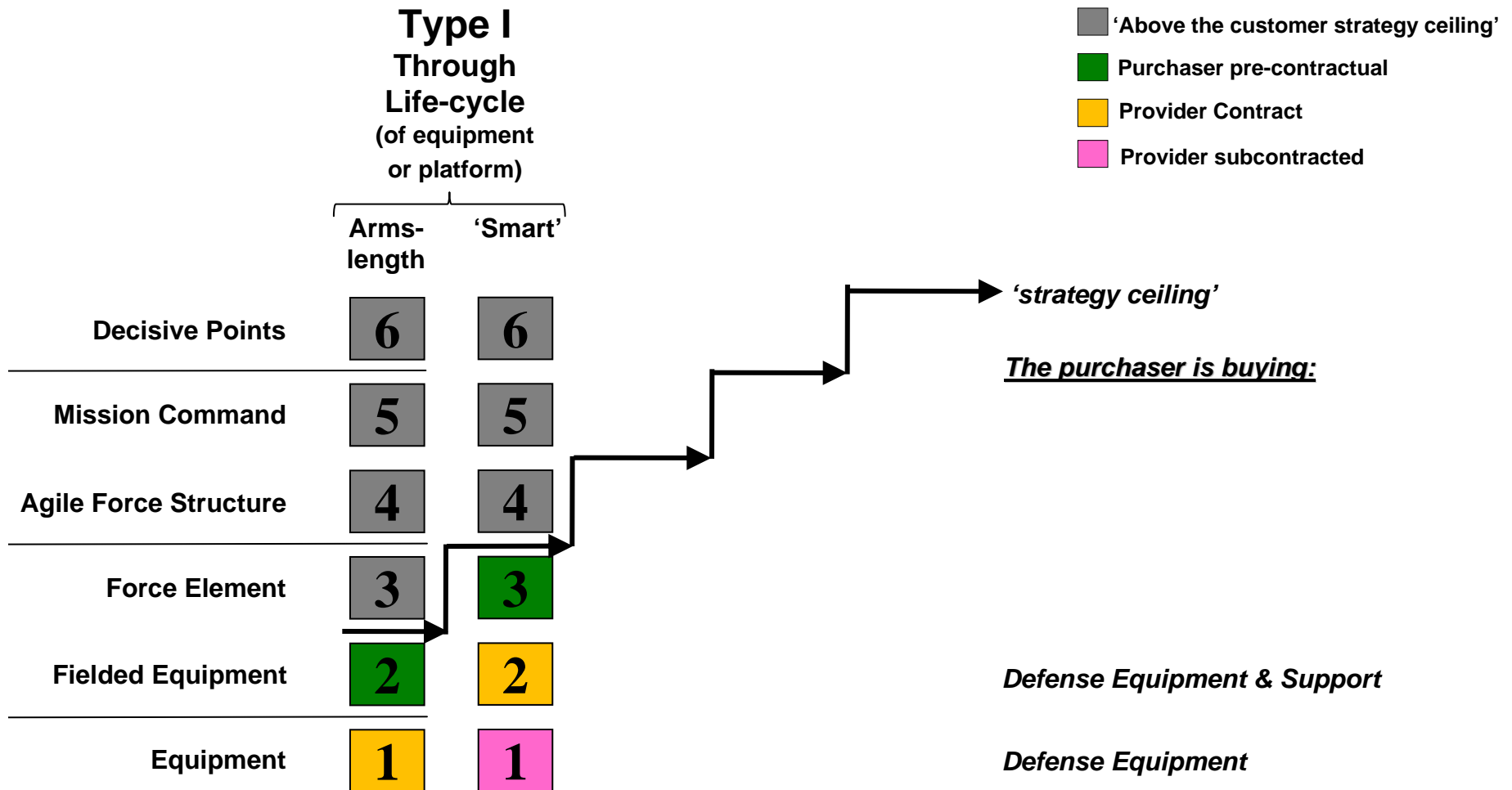

The Value Stairs: a progressive development of the value equation model

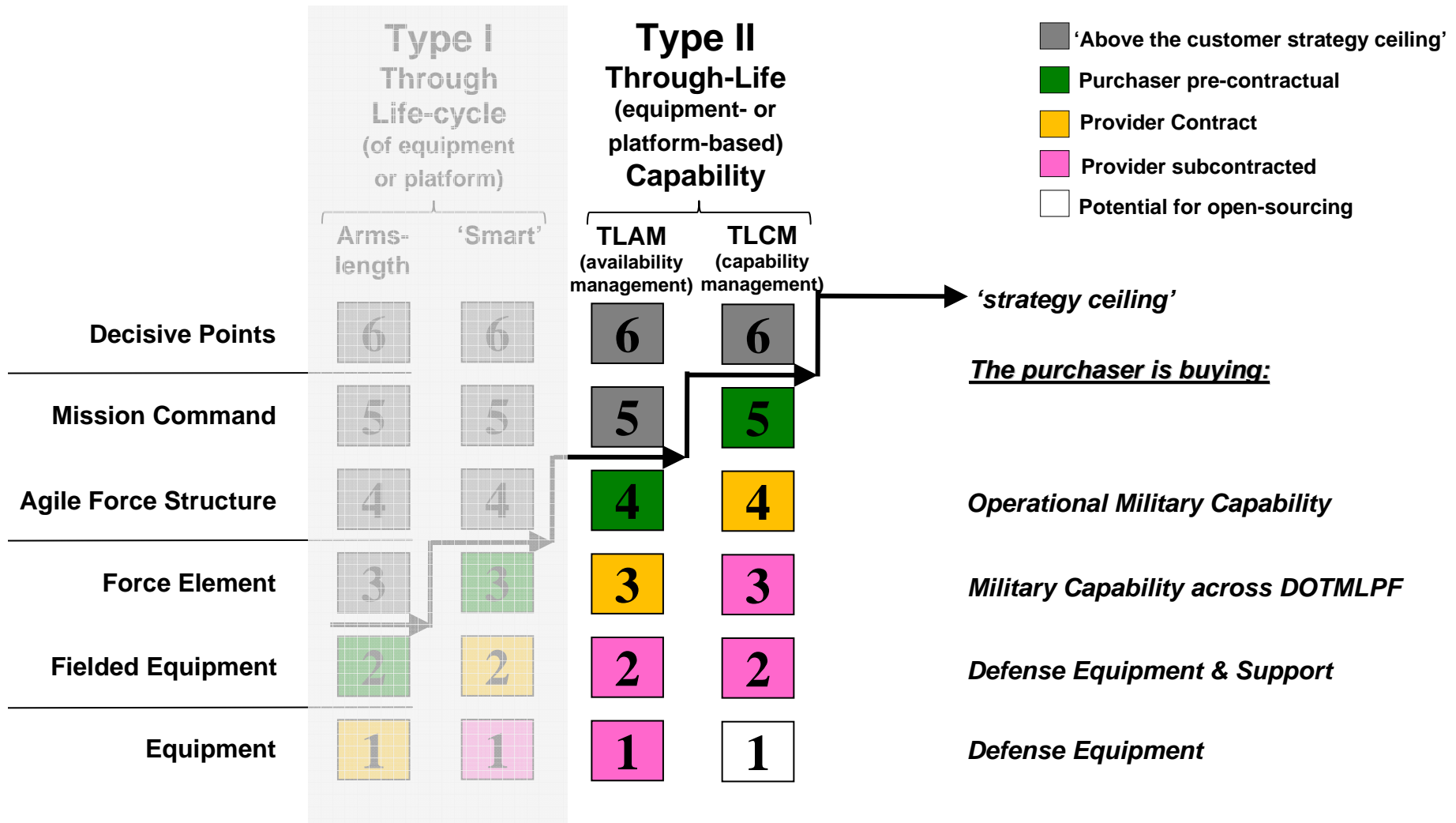

The Value Stairs: a progressive development of the value equation model

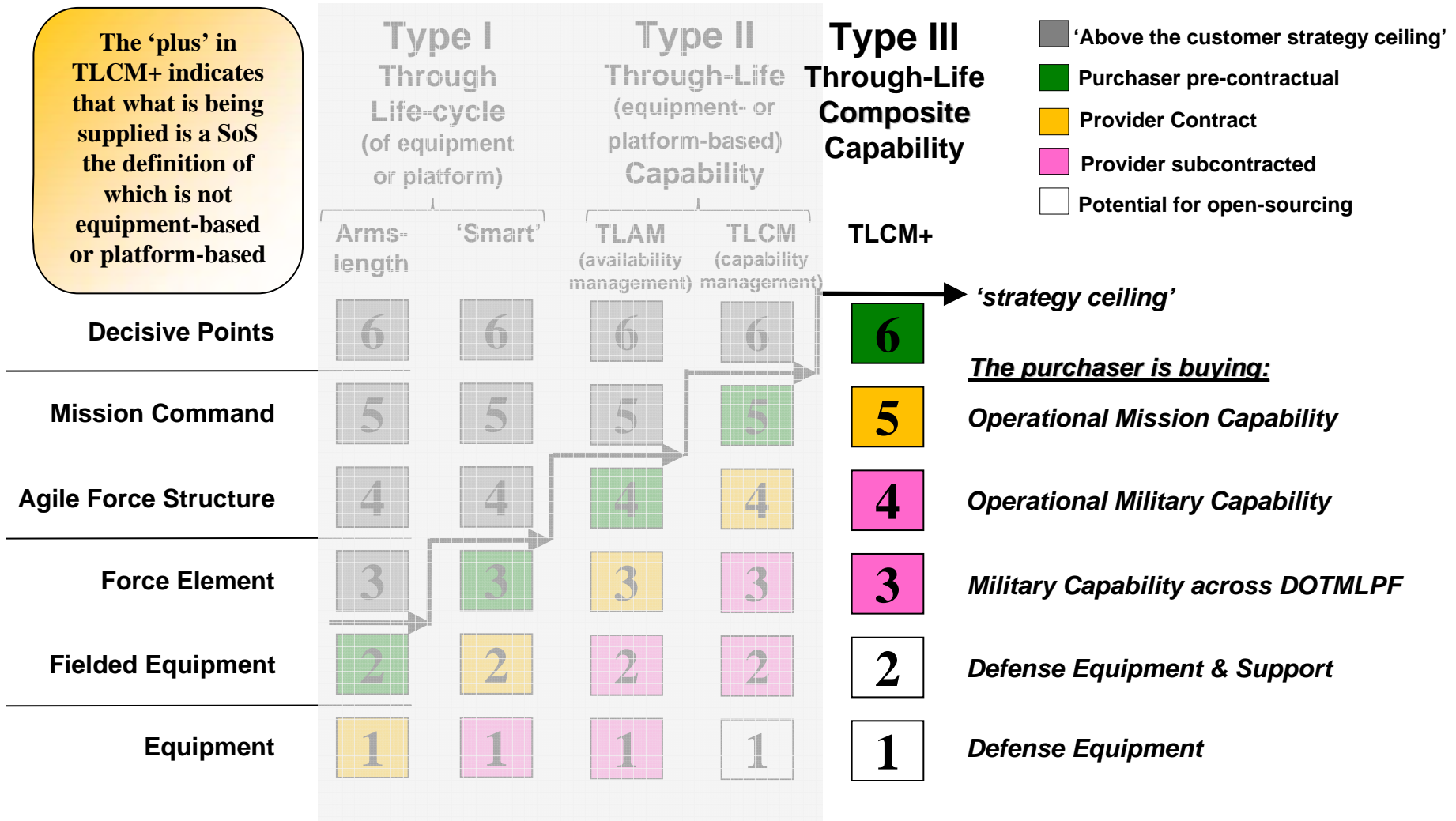

The value equation must evolve as the demand for the variety of operational behaviors changes

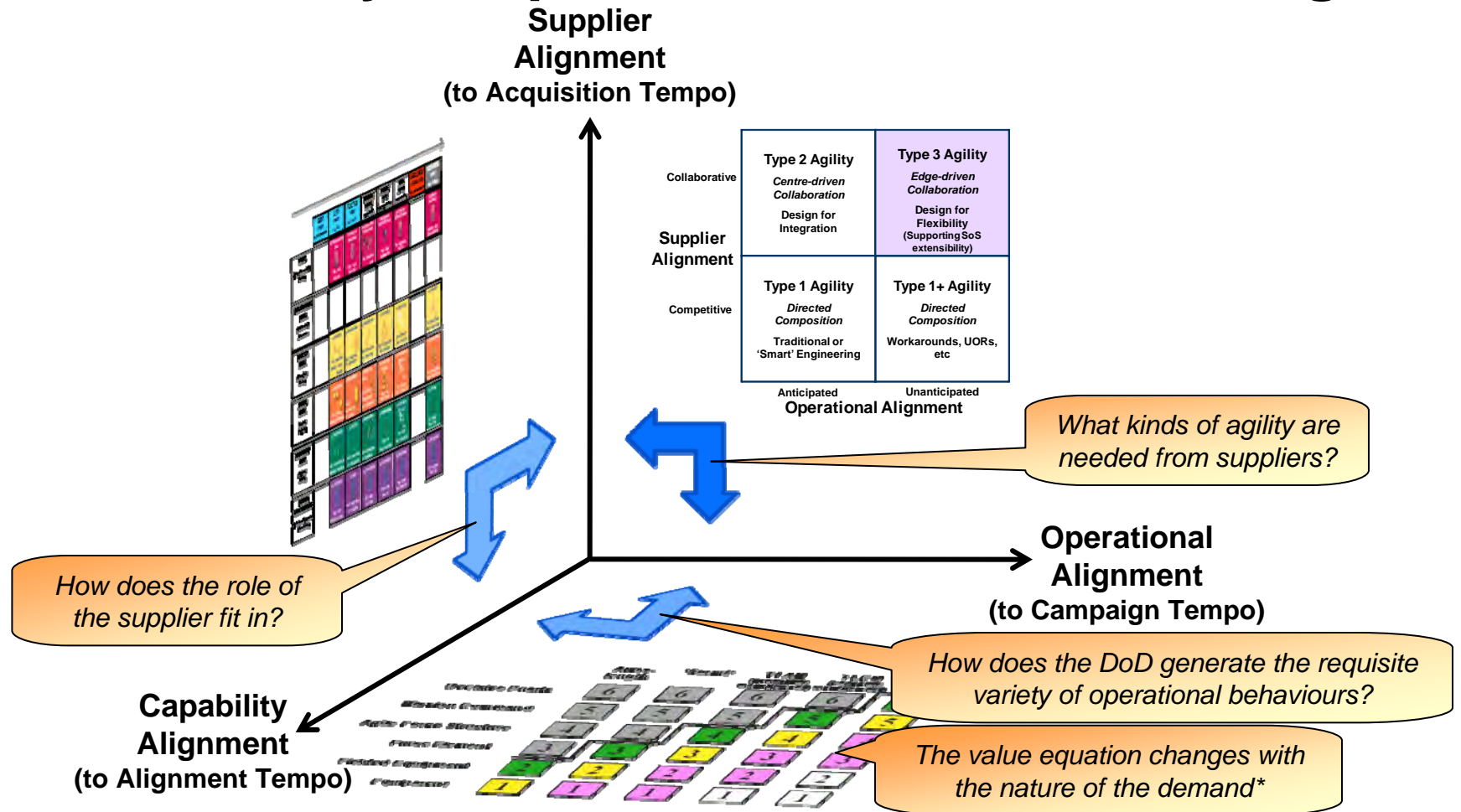

* See Boxer, P.J. (2008) *What Price Agility? Managing Through-Life Purchaser-Provider Relationships on the Basis of the Ability to Price Agility*, Navigator White Paper, Software Engineering Institute, Carnegie Mellon University, September 2008



Making the two models coexist

Talking about irregular or asymmetric warfare and institutionalizing counterinsurgency skills, ...

- **How do we institutionalize procurement of such capabilities – and the ability to get them fielded quickly?**
- **Why do we have to go outside the normal bureaucratic process?**

...

The challenge is whether in our bureaucracy and in our minds these two different paradigms can be made to coexist.

- **The key is to make sure that the strategy and risk assessment drives the procurement, rather than the other way around.**

....

Extracted from speech delivered by Secretary of Defense Robert M. Gates, National Defense University, Washington, D.C. September 29, 2008

- These forms of warfare, skills and abilities demand Type III Agility.
- This means modernization ‘+’, in which
 - Campaign Strategy and Interoperability Risk Assessment drive procurement.
 - The full Double ‘V’ cycle is managed to create value for Defense.
 - Suppliers support different value equation models on the value stairs depending on the nature of the demand.



Contact Information

Philip Boxer

Research, Technology and Systems Solutions Program,
Software Engineering Institute, Carnegie Mellon University

Email: pboxer@sei.cmu.edu

Mail:
Software Engineering Institute
4500 Fifth Avenue
Pittsburgh, PA 15213-2612
USA



Abstract

1. New kinds of threat and much wider varieties of demand on mission capabilities are requiring the military to achieve unprecedented levels of agility and responsiveness, and are driving the transformation of military capabilities.
2. The great benefit of net-enablement in this new strategic environment is that it enables mission capabilities to be orchestrated and composed from constituent capabilities within the context of systems of systems.
3. The presentation will outline three essential ways in which the foundational nature of the systems engineering task needs to be transformed to take advantage of these new possibilities, and will use examples from various military contexts to illustrate their applicability.
 - First, the definition of systems-of-interest also has to give an explicit account of the contexts-of-use from which emerge new forms of demand for mission capability.
 - Second, the definition of systems-of-interest has to be extended to include their socio-technical nature.
 - Third, it has to be possible to analyze how these new forms of demand translate into new patterns of interoperability (geometries-of-use) across systems of systems, thus defining the agility of systems of systems in terms of the required varieties of geometry-of-use that they must support.
4. The presentation will conclude by considering the impact this has on the suppliers' role, the acquisition process, and in particular the changes it introduces into how value is defined.



NO WARRANTY

THIS CARNEGIE MELLON UNIVERSITY AND SOFTWARE ENGINEERING INSTITUTE MATERIAL IS FURNISHED ON AN "AS-IS" BASIS. CARNEGIE MELLON UNIVERSITY MAKES NO WARRANTIES OF ANY KIND, EITHER EXPRESSED OR IMPLIED, AS TO ANY MATTER INCLUDING, BUT NOT LIMITED TO, WARRANTY OF FITNESS FOR PURPOSE OR MERCHANTABILITY, EXCLUSIVITY, OR RESULTS OBTAINED FROM USE OF THE MATERIAL. CARNEGIE MELLON UNIVERSITY DOES NOT MAKE ANY WARRANTY OF ANY KIND WITH RESPECT TO FREEDOM FROM PATENT, TRADEMARK, OR COPYRIGHT INFRINGEMENT.

Use of any trademarks in this presentation is not intended in any way to infringe on the rights of the trademark holder.

This Presentation may be reproduced in its entirety, without modification, and freely distributed in written or electronic form without requesting formal permission. Permission is required for any other use. Requests for permission should be directed to the Software Engineering Institute at permission@sei.cmu.edu.

This work was created in the performance of Federal Government Contract Number FA8721-05-C-0003 with Carnegie Mellon University for the operation of the Software Engineering Institute, a federally funded research and development center. The Government of the United States has a royalty-free government-purpose license to use, duplicate, or disclose the work, in whole or in part and in any manner, and to have or permit others to do so, for government purposes pursuant to the copyright license under the clause at 252.227-7013.





A-10 Thunderbolt II (Warthog) SYSTEMS ENGINEERING CASE STUDY

David R. Jacques, PhD, LtCol USAF (Ret)
Dennis D. Strouble, PhD



Air Force Center for Systems Engineering (AFIT/SY)
Air Force Institute of Technology
2950 Hobson Way, Wright-Patterson AFB OH 45433-7765

Concept Definition: A Historical Perspective (Based on A-10 Systems Engineering Case Study)

23 Oct 08

David Jacques
Air Force Institute of Technology
(david.jacques@afit.edu)



Overview



- Mission Area Analysis Today - JCIDS
- Mission Area Analysis circa 1960's
 - The A-X Example
- A-X Concept Formulation
- Comparison and Contrast
- Air Force Center for Systems Engineering Case Studies



(U) NORTHROP
RECOMMENDED-DESIGN GENERAL ARRANGEMENT
(Figure UNCLASSIFIED)

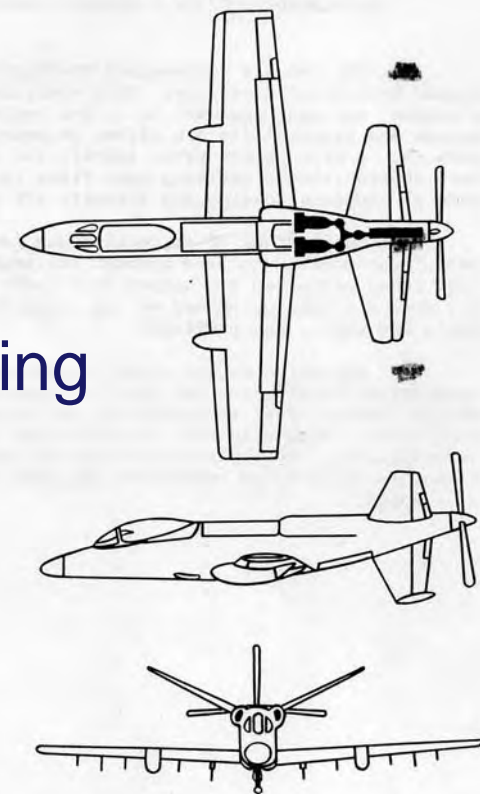



Decisions and Decision Making*



Decision – A Definition:

1. A choice from among a set of alternatives
2. An irrevocable allocation of resources

Steps in the Decision Making Process:

1. Formulation of preferences that, for the situation at hand, define good and bad and differentiate levels of goodness
2. Generation of a set of alternatives for consideration of choice
3. Evaluation of alternatives against the decision maker's preference
4. Selection of the preferred alternative in accordance with the decision maker's preference

* Drawn from several papers by G. Hazelrigg, appearing in the ASME Journal of Mechanical Design



Decision Making in Conceptual Design



- What are the operational capabilities that are needed?
- Should a conceptual design effort be undertaken?
- What mix of systems (legacy and new) are likely to achieve the desired operational capabilities?
- For materiel approaches (new systems), which system concept (usually a mixture of technologies) should be the basis of the design?
- Which technology for a given subsystem should be chosen?
- What existing hardware and software can be used?
- Is the envisioned concept technically feasible, based on cost, schedule and performance requirements?
- Should additional research be conducted before a decision is made?



JCIDS* Analysis

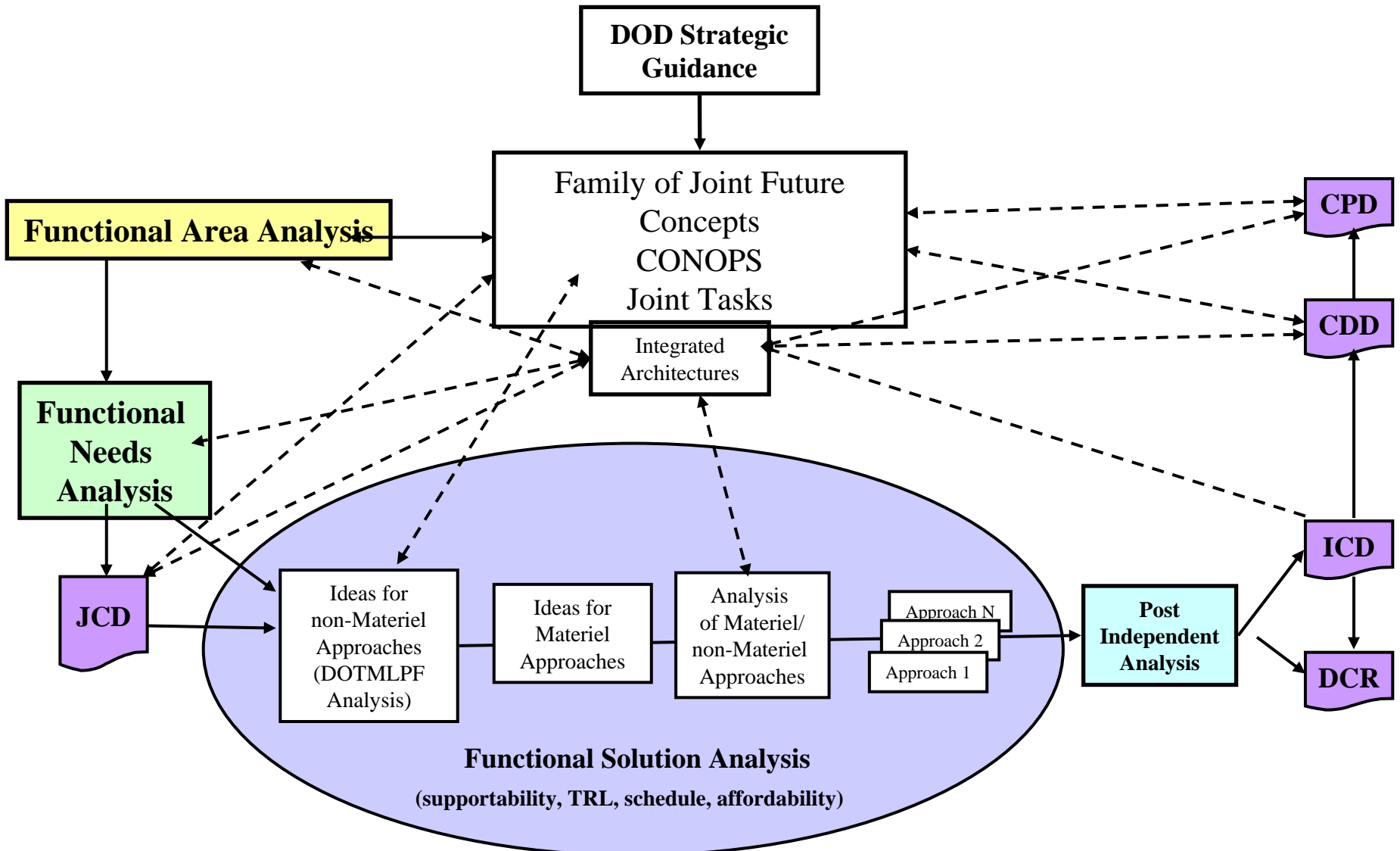

* Joint Capability Integration and Development System



What is an Architecture?



“The structure of components, their relationships, and the principles and guidelines governing their design and evolution over time.”
(IEEE STD 610.12 as stated in the *DoD Architecture Framework (DoDAF)*)

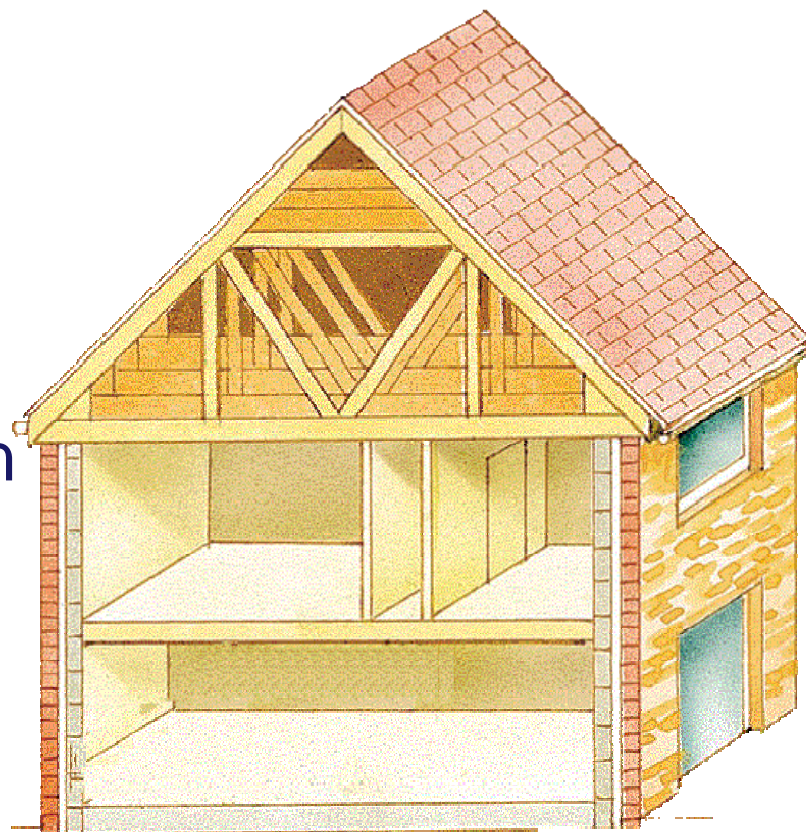

APXITEKTΩN (Greek) = Master Builder



Is JCIDS sound policy?



Recall our decision making process....

1. Formulation of preferences that, for the situation at hand, define good and bad and differentiate levels of goodness

FAA – Establish Tasks, Conditions, Attributes and Measures

2. Generation of a set of alternatives for consideration of choice

FNA considers current alternatives

Early FSA identifies future alternatives

3. Evaluation of alternatives against the decision maker's preference

FSA – Evaluates alternative approaches against FAA criteria

4. Selection of the preferred alternative in accordance with the decision maker's preference

Concept Decision based on FSA priorities and recommendations

This actually makes sense when you consider what is supposed to be done!



Is JCIDS Really New?



- The initial instruction (and manual) came out in 2003, but is it really new?
- Let's take a trip back in time – approximately 40 years – to the Close Air Support challenges of the 1960's





Lessons from Vietnam



- Air Force largely unprepared for Close Air Support (CAS) mission
 - A-1, A-37 had insufficient payload, loiter
 - Incompatible comm with ground units
- Army doctrine evolving towards air mobile tactics
 - Increased reliance on armed helicopters
 - Initiated development of AH-56 Cheyenne
- Johnson-McConnell Agreement
 - AF retained CAS mission, but recognized role of Army helicopters for fire support
 - Army gave up large fixed-wing transports





Task Definition



Three Mission Tasks

- Close Support Fire (CSF)
 - Armed Escort (AE)
 - Armed Reconnaissance (AR)
-
- CSF and AE were considered complementary
 - AR involved different weapons and acquisition systems, considered a secondary A-X mission due to parallel development of AC-130 gunship



The System of Systems Perspective

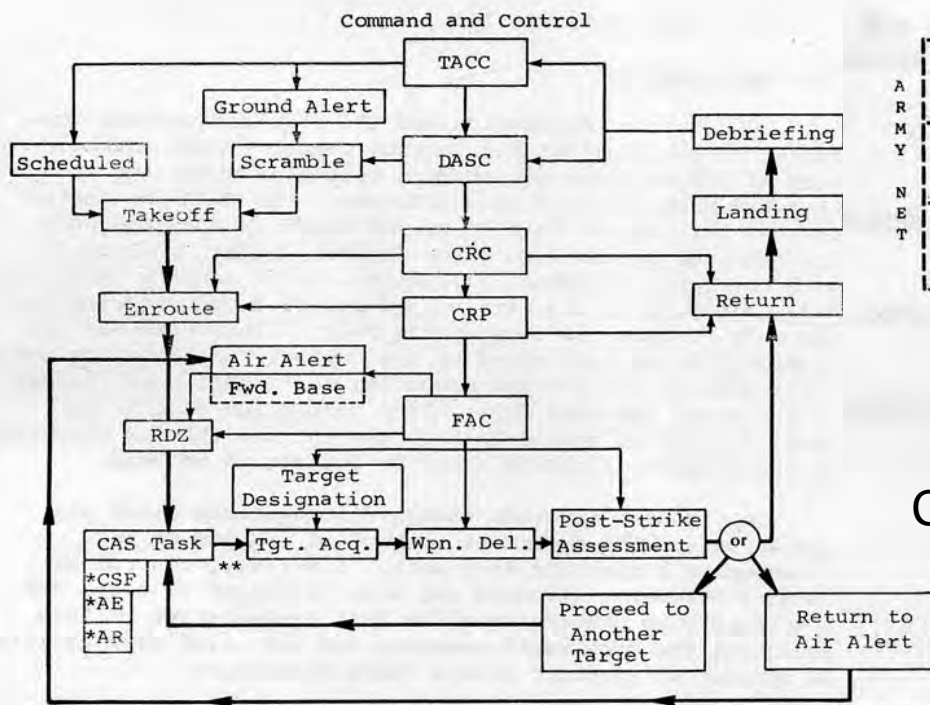

*AR—armed reconnaissance; AE—armed escort; CSF—close support fires
 **This sequence occurs every time with CSF and to varying degrees with AR and AE.

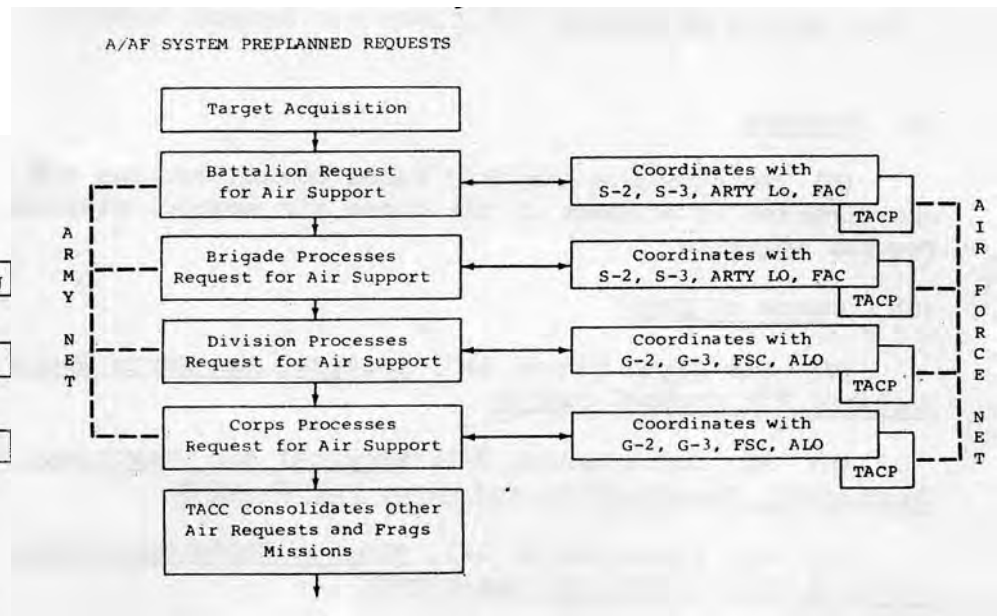

Coordination for Pre-Planned CAS Requests

But aren't these simply elements of a mission architecture?

The Tactical Air Control System (circa 1968)



Attributes and Measures



Only four key mission characteristics specified !

- **Responsiveness** considered not just speed, but basing locations, availability, loiter time over target, and ability to communicate with ground elements
- **Simplicity** emphasized ease of production, maintenance, and low cost
- **Lethality** made it clear that it was not an aircraft development effort, it was a weapon system development
- **Survivability** concerns would drive redundancy, component placement, protection systems, maneuverability, targeting systems, et.al.
- Mission characteristics drove performance parameters, which resulted in concept aircraft configurations
 - Alternatives evaluated against mission and cost effectiveness measures



Attributes and Measures (ctd.)

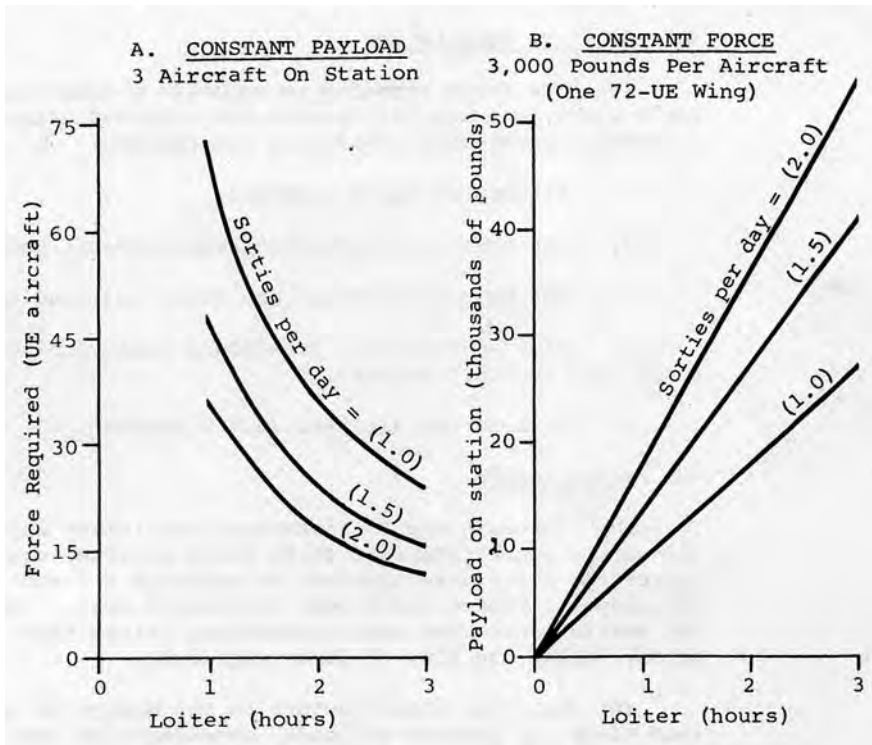

Impact of Loiter Time and Sortie Rate on Force Requirements

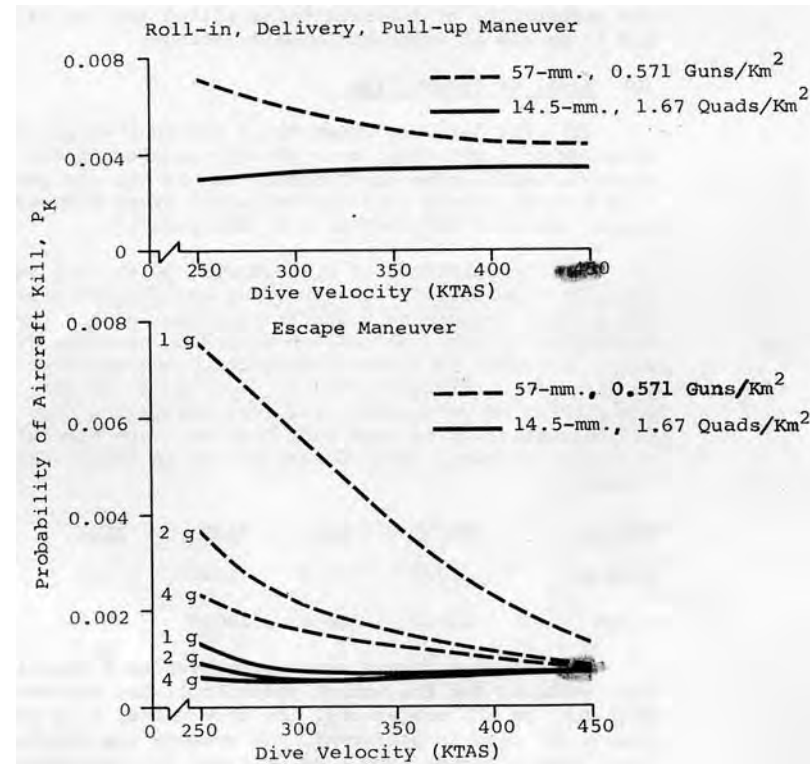

Relative Aircraft Attrition Versus Velocity and Maneuver

| | AFM 26-3
PLANNING MMH/FH | ACTUAL SEA
MMH/FH AVERAGE |
|--------|-----------------------------|------------------------------|
| F-4 | 30 | 33.2 |
| *F-105 | 40 | 27.6 |
| F-100 | 25 | 26.6 |
| F-5 | 17 | 15.5 |
| A-1 | 10 | 14.3 |
| A-37 | 7 | 7.8 |

Maintenance Man Hours/Flight Hour
for Vietnam era Aircraft



Capability of Existing Systems

- F-4, F-111 were the Air Force's primary tactical aircraft of the time
 - Both were expensive, and ill suited to CAS mission
- F-5
 - Initially the Air Force choice for a low-cost tactical fighter
 - Better air-to-air capability than A-7
- A-7D
 - Derivative of existing Navy aircraft
 - Favored by many in OSD, Congress
 - Could not carry a big gun, significantly lower loiter time
 - Would eventually be involved in a flyoff with A-10 prior to production decision
- Army Helicopters?
 - Roles and missions agreements prevented serious consideration



Aircraft Comparison



| | <u>A-1J</u> | <u>OV-10</u>
<u>(Impr.)</u> | <u>A-37B</u> | <u>A-X</u> | <u>A-7D</u> | <u>F-4C</u> |
|---|---------------|--------------------------------|----------------|--------------|--------------|----------------------------------|
| Operating weight empty (lb)
(includes crew, gun, ammunition) | 13,328 | 9,440 | 6,200 | 20,140 | 19,250 | 31,097
w/gun pod* |
| Internal fuel capacity (lb) | 2,280 | 3,680 | 2,974 | 7,000 | 9,750 | 12,818 |
| External load capacity—with FIF
(lb) | 9,392 | 4,394 | 4,826 | 16,860 | 14,000 | 14,085 |
| Maximum TOGW (lb) | 25,000 | 17,514 | 14,000 | 44,000 | 43,000 | 58,000 |
| Engines (number/type) | one
R-3350 | two
T-76 | two
J-85 | two
T-55 | one
TF-41 | two
J-79 |
| Useful load capacity (fuel and
ordnance—lbs) for takeoff
distance (Ground Run, S.L.,
Tropic Day) of: | | | | | | |
| 750 ft | 4,000** | 1,300** | 3,200** | 9,000 | -0- | -0- |
| 1,000 ft | 6,200** | 3,600 | 4,000** | 12,500 | -0- | -0- |
| Maximum speed, clean, S.L. (KTAS) | 277 | 262 | 417 | 400 | 607 | M 1.2 |
| Best cruise speed, 5,000 ft,
maximum ordnance (KTAS) | 170 | 170 | 265 | 240 | 315 | 420 |
| Ferry range, unrefueled (NM) | 2,800 | 2,600 | 1,560 | 2,600 | 2,600 | 1,600 |
| Number of ordnance stations | 15 | 7 | 8 | 10 | 8 | 5 |
| Internal guns (number/caliber) | four
20-mm | four
7.62-mm | one
7.62-mm | one
30-mm | one
20-mm | *(one
SUU-16
20-mm
pod) |

**Cannot land in this distance at any weight.



A-X Concepts



Requirements from Dec 1966 Requirements Action Directive

| Performance Parameter | Desired | Required |
|--|---------|----------|
| Gross Weight (lbs) | 22,500 | 30,000 |
| Payload - Mixed Ordnance (lbs) | 8,000 | 6,000 |
| Combat Radius (nautical miles) | --- | 200 |
| Loiter Time @ Combat Radius (hrs) | --- | 2 |
| Min Maneuvering Speed @ 5000 ft (knots) | 120 | 150 |
| Turn Radius @ Combat Weight (ft) | 1,000 | 2,000 |
| Max Speed @ Sea Level w/ Ext. Ordnance (knots) | 550 | 450 |

- Concept design studies conducted in 1967
 - Resulted in two government configurations, and four contractor configurations
- Concept determined to be feasible within existing technology
 - Most configurations used turbo-prop designs
 - Identified risk elements included gun/ammunition development and integration, and early IOC
 - Lean avionics packages defined to keep costs down
- Concept Formulation Package (predecessor to Initial Capability Document) completed in 1968



A-X Concepts



(U) GRUMMAN
RECOMMENDED DESIGN GENERAL ARRANGEMENT

(Figure UNCLASSIFIED)

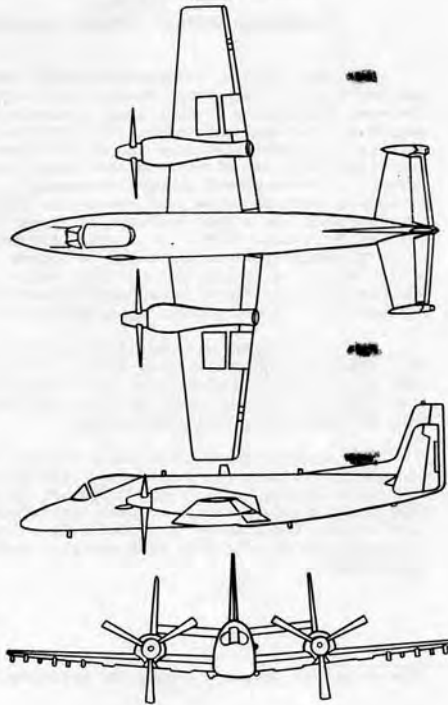

(U) GENERAL DYNAMICS
RECOMMENDED DESIGN GENERAL ARRANGEMENT

(Figure UNCLASSIFIED)

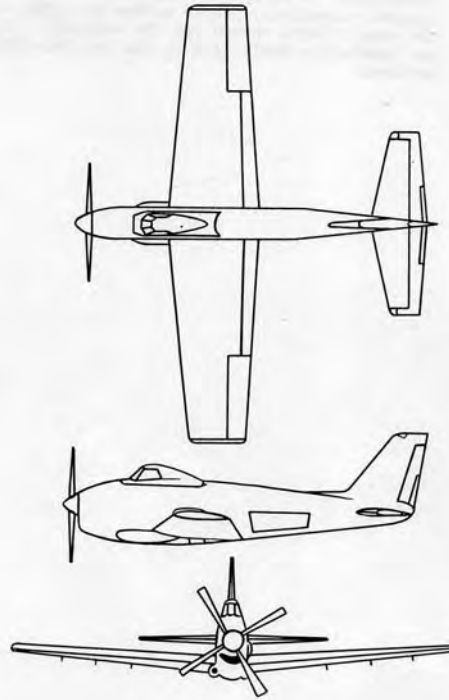

(U) McDONNELL DOUGLAS
RECOMMENDED DESIGN GENERAL ARRANGEMENT

(Figure UNCLASSIFIED)

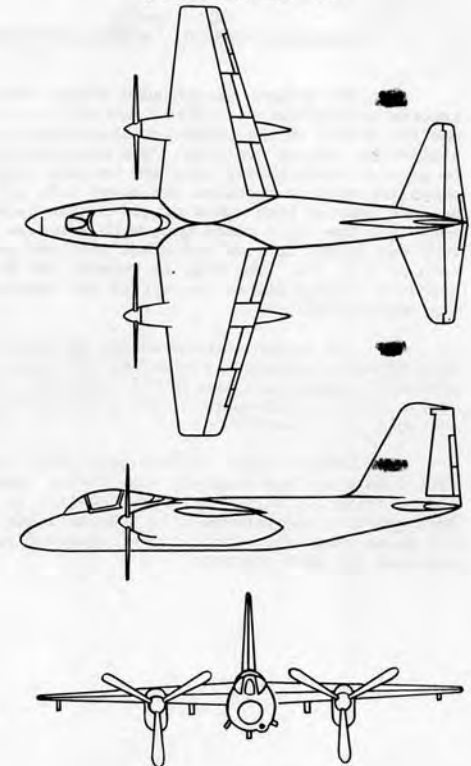

Notes: Significant design changes occurred during Concept Definition (now referred to as Concept Refinement)

- Single or twin turboprop propulsion gave way to twin turbofan (leveraged Navy S-37 aircraft development)
- Payload essentially doubled to 16,000 lbs – led to aircraft size/cost growth



JCIDS 40 Years Early?



Did the A-X concept formulation adhere to (in retrospect) JCIDS principles?

Yes ... , kind of ...

- Clear definition of tasks, conditions and measures (FAA)
- Consideration of a range of existing Air Force systems to provide the needed capability (FNA)
- Concept formulation traceable to previously defined tasks, conditions and measures (FSA)

Shortcomings

- No serious consideration of the full range of joint warfighting concepts to meet the capability needs



Summary



- The A-X concept formulation was rigorous and traceable to user needs
- While full consideration of joint concepts may not have been done, the emphasis was not on joint capabilities
- Aircraft has performed well, and is still in service today





Air Force Center for Systems Engineering Case Studies



Hubble Space Telescope

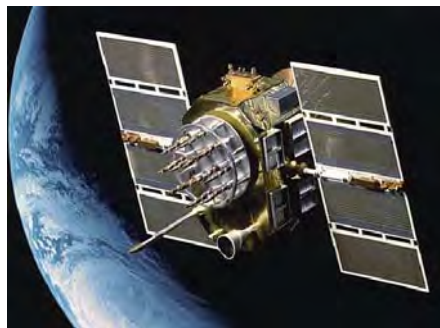

GPS (Global Positioning System)



F-111 Aardvark



C-5 Galaxy



B-2



A-10



Peacekeeper Intercontinental Ballistic Missile



TBMCS (Theater Battle Management Core Systems)

Website:

<http://www.afit.edu/cse/>



Ongoing & Future Case Studies



International Space Station



Underway

MH-53J/M Helicopter



FY09 Option

E-10



FY10 Option

Global Hawk



Underway

KC-135 Simulators



FY09 Start

T-6A Texan II



FY10 Start



Questions?





A-10 Thunderbolt II (Warthog) SYSTEMS ENGINEERING CASE STUDY

David R. Jacques, PhD, LtCol USAF (Ret)
Dennis D. Strouble, PhD



Air Force Center for Systems Engineering (AFIT/SY)
Air Force Institute of Technology
2950 Hobson Way, Wright-Patterson AFB OH 45433-7765

Sustaining Systems Engineering: The A-10 Example (Based on A-10 Systems Engineering Case Study)

23 Oct 08

David Jacques
Air Force Institute of Technology
(david.jacques@afit.edu)



Overview



- Systems Engineering in Sustainment Phase
- A-10 Development and Operational Service
- Aircraft Structural Integrity Program
- Structural Problems on the A-10
- HOG-UP/Service Life Extension
- Re-winging Decision and the A-10C
- Summary





SE Sustainment Activities



A Partial List:

- Execution of strategies for operations, sustainment and, when necessary, disposal
 - Maintain baselines, data, and supply chain
- Maintain Operational Suitability, Safety and Effectiveness
 - Monitoring and comparing performance and condition to design and prediction models
- Re-engineering of legacy system performance requirements and designs
- Decision analysis support for upgrades/mods and life extension decisions
 - May include modifications to maintenance concepts



Aircraft Structural Integrity Program (ASIP)



- ASIP Initiated in 1958
 - Monitor and evaluate structural health of AF aircraft
 - AFI-63-1001 requires plan, MIL-HDBK 1530 provides guidelines and details
- During 1970's and 80's
 - Damage Tolerance Assessments (DTA)
 - Inspection and modification programs
 - Fatigue tests on wing, fuselage, and full aircraft
 - Used to develop individual aircraft tracking program, and tech orders for inspection, maintenance and repair actions



A-10: Early Struggles



- Within the Air Force
 - Close Air Support (CAS) was considered less important than strategic bombing, air superiority, and interdiction
 - Tactical force mix required less expensive aircraft, but AF still favored fast multi-role fighters
 - F-5, A-7D were early choices for the CAS role
 - Reluctantly agreed to pursue specialized CAS aircraft





A-10: Early Struggles (ctd.)



Within the Army

- Unsatisfied with level of CAS provided by Air Force
- Doctrine evolving towards air mobile tactics
- Increased reliance on armed helicopters
- Initiated development of AH-56 Cheyenne
- Competed with AF for CAS development \$



Johnson-McConnell Agreement (1966)

- AF retained CAS mission, but recognized role of Army helicopters for fire support
- Army gave up large fixed-wing transports



A-10: The aircraft that almost wasn't!

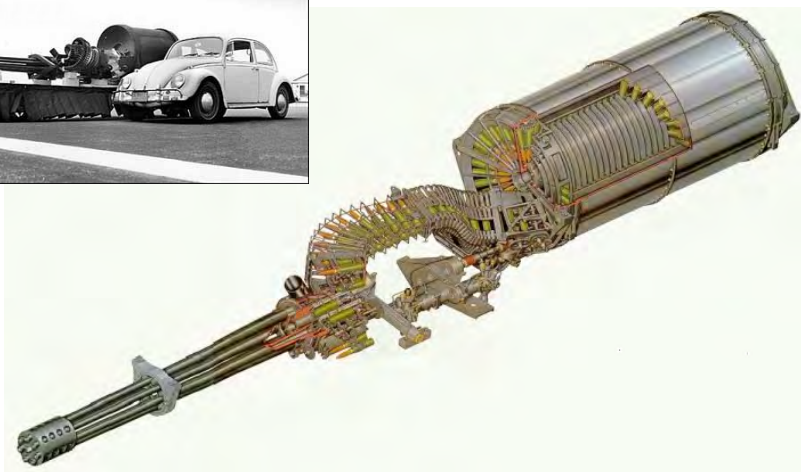

- Key sustainment features:

- Survivability – redundancy, shielded systems, engine placement
- Maintainability – interchangeable left/right side parts, simple skin panels, engine placement
- Cost Considerations – lean avionics (no night/adverse weather systems), ammunition cost reduction efforts



A-10 Deployment, and Debate



- Final production aircraft delivered in 1984
 - No service support for continued production (F-16 factor)
- Army Air-Land Battle doctrine
 - Greater reliance on Battlefield Air Interdiction (BAI)
 - Survivability concerns associated with greater SAM threat
 - By 1985, studies emerged suggesting an A-16 as a replacement for the A-10
- Defense Authorization Act for FY88-89
 - Directed completion of CAS/BAI Master Plan
 - Directed yet another CAS fly-off (A-10, F-16, A-7, AV-8, F/A-18)





Desert Storm



- Performance vindication
 - High effectiveness, and demonstrated survivability
 - High sortie rate, low maintenance man hours/flight hour
 - CAS F-16's performed poorly, reverted back to standard
- Post war decisions
 - Serious proposal floated by CSAF to give CAS and A-10 to Army in exchange for ATACMS, space mission, et.al.
 - AF decided to keep A-10, but in reduced numbers



A-10 Structural Configurations



| | | |
|----------------------------|---|---|
| Retrofit WOP Configuration | Intended for Aircraft 7-441 (not completed on all aircraft) | Thin wing center panel, cold worked at WS 0, Retrofit thick wing outer panel. Qualified to 6,000 hours Spectrum 3. |
| Production WOP | Aircraft 442-581 | Thin wing center panel, cold worked at WS 0, Production thick wing outer panel. Qualified to 6,000 hours Spectrum 3. |
| Thick Skin Configuration | Aircraft 582 and subsequent | Production increased wing center panel and outer panel thickness. Configuration qualified to 8,000 hour service life. |

Notes:

- Original design life was 6,000 flight hours
- Design load spectrum changed in 1977 based on measured fleet usage
- Fatigue test failed at less than 60% of new spectrum service life
- Resulting production and retrofit changes indicated above



ASIP Implementation



- Fairchild sold A-10 rights to Grumman in 1987
 - Fairchild ceases to exist shortly after
- Grumman delivers updated DTA and associated Force Structural Maintenance Plan (FSMP)
 - Never fully incorporated into tech orders, not accomplished
 - Difficulty with field inspections, budget constraints cited
- Analytical Condition Inspection (ACI)
 - Addressed some inspection locations, but on few aircraft
 - Cracks found in several locations in 1995, 96
 - Cracks classified as minor



And then, the wheels started to come off!



- 1994 – Northrop merges with Grumman
 - Although NG still the prime, most mods competed or done organically by government
 - “Fallout funds used to task NG to incorporate design changes into configuration baseline drawings...”
- 1995 Base Realignment and Closure (BRAC)
 - Closes McClellan AFB
 - Maintenance and repair operations moved to Hill AFB
 - Results in loss of 80% of experienced workforce by 2000
- 1997 – SPO competes prime sustainment contract
 - Lockheed Martin Systems Integration wins
 - NG expected to be part of team due to proposed LM-NG merger
- 1998 – LM-NG merger called off
 - NG reduced to supporting role



HOG UP



- 1998: Northrop Grumman delivers “A-10A Aircraft Wing Center Panel Rework-Fatigue Life Improvement” report
 - Detailed changes required to support 16,000 hour service life
 - Based on assumption that 1993 FSMP implemented
- 1999: SPO initiates HOG UP
 - Repair program vice modification
 - Allowed use of maintenance funding
 - Did not require acquisition approval
 - Configuration Control Board action not required
- HOG UP expands to catch other necessary changes
 - No composite assessment of structural risk
 - Cost growth from \$140M to \$600M, not including unprogrammed cost for WS-23 inspection and repair
 - No full-scale fatigue test to validate HOG UP



HOG UP Evolution



Hog Up 1999 and 2003

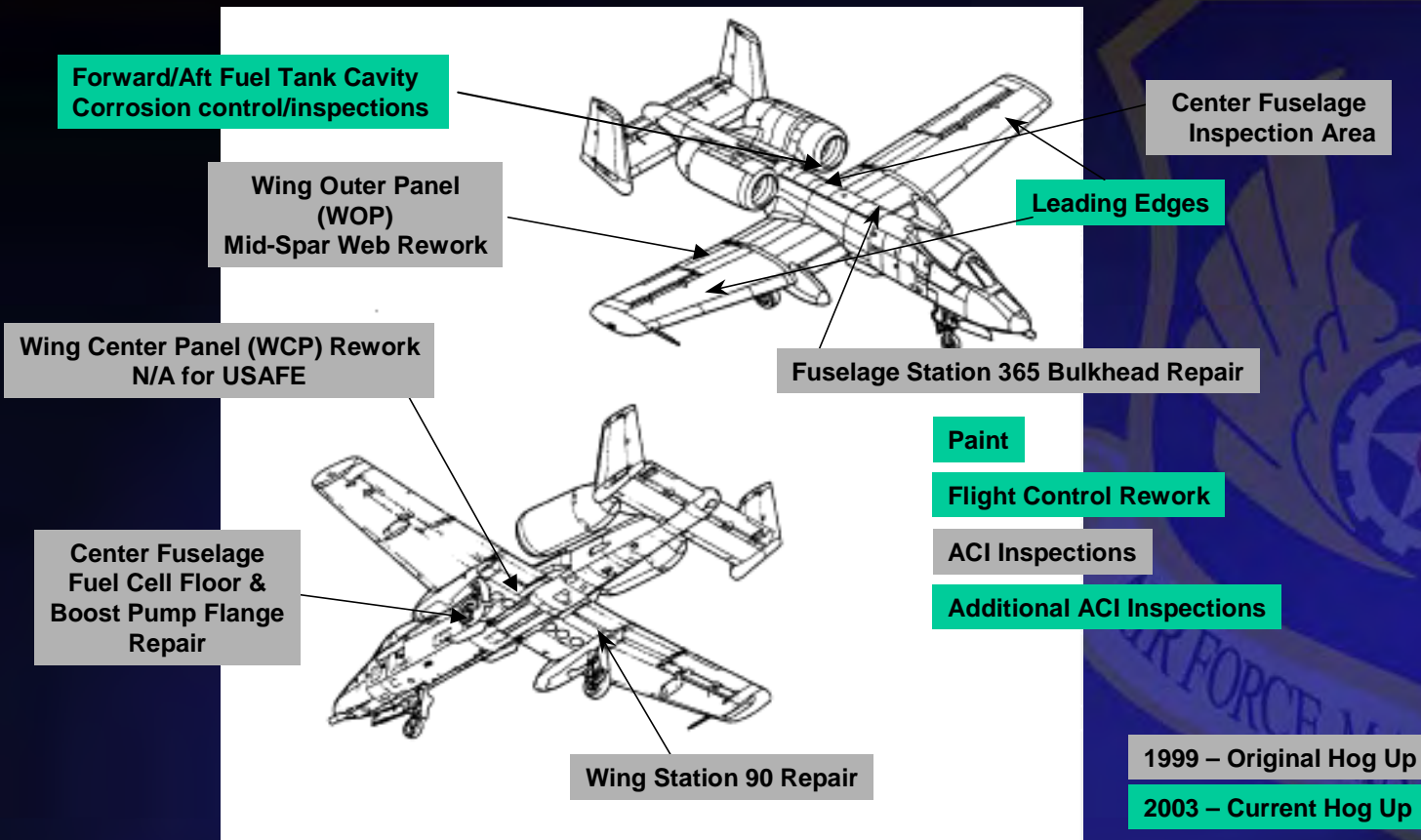



Sometimes, things have to get worse before they can get better!



- HOG UP delays due to WS-23 inspection and repair
 - Number of unusable wings higher than expected
 - Predictions that serviceable wings would run out by 2011
 - Back-up of aircraft in depot due to longer than expected repair times
- Catastrophic failure of HOG UP wing in fatigue test (2003)
 - Well short of 16,000 hour life expectancy
- 2005: AF completes business case analysis
 - Option 1: Organic sustainment of thin skinned wings, increase SLEP for all wings (\$4.6B)
 - Option 2: Buy 135 wings, increase SLEP for remaining wings (\$3.16B)
 - Option 3: Buy 242 wings and avoid cost of SLEP (\$1.72B)
- 2006: AF competes contract for new wings! (Option 3)
 - Boeing wins contract to build wings, to be installed on a Fairchild Republic aircraft, being maintained by Lockheed Martin!



Learning Principle 5*



Successful design, development and production is not enough to sustain a system throughout its life cycle.

- A-10 sustainment efforts were severely impacted by a number of factors
 - On-again, off-again retirement decisions
 - Vanishing prime contractor
 - BRAC, and general turnover of government personnel
- Loss of condition baseline led to initially poor decisions regarding life extension efforts
- A-10 sustainment has recovered, but after significant cost associated with the original HOG-UP program

* 6 Learning Principles are contained in the A-10 Case Study



A Second Life for a Modern Day Hog



- Low Altitude Safety and Targeting Enhancements (1990's)
- Embedded GPS/INS system added (1999)
- Precision Engagement (2005)
 - Results in A-10C Designation
- Replacement of TF-34 Engines (Proposed)





Air Force Center for Systems Engineering Case Studies



Hubble Space Telescope

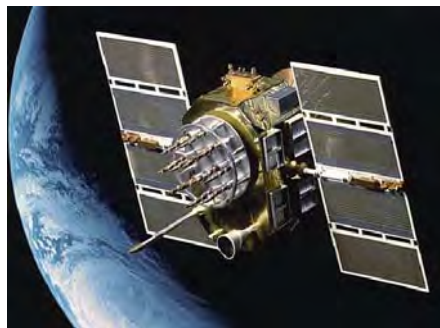

GPS (Global Positioning System)



F-111 Aardvark



C-5 Galaxy



B-2



A-10



Peacekeeper Intercontinental Ballistic Missile



TBMCS (Theater Battle Management Core Systems)

Website:

<http://www.afit.edu/cse/>



Ongoing & Future Case Studies



International Space Station



Underway

MH-53J/M Helicopter



FY09 Option

E-10



FY10 Option

Global Hawk



Underway

KC-135 Simulators



FY09 Start

T-6A Texan II



FY10 Start



Questions?





Improving Work Breakdown Structure (WBS) Guidance for Weapons Systems with Substantial Software

11th Annual NDIA Systems Engineering Conference

Christopher Miller

**supporting the
Office of the Deputy Director,
Software Engineering and System Assurance**

**SYSTEMS & SOFTWARE ENGINEERING
Office of the Deputy Under Secretary of Defense
for Acquisition and Technology
US Department of Defense**

October 2008



OUSD AT&L Organization

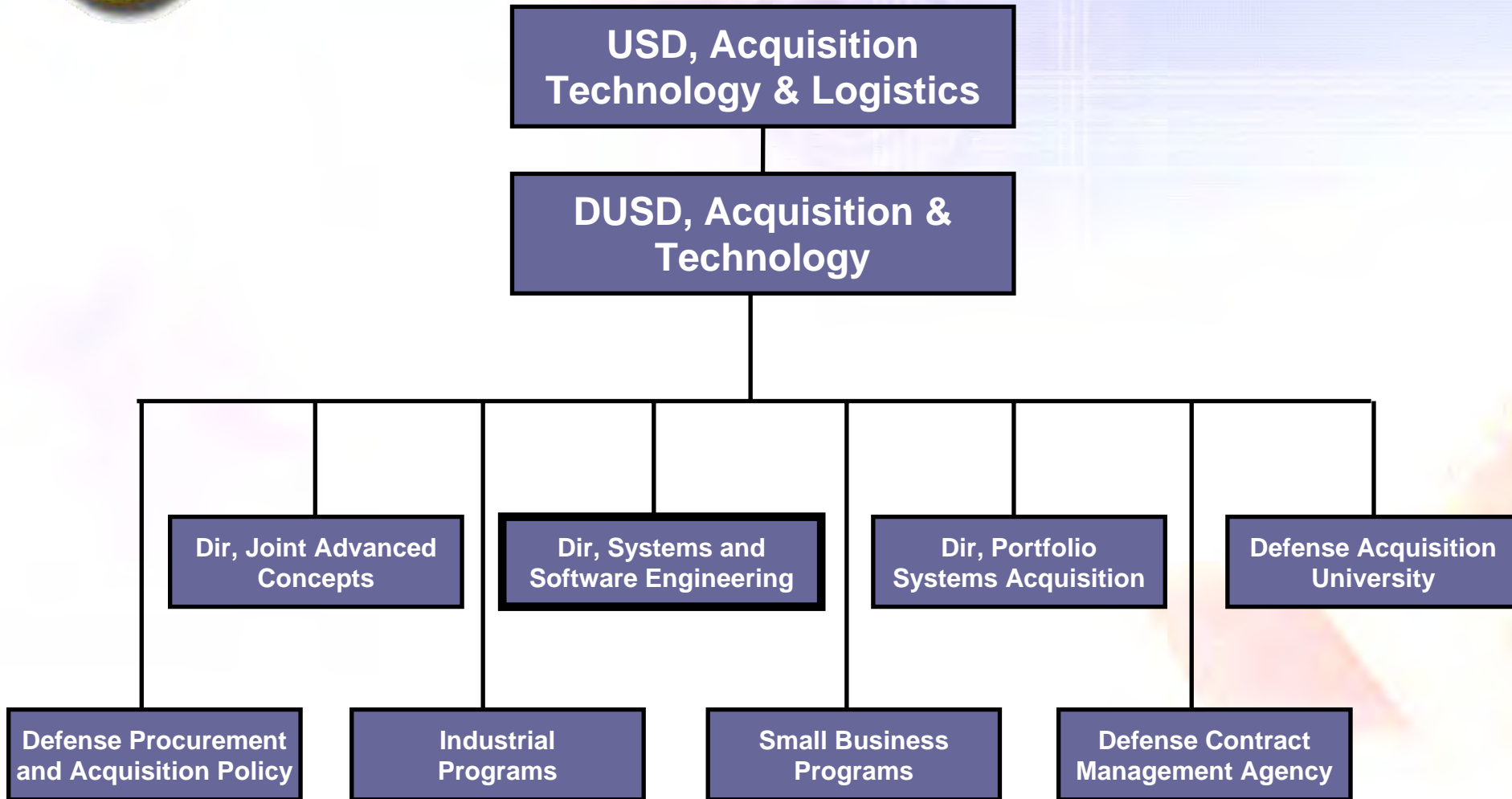



Systems and Software Engineering

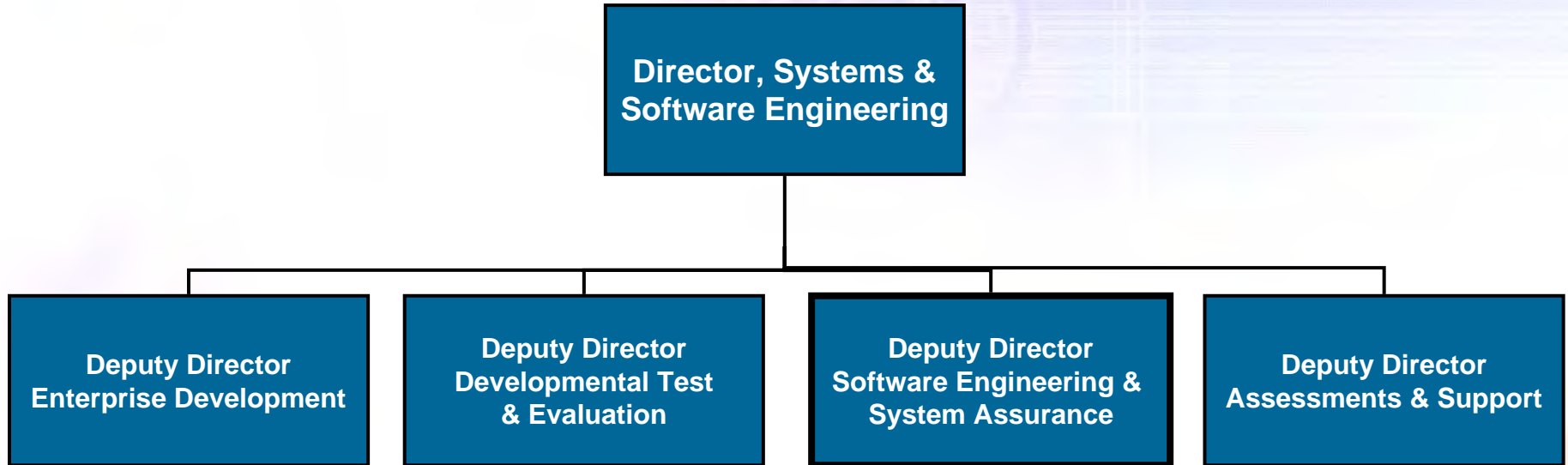

Notional View of Software Measurement

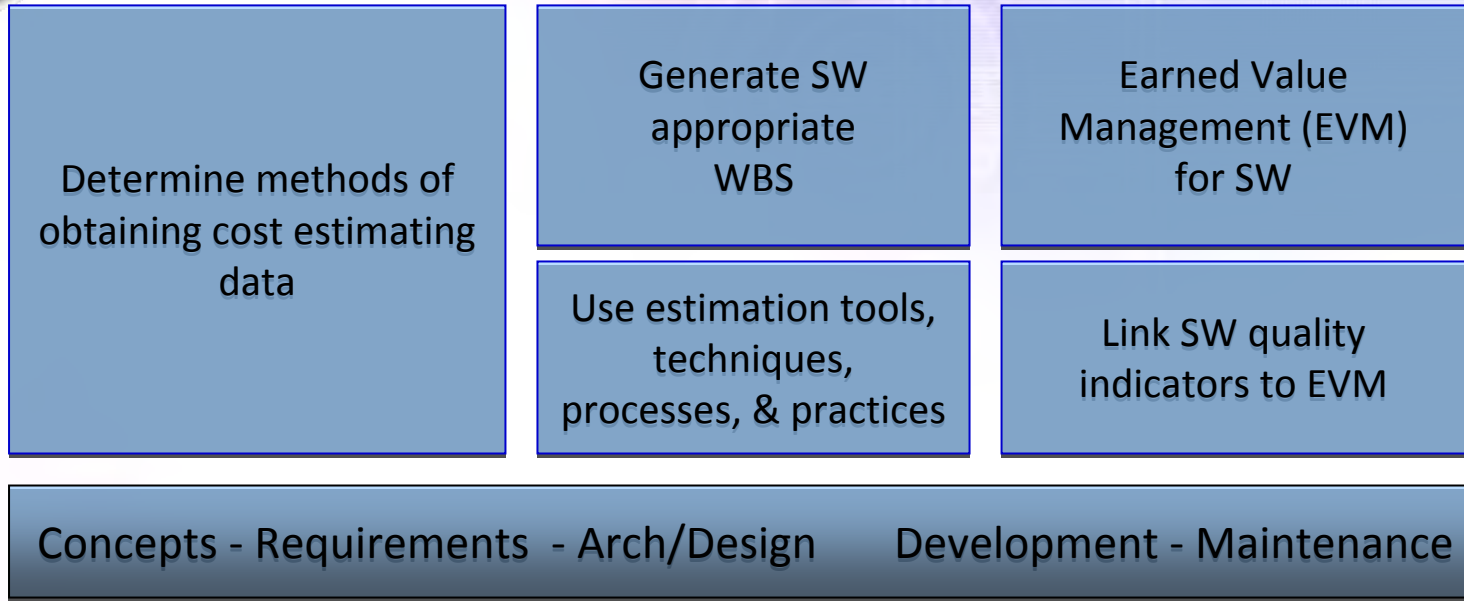

Software Engineering and Systems Assurance (SSA) initiatives

- Software Resources and Data Report: Feasibility Study
- **Revision of MIL-HDBK-881A to improve software guidance**
- Program feasibility analysis using estimation models
- Integration of software metrics with EVM to assess consistency of estimates



- Military Handbook 881A is the Department of Defense handbook on Work Breakdown Structures (WBS) for Defense Materiel Items
 - A WBS provides a consistent and visible framework for defining work and structuring contracts within a program
 - Approved guidance for DoD Departments & Agencies
 - Current version was released on 30 July 2005
 - MIL-HDBK-881A is controlled by the Office of the Undersecretary of Defense (Acquisition, Technology, and Logistics) (OUSD (AT&L)) Acquisition Resources and Analysis (ARA)

MIL-HDBK-881A due for update consideration



Software in MIL-HDBK-881A



- SSA initiated a Software Cost Control Working Group project to provide software recommendations
 - Including representation from the Services, DCMA, ARA, DAU, NDU, PA&E/DCARC and using NDIA software experts panel
- MIL-HDBK-881A revision objectives:
 - Make handbook acceptable of software engineering practice
 - Correct errors and inconsistencies
- Walkthrough of MIL-HDBK-881A revealed inconsistencies with respect to defense material items and software intensive systems development
 - Handling of System Development & Demonstration (SDD) phase software engineering activities is insufficient
 - Decision made to provide revisions versus complete rewrite



Comment Summary



- Notable changes:
 - Replace 'material item' with 'acquisition program'
 - Add words to make 'artifacts' equal to 'products'
 - Include words that make 'product-oriented' and 'DoDAF architecture' views acceptable WBS hierarchy structures
- Results
 - Compiled into Comment matrix
 - Drafted a new Appendix B for software

Comments by Severity

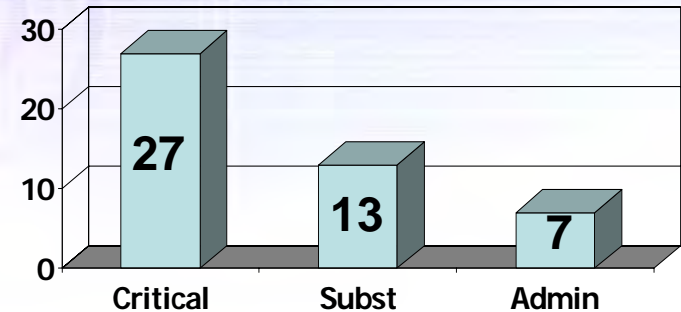

Critical comments directly support revision objectives

Substantive comments highlight incorrect, misleading, potentially unnecessary, or inconsistent text

Administrative comments captures typos, paragraph structure, etc.



Example #1 Revision



Comment Matrix Entry #16: Paragraph 1.7 WBS Evolution:

“For material item acquisitions, Since the system is mainly a concept at this point, it is not until the System Development and Demonstration (SDD) phase that the system is broken into its component parts and a detailed WBS can be developed. In the SDD phase, configuration items that describe the Program WBS are first identified and contracts can be awarded to develop these items. By the end of SDD, the WBS is fully defined to its lowest levels that best represents the system.

For software intensive systems and acquisition programs that involve procuring in single or very low volume, there needs to be a greater refinement of the engineering activities in the Technology Development phase within the Program WBS. For these types of acquisition programs, it is essential that both government and contractor can agree on a fully defined WBS at Milestone B, prior to entering SDD. “



Example #2 Revision



Comment Matrix Entry #25: Delete Paragraph 2.3.1 Specifications and Drawings:

“ The family of specifications and drawings, resulting from the progressive steps of the systems engineering process, provides the basis for the Program WBS, the Contract WBS, and its extensions.”

Rationale: For software intensive systems, specifications and drawing are products normally produced after PDR which is too late to drive the development of the initial Program WBS.



Overview of New Appendix B



- Leveraged text from draft MIL-HDBK-171
- Contains three WBS examples to encourage thoughtful tailoring based on project characteristics
- Emphasized use of standards and consistent use of terminology when defining WBS elements
- Maintained Appendix 'look and feel' as the other Appendices
- Included 'notes' to provide guidance on handling COTS and software development methodologies



MIL-HDBK-881A Project Summary



- Working group met our goal to provide a software community-coordinated set of recommendations to OUSD AT&L ARA as they began official review and update process
 - Maintained 'software' focus
- Reached out to industry members of NDIA to review the suggested changes
 - Validated recommended changes are improvements from industry perspective
 - Obtained additional examples to include in Appendix B
- Next steps will be determined based on results of ARA update (i.e., contents of MIL-HDBK-881B)

Questions/Discussion



Contact Information:

Christopher Miller

Software Engineering & Systems Assurance (SSA) Support

ODUSD(A&T) Systems & Software Engineering

Christopher.miller.ctr@osd.mil

The System Architecture Tradeoff Analysis Method[®] (SySATAM[®])

Mike Gagliardi and Bill Wood

® Architecture Tradeoff Analysis Method and ATAM are registered in the U.S. Patent and Trademark Office by Carnegie Mellon University.



Purpose of the System ATAM – 1

The System ATAM is a method that helps stakeholders ask the right questions to discover potentially problematic architectural decisions (risks)

Discovered risks can then be made the focus of mitigation activities—for examples:

- changing architecture
- further analysis
- extending prototyping.

Tradeoffs can be explicitly identified and documented

- Tradeoffs made already
- Upcoming tradeoffs



Purpose of the System ATAM – 2

The purpose is **NOT** to provide precise analyses. . . the purpose **IS** to discover risks created by architectural decisions.

We want to find *trends*: correlations between architectural decisions and predictions of system properties.



Presentation Outline

What is an ATAM?

Similarities and **Differences** between ATAM and System ATAM

Highlights of Differences

Experiences and results



Phase 2 – Stakeholders

The following is a partial list of potential stakeholders:

software architect

maintainer

tester

performance expert

security expert

project manager

customer (buyers, acquirers)

application builder

system administrator

service representative

system architect

developer

integrator

standards expert

reliability/availability expert

safety expert

product line manager

end user

mission specialist/planner

network administrator

domain representative

device H/W expert

What is an ATAM -1

Process

- Actors
 - sponsor (Program management) and architects (6)
 - Lead Evaluator – has lead evaluator training
 - Evaluation team (4)- all have taken ATAM training courses
 - Stakeholders (20)

Schedule

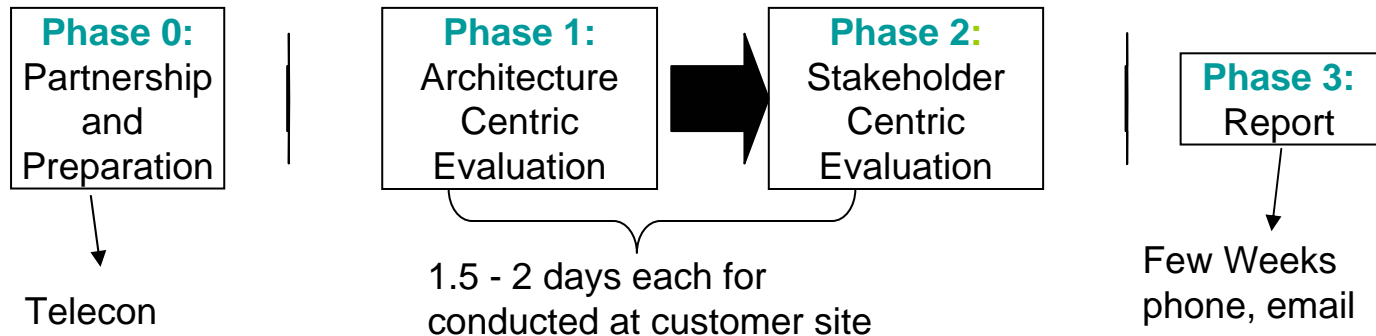

What is an ATAM -2

Technical Basis

- Business and Mission Drivers
 - New threats, capabilities, technology, automation, legacy
 - Scalability, schedules, budgets, joint, coalition, FMS
- There is a documented software architecture (SAD, UML Diagrams)
 - Multiple viewpoints, views, framework
- Quality attributes are the architecture drivers
 - Performance : avoid too slow, too late, bottlenecks
 - Availability : avoid fragility due to failures
 - Security : avoid spoofing, unauthorized access
 - Usability : avoid operator overload
 - Sustainability : avoid hard to update functions and new COTS
 - Interoperability, scalability, extensibility etc



What is an ATAM -3

Technical Basis (Continued)

- Scenarios represent the quality attributes
 - **Stimulus**, environment, **response**
 - “ A tank commander’s COP shows an identified threat, he has authorization to engage the threat, **when it comes within his range** he conducts a successful engagement and reports it via the COP”.
 - Elicited in a meeting with stakeholders (or from previous QAW)
- Architectural approaches can be identified and analyzed
 - Passive and active redundancy, publish/subscribe, client/server, reliable protocol
- Architectural Decisions
 - Provide a tool to assist with mapping spectrum allocation to force structure
 - Break down a system into components for transportation
 - Use a proxy-based pub/sub



What is an ATAM - 4

Technical Basis (Continued)

- Walking scenarios through the software architecture, and having the ATAM team and stakeholders probe the quality attributes exposes **architectural risks** and maps each risk to business drivers
- These risks can be “rolled up” into **risk themes** mapped to business drivers

Results- content

- A number of scenarios (10 to 15) are analyzed and documented
- Table of **risks**, **trade-offs**, **programmatic issues**, **atta-boys**
- Rollup of the risks into **risk themes**

Results- documents

- Summary Outbriefing after Stakeholder Phase (1 hour)
- Report (50, 60 pages) of findings with an Executive Summary (2 pages)



Commonalties and Differences -1

The System ATAM (including software) basically conforms to the ATAM process, technology, and results as follows

| | | |
|-----------|--|--|
| Process | Actors | System and Software Architects
Fast Tracking of subject matter experts (SME)
SM designers |
| | Phases | More careful scoping (what's in, what's out) |
| Technical | Architecture | Need system (block diagrams) and software architecture views and white papers |
| | Quality Attributes | A few additional QA (transportability, shake and bake, force modularity, spectrum management) |
| | Scenarios | Stress system aspects as well as software |
| | Analysis | Combination of system and software architects
System Architectural Approaches |
| Results | No differences in either the outbriefing or the report | |



Highlights of Experiences -1

ATAM

- Four 2 day courses providing the basic software architecture knowledge, including an ATAM team lead evaluator course
- Have conducted numerous ATAMS
- Have an ATAM Reference Guide for the team
- Have extensive set of templates to assist the team in all activities
- External organizations (commercial, DoD contractors) have qualified leads

SySATAM

- Have a process in-place for conducting SySATAMs
- Still in piloting Phase- have conducted 2 SySATAMs
- Have extensive set of templates to assist the team in all activities



Highlights of Experiences -2

SME Experiences

- On one system an Evaluation Team member was also an SME
- On the other the SME was a seasoned Mechanical Engineer and a domain expert
 - Took the SME training
 - Evaluation team had to initially prompt the SME for risks.

New Quality Attributes and associated risks

- Force Modularity, Mobility, Spectrum Management
- Logistics, installation, mechanical checks

New Considerations

- DoDAF operational views
- experimental simulation and analysis results
- white papers
- Manual versus automated activities are more prevalent



Highlights of Experiences -3

Architectural Representations

- System architecture documentation consists mainly of block diagrams and sequence diagrams and some DoDAF lower level views

Stakeholders

- System engineers tend to trump the software engineers
- Good exercise for system and software arch and eng to get on the same page

Surprises

- Preparation phase was easier than expected, scoping was straightforward



Highlights of Experiences - 4

Typical Risk Themes

- There are a number of significant system engineering issues that require further analysis as a basis for architectural decision
- CONOPS for Using Programs has not been updated/supplemented to take this system into effect
- Architectural support for flexibility is powerful. However, without careful management of flexibility it could become overly complex and impose an unnecessary cognitive burden on users.
- Approach to automate and reduce test time not thought out
- Fault Tolerance approach needs to be developed



Conceptual Flow of ATAM

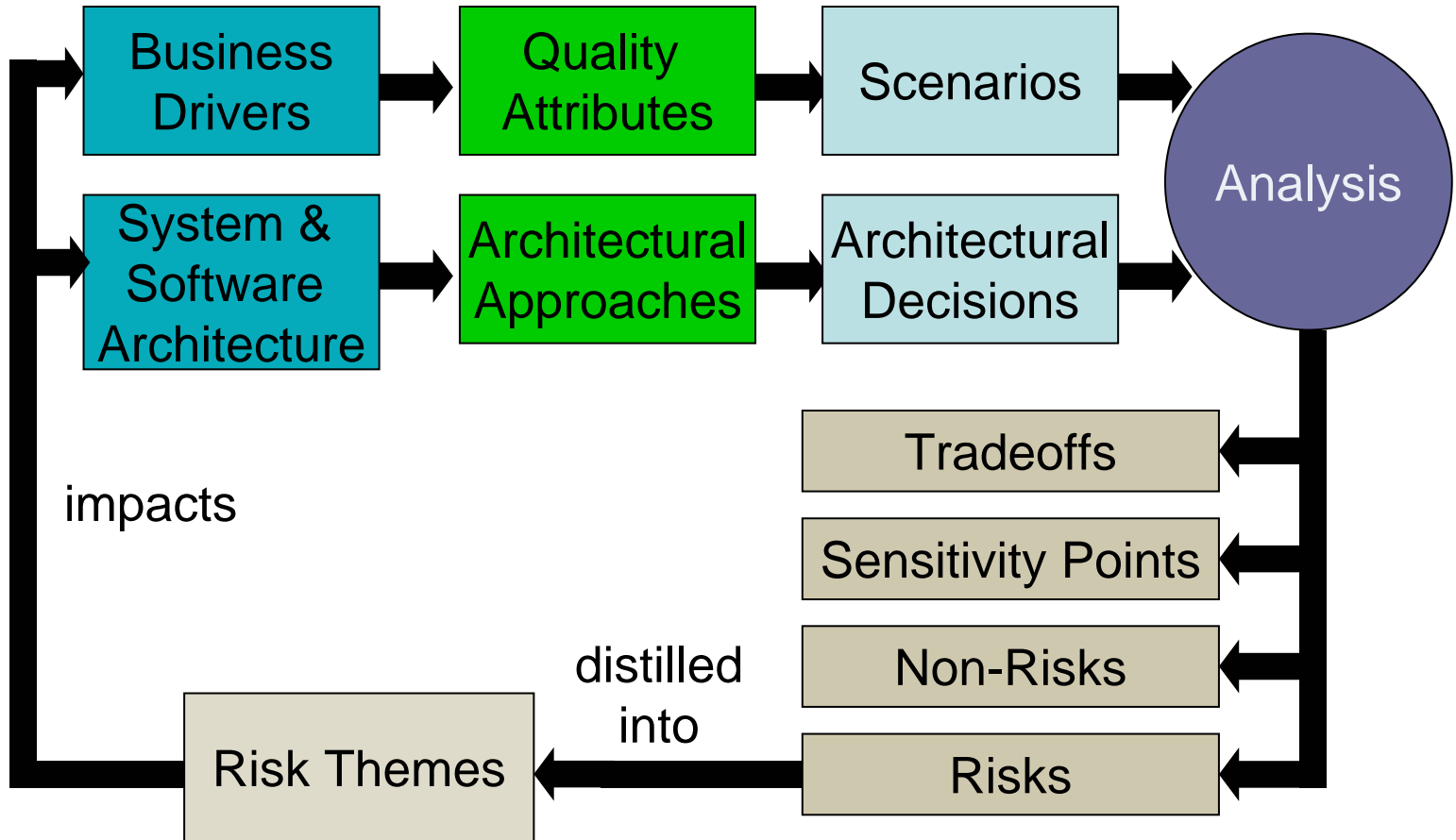

Conclusion

System ATAM is a natural extension to the ATAM

- Basic approach works just fine

SME is needed with functional/domain expertise

- Fast track training was effective

Risk Themes identified areas to help the programs choose what to explore to firm up the architecture

- Both software and system risks were revealed

Have been too busy “doing” to develop lessons learned

- But need to do more pilots first



For Additional Information

Jay Douglass
Business Development
Product Line Systems Program
Telephone: 412-268-6834
Email: jcd@sei.cmu.edu

Linda Northrop
Director
Product Line Systems Program
Telephone: 412-268-7638
Email: lmn@sei.cmu.edu

Technical Details:
Mike Gagliardi
Product Line Systems Program
Telephone: 412-268-7738
Email: mjg@sei.cmu.edu

U.S. Mail:
Software Engineering Institute
Carnegie Mellon University
4500 Fifth Avenue
Pittsburgh, PA 15213

World Wide Web:
<http://www.sei.cmu.edu/architecture>

SEI Fax: 412-268-5758



DoD Software Engineering and System Assurance



Kristen Baldwin

Deputy Director, Software Engineering and System Assurance

**Office of the Under Secretary of Defense
Acquisition, Technology and Logistics**

Elements of AT&L Strategy for Software



- Support Acquisition Success
 - Ensure effective and efficient software solutions across the acquisition spectrum of systems, SoS and capability portfolios
- Improve the State-of-the-Practice of Software Engineering
 - Advocate and lead software initiatives to improve the state-of-the-practices through transition of tools, techniques, etc.
- Leadership, Outreach and Advocacy
 - Implement at Department and National levels, a strategic plan for meeting Defense software requirements
- Foster Software Resources to meet DoD needs
 - Enable the US and global capability to meet Department software needs, in an assured and responsive manner

Promote World-Class Leadership for Defense Software Engineering



Top Software Issues*

1. The impact of requirements upon software is not consistently quantified and managed in development or sustainment. **“Requirements”**
2. Fundamental system engineering decisions are made without full participation of software engineering. **“SE/SW Integration”**
3. Software life-cycle planning and management by acquirers and suppliers is ineffective. **“SW Sustainment”**
4. The quantity and quality of software engineering expertise is insufficient to meet the demands of government and the defense industry. **“Human Capital”**
5. Traditional software verification techniques are costly and ineffective for dealing with the scale and complexity of modern systems. **“SW Testing”**
6. There is a failure to assure correct, predictable, safe, secure execution of complex software in distributed environments. **“SW Assurance”**
7. Inadequate attention is given to total lifecycle issues for COTS/NDI impacts on lifecycle cost and risk. **“SW COTS/NDI/Reuse”**

***NDIA Top Software Issues Workshop
August 2006**



OSD Software Systemic Analysis

- OSD(AT&L)/SSE Systemic Analysis Database
- Current Dataset: 68 reviews on 38 different ACAT 1D systems acquisition programs since early 2004
 - Approx 4,000 findings from these reviews placed into formal database repository
- Data extracted using the following key words:
 - Software
 - Systems-of-Systems (SoS)
 - Assurance
 - Architecture
 - Security
- 600+ findings resulted from the keyword search



Data Validation

- Data validation was conducted to:
 - Remove any extraneous records from the resulting report unrelated to SW
 - Ensure that positive, neutral, and negative findings were identified properly
- Resulted in 284 Directly Software Related Findings

Software Related Findings
Total: 284

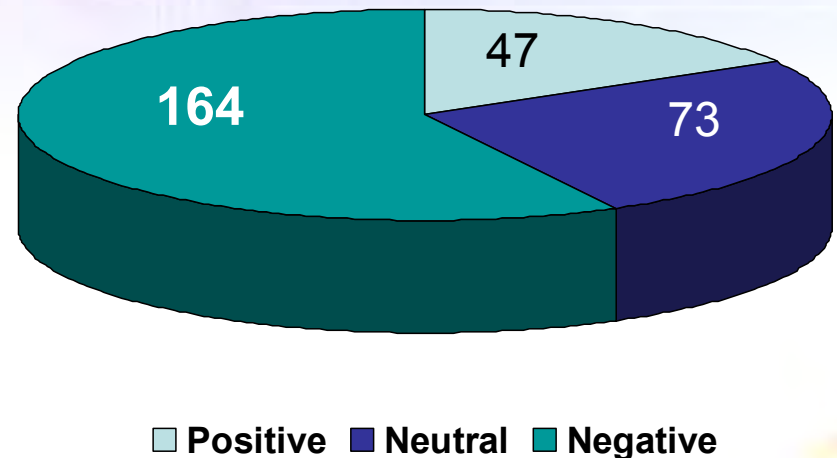

We examined these software findings without a predefined taxonomy in order to allow issue areas and recurring trends to emerge

What leads to Software Problems in DoD Programs?



 Tier 1 Trends – Level 1
 Tier 1 Trends – Level 2
(Derivative of Tier I Trend)
Last Updated: August 2008

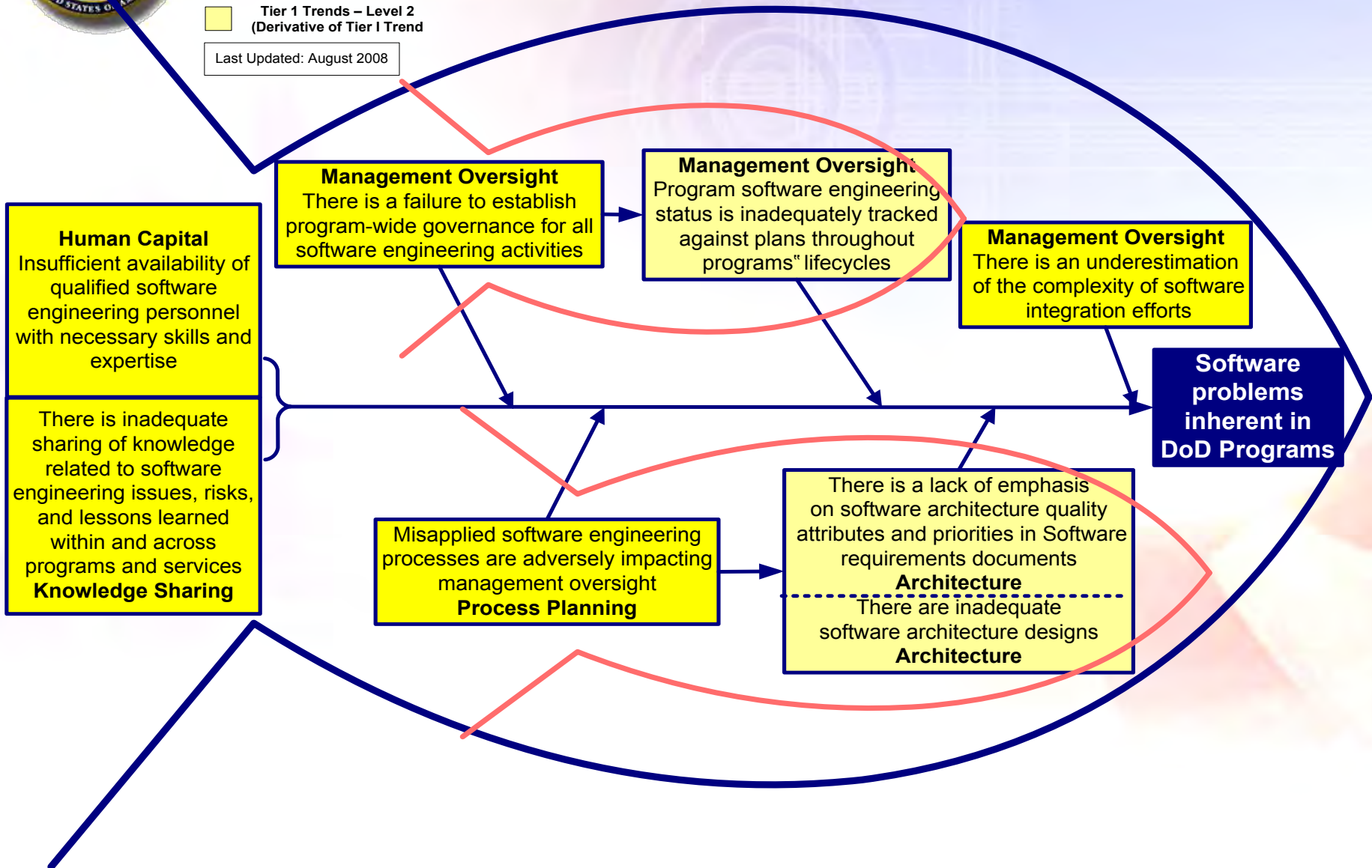



Detailed Results of Overarching Trends

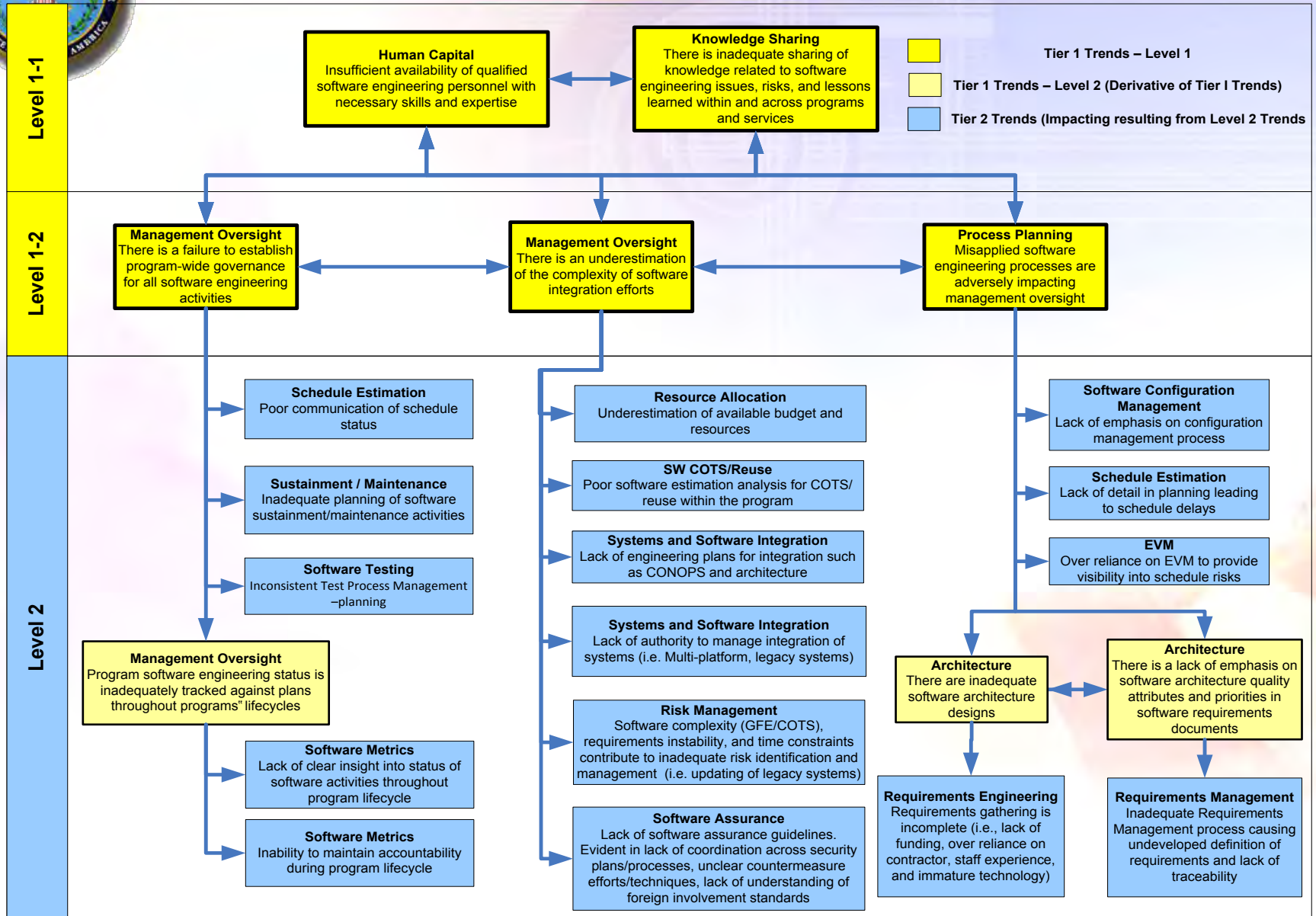

NDIA/DUSD(A&T)SSE Issues Validation



National Defense Industrial Association (NDIA)
Top 7 Software Issues
August 2006

DUSD(A&T) SSE Directorate
Program Review Software Systemic Analysis Findings

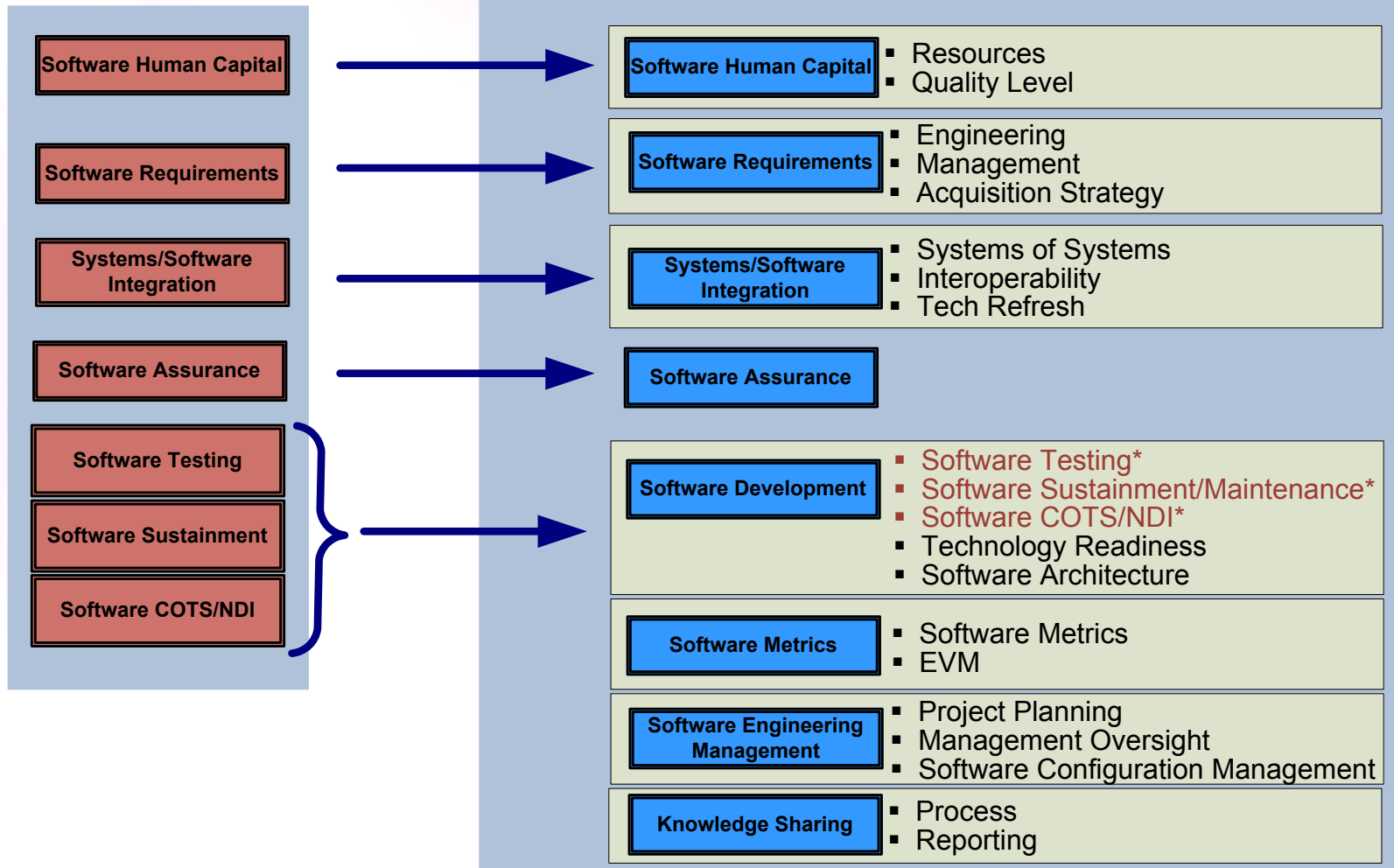

SW Roundtable Results



- Shared Army, Navy, Air Force software strategies
 - Found synergy in many areas
- Identified/prioritized 22 proposed initiatives to tackle software issues – Top 5 of these:
 - Synergize/Harmonize "core SW metrics" across DoD; develop approaches for incorporating them into gate reviews, processes, earned value
 - Organize start-up teams and infrastructure to facilitate software program success
 - Establish SE/SW architecture "review board" to engage early with programs and provide constructive suggestions
 - Define analysis process for reuse/reusable assets to improve estimation accuracy; including consideration of product features
 - Develop approaches for SW testing and evaluation to enable mission success

ODUSD(A&T) SSE/SSA Way Forward



- Goal: Prosecute top software and assurance issues
- SSA FY08/09 Activities:
 - SW Lifecycle Touchpoints: SW guidance to complement Enhanced SE and SE Technical Reviews
 - SW Human Capital Strategy: Graduate-level and DoD acquisition workforce software curricula
 - SE/SW Integration: Design a framework to define and measure integration. Partnership with academia, industry
 - SW Measurement: Guidance on collection and use of SW Data
 - SW Test, SW Reliability: New in FY09
 - System Assurance: SA Guidebook; Program Protection Policy/Guidance, DIB Cyber Security Strategy



DoD SW Community Way Forward

- Review all initiatives to determine opportunity for collaboration/augmentation
 - DoD Software Working Group
 - NDIA Software Expert Panel
- Discuss plans for individual initiatives (top 5) on Collaborator teleconferences
- Organize collaborator events for FY09
 - Focused working groups/workshops as appropriate
- Continue to increase software visibility in NDIA SE Conference
 - Plan event for FY09

Increased Priority for System Assurance



- *Threats*: Nation-state, terrorist, criminal, rogue developer who:
 - Gain control of IT/NSS/Weapons through supply chain opportunities
 - Exploit vulnerabilities remotely
- *Vulnerabilities*: All IT/NSS/Weapons (incl. systems, networks, applications)
 - Intentionally implanted logic (e.g., back doors, logic bombs, spyware)
 - Unintentional vulnerabilities maliciously exploited (e.g., poor quality or fragile code)
- *Consequences*: Stolen critical data & technology; corruption, denial of critical warfighting functionality

System Assurance is the confidence that the system functions as intended and is free of exploitable vulnerabilities, either intentionally or unintentionally designed or inserted during the lifecycle



Program Protection - The Road Ahead

- DoD System Assurance
 - Evolved from Software Assurance Efforts
 - Creates a „framework“ to integrate multiple security disciplines and policies
 - Leverages 5200.39: expanding CPI definition to include system assurance and total life cycle
- DoDI 5200.39 CPI: Three Categories of CPI:
 - Information, Technology, Components
- Programs will
 - Define CPI at Milestone A
 - Develop a Program Protection Plan (PPP) for Milestone B
 - Be Subject to Review and Oversight
 - Execute mitigation strategies (such as use of Trusted Foundries or Anti-Tamper)



Engineering for System Assurance

- “Engineering for System Assurance” V1.0 Guidebook signed out at NDIA October 1, 2008
- Posted on SSE Web site at:
 - <http://www.acq.osd.mil/sse/ssa/guidance.html>
- Provides guidance on how to address System Assurance through Systems Engineering processes
 - Aligns to DoD acquisition lifecycle processes with actionable criteria
 - Adds emphasis to ISO/IEC 15288 SE processes
- Enhanced IA focus and alignment with current processes
 - Focus on hardware, software and operational environment
 - Dovetails with Program Protection Planning (PPP) processes
 - Supports identification of trusted foundry resources
 - Informs Anti-tamper considerations



Expanding DoD Industry Partnership

- Acquisition Cyber Security is a long term interest for DoD
 - Fully anticipating Cyber Security is expected to be a ongoing priority for the new administration
- DoD will continue to take advantage of the global marketplace and COTS solutions
 - Engineering for System Assurance seeks to identify and fortify critical components allowing
- Industry is part of the solution
 - NDIA System Assurance Committee will continue to focus on the solution strategy
 - ITAA, GEIA, INCOSE, others all participate on this committee



Questions

Implications of Capability-based Planning on Requirements Engineering

Leonard Sadauskas

Presented at

NDIA SE Conference

Requirements Development & Management Session

22 October 2008

Disclaimer

The views and opinions expressed in this presentation are those of the author and do not reflect the policy of the Department of Defense

Scope of this Presentation

- Capability-based planning
- The problem and solution space interface
- The dual roles of measures of effectiveness (MOEs)
- Capability feedback process
- Issues, challenges and trends

Definitions

- **Capability-based planning (CBP):**
 - An overarching framework for planning under uncertainty that provides capabilities suitable for a wide range of modern-day challenges and circumstances while working within an economic framework that necessitates choice
- **Capabilities-Based Assessment (CBA)**
 - Study that identifies the capabilities (and operational performance criteria) required to successfully execute missions
- **Capability:**
 - The ability to execute a specified course of action
 - Move troops rapidly

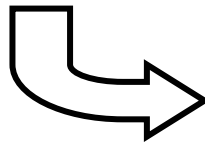

Candidate Solutions:

- **Truck**
- **Ship**
- **Aircraft**

Capabilities-based Planning Framework (work in progress since 2003)

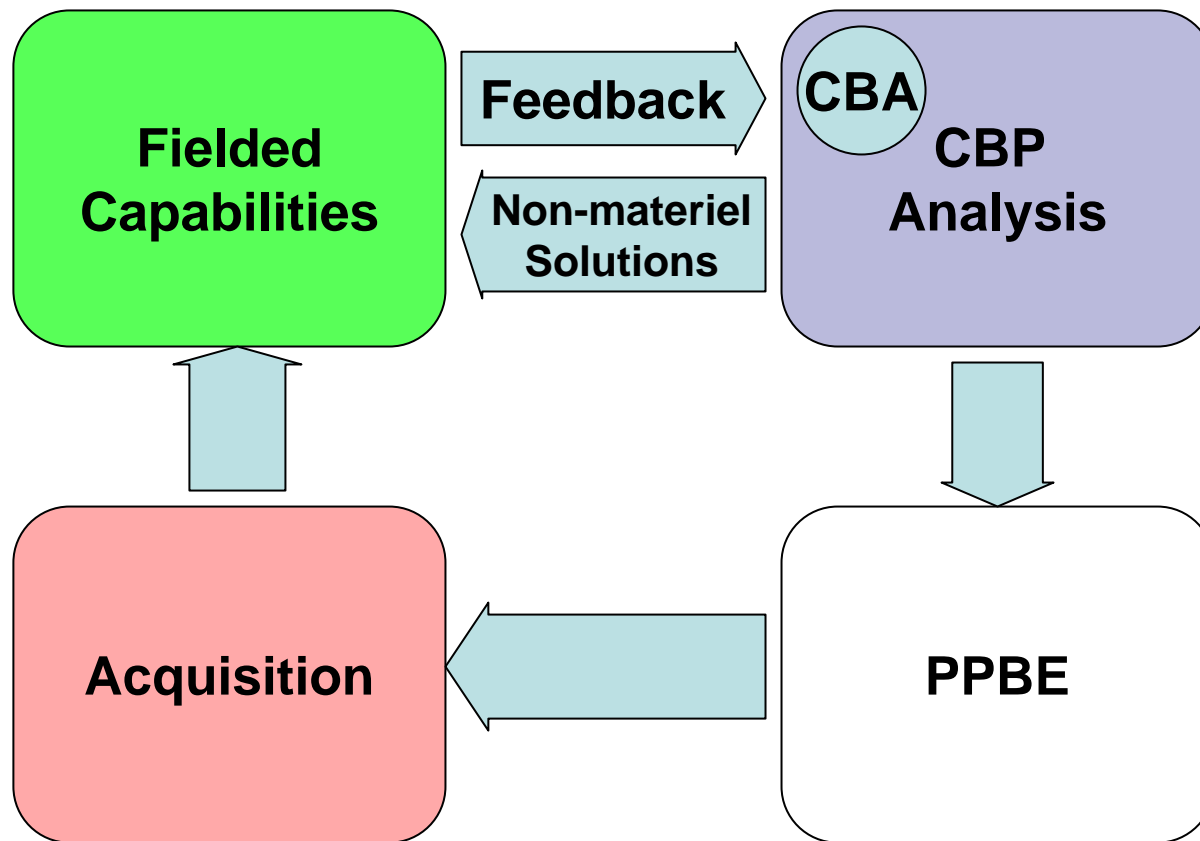

Focus of this Presentation

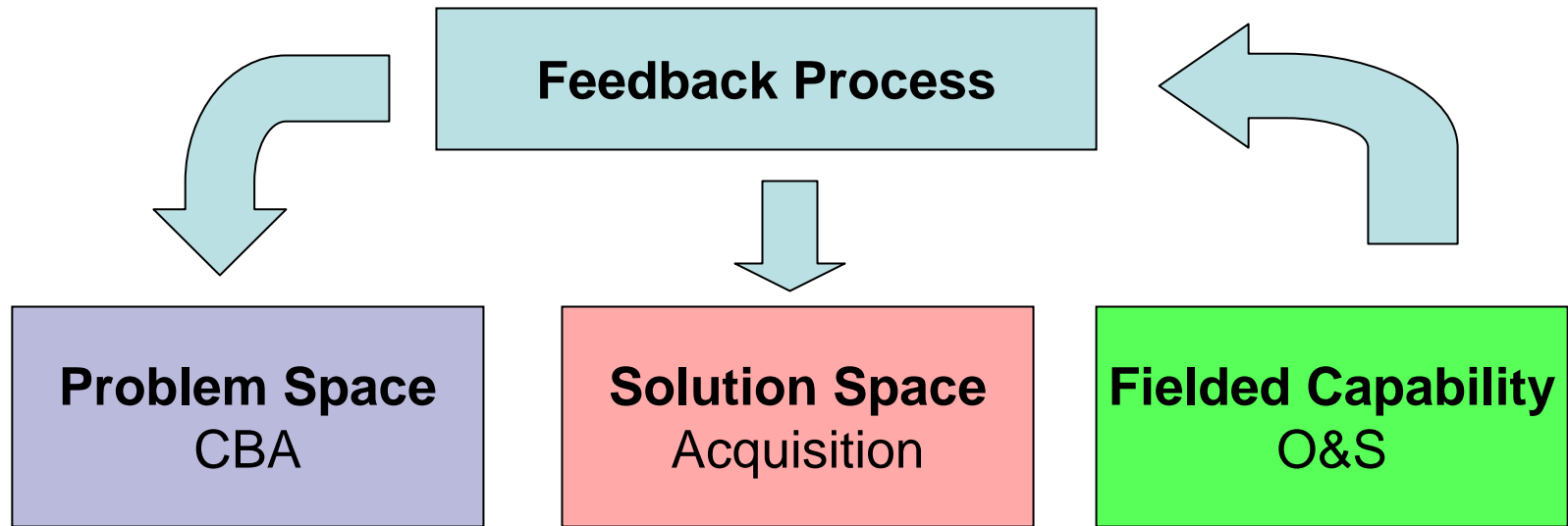

Draft CJCSI 3170.01G JCIDS Process and Acquisition Decisions

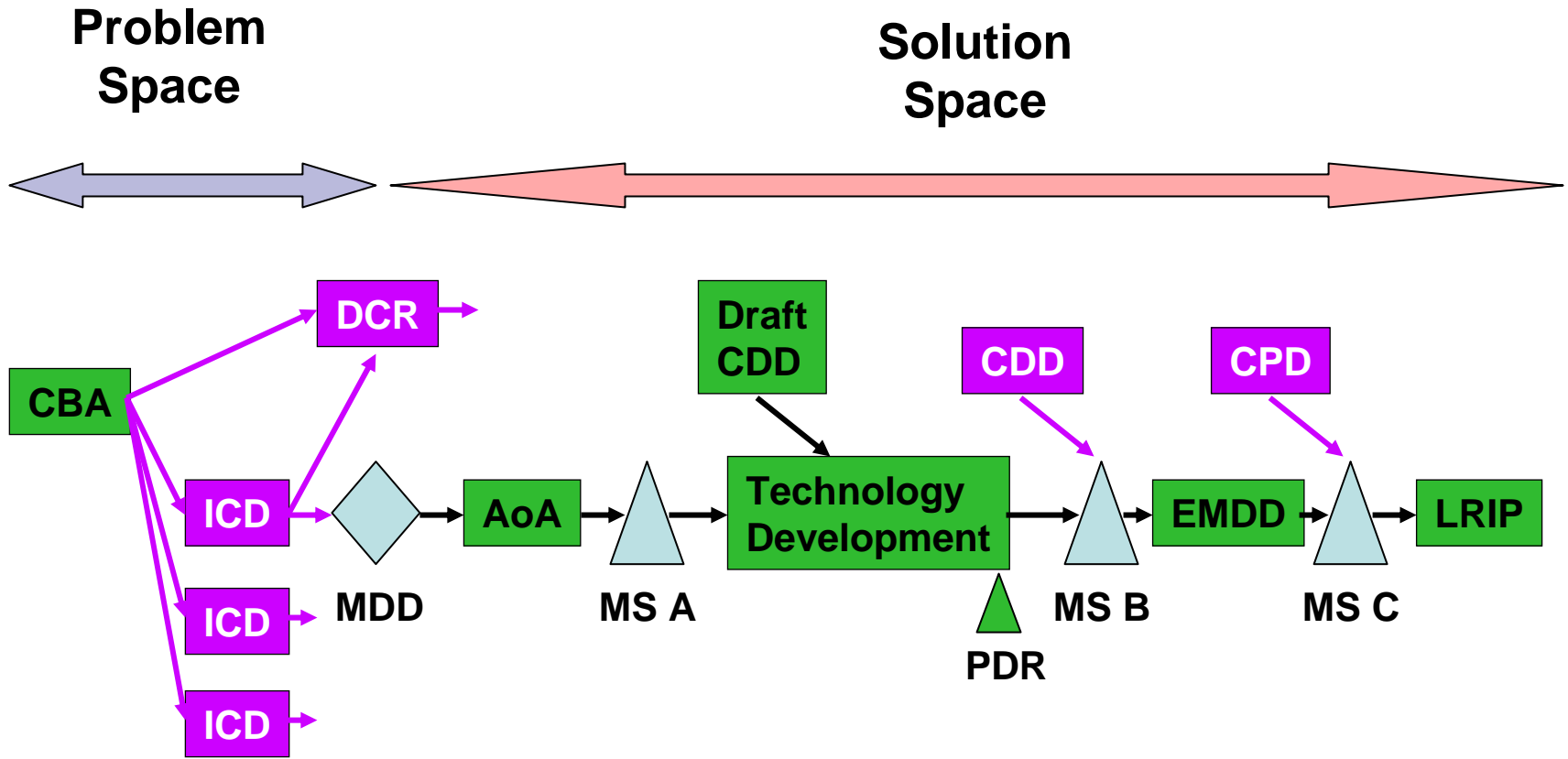

Capabilities-Based Assessment (CBA)

Existing
Guidance



FAA



What are
we talking
About?



FNA



How good
Are we at
Doing it?



FSA



What
Should we
Do about it?

From:
CBA User's Guide
V2 December 2006

Draft 5000.02 The Defense Acquisition Management Framework.

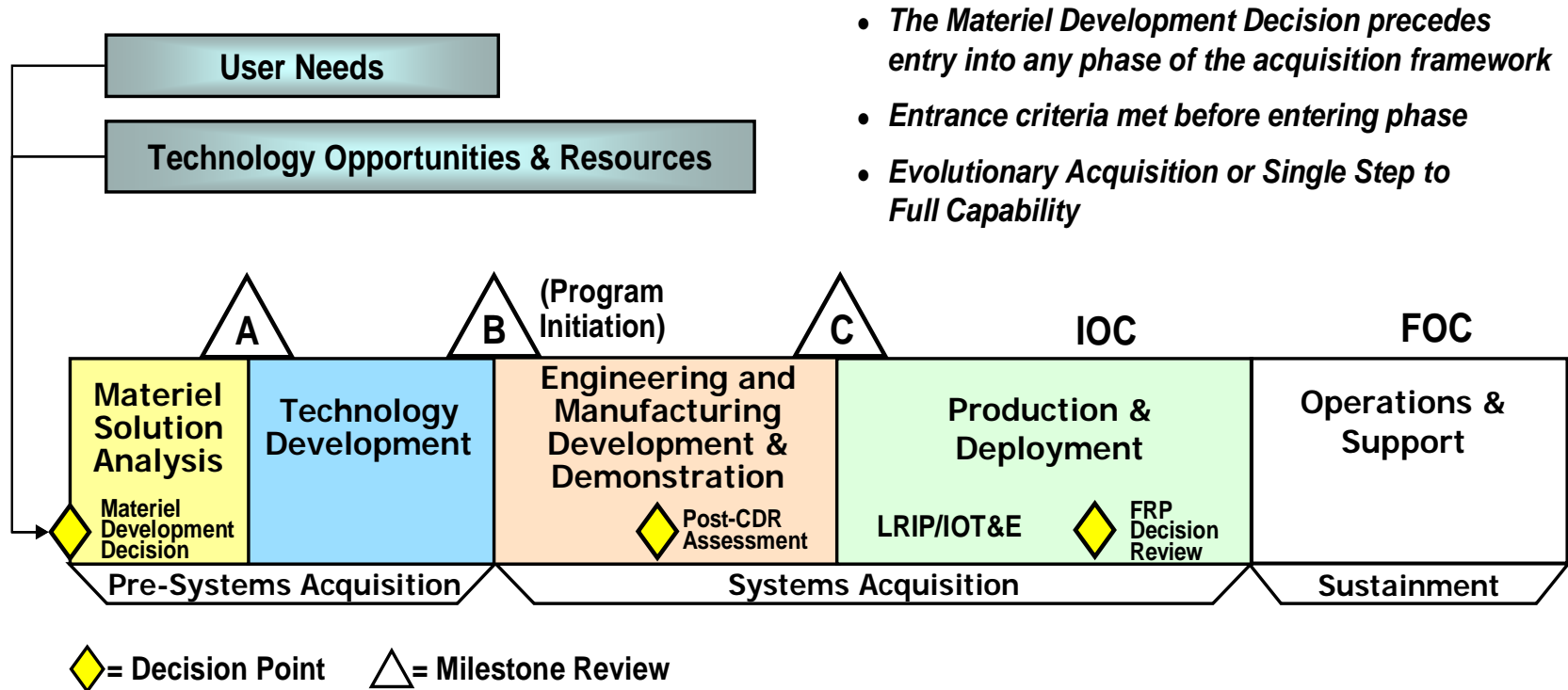

Problem / Solution Space Interface

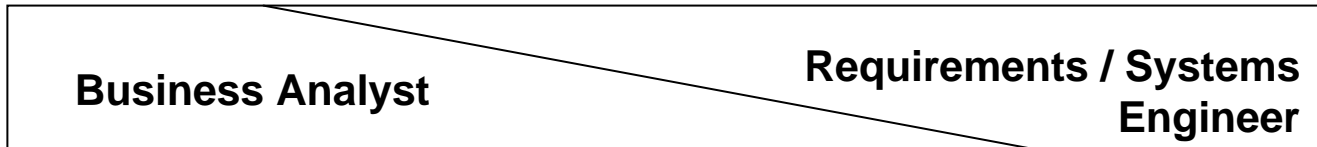
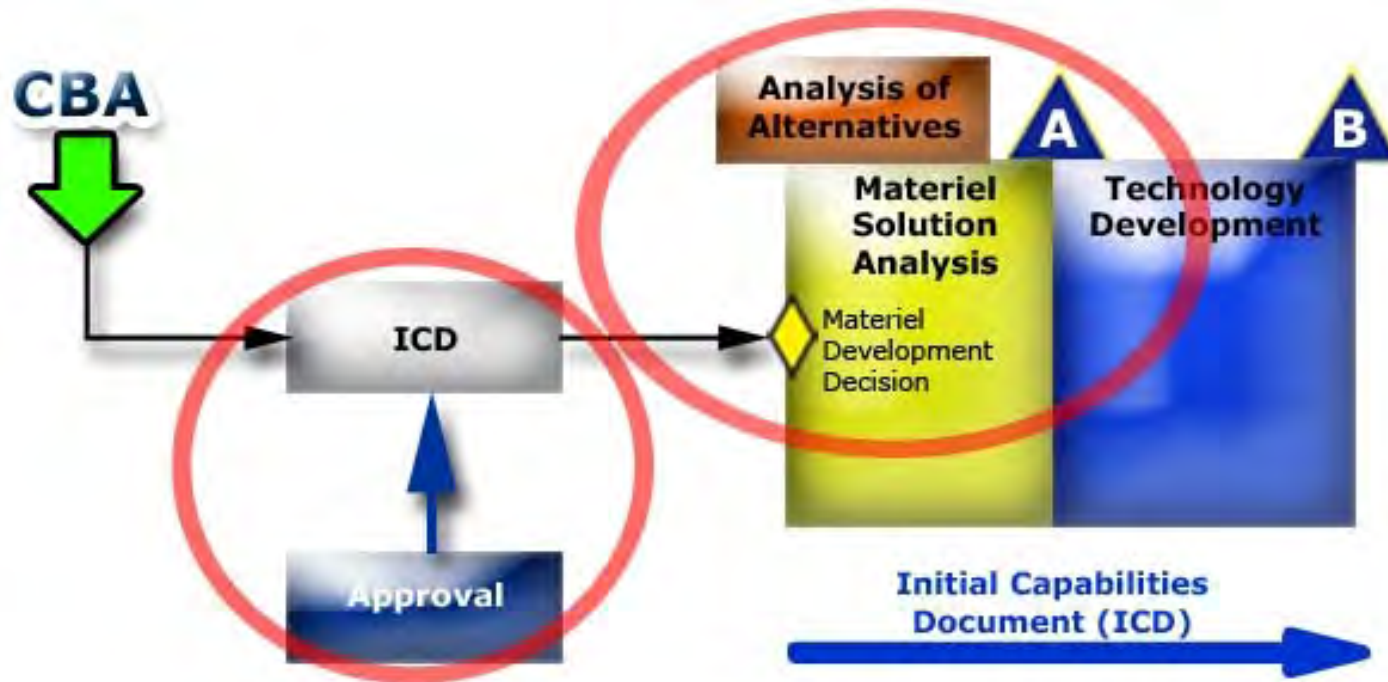

Information Transfer at the Interface

If your goal in software development is to "make the business case come true" (and by 'business case' I mean the initial justification for spending time, money, and effort on the development in the first place), then the most important thing to understand is: why are we building this? That is, what are the needs of the customers (or business)? **If you don't know, or clearly understand, the customer needs, then you cannot know if you are building the right system** - which then makes the technical correctness of the functional spec (what we intend to build) or the design spec (how we think it should work) a moot point.

Richard Zultner

30 Sep 2008 Requirements-Engineering Group

AoA and Effectiveness Analysis Process

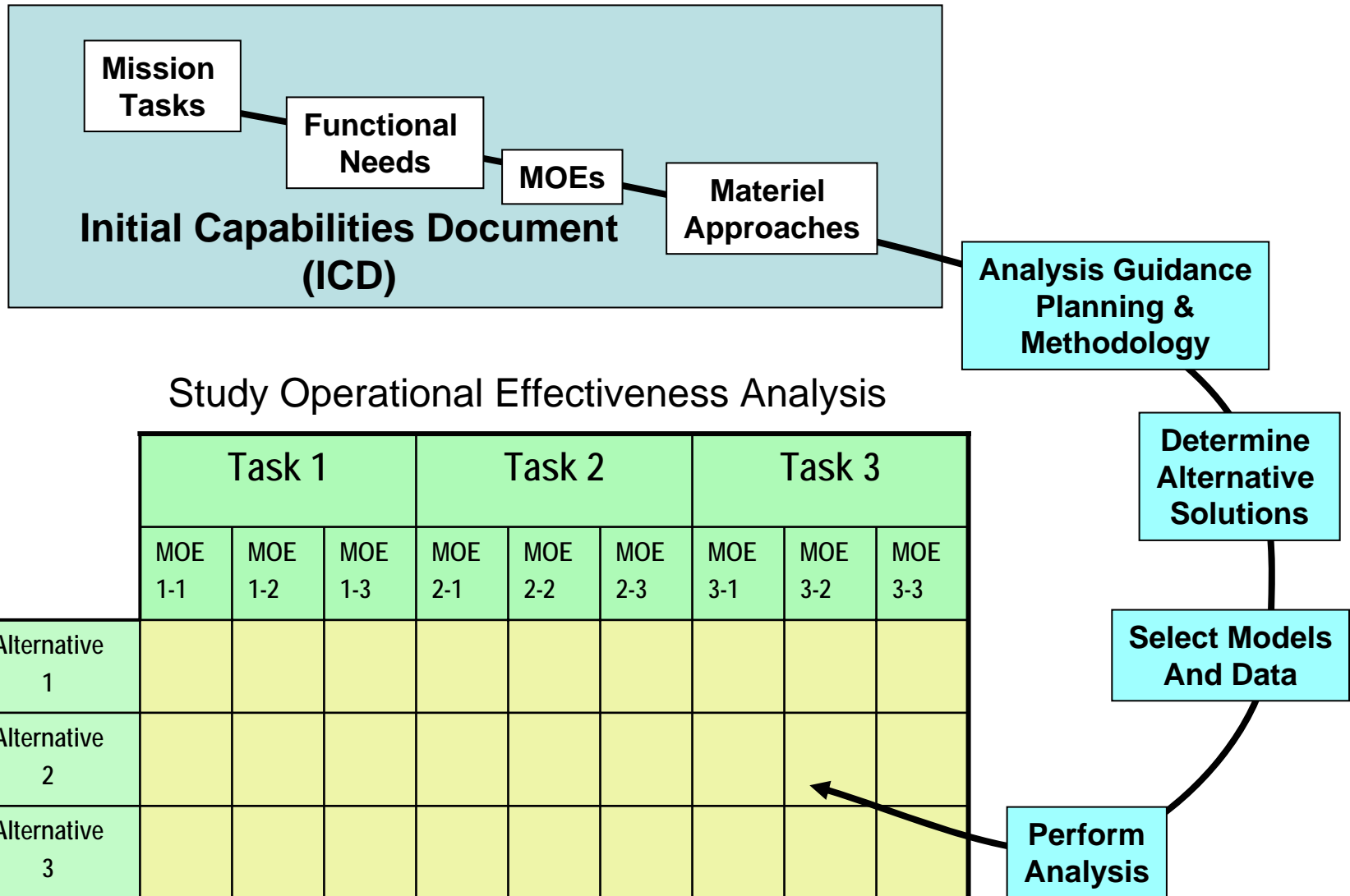

Definitions and Attributes of MOEs

- MOEs are standards against which the capability of a solution to meet the needs of a problem may be judged. The standards are specific properties that any potential solution must exhibit to some extent.
- Therefore, MOEs are independent of any solution.
- A meaningful MOE must be quantifiable and a measure to what degree the real objective is achieved.

The MOE is part of both the AoA and the CBP feedback process

Feedback Process

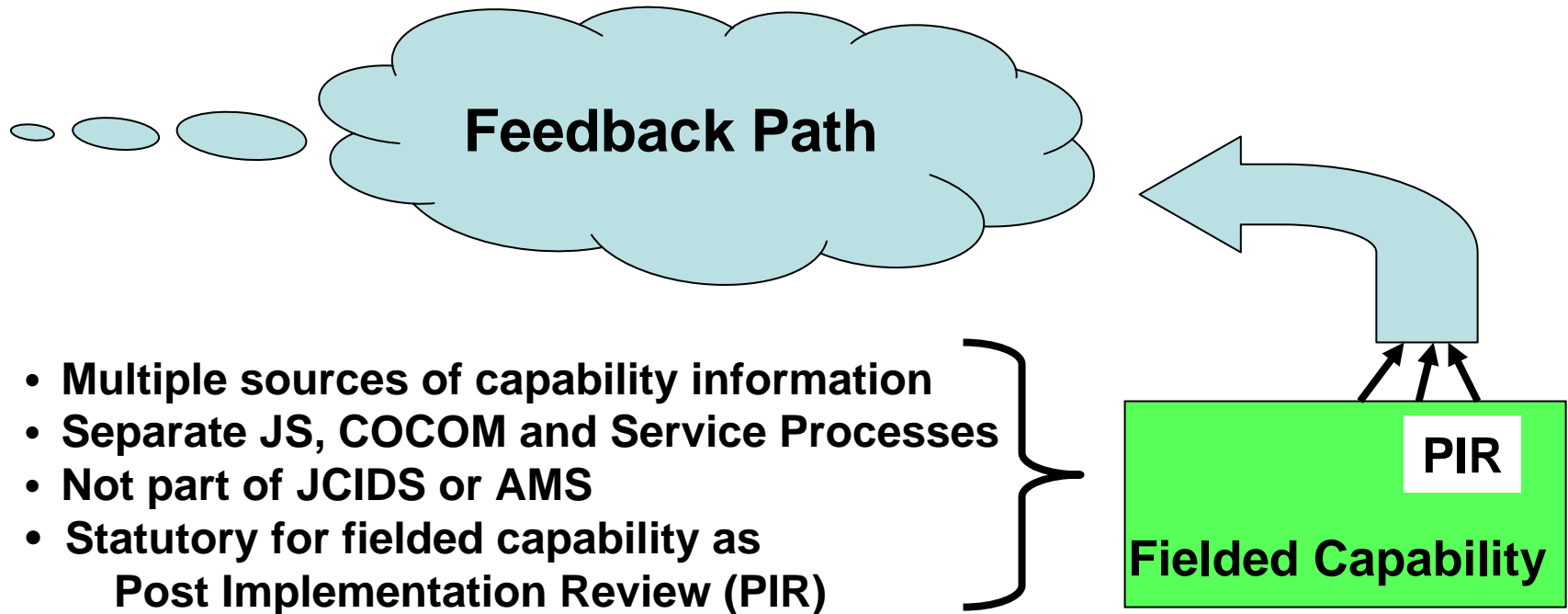

Post Implementation Review (PIR) Defined

An analysis of an investment or acquired system that is part of a capability portfolio, operating in its intended environment, using data collected from various sources to answer the question:

Did we get what we needed, and if not what to do about it?

PIR Information Path in Feedback Process

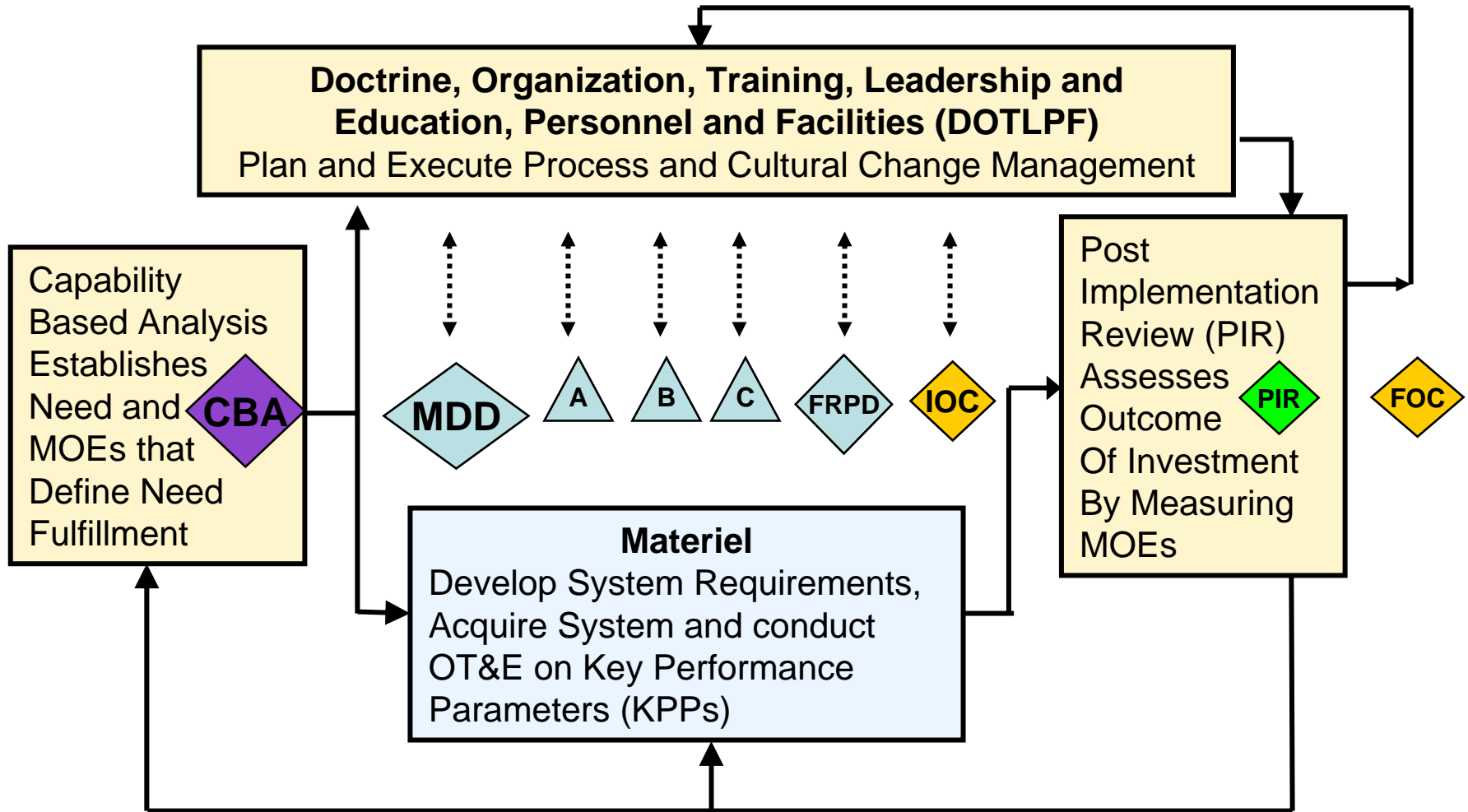

PIR in the Feedback Process

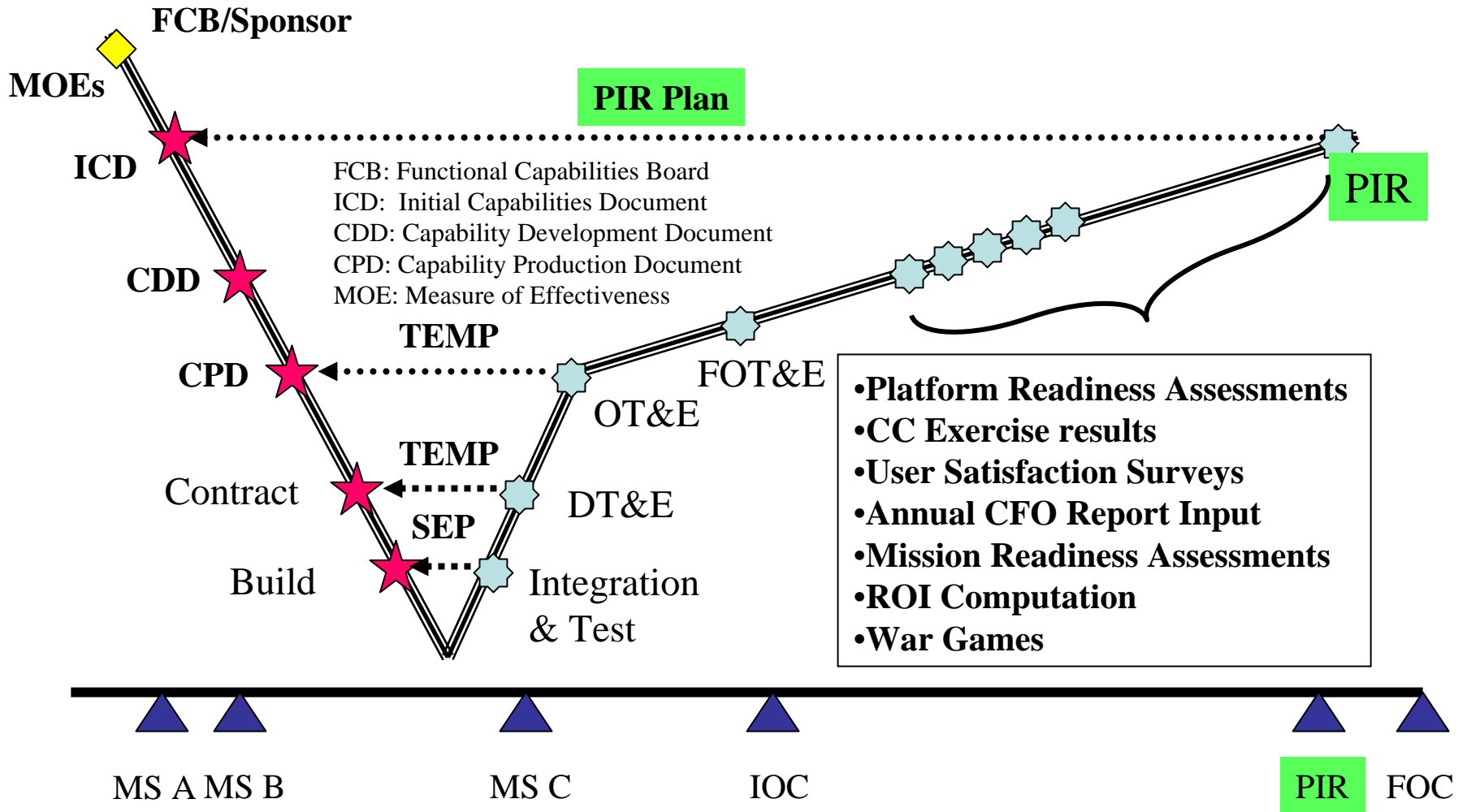

Opportunities, Challenges and Trends

Model Compatibility & Sharing Opportunity at the Problem-Solution Interface

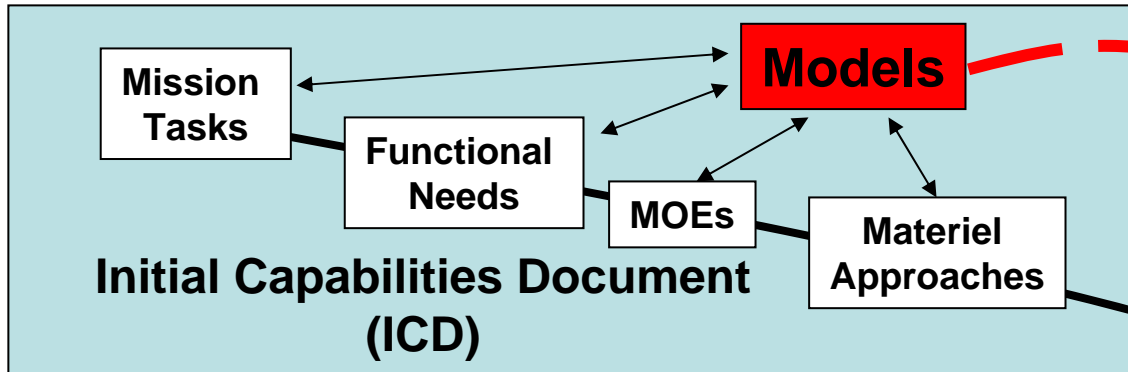

Study Operational Effectiveness Analysis

| | Task 1 | | | Task 2 | | | Task 3 | | |
|---------------|---------|---------|---------|---------|---------|---------|---------|---------|---------|
| | MOE 1-1 | MOE 1-2 | MOE 1-3 | MOE 2-1 | MOE 2-2 | MOE 2-3 | MOE 3-1 | MOE 3-2 | MOE 3-3 |
| Alternative 1 | | | | | | | | | |
| Alternative 2 | | | | | | | | | |
| Alternative 3 | | | | | | | | | |

Analysis Guidance
Planning &
Methodology

Determine
Alternative
Solutions

Select Models
And Data

Perform
Analysis

MOE Deficiencies in CBA

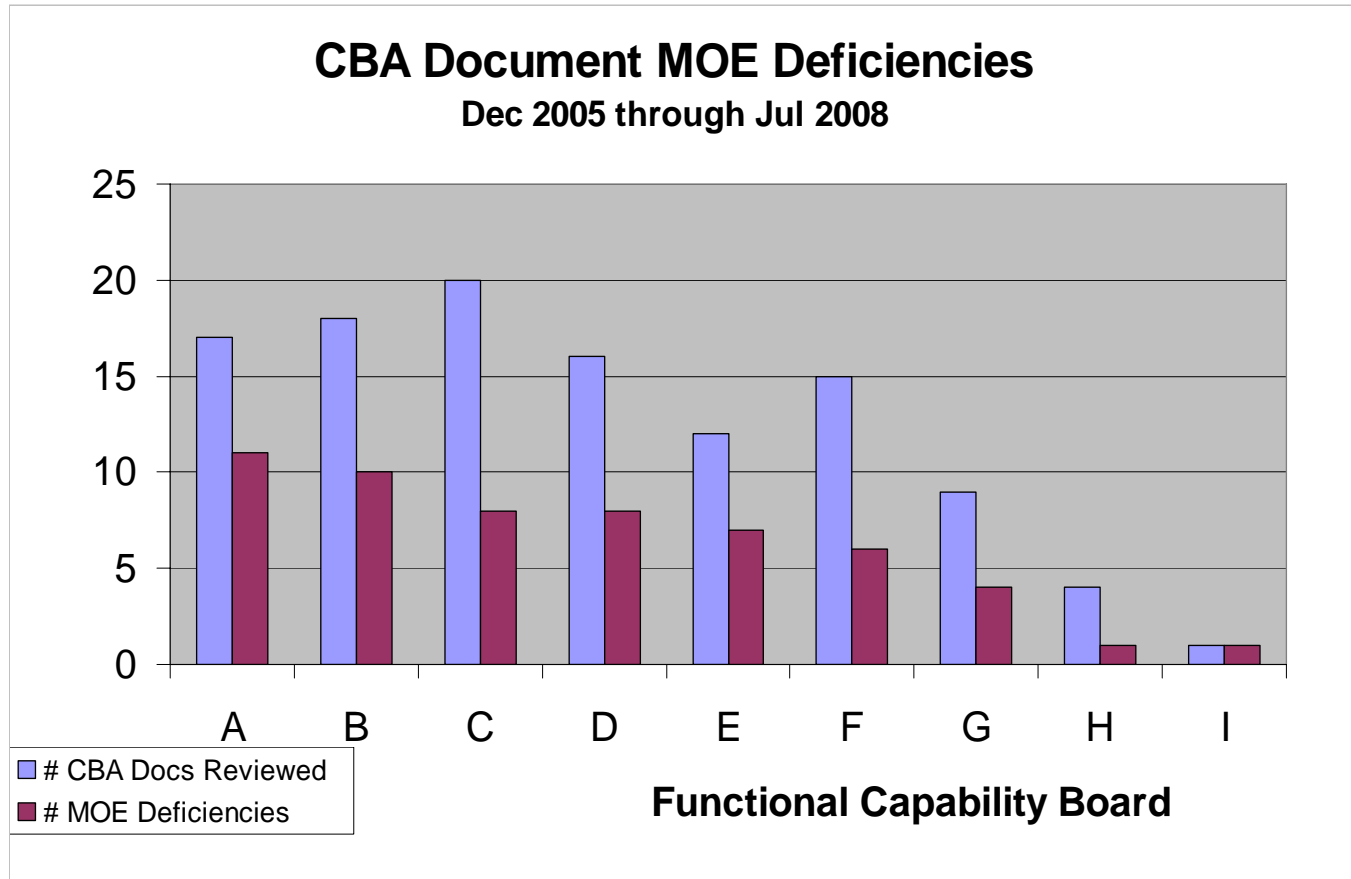

Potential Impact of MOE Deficiencies

- Likely Scenario:
 - 43% ICDs submitted to the JS for review during past 30 month period contained no MOEs
- Assumptions (conservatively stated)
 - Requirements volatility accounts for 10% of Program of Record cost overruns.
 - Lack of MOEs accounts for 10% of requirements volatility
 - The 2008 DoD Major Program cumulative expenditure is \$800B + \$800B less than major = \$1,600B
 - Cost overrun is 5% or \$80B
- Cost of not providing MOEs to the SE process:
 - $.1 \times .1 \times .43 \times \$80B = \$344M$

Recent Trends

- Publication of CBA Guide v2 by JS-J8 in Dec 2006
 - Describes CBA process
 - Guidance for study plan and planning
 - Discusses analytic approaches
 - Development of MOEs
- Implementation of requirements manager training and certification
 - USD(AT&L) Memoranda of 2 September 2008, Requirements Management Certification Training Program Policy, John Young
 - Includes training and certification of requirements authors, reviewers and validators
- Joint Staff considering shortening the CBA cycle to a month or two instead of a year or two.
 - Impact on development of MOEs not clear
 - May be signal that Problem-Solution interface boundary is shifting



Some Remaining MOE Issues

- How could MOEs be allocated?

$$\text{MOE}_{\text{Desired Capability}} = \text{MOE}_{\text{Existing Capability}} + \text{MOE}_{\text{Gap Capability}}$$

$$\text{MOE}_{\text{Gap Capability}} = \text{MOE}_{\text{DOTLPF}} + \square \text{MOE}_{\text{ICDs}}$$

where DOTLPF = f (Existing processes + changes needed
to maximize benefit of materiel investment)

- How could MOEs be traced?

Could MOEs be traced through the DOTLPF and materiel acquisition processes in a manner analogous to requirements tracing by the systems engineers?

PIR Input to JCA Assessment

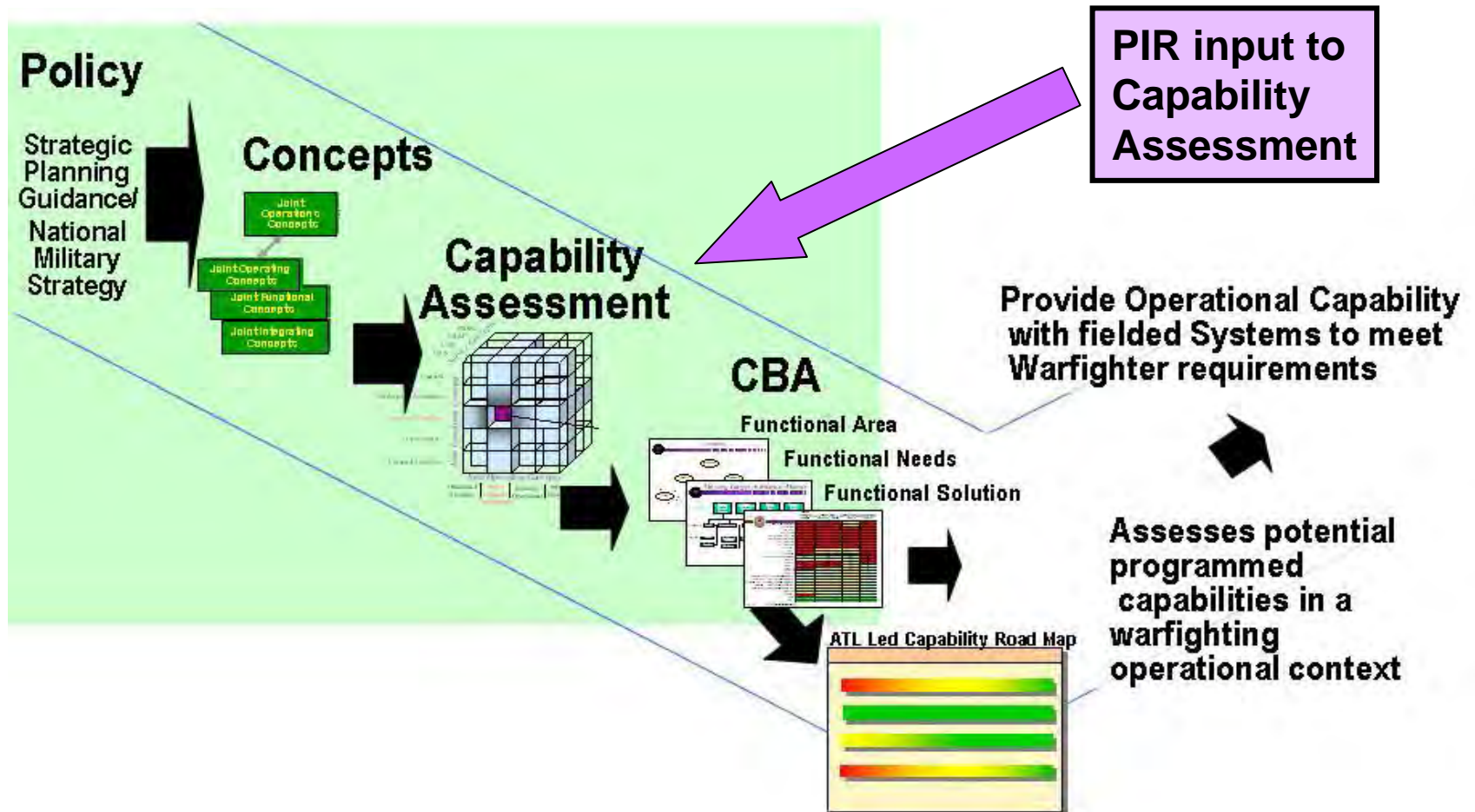

Models Bridge Layers of Requirements and Provide Verification Criteria

INCOSE Work Shop 08

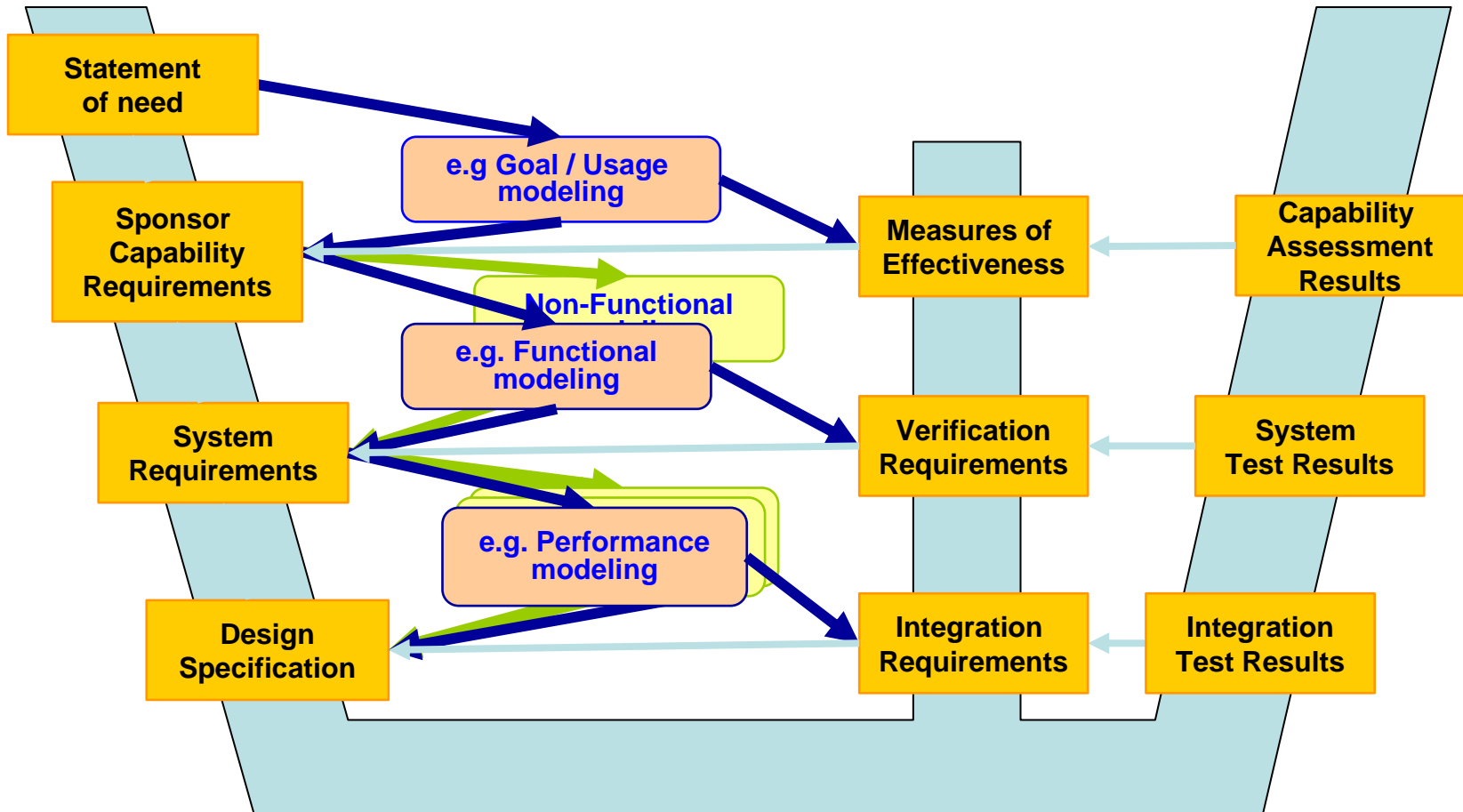

Typical MOE Situations

- Outcome metrics presented but measures deferred for CDD
- Study team not adequately staffed
- Study team neither tasked nor funded to undertake analytic approach needed to develop MOEs
- Outcome measures stated in narrative but solution performance parameters KPPs presented as MOEs
- CJCSM 3170.01 does not explicitly require MOEs for the ICD, Draft CJCSI 3170.01G has eliminated the term MOE
 - Uses the term desired effects
- Developed MOEs do not address desired outcomes

Cause - Effect Candidates

- Lack of capability analyst training
 - Analyst jumps into solution mode comfort zone
- Capability lexicon confusion
 - Miscommunication amongst analysts and reviewers
- Regulatory MOE requirement inconsistencies
 - Analyst takes path of least work
 - ICD approval available without MOEs
- Inadequate study team guidance
 - Analyst not steered to analytic approaches needed to develop MOEs



A Framework for Integrating Systems and Software Engineering

NDIA Systems
Engineering
Conference
San Diego, California

Art Pyster

art.pyster@stevens.edu

Richard Turner

richard.turner@stevens.edu

October 21, 2008

Agenda

- ▶ Rationale: Why integrate systems and software engineering?
- ▶ Touchpoint: A framework
- ▶ Initial Results
- ▶ Next steps

Rationale: Assertions

- ▶ **Interdependent** systems are those where:
 - ▶ A "major" portion of the capabilities/value of the system is delivered through software
 - ▶ A "major" portion of system quality attributes "largely" depend on software (safety, security, agility, reliability, availability, resilience,...)
- ▶ Today most high value systems are interdependent; that percentage is increasing
- ▶ In these systems, nearly all important decisions require equal consideration of software engineering and systems engineering expertise
 - ▶ Technical, management, personnel and customer concerns are included
- ▶ But, what does it mean to integrate SE and SwE?

Rationale: Questions needing answers

1. What outcomes do we expect from SE/SwE integration?
 - ▶ Does integration reduce key risks?
2. How do you measure integration or it's outcomes?
3. ***How and why do the SwE and SE activities conflict, complicate, or reinforce each other?***
4. How much integration is needed?
 - ▶ What is the scope of integration (development, operations, business areas...)?
 - ▶ Is more integration always better?
 - ▶ Is integration domain- or application-dependent?
5. Why haven't IPTs or CMMI solved this problem?

Rationale: Barriers to integration

- ▶ Historical context and vestigial prejudices
 - ▶ SE and SwE cultures are significantly different
 - ▶ SE and SwE have different educational backgrounds
 - ▶ SE and SwE vocabularies are similar but meanings differ
- ▶ SE and SwE process implementations are often incompatible (e.g. V versus spiral)
- ▶ SE and SwE may use the same tools differently (UML)
- ▶ No language to discuss integration of SE and SwE

Rationale: Issues needing to be addressed

1. **Vocabulary**. There is no precise way to talk about the integration of systems and software engineering.
2. **Measurement**. There is no precise way to talk about *how much* integration there is between systems and software engineering in a particular situation.
3. **Entanglement**. The complexity of the disciplines makes it difficult to identify where software and systems engineering touch.
4. **Value**. There is no comprehensive list of benefits that can be achieved by integrating systems and software engineering nor is there an understanding of the associated costs.

Touchpoint

- ▶ A framework to support the discussion of SE/SwE integration
- ▶ Simple and (seemingly) robust
- ▶ Provides a way to describe integration at the practitioner level
- ▶ Describes touchpoints where the two disciplines interact
- ▶ May help to describe the degree of “integratedness”

Touchpoint Framework: Components

- ▶ **Processes.** The ordered activities that define the systems and software engineering disciplines
- ▶ **Touchpoints (TPs).** The two discipline's processes *touch* when interactions between their constituent activities affect program risk or value – positively or negatively.
- ▶ **Faults.** A touchpoint may exist, but the process or activity may fail to produce its maximum value.
- ▶ **Resolution Strategies (RSs).** For each fault, there may be one or more actions that will eliminate the fault or reduce its impact.

Touchpoint Framework: Processes

- ▶ *ISO 15288* provides “harmonized” systems and software engineering processes
- ▶ Agreement, Organizational Project-enabling, Project, and Technical processes

| | | | | | |
|---------------------------------|------------------------------|----------|--------------------------------|-----------|-------------------------------------|
| Agreement | Acquisition | Project | Project Planning | Technical | Stakeholder Requirements Definition |
| | Supply | | Project Assessment and Control | | Requirements Analysis |
| Organizational Project-Enabling | Life Cycle Model Management | | Decision Management | | Architectural Design |
| | Infrastructure Management | | Risk Management | | Implementation |
| | Project Portfolio Management | | Configuration Management | | Integration |
| | Human Resource Management | | Information Management | | Verification |
| | Quality Management | | Measurement | | Transition |
| | | | | | Validation |
| | | | Operation | | |
| | | | Maintenance | | |
| | | Disposal | | | |

Touchpoint Framework: Faults

▶ Gap

- ▶ Logically, there should be an interaction between the corresponding SE and SwE processes, but the processes do not include one. A needed activity is therefore performed poorly, or not performed at all.

▶ Clash

- ▶ One or more activities in each of the two corresponding SE and SwE processes produce are incompatible and result in inconsistent results or inconsistent actions.

▶ Waste

- ▶ Activities in the two corresponding SE and SwE processes independently expend resources that produce the same result or take the same action with no added benefit to the program

Touchpoint Framework: Faults - Clashes

▶ Vocabulary

- ▶ SE/SW activities use the same terminology with different meanings, or terms not recognized by the other, making communication harder
 - ▶ Example: Object-oriented terminology

▶ Value

- ▶ Software and systems engineers in an organization or program value different process characteristics
 - ▶ Example: Stability of baselines

▶ Mental Model

- ▶ Software and systems engineers think differently about how to carry out process activities
 - ▶ Example: “part-of” relationships vs. “uses” relationships.

Touchpoint Framework: Example TP

| Process | Touchpoint | Fault | Type |
|----------------------|--|---|----------------------|
| Architectural Design | Systems architectures include significant software components to deliver critical capability | <i>Software-engineering architectures define layers of related functionality, while most systems-engineering methods are hierarchical structures.</i> | Clash – Mental Model |

Touchpoint Framework: Resolution Strategies

- ▶ There is a desire to fix faults, especially those with high impact on risk or value.
- ▶ For each fault, there may be one or more resolution strategies, which, when executed well, will eliminate the fault or at least reduce its impact.
 - ▶ In some cases, resolution strategies are known and just need to be applied
 - ▶ On the other hand, resolving some faults will require research
- ▶ Resolution strategies are grouped into four traditional categories: *process*, *people*, *environment*, and *technology*. Any number of resolution strategies in each category is possible for a fault.

Touchpoint Framework: Example RSs

| Process | Touchpoint | Fault | Type |
|--|--|---|----------------------|
| Architectural Design | Systems architectures include significant software components to deliver critical capability | <i>Software-engineering architectures define layers of related functionality, while most systems-engineering methods are hierarchical structures.</i> | Clash – Mental Model |
| Resolution Strategy | | | Category |
| Research must be conducted to resolve the clash between object-oriented and structured methods. Maier provides some of the best research in this area. | | | Technology |
| <i>Design software architecture to look just like system architecture. Make it easy for a system architect to understand. (SW systems mirror HW systems, e.g. relays, motors, etc). Then SW helps the system architect understand things in better detail.</i> | | | Process |
| <i>Middleware may be able to bridge the gap.</i> | | | Technology |

Touchpoint Framework: Measurement

- ▶ Provides a way to measure *how much* integration has been achieved and *how good* that integration is.
- ▶ The amount of integration is simply the total number of touchpoints in the implementation of the 25 processes – a higher number indicates more integration.
 - ▶ A somewhat more sophisticated approach associates a weight with each touchpoint to reflect its potential impact on program risk or value.
- ▶ The number of faults determines integration quality.
 - ▶ Faults can also be weighted based on their consequence.
- ▶ A fault that severely impacts an important touchpoint would be of far greater consequence than a fault that barely impacts a minor touchpoint.

Initial research: Piloting

- ▶ Process activities at the “touchpoint” level are generally not found in available traditional documentation (standard processes, WBS, plans)
 - ▶ Often technical management/practitioner activities
- ▶ Approach – interview SE and SwE leadership
 - ▶ Identified ~10 programs through OSD AT&L and NDIA
 - ▶ Interviewed each program to identify touchpoints, faults, resolution strategies and challenges; rigid “no attribution” policy
- ▶ Compared interview findings with the systemic analysis findings of AT&L/SSE Program Support Assessments

Piloting Results

- ▶ Touchpoint elements (TPs, Faults, RSs) identified by Systemic Analysis Category

| Category | Elements | No. of Projects |
|-------------------------------|----------|-----------------|
| Architecture | 12 | 6 |
| CM | 1 | 1 |
| EVM | 2 | 2 |
| Human Capital | 4 | 2 |
| Process Planning | 3 | 3 |
| Requirements | 23 | 10 |
| Risk Management | 2 | 2 |
| System Integration | 4 | 4 |
| Software Metrics (Visibility) | 4 | 3 |

Piloting Results

- ▶ Touchpoint elements not in Systemic Analysis Category

| Category | Elements | No. of Projects |
|-------------------|----------|-----------------|
| Contracting | 4 | 3 |
| Life Cycle | 7 | 4 |
| Technical Reviews | 2 | 2 |

Sample Architectural Design Process Findings

| Touchpoint | Fault | Type |
|--|--|------------|
| Architecture concept | Underutilized software capability | Gap |
| Resolution Strategy | | Category |
| Concept development should be performed jointly and careful trades made that reflect HW and SW capabilities, strengths, and weaknesses | | Process |
| Touchpoint | Fault | Type |
| Meeting non-functional requirements | HW reliability numbers are calculated to many decimal places, and include the contributions of very low-level WBS components. SW reliability is not understood and so ignored. | Gap |
| Resolution Strategy | | Category |
| <i>Research in integrated reliability approaches is needed</i> | | Technology |
| <i>Train systems and reliability engineers to understand software reliability</i> | | People |

Sample Requirements Analysis Process Findings

| Touchpoint | Fault | Type |
|---|--|----------------------|
| Software Requirements | SW specifications that limit trade space | Clash – Mental Model |
| Resolution Strategy | | Category |
| Define software requirements in terms of “what” not “how.” | | Process |
| SE and SW collaborate in the development of software requirements | | Process |

| Touchpoint | Fault | Type |
|--|---|----------------------|
| Requirement Maturation | The difference in speed of maturation between HW and SW requirements causes tension between SEs and SwEs. | Clash – Mental Model |
| Resolution Strategy | | Category |
| <i>Requirements management tools and processes need to better support iterative approaches to requirements maturation.</i> | | Technology |

Sample Life Cycle Management Process Finding

| Touchpoint | Fault | Type |
|--|--|---------------|
| SE and SW life cycles | Life cycle speeds differ causing perceived architecture instability and schedule coordination problems | Clash – Value |
| Resolution Strategy | | Category |
| <i>Involve SEs in software projects using iterative life cycles to gain comfort and trust.</i> | | People |

Conclusions and Next steps

- ▶ Framework seems useful
- ▶ Need much more data
 - ▶ More programs
 - ▶ More variety
- ▶ Refine and extend initial findings with new data
- ▶ Create products that make findings useful to programs

Questions and Discussion





Systems Engineering Analysis of Threat Reduction Systems Using a Collaborative Constructive Simulation Environment

NDIA Systems Engineering Conference
San Diego, CA
October 20-23, 2008

James E. Coolahan, Ph.D.

Roger L. West, Ph.D.

Joseph G. Kovalchik, Ph.D.

Johns Hopkins University Applied Physics Laboratory
11100 Johns Hopkins Road Laurel, MD 20723-6099

410-228-5155, 240-228-8383, 240-228-6264



coolahan@jhuapl.edu, Roger.West@jhuapl.edu,
Joseph.Kovalchik@jhuapl.edu

Andrew C. K. Wiedlea, Ph.D.

Defense Threat Reduction Agency
8725 John J. Kingman Road Stop 6201
Fort Belvoir, VA 22060-6201
703-767-3021

andrew.wiedlea@dtra.mil

Presentation Outline

- **Threat Reduction Analytic Objectives**
- **Original Long-Term Vision for the Constructive Simulation Environment**
- **Overview of Spiral Development / Analysis Approach**
- **Scenario Vignettes**
- **Nuclear Radiation Detection Modeling**
- **Behavior Module Characteristics**
- **Near-Term Plans**

The work presented herein was supported by the Defense Threat Reduction Agency (DTRA) under NAVSEA Contract N00024-03-D-6606, Task SG412.



Threat Reduction Analytic Objectives

Issues

- Many potential system solutions are being proposed for detection of materials important to Weapons of Mass Destruction (WMDs)
- System effectiveness evaluation requires analysis of system performance in operationally realistic tactical vignettes
- Material detection effectiveness is an element of broader campaign-level scenarios

Overall analysis objective:

- To enable system acquisition decision-making by constructing an analysis-of-alternatives capability

Immediate analysis objective

- Construct an analysis-of-alternatives capability focused on detection of nuclear materials



Original Long-Term Vision for the Constructive Simulation Environment

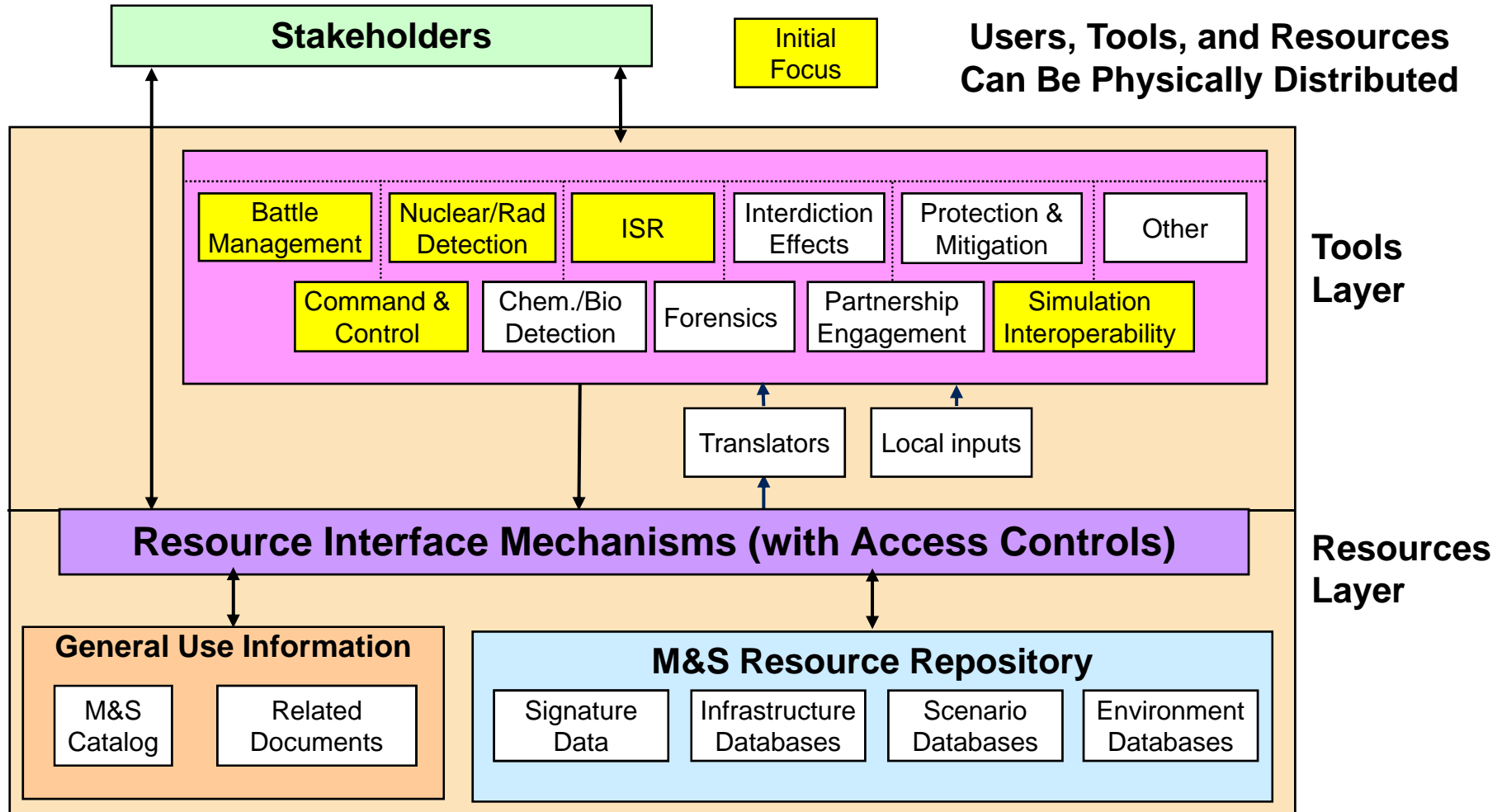

Overview of Spiral Development / Analysis Approach

- **Spiral 0 (April - July 2007)**
 - **Proof-of-concept use of Joint Semi-Automated Forces (JSAF) simulation for radiation detection in tactical vignette**
- **Spiral 1 (August 2007 – January 2008)**
 - **Setup of M&S laboratories at DTRA and JHU/APL**
 - **Development of checkpoint scenario vignettes**
 - **Development of higher fidelity JSAF radiation detection module and production of initial passive detection sensor performance**
- **Spiral 2 (February – September 2008)**
 - **Expansion of scenario vignettes, with 3D rendering**
 - **Development of Behavior Module linked with JSAF**
 - **Initial development of JSAF-embedded software for active concepts for nuclear material detection**



Spiral 0 Activities (April - July 2007)

- Evaluated several alternatives, and selected JSAF as simulation of choice to model tactical vignette in selected “100 x 100 mi. box”
- Obtained / installed JSAF simulation
- Modified JSAF sensor module to model radiation detector
- Obtained terrain database for selected area
- Set up “land bridge” scenario vignette and checkpoint in JSAF
- Performed multiple JSAF executions to generate sensor performance estimates, including multi-sensor detections
- Tabulated sensor performance data in spreadsheet for use during table-top exercise



Spiral 1 Activities (August 2007 – January 2008)

- Conducted trade-off study to determine most effective configurations of dual DTRA and JHU/APL systems engineering M&S laboratories
- Procured hardware and software for both M&S laboratories
- Instantiated three land-based scenario vignettes for checkpoints in JSAF, consistent with accepted campaign-level scenario
- Developed higher fidelity radiation detector module for JSAF
- Performed multiple short JSAF executions to get (preliminary) performance curves for a variety of passive radiation sensor types

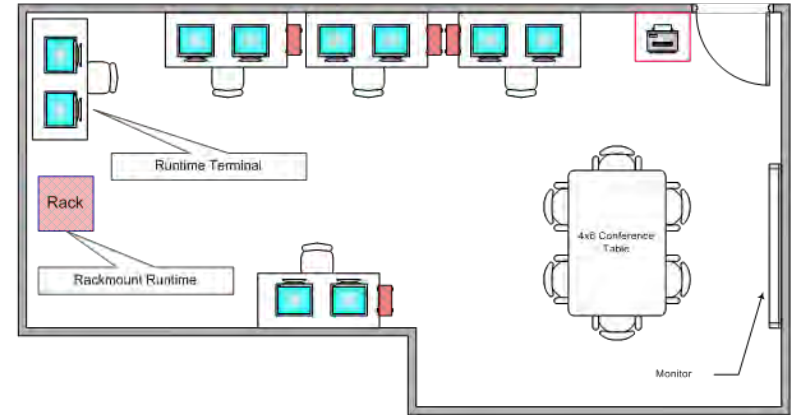

Spiral 2 Activities (February – September 2008)

- Instantiated five additional scenario vignettes in JSAF
- Incorporated 3D rendering of vignettes using JStealth, federated with JSAF
- Improved JSAF passive radiation detection module
- Developed a JSAF module to model active concepts for nuclear material detection
- Performed additional JSAF runs to explore the performance of selected combinations of sensors and to produce inputs for Joint Analysis System (JAS) campaign-level simulation executions
- Incorporated intelligent behavior for red and blue assets in JSAF
 - Federated new “Behavior Module” with JSAF, based on prior JHU/APL “commander federate” Independent Research and Development (IRAD) project
 - Incorporated tactics based on discussions with subject matter experts
- Developed a secure shared repository containing scenario information, sensor characteristics, and performance results from simulation executions



Constructive Simulation Environment Progress Toward Long-Term Vision

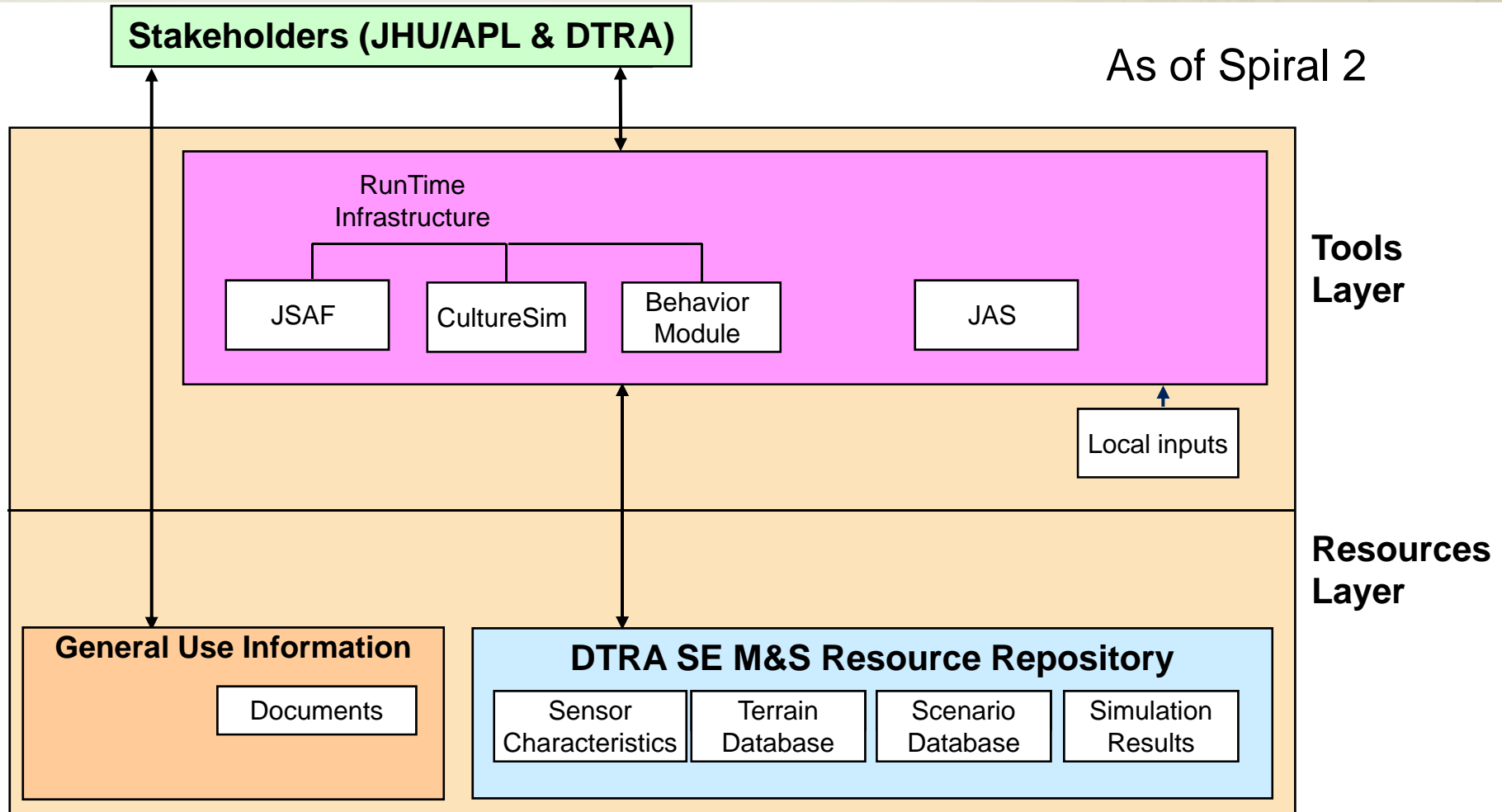

Scenario Vignettes (Three Types)

- **Land-based checkpoints to detect mobile nuclear material**
 - Rural / mountainous, limited road system
 - Rural / flatland, broader road system
 - Port area
- **Land-based detection of stationary / hidden nuclear material**
 - Rural hideout
 - Above-ground storage site
 - Underground facility
- **Detection of mobile nuclear material in maritime environment**
 - Straits
 - Open water

Nuclear Radiation Detection Modeling

Source Signal to Detector

$$S(e, r) = \frac{S_{gross} e^{-\bar{\lambda}(r)r}}{4\pi r^2} s(e, r)$$

Radiation Spectra Present at Detector Face

$s(e, r)$ Fractional spectral density present at the detector face (function of energy & range)

$S(e, r)$ Spectrum present at detector face

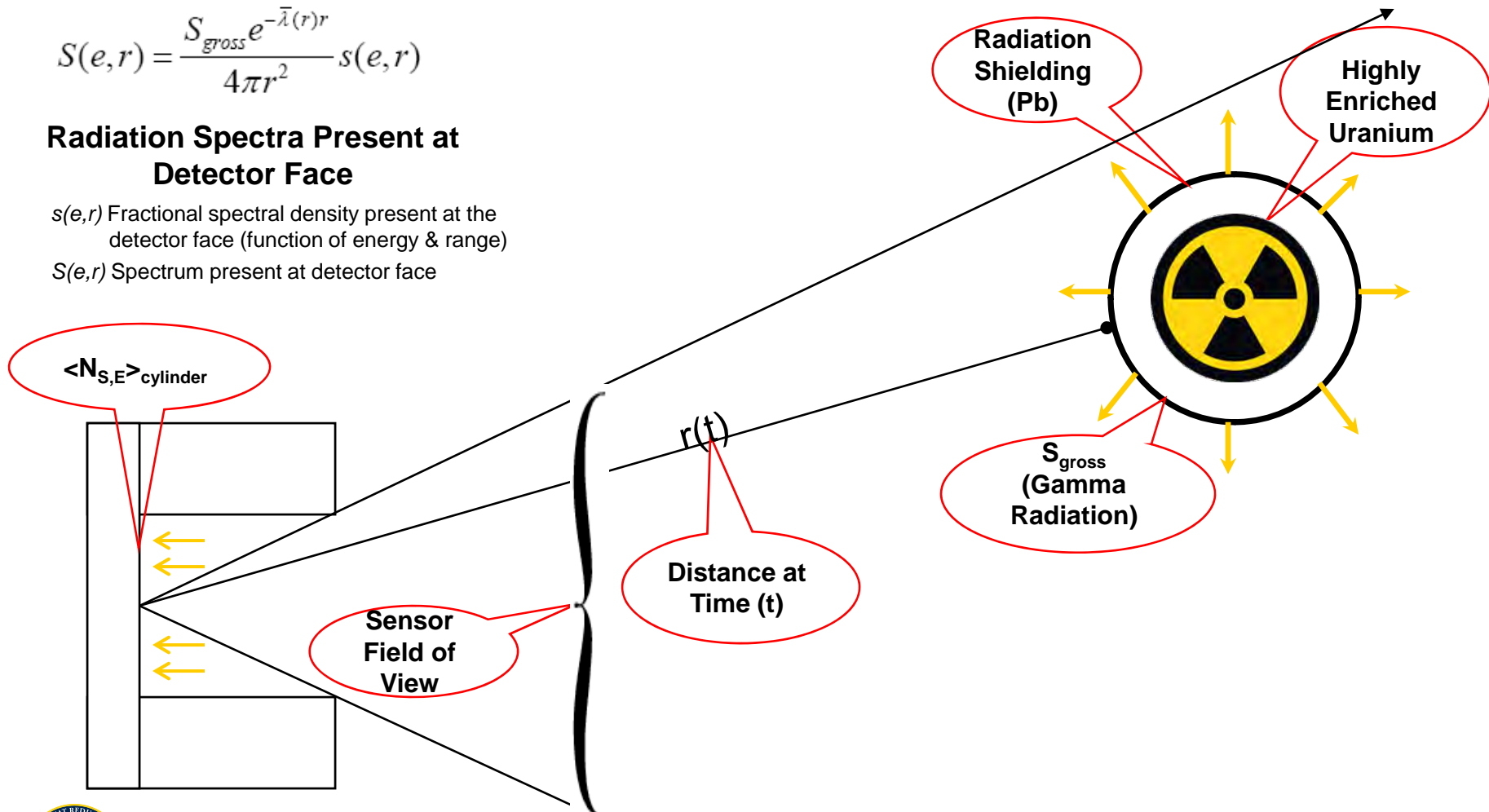

Sensor Model Input Constants

Sensor Model - Input Constants

B_{gross} = Gross background count (counts/sec) – Assume constant
 $\bar{\lambda}$ = atmospheric attenuation coefficient.

Properties dependent on detector type:

A_{sensor} = projected surface area of detector [m²]

FOV = field of view of sensor [deg]

$\bar{\epsilon}_B$ = Gross background count efficiency [unitless]

β_E = Fraction of gross background count in energy band E [unitless]

$\bar{\epsilon}_S$ = Gross source count efficiency [unitless]

σ_E = Fraction of gross source count in energy band E [unitless]

Sensor Model Functions

Sensor Model - Functions

Calculate background signal, $\langle N_{B,E} \rangle$ (assume constant B_{gross})

Calculate source signal, $\langle N_{S,E} \rangle$

Calculate signal-to-noise ratio (SNR)

Calculate detection probabilities, P_D , P_{FA}

Random draw for Detection Outcome

JSAF Source-Sensor Model Data Interactions

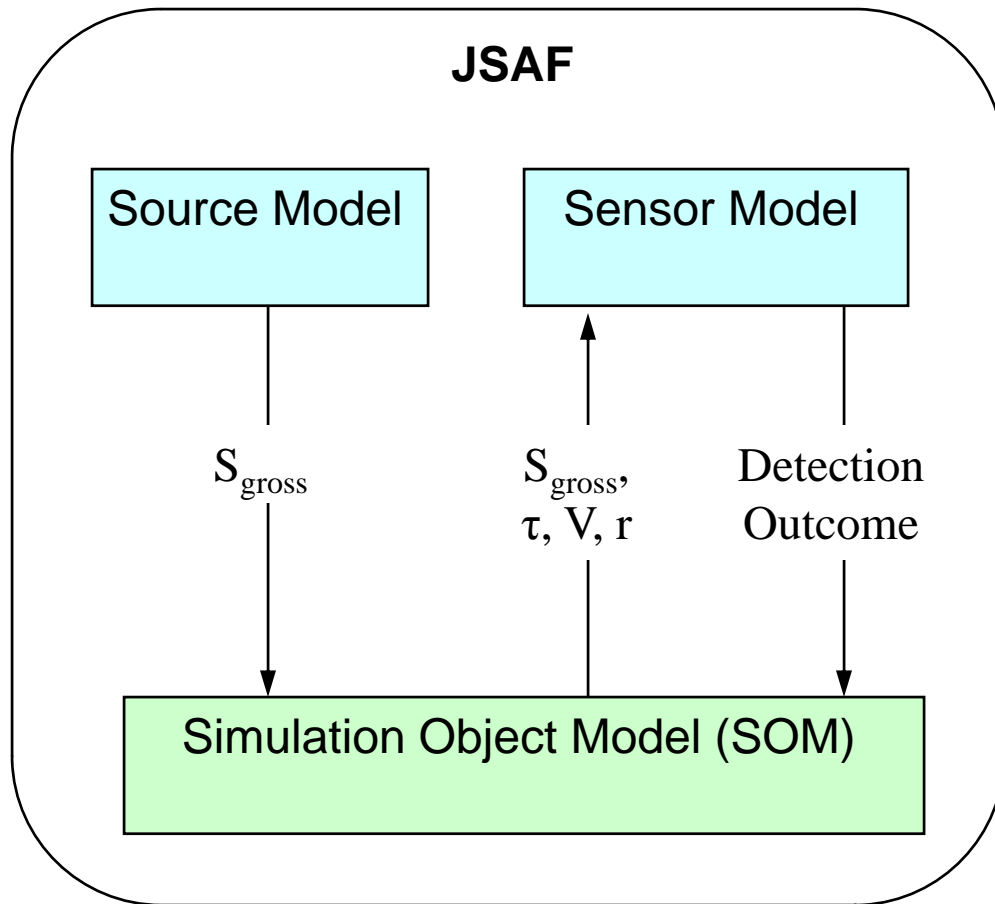

Where:

S_{gross} = Gross source count
(counts/sec)

τ = integration time interval (sec)

V = Relative velocity of target (m/s)

r = Range of target (m)

and “Detection Outcome” can be one of:

- No detection
- Positive detection
- False positive detection
- Negative detection
- False negative detection

Sensor Signal-to-Noise Ratio vs. P_D , P_{FA}

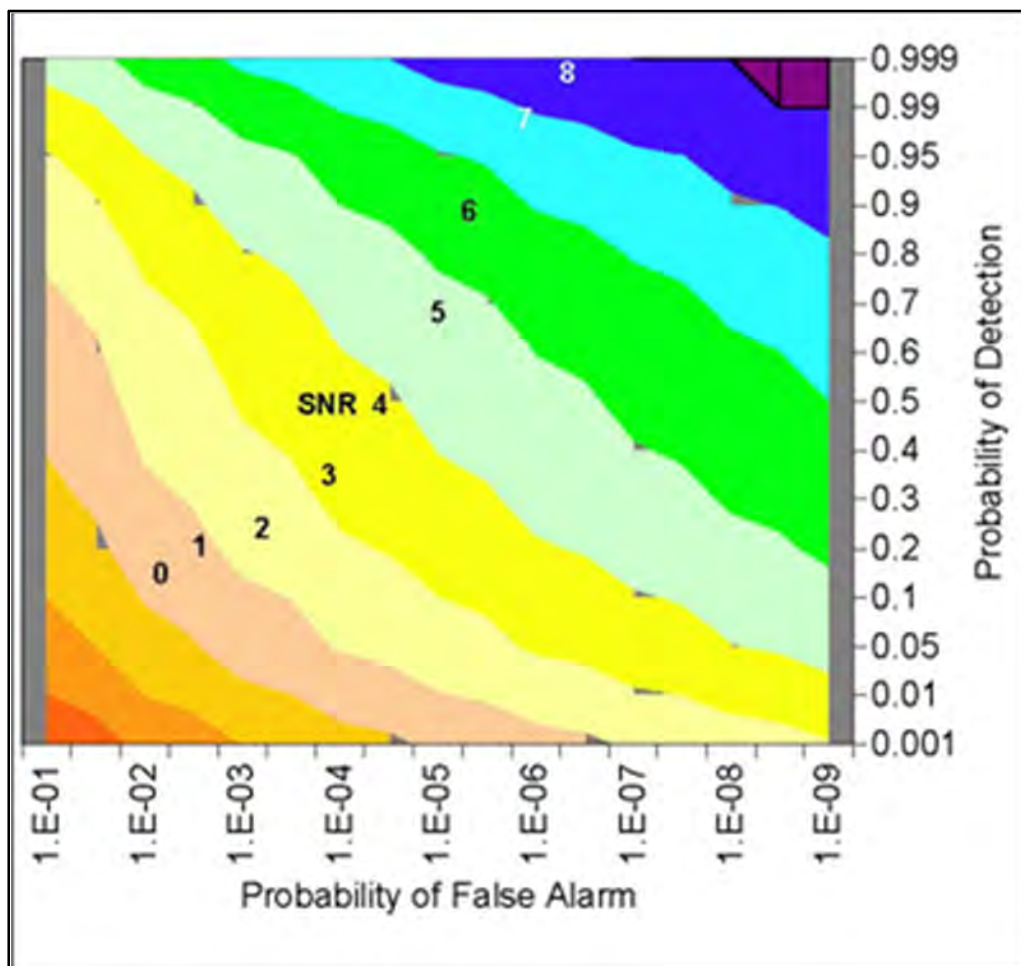

Nuclear Radiation Detection Modeling Physics for Active Detection

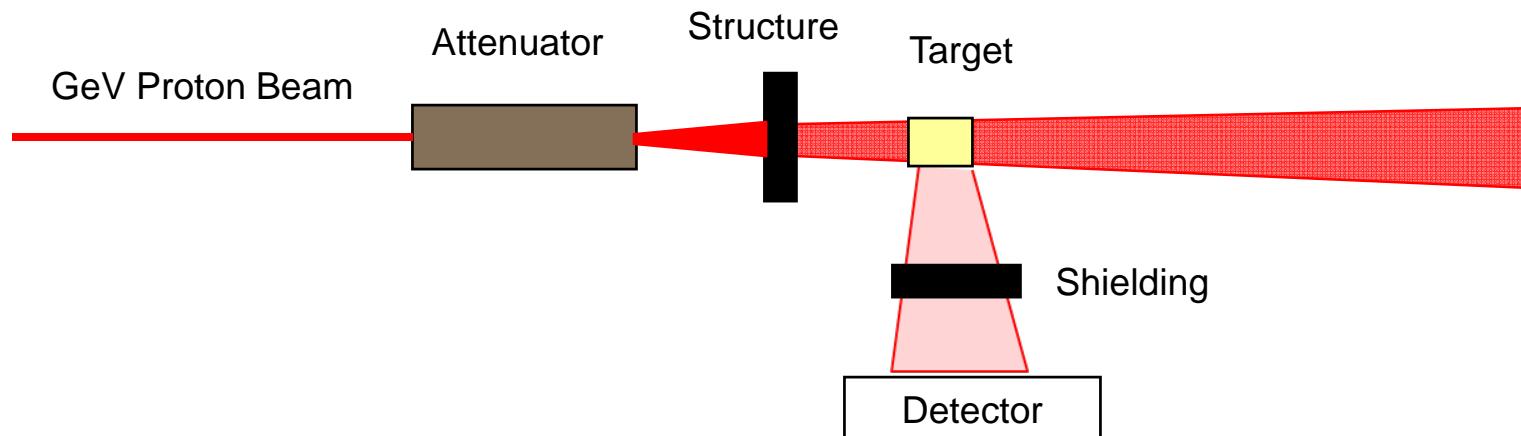

| Materials | | | |
|---------------|-----------------------|--|-------------------------|
| Attenuators | Structures | Targets | Shielding |
| Air, Graphite | Iron, Steel, Aluminum | Uranium (235, 238), Lead, Tungsten, Carbon, Calcium, Silicon | Iron, Lead, Wood, Water |

Motivation for the Behavior Module

Issue

- **Standard scripting for Red and Blue CONOPS in scenario vignettes in JSAF attributed insufficient reactive behavior to humans involved**
 - **For example, drivers of vehicles carrying nuclear materials simply proceeded to known checkpoints, were scanned, and detained**

Behavior Module needed to

- **Provide reactive CONOPS for Red and Blue assets, and background behaviors for Green entities**
- **Enable analysis of effectiveness of Blue CONOPS using various sensors in opposition to Red CONOPS, together with Green background activity**
- **Enable trades between CONOPS and sensor investment decisions**
 - **For example, given a sensor's maximum probability of detection, can an adjustment of resources to execute a CONOPS improve the ability to detect and interdict the nuclear material?**



Technology Basis for Behavior Module: Hybrid Reasoning Technology Framework

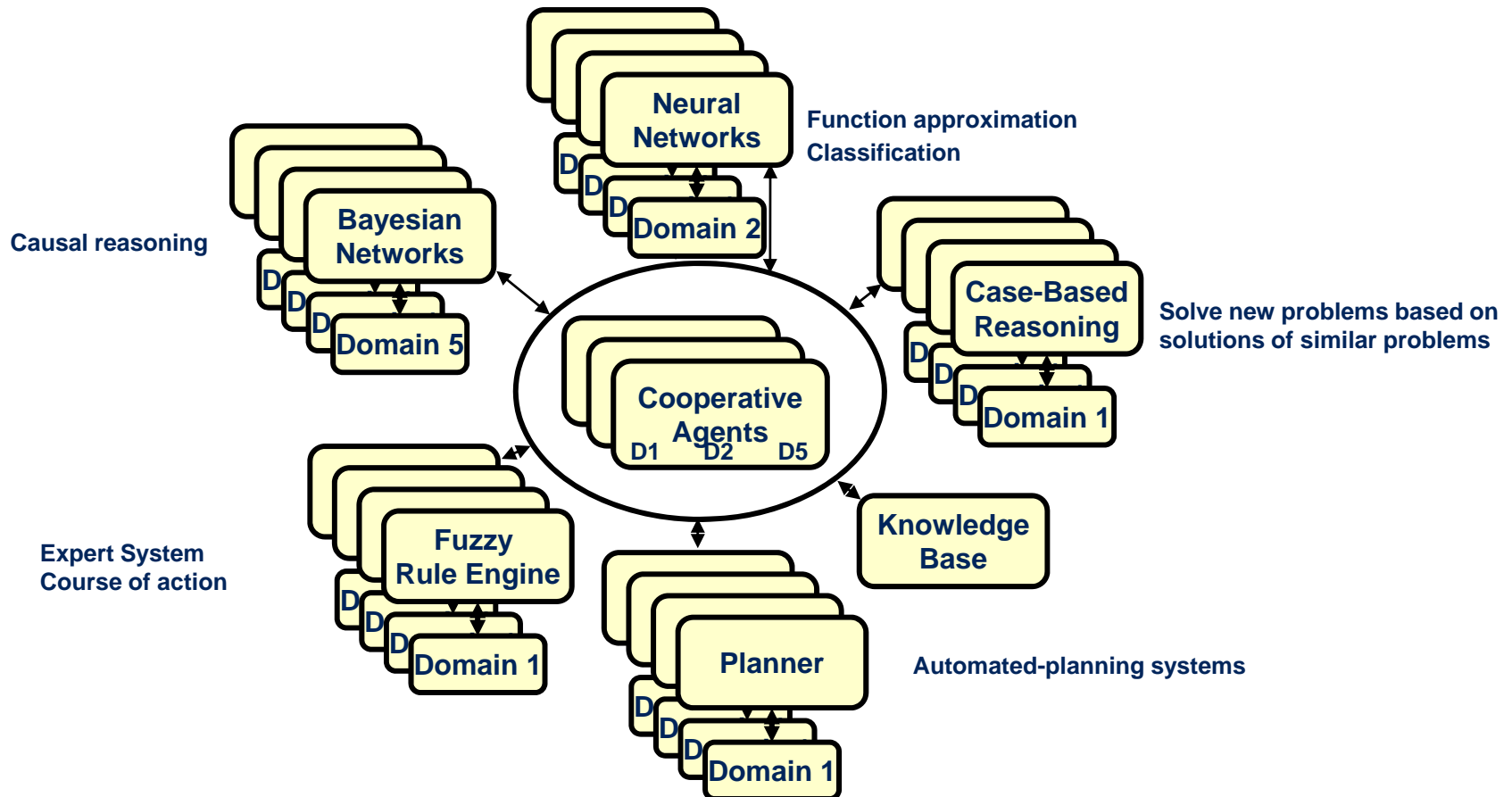

Hybrid Reasoning Framework Preparation and Use

- Analyst gains understanding of the decision process to be simulated
- Analyst maps appropriate reasoning technologies to the decision process
- Analyst creates a domain-specific file using reasoning software GUI editor and exports the domain-specific file for agent's future use
- Agents load domain-specific files as needed for their function, provide problem specific inputs (state), and use appropriate generic engines to create solution outputs

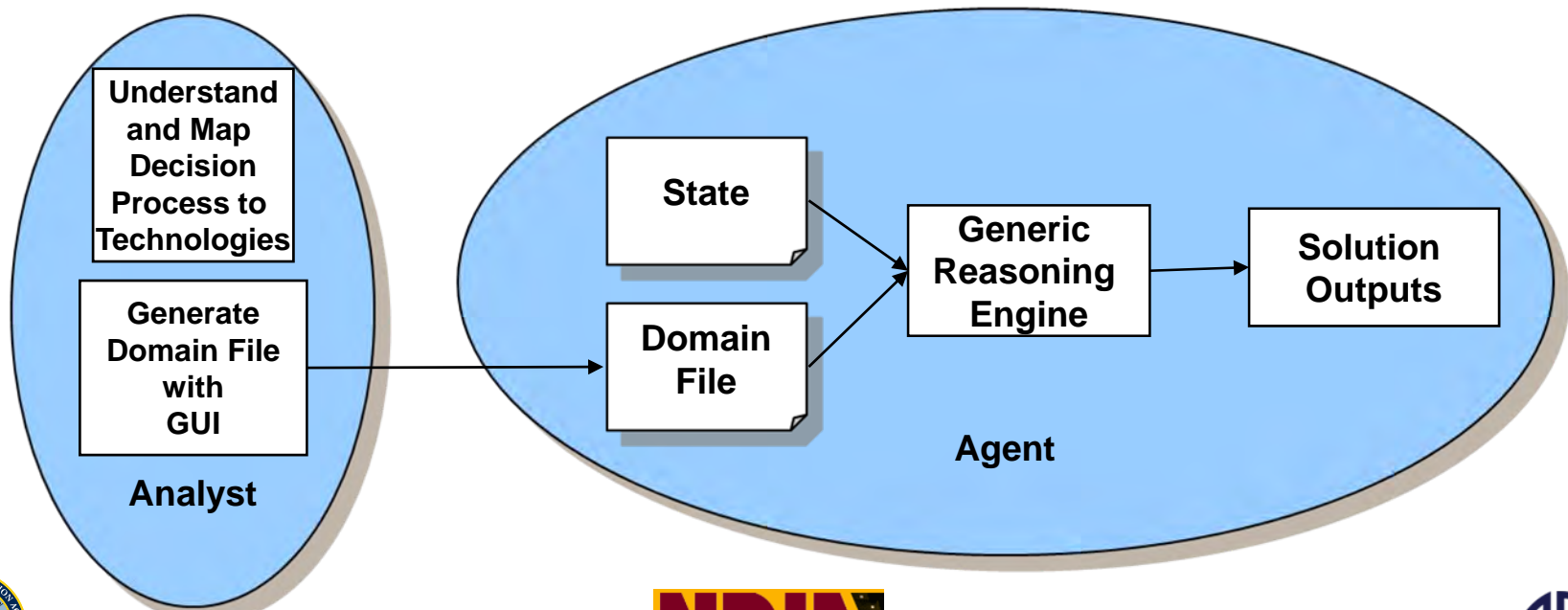

Baseline Concept for Enhanced Checkpoint Scenario Vignette Using Behavior Module

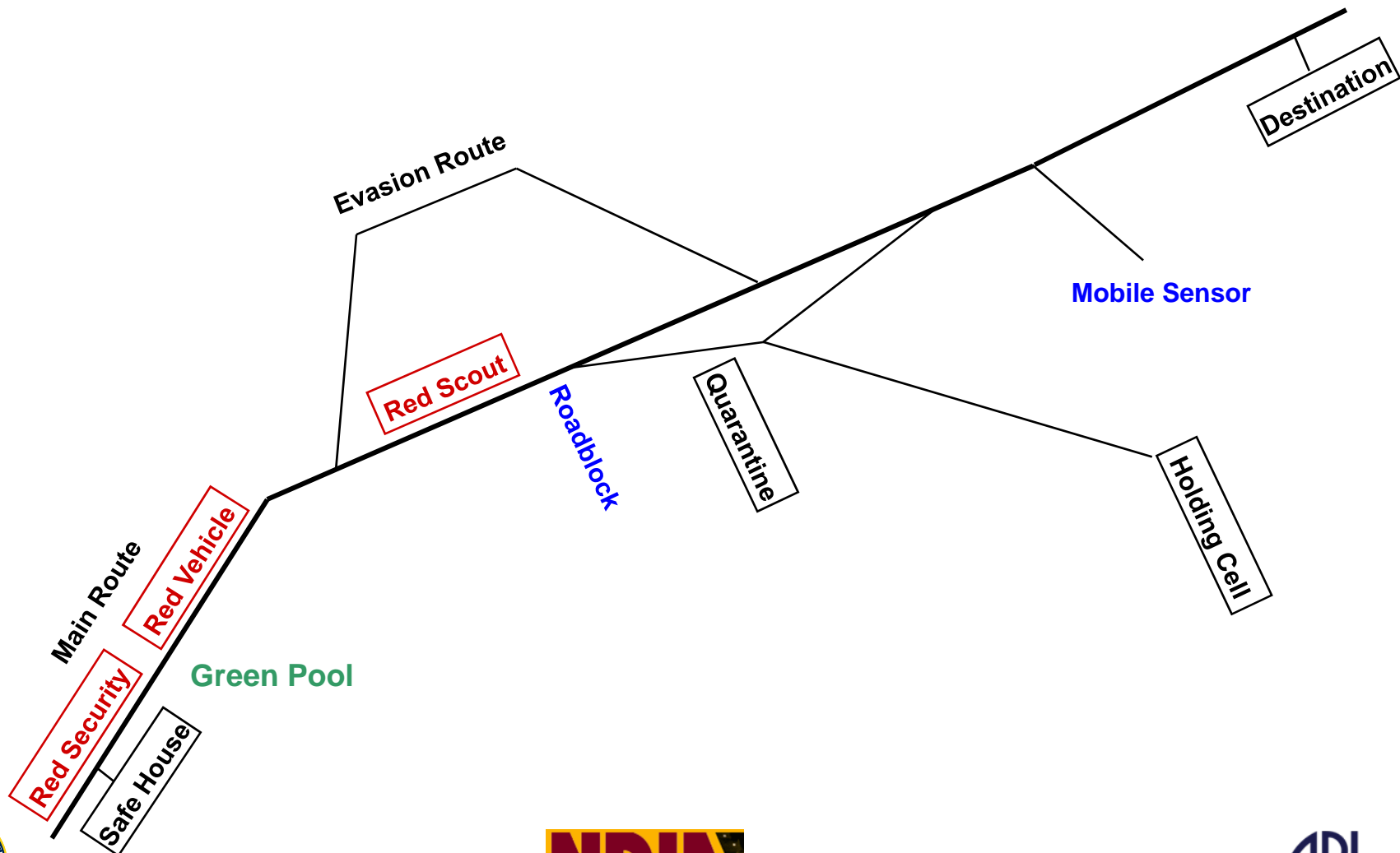

Behavior Module

Current Blue Checkpoint Behaviors

When a Red or green vehicle reaches a checkpoint, a roadblock prevents passage in one direction until the sensor reports

- If the reading is negative, the roadblock raises and allows the vehicle to pass
- If the reading is positive,
 - The vehicle is sent to a quarantine location
 - A mobile sensor platform is tasked to report to the quarantine location to conduct a second reading
 - If the second reading is negative, the vehicle is allowed to continue its journey
 - If the second reading is positive, the vehicle is sent to a holding location.
- Blue adjusts the roadblock to manage the length of the traffic backup
- Certain types of vehicles are randomly selected for checks. If the checkpoint queue gets too long, Blue communicates to the Blue selection point in order to reduce the percentage selected until the queue length is satisfactory.

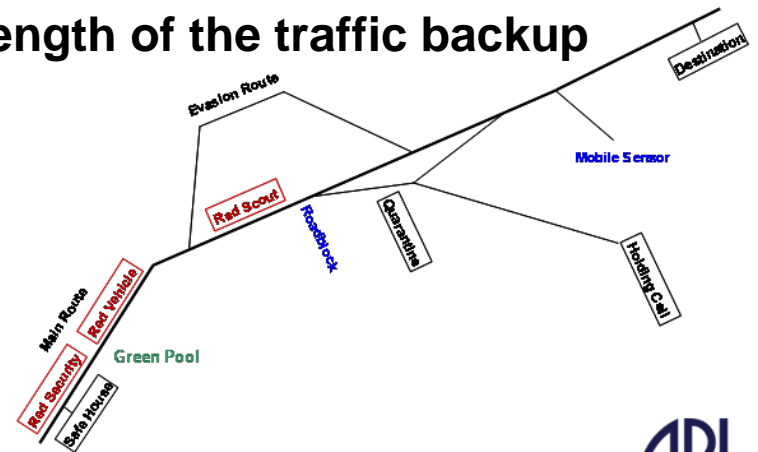

Behavior Module

Current Red Checkpoint Behaviors

- Red vehicle starts at safe house and travels to destination over existing roads
- Red vehicle is informed by a Red “scout” vehicle that a checkpoint is ahead so that the Red vehicle with weapons grade nuclear material either aborts or evades
- When a Blue checkpoint is seen, Red has option to:
 - Stop and pull over at the roadside for ten minutes to consider either aborting or continuing
 - Continue journey
 - Evade around checkpoint if possible
 - Abort and return to starting location
- Red either diverts or aborts if progress along the current route is too slow.

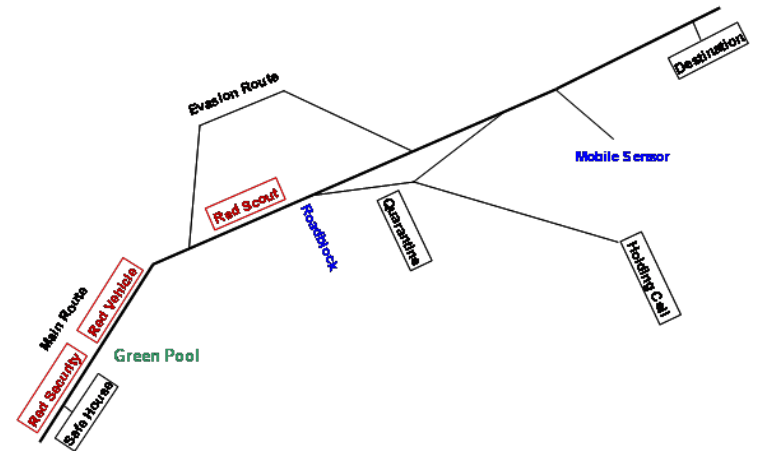

Behavior Module

Current Green Checkpoint Behaviors

- Background traffic without any nuclear sources
- Several green vehicles with medical nuclear sources are dispatched at random intervals to add to congestion at checkpoints

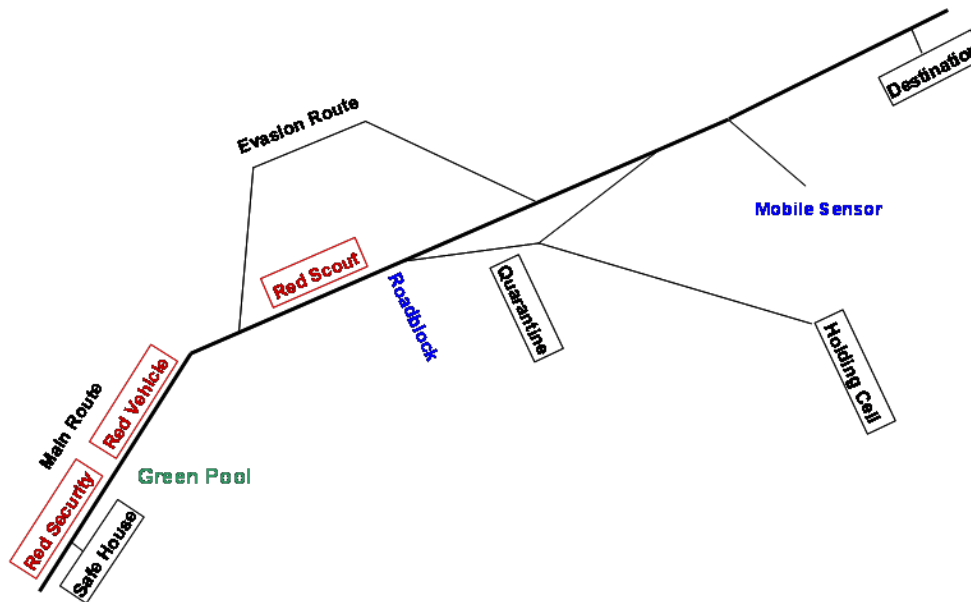

Near-Term Plans

Spiral 3 (October 2008 – September 2009)

- Enhance passive nuclear detection modeling
 - Spectroscopic capability for source and sensor
 - Gamma imaging capability for sensor
 - Passive fast and thermal neutron imaging for source and sensor
 - Thermal neutron directional / imaging capability for sensor
 - Fast neutron imaging for sensor
- Add fidelity to active nuclear detection concept modeling
 - Introduce active interrogation sources
 - Modify targeted material behavior
 - Modify passive sensor as needed to support active concepts
- Add behaviors to Behavior Module (selected based on perception of Red capabilities)
 - Blue – downstream checkpoints, traffic funneling to checkpoints, vehicle tagging and tracking, CONOPS variation based on nature of Blue forces
 - Red – Red security vehicle follower, bribery, rush-hour exploitation, peaceful demonstration, traffic accident diversion, limited attacks, etc.





Systems Engineering Plan and Systems Engineering Management Plan Alignment

NDIA 11th Annual
Systems Engineering Conference
October 21, 2008

Chet Bracuto
DoD OUSD A&T (SSE)

Bob Scheurer P.E., P.M.P.
Boeing Integrated Defense Systems



Purpose



Present efforts of SE Working Group discussions with recommendations for improving Acquirer and Supplier technical planning



Outline



-
- Problem Definition
 - Background
 - Future State
 - Approach
 - Traits of SEPs and SEMP
 - SEP – SEMP Comparisons and Findings
 - Vision of the Ideal SEMP
 - Data Item Description Update
 - Benefits
 - Way Forward
 - Questions/Answers



Problem Definition



The Need:

- Improved SE planning discipline to better facilitate program execution
- Better communication, integration, and efficiency between acquirer and suppliers
- Early technical planning (i.e. in RFP) to ensure that SE is scoped and priced adequately in the contractors' proposals
- Better planning alignment between acquirer and suppliers

Programs Need Improved Guidance
That Will Yield More Effective Planning



Background



- Systems Engineering Plan (SEP) is a DoD-developed (acquirer) technical planning document required for milestone approval
- Systems Engineering Management Plan (SEMP) is a contractor-developed (supplier) plan for the conduct, management, and control of the integrated engineering effort
- DoD SEP Preparation Guide was updated in October 2007 to improve completeness and consistency in SE planning
 - Highlighted five (5) key areas of SE planning
- Briefed NDIA SE Conference in October 2007 on feasibility of a single, unified plan
- Questions raised if other DoD policy and guidance needed updating (e.g., DI-MGMT-81024)



Background



Path to a Unified SE Plan October 2007

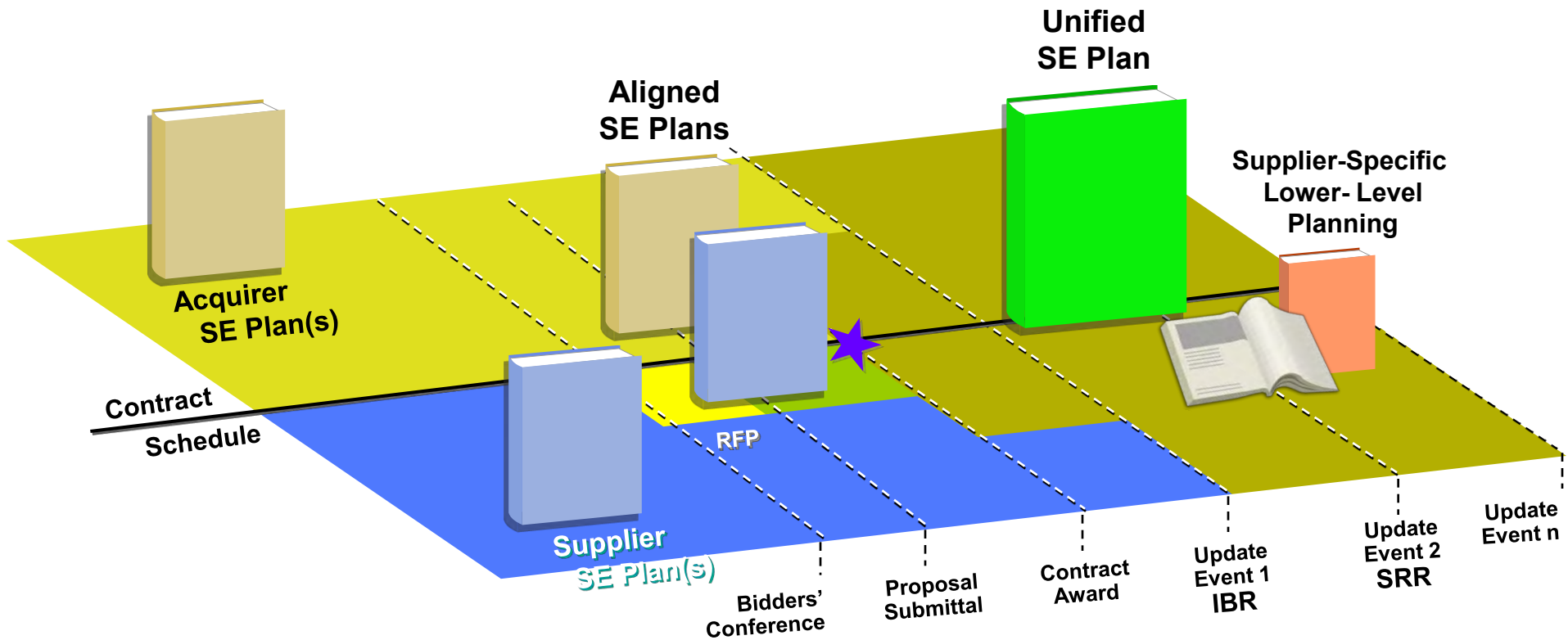



Approach



-
- Evaluated Feasibility of a Unified SE Plan
 - Launched Study to Explore the Current Environment on Programs Regarding SEPs and SEMP
 - Selected Five Boeing Programs for Review
 - Gained Understanding of Differences and Similarities Between the Two Documents (SEP / SEMP) in the Current Environment



Traits of the SEP



-
- Defines government (customer) technical planning expectations
 - What needs to happen from customer perspective

 - Describes overall approach in key areas
 - Requirements
 - Technical Staffing and Organizational Planning
 - Technical Baseline Management
 - Technical Review Planning
 - Integration with Program Management

 - Provides contractor guidance for systems engineering as applied to the acquisition program at hand

 - Identifies to program management and contract personnel the essential systems engineering activities and products required



Traits of the SEMP



-
- Responsive to the contract and the SEP
 - Defines contractor (supplier) technical planning
 - How it will be accomplished from the contractor perspective
 - Contractor further develops planning outlined in the SEP
 - Project (Supplier) team articulates details of their
 - Processes
 - Tools
 - Organization
 - etc.
 - Describes activities involved in the transformation from requirements to solution
 - Includes integration of subcontractor planning



SEP-SEMP Paragraph Comparisons



Common Areas of Discussion

Unique Areas of Discussion

SEP

SEMP

A Majority of SEP Sections Could Readily be Mapped to SEMP Sections



Specific Findings from SEP & SEMP Comparisons



- SEP and SEMP both deal with SE planning but from different perspectives
 - SEP focus is acquirer problem space
 - SEMP focus is supplier solution space
- Documents discuss similar subjects but are disconnected
 - Different language/terminology
 - Different paragraph structures

Alignment of Plans is Preferred Over Unification



SEP-SEMP Comparison Specific Findings



Over-all

- Stakeholders are different
 - SEP: Owner is Government (Acquirer)
 - SEMP: Owner is Contractor (Supplier)
- Details are different
 - SEP: Acquirer-focused problem definition
 - SEMP: Supplier-focused solution description
- Perspectives are different
 - SEP: Oversight focus
 - SEMP: Delivery focus



SEP-SEMP Comparison

Specific Findings



- **Requirements**
 - Emphasis is different
 - SEP: Key program requirements
 - SEMP: Translating requirements into product deliverables

- **Technical Staffing and Organizational Planning**
 - Differing types of talent needed by each organization
 - Organizational interfaces are key for alignment
 - Combined organizational details are unnecessary

- **Technical Baseline Management**
 - Different focus
 - SEP: What the Baselines are (descriptions)
 - SEMP: Achievement of the Baselines with Supporting Processes



SEP-SEMP Comparison Specific Findings



- **Technical Review Planning**
 - Common interests
 - Different preparation approach
 - SEP: Review Strategy; What's to be Reviewed
 - SEMP: 'How' it's Reviewed; 'What' is deferred to the IMP; 'When' is deferred to IMS

- **Integration with Program Management**
 - Different detail levels and focus
 - SEP: Integration of Planning between Government and Contractor
 - SEMP: Total Integration of Engineering Effort with Government and between Contractor, Associated Contractors, and Sub-Contractors



Vision of the Ideal SEMP



- Used regularly by the program for:
 - Consistency with DoD SEP
 - Communicating with the program personnel
 - How things get done on the program
 - Maintaining the baseline of program technical planning concepts
 - Introducing new team members to program objectives

- Improves program efficiency by:
 - Creating a uniform understanding of the program approach
 - Establishing a common program lexicon
 - Maintaining support of the technical margin (boundaries)

- Has on-going relevance via
 - Periodic updates, e.g., program reviews
 - Consistency with the contractor's goals and environment

SEP Content or Paragraph Leads to
SEMP Content / Paragraphs Containing Supporting Details



Data Item Description Update

- DID DI-MGMT-81024 (Systems Engineering Management Plan)
 - Last released in August 1990
 - Based on MIL-STD-499A
- DID outdated due to changes in DoD acquisition environment, lessons learned, references, etc.
- DID drives contractor to divert from newer Government SE policy and guidance



Data Item Description Update

- Team assembled June 2008 to investigate possible improvements
 - Emphasis to align SEMP DID with the SEP Prep Guide Topics
 - Team consisted of OSD and Services



Data Item Description Update

10 PREPARATION INSTRUCTIONS

10.1 Format. The SEMP format shall be selected by the contractor. Unless effective presentation would be degraded, the initially used format arrangement shall be used for subsequent submissions.

10.2 Content. The SEMP shall describe the contractor's planned systems engineering processes and approach, tailored as necessary to the program's contract, objectives, and overall technical and management approach. The SEMP shall describe the contractor's detailed operational plan for executing systems engineering and include, at a minimum the following SE related topics and processes:

- 1) Alignment with SEP Prep Guide Topics →
 - The topics detailed in the latest version of the Systems Engineering Plan (SEP) Preparation Guide as put forth by the Office of the Secretary of Defense, Systems and Software Engineering Directorate.
- 2) Alignment with Program SEP →
 - Government planning as detailed in the government SEP.
- 3) Contractor-Specific Planning →
 - Planning associated with application of the contractor's systems engineering processes as tailored to the program and at a level of detail necessary for the contractor to manage and execute the technical effort.
- 4) Plan Completeness →
 - Referenced lower-level and subcontractor technical plans, for example in the areas of risk management, requirements management, or configuration management, as determined necessary by the contractor to plan and execute a total systems engineering effort.
- 5) Planning Flexibility →
 - Other areas deemed necessary to execute systems engineering to meet the program's contract, objectives, and overall technical and management approach.

11. DISTRIBUTION STATEMENT

DISTRIBUTION STATEMENT A: Approved for public release; distribution is unlimited.

New DID Update Strengthens Alignment Between SEP and SEMP



Alignment via the Update of SEMP DID (DI-MGMT-81024)

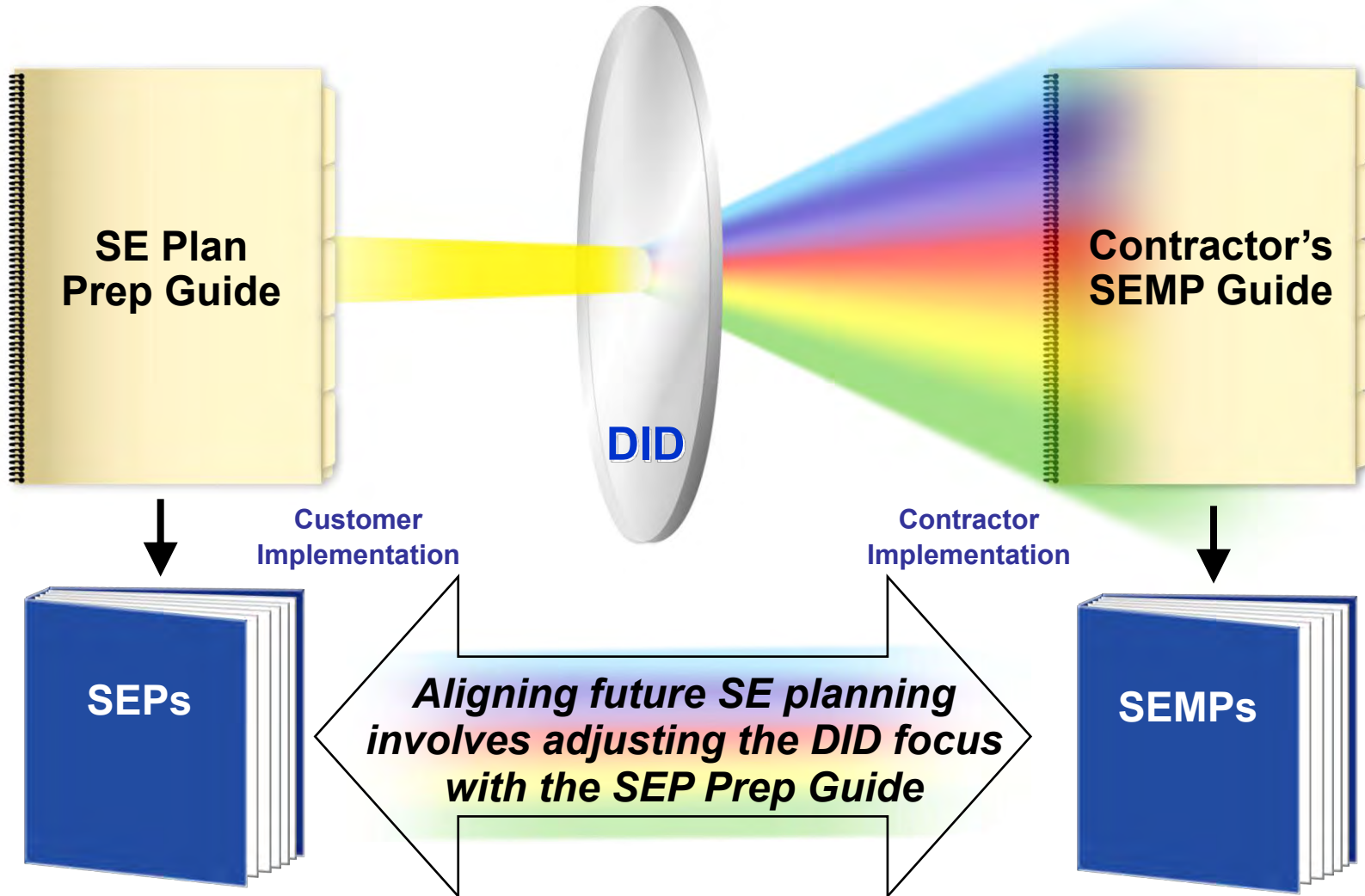



Future State



Path to a Seamlessly Aligned Set of SE Plans October 2008

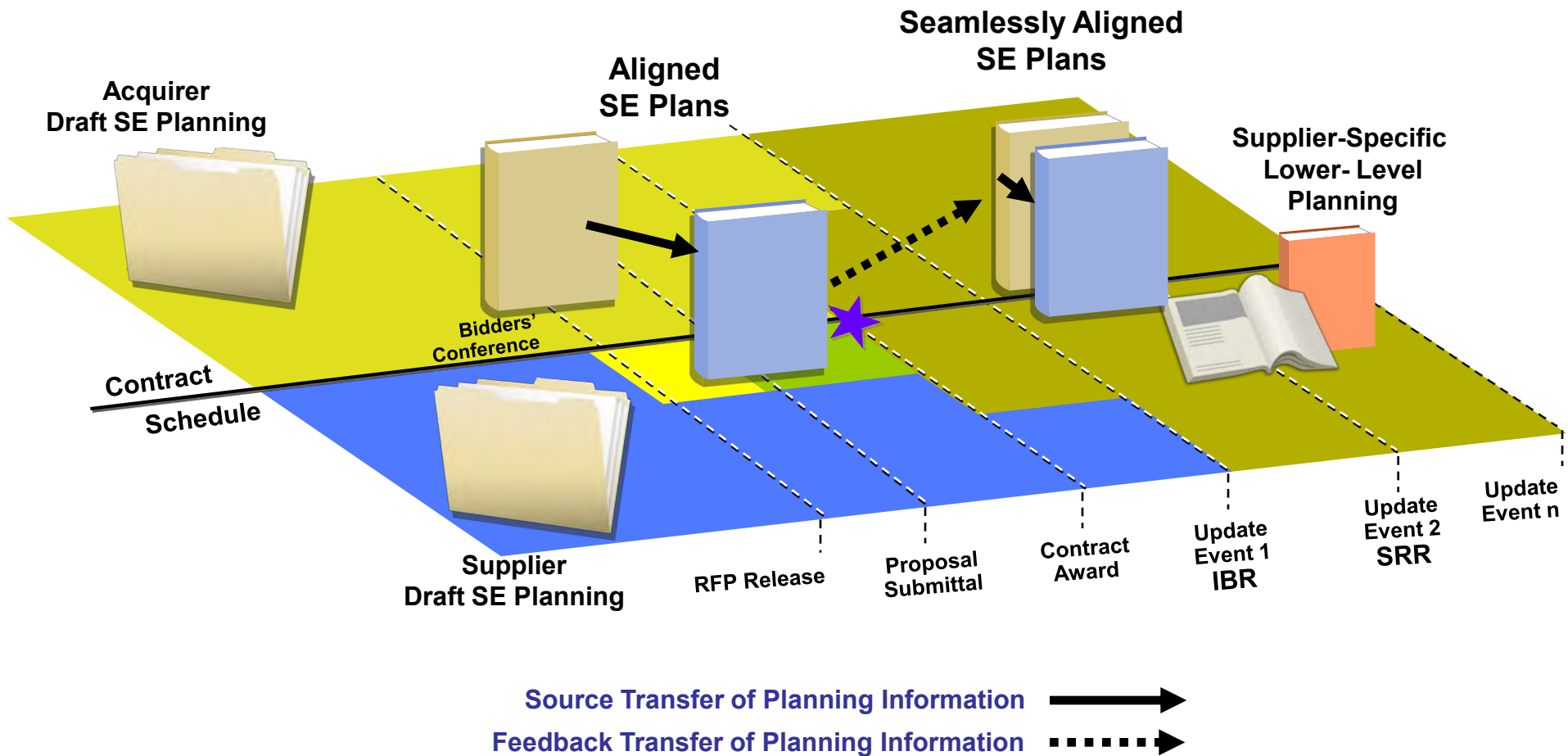



Benefits of SEP – SEMP Alignment



- Two good stand alone documents can be far better with alignment
 - Consistent planning
 - Reduction in duplication
 - Reasonable standardization
 - Continuity across plans



Way Forward



-
- Distribute Draft DI-MGMT-81024 for Industry and Government Comments
 - Consider Piloting on Programs
 - Revise and Release DI-MGMT-81024
 - Change Contractor Guidance in Response to Updated DID
 - Monitor Implementation and Feedback from Programs



Questions/Answers



Does this approach appear viable?

What improvements would you like to see?

What other recommendations would you make to achieve aligned planning?



Backup/Reference Material



SEP-SEMP Summary



| SEP Prep Guide | Program SEP Comments | Program SEMP |
|---|--|--|
| 1.Introduction | Consistent with SEP Prep Guide | Consistent with program SEP |
| 2. Program Requirements | Consistent with SEP Prep Guide | 1. SEMP covers SEP requirements
2. SEMP addresses design considerations in program plans and directives (section 8). Which are detailed plans. |
| 3. Technical Staffing and Organizational Planning | Consistent with SEP Prep Guide | 1. SEP and SEMP are consistent |
| 4. Technical Maturation and Planning | SEP Prep Guide emphasizes Requirements management and traceability while Program SEMP describes the SE process and RA/RM in context of the SE process. | 1. SEMP has a strong description of how the SE process is adapted to the program. |
| 5. Technical Review Planning | Program SEP provides good detail on technical reviews. | Doesn't appear to be covered in detail. References MIL-STD-1521B, May be covered in a detailed plan such as Quality Assurance Plan. |
| 6. Integration with Overall Program Management | Program SEP | Mostly not covered in the SEMP. Does provide a brief mention of the use of the IMP and IMS and application to Risk Management. This potentially deserves a stronger emphasis. For example there is not mention of the WBS. |
| | | Section 8 :Plans and Directives Process and Products – This section references more detailed plans. |

Represent Gaps



Specific Findings

Requirements



SEP

Output is management requirements

Over-all architecture for program lifecycle

Emphasizes program requirements specifics

- KPPs
- MOEs, e.g. Reliability or Maintainability
- Spiral Outs
- Capabilities
- Etc.

Defines lifecycle readiness of capabilities / requirement maturities

SEMP

Executable process for how technical management is done on the program

Defines the process to develop the requirements, not the actual requirements

Emphasis on SE Process for Analysis

Identification of participants in requirements process

Methods for transforming abstract to real

Built around WBS structure

Integration of all subordinate plans



Specific Findings



Technical Staffing & Organizational Planning

SEP

Acquirer-centric

- Govt. IPT Structure
- OIPTs
- WIPTs
- Govt LSI IPTs

Associated High-Level Contractor IPTs

SEMP

Supplier-centric

- Contractor and Supplier IPT Structure

Program organizational structure

- Subordinate considerations to program plan

Partnerships

Critical Skills



Specific Findings



Technical Baseline Management

SEP

Configuration Management / Data Management Activities

Responsible Entities

Specification Tree

Use of Technical Baseline and Technology Readiness Assessments

Identification of Relevant DIDs

SEMP

Specific configuration changes/updates to system

Interface management

Supplier-specific change management processes

Change review boards



Specific Findings

Technical Review Planning



SEP

Event-driven technical reviews

Management of reviews

Chairs, stakeholders

Facilitation of participation

Past Accomplishments and
Future Expectations

SEMP

Consistency with IMP

Events and Associated Reviews
summary

Review Planning may rely on
content of superior documents
(e.g., Program Execution Plan)



Specific Findings



Integration with Program Management

SEP

Integration with other planning

- Acquisition Strategy
- IMP/IMS
- External Functions
- Use of Technical Review Results (e.g., Baselines)

Execution requirements for SE activities

- Risk Management
- T&E Integration
- Verification & Validation Plan integration
- TEMP Traceability to Performance Reqmts

SEMP

Integration between program stakeholders

- Suppliers
- IPTs
- Customer
- Associate Contractors

Integration of the engineering effort

More detailed planning

- Scheduling
- Process integration
- Subcontract management
- Risk management



SE Planning Alignment Vision

Maturation Sequence

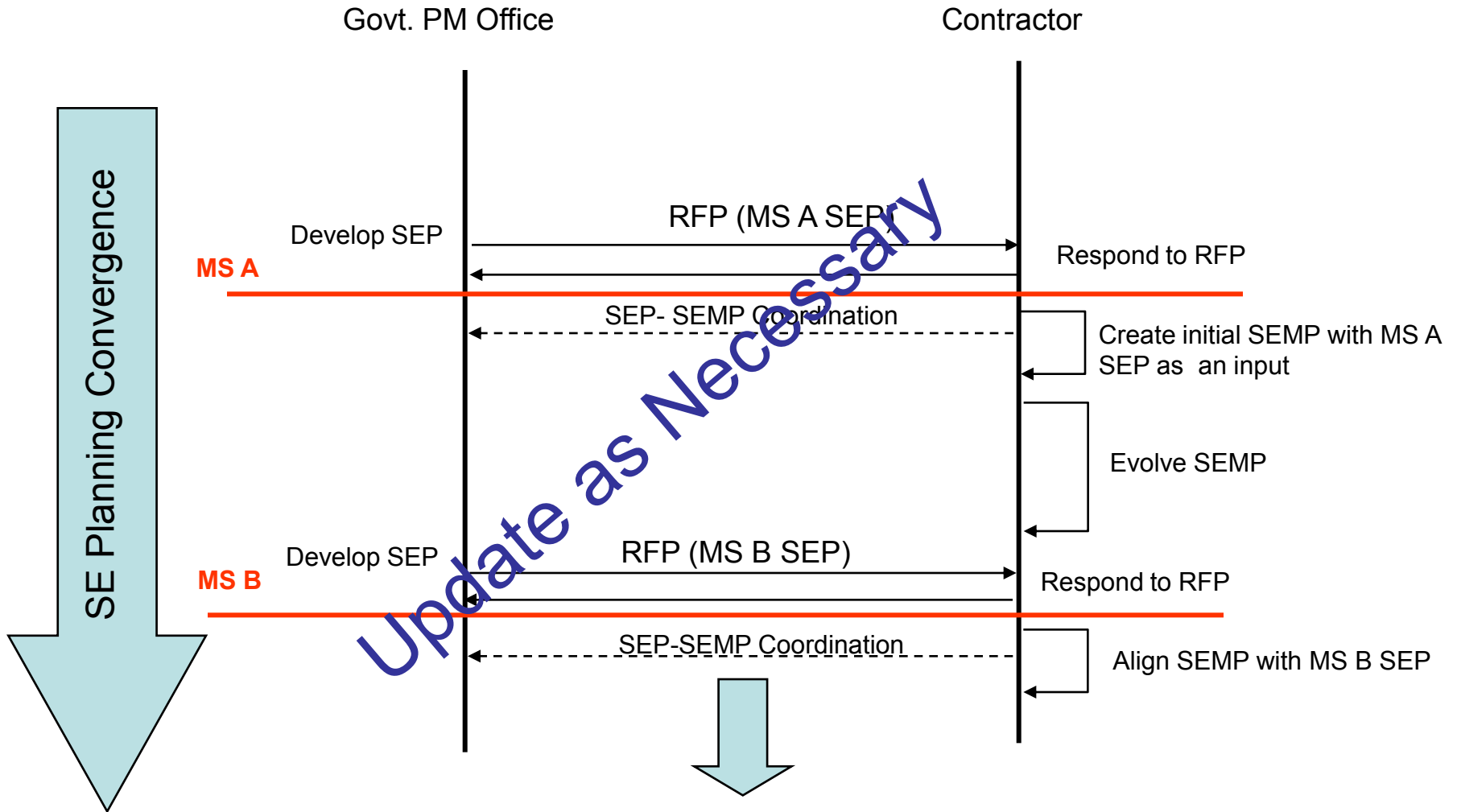

Continues for MS C and Full Rate Production

New Concepts and Trends

- How Future Trends in Systems and Software Technology Bode Well for Enabling Improved Acquisition and Performance in Defense Systems

11th Annual Systems Engineering Conference
October 20-23, 2008
Hyatt Regency Mission Bay
San Diego, CA
Theme: Technology – Tipping the Balance

Dr. Kenneth E. Nidiffer
Director of Strategic Plans for
Government Programs
nidiffer@sei.cmu.edu
703.908.1117



The Software Engineering Institute - Improving the Practice of Engineering: Create, Apply and Amplify

Federally Funded Research and Development Center

Created in 1984

Sponsored by the U.S. Department of Defense

Locations in Pittsburgh, PA; Washington, DC;
Frankfurt, Germany

Operated by Carnegie Mellon University



Software Engineering Institute

Carnegie Mellon

How Future Trends in Systems and Software
Engineering Technologies Bode Well for Enabling the
Military Mission
Dr. Kenneth E. Nidiffer

2

© 2008 Carnegie Mellon University

Overview

- Transformational Trends
 - Development
 - Acquisition
 - Human Element
 - Risk Management
 - Communications
- Ten Future Trends
- Wrap-up

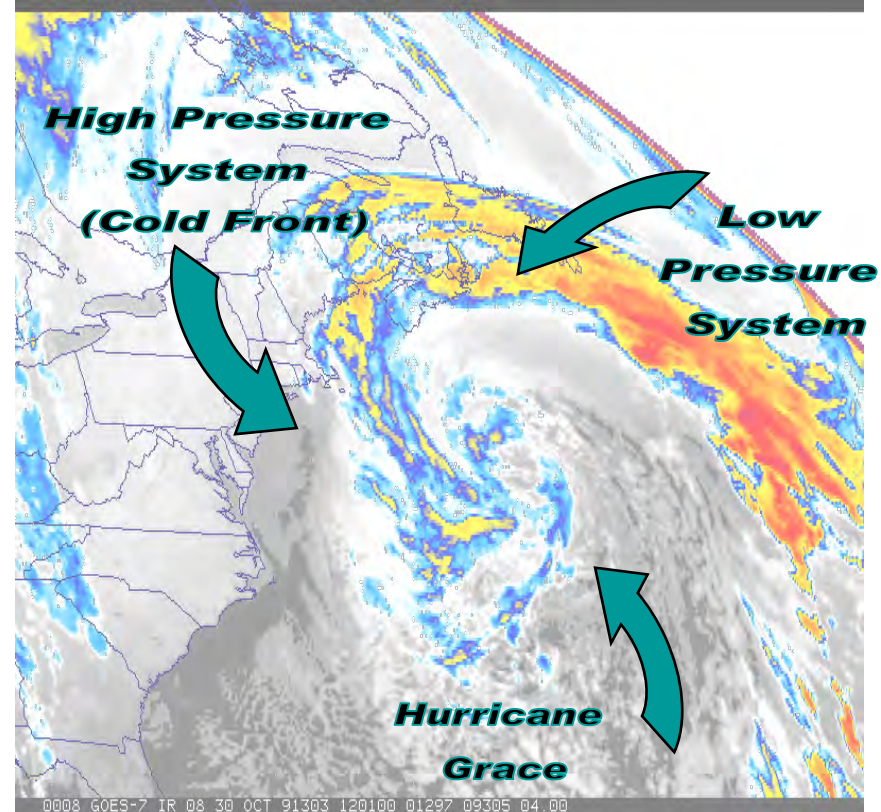
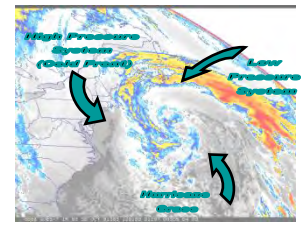

“Perfect Storm” Event, October 1991
National Oceanic & Atmospheric Administration



Development: Need for Space, Air, Ground, Water, Underwater Software-Intensive Systems that are Interconnected

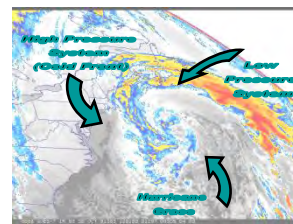

- Several million SLOC programs; “Hybrid” systems combining legacy re-use, COTS, new development
- Multi-contractor teams using different processes; dispersed engineering, development & operational locations
- New technologies create opportunities/challenges; products change/evolve, corporations mutate
- Business/operational needs change - often faster than full system capability can be implemented
- Skillset Shortfalls; Cost and schedule constraints
- Demands for increased integration, interoperability, system of system capabilities
- Enterprise perspectives/requirements; sustainment concerns



Development Complexity of Software-Intensive Systems is Increasing



The Acceleration of Innovation in the 21st Century: - Impacting Both Defense and Society

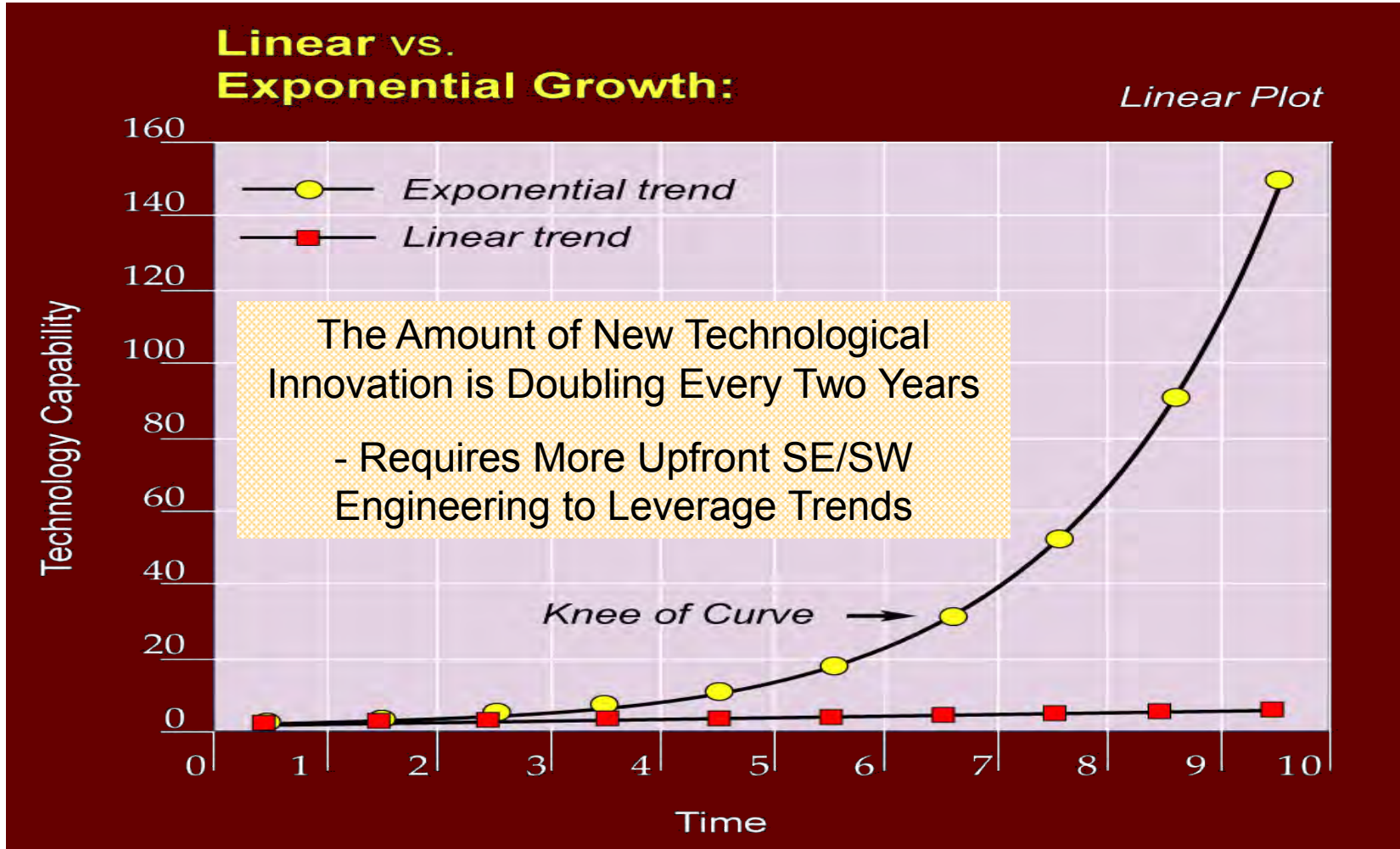
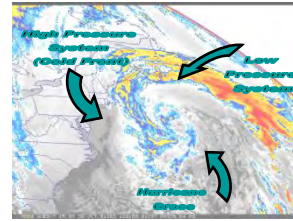

Augustine's Law: Growth of Software - Order of Magnitude Every 10 Years

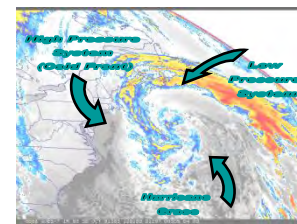

In The Beginning



1960's



F-4A
1000
LOC



1970's



F-15A
50,000
LOC



1980's



F-16C
300K
LOC



1990's



F-22
1.7M
LOC



2000+



F-35
>6M
LOC



Trend & Implications: Augustine's Law Will Hold

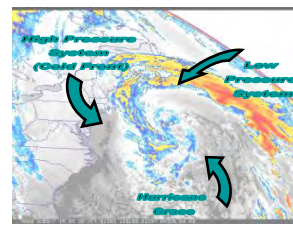

2080?



F-50 - 4.7B Lines of Code

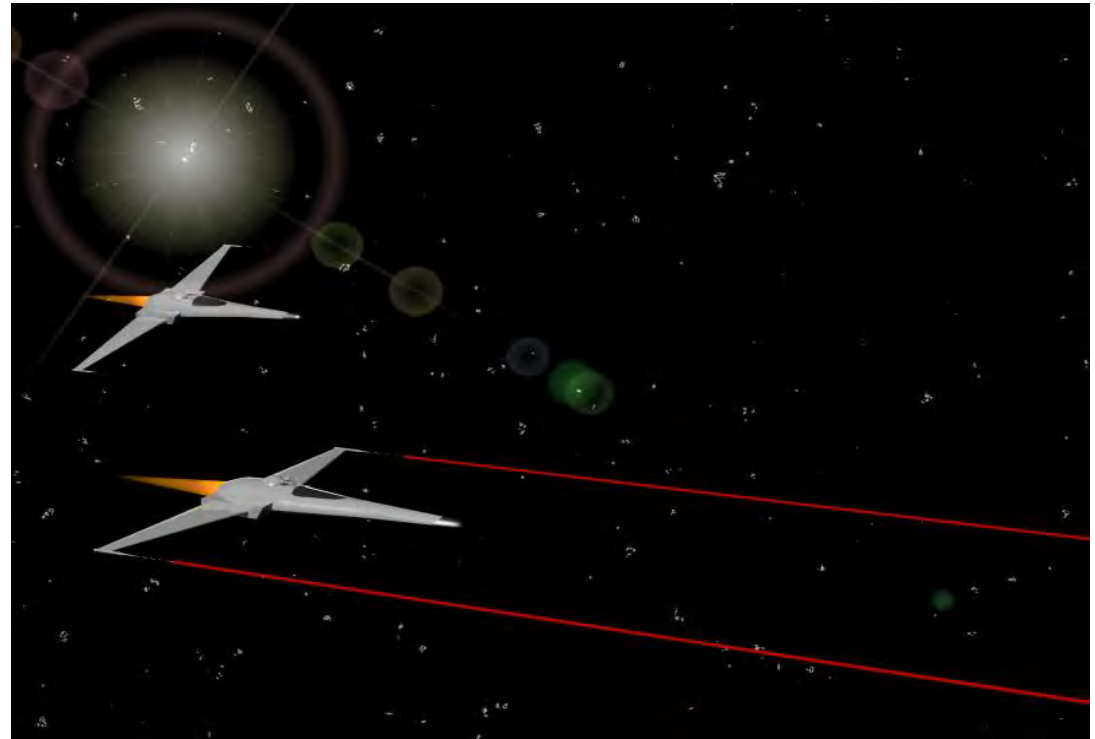

Need for increased functionality will be a forcing function to bring the fields of software and systems engineering closer together



Moore's Law: The Number of Transistors That Can be Placed on an Integrated Circuit is Doubling Approximately Every Two Years

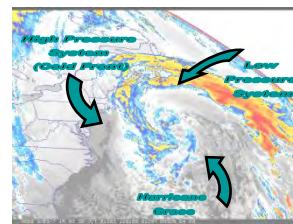

Integrated Circuit Complexity

Transistors Per Die

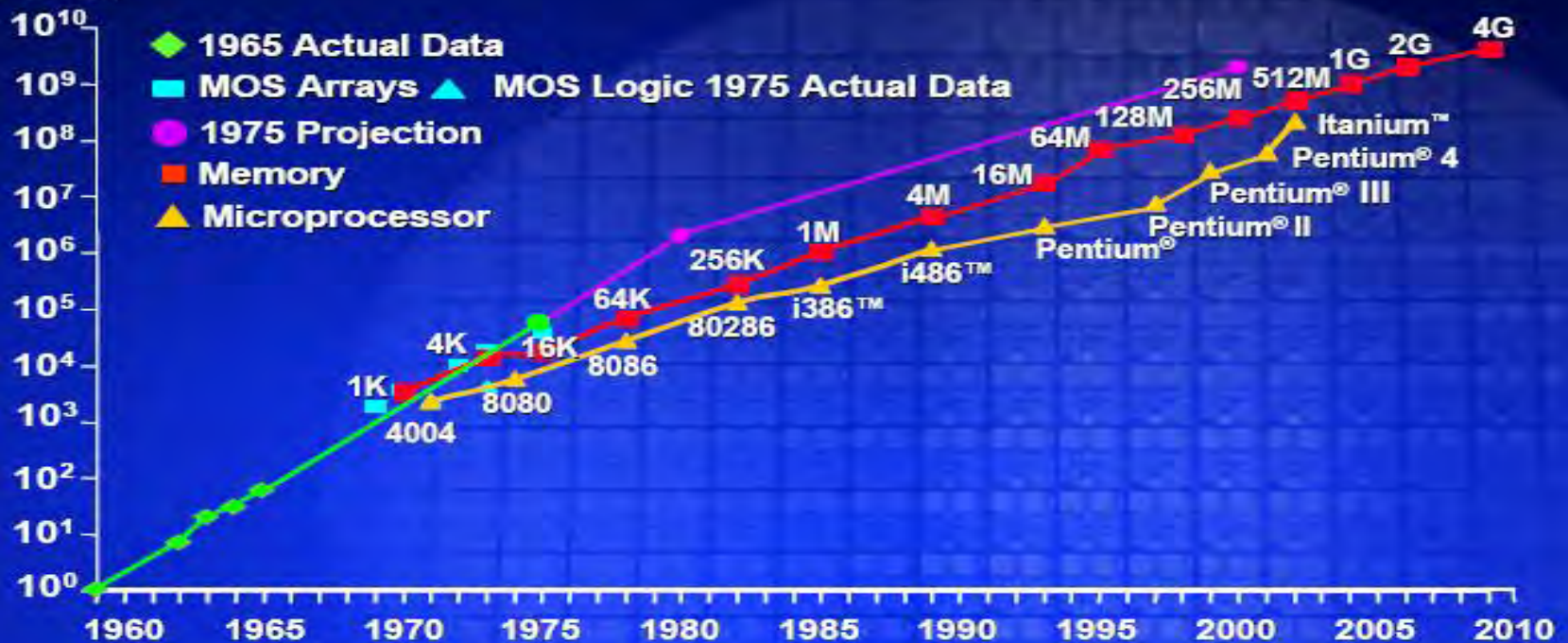

Source: Intel



Increased Technological Rate of Adoption

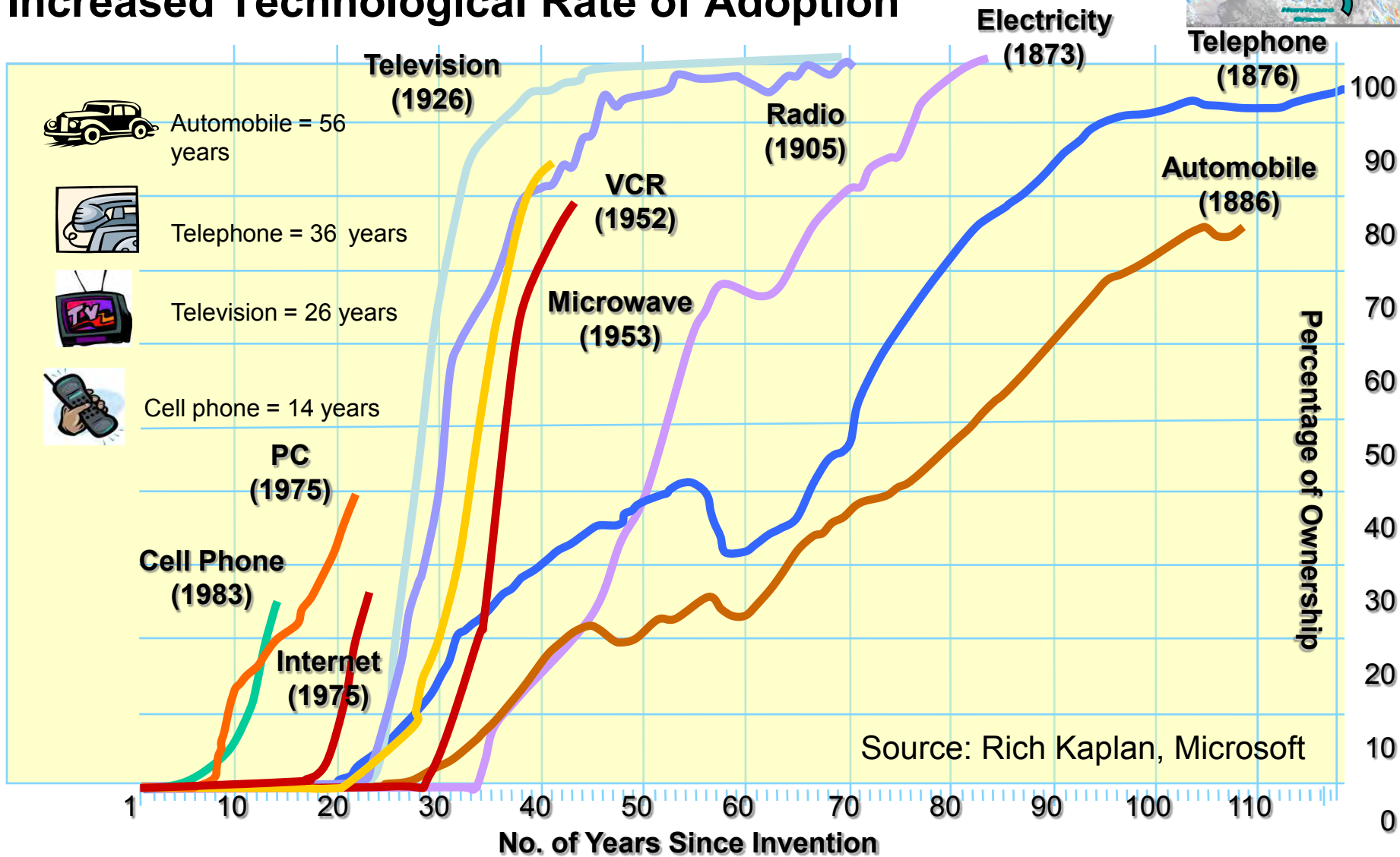
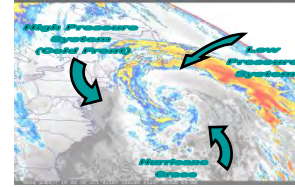

Acquisition: Life of a Program Manager in a System of Systems and/or Net-Centric Operation...

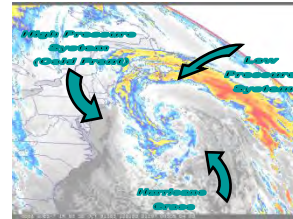

Acquisition: Effectively Managing Risk

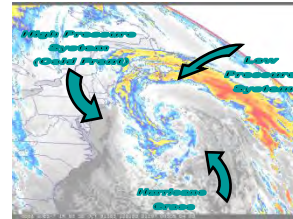

A Key Challenge is How to Obtain a Better Alignment of Risk Among the Relevant Stakeholders



Acquisition Performance – Flexible Boundary-Crossing Acquisition Structure

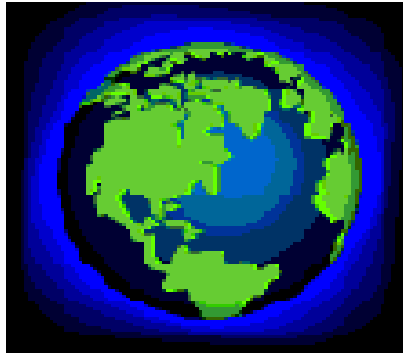
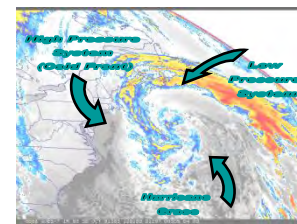

2005 study confirmed*:

- In advanced knowledge-based organizations, management’s desire for the flow of knowledge is greater than the desire to control boundaries
- Unlike the matrix organization, there is less impact on the dynamics of formal power and control
- **Important to measure the system in terms of user performance**

* Using Communities of Practice to Drive Organizational Performance and Innovation, 2005, APQ study

“Acquisition” ← Advanced Knowledge-Based Organizations (Big A)

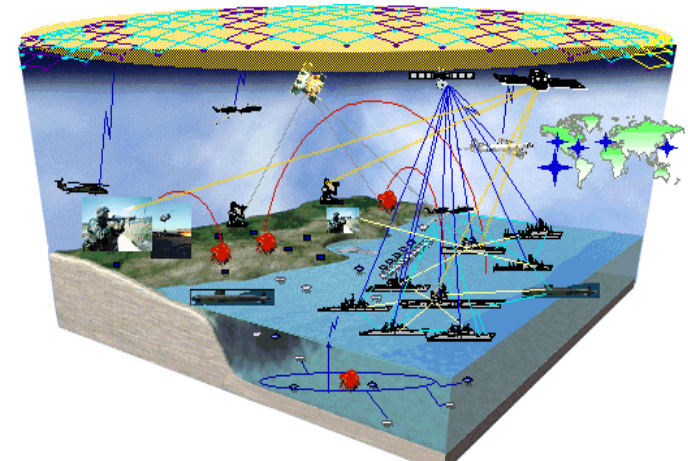
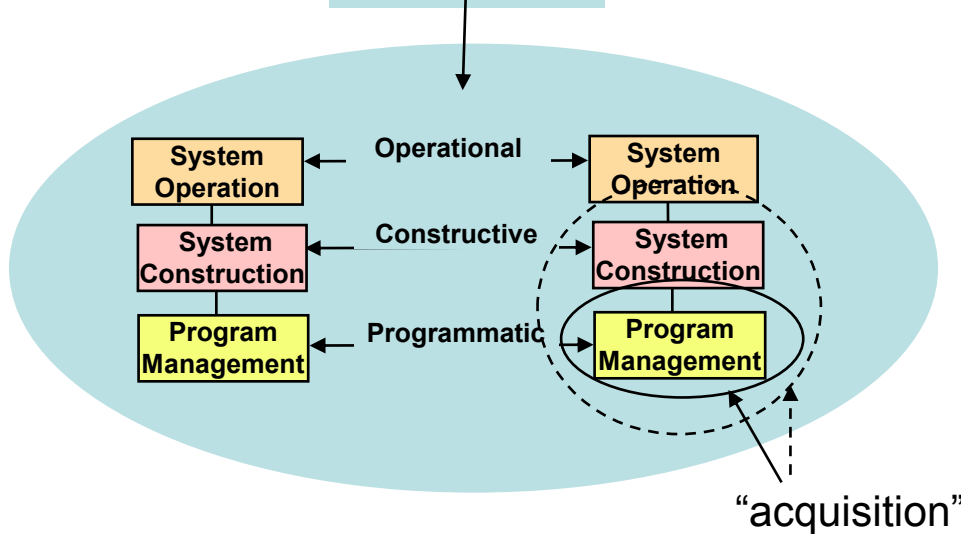

From “Science and Technology to Support FORCEnet,” Raytheon TD-06-008. Used by permission.

Ref: Jim Smith, (703) 908-8221, jds@sei.cmu.edu



Human Element

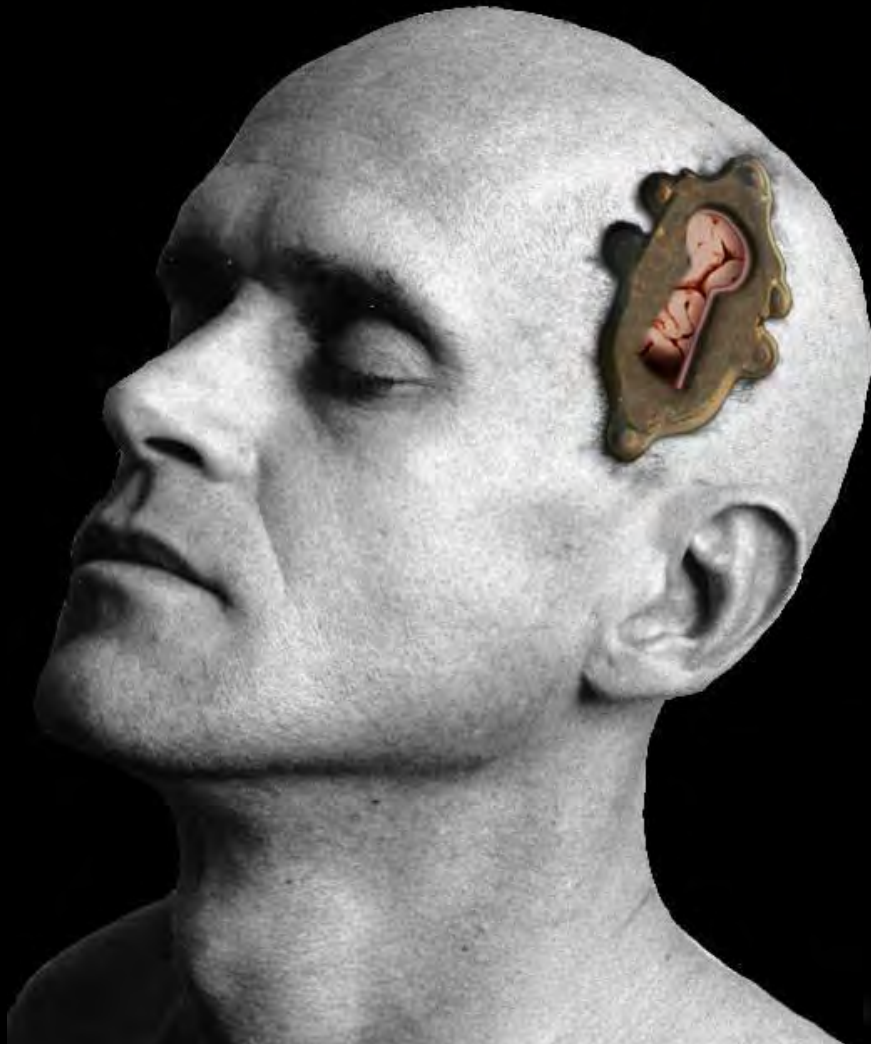

The ability of organizations to compete will increasingly depend on the innovation of the human element

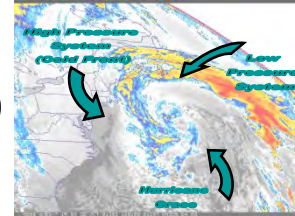

Society Drivers: Bimodal Demographics (Space Industry)

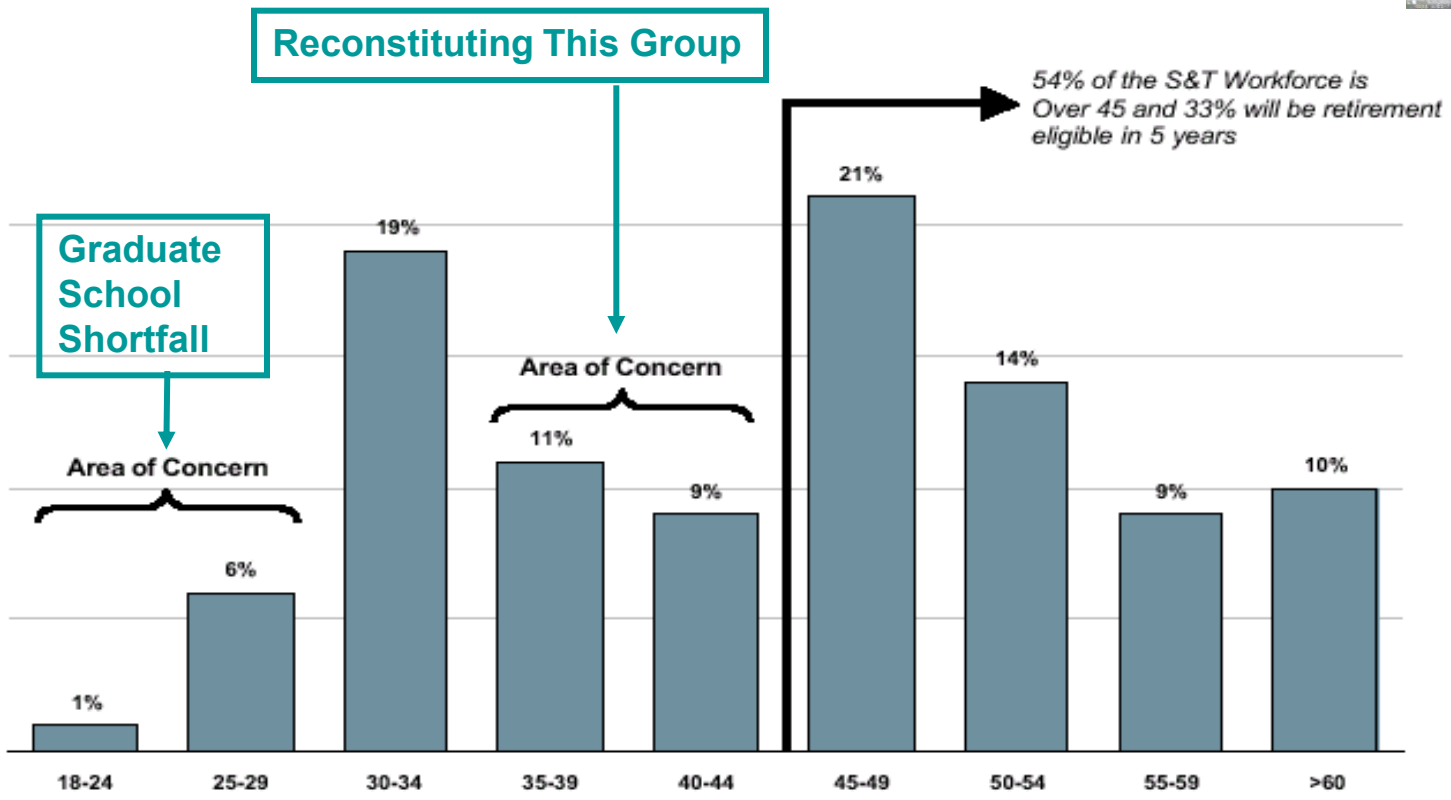

Average Space Industry S&E Workforce Age Distribution

Trend: Industry/Gov't Will Increasingly Focus on Attracting, Training and Retaining Systems Engineering Talent



Objective is for Software and Systems Engineering to Become More Integrated Versus Separated

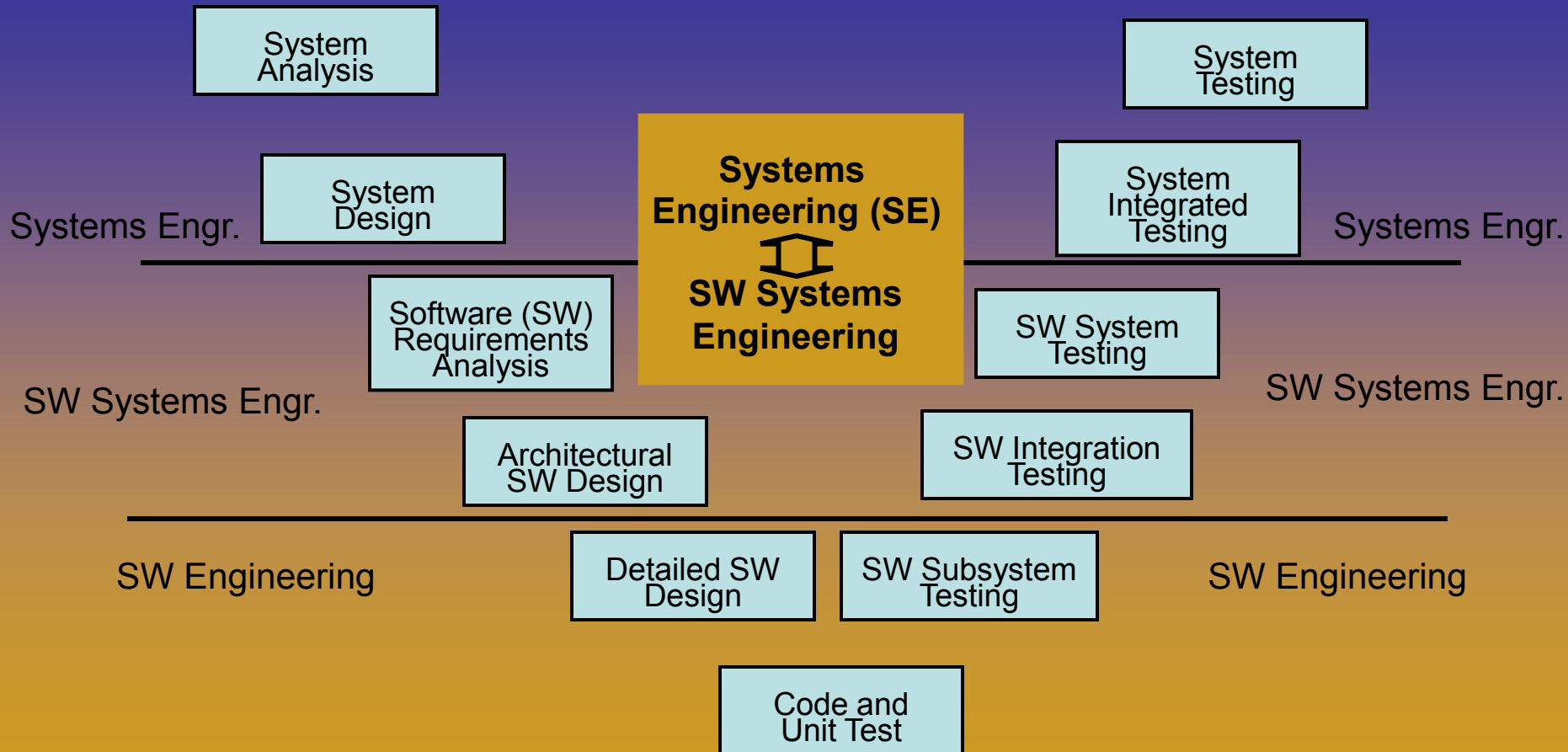
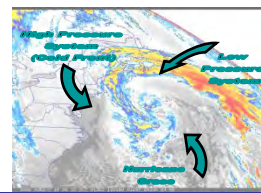

OSD Initiative: Integrated Software and Systems Engineering Curriculum



Human Element in the Work-Space Environment

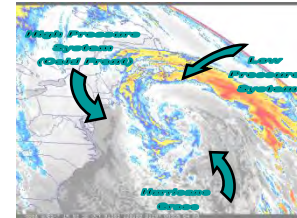

Timeline

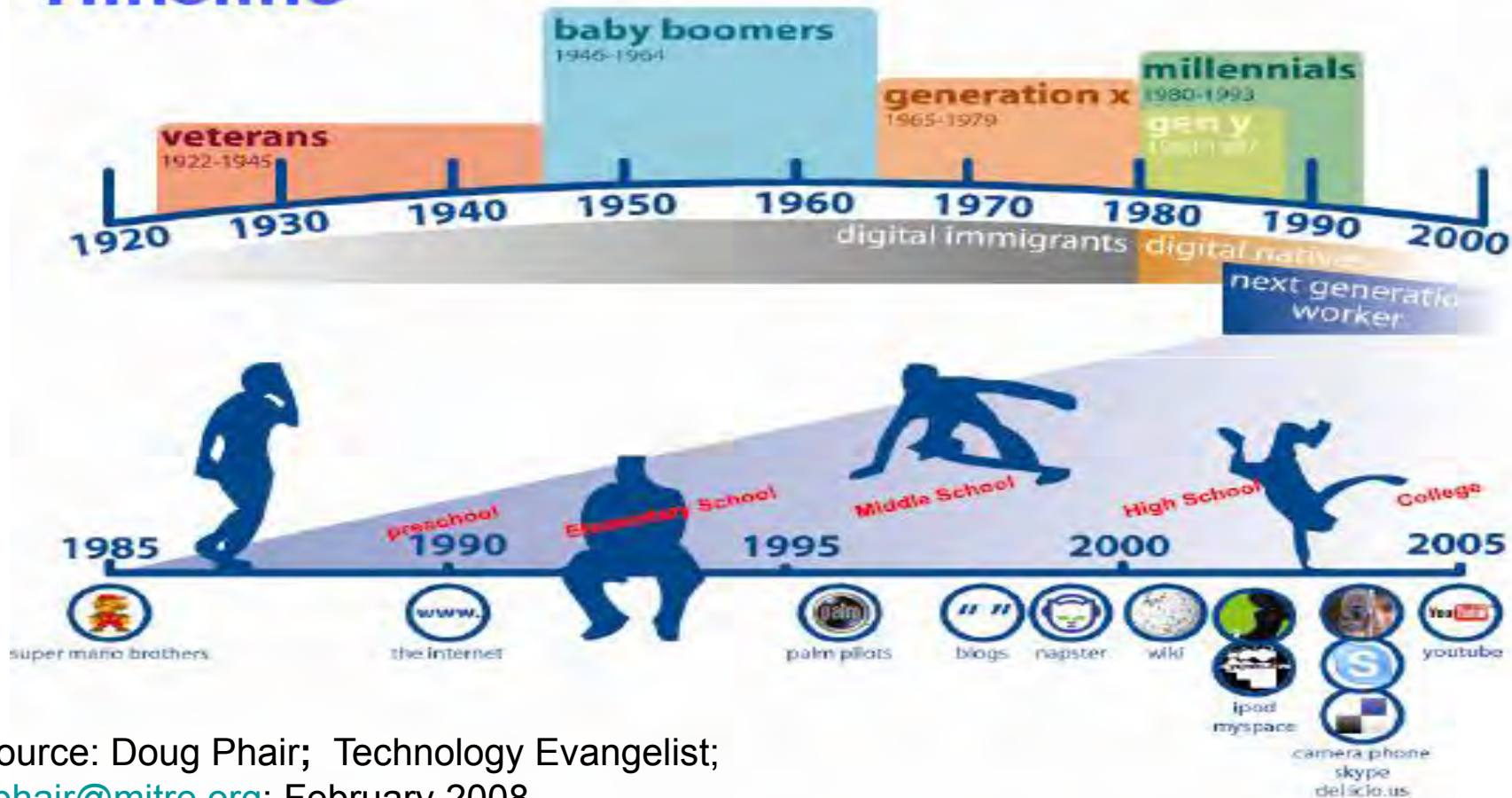

Source: Doug Phair; Technology Evangelist;
dphair@mitre.org; February 2008



Communication: Increased Capabilities in the Digital Spectrum Enables Improvements in Communication and Collaboration

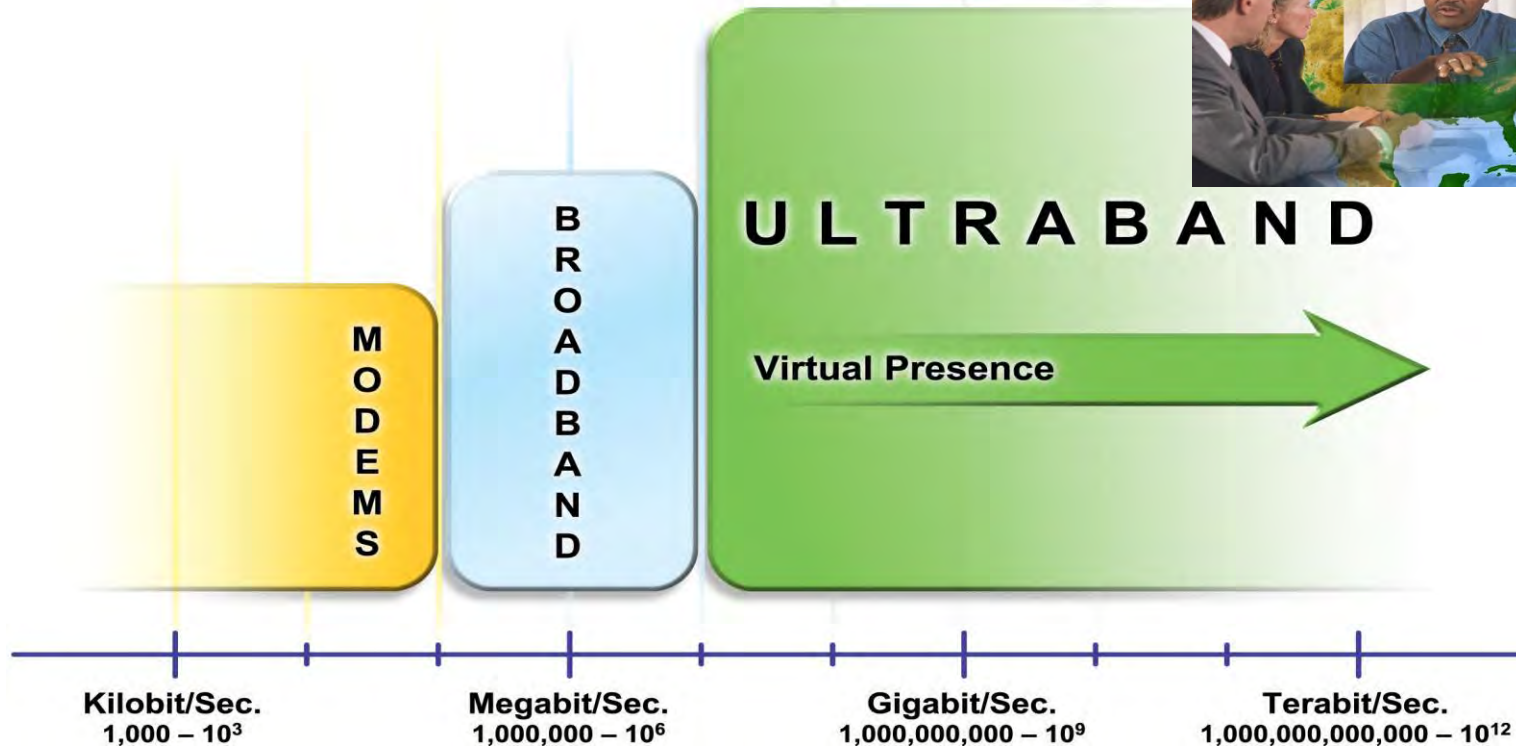
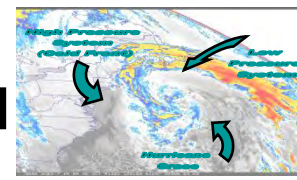

Rule #4: The best companies are the best collaborators*

* Friedman, Thomas L. *“The World Is Flat”*, Farrar, Straus and Giroux, 2005



Higher-Maturity Approaches to Process Improvement Are Important and Synergistic Trends

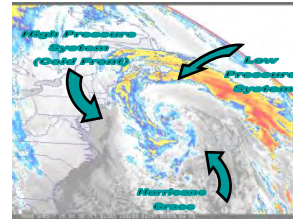

Data-Driven (e.g., Six Sigma, Lean)

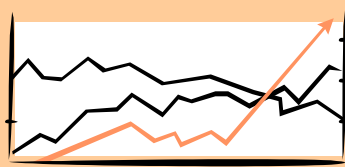

Optimizing

Quantitatively Managed

Determine what your processes can do (Voice of Process)

- Statistical Process Control

Clarify what your customer wants (Voice of Customer)

- Critical to Quality (CTQs)

Identify and prioritize improvement opportunities

- Causal analysis of data

Determine where your customers/competitors are going (Voice of Business)

- Design for Six Sigma

Model-Driven (e.g., CMM, CMMI)



Determine the industry best practice

- Benchmarking, models

Compare your current practices to the model

- Appraisal, education

Identify and prioritize improvement opportunities

- Implementation
- Institutionalization

Look for ways to optimize the processes

CMMI and Six Sigma,
Siviy, et al, 2007, Addison Wesley



Systems and Software Engineering: Ten Trends

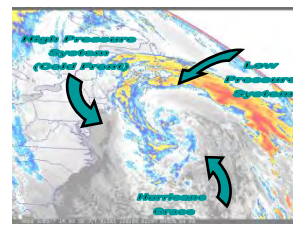

1. *Greater demands on systems and software engineers will stimulate growth in the field – nationally and internationally*
2. *Industry/Gov't will increasingly focus on attracting, training and retaining systems and software engineering talent – short and long run – with emphasis on providing a Generation Y work environment*
3. *Increased reliance on systems and software engineering processes and technologies to effectively manage the acquisition/"green" space*
4. *The laws of Augustine's and Moore will continue to hold and will continue to be a forcing function to bring the fields of software and systems engineering closer together*
5. *Improvements risk-reduction collaboration mechanisms will be significant enablers for increases in systems and software engineering communication and "decision velocity"*



Systems and Software Engineering: Ten Trends

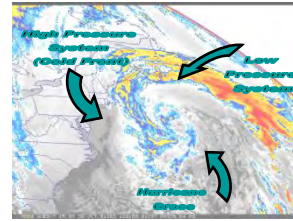

6. *Systems and software engineers will continually find way to innovative to reduce complexity*
7. *Increased importance of modeling and simulation*
8. *Increased customer requests for system and software engineering support will occur earlier in life cycle*
9. *Shift of systems and software engineering focus from the platform to the networks and ground systems*
10. *Process improvement will continue to be important!*





Questions?

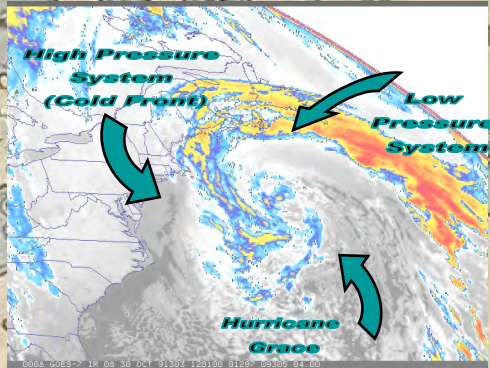

Recommended Readings

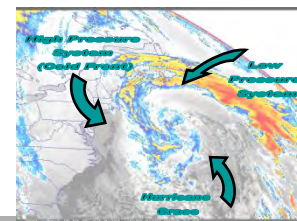

Buckman, Robert H. *Building a Knowledge-Driven Organization*. McGraw-Hill, New York, NY, 2004.

GAO Report: 08-467SP, Defense Acquisitions – Assessment of Selected Weapon Systems, March 2008

Chesbrough, Henry William. *Open Innovation: The New Imperative for Creating and Profiting from Technology*. Harvard Business School Publishing Corporation, Boston, MA 2003.

Drucker, Peter. *Managing in the Next Society*. Truman Talley Books, New York, NY, 2003.

Friedman, Thomas L. “*The World Is Flat*”, Farrar, Straus and Giroux, 2005

Gates, William H. III “*Business @ The Speed of Thought – Using a Digital Nervous System*”, Time Warner Books, 1999

Kurstedt, Harold and Pamela. *Systems and Software Engineering Interfaces, Dealing with the Bumpy Roads*, Participant Guide, March 2008

Malone, Thomas. *The Future of Work: How the New Order of Business Will Shape Your Organization, Your Management Style and Your Life*. Harvard Business School Publishing, Boston, MA, 2004. See <http://ccs.mit.edu/futureofwork/>

Nidiffer, Kenneth E. and Doland, Diana “Evolving Distributed Project Management”, special issue *IEEE Software*, Sept/Oct 2005

Northrop, Linda. *Ultra-Large-Scale Systems – The Software Challenge of the Future*, Software Engineering Institute, June 2006

Rouse, William B. et al, *Understanding R&D Value Creation with Organizational Simulation*, Tennenbaum Institute, H. Milton Stewart School of Industrial & Systems Engineering, Georgia Institute of Technology, Atlanta, GA 30332-0205, Oct 2006

Wladawsky-Berger, Irving. “The Future of IT in an On-Demand World.” IBM Server Group, Keynote address at OSBC 2005. Archived at <http://www.itconversations.com/shows/detail495.html>

0008 GOES-7 IR 08 30 OCT 91303 120100 01297 09305 04 00





ESOH In Acquisition OSD Expectations For Implementing DoDI 5000.02

National Defense Industrial Association
11th Annual Systems Engineering Conference
San Diego, California
October 21, 2008

Ms. Karen Gill (Booz Allen Hamilton) for

Ms. Patricia Huheey

Acquisition ESOH

Office of the Deputy Under Secretary of Defense
(Installations & Environment)



Outline

Acquisition, Technology and Logistics

- Background on DUSD(I&E)
- Policy Objectives & Principles
- Policy & OSD Expectations
- Initiatives and Focus Areas
 - DAU CLE 009 – “System Safety in Systems Engineering”
 - “System Safety - ESOH Management Evaluation Criteria for DoD Acquisition”
 - “ESOH in Acquisition – Integrating ESOH into Systems Engineering” Booklet



ESOH in Acquisition Leadership

Environment, Safety, and Occupational Health

Acquisition, Technology and Logistics

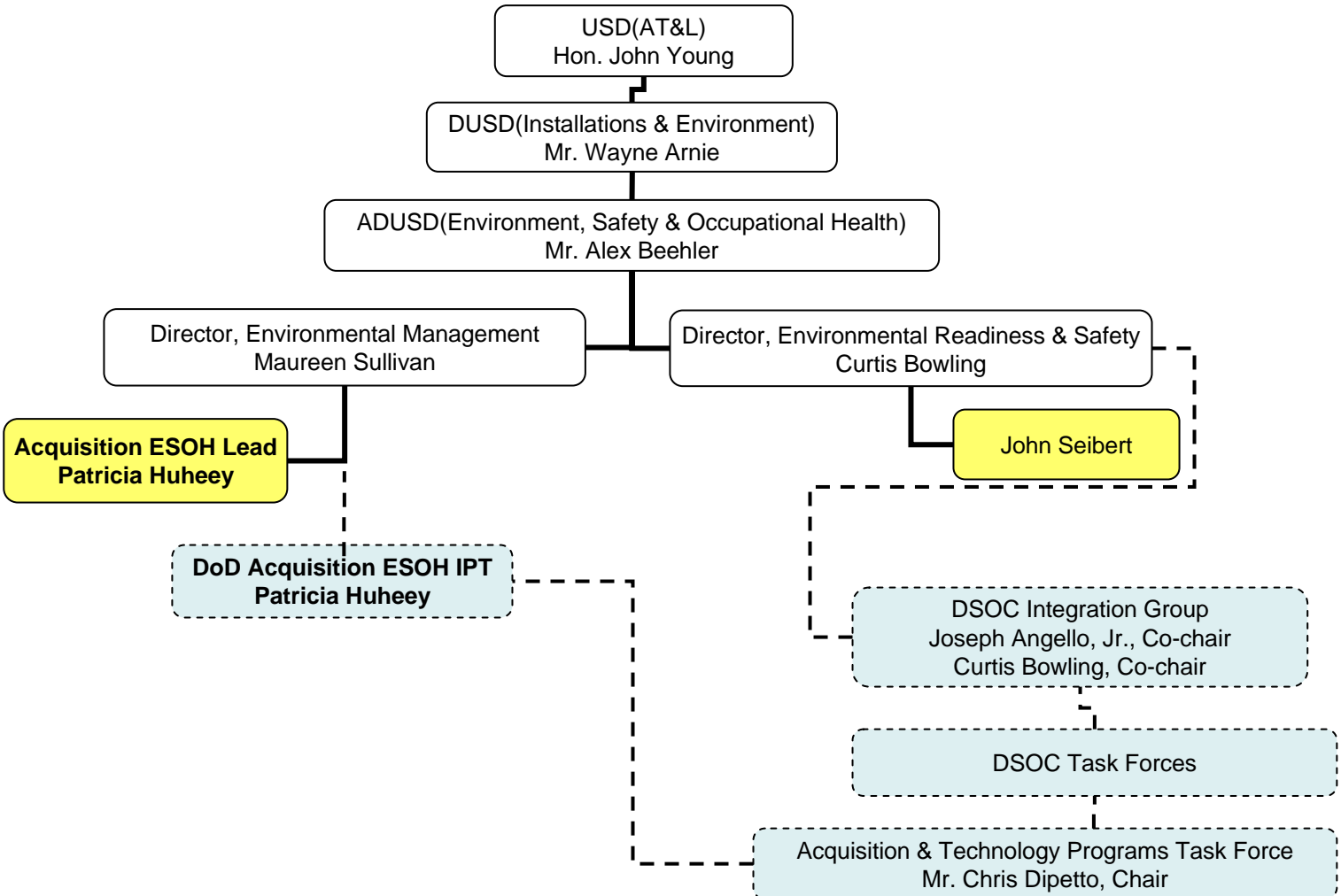



Role in Acquisition

Acquisition, Technology and Logistics

- DUSD(I&E) is the AT&L Advisor for ESOH issues
- Oversight of ACAT 1D, IAM, and AT&L Special Interest programs
- Focus on DoDI 5000.02 - ESOH in acquisition policy
- Identify OSD ESOH “expectations” in the Defense Acquisition Guidebook
- Provide guidance for policy implementation on the Acquisition Community Connection
- Provide ESOH input to CJCS 3170.01 series - JCIDS



Why Be Concerned With ESOH in Acquisition?

Acquisition, Technology and Logistics

- ESOH considerations affect the operational effectiveness and sustainability of the system
 - There is a relationship between the natural and workforce infrastructures and the military mission
 - Compliance requirements and encroachment influence how DoD maintains and trains with the system
 - System design, operation, and maintenance parameters determine the installation and workforce needs to train and maintain the system

Natural Infrastructure Management (NIM)

Acquisition, Technology and Logistics

- The essential principle of NIM is that air, land, and water resources are *assets that must be managed and sustained* for the values they provide to the military
- Natural infrastructure (NI) assets include
 - *Natural assets*: distinct ecological or physical components of natural infrastructure
 - *Statutory assets*: legally defined entitlements to access and use products and services of natural infrastructure

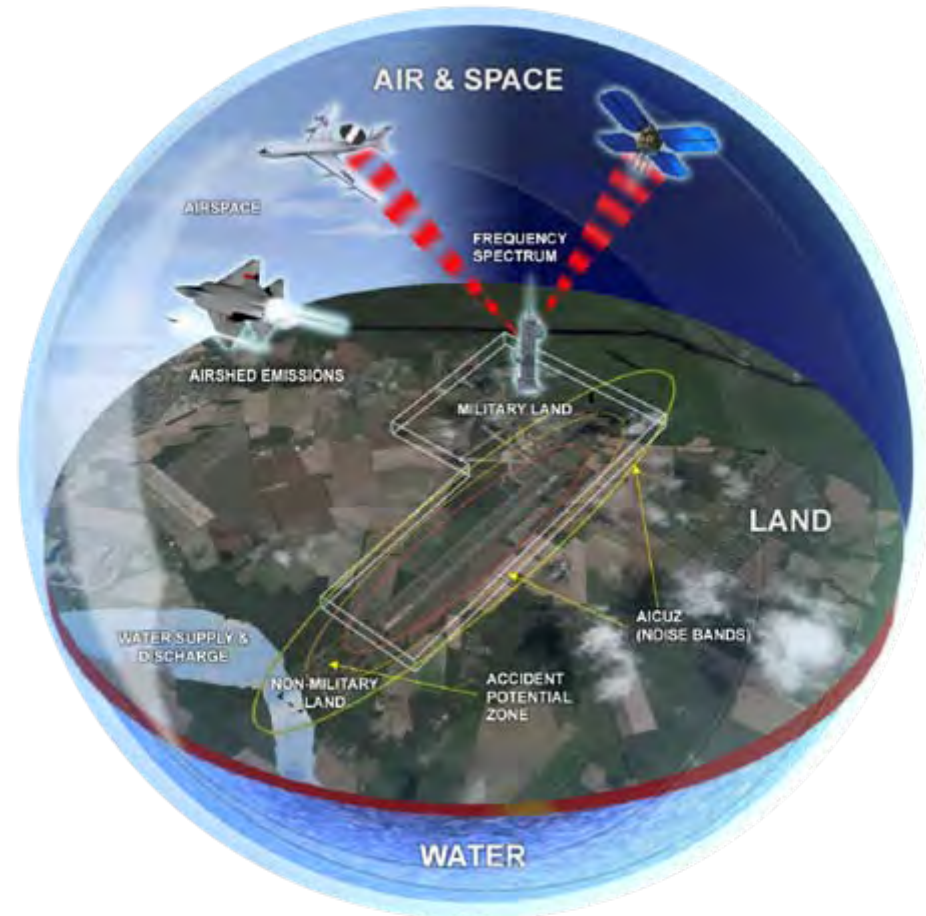

Leveraging NI asset values to support the mission



Plan Ahead & Influence the System Design

Acquisition, Technology and Logistics

- Identify system life-cycle ESOH risks early to influence design rather than address them afterwards as operational considerations
- System design is most effectively influenced through the system engineering process
 - Active participation in the IPTs is critical to success
- ESOH hazards and associated risks are best managed using a standard approach and structured process
- E, S, and OH inputs to systems engineering need to be optimized across the disciplines to meet cost and performance needs over the life cycle



Top Level Principles

Acquisition, Technology and Logistics

- Address safety throughout the acquisition process
- Use a total systems approach to minimize or eliminate characteristics that produce environmental, safety or health hazards
- Use the system safety process in MIL-STD-882D to eliminate ESOH hazards where possible and manage ESOH risks where hazards cannot be eliminated
- Coordinate ESOH risks with the User and formally accept risks at designated management level
- Manage and document hazardous and toxic materials associated with the system and plan for safe disposal



Life Cycle ESOH Risks

Acquisition, Technology and Logistics

- **ESOH risks may include:**
 - Hazardous and toxic materials and wastes
 - Environmental and occupational noise (e.g. litigation, lost productivity)
 - Personnel safety and occupational health (e.g. PPE, medical surveillance, lost work time, future VA benefits of injury/illness)
 - Regulatory compliance (e.g., pollution, record-keeping, non-compliance fines, litigation)
 - System component or software failures
- **Need to manage ESOH risks associated with:**
 - Routine operation and maintenance of the system
 - System failures
 - ESOH compliance requirements



DoD Acquisition Policies and Guidance

Acquisition, Technology and Logistics

- DoD Directive (DoDD) 5000.01, *The Defense Acquisition System* (12 May 2003)
- DoD Instruction (DoDI) 5000.02, *Operation of the Defense Acquisition System* (12 May 2003)
- MIL-STD-882D, *DoD Standard Practice for System Safety*
- Defense Acquisition Guidebook, <https://akss.dau.mil/dag>
- Acquisition Community Connection, ESOH Special Interest Area, <https://acc.dau.mil/ESOH>



Update Policy and Guidance

Acquisition, Technology and Logistics

- In 2007 coordinated with the Services and provided ESOH input update of DoDI 5000.02
 - “Facts of life” changes only (plus AT&L inputs)
 - Incorporated the 3 USD(AT&L) ESOH-System Safety Memos since 2003 and new EO 13423
 - Moved main ESOH section to the new Enclosure 12 - Systems Engineering and updated ESOH paragraphs
- Provided updated ESOH section to the Defense Acquisition Guidebook to reflect the upcoming changes to DoDI 5000.02 (will come out with updated 5000.02)

Paragraph 3.8.2.2

Life-Cycle Sustainment Considerations

Acquisition, Technology and Logistics

- Life-cycle sustainment considerations include supply; maintenance; transportation; sustaining engineering; data management; configuration management; manpower, personnel, training, habitability, survivability, **environment, safety (including explosives safety), and occupational health**; protection of critical program information and anti-tamper provisions; supportability; and interoperability.



Paragraph 3.8.3

Disposal

Acquisition, Technology and Logistics

- At the end of its useful life, a system shall be demilitarized and disposed of in accordance with **all legal and regulatory requirements and policy relating to safety (including explosives safety)**, security, and the environment.
- During the design process, PMs shall **document hazardous materials contained in the system in the Programmatic Environment, Safety, and Occupational Health Evaluation (PESHE)** (see paragraph E12.6.), and shall **estimate and plan** for the system's demilitarization and **safe disposal**.

E12.6 Environment, Safety, and Occupational Health



- The PM shall **integrate ESOH risk management into the overall systems engineering process for all developmental and sustaining engineering activities**. As part of risk reduction, the PM shall eliminate ESOH hazards where possible, and manage ESOH risks where hazards cannot be eliminated. **The PM shall use the methodology in MIL-STD-882D, *DoD Standard Practice for System Safety*.**
- PMs shall **report on the status of ESOH risks and acceptance decisions at technical reviews.**

E12.6 Environment, Safety, and Occupational Health, con't.

- Acquisition program reviews and fielding decisions shall address the status of all high and serious risks, and applicable ESOH technology requirements.
- ***Prior to exposing*** people, equipment, or the environment to known system-related ESOH hazards, the PM shall document that **the associated risks have been accepted** by the following acceptance authorities: the CAE for high risks, PEO-level for serious risks, and the PM for medium and low risks. **The user representative shall be part of this process throughout the life cycle** and shall provide formal concurrence prior to all serious and high risk acceptance decisions.

E12.6.1 Programmatic ESOH Evaluation (PESHE)

- 
- The PM for all programs, regardless of ACAT level, shall prepare a PESHE which incorporates the MIL-STD-882D process and includes the following:
 - identification of ESOH responsibilities
 - the strategy for integrating ESOH considerations into the systems engineering process
 - ★ **identification of ESOH risks and their status**
 - ★ **a description of the method for tracking hazards throughout the life cycle of the system**
 - ★ **identification of hazardous materials, wastes, and pollutants (discharges/emissions/ noise) associated with the system and plans for their minimization and/or safe disposal**
 - a compliance schedule covering *all system related activities* for the National Environmental Policy Act (NEPA) and Executive Order 12114
 - The **Acquisition Strategy** shall incorporate a **summary of the PESHE**, including the NEPA/EO 12114 compliance schedule



E12.6.2 National Environmental Policy Act/Executive Order 12114

Acquisition, Technology and Logistics

- The PM shall conduct and document NEPA/E.O. 12114 analyses for which the PM is the action proponent
- The PM shall *provide system-specific analyses and data to support other organizations' NEPA and EO 12114 analyses*
- The **CAE** (or for joint programs, the CAE of the Lead Executive Component) **or designee, is the approval authority for system-related NEPA and E.O. 12114 documentation**



Enclosure 12 Systems Engineering

E12.6.3 Mishap Investigation Support

Acquisition, Technology and Logistics

- PMs will support system-related Class A and B mishap investigations by **providing analyses of hazards that contributed to the mishap and recommendations for materiel risk mitigation measures**, especially those that minimize human errors.



MIL-STD-882D Eight Mandatory Steps

Acquisition, Technology and Logistics

1. Document the system safety approach – Document the Government and Contractors' approach to ESOH risk management
2. Identify hazards – Conduct hazard analyses of ever-increasing fidelity as the system design matures
3. Assess the risk – For each hazard, determine the associated level of risk
4. Identify risk mitigation measures – For each identified hazard, propose alternatives/controls to eliminate the hazard or reduce the risk of the hazard to an acceptable level
5. Reduce risk to an acceptable level – For each hazard, select the risk mitigation measure(s) to be used to eliminate the hazard or reduce the risk
6. Verify risk reduction – For each hazard, verify that the hazard has been eliminated or the risk mitigation measure(s) has reduced the risk of the hazard
7. Review hazards and accept risk by appropriate authority
8. Track hazards, their closures, and residual risk – Maintain a tracking system to document hazards, mitigation measures, and hazard status throughout the life cycle



MIL-STD-882D Order of Precedence

Acquisition, Technology and Logistics

Most to Least Preferred Risk Mitigation Measures

| | | |
|----|--|--|
| 1. | Eliminate hazards through design selection | If unable to eliminate an identified hazard, reduce the associated risk through design selection. |
| 2. | Incorporate safety devices | If unable to eliminate the hazard through design selection, reduce the risk using protective safety features or device. |
| 3. | Provide warning devices | If safety devices do not adequately lower the risk of the hazard, include a detection and warning system to alert personnel to the particular hazard. |
| 4. | Develop procedures and training | <p>Where it's impractical to eliminate hazards through design selection or to reduce associated risk to an acceptable level with safety and warning devices, incorporate special procedures and training. Procedures may include the use of personal protective equipment.</p> <p><u>Note:</u> For catastrophic or critical severity categories, avoid using warning, caution, or other written advisory as the <u>only</u> risk reduction method.</p> |



"System Safety in Systems Engineering" DAU CLE009

Acquisition, Technology and Logistics

- Roadmap for using the MIL-STD-882D System Safety methodology to integrate ESOH considerations into the SE process during each life cycle phase
- Maps System Safety analyses into the SE "V" model
- Never been done before by either the System Safety or SE communities—fundamental breakthrough in defining how the communities are supposed to work together
- Results to Date:
 - Available online April 2005
 - 3054 graduates as of OCT08

***ODUSD(I&E) - ESOH SME
and logistical support***

***ODUSD(A&T)/SSE - SE SME
and DAU SE courses***



System Safety - ESOH Management Evaluation Criteria for DoD Acquisition

Acquisition, Technology and Logistics

- Tool to assess SE technical discipline in the integration of ESOH using System Safety methodology
 - Technical and Program Reviews (self assessment)
 - Milestone Review Process (oversight assessment)
- Four key areas for evaluation
 - Planning
 - Requirements Analysis
 - Hazard analysis
 - Resources



System Safety - ESOH Management Evaluation Criteria for DoD Acquisition

Acquisition, Technology and Logistics

- Assessment criteria for each area for each life cycle phase
 - Weighted summation of four ratings to overall rating for each life cycle phase
- Incorporated into the next Defense Acquisition Program Support (DAPS) SE Assessment Methodology
- Available at Acquisition Community Connection
<https://acc.dau.mil/ESOH>



Integrating ESOH Into SE Booklet

Acquisition, Technology and Logistics



**Environment, Safety, and
Occupational Health (ESOH)
in Acquisition**

Integrating ESOH into Systems Engineering

- Builds on CLE009 and depicts when ESOH activities should be performed to influence system design throughout the systems engineering process
- System Safety-ESOH Mgt. Evaluation Criteria are included



Trish Huheey

ODUSD(I&E)

ESOH in Acquisition Lead

(703) 604-1846

patricia.huheey@osd.mil





BACKUP



NI Asset Valuation

Acquisition, Technology and Logistics

- Tenet: To make good decisions about managing assets, it helps to know something about their value!
- Corollary: Value depends on actual or potential use. Therefore, the process of identifying NI asset values can uncover innovative opportunities to use NI assets to support the mission.
 - *NI asset valuation is fundamentally about leveraging NI asset values to support the mission.*
- NI asset valuation is a set of approaches and techniques used to assess values of NI.

Update on
Survey on Modeling and Simulation
Support for the
Systems Engineering of Systems of
Systems

Judith Dahmann
Jim Hollenbach

Systems Engineering for Systems of Systems



- AT&L Released “Systems Engineering for Systems of Systems” Version 1.0 in August 2008
 - Characterizes SoS in the DoD Today
 - Identifies core elements of SoS SE
 - Discusses application of SE processes to SoS SE core elements
 - Highlights ‘emerging principles’
 - Briefly addresses M&S
- Requested M&S Committee provide input on use of M&S to support SE for SoS
- Purpose of this presentation is to
 - Summarize the response to date
 - Outline plans for next steps
 - Solicit additional input from community

SoS: A set or arrangement of systems that results when independent and useful systems are integrated into a larger system that delivers unique capabilities

Modeling and Simulation?

- How does the SoS SE Guide address M&S?
 - Initial .9 Version included M&S throughout the draft
 - The practitioner reviews indicate limited use of M&S
 - Main place where M&S was cited is in the emulation of systems not otherwise available for testing
 - Consequently the 1.0 Working Draft limited M&S to this area
 - Comments on the draft identified more uses of M&S
 - The final 1.0 Version has an M&S section and added places where M&S is discussed

Specific Request

- For each of the seven core elements of SoS systems engineering (SE) listed on the following pages, please share your views on:
 - The **potential** for applying modeling and simulation, including why M&S has potential value
 - Your **experience** using M&S for this SoS SE element, including the context of the application, the ways M&S was applied, the products produced, how they were used, and the value added by M&S
 - The **enablers** for use of M&S in this element, including what attributes made successful use of M&S possible (in cases where it was applied) and **barriers** that inhibited use of M&S (in cases where the potential is not being realized).

Timeline

- Pre-Release version of SoS SEG released in May 2008
- Dahmann briefed NDIA M&S Committee at June 2008 meeting
- June letter from Kristen Baldwin (then Acting Director for Systems and Software Engineering) requesting committee input
- Survey was sent out by Hollenbach in early July
- Responses were received in September
- Next steps outlined here

How did we get here?

Summary of Responses

- 19 Responses from 14 organizations
- 10 volunteers to help to synthesize the report on survey results
- Responses were of several types
 - Views and specific experiences
 - Perspective on issues
 - Views based on M&S for SE
 - Organizational experience
- 8 responses include descriptions of specific activities which are candidates for follow-up

Responses Overview

| Name | Organization | Indiv or Org input? | Response Type | Example | Help |
|------------------------|--|---------------------|--------------------------------|---------|------|
| LTC Favio Lopez | 3CE | Org | Views and specific experiences | X | X |
| David Dubuque | Aegis Technologies | Indiv | Perspective on issues | | |
| Danny Thomas | Aegis Technologies | Indiv | Perspective on issues | | |
| Robert Upchurch | Aegis Technologies | Org | Perspective on issues | | |
| Hugh Griffis | Air Force Aeronautical Sys Ctr (ASC/END) | Org | Organizational experience | | X |
| Terry Christian | Air Force Research Lab (AFRL/XPT) | Indiv | Organizational experience | | |
| Pin Chen | Australia DSTO (Maritime Ops) | Indiv | Views based on M&S for SE | | |
| William Tucker | Boeing Company | Org | Views and specific experiences | X | X |
| Frank Grange | Lockheed Martin | Indiv | Views and specific experiences | X | X |
| Steve Hall | Lockheed Martin | Indiv | Views and specific experiences | X | |
| Chett Harris | Lockheed Martin (IS&GS) | Indiv | Perspective on issues | | X |
| Koury, Polzer, et. al. | Lockheed Martin | Indiv but... | Views and specific experiences | X | X |
| Lan-Thau McGough | Marine Corps Systems Command | Org | Views and specific experiences | X | X |
| Dave Prochnow | MITRE | Indiv | Views and specific experiences | X | X |
| George Hazelrig | National Science Foundation | Indiv | Views based on M&S for SE | | ~ |
| Steve Lyda | Naval Air Systems Command (Air 4.7) | Indiv | Views based on M&S for SE | | |
| Kenneth Small | Naval Surface Warfare Cntr Dahlgren | Indiv | Perspective on issues | | |
| Thomas Haley | Naval Undersea Warfare Center | Indiv | Views based on M&S for SE | | X |
| Emily Andrew | Raytheon | Org | Views and specific experiences | X | X |

Government, industry, and FFRDC responses

Proposed Next Steps

- Convene team of volunteers to begin synthesis processes
 - Evening meeting during SE Conference to get started (Wed 5:30-6:30 pm in this room)
- Target February M&S Committee meeting in DC for brief-out of draft results
- Follow-up with
 - Written report
 - More in-depth look at specific activities which could serve as examples

Added inputs are welcome
Need these as soon as possible

Execution of the Acquisition M&S Master Plan Progress Report



NDIA Systems Engineering Conference
San Diego, California
20-23 October 2008

James W. Hollenbach
ODUSD(A&T)/SSE/DTE Support
Simulation Strategies, Inc.
jimh@simstrat.com, 727.824.0931

Outline

- ❑ AMSMP Development (Review)
- ❑ AMSMP Execution
 - Funding approach
 - Progress overview
- ❑ Future Plans
- ❑ Q&A/Status of Individual Actions

Acquisition M&S Governance Structure

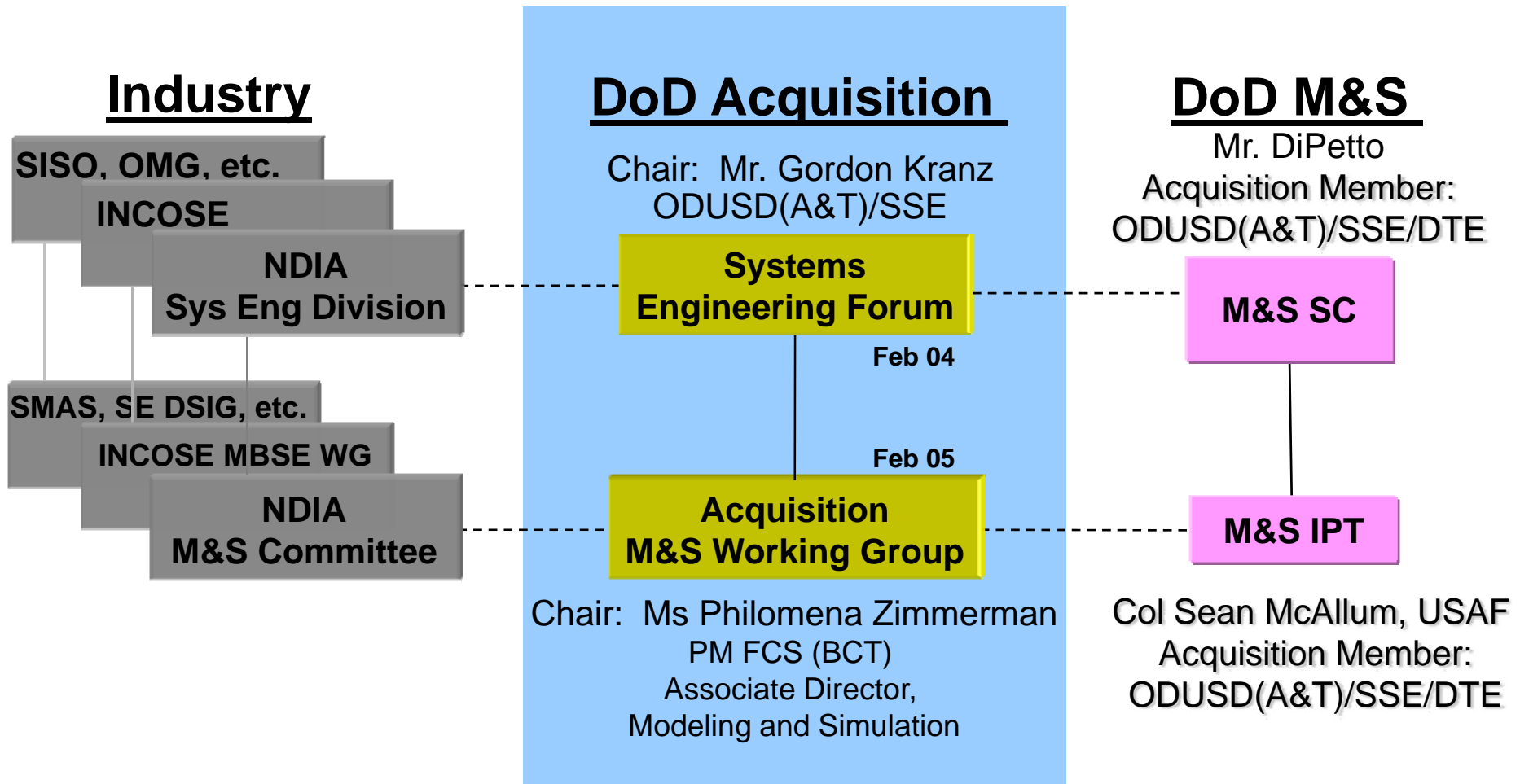

AMSWG is anchored in acquisition community and linked to industry and the DoD M&S community

Acquisition Modeling & Simulation Master Plan

❑ Purpose

“Improve M&S support to the DoD acquisition process...”

❑ Vision

“Optimally employ responsive, trustworthy, and cost-effective M&S capabilities to support defining, developing, testing, producing and sustaining America's capabilities that support the spectrum of DoD missions.”

Acquisition M&S

- ❑ Definition: M&S used to help define, design, develop, test, produce, operate, and sustain defense systems and systems-of-systems
- ❑ Scope: Across the acquisition life cycle

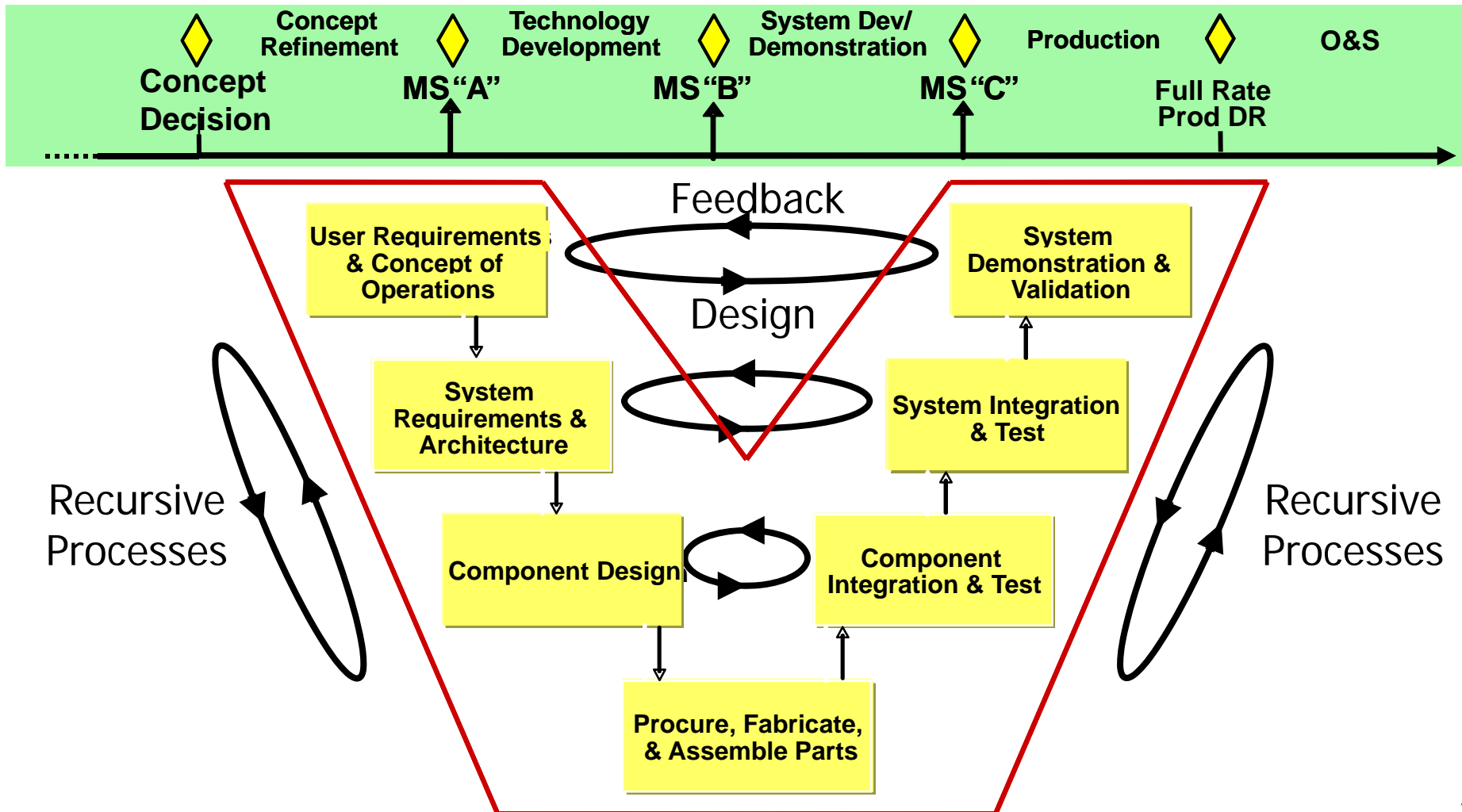

Potential M&S Benefits

- ❑ M&S can improve design (designs are models), integration, and evaluation
 - Accurately track complex relationships and micro-level interactions
 - Present macro-level measures of merit to decision makers
 - Earlier, more accurate understanding of a system, lowering risk
- ❑ Means to deal with the challenges of acquiring capabilities/systems of systems, with attendant dramatic increases in trade space and complexity
 - Track the many more entities, variables, interactions, etc.
 - Provide a shared understanding across vast development enterprises
- ❑ M&S can speed the design-evaluation cycle, saving time and money
- ❑ Provides a more defensible analytical underpinning for decisions
- ❑ Credible M&S surrogates for systems and forces can cost-effectively...
 - flesh-out the battlespace for live tests of individual systems
 - provide the only practical way to assess SoS capabilities as they evolve

AMSMP Strategy

- ❑ Not try to do the job of program/capability managers; rather, seek to empower them by
 - Removing systemic obstacles in their path
 - Identifying new options for approaching their tasks
- ❑ Foster widely-needed M&S capabilities that are beyond the reach of individual programs
- ❑ Address M&S issues and actions necessary to enable acquisition of joint capabilities (systems of systems)
- ❑ Lay out tasks as a Work Breakdown Structure (WBS)
 - Discrete tasks with identified leads and explicit deliverables
 - Easier to resource, schedule, and manage
 - Each contributes to better M&S support to acquisition

Acquisition M&S Master Plan Development Process

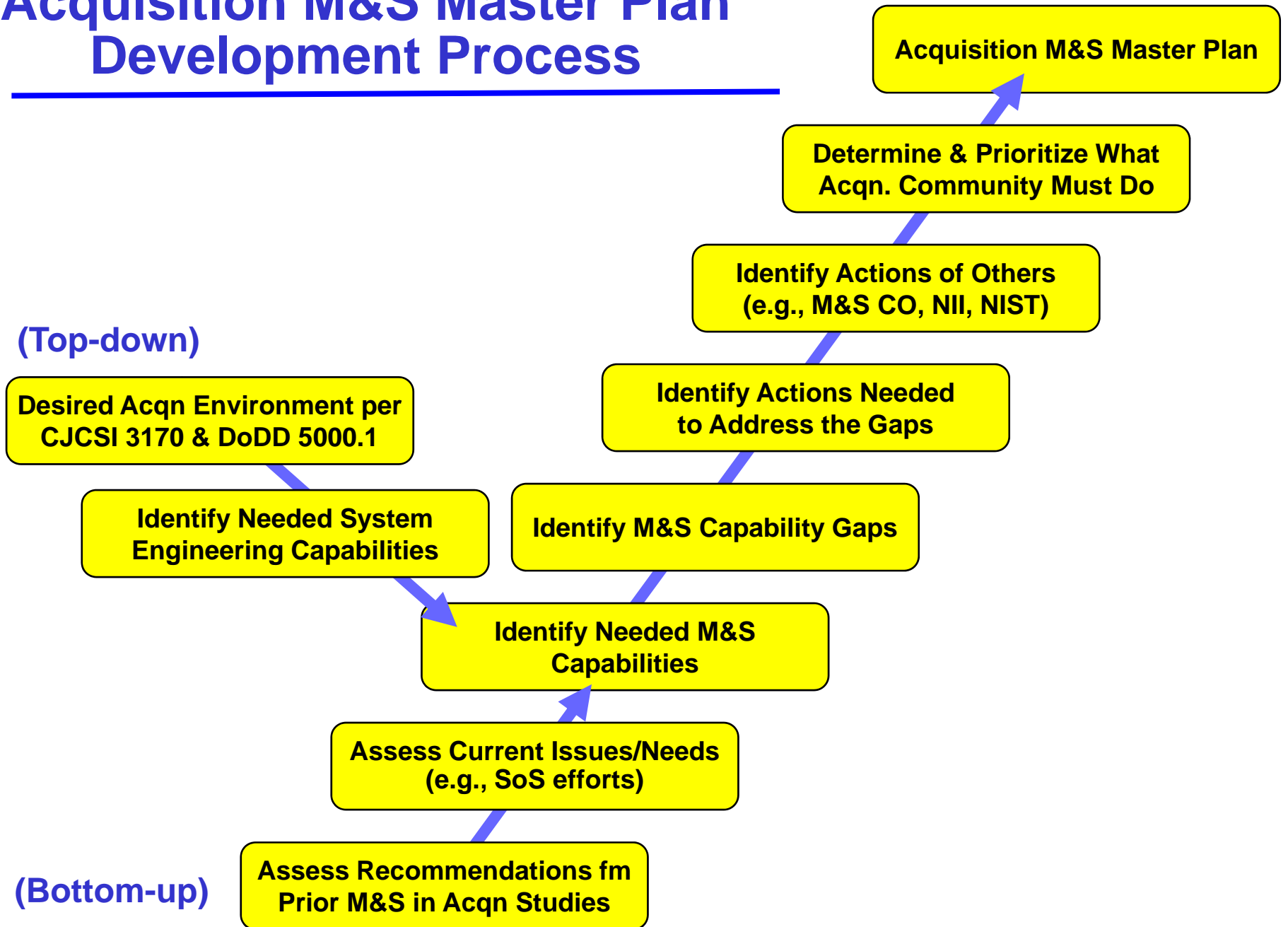

Assessment Highlights

- ❑ Widespread use of M&S in acquisition, but usually stove-piped
- ❑ Many M&S representation gaps and deficiencies
- ❑ Acquisition staffs mostly uninformed about M&S capabilities and limitations
- ❑ No requirement to document planned M&S support to acquisition
- ❑ No effective business model for developing, using, and maintaining broadly-needed M&S capabilities
- ❑ Weak contractual guidelines for M&S and data needs
- ❑ Lack of agreed standards for sharing info and interoperating M&S tools
- ❑ Hard to discover reusable M&S tools and data, insufficient info to evaluate reuse candidates, and lack of reuse incentives = little reuse
- ❑ Virtual ranges (Live-Virtual-Constructive simulation environments) aren't readily available
- ❑ VV&A often poor or non-existent; weak documentation & examination

Acquisition M&S Master Plan Structure



Department of Defense

Acquisition Modeling and Simulation Master Plan

Issued by the
DoD Systems Engineering Forum
April 17, 2006

1

- **Foreword**
- **Introduction**
 - Purpose
 - Vision
 - Scope
- **Objectives (5)**
- **Actions (40)**
 - Action
 - Rationale (why it's needed)
 - Discussion (implementation guidance)
 - Lead & supporting organizations
 - Products (what is expected)
 - Completion goal (year)
- **Execution Management**

<http://www.acq.osd.mil/sse/as/guidance.html>

Five Objectives, 40 Actions

Objective 1

Provide necessary policy and guidance

- 1-1 M&S management
- 1-2 Model-based systems engineering & collaborative environments
- 1-3 M&S in testing
- 1-4 M&S planning documentation
- 1-5 RFP & contract language
- 1-6 Information Assurance

Objective 2

Enhance the technical framework for M&S

- 2-1 Product development metamodel
- 2-2 Commercial SE standards
- 2-3 Distributed simulation standards
- 2-4 DoDAF utility
 - a) DoDAF 2.0 Systems Engineering Overlay
 - b) Standards for depiction & interchange
- 2-5 Metadata template for reusable resources

Objective 3

Improve model and simulation capabilities

- 3-1 Acquisition inputs to DoD M&S priorities
- 3-2 Best practices for model/sim development
- 3-3 Distributed LVC environments
 - a) Standards
 - b) Sim/lab/range compliance
 - c) Event services
- 3-4 Central funding of high-priority, broadly-needed models & sims
 - a) Prioritize needs
 - b) Pilot projects
 - c) Expansion as warranted

Objective 4

Improve model and simulation use

- 4-1 Help defining M&S strategy
- 4-2 M&S planning & employment best practices
- 4-3 Foster reuse
 - a) Business model
 - b) Responsibilities
 - c) Resource discovery
- 4-4 Info availability
 - a) Scenarios
 - b) Systems
 - c) Threats
 - d) Environment
- 4-5 VV&A
 - a) Documentation
 - b) Risk-based
 - c) Examination
- 4-6 COTS SE tools
- 4-7 M&S in acqn benefit metrics

Objective 5

Shape the workforce

- 5-1 Definition of required M&S competencies
- 5-2 Harvesting of commercial M&S lessons
- 5-3 Assemble Body of Knowledge for Acqn M&S
- 5-4 M&S education & training
 - a) DAU, DAG & on-line CLMs
 - b) Conferences, workshops & assist visits
- 5-5 MSIAC utility

Key

Broader than Acqn

Partially broader

Outline

- ❑ AMSMP Development (Review)
-  ❑ AMSMP Execution
 - Funding approach
 - Progress overview
- ❑ Future Plans
- ❑ Q&A/Status of Individual Actions

Funding Approach

Prioritized options to accomplish AMSMP actions

1. Accomplish via sweat equity
 - e.g., OUAD(A&T)/SSE M&S Cell (resource limited)
2. Compete for M&S Steering Committee funds (if > acqn)
 - only DoD-wide M&S Program Element
3. Compete for OSD funding “targets of opportunity”
 - e.g., study funds, end-of-year sweep
4. Submit as SBIR topics (just beginning)
5. Team with other organizations
 - e.g., NII & NAVAIR on Information Assurance (Action 1-6)
6. POM initiative (none so far, but under discussion)

Some Recent Funding Successes (1 of 4)

- ❑ Successfully competed for M&S SC funds for these projects, currently underway with SSE/DT&E oversight
 - 07-1-001f **Integrated Natural Environment Authoritative Representation Process** (AMSMP Action 4-4d)
 - Deliverable: Environmental Scenario Generator that provides better and more rapid generation of weather, space, and terrain representations
 - Program Manager: Col Mark Zettlemoyer, USAF (MSCA)
 - Performer: SAIC
 - \$2.3M**
 - 07-1-002f **M&S Resource Reuse Business Model** (AMSMP Action 4-3a)
 - Deliverable: Recommended business model (including policy, incentive structure, and procedures) for the reuse of M&S resources and a campaign plan for implementation
 - Program Manager: Mr. Chris DiPetto (was Lt Col White)
 - Performer: Center for Naval Analysis (Dr. Dennis Shea, et. al.)
 - \$800K**

Some Recent Funding Successes (2 of 4)

➤ 07-1-004f **Educating the M&S Workforce** (AMSMP Actions 5-1 and 5-3)

Deliverables:

- Required workforce M&S competencies
- Learning architecture to define content, instructional delivery methods, and scope

Program Manager: ODASN(RDA)/CHENG (W. Zimmerman)

Performer: Naval Postgraduate School, other academic partners,

\$3.2M

➤ 07-1-005f **VV&A Standardization** (AMSMP Action 4-5a)

Deliverables:

1. VV&A standardized documentation template
2. VV&A documentation tool to assist users
3. Policy and guidance updates

PM: Director, Navy Modeling and Simulation Office (K. Charlow)

Performer: SPAWAR

\$550K

Some Recent Funding Successes (3 of 4)

➤ **060-TR-01 Live Virtual Constructive Architecture Roadmap** (AMSMP Actions 2-3 and 3-3a)

Deliverables:

- Functional requirements for Live-Virtual-Constructive simulation environments
- Capabilities & limitations of various distributed simulation architectures in use across DoD (DIS, ALSP, HLA, TENA, CTIA)
- Comparative analyses of the architectures, middleware, business models, and standards management
- Analysis of alternatives
- Recommended roadmap

Oversight: P&R and DUSD (A&T)/SSE/DT&E

Program Manager: JFCOM (Mr. Ken Goad)

Performer: JFCOM, IDA, JHU APL, PEO-STRI

\$1.4M

Some Recent Funding Successes (4 of 4)

□ Successfully competed for OSD Study Funds for:

➤ **Study on Best Practices for M&S Tool Development**
(AMSMP Action 3-2)

Deliverables:

- Bibliography identifying sound practices
- Draft and final version of best practices for M&S tool development

Program Manager: Col Sean McAllum, USF, ODUSD(A&T)/SSE/DT&E

Performer: JHU APL

\$350K

➤ **Study on Management of Broadly-needed M&S tools**
(AMSMP Action 3-4)

Deliverables:

- Best practices for managing broadly needed M&S tools
- Recommended actions to improve DoD management of such tools

Program Manager: Col Sean McAllum, USF, ODUSD(A&T)/SSE/DT&E

Performer: JHU APL

\$500K

Execution Progress Overview

Objective 1

Provide necessary policy and guidance

- 1-1 M&S management
- 1-2 Model-based systems engineering & collaborative environments
- 1-3 M&S in testing
- 1-4 M&S planning documentation
- 1-5 RFP & contract language
- 1-6 Information assurance

Objective 2

Enhance the technical framework for M&S

- 2-1 Product development metamodel
- 2-2 Commercial SE standards
- 2-3 Distributed simulation standards
- 2-4 DoDAF utility
 - ~~a) DoDAF 2.0 Systems Engineering Overlay~~
 - b) Standards for depiction & interchange
- 2-5 Metadata template for reusable resources

Objective 3

Improve model and simulation capabilities

- 3-1 Acquisition inputs to DoD M&S priorities
- 3-2 Best practices for model/sim development
- 3-3 Distributed LVC environments
 - a) Standards
 - b) Sim/lab/range compliance
 - c) Event services
- 3-4 Central funding of high-priority, broadly-needed models & sims
 - a) Prioritize needs
 - b) Pilot projects
 - c) Expansion as warranted

Objective 4

Improve model and simulation use

- 4-1 Help defining M&S strategy
- 4-2 M&S planning & employment best practices
- 4-3 Foster reuse
 - a) Business model
 - b) Responsibilities
 - c) Resource discovery
- 4-4 Info availability
 - a) Scenarios
 - b) **Systems**
 - c) **Threats**
 - d) Environment
- 4-5 VV&A
 - a) Documentation
 - b) Risk-based
 - c) Examination
- 4-6 COTS SE tools
- 4-7 M&S in acqn benefit metrics

Objective 5

Shape the workforce

- 5-1 Definition of required M&S competencies
- 5-2 Harvesting of commercial M&S lessons
- 5-3 Assemble Body of Knowledge for Acqn M&S
- 5-4 M&S education & training
 - a) DAU, DAG & on-line CLMs
 - b) Conferences, workshops & assist visits
- 5-5 MSIAC utility

Outline

- ❑ AMSMP Development (Review)
- ❑ AMSMP Execution
 - Funding approach
 - Progress overview
-  ❑ Future Plans
- ❑ Q&A/Status of Individual Actions

Future Plans (FY09/10)

- ❑ Continue cooperatively executing the AMSMP
- ❑ Update AMSMP to reflect accomplishments, fact of life changes, and newly-identified needs (e.g, Virtual Battlespace Center for OSD acqn decisions). Make vision more specific.
- ❑ Ensure programs know about and can access deliverables
- ❑ Provide direct assistance to programs
 - At the request of SSE/Assessment and Support, have already conducted M&S review of Joint Light Tactical Vehicle and FCS
- ❑ Continue to educate and learn via outreach
 - Conferences and workshops, both defense & commercial
- ❑ Support development of useful standards
 - SISO, W3C Data Semantics WG, OMG, etc.
- ❑ Pursue additional resources (both people and \$)

Outline

- ❑ AMSMP Development (Review)
- ❑ AMSMP Execution
 - Funding approach
 - Progress overview
- ❑ Future Plans
-  ❑ Q&A/Status of Individual Actions
 - Will gladly discuss individual actions of interest

AMSMP Execution Progress Overview

Objective 1

Provide necessary policy and guidance

Objective 2

Enhance the technical framework for M&S

Objective 3

Improve model and simulation capabilities

Objective 4

Improve model and simulation use

Objective 5

Shape the workforce

1-1 M&S management

1-2 Model-based systems engineering & collaborative environments

1-3 M&S in testing

1-4 M&S planning documentation

1-5 RFP & contract language

1-6 Information assurance

2-1 Product development metamodel

2-2 Commercial SE standards

2-3 Distributed simulation standards

2-4 DoDAF utility

~~a) DoDAF 2.0 Systems Engineering Overlay~~

b) Standards for depiction & interchange

2-5 Metadata template for reusable resources

3-1 Acquisition inputs to DoD M&S priorities

3-2 Best practices for model/sim development

3-3 Distributed LVC environments

a) Standards
b) Sim/lab/range compliance
c) Event services

3-4 Central funding of high-priority, broadly-needed models & sims

a) Prioritize needs
b) Pilot projects
c) Expansion as warranted

4-1 Help defining M&S strategy

4-2 M&S planning & employment best practices

4-3 Foster reuse

a) Business model
b) Responsibilities
c) Resource discovery

4-4 Info availability

a) Scenarios
b) Systems
c) Threats
d) Environment

4-5 VV&A

a) Documentation
b) Risk-based
c) Examination

4-6 COTS SE tools

4-7 M&S in acqn benefit metrics

5-1 Definition of required M&S competencies

5-2 Harvesting of commercial M&S lessons

5-3 Assemble Body of Knowledge for Acqn M&S

5-4 M&S education & training

a) DAU, DAG & on-line CLMs
b) Conferences, workshops & assist visits

5-5 MSIAC utility

Separate presentation

Status of Individual Actions

**Caveat: Did not rate down progress for
lateness, unless stalled**

Objective 1: Provide Necessary Policy & Guidance

1-1. Provide effective, persistent DoD-wide M&S management to address cross-cutting M&S issues, coordinate actions

Lead: OUSD(AT&L) **Support:** OUSD(AT&L)/DS(SSE), OUSD(P&R), OUSD(C)/PA&E, etc.

Products: Revised DoDD 5000.59 (M&S Management), revised senior leadership management; and improved policies for M&S management. revised senior leadership management; and improved policies for M&S management.

Completion goal: 2006

- **New DoD M&S management structure in place; effectiveness questioned**
- **New DoD Directive finally released Aug 07, with promise of a follow-on DoDI to define key responsibilities and processes. SOP now proposed as substitute.**
- **No acquisition community leadership role on M&S SC (Training & Analysis do)**
- **Current project selection process does not fund only cross-cutting efforts, misusing M&S PE**

Next Steps:

- **Continue to argue for an SSE leadership role on M&S SC**
- **Advocate within M&S governance structure for a DoDI on M&S management**
- **Continue to propose an alternative approach to “C&CC Business Plan”**

Objective 1: Provide Necessary Policy & Guidance

1-2. Promote model-based systems engineering (MBSE) and M&S-enabled collaborative environments, at both the program and joint capability level

Lead: OUSD(AT&L)/DS(SSE); **Support:** Components

Products: Revised guidance in DAG

Completion goal: 2007

- **Current DAG mentions collaborative environments 14 times, simulation-based testing once, SBA twice, and MBSE not at all.**
- **Programs/companies often claim collaborative environments, but only partial**
- **MBSE a prominent part of INCOSE's SE Vision 2020**
- **Increasing industry use of MBSE concept & tools**
- **SSE submitted new DAG language May 07, but DAG revision stalled**

Next steps:

- **Continue advocacy for submitted DAG language; revise submittal if rejected**
- **Investigate possibility of a CLM on MBSE**

Objective 1: Provide Necessary Policy & Guidance

1-3. Establish policy and guidance on appropriate use of M&S to plan tests, to complement system live tests, and to evaluate joint capabilities

Co-leads: OUSD(AT&L)/DS, ODOT&E; **Support:** Components

Products: Revised policy and guidance in DoDI 5000.2 and DAG

Completion goal: 2007

- **DoDI 5000.2 is excellent at the program level, but not at the capability level**
- **Better discussion in SSE's latest DAG submission, but need more specificity**
- **JMETC launched, but many challenges ahead, including policy**
- **Services are getting more active (e.g., NAVAIR M&S Enterprise Initiative)**

Next steps:

- **NDIA M&S Cmte participate in DT&E Cmte effort; check for progress**
- **Track JMETC policy development, respond appropriately**
- **Continue working with NAVAIR M&S Enterprise to develop guidance**
- **Draft expanded policy and guidance, vet with the various stakeholders**
- **Submit additional changes to DAG (both T&E and M&S portions)**

Obj. 1: Provide Necessary Policy & Guidance (cont.)

1-4. Establish policy to require documented M&S planning at the joint capability & program levels as part of the Systems Engineering Plan, T&E Strategy and T&E Master Plan

Co-leads: OUSD(AT&L)/DS(SSE), ODOT&E; **Support:** Components

Products: Revised policy and guidance in DoDI 5000.2, DAG, and DOT&E TEMP Planning Guidance

Completion goal: 2007

- **AMSWG (SSE) submitted revised language to DoD 5000.2, DAG language and SEP Preparation Guide**
- **Partial acceptance of SEP language; DoDI 5000.2 and DAG updates stalled**
- **No action thus far regarding TEMP Planning Guidance**

Next steps:

- **Continue working with NAVAIR M&S Enterprise to develop guidance**
- **Draft/submit language for TEMP Planning Guidance**

Obj. 1: Provide Necessary Policy & Guidance (cont.)

1-5. Establish M&S-related guidelines for solicitations, source selections, and contracting.

Lead: OUSD(AT&L)/DS(SSE); **Support:** OUSD(AT&L)/DPAP, ODOT&E, Components

Products: Sample language in DoD publications (e.g., DAG, SEP Preparation Guide, Contracting for Systems Engineering Guidebook) regarding M&S requirements, data rights, and the responsibilities and liabilities of parties regarding sharing and reuse

Completion goal: 2007

- Solicited inputs from AMSWG members and industry (through NDIA M&S Cmte)
- AMSWG (SSE) submitted DAG language regarding source-selection criteria
- Presentation at Oct 07 NDIA Systems Engineering Conference
- **Action completion is overdue (2007) due to M&S Cell resource constraints**

Next steps:

- Further refinement and vetting of proposed guidance
- Synthesize best language & submit to DAG (update), SEP Preparation Guide, and Contracting for Systems Engineering Guidebook

Obj. 1: Provide Necessary Policy & Guidance (cont.)

1-6. Ensure practical guidelines for information assurance certification and accreditation of M&S federated networks falling under multiple Designated Accreditation Authorities (DAAs)

Lead: OASD(NII); **Support:** OUSD(AT&L)/DS(SSE), OUSD(I), NSA

Products: Proven, practical guidelines published in DAG and DoD 8500.2-H, per DoDI 8500.2 "Information Assurance Implementation," Feb 6, 2003

Completion goal: 2007

- **NII has published DoDI 8500.2, but AMSWG questions adequacy**
- **AMSWG-NII discussions held in 2007; NAVAIR procedures identified as a candidate to provide the additional specificity needed**
- **Awaiting delivery of NAVAIR procedures for (a) NII evaluation of compliance with 8500.2. (b) NII evaluation of suitability for revising 8500.2, and (c) AMSWG evaluation of suitability for inclusion in DAG**

Next steps:

- **Follow-up with NAVAIR to ensure submission of their procedures**
- **Conduct three evaluations mentioned above**
- **Draft, vet, and submit DAG language**

Objective 2: Enhance the Technical Framework for M&S

2-1. Develop a product development information metamodel & associated metadata extensions to the DoD Discovery Metadata Specification

Lead: OUSD(AT&L)/DS(SSE); **Support:** OASD(NII), Components

Products: Revised DDMS; revised guidance in DAG.

Completion goal: 2008

- JSF has developed a metamodel specification and provided it to M&S CO
- We requested, and M&S CO provided, Scudder assistance to work with JSF to evolve/refine its metamodel
- Working group has decided key issues and expects to publish a revised version shortly

Next steps:

- JSF to complete revised metadata specification
- Coordinate with M&S CO to vet more broadly (likely PA&E interest) and make this a DoD or (preferably) commercial standard
- Submit into DoD Standardization Program process

Objective 2: Enhance the Technical Framework for M&S

2-2. Support development of open commercial and non-proprietary standards for (model-based) systems engineering, such as OMG's Systems Modeling Language (SysML) and ISO Standard 10303 AP-233

Co-leads: OUSD(AT&L)/DS(SSE); DoD CIO **Support:** OASD(NII), DLA, OUSD(AT&L), **Products:** Standards suitable for use by DoD

- Action is complete for SysML and AP-233, but DoD awareness is lacking
- SysML v1.0 issued as an "available standard;" v 1.1 minor revision late 2008
- Increasing usage & teaching of SysML; major subject at INCOSE, NDIA
- Navy M&S Standards Steering Group has proposed SysML as a standard
- AP-233 SE data interchange standards being released incrementally
- COTS System Engineering tools are incorporating SysML and AP-233
- Nothing yet submitted to DoD Standardization Program and DISR

Next steps:

- Track SysML and AP-233 implementations, publicize results
- Investigate DoD Standardization Program process; submit SysML and AP-233
- Identify any needs for additional standards

Objective 2: Enhance the Technical Framework for M&S

2-3. Establish a forum to clarify the characteristics and application of various distributed simulation standards (ALSP, DIS, HLA, SI3, TENA, etc.) and examine opportunities for convergence

Lead: OUSD(AT&L) **Support:** OUSD(AT&L)/TRMC & DS(SSE), ODOT&E, Components

Products: (1) Information on strengths & weaknesses of the various standards; (2) agreement on policy and/or guidance on the use of distributed simulation standards; (3) a way ahead regarding distributed simulation standards

➤ **Completion goal:** 2007

- **M&S SC-funded LVC Architecture Roadmap in 2007, due out late 2008**
- **SE Forum is interested, has taken one briefing**
- **M&S Cell (Hollenbach) participating in this project, tracking progress and coordinating related M&S SC actions (HLA Way Ahead)**

Next steps:

- **Continue to participate; await final report**
- **Help shape M&S SC response**

Obj. 2: Enhance the Technical Framework for M&S (cont.)

2-4. Improve the utility of the DoD Architecture Framework (DoDAF) for acquisition

2-4(a) ~~Develop Systems Engineering Overlay (profile) for DoDAF v2.0~~

~~Lead: OUSD(AT&L)/DS; Support: OASD(NII), Components~~

~~Products: Acquisition Overlay for DoDAF v2.0~~

~~Completion goal: 2006~~

2-4(b) Support development of open commercial standards for the depiction and interchange of DoDAF-compliant architectures

Lead: OASD(NII) Support: OUSD(AT&L)/DS(SSE)

Products: Published standards suitable for adoption by DoD in DoDAF 2.0; revised guidance in DAG

Completion goal: 2007

- 2-4(a): DoDAF Overlay concept has been dropped, so this action is OBE
- 2-4(b): OMG's UPDM (UML Profile for DoDAF/MODAF) nearly finalized, NII has embraced UPDM as an element of DoDAF 2.0 development
- SE Forum considering the value and impact of DoDAF
- ASD(NII) is attempting to make DoDAF v2.0 more useful for acquisition
- Acquisition Community participation in DoDAF WG curtailed

Next steps:

- Increase involvement in DoDAF WG
- Submit UPDM to DoD Standardization Program / DISR Online
- Advocate use of UPDM for architecture data exchange

Obj. 2: Enhance the Technical Framework for M&S (cont.)

2-5. Establish a standard template of key characteristics (metadata) to describe (**discover**) reusable M&S resources

Lead: OUSD(AT&L) **Support:** OUSD(AT&L)/DS(**SSE**) & TRMC, OASD(NII), ODOT&E, Components

Products: Published standard template; usage guidance in DAG

Completion goal: 2007

- **M&S CO M&S COI Discovery Metadata project addresses this**
- **M&S Cell has coordinated with M&S CO to ensure no cross-threads with Action 2-1 (Product Development Metadata Specification)**
- **Version 1.0 published, being evaluated by users (e.g., MSRR, JDS, JRSG) who are providing feedback to refine it**

Next steps:

- **Draft, vet and submit DAG entry when final product is available**

Objective 3: Improve Model & Simulation Capabilities

3-1. Establish a process to ensure acquisition needs are reflected in DoD M&S priorities

Lead: OUSD(AT&L) **Support:** OUSD(AT&L)/DS(SSE), ODOT&E, DOD CIO, Components

Products: A method to capture and prioritize acquisition needs.

Completion goal: 2007

- **AMSWG has successfully obtained M&S SC funding for several projects**
- **AMSWG has started an effort to pursue SBIR opportunities**
- **AMSWG till does not have an effective voice in other venues that affect M&S capability, such as other S&T and DARPA**

Next steps:

- **Continue to pursue M&S SC and SBIR funding opportunities**
- **Investigate DoD S&T planning process to identify entry points**
- **Build list of acquisition M&S S&T needs**

Objective 3: Improve Model & Simulation Capabilities

3-2. Define and foster best practices for efficient development and evolution of credible M&S tools, incorporating user-defined requirements, a systems engineering approach, and appropriate verification & validation

Lead: OUSD(AT&L); **Support:** OUSD(AT&L)/DS(SSE), ODOT&E, DOD CIO, Components

Products: Best practices publication, available via MSIAC, DTIC, etc.; DAG guidance to use

Completion goal: 2008

- **Have obtained OSD study funds for the definition portion of this task**
- **SOW written**
- **Contracting with JHU APL to develop this best practice**

Next steps:

- **Assess JHU APL deliverable**
- **Foster its use (via Action 5-4)**

Obj 3: Improve Model & Simulation Capabilities (cont.)

3-3. Enable readily-available distributed live-virtual-constructive environments, leveraging related initiatives

3-3(a) Establish DoD-wide standards for distributed environments

Lead: OUSD(AT&L); **Support:** OUSD(AT&L)/TRMC & DS(SSE); ODOT&E; DOD CIO, Components

Products: Published standard; DODI (# TBD) policy to use

Completion goal: 2008

3-3(b) Make candidate simulations, labs and ranges compliant with these standards

Lead: Components; **Support:** OUSD(AT&L)/DS(SSE) & TRMC, ODOT&E

Products: A larger collection of simulations, labs, and ranges ready to be employed in distributed events

Completion goal: 2010

3-3(c) Ensure availability of services to help plan and conduct events

Lead: Components; **Support:** OUSD(AT&L), OUSD(AT&L)/TRMC, DISA

Products: Fee-based technical services to help users (e.g., PMs, Capability Managers, OTAs) plan and conduct distributed events

Completion goal: 2009

- **LVC Architecture Roadmap and JFCOM Joint Composable Object Model projects underway**
- **Virtual Battlespace Center Defense Science Board Task Force in work**
- **No funding yet available to do the rest**

Next steps:

- **Await LVC Architecture Roadmap, support implementation as appropriate**
- **Pursue POM initiative**

Obj 3: Improve Model & Simulation Capabilities (cont.)

3-4. Centrally fund and manage the development of high-priority, broadly-needed M&S tools

3-4(a) Identify and prioritize broadly-needed M&S tools

Lead: OUSD(AT&L); **Support:** OUSD(AT&L)/(SSE); ODOT&E, DOD CIO, Components

Products: Prioritized list of common M&S tool needs

Completion goal: 2007

3-4(b) Conduct one or more pilot projects to develop new M&S tools or update existing ones to meet these needs

Lead: OUSD(AT&L); **Support:** OUSD(AT&L)/DS(SSE), Components

Products: Proof of concept for managing the development/evolution of M&S tools to meet broadly-shared needs

Completion goal: 2008

3-4(c) Expand the scope of central M&S tool management as warranted by pilot project results and the list of common M&S needs

Lead: OUSD(AT&L); **Support:** OUSD(AT&L)/DS(SSE), ODOT&E, Components

Products: Capability to provide broadly-needed M&S tools in a more responsive and cost-effective way.

Completion goal: 2011

- **AMSWG submitted 3-4(b) pilot proposal to M&S SC, but it wasn't funded**
- **Funding obtained to have JHU APL identify best practices for managing broadly needed M&S tools and recommend DoD actions**

Next steps:

- **Assess JHU APL deliverables, pursue actions as appropriate**

Objective 4: Improve Model & Simulation Use

4-1. Provide potential acquisition M&S users the knowledge needed to formulate an effective M&S strategy via ready access to M&S expertise and information about M&S capabilities and gaps, reusable resources, lessons-learned, etc.

Lead: OUSD(AT&L); **Support:** OUSD(AT&L)/DS(SSE)

Products: Revised guidance in DAG; improved knowledge base in MSIAC; assist visits (e.g., by OUSD(AT&L)/DS(SSE))

Completion goal: 2008

- Revised guidance submitted to DAG
- SSE M&S Cell assisting as able, but resource limited, not widely advertised
- Navy coming on line, but no action from other Components
- 5-1 Education project Identified M&S Bodies of Knowledge that offer useful information

Next steps:

- Advertise and expand assist visits. SSE has made this a 2008 priority.
- Based on our experience, promote similar efforts by other Components
- Improve MSIAC expertise regarding M&S in acquisition (Action 5-5)

Objective 4: Improve Model & Simulation Use

4-2. Define and disseminate best practices for disciplined M&S planning & employment

Lead: OUSD(AT&L)/DS(SSE), **Support:** OUSD(AT&L), Components

Product: Revised best practices guidance in DAG and MSIAC

Completion goal: 2007

- High-level discussion included in “M&S for Systems Engineering” CLM
- Expanded discussion submitted in recent DAG revision
- M&S Planning and Employment Best Practices solicitation completed Apr 07
- NAVAIR M&S Enterprise is developing recommendations
- **Action completion is overdue (2007) due to M&S Cell resource constraints**

Next steps:

- **Continue working with NAVAIR M&S Enterprise to develop guidance**
- **Synthesize best practice, conduct AMSWG & NDIA reviews**

Obj. 4: Improve Model & Simulation Use (cont.)

4-3. Facilitate the sharing of reusable resources

4-3(a) Establish a DoD-wide business model for compensating providers of reusable M&S resources (e.g., information, software, services)

Lead: OUSD(AT&L); **Support:** OUSD(AT&L)/DS(SSE), OUSD(P&R), OUSD(C)/PA&E, Components

Product: Documented business model; revised policy and/or guidance in DoD 5000 series & DAG

Completion goal: 2007

- **M&S SC-funded M&S Resource Reuse Business Model study underway, will report out late 2008**
- **Study will identify key issues and recommend significant changes**
- **LVCAR will also address business model issues**
- **An effective business model is not yet established**

Next steps:

- **No further action needed yet; awaiting study outcome**
- **LVC Architecture Roadmap may have an impact**
- **Take action to implement study & LVCAR recommendations as appropriate**

Obj. 4: Improve Model & Simulation Use (cont.)

4-3. Facilitate the sharing of reusable resources

4-3(b) Establish DoD policy and/or guidance regarding responsibilities to share, protect and properly use M&S information, tools, and data

Co-Leads: OASD(NII), OUSD(AT&L), USD(I); **Support:** OUSD(AT&L)/DS(SSE) & DPAP, OUSD(P&R), OUSD(C)/PA&E, Components

Product: Revised policy and/or guidance in various issuances (e.g., DoD 5000 series, DAG, contracting guidance)

Completion goal: 2008

- **Drafted and submitted DAG language, but not yet included in DAG**
- **M&S Resource Reuse Business Model project may make recommendations on this subject**

Next steps:

- **Receive Business Model study report, take action as appropriate**
- **Draft language for contracting guide**
- **(DODI 5000.2 change may not be needed)**

Obj. 4: Improve Model & Simulation Use (cont.)

4-3. Facilitate the sharing of reusable resources

4-3(c) Enhance the means (e.g., directory service, registries, bulletin boards) to discover the existence of reusable resources required for M&S and contact information

Lead: OUSD(AT&L) **Support:** OUSD(AT&L)/DS(SSE), OUSD(P&R), OUSD(C)/PA&E, Components

Product: A better way to discover reusable resources. Re-orientation and integration of various DoD M&S resources repositories.

Completion goal: 2007

- **DDR&E-directed M&S CO project to develop a “M&S Resource Catalog” is underway**
- **We see a viable business model as a prerequisite**

Next steps:

- **Track M&S CO project, support as able**

Obj. 4: Improve Model & Simulation Use (cont.)

4-4. Define the types of information DoD organizations shall make available to others with a clearance and valid need to know and the processes to obtain them (per reuse business model). The process to obtain information should include an efficient mechanism for industry to request government data with specific "need to know" outside a specific contract environment.

4-4(a) Scenario data

Lead: OUSD(AT&L) **Support:** OCJCS(J8), OUSD(C)/PA&E, DIA, Components

Product: Approved scenarios and process to obtain

Completion goal: 2007

4-4(b) System-related data

Lead: OUSD(AT&L)/DS(SSE); **Support:** ODOT&E, Components

Product: Process to obtain authoritative system data (characteristics and performance, interactions, interfaces, logistic support, etc.) documented in the DAG and appropriate OASD (NII) policy documents.

Completion goal: 2008

4-4(c) Threat data

Lead: DIA; **Support:** OUSD(AT&L); OUSD(AT&L)/DS(SSE), ODOT&E, and Components

Product: Authoritative threat data and process to obtain

Completion goal: 2007

4-4(d) Natural environment data

Lead: DoD Natural Environment MSEAs (MSCAs); **Support:** OUSD(AT&L), OUSD(AT&L)/DS(SSE), Components

Product: Authoritative natural environment data and process to obtain

Completion goal: 2007

Action 4-4 Assessment

- Acquisition Support Division of DIA has briefed AMSWG and NDIA M&S Cmte on its support to acquisition programs
- MSIC has briefed NDIA M&S Cmte on TMAP program and provided instructions on how to request TMAP models
- Draft DAG language discusses threat data sources and traceability
- **No method exists “for industry to request government data with specific ‘need to know’ outside a specific contract environment”**
- M&S SC-funded Environmental Scenario Generator project underway
- **No progress in sharing U.S. system data**
- Joint Rapid Scenario Generation (JRSG) and Joint Data Alternatives (JDA) projects advertise they will address all the Action 4-4 info needs; time will tell

Next steps:

- **Monitor JRSG and JDA projects as resources permit**
- **Investigate data sharing policies of OSD, JCS, and other Components**
- **Investigate JSC, PAE, & Service scenario data availability & access**
- **Draft additional DAG language on all data types (interim prior to JRSG /JDA)**
- **Continue to build on Nov 07 PA&E-Boeing-NDIA M&S Cmte discussion**
- **Examine benefits of establishing a DoD Virtual Battlespace Center**

Obj. 4: Improve Model & Simulation Use (cont.)

4-5. Foster cost-effective VV&A

4-5(a) Require DoD-wide standardized documentation of VV&A

Lead: OUSD(AT&L); **Support:** OUSD(AT&L)/DS(SSE), ODOT&E, Components

Products: Revised policy in DODI 5000.2 and 5000.61; revised guidance in DAG

Completion goal: 2007

- **AMSWG-sponsored, M&S CO-funded project completed**
- **Documentation has been established as a MILSPEC 3022; commercial (SISO) standard to follow**
- **Tool to manage documentation is in beta testing**
- **AMSWG concern that draft M&S SC's "DoD M&S Strategic Vision" call for "practical verification, validation, and accreditation guidelines that vary by application area" (emphasis added) will undermine VV&A.**
- **PA&E resisting this requirement in DoDI 5000.61 revision**

Next steps:

- **Publicize standard and supporting tool**
- **Fight to have DoDI 5000.61 to maintain a consistent DoD policy and require documentation per MILSPEC**
- **Establish a commercial standard under SISO**

Obj. 4: Improve Model & Simulation Use (cont.)

4-5. Foster cost-effective VV&A

4-5(b) Develop risk-based methodology and associated guidelines for VV&A expenditures

Lead: OUSD(AT&L); **Support:** OUSD(AT&L)/DS(SSE), Components

Products: Updated DoDI 5000.61; revised policy and guidance in DoDI 5000.2 and DAG

Completion goal: 2007

- **M&S CO project underway, with promise it will address this issue**
- **NAVAIR M&S Enterprise developing M&S VV&A and risk management guidance**

Next steps:

- **Assess M&S Enterprise guidance**
- **Obtain update on M&S CO progress developing risk-based VV&A guidelines, support and take action as necessary**

Obj. 4: Improve Model & Simulation Use (cont.)

4-5. Foster cost-effective VV&A

4-5(c) Examine a program's VV&A when M&S informs major acquisition decisions and unambiguously state the purpose, key assumptions and significant limitations of each model/simulation when results are presented.

Lead: OUSD(AT&L)/DS(SSE) **Support:** DoD Components

Products: Guidance & training for oversight personnel; updates to DAG Chaps 4, 9

Completion goal: 2007

- Submitted DAG language on VV&A examination, but DAG update stalled
- SSE M&S Cell has given initial briefing to OUSD(A&T)/SSE/AS
- Navy may be addressing this; no other Component activities underway

Next steps:

- Broaden teaching on VV&A examination
- M&S Cell support SSE/AS to accomplish this during OSD program reviews
- Other AMSWG members take action within their Components

Obj. 4: Improve Model & Simulation Use (cont.)

4-6. Assess the use of COTS systems engineering tools (modeling environments) for collaborative architecture development

Lead: OUSD(AT&L)/DS(SSE); **Support:** OASD(NII), Components

Products: Revised guidance in DAG; enhanced M&S body of knowledge for dissemination

Completion goal: 2007

- **SysML and AP-233 already proving utility in COTS tools (market success)**
- **UPDM nearing finalization, can help with CADM and DARS weaknesses**
- **NIST “Systems Engineering Tool Interoperability Plug-fest” underway**
- **No inter-program use of COTS tools for architecture development thus far**

Next steps:

- **Investigate use of SE tools for collaborative architecture development**
- **Propose as a SBIR topic**

Obj. 4: Improve Model & Simulation Use (cont.)

4-7. Define and capture meaningful metrics for M&S utility in acquisition

Co-Leads: OUSD(AT&L), Dept. of the Navy **Support:** OUSD(AT&L)/DS(SSE),
Components

Products: Metric definitions in DAG; methods to capture and submit data in DAG;
data from individual projects in MSIAC, Body of Knowledge, etc.

Completion goal: 2007

- One of the top 5 acquisition M&S projects for M&S SC FY08 funding, but didn't make the cut
- Aegis Technologies conducted a study for M&S CO, but results not yet released

Next steps:

- Assess adequacy of M&S CO/AEgis Technologies' product
- Take further action as appropriate

Objective 5: Shape the Workforce

5-1. Define required M&S competencies for the acquisition workforce

Co-Leads: DAU and OUSD(AT&L)/DS(SSE); **Support:** OUSD(P&R), OUSD(AT&L)/DDRE, OUSD(C)/PA&E, Components

Product: Identified lead FIPT; workforce qualification requirements; management process & structure

Completion goal: 2008

- “Educating the M&S Workforce” project underway with Navy and M&S SC funding
- Academic institutions have begun to leverage this work
- Participated in beta version of GMU course “M&S in Acquisition Lifecycle”

Next steps:

- Receive final deliverables from M&S SC-funded project
- Monitor and assess effectiveness of emerging courses (e.g., GMU)
- Otherwise support implementation as appropriate

Objective 5: Shape the Workforce

5-2. Harvest lessons from commercial sector activities in the use of M&S to support product development

Lead: OUSD(AT&L)/DS(SSE); **Support:** OUSD(AT&L), Components

Products: Annual update to best practices in DAG and lessons from industry that should be considered by PMs in planning for M&S

Completion goal: Recurring; initial in 2007

- SSE participating in conferences, workshops, and literature review involving commercial industry use of M&S, capturing relevant points
- Increasing industry adoption of “Simulation-Based Design (SBD)”
- Action complete, but follow-on expansion needed

Next steps:

- Collect and consolidate findings, feed into Action 5-3 BoK
- Submit as SBIR topic

Objective 5: Shape the Workforce

5-3. Assemble and evolve the M&S Body of Knowledge (information set) relevant to acquisition

Lead: OUSD(AT&L); **Support:** OUSD(AT&L)/DS(SSE), Components

Product: Information base available to potential M&S users (e.g., PMs, CMs, OTAs); source material for education and training

Completion goal: Recurring; initial in 2006

- Action completed in 2007 as part of ongoing education project
- Several BoKs have been discovered
- Education project has synthesized a consolidated BoK, as has SimSummit
- Knowledge is still being developed (e.g., best practices)

Next steps:

- Harmonize with SimSummit BoK?
- Establish an effective configuration management process
- Make additional inputs as they are discovered or become available

Obj. 5: Shape the Workforce (cont.)

5-4. Educate and train the workforce to achieve required M&S competencies

5-4(a) Provide M&S knowledge via an expanded set of DAU courses, the Defense Acquisition Guide, and on-line CLMs

Lead: DAU; **Support:** OUSD(AT&L), OUSD(AT&L)/DS(SSE), Components

Product: Expanded set of DAU courses, improved M&S guidance in the Defense Acquisition Guide, on line Continuous Learning Modules; a better educated workforce

Completion goal: 2009

- CLM on “M&S for Systems Engineering” released, has >3900 graduates
- CLM on “M&S for Test & Evaluation” released, has >1600 graduates
- Universities and NPS are responding to “Educating the Workforce” findings and recommendations
- No change to DAU courses so far, but education project will be a catalyst

Next steps:

- Participate in prototype GMU course “M&S in the Acqn Lifecycle”
- Implement additional CLMs (Education Project expects to recommend ~10) as feasible
- Investigate status of DAG inputs

Obj. 5: Shape the Workforce (cont.)

5-4. Educate and train the workforce to achieve required M&S competencies

5-4(b) Provide M&S knowledge via conferences, workshops, and assist visits

Lead: OUSD(AT&L)/DS(SSE); **Support:** OUSD(AT&L), DAU, Components

Product: Annual outreach program; a better educated and trained workforce

Completion goal: Recurring; initial in 2006

- **Initial Outreach Plan approved by AMSWG; includes M&S tutorial for AS staff, DMSC, NDIA, and SISO presentations**
- **Add'l materials (e.g., best practices) in work**
- **Resource constrained**

Next steps:

- **Advertise and expand assist visits**
- **Hold workshops once recommended practices are in hand**

Obj. 5: Shape the Workforce (cont.)

5-5. Improve the knowledge and expertise available through the MSIAC to make it of greater utility to the acquisition community

Lead: OUSD(AT&L); **Support:** OUSD(AT&L)/DS(SSE), OUSD(P&R), OUSD(C)/PA&E, Components

Product: Plan of action with coordinated MSIAC CONOPS & staffing requirement; list of knowledge shortfalls that MSIAC will take on; success criteria & process to bring MSIAC up to criteria

Completion goal: 2008

- Only preliminary conversations with MSIAC contractor thus far
- No plan of action by MSIAC; they want AMSWG to tell them what to do

Next steps:

- Develop a plan of action to improve the M&S Information Analysis Center's usefulness to the acquisition community

Backup Material

AMSWG Membership (1 of 2)

| Organization | SE Forum Principal | Organization | AMSWG Member |
|--------------------|-------------------------------|--------------------------------|-------------------------------------|
| ODUSD (A&T) SSE | Ms. Kristin Baldwin,
Chair | ODUSD (A&T)
SSE/DT&E | Michael Truelove |
| Army | Mr. Doug Wiltsie | ASA(ALT) | John Gillis |
| Navy | Mr. Carl Siel | ASN(RDA) CHENG
MARCORSYSCOM | Bill Zimmerman
Lan-Thanh McGough |
| Air Force | Mr. Terry Jagers | SAF/AQR | Maj Carol Beverly |
| Joint Staff J-8 | Mr. Rick Westermeyer | JTAMDO | Jim Gill |
| PA&E | | CAIG | |
| DOT&E | Dr. Ernest Seglie | DOT&E | Bob Butterworth |
| OSD (AT&L) DDR&E | | M&S CO | Jim Anthony |
| OSD (AT&L) AR&A | Mr. Phil Rodgers | | |
| USJFCOM | Mr. Steve Derganc | | |
| USD(P&R)(R&T)/JAEC | | R&T/JAEC | Bob Halayko |
| OUSD(AT&L)(TRMC) | | TRMC | George Rumford |
| DAU | Dr. Jim McMichael | DAU SE | George Prosnik |
| MDA | Mr. Dennis Mays | | |

AMSWG Membership (2 of 2)

| Organization | SE Forum Principal | Organization | AMSWG Member |
|------------------|---------------------|----------------|------------------------|
| NGA | Dr. Tom Holzer | NGA | (John Placanica-Inact) |
| NASA | Mr. Stephen Kapurch | NASA/ESMD | (Mark Prill-Inact) |
| NSA | Mr. Kelly Miller | NSA | Craig Holcomb |
| DCMA | Ms Rebecca Davies | DCMA | Larry Cianciolo |
| SOCOM | Dr. Dale Uhler | SOCOM | Art Gibson |
| NII | Mr. Mike Kern | ASD (NII) Acq. | Bill May |
| OSD (AT&L)L&MR | | NSWC/CSS | (Marc Eadie-Inact) |
| OSD (AT&L) DP&AP | Shay Assad | | |
| DISA | Mr. Gerald Doyle | | |
| NSSO | Mr. Jay Parness | | |
| NRO | Mr. Vernon Grapes | | |
| DLA | Mr. David Falvey | | |
| NDIA | Mr. Bob Rassa | NDIA M&S Com. | Jim Hollenbach |
| INCOSE | Mr. David Walden | | |

A Decade of Studies on M&S Support to Acquisition

1. *Final Report of the Acquisition Task Force on M&S, 1994*
Sponsor: DDR&E (Dr. Anita Jones); Chair: VADM T. Parker, USN (Ret.)
2. *Naval Research Advisory Committee Report on M&S, 1994*
Sponsor: ASN(RDA); Chair: Dr. Delores Etter
3. *Collaborative Virtual Prototyping Assessment for Common Support Aircraft, 1995*
Sponsor: Naval Air Systems Command; conducted by JHU APL and NSMC
4. *Collaborative Virtual Prototyping Sector Study, 1996*
North American Technology & Industrial Base Organization; sponsor: NAVAIR
5. *Application of M&S to Acquisition of Major Weapon Systems, 1996*
American Defense Preparedness Association; sponsor: Navy Acqn. Reform Exec.
6. *Effectiveness of M&S in Weapon System Acquisition, 1996*
Sponsor: DTSE&E (Dr. Pat Sanders); conducted by SAIC (A. Patenaude)
7. *Technology for USN and USMC, Vol. 9: M&S, 1997*
Naval Studies Board, National Research Council; sponsor: CNO
8. *A Road Map for Simulation Based Acquisition, 1998*
Joint SBA Task Force (JHU APL lead); sponsor: Acquisition Council of EXCIMS

A Decade of Studies on M&S Support to Acquisition

9. *M&S for Analyzing Advanced Combat Concepts*, 1999
Defense Science Board Task Force (Co-chairs: L. Welch, T. Gold)
10. *Advanced Engineering Environments*, 1999
National Research Council; sponsor: NASA
11. *Survey of M&S in Acquisition*, 1999 and 2002
Sponsor: DOT&E/LFT&E; conducted by Hicks & Associates (A. Hillegas)
12. *Test and Evaluation*, 1999
Defense Science Board Task Force (Chair: C. Fields)
13. *“SIMTECH 2007” Workshop Report*, 2000
Military Operations Research Society (Chair: S. Starr)
14. *M&S in Manufacturing and Defense Systems Acquisition*, 2002
National Research Council; sponsor: DMSO
15. *M&S Support to the New DoD Acquisition Process*, 2004
NDIA Systems Engineering Div. M&S Committee; sponsor: PD, USD(AT&L)DS
16. *Missile Defense Phase III M&S*, 2004
Defense Science Board Task Force (Chair: W. Schneider)

Assessment of Current Issues/Needs

- ❑ Cooperative effort between AMSWG & NDIA M&S Committee
- ❑ AMSWG venue:
 - Air Force – Roe (Jan 05)
 - Army – Gillis, Wallace (Jan 05)
 - Navy – Vaughn (Feb 05)
 - Visits to NAWC/AD (ACETEF); Army RDECOM; AFMC (SIMAF, ICE)
- ❑ NDIA M&S Committee venue:
 - Joint SIAP Systems Engineering Organization (Aug 04)
 - Future Combat Systems (Sep 04)
 - Missile Defense Agency (Feb 05)
 - Lockheed Martin (Feb 05)
 - Raytheon (Apr 05)
 - Boeing (Apr 05)
 - Northrop Grumman (Jun 05)
 - BAE Systems (Aug 05)
- ❑ Affirmed many findings and recommendations from studies and provided new inputs as well

Top-Down Derivation/Traceability to Non-M&S Needs

CJCSI 3170 & DoDD 5000.1

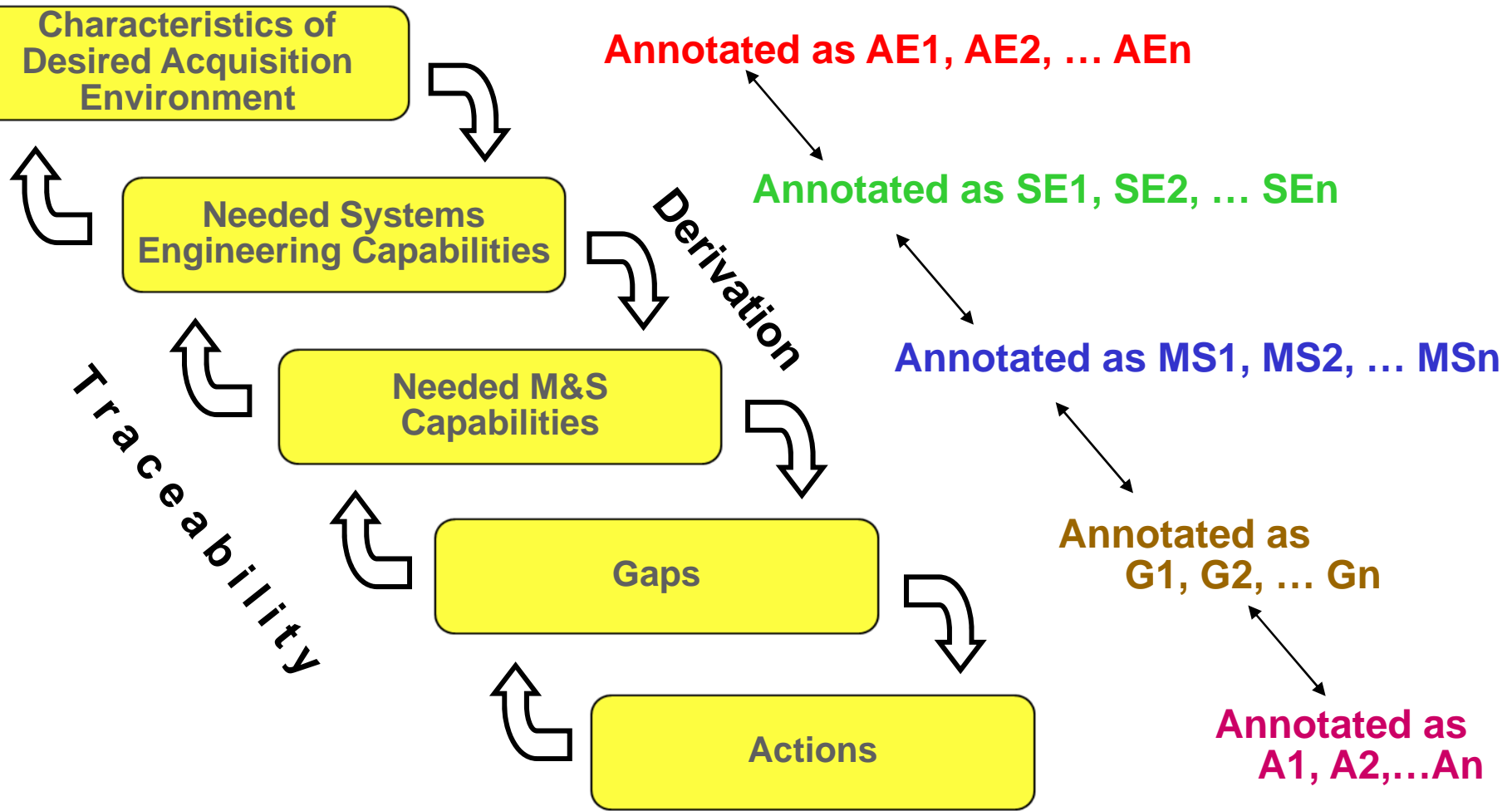

Desired Acquisition Environment: Key CJSCI 3170.01E Policies

- ^{AE1} Joint concepts-centric capabilities identification process to allow joint forces to meet the full range of military operations and challenges...
- ^{AE2} Assess existing and proposed capabilities in light of their contribution to future joint allied and coalition operations. ... Produce capability proposals that ^{AE3} consider the full range of DOTMLPF solutions in order to advance joint warfighting in a unilateral and multinational context.
- ^{AE4} New solution sets...crafted to deliver technologically sound, testable, sustainable and affordable increments of militarily useful capability.
- The ^{AE5} FoS and SoS solutions may also require systems delivered by multiple sponsors/materiel developers. ^{AE6}
- The process to identify capability gaps and potential solutions must be supported by a robust analytical process ^{AE7}
- JCIDS implements a capabilities-based approach that...requires a ^{AE8} collaborative process that utilizes joint concepts and integrated ^{AE9} architectures to ^{AE10} identify prioritized capability gaps and integrated DOTMLPF and policy approaches to resolve those gaps ^{AE11}

Desired Acquisition Environment: DoDD 5000.1 Acquisition Policies

“The primary objective of Defense acquisition is to acquire ^{AE12} quality products that satisfy user needs with measurable improvements to mission capability and operational support, in a ^{AE13} timely manner, and at a ^{AE14} fair and reasonable price.” ^{AE15}

Governing policies:

- Flexibility, ^{AE16} Responsiveness (time-phased capabilities, evolutionary acquisition), Innovation, ^{AE17} Discipline, Streamlined Effective Management
- Armaments Cooperation; ^{AE18} Collaboration; Competition; ^{AE19} Cost and Affordability; Cost Realism; Cost Sharing; Financial Management; Independent OTAs; Information Assurance; Information Superiority;
- ^{AE20} Integrated T&E; Intelligence Support; ^{AE21} Interoperability; ^{AE22} Knowledge-Based Acquisition; Legal Compliance; Performance-Based Acquisition;
- ^{AE23} Performance-Based Logistics; Products Services and Technologies [seek ^{AE24} most cost-effective solution over the system's life cycle], Professional Workforce, Program Information [complete, current, tailored]; Program Stability; R&D Protection; Safety; Small Business Participation; Software Intensive Systems; Streamlined Organizations; ^{AE25} Systems Engineering;
- ^{AE26} Technology Development and Transition; Total Systems Approach ^{AE27}
- Oct 04 policy memo: Technical reviews ... shall be event-driven ^{AE28}

Necessary Systems Engineering Capabilities

(which M&S can affect; derived from Desired Acquisition Environment)

- SE1.** Early, continuing systems engineering from an SoS/FoS capabilities perspective; seamless transition from JCIDS to acquisition
(AE1-3,5,9-11,16,20,21,25,27)
- SE2.** Lifecycle-wide exploration of the maximum available trade space, including time-phased requirements and technology insertion
(AE1-5,7,10,11,13,16,19,23-27)
- SE3.** Collaboration among all stake holders (multiple gov't and contractor organizations) for key enterprise-level SE decisions (AE6-8,10,18,22,25,27)
- SE4.** Rapid assessment of concept/design alternatives (AE2,4,7,10,14,16,19,25,28)
- SE5.** Comprehensive, accurate, event-based assessment of technical baselines; avoidance of costly fixes for problems discovered late
(AE2-4,7,9,10,12-17,19,20,22,24-26,28)
- SE6.** Focused, effective & efficient testing; including at the capability level
(AE1,2,4,5,9-11,13,15,19-22,25)
- SE7.** Appropriate reuse of all resources – information, software tools, expertise, facilities, ranges, etc. – across programs & organizations
(AE4,14,15,19,24,25)

Needed M&S Capabilities (1 of 2)

(derived from Needed Systems Engineering Capabilities)

MS1. Model-based systems engineering/design (SE1,2,4,5)

(Emerging concept under INCOSE, OMG, etc.; growing suite of COTS tools)

- Modeling environments to analyze requirements, develop system and software architectures, and perform detailed design (e.g. CAD, S/W)

MS2. M&S-enabled collaborative engineering environments (SE1,2,3,4,5,6)

- Interoperable M&S, data management, & manufacturing
 - M&S as a communication means
- Full range of M&S assessments
 - Models, simulations, and distributed live-virtual-constructive simulation federations, with option to immerse warfighters
- Traceability for coherence and decision analysis

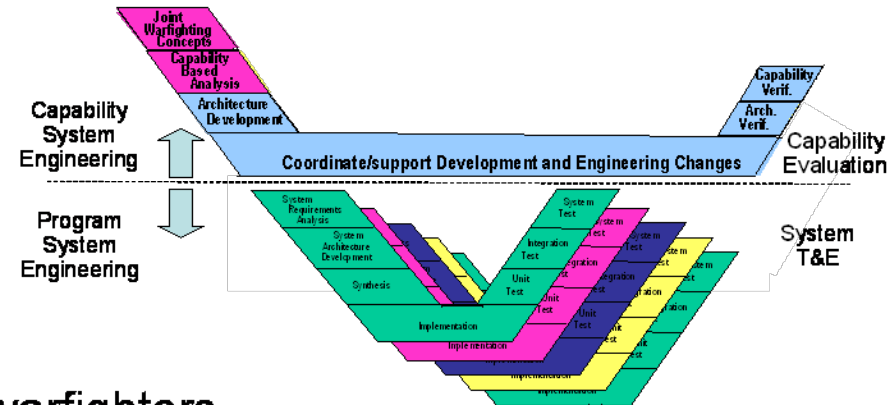

MS3. Model-Test-Fix-Model process across the life-cycle (SE4,5,6)

- Better test planning, more effective tests
- Increased M&S validity; credible surrogates; reuse savings

Needed M&S Capabilities (2 of 2)

- MS4.** M&S knowledge to formulate an effective acquisition strategy (SE2,3,4,5,7)
 - Ready access to M&S expertise and information about capabilities and gaps, reusable resources, lessons-learned, etc.
- MS5.** Disciplined M&S planning & employment (SE2,4,5,7)
 - Rigorous analysis of M&S requirements, alternatives, best course
 - Efficient configuration/initialization, execution and post-run analysis
 - Avoid inappropriate use; maximize cost-effective reuse across lifecycle
- MS6.** Efficient development/evolution of credible M&S tools (SE2,3,5,7)
 - A systems engineering approach with appropriate V&V
- MS7.** Access to authoritative, understandable data needed for M&S representations (SE2,3,4,5,7)
 - Reducing a major time and cost burden that inhibits M&S use
- MS8.** Inspection of M&S used to inform acquisition decisions (SE2,5,7)
 - Examine capabilities and limitations (VV&A) of M&S
 - During lead-up to program/technical reviews, OTRRs, DABs, etc.

Gaps

1. Management

- G1.** Robust but confused landscape of M&S activities; no clearly designated leadership or effective coordinating mechanism (MS1-8)
 - Current EXCIMS ineffective; little coordination for capabilities/SoS/FoS
- G2.** Inadequate constancy of purpose because time to fix problems >> tour length; “DoD has an attention deficit disorder” (MS2-7)
- G3.** Gov’t acquisition guidelines don’t promote M&S use or reuse (MS1-6)
- G4.** No DoD requirement for formal M&S planning to support acquisition (other than T&E) (MS1-5)
- G5.** No contractual guidelines regarding M&S and the data it needs (MS1-8)
- G6.** Gov’t typically doesn’t give contractors meaningful M&S guidance (MS1,2,6,8)
- G7.** Most DoD M&S takes a project, vice an enterprise, approach (MS2,3,6,7)
- G8.** No consensus on value of integrated architectures, nor responsibility for (MS1,2)
- G9.** Managing distributed collaboration is very hard (MS1-8)
- G10.** Public law precludes OT based solely on M&S, but no clear guidance on use for SoS/FoS T&E (MS2,3,5,6,8)

Gaps

2. Architecture/standards/technical framework

- G11.** No standard modeling notation (like UML v2.0) for capturing full range of information critical to system engineering (e.g., structure, behavior, requirements hierarchy/traceability, test cases, verification results) (MS1,2,6,7)
- G12.** No standard for interchanging systems engineering information (same examples as above) (MS1,2,6,7)
- G13.** No conceptual framework (like Open System Interconnect protocol stack) for data interchange (MS1,2,3,6,7)
- G14.** Lack of agreement on a common distributed simulation standard increases complexity and cost, limits simulation interoperability (MS2,5,6)
- G15.** DoDAF v1.0 is difficult to use for architecting due to lack of data-centricity and executability; some products of marginal value (MS1,2,6,7)
- G16.** Use of DoD-unique standards limits their user base, quality, COTS tool support, and opportunities for reuse (MS1,2,5,6)

Gaps

3. Model/simulation capabilities & use

G17. Many M&S tool gaps and deficiencies (MS1,2,3,5,7)

- What's modeled (e.g., urban warfare, comm networks, threats, system sustainment)
- Fidelity, granularity, interoperability
- Only limited consensus on common models to be used across a domain

G18. No good way to develop and maintain widely-needed M&S tools that cut across programs (MS5,6)

- Not incorporating mods by other organizations into “street version,” etc.

G19. M&S developers, not M&S users, tend to drive M&S development (MS6)

G20. In general, architecture development (modeling) is lagging, not collaborative, and not exploiting COTS SE tools (modeling environments) (MS1,2)

G21. No readily-available distributed M&S infrastructure (e.g., JDEP) (MS2,5)

G22. Hard to get security certification for multi-organization (company/Service) distributed simulation (MS2,3,5,6)

G23. Hard to get approval and security certification for M&S involving multiple compartmented programs (SAPs) (MS2,3,5,6,7)

Gaps

4. Trustworthiness/VV&A

G24. Post-development model validation expensive and slow (MS2,3,5,8)

G25. VV&A often weak or non-existent; documentation inconsistent (MS2,3,5,8)

- Plans to use M&S to avoid testing costs often rejected due to poor/no validation

G26. VV&A usually not enforced and also not examined during program reviews (MS2,3,5,6,8)

G27. Models and sims often not updated to reflect empirical evidence (e.g., test results) (MS2,3,5,8)

Gaps

5. Sharing/reuse and protection of tools & information

- G28.** Little reuse; only 7% of models & sims used on >1 program (MS2,5,6)
- G29.** Concurrent engineering requires an integrated process, data sharing and a coherent tool set, but <20% of programs have such a collaborative environment (MS2,7)
- G30.** Hard to discover reusable resources (software, info, services) (MS2,4,5,7)
 - M&S repositories are not integrated, lack an effective search capability, and are mostly empty
 - MSIAC knowledge/expertise is lacking
- G31.** Insufficient info (metadata) to evaluate data/reuse candidates (MS2,4,5,7)
- G32.** Hard to obtain reusable resources (MS2,4,5,7)
 - Industry to gov't: To protect proprietary info & competitive advantage
 - Gov't to industry: Contractual liabilities associated with GFE/GFI
 - Gov't to gov't: Concerns about misuse; cost to deliver and guide
- G33.** No incentives to encourage reuse (MS2,3,5,6)
 - Negative incentives include cost to make reusable, workload assisting users, vulnerability to criticism

[plus approval and security certification gaps 22 & 23 listed under M&S use]

Gaps

6. Research/S&T/tech base

G34. Conceptual foundation of M&S weak (MS5,6)

- E.g., theoretical understanding of modern warfare, human behavior, relating M&S at different granularities, dealing with uncertainty, agent-based modeling and generative analysis

G35. Little acquisition community input to DoD S&T management regarding needed M&S-related research (MS2,5,6)

7. Business model, metrics & ROI, funding and incentives

G36. No business model for how M&S capabilities should be developed, used and maintained (MS1-8)

G37. Metrics are critical to keep interest and funding up, but metrics regarding M&S use and cost-effectiveness are inadequate (MS1-8)

- M&S funding difficult to identify; most embedded within other PEs

G38. Too little funding (MS2-7)

Gaps

8. Workforce Shaping

- G39.** Body of knowledge for M&S support to acquisition is deficient, not managed (MS1,2,4-6,8)
- G40.** Acqn community managers and staffs mostly uninformed about M&S capabilities and limitations (MS1-8)
 - Weak acquisition personnel understanding of commercial M&S activities (“We don’t get out enough”)
 - Not enough M&S experts (no career path [except Army], no formal education or training)
- G41.** M&S developers lack understanding of modeling best practices, abstraction techniques, context dependencies, etc. (MS3,6)
- G42.** M&S users often not adequately trained (MS1,2,4,5,8)
- G43.** Insufficient M&S education options (MS2,4,5,6,8)

Virtual Battlespace Center

Advanced M&S to Inform OSD Acquisition Decisions



NDIA Systems Engineering Conference
San Diego, California
20-23 October 2008

James W. Hollenbach
ODUSD(A&T)/SSE/DTE Support
Simulation Strategies, Inc.
jimh@simstrat.com, 727.824.0931

Outline

- **Observations**
- **Virtual Battlespace Center Concept**
- **Modeling and Simulation in the VBC**
- **Protecting Business-Sensitive Information**
- **Organization Options**
- **Influence on Other M&S**
- **DSB Task Force Study**

Observations (1 of 3)

1. Acquiring capabilities is a huge challenge

- **Expanded trade space = dramatic increase in complexity**
 - Many more entities, variables, interactions, etc.
 - Development enterprises become vast, distributed
 - Many more stakeholders, with much at stake
- **Need systems engineering above individual system level**
 - Complexity precludes intuitive design and analysis
 - Program to program negotiations impractical
- **Need to assess capabilities, not just individual systems**
 - Many more forces & systems, bigger battlespace, more events
 - Scarcity of equipment constrains lab integration & live tests
 - Range size, security needs, and safety also limit live testing

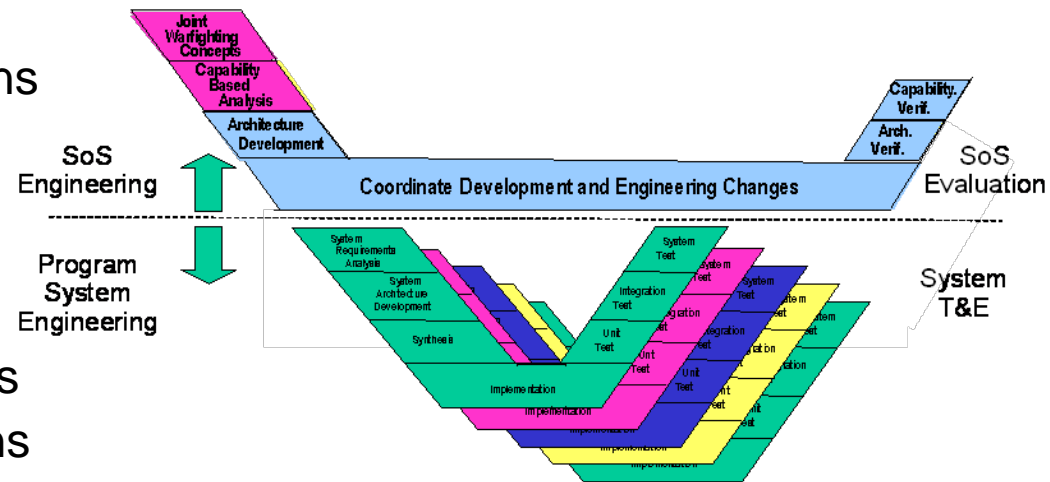

Observations (2 of 3)

2. **M&S can improve the design, integration, test, and assessment of capabilities and systems of systems**
 - **Earlier, more accurate designs and assessments of designs, lowering risk**
 - **Accurately track complex relationships and micro-level interactions; present macro-level measures of merit to decision makers**
 - **Defendable analytical underpinning for decisions**
 - **Several SoS efforts (e.g., JSSEO, FCS) provide glimpses of M&S benefits**
3. **DoD prime contractors have built joint battlespace simulations to help develop new warfighting capability/system concepts and to collaborate with their government customers & industry partners**
 - **But these virtual battlespaces are neither authoritative nor coherent**
 - Representations of blue systems they don't build aren't authoritative
 - They have different conceptual models of the battlespace and standards
 - **Thus many of their intended benefits are negated**
 - Inaccuracies can lead to bad business decisions
 - Government customers question their credibility
 - Collaboration with partners is hampered by incoherent representations

Observations (3 of 3)

4. **The Services also have various SoS simulation efforts to support their system development activities, such as:**
 - **Army's Cross-Command Collaboration Effort (3CE) and Modeling Architecture for Technology, Research and Experimentation (MATREX) Distributed Virtual Laboratory (DVL)**
 - **Air Force Integrated Collaborative Environment (AF-ICE)**
5. **OSD has no equivalent virtual battlespace...**
 - **to provide independent assessments of system concepts and designs**
 - **to plan and evaluate how individual systems function in a SoS**
 - **to assess capabilities as proposed and as evolutionary changes to a SoS occur**
6. **Hence corporate decisions are not as informed as they could be**

Virtual Battlespace Center Concept

- **Primary mission: Support OSD's corporate-level acquisition responsibilities with advanced M&S**
 - A persistent environment in which all DoD-level capability/ system of systems (SoS) design and analysis is conducted
 - A means to refine concepts and define requirements for both capabilities and individual systems
 - An objective view of how systems interoperate and perform
- **Secondary mission: Support analysis of DoD investment decisions and operational plans**
- **VBC will have the most credible representations of every system, force, and activity in the battlespace**
- **To do so, VBC must provide security for business-sensitive information**

VBC Modeling and Simulation

- **A wide range of M&S will be used in the VBC**
 - **Architecture modeling**
 - Design SoS topology, allocate functions, check completeness & efficiency
 - Using SE tools like System Architect, Core, Cradle
 - **Concept assessment modeling**
 - Comprehensive view of the entire trade-space to assess design decision impacts on key performance parameters (KPPs)
 - E.g., Georgia Tech's Collaborative Visualization Environment (CoVE)
 - **Distributed simulation**
 - Any mix of live, virtual, and constructive (LVC) simulation; much constructive simulation will be other than real-time
 - Multiple standard federations will provide an 80% solution
 - **Recursive levels of granularity for models, simulations, and federations**
 - Based on hierarchically-integrated conceptual models (common in engineering, but thus far quite uncommon in M&S)
 - **Other M&S TBD**

Why Won't JMETC Suffice?

- Joint Mission Environment Test Capability provides distributed simulation for operational testing of systems
 - Managed by the Testing in a Joint Environment Senior Steering Group
- Provides a sub-set of M&S capabilities needed by VBC
 - Doesn't include architecture modeling or concept assessment modeling
 - Distributed simulation is limited to real-time (TENA-based)
 - Is focused on a single level of granularity (platform level)
 - Won't adequately protect business-sensitive information

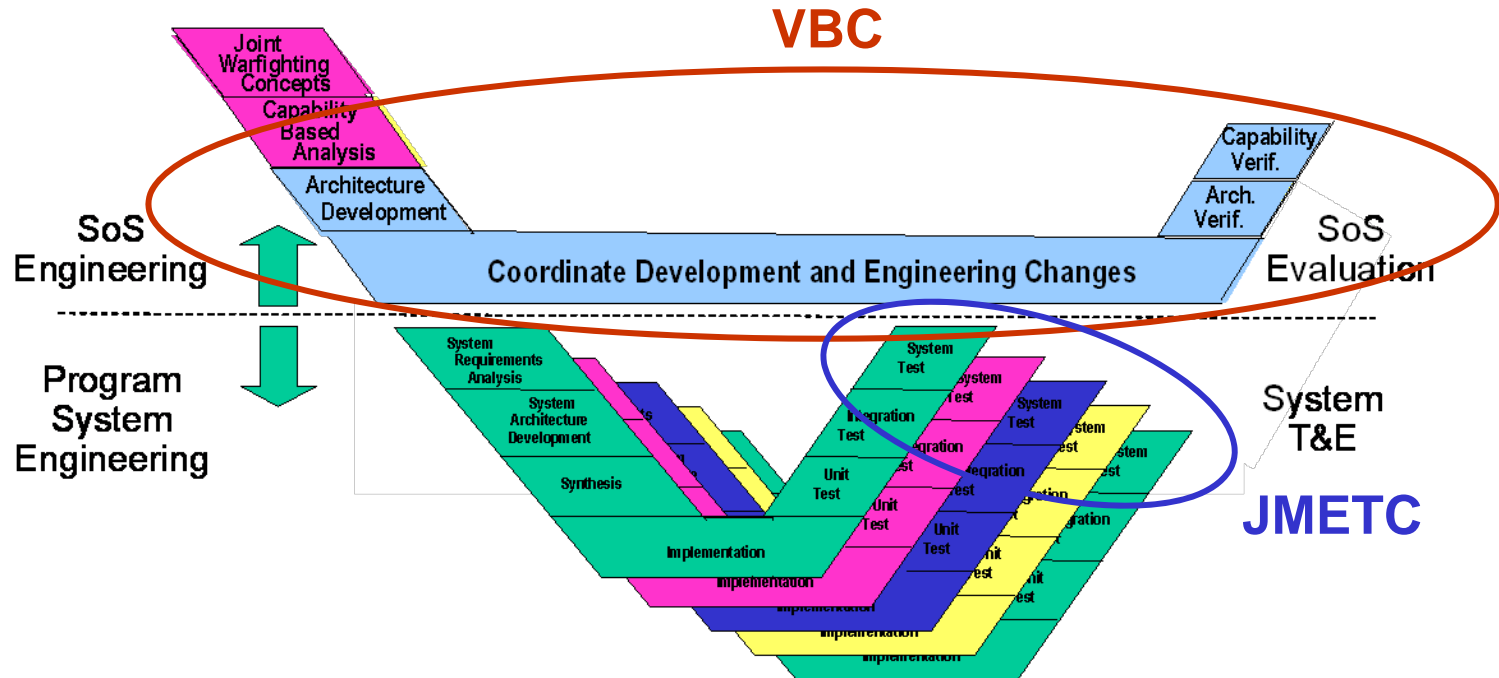

Need for Trustworthy Representations

- **Corporate-level decisions arising from VBC analyses will determine:**
 - what individual systems are procured or modernized;
 - the functional capabilities & interfaces each system must have;
 - the standards to which those systems must conform;
 - the schedule on which they must be developed or evolved; and
 - indirectly, the funding allocated to each
- **The risk of an erroneous representation leading to an incorrect decision must be minimized**
 - Decisions will be challenged unless the VBC representations and associated analyses are above reproach
- **VBC must have credible, trustworthy representations**
 - System data & algorithms must be traceable back to the most credible sources
- **Program offices & their contractors should be tasked to supply validated representations of their systems**
 - Requirements for these must first be carefully and unambiguously defined by the VBC

Protecting Business-Sensitive Information

- **To get trustworthy representations, business sensitive information (e.g., intellectual property, programmatic info) must be protected**
 - **Contractors fear compromising IP, undermining business opportunities**
 - **Program offices are concerned their program or reputation will be harmed**
 - **VBC must assure representation resource owners that misuse or compromise will not occur**
- **Distributed simulation technology provides some protection of sensitive information via encapsulation, but it can still be compromised by repeated observation of a system's behaviors**
 - **For instance, multi-sensor integration logic can be inferred from responses to various patterns of sensor inputs**
- **To prevent industrial espionage, VBC will have to tightly control access to its M&S representations**
 - **VBC personnel will operate the models and simulations, or**
 - **Other simulation owners participating in a distributed simulation will do so under non-disclosure agreements, with tightly limited data collection**

Organization Options

- **Capability/SoS management may be instituted under an evolved portfolio management concept or other organizational structure**
 - VBC would support whatever organization emerges
- **Candidate organizations to run the VBC include:**
 - Existing OUSD(AT&L) office
 - Defense agency or field activity, either existing or new
 - System command of a DoD Component (objectivity concerns)
 - FFRDC or UARC
 - Contractor recused from any other system acquisition work
 - Fire-walled division of a contractor (objectivity concerns)
- **Selection will require further study**

Impact on Other M&S

- **System assessment in the VBC would be a capstone event**
 - The system's performance and contribution to a desired DoD functional capability will be evaluated and its fate decided
- **System owners will want their own virtual battlespace to be as close as possible to the VBC's, so standards used in the VBC will foster alignment by the rest of acquisition M&S**
 - Architectures, battlespace conceptual models, & FOMs can be matched
 - Government-owned, non-IP data used in VBC (e.g., scenarios, threats, natural environment) can be shared under CRADAs
 - “One-off versions” of owner-provided representations could be shared using abstraction means (e.g., neural nets, response surface equations)
 - VV&A practices to ensure the trustworthiness of VBC representations will foster more diligent VV&A in other virtual battlespaces
- **Interoperability, reuse, and rapid, cost-effective composition of distributed simulation federations will all be enhanced**
 - As a side benefit, we'll achieve effective DoD M&S governance
 - Benefiting DoD's mission, our warfighters, and the nation

Next Step: DSB Task Force Study

- **A Defense Science Board Task Force is about to be convened to...**
 - **examine and refine the Virtual Battlespace Center concept**
 - **consider capability management approaches**
 - **develop a VBC concept of operations**
 - **identify and prioritize candidate M&S capabilities**
 - **recommend an organization to manage the VBC**
 - **verify or refute the VBC benefits asserted here**
- **Dr. Anita Jones and Dr. Ron Sega, both former DDR&E's, will co-chair**
- **If the DSB TF makes a positive recommendation, this will set the stage for a VBC initiative under the next administration**



Integration of Systems and Software Engineering:

Implications from Standards and Models Applied to DoD Acquisition Programs

NDIA 11th Annual
Systems Engineering Conference
San Diego, Ca.

October 23, 2008

Donald J. Gantzer

Lisa Reuss

Systems Engineering Support Office

supporting

ODUSD(A&T) Systems and Software Engineering (SSE)

Assessments and Support

[*donald.gantzer.ctr@osd.mil*](mailto:donald.gantzer.ctr@osd.mil)

[*lisa.reuss.ctr@osd.mil*](mailto:lisa.reuss.ctr@osd.mil)



Agenda



- Introduction
- Overview comparison of Systems Engineering (SE) process standards and models
- Some observations from review of SE Plans (SEPs)
- Some findings from Program Support Reviews (PSRs)
- NDIA Summary of SE and Software issues in DoD
- Summary implications of SE processes in DoD Acquisition Programs

Disclaimer: The views and opinions presented here are the authors' and do not necessarily represent DoD views.



Introduction



- DoD's **Defense Acquisition Guidebook** (DAG) has applied SE standards in developing its SE chapter 4, tailored to DoD acquisition policies and guidance
- **ISO/IEC 15288 – System life cycle processes** was recently updated and is in concert with an update to **ISO 12207 – Software life cycle processes** (*further “Harmonization” is ongoing*)
- A DAG update is imminent with changes due to new DoD acquisition policies [e.g., DoDI 5000.2) that...
 - Emphasizing enhanced (i.e., early] Systems Engineering (SE)
 - Moving Milestone B acquisition decision point to post Preliminary Design Review [PDR]
 - Changes to SE processes per ISO/IEC 15288 revision

Note: Acronym definitions are in backup slides



A Generic SE Process

Note: Was applied to Air Force IT/CSE SE Case Studies; <http://www.afit.edu/cse/>

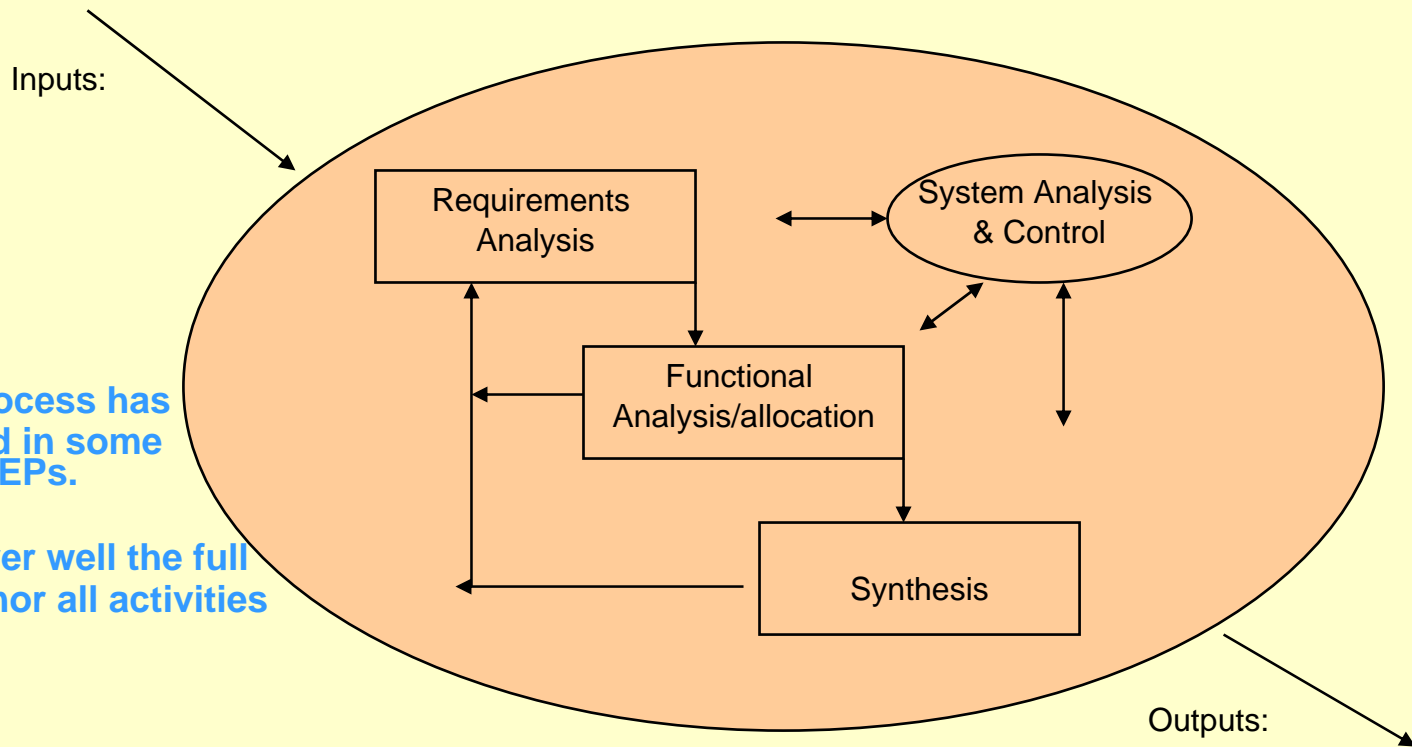

This simple process has been observed in some program SEPs.

It does not cover well the full SE life cycle, nor all activities of import

Sources: DoD Mil Std 499A/B and the Defense Acquisition University [DAU] SE Fundamentals, 2001



System Life Cycle Processes - ISO/IEC 15288: 2008*



**Changes highlighted in red*

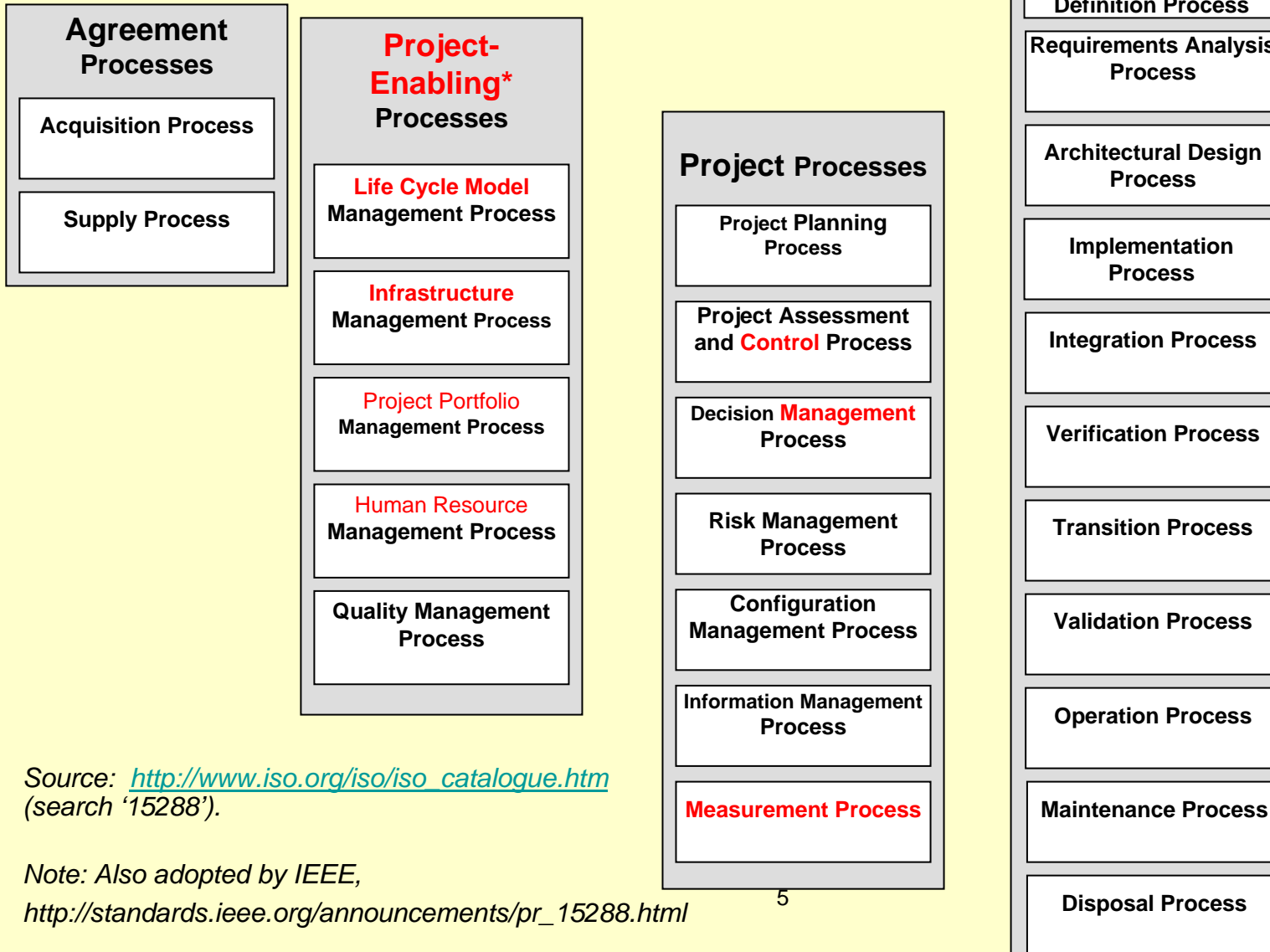

Source: http://www.iso.org/iso/iso_catalogue.htm (search '15288').

Note: Also adopted by IEEE, http://standards.ieee.org/announcements/pr_15288.html



Simplified Application of the SE 'V' approach

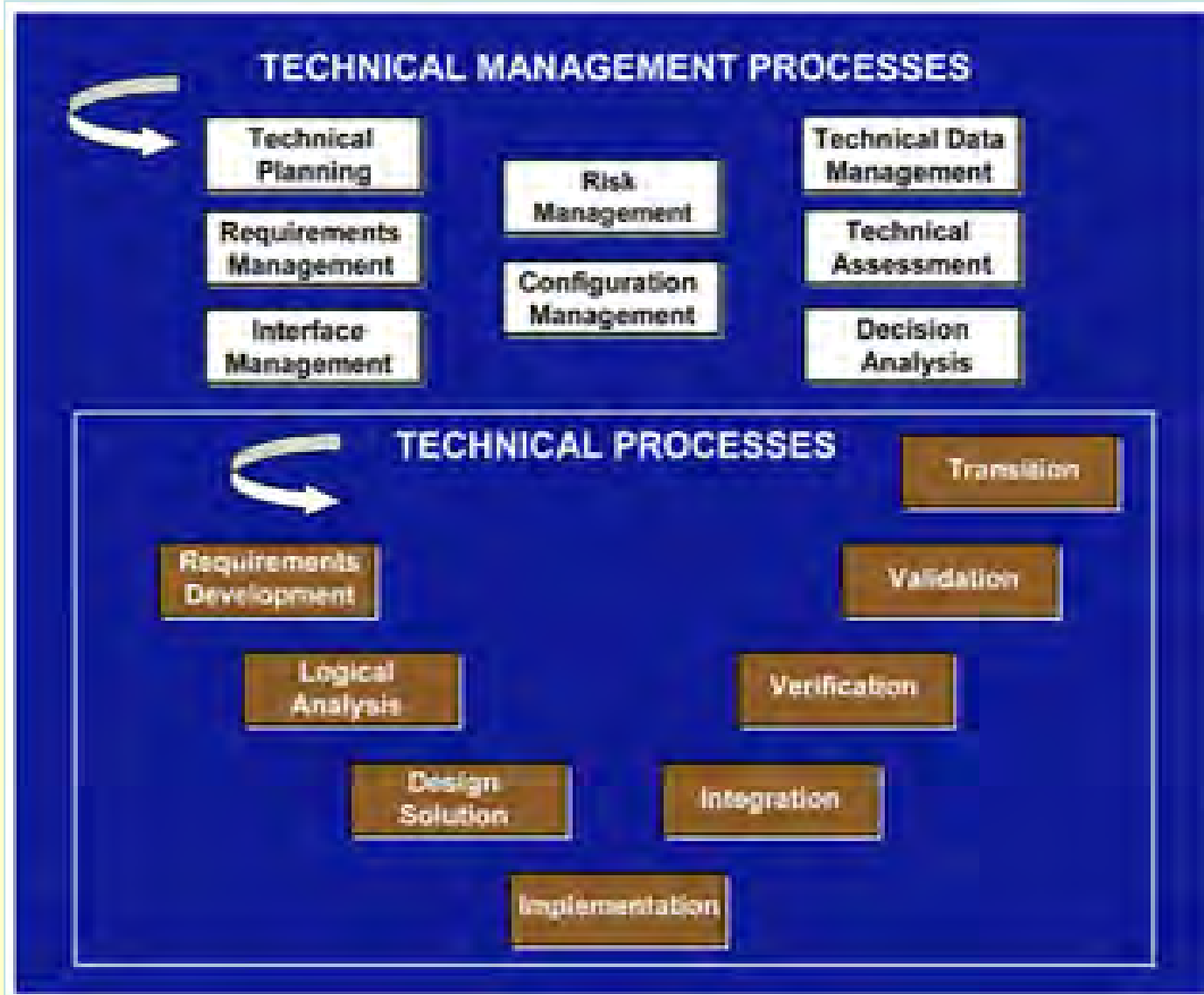

[Note: new DAG revision release imminent; tailored approach adapting ISO 15288: 2008]



SE Standards Example Mapping

- Management *(*see also other DAG chapters)*



| ISO/IEC 15288 | EIA - 632 | IEEE 1220 | CMMI®-ACQ [level 3] | DAG/SE (#4) |
|--------------------------------|------------------------------------|---|--|--|
| Project Planning | Planning | Planning and integrating the technical/SE effort | Project Planning; Integrated Project Management (Mgt.). Acquisition Technical Mgt. | Technical Planning (*see #11 Program Management) |
| Project Assessment and Control | Assessment; Control | Control; Technical reviews | Project Monitoring and Control | Technical Assessment; Interface Mngt.* |
| Measurement | Systems Analysis | Control | Measurement and Analysis | Decision Analysis* |
| Decision Management | Systems Analysis | Systems analysis | Decision Analysis and Resolution | Decision Analysis* |
| Risk Management | Systems Analysis | Systems analysis | Risk Management | Risk Management* |
| Configuration Management (CM) | Control | CM; integrated repository; System breakdown structure | CM; Requirements Management | CM; Requirements Management |
| Information Management | | Integrated data package | Project Planning; Measurement and Analysis | Technical Data Management |
| Acquisition and Supply | Acquisition and Supply | Development strategies | Agreement Mgt. Acquisition Technical Mgt. | <i>(*see other DAG chapters)</i> |
| Project -Enabling processes | Environment and Enterprise Support | Product and process improvement; Quality Mgt. | Organizational Process set; Process & Product Quality Assurance; Organization Training | <i>(*see other DAG chapters)</i> |



SE Standard Example Mapping – Technical *(*see also other DAG chapters)*



| ISO/IEC 15288 | EIA - 632 | IEEE 1220 | CMMI®-ACQ/L3 | DAG/SE (#4)* |
|-------------------------------------|--|---|---|---|
| Stakeholder Requirements Definition | Requirements Definition | Requirements analysis | Acquisition Requirements Development; Solicitation & Supplier Agreement Development | Stakeholder Requirements Definition* |
| Requirements Analysis | Systems Analysis | Requirements & Functional analysis; Systems Analysis; Modeling | Acquisition Requirements Development | Requirements Analysis* |
| Architectural Design | Solution Definition | Functional analysis; Synthesis; Modeling, Specifications/drawings | Technical Solution | Architecture Design |
| Implementation | Implementation | Prototyping; fabrication, assembly, production | Integrated Project Management | Implementation |
| Integration | | Integrated data package; Integration | Integrated Project Mngt. | Integration |
| Verification | System Verification | Functional & Design verification; Technical reviews; Test | Acquisition Verification | Verification
<i>(*see #9 – Integrated Test & Evaluation)</i> |
| Validation | Requirements & End Products Validation | Requirements validation; Test | Acquisition Validation | Validation
<i>(*see #9 – Integrated Test & Evaluation)</i> |
| Transition | Transition to Use | | | Transition |
| Operation; Maintenance; Disposal | | Support stage | | <i>*see other DAG (e.g., #5 Life Cycle Logistics)</i> |



Summary of SE Standards



- ISO/IEC 15288 is becoming the *leading* SE 'Standard'
 - ISO/IEC 12207 [and others – e.g., 15939 re Measurement process] working for 'harmony'
 - IEEE 'adopts' it with tailoring guidance; expect revision of IEEE 1220 [also for EIA-632]
 - INCOSE adopts/tailors it with much more detail
 - DoD's DAU DAG applies it with acquisition-oriented tailoring
 - It is a *standard* and so is a very high level '**What**' is best practice

- "reality is in the details"
 - the DAG, CMMI, and INCOSE all provide more details on what & how

- *Next – overview of DUSD(A&T) SSE (and NDIA) observations and finding regarding SEP reviews, PSRs analysis, workshop findings*



USD(AT&L) Systems Engineering Plan (SEP) Policy*



- “Provide a **context** within which I can make **decisions** about individual programs.”
- “Achieve **credibility and effectiveness** in the acquisition and **logistics** support processes.”
- “Help **drive good systems engineering** practices back into the way we do business.”

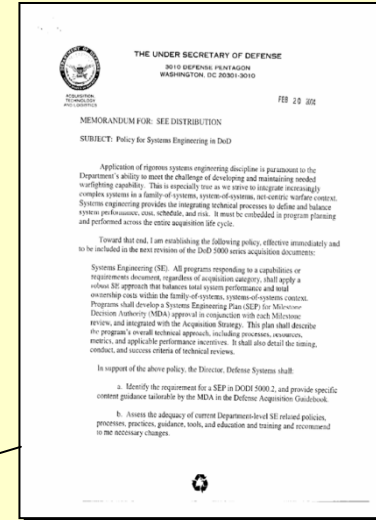

Programs shall develop a Systems Engineering Plan (SEP) for Milestone Decision Authority (MDA) approval in conjunction with each Milestone review, and integrated with the Acquisition Strategy. This plan shall describe the program’s overall technical approach, including processes, resources, metrics, and applicable performance incentives. It shall also detail the timing, conduct, and success criteria of technical reviews.

Note: colors are authors

*Full policy can be found at <http://www.acq.osd.mil/sse/policy.html>



SEP Purpose



➤ The SEP...

- Is the artifact of a program's technical planning activities usually led by a SE Working Integrated Product Team [SE WIPT]
 - Captures government processes and planning
 - Establishes roles, responsibilities, and authorities of both government personnel and contractors within government processes
- Covers the life cycle from concept, acquisition, etc., through sustainment of the system/program
- Is the Program Manager's technical management tool

Application of a quality technical planning process, by trained and experienced staff, leads to a good SEP



Technical Planning Focus Areas in SEPs

[there are variations per Milestone / Phase]



➤ Program Requirements

- Capabilities, CONOPS, and key performance parameters/attributes
- Statutory, Regulatory, Certification requirements
- Technology development, design considerations
- Data to monitor & compare to assumptions

➤ Technical Staffing and Organizational Planning

- Lead/Chief SE & functional Leads
- IPT Organization/Structure, staffing & skills, coordination
- Integration with contractors & external organizations

➤ Technical Baseline Management

- Technology maturity & risk
- Technical Baseline management responsibility & control
- Requirements traceability, verification & validation
- Specifications & Work breakdown Schedule (WBS)

➤ Technical Review Planning [Event driven]

- Technical review management (who chair, determines readiness & closure)
- Entry and exit criteria
- Stakeholder participation
- Peer participation [e.g., *independent* Subject Matter Experts [SMEs]]

➤ Integration with Overall Program Management

- Linkage to other program plans (e.g., Acquisition Strategy, Integrated Master Plan & Schedule, Test & Evaluation Management Plan (TEMP), production, sustainment/logistics plans or strategies, etc.)
- Risk Management Plan
- Contracting Considerations (e.g., SE incentives)

Source: ODUSD(A&T)SSE Systems Engineering Plan (SEP) Preparation Guide; 2008



Critical & Substantive Comments per SEP

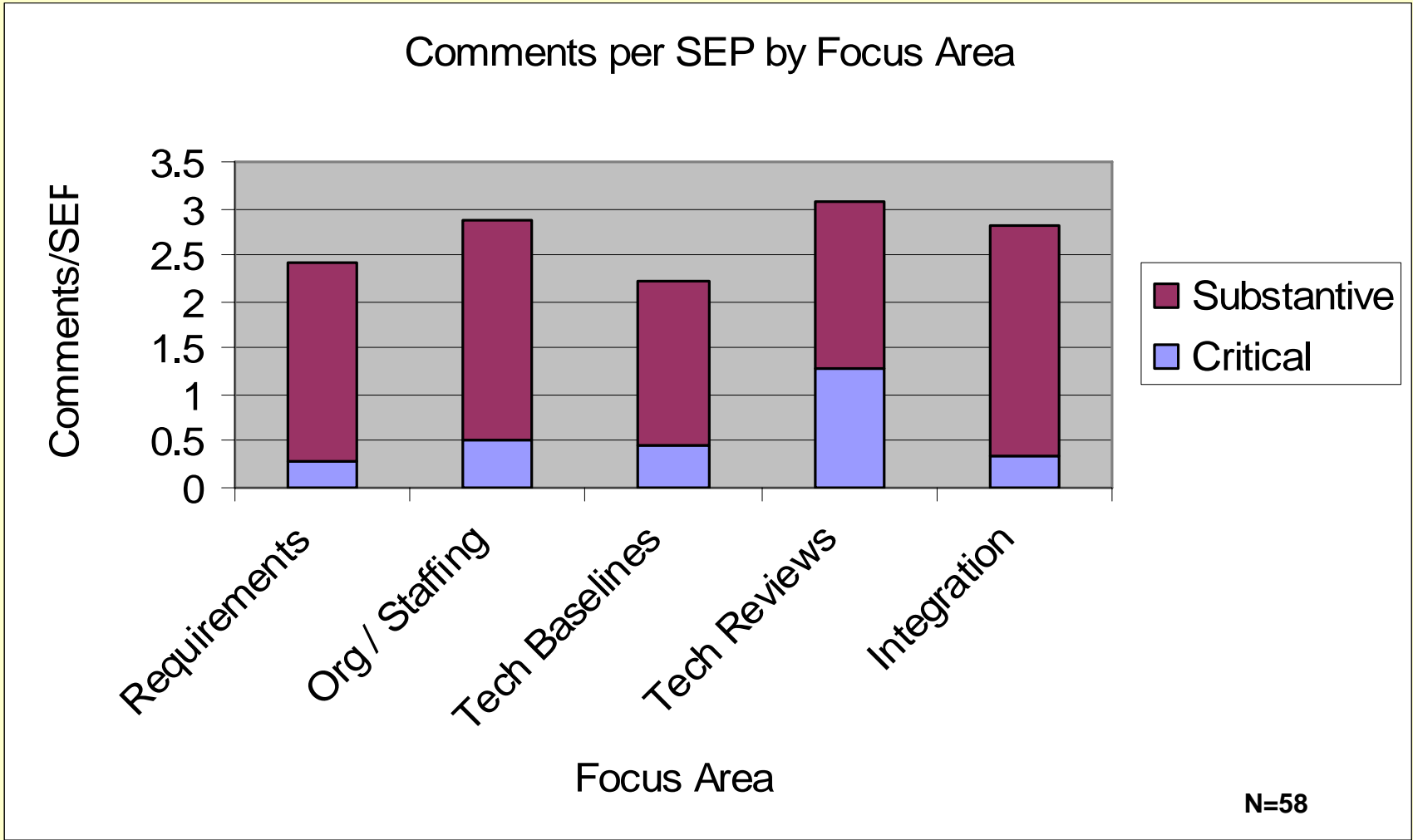



SEP References to SE Processes

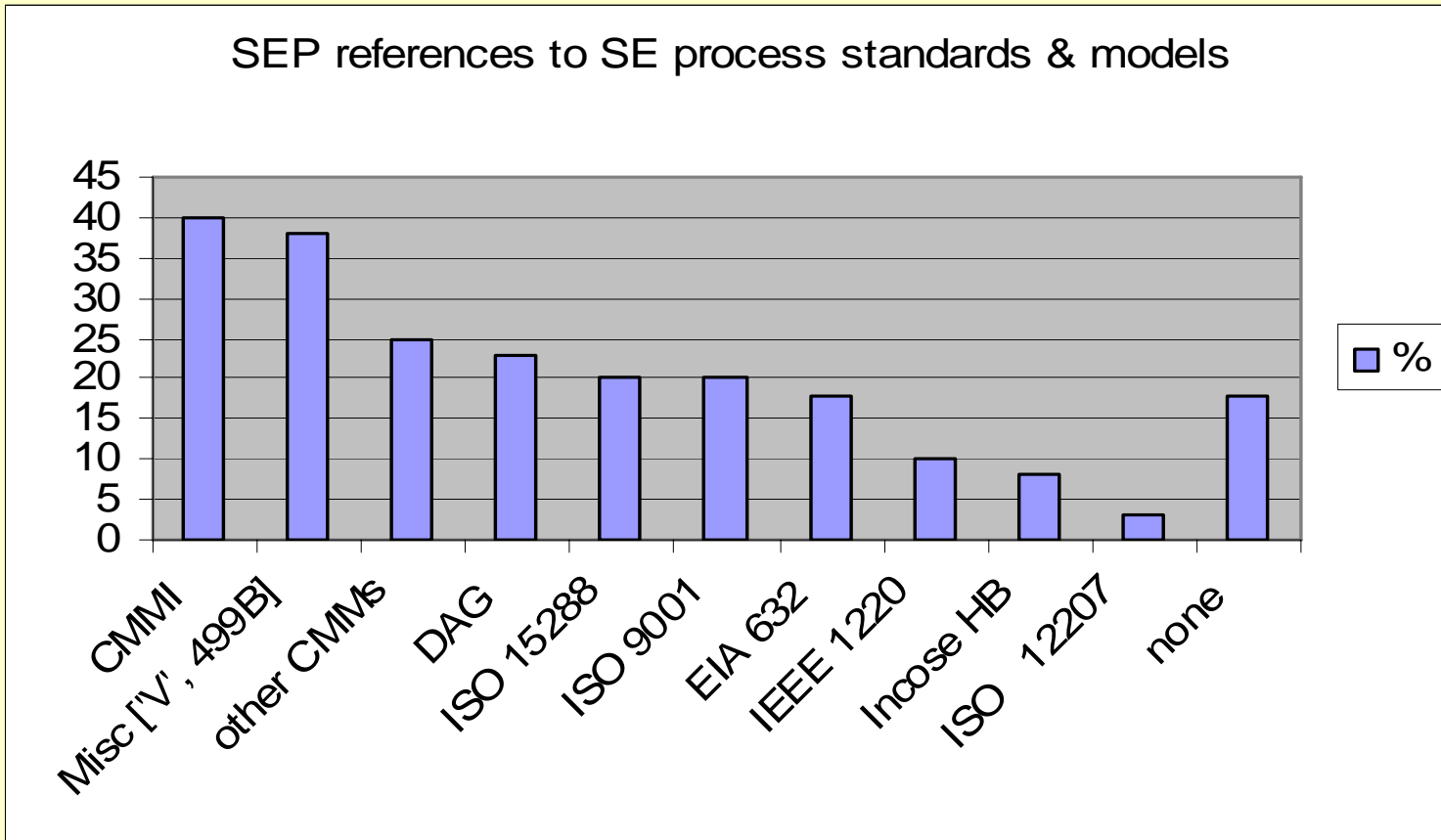

*other CMM = CMMI-AM, SW-CMM

Note: N =40; sum >100% due to several listed in many SEPs



SEP Observations on SE Practices



- CMMs clearly dominate; but simplified “V” or 499B are still applied
 - some use the CMMI-Acquisition Module (CMMI-AM);
 - CMMI for Acquisition (CMMI-ACQ) is too new to see any application
- Some programs list many – but not clear which, if any, actually are applied
- ~ 20% not referencing any particular SE standard/model
- Practically no information on what/how standards/models were tailored
- Some programs are referencing (adopting?) the Prime/Integration contractor’s SE set of processes
- SEPs usually only show or discuss in detail: *Requirements Management, Configuration Management, Risk Management, & Technical Review* approaches (T&E is addressed in the TEMP)

Need to see more details on tailored integrated SE approach



SEP Review Summary Observations

(~ 100 SEPs reviewed across life cycle phases)



- Lack complete **requirements** ([e.g., regulatory, statutory, certifications) sources
- Unclear understanding of **interfaces/coordination** with other programs/systems [i.e., System of Systems, Family of Systems (SoS/FoS)]
- Inadequate linking of Key Performance Parameters (**KPPs**), Attributes, Technical Performance Measurements (TPMs)
- Vague on design considerations and criteria/approach to **trades**
- Unclear, incomplete and inconsistent **organizational** roles /responsibilities/authorities of program functionals and IPTs; charters, chairs, members, products – link to WBS, EVMS, TPMs.
- Lack of clarity on approach, products, responsibilities for **CM [i.e., Technical Baseline Management]** – when does Government take control? CCB structure?
- Lack of complete and specific information on **Technical Reviews** – approach, chair, tailored entry/exit criteria, stakeholders/independent SMEs.
- Inadequate **Integrating SE** with other program plans/processes (e.g., Acquisition Strategy, IMS, EVM, Risk Management, production, sustainment/logistics)
- Lack of specifics as to **incentives/award fees** for good SE.
- Generic, not tailored, and vague **SE process** descriptions.



SEP *Bloopers* 😊

- “Task analyses conducted by *human and engineers* provide qualitative data to support”
- “Fifteen (15) trade studies are planned during the SDD phase. These trade studies are undefined at this time.”
- “Integrity is not an issue on the {Program}, because the program was put on contract during acquisition reform.”
- “The ... Program Manager and Systems Engineer monitor integration activities to ensure that the KPPs and the KSAs are *not* achieved.”
- “The ...communications are intended to support both the internal communications capabilities and external interfaces between the {Program} and *the rest of the world.*”
- “The {Program} technical reviews conducted during the PD and O&S phases are chaired by a *competent* person.”



System Acquisition Issues Identified and Captured



Next a summary of recent issues identified as they relate to SE activities:

- SE and SWE **issues** from NDIA-SE Workshops
- **Program Support Reviews** systemic analysis findings from ODUSD(A&T)SSE/Assessments and Support

We will list and compare similarities across these findings and SEP observations as they relate to the SE processes



NDIA-SE Top 5 Systems Engineering Issues



- Key SE effective **practices inconsistently** applied across all phases of the LC
- **Insufficient SE** applied **early** in program life cycle, compromising foundation for initial requirements and architecture development
- **Requirements not always well-managed**, e.g., ineffective translation of needed capabilities into executable requirements to achieve program success
- Quantity and quality of **SE expertise insufficient** to meet demands of government and defense industry
- **Collaborative environments**, e.g., SE tools, **inadequate** to effectively execute SE at joint capability, system of systems (SoS)*, and system levels.

**Significant note: issues relative to evolving acquisition strategies and environments were also a common theme. Although task group ultimately decided to capture these aspects as comments distributed across above 5 major issues, SoS issues are significant and in aggregate could be considered a “6th issue” added to this list.*

* From NDIA-SE task group; 2006 Full report can be found at <http://www.ndia.org>



NDIA-SE Top 7 Software Issues



1. The impact of **requirements** upon software is **not consistently quantified and managed** in development or sustainment.
2. Fundamental system engineering **decisions** are made **without full participation of software engineering**.
3. Software **life-cycle planning** and management by acquirers and suppliers is **ineffective**.
4. The quantity and quality of **software engineering expertise** is **insufficient** to meet the demands of government and the defense industry.
5. Traditional **software verification techniques** are **costly** and **ineffective** for dealing with the scale and complexity of modern systems.
6. There is a **failure to assure correct, predictable, safe, secure execution of complex software** in distributed environments.
7. Inadequate **attention** is given to total life cycle issues for **COTS/NDI** impacts on lifecycle cost and risk.

Source: NDIA Top Software Issues Workshop; August 2006; DOUSD(A&T)SSE/SSA



Top 10 Emerging Systemic Issues

[from ODUSD(A&T) Program Support Reviews; SSE Directorate, 8/07] (* specific to SE activities)



1. **Management**
 - IPT roles, responsibilities, authority, **poor communication**
 - **Inexperienced staff**, lack of technical expertise
2. **Requirements**
 - Creep/stability
 - **Tangible, measurable, testable**
3. **Systems Engineering**
 - Lack of a **rigorous approach**, technical expertise
 - **Process compliance**
4. **Staffing**
 - **Inadequate** Government program office staff
5. **Reliability**
 - Ambitious growth curves, **unrealistic requirements**
 - **Inadequate “test time”** for statistical calculations
6. **Acquisition Strategy**
 - Competing budget priorities, **schedule-driven**
 - Contracting issues, poor technical assumptions
7. **Schedule**
 - **Realism, compression**
8. **Test Planning**
 - Breadth, depth, resources
9. **Software**
 - Architecture, design/development discipline
 - **Staffing/skill** levels, organizational competency (process)
10. **Maintainability/ Logistics**
 - Sustainment costs not fully considered (short-sighted)
 - Supportability considerations traded

Major contributors to poor program performance



SE Issues Example Mapping – Management

(* SE processes with top issues – authors own)



| ISO/IEC 15288 | SE issues | SW issues | PSR findings | SEP observations |
|-------------------------------|--|---|---|---|
| Project Planning* | Inconsistent SE practices; insufficient early SE | Ineffective life cycle planning, estimation | IPT roles/ responsibilities; non rigorous SE approach; compressed schedule driven; coupling IMP/IMS/WBS | Incomplete; inconsistent; unclear responsibilities |
| Project Assessment & Control* | Inadequate tools | Ineffective management | Poor communication | see others |
| Measurement | | Requirements | | Usually little specifics (e.g., TPM allocations to IPTs) |
| Decision Management | | Key decisions made w/o SW participation | | Little details on who & how (other than IPTs communicate) |
| Risk Management* | | Inadequate re COTS/NDI | SE – SW integration | Lack of details, responsibility, risk mitigation |
| Configuration Management | | | | All key baselines not clearly defined; nor when transition to Government |
| Info. Mgt. | | | | |
| Acquisition & Supply | | Ineffective management | | Lack of SE specific incentives/award fees (sometimes too much responsibility deferred to Prime) |
| Project-Enabling processes* | Insufficient SE skills; inadequate collaborative environment | Insufficient SW engr. expertise; process compliance | Inexperienced, inadequate staff | |



SE Issues Example Mapping – Technical



(* SE processes with top issues –author’s own)

| ISO 15288 | SE issues | SW issues | PSR findings | SEP observations |
|-------------------------------------|--------------------------------|---|---|---|
| Stakeholder Requirements Definition | Not well managed or translated | | Poor definitions | |
| Requirements Analysis* | Not well managed or translated | Not consistently quantified & managed | Unrealistic reliability goals; test time | |
| Architectural Design | | | Poor technical assumptions; architecture design & development | |
| Implementation | | | | |
| Integration | | | | Lacks specifics on who & what re integrating elements, interfaces |
| Verification | | Costly & ineffective techniques for scale/ complexity | Test planning breadth / depth / resources inadequate | <i>(details would be from in TEMP reviews)</i> |
| Validation | | failure to assure proper execution | | Technical Reviews lack criteria, clear roles, participants |
| Transition | | | | Lacks details for Production & Deployment |
| Operations; Maintenance; Disposal | | | Sustainment / supportability lightly considered | Lacks details on O&S |



Total SE Capability vs. Project Performance

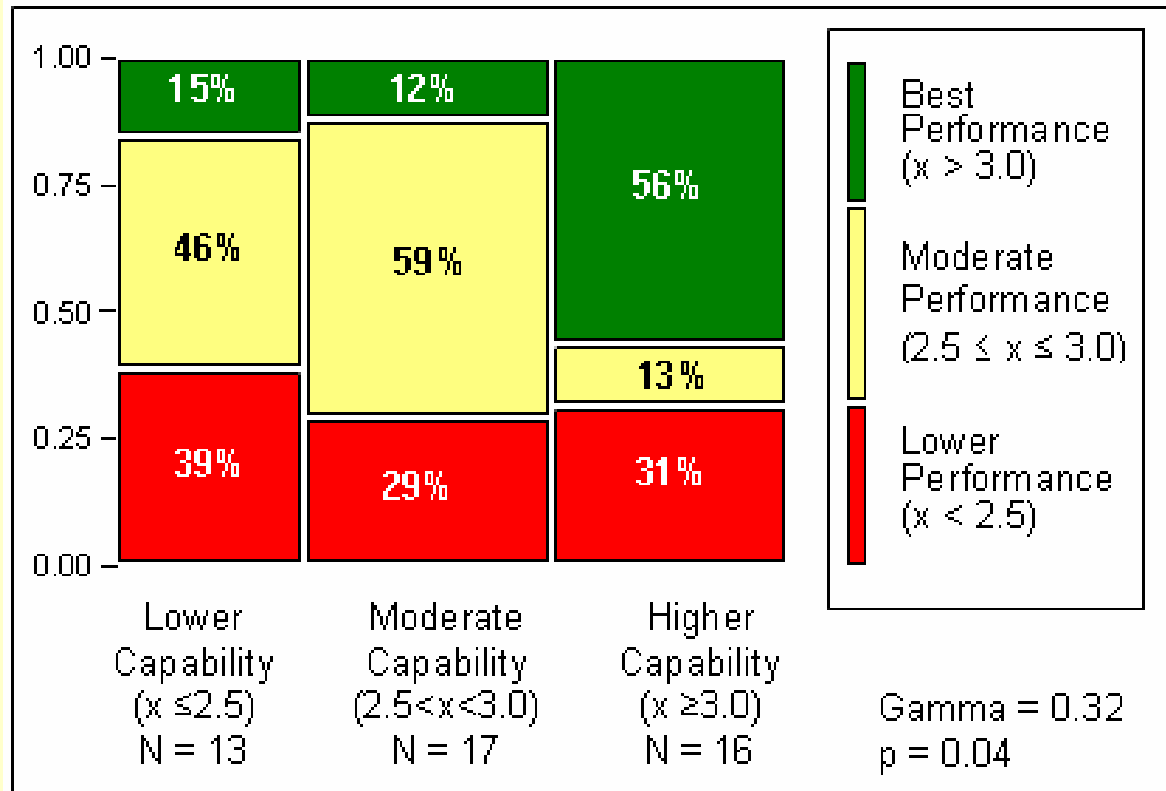

Source: "A Survey of Systems Engineering Effectiveness"
by: NDIA SEE Committee @INCOSE – Orlando
Chap. Geoff Draper, February 28, 2008

Projects with better Systems Engineering Capabilities deliver better Project Performance (cost, schedule, functionality)



Wrap Up

DoD and NDIA are already addressing some key issues, e.g.,

- SE technical planning guidance to program SE WIPTs
- Defense Acquisition Program Support (DAPS) Methodology update (for PSRs)
- SoS guide
- Engineering for System Assurance guide
- DT&E guide
- Updated DAG based on new DOD Acquisition Management Policy (DoDI 5000.2) and ISO 15288,
- Some SW Engineering focus areas (WBS, estimation,...)
- University affiliated SE research program
- DAU SE courses and Certification



Backups



- SE “V” for MS B: SD&D phase
- ISO/IEC -12207 Software life cycle process
- IEEE - 1220: SE Process
- EIA - 632: Processes for Engineering a System
- INCOSE SE Handbook – Planning Process example
- DoD’s Acquisition Life Cycle: Old vs *New*
- Early SE Initiation
- Acronyms
- References
- Links



ISO/IEC 12207:2008 : Software life cycle processes (*changes in red)

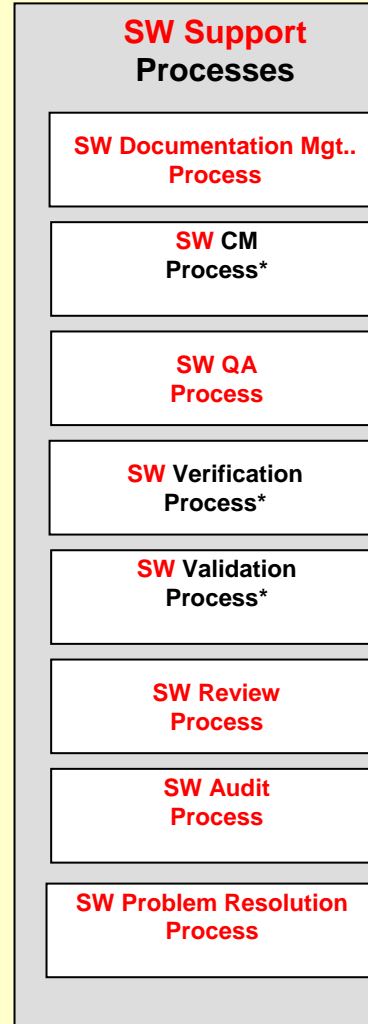
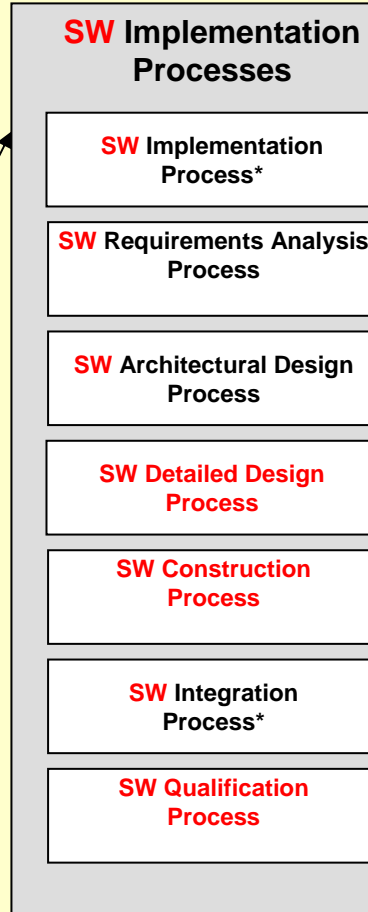
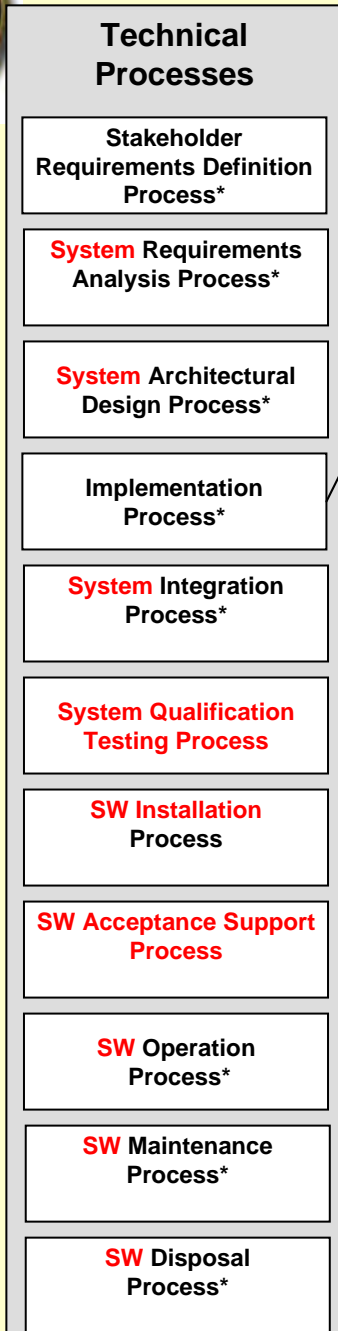

SW Reuse Processes:

- Domain Engineering
- Reuse Asset Mgt..
- Reuse Program Mgt..

Note: Agreement , Organizational Enabling, and Project processes are essentially the same as ISO/IEC 15288

** Implies SW similar to SE*

Source: IEEE Std 12207-2008



Clause 4 - General Requirements

1. SE process
2. Policies & procedures for SE
3. Planning the technical effort:
4. Development strategies
5. Modeling & prototyping
6. Integrated repository: data, tools.
7. Integrated data package: HW, SW
8. Specification tree
9. Drawing tree
10. System breakdown structure
11. Integration of the SE effort: concurrent engr., Int. teams
12. Technical reviews
13. Quality management
14. Product and process improvement: re-engineering, self-assessment, Lessons

Note: Standard includes detailed flows for each activity; and an example SEMP table of contents

Clause 6 – The SE Process

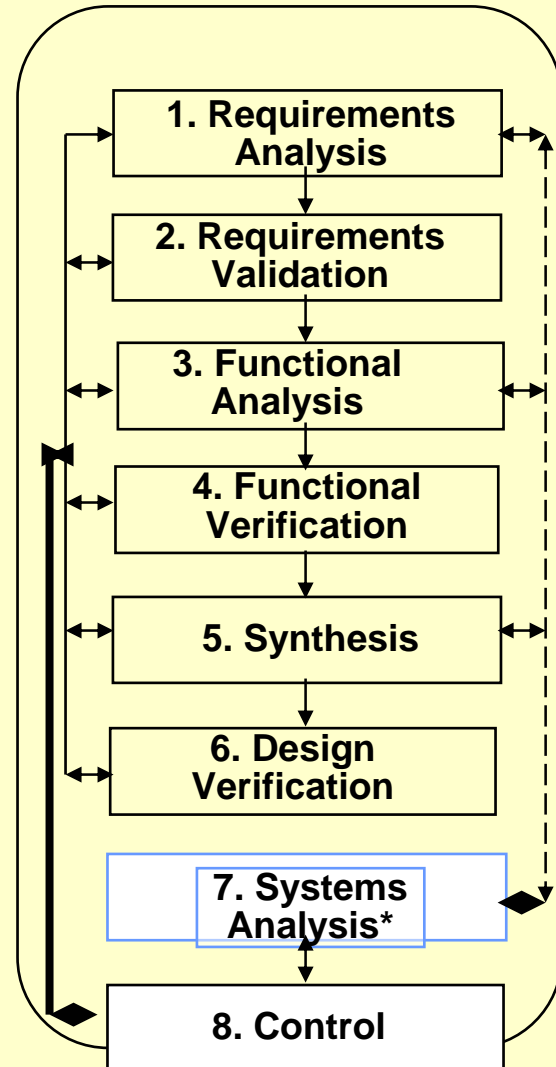

* Requirements/
Functional
/Design
trade
studies &
assess-
ments



EIA - 632: Processes for Engineering a System (1999; reaffirmed 2003)



(Source: INCOSE SE Handbook v2)

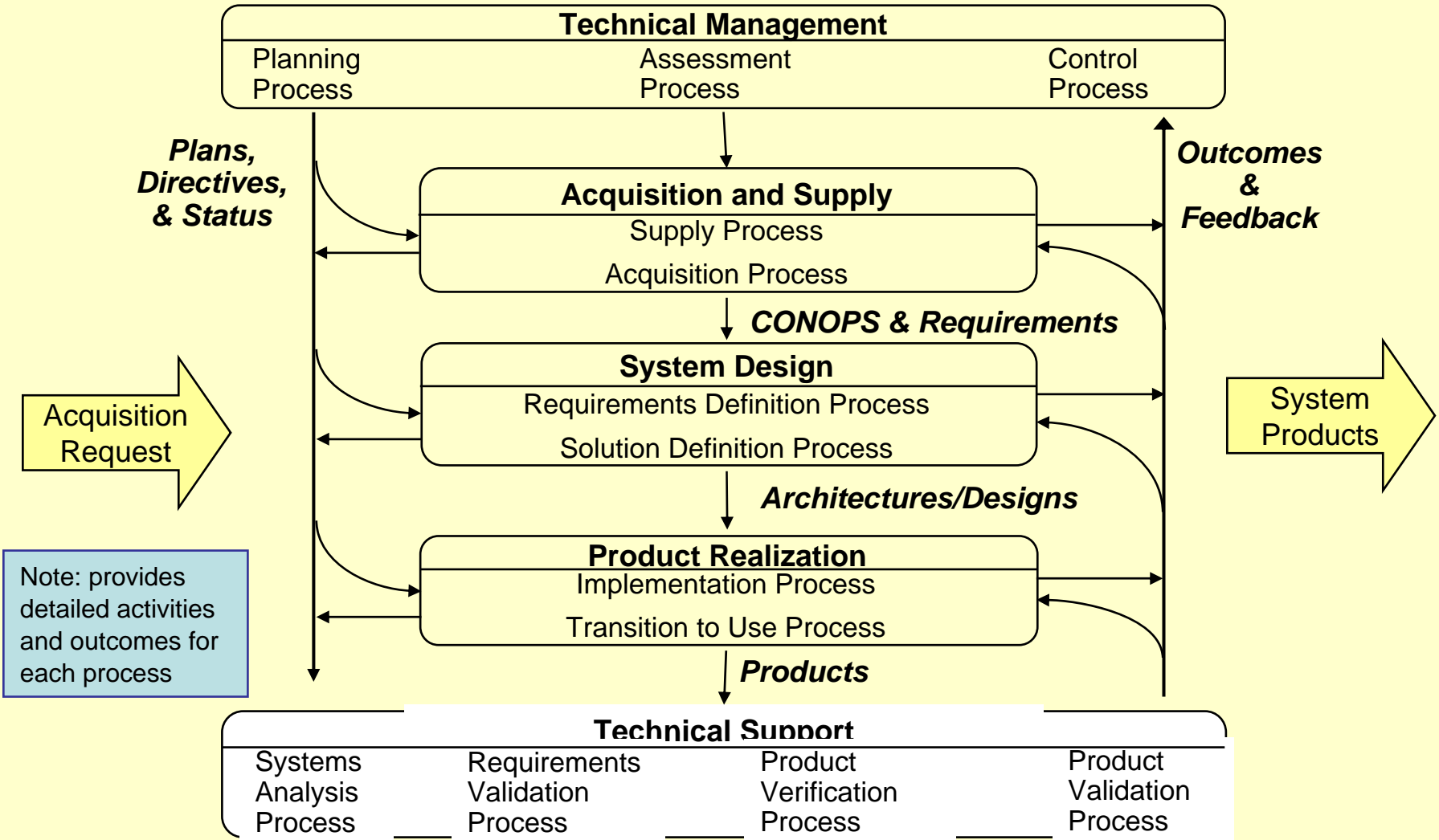

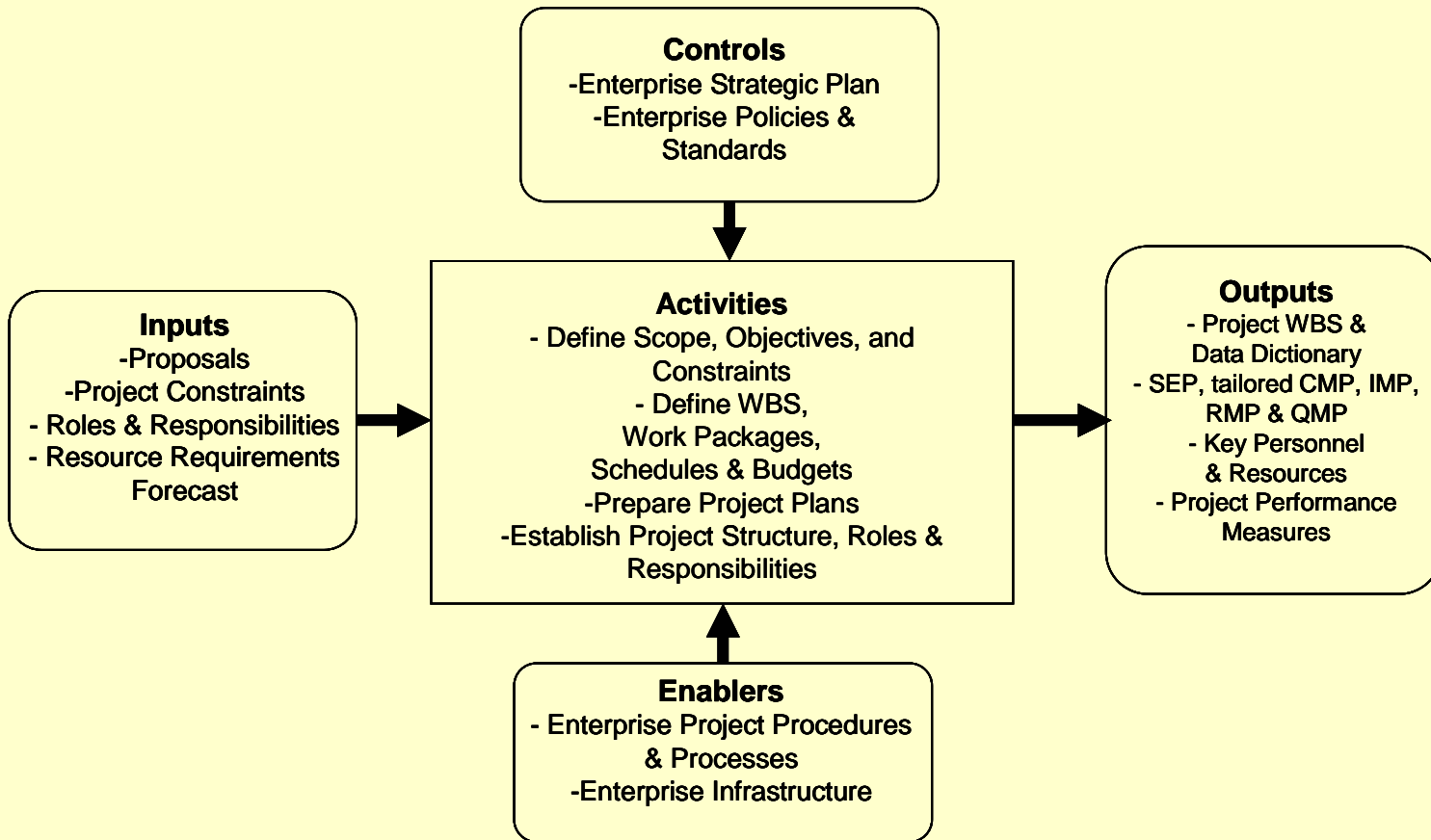

Figure 5-2 Context Diagram for the Project Planning Process

Note: Handbook is based generally on ISO 15288: 2002; will be updated to be in sync with 2008 version

Source: INCOSE SE Handbook v3.1



DOD's Acquisition Life Cycle: Old vs New



Old Life Cycle

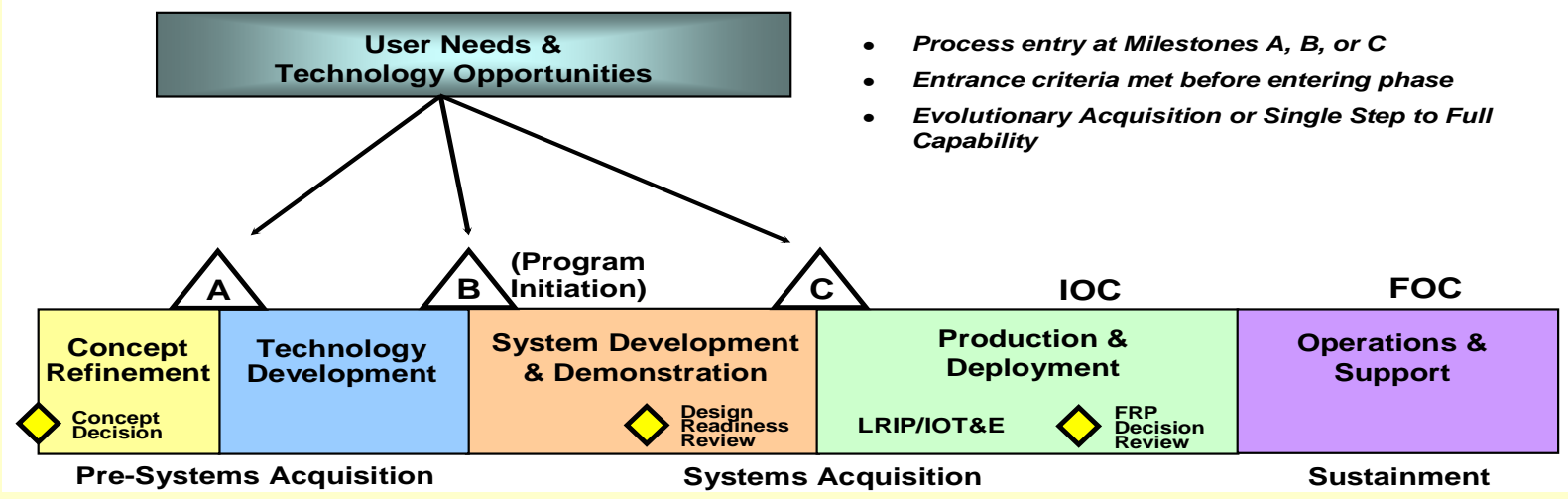

New Life Cycle

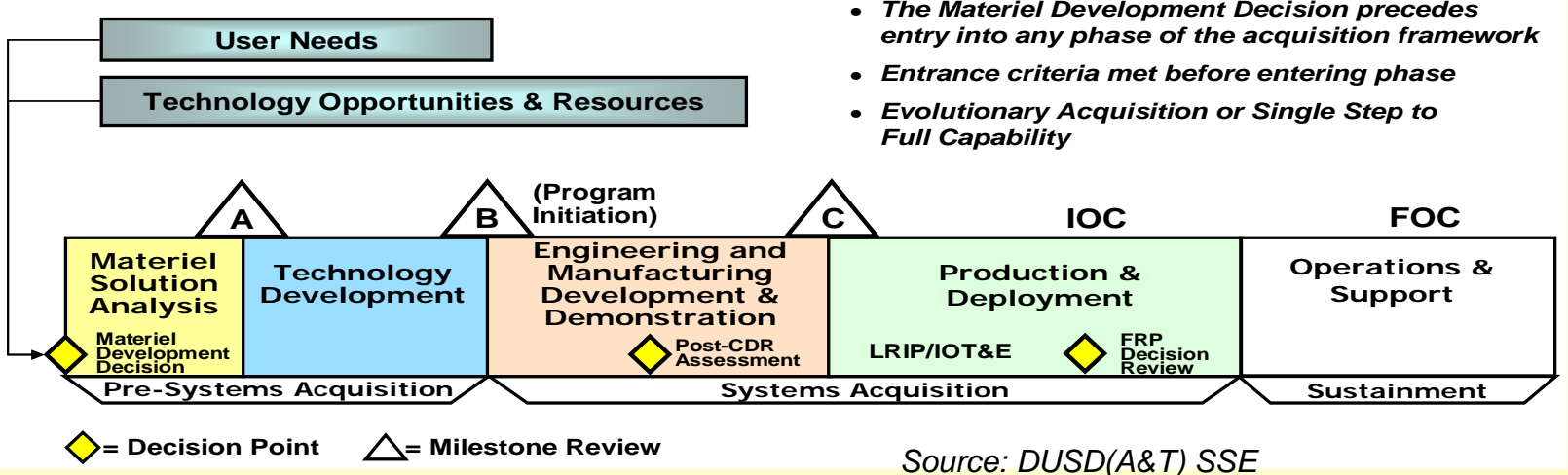

Source: DUSD(A&T) SSE



SE Provides a Technical Foundation for Acquisition *(based on new DoD Acquisition Policy)*

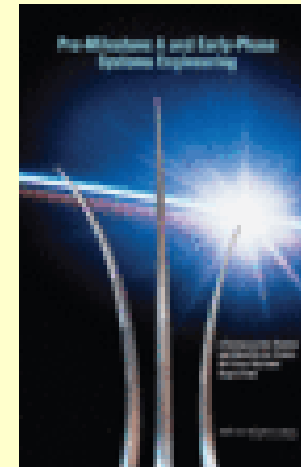
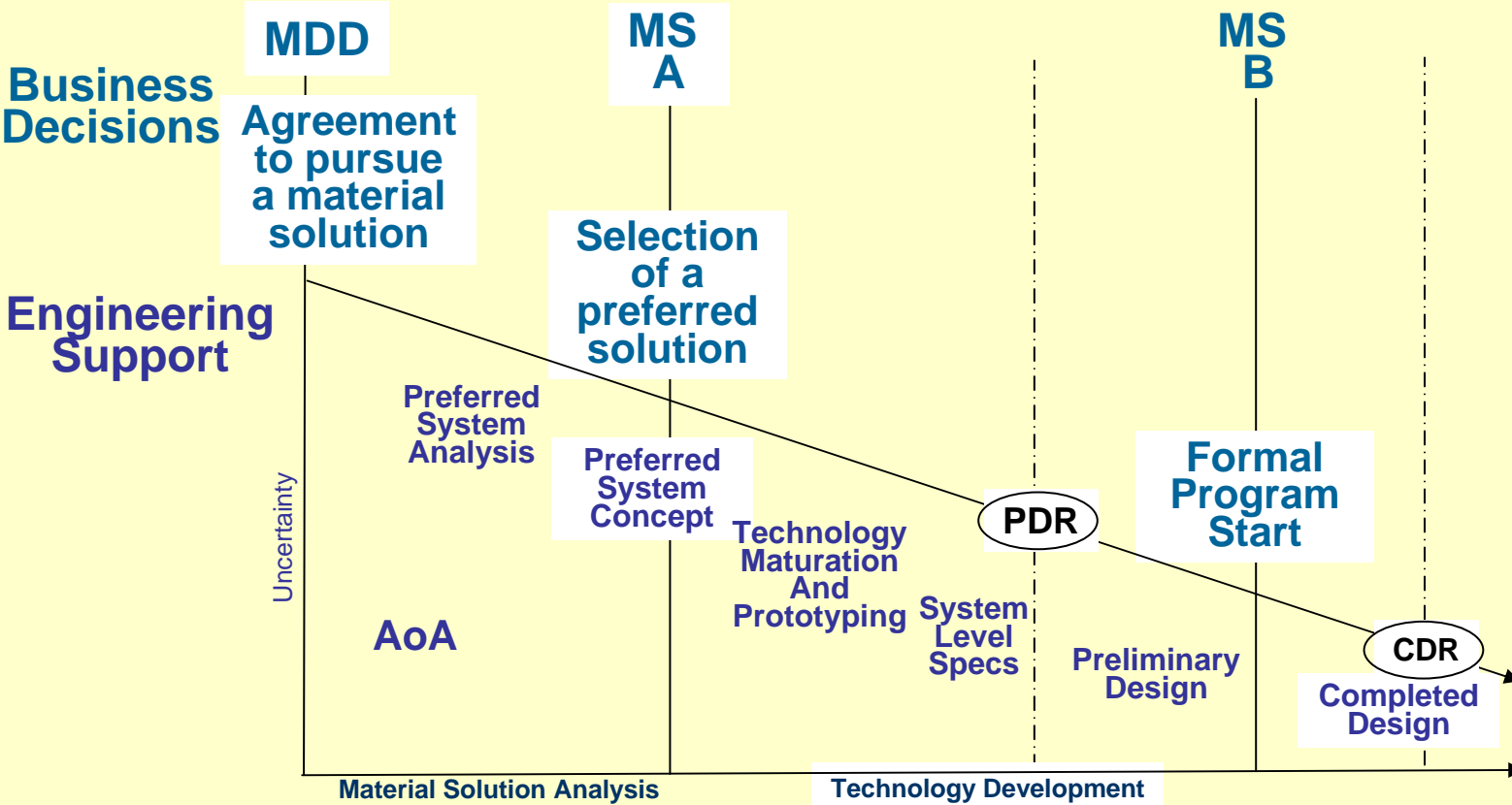

Source:
National Research Council

“Pre-Milestone A and Early-Phase Systems Engineering”
Jan 2008

Systems Engineering is most effective when it is initiated early to start a program right!



Acronyms/Definitions



- A&T – Acquisition and Technology [@ODUSD]
- ANSI – American National Standards Institute
- CMP – Configuration Management Plan
- DAG – Defense Acquisition Guidebook
- DAU – Defense Acquisition University
- DoD – U.S. Department of Defense
- DoDI – DoD Instruction
- EIA – Electronic Industries Alliance
- FRP – Full Rate Production
- GEIA – Government Electronics and Information Technology Association
- IEC – International Electrotechnical Commission
- IEEE – Institute for Electrical and Electronics Engineers
- INCOSE – International Council on Systems Engineering
- IOT&E – Integrated Operational Test & Evaluation
- IMP/IMS – Integrated Master Plan/Integrated Master Schedule
- ISO – International Standards Organization
- IOC – Initial Operating Capability
- IT – Information Technology
- LRIP – Low Rate Initial Production
- NDIA – National Defense Industries Association [SE division]
- PMI – Project Management Institute
- PSR – Program Support Review
- QA – Quality Assurance
- QMP – Quality Management Plan
- RMP – Risk Management Plan
- SE – Systems Engineering
- SEE – SE Effectiveness
- SEI – Software Engineering Institute [@Carnegie Mellon U.]
- SEMP – SE Management Plan
- SEP – Systems Engineering Plan
- SoS – System of Systems
- SSCI – Systems and Software Consortium
- SSA – Software Engineering and Systems Assurance
- SSE – Systems & Software Engineering Directorate [@ODUSD (A&T)]
- SW - Software
- SWE – Software [SW] Engineering



Some SE Related Process References



- **CMMI® – ACQ**: SEI/CMU, 11/07
- **Defense Acquisition Guidebook**, Chapter 4 - Systems Engineering; Defense Acquisition University, 2004 (*soon to be updated*)
- **EIA/IS - 632: 1998** - Processes for Engineering a System
- **IEEE 1220: 2005** Application and Management of the Systems Engineering Process
- **IEEE/EIA 12207: 2007** (adopted ISO/IEC 12207:2007)
- **INCOSE** Systems Engineering Handbook, v3.1; 8/2007
- **ISO/IEC 15288: 2007** System Engineering – System Life Cycle Processes
- NDIA **SE Effectiveness** (SEE) Study; 2008
- **Understanding and Leveraging a Supplier's CMMI Efforts**; ODUSD(A&T)SSE, 2007



Other References and Links



Some References:

- “Special Feature: Standards in Systems Engineering”, **INCOSE Insight** , April 2007 (see particularly K. Crowder, D. Kitterman, T. Doran, R. Harwell, and S. Arnold articles)
- CMMI – Next Steps; Kristen Baldwin, ODUSD(A&T)SSE/SSA, CMMI technology Conference; November, 2007
- “Harmonization of Systems and Software Engineering Processes”, James W. Moore; Mitre; June, 2007, brief for ASQ-DC meeting
- Issue on Systems Engineering, **CROSSTALK**, STSC, October 2007

Links:

- ANSI/EIA-632: <http://www.geia.org/index.asp?bid=552>
- CMMI: <http://www.sei.cmu.edu/cmmi/>
- DAU-DAG: <http://akss.dau.mil/dag/>
- IEEE - <http://www.ieee.org/web/standards/home/find.html>
- INCOSE – Standards site: <http://www.incose.org/practice/techactivities/standards.aspx>
- INCOSE Guide to SE BoK: <http://g2sebok.incose.org/>
- ISO: http://www.iso.org/iso/iso_catalogue.htm [look for ISO/IEC 15288, 12207]
- NDIA-SE: <http://www.ndia.org/Template.cfm?Section=Divisions> [then select SE]
- ODUSD (A&T) SSE: <http://www.acq.osd.mil/sse/>

A CONTINUOUS PROCESS VIEW OF SYSTEMS ENGINEERING FOR THE SUSTAINMENT PHASE

By: Paul Ratke

US Air Force

Oklahoma City Air Logistics Center

IT'S JUST ME

The views and opinions presented here are the author's. They are not necessarily representative of any official position of the US Government or any of its organizations.

What's this about?

- The acquisition lifecycle framework shows sustainment as a small and somewhat linear part of the lifecycle.
- An alternative view is useful to aid understanding of the sustainment phase.

Where is this going?

- Why have alternative views?
- What are the current views?
- What is the alternative view?
- What do we do with it?

Why have alternative views?

- ⦿ Different vantage points
- ⦿ “Pre-sustainment” phases emphasized
- ⦿ There is much to be gained

Why have alternative views?

(Different Vantage Points)

- ⦿ People have:
 - Different backgrounds
 - Different situations
 - Different understanding

- ⦿ Example:
 - Accident witnesses

Why have alternative views?

(Different Vantage Points)



What Did YOU See?

Why have alternative views?

(Different Vantage Points)



What Did YOU See?

Why have alternative views?

(Different Vantage Points)



What Did YOU See?



Why have alternative views?

(Different Vantage Points)

What Did YOU See?



Why have alternative views?

(Different Vantage Points)

- ⦿ Look at all sides of the issue
- ⦿ Different views ring with different people
 - Different backgrounds
 - Different situations
 - Different understanding
- ⦿ Both of these can clarify the common view

Why have alternative views?

(Different Vantage Points)

● Example: 2×3

• 1. Memorize it. $=6$

• 2. Explain it as $2+2+2$ or 

• 3. Explain it as $3+3$ or 

• 4. Explain it as

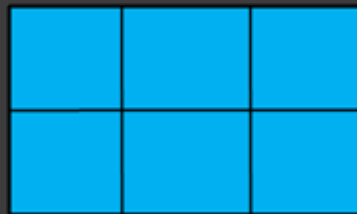

Why have alternative views?

(Different Vantage Points)

- ◎ Systems Engineering is loaded with many view points
 - Role (Government, Contractor)
 - Mission
 - Etc
 - Etc
 -Position in Life Cycle!.....

Why have alternative views?

(“Pre-Sustainment” Phases emphasized)

- LCSE, “Life-cycle”
- In vogue to say it
- Hard to grasp!
- Harder to do!!
- There are reasons to focus on early phases
- Where is SUSTAINMENT? – an example

Why have alternative views?

("Pre-Sustainment" Phases emphasized)

◎ DAU SYS302

- Capstone SE Leadership Course
- 80 Hrs, Six Team Exercises – Nice Course
 - Entry into Acquisition
 - Requirements Development
 - Technical Organization
 - Technical Baselines and Earned Value
 - Technical Reviews
 - Transition to Production

Why have alternative views?

("Pre-Sustainment" Phases emphasized)

- ⦿ Reasons ---
- ⦿ Start at the beginning
 - Hard to start at end, etc
- ⦿ Concept, Design, Mfg – \$1, \$10, \$100
- ⦿ These are good reasons!

Why have alternative views?

(Much to be gained)

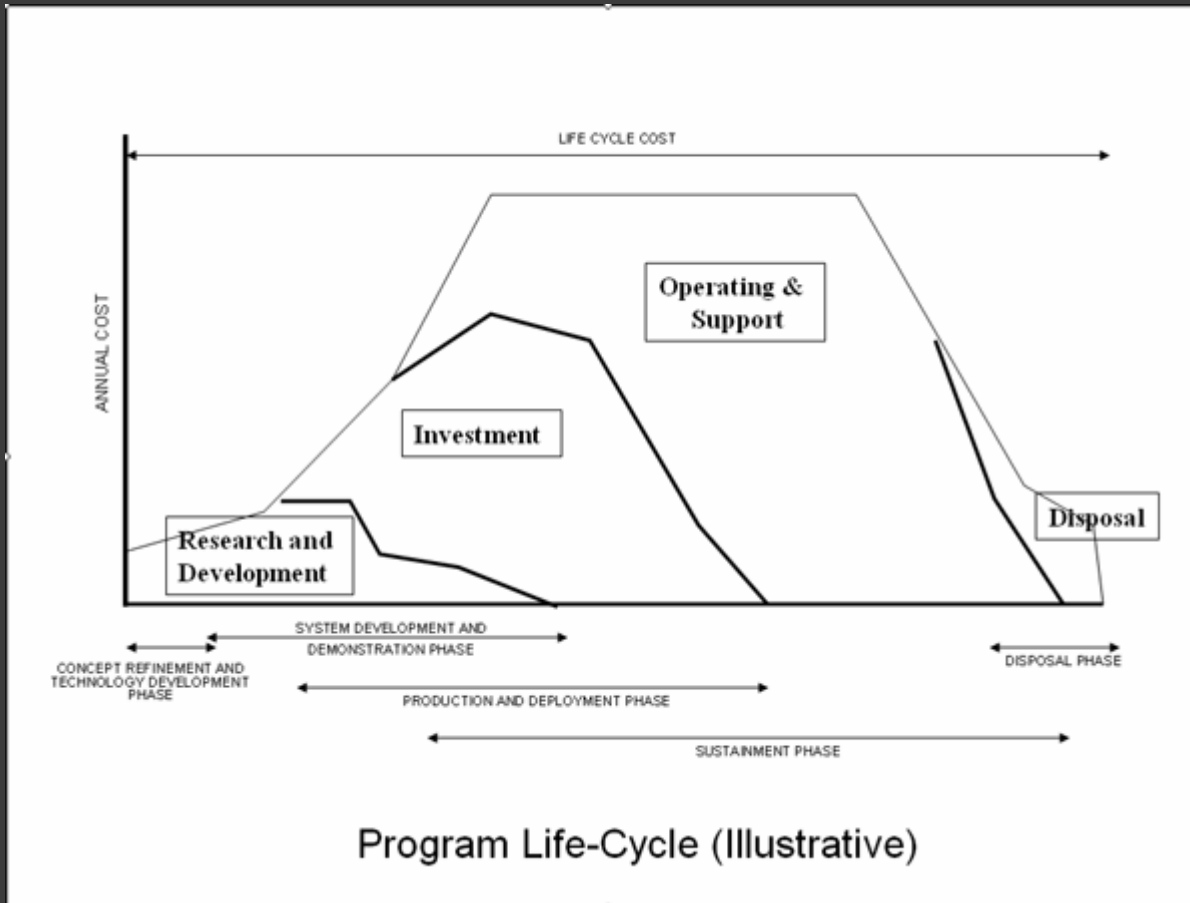

Why have alternative views?

(Much to be gained)

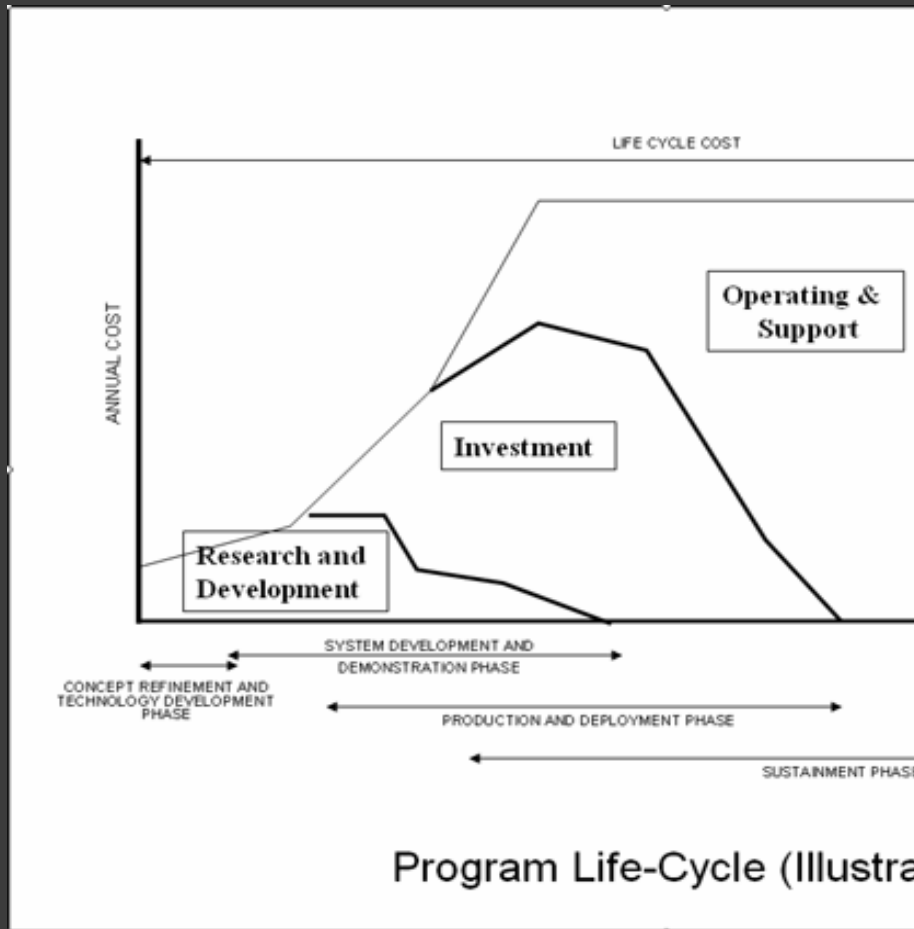

Why have alternative views?

(Much to be gained)

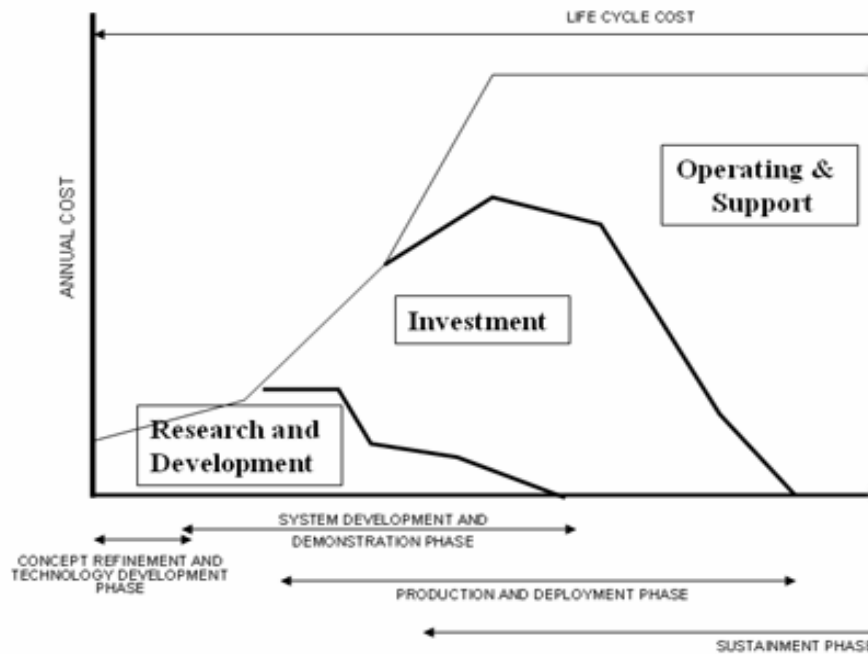

Program Life-Cycle (Illustration)

Why have alternative views?

(Much to be gained)

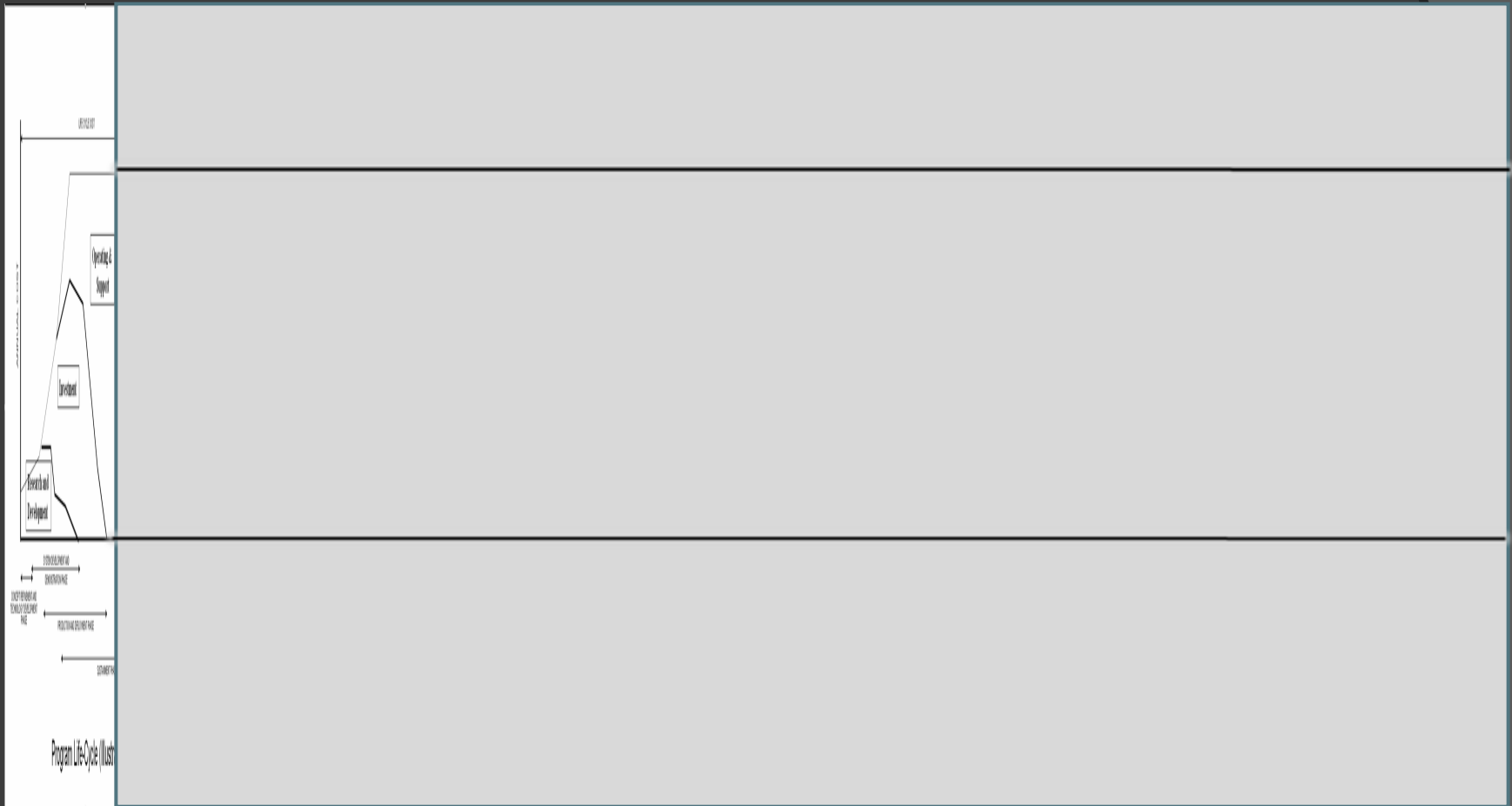

Why have alternative views?

(Much to be gained)

- ◎ \$1, \$10, \$100 – Concept, Design, Mfg
 - What about cost in operation? – 1000?
 - Fuel, Parts, Mission loss
- ◎ Future program avoidance \$!
 - Ability to Modify – ‘Modifiability’ as an ‘-ility’
 - B-58 & F-111 – avoid B-1?
 - KC-135 – avoid KC-next?

Where is this going?

- Why have alternative views?
- What are the current views?
- What is the alternative view?
- What do we do with it?

What are the current views?

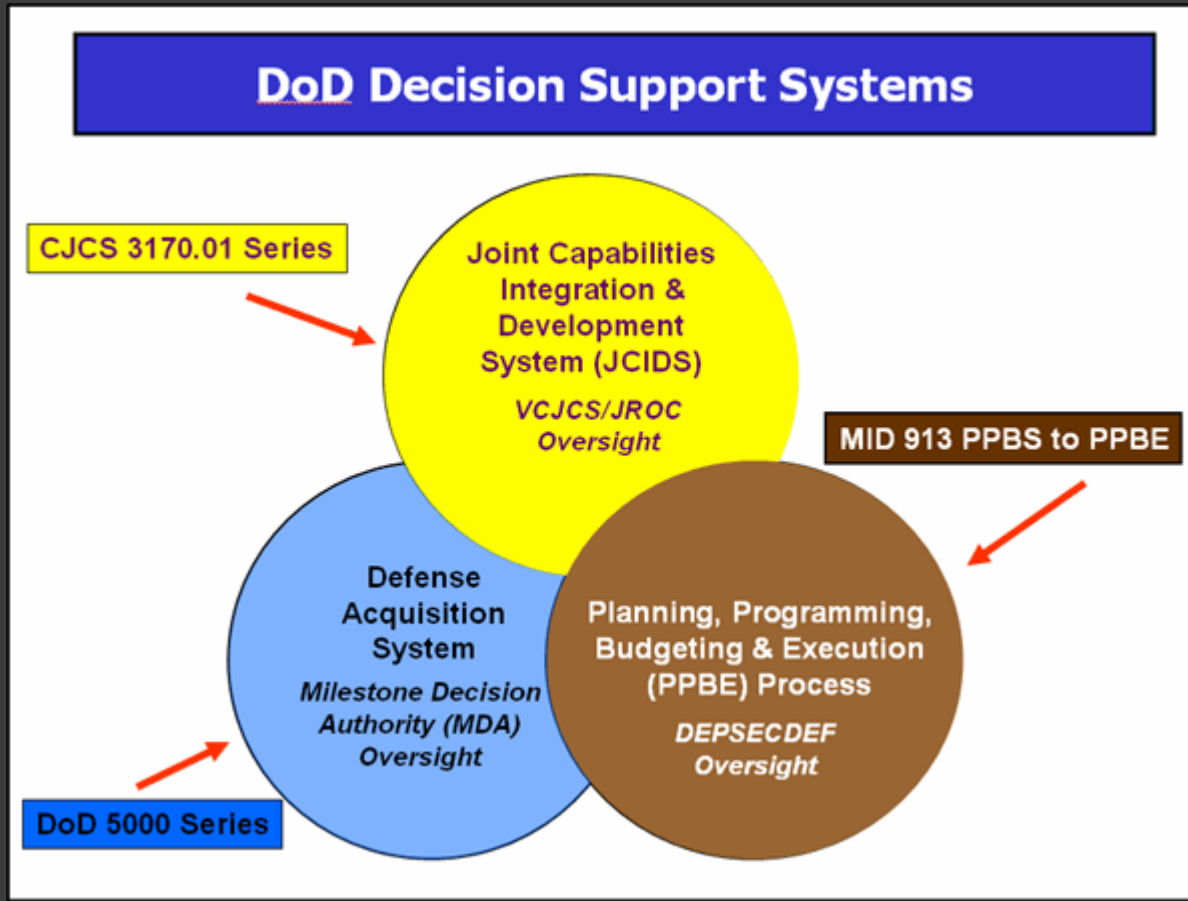

What are the current views?

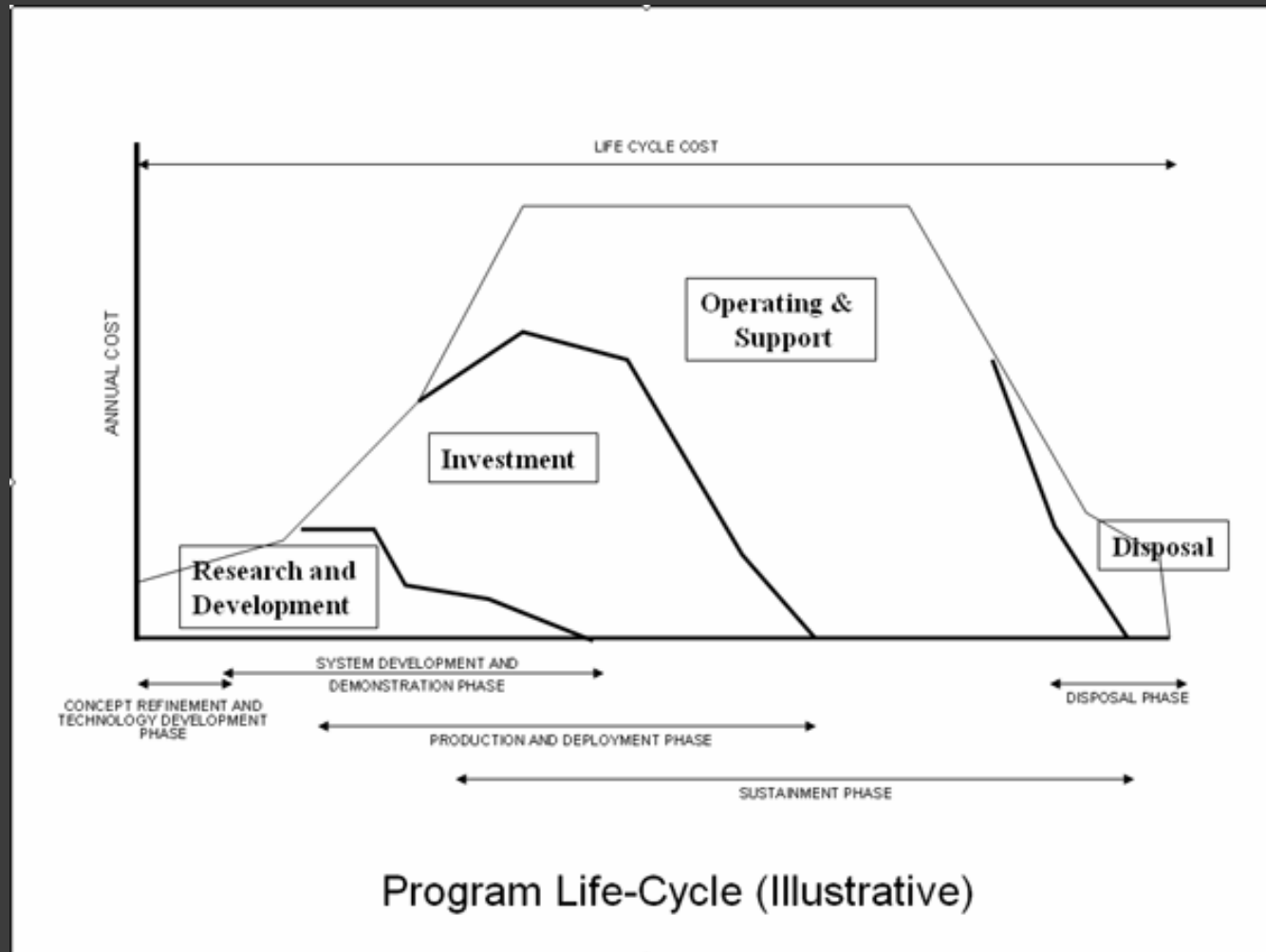

What are the current views?

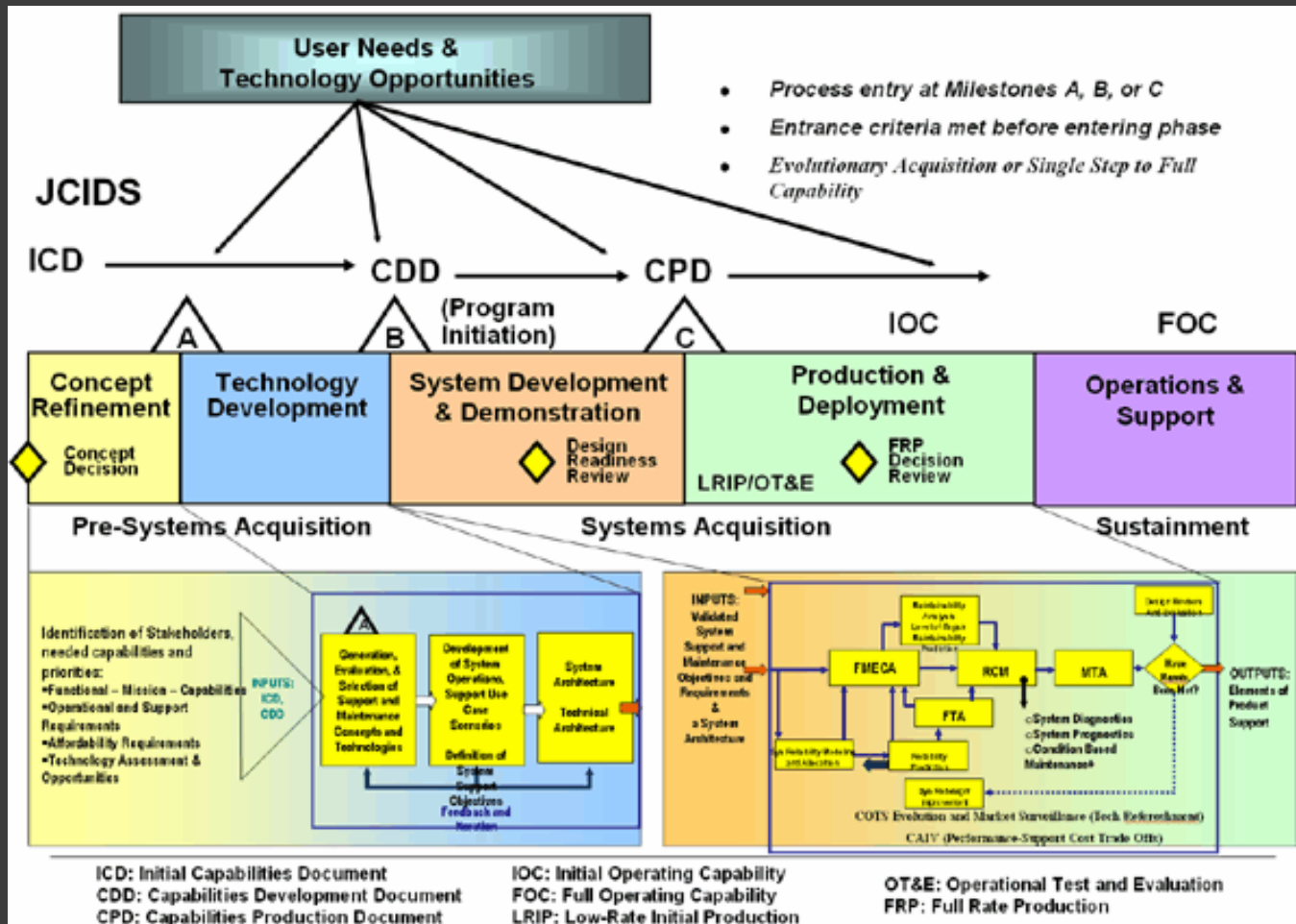

What are the current views?

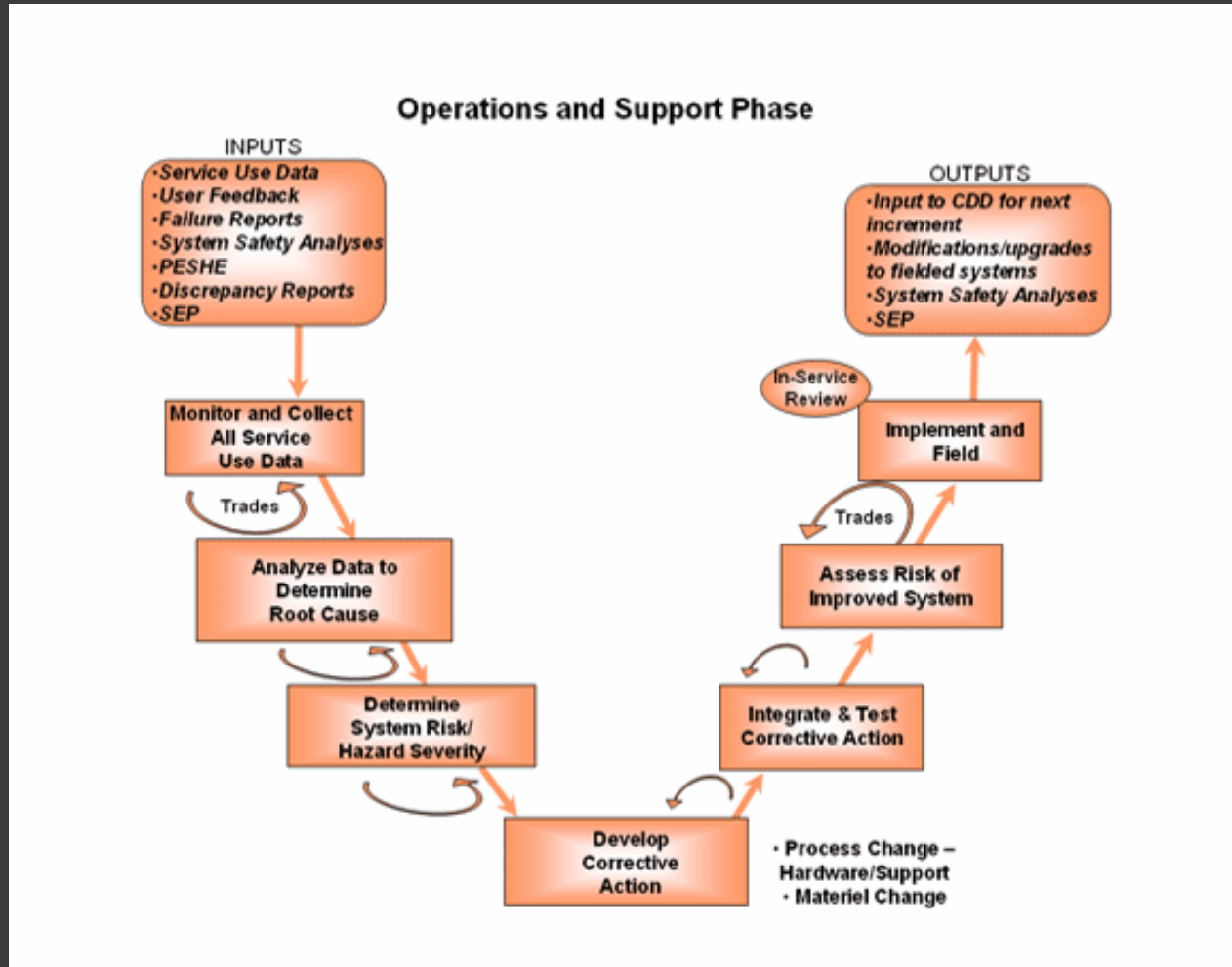

What are the current views?

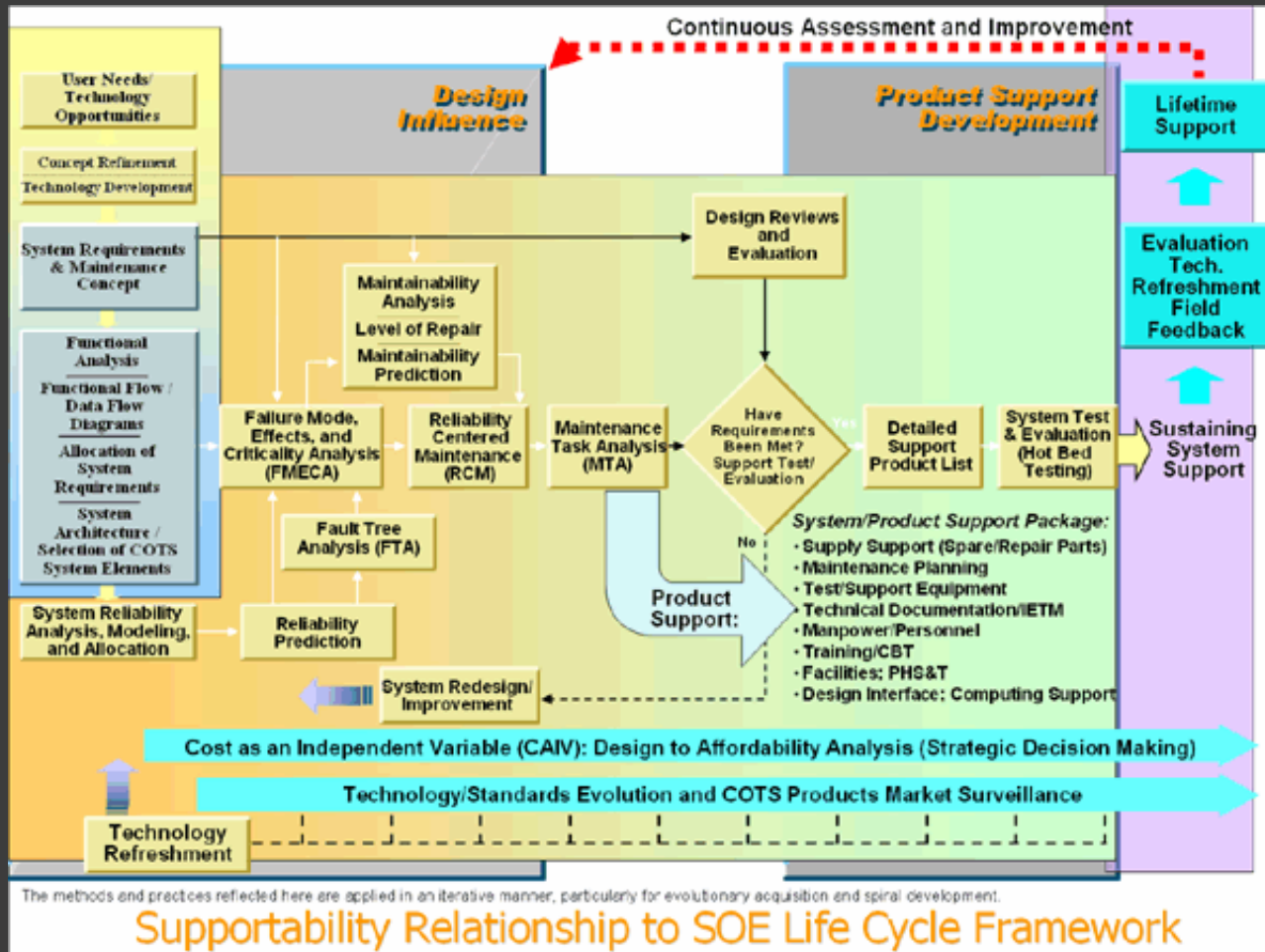

Where is this going?

- Why have alternative views?
- What are the current views?
- What is the alternative view?
- What do we do with it?

What is the alternative view?

- Utility Curve view
- Utility is “the state of being useful”
- Consider all the operational “usefulness” as the system’s “Utility”
- Consider what the user needs to be the “Need”

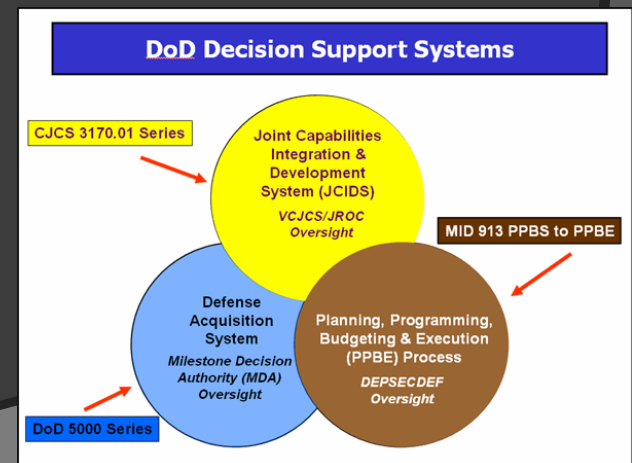

What is the alternative view?

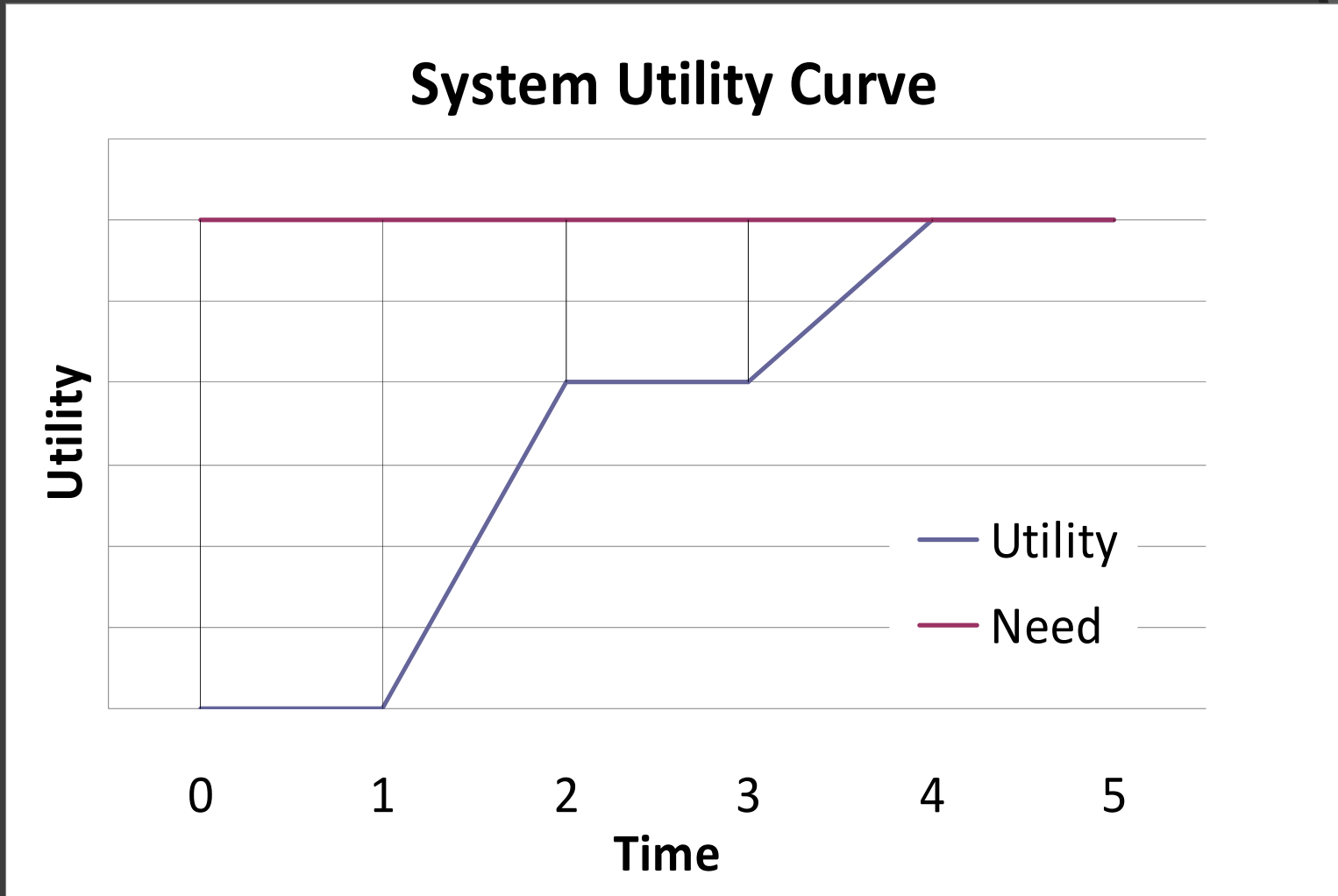

What is the alternative view?

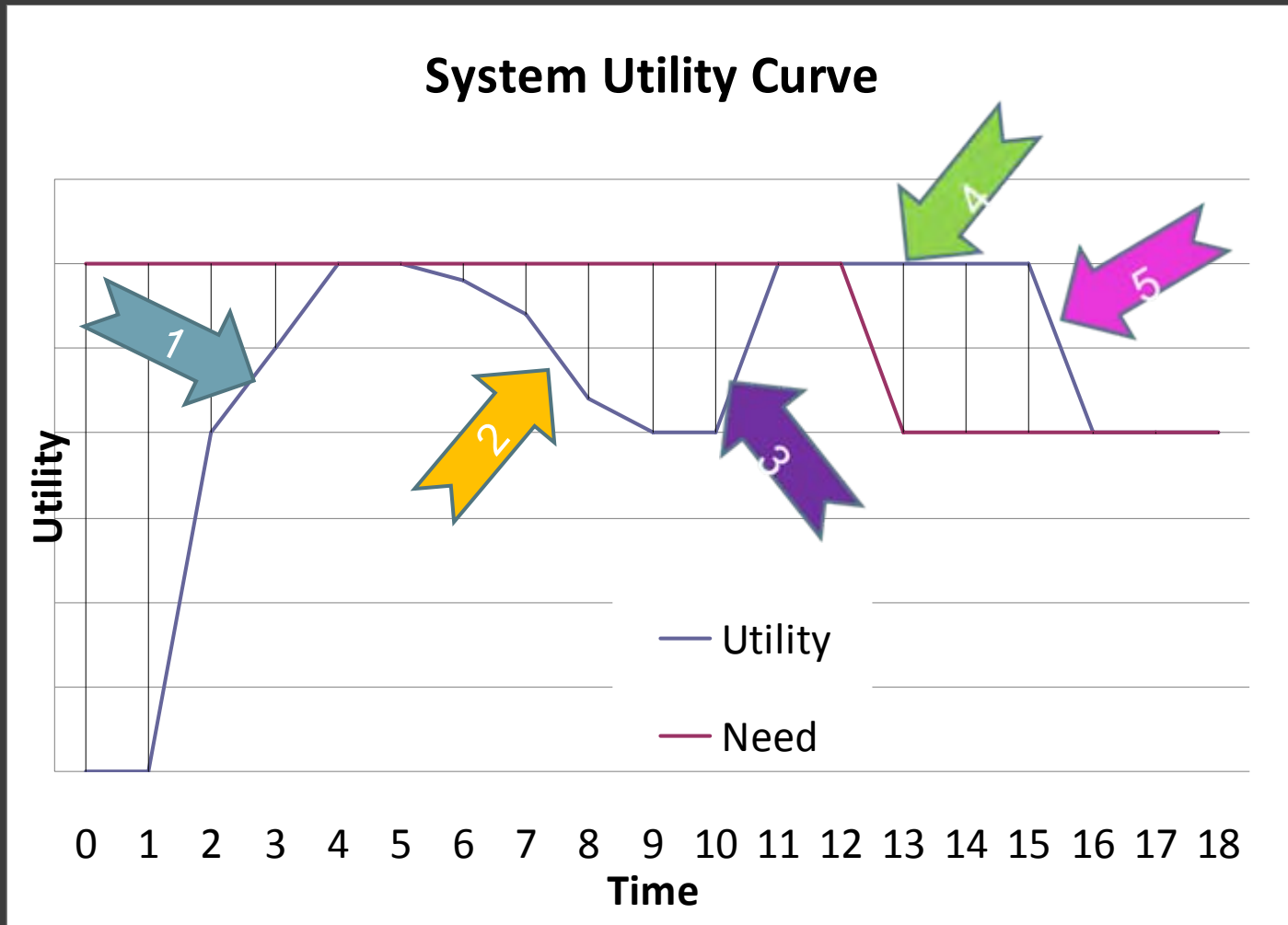

What is the alternative view?

- ⦿ DAG – Chp 5 indicates iterative monitoring
- ⦿ SE not once and done
- ⦿ When Utility does not match Need
 - Either- Effect a ‘non-material’ change
 - Or- Begin the modification process
- ⦿ Need an iterative engine during sustainment

What is the alternative view?

Utility Curve Engine for Sustainment

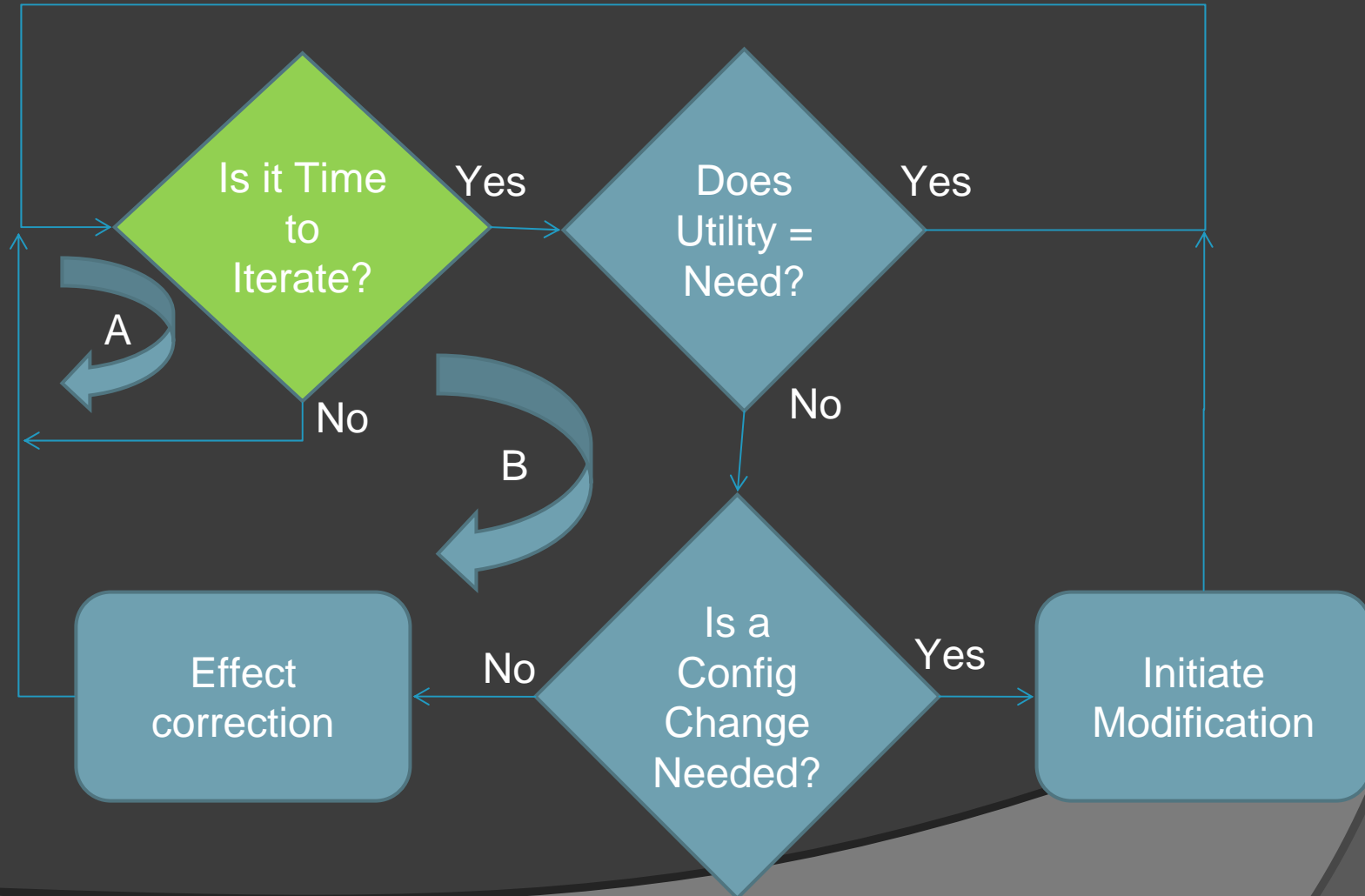

Where is this going?

- Why have alternative views?
- What are the current views?
- What is the alternative view?
- What do we do with it?

What do we do with it?

- ⦿ A different point of view?
- ⦿ How are we answering these questions?
- ⦿ What drives the cycle to start?
- ⦿ Do we know the current 'Need?'
- ⦿ Do we know the current 'Utility?'
- ⦿ How complete are our answers to these?

What do we do with it?

- BIG QUESTION

- What can we do to improve our answers?

Where have we been?

- Why have alternative views?
- What are the current views?
- What is the alternative view? – Utility Curve
- What do we do with it?

QUESTIONS?

The logo for LMI Government Consulting features the letters 'LMI' in a large, white, serif font. A small orange wave-like graphic is positioned above the 'I'. Below the letters, the words 'GOVERNMENT CONSULTING' are written in a smaller, white, sans-serif font.

GOVERNMENT CONSULTING

THE OPPORTUNITY TO MAKE A DIFFERENCE HAS NEVER BEEN GREATER

Progress Toward the Development of a Reliability Investment Cost Estimating Relationship

James A. Forbes, PhD, Deceased

E. Andrew Long

October 2008

Overview and Outline

- Background
- Development of model
 - Basic model
 - Intermediate model
 - Production/support cost model
- Summary and conclusions
- Next steps and future work



Work Sponsored by:

- Director of Operational Test and Evaluation
- Deputy Director, Assessments and Support, Systems and Software Engineering
- Deputy Under Secretary of Defense (Logistics and Materiel Readiness)

Although the support of the sponsors is gratefully acknowledged, positions expressed are those of LMI Government Consulting, and not official positions of the sponsors.



Study Objective and Approach

OBJECTIVE: Mathematical model that can be used to *predict the investment* in reliability required to achieve a given amount of *reliability improvement*

APPROACH: Four sub-models developed in three phases

Phase I

Empirical Research

- Investigate empirical relationships between reliability investment and life-cycle support costs

Phase II

A. Basic Model

- Develop investment/reliability improvement CER

B. Intermediate Model

- Develop model to determine effort and cost of reliability engineering process
- Develop production and support cost model

Phase III

Detailed Model

- Develop model that includes detail on cost drivers and impacts of engineering quality



Nov 06

Sep 07

Aug 08

Phase I (Empirical Research)

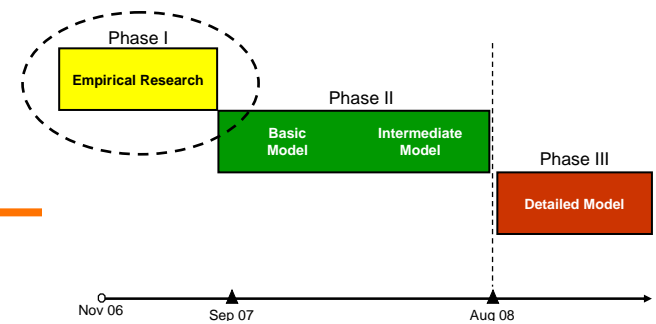

- Developed a preliminary relationship between investment in reliability (normalized by average production unit cost) and achieved reliability improvement
- Also, found that:
 - Generally, programs significantly improved system reliability with investment, though
 - under-investment in reliability may be large
 - Reliability goals, although established and articulated in operational requirements documents, do not appear to be driving either management or engineering effort

Phase IIA (Basic Model)

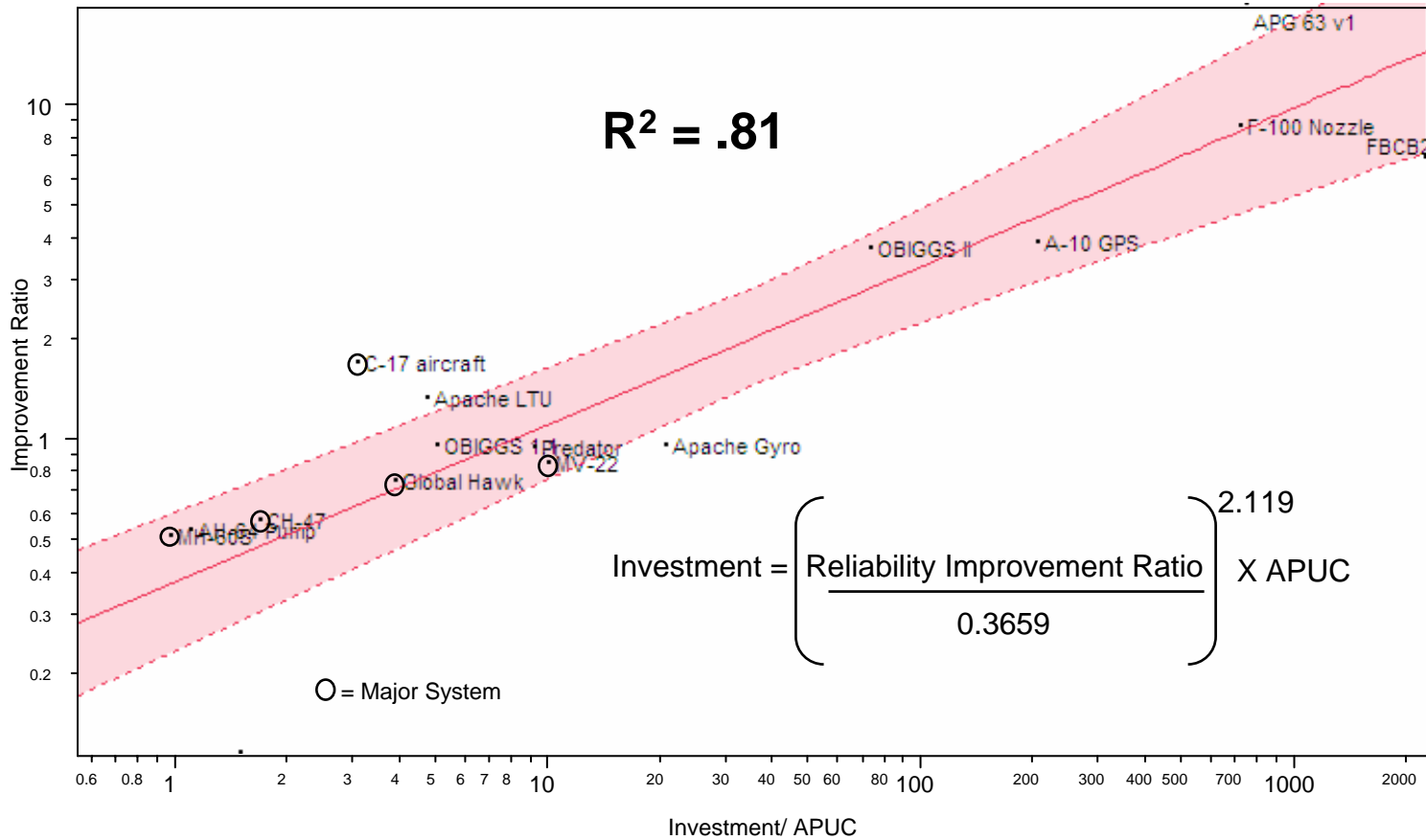
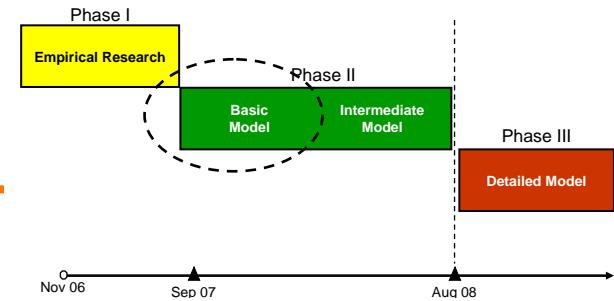

Phase IIB (Intermediate Model)

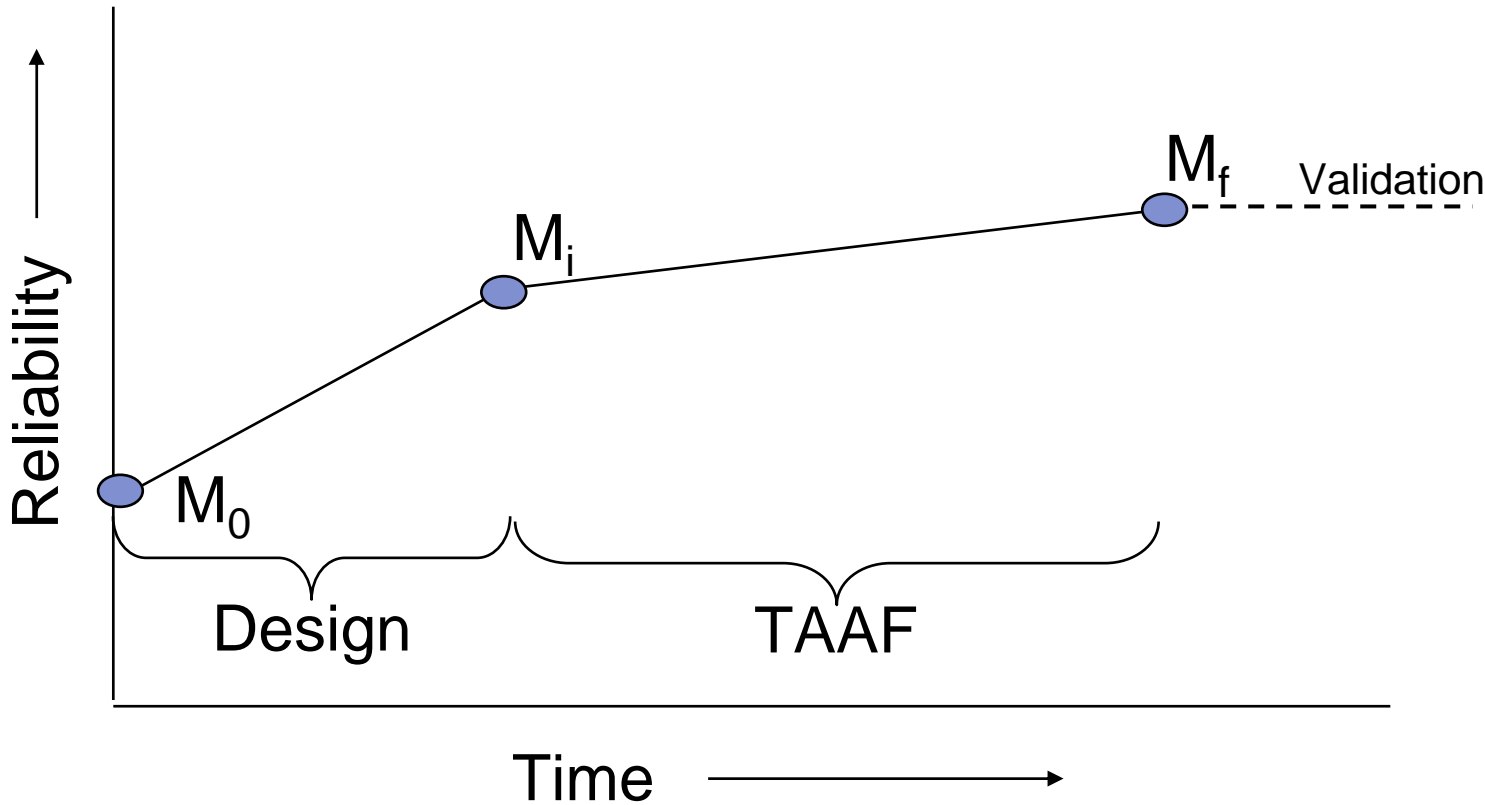
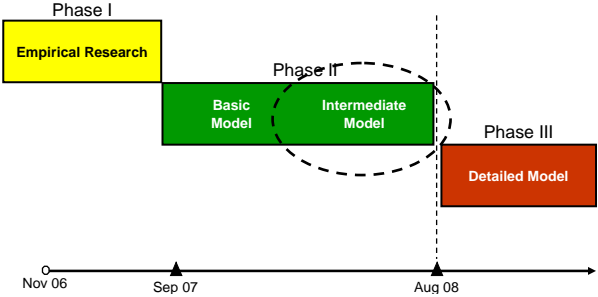

TAAF Period Equation Development

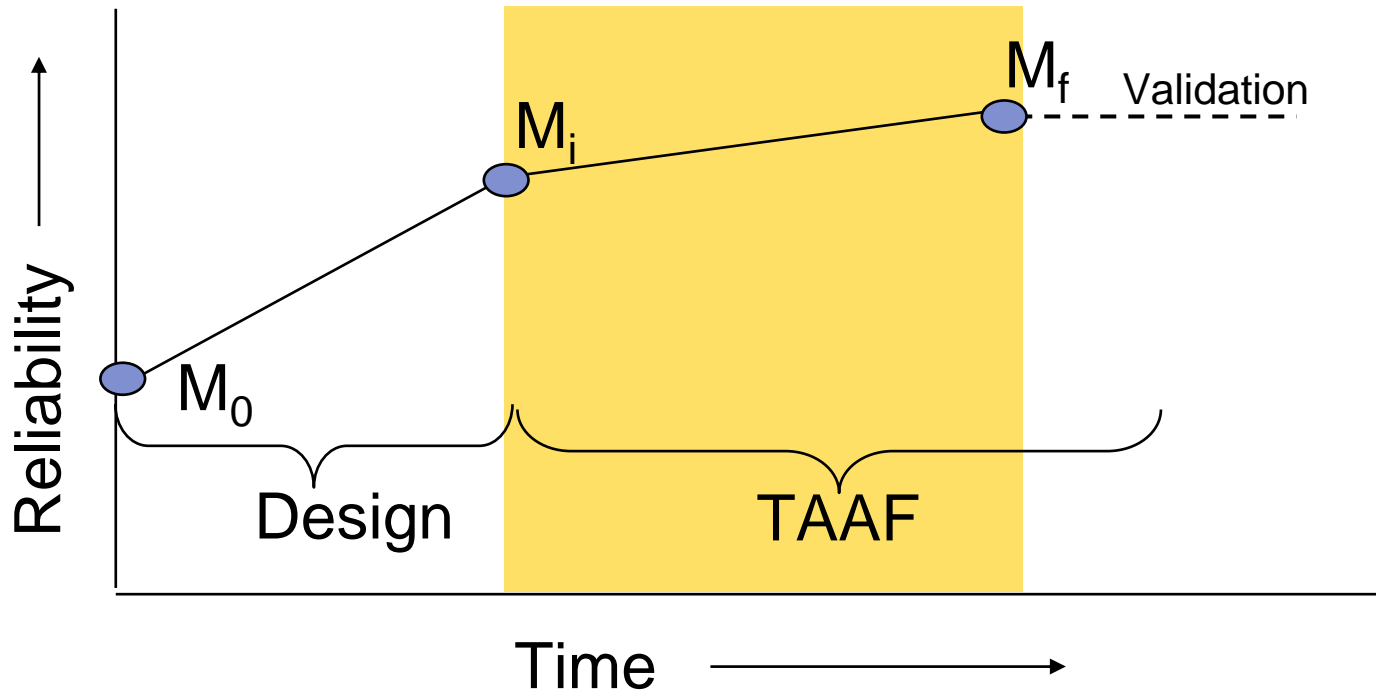
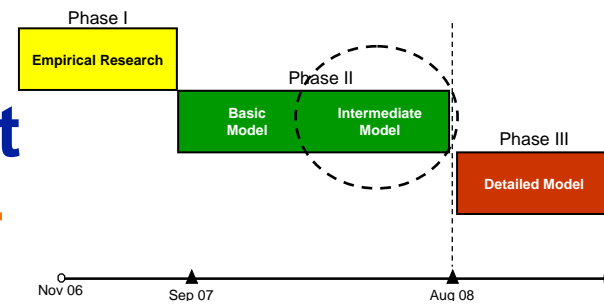

$$\frac{1}{M(\tau)} = \frac{1}{M_A} + \frac{1}{M_i} \left[(1 - \mu_d) + \frac{\mu_d}{1 + \tau} \right]$$

Based on math that underlies AMSAA's MPM

$$\gamma(\tau) = \frac{1}{CV^2} [C_0 \tau + \mu_b \ln(1 + \tau)]$$

LMI cost extension to AMPM



Comparing LMI Model of TAAF Cost with AMSAA Data

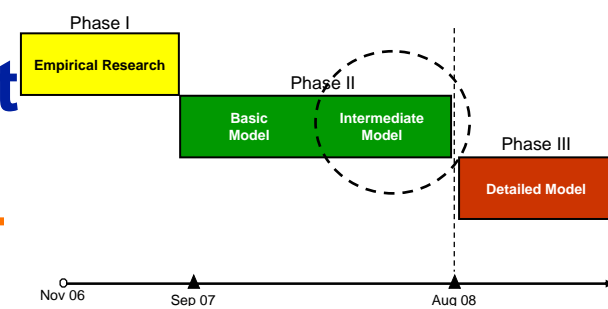

- Using 25 data points from eight platforms, inferred non-dimensional TAAF time τ from the AMPM and M_F/M_I (neglect λ_A) ratio of each data point
- Determined LMI model cost for each τ
 - Calibrated model by adjusting two parameters
- Compared costs estimated by model with AMSAA costs



AMSAA Cost vs. Model Predicted Cost to Achieve a Given Reliability

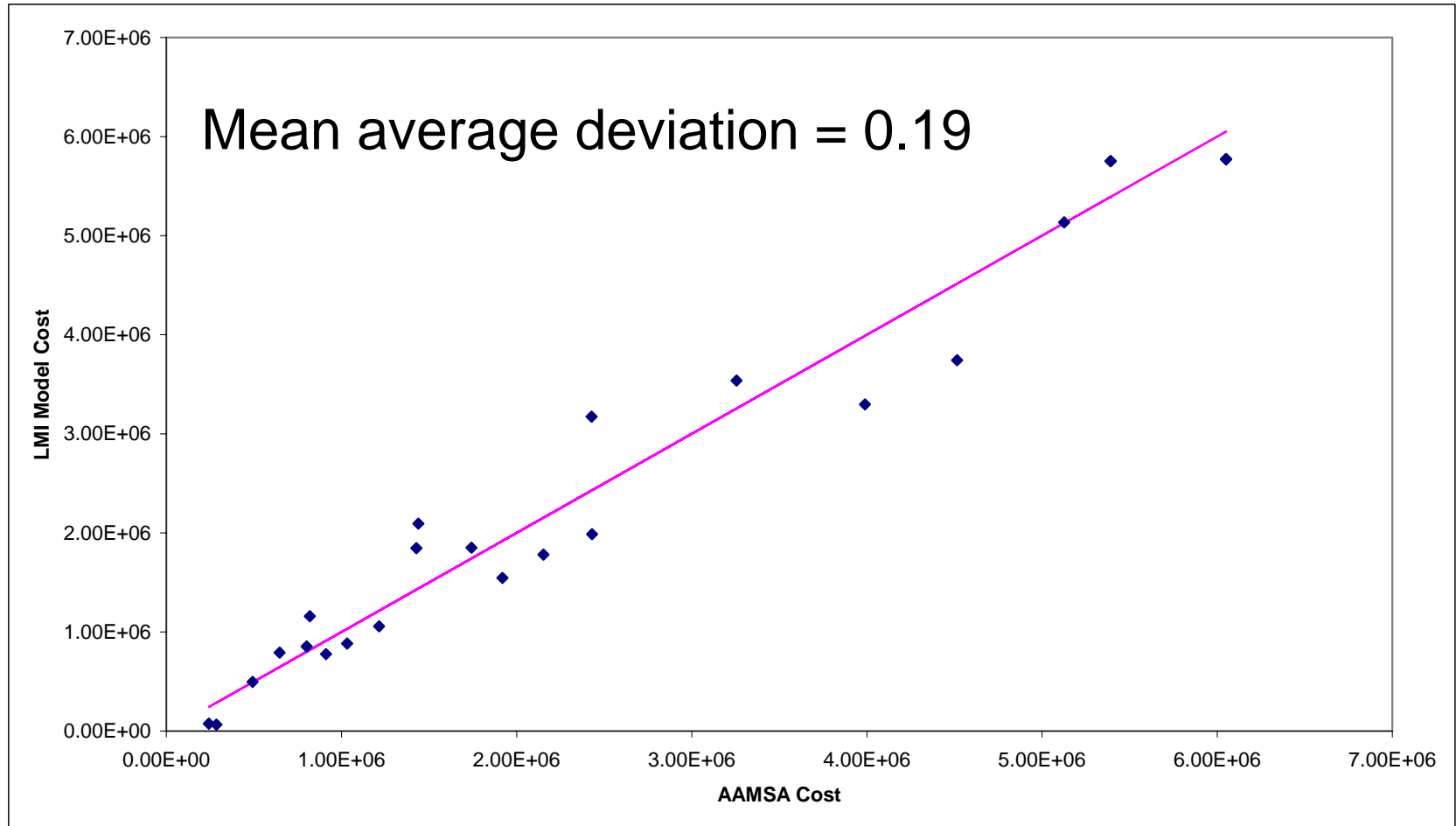

Approach to Design Phase Model

- Adopt A-mode, B-mode scheme from TAAF (and AMSAA) Model
 - Assumes process for identifying and removing B-modes is similar to TAAF
 - Engineering labor applied to PoF, HALT, durability, etc. plays role similar to test operation in TAAF
- Obtain improvement data from programs that implemented or are implementing proactive tasks (assumes will see only limited improvement if proactive tasks not performed)



Design Period Model Equation Development

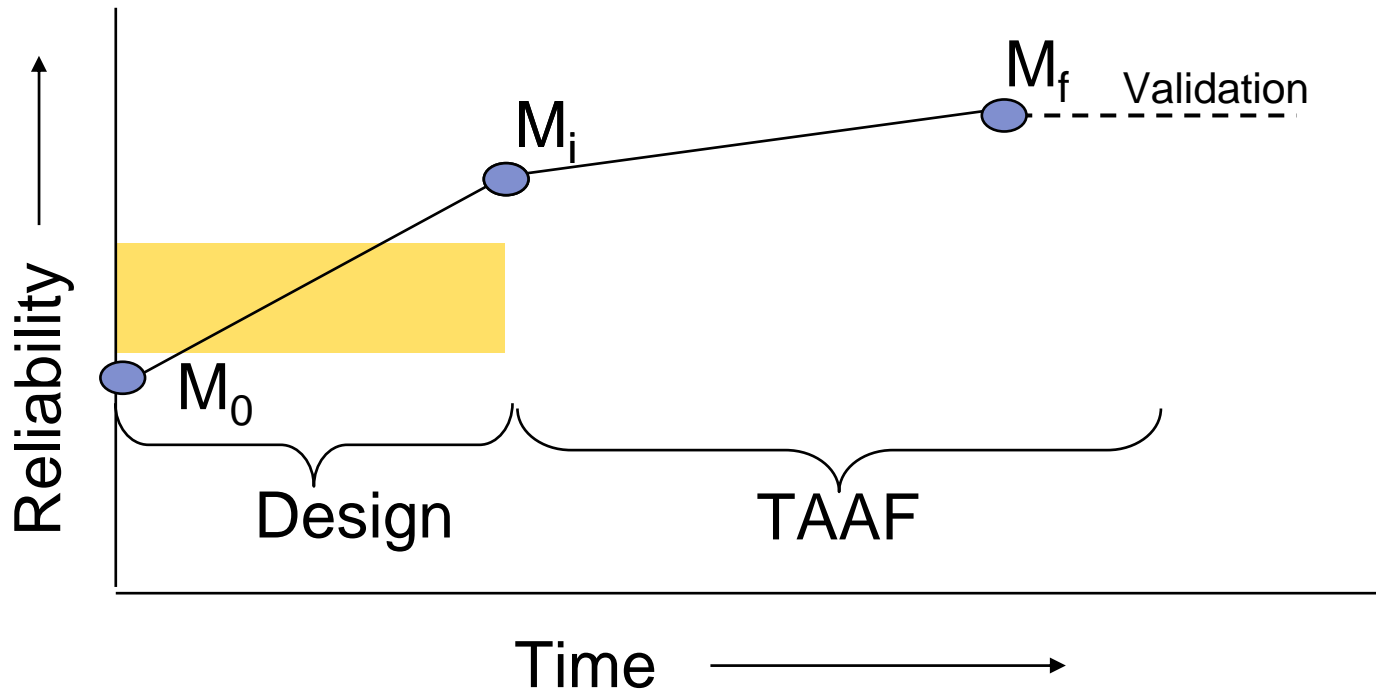
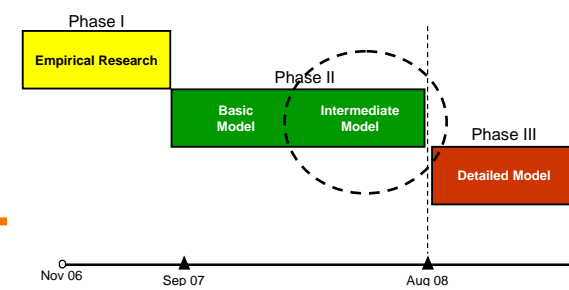

$$M(\tau) = M_A^2 \cdot M_0 \left[(1 + \mu_D) + \frac{\mu_D}{1 + \tau} \right] \quad \gamma(\tau) = \frac{1}{CV_D^2} \left[C_0^D \tau + \mu_B^D \ln(1 + \tau) \right]$$



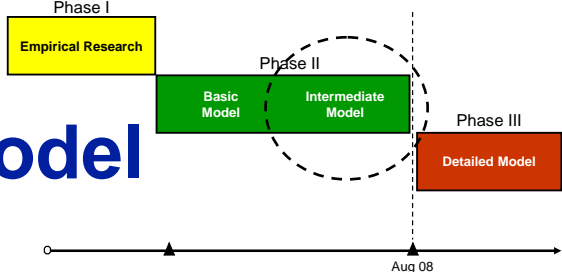

Initial Calibration of Design Period Model

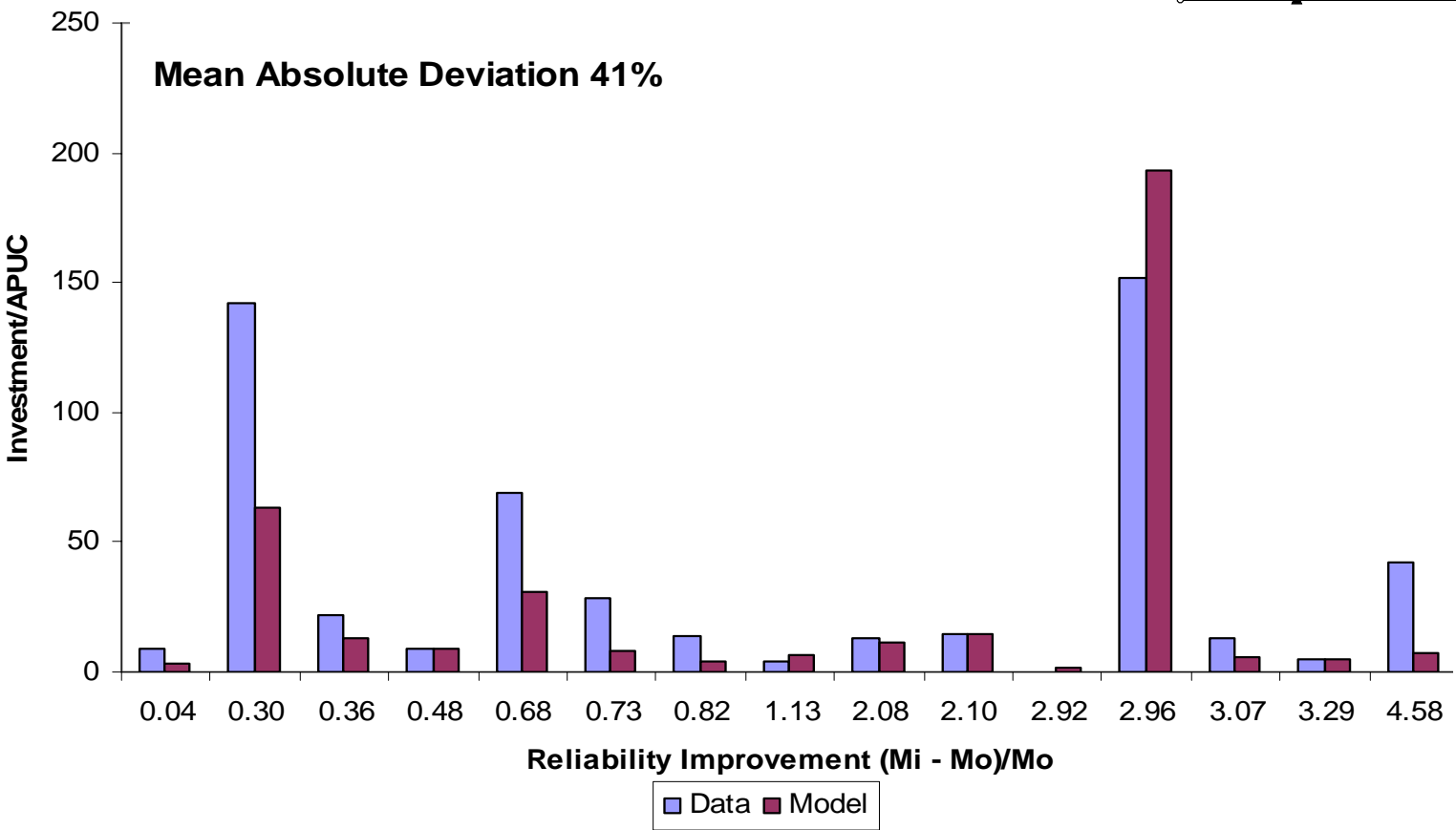

13 data for EFV, 1 datum for AIM-9X, 1 datum for MGS Stryker

Used 4 values for “goodness” parameter



Support Cost Model (+)

Simplified UAV Example



$$\text{Platform Dependability} = \frac{\text{Operational time} + \text{ready time}}{\text{Operational time} + \text{ready time} + \text{downtime}}$$

Investment (or lack of investment) in reliability improvement

Realized reliability

Platform dependability

Number of platforms required to achieve required system dependability

Per platform support cost

System production cost

System support cost

- Assume 20 hour operational + ready time.
- How large does a “flight” of n platforms need to be to assure at least one platform will be operational for 20 hours with a given confidence level?
- Intend to buy 20 flights.

LCC vs. Reliability Investment

Notional UAV Example

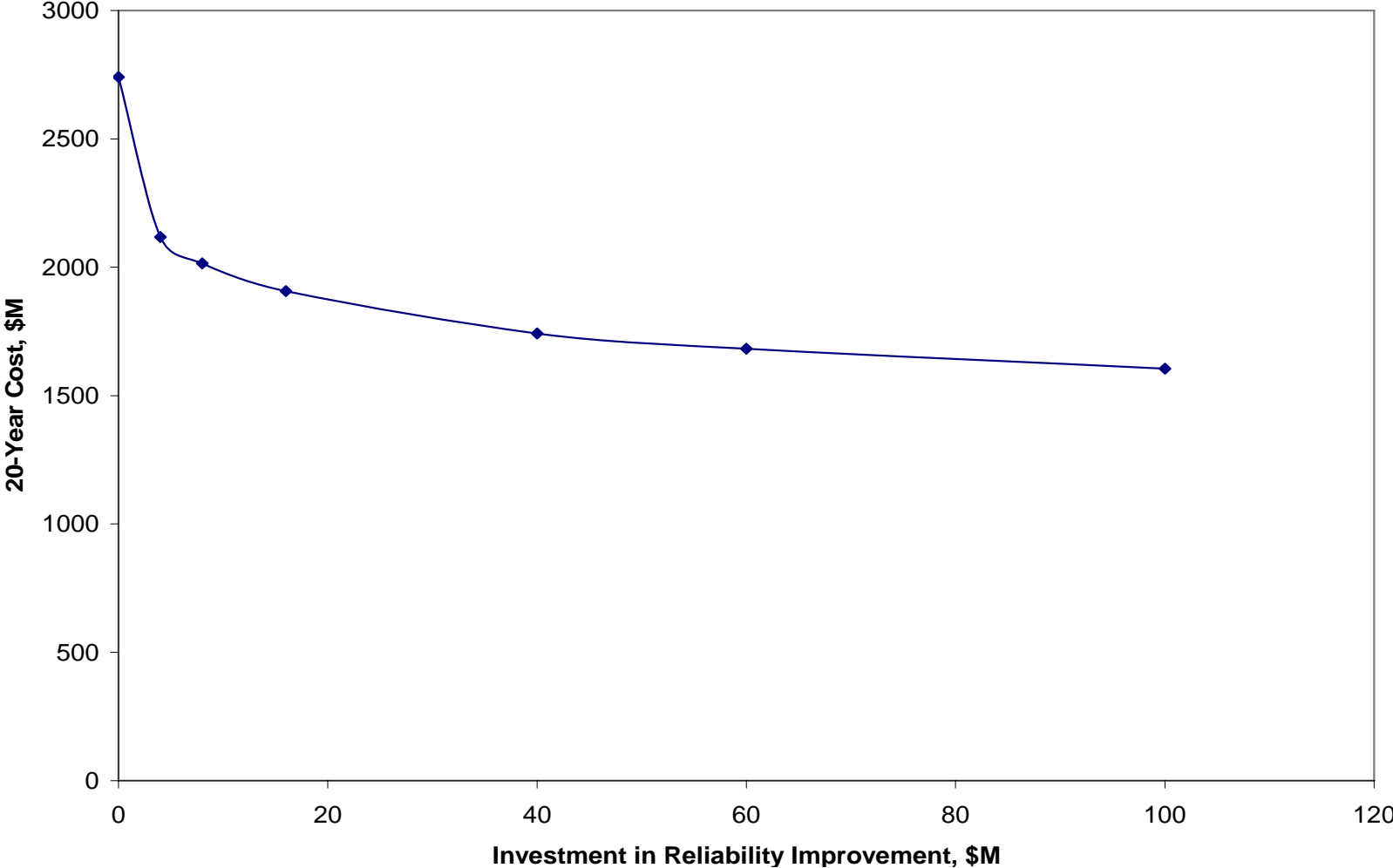

Summary and Conclusions

- Reasonably mature basic model, 17 data points, all of which were historical actuals
- Demonstrated that basic A-mode, B-mode premise of AMPM can be extended to cost estimating
 - TAAF period model well behaved, but limited by use of estimates rather than historical actuals
 - Design period model feasibility demonstrated, limited by use of estimates and number of data points
- Coupled basic model to LCC model



Next Steps and Future Work

- Continue adding additional data points to basic model
- In intermediate model
 - Replace TAAF period estimates with historical actuals and add additional platform types
 - For design period: more data points, more platform types, historical actuals
- Begin work on detailed model
- For all models, look for disconfirming evidence. Where do the models not work?



Headquarters U.S. Air Force

Integrity - Service - Excellence

USAF Implementation of Recommendations from National Research Council “Pre-Milestone A and Early-Phase Systems Engineering” Study Committee



**NDIA Systems Engineering Division
Annual Conference
San Diego, CA
23 October 2008**

**Jeff Loren
Engineering Policy Branch
SAF/AQRE (Alion Science & Technology)
703.588.7845**

U.S. AIR FORCE

jeff.loren@pentagon.af.mil



NRC Study Committee Report

U.S. AIR FORCE



“Pre-Milestone A and Early-Phase Systems Engineering: A Retrospective Review and Benefits for Future Air Force Systems Acquisition”

December 2007

http://books.nap.edu/catalog.php?record_id=12065



Findings and Recommendations

U.S. AIR FORCE

■ **Finding #1**

Attention to a few critical systems engineering processes and functions particularly during preparation for Milestones A and B is essential to ensuring that Air Force acquisition programs deliver products on time and on budget.

■ **Recommendation #1**

Air Force leadership should require that Milestones A and B be treated as critical milestones in every acquisition program and that ... the “Pre-Milestone A/B Checklist” ... be used to judge successful completion.



Findings and Recommendations

U.S. AIR FORCE

■ **Finding #2**

Creating a robust SE process requires experienced SEs with domain knowledge

■ **Recommendation #2**

Assess career field needs and develop a program to address



Implementation Approach - 2

U.S. AIR FORCE

- **Established Program Systems Engineer (PSE) shred under SPRDE**
- **Active engagement with SPRDE FIPT to influence DAU STM courses**
 - **Subject matter focus has been realigned**
 - **Provide additional emphasis on technology transition techniques and tools**
- **Provided 70+ SMEs to support competency assessments**
- **“Science, Mathematics, & Research for Transformation” (SMART) –funded by OSD; managed by NPS and ASEE**
 - **Akin to an undergraduate co-op program**
 - **Also used to provide opportunities for graduate students**
 - **Trying to change to automatic hire after award of degree rather than having to compete**



Implementation Approach - 2

Organic S&E Development

U.S. AIR FORCE

■ Update Apr 01 S&E Strategic Plan

Current & Future Requirements

Goal Areas

| | |
|---------------------------------------|-------------|
| Recruitment and retention initiatives | Math |
| | S&T |
| Education and training | Acquisition |
| Individual growth paths | Test |
| Awards and recognition | Sustainment |

■ NRC STEM Study (kicked off Aug 08; 15-month duration)

- Determine STEM needs of 26 functionals
- Fold recommended implementation strategy into S&E Strategic Plan update

■ RAND S&E Study (SAF/AQXD initiated)

- Estimating changes in S&E skills for emerging technical needs
- Two time horizons: near term (5 years), mid-term (10-15+ years)



Findings and Recommendations

U.S. AIR FORCE

■ **Finding #3**

Government, FFRDCs, and industry all have important roles throughout the life cycle

■ **Recommendation #3**

Pre-A decisions should be supported by rigorous SE processes and analyses involving teams of acquirers, users, and industry



U.S. AIR FORCE

Implementation Approach – 3 Continuous Capability Planning

■ Informed Time-Phased Requirements Development (ITPRD)

- Identify sponsoring MAJCOM personnel for collaborative requirements development**
- Insert acquisition (AFMC/AFSPC/AFRL) personnel into pre-MS/KDP-A/B process far enough in advance of the HPT to absorb context of program, execute SE processes, and affect content of KPP/KSAs and requirements that go into AoA planning and ICD/CDD/etc.**

■ Life Cycle Risk Management

- Comprehensive definition of risk and risk management; should begin at the earliest stages of capability/program planning (pre-MS/KDP-A capability planning effects), and continue throughout the total life cycle of the program**

■ Modeling, Simulation, and Analysis



U.S. AIR FORCE

Implementation Approach – 3 Life Cycle Management

■ High-Confidence Criteria

- Strategy should document multiple, viable trade space options for cost, schedule, capability-based performance requirements and technology**
- Strategy should support proper phasing/synchronization of requirements with on- and off-ramps**
- Requirements prioritized and properly time phased (cost/schedule)**
- Pre-M/S-B Risk Management plans complete, accurate, current and being followed**



U.S. AIR FORCE

Implementation Approach – 3 Technology Development

- **Technology Development and Transition Strategy**
 - Extends the scope of quantitative criteria beyond TRLs
 - Includes broader processes and cross-command forums to improve the rigor of early SE and contribute to “doable” requirements
 - Increases the probability that highest-priority shortfalls/gaps are addressed
 - Results in closer alignment between technology investments and system / capability needs

- **Transition Stage-Gating**
 - Provides a CONOPS for total technology insertion into the Acquisition & Sustainment Plan



U.S. AIR FORCE

Implementation Approach – 3 Technology Transition

- **AF Tech Transition Office (TTO) continues support to JCTD, QRF, TTI and other Tech Transition programs**
- **Tech Transition Program Initiative funded in FY10 POM (\$10M/yr)**
 - **Hardware prototyping**
 - **Bridge funding from Tech Demo to Program POM**
 - **Enterprise interface management / configuration control**
- **Developing R&D Strategic Framework to coordinate AF policy, programs and processes to transition technology through 6.1-6.8 to new program of record or change to existing program**



Findings and Recommendations

U.S. AIR FORCE

■ **Finding #4**

The organic development planning function that applied pre-A SE to a number of successful programs was allowed to lapse

■ **Recommendation #4**

A development planning function should be established in the military departments to coordinate the concept development and refinement phase of all acquisition programs to ensure that the capabilities ... as a whole are considered and that unifying strategies such as ... interoperability are addressed.



Implementation Approach - 4

U.S. AIR FORCE

- **Secured FY10 POM funding (\$37M/yr) for new PE for Requirements Analysis & Maturation (RAM) (“Development Planning”)**
- **Concept Development**
- **Requirements Analysis Support**
- **Establishing DP/RAM governance structure; single point of entry for MAJCOM DP requests**
- **Early SE Guide to be published 4Q CY08**
- **Institutionalize CCTD and ConSEP in policy**



U.S. AIR FORCE

Implementation Approach – 4 RD&E Investment Framework

Transition Assistance -- filling the “Valley of Death”

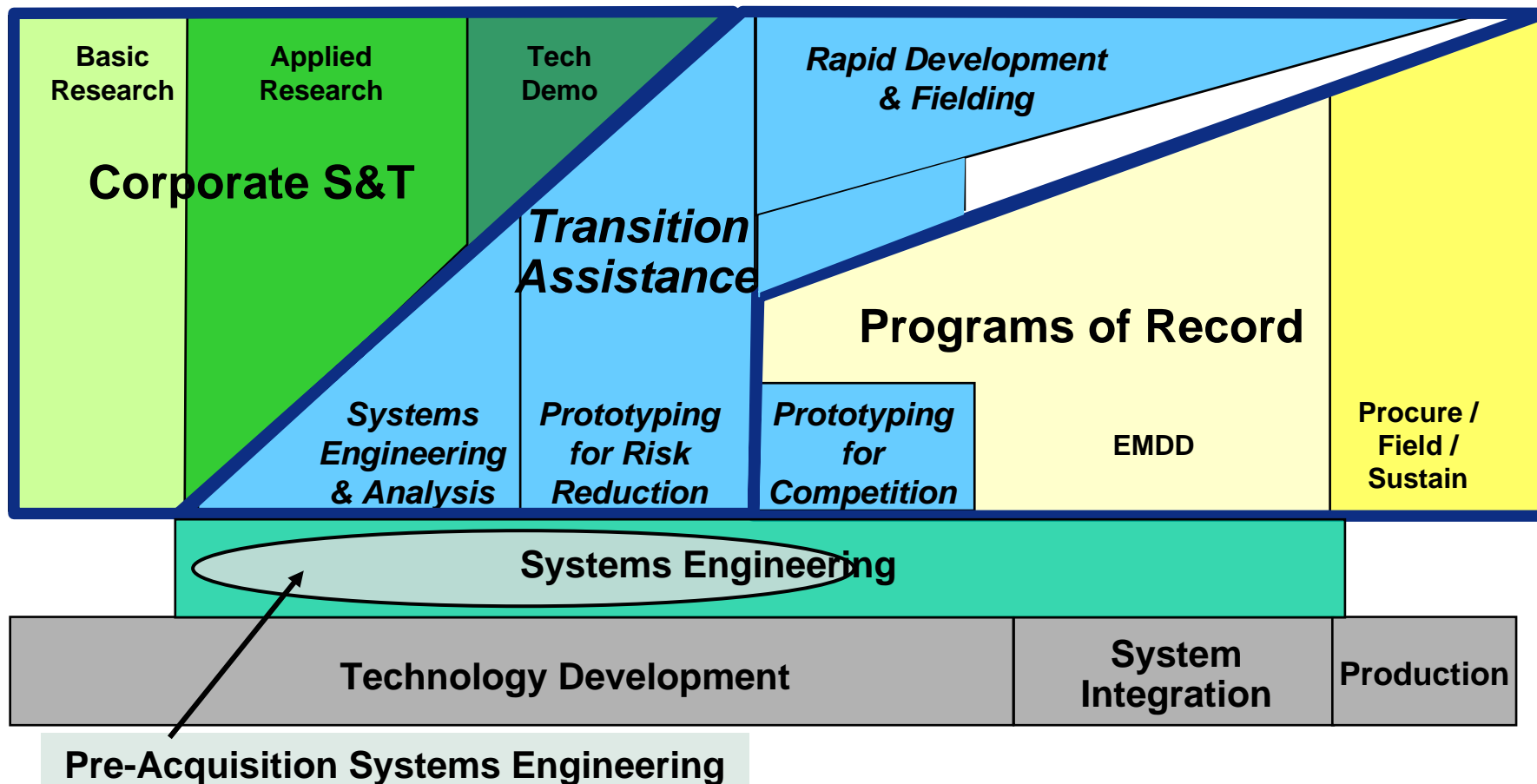

Integrity - Service - Excellence



Implementation Approach - 1

U.S. AIR FORCE

- **Checklist identifies 20 items in 7 principal areas**
- **Coverage for 16 of 20 exists in current policy and guidance**
- **Conducted informal order-of-magnitude assessment of current compliance across practitioner community**
- **In process of identifying process owners and key linkages for each item needing action**



Checklist – Concept Development

U.S. AIR FORCE

| | | CURRENT PROCESS | SUPPORTING DOCUMENTATION | PROCESS OWNER(S) | OPR(S) | KEY LINKAGE(S) |
|---|--|---|---|--|----------------------|--|
| 1 | Have at least two alternative concepts been evaluated? | AoA policy in AFI 10-601 | <ul style="list-style-type: none"> • PASEP (pre-AoA) • ASC process (post-AoA) • Early SE Guide | <ul style="list-style-type: none"> • OAS, A2/5 • AQR, AFMC/EN | Center XRs | <ul style="list-style-type: none"> • AoA and DP • ESE guide • SoS stds / practices |
| 2 | Can an initial capability be achieved within ~5 years from MS/KDP B? If not, can critical subsystems (or a key subset) be demonstrated within that timeframe? | New MAIS programs now require IOC within 5 years of MS A, per FY08 NDAA Section 811. No rqmt for non-MAIS programs. | <ul style="list-style-type: none"> • Concept SEP (ConSEP) • Transition Plan • 5000.2 update (PDR ahead of MS B) | A2/5 for DP/RAM and attestation process | Center XRs | <ul style="list-style-type: none"> • DT&E initiative • Risk Assessment • Cost estimating • Other enduring/ std processes • CCP Guide |
| 3 | Will high-risk new technologies have been matured prior to MS/KDP B? If not, is the risk mitigation plan adequate? | 10 USC 2366a requires TRL ~6 (defined by AF Policy Memo) at MS B | <ul style="list-style-type: none"> • Transition Plan • ConSEP • Competition & prototyping (Young memo, 5000.2 update) | <ul style="list-style-type: none"> • A2/5 • DP efforts and process leading to acq strategies | Center XRs with AFRL | <ul style="list-style-type: none"> • TD initiatives (RI3, TDTS) • CCP Guide |
| 4 | Have external interface complexities (incl. dependencies on other programs) been identified and minimized? Is there a plan to mitigate risks? | Part of JCIDS process; SoS SE guide | <ul style="list-style-type: none"> • Concept Characterization & Technical Description (CCTD) • CCP process for developing options • SoS engr (in Early SE Guide) | <ul style="list-style-type: none"> • AQR Guidance Memo mandates CCTD • A2/5 – process for developing option sets • AQR, AFMC/EN | Center XRs | <ul style="list-style-type: none"> • Early SE Guide • CCP Guide • AFMC/EN SoS eng practices • All enduring processes incl analysis • TD (RI3) |



Checklist – KPPs and CONOPS

U.S. AIR FORCE

| | | CURRENT PROCESS | SUPPORTING DOCUMENTATION | PROCESS OWNER(S) | OPR(S) | KEY LINKAGE(S) |
|---|--|---|--|---|--------------------|--|
| 5 | At MS/KDP A, have KPPs been identified in clear, comprehensive, concise, understandable terms? | AFI 10-601 (JCIDS implementation) (at early stages, MOEs are more appropriate than solution-focused KPPs) | <ul style="list-style-type: none"> • ConSEP • CCTD • I-CDD (to support system rqmts refinement and PDR prior to MS B) | <ul style="list-style-type: none"> • AFMC/CC attestation point • DP/RAM process | Center XRs | <ul style="list-style-type: none"> • ITPRD initiative • Attestation process • SE activities • LCM |
| 6 | At MS/KDP B, are major system-level requirements (including all KPPs) sufficiently well defined to provide a stable basis for system development? | AFI 10-601 (JCIDS implementation) (at early stages, MOEs are more appropriate than solution-focused KPPs) | <ul style="list-style-type: none"> • ConSEP • CCTD • CDD | AFMC/CC attestation process | SPM and center XRs | <ul style="list-style-type: none"> • DT&E initiative • All enduring processes including analysis • LCM |
| 7 | Has a CONOPS been developed showing that system operation can handle expected throughput and meet response time requirements? | | <ul style="list-style-type: none"> • ConSEP • CCTD • I-CDD | A2/5 DP/RAM process | SPM and center XRs | <ul style="list-style-type: none"> • Analysis framework • SoS practices and standards • Early SE – all enduring processes |



U.S. AIR FORCE

Checklist – Cost & Schedule, Performance Assessment

COST & SCHEDULE SCOPING

| | | | | | | |
|---|--|---|--|--|---|---|
| 8 | Are major cost and schedule drivers and risks explicitly identified, and is there a plan to track and reduce uncertainty? | <ul style="list-style-type: none"> • Evaluated within JROC process per JROCM 06-261. • Part of Acq strategy | Pre-A <ul style="list-style-type: none"> • ConSEP • Transition Plan Pre-B <ul style="list-style-type: none"> • SEP • RMP | <ul style="list-style-type: none"> • A2/5 for DP/RAM • Individual process owners for risk & cost assessment | SPM and center XRs depending on phase | <ul style="list-style-type: none"> • Early SE • Risk and integrated assessments • Other std/enduring processes |
| 9 | Have principal stakeholders accepted the confidence level (risk assessment) associated with cost estimates? | Cost Estimating policy & guidance (POE, ICE, etc.) | <ul style="list-style-type: none"> • CCTD • SEP • RMP | <ul style="list-style-type: none"> • Risk process (ACE-AFMC/EN) • Sufficiency Rvw (best of breed from Risk Team) • CE methodology | SPM and center XR depending on effort/phase | <ul style="list-style-type: none"> • Risk process • Cost estimating methodology |

PERFORMANCE ASSESSMENT

| | | | | | | |
|----|--|---|---|--|--|--|
| 10 | Are models and simulations adequate and appropriate to validate the selected concept and CONOPS against the KPPs? | <ul style="list-style-type: none"> • Operational Context rather than “CONOPS” per se • MOEs at earliest “checkpoints” | <ul style="list-style-type: none"> • ConSEP • CCTD • SEP | <ul style="list-style-type: none"> • A2/5 (DP); M&S owner as enabler • A2/5 from attestation perspective | SPM and/or center XRs depending on effort/phase; also need M&S owner | <ul style="list-style-type: none"> • DT&E initiative • Analysis Team products (M&S activity) |
| 11 | At MS/KDP B, do the requirements consider likely future mission growth over the life cycle? | SE/SEP guidance (Address in updates) | <ul style="list-style-type: none"> • SEP • Transition Plan | <ul style="list-style-type: none"> • AFMC/CC attestation • DP/RAM • SE | SPM with insights from earlier XR efforts | <ul style="list-style-type: none"> • ICD and I-CDD (validation) |



Checklist – Architecture, Risk

U.S. AIR FORCE

| | | CURRENT
PROCESS | SUPPORTING
DOCUMENTATION | PROCESS
OWNER(S) | OPR(S) | KEY
LINKAGE(S) |
|---------------------------------|--|--|---|---|--|--|
| ARCHITECTURE DEVELOPMENT | | | | | | |
| 12 | Has the system been partitioned to define segments that can be independently developed and tested? | Architecture views required per JCIDS | <ul style="list-style-type: none"> • ConSEP • CCTD • SEP | SE and DP/RAM | Center XRs and XPM depending on effort/phase | <ul style="list-style-type: none"> • DT&E initiative • SoS SE • ICD and I-CDD to validate approach • CCP Guide |
| 13 | By MS/KDP A, is there a plan to have information exchange protocols in place by MS/KDP B? | Architecture views required per JCIDS (OV-3, OV-5 and SV-6 should address) | <ul style="list-style-type: none"> • ConSEP • CCTD • SEP | <ul style="list-style-type: none"> • A2/5 for DP/RAM process • SE process including SoS | Center XRs and SPM | <ul style="list-style-type: none"> • SoS practices and standards • early SE • DP/RAM |
| 14 | At MS/KDP B, is the program plan structured to ensure that the contractor addresses rqmts decomposition / allocation to hardware, software, and human elements sufficiently early in development? | <ul style="list-style-type: none"> • SE guidance in MS B RFP • WBS | <ul style="list-style-type: none"> • Acquisition Strategy • IMP/IMS | <ul style="list-style-type: none"> • SE • AFMC/CC attestation | SPM | Attestation |



U.S. AIR FORCE

Checklist – Risk Assessment, Program Implementation

| | | CURRENT PROCESS | SUPPORTING DOCUMENTATION | PROCESS OWNER(S) | OPR(S) | KEY LINKAGE(S) |
|-------------------------------|--|---|---|--|--|---|
| RISK ASSESSMENT | | | | | | |
| 15 | Are all key risk drivers (including but not limited to critical technologies) identified? | 10-6 series? | <ul style="list-style-type: none"> • ConSEP • CCTD • SEP • TDTS | SoS engr processes; risk process (must begin early) | Center XRs and SPMs depending on effort/phase | <ul style="list-style-type: none"> • TD initiatives • Linkage betw risk, SE and SoS eng, Cost |
| PROGRAM IMPLEMENTATION | | | | | | |
| 16 | Does the program implementation plan account for necessary and sufficient # and skill levels of organic (military and civilian), FFRDC, and support contractor personnel to manage the program? | <ul style="list-style-type: none"> • SEP should be a resource-constrained plan • LCMP should address. | <ul style="list-style-type: none"> • Acq strategy • Transition Plan | A1 – should be accounted for in Mission Assignment process as well as during transition to a SPO – all functionals (including A2/5 for DP) need to be included in the assessment process | SPO Cadre and SPM (Center XR, EN, other functionals as needed) | In work (HCC definitions) |
| 17 | At MS/KDP A, is there a plan in place that identifies all necessary activities and resources to reach MS/KDP B? | LCMP | Early SE Guide | <ul style="list-style-type: none"> • A2/5 for DP/RAM • SE and SoS processes | Center XRs and SPMs w/resource allocation process | <ul style="list-style-type: none"> • SoS • SE • DP/RAM resource allocation • All enduring processes |



Checklist – Program Implementation

U.S. AIR FORCE

(2)

| | | CURRENT PROCESS | SUPPORTING DOCUMENTATION | PROCESS OWNER(S) | OPR(S) | KEY LINKAGE(S) |
|----|---|--|---|--|--|--|
| 18 | Is there a top-level system integration and test plan? | SEP and TEMP | <ul style="list-style-type: none"> • ConSEP • CCTD • Transition Plan | A2/5 (DP & attestation), PM, SE, SoS | TE Contractor | DT&E and TD initiatives, SoS practices |
| 19 | At MS/KDP B, are the necessary and sufficient program management and systems engineering management personnel in place? Have they been empowered to tailor processes and enforce requirements stability through IOC? | Usually based on PM and CE judgment and then articulated in SEP and LCMP. They are empowered to tailor processes. EMA instituted to add/improve discipline for requirements stability. | <ul style="list-style-type: none"> • ConSEP • Transition Plan | A1 (Mission Assignment Process) | SPO Cadre and SPM (Center XR, EN, other functionals as needed) | In work (HCC definitions) |
| 20 | Has the government attempted to align the duration of the program manager’s assignment with key milestones and deliverables? | New policy memo forthcoming | Transition Plan | Mission assignment process with senior officer moves | OSD | In work (OSD) |



Prototyping and Early SE

- Basic tenets of prototyping can help a program-to-be directly address 10 of the 20 checklist items -- at least one in each of the 7 areas
- A well-crafted prototyping plan can impact most if not all other items

PROTOTYPING AND EARLY SE CHECKLIST “BOX SCORE”

| | | | |
|----------------------------------|------------|--|------------|
| <i>Concept Development</i> | <i>2/4</i> | <i>Architecture Development</i> | <i>2/3</i> |
| <i>KPPs and CONOPS</i> | <i>1/3</i> | <i>Risk Assessment</i> | <i>1/1</i> |
| <i>Cost and Schedule Scoping</i> | <i>2/2</i> | <i>Program Implementation Strategy</i> | <i>1/5</i> |
| <i>Performance Assessment</i> | <i>1/2</i> | | |



Concept SE Process

U.S. AIR FORCE

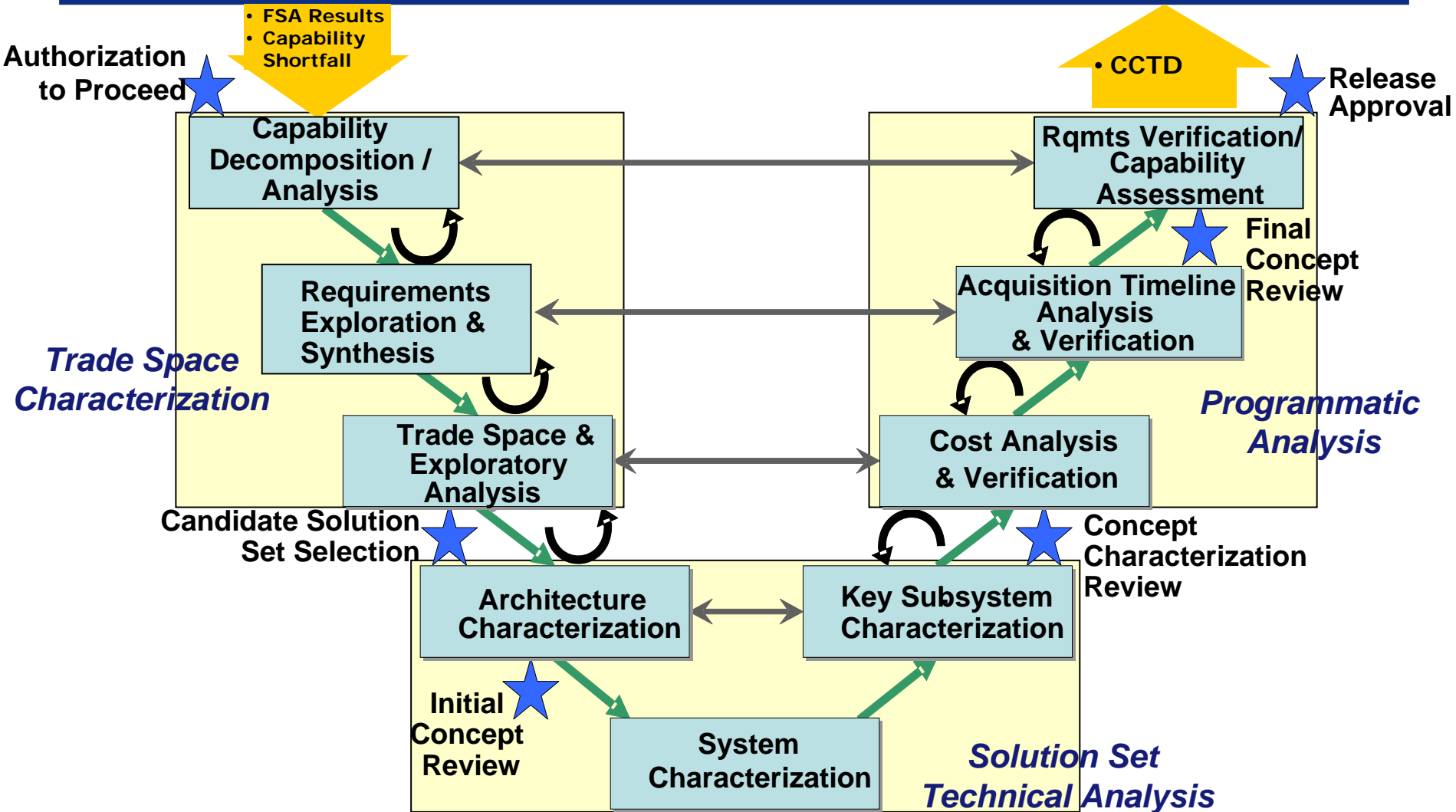



Attachment 1: Concept Characterization and Technical Description Format

Concept Characterization and Technical Description (CCTD)

for

Concept Name

DATE

Prepared by:

Name of Source (e.g. Concept Development Organization, AFRL, Corporation, etc)

NOTE: Subjects in boldface type listed in this Table of Contents are mandatory. Design and performance parameters (e.g. "weight, power, cooling, throughput") for identified studies, analyses, and/or experiments should be selected on the basis of relevance to the concept, mission description, etc. Approaches and assumptions should reflect the anticipated purpose of the technical planning (e.g. strategic planning, AoA, weapon system technology demonstration). Descriptive detail should be consistent with the concept's level of maturity/fidelity and the purpose for which the concept is being developed. This document is not expected to be at the level of a formal submittal such as a milestone review product.

TABLE OF CONTENTS

- 1. **Mission / Capability Need Statement / CONOPS**.....
- 2. **Concept Overview**.....
- 3. **Trade Space Definition / Characterization**.....
 - 3.1 Top-Level Architecture.....
 - 3.2 Principal Interfaces.....
 - 3.3 Operating Regime.....
 - 3.4 Key System Parameters.....
- 4. **Studies, Analyses, Experiments**.....
 - 4.1 Parametric Studies (e.g., weight, power, cooling, throughput).....
 - 4.2 Analyses (e.g., HSI considerations, supportability concepts).....
 - 4.3 Experiments.....
 - 4.4 Conclusions.....
- 5. **Concept Characterization / Design**.....
 - 5.1 Common Analysis Assumptions.....
 - 5.2 Operating Regime.....
 - 5.3 Interface / Interoperability / System-of-Systems Approach.....
 - 5.4 Critical Subsystem Design and Sizing.....
 - 5.5 Supportability / Sustainment Features.....
 - 5.6 Configuration Summary.....
 - 5.7 Analysis Results.....
 - 5.8 Concept Design Conclusions (Capability Performance Description).....
- 6. **Program Characterization**.....
 - 6.1 Critical Technologies.....
 - 6.2 Technology Maturation Approach.....
 - 6.3 Test & Evaluation / Verification & Validation Approach.....
 - 6.4 Prototyping Approach.....
 - 6.5 Manufacturing / Producibility Approach.....
 - 6.6 Sustainment / Supportability Approach.....
 - 6.7 Schedule Assumptions.....
 - 6.8 Cost Analysis Assumptions.....
 - 6.9 Cost Estimates.....
 - 6.10 Risk Assessment.....
- 7. **Conclusions**.....
- 8. **Recommendations (if applicable)**.....



Materiel Command's Requirements Analysis & Maturation (RAM)

[My AFKN](#)
[AFKN Links](#)
[CoP Links](#)
[* View *](#)
[Upload](#)
[Add Link](#)
[Search](#)
[My Documents](#)
[Root Folder](#) » **7. Draft Working Misc Files**

| Type | Title | Counts/
Versions | Owner | Date
Modified | Email
This | Reserved | Functions |
|----------------------|--|--------------------------------------|-----------------------|-----------------------------------|--------------------------------|--------------------------|---------------------------|
| | Briefings presented | =0, =5 | | 6/25/2008 | | | |
| | Draft Checklists | =0, =6 | | 6/26/2008 | | | |
| | Draft Policy | =0, =1 | | 6/25/2008 | | | |
| | Draft process briefs | =0, =1 | | 6/25/2008 | | | |
| | Draft RAM Strategic Plan | =0, =1 | | 9/18/2008 | | | |
| | Estimating Guide/Templates | =0, =1 | | 9/17/2008 | | | |
| | Prioritization | =2, =0 | | 7/24/2008 | | | |

[My Profile](#) | [AFKN Feedback](#) | [AFKN Support](#) | [Metrics](#)

"Everything has been said before, but since nobody listens we have to keep going back and beginning all over again."
-- Andre Gide, Le traite du Narcisse

RCM Applied to the CH-47 Chinook Heavy Lift Helicopter



For the Warfighter – With the Warfighter



Presentation Agenda



- Reliability Centered Maintenance (RCM) overview
- CH-47 Chinook Introduction
- Application of RCM Principles to the CH-47D:
 - Maintenance Program
 - Special Tools and Test Equipment (STTE)
 - Unique Identification (UID)
 - Condition Based Maintenance Plus (CBM+)



What is Reliability Centered Maintenance?

RCM

A zero-based, structured process used to identify the failure management strategies required to ensure an asset meets its mission requirements in its operational environment in the *most safe and cost effective* manner.

Real honest to goodness output that meets the needs of the organization

RCM

A **zero-based**, structured process used to identify the failure management strategies required to ensure an asset meets its mission requirements in its operational environment in the *most safe and cost effective* manner.

Zero-Based

RCM

A zero-based, structured process used to identify the **failure management strategies** required to ensure an asset meets its mission requirements in its operational environment in the *most safe and cost effective* manner.

Failure Management Strategies

RCM

A zero-based, structured process used to identify the failure management strategies required to ensure an asset meets its mission requirements in its **operational environment** in the *most safe and cost effective* manner.

Operational Environment



The RCM Process

RCM

- 1. Functions**
- 2. Functional Failures**
- 3. Failure Modes**
- 4. Failure Effects**
- 5. Failure Consequences**
- 6. Proactive Maintenance and Intervals**
- 7. Default Strategies**

Application of Reliability Centered Maintenance to the CH-47D



Application of RCM to the CH-47



- **To reverse the trend of increasing Operation and Support costs**
- **Chief focus of maintenance had been on the prevention of failures**
 - Common assumption that, in most cases, equipment “wears out” and inevitably becomes less reliable with age
- **With RCM analysis, focus began to shift from preventing failures to managing the consequences of failures as they affect the aircraft as a whole.**



RCM Working Group



Systems Engineer

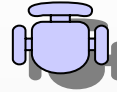

Test Pilot



Depot Rep

Flight Engineer/ Crew Chief



Equipment Manufacturer

Mechanic



Instructor Pilot

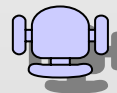

Facilitator

In the absence of specific data on failure rates and characteristics, intervals are largely determined based on service experience.

Often the most truthful source of data



Maintenance Transformation



BEFORE RCM

200 Hour Phase maintenance

AFTER RCM

400 Hour Cycle Service Plan
200 Hour Servicing/Inspection

- Number of Phase Maintenance tasks reduced by **73%**
- Phase Maintenance requires **50% fewer** man hours to complete
 - 200 Phase: ~67 days downtime
 - 400 hour Cycle Service: ~19 days downtime
 - 200 hour Cycle Service: ~10 days downtime
- Produced an increase in readiness!



Application of RCM to the CH-47



- Eliminated unnecessary tasks
 - Eliminated Duplication of Effort
 - 200 Hour Phase Maintenance Program: Independent Activities
 - 400 Hour Cycle Service: Supportive Activities
 - Technical Justification
 - Pitot Static System Check
 - In response to single events
 - Retorque droop stop bolts (due to bad lot of hydrogen embrittlement)
 - Extended intervals
 - Wheel bearing repacking (Extended from 200 to 400 hours)
 - Move to On-Condition Maintenance
 - Brake pad replacement

Maintenance
Pre-Flight
Daily
Corrosion Inspection
Special Inspections



200 Flight Hour Phase Maintenance to 400 Flight Hour Cycle Service Plan



| | # of Tasks <u>Before</u> RCM |
|-----------------------|------------------------------|
| 200 Flight Hour Phase | 428 |

| | # of Tasks <u>After</u> RCM |
|---|-----------------------------|
| 200 Flight Hour Servicing
and Inspection | 68 |
| 400 Flight Hour Cycle
Service Plan | 48 |
| Total | 116 |



Application of RCM to the CH-47



- RCM implementation began in 2004.
 - In August 2007, the CH-47 achieved its readiness goal of 75% Fully Mission Capable (FMC) for the first time!



CHINOOK (CH47D) TOTAL ARMY

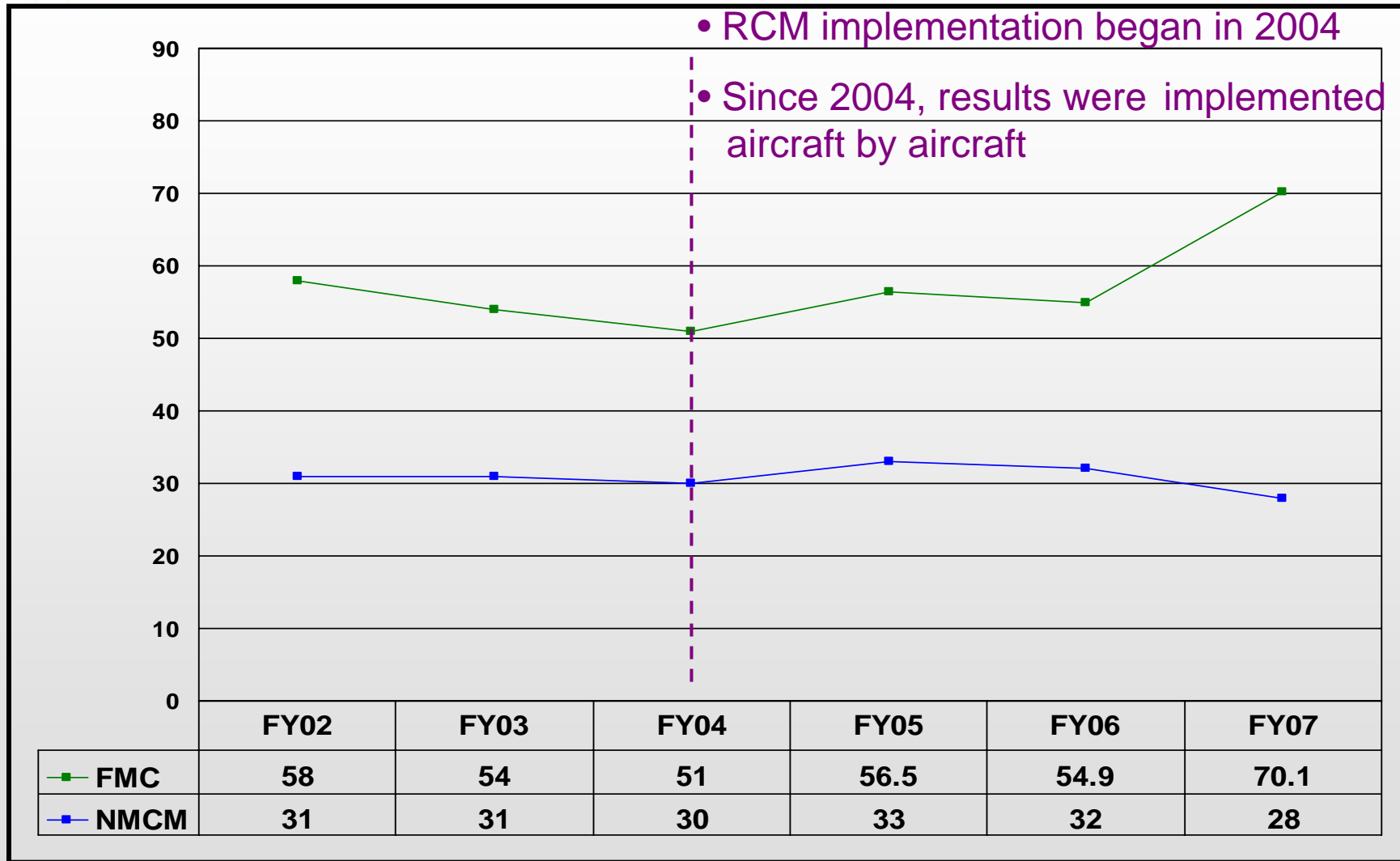

DA GOAL 75% FMC

FY02 – FY07

SOURCE OF DATA: RIDB

**Power and Value of RCM go far
beyond equipment maintenance**

RCM Principles Applied to Special Tools and Test Equipment (STTE)



STTE



- Analysis initiated to determine suitable Basis of Issue (BOI) to support Army Transformation
- BOI for STTE that was being used estimated by Boeing ~1960s
 - Assumption that units stayed together
 - 1 of every applicable Tool was allotted per 25 Helicopters
- Needed to determine suitable BOI so the Field could operate under the new doctrine of Split Based Ops



Army Transformation Affect on STTE



Combat Aviation Brigade (CAB)

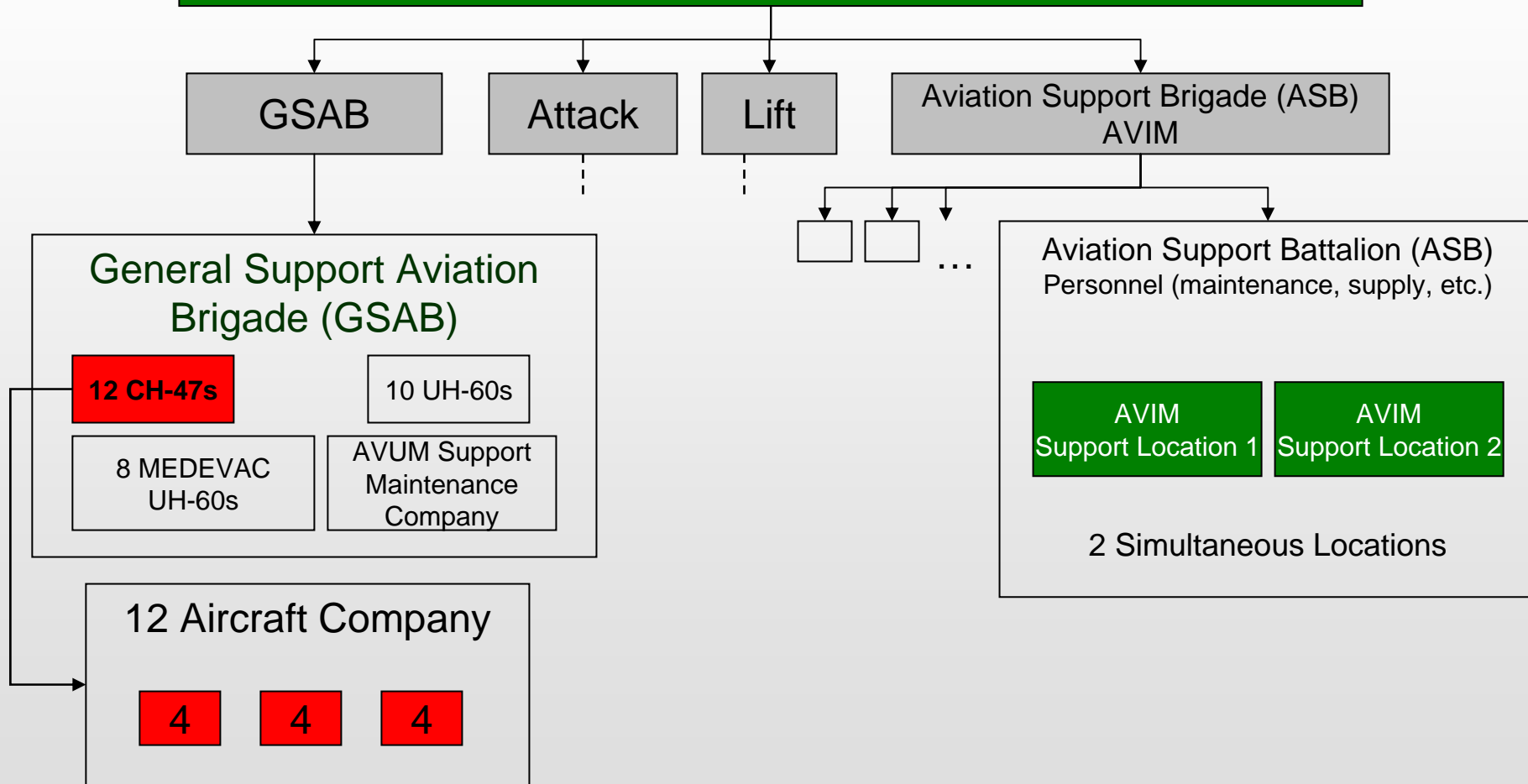



STTE



- How do RCM Principles apply to STTE (tools)?
 - Allows a clear understanding of the Operating Context
 - Reviewed all maintenance tasks and analyzed tools
 - What tools were currently recommended versus what was needed
 - Functions, Functional Failures, Failure Modes and Failure Effects, and Failure Consequences
- Determined new BOI to support Army Transformation



RCM Principles Applied to STTE



"The Big List" Before

- 422 STTE line items

CH-47 STTE After

- 224 STTE line items

- Purged obsolete tools
 - All -712 engine tools purged (~120)
- Many items that were identified as STTE but were common tools
 - Dial Indicator
- Purged unnecessary tools
 - STVA (Self Tuning Vibration Absorber) Trailer Adapter



RCM Principles Applied to STTE



- Increased BOI in most cases
 - *Example: Actuator Safety Blocks and Rotor Head Lockout Pins from 1 set per 25 aircraft to 1 set per aircraft*
 - Field will be supplied with what they need
- Established Accountability
 - In process of putting all STTE on the MTOE (Modified Table of Organization and Equipment)
 - Means it must be inventoried and accounted for
 - Most STTE before this process were not required to be inventoried.



RCM Principles Applied to STTE



- Acquisition of additional STTE began 2 years ago
- First two units equipped in May and June 2007
- Analysis results justified an increase in STTE funding
 - As a results, the PM awarded \$6M additional funding per year for the next 10 years
 - Funds 2 Combat Aviation Brigades
- The real success is that the guy in the Field has the tools he needs!!

Unique Identification



DoD UID Mandate: Parts Marking



- July 2003, Office of the Under Secretary of Defense set forth policy to uniquely identify all legacy and new asset parts with a 2-D barcode if a part meets 1 or more of 5 criteria



- Raises important concerns: *how to mark, where to mark, and how to safely mark*
- CH-47: Approximately 1,000 components required to be marked
- Independent study performed on 300 components



AP



DoD UID Mandate: Parts Marking



- Realized that Parts Marking Decisions in such a critical environment require analysis
- Parts marking solutions identified using RCM Principles
 - Systematic review of all Failure Modes, Failure Effects, and Consequences of each marking opportunity

Systems Engineer

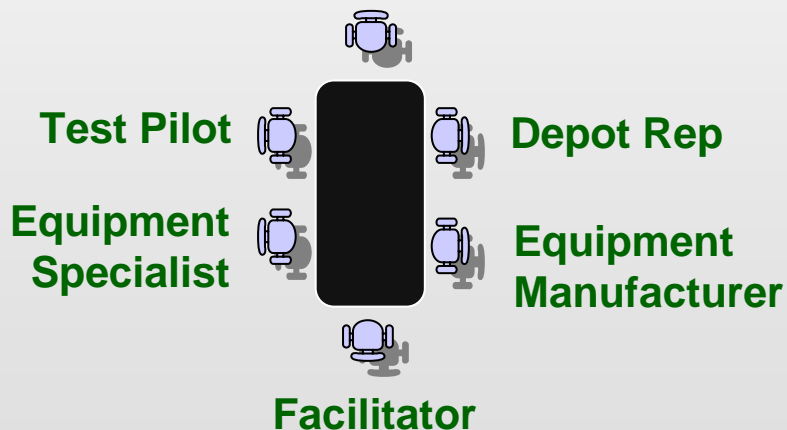

- Facilitated Group Approach
 - Ensures the right people who are sensitive to the hazards of the equipment in its operating environment are the decision makers

- Incorporates safety and operating context into the core of the parts marking decision making.



DoD UID Mandate: Parts Marking



Results:

- ~280 items approved for label marking
- 100 items under review for marking approval
- 167 Direct Part Marking Candidates
- Over 13,000 items marked in the DoD UID registry

CBM+

CBM and RCM

- CBM: Powerful Failure Management Strategy that allows
 - ▶ Impending failure to be identified *before the failure occurs* so that proactive action can be taken in enough time to *manage the consequences of failure*.
 - Ex. Measuring brake pads, eddy current, continuous monitoring, etc.
- In other words, failure is handled on the equipment custodian's terms – *not the equipment's terms*
- CBM and RCM are often mistaken as two different processes. *They are not!*

DoDI 4151.22

- 2 December 2007, Mr. John Young, the Under Secretary of Defense for Acquisition, Technology, and Logistics signed DoDI 4151.22, *Condition Based Maintenance Plus (CBM+) for Materiel Maintenance*
 - ▶ Establishes policy for the application of Reliability Centered Maintenance (RCM) and Condition Based Maintenance Plus (CBM+)
 - ▶ CBM+ is intended ...“to expand the application of sensors on weapons systems enhancing maintenance efficiency and effectiveness...”
 - ▶ CBM must be performed correctly in order to achieve the DoD’s goals.

RCM

- 1. Functions**
- 2. Functional Failures**
- 3. Failure Modes**
- 4. Failure Effects**
- 5. Failure Consequences**
- 6. Proactive Maintenance and Intervals**
- 7. Default Strategies**

RCM

1. Functions
2. Functional Failures
3. Failure Modes
4. Failure Effects
5. Failure Consequences
6. Proactive Maintenance and Intervals
7. Default Strategies

Consideration of Condition Based Maintenance

Start by Identifying Failure Modes to be managed

- Physical assets are managed *at the Failure Mode level*
 - ▶ Failure Mode: What specifically causes a Functional Failure
- CH-47 example
 - ▶ Failure Mode: *Drive shaft hanger bearing wears due to normal use*

Detect Evidence of Impending Failure

- Nearly all Functional Failures give some sort of evidence that failure is imminent.
 - ▶ Referred to as a *Potential Failure Condition* or “P”
- Failure Mode: *Drive shaft hanger bearing wears due to normal use*
 - ▶ P_1 : Vibration that is detectable via a continuous monitoring device applied directly to the equipment.
 - ▶ P_2 : Vibration that is detectable by the crew by feeling the drive shafting area from inside the cabin in flight.

P-F Curve

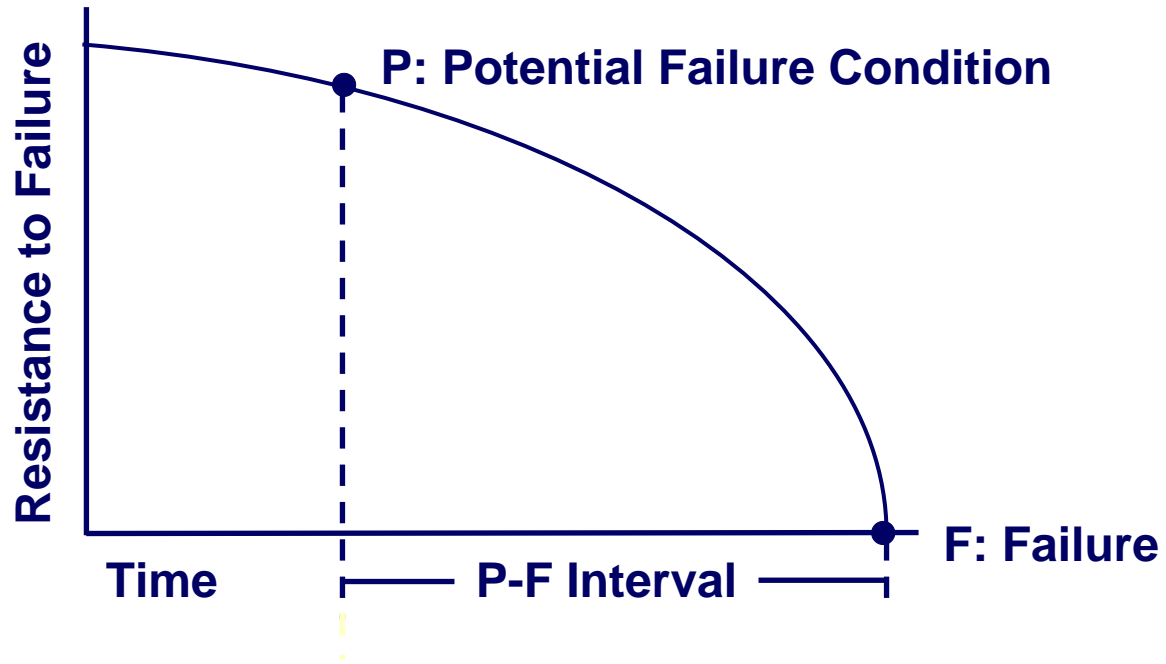

Failure Mode: *Drive Shaft Hanger Bearing wears due to normal use*

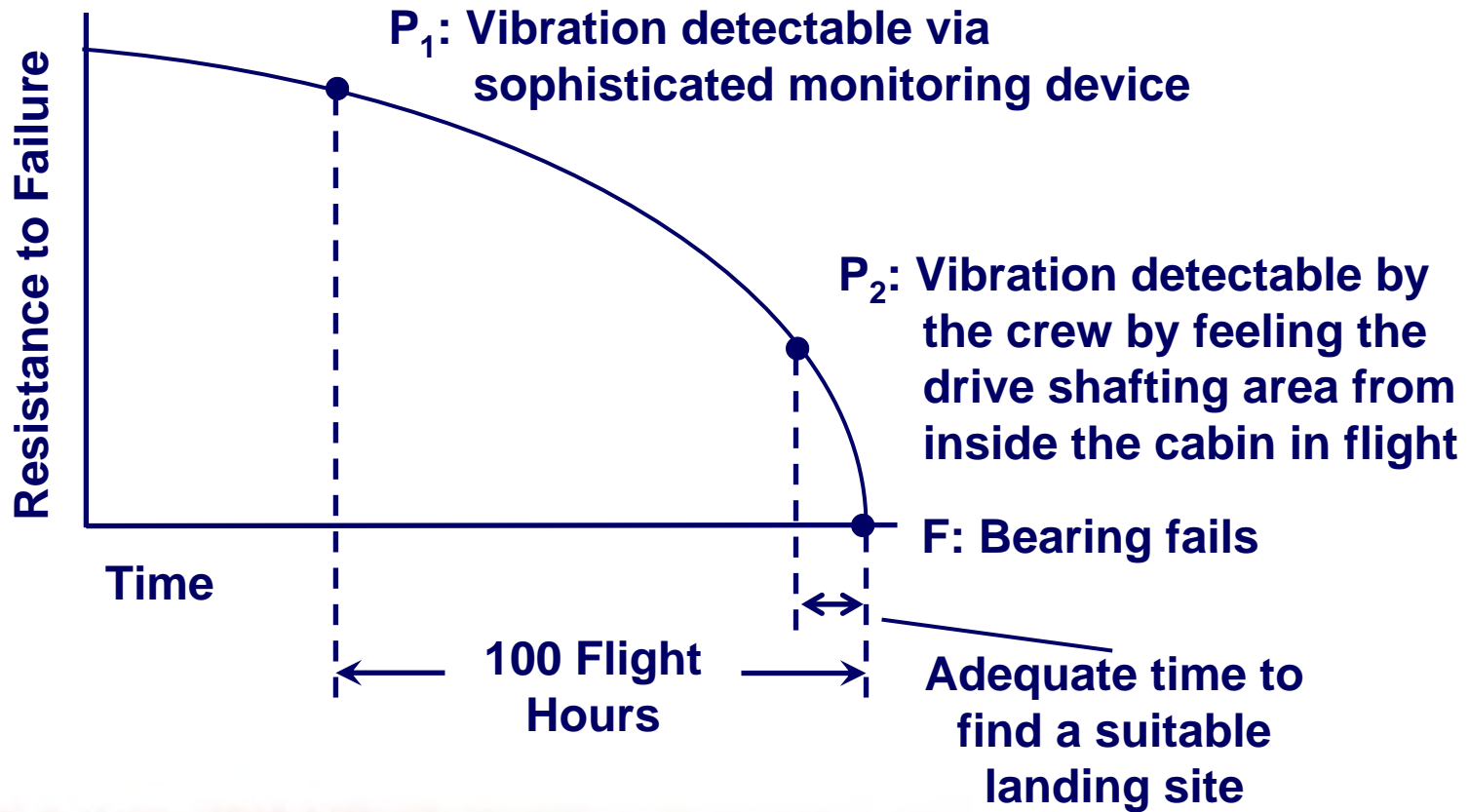

Failure Mode: *Drive Shaft Hanger Bearing wears due to normal use*

- It would likely be practical to check the data at intervals less than 100 flight hours
- It would be equally practical to feel for vibration in flight every 30 minutes

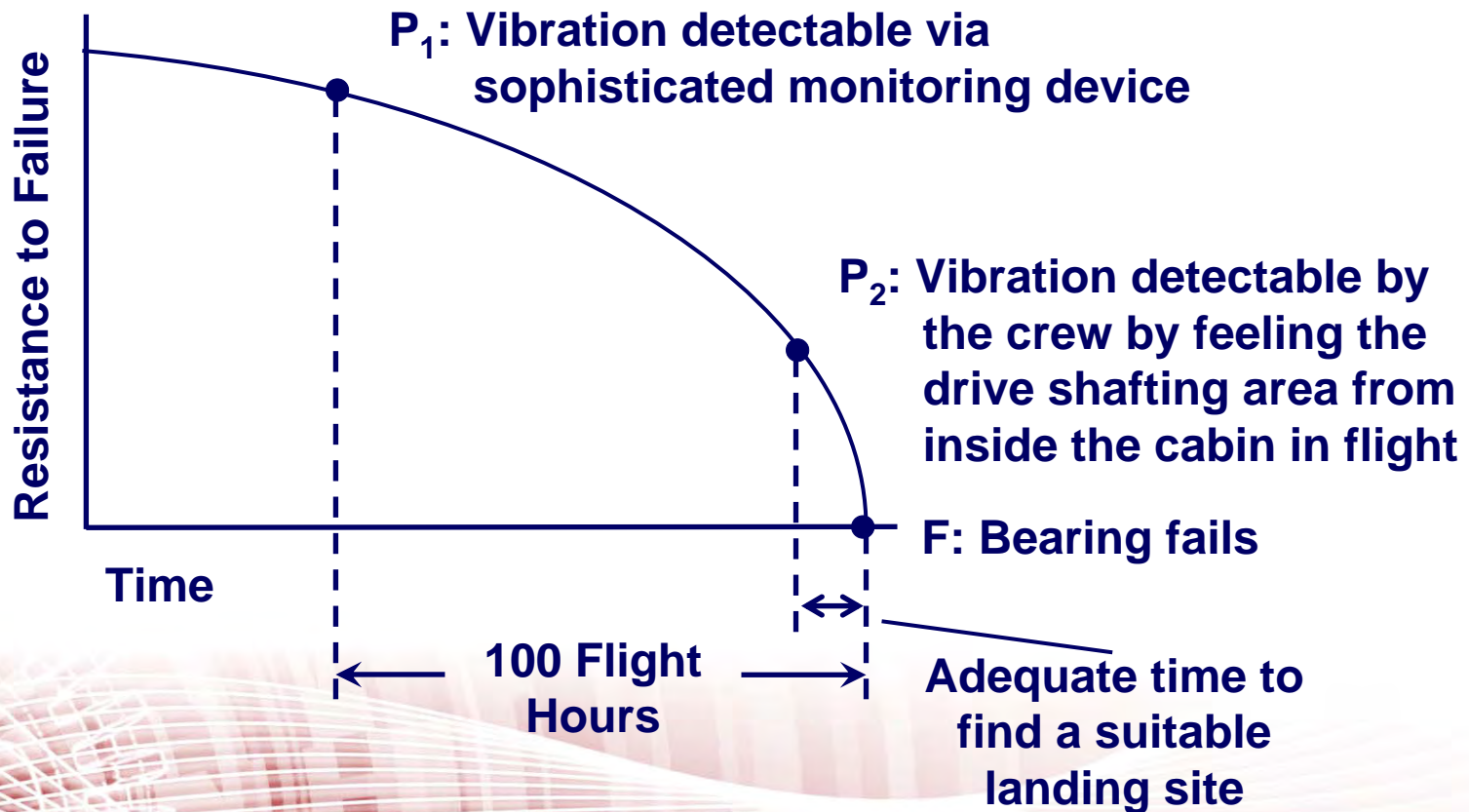



CH-47 CBM+



- 49 specific CH-47 components selected for CBM+ analysis.
- Acknowledge that a FMEA is required to properly implement CBM+ strategy
- Components evaluated to identify Failure Modes that could be monitored.
 - Forward Transmission: 13 Failure Modes such as
 - Stationary ring gear wears due to normal use.
 - FWD transmission 1st stage planetary carrier splines wear due to normal use.
 - FWD transmission spiral bevel pinion gear wears due to normal use.
- Each Failure Mode prioritized for CBM+ Implementation based upon
 - Failure consequences
 - Frequency of failure
 - Effort required for implementation (ex. cost of equipment, training, etc.)
- 161 Failure Modes were identified as candidates for Condition Based Maintenance

RCM Implementation



What RCM Achieved

- *“RCM makes you take a real hard look at what you’re doing.”*
- RCM offers results to better support the Warfighter
 - Reduced Downtime and improved Readiness
 - Reduction of workload to the soldier
 - Relieves unnecessary burdens
 - Improved Health of Aircraft
 - RCM has the ability to change the maintenance philosophy



Nancy Regan

256-428-8868

NancyRegan@TheForceInc.com



Enhancing Systems Engineering Planning and Practices

Sue O'Brien

Acting Director - RSESC

Rotorcraft Systems Engineering and Simulation Center

256-824-6133

obriens@uah.edu

Dawn Sabados, Ph.D.
Research Engineer III



RSESC/Army –

Cost Sharing Cooperative Agreement Initial Goals

- In August 2002 UAH was competitively awarded cooperative agreement – AMRDEC/PEO Aviation and UAHuntsville
 - Establish a technical center to elevate rotorcraft knowledge and skill levels in Northern Alabama headquartered at UAHuntsville.
 - Establish degreed SE academic programs
 - Provide System Engineering Support to Redstone agencies
 - Support the sustaining engineering needs of the Army Aviation
 - Life Cycle Management
 - Systems Engineering
 - Reliability Centered Maintenance
 - Helicopter Aerodynamics

\$1.1 Million Investment by UAH



RSESC

- Multifaceted Organization Focused on Applied Systems Engineering
- Independent Assessments
- Systems Engineering Support
- Hardware Design, Analysis, Fabrication and Testing
- Non Destructive Testing and Evaluation
- Reverse Engineering
- Health Monitoring
- Damage Tolerance

- Projects funded through NASA, PEO Aviation, PEO Missiles and Space, OSD, and Industry

Education and Training

- Developed two new Master of Science Programs
 - Rotorcraft Systems Engineering
 - Missile Systems Engineering
- 56 Master of Science Degrees Conferred – Redstone Engineers
- 2 Current PhD students
- Developing two new AMRDEC / PEO related curricula
 - Reliability Engineering
 - Acquisition Engineering

RSESC Curriculum

MSE–Rotorcraft & Missile Systems Eng.

1st Semester

- Selected Topics in Mathematics
- Statistical Methods for Engineers
- Aircraft Stability and Control

3rd Semester

- Rotorcraft Design II
- Performance Flight Testing
- Modeling and Simulation

2nd Semester

- Helicopter Theory
- Aerospace Systems Engineering
- Rotorcraft Design I

4th Semester

- Engineering Reliability
- System Safety
- Aviation Systems Simulation

1st Semester

- Missile Aerodynamics
- Rocket Propulsion
- Aero Systems Engineering

3rd Semester

- Stability and Control
- Performance Flight Testing
- Reliability Engineering

2nd Semester

- Missile Design
- Graduate Engineering Analysis
- Statistical Methods

4th Semester

- System Simulation
- System Modeling & Analysis
- Integrated Product & Process Design

RSESC Labs

- Two System Engineering Labs w/ full SE software resources
- Aero Simulation Lab
- Electrical and Mechanical Design and Manufacture Lab with a Machine Shop
- Modal Testing
- Environmental Testing
- Systems Design and Testing Lab
- NDE/NDT



SE Planning, Design, Simulate, Develop, Fabricate and Test

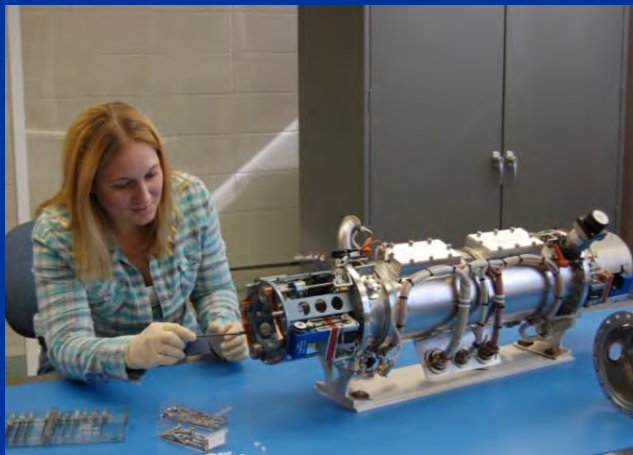
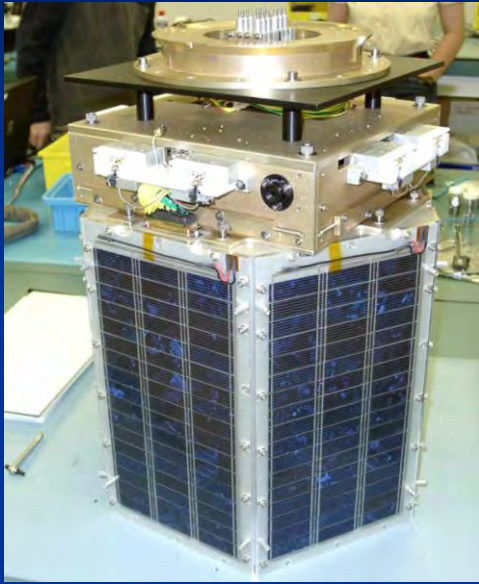

UAHuntsville
Rotorcraft Systems Engineering and Simulation Center

Design and Analysis

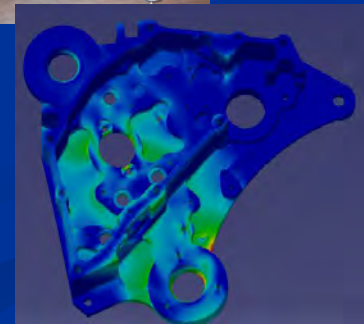
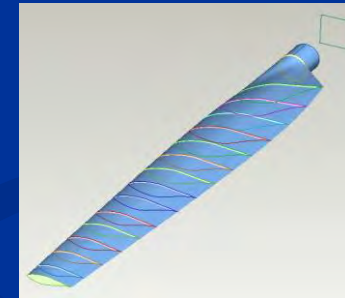

- Prototype Designs
- Independent Analysis
- Specialty Analysis

Systems Engineering Labs

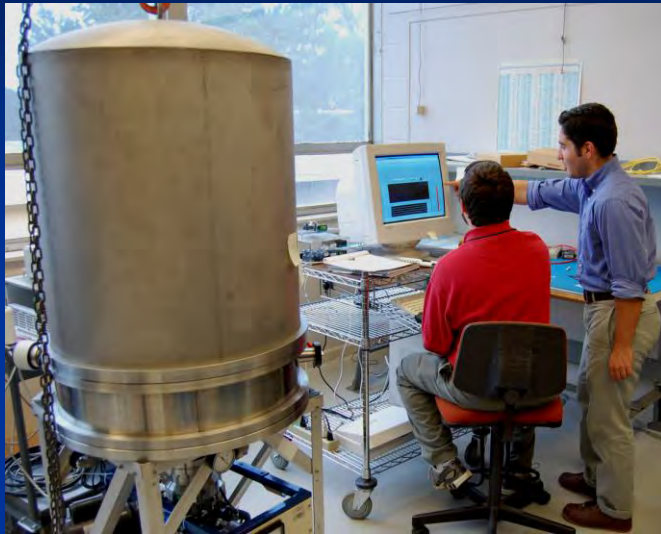

Fully Integrated SE Lab
 Analysis and System Engineering
 Software
 Integrated with CAD Lab,
 Computer Cluster, Rapid
 Prototyping Machines



| KEY PERFORMANCE PARAMETERS
[GO / NO GO CRITERIA] | | COMPANY 1 | | | |
|---|--|----------------|---|-------------------|---|
| | | 9780-0095/0129 | | 9780-0073 / -0074 | |
| K.P.P. 1 | AC: 400Hz, 3 Phase, 115/200V, 47kVA Cont., 69kVA Peak | - | - | - | - |
| | DC: 28V, 210A Cont., 500A Peak | - | - | - | - |
| | HYD.: 12 gpm @ 3350psig (start), 15 gpm @ 3000psig (service) | GO | - | GO | - |
| | PNEU.: 30lb/min @ 30-50 psig | - | - | - | - |

| KEY SYSTEM ATTRIBUTES | | Yes/No | COMMENTS |
|-----------------------|-------------------------|--------|--|
| K.S.A. 1 | Simultaneous Operations | YES | A/C, DC, Hydraulic and Pneumatic |
| K.S.A. 2 | Mobility | ? | Trailer
L X W X H = 13' X 6.9' X 6.9' |
| K.S.A. 3 | Transportability | YES | Weight = 7,700 lbs (wet) |
| K.S.A. 4 | Reliability | ? | |

**Systems Engineering Toolkit
&
System Engineering Projects**

Revitalization of SE in DoD

- In February 2004, the Department of Defense mandated the revitalization of systems engineering throughout all the services
- All acquisition category level programs were required to create system engineering plans (SEP)
- From this mandate the Office of the Deputy Under the Secretary of Defense (OSD) created a SEP Preparation Guide for all programs to follow.

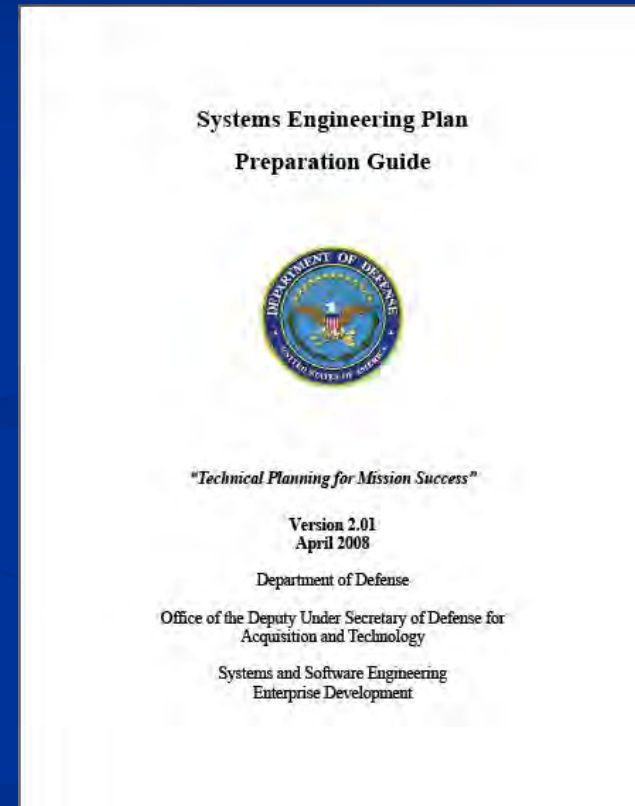

Problem Statement

- Systems Engineering is highly complex subject
- Data is required in many engineering fields
- Metrics need to be determined to ensure systems engineering is performed effectively and efficiently
- One method to collect data and to create metrics was through a web based SE tool

Solution

- The Rotorcraft Center's initial response to support PEO-Aviation and PEO-Missiles and Space in enhancing systems engineering planning was to create a checklist to ensure the requirements for systems planning were met in the SEP.
- This checklist evolved into the Systems Engineering Toolkit to ease the burden of creating a SEP and to create a means for metrics, sharing of information and application based learning to enhance systems engineering planning.

Metric/Effectiveness

- Real time training
- Improved means to determine of areas of difficulty
- Clear Indication of the amount of time to create the document
- Ability to collect statistics on users and level of experience
- Time spent planning rather than formatting and issues with writing a complex document

Systems Engineering Toolkit (SET)

- The Systems Engineering Toolkit presently assists in creating SEPs.
- It is anticipated that future versions will be composed of several systems engineering tools.
- The tool is
 - Configuration Controlled with Global Access
 - Web based for generating Plans and Technical Documents
 - Tailorable to the Projects Needs, Phase and ACAT Level
 - Modular/adaptable system to many different documents, applications, and phases
- Available to DoD agencies

SEP Preparation

- SEP portion of the tool is created from:
 - OSD Preparation Guide
 - DAG Guide
 - Briefings from OSD on SEP content
- Beta Version of SET released June 2007
- SET Version 1.0 released March, 2008 based on SEP Guidance V. 2.01

Title and Coordination Pages
Table of Contents

1. Introduction

1.1 Program Descriptions and Applicable Documents

1.2 Current Program Status

1.3 Approach for SEP Updates

2. Systems

2.1 Systems

2.2 Systems

2.3 Systems

2.4 Technical

2.5 Introduction

1 Introduction

1.1 Program Descriptions and Applicable Documents

1.2 Current Program Status

1.3 Approach for SEP Updates

2 Program Requirements

2.1 Capabilities, Requirements and Concept(s) of Operation

2.2 Other Requirements Linked to the Preferred Systems Concept

2.3 Critical Technologies

2.4 Technology Maturation Cost / Schedule Constraints

2.5 Technology Development and Evolving Acquisition Strategy

3 Technical Staffing and Organizational Planning

3.1 Lead/Chief Systems Engineer and Technical Authorities (Function)

3.2 IPT Organization/Structure

3.3 IPT Staffing/Functional Skills

3.4 IPT Coordination

3.5 Integration with Contractors and External Organizations

4 Technology Maturation and Technical Planning

4.1 Technology Maturation Responsibility

4.2 Requirements Traceability and Verification

4.3 Technical Maturity and Risk

4.4 Mapping the Technical Baseline to the Preferred System Concept

4.5 Updating and Documenting the Preferred System Concept

5 Technical Review Planning

5.1 Event-Driven Technical Reviews

5.2 Technical Review Management

5.3 Independent Chairing of Technical Reviews

5.4 Stakeholder Participation in Technical Reviews

5.5 Peer Participation at Technical Reviews

6 Integration with Overall Management of the Program

6.1 Linkage with Other Program Plans

6.2 Use of Critical Paths and Technical Reviews

6.3 Risk Management Integration

6.4 Test and Evaluation and Life-Cycle Sustainment Integration

6.5 Contracting Considerations

MS A & TD

ODUSD (A&T) Systems and Software Engineering/Enterprise Development
ATL-ED@osd.mil

SEP Preparation Tool

SYSTEMS ENGINEERING SET TOOLKIT

Welcome to the System Engineering Toolkit (SET)

Please log in

User Name

Password

New User?
[Register for SET](#)
Eligibility: DoD, All Service Branches, Government Contractors

Help
[Support](#)
[Users Guide](#)

FAQs
[How do I register for SET?](#)
[How do I reset my password?](#)
[What is SET?](#)

- Integrated review process
- Eight types of users
- Currently creates SEP into PDF documents, unchangeable only from within the SET preparation tool
- Secure and controlled access to programs
- Allows multiple users working on the same document at any time

SEP Planning Tool



Navigation tree based on SEP Preparation Guide TOC

- [Generate Reports](#)
- [Manage Users](#)
- [Configure SEP](#)
- [Title & Coordination](#)
- [Approval Sheet](#)

- Based on OSD Guidance
- 1 Introduction
 - 1.1 Program Description and Applicable Documents
 - 1.2 Current Program Status
 - 1.3 Approach for SEP Updates
 - + 2 Program Requirements
 - + 3 Technical Staffing and Organizational Planning
 - + 4 Technology Maturation and Planning
 - + 5 Technical Review Planning
 - + 6 Integration with Overall Management of the Program

- [Attachments](#)
- [Images](#)
- [Acronym List](#)



[Webmaster](#)
[Disclaimer](#)

[Contact Us](#)
[FAQ](#)

©2007 All Rights Reserved UAH
Patent Pending

Account: Sue O'Brien ([Logout](#)) Active SEP: Tool Demo

Available Documents

| Document | Permissions |
|------------------------------------|-------------------------------|
| Test SEP | Read, Approve, Write |
| TEST SEP2V2 | Write |
| LUH | Admin |
| Aviation Systems Test SEP | Admin |
| Tool Demo | Write, Admin, Version Control |
| Joint Air to Ground Missile (JAGM) | Write, Peer Approve, Admin |
| BlackHawk UH60M | Admin |
| JAVELIN | Admin |

Multiple SEPs and Permission Levels Available to Users

Messages

| Date | From | Subject |
|------|------|---------|
| | | |

Message Area

Section Change Log

| Section | Editor | Date |
|---|--------------|-------------|
| 2.1.i Table of KPPs | Lisa Liever | 22-APR-2008 |
| 3.5.a How will the program facilitate interaction among the SE Working-level Integrated Product Teams (WIPT), other government organizations, and contractors (as applicable) on technical tasks, activities, and responsibilities (e.g. requirements, technical baseline, technical reviews)? How will the program's organization and structure facilitate clear communication of technical guidance among these organizations engaged in SE activities? How will technical review entrance and exit criteria be handled between these organizations? How will the SE WIPT contribute to and document the technical and management approach? | Dawn Sabados | 19-MAR-2008 |

Change Log

Account Options

- [User Options](#)
- [Change Password](#)

©2007 All Rights Reserved UAH
Patent Pending

SEP Planning Tool



[Generate Reports](#) [My Page](#)
[Manage Users](#)
[Configure SEP](#)
[Title & Coordination](#)
[Approval Sheet](#)

- Based on OSD Guidance
- 1 Introduction
 - 1.1 Program Description and Applicable Documents
 - 1.2 Current Program Status
 - 1.3 Approach for SEP Updates
 - + 2 Program Requirements
 - + 3 Technical Staffing and Organizational Planning
 - + 4 Technology Maturation and Planning
 - + 5 Technical Review Planning
 - + 6 Integration with Overall Management of the Program

[Attachments](#)
[Images](#)
[Acronym List](#)



[Webmaster](#)
[Disclaimer](#)

©2007 All Rights Reserved UAH
Patent Pending



[Contact Us](#)
[FAQ](#)

Account: Sue O'Brien ([Logout](#)) Active SEP: Tool Demo

Section not complete. Cannot be submitted at this time.

Current Program Status

- a. Summarize the overall Acquisition Strategy emphasizing that it is event driven.
- b. Provide a program schedule which shows major milestones; SE technical reviews; and notional dates for major events (developmental, operational, and live fire test phases; deliveries; certifications; contract awards; training; site activities, etc.)
- c. Highlight the major activities that tie into independent reviews, risk reduction activities, and program milestones.
- e. What technical refreshes are planned?
- f. What are the top-level risks associated with the program and 6.3. Referencing these sections must be done.
- g. How will the technical requirements be managed?
- d. How does the Acquisition Strategy address the maturity of technologies to be used?

©2007 All Rights Reserved UAH
Patent Pending



[Generate Reports](#) [My Page](#)
[Manage Users](#)
[Title & Coordination](#)
[Approval Sheet](#)

- Based on OSD Guidance
- 1 Introduction
 - 2 Systems Engineering Application to Life Cycle Phases
 - + 2.1 System Capabilities, Requirements, and Design Considerations
 - + 2.2 Systems Engineering Organizational Structure
 - + 2.3 Systems Engineering Process
 - + 2.4 Technical Management and Control
 - + 2.5 Integration with Other Program Management Control Effects

[Attachments](#)
[Images](#)
[Acronym List](#)



[Webmaster](#)
[Disclaimer](#)

©2007 All Rights Reserved UAH
Patent Pending



[Contact Us](#)
[FAQ](#)

Account: Sue O'Brien ([Logout](#)) Active SEP: Joint Air to Ground Missile (JAGM)

b. Given the Requirements outlined in System Capabilities, Requirements, and Design Considerations, who are the appropriate technical authorities?

B / **I** / **U**

The SE Directorate is organized to support each JAMS Product and SE functional area. The JAGM system Division Chief is the JAGM system LSE and coordinates with the Navy counterpart LSE. The LSE's primary responsibility is the day-to-day application of systems engineering principles, processes, and products and coordinates with the SE Director, the JAGM system Product Manager, and JAMS Project Manager (PM) through joint IPT process.



Notes

Para with reference to SEIT was moved to 2.2.1.

Reviewer Comments

| Date | Reviewer | Comment |
|------|----------|---------|
| | | |

©2007 All Rights Reserved UAH
Patent Pending

Document Generation

- Configuration controlled with automatic change logs
- Creates two types of PDF documents

The screenshot displays the SET Toolkit web application interface. The main content area shows a document preview with the following sections:

- 1 Introduction**
Introduce the purpose of the SEP, who will use it, and how it will be used to define the conduct, management, and control of technical aspects of the program from concept to disposal. What are the plans to link the contractor's Systems Engineering Management Plan (SEMP) to the SEP?

Introduce the approach to update the SEP in the Technology Development phase and throughout the life cycle as a living document.
- 1.1 Program Description and Applicable Documents**
Provide a top-level mission description summarizing user requirements documented in the Initial Capabilities Document (ICD) and draft Capability Development Document (CDD).

Enter a top-level system description conveying overall key aspects of the program. Include a notional diagram of the system. Use the appropriate DoD Architecture Framework views (e.g. Operational View-1). (When referencing details in other documents, reference by section and page of the document.)

Below the text is a table titled "Table 1.1 Table of Applicable Documents":

| Document Name | Date | Status | Point of Contact |
|---|------|--------|------------------|
| Discuss the documents tabulated above. What is the relationship between the SEP and these documents? Detail the linkage to other program documents. | | | |

Below the table is section "1.2 Current Program Status":

- 1.2 Current Program Status**
Summarize the overall Acquisition Strategy emphasizing that it is event driven.

Provide a program schedule which shows major milestones; SE technical reviews; and notional dates for major events (developmental, operational, and live fire test phases; deliveries, verifications; contract awards; training; etc activation, etc.)

Highlight the major activities that the program conducted to date such as outcomes of technical reviews, test phases, independent reviews, risk reduction activities, trade studies, etc.

What technical refreshes are planned in the System Development and Demonstration (SDI) phase?

What are the top level risks associated with technology and risk closure plans? Note: there is discussion of risk in sections 4.5 and 6.3. Referencing these sections may be appropriate.

How will the technical requirements and technical risks be addressed given program funding and schedule constraints?

The interface includes a left sidebar with navigation links: "Generate Reports", "My Page", "Manage Users", "Configure SEP", "Title & Coordination", "Approval Sheet", "Based on OSD Guidance", and "Attachments". The bottom right corner shows a sidebar with "Current Version" (Generate Draft), "Document with notes and comments" (Generate Working Copy), and "Previous Versions". The footer contains "UAH" logo, "Webmaster Disclaimer", "Contact Us", "FAQ", and "©2007 All Rights Reserved UAH".

Systems Engineering Toolkit

■ Benefits

- Most up-to-date information
- Ability to leverage strengths of other projects/programs
- Uniformity of Process
- Decrease Approval Timeline
- Team-Based SEP Generation = Consistent Execution
- Minimize “Shelf-Ware”
- Means to collect metrics and best applied practices

■ Ten Organizations interested in or using the tool

- | | |
|---|----------------------------------|
| ■ PEO Aviation | ■ TARDEC |
| ■ PEO Missiles and Space | ■ PEO IEW&S |
| ■ Joint PEO Chemical & Biological Defense | ■ PEO C3T |
| ■ NAVAIR in support of JPEO CBD | ■ PEO CS&CSS |
| ■ AMRDEC | ■ Marines in support of JPEO CBD |

UAHuntsville's Involvement in SE

- Partnership created with AMRDEC in Huntsville to support Project offices in SEP development
- Training, educating and mentoring on tools, metrics and teaming in relation to systems engineering
- Active member of the Army Systems Engineering Forum since its inception
- Reviewing and creating workshops in Systems Engineering Planning for PEO-Aviation, PEO-Missiles and Space and NASA/MSFC
- Developing processes to assist in SE activities for NASA/MSFC
- Determining the effectiveness of SE
- Teaming
- Tailoring for the SEMP and SE Processes
- Modeling and Simulation of SE Processes



Center for Modeling, Simulation and Analysis



College of Engineering

Industrial and Systems Engineering and Engineering Management

Industrial and Systems Engineering and Engineering Management



SER-UARC

- January 23, 2008 OSD sent a notice regarding creating a Systems Engineering Research (SER) University Affiliated Research Center (UARC).
- UAHuntsville partnered with Stevens Institute of Technology, Univ. of Southern CA and 14 other universities
- Two initial tasks have been identified that RSESC will be involved in
 - SE Effectiveness
 - Evaluating Methods, Processes and Tools (MPTs)



U.S. Department of Defense

Office of the Deputy Under Secretary of Defense (Acquisition and Technology) Systems and Software Engineering

Summary

- Vast experience in applied systems engineering processes, hardware and software development to add value to overall project success
- Experience in Systems Engineering and the practices of OSD and NASA
- Utilizing graduate and undergraduates on research projects to combine theory with practical applications and to help mentor engineers and scientists entering in the workforce
- Willing to partner with other universities and organizations bringing together the best assets to the community
- Systems Engineering Toolkit (SET) is available to the DoD PM offices and NASA

UAHuntsville and the Rotorcraft Systems Engineering and Simulation Center is committed to becoming one of the top research centers for Systems Engineering

System Concept of Operations: Standards, Practices and Reality

Nicole Roberts, L-3 Communications

Robert Edson, ANSER

- Problem Statement
- Approach
- What is a CONOPS?
- Standards
- Literature Review
- Case Studies
- Survey
- CONOPS Development Process
- CONOPS Evaluation Criteria
- Recommendations

- Inconsistent and ineffective use of ConOps in the Systems Engineering life cycle.
 - Saw through initial survey
- Objectives
 - Explore Industry Use of ConOps
 - Define a quality ConOps
 - Develop Evaluation Criteria for ConOps goodness

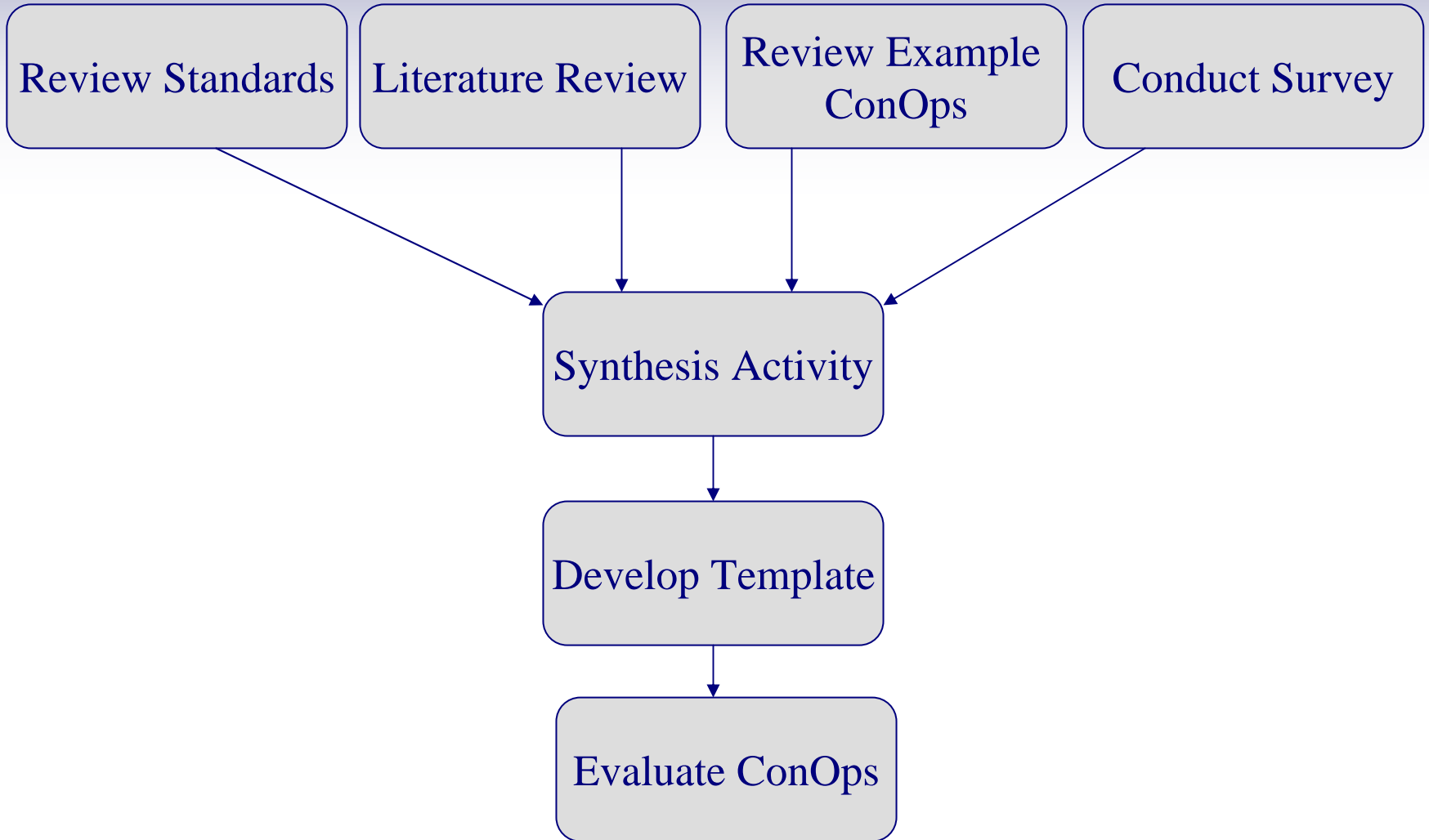

What is a ConOps?

A Concept of Operations (ConOps) document is produced early in the requirements definition process to describe what the system will do (not how it will do it) and why (rationale). It should also define any critical, top-level performance requirements or objectives (stated either qualitatively or quantitatively) and system rationale.

(Systems Engineering Handbook INCOSE-TP-2003-016-02, Version 2a, 1 June 2004)

| Agency | Title | Year | Highlights |
|-------------|---|------|--|
| GEIA | Processes for Engineering a System | 1999 | <ul style="list-style-type: none"> DoD and IEEE approved No details, just says to have one with RFP |
| CMMI | Guidelines for Creating a Product Line Concept of Operations | 1999 | <ul style="list-style-type: none"> Specific for building a ConOps for a large run one product line Good techniques that can be applied to system ConOps also |
| ANSI / AIAA | Guide for the Preparation of Operational Concept Documents | 1992 | <ul style="list-style-type: none"> Names it as an Operational Concept Document (OCD) Most complete instruction for building a ConOps |
| INCOSE | INCOSE Systems Engineering Handbook | 2004 | <ul style="list-style-type: none"> Defines what a ConOps is and should include Does not give instruction on how to build one Describes what other phases it is an input to |
| IEEE | IEEE Guide for Information Technology – System Definition – Concept of Operations (ConOps) Document | 1998 | <ul style="list-style-type: none"> Gives instruction on how to build a ConOps and what to include Focused on software but can be used for other Only one that says to include proposed systems in this document |

■ Definitions

- To clearly define the operational boundaries and to capture the needs of the user community. (Herald and Verma)
- Provide stakeholder consensus, measures of effectiveness, standards of acceptance and system design/architecting purposes. (Ring)
- To provide verified accurate work process information to validate and defend projects and enable management decisions. (Nichols)
- A document that focuses on the achievement, performance and basic technological necessities of the system. (Cakmak and Gokpinar)

- Reviewed 6 ConOps
- 50% appear to be satisfactory
- Example: SOFIA Science and Mission Operations Plan
 - Focus on system use
 - List of key personnel and their responsibilities
 - Use of system by personnel
 - Facilities information
 - Training, support, logistics and maintenance information included

- Conducted to understand how industry is using ConOps and what is considered a ConOps
- 27 Questions
- 3 Sections
 - Basic Overview of the individual and ConOps use
 - Questions for people who have worked with ConOps
 - Questions for those who have been a ConOps author
- 108 responses from 18 companies and organizations
 - DoD, L-3 Communications, Raytheon, Boeing, Lockheed Martin, USAF, Bell Helicopter, Texas Instruments, Honeywell, General Dynamics, Army, and more

Survey Results: Demographics

- 48% Systems or Lead Systems Engineers
- From 1 month to 54 years in the industry
- Worked between 1 and 100 programs with 19.9 as the average

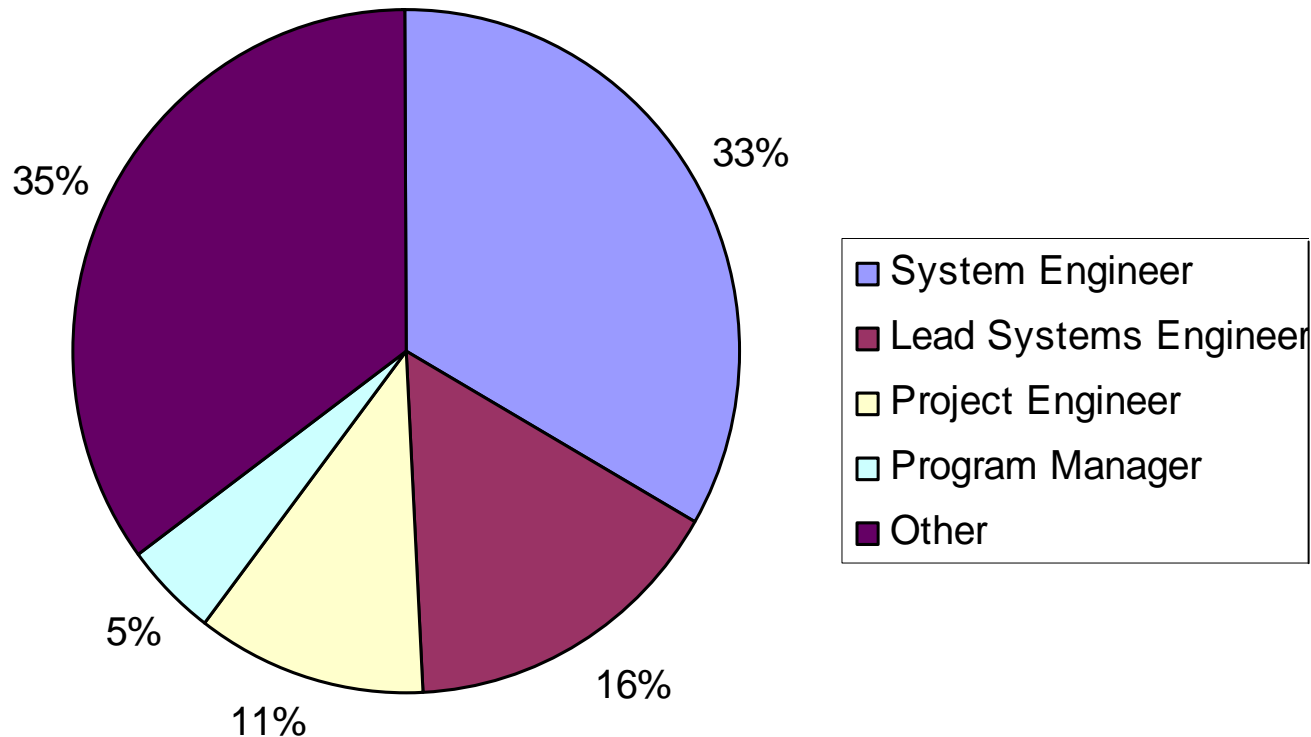

- 100% said they would find one useful
- 36% have never worked a program with a ConOps
- Stated ConOps Purpose
 - 89% - Define the system use
 - 71% - Define the system boundaries
 - 37% - Define the system
 - 28% - Define system details
- Program Phases to be helped by ConOps
 - 88% - Requirements Development
 - 83% - System Design
 - 70% - Planning for Test

Survey Results: ConOp Experience

- Average number of programs with a fully developed ConOps is 4.4
- 36% have never worked a program with a ConOps
- 76% of those who have worked with a ConOps ranked them as a 4 or 5
- 85% of those who worked with a ConOps had regular access to it

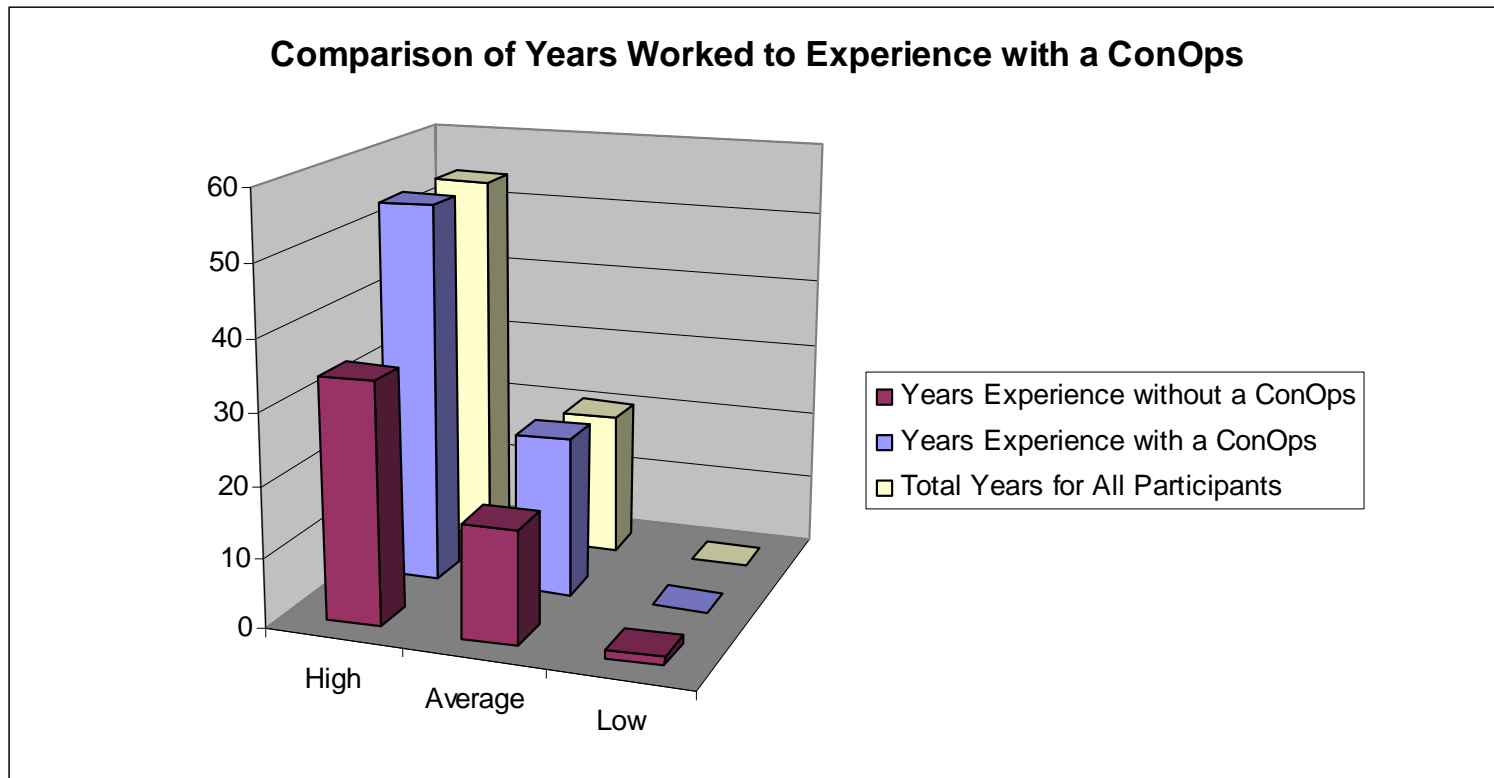

- 31% completed by bid phase, 27% by program start-up
- 50% were not updated throughout the lifecycle
- 76% of the ConOps were written and graphical
- 28% of respondents have been an author
- 55% of authors were a systems or lead systems engineer
- Customer involved 74% of the time and user 70% with 11 people involved on average
- 3% of the time no one besides the author was involved
- Standards used 50% of the time
- Average time to develop is 78 days
- 75% of the time the author personally used the ConOps

- Everyone wants a ConOps but only one-third of all programs have one
- Requirements Development and System Design would be helped most by a ConOps
- Need qualified, experienced systems engineer developing the ConOps with multiple inputs
- Industry is not utilizing developed ConOps to their advantage throughout the lifecycle – Only 4% used through to the end

- Do not list any specifics
- Do not describe how a process or how a function should be performed only list the needs
- Include all stakeholders or representatives for each area
- Limit the group to less than fifteen people
- Representatives need the authority to make final decisions
- Have everyone convene in one place at the same time at least twice
- Author/moderator needs the skills to guide the group and keep them on track
- Get interviews with all users not in the group then share
- Limit the document size without limiting the information
- Make sure the level of language is not too technical to understand
- Customize. Include information and change the format so all understand the needs

ConOps Development Outline

| Section Number | Title | Key Elements |
|----------------|---------------------------|---|
| 1 | Introduction | <ul style="list-style-type: none"> - Brief overview - Stakeholders |
| 2 | References | |
| 3 | Problem Statement | <ul style="list-style-type: none"> - High level problem statement |
| 4 | Program or System History | <ul style="list-style-type: none"> - Current likes and dislikes - Current needs |
| 5 | System Use | <p>Detailed explanation of the system use including</p> <ul style="list-style-type: none"> - Users - External system interfaces |
| 6 | System Boundaries | <ul style="list-style-type: none"> - Graphic representation of the external system interfaces - Text explanation of the details of each interface |
| 7 | System Environment | <ul style="list-style-type: none"> - Basic system operating environment - Operator environment - Maintainer environment |

ConOps Development Outline

| Section Number | Title | Key Elements |
|----------------|--------------------------|---|
| 8 | Constraints | <p>Details that are truly a must to be designed around, possibly including:</p> <ul style="list-style-type: none"> -Cost -Technologies -Weight -Space to design in -Performance -Schedule -Power -Life expectancy -Environment |
| 9 | System Models | Models or simulations that help to show how the system will be used |
| 9 | System Peripherals | <ul style="list-style-type: none"> -Training -Supportability -Maintainability |
| 10 | Expected Output | <ul style="list-style-type: none"> - Summary of what is to be done - Prioritization of what is to be done - Measure of effectiveness |
| 11 | Acronyms and Definitions | |

- Does it include all required sections
 - If not is there sufficient reasoning why not
 - If there are more, is it too much information
- Were all stakeholder groups represented
- Does it define just the needs and not the how
- Does it include all standards the system will be required to adhere to
- Does it include the system boundaries and inputs and outputs
- Model to prove that the system is possible with all the information given

- All systems should have a Concept of Operations
- Use the ANSI/AIAA standard for help
- ConOps initial development should be done before requirements development if not earlier
- ConOps should be updated throughout the program lifecycle
- ConOps should be controlled and made accessible to all stakeholders working on the program
- If you do not know what you are trying to get you will never know if you accomplished it or not
- The contractor should own their ConOps but ensure customer involvement during updates

Questions?

The background of the slide is a deep blue space scene. On the left, a large portion of the Earth is visible, showing continents and oceans. In the upper left, a bright sun or star is partially obscured by a red, glowing ring, creating a lens flare effect. The Northrop Grumman logo is positioned in the upper right corner.

NORTHROP GRUMMAN

DEFINING THE FUTURE

Counting Software Size: Is It as Easy as Buying A Gallon of Gas?

October 22, 2008

NDIA – 11th Annual Systems Engineering Conference
Lori Vaughan and Dean Caccavo
Northrop Grumman Mission Systems
Office of Cost Estimation and Risk Analysis

Agenda

- Introduction
- Standards and Definitions
- Sample
- Implications
- Summary

Introduction



- In what ways is software like gasoline?
- In what ways is software not like gasoline?



Is There a Standard for Counting Software?

- Since, increasing percent of our DoD systems are reliant on software we need to be able to quantify the software size
 - Historical data collection
 - Estimation and planning
 - Tracking and monitoring during program performance
- Software effort is proportional to the size of the software being developed
 - *SW Engineering Economics* 1981 by Dr. Barry Boehm
- “Counting” infers there is a standard
- Experience as a prime integrator
 - Do not see a standard being followed

There are software counting standards but the message isn't out or it is not being followed consistently

From Wikipedia, the free encyclopedia

Source lines of code (SLOC) is a [software metric](#) used to measure the size of a [software program](#) by counting the number of lines in the text of the program's [source code](#). SLOC is typically used to predict the amount of effort that will be required to develop a program, as well as to estimate [programming productivity](#) or effort once the software is produced."

- Variety of Software Languages in which source code is written
 - A to Z
 - Ada, Assembler, C, C++, C#, COBOL, Fortran, Java, JavaScript, Pascal, Perl and SQL to name just a few

Source Line of Code definition: Physical and Logical

- Software Engineering Institute (SEI) has developed checklist as part of a system of definition checklists to support measurement definitions
[Software Size Measurement: A Framework for Counting Source Statements.](#)

Definition Checklist for Source Statement Counts

Definition name: Logical Source Statements Date: 8/7/92
(basic definition) Originator: SEI

Measurement unit: Physical source lines
 Logical source statements

| Statement type | Definition <input checked="" type="checkbox"/> | Data array <input type="checkbox"/> | Includes | Excludes |
|---|--|-------------------------------------|----------|----------|
| <i>When a line or statement contains more than one type, classify it as the type with the highest precedence.</i> | | | | |
| 1 Executable | Order of precedence -> | | 1 | ✓ |
| 2 Nonexecutable | | | 2 | ✓ |
| 3 Declarations | | | 3 | ✓ |
| 4 Compiler directives | | | | |
| 5 Comments | | | | |
| 6 On their own lines | | | 4 | ✓ |
| 7 On lines with source code | | | 5 | ✓ |
| 8 Banners and nonblank spacers | | | 6 | ✓ |
| 9 Blank (empty) comments | | | 7 | ✓ |
| 10 Blank lines | | | 8 | ✓ |
| 11 | | | | |
| 12 | | | | |

- Physical SLOC: One physical SLOC is corresponding to one line starting with the first character and ending by carriage return or an end of file marker of the same line and which excludes the blank and comment line.
- Logical SLOC: Lines of code intended to measure “statements” which normally terminated with a semicolon or a carriage return. Logical SLOC are not sensitive to format, style and conventions, but they are language dependent.

Source Line of Code Samples

```
for (i=0; i<100; ++i) printf("hello"); /* How many lines of code is this? */
```

- 1 Physical Line of Code LOC
- 2 Logical Lines of Code LOC (for statement and `printf` statement)
- 1 Comment Line

```
for (i=0; i<100; ++i)
```

```
{
```

```
printf("hello");
```

```
} /* Now how many lines of code is this? */
```

- 4 Physical Lines of Code LOC (Is placing braces work to be estimated?)
- 2 Logical Line of Code LOC (What about all the work writing non-statement lines?)
- 1 Comment Line (Tools must account for all code and comments regardless of comment placement.)

Note the logical count is independent of the programming style and conventions

Implications of SLOC Counts

Typical Simplified Software Cost Estimation Formula



- Suppose you were given this simplified software cost formula and you received data from two separate contractors and were asked to determine relative development costs?
- What would that impact?
 - Size
 - Productivity
 - Hours

Implication Illustration – Historical

Contractor A

Physical Coordinate Perspective

| | |
|--------------|---|
| SLOC Count | 500 KSLOC |
| Effort | 2500 Person Months (PM) |
| Productivity | 500 KSLOC ÷ 2500 PM = 200 ESLOC/PM |

Contractor B

Logical Coordinate Perspective

| | |
|--------------|---|
| SLOC Count | 312.5 KSLOC |
| Effort | 2500 (PM) |
| Productivity | 312.5 KSLOC ÷ 2500 PM = 125 ESLOC/PM |

Without understanding the basis of the Software SLOC count, it looks like Contractor A is more productive. Is this correct?

Implication Illustration – Estimate Comparison

Contractor A

| | |
|-------------------------|--------------------------------------|
| Estimated Size | 600 KSLOC |
| Historical Productivity | 200 ESLOC/PM |
| Estimated Effort | 3,000 PM |
| Estimated Cost | 3,000 PM X
\$20K = \$ 60 M |

Contractor B

| | |
|-------------------------|--------------------------------------|
| Estimated Size | 600 KSLOC |
| Historical Productivity | 125 ESLOC/PM |
| Estimated Effort | 4,800 PM |
| Estimated Cost | 4,800 PM X
\$20K = \$ 96 M |

- Attributes of a good code counter
 - Non Proprietary
 - Available to the public
 - Platform independent
 - Support multiple programming languages
 - Count both physical and logical SLOC
 - Limited Public License or “Copyleft” type agr
- <http://sunset.usc.edu/research/CODECOUNT/>



Sample 1.0::SLOC Counting

The Totals

| <i>Total Lines</i> | <i>Blank Lines</i> | <i>Comments Whole</i> | <i>Comments Embedded</i> | <i>Compiler Data Direct.</i> | <i>Compiler Data Decl.</i> | <i>Exec. Instr.</i> | <i>Number of Files</i> | <i>File SLOC</i> | <i>SLOC Type</i> | <i>Definition</i> |
|--------------------|--------------------|-----------------------|--------------------------|------------------------------|----------------------------|---------------------|------------------------|------------------|------------------|-------------------|
| 33991 | 3855 | 8465 | 19 | 250 | 6815 | 14606 | 336 | 21671 | CODE | Physical |
| 33991 | 3855 | 8465 | 19 | 250 | 2775 | 10667 | 336 | 13692 | CODE | Logical |
| 1135 | 42 | 0 | 0 | 0 | 1093 | 0 | 47 | 1093 | DATA | Physical |

Number of files successfully accessed..... 383 out of 383

Ratio of Physical to Logical SLOC..... 1.58

- What programming languages are covered today
 - Ada , Assembler(s), Jovial, Pascal, COBOL, Fortran, MUL – Markup Language, Java, C/C++ , C#, JavaScript, Visual Basic and Visual Basic Script
- What is included for each language
 - Read me file
 - Logical Standard (word table)
 - C source code of language specific counter
 - Sample input, source files and output file

***USC Center for Systems and Software Engineering (CSSE) CodeCount™
suite supports many languages***

Imagine Software Code Counting...

- As an integral part of your program's change management system
- Improving your ability to perform Root cause Analysis
- Normalized code counts of existing software that are automatically uploaded to your historical database
- A historical repository of software size that could be used for estimation purposes and parametric model calibration
- Improving the representative nature of Parametric and Predictive Modeling
- Being consistent....

Summary

- Recognize underlying implications of Physical and Logical software sizing
- Assess appropriateness and magnitude of code count measurement
- Consider widespread standardization and integration into acquisition process



NORTHROP GRUMMAN

DEFINING THE FUTURE

The background of the slide is a deep blue space scene. On the left, a large portion of the Earth is visible, showing continents and clouds. In the upper left, a bright sun or star is partially obscured by a lens flare effect, with a red and orange glow. The overall atmosphere is futuristic and high-tech.

NORTHROP GRUMMAN

DEFINING THE FUTURE

Reuse Readiness Levels: A Framework for Decision Making

NDIA Systems Engineering Conference
October 20-23, 2008

Steven Wong
Northrop Grumman Mission Systems

- Reuse and Maturity
- Measures of Maturity - Technology Readiness Levels
 - Background
 - Applicability to Software
 - Limitations
- Reuse Readiness Levels
 - Motivation
 - Background
 - SEI
 - NASA
 - Northrop Grumman Approach
 - Reuse Attributes
 - Decision Analysis Resolution Process
- Outcomes

To Reuse or Not to Reuse Software?

- “Good reuse ” economizes time and money; ensures quality
 - Increased dependability
 - Compliance to standards
 - Accelerated development
 - Economies of Scale
 - Reduce product and process risk
- “Bad reuse ” introduces risk resulting in cost and schedule growth
 - Incompatibility
 - Obsolescence
 - Breakage
 - Requirements differences
 - Unfamiliarity

How can one make an *a priori* distinction between good and bad reuse?

7.5. -- Technology Maturity

Technology maturity shall measure the degree to which proposed critical technologies meet program objectives. **Technology maturity is a principal element of program risk.** A technology readiness assessment shall examine program concepts, technology requirements, and demonstrated technology capabilities to determine technological maturity.

The PM shall identify critical technologies via the work breakdown structure (WBS) (see 5.3.1). **Technology readiness assessments for critical technologies shall occur sufficiently prior to milestone decision points B and C to provide useful technology maturity information to the acquisition review process.**

The Component Science and Technology (S&T) Executive shall direct the technology readiness assessment and, for ACAT ID and ACAT IA programs, **submit the findings to the Deputy Under Secretary of Defense (S&T) (DUSD(S&T)) with a recommended technology readiness level (TRL) for each critical technology.** In cooperation with the Component S&T Executive and the program office, the DUSD(S&T) shall evaluate the technology readiness assessment and, if he/she concurs, forward findings to the OIPT leader and DAB. If the DUSD(S&T) does not concur with the technology readiness assessment findings, an independent technology readiness assessment, under the direction of the DUSD(S&T), shall be required.

A Definition

- *Technology Readiness Levels (TRL)* are used to assess the maturity of a practically-applied scientific/engineering invention (materials, components, methods, devices, etc.) prior to its incorporation into a system
- A method for assessing how much **risk** is potentially involved with adopting a technology
- TRLs assume that a technology is less suitable for immediate usage when it is newly invented or conceptualized
- A technology becomes sufficiently proven (i.e., mature) after being subjected to experimentation, refinement, and increasingly demonstrated and tested in a realistic environment
- Examples: Hardware TRL, Software TRL, Manufacturing TRL, Biomedical TRL



Technology Readiness Levels

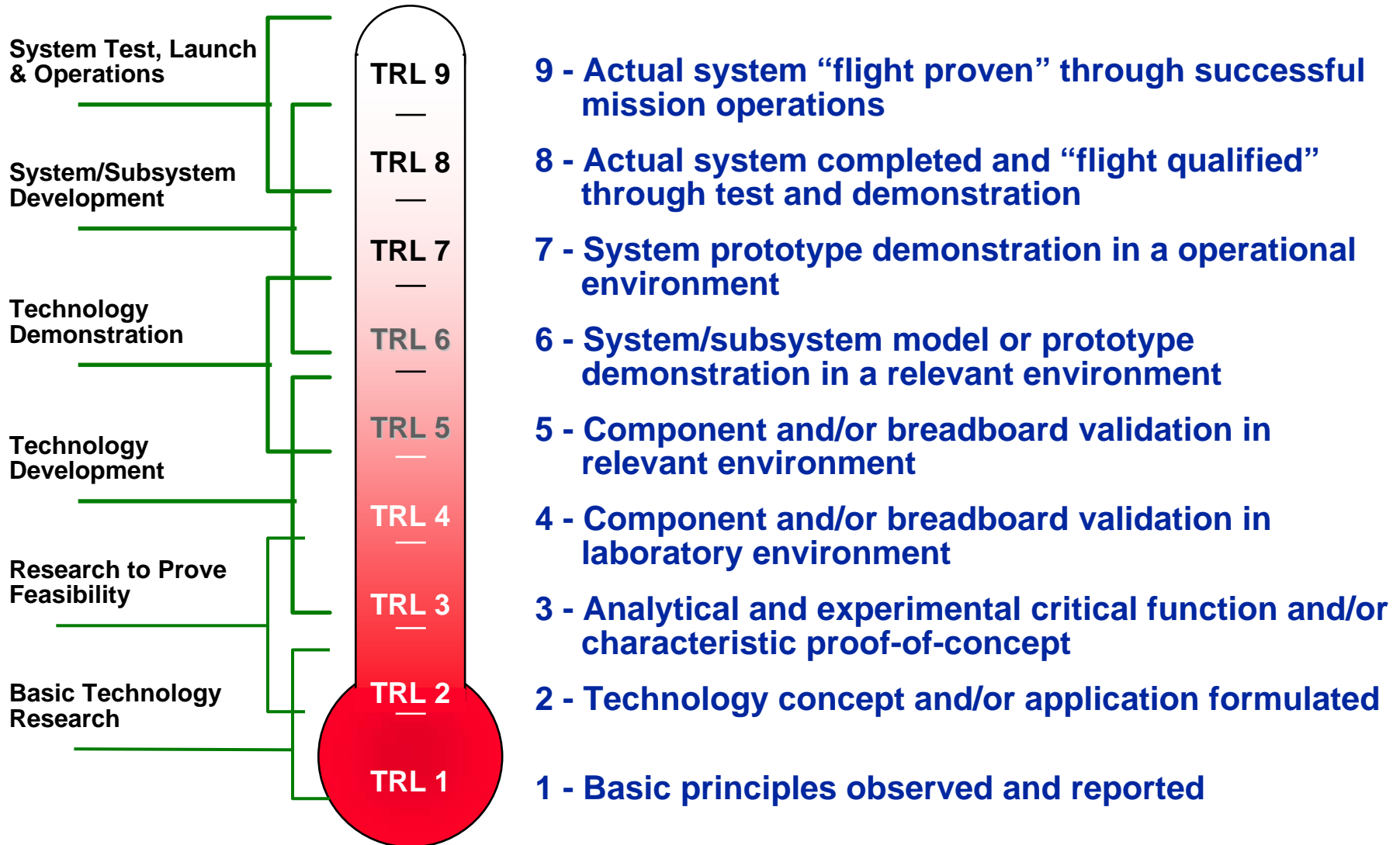

Software Readiness Levels (SWRL) Missile Defense Agency (MDA)

Engineering Manufacturing Readiness Levels (Hardware)

- **EMRL 1**
 - Breadboard
 - **EMRL 2**
 - Prototype
 - **EMRL 3**
 - Advanced development
 - **EMRL 4**
 - Similar production
 - **EMRL 5**
 - FRP
- **SWRL 1**
 - Concept
 - **SWRL 2**
 - Prototype
 - **SWRL 3**
 - Development
 - **SWRL 4**
 - Functional
 - **SWRL 5**
 - Deployable

Software Readiness Levels

Concept Design

SWRL 2

DR1

SWRL 4

DR2

SWRL 5

Capability Demonstration



TRL Software Descriptions – DUSD(S&T) TRA Deskbook 2005



| Technology Readiness Level | Software Description |
|--|---|
| 1. Basic principles observed and reported | Lowest level of software technology readiness. A new software domain is being investigated by the basic research community. This level extends to the development of basic use, basic properties of software architecture, mathematical formulations, and general algorithms. |
| 2. Technology concept and/or application formulated | Once basic principles are observed, practical applications can be invented. Applications are speculative, and there may be no proof or detailed analysis to support the assumptions. Examples are limited to analytic studies using synthetic data. |
| 3. Analytical and experimental critical function and/or characteristic proof of concept | Active R&D is initiated. The level at which scientific feasibility is demonstrated through analytical and laboratory studies. This level extends to the development of limited functionality environments to validate critical properties and analytical predictions using nonintegrated software components and partially representative data. |
| 4. Module and/or subsystem validation in a laboratory environment (i.e., software Prototype development environment). | Basic software components are integrated to establish that they will work together. They are relatively primitive with regard to efficiency and robustness compared with the eventual system. Architecture development initiated to include interoperability, reliability, maintainability, extensibility, scalability, and security issues. Emulation with current/legacy elements as appropriate. Prototypes developed to demonstrate different aspects of eventual system. |
| 5. Module and/or subsystem validation in a relevant Environment | Level at which software technology is ready to start integration with existing systems. The prototype implementations conform to target environment / interfaces. Experiments with realistic problems. Simulated interfaces to existing systems. System software architecture established. Algorithms run on a processor(s) with characteristics expected in the operational environment. |
| 6. Module and/or subsystem validation in a relevant end-to-end environment) | Level at which the engineering feasibility of a software technology is demonstrated. This level extends to laboratory prototype implementations on full-scale realistic problems in which the software technology is partially integrated with existing hardware/software systems |
| 7. System prototype demonstration in an operational high-fidelity environment | Level at which the program feasibility of a software technology is demonstrated. This level extends to operational environment prototype implementations where critical technical risk functionality is available for demonstration and a test in which the software technology is well integrated with operational hardware/software systems. |
| 8. Actual system completed and mission qualified through test and demonstration in an operational environment | Level at which a software technology is fully integrated with operational hardware and software systems. Software development documentation is complete. All functionality tested in simulated and operational scenarios. |
| 9. Actual system proven through successful mission-proven operational capabilities | Level at which a software technology is <u>readily repeatable and reusable</u> . The software based on the technology is fully integrated with operational hardware/software systems. All software documentation verified. Successful operational experience. Sustaining software engineering support in place. Actual system. |

- Software differs from hardware in that taking an operational product and using it in a new context or system does not necessarily correlate to system success in performance or in achieving planned cost and schedule benefits
 - In some situations it may introduce more complications and problems than if the code was not reused



- TRLs inherently assume “good reuse”
 - Increased dependability
 - Reduce product and process risk
 - Accelerated development
- TRLs do not adequately address “bad reuse” or COTS/GOTS and OSS
 - Obsolescence
 - Breakage
 - Requirements and usage differences
 - Unfamiliarity

Software Reuse Root Cause Analysis

Six Sigma Project #1299

Reusable components

Product requirements

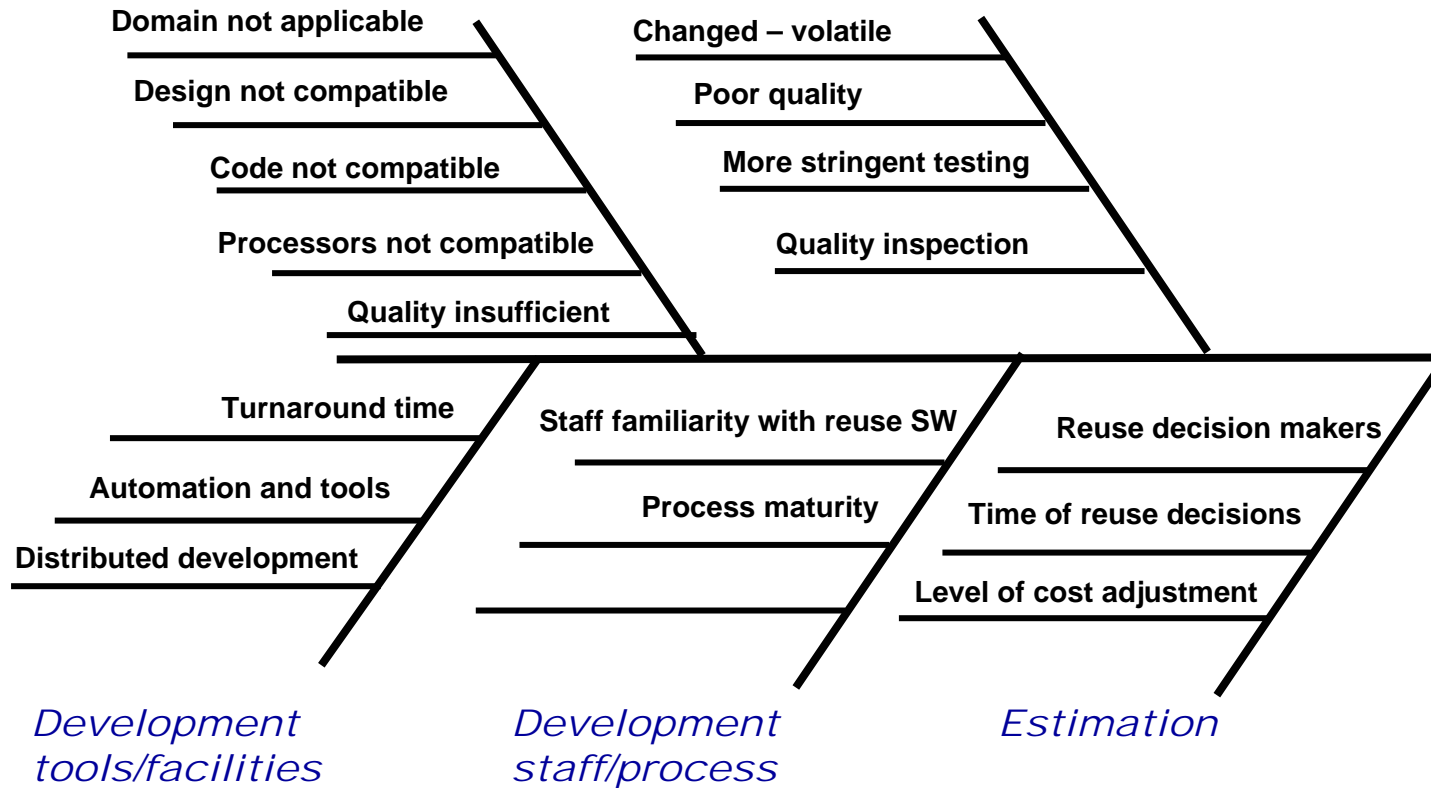

SW reuse is less than planned because of:

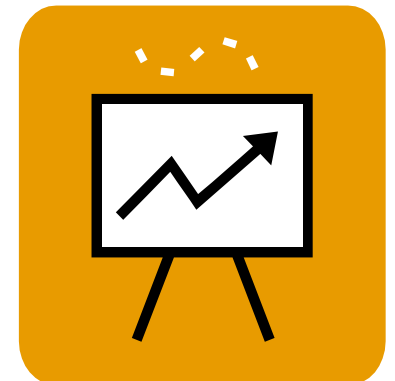

RRL Background

Software Engineering Institute (SEI)



- TRL for Non-Developmental Item Software (Smith 2004)
 - Requirements Satisfaction
 - Rates how well requirements, including functional (e.g., throughput, accuracy, latency) and non-functional (e.g., reliability, maintainability) are allocated to a given software product or technology to be satisfied by it.
 - Accounts for the number of requirements are satisfied as well as any provided functionality that is not required
 - Environmental Fidelity
 - Addresses how faithfully the development environment of the software asset has been demonstrated to operate in the target operational environment.
 - Product Criticality
 - The degree to which the target system is dependent upon, or inseparable from the product or technology.
 - Product Aging
 - The availability of the product over its lifespan relative to the requirements of the system under development
 - Product Maturity
 - Maturity of the software product or technology relative to three distinct modes/domains: COTS, GOTS, OSS

RRL Background

SEI (page 2)

- ImpACT Methodology for COTS (Smith 2005)
 - Importance
 - Criticality to the system; difficulty of effecting a work-around if the technology or product doesn't work (or isn't available)
 - Availability
 - The degree to which the product or technology is commercially available
 - Capability
 - The functional fit (or misfit) between the product or technology and the requirements of the system
 - Timeframe
 - A measure of how the lifecycle of the product or technology matches the lifecycle for the system. Will it be available when needed? Over the life of the system?



National Aeronautics and Space Agency (NASA)

- NASA Earth Science Data Systems (ESDS) Software Reuse Working Group (Wolfe, Marshall, 2007-2008)
 - Determine reuse maturity of software assets being prepared for reuse
 - Initially developed for the Earth science domain, applicable to general
 - Promote, facilitate, catalog and incentivize reuse
 - Reuse Enablement System
 - Web-based portal, Reuse metadata of an existing software asset
 - Aligned with familiar 1-9 scale TRL
- Topic Areas
 - Portability
 - Extensibility
 - Documentation
 - Support
 - Packaging
 - Intellectual Property
 - Standards Compliance
 - Verification and Testing
 - Modularity



NASA RRL Topic Areas and Rating Scale

| | Portability | Extensibility | Documentation | Support | Packaging | Intellectual Property issues | Standards compliance | Verification & Testing | Modularity |
|----------------|--|---|--|---|--|--|--|--|---|
| Level 1 | The software is not portable at any cost | No ability to extend or modify program behavior | Limited internal documentation available | No support available | Source code available | Potential owners and stakeholders of product have been identified. | Follows no particular standard | No testing performed | No designs for modularity or reuse |
| Level 2 | Some parts of the software may be portable | Prohibitive costs and efforts need to modify or extend the system | Fully commented source code available | Known contact available | | Relevant intellectual policies of potential owners and stakeholders have been reviewed. | Follows some parts of common standards and best practices | Software application formulated and unit testing performed | |
| Level 3 | The software is only portable with significant costs | Can be extended with the input of considerable time and effort on par with recreating system separately | Basic external documentation available | Original developers provide proactive support | Detailed installation instructions available | Intellectual property agreements have been proposed to potential stakeholders. | Follows a company-wide standard for development and testing | Testing includes testing for error conditions and proof of handling input errors | Modularity at major system or subsystem level only |
| Level 4 | The software may be portable at a reasonable cost | Can be modified and extended through configuration changes, minimal modification of source | Reference manual available | Latest updates or patches are available but not very frequently | | Potential stakeholders have negotiated on intellectual property agreements and authorship issues. | Most components follow a complete, universal standard, but not validated | Software application demonstrated in a laboratory environment | |
| Level 5 | The software is moderately portable | Consideration for future extensibility designed into system, extensibility approach somewhat defined | User manual available | Informal user community available | Software is easily configurable for different environments | Agreement and approval on authorship, attribution, and intellectual property issues has been obtained from stakeholders. | All components follow a universal standard, but only partially validated | Software application tested and validated in a laboratory environment | Partial segregation of generic and specific functionality |
| Level 6 | The software is portable | Designed from the start to allow easy extensibility, provides many points of extensibility and a thorough and detailed extensibility plan | Tutorials available | Centralized support available | | Authorship, attribution, and intellectual property statements have been drafted to reflect agreement among stakeholders on intellectual property and authorship. | Validated to follow a specific proprietary standard | Software application demonstrated in a relevant environment (Earth science related) | |
| Level 7 | The software is highly portable | Proven to be extensible internally, code structured to provide loose coupling and high cohesion | Interface guide available | Organized/defined support by the original developer available | OS detect and auto-build for supported platforms | Authorship and intellectual property statements included in product prototype. | Validated to comply to a specific open standard | Software application tested and validated in a relevant environment (Earth science related) | Clear delineations of specific and reusable components |
| Level 8 | | Proven extensibility on a major external program, provides a clear plan for modifying and extending features | Extension guide and/or Design/Development guide available | Support by organization available | | Manifestation of authorship, attribution, and intellectual property statements reviewed in product prototype before product release. | Proven by validation to comply with a "gold" standard | Software application "qualified" through test and demonstration (meets requirements) and successfully delivered to the Earth science environment | |
| Level 9 | The software is completely portable | Proven extensibility in multiple scenarios, provides specific documentation and features to build extensions | Full software lifecycle engineering design documentation available | Large user community with well-defined support available | GUI installation environment provided | Reviewed authorship, attribution, and intellectual property statements packaged with product for release. | "Gold" standard compliance of entire system and development, independently validated | Actual software application tested and validated through successful use of application output | All functions and data encapsulated into objects or accessible through web service interfaces |

Northrop Grumman (NGC) Reuse Readiness Level Framework

- NGC is developing *Reuse Readiness Levels* (RRL) as a decision framework to evaluate the technical viability of leveraging existing software
 - Merges the TRL concept with NGC's Decision Analysis and Resolution (DAR) process
 - Aligned with the 1-9 ascending TRL scale
 - DAR
 - Reduces subjectivity, increases rigor and consistency
 - Encourages disciplined objective thinking and stakeholder buy-in via evidence
 - Ensures best possible solutions for high risk decisions
 - Avoids premature commitment to a point design
 - Flexible – fits all situations
 - Multi-attribute / multivariate considered
 - DAR allows tailoring
 - Applicable to product line, non-product line, COTS, GOTS, NDI, OSS, etc.



Results in well-reasoned, timely software reuse decisions and better software estimates and plans

NGC Reuse Readiness Attributes

- Resources
 - Supporting processes and resources
 - Software familiarity
 - Developer experience
- Readability
 - Quantity and level of documentation
 - Accuracy and completeness of documentation
- Usability
 - Configurability, Openness and Modularity
 - Extensibility
 - Scalability
 - Well-defined and stable interfaces
- Maturity
 - Product life cycle stage
 - Maintenance
- Compatibility
 - Platform compatibility
 - Version compatibility
 - Language compatibility
- Tailoring / Rework
 - Restructuring / Re-factoring
 - Re-engineering
 - Re-implementation
 - Re-integration and Re-test
- Transportability
 - Architecture / design synchronization
 - Percentage of translation to new context
 - Index of new requirements incorporation



RRL NGC – Attributes (1 of 3)

| # | Category | Attribute | Description |
|---|-------------|--|---|
| 1 | Resources | Supporting Processes and Resources | The consonance of the development methods and activities to the integration of the reuse software in the new context/system as well as the accessibility and availability of expertise related to the reuse software (either internal or external to the organization). |
| 2 | Resources | Software Familiarity | The level of understanding and practice that the development team has in working with the reuse software. |
| 3 | Resources | Developer Experience | The knowledge, skill, proficiency and expertise of the development team within the system domain. |
| 4 | Readability | Quantity and Level of Documentation | The amount and the detail of available descriptions of the software such as: annotation in the code, reference manuals, style guides, developer user guides, use cases, etc. |
| 5 | Readability | Accuracy and Completeness of Documentation | The degree to which the reuse software documentation is comprehensive, usable and reliably describes and explains the product. |
| 6 | Usability | Configurability, Openness and Modularity | The extent to which the reuse software may be added, upgraded and have its components replaced; as well as the efficient separation of system concerns realized through the logical boundaries between components. |
| 7 | Usability | Extensibility | The ability of the system to accommodate future growth either through the addition of new functionality or through the modification of existing functionality while minimizing the impact to other existing system functions or infrastructure. |
| 8 | Usability | Scalability | The degree to which the design of the reuse software handles increasing amounts of work, data, throughput, quantities, resources, etc. with graceful or no degradation in performance. |

RRL NGC – Attributes (2 of 3)

| # | Category | Attribute | Description |
|----|---------------|------------------------------------|---|
| 9 | Usability | Well-defined and Stable Interfaces | The clarity, understandability and integrity of the reuse software (internal and external) interfaces as well as the robustness of the interfaces under changing, stressing or anomalous conditions |
| 10 | Maturity | Product Life Cycle Stage | The current point in the reuse software's evolution (ranging from "bleeding edge" new to obsolete) and the degree to which it has been tried, tested and proven in a working system. Factors to consider: usage and acceptance in the domain and the Industry |
| 11 | Maturity | Maintenance | The required resources to upkeep of the reuse software for correcting faults and keeping it operational. Factors to consider: Software Problem Report history, number and frequency of software patches, etc. |
| 12 | Compatibility | Platform Compatibility | The degree to which the original hardware architecture and software framework on which reuse software runs is similar or complimentary to the new context/system. Factors to consider: computer architecture, operating system, graphical user interface, etc. |
| 13 | Compatibility | Version Compatibility | The level at which the reuse software behaves in the intended and expected manner when it interacts with the other software components, products, tools, environments and platforms in the new context/system. Factors to consider: rate of change/upgrades of underlying products, frequency of synchronization points, etc. |
| 14 | Compatibility | Language Compatibility | The extent to which the programming set of instructions of the reuse software requires translation, reimplementation, or re-compilation in order to work in the new context/system |

RRL NGC – Attributes (3 of 3)

| # | Category | Attribute | Description |
|----|--------------------|--|---|
| 15 | Tailoring / Rework | Restructuring / Re-factoring | The extent to which the existing software needs to be cleaned up - i.e.; improve its understandability; remove extraneous (dead) code, make the internal structure and design more efficient, maintainable and amenable to change, etc. |
| 16 | Tailoring / Rework | Re-engineering | The amount of reverse engineering or learning required to modify the design for integration in the new context/system. |
| 17 | Tailoring / Rework | Re-implementation | The amount of adaptation of the existing code and/or the addition of new code to meet the objectives and environment of the new context/system |
| 18 | Tailoring / Rework | Re-integration and Re-test | The effort to combine the existing software into the new context/system and verify that resulting product functions within performance, reliability, and other criteria in the new system/context |
| 19 | Transportability | Architecture/Design Synchronization | The degree of similarity of the structure in which the reusable software will interact in the new context/system. Factors to consider: reuse of an entire product or functional components; control mechanisms, data exchange, logical dependencies |
| 20 | Transportability | Percentage of Translation to New Context | The percentage change in the behavior, conditions and/or constraints in which the reuse software will operate in the new context/system. Factors to consider: operational scenarios, operational threads, use cases, etc. |
| 21 | Transportability | Index of New Requirements Incorporation | The ratio of component level requirements allocated to the reuse software that are new relative to a normalized measure of the requirements that are already fully and partially satisfied by the software |

Comparison of Reuse Attributes

| NGC RRL | NASA RRL | Army SW TRL | SEI NDI |
|---|--------------------------|---|--|
| Resources | | | |
| Supporting Processes and Resources | Support | Development Process | |
| Software Familiarity | | | |
| Developer Experience | | | |
| Readability | | | |
| Accuracy and Completeness of Documentation | Documentation | Previous System Documents / Code | |
| Level of Documentation | | | |
| Usability | | | |
| Open Architecture / Modularity | Modularity | | |
| Configurability and Openness | Portability | | |
| Extensibility across Platforms | Extensibility | | |
| Scalability | | | |
| Well-defined and Stable Interfaces | Standards Compliance | | |
| Compatibility | | | |
| Platform Compatibility | Packaging | Development Environment | Environment Fidelity |
| Version Compatibility | | Test (Verify) Environment | |
| Language Compatibility | | | |
| Maturity | | | |
| Years in Operation | Verification and Testing | Technology Prototyped/ Used Existing System | |
| Maintenance | | Open Problem Reports | Maturity |
| Upgrades / Technology Insertion | | | |
| Rework | | | |
| Restructuring/Refactoring | | Change To Code | |
| Re-engineering | | | |
| Re-implementation | | | |
| Re-integration and Re-test | | | |
| Transportability | | | |
| Number of Contexts/Instantiations in which reused | | Studies / Test Use Results | |
| Architecture/Design Synchronization | | | Technology Critical |
| Percentage of Translation to New Context | | | |
| Other | | | |
| Index of New Requirements Incorporation | | Precision / Performance | Requirements (Functional and Non-Functional) |
| | Intellectual Property | | Availability |
| | | Safety / Security | |

Standard Process Manual 944 – Decision Analysis and Resolution

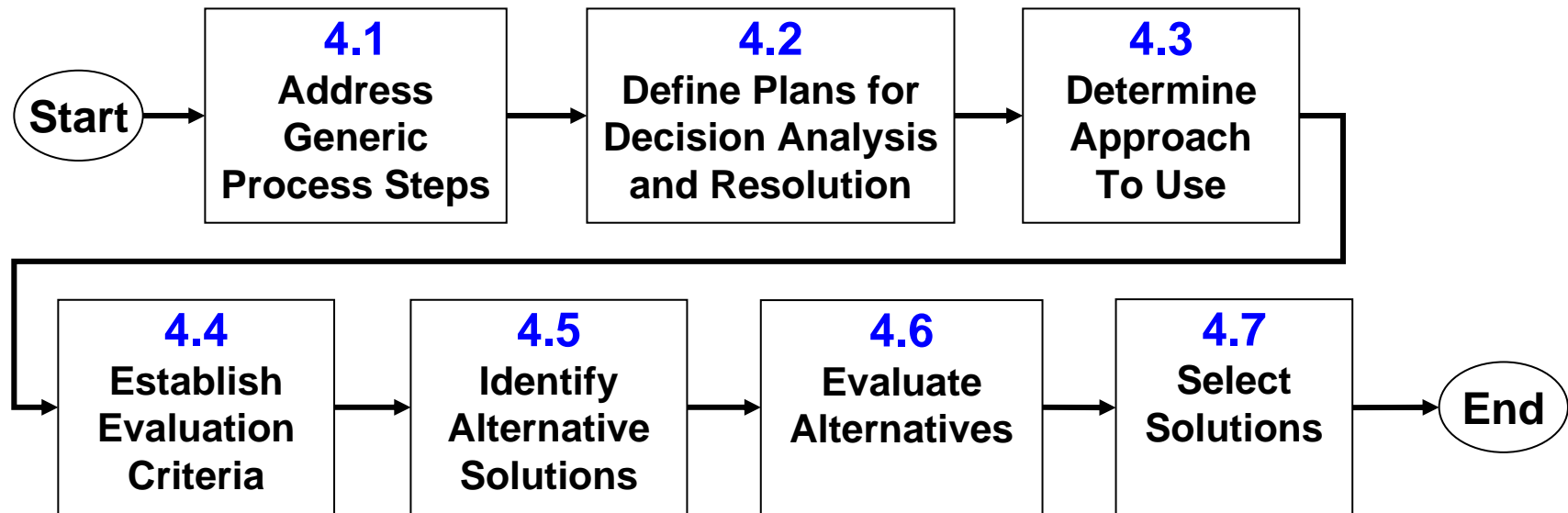

- Sample Methodologies

- Trade Study
- ➔ – Simple Multi-Attribute Rating Technique (SMART)
- Analytical Hierarchy Process (AHP)
- Pay-off table with application of an analysis technique (MiniMax, Expected Value, MaxiMax, Minimum Regret, etc.)
- Decision Trees and Influence Diagrams
- Simulation
- Group Techniques (e.g., Delphi)

Reuse Readiness Levels – NGC Approach

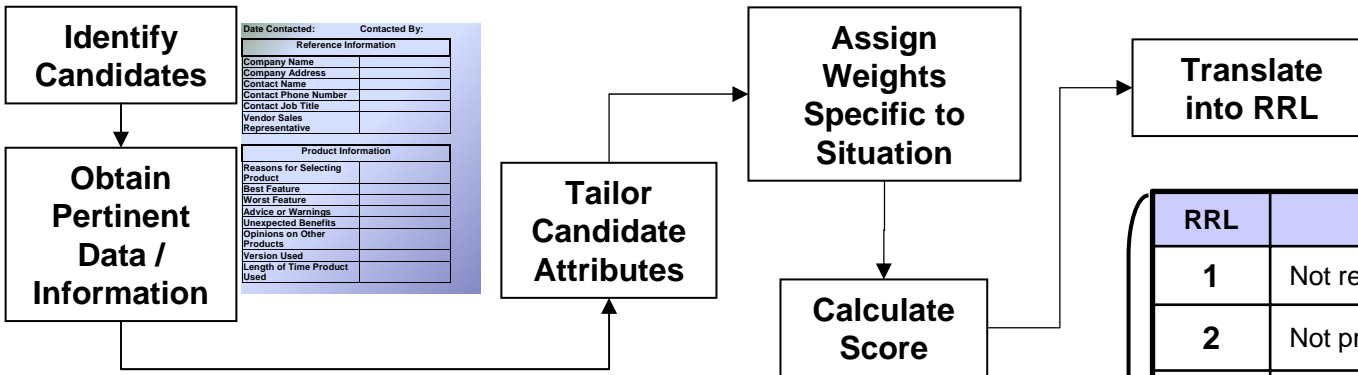

Sensitivity analysis: Green = 1st highest score, Yellow = 2nd highest score, Red = 3rd highest score

| No. | Evaluation Criteria | Evaluation Method | Scoring Function | Weight (%) | Reuse Asset 1 | | COTS A | |
|---------------|--|-------------------|------------------|---------------|---------------|----------------|--------|----------------|
| | | | | | Score | Weighted Score | Score | Weighted Score |
| 1 | Supporting Processes and Resources | | | 2.0% | 2.0 | 0.04 | 4.2 | 0.08 |
| 2 | Software Familiarity | | | 2.0% | 9.8 | 0.20 | 4.8 | 0.10 |
| 3 | Developer Experience | | | 10.0% | 1.6 | 0.16 | 3.5 | 0.35 |
| 4 | Quantity and Level of Documentation | | | 1.0% | 0.1 | 0.00 | 8.2 | 0.08 |
| 5 | Accuracy and Completeness of Documentation | | | 1.0% | 1.3 | 0.01 | 3.0 | 0.03 |
| 6 | Configurability, Openness and Modularity | | | 17.0% | 4.0 | 0.67 | 5.2 | 0.89 |
| 7 | Extensibility | | | 8.0% | 7.8 | 0.62 | 5.5 | 0.44 |
| 8 | Scalability | | | 5.0% | 8.1 | 0.41 | 6.5 | 0.33 |
| 9 | Well-defined and Stable Interfaces | | | 12.0% | 1.8 | 0.22 | 1.0 | 0.12 |
| 10 | Product Life Cycle Stage | | | 5.0% | 2.3 | 0.12 | 1.7 | 0.09 |
| 11 | Maintenance | | | 3.0% | 7.6 | 0.23 | 9.0 | 0.27 |
| 12 | Platform Compatibility | | | 0.0% | 0.0 | 0.00 | 0.0 | 0.00 |
| 13 | Version Compatibility | | | 7.0% | 5.1 | 0.36 | 2.1 | 0.15 |
| 14 | Language Compatibility | | | 0.0% | 4.3 | 0.00 | 2.0 | 0.00 |
| 15 | Restructuring / Re-factoring | | | 6.0% | 2.2 | 0.13 | 3.0 | 0.18 |
| 16 | Re-engineering | | | 0.0% | 0.0 | 0.00 | 0.0 | 0.00 |
| 17 | Re-implementation | | | 4.0% | 9.1 | 0.36 | 3.0 | 0.12 |
| 18 | Re-integration and Re-test | | | 4.0% | 2.0 | 0.08 | 2.0 | 0.08 |
| 19 | Architecture/Design Synchronization | | | 8.0% | 1.8 | 0.15 | 1.5 | 0.12 |
| 20 | Percentage of Translation to New Context | | | 0.0% | 4.0 | 0.00 | 3.5 | 0.00 |
| 21 | Index of New Requirements Incorporation | | | 5.0% | 3.8 | 0.19 | 2.7 | 0.14 |
| TOTAL: | | | | 100.0% | | 3.94 | | 3.55 |

| RRL | Description |
|-----|---|
| 1 | Not reusable in the given context |
| 2 | Not practical to reuse in the given context |
| 3 | Conceptual reuse possible; significant risk to implementation |
| 4 | Reuse with 6 or more attributes of concern - assume substantial cost and risk |
| 5 | Reuse with 3 to 6 attributes of concern - assume a reasonable amount of cost and risk |
| 6 | Reuse with 1 to 3 attributes of concern - potential for some cost and risk |
| 7 | High reuse with minimum cost and risk |
| 8 | Demonstrated reuse by multiple adopters |
| 9 | Proven serial reuse by multiple skills and experience level |

- Decisions / Assessments
 - Technical viability and rank order of reuse candidate software
 - Justification not to reuse
 - Investment in maturing a potential reuse asset
 - Use as a component to determine an overall for Software TRL of a critical technology
- Insight
 - Understanding of the level risk associated with incorporating software technologies into a system or solution
 - Sensitivity of driving factors that affect reuse success
 - Degree of modification (effort) required to reuse the product
 - Improved size and cost estimates

NORTHROP GRUMMAN

DEFINING THE FUTURE