



**NAVAL
POSTGRADUATE
SCHOOL**

MONTEREY, CALIFORNIA

THESIS

**EVALUATING THE MEASURE OF EFFECTIVENESS
OF USING A DEPLOYED COMMAND AND CONTROL
SYSTEM ON LAND BATTLEFIELD**

by

William Goh

September 2015

Thesis Advisor:

Co-Advisor:

Gary O. Langford

Douglas H. Nelson

Approved for public release; distribution is unlimited

THIS PAGE INTENTIONALLY LEFT BLANK

| REPORT DOCUMENTATION PAGE | | | <i>Form Approved OMB No. 0704-0188</i> | |
|---|---|--|---|--|
| Public reporting burden for this collection of information is estimated to average 1 hour per response, including the time for reviewing instruction, searching existing data sources, gathering and maintaining the data needed, and completing and reviewing the collection of information. Send comments regarding this burden estimate or any other aspect of this collection of information, including suggestions for reducing this burden, to Washington headquarters Services, Directorate for Information Operations and Reports, 1215 Jefferson Davis Highway, Suite 1204, Arlington, VA 22202-4302, and to the Office of Management and Budget, Paperwork Reduction Project (0704-0188) Washington, DC 20503. | | | | |
| 1. AGENCY USE ONLY <i>(Leave blank)</i> | 2. REPORT DATE September 2015 | 3. REPORT TYPE AND DATES COVERED Master's thesis | | |
| 4. TITLE AND SUBTITLE EVALUATING THE MEASURE OF EFFECTIVENESS OF USING A DEPLOYED COMMAND AND CONTROL SYSTEM ON LAND BATTLEFIELD | | | 5. FUNDING NUMBERS | |
| 6. AUTHOR(S) Goh, William | | | | |
| 7. PERFORMING ORGANIZATION NAME(S) AND ADDRESS(ES) Naval Postgraduate School Monterey, CA 93943-5000 | | | 8. PERFORMING ORGANIZATION REPORT NUMBER | |
| 9. SPONSORING /MONITORING AGENCY NAME(S) AND ADDRESS(ES) N/A | | | 10. SPONSORING / MONITORING AGENCY REPORT NUMBER | |
| 11. SUPPLEMENTARY NOTES The views expressed in this thesis are those of the author and do not reflect the official policy or position of the Department of Defense or the U.S. Government. IRB Protocol number ___N/A___. | | | | |
| 12a. DISTRIBUTION / AVAILABILITY STATEMENT Approved for public release; distribution is unlimited | | | 12b. DISTRIBUTION CODE | |
| 13. ABSTRACT (maximum 200 words) With military systems becoming increasingly connected and more agile to handle multiple scenarios through technological advances, the challenge remains to design a command and control (C2) system that fulfills the rising user expectation given the constraints enforced in the land battlefield. While there is always ongoing effort to narrow the gap between users' expectation and constraints on the land battlefield through integrating more sensors, there is a need to manage the users' expectation to ensure the effective use of the system for their operations through constant evaluation of the measures of effectiveness (MOE). The Langford nine-step methodology provides a repeatable process to successfully develop twelve pairs of meaningful MOEs using the integrative framework to evaluate the effectiveness of using a deployed C2 system in the land battlefield. The integrative framework provides the comprehensive guidelines to develop the MOE with objective values and subjective criteria. The nine-step method's repeatability facilitates the evaluation of the effectiveness of the C2 for each system refinement (firmware/software/system upgrade) or new requirements (addition of sensor/ communication system/protocol). Each evaluation provides opportunities for the system, process, and organization to improve. | | | | |
| 14. SUBJECT TERMS command and control (C2), measure of effectiveness (MOE), land battlefield | | | 15. NUMBER OF PAGES 103 | |
| | | | 16. PRICE CODE | |
| 17. SECURITY CLASSIFICATION OF REPORT Unclassified | 18. SECURITY CLASSIFICATION OF THIS PAGE Unclassified | 19. SECURITY CLASSIFICATION OF ABSTRACT Unclassified | 20. LIMITATION OF ABSTRACT UU | |

THIS PAGE INTENTIONALLY LEFT BLANK

Approved for public release; distribution is unlimited

**EVALUATING THE MEASURE OF EFFECTIVENESS OF USING A
DEPLOYED COMMAND AND CONTROL SYSTEM ON LAND BATTLEFIELD**

William Goh

Civilian, Singapore Technologies Electronics Limited, Singapore
B.Eng (Computer Engineering), Nanyang Technological University, 2006

Submitted in partial fulfillment of the
requirements for the degree of

Submitted in partial fulfillment of the
requirements for the degree of

MASTER OF SCIENCE IN SYSTEMS ENGINEERING

from the

**NAVAL POSTGRADUATE SCHOOL
September 2015**

Approved by: Gary O. Langford
Thesis Advisor

Douglas H. Nelson
Thesis Co-Advisor

Ronald E. Giachetti
Chair, Department of Systems Engineering

THIS PAGE INTENTIONALLY LEFT BLANK

ABSTRACT

With military systems becoming increasingly connected and more agile to handle multiple scenarios through technological advances, the challenge remains to design a command and control (C2) system that fulfills the rising user expectation given the constraints enforced in the land battlefield.

While there is always ongoing effort to narrow the gap between users' expectation and constraints on the land battlefield through integrating more sensors, there is a need to manage the users' expectation to ensure the effective use of the system for their operations through constant evaluation of the measures of effectiveness (MOE).

The Langford nine-step methodology provides a repeatable process to successfully develop twelve pairs of meaningful MOEs using the integrative framework to evaluate the effectiveness of using a deployed C2 system in the land battlefield. The integrative framework provides the comprehensive guidelines to develop the MOE with objective values and subjective criteria. The nine-step method's repeatability facilitates the evaluation of the effectiveness of the C2 for each system refinement (firmware/software/system upgrade) or new requirements (addition of sensor/communication system/protocol). Each evaluation provides opportunities for the system, process, and organization to improve.

THIS PAGE INTENTIONALLY LEFT BLANK

TABLE OF CONTENTS

| | | |
|-------------|--|-----------|
| I. | INTRODUCTION..... | 1 |
| A. | USER EXPECTATION OF COMMAND AND CONTROL SYSTEMS IN THE LAND BATTLEFIELD | 1 |
| B. | PROBLEM IDENTIFICATION | 2 |
| C. | SCOPE | 3 |
| D. | ORGANIZATION OF STUDY | 3 |
| II. | BACKGROUND | 5 |
| A. | COMMAND AND CONTROL | 5 |
| B. | C2 SYSTEM IN LAND BATTLEFIELD | 8 |
| 1. | Network-Centric Warfare..... | 8 |
| 2. | System of Systems | 9 |
| C. | STAKEHOLDER ANALYSIS | 11 |
| D. | SAFETY STANDARD..... | 14 |
| E. | LIMITATION AND CONSTRAINT | 15 |
| 1. | Communication..... | 15 |
| 2. | Stability | 16 |
| III. | LITERATURE REVIEW MEASURES OF EFFECTIVENESS..... | 19 |
| A. | MEASURES OF EFFECTIVENESS AS TECHNICAL MEASUREMENTS | 19 |
| B. | MEASURES OF EFFECTIVENESS OPERATIONAL TESTING AND EVALUATION | 21 |
| C. | MEASURES OF EFFECTIVENESS AS THE FULFILLMENT OF STAKEHOLDERS' NEEDS | 22 |
| D. | MEASURES OF EFFECTIVENESS AS DETERMINANTS OF THE INTEGRATIVE FRAMEWORK..... | 24 |
| IV. | METHODOLOGY TO DEVELOP MEASURE OF EFFECTIVENESS..... | 27 |
| A. | NINE-STEP METHODOLOGY | 27 |
| B. | SUMMARY | 32 |
| V. | DEVELOPMENT OF THE MEASURE OF EFFECTIVENESS..... | 33 |
| A. | TERMINOLOGY DEFINITION OF A COMMAND AND CONTROL SYSTEM..... | 33 |
| B. | COMMAND AND CONTROL SYSTEM BOUNDARIES AND FUNCTIONS DELINEATION..... | 33 |
| 1. | To Command..... | 35 |

| | | |
|-----|---|----|
| 2. | To Control..... | 36 |
| C. | LIFE-CYCLE ANALYSIS OF USING A DEPLOYED COMMAND AND CONTROL SYSTEM IN THE BATTLEFIELD | 37 |
| D. | COMMAND AND CONTROL SYSTEM IN THE LAND BATTLEFIELD REQUIREMENT DEFINITION | 38 |
| E. | POSITED COMMAND AND CONTROL SYSTEM SOLUTION SET | 40 |
| F. | DETERMINE THEORETICAL FOUNDATION..... | 43 |
| 1. | Command Concept | 43 |
| 2. | Control Theory | 44 |
| G. | INTEGRATIVE FRAMEWORK FORMALIZATION | 45 |
| 1. | Cognitive Domain MOE..... | 46 |
| 2. | Procedural Domain MOE | 51 |
| H. | ANALYZE AND EVALUATE EFFECTIVENESS | 58 |
| 1. | Cognition Domain MOE Calculation..... | 59 |
| 2. | Procedure Domain MOE Calculation..... | 67 |
| VI. | CONCLUSION | 77 |
| | LIST OF REFERENCES..... | 81 |
| | INITIAL DISTRIBUTION LIST | 83 |

LIST OF FIGURES

| | | |
|------------|--|----|
| Figure 1. | Hierarchy of C2 Components (from Bornman 1993, 16)..... | 6 |
| Figure 2. | Stakeholder Analysis for a Typical C2 System Program..... | 11 |
| Figure 3. | Technical Measures Relationships (from Roedler and Jones 2005, 15) | 20 |
| Figure 4. | Measure of Effectiveness Development Process (from Sproles 2002, 255) | 23 |
| Figure 5. | Integrative Framework (from Langford 2014, 7) | 25 |
| Figure 6. | Linkage between Measures of Effectiveness and Fitness-for-Purpose (from Langford 2014, 8) | 25 |
| Figure 7. | Nine-Step Methodology to Characterize MOEs (from Langford 2014, 14) | 28 |
| Figure 8. | Integrative Framework (from Langford 2014, 7) | 31 |
| Figure 9. | Integrative Framework with Measure of Effectiveness Domain Description (from Langford 2012, 89)..... | 31 |
| Figure 10. | Measure of Effectiveness Framework Cardinal Points (from Langford 2014, 15) | 32 |
| Figure 11. | Functional Decomposition of “To Manage” | 34 |
| Figure 12. | Functional Decomposition of “To Command” | 34 |
| Figure 13. | Function Decomposition of “To Control” | 35 |
| Figure 14. | Task Assignment Scenarios | 38 |
| Figure 15. | Command and Control System in the Land Battlefield Concept..... | 41 |
| Figure 16. | Information Exchange..... | 42 |
| Figure 17. | Software Architecture of the Command and Control System | 43 |
| Figure 18. | Lawson’s Model (from Lawson 1981, 7) | 45 |
| Figure 19. | Modified Integrative Framework (from Langford 2014, 15)..... | 46 |
| Figure 20. | External Physical Context..... | 56 |
| Figure 21. | Internal Physical Context Diagram..... | 56 |
| Figure 22. | C2 System MOE Evaluation..... | 59 |
| Figure 23. | Cognition Domain MOE Evaluation | 60 |
| Figure 24. | Procedure Domain MOE Evaluation | 68 |

THIS PAGE INTENTIONALLY LEFT BLANK

LIST OF TABLES

| | | |
|-----------|--|----|
| Table 1. | Software Safety Criticality Matrix (from DOD 2012, 16)..... | 14 |
| Table 2. | Level of Rigor Tasks (from DOD 2012, 16)..... | 15 |
| Table 3. | Measures of Effectiveness Selection Guidelines (from Roedler and Jones 2005, 36) | 21 |
| Table 4. | Characteristics of a Good Measure of Effectiveness (from Stevens 1986, 55) | 22 |
| Table 5. | Measure of Effectiveness Development Rules (from Stevens 1986, 55–56) | 22 |
| Table 6. | Command and Control System Requirements | 40 |
| Table 7. | List of Measures of Effectiveness to Evaluate the Command and Control System in the Land Battlefield | 58 |
| Table 8. | System Functionality Prediction MOE-g..... | 62 |
| Table 9. | System Functionality Expectation MOE-c | 63 |
| Table 10. | System Experience MOE-e..... | 64 |
| Table 11. | System Responsiveness MOE-e | 66 |
| Table 12. | Influence of Procedures When System is in use MOE-i..... | 69 |
| Table 13. | Influence of Procedures When System is not in use MOE-f | 70 |
| Table 14. | System Functional Resource Utilization Validity MOE-u | 71 |
| Table 15. | System Functional Boundary Conditions MOE-b | 72 |
| Table 16. | System Selection Validity MOE-s | 73 |
| Table 17. | System Operational Context Validity MOE-x..... | 74 |

THIS PAGE INTENTIONALLY LEFT BLANK

LIST OF ACRONYMS AND ABBREVIATIONS

| | |
|---------|---|
| AAR | After-Action Review |
| BMS | Battlefield Management System |
| C2 | Command and Control |
| C4ISR | Command, Control, Communications, Computer, Intelligence, Surveillance and Reconnaissance |
| CEC | Collaborative Engagement Capabilities |
| COI | Critical Operational Issue |
| COTS | Commercial-off-the-Shelf |
| DOD | Department of Defense |
| EMMI | Energy, Matter, Material Wealth, and Information |
| GFE | Government-Furnished Equipment |
| GOTS | Government-off-the-Shelf |
| GUI | Graphical User Interface |
| HQ | Headquarters |
| KPP | Key Performance Parameters |
| LOR | Level of Rigor |
| LOS | Line-of-Sight |
| MIL-STD | Military Standard |
| MOE | Measure of Effectiveness |
| MOP | Measure of Performance |
| NCW | Network-Centric Warfare |
| NDI | Non-Developmental Item |
| OT&E | Operational Test and Evaluation |
| SAF | Singapore Armed Forces |
| SE | Systems Engineering |
| SOA | Service-Oriented Architecture |
| SOTM | Satellite Communications-on-the-Move |
| SoS | System of Systems |
| SwCIs | Software Criticality Indices |
| TPM | Technical Performance Measures |

| | |
|-----|-------------------------|
| UAV | Unmanned Aerial Vehicle |
| UHF | Ultra High Frequency |
| VHF | Very High Frequency |

EXECUTIVE SUMMARY

With advancement in technologies such as platform onboard sensors, combat communication systems, computing power and human system integration devices to achieve wider coverage, higher data bandwidth, faster system response, and improved user experience, there are increasing requirements to integrate more subsystems to the command and control (C2) system to further enhance the situational awareness in the network-centric environment and improve critical decision making in the land battlefield.

However, given the constraints and challenges in the land battlefield, such as terrain, canopy, and equipment life cycle, there is a need to assess the benefits and limitations of integrating to ensure the best bang for the buck. Therefore, there is a need to constantly evaluate the measures of effectiveness (MOE) of using the deployed C2 system to better manage users' expectations in terms of additional requirements to integrate better sensor equipment to enhance situational awareness in the land battlefield for faster and quality decision-making.

Langford (2014) explains “the what,” “the when” and “the how” with regards to MOE. “The what” must be interpreted within a particular context, regardless of type. Without boundaries, it is uncertain what *dimensionality* means in terms of effectiveness, let alone how it can be compared or how meaningful such a comparison might be. “The how” and “the when” are seemingly attached to milestones in the acquisition parlance rather than to the merits of any theoretical foundation. Langford (2014, 8–12) proposes developing MOEs using an integrative framework.

The integrative framework is used to develop 12 pairs of MOEs to evaluate the effectiveness of using the deployed C2 system in the battlefield. The integrative framework provides the comprehensive guidelines to develop the MOEs with objective values and subjective criteria. The nine-step method's repeatability facilitates the evaluation of the effectiveness of the C2 for each system refinement (firmware/software/system upgrade) or new requirements (addition of

sensor/communication system/protocol). Each evaluation should indicate opportunities for the system, process, and organization to improve.

The developed 12 pairs of C2 MOEs allow stakeholders to evaluate the system and the use of the integrative framework to produce a repeatable MOE that provides cost saving opportunities for system refinement and new iterations of system development. The 12 pairs of the C2 MOEs are used to evaluate the effectiveness of deploying the Battlefield Management System (BMS) in the land platform.

LIST OF REFERENCES

Langford, Gary. 2014. *Building the Determinants of Cyber Deterrence Effectiveness*. Unpublished manuscript.

ACKNOWLEDGMENTS

I am grateful for the guidance, patience, and reassurance of my thesis advisor, Dr. Gary Langford, to allow me to complete this thesis. Working on the thesis has provided me deeper insight on C2, and his advice has been invaluable in triggering my thought processes and helping me focus on the key ideas that have been helpful in the thesis. I am deeply grateful and have benefited greatly from his insight into solving large and complex problems.

I would also like to thank my thesis co-advisor, Dr. Douglas Nelson, for the support he has rendered me.

Finally, I wish to express my thanks to my wife and family for their love and support, and also to the friends whom I have met during the course of my studies. Thank you for the company and friendship. This has been a memorable phase of my life.

THIS PAGE INTENTIONALLY LEFT BLANK

I. INTRODUCTION

With the rapid improvement in technology in recent years, we are seeing that land platform systems are becoming more precise and accurate. Onboard sensors, more flexible communication systems, advanced computing power, and more robust human system integration devices achieve wider coverage, higher data bandwidth, faster system response, and improved user experience. These technological advancements lead to stakeholders' interest in harnessing the capability into the command and control (C2) system for better situational awareness and decision-making. This interest further translates into requirement for these subsystems integration into the C2 system.

To manage stakeholders' expectations, there is a need to evaluate the effectiveness of the deployed C2 system having implemented with the new requirements. The measures of effectiveness (MOEs) of using the deployed C2 system are developed using an integrative framework to evaluate the system's fitness-for-purpose.

A. USER EXPECTATION OF COMMAND AND CONTROL SYSTEMS IN THE LAND BATTLEFIELD

The changes that have taken place over the years in military affairs have affected the end-users' expectation of using the C2 system in the land battlefield. In the 20th century, the C2 system was described as follows:

C2 System consists of a collection of denotable things that are used to perform the C2 function: physical elements (e.g., equipment, such as transmitters and receivers, computers, a signal book, status boards and other decision support hardware, code breaking facilities, and signal flags); human elements (e.g., communicators, staffs, intelligence analysts, and the commander himself); and procedural elements (e.g., table of organization and command relationships, the content of a signal book, and the content of a manual of training or doctrine). This collection of things is presumed in most usage to be integrated. The purpose of the C2 system is to facilitate the C2 process. (Hughes 1989)

However, traditional military missions have evolved over the years, as Alberts and Hayes (2006) described:

Today's missions differ from traditional military missions, not just at the margins, but qualitatively. Today's missions are simultaneously more complex and more dynamic, requiring the collective capabilities and efforts of many organizations in order to succeed. This requirement for assembling a diverse set of capabilities and organizations into an effective coalition is accompanied by shrinking windows of response opportunity. Traditional approaches to C2 are not up to the challenge. Simply stated, they lack the agility required in the 21st century.

As a result of technological breakthroughs in research and development, increasing asymmetrical challenges, the transition from stand-alone systems to increasingly interconnected systems (e.g., the emergence of system of systems (SoS) ideology and the network-centric warfare (NCW)), user expectations on the C2 system has inevitably increased. The rising user expectations have led to an increase in requirements to integrate the C2 system with more and better subsystems to provide enhanced situational awareness for better decision-making. In addition, C2 systems are expected to be more agile in terms of system configuration and deployment time to meet the faster pace of mission dynamism.

Although the purpose of Command and Control has remained unchanged since the earliest military forces engaged one another, the way we have thought about Command and Control and the means by which the functions of Command and Control have been accomplished have changed significantly over the course of history. These changes have resulted from the coevolution of Command and Control Approaches with technology, the nature of military operations, the capabilities of forces, and the environments in which militaries operate. (Alberts and Hayes 2006)

B. PROBLEM IDENTIFICATION

With the increased demand to integrate more subsystems into the C2 system to enhance situational awareness and faster and better decision-making, there is a need to evaluate the outcomes (performance and experience) in order to determine the value (subjective and objective) and whether the effort for performing the integration meets the return on investment. Thus, MOEs are widely applied to measure and evaluate the performance of C2 systems in a combat context. However, the challenge lies on the

assumption made for developing the MOEs, which sometimes tend to be short-sighted and narrow.

Langford (2014) describes the challenges as follows:

Today, the selections of key factors in determining the measures of effectiveness are made without a consistent approach and with no underlying theory to their guide selection. The current ideas and application of measures of effectiveness incorrectly emphasize outcomes based on conjecture that some aspect of a performance measure or metric is an indicator of utility for a system's fitness. (Langford 2014, 18)

Bornman (1993) describes the problem statement for developing C2 MOE as follows:

The lack of a standardized set of C2MOE has resulted in the development of measures on a study-by-study basis. Most previous C2MOE have not clearly linked changes in C2 systems or doctrine to battle outcome. C2MOE have tended to be anecdotal in nature. They have depended upon a high degree of human interaction, and thus, have been prone to inconsistency in either measure or application. In addition, because C2MOE are difficult to identify, in most studies and evaluations very few are used. Evaluating a C2 system with just one of two MOE can limit the focus of a study and place the resulting conclusions in jeopardy. (Bornman 1993, 15)

Therefore, it is important to address the challenge of MOE development so that a meaningful assessment can be performed to evaluate the effectiveness of using the deployed C2 system in the land battlefield.

C. SCOPE

This thesis consists of four parts: first, a study of the concept of C2 systems in the land battlefield; second, a study of the various concepts of developing MOEs; third, an evaluation of MOEs using Langford's nine-step method and integrative framework; and fourth, a conclusion and recommendation for future work.

D. ORGANIZATION OF STUDY

This thesis consists of six chapters:

Chapter I: Introduction

Chapter II: Background

Chapter III: Literature Review: Measure of Effectiveness

Chapter IV: Methodology to Develop Measure of Effectiveness

Chapter V: Development of Measure of Effectiveness

Chapter VI: Conclusion

This chapter identifies and describes the challenges of MOE development to manage the user expectation of using the deployed C2 system on the land battlefield. The next chapter provides a literature review on the background of the C2 system and the rising user expectation resulting in its transition from stand-alone system to the interconnected system of systems.

II. BACKGROUND

This chapter provides the background studies of the C2 system and its transition from stand-alone system to the interconnected system of systems. It is important to understand the C2 system using the definition of command and control. As the expectation of the stakeholder is to stay connected in the battlefield for better situational awareness and decision-making, there is an increasing requirement to integrate faster and better subsystems (sensor, communication device and processor) to the C2 system. However, there is a need to recognize the limitations and constraints on the land battlefield to implement these requirements. There is also a need to consider the system safety aspect while evaluating the feasibility of the solution.

A. COMMAND AND CONTROL

Command and control (C2) is defined by Joint Chiefs of Staff Publication 1 (JCS Pub 1) as

the exercise of authority and direction by a properly designated commander over assigned forces in the accomplishment of his mission. Command and control functions are performed through an arrangement of personnel, equipment, communications, facilities, and procedures which are employed by a commander in planning, directing, coordinating, and controlling forces and operations in the accomplishment of this mission.

The C2 capability can be further decomposed into *command* and *control* to distinguish between the two terms:

Command is the art of assigning missions, prioritizing resources, guiding and directing subordinates, and focusing the entire division's energy to accomplish clear objectives. (Bornman 1993, 15).

Control is the science of defining limits, computing requirements, allocating resources, prescribing requirements for reports, monitoring performance, identifying and correcting deviations from guidance, and directing subordinate actions to accomplish the commander's intent. (Bornman 1993, 15).

From the definitions, C2 can be thought of as having six components: physical entities, structure, tasks or activities, process, function, and doctrinal objective or

mission, as shown in Figure 1 (Bornman 1993, 16). As shown in Figure 1, the lower components are derived from the higher components, reflecting the policy that doctrine drives the development of training, organizational structures, leaders, and material equipment (Bornman 1993, 15–16). The evaluation of the mission success uses the bottom up approach to assess the effectiveness of each component and its influence to the next higher component.

Figure 1. Hierarchy of C2 Components (from Bornman 1993, 16)

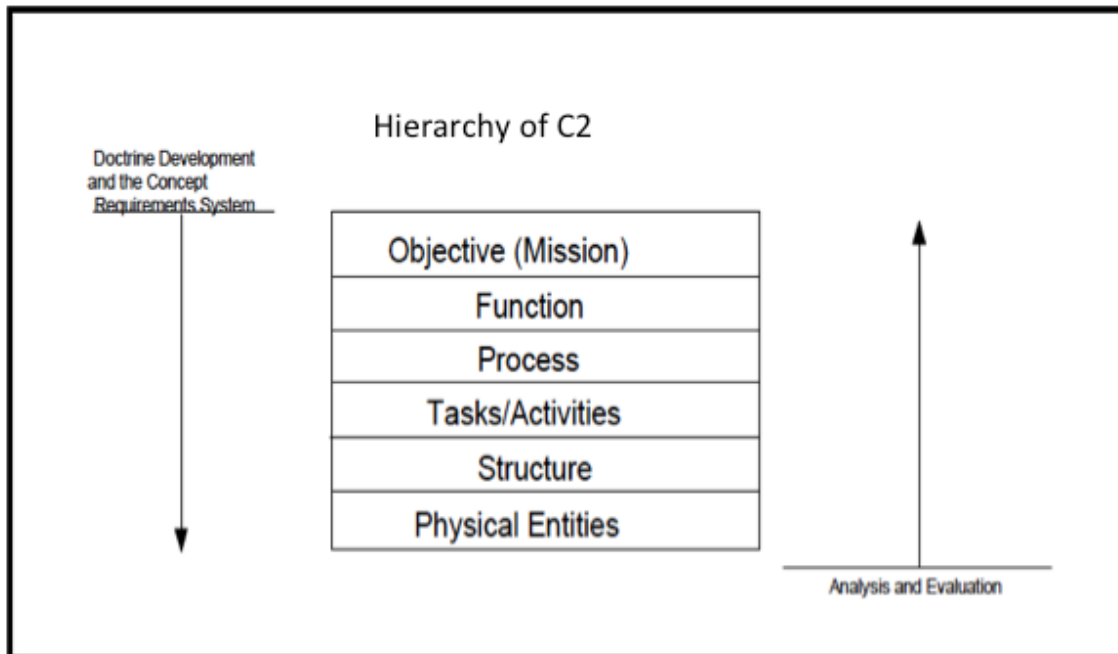

(1) Physical Entities

Bornman (1993, 16) refers *physical entities* to equipment, software facilities, and people. These are arranged into structures

(2) Structure

Bornman (1993, 16) describes the *structure* as “the arrangement and interrelationships of physical entities, procedures, protocols, concepts of operation, and information patterns.”

(3) Tasks/Activities

Bornman (1993, 16) refers *tasks* or *activities* to individual and collective work or actions taken by the entities and the structure as a part of a process.

(4) Process

Bornman (1993, 16) refers *process* to the arrangement and interrelationships of tasks or activities that are performed to fulfill functions defined by doctrine.

(5) Function

Langford (2013, 13) describes a function as “a set of actions that result when two objects interact. Processes within the objects enable the functions. A function is a trait of the relation(s) between or behavior(s) of objects that change when two or more objects interact. A function is measurable by performance of the bi-object’s properties or traits, either individually or pairwise. Functions arise due to the enactments of the mechanisms of at least two objects.” In the same article, Langford explains that a function is “measured by performance of the relations between the interacting objects that created the function.” A function is characterized by the perspective of a stakeholder.

A formal definition of function from Langford also include:

- Object O and Object P create a function f if and only if.
- Object O interacts with Object P.
- Function f is the set of all actions that are a consequence of Object O interacting with Object P.
- An action is defined as the release or receipt of EMMI (Langford 2013, 308).
- EMMI represents energy, matter, material wealth, and information. EMMI activates mechanisms.
- Object O is changed by its mechanism(s) because of an interaction with Object P, or Object P is changed by its mechanism(s) because of an interaction with Object O, or both Object O and Object P are changed by their respective mechanism(s) because of an interaction.
- Mechanism is set of rules and logic constrained by context and environment that govern the transformation of EMMI by objects.

- A change is defined as the difference between an object before interaction and the same object after interaction. (Langford 2013, 308)

(6) Objectives/Missions

Bornman (1993, 16) describes *objectives* or *missions* as the descriptive terms used to identify desired end states or achievements as a result of employing operational forces.

B. C2 SYSTEM IN LAND BATTLEFIELD

1. Network-Centric Warfare

It is important to understand the significant contributions of communication towards measuring the effectiveness of C2. The commander communicates with his subordinate for task assignment (command) and the subordinate communicates with the commander for task update during task monitoring (control) and this communication must be maintained consistently to ensure the task is accomplished within the allocated resources and constraint. Consider the combat team mission in the land battlefield. The combat team consists of four land platforms connected with one another in the combat team network. In addition, the commander of the combat team is connected to the higher command, i.e., HQ in the command post, via the command network. Through constant communication (position update, task status update, and combat status update) between the commander and his subordinates and the commander to the higher command, the commander is able to establish the situation awareness in the battlefield to make informed decision. In addition, the communication must be reliable (with minimal or no disruption due to interference caused by terrain, canopy in the forested area and signal jamming) and secured (using message encryption and frequency protection) to establish trust between the commanders and the subordinates to accomplish task.

As the result of technological advancements with the transition from stand-alone systems to increasingly interconnected systems, operation troops nowadays are well connected in the information networks to perform their tasks. NCW is described by the Department of Defense (DOD 2005) as follows:

Network-centric warfare is an emerging theory of war in the Information Age. It is also a concept that, at the highest level, constitutes the military's

response to the Information Age. The term network-centric warfare broadly describes the combination of strategies, emerging tactics, techniques, and procedures, and organizations that a fully or even a partially networked force can employ to create a decisive warfighting advantage. (DOD 2005, 3)

2. System of Systems

In the network-centric driven environment, there is an increasing need for interoperability between the C2 system and other military systems. For instance, the commanders in the armor combat team can link up and collaborate via an ad-hoc tactical network, gain better awareness of the enemy situation using the payload information from the unmanned aerial vehicle (UAV), send information back to higher command via the satellite link, and fuse intelligences to establish the common situational picture. Therefore, the C2 system has emerged as a System of Systems (SoS).

Maier (n.d.) describes SoS as:

SoS should be distinguished from large but monolithic systems by the independence of their components, their evolutionary nature, emergent behaviors, and a geographic extent that limit the interaction of their components to information exchange. Within these properties are further subdivisions. For example, a distinction between systems which are organized and managed to express particular functions, and those in which desired behaviors must emerge through voluntary and collaborative interaction.

Maier (n.d.) further distinguishes SoS from large and complex but monolithic systems with the following five characteristics:

a. Operational Independence of the Elements

The SoS is comprised of several independent systems, which are functional at stand-alone deployment. For instance, consider the integration between the C2 system and the platform navigation system in which the C2 system collects positional updates from the navigation system and broadcast to other friendly forces for blue force tracking. If the connection between the C2 system and the navigation system is broken or intermittent (e.g., loose wiring connection), the operator would be able to share his or her

location through manual means (compass and map), and the navigation system would still be able to receive a geographical location from the satellite.

b. Managerial Independence of the Elements

Consider the tactical network that connects the C2 systems in the mobile land platforms (e.g., infantry fighting vehicle or main battle tank). The network system governs the membership of the platforms such that the platforms can join the network via governed network protocols, message format, and operation bandwidth (e.g., via UHF/VHF/satellite connection) for task collaboration. On completion of the collaboration, the platforms can leave the network to execute individual tasks. While these component systems are able to operate as a SoS when they are integrated together, the subsystems continue to maintain individual, independent operational existence while being a part of the SoS.

c. Evolutionary Development

Consider the geographical challenges of implementing cooperative engagement capabilities (CEC) in the land battlefield context where lines of sight (LOS) among the platforms in the combat team are hindered by terrain and vegetation, thus affecting team communication and threat detection, classification, tracking, and engagement. Through ongoing technological research and development, the CEC in the form of SoS evolves gradually.

d. Emergent Behavior

Consider the long-range sense-and-strike mission in which the UAV pipes the surveillance picture to the C2 system in the armor battle group via the satellite link. The commander assesses the situation and executes an artillery attack command via the satellite link or tactical network to the artillery battery to engage the threat. In this scenario, the combination of the functions leads to an emergence, i.e., new sense-and-strike capability, that cannot be performed by each individual system (the UAV system, the C2 system, and the artillery firing system).

e. Geographic Distribution

Consider Satcom-on-the-Move (SOTM), which is the key enabler for long distance communication in the land battlefield. Land platforms equipped with the ruggedized onboard satellite antenna are able to communicate C2 information (intelligence on enemy situation report) over a long range back to the HQ at high data bandwidth.

C. STAKEHOLDER ANALYSIS

Consider a simplified stakeholder analysis for C2 system program where there are three groups of stakeholders, the Army capability development office, the program team, and the defense contractor team, as illustrated in Figure 2.

Figure 2. Stakeholder Analysis for a Typical C2 System Program

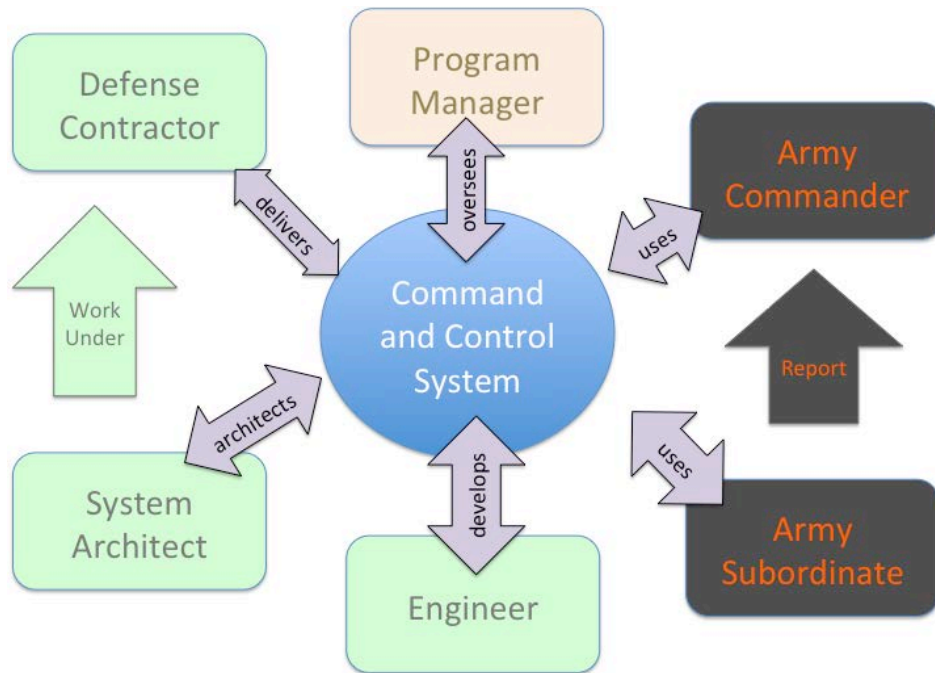

The end-user (the Army) need for the C2 system to provide them with situational awareness and decision making aids is identified as the most important requirement in the system. Both Army commander and Army subordinate use the C2 system during mission operations (the mode of usage shall be discussed in a subsequent section). The program

manager works with the Army on the development of the capability and the needs identification for the C2 system. When the system concept for a development item is defined and commented on through the acquisition process, the acquisition authority subsequently contracts with the defense contractor(s) to further refine, develop, and deliver the system. Therefore, with domain expertise in the capability and operational area, the program team is in charge of architecting the system at the capability and operational level, and the system architect under the defense contractor team (software provider, hardware vendor, system integrator) shall assume the responsibility of developing the functional and physical architecture (interface between subsystems, software architecture, power distribution, network connection and messaging protocol). The engineer (software, hardware, systems) develops the C2 system based on the approved architecture design by the stakeholders.

The acquisition processes, the development processes, and the operational processes, each contribute to the effectiveness of the operational system. That effectiveness can be reflected in two domains—the functional domain and the process domain. The functional domain reflects the stakeholders’ functional performances while the process domain reflects the stakeholders’ processes. Functional performances are measurable and quantifiable, whereas the process activities are verifiable. Thus, the role of the program manager is captured through the functions and processes of TO MANAGE (Langford 2012, 138–146). For each of the stakeholders a set of functions and processes are designated as those having the most influence on effectiveness. That designation of importance is determined by the subject matter experts who are most familiar with the implementation of the functions that are deemed most important to the outcomes associated with each life cycle phase in a system’s development. See Figure 5 for a general depiction of measures of effectiveness and subsequent discussion for the specifics.

A key aspect in determining effectiveness of a C2 system is based on the system architecture. The life cycle phases of a C2 architecture are first driven by the stakeholders’ needs. Stakeholders’ perspective should reflect their individual needs, that when combined form the operating of a C2 system. For example, from the operators’

perspective (army commander and subordinate), the desired expectations of the C2 system are performance, interoperability, ease of use, maintenance, and system safety. The C2 systems shall be able to integrate and be interoperable (“plug and play”) with other subsystems (e.g., new weapon system and communication system) with minimal configuration change. Measures of effectiveness (MOEs) and functional measures of performance (MOPs) are evaluated and given to the program manager, as feedback to ensure compliance with stakeholder needs to ensure that the C2 system performs to its desired capability.

From the program manager’s perspective, providing value-added services and meeting operators’ expectations are the driving factors towards a service-oriented architecture (SOA) that supports a high degree of reusability. In addition, new sensor systems can be integrated with the C2 system with minimal code revision as the processing units are developed. However, there is a need to ensure modularity during software development so that reuse of the software module is possible.

While providing a robust C2 system using SOA, there is also a need to ensure information assurance, especially when there is communication between the commander and the subordinate over a tactical network during operation. There is a need to encrypt the data message so that information exchange is not compromised. With message size increased for transmission, the effective information exchange would inevitably be affected. In addition, with the need for authentication, virus scanning, and restricted customization, the ease of use is also affected. Furthermore, there is a need to protect the security policy implementation through employing selected defense contractors, and a need for new subsystem integration. There is also a need to conduct extensive tests to ensure the security integrity of the system is not compromised, thus lengthening the development life cycle. Hence, the advantage of adopting SOA to shorten development time is traded-off with longer testing for information assurance. The implications of Figure 2 to the overall considerations for measuring effectiveness are apparent in the interactions between the stakeholders.

D. SAFETY STANDARD

As the C2 system is most often dominated by software development, there is a need to ensure that the C2 software architecture conforms to system safety practices, such as MIL-STD-882E (DOD 2012). The practice facilitates stakeholder communication in term of hazard identification and analysis so that proper measures are taken to pre-empt or mitigate the hazard.

Software is defined in MIL-STD-882E (DOD 2012) as

a combination of associated computer instructions and computer data that enable a computer to perform computational or control functions. Software includes computer programs, procedures, rules, and any associated documentation pertaining to the operation of a computer system. Software includes new development, complex programmable logic devices (firmware), Non-Developmental Item (NDI), Commercial-off-the-Shelf (COTS), Government-off-the-Shelf (GOTS), re-used, Government-Furnished Equipment (GFE), and Government-developed software used in the system.

Tables 1 and 2 represent the software safety critical matrix that establishes the Software Criticality Indices (SwCIs). The score of the indices determines the expected level of rigor (LOR) tasks to be carried out to address the safety related issue. Each SwCI recommends the level of rigor task to be performed to ensure the C2 system is safe for operation.

Table 1. Software Safety Criticality Matrix (from DOD 2012, 16)

| SOFTWARE SAFETY CRITICALITY MATRIX (from DOD 2012, 16) | | | | |
|--|---------------------------------------|--------------|--------------|----------------|
| | SEVERITY CATEGORY (from DOD 2012, 16) | | | |
| Software Control Category | Catastrophic (1) | Critical (2) | Marginal (3) | Negligible (4) |
| 1 | SwCI 1 | SwCI 1 | SwCI 3 | SwCI 4 |
| 2 | SwCI 1 | SwCI 2 | SwCI 3 | SwCI 4 |
| 3 | SwCI 2 | SwCI 3 | SwCI 4 | SwCI 4 |
| 4 | SwCI 3 | SwCI 4 | SwCI 4 | SwCI 4 |
| 5 | SwCI 5 | SwCI 5 | SwCI 5 | SwCI 5 |

The software control category (score 1 to 5) is determined by the degree of automation that the software function provides to the operational command. Consider the firing command. The score of 1 implies that the software has full control over the function, i.e., the firing command is automated by the software, and the score of 5 implies the software function does not have any influence or impact to the firing command. This score is compared to the severity category to determine the LOR required to ensure the potential hazard is either removed or mitigated through procedures. For instance, if the software function has influence on the weapon system, i.e., the operator can issue a firing command using the C2 software function, this function would be allocated a score of 2 or 3 through stakeholders' consensus. The potential hazard identified from this function is occurrence of firing on friendly force in the event when the operator perceives the friendly force as threat in the C2 situational picture and issues a firing command. The severity of this hazard is considered Catastrophic (1). Therefore, the SwCI is considered as 1 and the level of rigor to be conducted on this function to ensure system safety is displayed in Table 2:

Table 2. Level of Rigor Tasks (from DOD 2012, 16)

| SwCI | Level of Rigor Tasks |
|--------|---|
| SwCI 1 | Program shall perform analysis of requirements, architecture, design, and code; and conduct in-depth safety-specific testing. |
| SwCI 2 | Program shall perform analysis of requirements, architecture, and design; and conduct in-depth safety-specific testing. |
| SwCI 3 | Program shall perform analysis of requirements and architecture; and conduct in-depth safety-specific testing. |
| SwCI 4 | Program shall conduct safety-specific testing. |
| SwCI 5 | Once assessed by safety engineering as Not Safety, then no safety-specific analysis or verification is required. |

E. LIMITATION AND CONSTRAINT

1. Communication

Communication is the key element for two or more stations to exchange information. Typical information is exchanged in two manners: either through voice

communication or data communication in the form of message in byte or bit. The information exchanged can be the current location, target position, or request for replenishment support, for example. Consider the different kinds of communication: a fleet commander requesting the location of his fleet for better situational awareness; a fire support officer requesting an air strike; a logistics officer requesting replenishment; an intelligence officer requesting the latest update; or a commanding officer requesting the status update to support his troops. The data message can be exchanged via various means, such as tactical combat radio, re-broadcast station, and satellite connection.

The C2 system is generally a collaborative system between the commander and his subordinates. The following heuristics that the collaborative system should possess, as described by Maier (Maier 1999), are used to critique the communications portion of the C2 system architecture:

Ensuring cooperation: A collaborative system exists because the partially independent elements decide to collaborate. The designer must consider why they will choose to collaborate and foster those reasons in the design (Maier and Rechtin 2009).

2. Stability

Consider the mission during the battle. There is often a need for the commander to maintain constant communication with his troops to ensure timely commands are given and control is maintained consistently. Interruption occurs whenever there is a break in communication, such as blockage, terrain masking, and equipment breakdown. Maintaining stability in C2 is fundamental to task completion.

Langford (2012, 111) describes stability in a system as:

For a system to exist and sustain itself as a system, it requires some semblance of metastability, i.e., dynamic stability to continue as system... Metastability is the intrinsic property of a group of objects that persists in an apparent equilibrium of interactions between objects where only a small disturbance in the established interaction can dramatically change (reduce or increase) the system's lifetime. (Langford 2012, 111)

System metastability is important to ensure the success of the mission. During the collaboration, information would not be exchanged effectively when there is constant

interruption caused by network failure, equipment failure, or software failure. The mission is deemed a failure because the system cannot sustain itself throughout the lifetime. The heuristic shared by Maier and Rechtin (Maier and Rechtin 2009), which the collaborative system should possess, is used as the critique for the C2 system architecture. It reads:

Stable intermediate forms: A collaborative system designer must pay closer attention to the intermediate steps in a planned evolution. The collaborative system will take on intermediate forms dynamically and without direction as part of its nature. (Maier and Rechtin 2009)

Given the land battlefield environment where communication is limited by the terrain, canopy, and vegetation, it is common to lose connection between the commander and the subordinate. As a result, cooperation is limited due to a physical communication breakdown. All stakeholders indicated in Figure 2 agree there is a need to minimize loss of connection by typically employing additional tactical radio with different frequency wavelengths for redundancy, deploying a re-broadcast station to bridge the communication, or deploying more forces to relay communication.

However, each action incurs additional manpower and resource cost in which the commander must consider and prepare to tradeoff for continual communication. Thus, there is a need to evaluate the MOE of using the C2 system in light of the increasing requirement for more subsystem integration.

This chapter has provided the background studies of the C2 system and the challenges to meet user expectation. The next chapter shall emphasis on the literature review of MOEs.

THIS PAGE INTENTIONALLY LEFT BLANK

III. LITERATURE REVIEW MEASURES OF EFFECTIVENESS

A. MEASURES OF EFFECTIVENESS AS TECHNICAL MEASUREMENTS

Roedler and Jones (2005, 9) define measures of effectiveness (MOEs) as “operational measures of success that are closely related to the achievement of mission or operational objectives.” They refer MOEs to “a subset of technical measurement,” as illustrated in Figure 3, which is the set of measurement activities used to provide the stakeholder with insight into the progress of defining, developing, and sustaining the product or service. In a general sense, measures of effectiveness are “intended to determine to what extent objectives are accomplished and how well the results compare with the desired results” (Roedler and Jones 2005, 9).

Roedler and Jones (2005, 6) include the following as technical measurement:

- KPPs are a critical subset of the performance parameters, representing the most critical capabilities and characteristics.
- MOPs characterize the physical or functional attributes related to the system operation.
- TPMs measure attributes of a system element within the system to determine how well the system or system element is satisfying specified requirements.

Figure 3. Technical Measures Relationships (from Roedler and Jones 2005, 15)

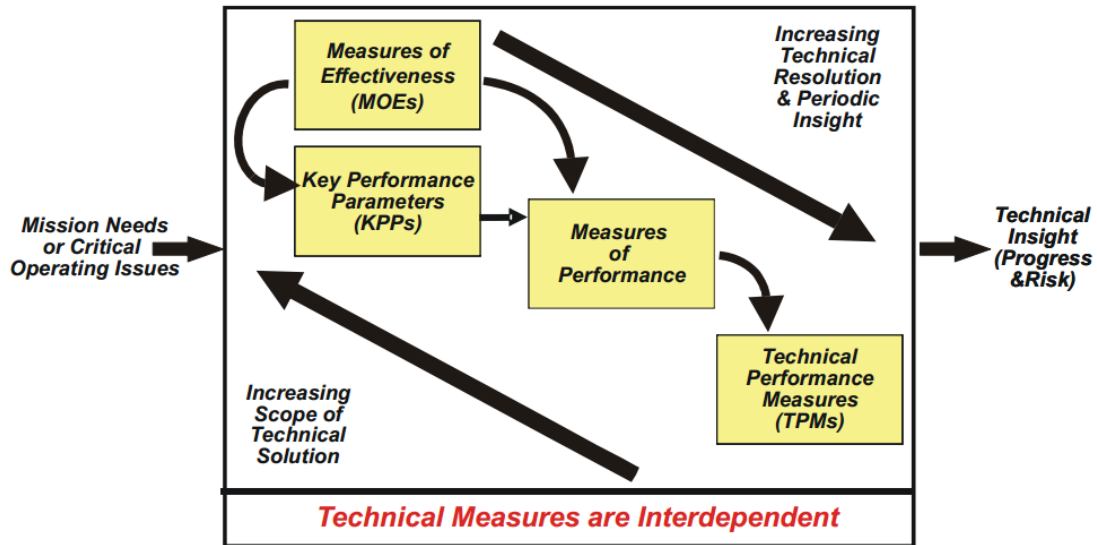

MOEs are used to:

- Compare operational alternatives.
- Investigate performance sensitivities to changes in assumptions from the user's view.
- Define operational performance requirements.
- Evaluate the achievement of key operational performances.
- Serve as the standard of acceptance and evaluation for the technical solution. (Roedler and Jones 2005, 9–10)

Roedler and Jones (2005) provide a set of guidelines to select MOEs, as listed in Table 3.

Table 3. Measures of Effectiveness Selection Guidelines (from Roedler and Jones 2005, 36)

| MOE Selection Guidelines |
|--|
| Provides insight into at least one operational objective or mission requirement. |
| MOEs should not be strongly correlated; they should provide insight into different aspects of the operational alternative. |
| Select and define in the context of the operational objective: no predefined MOEs/values. |
| Select and define independent of the alternatives at hand; represent an independent means to collectively evaluate the alternatives. |
| Select only a few MOE/MOPs, which may be an order of magnitude more TPMs. |
| Each KPP should have an associated MOE or MOP. |

B. MEASURES OF EFFECTIVENESS OPERATIONAL TESTING AND EVALUATION

Operational testing and evaluation (OT&E) is considered as a major milestone in the project implementation cycle. The success of project implementation relies heavily on the completion of the OT&E because OT&E usually takes up a large portion of the payment milestone from contractor’s perspective. From the user’s perspective, the OT&E completion provides the level of confidence on the system readiness to be deployed in the field. Therefore, it is essential that the system MOE be addressed as part of OT&E completion.

In the OT&E context, Stevens (1986) defines MOEs as “any set of criteria established to determine the resolution of a critical issue.” Generally, the OT&E passing criteria set the guidelines to develop the MOEs. Stevens (1986) lists the following characteristics to describe a good MOE and seven MOE development rules as tabulated in Tables 4 and 5, respectively.

Table 4. Characteristics of a Good Measure of Effectiveness (from Stevens 1986, 55)

| Characteristics of a Good MOE |
|--|
| The MOE should be relevant (Stevens 1986, 55). |
| The set of MOE should be complete (Stevens 1986, 55). |
| The MOE should be precisely defined (Stevens 1986, 55). |
| The MOE sets should be mutually exclusive (Stevens 1986, 55). |
| The MOE should be expressed in terms that are meaningful to testers and developers (Stevens 1986, 55). |
| MOE meaning should not be open to interpretation with the passage of time (Stevens 1986, 55). |
| MOE inputs should be measureable (Stevens 1986, 55). |

Table 5. Measure of Effectiveness Development Rules (from Stevens 1986, 55–56)

| MOE Development Rules |
|--|
| There should be one MOE for each mission capability. |
| Decision-makers shall assign MOE weights. |
| Missions/scenarios should be fully defined before measurement collection during testing. |
| Measurements should not interfere with system operation. |
| MOE quantitative measurements should be stated as probabilities. |
| All qualitative measurements should use the same standard. |
| When recording system failures during testing, include system & hardware failures. |

C. MEASURES OF EFFECTIVENESS AS THE FULFILLMENT OF STAKEHOLDERS' NEEDS

Sproles (2002) proposed the MOE development should “evaluate the performance of the system in relation to mission accomplishment,” with focus and emphasis on stakeholder needs and requirements. Sproles (2002) emphasized the use of MOEs to address critical operational issues (COIs), defined “as an emergent property that the system must have in order to perform its function [and] that a solution to a need must possess in order to meet the need” (256–57). Sproles further clarified the difference between the formulation of the MOE and MOP:

An MOE refers to the effectiveness of a solution and is independent of any particular solution; an MOP refers to the actual performance of an entity... An MOE will indicate a property which a potential solution must possess in order to meet a need: An MOP will tell what something is capable of doing, even if this is not necessarily what the stakeholders want it to do. The difference between effectiveness and performance as applied to a solution to a need is that effectiveness is a quality of fitness for service or of producing the results for which it was intended. Performance is the quality of doing something, and doing something does not necessarily indicate fitness for service. (Sproles 2000, 56–57)

The MOE development process as proposed by Sproles is the system engineering approach that begins with a series of reviews from gathering users' requirements, design, and feasibility studies to determine the most effective solution. Once the solution is selected, the MOEs are then developed to evaluate the effectiveness of the system to operate during the mission. Figure 4 illustrates the development process of the MOEs from Sproles.

Figure 4. Measure of Effectiveness Development Process (from Sproles 2002, 255)

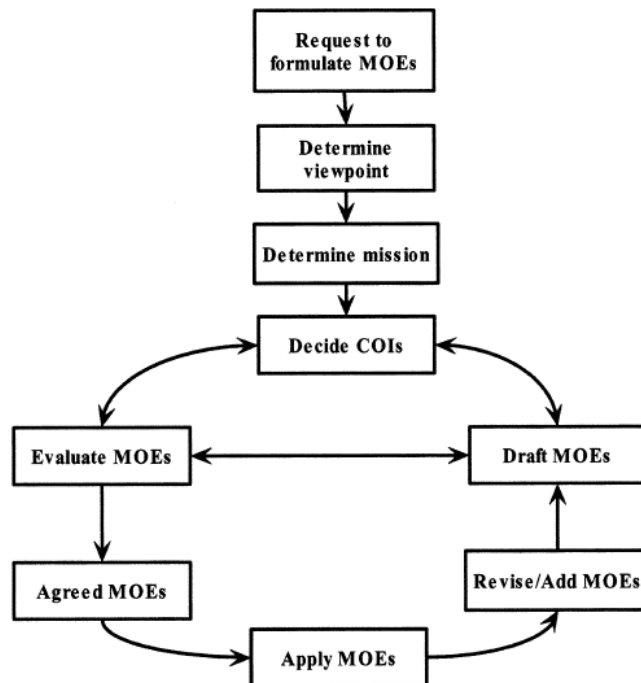

However, an MOE developed through this process is geared towards the COIs, which are driven by the stakeholders' perspective of the system; therefore, the application of the MOE is limited solely to mission performance.

D. MEASURES OF EFFECTIVENESS AS DETERMINANTS OF THE INTEGRATIVE FRAMEWORK

MOE is defined as “the single-most often touted and applied method of thought of how well one is doing” (Langford 2014, 8). Langford explained that “the what” to measure for effectiveness must be interpreted within a particular context, regardless of type. Without boundaries, it is uncertain what dimensionality means in terms of effectiveness, let alone how it could be compared and how meaningful such a comparison might be. And “the how” and “the when” are seemingly attached to milestones in the acquisition parlance rather than to the merits of any theoretical foundation. Langford (2014) proposed developing MOEs using an integrative framework as illustrated in Figure 5 (Langford 2014, 8–12). Within the integrative framework (objects and processes), each of the intersections between objects and processes has a set of MOEs (Langford 2014, 8–12). The first set is related to the process frame. MOEs that are related to processes are verifiable and, as such, are not quantifiable. The second set of MOEs is related to the object frame. MOEs that are related to objects (e.g., physical objects, functions, and behaviors) are quantifiable. One insight observed from the integrative framework of MOEs is normally seen as being quantifiable, but in fact, half of them are not. For example, the measure of effectiveness for physical objects and functions is quantifiable through data measurement, i.e., mission log collection, and database, and the analysis of the data provides the objective value in determine whether the objects or functions have fulfilled or exceed the user expectation during task execution. As for behaviors, i.e., leadership in command and control, style in task execution, it is rather towards the subjective approach to evaluate the effectiveness in mission accomplishment.

Figure 5. Integrative Framework (from Langford 2014, 7)

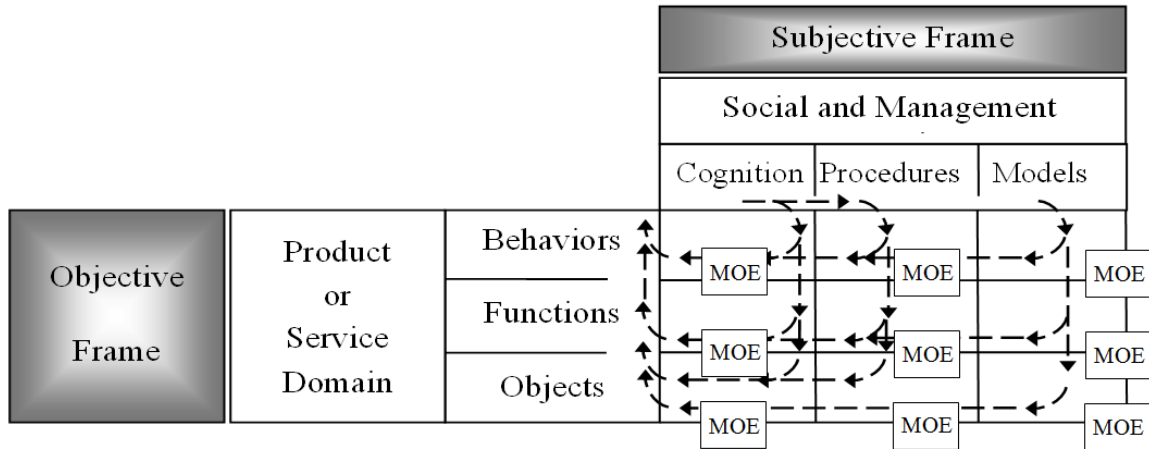

As illustrated in Figure 6, fitness-for-purpose is defined as “the real knowledge that a potential user needs to have is whether the product or service, decision or judgment, plan or outcome, technology or engineering is good for a purpose” (Langford 2014, 18).

Figure 6. Linkage between Measures of Effectiveness and Fitness-for-Purpose (from Langford 2014, 8)

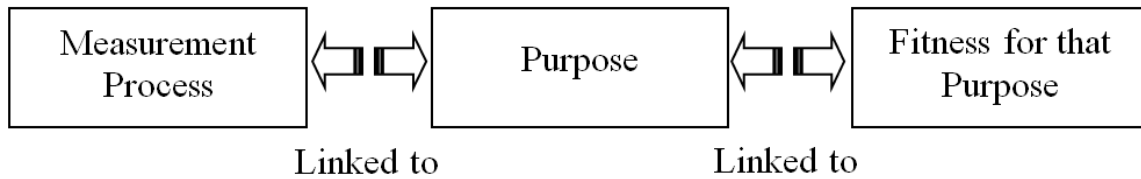

This chapter has provided the literature review of various MOE development processes and techniques. Langford’s integrative framework shall be used in the next chapter for MOE development.

THIS PAGE INTENTIONALLY LEFT BLANK

IV. METHODOLOGY TO DEVELOP MEASURE OF EFFECTIVENESS

The previous chapter provides the literature review of various MOE development processes and techniques. With technological advances in the sensor and processing systems, there is a growing interest to integrate these systems into the C2 system to achieve better and faster situational awareness and decision making aid. However, there is a need to evaluate the outcomes (performance and experience) to determine the value (subjective and objective) of fulfilling the requirements. These evaluations would better manage the user expectations in terms of the return on investment to perform the integration. Thus, MOEs are widely applied to measure and evaluate the performance of C2 systems in a combat context. This chapter covers the nine-step methodology using integrative framework to develop MOE for evaluating the effectiveness of the C2 system in the land battlefield.

A. NINE-STEP METHODOLOGY

The measures of effectiveness (MOEs) of C2 systems on land battlefields are developed and evaluated using the nine-step methodology. The nine-step methodology was developed to unify the concepts of MOEs into a repeatable, validated process and to identify MOEs associated with both development and operations (Langford 2014, 10). A flow diagram of the nine-step methodology is displayed in Figure 7. Using the nine-step methodology and the integrative framework, 12 pairs of MOEs are developed.

Figure 7. Nine-Step Methodology to Characterize MOEs (from Langford 2014, 14)

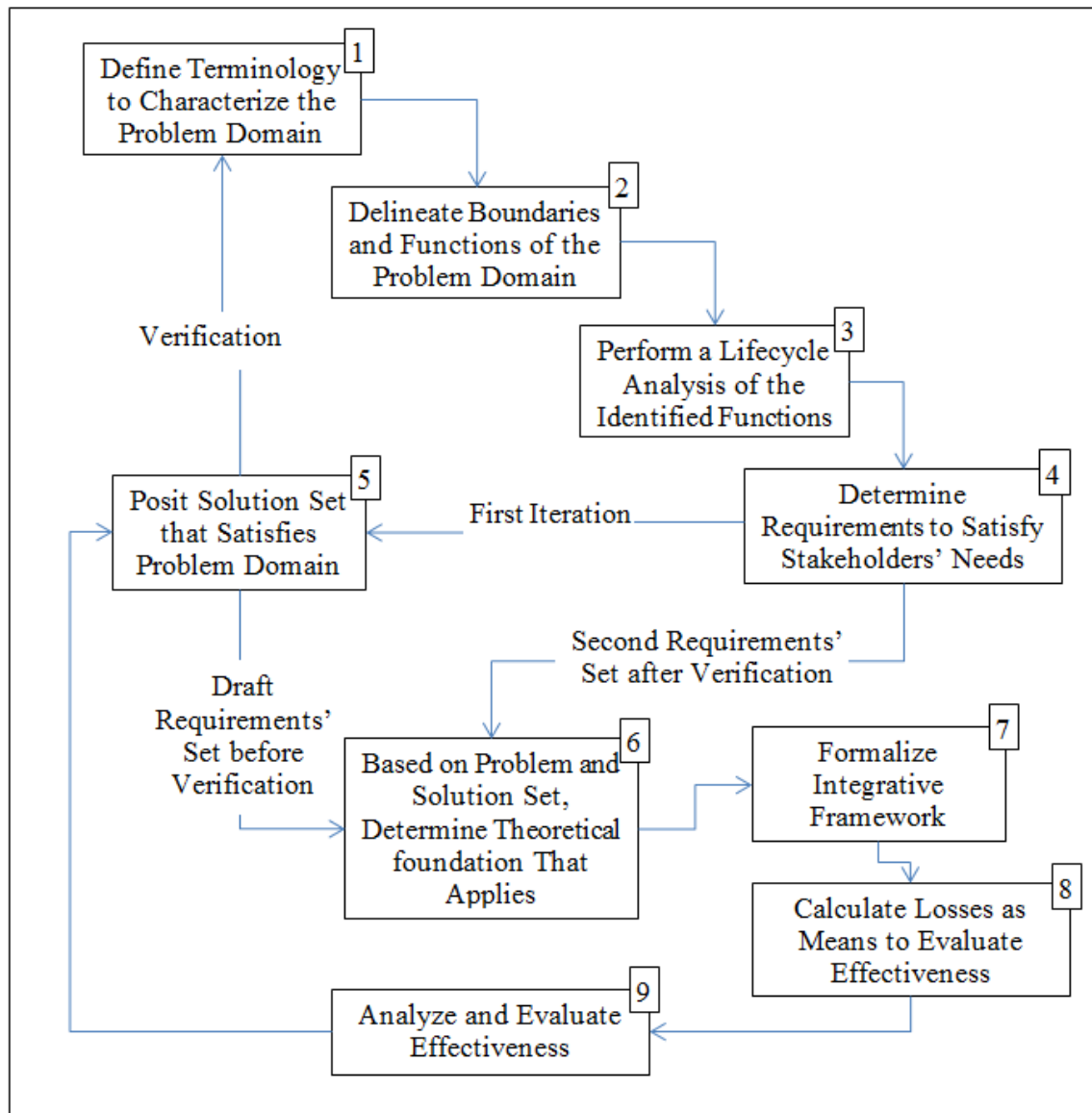

The nine steps are described below (Langford 2014, 10–13):

(1) Define Terminology

These terms that are used in Figure 5 are mathematically defined and formalized through predicate calculus (Langford 2014). The result is a consistent set of defined terms

that combine to provide a validity structure for the integrative framework and the MOEs and MOPS.

(2) Delineate Boundaries and Functions

The functional decomposition of “To Command” and “To Control” are performed and analyzed. The boundaries are described through physical, functional, and behavioral domains (Langford 2012). The problem domain lies within these three types of boundaries. For the C2 system, the boundaries extend beyond the developed system to the domain(s) of the adversary. The MOEs extend to the boundaries and encapsulate all functions and solutions (Langford 2012).

(3) Perform Life Cycle Analysis

In the language of life cycle analysis, functions are measured and quantified from the different perspectives of the stakeholders. The function of ‘to receive’ is different from the function ‘to transmit’, but both functions are necessary for the higher level function of ‘to communicate’. Life cycle analysis is best performed at the highest level of abstraction within the functional domain so as to capture the overall perspective of the MOEs.

(4) Define Requirements

This section specifies the requirements that satisfy stakeholder needs (Langford 2014). These requirements would be used for MOE traceability and validation. There are commensurate MOEs for that capture processes that must occur. These processes are verifiable—either performed or not performed (Langford 2014).

(5) Postulate Solution Set

This section conceptualizes and characterizes a set of solutions that satisfy stakeholder needs (Langford 2014). The set of alternative solutions exists within the boundaries of the problem.

(6) Determine Theoretical Foundation

MOEs are sensitive to the theory on which measurements are referenced. Logically, the theoretical underpinning should be consistent throughout the boundaries, so that the MOEs have structure, semantic, and syntax validity (Langford 2014).

(7) Formalize Integrative Framework

This section maps the processes (used in the MOEs) to physical objects (functions used in MOEs) through the integrative framework (Langford 2014). Langford (2014) describes the framework as follows:

The framework captures the product and management needs in the nexus formed by the intersection of an objective frame and a subjective frame. Within the integrative framework (objects and processes), each of the intersections between objects and process has a pair of MOEs. The first set is related to the process frame. MOEs that are related to processes are verifiable, and as such are not quantifiable. The second set of MOEs is related to the object frame. MOEs that are related to objects (e.g., physical objects, functions, and behaviors) are quantifiable. We normally think of MOEs as being quantifiable, but in fact half of them (the processes) are not quantifiable (only verifiable). Figure 8 displays the framework's two frames: the object (objective) frame and the process (subjective) frame. The arrows in Figure 8 indicate the interaction sequencing as the framework is applied when developing MOEs for the product or service. The sequence of moving from the subjective frame through the objective frame illustrates that the functional analysis portion follows from the cognitive processes, the mechanistic process, and the model process. The sequence begins with cognitive structures, completing a cardinal point before moving on to the next.

Figure 8. Integrative Framework (from Langford 2014, 7)

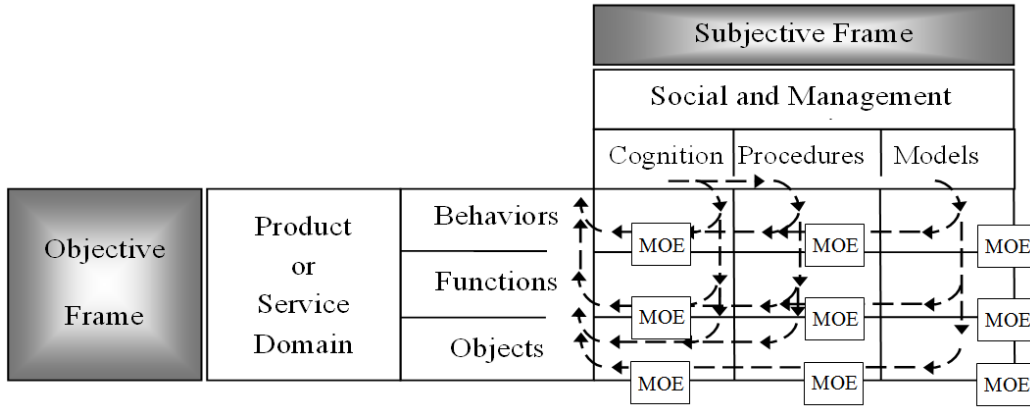

Each process-object intersection creates the area of interest for the MOE development as illustrated in Figure 9. Figure 10 lists the MOEs under each intersection as described by Langford (2014, 15).

Figure 9. Integrative Framework with Measure of Effectiveness Domain Description (from Langford 2012, 89)

| | | | Integration method | | |
|---|--------------------------------------|--|---|--|---|
| | | | Processes | | |
| | | | Abstractions (and reasoning) | Mechanisms, procedures, activities | Models, representations |
| O B J E C T I V E | P r o d u c t | User behaviors (associated with or due to product*service) | Conceptualization pertinent to user behaviors due to product*service | Process and mechanisms describing user behaviors due to product*service | Models or representations of the user behaviors |
| | F u n c t i o n | Functions (associated with or because of objects that comprise product*service) | Conceptualization delineating uses provided by product*service | Process and mechanisms achieving complete portrayal of product*service functions | Models or representations showing all functions |
| | O b j e c t | Physical entities (associated with or because of objects that comprise product*service) | Identifying and interpreting the product*service physical artifacts, and ascribing meaning | Process and mechanisms resulting in the development of all physical elements | Models or representations of all physical elements |

Figure 10. Measure of Effectiveness Framework Cardinal Points (from Langford 2014, 15)

| | | Processes | | |
|---------|----------------------------|--|--|--|
| | | Cognition | Procedures | Models & Representations |
| Objects | User Behaviors | Conceptualization of stakeholder behaviors (MOE-a) when the product*service is used; and when it not used (or available) (MOE-p) | Influence of procedures on processes and mechanisms describing user behaviors due to product*service (MOE-i); Influence describing user behaviors due to lack of product*service (MOE-f) | Comparison of expectations of models or representations of stakeholder behaviors to actions (MOE-t); Evaluation of behaviors to predicted actions (MOE-v) |
| | Functions | Prognostication of consequences of interactions between objects through exchange of EMMI (MOE-g); & Expectations of interactions (MOE-c) | Availability and Validity of processes and mechanisms that determine resource utilizations for functions (MOE-u); Processes and mechanisms that define the boundary conditions for anticipated operations of all functions (MOE-b) | Models/representations showing all functional performances (MOE-n); Models/representations showing all functional performance's quality (MOE-q) |
| | Physical Entities - Object | Experience with posited objects (MOE-e) & anticipated responses of posited objects (MOE-r) | Availability and Validity of processes and mechanisms resulting in the selection and development of all physical elements (MOE-s); Processes and mechanisms resulting in the development of all physical elements and operational contexts (MOE-x) | Models or representations of all physical elements, (structures, properties, traits, and attributes (MOE-o); Models or representations of all social, political, economic elements (MOE-j) |

B. SUMMARY

This section evaluates the effectiveness of using a C2 system on the battlefield to achieve mission objectives through the use of the MOE.

This chapter walks through the Langford nine-step methodology for MOE development. The next chapter shall use the methodology to develop the MOE for using a deployed C2 system in the land battlefield.

V. DEVELOPMENT OF THE MEASURE OF EFFECTIVENESS

This chapter discusses the C2 MOEs development using the Langford's nine-step methodology; these C2 MOEs are applied to evaluate the effectiveness of an actual C2 system.

A. TERMINOLOGY DEFINITION OF A COMMAND AND CONTROL SYSTEM

The following are used as the terminology definition of a C2 system to develop the MOEs:

- *Command*: Command is the art of assigning missions, prioritizing resources, guiding and directing subordinates, and focusing the entire division's energy to accomplish clear objectives (Bornman 1993, 15).
- *Control*: Control is the science of defining limits, computing requirements, allocating resources, prescribing requirements for reports, monitoring performance, identifying and correcting deviations from guidance, and directing subordinate actions to accomplish the commander's intent (Bornman 1993, 15).
- *Command and Control System*: A *command and control system* consists of a collection of denotable things that are used to perform the C2 function: physical elements e.g., equipment, such as transmitters and receivers, computers, a signal book, status boards and other decision support hardware, code breaking facilities, and signal flags); human elements (e.g., communicators, staffs, intelligence analysts, and the commander himself); and procedural elements (e.g., table of organization and command relationships, the content of a signal book, and the content of a manual of training or doctrine) (Hughes 1989).
- *Measures of Effectiveness*: Langford describes MOEs as a combination of measures that embody the approaches of outcome-based, information-based, and scenario-based determinants. (Langford 2014, 7).

B. COMMAND AND CONTROL SYSTEM BOUNDARIES AND FUNCTIONS DELINEATION

Figures 11, 12, and 13 illustrate the functional decomposition of "To Manage," "To Command" and "To Control." Langford (2012) describes command and control within the "To Manage" function.

Figure 11. Functional Decomposition of “To Manage”

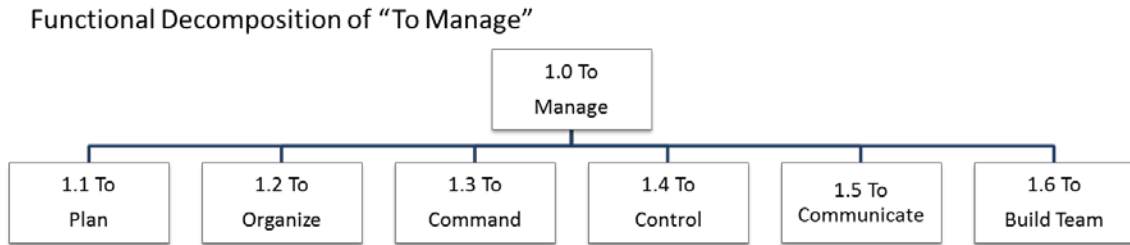

Figure 12. Functional Decomposition of “To Command”

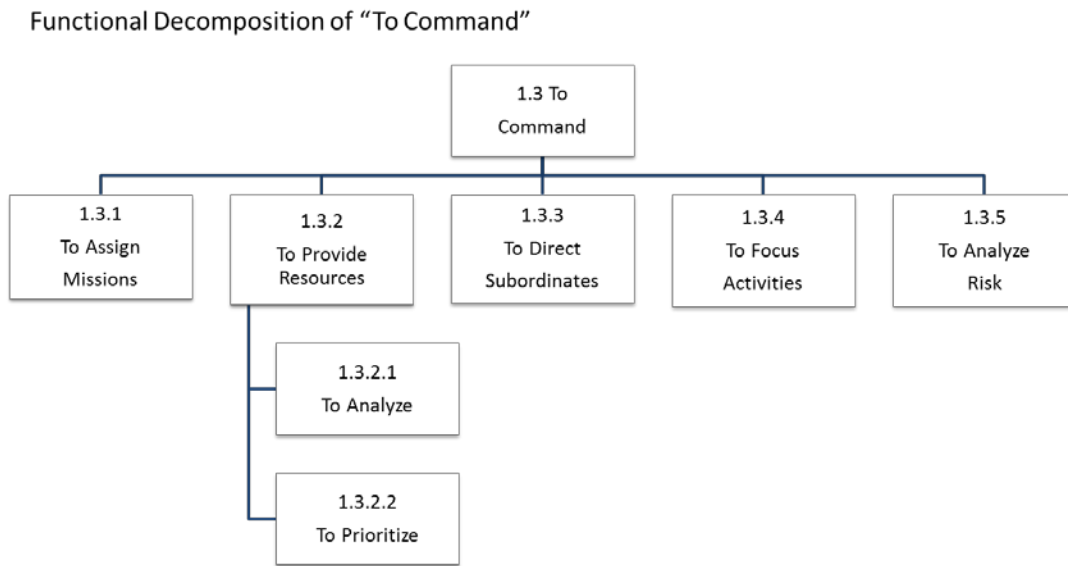
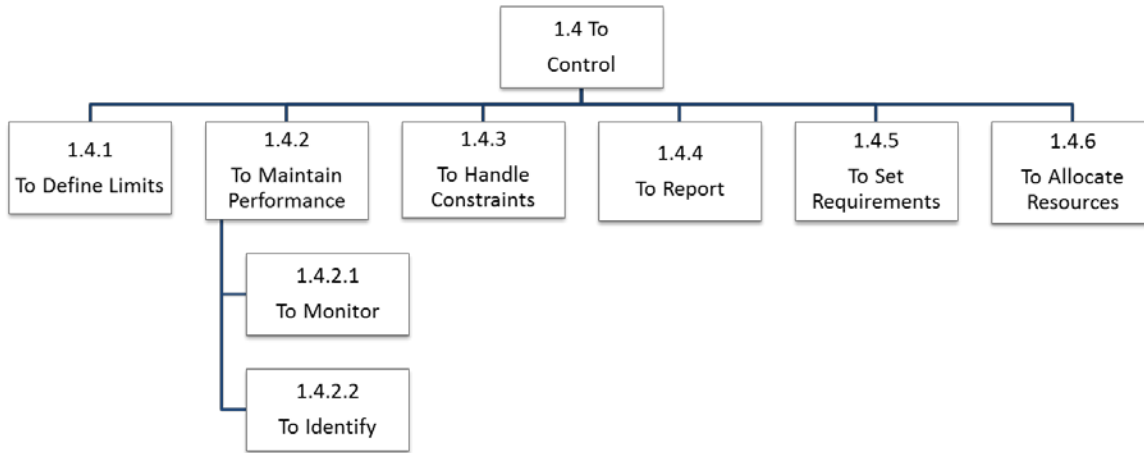

Figure 13. Function Decomposition of “To Control”

Functional Decomposition of “To Control”



1. To Command

The function “to command” includes the available C2 system activities required for the commander to lead his subordinates.

a. To Perform the Act of Assigning Mission

The commander assigns the task to his subordinate using the C2 system.

b. To Provide Resources (Analyze and Prioritize)

The commander provides the necessary resources (e.g., logistics support, enemy situation report, task priority, and task difficulties) to the subordinate to accomplish the task. Normally, the task is embedded in the task order sent over the tactical network using the C2 system.

c. To Direct Subordinates

The instructions (e.g., time to arrive, ammunition information, potential threat information, task objectives, destination, contingency plan, and recovery plan) to the

subordinate to accomplish the task is embedded in the task order disseminated using the C2 system.

d. To Analyze Risk (Identify and Assess)

During task execution, the commander monitors the progress of the subordinate via the C2 system to identify and assess any potential risk that might jeopardize the task. The subordinate provides a periodic task update to the commander via the C2 system.

2. To Control

The function “to control” includes the actions taken by the commander to ensure that the task assigned to the subordinates is accomplished. Consider the scenario in which the subordinate has failed to accomplish the task. The reasons for task failure could be obstacles encountered during maneuver, critical equipment failure, manpower loss, and changes in mission priority from higher command. In this situation, the commander re-plans the task and assigns the task to the subordinate via the C2 system. The subordinate receives the task reassignment order via the C2 system and proceeds to execute the task.

a. To Define Limits

During the task assignment, the commander sets the operation limit (e.g., operating range, sector of interest, task duration, and engagement protocol) to ensure that subordinates are well oriented to executing the task.

b. To Negotiate

The commander handles any conflicts of task (e.g., subordinate A enters into subordinate B’s task sector) during task execution. The C2 system supports the function through providing the common situational picture to the commander.

c. To Deal with Constraints

During a situation in which subordinates are unable to complete the task due to constraints, the commander analyzes the situation, analyzes the alternatives, and

reassigns the task to the subordinate using the C2 system so that the mission objective can be met.

d. To Determine Requirements

The commander ensures that his subordinates are aware of the task completion criteria through a set of measurements provided by the C2 system.

e. To Allocate Resources

During a situation in which the subordinates are unable to complete the task due to constraints, the commander analyzes the situation and allocates resources to the subordinate via the C2 system so that the mission objective can be met.

f. To Report

During task execution, the subordinate provides a periodic update to the commander on the task status via the C2 system.

g. To Track Performance

The commander ensures that his subordinates are aware of the task completion criteria and their performance according to the task instruction.

C. LIFE-CYCLE ANALYSIS OF USING A DEPLOYED COMMAND AND CONTROL SYSTEM IN THE BATTLEFIELD

Consider the task assignment scenarios illustrated in Figure 14. The C2 process cycle consists of four stages: planning, command, control, and recover. The commander plans the task and then assigns it to his subordinates. The task assignment message is transmitted over the tactical network to be received by the subordinate's station. The subordinate's C2 system processes the task to be displayed for the subordinate's acknowledgement. After the task acknowledgement, the subordinates proceed to execute the task. During the execution, the commander monitors the progress by tracking their movement and task update. Upon completion of the task, the commander issues a recovery command for the subordinates to recover from the task. In the event when the

task is not executed or failed to complete, the commander would re-plan and reassign task to the subordinates.

Figure 14. Task Assignment Scenarios

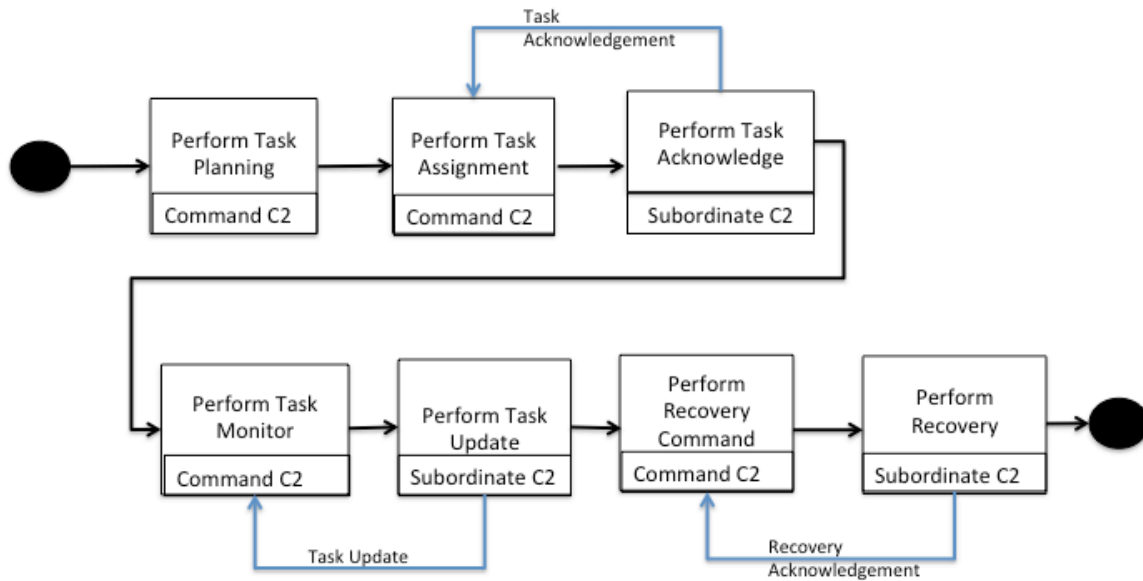

D. COMMAND AND CONTROL SYSTEM IN THE LAND BATTLEFIELD REQUIREMENT DEFINITION

For the commander on the land platform to send task assignment using the C2 system to subordinates on another land platform, each land platform shall be equipped with the C2 system connected to the communication system for information exchange. The C2 system shall be integrated with the tactical network system that connects the combat team. Each C2 system joins or leaves the tactical network using the operator call-sign as identification. During task execution, the commander shall be able to track the movement of the subordinate for task monitoring. Therefore, the C2 system shall be connected to the onboard navigation system to receive position information and broadcast at regular intervals. The C2 system shall plot the position information received on the graphical map in the display system to establish the common situational picture in the combat team. The C2 system shall be integrated with the database system installed in the

mission computer to log the transaction record between commander and subordinates throughout the mission. The C2 system shall be integrated with the onboard sighting system to acquire threat range, and the information shall be plotted and broadcasted to establish common situational picture in the combat team. The C2 system shall allow operators to create, edit, view, send, and acknowledge tasks. The C2 system design shall conform to the open architecture standard to facilitate integration and collaboration with other systems. The C2 requirement is tabulated in Table 6.

Table 6. Command and Control System Requirements

| Capabilities | Requirements | Description |
|---------------------|--------------|---|
| Command and Control | REQ.1 | The system shall be integrated with the communication system to exchange information between units during a mission. |
| | REQ.2 | The system shall be integrated with the tactical network system to establish an information exchange session for the combat team during the mission. Each system enters or leaves the network through the operator's call-sign as identification. |
| | REQ.3 | The system shall be integrated with the navigation system to receive position updates for navigation during the mission. |
| | REQ.4 | The system shall be integrated with the database system to store mission information, such as friendly forces track, target information, and task allocation. |
| | REQ.6 | The system shall provide a computer display for operators to access and input information for task assignment and monitoring during the mission |
| | REQ.7 | The system shall be integrated with the sighting system to acquire threat range, and the information shall be shared through broadcast in the tactical network. |
| | REQ.8 | The system design shall conform to open architecture standard with extensible interface to integrate with other external systems. |
| | REQ.9 | The system shall provide operators with tools to create, edit, view, send, and acknowledge tasks. |

E. POSITED COMMAND AND CONTROL SYSTEM SOLUTION SET

The land platforms in which the C2 system is installed and deployed are the armored vehicles illustrated in Figure 15. The armored vehicle team forms the tactical network to facilitate information exchange to establish the common battlefield situation. This concept is similar to the Battlefield Management System (BMS) deployed in Singapore Armed Force (SAF) (Pan 2007). From Figure 15, the commander is able to gain situational awareness in which he knows where his friendly forces are and what the

characterization of the threat is using the C2 system. If the commander wants to engage the threat, he can assign a task to his subordinate base on his assessment on the situation.

Figure 15. Command and Control System in the Land Battlefield Concept

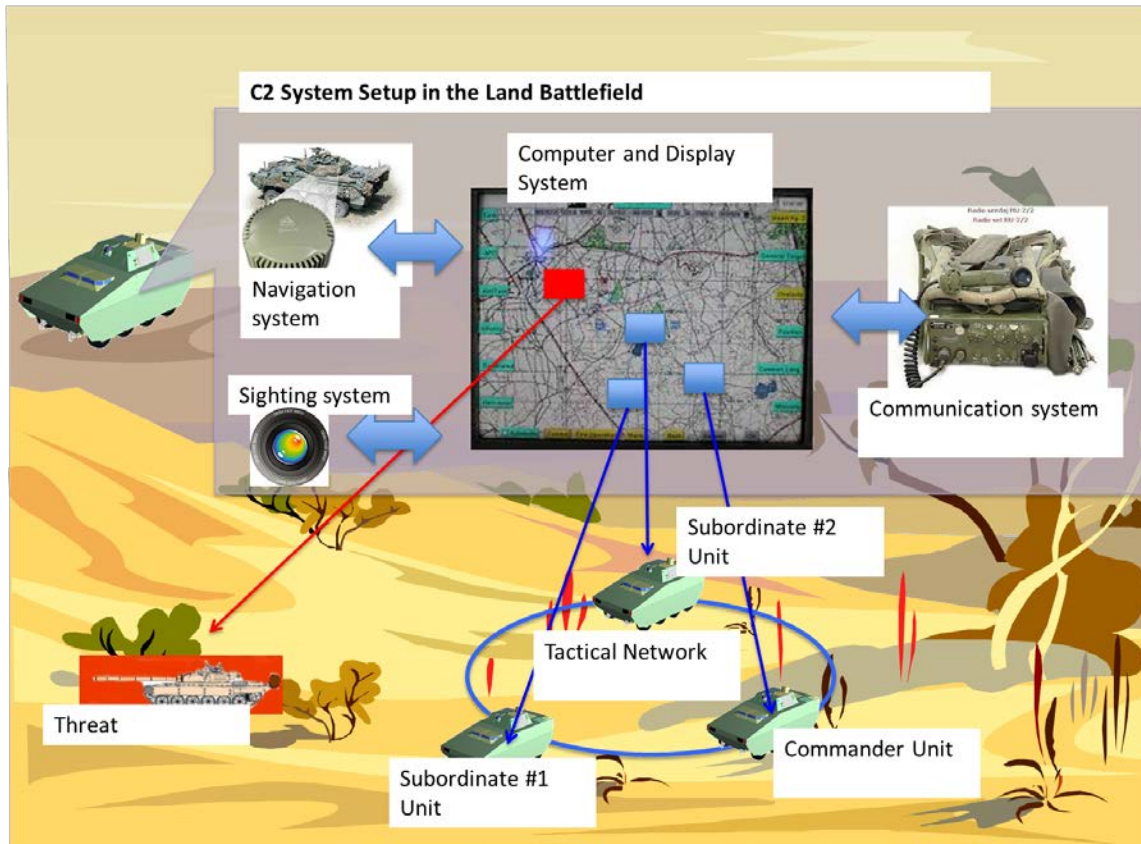

To achieve the C2 capabilities for the land platform system, it is important to identify the interaction between the C2 and the various subsystems in the platform illustrated in Figure 16. Each platform is equipped with a mission computer, navigation system, sighting system, and communication system. The C2 system interacts with the navigation system for location update and the C2 system interacts with the communication system to exchange information among the combat team. The C2 system interacts with the sighting system for range information. All the information is processed by the C2 system to establish a common situation picture among the combat team. The C2 system is installed in the computer, which connects physically to the rest of the

subsystems (navigation and communication system). Each land platform would be installed with the similar configuration so that during mission, the commander can establish a common situational picture graphically through the computer display via the information exchange, such position, peer location, and task messages. Each operator's call-sign (e.g., commander, subordinate #1, and subordinate #2) in the combat team is used for identification during the tactical network establishment.

To ensure the commander's tank is able to interact with his subordinate tank, both C2 systems use the same messaging protocol with defined message format. For example, the movement of the subordinate is retrieved by the subordinate C2 system through its interaction with the subordinate navigation system. The subordinate C2 system would transmit the location message to the commander's C2 system so that the commander is able to track his subordinate's movement.

Figure 16. Information Exchange

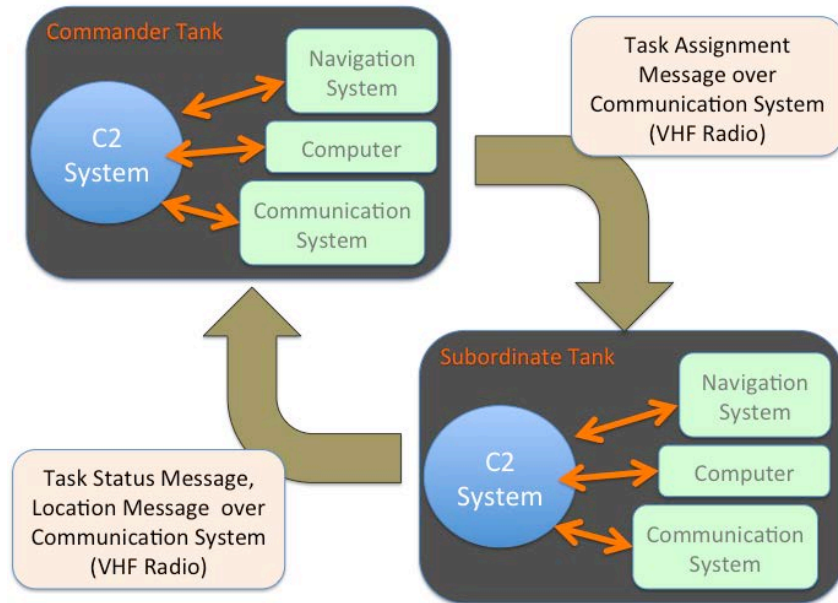

The software architecture of the C2 system is illustrated in Figure 17. The software architecture consists of three layers: presentation, application, and data. The presentation layer interacts with operators through the graphical user interface (GUI), and

user input would be passed to the application layer for processing. The application layer processes the user input and retrieves the information from the data layer. The data layer interacts with the database and the subsystems to collect the information and return it to the application layer for processing. Upon processing completion, the application layer returns the result to the presentation layer to present it to the operator through the GUI.

Figure 17. Software Architecture of the Command and Control System

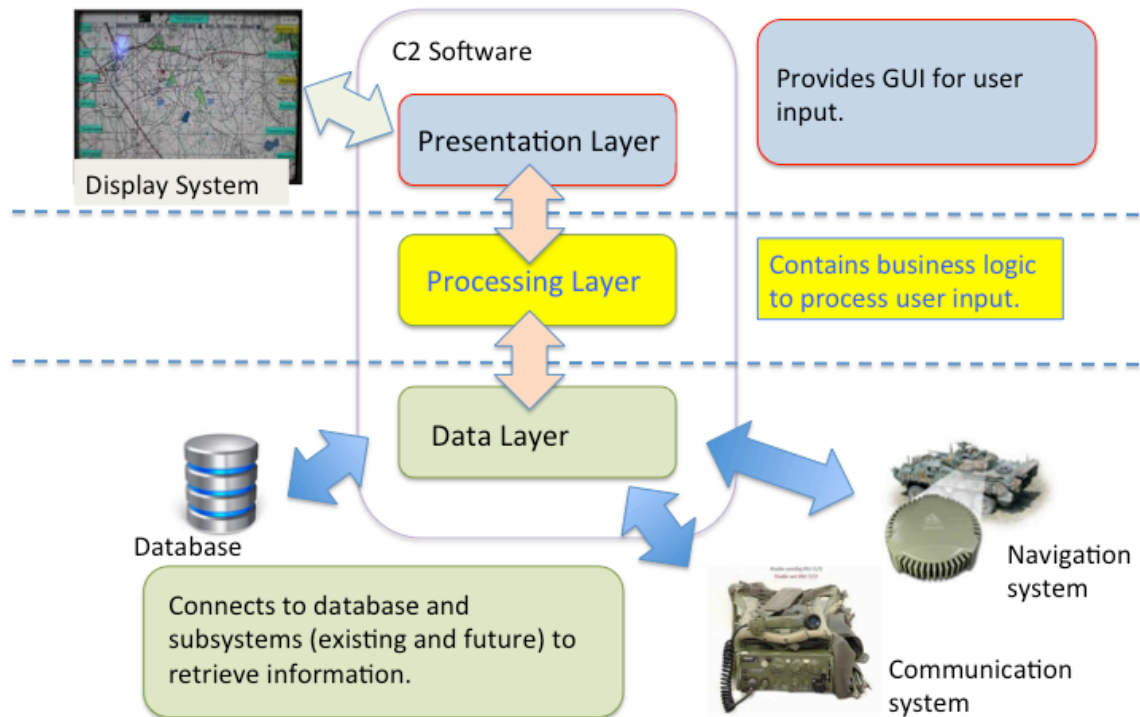

F. DETERMINE THEORETICAL FOUNDATION

Command concept and control theory are fundamental in determining the success usage of the deployed C2 on the land battlefield.

1. Command Concept

Builder, Bankes, and Nordin provide the definition of the command concept as:

A vision of prospective military operations that informs the making of command decisions during that operation. (1999, 14)

Builder, Bankes, and Nordin go on and provide the following recommendation on the ideal factors to be available in the command concept:

- Time scales that reveal adequate preparation and readiness, not just of the concept but of the armed forces tasked with carrying out that concept.
- Awareness of the key physical, geographical, and meteorological features of the battle space—situational awareness—that will enable the concept to be realized.
- A structuring of forces consistent with the battle tasks to be accomplished.
- Congruence of the concept with the means for conducting the battle.
- Knowledge of what can be accomplished, from the highest to the lowest levels of command.
- Intelligence on what the enemy is expected to do, including confirming and refuting signs to be looked for throughout the coming engagement.
- Knowledge of what the enemy is trying to accomplish, not just what its capabilities and dispositions may be.
- Knowledge of what the concept-originating commander and his forces should be able to do and how to do it, with all of the problems and opportunities, not just the required deployments, logistics, and schedules, but also the nature of the clashes and what to expect in the confusion of battle.
- Indicators of the failure of, or flaws in, the command concept and ways of identifying and communicating information that would change or cancel the concept.
- A contingency plan in the event of failure of the concept and the resulting operation (Builder, Bankes, and Nordin 1999, 21–22).

2. Control Theory

Lawson's model uses control theory to describe the C2 process as:

coordinating the activities of multiple independent units and adapting to exogenous change in the battlefield to that of the activities performed in the control of the industrial processes (Lawson 1981, 5).

Control theory, as illustrated in Figure 18, relates to the control aspect of the C2. Lawson's model explains how the commander senses the situation, through either

feedback from subordinates or from ground assessment, and makes decision to lead the battlefield to the desired state that determines the mission success.

Figure 18. Lawson's Model (from Lawson 1981, 7)

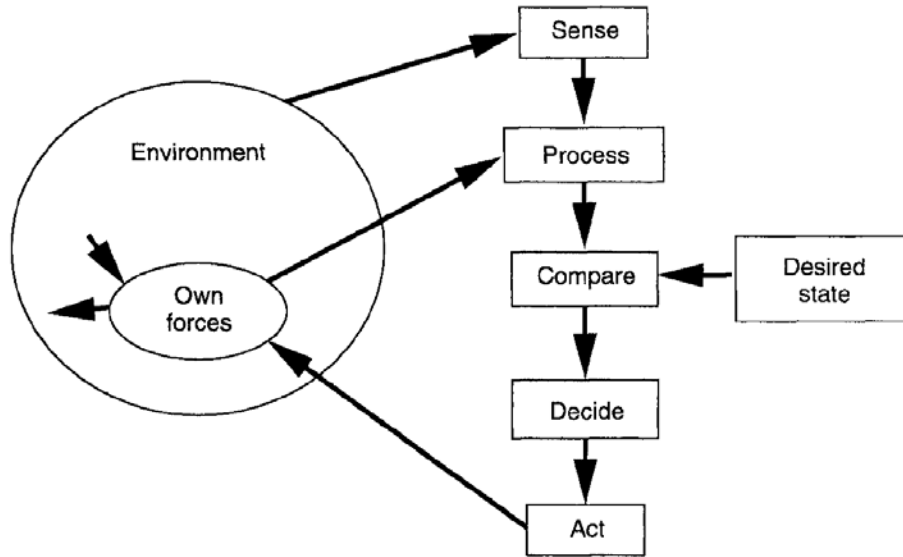

G. INTEGRATIVE FRAMEWORK FORMALIZATION

The research work in this thesis shall apply the cognitive and procedure domain within the Langford's integrative framework to develop MOE as illustrated in Figure 19.

Figure 19. Modified Integrative Framework (from Langford 2014, 15)

| | | Processes | |
|----------------|----------------------------|--|--|
| | | Cognition | Procedures |
| Objects | User Behaviors | Conceptualization of stakeholder behaviors (MOE-a) when the product*service is used; and when it not used (or available) (MOE-p) | Influence of procedures on processes and mechanisms describing user behaviors due to product*service (MOE-i); Influence describing user behaviors due to lack of product*service (MOE-f) |
| | Functions | Prognostication of consequences of interactions between objects through exchange of EMMI (MOE-g): & Expectations of interactions (MOE-c) | Availability and Validity of processes and mechanisms that determine resource utilizations for functions (MOE-u); Processes and mechanisms that define the boundary conditions for anticipated operations of all functions (MOE-b) |
| | Physical Entities - Object | Experience with posited objects (MOE-e) & anticipated responses of posited objects (MOE-r) | Availability and Validity of processes and mechanisms resulting in the selection and development of all physical elements (MOE-s); Processes and mechanisms resulting in the development of all physical elements and operational contexts (MOE-x) |

1. Cognitive Domain MOE

Langford (2012) describes the cognitive domain and its impact on the product or service as follows:

The cognitive domain involves the abstractions and reasoning that take place when thinking about a particular subject. All types and modes of thinking are involved with the cognitive domain, including conceptualization and interpretation.... For the cognitive domain, the relations between concepts that are important to the user and reflective of the user's intentions should be represented in the product of service through the design of objects, the enactment(s) of functions that reflect the uses as well as the decisions that will be made with or as a consequence of the product or service. (89)

The cognitive domain MOE consists of three pairs of MOEs, cognition-user, cognition-function and cognition-object. Each set contains two MOEs for evaluation.

a. Cognition-User MOE (MOE-a, MOE-p)

The objective of the cognition-user MOE is to assess the value of the C2 system to the end-user in mission accomplishment. In addition, it can also provide the feasibility studies for new requirement, i.e., integration with new subsystem. The two MOEs relate to different underlying measures: MOE-a (relates to processes and activities that are measured by verification) and MOE-p (relates to MOPs to functions that are quantifiable).

- (1) MOE-a: Stakeholder's performance when system processes are available (or not available) for use

MOE-a characterizes the processes and activities that must occur in order to formulate and execute tasks. The basic question is—are the requisite processes in place and operative? This question is verifiably, yes or no. Consider the three processes: gain awareness of the battle situation (e.g., receive a mission from higher command), make a decision (part of which is to be decision-fit), and then execute the decision (e.g., assign or reassignment tasks).

The verification is conducted through mission log analysis and feedback from the user during an After-Action-Review (AAR). MOE-a provides insight into the C2 system influence on user performance.

Similarly, the time taken to make a decision and the time taken to execute the decision are referenced to the

- (2) MOE-p: Stakeholder's performance when system functions are available (or not available) for use

This set of MOEs provides a measurement of the end-user's cognitive functioning when three functions are performed, i.e., gain awareness of the battle situation (e.g., receive a mission from higher command); make a decision (part of which is to be decision-fit); and then execute the decision (e.g., assign or reassignment tasks). The

measurement parameters, i.e., the MOPs, are the time taken to gain awareness of the battle situation, the time taken to make a decision, and the time taken to order execution.

The evaluation is conducted through analysis of the user's mission log and sensor performances during an AAR. MOE-p provides insight into user performance with and without the C2 system influence.

$$MOE - p = \frac{\textit{Time taken from mission received to plan and make decision}}{\textit{Time taken from mission to order execution}} \quad (1)$$

b. Cognition-Function MOE (MOE-g, MOE-c)

The objective of the cognition-function MOE is to assess the value of the C2 system functions in terms of information exchange. It evaluates how effective does the information presented to the user via the C2 functions contribute to the situational awareness and decision-making. For situational awareness, the C2 system shall monitor the transaction between the functions, i.e., tracking own position against threat position, tracking task expiration, and alert user of any incoming threat or task overdue. For decision-making, the C2 system shall process the transaction between the functions, i.e., send/receive task assignment, send/receive task status update, and send/receive position update, to enable user to assess and respond to the situation. In addition, this pair of MOES can also provide the feasibility studies for new requirement, i.e., refine the function. Two MOEs, MOE-g and MOE-c are developed.

(1) MOE-g: System Functionality Prognostication

This pair of MOEs provides a measurement of the users' ability to prognosticate the outcome of the C2 system function. It is of critical importance that the C2 system is predictable to ensure trust established between the user and the C2 system. For instance, the user should predict a warning alert from the C2 system when the moving unit enters into the firing sector or encounters an obstacle during maneuver. The system warning alert can be implemented by using the mission monitor module in the C2 system to

compare the unit location retrieved from the navigation system against the existing danger boundary stored in the database system.

The evaluation is conducted through mission log analysis and feedback from user during AAR. MOE-g evaluates how well the C2 system functions monitor the situation in the land battlefield, i.e., tracking own position against threat position, and tracking task expiration, and alert user of any incoming threat or task overdue.

$$MOE-g = fn_1 \times w_1 + fn_2 \times w_2 + \dots + fn_x \times w_x \quad (2)$$

$$= \sum_{x=1}^y fn_x \times w_x$$

Where fn is the C2 system function score and w_x is the weightage allocated to the function. Each C2 system function score is allocated 1 to 5 with 1 as the least desired and the weightage is allocated 1 to 5 with 1 as the least important.

(2) MOE-c: System Functionality Expectation

MOE-c verifies that the C2 system enacts the functions, i.e., send/receive task assignment, send/receive task status update, send/receive and position update, and present to user to facilitate decision-making. The verification is conducted through mission log analysis and feedback from users during an AAR. The C2 system functionality expectation MOE-c identifies user satisfaction based on system expectation of having or not having the functions available.

c. Cognition-Object MOE (MOE-e, MOE-r)

The C2 system is comprised of several C2 physical objects (e.g., computer, navigation equipment, display, keyboard, mouse, sighting equipment, and combat radio) connected to provide the situational awareness and decision making aids. The objective of the cognitive-object MOE pair is to determine the value of the physical objects in terms of the users' experience and the responsiveness to support the mission. Two MOEs, MOE-e and MOE-r are developed.

(1) MOE-e: System Experience

The operators for the C2 systems may execute actions related to the two C2 functions: command and control. The MOE-e evaluates the user experience with the C2 physical object (computer, navigation equipment, display, keyboard, mouse, sighting equipment and combat radio) contribute to the mission accomplishment. Interactions with the physical objects are often referred to as Man-Machine Interface or Human Systems Integration. If the user interface creates inefficiency in operation due to excessive tree or hierarchical structures to navigate accessing data, then the effectiveness of the task and its impacts on the mission operations will be known through an evaluation. MOE-e deals with the human-machine interface. The evaluation is conducted through mission log analysis and feedback from user during an AAR.

$$\begin{aligned} MOE-e &= obj_1 \times w_1 + obj_2 \times w_2 + \dots + obj_x \times w_x \\ &= \sum_{x=1}^y obj_x \times w_x \end{aligned} \quad (3)$$

where obj_x is the C2 physical object score and w_x is the weightage allocated to the function. Each C2 physical object score is allocated 1 to 5 with 1 as the least desired and the weightage is allocated 1 to 5 with 1 as the least important.

(2) MOE-r: System Responsiveness

The objective of the MOE-r is to evaluate the responsiveness of the C2 system when the connected physical C2 objects interact with one another. Consider an interaction between a user and a computer interface that is necessary to carry out an assigned task. The user inputs the task instruction into the display system. The software interface receives/ processes/ transmits the task assignment message using the combat radio connected to the computer. The interaction between the physical objects is evaluated in terms of their responsiveness and the low MOE-r indicates the needs to review the interface between the objects. MOE-r is a functional measurement of system performance in response to queries from users. The evaluation is conducted through mission log analysis and feedback from users during an AAR.

$$MOE-r = obj_1 \times w_1 + obj_2 \times w_2 + \dots + obj_x \times w_x \quad (4)$$

$$= \sum_{x=1}^y obj_x \times w_x$$

where obj_x is the C2 physical object score and w_x is the weightage allocated to the function. Each C2 physical object score is allocated 1 to 5 with 1 as the least desired and the weightage is allocated 1 to 5 with 1 as the least important.

2. Procedural Domain MOE

Langford (2012, 91) describes the procedural domain and its influence over the product or service as follows:

Procedural structures, i.e., “paradox,” take into account the stakeholder requirements for differentiating products and services from “other” products and services. Especially important for new product or service development is the demand to distinguish the product or service from competitive offerings. User behaviors often reflect the novelty in products and services in their feelings toward their work, their colleagues, and their involvement in teamness.

The procedural domain MOE consists of three set of MOEs, procedure-user, procedure-function and procedure-object. Each pair contains two MOEs for evaluation.

a. Procedure-Behavior MOE (MOE-i, MOE-f)

The objective of the procedure-user MOE is to measure task efficiency of the C2 system in terms of the task workflow. The procedure-user MOE enables the user to determine the desired workflow towards mission accomplishment. Two MOEs, MOE-i and MOE-j are developed.

(1) MOE-i: Influence of Procedures When System Is in Use

This pair of MOEs provides a measurement on the individual end-user performance driven by the procedures/workflow of executing the task while using the C2 system. The measurement parameter consists of recording the steps taken to gain awareness of the battle situation and to execute decisions (e.g., task assignment or task reassignment). In addition, this pair of MOEs can be reused to evaluate the effectiveness

of the C2 system for new requirements (e.g., change in workflow/procedure, and improving human system interface).

The evaluation is conducted through mission log analysis and feedback from users during an AAR. The MOE-i provides insight into the individual end-user performance driven by the procedures/workflow of executing the task while using the C2 system.

$$\begin{aligned}
 MOE-i &= behavior_1 \times w_1 + behavior_2 \times w_2 + \dots + behavior_x \times w_x \quad (5) \\
 &= \sum_{x=1}^y behavior_x \times w_x
 \end{aligned}$$

where *behavior* is the user score and w_x is the weightage allocated to the function. Each user score is allocated 1 to 5 with 1 as the least desired and the weightage is allocated 1 to 5 with 1 as the least important.

(2) MOE-f: Influence of Procedures When System Is Not in Use

This pair of MOEs provides a measurement of the individual end-user performance driven by the procedures/workflow of executing the task without using the C2 system. The measurement parameter consists of recording the steps taken to gain awareness of the battle situation to execute decisions (e.g., task assignment or task reassignment) and to realize the decision outcome.

The evaluation is conducted through mission log analysis and feedback from users during an AAR. The MOE-f provides insight into the individual end-user performance driven by the procedures/workflow of executing the task while not using the C2 system.

$$\begin{aligned}
 MOE-f &= behavior_1 \times w_1 + behavior_2 \times w_2 + \dots + behavior_x \times w_x \quad (6) \\
 &= \sum_{x=1}^y behavior_x \times w_x
 \end{aligned}$$

where *behavior* is the user score and w_x is the weightage allocated to the function. Each user score is allocated 1 to 5 with 1 as the least desired and the weightage is allocated 1 to 5 with 1 as the least important.

b. Procedure-Function MOE (MOE-u, MOE-b)

The objective of the procedure-function MOE is to evaluate how well the C2 functions fit into the user workflow. Consider the threat encounter workflow. It is rational for commander to exercise his judgment based on his training and experience to either engage the threat or evacuate in this critical junction. In this case, the voice communication between the commander and his subordinate using the combat radio would be preferred to using C2 function for task assignment. However, if the C2 system is closely integrated with subsystems (weapon system, sighting system, communication system) so that the C2 functions can track any high intensity engagement activities can auto-update to higher command for support reinforcement without the need for the commander to spend additional effort to update the situation, the C2 function would score higher MOE in term of procedure support. Two MOEs, MOE-u, and MOE-b are developed.

(1) MOE-u: System Functional Resource Utilization Validity

The objective of the MOE-u is to evaluate the C2 system function to support the mission workflow in the land battlefield. For instance, any C2 system function of low utilization during the mission would score a low MOE-u. This indicates there is a preferred alternative, i.e., using voice command to assign task, over the C2 system function. Therefore, MOE-u helps to bridge the gap between the user expectation and the C2 system developer through recognizing the actual value of the C2 system functions towards the user’s mission accomplishment

$$MOE-u = fn_1 \times w_1 + fn_2 \times w_2 + \dots + fn_x \times w_x \quad (7)$$

$$= \sum_{x=1}^y fn_x \times w_x$$

where fn_x is the C2 system function score and w_x is the weightage allocated to the function. Each C2 system function score is allocated 1 to 5 with 1 as the least desired and the weightage is allocated 1 to 5 with 1 as the least important.

(2) **MOE-b: System Functional Boundary Conditions**

The objective of the MOE-b is to evaluate the C2 system functions in term of how well the functions interact with external system. For instance, the sense-and-strike mission that involves interaction between the C2 system function and the UAV for the “sense,” and the interaction between the C2 system function and the artillery system for the “strike.” The evaluation is conducted through mission log analysis and feedback from users during an AAR. A low MOE-b score indicates the limitation of the C2 system function for improvement.

$$MOE-b = fn_1 \times w_1 + fn_2 \times w_2 + \dots + fn_x \times w_x \quad (8)$$

$$= \sum_{x=1}^y fn_x \times w_x$$

where fn_x is the C2 system function score and w_x is the weightage allocated to the function. Each C2 system function score is allocated 1 to 5 with 1 as the least desired and the weightage is allocated 1 to 5 with 1 as the least important.

c. Procedure-Object MOE (MOE-s, MOE-x)

The C2 system is comprised of several C2 physical objects (computer, navigation equipment, display, keyboard, mouse, sighting equipment and combat radio) connected to provide the situational awareness and decision making aids. The objective of the procedure-object MOE pair is to determine the value of the physical objects in term of their suitability to support the mission. Consider the disruption due to equipment faults during the mission. The challenge to recover the system and resume the task execution depends on the spare availability, system configuration, work-around option and support element available. For instance, users can execute the task using the touch screen display if the keyboard is faulty; users can change communication frequency with minimal hassle if the main channel is jammed; there are spare batteries available to power the equipment

if the main power source is down. In addition, it can also provide the feasibility studies for object replacement, i.e., replace the computer system with mobile computing device, and replace the keyboard with controller. Two MOEs, MOE-s and MOE-x are developed. Different stakeholders (project manager, system architect, engineers, end-users) can participate in the evaluation and the MOE score would be reviewed during stakeholders' meeting.

(1) MOE-s: System Selection Validity

The objective of the MOE-s is to validate the effectiveness of the C2 system in term of system setup; configuration, operation, troubleshooting and mission log collection, i.e., to question the support effort for the use of the C2 system. For instance, consider the procedure and effort required to replace the faulty item during the mission would determine its effectiveness to the overall C2 system.

$$MOE-s = \sum_{x=1}^y obj_x \times w_x \quad (9)$$

where obj_x is the C2 physical object score and w_x is the weightage allocated to the function. Each C2 physical object score is allocated 1 to 5 with 1 as the least desired and the weightage is allocated 1 to 5 with 1 as the least important.

(2) MOE-x: System Operational Context Validity

Figure 20 and Figure 21 illustrate the C2 system interaction for external systems and internal systems, respectively.

Figure 20. External Physical Context

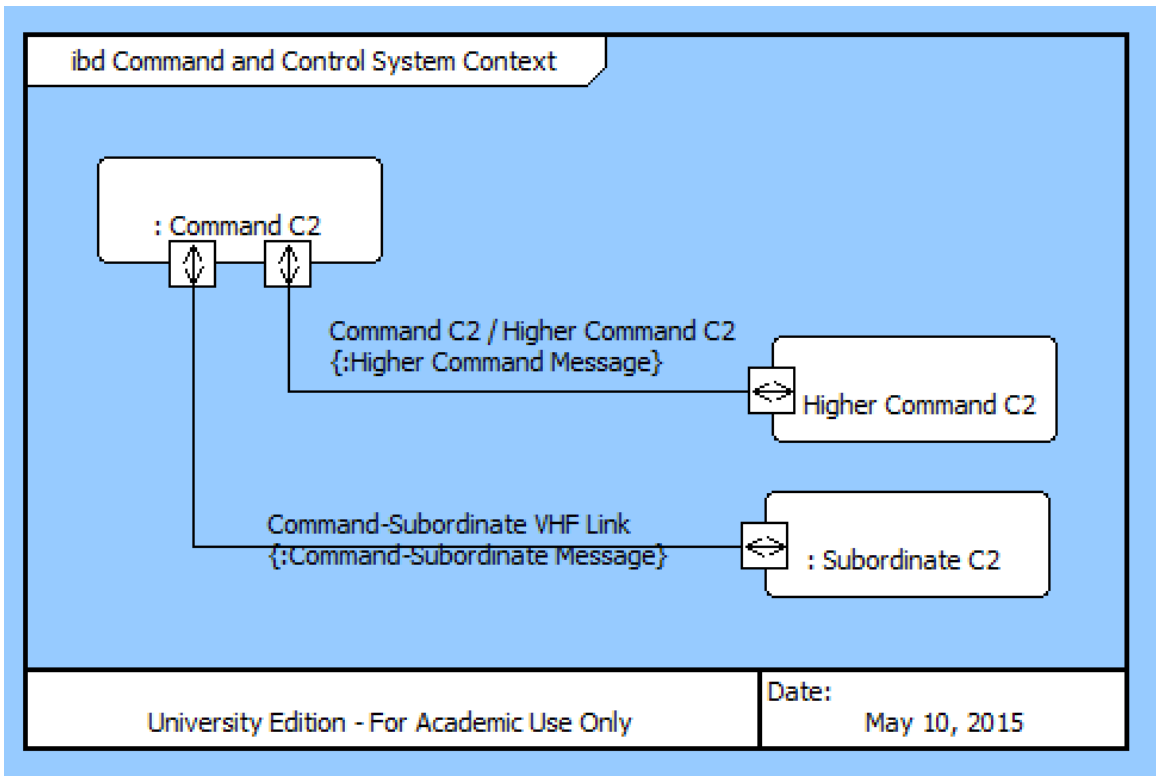
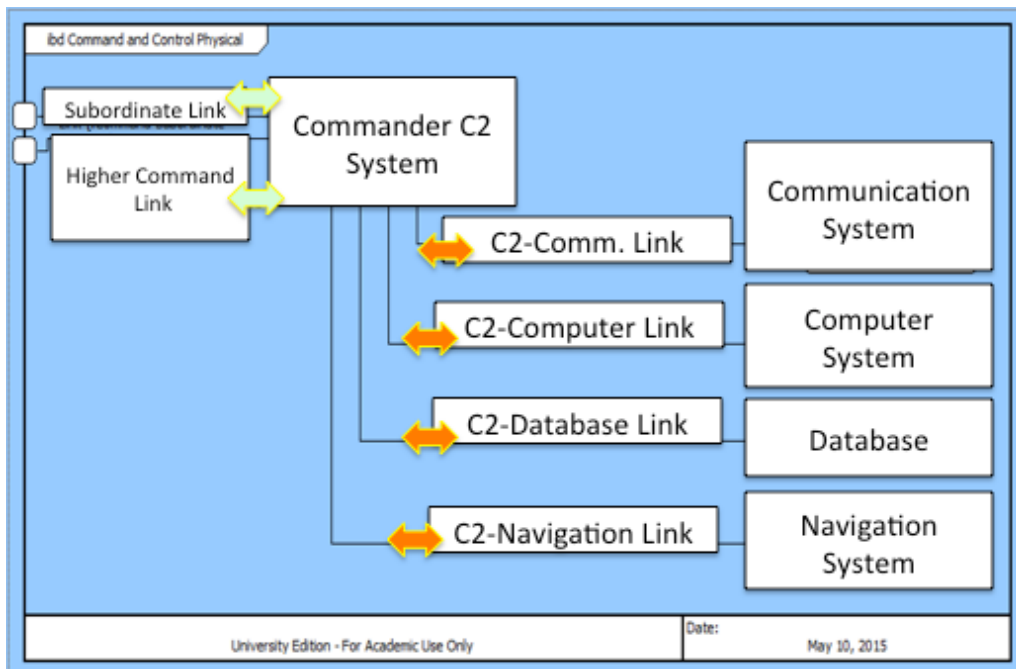

Figure 21. Internal Physical Context Diagram



The external interaction consists of the communication links between the commander C2 system and the subordinate C2 system and the higher command C2 system and the commander C2 system. The data exchange (task assignment, task status, position update) is facilitated via connection link between the stations. The internal interaction contains the links between the C2 system and subsystems in the land platform. The objective of the MOE-x is to evaluate the C2 system interaction with other systems so that limitation can be identified and improved.

$$MOE-e = obj_1 \times w_1 + obj_2 \times w_2 + \dots + obj_x \times w_x \quad (10)$$

$$= \sum_{x=1}^y obj_x \times w_x$$

where obj_x is the C2 physical object score and w_x is the weightage allocated to the function. Each C2 physical object score is allocated 1 to 5 with 1 as the least desired and the weightage is allocated 1 to 5 with 1 as the least important.

H. ANALYZE AND EVALUATE EFFECTIVENESS

The 12 pairs of MOEs as tabulated in Table 7 are used to evaluate the effectiveness of using the C2 system used in armor combat team as illustrated in Figure 25. Both cognition and procedure domain MOEs are calculated and the result are tabulated. The system to be evaluated in the C2 system deployed on the land platform, taking reference from the Battlefield Management System (BMS) deployed in Singapore Armed Force (SAF) (Pan 2007).

Table 7. List of Measures of Effectiveness to Evaluate the Command and Control System in the Land Battlefield

| Domain | MOE | Description |
|--------------------|-------|--|
| Cognition-User | MOE-a | Stakeholder's performance when system in use |
| | MOE-p | Stakeholder's performance when system not in use |
| Cognition-Function | MOE-g | System Functionality Prediction |
| | MOE-c | System Functionality Expectation |
| Cognition-Object | MOE-e | System Experience |
| | MOE-r | System Responsiveness |
| Procedure-Behavior | MOE-i | Influence on procedure when system in use |
| | MOE-f | Influence on procedure when system in not in use |
| Procedure-Function | MOE-u | System Functional Resource Utilization Validity |
| | MOE-b | System Functional Boundary Conditions |
| Procedure-Object | MOE-s | System Selection Validity |
| | MOE-x | System Operational Context Validity |

Figure 22. C2 System MOE Evaluation

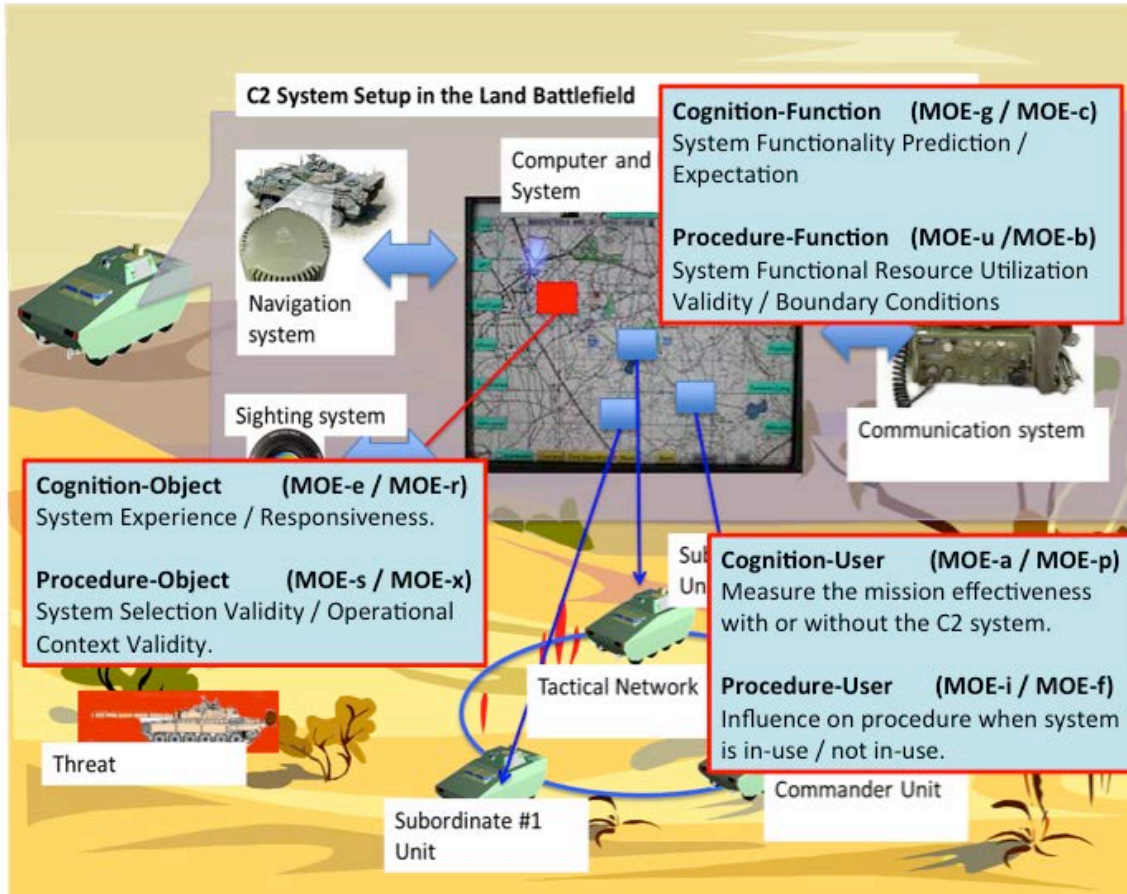

1. Cognition Domain MOE Calculation

To calculate the MOE at the cognition domain, the scenario is illustrated in Figure 26. Consider the C2 systems in the armor combat team are connected in the tactical network and the operators are using the C2 system.

Figure 23. Cognition Domain MOE Evaluation

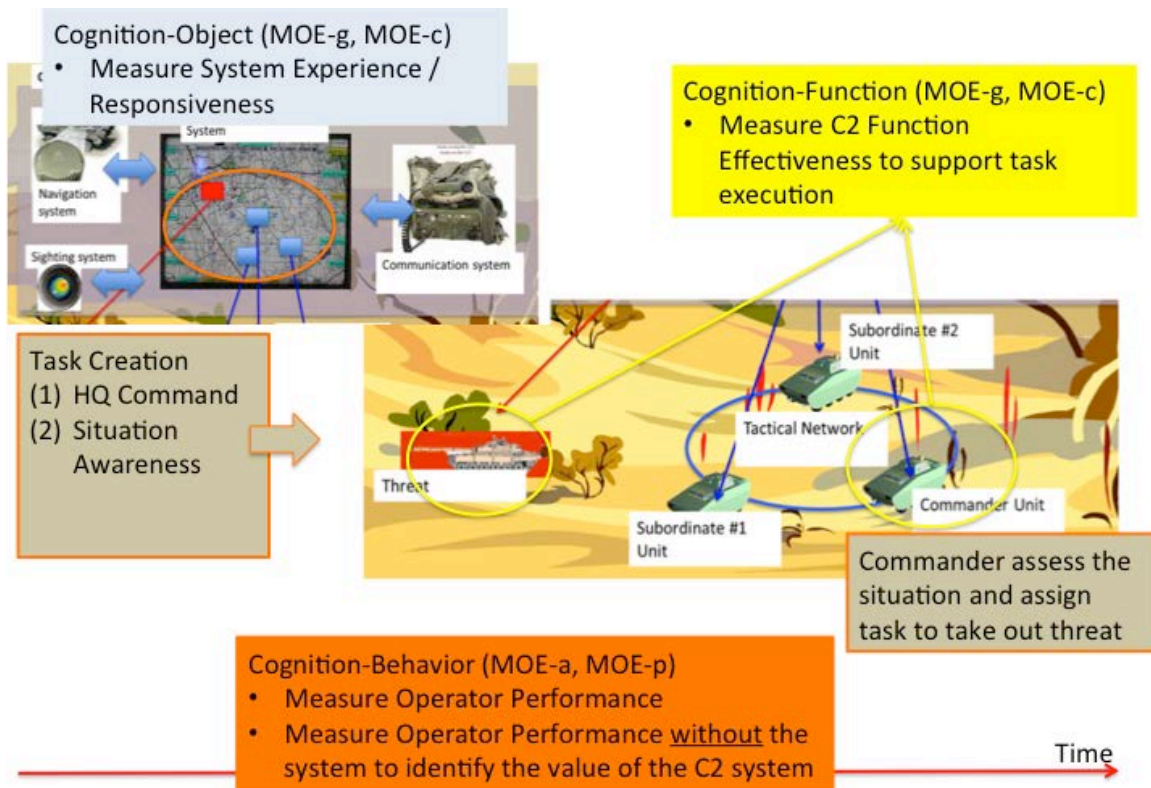

a. Calculate Cognition-User MOEs (MOE-a / MOE-p)

Let the time taken for the commander to receive order from higher HQ and proceed to plan, assign, monitor and accomplish task be x_{MOE-a} , the time frame for the task to complete from order receipt be y_{MOE-a} . The MOE-a is calculated as

$$MOE - a = \frac{x_{MOE-a}}{y_{MOE-a}}$$

For MOE-p calculation, consider the C2 systems are not in use and the commander would rely on voice communication using the combat radio to receive order from higher HQ, perform situational awareness, task planning, assignment and monitoring. Let the time taken for the commander to receive order from higher HQ and proceed to plan, assign, monitor and accomplish task be x_{MOE-p} , the timeframe for the task to complete from order receipt be y_{MOE-p} . MOE-p is calculated as follows:

$$MOE - p = \frac{x_{MOE-p}}{y_{MOE-p}}$$

Given that each task has a different timeframe and the execution time to complete the task tends to vary hence it is more useful to calculate this pair of MOEs based on per task basis. However, it is desirable that the overall MOE-a value is lesser than MOE-p to indicate the operator would perform better in their mission execution with the use of C2 system. In addition, this pair of MOE can be repeated to evaluate new requirement to manage expectation.

b. Calculate Cognition-Function MOEs (MOE-g / MOE-c)

MOE-g provides a measurement on the end-users' ability to prognosticate the C2 system function predictability. It is of critical importance that the C2 system is predictable to ensure trust established between the user and the C2 system. The MOE-g is calculated as shown in Table 8. Four scenarios are chosen namely, threat within range, poor communication coverage, task incompetency and poor navigation signal to evaluate the system functionality prediction, MOE-g of the system. The objective is to evaluate the effectiveness of the C2 system on reaction to situation, i.e., how fast /accurate does

the C2 system detect/manage the threat. Different stakeholders (project manager, system architect, engineers, and end-users) can participate in the evaluation and the overall MOE-g score would be reviewed during stakeholders' meeting.

Table 8. System Functionality Prediction MOE-g

| S/N | Scenario | System Function Action | Aggregated Score (1-Poor, 5-Good) | Weight (1-Non-Priority, 5-Priority) | MOE-g |
|-------|---|---|-----------------------------------|-------------------------------------|-------|
| 1 | Threat Within Range | Sensory function and monitoring function trigger system alert | 3 | 5 | 15 |
| 2 | Poor Communication Coverage | Communication sensory function trigger system alert | 3 | 5 | 15 |
| 3 | Task Incompetency (e.g., low ammunition, fuel, and logistics) | Platform sensory function triggers system alert | 3 | 4 | 12 |
| 4 | Poor Navigation Signal | Navigation sensory function trigger system alert | 4 | 4 | 16 |
| Total | | | | | 58 |

From the score, MOE-g can be improved through implementation of data analytic mechanism to enhance the prediction, i.e., terrain / high canopy area to pre-empt poor communication and navigation signal.

The C2 system functionality expectation MOE-c identifies user satisfaction based on system expectation is tabulated in Table 9. Five functions are chosen namely, task assignment, allocate resource, analyze risk, and poor navigation signal to evaluate the system functionality expectation, MOE-g of the system. The objective is to evaluate the effectiveness of the C2 function in mission accomplishment, i.e., how much does the C2 function contributes to command and control. Different stakeholders (project manager, system architect, engineers, end-users) can participate in the evaluation and the overall MOE-c score would be reviewed during stakeholders' meeting.

Table 9. System Functionality Expectation MOE-c

| S/N | Function | Expectation | Aggregated Score (1-Poor, 5-Good) | Weight (1-Non-Priority, 5-Priority) | MOE-c |
|-----|----------------------|--|-----------------------------------|-------------------------------------|-------|
| 1 | Task Assignment | Expect system to indicate the task assignment message is sent and received. Expect system to indicate the task progress status based on assignee's task feedback. Expect system to alert operator on task expiry or incomplete task. | 3 | 5 | 15 |
| 2 | Allocate Resource | Expect system to provide list of available resource (e.g., terrain information, threat analysis, and support element) | 4 | 5 | 20 |
| 3 | Analyze Risk | Expect system to update situation picture especially threat at regular interval. | 4 | 3 | 12 |
| 4 | Negotiate Constraint | Expect system to update situation picture especially remaining resources at regular interval. | 4 | 3 | 12 |
| 5 | Report | Expect system to indicate the task assignment message is sent and received. | 3 | 5 | 15 |
| | | | | Total | 69 |

One challenge faced to achieve high MOE-c score is that the terrain on the land battlefield constantly affects the network performance that often led to dropped C2

messages or late C2 messages. While there are recommendations to improve the network performance such as smaller message size, rebroadcast station deployment and instilling network discipline, communication in the land battlefield still remains an operational challenge.

c. Calculate Cognition-Object MOEs (MOE- e / MOE-r)

MOE-e provides insight into the effectiveness of system usage related to command and control. The MOE-e is calculated as shown in Table 10. The C2 system comprises of several physical objects connected together to provide the situational awareness and decision making tool for the operators. The objective of the MOE-e is to determine whether the physical object is the right tool for the operation, i.e., to question the effectiveness of the physical object to mission accomplishment. Different stakeholders (project manager, system architect, engineers, and end-users) can participate in the evaluation and the overall MOE-e score would be reviewed during stakeholders' meeting. Based on the result, there is a need to improve the score of the human interface by looking at the different alternative of human interface (touch screen, application input form, and button layout).

Table 10. System Experience MOE-e

| S/N | C2 Physical Object | Usage Description | Experience Score (1-Poor, 5-Good) | Weight (1-Non-Priority, 5-Priority) | MOE - e |
|-----|--------------------|--|-----------------------------------|-------------------------------------|---------|
| 1 | Display system | Display situation picture Provides Graphical User Interface (GUI) | 4 | 5 | 20 |
| 2 | Computer system | Processes the C2 Function | 3 | 2 | 6 |
| 3 | Human Interface | Provides interface for operator input | 2 | 5 | 10 |

| S/N | C2 Physical Object | Usage Description | Experience Score (1-Poor, 5-Good) | Weight (1-Non-Priority, 5-Priority) | MOE - e |
|-----|--------------------|--|-----------------------------------|-------------------------------------|---------|
| 4 | C2 Software | Provides C2 Function | 3 | 5 | 15 |
| 5 | Sighting system | Provides interface for operator to measure range | 3 | 3 | 9 |
| 6 | Comm. System | Provides tactical communication. | 3 | 3 | 9 |
| 7 | Navigation System | Provides position update | 5 | 2 | 10 |
| 8 | Network System | Connects the combat team | 2 | 3 | 6 |
| | | | | Total | 85 |

The C2 system response MOE-r provides insight into the effectiveness of system usage related to command and control. The MOE-r is calculated as shown in Table 11. The C2 system is comprised of several physical objects connected together to provide the situational awareness and decision making tool for the operators. The objective of the MOE-r is to determine whether the right tool is operating effectively, i.e., to question on the physical object's specification to mission accomplishment. Different stakeholders (project manager, system architect, engineers, end-users) can participate in the evaluation and the overall MOE-r score would be reviewed during stakeholders' meeting. Based on the result, there is a need to improve the score of the network system by looking at the network configuration (number of stations in a network, allowable message size, and information exchange schema).

Table 11. System Responsiveness MOE-e

| S/N | C2 Object | Usage Description | Responsive Score (1-Poor, 5-Good) | Weight (1-Non-Priority, 5-Priority) | MOE - r |
|-----|-------------------|--|-----------------------------------|-------------------------------------|---------|
| 1 | Display system | Display situation picture Provides Graphical User Interface (GUI) | 4 | 5 | 20 |
| 2 | Computer System | Processes the C2 Function | 3 | 5 | 15 |
| 3 | Human Interface | Provides interface for operator input | 5 | 5 | 25 |
| 4 | C2 Software | Provides C2 Function | 3 | 5 | 15 |
| 5 | Sighting System | Provides interface for operator to measure range | 3 | 5 | 15 |
| 6 | Comm. System | Provides tactical communication. | 3 | 5 | 15 |
| 7 | Navigation System | Provides position update | 5 | 5 | 25 |
| 8 | Network System | Connects the combat team | 2 | 5 | 10 |
| | | | | Total | 140 |

One challenge to achieve high MOE-e and MOE-r scores lies in the system integration. Langford (2012) described, “The more ambitious the integration, and the more out of control are the interfaces, i.e., not under change control or management, the more difficult the integration of the new product or service into the existing users’ environment and enterprise.” Therefore, the system integrator plays an important role to work with the different stakeholders to ensure the C2 objects are integrated into the C2

systems of better user experience and responsiveness. In addition, there is a need to start integration early and evaluate the MOEs with each integrated build so that any potential risk can be mitigated and resolved.

2. Procedure Domain MOE Calculation

To calculate the MOE at the procedure domain, the scenario is illustrated in Figure 27. Consider the C2 systems in the armor combat team are connected in the tactical network and the operators are using the C2 system. The C2 system is comprised of several physical objects connected together to provide the situational awareness and decision making tool for the operators. The objective of the MOE-r is to determine whether the right tool is operating effectively, i.e., to question on the physical object's specification to mission accomplishment. Different stakeholders (project manager, system architect, engineers, end-users) can participate in the evaluation and the overall MOE-r score would be reviewed during stakeholders' meeting. Based on the result, there is a need to improve the score of the network system by looking at the network configuration (number of stations in a network, allowable message size, and information exchange schema).

Figure 24. Procedure Domain MOE Evaluation

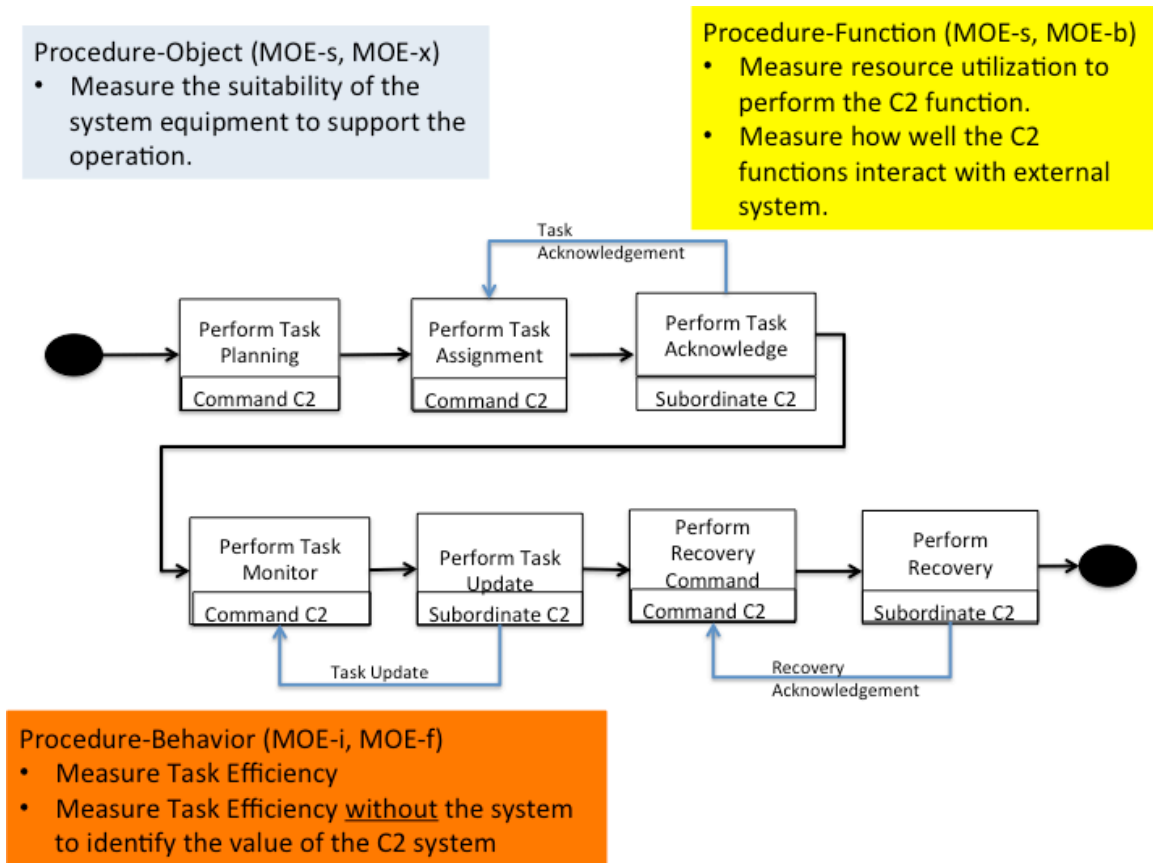

a. Calculate Procedure-Behavior MOEs (MOE- i / MOE- f)

The MOE-i provides insight into the individual end-user performance driven by the procedures/workflow of executing the task while using the C2 system. The MOE-i is calculated as shown in Table 12. The C2 procedure is comprised of several activities such as task planning, task assignment, task monitoring and recovery. The objective of the MOE-i is to determine how effective the operator accomplishes the mission with the use of the C2 system, i.e., to quantify the value by the C2 system / add-on requirement. Different stakeholders (project manager, system architect, engineers, and end-users) can participate in the evaluation and the overall MOE-i score would be reviewed during stakeholders' meeting.

Table 12. Influence of Procedures When System is in use MOE-i

| S/N | C2 Procedures | Aggregated Score (1-Poor, 5-Good) | Weight (1-Non-Priority, 5-Priority) | MOE-i |
|-----|--------------------------|-----------------------------------|-------------------------------------|-------|
| 1 | Perform Task Planning | 4 | 5 | 20 |
| 2 | Perform Task Assignment | 4 | 5 | 20 |
| 3 | Perform Task Acknowledge | 4 | 3 | 12 |
| 4 | Perform Task Monitoring | 4 | 5 | 20 |
| 5 | Perform Task Update | 4 | 5 | 20 |
| 6 | Perform Recovery Command | 4 | 3 | 12 |
| 7 | Perform Recovery | 4 | 3 | 12 |
| | | | Total | 116 |

MOE-f provides a measurement of the individual end-user performance driven by the procedures/workflow of executing the task without using the C2 system. The C2 procedure is comprised of several activities such as task planning, task assignment, task monitoring and recovery. The objective of the MOE-j is to determine how effective the operator accomplishes the mission without the use of the C2 system. Different stakeholders (project manager, system architect, engineers, and end-users) can participate in the evaluation and the overall MOE-i score would be reviewed during stakeholders' meeting. The intention is to evaluate the value of C2 system by analyzing the difference between MOE-i and MOE-f. The MOE-f is calculated as shown in Table 13.

Table 13. Influence of Procedures When System is not in use MOE-f

| S/N | C2 Procedures | Aggregated Score (1-Poor, 5-Good) | Weight (1-Non-Priority, 5-Priority) | MOE-f |
|-----|--------------------------|-----------------------------------|-------------------------------------|-------|
| 1 | Perform Task Planning | 2 | 5 | 10 |
| 2 | Perform Task Assignment | 2 | 5 | 10 |
| 3 | Perform Task Acknowledge | 4 | 3 | 12 |
| 4 | Perform Task Monitoring | 2 | 5 | 10 |
| 5 | Perform Task Update | 4 | 5 | 20 |
| 6 | Perform Recovery Command | 4 | 3 | 12 |
| 7 | Perform Recovery | 4 | 3 | 12 |
| | | | Total | 86 |

Both MOE-i and MOE-f score are highly influenced by factors such as leadership, amount of training and competency. However, it is desirable that MOE-i scores higher than MOE-f. In addition, this pair of MOEs can be repeated to evaluate new requirement to manage expectation.

b. Calculate Procedure-Function MOEs (MOE- u / MOE- b)

MOE-u provides a metric that measures how well the C2 functions support the C2 procedure. A low MOE score indicates the need to re-assess the system function so that procedure can be improved. The C2 procedure is comprised of several activities such as task planning, task assignment, task monitoring and recovery. The objective of the MOE-u is to determine how effective the C2 function supports the C2 procedure, i.e., is it worth paying for the C2 function to support the procedure. Different stakeholders (project manager, system architect, engineers, and end-users) can participate in the evaluation and the overall MOE-u score would be reviewed during stakeholders' meeting. The MOE-u is calculated as shown in Table 14.

Table 14. System Functional Resource Utilization Validity MOE-u

| S/N | C2 Procedures | Supported by C2 Function | Utilization (1-Poor, 5-Good) | Weight (1-Non-Priority, 5-Priority) | MOE-u |
|-----|--------------------------|--------------------------|------------------------------|-------------------------------------|-------|
| 1 | Perform Task Planning | Allocate Resource | 4 | 5 | 20 |
| 2 | Perform Task Assignment | Task Assignment | 4 | 5 | 20 |
| 3 | Perform Task Acknowledge | Task Acknowledgement | 4 | 3 | 12 |
| 4 | Perform Task Monitoring | Monitor Performance | 4 | 5 | 20 |
| 5 | Perform Task Update | Report | 4 | 5 | 20 |
| 6 | Perform Recovery Command | Task Assignment | 4 | 3 | 12 |
| 7 | Perform Recovery | Monitor Performance | 4 | 3 | 12 |
| | | | | Total | 116 |

MOE-b evaluates the C2 system functions in term of how well the functions interact with external system. A low MOE score indicates the need to re-assess the interactions between the system’s functions and external systems. The MOE-b is calculated as shown in Table 15. Based on the result, the handheld system does not interact well with the C2 functions. Therefore, there is a need to review the workflow of using handheld system, i.e., connection to C2 system, synchronization between handheld system and computer system, and function accessibility, to interact with the C2 functions.

Table 15. System Functional Boundary Conditions MOE-b

| S/N | External System | Interaction with C2 Functions | Boundary Condition Score (1-Poor, 5-Good) | Weight (1-Non-Priority, 5-Priority) | MOE-b |
|-------|-------------------------------------|--|---|-------------------------------------|-------|
| 1 | Higher HQ C2 System | Higher HQ assigns mission order to commander using the C2 Functions. Exchange situation picture through the common C2 Functions and C2 Messages | 4 | 5 | 20 |
| 2 | Long Range Sensor System (e.g. UAV) | Provides intelligence information as input argument to C2 functions | 3 | 3 | 9 |
| 3 | Support System | Exchange situation picture through the common C2 Functions and C2 Messages | 3 | 3 | 9 |
| 4 | Handheld System | Exchange situation picture through the common C2 Functions and C2 Messages | 2 | 2 | 4 |
| Total | | | | | 42 |

It is desirable to achieve high MOE-u score to ensure that the C2 functions are fully utilized to support the C2 process. From the MOE-b score, further enhancement can be implemented to improve the integration with external system, subject to operational need. These MOE pairs are repeatable to evaluate future C2 system development.

c. *Calculate Procedure-Object MOEs (MOE- s / MOE- x)*

The objective of the MOE-s is to validate the effectiveness of the C2 system in term of system setup; configuration, operation, troubleshooting and mission log collection, i.e., to question the support effort for the use of the C2 system. MOE-s is calculated as shown in Table 16. Different stakeholders (project manager, system architect, engineers, and end-users) can participate in the evaluation and the overall MOE-s score would be reviewed during stakeholders' meeting.

Table 16. System Selection Validity MOE-s

| S/N | C2 Object | Setup Arrangement | Selection Score (1-Poor, 5-Good) | Weight (1-Non-Priority, 5-Priority) | MOE-s |
|-----|----------------------|---|----------------------------------|-------------------------------------|-------|
| 1 | Computer System | Connected to LAN with the rest of the C2 Objects. | 4 | 5 | 20 |
| 2 | Database System | Installed in the Computer System | 4 | 4 | 16 |
| 3 | Display System | Connected to the Sighting and Computer System | 4 | 5 | 20 |
| 4 | Navigation System | Connected to the Computer System in the LAN. | 4 | 3 | 12 |
| 5 | Sighting System | Connected to the Computer System in the LAN. | 4 | 3 | 12 |
| 6 | Communication System | Connected to the Computer System in the LAN. | 4 | 5 | 20 |
| 7 | C2 Software | Installed in the Computer System | 4 | 5 | 20 |
| | | | | Total | 120 |

The objective of the MOE-x is to evaluate the C2 system interaction with other systems so that limitation can be identified and improved. The MOE-x is calculated as shown in Table 17. Different stakeholders (project manager, system architect, engineers, and end-users) can participate in the evaluation and the overall MOE-x score would be reviewed during stakeholders' meeting.

Table 17. System Operational Context Validity MOE-x

| S/N | External Object | Interaction with C2 Functions | System Operational Context (1-Poor, 5-Good) | Weight (1-Non-Priority, 5-Priority) | MOE-x |
|-----|-------------------|---|---|-------------------------------------|-------|
| 1 | Computer System | Processes the C2 functions. | 4 | 5 | 20 |
| 2 | Database System | Records the C2 functions transaction | 4 | 4 | 16 |
| 3 | Display System | Provides user interface to input operator's argument to the C2 functions | 4 | 5 | 20 |
| 4 | Navigation System | Provides navigation information as input argument to the C2 functions (report location) | 4 | 3 | 12 |
| 5 | Sighting System | Provides laser range information as input argument to the C2 functions (report threat range). | 4 | 3 | 12 |
| 6 | Comm. System | Sends and receives C2 messages generated from C2 functions | 4 | 5 | 20 |
| | | | | Total | 120 |

It is desirable to achieve high MOE-s and MOE-x score to ensure that the C2 objects are integrated to support the C2 process. The scores are subjected to change due to user proficiency, and equipment wear and tear. These MOE pairs are repeatable to evaluate the effectiveness of integration with new system.

This chapter covers the nine-step methods to evaluate the effectiveness of using a deployed C2 system in the land battlefield. The integrative framework has proven to be useful to develop the MOEs that are meaningful and repeatable to evaluate an existing C2 system. The next chapter shall conclude the research work and further research.

THIS PAGE INTENTIONALLY LEFT BLANK

VI. CONCLUSION

This research provides a learning opportunity to develop the deeper understanding in the C2 system and various MOE development processes and methods. In addition, this research serves to emphasize the importance of developing meaningful MOEs to evaluate the effectiveness of using the deployed C2 system in the land battlefield. The MOEs can be reused to evaluate new requirement to access the feasibility and better manage user expectation.

(1) Major Findings

To successfully develop 12 pairs of measures of effectiveness (MOEs) with the integrative framework, the nine-step methodology is applied. The integrative framework provides the comprehensive guideline to develop the MOE with objective values and subjective criteria. The nine-step method's repeatability facilitates the evaluation of the effectiveness of the C2 for each system refinement (firmware/software/system upgrade) or new requirements (additional of sensor/communication system/protocol). Each evaluation should indicate opportunities for the system, process, and organization to improve.

The developed set of C2 MOEs allows stakeholders to evaluate the system, and the use of the integrative framework to produce repeatable MOEs provides cost-savings opportunities for system refinement and a new iteration of system development.

(2) Further Research

Further research can deploy the 12 pairs of MOEs to evaluate the use of deployed C2 systems in different land platforms (e.g., command post, mobile platform, and handheld C2 systems).

(3) Conclusion

The end-user (the Army) need for the C2 system to provide them with situational awareness and decision making aids is identified as the most important factor in their

expectation of the system. As the expectation of the stakeholder to stay connected in the battlefield for better situational awareness and decision-making, there is an increasing requirement to integrate faster and better subsystems (sensor, communication device and processor) to the C2 system. However, there is a need to recognize the limitation and constraint on the land battlefield and also to maintain the safety aspect of the system so as to provide a realistic assessment on the feasibility of the requirements. To manage stakeholders' expectation, there is a need to evaluate the effectiveness of the deployed C2 system having implemented with the new requirements. The measures of effectiveness (MOEs) of using the deployed C2 system are developed using an integrative framework to evaluate the system's fitness-for-purpose.

The key functions of "To Command" and "To Control" are decomposed and analyzed. The MOE development was achieved by the decomposition and analysis of the C2 function with respect to the user expectation. The boundaries are described through physical, functional, and behavioral domains (Langford 2012). The problem domain lies within these three types of boundaries. For the C2 system, the boundaries extend beyond the developed system to the domain(s) of the adversary. The MOEs extend to the boundaries and encapsulate all functions and solutions (Langford 2012).

A key aspect in determining effectiveness of a C2 system is based on the system architecture. The life cycle phases of the C2 architecture are first driven by the stakeholders' needs. Stakeholders' perspective should reflect their individual needs, that when combined form the operating a C2 system. Measures of effectiveness (MOEs) and functional measures of performance (MOPs) are evaluated and given to the program manager, as feedback to ensure compliance with stakeholder needs to ensure that the C2 system performs to its desired capability.

The measures of effectiveness (MOEs) of C2 systems on land battlefields are developed and evaluated using the nine-step methodology. The nine-step methodology was developed to unify the concepts of MOEs into a repeatable, validated process and to identify MOEs associated with both development and operations (Langford 2014, 10). Using the nine-step methodology and the integrative framework, 12 pairs of MOEs are developed.

The nine-step method's repeatability facilitates the evaluation of the effectiveness of the C2 for each system refinement (firmware/software/system upgrade) or new requirements (additional of sensor/communication system/protocol). Each evaluation should indicate opportunities for the system, process, and organization to improve. The developed set of C2 MOEs allows stakeholders to evaluate the system, and the use of the integrative framework to produce repeatable MOEs provides cost-savings opportunities for system refinement and a new iteration of system development.

This thesis has fulfilled the research objectives and this research has provided learning opportunities to develop meaningful MOEs that evaluate the use of deployed C2 system in the land battlefield.

THIS PAGE INTENTIONALLY LEFT BLANK

LIST OF REFERENCES

- Alberts, D. S., & Hayes, R. E. 2003. *Power to the Edge: Command and Control in the information Age*. Washington, DC: DOD Command and Control Research Program.
- Alberts, D. S., & Hayes, R. E. 2006. *Understanding Command and Control*. Washington, DC: DOD Command and Control Research Program.
- Bornman, L. G., Jr. 1993. *Command and Control Measures of Effectiveness Handbook*. Technical Document TRAC-TD-0393. Fort Leavenworth, KS: Study and Analysis Center.
- Builder, Carl H., Steven C. Bankes, and Richard Nordin. 1999. *Command Concepts: A Theory Derived from the Practice of Command and Control*. Santa Monica, CA: National Defense Research Institute.
- Department of Defense (DOD). 2005. *The Implementation of Network-Centric Warfare*. Office of Force Transformation. Washington, DC: Government Printing Office.
- Department of Defense (DOD). 2012. *Standard Practice for System Safety (MIL-STD-882E)*. Washington, DC: Department of Defense.
- Hee Hon, Pang. 2007. *Battlefield Management Systems: Perspective from Singapore*. London, Great Britain. Royal United Services Institute.
- Hughes, Wayne P. 1989. *Command and Control within the Framework of a Theory of Combat*. Monterey, CA: Naval Postgraduate School.
- Joint Chiefs of Staff. (2013, March 25). *Joint Publication 1, Doctrine for the Armed Forces of the United States*. Retrieved from Defense Technical Information Center: http://www.dtic.mil/doctrine/new_pubs/jp1.pdf
- Langford, Gary. 2012. *Engineering Systems Integration: Theory, Metrics, and Methods*. Boca Raton, FL: CRC Press.
- Langford, Gary. 2013. *Toward A General Theory of Systems Integration: Research in the Context of Systems Engineering*. Adelaide, SA: University of South Australia, Defence and Systems Institute (DASI) School of Electrical and Information Engineering.
- . 2014. *Building the Determinants of Cyber Deterrence Effectiveness*. Unpublished manuscript.
- Lawson, J. S. 1981, March. "Command and Control as a Process." *IEEE Control Systems Magazine*, 5–6.

- Maier, M. W. n.d. "Architecting Principles for Systems-of-Systems." *Info/Ed: Enterprise and Systems Architecture*: <http://www.cesames.net/fichier.php?id=252>
- Maier, M. W., & Rechtin, E. 2009. *The Art of Systems Architecting*, 3rd ed. Boca Raton, FL: CRC Press.
- Rechtin, E. 1991. *Systems Architecting: Creating & Building Complex Systems*. Los Angeles, CA: Prentice Hall.
- Roedler, Garry J., and Cheryl Jones. 2005. "Technical Measurement; A Collaborative project, PSM, INCOSE, and Industry." INCOSE.
- Sproles, Noel. 2000. "Coming to Grips with Measures of Effectiveness." *Systems Engineering* 3, no. 1: 50–58.
- Sproles, Noel. 2002. "Formulating Measures of Effectiveness." *Systems Engineering* 5 (4): 253–63.
- Stevens, Roger T. 1986. *Operational Test & Evaluation: A Systems Engineering Process*. Malabar, FL: Robert E. Krieger Publishing.
- Taguchi, G., S. Chowdhury, and Y. Wu. 2005. *Taguchi's Quality Engineering Handbook*. Hoboken, NJ: John Wiley.

INITIAL DISTRIBUTION LIST

1. Defense Technical Information Center
Ft. Belvoir, Virginia
2. Dudley Knox Library
Naval Postgraduate School
Monterey, California